



# GENUINE PARTS

## INSTALLATION INSTRUCTIONS

<b>DESCRIPTION:</b>	Tow Hitch Receiver
<b>APPLICATION:</b>	JX (2013)
<b>PART NUMBER:</b>	Tow Hitch Receiver (999T5 RZ100)

Installation of this accessory first requires installation of additional parts:

- Tow Hitch Finisher (999T5 RZ030)
- Trailer Tow Harness (999T8 YZ000)

### KIT CONTENTS:

Item	Qty.	Part Description	Service Part Number
A	1	Tow Hitch Receiver	51170 3KA0A
B	10	Bolt - FLG (M12)	11-25 N2101
C	1	Installation Instruction Replacement Template	N/A

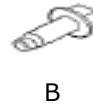
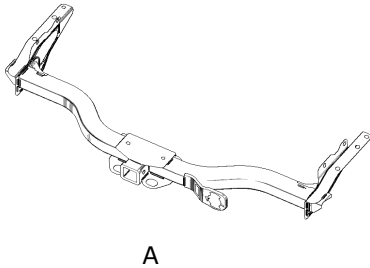

### TOOLS REQUIRED:

- Socket Wrench
- 9" Socket Extension
- 13mm Socket
- 17mm Socket
- Torque Wrench
- Safety Glasses

### PRE-INSTALLATION WARNINGS, CAUTIONS, CRITICAL STEPS, and NOTES:

- Before Hitch installation, the following parts must have installation started:
  - Tow Hitch Finisher (999T5 RZ030)
  - Trailer Tow Harness (999T8 YZ000)
- Dealer Installation Recommended. Instructions may refer to Service Manual.
- This product complies with SAE J684

### ⚠ WARNING

- See owners manual for vehicle towing rating.
- Make sure the vehicle has cooled down prior to beginning this installation procedure. One of the steps within the procedure requires that the exhaust be lowered. Failure to observe this warning could result in bodily injury.

### ⚠ CAUTION

- Make sure that vehicle back door is closed before beginning.
- Be careful of sharp edges and hanging components when under vehicle.
- Bolts must be tightened according to the specified torque values.

## INSTALLATION PROCEDURE:

1) Raise and secure vehicle on lift.

**a) Confirm Installation of the following parts has been started before proceeding further:**

- Tow Hitch Finisher (999T5 RZ030)
- Trailer Tow Harness (999T8 YZ000)

2) Lower spare tire and store in safe place for later use. (See Owners Manual)

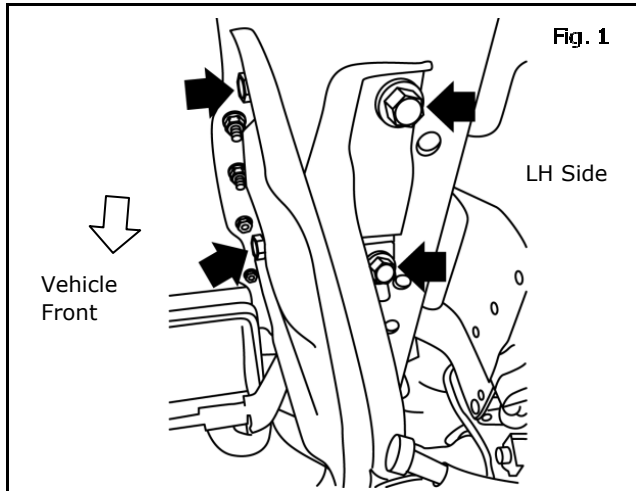

- 3) Remove tow hook.
- Remove four bolts and discard.
  - Discard tow hook.

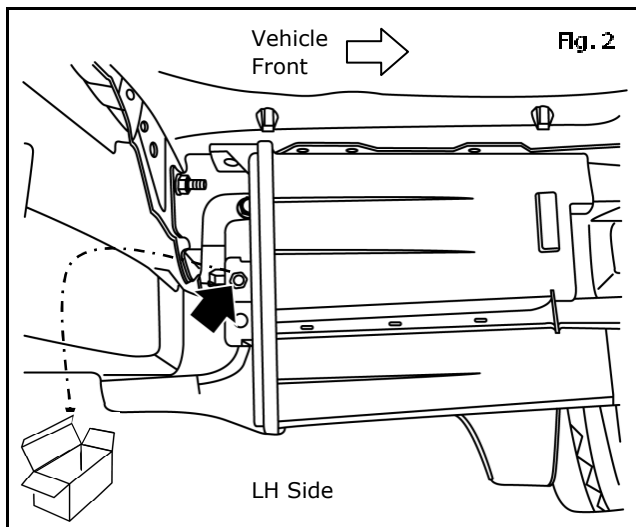

- 4) Remove evap canister bolt and position evap canister aside.
- Allow Evap Canister to hang freely.
  - Save bolt for re-installation step.

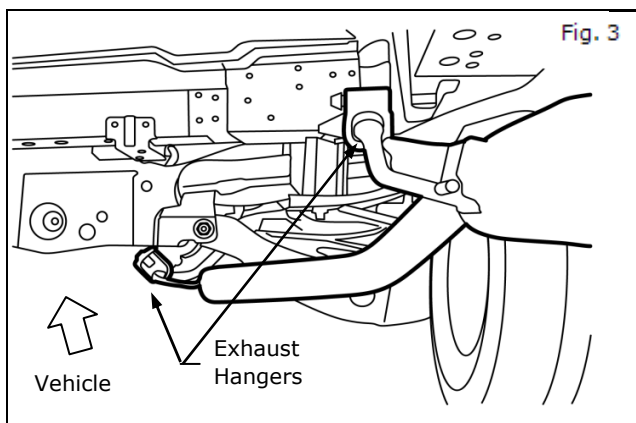

- 5) Remove Rubber exhaust pipe hangers from their brackets as shown in figure 3.
- Allow Exhaust to hang freely.

## INSTALLATION PROCEDURE:

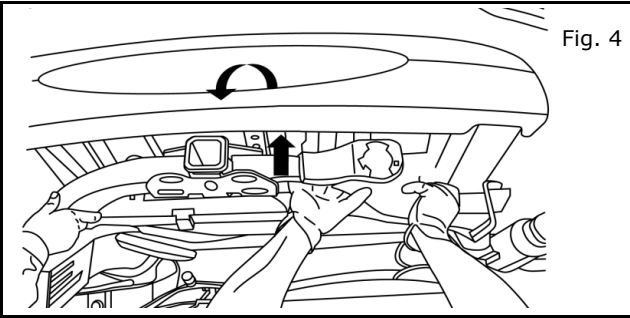

- 6) Rotate hitch into position with the help of an assistant.

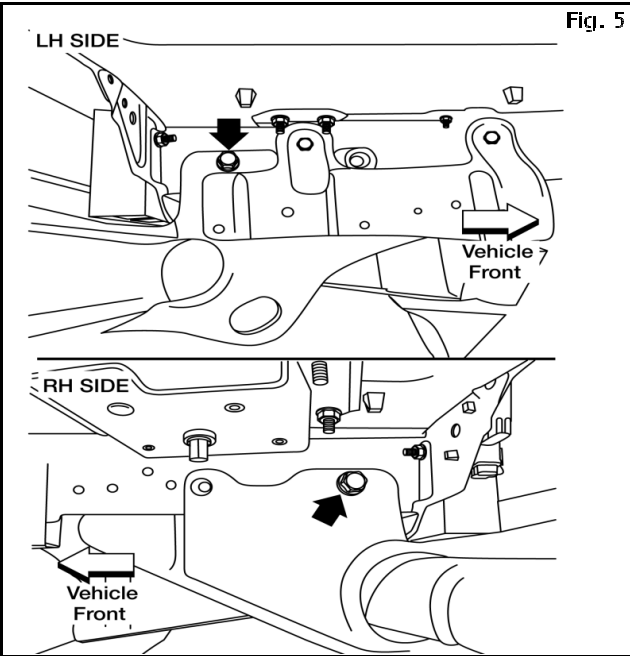

- 7) Install one bolt at each side as shown in figure 5.  
a) Thread bolts in at least half way, but do not tighten.

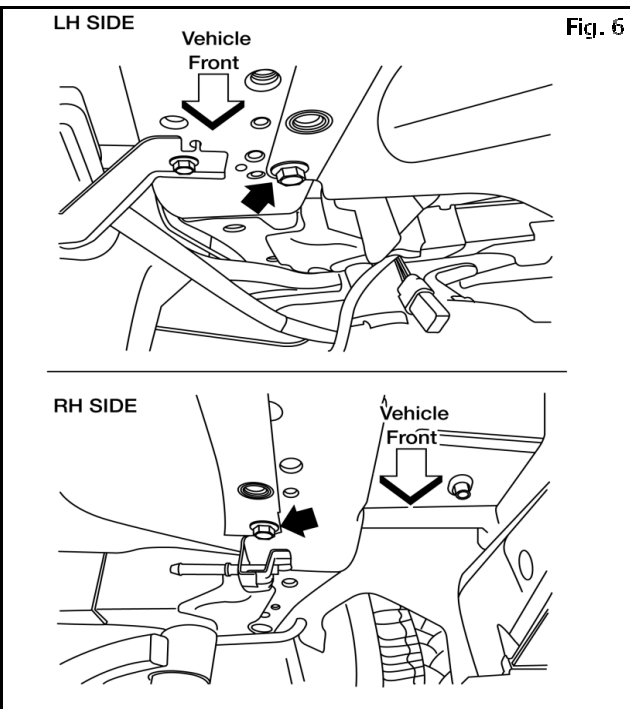

- 8) Install one locator bolt at each side as shown in  
a) Thread bolts in at least half way, but do not tighten.



## WARNING

Thread bolt on each side in at least half way, but do not fully tighten, so the hitch is secure. Failure to properly secure the hitch can result in injury to the installer, his assistant or damage to hitch.

**INSTALLATION PROCEDURE:**

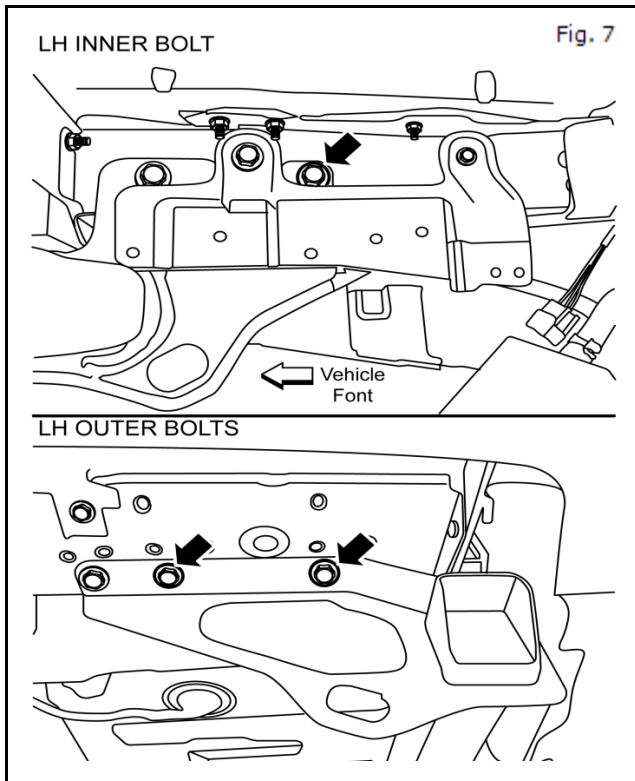

- 9) Install remaining three bolts at LH side as shown in figure 7.
- a) Thread bolts in at least half way, but do not tighten.

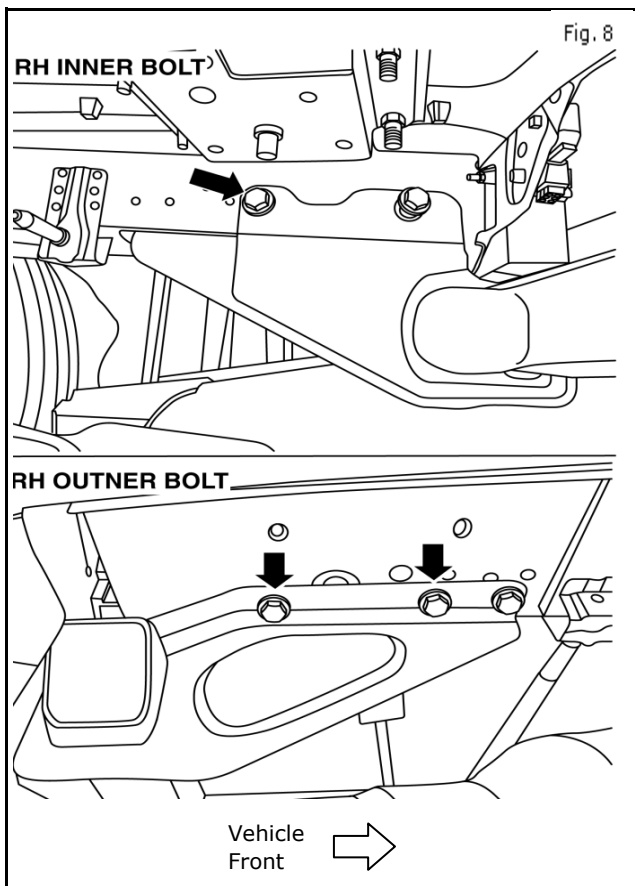

- 10) Install remaining three bolts at RH side as shown in figure 8.
- a) Thread bolts in at least half way, but do not tighten.

## INSTALLATION PROCEDURE:

- 11) Using sequence below, tighten all ten bolts that secure the trailer hitch to 110 N-m (81 ft-lb).
  - a) First, tighten LH bolt shown in Fig 6, Step 8.
  - b) Second, tighten RH bolt shown in Fig 6, Step 8.
  - c) Third, tighten remaining four vertical bolts (LH & RH **Outer** bolts) shown in Figs 7 & 8 , Steps 9 & 10.
  - d) Lastly, tighten remaining four horizontal bolts (LH & RH **Inner** bolts) shown in Figs 7 & 8 , Steps 9 & 10.
- 12) Install exhaust pipe to each of the two hangers removed in step 5.
- 13) Install EVAP canister removed in step 4. Secure with one bolt removed. Torque to 27 N-m (20 ft-lb).
- 14) Complete installation of Trailer Tow Harness.
  - a) See installation instructions for Trailer Tow Harness (999T8 YZ000).
- 15) Complete installation of Tow Hitch Finisher.
  - a) See installation instructions for Tow Hitch Finisher (999T5 RZ030).
- 16) Install spare tire removed in step 2. (See Owners Manual)
- 17) Lower and remove vehicle from lift. Installation is completed.