

**SECTION MA**  
**MAINTENANCE**

A  
B  
C  
D  
E  
F  
G  
H  
I  
J  
K  
L  
M  
N  
O

**CONTENTS**

<p><b>PREPARATION ..... 4</b></p> <p><b>PREPARATION ..... 4</b>                  Special Service Tool .....4                  Commercial Service Tool .....4</p> <p><b>PERIODIC MAINTENANCE ..... 5</b></p> <p><b>GENERAL MAINTENANCE ..... 5</b>                  Explanation of General Maintenance .....5</p> <p><b>PERIODIC MAINTENANCE ..... 7</b>                  Introduction of Periodic Maintenance .....7</p> <p><b>RECOMMENDED FLUIDS AND LUBRICANTS .....11</b>                  Fluids and Lubricants ..... 11                  SAE Viscosity Number .....13                  Anti-Freeze Coolant Mixture Ratio ..... 13</p> <p><b>ENGINE MAINTENANCE (MR FOR NISMO RS MODELS) .....15</b></p> <p><b>DRIVE BELT .....15</b>                  DRIVE BELT : Exploded View ..... 15                  DRIVE BELT : Inspection ..... 15                  DRIVE BELT : Adjustment ..... 15</p> <p><b>ENGINE COOLANT .....15</b>                  ENGINE COOLANT : Inspection .....16                  ENGINE COOLANT : Draining .....16                  ENGINE COOLANT : Refilling .....17                  ENGINE COOLANT : Flushing ..... 18</p> <p><b>RADIATOR CAP .....19</b>                  RADIATOR CAP : Inspection ..... 19</p> <p><b>RADIATOR .....20</b>                  RADIATOR : Inspection .....20</p> <p><b>FUEL LINES .....20</b>                  FUEL LINES : Inspection .....20</p>	<p><b>AIR CLEANER FILTER .....20</b>                  AIR CLEANER FILTER : Removal and Installation .....20                  AIR CLEANER FILTER : Inspection (Viscous Paper Type) .....21</p> <p><b>ENGINE OIL .....21</b>                  ENGINE OIL : Draining .....21                  ENGINE OIL : Refilling .....22</p> <p><b>OIL FILTER .....22</b>                  OIL FILTER : Removal and Installation .....22                  OIL FILTER : Inspection .....23</p> <p><b>SPARK PLUG .....23</b>                  SPARK PLUG : Removal and Installation .....23                  SPARK PLUG : Inspection .....23</p> <p><b>EVAP VAPOR LINES .....24</b>                  EVAP VAPOR LINES : Inspection .....24</p> <p><b>ENGINE MAINTENANCE (MR EXCEPT FOR NISMO RS MODELS) .....25</b></p> <p><b>DRIVE BELT .....25</b>                  DRIVE BELT : Inspection .....25</p> <p><b>ENGINE COOLANT .....25</b>                  ENGINE COOLANT : Inspection .....25                  ENGINE COOLANT : Draining and Filling .....26                  ENGINE COOLANT : Flushing .....29</p> <p><b>RADIATOR CAP .....30</b>                  RADIATOR CAP : Radiator Cap Inspection .....30</p> <p><b>FUEL LINES .....30</b>                  FUEL LINES : Inspection .....30</p> <p><b>AIR CLEANER FILTER .....30</b>                  AIR CLEANER FILTER : Removal and Installation .....31</p> <p><b>ENGINE OIL .....31</b>                  ENGINE OIL : Draining .....31</p>
--	---



ENGINE OIL : Refilling .....	31	<b>DISC BRAKE</b> .....	<b>44</b>
<b>OIL FILTER</b> .....	<b>32</b>	DISC BRAKE : Inspection .....	44
OIL FILTER : Removal and Installation .....	32	DISC BRAKE : Front Disc Brake .....	45
OIL FILTER : Inspection .....	32	DISC BRAKE : Rear Disc Brake .....	45
<b>SPARK PLUG</b> .....	<b>33</b>	<b>STEERING GEAR AND LINKAGE</b> .....	<b>45</b>
SPARK PLUG : Removal and Installation .....	33	STEERING GEAR AND LINKAGE : Inspection .....	46
SPARK PLUG : Inspection .....	33	<b>AXLE AND SUSPENSION PARTS</b> .....	<b>46</b>
<b>EVAP VAPOR LINES</b> .....	<b>34</b>	AXLE AND SUSPENSION PARTS : Inspection .....	46
EVAP VAPOR LINES : Inspection .....	34	<b>DRIVE SHAFT</b> .....	<b>46</b>
<b>CHASSIS MAINTENANCE</b> .....	<b>35</b>	DRIVE SHAFT : Inspection .....	46
<b>EXHAUST SYSTEM</b> .....	<b>35</b>	<b>BODY MAINTENANCE</b> .....	<b>47</b>
EXHAUST SYSTEM : Inspection .....	35	<b>LOCKS, HINGES AND HOOD LATCH</b> .....	<b>47</b>
<b>CVT FLUID (RE0F10B)</b> .....	<b>35</b>	LOCKS, HINGES AND HOOD LATCH : Lubricat- ing .....	47
CVT FLUID (RE0F10B) : Inspection .....	35	<b>SEAT BELT, BUCKLES, RETRACTORS, AN- CHORS AND ADJUSTERS</b> .....	<b>47</b>
<b>CVT FLUID (RE0F10D)</b> .....	<b>36</b>	SEAT BELT, BUCKLES, RETRACTORS, AN- CHORS AND ADJUSTERS : Inspection .....	47
CVT FLUID (RE0F10D) : Inspection .....	36	<b>SERVICE DATA AND SPECIFICATIONS (SDS)</b> .....	<b>48</b>
<b>GEAR OIL (RS6F94R)</b> .....	<b>36</b>	<b>SERVICE DATA AND SPECIFICATIONS (SDS)</b> .....	<b>48</b>
GEAR OIL (RS6F94R) : Inspection .....	36	<b>DRIVE BELT (MR FOR NISMO RS MODELS)</b> .....	<b>48</b>
GEAR OIL (RS6F94R) : Draining .....	37	DRIVE BELT (MR FOR NISMO RS MODELS) : Drive Belt .....	48
GEAR OIL (RS6F94R) : Refilling .....	37	<b>DRIVE BELT (MR EXCEPT FOR NISMO RS MOD- ELS)</b> .....	<b>48</b>
<b>GEAR OIL (RS6F52H)</b> .....	<b>37</b>	DRIVE BELT (MR EXCEPT FOR NISMO RS MODELS) : Drive Belt .....	48
GEAR OIL (RS6F52H) : Inspection .....	37	<b>ENGINE COOLANT (MR FOR NISMO RS MOD- ELS)</b> .....	<b>48</b>
GEAR OIL (RS6F52H) : Draining .....	38	ENGINE COOLANT (MR FOR NISMO RS MOD- ELS) : Periodical Maintenance Specification .....	48
GEAR OIL (RS6F52H) : Refilling .....	38	<b>ENGINE COOLANT (MR EXCEPT FOR NISMO RS MODELS)</b> .....	<b>48</b>
<b>CLUTCH FLUID</b> .....	<b>38</b>	ENGINE COOLANT (MR EXCEPT FOR NISMO RS MODELS) : Periodical Maintenance Specifica- tion .....	48
CLUTCH FLUID : Inspection .....	38	<b>ENGINE OIL (MR FOR NISMO RS MODELS)</b> .....	<b>48</b>
<b>TRANSFER OIL</b> .....	<b>39</b>	ENGINE OIL (MR FOR NISMO RS MODELS) : Periodical Maintenance Specification .....	48
TRANSFER OIL : Inspection .....	39	<b>ENGINE OIL (MR EXCEPT FOR NISMO RS MOD- ELS)</b> .....	<b>48</b>
TRANSFER OIL : Draining .....	39	ENGINE OIL (MR EXCEPT FOR NISMO RS MODELS) : Periodical Maintenance Specification... ..	48
TRANSFER OIL : Refilling .....	40	<b>SPARK PLUG (MR FOR NISMO RS MODELS)</b> .....	<b>49</b>
<b>REAR PROPELLER SHAFT</b> .....	<b>40</b>	SPARK PLUG (MR FOR NISMO RS MODELS) : Spark Plug .....	49
REAR PROPELLER SHAFT : Inspection .....	40		
<b>REAR DIFFERENTIAL GEAR OIL</b> .....	<b>40</b>		
REAR DIFFERENTIAL GEAR OIL : Inspection .....	41		
REAR DIFFERENTIAL GEAR OIL : Draining .....	41		
REAR DIFFERENTIAL GEAR OIL : Refilling .....	41		
<b>WHEELS (BONDING WEIGHT TYPE)</b> .....	<b>41</b>		
WHEELS (BONDING WEIGHT TYPE) : Wheel Balance Adjustment .....	41		
WHEELS (BONDING WEIGHT TYPE) : Tire Rota- tion .....	43		
<b>BRAKE FLUID LEVEL AND LEAKS</b> .....	<b>43</b>		
BRAKE FLUID LEVEL AND LEAKS : Inspection ...	43		
<b>BRAKE LINES AND CABLES</b> .....	<b>43</b>		
BRAKE LINES AND CABLES : Inspection .....	44		
<b>BRAKE FLUID</b> .....	<b>44</b>		
BRAKE FLUID : Changing .....	44		

<b>SPARK PLUG (MR EXCEPT FOR NISMO RS MODELS) .....</b>	<b>49</b>	<b>ROAD WHEEL .....</b>	<b>49</b>
SPARK PLUG (MR EXCEPT FOR NISMO RS MODELS) : Spark Plug .....	49	ROAD WHEEL : Road Wheel .....	49

A  
B  
C  
D  
E  
F  
G  
H  
I  
J  
K  
L  
M  
N  
O

MA

# PREPARATION

< PREPARATION >

## PREPARATION

### PREPARATION

#### Special Service Tool

INFOID:000000011463941

The actual shapes of TechMate tools may differ from those of special service tools illustrated here.

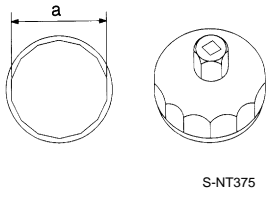
Tool number (TechMate No.) Tool name	Description
KV10115801 (J 38956) Oil filter wrench <div style="text-align: center;">  <p>S-NT375</p> </div>	Removing and installing oil filter <b>a: 64.3 mm (2.531 in)</b>

#### Commercial Service Tool

INFOID:000000011463942

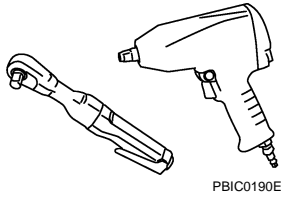
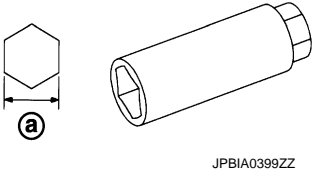
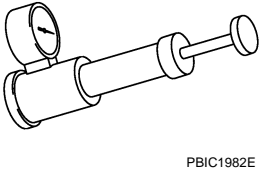
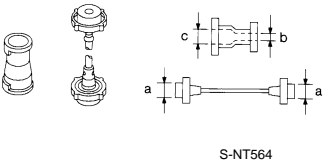
Tool name	Description
Power tool <div style="text-align: center;">  <p>PBIC0190E</p> </div>	Loosening nuts and bolts
Spark plug wrench <div style="text-align: center;">  <p>JPBIA0399ZZ</p> </div>	Removing and installing spark plug a : 14 mm (0.55 in)
Radiator cap tester <div style="text-align: center;">  <p>PBIC1982E</p> </div>	Checking radiator and radiator cap
Radiator cap tester adapter <div style="text-align: center;">  <p>S-NT564</p> </div>	Adapting radiator cap tester to radiator cap and radiator filler neck <b>a: 28 (1.10) dia.</b> <b>b: 31.4 (1.236) dia.</b> <b>c: 41.3 (1.626) dia.</b> Unit: mm (in)

# GENERAL MAINTENANCE

< PERIODIC MAINTENANCE >

## PERIODIC MAINTENANCE

### GENERAL MAINTENANCE

#### Explanation of General Maintenance

INFOID:0000000011463943

General maintenance includes those items which should be checked during the normal day-to-day operation of the vehicle. They are essential if the vehicle is to continue operating properly. The owners can perform checks and inspections themselves or have their **NISSAN** dealers do them.

#### OUTSIDE THE VEHICLE

The maintenance items listed here should be performed from time to time, unless otherwise specified.

Item		Reference page
<b>Tires</b>	Check the pressure with a gauge often and always prior to long distance trips. Adjust the pressure in all tires, including the spare, to the specified pressure. Check carefully for damage, cuts or excessive wear.	<a href="#">WT-43</a>
<b>Wheel nuts</b>	When checking the tires, make sure no nuts are missing, and check for any loose nuts. Tighten if necessary.	—
<b>Tire rotation</b>	Tires should be rotated every 5,000 miles (8,000 km).	<a href="#">WT-38</a>
<b>Tire Pressure Monitoring System (TPMS) transmitter components</b>	Replace the TPMS transmitter grommet seal, valve core and cap when the tires are replaced due to wear or age.	<a href="#">WT-40</a>
<b>Wheel alignment and balance</b>	If the vehicle should pull to either side while driving on a straight and level road, or if you detect uneven or abnormal tire wear, there may be a need for wheel alignment. If the steering wheel or seat vibrates at normal highway speeds, wheel balancing may be needed. For additional information regarding tires, refer to "Important Tire Safety Information" (US) or "Tire Safety Information" (Canada) in the NISSAN Warranty Information Booklet.	<a href="#">FSU-7</a> <a href="#">RSU-7(2WD)</a> <a href="#">RSU-22(AWD)</a> <a href="#">WT-37</a>
<b>Windshield</b>	Clean the windshield on a regular basis. Check the windshield at least every six months for cracks or other damage. Repair as necessary.	—
<b>Windshield wiper blades</b>	Check for cracks or wear if they do not wipe properly.	—
<b>Doors and engine hood</b>	Check that all doors and the engine hood operate smoothly as well as the back door, trunk lid and back hatch. Also make sure that all latches lock securely. Lubricate if necessary. Make sure that the secondary latch keeps the hood from opening when the primary latch is released. When driving in areas using road salt or other corrosive materials, check lubrication frequently.	<a href="#">MA-47</a>
<b>Lamps</b>	Make sure that the headlamps, stop lamps, tail lamps, turn signal lamps, and other lamps are all operating properly and installed securely. Also check headlamp aim. Clean the headlamps on a regular basis.	—

#### INSIDE THE VEHICLE

The maintenance items listed here should be checked on a regular basis, such as when performing periodic maintenance, cleaning the vehicle, etc.

Item		Reference page
<b>Warning lamps and chimes</b>	Make sure that all warning lamps and chimes are operating properly.	—
<b>Windshield wiper and washer</b>	Check that the wipers and washer operate properly and that the wipers do not streak.	—
<b>Windshield defroster</b>	Check that the air comes out of the defroster outlets properly and in sufficient quantity when operating the heater or air conditioning.	—
<b>Steering wheel</b>	Check that it has the specified play. Check for changes in the steering condition, such as excessive play, hard steering or strange noises. <b>Free play: Less than 35 mm (1.38 in)</b>	—

## GENERAL MAINTENANCE

### < PERIODIC MAINTENANCE >

Item		Reference page
<b>Seats</b>	Check seat position controls such as seat adjusters, seatback recliner, etc. to make sure they operate smoothly and that all latches lock securely in every position. Check that the head restraints move up and down smoothly and that the locks (if equipped) hold securely in all latched positions. Check that the latches lock securely for folding-down rear seatbacks.	—
<b>Seat belts</b>	Check that all parts of the seat belt system (e.g. buckles, anchors, adjusters and retractors) operate properly and smoothly and are installed securely. Check the belt webbing for cuts, fraying, wear or damage.	<a href="#">MA-47</a>
<b>Accelerator pedal</b>	Check the pedal for smooth operation and make sure the pedal does not catch or require uneven effort. Keep the floor mats away from the pedal.	—
<b>Brakes</b>	Check that the brake does not pull the vehicle to one side when applied.	—
<b>Brake pedal and booster</b>	Check the pedal for smooth operation and make sure it has the proper distance under it when depressed fully. Check the brake booster function. Be sure to keep floor mats away from the pedal.	<a href="#">BR-9</a> <a href="#">BR-15</a>
<b>Clutch pedal</b>	Make sure the pedal operates smoothly and check that it has the proper free play.	<a href="#">CL-6</a>
<b>Parking brake</b>	Check that the lever or pedal has the proper travel and make sure that the vehicle is held securely on a fairly steep hill when only the parking brake is applied.	<a href="#">PB-4</a>
<b>CVT P (Park) position mechanism</b>	On a fairly steep hill check that the vehicle is held securely with the selector lever in the “P” position without applying any brakes.	—

### UNDER THE HOOD AND VEHICLE

The maintenance items listed here should be checked periodically (e.g. each time you check the engine oil or refuel).

Item		Reference page
<b>Windshield washer fluid</b>	Check that there is adequate fluid in the tank.	—
<b>Engine coolant level</b>	Check the coolant level when the engine is cold.	<a href="#">MA-16</a> <a href="#">MA-25</a>
<b>Radiator and hoses</b>	Check the front of the radiator and clean off any dirt, insects, leaves, etc., that may have accumulated. Make sure the radiator hoses have no cracks, deformation, deterioration or loose connections.	<a href="#">MA-20</a>
<b>Brake and clutch fluid levels</b>	Make sure that the brake and clutch fluid level(s) are(is) between the “MAX” and “MIN” lines on the reservoir(s).	<a href="#">MA-43</a> <a href="#">MA-38</a>
<b>Battery</b>	Check the fluid level in each cell. It should be between the “MAX” and “MIN” lines. Vehicles operated in high temperatures or under severe conditions require frequent checks of the battery fluid level.	<a href="#">PG-108</a>
<b>Engine drive belts</b>	Make sure that no belt is frayed, worn, cracked or oily.	<a href="#">MA-15</a> <a href="#">MA-25</a>
<b>Engine oil level</b>	Check the level on the oil level gauge after parking the vehicle on a level spot and turning off the engine.	<a href="#">LU-9</a> <a href="#">LU-28</a>
<b>Exhaust system</b>	Make sure there are no loose supports, cracks or holes. If the sound of the exhaust seems unusual or there is a smell of exhaust fumes, immediately locate the trouble and correct it.	<a href="#">MA-35</a>
<b>Underbody</b>	The underbody is frequently exposed to corrosive substances such as those used on icy roads or to control dust. It is very important to remove these substances, otherwise rust will form on the floor pan, frame, fuel lines and around the exhaust system. At the end of winter, the underbody should be thoroughly flushed with plain water, being careful to clean those areas where mud and dirt can easily accumulate.	—
<b>Fluid leaks</b>	Check under the vehicle for fuel, oil, water or other fluid leaks after the vehicle has been parked for a while. Water dripping from the air conditioner after use is normal. If you should notice any leaks or gasoline fumes are evident, check for the cause and correct it immediately.	—

# PERIODIC MAINTENANCE

< PERIODIC MAINTENANCE >

## PERIODIC MAINTENANCE

### Introduction of Periodic Maintenance

INFOID:000000011463944

The following tables show the normal maintenance schedule. Depending upon weather and atmospheric conditions, varying road surfaces, individual driving habits and vehicle usage, additional or more frequent maintenance may be required.

**Periodic maintenance beyond the last period shown on the tables requires similar maintenance.**

### Emission Control System Maintenance

Abbreviations: R = Replace. I = Inspect. Correct or replace if necessary.

MAINTENANCE OPERATION		MAINTENANCE INTERVAL								
		5 (8)	10 (16)	15 (24)	20 (32)	25 (40)	30 (48)	35 (56)	40 (64)	45 (72)
Perform at number of miles, kilometers or months, whichever comes first.	Miles x 1,000 (km x 1,000) Months	6	12	18	24	30	36	42	48	54
Drive belt	NOTE (1)								I*	
Air cleaner filter	NOTE (2)						R			
EVAP vapor lines					I*				I*	
Fuel lines					I*				I*	
Fuel filter	NOTE (3)									
Engine coolant*	NOTE (4)(5)									
Engine oil		R	R	R	R	R	R	R	R	R
Engine oil filter (Use genuine NISSAN engine oil filter or equivalent)		R	R	R	R	R	R	R	R	R
Spark plugs (Iridium/platinum-tipped type)	NOTE (6)	Replace every 105,000 miles (168,000 km)								
Intake and exhaust valve clearance*	NOTE (7)									

MAINTENANCE OPERATION		MAINTENANCE INTERVAL								
		50 (80)	55 (88)	60 (96)	65 (104)	70 (112)	75 (120)	80 (128)	85 (136)	90 (144)
Perform at number of miles, kilometers or months, whichever comes first.	Miles x 1,000 (km x 1,000) Months	60	66	72	78	84	90	96	102	108
Drive belt	NOTE (1)	I*		I*		I*		I*		I*
Air cleaner filter	NOTE (2)			R						R
EVAP vapor lines				I*				I*		
Fuel lines				I*				I*		
Fuel filter	NOTE (3)									
Engine coolant*	NOTE (4)(5)									
Engine oil		R	R	R	R	R	R	R	R	R
Engine oil filter (Use genuine NISSAN engine oil filter or equivalent)		R	R	R	R	R	R	R	R	R
Spark plugs (Iridium/platinum-tipped type)	NOTE (6)	Replace every 105,000 miles (168,000 km)								
Intake and exhaust valve clearance*	NOTE (7)									

A  
B  
C  
D  
E  
F  
G  
H  
I  
J  
K  
L  
M  
N  
O

MA

# PERIODIC MAINTENANCE

## < PERIODIC MAINTENANCE >

MAINTENANCE OPERATION		MAINTENANCE INTERVAL						Reference Page	
		Miles x 1,000 (km x 1,000) Months	95 (152) 114	100 (160) 120	105 (168) 126	110 (176) 132	115 (184) 138		120 (192) 144
Perform at number of miles, kilometers or months, whichever comes first.									
Drive belt	NOTE (1)		I*			I*		I*	<a href="#">MA-15</a> <a href="#">MA-25</a>
Air cleaner filter	NOTE (2)							R	<a href="#">MA-20</a> <a href="#">MA-31</a>
EVAP vapor lines			I*					I*	<a href="#">MA-24</a> <a href="#">MA-34</a>
Fuel lines			I*					I*	<a href="#">MA-20</a> <a href="#">MA-30</a>
Fuel filter	NOTE (3)								—
Engine coolant*	NOTE (4)(5)								<a href="#">MA-16</a> <a href="#">MA-26</a>
Engine oil		R	R	R	R	R	R	R	<a href="#">MA-21</a> <a href="#">MA-31</a>
Engine oil filter (Use genuine NISSAN engine oil filter or equivalent)		R	R	R	R	R	R	R	<a href="#">MA-22</a> <a href="#">MA-32</a>
Spark plugs (Iridium/platinum-tipped type)	NOTE (6)	Replace every 105,000 miles (168,000 km)							<a href="#">MA-23</a> <a href="#">MA-33</a>
Intake and exhaust valve clearance*	NOTE (7)								<a href="#">EM-14</a> <a href="#">EM-178</a>

### NOTE:

- (1) After 40,000 miles (64,000 km) or 48 months, inspect every 10,000 miles (16,000 km) or 12 months. Replace the drive belts if found damaged.
- (2) If operating mainly in dusty conditions, more frequent maintenance may be required.
- (3) Maintenance-free item. For service procedures, refer to the FL section.
- (4) First replacement interval is 105,000 miles (168,000 km) or 84 months. After first replacement, replace every 75,000 miles (120,000 km) or 60 months.
- (5) Use only Genuine NISSAN Long Life Antifreeze/Coolant (blue) or equivalent with proper mixture ratio of 50% anti-freeze and 50% demineralized or distilled water. Mixing any other type of coolant or the use of non-distilled water will reduce the life expectancy of the factory fill coolant.
- (6) Replace spark plug when the plug gap exceeds 1.1 mm (0.043 in) even if within specified periodic replacement mileage.
- (7) Periodic maintenance is not required. However, if valve noise increases, inspect valve clearance.

\* Maintenance items and intervals with "\*" are recommended by NISSAN for reliable vehicle operation. The owner need not perform such maintenance in order to maintain the emission warranty or manufacturer recall liability. Other maintenance items and intervals are required.

## Chassis and Body Maintenance

Abbreviations: R = Replace. I = Inspect. Correct or replace if necessary.

MAINTENANCE OPERATION		MAINTENANCE INTERVAL								
		Miles x 1,000 (km x 1,000) Months	5 (8) 6	10 (16) 12	15 (24) 18	20 (32) 24	25 (40) 30	30 (48) 36	35 (56) 42	40 (64) 48
Perform at number of miles, kilometers or months, whichever comes first.										
Brake lines & cables			I		I		I		I	
Brake pads & rotors★			I		I		I		I	
Brake fluid★					R				R	
CVT fluid	NOTE (1)		I		I		I		I	
Manual transaxle gear oil	NOTE (2)		I		I		I		I	
Transfer fluid and differential gear oil	NOTE (2)		I		I		I		I	
Steering gear & linkage, axle & suspension parts★					I				I	



# PERIODIC MAINTENANCE

< PERIODIC MAINTENANCE >

MAINTENANCE OPERATION		MAINTENANCE INTERVAL									
Perform at number of miles, kilometers or months, whichever comes first.	Miles x 1,000 (km x 1,000)	5 (8)	10 (16)	15 (24)	20 (32)	25 (40)	30 (48)	35 (56)	40 (64)	45 (72)	
	Months	6	12	18	24	30	36	42	48	54	
Tire rotation	NOTE (3)										
Propeller shaft (AWD) & drive shaft boots★			I		I		I		I		
Exhaust system★					I				I		
In-cabin microfilter				R			R			R	

A  
B  
C  
D

MAINTENANCE OPERATION		MAINTENANCE INTERVAL									
Perform at number of miles, kilometers or months, whichever comes first.	Miles x 1,000 (km x 1,000)	50 (80)	55 (88)	60 (96)	65 (104)	70 (112)	75 (120)	80 (128)	85 (136)	90 (144)	
	Months	60	66	72	78	84	90	96	102	108	
Brake lines & cables		I		I		I		I		I	
Brake pads & rotors★		I		I		I		I		I	
Brake fluid★				R				R			
CVT fluid	NOTE (1)	I		I		I		I		I	
Manual transaxle gear oil	NOTE (2)	I		I		I		I		I	
Transfer fluid and differential gear oil	NOTE (2)	I		I		I		I		I	
Steering gear & linkage, axle & suspension parts★				I				I			
Tire rotation	NOTE (3)										
Propeller shaft (AWD) & drive shaft boots★		I		I		I		I		I	
Exhaust system★				I				I			
In-cabin microfilter				R			R			R	

E  
F  
G  
H  
I  
J

MAINTENANCE OPERATION		MAINTENANCE INTERVAL						Reference Page
Perform at number of miles, kilometers or months, whichever comes first.	Miles x 1,000 (km x 1,000)	95 (152)	100 (160)	105 (168)	110 (176)	115 (184)	120 (192)	
	Months	114	120	126	132	138	144	
Brake lines & cables			I		I		I	<a href="#">MA-44</a>
Brake pads & rotors★			I		I		I	<a href="#">MA-44</a>
Brake fluid★			R				R	<a href="#">MA-44</a>
CVT fluid	NOTE (1)		I		I		I	<a href="#">MA-35</a> <a href="#">MA-36</a>
Manual transaxle gear oil	NOTE (2)		I		I		I	<a href="#">MA-36</a> <a href="#">MA-37</a>
Transfer fluid and differential gear oil	NOTE (2)		I		I		I	<a href="#">MA-39</a> <a href="#">MA-41</a>
Steering gear & linkage, axle & suspension parts★			I				I	<a href="#">MA-46</a> <a href="#">MA-46</a>
Tire rotation	NOTE (3)							<a href="#">MA-5</a> <a href="#">MA-43</a>
Propeller shaft (AWD) & drive shaft boots★			I		I		I	<a href="#">MA-40</a> <a href="#">MA-46</a>
Exhaust system★			I				I	<a href="#">MA-35</a>
In-cabin microfilter				R			R	<a href="#">VTL-16</a>

K  
L  
M  
N  
O

MA

# PERIODIC MAINTENANCE

## < PERIODIC MAINTENANCE >

### NOTE:

- Maintenance items with “★” should be performed more frequently according to “Maintenance Under Severe Driving Conditions”.
- (1) Use only Genuine NISSAN CVT fluid. If towing a trailer, using a camper or a car-top carrier or driving on rough or muddy roads, inspect CVT fluid deterioration at NISSAN dealer every 60,000 miles (96,000 km), then change CVT fluid if necessary. And if the inspection is not performed, change (not just inspect) CVT fluid every 60,000 miles (96,000 km). Using transmission fluid other than Genuine NISSAN CVT Fluid will damage the CVT, which is not covered by the NISSAN new vehicle limited warranty.
- (2) If towing a trailer, using a camper or car-top carrier, or driving on rough or muddy roads, change (not just inspect) oil at every 20,000 miles (32,000 km) or 24 months.
- (3) Refer to “Tire rotation” under the “GENERAL MAINTENANCE” heading earlier in this section.

### MAINTENANCE UNDER SEVERE DRIVING CONDITIONS

The maintenance intervals shown on the preceding pages are for normal operating conditions. If the vehicle is mainly operated under severe driving conditions as shown below, more frequent maintenance must be performed on the following items as shown in the table.

#### Severe driving conditions

- Repeated short trips of less than 5 miles (8 km).
- Repeated short trips of less than 10 miles (16 km) with outside temperatures remaining below freezing.
- Operating in hot weather in stop-and-go “rush hour” traffic.
- Extensive idling and/or low speed driving for long distances, such as police, taxi or door-to-door delivery use.
- Driving in dusty conditions.
- Driving on rough, muddy, or salt spread roads.
- Towing a trailer, using a camper or a car-top carrier.

Maintenance operation: Inspect = Inspect and correct or replace as necessary.

Maintenance item	Maintenance operation	Maintenance interval	Reference page
Brake fluid	Replace	Every 10,000 miles (16,000 km) or 12 months	<a href="#">MA-44</a>
Brake pads & rotors	Inspect	Every 5,000 miles (8,000 km) or 6 months	<a href="#">MA-44</a>
Steering gear & linkage, axle & suspension parts	Inspect	Every 5,000 miles (8,000 km) or 6 months	<a href="#">MA-46</a> <a href="#">MA-46</a>
Propeller shaft (AWD) & drive shaft boots	Inspect	Every 5,000 miles (8,000 km) or 6 months	<a href="#">MA-40</a> <a href="#">MA-46</a>
Exhaust system	Inspect	Every 5,000 miles (8,000 km) or 6 months	<a href="#">MA-35</a>

# RECOMMENDED FLUIDS AND LUBRICANTS

< PERIODIC MAINTENANCE >

## RECOMMENDED FLUIDS AND LUBRICANTS

### Fluids and Lubricants

INFOID:000000011463945

The following are approximate capacities. The actual refill capacities may be slightly different. When refilling, follow the procedures described elsewhere in this manual.

Description			Capacity (Approximate)			Recommended Fluids/Lubricants	
			Liter	US measure	Imp measure		
Fuel	2WD models		50.0	13-1/4 gal	11 gal	Unleaded gasoline with an octane rating of at least 87 AKI (RON 91)	
	AWD models		45.0	11-7/8 gal	9-7/8 gal		
Engine oil Drain and refill	With oil filter change	For NISMO RS models	4.5	4-6/8 qt	4 qt	For NISMO RS models: <ul style="list-style-type: none"> <li>Genuine NISSAN engine oil or equivalent</li> <li>Engine oil with API Certification Mark*1, Viscosity SAE 5W-30</li> <li>As an alternative to this recommended oil, SAE 5W-30 or SAE 10W-30 conventional petroleum based oils may be used and meet all specifications and requirements necessary to maintain the New Vehicle Limited Warranty.</li> </ul> Except for NISMO RS models: <ul style="list-style-type: none"> <li>Genuine NISSAN engine oil or equivalent</li> <li>Engine oil with API Certification Mark*1, Viscosity SAE 0W-20</li> <li>As an alternative to this recommended oil, SAE 5W-30 conventional petroleum based oils may be used and meet all specifications and requirements necessary to maintain the New Vehicle Limited Warranty.</li> </ul> *1: For additional information, see "Engine Oil Recommendation".	
		Except for NISMO RS models	4.3	4-4/8 qt	3-6/8 qt		
	Without oil filter change	For NISMO RS models	4.3	4-4/8 qt	3-6/8 qt		
		Except for NISMO RS models	4.1	4-3/8 qt	3-5/8 qt		
Dry engine (engine overhaul)		For NISMO RS models	5.4	5-6/8 qt	4-6/8 qt		
		Except for NISMO RS models	5.2	5-4/8 qt	4-5/8 qt		
Cooling system	With reservoir tank	For NISMO RS models	M/T models	7.9	8-3/8 qt	7 qt	<ul style="list-style-type: none"> <li>Pre-diluted Genuine NISSAN Long Life Anti freeze / Coolant (blue) or equivalent</li> </ul>
			CVT models	8.1	8-1/2 qt	7-1/8 qt	
		Except for NISMO RS models	M/T models	8.5	9 qt	7-1/2 qt	
			CVT models	8.7	9-2/8 qt	7-5/8 qt	
	Reservoir tank			0.6	5/8 qt	1/2 qt	

A  
B  
C  
D  
E  
F  
G  
H  
I  
J  
K  
L  
M  
N  
O

MA

# RECOMMENDED FLUIDS AND LUBRICANTS

< PERIODIC MAINTENANCE >

Description		Capacity (Approximate)			Recommended Fluids/Lubricants
		Liter	US measure	Imp measure	
Manual transaxle fluid (MTF)	RS6F94R	2.0	4-1/4 pt	3-1/2 pt	For NISMO RS models: <ul style="list-style-type: none"> <li>Genuine NISSAN Manual Transmission Fluid (MTF) HQ Multi 75W-85 or equivalent</li> <li>If Genuine NISSAN Manual Transmission Fluid (MTF) HQ Multi 75W-85 is hard to obtain, API GL-4, Viscosity SAE 75W-85 may be used as a temporary replacement. However, use Genuine NISSAN gear oil as soon as it is available.</li> </ul> Except for NISMO RS models: <ul style="list-style-type: none"> <li>Genuine NISSAN Manual Transmission Fluid (MTF) TL/JR Type 75W-80, or equivalent</li> <li>If Genuine NISSAN Manual Transmission Fluid (MTF) TL/JR Type is not available, API GL-4+, Viscosity SAE 75W-80 may be used as a temporary replacement. However, use Genuine NISSAN Manual Transmission Fluid (MTF) TL/JR Type as soon as it is available.</li> </ul>
	RS6F52H	1.9	4 pt	3-3/8 pt	
CVT fluid	RE0F10B	8.6	9-1/8 qt	7-5/8 qt	For NISMO RS models: <ul style="list-style-type: none"> <li>Genuine NISSAN CVT Fluid NS-2</li> <li>NISSAN recommends using Genuine NISSAN CVT Fluid NS-2 ONLY in NISSAN CVTs. Do not mix with other fluids. Using fluids that are not equivalent to Genuine NISSAN CVT Fluid NS-2 may damage the CVT. Damage caused by the use of fluids other than as recommended is not covered under NISSAN's New Vehicle Limited Warranty.</li> </ul> Except for NISMO RS models: <ul style="list-style-type: none"> <li>Genuine NISSAN CVT Fluid NS-3</li> <li>NISSAN recommends using Genuine NISSAN CVT Fluid NS-3 ONLY in NISSAN CVTs. Do not mix with other fluids. Using fluids that are not equivalent to Genuine NISSAN CVT Fluid NS-3 may damage the CVT. Damage caused by the use of fluids other than as recommended is not covered under NISSAN's New Vehicle Limited Warranty.</li> </ul>
	RE0F10D	7.9	8-3/8 qt	7 qt	
Transfer fluid		0.37	3/4 pt	5/8 pt	<ul style="list-style-type: none"> <li>Genuine NISSAN Differential Oil Hypoid Super GL-5 80W-90 or equivalent (mineral oil)</li> </ul>
Differential gear oil		0.4	7/8 pt	3/4 pt	
Brake and clutch fluid		—	—	—	<ul style="list-style-type: none"> <li>Genuine NISSAN Super Heavy Duty Brake Fluid* or equivalent DOT 3 (US FMVSS No. 116)</li> <li>*: Available in mainland U.S.A. through a NISSAN dealer.</li> </ul>
Multi-purpose grease		—	—	—	<ul style="list-style-type: none"> <li>NLGI No. 2 (Lithium soap base)</li> </ul>
Windshield washer fluid		4.5	4-3/4 qt	4 qt	<ul style="list-style-type: none"> <li>Genuine NISSAN Windshield Washer Concentrate Cleaner &amp; Anti-Freeze or equivalent</li> </ul>

# RECOMMENDED FLUIDS AND LUBRICANTS

## < PERIODIC MAINTENANCE >

Description	Capacity (Approximate)			Recommended Fluids/Lubricants
	Liter	US measure	Imp measure	
Air conditioning system refrigerant	0.40 ± 0.05 kg	0.88 ± 0.10 lb	0.88 ± 0.10 lb	<ul style="list-style-type: none"> <li>HFC-134a (R-134a)</li> <li>For further details, see "Air conditioner specification label".</li> </ul>
Air conditioning system oil	120 mℓ	4.1 fl oz	4.2 fl oz	<ul style="list-style-type: none"> <li>A/C System Oil Type R (DH-PR)</li> <li>For further details, see "Air conditioner specification label".</li> </ul>

## SAE Viscosity Number

INFOID:000000011463946

NISSAN recommends the use of an energy conserving oil in order to improve fuel economy. Select only engine oils that meet the American Petroleum Institute (API) certification and International Lubrication Standardization and Approval Committee (ILSAC) certification and SAE viscosity standard. These oils have the API certification mark on the front of the container. Oils which do not have the specified quality label should not be used as they could cause engine damage.

- For NISMO RS models



1. API certification mark

2. API service symbol

- Except for NISMO RS models



1. API certification mark

2. API service symbol

## Anti-Freeze Coolant Mixture Ratio

INFOID:000000011463947

The engine cooling system is filled at the factory with a pre-diluted mixture of 50% Genuine NISSAN Long Life Antifreeze/Coolant (blue) and 50% water to provide year-round anti-freeze and coolant protection. The anti-freeze solution contains rust and corrosion inhibitors. Additional engine cooling system additives are not necessary.

### **WARNING:**

- Never remove the radiator or coolant reservoir cap when the engine is hot. Wait until the engine and radiator cool down. Serious burns could be caused by high pressure fluid escaping from the radiator.

## RECOMMENDED FLUIDS AND LUBRICANTS

### < PERIODIC MAINTENANCE >

---

- The radiator is equipped with a pressure type radiator cap. To prevent engine damage, use only a genuine NISSAN radiator cap.

**CAUTION:**

- When adding or replacing coolant, be sure to use only Genuine NISSAN Long Life Antifreeze/Coolant (blue) or equivalent. Genuine NISSAN Long Life Antifreeze/Coolant (blue) is pre-diluted to provide antifreeze protection to -34°F (-37°C). If additional freeze protection is needed due to weather where you operate your vehicle, add Genuine NISSAN Long Life Antifreeze/Coolant (blue) concentrate following the directions on the container. If an equivalent coolant other than Genuine NISSAN Long Life Antifreeze/Coolant (blue) is used, follow the coolant manufacturer's instructions to maintain minimum antifreeze protection to -34°F (-37°C). The use of other types of coolant solutions other than Genuine NISSAN Long Life Antifreeze/Coolant (blue) or equivalent may damage the engine cooling system.
- Mixing any other type of coolant other than Genuine NISSAN Long Life Antifreeze/Coolant (blue), including Genuine NISSAN Long Life Antifreeze/Coolant (green), or the use of non-distilled water will reduce the life expectancy of the factory-fill coolant.

# ENGINE MAINTENANCE (MR FOR NISMO RS MODELS)

< PERIODIC MAINTENANCE >

## ENGINE MAINTENANCE (MR FOR NISMO RS MODELS)

### DRIVE BELT

#### DRIVE BELT : Exploded View

INFOID:000000011735074

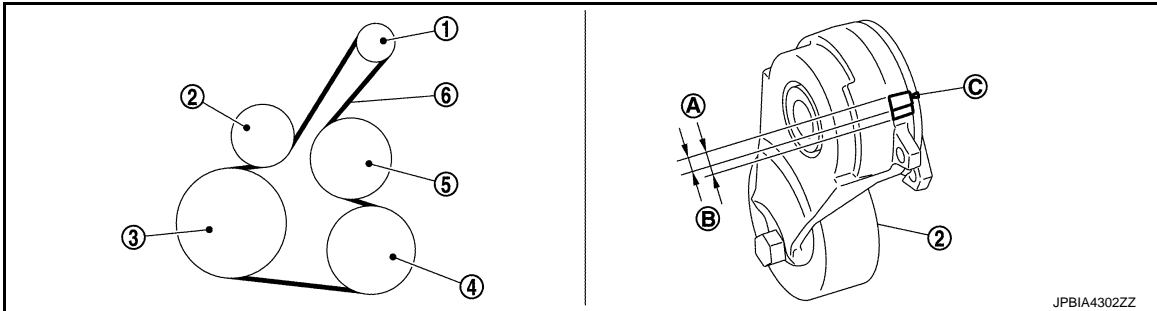

- |                       |   |                      |
|-----------------------|---|----------------------|
| 1. Alternator         | 2. Drive belt auto-tensioner              | 3. Crankshaft pulley |
| 4. A/C compressor     | 5. Water pump                             | 6. Drive belt        |
| A. Possible use range | B. Range when new drive belt is installed | C. Indicator         |

#### DRIVE BELT : Inspection

INFOID:000000011735075

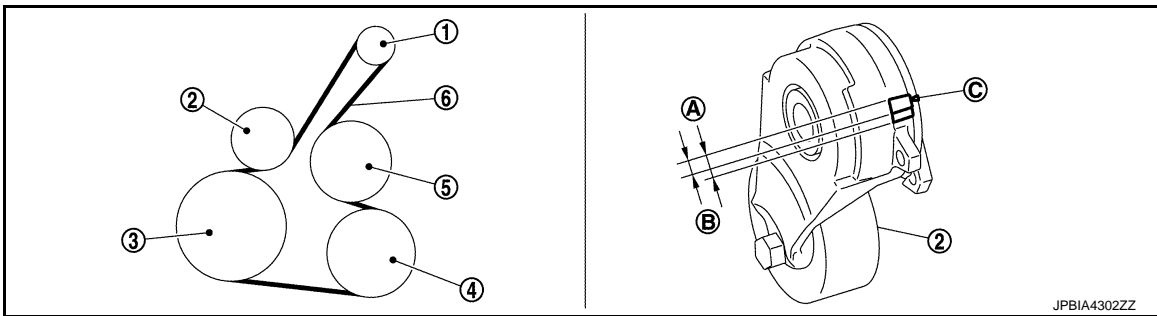

- |                       |   |                      |
|-----------------------|---|----------------------|
| 1. Alternator         | 2. Drive belt auto-tensioner              | 3. Crankshaft pulley |
| 4. A/C compressor     | 5. Water pump                             | 6. Drive belt        |
| A. Possible use range | B. Range when new drive belt is installed | C. Indicator         |

#### **WARNING:**

**Perform this step when engine is stopped.**

- Check that the indicator (C) (notch on fixed side) of drive belt auto-tensioner is within the possible use range (A) in the figure.

#### **NOTE:**

- Check the drive belt auto-tensioner indication when the engine is cold.
- When new drive belt is installed, the indicator (notch on fixed side) should be within the range (B) in the figure.
- Visually check entire drive belt for wear, damage or cracks.
- If the indicator (notch on fixed side) is out of the possible use range or belt is damaged, replace drive belt.

#### DRIVE BELT : Adjustment

INFOID:000000011735076

Refer to : [EM-138, "Drive Belt"](#).

### ENGINE COOLANT

MA

# ENGINE MAINTENANCE (MR FOR NISMO RS MODELS)

< PERIODIC MAINTENANCE >

## ENGINE COOLANT : Inspection

INFOID:000000011735081

### LEVEL

- Check that the reservoir tank engine coolant level is within the "MIN" to "MAX" when the engine is cool.

A : MAX

B : MIN

- Adjust the engine coolant level if necessary.

#### CAUTION:

Refill Genuine NISSAN Long Life Antifreeze/Coolant (blue) or equivalent in its quality mixed with water (distilled or demineralized). Refer to [MA-11, "Fluids and Lubricants"](#).

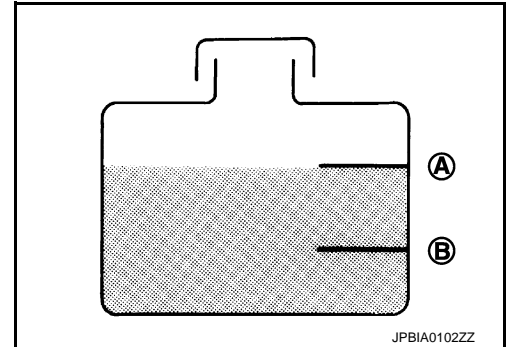

### LEAKAGE

- To check for leakage, apply pressure to the cooling system with the radiator cap tester (commercial service tool) (A) and the radiator cap tester adapter (commercial service tool) (B).

Testing pressure: Refer to [CO-27, "Radiator"](#).

#### WARNING:

Never remove radiator cap when engine is hot. Serious burns may occur from high-pressure engine coolant escaping from engine cooling system.

#### CAUTION:

Higher test pressure than specified may cause radiator damage.

#### NOTE:

In a case that engine coolant decreases, replenish radiator with engine coolant.

- If anything is found, repair or replace damaged parts.

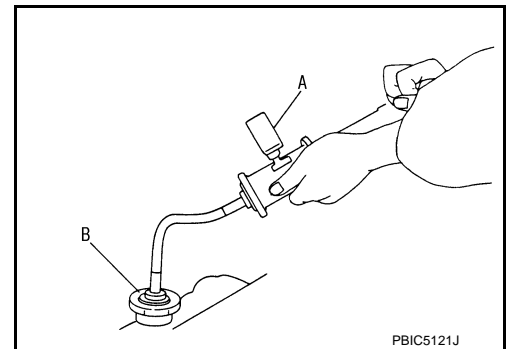

## ENGINE COOLANT : Draining

INFOID:000000011735082

#### WARNING:

- Never remove radiator cap when engine is hot. Serious burns may occur from high-pressure engine coolant escaping from radiator.
- Wrap a thick cloth around the radiator cap. Slowly turn it a quarter of a turn to release built-up pressure. Then turn it all the way.

1. Connect drain hose.

- Use a general-purpose hose with the dimensions shown in the figure.

A :  $\phi$  8 mm (0.31 in)

B : 300 mm (11.81 in)

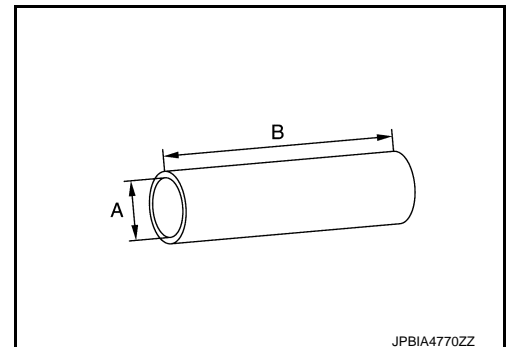



# ENGINE MAINTENANCE (MR FOR NISMO RS MODELS)

## < PERIODIC MAINTENANCE >

- Open radiator drain plug (A) at the bottom of radiator, and then remove radiator cap.

↩ : Vehicle front

### CAUTION:

**Perform this step when engine is cold.**

- When draining all of engine coolant in the system, open water drain plugs on cylinder block. Refer to [EM-71, "Setting"](#).

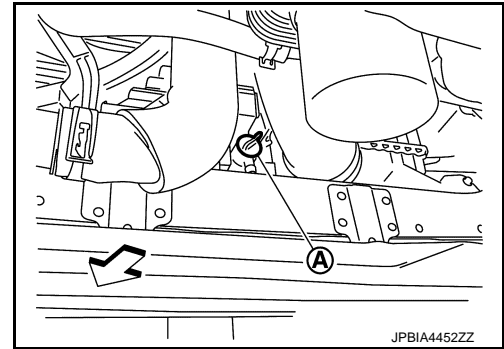

- Remove reservoir tank if necessary, and drain engine coolant and clean reservoir tank before installing. Refer to [CO-15, "Exploded View"](#).
- Check drained engine coolant for contaminants such as rust, corrosion or discoloration. If contaminated, flush the engine cooling system. Refer to [MA-18, "ENGINE COOLANT : Flushing"](#).
- Disconnect drain hose.

## ENGINE COOLANT : Refilling

INFOID:000000011735083

### CAUTION:

- Do not reuse O-rings.
- Do not put additive such as waterleak preventive, since it may cause cooling waterway clogging.
- When refilling use Genuine NISSAN Long Life Antifreeze/Coolant (blue) or equivalent in its quality mixed with water (distilled or demineralized). Refer to [MA-11, "Fluids and Lubricants"](#).

- Install reservoir tank if removed, and install radiator drain plug.

### CAUTION:

**Be sure to clean drain plug and install with new O-ring.**

**Radiator drain plug** : Refer to [CO-15, "Exploded View"](#).

- If water drain plugs on cylinder block are removed, close and tighten them. Refer to [EM-71, "Setting"](#).
- Check that each hose clamp has been firmly tightened.
  - Remove air duct (suction side). Refer to [EM-27, "Exploded View"](#).
  - Disconnect vacuum hose break booster side, and removal vacuum tube from clamp. Refer to [BR-42, "Exploded View"](#).
  - Disconnect heater hose (1) at position (↔) in the figure.

↩ : Vehicle front

- Enhance heater hose as high as possible.

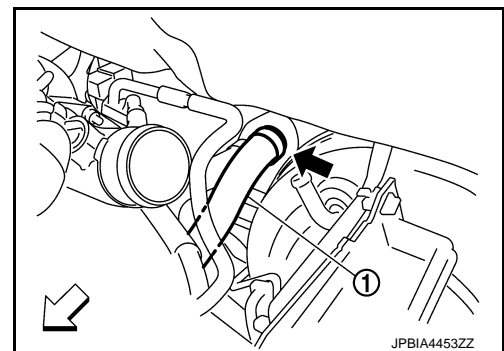

- Fill radiator (1) to specified level.

### CAUTION:

**Never adhere the engine coolant to electronic equipments (alternator etc.).**

- Pour coolant slowly of less than 2 ℓ (2-1/8 US qt, 1-3/4 Imp qt) a minute to allow air in system to escape.
- When engine coolant overflows disconnected heater hose, connect heater hose, and continue filling the engine coolant.

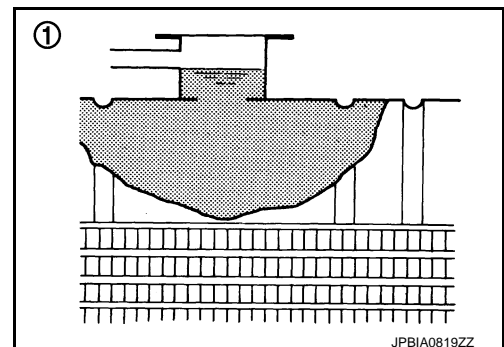

# ENGINE MAINTENANCE (MR FOR NISMO RS MODELS)

## < PERIODIC MAINTENANCE >

### Engine coolant capacity (With reservoir tank at "MAX" level)

Refer to [CO-27, "Periodical Maintenance Specification"](#).

7. Refill reservoir tank to "MAX" level line with engine coolant.

A : MAX  
B : MIN

### Reservoir tank engine coolant capacity (At "MAX" level)

Refer to [CO-27, "Periodical Maintenance Specification"](#).

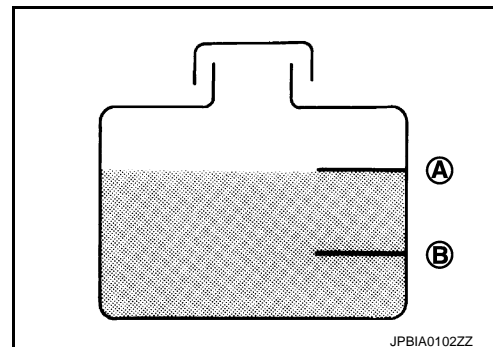

8. Install air duct (suction side). Refer to [EM-27, "Exploded View"](#).
9. Install radiator cap.
10. Warm up engine until opening thermostat. Standard for warming-up time is approximately 10 minutes at 3,000 rpm.
  - Check thermostat opening condition by touching radiator hose (lower) to see a flow of warm water.

**CAUTION:**  
**Watch water temperature gauge so as not to overheat engine.**
11. Stop the engine and cool down to less than approximately 50°C (122°F).
  - Cool down using fan to reduce the time.
  - If necessary, refill radiator up to filler neck with engine coolant.

**CAUTION:**  
**Never adhere the engine coolant to electronic equipments (alternator etc.).**
12. Refill reservoir tank to "MAX" level line with engine coolant.
13. Repeat steps 6 through 11 two or more times with radiator cap installed until engine coolant level no longer drops.
14. Check cooling system for leakage with engine running.
15. Warm up the engine, and check for sound of engine coolant flow while running engine from idle up to 3,000 rpm with heater temperature controller set at several position between "COOL" and "WARM".
  - Sound may be noticeable at heater unit.
16. Repeat step 15 three times.
17. If sound is heard, bleed air from cooling system by repeating step 6 through 11 until reservoir tank level no longer drops.

## ENGINE COOLANT : Flushing

INFOID:000000011735084

1. Install radiator drain plug.

**CAUTION:**

**Be sure to clean drain plug and install with new O-ring.**

**Radiator drain plug** : Refer to [CO-15, "Exploded View"](#).

- If water drain plugs on cylinder block are removed, close and tighten them. Refer to [EM-71, "Setting"](#).
2. Remove air duct (suction side), air cleaner cover assembly and air cleaner body assembly. Refer to [EM-27, "Exploded View"](#).
  3. Disconnect vacuum hose break booster side, and remove vacuum tube from clamp. Refer to .

# ENGINE MAINTENANCE (MR FOR NISMO RS MODELS)

## < PERIODIC MAINTENANCE >

4. Disconnect heater hose (1) at position (←) in the figure.

← : Vehicle front

- Enhance heater as high as possible.

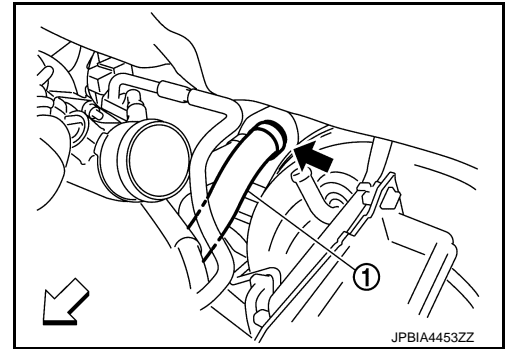

5. Fill radiator and reservoir tank with water and reinstall radiator cap.
  - When engine coolant over flows disconnected heater hose, connect heater hose, and continue filling the engine coolant.
6. Connect vacuum hose, and install vacuum tube.
7. Install air duct (suction side), air cleaner cover assembly and air cleaner body assembly. Refer to [EM-27, "Exploded View"](#).
8. Run the engine and warm it up to normal operating temperature.
9. Rev the engine two or three times under no-load.
10. Stop the engine and wait until it cools down.
11. Drain water from the system. Refer to [MA-16, "ENGINE COOLANT : Draining"](#).
12. Repeat steps 1 through 9 until clear water begins to drain from radiator.

## RADIATOR CAP

### RADIATOR CAP : Inspection

INFOID:000000011735085

- Check valve seat (A) of radiator cap.

B : Metal plunger

- Check that valve seat is swollen to the extent that the edge of the plunger cannot be seen when watching it vertically from the top.
- Check that valve seat has no soil and damage.

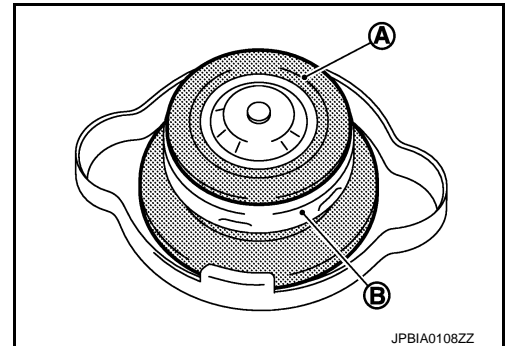

- Pull negative-pressure valve to open it, and that it close completely when released.
- Check that there is no dirt or damage on the valve seat of radiator cap negative-pressure valve.
- Check that there are no unusualness in the opening and closing conditions of negative-pressure valve.

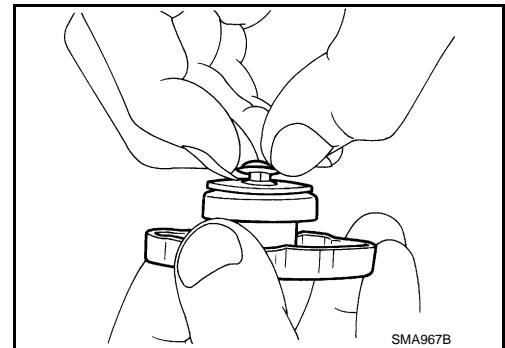

A  
B  
C  
D  
E  
F  
G  
H  
I  
J  
K  
L  
M  
N  
O  
MA

# ENGINE MAINTENANCE (MR FOR NISMO RS MODELS)

## < PERIODIC MAINTENANCE >

- Check radiator cap relief pressure.

**Standard and Limit** : Refer to [CO-27, "Radiator"](#).

- When connecting radiator cap to the radiator cap tester (commercial service tool) (A) and the radiator cap tester adapter (commercial service tool) (B), apply engine coolant to the cap seal surface.

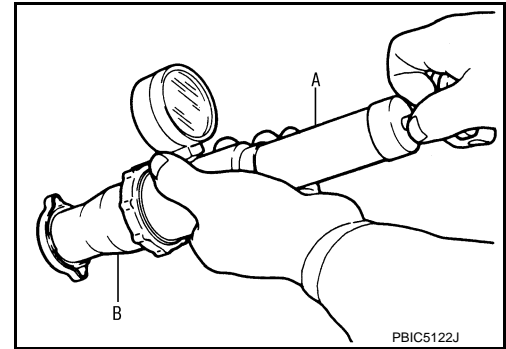

- Replace radiator cap if there is an unusualness related to the above three.

### **CAUTION:**

**When installing radiator cap, thoroughly wipe out the radiator filler neck to remove any waxy residue or foreign material.**

## RADIATOR

### RADIATOR : Inspection

INFOID:000000011735086

Check radiator for mud or clogging. If necessary, clean radiator as follows.

### **CAUTION:**

- **Be careful not to bend or damage radiator fins.**
  - **When radiator is cleaned without removal, remove all surrounding parts such as radiator cooling fan assembly and horns. Then tape harness and harness connectors to prevent water from entering.**
1. Apply water by hose to the back side of the radiator core vertically downward.
  2. Apply water again to all radiator core surfaces once per minute.
  3. Stop washing if any stains no longer flow out from radiator.
  4. Blow air into the back side of radiator core vertically downward.
    - Use compressed air lower than 490 kPa (4.9 bar, 5 kg/cm<sup>2</sup>, 71 psi) and keep distance more than 30 cm (11.81 in).
  5. Blow air again into all the radiator core surfaces once per minute until no water sprays out.

## FUEL LINES

### FUEL LINES : Inspection

INFOID:000000011735505

Inspect fuel lines, fuel filler cap, and fuel tank for improper attachment, leakage, cracks, damage, loose connections, chafing or deterioration.

- A : Engine
- B : Fuel line
- C : Fuel tank

If necessary, repair or replace damaged parts.

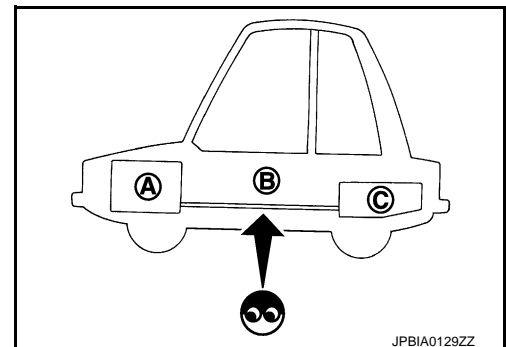

## AIR CLEANER FILTER

### AIR CLEANER FILTER : Removal and Installation

INFOID:000000011735077

#### REMOVAL

# ENGINE MAINTENANCE (MR FOR NISMO RS MODELS)

## < PERIODIC MAINTENANCE >

1. Remove air duct inlet (upper) (1).
2. Unhook the tabs (A) of both ends of the air cleaner cover.

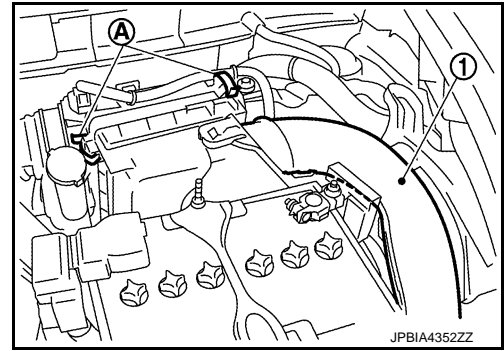

3. Remove the air cleaner filter (1) and air cleaner body (2) from the air cleaner case.
4. Remove the air cleaner filter from the air cleaner body.

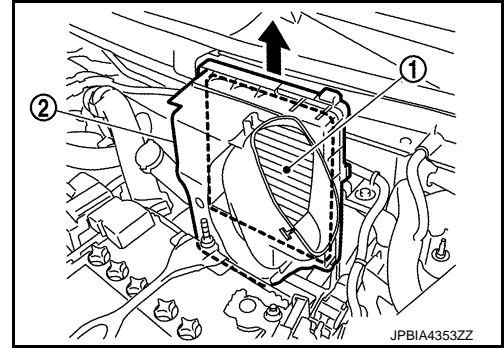

## INSTALLATION

Note the following, and install in the reverse order of removal.

- Fixing clips shall be fixed after inserting air cleaner body protrusion to air cleaner case notch hole.
- Make sure that whether air cleaner body has been firmly installed by shaking it.

## AIR CLEANER FILTER : Inspection (Viscous Paper Type)

INFOID:000000011735078

### INSPECTION AFTER REMOVAL

Examine with eyes that there is no stain, clogging, or damage on air cleaner element.

- Remove dusts (such as dead leaves) on air cleaner element surface and inside cleaner case.
- If clogging or damage is observed, replace the air cleaner element.

### **CAUTION:**

**Never clean the viscous paper type air cleaner element by blowing as there is a risk of deterioration of its performance**

### MAINTENANCE INTERVAL

Refer to [MA-7, "Introduction of Periodic Maintenance"](#).

## ENGINE OIL

### ENGINE OIL : Draining

INFOID:000000011735087

### **WARNING:**

- **Be careful not to get burned, as engine oil may be hot.**
- **Prolonged and repeated contact with used engine oil may cause skin cancer. Try to avoid direct skin contact with used engine oil. If skin contact is made, wash thoroughly with soap or hand cleaner as soon as possible.**

1. Warm up the engine, and check for engine oil leakage from engine components. Refer to [LU-9, "Inspection"](#).
2. Stop the engine and wait for 10 minutes.
3. Loosen oil filler cap.
4. Remove drain plug and then drain engine oil.

A  
B  
C  
D  
E  
F  
G  
H  
I  
J  
K  
L  
M  
N  
O

MA

# ENGINE MAINTENANCE (MR FOR NISMO RS MODELS)

< PERIODIC MAINTENANCE >

## ENGINE OIL : Refilling

INFOID:000000011735088

1. Install drain plug with new drain plug washer. Refer to [EM-45, "Exploded View"](#).

**CAUTION:**

Be sure to clean drain plug and install with new drain plug washer.

**Tightening torque** : Refer to [EM-45, "Exploded View"](#).

2. Refill with new engine oil.  
**Engine oil specification and viscosity:** Refer to [MA-11, "Fluids and Lubricants"](#).

**Engine oil capacity** : Refer to [LU-19, "Periodical Maintenance Specification"](#).

**CAUTION:**

- The refill capacity depends on the engine oil temperature and drain time. Use these specifications for reference only.
  - Always use oil level gauge to determine the proper amount of engine oil in the engine.
3. Warm up engine and check area around drain plug and oil filter for engine oil leakage.
  4. Stop engine and wait for 10 minutes.
  5. Check the engine oil level. Refer to [LU-9, "Inspection"](#).

## OIL FILTER

### OIL FILTER : Removal and Installation

INFOID:000000011735089

#### REMOVAL

1. Remove engine under cover.
2. Using oil filter wrench [SST: KV10115801 (J-38956)] (A), remove oil filter.

⇐ : Vehicle front

**CAUTION:**

- Oil filter is provided with relief valve. Use genuine NISSAN oil filter or equivalent.
- Be careful not to get burned when engine and engine oil may be hot.
- When removing, prepare a shop cloth to absorb any engine oil leakage or spillage.
- Completely wipe off any engine oil that adheres to engine and vehicle.

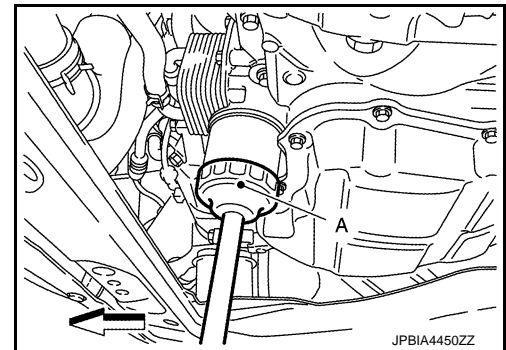

#### INSTALLATION

1. Remove foreign materials adhering to the oil filter installation surface.
2. Apply new engine oil to the oil seal contact surface of new oil filter.

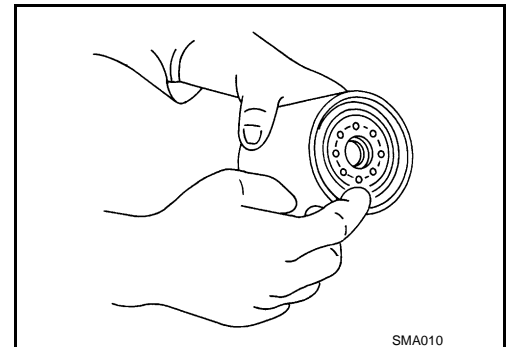

# ENGINE MAINTENANCE (MR FOR NISMO RS MODELS)

## < PERIODIC MAINTENANCE >

3. Screw oil filter manually until it touches the installation surface, then tighten it by 2/3 turn (A). Or tighten to specification.

### Oil filter:

: 17.7 N·m (1.8 kg·m, 13 ft·lb)

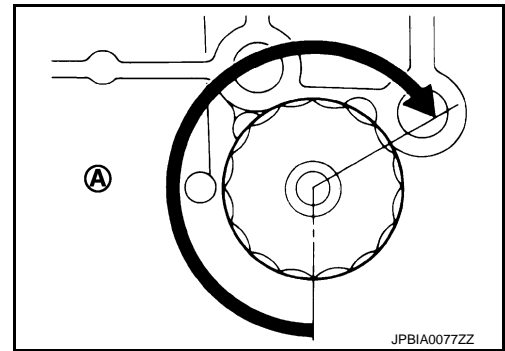

INFOID:000000011735090

## OIL FILTER : Inspection

### INSPECTION AFTER INSTALLATION

1. Check the engine oil level. Refer to [LU-9, "Inspection"](#).
2. Start the engine, and check that there is no leakage of engine oil.
3. Stop the engine and wait for 10 minutes.
4. Check the engine oil level, and adjust the level. Refer to [LU-9, "Inspection"](#).

## SPARK PLUG

### SPARK PLUG : Removal and Installation

INFOID:000000011735079

#### REMOVAL

1. Remove engine cover. Refer to [EM-26, "Exploded View"](#).
2. Remove air inlet tube assembly. Refer to [EM-32, "Exploded View"](#).
3. Remove ignition coil.
4. Remove spark plug with a spark plug wrench (commercial service tool).

a : 14 mm (0.55 in)

### CAUTION:

Never drop or shock spark plug.

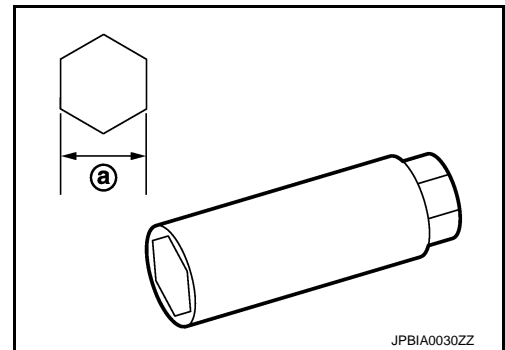

#### INSTALLATION

Install in the reverse order of removal.

### SPARK PLUG : Inspection

INFOID:000000011735080

#### INSPECTION AFTER REMOVAL

Use the standard type spark plug for normal condition.

Spark plug (Standard type) : Refer to [EM-138, "Spark Plug"](#).

### CAUTION:

A  
B  
C  
D  
E  
F  
G  
H  
I  
J  
K  
L  
M  
N  
O  
MA



# ENGINE MAINTENANCE (MR FOR NISMO RS MODELS)

## < PERIODIC MAINTENANCE >

- Never drop or shock spark plug.
- Never use a wire brush for cleaning.
- If plug tip is covered with carbon, spark plug cleaner may be used.

**Cleaner air pressure** : Less than 588 kPa (6 kg/cm<sup>2</sup>, 85 psi)

**Cleaning time** : Less than 20 seconds

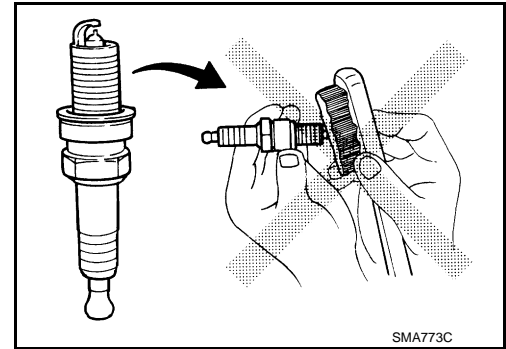

- Spark plug gap adjustment is not required between replacement intervals.
- Measure spark plug gap. when it exceeds the limit, replace spark plug even if it is with in the specified replacement mileage. Refer to [EM-138, "Spark Plug"](#).

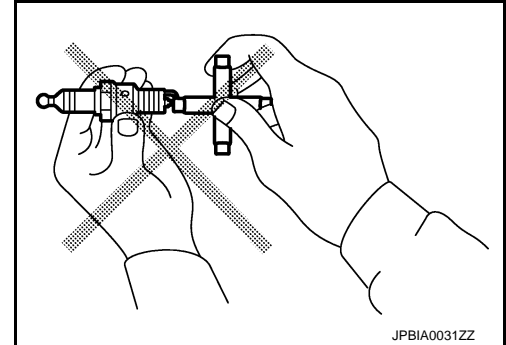

## EVAP VAPOR LINES

### EVAP VAPOR LINES : Inspection

INFOID:000000011463966

1. Visually inspect EVAP vapor lines for improper attachment and for cracks, damage, loose connections, chafing and deterioration. Refer to [EC-575, "Inspection"](#).
2. Inspect fuel tank filler cap vacuum relief valve for clogging, sticking, etc. Refer to [EC-388, "Component Inspection"](#).



# ENGINE MAINTENANCE (MR EXCEPT FOR NISMO RS MODELS)

< PERIODIC MAINTENANCE >

## ENGINE MAINTENANCE (MR EXCEPT FOR NISMO RS MODELS)

### DRIVE BELT

#### DRIVE BELT : Inspection

INFOID:000000011738823

#### INSPECTION

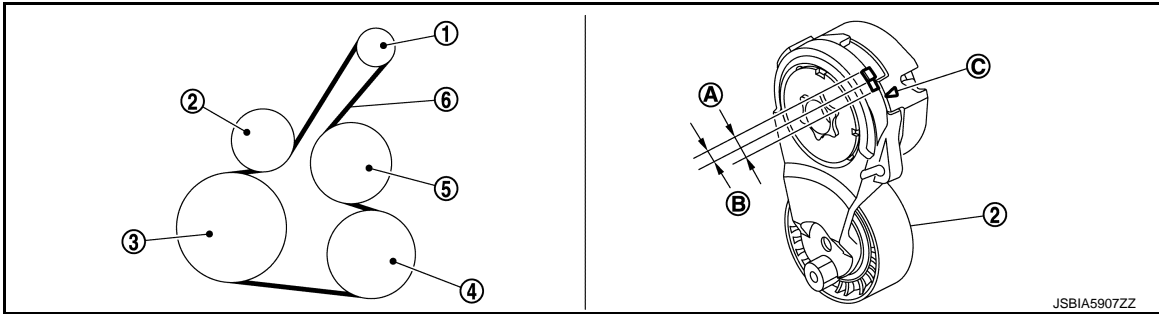

- |                       |   |                      |
|-----------------------|---|----------------------|
| 1. Alternator         | 2. Drive belt auto tensioner              | 3. Crankshaft pulley |
| 4. A/C compressor     | 5. Water pump                             | 6. Drive belt        |
| A. Possible use range | B. Range when new drive belt is installed | C. Indicator         |

#### **WARNING:**

**Perform this step when engine is stopped.**

- Check that the indicator (C) (notch on fixed side) of drive belt auto-tensioner is within the possible use range (A) in the figure.

#### **NOTE:**

- Check the drive belt auto-tensioner indication when the engine is cold.
- When new drive belt is installed, the indicator (notch on fixed side) should be within the range (B) in the figure.
- Visually check entire drive belt for wear, damage or cracks.
- If the indicator (notch on fixed side) is out of the possible use range or belt is damaged, replace drive belt.

### ENGINE COOLANT

#### ENGINE COOLANT : Inspection

INFOID:000000011735091

#### LEVEL

- Check that the reservoir tank engine coolant level is within the "MIN" to "MAX" when the engine is cool.

A : MAX

B : MIN

- Adjust the engine coolant level if necessary.

#### **CAUTION:**

**Refill Genuine NISSAN Long Life Antifreeze/Coolant (blue) or equivalent in its quality mixed with water (distilled or demineralized). Refer to [MA-11, "Fluids and Lubricants"](#).**

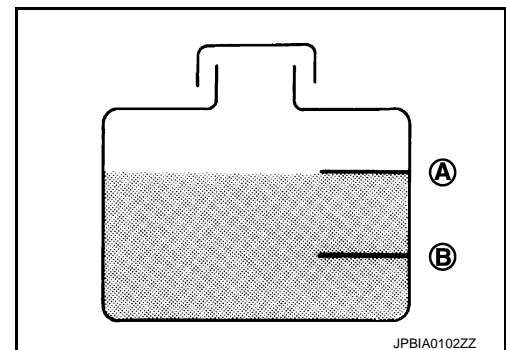

#### LEAKAGE

MA

# ENGINE MAINTENANCE (MR EXCEPT FOR NISMO RS MODELS)

## < PERIODIC MAINTENANCE >

- To check for leakage, apply pressure to the cooling system with the radiator cap tester (commercial service tool) (A) and the radiator cap tester adapter (commercial service tool) (B).

Testing pressure: Refer to [CO-27, "Radiator"](#).

### WARNING:

Never remove radiator cap when engine is hot. Serious burns may occur from high-pressure engine coolant escaping from engine cooling system.

### CAUTION:

Higher test pressure than specified may cause radiator damage.

### NOTE:

- If a case that engine coolant decreases, replenish radiator with engine coolant.
- If anything is found, repair or replace damaged parts.

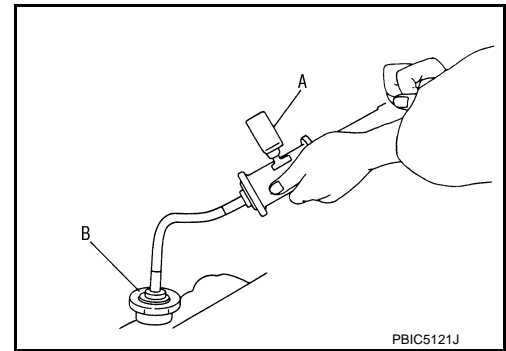

## ENGINE COOLANT : Draining and Filling

INFOID:000000011735092

### CAUTION:

- Never apply additive agent like anti-leakage sealant. Doing so may cause coolant passage clog.
- When refilling use Genuine NISSAN Long Life Antifreeze/Coolant (blue) or equivalent in its quality mixed with water (distilled or demineralized). Refer to [MA-11, "Fluids and Lubricants"](#).
- Never dilute using water.

## DRAINING

### WARNING:

Never open the radiator cap or drain plug when the engine is hot. Hot liquid may spray out, causing serious injury.

### CAUTION:

- Never spill coolant on the drive belt while working.
- Be sure to perform this operation when coolant temperature is cold.

1. Turn the ignition switch ON, wait for 10 seconds or more, and then turn it OFF again.
2. Connect drain hose.
  - Use a general-purpose hose with the dimensions show in the figure.

A :  $\phi$  8 mm (0.31 in)

B : 300 mm (11.81 in)

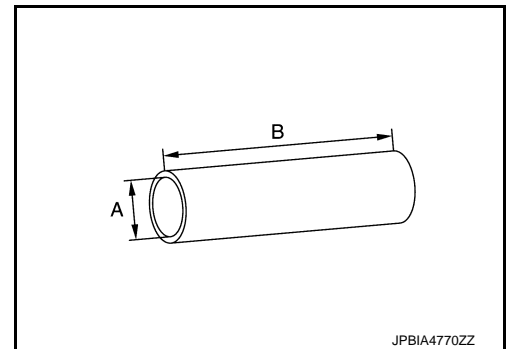

3. Open radiator drain plug (A) at the bottom of radiator, and then remove radiator cap.

← : Vehicle front

### CAUTION:

Perform this step when engine is cold.

- When draining all of engine coolant in the system, open water drain plugs on cylinder block. Refer to [EM-71, "Setting"](#).

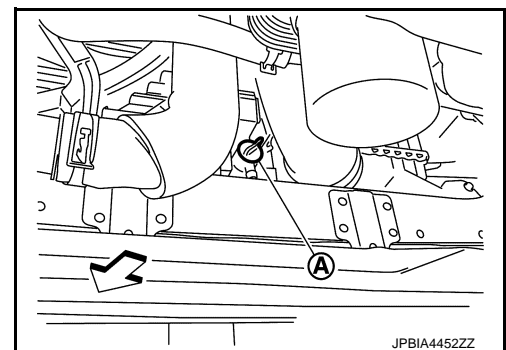

4. Remove reservoir tank if necessary, and drain engine coolant and clean reservoir tank before installing. Refer to [CO-15, "Exploded View"](#).

# ENGINE MAINTENANCE (MR EXCEPT FOR NISMO RS MODELS)

## < PERIODIC MAINTENANCE >

5. Check drained engine coolant for contaminants such as rust, corrosion or discoloration. If contaminated, flush the engine cooling system. Refer to [MA-29, "ENGINE COOLANT : Flushing"](#).
6. Disconnect drain hose.

## REFILLING

1. Install reservoir tank. Refer to [CO-45, "Exploded View"](#).
2. Install the radiator drain plug.
  - Replace the drain plug O-ring with a new one.

### CAUTION:

**Be sure to clean drain plug and install with new O-ring.**

**Radiator drain plug** : Refer to [CO-15, "Exploded View"](#).

- If water drain plugs on cylinder block are removed, close and tighten them. Refer to [EM-71, "Setting"](#).
3. Check that each hose clamp is firmly tightened.
4. Remove the cowl top extension. Refer to [EXT-30, "Removal and Installation"](#).
5. Perform the following procedure for draining the air from piping.

Ⓜ If using CONSULT

1. Turn the ignition switch ON again and use CONSULT "WORK SUPPORT" mode to perform "ENGINE COOLANT BYPASS VALVE". Refer to [EC-656, "CONSULT Function"](#).

### CAUTION:

**Never start engine.**

### NOTE:

CONSULT can be used to open the bypass valve on the multi-way control valve.

2. Separate the hose clamp (1) and heater hose (2) at the position shown in the figure (←), and hold the end of the hose at the same height.

← : Vehicle front

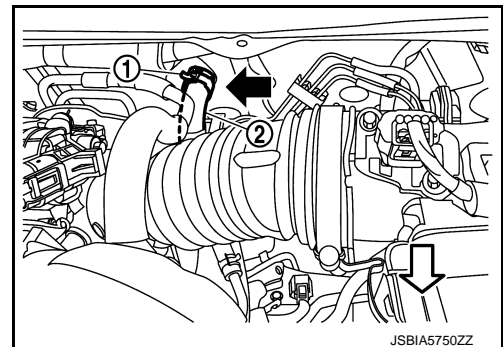

3. Fill with coolant at a speed of 3 L/min or less (like pouring water with a kettle) until it fills the radiator cap (1) neck.
  - If coolant comes out from the heater hose when filling with coolant, connect the heater hose and continue filling with coolant.

### CAUTION:

- Filling with coolant at a high speed may allow air to mix with coolant. Be sure to fill with coolant slowly, observing the above speed.
- Never spill coolant on any electrical equipment (such as the alternator) during the operation.

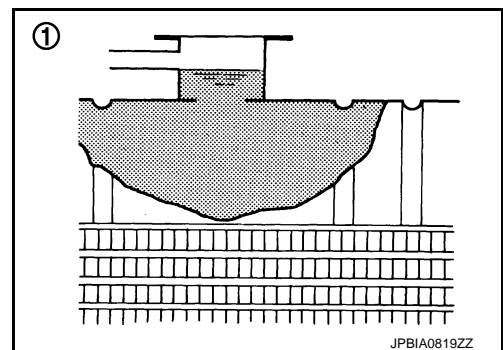

ⓧ When not using CONSULT

A  
B  
C  
D  
E  
F  
G  
H  
I  
J  
K  
L  
M  
N  
O

MA

# ENGINE MAINTENANCE (MR EXCEPT FOR NISMO RS MODELS)

## < PERIODIC MAINTENANCE >

1. Separate the hose clamp (1) and heater hose (2) at the position as shown in the figure (←), and hold the end of the hose at the same height.

← : Vehicle front

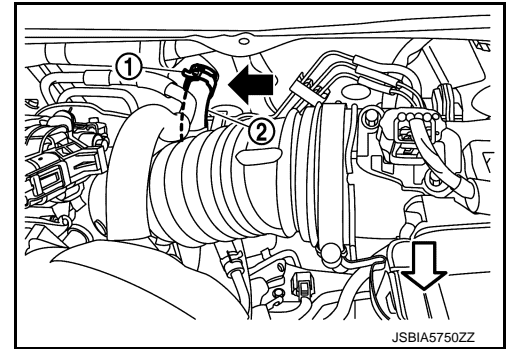

2. Fill with coolant at a speed of 3 L/min or less (like pouring water with a kettle) until it fills the radiator cap (1) neck.
  - If coolant comes out from the heater hose while adding coolant, connect the heater hose and continue adding coolant.

### CAUTION:

- Filling with coolant at a high speed may allow air to mix with coolant. Be sure to fill with coolant slowly, observing the above speed.
- Never spill coolant on any electrical equipment (such as the alternator) during the operation.

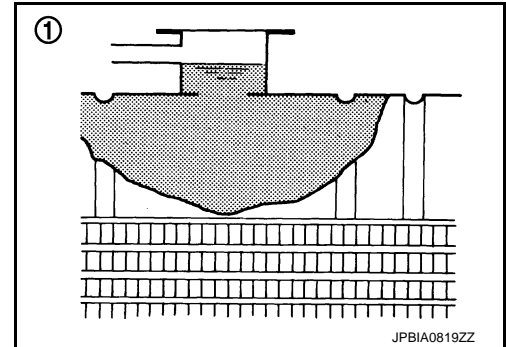

6. Fill with coolant to "MAX" line of reservoir tank.

A : MAX

B : MIN

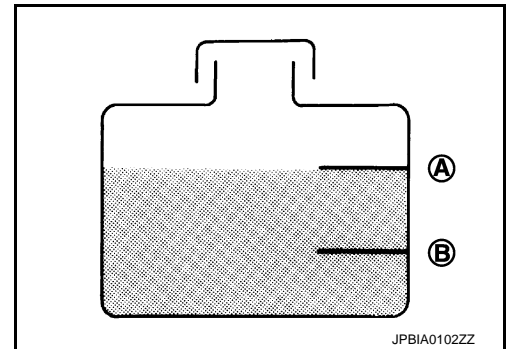

7. Install the cowl top extension. Refer to [EXT-30, "Removal and Installation"](#).
8. Install the radiator cap.
9. Perform the following operation for warming up the engine.

☐ When using CONSULT

1. Start the engine, and set the heater control temperature to "FULL HOT".
2. Use CONSULT "WORK SUPPORT" mode to perform "ENGINE COOLANT BYPASS VALVE". Refer to [EC-656, "CONSULT Function"](#).

### NOTE:

CONSULT can be used to open the bypass valve on the multi-way control valve.

- Check that there is no coolant leakage from the drain plug and heater hose connections.

☒ When not using CONSULT

1. Start the engine and set the heater control temperature to "FULL HOT".
  2. Warm up the engine until the bypass valve on the multi-way control valve opens. The warm-up time should be approximately 10 minutes at 3,000 rpm.
- Check that the bypass valve on the multi-way control valve is open by touching the radiator hose (lower) with a hand and checking that warm water is flowing.

### CAUTION:

**Be careful that coolant does not overheat.**

- Check that there is no coolant leakage from the drain plug and heater hose connections.
10. Stop the engine.

# ENGINE MAINTENANCE (MR EXCEPT FOR NISMO RS MODELS)

## < PERIODIC MAINTENANCE >

11. When the engine is cold (approximately 50°C or less), remove the radiator cap and check the coolant level. If the level is low, fill with coolant again until it fills the radiator cap neck, and then repeat operation from step 7.

**CAUTION:**

**Never spill coolant on any electrical equipment (such as the alternator) during the operation.**

12. When the coolant level stabilizes, fill with coolant up to the "MAX" line of reservoir tank.

## CHECK WATER FLOW SOUND

**CAUTION:**

**Prior to check, be sure to close windows, doors, and hood, and turn off radio and other electrical loads.**

1. Allow the engine to cool (to approximately 50°C or less).
2. Set the temperature of the heater control to "FULL HOT".
3. Start engine. Perform the following cycle three times. Keep the engine speed at 1,000 rpm for approximately 30 seconds and then increase it gradually to 3,000 rpm.
4. During the operation described above in step 3, check for water flow sound from heater core.
5. If water flow sounds are heard, fill with coolant to the radiator cap neck at a speed of 3 L/min or less (like pouring water with a kettle), and then repeat the operations from step 7 of "Filling Engine Coolant" to step 4 of "How to Check Water Flow Sound".

**CAUTION:**

- **Filling with coolant at a high speed may allow air to mix with coolant. Be sure to fill with coolant slowly, observing the speed specified above.**
- **Never spill coolant on any electrical equipment (such as the alternator) during the operation.**

## ENGINE COOLANT : Flushing

INFOID:000000011735093

1. Install radiator drain plug.

**CAUTION:**

**Be sure to clean drain plug and install with new O-ring.**

**Radiator drain plug** : Refer to [CO-15, "Exploded View"](#).

- If water drain plugs on cylinder block are removed, close and tighten them. Refer to [EM-71, "Setting"](#).
2. Remove air duct (suction side), air cleaner cover assembly and air cleaner body assembly. Refer to [EM-27, "Exploded View"](#).
  3. Disconnect vacuum hose booster side, and remove vacuum tube from clamp.
  4. Disconnect heater hose (1) at position (←) in the figure.

← : Vehicle front

- Enhance heater as high as possible.

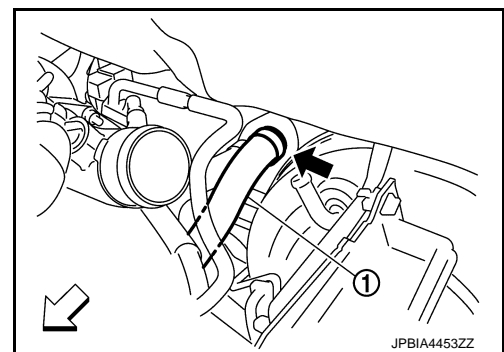

5. Fill radiator and reservoir tank with water and reinstall radiator cap.
  - When engine coolant overflows disconnected heater hose, connect heater hose, and continue filling the engine coolant.
6. Connect vacuum hose, and install vacuum tube.
7. Install air duct (suction side), air cleaner cover assembly and air cleaner body assembly. Refer to [EM-27, "Exploded View"](#).
8. Run the engine and warm it up to normal operating temperature.
9. Rev the engine two or three times under no-load.
10. Stop the engine and wait until it cools down.
11. Drain water from the system. Refer to [MA-26, "ENGINE COOLANT : Draining and Filling"](#).

# ENGINE MAINTENANCE (MR EXCEPT FOR NISMO RS MODELS)

## < PERIODIC MAINTENANCE >

12. Repeat steps 1 through 9 until clear water begins to drain from radiator.

### RADIATOR CAP

#### RADIATOR CAP : Radiator Cap Inspection

INFOID:000000011739142

- Visually check valve seat of the radiator cap vacuum valve for dirt and damage.

#### **CAUTION:**

Check valve seat (A) visually in vertical position. If the valve seat is excessively extended so that lower metal plunger (B) is not visible, replace the radiator cap.

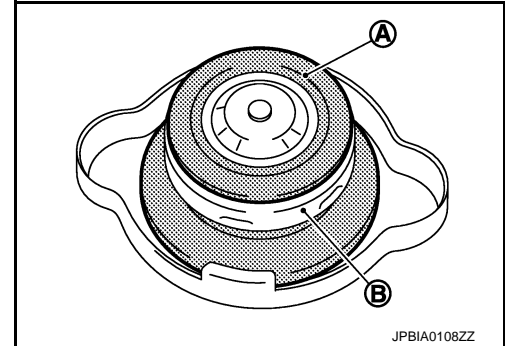

- Move the vacuum valve and check for smooth opening and closing.

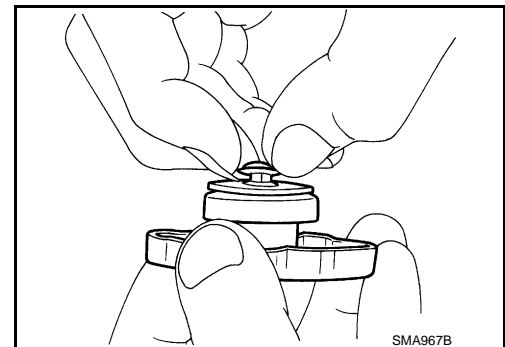

- Connect radiator cap tester (commercial service tool) (A) and apply pressure to check opening pressure of the pressure regulating valve.

**Standard  
Limit**

: Refer to [CO-57, "Radiator"](#).

- Be sure to apply water or LLC to the cap seals when connecting the radiator cap to the radiator cap tester.
- Replace radiator cap if vacuum valve is malfunctioning or if the valve opening pressure is outside (is lower than) the limit.

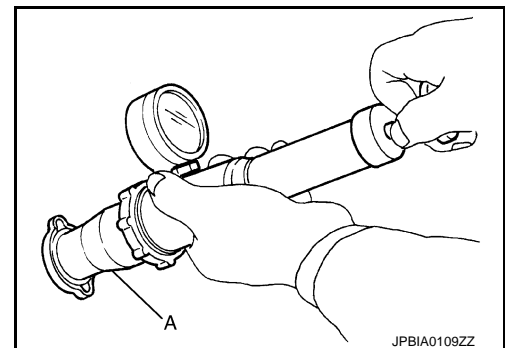

### FUEL LINES

#### FUEL LINES : Inspection

INFOID:000000011735507

Inspect fuel lines, fuel filler cap, and fuel tank for improper attachment, leakage, cracks, damage, loose connections, chafing or deterioration.

- A : Engine
- B : Fuel line
- C : Fuel tank

If necessary, repair or replace damaged parts.

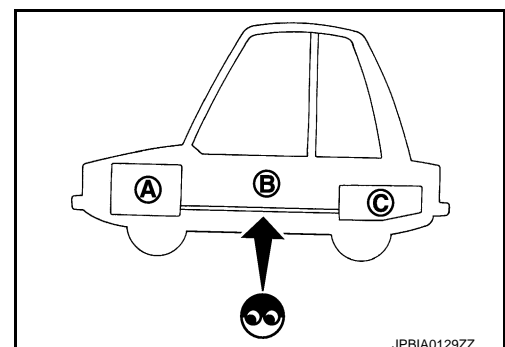

### AIR CLEANER FILTER



# ENGINE MAINTENANCE (MR EXCEPT FOR NISMO RS MODELS)

< PERIODIC MAINTENANCE >

## AIR CLEANER FILTER : Removal and Installation

INFOID:000000011738825

### REMOVAL

1. Remove the inlet air duct (upper) (1).
2. Unhook the tabs (A) of both ends of the air cleaner cover.

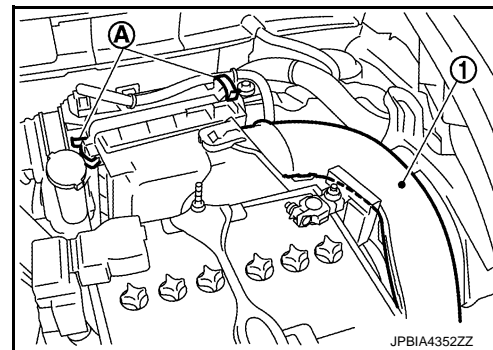

3. Remove the air cleaner filter (1) and air cleaner body (2) from the air cleaner case.
4. Remove the air cleaner filter from the air cleaner body.

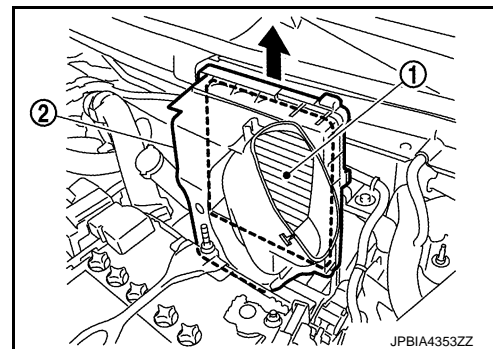

### INSTALLATION

Note the following, and install in the reverse order of removal.

- Fixing clips shall be fixed after inserting air cleaner body protrusion to air cleaner case notch hole.
- Make sure that whether air cleaner body has been firmly installed by shaking it.

## ENGINE OIL

### ENGINE OIL : Draining

INFOID:000000011735508

#### **WARNING:**

- Be careful not to get burned, as engine oil may be hot.
- Prolonged and repeated contact with used engine oil may cause skin cancer. Try to avoid direct skin contact with used engine oil. If skin contact is made, wash thoroughly with soap or hand cleaner as soon as possible.

1. Warm up the engine, and check for engine oil leakage from engine components. Refer to [LU-9. "Inspection"](#).
2. Stop the engine and wait for 10 minutes.
3. Loosen oil filler cap.
4. Remove drain plug and then drain engine oil.

### ENGINE OIL : Refilling

INFOID:000000011735509

1. Install drain plug with new drain plug washer. Refer to [EM-45. "Exploded View"](#).

#### **CAUTION:**

Be sure to clean drain plug and install with new drain plug washer.

**Tightening torque** : Refer to [EM-45. "Exploded View"](#).

2. Refill with new engine oil.  
**Engine oil specification and viscosity:** Refer to [MA-11. "Fluids and Lubricants"](#).

# ENGINE MAINTENANCE (MR EXCEPT FOR NISMO RS MODELS)

## < PERIODIC MAINTENANCE >

Engine oil capacity : Refer to [LU-19. "Periodical Maintenance Specification"](#).

### CAUTION:

- The refill capacity depends on the engine oil temperature and drain time. Use these specifications for reference only.
  - Always use oil level gauge to determine the proper amount of engine oil in the engine.
3. Warm up engine and check area around drain plug and oil filter for engine oil leakage.
  4. Stop engine and wait for 10 minutes.
  5. Check the engine oil level. Refer to [LU-9. "Inspection"](#).

## OIL FILTER

### OIL FILTER : Removal and Installation

INFOID:000000011739362

#### REMOVAL

1. Remove oil filter using an oil filter wrench [SST: KV10115801] (A).

⇐ : Vehicle front

### CAUTION:

- Never get burned when engine or engine oil is heated.
- Use a shop cloth to absorb engine oil leakage when removing.
- Never spill engine oil on the drive belt.
- Completely wipe away any engine oil spilled on the engine and vehicle.

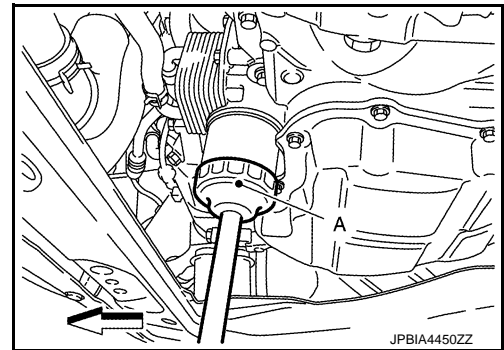

#### INSTALLATION

1. Eliminate foreign materials on the oil filter mounting surface.
2. Apply engine oil to the full circumference of the oil seal on a new oil filter.

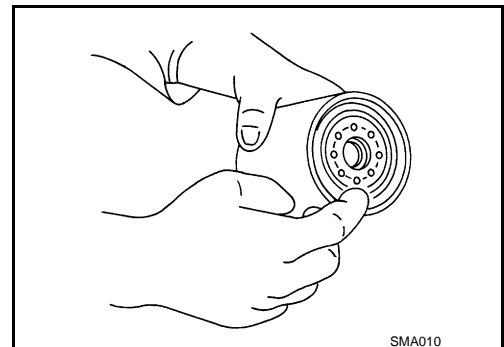

3. Screw in oil filter by hand until it contacts mounting surface on the engine, and then screw in another 2/3 of a turn (A).

### NOTE:

Tightening torque is 17.7 N·m (1.8 kg·m).

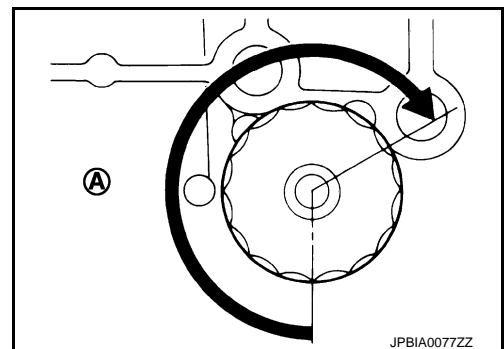

### OIL FILTER : Inspection

INFOID:000000011739363

#### INSPECTION AFTER INSTALLATION

1. Use the oil level gauge and check that the oil level is within the standard. Refer to [LU-28. "Inspection"](#).



# ENGINE MAINTENANCE (MR EXCEPT FOR NISMO RS MODELS)

## < PERIODIC MAINTENANCE >

2. Start the engine. Check for fuel leakage.
3. Stop the engine. After stopping it, leave it for 10 minutes or more.
4. Check the engine oil level again. Fill with engine oil to adjust oil level if necessary. Refer to [LU-28, "Inspection"](#).

## SPARK PLUG

### SPARK PLUG : Removal and Installation

INFOID:000000011738826

#### REMOVAL

1. Remove the engine cover. Refer to [EM-190, "Exploded View"](#).
2. Remove air inlet tube 2. Refer to [EM-193, "Removal and Installation"](#).
3. Remove the ignition coil. Refer to [EM-213, "Exploded View"](#).
4. Remove spark plug with a spark plug wrench (commercial service tool).

a : 14 mm (0.55 in)

#### CAUTION:

Never drop or shock spark plug.

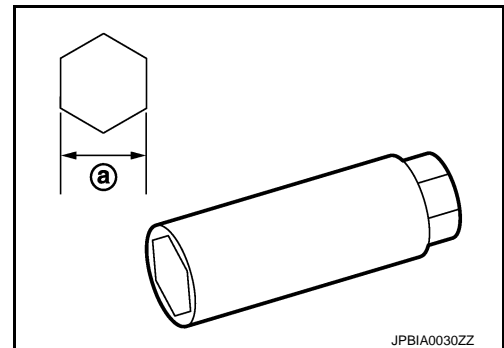

#### INSTALLATION

Install in the reverse order of removal.

### SPARK PLUG : Inspection

INFOID:000000011738827

#### INSPECTION AFTER REMOVAL

Use the standard type spark plug for normal condition.

Spark plug (Standard type) : Refer to [EM-138, "Spark Plug"](#).

#### CAUTION:

- Never drop or shock spark plug.
- Never use a wire brush for cleaning.
- If plug tip is covered with carbon, spark plug cleaner may be used.

Cleaner air pressure : Less than 588 kPa (6 kg/cm<sup>2</sup>, 85 psi)

Cleaning time : Less than 20 seconds

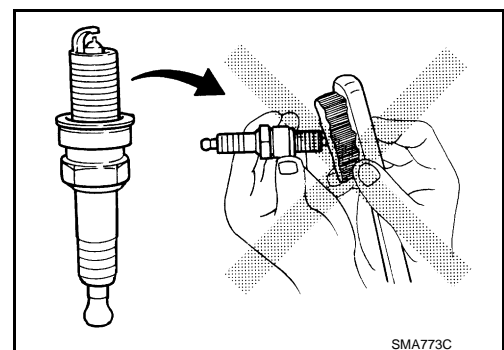

- Spark plug gap adjustment is not required between replacement intervals.
- Measure spark plug gap. when it exceeds the limit, replace spark plug even if it is with in the specified replacement mileage. Refer to [EM-138, "Spark Plug"](#).

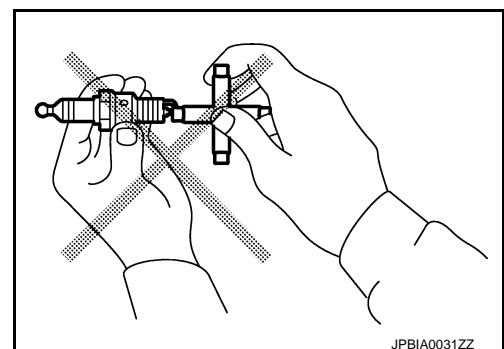

A  
B  
C  
D  
E  
F  
G  
H  
I  
J  
K  
L  
M  
N  
O

MA

## ENGINE MAINTENANCE (MR EXCEPT FOR NISMO RS MODELS)

< PERIODIC MAINTENANCE >

---

### EVAP VAPOR LINES

#### EVAP VAPOR LINES : Inspection

INFOID:000000011675796

1. Visually inspect EVAP vapor lines for improper attachment and for cracks, damage, loose connections, chafing and deterioration. Refer to [EC-1251, "Inspection"](#).
2. Inspect fuel tank filler cap vacuum relief valve for clogging, sticking, etc.  
Refer to [EC-1008, "Component Inspection"](#).

# CHASSIS MAINTENANCE

< PERIODIC MAINTENANCE >

## CHASSIS MAINTENANCE

### EXHAUST SYSTEM

#### EXHAUST SYSTEM : Inspection

INFOID:0000000011735670

Check exhaust pipes, muffler, and mounting for improper attachment, leakage, cracks, damage or deterioration.

- If anything is found, repair or replace damaged parts.

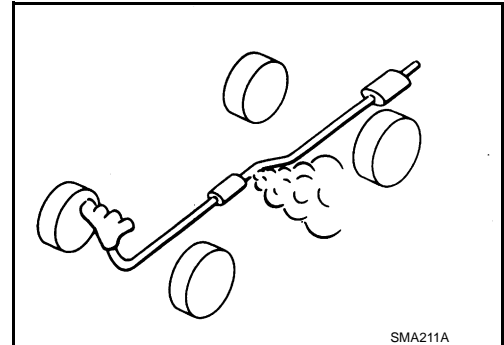

#### CVT FLUID (RE0F10B)

#### CVT FLUID (RE0F10B) : Inspection

INFOID:0000000011740796

#### CHECKING CVT FLUID

The fluid level should be checked with the fluid warmed up to 50 to 80°C (122 to 176°F). The fluid level check procedure is as follows:

1. Check for fluid leakage.
2. With the engine warmed up, drive the vehicle in an urban area. When ambient temperature is 20°C (68°F), it takes about 10 minutes for the CVT fluid to warm up to 50 to 80°C (122 to 176°F).
3. Park the vehicle on a level surface.
4. Apply parking brake firmly.
5. With engine at idle, while depressing brake pedal, move shift selector throughout the entire shift range.
6. Pull out the CVT fluid level gauge from the CVT fluid charging pipe after pressing the tab on the CVT fluid level gauge to release the lock.

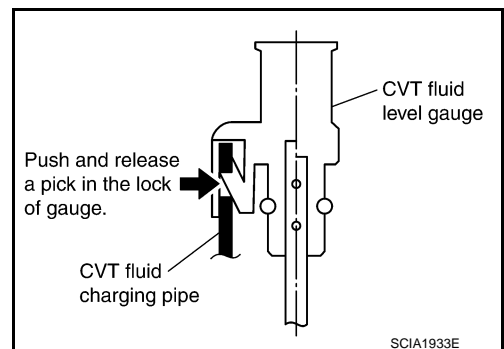
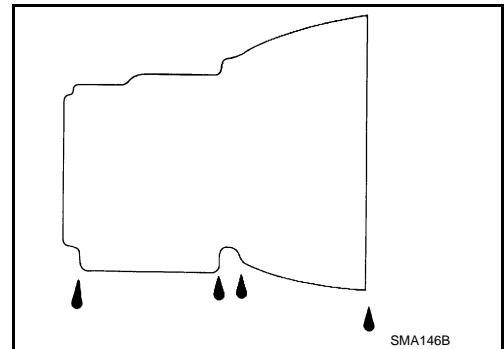

7. Wipe fluid off the CVT fluid level gauge. Insert the CVT fluid level gauge rotating 180° from the originally installed position, then securely push the CVT fluid level gauge until it meets the top end of the CVT fluid charging pipe.

**CAUTION:**

**When wiping away the CVT fluid level gauge, always use lint-free paper, not a cloth rag.**

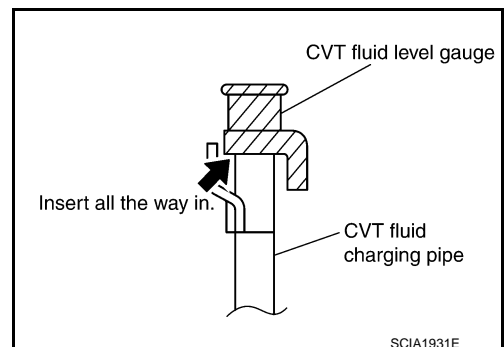

A  
B  
C  
D  
E  
F  
G  
H  
I  
J  
K  
L  
M  
N  
O

MA

# CHASSIS MAINTENANCE

## < PERIODIC MAINTENANCE >

8. Place the selector lever in "P" or "N" and check that the fluid level is within the specified range.

**CAUTION:**

**When reinstalling CVT fluid level gauge, insert it into the CVT fluid charging pipe and rotate it to the original installation position until securely locked.**

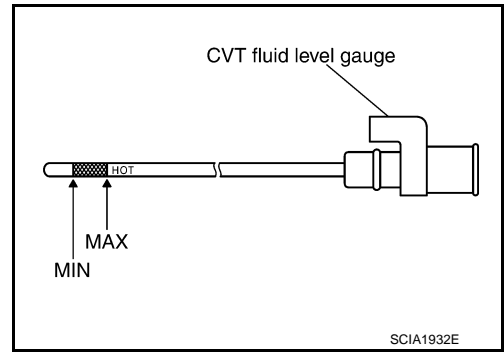

### CVT FLUID CONDITION

Check CVT fluid condition.

- If CVT fluid is very dark or smells burned, check operation of CVT. Flush cooling system after repair of CVT.
- If CVT fluid contains frictional material (clutches, brakes, etc.), replace radiator and flush cooler line using cleaning solvent and compressed air after repair of CVT. Refer to [TM-220, "Cleaning"](#).

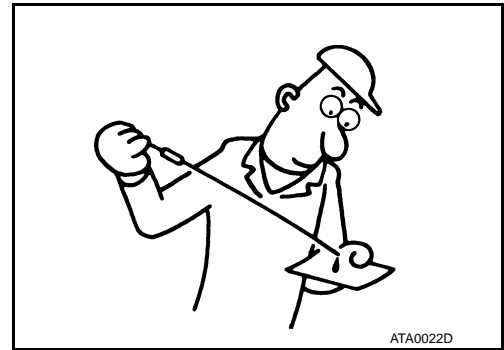

Fluid status	Conceivable cause	Required operation
Varnished (viscous varnish state)	CVT fluid become degraded due to high temperatures.	Replace the CVT fluid and check the CVT main unit and the vehicle for malfunctions (wire harnesses, cooler pipes, etc.)
Milky white or cloudy	Water in the fluid	Replace the CVT fluid and check for places where water is getting in.
Large amount of metal powder mixed in	Unusual wear of sliding parts within CVT	Replace the CVT fluid and check for improper operation of the CVT.

### CVT FLUID (RE0F10D)

#### CVT FLUID (RE0F10D) : Inspection

INFOID:000000011735673

#### FLUID LEAKAGE

- Check transaxle surrounding area (oil seal and plug etc.)for fluid leakage.
- If anything is found, repair or replace damaged parts and adjust CVT fluid level. Refer to [TM-437, "Adjustment"](#).

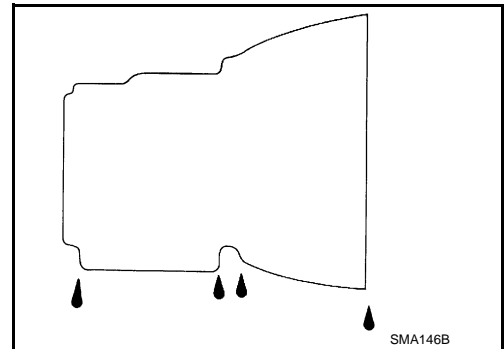

### GEAR OIL (RS6F94R)

#### GEAR OIL (RS6F94R) : Inspection

INFOID:000000011735674

#### OIL LEAKAGE

Make sure that gear oil is not leaking from transaxle or around it.

#### OIL LEVEL

# CHASSIS MAINTENANCE

## < PERIODIC MAINTENANCE >

1. Remove filler plug (1) and gasket from transaxle case.
2. Check the oil level from filler plug mounting hole as shown in the figure.  
**CAUTION:**  
**Never start engine while checking oil level.**
3. Set a gasket on filler plug and then install it to transaxle case.  
**CAUTION:**  
**Never reuse gasket.**
4. Tighten filler plug to the specified torque. Refer to [TM-32, "Exploded View"](#).

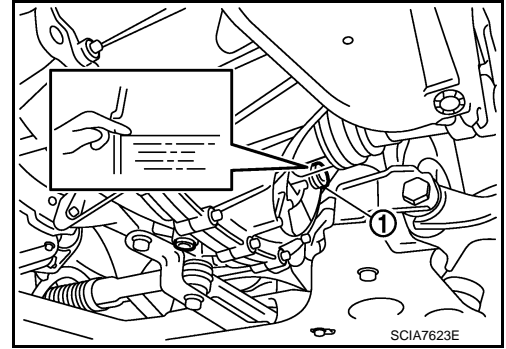

INFOID:000000011735675

## GEAR OIL (RS6F94R) : Draining

1. Start engine and let it run to warm up transaxle.
2. Stop engine. Remove drain plug (1) and gasket, using a socket [Commercial service tool] and then drain gear oil.
3. Set a gasket on drain plug and install it to clutch housing, using a socket [Commercial service tool].  
**CAUTION:**  
**Never reuse gasket.**
4. Tighten drain plug to the specified torque. Refer to [TM-32, "Exploded View"](#).

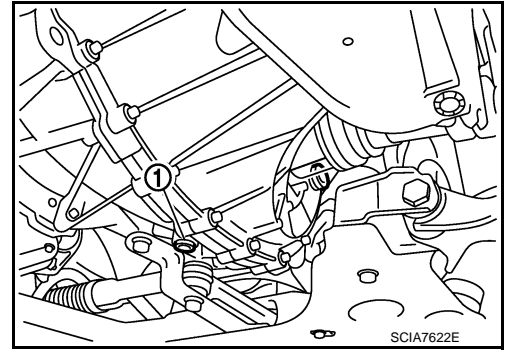

INFOID:000000011735676

## GEAR OIL (RS6F94R) : Refilling

1. Remove filler plug (1) and gasket from transaxle case.
2. Fill with new gear oil until oil level reaches the specified limit at filler plug mounting hole as shown in the figure.

**Oil grade and viscosity** : Refer to [MA-11, "Fluids and Lubricants"](#).

**Oil capacity** : Refer to [TM-67, "General Specifications"](#).

3. After refilling gear oil, check the oil level. Refer to [MA-36, "GEAR OIL \(RS6F94R\) : Inspection"](#).
4. Set a gasket on filler plug and then install it to transaxle case.  
**CAUTION:**  
**Never reuse gasket.**
5. Tighten filler plug to the specified torque. Refer to [TM-32, "Exploded View"](#).

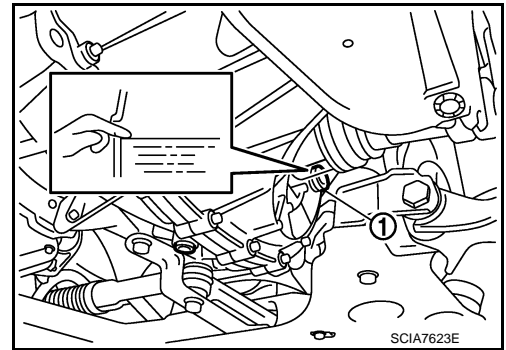

INFOID:000000011735677

## GEAR OIL (RS6F52H)

## GEAR OIL (RS6F52H) : Inspection

### OIL LEAKAGE

Make sure that gear oil is not leaking from transaxle or around it.

### OIL LEVEL

A  
B  
C  
D  
E  
F  
G  
H  
I  
J  
K  
L  
M  
N  
O

MA

# CHASSIS MAINTENANCE

## < PERIODIC MAINTENANCE >

1. Remove filler plug (1) and gasket from transaxle case.
2. Check the oil level from filler plug mounting hole as shown in the figure.  
**CAUTION:**  
**Never start engine while checking oil level.**
3. Set a gasket on filler plug and then install it to transaxle case.  
**CAUTION:**  
**Never reuse gasket.**
4. Tighten filler plug to the specified torque. Refer to [TM-87](#), "[Exploded View](#)".

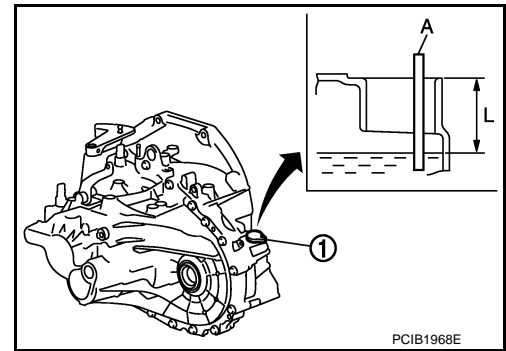

INFOID:000000011735678

## GEAR OIL (RS6F52H) : Draining

1. Start engine and let it run to warm up transaxle.
2. Stop engine. Remove drain plug (1) and gasket, using a socket [Commercial service tool] and then drain gear oil.
3. Set a gasket on drain plug and install it to clutch housing, using a socket [Commercial service tool].  
**CAUTION:**  
**Never reuse gasket.**
4. Tighten drain plug to the specified torque. Refer to [TM-85](#), "[Exploded View](#)".

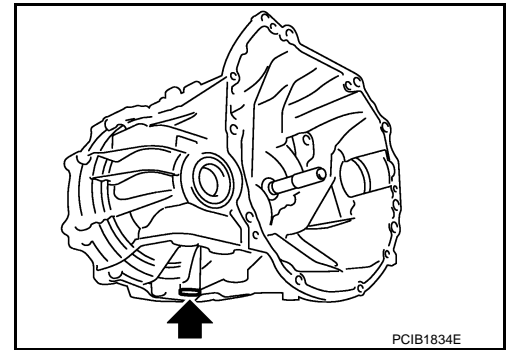

INFOID:000000011735679

## GEAR OIL (RS6F52H) : Refilling

### Refilling

1. Remove plug (1). Fill the transaxle with new oil and check the oil level (L) using suitable gauge (A) as shown.

**Oil grade and capacity** : Refer to [TM-142](#), "[General Specification](#)".

**Oil level (L)** : 38.5 - 45.5 mm (1.516 - 1.791 in)

2. Install a new O-ring onto plug (1) and then install it to transaxle. Tighten to the specified torque. Refer to [TM-87](#), "[Exploded View](#)".

**CAUTION:**  
**Do not reuse O-ring.**

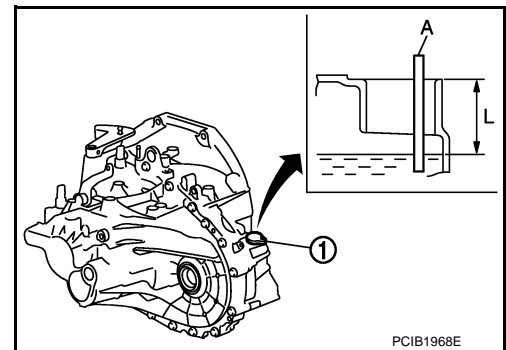

## CLUTCH FLUID

### CLUTCH FLUID : Inspection

INFOID:000000011735680

### FLUID LEAKAGE

- Check clutch line for cracks, deterioration or other damage. Replace any damaged parts.
- Check for fluid leakage by fully depressing clutch pedal while engine is running.

**CAUTION:**

**If leakage occurs around joints, reinstall the joints or, if necessary, replace damaged parts.**

### FLUID LEVEL

# CHASSIS MAINTENANCE

## < PERIODIC MAINTENANCE >

- Check that the fluid level in the reservoir tank is within the specified range (MAX – MIN lines).
- Visually check for any clutch fluid leakage around the reservoir tank.
- Check the clutch system for any leakage if the fluid level is extremely low (lower than MIN).

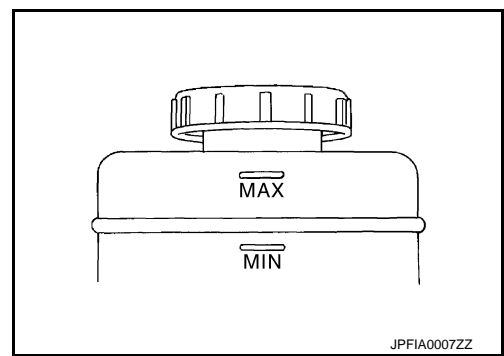

## TRANSFER OIL

### TRANSFER OIL : Inspection

INFOID:000000011735751

### OIL LEAKAGE

Check transfer surrounding area (oil seal, drain plug, filler plug, and transfer case etc.) for oil leakage.

### OIL LEVEL

1. Remove filler plug (1) and gasket. Then check that oil is filled up from mounting hole for the filler plug.

←: Vehicle front

#### **CAUTION:**

**Never start engine while checking oil level.**

2. Before installing filler plug, set a new gasket. Install filler plug on transfer and tighten to the specified torque. Refer to [DLN-116](#), "[Exploded View](#)".

#### **CAUTION:**

**Never reuse gasket.**

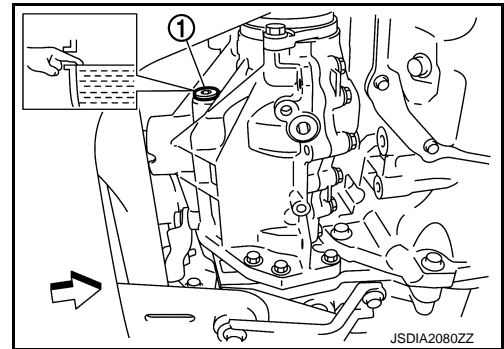

INFOID:000000011735752

### TRANSFER OIL : Draining

1. Run the vehicle to warm up the transfer unit sufficiently.
2. Stop the engine and remove the drain plug (1) and gasket to drain the transfer oil.

←: Vehicle front

3. Before installing drain plug, set a new gasket. Install drain plug on the transfer and tighten to the specified torque. Refer to [DLN-116](#), "[Exploded View](#)".

#### **CAUTION:**

**Never reuse gasket.**

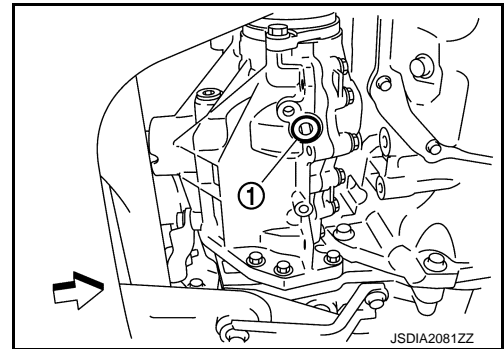

INFOID:000000011735753

# CHASSIS MAINTENANCE

< PERIODIC MAINTENANCE >

## TRANSFER OIL : Refilling

INFOID:000000011735754

1. Remove filler plug (1) and gasket. Then fill oil up to mounting hole for the filler plug.

⇐ Vehicle front

**Oil and viscosity**

: Refer to [MA-11, "Fluids and Lubricants"](#).

**Oil capacity**

: Refer to [DLN-120, "General Specifications"](#).

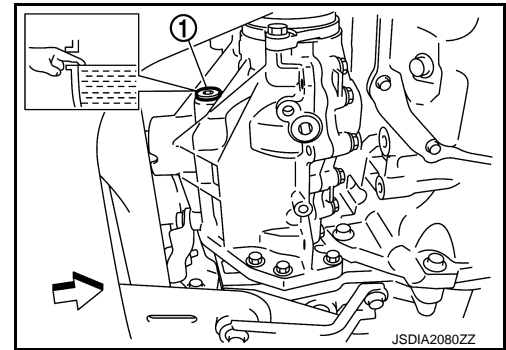

### CAUTION:

**Carefully fill the oil. (Fill up for approximately 3 minutes.)**

2. Leave the vehicle for 3 minutes, and check the oil level again.
3. Before installing filler plug, set a new gasket. Install filler plug on transfer and tighten to the specified torque. Refer to [DLN-116, "Exploded View"](#).

### CAUTION:

**Never reuse gasket.**

## REAR PROPELLER SHAFT

### REAR PROPELLER SHAFT : Inspection

INFOID:000000011735754

#### APPEARANCE AND NOISE

- Check the propeller shaft tube surface for dents or cracks. If damaged, replace propeller shaft assembly.
- If center bearing is noisy or damaged, replace propeller shaft assembly.

#### VIBRATION

If vibration is present at high speed, inspect propeller shaft runout first.

1. With a dial indicator, measure propeller shaft runout at runout measuring points by rotating final drive companion flange with hands.

**Propeller shaft runout**

: Refer to [DLN-128, "Propeller Shaft Runout"](#).

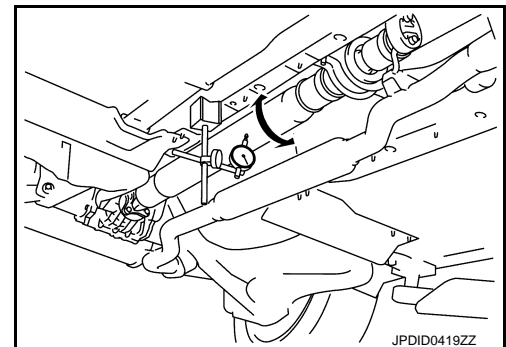

- Propeller shaft runout measuring point (Point "Δ")

⇐ : Front

**Dimension**

**A: 542 mm (21.34 in)**

**B: 516.5 mm (20.33 in)**

2. If runout still exceeds specifications, separate propeller shaft at final drive companion flange or transfer companion flange; then change the phase between companion flange and propeller shaft by the one bolt hole at a time and install propeller shaft.
3. Check runout again. If runout still exceeds specifications, replace propeller shaft assembly.
4. Check the vibration by driving vehicle.

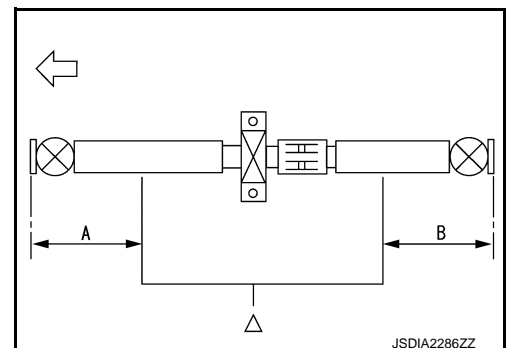

## REAR DIFFERENTIAL GEAR OIL



# CHASSIS MAINTENANCE

< PERIODIC MAINTENANCE >

## REAR DIFFERENTIAL GEAR OIL : Inspection

INFOID:000000011735755

### OIL LEAKAGE

Check rear final drive surrounding area (oil seal, drain plug, filler plug, and gear carrier, etc.) for oil leakage.

### OIL LEVEL

1. Remove filler plug (1) and check oil level from filler plug mounting hole as shown in the figure.

**CAUTION:**

**Never start engine while checking oil level.**

2. Set a new gasket on filler plug and install it on final drive assembly. Refer to [DLN-157, "Exploded View"](#).

**CAUTION:**

**Never reuse gasket.**

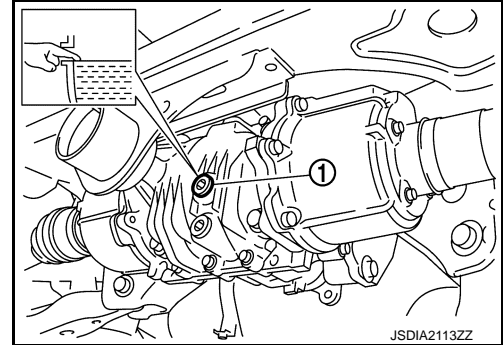

## REAR DIFFERENTIAL GEAR OIL : Draining

INFOID:000000011735756

1. Stop engine.
2. Remove drain plug (1) and drain gear oil.
3. Set a new gasket on drain plug and install it to final drive assembly and tighten to the specified torque. Refer to [DLN-157, "Exploded View"](#).

**CAUTION:**

**Never reuse gasket.**

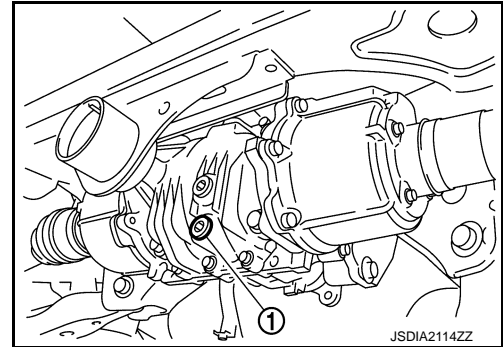

## REAR DIFFERENTIAL GEAR OIL : Refilling

INFOID:000000011735757

1. Remove filler plug (1). Fill with new gear oil until oil level reaches the specified level near filler plug mounting hole.

**Oil grade and viscosity** : Refer to [MA-11, "Fluids and Lubricants"](#).

**Oil capacity** : Refer to [DLN-174, "General Specification"](#).

2. After refilling oil, check oil level. Set a new gasket to filler plug, then install it to final drive assembly. Refer to [DLN-157, "Exploded View"](#).

**CAUTION:**

**Never reuse gasket.**

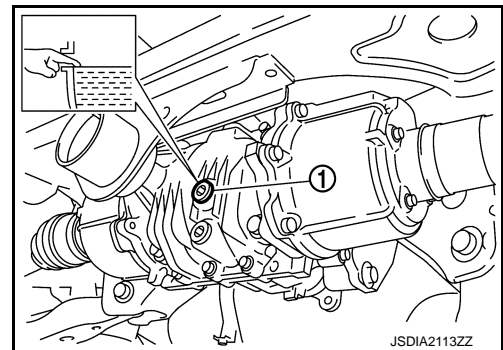

## WHEELS (BONDING WEIGHT TYPE)

### WHEELS (BONDING WEIGHT TYPE) : Wheel Balance Adjustment

INFOID:000000011735758

#### PREPARATION BEFORE ADJUSTMENT

Using releasing agent, remove double-faced adhesive tape from the road wheel.

**CAUTION:**

- Be careful not to scratch the road wheel during removal.
- After removing double-faced adhesive tape, wipe clean traces of releasing agent from the road wheel.

A  
B  
C  
D  
E  
F  
G  
H  
I  
J  
K  
L  
M  
N  
O

# CHASSIS MAINTENANCE

## < PERIODIC MAINTENANCE >

### ADJUSTMENT

- The details of the adjustment procedure are different for each model of wheel balancer. Therefore, refer to each instruction manual.
- If a tire balance machine has adhesion balance weight mode settings and drive-in weight mode setting, select and adjust a drive-in weight mode suitable for aluminum wheels.

1. Set road wheel on tire balance machine using the center hole as a guide. Start the tire balance machine.
2. When inner and outer unbalance values are shown on the tire balance machine indicator, multiply outer unbalance value by  $5/3$  to determine balance weight that should be used. Select the outer balance weight with a value closest to the calculated value above and install to the designated outer position of, or at the designated angle in relation to the road wheel.

#### CAUTION:

- **Never install the inner balance weight before installing the outer balance weight.**
- **Before installing the balance weight, always to clean the mating surface of the road wheel.**

- a. Indicated unbalance value  $\times 5/3$  = balance weight to be installed

#### Calculation example:

$23 \text{ g (0.81 oz)} \times 5/3 = 38.33 \text{ g (1.35 oz)} \Rightarrow 40 \text{ g (1.41 oz)}$  balance weight (closer to calculated balance weight value)

#### NOTE:

Note that balance weight value must be closer to the calculated balance weight value.

#### Example:

$37.4 \Rightarrow 35 \text{ g (1.23 oz)}$

$37.5 \Rightarrow 40 \text{ g (1.41 oz)}$

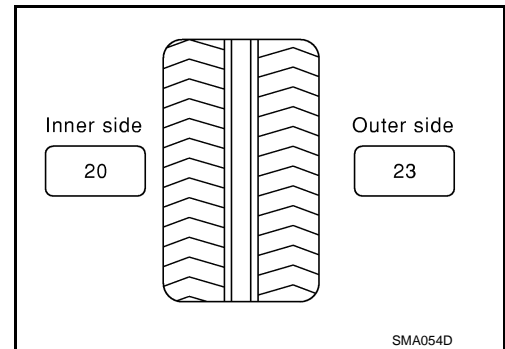

- b. Installed balance weight in the position.

- When installing balance weight (1) to road wheels, set it into the grooved area (A) on the inner wall of the road wheel as shown in the figure so that the balance weight center (B) is aligned with the tire balance machine indication position (angle) (C).

#### CAUTION:

- **Always use genuine NISSAN balance weights.**
- **Balance weights are non-reusable; always replace with new ones.**
- **Never install three or more sheets of balance weight.**

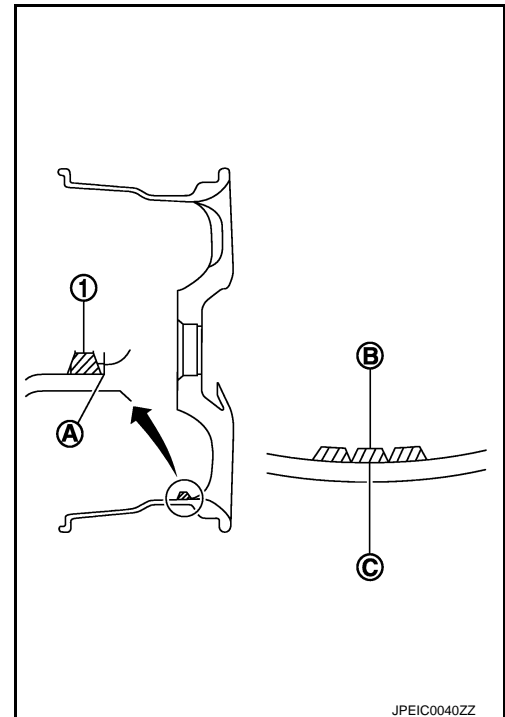

# CHASSIS MAINTENANCE

## < PERIODIC MAINTENANCE >

- c. If calculated balance weight value exceeds 50 g (1.76 oz), install two balance weight sheets in line with each other as shown in the figure.

**CAUTION:**

**Never install one balance weight sheet on top of another.**

3. Start the tire balance machine again.
4. Install drive-in balance weight on inner side of road wheel in the tire balance machine indication position (angle).

**CAUTION:**

**Never install three or more balance weight.**

5. Start the tire balance machine. Check that the inner and outer residual unbalance value is within the allowable unbalance value.

**CAUTION:**

**If either residual unbalance value exceeds limit, repeat installation procedures.**

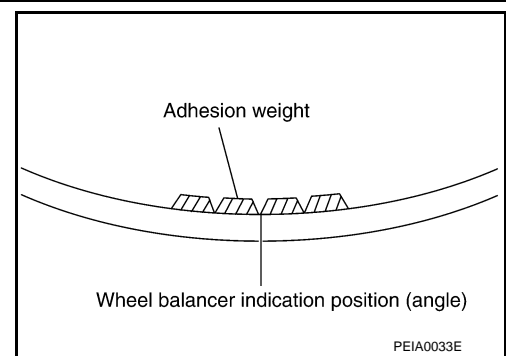

### Allowable unbalance value

Dynamic (At flange) : Refer to [WT-43, "Road Wheel"](#).

Static (At flange) : Refer to [WT-43, "Road Wheel"](#).

## WHEELS (BONDING WEIGHT TYPE) : Tire Rotation

INFOID:000000011735759

- Follow the maintenance schedule for tire rotation service intervals. Refer to [MA-5, "Explanation of General Maintenance"](#).
- When installing the wheel, tighten wheel nuts to the specified torque. Refer to [WT-39, "Exploded View"](#).

**CAUTION:**

- **Never include the T-type spare tire when rotating the tires.**
- **When installing wheels, tighten them diagonally by dividing the work two to three times in order to prevent the wheels from developing any distortion.**
- **Be careful not to tighten wheel nut at torque exceeding the criteria.**
- **Use NISSAN genuine wheel nut.**
- Perform the ID registration, after tire rotation. Refer to [WT-20, "Work Procedure"](#).

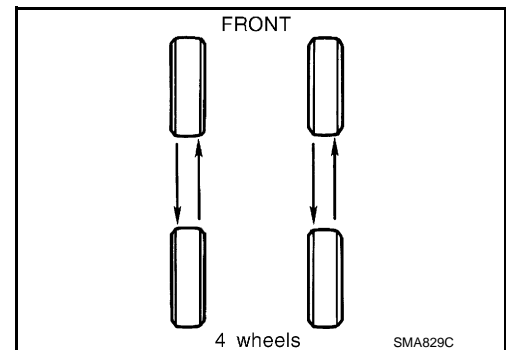

## BRAKE FLUID LEVEL AND LEAKS

### BRAKE FLUID LEVEL AND LEAKS : Inspection

INFOID:000000011463986

- If fluid level is extremely low, check brake system for leaks.

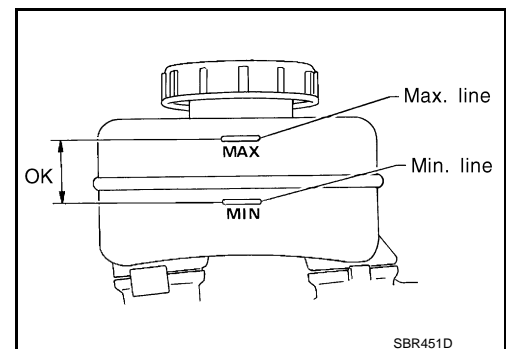

## BRAKE LINES AND CABLES

MA

# CHASSIS MAINTENANCE

< PERIODIC MAINTENANCE >

## BRAKE LINES AND CABLES : Inspection

INFOID:000000011463987

- Check brake fluid lines and parking brake cables for improper attachment, leaks, chafing, abrasions, deterioration, etc.

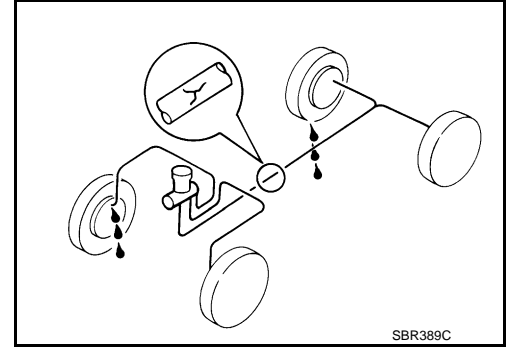

## BRAKE FLUID

### BRAKE FLUID : Changing

INFOID:000000011463988

1. Drain brake fluid from each bleed valve.
2. Refill until new brake fluid comes out from each bleed valve. Use same procedure as in bleeding hydraulic system to refill brake fluid.  
Refer to [BR-13. "Bleeding Brake System"](#).
  - Refill with recommended brake fluid.  
Refer to [MA-11. "Fluids and Lubricants"](#).
  - Never reuse drained brake fluid.
  - Be careful not to splash brake fluid on painted areas.

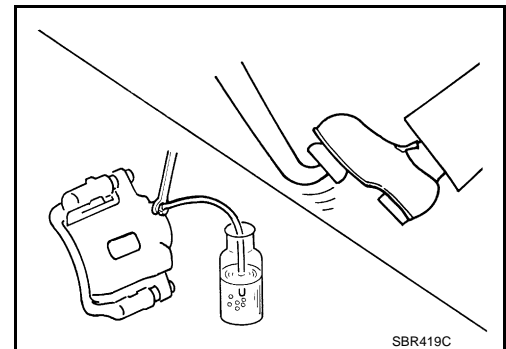

## DISC BRAKE

### DISC BRAKE : Inspection

INFOID:000000011463989

#### DISC ROTOR

Check condition, wear, and damage.

#### CALIPER

- Check for leakage.

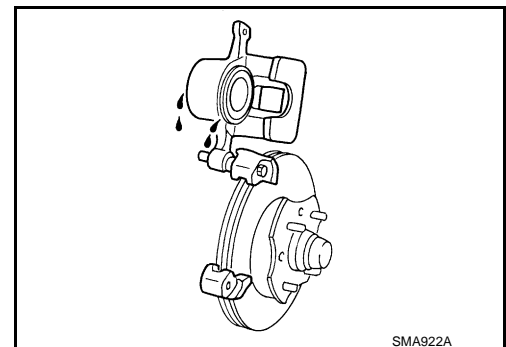

## BRAKE PAD

# CHASSIS MAINTENANCE

## < PERIODIC MAINTENANCE >

- Check for wear or damage.

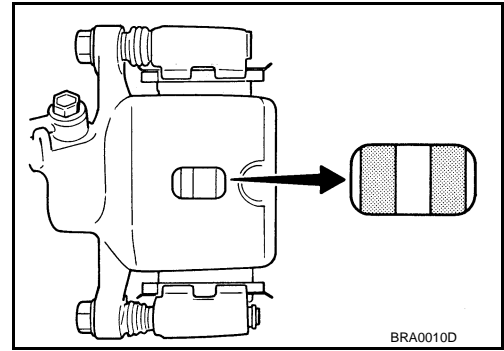

### DISC BRAKE : Front Disc Brake

INFOID:000000011735895

#### EXCEPT NISMO RS

Unit: mm (in)

Item		Limit
Brake pad	Wear thickness	2.0 (0.079)
	Wear thickness	24.0 (0.945)
Disc rotor	Thickness variation (measured at 8 positions)*	0.008 (0.0003)
	Runout (with it attached to the vehicle)	0.035 (0.0014)

\*To check if rotor imbalance, rotor runout deformation is occurred.

#### NISMO RS

Unit: mm (in)

Item		Limit
Brake pad	Wear thickness	2.0 (0.079)
	Wear thickness	26.0 (1.024)
Disc rotor	Thickness variation (measured at 8 positions)*	0.008 (0.0003)
	Runout (with it attached to the vehicle)	0.035 (0.0014)

\*To check if rotor imbalance, rotor runout deformation is occurred.

### DISC BRAKE : Rear Disc Brake

INFOID:000000011735896

#### EXCEPT NISMO RS

Unit: mm (in)

Item		Limit
Brake pad	Wear thickness	2.0 (0.079)
	Wear thickness	8.0 (0.315)
Disc rotor	Thickness variation (measured at 8 positions)*	0.016 (0.0006)
	Runout (with it attached to the vehicle)	0.1 (0.004)

\*To check if rotor imbalance, rotor runout deformation is occurred.

#### NISMO RS

Unit: mm (in)

Item		Limit
Brake pad	Wear thickness	2.0 (0.079)
	Wear thickness	14.0 (0.551)
Disc rotor	Thickness variation (measured at 8 positions)*	0.016 (0.0006)
	Runout (with it attached to the vehicle)	0.1 (0.004)

\*To check if rotor imbalance, rotor runout deformation is occurred.

## STEERING GEAR AND LINKAGE

A  
B  
C  
D  
E  
F  
G  
H  
I  
J  
K  
L  
M  
N  
O

MA

# CHASSIS MAINTENANCE

< PERIODIC MAINTENANCE >

## STEERING GEAR AND LINKAGE : Inspection

INFOID:000000011463992

### STEERING GEAR

- Check gear housing and boots for looseness, damage and grease leakage.
- Check connection with steering column for looseness.

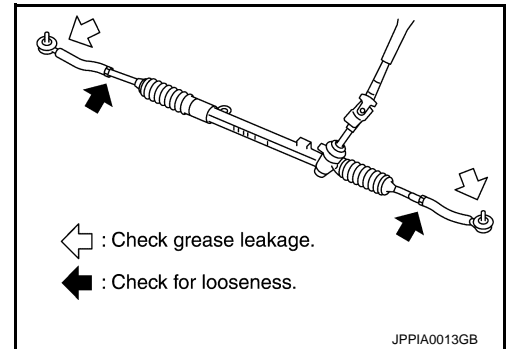

### STEERING LINKAGE

Check ball joint, dust cover and other component parts for looseness, wear, damage and grease leakage.

## AXLE AND SUSPENSION PARTS

### AXLE AND SUSPENSION PARTS : Inspection

INFOID:000000011463993

Check front and rear axle and suspension parts for excessive play, cracks, wear or other damage.

- Shake each wheel to check for excessive play.
- Check wheel bearings for smooth operation.
- Check axle and suspension nuts and bolts for looseness.
- Check strut (shock absorber) for oil leakage or other damage.
- Check suspension ball joint for grease leakage and ball joint dust cover for cracks or other damage.

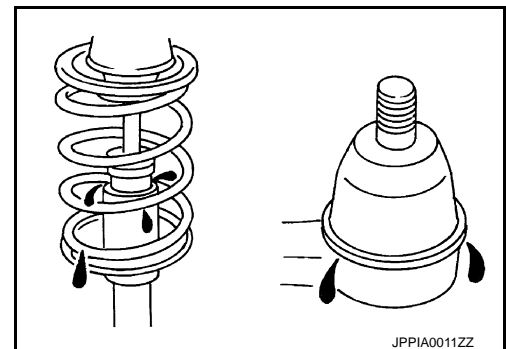
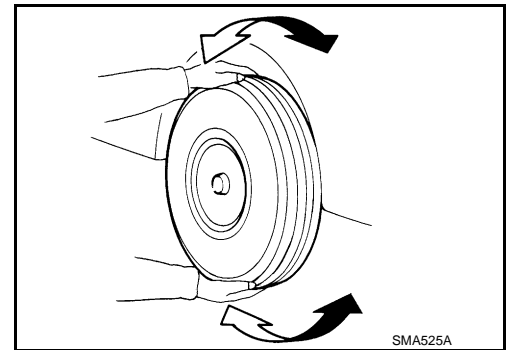

### DRIVE SHAFT

### DRIVE SHAFT : Inspection

INFOID:000000011463994

Check boot and drive shaft for cracks, wear, damage and grease leakage.

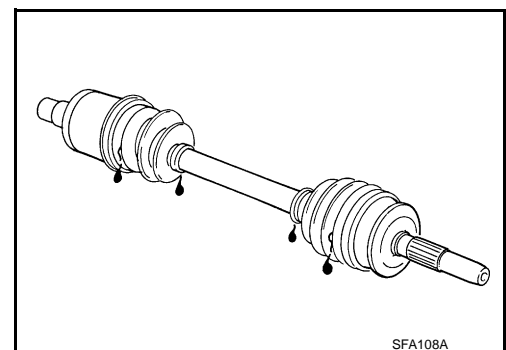

# BODY MAINTENANCE

< PERIODIC MAINTENANCE >

## BODY MAINTENANCE

### LOCKS, HINGES AND HOOD LATCH

#### LOCKS, HINGES AND HOOD LATCH : Lubricating

INFOID:000000011463995

For hood and hood lock illustration.

- Hood: Refer to [DLK-125, "Exploded View"](#).
- Hood lock: Refer to [DLK-155, "Exploded View"](#).

For door and door lock illustration.

- Front door: Refer to [DLK-136, "Exploded View"](#).
- Front door lock: Refer to [DLK-158, "Exploded View"](#).
- Rear door: Refer to [DLK-141, "Exploded View"](#).
- Rear door lock: Refer to [DLK-162, "Exploded View"](#).

For back door and back door lock illustration.

- Back door: Refer to [DLK-146, "Exploded View"](#).
- Back door lock: Refer to [DLK-165, "Exploded View"](#).

### SEAT BELT, BUCKLES, RETRACTORS, ANCHORS AND ADJUSTERS

#### SEAT BELT, BUCKLES, RETRACTORS, ANCHORS AND ADJUSTERS : Inspection

INFOID:000000011463996

For front seat belt illustration. Refer to [SB-4, "Exploded View"](#).

For rear seat belt illustration. Refer to [SB-10, "Exploded View"](#).

#### **CAUTION:**

- **After any collision, inspect all seat belt assemblies, including retractors and other attached hardwares (i.e. anchor bolt, guide rail set). Nissan recommends to replace all seat belt assemblies in use during a collision, unless not damaged and properly operating after minor collision.**

**Also inspect seat belt assemblies not in use during a collision, and replace if damaged or improperly operating.**

**Seat belt pre-tensioner should be replaced even if the seat belts are not in use during a frontal collision where the driver and passenger air bags are deployed.**

- **If any component of seat belt assembly is questionable, do not repair.**

**Replace as seat belt assembly.**

- **If webbing is cut, frayed, or damaged, replace belt assembly.**
- **Never oil tongue and buckle.**
- **Use a genuine NISSAN seat belt assembly.**

For details, refer to [SB-6, "SEAT BELT RETRACTOR : Inspection"](#), [SB-13, "SEAT BELT RETRACTOR : Inspection"](#) in SB section.

- Check anchors for loose mounting
- Check belts for damage
- Check retractor for smooth operation
- Check function of buckles and tongues when buckled and released

A  
B  
C  
D  
E  
F  
G  
H  
I  
J  
K  
L  
M  
N  
O

MA

## SERVICE DATA AND SPECIFICATIONS (SDS)

< SERVICE DATA AND SPECIFICATIONS (SDS)

## SERVICE DATA AND SPECIFICATIONS (SDS)

SERVICE DATA AND SPECIFICATIONS (SDS)

DRIVE BELT (MR FOR NISMO RS MODELS)

DRIVE BELT (MR FOR NISMO RS MODELS) : Drive Belt

INFOID:000000011736834

DRIVE BELT

Tension of drive belt	Belt tension is not necessary, as it is automatically adjusted by drive belt auto-tensioner.
-----------------------	--

DRIVE BELT (MR EXCEPT FOR NISMO RS MODELS)

DRIVE BELT (MR EXCEPT FOR NISMO RS MODELS) : Drive Belt

INFOID:000000011736897

DRIVE BELT

Tension of drive belt	Belt tension is not necessary, as it is automatically adjusted by drive belt auto-tensioner.
-----------------------	--

ENGINE COOLANT (MR FOR NISMO RS MODELS)

ENGINE COOLANT (MR FOR NISMO RS MODELS) : Periodical Maintenance Specification

INFOID:000000011736836

ENGINE COOLANT CAPACITY (APPROXIMATE)

Unit: ℓ (US qt, Imp qt)

Engine coolant capacity (With reservoir tank at "MAX" level)	M/T models	7.9 (8- 3/8, 7)
	CVT models	8.1 (8- 1/2, 7-1/8)
Reservoir tank engine coolant capacity (At "MAX" level)		0.6 (5/8, 1/2)

ENGINE COOLANT (MR EXCEPT FOR NISMO RS MODELS)

ENGINE COOLANT (MR EXCEPT FOR NISMO RS MODELS) : Periodical Maintenance Specification

INFOID:000000011736837

ENGINE COOLANT CAPACITY (APPROXIMATE)

Unit: ℓ (US qt, Imp qt)

Engine coolant capacity (With reservoir tank at "MAX" level)	M/T models	8.5 (9, 7-1/2)
	CVT models	8.7 (9-2/8, 7-5/8)
Reservoir tank engine coolant capacity (At "MAX" level)		0.6 (5/8, 1/2)

ENGINE OIL (MR FOR NISMO RS MODELS)

ENGINE OIL (MR FOR NISMO RS MODELS) : Periodical Maintenance Specification

INFOID:000000011736838

ENGINE OIL CAPACITY (APPROXIMATE)

Unit: ℓ (US qt, Imp qt)

Drain and refill	With oil filter change	4.5 (4-6/8, 4)
	Without oil filter change	4.3 (4-4/8, 3-6/8)
Dry engine (Overhaul)		5.4 (5-6/8, 4-6/8)

ENGINE OIL (MR EXCEPT FOR NISMO RS MODELS)

ENGINE OIL (MR EXCEPT FOR NISMO RS MODELS) : Periodical Maintenance



# SERVICE DATA AND SPECIFICATIONS (SDS)

## < SERVICE DATA AND SPECIFICATIONS (SDS)

### Specification

INFOID:0000000011736839

#### ENGINE OIL CAPACITY (APPROXIMATE)

Unit: ℓ (US qt, Imp qt)

Drain and refill	With oil filter change	4.3 (4-4/8, 3-6/8)
	Without oil filter change	4.1 (4-3/8, 3-5/8)
Dry engine (Overhaul)		5.2 (5-4/8, 4-5/8)

#### SPARK PLUG (MR FOR NISMO RS MODELS)

#### SPARK PLUG (MR FOR NISMO RS MODELS) : Spark Plug

INFOID:0000000011786395

#### SPARK PLUG

Unit: mm (in)

Make	NGK	
Standard type	DILKAR7C9H	
Gap (Nominal)	Standard	0.9 (0.035)
	Limit	1.1 (0.043)

#### SPARK PLUG (MR EXCEPT FOR NISMO RS MODELS)

#### SPARK PLUG (MR EXCEPT FOR NISMO RS MODELS) : Spark Plug

INFOID:0000000011738998

#### SPARK PLUG

Unit: mm (in)

Make	NGK	
Standard type	DILKAR7E9HS	
Gap (Nominal)	Standard	0.9 (0.035)
	Limit	1.1 (0.043)

#### ROAD WHEEL

#### ROAD WHEEL : Road Wheel

INFOID:0000000011736854

#### CONVENTIONAL

Item		Limit
Runout	Axial runout	Less than 0.3 mm (0.012 in)
	Radial runout	
Allowable unbalance	Dynamic (At flange)	Less than 5 g (0.17 oz) (one side)
	Static (At flange)	Less than 10 g (0.35 oz)

#### EMERGENCY

##### Except NISMO RS

Item		Limit
Runout	Axial runout (Average)	Less than 1.2 mm (0.047 in)
	Radial runout (Average)	Less than 1.3 mm (0.051 in)

##### NISMO RS

Item		Limit
Runout	Axial runout (Average)	Less than 1.5 mm (0.059 in)
	Radial runout (Average)	Less than 1.5 mm (0.059 in)

A  
B  
C  
D  
E  
F  
G  
H  
I  
J  
K  
L  
M  
N  
O

MA