

SECTION **FAX**
FRONT AXLE

A
B
C

FAX

CONTENTS

E

TYPE 1	FRONT DRIVE SHAFT BOOT	15	F
HOW TO USE THIS MANUAL	2WD	15	
HOW TO USE THIS SECTION	2WD : Exploded View	15	G
Information	2WD : Removal and Installation	16	
	2WD : Inspection	20	
PRECAUTION	AWD	20	H
PRECAUTIONS	AWD : Exploded View	20	
Precaution for Supplemental Restraint System (SRS) "AIR BAG" and "SEAT BELT PRE-TEN- SIONER"	AWD : Removal and Installation	22	
Precautions for Drive Shaft	AWD : Inspection	26	I
Precautions for Removing Battery Terminal	FRONT DRIVE SHAFT	27	
PREPARATION	2WD	27	J
PREPARATION	2WD : Exploded View	27	
Special Service Tool	2WD : Removal and Installation	28	
Commercial Service Tools	2WD : Disassembly and Assembly	32	K
SYMPTOM DIAGNOSIS	2WD : Inspection	43	
NOISE, VIBRATION AND HARSHNESS (NVH) TROUBLESHOOTING	AWD	43	L
NVH Troubleshooting Chart	AWD : Exploded View	43	
PERIODIC MAINTENANCE	AWD : Removal and Installation	45	
FRONT WHEEL HUB AND KNUCKLE	AWD : Disassembly and Assembly	49	M
Inspection	AWD : Inspection	56	
FRONT DRIVE SHAFT	SERVICE DATA AND SPECIFICATIONS (SDS)	57	N
Inspection	SERVICE DATA AND SPECIFICATIONS (SDS)	57	
REMOVAL AND INSTALLATION	Wheel Bearing	57	O
FRONT WHEEL HUB AND KNUCKLE	Drive Shaft	57	
Exploded View	TYPE 2		
Removal and Installation	HOW TO USE THIS MANUAL	58	P
Inspection	HOW TO USE THIS SECTION	58	
	Information	58	
	PRECAUTION	59	
	PRECAUTIONS	59	

Precaution for Supplemental Restraint System (SRS) "AIR BAG" and "SEAT BELT PRE-TENSIONER"	59	FRONT DRIVE SHAFT BOOT	70
Precautions for Drive Shaft	59	2WD	70
Precautions for Removing Battery Terminal	59	2WD : Exploded View	70
PREPARATION	61	2WD : Removal and Installation	71
PREPARATION	61	2WD : Inspection	75
Special Service Tool	61	AWD	75
Commercial Service Tools	62	AWD : Exploded View	75
SYMPTOM DIAGNOSIS	63	AWD : Removal and Installation	76
NOISE, VIBRATION AND HARSHNESS (NVH) TROUBLESHOOTING	63	AWD : Inspection	80
NVH Troubleshooting Chart	63	FRONT DRIVE SHAFT	82
PERIODIC MAINTENANCE	64	2WD	82
FRONT WHEEL HUB AND KNUCKLE	64	2WD : Exploded View	82
Inspection	64	2WD : Removal and Installation	83
FRONT DRIVE SHAFT	65	2WD : Disassembly and Assembly	87
Inspection	65	2WD : Inspection	96
REMOVAL AND INSTALLATION	66	AWD	96
FRONT WHEEL HUB AND KNUCKLE	66	AWD : Exploded View	96
Exploded View	66	AWD : Removal and Installation	97
Removal and Installation	66	AWD : Disassembly and Assembly	101
Inspection	68	AWD : Inspection	108
		SERVICE DATA AND SPECIFICATIONS (SDS)	109
		SERVICE DATA AND SPECIFICATIONS (SDS)	109
		Wheel Bearing	109
		Drive Shaft	109

HOW TO USE THIS SECTION

< HOW TO USE THIS MANUAL >

[TYPE 1]

HOW TO USE THIS MANUAL

HOW TO USE THIS SECTION

Information

INFOID:0000000012990041

Service information	Model information
TYPE 1	For NISMO models
TYPE 2	Except for NISMO models

A

B

C

FAX

E

F

G

H

I

J

K

L

M

N

O

P

PRECAUTION

PRECAUTIONS

Precaution for Supplemental Restraint System (SRS) "AIR BAG" and "SEAT BELT PRE-TENSIONER"

INFOID:000000012201543

The Supplemental Restraint System such as "AIR BAG" and "SEAT BELT PRE-TENSIONER", used along with a front seat belt, helps to reduce the risk or severity of injury to the driver and front passenger for certain types of collision. This system includes seat belt switch inputs and dual stage front air bag modules. The SRS system uses the seat belt switches to determine the front air bag deployment, and may only deploy one front air bag, depending on the severity of a collision and whether the front occupants are belted or unbelted. Information necessary to service the system safely is included in the "SRS AIR BAG" and "SEAT BELT" of this Service Manual.

WARNING:

Always observe the following items for preventing accidental activation.

- To avoid rendering the SRS inoperative, which could increase the risk of personal injury or death in the event of a collision that would result in air bag inflation, it is recommended that all maintenance and repair be performed by an authorized NISSAN/INFINITI dealer.
- Improper repair, including incorrect removal and installation of the SRS, can lead to personal injury caused by unintentional activation of the system. For removal of Spiral Cable and Air Bag Module, see "SRS AIR BAG".
- Never use electrical test equipment on any circuit related to the SRS unless instructed to in this Service Manual. SRS wiring harnesses can be identified by yellow and/or orange harnesses or harness connectors.

PRECAUTIONS WHEN USING POWER TOOLS (AIR OR ELECTRIC) AND HAMMERS

WARNING:

Always observe the following items for preventing accidental activation.

- When working near the Air Bag Diagnosis Sensor Unit or other Air Bag System sensors with the ignition ON or engine running, never use air or electric power tools or strike near the sensor(s) with a hammer. Heavy vibration could activate the sensor(s) and deploy the air bag(s), possibly causing serious injury.
- When using air or electric power tools or hammers, always switch the ignition OFF, disconnect the battery or batteries, and wait at least 3 minutes before performing any service.

Precautions for Drive Shaft

INFOID:000000012201544

- Observe the following precautions when disassembling and assembling drive shaft.
 - Never disassemble joint sub-assembly because it is non-overhaul parts.
 - Perform work in a location which is as dust-free as possible.
 - Clean the parts, before disassembling and assembling.
 - Prevent the entry of foreign objects during disassembly of the service location.
 - Reassemble disassembled parts carefully in the correct order. If work is interrupted, a clean cover must be placed over parts.
 - Use paper waste. Fabric shop cloths must not be used because of the danger of lint adhering to parts.
 - Clean disassembled parts (except for rubber parts) with kerosene which shall be removed by blowing with air or wiping with paper waste.

Precautions for Removing Battery Terminal

INFOID:000000012833641

When disconnecting the battery terminal, pay attention to the following.

- Always use a 12V battery as power source.
- Never disconnect battery terminal while engine is running.

PRECAUTIONS

[TYPE 1]

< PRECAUTION >

- When removing the 12V battery terminal, turn OFF the ignition switch and wait at least 30 seconds.
- For vehicles with the engine listed below, remove the battery terminal after a lapse of the specified time:

D4D engine	: 20 minutes	YS23DDT	: 4 minutes
HRA2DDT	: 12 minutes	YS23DDTT	: 4 minutes
K9K engine	: 4 minutes	ZD30DDTi	: 60 seconds
M9R engine	: 4 minutes	ZD30DDTT	: 60 seconds
R9M engine	: 4 minutes		
V9X engine	: 4 minutes		
YD25DDTi	: 2 minutes		

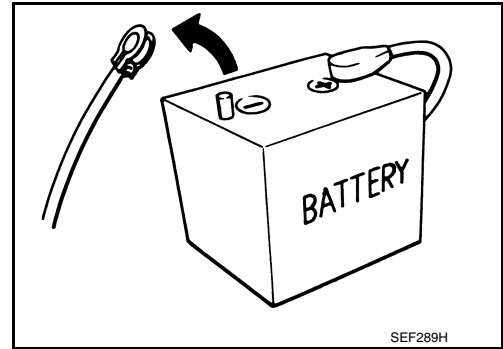

A
B
C

FAX

NOTE:

ECU may be active for several tens of seconds after the ignition switch is turned OFF. If the battery terminal is removed before ECU stops, then a DTC detection error or ECU data corruption may occur.

- After high-load driving, if the vehicle is equipped with the V9X engine, turn the ignition switch OFF and wait for at least 15 minutes to remove the battery terminal.

NOTE:

- Turbocharger cooling pump may operate in a few minutes after the ignition switch is turned OFF.
- Example of high-load driving
 - Driving for 30 minutes or more at 140 km/h (86 MPH) or more.
 - Driving for 30 minutes or more on a steep slope.
- For vehicles with the 2-batteries, be sure to connect the main battery and the sub battery before turning ON the ignition switch.

NOTE:

If the ignition switch is turned ON with any one of the terminals of main battery and sub battery disconnected, then DTC may be detected.

- After installing the 12V battery, always check "Self Diagnosis Result" of all ECUs and erase DTC.

NOTE:

The removal of 12V battery may cause a DTC detection error.

E
F
G
H
I
J
K
L
M
N
O
P

PREPARATION

< PREPARATION >

[TYPE 1]

PREPARATION

PREPARATION

Special Service Tool

INFOID:000000012201519

The actual shapes of TechMate tools may differ from those of special service tools illustrated here.

Tool number (TechMate No.) Tool name	Description
KV40104000 (—) Hub lock nut wrench a: 85 mm (3.35 in) b: 65 mm (2.56 in)	Removing and Installing wheel hub lock nut.
KV40107300 (—) Boot band crimping tool	Installing boot band
KV40107310 (—) Boot band crimping tool	Installing boot band (2WD)
KV40107500 (—) Drive shaft attachment	Removing drive shaft
KV38107900 (—) Protector a: 32 mm (1.26 in) dia.	Installing drive shaft

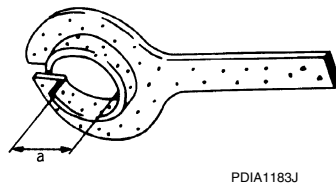
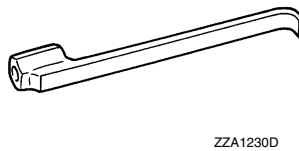
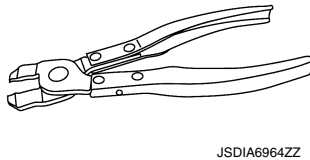
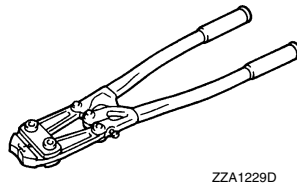
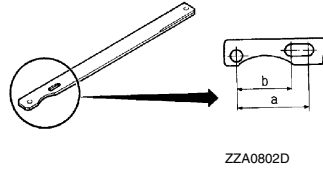

PREPARATION

< PREPARATION >

[TYPE 1]

Commercial Service Tools

INFOID:000000012201520

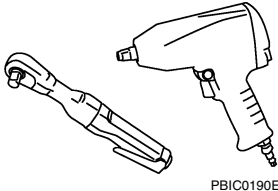
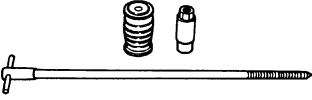
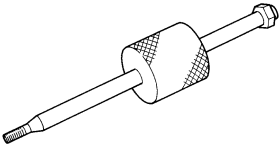
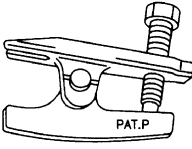
Tool name	Description
Power tool  <p>PBIC0190E</p>	Loosening bolts and nuts
Drive shaft puller  <p>JPDIG0152ZZ</p>	Removing drive shaft joint sub assembly
Sliding hammer  <p>ZZA0023D</p>	Removing drive shaft
Ball joint remover  <p>NT146</p>	Removing hub bolt

A
B
C
FAX
E
F
G
H
I
J
K
L
M
N
O
P

NOISE, VIBRATION AND HARSHNESS (NVH) TROUBLESHOOTING

< SYMPTOM DIAGNOSIS >

[TYPE 1]

SYMPTOM DIAGNOSIS

NOISE, VIBRATION AND HARSHNESS (NVH) TROUBLESHOOTING

NVH Troubleshooting Chart

INFOID:000000012201521

Use chart below to find the cause of the symptom. If necessary, repair or replace these parts.

Reference			—	—	—	—	—	—	—	—	—	—	—	—				
			FAX-43 (2WD), FAX-56 (AWD)	FAX-11	FAX-13	NVH in FAX and FSU sections		Refer to FRONT AXLE in this chart		NVH in WT section		NVH in WT section		Refer to DRIVE SHAFT in this chart				
Possible cause and SUSPECTED PARTS			Excessive joint angle	Joint sliding resistance	Imbalance	Improper installation, looseness		Parts interference	Wheel bearing damage	FRONT AXLE AND FRONT SUSPENSION		FRONT AXLE	TIRE	ROAD WHEEL	DRIVE SHAFT	BRAKE	STEERING	
Symptom	DRIVE SHAFT	Noise	x	x					x	x	x	x	x	x	x	x	x	
		Shake	x		x				x	x	x	x	x		x	x	x	
	FRONT AXLE	Noise				x	x	x	x		x	x	x	x	x	x	x	x
		Shake				x	x	x	x		x	x	x	x	x	x	x	x
		Vibration				x	x	x	x		x		x		x		x	x
		Shimmy				x	x		x		x	x		x	x	x	x	x
		Judder				x			x		x	x		x	x	x	x	x
		Poor quality ride or handling				x	x		x		x		x	x				

x: Applicable

FRONT WHEEL HUB AND KNUCKLE

< PERIODIC MAINTENANCE >

[TYPE 1]

PERIODIC MAINTENANCE

FRONT WHEEL HUB AND KNUCKLE

Inspection

INFOID:0000000012201522

COMPONENT PART

Check that the mounting conditions (looseness, backlash) of each component and component conditions (wear, damage) are normal.

WHEEL HUB ASSEMBLY (BEARING-INTEGRATED TYPE)

Check the following items, and replace the part if necessary.

- Move wheel hub assembly in the axial direction by hand. Check there is no looseness of wheel bearing.

Axial end play : Refer to [FAX-57, "Wheel Bearing"](#).

- Rotate wheel hub assembly and check there is no unusual noise or other irregular conditions. If there is any of irregular conditions, replace wheel hub assembly.

A
B
C
E
F
G
H
I
J
K
L
M
N
O
P

FAX

FRONT DRIVE SHAFT

< PERIODIC MAINTENANCE >

[TYPE 1]

FRONT DRIVE SHAFT

Inspection

INFOID:000000012201523

Check the following items, and replace the part if necessary.

- Check drive shaft mounting point and joint for looseness and other damage.

CAUTION:

Replace entire drive shaft assembly when noise or vibration occurs from drive shaft.

- Check boot for cracks and other damage.

FRONT WHEEL HUB AND KNUCKLE

< REMOVAL AND INSTALLATION >

[TYPE 1]

REMOVAL AND INSTALLATION

FRONT WHEEL HUB AND KNUCKLE

Exploded View

INFOID:0000000012201524

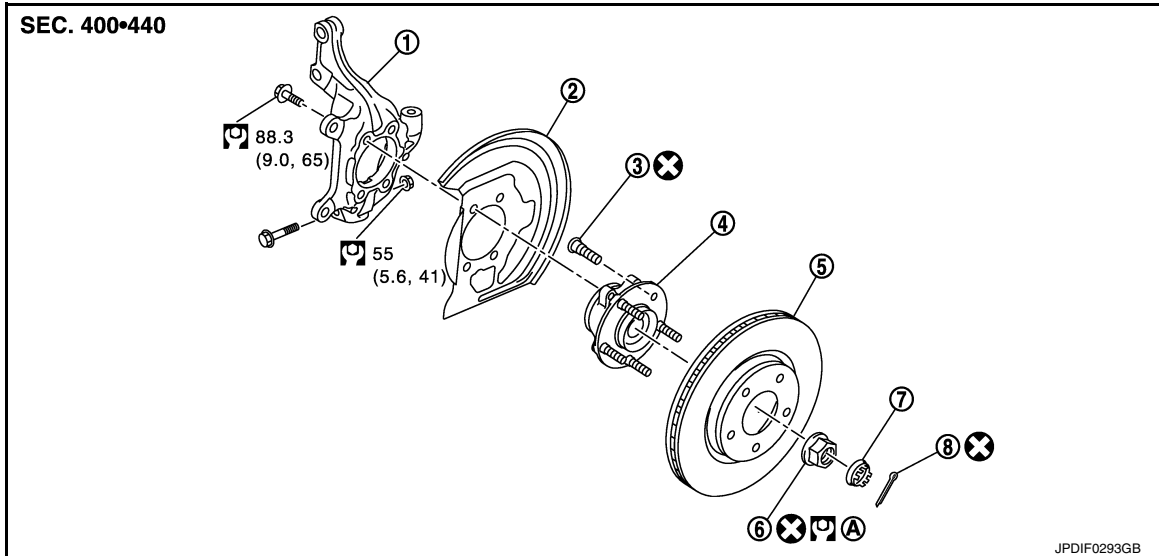

- | | | |
|---|-----------------|-----------------------|
| 1. Steering knuckle | 2. Splash guard | 3. Hub bolt |
| 4. Wheel hub assembly (Bearing-integrated type) | 5. Disc rotor | 6. Wheel hub lock nut |
| 7. Adjusting cap | 8. Cotter pin | |

A. Tightening must be done following the installation procedure. Refer to [FAX-11, "Removal and Installation"](#).

⊗: Always replace after every disassembly.

⊞: N·m (kg-m, ft-lb)

Removal and Installation

INFOID:0000000012201525

REMOVAL

1. Remove tires with power tool. Refer to [WT-39, "Removal and Installation"](#).
2. Remove wheel sensor and sensor harness. Refer to [BRC-147, "FRONT WHEEL SENSOR : Exploded View"](#).
3. Remove lock plate from strut assembly. Refer to [BR-25, "FRONT : Removal and Installation"](#).
4. Remove caliper assembly. Hang caliper assembly not to interfere with work. Refer to [BR-55, "BRAKE CALIPER ASSEMBLY : Removal and Installation"](#).

CAUTION:

Never depress brake pedal while brake caliper is removed.

5. Remove disc rotor.

CAUTION:

FRONT WHEEL HUB AND KNUCKLE

< REMOVAL AND INSTALLATION >

[TYPE 1]

- Put matching marks (A) on the wheel hub assembly and the disc rotor before removing the disc rotor.
- Never drop disc rotor.

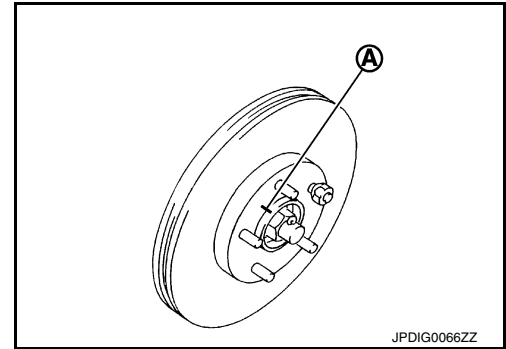

6. Remove cotter pin, and adjusting cap, and then loosen wheel hub lock nut with power tool.
7. Patch wheel hub lock nut with a piece of wood. Hammer the wood to disengage wheel hub assembly from drive shaft.

NOTE:

Use suitable puller, if wheel hub assembly and drive shaft cannot be separated even after performing the above procedure.

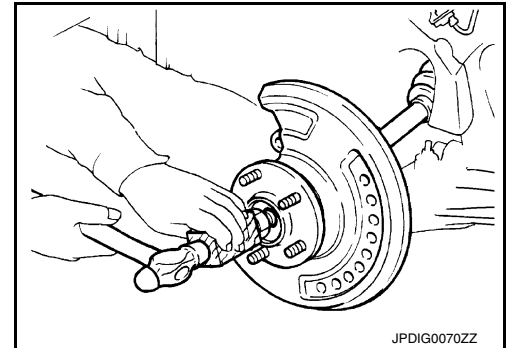

8. Remove wheel hub lock nut.
9. Remove steering outer socket from steering knuckle. Refer to [ST-17, "Removal and Installation"](#).
10. Remove strut assembly from steering knuckle. Refer to [FSU-9, "Removal and Installation"](#).
11. Suspend the drive shaft with suitable wire.

CAUTION:

- Never place drive shaft joint at an extreme angle. Also be careful not to overextend slide joint.
- Never allow drive shaft to hang down without support for joint sub-assembly, shaft and the other parts.

12. Remove steering knuckle from transverse link.
13. Remove wheel hub assembly and splash guard from steering knuckle.
14. Remove hub bolts (1) from wheel hub assembly, using the ball joint remover (A) (commercial service tool).

CAUTION:

- Remove hub bolt only when necessary.
- Never hammer the hub bolt to avoid impact to the wheel hub assembly.
- Pull out the hub bolt in a direction perpendicular to the wheel hub assembly.

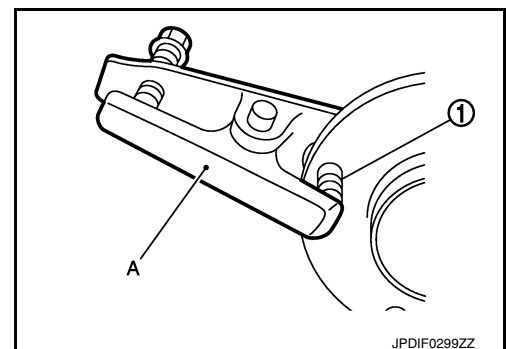

15. Perform inspection after removal. Refer to [FAX-13, "Inspection"](#).

INSTALLATION

Note the following, and install in the reverse order of the removal.

FRONT WHEEL HUB AND KNUCKLE

< REMOVAL AND INSTALLATION >

[TYPE 1]

- Place a washer (A) as shown in the figure to install the hub bolts (1) by using the tightening force of the nut (B).

CAUTION:

- Check that there is no clearance between wheel hub assembly, and hub bolt.
- Never reuse hub bolt.
- Never reuse steering knuckle and transverse link fixing nut.
- Clean the matching surface of wheel hub lock nut and wheel hub assembly.

CAUTION:

Never apply lubricating oil to these matching surface.

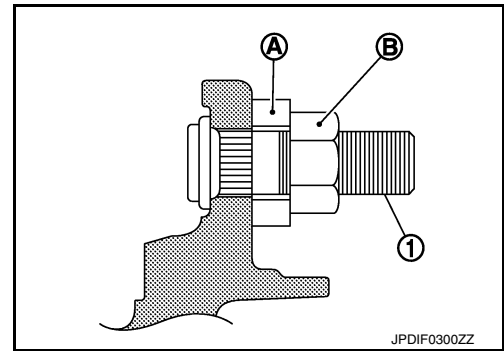

- Clean the matching surface of drive shaft, wheel hub assembly. And then apply paste [service parts (440037S000)] to surface (A) of joint sub-assembly of drive shaft.

CAUTION:

Apply paste to cover entire flat surface of joint sub-assembly of drive shaft.

Amount paste : 1.0 – 3.0 g (0.04 – 0.10 oz)

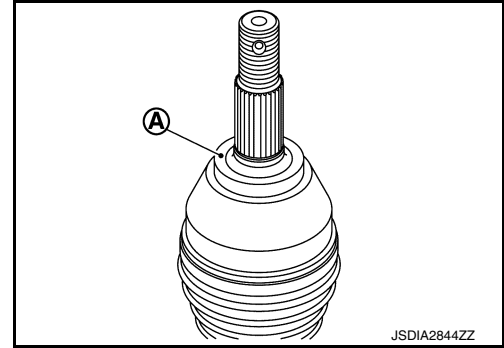

- Use the following torque range for tightening the wheel hub lock nut.

 : 180 – 185 N·m (18.4 – 18.8 kg-m, 133 – 136 ft-lb)

CAUTION:

- Since the drive shaft is assembled by press-fitting, use the tightening torque range for the wheel hub lock nut.
- Be sure to use torque wrench to tighten the wheel hub lock nut. Never use a power tool.
- Never reuse wheel hub lock nut.

NOTE:

Wheel hub lock nut tightening torque does not over torque for avoiding axle noise, and does not less than torque for avoiding looseness.

- Align the matching marks that have been made during removal when reusing the disc rotor.
- When installing a cotter pin (1) and adjusting cap (2), securely bend the basal portion to prevent rattles.

CAUTION:

Never reuse cotter pin.

- Perform the final tightening of each of parts under unladen conditions, which were removed when removing wheel hub assembly and steering knuckle.
- Perform inspection after installation. Refer to [FAX-13, "Inspection"](#).

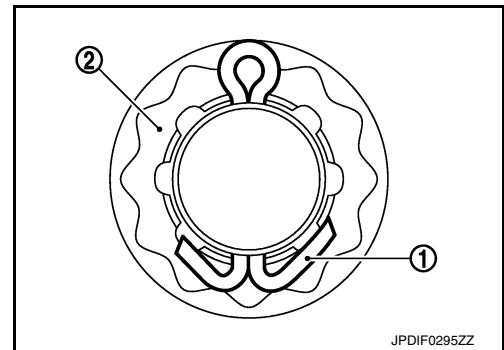

INFOID:0000000112201526

Inspection

INSPECTION AFTER REMOVAL

Check the following items, and replace the part if necessary.

- Check components for deformation, cracks, and other damage.
- Check boots of transverse link and steering outer socket ball joint for breakage, axial end play, and swing torque. Refer to [FSU-13, "Inspection"](#) and [ST-19, "Inspection"](#).

INSPECTION AFTER INSTALLATION

FRONT WHEEL HUB AND KNUCKLE

< REMOVAL AND INSTALLATION >

[TYPE 1]

1. Check wheel sensor harness for proper connection. Refer to [BRC-147. "FRONT WHEEL SENSOR : Exploded View"](#).
2. Check the wheel alignment. Refer to [FSU-7. "Inspection"](#).
3. Adjust neutral position of steering angle sensor. Refer to [BRC-63. "Work Procedure"](#).

FRONT DRIVE SHAFT BOOT

< REMOVAL AND INSTALLATION >

[TYPE 1]

FRONT DRIVE SHAFT BOOT

2WD

2WD : Exploded View

INFOID:000000012201527

LEFT SIDE

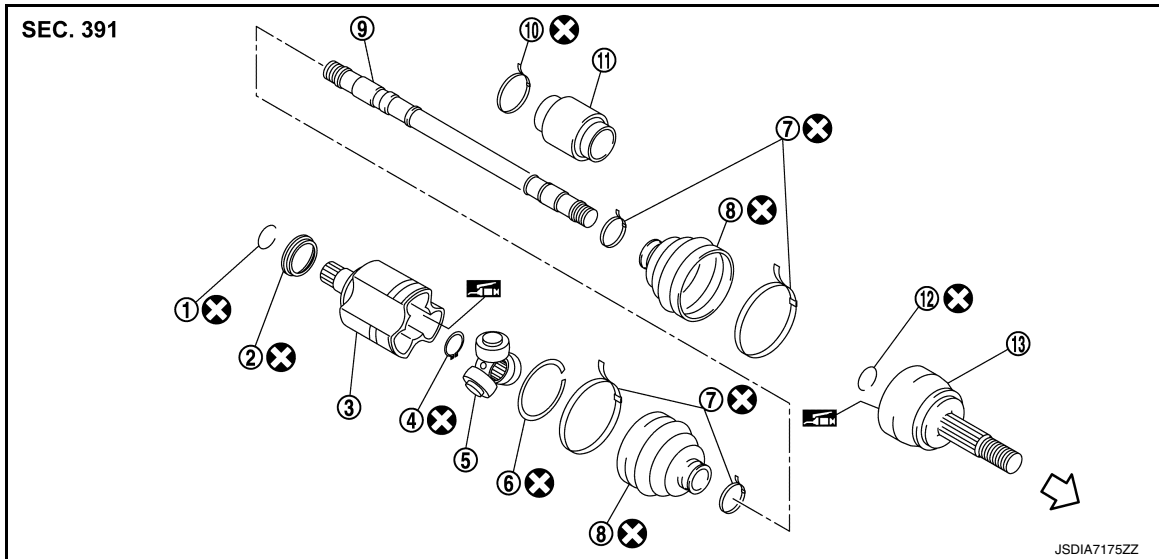

- | | | |
|------------------------|--------------------|-------------------|
| 1. Circular clip | 2. Dust shield | 3. Housing |
| 4. Snap ring | 5. Spider assembly | 6. Stopper ring |
| 7. Boot band | 8. Boot | 9. Shaft |
| 10. Damper band | 11. Dynamic damper | 12. Circular clip |
| 13. Joint sub-assembly | | |

← : Wheel side

: Fill NISSAN Genuine grease or equivalent.

: Always replace after every disassembly.

RIGHT SIDE

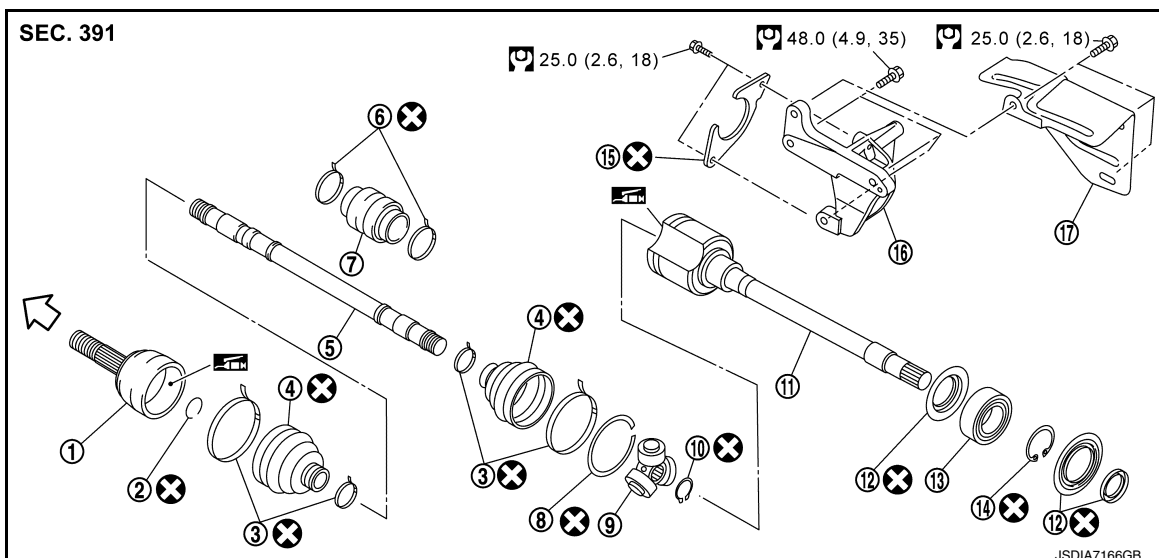

- | | | |
|-----------------------|------------------|----------------|
| 1. Joint sub-assembly | 2. Circular clip | 3. Boot band |
| 4. Boot | 5. Shaft | 6. Damper band |

A
B
C
FAX
E
F
G
H
I
J
K
L
M
N
O
P

FRONT DRIVE SHAFT BOOT

[TYPE 1]

< REMOVAL AND INSTALLATION >

- | | | |
|-----------------------------|--------------------|--------------------|
| 7. Dynamic damper | 8. Stopper ring | 9. Spider assembly |
| 10. Snap ring | 11. Housing | 12. Dust shield |
| 13. Support bearing | 14. Snap ring | 15. Plate |
| 16. Support bearing bracket | 17. Heat insulator | |

⇐ : Wheel side

 : Fill NISSAN Genuine grease or equivalent.

 : Always replace after every disassembly.

 : N·m (kg·m, ft·lb)

2WD : Removal and Installation

INFOID:000000012201528

REMOVAL

Wheel Side

1. Remove tires with power tool. Refer to [WT-39, "Removal and Installation"](#).
2. Remove wheel sensor and sensor harness. Refer to [BRC-147, "FRONT WHEEL SENSOR : Exploded View"](#).
3. Remove lock plate from strut assembly. Refer to [BR-25, "FRONT : Removal and Installation"](#).
4. Remove caliper assembly. Hang caliper assembly not to interfere with work. Refer to [BR-55, "BRAKE CALIPER ASSEMBLY : Removal and Installation"](#).

CAUTION:

Never depress brake pedal while brake caliper is removed.

5. Remove disc rotor.

CAUTION:

- Put matching marks (A) on the wheel hub assembly and the disc rotor before removing the disc rotor.
- Never drop disc rotor.

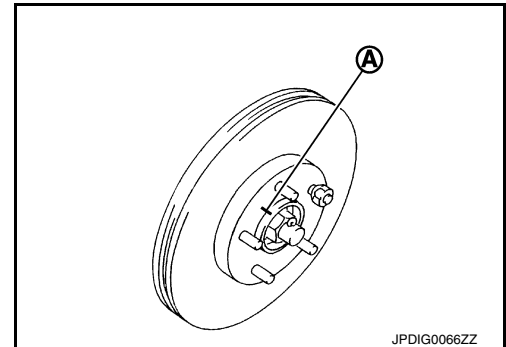

6. Remove cotter pin, and adjusting cap, and then loosen wheel hub lock nut with power tool.

7. Patch wheel hub lock nut with a piece of wood. Hammer the wood to disengage wheel hub assembly from drive shaft.

NOTE:

Use suitable puller, if wheel hub assembly and drive shaft cannot be separated even after performing the above procedure.

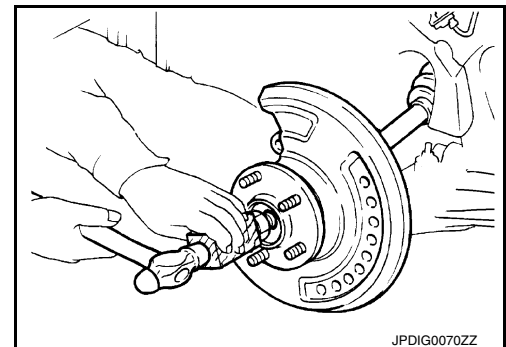

8. Remove wheel hub lock nut.
9. Remove strut assembly from steering knuckle. Refer to [FSU-9, "Removal and Installation"](#).
10. Remove drive shaft from wheel hub assembly.

CAUTION:

- Never place drive shaft joint at an extreme angle. Also be careful not to overextend slide joint.
- Never allow drive shaft to hang down without support for joint sub-assembly, shaft and the other parts.

FRONT DRIVE SHAFT BOOT

[TYPE 1]

< REMOVAL AND INSTALLATION >

11. Remove boot bands, and then remove boot from joint sub-assembly.
12. Screw drive shaft puller (A) (commercial service tool) into joint sub-assembly screw part to a length of 30 mm (1.18 in) or more. Support drive shaft with one hand and pull out joint sub-assembly from shaft.

CAUTION:

- Align drive shaft puller and drive shaft and remove them by pulling firmly and uniformly.
- If joint sub-assembly cannot be pulled out, try after removing drive shaft from vehicle. Refer to [FAX-28. "2WD : Removal and Installation"](#).

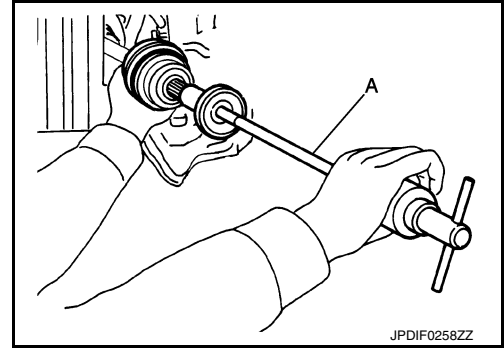

13. Remove circular clip (1) from shaft.
14. Remove boot from shaft.

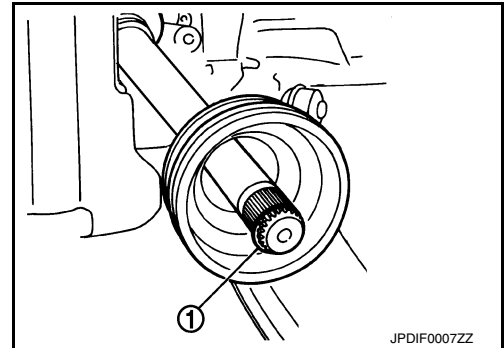

Transaxle Side

- Remove boot after removing drive shaft.
- Remove: Refer to [FAX-28. "2WD : Removal and Installation"](#).
- Disassembly: Refer to [FAX-32. "2WD : Disassembly and Assembly"](#).

INSTALLATION

Wheel Side

1. Clean the old grease on joint sub-assembly with paper waste.
2. Fill serration slot joint sub-assembly (1) with NISSAN genuine grease or equivalent until the serration slot and ball groove become full to the brim.

CAUTION:

After applying grease, use a paper waste to wipe off old grease that has oozed out.

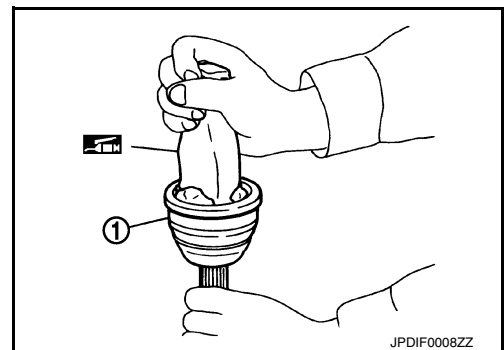

3. Install boot and boot bands to shaft.
CAUTION:
 - Wrap serration on shaft with tape to protect the boot from damage.
 - Never reuse boot and boot band.
4. Remove the tape wrapped around the serration on shaft.

A
B
C
FAX
E
F
G
H
I
J
K
L
M
N
O
P

FRONT DRIVE SHAFT BOOT

< REMOVAL AND INSTALLATION >

[TYPE 1]

5. Position the circular clip (1) on groove at the shaft edge.

CAUTION:

Never reuse circular clip.

NOTE:

Drive joint inserter is recommended when installing circular clip.

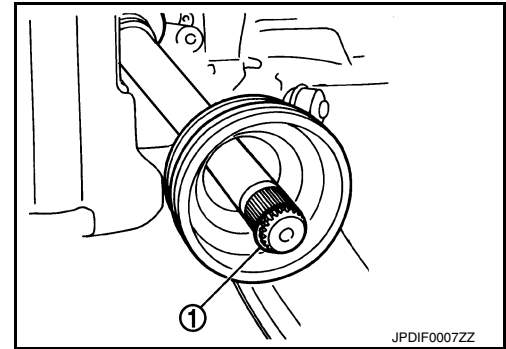

6. Align both center axes of the shaft edge and joint sub-assembly. Then assemble shaft with joint sub-assembly holding circular clip.

7. Install joint sub-assembly (1) to shaft using plastic hammer.

CAUTION:

- Check circular clip is properly positioned on groove of the joint sub-assembly.
- Confirm that joint sub-assembly is correctly engaged while rotating drive shaft.

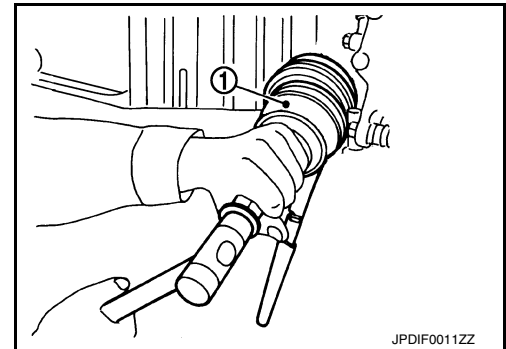

8. Apply the specified amount of grease into the boot inside from large diameter side of boot.

Grease amount : Refer to [FAX-57, "Drive Shaft"](#).

9. Install the boot securely into grooves (indicated by "*" marks) shown in the figure.

- a. For NISMO RS models

CAUTION:

If grease adheres to the boot mounting surface (indicated by "*" marks) on the shaft or joint sub-assembly, boot may be removed. Remove all grease from the boot mounting surface.

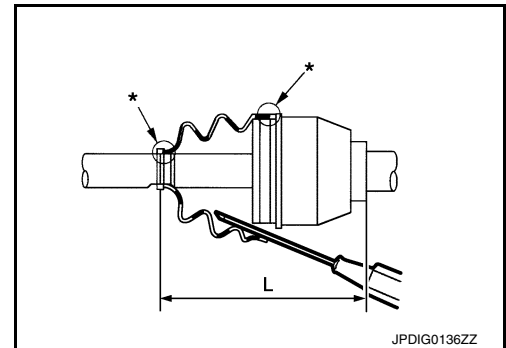

- b. Except for NISMO RS models

CAUTION:

If grease adheres to the boot mounting surface (indicated by "*" marks) on the shaft or joint sub-assembly, boot may be removed. Remove all grease from the boot mounting surface.

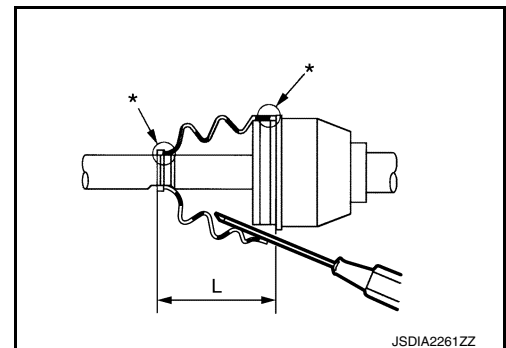

10. To prevent the deformation of the boot, adjust the boot installation length (L) to the specified value shown below by inserting the suitable tool into inside of the boot from the large diameter side of the boot and discharging the inside air.

FRONT DRIVE SHAFT BOOT

< REMOVAL AND INSTALLATION >

[TYPE 1]

L : Refer to [FAX-57, "Drive Shaft"](#).

CAUTION:

- If the boot installation length exceeds the standard, it may cause breakage of the boot.
- Be careful not to touch the inside of the boot with a tip of tool.

11. Secure the large and small ends of the boot with boot bands using the boot band crimping tool (A) [SST:KV40107300 (—)].

CAUTION:

- Never reuse boot band.

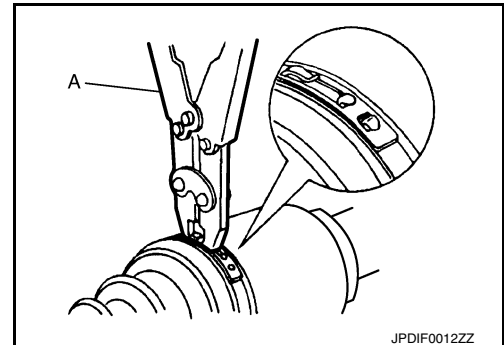

- Secure boot band so that dimension (M) meets the specification as shown in the figure.

Dimension (M) : 1.0 – 4.0 mm (0.039 – 0.157 in)

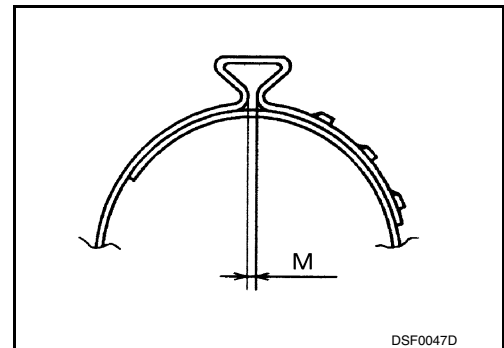

12. Check that displacement does not occur when boot is rotated with the joint sub-assembly and shaft fixed.

CAUTION:

- Reinstall them using boot bands when boot installation positions become incorrect.
- Never reuse boot band.

13. Clean the matching surface of wheel hub lock nut and wheel hub assembly.

CAUTION:

Never apply lubricating oil to these matching surface.

14. Clean the matching surface of drive shaft, wheel hub assembly. And then apply paste [service parts (440037S000)] to surface (A) of joint sub-assembly of drive shaft.

CAUTION:

Apply paste to cover entire flat surface of joint sub-assembly of drive shaft.

Amount paste : 1.0 – 3.0 g (0.04 – 0.10 oz)

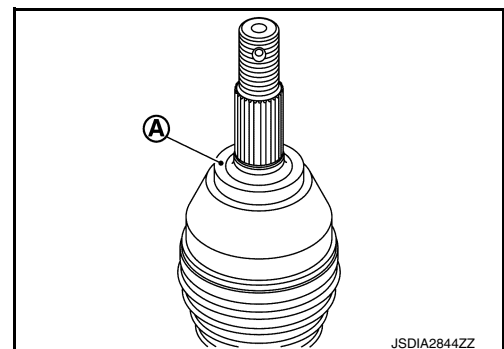

15. Insert drive shaft to wheel hub assembly, and then temporarily tighten wheel hub lock nut.

CAUTION:

- Be sure to use torque wrench to tighten the wheel hub lock nut. Never use a power tool.
- Never reuse wheel hub lock nut.

16. Install strut assembly to steering knuckle. Refer to [FSU-9, "Exploded View"](#).

17. Install disc rotor. Refer to [FAX-11, "Removal and Installation"](#).

18. Install caliper assembly to steering knuckle. Refer to [BR-55, "BRAKE CALIPER ASSEMBLY : Removal and Installation"](#).

19. Install lock plate to strut assembly. Refer to [BR-25, "FRONT : Removal and Installation"](#).

FRONT DRIVE SHAFT BOOT

[TYPE 1]

< REMOVAL AND INSTALLATION >

20. Install wheel sensor and sensor harness. Refer to [BRC-147, "FRONT WHEEL SENSOR : Exploded View"](#).
21. Use the following torque range for tightening the wheel hub lock nut.

 : 180 – 185 N·m (18.4 – 18.8 kg-m, 133 – 136 ft-lb)

CAUTION:

- Since the drive shaft is assembled by press-fitting, use the tightening torque range for the wheel hub lock nut.
- Be sure to use torque wrench to tighten the wheel hub lock nut. Never use a power tool.
- Never reuse wheel hub lock nut.

NOTE:

Wheel hub lock nut tightening torque does not over torque for avoiding axle noise, and does not less than torque for avoiding looseness.

22. When installing a cotter pin (1) and adjusting cap (2), securely bend the basal portion to prevent rattles.

CAUTION:

Never reuse cotter pin.

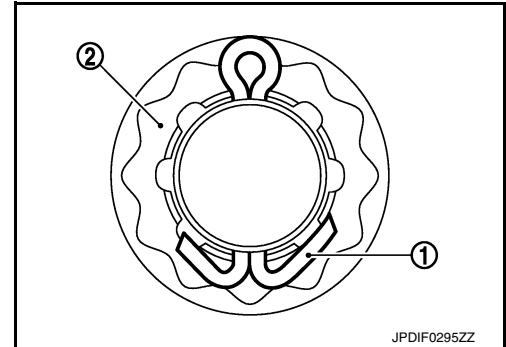

23. Install tires. Refer to [WT-39, "Exploded View"](#).
24. Perform inspection after installation. Refer to [FAX-20, "2WD : Inspection"](#).

Transaxle Side

- Install drive shaft to vehicle.
- Installation: Refer to [FAX-28, "2WD : Removal and Installation"](#).
- Assembly: Refer to [FAX-32, "2WD : Disassembly and Assembly"](#).

2WD : Inspection

INFOID:000000012201529

INSPECTION AFTER INSTALLATION

1. Check wheel sensor harness for proper connection. Refer to [BRC-147, "FRONT WHEEL SENSOR : Exploded View"](#).
2. Check the wheel alignment. Refer to [FSU-7, "Inspection"](#).
3. Adjust neutral position of steering angle sensor. Refer to [BRC-63, "Work Procedure"](#).

AWD

AWD : Exploded View

INFOID:000000012201530

LEFT SIDE

FRONT DRIVE SHAFT BOOT

< REMOVAL AND INSTALLATION >

[TYPE 1]

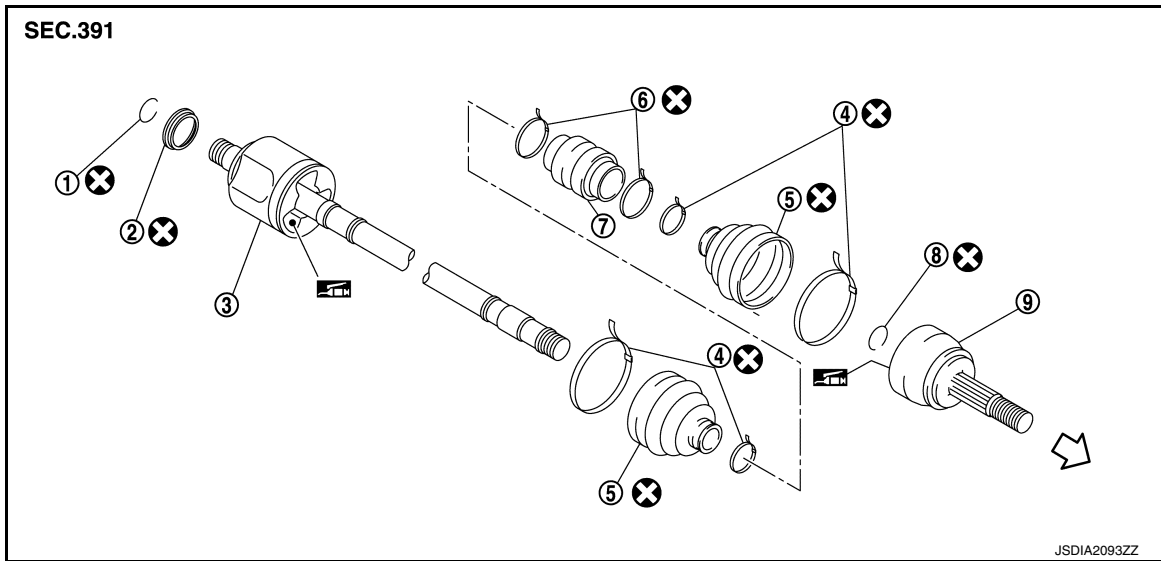

- | | | |
|-------------------|------------------|-----------------------|
| 1. Circular clip | 2. Dust shield | 3. Housing assembly |
| 4. Boot band | 5. Boot | 6. Damper band |
| 7. Dynamic damper | 8. Circular clip | 9. Joint sub-assembly |

← : Wheel side

: Fill NISSAN Genuine grease or equivalent.

: Always replace after every disassembly.

RIGHT SIDE

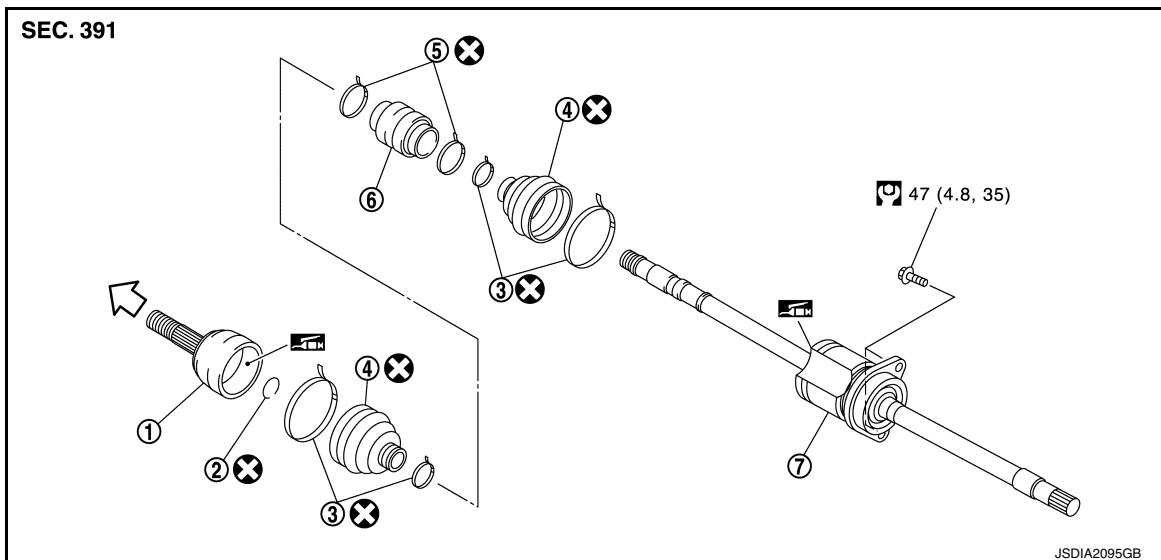

- | | | |
|-----------------------|------------------|-------------------|
| 1. Joint sub-assembly | 2. Circular clip | 3. Boot band |
| 4. Boot | 5. Damper band | 6. Dynamic damper |
| 7. Housing assembly | | |

← : Wheel side

: Fill NISSAN Genuine grease or equivalent.

: Always replace after every disassembly.

: N·m (kg·m, ft·lb)

A
B
C
FAX
E
F
G
H
I
J
K
L
M
N
O
P

FRONT DRIVE SHAFT BOOT

< REMOVAL AND INSTALLATION >

[TYPE 1]

AWD : Removal and Installation

INFOID:000000012201531

REMOVAL

Wheel Side

1. Remove tires with power tool. Refer to [WT-39, "Removal and Installation"](#).
2. Remove wheel sensor and sensor harness. Refer to [BRC-147, "FRONT WHEEL SENSOR : Exploded View"](#).
3. Remove lock plate from strut assembly. Refer to [BR-25, "FRONT : Removal and Installation"](#).
4. Remove caliper assembly. Hang caliper assembly not to interfere with work. Refer to [BR-55, "BRAKE CALIPER ASSEMBLY : Removal and Installation"](#).

CAUTION:

Never depress brake pedal while brake caliper is removed.

5. Remove disc rotor.

CAUTION:

- Put matching marks (A) on the wheel hub assembly and the disc rotor before removing the disc rotor.
- Never drop disc rotor.

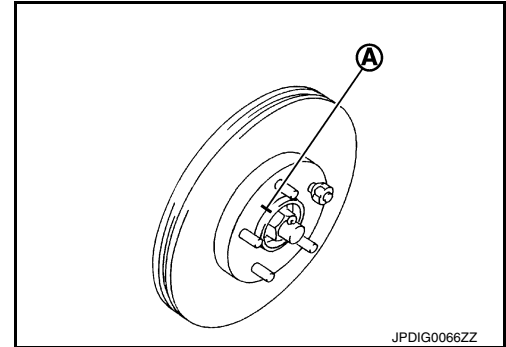

6. Remove cotter pin, and adjusting cap, and then loosen wheel hub lock nut with power tool.
7. Patch wheel hub lock nut with a piece of wood. Hammer the wood to disengage wheel hub assembly from drive shaft.

NOTE:

Use suitable puller, if wheel hub assembly and drive shaft cannot be separated even after performing the above procedure.

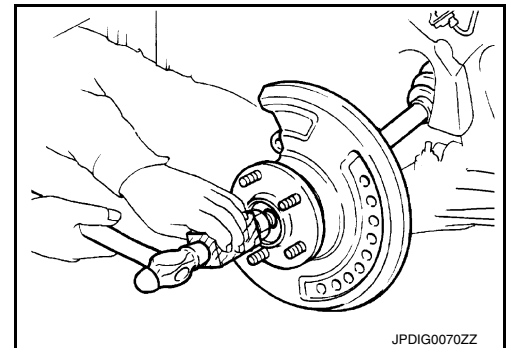

8. Remove wheel hub lock nut.
9. Remove strut assembly from steering knuckle. Refer to [FSU-9, "Removal and Installation"](#).
10. Remove drive shaft from wheel hub assembly.

CAUTION:

 - Never place drive shaft joint at an extreme angle. Also be careful not to overextend slide joint.
 - Never allow drive shaft to hang down without support for joint sub-assembly, shaft and the other parts.
11. Remove boot bands, and then remove boot from joint sub-assembly.

FRONT DRIVE SHAFT BOOT

[TYPE 1]

< REMOVAL AND INSTALLATION >

12. Screw drive shaft puller (A) (commercial service tool) into joint sub-assembly screw part to a length of 30 mm (1.18 in) or more. Support drive shaft with one hand and pull out joint sub-assembly from shaft.

CAUTION:

- Align drive shaft puller and drive shaft and remove them by pulling firmly and uniformly.
- If joint sub-assembly cannot be pulled out, try after removing drive shaft from vehicle. Refer to [FAX-45. "AWD : Removal and Installation"](#).

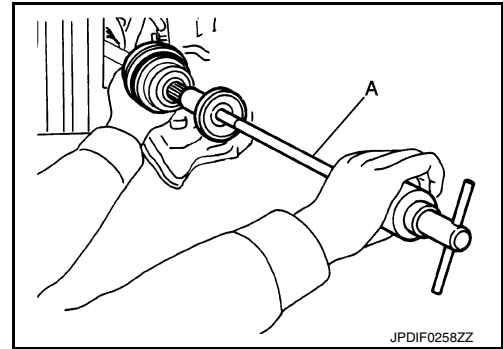

13. Remove circular clip (1) from shaft.
14. Remove boot from shaft.

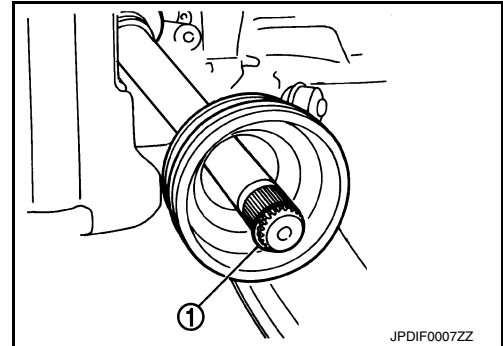

Transaxle Side

- Remove boot after removing drive shaft.
- Remove: Refer to [FAX-45. "AWD : Removal and Installation"](#).
- Disassembly: Refer to [FAX-49. "AWD : Disassembly and Assembly"](#).

INSTALLATION

Wheel Side

1. Clean the old grease on joint sub-assembly with paper waste.
2. Fill serration slot joint sub-assembly (1) with NISSAN genuine grease or equivalent until the serration slot and ball groove become full to the brim.

CAUTION:

After applying grease, use a paper waste to wipe off old grease that has oozed out.

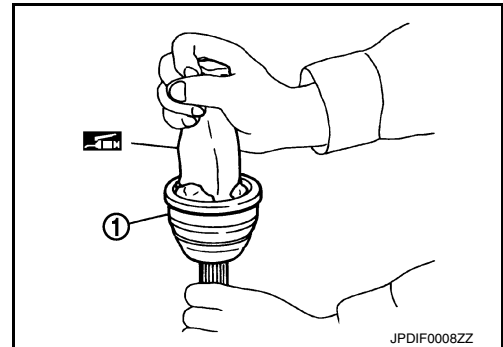

3. Install boot and boot bands to shaft.
CAUTION:
 - Wrap serration on shaft with tape to protect the boot from damage.
 - Never reuse boot and boot band.
4. Remove the tape wrapped around the serration on shaft.

A
B
C
FAX
E
F
G
H
I
J
K
L
M
N
O
P

FRONT DRIVE SHAFT BOOT

< REMOVAL AND INSTALLATION >

[TYPE 1]

5. Position the circular clip (1) on groove at the shaft edge.

CAUTION:

Never reuse circular clip.

NOTE:

Drive joint inserter is recommended when installing circular clip.

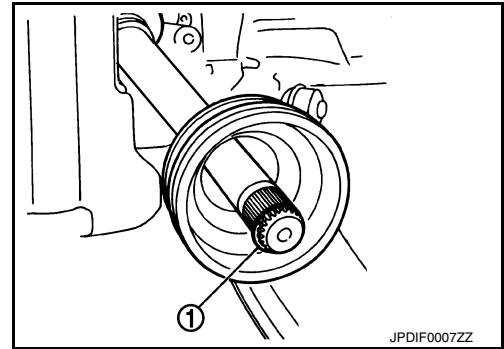

6. Align both center axes of the shaft edge and joint sub-assembly. Then assemble shaft with joint sub-assembly holding circular clip.

7. Install joint sub-assembly (1) to shaft using plastic hammer.

CAUTION:

- Check circular clip is properly positioned on groove of the joint sub-assembly.
- Confirm that joint sub-assembly is correctly engaged while rotating drive shaft.

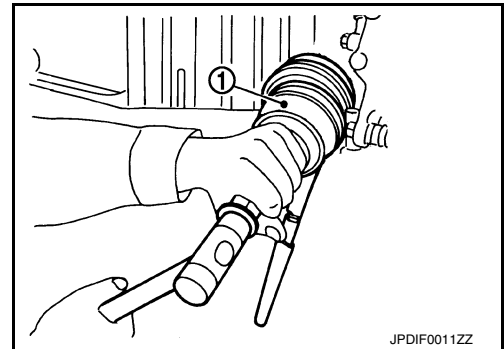

8. Apply the specified amount of grease into the boot inside from large diameter side of boot.

Grease amount : Refer to [FAX-57, "Drive Shaft"](#).

9. Install the boot securely into grooves (indicated by "*" marks) shown in the figure.

CAUTION:

If grease adheres to the boot mounting surface (indicated by "*" marks) on the shaft or joint sub-assembly, boot may be removed. Remove all grease from the boot mounting surface.

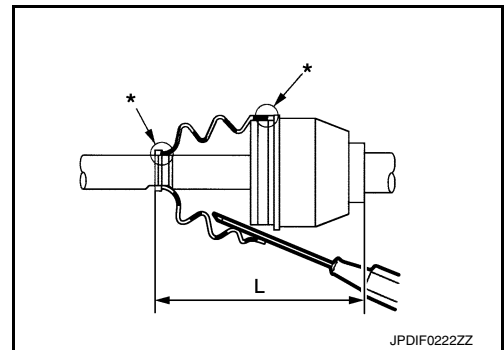

10. To prevent the deformation of the boot, adjust the boot installation length (L) to the specified value shown below by inserting the suitable tool into inside of the boot from the large diameter side of the boot and discharging the inside air.

L : Refer to [FAX-57, "Drive Shaft"](#).

CAUTION:

- If the boot installation length exceeds the standard, it may cause breakage of the boot.
- Be careful not to touch the inside of the boot with a tip of tool.

FRONT DRIVE SHAFT BOOT

< REMOVAL AND INSTALLATION >

[TYPE 1]

11. Secure the large and small ends of the boot with boot bands using the boot band crimping tool (A) [SST:KV40107300 (—)].

CAUTION:

- Never reuse boot band.

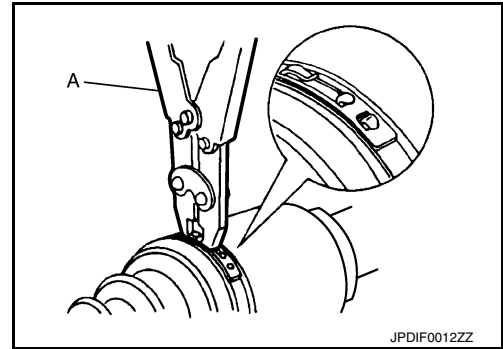

- Secure boot band so that dimension (M) meets the specification as shown in the figure.

Dimension (M) : 2.0 – 3.0 mm (0.079 – 0.118 in)

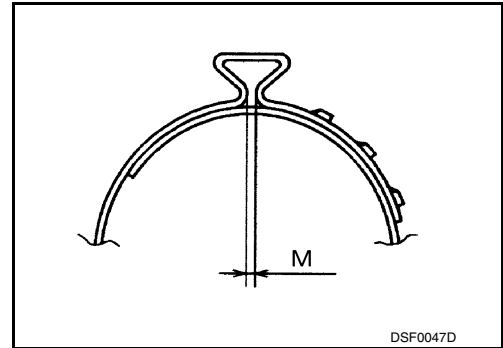

12. Check that displacement does not occur when boot is rotated with the joint sub-assembly and shaft fixed.

CAUTION:

- Reinstall them using boot bands when boot installation positions become incorrect.
- Never reuse boot band.

13. Clean the matching surface of wheel hub lock nut and wheel hub assembly.

CAUTION:

Never apply lubricating oil to these matching surface.

14. Clean the matching surface of drive shaft, wheel hub assembly. And then apply paste [service parts (440037S000)] to surface (A) of joint sub-assembly of drive shaft.

CAUTION:

Apply paste to cover entire flat surface of joint sub-assembly of drive shaft.

Amount paste : 1.0 – 3.0 g (0.04 – 0.10 oz)

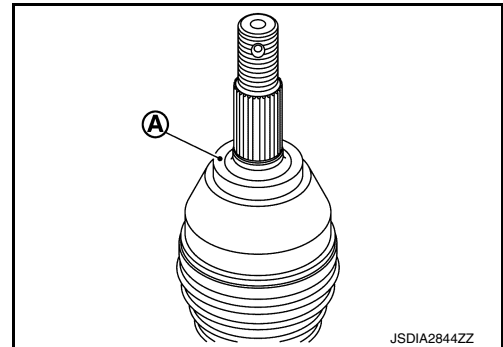

15. Insert drive shaft to wheel hub assembly, and then temporarily tighten wheel hub lock nut.

CAUTION:

- Be sure to use torque wrench to tighten the wheel hub lock nut. Never use a power tool.
- Never reuse wheel hub lock nut.

16. Install strut assembly to steering knuckle. Refer to [FSU-9, "Exploded View"](#).

17. Install disc rotor. Refer to [FAX-11, "Removal and Installation"](#).

18. Install caliper assembly to steering knuckle. Refer to [BR-55, "BRAKE CALIPER ASSEMBLY : Removal and Installation"](#).

19. Install lock plate to strut assembly. Refer to [BR-25, "FRONT : Removal and Installation"](#).

20. Install wheel sensor and sensor harness. Refer to [BRC-147, "FRONT WHEEL SENSOR : Exploded View"](#).

21. Use the following torque range for tightening the wheel hub lock nut.

 : **180 – 185 N·m (18.4 – 18.8 kg·m, 133 – 136 ft·lb)**

A
B
C
FAX
E
F
G
H
I
J
K
L
M
N
O
P

FRONT DRIVE SHAFT BOOT

< REMOVAL AND INSTALLATION >

[TYPE 1]

CAUTION:

- Since the drive shaft is assembled by press-fitting, use the tightening torque range for the wheel hub lock nut.
- Be sure to use torque wrench to tighten the wheel hub lock nut. Never use a power tool.
- Never reuse wheel hub lock nut.

NOTE:

Wheel hub lock nut tightening torque does not over torque for avoiding axle noise, and does not less than torque for avoiding looseness.

22. When installing a cotter pin (1) and adjusting cap (2), securely bend the basal portion to prevent rattles.

CAUTION:

Never reuse cotter pin.

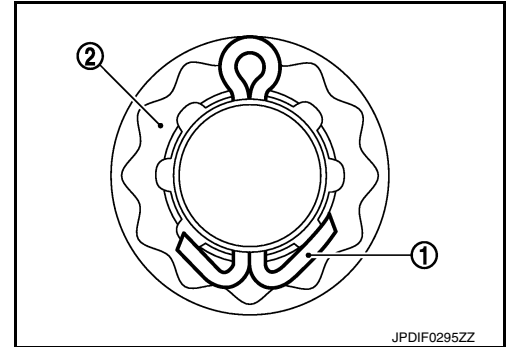

23. Install tires. Refer to [WT-39, "Exploded View"](#).

24. Perform inspection after installation. Refer to [FAX-26, "AWD : Inspection"](#).

Transaxle Side

- Install drive shaft to vehicle.
- Installation: Refer to [FAX-45, "AWD : Removal and Installation"](#).
- Assembly: Refer to [FAX-49, "AWD : Disassembly and Assembly"](#).

AWD : Inspection

INFOID:000000012201532

INSPECTION AFTER INSTALLATION

1. Check wheel sensor harness for proper connection. Refer to [BRC-147, "FRONT WHEEL SENSOR : Exploded View"](#).
2. Check the wheel alignment. Refer to [FSU-7, "Inspection"](#).
3. Adjust neutral position of steering angle sensor. Refer to [BRC-63, "Work Procedure"](#).

FRONT DRIVE SHAFT

< REMOVAL AND INSTALLATION >

[TYPE 1]

FRONT DRIVE SHAFT

2WD

2WD : Exploded View

INFOID:000000012201533

LEFT SIDE

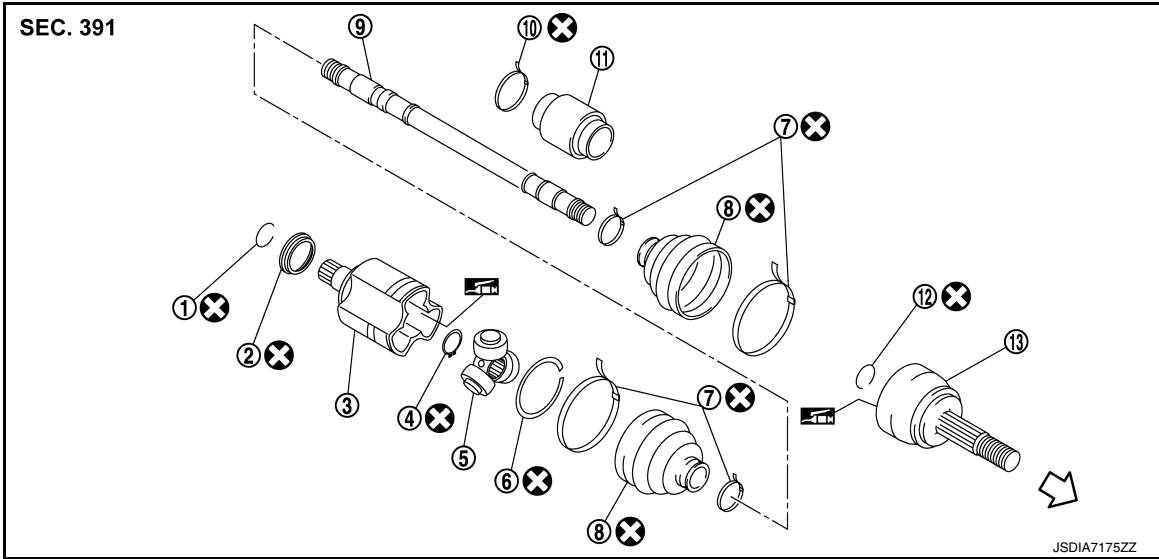

- | | | |
|------------------------|--------------------|-------------------|
| 1. Circular clip | 2. Dust shield | 3. Housing |
| 4. Snap ring | 5. Spider assembly | 6. Stopper ring |
| 7. Boot band | 8. Boot | 9. Shaft |
| 10. Damper band | 11. Dynamic damper | 12. Circular clip |
| 13. Joint sub-assembly | | |

← : Wheel side

: Fill NISSAN Genuine grease or equivalent.

: Always replace after every disassembly.

RIGHT SIDE

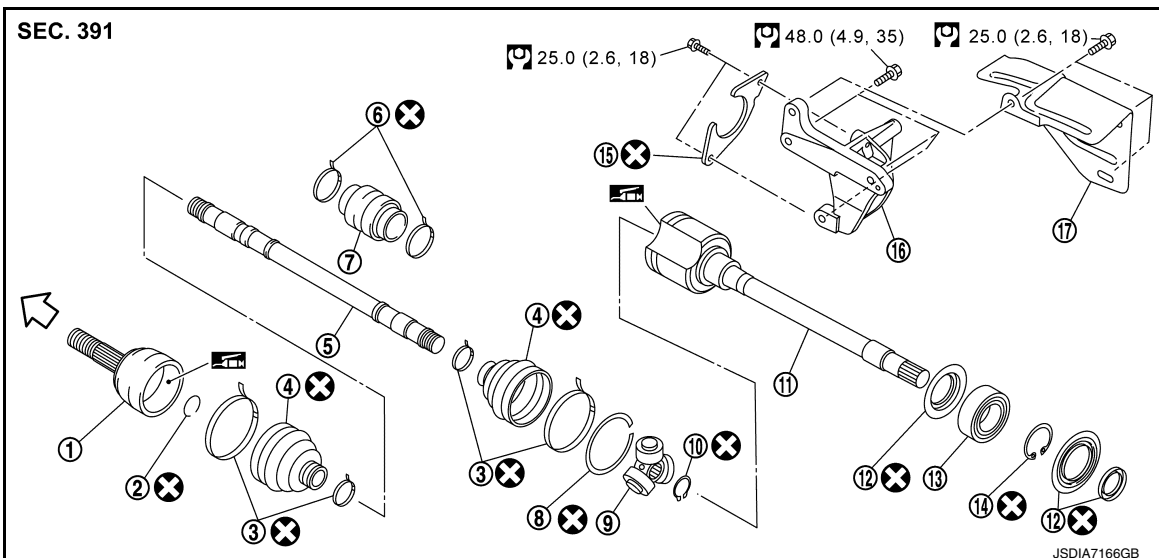

- | | | |
|-----------------------|------------------|----------------|
| 1. Joint sub-assembly | 2. Circular clip | 3. Boot band |
| 4. Boot | 5. Shaft | 6. Damper band |

A
B
C
FAX
E
F
G
H
I
J
K
L
M
N
O
P

FRONT DRIVE SHAFT

[TYPE 1]

< REMOVAL AND INSTALLATION >

- | | | |
|-----------------------------|--------------------|--------------------|
| 7. Dynamic damper | 8. Stopper ring | 9. Spider assembly |
| 10. Snap ring | 11. Housing | 12. Dust shield |
| 13. Support bearing | 14. Snap ring | 15. Plate |
| 16. Support bearing bracket | 17. Heat insulator | |

⇐ : Wheel side

 : Fill NISSAN Genuine grease or equivalent.

 : Always replace after every disassembly.

 : N·m (kg·m, ft·lb)

2WD : Removal and Installation

INFOID:000000012201534

REMOVAL

Left Side

1. Remove tires with power tool. Refer to [WT-39, "Removal and Installation"](#).
2. Remove wheel sensor and sensor harness. Refer to [BRC-147, "FRONT WHEEL SENSOR : Exploded View"](#).
3. Remove lock plate from strut assembly. Refer to [BR-25, "FRONT : Removal and Installation"](#).
4. Remove caliper assembly. Hang caliper assembly not to interfere with work. Refer to [BR-55, "BRAKE CALIPER ASSEMBLY : Removal and Installation"](#).

CAUTION:

Never depress brake pedal while brake caliper is removed.

5. Remove disc rotor.

CAUTION:

- Put matching marks (A) on the wheel hub assembly and the disc rotor before removing the disc rotor.
- Never drop disc rotor.

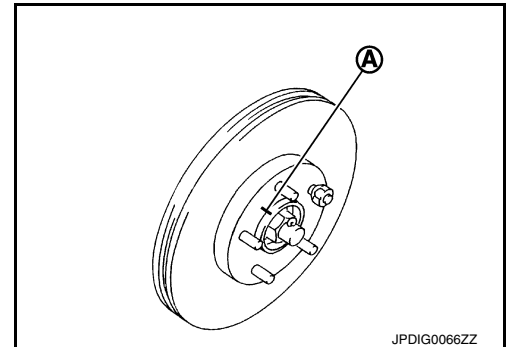

6. Remove cotter pin, and adjusting cap, and then loosen wheel hub lock nut with power tool.

7. Patch wheel hub lock nut with a piece of wood. Hammer the wood to disengage wheel hub assembly from drive shaft.

NOTE:

Use suitable puller, if wheel hub assembly and drive shaft cannot be separated even after performing the above procedure.

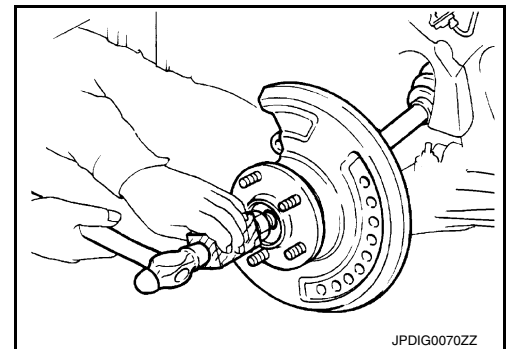

8. Remove wheel hub lock nut.
9. Remove strut assembly from steering knuckle. Refer to [FSU-9, "Removal and Installation"](#).
10. Remove drive shaft from wheel hub assembly.

CAUTION:

- Never place drive shaft joint at an extreme angle. Also be careful not to overextend slide joint.
- Never allow drive shaft to hang down without support for joint sub-assembly, shaft and the other parts.

FRONT DRIVE SHAFT

< REMOVAL AND INSTALLATION >

[TYPE 1]

11. Use the drive shaft attachment (A) [SST:KV40107500 (—)] and a sliding hammer (B) (commercial service tool) while inserting tip of the drive shaft attachment between shaft and transaxle assembly, and then remove drive shaft from transaxle assembly.

CAUTION:

- Never place drive shaft joint at an extreme angle when removing drive shaft. Also be careful not to overextend slide joint.
- Confirm that the circular clip is attached to the drive shaft.

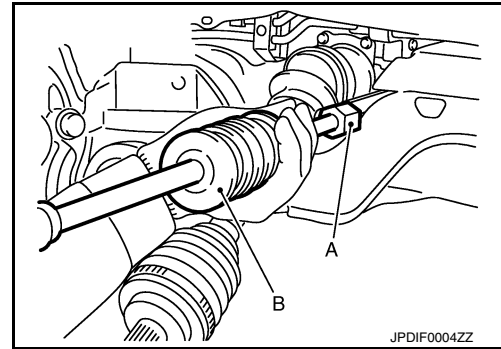

A
B
C

FAX

Right Side

1. Remove tires with power tool. Refer to [WT-39, "Removal and Installation"](#).
2. Remove wheel sensor and sensor harness. Refer to [BRC-147, "FRONT WHEEL SENSOR : Exploded View"](#).
3. Remove lock plate from strut assembly. Refer to [BR-25, "FRONT : Removal and Installation"](#).
4. Remove caliper assembly. Hang caliper assembly not to interfere with work. Refer to [BR-55, "BRAKE CALIPER ASSEMBLY : Removal and Installation"](#).

CAUTION:

Never depress brake pedal while brake caliper is removed.

5. Remove disc rotor.

CAUTION:

- Put matching marks (A) on the wheel hub assembly and the disc rotor before removing the disc rotor.
- Never drop disc rotor.

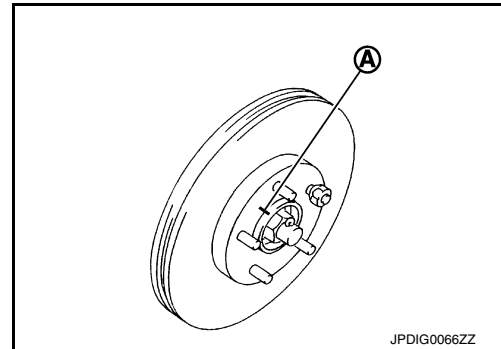

E
F
G
H
I
J
K

6. Remove cotter pin, and adjusting cap, and then loosen wheel hub lock nut with power tool.
7. Patch wheel hub lock nut with a piece of wood. Hammer the wood to disengage wheel hub assembly from drive shaft.

NOTE:

Use suitable puller, if wheel hub assembly and drive shaft cannot be separated even after performing the above procedure.

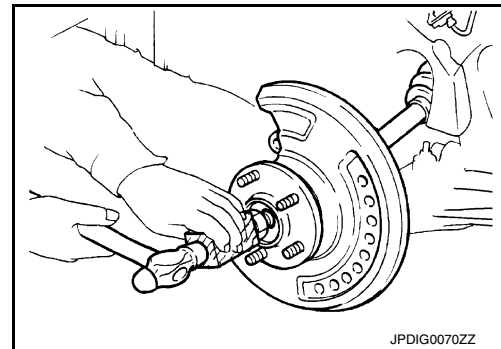

L
M
N
O

8. Remove wheel hub lock nut.
9. Remove strut assembly from steering knuckle. Refer to [FSU-9, "Removal and Installation"](#).
10. Remove drive shaft from wheel hub assembly.

CAUTION:

- Never place drive shaft joint at an extreme angle. Also be careful not to overextend slide joint.
- Never allow drive shaft to hang down without support for joint sub-assembly, shaft and the other parts.

11. Remove plate from support bearing bracket.
12. Remove drive shaft assembly from transaxle assembly.

P

FRONT DRIVE SHAFT

< REMOVAL AND INSTALLATION >

[TYPE 1]

CAUTION:

Never place drive shaft joint at an extreme angle when removing drive shaft. Also be careful not to overextend slide joint.

13. Remove heat insulator.
14. Remove support bearing bracket.

INSTALLATION

Note the following, and install in the reverse order of removal.

Left Side

- Always replace differential side oil seal with new one when installing drive shaft. Refer to [TM-81](#), "Removal and Installation".
- Place the protector (A) [SST:KV38107900 (—)] onto transaxle assembly to prevent damage to the differential side oil seal while inserting drive shaft. Slide drive shaft sliding joint and tap with a hammer to install securely.

CAUTION:

- Check that circular clip is completely engaged.
- Never reuse circular clip.
- Never reuse differential side oil seal.

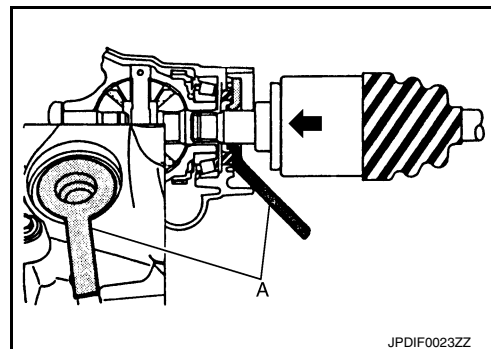

- Clean the matching surface of wheel hub lock nut and wheel hub assembly.

CAUTION:

Never apply lubricating oil to these matching surface.

- Clean the matching surface of drive shaft and wheel hub assembly. And then apply paste [service parts (440037S000)] to surface (A) of joint sub-assembly of drive shaft.

CAUTION:

Apply paste to cover entire flat surface of joint sub-assembly of drive shaft.

Amount paste : 1.0 – 3.0 g (0.04 – 0.10 oz)

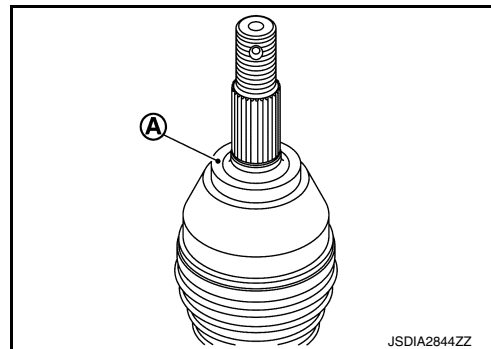

- Use the following torque range for tightening the wheel hub lock nut.

 : 180 – 185 N·m (18.4 – 18.8 kg-m, 133 – 136 ft-lb)

CAUTION:

- Since the drive shaft is assembled by press-fitting, use the tightening torque range for the wheel hub lock nut.
- Be sure to use torque wrench to tighten the wheel hub lock nut. Never use a power tool.
- Never reuse wheel hub lock nut.

NOTE:

Wheel hub lock nut tightening torque does not over torque for avoiding axle noise, and does not less than torque for avoiding looseness.

- Align the matching marks that have been made during removal when reusing the disc rotor.

FRONT DRIVE SHAFT

[TYPE 1]

< REMOVAL AND INSTALLATION >

- When installing a cotter pin (1) and adjusting cap (2), securely bend the basal portion to prevent rattles.

CAUTION:

Never reuse cotter pin.

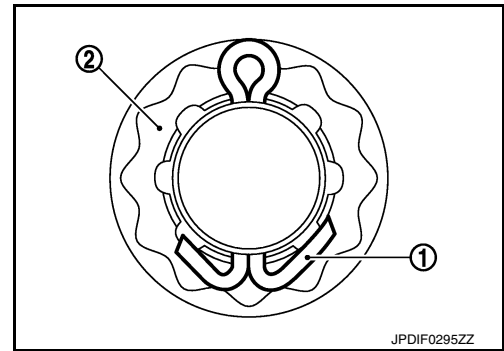

- Perform the final tightening of each of parts under unladen conditions, which were removed when removing wheel hub assembly and steering knuckle.
- Perform inspection after installation. Refer to [FAX-43, "2WD : Inspection"](#).

Right Side

- Always replace differential side oil seal with new one when installing drive shaft. Refer to [TM-81, "Removal and Installation"](#).

- Install support bearing bracket (1) in following procedure,
 - Temporarily tighten mounting bolts (A), (B), (C), then tighten them to specified torque.
 - Set plate (2) so that notch (D) becomes upper side. Temporarily tighten mounting bolts (E), (F), then tighten them to specified torque.

CAUTION:

Never reuse plate.

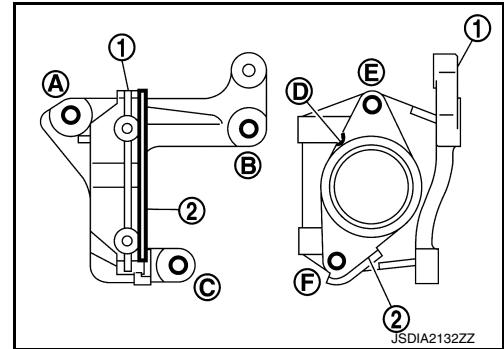

- Place the protector (A) [SST:KV38107900 (—)] onto transaxle assembly to prevent damage to the differential side oil seal while inserting drive shaft. Slide drive shaft sliding joint and tap with a hammer to install securely.

CAUTION:

Never reuse differential oil seal.

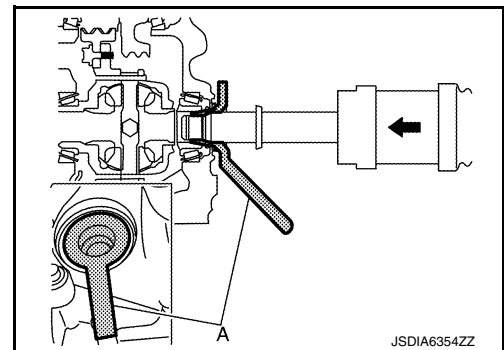

- To install mounting nuts of the heat insulator (1), temporarily tighten them in numerical order shown in the figure and tighten them to the specified torque.

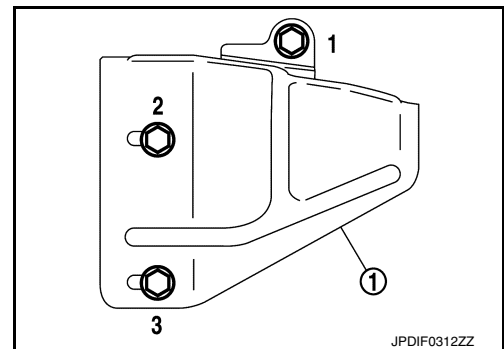

- Clean the matching surface of wheel hub lock nut and wheel hub assembly.

CAUTION:

Never apply lubricating oil to these matching surface.

FRONT DRIVE SHAFT

< REMOVAL AND INSTALLATION >

[TYPE 1]

- Clean the matching surface of drive shaft and wheel hub assembly. And then apply paste [service parts (440037S000)] to surface (A) of joint sub-assembly of drive shaft.

CAUTION:

Apply paste to cover entire flat surface of joint sub-assembly of drive shaft.

Amount paste : 1.0 – 3.0 g (0.04 – 0.10 oz)

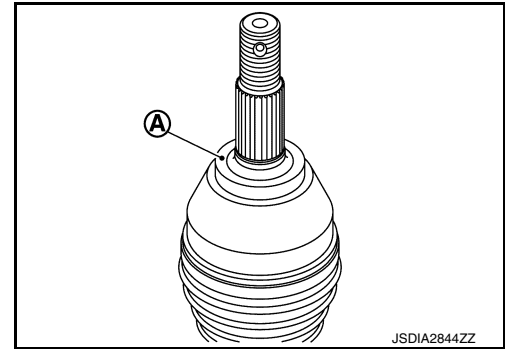

- Use the following torque range for tightening the wheel hub lock nut.

 : **180 – 185 N·m (18.4 – 18.8 kg-m, 133 – 136 ft-lb)**

CAUTION:

- Since the drive shaft is assembled by press-fitting, use the tightening torque range for the wheel hub lock nut.
- Be sure to use torque wrench to tighten the wheel hub lock nut. Never use a power tool.
- Never reuse wheel hub lock nut.

NOTE:

Wheel hub lock nut tightening torque does not over torque for avoiding axle noise, and does not less than torque for avoiding looseness.

- Align the matching marks that have been made during removal when reusing the disc rotor.
- When installing a cotter pin (1) and adjusting cap (2), securely bend the basal portion to prevent rattles.

CAUTION:

Never reuse cotter pin.

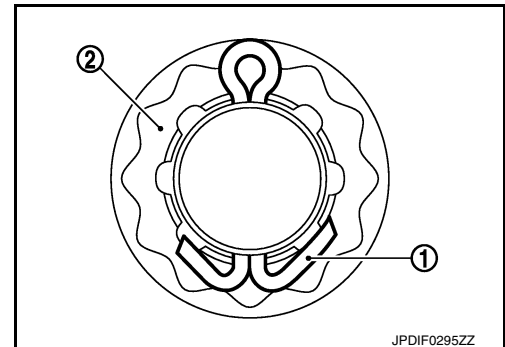

- Perform the final tightening of each of parts under unladen conditions, which were removed when removing wheel hub assembly and steering knuckle.
- Perform inspection after installation. Refer to [FAX-43, "2WD : Inspection"](#).

2WD : Disassembly and Assembly

INFOID:000000012201535

DISASSEMBLY

Wheel Side

1. Fix shaft with a vise.

CAUTION:

Protect shaft using aluminum or copper plates when fixing with a vise.

2. Remove boot bands, and then remove boot from joint sub-assembly.

FRONT DRIVE SHAFT

< REMOVAL AND INSTALLATION >

[TYPE 1]

3. Screw drive shaft puller (A) (commercial service tool) into joint sub-assembly screw part to a length of 30 mm (1.18 in) or more. Support drive shaft with one hand and pull out joint sub-assembly from shaft.

CAUTION:

- Align drive shaft puller and drive shaft and remove them by pulling firmly and uniformly.
- If joint sub-assembly cannot be removed after five or more unsuccessful attempts, replace shaft and joint sub-assembly as a set.

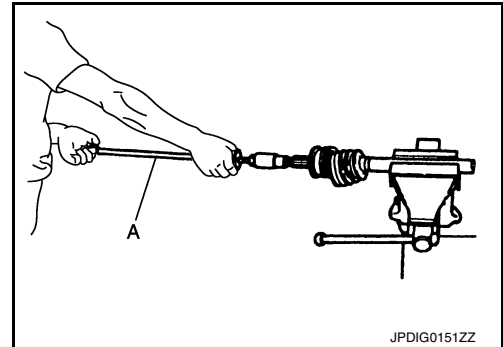

4. Remove circular clip from shaft.
5. Remove boot from shaft.

Transaxle Side (Left Drive Shaft)

1. Fix shaft with a vise.

CAUTION:

Protect shaft using aluminum or copper plates when fixing with a vise.

2. Remove boot bands, and then remove boot from housing assembly.
3. Remove stopper ring.
4. Put matching marks on housing assembly and shaft, and then pull out housing assembly from shaft.

CAUTION:

Use paint or an equivalent for matching marks. Never scratch the surfaces.

5. Clean old grease on housing with paper waste.
6. Put matching marks (A) on the spider assembly and shaft.

CAUTION:

Use paint or an equivalent for matching marks. Never scratch the surfaces.

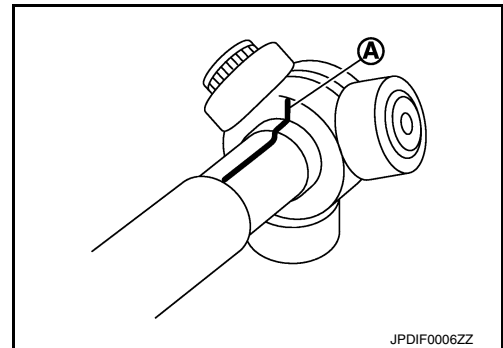

7. Remove snap ring (1), and then remove spider assembly from shaft.

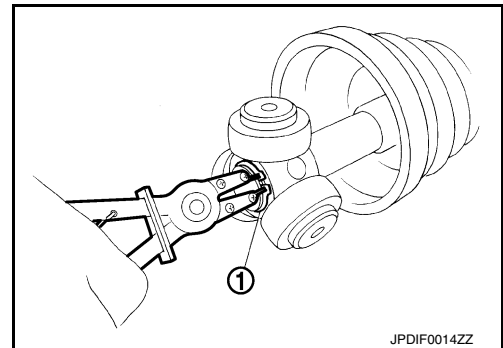

8. Remove boot from shaft.
9. Remove circular clip from housing assembly.
10. Remove dust shield from housing assembly.
11. Remove damper bands, then remove dynamic damper from shaft.

Transaxle Side (Right Drive Shaft)

1. Fix shaft with a vise.

CAUTION:

Protect shaft using aluminum or copper plates when fixing with a vise.

A
B
C
FAX

E
F
G
H
I
J
K
L
M
N
O
P

FRONT DRIVE SHAFT

[TYPE 1]

< REMOVAL AND INSTALLATION >

2. Remove boot bands, and then remove boot from housing assembly.
3. Remove stopper ring.
4. Put matching marks on housing assembly and shaft, and then pull out housing assembly from shaft.

CAUTION:

Use paint or an equivalent for matching marks. Never scratch the surfaces.

5. Clean old grease on housing with paper waste.
6. Put matching marks (A) on the spider assembly and shaft.

CAUTION:

Use paint or an equivalent for matching marks. Never scratch the surfaces.

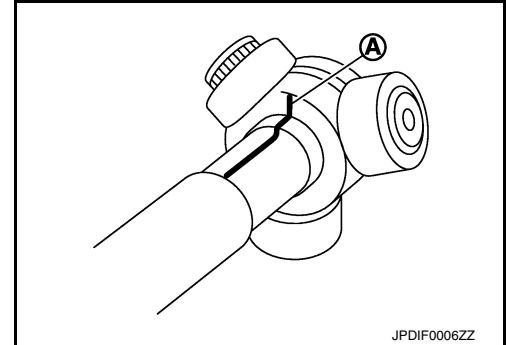

7. Remove snap ring (1), and then remove spider assembly from shaft.

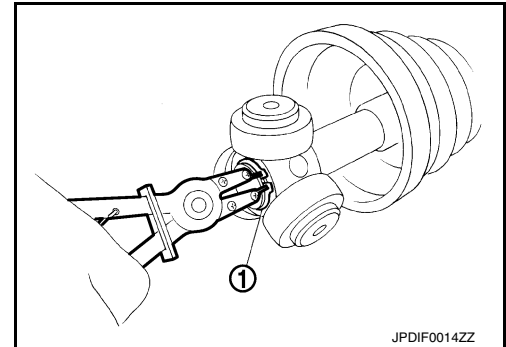

8. Remove boot from shaft.
9. Remove support bearing, follow the procedur described below.
 - a. Remove dust shield from housing.

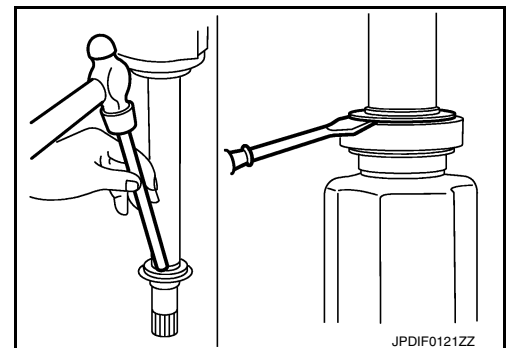

- b. Remove snap ring (1).

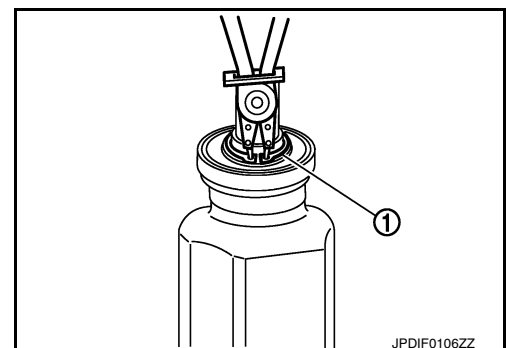

FRONT DRIVE SHAFT

[TYPE 1]

< REMOVAL AND INSTALLATION >

- c. Press out support bearing from housing.

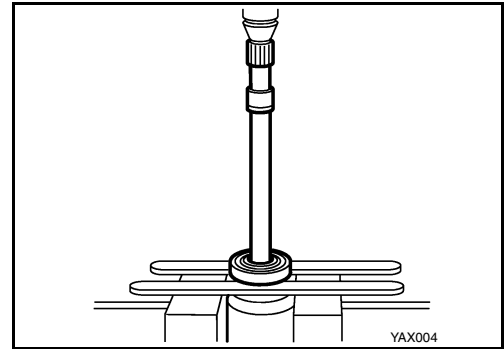

- d. Remove dust shield from housing.
10. Remove damper bands, then remove dynamic damper from shaft.

ASSEMBLY

Wheel Side

1. Clean the old grease on joint sub-assembly with paper waste.
2. Fill serration slot joint sub-assembly (1) with NISSAN genuine grease or equivalent until the serration slot and ball groove become full to the brim.

CAUTION:

After applying grease, use a paper waste to wipe off old grease that has oozed out.

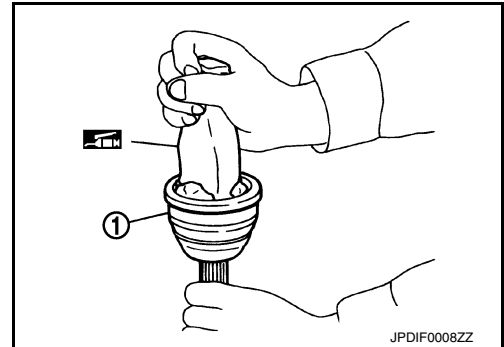

3. Install boot and boot bands to shaft.

CAUTION:

- Wrap serration on shaft with tape (A) to protect the boot from damage.
- Never reuse boot and boot band.

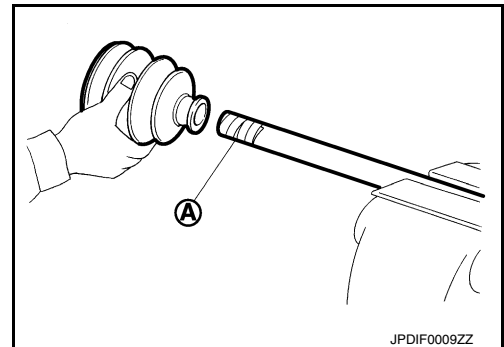

4. Remove the tape wrapped around the serration on shaft.
5. Position the circular clip (1) on groove at the shaft edge.

CAUTION:

Never reuse circular clip.

NOTE:

Drive joint inserter is recommended when installing circular clip.

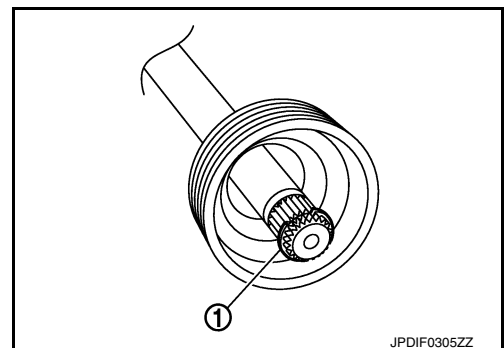

A
B
C
FAX
E
F
G
H
I
J
K
L
M
N
O
P

FRONT DRIVE SHAFT

[TYPE 1]

< REMOVAL AND INSTALLATION >

- Align both center axes of the shaft edge and joint sub-assembly. Then assemble shaft with joint sub-assembly holding circular clip.
- Install joint sub-assembly to shaft using plastic hammer.

CAUTION:

- Check circular clip is properly positioned on groove of the joint sub-assembly.
- Confirm that joint sub-assembly is correctly engaged while rotating drive shaft.

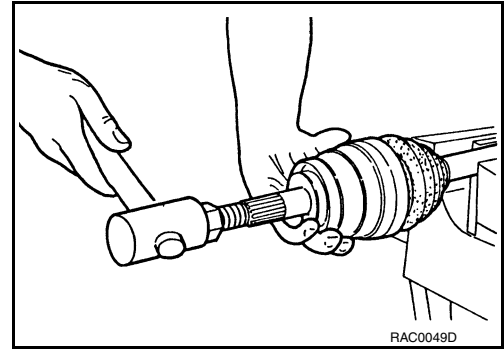

- Apply the specified amount of grease into the boot inside from large diameter side of boot.

Grease amount : Refer to [FAX-57, "Drive Shaft"](#).

- Install the boot securely into grooves (indicated by "*" marks) shown in the figure.

CAUTION:

If grease adheres to the boot mounting surface (indicated by "*" marks) on the shaft or joint sub-assembly, boot may be removed. Remove all grease from the boot mounting surface.

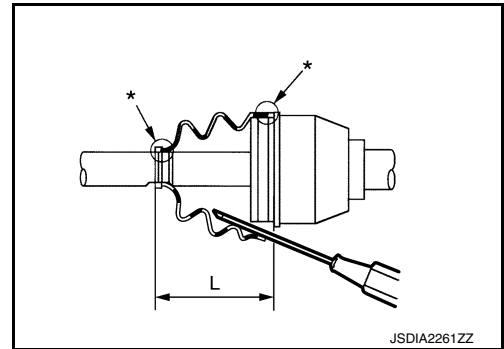

- To prevent the deformation of the boot, adjust the boot installation length (L) to the specified value shown below by inserting the suitable tool into inside of the boot from the large diameter side of the boot and discharging the inside air.

L : Refer to [FAX-57, "Drive Shaft"](#).

CAUTION:

- If the boot installation length exceeds the standard, it may cause breakage of the boot.
- Be careful not to touch the inside of the boot with a tip of tool.

- Secure the large and small ends of the boot with boot bands using the boot band crimping tool (A) [SST:KV40107300 (—)].

CAUTION:

- Never reuse boot band.

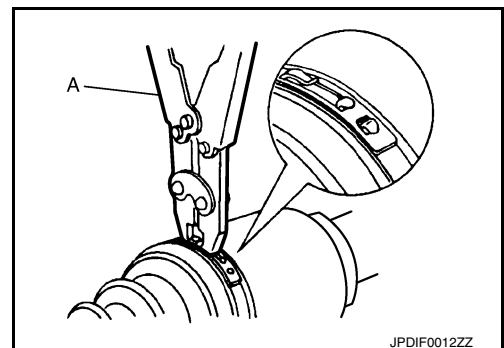

FRONT DRIVE SHAFT

< REMOVAL AND INSTALLATION >

[TYPE 1]

- Secure boot band so that dimension (M) meets the specification as shown in the figure.

Dimension (M) : 1.0 – 4.0 mm (0.039 – 0.157 in)

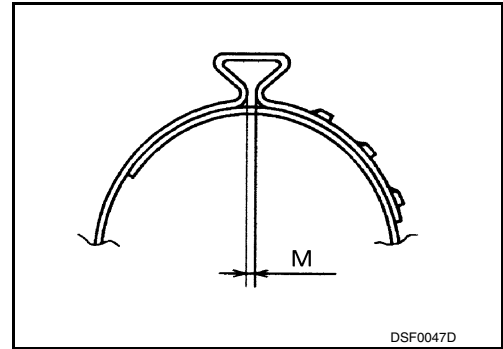

12. Check that displacement does not occur when boot is rotated with the joint sub-assembly and shaft fixed.

CAUTION:

- Reinstall them using boot bands when boot installation positions become incorrect.
- Never reuse boot band.

Transaxle Side (Left Drive Shaft)

1. Clean the old grease on housing with paper waste.
2. Install dust shield to housing assembly.

CAUTION:

Never reuse dust shield.

3. Install circular clip to housing assembly.

CAUTION:

Never reuse circular clip.

4. Install dynamic damper, follow the procedure described below.
 - a. Install dynamic damper to shaft.

- b. Secure dynamic damper with bands in the following specified position (A) when installing.

CAUTION:

Never reuse boot bands.

A : Refer to [FAX-57, "Drive Shaft"](#).

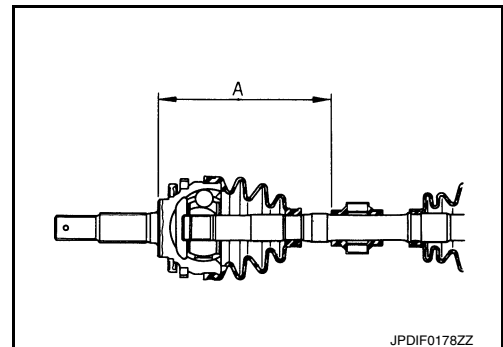

- c. Install boot bands securely as shown in the figure.

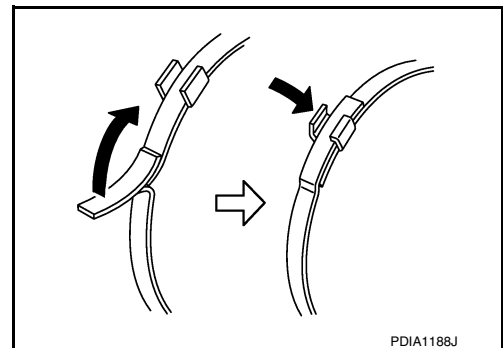

5. Install boot and boot bands to housing assembly.

CAUTION:

FRONT DRIVE SHAFT

< REMOVAL AND INSTALLATION >

[TYPE 1]

- Wrap serration on housing assembly with tape (A) to protect the boot from damage.
- Never reuse boot and boot band.

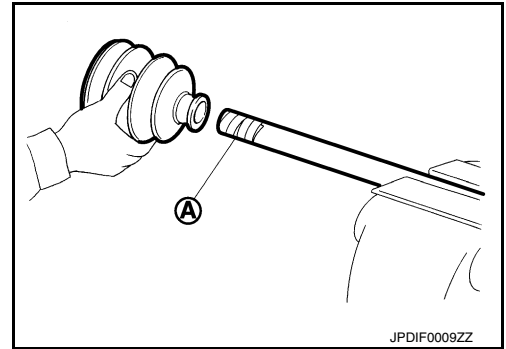

6. Remove the tape wrapped around the serration on shaft.
7. To install the spider assembly (1), align it with the matching marks (A) on the shaft (2) put during the removal, and direct the serration mounting surface (B) to the shaft.

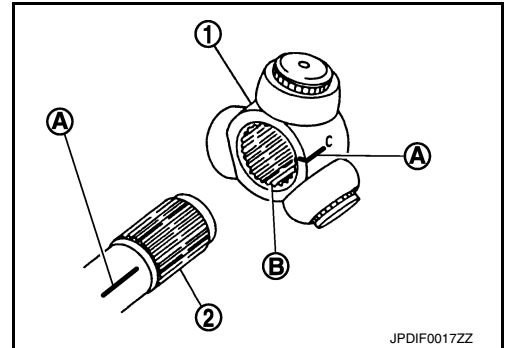

8. Secure spider assembly onto shaft with snap ring (1).
CAUTION:
Never reuse snap ring.

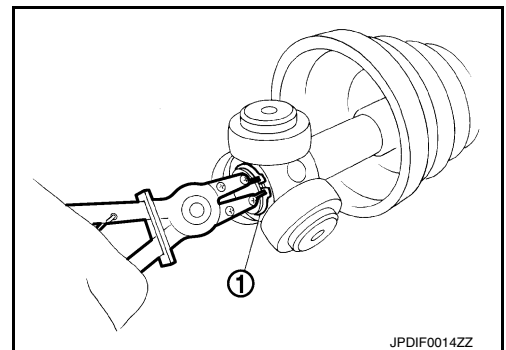

9. Apply the appropriate amount of grease to spider assembly and sliding surface.
10. Align matching marks put during the removal of housing assembly.
11. Install stopper ring.
CAUTION:
Never reuse stopper ring.
12. Apply NISSAN genuine grease (refer to parts catalog) to housing assembly.

Grease amount : Refer to [FAX-57, "Drive Shaft"](#).

13. Install the boot securely into grooves (indicated by "*" marks) shown in the figure.
CAUTION:
If grease adheres to the boot mounting surface (indicated by "*" marks) on the shaft or housing assembly, boot may be removed. Remove all grease from the boot mounting surface.

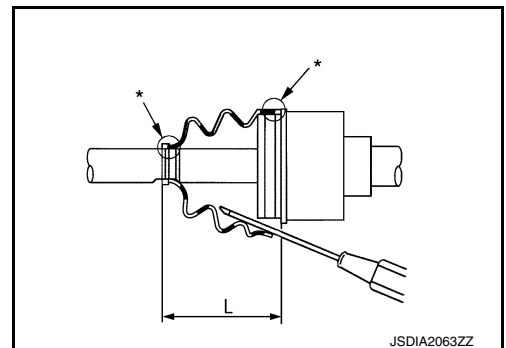

FRONT DRIVE SHAFT

< REMOVAL AND INSTALLATION >

[TYPE 1]

14. To prevent the deformation of the boot, adjust the boot installation length to the value shown below (L) by inserting the suitable tool into the inside of boot from the large diameter side of boot and discharging inside air.

L : Refer to [FAX-57, "Drive Shaft"](#).

CAUTION:

- If the boot installation length exceeds the standard, it may cause breakage of the boot.
- Be careful not to touch the inside of the boot with the tip of tool.

15. Fix large diameter side and small diameter side of boot with boot band.

- a. Set boot band to the drive shaft boot groove and temporarily fix pawl (A) of boot band to (B) of boot band.

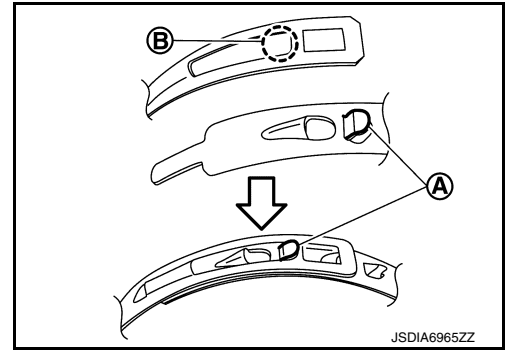

- b. Tighten boot band protrusions (B) with boot band crimping tool (A) [SST:KV40107310 (—)] in the direction shown by arrows.

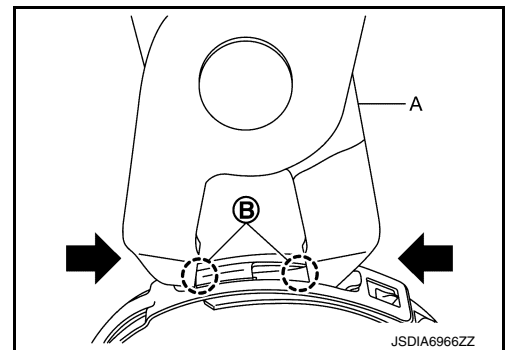

CAUTION:

Securely install boot band (A) to boot band pawl (B).

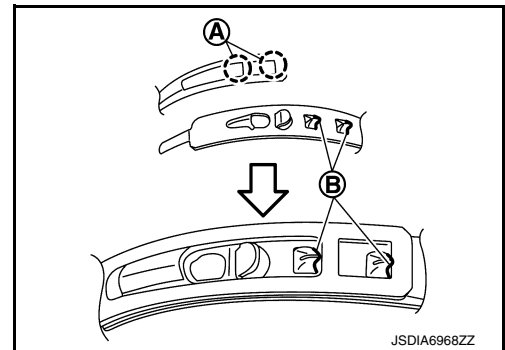

16. Check that displacement does not occur when boot is rotated with the housing assembly fixed.

CAUTION:

- If displacement occurs, reinstall band.
- Never reuse boot band.

Transaxle Side (Right Drive Shaft)

1. Clean the old grease on housing with paper waste.
2. Install dynamic damper, follow the procedure described below.
 - a. Install dynamic damper to shaft.

FRONT DRIVE SHAFT

[TYPE 1]

< REMOVAL AND INSTALLATION >

- b. Secure dynamic damper with bands in the following specified position (A) when installing.

CAUTION:

Never reuse bands.

A : Refer to [FAX-57, "Drive Shaft"](#).

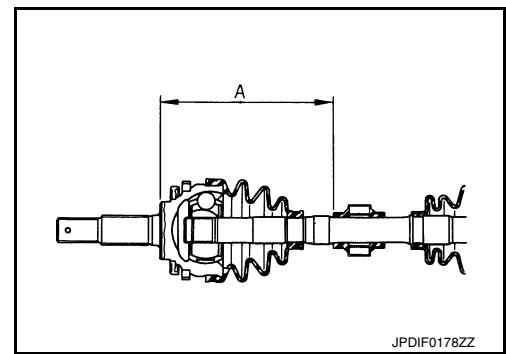

- c. Install boot bands securely as shown in the figure.

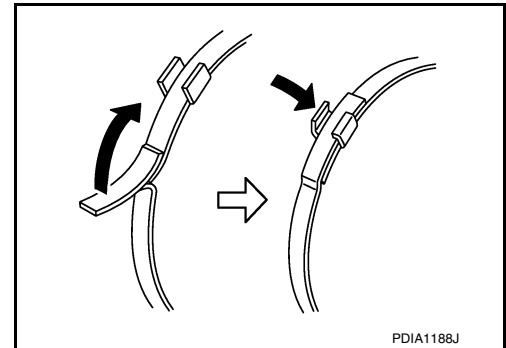

3. Install support bearing, follow the procedure described below.

- a. Install dust shield to housing.

CAUTION:

Never reuse dust shield.

- b. Press support bearing (1) onto housing to using the suitable tool (A).

CAUTION:

Never reuse support bearing.

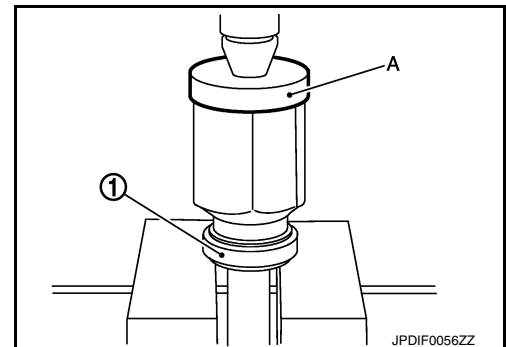

- c. Install snap ring (1).

CAUTION:

Never reuse snap ring.

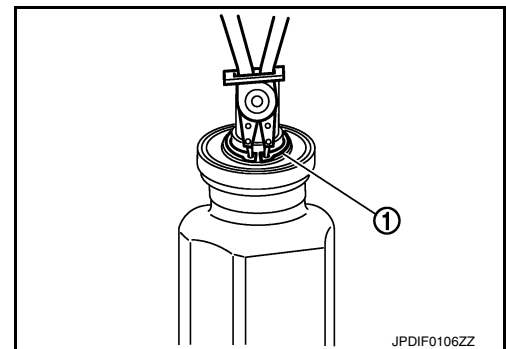

FRONT DRIVE SHAFT

< REMOVAL AND INSTALLATION >

[TYPE 1]

- d. Install dust shields.

CAUTION:

Never reuse dust shields.

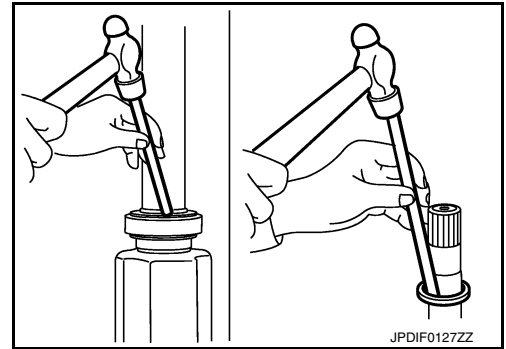

A
B
C

4. Install boot and boot bands to housing assembly.

CAUTION:

- Wrap serration on housing assembly with tape (A) to protect the boot from damage.
- Never reuse boot and boot band.

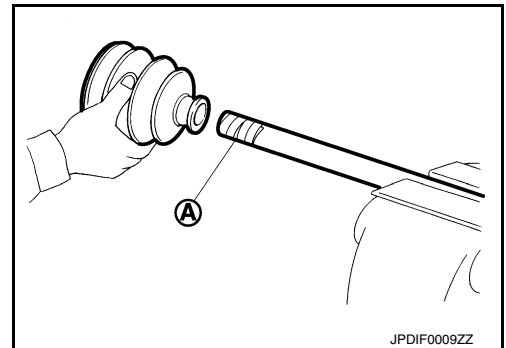

E
F
G
H

5. Remove the tape wrapped around the serration on shaft.

6. To install the spider assembly (1), align it with the matching marks (A) on the shaft (2) put during the removal, and direct the serration mounting surface (B) to the shaft.

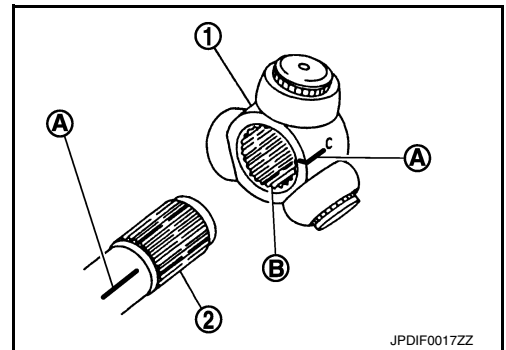

I
J
K
L

7. Secure spider assembly onto shaft with snap ring (1).

CAUTION:

Never reuse snap ring.

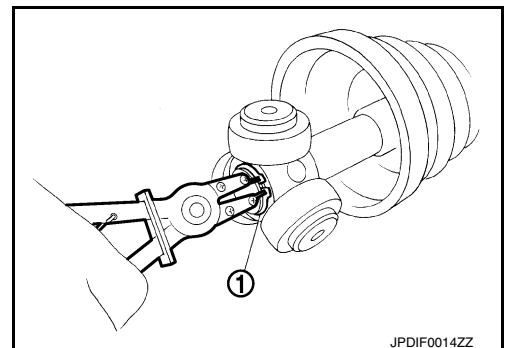

M
N
O
P

8. Apply the appropriate amount of grease to spider assembly and sliding surface.

9. Align matching marks put during the removal of housing assembly.

10. Install stopper ring.

CAUTION:

Never reuse stopper ring.

11. Apply NISSAN genuine grease (refer to parts catalog) to housing assembly.

FRONT DRIVE SHAFT

< REMOVAL AND INSTALLATION >

[TYPE 1]

Grease amount : Refer to [FAX-57, "Drive Shaft"](#).

12. Install the boot securely into grooves (indicated by "*" marks) shown in the figure.

a. For NISMO RS models.

CAUTION:

If grease adheres to the boot mounting surface (indicated by "*" marks) on the shaft or housing assembly, boot may be removed. Remove all grease from the boot mounting surface.

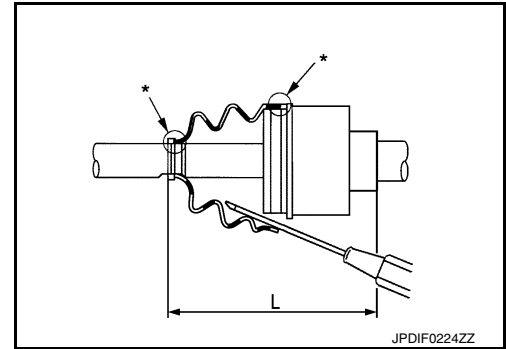

b. Except for NISMO RS models.

CAUTION:

If grease adheres to the boot mounting surface (indicated by "*" marks) on the shaft or housing assembly, boot may be removed. Remove all grease from the boot mounting surface.

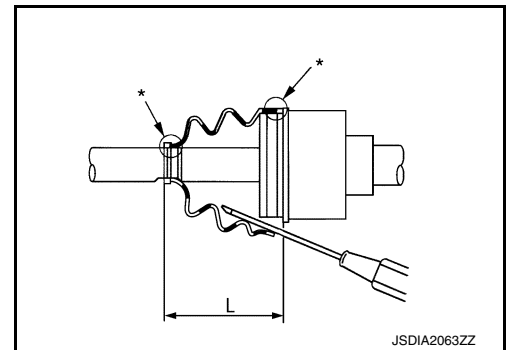

13. To prevent the deformation of the boot, adjust the boot installation length to the value shown below (L) by inserting the suitable tool into the inside of boot from the large diameter side of boot and discharging inside air.

L : Refer to [FAX-57, "Drive Shaft"](#).

CAUTION:

- If the boot installation length exceeds the standard, it may cause breakage of the boot.
- Be careful not to touch the inside of the boot with the tip of tool.

14. Fix large diameter side and small diameter side of boot with boot band.

a. Set boot band to the drive shaft boot groove and temporarily fix pawl (A) of boot band to (B) of boot band.

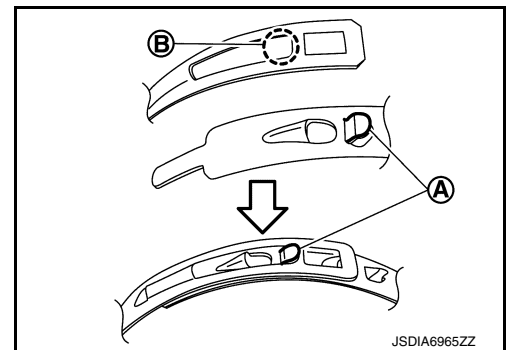

FRONT DRIVE SHAFT

[TYPE 1]

< REMOVAL AND INSTALLATION >

- b. Tighten boot band protrusions (B) with boot band crimping tool (A) [SST:KV40107310 (—)] in the direction shown by arrows.

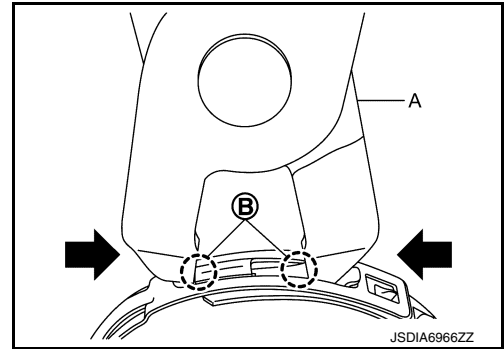

CAUTION:

Securely install boot band (A) to boot band pawl (B).

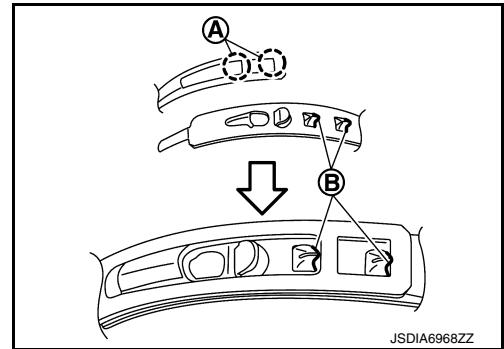

15. Check that displacement does not occur when boot is rotated with the housing assembly fixed.

CAUTION:

- If displacement occurs, reinstall band.
- Never reuse boot band.

2WD : Inspection

INFOID:000000012201536

INSPECTION AFTER INSTALLATION

1. Check wheel sensor harness for proper connection. Refer to [BRC-147. "FRONT WHEEL SENSOR : Exploded View"](#).
2. Check the wheel alignment. Refer to [FSU-7. "Inspection"](#).
3. Adjust neutral position of steering angle sensor. Refer to [BRC-63. "Work Procedure"](#).

AWD

AWD : Exploded View

INFOID:000000012201537

LEFT SIDE

FRONT DRIVE SHAFT

< REMOVAL AND INSTALLATION >

[TYPE 1]

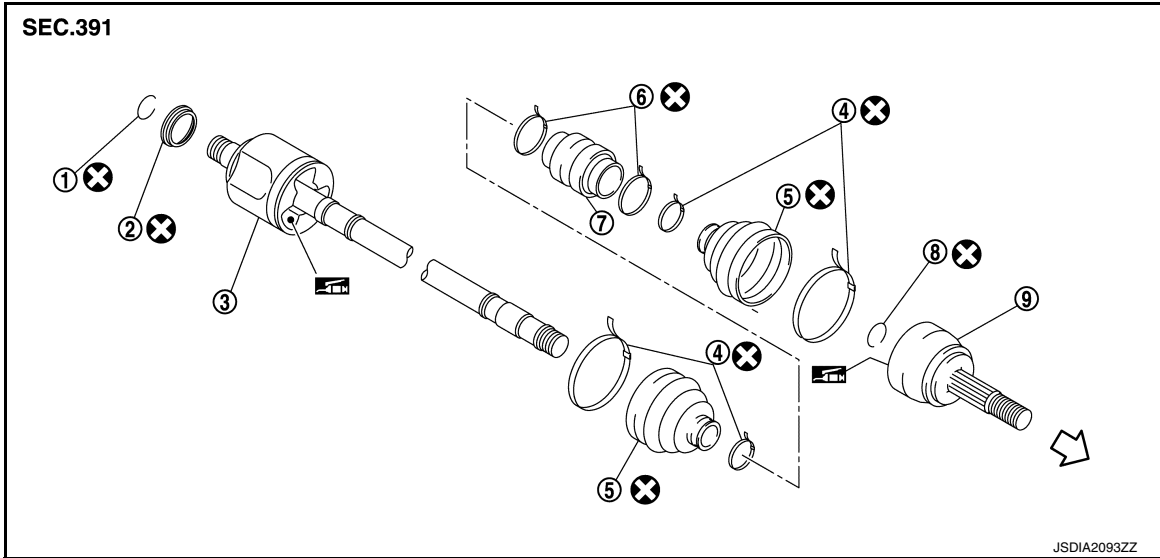

- | | | |
|-------------------|------------------|-----------------------|
| 1. Circular clip | 2. Dust shield | 3. Housing assembly |
| 4. Boot band | 5. Boot | 6. Damper band |
| 7. Dynamic damper | 8. Circular clip | 9. Joint sub-assembly |

← : Wheel side

: Fill NISSAN Genuine grease or equivalent.

: Always replace after every disassembly.

RIGHT SIDE

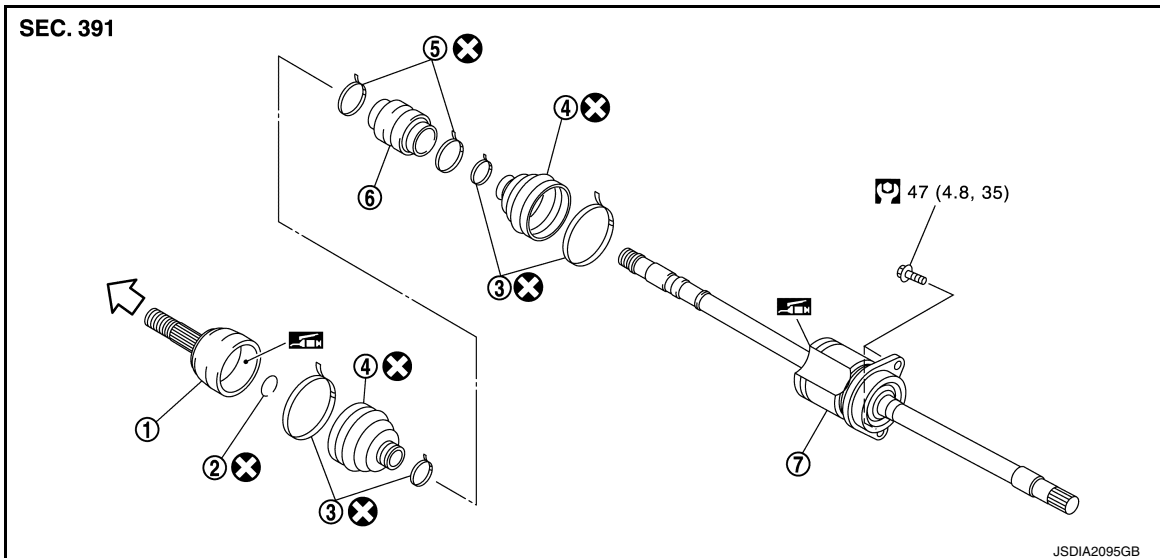

- | | | |
|-----------------------|------------------|-------------------|
| 1. Joint sub-assembly | 2. Circular clip | 3. Boot band |
| 4. Boot | 5. Damper band | 6. Dynamic damper |
| 7. Housing assembly | | |

← : Wheel side

: Fill NISSAN Genuine grease or equivalent.

: Always replace after every disassembly.

: N·m (kg·m, ft·lb)

FRONT DRIVE SHAFT

< REMOVAL AND INSTALLATION >

[TYPE 1]

AWD : Removal and Installation

INFOID:000000012201538

REMOVAL

Left Side

1. Remove tires with power tool. Refer to [WT-39, "Removal and Installation"](#).
2. Remove wheel sensor and sensor harness. Refer to [BRC-147, "FRONT WHEEL SENSOR : Exploded View"](#).
3. Remove lock plate from strut assembly. Refer to [BR-25, "FRONT : Removal and Installation"](#).
4. Remove caliper assembly. Hang caliper assembly not to interfere with work. Refer to [BR-55, "BRAKE CALIPER ASSEMBLY : Removal and Installation"](#).

CAUTION:

Never depress brake pedal while brake caliper is removed.

5. Remove disc rotor.

CAUTION:

- Put matching marks (A) on the wheel hub assembly and the disc rotor before removing the disc rotor.
- Never drop disc rotor.

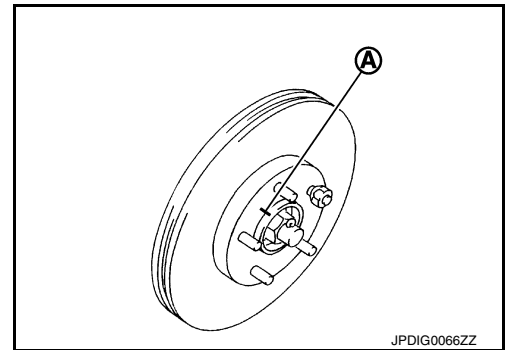

6. Remove cotter pin, and adjusting cap, and then loosen wheel hub lock nut with power tool.
7. Patch wheel hub lock nut with a piece of wood. Hammer the wood to disengage wheel hub assembly from drive shaft.

NOTE:

Use suitable puller, if wheel hub assembly and drive shaft cannot be separated even after performing the above procedure.

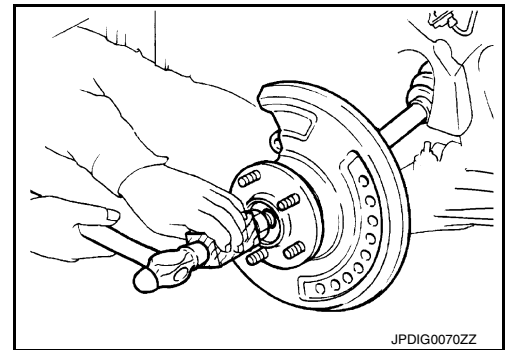

8. Remove wheel hub lock nut.
9. Remove strut assembly from steering knuckle. Refer to [FSU-9, "Removal and Installation"](#).
10. Remove drive shaft from wheel hub assembly.

CAUTION:

- Never place drive shaft joint at an extreme angle. Also be careful not to overextend slide joint.
- Never allow drive shaft to hang down without support for joint sub-assembly, shaft and the other parts.

11. Use the drive shaft attachment (A) [SST:KV40107500 (—)] and a sliding hammer (B) (commercial service tool) while inserting tip of the drive shaft attachment between shaft and transaxle assembly, and then remove drive shaft from transaxle assembly.

CAUTION:

- Never place drive shaft joint at an extreme angle when removing drive shaft. Also be careful not to overextend slide joint.
- Confirm that the circular clip is attached to the drive shaft.

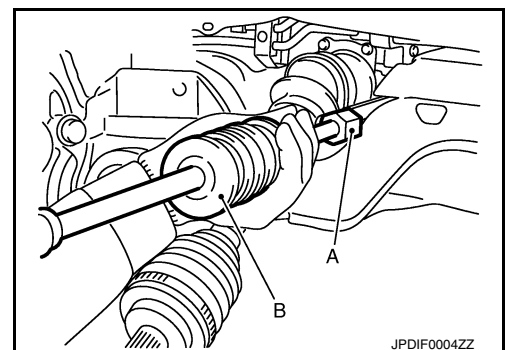

A
B
C
FAX
E
F
G
H
I
J
K
L
M
N
O
P

FRONT DRIVE SHAFT

< REMOVAL AND INSTALLATION >

[TYPE 1]

Right Side

1. Remove tires with power tool. Refer to [WT-39, "Removal and Installation"](#).
2. Remove wheel sensor and sensor harness. Refer to [BRC-147, "FRONT WHEEL SENSOR : Exploded View"](#).
3. Remove lock plate from strut assembly. Refer to [BR-25, "FRONT : Removal and Installation"](#).
4. Remove caliper assembly. Hang caliper assembly not to interfere with work. Refer to [BR-55, "BRAKE CALIPER ASSEMBLY : Removal and Installation"](#).

CAUTION:

Never depress brake pedal while brake caliper is removed.

5. Remove disc rotor.

CAUTION:

- Put matching marks (A) on the wheel hub assembly and the disc rotor before removing the disc rotor.
- Never drop disc rotor.

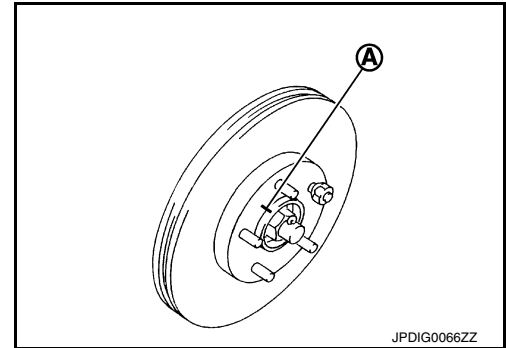

6. Remove cotter pin, and adjusting cap, and then loosen wheel hub lock nut with power tool.
7. Patch wheel hub lock nut with a piece of wood. Hammer the wood to disengage wheel hub assembly from drive shaft.

NOTE:

Use suitable puller, if wheel hub assembly and drive shaft cannot be separated even after performing the above procedure.

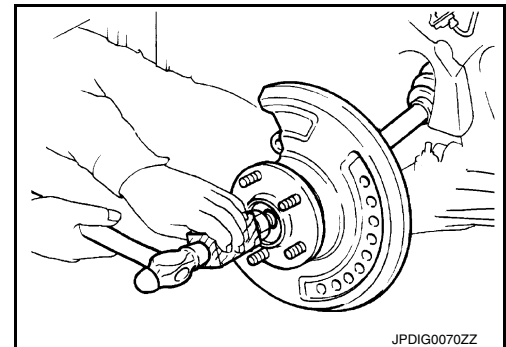

8. Remove wheel hub lock nut.
9. Remove strut assembly from steering knuckle. Refer to [FSU-9, "Removal and Installation"](#).
10. Remove drive shaft from wheel hub assembly.

CAUTION:

- Never place drive shaft joint at an extreme angle. Also be careful not to overextend slide joint.
- Never allow drive shaft to hang down without support for joint sub-assembly, shaft and the other parts.

11. Remove bearing housing bolts.
12. Remove drive shaft assembly from transfer assembly.

CAUTION:

Never place drive shaft joint at an extreme angle when removing drive shaft. Also be careful not to overextend slide joint.

INSTALLATION

Note the following, and install in the reverse order of removal.

Left Side

- Always replace differential side oil seal with new one when installing drive shaft. Refer to [TM-340, "Removal and Installation"](#).

FRONT DRIVE SHAFT

[TYPE 1]

< REMOVAL AND INSTALLATION >

- Place the protector (A) [SST:KV38107900 (—)] onto tranaxle assembly to prevent damage to the oil seal while inserting drive shaft. Slide drive shaft sliding joint and tap with a hammer to install securely.

CAUTION:

- Check that circular clip is completely engaged.
- Never reuse circular clip.
- Never reuse differential side oil seal.

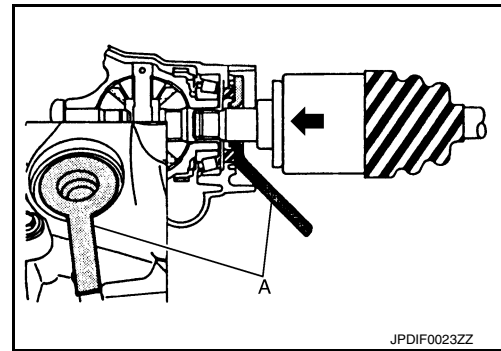

- Clean the matching surface of wheel hub lock nut and wheel hub assembly.

CAUTION:

Never apply lubricating oil to these matching surface.

- Clean the matching surface of drive shaft and wheel hub assembly. And then apply paste [service parts (440037S000)] to surface (A) of joint sub-assembly of drive shaft.

CAUTION:

Apply paste to cover entire flat surface of joint sub-assembly of drive shaft.

Amount paste : 1.0 – 3.0 g (0.04 – 0.10 oz)

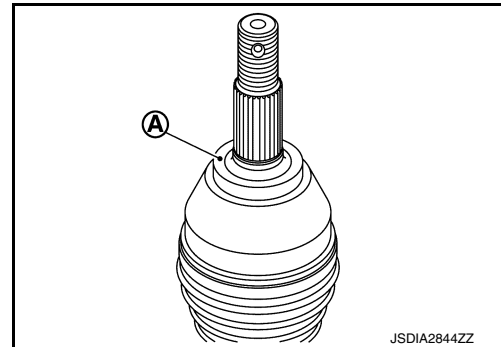

- Use the following torque range for tightening the wheel hub lock nut.

 : 180 – 185 N·m (18.4 – 18.8 kg-m, 133 – 136 ft-lb)

CAUTION:

- Since the drive shaft is assembled by press-fitting, use the tightening torque range for the wheel hub lock nut.
- Be sure to use torque wrench to tighten the wheel hub lock nut. Never use a power tool.
- Never reuse wheel hub lock nut.

NOTE:

Wheel hub lock nut tightening torque does not over torque for avoiding axle noise, and does not less than torque for avoiding looseness.

- Align the matching marks that have been made during removal when reusing the disc rotor.
- When installing a cotter pin (1) and adjusting cap (2), securely bend the basal portion to prevent rattles.

CAUTION:

Never reuse cotter pin.

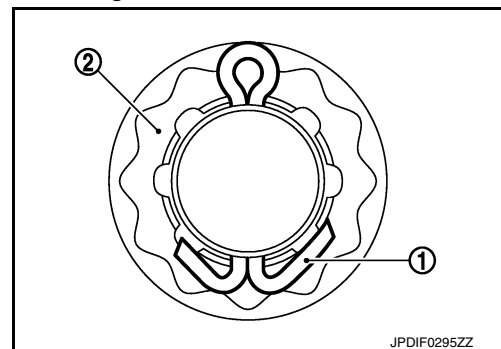

- Perform the final tightening of each of parts under unladen conditions, which were removed when removing wheel hub assembly and steering knuckle.
- Perform inspection after installation. Refer to [FAX-56, "AWD : Inspection"](#).

Right Side

- Always replace transfer cover oil seal (inner) and transfer cover oil seal (outer) with new one when installing drive shaft. Refer to [DLN-94, "Removal and Installation"](#).

FRONT DRIVE SHAFT

< REMOVAL AND INSTALLATION >

[TYPE 1]

- Place the protector (A) [SST:KV38107900 (—)] onto transfer assembly to prevent damage to the transfer cover oil seal (inner) and transfer cover oil seal (outer) while inserting drive shaft. Slide drive shaft sliding joint and tap with a hammer to install securely.

CAUTION:

Never reuse transfer cover oil seal (inner) and transfer cover oil seal (outer).

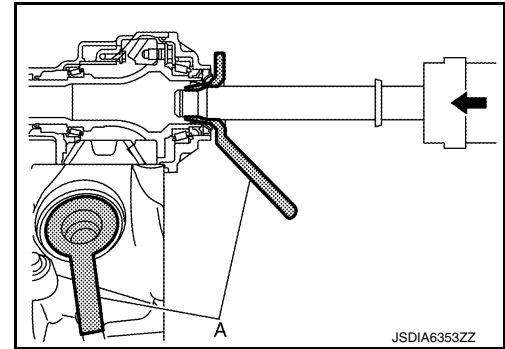

- Tighten the bearing housing bolt to the specified torque. Refer to [FAX-43. "AWD : Exploded View"](#).
- Clean the matching surface of wheel hub lock nut and wheel hub assembly.

CAUTION:

Never apply lubricating oil to these matching surface.

- Clean the matching surface of drive shaft and wheel hub assembly. And then apply paste [service parts (440037S000)] to surface (A) of joint sub-assembly of drive shaft.

CAUTION:

Apply paste to cover entire flat surface of joint sub-assembly of drive shaft.

Amount paste : 1.0 – 3.0 g (0.04 – 0.10 oz)

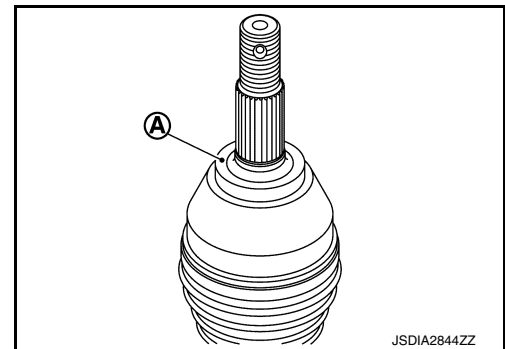

- Use the following torque range for tightening the wheel hub lock nut.

 : 180 – 185 N·m (18.4 – 18.8 kg-m, 133 – 136 ft-lb)

CAUTION:

- Since the drive shaft is assembled by press-fitting, use the tightening torque range for the wheel hub lock nut.
- Be sure to use torque wrench to tighten the wheel hub lock nut. Never use a power tool.
- Never reuse wheel hub lock nut.

NOTE:

Wheel hub lock nut tightening torque does not over torque for avoiding axle noise, and does not less than torque for avoiding looseness.

- Align the matching marks that have been made during removal when reusing the disc rotor.
- When installing a cotter pin (1) and adjusting cap (2), securely bend the basal portion to prevent rattles.

CAUTION:

Never reuse cotter pin.

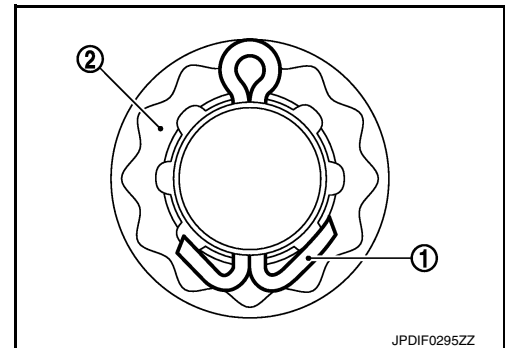

- Perform the final tightening of each of parts under unladen conditions, which were removed when removing wheel hub assembly and steering knuckle.
- Perform inspection after installation. Refer to [FAX-56. "AWD : Inspection"](#).

FRONT DRIVE SHAFT

< REMOVAL AND INSTALLATION >

[TYPE 1]

AWD : Disassembly and Assembly

INFOID:000000012201539

DISASSEMBLY

Wheel Side

1. Fix shaft with a vise.
CAUTION:
Protect shaft using aluminum or copper plates when fixing with a vise.

2. Remove boot bands, and then remove boot from joint sub-assembly.
3. Screw drive shaft puller (A) (commercial service tool) into joint sub-assembly screw part to a length of 30 mm (1.18 in) or more. Support drive shaft with one hand and pull out joint sub-assembly from shaft.

CAUTION:

- Align drive shaft puller and drive shaft and remove them by pulling firmly and uniformly.
- If joint sub-assembly cannot be removed after five or more unsuccessful attempts, replace shaft and joint sub-assembly as a set.

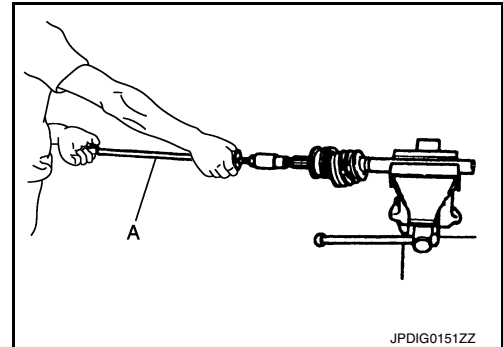

4. Remove circular clip from shaft.
5. Remove boot from shaft.

Transaxle Side (Left Drive Shaft)

1. Fix shaft with a vise.
CAUTION:
Protect shaft using aluminum or copper plates when fixing with a vise.
2. Remove wheel side boot from joint sub-assembly. Refer to [FAX-22, "AWD : Removal and Installation"](#).
3. Remove dynamic damper as per the following instructions:
 - a. Remove damper band.
 - b. Remove dynamic damper from housing assembly.
4. Remove boot bands, then remove boot from housing assembly.
5. Remove circular clip from housing assembly.
6. Remove dust shield from housing assembly.

Transaxle Side (Right Drive Shaft)

1. Fix shaft with a vise.
CAUTION:
Protect shaft using aluminum or copper plates when fixing with a vise.
2. Remove wheel side boot from joint sub-assembly. Refer to [FAX-22, "AWD : Removal and Installation"](#).
3. Remove dynamic damper as per the following instructions:
 - a. Remove damper band.
 - b. Remove dynamic damper from housing assembly.
4. Remove boot bands, then remove boot from housing assembly.

ASSEMBLY

Wheel Side

1. Clean the old grease on joint sub-assembly with paper waste.

FRONT DRIVE SHAFT

< REMOVAL AND INSTALLATION >

[TYPE 1]

- Fill serration slot joint sub-assembly (1) with NISSAN genuine grease or equivalent until the serration slot and ball groove become full to the brim.

CAUTION:

After applying grease, use a paper waste to wipe off old grease that has oozed out.

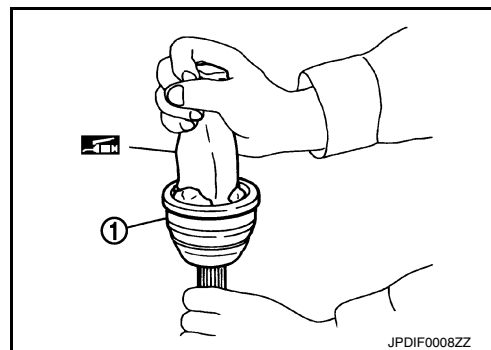

- Install boot and boot bands to shaft.

CAUTION:

- Wrap serration on shaft with tape (A) to protect the boot from damage.
- Never reuse boot and boot band.

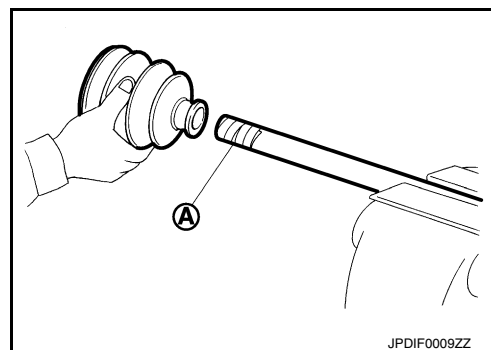

- Remove the tape wrapped around the serration on shaft.

- Position the circular clip (1) on groove at the shaft edge.

CAUTION:

Never reuse circular clip.

NOTE:

Drive joint inserter is recommended when installing circular clip.

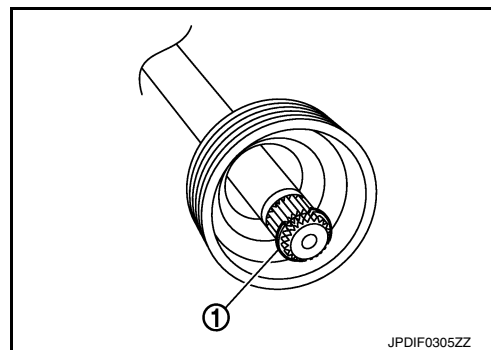

- Align both center axes of the shaft edge and joint sub-assembly. Then assemble shaft with joint sub-assembly holding circular clip.

- Install joint sub-assembly to shaft using plastic hammer.

CAUTION:

- Check circular clip is properly positioned on groove of the joint sub-assembly.
- Confirm that joint sub-assembly is correctly engaged while rotating drive shaft.

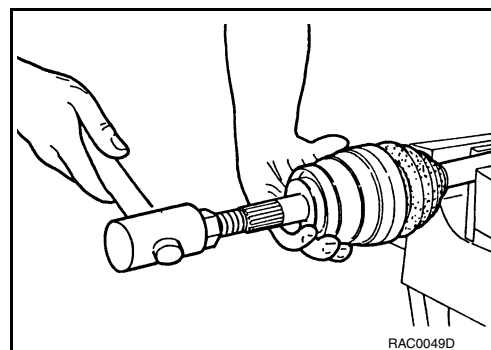

- Apply the specified amount of grease into the boot inside from large diameter side of boot.

Grease amount : Refer to [FAX-57, "Drive Shaft"](#).

- Install the boot securely into grooves (indicated by "*" marks) shown in the figure.

FRONT DRIVE SHAFT

< REMOVAL AND INSTALLATION >

[TYPE 1]

- a. For NISMO RS models.

CAUTION:

If grease adheres to the boot mounting surface (indicated by “*” marks) on the shaft or joint sub-assembly, boot may be removed. Remove all grease from the boot mounting surface.

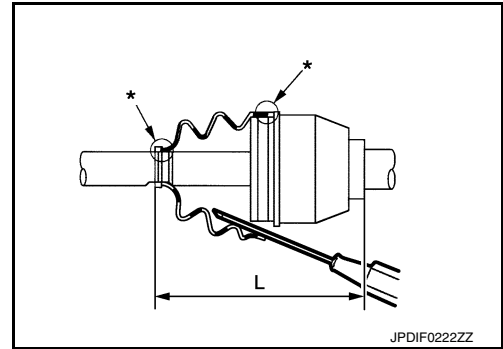

- b. Except for NISMO RS models.

CAUTION:

If grease adheres to the boot mounting surface (indicated by “*” marks) on the shaft or joint sub-assembly, boot may be removed. Remove all grease from the boot mounting surface.

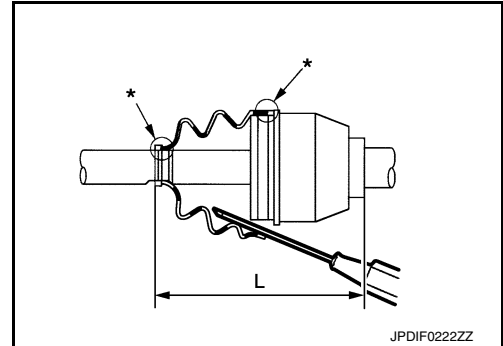

10. To prevent the deformation of the boot, adjust the boot installation length (L) to the specified value shown below by inserting the suitable tool into inside of the boot from the large diameter side of the boot and discharging the inside air.

L : Refer to [FAX-57, "Drive Shaft"](#).

CAUTION:

- If the boot installation length exceeds the standard, it may cause breakage of the boot.
- Be careful not to touch the inside of the boot with a tip of tool.

11. Secure the large and small ends of the boot with boot bands using the boot band crimping tool (A) [SST:KV40107300 (—)].

CAUTION:

- Never reuse boot band.

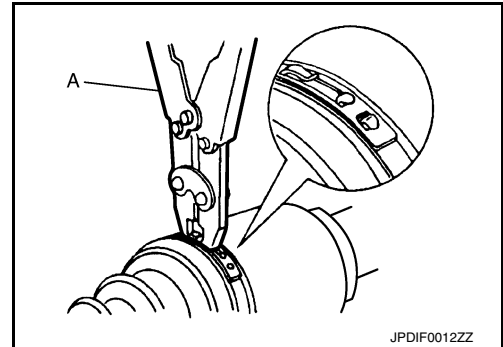

- Secure boot band so that dimension (M) meets the specification as shown in the figure.

Dimension (M) : 2.0 – 3.0 mm (0.079 – 0.118 in)

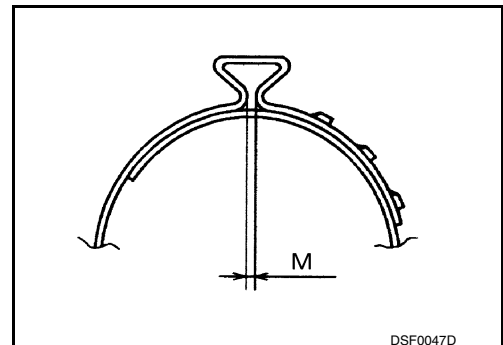

12. Check that displacement does not occur when boot is rotated with the joint sub-assembly and shaft fixed.

CAUTION:

- Reinstall them using boot bands when boot installation positions become incorrect.

A
B
C
FAX
E
F
G
H
I
J
K
L
M
N
O
P

FRONT DRIVE SHAFT

[TYPE 1]

< REMOVAL AND INSTALLATION >

- **Never reuse boot band.**

Transaxle Side (Left Drive Shaft)

1. Clean the old grease on housing assembly with paper waste.
2. Install dust shield to housing assembly.

CAUTION:

Never reuse dust shield.

3. Install circular clip to housing.

CAUTION:

Never reuse circular clip.

4. Install boot and boot bands to housing assembly.

CAUTION:

- **Wrap serration on housing assembly with tape (A) to protect the boot from damage.**
- **Never reuse boot and boot band.**

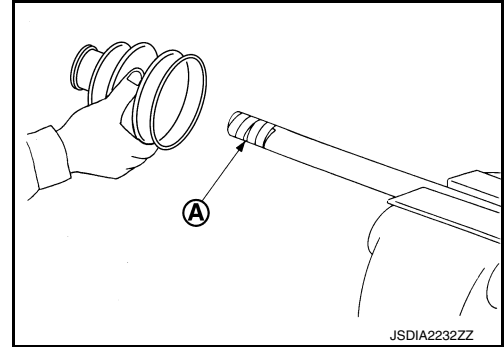

5. Remove the tape wrapped around the serration on shaft.
6. Apply NISSAN genuine grease (refer to parts catalog) to housing assembly.

Grease amount : Refer to [FAX-57, "Drive Shaft"](#).

7. Install the boot securely into grooves (indicated by "*" marks) shown in the figure.

- a. For NISMO RS models.

CAUTION:

If grease adheres to the boot mounting surface (indicated by "*" marks) on the shaft or housing assembly, boot may be removed. Remove all grease from the boot mounting surface.

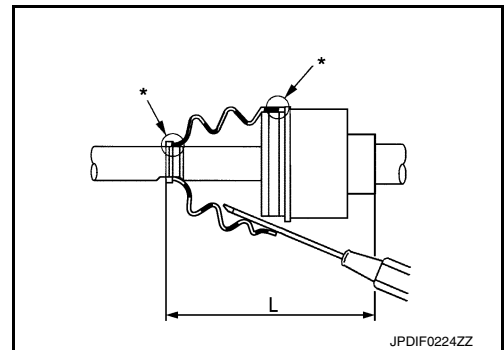

- b. Except for NISMO RS models.

CAUTION:

If grease adheres to the boot mounting surface (indicated by "*" marks) on the shaft or housing assembly, boot may be removed. Remove all grease from the boot mounting surface.

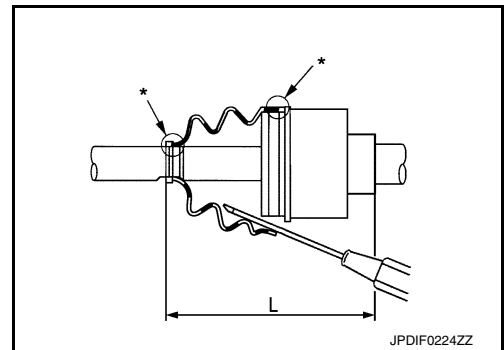

8. To prevent the deformation of the boot, adjust the boot installation length to the value shown below (L) by inserting the suitable tool into the inside of boot from the large diameter side of boot and discharging inside air.

L : Refer to [FAX-57, "Drive Shaft"](#).

FRONT DRIVE SHAFT

< REMOVAL AND INSTALLATION >

[TYPE 1]

CAUTION:

- If the boot installation length exceeds the standard, it may cause breakage of the boot.
- Be careful not to touch the inside of the boot with the tip of tool.

9. Install boot bands securely.

CAUTION:

Never reuse boot bands.

a. Put boot band in the groove on drive shaft boot. Then fit pawls (←) into holes to temporary installation.

NOTE:

For the large diameter side, fit projection (A) and guide slit (B) at first.

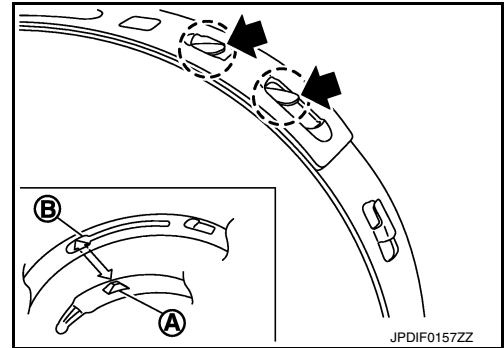

b. Pinch projection on the band with suitable pliers to tighten band.
c. Insert the tip of band into the lower part of pawl (marked with dotted circle) as shown in the figure.

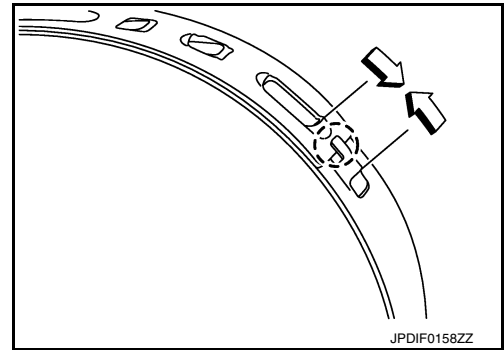

10. Check that displacement does not occur when boot is rotated with the housing assembly fixed.

CAUTION:

- If displacement occurs, reinstall band.
- Never reuse boot band.

11. Install dynamic damper, follow the procedure described below.

a. Install dynamic damper to shaft.

b. Secure dynamic damper with bands in the following specified position (A) when installing.

CAUTION:

Never reuse boot bands.

A : Refer to [FAX-57, "Drive Shaft"](#).

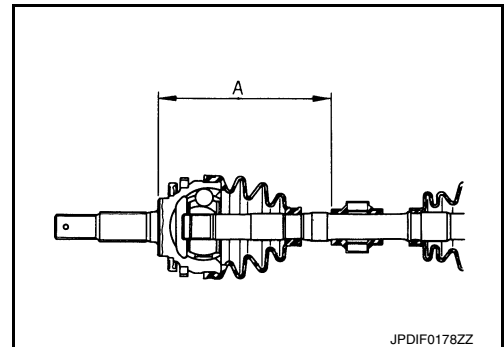

FRONT DRIVE SHAFT

< REMOVAL AND INSTALLATION >

[TYPE 1]

c. Install boot bands securely as shown in the figure.

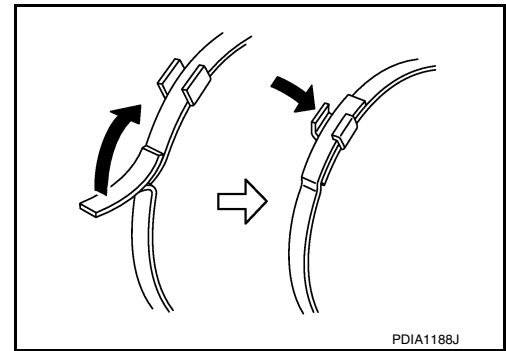

12. Install boot to the wheel side. Refer to [FAX-22. "AWD : Removal and Installation"](#).

Transaxle Side (Right Drive Shaft)

1. Clean the old grease on housing assembly with paper waste.
2. Install boot and boot bands to housing assembly.

CAUTION:

- Wrap serration on housing assembly with tape (A) to protect the boot from damage.
- Never reuse boot and boot band.

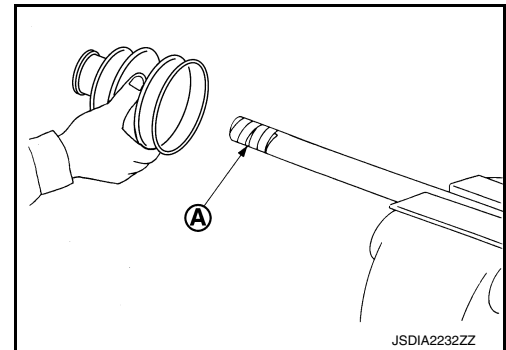

3. Remove the tape wrapped around the serration on shaft.
4. Apply NISSAN genuine grease (refer to parts catalog) to housing assembly.

Grease amount : Refer to [FAX-57. "Drive Shaft"](#).

5. Install the boot securely into grooves (indicated by "*" marks) shown in the figure.

a. For NISMO RS models

CAUTION:

If grease adheres to the boot mounting surface (indicated by "*" marks) on the shaft or housing assembly, boot may be removed. Remove all grease from the boot mounting surface.

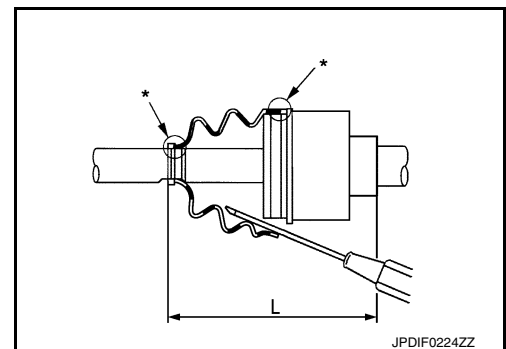

b. Except for NISMO RS models

CAUTION:

If grease adheres to the boot mounting surface (indicated by "*" marks) on the shaft or housing assembly, boot may be removed. Remove all grease from the boot mounting surface.

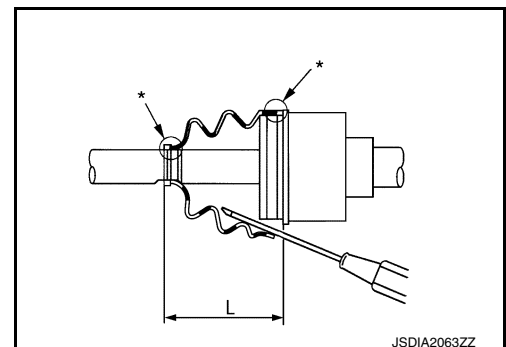

FRONT DRIVE SHAFT

< REMOVAL AND INSTALLATION >

[TYPE 1]

6. To prevent the deformation of the boot, adjust the boot installation length to the value shown below (L) by inserting the suitable tool into the inside of boot from the large diameter side of boot and discharging inside air.

L : Refer to [FAX-57, "Drive Shaft"](#).

CAUTION:

- If the boot installation length exceeds the standard, it may cause breakage of the boot.
- Be careful not to touch the inside of the boot with the tip of tool.

7. Install boot bands securely.

CAUTION:

Never reuse boot bands.

- a. Put boot band in the groove on drive shaft boot. Then fit pawls (←) into holes to temporary installation.

NOTE:

For the large diameter side, fit projection (A) and guide slit (B) at first.

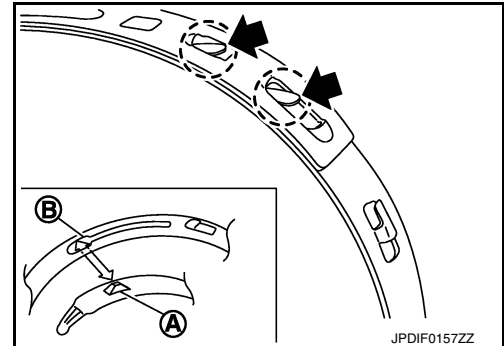

- b. Pinch projection on the band with suitable pliers to tighten band.
c. Insert the tip of band into the lower part of pawl (marked with dotted circle) as shown in the figure.

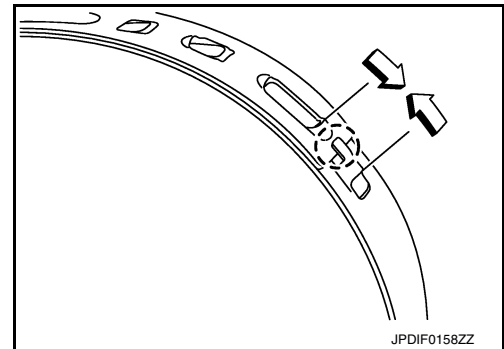

8. Check that displacement does not occur when boot is rotated with the housing assembly fixed.

CAUTION:

- If displacement occurs, reinstall band.
- Never reuse boot band.

9. Install dynamic damper, follow the procedure described below.

- a. Install dynamic damper to shaft.
b. Secure dynamic damper with bands in the following specified position (A) when installing.

CAUTION:

Never reuse bands.

A : Refer to [FAX-57, "Drive Shaft"](#).

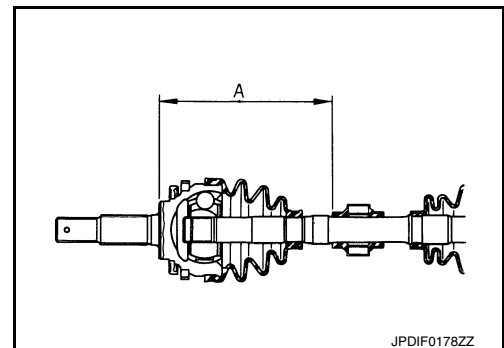

FRONT DRIVE SHAFT

< REMOVAL AND INSTALLATION >

[TYPE 1]

c. Install boot bands securely as shown in the figure.

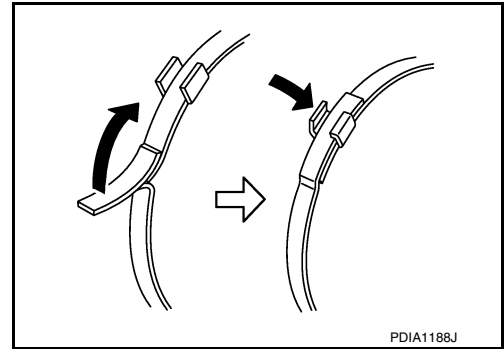

10. Install boot to the wheel side. Refer to [FAX-22. "AWD : Removal and Installation"](#).

AWD : Inspection

INFOID:000000012201540

INSPECTION AFTER INSTALLATION

1. Check wheel sensor harness for proper connection. Refer to [BRC-147. "FRONT WHEEL SENSOR : Exploded View"](#).
2. Check the wheel alignment. Refer to [FSU-7. "Inspection"](#).
3. Adjust neutral position of steering angle sensor. Refer to [BRC-63. "Work Procedure"](#).

SERVICE DATA AND SPECIFICATIONS (SDS)

< SERVICE DATA AND SPECIFICATIONS (SDS)

[TYPE 1]

SERVICE DATA AND SPECIFICATIONS (SDS)

SERVICE DATA AND SPECIFICATIONS (SDS)

Wheel Bearing

INFOID:0000000012201541

Item	Standard
Axial end play	0.05 mm (0.002 in) or less

Drive Shaft

INFOID:0000000012201542

2WD (Except for NISMO RS models)

Item		Standard	
		Left side	Right side
Grease quantity	Wheel side	115 – 125 g (4.05 – 4.40 oz)	
	Transaxle side	132 – 142 g (4.65 – 5.00 oz)	
Boots installed length*	Wheel side	97.1 mm (3.82 in)	
	Transaxle side	85.0 mm (3.35 in)	
Dimension of dynamic damper*		267 – 273 mm (10.51 – 10.75 in)	257 – 263 mm (10.12 – 10.35 in)

*: For measuring position, refer to [FAX-32, "2WD : Disassembly and Assembly"](#).

2WD (For NISMO RS models)

Item		Standard	
		Left side	Right side
Grease quantity	Wheel side	115 – 135 g (4.06 – 4.76 oz)	
	Transaxle side	215 – 235 g (7.58 – 8.28 oz)	
Boots installed length*	Wheel side	133.5 mm (5.26 in)	
	Transaxle side	185.1mm (6.34 in)	173.1mm (6.81 in)
Dimension of dynamic damper*		249 – 255 mm (9.80 – 10.04 in)	252 – 258 mm (9.92 – 10.16 in)

*: For measuring position, refer to [FAX-32, "2WD : Disassembly and Assembly"](#).

AWD

Item		Standard	
		Left side	Right side
Grease quantity	Wheel side	88 – 108 g (3.01 – 3.80 oz)	
	Transaxle side	114 – 124 g (4.02 – 4.37 oz)	
Boots installed length*	Wheel side	95.4 mm (3.75 in)	
	Transaxle side	93.2 mm (3.66 in)	
Dimension of dynamic damper*		267 – 273 mm (10.51 – 10.75 in)	

*: For measuring position, refer to [FAX-32, "2WD : Disassembly and Assembly"](#).

HOW TO USE THIS SECTION

< HOW TO USE THIS MANUAL >

[TYPE 2]

HOW TO USE THIS MANUAL

HOW TO USE THIS SECTION

Information

INFOID:0000000012990169

Service information	Model information
TYPE 1	For NISMO models
TYPE 2	Except for NISMO models

PRECAUTION

PRECAUTIONS

Precaution for Supplemental Restraint System (SRS) "AIR BAG" and "SEAT BELT PRE-TENSIONER"

INFOID:000000012201516

The Supplemental Restraint System such as "AIR BAG" and "SEAT BELT PRE-TENSIONER", used along with a front seat belt, helps to reduce the risk or severity of injury to the driver and front passenger for certain types of collision. This system includes seat belt switch inputs and dual stage front air bag modules. The SRS system uses the seat belt switches to determine the front air bag deployment, and may only deploy one front air bag, depending on the severity of a collision and whether the front occupants are belted or unbelted. Information necessary to service the system safely is included in the "SRS AIR BAG" and "SEAT BELT" of this Service Manual.

WARNING:

Always observe the following items for preventing accidental activation.

- To avoid rendering the SRS inoperative, which could increase the risk of personal injury or death in the event of a collision that would result in air bag inflation, it is recommended that all maintenance and repair be performed by an authorized NISSAN/INFINITI dealer.
- Improper repair, including incorrect removal and installation of the SRS, can lead to personal injury caused by unintentional activation of the system. For removal of Spiral Cable and Air Bag Module, see "SRS AIR BAG".
- Never use electrical test equipment on any circuit related to the SRS unless instructed to in this Service Manual. SRS wiring harnesses can be identified by yellow and/or orange harnesses or harness connectors.

PRECAUTIONS WHEN USING POWER TOOLS (AIR OR ELECTRIC) AND HAMMERS

WARNING:

Always observe the following items for preventing accidental activation.

- When working near the Air Bag Diagnosis Sensor Unit or other Air Bag System sensors with the ignition ON or engine running, never use air or electric power tools or strike near the sensor(s) with a hammer. Heavy vibration could activate the sensor(s) and deploy the air bag(s), possibly causing serious injury.
- When using air or electric power tools or hammers, always switch the ignition OFF, disconnect the battery or batteries, and wait at least 3 minutes before performing any service.

Precautions for Drive Shaft

INFOID:000000012201517

- Observe the following precautions when disassembling and assembling drive shaft.
 - Never disassemble joint sub-assembly because it is non-overhaul parts.
 - Perform work in a location which is as dust-free as possible.
 - Clean the parts, before disassembling and assembling.
 - Prevent the entry of foreign objects during disassembly of the service location.
 - Reassemble disassembled parts carefully in the correct order. If work is interrupted, a clean cover must be placed over parts.
 - Use paper waste. Fabric shop cloths must not be used because of the danger of lint adhering to parts.
 - Clean disassembled parts (except for rubber parts) with kerosene which shall be removed by blowing with air or wiping with paper waste.

Precautions for Removing Battery Terminal

INFOID:000000012833639

When disconnecting the battery terminal, pay attention to the following.

- Always use a 12V battery as power source.
- Never disconnect battery terminal while engine is running.

A
B
C
FAX
E
F
G
H
I
J
K
L
M
N
O
P

PRECAUTIONS

[TYPE 2]

< PRECAUTION >

- When removing the 12V battery terminal, turn OFF the ignition switch and wait at least 30 seconds.
- For vehicles with the engine listed below, remove the battery terminal after a lapse of the specified time:

D4D engine	: 20 minutes	YS23DDT	: 4 minutes
HRA2DDT	: 12 minutes	YS23DDTT	: 4 minutes
K9K engine	: 4 minutes	ZD30DDTi	: 60 seconds
M9R engine	: 4 minutes	ZD30DDTT	: 60 seconds
R9M engine	: 4 minutes		
V9X engine	: 4 minutes		
YD25DDTi	: 2 minutes		

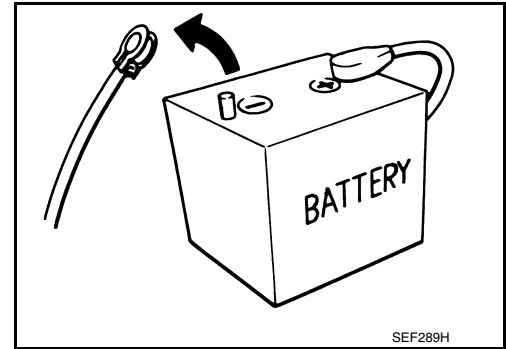

NOTE:

ECU may be active for several tens of seconds after the ignition switch is turned OFF. If the battery terminal is removed before ECU stops, then a DTC detection error or ECU data corruption may occur.

- After high-load driving, if the vehicle is equipped with the V9X engine, turn the ignition switch OFF and wait for at least 15 minutes to remove the battery terminal.

NOTE:

- Turbocharger cooling pump may operate in a few minutes after the ignition switch is turned OFF.
- Example of high-load driving
 - Driving for 30 minutes or more at 140 km/h (86 MPH) or more.
 - Driving for 30 minutes or more on a steep slope.
- For vehicles with the 2-batteries, be sure to connect the main battery and the sub battery before turning ON the ignition switch.

NOTE:

If the ignition switch is turned ON with any one of the terminals of main battery and sub battery disconnected, then DTC may be detected.

- After installing the 12V battery, always check "Self Diagnosis Result" of all ECUs and erase DTC.

NOTE:

The removal of 12V battery may cause a DTC detection error.

PREPARATION

< PREPARATION >

[TYPE 2]

PREPARATION

PREPARATION

Special Service Tool

INFOID:0000000012201546

The actual shapes of TechMate tools may differ from those of special service tools illustrated here.

Tool number (TechMate No.) Tool name	Description
KV40104000 (—) Hub lock nut wrench a: 85 mm (3.35 in) b: 65 mm (2.56 in)	Removing and Installing wheel hub lock nut.
KV40107300 (—) Boot band crimping tool	Installing boot band
KV40107500 (—) Drive shaft attachment	Removing drive shaft
KV38107900 (—) Protector a: 32 mm (1.26 in) dia.	Installing drive shaft

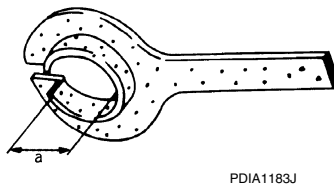
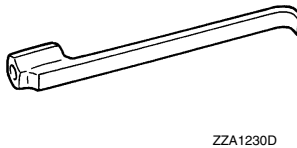
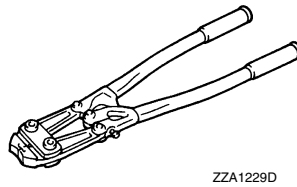
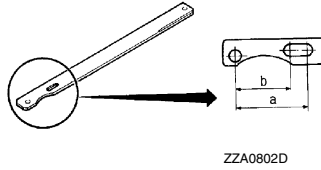

A
B
C
FAX
E
F
G
H
I
J
K
L
M
N
O
P

PREPARATION

< PREPARATION >

[TYPE 2]

Commercial Service Tools

INFOID:000000012201547

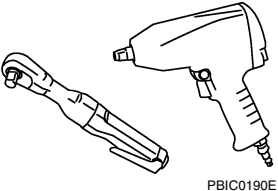
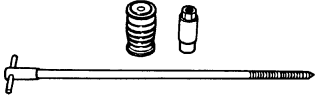
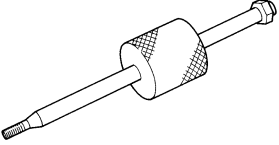
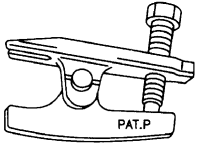
Tool name	Description
<p>Power tool</p>  <p>PBI0190E</p>	<p>Loosening bolts and nuts</p>
<p>Drive shaft puller</p>  <p>JPDIG0152ZZ</p>	<p>Removing drive shaft joint sub assembly</p>
<p>Sliding hammer</p>  <p>ZZA0023D</p>	<p>Removing drive shaft</p>
<p>Ball joint remover</p>  <p>PAT.P</p> <p>NT146</p>	<p>Removing hub bolt</p>

NOISE, VIBRATION AND HARSHNESS (NVH) TROUBLESHOOTING

< SYMPTOM DIAGNOSIS >

[TYPE 2]

SYMPTOM DIAGNOSIS

NOISE, VIBRATION AND HARSHNESS (NVH) TROUBLESHOOTING

NVH Troubleshooting Chart

INFOID:000000012201548

Use chart below to find the cause of the symptom. If necessary, repair or replace these parts.

Reference			—	FAX-96 (2WD), FAX-108 (AWD)	—	FAX-66	—	FAX-68	NVH in FAX and FSU sections	Refer to FRONT AXLE in this chart	NVH in WT section	NVH in WT section	Refer to DRIVE SHAFT in this chart	NVH in BR section	NVH in ST section	
Possible cause and SUSPECTED PARTS			Excessive joint angle	Joint sliding resistance	Imbalance	Improper installation, looseness	Parts interference	Wheel bearing damage	FRONT AXLE AND FRONT SUSPENSION	FRONT AXLE	TIRE	ROAD WHEEL	DRIVE SHAFT	BRAKE	STEERING	
Symptom	DRIVE SHAFT	Noise	x	x				x	x	x	x	x		x	x	
		Shake	x		x			x	x	x	x	x		x	x	
	FRONT AXLE	Noise				x	x	x	x		x	x	x	x	x	x
		Shake				x	x	x	x		x	x	x	x	x	x
		Vibration				x	x	x	x		x		x		x	
		Shimmy				x	x		x		x	x		x	x	x
		Judder				x			x		x	x		x	x	x
		Poor quality ride or handling				x	x		x		x	x				

x: Applicable

A
B
C
D
E
F
G
H
I
J
K
L
M
N
O
P

FAX

PERIODIC MAINTENANCE

FRONT WHEEL HUB AND KNUCKLE

Inspection

INFOID:000000012201549

COMPONENT PART

Check that the mounting conditions (looseness, backlash) of each component and component conditions (wear, damage) are normal.

WHEEL HUB ASSEMBLY (BEARING-INTEGRATED TYPE)

Check the following items, and replace the part if necessary.

- Move wheel hub assembly in the axial direction by hand. Check there is no looseness of wheel bearing.

Axial end play : Refer to [FAX-109, "Wheel Bearing"](#).

- Rotate wheel hub assembly and check there is no unusual noise or other irregular conditions. If there is any of irregular conditions, replace wheel hub assembly.

FRONT DRIVE SHAFT

< PERIODIC MAINTENANCE >

[TYPE 2]

FRONT DRIVE SHAFT

Inspection

INFOID:000000012201550

Check the following items, and replace the part if necessary.

- Check drive shaft mounting point and joint for looseness and other damage.

CAUTION:

Replace entire drive shaft assembly when noise or vibration occurs from drive shaft.

- Check boot for cracks and other damage.

A

B

C

FAX

E

F

G

H

I

J

K

L

M

N

O

P

FRONT WHEEL HUB AND KNUCKLE

< REMOVAL AND INSTALLATION >

[TYPE 2]

REMOVAL AND INSTALLATION

FRONT WHEEL HUB AND KNUCKLE

Exploded View

INFOID:000000012201551

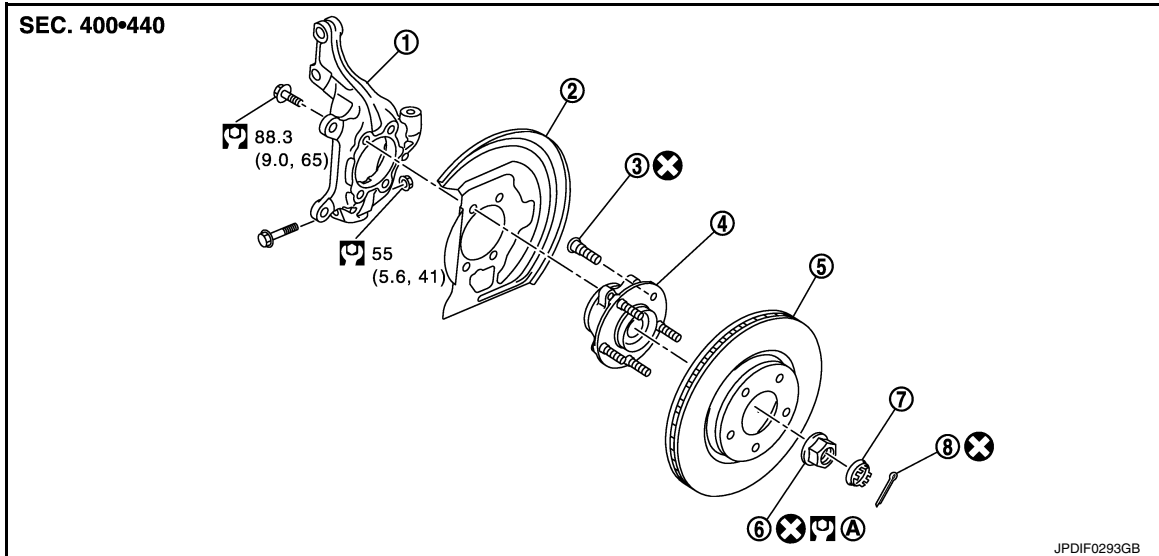

- | | | |
|---|-----------------|-----------------------|
| 1. Steering knuckle | 2. Splash guard | 3. Hub bolt |
| 4. Wheel hub assembly (Bearing-integrated type) | 5. Disc rotor | 6. Wheel hub lock nut |
| 7. Adjusting cap | 8. Cotter pin | |

A. Tightening must be done following the installation procedure. Refer to [FAX-66. "Removal and Installation"](#).

⊗: Always replace after every disassembly.

⊞: N·m (kg-m, ft-lb)

Removal and Installation

INFOID:000000012201552

REMOVAL

1. Remove tires with power tool. Refer to [WT-39. "Removal and Installation"](#).
2. Remove wheel sensor and sensor harness. Refer to [BRC-147. "FRONT WHEEL SENSOR : Exploded View"](#).
3. Remove lock plate from strut assembly. Refer to [BR-25. "FRONT : Removal and Installation"](#).
4. Remove caliper assembly. Hang caliper assembly not to interfere with work. Refer to [BR-55. "BRAKE CALIPER ASSEMBLY : Removal and Installation"](#).

CAUTION:

Never depress brake pedal while brake caliper is removed.

5. Remove disc rotor.

CAUTION:

FRONT WHEEL HUB AND KNUCKLE

< REMOVAL AND INSTALLATION >

[TYPE 2]

- Put matching marks (A) on the wheel hub assembly and the disc rotor before removing the disc rotor.
- Never drop disc rotor.

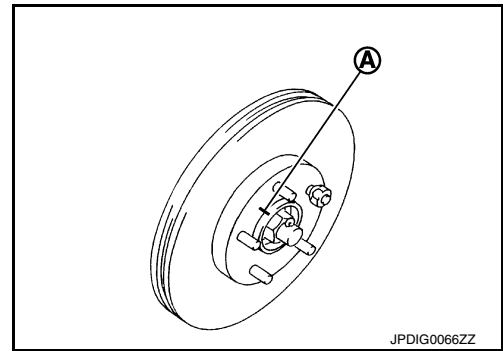

A
B
C

6. Remove cotter pin, and adjusting cap, and then loosen wheel hub lock nut with power tool.
7. Patch wheel hub lock nut with a piece of wood. Hammer the wood to disengage wheel hub assembly from drive shaft.

NOTE:

Use suitable puller, if wheel hub assembly and drive shaft cannot be separated even after performing the above procedure.

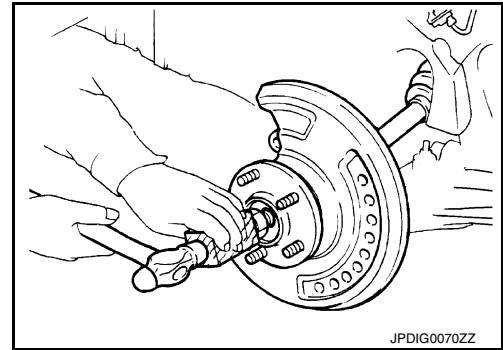

FAX

E
F
G

8. Remove wheel hub lock nut.
9. Remove steering outer socket from steering knuckle. Refer to [ST-17, "Removal and Installation"](#).
10. Remove strut assembly from steering knuckle. Refer to [FSU-9, "Removal and Installation"](#).
11. Suspend the drive shaft with suitable wire.

CAUTION:

- Never place drive shaft joint at an extreme angle. Also be careful not to overextend slide joint.
- Never allow drive shaft to hang down without support for joint sub-assembly, shaft and the other parts.

12. Remove steering knuckle from transverse link.
13. Remove wheel hub assembly and splash guard from steering knuckle.
14. Remove hub bolts (1) from wheel hub assembly, using the ball joint remover (A) (commercial service tool).

CAUTION:

- Remove hub bolt only when necessary.
- Never hammer the hub bolt to avoid impact to the wheel hub assembly.
- Pull out the hub bolt in a direction perpendicular to the wheel hub assembly.

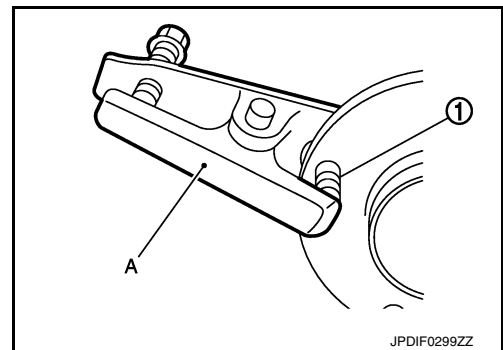

H
I
J

K
L
M

15. Perform inspection after removal. Refer to [FAX-68, "Inspection"](#).

INSTALLATION

Note the following, and install in the reverse order of the removal.

N
O
P

FRONT WHEEL HUB AND KNUCKLE

[TYPE 2]

< REMOVAL AND INSTALLATION >

- Place a washer (A) as shown in the figure to install the hub bolts (1) by using the tightening force of the nut (B).

CAUTION:

- Check that there is no clearance between wheel hub assembly, and hub bolt.
- Never reuse hub bolt.
- Never reuse steering knuckle and transverse link fixing nut.
- Clean the matching surface of wheel hub lock nut and wheel hub assembly.

CAUTION:

Never apply lubricating oil to these matching surface.

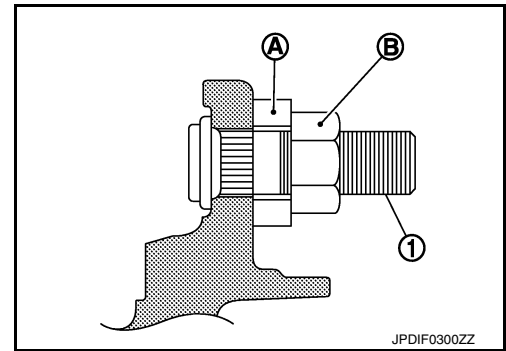

- Clean the matching surface of drive shaft, wheel hub assembly. And then apply paste [service parts (440037S000)] to surface (A) of joint sub-assembly of drive shaft.

CAUTION:

Apply paste to cover entire flat surface of joint sub-assembly of drive shaft.

Amount paste : 1.0 – 3.0 g (0.04 – 0.10 oz)

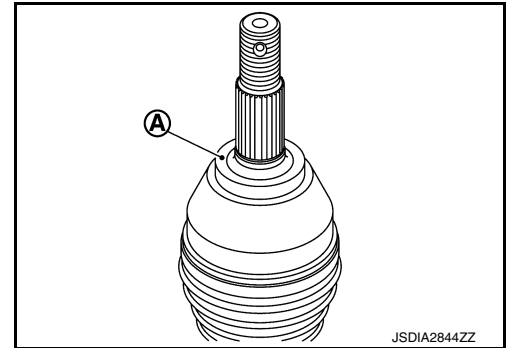

- Use the following torque range for tightening the wheel hub lock nut.

 : 180 – 185 N·m (18.4 – 18.8 kg-m, 133 – 136 ft-lb)

CAUTION:

- Since the drive shaft is assembled by press-fitting, use the tightening torque range for the wheel hub lock nut.
- Be sure to use torque wrench to tighten the wheel hub lock nut. Never use a power tool.
- Never reuse wheel hub lock nut.

NOTE:

Wheel hub lock nut tightening torque does not over torque for avoiding axle noise, and does not less than torque for avoiding looseness.

- Align the matching marks that have been made during removal when reusing the disc rotor.
- When installing a cotter pin (1) and adjusting cap (2), securely bend the basal portion to prevent rattles.

CAUTION:

Never reuse cotter pin.

- Perform the final tightening of each of parts under unladen conditions, which were removed when removing wheel hub assembly and steering knuckle.
- Perform inspection after installation. Refer to [FAX-68, "Inspection"](#).

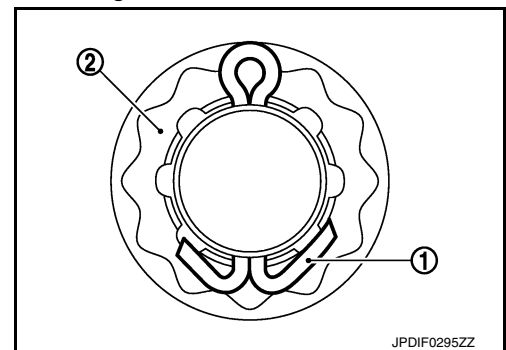

INFOID:000000012201553

Inspection

INSPECTION AFTER REMOVAL

Check the following items, and replace the part if necessary.

- Check components for deformation, cracks, and other damage.
- Check boots of transverse link and steering outer socket ball joint for breakage, axial end play, and swing torque. Refer to [FSU-13, "Inspection"](#) and [ST-19, "Inspection"](#).

INSPECTION AFTER INSTALLATION

FRONT WHEEL HUB AND KNUCKLE

[TYPE 2]

< REMOVAL AND INSTALLATION >

1. Check wheel sensor harness for proper connection. Refer to [BRC-147, "FRONT WHEEL SENSOR : Exploded View"](#).
2. Check the wheel alignment. Refer to [FSU-7, "Inspection"](#).
3. Adjust neutral position of steering angle sensor. Refer to [BRC-63, "Work Procedure"](#).

A

B

C

FAX

E

F

G

H

I

J

K

L

M

N

O

P

FRONT DRIVE SHAFT BOOT

< REMOVAL AND INSTALLATION >

[TYPE 2]

FRONT DRIVE SHAFT BOOT

2WD

2WD : Exploded View

INFOID:000000012201554

LEFT SIDE

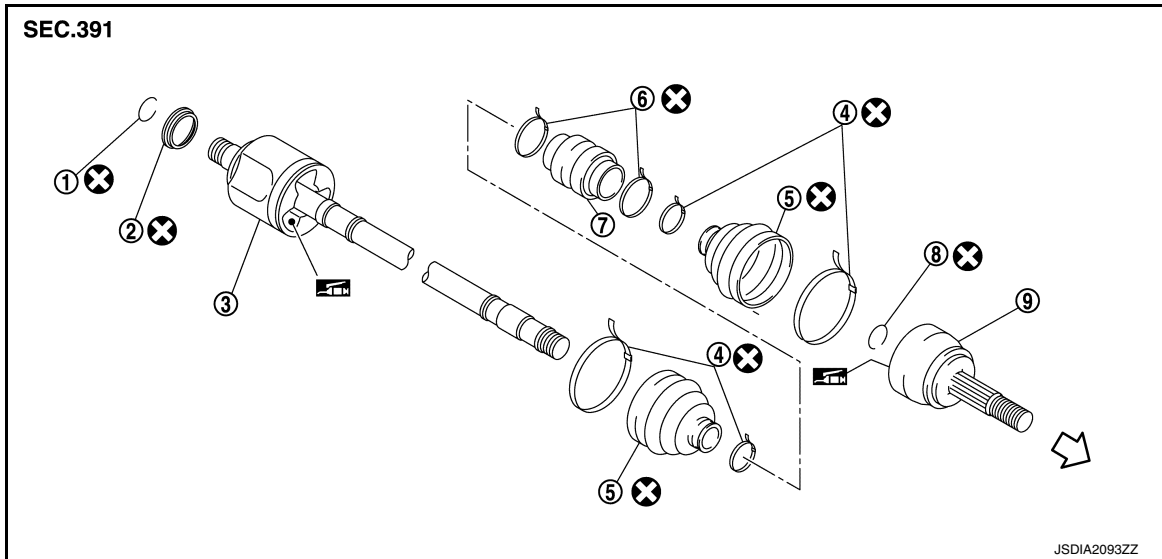

- | | | |
|-------------------|------------------|-----------------------|
| 1. Circular clip | 2. Dust shield | 3. Housing assembly |
| 4. Boot band | 5. Boot | 6. Damper band |
| 7. Dynamic damper | 8. Circular clip | 9. Joint sub-assembly |

← : Wheel side

: Fill NISSAN Genuine grease or equivalent.

: Always replace after every disassembly.

RIGHT SIDE

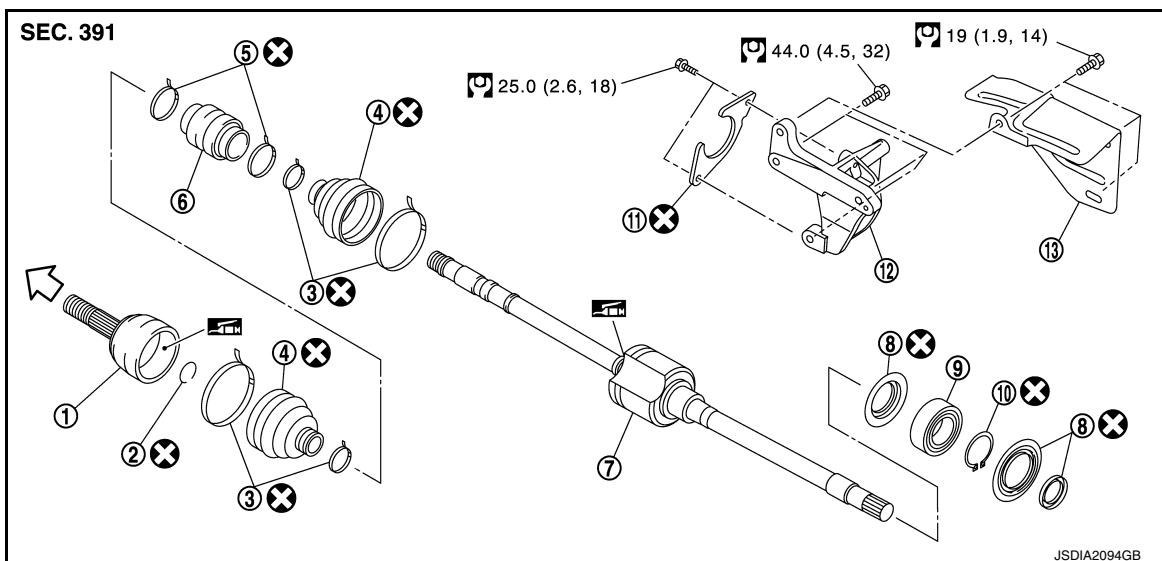

- | | | |
|-----------------------|------------------|-----------------------------|
| 1. Joint sub-assembly | 2. Circular clip | 3. Boot band |
| 4. Boot | 5. Damper band | 6. Dynamic damper |
| 7. Housing assembly | 8. Dust shield | 9. Support bearing |
| 10. Snap ring | 11. Plate | 12. Support bearing bracket |

FRONT DRIVE SHAFT BOOT

< REMOVAL AND INSTALLATION >

[TYPE 2]

13. Heat insulator

↩ : Wheel side

 : Fill NISSAN Genuine grease or equivalent.

 : Always replace after every disassembly.

 : N·m (kg-m, ft-lb)

2WD : Removal and Installation

INFOID:000000012201555

REMOVAL

Wheel Side

1. Remove tires with power tool. Refer to [WT-39, "Removal and Installation"](#).
2. Remove wheel sensor and sensor harness. Refer to [BRC-147, "FRONT WHEEL SENSOR : Exploded View"](#).
3. Remove lock plate from strut assembly. Refer to [BR-25, "FRONT : Removal and Installation"](#).
4. Remove caliper assembly. Hang caliper assembly not to interfere with work. Refer to [BR-55, "BRAKE CALIPER ASSEMBLY : Removal and Installation"](#).

CAUTION:

Never depress brake pedal while brake caliper is removed.

5. Remove disc rotor.

CAUTION:

- Put matching marks (A) on the wheel hub assembly and the disc rotor before removing the disc rotor.
- Never drop disc rotor.

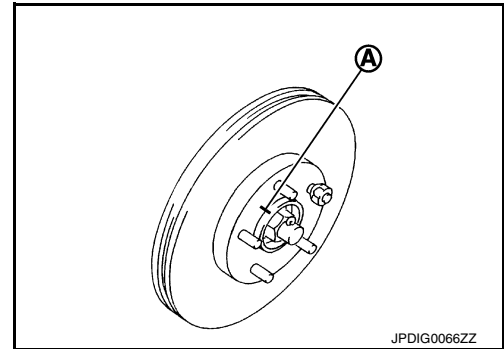

6. Remove cotter pin, and adjusting cap, and then loosen wheel hub lock nut with power tool.
7. Patch wheel hub lock nut with a piece of wood. Hammer the wood to disengage wheel hub assembly from drive shaft.

NOTE:

Use suitable puller, if wheel hub assembly and drive shaft cannot be separated even after performing the above procedure.

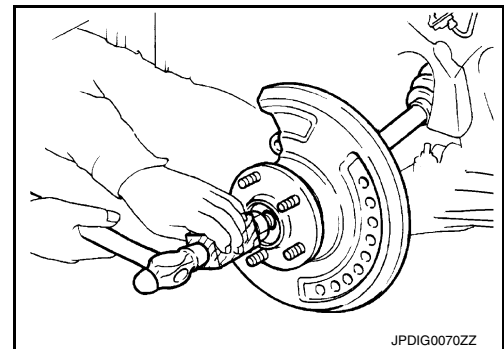

8. Remove wheel hub lock nut.
9. Remove strut assembly from steering knuckle. Refer to [FSU-9, "Removal and Installation"](#).
10. Remove drive shaft from wheel hub assembly.

CAUTION:

- Never place drive shaft joint at an extreme angle. Also be careful not to overextend slide joint.
- Never allow drive shaft to hang down without support for joint sub-assembly, shaft and the other parts.

11. Remove boot bands, and then remove boot from joint sub-assembly.

A
B
C
E
F
G
H
I
J
K
L
M
N
O
P

FAX

FRONT DRIVE SHAFT BOOT

[TYPE 2]

< REMOVAL AND INSTALLATION >

12. Screw drive shaft puller (A) (commercial service tool) into joint sub-assembly screw part to a length of 30 mm (1.18 in) or more. Support drive shaft with one hand and pull out joint sub-assembly from shaft.

CAUTION:

- Align drive shaft puller and drive shaft and remove them by pulling firmly and uniformly.
- If joint sub-assembly cannot be pulled out, try after removing drive shaft from vehicle. Refer to [FAX-83, "2WD : Removal and Installation"](#).

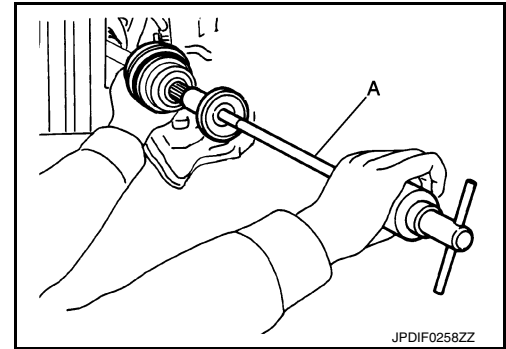

13. Remove circular clip (1) from shaft.
14. Remove boot from shaft.

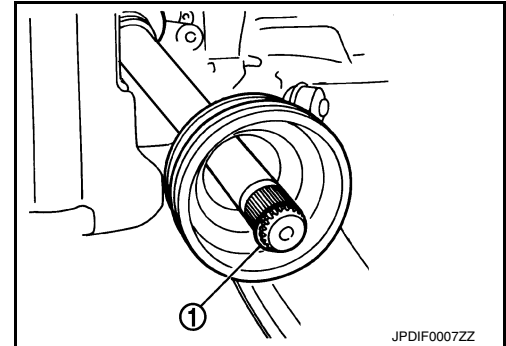

Transaxle Side

- Remove boot after removing drive shaft.
- Remove: Refer to [FAX-83, "2WD : Removal and Installation"](#).
- Disassembly: Refer to [FAX-87, "2WD : Disassembly and Assembly"](#).

INSTALLATION

Wheel Side

1. Clean the old grease on joint sub-assembly with paper waste.
2. Fill serration slot joint sub-assembly (1) with NISSAN genuine grease or equivalent until the serration slot and ball groove become full to the brim.

CAUTION:

After applying grease, use a paper waste to wipe off old grease that has oozed out.

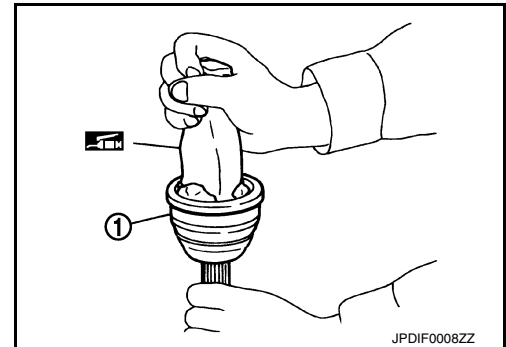

3. Install boot and boot bands to shaft.
CAUTION:
 - Wrap serration on shaft with tape to protect the boot from damage.
 - Never reuse boot and boot band.
4. Remove the tape wrapped around the serration on shaft.

FRONT DRIVE SHAFT BOOT

< REMOVAL AND INSTALLATION >

[TYPE 2]

5. Position the circular clip (1) on groove at the shaft edge.

CAUTION:

Never reuse circular clip.

NOTE:

Drive joint inserter is recommended when installing circular clip.

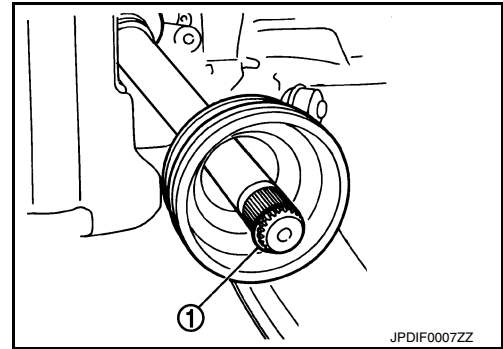

6. Align both center axes of the shaft edge and joint sub-assembly. Then assemble shaft with joint sub-assembly holding circular clip.

7. Install joint sub-assembly (1) to shaft using plastic hammer.

CAUTION:

- Check circular clip is properly positioned on groove of the joint sub-assembly.
- Confirm that joint sub-assembly is correctly engaged while rotating drive shaft.

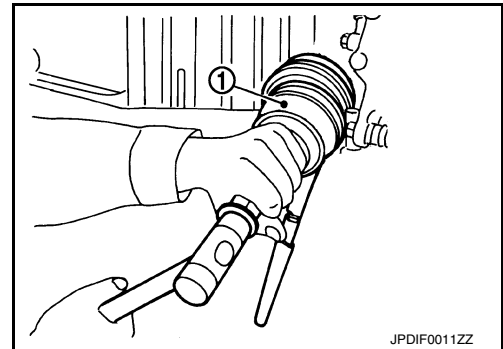

8. Apply the specified amount of grease into the boot inside from large diameter side of boot.

Grease amount : Refer to [FAX-109, "Drive Shaft"](#).

9. Install the boot securely into grooves (indicated by "*" marks) shown in the figure.

CAUTION:

If grease adheres to the boot mounting surface (indicated by "*" marks) on the shaft or joint sub-assembly, boot may be removed. Remove all grease from the boot mounting surface.

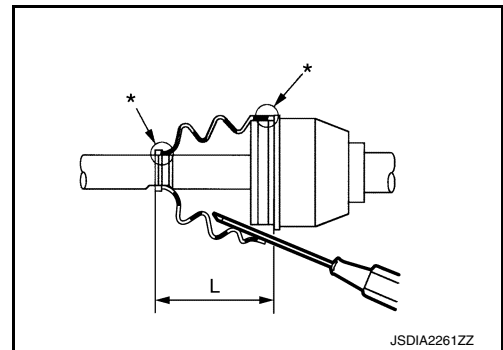

10. To prevent the deformation of the boot, adjust the boot installation length (L) to the specified value shown below by inserting the suitable tool into inside of the boot from the large diameter side of the boot and discharging the inside air.

L : Refer to [FAX-109, "Drive Shaft"](#).

CAUTION:

- If the boot installation length exceeds the standard, it may cause breakage of the boot.
- Be careful not to touch the inside of the boot with a tip of tool.

A
B
C
FAX
E
F
G
H
I
J
K
L
M
N
O
P

FRONT DRIVE SHAFT BOOT

< REMOVAL AND INSTALLATION >

[TYPE 2]

11. Secure the large and small ends of the boot with boot bands using the boot band crimping tool (A) [SST:KV40107300 (—)].

CAUTION:

- Never reuse boot band.

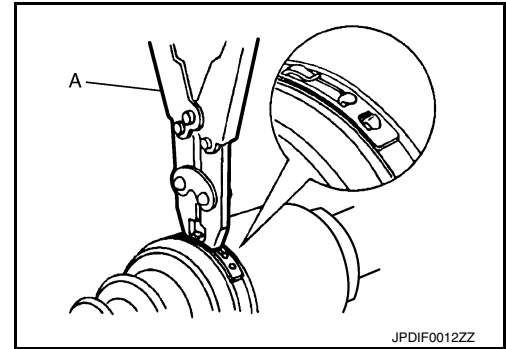

- Secure boot band so that dimension (M) meets the specification as shown in the figure.

Dimension (M) : 2.0 – 3.0 mm (0.079 – 0.118 in)

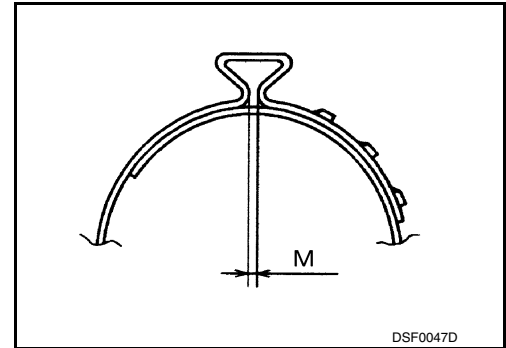

12. Check that displacement does not occur when boot is rotated with the joint sub-assembly and shaft fixed.

CAUTION:

- Reinstall them using boot bands when boot installation bands become incorrect.
- Never reuse boot band.

13. Clean the matching surface of wheel hub lock nut and wheel hub assembly.

CAUTION:

Never apply lubricating oil to these matching surface.

14. Clean the matching surface of drive shaft, wheel hub assembly. And then apply paste [service parts (440037S000)] to surface (A) of joint sub-assembly of drive shaft.

CAUTION:

Apply paste to cover entire flat surface of joint sub-assembly of drive shaft.

Amount paste : 1.0 – 3.0 g (0.04 – 0.10 oz)

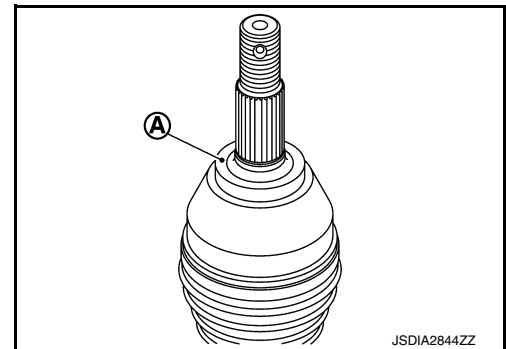

15. Insert drive shaft to wheel hub assembly, and then temporarily tighten wheel hub lock nut.

CAUTION:

- Be sure to use torque wrench to tighten the wheel hub lock nut. Never use a power tool.
- Never reuse wheel hub lock nut.

16. Install strut assembly to steering knuckle. Refer to [FSU-9, "Exploded View"](#).

17. Install disc rotor. Refer to [FAX-66, "Removal and Installation"](#).

18. Install caliper assembly to steering knuckle. Refer to [BR-55, "BRAKE CALIPER ASSEMBLY : Removal and Installation"](#).

19. Install lock plate to strut assembly. Refer to [BR-25, "FRONT : Removal and Installation"](#).

20. Install wheel sensor and sensor harness. Refer to [BRC-147, "FRONT WHEEL SENSOR : Exploded View"](#).

21. Use the following torque range for tightening the wheel hub lock nut.

 : 180 – 185 N·m (18.4 – 18.8 kg-m, 133 – 136 ft-lb)

FRONT DRIVE SHAFT BOOT

< REMOVAL AND INSTALLATION >

[TYPE 2]

CAUTION:

- Since the drive shaft is assembled by press-fitting, use the tightening torque range for the wheel hub lock nut.
- Be sure to use torque wrench to tighten the wheel hub lock nut. Never use a power tool.
- Never reuse wheel hub lock nut.

NOTE:

Wheel hub lock nut tightening torque does not over torque for avoiding axle noise, and does not less than torque for avoiding looseness.

22. When installing a cotter pin (1) and adjusting cap (2), securely bend the basal portion to prevent rattles.

CAUTION:

Never reuse cotter pin.

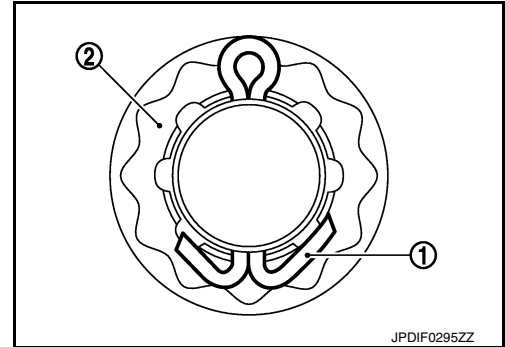

23. Install tires. Refer to [WT-39, "Exploded View"](#).

24. Perform inspection after installation. Refer to [FAX-75, "2WD : Inspection"](#).

Transaxle Side

- Install drive shaft to vehicle.
- Installation: Refer to [FAX-83, "2WD : Removal and Installation"](#).
- Assembly: Refer to [FAX-87, "2WD : Disassembly and Assembly"](#).

2WD : Inspection

INFOID:000000012201556

INSPECTION AFTER INSTALLATION

1. Check wheel sensor harness for proper connection. Refer to [BRC-147, "FRONT WHEEL SENSOR : Exploded View"](#).
2. Check the wheel alignment. Refer to [FSU-7, "Inspection"](#).
3. Adjust neutral position of steering angle sensor. Refer to [BRC-63, "Work Procedure"](#).

AWD

AWD : Exploded View

INFOID:000000012201557

LEFT SIDE

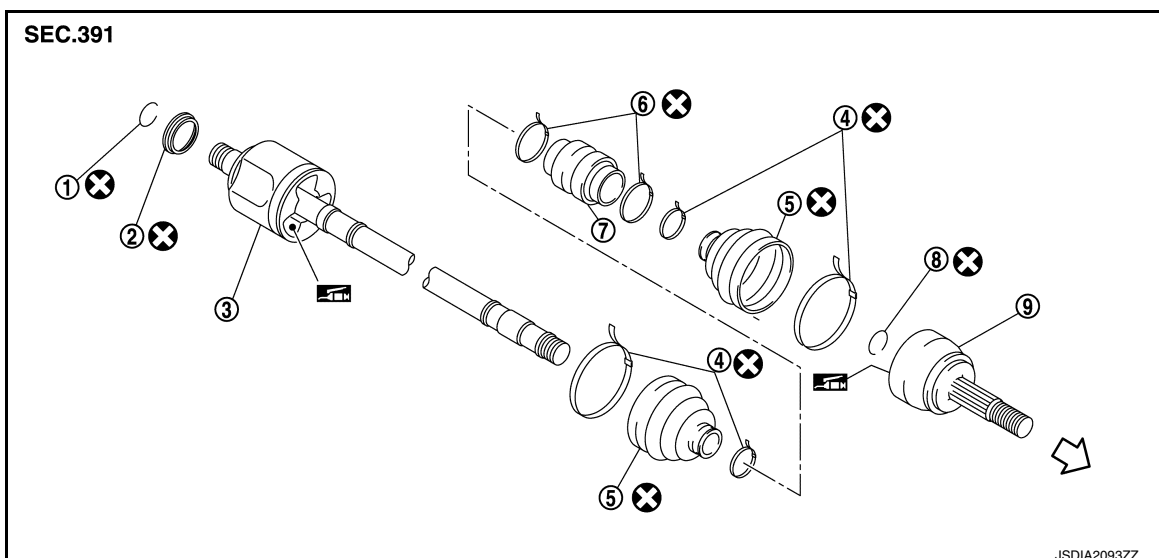

FRONT DRIVE SHAFT BOOT

< REMOVAL AND INSTALLATION >

[TYPE 2]

- | | | |
|-------------------|------------------|-----------------------|
| 1. Circular clip | 2. Dust shield | 3. Housing assembly |
| 4. Boot band | 5. Boot | 6. Damper band |
| 7. Dynamic damper | 8. Circular clip | 9. Joint sub-assembly |

↶ : Wheel side

 : Fill NISSAN Genuine grease or equivalent.

 : Always replace after every disassembly.

RIGHT SIDE

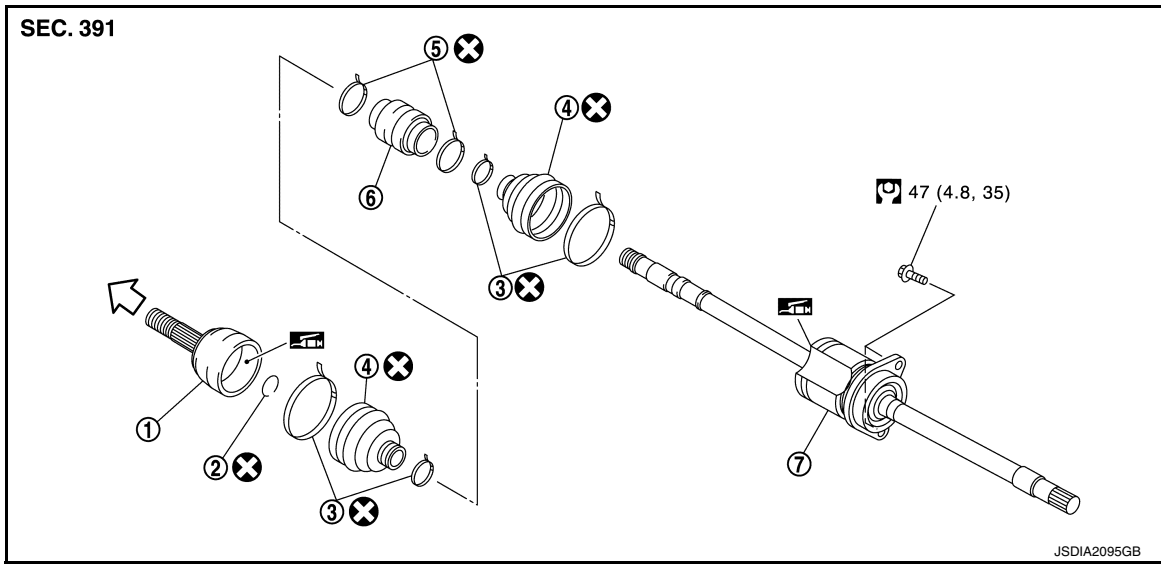

- | | | |
|-----------------------|------------------|-------------------|
| 1. Joint sub-assembly | 2. Circular clip | 3. Boot band |
| 4. Boot | 5. Damper band | 6. Dynamic damper |
| 7. Housing assembly | | |

↶ : Wheel side

 : Fill NISSAN Genuine grease or equivalent.

 : Always replace after every disassembly.

 : N·m (kg-m, ft-lb)

AWD : Removal and Installation

INFOID:000000012201558

REMOVAL

Wheel Side

1. Remove tires with power tool. Refer to [WT-39, "Removal and Installation"](#).
2. Remove wheel sensor and sensor harness. Refer to [BRC-147, "FRONT WHEEL SENSOR : Exploded View"](#).
3. Remove lock plate from strut assembly. Refer to [BR-25, "FRONT : Removal and Installation"](#).
4. Remove caliper assembly. Hang caliper assembly not to interfere with work. Refer to [BR-55, "BRAKE CALIPER ASSEMBLY : Removal and Installation"](#).

CAUTION:

Never depress brake pedal while brake caliper is removed.

5. Remove disc rotor.

CAUTION:

FRONT DRIVE SHAFT BOOT

< REMOVAL AND INSTALLATION >

[TYPE 2]

- Put matching marks (A) on the wheel hub assembly and the disc rotor before removing the disc rotor.
- Never drop disc rotor.

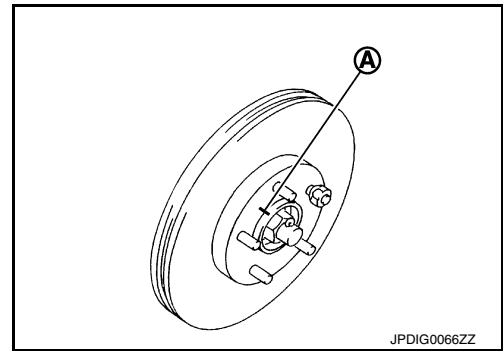

A
B
C

6. Remove cotter pin, and adjusting cap, and then loosen wheel hub lock nut with power tool.
7. Patch wheel hub lock nut with a piece of wood. Hammer the wood to disengage wheel hub assembly from drive shaft.

NOTE:

Use suitable puller, if wheel hub assembly and drive shaft cannot be separated even after performing the above procedure.

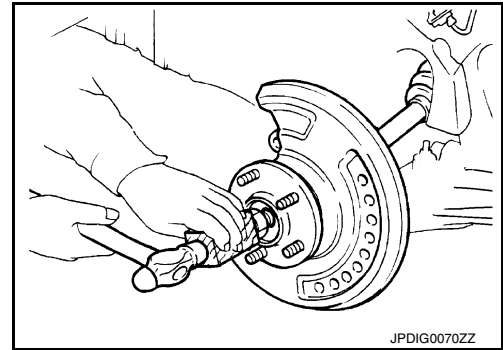

FAX

E
F
G

8. Remove wheel hub lock nut.
9. Remove strut assembly from steering knuckle. Refer to [FSU-9. "Removal and Installation"](#).
10. Remove drive shaft from wheel hub assembly.

CAUTION:

- Never place drive shaft joint at an extreme angle. Also be careful not to overextend slide joint.
- Never allow drive shaft to hang down without support for joint sub-assembly, shaft and the other parts.

H
I
J

11. Remove boot bands, and then remove boot from joint sub-assembly.
12. Screw drive shaft puller (A) (commercial service tool) into joint sub-assembly screw part to a length of 30 mm (1.18 in) or more. Support drive shaft with one hand and pull out joint sub-assembly from shaft.

CAUTION:

- Align drive shaft puller and drive shaft and remove them by pulling firmly and uniformly.
- If joint sub-assembly cannot be pulled out, try after removing drive shaft from vehicle. Refer to [FAX-97. "AWD : Removal and Installation"](#).

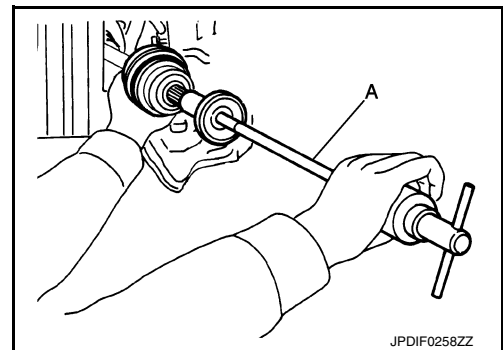

K
L
M

13. Remove circular clip (1) from shaft.
14. Remove boot from shaft.

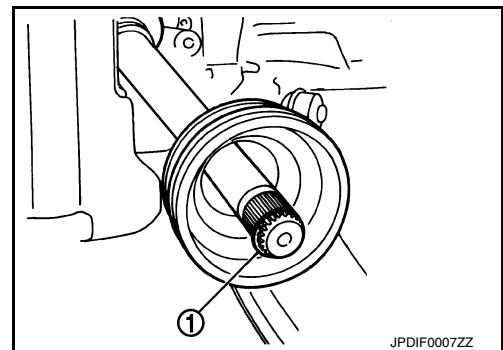

N
O
P

Transaxle Side

- Remove boot after removing drive shaft.

FRONT DRIVE SHAFT BOOT

[TYPE 2]

< REMOVAL AND INSTALLATION >

- Remove: Refer to [FAX-97, "AWD : Removal and Installation"](#).
- Disassembly: Refer to [FAX-101, "AWD : Disassembly and Assembly"](#).

INSTALLATION

Wheel Side

1. Clean the old grease on joint sub-assembly with paper waste.
2. Fill serration slot joint sub-assembly (1) with NISSAN genuine grease or equivalent until the serration slot and ball groove become full to the brim.

CAUTION:

After applying grease, use a paper waste to wipe off old grease that has oozed out.

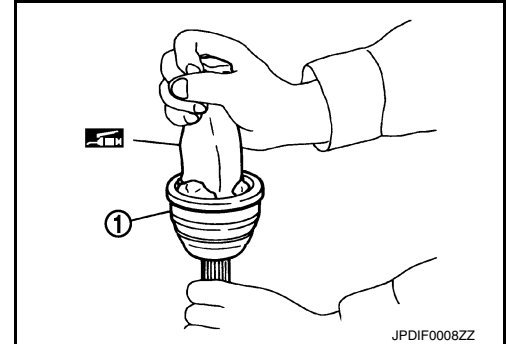

3. Install boot and boot bands to shaft.

CAUTION:

- Wrap serration on shaft with tape to protect the boot from damage.
- Never reuse boot and boot band.

4. Remove the tape wrapped around the serration on shaft.
5. Position the circular clip (1) on groove at the shaft edge.

CAUTION:

Never reuse circular clip.

NOTE:

Drive joint inserter is recommended when installing circular clip.

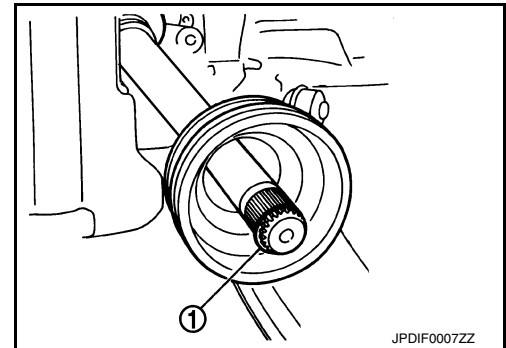

6. Align both center axes of the shaft edge and joint sub-assembly. Then assemble shaft with joint sub-assembly holding circular clip.
7. Install joint sub-assembly (1) to shaft using plastic hammer.

CAUTION:

- Check circular clip is properly positioned on groove of the joint sub-assembly.
- Confirm that joint sub-assembly is correctly engaged while rotating drive shaft.

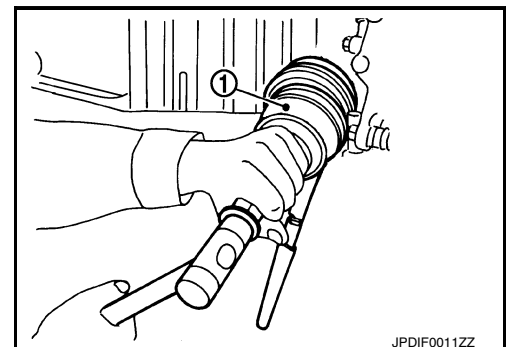

8. Apply the specified amount of grease into the boot inside from large diameter side of boot.

Grease amount : Refer to [FAX-109, "Drive Shaft"](#).

FRONT DRIVE SHAFT BOOT

[TYPE 2]

< REMOVAL AND INSTALLATION >

9. Install the boot securely into grooves (indicated by "*" marks) shown in the figure.

CAUTION:

If grease adheres to the boot mounting surface (indicated by "*" marks) on the shaft or joint sub-assembly, boot may be removed. Remove all grease from the boot mounting surface.

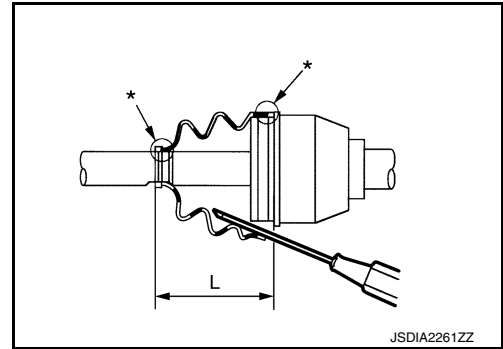

10. To prevent the deformation of the boot, adjust the boot installation length (L) to the specified value shown below by inserting the suitable tool into inside of the boot from the large diameter side of the boot and discharging the inside air.

L : Refer to [FAX-109, "Drive Shaft"](#).

CAUTION:

- If the boot installation length exceeds the standard, it may cause breakage of the boot.
- Be careful not to touch the inside of the boot with a tip of tool.

11. Secure the large and small ends of the boot with boot bands using the boot band crimping tool (A) [SST:KV40107300 (—)].

CAUTION:

- Never reuse boot band.

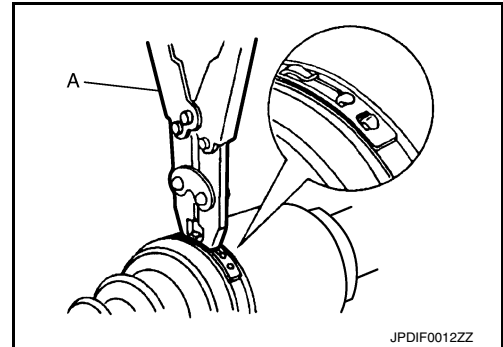

- Secure boot band so that dimension (M) meets the specification as shown in the figure.

Dimension (M) : 2.0 – 3.0 mm (0.079 – 0.118 in)

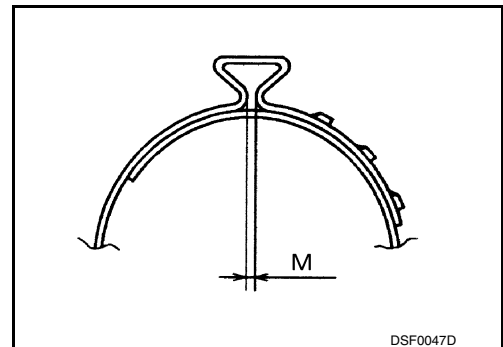

12. Check that displacement does not occur when boot is rotated with the joint sub-assembly and shaft fixed.

CAUTION:

- Reinstall them using boot bands when boot installation positions become incorrect.
- Never reuse boot band.

13. Clean the matching surface of wheel hub lock nut and wheel hub assembly.

CAUTION:

Never apply lubricating oil to these matching surface.

FRONT DRIVE SHAFT BOOT

[TYPE 2]

< REMOVAL AND INSTALLATION >

14. Clean the matching surface of drive shaft, wheel hub assembly. And then apply paste [service parts (440037S000)] to surface (A) of joint sub-assembly of drive shaft.

CAUTION:

Apply paste to cover entire flat surface of joint sub-assembly of drive shaft.

Amount paste : 1.0 – 3.0 g (0.04 – 0.10 oz)

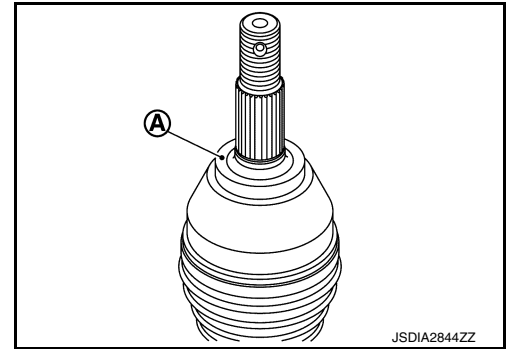

15. Insert drive shaft to wheel hub assembly, and then temporarily tighten wheel hub lock nut.

CAUTION:

- Be sure to use torque wrench to tighten the wheel hub lock nut. Never use a power tool.
- Never reuse wheel hub lock nut.

16. Install strut assembly to steering knuckle. Refer to [FSU-9, "Exploded View"](#).
17. Install disc rotor. Refer to [FAX-66, "Removal and Installation"](#).
18. Install caliper assembly to steering knuckle. Refer to [BR-55, "BRAKE CALIPER ASSEMBLY : Removal and Installation"](#).
19. Install lock plate to strut assembly. Refer to [BR-25, "FRONT : Removal and Installation"](#).
20. Install wheel sensor and sensor harness. Refer to [BRC-147, "FRONT WHEEL SENSOR : Exploded View"](#).
21. Use the following torque range for tightening the wheel hub lock nut.

 : 180 – 185 N·m (18.4 – 18.8 kg-m, 133 – 136 ft-lb)

CAUTION:

- Since the drive shaft is assembled by press-fitting, use the tightening torque range for the wheel hub lock nut.
- Be sure to use torque wrench to tighten the wheel hub lock nut. Never use a power tool.
- Never reuse wheel hub lock nut.

NOTE:

Wheel hub lock nut tightening torque does not over torque for avoiding axle noise, and does not less than torque for avoiding looseness.

22. When installing a cotter pin (1) and adjusting cap (2), securely bend the basal portion to prevent rattles.

CAUTION:

Never reuse cotter pin.

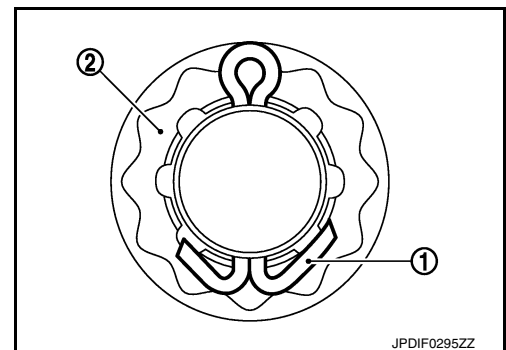

23. Install tires. Refer to [WT-39, "Exploded View"](#).
24. Perform inspection after installation. Refer to [FAX-80, "AWD : Inspection"](#).

Transaxle Side

- Install drive shaft to vehicle.
- Installation: Refer to [FAX-97, "AWD : Removal and Installation"](#).
- Assembly: Refer to [FAX-101, "AWD : Disassembly and Assembly"](#).

AWD : Inspection

INFOID:000000012201559

INSPECTION AFTER INSTALLATION

FRONT DRIVE SHAFT BOOT

[TYPE 2]

< REMOVAL AND INSTALLATION >

1. Check wheel sensor harness for proper connection. Refer to [BRC-147, "FRONT WHEEL SENSOR : Exploded View"](#).
2. Check the wheel alignment. Refer to [FSU-7, "Inspection"](#).
3. Adjust neutral position of steering angle sensor. Refer to [BRC-63, "Work Procedure"](#).

A

B

C

FAX

E

F

G

H

I

J

K

L

M

N

O

P

FRONT DRIVE SHAFT

< REMOVAL AND INSTALLATION >

[TYPE 2]

FRONT DRIVE SHAFT

2WD

2WD : Exploded View

INFOID:000000012201560

LEFT SIDE

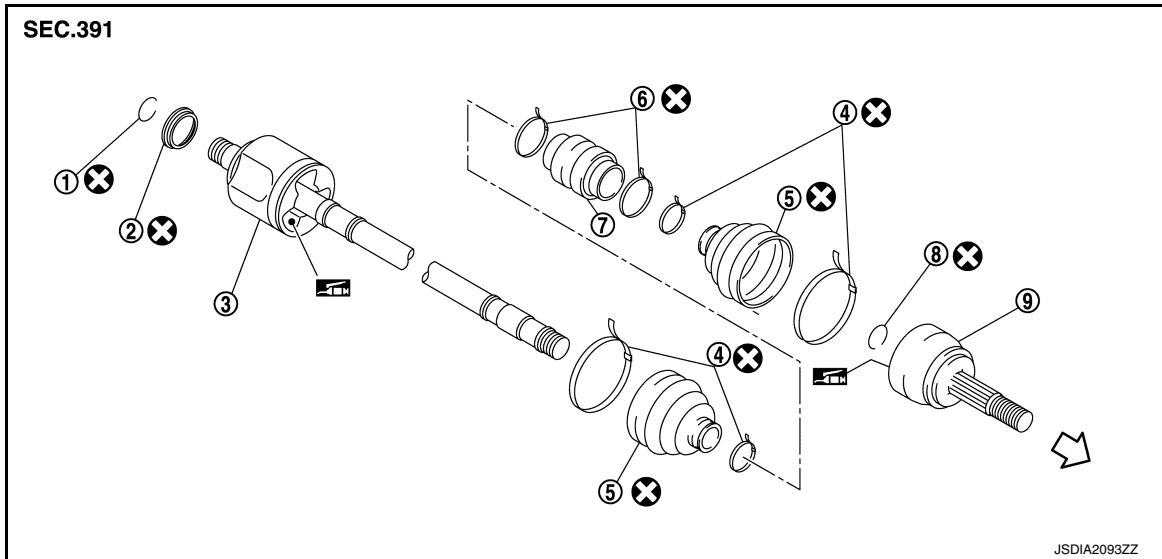

- | | | |
|-------------------|------------------|-----------------------|
| 1. Circular clip | 2. Dust shield | 3. Housing assembly |
| 4. Boot band | 5. Boot | 6. Damper band |
| 7. Dynamic damper | 8. Circular clip | 9. Joint sub-assembly |

⇐ : Wheel side

: Fill NISSAN Genuine grease or equivalent.

: Always replace after every disassembly.

RIGHT SIDE

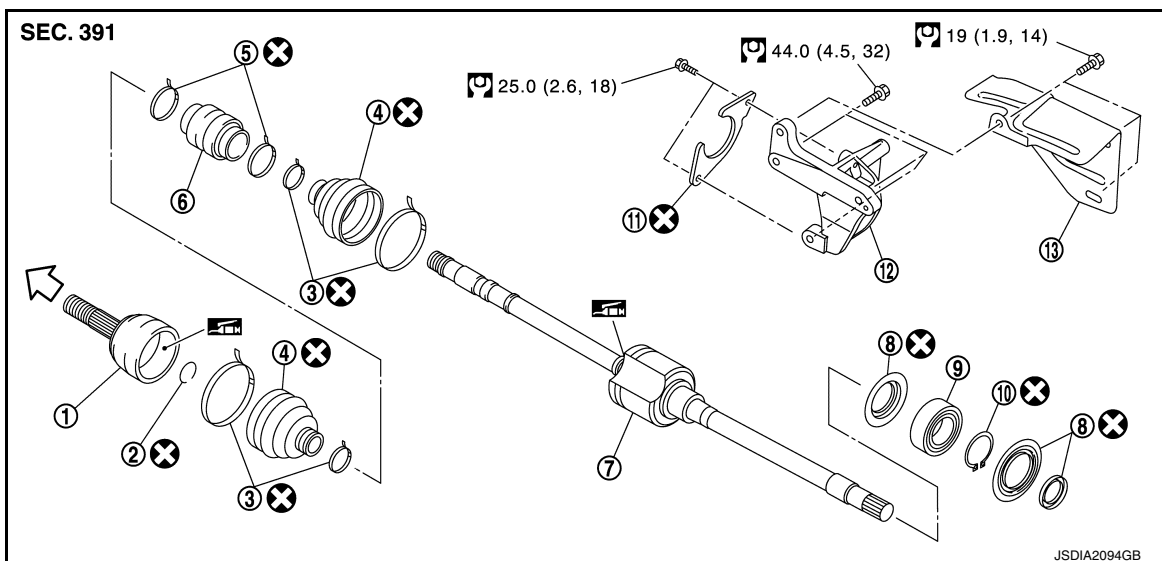

- | | | |
|-----------------------|------------------|-----------------------------|
| 1. Joint sub-assembly | 2. Circular clip | 3. Boot band |
| 4. Boot | 5. Damper band | 6. Dynamic damper |
| 7. Housing assembly | 8. Dust shield | 9. Support bearing |
| 10. Snap ring | 11. Plate | 12. Support bearing bracket |

FRONT DRIVE SHAFT

< REMOVAL AND INSTALLATION >

[TYPE 2]

13. Heat insulator

↔ : Wheel side

 : Fill NISSAN Genuine grease or equivalent.

 : Always replace after every disassembly.

 : N·m (kg-m, ft-lb)

2WD : Removal and Installation

INFOID:000000012201561

REMOVAL

Left Side

1. Remove tires with power tool. Refer to [WT-39, "Removal and Installation"](#).
2. Remove wheel sensor and sensor harness. Refer to [BRC-147, "FRONT WHEEL SENSOR : Exploded View"](#).
3. Remove lock plate from strut assembly. Refer to [BR-25, "FRONT : Removal and Installation"](#).
4. Remove caliper assembly. Hang caliper assembly not to interfere with work. Refer to [BR-55, "BRAKE CALIPER ASSEMBLY : Removal and Installation"](#).

CAUTION:

Never depress brake pedal while brake caliper is removed.

5. Remove disc rotor.

CAUTION:

- Put matching marks (A) on the wheel hub assembly and the disc rotor before removing the disc rotor.
- Never drop disc rotor.

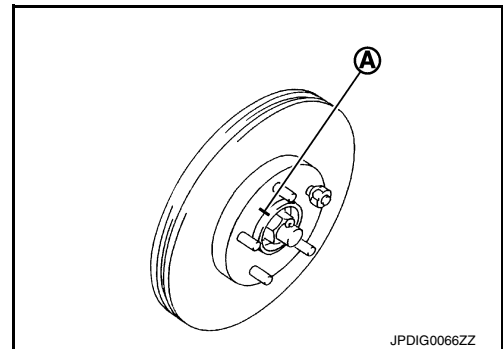

6. Remove cotter pin, and adjusting cap, and then loosen wheel hub lock nut with power tool.
7. Patch wheel hub lock nut with a piece of wood. Hammer the wood to disengage wheel hub assembly from drive shaft.

NOTE:

Use suitable puller, if wheel hub assembly and drive shaft cannot be separated even after performing the above procedure.

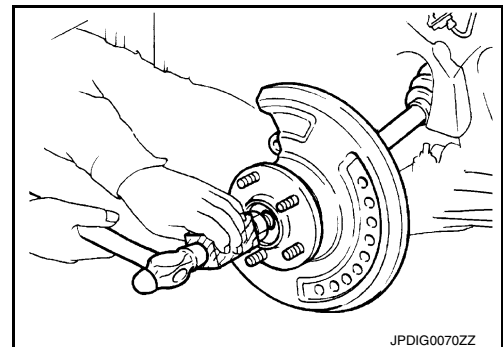

8. Remove wheel hub lock nut.
9. Remove strut assembly from steering knuckle. Refer to [FSU-9, "Removal and Installation"](#).
10. Remove drive shaft from wheel hub assembly.

CAUTION:

- Never place drive shaft joint at an extreme angle. Also be careful not to overextend slide joint.
- Never allow drive shaft to hang down without support for joint sub-assembly, shaft and the other parts.

A
B
C
E
F
G
H
I
J
K
L
M
N
O
P

FAX

FRONT DRIVE SHAFT

< REMOVAL AND INSTALLATION >

[TYPE 2]

11. Use the drive shaft attachment (A) [SST:KV40107500 (—)] and a sliding hammer (B) (commercial service tool) while inserting tip of the drive shaft attachment between shaft and transaxle assembly, and then remove drive shaft from transaxle assembly.

CAUTION:

- Never place drive shaft joint at an extreme angle when removing drive shaft. Also be careful not to overextend slide joint.
- Confirm that the circular clip is attached to the drive shaft.

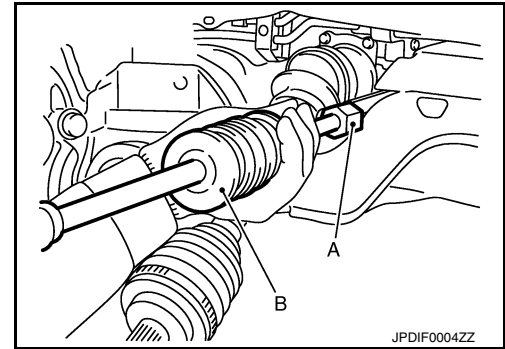

Right Side

1. Remove tires with power tool. Refer to [WT-39, "Removal and Installation"](#).
2. Remove wheel sensor and sensor harness. Refer to [BRC-147, "FRONT WHEEL SENSOR : Exploded View"](#).
3. Remove lock plate from strut assembly. Refer to [BR-25, "FRONT : Removal and Installation"](#).
4. Remove caliper assembly. Hang caliper assembly not to interfere with work. Refer to [BR-55, "BRAKE CALIPER ASSEMBLY : Removal and Installation"](#).

CAUTION:

Never depress brake pedal while brake caliper is removed.

5. Remove disc rotor.

CAUTION:

- Put matching marks (A) on the wheel hub assembly and the disc rotor before removing the disc rotor.
- Never drop disc rotor.

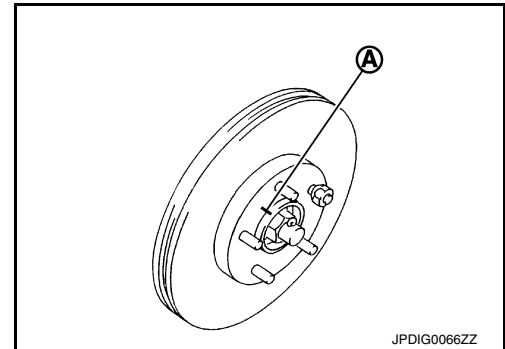

6. Remove cotter pin, and adjusting cap, and then loosen wheel hub lock nut with power tool.
7. Patch wheel hub lock nut with a piece of wood. Hammer the wood to disengage wheel hub assembly from drive shaft.

NOTE:

Use suitable puller, if wheel hub assembly and drive shaft cannot be separated even after performing the above procedure.

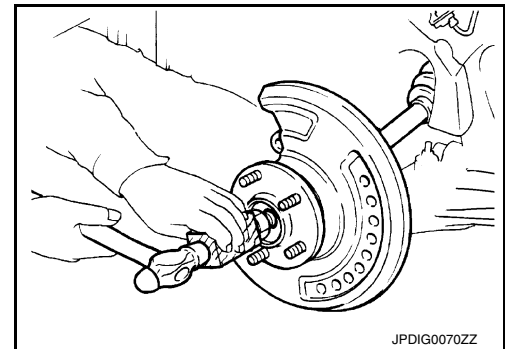

8. Remove wheel hub lock nut.
9. Remove strut assembly from steering knuckle. Refer to [FSU-9, "Removal and Installation"](#).
10. Remove drive shaft from wheel hub assembly.

CAUTION:

- Never place drive shaft joint at an extreme angle. Also be careful not to overextend slide joint.
- Never allow drive shaft to hang down without support for joint sub-assembly, shaft and the other parts.

11. Remove plate from support bearing bracket.
12. Remove drive shaft assembly from transaxle assembly.

FRONT DRIVE SHAFT

< REMOVAL AND INSTALLATION >

[TYPE 2]

CAUTION:

Never place drive shaft joint at an extreme angle when removing drive shaft. Also be careful not to overextend slide joint.

13. Remove heat insulator.
14. Remove support bearing bracket.

INSTALLATION

Note the following, and install in the reverse order of removal.

Left Side

- Always replace differential side oil seal with new one when installing drive shaft. Refer to [TM-23. "Removal and Installation"](#).

- Place the protector (A) [SST:KV38107900 (—)] onto transaxle assembly to prevent damage to the differential side oil seal while inserting drive shaft. Slide drive shaft sliding joint and tap with a hammer to install securely.

CAUTION:

- Check that circular clip is completely engaged.
- Never reuse circular clip.
- Never reuse differential side oil seal.

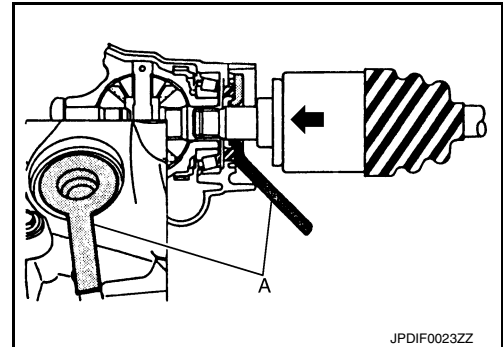

- Clean the matching surface of wheel hub lock nut and wheel hub assembly.

CAUTION:

Never apply lubricating oil to these matching surface.

- Clean the matching surface of drive shaft and wheel hub assembly. And then apply paste [service parts (440037S000)] to surface (A) of joint sub-assembly of drive shaft.

CAUTION:

Apply paste to cover entire flat surface of joint sub-assembly of drive shaft.

Amount paste : 1.0 – 3.0 g (0.04 – 0.10 oz)

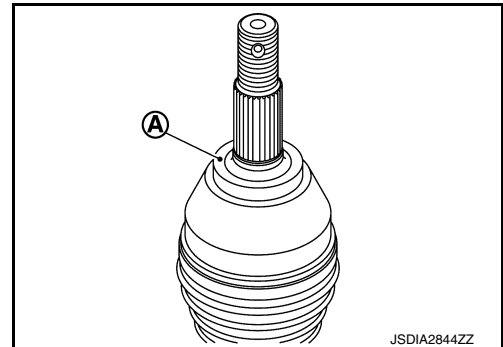

- Use the following torque range for tightening the wheel hub lock nut.

 : 180 – 185 N·m (18.4 – 18.8 kg-m, 133 – 136 ft-lb)

CAUTION:

- Since the drive shaft is assembled by press-fitting, use the tightening torque range for the wheel hub lock nut.
- Be sure to use torque wrench to tighten the wheel hub lock nut. Never use a power tool.
- Never reuse wheel hub lock nut.

NOTE:

Wheel hub lock nut tightening torque does not over torque for avoiding axle noise, and does not less than torque for avoiding looseness.

- Align the matching marks that have been made during removal when reusing the disc rotor.

FRONT DRIVE SHAFT

[TYPE 2]

< REMOVAL AND INSTALLATION >

- When installing a cotter pin (1) and adjusting cap (2), securely bend the basal portion to prevent rattles.

CAUTION:

Never reuse cotter pin.

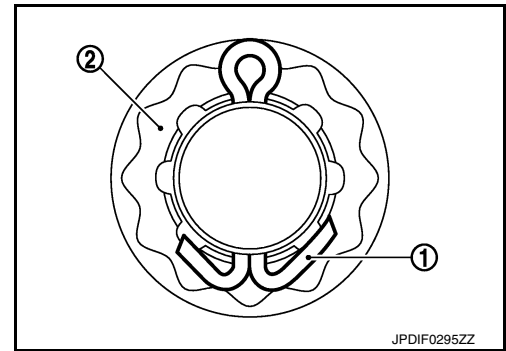

- Perform the final tightening of each of parts under unladen conditions, which were removed when removing wheel hub assembly and steering knuckle.
- Perform inspection after installation. Refer to [FAX-96, "2WD : Inspection"](#).

Right Side

- Always replace differential side oil seal with new one when installing drive shaft. Refer to [TM-23, "Removal and Installation"](#).

- Install support bearing bracket (1) in following procedure,
 - Temporarily tighten mounting bolts (A), (B), (C), then tighten them to specified torque.
 - Set plate (2) so that notch (D) becomes upper side. Temporarily tighten mounting bolts (E), (F), then tighten them to specified torque.

CAUTION:

Never reuse plate.

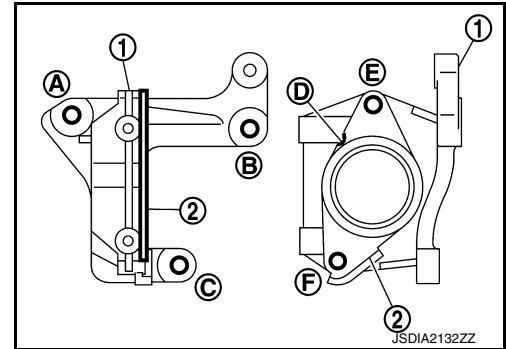

- Place the protector (A) [SST:KV38107900 (—)] onto transaxle assembly to prevent damage to the differential side oil seal while inserting drive shaft. Slide drive shaft sliding joint and tap with a hammer to install securely.

CAUTION:

Never reuse differential oil seal.

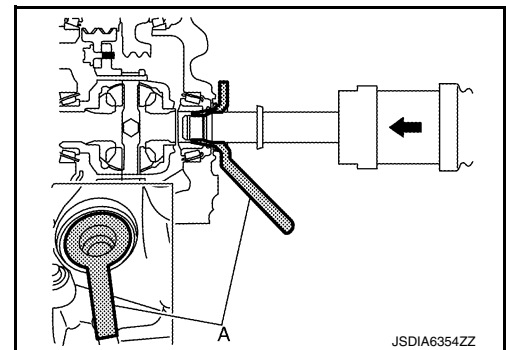

- To install mounting nuts of the heat insulator (1), temporarily tighten them in numerical order shown in the figure and tighten them to the specified torque.

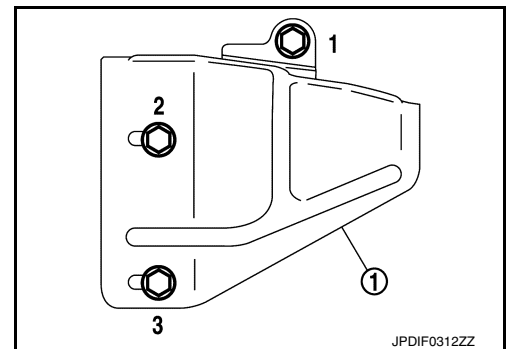

- Clean the matching surface of wheel hub lock nut and wheel hub assembly.

CAUTION:

Never apply lubricating oil to these matching surface.

FRONT DRIVE SHAFT

< REMOVAL AND INSTALLATION >

[TYPE 2]

- Clean the matching surface of drive shaft and wheel hub assembly. And then apply paste [service parts (440037S000)] to surface (A) of joint sub-assembly of drive shaft.

CAUTION:

Apply paste to cover entire flat surface of joint sub-assembly of drive shaft.

Amount paste : 1.0 – 3.0 g (0.04 – 0.10 oz)

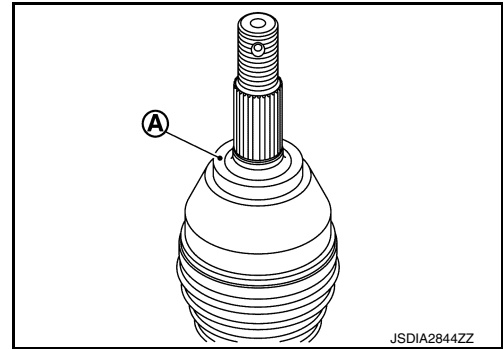

A

B

C

FAX

- Use the following torque range for tightening the wheel hub lock nut.

 : 180 – 185 N·m (18.4 – 18.8 kg-m, 133 – 136 ft-lb)

E

CAUTION:

- Since the drive shaft is assembled by press-fitting, use the tightening torque range for the wheel hub lock nut.
- Be sure to use torque wrench to tighten the wheel hub lock nut. Never use a power tool.
- Never reuse wheel hub lock nut.

F

G

NOTE:

Wheel hub lock nut tightening torque does not over torque for avoiding axle noise, and does not less than torque for avoiding looseness.

H

- Align the matching marks that have been made during removal when reusing the disc rotor.
- When installing a cotter pin (1) and adjusting cap (2), securely bend the basal portion to prevent rattles.

I

J

K

CAUTION:

Never reuse cotter pin.

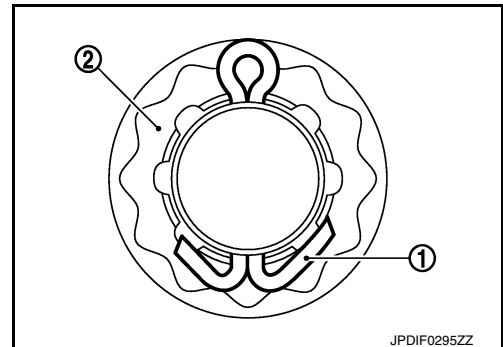

L

M

- Perform the final tightening of each of parts under unladen conditions, which were removed when removing wheel hub assembly and steering knuckle.
- Perform inspection after installation. Refer to [FAX-96, "2WD : Inspection"](#).

2WD : Disassembly and Assembly

INFOID:0000000112201562

DISASSEMBLY

Wheel Side

1. Fix shaft with a vise.

CAUTION:

Protect shaft using aluminum or copper plates when fixing with a vise.

2. Remove boot bands, and then remove boot from joint sub-assembly.

N

O

P

FRONT DRIVE SHAFT

[TYPE 2]

< REMOVAL AND INSTALLATION >

3. Screw drive shaft puller (A) (commercial service tool) into joint sub-assembly screw part to a length of 30 mm (1.18 in) or more. Support drive shaft with one hand and pull out joint sub-assembly from shaft.

CAUTION:

- Align drive shaft puller and drive shaft and remove them by pulling firmly and uniformly.
- If joint sub-assembly cannot be removed after five or more unsuccessful attempts, replace shaft and joint sub-assembly as a set.

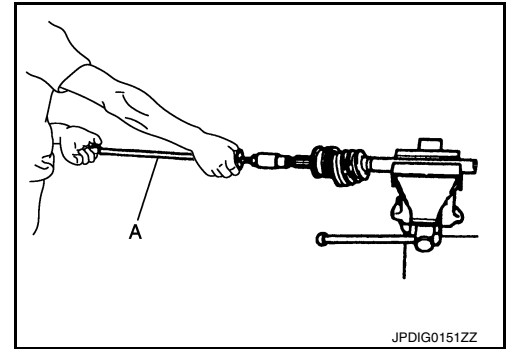

4. Remove circular clip from shaft.
5. Remove boot from shaft.

Transaxle Side (Left Drive Shaft)

1. Fix shaft with a vise.

CAUTION:

Protect shaft using aluminum or copper plates when fixing with a vise.

2. Remove wheel side boot from joint sub-assembly. Refer to [FAX-83. "2WD : Removal and Installation"](#).
3. Remove dynamic damper as per the following instructions:
 - a. Remove damper band.
 - b. Remove dynamic damper from housing assembly.
4. Remove boot bands, then remove boot from housing assembly.
5. Remove circular clip from housing assembly.
6. Remove dust shield from housing assembly.

Transaxle Side (Right Drive Shaft)

1. Fix shaft with a vise.

CAUTION:

Protect shaft using aluminum or copper plates when fixing with a vise.

2. Remove wheel side boot from joint sub-assembly. Refer to [FAX-83. "2WD : Removal and Installation"](#).
3. Remove dynamic damper as per the following instructions:
 - a. Remove damper band.
 - b. Remove dynamic damper from housing assembly.
4. Remove boot bands, then remove boot from housing assembly.
5. Remove support bearing, follow the procedure described below.
 - a. Remove dust shield from housing.

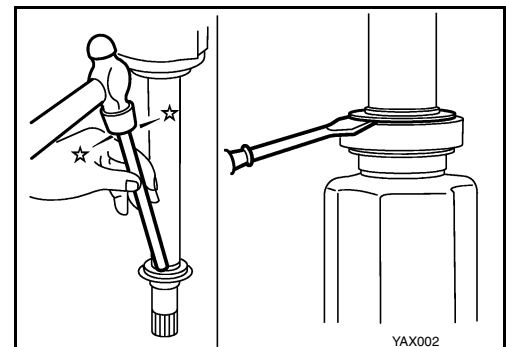

FRONT DRIVE SHAFT

< REMOVAL AND INSTALLATION >

[TYPE 2]

- b. Remove snap ring (1).

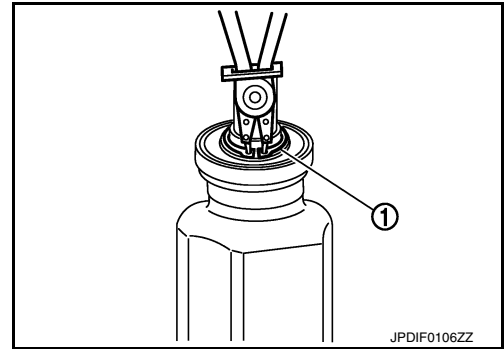

- c. Press out support bearing from housing.

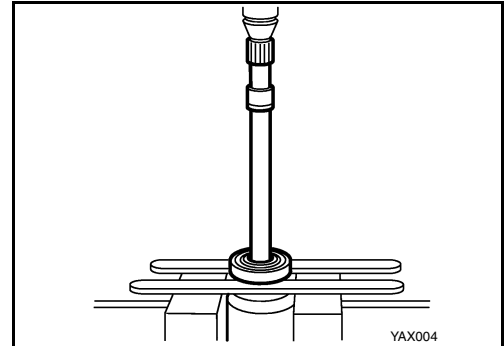

- d. Remove dust shield from housing.

ASSEMBLY

Wheel Side

1. Clean the old grease on joint sub-assembly with paper waste.
2. Fill serration slot joint sub-assembly (1) with NISSAN genuine grease or equivalent until the serration slot and ball groove become full to the brim.

CAUTION:

After applying grease, use a paper waste to wipe off old grease that has oozed out.

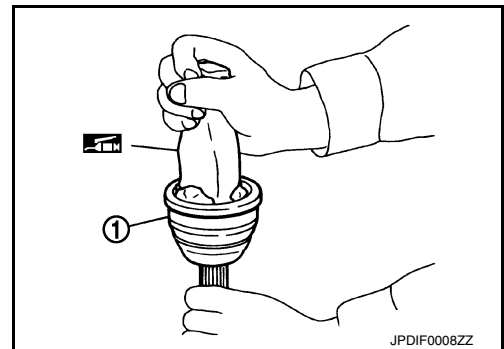

3. Install boot and boot bands to shaft.

CAUTION:

- Wrap serration on shaft with tape (A) to protect the boot from damage.
- Never reuse boot and boot band.

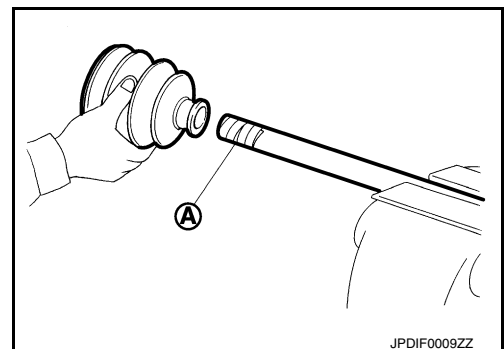

4. Remove the tape wrapped around the serration on shaft.

A
B
C
FAX
E
F
G
H
I
J
K
L
M
N
O
P

FRONT DRIVE SHAFT

< REMOVAL AND INSTALLATION >

[TYPE 2]

5. Position the circular clip (1) on groove at the shaft edge.

CAUTION:

Never reuse circular clip.

NOTE:

Drive joint inserter is recommended when installing circular clip.

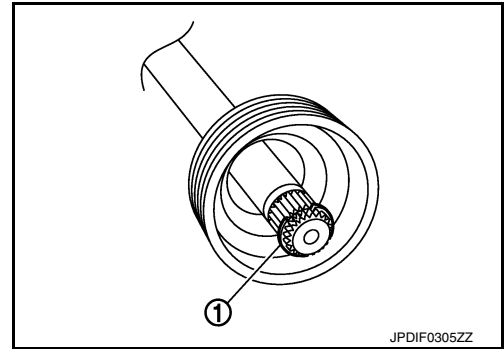

6. Align both center axes of the shaft edge and joint sub-assembly. Then assemble shaft with joint sub-assembly holding circular clip.
7. Install joint sub-assembly to shaft using plastic hammer.

CAUTION:

- Check circular clip is properly positioned on groove of the joint sub-assembly.
- Confirm that joint sub-assembly is correctly engaged while rotating drive shaft.

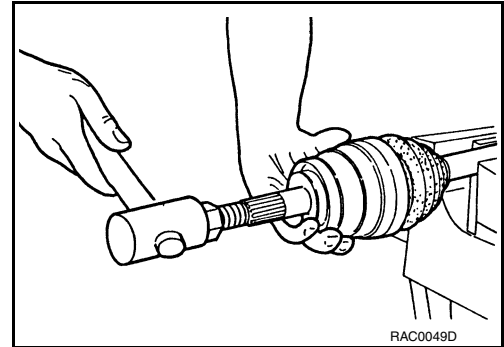

8. Apply the specified amount of grease into the boot inside from large diameter side of boot.

Grease amount : Refer to [FAX-109, "Drive Shaft"](#).

9. Install the boot securely into grooves (indicated by "*" marks) shown in the figure.

CAUTION:

If grease adheres to the boot mounting surface (indicated by "*" marks) on the shaft or joint sub-assembly, boot may be removed. Remove all grease from the boot mounting surface.

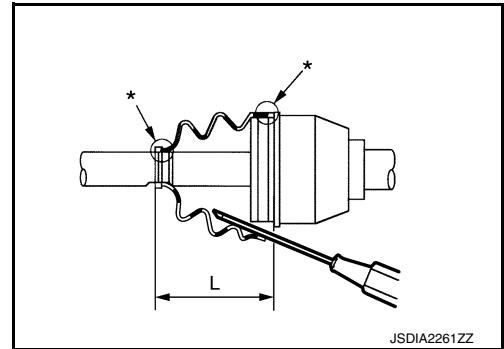

10. To prevent the deformation of the boot, adjust the boot installation length (L) to the specified value shown below by inserting the suitable tool into inside of the boot from the large diameter side of the boot and discharging the inside air.

L : Refer to [FAX-109, "Drive Shaft"](#).

CAUTION:

- If the boot installation length exceeds the standard, it may cause breakage of the boot.
- Be careful not to touch the inside of the boot with a tip of tool.

FRONT DRIVE SHAFT

[TYPE 2]

< REMOVAL AND INSTALLATION >

11. Secure the large and small ends of the boot with boot bands using the boot band crimping tool (A) [SST:KV40107300 (—)].

CAUTION:

- **Never reuse boot band.**

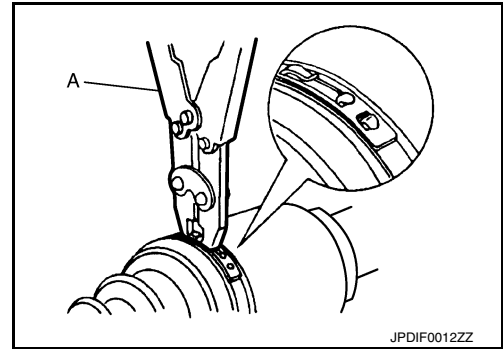

- **Secure boot band so that dimension (M) meets the specification as shown in the figure.**

Dimension (M) : 2.0 – 3.0 mm (0.079 – 0.118 in)

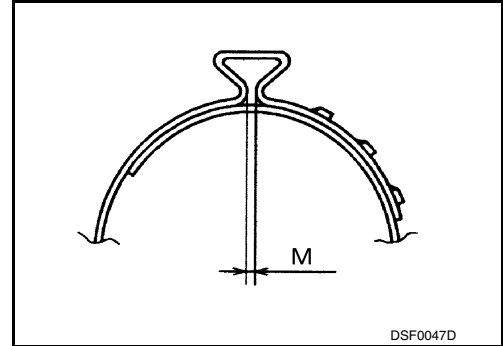

12. Check that displacement does not occur when boot is rotated with the joint sub-assembly and shaft fixed.

CAUTION:

- **Reinstall them using boot bands when boot installation positions become incorrect.**
- **Never reuse boot band.**

Transaxle Side (Left Drive Shaft)

1. Clean the old grease on housing assembly with paper waste.
2. Install dust shield to housing assembly.

CAUTION:

Never reuse dust shield.

3. Install circular clip to housing.

CAUTION:

Never reuse circular clip.

4. Install boot and boot bands to housing assembly.

CAUTION:

- **Wrap serration on housing assembly with tape (A) to protect the boot from damage.**
- **Never reuse boot and boot band.**

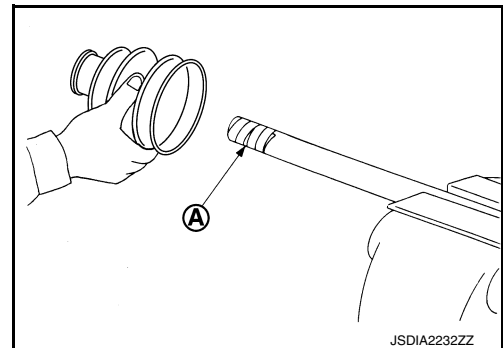

5. Remove the tape wrapped around the serration on shaft.
6. Apply NISSAN genuine grease (refer to parts catalog) to housing assembly.

Grease amount : Refer to [FAX-109, "Drive Shaft"](#).

FRONT DRIVE SHAFT

< REMOVAL AND INSTALLATION >

[TYPE 2]

7. Install the boot securely into grooves (indicated by "*" marks) shown in the figure.

CAUTION:

If grease adheres to the boot mounting surface (indicated by "*" marks) on the shaft or housing assembly, boot may be removed. Remove all grease from the boot mounting surface.

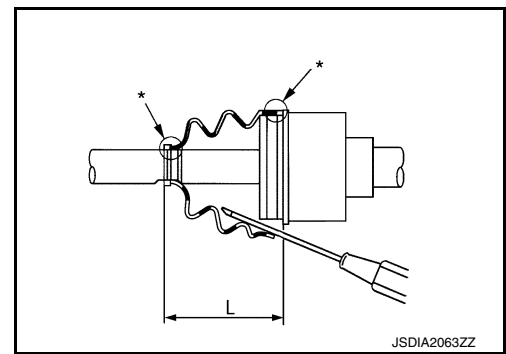

8. To prevent the deformation of the boot, adjust the boot installation length to the value shown below (L) by inserting the suitable tool into the inside of boot from the large diameter side of boot and discharging inside air.

L : Refer to [FAX-109, "Drive Shaft"](#).

CAUTION:

- If the boot installation length exceeds the standard, it may cause breakage of the boot.
- Be careful not to touch the inside of the boot with the tip of tool.

9. Install boot bands securely.

CAUTION:

Never reuse boot bands.

- a. Put boot band in the groove on drive shaft boot. Then fit pawls (←) into holes to temporary installation.

NOTE:

For the large diameter side, fit projection (A) and guide slit (B) at first.

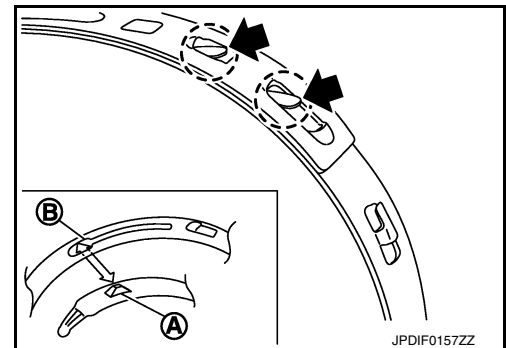

- b. Pinch projection on the band with suitable pliers to tighten band.
c. Insert the tip of band into the lower part of pawl (marked with dotted circle) as shown in the figure.

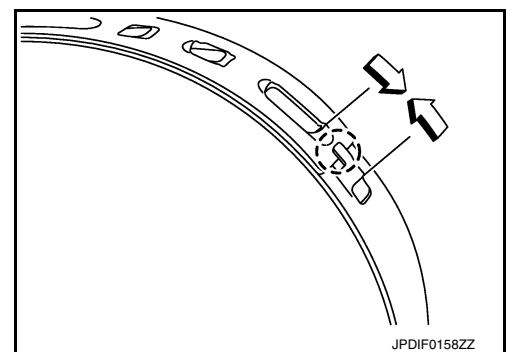

10. Check that displacement does not occur when boot is rotated with the housing assembly fixed.

CAUTION:

- If displacement occurs, reinstall band.
- Never reuse boot band.

11. Install dynamic damper, follow the procedure described below.

- a. Install dynamic damper to shaft.

FRONT DRIVE SHAFT

[TYPE 2]

< REMOVAL AND INSTALLATION >

- b. Secure dynamic damper with bands in the following specified position (A) when installing.

CAUTION:

Never reuse boot bands.

A : Refer to [FAX-109, "Drive Shaft"](#).

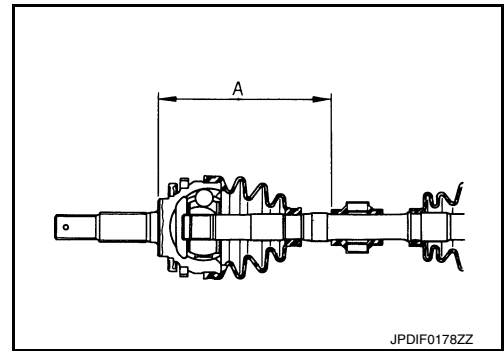

- c. Install boot bands securely as shown in the figure.

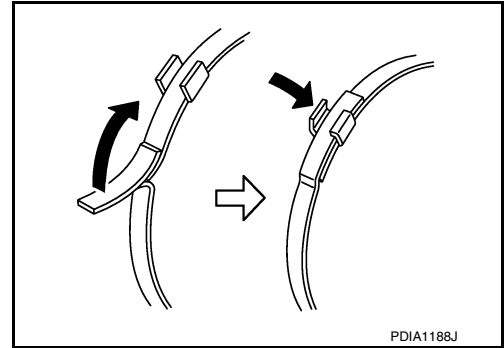

12. Install boot to the wheel side. Refer to [FAX-71, "2WD : Removal and Installation"](#).

Transaxle Side (Right Drive Shaft)

1. Clean the old grease on housing assembly with paper waste.
2. Install support bearing, follow the procedure described below.
 - a. Install dust shield to housing.

CAUTION:

Never reuse dust shield.

- b. Press support bearing (1) onto housing to using the suitable tool (A).

CAUTION:

Never reuse support bearing.

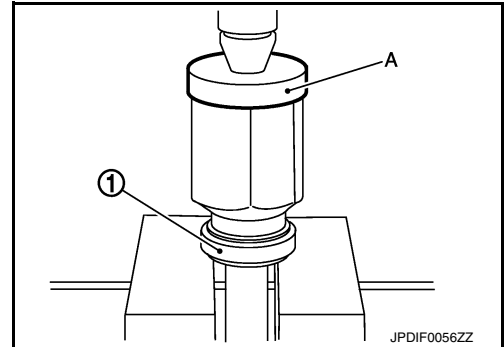

- c. Install snap ring (1).

CAUTION:

Never reuse snap ring.

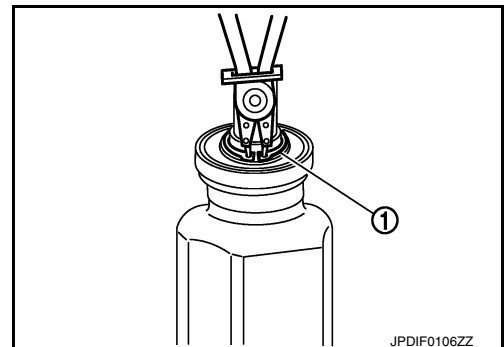

A
B
C
FAX
E
F
G
H
I
J
K
L
M
N
O
P

FRONT DRIVE SHAFT

[TYPE 2]

< REMOVAL AND INSTALLATION >

- d. Install dust shields.

CAUTION:

Never reuse dust shields.

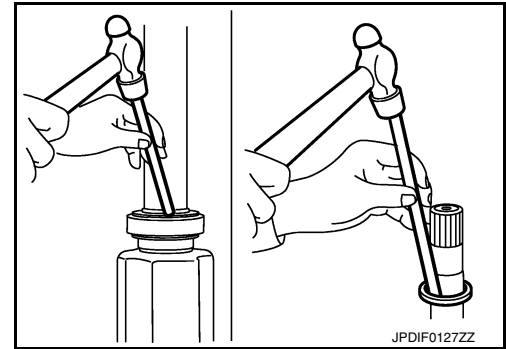

3. Install boot and boot bands to housing assembly.

CAUTION:

- Wrap serration on housing assembly with tape (A) to protect the boot from damage.
- Never reuse boot and boot band.

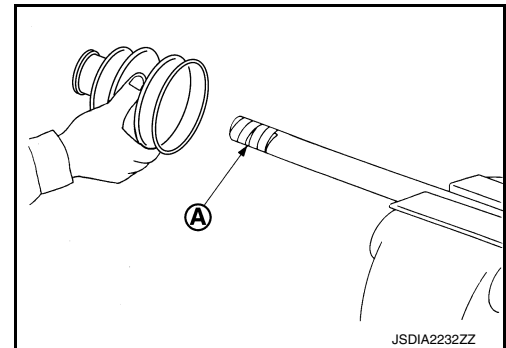

4. Remove the tape wrapped around the serration on shaft.

5. Apply NISSAN genuine grease (refer to parts catalog) to housing assembly.

Grease amount : Refer to [FAX-109, "Drive Shaft"](#).

6. Install the boot securely into grooves (indicated by "*" marks) shown in the figure.

CAUTION:

If grease adheres to the boot mounting surface (indicated by "*" marks) on the shaft or housing assembly, boot may be removed. Remove all grease from the boot mounting surface.

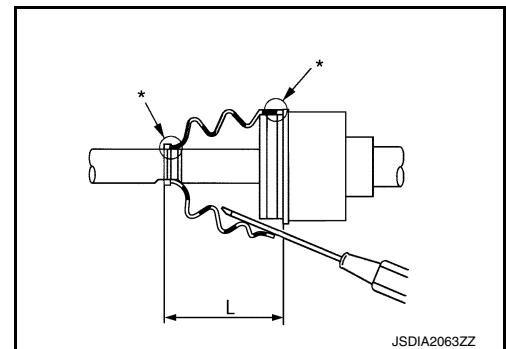

7. To prevent the deformation of the boot, adjust the boot installation length to the value shown below (L) by inserting the suitable tool into the inside of boot from the large diameter side of boot and discharging inside air.

L : Refer to [FAX-109, "Drive Shaft"](#).

CAUTION:

- If the boot installation length exceeds the standard, it may cause breakage of the boot.
- Be careful not to touch the inside of the boot with the tip of tool.

8. Install boot bands securely.

CAUTION:

Never reuse boot bands.

FRONT DRIVE SHAFT

[TYPE 2]

< REMOVAL AND INSTALLATION >

- a. Put boot band in the groove on drive shaft boot. Then fit pawls (←) into holes to temporary installation.

NOTE:

For the large diameter side, fit projection (A) and guide slit (B) at first.

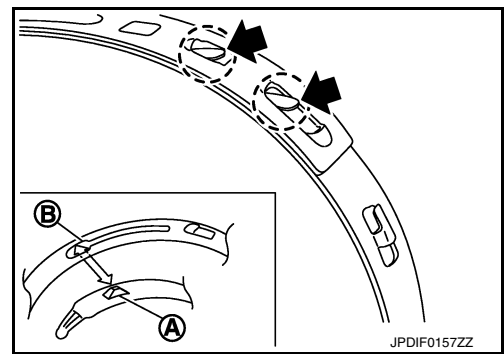

- b. Pinch projection on the band with suitable pliers to tighten band.
c. Insert the tip of band into the lower part of pawl (marked with dotted circle) as shown in the figure.

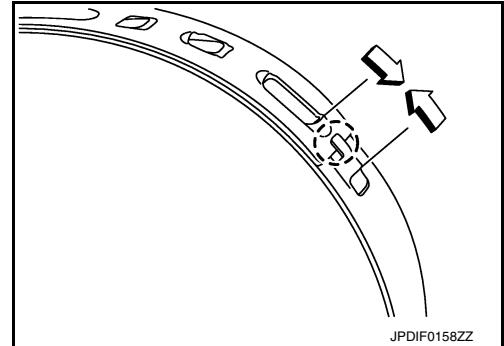

9. Check that displacement does not occur when boot is rotated with the housing assembly fixed.

CAUTION:

- If displacement occurs, reinstall band.
- Never reuse boot band.

10. Install dynamic damper, follow the procedure described below.

- a. Install dynamic damper to shaft.
b. Secure dynamic damper with bands in the following specified position (A) when installing.

CAUTION:

Never reuse bands.

A : Refer to [FAX-109, "Drive Shaft"](#).

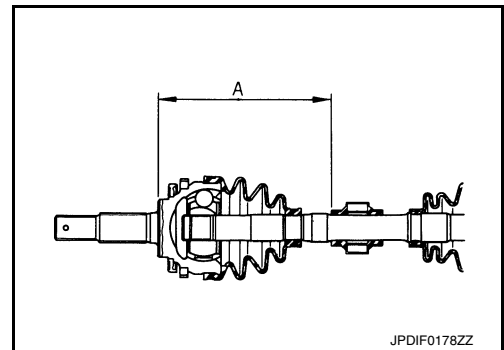

- c. Install boot bands securely as shown in the figure.

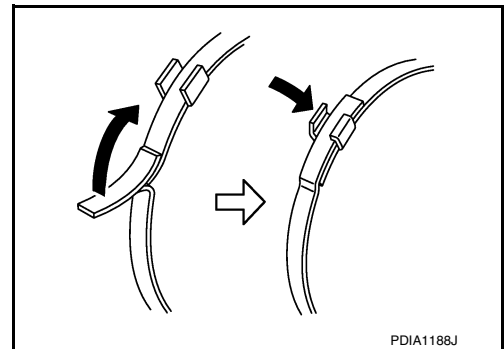

11. Install boot to the wheel side. Refer to [FAX-71, "2WD : Removal and Installation"](#).

A
B
C
FAX
E
F
G
H
I
J
K
L
M
N
O
P

FRONT DRIVE SHAFT

< REMOVAL AND INSTALLATION >

[TYPE 2]

2WD : Inspection

INFOID:000000012201563

INSPECTION AFTER INSTALLATION

1. Check wheel sensor harness for proper connection. Refer to [BRC-147. "FRONT WHEEL SENSOR : Exploded View"](#).
2. Check the wheel alignment. Refer to [FSU-7. "Inspection"](#).
3. Adjust neutral position of steering angle sensor. Refer to [BRC-63. "Work Procedure"](#).

AWD

AWD : Exploded View

INFOID:000000012201564

LEFT SIDE

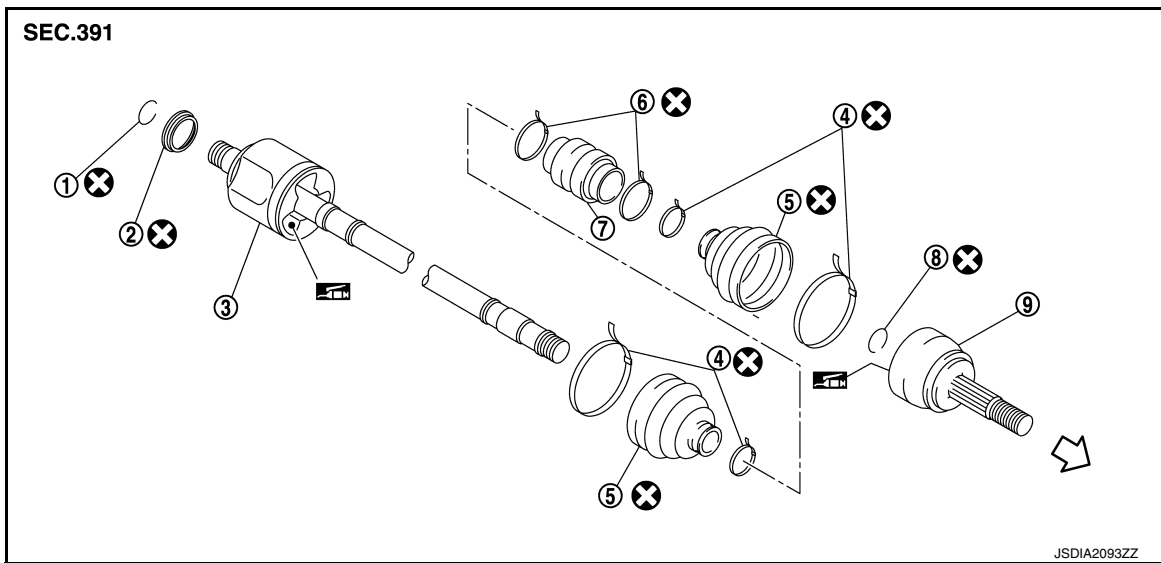

- | | | |
|-------------------|------------------|-----------------------|
| 1. Circular clip | 2. Dust shield | 3. Housing assembly |
| 4. Boot band | 5. Boot | 6. Damper band |
| 7. Dynamic damper | 8. Circular clip | 9. Joint sub-assembly |

⇨ : Wheel side

: Fill NISSAN Genuine grease or equivalent.

: Always replace after every disassembly.

RIGHT SIDE

FRONT DRIVE SHAFT

< REMOVAL AND INSTALLATION >

[TYPE 2]

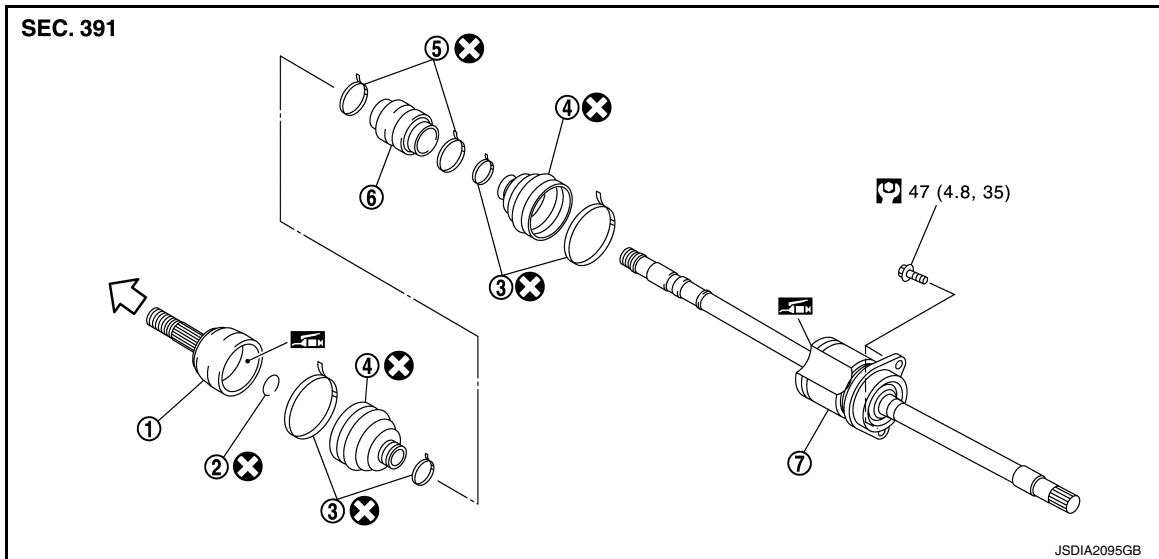

- | | | |
|-----------------------|------------------|-------------------|
| 1. Joint sub-assembly | 2. Circular clip | 3. Boot band |
| 4. Boot | 5. Damper band | 6. Dynamic damper |
| 7. Housing assembly | | |

← : Wheel side

: Fill NISSAN Genuine grease or equivalent.

: Always replace after every disassembly.

: N·m (kg-m, ft-lb)

AWD : Removal and Installation

INFOID:000000012201565

REMOVAL

Left Side

1. Remove tires with power tool. Refer to [WT-39, "Removal and Installation"](#).
2. Remove wheel sensor and sensor harness. Refer to [BRC-147, "FRONT WHEEL SENSOR : Exploded View"](#).
3. Remove lock plate from strut assembly. Refer to [BR-25, "FRONT : Removal and Installation"](#).
4. Remove caliper assembly. Hang caliper assembly not to interfere with work. Refer to [BR-55, "BRAKE CALIPER ASSEMBLY : Removal and Installation"](#).

CAUTION:

Never depress brake pedal while brake caliper is removed.

5. Remove disc rotor.

CAUTION:

- Put matching marks (A) on the wheel hub assembly and the disc rotor before removing the disc rotor.
- Never drop disc rotor.

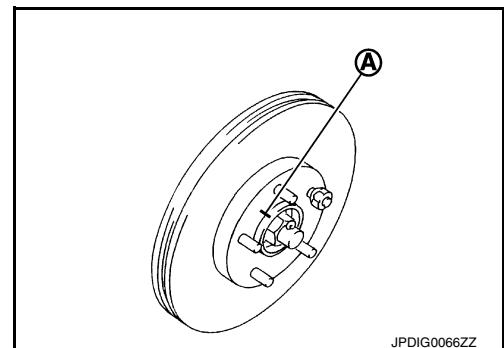

6. Remove cotter pin, and adjusting cap, and then loosen wheel hub lock nut with power tool.

FRONT DRIVE SHAFT

< REMOVAL AND INSTALLATION >

[TYPE 2]

7. Patch wheel hub lock nut with a piece of wood. Hammer the wood to disengage wheel hub assembly from drive shaft.

NOTE:

Use suitable puller, if wheel hub assembly and drive shaft cannot be separated even after performing the above procedure.

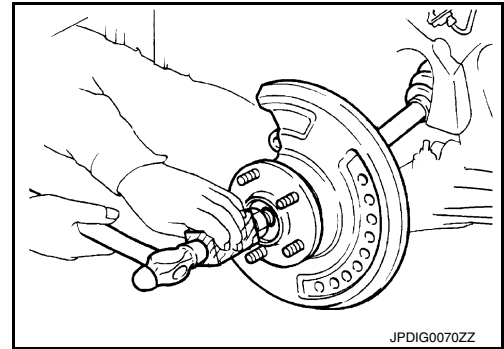

8. Remove wheel hub lock nut.
9. Remove strut assembly from steering knuckle. Refer to [FSU-9, "Removal and Installation"](#).
10. Remove drive shaft from wheel hub assembly.

CAUTION:

- Never place drive shaft joint at an extreme angle. Also be careful not to overextend slide joint.
- Never allow drive shaft to hang down without support for joint sub-assembly, shaft and the other parts.

11. Use the drive shaft attachment (A) [SST:KV40107500 (—)] and a sliding hammer (B) (commercial service tool) while inserting tip of the drive shaft attachment between shaft and transaxle assembly, and then remove drive shaft from transaxle assembly.

CAUTION:

- Never place drive shaft joint at an extreme angle when removing drive shaft. Also be careful not to overextend slide joint.
- Confirm that the circular clip is attached to the drive shaft.

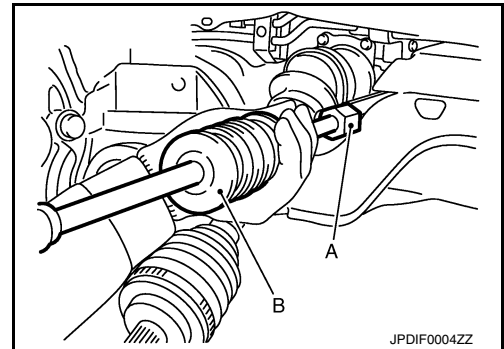

Right Side

1. Remove tires with power tool. Refer to [WT-39, "Removal and Installation"](#).
2. Remove wheel sensor and sensor harness. Refer to [BRC-147, "FRONT WHEEL SENSOR : Exploded View"](#).
3. Remove lock plate from strut assembly. Refer to [BR-25, "FRONT : Removal and Installation"](#).
4. Remove caliper assembly. Hang caliper assembly not to interfere with work. Refer to [BR-55, "BRAKE CALIPER ASSEMBLY : Removal and Installation"](#).

CAUTION:

Never depress brake pedal while brake caliper is removed.

5. Remove disc rotor.

CAUTION:

- Put matching marks (A) on the wheel hub assembly and the disc rotor before removing the disc rotor.
- Never drop disc rotor.

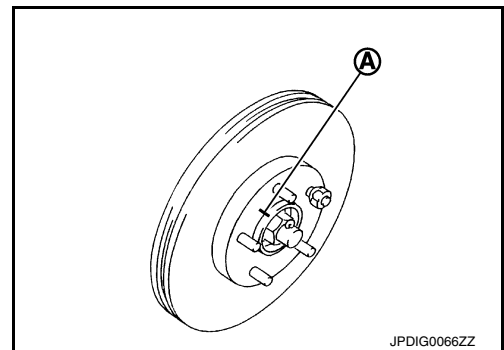

6. Remove cotter pin, and adjusting cap, and then loosen wheel hub lock nut with power tool.

FRONT DRIVE SHAFT

< REMOVAL AND INSTALLATION >

[TYPE 2]

7. Patch wheel hub lock nut with a piece of wood. Hammer the wood to disengage wheel hub assembly from drive shaft.

NOTE:

Use suitable puller, if wheel hub assembly and drive shaft cannot be separated even after performing the above procedure.

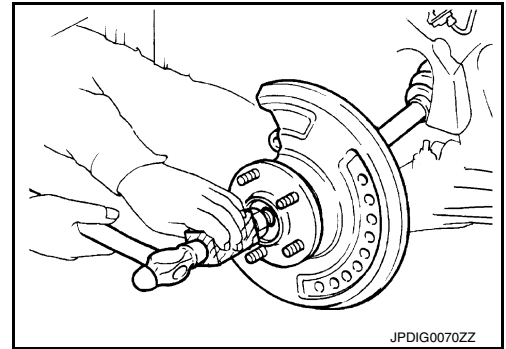

8. Remove wheel hub lock nut.
9. Remove strut assembly from steering knuckle. Refer to [FSU-9, "Removal and Installation"](#).

10. Remove drive shaft from wheel hub assembly.

CAUTION:

- Never place drive shaft joint at an extreme angle. Also be careful not to overextend slide joint.
- Never allow drive shaft to hang down without support for joint sub-assembly, shaft and the other parts.

11. Remove bearing housing bolts.

12. Remove drive shaft assembly from transfer assembly.

CAUTION:

Never place drive shaft joint at an extreme angle when removing drive shaft. Also be careful not to overextend slide joint.

INSTALLATION

Note the following, and install in the reverse order of removal.

Left Side

- Always replace differential side oil seal with new one when installing drive shaft. Refer to [TM-566, "Removal and Installation"](#).

- Place the protector (A) [SST:KV38107900 (—)] onto tranaxle assembly to prevent damage to the oil seal while inserting drive shaft. Slide drive shaft sliding joint and tap with a hammer to install securely.

CAUTION:

- Check that circular clip is completely engaged.
- Never reuse circular clip.
- Never reuse differential side oil seal.

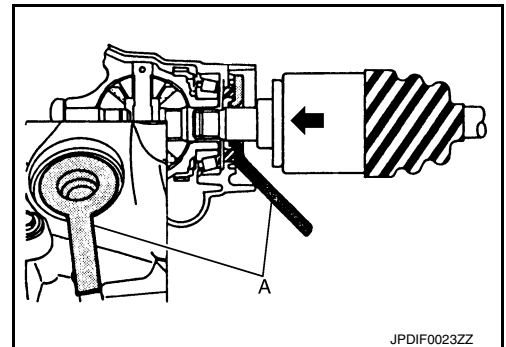

- Clean the matching surface of wheel hub lock nut and wheel hub assembly.

CAUTION:

Never apply lubricating oil to these matching surface.

- Clean the matching surface of drive shaft and wheel hub assembly. And then apply paste [service parts (440037S000)] to surface (A) of joint sub-assembly of drive shaft.

CAUTION:

Apply paste to cover entire flat surface of joint sub-assembly of drive shaft.

Amount paste : 1.0 – 3.0 g (0.04 – 0.10 oz)

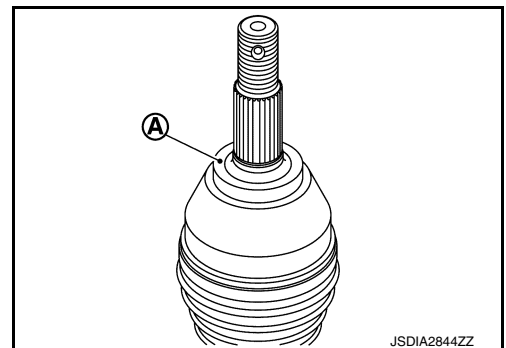

- Use the following torque range for tightening the wheel hub lock nut.

FRONT DRIVE SHAFT

< REMOVAL AND INSTALLATION >

[TYPE 2]

 : 180 – 185 N·m (18.4 – 18.8 kg-m, 133 – 136 ft-lb)

CAUTION:

- Since the drive shaft is assembled by press-fitting, use the tightening torque range for the wheel hub lock nut.
- Be sure to use torque wrench to tighten the wheel hub lock nut. Never use a power tool.
- Never reuse wheel hub lock nut.

NOTE:

Wheel hub lock nut tightening torque does not over torque for avoiding axle noise, and does not less than torque for avoiding looseness.

- Align the matching marks that have been made during removal when reusing the disc rotor.
- When installing a cotter pin (1) and adjusting cap (2), securely bend the basal portion to prevent rattles.

CAUTION:

Never reuse cotter pin.

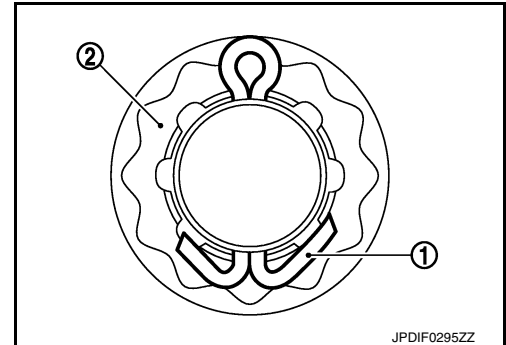

- Perform the final tightening of each of parts under unladen conditions, which were removed when removing wheel hub assembly and steering knuckle.
- Perform inspection after installation. Refer to [FAX-108, "AWD : Inspection"](#).

Right Side

- Always replace transfer cover oil seal (inner) and transfer cover oil seal (outer) with new one when installing drive shaft. Refer to [DLN-94, "Removal and Installation"](#).
- Place the protector (A) [SST:KV38107900 (—)] onto transfer assembly to prevent damage to the transfer cover oil seal (inner) and transfer cover oil seal (outer) while inserting drive shaft. Slide drive shaft sliding joint and tap with a hammer to install securely.

CAUTION:

Never reuse transfer cover oil seal (inner) and transfer cover oil seal (outer).

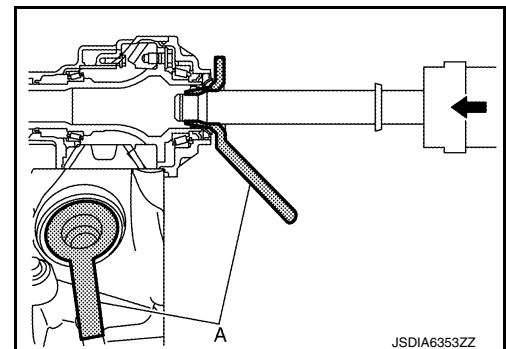

- Tighten the bearing housing bolt to the specified torque. Refer to [FAX-96, "AWD : Exploded View"](#).
- Clean the matching surface of wheel hub lock nut and wheel hub assembly.

CAUTION:

Never apply lubricating oil to these matching surface.

- Clean the matching surface of drive shaft and wheel hub assembly. And then apply paste [service parts (440037S000)] to surface (A) of joint sub-assembly of drive shaft.

CAUTION:

Apply paste to cover entire flat surface of joint sub-assembly of drive shaft.

Amount paste : 1.0 – 3.0 g (0.04 – 0.10 oz)

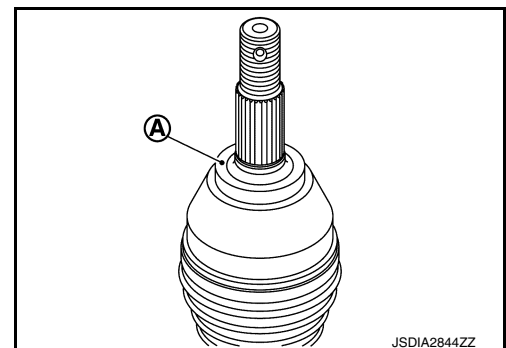

- Use the following torque range for tightening the wheel hub lock nut.

FRONT DRIVE SHAFT

< REMOVAL AND INSTALLATION >

[TYPE 2]

 : 180 – 185 N·m (18.4 – 18.8 kg·m, 133 – 136 ft·lb)

CAUTION:

- Since the drive shaft is assembled by press-fitting, use the tightening torque range for the wheel hub lock nut.
- Be sure to use torque wrench to tighten the wheel hub lock nut. Never use a power tool.
- Never reuse wheel hub lock nut.

NOTE:

Wheel hub lock nut tightening torque does not over torque for avoiding axle noise, and does not less than torque for avoiding looseness.

- Align the matching marks that have been made during removal when reusing the disc rotor.
- When installing a cotter pin (1) and adjusting cap (2), securely bend the basal portion to prevent rattles.

CAUTION:

Never reuse cotter pin.

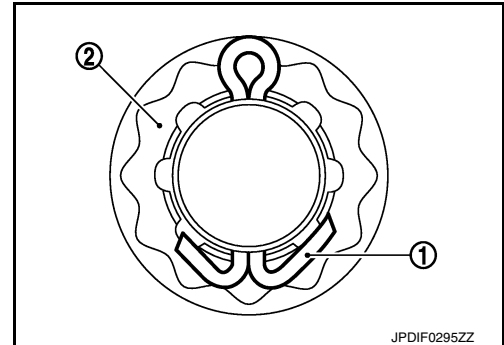

- Perform the final tightening of each of parts under unladen conditions, which were removed when removing wheel hub assembly and steering knuckle.
- Perform inspection after installation. Refer to [FAX-108, "AWD : Inspection"](#).

AWD : Disassembly and Assembly

INFOID:000000012201566

DISASSEMBLY

Wheel Side

1. Fix shaft with a vise.

CAUTION:

Protect shaft using aluminum or copper plates when fixing with a vise.

2. Remove boot bands, and then remove boot from joint sub-assembly.
3. Screw drive shaft puller (A) (commercial service tool) into joint sub-assembly screw part to a length of 30 mm (1.18 in) or more. Support drive shaft with one hand and pull out joint sub-assembly from shaft.

CAUTION:

- Align drive shaft puller and drive shaft and remove them by pulling firmly and uniformly.
- If joint sub-assembly cannot be removed after five or more unsuccessful attempts, replace shaft and joint sub-assembly as a set.

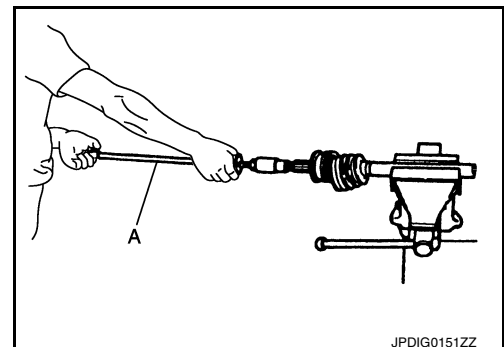

4. Remove circular clip from shaft.
5. Remove boot from shaft.

Transaxle Side (Left Drive Shaft)

1. Fix shaft with a vise.

CAUTION:

Protect shaft using aluminum or copper plates when fixing with a vise.

2. Remove wheel side boot from joint sub-assembly. Refer to [FAX-76, "AWD : Removal and Installation"](#).
3. Remove dynamic damper as per the following instructions:
 - a. Remove damper band.

FRONT DRIVE SHAFT

[TYPE 2]

< REMOVAL AND INSTALLATION >

- b. Remove dynamic damper from housing assembly.
4. Remove boot bands, then remove boot from housing assembly.
5. Remove circular clip from housing assembly.
6. Remove dust shield from housing assembly.

Transaxle Side (Right Drive Shaft)

1. Fix shaft with a vise.

CAUTION:

Protect shaft using aluminum or copper plates when fixing with a vise.

2. Remove wheel side boot from joint sub-assembly. Refer to [FAX-76, "AWD : Removal and Installation"](#).
3. Remove dynamic damper as per the following instructions:
 - a. Remove damper band.
 - b. Remove dynamic damper from housing assembly.
4. Remove boot bands, then remove boot from housing assembly.

ASSEMBLY

Wheel Side

1. Clean the old grease on joint sub-assembly with paper waste.
2. Fill serration slot joint sub-assembly (1) with NISSAN genuine grease or equivalent until the serration slot and ball groove become full to the brim.

CAUTION:

After applying grease, use a paper waste to wipe off old grease that has oozed out.

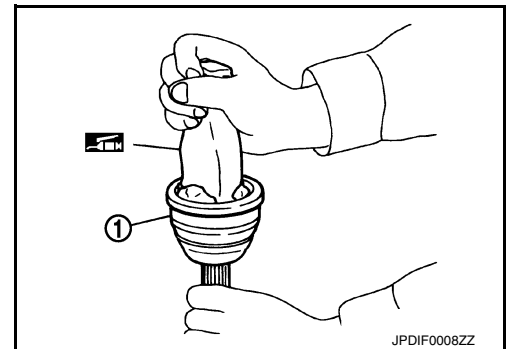

3. Install boot and boot bands to shaft.

CAUTION:

- Wrap serration on shaft with tape (A) to protect the boot from damage.
- Never reuse boot and boot band.

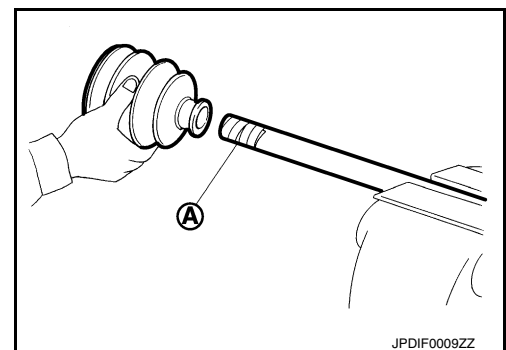

4. Remove the tape wrapped around the serration on shaft.
5. Position the circular clip (1) on groove at the shaft edge.

CAUTION:

Never reuse circular clip.

NOTE:

Drive joint inserter is recommended when installing circular clip.

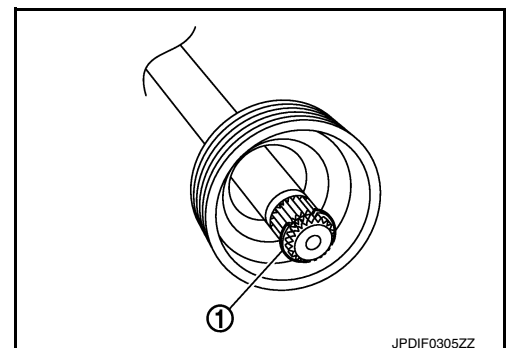

FRONT DRIVE SHAFT

< REMOVAL AND INSTALLATION >

[TYPE 2]

- Align both center axes of the shaft edge and joint sub-assembly. Then assemble shaft with joint sub-assembly holding circular clip.
- Install joint sub-assembly to shaft using plastic hammer.

CAUTION:

- Check circular clip is properly positioned on groove of the joint sub-assembly.
- Confirm that joint sub-assembly is correctly engaged while rotating drive shaft.

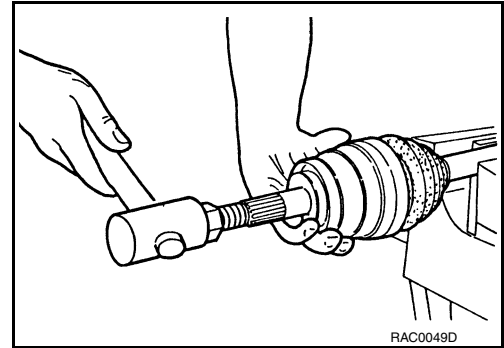

- Apply the specified amount of grease into the boot inside from large diameter side of boot.

Grease amount : Refer to [FAX-109, "Drive Shaft"](#).

- Install the boot securely into grooves (indicated by "*" marks) shown in the figure.

CAUTION:

If grease adheres to the boot mounting surface (indicated by "*" marks) on the shaft or joint sub-assembly, boot may be removed. Remove all grease from the boot mounting surface.

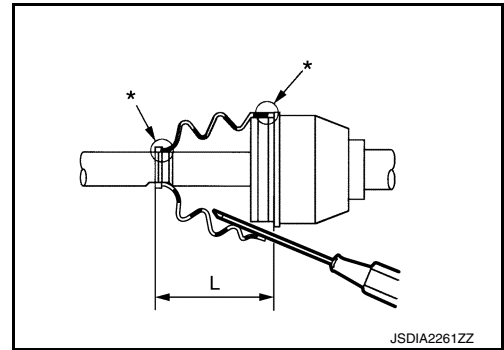

- To prevent the deformation of the boot, adjust the boot installation length (L) to the specified value shown below by inserting the suitable tool into inside of the boot from the large diameter side of the boot and discharging the inside air.

L : Refer to [FAX-109, "Drive Shaft"](#).

CAUTION:

- If the boot installation length exceeds the standard, it may cause breakage of the boot.
- Be careful not to touch the inside of the boot with a tip of tool.

- Secure the large and small ends of the boot with boot bands using the boot band crimping tool (A) [SST:KV40107300 (—)].

CAUTION:

- Never reuse boot band.

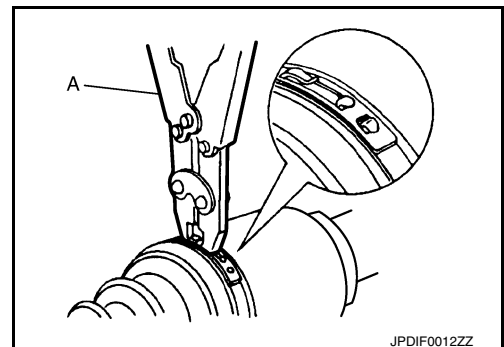

FRONT DRIVE SHAFT

< REMOVAL AND INSTALLATION >

[TYPE 2]

- Secure boot band so that dimension (M) meets the specification as shown in the figure.

Dimension (M) : 2.0 – 3.0 mm (0.079 – 0.118 in)

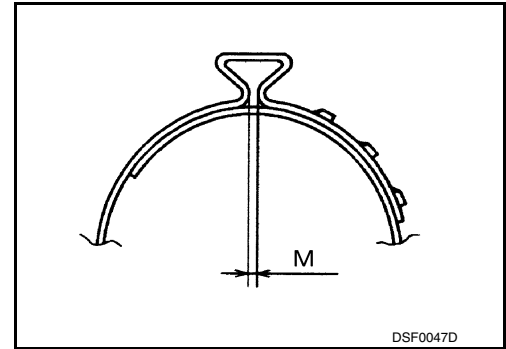

12. Check that displacement does not occur when boot is rotated with the joint sub-assembly and shaft fixed.

CAUTION:

- Reinstall them using boot bands when boot installation positions become incorrect.
- Never reuse boot band.

Transaxle Side (Left Drive Shaft)

1. Clean the old grease on housing assembly with paper waste.
2. Install dust shield to housing assembly.

CAUTION:

Never reuse dust shield.

3. Install circular clip to housing.

CAUTION:

Never reuse circular clip.

4. Install boot and boot bands to housing assembly.

CAUTION:

- Wrap serration on housing assembly with tape (A) to protect the boot from damage.
- Never reuse boot and boot band.

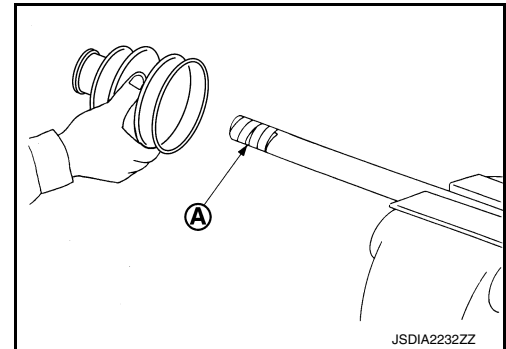

5. Remove the tape wrapped around the serration on shaft.
6. Apply NISSAN genuine grease (refer to parts catalog) to housing assembly.

Grease amount : Refer to [FAX-109, "Drive Shaft"](#).

7. Install the boot securely into grooves (indicated by "*" marks) shown in the figure.

CAUTION:

If grease adheres to the boot mounting surface (indicated by "*" marks) on the shaft or housing assembly, boot may be removed. Remove all grease from the boot mounting surface.

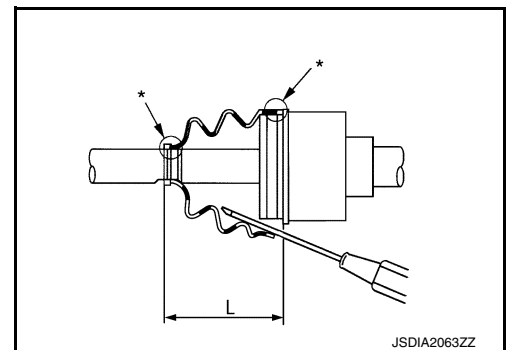

8. To prevent the deformation of the boot, adjust the boot installation length to the value shown below (L) by inserting the suitable tool into the inside of boot from the large diameter side of boot and discharging inside air.

FRONT DRIVE SHAFT

< REMOVAL AND INSTALLATION >

[TYPE 2]

L : Refer to [FAX-109, "Drive Shaft"](#).

CAUTION:

- If the boot installation length exceeds the standard, it may cause breakage of the boot.
- Be careful not to touch the inside of the boot with the tip of tool.

9. Install boot bands securely.

CAUTION:

Never reuse boot bands.

a. Put boot band in the groove on drive shaft boot. Then fit pawls (←) into holes to temporary installation.

NOTE:

For the large diameter side, fit projection (A) and guide slit (B) at first.

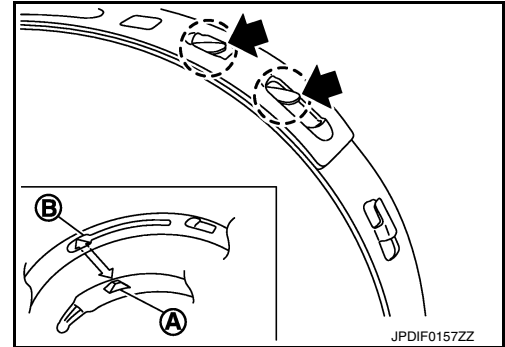

b. Pinch projection on the band with suitable pliers to tighten band.

c. Insert the tip of band into the lower part of pawl (marked with dotted circle) as shown in the figure.

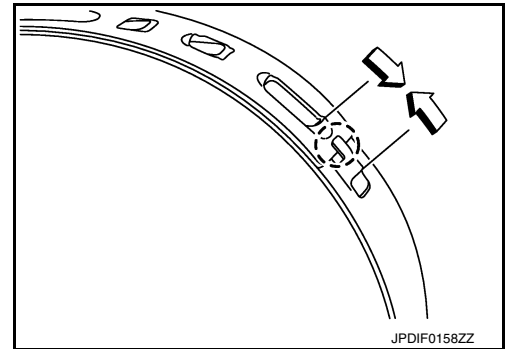

10. Check that displacement does not occur when boot is rotated with the housing assembly fixed.

CAUTION:

- If displacement occurs, reinstall band.
- Never reuse boot band.

11. Install dynamic damper, follow the procedure described below.

a. Install dynamic damper to shaft.

b. Secure dynamic damper with bands in the following specified position (A) when installing.

CAUTION:

Never reuse boot bands.

A : Refer to [FAX-109, "Drive Shaft"](#).

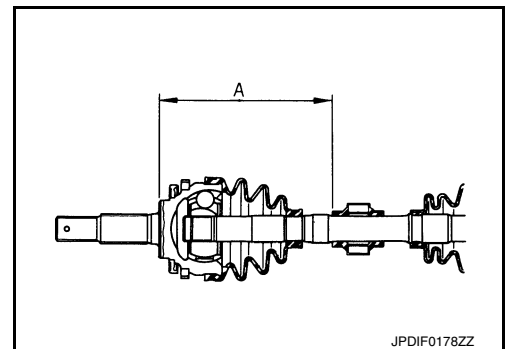

FRONT DRIVE SHAFT

< REMOVAL AND INSTALLATION >

[TYPE 2]

- c. Install boot bands securely as shown in the figure.

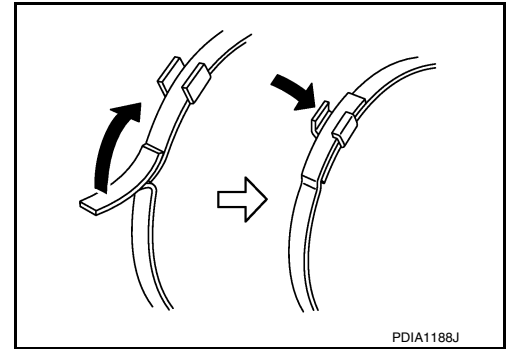

12. Install boot to the wheel side. Refer to [FAX-76. "AWD : Removal and Installation"](#).

Transaxle Side (Right Drive Shaft)

1. Clean the old grease on housing assembly with paper waste.
2. Install boot and boot bands to housing assembly.

CAUTION:

- Wrap serration on housing assembly with tape (A) to protect the boot from damage.
- Never reuse boot and boot band.

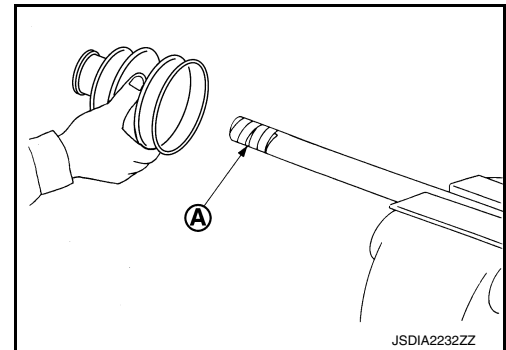

3. Remove the tape wrapped around the serration on shaft.
4. Apply NISSAN genuine grease (refer to parts catalog) to housing assembly.

Grease amount : Refer to [FAX-109. "Drive Shaft"](#).

5. Install the boot securely into grooves (indicated by "*" marks) shown in the figure.

CAUTION:

If grease adheres to the boot mounting surface (indicated by "*" marks) on the shaft or housing assembly, boot may be removed. Remove all grease from the boot mounting surface.

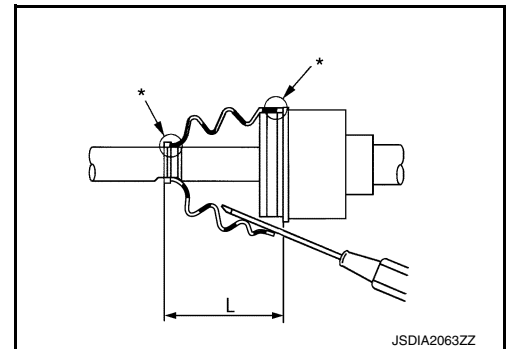

6. To prevent the deformation of the boot, adjust the boot installation length to the value shown below (L) by inserting the suitable tool into the inside of boot from the large diameter side of boot and discharging inside air.

L : Refer to [FAX-109. "Drive Shaft"](#).

CAUTION:

- If the boot installation length exceeds the standard, it may cause breakage of the boot.
- Be careful not to touch the inside of the boot with the tip of tool.

7. Install boot bands securely.

CAUTION:

Never reuse boot bands.

FRONT DRIVE SHAFT

[TYPE 2]

< REMOVAL AND INSTALLATION >

- a. Put boot band in the groove on drive shaft boot. Then fit pawls (←) into holes to temporary installation.

NOTE:

For the large diameter side, fit projection (A) and guide slit (B) at first.

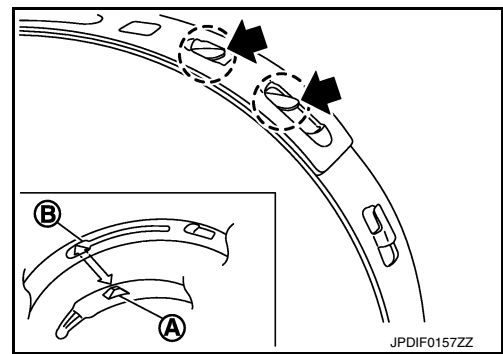

- b. Pinch projection on the band with suitable pliers to tighten band.
c. Insert the tip of band into the lower part of pawl (marked with dotted circle) as shown in the figure.

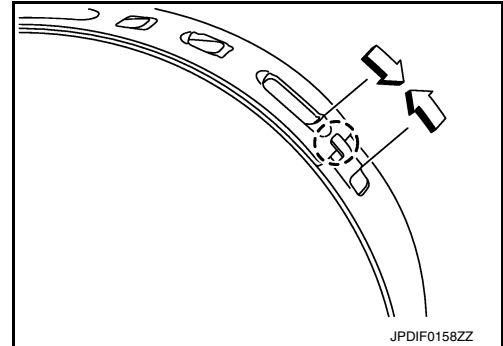

8. Check that displacement does not occur when boot is rotated with the housing assembly fixed.

CAUTION:

- If displacement occurs, reinstall band.
- Never reuse boot band.

9. Install dynamic damper, follow the procedure described below.

- a. Install dynamic damper to shaft.
b. Secure dynamic damper with bands in the following specified position (A) when installing.

CAUTION:

Never reuse bands.

A : Refer to [FAX-109, "Drive Shaft"](#).

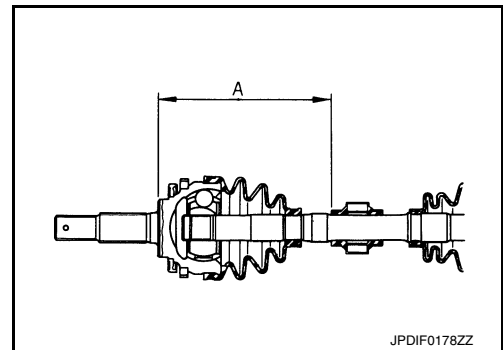

- c. Install boot bands securely as shown in the figure.

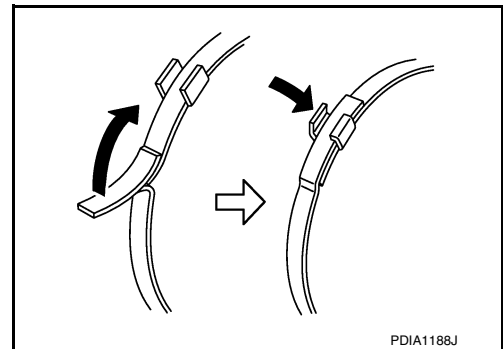

10. Install boot to the wheel side. Refer to [FAX-76, "AWD : Removal and Installation"](#).

A
B
C
FAX
E
F
G
H
I
J
K
L
M
N
O
P

FRONT DRIVE SHAFT

< REMOVAL AND INSTALLATION >

[TYPE 2]

AWD : Inspection

INFOID:000000012201567

INSPECTION AFTER INSTALLATION

1. Check wheel sensor harness for proper connection. Refer to [BRC-147. "FRONT WHEEL SENSOR : Exploded View"](#).
2. Check the wheel alignment. Refer to [FSU-7. "Inspection"](#).
3. Adjust neutral position of steering angle sensor. Refer to [BRC-63. "Work Procedure"](#).

SERVICE DATA AND SPECIFICATIONS (SDS)

< SERVICE DATA AND SPECIFICATIONS (SDS)

[TYPE 2]

SERVICE DATA AND SPECIFICATIONS (SDS)

SERVICE DATA AND SPECIFICATIONS (SDS)

Wheel Bearing

INFOID:0000000012201568

Item	Standard
Axial end play	0.05 mm (0.002 in) or less

Drive Shaft

INFOID:0000000012201569

2WD

Item	Standard	
	Left side	Right side
Grease quantity	Wheel side	115 – 125 g (4.05 – 4.40 oz)
	Transaxle side	132 – 142 g (4.65 – 5.00 oz)
Boots installed length*	Wheel side	97.1 mm (3.82 in)
	Transaxle side	85.0 mm (3.35 in)
Dimension of dynamic damper*	M/T models	267 – 273 mm (10.51 – 10.75 in)
	CVT models	257 – 263 mm (10.12 – 10.35 in)

*: For measuring position, refer to [FAX-87, "2WD : Disassembly and Assembly"](#).

AWD

Item	Standard	
Grease quantity	Wheel side	88 – 108 g (3.10 – 3.80 oz)
	Transaxle side	126 – 136 g (4.45 – 4.79 oz)
Boots installed length*	Wheel side	95.4 mm (3.75 in)
	Transaxle side	93.8 mm (3.69 in)
Dimension of dynamic damper*	267 – 273 mm (10.51 – 10.75 in)	

*: For measuring position, refer to [FAX-101, "AWD : Disassembly and Assembly"](#).