

SECTION **MIR**
MIRRORS

A
B
C
D
E
F
G
H
I
J
K
M
N
O
P

CONTENTS

PRECAUTION	2	SQUEAK AND RATTLE TROUBLE DIAG- NOSES	10
PRECAUTIONS	2	Work Flow	10
Precaution for Supplemental Restraint System (SRS) "AIR BAG" and "SEAT BELT PRE-TEN- SIONER"	2	Inspection Procedure	12
Precautions for Removing Battery Terminal	2	Diagnostic Worksheet	14
PREPARATION	4	REMOVAL AND INSTALLATION	16
PREPARATION	4	INSIDE MIRROR	16
Commercial Service Tools	4	Exploded View	16
SYSTEM DESCRIPTION	5	Removal and Installation	16
COMPONENT PARTS	5	OUTSIDE MIRROR	17
Component Description	5	Exploded View	17
WIRING DIAGRAM	6	DOOR MIRROR ASSEMBLY	17
DOOR MIRROR SYSTEM	6	DOOR MIRROR ASSEMBLY : Removal and In- stallation	17
Wiring Diagram	6	DOOR MIRROR ASSEMBLY : Disassembly and Assembly	18
DTC/CIRCUIT DIAGNOSIS	9	GLASS MIRROR	19
DOOR MIRROR REMOTE CONTROL SWITCH (MIRROR SWITCH/CHANGEVER SWITCH)	9	GLASS MIRROR : Removal and Installation	19
Component Inspection	9	DOOR MIRROR COVER	20
SYMPTOM DIAGNOSIS	10	DOOR MIRROR COVER : Removal and Installa- tion	20
		DOOR MIRROR REMOTE CONTROL SWITCH	21
		Exploded View	21
		Removal and Installation	21

MIR

PRECAUTIONS

< PRECAUTION >

PRECAUTION

PRECAUTIONS

Precaution for Supplemental Restraint System (SRS) "AIR BAG" and "SEAT BELT PRE-TENSIONER"

INFOID:000000012201497

The Supplemental Restraint System such as "AIR BAG" and "SEAT BELT PRE-TENSIONER", used along with a front seat belt, helps to reduce the risk or severity of injury to the driver and front passenger for certain types of collision. This system includes seat belt switch inputs and dual stage front air bag modules. The SRS system uses the seat belt switches to determine the front air bag deployment, and may only deploy one front air bag, depending on the severity of a collision and whether the front occupants are belted or unbelted. Information necessary to service the system safely is included in the "SRS AIR BAG" and "SEAT BELT" of this Service Manual.

WARNING:

Always observe the following items for preventing accidental activation.

- To avoid rendering the SRS inoperative, which could increase the risk of personal injury or death in the event of a collision that would result in air bag inflation, it is recommended that all maintenance and repair be performed by an authorized NISSAN/INFINITI dealer.
- Improper repair, including incorrect removal and installation of the SRS, can lead to personal injury caused by unintentional activation of the system. For removal of Spiral Cable and Air Bag Module, see "SRS AIR BAG".
- Never use electrical test equipment on any circuit related to the SRS unless instructed to in this Service Manual. SRS wiring harnesses can be identified by yellow and/or orange harnesses or harness connectors.

PRECAUTIONS WHEN USING POWER TOOLS (AIR OR ELECTRIC) AND HAMMERS

WARNING:

Always observe the following items for preventing accidental activation.

- When working near the Air Bag Diagnosis Sensor Unit or other Air Bag System sensors with the ignition ON or engine running, never use air or electric power tools or strike near the sensor(s) with a hammer. Heavy vibration could activate the sensor(s) and deploy the air bag(s), possibly causing serious injury.
- When using air or electric power tools or hammers, always switch the ignition OFF, disconnect the battery or batteries, and wait at least 3 minutes before performing any service.

Precautions for Removing Battery Terminal

INFOID:000000012964927

When disconnecting the battery terminal, pay attention to the following.

- Always use a 12V battery as power source.
- Never disconnect battery terminal while engine is running.
- When removing the 12V battery terminal, turn OFF the ignition switch and wait at least 30 seconds.
- For vehicles with the engine listed below, remove the battery terminal after a lapse of the specified time:

D4D engine	: 20 minutes	YS23DDT	: 4 minutes
HRA2DDT	: 12 minutes	YS23DDTT	: 4 minutes
K9K engine	: 4 minutes	ZD30DDTi	: 60 seconds
M9R engine	: 4 minutes	ZD30DDTT	: 60 seconds
R9M engine	: 4 minutes		
V9X engine	: 4 minutes		
YD25DDTi	: 2 minutes		

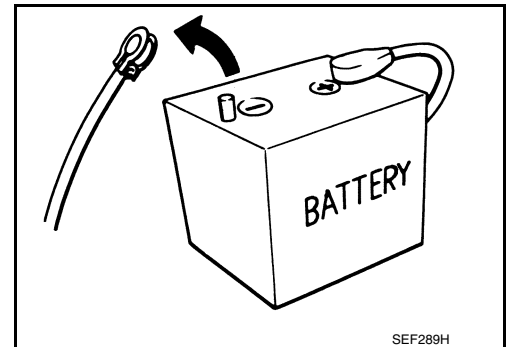

SEF289H

NOTE:

ECU may be active for several tens of seconds after the ignition switch is turned OFF. If the battery terminal is removed before ECU stops, then a DTC detection error or ECU data corruption may occur.

- After high-load driving, if the vehicle is equipped with the V9X engine, turn the ignition switch OFF and wait for at least 15 minutes to remove the battery terminal.

NOTE:

PRECAUTIONS

< PRECAUTION >

- Turbocharger cooling pump may operate in a few minutes after the ignition switch is turned OFF.
- Example of high-load driving
 - Driving for 30 minutes or more at 140 km/h (86 MPH) or more.
 - Driving for 30 minutes or more on a steep slope.
- For vehicles with the 2-batteries, be sure to connect the main battery and the sub battery before turning ON the ignition switch.

A

B

C

NOTE:

If the ignition switch is turned ON with any one of the terminals of main battery and sub battery disconnected, then DTC may be detected.

- After installing the 12V battery, always check "Self Diagnosis Result" of all ECUs and erase DTC.

D

E

F

G

H

I

J

K

MIR

M

N

O

P

PREPARATION

< PREPARATION >

PREPARATION

PREPARATION

Commercial Service Tools

INFOID:000000012201500

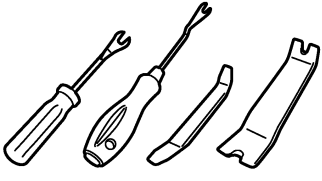
Tool name	Description
Remover tool  JMKIA3050ZZ	Removes the clips, pawls and metal clips

COMPONENT PARTS

< SYSTEM DESCRIPTION >

SYSTEM DESCRIPTION

COMPONENT PARTS

Component Description

INFOID:0000000012201501

Item	Function
Door mirror remote control switch (mirror switch)	It supplies power to mirror motor through mirror switch and changeover switch.
Door mirror remote control switch (changeover switch)	It transmits the LH/RH control of door mirror that supplies power.
Door mirror motor	It makes mirror face operate from side to side and up and down via integrated motor.

A

B

C

D

E

F

G

H

I

J

K

MIR

M

N

O

P

DOOR MIRROR SYSTEM

< WIRING DIAGRAM >

WIRING DIAGRAM

DOOR MIRROR SYSTEM

Wiring Diagram

INFOID:000000012201502

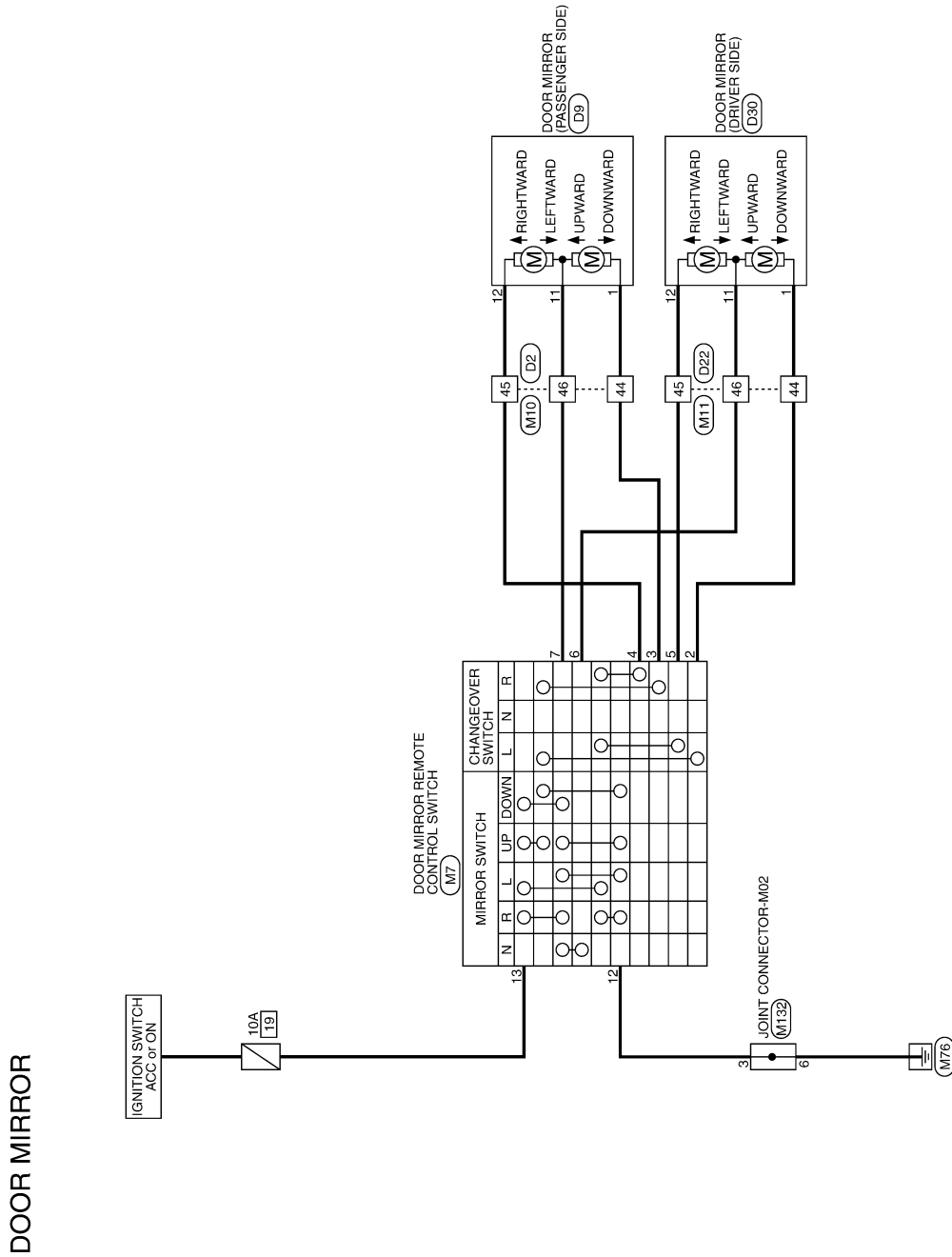

DOOR MIRROR SYSTEM

< WIRING DIAGRAM >

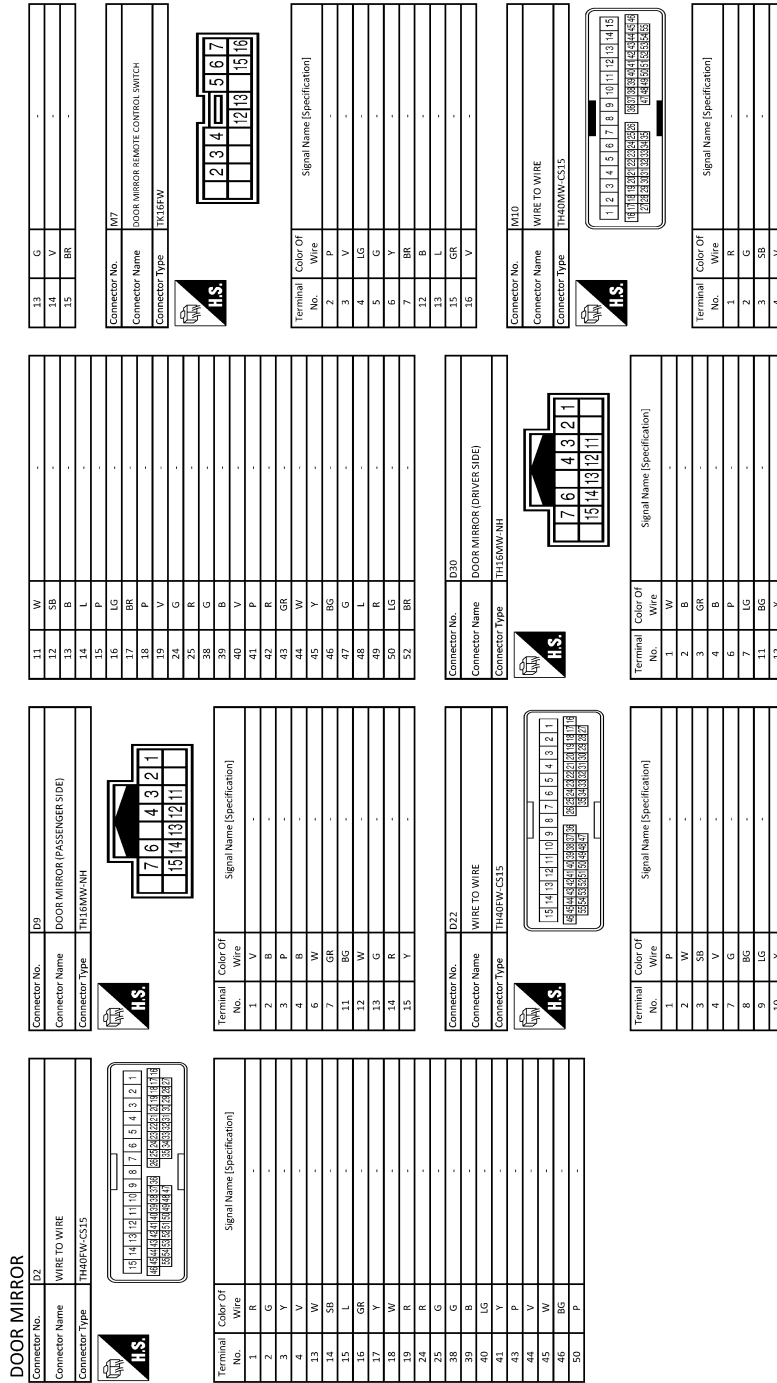

JRLWF5309GB

A
B
C
D
E
F
G
H
I
J
K
M
N
O
P

MIR

DOOR MIRROR SYSTEM

< WIRING DIAGRAM >

DOOR MIRROR

13	GR	-	-
14	GR	-	-
15	GR	-	-
16	SHIELD	-	-
17	W	-	-
18	V	-	-
19	G	-	-
20	L	-	-
21	R	-	-
22	G	-	-
23	B	-	-
24	BR	-	-
25	G	-	-
26	B	-	-
27	G	-	-
28	V	-	-
29	Y	-	-
30	GR	-	-
31	L	-	-
32	V	-	-
33	R	-	-
34	LG	-	-
35	BR	-	-
36	P	-	-

Connector No.	M11
Connector Name	WIRE TO WIRE
Connector Type	TH40DW-C515



Terminal No.	Color Of Wire	Signal Name (Specification)
1	GR	-
2	W	-
3	SB	-
4	V	-
5	R	-
6	G	-
7	LG	-
8	Y	-
9	GR	-
10	GR	-
11	GR	-
12	GR	-
13	B	-
14	L	-
15	P	-
16	SHIELD	-
17	R	-
18	B	-

37	W	-	-
38	BR	-	-
39	W	-	-
40	M	-	-
41	B	-	-
42	V	-	-
43	P	-	-
44	V	-	-
45	G	-	-
46	Y	-	-
47	GR	-	-
48	L	-	-
49	R	-	-
50	LG	-	-
51	BR	-	-
52	BR	-	-

Connector No.	M132
Connector Name	JOINT CONNECTOR-M02
Connector Type	HN20FL-DC

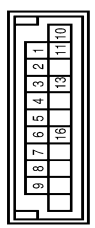

Terminal No.	Color Of Wire	Signal Name (Specification)
1	B	-
2	B	-
3	B	-
4	B	-
5	B	-
6	B	-
7	B	-
8	B	-
9	B	-
10	LG	-
11	LG	-
12	LG	-
13	LG	-
14	LG	-
15	LG	-
16	LG	-

DOOR MIRROR REMOTE CONTROL SWITCH (MIRROR SWITCH/ CHANGEOVER SWITCH)

< DTC/CIRCUIT DIAGNOSIS >

DTC/CIRCUIT DIAGNOSIS

DOOR MIRROR REMOTE CONTROL SWITCH (MIRROR SWITCH/ CHANGEOVER SWITCH)

Component Inspection

INFOID:0000000012201503

1. CHECK MIRROR SWITCH & CHANGEOVER SWITCH

1. Turn ignition switch OFF.
2. Disconnect door mirror remote control switch connector.
3. Check door mirror remote control switch.

Door mirror remote control switch		condition		Continuity	
Terminal		Change over switch	Mirror switch		
Driver side	13	6	LEFT	RIGHT	
	12	5		LEFT	
	13	5		UP	
	12	6		DOWN	
	13	2		RIGHT	RIGHT
	12	6			LEFT
	13	6			UP
	12	2			DOWN
Passenger side	13	7	RIGHT	RIGHT	
	12	4		LEFT	
	13	4		UP	
	12	7		DOWN	
	13	3		LEFT	RIGHT
	12	7			LEFT
	13	7			UP
	12	3			DOWN

Is the inspection result normal?

YES >> INSPECTION END.

NO >> Replace door mirror remote control switch. Refer to [MIR-21, "Removal and Installation"](#).

MIR

SQUEAK AND RATTLE TROUBLE DIAGNOSES

< SYMPTOM DIAGNOSIS >

SYMPTOM DIAGNOSIS

SQUEAK AND RATTLE TROUBLE DIAGNOSES

Work Flow

INFOID:000000012201504

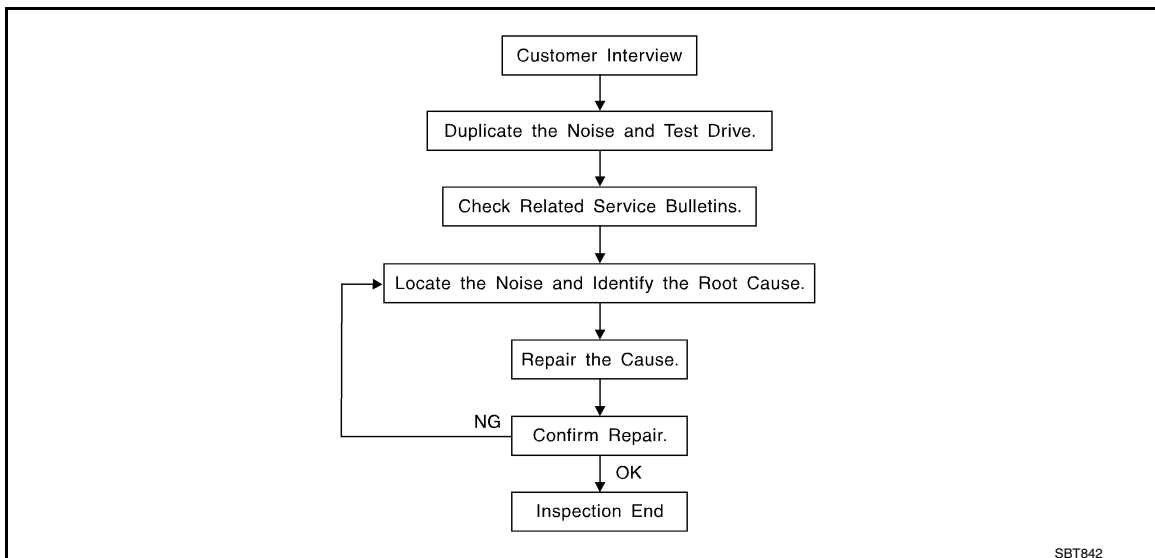

CUSTOMER INTERVIEW

Interview the customer if possible, to determine the conditions that exist when the noise occurs. Use the Diagnostic Worksheet during the interview to document the facts and conditions when the noise occurs and any customer comments. Refer to [MIR-14, "Diagnostic Worksheet"](#). This information is necessary to duplicate the conditions that exist when the noise occurs.

- The customer may not be able to provide a detailed description or the location of the noise. Attempt to obtain all the facts and conditions that exist when the noise occurs (or does not occur).
- If there is more than one noise in the vehicle, perform a diagnosis and repair the noise that the customer is concerned about. This can be accomplished by performing a test drive with the customer.
- After identifying the type of noise, isolate the noise in terms of its characteristics. The noise characteristics are provided so that the customer, service adviser, and technician use the same language when describing the noise.
- Squeak – (Like tennis shoes on a clean floor)
Squeak characteristics include the light contact / fast movement / brought on by road conditions / hard surfaces = high-pitched noise / softer surfaces = low-pitched noises / edge to surface = chirping
- Creak – (Like walking on an old wooden floor)
Creak characteristics include firm contact / slow movement/twisting with a rotational movement / pitch dependent on materials / often brought on by activity.
- Rattle – (Like shaking a baby rattle)
Rattle characteristics include fast repeated contact / vibration or similar movement / loose parts/missing clip or fastener / incorrect clearance.
- Knock – (Like a knock on a door)
Knock characteristics include hollow sounds / sometimes repeating / often brought on by driver action.
- Tick – (Like a clock second hand)
Tick characteristics include gentle contacting of light materials / loose components / can be caused by driver action or road conditions.
- Thump – (Heavy, muffled knock noise)
Thump characteristics include softer knock / dull sounds often brought on by activity.
- Buzz – (Like a bumblebee)
Buzz characteristics include high frequency rattle / firm contact.
- Often the degree of acceptable noise level varies depending upon the person. A noise that a technician may judge as acceptable may be very irritating to a customer.
- Weather conditions, especially humidity and temperature, may have a great effect on noise level.

DUPLICATE THE NOISE AND TEST DRIVE

SQUEAK AND RATTLE TROUBLE DIAGNOSES

< SYMPTOM DIAGNOSIS >

If possible, drive the vehicle with the customer until the noise is duplicated. Note any additional information on the Diagnostic Worksheet regarding the conditions or location of the noise. This information can be used to duplicate the same conditions when the repair is reconfirmed.

If the noise can be duplicated easily during the test drive, to help identify the source of the noise, try to duplicate the noise with the vehicle stopped by doing one or all of the following items:

- 1) Close a door.
 - 2) Tap or push/pull around the area where the noise appears to be coming from.
 - 3) Rev the engine.
 - 4) Use a floor jack to recreate vehicle "twist".
 - 5) At idle, apply engine load (electrical load, half-clutch on M/T models, drive position on A/T models).
 - 6) Raise the vehicle on a hoist and hit a tire with a rubber hammer.
- Drive the vehicle and attempt to duplicate the conditions the customer states exist when the noise occurs.
 - If it is difficult to duplicate the noise, drive the vehicle slowly on an undulating or rough road to stress the vehicle body.

CHECK RELATED SERVICE BULLETINS

After verifying the customer concern or symptom, check ASIST for Technical Service Bulletins (TSBs) related to the concern or symptom.

If a TSB relates to the symptom, follow the procedure to repair the noise.

LOCATE THE NOISE AND IDENTIFY THE ROOT CAUSE

1. Narrow down the noise to a general area. To help pinpoint the source of the noise, use a listening tool (Chassis ear: J-39570, engine ear, and mechanics stethoscope).
2. Narrow down the noise to a more specific area and identify the cause of the noise by:
 - Removing the component(s) in the area that is / are suspected to be the cause of the noise. Do not use too much force when removing clips and fasteners, otherwise clips and fasteners can be broken or lost during the repair, resulting in the creation of new noise.
 - Tapping or pushing/pulling the component(s) that is / are suspected to be the cause of the noise. Do not tap or push/pull the component(s) with excessive force, otherwise the noise is eliminated only temporarily.
 - Feeling for a vibration by hand by touching the component(s) that is / are suspected to be the cause of the noise.
 - Placing a piece of paper between components that are suspected to be the cause of the noise.
 - Looking for loose components and contact marks.
Refer to [MIR-12. "Inspection Procedure"](#).

REPAIR THE CAUSE

- If the cause is a loose component, tighten the component securely.
- If the cause is insufficient clearance between components:
 - Separate components by repositioning or loosening and retightening the components, if possible.
 - Insulate components with a suitable insulator such as urethane pads, foam blocks, felt cloth tape, or urethane tape. A NISSAN Squeak and Rattle Kit (J-50397) is available through the authorized NISSAN Parts Department.

CAUTION:

Never use excessive force as many components are constructed of plastic and may be damaged.

NOTE:

Always check with the Parts Department for the latest parts information.

The following materials are contained in the NISSAN Squeak and Rattle Kit (J-50397) are listed on the inside cover of the kit; and can each be ordered separately as needed.

URETHANE PADS [1.5 mm (0.059 in) thick]

Insulates connectors, harness, etc.

- 76268-9E005: 100 × 135 mm (3.937 × 5.315 in)
- 76884-71L01: 60 × 85 mm (2.362 × 3.346 in)
- 76884-71L02: 15 × 25 mm (0.591 × 0.984 in)

INSULATOR (Foam blocks)

Insulates components from contact. Can be used to fill space behind a panel.

- 73982-9E000: 45 mm (1.772 in) thick, 50 × 50 mm (1.969 × 1.969 in)
- 73982-50Y00: 10 mm (0.394 in) thick, 50 × 50 mm (1.969 × 1.969 in)

INSULATOR (Light foam block)

80845-71L00: 30 mm (1.181 in) thick, 30 × 50 mm (1.181 × 1.969 in)

FELT CLOTHTAPE

SQUEAK AND RATTLE TROUBLE DIAGNOSES

< SYMPTOM DIAGNOSIS >

Used to insulate where movement does not occur. Ideal for instrument panel applications.

- 68370-4B000: 15 × 25 mm (0.591 × 0.984 in) pad
- 68239-13E00: 5 mm (0.197 in) wide tape roll

The following materials, not found in the kit, can also be used to repair squeaks and rattles.

UHMW (TEFLON) TAPE

Insulates where slight movement is present. Ideal for instrument panel applications.

SILICONE GREASE

Used in place of UHMW tape that is visible or does not fit. Only lasts a few months.

SILICONE SPRAY

Used when grease cannot be applied.

DUCT TAPE

Used to eliminate movement.

CONFIRM THE REPAIR

After repair is complete, test drive the vehicle to confirm that the cause of noise is repaired by test driving the vehicle. Operate the vehicle under the same conditions as when the noise originally occurred. Refer to the notes on the Diagnostic Worksheet.

Inspection Procedure

INFOID:000000012201505

Refer to Table of Contents for specific component removal and installation information.

INSTRUMENT PANEL

Most incidents are caused by contact and movement between:

1. The cluster lid A and instrument panel
2. Acrylic lens and combination meter housing
3. Instrument panel to front pillar garnish
4. Instrument panel to windshield
5. Instrument panel mounting pins
6. Wiring harnesses behind the combination meter
7. A/C defroster duct and duct joint

These incidents can usually be located by tapping or moving the components to duplicate the noise or by pressing on the components while driving to stop the noise. Most of these incidents can be repaired by applying felt cloth tape or silicon spray (in hard to reach areas). Urethane pads can be used to insulate wiring harness.

CAUTION:

Never use silicone spray to isolate a squeak or rattle. If the area is saturated with silicone, the recheck of repair becomes impossible.

CENTER CONSOLE

Components to check include:

1. Shifter assembly cover to finisher
2. A/C control unit and cluster lid C
3. Wiring harnesses behind audio and A/C control unit

The instrument panel repair and isolation procedures also apply to the center console.

DOORS

Check the following items:

1. Finisher and inner panel making a slapping noise
2. Inside handle escutcheon connection to door finisher
3. Wiring harnesses tapping
4. Door striker out of alignment causing a popping noise on starts and stops

Tapping, moving the components, or pressing on them while driving to duplicate the conditions can isolate many of these incidents. The areas can usually be insulated with felt cloth tape or insulator foam blocks from the NISSAN Squeak and Rattle Kit (J-50397) to repair the noise.

TRUNK

Trunk noises are often caused by a loose jack or loose items put into the trunk by the customer.

In addition check for the following items:

SQUEAK AND RATTLE TROUBLE DIAGNOSES

< SYMPTOM DIAGNOSIS >

1. Trunk lid dumpers out of adjustment
2. Trunk lid striker out of adjustment
3. Trunk lid torsion bars knocking together
4. A loose license plate or bracket

Most of these incidents can be repaired by adjusting, securing, or insulating the item(s) or component(s) causing the noise.

SUNROOF/HEADLINING

Noises in the sunroof / headlining area can often be traced to one of the following items:

1. Sunroof lid, rail, linkage, or seals making a rattle or light knocking noise
2. Sunvisor shaft shaking in the holder
3. Front or rear windshield touching headlining and squeaking

Again, pressing on the components to stop the noise while duplicating the conditions can isolate most of these incidents. Repairs usually consist of insulating with felt cloth tape.

SEATS

When isolating seat noise it is important to note the position the seat is in and the load placed on the seat when the noise occurs. These conditions should be duplicated when verifying and isolating the cause of the noise.

Causes of seat noise include:

1. Headrest rods and holder
2. A squeak between the seat pad cushion and frame
3. The rear seatback lock and bracket

These noises can be isolated by moving or pressing on the suspected components while duplicating the conditions under which the noise occurs. Most of these incidents can be repaired by repositioning the component or applying urethane tape to the contact area.

UNDERHOOD

Some interior noise may be caused by components under the hood or on the engine wall. The noise is then transmitted into the passenger compartment.

Causes of transmitted underhood noise include:

1. Any component mounted to the engine wall
2. Components that pass through the engine wall
3. Engine wall mounts and connectors
4. Loose radiator mounting pins
5. Hood bumpers out of adjustment
6. Hood striker out of adjustment

These noises can be difficult to isolate since they cannot be reached from the interior of the vehicle. The best method is to secure, move, or insulate one component at a time and test drive the vehicle. Also, engine RPM or load can be changed to isolate the noise. Repairs can usually be made by moving, adjusting, securing, or insulating the component causing the noise.

A
B
C
D
E
F
G
H
I
J
K
M
N
O
P

MIR

SQUEAK AND RATTLE TROUBLE DIAGNOSES

< SYMPTOM DIAGNOSIS >

Diagnostic Worksheet

INFOID:000000012201506



SQUEAK & RATTLE DIAGNOSTIC WORKSHEET

Dear Nissan Customer:

We are concerned about your satisfaction with your Nissan vehicle. Repairing a squeak or rattle sometimes can be very difficult. To help us fix your Nissan right the first time, please take a moment to note the area of the vehicle where the squeak or rattle occurs and under what conditions. You may be asked to take a test drive with a service advisor or technician to ensure we confirm the noise you are hearing.

I. WHERE DOES THE NOISE COME FROM? (circle the area of the vehicle)

The illustrations are for reference only, and may not reflect the actual configuration of your vehicle.

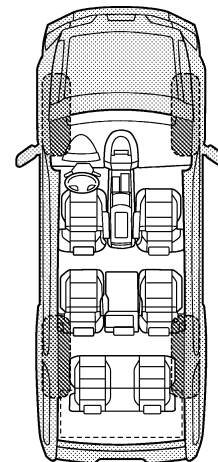
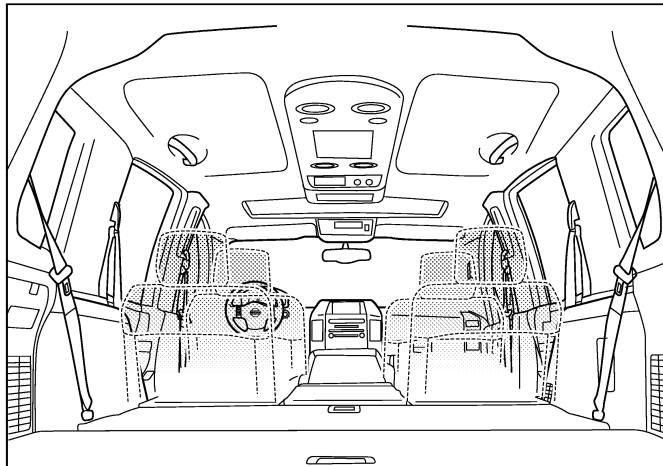
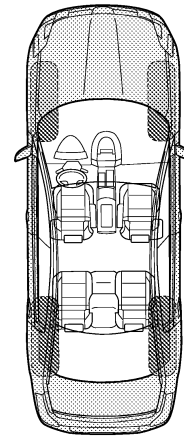
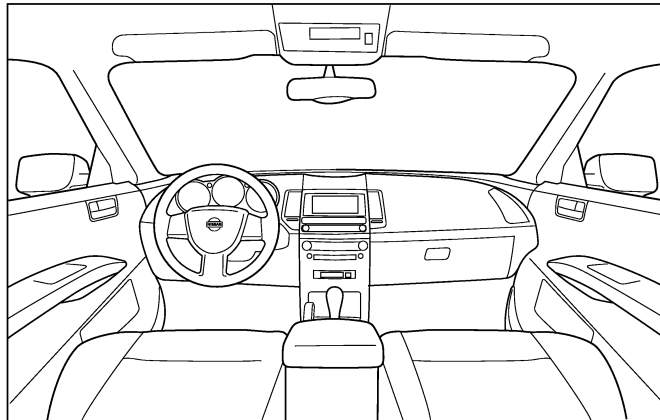

Continue to page 2 of the worksheet and briefly describe the location of the noise or rattle. In addition, please indicate the conditions which are present when the noise occurs.

PIIB8740E

SQUEAK AND RATTLE TROUBLE DIAGNOSES

< SYMPTOM DIAGNOSIS >

SQUEAK & RATTLE DIAGNOSTIC WORKSHEET - page 2

Briefly describe the location where the noise occurs:

II. WHEN DOES IT OCCUR? (please check the boxes that apply)

- | | |
|---|--|
| <input type="checkbox"/> anytime | <input type="checkbox"/> after sitting out in the rain |
| <input type="checkbox"/> 1st time in the morning | <input type="checkbox"/> when it is raining or wet |
| <input type="checkbox"/> only when it is cold outside | <input type="checkbox"/> dry or dusty conditions |
| <input type="checkbox"/> only when it is hot outside | <input type="checkbox"/> other: |

III. WHEN DRIVING:

- through driveways
- over rough roads
- over speed bumps
- only about ____ mph
- on acceleration
- coming to a stop
- on turns: left, right or either (circle)
- with passengers or cargo
- other: _____
- after driving ____ miles or ____ minutes

IV. WHAT TYPE OF NOISE

- squeak (like tennis shoes on a clean floor)
- creak (like walking on an old wooden floor)
- rattle (like shaking a baby rattle)
- knock (like a knock at the door)
- tick (like a clock second hand)
- thump (heavy, muffled knock noise)
- buzz (like a bumble bee)

TO BE COMPLETED BY DEALERSHIP PERSONNEL

Test Drive Notes:

	YES	NO	Initials of person performing
Vehicle test driven with customer	<input type="checkbox"/>	<input type="checkbox"/>	_____
- Noise verified on test drive	<input type="checkbox"/>	<input type="checkbox"/>	_____
- Noise source located and repaired	<input type="checkbox"/>	<input type="checkbox"/>	_____
- Follow up test drive performed to confirm repair	<input type="checkbox"/>	<input type="checkbox"/>	_____

VIN: _____ Customer Name: _____
W.O.# _____ Date: _____

This form must be attached to Work Order

PIIB8742E

A
B
C
D
E
F
G
H
I
J
K
M
N
O
P

MIR

INSIDE MIRROR

< REMOVAL AND INSTALLATION >

REMOVAL AND INSTALLATION

INSIDE MIRROR

Exploded View

INFOID:000000012201507

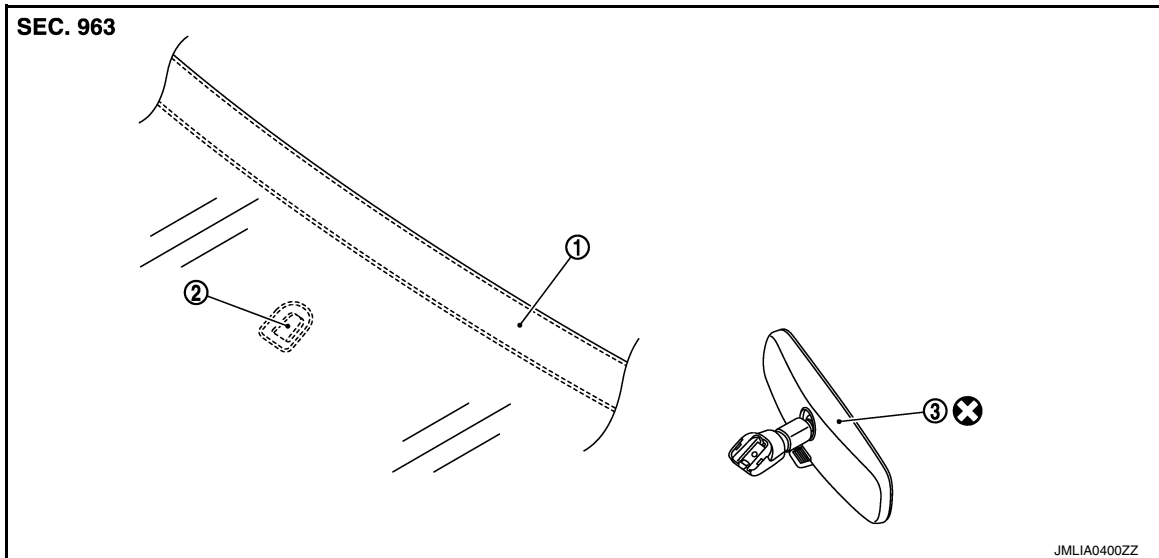

1. Windshield glass

2. Mirror base

3. Inside mirror assembly

⊗ : Always replace after every disassembly.

Removal and Installation

INFOID:000000012201508

CAUTION:

Never reuse the inside mirror assembly disassembled from mirror base.

REMOVAL

Slide the inside mirror assembly upward to remove.

NOTE:

Insert flat-bladed screwdriver (A) under the inside mirror (1). Slide the inside mirror to the upper side while pushing the pawl downward.

⊗ : Always replace after every disassembly.

CAUTION:

Never use excessive force to remove the inside mirror because it is inserted tightly into the mirror base.

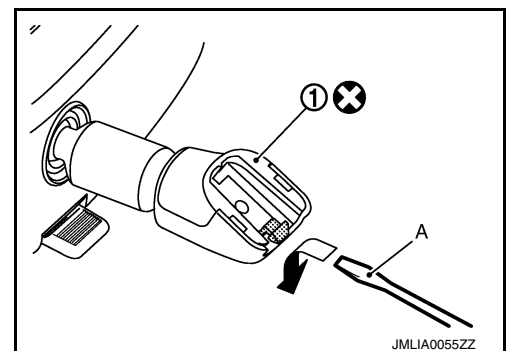

INSTALLATION

Install in the reverse order of removal.

OUTSIDE MIRROR

< REMOVAL AND INSTALLATION >

OUTSIDE MIRROR

Exploded View

INFOID:000000012201509

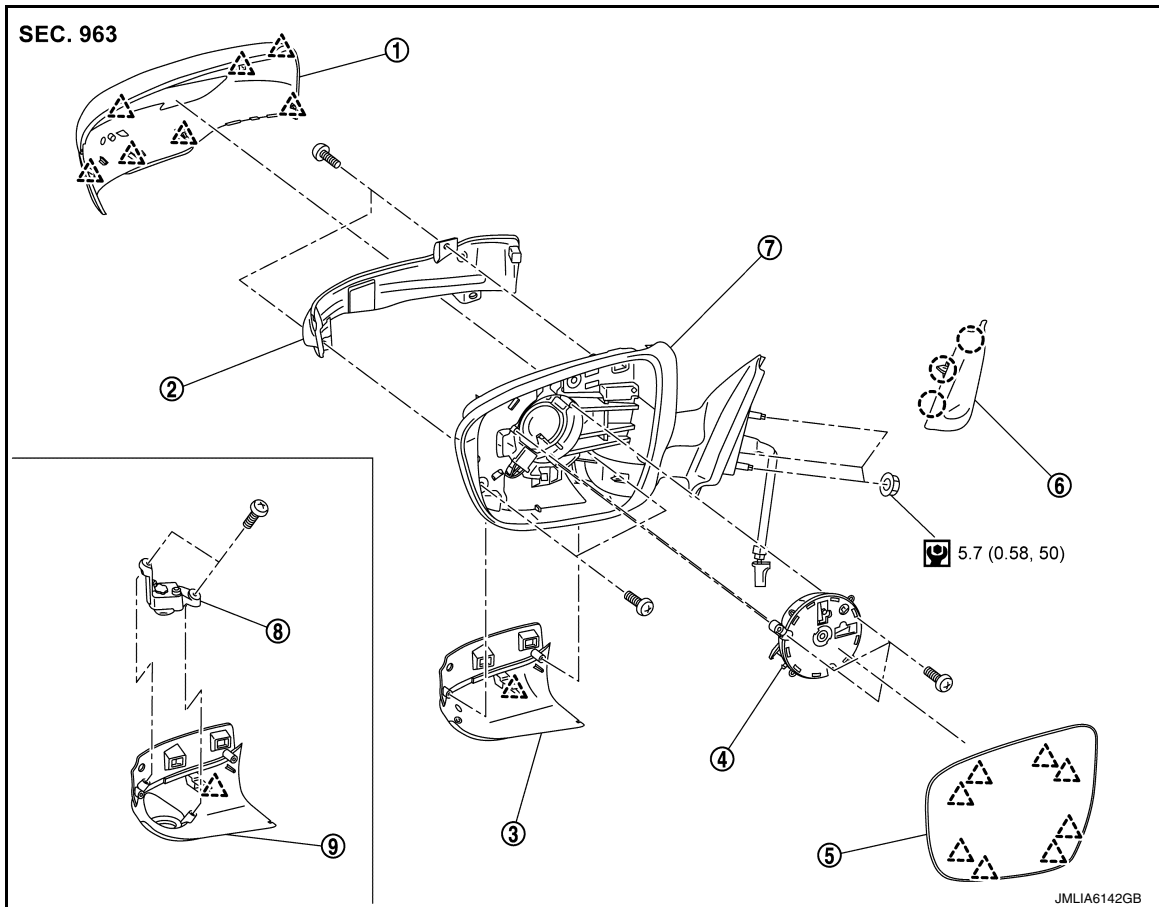

- | | | |
|-------------------------|--|---|
| 1. Door mirror cover | 2. Side turn signal lamp | 3. Door mirror finisher
(without around view monitor system) |
| 4. Door mirror actuator | 5. Glass mirror | 6. Door mirror corner cover |
| 7. Door mirror housing | 8. Side camera assembly
(with around view monitor system) | 9. Side camera finisher
(with around view monitor system) |

 : Clip

 : Pawl

 N·m (kg·m, in·lb)

DOOR MIRROR ASSEMBLY

DOOR MIRROR ASSEMBLY : Removal and Installation

INFOID:000000012201510

CAUTION:

When removing, always use a remover tool that is made of plastic.

REMOVAL

A
B
C
D
E
F
G
H
I
J
K
M
N
O
P

MIR

OUTSIDE MIRROR

< REMOVAL AND INSTALLATION >

1. Disengage door mirror corner cover fixing clips using a remover tool (A), and then remove door mirror corner cover.

 : Clip

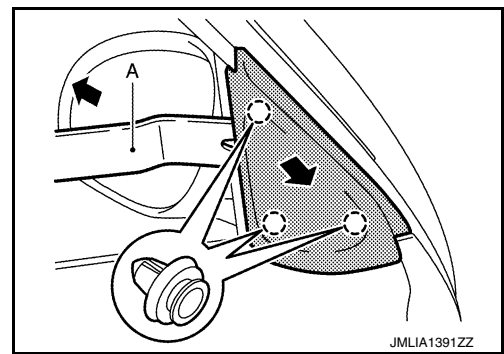

2. Remove front door finisher. Refer to [INT-13, "Removal and Installation"](#).
3. Disconnect door mirror harness connector.
4. Remove door mirror mounting nuts, and then remove door mirror assembly.

INSTALLATION

Install in the reverse order of removal.

DOOR MIRROR ASSEMBLY : Disassembly and Assembly

INFOID:000000012201511

DISASSEMBLY

1. Remove door mirror assembly. Refer to [MIR-17, "DOOR MIRROR ASSEMBLY : Removal and Installation"](#).
2. Remove glass mirror. Refer to [MIR-19, "GLASS MIRROR : Removal and Installation"](#).
3. Remove door mirror actuator mounting bolts (A), and disconnect harness connector (B), and then remove door mirror actuator.

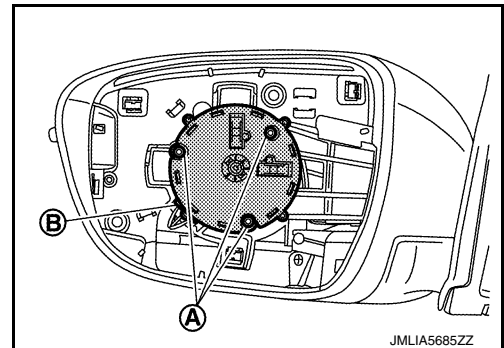

4. Disengage door mirror cover and door mirror finisher (without around view monitor system) or side camera finisher (with around view monitor system). Refer to [MIR-20, "DOOR MIRROR COVER : Removal and Installation"](#).
5. Disconnect side camera harness connector (with around view monitor system).
6. Remove side camera bracket fixing screws (A), and then remove side camera assembly from door mirror finisher. (with around view monitor system)

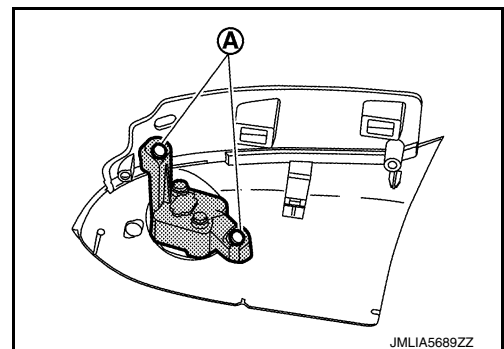

7. Remove side turn signal lamp. Refer to the following.
 - Xenon type: Refer to [EXL-104, "Removal and Installation"](#).
 - Halogen type: Refer to [EXL-215, "Removal and Installation"](#).

ASSEMBLY

Note the following item, and then assemble in the reverse order of disassembly.

OUTSIDE MIRROR

< REMOVAL AND INSTALLATION >

CAUTION:

Perform side camera image calibration (with side camera). Refer to [AV-116, "CALIBRATING CAMERA IMAGE \(AROUND VIEW MONITOR\) : Description"](#).

GLASS MIRROR

GLASS MIRROR : Removal and Installation

INFOID:000000012201512

REMOVAL

1. Place the glass mirror inward.
2. Apply protective tape (A) on door mirror housing and glass mirror to protect it from damage.

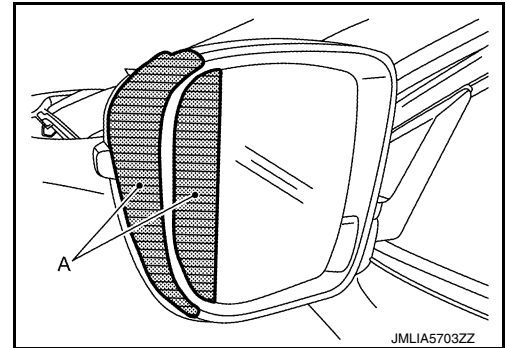

3. Insert remover tool (A) into the recess at outside between glass mirror and door mirror actuator, and then disengage the door mirror fixing pawls.

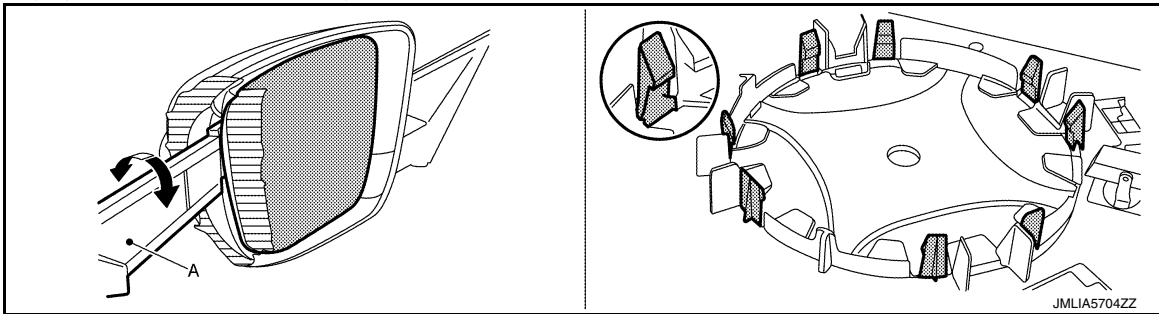

CAUTION:

Remove the pawls slowly so they are not damaged.

NOTE:

Insert remover tool into recesses, and push up while rotating (twisting) to make work easier.

4. Disconnect heater mirror terminals (A). (with heater mirror)

CAUTION:

Make a mark (short note, photo, etc.) of terminals layout, before disassembly.

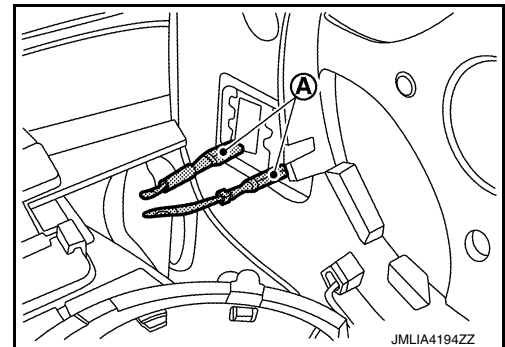

5. Remove glass mirror.

INSTALLATION

Note the following item, and then install in the reverse order of removal.

CAUTION:

After installation, visually check that pawls are securely engaged.

A
B
C
D
E
F
G
H
I
J
K
M
N
O
P

MIR

OUTSIDE MIRROR

< REMOVAL AND INSTALLATION >

DOOR MIRROR COVER

DOOR MIRROR COVER : Removal and Installation

INFOID:000000012201513

REMOVAL

1. Remove the glass mirror. Refer to [MIR-19. "GLASS MIRROR : Removal and Installation"](#).
2. Remove door mirror finisher (without around view monitor system) or side camera finisher (with around view monitor system) fixing screws (A), disengage door mirror cover and door mirror finisher (without around view monitor system) or side camera finisher (with around view monitor system) fixing pawls pushed in the direction of the arrows as shown in figure.

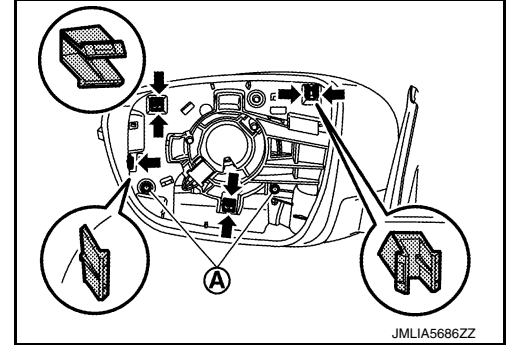

3. Disengage door mirror cover fixing pawls, and then remove door mirror cover (1) and door mirror finisher (without around view monitor system) or side camera finisher (with around view monitor system) (2).

 : Pawl

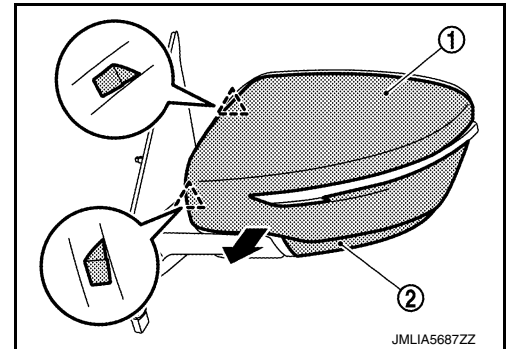

4. Disconnect side camera harness connector. (with around view monitor system)
5. Disengage door mirror cover fixing pawls, remove door mirror cover (1) from door mirror finisher (without around view monitor system) or side camera finisher (with around view monitor system) (2) indicated by arrows as shown in the figure.

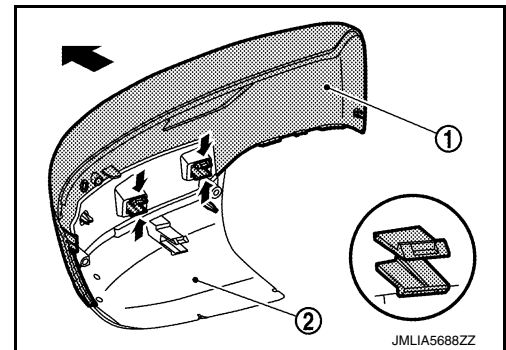

INSTALLATION

Note the following item and then install in the reverse order of removal.

CAUTION:

After installation, visually check that pawls are securely engaged.

DOOR MIRROR REMOTE CONTROL SWITCH

< REMOVAL AND INSTALLATION >

DOOR MIRROR REMOTE CONTROL SWITCH

Exploded View

INFOID:000000012201514

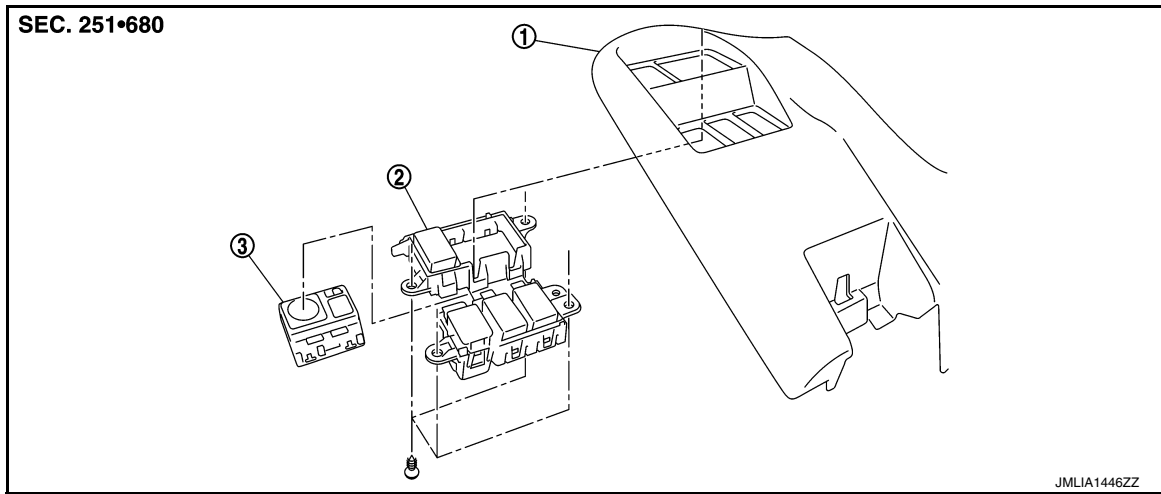

1. Instrument lower panel

2. Switch bracket

3. Door mirror remote control switch

Removal and Installation

INFOID:000000012201515

REMOVAL

1. Remove the instrument lower panel. Refer to [IP-13. "Removal and Installation"](#).
2. Remove mounting screws and remove switch bracket from instrument lower panel.
3. Remove door mirror remote control switch (1) from switch bracket (2) using remover tool (A).

 : Pawl

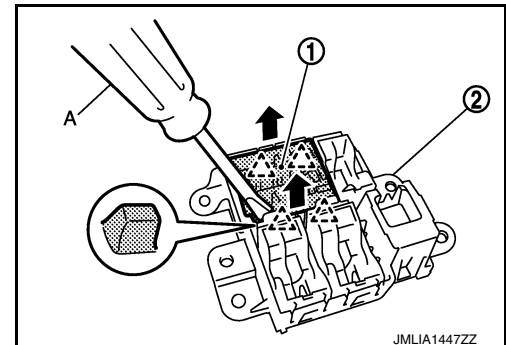

INSTALLATION

Install in the reverse order of removal.

A
B
C
D
E
F
G
H
I
J
K
M
N
O
P

MIR