

SECTION **DEF**
DEFOGGER

A
B
C

CONTENTS

PRECAUTION	3	REAR WINDOW DEFOGGER : CONSULT Function (BCM - REAR DEFOGGER)	11	F
PRECAUTIONS	3	DIAGNOSIS SYSTEM (IPDM E/R)	13	G
Precaution for Supplemental Restraint System (SRS) "AIR BAG" and "SEAT BELT PRE-TENSIONER"	3	WITH INTELLIGENT KEY	13	H
SYSTEM DESCRIPTION	4	WITH INTELLIGENT KEY : Diagnosis Description	13	
COMPONENT PARTS	4	WITH INTELLIGENT KEY : CONSULT Function (IPDM E/R)	15	I
Component Parts Location	4	WITHOUT INTELLIGENT KEY	17	J
Component Description	4	WITHOUT INTELLIGENT KEY : Diagnosis Description	17	
SYSTEM	6	WITHOUT INTELLIGENT KEY : CONSULT Function (IPDM E/R)	19	K
WITH AUTO A/C	6	ECU DIAGNOSIS INFORMATION	21	
WITH AUTO A/C : System Diagram	6	BCM, IPDM E/R	21	
WITH AUTO A/C : System Description	6	List of ECU Reference	21	
WITHOUT AUTO A/C	6	BASIC INSPECTION	22	DEF
WITHOUT AUTO A/C : System Diagram	6	DIAGNOSIS AND REPAIR WORK FLOW	22	
WITHOUT AUTO A/C : System Description	7	Work Flow	22	M
DIAGNOSIS SYSTEM (BCM) (WITH INTELLIGENT KEY SYSTEM)	8	DTC/CIRCUIT DIAGNOSIS	23	N
COMMON ITEM	8	REAR WINDOW DEFOGGER SWITCH	23	
COMMON ITEM : CONSULT Function (BCM - COMMON ITEM)	8	WITH AUTO A/C	23	O
REAR WINDOW DEFOGGER	9	WITH AUTO A/C : Description	23	
REAR WINDOW DEFOGGER : CONSULT Function (BCM - REAR DEFOGGER)	9	WITH AUTO A/C : Component Function Check	23	
DIAGNOSIS SYSTEM (BCM) (WITHOUT INTELLIGENT KEY SYSTEM)	11	WITH AUTO A/C : Diagnosis Procedure	23	P
COMMON ITEM	11	WITHOUT AUTO A/C	23	
COMMON ITEM : CONSULT Function (BCM - COMMON ITEM)	11	WITHOUT AUTO A/C : Description	23	
REAR WINDOW DEFOGGER	11	WITHOUT AUTO A/C : Component Function Check	23	
		WITHOUT AUTO A/C : Diagnosis Procedure	23	
		WITHOUT AUTO A/C : Component Inspection	24	

D
E

F
G

H
I

J
K

M

N
O

P

REAR WINDOW DEFOGGER RELAY	26	Description	35
Description	26	Diagnosis Procedure	35
Component Function Check	26		
Diagnosis Procedure	26		
REAR WINDOW DEFOGGER	27	REAR WINDOW DEFOGGER DOES NOT OPERATE BUT BOTH DOOR MIRROR DEFOGGERS OPERATE	36
Description	27	Diagnosis Procedure	36
Component Function Check	27		
Diagnosis Procedure	27	DOOR MIRROR DEFOGGER DOES NOT OPERATE	37
Component Inspection	28		
DOOR MIRROR DEFOGGER	30	BOTH SIDES	37
Description	30	BOTH SIDES : Description	37
Component Function Check	30	BOTH SIDES : Diagnosis Procedure	37
Diagnosis Procedure	30	DRIVER SIDE	37
DRIVER SIDE DOOR MIRROR DEFOGGER ...	31	DRIVER SIDE : Description	37
Description	31	DRIVER SIDE : Diagnosis Procedure	37
Component Function Check	31	PASSENGER SIDE	37
Diagnosis Procedure	31	PASSENGER SIDE : Description	37
PASSENGER SIDE DOOR MIRROR DEFOGGER	32	PASSENGER SIDE : Diagnosis Procedure	37
Description	32	ON IS NOT DISPLAYED WHEN PRESSING REAR WINDOW DEFOGGER SWITCH BUT IT IS OPERATED	39
Component Function Check	32	Diagnosis Procedure	39
Diagnosis Procedure	32	REAR WINDOW DEFOGGER INDICATOR DOES NOT ILLUMINATE	40
REAR WINDOW DEFOGGER FEEDBACK SIGNAL	33	Diagnosis Procedure	40
Description	33	REMOVAL AND INSTALLATION	41
Component Function Check	33	FILAMENT	41
Diagnosis Procedure	33	Inspection and Repair	41
REAR WINDOW DEFOGGER SYSTEM	34	CONDENSER	43
Wiring Diagram - DEFOGGER CONTROL SYSTEM -	34	Exploded View	43
SYMPTOM DIAGNOSIS	35	Removal and Installation	43
ALL DEFOGGER SYSTEMS DO NOT OPERATE	35		

PRECAUTIONS

< PRECAUTION >

PRECAUTION

PRECAUTIONS

Precaution for Supplemental Restraint System (SRS) "AIR BAG" and "SEAT BELT PRE-TENSIONER"

INFOID:000000007579478

The Supplemental Restraint System such as "AIR BAG" and "SEAT BELT PRE-TENSIONER", used along with a front seat belt, helps to reduce the risk or severity of injury to the driver and front passenger for certain types of collision. This system includes seat belt switch inputs and dual stage front air bag modules. The SRS system uses the seat belt switches to determine the front air bag deployment, and may only deploy one front air bag, depending on the severity of a collision and whether the front occupants are belted or unbelted. Information necessary to service the system safely is included in the "SRS AIR BAG" and "SEAT BELT" of this Service Manual.

WARNING:

Always observe the following items for preventing accidental activation.

- To avoid rendering the SRS inoperative, which could increase the risk of personal injury or death in the event of a collision that would result in air bag inflation, all maintenance must be performed by an authorized NISSAN/INFINITI dealer.
- Improper maintenance, including incorrect removal and installation of the SRS, can lead to personal injury caused by unintentional activation of the system. For removal of Spiral Cable and Air Bag Module, see "SRS AIR BAG".
- Never use electrical test equipment on any circuit related to the SRS unless instructed to in this Service Manual. SRS wiring harnesses can be identified by yellow and/or orange harnesses or harness connectors.

PRECAUTIONS WHEN USING POWER TOOLS (AIR OR ELECTRIC) AND HAMMERS

WARNING:

Always observe the following items for preventing accidental activation.

- When working near the Air Bag Diagnosis Sensor Unit or other Air Bag System sensors with the ignition ON or engine running, never use air or electric power tools or strike near the sensor(s) with a hammer. Heavy vibration could activate the sensor(s) and deploy the air bag(s), possibly causing serious injury.
- When using air or electric power tools or hammers, always switch the ignition OFF, disconnect the battery, and wait at least 3 minutes before performing any service.

A
B
C
D
E
F
G
H
I
J
K
DEF
M
N
O
P

DEF

COMPONENT PARTS

< SYSTEM DESCRIPTION >

SYSTEM DESCRIPTION

COMPONENT PARTS

Component Parts Location

INFOID:000000007579480

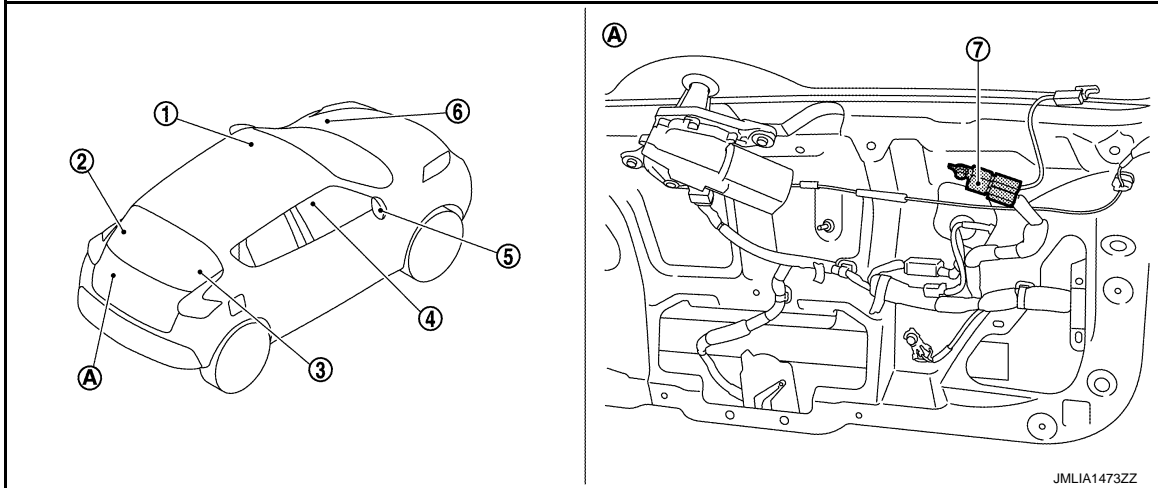

- | | | |
|--|-----------------------------------|---|
| 1. BCM
Refer to BCS-6. "BODY CONTROL SYSTEM : Component Parts Location" | 2. Rear window defogger connector | 3. Rear window defogger connector |
| 4. Multidisplay unit*1
A/C control*2
(Rear window defogger switch) | 5. Door mirror defogger*3 | 6. IPDM E/R
Refer to PCS-5. "Component Parts Location" |
| 7. Condenser | | |

*1:With automatic A/C

*2:With manual A/C

*3:For models with door mirror defogger

Component Description

INFOID:000000007579481

BCM	<ul style="list-style-type: none"> Transmits rear window defogger control signal to IPDM E/R via CAN communication Performs the timer control of rear window defogger
IPDM E/R	<ul style="list-style-type: none"> Rear window defogger relay is installed. Receives rear window defogger control signal from BCM via CAN communication. Controls rear window defogger relay.
<ul style="list-style-type: none"> Multidisplay unit*1 A/C control*2 	<ul style="list-style-type: none"> The rear window defogger switch is installed Turns the indicator lamp ON when detecting the operation of rear window defogger
Rear window defogger switch	<ul style="list-style-type: none"> Rear window defogger and door mirror defogger*3 are operated by turning the rear window defogger switch ON. The indicator lamp in the rear window defogger illuminates when the rear window defogger is operating.
Rear window defogger relay	Operates rear window defogger and door mirror defogger*3 with IPDM E/R control.
Rear window defogger	Heats the heating wire with the power supply from the rear window defogger relay to prevent the rear window from fogging up.
Door mirror defogger*3	Heats the heating wire with the power supply from the rear window defogger relay to prevent the door mirror from fogging up.

COMPONENT PARTS

< SYSTEM DESCRIPTION >

*1:With automatic A/C

*2:With manual A/C

*3:For models with door mirror defogger

A

B

C

D

E

F

G

H

I

J

K

DEF

M

N

O

P

SYSTEM

< SYSTEM DESCRIPTION >

SYSTEM

WITH AUTO A/C

WITH AUTO A/C : System Diagram

INFOID:000000007579482

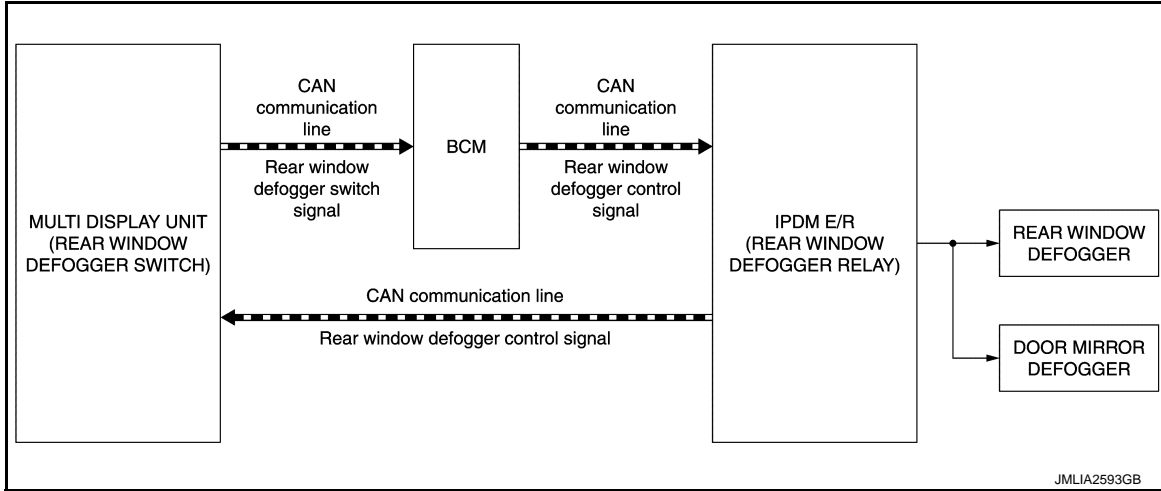

WITH AUTO A/C : System Description

INFOID:000000007579483

OPERATION DESCRIPTION

- BCM detects that the rear window defogger switch turns ON while ignition switch is ON, and then transmits the rear window defogger control signal to IPDM E/R via CAN communication for approximately 15 minutes.
- IPDM E/R turns rear window defogger relay ON when it receives rear window defogger control signal.
- The power is supplied to rear window defogger and door mirror defogger* when the rear window defogger relay turns ON.
- When rear window defogger is activated, indicator lamp on rear window defogger switch turns ON.

*: For models with door mirror defogger.

TIMER FUNCTION

- BCM transmits rear window defogger control signal to IPDM E/R for approximately 15 minutes when rear window defogger switch is turns ON while ignition switch is ON. Then, IPDM E/R activates rear window defogger and door mirror defogger*.
- The timer is cancelled if the rear window defogger switch is pressed again during timer operation. BCM stops the output of rear window defogger control signal. The same action occurs during timer operation if the ignition switch is OFF.

*: For models with door mirror defogger.

WITHOUT AUTO A/C

WITHOUT AUTO A/C : System Diagram

INFOID:000000007579484

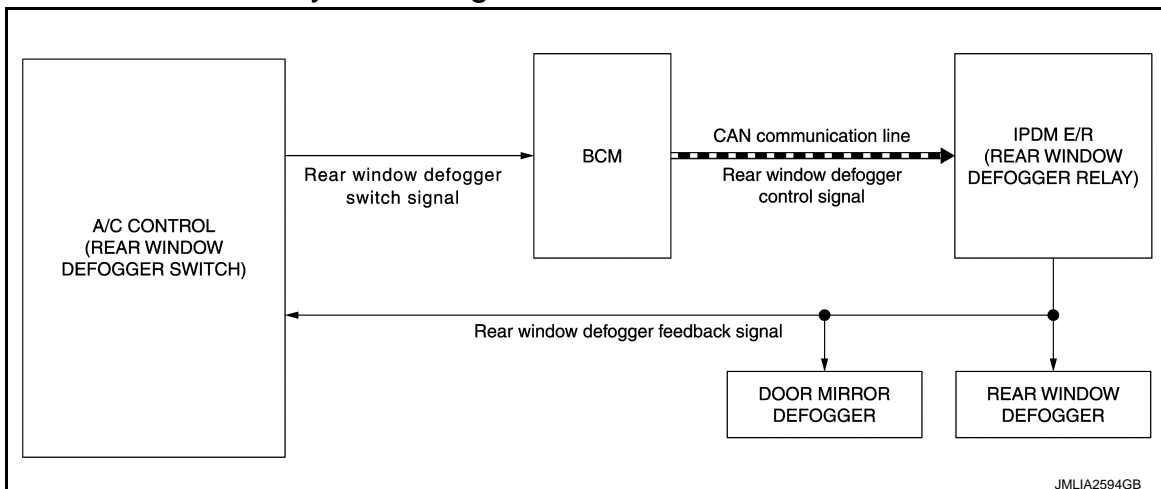

SYSTEM

< SYSTEM DESCRIPTION >

WITHOUT AUTO A/C : System Description

INFOID:000000007579485

OPERATION DESCRIPTION

- BCM detects that rear window defogger switch turns ON while ignition switch is ON, and then transmits rear window defogger control signal to IPDM E/R via CAN communication for approximately 15 minutes.
- IPDM E/R turns rear window defogger relay ON when it receives rear window defogger control signal.
- The power is supplied to rear window defogger and door mirror defogger* when rear window defogger relay turns ON.
- When rear window defogger is activated, indicator lamp on rear window defogger switch turns ON.

*: For models with door mirror defogger.

TIMER FUNCTION

- BCM transmits rear window defogger control signal to IPDM E/R for approximately 15 minutes when the rear window defogger switch is turns ON while ignition switch is ON. Then, IPDM E/R activates rear window defogger and door mirror defogger*.
- The timer is cancelled if the rear window defogger switch is pressed again during timer operation. BCM stops the output of rear window defogger control signal. The same action occurs during timer operation if the ignition switch is OFF.

*: For models with door mirror defogger.

A
B
C
D
E
F
G
H
I
J
K
DEF
M
N
O
P

DEF

DIAGNOSIS SYSTEM (BCM) (WITH INTELLIGENT KEY SYSTEM)

< SYSTEM DESCRIPTION >

DIAGNOSIS SYSTEM (BCM) (WITH INTELLIGENT KEY SYSTEM) COMMON ITEM

COMMON ITEM : CONSULT Function (BCM - COMMON ITEM)

INFOID:000000007808994

APPLICATION ITEM

CONSULT performs the following functions via CAN communication with BCM.

Diagnosis mode	Function Description
Work Support	Changes the setting for each system function.
Self Diagnostic Result	Displays the diagnosis results judged by BCM.
CAN Diag Support Monitor	Monitors the reception status of CAN communication viewed from BCM.
Data Monitor	The BCM input/output signals are displayed.
Active Test	The signals used to activate each device are forcibly supplied from BCM.
Ecu Identification	The BCM part number is displayed.
Configuration	<ul style="list-style-type: none"> Read and save the vehicle specification. Write the vehicle specification when replacing BCM.

SYSTEM APPLICATION

BCM can perform the following functions for each system.

NOTE:

It can perform the diagnosis modes except the following for all sub system selection items.

×: Applicable item

System	Sub system selection item	Diagnosis mode		
		Work Support	Data Monitor	Active Test
Door lock	DOOR LOCK	×	×	×
Rear window defogger	REAR DEFOGGER		×	×
Warning chime	BUZZER		×	×
Interior room lamp timer	INT LAMP	×	×	×
Exterior lamp	HEAD LAMP	×	×	×
Wiper and washer	WIPER	×	×	×
Turn signal and hazard warning lamps	FLASHER	×	×	×
Air conditioning system	AIR CONDITONER		×	×*
<ul style="list-style-type: none"> Intelligent Key system Engine start system 	INTELLIGENT KEY	×	×	×
Combination switch	COMB SW		×	
Body control system	BCM	×		
NVIS - NATS	IMMU	×	×	×
Interior room lamp battery saver	BATTERY SAVER	×	×	×
Back door open	TRUNK		×	
Theft warning alarm	THEFT ALM	×	×	×
RAP	RETAINED PWR		×	
Signal buffer system	SIGNAL BUFFER		×	×
TPMS	AIR PRESSURE MONITOR	×	×	×

NOTE:

*: For models with automatic A/C, this diagnosis mode is not used.

FREEZE FRAME DATA (FFD)

The BCM records the following vehicle condition at the time a particular DTC is detected, and displays on CONSULT.

DIAGNOSIS SYSTEM (BCM) (WITH INTELLIGENT KEY SYSTEM)

< SYSTEM DESCRIPTION >

CONSULT screen item	Indication/Unit	Description		
Vehicle Speed	km/h	Vehicle speed of the moment a particular DTC is detected		A
Odo/Trip Meter	km	Total mileage (Odometer value) of the moment a particular DTC is detected		
Vehicle Condition	SLEEP>LOCK	Power position status of the moment a particular DTC is detected	While turning BCM status from low power consumption mode to normal mode (Power position is "LOCK".)	B
	SLEEP>OFF		While turning BCM status from low power consumption mode to normal mode (Power position is "OFF".)	C
	LOCK>ACC		While turning power position from "LOCK"* to "ACC"	
	ACC>ON		While turning power position from "ACC" to "IGN"	D
	RUN>ACC		While turning power position from "RUN" to "ACC" (Vehicle is stopping and selector lever is except P position.)	
	CRANK>RUN		While turning power position from "CRANKING" to "RUN" (From cranking up the engine to run it)	E
	RUN>URGENT		While turning power position from "RUN" to "ACC" (Emergency stop operation)	
	ACC>OFF		While turning power position from "ACC" to "OFF"	F
	OFF>LOCK		While turning power position from "OFF" to "LOCK"*	
	OFF>ACC		While turning power position from "OFF" to "ACC"	G
	ON>CRANK		While turning power position from "IGN" to "CRANKING"	
	OFF>SLEEP		While turning BCM status from normal mode (Power position is "OFF".) to low power consumption mode	H
	LOCK>SLEEP		While turning BCM status from normal mode (Power position is "LOCK".) to low power consumption mode	
	LOCK		Power position is "LOCK"*	I
	OFF		Power position is "OFF" (Ignition switch OFF)	
	ACC		Power position is "ACC" (Ignition switch ACC)	J
	ON		Power position is "IGN" (Ignition switch ON with engine stopped)	
	ENGINE RUN		Power position is "RUN" (Ignition switch ON with engine running)	K
CRANKING	Power position is "CRANKING" (At engine cranking)			
IGN Counter	0 - 39	The number of times that ignition switch is turned ON after DTC is detected <ul style="list-style-type: none"> • The number is 0 when a malfunction is detected now. • The number increases like 1 → 2 → 3...38 → 39 after returning to the normal condition whenever ignition switch OFF → ON. • The number is fixed to 39 until the self-diagnosis results are erased if it is over 39. 		DEF

NOTE:

*: Power position shifts to "LOCK" from "OFF", when ignition switch is in the OFF position, selector lever is in the P position (A/T models and CVT models), and any of the following conditions are met.

- Closing door
- Opening door
- Door is locked using door request switch
- Door is locked using Intelligent Key

The power position shifts to "ACC" when the push-button ignition switch (push switch) is pushed at "LOCK".

REAR WINDOW DEFOGGER

REAR WINDOW DEFOGGER : CONSULT Function (BCM - REAR DEFOGGER)

INFOID:000000007579487

Data monitor

DIAGNOSIS SYSTEM (BCM) (WITH INTELLIGENT KEY SYSTEM)

< SYSTEM DESCRIPTION >

Monitor Item	Description
REAR DEF SW	Displays "Press (ON)/other (OFF)" status determined with the rear window defogger switch.
PUSH SW	Indicates [ON/OFF] condition of push switch.

ACTIVE TEST

Test Item	Description
REAR DEFOGGER	Rear window defogger operates when "ON" on CONSULT screen is touched.

DIAGNOSIS SYSTEM (BCM) (WITHOUT INTELLIGENT KEY SYSTEM)

< SYSTEM DESCRIPTION >

DIAGNOSIS SYSTEM (BCM) (WITHOUT INTELLIGENT KEY SYSTEM) COMMON ITEM

COMMON ITEM : CONSULT Function (BCM - COMMON ITEM)

INFOID:000000007808995

APPLICATION ITEM

CONSULT performs the following functions via CAN communication with BCM.

Diagnosis mode	Function Description
Work Support	Changes the setting for each system function.
Self Diagnostic Result	Displays the diagnosis results judged by BCM.
CAN Diag Support Monitor	Monitors the reception status of CAN communication viewed from BCM.
Data Monitor	The BCM input/output signals are displayed.
Active Test	The signals used to activate each device are forcibly supplied from BCM.
Ecu Identification	The BCM part number is displayed.
Configuration	<ul style="list-style-type: none"> Read and save the vehicle specification. Write the vehicle specification when replacing BCM.

SYSTEM APPLICATION

BCM can perform the following functions for each system.

NOTE:

It can perform the diagnosis modes except the following for all sub system selection items.

x: Applicable item

System	Sub system selection item	Diagnosis mode		
		Work Support	Data Monitor	Active Test
Door lock	DOOR LOCK	x	x	x
Rear window defogger	REAR DEFOGGER		x	x
Warning chime	BUZZER		x	x
Interior room lamp control	INT LAMP	x	x	x
Remote keyless entry system	MULTI REMOTE ENT	x	x	x
Exterior lamp	HEAD LAMP	x	x	x
Wiper and washer	WIPER	x	x	x
Turn signal and hazard warning lamps	FLASHER		x	x
Air conditioning system	AIR CONDITONER		x	x
Combination switch	COMB SW		x	
Body control system	BCM	x		
NATS	IMMU	x		x
Interior room lamp battery saver	BATTERY SAVER	x	x	x
Back door open	TRUNK		x	
Theft warning alarm	THEFT ALM	x	x	x
RAP system	RETAINED PWR		x	x
Signal buffer system	SIGNAL BUFFER		x	x
Panic alarm	PANIC ALARM			x
TPMS	AIR PRESSUE MONITOR	x	x	x

REAR WINDOW DEFOGGER

REAR WINDOW DEFOGGER : CONSULT Function (BCM - REAR DEFOGGER)

INFOID:000000007579489

Data monitor

DIAGNOSIS SYSTEM (BCM) (WITHOUT INTELLIGENT KEY SYSTEM)

< SYSTEM DESCRIPTION >

Monitor Item	Description
REAR DEF SW	Displays "Press (ON)/other (OFF)" status determined with the rear window defogger switch.
IGN ON SW	Indicates [ON/OFF] condition of ignition switch in ON position.
ACC ON SW	Indicates [ON/OFF] condition of ignition switch ACC position.

ACTIVE TEST

Test Item	Description
REAR DEFOGGER	Rear window defogger operates when "ON" on CONSULT screen is touched.

DIAGNOSIS SYSTEM (IPDM E/R)

< SYSTEM DESCRIPTION >

DIAGNOSIS SYSTEM (IPDM E/R)

WITH INTELLIGENT KEY

WITH INTELLIGENT KEY : Diagnosis Description

INFOID:000000007808996

AUTO ACTIVE TEST

Description

In auto active test mode, the IPDM E/R sends a drive signal to the following systems to check their operation.

- Rear window defogger
- Front wiper motor
- Parking lamp
- License plate lamp
- Tail lamp
- Side marker lamp
- Front fog lamp
- Headlamp (LO, HI)
- A/C compressor (magnet clutch)
- Cooling fan

Operation Procedure

CAUTION:

Wiper arm interferes with food when wiper is operated while wiper arm is in the raised position. Always perform auto active test without setting wiper arm in the raised position. Always pour water on front windshield glass in advance to auto active test so that damage on front windshield glass surface is prevented.

1. Turn the ignition switch OFF.
2. Turn the ignition switch ON, and within 20 seconds, press the driver door switch 10 times. Then turn the ignition switch OFF.

CAUTION:

Close passenger door.

3. Turn the ignition switch ON within 10 seconds. After that the horn sounds once and the auto active test starts.

CAUTION:

Engine starts when ignition switch is turned ON while brake pedal is depressed.

4. After a series of the following operations is repeated 3 times, auto active test is completed.

NOTE:

- When auto active test mode has to be cancelled halfway through test, turn the ignition switch OFF.
- When auto active test is not activated, door switch may be the cause. Check door switch. Refer to [DLK-71, "Component Function Check"](#).

Inspection in Auto Active Test Mode

When auto active test mode is actuated, the following operation sequence is repeated 3 times.

Operation sequence	Inspection location	Operation
1	Rear window defogger	10 seconds
2	Front wiper motor	LO for 5 seconds → HI for 5 seconds
3	<ul style="list-style-type: none">• Parking lamp• License plate lamp• Tail lamp• Side marker lamp• Front fog lamp	10 seconds
4	Headlamp	LO for 10 seconds → HI ON ↔ OFF 5 times
5	A/C compressor (magnet clutch)	ON ↔ OFF 5 times
6	Cooling fan	50% duty for 5 seconds → 100% duty for 5 seconds

DIAGNOSIS SYSTEM (IPDM E/R)

< SYSTEM DESCRIPTION >

Concept of auto active test

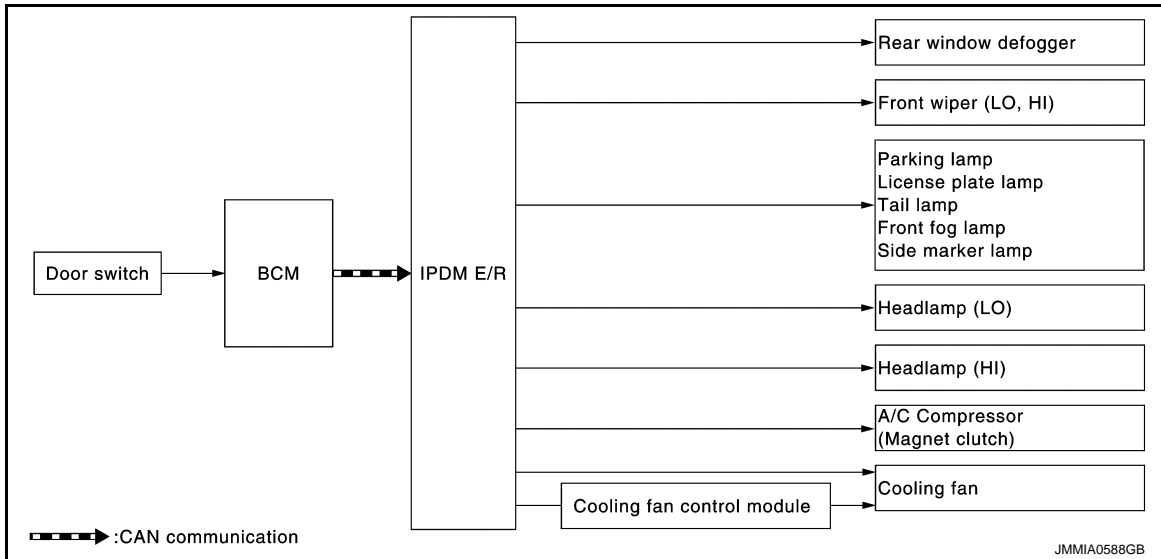

- IPDM E/R starts the auto active test with the door switch signals transmitted by BCM via CAN communication. Therefore, the CAN communication line between IPDM E/R and BCM is considered normal if the auto active test starts successfully.
- The auto active test facilitates troubleshooting if any systems controlled by IPDM E/R cannot be operated.

Diagnosis chart in auto active test mode

Symptom	Inspection contents	Possible cause
Rear window defogger does not operate	Perform auto active test. Does the rear window defogger operate?	YES BCM signal input circuit
		NO <ul style="list-style-type: none"> • Rear window defogger • Rear window defogger ground circuit • Harness or connector between IPDM E/R and rear window defogger • IPDM E/R
Any of the following components do not operate <ul style="list-style-type: none"> • Parking lamp • License plate lamp • Tail lamp • Side marker lamp • Front fog lamp • Headlamp (HI, LO) • Front wiper motor 	Perform auto active test. Does the applicable system operate?	YES BCM signal input circuit
		NO <ul style="list-style-type: none"> • Lamp or motor • Lamp or motor ground circuit • Harness or connector between IPDM E/R and applicable system • IPDM E/R
A/C compressor does not operate	Perform auto active test. Does the magnet clutch operate?	YES <ul style="list-style-type: none"> • A/C amp. signal input circuit • CAN communication signal between A/C amp. and ECM • CAN communication signal between ECM and IPDM E/R
		NO <ul style="list-style-type: none"> • Magnet clutch • Harness or connector between IPDM E/R and magnet clutch • IPDM E/R

DIAGNOSIS SYSTEM (IPDM E/R)

< SYSTEM DESCRIPTION >

Symptom	Inspection contents		Possible cause
Cooling fan does not operate	Perform auto active test. Does the cooling fan operate?	YES	<ul style="list-style-type: none"> ECM signal input circuit CAN communication signal between ECM and IPDM E/R
		NO	<ul style="list-style-type: none"> Harness or connector between IPDM E/R and cooling fan relay Harness or connector between IPDM E/R and cooling fan control module. Harness or connector between cooling fan control module and cooling fan motor Cooling fan motor Cooling fan relay Cooling fan control module IPDM E/R

WITH INTELLIGENT KEY : CONSULT Function (IPDM E/R)

INFOID:000000007808997

APPLICATION ITEM

CONSULT performs the following functions via CAN communication with IPDM E/R.

Diagnosis mode	Description
Ecu Identification	Allows confirmation of IPDM E/R part number.
Self Diagnostic Result	Displays the diagnosis results judged by IPDM E/R.
Data Monitor	Displays the real-time input/output data from IPDM E/R input/output data.
Active Test	IPDM E/R can provide a drive signal to electronic components to check their operations.
CAN Diag Support Monitor	The results of transmit/receive diagnosis of CAN communication can be read.

SELF DIAGNOSTIC RESULT

Refer to [PCS-23, "DTC Index"](#).

DATA MONITOR

Monitor item

Monitor Item [Unit]	MAIN SIGNALS	Description
RAD FAN REQ [%]	×	Displays the value of the cooling fan speed request signal received from ECM via CAN communication.
AC COMP REQ [Off/On]	×	Displays the status of the A/C compressor request signal received from ECM via CAN communication.
TAIL&CLR REQ [Off/On]	×	Displays the status of the position light request signal received from BCM via CAN communication.
HL LO REQ [Off/On]	×	Displays the status of the low beam request signal received from BCM via CAN communication.
HL HI REQ [Off/On]	×	Displays the status of the high beam request signal received from BCM via CAN communication.
FR FOG REQ [Off/On]	×	Displays the status of the front fog light request signal received from BCM via CAN communication.
FR WIP REQ [Stop/1LOW/Low/Hi]	×	Displays the status of the front wiper request signal received from BCM via CAN communication.
WIP AUTO STOP [STOP P/ACT P]	×	Displays the status of the front wiper auto stop signal judged by IPDM E/R.
WIP PROT [Off/BLOCK]	×	Displays the status of the front wiper fail-safe operation judged by IPDM E/R.
IGN RLY1 -REQ [Off/On]		Displays the status of the ignition switch ON signal received from BCM via CAN communication.

DIAGNOSIS SYSTEM (IPDM E/R)

< SYSTEM DESCRIPTION >

Monitor Item [Unit]	MAIN SIGNALS	Description
IGN RLY [Off/On]	×	Displays the status of the ignition relay judged by IPDM E/R.
PUSH SW [Off/On]		Displays the status of the push-button ignition switch judged by IPDM E/R.
INTER/NP SW [Off/On]		Displays the status of the ignition power supply (M/T models) or shift position (CVT models) judged by IPDM E/R.
ST RLY CONT [Off/On]		Displays the status of the starter relay status signal received from BCM via CAN communication.
IHBT RLY -REQ [Off/On]		Displays the status of the starter control relay signal received from BCM via CAN communication.
ST/INH RLY [Off/ ST ON/INH ON/UNKWN]		Displays the status of the starter relay and starter control relay judged by IPDM E/R.
DETENT SW [Off/On]		Displays the status of the CVT shift selector (detention switch) judged by IPDM E/R.
S/L RLY -REQ [Off/On]		NOTE: This item is indicated, but not monitored.
S/L STATE [LOCK/UNLK/UNKWN]		NOTE: This item is indicated, but not monitored.
DTRL REQ [Off/On]		Displays the status of the daytime running light request signal received from BCM via CAN communication.
OIL P SW [Open/Close]		NOTE: This item is indicated, but not monitored.
HOOD SW [Off/On]		NOTE: This item is indicated, but not monitored.
HL WASHER REQ [Off/On]		NOTE: This item is indicated, but not monitored.
THFT HRN REQ [Off/On]		Displays the status of the theft warning horn request signal received from BCM via CAN communication.
HORN CHIRP [Off/On]		Displays the status of the horn reminder request signal received from BCM via CAN communication.

ACTIVE TEST

Test item

Test item	Operation	Description
HORN	On	Operates horn relay for 20 ms.
REAR DEFOGGER	Off	OFF
	On	Operates the rear window defogger relay.
FRONT WIPER	Off	OFF
	Lo	Operates the front wiper relay.
	Hi	Operates the front wiper relay and front wiper high relay.
MOTOR FAN	1	OFF
	2	Transmits 50% pulse duty signal (PWM signal) to the cooling fan control module.
	3	Transmits 75% pulse duty signal (PWM signal) to the cooling fan control module.
	4	Transmits 100% pulse duty signal (PWM signal) to the cooling fan control module.
HEAD LAMP WASHER	On	NOTE: This item is indicated, but cannot be tested.

DIAGNOSIS SYSTEM (IPDM E/R)

< SYSTEM DESCRIPTION >

Test item	Operation	Description
EXTERNAL LAMPS	Off	OFF
	TAIL	Operates the tail lamp relay.
	Lo	Operates the headlamp low relay.
	Hi	Operates the headlamp low relay and ON/OFF the headlamp high relay at 1 second intervals.
	Fog	Operates the front fog lamp relay.

WITHOUT INTELLIGENT KEY

WITHOUT INTELLIGENT KEY : Diagnosis Description

INFOID:000000007808998

AUTO ACTIVE TEST

Description

In auto active test mode, the IPDM E/R sends a drive signal to the following systems to check their operation.

- Rear window defogger
- Front wiper motor
- Parking lamp
- License plate lamp
- Tail lamp
- Side marker lamp
- Front fog lamp
- Headlamp (LO, HI)
- A/C compressor (magnet clutch)
- Cooling fan

Operation Procedure

CAUTION:

Wiper arm interferes with food when wiper is operated while wiper arm is in the raised position. Always perform auto active test without setting wiper arm in the raised position. Always pour water on front windshield glass in advance to auto active test so that damage on front windshield glass surface is prevented.

1. Turn the ignition switch OFF.
2. Turn the ignition switch ON, and within 20 seconds, press the driver door switch 10 times. Then turn the ignition switch OFF.

CAUTION:

Close passenger door.

3. Turn the ignition switch ON within 10 seconds. After that the horn sounds once and the auto active test starts.

CAUTION:

Engine starts when ignition switch is turned ON while brake pedal is depressed.

4. After a series of the following operations is repeated 3 times, auto active test is completed.

NOTE:

- When auto active test mode has to be cancelled halfway through test, turn the ignition switch OFF.
- When auto active test is not activated, door switch may be the cause. Check door switch. Refer to [DLK-201, "Component Function Check"](#).

Inspection in Auto Active Test Mode

When auto active test mode is actuated, the following operation sequence is repeated 3 times.

Operation sequence	Inspection location	Operation
1	Rear window defogger	10 seconds
2	Front wiper motor	LO for 5 seconds → HI for 5 seconds

DIAGNOSIS SYSTEM (IPDM E/R)

< SYSTEM DESCRIPTION >

Operation sequence	Inspection location	Operation
3	<ul style="list-style-type: none"> • Parking lamp • License plate lamp • Tail lamp • Side marker lamp • Front fog lamp 	10 seconds
4	Headlamp	LO for 10 seconds → HI ON ↔ OFF 5 times
5	A/C compressor (magnet clutch)	ON ↔ OFF 5 times
6	Cooling fan	50% duty for 5 seconds → 100% duty for 5 seconds

Concept of auto active test

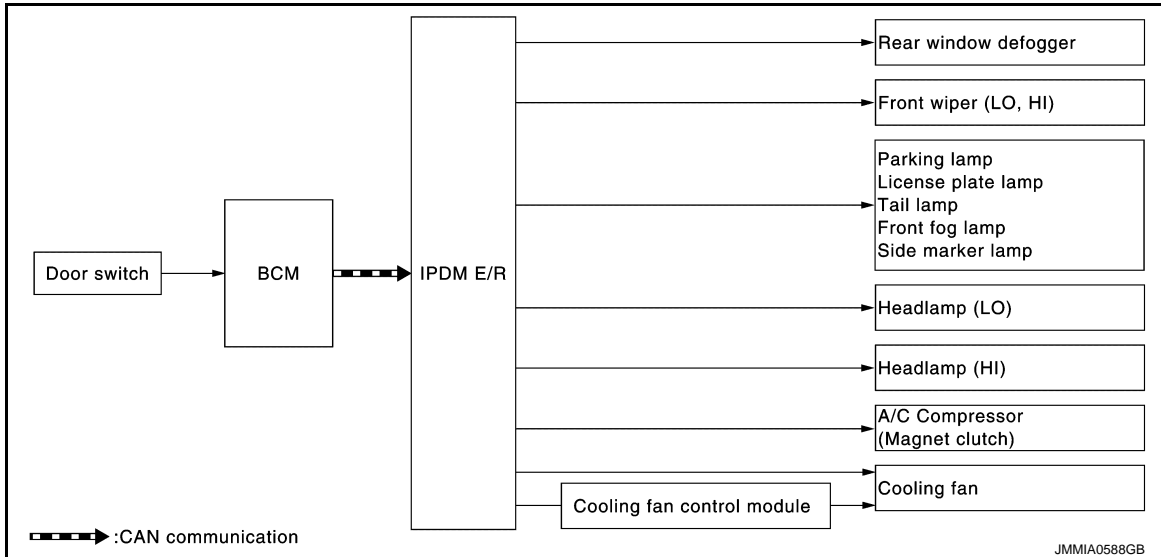

- IPDM E/R starts the auto active test with the door switch signals transmitted by BCM via CAN communication. Therefore, the CAN communication line between IPDM E/R and BCM is considered normal if the auto active test starts successfully.
- The auto active test facilitates troubleshooting if any systems controlled by IPDM E/R cannot be operated.

Diagnosis chart in auto active test mode

Symptom	Inspection contents	Possible cause	
Rear window defogger does not operate	Perform auto active test. Does the rear window defogger operate?	YES	BCM signal input circuit
		NO	<ul style="list-style-type: none"> • Rear window defogger • Rear window defogger ground circuit • Harness or connector between IPDM E/R and rear window defogger • IPDM E/R
Any of the following components do not operate <ul style="list-style-type: none"> • Parking lamp • License plate lamp • Tail lamp • Side marker lamp • Front fog lamp • Headlamp (HI, LO) • Front wiper motor 	Perform auto active test. Does the applicable system operate?	YES	BCM signal input circuit
		NO	<ul style="list-style-type: none"> • Lamp or motor • Lamp or motor ground circuit • Harness or connector between IPDM E/R and applicable system • IPDM E/R

DIAGNOSIS SYSTEM (IPDM E/R)

< SYSTEM DESCRIPTION >

Symptom	Inspection contents		Possible cause
A/C compressor does not operate	Perform auto active test. Does the magnet clutch operate?	YES	<ul style="list-style-type: none"> A/C amp. signal input circuit CAN communication signal between A/C amp. and ECM CAN communication signal between ECM and IPDM E/R
		NO	<ul style="list-style-type: none"> Magnet clutch Harness or connector between IPDM E/R and magnet clutch IPDM E/R
Cooling fan does not operate	Perform auto active test. Does the cooling fan operate?	YES	<ul style="list-style-type: none"> ECM signal input circuit CAN communication signal between ECM and IPDM E/R
		NO	<ul style="list-style-type: none"> Harness or connector between IPDM E/R and cooling fan relay Harness or connector between IPDM E/R and cooling fan control module. Harness or connector between cooling fan control module and cooling fan motor Cooling fan motor Cooling fan relay Cooling fan control module IPDM E/R

WITHOUT INTELLIGENT KEY : CONSULT Function (IPDM E/R)

INFOID:000000007808999

APPLICATION ITEM

CONSULT performs the following functions via CAN communication with IPDM E/R.

Diagnosis mode	Description
Ecu Identification	Allows confirmation of IPDM E/R part number.
Self Diagnostic Result	Displays the diagnosis results judged by IPDM E/R.
Data Monitor	Displays the real-time input/output data from IPDM E/R input/output data.
Active Test	IPDM E/R can provide a drive signal to electronic components to check their operations.
CAN Diag Support Monitor	The results of transmit/receive diagnosis of CAN communication can be read.

SELF DIAGNOSTIC RESULT

Refer to [PCS-50. "DTC Index"](#).

DATA MONITOR

Monitor item

Monitor Item [Unit]	MAIN SIGNALS	Description
RAD FAN REQ [%]	×	Displays the value of the cooling fan speed request signal received from ECM via CAN communication.
AC COMP REQ [Off/On]	×	Displays the status of the A/C compressor request signal received from ECM via CAN communication.
TAIL&CLR REQ [Off/On]	×	Displays the status of the position light request signal received from BCM via CAN communication.
HL LO REQ [Off/On]	×	Displays the status of the low beam request signal received from BCM via CAN communication.
HL HI REQ [Off/On]	×	Displays the status of the high beam request signal received from BCM via CAN communication.
FR FOG REQ [Off/On]	×	Displays the status of the front fog light request signal received from BCM via CAN communication.

DIAGNOSIS SYSTEM (IPDM E/R)

< SYSTEM DESCRIPTION >

Monitor Item [Unit]	MAIN SIG- NALS	Description
FR WIP REQ [Stop/1LOW/Low/Hi]	×	Displays the status of the front wiper request signal received from BCM via CAN communication.
WIP AUTO STOP [STOP P/ACT P]	×	Displays the status of the front wiper auto stop signal judged by IPDM E/R.
WIP PROT [Off/BLOCK]	×	Displays the status of the front wiper fail-safe operation judged by IPDM E/R.
IGN RLY [Off/On]	×	Displays the status of the ignition relay judged by IPDM E/R.
INTER/NP SW [Off/On]		Displays the status of the shift position (CVT models) judged by IPDM E/R.
ST RLY REQ [Off/On]		Displays the status of the starter relay status signal received from BCM via CAN communication.
DTRL REQ [Off/On]		Displays the status of the daytime running light request signal received from BCM via CAN communication.
OIL P SW [Open/Close]		NOTE: This item is indicated, but not monitored.
HOOD SW [Off/On]		NOTE: This item is indicated, but not monitored.
HL WASHER REQ [Off/On]		NOTE: This item is indicated, but not monitored.
THFT HRN REQ [Off/On]		Displays the status of the theft warning horn request signal received from BCM via CAN communication.
HORN CHIRP [Off/On]		Displays the status of the horn reminder request signal received from BCM via CAN communication.

ACTIVE TEST

Test item

Test item	Operation	Description
HORN	On	Operates horn relay for 20 ms.
REAR DEFOGGER	Off	OFF
	On	Operates the rear window defogger relay.
FRONT WIPER	Off	OFF
	Lo	Operates the front wiper relay.
	Hi	Operates the front wiper relay and front wiper high relay.
MOTOR FAN	1	OFF
	2	Transmits 50% pulse duty signal (PWM signal) to the cooling fan control module.
	3	Transmits 75% pulse duty signal (PWM signal) to the cooling fan control module.
	4	Transmits 100% pulse duty signal (PWM signal) to the cooling fan control module.
HEAD LAMP WASHER	On	NOTE: This item is indicated, but cannot be tested.
	Off	OFF
EXTERNAL LAMPS	TAIL	Operates the tail lamp relay.
	Lo	Operates the headlamp low relay.
	Hi	Operates the headlamp low relay and ON/OFF the headlamp high relay at 1 second intervals.
	Fog	Operates the front fog lamp relay.

BCM, IPDM E/R

< ECU DIAGNOSIS INFORMATION >

ECU DIAGNOSIS INFORMATION

BCM, IPDM E/R

List of ECU Reference

INFOID:000000007579494

ECU		Reference
BCM	(With Intelligent Key system)	BCS-35, "Reference Value"
		BCS-56, "Fail-safe"
		BCS-57, "DTC Inspection Priority Chart"
		BCS-58, "DTC Index"
	(Without Intelligent Key system)	BCS-108, "Reference Value"
		BCS-121, "Fail-safe"
		BCS-122, "DTC Inspection Priority Chart"
		BCS-122, "DTC Index"
IPDM E/R	(With Intelligent Key system)	PCS-16, "Reference Value"
		PCS-22, "Fail-Safe"
		PCS-23, "DTC Index"
	(Without Intelligent Key system)	PCS-44, "Reference Value"
		PCS-49, "Fail-Safe"
		PCS-50, "DTC Index"

A
B
C
D
E
F
G
H
I
J
K
L
M
N
O
P

DEF

DIAGNOSIS AND REPAIR WORK FLOW

< BASIC INSPECTION >

BASIC INSPECTION

DIAGNOSIS AND REPAIR WORK FLOW

Work Flow

INFOID:000000007579495

DETAILED FLOW

1.OBTAIN INFORMATION ABOUT SYMPTOM

Interview the customer to obtain the malfunction information (conditions and environment when the malfunction occurred) as much as possible when the customer brings the vehicle in.

>> GO TO 2.

2.CHECK FOR DTC

Perform self diagnosis with CONSULT.

Is any DTC detected?

YES-1 >> BCM: Refer to [BCS-58. "DTC Index"](#) (With Intelligent Key system) or [BCS-122. "DTC Index"](#) (Without Intelligent Key system).

YES-2 >> IPDM E/R: Refer to [PCS-23. "DTC Index"](#) (With Intelligent Key system) or [PCS-50. "DTC Index"](#) (Without Intelligent Key system).

NO >> GO TO 3.

3.REPRODUCE THE MALFUNCTION INFORMATION

Check the malfunction on the vehicle that the customer describes.

Inspect the relation of the symptoms and the condition when the symptoms occur.

>> GO TO 4.

4.IDENTIFY THE MALFUNCTIONING SYSTEM WITH "SYMPTOM DIAGNOSIS"

Use "Symptom diagnosis" from the symptom inspection result in step 3. Then identify where to start performing the diagnosis based on possible causes and symptoms.

>> GO TO 5.

5.IDENTIFY MALFUNCTIONING PARTS WITH "COMPONENT DIAGNOSIS"

Perform the diagnosis with "Component diagnosis" of the applicable system.

>> GO TO 6.

6.REPAIR OR REPLACE THE MALFUNCTIONING PARTS

Repair or replace the specified malfunctioning parts.

>> GO TO 7.

7.FINAL CHECK

Check that malfunctions are not reproduced when obtaining the malfunction information from the customer, referring to the symptom inspection result in step 3.

Are all malfunctions corrected?

YES >> INSPECTION END

NO >> GO TO 4.

REAR WINDOW DEFOGGER SWITCH

< DTC/CIRCUIT DIAGNOSIS >

DTC/CIRCUIT DIAGNOSIS

REAR WINDOW DEFOGGER SWITCH WITH AUTO A/C

WITH AUTO A/C : Description

INFOID:000000007579496

- The rear window defogger is operated by turning the rear window defogger switch ON.
- The indicator lamp in the rear window defogger switch illuminates when the rear window defogger is operating.

WITH AUTO A/C : Component Function Check

INFOID:000000007579497

1.CHECK REAR WINDOW DEFOGGER SWITCH FUNCTION

Check that the indicator lamp of rear window defogger illuminates when rear window defogger switch ON.

Is the inspection result normal?

- YES >> Rear window defogger switch function is OK.
- NO >> Refer to [DEF-23, "WITH AUTO A/C : Diagnosis Procedure"](#)

WITH AUTO A/C : Diagnosis Procedure

INFOID:000000007579498

1.CHECK MULTI DISPLAY UNIT (REAR WINDOW DEFOGGER SWITCH)

Does multi display unit (rear window defogger switch) operate normally?

Refer to [DEF-23, "WITH AUTO A/C : Description"](#).

Is the inspection result normal?

- YES >> INSPECTION END
- NO >> Replace multi display unit (rear window defogger switch).

WITHOUT AUTO A/C

WITHOUT AUTO A/C : Description

INFOID:000000007579499

- The rear window defogger is operated by turning the rear window defogger switch ON.
- The indicator lamp in the rear window defogger switch illuminates when the rear window defogger is operating.

WITHOUT AUTO A/C : Component Function Check

INFOID:000000007579500

1.CHECK FUNCTION

Check (REAR DEF SW) in BCM "DATA MONITOR" mode using CONSULT when rear window defogger switch is ON.

Is the inspection result normal?

- YES >> Rear window defogger switch function is OK.
- NO >> Refer to [DEF-23, "WITHOUT AUTO A/C : Diagnosis Procedure"](#).

WITHOUT AUTO A/C : Diagnosis Procedure

INFOID:000000007579501

1.CHECK BCM OUTPUT SIGNAL

1. Turn ignition switch OFF.
2. Disconnect A/C control connector.
3. Check voltage between A/C control harness connector and ground.

(+)		(-)	Voltage (V) (Approx.)
A/C control			
Connector	Terminal		
M53	3	Ground	12

Is the inspection result normal?

A
B
C
D
E
F
G
H
I
J
K
DEF
M
N
O
P

REAR WINDOW DEFOGGER SWITCH

< DTC/CIRCUIT DIAGNOSIS >

- YES >> GO TO 3.
NO >> GO TO 2.

2.CHECK REAR WINDOW DEFOGGER SWITCH CIRCUIT

1. Disconnect BCM connector.
2. Check continuity between BCM harness connector and A/C control harness connector.

BCM			A/C control		Continuity
Connector		Terminal	Connector	Terminal	
With Intelligent Key system	M65	15	M53	3	Existed
Without Intelligent Key system	M68	10			

3. Check continuity between BCM harness connector and ground.

BCM			Ground	Continuity
Connector		Terminal		
With Intelligent Key system	M65	15		Not existed
Without Intelligent Key system	M68	10		

Is the inspection result normal?

- YES >> Replace BCM. Refer to [BCS-80, "Removal and Installation"](#) (With Intelligent Key system) or [BCS-141, "Removal and Installation"](#) (Without Intelligent Key system).

- NO >> Repair or replace harness.

3.CHECK GROUND CIRCUIT

Check continuity between A/C control harness connector and ground.

A/C control		Ground	Continuity
Connector	Terminal		
M53	8		Existed

Is the inspection result normal?

- YES >> GO TO 4.
NO >> Repair or replace harness.

4.CHECK REAR WINDOW DEFOGGER SWITCH

Refer to [DEF-24, "WITHOUT AUTO A/C : Component Inspection"](#).

Is the inspection result normal?

- YES >> GO TO 5.
NO >> Replace A/C control. Refer to [HAC-134, "Removal and Installation"](#).

5.CHECK INTERMITTENT INCIDENT

Refer to [GI-43, "Intermittent Incident"](#).

Is the inspection result normal?

>> INSPECTION END

WITHOUT AUTO A/C : Component Inspection

INFOID:000000007579502

1.CHECK REAR WINDOW DEFOGGER SWITCH

1. Turn ignition switch OFF.
2. Disconnect A/C control connector.
3. Check continuity between A/C control terminals.

REAR WINDOW DEFOGGER SWITCH

< DTC/CIRCUIT DIAGNOSIS >

A/C control		Condition		Continuity
Terminal				
3	8	Rear window defogger switch	Pressed	Existed
			Released	Not existed

Is the inspection result normal?

YES >> INSPECTION END

NO >> Replace A/C control. Refer to [HAC-134, "Removal and Installation"](#).

A
B
C
D
E
F
G
H
I
J
K
DEF
M
N
O
P

DEF

REAR WINDOW DEFOGGER RELAY

< DTC/CIRCUIT DIAGNOSIS >

REAR WINDOW DEFOGGER RELAY

Description

INFOID:000000007579503

The rear window defogger is operated by turning the rear window defogger switch ON.

Component Function Check

INFOID:000000007579504

1.CHECK FUNCTION

1. Perform IPDM E/R Active Test ("REAR DEFOGGER") using CONSULT.
2. Touch "ON".
3. Check that the rear window heating wire is getting warmer.

Is the inspection result normal?

- YES >> Rear window defogger relay function is OK.
NO >> Refer to [DEF-26, "Diagnosis Procedure"](#).

Diagnosis Procedure

INFOID:000000007579505

1.CHECK FUSE

1. Turn ignition switch OFF.
2. Check the 15A fuse (No. 41 and 42 located in IPDM E/R).

Is the inspection result normal?

- YES >> GO TO 2.
NO >> Replace the blown fuse after repairing the affected circuit if a fuse is blown.

2.CHECK IPDM E/R OUTPUT SIGNAL

1. Perform IPDM E/R Active Test ("REAR DEFOGGER") using CONSULT.
2. Touch "ON".
3. Check voltage between IPDM E/R harness connector and ground.

(+)		(-)	CONSULT Active Test condition	Voltage (V) (Approx.)	
IPDM E/R					
Connector	Terminal				
E11	14	Ground	REAR DEFOGGER	ON	9 – 16 V
				OFF	0

Is the inspection result normal?

- YES >> INSPECTION END
NO >> Replace IPDM E/R. Refer to [PCS-31, "Removal and Installation"](#) (With Intelligent Key system) or [PCS-59, "Removal and Installation"](#) (Without Intelligent Key system).

REAR WINDOW DEFOGGER

< DTC/CIRCUIT DIAGNOSIS >

REAR WINDOW DEFOGGER

Description

INFOID:000000007579506

Heats the heating wire with the power supply from the rear window defogger relay to prevent the rear window from fogging up.

Component Function Check

INFOID:000000007579507

1.CHECK FUNCTION

1. Perform IPDM E/R Active Test ("REAR DEFOGGER") using CONSULT.
2. Touch "ON".
3. Check that the rear window heating wire is getting warmer.

Is the inspection result normal?

- YES >> Rear window defogger is OK.
NO >> Refer to [DEF-26, "Diagnosis Procedure"](#).

Diagnosis Procedure

INFOID:000000007579508

1.CHECK REAR WINDOW DEFOGGER POWER SUPPLY CIRCUIT

1. Turn ignition switch OFF.
2. Disconnect rear window defogger connector.
3. Turn ignition switch ON.
4. Check voltage between rear window defogger harness connector and ground.

(+)		(-)	Condition	Voltage (V) (Approx.)
Connector	Terminal			
D202	1	Ground	Rear window defogger switch	ON Battery voltage OFF 0

Is the inspection result normal?

- YES >> GO TO 2.
NO >> GO TO 4.

2.CHECK REAR WINDOW DEFOGGER GROUND CIRCUIT

1. Turn ignition switch OFF.
2. Check continuity between rear window defogger harness connector and ground.

Rear window defogger		Ground	Continuity
Connector	Terminal		
D203	2		Existed

Is the inspection result normal?

- YES >> GO TO 3.
NO >> Repair or replace harness.

3.CHECK FILAMENT

Refer to [DEF-41, "Inspection and Repair"](#).

Is the inspection result normal?

- YES >> GO TO 5.
NO >> Repair filament.

4.CHECK REAR WINDOW DEFOGGER POWER SUPPLY CIRCUIT 1

1. Turn ignition switch OFF.
2. Disconnect condenser connector.
3. Check continuity between condenser harness connector and rear window defogger harness connector.

REAR WINDOW DEFOGGER

< DTC/CIRCUIT DIAGNOSIS >

Condenser		Rear window defogger		Continuity
Connector	Terminal	Connector	Terminal	
D201	2	D202	1	Existed

4. Check continuity between condenser connector and ground.

Condenser		Ground	Continuity
Connector	Terminal		
D201	2		Not existed

Is the inspection result normal?

YES >> GO TO 5.

NO >> Repair or replace harness.

5. CHECK REAR WINDOW DEFOGGER POWER SUPPLY CIRCUIT 2

1. Disconnect IPDM E/R connectors.
2. Check continuity between IPDM E/R harness connector and condenser harness connector.

IPDM E/R		Condenser		Continuity
Connector	Terminal	Connector	Terminal	
E11	14	D103	1	Existed

3. Check continuity between IPDM E/R connector and ground.

IPDM E/R		Ground	Continuity
Connector	Terminal		
E11	14		Not existed

Is the inspection result normal?

YES >> GO TO 6.

NO >> Repair or replace harness.

6. CHECK CONDENSER

Refer to [DEF-28. "Component Inspection"](#).

Is the inspection result normal?

YES >> GO TO 7.

NO >> Replace condenser. Refer to [DEF-43. "Removal and Installation"](#).

7. CHECK INTERMITTENT INCIDENT

Refer to [GI-43. "Intermittent Incident"](#)

Is the inspection result normal?

YES >> INSPECTION END

NO >> Repair or replace harness or connector.

Component Inspection

INFOID:000000007579509

1. CHECK CONDENSER

1. Turn ignition switch OFF.
2. Disconnect condenser connector.
3. Check continuity between condenser connector and ground part of condenser.

Condenser		Ground part of condenser	Continuity
Connector	Terminal		
D103	1		Not existed
D202	2		

4. Check continuity between condenser terminals.

REAR WINDOW DEFOGGER

< DTC/CIRCUIT DIAGNOSIS >

Condenser				Continuity
Connector	Terminal	Connector	Terminal	
D103	1	D202	2	Existed

Is the inspection result normal?

YES >> INSPECTION END

NO >> Replace condenser. Refer to [DEF-43. "Removal and Installation"](#).

A
B
C
D
E
F
G
H
I
J
K
DEF
M
N
O
P

DEF

DOOR MIRROR DEFOGGER

< DTC/CIRCUIT DIAGNOSIS >

DOOR MIRROR DEFOGGER

Description

INFOID:000000007579510

Heats the heating wire with the power supply from the rear window defogger relay to prevent the door mirror from fogging up.

Component Function Check

INFOID:000000007579511

1. CHECK DOOR MIRROR DEFOGGER

1. Perform IPDM E/R Active Test ("REAR DEFOGGER") using CONSULT.
2. Touch "ON".
3. Check that both side door mirror glasses are getting warmer.

Is the inspection result normal?

- YES >> Door mirror defogger is OK.
NO >> Refer to [DEF-30, "Diagnosis Procedure"](#).

Diagnosis Procedure

INFOID:000000007579512

1. CHECK FUSE

1. Turn ignition switch OFF.
2. Check 10A fuse [No.22, located in fuse block (J/B)].

Is the inspection result normal?

- YES >> GO TO 2.
NO >> Replace the blown fuse after repairing the affected circuit if a fuse is blown.

2. CHECK DOOR MIRROR DEFOGGER CIRCUIT

1. Disconnect IPDM E/R connector and door mirror (both sides) connector.
2. Check continuity between IPDM E/R harness connector and door mirror (driver side) harness connector.

IPDM E/R		Door mirror (driver side)		Continuity
Connector	Terminal	Connector	Terminal	
E11	14	D29	3	Existed

3. Check continuity between IPDM E/R harness connector and ground.

IPDM E/R		Ground	Continuity
Connector	Terminal		
E11	14		Not existed

Is the inspection result normal?

- YES >> GO TO 3.
NO >> Repair or replace harness.

3. CHECK INTERMITTENT INCIDENT

Check intermittent incident.

Refer to [GI-43, "Intermittent Incident"](#).

>> INSPECTION END

DRIVER SIDE DOOR MIRROR DEFOGGER

< DTC/CIRCUIT DIAGNOSIS >

DRIVER SIDE DOOR MIRROR DEFOGGER

Description

INFOID:000000007579513

Heats the heating wire with the power supply from the rear window defogger relay to prevent the door mirror from fogging up.

Component Function Check

INFOID:000000007579514

1.CHECK DRIVER SIDE DOOR MIRROR DEFOGGER

1. Perform IPDM E/R Active Test ("REAR DEFOGGER") using CONSULT.
2. Touch "ON".
3. Check that the driver side door mirror glass is getting warmer.

Is the inspection result normal?

- YES >> Driver side door mirror defogger is OK.
 NO >> Refer to [DEF-31, "Diagnosis Procedure"](#).

Diagnosis Procedure

INFOID:000000007579515

1.CHECK POWER SUPPLY CIRCUIT

1. Turn ignition switch OFF.
2. Disconnect door mirror (driver side) connector.
3. Turn ignition switch ON.
4. Check voltage between door mirror (driver side) harness connector and ground.

(+)		(-)	Condition	Voltage (V) (Approx.)
Door mirror (driver side) Connector	Terminal			
D29	3	Ground	Rear window defogger switch ON	Battery voltage
			OFF	0

Is the inspection result normal?

- YES >> GO TO 2.
 NO >> Repair or replace harness.

2.CHECK GROUND CIRCUIT

1. Turn ignition switch OFF.
2. Check continuity between door mirror (driver side) harness connector and ground.

Door mirror (driver side)		Ground	Continuity
Connector	Terminal		
D29	2		Existed

Is the inspection result normal?

- YES >> Replace door mirror glass (driver side). Refer to [MIR-14, "DOOR MIRROR ASSEMBLY : Removal and Installation"](#)
 NO >> Repair or replace harness.

A
B
C
D
E
F
G
H
I
J
K
DEF
M
N
O
P

PASSENGER SIDE DOOR MIRROR DEFOGGER

< DTC/CIRCUIT DIAGNOSIS >

PASSENGER SIDE DOOR MIRROR DEFOGGER

Description

INFOID:000000007579516

Heats the heating wire with the power supply from the rear window defogger relay to prevent the door mirror from fogging up.

Component Function Check

INFOID:000000007579517

1.CHECK PASSENGER SIDE DOOR MIRROR DEFOGGER

1. Perform IPDM E/R Active Test ("REAR DEFOGGER") using CONSULT.
2. Touch "ON".
3. Check that the passenger side door mirror glass is getting warmer.

Is the inspection result normal?

- YES >> Passenger side door mirror defogger is OK.
NO >> Refer to [DEF-32, "Diagnosis Procedure"](#).

Diagnosis Procedure

INFOID:000000007579518

1.CHECK POWER SUPPLY CIRCUIT

1. Turn ignition switch OFF.
2. Disconnect door mirror (passenger side) connector.
3. Turn ignition switch ON.
4. Check voltage between door mirror (passenger side) harness connector and ground.

(+)		(-)	Condition		Voltage (V) (Approx.)
Door mirror (passenger side) Connector	Terminal				
D8	3	Ground	Rear window defogger switch	ON	Battery voltage
				OFF	0

Is the inspection result normal?

- YES >> GO TO 2.
NO >> Repair or replace harness.

2.CHECK GROUND CIRCUIT

1. Turn ignition switch OFF.
2. Check continuity between door mirror (passenger side) harness connector and ground.

Door mirror (passenger side)		Ground	Continuity
Connector	Terminal		
D8	2		Existed

Is the inspection result normal?

- YES >> Replace door mirror glass (passenger side). Refer to [MIR-14, "DOOR MIRROR ASSEMBLY : Removal and Installation"](#)
NO >> Repair or replace harness.

REAR WINDOW DEFOGGER FEEDBACK SIGNAL

< DTC/CIRCUIT DIAGNOSIS >

REAR WINDOW DEFOGGER FEEDBACK SIGNAL

Description

INFOID:000000007579522

Turns the indicator lamp in the rear window defogger switch ON when operating the rear window defogger.

Component Function Check

INFOID:000000007579523

1.CHECK REAR WINDOW DEFOGGER FEEDBACK SIGNAL

Check that the indicator lamp of rear window defogger switch is illuminated when turning the rear window defogger switch ON.

Is the inspection result normal?

- OK >> Rear window defogger feedback signal is OK.
- NG >> Refer to [DEF-33. "Diagnosis Procedure"](#).

Diagnosis Procedure

INFOID:000000007579524

1.CHECK REAR WINDOW DEFOGGER FEEDBACK SIGNAL

1. Turn ignition switch OFF.
2. Disconnect A/C control connector.
3. Turn ignition switch ON.
4. Check voltage between A/C control harness connector and ground.

A/C control		Ground	Condition		Voltage (V) (Approx.)
Connector	Terminal		Rear window defogger switch	ON	Battery voltage
M53	4			OFF	0

Is the inspection result normal?

- YES >> Replace A/C control.
- NO >> Repair or replace harness.

A
B
C
D
E
F
G
H
I
J
K
M
N
O
P

DEF

REAR WINDOW DEFOGGER SYSTEM

< DTC/CIRCUIT DIAGNOSIS >

REAR WINDOW DEFOGGER SYSTEM

Wiring Diagram - DEFOGGER CONTROL SYSTEM -

INFOID:000000007579525

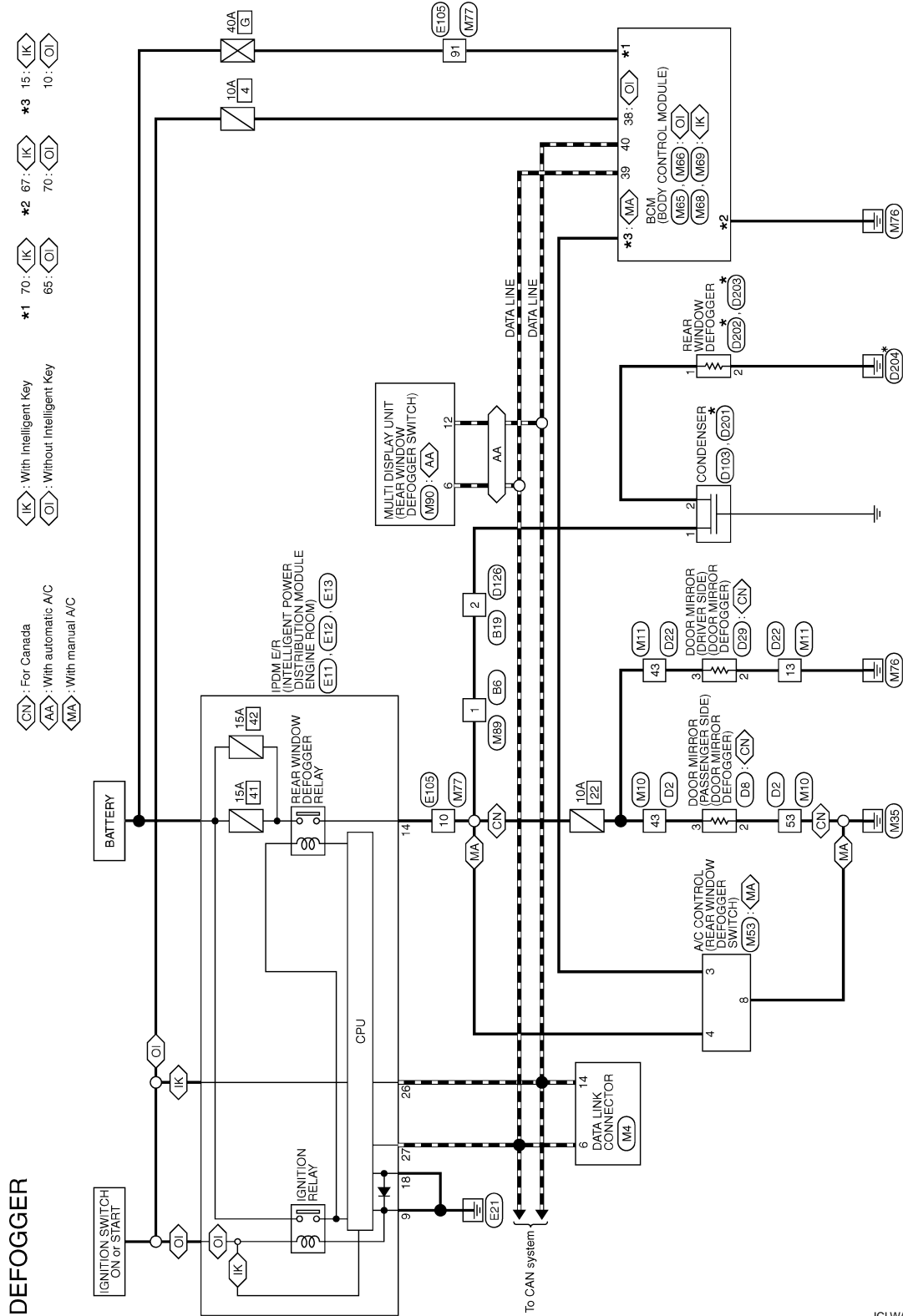

★: This connector is not shown in "Harness Layout".

2010/08/30

JCLWA4334GB

ALL DEFOGGER SYSTEMS DO NOT OPERATE

< SYMPTOM DIAGNOSIS >

SYMPTOM DIAGNOSIS

ALL DEFOGGER SYSTEMS DO NOT OPERATE

Description

INFOID:000000007579526

Rear window defogger and door mirror defogger do not operate when rear window defogger switch operated.

Diagnosis Procedure

INFOID:000000007579527

1. CHECK REAR WINDOW DEFOGGER SWITCH

Check rear window defogger switch.

Refer to [DEF-23, "WITH AUTO A/C : Component Function Check"](#) (With Auto A/C) or [DEF-23, "WITHOUT AUTO A/C : Component Function Check"](#) (Without Auto A/C).

Is the inspection result normal?

YES >> GO TO 2.

NO >> Repair or replace the malfunctioning parts.

2. CHECK REAR WINDOW DEFOGGER RELAY

Check rear window defogger relay.

Refer to [DEF-26, "Component Function Check"](#).

Is the inspection result normal?

YES >> GO TO 3.

NO >> Repair or replace the malfunctioning parts.

3. CHECK REAR WINDOW DEFOGGER

Check rear window defogger.

Refer to [DEF-27, "Component Function Check"](#).

Is the inspection result normal?

YES >> GO TO 4.

NO >> Repair or replace the malfunctioning parts.

4. CONFIRM THE OPERATION

Confirm the operation again.

Is the inspection result normal?

YES >> Check intermittent incident. Refer to [GI-43, "Intermittent Incident"](#).

NO >> GO TO 1.

A
B
C
D
E
F
G
H
I
J
K
DEF
M
N
O
P

REAR WINDOW DEFOGGER DOES NOT OPERATE BUT BOTH DOOR MIRROR DEFOGGERS OPERATE

< SYMPTOM DIAGNOSIS >

REAR WINDOW DEFOGGER DOES NOT OPERATE BUT BOTH DOOR MIRROR DEFOGGERS OPERATE

Diagnosis Procedure

INFOID:000000007579528

1.CHECK REAR WINDOW DEFOGGER

Check rear window defogger.

Refer to [DEF-27, "Component Function Check"](#).

Is the inspection result normal?

YES >> GO TO 2.

NO >> Repair or replace the malfunctioning parts.

2.CONFIRM THE OPERATION

Confirm the operation again

Is the inspection result normal?

YES >> Check intermittent incident. Refer to [GI-43, "Intermittent Incident"](#).

NO >> GO TO 1.

DOOR MIRROR DEFOGGER DOES NOT OPERATE

< SYMPTOM DIAGNOSIS >

DOOR MIRROR DEFOGGER DOES NOT OPERATE BOTH SIDES

BOTH SIDES : Description

INFOID:000000007579529

Both door mirror defoggers do not operate.

BOTH SIDES : Diagnosis Procedure

INFOID:000000007579530

1.CHECK REAR WINDOW DEFOGGER

Check rear window defogger.

Refer to [DEF-27, "Component Function Check"](#).

Is the inspection result normal?

YES >> GO TO 2.

NO >> Repair or replace the malfunctioning parts.

2.CHECK DOOR MIRROR DEFOGGER

Check door mirror defogger.

Refer to [DEF-30, "Component Function Check"](#).

Is the inspection result normal?

YES >> GO TO 3.

NO >> Repair or replace the malfunctioning parts.

3.CONFIRM THE OPERATION

Confirm the operation again.

Is the inspection result normal?

YES >> Check intermittent incident. Refer to [GI-43, "Intermittent Incident"](#).

NO >> GO TO 1.

DRIVER SIDE

DRIVER SIDE : Description

INFOID:000000007579531

Driver side door mirror defogger does not operate but passenger side door mirror defogger operates.

DRIVER SIDE : Diagnosis Procedure

INFOID:000000007579532

1.CHECK DRIVER SIDE DOOR MIRROR DEFOGGER

Check driver side door mirror defogger.

Refer to [DEF-30, "Component Function Check"](#).

Is the inspection result normal?

YES >> GO TO 2.

NO >> Repair or replace the malfunctioning parts.

2.CONFIRM THE OPERATION

Confirm the operation again.

Is the inspection result normal?

YES >> Check intermittent incident. Refer to [GI-43, "Intermittent Incident"](#).

NO >> GO TO 1.

PASSENGER SIDE

PASSENGER SIDE : Description

INFOID:000000007579533

Passenger side door mirror defogger does not operate but driver side door mirror defogger operates.

PASSENGER SIDE : Diagnosis Procedure

INFOID:000000007579534

1.CHECK PASSENGER SIDE DOOR MIRROR DEFOGGER.

A
B
C
D
E
F
G
H
I
J
K
DEF
M
N
O
P

DOOR MIRROR DEFOGGER DOES NOT OPERATE

< SYMPTOM DIAGNOSIS >

Check passenger side door mirror defogger.

Refer to [DEF-30, "Component Function Check"](#).

Is the inspection result normal?

YES >> GO TO 2.

NO >> Repair or replace the malfunctioning parts.

2.CONFIRM THE OPERATION

Confirm the operation again.

Is the inspection result normal?

YES >> Check intermittent incident. Refer to [GI-43, "Intermittent Incident"](#).

NO >> GO TO 1.

ON IS NOT DISPLAYED WHEN PRESSING REAR WINDOW DEFOGGER SWITCH BUT IT IS OPERATED

< SYMPTOM DIAGNOSIS >

ON IS NOT DISPLAYED WHEN PRESSING REAR WINDOW DEFOGGER SWITCH BUT IT IS OPERATED

Diagnosis Procedure

INFOID:000000007579535

1.CHECK MULTI DISPLAY UNIT FUNCTION

Check that the multi display unit is operating normally.

Refer to [HAC-37, "Work Flow"](#).

Is the inspection result normal?

YES >> GO TO 2.

NO >> Repair or replace the malfunctioning parts.

2.CONFIRM THE OPERATION

Confirm the operation again.

Is the inspection result normal?

YES >> Check intermittent incident. Refer to [GI-43, "Intermittent Incident"](#).

NO >> GO TO 1.

A
B
C
D
E
F
G
H
I
J
K
DEF
M
N
O
P

REAR WINDOW DEFOGGER INDICATOR DOES NOT ILLUMINATE

< SYMPTOM DIAGNOSIS >

REAR WINDOW DEFOGGER INDICATOR DOES NOT ILLUMINATE

Diagnosis Procedure

INFOID:000000007579536

1. CHECK A/C CONTROL (REAR WINDOW DEFOGGER SWITCH)

Check that rear window defogger operates.

Is the inspection result normal?

- YES >> Replace A/C control (rear window defogger switch).
- NO >> Check rear window defogger system. Refer to [DEF-22, "Work Flow"](#)

FILAMENT

< REMOVAL AND INSTALLATION >

REMOVAL AND INSTALLATION

FILAMENT

Inspection and Repair

INFOID:000000007579537

INSPECTION

1. When measuring voltage, wrap tin foil around the top of the negative probe. Then press the foil against the wire with your finger.

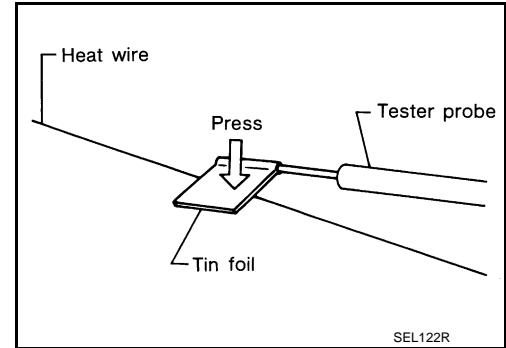

2. Attach probe circuit tester (in Volt range) to middle portion of each filament.

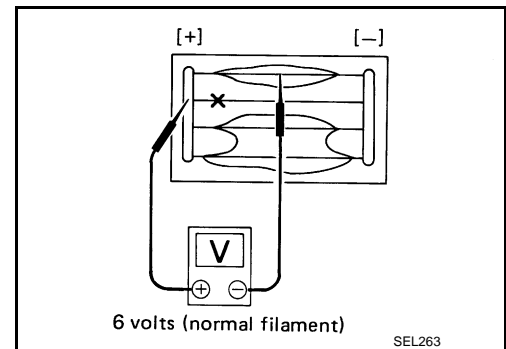

3. If a filament is burned out, circuit tester registers 0 or battery voltage.
4. To locate burned out point, move probe to left and right along filament. Test needle will swing abruptly when probe passes the point.

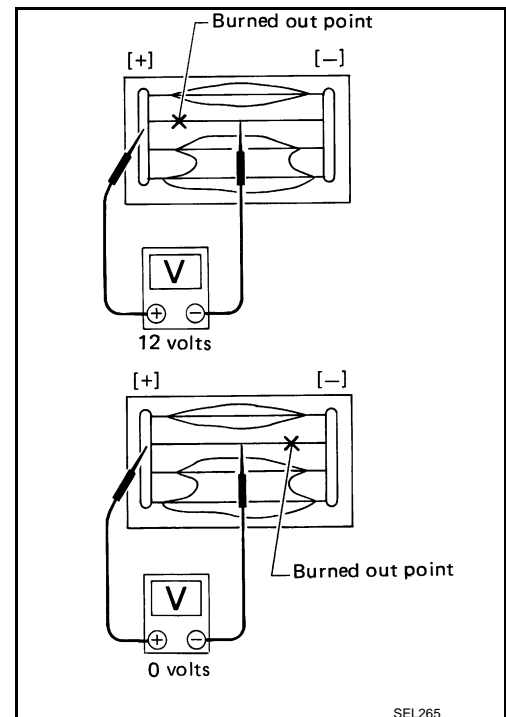

REPAIR

REPAIR EQUIPMENT

- Conductive silver composition (Dupont No. 4817 or equivalent)

A
B
C
D
E
F
G
H
I
J
K
DEF
M
N
O
P

FILAMENT

< REMOVAL AND INSTALLATION >

- Ruler 30 cm (11.8 in) long
- Drawing pen
- Heat gun
- Alcohol
- Cloth

REPAIRING PROCEDURE

1. Wipe broken heat wire and its surrounding area clean with a cloth dampened in alcohol.
2. Apply a small amount of conductive silver composition to tip of drawing pen. Shake silver composition container before use.
3. Place ruler on glass along broken line. Deposit conductive silver composition on break with drawing pen. Slightly overlap existing heat wire on both sides [preferably 5 mm (0.20 in)] of the break.

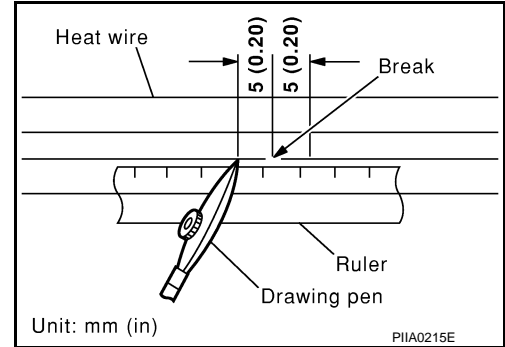

4. After repair has been completed, check repaired wire for continuity. This check should be conducted 10 minutes after silver composition is deposited. Do not touch repaired area while test is being conducted.

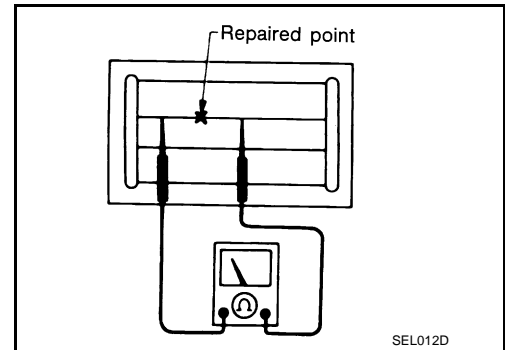

5. Apply a constant stream of hot air directly to the repaired area for approximately 20 minutes with a heat gun. A minimum distance of 3 cm (1.2 in) should be kept between repaired area and hot air outlet. If a heat gun is not available, let the repaired area dry for 24 hours.

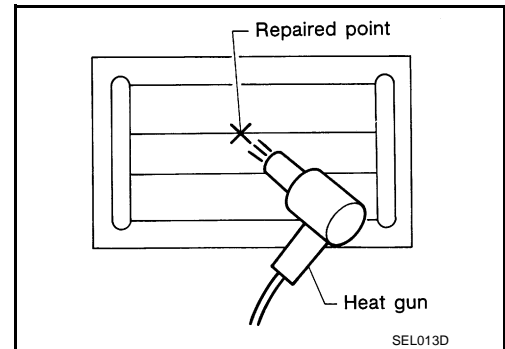

CONDENSER

< REMOVAL AND INSTALLATION >

CONDENSER

Exploded View

INFOID:000000007579538

Refer to [INT-37. "Exploded View"](#)

Removal and Installation

INFOID:000000007579539

REMOVAL

1. Remove the back door lower finisher.
Refer to [INT-38. "BACK DOOR LOWER FINISHER : Removal and Installation"](#)
2. Remove bolt (A), and then remove condenser (1) from the vehicle body.

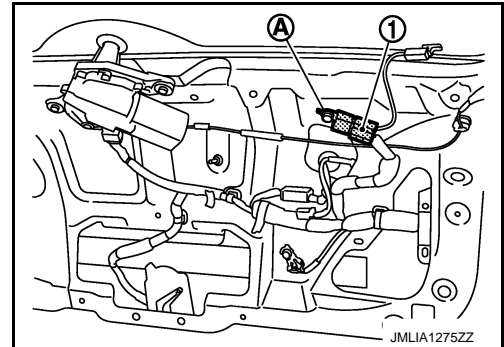

INSTALLATION

Install in the reverse order of removal.

A
B
C
D
E
F
G
H
I
J
K

DEF

M
N
O
P