

MWI

SECTION

METER, WARNING LAMP & INDICATOR

A
B
C
D
E
F
G
H
I
J
K
L
M
O
P

CONTENTS

PRECAUTION	3	OIL PRESSURE WARNING LAMP : System Description	12
PRECAUTIONS	3	METER ILLUMINATION CONTROL	12
Precaution for Supplemental Restraint System (SRS) "AIR BAG" and "SEAT BELT PRE-TENSIONER"	3	METER ILLUMINATION CONTROL : System Diagram	12
PREPARATION	4	METER ILLUMINATION CONTROL : System Description	12
PREPARATION	4	METER EFFECT FUNCTION	13
Commercial Service Tools	4	METER EFFECT FUNCTION : System Diagram	13
SYSTEM DESCRIPTION	5	METER EFFECT FUNCTION : System Description	13
COMPONENT PARTS	5	INFORMATION DISPLAY	14
METER SYSTEM	5	INFORMATION DISPLAY : System Diagram	14
METER SYSTEM : Component Parts Location	5	INFORMATION DISPLAY : System Description	14
METER SYSTEM : Component Description	6	OPERATION	18
SYSTEM	7	Switch Name and Function	18
METER SYSTEM	7	DIAGNOSIS SYSTEM (COMBINATION METER)	19
METER SYSTEM : System Diagram	7	On Board Diagnosis Function	19
METER SYSTEM : System Description	7	CONSULT Function	20
METER SYSTEM : Fail-Safe	9	ECU DIAGNOSIS INFORMATION	24
SPEEDOMETER	10	COMBINATION METER	24
SPEEDOMETER : System Diagram	10	Reference Value	24
SPEEDOMETER : System Description	10	Fail-Safe	30
TACHOMETER	10	DTC Index	31
TACHOMETER : System Diagram	11	IPDM E/R	32
TACHOMETER : System Description	11	List of ECU Reference	32
SHIFT POSITION INDICATOR	11	WIRING DIAGRAM	33
SHIFT POSITION INDICATOR : System Diagram	11	METER SYSTEM	33
SHIFT POSITION INDICATOR : System Description	11	Wiring Diagram	33
OIL PRESSURE WARNING LAMP	11	BASIC INSPECTION	35
OIL PRESSURE WARNING LAMP : System Diagram	12		

MWI

DIAGNOSIS AND REPAIR WORKFLOW (METER SYSTEM)	35	Component Inspection	45
Work flow	35	A/C AUTO AMP. CONNECTION RECOGNITION SIGNAL CIRCUIT	47
DTC/CIRCUIT DIAGNOSIS	37	Diagnosis Procedure	47
U1000 CAN COMM CIRCUIT	37	SYMPTOM DIAGNOSIS	48
Description	37	THE FUEL GAUGE INDICATOR DOES NOT OPERATE	48
DTC Logic	37	Description	48
Diagnosis Procedure	37	Diagnosis Procedure	48
U1010 CONTROL UNIT (CAN)	38	THE OIL PRESSURE WARNING LAMP DOES NOT TURN ON	49
Description	38	Description	49
DTC Logic	38	Diagnosis Procedure	49
Diagnosis Procedure	38	THE OIL PRESSURE WARNING LAMP DOES NOT TURN OFF	50
B2205 VEHICLE SPEED	39	Description	50
Description	39	Diagnosis Procedure	50
DTC Logic	39	THE AMBIENT TEMPERATURE DISPLAY IS INCORRECT	51
Diagnosis Procedure	39	Description	51
B2267 ENGINE SPEED	40	Diagnosis Procedure	51
Description	40	NORMAL OPERATING CONDITION	52
DTC Logic	40	INFORMATION DISPLAY	52
Diagnosis Procedure	40	INFORMATION DISPLAY : Description	52
B2268 WATER TEMP	41	REMOVAL AND INSTALLATION	53
Description	41	COMBINATION METER	53
DTC Logic	41	Exploded View	53
Diagnosis Procedure	41	Removal and Installation	53
POWER SUPPLY AND GROUND CIRCUIT	42	Disassembly and Assembly	54
COMBINATION METER	42		
COMBINATION METER : Diagnosis Procedure ...	42		
FUEL LEVEL SENSOR SIGNAL CIRCUIT	43		
Component Function Check	43		
Diagnosis Procedure	43		

PRECAUTIONS

< PRECAUTION >

PRECAUTION

PRECAUTIONS

Precaution for Supplemental Restraint System (SRS) "AIR BAG" and "SEAT BELT PRE-TENSIONER"

INFOID:000000007577762

The Supplemental Restraint System such as "AIR BAG" and "SEAT BELT PRE-TENSIONER", used along with a front seat belt, helps to reduce the risk or severity of injury to the driver and front passenger for certain types of collision. This system includes seat belt switch inputs and dual stage front air bag modules. The SRS system uses the seat belt switches to determine the front air bag deployment, and may only deploy one front air bag, depending on the severity of a collision and whether the front occupants are belted or unbelted. Information necessary to service the system safely is included in the "SRS AIR BAG" and "SEAT BELT" of this Service Manual.

WARNING:

Always observe the following items for preventing accidental activation.

- To avoid rendering the SRS inoperative, which could increase the risk of personal injury or death in the event of a collision that would result in air bag inflation, all maintenance must be performed by an authorized NISSAN/INFINITI dealer.
- Improper maintenance, including incorrect removal and installation of the SRS, can lead to personal injury caused by unintentional activation of the system. For removal of Spiral Cable and Air Bag Module, see "SRS AIR BAG".
- Never use electrical test equipment on any circuit related to the SRS unless instructed to in this Service Manual. SRS wiring harnesses can be identified by yellow and/or orange harnesses or harness connectors.

PRECAUTIONS WHEN USING POWER TOOLS (AIR OR ELECTRIC) AND HAMMERS

WARNING:

Always observe the following items for preventing accidental activation.

- When working near the Air Bag Diagnosis Sensor Unit or other Air Bag System sensors with the ignition ON or engine running, never use air or electric power tools or strike near the sensor(s) with a hammer. Heavy vibration could activate the sensor(s) and deploy the air bag(s), possibly causing serious injury.
- When using air or electric power tools or hammers, always switch the ignition OFF, disconnect the battery, and wait at least 3 minutes before performing any service.

A
B
C
D
E
F
G
H
I
J
K
L
M
O
P

MWI

PREPARATION

< PREPARATION >

PREPARATION

PREPARATION

Commercial Service Tools

INFOID:000000007577763

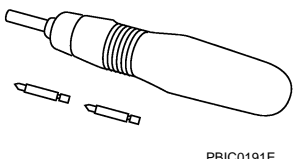
Tool name	Description
<p data-bbox="162 514 267 546">Power tool</p>  <p data-bbox="820 619 901 651">PBIC0191E</p>	<p data-bbox="1006 514 1193 546">Loosening screws</p>

COMPONENT PARTS

< SYSTEM DESCRIPTION >

SYSTEM DESCRIPTION

COMPONENT PARTS

METER SYSTEM

METER SYSTEM : Component Parts Location

INFOID:000000007577764

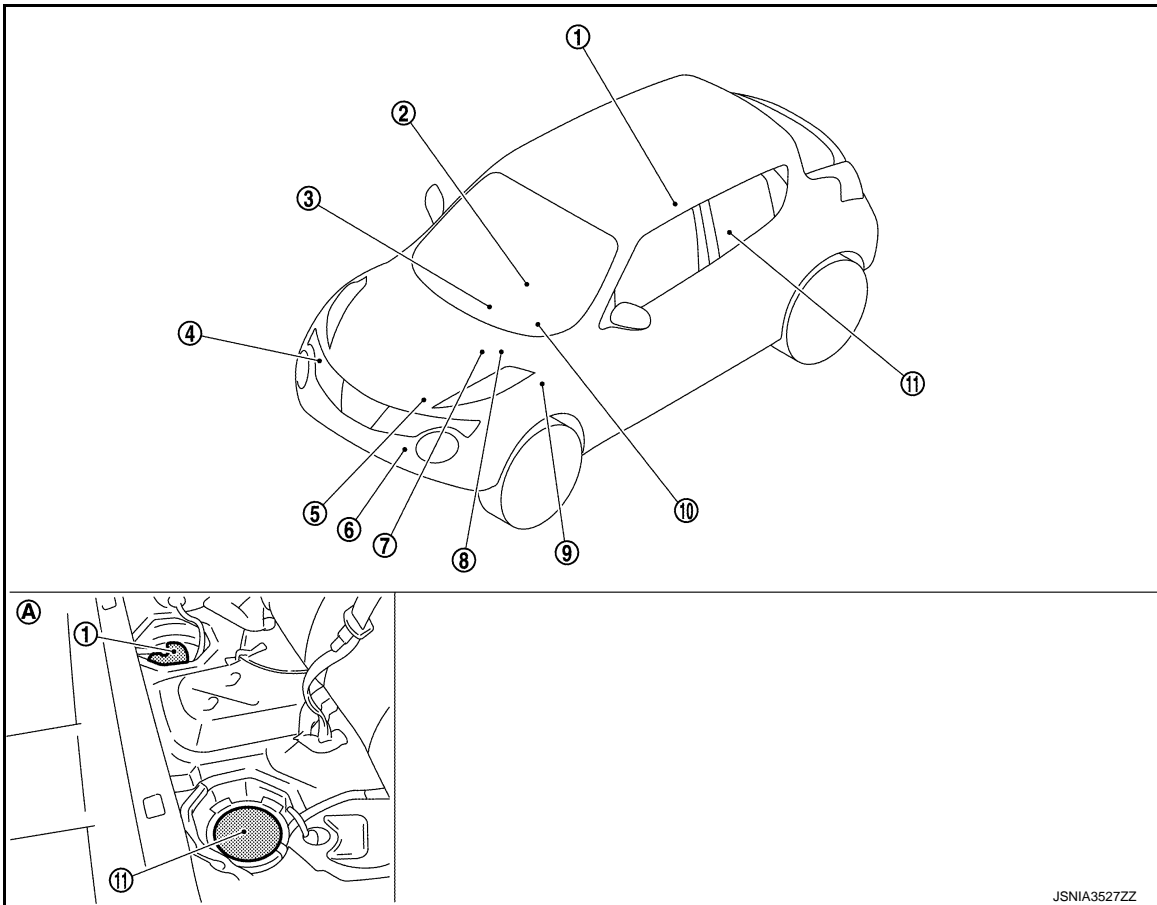

- | | | |
|--|--|--|
| 1. Fuel level sensor unit (main) | 2. CVT shift selector
Refer to TM-69, "CVT CONTROL SYSTEM : Component Parts Location" | 3. A/C auto amp.
Refer to HAC-7, "Component Description" |
| 4. Washer level switch | 5. ECM
Refer to EC-16, "ENGINE CONTROL SYSTEM : Component Parts Location" | 6. Ambient sensor
Refer to HAC-6, "Component Parts Location" |
| 7. ABS actuator and electric unit (control unit)
Refer to BRC-8, "Component Parts Location" | 8. TCM
Refer to TM-69, "CVT CONTROL SYSTEM : Component Parts Location" | 9. BCM
Refer to BCS-6, "BODY CONTROL SYSTEM : Component Parts Location" (WITH INTELLIGENT KEY SYSTEM)
Refer to BCS-83, "BODY CONTROL SYSTEM : Component Parts Location" (WITHOUT INTELLIGENT KEY SYSTEM) |
| 10. Combination meter | 11. Fuel level sensor unit (sub) | |
| A. Rear seat (bottom) | | |

A
B
C
D
E
F
G
H
I
J
K
L
M
N
O
P

MWI

COMPONENT PARTS

< SYSTEM DESCRIPTION >

METER SYSTEM : Component Description

INFOID:000000007577765

Unit	Description
Combination meter	<ul style="list-style-type: none"> • Provides the driver with various kinds of vehicle information via the CAN communication line and the use of signals through the hard wire. • Includes the signal buffer to transmit received signals to other units. • For functions of the combination meter, refer to MWI-7. "METER SYSTEM : System Description".
ECM	<p>Transmits the following signals to the combination meter via CAN communication.</p> <ul style="list-style-type: none"> • Engine speed signal • Engine coolant temperature signal • Engine status signal • Fuel consumption monitor signal • Fuel filler cap warning display signal • Oil pressure warning lamp signal
ABS actuator and electric unit (control unit)	<p>Transmits the vehicle speed signal to the combination meter via CAN communication.</p>
BCM	<p>Transmits the following signals to the combination meter via CAN communication.</p> <ul style="list-style-type: none"> • Door switch signal • Position light request signal • Low tire pressure warning lamp signal
TCM	<p>Transmits the following signals to the combination meter.</p> <ul style="list-style-type: none"> • Shift position signal • Manual mode shift refusal signal • Manual mode signal • Non-manual mode signal • Manual mode shift up signal • Manual mode shift down signal
CVT shift selector	<p>Transmits the following signals to the combination meter.</p> <ul style="list-style-type: none"> • Manual mode signal • Non-manual mode signal • Manual mode shift up signal • Manual mode shift down signal
Fuel level sensor unit	<p>Transmits the fuel level sensor signal to the combination meter.</p>
Ambient sensor	<p>Transmits the ambient sensor signal to the A/C auto amp. and the combination meter.</p>
A/C auto amp.	<p>Transmits the A/C auto amp. connection recognition signal to the combination meter.</p>
Washer level switch	<p>Transmits the washer level switch signal to the combination meter.</p>

SYSTEM

< SYSTEM DESCRIPTION >

SYSTEM

METER SYSTEM

METER SYSTEM : System Diagram

INFOID:000000007577766

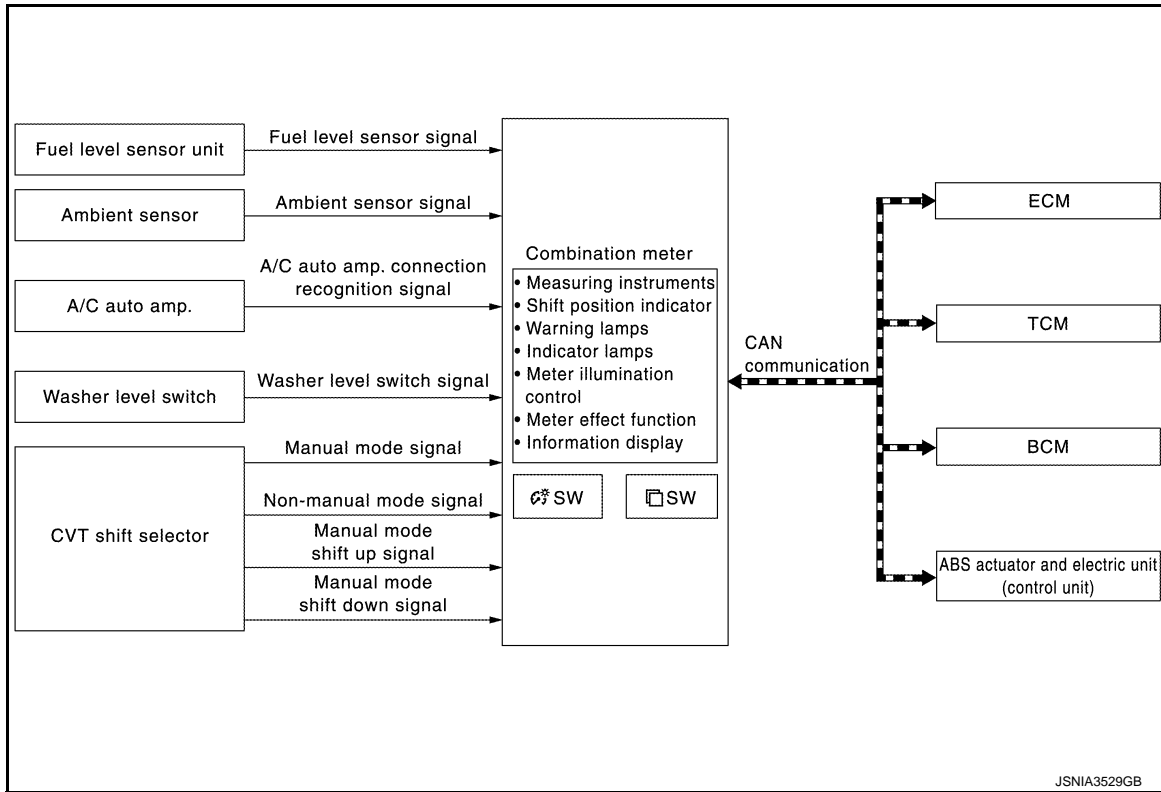

JSNIA3529GB

METER SYSTEM : System Description

INFOID:000000007577767

COMBINATION METER

- The combination meter receives necessary signals from each unit, switch, and sensor to control the following functions.
 - Measuring instruments
 - Shift position indicator
 - Warning lamps
 - Indicator lamps
 - Meter illumination control
 - Meter effect function
 - Information display
- The combination meter incorporates a buzzer function that sounds an audible alarm with the integrated buzzer device. Refer to [WCS-5. "Combination Meter"](#) for further details.
- The combination meter includes an on board diagnosis function.
- The combination meter can be diagnosed with CONSULT.

METER CONTROL FUNCTION LIST

System	Description	Reference
Measuring instruments	Speedometer	Indicates vehicle speed. MWI-10. "SPEEDOMETER : System Description"
	Tachometer	Indicates engine speed. MWI-11. "TACHOMETER : System Description"

SYSTEM

< SYSTEM DESCRIPTION >

System		Description	Reference	
Shift position indicator (CVT models)		Display shift position. (CVT models)	MWI-11, "SHIFT POSITION INDICATOR : System Description"	
Warning lamp/indicator lamp	Oil pressure warning lamp	The warning lamp turns ON or turns OFF, according to engine hydraulic pressure.	MWI-12, "OIL PRESSURE WARNING LAMP : System Description"	
Meter illumination control	Meter illumination control function	Switches back and forth between daytime mode and nighttime mode, according to a light switch position.	MWI-12, "METER ILLUMINATION CONTROL : System Description"	
	Meter illumination on/off control function	The meter illumination turns ON/OFF, according to the status of ignition switch and a cranking condition.		
	Buck light illumination control function	The operation of the illumination control switch allows the brightness adjustment of meter illumination.		
Meter effect function	Engine-start effect function	Controls pointers of combination meter and meter illumination at engine start to produce illumination effects.	MWI-13, "METER EFFECT FUNCTION : System Description"	
Information display	Engine coolant temperature gauge		MWI-14, "INFORMATION DISPLAY : System Description"	
	Fuel gauge			
	Odo/trip meter			
	Ambient temperature			
	Trip computer	Current fuel consumption		
		Average fuel consumption		
		Distance to empty		
		Travel time		
		Torque distribution indicator		
	Interrupt indication	Meter illumination level		
		Distance to empty		
		Warning		Low fuel warning
	Fuel filler cap warning			Warns, according to the tightening condition of fuel filler cap.
Low tire pressure warning	Warns, according to tire inflation pressure.			
			EC-51, "FUEL FILLER CAP WARNING SYSTEM : System Description"	
			MWI-14, "INFORMATION DISPLAY : System Description"	

ARRANGEMENT OF COMBINATION METER

SYSTEM

< SYSTEM DESCRIPTION >

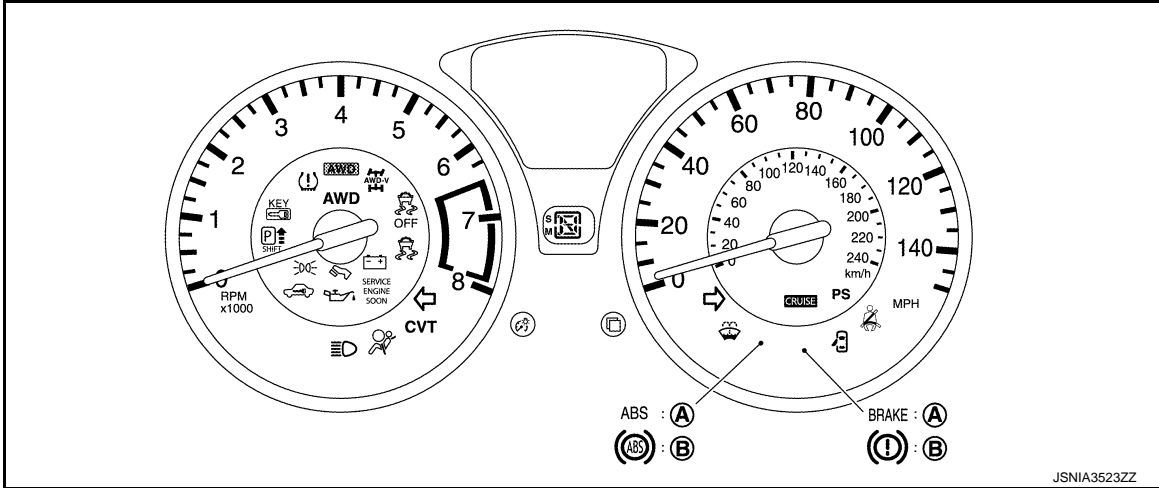

A. For U.S.A.

B. For Canada

METER SYSTEM : Fail-Safe

INFOID:000000007577768

FAIL-SAFE

The combination meter activates the fail-safe control if CAN communication with each unit is malfunctioning.

Function		Specifications
Speedometer		Reset to zero by suspending communication.
Tachometer		
Engine coolant temperature gauge		
Illumination control		When suspending communication, changes to nighttime mode.
Shift position indicator		When suspending communication, not indicate.
Information display	Instantaneous fuel consumption	<ul style="list-style-type: none"> When reception time of an abnormal signal is 2 seconds or less, the last received datum is used for calculation to indicate the result. When reception time of an abnormal signal is more than two seconds, the last result calculated during normal condition is indicated.
	Average fuel consumption	
	Possible driving distance	
	Torque distribution indicator	
	Low tire pressure warning	The display turns OFF by suspending communication.
Buzzer		The buzzer turns OFF by suspending communication.

A
B
C
D
E
F
G
H
I
J
K
L
M

MWI

SYSTEM

< SYSTEM DESCRIPTION >

Function		Specifications
Warning lamp/indicator lamp	ABS warning lamp	The lamp turns ON by suspending communication.
	Malfunction indicator lamp	
	VDC OFF indicator lamp	
	EPS warning lamp	
	AWD warning lamp	
	Brake warning lamp	
	VDC warning lamp	The lamp turns OFF by suspending communication.
	High beam indicator lamp	
	Turn signal indicator lamp	
	Door warning lamp	
	Tail lamp indicator lamp	
	Engine start operation indicator lamp	
	Shift P warning lamp	
	Oil pressure warning lamp	
	CRUISE indicator lamp	
	AWD mode indicator lamp (AWD)	
	AWD mode indicator lamp (AWD-V)	
	Key warning lamp	
	CVT indicator lamp	
	Low tire pressure warning lamp	

SPEEDOMETER

SPEEDOMETER : System Diagram

INFOID:000000007577769

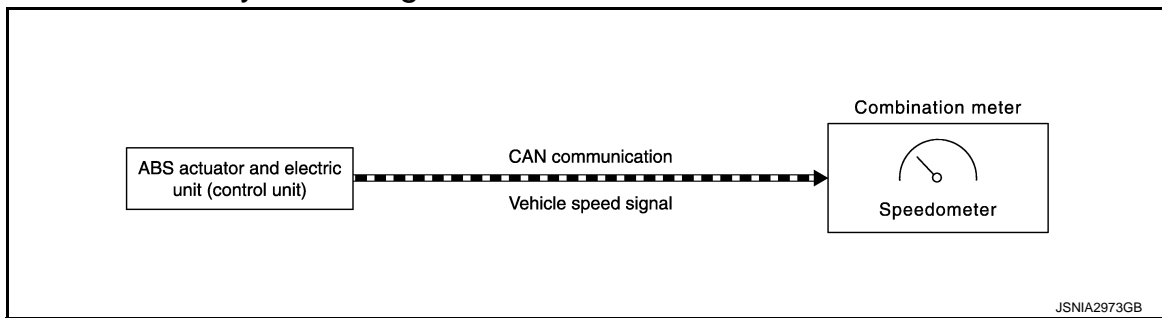

SPEEDOMETER : System Description

INFOID:000000007577770

- The ABS actuator and electric unit (control unit) converts the rectangular wave signal provided by the wheel sensor to a vehicle speed signal and transmits it to the combination meter via CAN communication.
- The combination meter indicates the vehicle speed to the speedometer according to the vehicle speed signal received via CAN communication.

TACHOMETER

SYSTEM

< SYSTEM DESCRIPTION >

TACHOMETER : System Diagram

INFOID:000000007577771

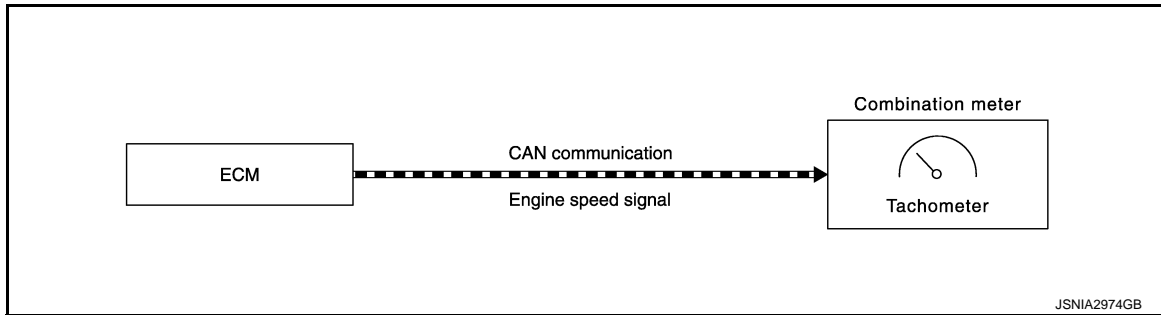

TACHOMETER : System Description

INFOID:000000007577772

- ECM converts the pulse signal provided by the crankshaft position sensor to an engine speed signal and transmits it to the combination meter via CAN communication.
- The combination meter indicates the engine speed to the tachometer according to the engine speed signal received via CAN communication.

SHIFT POSITION INDICATOR

SHIFT POSITION INDICATOR : System Diagram

INFOID:000000007577773

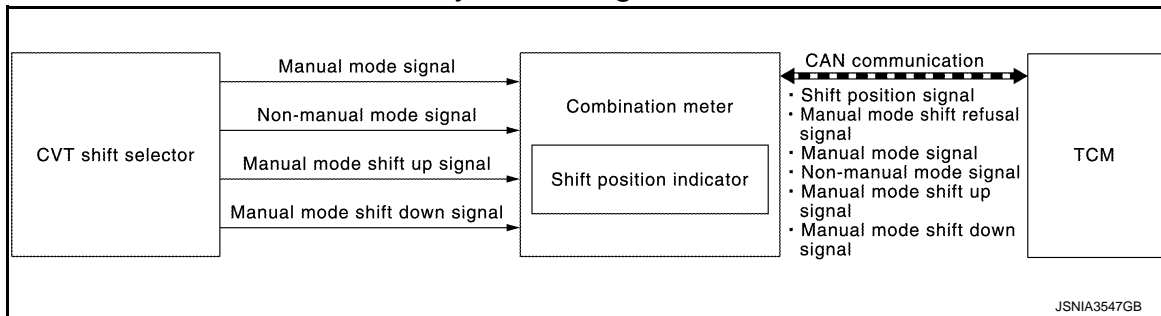

SHIFT POSITION INDICATOR : System Description

INFOID:000000007577774

The combination meter receives the shift position signal from TCM via CAN communication, and displays the shift position to the shift position indicator.

MANUAL MODE

- The combination meter receives the manual mode signal, non-manual mode signal, manual mode shift up signal, and manual mode shift down signal from CVT shift selector and transmits them to TCM via CAN communication.
- TCM recognizes the manual mode operation status according to the manual mode signal, non-manual mode signal, manual mode shift up signal, and manual mode shift down signal received via CAN communication and transmits the manual mode indicator signal to the combination meter via CAN communication.
- The combination meter indicates shift position according to the shift position signal received via CAN communication.

NON-MANUAL MODE

- TCM transmits the shift position signal to the combination meter via CAN communication.
- The combination meter indicates shift position according to the shift position signal received via CAN communication.

SHIFT REFUSAL WARNING AND ALARM

- TCM sends a manual mode shift refusal signal to the combination meter via CAN communication when shift-up and shift-down can not be operated in manual mode.
- The combination meter blinks the shift position indicator and sounds a buzzer according to a manual mode shift refusal signal received via CAN communication.

OIL PRESSURE WARNING LAMP

A
B
C
D
E
F
G
H
I
J
K
L
M
N
O
P

MWI

SYSTEM

< SYSTEM DESCRIPTION >

OIL PRESSURE WARNING LAMP : System Diagram

INFOID:000000007577775

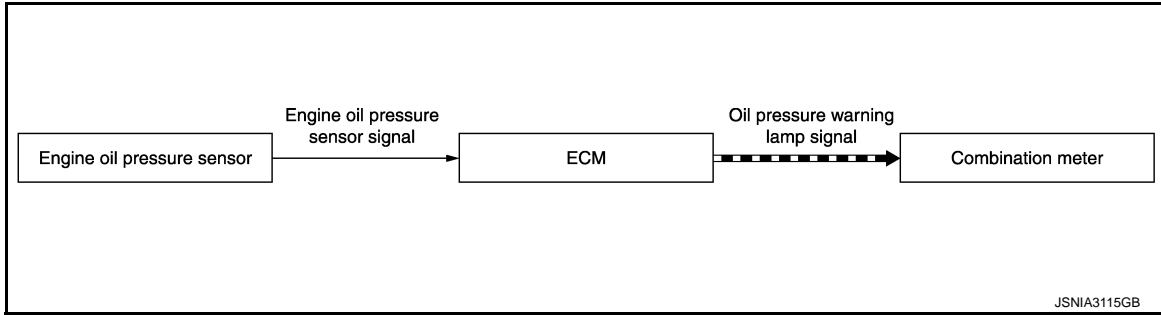

OIL PRESSURE WARNING LAMP : System Description

INFOID:000000007577776

The combination meter turns the oil pressure warning lamp ON when receiving ECM to the oil pressure warning lamp signal via CAN communication. For details, refer to [EC-34. "Oil Pressure Warning Lamp"](#).

METER ILLUMINATION CONTROL

METER ILLUMINATION CONTROL : System Diagram

INFOID:000000007577777

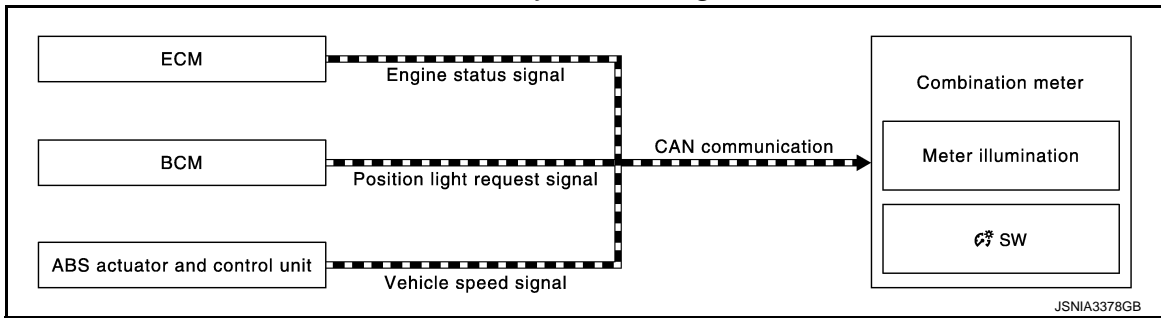

METER ILLUMINATION CONTROL : System Description

INFOID:000000007577778

METER ILLUMINATION CONTROL FUNCTION

- Combination meter controls meter illumination, based on the following signal.
 - Position light request signal
- The combination meter switches mode between Daytime mode and Nighttime mode, according to the following conditions.

Condition		Meter illumination	
Combination switch (lighting switch)	1ST or 2ND position	Nighttime mode	
	AUTO POSITION	Outdoor: Bright*	Daytime mode
		Outdoor: Dark*	Nighttime mode
	Off	Daytime mode	

*: For further information, refer to [INL-9. "ILLUMINATION CONTROL SYSTEM : System Description"](#).

BUCK LIGHT ILLUMINATION CONTROL FUNCTION

The operation of the illumination control switch allows the brightness adjustment of meter illumination.

Meter illumination	The number of adjustable steps
Daytime	12 step
Nighttime	12 step



METER ILLUMINATION ON/OFF CONTROL FUNCTION

- Combination meter turns ON meter illumination when the following condition is satisfied:
 - Ignition switch ON

SYSTEM

< SYSTEM DESCRIPTION >

- Combination meter turns OFF meter illumination when any of the following condition is satisfied:
 - During a crank with vehicle speed less than 1 km/h (0.6 MPH) and ACC power supply OFF
 - Ignition switch OFF or ACC power supply OFF
- The combination meter receives the following signals to control meter illumination.

Signal name	Signal path
Ignition signal	—
Engine status signal	ECM  Combination meter
Vehicle speed signal	ABS actuator and control unit (control unit)  Combination meter

METER EFFECT FUNCTION

METER EFFECT FUNCTION : System Diagram

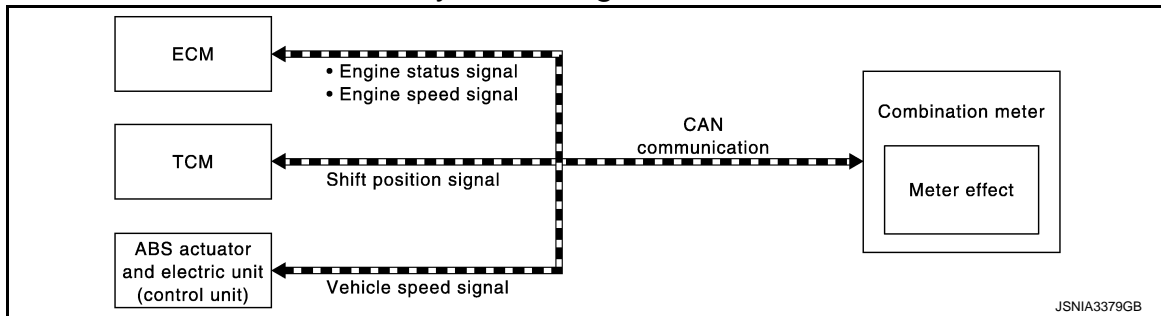

METER EFFECT FUNCTION : System Description

INFOID:000000007577780

ENGINE-START EFFECT FUNCTION

When recognizing an engine start, the combination meter controls the following items for producing the effect.

- Speedometer
- Tachometer
- Each meter pointer illumination
- Meter illumination
- Information display illumination
- Shift position indicator (CVT models)
- Start-up illumination (M/T models)

Meter and Illumination Operations During Engine-start Effect

The combination meter controls the following items during the engine-start effect.

Control item	Operation
Speedometer	Sweeps the pointer.
Tachometer	Sweeps the pointer.
Each meter pointer illumination	Turns on the illumination at the effect level.
Meter illumination	Increases the brightness to the effect level in stages.
Information display illumination	Turns on the illumination at the normal brightness level.
Shift position indicator (CVT models)	Turns ON at effect level brightness after staying OFF for 2 seconds.
Start-up illumination (M/T models)	Turns ON/OFF in stages between OFF and the effect level brightness.

NOTE:

The pointers are stopped and illumination is turned off while cranking the engine.

Engine Start Judgement

The combination meter judges “engine-start” and activates the engine-start effect only once when the following operational conditions are all satisfied.

A
B
C
D
E
F
G
H
I
J
K
L
M

MWI

O
P

SYSTEM

< SYSTEM DESCRIPTION >



Operational condition	
Ignition switch	ON position
Vehicle speed	Less than 1 km/h (0.6 MPH)
Engine state	Other than the time of cranking the engine
	500 rpm or more
Shift position (CVT models)	"P" range

NOTE:

ENGINE-START EFFECT exits when any of the above operational conditions is cancelled during the engine-start effect.

Signal Path

The combination meter judges "engine-start", according to the following signals and activates the engine-start effect function.

Signal name	Signal source
Ignition signal	—
Shift position signal	TCM  → Combination meter
Engine speed signal	ECM  → Combination meter
Engine status signal	
Vehicle speed signal	ABS actuator and electric unit (control unit)  → Combination meter

NOTE:

The engine-start effect function ends if any one of the above conditions is lost during the activation of this function.

INFORMATION DISPLAY

INFORMATION DISPLAY : System Diagram

INFOID:000000007577781

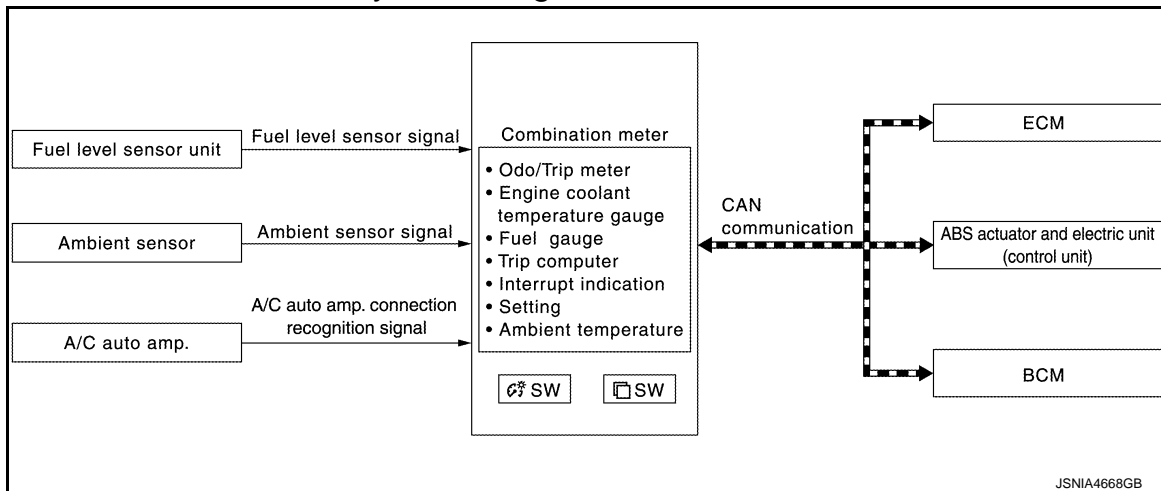

JSNIA4668GB

INFORMATION DISPLAY : System Description

INFOID:000000007577782

DESCRIPTION

- The combination meter receives signals necessary for controlling the operation of the information display from each unit, sensor and switch.
- The combination meter incorporates a trip computer that displays the warning/information according to the information received from each unit, sensor and switch.
- The combination meter shows the following functions on the information display.
 - Odo/trip meter

SYSTEM

< SYSTEM DESCRIPTION >

- Engine coolant temperature gauge
- Fuel gauge
- Trip computer
- Interrupt indication
- Ambient temperature

ODO/TRIP METER

The combination meter calculates mileage, based on the following signals and displays the mileage on the information display.

Signal name	Signal path
Ignition signal	—
Vehicle speed signal	ABS actuator and electric unit (control unit)  → Combination meter

ENGINE COOLANT TEMPERATURE GAUGE

- ECM reads the engine coolant temperature signal from the engine coolant temperature sensor and transmits the signal to the combination meter via CAN communication.
- The combination meter indicates the engine coolant temperature to the water temperature gauge according to the engine coolant temperature signal received via CAN communication.

Signal name	Signal path
Ignition signal	—
Engine coolant temperature signal	ECM  → Combination meter

FUEL GAUGE

Control Outline

The combination meter reads the fuel level sensor signal from the fuel level sensor unit and indicates the fuel level to the fuel gauge.



Signal name	Signal path
Ignition signal	—
Fuel level sensor signal	Fuel level sensor unit  → Combination meter

Refuel Control

The unit judges that the driver is refueling the vehicle and accelerates the fuel gauge segment movement if the fuel level changes by 15 ℓ (4 US gal, 3 - 1/4 Imp gal) or more.

AMBIENT TEMPERATURE

The combination meter calculates ambient temperature based on the following signals, and the calculated value is displayed on the information display.

Signal name	Signal path
Ignition signal	—
Ambient sensor signal	Ambient sensor  → Combination meter
A/C auto amp. recognition signal	A/C auto amp.  → Combination meter
Vehicle speed signal	ABS actuator and electric unit (control unit)  → Combination meter

NOTE:

- The indicated temperature is corrected based on an ignition signal, ambient temperature detected by the ambient sensor, and vehicle speed signal. The indicated temperature is not raised under vehicle speed less than 20 km/h (12 MPH).

A
B
C
D
E
F
G
H
I
J
K
L
M

MWI

O
P

SYSTEM



< SYSTEM DESCRIPTION >

- The ambient sensor input value that is displayed on “Data Monitor” of CONSULT is the value before the correction. It may not match the indicated temperature on the information display.
- Depending on engine heat or heat on the road surfaces, an ambient temperature may be indicated higher than actual one.

TRIP COMPUTER

Current Fuel Consumption

The combination meter calculates current fuel consumption based on the following signals, and the calculated value is displayed on the information display.



Signal name	Signal path
Ignition signal	—
Fuel consumption monitor signal	ECM  → Combination meter
Vehicle speed signal	ABS actuator and electric unit (control unit)  → Combination meter

NOTE:

- Current fuel consumption on the information display is updated approximately every 0.5 seconds.
- Current fuel consumption on the information display shows 0 l/100km (0 mpg) when vehicle speed is 0 km/h (0 MPH).

Average Fuel Consumption

The combination meter calculates average fuel consumption based on the following signals, and the calculated value is displayed on the information display.



Signal name	Signal path
Ignition signal	—
Fuel consumption monitor signal	ECM  → Combination meter
Vehicle speed signal	ABS actuator and electric unit (control unit)  → Combination meter

NOTE:

- Average fuel consumption on the information display is updated approximately every 30 seconds.
- Soon after a reset or when the ignition switch is turned ON right after battery removal and installation, “—” is displayed until after a travel of 30 seconds and approximately 500 m (0.31 mile).

Distance to Empty

The combination meter calculates distance to empty based on the following signals, and the calculated value is displayed on the information display.

Signal name	Signal path
Ignition signal	—
Fuel level sensor signal	Fuel level sensor unit  → Combination meter
Fuel consumption monitor signal	ECM  → Combination meter
Vehicle speed signal	ABS actuator and electric unit (control unit)  → Combination meter

NOTE:

- Distance to empty on the information display is updated approximately every 30 seconds.
- When the ignition switch is turned ON right after battery removal and installation, “—” is displayed until after a travel of 30 seconds.
- The indicated values may not match each other when refueling with the ignition switch ON.

Travel Time

The combination meter measures and displays travel time (ignition switch ON time).

SYSTEM

< SYSTEM DESCRIPTION >

Torque Distribution Indicator

Refer to [DLN-12, "Torque Distribution Indicator"](#).

INTERRUPT INDICATION

- The combination meter displays an interrupt regarding a warning, alert, and maintenance on the information display, based on signals received from each unit and switch.
- When conditions are satisfied, the normal screen switches to a warning screen to display an interrupt.

Meter Illumination Level

The combination meter displays the illuminance level of the back light on the information display by turning the meter control switch.

Low Fuel Warning

- When all the following operating conditions are satisfied, the combination meter displays a low fuel warning on the information display by an interrupt.

Operating condition		
Ignition switch	ON	
Fuel remaining quantity*	2WD	Approximately 9.9 ℓ (2-5/8 US gal, 2-1/8 Imp gal) or less [1.4 ℓ (3/8 US gal, 1/4 Imp gal) fuel residues included]
	AWD	Approximately 6.9 ℓ (1-7/8 US gal, 1-1/2 Imp gal) or less [1.4 ℓ (3/8 US gal, 1/4 Imp gal) fuel residues included]

*: With the vehicle in a horizontal position

- The combination meter judges showing/hiding of “low fuel warning”, according to the signals below:

Signal name	Signal path
Ignition signal	—
Fuel level sensor signal	Fuel level sensor Combination meter

Fuel Filler Cap Warning

- The combination meter judges showing/hiding of “fuel filler cap warning”, according to the signals below:

Signal name	Signal path
Ignition signal	—
Fuel filler cap warning display signal	ECM Combination meter

- For further information, refer to [EC-51, "FUEL FILLER CAP WARNING SYSTEM : System Description"](#).

Low Tire Pressure Warning

- The combination meter judges showing/hiding of “low tire pressure warning”, according to the signals below:

Signal name	Signal Path
Ignition signal	—
Low tire pressure warning lamp signal	BCM Combination meter

- For further information, refer to [WT-8, "System Description"](#).

A
B
C
D
E
F
G
H
I
J
K
L
M
MWI
O
P

OPERATION

< SYSTEM DESCRIPTION >

OPERATION

Switch Name and Function

INFOID:000000007577783

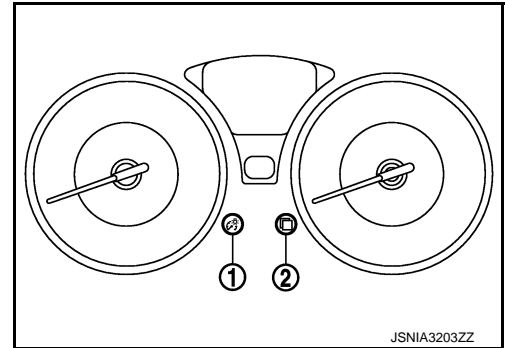

Switch name	Operation	Description
Illumination control switch (1)	Press	An illuminance level of the back light of the combination meter can be adjusted.
Meter control switch (2)		<ul style="list-style-type: none">The information display screen can be switched.An indicated value of the trip computer can be reset by pressing and holding the meter control switch.

DIAGNOSIS SYSTEM (COMBINATION METER)

< SYSTEM DESCRIPTION >

DIAGNOSIS SYSTEM (COMBINATION METER)

On Board Diagnosis Function

INFOID:000000007577784

ON BOARD DIAGNOSIS ITEM

The combination meter allows the following diagnosis items with the on-board diagnosis function.

Diagnosis item	
Drive circuit check	<ul style="list-style-type: none"> • Speedometer • Tachometer
LCD (liquid crystal display) check	Information display

METHOD OF STARTING

1. Turn ignition switch ON, and switch the trip meter to "trip A" or "trip B".
2. Turn ignition switch OFF.
3. While pressing the meter control switch (1), turn ignition switch ON.
4. Make sure that the trip meter displays "0000.0".
5. Press the meter control switch at least 3 times. (Within 7 seconds after the ignition switch is turned ON.)

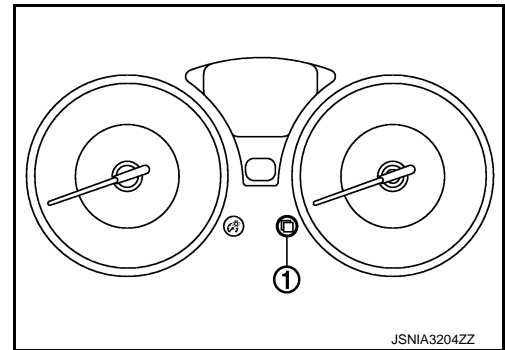

6. The combination meter is turned to self-diagnosis mode. All of the segments of engine coolant temperature gauge, fuel gauge, odo/trip meter, shift position indicator (A) for CVT models and information display illuminate.

NOTE:

- Check combination meter power supply and ground circuit when the self-diagnosis mode of the combination meter does not start. Replace combination meter if power supply and ground circuit are normal.
- If any of the dots are not displayed, replace combination meter.
- For M/T models, start-up lamp (B) illuminate instead of shift position indicator.

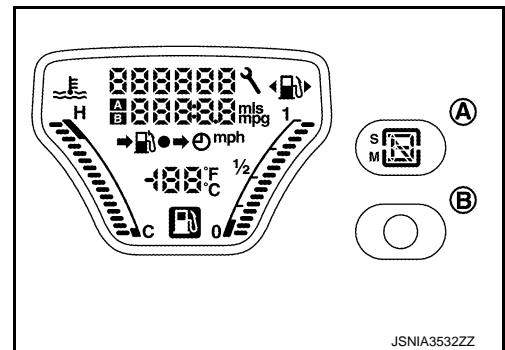

7. Each meter activates by pressing the meter control switch.

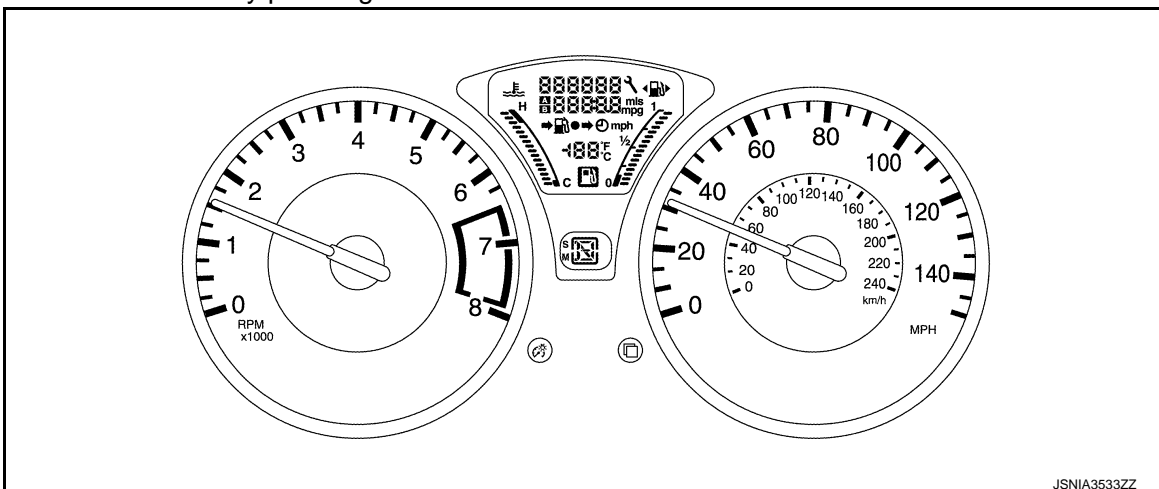

A

B

C

D

E

F

G

H

I

J

K

L

M

MWI

O

P

DIAGNOSIS SYSTEM (COMBINATION METER)

< SYSTEM DESCRIPTION >

NOTE:

- If any of the meters or gauges is not activated, replace combination meter.
- The figure is reference.

CONSULT Function

INFOID:000000007577785

CONSULT APPLICATION ITEMS

CONSULT can perform the following diagnosis modes via CAN communication and the combination meter.

System	Diagnosis mode	Description
METER/M&A	Self Diagnostic Result	The combination meter checks the conditions and displays memorized errors.
	Data Monitor	Displays the combination meter input/output data in real time.
	W/L ON History	Lighting history of the warning lamp and indicator lamp can be checked.

SELF DIAG RESULT

Refer to [MWI-31. "DTC Index"](#).

DATA MONITOR

Display Item List

X: Applicable

Display item [Unit]	MAIN SIGNALS	Description
SPEED METER [km/h]	X	Value of vehicle speed signal received from ABS actuator and electric unit (control unit) via CAN communication. NOTE: 655.35 is displayed when the malfunction signal is received.
SPEED OUTPUT [km/h]	X	Vehicle speed signal value transmitted to other units via CAN communication. NOTE: 655.35 is displayed when the malfunction signal is received.
ODO OUTPUT [km/h or mph]		Odometer signal value transmitted to other units via CAN communication.
TACHO METER [rpm]	X	Value of the engine speed signal received from ECM via CAN communication. NOTE: 8191.875 is displayed when the malfunction signal is received.
FUEL METER [L]	X	Fuel level indicated on combination meter.
W TEMP METER [°C]	X	Value of engine coolant temperature signal is received from ECM via CAN communication. NOTE: 215 is displayed when the malfunction signal is input.
FUEL CAP W/L [On/Off]		Status of fuel filler cap warning display detected from fuel filler cap warning display signal received from ECM via CAN communication.
ABS W/L [On/Off]		Status of ABS warning lamp detected from ABS warning lamp signal is received from ABS actuator and electric unit (control unit) via CAN communication.
VDC/TCS IND [On/Off]		Status of VDC OFF indicator lamp detected from VDC OFF indicator lamp signal is received from ABS actuator and electric unit (control unit) via CAN communication.
SLIP IND [On/Off]		Status of VDC warning lamp detected from VDC warning lamp signal received from ABS actuator and electric unit (control unit) via CAN communication.
BRAKE W/L [On/Off]		Status of brake warning lamp detected from brake warning lamp signal is received from ABS actuator and electric unit (control unit) via CAN communication. NOTE: Displays "Off" if the brake warning lamp is illuminated when the valve check starts, the parking brake switch is turned ON or the brake fluid level switch is turned ON.
DOOR W/L [On/Off]		Status of door open warning lamp detected from door switch signal received from BCM via CAN communication.

DIAGNOSIS SYSTEM (COMBINATION METER)

< SYSTEM DESCRIPTION >

Display item [Unit]	MAIN SIGNALS	Description	A
HI-BEAM IND [On/Off]		Status of high beam indicator lamp detected from high beam request signal is received from BCM via CAN communication.	A
TURN IND [On/Off]		Status of turn indicator lamp detected from turn indicator signal is received from BCM via CAN communication.	B
LIGHT IND [On/Off]		Status of tail lamp indicator lamp detected from position light request signal is received from BCM via CAN communication.	C
OIL W/L [On/Off]		Status of oil pressure warning lamp detected from oil pressure warning lamp signal is received from ECM via CAN communication.	D
MIL [On/Off]		Status of malfunction indicator lamp detected from malfunctioning indicator lamp signal is received from ECM via CAN communication.	D
GLOW IND [Off]		This item is displayed, but cannot be monitored.	E
C-ENG2 W/L [Off]		This item is displayed, but cannot be monitored.	E
CRUISE IND [On/Off]		Status of CRUISE indicator lamp detected from ASCD status signal is received from ECM via CAN communication.	F
SET IND [Off]		This item is displayed, but cannot be monitored.	G
CVT IND [On/Off]		Status of CVT indicator lamp detected from CVT status signal is received from TCM via CAN communication.	G
4WD W/L [On/Off]		Status of AWD warning lamp judged from AWD warning lamp signal received from AWD control module with CAN communication line.	H
4WD LOCK IND [On/Off]		Status of AWD mode indicator lamp (AWD-V) judged from AWD mode indicator signal received from AWD control module with CAN communication line.	I
FUEL W/L [On/Off]		Low fuel warning status detected by the identified fuel level.	I
AIR PRES W/L [On/Off]		Status of low tire pressure warning lamp judged from low tire pressure warning lamp signal received from BCM from CAN communication line.	J
KEY G/Y W/L [On/Off]		Status of KEY warning lamp (G/Y) detected from KEY warning lamp signal is received from BCM via CAN communication.	K
KEY KNOB W/L [On/Off]		Status of shift P warning lamp detected from shift P warning lamp signal is received from BCM via CAN communication.	K
EPS W/L [On/Off]		Status of EPS warning lamp detected from EPS warning lamp signal is received from EPS control unit via CAN communication.	L
DPF W/L [Off]		This item is displayed, but cannot be monitored.	L
LCD [B&P N, B&P I, SFT P, BATT, NO KY, LK WN] ^{*1} [C&P N, C&P I, SFT P, BATT, NO KY, LK WN] ^{*2}		Status of engine start operation indicator lamp, shift P warning lamp and KEY warning lamp, detected from engine start operation indicator lamp signal, shift P warning lamp signal and KEY warning lamp signal are received from BCM via CAN communication.	M
SHIFT IND [P, R, N, D, M1, M2, M3, M4, M5, M6]		Status of shift position indicator judged from shift position signal received from TCM with CAN communication line.	O
O/D OFF SW [Off]		This item is displayed, but cannot be monitored.	P
M RANGE SW [On/Off]		Status of manual mode switch.	P
NM RANGE SW [On/Off]		Status of non-manual mode switch.	P
AT SFT UP SW [On/Off]		Status of manual mode shift up switch.	P

MWI

DIAGNOSIS SYSTEM (COMBINATION METER)

< SYSTEM DESCRIPTION >

Display item [Unit]	MAIN SIGNALS	Description
AT SFT DWN SW [On/Off]		Status of manual mode shift down switch.
PKB SW [On/Off]		Status of parking brake switch.
BUCKLE SW [On/Off]		Status of seat belt buckle switch (driver side).
BRAKE SW [Off]		This item is displayed, but cannot be monitored.
BRAKE OIL SW [On/Off]		Status of brake fluid level switch.
A/C AMP CONN [On/Off]		Status of A/C auto amp. connection recognition signal.
PASS BUCKLE SW [Off]		This item is displayed, but cannot be monitored.
DISTANCE [km]		Value of distance to empty calculated by combination meter.
OUTSIDE TEMP [°C or °F]		Ambient temperature value converted from ambient sensor signal received from ambient sensor. NOTE: This may not match with the temperature value indicated on the information display. (Because the information display value is a corrected value from the ambient sensor input value.)
FUEL LOW SIG [On/Off]		Status of fuel level low warning signal to output to AV control unit via CAN communication.
BUZZER [On/Off]	X	Buzzer status (in the combination meter) is detected from the buzzer output signal received from each unit via CAN communication and the warning output condition of the combination meter.
ASCD SPD BLNK [On/Off]		Blinking status of ASCD or speed limiter set vehicle speed that is judged by the ASCD status signal received from ECM via CAN communication.
ASCD STATUS [Off, ASCD, CRUISE, SL ON, SL SET]		Display status of ASCD and speed limiter status display judged by the ASCD status signal received from ECM via CAN communication.
ASCD REQ SPD [km/h/Off]		ASCD or speed limiter set vehicle speed value that is judged by the ASCD status signal received from ECM via CAN communication.
TPMS PRESS L [On/Off]		Status of low tire pressure warning judged from low tire pressure warning lamp signal received from BCM with CAN communication line.

- *1: CVT models
- *2: M/T models

NOTE:

Some items are not available according to vehicle specification.

W/L ON HISTORY

- Stores histories when warning/indicator lamp is turned on.
- "W/L ON HISTORY" indicates the "TIME" when the warning/indicator lamp is turned on.
- The "TIME" above is:
 - 0: The condition that the warning/indicator lamp has been turned on 1 or more times after starting the engine and waiting for 30 seconds.
 - 1 - 39: The number of times the engine was restarted after the 0 condition.
 - NO W/L ON HISTORY: Stores NO (0) turning on history of warning/indicator lamp.

NOTE:

- W/L ON HISTORY is not stored for approximately 30 seconds after the engine starts.
- Brake warning lamp does not store any history when the parking brake is applied or the brake fluid level gets low.

Display Item

DIAGNOSIS SYSTEM (COMBINATION METER)

< SYSTEM DESCRIPTION >

Display item	Description	
ABS W/L	Lighting history of ABS warning lamp.	A
VDC/TCS IND	Lighting history of VDC OFF indicator lamp.	
SLIP IND	Lighting history of VDC warning lamp.	B
BRAKE W/L	Lighting history of brake warning lamp.	
DOOR W/L	Lighting history of door open warning.	C
OIL W/L	Lighting history of oil pressure warning lamp.	
C-ENG W/L	Lighting history of malfunction indicator lamp.	D
CRUISE IND	Lighting history of CRUISE indicator lamp.	
CVT IND	Lighting history of CVT indicator lamp.	
4WD W/L	Lighting history of AWD warning lamp.	E
FUEL W/L	Lighting history of low fuel level warning lamp.	
AIR PRES W/L	Lighting history of low tire pressure warning lamp.	
KEY G/Y W/L	Lighting history of KEY warning lamp (G/Y).	F
KEY KNOB W/L	Lighting history of Shift P warning lamp.	
EPS W/L	Lighting history of EPS warning lamp.	G

NOTE:

In items displayed on the CONSULT screen, only those listed in the above table are used.

A
B
C
D
E
F
G
H
I
J
K
L
M
O
P

MWI

COMBINATION METER

< ECU DIAGNOSIS INFORMATION >

ECU DIAGNOSIS INFORMATION

COMBINATION METER

Reference Value

INFOID:000000007577786

VALUES ON THE DIAGNOSIS TOOL

Monitor Item	Condition		Value/Status
SPEED METER [km/h]	Ignition switch ON	While driving	Input value of vehicle speed signal (CAN communication signal) NOTE: 655.35 is displayed when the malfunction signal is received
SPEED OUTPUT [km/h]	Ignition switch ON	While driving	Output value of vehicle speed signal (CAN communication signal) NOTE: 655.35 is displayed when the malfunction signal is received
ODO OUTPUT [km/h or mph]	Ignition switch ON	—	Output value of odometer signal (CAN communication signal)
TACHO METER [rpm]	Ignition switch ON	Engine running	Input value of engine speed signal (CAN communication signal) NOTE: 8191.875 is displayed when the malfunction signal is received
FUEL METER [L]	Ignition switch ON	—	Input value of fuel level sensor signal
W TEMP METER [°C]	Ignition switch ON	—	Input value of engine coolant temperature signal (CAN communication signal) NOTE: 215 is displayed when the malfunction signal is input
FUEL CAP W/L	Ignition switch ON	Fuel filler cap warning display ON	On
		Fuel filler cap warning display OFF	Off
ABS W/L	Ignition switch ON	ABS warning lamp ON	On
		ABS warning lamp OFF	Off
VDC/TCS IND	Ignition switch ON	VDC OFF indicator lamp ON	On
		VDC OFF indicator lamp OFF	Off
SLIP IND	Ignition switch ON	VDC warning lamp ON	On
		VDC warning lamp OFF	Off
BRAKE W/L	Ignition switch ON	Brake warning lamp ON	On
		Brake warning lamp OFF	Off
DOOR W/L	Ignition switch ON	Door open warning lamp ON	On
		Door open warning lamp OFF	Off
HI-BEAM IND	Ignition switch ON	High-beam indicator lamp ON	On
		High-beam indicator lamp OFF	Off
TURN IND	Ignition switch ON	Turn signal indicator lamp ON	On
		Turn signal indicator lamp OFF	Off
LIGHT IND	Ignition switch ON	Tail lamp indicator lamp ON	On
		Tail lamp indicator lamp OFF	Off

COMBINATION METER

< ECU DIAGNOSIS INFORMATION >

Monitor Item	Condition		Value/Status	
OIL W/L	Ignition switch ON	Oil pressure warning lamp ON	On	A
		Oil pressure warning lamp OFF	Off	
MIL	Ignition switch ON	Malfunction indicator lamp ON	On	B
		Malfunction indicator lamp OFF	Off	
GLOW IND	Ignition switch ON	NOTE: This item is displayed, but cannot be monitored.	Off	C
C-ENG2 W/L	Ignition switch ON	NOTE: This item is displayed, but cannot be monitored.	Off	D
CRUISE IND	Ignition switch ON	CRUISE indicator lamp ON	On	
		CRUISE indicator lamp OFF	Off	E
SET IND	Ignition switch ON	NOTE: This item is displayed, but cannot be monitored.	Off	F
CVT IND	Ignition switch ON	CVT indicator ON	On	
		CVT indicator OFF	Off	
4WD W/L	Ignition switch ON	AWD warning lamp ON	On	G
		AWD warning lamp OFF	Off	
4WD LOCK IND	Ignition switch ON	AWD mode indicator lamp (AWD-V) ON	On	H
		AWD mode indicator lamp (AWD-V) OFF	Off	
FUEL W/L	Ignition switch ON	During low fuel warning indication	On	
		Other than the above	Off	I
AIR PRESS W/L	Ignition switch ON	Low tire pressure warning lamp ON	On	
		Other than the above	Off	J
KEY G/Y W/L	Ignition switch ON	During Intelligent Key system malfunction indication	On	
		Other than the above	Off	K
KEY KNOB W/L	Ignition switch ON	SHIFT P warning lamp ON	On	
		SHIFT P warning lamp OFF	Off	
EPS W/L	Ignition switch ON	EPS warning lamp ON	On	L
		EPS warning lamp OFF	Off	
DPF W/L	Ignition switch ON	NOTE: This item is displayed, but cannot be monitored.	Off	M

MWI

O

P

COMBINATION METER

< ECU DIAGNOSIS INFORMATION >

Monitor Item	Condition		Value/Status
LCD	Ignition switch LOCK or ACC	Engine start operation indicator lamp ON (CVT models)	B&P N
	Ignition switch ON	Engine start operation indicator lamp ON (CVT models)	B&P I
	Ignition switch LOCK or ACC	Engine start operation indicator lamp ON (M/T models)	C&P N
	Ignition switch ON	Engine start operation indicator lamp ON (M/T models)	C&P I
	Ignition switch LOCK	During P position warning indication	SFT P
	Ignition switch LOCK	During Intelligent Key low battery warning indication	BATT
	Ignition switch ON	During take away warning indication	NO KY
	Ignition switch ON	During ACC warning indication	LK WN
SHIFT IND	Ignition switch ON	Shift position indicator P display	P
		Shift position indicator R display	R
		Shift position indicator N display	N
		Shift position indicator D display	D
		Shift position indicator M1 display	M1
		Shift position indicator M2 display	M2
		Shift position indicator M3 display	M3
		Shift position indicator M4 display	M4
		Shift position indicator M5 display	M5
		Shift position indicator M6 display	M6
O/D OFF SW	Ignition switch ON	NOTE: This item is displayed, but cannot be monitored.	Off
M RANGE SW	Ignition switch ON	Selector lever in manual mode position	On
		Other than the above	Off
NM RANGE SW	Ignition switch ON	Selector lever in manual mode position	Off
		Other than the above	On
AT SFT UP SW	Ignition switch ON	Selector lever in + position	On
		Other than the above	Off
AT SFT DWN SW	Ignition switch ON	Selector lever in – position	On
		Other than the above	Off
PKB SW	Ignition switch ON	Parking brake switch ON	On
		Parking brake switch OFF	Off
BUCKLE SW	Ignition switch ON	Driver seat belt not fastened	On
		Driver seat belt fastened	Off
BRAKE SW	Ignition switch ON	NOTE: This item is displayed, but cannot be monitored.	Off
BRAKE OIL SW	Ignition switch ON	Brake fluid level switch ON	On
		Brake fluid level switch OFF	Off

COMBINATION METER

< ECU DIAGNOSIS INFORMATION >

Monitor Item	Condition		Value/Status
A/C AMP CONN	Ignition switch ON	Other than the following	On
		Receives A/C auto amp. connection recognition signal	Off
PASS BUCKLE SW	Ignition switch ON	NOTE: This item is displayed, but cannot be monitored.	Off
DISTANCE [km]	Ignition switch ON	—	Distance to empty calculated by combination meter
OUTSIDE TEMP [°C or °F]	Ignition switch ON	—	Input value of ambient sensor signal (CAN communication signal) NOTE: This may not match the indicated value on the information display.
FUEL LOW SIG	Ignition switch ON	During low fuel warning indication	On
		Other than above	Off
BUZZER	Ignition switch ON	Buzzer ON	On
		Buzzer OFF	Off
ASCD SPD BLNK	Ignition switch ON	Set vehicle speed indicator blinking	On
		Set vehicle speed indicator not blinking	Off
ASCD STATUS	Ignition switch ON	ASCD and speed limiter system OFF	Off
		ASCD system ON	ASCD
		ASCD set vehicle speed	CRUISE
ASCD REQ SPD [km/h or Off]	Ignition switch ON	While driving	Same value as ASCD or speed limiter set vehicle speed
TPMS PRESS L	Ignition switch ON	Low tire pressure warning display ON	On
		Low tire pressure warning display OFF	Off

NOTE:

Some items are not available according to vehicle specification.

TERMINAL LAYOUT

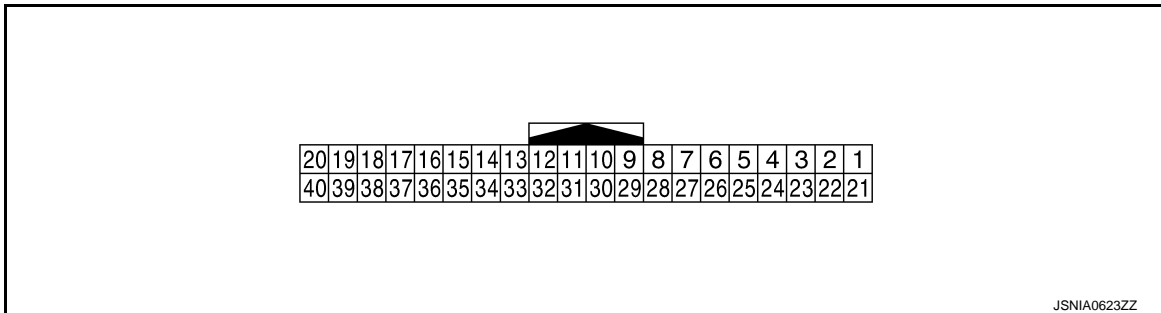

PHYSICAL VALUES

Terminal No. (Wire color)		Description		Condition	Value (Approx.)
+	-	Signal name	Input/Output		
1 (L)	—	CAN-H	—	—	—
2 (P)	—	CAN-L	—	—	—

COMBINATION METER

< ECU DIAGNOSIS INFORMATION >

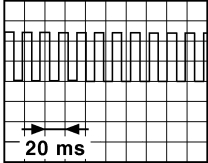
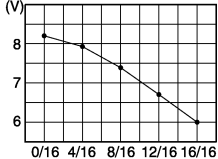
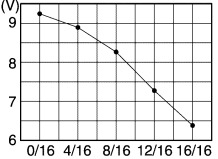
Terminal No. (Wire color)		Description		Condition	Value (Approx.)
+	-	Signal name	Input/ Output		
4 (Y)	Ground	Vehicle speed signal (8-pulse)	Output	Ignition switch ON	Speedometer operated [When vehicle speed is ap- prox. 40 km/h (25 MPH)]
					<p>NOTE: The maximum voltage varies de- pending on the specification (destination unit).</p>  <p style="text-align: right; font-size: small;">JSNIA0012GB</p>
6 (BR)	Ground	Fuel level sensor signal	Input	Ignition switch ON	—
					<p>2WD</p>  <p style="text-align: right; font-size: small;">JSNIA3305ZZ</p> <p>AWD</p>  <p style="text-align: right; font-size: small;">JSNIA3721ZZ</p>
7 (R)	Ground	Air bag signal	Input	Ignition switch ON	Air bag warning lamp ON
					Air bag warning lamp OFF
8* (Y)	—	—	—	—	—
9 (O)	Ground	Seat belt buckle switch sig- nal (driver side)	Input	Engine idling	When driver seat belt is fas- tened.
					When driver seat belt is un- fastened.
10 (SB)	Ground	Parking brake switch signal	Input	Ignition switch ON	Parking brake applied.
					Parking brake released.
11 (G)	Ground	Brake fluid level switch sig- nal	Input	Ignition switch ON	Brake fluid level is normal
					Brake fluid level is less than LOW level

COMBINATION METER

< ECU DIAGNOSIS INFORMATION >

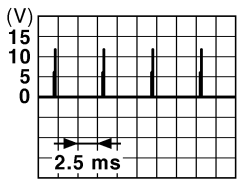
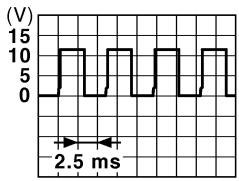
Terminal No. (Wire color)		Description		Condition	Value (Approx.)
+	-	Signal name	Input/ Output		
13 (B)	Ground	Illumination control signal	Output	Ignition switch ON	<ul style="list-style-type: none"> Lighting switch 1ST When meter illumination is maximum  <p style="text-align: right; font-size: small;">JPNIA1687GB</p>
					<ul style="list-style-type: none"> Lighting switch 1ST When meter illumination is step 6  <p style="text-align: right; font-size: small;">JPNIA1686GB</p>
					<ul style="list-style-type: none"> Lighting switch 1ST When meter illumination is minimum <p style="text-align: center;">12 V</p>
14 (V)	Ground	Manual mode shift up signal	Input	Ignition switch ON	Selector lever UP operation
					Other than the above
15 (L)	Ground	ACC power supply	Input	Ignition switch ACC	—
16 (O)	Ground	Manual mode shift down signal	Input	Ignition switch ON	Selector lever DOWN operation
					Other than the above
17 (W)	Ground	Washer level switch signal	Input	Ignition switch ON	Low washer fluid warning lamp ON
					Low washer fluid warning lamp OFF
18 (R)	Ground	Security signal	Input	Ignition switch ON	Security indicator lamp ON
					Security indicator lamp OFF
19 (GR)	Ground	Ambient sensor signal	Input	Ignition switch ON	Changes depending to ambient temperature.
20 (LG)	Ground	Ambient sensor ground	—	Ignition switch ON	—
21 (B)	Ground	Ground	—	Ignition switch ON	—
22 (B)	Ground	Ground	—	Ignition switch ON	—

A
B
C
D
E
F
G
H
I
J
K
L
M
O
P

MWI

COMBINATION METER

< ECU DIAGNOSIS INFORMATION >

Terminal No. (Wire color)		Description		Condition		Value (Approx.)
+	-	Signal name	Input/ Output			
23 (B)	Ground	Ground	—	Ignition switch ON	—	0 V
24 (L)	Ground	Fuel level sensor ground	—	Ignition switch ON	—	0 V
25 (B)	Ground	VDC ground	—	Ignition switch ON	—	0 V
27 (LG)	Ground	Battery power supply	Input	Ignition switch OFF	—	Battery voltage
28 (GR)	Ground	Ignition signal	Input	Ignition switch ON	—	Battery voltage
31 (P)	Ground	A/C auto amp. connection recognition signal	Input	Ignition switch ON	—	5 V
36 (LG)	Ground	Manual mode signal	Input	Ignition switch ON	Selector manual mode po- sition	0 V
					Other than the above	12 V
37 (Y)	Ground	Non-manual mode signal	Input	Ignition switch ON	Selector manual mode po- sition	12 V
					Other than the above	0 V
38 (P)	Ground	Alternator signal	Input	Ignition switch ON	Charge warning lamp ON	2 V
					Charge warning lamp OFF	12 V

*: This harness is not used.

Fail-Safe

INFOID:000000007577787

FAIL-SAFE

The combination meter activates the fail-safe control if CAN communication with each unit is malfunctioning.

Function		Specifications
Speedometer		Reset to zero by suspending communication.
Tachometer		
Engine coolant temperature gauge		
Illumination control		When suspending communication, changes to nighttime mode.
Shift position indicator		When suspending communication, not indicate.
Information display	Instantaneous fuel consumption	<ul style="list-style-type: none"> When reception time of an abnormal signal is 2 seconds or less, the last received datum is used for calculation to indicate the result. When reception time of an abnormal signal is more than two seconds, the last result calculated during normal condition is indicated.
	Average fuel consumption	
	Possible driving distance	
	Torque distribution indicator	
	Low tire pressure warning	The display turns OFF by suspending communication.
Buzzer		The buzzer turns OFF by suspending communication.

COMBINATION METER

< ECU DIAGNOSIS INFORMATION >

	Function	Specifications	
Warning lamp/indicator lamp	ABS warning lamp	The lamp turns ON by suspending communication.	A
	Malfunction indicator lamp		B
	VDC OFF indicator lamp		C
	EPS warning lamp		
	AWD warning lamp		
	Brake warning lamp		
	VDC warning lamp	The lamp turns OFF by suspending communication.	D
	High beam indicator lamp		E
	Turn signal indicator lamp		F
	Door warning lamp		G
	Tail lamp indicator lamp		H
	Engine start operation indicator lamp		
	Shift P warning lamp		
	Oil pressure warning lamp		
	CRUISE indicator lamp		
	AWD mode indicator lamp (AWD)		
	AWD mode indicator lamp (AWD-V)		
	Key warning lamp		
CVT indicator lamp			
Low tire pressure warning lamp	After blinking for 1 minute, the lamp remains ON.	I	

DTC Index

INFOID:000000007577788

Display contents of CONSULT	Diagnostic item is detected when...	Refer to	
CAN COMM CIRCUIT [U1000]	When combination meter is not transmitting or receiving CAN communication signal for 2 seconds or more.	MWI-37. "Diagnosis Procedure"	J
CONTROL UNIT (CAN) [U1010]	When detecting error during the initial diagnosis of the CAN controller of combination meter.	MWI-38. "Diagnosis Procedure"	K
VEHICLE SPEED [B2205]	The abnormal vehicle speed signal is input from the ABS actuator and electric unit (control unit) for 2 seconds or more.	MWI-39. "Diagnosis Procedure"	L
ENGINE SPEED [B2267]	If ECM continuously transmits abnormal engine speed signals for 2 seconds or more.	MWI-40. "Diagnosis Procedure"	M
WATER TEMP [B2268]	If ECM continuously transmits abnormal engine coolant temperature signals for 60 seconds or more.	MWI-41. "Diagnosis Procedure"	MWI

IPDM E/R

< ECU DIAGNOSIS INFORMATION >

IPDM E/R

List of ECU Reference

INFOID:000000007577789

ECU	Reference
IPDM E/R	PCS-16, "Reference Value" (WITH I-KEY) or PCS-44, "Reference Value" (WITHOUT I-KEY)
	PCS-22, "Fail-Safe" (WITH I-KEY) or PCS-49, "Fail-Safe" (WITHOUT I-KEY)
	PCS-23, "DTC Index" (WITH I-KEY) or PCS-50, "DTC Index" (WITHOUT I-KEY)

METER SYSTEM

< WIRING DIAGRAM >

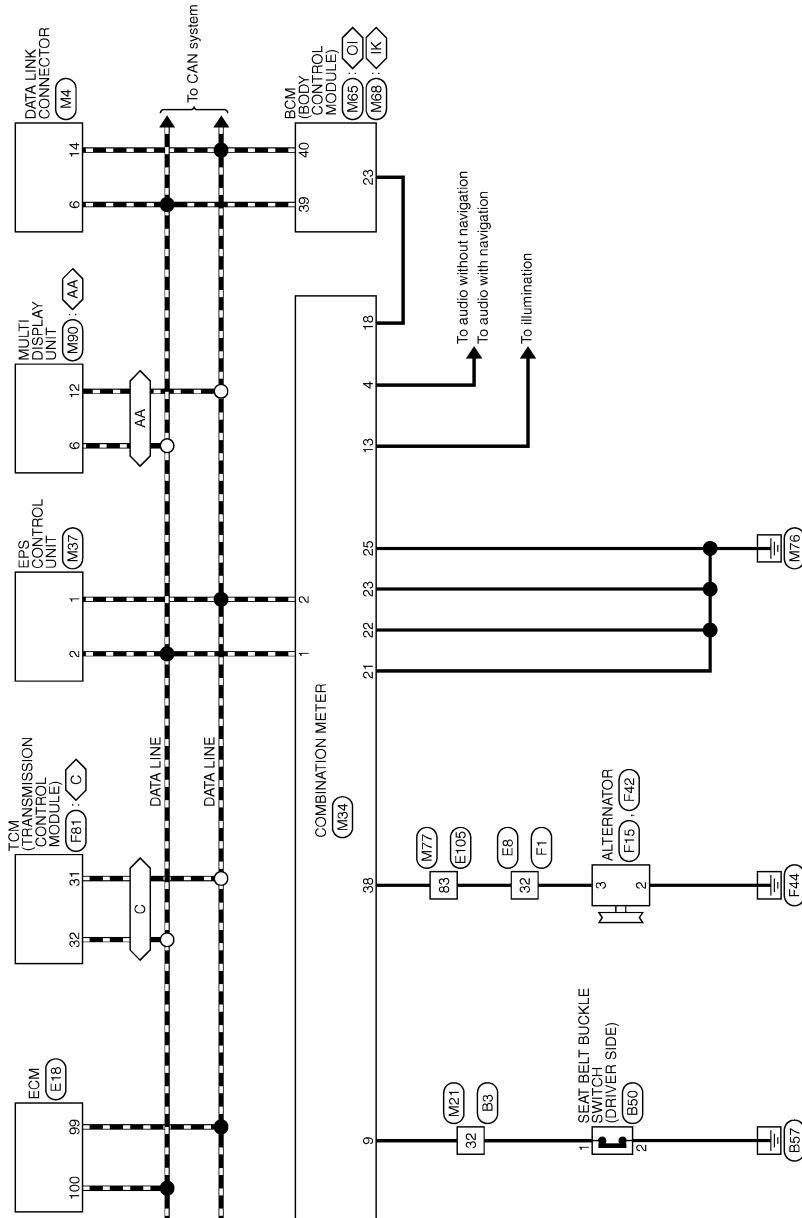

DIAGNOSIS AND REPAIR WORKFLOW (METER SYSTEM)

< BASIC INSPECTION >

BASIC INSPECTION

DIAGNOSIS AND REPAIR WORKFLOW (METER SYSTEM)

Work flow

INFOID:000000007577791

OVERALL SEQUENCE

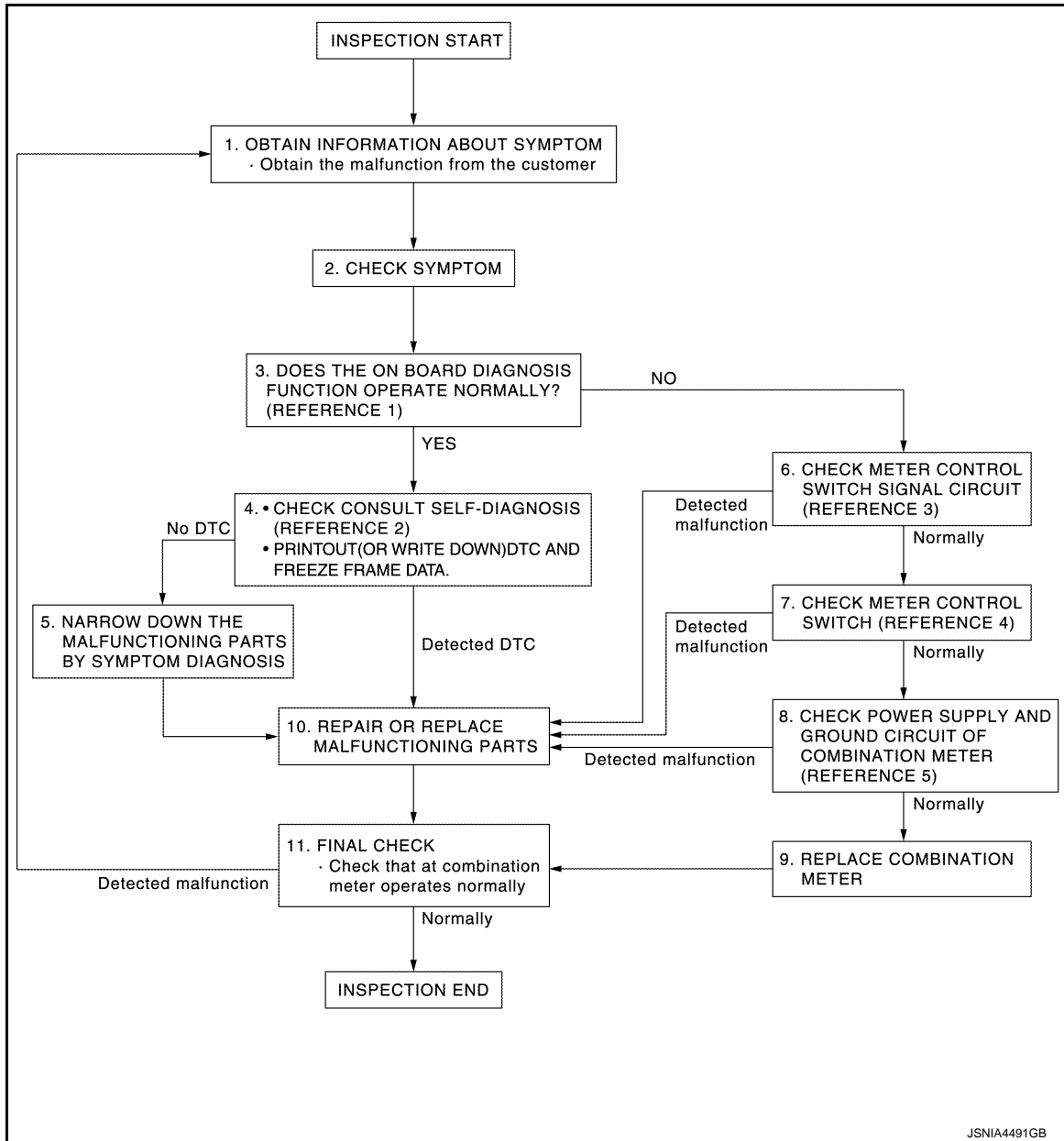

- Reference 1...[MWI-19, "On Board Diagnosis Function"](#).
- Reference 2...[MWI-31, "DTC Index"](#).
- Reference 3...[MWI-42, "COMBINATION METER : Diagnosis Procedure"](#).

DETAILED FLOW

1.OBTAIN INFORMATION ABOUT SYMPTOM

Interview the customer to obtain as much information as possible about the conditions and environment under which the malfunction occurred.

>> GO TO 2.

2.CHECK SYMPTOM

DIAGNOSIS AND REPAIR WORKFLOW (METER SYSTEM)

< BASIC INSPECTION >

- Check the symptom based on the information obtained from the customer.
- Check that any other malfunctions are present.

>> GO TO 3.

3. CHECK ON BOARD DIAGNOSIS OPERATION

Check that the on board diagnosis function operates. Refer to [MWI-19, "On Board Diagnosis Function"](#).

Does the on board diagnosis function operate normally?

YES >> GO TO 4.

NO >> GO TO 6.

4. CHECK CONSULT SELF-DIAGNOSIS RESULTS

1. Connect CONSULT and perform self-diagnosis. Refer to [MWI-31, "DTC Index"](#).

2. When DTC is detected, follow the instructions below:

- Record DTC and Freeze Frame Data.

Are self-diagnosis results normal?

YES >> GO TO 5.

NO >> GO TO 8.

5. NARROW DOWN THE MALFUNCTIONING PARTS BY SYMPTOM DIAGNOSIS

Perform symptom diagnosis and narrow down the malfunctioning parts.

>> GO TO 8.

6. CHECK COMBINATION METER POWER SUPPLY AND GROUND CIRCUITS

Check combination meter power supply and ground circuits. Refer to [MWI-42, "COMBINATION METER : Diagnosis Procedure"](#).

Is inspection result OK?

YES >> GO TO 7.

NO >> GO TO 8.

7. REPLACE COMBINATION METER

Replace combination meter.

>> GO TO 9.

8. REPAIR OR REPLACE MALFUNCTIONING PARTS

Repair or replace the malfunctioning parts.

NOTE:

If DTC is displayed, erase DTC after repair or replace malfunctioning parts.

>> GO TO 9.

9. FINAL CHECK

Check that the combination meter operates normally.

Do they operate normally?

YES >> INSPECTION END

NO >> GO TO 1.

U1000 CAN COMM CIRCUIT

< DTC/CIRCUIT DIAGNOSIS >

DTC/CIRCUIT DIAGNOSIS

U1000 CAN COMM CIRCUIT

Description

INFOID:000000007577792

CAN (Controller Area Network) is a serial communication system for real time application. It is an on-vehicle multiplex communication system with high data communication speed and excellent error detectability. Many electronic control units are equipped onto vehicles, and each control unit shares information and links with other control units during operation (not independent). In CAN communication, control units are connected with two communication lines (CAN-H line, CAN-L line) allowing a high rate of information transmission with less wiring. Each control unit transmits/receives data but selectively reads required data only.

CAN Communication Signal Chart. Refer to [LAN-28, "CAN COMMUNICATION SYSTEM : CAN Communication Signal Chart"](#).

DTC Logic

INFOID:000000007577793

DTC DETECTION LOGIC

DTC	Display contents of CONSULT	Diagnostic item is detected when...	Probable malfunction location
U1000	CAN COMM CIRCUIT	When combination meter is not transmitting or receiving CAN communication signal for 2 seconds or more.	CAN communication system

Diagnosis Procedure

INFOID:000000007577794

1. PERFORM SELF DIAGNOSTIC

1. Turn ignition switch ON and wait for 2 seconds or more.
2. Check "Self Diagnostic Result" of "METER/M&A".

Is "CAN COMM CIRCUIT" displayed?

- YES >> Refer to [LAN-15, "Trouble Diagnosis Flow Chart"](#).
NO >> Refer to [GI-43, "Intermittent Incident"](#).

A
B
C
D
E
F
G
H
I
J
K
L
M
O
P

MWI

U1010 CONTROL UNIT (CAN)

< DTC/CIRCUIT DIAGNOSIS >

U1010 CONTROL UNIT (CAN)

Description

INFOID:000000007577795

Initial diagnosis of combination meter.

DTC Logic

INFOID:000000007577796

DTC DETECTION LOGIC

DTC	Display contents of CONSULT	Diagnostic item is detected when...	Probable malfunction location
U1010	CONTROL UNIT (CAN)	When detecting error during the initial diagnosis of the CAN controller of combination meter.	Combination meter

Diagnosis Procedure

INFOID:000000007577797

1. REPLACE COMBINATION METER

When DTC "U1010" is detected, replace combination meter.

>> INSPECTION END

B2205 VEHICLE SPEED

< DTC/CIRCUIT DIAGNOSIS >

B2205 VEHICLE SPEED

Description

INFOID:000000007577798

Vehicle speed signal is transmitted from ABS actuator and electric unit (control unit) via CAN communication to combination meter.

DTC Logic

INFOID:000000007577799

DTC DETECTION LOGIC

DTC	Display contents of CONSULT	Diagnostic item is detected when...	Probable malfunction location
B2205	VEHICLE SPEED	An abnormal vehicle speed signal is input from ABS actuator and electric unit (control unit) for 2 seconds or more	<ul style="list-style-type: none">• Wheel sensor• ABS actuator and electric unit (control unit)

Diagnosis Procedure

INFOID:000000007577800

1. PERFORM SELF-DIAGNOSIS OF ABS ACTUATOR AND ELECTRIC UNIT (CONTROL UNIT)

Perform "Self Diagnostic Result" of "ABS", and repair or replace malfunctioning parts.

>> Refer to [BRC-38, "CONSULT Function"](#).

A
B
C
D
E
F
G
H
I
J
K
L
M
O
P

MWI

B2267 ENGINE SPEED

< DTC/CIRCUIT DIAGNOSIS >

B2267 ENGINE SPEED

Description

INFOID:000000007577801

The engine speed signal is transmitted from ECM to the combination meter via CAN communication.

DTC Logic

INFOID:000000007577802

DTC DETECTION LOGIC

DTC	Display contents of CONSULT	Diagnostic item is detected when...	Probable malfunction location
B2267	ENGINE SPEED	ECM continuously transmits abnormal engine speed signals for 2 seconds or more	<ul style="list-style-type: none">• Crankshaft position sensor (POS)• ECM

Diagnosis Procedure

INFOID:000000007577803

1. PERFORM SELF-DIAGNOSIS OF ECM

Perform "Self Diagnostic Result" of "ENGINE", and repair or replace malfunctioning parts.

>> Refer to [EC-102, "DTC Index"](#).

B2268 WATER TEMP

< DTC/CIRCUIT DIAGNOSIS >

B2268 WATER TEMP

Description

INFOID:000000007577804

The engine coolant temperature signal is transmitted from ECM to the combination meter via CAN communication.

DTC Logic

INFOID:000000007577805

DTC DETECTION LOGIC

DTC	Display contents of CONSULT	Diagnostic item is detected when...	Probable malfunction location
B2268	WATER TEMP	ECM continuously transmits abnormal engine coolant temperature signals for 60 seconds or more	<ul style="list-style-type: none">• Engine coolant temperature sensor• ECM

Diagnosis Procedure

INFOID:000000007577806

1. PERFORM SELF-DIAGNOSIS OF ECM

Perform "Self Diagnosis Result" of "ENGINE", and repair or replace malfunctioning parts.

>> Refer to [EC-102, "DTC Index"](#).

A
B
C
D
E
F
G
H
I
J
K
L
M
O
P

MWI

POWER SUPPLY AND GROUND CIRCUIT

< DTC/CIRCUIT DIAGNOSIS >

POWER SUPPLY AND GROUND CIRCUIT COMBINATION METER

COMBINATION METER : Diagnosis Procedure

INFOID:000000007577807

1. CHECK FUSE

Check for blown fuses.

Power source	Fuse No.
Battery	11
Ignition switch ON or START	5
Ignition switch ACC or ON	18 (Without intelligent key)
	19 (With intelligent key)

Is the inspection result normal?

YES >> GO TO 2.

NO >> Be sure to eliminate cause of malfunction before installing new fuse.

2. CHECK POWER SUPPLY CIRCUIT

Check voltage between combination meter harness connector and ground.

Terminals		Ground	Ignition switch position	Voltage (Approx.)
(+)	(-)			
Combination meter				
Connector	Terminal		OFF	Battery voltage
M34	27		ACC	
	15		ON	
	28			

Is the inspection result normal?

YES >> GO TO 3.

NO >> Check harness between combination meter and fuse.

3. CHECK GROUND CIRCUIT

1. Turn ignition switch OFF.
2. Disconnect combination meter connector.
3. Check continuity between combination meter harness connector and ground.

Combination meter		Ground	Continuity
Connector	Terminal		Existed
M34	21		
	22		
	23		
	25		

Is the inspection result normal?

YES >> INSPECTION END

NO >> Repair harness or connector.

FUEL LEVEL SENSOR SIGNAL CIRCUIT

< DTC/CIRCUIT DIAGNOSIS >

FUEL LEVEL SENSOR SIGNAL CIRCUIT

Component Function Check

INFOID:000000007577808

2WD MODELS

1.CHECK COMBINATION METER OUTPUT SIGNAL

Select the "Data Monitor" for the "METER/M&A" and compare the "FUEL METER" monitor value with the fuel gauge reading on the combination meter.

Fuel gauge indication position	Reference value of data monitor [L]
16/16	Approx. 45.0
14/16	Approx. 40.7
12/16	Approx. 36.5
10/16	Approx. 30.6
8/16	Approx. 24.7
6/16	Approx. 19.0
4/16	Approx. 13.2
2/16	Approx. 7.7
0/16	Approx. 2.2

Does monitor value match fuel gauge reading?

YES >> INSPECTION END

NO >> Replace combination meter. Refer to [MWI-53, "Removal and Installation"](#).

AWD MODELS

1.CHECK COMBINATION METER OUTPUT SIGNAL

Select the "Data Monitor" for the "METER/M&A" and compare the "FUEL METER" monitor value with the fuel gauge reading on the combination meter.

Fuel gauge indication position	Reference value of data monitor [L]
16/16	Approx. 45.0
14/16	Approx. 38.5
12/16	Approx. 33.0
10/16	Approx. 28.0
8/16	Approx. 23.5
6/16	Approx. 19.0
4/16	Approx. 14.2
2/16	Approx. 9.9
0/16	Approx. 6.2

Does monitor value match fuel gauge reading?

YES >> INSPECTION END

NO >> Replace combination meter. Refer to [MWI-53, "Removal and Installation"](#).

Diagnosis Procedure

INFOID:000000007577809

1.CHECK COMBINATION METER INPUT SIGNAL

1. Turn ignition switch ON.
2. Check voltage between combination meter harness connector and ground.

FUEL LEVEL SENSOR SIGNAL CIRCUIT

< DTC/CIRCUIT DIAGNOSIS >

Terminals		Voltage (Approx.)
(+)	(-)	
Combination meter		
Connector	Terminal	Ground
M34	6	

Does it match fuel gauge reading?

YES >> GO TO 2.

NO >> Replace the combination meter. Refer to [MWI-53. "Removal and Installation"](#).

2. CHECK FUEL LEVEL SENSOR CIRCUIT

- Turn ignition switch OFF.
- Disconnect combination meter connector and fuel level sensor unit connector.
- Check continuity between combination meter harness connector terminal and fuel level sensor unit harness connector terminal.

Combination meter		Fuel level sensor unit		Continuity
Connector	Terminal	Connector	Terminal	
M34	6	B46	2	Existed

- Check continuity between combination meter harness connector terminal and ground.

Combination meter		Ground	Continuity
Connector	Terminal		
M34	6		Not existed

Is the inspection result normal?

YES >> GO TO 3.

NO >> Repair harness or connector.

3. CHECK FUEL LEVEL SENSOR GROUND CIRCUIT

Check continuity between fuel level sensor unit harness connector terminal and combination meter harness connector terminal.

Fuel level sensor unit		Combination meter		Continuity
Connector	Terminal	Connector	Terminal	
B46	5	M34	24	Existed

Is the inspection result normal?

YES >> INSPECTION END

NO >> Repair harness or connector.

FUEL LEVEL SENSOR SIGNAL CIRCUIT

< DTC/CIRCUIT DIAGNOSIS >

Component Inspection

INFOID:000000007577810

2WD MODELS

1.REMOVE FUEL LEVEL SENSOR UNIT (MAIN)

Remove the fuel level sensor unit (main). Refer to [FL-6, "2WD : Removal and Installation"](#).

>> GO TO 2.

2.CHECK FUEL LEVEL SENSOR UNIT (MAIN)

Check the resistance between fuel level sensor unit and fuel pump.

Terminals		Condition	Resistance (Ω) (Approx.)	Height [mm (in)]
Fuel level sensor unit (main)				
2	5	Full* (A)	51	142.8 (5.62)
		Empty* (B)	283	14.3 (0.563)

*: When float rod is contact with stopper.

Is inspection result OK?

YES >> INSPECTION END

NO >> Replace fuel level sensor unit and fuel pump (main). Refer to [FL-6, "2WD : Removal and Installation"](#).

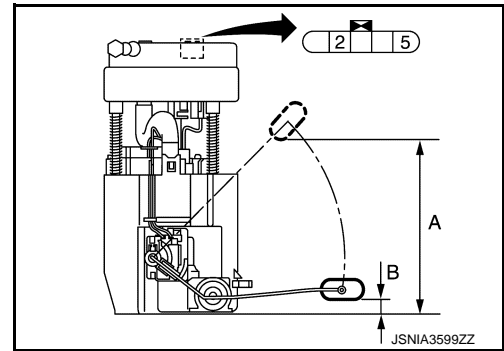

AWD MODELS

1.REMOVE FUEL LEVEL SENSOR UNIT (MAIN)

Remove the fuel level sensor unit (main). Refer to [FL-10, "AWD : Removal and Installation"](#).

>> GO TO 2.

2.CHECK FUEL LEVEL SENSOR UNIT (MAIN)

Check the resistance between fuel level sensor unit and fuel pump.

Terminals		Condition	Resistance (Ω) (Approx.)	Height [mm (in)]
Fuel level sensor unit (main)				
5	2	Full* (A)	25.5	147.4 (5.8)
		Empty* (B)	99.5	13.3 (0.524)
6	7	—	0	—

*: When float rod is contact with stopper.

Is inspection result OK?

YES >> GO TO 3.

NO >> Replace fuel level sensor unit and fuel pump (main). Refer to [FL-10, "AWD : Removal and Installation"](#).

3.REMOVE FUEL LEVEL SENSOR UNIT (SUB)

Remove the fuel level sensor unit (sub). Refer to [FL-10, "AWD : Removal and Installation"](#).

>> GO TO 4.

4.CHECK FUEL LEVEL SENSOR UNIT (SUB)

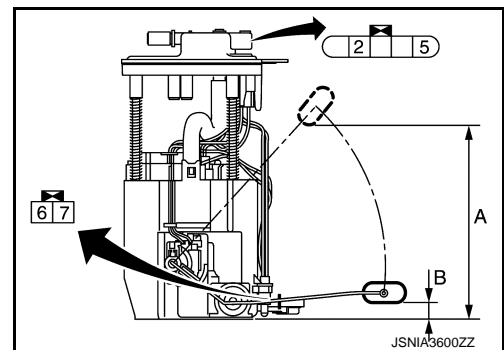

FUEL LEVEL SENSOR SIGNAL CIRCUIT

< DTC/CIRCUIT DIAGNOSIS >

Check the resistance between fuel level sensor unit (sub).

Terminals		Condition	Resistance (Ω) (Approx.)	Height [mm (in)]
Fuel level sensor unit (sub)				
7	6	Full* (A)	25.5	157.4 (6.2)
		Empty* (B)	183.5	7.1 (0.28)

*: When float rod is contact with stopper.

Is inspection result OK?

YES >> INSPECTION END

NO >> Replace fuel level sensor unit (sub). Refer to [FL-10, "AWD : Removal and Installation"](#).

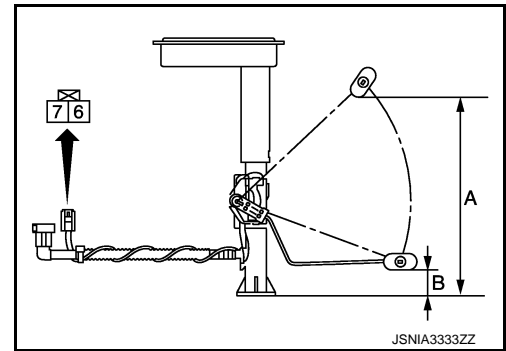

A/C AUTO AMP. CONNECTION RECOGNITION SIGNAL CIRCUIT

< DTC/CIRCUIT DIAGNOSIS >

A/C AUTO AMP. CONNECTION RECOGNITION SIGNAL CIRCUIT

Diagnosis Procedure

INFOID:000000007577811

1. CHECK A/C AUTO AMP. CONNECTION RECOGNITION SIGNAL

1. Turn ignition switch ON.
2. Check voltage between combination meter harness connector and ground.

Terminals		Voltage (Approx.)
(+)	(-)	
Combination meter		Ground
Connector	Terminal	
M34	31	
		5 V

Is the inspection result normal?

- YES >> INSPECTION END
NO >> GO TO 2.

2. CHECK A/C AUTO AMP. CONNECTION RECOGNITION SIGNAL CIRCUIT

1. Turn ignition switch OFF.
2. Disconnect combination meter connector and A/C auto amp. connector.
3. Check continuity between combination meter harness connector and A/C auto amp. harness connector.

Combination meter		A/C auto amp.		Continuity
Connector	Terminal	Connector	terminal	
M34	31	M50	9	Existed

4. Check continuity between combination meter harness connector and ground.

Combination meter		Ground	Continuity
Connector	Terminal		
M34	31		Not existed

Is the inspection result normal?

- YES >> INSPECTION END
NO >> Repair harness or connector.

A
B
C
D
E
F
G
H
I
J
K
L
M
O
P



THE FUEL GAUGE INDICATOR DOES NOT OPERATE

< SYMPTOM DIAGNOSIS >

SYMPTOM DIAGNOSIS

THE FUEL GAUGE INDICATOR DOES NOT OPERATE

Description

INFOID:000000007577812

Fuel gauge will not indicate from a certain position.

Diagnosis Procedure

INFOID:000000007577813

1. CHECK COMBINATION METER OUTPUT SIGNAL

1. Connect CONSULT.
2. Select the "Data Monitor" for the "METER/M&A" and compare the "FUEL METER" monitor value with the fuel gauge reading on the combination meter. Refer to [MWI-43. "Component Function Check"](#).

Does monitor value match fuel gauge reading?

YES >> GO TO 2.

NO >> Replace combination meter. Refer to [MWI-53. "Removal and Installation"](#).

2. CHECK FUEL LEVEL SENSOR SIGNAL CIRCUIT

Check the fuel level sensor signal circuit. Refer to [MWI-43. "Diagnosis Procedure"](#).

Is the inspection result normal?

YES >> GO TO 3.

NO >> Repair harness or connector.

3. CHECK FUEL LEVEL SENSOR UNIT

Perform a unit check for the fuel level sensor unit. Refer to [MWI-45. "Component Inspection"](#).

Is the inspection result normal?

YES >> GO TO 4.

NO >> Replace fuel level sensor unit (main or sub). Refer to [FL-6. "2WD : Removal and Installation"](#) (2WD models) or [FL-10. "AWD : Removal and Installation"](#) (AWD models).

4. CHECK FLOAT INTERFERENCE

Check that the float arm interferes with or binds to other components in the fuel tank.

Is the inspection result normal?

YES >> Replace combination meter. Refer to [MWI-53. "Removal and Installation"](#).

NO >> Repair or replace malfunctioning parts.

THE OIL PRESSURE WARNING LAMP DOES NOT TURN ON

< SYMPTOM DIAGNOSIS >

THE OIL PRESSURE WARNING LAMP DOES NOT TURN ON

Description

INFOID:000000007577814

The oil pressure warning lamp stays off when the ignition switch is turned ON.

Diagnosis Procedure

INFOID:000000007577815

1. CHECK COMBINATION METER INPUT SIGNAL

-
1. Start the engine.
 2. Select "Data Monitor" in "METER/M&A" to check that the oil pressure warning lamp state is consistent with the "OIL W/L" monitor value.

Is the inspection result normal?

YES >> INSPECTION END

NO >> Replace combination meter. Refer to [MWI-53. "Removal and Installation"](#).

A
B
C
D
E
F
G
H
I
J
K
L
M
O
P

MWI

THE OIL PRESSURE WARNING LAMP DOES NOT TURN OFF

< SYMPTOM DIAGNOSIS >

THE OIL PRESSURE WARNING LAMP DOES NOT TURN OFF

Description

INFOID:000000007577816

The oil pressure warning lamp remains illuminated while the engine is running (normal oil pressure).

Diagnosis Procedure

INFOID:000000007577817

1.CHECK COMBINATION METER INPUT SIGNAL

1. Start the engine.
2. Select "Data Monitor" in "METER/M&A" to check that the oil pressure warning lamp state is consistent with the "OIL W/L" monitor value.

Is the inspection result normal?

YES >> INSPECTION END

NO >> Replace combination meter. Refer to [MWI-53. "Removal and Installation"](#).

THE AMBIENT TEMPERATURE DISPLAY IS INCORRECT

< SYMPTOM DIAGNOSIS >

THE AMBIENT TEMPERATURE DISPLAY IS INCORRECT

Description

INFOID:000000007577818

- The displayed ambient air temperature is higher than the actual temperature.
- The displayed ambient air temperature is lower than the actual temperature.

Diagnosis Procedure

INFOID:000000007577819

NOTE:

Check that the symptom is not applicable to the normal operating condition before starting diagnosis. Refer to [MWI-52, "INFORMATION DISPLAY : Description"](#).

1.CHECK AMBIENT SENSOR SIGNAL CIRCUIT

Check the ambient sensor signal circuit. Refer to [HAC-50, "Diagnosis Procedure"](#).

Is the inspection result normal?

YES >> GO TO 2.

NO >> Repair harness or connector.

2.CHECK A/C AUTO AMP. CONNECTION RECOGNITION SIGNAL CIRCUIT

Check the A/C auto amp. connection recognition signal circuit. Refer to [MWI-47, "Diagnosis Procedure"](#).

Is the inspection result normal?

YES >> GO TO 3.

NO >> Repair harness or connector.

3.CHECK AMBIENT SENSOR

Perform the part check for the ambient sensor. Refer to [HAC-51, "Component Inspection"](#).

Is the inspection result normal?

YES >> Replace combination meter. Refer to [MWI-53, "Removal and Installation"](#).

NO >> Replace ambient sensor. Refer to [HAC-86, "Removal and Installation"](#).

A
B
C
D
E
F
G
H
I
J
K
L
M
O
P

MWI

NORMAL OPERATING CONDITION

< SYMPTOM DIAGNOSIS >

NORMAL OPERATING CONDITION INFORMATION DISPLAY

INFORMATION DISPLAY : Description

INFOID:000000007577820

AMBIENT TEMPERATURE

The displayed ambient temperature on the information display may differ from the actual temperature because it is a corrected value calculated from the ambient sensor signal by the combination meter. Refer to [MWI-14, "INFORMATION DISPLAY : System Description"](#) for details on the correction process.

DISTANCE TO EMPTY

The calculated distance to empty may differ from the actual distance to empty if the refueling amount is approximately 15 ℓ (4 US gal, 3-1/4 Imp gal) or less. This is because the refuel control (moves the fuel gauge needle quicker than normal judging that the driver is refueling the vehicle) is not performing.

COMBINATION METER

< REMOVAL AND INSTALLATION >

REMOVAL AND INSTALLATION

COMBINATION METER

Exploded View

INFOID:000000007577821

REMOVAL

Refer to [IP-11, "Exploded View"](#).

DISASSEMBLY

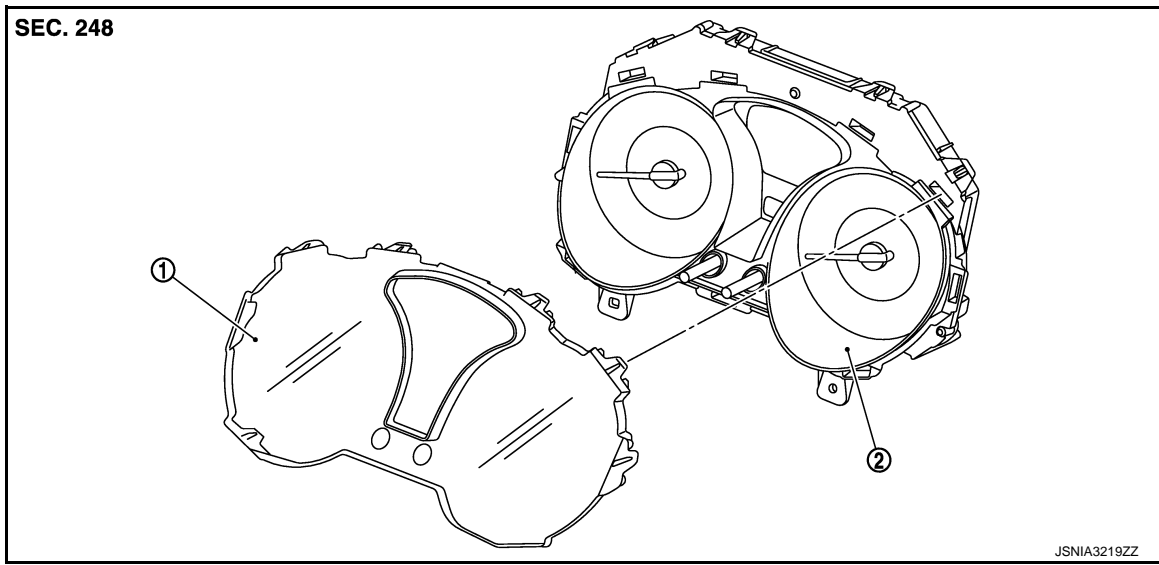

1. Front cover

2. Unified meter control unit

Removal and Installation

INFOID:000000007577822

REMOVAL

1. Remove cluster lid A. Refer to [IP-12, "Removal and Installation"](#).
2. Remove the mounting screws of the combination meter.
3. Pull the combination meter straight to disengage resin clips. (The figure shows the clip positions on the back of the combination meter.)

CAUTION:

Never damage the front cover.

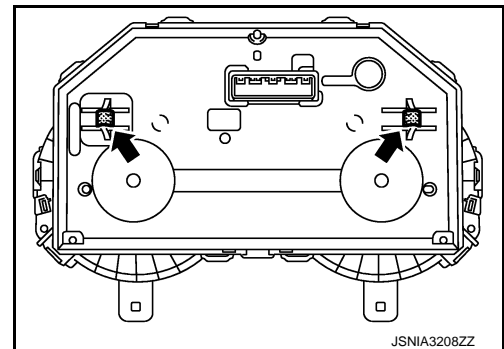

COMBINATION METER

< REMOVAL AND INSTALLATION >

- Turn the lower part of the combination meter in the direction of the arrow to remove the combination meter from the instrument panel assembly.

CAUTION:

Never damage the front cover.

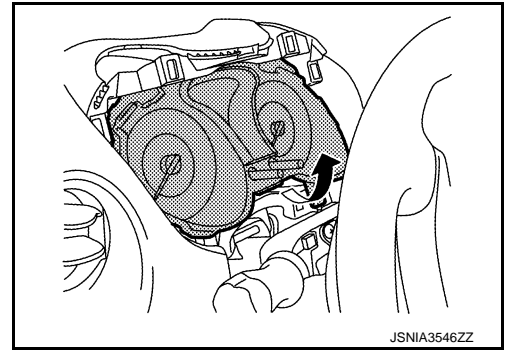

- Remove connector to remove the combination meter.

CAUTION:

Never damage the front cover.

INSTALLATION

Install in the reverse order of removal.

Disassembly and Assembly

INFOID:000000007577823

DISASSEMBLY

- Disengage the pawls (2 on the sides, 3 on the lower part) of the combination meter.
- Insert the removal tool into the clearance (in the order of A, B) between the front cover and the meter control unit. Remove 4 pawls on the upper side of the front cover by turning the tool while increasing the clearance.

CAUTION:

Wrap the removal tools with protective tape to prevent scratches.

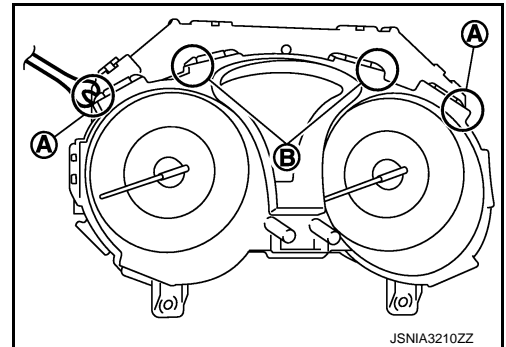

- Pull the front cover straight to remove it from the meter control unit assembly.

CAUTION:

Never damage the front cover.

Never touch the pointer and the crystalline liquid.

ASSEMBLY

Install the front cover straight to the meter control unit assembly and engage all the pawl.

CAUTION:

Never damage the front cover.