

SECTION **SE**  
SEAT

A  
B  
C  
D  
E  
F  
G  
H  
I  
SE  
K  
L  
M  
N  
O  
P

CONTENTS

<b>PRECAUTION</b> .....	2	<b>SQUEAK AND RATTLE TROUBLE DIAG- NOSES</b> .....	9
<b>PRECAUTIONS</b> .....	2	Work Flow .....	9
Precaution for Supplemental Restraint System (SRS) "AIR BAG" and "SEAT BELT PRE-TEN- SIONER" .....	2	Inspection Procedure .....	11
Service Notice .....	2	Diagnostic Worksheet .....	13
Precaution for Work .....	2	<b>REMOVAL AND INSTALLATION</b> .....	15
<b>PREPARATION</b> .....	4	<b>FRONT SEAT</b> .....	15
<b>PREPARATION</b> .....	4	Exploded View .....	15
Special Service Tool .....	4	Removal and Installation .....	18
Commercial Service Tool .....	4	<b>SEATBACK</b> .....	18
<b>CLIP LIST</b> .....	5	SEATBACK : Disassembly and Assembly .....	18
Clip List .....	5	<b>SEAT CUSHION</b> .....	19
<b>SYSTEM DESCRIPTION</b> .....	6	SEAT CUSHION : Disassembly and Assembly .....	19
<b>COMPONENT PARTS</b> .....	6	<b>REAR SEAT</b> .....	23
<b>HEATED SEAT SYSTEM</b> .....	6	Exploded View .....	23
HEATED SEAT SYSTEM : Component Parts Lo- cation .....	6	<b>SEAT CUSHION</b> .....	26
HEATED SEAT SYSTEM : Component Descrip- tion .....	6	SEAT CUSHION : Removal and Installation .....	26
<b>SYSTEM</b> .....	7	SEAT CUSHION : Disassembly and Assembly .....	26
<b>HEATED SEAT SYSTEM</b> .....	7	<b>SEATBACK</b> .....	26
HEATED SEAT SYSTEM : System Description .....	7	SEATBACK : Removal and Installation .....	27
<b>WIRING DIAGRAM</b> .....	8	SEATBACK : Disassembly and Assembly .....	28
<b>HEATED SEAT SYSTEM</b> .....	8	<b>SEATBACK HINGE</b> .....	32
Wiring Diagram .....	8	SEATBACK HINGE : Removal and Installation .....	32
<b>SYMPTOM DIAGNOSIS</b> .....	9	<b>SEATBACK STRIKER</b> .....	33
		SEATBACK STRIKER : Removal and Installation .....	33
		<b>HEATED SEAT SWITCH</b> .....	35
		Exploded View .....	35
		Removal and Installation .....	35

# PRECAUTIONS

< PRECAUTION >

## PRECAUTION

### PRECAUTIONS

#### Precaution for Supplemental Restraint System (SRS) "AIR BAG" and "SEAT BELT PRE-TENSIONER"

INFOID:000000007578153

The Supplemental Restraint System such as "AIR BAG" and "SEAT BELT PRE-TENSIONER", used along with a front seat belt, helps to reduce the risk or severity of injury to the driver and front passenger for certain types of collision. This system includes seat belt switch inputs and dual stage front air bag modules. The SRS system uses the seat belt switches to determine the front air bag deployment, and may only deploy one front air bag, depending on the severity of a collision and whether the front occupants are belted or unbelted. Information necessary to service the system safely is included in the "SRS AIR BAG" and "SEAT BELT" of this Service Manual.

#### **WARNING:**

**Always observe the following items for preventing accidental activation.**

- **To avoid rendering the SRS inoperative, which could increase the risk of personal injury or death in the event of a collision that would result in air bag inflation, all maintenance must be performed by an authorized NISSAN/INFINITI dealer.**
- **Improper maintenance, including incorrect removal and installation of the SRS, can lead to personal injury caused by unintentional activation of the system. For removal of Spiral Cable and Air Bag Module, see "SRS AIR BAG".**
- **Never use electrical test equipment on any circuit related to the SRS unless instructed to in this Service Manual. SRS wiring harnesses can be identified by yellow and/or orange harnesses or harness connectors.**

#### PRECAUTIONS WHEN USING POWER TOOLS (AIR OR ELECTRIC) AND HAMMERS

#### **WARNING:**

**Always observe the following items for preventing accidental activation.**

- **When working near the Air Bag Diagnosis Sensor Unit or other Air Bag System sensors with the ignition ON or engine running, never use air or electric power tools or strike near the sensor(s) with a hammer. Heavy vibration could activate the sensor(s) and deploy the air bag(s), possibly causing serious injury.**
- **When using air or electric power tools or hammers, always switch the ignition OFF, disconnect the battery, and wait at least 3 minutes before performing any service.**

#### Service Notice

INFOID:000000007578154

- When removing or installing various parts, place a cloth or padding onto the vehicle body to prevent scratches.
- Handle trim, molding, instruments, grille, etc. carefully during removing or installing. Be careful not to oil or damage them.
- Apply sealing compound where necessary when installing parts.
- When applying sealing compound, be careful that the sealing compound does not protrude from parts.
- When replacing any metal parts (for example body outer panel, members, etc.), be sure to take rust prevention measures.

#### Precaution for Work

INFOID:000000007578155

- When removing or disassembling each component, be careful not to damage or deform it. If a component may be subject to interference, be sure to protect it with a shop cloth.
- When removing (disengaging) components with a screwdriver or similar tool, be sure to wrap the component with a shop cloth or vinyl tape to protect it.
- Protect the removed parts with a shop cloth and keep them.
- Replace a deformed or damaged clip.
- If a part is specified as a non-reusable part, always replace it with new one.
- Be sure to tighten bolts and nuts securely to the specified torque.
- After re-installation is completed, be sure to check that each part works normally.
- Follow the steps below to clean components.
  - Water soluble foul: Dip a soft cloth into lukewarm water, and wring the water out of the cloth to wipe the fouled area.

# PRECAUTIONS

## < PRECAUTION >

---

- Then rub with a soft and dry cloth.
- Oily foul: Dip a soft cloth into lukewarm water with mild detergent (concentration: within 2 to 3%), and wipe the fouled area.  
Then dip a cloth into fresh water, and wring the water out of the cloth to wipe the detergent off. Then rub with a soft and dry cloth.
- Never use organic solvent such as thinner, benzene, alcohol, and gasoline.
- For genuine leather seats, use a genuine leather seat cleaner.

A

B

C

D

E

F

G

H

I

SE

K

L

M

N

O

P

# PREPARATION

< PREPARATION >

## PREPARATION

### PREPARATION

#### Special Service Tool

INFOID:000000007578156

The actual shapes of Kent-Moore tools may differ from those of special service tools illustrated here.

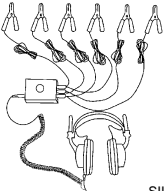
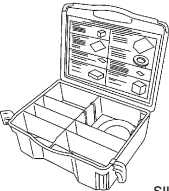
Tool number (Kent-Moore No.) Tool name	Description
<p>(J39570) Chassis ear</p>  <p style="text-align: right;">SIIA0993E</p>	<p>Locates the noise</p>
<p>(J43980) NISSAN Squeak and Rattle Kit</p>  <p style="text-align: right;">SIIA0994E</p>	<p>Repairs the cause of noise</p>

#### Commercial Service Tool

INFOID:000000007578157

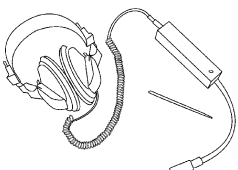
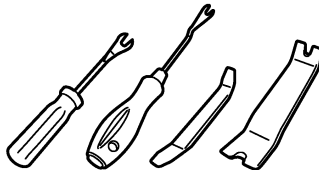
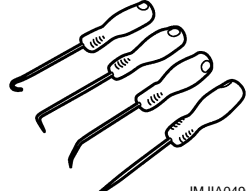
Tool name	Description
<p>Engine ear</p>  <p style="text-align: right;">SIIA0995E</p>	<p>Locates the noise</p>
<p>Remover tool</p>  <p style="text-align: right;">JMKIA3050ZZ</p>	<p>Removes the clips, pawls and metal clips</p>
<p>Hook and pick tool</p>  <p style="text-align: right;">JMJIA0490ZZ</p>	<p>Removes the snap pins</p>

# CLIP LIST

< PREPARATION >

## CLIP LIST

### Clip List

INFOID:000000007578158

Shapes	Removal & Installation	Shapes	Removal & Installation
	<p><b>Removal:</b> Remove by bending up with flat-bladed screwdrivers or clip remover.</p>	<p>Clip A Clip B</p>	<p><b>Removal:</b></p> <p>Finisher Clip A Flat-bladed screwdriver Clip B</p>
	<p><b>Removal:</b> Remove with a clip remover.</p>	<p>Clip A Clip B (Grommet)</p>	<p><b>Removal:</b></p> <p>Flat-bladed screwdriver Finisher Body panel Clip A Clip B (Grommet)</p>
	<p><b>Removal:</b> Push center pin to catching position. (Do not remove center pin by hitting it.)</p> <p>Push</p> <p><b>Installation:</b></p> <p>Push</p>		<p><b>Removal:</b> Holder portion of clip must be spread out to remove rod.</p>
	<p><b>Removal:</b> Remove by bending up with flat-bladed screwdrivers or clip remover.</p> <p>Clip Finisher</p>		<p><b>Removal:</b></p> <ol style="list-style-type: none"> <li>Screw out with a Phillips screwdriver.</li> <li>Remove female portion with flat-bladed screwdriver.</li> </ol>
	<p><b>Removal:</b></p>		<p><b>Removal:</b></p> <p>Rotate 45° to remove.</p> <p><b>Installation:</b></p>
	<p><b>Removal:</b></p>		<p><b>Removal:</b></p>

JMJIA3734GB

A  
B  
C  
D  
E  
F  
G  
H  
I  
SE  
K  
L  
M  
N  
O  
P

# COMPONENT PARTS

< SYSTEM DESCRIPTION >

## SYSTEM DESCRIPTION

### COMPONENT PARTS

#### HEATED SEAT SYSTEM

#### HEATED SEAT SYSTEM : Component Parts Location

INFOID:000000007578159

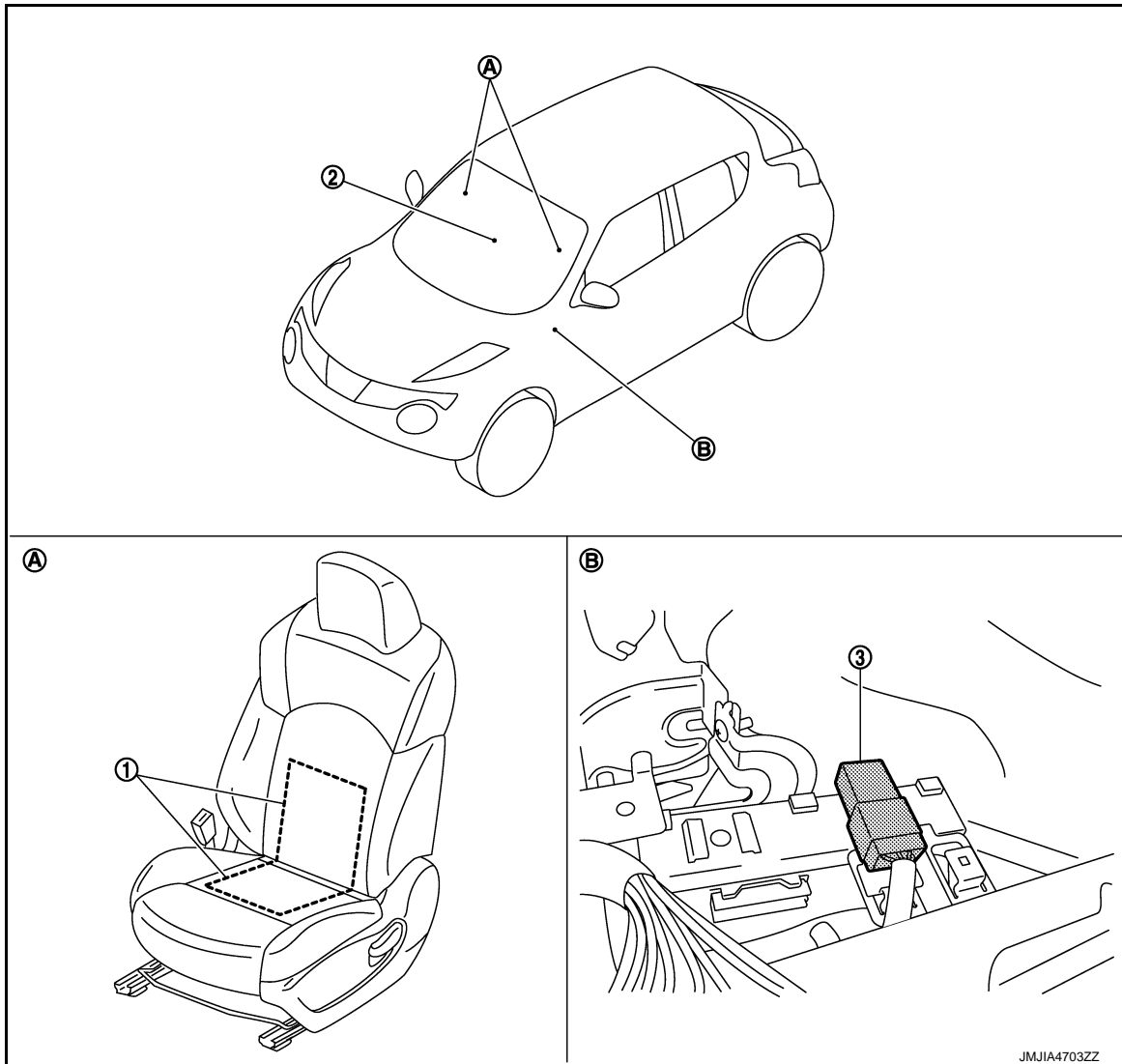

JMJIA4703ZZ

1. Seat heater

2. Heated seat switch

3. Heated seat relay

A. Front seat

B. Front LH of passenger room

#### HEATED SEAT SYSTEM : Component Description

INFOID:000000007578160

Item	Function
Heated seat switch	Supplies power supply to heated seat and operates switching of HI/LO of heated seat and ON/OFF of the system
Seat heater	Built-in in seat, the heater operates with the power supplied by heated seat switch
Heated seat relay	Supplies power to the heated seat switch in accordance with the key switch position that is ON or START

# SYSTEM

< SYSTEM DESCRIPTION >

---

## SYSTEM

### HEATED SEAT SYSTEM

#### HEATED SEAT SYSTEM : System Description

INFOID:000000007578161

Heated seat is a system that operates when ignition switch is in ON position.

#### HEATER OPERATION

- When the heated seat switch is ON, seat cushion heater and seat back heater operate.
- Temperature of seat can be adjusted by operating on heated seat switch.

A

B

C

D

E

F

G

H

I

SE

K

L

M

N

O

P

# HEATED SEAT SYSTEM

< WIRING DIAGRAM >

## WIRING DIAGRAM

### HEATED SEAT SYSTEM

#### Wiring Diagram

INFOID:000000007578162

For connector terminal arrangements, harness layouts, and alphabets in a  (option abbreviation; if not described in wiring diagram), refer to [GI-12. "Connector Information"](#).

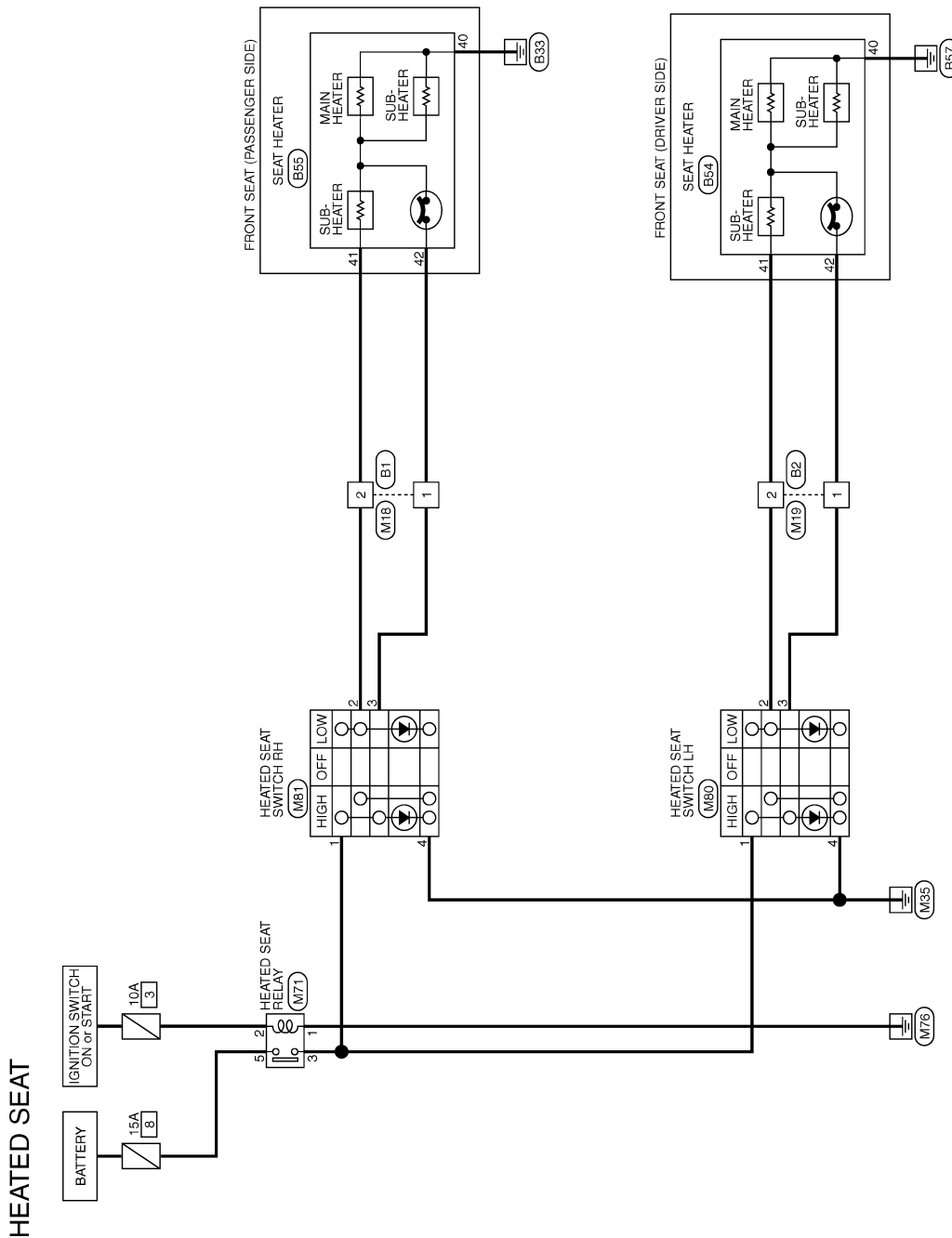

2010/08/30

JCJWA1282GB



# SQUEAK AND RATTLE TROUBLE DIAGNOSES

< SYMPTOM DIAGNOSIS >

## SYMPTOM DIAGNOSIS

### SQUEAK AND RATTLE TROUBLE DIAGNOSES

#### Work Flow

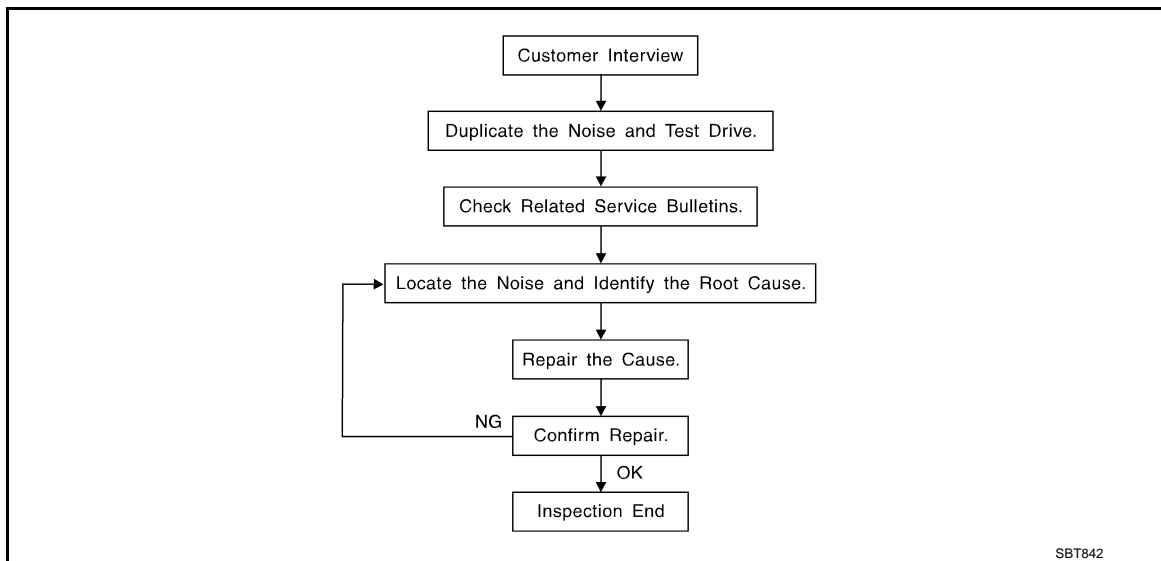

#### CUSTOMER INTERVIEW

Interview the customer if possible, to determine the conditions that exist when the noise occurs. Use the Diagnostic Worksheet during the interview to document the facts and conditions when the noise occurs and any of customer's comments; refer to [SE-13. "Diagnostic Worksheet"](#). This information is necessary to duplicate the conditions that exist when the noise occurs.

- The customer may not be able to provide a detailed description or the location of the noise. Attempt to obtain all the facts and conditions that exist when the noise occurs (or does not occur).
- If there is more than one noise in the vehicle, perform a diagnosis and repair the noise that the customer is concerned about. This can be accomplished by performing a cruise test on the vehicle with the customer.
- After identifying the type of noise, isolate the noise in terms of its characteristics. The noise characteristics are provided so the customer, service adviser and technician are all speaking the same language when defining the noise.
- Squeak – (Like tennis shoes on a clean floor)  
Squeak characteristics include the light contact/fast movement/brought on by road conditions/hard surfaces = higher pitch noise/softer surfaces = lower pitch noises/edge to surface = chirping
- Creak – (Like walking on an old wooden floor)  
Creak characteristics include firm contact/slow movement/twisting with a rotational movement/pitch dependent on materials/often brought on by activity.
- Rattle – (Like shaking a baby rattle)  
Rattle characteristics include the fast repeated contact/vibration or similar movement/loose parts/missing clip or fastener/incorrect clearance.
- Knock – (Like a knock on a door)  
Knock characteristics include hollow sounding/sometimes repeating/often brought on by driver action.
- Tick – (Like a clock second hand)  
Tick characteristics include gentle contacting of light materials/loose components/can be caused by driver action or road conditions.
- Thump – (Heavy, muffled knock noise)  
Thump characteristics include softer knock/dead sound often brought on by activity.
- Buzz – (Like a bumblebee)  
Buzz characteristics include high frequency rattle/firm contact.
- Often the degree of acceptable noise level will vary depending up on the person. A noise that a technician may judge as acceptable may be very irritating to the customer.
- Weather conditions, especially humidity and temperature, may have a great effect on noise level.

#### DUPLICATE THE NOISE AND TEST DRIVE

# SQUEAK AND RATTLE TROUBLE DIAGNOSES

## < SYMPTOM DIAGNOSIS >

If possible, drive the vehicle with the customer until the noise is duplicated. Note any additional information on the Diagnostic Worksheet regarding the conditions or location of the noise. This information can be used to duplicate the same conditions when the repair is reconfirmed.

If the noise can be duplicated easily during the test drive, to help identify the source of the noise, try to duplicate the noise with the vehicle stopped by doing one or all of the following:

- 1) Close a door.
  - 2) Tap or push/pull around the area where the noise appears to be coming from.
  - 3) Rev the engine.
  - 4) Use a floor jack to recreate vehicle "twist".
  - 5) At idle, apply engine load (electrical load, half-clutch on M/T models, drive position on A/T models).
  - 6) Raise the vehicle on a hoist and hit a tire with a rubber hammer.
- Drive the vehicle and attempt to duplicate the conditions the customer states exist when the noise occurs.
  - If it is difficult to duplicate the noise, drive the vehicle slowly on an undulating or rough road to stress the vehicle body.

## CHECK RELATED SERVICE BULLETINS

After verifying the customer concern or symptom, check ASIST for Technical Service Bulletins (TSBs) related to that concern or symptom.

If a TSB relates to the symptom, follow the procedure to repair the noise.

## LOCATE THE NOISE AND IDENTIFY THE ROOT CAUSE

1. Narrow down the noise to a general area. To help pinpoint the source of the noise, use a listening tool (Chassis ear: J-39570, Engine ear and mechanics stethoscope).
2. Narrow down the noise to a more specific area and identify the cause of the noise by:
  - Removing the components in the area that is are suspected to be the cause of the noise.  
Do not use too much force when removing clips and fasteners, otherwise clips and fastener can be broken or lost during the repair, resulting in the creation of new noise.
  - Tapping or pushing/pulling the component that is are suspected to be the cause of the noise.  
Do not tap or push/pull the component with excessive force, otherwise the noise will be eliminated only temporarily.
  - Feeling for a vibration by hand by touching the component(s) that is are suspected to be the cause of the noise.
  - Placing a piece of paper between components that are suspected to be the cause of the noise.
  - Looking for loose components and contact marks.  
Refer to [SE-11, "Inspection Procedure"](#).

## REPAIR THE CAUSE

- If the cause is a loose component, tighten the component securely.
- If the cause is insufficient clearance between components:
  - Separate components by repositioning or loosening and retightening the component, if possible.
  - Insulate components with a suitable insulator such as urethane pads, foam blocks, felt cloth tape or urethane tape. A Nissan Squeak and Rattle Kit (J-43980) is available through the authorized Nissan Parts Department.

### **CAUTION:**

**Never use excessive force as many components are constructed of plastic and may be damaged.**

### **NOTE:**

Always check with the Parts Department for the latest parts information.

The following materials are contained in the Nissan Squeak and Rattle Kit (J-43980). Each item can be ordered separately as needed.

URETHANE PADS [1.5 mm (0.059 in) thick]

Insulates connectors, harness, etc.

76268-9E005: 100 × 135 mm (3.94 × 5.31 in)/76884-71L01: 60 × 85 mm (2.36 × 3.35 in)/76884-71L02: 15 × 25 mm (0.59 × 0.98 in)

INSULATOR (Foam blocks)

Insulates components from contact. Can be used to fill space behind a panel.

73982-9E000: 45 mm (1.77 in) thick, 50 × 50 mm (1.97 × 1.97 in)/73982-

50Y00: 10 mm (0.39 in) thick, 50 × 50 mm (1.97 × 1.97 in)

INSULATOR (Light foam block)

80845-71L00: 30 mm (1.18 in) thick, 30 × 50 mm (1.18 × 1.97in)

FELT CLOTHTAPE

Used to insulate where movement does not occur. Ideal for instrument panel applications.

# SQUEAK AND RATTLE TROUBLE DIAGNOSES

## < SYMPTOM DIAGNOSIS >

68370-4B000: 15 × 25 mm (0.59 × 0.98 in) pad/68239-13E00: 5 mm (0.20 in) wide tape roll

The following materials, not found in the kit, can also be used to repair squeaks and rattles.

### UHMW (TEFLON) TAPE

Insulates where slight movement is present. Ideal for instrument panel applications.

### SILICONE GREASE

Used in place of UHMW tape that is be visible or does not fit. Will only last a few months.

### SILICONE SPRAY

Used when grease cannot be applied.

### DUCT TAPE

Used to eliminate movement.

## CONFIRM THE REPAIR

Confirm that the cause of a noise is repaired by test driving the vehicle. Operate the vehicle under the same conditions as when the noise originally occurred. Refer to the notes on the Diagnostic Worksheet.

## Inspection Procedure

INFOID:000000007578164

Refer to Table of Contents for specific component removal and installation information.

## INSTRUMENT PANEL

Most incidents are caused by contact and movement between:

1. The cluster lid A and instrument panel
2. Acrylic lens and combination meter housing
3. Instrument panel to front pillar garnish
4. Instrument panel to windshield
5. Instrument panel mounting pins
6. Wiring harnesses behind the combination meter
7. A/C defroster duct and duct joint

These incidents can usually be located by tapping or moving the components to duplicate the noise or by pressing on the components while driving to stop the noise. Most of these incidents can be repaired by applying felt cloth tape or silicon spray (in hard to reach areas). Urethane pads can be used to insulate wiring harness.

### **CAUTION:**

**Never use silicone spray to isolate a squeak or rattle. If the area is saturated with silicone, the recheck of repair becomes impossible.**

## CENTER CONSOLE

Components to pay attention to include:

1. Shifter assembly cover to finisher
2. A/C control unit and cluster lid C
3. Wiring harnesses behind audio and A/C control unit

The instrument panel repair and isolation procedures also apply to the center console.

## DOORS

Pay attention to the following:

1. Finisher and inner panel making a slapping noise
2. Inside handle escutcheon to door finisher
3. Wiring harnesses tapping
4. Door striker out of alignment causing a popping noise on starts and stops

Tapping or moving the components or pressing on them while driving to duplicate the conditions can isolate many of these incidents. The areas can usually be insulated with felt cloth tape or insulator foam blocks from the Nissan Squeak and Rattle Kit (J-43980) to repair the noise.

## TRUNK

Trunk noises are often caused by a loose jack or loose items put into the trunk by the customer.

In addition look for the following:

1. Trunk lid dumpers out of adjustment
2. Trunk lid striker out of adjustment

# SQUEAK AND RATTLE TROUBLE DIAGNOSES

## < SYMPTOM DIAGNOSIS >

---

3. The trunk lid torsion bars knocking together
4. A loose license plate or bracket

Most of these incidents can be repaired by adjusting, securing or insulating the item(s) or component(s) causing the noise.

### SUNROOF/HEADLINING

Noises in the sunroof/headlining area can often be traced to one of the following:

1. Sunroof lid, rail, linkage or seals making a rattle or light knocking noise
2. Sunvisor shaft shaking in the holder
3. Front or rear windshield touching headlining and squeaking

Again, pressing on the components to stop the noise while duplicating the conditions can isolate most of these incidents. Repairs usually consist of insulating with felt cloth tape.

### SEATS

When isolating seat noise it's important to note the position the seats in and the load placed on the seat when the noise occurs. These conditions should be duplicated when verifying and isolating the cause of the noise.

Cause of seat noise include:

1. Headrest rods and holder
2. A squeak between the seat pad cushion and frame
3. The rear seatback lock and bracket

These noises can be isolated by moving or pressing on the suspected components while duplicating the conditions under which the noise occurs. Most of these incidents can be repaired by repositioning the component or applying urethane tape to the contact area.

### UNDERHOOD

Some interior noise may be caused by components under the hood or on the engine wall. The noise is then transmitted into the passenger compartment.

Causes of transmitted underhood noise include:

1. Any component mounted to the engine wall
2. Components that pass through the engine wall
3. Engine wall mounts and connectors
4. Loose radiator mounting pins
5. Hood bumpers out of adjustment
6. Hood striker out of adjustment

These noises can be difficult to isolate since they cannot be reached from the interior of the vehicle. The best method is to secure, move or insulate one component at a time and test drive the vehicle. Also, engine RPM or load can be changed to isolate the noise. Repairs can usually be made by moving, adjusting, securing, or insulating the component causing the noise.

# SQUEAK AND RATTLE TROUBLE DIAGNOSES

< SYMPTOM DIAGNOSIS >

## Diagnostic Worksheet

INFOID:000000007578165



### SQUEAK & RATTLE DIAGNOSTIC WORKSHEET

Dear Nissan Customer:

We are concerned about your satisfaction with your Nissan vehicle. Repairing a squeak or rattle sometimes can be very difficult. To help us fix your Nissan right the first time, please take a moment to note the area of the vehicle where the squeak or rattle occurs and under what conditions. You may be asked to take a test drive with a service advisor or technician to ensure we confirm the noise you are hearing.

#### I. WHERE DOES THE NOISE COME FROM? (circle the area of the vehicle)

The illustrations are for reference only, and may not reflect the actual configuration of your vehicle.

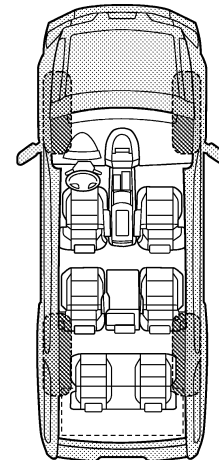
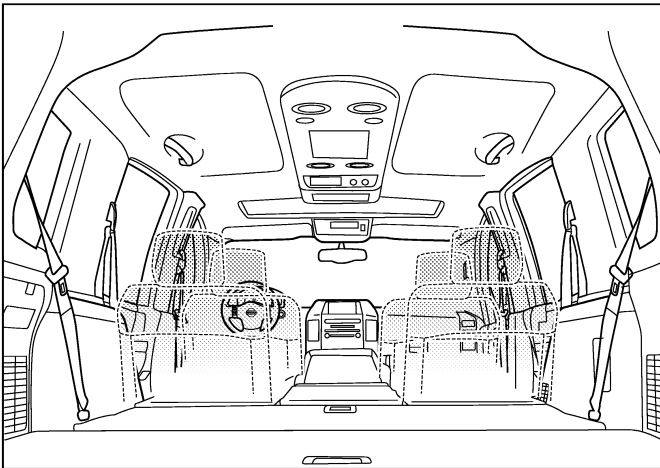
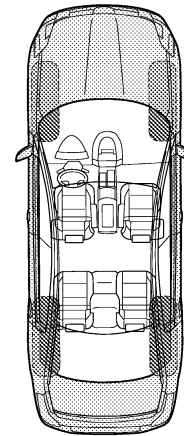
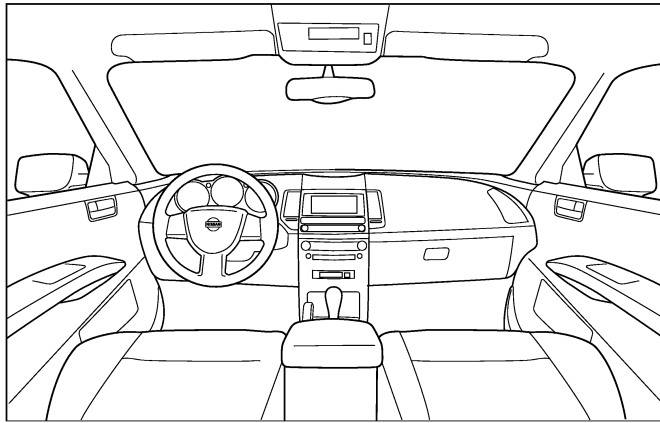

Continue to page 2 of the worksheet and briefly describe the location of the noise or rattle. In addition, please indicate the conditions which are present when the noise occurs.

PIIB8740E

A  
B  
C  
D  
E  
F  
G  
H  
I  
SE  
K  
L  
M  
N  
O  
P

# SQUEAK AND RATTLE TROUBLE DIAGNOSES

< SYMPTOM DIAGNOSIS >

## SQUEAK & RATTLE DIAGNOSTIC WORKSHEET - page 2

Briefly describe the location where the noise occurs:

---

---

### II. WHEN DOES IT OCCUR? (please check the boxes that apply)

- |   |  |
|---|--|
| <input type="checkbox"/> anytime                      | <input type="checkbox"/> after sitting out in the rain |
| <input type="checkbox"/> 1st time in the morning      | <input type="checkbox"/> when it is raining or wet     |
| <input type="checkbox"/> only when it is cold outside | <input type="checkbox"/> dry or dusty conditions       |
| <input type="checkbox"/> only when it is hot outside  | <input type="checkbox"/> other:                        |

### III. WHEN DRIVING:

- through driveways
- over rough roads
- over speed bumps
- only about \_\_\_\_ mph
- on acceleration
- coming to a stop
- on turns: left, right or either (circle)
- with passengers or cargo
- other: \_\_\_\_\_
- after driving \_\_\_\_ miles or \_\_\_\_ minutes

### IV. WHAT TYPE OF NOISE

- squeak (like tennis shoes on a clean floor)
- creak (like walking on an old wooden floor)
- rattle (like shaking a baby rattle)
- knock (like a knock at the door)
- tick (like a clock second hand)
- thump (heavy, muffled knock noise)
- buzz (like a bumble bee)

## TO BE COMPLETED BY DEALERSHIP PERSONNEL

### Test Drive Notes:

---

---

---

	YES	NO	Initials of person performing
Vehicle test driven with customer	<input type="checkbox"/>	<input type="checkbox"/>	_____
- Noise verified on test drive	<input type="checkbox"/>	<input type="checkbox"/>	_____
- Noise source located and repaired	<input type="checkbox"/>	<input type="checkbox"/>	_____
- Follow up test drive performed to confirm repair	<input type="checkbox"/>	<input type="checkbox"/>	_____

VIN: \_\_\_\_\_ Customer Name: \_\_\_\_\_  
W.O.# \_\_\_\_\_ Date: \_\_\_\_\_

This form must be attached to Work Order

PIIB8742E

# FRONT SEAT

< REMOVAL AND INSTALLATION >

## REMOVAL AND INSTALLATION

### FRONT SEAT

Exploded View

INFOID:000000007578166

DRIVER SEAT

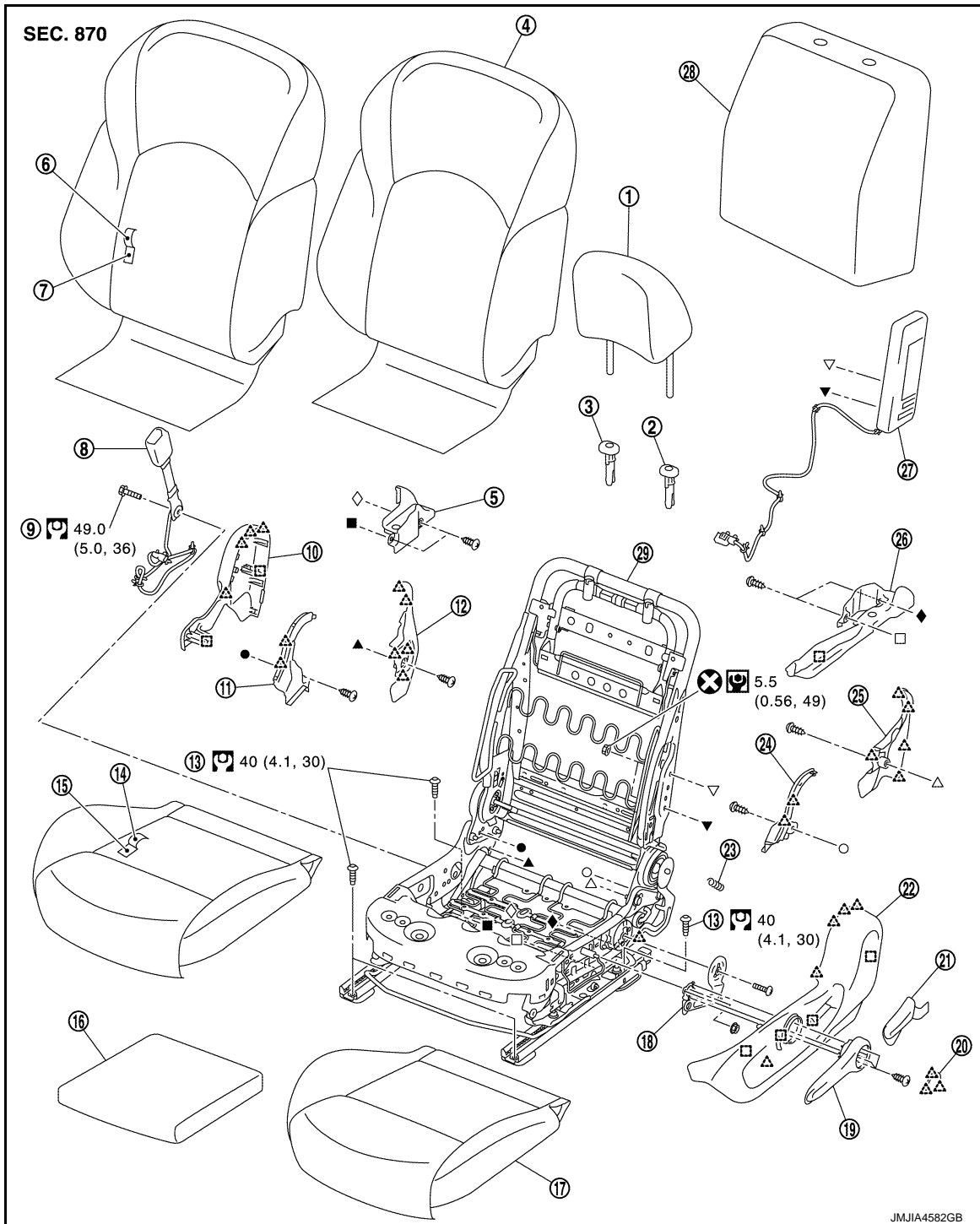

- |  |                             |   |
|--|-----------------------------|---|
| 1. Headrest                                  | 2. Headrest holder (locked) | 3. Headrest holder (free)                   |
| 4. Seatback assembly (with heater seat only) | 5. Inner lower cover        | 6. Seatback trim (without heater seat only) |

A  
B  
C  
D  
E  
F  
G  
H  
I  
SE  
K  
L  
M  
N  
O  
P

## FRONT SEAT

### < REMOVAL AND INSTALLATION >

---

- |   |  |  |
|---|--|--|
| 7. Seatback pad<br>(without heater seat only) | 8. Seat belt buckle                                  | 9. Anchor bolt                                     |
| 10. Seat cushion inner finisher               | 11. Reclining device inner cover (front)             | 12. Reclining device inner cover (rear)            |
| 13. TORX bolt                                 | 14. Seat cushion trim<br>(without heater seat only)  | 15. Seat cushion pad<br>(without heater seat only) |
| 16. Seat cushion silencer                     | 17. Seat cushion assembly<br>(with heater seat only) | 18. Lifter link                                    |
| 19. Lifter lever knob                         | 20. Lifter lever knob cap                            | 21. Reclining lever knob                           |
| 22. Seat cushion outer finisher               | 23. Spring   | 24. Reclining device outer cover (front)           |
| 25. Reclining device outer cover (rear)       | 26. Outer lower cover                                | 27. Side air bag module                            |
| 28. Seatback silencer                         | 29. Seat frame & adjuster assembly                   |  |

 : Pawl

 : Metal clip

 : Do not reuse

 : N·m (kg-m, in-lb)

 : N·m (kg-m, ft-lb)

### PASSENGER SEAT



# FRONT SEAT

< REMOVAL AND INSTALLATION >

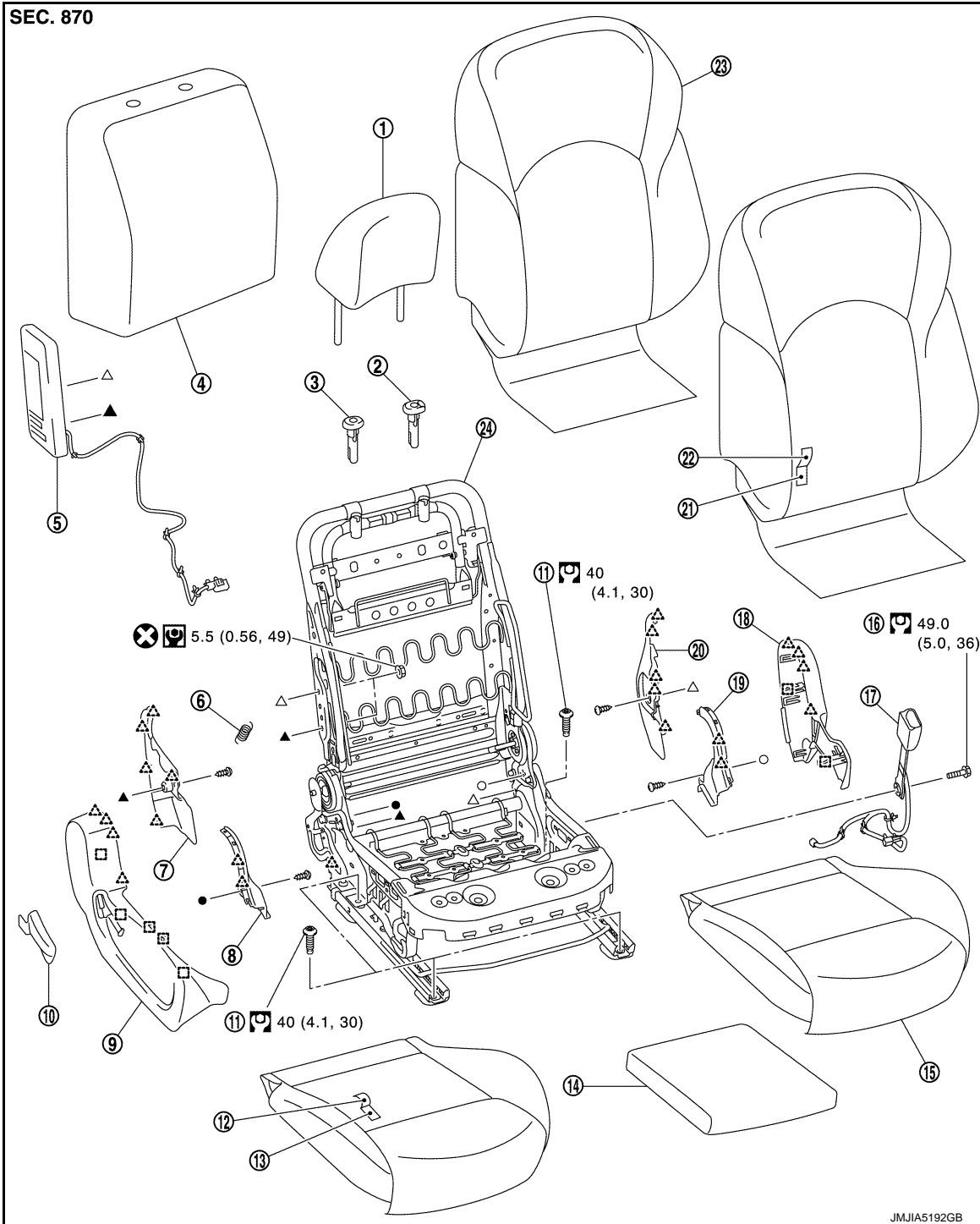





- |   |  |  |
|---|--|--|
| 1. Headrest   | 2. Headrest holder (locked)                        | 3. Headrest holder (free)                            |
| 4. Seatback silencer                                | 5. Side air bag module                             | 6. Spring  |
| 7. Reclining device outer cover (rear)              | 8. Reclining device outer cover (front)            | 9. Seat cushion outer finisher                       |
| 10. Reclining lever knob                            | 11. TORX bolt                                      | 12. Seat cushion silencer                            |
| 13. Seat cushion trim<br>(without heater seat only) | 14. Seat cushion pad<br>(without heater seat only) | 15. Seat cushion assembly<br>(with heater seat only) |
| 16. Anchor bolt                                     | 17. Seat belt buckle                               | 18. Seat cushion inner finisher                      |
| 19. Reclining device inner cover (front)            | 20. Reclining device inner cover (rear)            | 21. Seatback pad<br>(without heater seat only)       |
| 22. Seatback trim<br>(without heater seat only)     | 23. Seatback assembly<br>(with heater seat only)   | 24. Seat frame & adjuster assembly                   |

A  
B  
C  
D  
E  
F  
G  
H  
I  
SE  
K  
L  
M  
N

# FRONT SEAT

## < REMOVAL AND INSTALLATION >

-  : Pawl
-  : Metal clip
-  : Do not reuse
-  : N·m (kg-m, in-lb)
-  : N·m (kg-m, ft-lb)

## Removal and Installation

INFOID:000000007578167

### REMOVAL

#### **CAUTION:**

**Before servicing, disconnect the battery cable from negative terminal or remove the fuse.**

1. Remove headrest.
2. Set the seatback vertically.
3. Slide seat to the frontmost position.
4. Remove rear outer mounting TORX bolt.
5. Remove rear inner mounting TORX bolt.
6. Slide seat to the rearmost position.
7. Remove front outer mounting TORX bolt.
8. Remove front inner mounting TORX bolt.
9. Remove seat cushion lower harness connectors and harness fixing clamps.

#### **CAUTION:**

**Before performing removal operation, check the installation position of harness connectors and harness fixing clamps.**

10. Remove seat from the vehicle.

#### **CAUTION:**

**When removing and installing, use shop cloths to protect parts from damage.**

### INSTALLATION

Note the following items, and install in the reverse order of removal.

#### **CAUTION:**

- When removing and installing, use shop cloths to protect parts from damage.
- When installing, tighten mounting TORX bolts according to the numerical order (1, 2, 3, and 4 as shown in the figure), starting from front inner mounting TORX bolt.

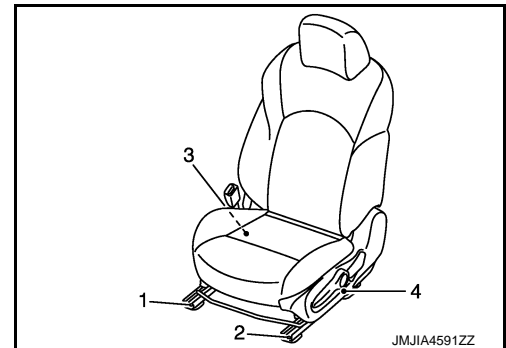

- Always fix the harness fixing clamp in position.

## SEATBACK

### SEATBACK : Disassembly and Assembly

INFOID:000000007578168

### DISASSEMBLY

#### **CAUTION:**

**For models with heater seat, always replace heater seat as a seatback assembly without disassembling trim and pad.**

1. Remove seatback retainer installed in the lower portion of seat cushion.
2. Remove harness installed in the lower portion of seat cushion.

# FRONT SEAT

## < REMOVAL AND INSTALLATION >

1. Disconnect seatback heater unit harness connector (A). (with heater seat only.)
2. Remove seatback heater unit harness connector fixing clips (A) and harness fixing clamp (B). (with heater seat only)
3. Remove side air bag module harness connector fixing clips (C) and harness fixing clamp (D).

← : Vehicle front

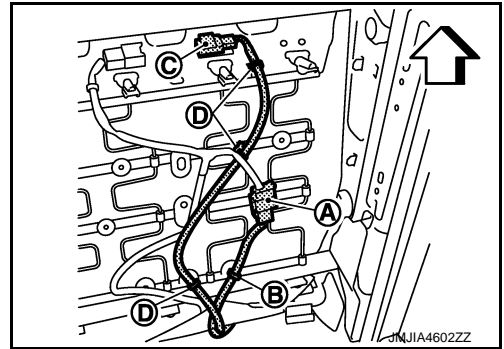

3. Open seatback fastener (A) and remove seatback retainer (B).

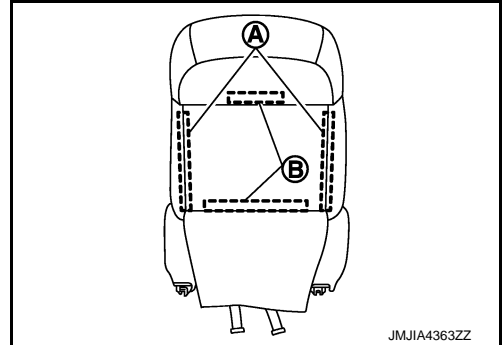

4. Remove side air bag module harness fixing clamps from seat frame & adjuster assembly.
5. Use pincers, etc., to press up pawls as shown by the arrows in the figure, and remove headrest holder from seatback.

### CAUTION:

**Before installing headrest holder check its orientation. (front/rear and right/left)**

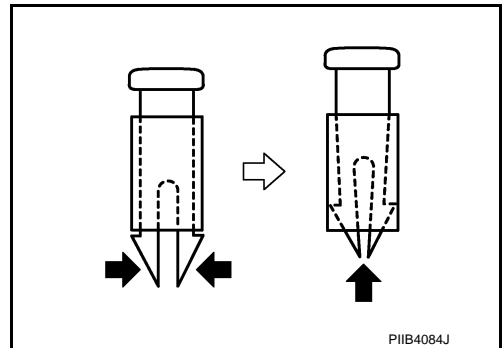

6. Remove side air bag module mounting nuts.
7. Remove seatback trim and seatback pad from seat frame & adjuster assembly.

### CAUTION:

**Never subject side air bag module to impact by dropping or hitting.**

8. Remove side air bag module from seatback pad.
9. Separate the seatback trim and seatback pad. (without heater seat only)  
Remove hog rings, and separate the seatback trim and seatback pad.

### CAUTION:

**Before performing separating operation, check the installation position of hog rings.**

10. Remove seatback silencer from seat frame & adjuster assembly.

## ASSEMBLY

Note the following, and assemble in the reverse order of disassembly.

### CAUTION:

**Always install the hog ring in position.**

## SEAT CUSHION

## SEAT CUSHION : Disassembly and Assembly

INFOID:000000007578169

## DISASSEMBLY

### CAUTION:

# FRONT SEAT

## < REMOVAL AND INSTALLATION >

**For models with heater seat, always replace heater seat as a seat cushion assembly without disassembling trim and pad.**

1. Remove seat cushion outer finisher.

1. Disengage pawls and remove lifter lever knob cap (1). (Driver seat only)
2. Remove fixing screws and remove lifter lever knob (2). (Driver seat only)

 : Pawl

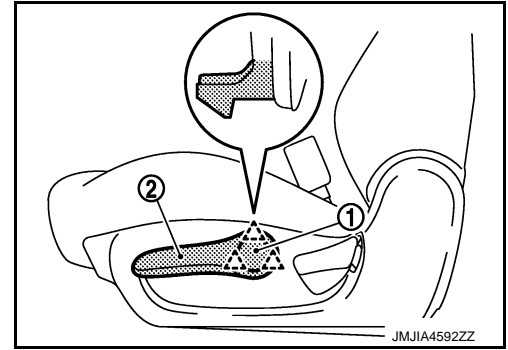

3. Disengage pawl using a screwdriver while pulling reclining lever knob. Slide reclining lever knob toward seat front and remove it.

 : Pawl

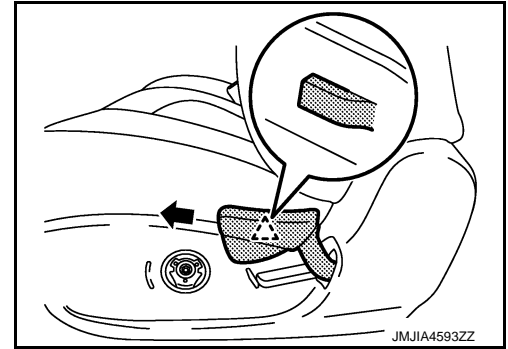

4. Pull seat cushion outer finisher toward seat front. Disengage pawls and metal clips. Slide seat cushion outer finisher toward seat front. Remove seat cushion outer finisher.

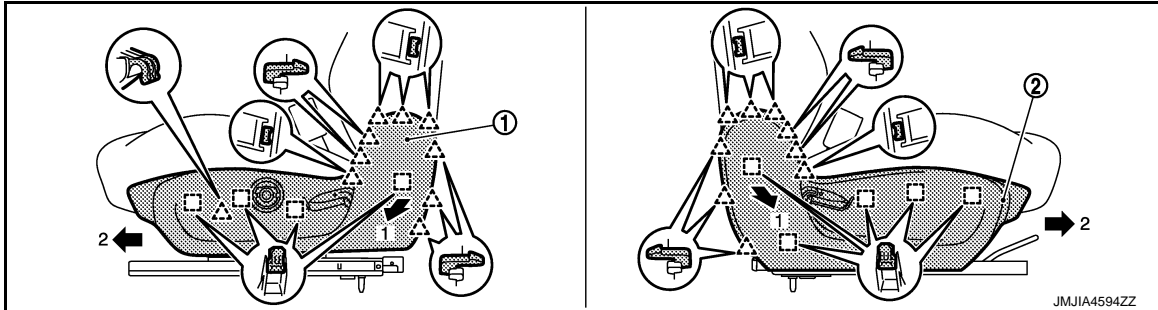

1. Seat cushion outer finisher (Driver seat)

2. Seat cushion outer finisher (Passenger seat)

 : Pawl

 : Metal clip

2. Remove harness installed in the lower portion of seat cushion.

1. Disconnect seat cushion heater unit harness connector (A). (with heater seat only)
2. Remove seat cushion heater unit harness connector fixing clip (B) and harness fixing clamps (C). (with heater seat only)
3. Remove seat belt buckle harness connector fixing clip (D) and harness fixing clamps (E).

 : Vehicle front

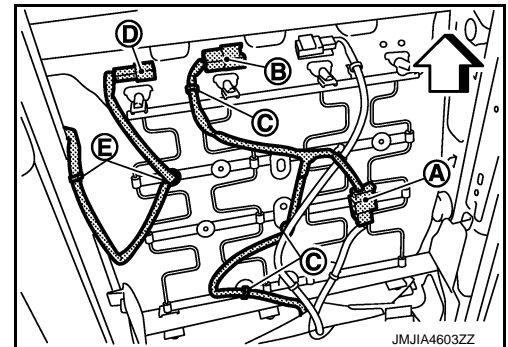

# FRONT SEAT

## < REMOVAL AND INSTALLATION >

3. Remove seat cushion inner finisher.
  1. Remove harness fixing clamp of seat belt buckle installed on seat frame & adjuster assembly.
  2. Remove seat belt buckle mounting anchor bolt, and then remove seat belt buckle from seat frame & adjuster assembly.
  3. Pull seat cushion inner finisher forward. Disengage pawls and metal clips.

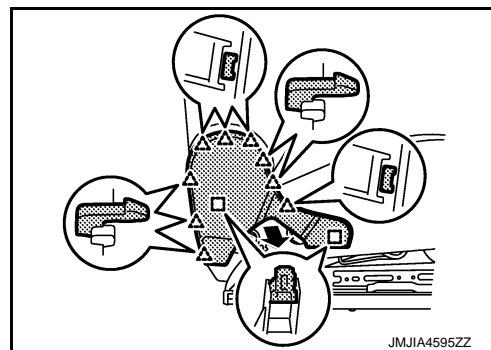
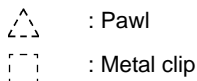

4. Remove seat cushion retainer from seat frame & adjuster assembly. Remove seat cushion trim and seat cushion pad.
5. Remove hog rings, and separate the seat cushion trim and seat cushion pad. (without heater seat only)  
**CAUTION:**  
**Before performing separating operation, check the installation position of hog rings.**
6. Remove seat cushion silencer from seat frame & adjuster assembly.
7. Remove seatback trim and seatback pad from seat frame & adjuster assembly.  
Refer to [SE-18, "SEATBACK : Disassembly and Assembly"](#).
8. Remove reclining device cover.
  - Remove fixing screw, and then remove reclining device outer cover (front and rear).
  - Remove fixing screw, and then remove reclining device inner cover (front and rear).
9. Remove following parts from seat frame & adjuster assembly.
  - Remove reclining spring.
  - Remove fixing screws. Pull outer lower cover toward seat outer. Disengage metal clips. Remove outer lower cover. (driver seat only)
  - Remove fixing screws, and then remove inner lower cover. (driver seat only)

## ASSEMBLY

Note the following, and assemble in the reverse order of disassembly.

- CAUTION:**
- Always install the hog rings in position.

## FRONT SEAT

### < REMOVAL AND INSTALLATION >

- When installing seat cushion finisher, always slide seat cushion outer finisher toward seat rear, engage portion (A) of seat frame & adjuster assembly and portion (B) of seat cushion outer finisher, and then install pawls and metal clips of seat cushion outer finisher.

← : Vehicle front

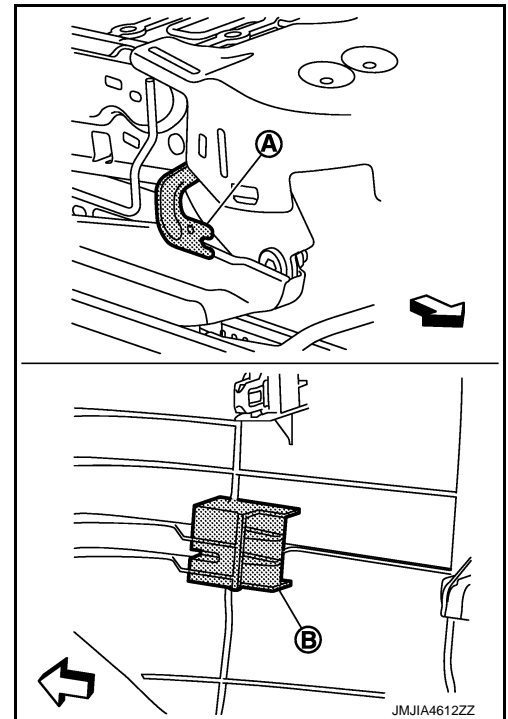

# REAR SEAT

< REMOVAL AND INSTALLATION >

## REAR SEAT

Exploded View

INFOID:000000007578170

2WD models

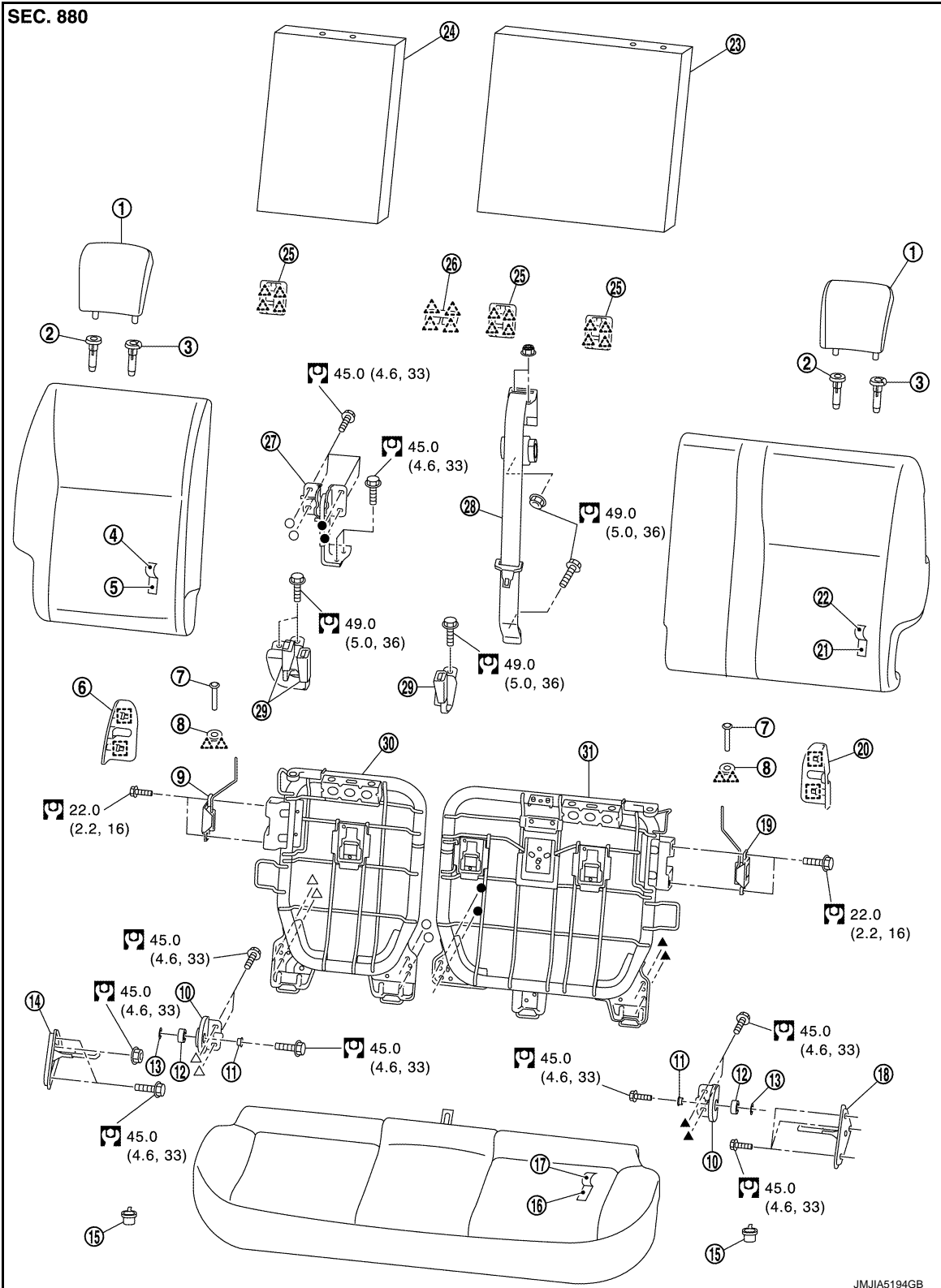

- |                     |                           |                             |
|---------------------|---------------------------|-----------------------------|
| 1. Headrest         | 2. Headrest holder (free) | 3. Headrest holder (locked) |
| 4. Seatback trim RH | 5. Seatback pad RH        | 6. Seat lock cover RH       |

## REAR SEAT

### < REMOVAL AND INSTALLATION >

---

- |                               |                                |                              |
|-------------------------------|--------------------------------|------------------------------|
| 7. Seatback lock knob         | 8. Seatback lock knob finisher | 9. Seatback lock assembly RH |
| 10. Side hinge                | 11. Bush                       | 12. Spacer                   |
| 13. Lock washer               | 14. Striker RH                 | 15. Seat cushion hook        |
| 16. Seat cushion pad          | 17. Seat cushion trim          | 18. Striker LH               |
| 19. Seatback lock assembly LH | 20. Seat lock cover LH         | 21. Seatback pad LH          |
| 22. Seatback trim LH          | 23. Seatback silencer LH       | 24. Seatback silencer RH     |
| 25. Seatback tether cover     | 26. Center seat belt finisher  | 27. Center hinge             |
| 28. Center seat belt          | 29. Seat belt buckle           | 30. Seatback frame RH        |
| 31. Seatback frame LH         |                                |                              |

 : Pawl

 : Metal clip

 : N·m (kg-m, ft-lb)



# REAR SEAT

< REMOVAL AND INSTALLATION >

AWD models

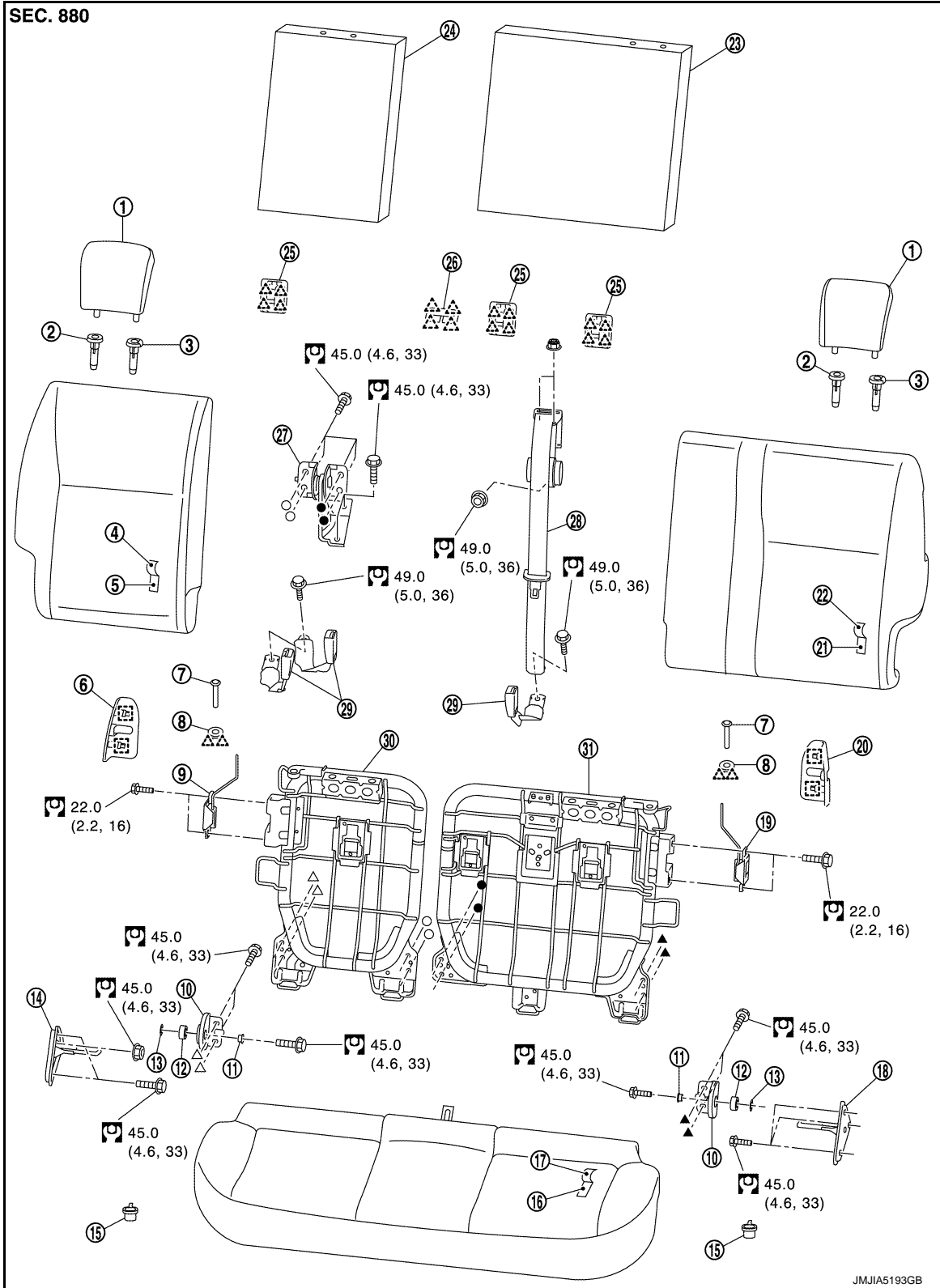

- |                       |                                |                              |
|-----------------------|--------------------------------|------------------------------|
| 1. Headrest           | 2. Headrest holder (free)      | 3. Headrest holder (locked)  |
| 4. Seatback trim RH   | 5. Seatback pad RH             | 6. Seat lock cover RH        |
| 7. Seatback lock knob | 8. Seatback lock knob finisher | 9. Seatback lock assembly RH |
| 10. Side hinge        | 11. Bush                       | 12. Spacer                   |
| 13. Lock washer       | 14. Striker RH                 | 15. Seat cushion hook        |
| 16. Seat cushion pad  | 17. Seat cushion trim          | 18. Striker LH               |

A  
B  
C  
D  
E  
F  
G  
H  
I  
SE  
K  
L  
M  
N  
O  
P

## REAR SEAT

### < REMOVAL AND INSTALLATION >

- |                               |                               |                          |
|-------------------------------|-------------------------------|--------------------------|
| 19. Seatback lock assembly LH | 20. Seat lock cover LH        | 21. Seatback pad LH      |
| 22. Seatback trim LH          | 23. Seatback silencer LH      | 24. Seatback silencer RH |
| 25. Seatback tether cover     | 26. Center seat belt finisher | 27. Center hinge         |
| 28. Center seat belt          | 29. Seat belt buckle          | 30. Seatback frame RH    |
| 31. Seatback frame LH         |                               |                          |

 : Pawl

 : Metal clip

 : N·m (kg·m, ft·lb)

## SEAT CUSHION

### SEAT CUSHION : Removal and Installation

INFOID:000000007578171

#### REMOVAL

1. Lift up seat cushion at a close position (B) of engaging portion (A) and disengage seat cushion hook.

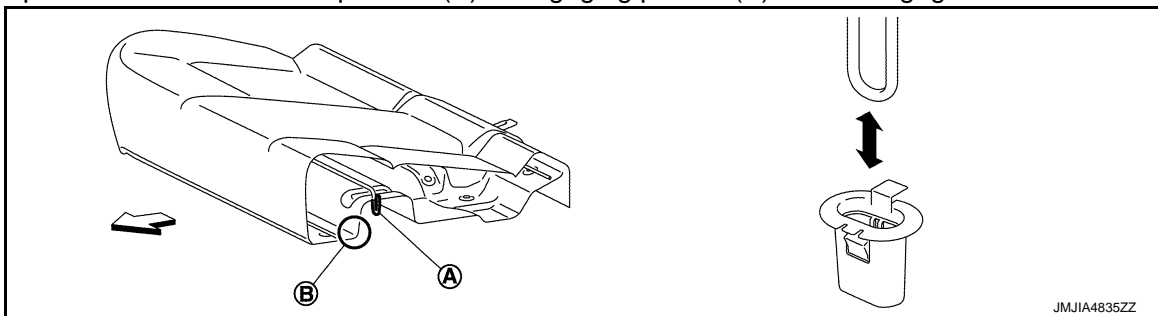

 : Vehicle front

#### **CAUTION:**

Seat cushion wire close to engaging portion deforms, if excessive force is applied to seat cushion front end when removing seat cushion.

To avoid the deformation, be careful to remove seat cushion while applying force to close position, as much as possible, of engaging portion.

2. Pull out seat belt buckle from seat cushion.
3. Remove seat cushion from the vehicle.

#### **CAUTION:**

When removing and installing, use shop cloths to protect parts from damage.

#### INSTALLATION

Note the following item, and install in the reverse order of removal.

#### **CAUTION:**

When removing and installing, use shop cloths to protect parts from damage.

### SEAT CUSHION : Disassembly and Assembly

INFOID:000000007578172

#### DISASSEMBLY

Remove hog rings, and separate the seat cushion trim and seat cushion pad.

#### **CAUTION:**

Before performing separating operation, check the installation position of hog rings.

#### ASSEMBLY

Note the following item, and assemble in the reverse order of disassembly.

#### **CAUTION:**

Always install the hog ring in position.

## SEATBACK

# REAR SEAT

< REMOVAL AND INSTALLATION >

## SEATBACK : Removal and Installation

INFOID:000000007578173

### LH SIDE SEATBACK

Removal

**CAUTION:**

**Remove seatback with seat cushion installed.**

1. Temporarily move seat cushion to the position where center anchor of center seat belts can be removed.
2. Remove center anchor mounting bolt of center seat belt. Remove center anchor.
3. Return seat cushion to the normal position.
4. Unlock seatback lock assembly. Tilt seatback toward vehicle front. Remove headrests.
5. Fold seatback toward vehicle front.
6. Pull up seatback carpet (A). Remove mounting bolts (B) of seatback hinge portion.

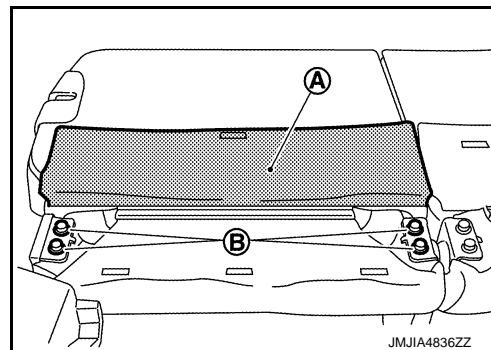

7. Remove seatback from the vehicle.

**CAUTION:**

**When removing and installing, use shop cloths to protect parts from damage.**

Installation

Note the following items, and install in the reverse order of removal.

**CAUTION:**

- When removing and installing, use shop cloths to protect parts from damage.
- Install seat cushion to the vehicle, and then install seatback.
- Temporarily tighten bolts, fold up seatback, check that lock and striker do not interfere, and then tighten bolts.
- When installing seatback, tighten mounting bolts according to the numerical order (1, 2, 3, and 4 as shown in the figure).

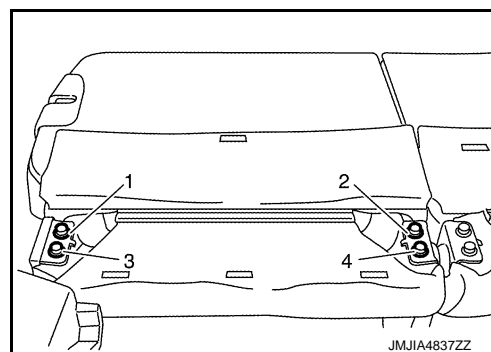

### RH SIDE SEATBACK

Removal

**CAUTION:**

**Remove seatback with seat cushion installed.**

1. Unlock seatback lock assembly. Tilt seatback toward vehicle front. Remove headrests.
2. Fold seatback toward vehicle front.

# REAR SEAT

## < REMOVAL AND INSTALLATION >

3. Pull up seatback carpet (A). Remove mounting bolts (B) of seatback hinge portion.

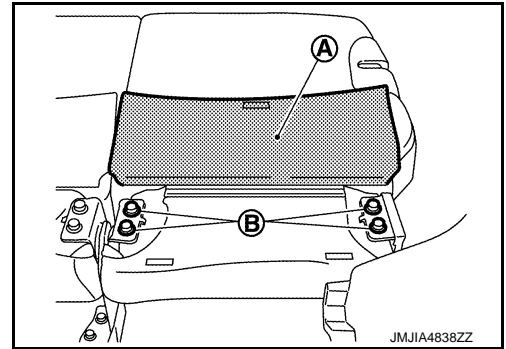

4. Remove seatback from the vehicle.

**CAUTION:**

When removing and installing, use shop cloths to protect parts from damage.

### Installation

Note the following items, and install in the reverse order of removal.

**CAUTION:**

- When removing and installing, use shop cloths to protect parts from damage.
- Install seat cushion to the vehicle, and then install seatback.
- Temporarily tighten bolts, fold up seatback, check that lock and striker do not interfere, and then tighten bolts.
- When installing seatback, tighten mounting bolts according to the numerical order (1, 2, 3, and 4 as shown in the figure).

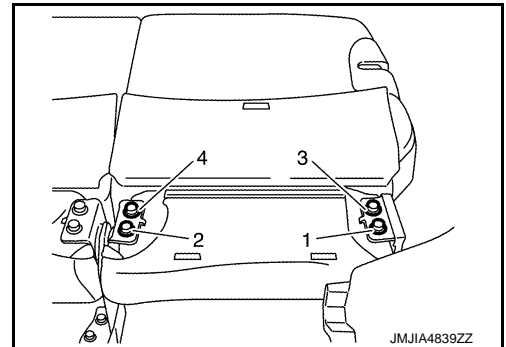

## SEATBACK : Disassembly and Assembly

INFOID:000000007578174

### DISASSEMBLY

#### LH side seatback

1. Remove headrest holder.
  1. Pull seat lock cover in direction indicated by the arrow as shown in the figure. Remove seat lock cover.

 : Metal clip

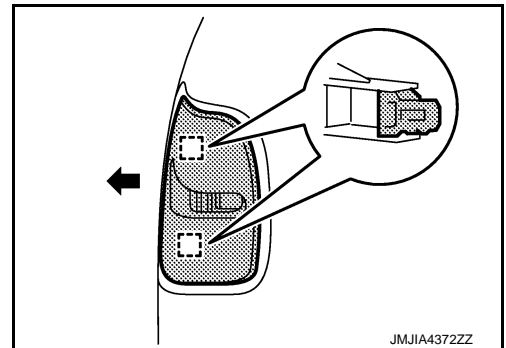

# REAR SEAT

## < REMOVAL AND INSTALLATION >

2. Pull tether cover in direction indicated by the arrow as shown in the figure. Remove tether cover.

 : Pawl

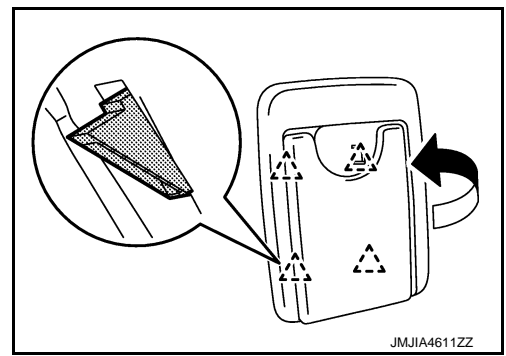

3. Open seatback fastener (A) and remove seatback retainer (B).

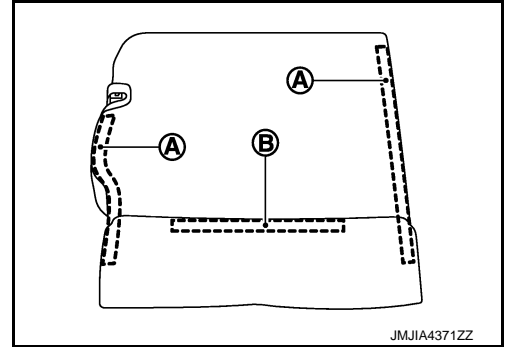

4. Use pincers, etc., to press up pawls as shown by the arrows in the figure, and remove headrest holder from seatback.

**CAUTION:**

**Before installing headrest holder check its orientation. (front/rear and right/left)**

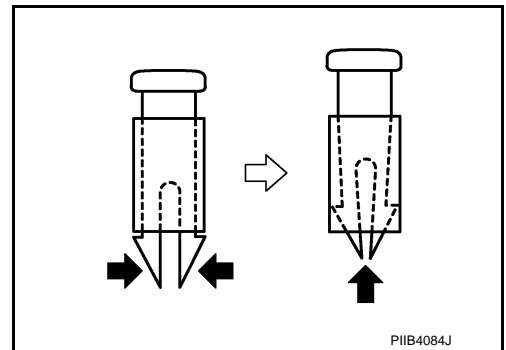

2. Remove seatback lock knob finisher.
  1. Rotate seatback lock knob counterclockwise. Remove seatback lock knob.

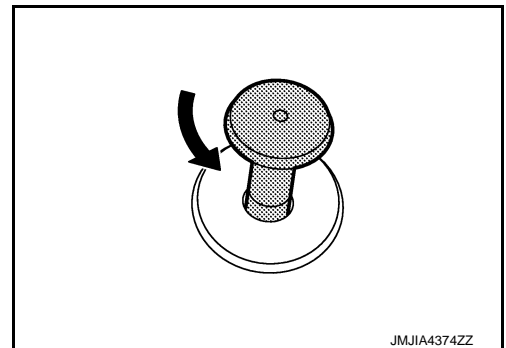

A  
B  
C  
D  
E  
F  
G  
H  
I  
SE  
K  
L  
M  
N  
O  
P

## REAR SEAT

### < REMOVAL AND INSTALLATION >

2. Push up seatback lock knob finisher while pressing pawls indicated by arrows as shown in the figure. Remove seatback lock finisher from seatback.

**CAUTION:**

**When installing seatback lock knob finisher, check front and rear orientation and be careful to install it normally.**

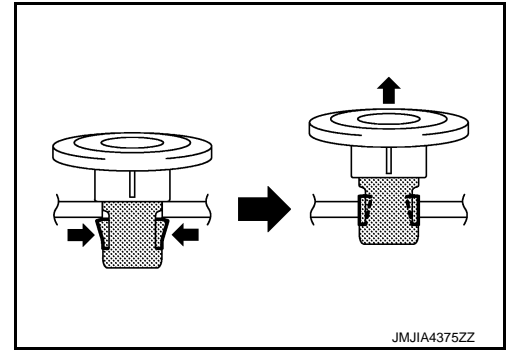

3. Remove center seat belt finisher from seatback.  
Lift up front of center seat belt finisher. Disengage front pawls. Pull center seat belt finisher toward seat front. Disengage rear pawls.

 : Pawl

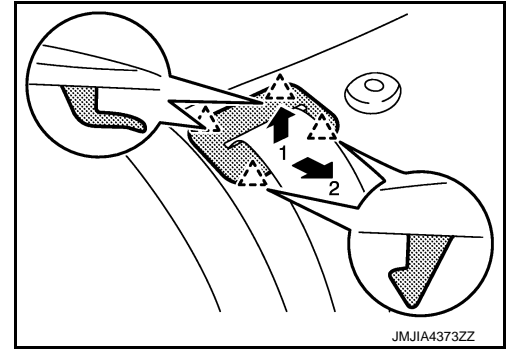

4. Remove seatback trim and seatback pad from seatback frame
5. Remove hog rings, and separate the seatback trim and seatback pad.  
**CAUTION:**  
**Before performing separating operation, check the installation position of hog rings.**
6. Remove seatback silencer from seatback frame.
7. Remove seatback lock assembly mounting bolts, and then remove seatback lock assembly from seatback frame.
8. Remove center seat belt retractor from seatback frame.  
Refer to [SB-12. "SEAT BELT RETRACTOR : Removal and Installation"](#).

RH side seatback

1. Remove headrest holder.
  1. Pull seat lock cover in direction indicated by the arrow as shown in the figure. Remove seat lock cover.

 : Metal clip

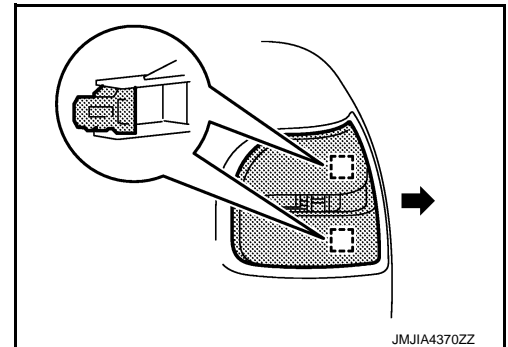

# REAR SEAT

## < REMOVAL AND INSTALLATION >

2. Pull tether cover in direction indicated by the arrow as shown in the figure. Remove tether cover.

 : Pawl

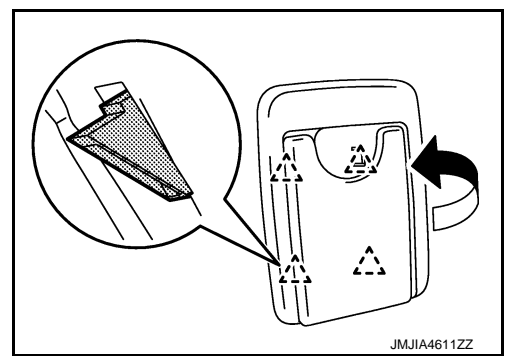

3. Open seatback fastener (A) and remove seatback retainer (B).

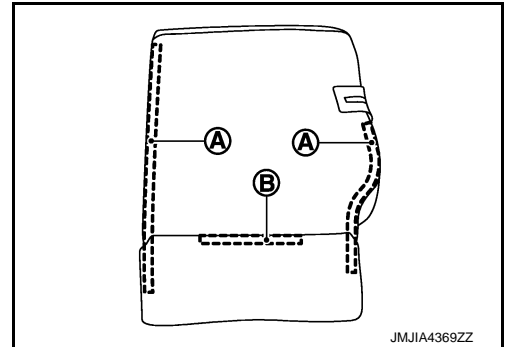

4. Use pincers, etc., to press up pawls as shown by the arrows in the figure, and remove headrest holder from seatback.

**CAUTION:**

**Before installing headrest holder check its orientation. (front/rear and right/left)**

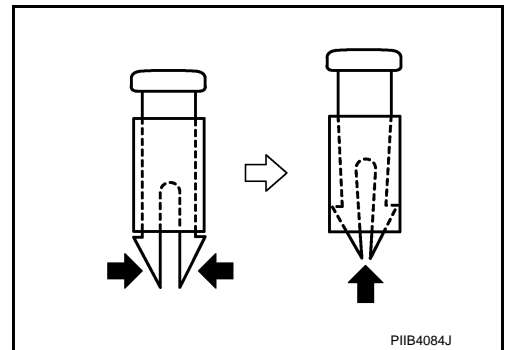

2. Remove seatback lock knob finisher.
  1. Rotate seatback lock knob counterclockwise. Remove seatback lock knob.

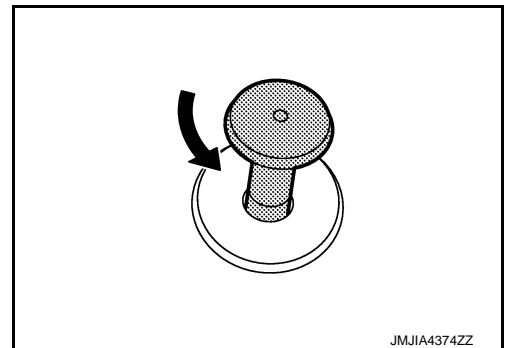

A  
B  
C  
D  
E  
F  
G  
H  
I  
SE  
K  
L  
M  
N  
O  
P

## REAR SEAT

### < REMOVAL AND INSTALLATION >

2. Push up seatback lock knob finisher while pressing pawls indicated by arrows as shown in the figure. Remove seatback lock finisher from seatback.

**CAUTION:**

**When installing seatback lock knob finisher, check front and rear orientation and be careful to install it normally.**

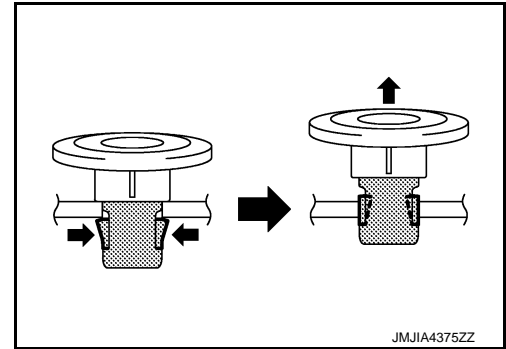

3. Remove seatback trim and seatback pad from seatback frame.
4. Remove hog rings, and separate the seatback trim and seatback pad.  
**CAUTION:**  
**Before performing separating operation, check the installation position of hog rings.**
5. Remove seatback silencer from seatback frame.
6. Remove seatback lock assembly mounting bolts, and then remove seatback lock assembly from seatback frame.

### INSTALLATION

Note the following, and assemble in the reverse order of disassembly.

**CAUTION:**

**Always install the hog ring in position.**

### SEATBACK HINGE

#### SEATBACK HINGE : Removal and Installation

INFOID:000000007578175

### CENTER HINGE

#### Removal

1. Remove seatback LH and RH from the vehicle.  
Refer to [SE-27, "SEATBACK : Removal and Installation"](#).
2. Remove seat cushion from the vehicle.  
Refer to [SE-26, "SEAT CUSHION : Removal and Installation"](#).
3. Remove center hinge mounting bolts, and then remove center hinge from the vehicle.

#### Installation

Note the following items, and install in the reverse order of removal.

**CAUTION:**

**When installing center hinge, tighten mounting bolts to the specified torque according to the numerical order as shown in the figure**



## REAR SEAT

### < REMOVAL AND INSTALLATION >

1. Temporarily tighten mounting bolt (1).
2. Tighten mounting bolts in numerical order (2 and 3 as shown in the figure) to the specified torque.  
For the specified torque, refer to [SE-23. "Exploded View"](#).

← : Vehicle front

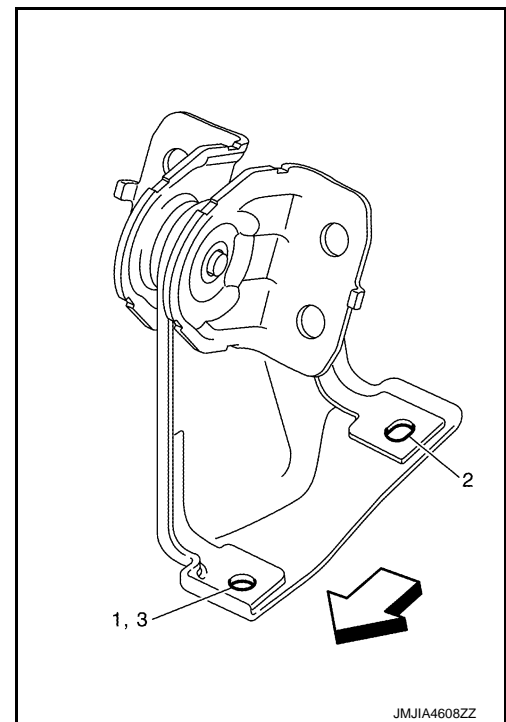

### SIDE HINGE

#### Removal

1. Remove seatback from the vehicle.  
Refer to [SE-27. "SEATBACK : Removal and Installation"](#).
2. Remove side hinge mounting bolt, and then remove side hinge from luggage side lower finisher.

#### Installation

Installation is the reverse order of removal. Tighten bolts to the specified torque.  
For the specified torque, refer to [SE-23. "Exploded View"](#).

### SEATBACK STRIKER

#### SEATBACK STRIKER : Removal and Installation

INFOID:000000007578176

#### REMOVAL

1. Remove seatback LH and RH from the vehicle.  
Refer to [SE-27. "SEATBACK : Removal and Installation"](#).
2. Remove seat cushion from the vehicle.  
Refer to [SE-26. "SEAT CUSHION : Removal and Installation"](#).
3. Remove side hinge from the vehicle.  
Refer to [SE-32. "SEATBACK HINGE : Removal and Installation"](#).
4. Remove luggage side lower finisher from the vehicle.  
Refer to [INT-34. "LUGGAGE SIDE LOWER FINISHER : Removal and Installation"](#).
5. Remove outer anchor mounting anchor bolt, and then remove outer anchor.
6. Remove mounting bolts or nuts of striker, and then remove striker from the vehicle.

#### INSTALLATION

Note the following items, and install in the reverse order of removal.

#### **CAUTION:**

**When installing striker, tighten mounting bolts or nuts to the specified torque according to the numerical order as shown in the figure.**

## REAR SEAT

### < REMOVAL AND INSTALLATION >

1. Temporarily tighten mounting bolts in numerical order (1 and 2 as shown in the figure).
2. Tighten mounting bolts or nuts to the specified torque in numerical order (3, 4, and 5 as shown in the figure).  
For the specified torque, refer to [SE-23, "Exploded View"](#).

← : Vehicle front

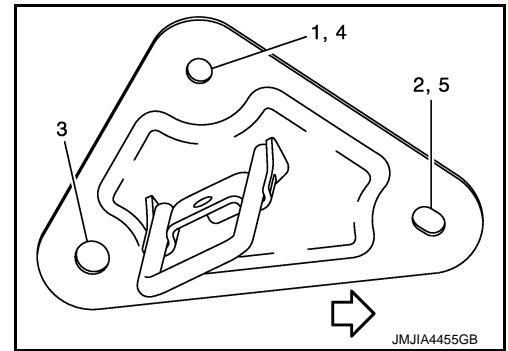

# HEATED SEAT SWITCH

< REMOVAL AND INSTALLATION >

## HEATED SEAT SWITCH

### Exploded View

INFOID:000000007578177

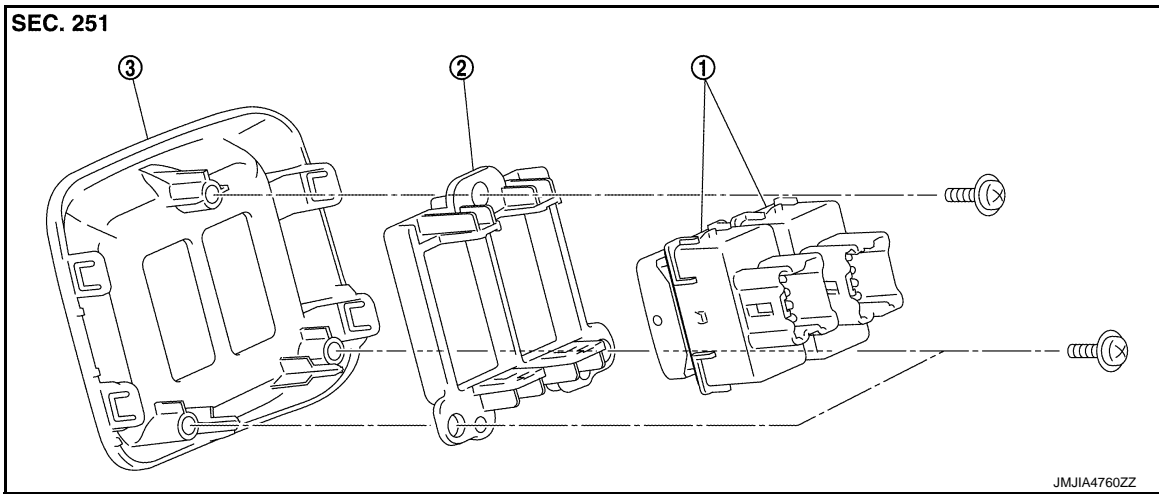

1. Heated seat switch
2. Switch bracket
3. Console switch finisher

### Removal and Installation

INFOID:000000007578178

#### REMOVAL

##### **CAUTION:**

**When removing and installing, use shop cloths to protect from damage.**

1. Remove the console switch finisher. Refer to [IP-22, "Removal and Installation"](#).
2. Remove mounting screws and remove switch bracket (1) from console switch finisher.
3. Remove heated seat switch RH (2) and heated seat switch LH (3) from switch bracket (1) using remover tool (A).



: Pawl

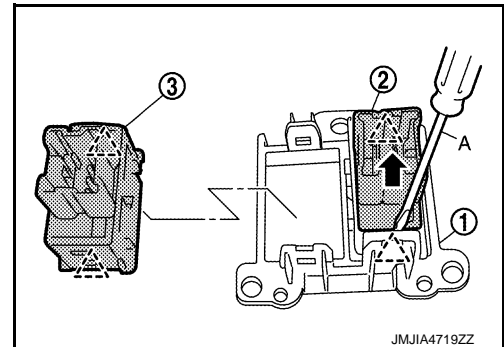

#### INSTALLATION

Install in the reverse order of removal.

A  
B  
C  
D  
E  
F  
G  
H  
I  
SE  
K  
L  
M  
N  
O  
P