

A
B
C

WW

SECTION

WIPER & WASHER

CONTENTS

<p>PRECAUTION 3</p> <p>PRECAUTIONS 3</p> <p style="padding-left: 20px;">Precaution for Supplemental Restraint System (SRS) "AIR BAG" and "SEAT BELT PRE-TENSIONER"3</p> <p style="padding-left: 20px;">Precaution for Procedure without Cowl Top Cover.....3</p> <p>SYSTEM DESCRIPTION 4</p> <p>COMPONENT PARTS 4</p> <p style="padding-left: 20px;">Component Parts Location4</p> <p style="padding-left: 20px;">Component Description4</p> <p style="padding-left: 20px;">Washer Switch5</p> <p>SYSTEM 6</p> <p>FRONT WIPER AND WASHER SYSTEM6</p> <p style="padding-left: 20px;">FRONT WIPER AND WASHER SYSTEM : System Diagram6</p> <p style="padding-left: 20px;">FRONT WIPER AND WASHER SYSTEM : System Description6</p> <p style="padding-left: 20px;">FRONT WIPER AND WASHER SYSTEM : System Description7</p> <p style="padding-left: 20px;">FRONT WIPER AND WASHER SYSTEM : Fail-Safe8</p> <p>REAR WIPER AND WASHER SYSTEM9</p> <p style="padding-left: 20px;">REAR WIPER AND WASHER SYSTEM : System Diagram9</p> <p style="padding-left: 20px;">REAR WIPER AND WASHER SYSTEM : System Description9</p> <p style="padding-left: 20px;">REAR WIPER AND WASHER SYSTEM : Fail-safe 10</p> <p>DIAGNOSIS SYSTEM (BCM) (WITH INTELLIGENT KEY SYSTEM)12</p> <p>COMMON ITEM12</p> <p style="padding-left: 20px;">COMMON ITEM : CONSULT Function (BCM - COMMON ITEM) 12</p> <p>WIPER13</p>	<p style="text-align: right;">D E F G H I J K L M N O P</p> <p style="padding-left: 20px;">WIPER : CONSULT Function - WIPER13</p> <p>DIAGNOSIS SYSTEM (BCM) (WITHOUT INTELLIGENT KEY SYSTEM)15</p> <p>COMMON ITEM15</p> <p style="padding-left: 20px;">COMMON ITEM : CONSULT Function (BCM - COMMON ITEM)15</p> <p>WIPER15</p> <p style="padding-left: 20px;">WIPER : CONSULT Function (BCM - WIPER)15</p> <p>DIAGNOSIS SYSTEM (IPDM E/R)17</p> <p>WITH INTELLIGENT KEY17</p> <p style="padding-left: 20px;">WITH INTELLIGENT KEY : Diagnosis Description17</p> <p style="padding-left: 20px;">WITH INTELLIGENT KEY : CONSULT Function (IPDM E/R)19</p> <p>WITHOUT INTELLIGENT KEY21</p> <p style="padding-left: 20px;">WITHOUT INTELLIGENT KEY : Diagnosis Description21</p> <p style="padding-left: 20px;">WITHOUT INTELLIGENT KEY : CONSULT Function (IPDM E/R)23</p> <p>ECU DIAGNOSIS INFORMATION25</p> <p>BCM, IPDM E/R25</p> <p style="padding-left: 20px;">List of ECU Reference25</p> <p>BASIC INSPECTION26</p> <p>DIAGNOSIS AND REPAIR WORK FLOW26</p> <p style="padding-left: 20px;">Work Flow26</p> <p>DTC/CIRCUIT DIAGNOSIS29</p> <p>WIPER AND WASHER FUSE29</p> <p style="padding-left: 20px;">Diagnosis Procedure29</p> <p>FRONT WIPER MOTOR LO CIRCUIT30</p> <p style="padding-left: 20px;">Component Function Check30</p> <p style="padding-left: 20px;">Diagnosis Procedure30</p>
--	---



FRONT WIPER MOTOR HI CIRCUIT	31	WASHER PUMP	49
Component Function Check	31	Exploded View	49
Diagnosis Procedure	31	Removal and Installation	49
FRONT WIPER STOP POSITION SIGNAL CIRCUIT	32	WASHER LEVEL SWITCH	50
Component Function Check	32	Removal and Installation	50
Diagnosis Procedure	32	FRONT WASHER NOZZLE AND TUBE	51
FRONT WIPER MOTOR GROUND CIRCUIT ...	33	Exploded View	51
Diagnosis Procedure	33	Hydraulic Layout	51
WASHER SWITCH	34	Removal and Installation	51
Component Inspection	34	Inspection and Adjustment	52
REAR WIPER MOTOR CIRCUIT	35	FRONT WIPER ARM	54
Component Function Check	35	Exploded View	54
Diagnosis Procedure	35	Removal and Installation	54
REAR WIPER STOP POSITION SIGNAL CIRCUIT	37	Adjustment	55
Component Function Check	37	FRONT WIPER BLADE	56
Diagnosis Procedure	37	Exploded View	56
WIPER AND WASHER SYSTEM	39	Removal and Installation	56
Wiring Diagram - WIPER AND WASHER SYSTEM -	39	Replacement	56
TEM -	39	FRONT WIPER DRIVE ASSEMBLY	58
SYMPTOM DIAGNOSIS	40	Exploded View	58
WIPER AND WASHER SYSTEM SYMPTOMS	40	Removal and Installation	59
Symptom Table	40	Disassembly and Assembly	59
NORMAL OPERATING CONDITION	44	WIPER AND WASHER SWITCH	60
Description	44	Exploded View	60
FRONT WIPER DOES NOT OPERATE	45	REAR WIPER ARM	61
Description	45	Exploded View	61
Diagnosis Procedure	45	Removal and Installation	61
REMOVAL AND INSTALLATION	47	Adjustment	61
WASHER TANK	47	REAR WIPER MOTOR	63
Exploded View	47	Exploded View	63
Removal and Installation	47	Removal and Installation	63
		REAR WASHER NOZZLE AND TUBE	64
		Hydraulic Layout	64
		Removal and Installation	64
		Inspection and Adjustment	65

PRECAUTIONS

< PRECAUTION >

PRECAUTION

PRECAUTIONS

Precaution for Supplemental Restraint System (SRS) "AIR BAG" and "SEAT BELT PRE-TENSIONER"

INFOID:000000007579540

The Supplemental Restraint System such as "AIR BAG" and "SEAT BELT PRE-TENSIONER", used along with a front seat belt, helps to reduce the risk or severity of injury to the driver and front passenger for certain types of collision. This system includes seat belt switch inputs and dual stage front air bag modules. The SRS system uses the seat belt switches to determine the front air bag deployment, and may only deploy one front air bag, depending on the severity of a collision and whether the front occupants are belted or unbelted. Information necessary to service the system safely is included in the "SRS AIR BAG" and "SEAT BELT" of this Service Manual.

WARNING:

Always observe the following items for preventing accidental activation.

- To avoid rendering the SRS inoperative, which could increase the risk of personal injury or death in the event of a collision that would result in air bag inflation, all maintenance must be performed by an authorized NISSAN/INFINITI dealer.
- Improper maintenance, including incorrect removal and installation of the SRS, can lead to personal injury caused by unintentional activation of the system. For removal of Spiral Cable and Air Bag Module, see "SRS AIR BAG".
- Never use electrical test equipment on any circuit related to the SRS unless instructed to in this Service Manual. SRS wiring harnesses can be identified by yellow and/or orange harnesses or harness connectors.

PRECAUTIONS WHEN USING POWER TOOLS (AIR OR ELECTRIC) AND HAMMERS

WARNING:

Always observe the following items for preventing accidental activation.

- When working near the Air Bag Diagnosis Sensor Unit or other Air Bag System sensors with the ignition ON or engine running, never use air or electric power tools or strike near the sensor(s) with a hammer. Heavy vibration could activate the sensor(s) and deploy the air bag(s), possibly causing serious injury.
- When using air or electric power tools or hammers, always switch the ignition OFF, disconnect the battery, and wait at least 3 minutes before performing any service.

Precaution for Procedure without Cowl Top Cover

INFOID:000000007579541

When performing the procedure after removing cowl top cover, cover the lower end of windshield with urethane, etc to prevent damage to windshield.

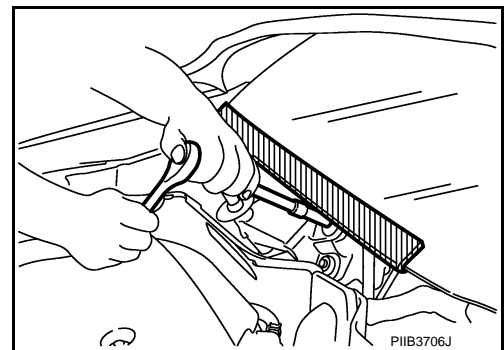

COMPONENT PARTS

< SYSTEM DESCRIPTION >

SYSTEM DESCRIPTION

COMPONENT PARTS

Component Parts Location

INFOID:000000007579542

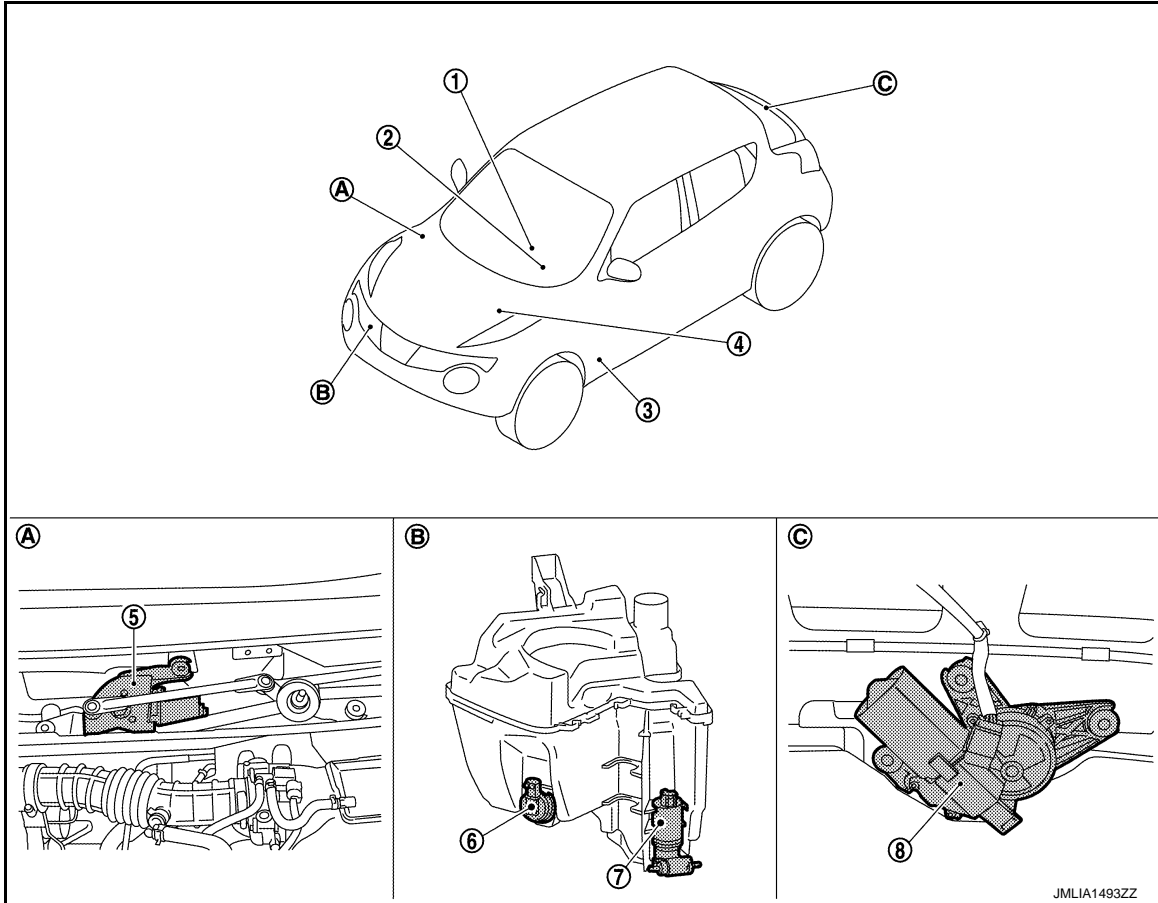

- | | | |
|---|---------------------------------------|--|
| 1. Combination switch | 2. Combination meter | 3. BCM
Refer to BCS-6. "BODY CONTROL SYSTEM : Component Parts Location" |
| 4. IPDM E/R
Refer to PCS-5. "Component Parts Location" | 5. Front wiper motor | 6. Washer level switch* |
| 7. Washer pump | 8. Rear wiper motor | |
| A. Cowl top, right side of engine room | B. Behind front fender protector (RH) | C. Back door lower finisher inside |

*: For Canada

Component Description

INFOID:000000007579543

Part	Description
IPDM E/R	<ul style="list-style-type: none"> Controls the integrated relay according to the request (via CAN communication) from BCM. Performs the auto stop control of the front wiper.
BCM	<ul style="list-style-type: none"> Judges the each switch status by the combination switch reading function. Requests (via CAN communication) the front wiper relay and the front wiper high relay ON to IPDM E/R. Supplies power to the wiper motor. Performs the auto stop control of the rear wiper.

COMPONENT PARTS

< SYSTEM DESCRIPTION >

Part	Description
Combination switch (Wiper & washer switch)	Refer to BCS-9, "COMBINATION SWITCH READING SYSTEM : System Description" .
Washer switch	Refer to WW-5, "Washer Switch" .
Washer pump	<ul style="list-style-type: none"> Washer fluid is sprayed according to washer switch states. Switching between front washer and rear washer is performed according to the voltage polarity change to washer pump.
Washer level switch*	Refer to MWI-6, "METER SYSTEM : Component Description" .
Front wiper motor	<ul style="list-style-type: none"> IPDM E/R controls front wiper operation. Front wiper stop position signal is transmitted to IPDM E/R.
Rear wiper motor	<ul style="list-style-type: none"> BCM controls rear wiper operation. Rear wiper stop position signal is transmitted to BCM.
Combination meter	Transmits the vehicle speed signal to BCM via CAN communication.

*: For Canada

Washer Switch

INFOID:000000007579544

- Washer switch is integrated with combination switch.
- Combination switch operates front washer or rear washer by changing voltage polarity to be supplied to washer pump.

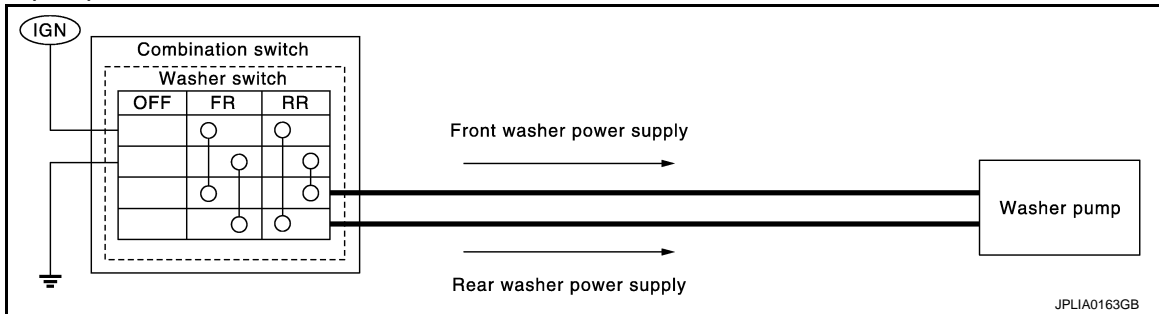

A
B
C
D
E
F
G
H
I
J
K
L
M
N
O
P

WW

SYSTEM

< SYSTEM DESCRIPTION >

SYSTEM

FRONT WIPER AND WASHER SYSTEM

FRONT WIPER AND WASHER SYSTEM : System Diagram

INFOID:000000007579545

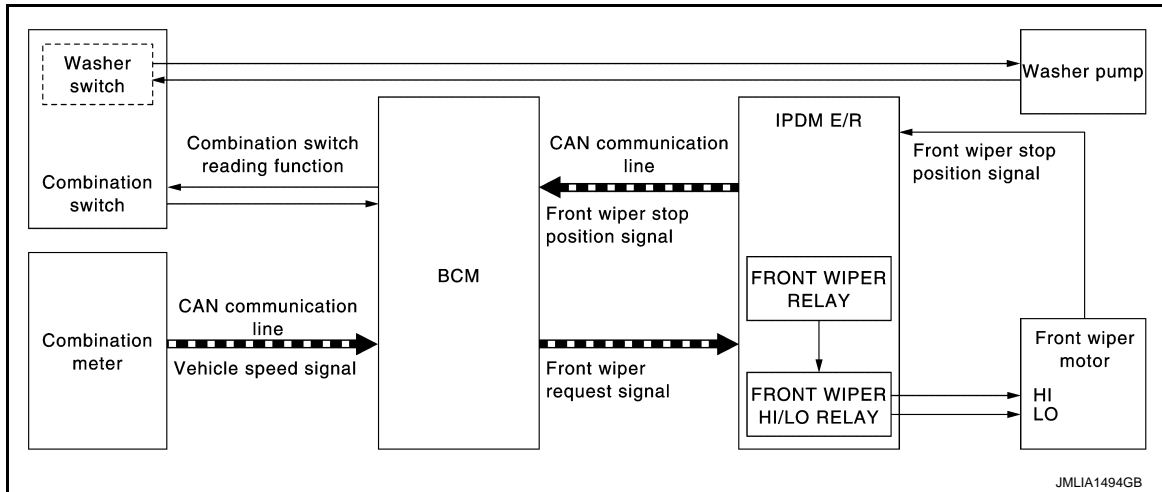

FRONT WIPER AND WASHER SYSTEM : System Description

INFOID:000000007579546

OUTLINE

The front wiper is controlled by each function of BCM and IPDM E/R.

Control by BCM

- Combination switch reading function
- Front wiper control function

Control by IPDM E/R

- Front wiper control function
- Relay control function

FRONT WIPER BASIC OPERATION

- BCM detects the combination switch condition by the combination switch reading function.
- BCM transmits the front wiper request signal to IPDM E/R via CAN communication depending on each operating condition of the front wiper.
- IPDM E/R turns ON/OFF the integrated front wiper relay and the front wiper high relay according to the front wiper request signal. IPDM E/R provides the power supply to operate the front wiper HI/LO operation.
- Washer level sensor switch signal is transmitted to combination meter via BCM, when window washer fluid level is less than washer level sensor.

FRONT WIPER LO OPERATION

- BCM transmits the front wiper request signal (LO) to IPDM E/R via CAN communication according to the front wiper LO operating condition.

Front wiper LO operating condition

- Ignition switch ON
- Front wiper switch LO or front wiper switch MIST (while pressing)
- IPDM E/R turns ON the integrated front wiper relay according to the front wiper request signal (LO).

FRONT WIPER HI OPERATION

- BCM transmits the front wiper request signal (HI) to IPDM E/R via CAN communication according to the front wiper HI operating condition.

Front wiper HI operating condition

- Ignition switch ON
- Front wiper switch HI
- IPDM E/R turns ON the integrated front wiper relay and the front wiper high relay according to the front wiper request signal (HI).

SYSTEM

< SYSTEM DESCRIPTION >

FRONT WIPER AND WASHER SYSTEM : System Description

INFOID:000000007579547

FRONT WIPER INT OPERATION

- BCM transmits the front wiper request signal (INT) to IPDM E/R via CAN communication depending on the front wiper INT operating condition and intermittent operation delay interval according to the wiper intermittent dial position.

Front wiper INT operating condition

- Ignition switch ON
- Front wiper switch INT
- IPDM E/R turns ON the integrated front wiper relay so that the front wiper is operated only once according to the front wiper request signal (INT).
- BCM detects stop position/except stop position of the front wiper motor according to the front wiper stop position signal received from IPDM E/R via CAN communication.
- BCM transmits the front wiper request signal (INT) again after the intermittent operation delay interval.

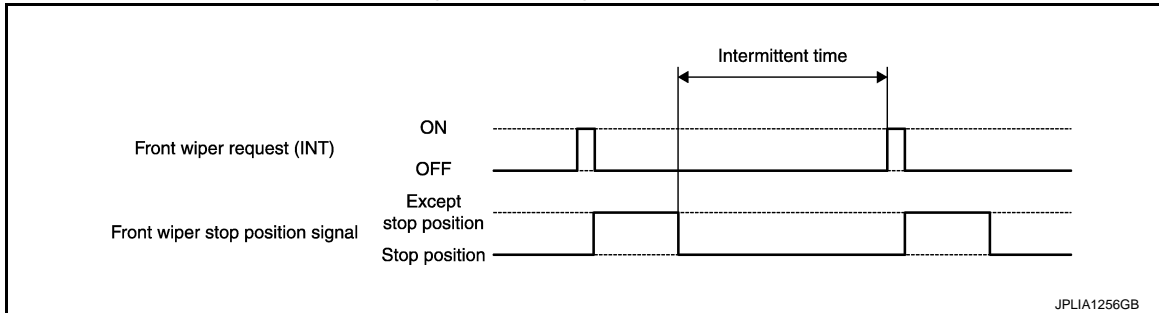

NOTE:

Factory setting of the front wiper intermittent operation is operation not linked with vehicle speed. Front wiper intermittent operation can be set to operation linked or not linked with vehicle speed using CONSULT. Refer to [WW-13. "WIPER : CONSULT Function - WIPER"](#).

Front wiper intermittent operation with vehicle speed

- BCM calculates the intermittent operation delay interval from the following
 - Vehicle speed signal
 - Wiper intermittent dial position

Unit: Second

Wiper intermittent dial position	Intermittent operation interval	Intermittent operation delay Interval		
		Vehicle speed		
		0 – 5 km/h (0 – 3.1 MPH)	5 – 65 km/h (3.1 – 40.4 MPH)*	65 km/h (40.4 MPH) or more
1	Short ↑	1	0.4	0.24
2		2.5	1	0.6
3		5	2	1.2
4		7.5	3	1.8
5		12.5	5	3
6	Long ↓	25	10	6
7		40	16	9.6

*: When operation setting is not linked with vehicle speed.

FRONT WIPER AUTO STOP OPERATION

- BCM stops transmitting the front wiper request signal when the front wiper switch is turned OFF.
- IPDM E/R detects the front wiper stop position signal from the front wiper motor and detects the front wiper motor position (stop position/except stop position).

SYSTEM

< SYSTEM DESCRIPTION >

- When the front wiper request signal is stopped, IPDM E/R turns ON the front wiper relay until the front wiper motor returns to the stop position.

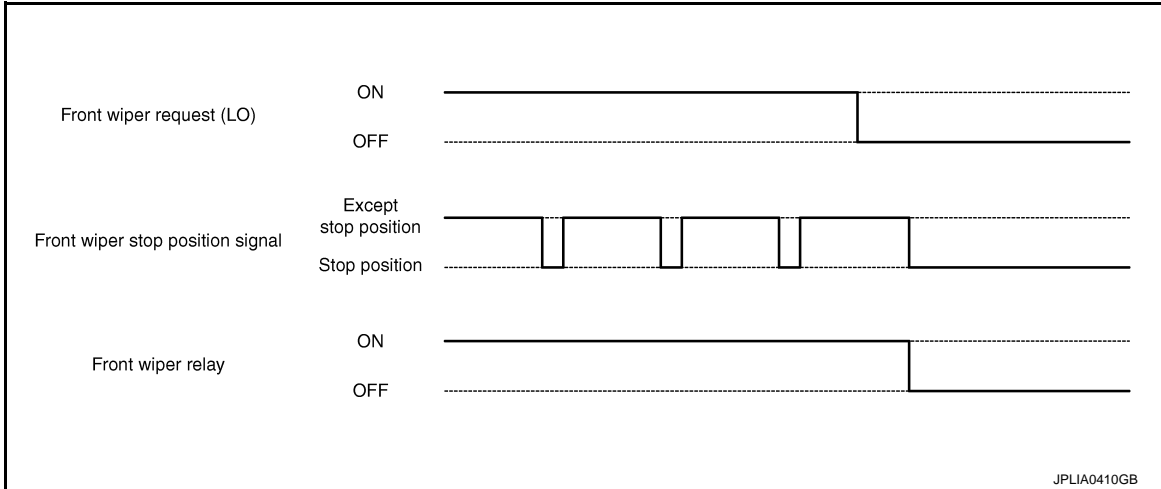

NOTE:

- BCM stops the transmitting of the front wiper request signal when the ignition switch is OFF.
- IPDM E/R turns the front wiper relay OFF when the ignition switch is OFF.

FRONT WIPER OPERATION LINKED WITH WASHER

- BCM transmits the front wiper request signal (LO) to IPDM E/R via CAN communication according to the washer linked operating condition of the front wiper.
- BCM transmits the front wiper request signal (LO) so that the front wiper operates approximately 2 times when the front washer switch OFF is detected.

Washer linked operating condition of front wiper

- Turn ignition switch ON
- Front washer switch ON (0.4 second or more)
- IPDM E/R turns ON the integrated front wiper relay according to the front wiper request signal (LO).
- The washer pump is grounded through the combination switch with the front washer switch ON.

FRONT WIPER SERVICE POSITION OPERATION

- Front wiper operates in LO, stops, and then stays in lock back position when front washer switch is turned ON while ignition switch is OFF.
- BCM transmits front wiper service position signal via CAN communication according to the front wiper service position function operating conditions.

Operation conditions of front wiper service position function

- Turn ignition switch OFF (within 1 minutes)
- Front wiper switch ON (0.4 second or more)
- Front wiper operates at LO and then stops when IPDM E/R detects front wiper service position signal.
- Front wiper service position function is cancelled when front wiper washer switch is turned ON within 1 minute after turning ignition switch OFF. Front wiper service position function when front wiper switch (INT, LO, HI, MIST or WASHER) is turned ON within 1 minute or more after turning ignition switch OFF.

NOTE:

Front wiper does not operate even if front wiper switch (INT, LO, or HI) is ON when ignition switch is turned ON while front wiper is stopped according to front wiper service position function.

FRONT WIPER AND WASHER SYSTEM : Fail-Safe

INFOID:000000007579548

When CAN communication with ECM and BCM is impossible, IPDM E/R performs fail-safe control. After CAN communication recovers normally, it also returns to normal control.

If No CAN Communication Is Available With BCM

SYSTEM

< SYSTEM DESCRIPTION >

Control part	Fail-safe operation
Front wiper motor	<ul style="list-style-type: none"> The status just before activation of fail-safe control is maintained until the ignition switch is turned OFF while the front wiper is operating at LO or HI speed. The wiper is operated at LO speed until the ignition switch is turned OFF if the fail-safe control is activated while the front wiper is set in the INT mode and the front wiper motor is operating. Returns automatically wiper to stop position when ignition switch is turned ON if fail-safe control is activated while front wiper motor is operated and wiper stop in the other position than stop position. The status is held at service position if the fail-safe control is activated while the service position function is operating.

IPDM E/R detects front wiper stop position by a front wiper stop position signal.
When a front wiper stop position signal is in the conditions listed below, IPDM E/R stops power supply to wiper after repeating a front wiper 10 seconds activation and 20 seconds stop.

Ignition switch	Front wiper switch	Front wiper stop position signal
ON	OFF	The front wiper stop position signal (stop position) cannot be input for 10 seconds.
	ON	The front wiper stop position signal does not change for 10 seconds.

NOTE:

This operation status can be confirmed on the IPDM E/R “Data Monitor” that displays “BLOCK” for the item “WIP PROT” while the wiper is stopped.

REAR WIPER AND WASHER SYSTEM

REAR WIPER AND WASHER SYSTEM : System Diagram

INFOID:000000007579549

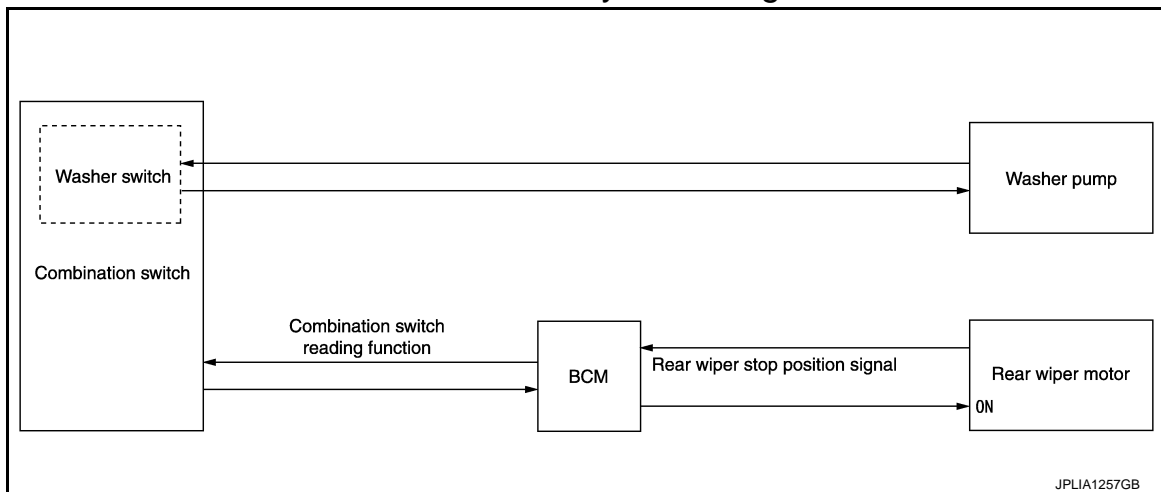

REAR WIPER AND WASHER SYSTEM : System Description

INFOID:000000007579550

OUTLINE

The rear wiper is controlled by each function of BCM.

Control by BCM

- Combination switch reading function
- Rear wiper control function

REAR WIPER BASIC OPERATION

- BCM detects the combination switch condition by the combination switch reading function.
- BCM controls the rear wiper to start or stop.

REAR WIPER ON OPERATION

- BCM supplies power to the rear wiper motor according to the rear wiper ON operating condition.

Rear wiper ON operating condition

- Ignition switch ON
- Rear wiper switch ON

SYSTEM

< SYSTEM DESCRIPTION >

REAR WIPER INT OPERATION

- BCM supplies power to the rear wiper motor according to the INT operating condition.

Rear wiper INT operating condition

- Ignition switch ON
- Rear wiper switch INT
- BCM controls the rear wiper to operate once.
- BCM detects the rear wiper motor stopping position.
- BCM supplies power to the rear wiper motor after an intermittent from the stop of the rear wiper motor.

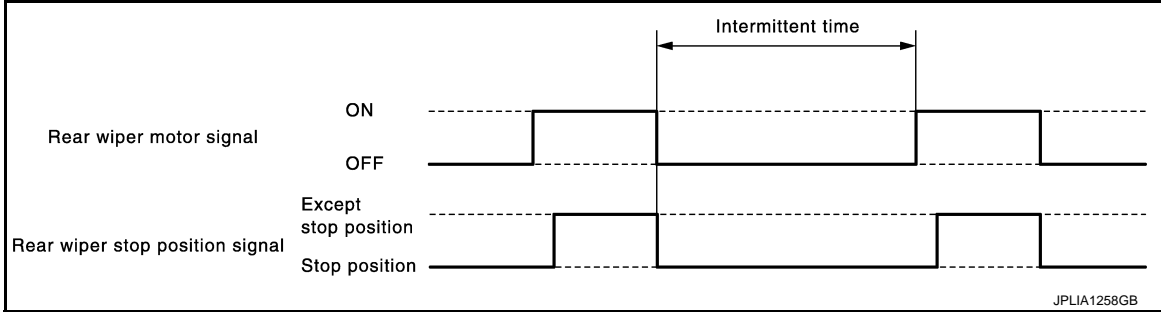

REAR WIPER AUTO STOP OPERATION

- BCM stops supplying power to the rear wiper motor when the rear wiper switch is turned OFF.
- BCM reads a rear wiper stop position signal from the rear wiper motor to detect a rear wiper motor position.
- When the rear wiper motor is at other than the stopping position, BCM continues to supply power to the rear wiper motor until it returns to the stopping position.

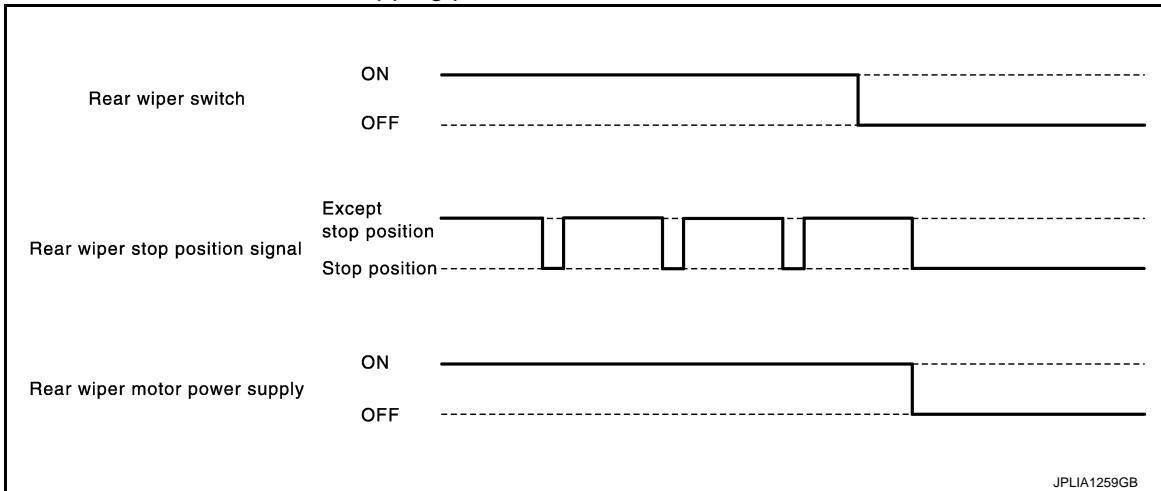

NOTE:

BCM stops supplying power to the rear wiper motor when the ignition switch is turned OFF.

REAR WIPER OPERATION LINKED WITH WASHER

- BCM supplies power to the rear wiper motor according to the washer linked operating condition of rear wiper. When the rear washer switch is turned OFF, BCM controls rear wiper to operate approximately 3 times.

Washer linked operating condition of rear wiper

- Ignition switch ON
- Rear washer switch ON (0.4 second or more)
- The washer pump is grounded through the combination switch with the rear washer switch ON.

REAR WIPER AND WASHER SYSTEM : Fail-safe

INFOID:000000007579551

REAR WIPER MOTOR PROTECTION

BCM detects the rear wiper stopping position according to the rear wiper stop position signal.

When the rear wiper stop position signal does not change for more than 5 seconds while driving the rear wiper, BCM stops power supply to protect the rear wiper motor.

Condition of cancellation

SYSTEM

< SYSTEM DESCRIPTION >

1. More than 1 minute is passed after the rear wiper stop.
2. Turn rear wiper switch OFF.
3. Operate the rear wiper switch or rear washer switch.

A

B

C

D

E

F

G

H

I

J

K

WW

M

N

O

P

DIAGNOSIS SYSTEM (BCM) (WITH INTELLIGENT KEY SYSTEM)

< SYSTEM DESCRIPTION >

DIAGNOSIS SYSTEM (BCM) (WITH INTELLIGENT KEY SYSTEM) COMMON ITEM

COMMON ITEM : CONSULT Function (BCM - COMMON ITEM)

INFOID:000000007812826

APPLICATION ITEM

CONSULT performs the following functions via CAN communication with BCM.

Diagnosis mode	Function Description
Work Support	Changes the setting for each system function.
Self Diagnostic Result	Displays the diagnosis results judged by BCM.
CAN Diag Support Monitor	Monitors the reception status of CAN communication viewed from BCM.
Data Monitor	The BCM input/output signals are displayed.
Active Test	The signals used to activate each device are forcibly supplied from BCM.
Ecu Identification	The BCM part number is displayed.
Configuration	<ul style="list-style-type: none"> Read and save the vehicle specification. Write the vehicle specification when replacing BCM.

SYSTEM APPLICATION

BCM can perform the following functions for each system.

NOTE:

It can perform the diagnosis modes except the following for all sub system selection items.

×: Applicable item

System	Sub system selection item	Diagnosis mode		
		Work Support	Data Monitor	Active Test
Door lock	DOOR LOCK	×	×	×
Rear window defogger	REAR DEFOGGER		×	×
Warning chime	BUZZER		×	×
Interior room lamp timer	INT LAMP	×	×	×
Exterior lamp	HEAD LAMP	×	×	×
Wiper and washer	WIPER	×	×	×
Turn signal and hazard warning lamps	FLASHER	×	×	×
Air conditioning system	AIR CONDITONER		×	×*
<ul style="list-style-type: none"> Intelligent Key system Engine start system 	INTELLIGENT KEY	×	×	×
Combination switch	COMB SW		×	
Body control system	BCM	×		
NVIS - NATS	IMMU	×	×	×
Interior room lamp battery saver	BATTERY SAVER	×	×	×
Back door open	TRUNK		×	
Theft warning alarm	THEFT ALM	×	×	×
RAP	RETAINED PWR		×	
Signal buffer system	SIGNAL BUFFER		×	×
TPMS	AIR PRESSURE MONITOR	×	×	×

NOTE:

*: For models with automatic A/C, this diagnosis mode is not used.

FREEZE FRAME DATA (FFD)

The BCM records the following vehicle condition at the time a particular DTC is detected, and displays on CONSULT.

DIAGNOSIS SYSTEM (BCM) (WITH INTELLIGENT KEY SYSTEM)

< SYSTEM DESCRIPTION >

CONSULT screen item	Indication/Unit	Description	
Vehicle Speed	km/h	Vehicle speed of the moment a particular DTC is detected	
Odo/Trip Meter	km	Total mileage (Odometer value) of the moment a particular DTC is detected	
Vehicle Condition	SLEEP>LOCK	Power position status of the moment a particular DTC is detected	While turning BCM status from low power consumption mode to normal mode (Power position is "LOCK".)
	SLEEP>OFF		While turning BCM status from low power consumption mode to normal mode (Power position is "OFF".)
	LOCK>ACC		While turning power position from "LOCK"* to "ACC"
	ACC>ON		While turning power position from "ACC" to "IGN"
	RUN>ACC		While turning power position from "RUN" to "ACC" (Vehicle is stopping and selector lever is except P position.)
	CRANK>RUN		While turning power position from "CRANKING" to "RUN" (From cranking up the engine to run it)
	RUN>URGENT		While turning power position from "RUN" to "ACC" (Emergency stop operation)
	ACC>OFF		While turning power position from "ACC" to "OFF"
	OFF>LOCK		While turning power position from "OFF" to "LOCK"*
	OFF>ACC		While turning power position from "OFF" to "ACC"
	ON>CRANK		While turning power position from "IGN" to "CRANKING"
	OFF>SLEEP		While turning BCM status from normal mode (Power position is "OFF".) to low power consumption mode
	LOCK>SLEEP		While turning BCM status from normal mode (Power position is "LOCK".) to low power consumption mode
	LOCK		Power position is "LOCK"*
	OFF		Power position is "OFF" (Ignition switch OFF)
	ACC		Power position is "ACC" (Ignition switch ACC)
	ON		Power position is "IGN" (Ignition switch ON with engine stopped)
ENGINE RUN	Power position is "RUN" (Ignition switch ON with engine running)		
CRANKING	Power position is "CRANKING" (At engine cranking)		
IGN Counter	0 - 39	<p>The number of times that ignition switch is turned ON after DTC is detected</p> <ul style="list-style-type: none"> • The number is 0 when a malfunction is detected now. • The number increases like 1 → 2 → 3...38 → 39 after returning to the normal condition whenever ignition switch OFF → ON. • The number is fixed to 39 until the self-diagnosis results are erased if it is over 39. 	

NOTE:

*: Power position shifts to "LOCK" from "OFF", when ignition switch is in the OFF position, selector lever is in the P position (A/T models and CVT models), and any of the following conditions are met.

- Closing door
- Opening door
- Door is locked using door request switch
- Door is locked using Intelligent Key

The power position shifts to "ACC" when the push-button ignition switch (push switch) is pushed at "LOCK".

WIPER

WIPER : CONSULT Function - WIPER

INFOID:000000007579553

WORK SUPPORT

DIAGNOSIS SYSTEM (BCM) (WITH INTELLIGENT KEY SYSTEM)

< SYSTEM DESCRIPTION >

Service item	Setting item	Description
WIPER SPEED SETTING	On	With vehicle speed (Front wiper intermittent time linked with the vehicle speed and wiper intermittent dial position)
	Off*	Without vehicle speed (Front wiper intermittent time linked with the wiper intermittent dial position)

*:Factory setting

DATA MONITOR

Monitor Item [Unit]	Description
PUSH SW [Off/On]	The switch status input from push-button ignition switch
VEH SPEED 1 [km/h]	Displays the value of the vehicle speed signal received from combination meter via CAN communication
FR WIPER HI [Off/On]	Status of each switch judged by BCM using the combination switch reading function
FR WIPER LOW [Off/On]	
FR WASHER SW [Off/On]	
FR WIPER INT [Off/On]	
FR WIPER STOP [Off/On]	Displays the status of the front wiper stop position signal received from IPDM E/R via CAN communication.
INT VOLUME [1 - 7]	Status of each switch judged by BCM using the combination switch reading function
RR WIPER ON [Off/On]	Status of each switch judged by BCM using the combination switch reading function
RR WIPER INT [Off/On]	
RR WASHER SW [Off/On]	
RR WIPER STOP [Off/On]	Rear wiper motor (stop position) status input from the rear wiper motor
H/L WASH SW [Off/On]	NOTE: The item is indicated, but not monitored

ACTIVE TEST

Test item	Operation	Description
FR WIPER	Hi	Transmits the front wiper request signal (HI) to IPDM E/R via CAN communication to operate the front wiper HI operation.
	Lo	Transmits the front wiper request signal (LO) to IPDM E/R via CAN communication to operate the front wiper LO operation.
	INT	Transmits the front wiper request signal (INT) to IPDM E/R via CAN communication to operate the front wiper INT operation.
	Off	Stops transmitting the front wiper request signal to stop the front wiper operation.
RR WIPER	On	Output the voltage to operate the rear wiper motor.
	Off	Stops the voltage to stop the rear wiper motor.

DIAGNOSIS SYSTEM (BCM) (WITHOUT INTELLIGENT KEY SYSTEM)

< SYSTEM DESCRIPTION >

DIAGNOSIS SYSTEM (BCM) (WITHOUT INTELLIGENT KEY SYSTEM) COMMON ITEM

COMMON ITEM : CONSULT Function (BCM - COMMON ITEM)

INFOID:000000007812833

APPLICATION ITEM

CONSULT performs the following functions via CAN communication with BCM.

Diagnosis mode	Function Description
Work Support	Changes the setting for each system function.
Self Diagnostic Result	Displays the diagnosis results judged by BCM.
CAN Diag Support Monitor	Monitors the reception status of CAN communication viewed from BCM.
Data Monitor	The BCM input/output signals are displayed.
Active Test	The signals used to activate each device are forcibly supplied from BCM.
Ecu Identification	The BCM part number is displayed.
Configuration	<ul style="list-style-type: none"> Read and save the vehicle specification. Write the vehicle specification when replacing BCM.

SYSTEM APPLICATION

BCM can perform the following functions for each system.

NOTE:

It can perform the diagnosis modes except the following for all sub system selection items.

x: Applicable item

System	Sub system selection item	Diagnosis mode		
		Work Support	Data Monitor	Active Test
Door lock	DOOR LOCK	x	x	x
Rear window defogger	REAR DEFOGGER		x	x
Warning chime	BUZZER		x	x
Interior room lamp control	INT LAMP	x	x	x
Remote keyless entry system	MULTI REMOTE ENT	x	x	x
Exterior lamp	HEAD LAMP	x	x	x
Wiper and washer	WIPER	x	x	x
Turn signal and hazard warning lamps	FLASHER		x	x
Air conditioning system	AIR CONDITONER		x	x
Combination switch	COMB SW		x	
Body control system	BCM	x		
NATS	IMMU	x		x
Interior room lamp battery saver	BATTERY SAVER	x	x	x
Back door open	TRUNK		x	
Theft warning alarm	THEFT ALM	x	x	x
RAP system	RETAINED PWR		x	x
Signal buffer system	SIGNAL BUFFER		x	x
Panic alarm	PANIC ALARM			x
TPMS	AIR PRESSUE MONITOR	x	x	x

WIPER

WIPER : CONSULT Function (BCM - WIPER)

INFOID:000000007579555

WORK SUPPORT

DIAGNOSIS SYSTEM (BCM) (WITHOUT INTELLIGENT KEY SYSTEM)

< SYSTEM DESCRIPTION >

Service item	Setting item	Description
WIPER SPEED SETTING	On	With vehicle speed (Front wiper intermittent time linked with the vehicle speed and wiper intermittent dial position)
	Off*	Without vehicle speed (Front wiper intermittent time linked with the wiper intermittent dial position)

*: Factory setting

DATA MONITOR

Monitor Item [Unit]	Description
IGN ON SW [On/Off]	Ignition switch ON status judged from ignition power supply.
IGN SW CAN [On/Off]	Ignition switch ON status received from IPDM E/R with CAN communication.
FR WIPER HI [On/Off]	Each switch status that BCM judges from the combination switch reading function.
FR WIPER LOW [On/Off]	
FR WIPER INT [On/Off]	
FR WASHER SW [On/Off]	
INT VOLUME [1 - 7]	Each switch status that BCM judges from the combination switch reading function.
FR WIPER STOP [On/Off]	Front wiper motor (stop position) status received from IPDM E/R with CAN communication.
VEHICLE SPEED [km/h]	The value of the vehicle speed signal received from combination meter with CAN communication.
RR WIPER ON [On/Off]	Each switch status that BCM judges from the combination switch reading function.
RR WIPER INT [On/Off]	
RR WASHER SW [On/Off]	
RR WIPER STOP [On/Off]	Rear wiper motor (stop position) status input from the rear wiper motor.
REVERSE SW CAN [On/Off]	Reverse position status as judged from TCM with CAN communication.

ACTIVE TEST

Test item	Operation	Description
FR WIPER	Hi	Transmits the front wiper request signal (HI) to IPDM E/R with CAN communication to operate the front wiper HI operation.
	Lo	Transmits the front wiper request signal (LO) to IPDM E/R with CAN communication to operate the front wiper LO operation.
	INT	Transmits the front wiper request signal (INT) to IPDM E/R with CAN communication to operate the front wiper INT operation.
	Off	Stops transmitting the front wiper request signal to stop the front wiper operation.
RR WIPER	On	Outputs the voltage to operate the rear wiper motor.
	Off	Stops the voltage to stop.

DIAGNOSIS SYSTEM (IPDM E/R)

< SYSTEM DESCRIPTION >

DIAGNOSIS SYSTEM (IPDM E/R) WITH INTELLIGENT KEY

WITH INTELLIGENT KEY : Diagnosis Description

INFOID:000000007812838

AUTO ACTIVE TEST

Description

In auto active test mode, the IPDM E/R sends a drive signal to the following systems to check their operation.

- Rear window defogger
- Front wiper motor
- Parking lamp
- License plate lamp
- Tail lamp
- Side marker lamp
- Front fog lamp
- Headlamp (LO, HI)
- A/C compressor (magnet clutch)
- Cooling fan

Operation Procedure

CAUTION:

Wiper arm interferes with food when wiper is operated while wiper arm is in the raised position. Always perform auto active test without setting wiper arm in the raised position. Always pour water on front windshield glass in advance to auto active test so that damage on front windshield glass surface is prevented.

1. Turn the ignition switch OFF.
2. Turn the ignition switch ON, and within 20 seconds, press the driver door switch 10 times. Then turn the ignition switch OFF.

CAUTION:

Close passenger door.

3. Turn the ignition switch ON within 10 seconds. After that the horn sounds once and the auto active test starts.

CAUTION:

Engine starts when ignition switch is turned ON while brake pedal is depressed.

4. After a series of the following operations is repeated 3 times, auto active test is completed.

NOTE:

- When auto active test mode has to be cancelled halfway through test, turn the ignition switch OFF.
- When auto active test is not activated, door switch may be the cause. Check door switch. Refer to [DLK-71, "Component Function Check"](#).

Inspection in Auto Active Test Mode

When auto active test mode is actuated, the following operation sequence is repeated 3 times.

Operation sequence	Inspection location	Operation
1	Rear window defogger	10 seconds
2	Front wiper motor	LO for 5 seconds → HI for 5 seconds
3	<ul style="list-style-type: none">• Parking lamp• License plate lamp• Tail lamp• Side marker lamp• Front fog lamp	10 seconds
4	Headlamp	LO for 10 seconds → HI ON ↔ OFF 5 times
5	A/C compressor (magnet clutch)	ON ↔ OFF 5 times
6	Cooling fan	50% duty for 5 seconds → 100% duty for 5 seconds

DIAGNOSIS SYSTEM (IPDM E/R)

< SYSTEM DESCRIPTION >

Concept of auto active test

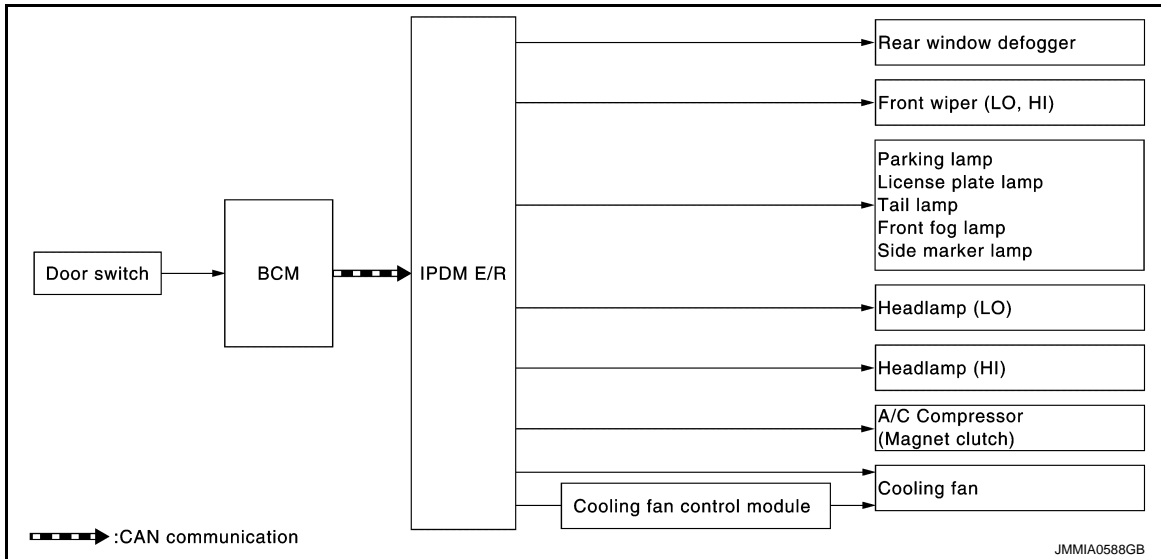

- IPDM E/R starts the auto active test with the door switch signals transmitted by BCM via CAN communication. Therefore, the CAN communication line between IPDM E/R and BCM is considered normal if the auto active test starts successfully.
- The auto active test facilitates troubleshooting if any systems controlled by IPDM E/R cannot be operated.

Diagnosis chart in auto active test mode

Symptom	Inspection contents	Possible cause
Rear window defogger does not operate	Perform auto active test. Does the rear window defogger operate?	YES BCM signal input circuit
		NO <ul style="list-style-type: none"> • Rear window defogger • Rear window defogger ground circuit • Harness or connector between IPDM E/R and rear window defogger • IPDM E/R
Any of the following components do not operate <ul style="list-style-type: none"> • Parking lamp • License plate lamp • Tail lamp • Side marker lamp • Front fog lamp • Headlamp (HI, LO) • Front wiper motor 	Perform auto active test. Does the applicable system operate?	YES BCM signal input circuit
		NO <ul style="list-style-type: none"> • Lamp or motor • Lamp or motor ground circuit • Harness or connector between IPDM E/R and applicable system • IPDM E/R
A/C compressor does not operate	Perform auto active test. Does the magnet clutch operate?	YES <ul style="list-style-type: none"> • A/C amp. signal input circuit • CAN communication signal between A/C amp. and ECM • CAN communication signal between ECM and IPDM E/R
		NO <ul style="list-style-type: none"> • Magnet clutch • Harness or connector between IPDM E/R and magnet clutch • IPDM E/R

DIAGNOSIS SYSTEM (IPDM E/R)

< SYSTEM DESCRIPTION >

Symptom	Inspection contents	Possible cause
Cooling fan does not operate	Perform auto active test. Does the cooling fan operate?	YES <ul style="list-style-type: none"> ECM signal input circuit CAN communication signal between ECM and IPDM E/R
		NO <ul style="list-style-type: none"> Harness or connector between IPDM E/R and cooling fan relay Harness or connector between IPDM E/R and cooling fan control module. Harness or connector between cooling fan control module and cooling fan motor Cooling fan motor Cooling fan relay Cooling fan control module IPDM E/R

WITH INTELLIGENT KEY : CONSULT Function (IPDM E/R)

INFOID:000000007812839

APPLICATION ITEM

CONSULT performs the following functions via CAN communication with IPDM E/R.

Diagnosis mode	Description
Ecu Identification	Allows confirmation of IPDM E/R part number.
Self Diagnostic Result	Displays the diagnosis results judged by IPDM E/R.
Data Monitor	Displays the real-time input/output data from IPDM E/R input/output data.
Active Test	IPDM E/R can provide a drive signal to electronic components to check their operations.
CAN Diag Support Monitor	The results of transmit/receive diagnosis of CAN communication can be read.

SELF DIAGNOSTIC RESULT

Refer to [PCS-23, "DTC Index"](#).

DATA MONITOR

Monitor item

Monitor Item [Unit]	MAIN SIGNALS	Description
RAD FAN REQ [%]	×	Displays the value of the cooling fan speed request signal received from ECM via CAN communication.
AC COMP REQ [Off/On]	×	Displays the status of the A/C compressor request signal received from ECM via CAN communication.
TAIL&CLR REQ [Off/On]	×	Displays the status of the position light request signal received from BCM via CAN communication.
HL LO REQ [Off/On]	×	Displays the status of the low beam request signal received from BCM via CAN communication.
HL HI REQ [Off/On]	×	Displays the status of the high beam request signal received from BCM via CAN communication.
FR FOG REQ [Off/On]	×	Displays the status of the front fog light request signal received from BCM via CAN communication.
FR WIP REQ [Stop/1LOW/Low/Hi]	×	Displays the status of the front wiper request signal received from BCM via CAN communication.
WIP AUTO STOP [STOP P/ACT P]	×	Displays the status of the front wiper auto stop signal judged by IPDM E/R.
WIP PROT [Off/BLOCK]	×	Displays the status of the front wiper fail-safe operation judged by IPDM E/R.
IGN RLY1 -REQ [Off/On]		Displays the status of the ignition switch ON signal received from BCM via CAN communication.

DIAGNOSIS SYSTEM (IPDM E/R)

< SYSTEM DESCRIPTION >

Monitor Item [Unit]	MAIN SIGNALS	Description
IGN RLY [Off/On]	×	Displays the status of the ignition relay judged by IPDM E/R.
PUSH SW [Off/On]		Displays the status of the push-button ignition switch judged by IPDM E/R.
INTER/NP SW [Off/On]		Displays the status of the ignition power supply (M/T models) or shift position (CVT models) judged by IPDM E/R.
ST RLY CONT [Off/On]		Displays the status of the starter relay status signal received from BCM via CAN communication.
IHBT RLY -REQ [Off/On]		Displays the status of the starter control relay signal received from BCM via CAN communication.
ST/INH RLY [Off/ ST ON/INH ON/UNKWN]		Displays the status of the starter relay and starter control relay judged by IPDM E/R.
DETENT SW [Off/On]		Displays the status of the CVT shift selector (detention switch) judged by IPDM E/R.
S/L RLY -REQ [Off/On]		NOTE: This item is indicated, but not monitored.
S/L STATE [LOCK/UNLK/UNKWN]		NOTE: This item is indicated, but not monitored.
DTRL REQ [Off/On]		Displays the status of the daytime running light request signal received from BCM via CAN communication.
OIL P SW [Open/Close]		NOTE: This item is indicated, but not monitored.
HOOD SW [Off/On]		NOTE: This item is indicated, but not monitored.
HL WASHER REQ [Off/On]		NOTE: This item is indicated, but not monitored.
THFT HRN REQ [Off/On]		Displays the status of the theft warning horn request signal received from BCM via CAN communication.
HORN CHIRP [Off/On]		Displays the status of the horn reminder request signal received from BCM via CAN communication.

ACTIVE TEST

Test item

Test item	Operation	Description
HORN	On	Operates horn relay for 20 ms.
REAR DEFOGGER	Off	OFF
	On	Operates the rear window defogger relay.
FRONT WIPER	Off	OFF
	Lo	Operates the front wiper relay.
	Hi	Operates the front wiper relay and front wiper high relay.
MOTOR FAN	1	OFF
	2	Transmits 50% pulse duty signal (PWM signal) to the cooling fan control module.
	3	Transmits 75% pulse duty signal (PWM signal) to the cooling fan control module.
	4	Transmits 100% pulse duty signal (PWM signal) to the cooling fan control module.
HEAD LAMP WASHER	On	NOTE: This item is indicated, but cannot be tested.

DIAGNOSIS SYSTEM (IPDM E/R)

< SYSTEM DESCRIPTION >

Test item	Operation	Description
EXTERNAL LAMPS	Off	OFF
	TAIL	Operates the tail lamp relay.
	Lo	Operates the headlamp low relay.
	Hi	Operates the headlamp low relay and ON/OFF the headlamp high relay at 1 second intervals.
	Fog	Operates the front fog lamp relay.

WITHOUT INTELLIGENT KEY

WITHOUT INTELLIGENT KEY : Diagnosis Description

INFOID:000000007812840

AUTO ACTIVE TEST

Description

In auto active test mode, the IPDM E/R sends a drive signal to the following systems to check their operation.

- Rear window defogger
- Front wiper motor
- Parking lamp
- License plate lamp
- Tail lamp
- Side marker lamp
- Front fog lamp
- Headlamp (LO, HI)
- A/C compressor (magnet clutch)
- Cooling fan

Operation Procedure

CAUTION:

Wiper arm interferes with food when wiper is operated while wiper arm is in the raised position. Always perform auto active test without setting wiper arm in the raised position. Always pour water on front windshield glass in advance to auto active test so that damage on front windshield glass surface is prevented.

1. Turn the ignition switch OFF.
2. Turn the ignition switch ON, and within 20 seconds, press the driver door switch 10 times. Then turn the ignition switch OFF.

CAUTION:

Close passenger door.

3. Turn the ignition switch ON within 10 seconds. After that the horn sounds once and the auto active test starts.

CAUTION:

Engine starts when ignition switch is turned ON while brake pedal is depressed.

4. After a series of the following operations is repeated 3 times, auto active test is completed.

NOTE:

- When auto active test mode has to be cancelled halfway through test, turn the ignition switch OFF.
- When auto active test is not activated, door switch may be the cause. Check door switch. Refer to [DLK-201, "Component Function Check"](#).

Inspection in Auto Active Test Mode

When auto active test mode is actuated, the following operation sequence is repeated 3 times.

Operation sequence	Inspection location	Operation
1	Rear window defogger	10 seconds
2	Front wiper motor	LO for 5 seconds → HI for 5 seconds

DIAGNOSIS SYSTEM (IPDM E/R)

< SYSTEM DESCRIPTION >

Operation sequence	Inspection location	Operation
3	<ul style="list-style-type: none"> • Parking lamp • License plate lamp • Tail lamp • Side marker lamp • Front fog lamp 	10 seconds
4	Headlamp	LO for 10 seconds → HI ON ↔ OFF 5 times
5	A/C compressor (magnet clutch)	ON ↔ OFF 5 times
6	Cooling fan	50% duty for 5 seconds → 100% duty for 5 seconds

Concept of auto active test

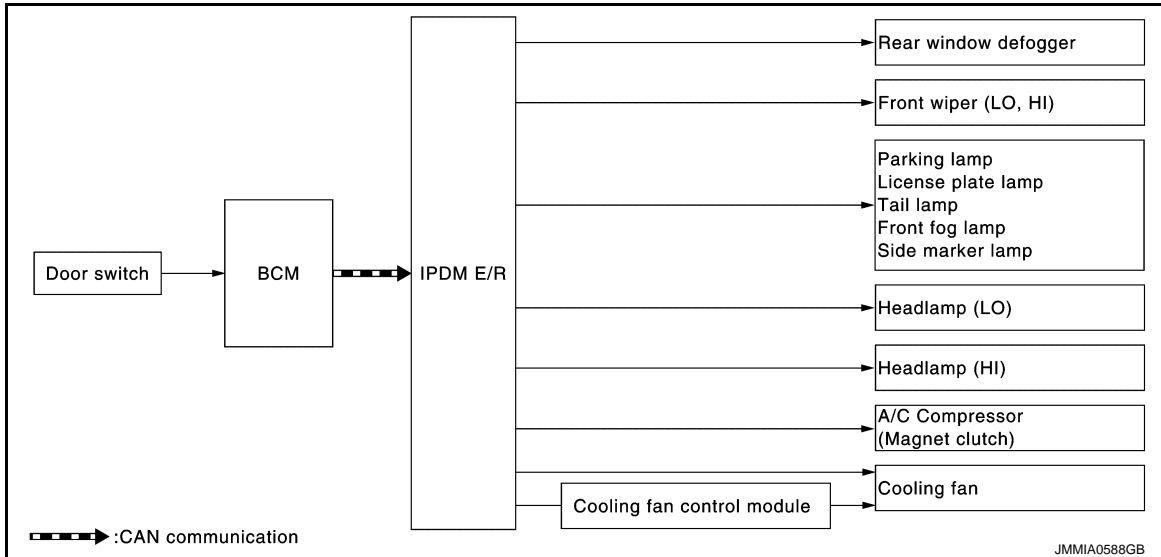

- IPDM E/R starts the auto active test with the door switch signals transmitted by BCM via CAN communication. Therefore, the CAN communication line between IPDM E/R and BCM is considered normal if the auto active test starts successfully.
- The auto active test facilitates troubleshooting if any systems controlled by IPDM E/R cannot be operated.

Diagnosis chart in auto active test mode

Symptom	Inspection contents	Possible cause	
Rear window defogger does not operate	Perform auto active test. Does the rear window defogger operate?	YES	BCM signal input circuit
		NO	<ul style="list-style-type: none"> • Rear window defogger • Rear window defogger ground circuit • Harness or connector between IPDM E/R and rear window defogger • IPDM E/R
Any of the following components do not operate <ul style="list-style-type: none"> • Parking lamp • License plate lamp • Tail lamp • Side marker lamp • Front fog lamp • Headlamp (HI, LO) • Front wiper motor 	Perform auto active test. Does the applicable system operate?	YES	BCM signal input circuit
		NO	<ul style="list-style-type: none"> • Lamp or motor • Lamp or motor ground circuit • Harness or connector between IPDM E/R and applicable system • IPDM E/R

DIAGNOSIS SYSTEM (IPDM E/R)

< SYSTEM DESCRIPTION >

Symptom	Inspection contents		Possible cause
A/C compressor does not operate	Perform auto active test. Does the magnet clutch operate?	YES	<ul style="list-style-type: none"> A/C amp. signal input circuit CAN communication signal between A/C amp. and ECM CAN communication signal between ECM and IPDM E/R
		NO	<ul style="list-style-type: none"> Magnet clutch Harness or connector between IPDM E/R and magnet clutch IPDM E/R
Cooling fan does not operate	Perform auto active test. Does the cooling fan operate?	YES	<ul style="list-style-type: none"> ECM signal input circuit CAN communication signal between ECM and IPDM E/R
		NO	<ul style="list-style-type: none"> Harness or connector between IPDM E/R and cooling fan relay Harness or connector between IPDM E/R and cooling fan control module. Harness or connector between cooling fan control module and cooling fan motor Cooling fan motor Cooling fan relay Cooling fan control module IPDM E/R

WITHOUT INTELLIGENT KEY : CONSULT Function (IPDM E/R)

INFOID:000000007812841

APPLICATION ITEM

CONSULT performs the following functions via CAN communication with IPDM E/R.

Diagnosis mode	Description
Ecu Identification	Allows confirmation of IPDM E/R part number.
Self Diagnostic Result	Displays the diagnosis results judged by IPDM E/R.
Data Monitor	Displays the real-time input/output data from IPDM E/R input/output data.
Active Test	IPDM E/R can provide a drive signal to electronic components to check their operations.
CAN Diag Support Monitor	The results of transmit/receive diagnosis of CAN communication can be read.

SELF DIAGNOSTIC RESULT

Refer to [PCS-50, "DTC Index"](#).

DATA MONITOR

Monitor item

Monitor Item [Unit]	MAIN SIG- NALS	Description
RAD FAN REQ [%]	×	Displays the value of the cooling fan speed request signal received from ECM via CAN communication.
AC COMP REQ [Off/On]	×	Displays the status of the A/C compressor request signal received from ECM via CAN communication.
TAIL&CLR REQ [Off/On]	×	Displays the status of the position light request signal received from BCM via CAN communication.
HL LO REQ [Off/On]	×	Displays the status of the low beam request signal received from BCM via CAN communication.
HL HI REQ [Off/On]	×	Displays the status of the high beam request signal received from BCM via CAN communication.
FR FOG REQ [Off/On]	×	Displays the status of the front fog light request signal received from BCM via CAN communication.

DIAGNOSIS SYSTEM (IPDM E/R)

< SYSTEM DESCRIPTION >

Monitor Item [Unit]	MAIN SIG- NALS	Description
FR WIP REQ [Stop/1LOW/Low/Hi]	×	Displays the status of the front wiper request signal received from BCM via CAN communication.
WIP AUTO STOP [STOP P/ACT P]	×	Displays the status of the front wiper auto stop signal judged by IPDM E/R.
WIP PROT [Off/BLOCK]	×	Displays the status of the front wiper fail-safe operation judged by IPDM E/R.
IGN RLY [Off/On]	×	Displays the status of the ignition relay judged by IPDM E/R.
INTER/NP SW [Off/On]		Displays the status of the shift position (CVT models) judged by IPDM E/R.
ST RLY REQ [Off/On]		Displays the status of the starter relay status signal received from BCM via CAN communication.
DTRL REQ [Off/On]		Displays the status of the daytime running light request signal received from BCM via CAN communication.
OIL P SW [Open/Close]		NOTE: This item is indicated, but not monitored.
HOOD SW [Off/On]		NOTE: This item is indicated, but not monitored.
HL WASHER REQ [Off/On]		NOTE: This item is indicated, but not monitored.
THFT HRN REQ [Off/On]		Displays the status of the theft warning horn request signal received from BCM via CAN communication.
HORN CHIRP [Off/On]		Displays the status of the horn reminder request signal received from BCM via CAN communication.

ACTIVE TEST

Test item

Test item	Operation	Description
HORN	On	Operates horn relay for 20 ms.
REAR DEFOGGER	Off	OFF
	On	Operates the rear window defogger relay.
FRONT WIPER	Off	OFF
	Lo	Operates the front wiper relay.
	Hi	Operates the front wiper relay and front wiper high relay.
MOTOR FAN	1	OFF
	2	Transmits 50% pulse duty signal (PWM signal) to the cooling fan control module.
	3	Transmits 75% pulse duty signal (PWM signal) to the cooling fan control module.
	4	Transmits 100% pulse duty signal (PWM signal) to the cooling fan control module.
HEAD LAMP WASHER	On	NOTE: This item is indicated, but cannot be tested.
	Off	OFF
EXTERNAL LAMPS	TAIL	Operates the tail lamp relay.
	Lo	Operates the headlamp low relay.
	Hi	Operates the headlamp low relay and ON/OFF the headlamp high relay at 1 second intervals.
	Fog	Operates the front fog lamp relay.

BCM, IPDM E/R

< ECU DIAGNOSIS INFORMATION >

ECU DIAGNOSIS INFORMATION

BCM, IPDM E/R

List of ECU Reference

INFOID:000000007579560

ECU		Reference
BCM	(With Intelligent Key system)	BCS-35, "Reference Value"
		BCS-56, "Fail-safe"
		BCS-57, "DTC Inspection Priority Chart"
		BCS-58, "DTC Index"
	(Without Intelligent Key system)	BCS-108, "Reference Value"
		BCS-121, "Fail-safe"
		BCS-122, "DTC Inspection Priority Chart"
		BCS-122, "DTC Index"
IPDM E/R	(With Intelligent Key system)	PCS-16, "Reference Value"
		PCS-22, "Fail-Safe"
		PCS-23, "DTC Index"
	(Without Intelligent Key system)	PCS-44, "Reference Value"
		PCS-49, "Fail-Safe"
		PCS-50, "DTC Index"

A
B
C
D
E
F
G
H
I
J
K
L
M
N
O
P

WW

DIAGNOSIS AND REPAIR WORK FLOW

< BASIC INSPECTION >

BASIC INSPECTION

DIAGNOSIS AND REPAIR WORK FLOW

Work Flow

INFOID:000000007812842

OVERALL SEQUENCE

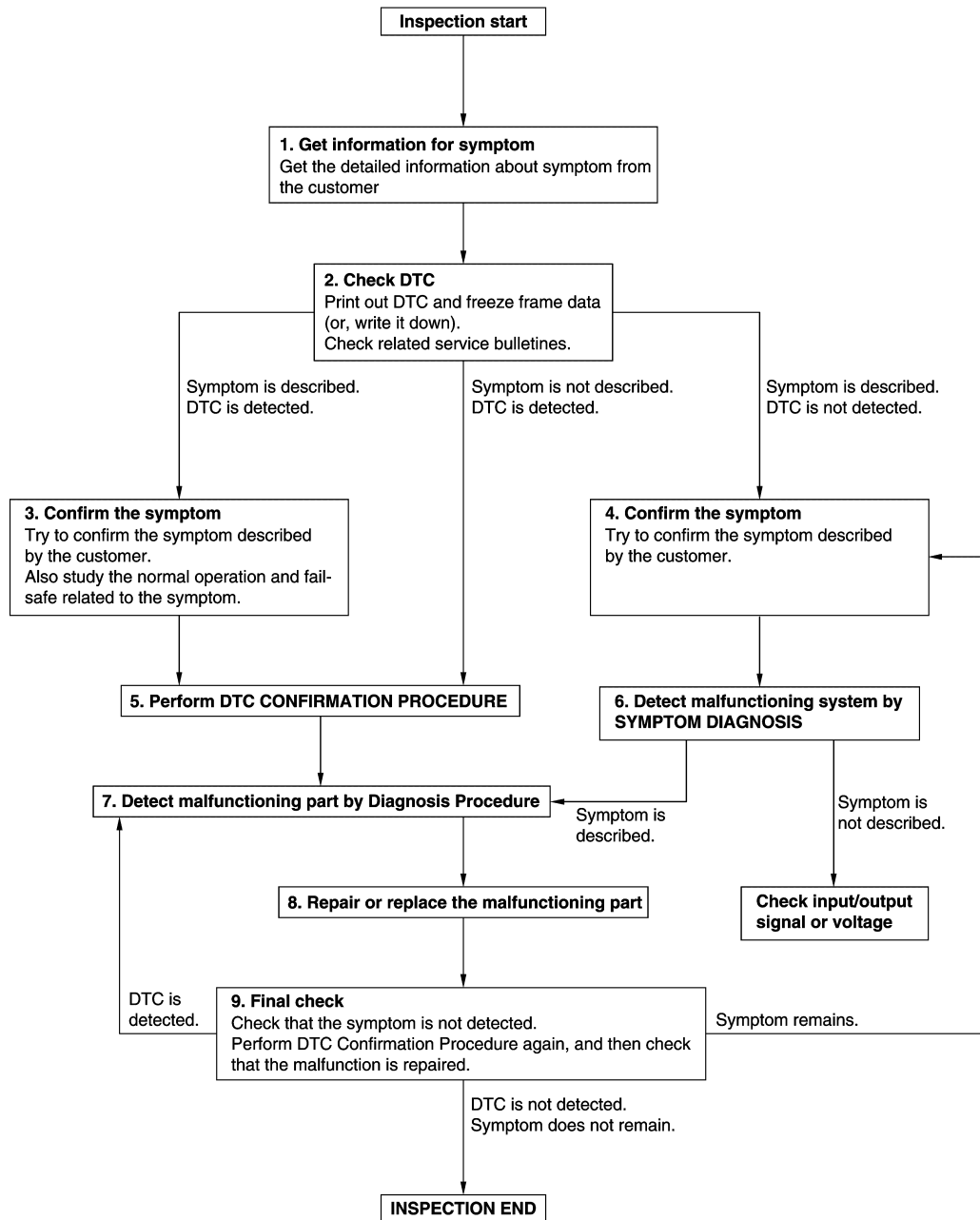

JMKIA8652GB

DETAILED FLOW

DIAGNOSIS AND REPAIR WORK FLOW

< BASIC INSPECTION >

1. GET INFORMATION FOR SYMPTOM

1. Get detailed information from the customer about the symptom (the condition and the environment when the incident/malfunction occurs).
2. Check operation condition of the function that is malfunctioning.

>> GO TO 2.

2. CHECK DTC

1. Check DTC.
2. Perform the following procedure if DTC is detected.
 - Record DTC and freeze frame data (Print them out using CONSULT.)
 - Erase DTC.
 - Study the relationship between the cause detected by DTC and the symptom described by the customer.
3. Check related service bulletins for information.

Are any symptoms described and any DTC detected?

Symptom is described, DTC is detected>>GO TO 3.

Symptom is described, DTC is not detected>>GO TO 4.

Symptom is not described, DTC is detected>>GO TO 5.

3. CONFIRM THE SYMPTOM

Try to confirm the symptom described by the customer.

Also study the normal operation and fail-safe related to the symptom.

Verify relation between the symptom and the condition when the symptom is detected.

>> GO TO 5.

4. CONFIRM THE SYMPTOM

Try to confirm the symptom described by the customer.

Verify relation between the symptom and the condition when the symptom is detected.

>> GO TO 6.

5. PERFORM DTC CONFIRMATION PROCEDURE

Perform DTC CONFIRMATION PROCEDURE for the detected DTC, and then check that DTC is detected again. At this time, always connect CONSULT to the vehicle, and check self diagnostic results in real time.

If two or more DTCs are detected, refer to following reference, and determine trouble diagnosis order.

BCM

- With Intelligent Key System: Refer to [BCS-57, "DTC Inspection Priority Chart"](#).
- Without Intelligent Key System: Refer to [BCS-122, "DTC Inspection Priority Chart"](#).

IPDM E/R

- With Intelligent Key System: Refer to [PCS-23, "DTC Index"](#).
- Without Intelligent Key System: Refer to [PCS-50, "DTC Index"](#).

NOTE:

- Freeze frame data is useful if the DTC is not detected.
- Perform Component Function Check if DTC CONFIRMATION PROCEDURE is not included on Service Manual. This simplified check procedure is an effective alternative though DTC cannot be detected during this check.

If the result of Component Function Check is NG, it is the same as the detection of DTC by DTC CONFIRMATION PROCEDURE.

Is DTC detected?

YES >> GO TO 7.

NO >> Check according to [GI-43, "Intermittent Incident"](#).

6. DETECT MALFUNCTIONING SYSTEM BY SYMPTOM DIAGNOSIS

Detect malfunctioning system according to SYMPTOM DIAGNOSIS based on the confirmed symptom in step 4, and determine the trouble diagnosis order based on possible causes and symptom.

Is the symptom described?

A
B
C
D
E
F
G
H
I
J
K
M
N
O
P

WW

DIAGNOSIS AND REPAIR WORK FLOW

< BASIC INSPECTION >

YES >> GO TO 7.

NO >> Monitor input data from related sensors or check voltage of related module terminals using CONSULT.

7. DETECT MALFUNCTIONING PART BY DIAGNOSIS PROCEDURE

Inspect according to Diagnosis Procedure of the system.

Is malfunctioning part detected?

YES >> GO TO 8.

NO >> Check according to [GI-43. "Intermittent Incident"](#).

8. REPAIR OR REPLACE THE MALFUNCTIONING PART

1. Repair or replace the malfunctioning part.
2. Reconnect parts or connectors disconnected during Diagnosis Procedure again after repair and replacement.
3. Check DTC. If DTC is detected, erase it.

>> GO TO 9.

9. FINAL CHECK

When DTC is detected in step 2, perform DTC CONFIRMATION PROCEDURE again, and then check that the malfunction is repaired securely.

When symptom is described by the customer, refer to confirmed symptom in step 3 or 4, and check that the symptom is not detected.

Is DTC detected and does symptom remain?

YES-1 >> DTC is detected: GO TO 7.

YES-2 >> Symptom remains: GO TO 4.

NO >> Before returning the vehicle to the customer, always erase DTC.

WIPER AND WASHER FUSE

< DTC/CIRCUIT DIAGNOSIS >

DTC/CIRCUIT DIAGNOSIS

WIPER AND WASHER FUSE

Diagnosis Procedure

INFOID:000000007579562

1. CHECK FUSES

Check that the following fuses is not fusing.

Unit	Location	No.	Capacity
Front wiper motor	IPDM E/R	45	30 A
Washer pump	Fuse block (J/B)	2	10 A

Is the inspection result normal?

YES >> INSPECTION END

NO >> Replace the fuse with a new one after repairing the applicable circuit.

A
B
C
D
E
F
G
H
I
J
K
L
M
N
O
P

WW

FRONT WIPER MOTOR LO CIRCUIT

< DTC/CIRCUIT DIAGNOSIS >

FRONT WIPER MOTOR LO CIRCUIT

Component Function Check

INFOID:000000007579563

1. CHECK FRONT WIPER LO OPERATION

CONSULT ACTIVE TEST

1. Select "FRONT WIPER" of IPDM E/R active test item.
2. With operating the test item, check front wiper operation.

Lo : Front wiper (LO) operation

Off : Stop the front wiper.

Is front wiper (LO) operation normally?

- YES >> Front wiper motor LO circuit is normal.
 NO >> Refer to [WW-30, "Diagnosis Procedure"](#).

Diagnosis Procedure

INFOID:000000007579564

1. CHECK FRONT WIPER MOTOR (LO) OUTPUT VOLTAGE

CONSULT ACTIVE TEST

1. Turn ignition switch OFF.
2. Disconnect front wiper motor connector.
3. Turn ignition switch ON.
4. Select "FRONT WIPER" of IPDM E/R active test item.
5. With operating the test item, check voltage between front wiper motor harness connector and ground.

(+)		(-)	Condition	Voltage (Approx.)	
Front wiper motor					
Connector	Terminal				
E20	2	Ground	FRONT WIPER	Lo	Battery voltage
				Off	0 V

Is the inspection result normal?

- YES >> Replace front wiper motor.
 NO >> GO TO 2.

2. CHECK FRONT WIPER MOTOR (LO) CIRCUIT

1. Turn ignition switch OFF.
2. Disconnect IPDM E/R connector.
3. Check continuity between IPDM E/R harness connector and front wiper motor harness connector.

IPDM E/R		Front wiper motor		Continuity
Connector	Terminal	Connector	Terminal	
E14	45	E20	2	Existed

4. Check continuity between IPDM E/R harness connector and ground.

IPDM E/R		Ground	Continuity
Connector	Terminal		
E14	45		Not existed

Is the inspection result normal?

- YES >> Replace IPDM E/R.
 NO >> Repair or replace harness.

FRONT WIPER MOTOR HI CIRCUIT

< DTC/CIRCUIT DIAGNOSIS >

FRONT WIPER MOTOR HI CIRCUIT

Component Function Check

INFOID:000000007579565

1. CHECK FRONT WIPER HI OPERATION

CONSULT ACTIVE TEST

1. Select "FRONT WIPER" of IPDM E/R active test item.
2. With operating the test item, check front wiper operation.

Hi : Front wiper (HI) operation

Off : Stop the front wiper.

Is front wiper (HI) operation normally?

- YES >> Front wiper motor HI circuit is normal.
 NO >> Refer to [WW-31, "Diagnosis Procedure"](#).

Diagnosis Procedure

INFOID:000000007579566

1. CHECK FRONT WIPER MOTOR (HI) OUTPUT VOLTAGE

CONSULT ACTIVE TEST

1. Turn ignition switch OFF.
2. Disconnect front wiper motor connector.
3. Turn ignition switch ON.
4. Select "FRONT WIPER" of IPDM E/R active test item.
5. With operating the test item, check voltage between front wiper motor harness connector and ground.

(+)		(-)	Condition	Voltage (Approx.)	
Front wiper motor					
Connector	Terminal				
E20	1	Ground	FRONT WIPER	Hi	Battery voltage
				Off	0 V

Is the inspection result normal?

- YES >> Replace front wiper motor.
 NO >> GO TO 2.

2. CHECK FRONT WIPER MOTOR (HI) CIRCUIT

1. Turn ignition switch OFF.
2. Disconnect IPDM E/R connector.
3. Check continuity between IPDM E/R harness connector and front wiper motor harness connector.

IPDM E/R		Front wiper motor		Continuity
Connector	Terminal	Connector	Terminal	
E14	39	E20	1	Existed

4. Check continuity between IPDM E/R harness connector and ground.

IPDM E/R		Ground	Continuity
Connector	Terminal		
E14	39		Not existed

Is the inspection result normal?

- YES >> Replace IPDM E/R.
 NO >> Repair or replace harness.

A
B
C
D
E
F
G
H
I
J
K
M
N
O
P

WW

FRONT WIPER STOP POSITION SIGNAL CIRCUIT

< DTC/CIRCUIT DIAGNOSIS >

FRONT WIPER STOP POSITION SIGNAL CIRCUIT

Component Function Check

INFOID:000000007579567

1. CHECK FRONT WIPER STOP POSITION SIGNAL

CONSULT DATA MONITOR

1. Select "WIP AUTO STOP" of IPDM E/R data monitor item.
2. Operate the front wiper.
3. With the front wiper operation, check the monitor status.

Monitor item	Condition		Monitor status
WIP AUTO STOP	Front wiper motor	Stop position	STOP P
		Except stop position	ACT P

Is the status of item normal?

- YES >> Front wiper stop position signal circuit is normal.
NO >> Refer to [WW-32, "Diagnosis Procedure"](#).

Diagnosis Procedure

INFOID:000000007579568

1. CHECK IPDM E/R OUTPUT VOLTAGE

1. Turn ignition switch OFF.
2. Disconnect front wiper motor connector.
3. Turn ignition switch ON.
4. Check voltage between front wiper motor harness connector and ground.

(+)		(-)	Voltage (Approx.)
Front wiper motor			
Connector	Terminal	Ground	Battery voltage
E20	4		

Is the inspection result normal?

- YES >> Replace front wiper motor.
NO >> GO TO 2.

2. CHECK FRONT WIPER MOTOR CIRCUIT

1. Turn ignition switch OFF.
2. Disconnect IPDM E/R connector.
3. Check continuity between IPDM E/R harness connector and front wiper motor harness connector.

IPDM E/R		Front wiper motor		Continuity
Connector	Terminal	Connector	Terminal	
E13	25	E20	4	Existed

4. Check continuity between IPDM E/R harness connector and ground.

IPDM E/R		Ground	Continuity
Connector	Terminal		
E13	25		Not existed

Is the inspection result normal?

- YES >> Replace IPDM E/R.
NO >> Repair or replace harness.

FRONT WIPER MOTOR GROUND CIRCUIT

< DTC/CIRCUIT DIAGNOSIS >

FRONT WIPER MOTOR GROUND CIRCUIT

Diagnosis Procedure

INFOID:000000007579569

1. CHECK FRONT WIPER MOTOR GROUND CIRCUIT

1. Turn ignition switch OFF.
2. Disconnect front wiper motor connector.
3. Check continuity between front wiper motor harness connector and ground.

Front wiper motor		Ground	Continuity
Connector	Terminal		
E20	5		Existed

Is the inspection result normal?

- YES >> INSPECTION END
NO >> Repair or replace harness.

A
B
C
D
E
F
G
H
I
J
K
M
N
O
P

WW

WASHER SWITCH

< DTC/CIRCUIT DIAGNOSIS >

WASHER SWITCH

Component Inspection

INFOID:000000007579570

1. CHECK WASHER SWITCH

1. Turn ignition switch OFF.
2. Disconnect combination switch connector.
3. Check continuity between the combination switch terminals.

- A : Terminal 4
- B : Terminal 6
- C : Terminal 3
- D : Terminal 1

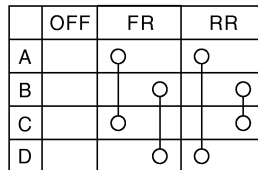

JPLIA0164GB

Combination switch		Condition	Continuity
Terminal			
3	4	Front washer switch ON	Existed
1	6		
1	4	Rear washer switch ON	
6	3		

Is the inspection result normal?

YES >> INSPECTION END

NO >> Replace combination switch (Wiper and washer switch).

REAR WIPER MOTOR CIRCUIT

< DTC/CIRCUIT DIAGNOSIS >

REAR WIPER MOTOR CIRCUIT

Component Function Check

INFOID:000000007579571

1. CHECK REAR WIPER ON OPERATION

CONSULT ACTIVE TEST

1. Select "RR WIPER" of BCM active test item.
2. With operating the test item, check rear wiper operation.

On : Rear wiper ON operation

Off : Stop the rear wiper.

Is rear wiper operation normally?

- YES >> Rear wiper motor circuit is normal.
 NO >> Refer to [WW-35, "Diagnosis Procedure"](#).

Diagnosis Procedure

INFOID:000000007579572

1. CHECK REAR WIPER MOTOR OUTPUT VOLTAGE

CONSULT ACTIVE TEST

1. Turn ignition switch OFF.
2. Disconnect rear wiper motor connector.
3. Turn ignition switch ON.
4. Select "RR WIPER" of BCM active test item.
5. With operating the test item, check voltage between rear wiper motor harness connector and ground.

(+)		(-)	Condition		Voltage (Approx.)
Rear wiper motor					
Connector	Terminal				
D112	1	Ground	REAR WIPER	On	Battery voltage
				Off	0 V

Is the inspection result normal?

- YES >> GO TO 3.
 NO >> GO TO 2.

2. CHECK REAR WIPER MOTOR CIRCUIT

1. Turn ignition switch OFF.
2. Disconnect BCM connector.
3. Check continuity between BCM harness connector and rear wiper motor harness connector.

BCM			Rear wiper motor		Continuity
Connector	Terminal		Connector	Terminal	
With Intelligent Key system	B10	54	D112	1	Existed
Without Intelligent Key system	B9	53			

4. Check continuity between BCM harness connector and ground.

BCM			Ground	Continuity
Connector	Terminal			
With Intelligent Key system	B10	54	Ground	Not existed
Without Intelligent Key system	B9	53		

REAR WIPER MOTOR CIRCUIT

< DTC/CIRCUIT DIAGNOSIS >

Is the inspection result normal?

YES >> Replace BCM. Refer to [BCS-80, "Removal and Installation"](#) (with Intelligent Key system) or [BCS-141, "Removal and Installation"](#) (without Intelligent Key system).

NO >> Repair or replace harness.

3. CHECK REAR WIPER MOTOR GROUND OPEN CIRCUIT

Check continuity between rear wiper motor harness connector and ground.

Rear wiper motor		Ground	Continuity
Connector	Terminal		
D112	3		Existed

Is the inspection result normal?

YES >> Replace rear wiper motor.

NO >> Repair or replace harness.

REAR WIPER STOP POSITION SIGNAL CIRCUIT

< DTC/CIRCUIT DIAGNOSIS >

REAR WIPER STOP POSITION SIGNAL CIRCUIT

Component Function Check

INFOID:000000007579573

1. CHECK REAR WIPER STOP POSITION SIGNAL

CONSULT DATA MONITOR

1. Select "WIPER" of BCM data monitor item.
2. Operate the rear wiper.
3. Check that "RR WIPER STOP" changes to "On" and "Off" linked with the wiper operation.

Monitor item	Condition		Monitor status
RR WIPER STOP	Rear wiper motor	Stop position	On
		Except stop position	Off

Is the status of item normal?

- YES >> Rear wiper stop position signal circuit is normal.
 NO >> Refer to [WW-37. "Diagnosis Procedure"](#).

Diagnosis Procedure

INFOID:000000007579574

1. CHECK REAR WIPER MOTOR OUTPUT VOLTAGE

1. Turn ignition switch OFF.
2. Disconnect rear wiper motor connector.
3. Turn ignition switch ON.
4. Check voltage between rear wiper motor harness connector and ground.

(+)		(-)	Voltage (Approx.)
Rear wiper motor			
Connector	Terminal	Ground	Battery voltage
D112	2		

Is the inspection result normal?

- YES >> Replace rear wiper motor.
 NO >> GO TO 2.

2. CHECK REAR WIPER MOTOR CIRCUIT

1. Turn ignition switch OFF.
2. Disconnect BCM connector.
3. Check continuity between BCM harness connector and rear wiper motor harness connector.

BCM			Rear wiper motor		Continuity
Connector	Terminal	Connector	Terminal		
With Intelligent Key system	B10	44	D112	2	Existed
Without Intelligent Key system	B9	41			

4. Check continuity between BCM harness connector and ground.

BCM			Ground	Continuity
Connector	Terminal			
With Intelligent Key system	B10	44		Not existed
Without Intelligent Key system	B9	41		

Is the inspection result normal?

REAR WIPER STOP POSITION SIGNAL CIRCUIT

< DTC/CIRCUIT DIAGNOSIS >

- YES >> Replace BCM. Refer to [BCS-80, "Removal and Installation"](#) (with Intelligent Key system) or [BCS-141, "Removal and Installation"](#) (without Intelligent Key system).
- NO >> Repair or replace harness.

WIPER AND WASHER SYSTEM

< DTC/CIRCUIT DIAGNOSIS >

WIPER AND WASHER SYSTEM

Wiring Diagram - WIPER AND WASHER SYSTEM -

INFOID:000000007579575

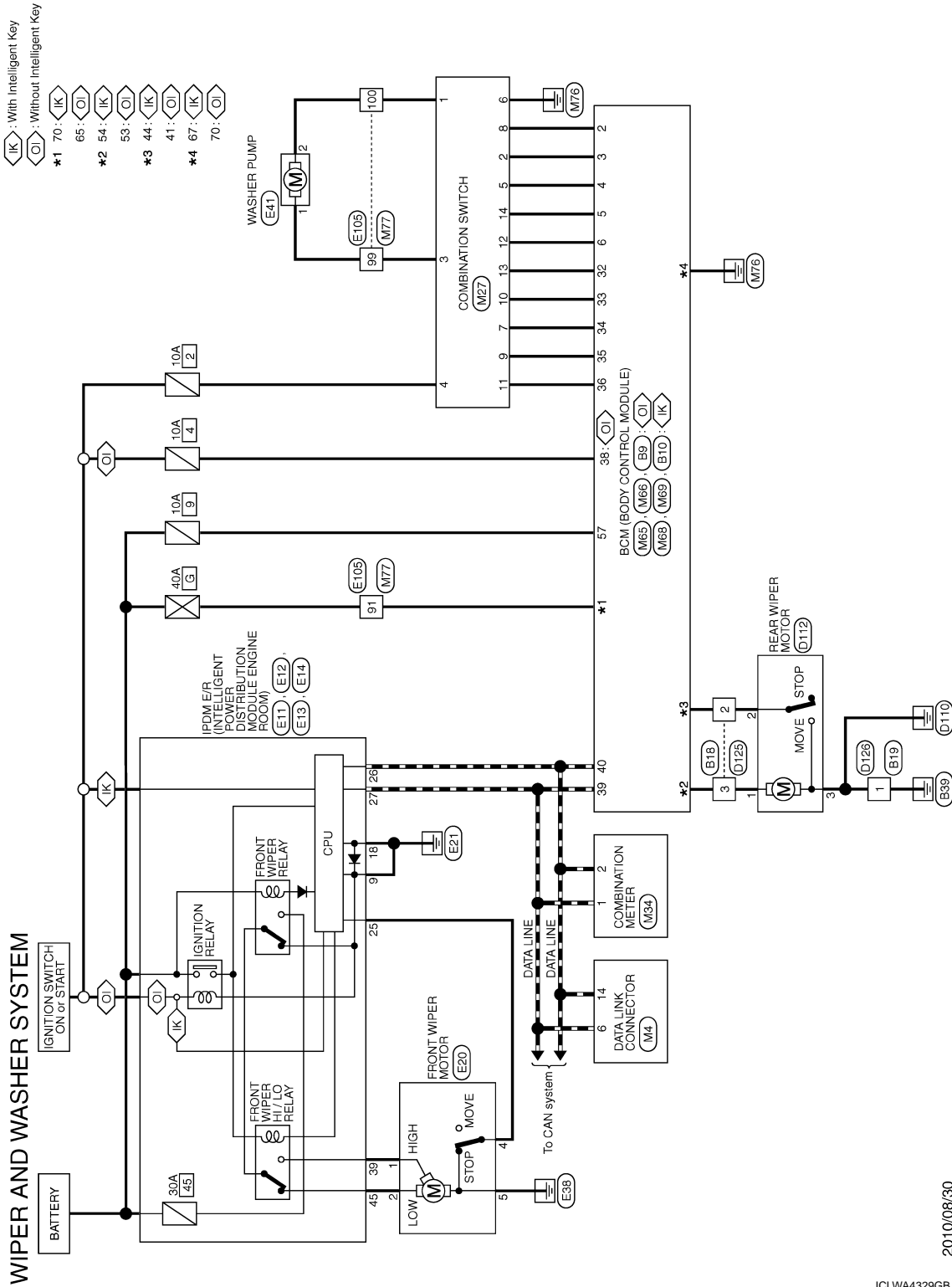

2010/08/30

JCLWA4329GB

A
B
C
D
E
F
G
H
I
J
K
L
M
N
O
P

WW

WIPER AND WASHER SYSTEM SYMPTOMS

< SYMPTOM DIAGNOSIS >

SYMPTOM DIAGNOSIS

WIPER AND WASHER SYSTEM SYMPTOMS

Symptom Table

INFOID:000000007579576

Symptom	Probable malfunction location	Inspection item	
Front wiper does not operate	HI only	<ul style="list-style-type: none"> Combination switch Harness between combination switch and BCM BCM 	Combination switch Refer to BCS-78, "Symptom Table" (With Intelligent Key system) or BCS-139, "Symptom Table" (Without Intelligent Key system).
		<ul style="list-style-type: none"> IPDM E/R Harness between IPDM E/R and front wiper motor Front wiper motor 	Front wiper motor (HI) circuit Refer to WW-31, "Component Function Check" .
		Front wiper request signal <ul style="list-style-type: none"> BCM IPDM E/R 	IPDM E/R Data monitor "FR WIP REQ"
	LO and INT	<ul style="list-style-type: none"> Combination switch Harness between combination switch and BCM BCM 	Combination switch Refer to BCS-78, "Symptom Table" (With Intelligent Key system) or BCS-139, "Symptom Table" (Without Intelligent Key system).
		<ul style="list-style-type: none"> IPDM E/R Harness between IPDM E/R and front wiper motor Front wiper motor 	Front wiper motor (LO) circuit Refer to WW-30, "Component Function Check" .
		Front wiper request signal <ul style="list-style-type: none"> BCM IPDM E/R 	IPDM E/R Data monitor "FR WIP REQ"
	INT only	<ul style="list-style-type: none"> Combination switch Harness between combination switch and BCM BCM 	Combination switch Refer to BCS-78, "Symptom Table" (With Intelligent Key system) or BCS-139, "Symptom Table" (Without Intelligent Key system).
		Front wiper request signal <ul style="list-style-type: none"> BCM IPDM E/R 	IPDM E/R Data monitor "FR WIP REQ"
	HI, LO and INT	SYMPTOM DIAGNOSIS Refer to WW-45, "Diagnosis Procedure" .	

WIPER AND WASHER SYSTEM SYMPTOMS

< SYMPTOM DIAGNOSIS >

Symptom	Probable malfunction location	Inspection item	
Front wiper does not stop	HI only	<ul style="list-style-type: none"> • Combination switch • BCM 	Combination switch Refer to BCS-78, "Symptom Table" (With Intelligent Key system) or BCS-139, "Symptom Table" (Without Intelligent Key system).
		Front wiper request signal <ul style="list-style-type: none"> • BCM • IPDM E/R 	IPDM E/R Data monitor "FR WIP REQ"
		IPDM E/R	—
	LO only	<ul style="list-style-type: none"> • Combination switch • BCM 	Combination switch Refer to BCS-78, "Symptom Table" (With Intelligent Key system) or BCS-139, "Symptom Table" (Without Intelligent Key system).
		Front wiper request signal <ul style="list-style-type: none"> • BCM • IPDM E/R 	IPDM E/R Data monitor "FR WIP REQ"
		IPDM E/R	—
	INT only	<ul style="list-style-type: none"> • Combination switch • BCM 	Combination switch refer to BCS-78, "Symptom Table" (With Intelligent Key system) or BCS-139, "Symptom Table" (Without Intelligent Key system).
		Front wiper request signal <ul style="list-style-type: none"> • BCM • IPDM E/R 	IPDM E/R Data monitor "FR WIP REQ"

A
B
C
D
E
F
G
H
I
J
K
M
N
O
P

WW

WIPER AND WASHER SYSTEM SYMPTOMS

< SYMPTOM DIAGNOSIS >

Symptom	Probable malfunction location	Inspection item	
Front wiper does not operate normally	Intermittent adjustment cannot be performed	<ul style="list-style-type: none"> • Combination switch • Harness between combination switch and BCM • BCM 	Combination switch Refer to BCS-78, "Symptom Table" (With Intelligent Key system) or BCS-139, "Symptom Table" (Without Intelligent Key system).
		BCM	—
	Intermittent control linked with vehicle speed cannot be performed	Check the wiper setting is linked with vehicle speed. Refer to WW-13, "WIPER : CONSULT Function - WIPER" (With Intelligent Key system) or WW-15, "WIPER : CONSULT Function (BCM - WIPER)" (Without Intelligent Key system).	
	Service positioning operation does not operate	<ul style="list-style-type: none"> • Combination switch • BCM • IPDM E/R 	Combination switch Refer to BCS-78, "Symptom Table" (With Intelligent Key system) or BCS-139, "Symptom Table" (Without Intelligent Key system).
	Wiper is not linked to the washer operation	<ul style="list-style-type: none"> • Combination switch • Harness between combination switch and BCM • BCM 	Combination switch Refer to BCS-78, "Symptom Table" (With Intelligent Key system) or BCS-139, "Symptom Table" (Without Intelligent Key system).
	BCM	—	
Does not return to stop position [Repeatedly operates for 10 seconds and then stops for 20 seconds. After that, it stops the operation. (Fail-safe)]	<ul style="list-style-type: none"> • IPDM E/R • Harness between IPDM E/R and front wiper motor • Front wiper motor 	Front wiper stop position signal circuit Refer to WW-32, "Component Function Check" .	
Rear wiper does not operate	ON only	<ul style="list-style-type: none"> • Combination switch • Harness between combination switch and BCM • BCM 	Combination switch Refer to BCS-78, "Symptom Table" (With Intelligent Key system) or BCS-139, "Symptom Table" (Without Intelligent Key system).
	INT only	<ul style="list-style-type: none"> • Combination switch • Harness between combination switch and BCM • BCM 	Combination switch Refer to BCS-78, "Symptom Table" (With Intelligent Key system) or BCS-139, "Symptom Table" (Without Intelligent Key system).
	ON and INT	<ul style="list-style-type: none"> • Combination switch • Harness between combination switch and BCM • BCM 	Combination switch Refer to BCS-78, "Symptom Table" (With Intelligent Key system) or BCS-139, "Symptom Table" (Without Intelligent Key system).
		<ul style="list-style-type: none"> • BCM • Harness between rear wiper motor and BCM • Harness between rear wiper motor and ground • Rear wiper motor 	Rear wiper motor circuit Refer to WW-35, "Component Function Check" .

WIPER AND WASHER SYSTEM SYMPTOMS

< SYMPTOM DIAGNOSIS >

Symptom		Probable malfunction location	Inspection item
Rear wiper does not stop	ON only	<ul style="list-style-type: none"> Combination switch BCM 	Combination switch Refer to BCS-78, "Symptom Table" (With Intelligent Key system) or BCS-139, "Symptom Table" (Without Intelligent Key system).
	INT only	<ul style="list-style-type: none"> Combination switch BCM 	Combination switch Refer to BCS-78, "Symptom Table" (With Intelligent Key system) or BCS-139, "Symptom Table" (Without Intelligent Key system).
Rear wiper does not operate normally	Wiper is not linked to the washer operation	<ul style="list-style-type: none"> Combination switch Harness between rear wiper motor and BCM BCM 	Combination switch Refer to BCS-78, "Symptom Table" (With Intelligent Key system) or BCS-139, "Symptom Table" (Without Intelligent Key system).
		BCM	—
	Rear wiper does not return to the stop position. [Stops after a five-second operation. (Fail-safe)]	<ul style="list-style-type: none"> BCM Harness between rear wiper motor and BCM Rear wiper motor 	Rear wiper stop position signal circuit Refer to WW-37, "Component Function Check" .

A
B
C
D
E
F
G
H
I
J
K
L
M
N
O
P

WW

NORMAL OPERATING CONDITION

< SYMPTOM DIAGNOSIS >

NORMAL OPERATING CONDITION

Description

INFOID:000000007579577

FRONT WIPER MOTOR PROTECTION FUNCTION

- IPDM E/R may stop the front wiper to protect the front wiper motor if any obstruction (operation resistance) such as a large amount of snow is detected during the front wiper operation.
- At that time turn OFF the front wiper and remove the foreign object. Then wait for approximately 20 seconds or more and reactivate the front wiper. The wiper will operate normally.

REAR WIPER MOTOR PROTECTION FUNCTION

- BCM may stop rear wiper to protect the rear wiper motor when the rear wiper is stopped for 5 seconds or more due to a snowfall.
- Rear wiper operates normally one minute after the obstacles are removed with rear wiper OFF.

FRONT WIPER DOES NOT OPERATE

< SYMPTOM DIAGNOSIS >

FRONT WIPER DOES NOT OPERATE

Description

INFOID:000000007579578

The front wiper does not operate under any operation conditions.

Diagnosis Procedure

INFOID:000000007579579

1. CHECK WIPER RELAY OPERATION

CONSULT ACTIVE TEST

1. Select "FRONT WIPER" of IPDM E/R active test item.
2. With operating the test item, check front wiper operation.

Lo : Front wiper LO operation

Hi : Front wiper HI operation

Off : Stop the front wiper.

Is front wiper operation normally?

YES >> GO TO 5.

NO >> GO TO 2.

2. CHECK FRONT WIPER MOTOR FUSE

Check front wiper motor fuse. Refer to [WW-29, "Diagnosis Procedure"](#).

Is the inspection result normal?

YES >> GO TO 3.

NO >> Replace the fuse after repairing the applicable circuit.

3. CHECK FRONT WIPER MOTOR GROUND CIRCUIT

Check front wiper motor ground circuit. Refer to [WW-33, "Diagnosis Procedure"](#).

Is the inspection result normal?

YES >> GO TO 4.

NO >> Repair or replace harness.

4. CHECK FRONT WIPER MOTOR INPUT VOLTAGE

CONSULT ACTIVE TEST

1. Turn ignition switch OFF.
2. Disconnect front wiper motor connector.
3. Turn ignition switch ON.
4. Select "FRONT WIPER" of IPDM E/R active test item.
5. With operating the test item, check voltage between front wiper motor harness connector and ground.

(+)		(-)	Condition	Voltage (Approx.)
Front wiper motor				
Connector	Terminal			
E20	2	Ground	Lo	Battery voltage
			Off	0 V
	1		Hi	Battery voltage
			Off	0 V

Is the inspection result normal?

YES >> Replace front wiper motor.

NO >> Replace IPDM E/R.

5. CHECK FRONT WIPER REQUEST SIGNAL INPUT

CONSULT DATA MONITOR

1. Select "FR WIP REQ" of IPDM E/R data monitor item.
2. Switch the front wiper switch to HI and LO.

A
B
C
D
E
F
G
H
I
J
K
M
N
O
P

WW

FRONT WIPER DOES NOT OPERATE

< SYMPTOM DIAGNOSIS >

3. With operating the front wiper switch, check the status of "FR WIP REQ".

Monitor item	Condition		Monitor status
FR WIP REQ	Front wiper switch HI	On	Hi
		Off	Stop
	Front wiper switch LO	On	Low
		Off	Stop

Is the inspection result normal?

YES >> Replace IPDM E/R.

NO >> GO TO 6.

6. CHECK COMBINATION SWITCH

Perform the inspection of the combination switch. Refer to [BCS-78. "Symptom Table"](#) (with Intelligent Key system) or [BCS-139. "Symptom Table"](#) (without Intelligent Key system).

Is combination switch normal?

YES >> Replace BCM. Refer to [BCS-80. "Removal and Installation"](#) (with Intelligent Key system) or [BCS-141. "Removal and Installation"](#) (without Intelligent Key system).

NO >> Repair or replace the applicable parts.

WASHER TANK

< REMOVAL AND INSTALLATION >

REMOVAL AND INSTALLATION

WASHER TANK

Exploded View

INFOID:000000007579580

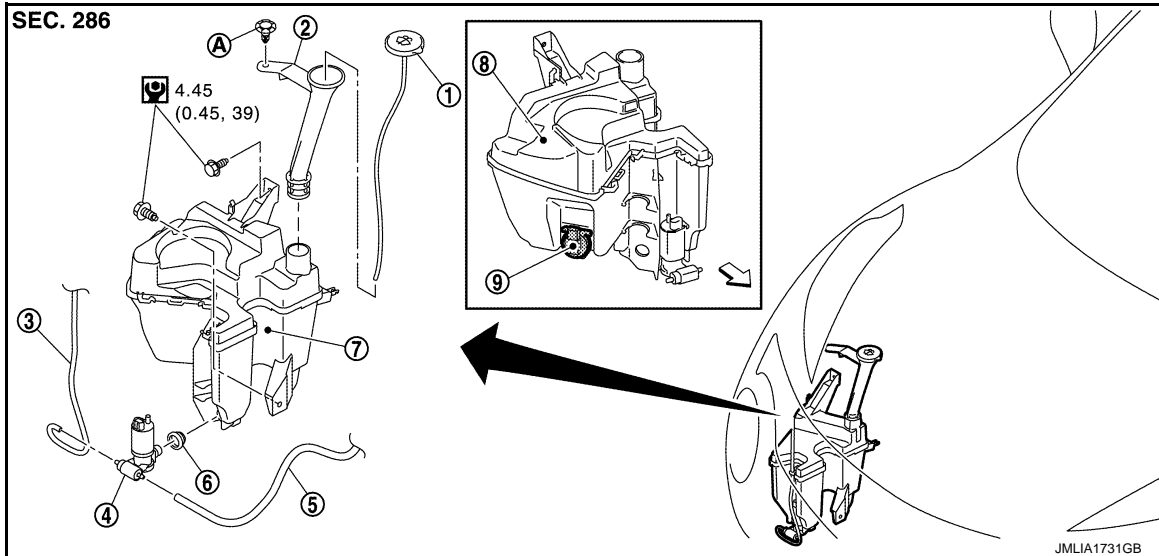

- | | | |
|--------------------------|-------------------------------------|---|
| 1. Washer tank inlet cap | 2. Washer tank inlet | 3. Front washer tube |
| 4. Washer pump | 5. Rear washer tube | 6. Packing |
| 7. Washer tank | 8. Washer tank (Canada models only) | 9. Washer level sensor (Canada models only) |

A : Clip

← : Vehicle front

 : N·m (kg·m, in·lb)

Removal and Installation

INFOID:000000007579581

REMOVAL

1. Fully open hood.
2. Remove washer tank inlet fixing clip (A).
3. Pull out washer tank inlet (1) from washer tank.

← : Vehicle front

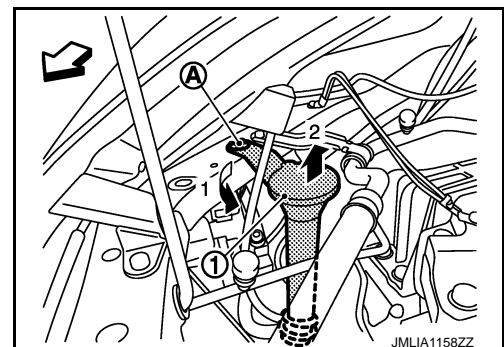

4. Remove fender protector RH (front). Refer to [EXT-21, "Removal and Installation"](#).
5. Disconnect washer pump connector.
6. Disconnect washer level switch connector (Canada models only).
7. Disconnect front washer tube and rear washer tube.
8. Remove washer tank mounting bolts.

INSTALLATION

Note the following item, and then install in the reverse order of removal.

A
B
C
D
E
F
G
H
I
J
K
M
N
O
P

WW

WASHER TANK

< REMOVAL AND INSTALLATION >

CAUTION:

Add water up to the top of washer tank inlet after installing and check that there is no leakage.

WASHER PUMP

< REMOVAL AND INSTALLATION >

WASHER PUMP

Exploded View

INFOID:000000007579582

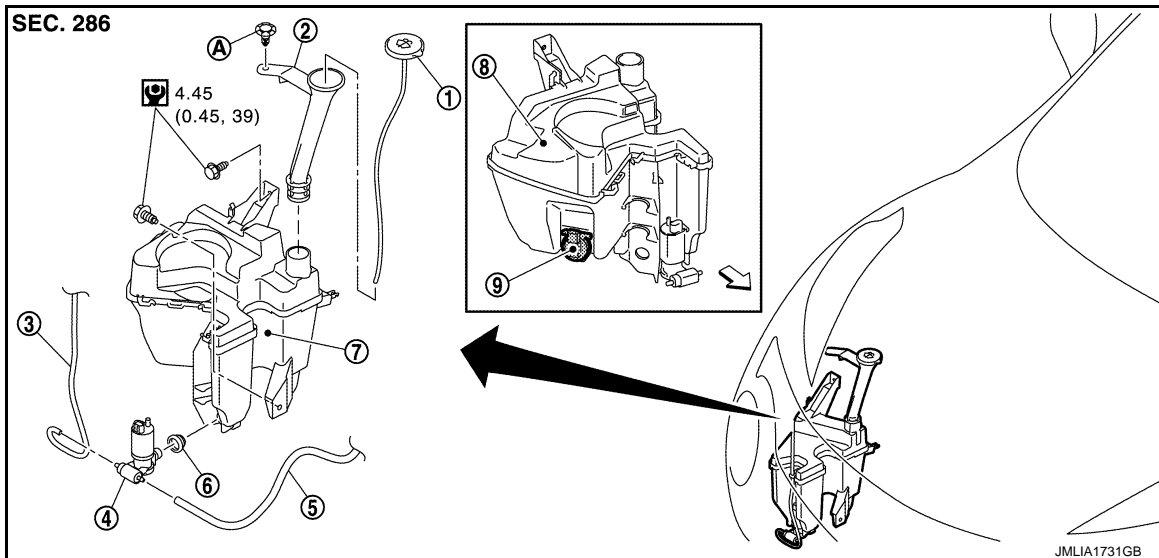

- | | | |
|--------------------------|-------------------------------------|---|
| 1. Washer tank inlet cap | 2. Washer tank inlet | 3. Front washer tube |
| 4. Washer pump | 5. Rear washer tube | 6. Packing |
| 7. Washer tank | 8. Washer tank (Canada models only) | 9. Washer level sensor (Canada models only) |

A : Clip

← : Vehicle front

⊙ : N-m (kg-m, in-lb)

Removal and Installation

INFOID:000000007579583

REMOVAL

1. Remove fender protector RH (front). Refer to [EXT-21. "Removal and Installation"](#).
2. Disconnect washer pump connector.
3. Disconnect front washer tube and rear washer tube.
4. Remove washer pump from the washer tank.
5. Remove packing from washer tank.

INSTALLATION

Note the following items, and then install in the reverse order of removal.

CAUTION:

- Check that there is no leakage after installation or replace packing with new part if it has been damaged.
- Never twist the packing when installing the washer pump.

A
B
C
D
E
F
G
H
I
J
K
WW
M
N
O
P

WASHER LEVEL SWITCH

< REMOVAL AND INSTALLATION >

WASHER LEVEL SWITCH

Removal and Installation

INFOID:000000007579584

The washer level switch must be replaced together with the washer tank as an assembly. Refer to [WW-47](#), "[Removal and Installation](#)".

FRONT WASHER NOZZLE AND TUBE

< REMOVAL AND INSTALLATION >

FRONT WASHER NOZZLE AND TUBE

Exploded View

INFOID:000000007579585

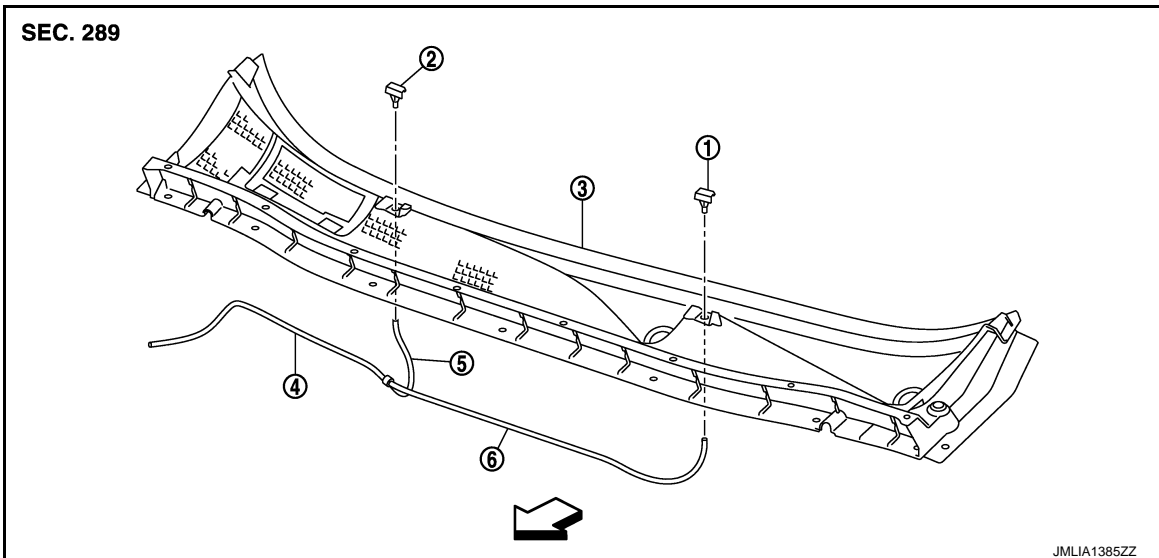

- | | | |
|----------------------------------|---------------------------|-------------------------|
| 1. Front washer nozzle LH | 2. Front washer nozzle RH | 3. Cowl top cover |
| 4. Front washer tube (tank side) | 5. Front washer tube RH | 6. Front washer tube LH |

← : Vehicle front

Hydraulic Layout

INFOID:000000007579586

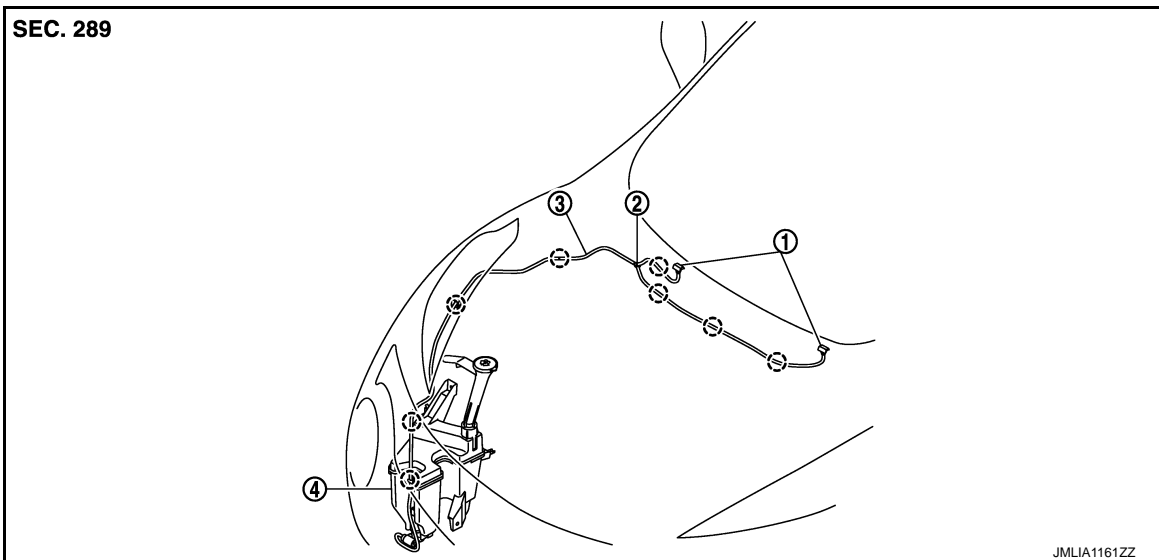

- | | | |
|------------------------|----------------|----------------------|
| 1. Front washer nozzle | 2. Check valve | 3. Front washer tube |
| 4. Washer tank | | |

⊙ : Clip

Removal and Installation

INFOID:000000007579587

REMOVAL

1. Remove cowl top cover. Refer to [EXT-20, "Removal and Installation"](#).
2. Disconnect front washer tube from front washer nozzle.

FRONT WASHER NOZZLE AND TUBE

< REMOVAL AND INSTALLATION >

- While pressing pawl (A) on the cowl top cover front side of front washer nozzle (1), remove front washer nozzle from cowl top cover.

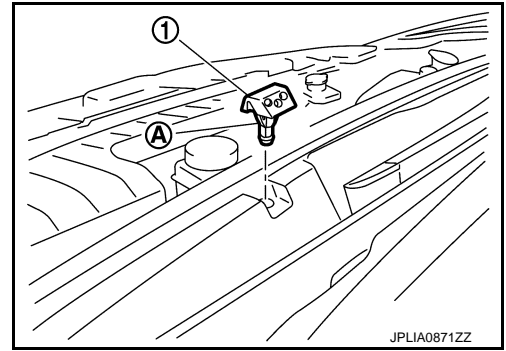

INSTALLATION

Note the following item, and then install in the reverse order of removal.

CAUTION:

The spray positions differ, check that left and right nozzles are installed correctly.

Inspection and Adjustment

INFOID:000000007579588

INSPECTION

Check valve Inspection

Check that air can pass through the hose by blowing forward (toward the nozzle (1)), and check that air cannot pass through by sucking.

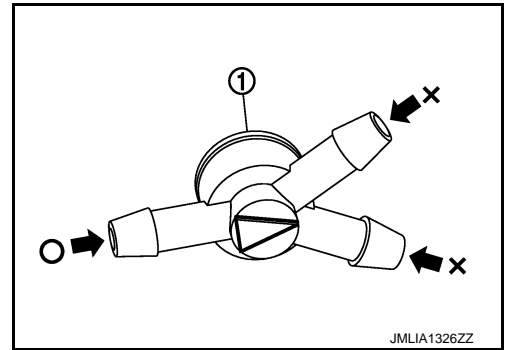

ADJUSTMENT

Washer Nozzle Spray Position Adjustment

Adjust spray positions to match the positions shown in the figure.

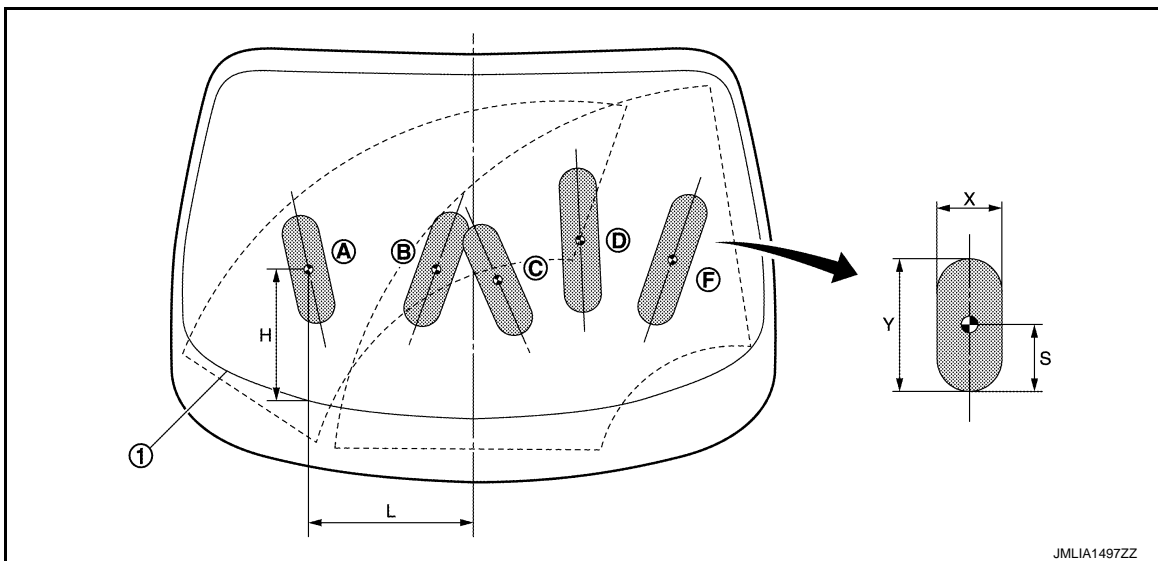

1. Black printed frame line

▨ : Spray area

● : Target spray position

FRONT WASHER NOZZLE AND TUBE

< REMOVAL AND INSTALLATION >

Unit: mm (in)

Spray position	H	L	X	Y	S
A	244 (9.61)	350 (13.78)	80 (3.15)	238 (9.37)	78 (3.07)
B	284 (11.18)	93 (3.66)	80 (3.15)	257 (10.12)	89 (3.50)
C	258 (10.16)	70.5 (2.78)	80 (3.15)	255 (10.04)	82 (3.23)
D	309 (12.17)	234 (9.21)	80 (3.15)	312 (12.28)	95 (3.74)
E	235 (9.25)	413 (16.26)	80 (3.15)	295 (11.61)	90 (3.54)

Insert a needle or similar object (A) into the spray opening (1) and move up/down and left/right to adjust the spray position.

NOTE:

If wax or dust gets into the nozzle, remove wax or dust with a needle or small pin.

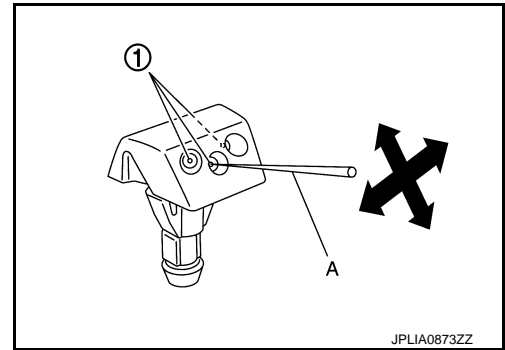

A
B
C
D
E
F
G
H
I
J
K

WW

M
N
O
P

FRONT WIPER ARM

< REMOVAL AND INSTALLATION >

FRONT WIPER ARM

Exploded View

INFOID:000000007579589

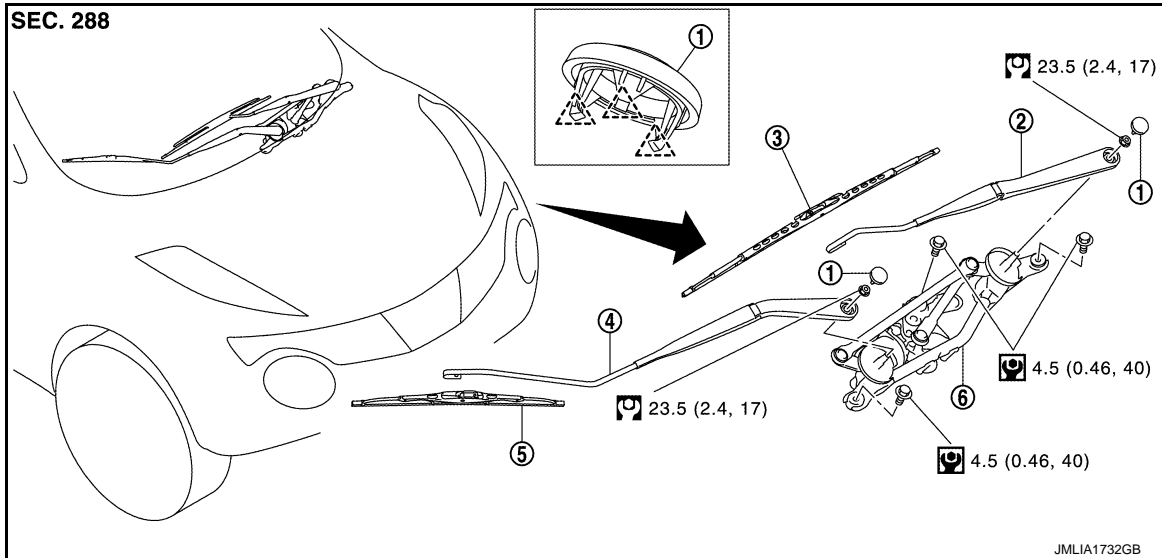

- | | | |
|------------------------|-------------------------|-------------------------------|
| 1. Front wiper arm cap | 2. Front wiper arm LH | 3. Front wiper blade LH |
| 4. Front wiper arm RH | 5. Front wiper blade RH | 6. Front wiper drive assembly |

 : Pawl

 : N·m (kg-m, in-lb)

 : N·m (kg-m, ft-lb)

Removal and Installation

INFOID:000000007579590

REMOVAL

1. Operate front wiper to move it to the auto stop position.
2. Open the hood.
3. Disengage front wiper arm cap (1) fixing pawls with a remover tool (A), and then remove front wiper arm cap from the wiper arm (2).

 : Pawl

 : Vehicle front

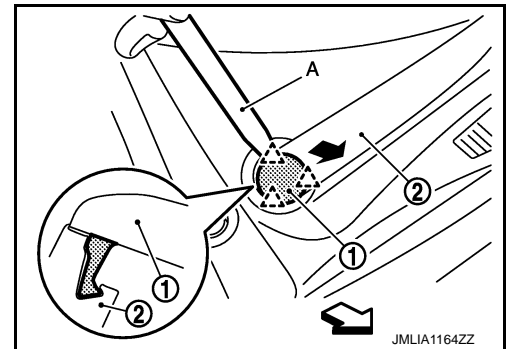

4. Remove front wiper arm mounting nuts.
5. Raise front wiper arm, and then remove front wiper arm from the vehicle.

INSTALLATION

FRONT WIPER ARM

< REMOVAL AND INSTALLATION >

1. Clean wiper arm mount as shown in the figure to prevent nuts from being loosened.
2. Operate front wiper motor to move the front wiper to the auto stop position.
3. Adjust front wiper blade position. Refer to [WW-55, "Adjustment"](#).
4. Install front wiper arm by tightening the mounting nuts.
5. Inject the washer fluid.
6. Operate front wiper to move it to the auto stop position.
7. Check that the front wiper blades stop at the specified position.
8. Install front wiper arm caps.

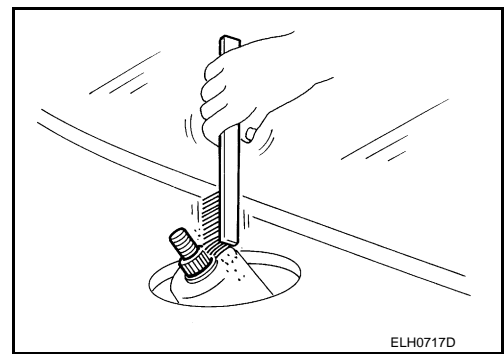

Adjustment

INFOID:000000007579591

WIPER BLADE POSITION ADJUSTMENT

Clearance between the end of cowl top cover/ front fender protector and the top of wiper blade center

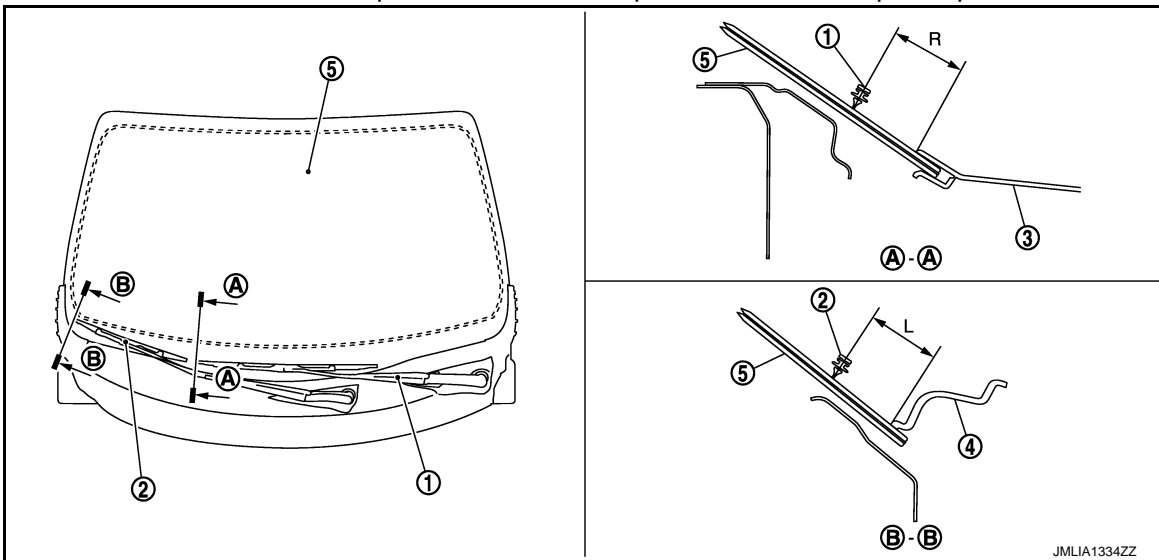

- | | | |
|-----------------------|------------------------------|-------------------|
| 1. Front wiper arm LH | 2. Front wiper arm RH | 3. Cowl top cover |
| 4. Front fender cover | 5. Windshield glass assembly | |

Standard clearance

R : 37.7 ± 7.5 mm (1.484 ± 0.295 in)

L : 46.8 ± 7.5 mm (1.843 ± 0.295 in)

A
B
C
D
E
F
G
H
I
J
K
L
M
N
O
P

WW

FRONT WIPER BLADE

< REMOVAL AND INSTALLATION >

FRONT WIPER BLADE

Exploded View

INFOID:000000007579592

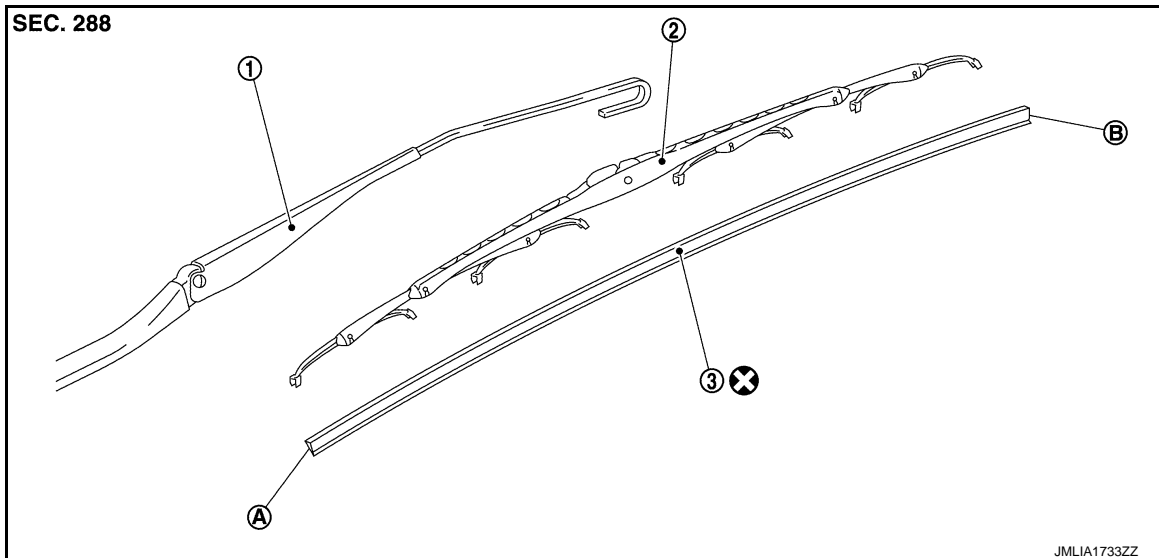

- 1. Wiper arm
 - 2. Wiper blade
 - 3. Wiper refill
- A : Wiper refill end
B: : Wiper refill tip
⊗ : Do not reuse

Removal and Installation

INFOID:000000007579593

REMOVAL

Push up the lever (A) of wiper blade (1), while sliding wiper blade toward the direction of the arrow to remove it from wiper arm (2).

CAUTION:

Be careful not to drop the wiper blade onto the windshield glass.

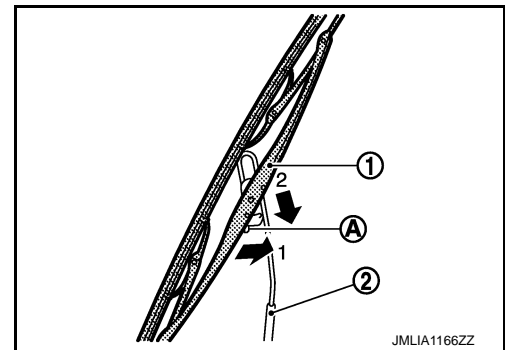

INSTALLATION

1. Install wiper blade into wiper arm.
2. Install wiper arm.

Replacement

INFOID:000000007579594

1. Remove the wiper blade from the wiper arm. Refer to [WW-56, "Removal and Installation"](#).

FRONT WIPER BLADE

< REMOVAL AND INSTALLATION >

- Pinch the vertebra with tenailles (A) and slide the wiper refill (2) toward the direction of the arrow 2 to remove.

NOTE:

Be careful not to damage the wiper blade (1).

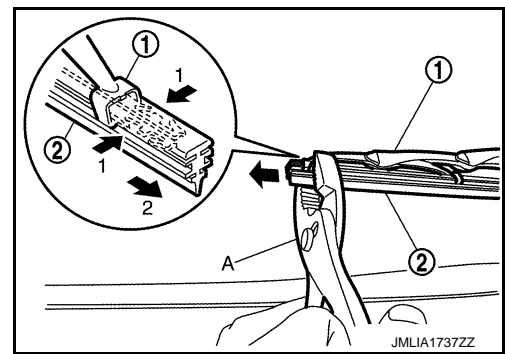

- Insert the new wiper refill kit (2) as shown in the figure to the wiper blade (1) until the stopper at the wiper refill end fits into the tab on wiper blade.

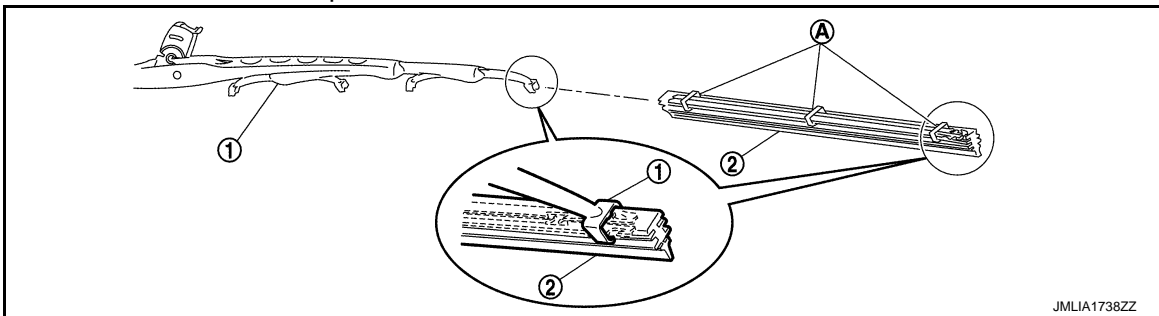

NOTE:

- Insert the wiper refill to be held securely by tab of wiper blade.
- After the wiper refill is fully inserted, remove the holder (A).
- The refill kit is provided as a set attached to service parts.

- After installing the new wiper refill (1) check that the vertebra (2) is well inserted into the wiper refill (1).

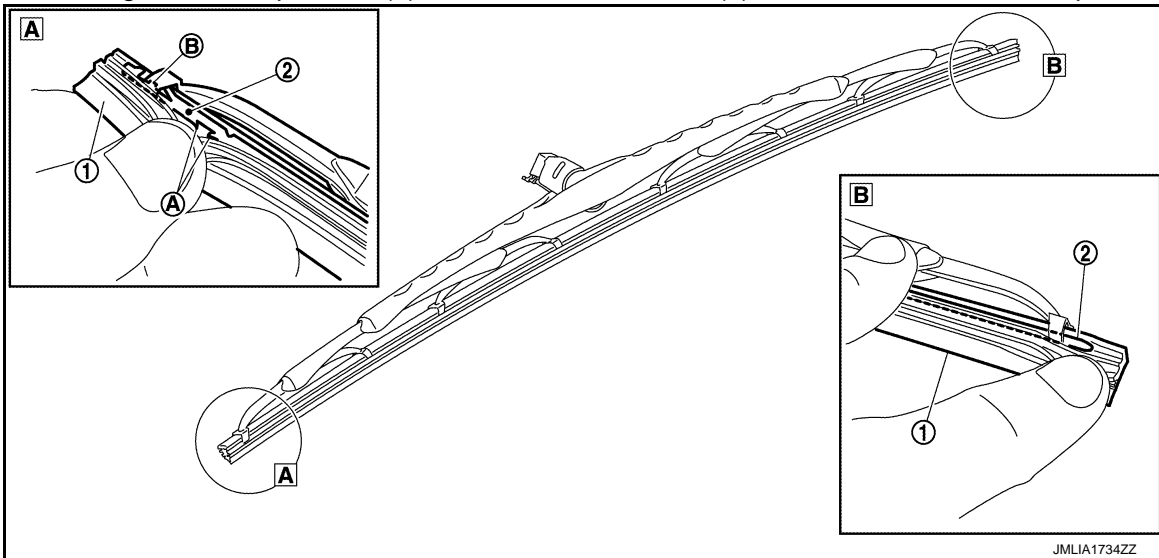

NOTE:

Check the following items after replacing wiper refill.

- Wiper refill is not twisted at all.
- Wiper refill thoroughly fits in the tab (B) on wiper blade.
- Wiper refill is inserted from the proper direction.
- The stopper (A) is inserted into the wiper refill.

A
B
C
D
E
F
G
H
I
J
K
L
M
N
O
P

WW

FRONT WIPER DRIVE ASSEMBLY

< REMOVAL AND INSTALLATION >

FRONT WIPER DRIVE ASSEMBLY

Exploded View

INFOID:000000007579595

REMOVAL

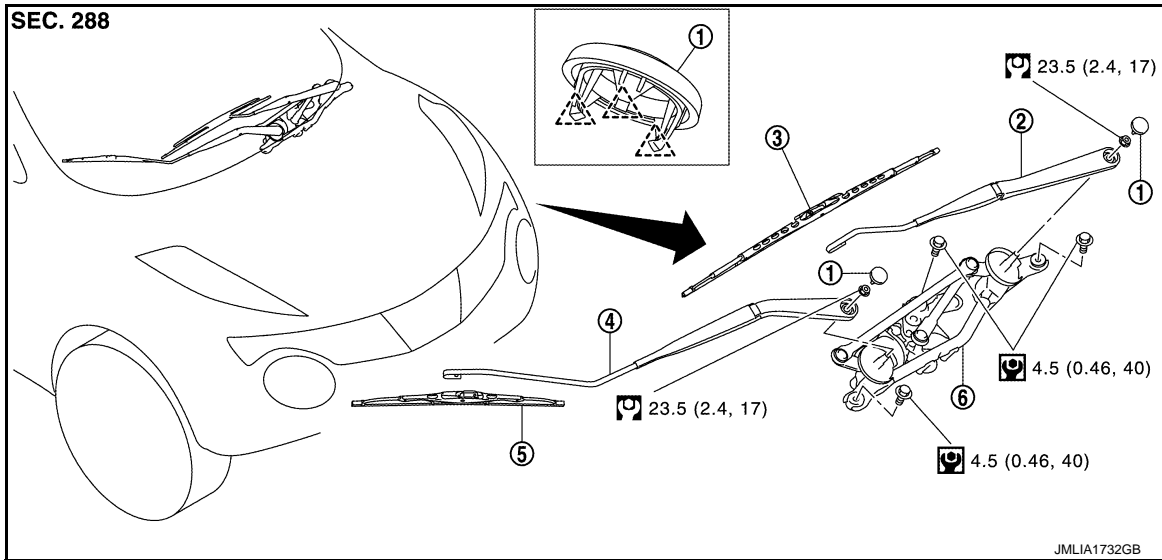

- | | | |
|------------------------|-------------------------|-------------------------------|
| 1. Front wiper arm cap | 2. Front wiper arm LH | 3. Front wiper blade LH |
| 4. Front wiper arm RH | 5. Front wiper blade RH | 6. Front wiper drive assembly |

 : Pawl

 : N·m (kg·m, in·lb)

 : N·m (kg·m, ft·lb)

DISASSEMBLY

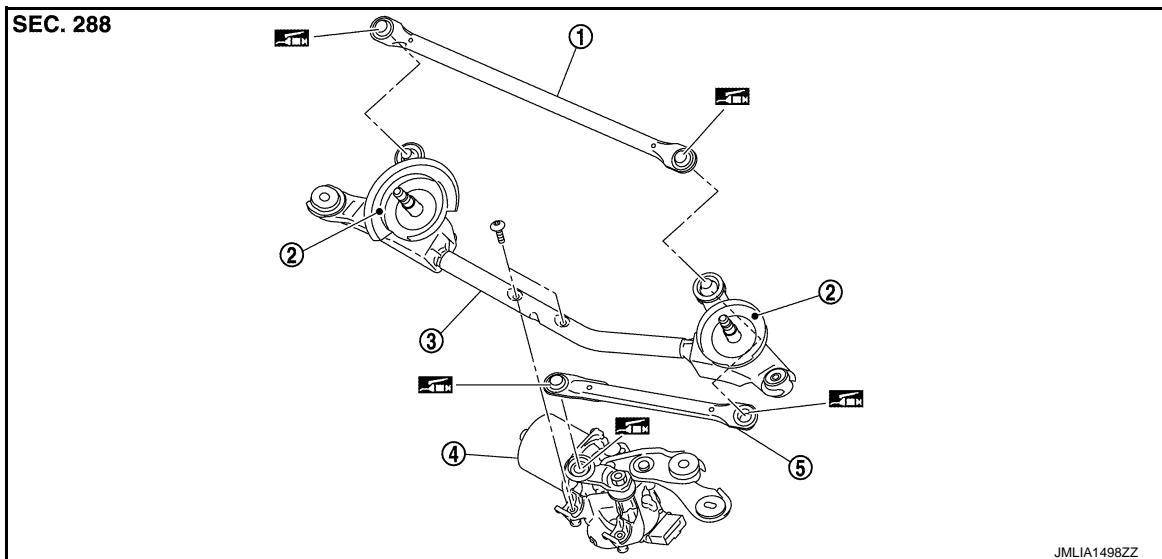

- | | | |
|--------------------------|--------------------------|----------------------|
| 1. Front wiper linkage 1 | 2. Shaft seal | 3. Front wiper frame |
| 4. Front wiper motor | 5. Front wiper linkage 2 | |

 : Nissan MP special grease No.2

FRONT WIPER DRIVE ASSEMBLY

< REMOVAL AND INSTALLATION >

Removal and Installation

INFOID:000000007579596

REMOVAL

1. Remove front wiper arms (LH and RH). Refer to [WW-54, "Removal and Installation"](#).
2. Remove cowl top cover. Refer to [EXT-20, "Removal and Installation"](#).
3. Disconnect the front wiper motor connector.
4. Remove the mounting bolts from front wiper drive assembly.
5. Remove the front wiper drive assembly from the vehicle.

INSTALLATION

1. Install the front wiper drive assembly to the vehicle.
2. Connect front wiper motor connector.
3. Operate front wiper to move it to the auto stop position.
4. Install cowl top cover. Refer to [EXT-20, "Removal and Installation"](#).
5. Install front wiper arms. Refer to [WW-54, "Removal and Installation"](#).

Disassembly and Assembly

INFOID:000000007579597

DISASSEMBLY

1. Remove the front wiper linkage 1 and 2 from the front wiper drive assembly.
CAUTION:
Never bend the linkage or damage the plastic part of the ball joint when removing the wiper linkage.
2. Remove the front wiper motor mounting screws, and then remove the front wiper motor from the front wiper frame.

ASSEMBLY

1. Connect the front wiper motor connector.
2. Operate the front wiper to move it to the auto stop position.
3. Disconnect the front wiper motor connector.
4. Install the front wiper motor to the front wiper frame.
5. Install the front wiper linkage 2 to the front wiper motor and the front wiper frame.
6. Install the front wiper linkage 1 to the front wiper frame.
CAUTION:
 - **Never drop front wiper motor or cause it to come into contact with other parts.**
 - **Be careful for the grease condition at the front wiper motor and front wiper linkage joint (retainer). Apply Multi-purpose grease or an equivalent if necessary.**

A
B
C
D
E
F
G
H
I
J
K
M
N
O
P

WW

WIPER AND WASHER SWITCH

< REMOVAL AND INSTALLATION >

WIPER AND WASHER SWITCH

Exploded View

INFOID:000000007579598

Wiper and washer switch is integrated in the combination switch. Refer to [BCS-81, "Exploded View"](#).

REAR WIPER ARM

< REMOVAL AND INSTALLATION >

REAR WIPER ARM

Exploded View

INFOID:000000007579599

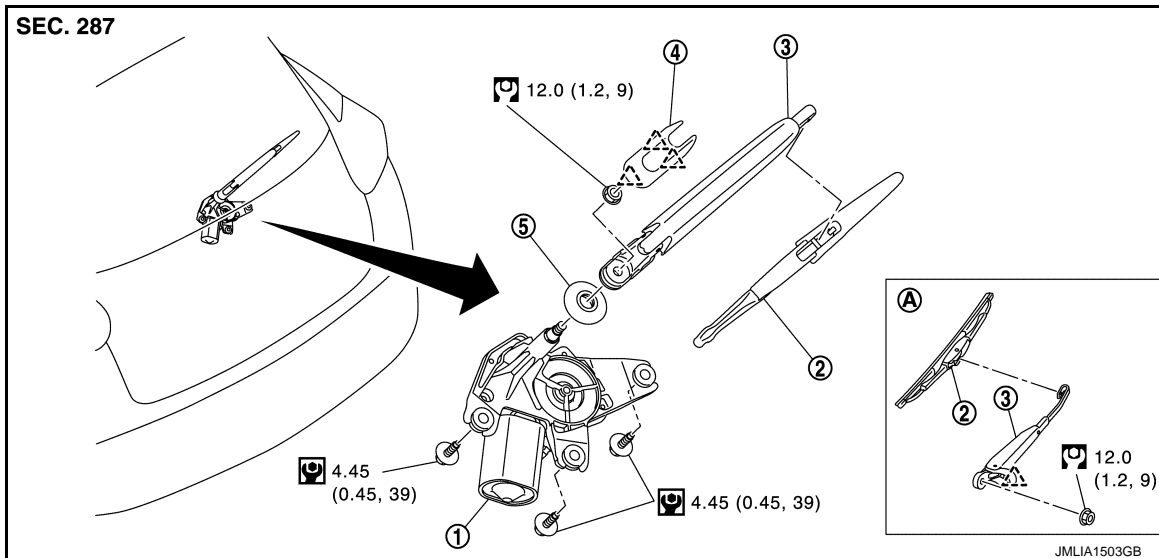

- 1. Rear wiper motor
- 2. Rear wiper blade
- 3. Rear wiper arm
- 4. Rear wiper arm cover
- 5. Rear wiper pivot seal

A : Canada models only

 : Pawl

 : N·m (kg·m, in·lb)

 : N·m (kg·m, ft·lb)

Removal and Installation

INFOID:000000007579600

REMOVAL

1. Operate rear wiper to the auto stop position.
2. Remove rear wiper arm cover.
3. Remove rear wiper arm mounting nut.
4. Remove wiper arm from the vehicle.

INSTALLATION

1. Clean wiper arm mount as shown in the figure to prevent nut from being loosened.
2. Operate the rear wiper motor to the auto stop position.
3. Adjust the rear wiper blade position. Refer to [WW-61, "Adjustment"](#).
4. Install the rear wiper arm by tightening the mounting nut.
5. Inject the washer fluid.
6. Operate the rear wiper to the auto stop position.
7. Check that the rear wiper blades stop at the specified position.
8. Install the rear wiper arm cover.

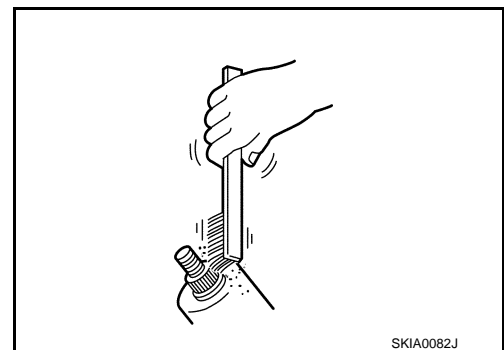

Adjustment

INFOID:000000007579601

REAR WIPER BLADE POSITION ADJUSTMENT

REAR WIPER ARM

< REMOVAL AND INSTALLATION >

Set the wiper blade top on the defrosting wire (A) (clearance between the end of back door glass and the top of wiper blade center).

Standard clearance

1. Rear wiper blade
 2. Back door window glass
 3. Back door panel
- A : Rear defogger wire print
L : 67.5 ± 7.5 mm (2.657 ± 0.295 in)

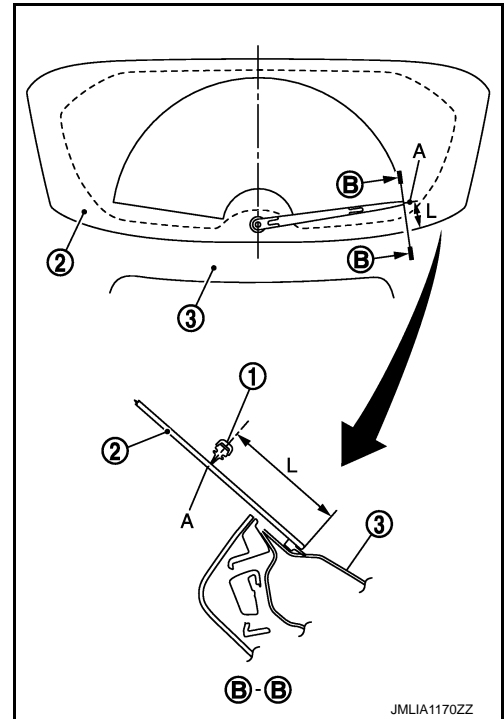

REAR WIPER MOTOR

< REMOVAL AND INSTALLATION >

REAR WIPER MOTOR

Exploded View

INFOID:000000007579602

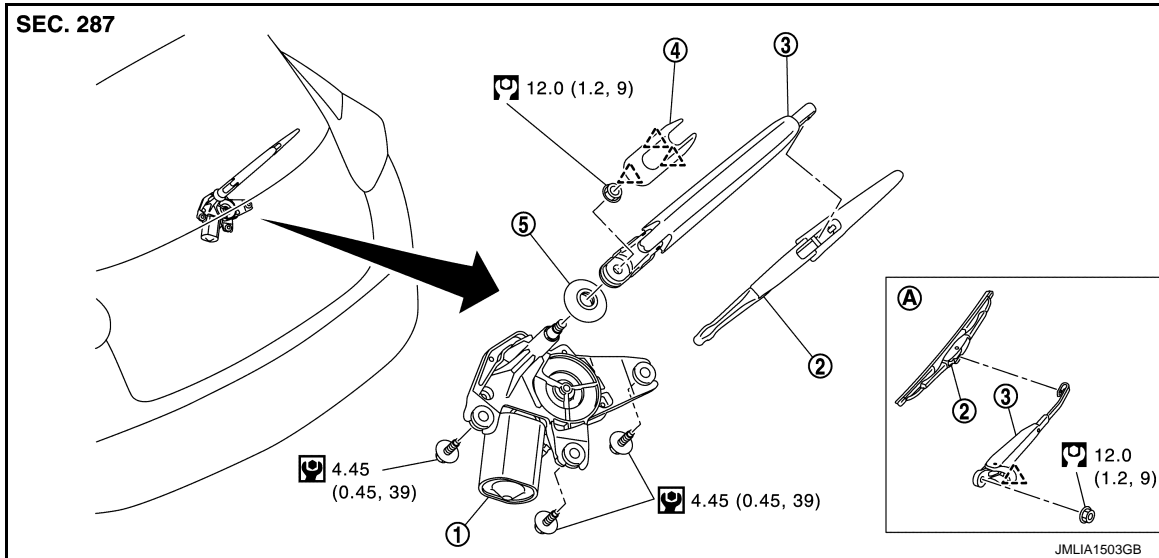

- 1. Rear wiper motor
- 2. Rear wiper blade
- 3. Rear wiper arm
- 4. Rear wiper arm cover
- 5. Rear wiper pivot seal

A : Canada models only

 : Pawl

 : N·m (kg-m, in-lb)

 : N·m (kg-m, ft-lb)

Removal and Installation

INFOID:000000007579603

REMOVAL

1. Remove rear wiper arm. Refer to [WW-61, "Removal and Installation"](#).
2. Remove back door lower finisher. Refer to [INT-38, "BACK DOOR SIDE FINISHER : Removal and Installation"](#).
3. Disconnect rear wiper motor connector.
4. Remove rear wiper motor mounting bolts.
5. Remove rear wiper motor from the vehicle.
6. Remove the pivot seal.

INSTALLATION

Install in the reverse order of removal.

A
B
C
D
E
F
G
H
I
J
K
L
M
N
O
P

WW

REAR WASHER NOZZLE AND TUBE

< REMOVAL AND INSTALLATION >

REAR WASHER NOZZLE AND TUBE

Hydraulic Layout

INFOID:000000007579604

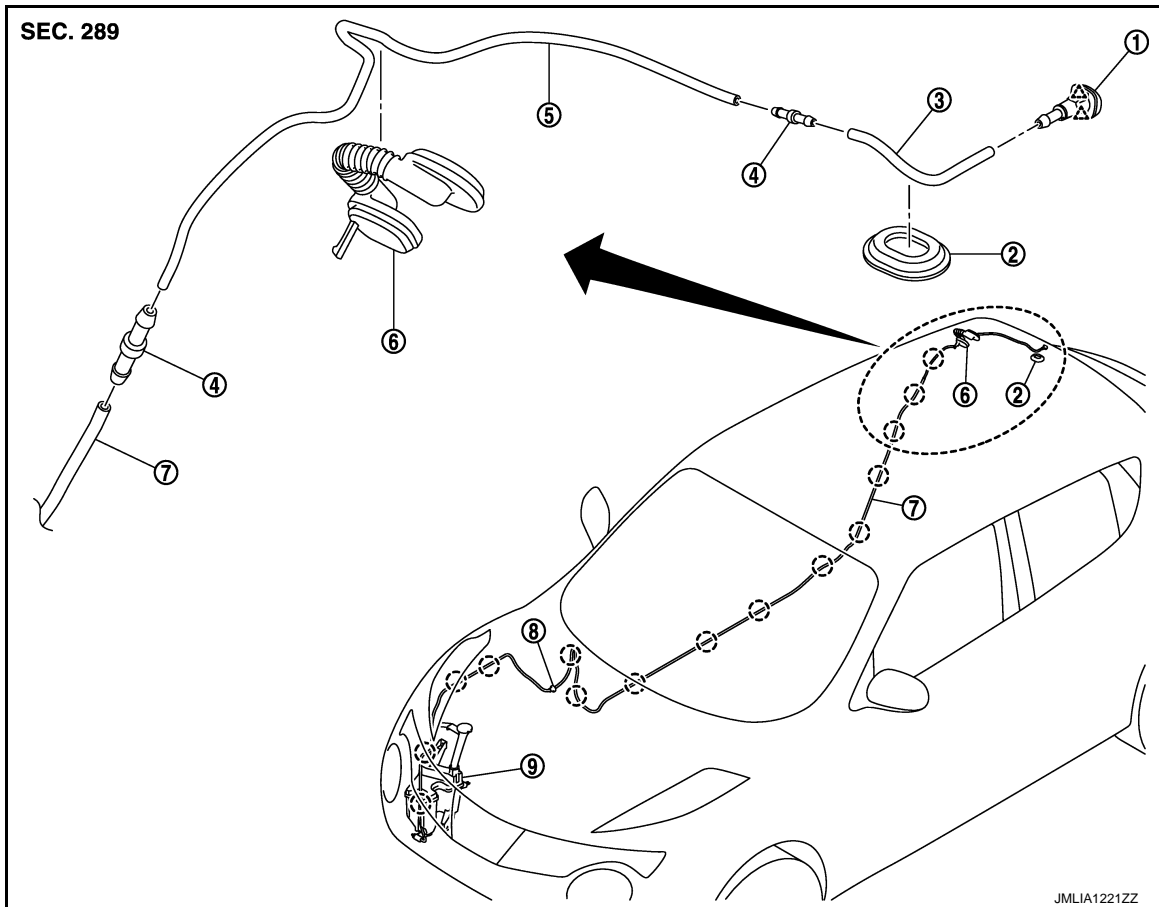

- | | | |
|-----------------------|-----------------------|--------------------------|
| 1. Rear washer nozzle | 2. Plug | 3. Rear washer tube |
| 4. Joint | 5. Second washer tube | 6. Back door seal rubber |
| 7. Front washer tube | | |
- : Clip
△ : Pawl

Removal and Installation

INFOID:000000007579605

REMOVAL

1. Remove luggage side upper finisher RH. Refer to [INT-35. "LUGGAGE SIDE UPPER FINISHER : Removal and Installation"](#).
2. Disconnect rear washer tube (2) fixing clip and then remove rear washer tube joint (2) from rear washer tube.

○ : Clip

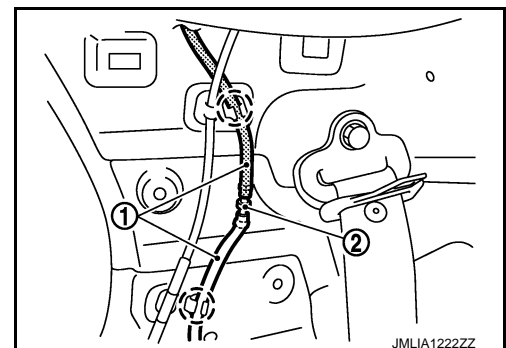

REAR WASHER NOZZLE AND TUBE

< REMOVAL AND INSTALLATION >

3. Fully open back door.
4. Remove back door seal rubber (2), and then remove rear washer tube (3) from back door seal rubber.
5. Remove plug (1).

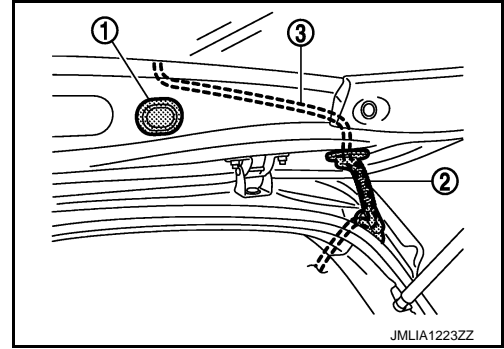

6. Disengage rear washer nozzle (1) fixing pawl with a flat-bladed screwdriver (A) and remove the rear washer nozzle.

CAUTION:

Wrap the flat-bladed screwdriver into a protective tape (B) to protect the part from damage.

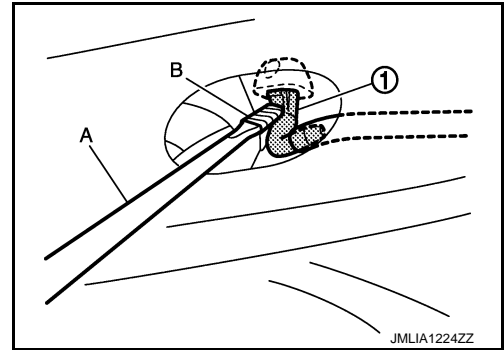

7. Remove rear washer nozzle from the rear washer tube.

INSTALLATION

Install in the reverse order of removal.

Inspection and Adjustment

INFOID:000000007579606

INSPECTION

Washer Nozzle Inspection

Check that air can pass through the hose by blowing forward (toward the nozzle), and check that air cannot pass through by sucking.

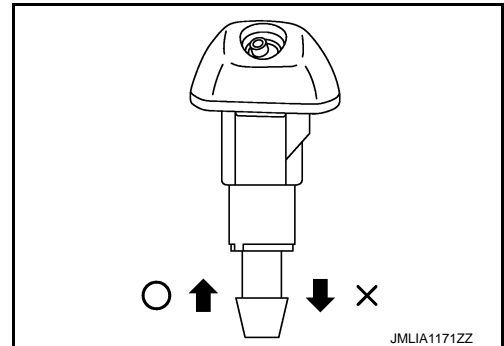

ADJUSTMENT

Washer Nozzle Spray Position adjustment

A
B
C
D
E
F
G
H
I
J
K
WW
M
N
O
P

REAR WASHER NOZZLE AND TUBE

< REMOVAL AND INSTALLATION >

Adjust spray positions to match the positions shown in the figure.

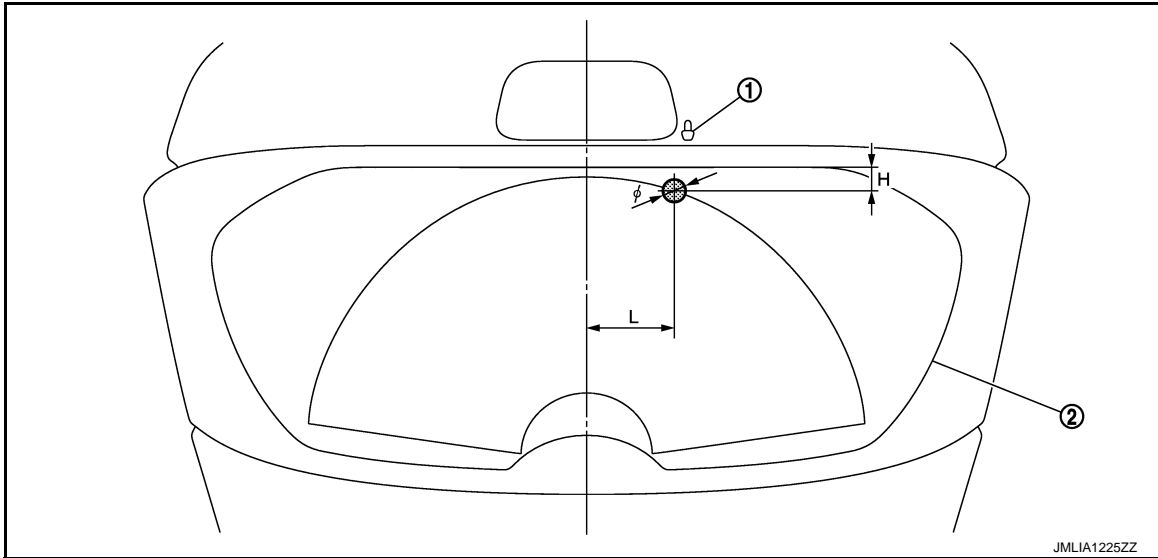

1. Rear washer nozzle

2. Black print frame line

Unit: mm (in)

L: Length	H : Height	φ : Spray area
122.8 (4.83)	32.8 (1.29)	30 (1.18)

Insert a needle or similar object (A) into the spray opening (1) and move up/down and left/right to adjust the spray position.

NOTE:

If wax or dust gets into the spray opening of rear washer nozzle (2), remove wax or dust with a needle or small pin.

