

SECTION **EX**
EXHAUST SYSTEM

A

EX

C

D

E

CONTENTS

MR16DDT			
PERIODIC MAINTENANCE	4		F
EXHAUST SYSTEM	4		
Inspection	4		G
REMOVAL AND INSTALLATION	5		
EXHAUST SYSTEM	5		H
Exploded View	5		
Removal and Installation	8		
Inspection	11		I
PRECAUTION	2		
PRECAUTIONS	2		
Precautions for Removing Battery Terminal	2		
Removal and Installation	2		
PREPARATION	3		
PREPARATION	3		
Special Service Tools	3		
Commercial Service Tools	3		
			J
			K
			L
			M
			N
			O
			P

< PRECAUTION >

PRECAUTION

PRECAUTIONS

Precautions for Removing Battery Terminal

INFOID:000000010715368

- When removing the 12V battery terminal, turn OFF the ignition switch and wait at least 30 seconds.

NOTE:

ECU may be active for several tens of seconds after the ignition switch is turned OFF. If the battery terminal is removed before ECU stops, then a DTC detection error or ECU data corruption may occur.

- For vehicles with the 2-batteries, be sure to connect the main battery and the sub battery before turning ON the ignition switch.

NOTE:

If the ignition switch is turned ON with any one of the terminals of main battery and sub battery disconnected, then DTC may be detected.

- After installing the 12V battery, always check "Self Diagnosis Result" of all ECUs and erase DTC.

NOTE:

The removal of 12V battery may cause a DTC detection error.

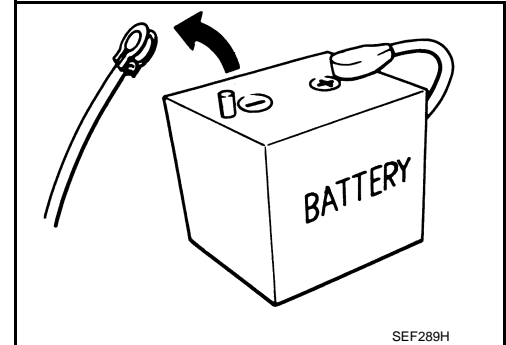

Removal and Installation

INFOID:000000008275063

CAUTION:

- Be sure to use genuine exhaust system parts or equivalents which are specially designed for heat resistance, corrosion resistance, and shape.
- Perform the operation with the exhaust system fully cooled down because the system will be hot just after engine stops.
- Be careful not to cut your hand on the heat insulator edge.

PREPARATION

< PREPARATION >

[MR16DDT]

PREPARATION

PREPARATION

Special Service Tools

INFOID:000000008275064

A

EX

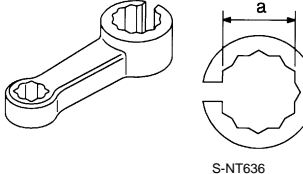
Tool number (TechMateNo.) Tool name	Description
KV10114400 (J-38365) Heated oxygen sensor wrench 	Loosening or tightening heated oxygen sensor 2 (2WD models) a: For 22 mm (0.87 in) width hexagon nut

C

D

E

Commercial Service Tools

INFOID:000000008275065

F

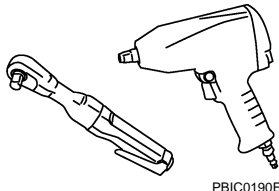
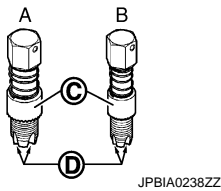
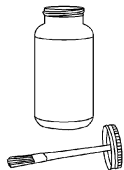
Tool name	Description
Power tool 	Loosening nuts and bolts
Heated oxygen sensor thread cleaner 	Reconditioning the exhaust system threads before installing a new heated oxygen sensor (Use with anti-seize lubricant shown below.) A: J-43897-18 [18 mm (0.71 in) dia.] for zirconia heated oxygen sensor B: J-43897-12 [12 mm (0.47 in) dia.] for titania heated oxygen sensor C: Mating surface shave cylinder D: Flutes
Anti-seize lubricant (Permatex 133AR or equivalent meeting MIL specification MIL-A-907) 	Lubricating heated oxygen sensor thread cleaner when reconditioning exhaust system threads

G

H

I

J

K

L

M

N

O

P

PERIODIC MAINTENANCE

EXHAUST SYSTEM

Inspection

INFOID:000000008275066

Check exhaust pipes, muffler, and mounting for improper attachment, leakage, cracks, damage or deterioration.

- If anything is found, repair or replace damaged parts.

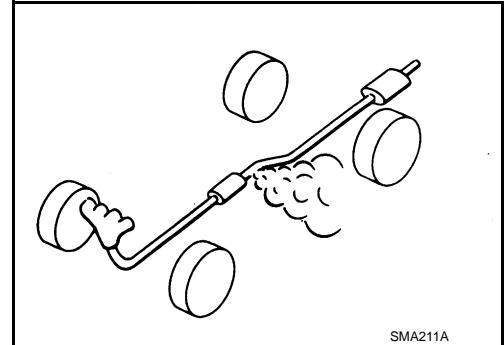

EXHAUST SYSTEM

< REMOVAL AND INSTALLATION >

[MR16DDT]

REMOVAL AND INSTALLATION

EXHAUST SYSTEM

Exploded View

INFOID:000000008275067

A

EX

2WD (Standard models)

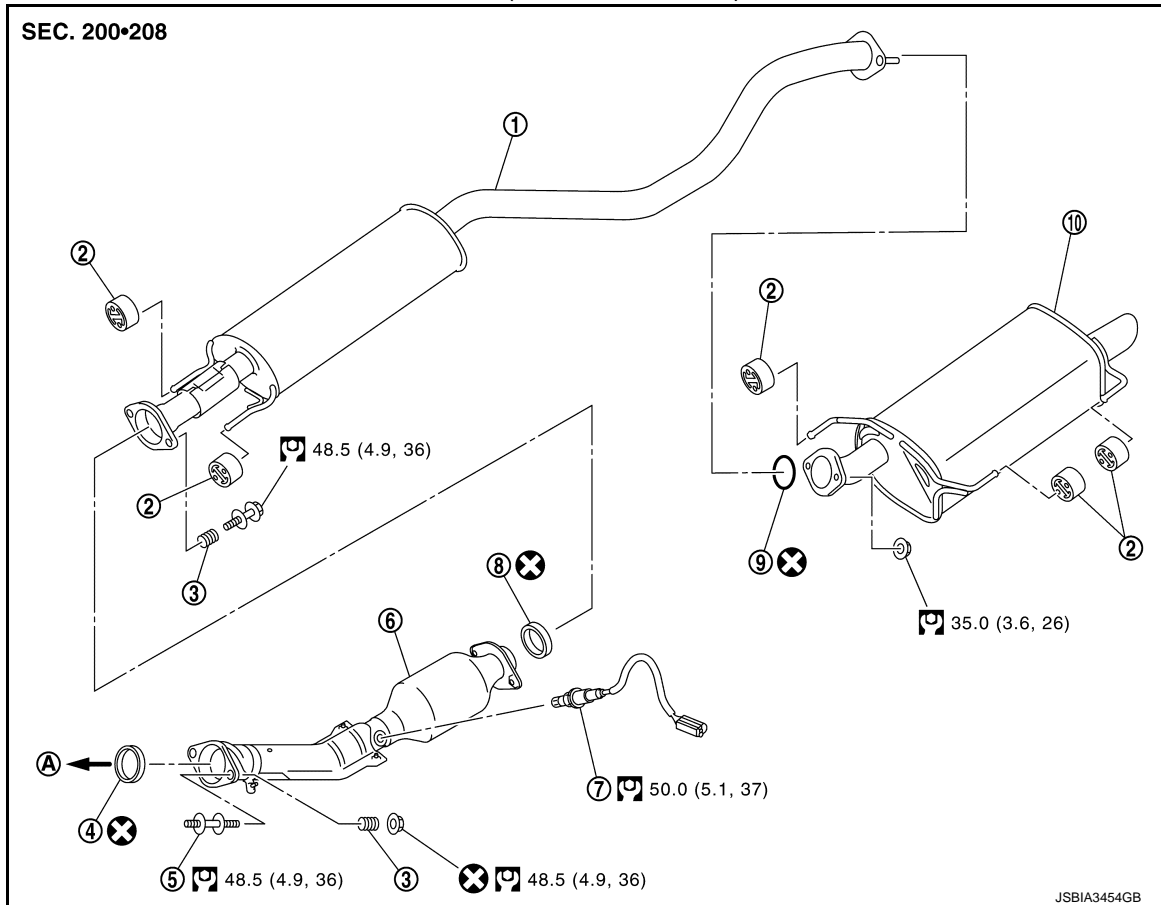

C

D

E

F

G

H

I

J

K

- | | | |
|---------------------------|--------------------|-----------------------|
| 1. Center muffler | 2. Mounting rubber | 3. Spring |
| 4. Seal bearing | 5. Stud bolt | 6. Exhaust front tube |
| 7. Heated oxygen sensor 2 | 8. Seal bearing | 9. Ring gasket |
| 10. Main muffler | | |
| A. To catalyst convertor | | |

L

M

: N·m (kg·m, ft·lb)

N

: Always replace after every disassembly.

O

P

EXHAUST SYSTEM

< REMOVAL AND INSTALLATION >

[MR16DDT]

2WD (NISMO models)

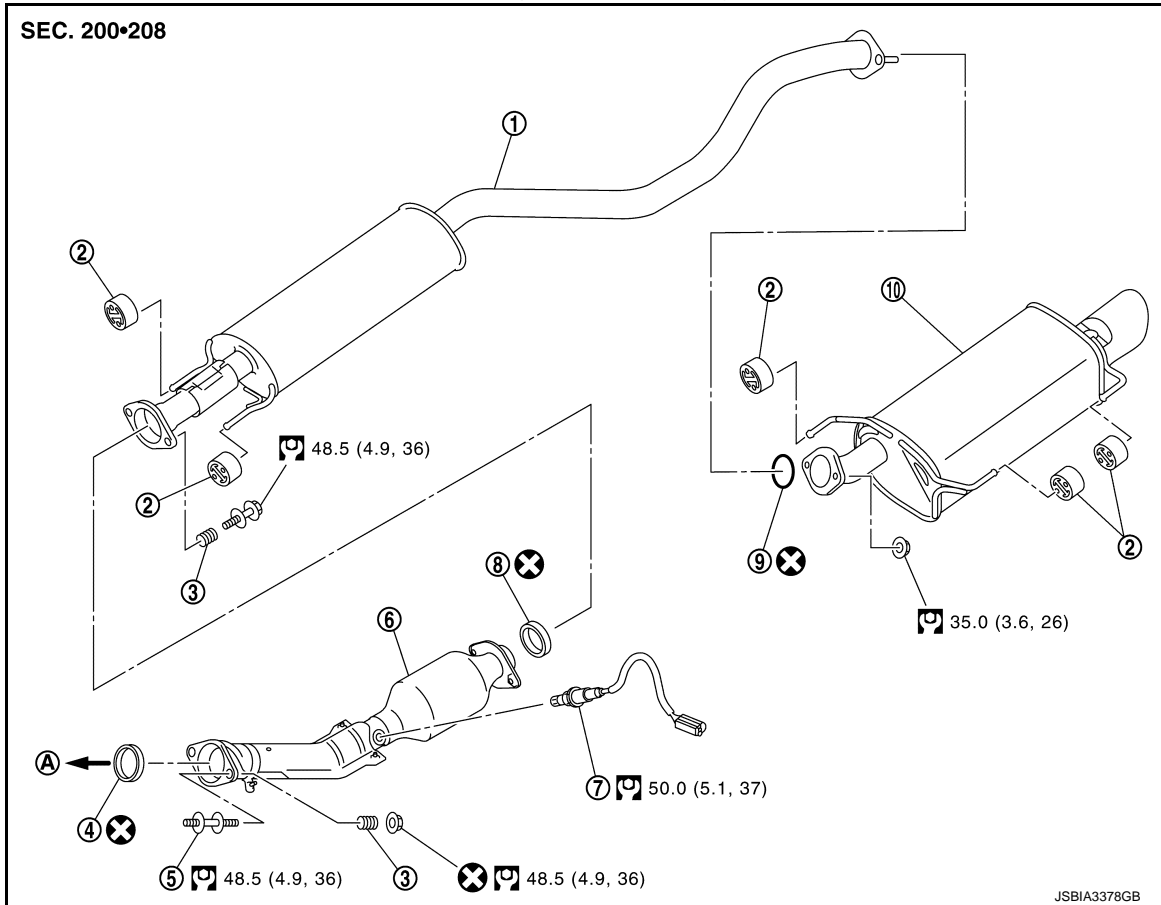

- | | | |
|---------------------------|--------------------|-----------------------|
| 1. Center muffler | 2. Mounting rubber | 3. Spring |
| 4. Seal bearing | 5. Stud bolt | 6. Exhaust front tube |
| 7. Heated oxygen sensor 2 | 8. Seal bearing | 9. Ring gasket |
| 10. Main muffler | | |
- A. To catalyst converter

: N·m (kg-m, ft-lb)

: Always replace after every disassembly.

EXHAUST SYSTEM

< REMOVAL AND INSTALLATION >

[MR16DDT]

AWD (Standard models)

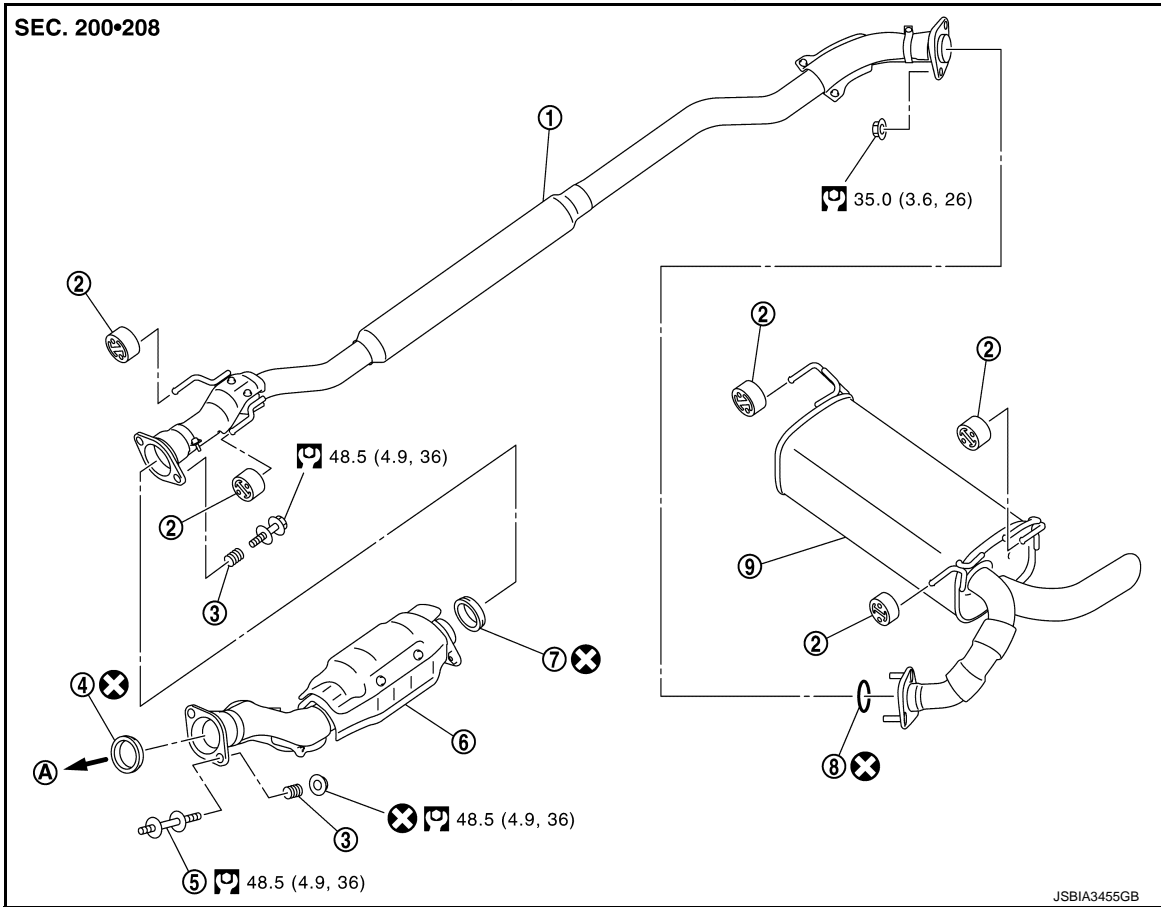

- | | | |
|-----------------|--------------------|-----------------------|
| 1. Center pipe | 2. Mounting rubber | 3. Spring |
| 4. Seal bearing | 5. Stud bolt | 6. Exhaust front tube |
| 7. Seal bearing | 8. Ring gasket | 9. Main muffler |
- A. To catalyst convertor

: N·m (kg-m, ft-lb)

: Always replace after every disassembly.

A

EX

C

D

E

F

G

H

I

J

K

L

M

N

O

P

EXHAUST SYSTEM

< REMOVAL AND INSTALLATION >

[MR16DDT]

AWD (NISMO models)

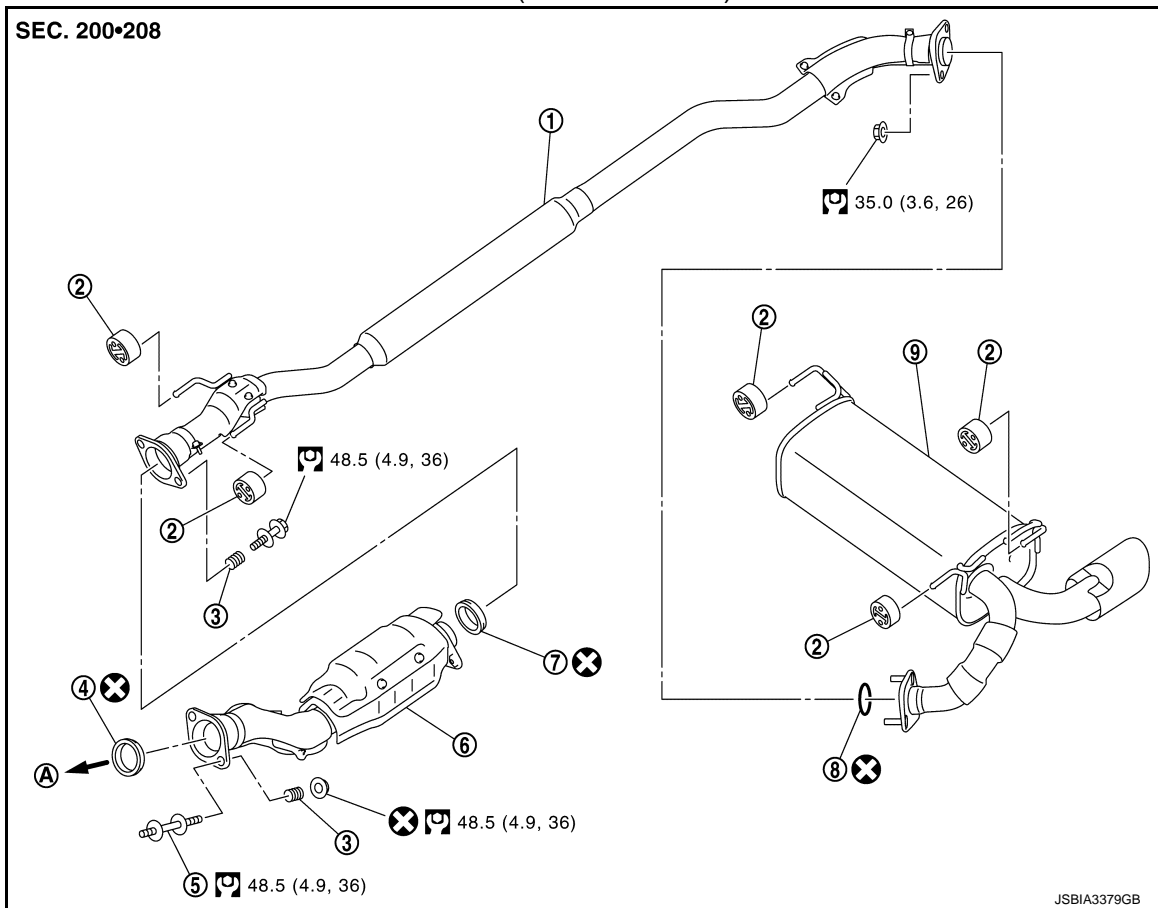

- | | | |
|-----------------|--------------------|-----------------------|
| 1. Center pipe | 2. Mounting rubber | 3. Spring |
| 4. Seal bearing | 5. Stud bolt | 6. Exhaust front tube |
| 7. Seal bearing | 8. Ring gasket | 9. Main muffler |
- A. To catalyst converter

: N·m (kg·m, ft·lb)

: Always replace after every disassembly.

Removal and Installation

INFOID:000000008275068

REMOVAL

- Disconnect each joint and mounting.
- Remove heated oxygen sensor 2 with following procedure (2WD models):
- Using heated oxygen sensor wrench [SST: KV10114400 (J-38365)] (A), removal heated oxygen sensor 2 (1).

CAUTION:

- Never damage heated oxygen sensor 2.

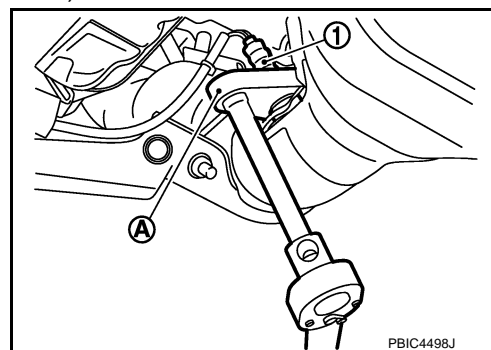

INSTALLATION

Note the following, and install in the reverse order of removal.

CAUTION:

- Always replace seal bearings with new ones when reassembling.

EXHAUST SYSTEM

[MR16DDT]

< REMOVAL AND INSTALLATION >

- Discard any heated oxygen sensor 2 which has been dropped onto a hard surface such as a concrete floor. Use a new one.
- Before installing a new heated oxygen sensor 2, clean exhaust system threads using the heated oxygen sensor thread cleaner [commercial service tool: J-43897-18 or J-43897-12] and apply anti-seize lubricant (commercial service tool).
- Never over torque heated oxygen sensor 2. Doing so may cause damage to the heated oxygen sensor 2, resulting in the “MIL” coming on.
- Prevent rust preventives from adhering to the sensor body.
- If heat insulator is badly deformed, repair or replace it. If deposits such as mud pile up on the heat insulator, remove them.
- When installing heat insulator avoid large gaps or interference between heat insulator and each exhaust pipe.
- Remove deposits from the sealing surface of each connection. Connect them securely to avoid gas leakage.
- When installing each mounting rubber, use silicon oil to avoid twisting.
- Temporarily tighten mounting nuts and bolts. Check each part for unusual interference and mounting rubber interference, and then tighten them to the specified torque.
- When installing each mounting rubber, avoid twisting or unusual extension in up/down, front/rear and right/left directions.
- Install seal bearing according to the following instructions.

CAUTION:

The structure of seal bearing depends on the mounting portion. When installing seal bearings, be careful not to install wrong one.

- Ⓐ : Exhaust manifold side
- Ⓑ : Mesh
- Ⓒ : Exhaust front tube side
- Ⓓ : Pawl (projection)

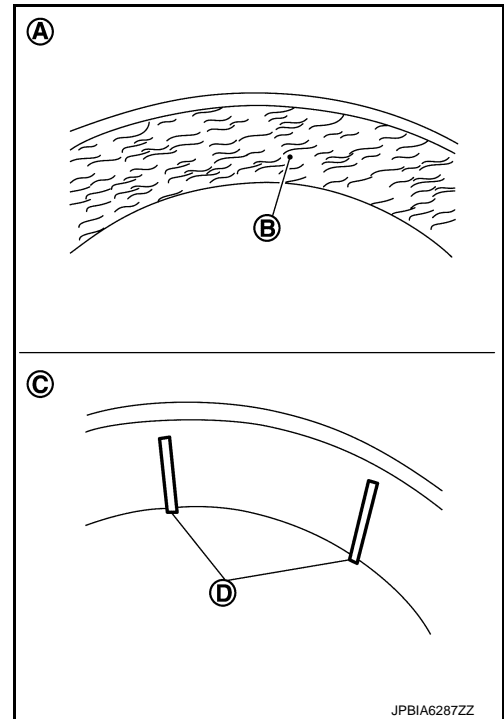

Exhaust Manifold to Exhaust Front Tube

1. Place a piece of wood (A) on seal bearing (2) and securely insert the seal bearing on the exhaust manifold (1) side, using a plastic hammer (B).

CAUTION:

- Never damage the seal bearing surface during insertion.
- If seal bearing is inserted by hammering directly without using a piece of wood, the seal bearing is deformed and exhaust gas leaks. To insert seal bearing, always use a piece of wood and insert straight.

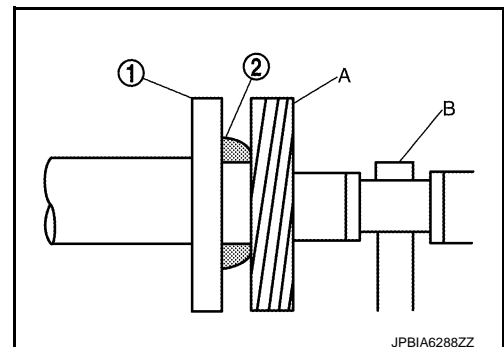

EXHAUST SYSTEM

< REMOVAL AND INSTALLATION >

[MR16DDT]

- Check that seal bearing (1) is in absolute contact (C) with the flange (A). If there is clearance (B), insert seal bearing straight by hand to bring the seal bearing into absolute contact with the flange.

CAUTION:

- Never use a tool for insertion.
- Never insert seal bearing by tightening exhaust front tube.

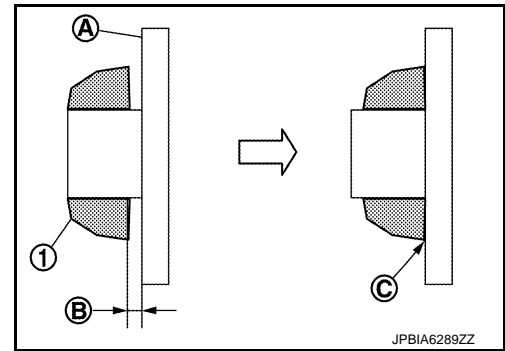

- With spring (3), tighten nut (4).

- 1 : Exhaust manifold
- 2 : Seal bearing
- 5 : Stud bolt
- 6 : Exhaust front tube

CAUTION:

- Fasten stud bolts to the flange of exhaust manifold side to the specified torque before fastening mounting nuts.
- Ensure springs are seated correctly on the flange and not sitting on (A).
- Be careful that stud bolt does not interfere with mounting hole of exhaust front tube (←).

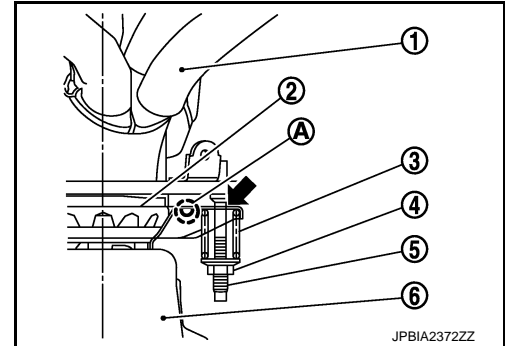

- After installing, check that stud bolt does not interfere with mounting hole of exhaust front tube.

Exhaust Front Tube to Main Muffler

- Securely insert seal bearing (2) into exhaust front tube (1) side in the direction as shown in the figure.

- 3 : Spring
- 4 : Bolt
- 5 : Main muffler

CAUTION:

Be careful not to damage seal bearing surface when installing.

- With spring, tighten bolt.

CAUTION:

- Ensure springs are seated correctly on the flange and not sitting on (A).
- Be careful that bolt does not interfere with mounting hole of main muffler (←).

- After installing, check that bolt does not interfere with mounting hole of main muffler.

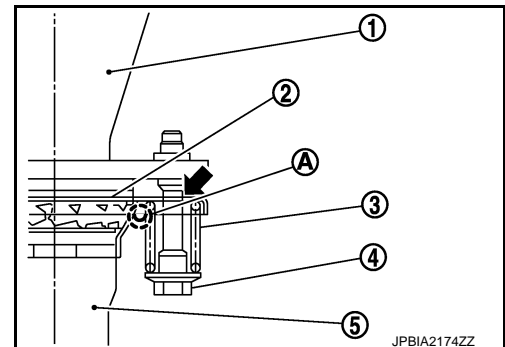

Main Muffler to Post Muffler

- Securely insert seal bearing (2) into main muffler (1) side in the direction as shown in the figure.

- 3 : Spring
- 4 : Bolt
- 5 : Post muffler

CAUTION:

Be careful not to damage seal bearing surface when installing.

- With spring, tighten bolt.

CAUTION:

- Ensure springs are seated correctly on the flange and not sitting on (A).
- Be careful that bolt does not interfere with mounting hole of post muffler (←).

- After installing, check that bolt does not interfere with mounting hole of post muffler.

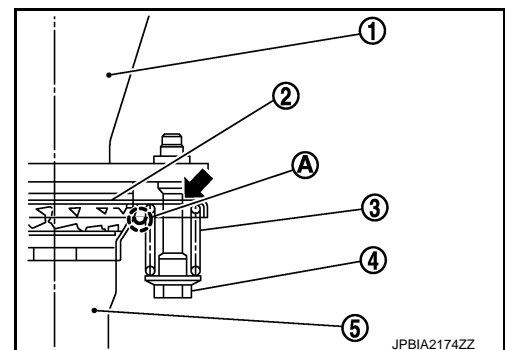

EXHAUST SYSTEM

< REMOVAL AND INSTALLATION >

[MR16DDT]

Inspection

INFOID:000000008275069

A

INSPECTION AFTER INSTALLATION

- Check clearance between tail tube and rear bumper is even.
- With engine running, check exhaust tube joints for gas leakage and unusual noises.
- Check to ensure that mounting brackets and mounting rubbers are installed properly and free from undue stress. Improper installation could result in excessive noise and vibration.

EX

C

D

E

F

G

H

I

J

K

L

M

N

O

P