

SECTION **EXT**  
EXTERIOR

A  
B  
C  
D  
E  
F  
G  
H  
I  
J  
L  
M  
N  
O  
P

CONTENTS

<b>PRECAUTION</b> .....	3	<b>SILL COVER</b> .....	27
<b>PRECAUTIONS</b> .....	3	Exploded View .....	27
Precaution for Supplemental Restraint System (SRS) "AIR BAG" and "SEAT BELT PRE-TEN- SIONER" .....	3	Removal and Installation .....	27
Precaution for Procedure without Cowl Top Cover.....	3	<b>FLOOR SIDE FAIRING</b> .....	29
<b>PREPARATION</b> .....	4	Exploded View .....	29
<b>PREPARATION</b> .....	4	Removal and Installation .....	29
Special Service Tools .....	4	<b>FILLET MOLDING</b> .....	30
Commercial Service Tools .....	4	Exploded View .....	30
<b>SYMPTOM DIAGNOSIS</b> .....	5	<b>FRONT FILLET MOLDING</b> .....	30
<b>SQUEAK AND RATTLE TROUBLE DIAG- NOSES</b> .....	5	FRONT FILLET MOLDING : Removal and Instal- lation .....	30
Work Flow .....	5	<b>REAR FILLET MOLDING</b> .....	31
Inspection Procedure .....	7	REAR FILLET MOLDING : Removal and Installa- tion .....	31
Diagnostic Worksheet .....	9	<b>ROOF SIDE MOLDING</b> .....	32
<b>REMOVAL AND INSTALLATION</b> .....	11	Exploded View .....	32
<b>FRONT BUMPER</b> .....	11	Removal and Installation .....	32
Exploded View .....	11	<b>DOOR OUTSIDE MOLDING</b> .....	35
Removal and Installation .....	14	Exploded View .....	35
<b>REAR BUMPER</b> .....	17	<b>FRONT DOOR OUTSIDE MOLDING</b> .....	35
Exploded View .....	17	FRONT DOOR OUTSIDE MOLDING : Removal and Installation .....	35
Removal and Installation .....	19	<b>REAR DOOR OUTSIDE MOLDING</b> .....	36
<b>FRONT GRILLE</b> .....	21	REAR DOOR OUTSIDE MOLDING : Removal and Installation .....	36
Exploded View .....	21	<b>DOOR SASH TAPE</b> .....	37
Removal and Installation .....	22	Exploded View .....	37
<b>COWL TOP</b> .....	24	<b>FRONT DOOR SASH TAPE</b> .....	37
Exploded View .....	24	FRONT DOOR SASH TAPE : Removal and Instal- lation .....	37
Removal and Installation .....	25	<b>REAR DOOR SASH TAPE</b> .....	39
<b>FENDER PROTECTOR</b> .....	26	REAR DOOR SASH TAPE : Removal and Instal- lation .....	39
Exploded View .....	26		
Removal and Installation .....	26		

EXT

---

<b>REAR FENDER COVER</b> .....	<b>42</b>	Removal and Installation .....	43
Exploded View .....	42		
Removal and Installation .....	42		
<b>BACK DOOR FINISHER</b> .....	<b>43</b>	<b>REAR SPOILER</b> .....	<b>45</b>
Exploded View .....	43	Exploded View .....	45
		Removal and Installation .....	45

# PRECAUTIONS

< PRECAUTION >

## PRECAUTION

### PRECAUTIONS

#### Precaution for Supplemental Restraint System (SRS) "AIR BAG" and "SEAT BELT PRE-TENSIONER"

INFOID:000000008275203

The Supplemental Restraint System such as "AIR BAG" and "SEAT BELT PRE-TENSIONER", used along with a front seat belt, helps to reduce the risk or severity of injury to the driver and front passenger for certain types of collision. This system includes seat belt switch inputs and dual stage front air bag modules. The SRS system uses the seat belt switches to determine the front air bag deployment, and may only deploy one front air bag, depending on the severity of a collision and whether the front occupants are belted or unbelted. Information necessary to service the system safely is included in the "SRS AIR BAG" and "SEAT BELT" of this Service Manual.

#### **WARNING:**

Always observe the following items for preventing accidental activation.

- To avoid rendering the SRS inoperative, which could increase the risk of personal injury or death in the event of a collision that would result in air bag inflation, all maintenance must be performed by an authorized NISSAN/INFINITI dealer.
- Improper maintenance, including incorrect removal and installation of the SRS, can lead to personal injury caused by unintentional activation of the system. For removal of Spiral Cable and Air Bag Module, see "SRS AIR BAG".
- Never use electrical test equipment on any circuit related to the SRS unless instructed to in this Service Manual. SRS wiring harnesses can be identified by yellow and/or orange harnesses or harness connectors.

#### PRECAUTIONS WHEN USING POWER TOOLS (AIR OR ELECTRIC) AND HAMMERS

#### **WARNING:**

Always observe the following items for preventing accidental activation.

- When working near the Air Bag Diagnosis Sensor Unit or other Air Bag System sensors with the ignition ON or engine running, never use air or electric power tools or strike near the sensor(s) with a hammer. Heavy vibration could activate the sensor(s) and deploy the air bag(s), possibly causing serious injury.
- When using air or electric power tools or hammers, always switch the ignition OFF, disconnect the battery, and wait at least 3 minutes before performing any service.

#### Precaution for Procedure without Cowl Top Cover

INFOID:000000008275204

When performing the procedure after removing cowl top cover, cover the lower end of windshield with urethane, etc to prevent damage to windshield.

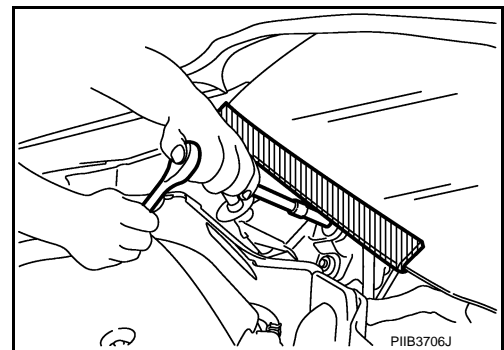

# PREPARATION

< PREPARATION >

## PREPARATION

### PREPARATION

#### Special Service Tools

INFOID:000000008275205

The actual shapes of Kent-Moore tools may differ from those of special service tools illustrated here.

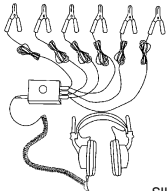
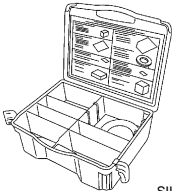
Tool number (Kent-Moore No.) Tool name	Description
<p>(J-39570) Chassis ear</p>  <p style="text-align: center;">SIIA0993E</p>	<p>Locates the noise</p>
<p>(J-43980) NISSAN Squeak and Rattle Kit</p>  <p style="text-align: center;">SIIA0994E</p>	<p>Repairs the cause of noise</p>

#### Commercial Service Tools

INFOID:000000008275206

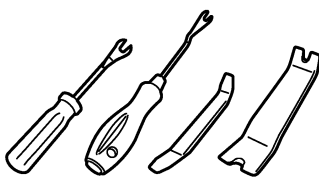
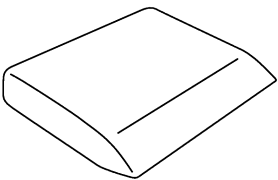
Tool name	Description
<p>Remover tool</p>  <p style="text-align: center;">JMKIA3050ZZ</p>	<p>Removes clips, pawls and metal clips</p>
<p>Squeegee</p>  <p style="text-align: center;">JMKIA5809ZZ</p>	<p>Paste up of the door sash tape</p>

# SQUEAK AND RATTLE TROUBLE DIAGNOSES

< SYMPTOM DIAGNOSIS >

## SYMPTOM DIAGNOSIS

### SQUEAK AND RATTLE TROUBLE DIAGNOSES

#### Work Flow

INFOID:000000008275207

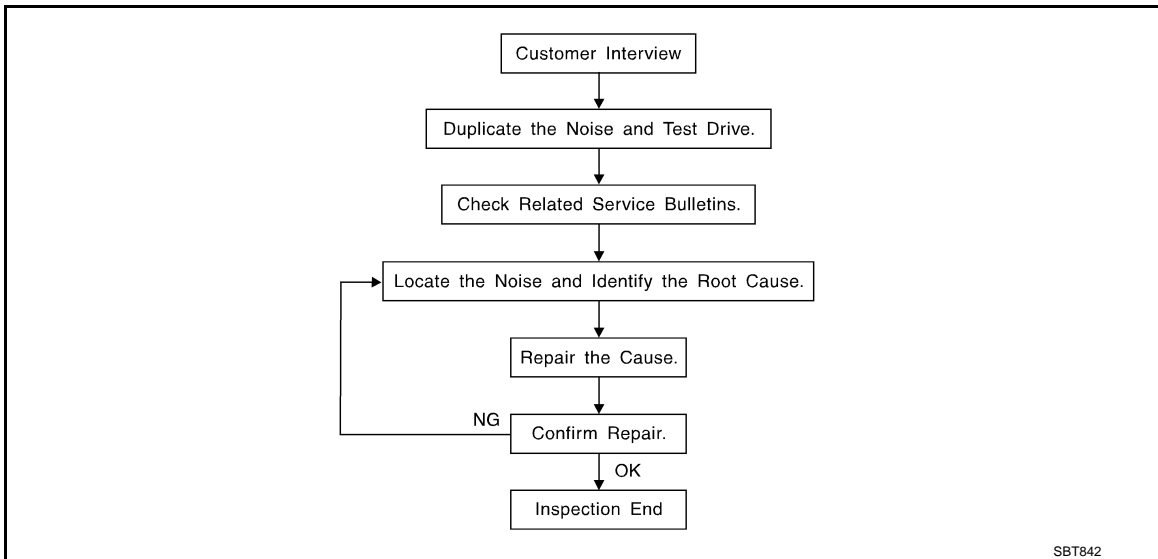

#### CUSTOMER INTERVIEW

Interview the customer if possible, to determine the conditions that exist when the noise occurs. Use the Diagnostic Worksheet during the interview to document the facts and conditions when the noise occurs and any customer comments. Refer to [EXT-9. "Diagnostic Worksheet"](#). This information is necessary to duplicate the conditions that exist when the noise occurs.

- The customer may not be able to provide a detailed description or the location of the noise. Attempt to obtain all the facts and conditions that exist when the noise occurs (or does not occur).
- If there is more than one noise in the vehicle, perform a diagnosis and repair the noise that the customer is concerned about. This can be accomplished by performing a test drive with the customer.
- After identifying the type of noise, isolate the noise in terms of its characteristics. The noise characteristics are provided so that the customer, service adviser, and technician use the same language when describing the noise.
- Squeak – (Like tennis shoes on a clean floor)  
Squeak characteristics include the light contact / fast movement / brought on by road conditions / hard surfaces = high-pitched noise / softer surfaces = low-pitched noises / edge to surface = chirping
- Creak – (Like walking on an old wooden floor)  
Creak characteristics include firm contact / slow movement/twisting with a rotational movement / pitch dependent on materials / often brought on by activity.
- Rattle – (Like shaking a baby rattle)  
Rattle characteristics include fast repeated contact / vibration or similar movement / loose parts/missing clip or fastener / incorrect clearance.
- Knock – (Like a knock on a door)  
Knock characteristics include hollow sounds / sometimes repeating / often brought on by driver action.
- Tick – (Like a clock second hand)  
Tick characteristics include gentle contacting of light materials / loose components / can be caused by driver action or road conditions.
- Thump – (Heavy, muffled knock noise)  
Thump characteristics include softer knock / dull sounds often brought on by activity.
- Buzz – (Like a bumblebee)  
Buzz characteristics include high frequency rattle / firm contact.
- Often the degree of acceptable noise level varies depending upon the person. A noise that a technician may judge as acceptable may be very irritating to a customer.
- Weather conditions, especially humidity and temperature, may have a great effect on noise level.

#### DUPLICATE THE NOISE AND TEST DRIVE

# SQUEAK AND RATTLE TROUBLE DIAGNOSES

## < SYMPTOM DIAGNOSIS >

If possible, drive the vehicle with the customer until the noise is duplicated. Note any additional information on the Diagnostic Worksheet regarding the conditions or location of the noise. This information can be used to duplicate the same conditions when the repair is reconfirmed.

If the noise can be duplicated easily during the test drive, to help identify the source of the noise, try to duplicate the noise with the vehicle stopped by doing one or all of the following items:

- 1) Close a door.
  - 2) Tap or push/pull around the area where the noise appears to be coming from.
  - 3) Rev the engine.
  - 4) Use a floor jack to recreate vehicle "twist".
  - 5) At idle, apply engine load (electrical load, half-clutch on M/T models, drive position on A/T models).
  - 6) Raise the vehicle on a hoist and hit a tire with a rubber hammer.
- Drive the vehicle and attempt to duplicate the conditions the customer states exist when the noise occurs.
  - If it is difficult to duplicate the noise, drive the vehicle slowly on an undulating or rough road to stress the vehicle body.

## CHECK RELATED SERVICE BULLETINS

After verifying the customer concern or symptom, check ASIST for Technical Service Bulletins (TSBs) related to the concern or symptom.

If a TSB relates to the symptom, follow the procedure to repair the noise.

## LOCATE THE NOISE AND IDENTIFY THE ROOT CAUSE

1. Narrow down the noise to a general area. To help pinpoint the source of the noise, use a listening tool (Chassis ear: J-39570, engine ear, and mechanics stethoscope).
2. Narrow down the noise to a more specific area and identify the cause of the noise by:
  - Removing the component(s) in the area that is / are suspected to be the cause of the noise.  
Do not use too much force when removing clips and fasteners, otherwise clips and fasteners can be broken or lost during the repair, resulting in the creation of new noise.
  - Tapping or pushing/pulling the component(s) that is / are suspected to be the cause of the noise.  
Do not tap or push/pull the component(s) with excessive force, otherwise the noise is eliminated only temporarily.
  - Feeling for a vibration by hand by touching the component(s) that is / are suspected to be the cause of the noise.
  - Placing a piece of paper between components that are suspected to be the cause of the noise.
  - Looking for loose components and contact marks.  
Refer to [EXT-7. "Inspection Procedure"](#).

## REPAIR THE CAUSE

- If the cause is a loose component, tighten the component securely.
- If the cause is insufficient clearance between components:
  - Separate components by repositioning or loosening and retightening the components, if possible.
  - Insulate components with a suitable insulator such as urethane pads, foam blocks, felt cloth tape, or urethane tape. A NISSAN Squeak and Rattle Kit (J-43980) is available through the authorized NISSAN Parts Department.

### **CAUTION:**

**Never use excessive force as many components are constructed of plastic and may be damaged.**

### **NOTE:**

Always check with the Parts Department for the latest parts information.

The following materials are contained in the NISSAN Squeak and Rattle Kit (J-43980). Each item can be ordered separately as needed.

URETHANE PADS [1.5 mm (0.059 in) thick]

Insulates connectors, harness, etc.

- 76268-9E005: 100 × 135 mm (3.937 × 5.315 in)
- 76884-71L01: 60 × 85 mm (2.362 × 3.346 in)
- 76884-71L02: 15 × 25 mm (0.591 × 0.984 in)

INSULATOR (Foam blocks)

Insulates components from contact. Can be used to fill space behind a panel.

- 73982-9E000: 45 mm (1.772 in) thick, 50 × 50 mm (1.969 × 1.969 in)
- 73982-50Y00: 10 mm (0.394 in) thick, 50 × 50 mm (1.969 × 1.969 in)

INSULATOR (Light foam block)

80845-71L00: 30 mm (1.181 in) thick, 30 × 50 mm (1.181 × 1.969 in)

FELT CLOTHTAPE

# SQUEAK AND RATTLE TROUBLE DIAGNOSES

## < SYMPTOM DIAGNOSIS >

Used to insulate where movement does not occur. Ideal for instrument panel applications.

- 68370-4B000: 15 × 25 mm (0.591 × 0.984 in) pad
- 68239-13E00: 5 mm (0.197 in) wide tape roll

The following materials, not found in the kit, can also be used to repair squeaks and rattles.

### UHMW (TEFLON) TAPE

Insulates where slight movement is present. Ideal for instrument panel applications.

### SILICONE GREASE

Used in place of UHMW tape that is visible or does not fit. Only lasts a few months.

### SILICONE SPRAY

Used when grease cannot be applied.

### DUCT TAPE

Used to eliminate movement.

## CONFIRM THE REPAIR

After repair is complete, test drive the vehicle to confirm that the cause of noise is repaired by test driving the vehicle. Operate the vehicle under the same conditions as when the noise originally occurred. Refer to the notes on the Diagnostic Worksheet.

## Inspection Procedure

INFOID:000000008275208

Refer to Table of Contents for specific component removal and installation information.

## INSTRUMENT PANEL

Most incidents are caused by contact and movement between:

1. The cluster lid A and instrument panel
2. Acrylic lens and combination meter housing
3. Instrument panel to front pillar garnish
4. Instrument panel to windshield
5. Instrument panel mounting pins
6. Wiring harnesses behind the combination meter
7. A/C defroster duct and duct joint

These incidents can usually be located by tapping or moving the components to duplicate the noise or by pressing on the components while driving to stop the noise. Most of these incidents can be repaired by applying felt cloth tape or silicon spray (in hard to reach areas). Urethane pads can be used to insulate wiring harness.

### **CAUTION:**

**Never use silicone spray to isolate a squeak or rattle. If the area is saturated with silicone, the recheck of repair becomes impossible.**

## CENTER CONSOLE

Components to check include:

1. Shifter assembly cover to finisher
2. A/C control unit and cluster lid C
3. Wiring harnesses behind audio and A/C control unit

The instrument panel repair and isolation procedures also apply to the center console.

## DOORS

Check the following items:

1. Finisher and inner panel making a slapping noise
2. Inside handle escutcheon connection to door finisher
3. Wiring harnesses tapping
4. Door striker out of alignment causing a popping noise on starts and stops

Tapping, moving the components, or pressing on them while driving to duplicate the conditions can isolate many of these incidents. The areas can usually be insulated with felt cloth tape or insulator foam blocks from the NISSAN Squeak and Rattle Kit (J-43980) to repair the noise.

## TRUNK

Trunk noises are often caused by a loose jack or loose items put into the trunk by the customer.

In addition check for the following items:

A

B

C

D

E

F

G

H

I

J

EXT

L

M

N

O

P

# SQUEAK AND RATTLE TROUBLE DIAGNOSES

## < SYMPTOM DIAGNOSIS >

---

1. Trunk lid dumpers out of adjustment
2. Trunk lid striker out of adjustment
3. Trunk lid torsion bars knocking together
4. A loose license plate or bracket

Most of these incidents can be repaired by adjusting, securing, or insulating the item(s) or component(s) causing the noise.

## SUNROOF/HEADLINING

Noises in the sunroof / headlining area can often be traced to one of the following items:

1. Sunroof lid, rail, linkage, or seals making a rattle or light knocking noise
2. Sunvisor shaft shaking in the holder
3. Front or rear windshield touching headlining and squeaking

Again, pressing on the components to stop the noise while duplicating the conditions can isolate most of these incidents. Repairs usually consist of insulating with felt cloth tape.

## SEATS

When isolating seat noise it is important to note the position the seat is in and the load placed on the seat when the noise occurs. These conditions should be duplicated when verifying and isolating the cause of the noise.

Causes of seat noise include:

1. Headrest rods and holder
2. A squeak between the seat pad cushion and frame
3. The rear seatback lock and bracket

These noises can be isolated by moving or pressing on the suspected components while duplicating the conditions under which the noise occurs. Most of these incidents can be repaired by repositioning the component or applying urethane tape to the contact area.

## UNDERHOOD

Some interior noise may be caused by components under the hood or on the engine wall. The noise is then transmitted into the passenger compartment.

Causes of transmitted underhood noise include:

1. Any component mounted to the engine wall
2. Components that pass through the engine wall
3. Engine wall mounts and connectors
4. Loose radiator mounting pins
5. Hood bumpers out of adjustment
6. Hood striker out of adjustment

These noises can be difficult to isolate since they cannot be reached from the interior of the vehicle. The best method is to secure, move, or insulate one component at a time and test drive the vehicle. Also, engine RPM or load can be changed to isolate the noise. Repairs can usually be made by moving, adjusting, securing, or insulating the component causing the noise.



# SQUEAK AND RATTLE TROUBLE DIAGNOSES

< SYMPTOM DIAGNOSIS >

## Diagnostic Worksheet

INFOID:000000008275209



### SQUEAK & RATTLE DIAGNOSTIC WORKSHEET

Dear Nissan Customer:

We are concerned about your satisfaction with your Nissan vehicle. Repairing a squeak or rattle sometimes can be very difficult. To help us fix your Nissan right the first time, please take a moment to note the area of the vehicle where the squeak or rattle occurs and under what conditions. You may be asked to take a test drive with a service advisor or technician to ensure we confirm the noise you are hearing.

#### I. WHERE DOES THE NOISE COME FROM? (circle the area of the vehicle)

The illustrations are for reference only, and may not reflect the actual configuration of your vehicle.

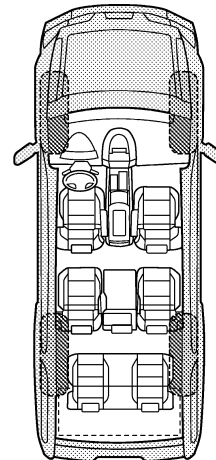
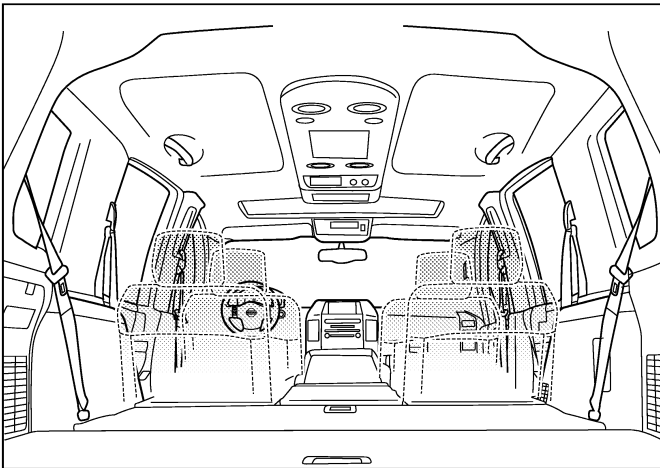
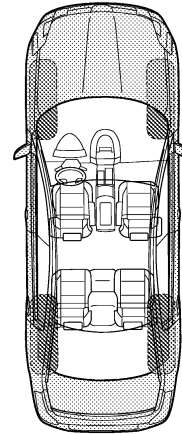
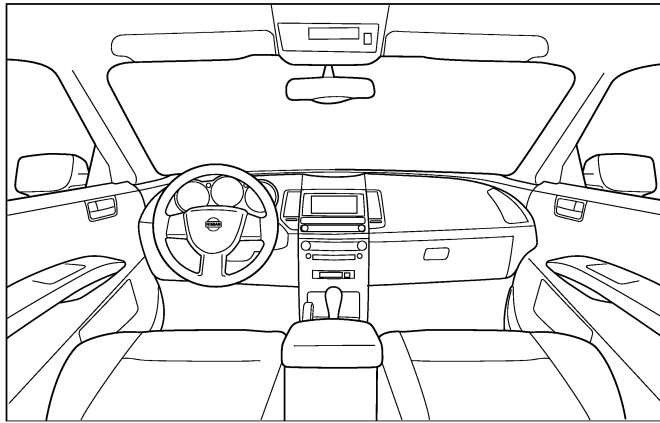

Continue to page 2 of the worksheet and briefly describe the location of the noise or rattle. In addition, please indicate the conditions which are present when the noise occurs.

PIIB8740E

A  
B  
C  
D  
E  
F  
G  
H  
I  
J  
EXT  
L  
M  
N  
O  
P

# SQUEAK AND RATTLE TROUBLE DIAGNOSES

< SYMPTOM DIAGNOSIS >

## SQUEAK & RATTLE DIAGNOSTIC WORKSHEET - page 2

Briefly describe the location where the noise occurs:

---

---

### II. WHEN DOES IT OCCUR? (please check the boxes that apply)

- |   |  |
|---|--|
| <input type="checkbox"/> anytime                      | <input type="checkbox"/> after sitting out in the rain |
| <input type="checkbox"/> 1st time in the morning      | <input type="checkbox"/> when it is raining or wet     |
| <input type="checkbox"/> only when it is cold outside | <input type="checkbox"/> dry or dusty conditions       |
| <input type="checkbox"/> only when it is hot outside  | <input type="checkbox"/> other:                        |

### III. WHEN DRIVING:

- through driveways
- over rough roads
- over speed bumps
- only about \_\_\_\_ mph
- on acceleration
- coming to a stop
- on turns: left, right or either (circle)
- with passengers or cargo
- other: \_\_\_\_\_
- after driving \_\_\_\_ miles or \_\_\_\_ minutes

### IV. WHAT TYPE OF NOISE

- squeak (like tennis shoes on a clean floor)
- creak (like walking on an old wooden floor)
- rattle (like shaking a baby rattle)
- knock (like a knock at the door)
- tick (like a clock second hand)
- thump (heavy, muffled knock noise)
- buzz (like a bumble bee)

## TO BE COMPLETED BY DEALERSHIP PERSONNEL

### Test Drive Notes:

---

---

---

	YES	NO	Initials of person performing
Vehicle test driven with customer	<input type="checkbox"/>	<input type="checkbox"/>	_____
- Noise verified on test drive	<input type="checkbox"/>	<input type="checkbox"/>	_____
- Noise source located and repaired	<input type="checkbox"/>	<input type="checkbox"/>	_____
- Follow up test drive performed to confirm repair	<input type="checkbox"/>	<input type="checkbox"/>	_____

VIN: \_\_\_\_\_ Customer Name: \_\_\_\_\_  
W.O.# \_\_\_\_\_ Date: \_\_\_\_\_

This form must be attached to Work Order

PIIB8742E

# FRONT BUMPER

< REMOVAL AND INSTALLATION >

## REMOVAL AND INSTALLATION

### FRONT BUMPER

Exploded View

INFOID:000000008275210

Regular Grade

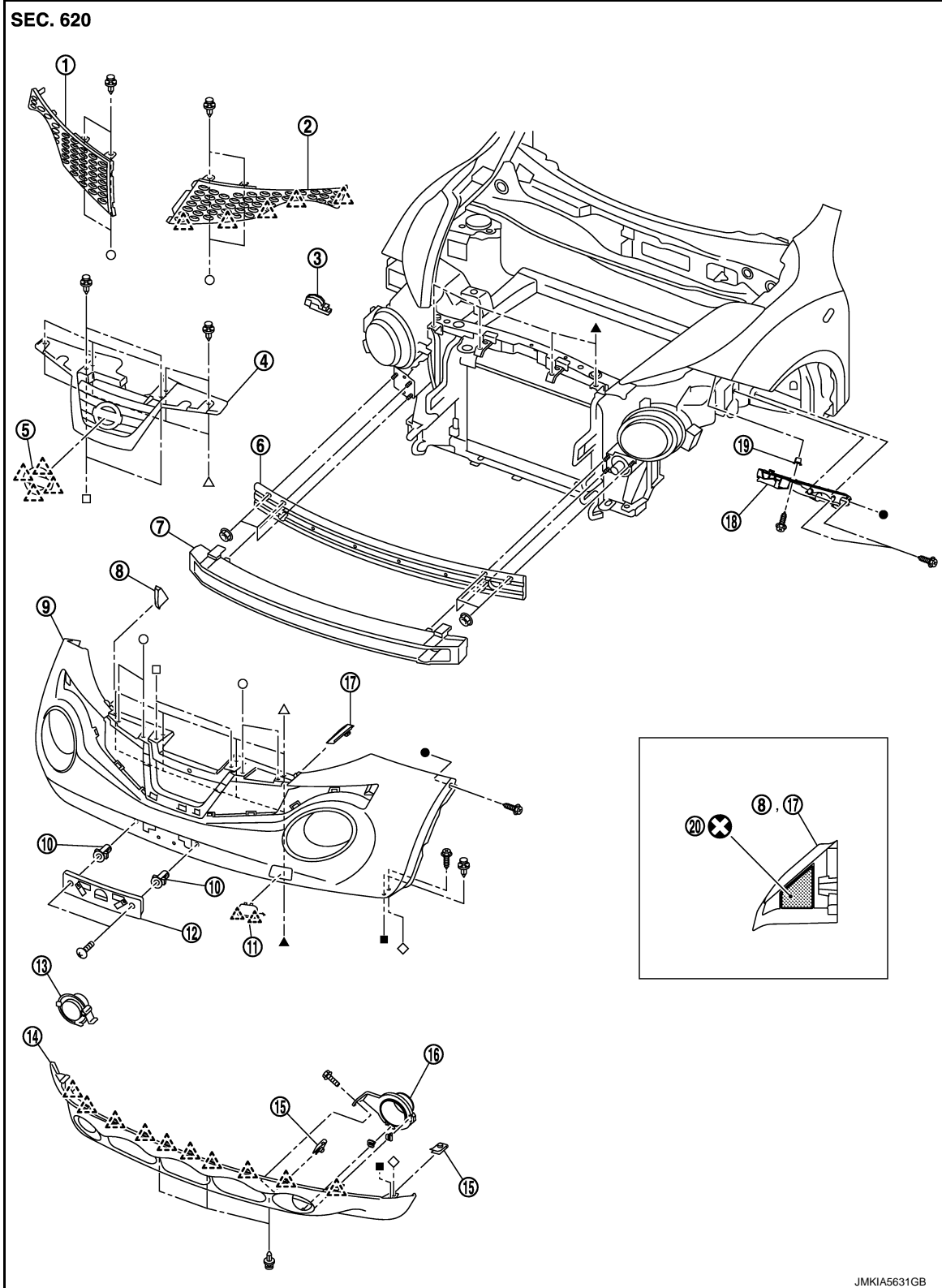

A

B

C

D

E

F

G

H

I

J

EXT

L

M

N

O

P

## FRONT BUMPER

### < REMOVAL AND INSTALLATION >

---

- |                          |   |                            |
|--------------------------|---|----------------------------|
| 1. Front side grille RH  | 2. Front side grille LH                         | 3. Bumper side bracket RH  |
| 4. Front center grille   | 5. Emblem                                       | 6. Bumper reinforcement    |
| 7. Energy absorber       | 8. Bumper end rubber RH                         | 9. Bumper fascia           |
| 10. Screw grommet        | 11. Bumper bracket cover                        | 12. License plate bracket  |
| 13. Front fog bracket RH | 14. Bumper fascia lower                         | 15. U nut                  |
| 16. Front fog bracket LH | 17. Bumper end rubber LH                        | 18. Bumper side bracket LH |
| 19. Screw grommet        | 20. Double-sided tape<br>[t: 1.2 mm (0.047 in)] |                            |



: Pawl



: Always replace after every disassembly.

# FRONT BUMPER

< REMOVAL AND INSTALLATION >

NISMO Grade

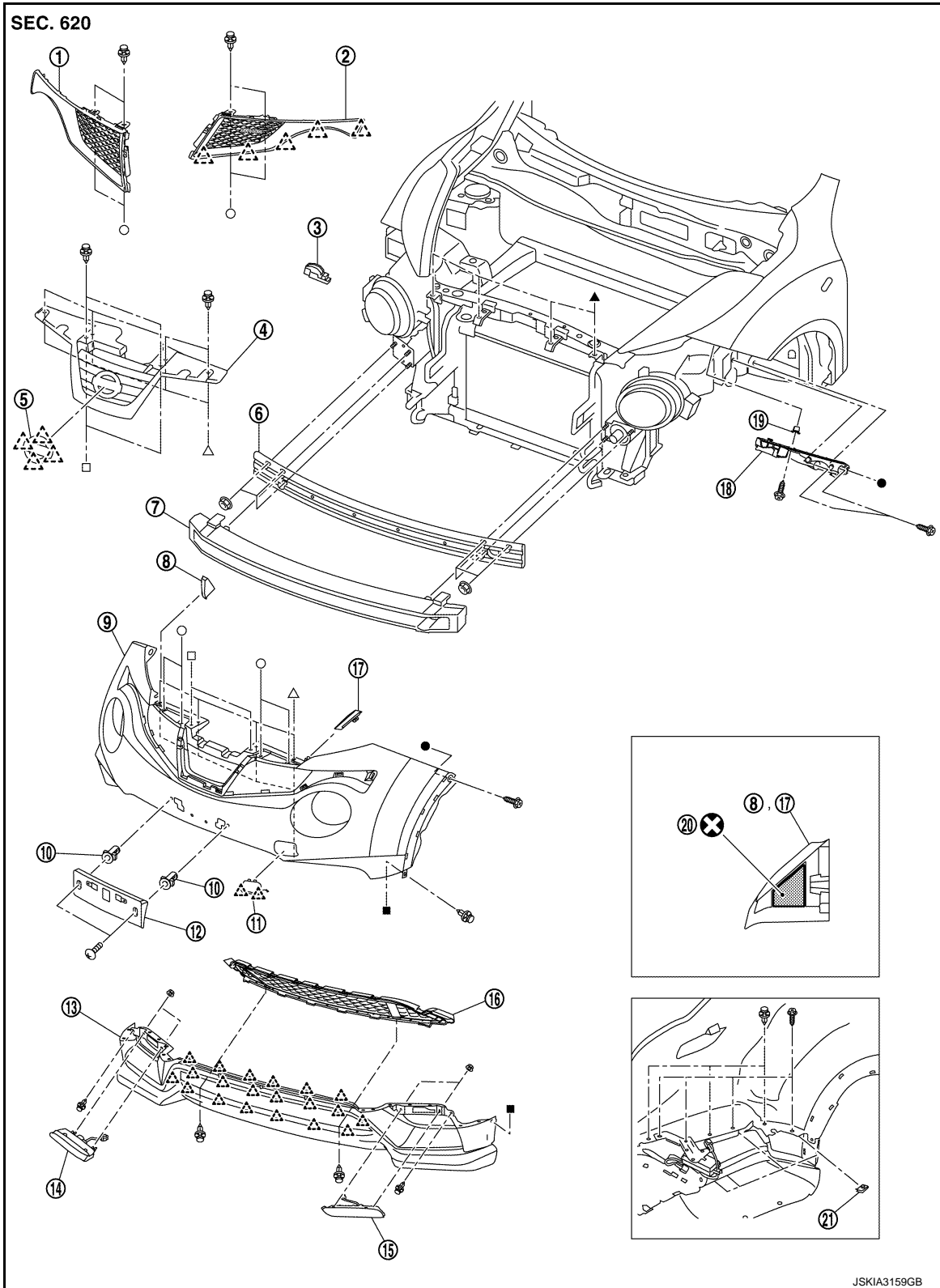

- |                         |                               |                               |
|-------------------------|-------------------------------|-------------------------------|
| 1. Front side grille RH | 2. Front side grille LH       | 3. Bumper side bracket RH     |
| 4. Front center grille  | 5. Emblem                     | 6. Bumper reinforcement       |
| 7. Energy absorber      | 8. Bumper end rubber RH       | 9. Bumper fascia              |
| 10. Screw grommet       | 11. Bumper bracket cover      | 12. License plate bracket     |
| 13. Bumper fascia lower | 14. Day time running light RH | 15. Day time running light LH |
| 16. Front bumper grille | 17. Bumper end rubber LH      | 18. Bumper side bracket LH    |

A  
B  
C  
D  
E  
F  
G  
H  
I  
J  
EXT  
L  
M  
N  
O  
P

# FRONT BUMPER

## < REMOVAL AND INSTALLATION >

19. Screw grommet

20. Double-sided tape  
[t: 1.2 mm (0.047 in)]

21. U nut

 : Pawl

 : Always replace after every disassembly.

## Removal and Installation

INFOID:000000008275211

### CAUTION:

Bumper fascia is made of resin. Never apply strong force to it, and be careful to prevent contact with oil.

### REMOVAL

1. Fully open hood assembly.
2. Remove clips (A) of bumper upper side.

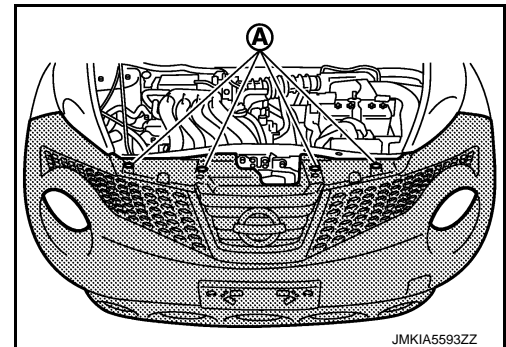

3. Remove front fillet molding front side. Refer to [EXT-30. "FRONT FILLET MOLDING : Removal and Installation"](#).
4. Remove bumper fascia assembly fixing screws (A) (LH and RH).

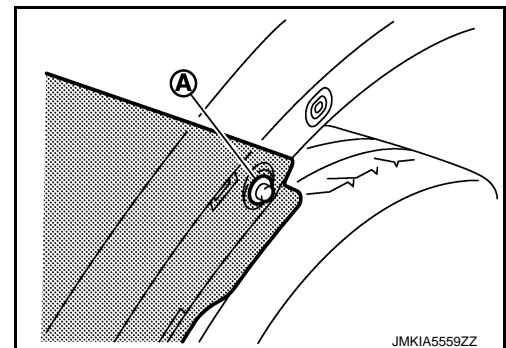

5. Remove air guide fixing screws, and then remove air guide (LH and RH). Refer to [EXT-26. "Exploded View"](#).
6. Remove clips of bumper lower side.
7. Pull bumper fascia side toward the vehicle side to disengage the fitting of bumper side bracket and bumper fascia side as shown by the arrow in the figure.

 : Pawl

### CAUTION:

When removing bumper fascia assembly, 2 workers are required so as to prevent it from dropping.

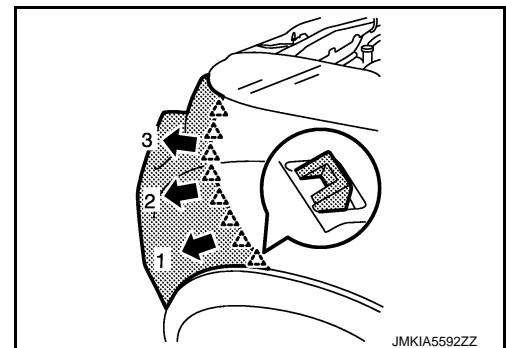

8. Disconnect front fog lamp harness connectors. (with fog lamp)
9. Disconnect day time running light harness connectors. (For NISMO Grade)
10. Remove bumper fascia assembly.

# FRONT BUMPER

## < REMOVAL AND INSTALLATION >

11. Remove the following parts after removing bumper fascia assembly.
  - Day time running light (LH and RH). Refer to [EXL-90, "Removal and Installation"](#).
  - Front fog lamp assembly (LH and RH). (with fog lamp). Refer to [EXL-91, "Removal and Installation"](#).
  - Front fog lamp finishers (LH and RH). (without fog lamp)
  - Bumper fascia lower
  - License plate bracket
  - Front bumper grille
12. Remove bumper energy absorber.
13. Remove bumper reinforcement mounting nuts, and then remove bumper reinforcement.
14. Remove bumper side bracket mounting screws, and then remove bumper side bracket.

## INSTALLATION

Note the following items, and then install in the reverse order of removal.

### NOTE:

- The following table shows the specified values for checking normal installation status.
- Fitting adjustment cannot be performed.

Regular Grade

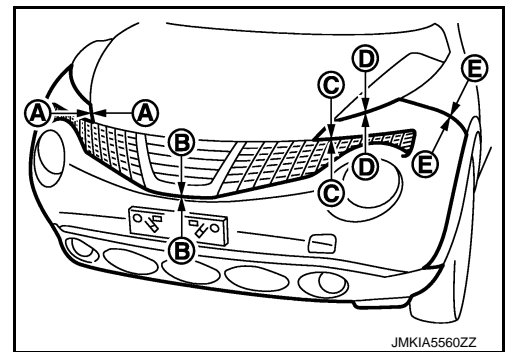

Portion		Clearance	Surface height difference
Bumper fascia assembly – Hood	A – A	2.0 – 6.0 mm (0.079 – 0.236 in)	(–2.0) – (+1.0) mm [(–0.079) – (+0.039) in]
Bumper fascia assembly – Front center grille	B – B	0.3 – 2.7 mm (0.012 – 0.106 in)	—
Bumper fascia assembly – Front side grille (Regular)	C – C	0.5 – 2.5 mm (0.020 – 0.098 in)	—
Bumper fascia assembly – Front combination lamp	D – D	0.5 – 3.5 mm (0.020 – 0.138 in)	—
Bumper fascia assembly – Front fender	E – E	0.0 – 1.0 mm (0.000 – 0.039 in)	(–0.3) – (+1.7) mm [(–0.012) – (+0.067) in]

NISMO Grade

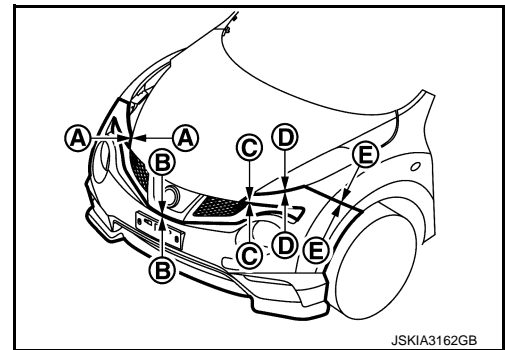

A  
B  
C  
D  
E  
F  
G  
H  
I  
J  
EXT  
L  
M  
N  
O  
P

## FRONT BUMPER

< REMOVAL AND INSTALLATION >

Portion		Clearance	Surface height difference
Bumper fascia assembly – Hood	A – A	2.0 – 6.0 mm (0.079 – 0.236 in)	(-2.0) – (+1.0) mm [(-0.079) – (+0.039) in]
Bumper fascia assembly – Front center grille	B – B	0.3 – 2.7 mm (0.012 – 0.106 in)	—
Bumper fascia assembly – Front side grille (NISMO)	C – C	0.5 – 1.5 mm (0.020 – 0.059 in)	—
Bumper fascia assembly – Front combination lamp	D – D	0.5 – 3.5 mm (0.020 – 0.138 in)	—
Bumper fascia assembly – Front fender	E – E	0.0 – 1.0 mm (0.000 – 0.039 in)	(-0.3) – (+1.7) mm [(-0.012) – (+0.067) in]



# REAR BUMPER

< REMOVAL AND INSTALLATION >

## REAR BUMPER

Exploded View

INFOID:000000008275212

Regular Grade

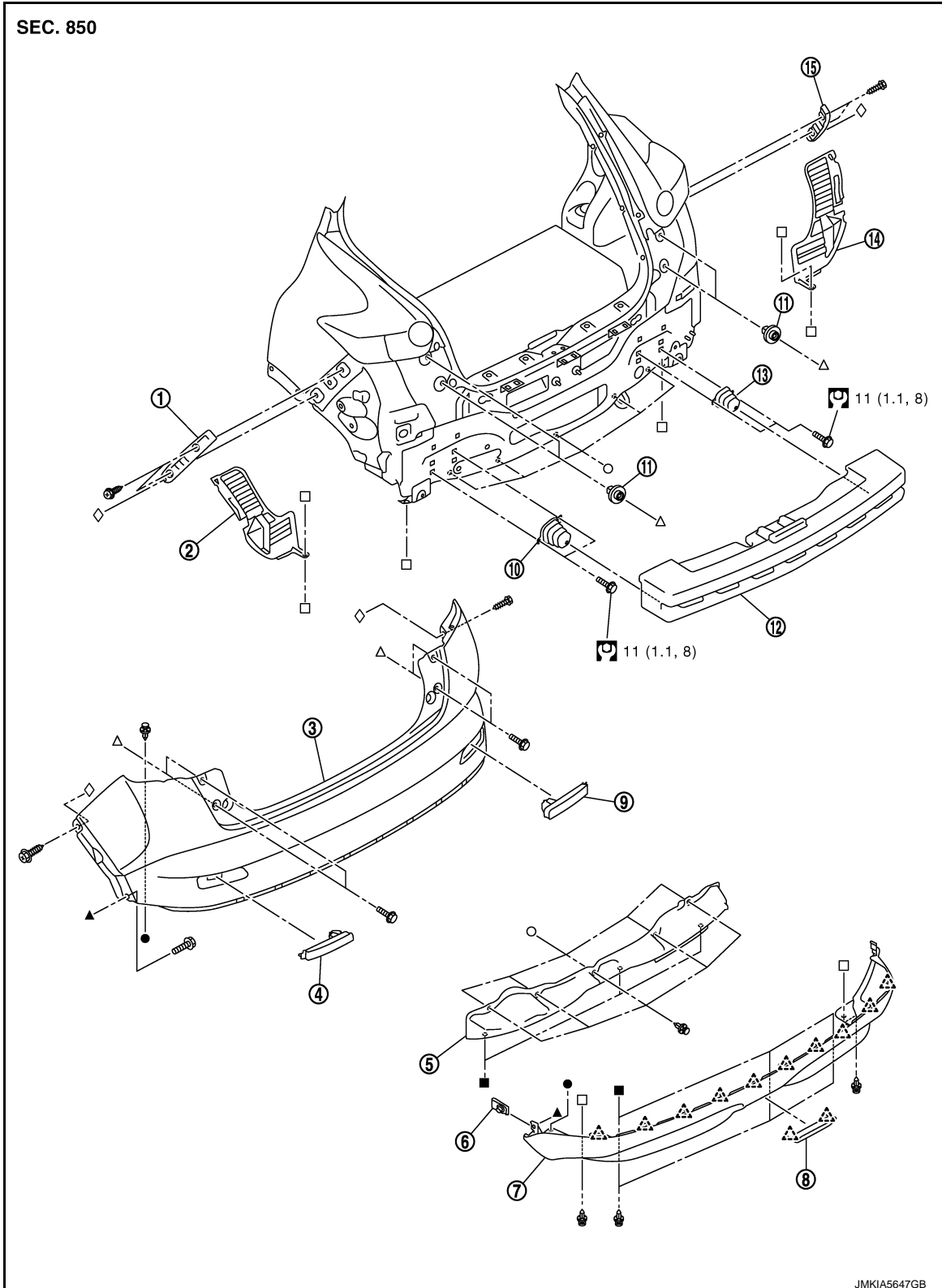

1. Bumper side bracket LH
4. Reflex reflector LH

2. Bumper closing LH
5. Rear panel lower

3. Bumper fascia assembly
6. U nut

A  
B  
C  
D  
E  
F  
G  
H  
I  
J  
EXT  
L  
M  
N  
O  
P

# REAR BUMPER

## < REMOVAL AND INSTALLATION >

- |                        |                       |                            |
|------------------------|-----------------------|----------------------------|
| 7. Bumper fascia lower | 8. Bumper finisher    | 9. Reflex reflector RH     |
| 10. Bumper stay LH     | 11. screw grommet     | 12. Bumper energy absorber |
| 13. Bumper stay RH     | 14. Bumper closing RH | 15. Bumper side bracket RH |

 : Pawl

 : N-m (kg-m, ft-lb)

### NISMO Grade

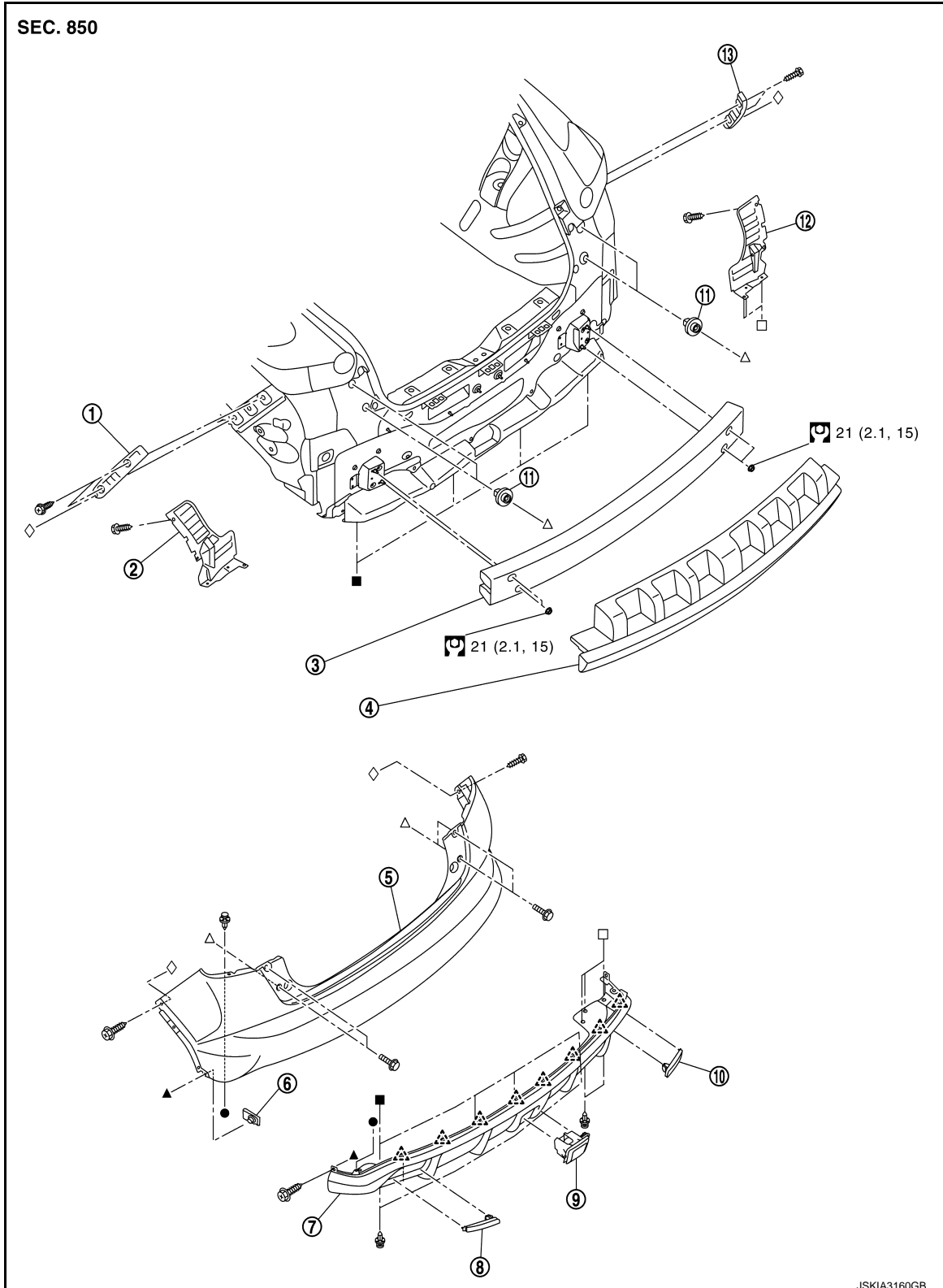

# REAR BUMPER

## < REMOVAL AND INSTALLATION >

- |                           |                           |                          |
|---------------------------|---------------------------|--------------------------|
| 1. Bumper side bracket LH | 2. Bumper closing LH      | 3. Bumper reinforcement  |
| 4. Bumper energy absorber | 5. Bumper fascia assembly | 6. U nut                 |
| 7. Bumper fascia lower    | 8. Reflex reflector LH    | 9. Rear fog lamp housing |
| 10. Reflex reflector RH   | 11. Screw grommet         | 12. Bumper closing RH    |
| 13. Bumper stay RH        |                           |                          |

 : Pawl

 : N·m (kg-m, ft-lb)

## Removal and Installation

INFOID:000000008275213

### CAUTION:

**Bumper fascia is made of resin. Never apply strong force to it, and be careful to prevent contact with oil.**

### REMOVAL

1. Fully open back door.
2. Remove bumper fascia mounting screws of rear combination lamp (LH and RH) lower side.
3. Remove rear fillet molding rear side. Refer to [EXT-31, "REAR FILLET MOLDING : Removal and Installation"](#).
4. Remove bumper closing.
5. Remove clips of bumper lower side.
6. Remove bumper fascia assembly fixing screws (A) (LH and RH).

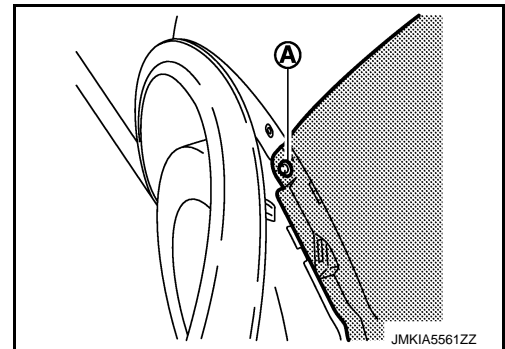

7. Pull bumper fascia side toward the vehicle side to disengage the fitting of bumper side bracket and bumper fascia side as shown by the arrow in the figure.

 : Pawl

### CAUTION:

**When removing bumper fascia, 2 workers are required so as to prevent it from dropping.**

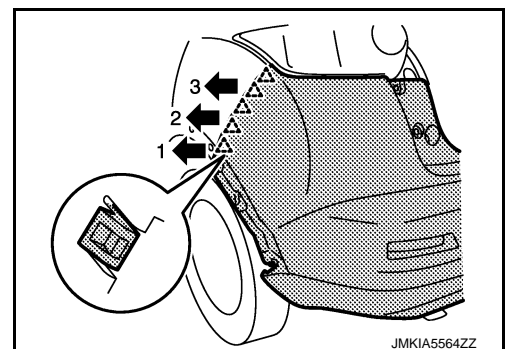

8. Remove bumper fascia assembly.
9. Remove the following parts after removing rear bumper fascia.
  - Bumper fascia lower
  - Bumper finisher
  - Reflex reflector (LH and RH).
  - Rear fog lamp housing (For NISMO grade). Refer to [EXL-103, "Removal and Installation"](#).
10. Remove bumper energy absorber.
11. Remove rear panel lower.
12. Remove bumper stay (LH and RH).
13. Remove bumper side bracket fixing screws, and then remove bumper side bracket (LH and RH).

# REAR BUMPER

## < REMOVAL AND INSTALLATION >

### INSTALLATION

Note the following items, and then install in the reverse order of removal.

**NOTE:**

- The following table shows the specified values for checking normal installation status.
- Fitting adjustment cannot be performed.

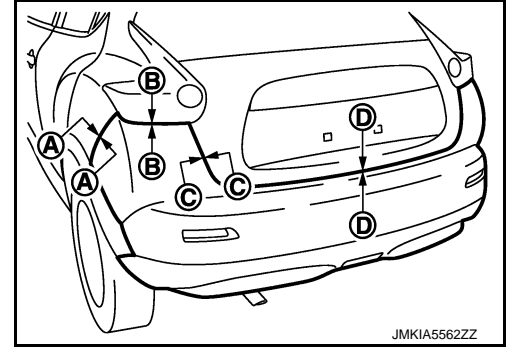

Portion		Clearance	Surface height difference
Bumper fascia assembly – Rear fender	A – A	0.0 – 1.0 mm (0.000 – 0.039 in)	(-0.3) – (+1.7) mm [(-0.012) – (+0.067) in]
Bumper fascia assembly – Rear combination lamp	B – B	0.2 – 3.0 mm (0.008 – 0.118 in)	—
Bumper fascia assembly – Back door	C – C	3.0 – 7.0 mm (0.118 – 0.276 in)	0.0 – 4.0 mm (0.000 – 0.157 in)
	D – D	6.0 – 10.0 mm (0.236 – 0.394 in)	0.0 – 4.0 mm (0.000 – 0.157 in)

# FRONT GRILLE

< REMOVAL AND INSTALLATION >

## FRONT GRILLE

Exploded View

INFOID:000000008275214

Regular Grade

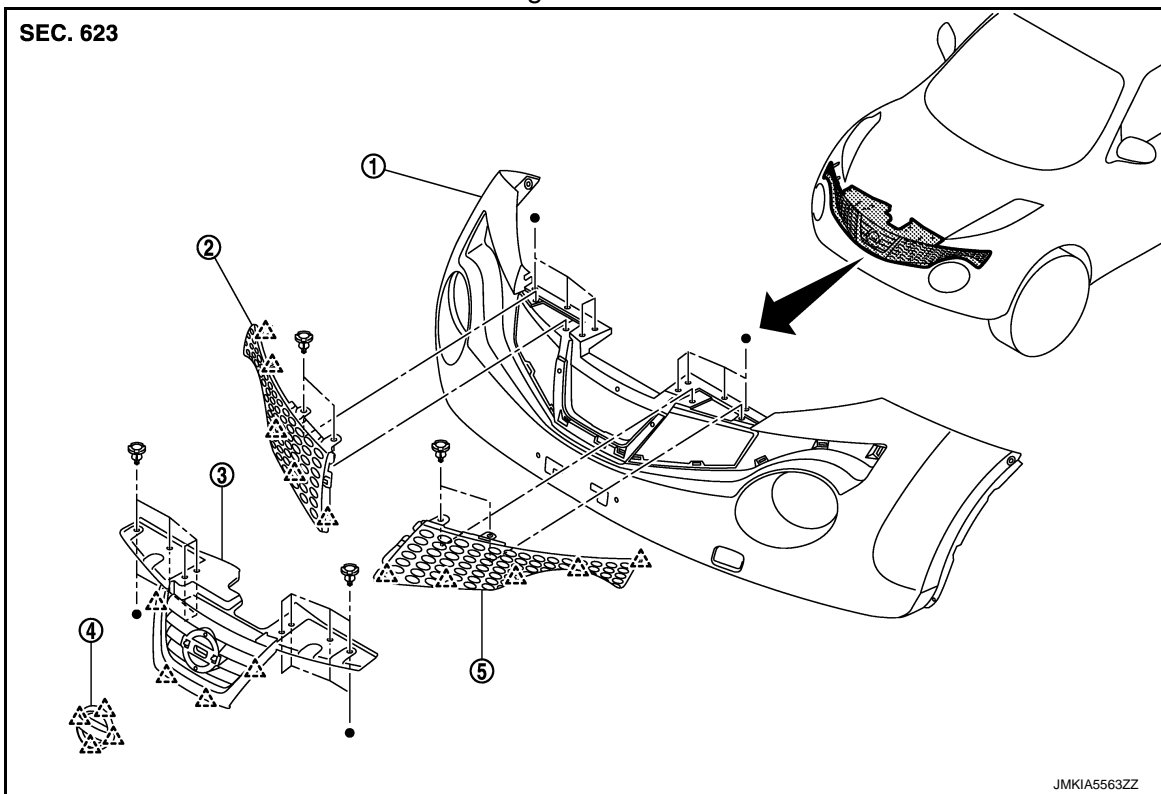

1. Bumper fascia assembly

2. Front side grille RH

3. Front center grille

4. Emblem

5. Front side grille LH

 : Pawl

A  
B  
C  
D  
E  
F  
G  
H  
I  
J  
EXT  
L  
M  
N  
O  
P

# FRONT GRILLE

< REMOVAL AND INSTALLATION >

NISMO Grade

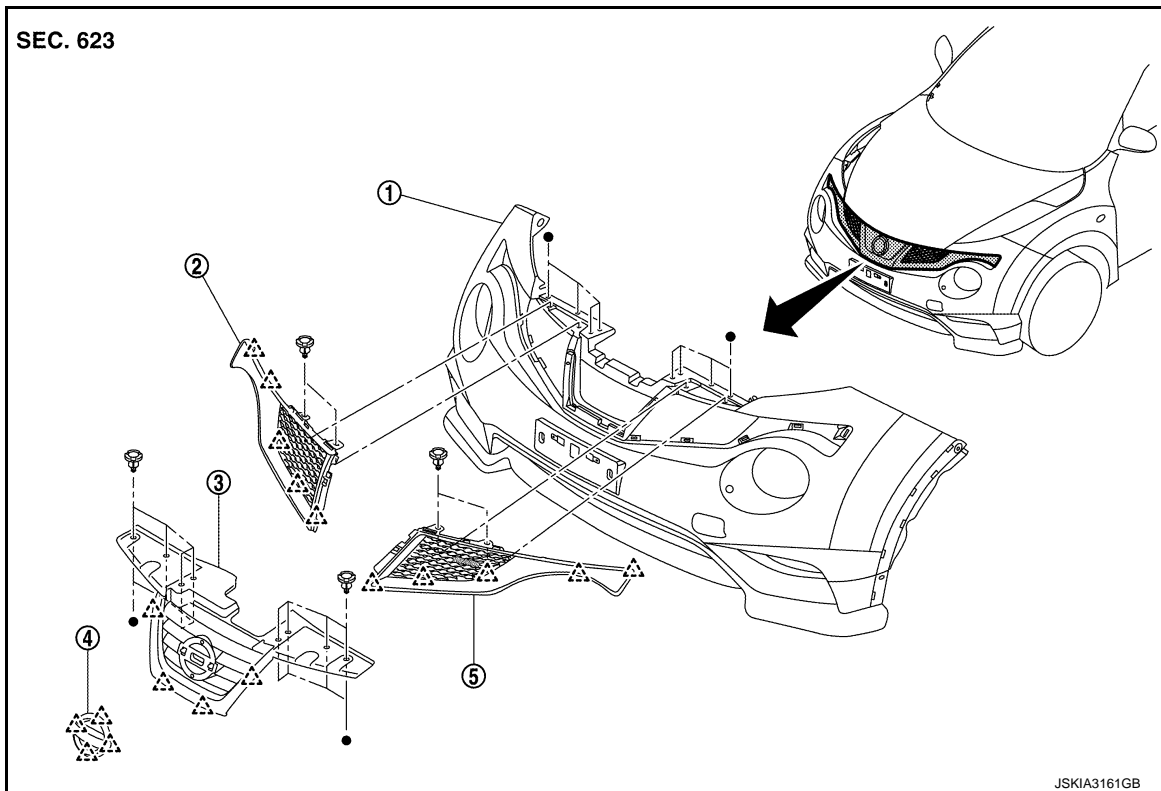

1. Bumper fascia assembly

2. Front side grille RH

3. Front center grille

4. Emblem

5. Front side grille LH

△ : Pawl

## Removal and Installation

INFOID:000000008275215

### REMOVAL

#### CAUTION:

When remove front grilles (1) apply protective tape (A) on the bumper fascia (2) to protect the painted surface from damage.

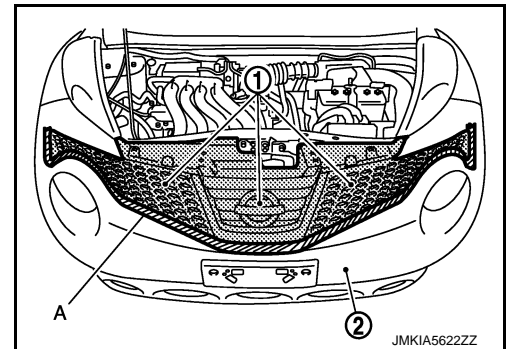

1. Fully open hood assembly.

# FRONT GRILLE

## < REMOVAL AND INSTALLATION >

2. Remove front center grille upper fixing clips (A).

**CAUTION:**

Apply protective tape (B) around bumper fascia.

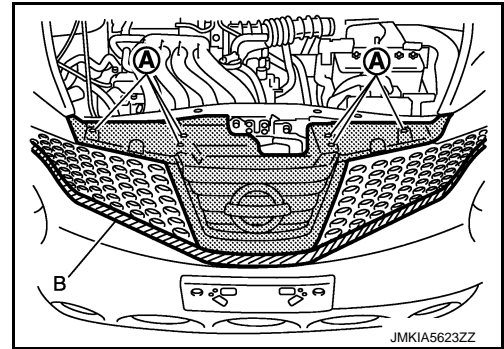

3. Disengage fixing pawls from back side while pulling front center grille to ward vehicle front, and then remove front center grille.

 : Pawl

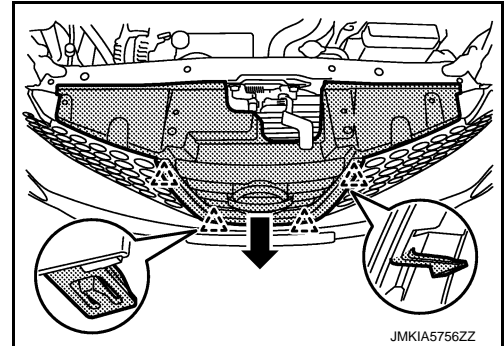

4. Remove front side grille (LH and RH) upper fixing clips (A).
5. Disengage fixing pawls from back side of front side grille (LH and RH).

 : Pawl

**CAUTION:**

Apply protective tape (B) around bumper fascia.

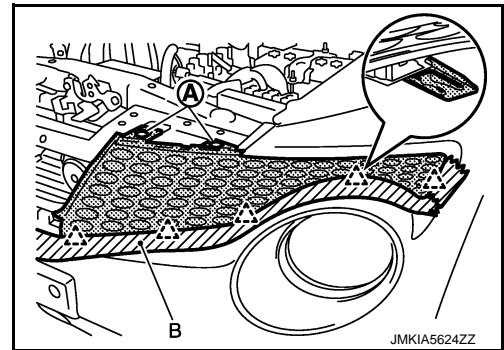

6. Remove front side grille (LH and RH) to ward vehicle front.
7. Remove emblem after removing front grille.

## INSTALLATION

Install in the reverse order of removal.

A  
B  
C  
D  
E  
F  
G  
H  
I  
J  
EXT  
L  
M  
N  
O  
P

# COWL TOP

< REMOVAL AND INSTALLATION >

## COWL TOP

Exploded View

INFOID:000000008275216

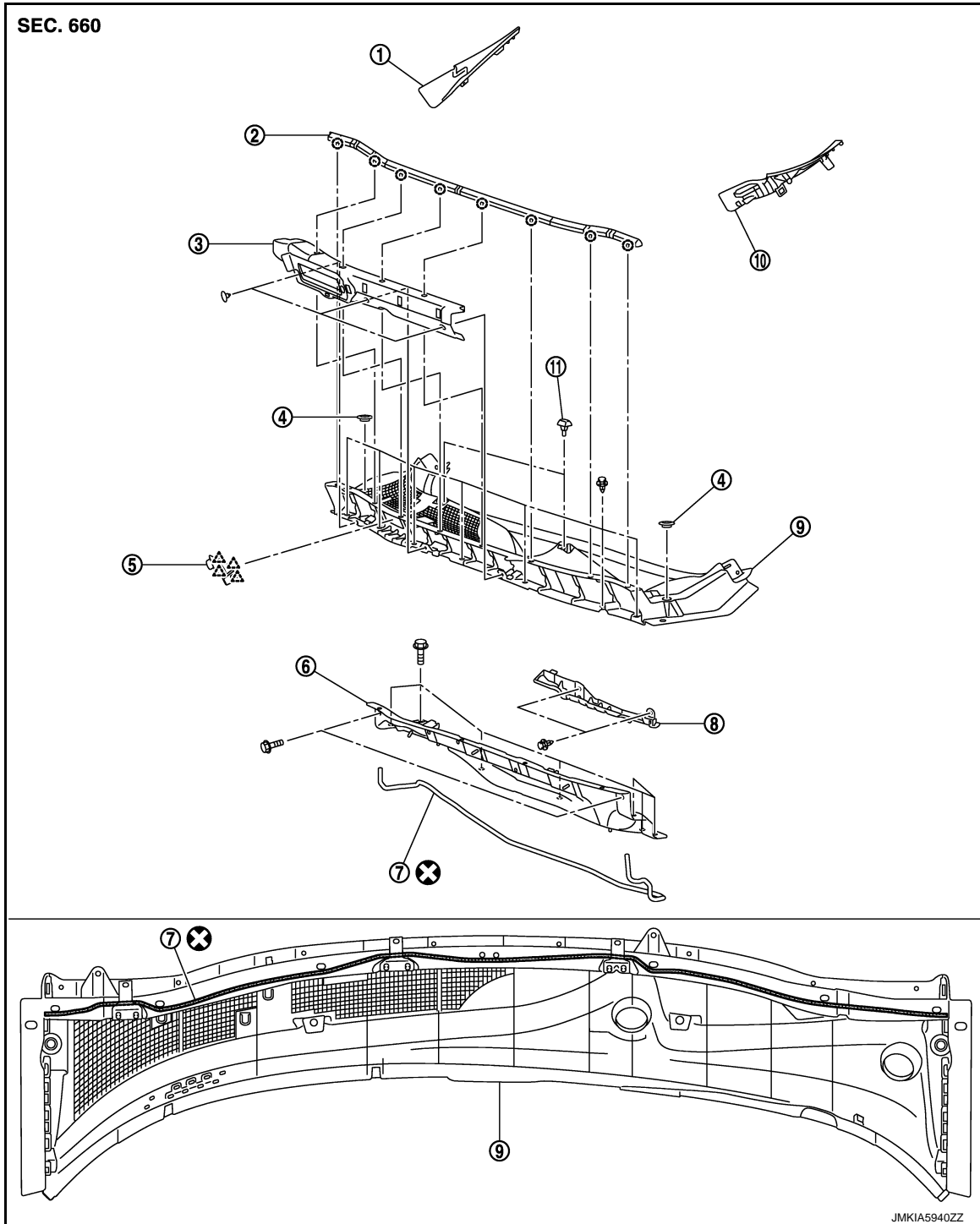

- |                                    |                        |                       |
|------------------------------------|------------------------|-----------------------|
| 1. Front fender cover RH           | 2. Cowl top cover seal | 3. Cowl top insulator |
| 4. Blind plug RH                   | 5. Cowl top cover cap  | 6. Cowl top extension |
| 7. EPT seal [t: 3.0 mm (0.118 in)] | 8. Air intake cover    | 9. Cowl top cover     |
| 10. Front fender cover LH          | 11. Washer nozzle      |                       |

○ : Clip



# COWL TOP

## < REMOVAL AND INSTALLATION >

 : Pawl

 : Always replace after every disassembly.

## Removal and Installation

INFOID:000000008275217

### REMOVAL

1. Fully open hood assembly.
2. Remove front wiper arm (LH and RH). Refer to [WW-54, "Removal and Installation"](#).
3. Disconnect washer tube joint on cowl top cover RH.
4. Remove cowl top seal fixing clips, and then remove cowl top seal.
5. Remove cowl top insulator fixing clips, and then remove cowl top insulator.
6. Remove front fender cover (LH and RH).
7. Remove cowl top cover fixing clips.
8. Pull forward to release cowl top cover from windshield glass.

#### **CAUTION:**

**When performing the procedure after removing cowl top cover, cover the lower end of windshield glass with urethane etc.**

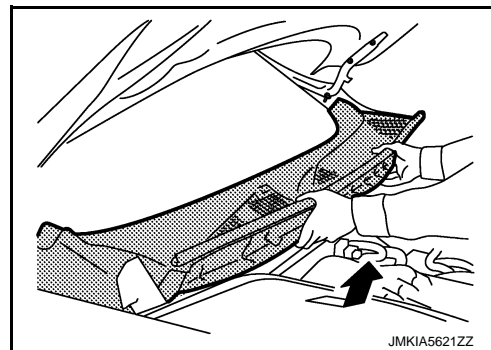

9. Remove cowl top cover.
10. Remove the following parts after removing cowl top cover.
  - EPT sealer
  - Washer tube
  - Washer nozzle (LH and RH). Refer to [WW-51, "Removal and Installation"](#).
11. Remove front wiper drive assembly. Refer to [WW-59, "Removal and Installation"](#).
12. Remove cowl top extension mounting bolts, and then remove cowl top extension.

### INSTALLATION

Note the following items and then, install in the reverse order of removal.

#### **CAUTION:**

- Clean the joint between the cowl top cover and the windshield, and then install them.
- Replace the EPT sealer on the back surface with new EPT sealer when reusing the cowl top cover.
- Remove the EPT sealer remaining on the cowl top cover using a double-faced adhesive tape remove.
- To maintain adhesion, never wash the vehicle within 24 hours after installation.
- Perform the stop position adjustment at the installation of the front wiper arms. Refer to [WW-55, "Adjustment"](#).

# FENDER PROTECTOR

< REMOVAL AND INSTALLATION >

## FENDER PROTECTOR

Exploded View

INFOID:000000008275218

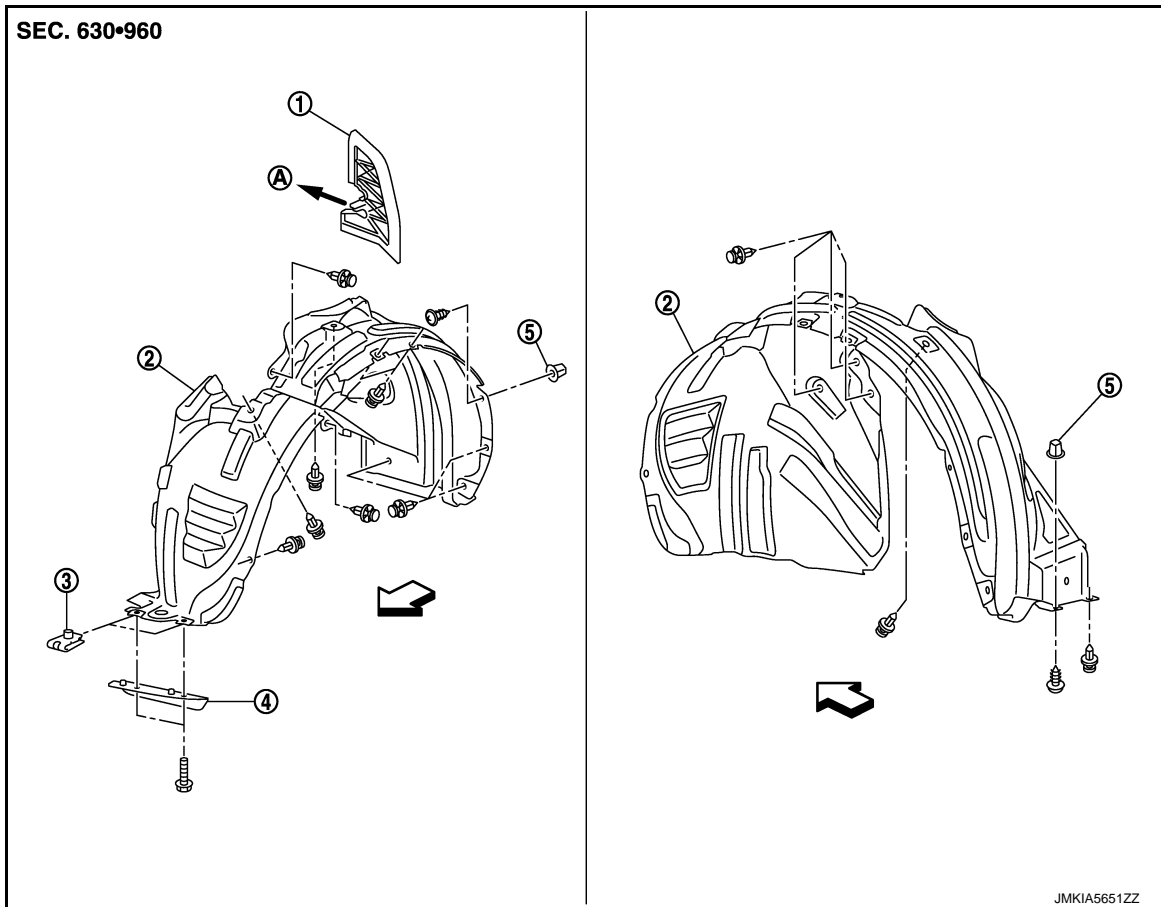

1. Hoodledge insulator

2. Fender protector

3. U nut

4. Air guide

5. Screw grommet

A. To hoodledge panel

← : Vehicle front

## Removal and Installation

INFOID:000000008275219

### REMOVAL

1. Remove front fillet molding. Refer to [EXT-30, "FRONT FILLET MOLDING : Removal and Installation"](#).
2. Remove air guide fixing bolts, and then remove air guide.
3. Remove front fender protector mounting screws and clips.
4. Remove front fender protector from wheel house.

### INSTALLATION

Install in the reverse order of removal.

# SILL COVER

< REMOVAL AND INSTALLATION >

## SILL COVER

Exploded View

INFOID:000000008275220

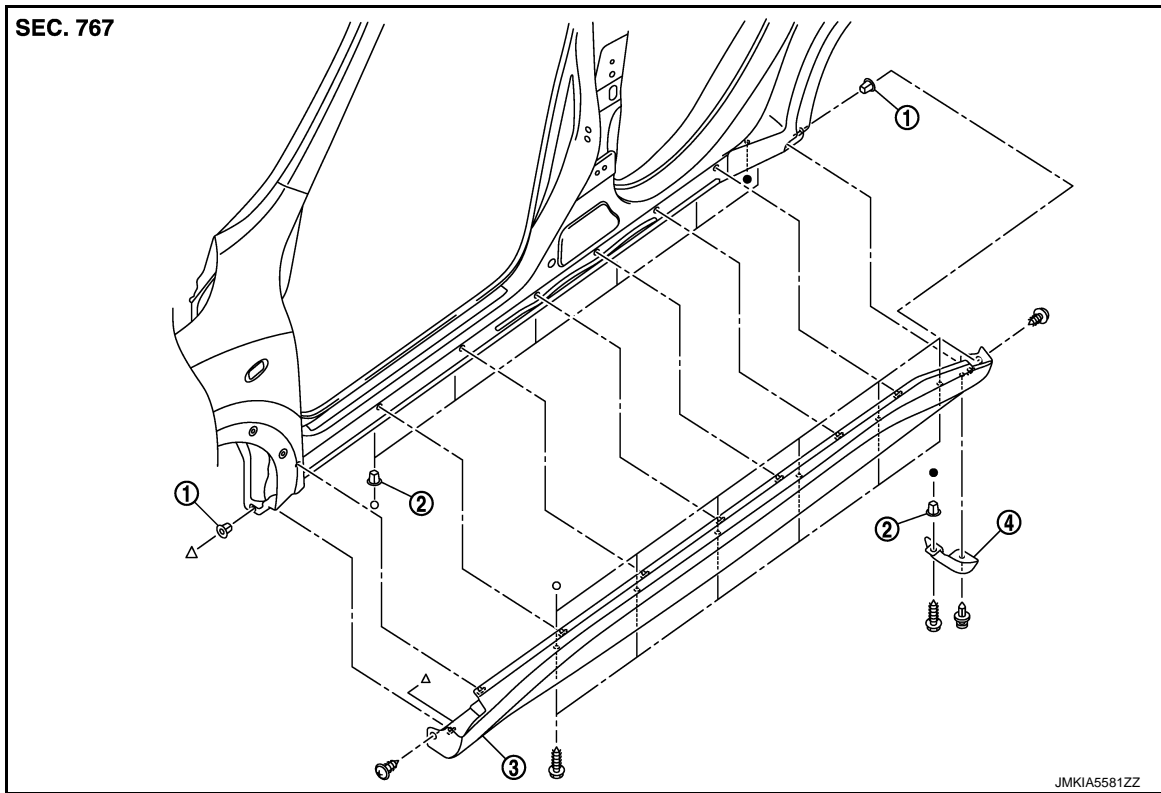

- 1. Screw grommet
- 4. Wind deflector

- 2. Screw grommet

- 3. Sill cover

## Removal and Installation

INFOID:000000008275221

EXT

### REMOVAL

1. Remove sill cover front end fixing screw (A).

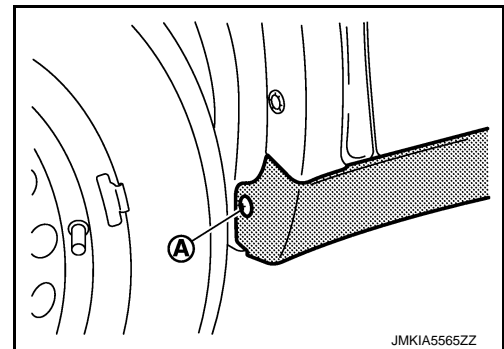

## SILL COVER

### < REMOVAL AND INSTALLATION >

2. Remove sill cover rear end fixing screw (A).

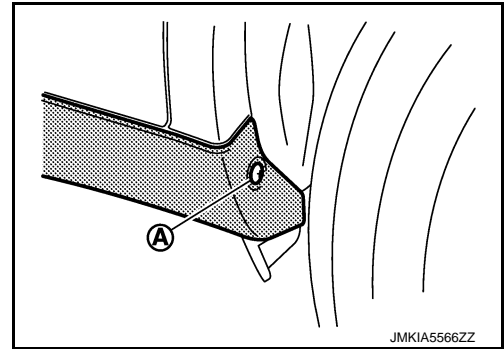

3. Remove sill cover lower side fixing screws.
4. Fully open front door and rear door.
5. Remove clips from sill cover back side with a remover tool (A).

 : Clip

**CAUTION:**  
Apply protective tape (B) on the body to protect the painted surface from damage.

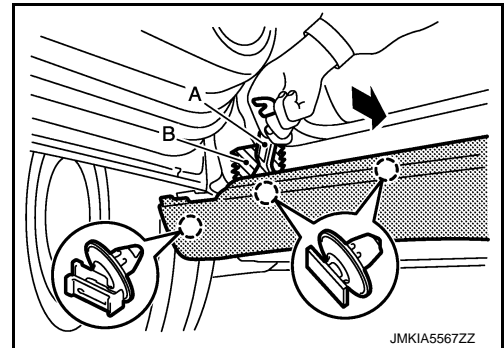

6. Remove sill cover from body side.

### INSTALLATION

Note the following item, and then install in the reverse order of removal.

**CAUTION:**

When installing sill cover, check that clips are securely fitted in body panel holes, and then press clips in.

# FLOOR SIDE FAIRING

< REMOVAL AND INSTALLATION >

## FLOOR SIDE FAIRING

Exploded View

INFOID:000000008275222

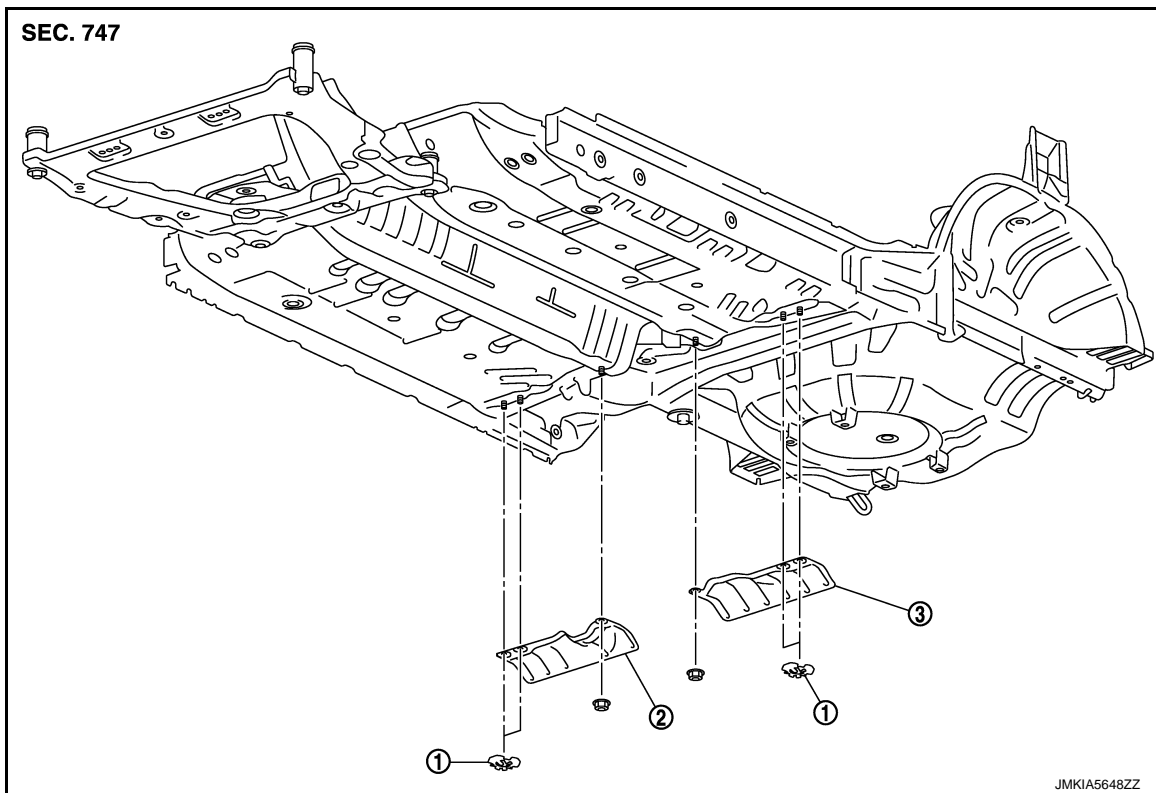

1. Push spring nut

2. Floor under cover RH

3. Floor under cover LH

### Removal and Installation

INFOID:000000008275223

#### REMOVAL

##### FLOOR UNDER COVER

Remove floor under cover mounting nut and push spring nuts, and then remove floor under cover.

#### INSTALLATION

Install in the reverse order of removal.

A  
B  
C  
D  
E  
F  
G  
H  
I  
J  
L  
M  
N  
O  
P

EXT

# FILLET MOLDING

< REMOVAL AND INSTALLATION >

## FILLET MOLDING

Exploded View

INFOID:000000008275224

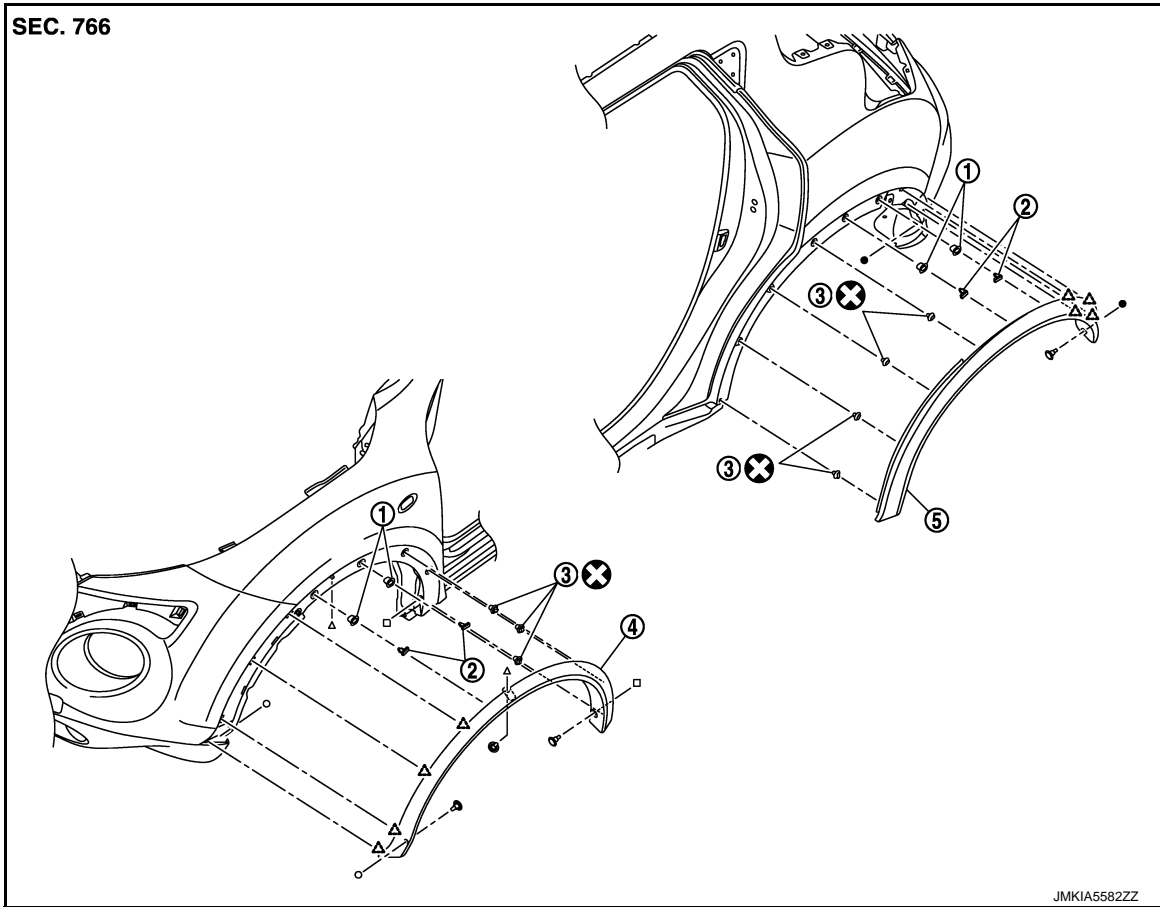

- |                         |                        |         |
|-------------------------|------------------------|---------|
| 1. Grommet              | 2. Clip                | 3. Clip |
| 4. Front fillet molding | 5. Rear fillet molding |         |

△ : Pawl

⊗ : Always replace after every disassembly.

## FRONT FILLET MOLDING

### FRONT FILLET MOLDING : Removal and Installation

INFOID:000000008275225

#### REMOVAL

1. Remove front fillet molding fixing clips.
2. Remove front fillet molding front side fixing pawls.

△ : Pawl

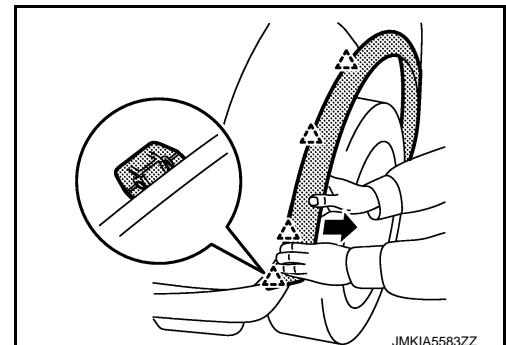

# FILLET MOLDING

## < REMOVAL AND INSTALLATION >

- Using remover tool (A), disengage the clips from front fillet molding by starting from front side.

 : Clip

### CAUTION:

- Apply a protective tape (B) on the body to protect the painted surface from damage.
- Never pull fillet molding strongly.

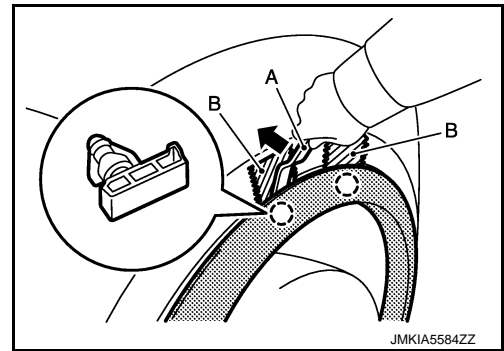

## INSTALLATION

Note the following items, and then install in the reverse order of removal.

### CAUTION:

- Always replace fillet molding fixing clips.
- When installing front fillet molding, check that blind clips and pawls are securely fitted in panel holes on body, and then press them in.

## REAR FILLET MOLDING

### REAR FILLET MOLDING : Removal and Installation

INFOID:000000008275226

## REMOVAL

- Remove fillet molding fixing clip from end of sill cover.
- Remove rear fillet molding rear side fixing pawls.

 : Pawl

### CAUTION:

Never pull the rear fillet molding strongly.

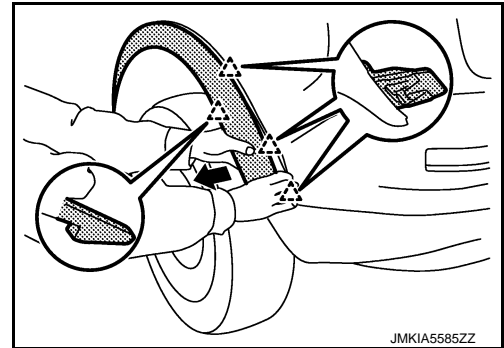

- Using remover tool (A), disengage the clips from rear fillet molding by starting from rear side.

 : Clip

### CAUTION:

- Apply a protective tape (B) on the body to protect the painted surface from damage.
- Never pull the rear fillet molding strongly.

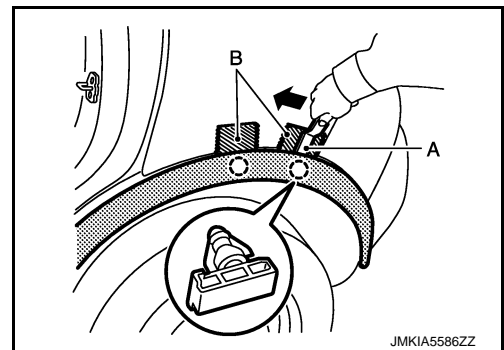

## INSTALLATION

Note the following items, and then install in the reverse order of removal.

### CAUTION:

- Always replace fillet molding fixing clips.
- When installing rear fillet molding, check that blind clips and pawls are securely fitted in panel holes on body, and then press them in.

# ROOF SIDE MOLDING

< REMOVAL AND INSTALLATION >

## ROOF SIDE MOLDING

Exploded View

INFOID:000000008275227

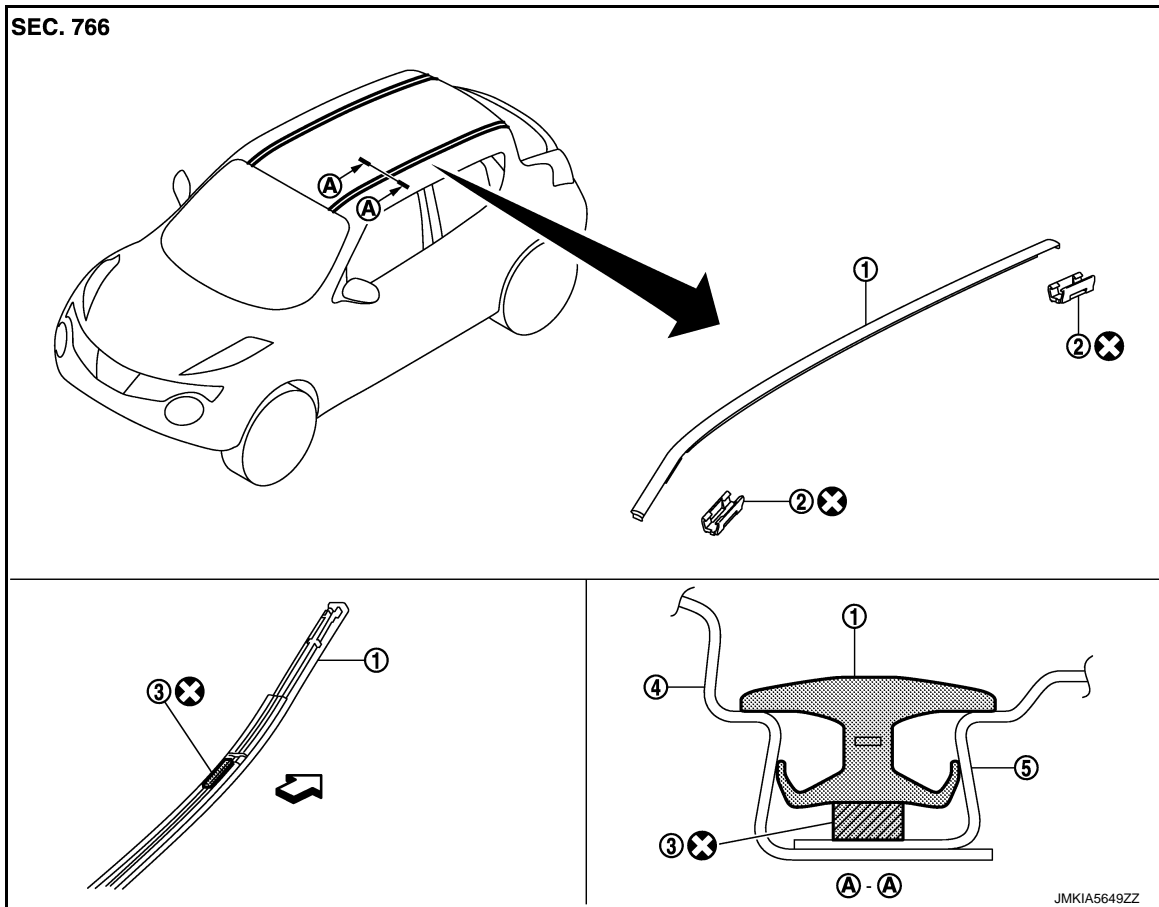

1. Roof side molding                      2. Roof side molding clip                      3. Double-sided tape [t: 2.5 mm (0.098 in)]

4. Body side outer panel                      5. Roof panel

↔ : Vehicle front

⊗ : Always replace after every disassembly.

## Removal and Installation

INFOID:000000008275228

### REMOVAL

#### ROOF SIDE MODLDING

1. Disengage roof side molding rear side fixing clip, using a remover tool (A).

⊖ : Clip

↔ : Vehicle front

#### **CAUTION:**

Apply protective tape (B) on body to protect the painted surface from damage.

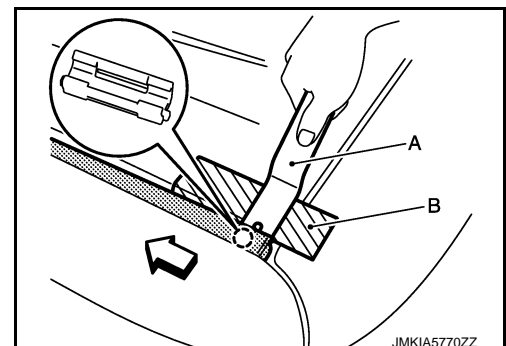



# ROOF SIDE MOLDING

## < REMOVAL AND INSTALLATION >

2. Pull up roof side molding from rear end to front end.

↔ : Vehicle front

### CAUTION:

Never pull the roof side molding strongly.

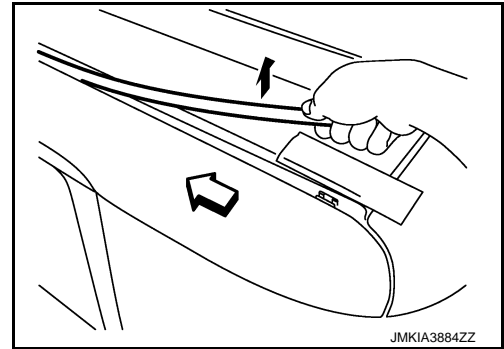

3. Disengage windshield molding and clip at the front end of roof side molding, and then remove while pulling out toward vehicle rear.

○ : Clip

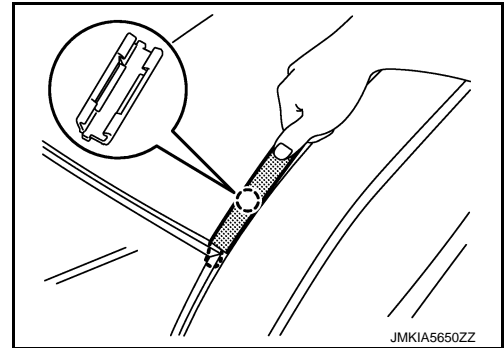

## REMOVAL AND INSTALLATION OF ROOF SIDE MOLDING CLIP

### REMOVAL

1. Remove roof side molding.
2. Heat adhesive tape interface using a dryer, and then peel roof side molding clips (body side) using long-nose pliers.

### CAUTION:

Be careful not to damage the body.

### INSTALLATION

1. Clean tape removed surface with a shop cloth soaked in white gasoline or IPA.
2. Use two-part epoxy adhesive.

**Adhesive** : 3M-weld DP-100 or equivalent

3. Apply adhesive evenly to clip tape surface.

**Thickness** : Approximately 0.5 mm (0.020 in)

4. Position applied parts to the proper location, and then sufficiently press-fit until the adhesive protrudes to tape side.

**Press-fit limit** : 19.6 N× 2 seconds

5. Tape roof side molding clips after press fit, and temporarily hold it for specified time based on the following.

**5 to 10°C (41 to 50°F)** : 1 hour or more

**11 to 23°C (52 to 73°F)** : 30 minutes or more

**24°C or more (75°F or more)** : 15 minutes or more

### CAUTION:

- Use double-sided tape after hardening for roof side molding clips.
- Securely insert molding rear end cap onto roof rear end cutout (installation standard).
- When installing roof side molding of windshield glass portion, check that body side molding fastener is securely inserted and then press in.

## ROOF SIDE MOLDING

< REMOVAL AND INSTALLATION >

---

- **Never wash the vehicle within 24 hours so as to keep adhesive.**

# DOOR OUTSIDE MOLDING

< REMOVAL AND INSTALLATION >

## DOOR OUTSIDE MOLDING

Exploded View

INFOID:000000008275229

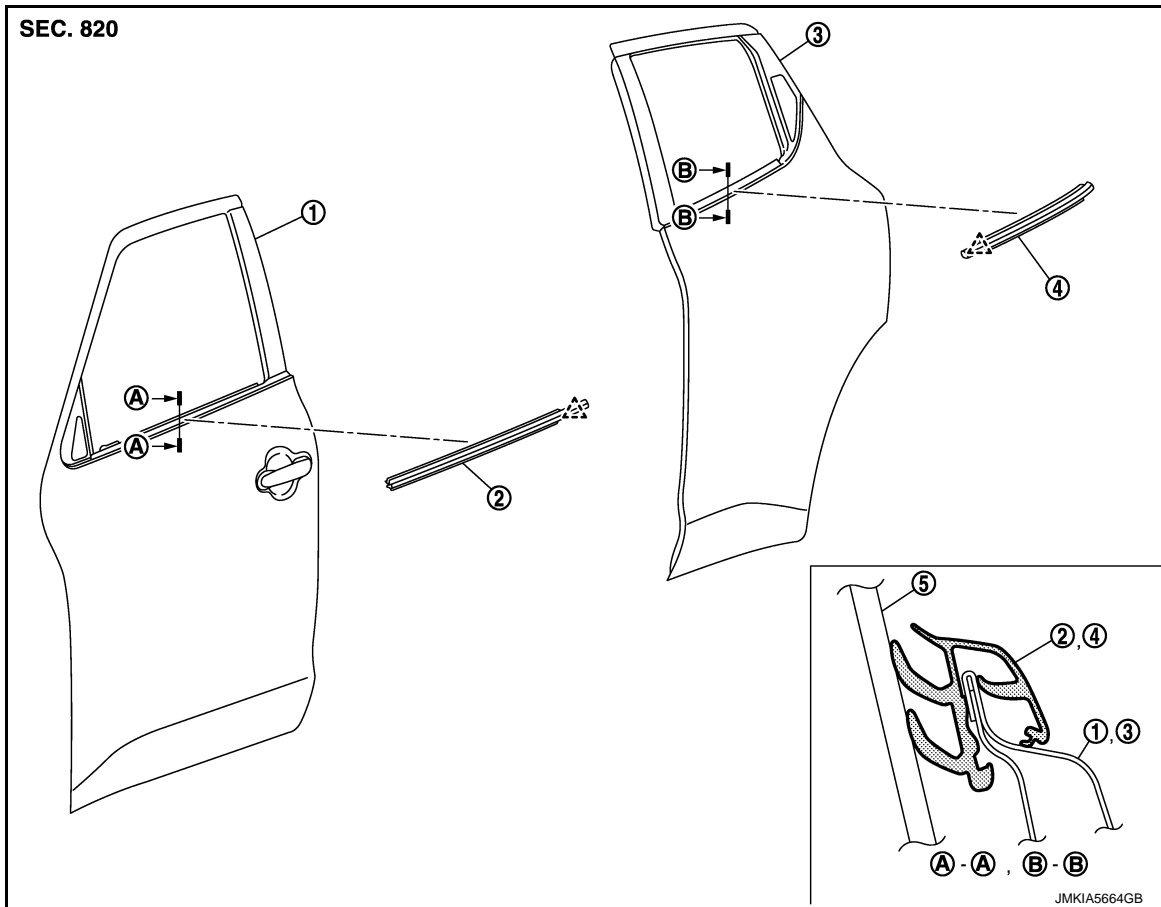

- |                              |                               |                    |
|------------------------------|-------------------------------|--------------------|
| 1. Front door panel          | 2. Front door outside molding | 3. Rear door panel |
| 4. Rear door outside molding | 5. Door glass                 |                    |

 : Pawl

## FRONT DOOR OUTSIDE MOLDING

### FRONT DOOR OUTSIDE MOLDING : Removal and Installation

INFOID:000000008275230

#### REMOVAL

1. Fully open front door glass.
2. Twist door outside molding toward the outside of the vehicle, and then lift up and remove it while disengaging the pawls.

 : Pawl

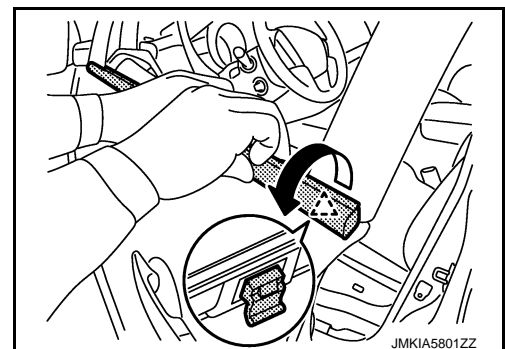

#### INSTALLATION

Note the following item, and then install in the reverse order of removal.

**CAUTION:**

A  
B  
C  
D  
E  
F  
G  
H  
I  
J

EXT

L

M

N

O

P

# DOOR OUTSIDE MOLDING

## < REMOVAL AND INSTALLATION >

When installing front door outside molding, check that pawl (1) is accurately aligned with mounting hole (2), then press in.

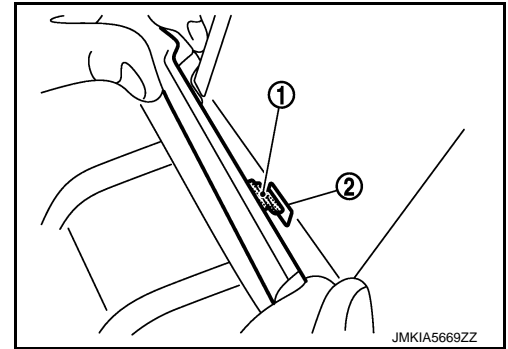

## REAR DOOR OUTSIDE MOLDING

### REAR DOOR OUTSIDE MOLDING : Removal and Installation

INFOID:000000008275231

#### REMOVAL

1. Fully open rear door glass.
2. Twist rear door outside molding toward vehicle outside and remove molding while disengaging it from door panel.

 : Pawl

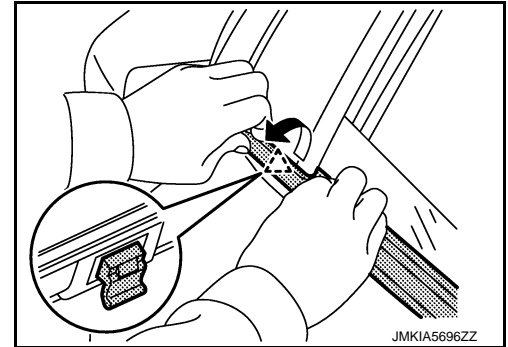

3. Slide rear door outside molding (1) toward vehicle front, and then pull molding out from rear door handle (2).

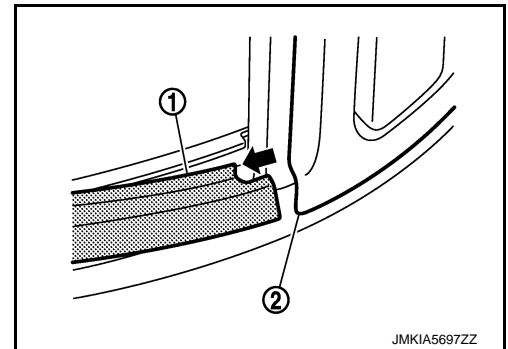

#### INSTALLATION

Note the following item, and then install in the reverse order of removal.

#### **CAUTION:**

When installing rear door outside molding, check that pawl (1) is accurately aligned with mounting hole (2), then press in.

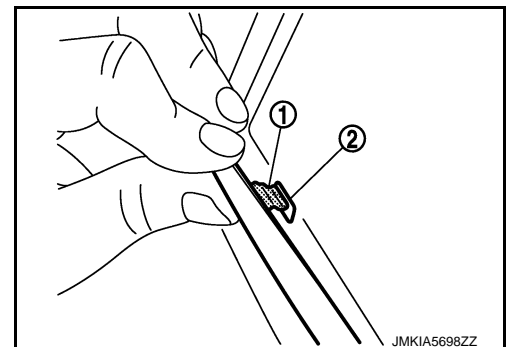

# DOOR SASH TAPE

< REMOVAL AND INSTALLATION >

## DOOR SASH TAPE

Exploded View

INFOID:000000008275232

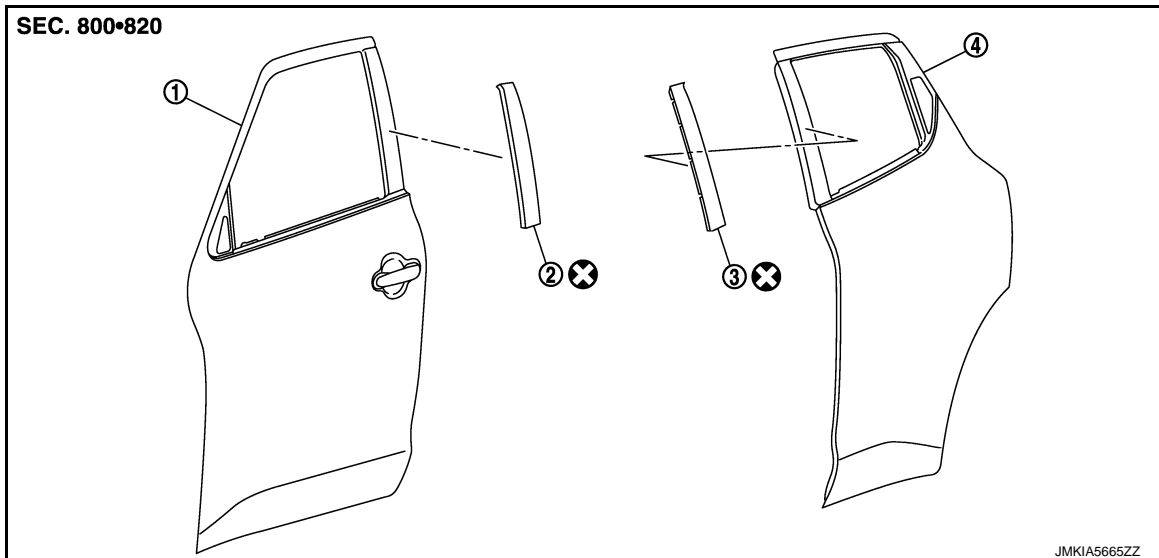

1. Front door panel
2. Front door sash tape
3. Rear door sash tape
4. Rear door panel

⊗ : Always replace after every disassembly.

### FRONT DOOR SASH TAPE

#### FRONT DOOR SASH TAPE : Removal and Installation

INFOID:000000008275233

##### REMOVAL

Heat door sash tape surface using a dryer, and then peel door sash tape.

##### **CAUTION:**

**Never damage painted surface of door panel.**

##### INSTALLATION

##### **NOTE:**

For installation position of door sash tape, refer to the position as shown in the figure.

A  
B  
C  
D  
E  
F  
G  
H  
I  
J  
EXT  
L  
M  
N  
O  
P

# DOOR SASH TAPE

## < REMOVAL AND INSTALLATION >

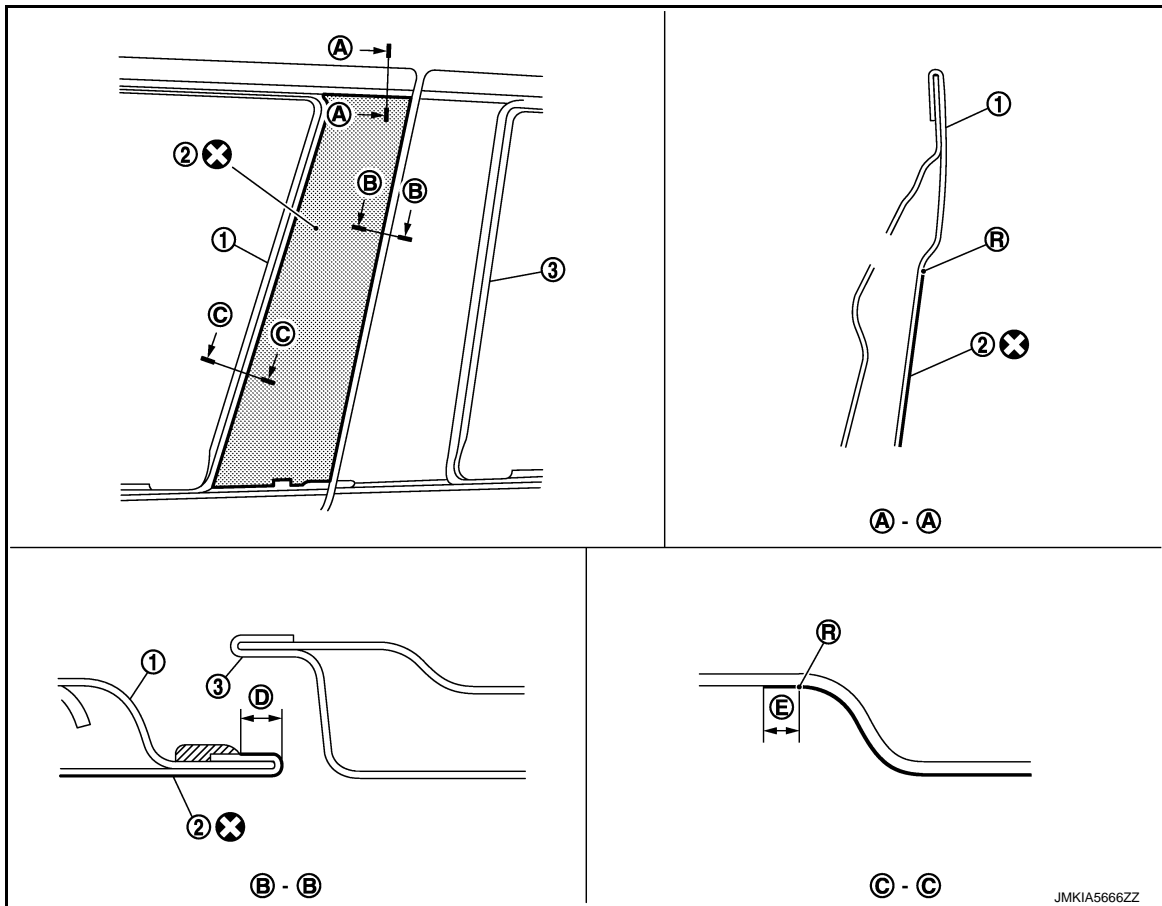

1. Front door panel

2. Front door sash tape

3. Rear door panel

R. Radius

⊗ : Always replace after every disassembly.

D : 2.0 mm (0.08 in)

E : 4.0 mm (0.16 in)

### CAUTION:

- Degrease door panel mounting surface for sash tape.
- Paint grain or dust on mounting surface of sash tape may spoil exterior appearance if it remains. Clean the mounting surface and check that no paint grain or dust remains, before starting the operation.
- Never reuse blackout tape.

1. Affix door sash tape align blackout tape upper portion to rear door outer upper end.
2. Affix door sash tape (2) to door panel (3) by applying pressure using a squeegee (A) while peeling off release coated paper (1).

### NOTE:

- Peel release coated paper at distance of 10 – 20 mm (0.394 – 0.787 in) ahead (B) of squeegee and affix blackout paper.
- To prevent any bubbles from forming, slightly lift the portion, not yet affixed using squeegee, so that portion does not contact with panel surface. Apply pressure and affix at a low and constant speed using squeegee tilted at 40 – 50° angle (pushing direction) (C) 30 – 45° angle (pulling direction) (D).

# DOOR SASH TAPE

## < REMOVAL AND INSTALLATION >

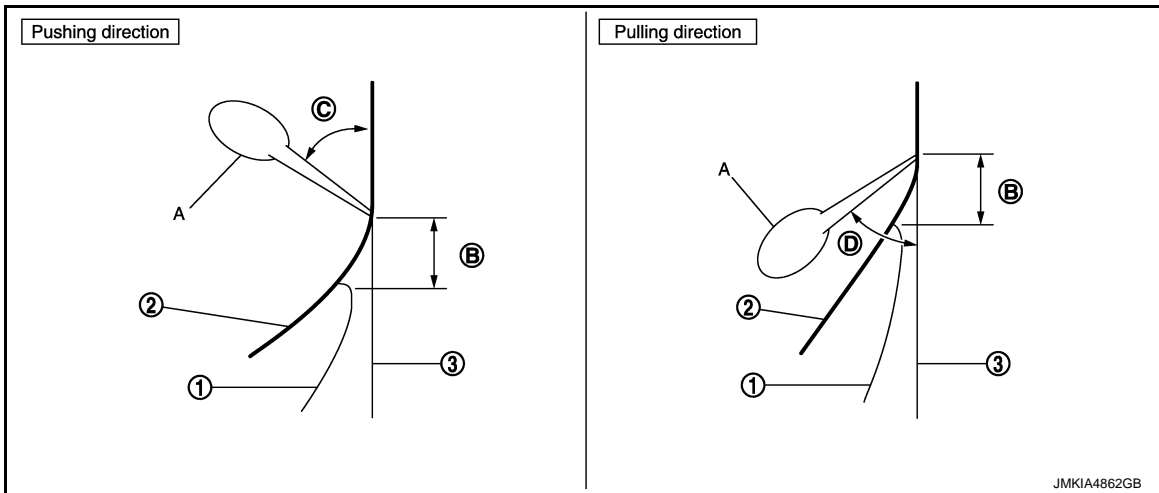

- For small radius portion of hemming part, gradually apply pressure and affix door sash tape (1) using squeegee (A) in 1 – 3 steps.

**CAUTION:**

**Never wash the vehicle with in 24 hours so as to keep adhesive.**

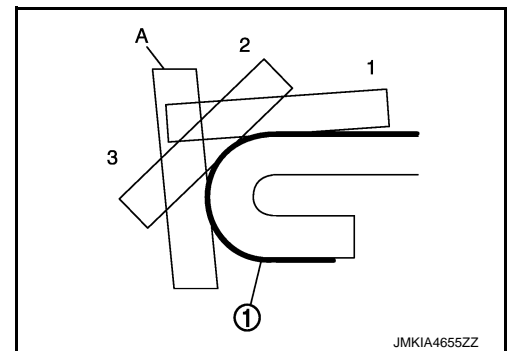

## REAR DOOR SASH TAPE

### REAR DOOR SASH TAPE : Removal and Installation

INFOID:000000008275234

#### REMOVAL

Heat door sash tape surface using a dryer, and then peel door sash tape.

**CAUTION:**

**Never damage painted surface of door panel.**

#### INSTALLATION

**NOTE:**

For installation position of door sash tape, refer to the position as shown in the figure.

A  
B  
C  
D  
E  
F  
G  
H  
I  
J  
EXT  
L  
M  
N  
O  
P

# DOOR SASH TAPE

## < REMOVAL AND INSTALLATION >

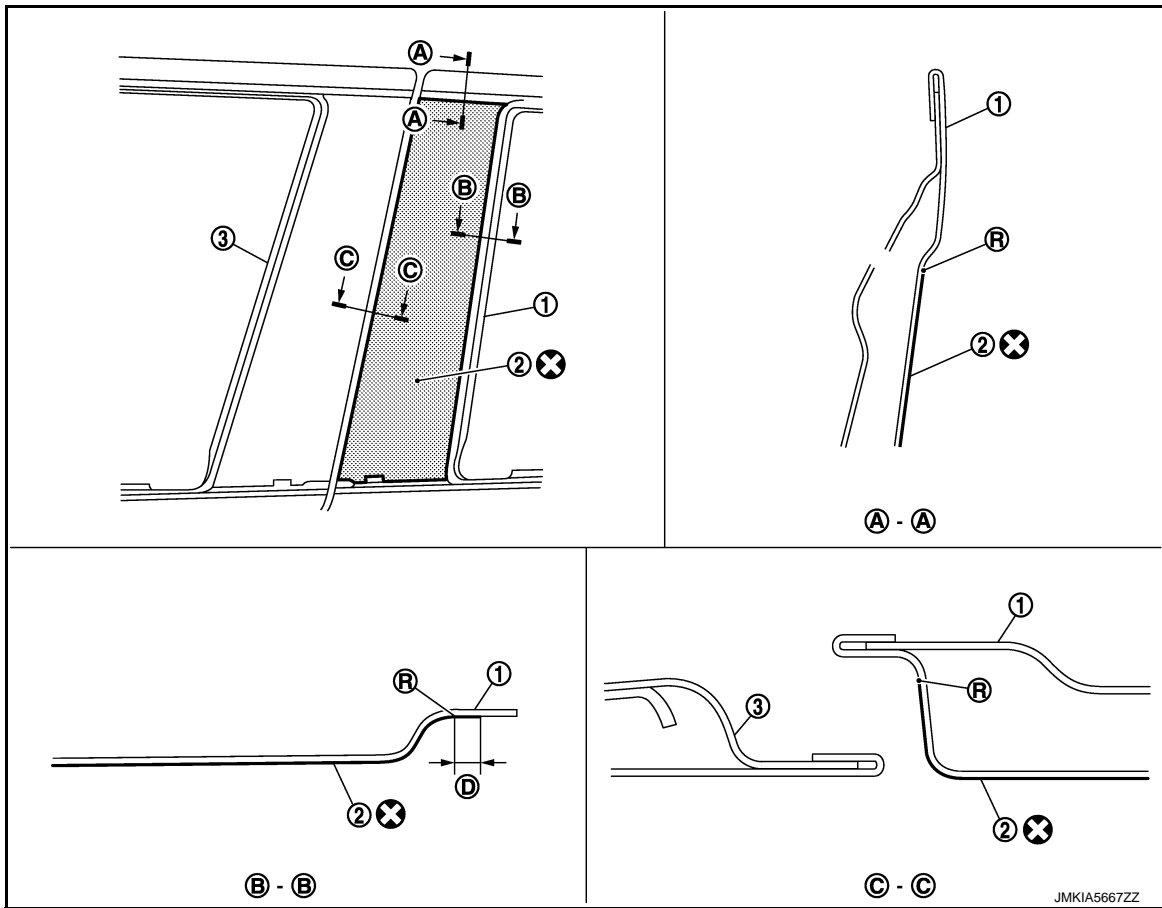

1. Rear door panel

2. Rear door sash tape

3. Front door panel

R. Radius

⊗ : Always replace after every disassembly.

D : 2.0 mm (0.08 in)

### CAUTION:

- Degrease door panel mounting surface for door sash tape.
- Paint grain or dust on mounting surface of door sash tape may spoil exterior appearance if it remains. Clean the mounting surface and check that no paint grain or dust remains, before starting the operation.
- Never reuse door sash tape.

1. Affix door sash tape align door sash tape upper portion to rear door outer upper end.
2. Affix door sash tape (2) to door panel (3) by applying pressure using a squeegee (A) while peeling off release coated paper (1).

### NOTE:

- Peel release coated paper at distance of 10 – 20 mm (0.394 – 0.787 in) ahead (B) of squeegee and affix blackout paper.
- To prevent any bubbles from forming, slightly lift the portion, not yet affixed using squeegee, so that portion does not contact with panel surface. Apply pressure and affix at a low and constant speed using squeegee tilted at 40 – 50° angle (pushing direction) (C) 30 – 45° angle (pulling direction) (D).

JMK1A5667ZZ



# DOOR SASH TAPE

## < REMOVAL AND INSTALLATION >

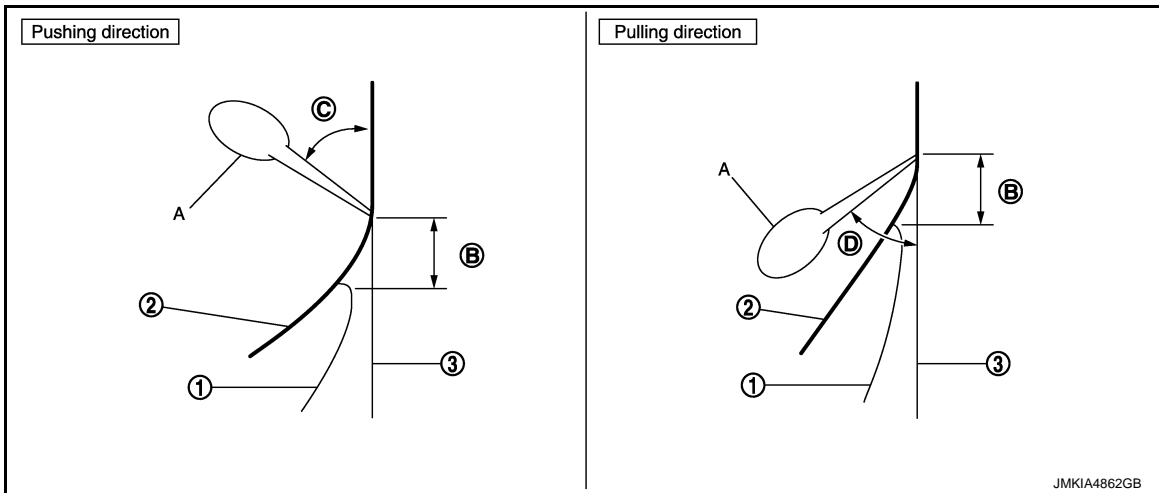

3. For small radius portion of hemming part, gradually apply pressure and affix door sash tape (1) using squeegee (A) in 1 – 3 steps.

**CAUTION:**

**Never wash the vehicle with in 24 hours so as to keep adhesive.**

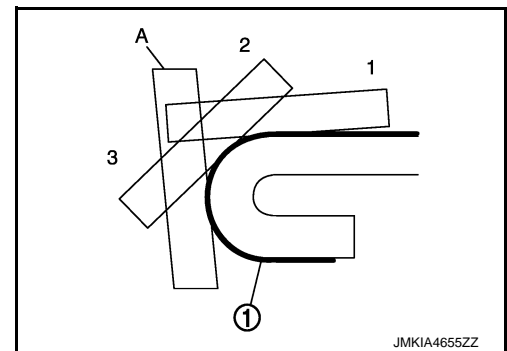

A  
B  
C  
D  
E  
F  
G  
H  
I  
J  
L  
M  
N  
O  
P

EXT

# REAR FENDER COVER

< REMOVAL AND INSTALLATION >

## REAR FENDER COVER

### Exploded View

INFOID:000000008275235

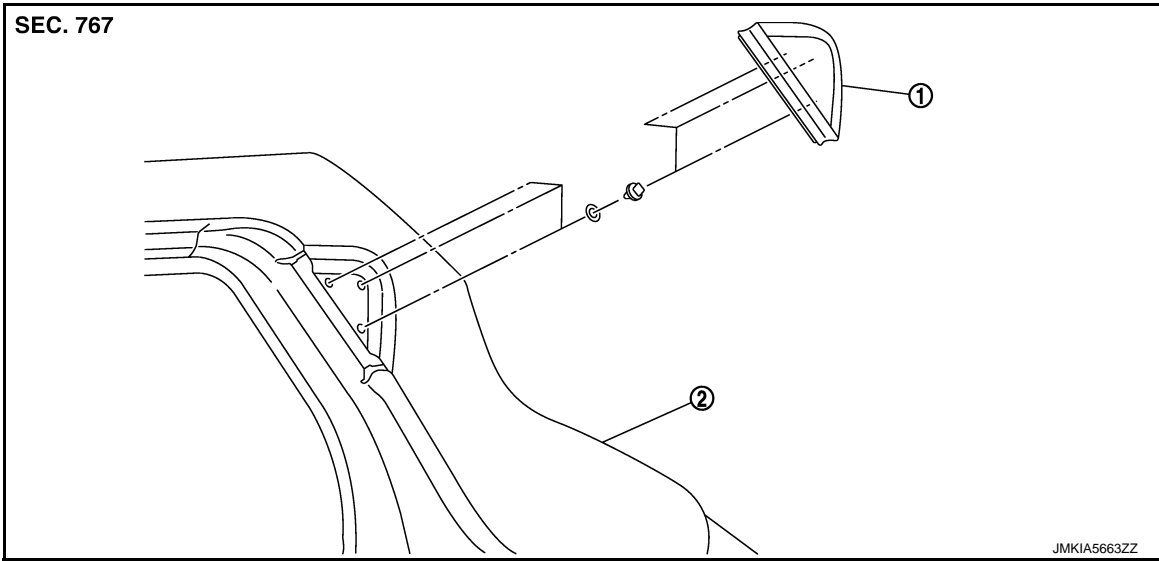

1. Rear fender cover

2. Rear fender

### Removal and Installation

INFOID:000000008275236

#### REMOVAL

Disengage rear fender cover fixing clips using remover tool (A), and then remove rear fender cover.

#### CAUTION:

Apply protective tape (B) to the body side to protect from damage.

 : Clip

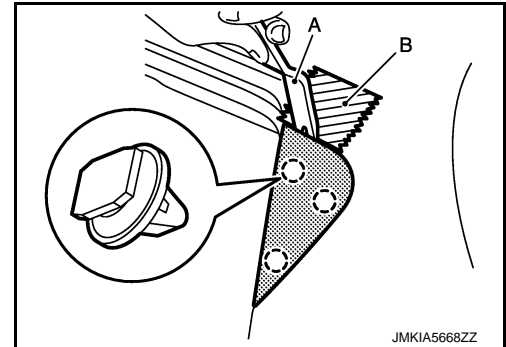

#### INSTALLATION

Note the following item, and install in the reverse order of removal.

#### CAUTION:

When installing rear fender cover, check that clips are securely fitted in body panel holes, and then press them it.

# BACK DOOR FINISHER

< REMOVAL AND INSTALLATION >

## BACK DOOR FINISHER

Exploded View

INFOID:000000008275237

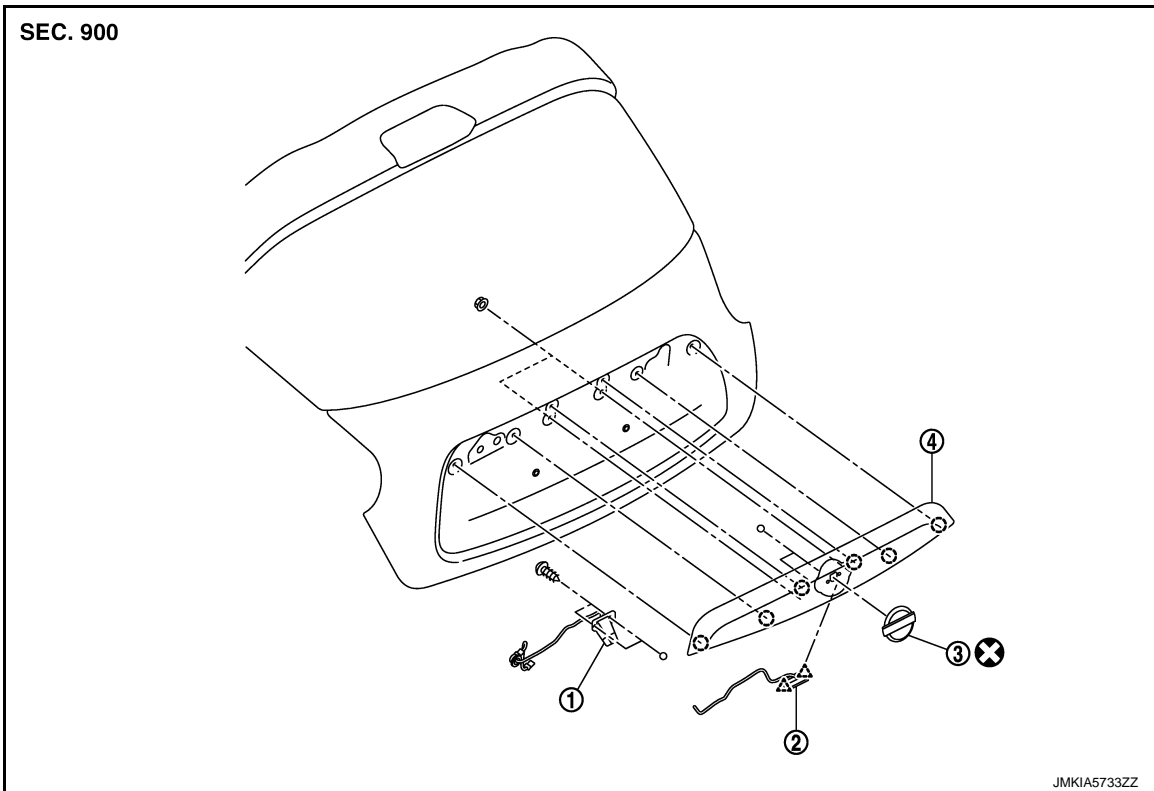

1. Rear view camera                      2. Back door opener request switch      3. Emblem  
4. Back door finisher

○ : Clip

△ : Pawl

⊗ : Always replace after every disassembly.

## Removal and Installation

INFOID:000000008275238

### REMOVAL

1. Remove back door trim. Refer to [INT-38. "BACK DOOR LOWER FINISHER : Removal and Installation"](#).
2. Remove back door finisher mounting nuts.
3. Disconnect license lamp, back door opener request switch and rear view camera harness connectors.
4. Remove harness grommet.
5. Disengage back door finisher fixing clips using a remover tool (A), and then remove back door finisher.
6. Disengage fixing clips at both ends of back door finisher from inside of back door.

○ : Clip

### CAUTION:

- Apply protect tape (B) on back door panel to protect the painted surface from damage.
- Never pull back door finisher strongly.

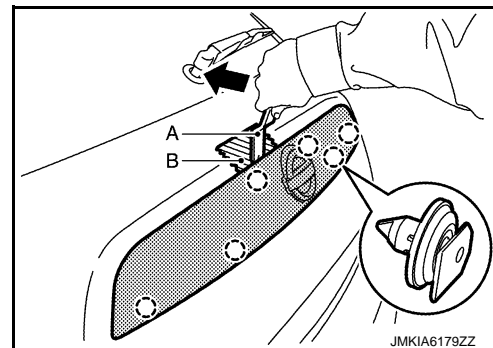

### INSTALLATION

A  
B  
C  
D  
E  
F  
G  
H  
I  
J

EXT

L  
M  
N  
O  
P

## BACK DOOR FINISHER

< REMOVAL AND INSTALLATION >

---

Note the following item, and then install in the reverse order of removal.

**CAUTION:**

**When installing back door finisher, check that clip are securely in body panel holes, and press them in.**

# REAR SPOILER

< REMOVAL AND INSTALLATION >

## REAR SPOILER

### Exploded View

INFOID:000000009152635

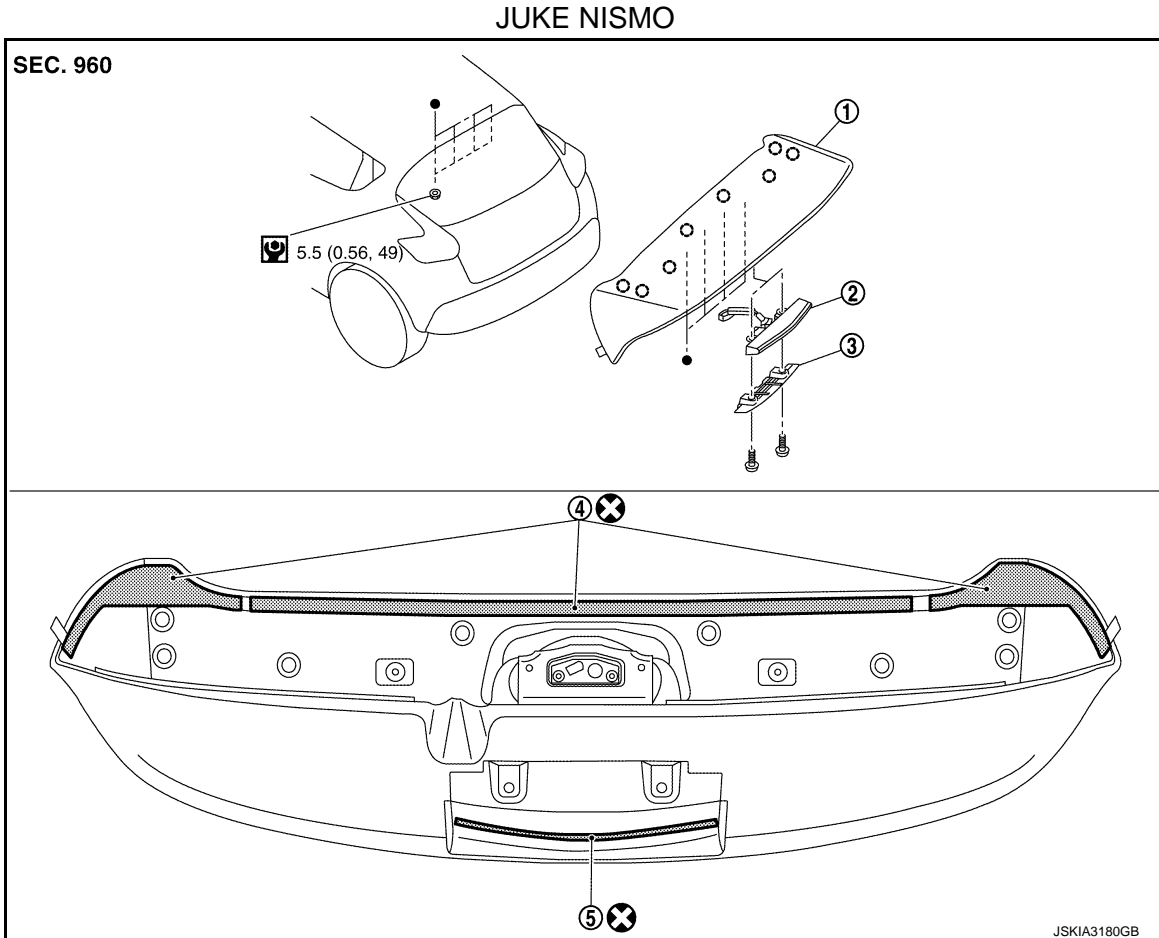

1. Rear spoiler
2. High-mounted stop lamp
3. High-mounted stop lamp cover
4. Double-sided tape[t: 2.0 mm (0.079 in)]
5. Double-sided tape[t: 1.2 mm (0.047 in)]

 : N·m (kg·m, in·lb)

 : Always replace after every disassembly.

## Removal and Installation

INFOID:000000009152636

### REMOVAL

1. Remove fixing grommet.
2. Remove rear spoiler mounting nuts.
3. Cut rear spoiler fixing double-sided tape.
4. Remove rear spoiler fixing clips.
5. Disconnect high-mounted stop lamp harness connector, and then remove rear spoiler.
6. Remove the following parts after removing rear spoiler:
  - High-mounted stop lamp cover.
  - High-mounted stop lamp. Refer to [EXL-100, "Exploded View"](#).

### INSTALLATION

Note the following items, and then install in the reverse order of removal.

#### CAUTION:

- Never damage the back door assembly.

A  
B  
C  
D  
E  
F  
G  
H  
I  
J

EXT

L

M

N

O

P

## REAR SPOILER

### < REMOVAL AND INSTALLATION >

---

- **Replace the double-sided tape on the back surface with new double-sided tape when reusing the rear spoiler.**
- **Remove double-sided tape remaining on back door assembly and back of rear spoiler with a double-sided tape remover, after removing rear spoiler.**
- **When installing, visually check the rear spoiler and clips, then replace them with new parts if they are damaged.**
- **When installing rear spoiler, check clips and bolts are securely in back door assembly holes, and press them in.**
- **Never wash the vehicle within 24 hours after installing so as to keep adhesive.**