

SECTION **WCS**

WARNING CHIME SYSTEM

A
B
C
D
E
F
G
H
I
J
K
L
M
O
P

CONTENTS

<p>PRECAUTION 3</p> <p>PRECAUTIONS 3</p> <p style="padding-left: 20px;">Precaution for Supplemental Restraint System (SRS) "AIR BAG" and "SEAT BELT PRE-TENSIONER"3</p> <p>SYSTEM DESCRIPTION 4</p> <p>COMPONENT PARTS 4</p> <p style="padding-left: 20px;">Component Parts Location4</p> <p style="padding-left: 20px;">Component Description4</p> <p style="padding-left: 20px;">Combination Meter5</p> <p>SYSTEM 6</p> <p>WARNING CHIME SYSTEM6</p> <p style="padding-left: 20px;">WARNING CHIME SYSTEM : System Diagram6</p> <p style="padding-left: 20px;">WARNING CHIME SYSTEM : System Description6</p> <p style="padding-left: 20px;">WARNING CHIME SYSTEM : Fail-Safe7</p> <p>LIGHT REMINDER WARNING CHIME7</p> <p style="padding-left: 20px;">LIGHT REMINDER WARNING CHIME : System Diagram7</p> <p style="padding-left: 20px;">LIGHT REMINDER WARNING CHIME : System Description8</p> <p>SEAT BELT WARNING CHIME9</p> <p style="padding-left: 20px;">SEAT BELT WARNING CHIME : System Diagram9</p> <p style="padding-left: 20px;">SEAT BELT WARNING CHIME : System Description9</p> <p>PARKING BRAKE RELEASE WARNING CHIME..... 10</p> <p style="padding-left: 20px;">PARKING BRAKE RELEASE WARNING CHIME : System Diagram 10</p> <p style="padding-left: 20px;">PARKING BRAKE RELEASE WARNING CHIME : System Description 11</p> <p>KEY WARNING CHIME 12</p> <p style="padding-left: 20px;">KEY WARNING CHIME : System Diagram 12</p> <p style="padding-left: 20px;">KEY WARNING CHIME : System Description 12</p>	<p>DIAGNOSIS SYSTEM (COMBINATION METER)14</p> <p style="padding-left: 20px;">CONSULT Function14</p> <p>DIAGNOSIS SYSTEM (BCM) (WITH INTELLIGENT KEY SYSTEM) 18</p> <p>COMMON ITEM18</p> <p style="padding-left: 20px;">COMMON ITEM : CONSULT Function (BCM - COMMON ITEM)18</p> <p>BUZZER19</p> <p style="padding-left: 20px;">BUZZER : CONSULT Function (BCM - BUZZER)...19</p> <p>DIAGNOSIS SYSTEM (BCM) (WITHOUT INTELLIGENT KEY SYSTEM)21</p> <p>COMMON ITEM21</p> <p style="padding-left: 20px;">COMMON ITEM : CONSULT Function (BCM - COMMON ITEM)21</p> <p>BUZZER21</p> <p style="padding-left: 20px;">BUZZER : CONSULT Function (BCM - BUZZER)...21</p> <p>ECU DIAGNOSIS INFORMATION23</p> <p>COMBINATION METER23</p> <p style="padding-left: 20px;">Reference Value23</p> <p style="padding-left: 20px;">Fail-Safe29</p> <p style="padding-left: 20px;">DTC Index30</p> <p>BCM (BODY CONTROL MODULE)31</p> <p style="padding-left: 20px;">List of ECU Reference31</p> <p>WIRING DIAGRAM32</p> <p>WARNING CHIME SYSTEM32</p> <p style="padding-left: 20px;">Wiring Diagram32</p> <p>BASIC INSPECTION33</p> <p>DIAGNOSIS AND REPAIR WORKFLOW33</p> <p style="padding-left: 20px;">Work Flow33</p>
---	--

WCS

DTC/CIRCUIT DIAGNOSIS	35	SYMPTOM DIAGNOSIS	40
POWER SUPPLY AND GROUND CIRCUIT	35	THE PARKING BRAKE RELEASE WARNING CONTINUES SOUNDING, OR DOES NOT SOUND	40
COMBINATION METER	35	Description	40
COMBINATION METER : Diagnosis Procedure ...	35	Diagnosis Procedure	40
METER BUZZER CIRCUIT	36	THE LIGHT REMINDER WARNING DOES NOT SOUND	41
Component Function Check	36	Description	41
Diagnosis Procedure	36	Diagnosis Procedure	41
SEAT BELT BUCKLE SWITCH SIGNAL CIRCUIT	37	THE SEAT BELT WARNING CONTINUES SOUNDING, OR DOES NOT SOUND	42
Component Function Check	37	Description	42
Diagnosis Procedure	37	Diagnosis Procedure	42
Component Inspection	37	THE KEY WARNING DOES NOT SOUND (WITHOUT INTELLIGENT KEY)	43
PARKING BRAKE SWITCH SIGNAL CIRCUIT	39	Description	43
Diagnosis Procedure	39	Diagnosis Procedure	43
Component Inspection	39		

PRECAUTIONS

< PRECAUTION >

PRECAUTION

PRECAUTIONS

Precaution for Supplemental Restraint System (SRS) "AIR BAG" and "SEAT BELT PRE-TENSIONER"

INFOID:000000008273695

The Supplemental Restraint System such as "AIR BAG" and "SEAT BELT PRE-TENSIONER", used along with a front seat belt, helps to reduce the risk or severity of injury to the driver and front passenger for certain types of collision. This system includes seat belt switch inputs and dual stage front air bag modules. The SRS system uses the seat belt switches to determine the front air bag deployment, and may only deploy one front air bag, depending on the severity of a collision and whether the front occupants are belted or unbelted. Information necessary to service the system safely is included in the "SRS AIR BAG" and "SEAT BELT" of this Service Manual.

WARNING:

Always observe the following items for preventing accidental activation.

- To avoid rendering the SRS inoperative, which could increase the risk of personal injury or death in the event of a collision that would result in air bag inflation, all maintenance must be performed by an authorized NISSAN/INFINITI dealer.
- Improper maintenance, including incorrect removal and installation of the SRS, can lead to personal injury caused by unintentional activation of the system. For removal of Spiral Cable and Air Bag Module, see "SRS AIR BAG".
- Never use electrical test equipment on any circuit related to the SRS unless instructed to in this Service Manual. SRS wiring harnesses can be identified by yellow and/or orange harnesses or harness connectors.

PRECAUTIONS WHEN USING POWER TOOLS (AIR OR ELECTRIC) AND HAMMERS

WARNING:

Always observe the following items for preventing accidental activation.

- When working near the Air Bag Diagnosis Sensor Unit or other Air Bag System sensors with the ignition ON or engine running, never use air or electric power tools or strike near the sensor(s) with a hammer. Heavy vibration could activate the sensor(s) and deploy the air bag(s), possibly causing serious injury.
- When using air or electric power tools or hammers, always switch the ignition OFF, disconnect the battery, and wait at least 3 minutes before performing any service.

A
B
C
D
E
F
G
H
I
J
K
L
M
O
P

WCS

COMPONENT PARTS

< SYSTEM DESCRIPTION >

SYSTEM DESCRIPTION

COMPONENT PARTS

Component Parts Location

INFOID:000000008273696

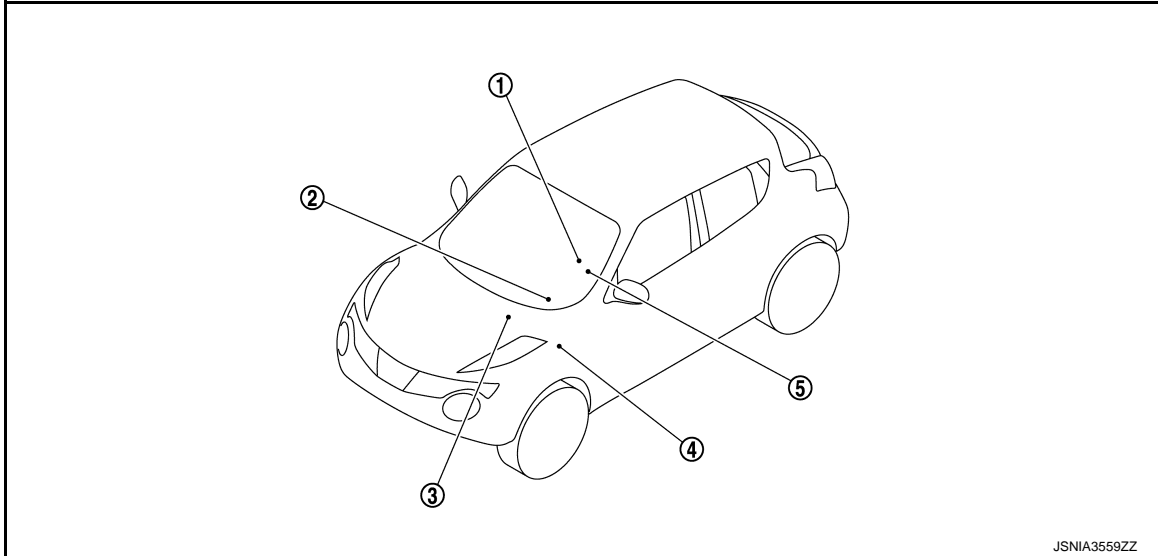

- | | | |
|--|--|--|
| 1. Parking brake switch | 2. Combination meter | 3. ABS actuator and electric unit (control unit)
Refer to BRC-8, "Component Parts Location" . |
| 4. BCM
Refer to BCS-6, "BODY CONTROL SYSTEM : Component Parts Location" (WITH INTELLIGENT KEY SYSTEM).
Refer to BCS-84, "BODY CONTROL SYSTEM : Component Parts Location" (WITHOUT INTELLIGENT KEY SYSTEM). | 5. Seat belt buckle switch (driver side) | |

Component Description

INFOID:000000008273697

Unit	Description
Combination meter	<ul style="list-style-type: none"> Receives a buzzer output signal from the BCM with CAN communication line and sounds the buzzer. Judges whether the parking brake is released from the vehicle speed signal received from the ABS actuator and electric unit (control unit) with CAN communication line and the parking brake switch signal from the parking brake switch, and sounds the buzzer if necessary.
BCM	Based on the signals received from various units and switches, transmits the buzzer output signal to the combination meter via CAN communication.
ABS actuator and electric unit (control unit)	Transmits the vehicle speed signal to combination meter via CAN communication.
Seat belt buckle switch (driver side)	Transmits a seat belt buckle switch signal (driver side) to the combination meter.
Combination switch (Lighting switch)	Transmits the combination switch signal to BCM.
Front door switch (driver side)	Transmits the driver side door switch signal to BCM.

COMPONENT PARTS

< SYSTEM DESCRIPTION >

Unit	Description
Key switch	Transmits the key switch signal to BCM.
Parking brake switch	Transmits the parking brake switch signal to the combination meter.

Combination Meter

INFOID:000000008273698

The buzzer (1) for the warning chime system is integrated in the combination meter.

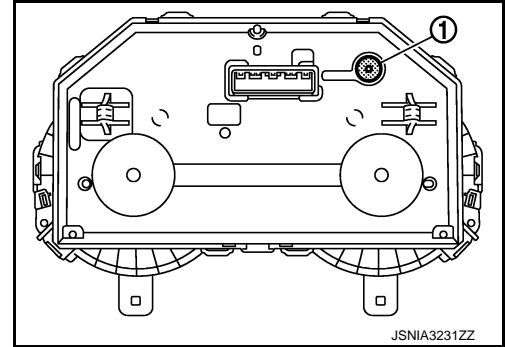

A
B
C
D
E
F
G
H
I
J
K
L
M
O
P

WCS

SYSTEM

< SYSTEM DESCRIPTION >

SYSTEM

WARNING CHIME SYSTEM

WARNING CHIME SYSTEM : System Diagram

INFOID:000000008273699

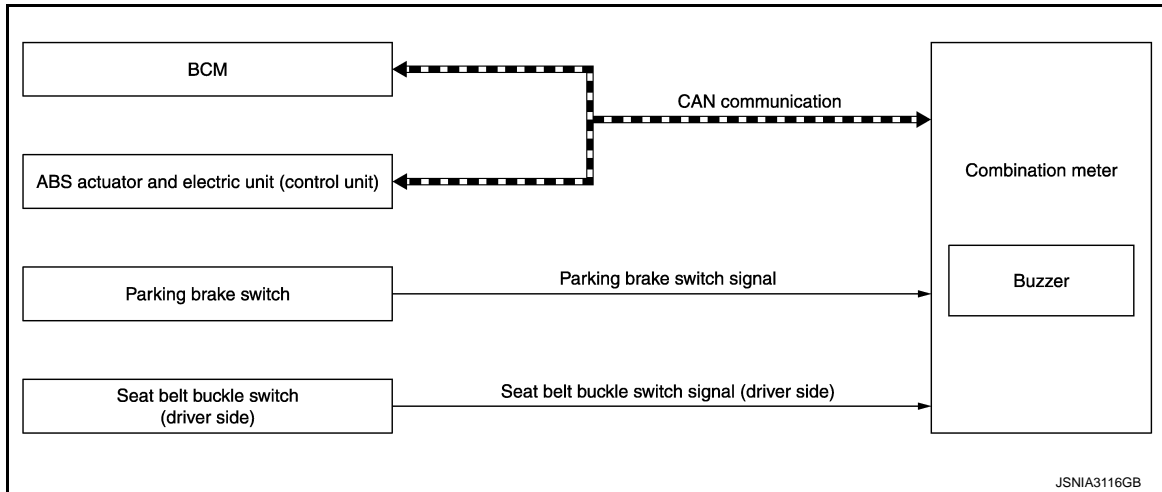

WARNING CHIME SYSTEM : System Description

INFOID:000000008273700

COMBINATION METER

The combination meter sounds the alarm buzzer installed in the combination meter when receiving the buzzer output signal transmitted from each unit.

BCM

BCM receives signals from various units and transmits a buzzer output signal to the combination meter via CAN communication if it judges that the warning buzzer should be activated.

WARNING CHIME FUNCTION LIST

Warning functions	Out line	Warning judgment unit	Refer to
Light reminder warning chime	The warning chime sounds when the ignition switch is in OFF or ACC position with the combination switch (lighting switch) in the 1st or 2nd position and the driver side door open.	BCM	WCS-8, "LIGHT REMINDER WARNING CHIME : System Description"
Seat belt warning chime	The warning chime sounds when the driver seat belt is unfastened with the ignition switch in ON position.	BCM	WCS-9, "SEAT BELT WARNING CHIME : System Description"
Parking brake release warning chime	The warning chime sounds when the ignition switch is in ON position with the parking brake in operation and the vehicle speed 7 km/h (4.3 MPH) or more.	Combination meter	WCS-11, "PARKING BRAKE RELEASE WARNING CHIME : System Description"
Key warning chime (Without intelligent key)	The warning chime sounds when the ignition switch is in OFF or ACC position with the key inserted and the driver side door open.	BCM	WCS-12, "KEY WARNING CHIME : System Description"

SYSTEM

< SYSTEM DESCRIPTION >

WARNING CHIME SYSTEM : Fail-Safe

INFOID:000000008273701

FAIL-SAFE

The combination meter activates the fail-safe control if CAN communication with each unit is malfunctioning.

Function		Specifications
Speedometer		Reset to zero by suspending communication.
Tachometer		
Engine coolant temperature gauge		
Illumination control		When suspending communication, changes to nighttime mode.
Shift position indicator		When suspending communication, not indicate.
Information display	Instantaneous fuel consumption	<ul style="list-style-type: none"> When reception time of an abnormal signal is 2 seconds or less, the last received datum is used for calculation to indicate the result. When reception time of an abnormal signal is more than two seconds, the last result calculated during normal condition is indicated.
	Average fuel consumption	
	Possible driving distance	
	Torque distribution indicator	
Buzzer		The buzzer turns OFF by suspending communication.
Warning lamp/indicator lamp	ABS warning lamp	The lamp turns ON by suspending communication.
	Malfunction indicator lamp	
	VDC OFF indicator lamp	
	EPS warning lamp	
	AWD warning lamp	
	Brake warning lamp	
	VDC warning lamp	The lamp turns OFF by suspending communication.
	High beam indicator lamp	
	Turn signal indicator lamp	
	Door warning lamp	
	Tail lamp indicator lamp	
	Engine start operation indicator lamp	
	Shift P warning lamp	
	Oil pressure warning lamp	
	CRUISE indicator lamp	
	AWD mode indicator lamp (AWD)	
	AWD mode indicator lamp (AWD-V)	
	Key warning lamp	
	CVT indicator lamp	
Low tire pressure warning lamp	After blinking for 1 minute, the lamp remains ON.	

LIGHT REMINDER WARNING CHIME

LIGHT REMINDER WARNING CHIME : System Diagram

INFOID:000000008273702

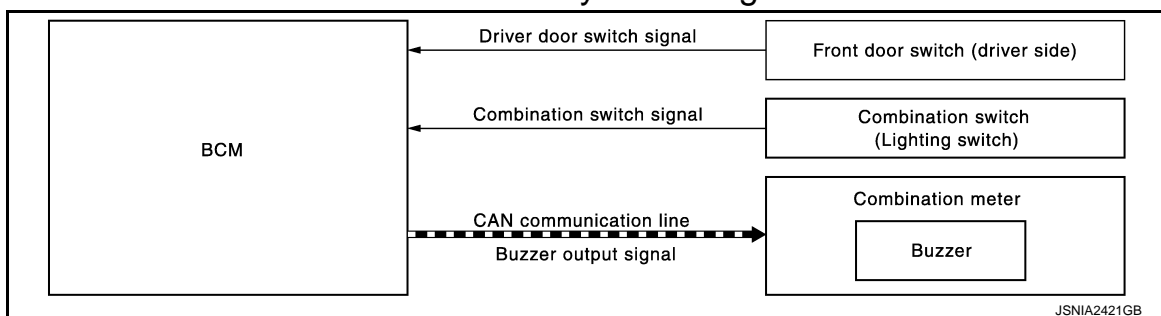

SYSTEM

< SYSTEM DESCRIPTION >

LIGHT REMINDER WARNING CHIME : System Description

INFOID:000000008273703

WARNING CHIME OPERATION CONDITIONS

If all of the following conditions are fulfilled.

Operation conditions	
Ignition switch	OFF or ACC position
Combination switch (Lighting switch)	1st or 2nd position
Driver side door	Open [front door switch (driver side) ON]

WARNING CHIME CANCEL CONDITIONS

Warning is canceled if any of the following conditions is fulfilled.

Operation conditions	
Ignition switch	ON
Combination switch (Lighting switch)	OFF or AUTO position
Driver side door	Close [front door switch (driver side) OFF]

SIGNAL PATH

1. BCM requires warning chime output to combination meter when it judges light reminder warning chime is necessary from signals below.

Signal name	Signal path
Ignition switch signal	—
Combination switch signal	Combination switch (Lighting switch) → BCM
Driver door switch signal	Front door switch (driver side) → BCM

2. Combination meter sounds integrated buzzer, following the warning chime output requirement (below signal) from BCM.

Signal name	Signal path
Buzzer output signal	BCM  → Combination meter

SYSTEM

< SYSTEM DESCRIPTION >

TIMING CHART

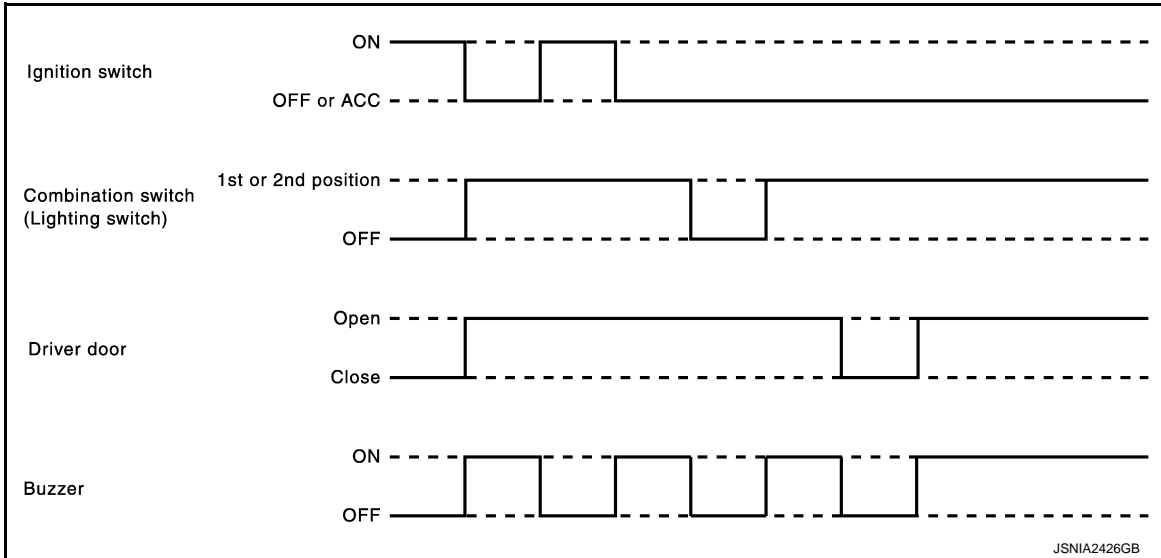

SEAT BELT WARNING CHIME

SEAT BELT WARNING CHIME : System Diagram

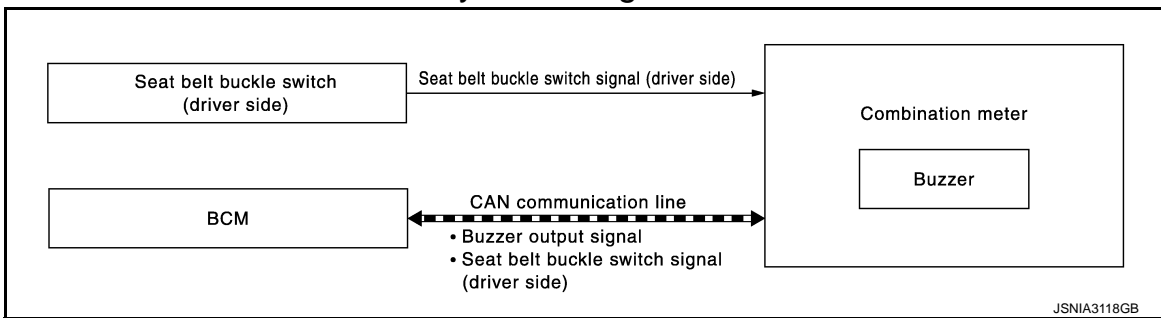

SEAT BELT WARNING CHIME : System Description

INFOID:000000008273705

WARNING OPERATION CONDITIONS

If all of the following conditions are fulfilled.

Operation conditions	
Ignition switch	ON
Driver seat belt	Unfastened [seat belt buckle switch (driver side) ON]

WARNING CANCEL CONDITIONS

Warning is canceled if any of the following conditions is fulfilled.

Operation conditions	
Ignition switch	OFF
Seat belt (driver side)	Fastened (driver side seat belt buckle switch OFF)
6 seconds after the start of warning sound	

SIGNAL PATH

1. BCM requires warning chime output to combination meter when it judges seat belt warning chime is necessary from signals below.

A
B
C
D
E
F
G
H
I
J
K
L
M
O
P

WCS

SYSTEM

< SYSTEM DESCRIPTION >

Signal name	Signal path
Ignition switch signal	—
Seat belt buckle switch signal (driver side)	Seat belt buckle switch (driver side) → Combination meter CAN → BCM

- Combination meter sounds integrated buzzer, following the warning chime output requirement (below signal) from BCM.

Signal name	Signal path
Buzzer output signal	BCM → CAN → Combination meter

TIMING CHART

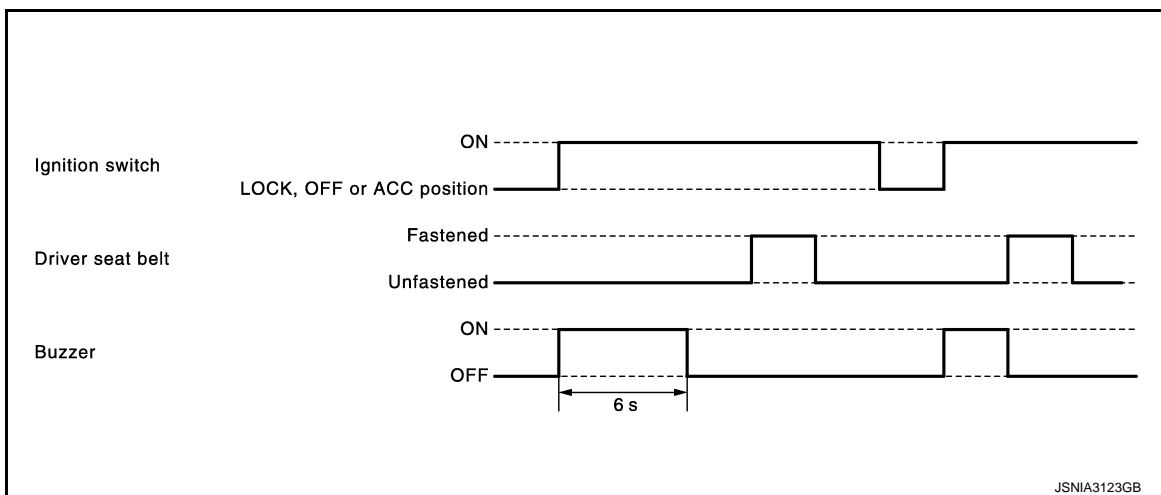

JSNIA3123GB

SOUND SPECIFICATION

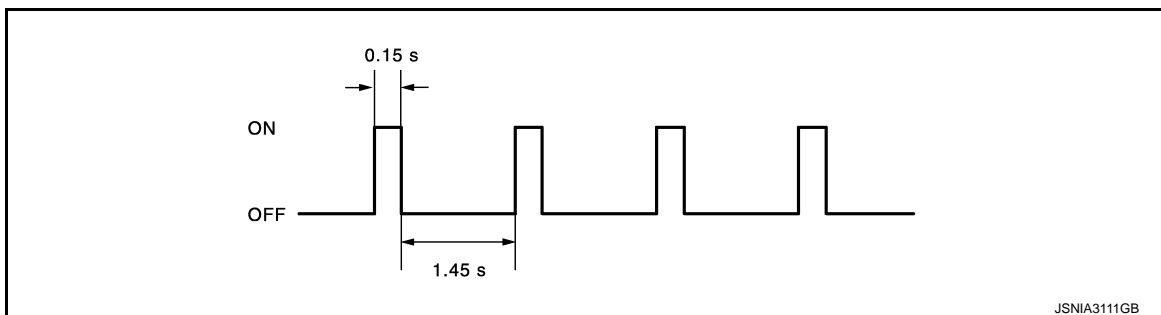

JSNIA3111GB

PARKING BRAKE RELEASE WARNING CHIME

PARKING BRAKE RELEASE WARNING CHIME : System Diagram

INFOID:000000008273706

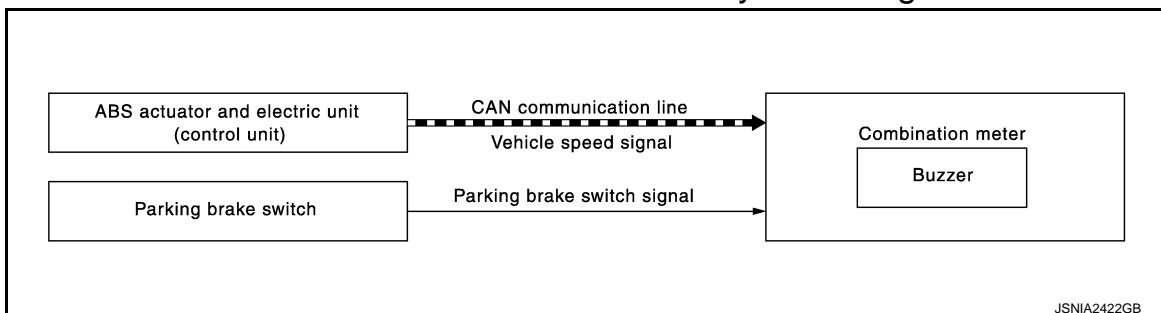

JSNIA2422GB

SYSTEM

< SYSTEM DESCRIPTION >

PARKING BRAKE RELEASE WARNING CHIME : System Description

INFOID:000000008273707

WARNING OPERATION CONDITIONS

If all of the following conditions are fulfilled.

Operation conditions	
Ignition switch	ON
Parking brake	During the operation (parking brake switch ON)
Vehicle speed	Approximately 7 km/h (4.3 MPH) or more

WARNING CANCEL CONDITIONS

Warning is canceled if any of the following conditions are fulfilled.

Operation conditions	
Ignition switch	OFF
Parking brake	Release condition (parking brake switch OFF)
Vehicle speed	Approximately 3 km/h (1.9 MPH) or less

SIGNAL PATH

Combination meter sounds integrated buzzer when it judges that parking brake release warning chime is necessary from signals below.

Signal name	Signal path
Ignition switch signal	—
Parking brake switch signal	Parking brake switch → Combination meter
Vehicle speed signal	ABS actuator and electric unit (control unit) ^{CAN} → Combination meter

TIMING CHART

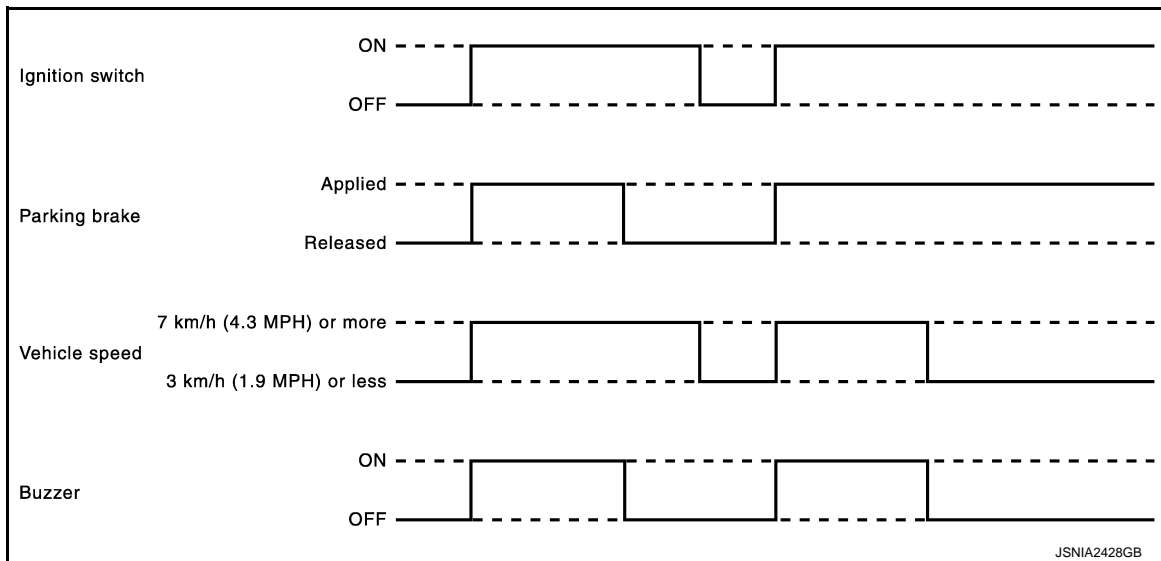

A
B
C
D
E
F
G
H
I
J
K
L
M
N
O
P

WCS

SYSTEM

< SYSTEM DESCRIPTION >

SOUND SPECIFICATION

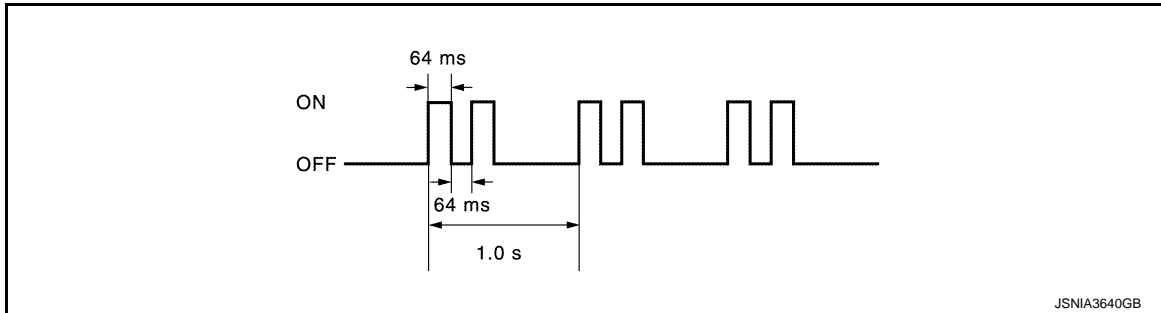

KEY WARNING CHIME

KEY WARNING CHIME : System Diagram

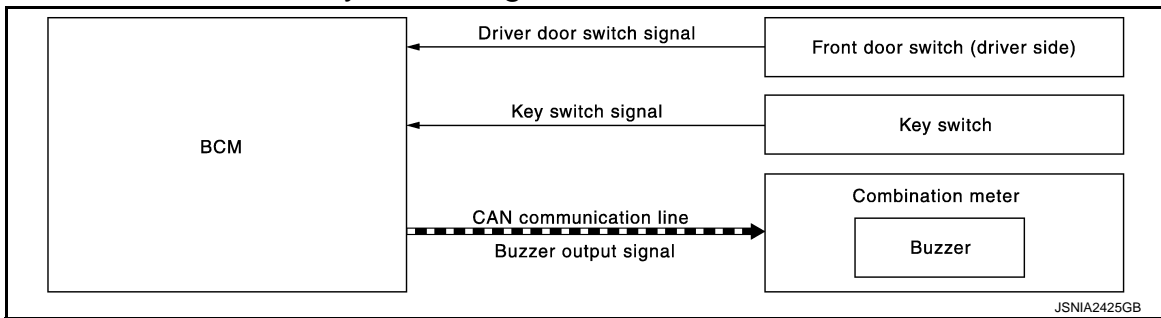

KEY WARNING CHIME : System Description

INFOID:000000008273709

DESCRIPTION

The warning chime sounds when the ignition switch is in OFF or ACC position with the key inserted and the driver side door open.

WARNING OPERATION CONDITIONS

The BCM transmits the buzzer output signal to combination meter with CAN communication line when all of the following operation conditions are met. When combination meter receives buzzer output signal, it sounds the buzzer.

Operation conditions	
Ignition switch	OFF or ACC position
Key switch	ON (state that inserted key in key cylinder)
Driver side door	Open [front door switch (driver side) ON]

WARNING CANCEL CONDITIONS

Warning is canceled if any of the following conditions is fulfilled.

Operation conditions	
Ignition switch	ON
Key switch	OFF (state that removed key from key cylinder)
Driver side door	Close [front door switch (driver side) OFF]

SIGNAL PATH

1. BCM requires warning chime output to combination meter when it judges key warning chime is necessary from signals below.

SYSTEM

< SYSTEM DESCRIPTION >

Signal name	Signal path
Ignition switch signal	—
Key switch signal	Key switch → BCM
Driver door switch signal	Front door switch (driver side) → BCM

2. Combination meter sounds integrated buzzer, following the warning chime output requirement (below signal) from BCM.

Signal name	Signal path
Buzzer output signal	BCM  → Combination meter

TIMING CHART

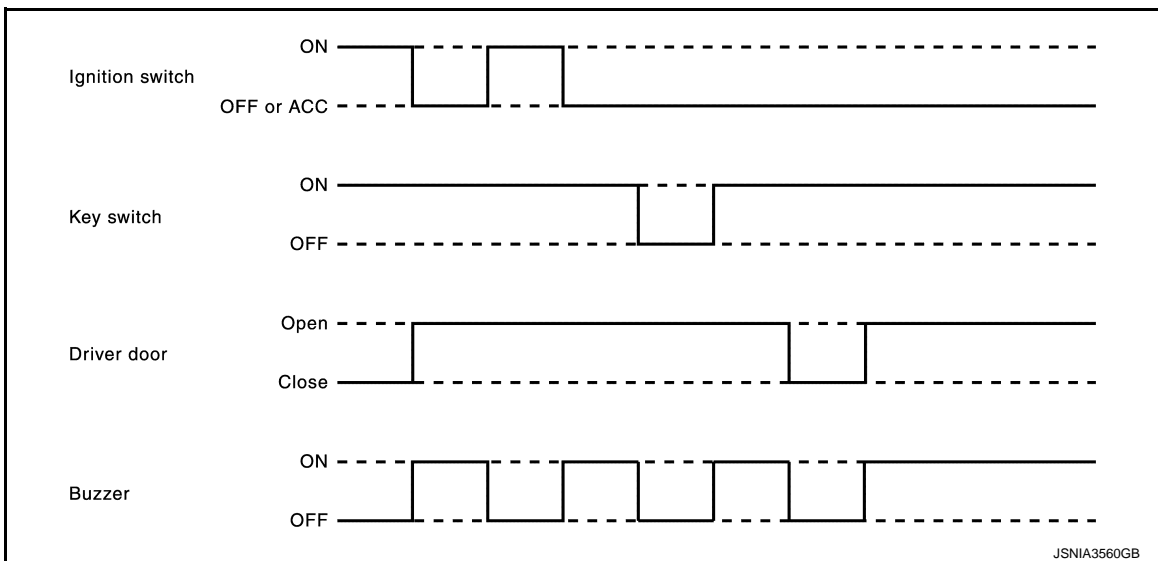

SOUND SPECIFICATION

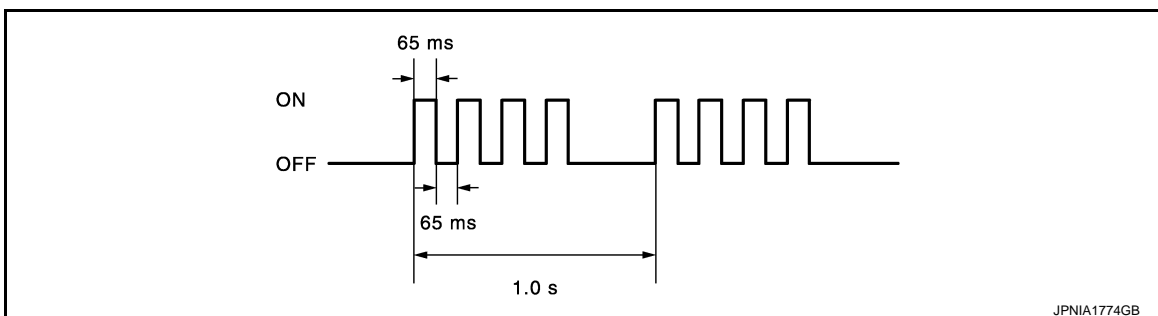

A
B
C
D
E
F
G
H
I
J
K
L
M
O
P

WCS

DIAGNOSIS SYSTEM (COMBINATION METER)

< SYSTEM DESCRIPTION >

DIAGNOSIS SYSTEM (COMBINATION METER)

CONSULT Function

INFOID:000000008770158

CONSULT APPLICATION ITEMS

CONSULT can perform the following diagnosis modes via CAN communication and the combination meter.

System	Diagnosis mode	Description
METER/M&A	Self Diagnostic Result	The combination meter checks the conditions and displays memorized errors.
	Data Monitor	Displays the combination meter input/output data in real time.
	Warning History	Lighting history of the warning lamp and indicator lamp can be checked.

SELF DIAG RESULT

Refer to [MWI-31, "DTC Index"](#).

DATA MONITOR

NOTE:

The following table includes information (items) inapplicable to this vehicle. For information (items) applicable to this vehicle, refer to CONSULT display items.

Display Item List

X: Applicable

Display item [Unit]	MAIN SIGNALS	Description
SPEED METER [km/h]	X	Value of vehicle speed signal received from ABS actuator and electric unit (control unit) via CAN communication. NOTE: 655.35 is displayed when the malfunction signal is received.
SPEED OUTPUT [km/h]	X	Vehicle speed signal value transmitted to other units via CAN communication. NOTE: 655.35 is displayed when the malfunction signal is received.
ODO OUTPUT [km/h or mph]		Odometer signal value transmitted to other units via CAN communication.
TACHO METER [rpm]	X	Value of the engine speed signal received from ECM via CAN communication. NOTE: 8191.875 is displayed when the malfunction signal is received.
FUEL METER [L]	X	Fuel level indicated on combination meter.
W TEMP METER [°C]	X	Value of engine coolant temperature signal is received from ECM via CAN communication. NOTE: 215 is displayed when the malfunction signal is input.
FUEL CAP W/L [On/Off]		Status of fuel filler cap warning display detected from fuel filler cap warning display signal received from ECM via CAN communication.
ABS W/L [On/Off]		Status of ABS warning lamp detected from ABS warning lamp signal is received from ABS actuator and electric unit (control unit) via CAN communication.
VDC/TCS IND [On/Off]		Status of VDC OFF indicator lamp detected from VDC OFF indicator lamp signal is received from ABS actuator and electric unit (control unit) via CAN communication.
SLIP IND [On/Off]		Status of VDC warning lamp detected from VDC warning lamp signal received from ABS actuator and electric unit (control unit) via CAN communication.
BRAKE W/L [On/Off]		Status of brake warning lamp detected from brake warning lamp signal is received from ABS actuator and electric unit (control unit) via CAN communication. NOTE: Displays "Off" if the brake warning lamp is illuminated when the valve check starts, the parking brake switch is turned ON or the brake fluid level switch is turned ON.
DOOR W/L [On/Off]		Status of door open warning lamp detected from door switch signal received from BCM via CAN communication.

DIAGNOSIS SYSTEM (COMBINATION METER)

< SYSTEM DESCRIPTION >

Display item [Unit]	MAIN SIGNALS	Description	A
HI-BEAM IND [On/Off]		Status of high beam indicator lamp detected from high beam request signal is received from BCM via CAN communication.	A
TURN IND [On/Off]		Status of turn indicator lamp detected from turn indicator signal is received from BCM via CAN communication.	B
LIGHT IND [On/Off]		Status of tail lamp indicator lamp detected from position light request signal is received from BCM via CAN communication.	C
OIL W/L [On/Off]		Status of oil pressure warning lamp detected from oil pressure warning lamp signal is received from ECM via CAN communication.	D
MIL [On/Off]		Status of malfunction indicator lamp detected from malfunctioning indicator lamp signal is received from ECM via CAN communication.	D
GLOW IND [Off]		This item is displayed, but cannot be monitored.	E
C-ENG2 W/L [Off]		This item is displayed, but cannot be monitored.	E
CRUISE IND [On/Off]		Status of CRUISE indicator lamp detected from ASCD status signal is received from ECM via CAN communication.	F
SET IND [Off]		This item is displayed, but cannot be monitored.	G
CVT IND [On/Off]		Status of CVT indicator lamp detected from CVT status signal is received from TCM via CAN communication.	G
4WD W/L [On/Off]		Status of AWD warning lamp judged from AWD warning lamp signal received from AWD control module with CAN communication line.	H
4WD LOCK IND [On/Off]		Status of AWD mode indicator lamp (AWD-V) judged from AWD mode indicator signal received from AWD control module with CAN communication line.	I
FUEL W/L [On/Off]		Low fuel warning status detected by the identified fuel level.	I
AIR PRES W/L [On/Off]		Status of low tire pressure warning lamp judged from low tire pressure warning lamp signal received from BCM from CAN communication line.	J
KEY G/Y W/L [On/Off]		Status of KEY warning lamp (G/Y) detected from KEY warning lamp signal is received from BCM via CAN communication.	K
KEY KNOB W/L [On/Off]		Status of shift P warning lamp detected from shift P warning lamp signal is received from BCM via CAN communication.	K
EPS W/L [On/Off]		Status of EPS warning lamp detected from EPS warning lamp signal is received from EPS control unit via CAN communication.	L
DPF W/L [Off]		This item is displayed, but cannot be monitored.	L
LCD [B&P N, B&P I, SFT P, BATT, NO KY, LK WN] ^{*1} [C&P N, C&P I, SFT P, BATT, NO KY, LK WN] ^{*2}		Status of engine start operation indicator lamp, shift P warning lamp and KEY warning lamp, detected from engine start operation indicator lamp signal, shift P warning lamp signal and KEY warning lamp signal are received from BCM via CAN communication.	M
SHIFT IND [P, R, N, D, M1, M2, M3, M4, M5, M6]		Status of shift position indicator judged from shift position signal received from TCM with CAN communication line.	O
O/D OFF SW [Off]		This item is displayed, but cannot be monitored.	P
M RANGE SW [On/Off]		Status of manual mode switch.	P
NM RANGE SW [On/Off]		Status of non-manual mode switch.	P
AT SFT UP SW [On/Off]		Status of manual mode shift up switch.	P

WCS

DIAGNOSIS SYSTEM (COMBINATION METER)

< SYSTEM DESCRIPTION >

Display item [Unit]	MAIN SIGNALS	Description
AT SFT DWN SW [On/Off]		Status of manual mode shift down switch.
PKB SW [On/Off]		Status of parking brake switch.
BUCKLE SW [On/Off]		Status of seat belt buckle switch (driver side).
BRAKE SW [Off]		This item is displayed, but cannot be monitored.
BRAKE OIL SW [On/Off]		Status of brake fluid level switch.
A/C AMP CONN [On/Off]		Status of A/C auto amp. connection recognition signal.
PASS BUCKLE SW [Off]		This item is displayed, but cannot be monitored.
DISTANCE [km]		Value of distance to empty calculated by combination meter.
OUTSIDE TEMP [°C or °F]		Ambient temperature value converted from ambient sensor signal received from ambient sensor. NOTE: This may not match with the temperature value indicated on the information display. (Because the information display value is a corrected value from the ambient sensor input value.)
FUEL LOW SIG [On/Off]		Status of fuel level low warning signal to output to AV control unit via CAN communication.
BUZZER [On/Off]	X	Buzzer status (in the combination meter) is detected from the buzzer output signal received from each unit via CAN communication and the warning output condition of the combination meter.
ASCD SPD BLNK [On/Off]		Blinking status of ASCD or speed limiter set vehicle speed that is judged by the ASCD status signal received from ECM via CAN communication.
ASCD STATUS [Off, ASCD, CRUISE, SL ON, SL SET]		Display status of ASCD and speed limiter status display judged by the ASCD status signal received from ECM via CAN communication.
ASCD REQ SPD [km/h/Off]		ASCD or speed limiter set vehicle speed value that is judged by the ASCD status signal received from ECM via CAN communication.
TPMS PRESS L [On/Off]		Status of low tire pressure warning judged from low tire pressure warning lamp signal received from BCM with CAN communication line.

- *1: CVT models
- *2: M/T models

NOTE:

Some items are not available according to vehicle specification.

Warning History

- Stores histories when warning/indicator lamp is turned on.
- “Warning History” indicates the “TIME” when the warning/indicator lamp is turned on.
- The “TIME” above is:
 - 0: The condition that the warning/indicator lamp has been turned on 1 or more times after starting the engine and waiting for 30 seconds.
 - 1 - 39: The number of times the engine was restarted after the 0 condition.
 - NO Warning History: Stores NO (0) turning on history of warning/indicator lamp.

NOTE:

- Warning History is not stored for approximately 30 seconds after the engine starts.
- Brake warning lamp does not store any history when the parking brake is applied or the brake fluid level gets low.

Display Item

DIAGNOSIS SYSTEM (COMBINATION METER)

< SYSTEM DESCRIPTION >

Display item	Description	
ABS W/L	Lighting history of ABS warning lamp.	A
VDC/TCS IND	Lighting history of VDC OFF indicator lamp.	
SLIP IND	Lighting history of VDC warning lamp.	B
BRAKE W/L	Lighting history of brake warning lamp.	
DOOR W/L	Lighting history of door open warning.	C
OIL W/L	Lighting history of oil pressure warning lamp.	
C-ENG W/L	Lighting history of malfunction indicator lamp.	D
CRUISE IND	Lighting history of CRUISE indicator lamp.	
CVT IND	Lighting history of CVT indicator lamp.	
4WD W/L	Lighting history of AWD warning lamp.	E
FUEL W/L	Lighting history of low fuel level warning lamp.	
AIR PRES W/L	Lighting history of low tire pressure warning lamp.	
KEY G/Y W/L	Lighting history of KEY warning lamp (G/Y).	F
KEY KNOB W/L	Lighting history of Shift P warning lamp.	
EPS W/L	Lighting history of EPS warning lamp.	G

NOTE:

In items displayed on the CONSULT screen, only those listed in the above table are used.

WCS

DIAGNOSIS SYSTEM (BCM) (WITH INTELLIGENT KEY SYSTEM)

< SYSTEM DESCRIPTION >

DIAGNOSIS SYSTEM (BCM) (WITH INTELLIGENT KEY SYSTEM) COMMON ITEM

COMMON ITEM : CONSULT Function (BCM - COMMON ITEM)

INFOID:000000009300379

APPLICATION ITEM

CONSULT performs the following functions via CAN communication with BCM.

Diagnosis mode	Function Description
Work Support	Changes the setting for each system function.
Self Diagnostic Result	Displays the diagnosis results judged by BCM.
CAN Diag Support Monitor	Monitors the reception status of CAN communication viewed from BCM.
Data Monitor	The BCM input/output signals are displayed.
Active Test	The signals used to activate each device are forcibly supplied from BCM.
Ecu Identification	The BCM part number is displayed.
Configuration	<ul style="list-style-type: none"> Read and save the vehicle specification. Write the vehicle specification when replacing BCM.

SYSTEM APPLICATION

BCM can perform the following functions for each system.

NOTE:

It can perform the diagnosis modes except the following for all sub system selection items.

×: Applicable item

System	Sub system selection item	Diagnosis mode		
		Work Support	Data Monitor	Active Test
Door lock	DOOR LOCK	×	×	×
Rear window defogger	REAR DEFOGGER		×	×
Warning chime	BUZZER		×	×
Interior room lamp timer	INT LAMP	×	×	×
Exterior lamp	HEAD LAMP	×	×	×
Wiper and washer	WIPER	×	×	×
Turn signal and hazard warning lamps	FLASHER	×	×	×
Air conditioning system	AIR CONDITONER		×	×*
<ul style="list-style-type: none"> Intelligent Key system Engine start system 	INTELLIGENT KEY	×	×	×
Combination switch	COMB SW		×	
Body control system	BCM	×		
NVIS - NATS	IMMU	×	×	×
Interior room lamp battery saver	BATTERY SAVER	×	×	×
Back door open	TRUNK		×	
Theft warning alarm	THEFT ALM	×	×	×
RAP	RETAINED PWR		×	
Signal buffer system	SIGNAL BUFFER		×	×
TPMS	AIR PRESSURE MONITOR	×	×	×

NOTE:

*: For models with automatic A/C, this diagnosis mode is not used.

FREEZE FRAME DATA (FFD)

The BCM records the following vehicle condition at the time a particular DTC is detected, and displays on CONSULT.

DIAGNOSIS SYSTEM (BCM) (WITH INTELLIGENT KEY SYSTEM)

< SYSTEM DESCRIPTION >

CONSULT screen item	Indication/Unit	Description	
Vehicle Speed	km/h	Vehicle speed of the moment a particular DTC is detected	
Odo/Trip Meter	km	Total mileage (Odometer value) of the moment a particular DTC is detected	
Vehicle Condition	SLEEP>LOCK	Power position status of the moment a particular DTC is detected	While turning BCM status from low power consumption mode to normal mode (Power position is "LOCK".)
	SLEEP>OFF		While turning BCM status from low power consumption mode to normal mode (Power position is "OFF".)
	LOCK>ACC		While turning power position from "LOCK"* to "ACC"
	ACC>ON		While turning power position from "ACC" to "IGN"
	RUN>ACC		While turning power position from "RUN" to "ACC" (Vehicle is stopping and selector lever is except P position.)
	CRANK>RUN		While turning power position from "CRANKING" to "RUN" (From cranking up the engine to run it)
	RUN>URGENT		While turning power position from "RUN" to "ACC" (Emergency stop operation)
	ACC>OFF		While turning power position from "ACC" to "OFF"
	OFF>LOCK		While turning power position from "OFF" to "LOCK"*
	OFF>ACC		While turning power position from "OFF" to "ACC"
	ON>CRANK		While turning power position from "IGN" to "CRANKING"
	OFF>SLEEP		While turning BCM status from normal mode (Power position is "OFF".) to low power consumption mode
	LOCK>SLEEP		While turning BCM status from normal mode (Power position is "LOCK".) to low power consumption mode
	LOCK		Power position is "LOCK"*
	OFF		Power position is "OFF" (Ignition switch OFF)
	ACC		Power position is "ACC" (Ignition switch ACC)
	ON		Power position is "IGN" (Ignition switch ON with engine stopped)
ENGINE RUN	Power position is "RUN" (Ignition switch ON with engine running)		
CRANKING	Power position is "CRANKING" (At engine cranking)		
IGN Counter	0 - 39	<p>The number of times that ignition switch is turned ON after DTC is detected</p> <ul style="list-style-type: none"> The number is 0 when a malfunction is detected now. The number increases like 1 → 2 → 3...38 → 39 after returning to the normal condition whenever ignition switch OFF → ON. The number is fixed to 39 until the self-diagnosis results are erased if it is over 39. 	

NOTE:

*: Power position shifts to "LOCK" from "OFF", when ignition switch is in the OFF position, selector lever is in the P position (A/T models and CVT models), and any of the following conditions are met.

- Closing door
- Opening door
- Door is locked using door request switch
- Door is locked using Intelligent Key

The power position shifts to "ACC" when the push-button ignition switch (push switch) is pushed at "LOCK".

BUZZER

BUZZER : CONSULT Function (BCM - BUZZER)

INFOID:000000008273712

CONSULT APPLICATION ITEMS

Test item	Diagnosis mode	Description
BUZZER	Data Monitor	Displays BCM input data in real time.
	Active Test	Operation of electrical loads can be checked by sending driving signal to them.

DIAGNOSIS SYSTEM (BCM) (WITH INTELLIGENT KEY SYSTEM)

< SYSTEM DESCRIPTION >

DATA MONITOR

NOTE:

The following table includes information (items) inapplicable to this vehicle. For information (items) applicable to this vehicle, refer to CONSULT display items.

Display item [Unit]	Description
PUSH SW [On/Off]	Status of push-button ignition switch judged by BCM.
UNLK SEN-DR [On/Off]	Status of unlock sensor judged by BCM.
VEH SPEED 1 [km/h]	Value of vehicle speed signal received from combination meter with CAN communication line.
TAIL LAMP SW [On/Off]	Status of lighting switch judged by BCM using the combination switch readout function.
FR FOG SW [On/Off]	Status of front fog lamp switch judged by BCM using the combination switch readout function.
DOOR SW-DR [On/Off]	Status of driver side door switch judged by BCM.
CDL LOCK SW [On/Off]	Status of door lock unlock switch judged by BCM.

ACTIVE TEST

Display item [Unit]	Description
SEAT BELT WARN TEST	The seat belt warning chime operation can be checked by operating the relevant function (On/Off).
KEY REMINDER WARN	The key warning chime operation can be checked by operating the relevant function (On/Off).
LIGHT WARN ALM	The light warning chime operation can be checked by operating the relevant function (On/Off).

DIAGNOSIS SYSTEM (BCM) (WITHOUT INTELLIGENT KEY SYSTEM)

< SYSTEM DESCRIPTION >

DIAGNOSIS SYSTEM (BCM) (WITHOUT INTELLIGENT KEY SYSTEM) COMMON ITEM

COMMON ITEM : CONSULT Function (BCM - COMMON ITEM)

INFOID:000000009300380

APPLICATION ITEM

CONSULT performs the following functions via CAN communication with BCM.

Diagnosis mode	Function Description
Work Support	Changes the setting for each system function.
Self Diagnostic Result	Displays the diagnosis results judged by BCM.
CAN Diag Support Monitor	Monitors the reception status of CAN communication viewed from BCM.
Data Monitor	The BCM input/output signals are displayed.
Active Test	The signals used to activate each device are forcibly supplied from BCM.
Ecu Identification	The BCM part number is displayed.
Configuration	<ul style="list-style-type: none"> Read and save the vehicle specification. Write the vehicle specification when replacing BCM.

SYSTEM APPLICATION

BCM can perform the following functions for each system.

NOTE:

It can perform the diagnosis modes except the following for all sub system selection items.

x: Applicable item

System	Sub system selection item	Diagnosis mode		
		Work Support	Data Monitor	Active Test
Door lock	DOOR LOCK	x	x	x
Rear window defogger	REAR DEFOGGER		x	x
Warning chime	BUZZER		x	x
Interior room lamp control	INT LAMP	x	x	x
Remote keyless entry system	MULTI REMOTE ENT	x	x	x
Exterior lamp	HEAD LAMP	x	x	x
Wiper and washer	WIPER	x	x	x
Turn signal and hazard warning lamps	FLASHER		x	x
Air conditioning system	AIR CONDITONER		x	x
Combination switch	COMB SW		x	
Body control system	BCM	x		
NATS	IMMU	x		x
Interior room lamp battery saver	BATTERY SAVER	x	x	x
Back door open	TRUNK		x	
Theft warning alarm	THEFT ALM	x	x	x
RAP system	RETAINED PWR		x	x
Signal buffer system	SIGNAL BUFFER		x	x
Panic alarm	PANIC ALARM			x
TPMS	AIR PRESSUE MONITOR	x	x	x

BUZZER

BUZZER : CONSULT Function (BCM - BUZZER)

INFOID:000000008273714

CONSULT APPLICATION ITEMS

DIAGNOSIS SYSTEM (BCM) (WITHOUT INTELLIGENT KEY SYSTEM)

< SYSTEM DESCRIPTION >

Test item	Diagnosis mode	Description
BUZZER	Data Monitor	Displays BCM input data in real time.
	Active Test	Operation of electrical loads can be checked by sending driving signal to them.

DATA MONITOR

NOTE:

The following table includes information (items) inapplicable to this vehicle. For information (items) applicable to this vehicle, refer to CONSULT display items.

Display item [Unit]	Description
IGN ON SW [On/Off]	Status of ignition switch judged by BCM.
KEY ON SW [On/Off]	Status of key switch judged by BCM.
DOOR SW-DR [km/h]	Status of driver side door switch judged by BCM.
REVERSE SW CAN [On/Off]	This item is displayed, but cannot be monitored.
TAIL LAMP SW [On/Off]	Status of lighting switch judged by BCM using the combination switch readout function.
FR FOG SW [On/Off]	Status of front fog lamp switch judged by BCM using the combination switch readout function.
BUCKLE SW [On/Off]	Status of seat belt buckle switch (driver side) received from combination meter with CAN communication line.
VEHICLE SPEED [km/h]	Value of vehicle speed signal received from combination meter with CAN communication line.

ACTIVE TEST

Display item [Unit]	Description
SEAT BELT WARN TEST	The seat belt warning chime operation can be checked by operating the relevant function (On/Off).
IGN KEY WARN ALM	The key warning chime operation can be checked by operating the relevant function (On/Off).
LIGHT WARN ALM	The light warning chime operation can be checked by operating the relevant function (On/Off).

COMBINATION METER

< ECU DIAGNOSIS INFORMATION >

ECU DIAGNOSIS INFORMATION

COMBINATION METER

Reference Value

INFOID:000000008770161

VALUES ON THE DIAGNOSIS TOOL

NOTE:

The following table includes information (items) inapplicable to this vehicle. For information (items) applicable to this vehicle, refer to CONSULT display items.

Monitor Item	Condition		Value/Status
SPEED METER [km/h]	Ignition switch ON	While driving	Input value of vehicle speed signal (CAN communication signal) NOTE: 655.35 is displayed when the malfunction signal is received
SPEED OUTPUT [km/h]	Ignition switch ON	While driving	Output value of vehicle speed signal (CAN communication signal) NOTE: 655.35 is displayed when the malfunction signal is received
ODO OUTPUT [km/h or mph]	Ignition switch ON	—	Output value of odometer signal (CAN communication signal)
TACHO METER [rpm]	Ignition switch ON	Engine running	Input value of engine speed signal (CAN communication signal) NOTE: 8191.875 is displayed when the malfunction signal is received
FUEL METER [L]	Ignition switch ON	—	Input value of fuel level sensor signal
W TEMP METER [°C]	Ignition switch ON	—	Input value of engine coolant temperature signal (CAN communication signal) NOTE: 215 is displayed when the malfunction signal is input
FUEL CAP W/L	Ignition switch ON	Fuel filler cap warning display ON	On
		Fuel filler cap warning display OFF	Off
ABS W/L	Ignition switch ON	ABS warning lamp ON	On
		ABS warning lamp OFF	Off
VDC/TCS IND	Ignition switch ON	VDC OFF indicator lamp ON	On
		VDC OFF indicator lamp OFF	Off
SLIP IND	Ignition switch ON	VDC warning lamp ON	On
		VDC warning lamp OFF	Off
BRAKE W/L	Ignition switch ON	Brake warning lamp ON	On
		Brake warning lamp OFF	Off
DOOR W/L	Ignition switch ON	Door open warning lamp ON	On
		Door open warning lamp OFF	Off
HI-BEAM IND	Ignition switch ON	High-beam indicator lamp ON	On
		High-beam indicator lamp OFF	Off
TURN IND	Ignition switch ON	Turn signal indicator lamp ON	On
		Turn signal indicator lamp OFF	Off

A

B

C

D

E

F

G

H

I

J

K

L

M

WCS

O

P

COMBINATION METER

< ECU DIAGNOSIS INFORMATION >

Monitor Item	Condition		Value/Status
LIGHT IND	Ignition switch ON	Tail lamp indicator lamp ON	On
		Tail lamp indicator lamp OFF	Off
OIL W/L	Ignition switch ON	Oil pressure warning lamp ON	On
		Oil pressure warning lamp OFF	Off
MIL	Ignition switch ON	Malfunction indicator lamp ON	On
		Malfunction indicator lamp OFF	Off
GLOW IND	Ignition switch ON	NOTE: This item is displayed, but cannot be monitored.	Off
C-ENG2 W/L	Ignition switch ON	NOTE: This item is displayed, but cannot be monitored.	Off
CRUISE IND	Ignition switch ON	CRUISE indicator lamp ON	On
		CRUISE indicator lamp OFF	Off
SET IND	Ignition switch ON	NOTE: This item is displayed, but cannot be monitored.	Off
CVT IND	Ignition switch ON	CVT indicator ON	On
		CVT indicator OFF	Off
4WD W/L	Ignition switch ON	AWD warning lamp ON	On
		AWD warning lamp OFF	Off
4WD LOCK IND	Ignition switch ON	AWD mode indicator lamp (AWD-V) ON	On
		AWD mode indicator lamp (AWD-V) OFF	Off
FUEL W/L	Ignition switch ON	During low fuel warning indication	On
		Other than the above	Off
AIR PRESS W/L	Ignition switch ON	Low tire pressure warning lamp ON	On
		Other than the above	Off
KEY G/Y W/L	Ignition switch ON	During Intelligent Key system malfunction indication	On
		Other than the above	Off
KEY KNOB W/L	Ignition switch ON	SHIFT P warning lamp ON	On
		SHIFT P warning lamp OFF	Off
EPS W/L	Ignition switch ON	EPS warning lamp ON	On
		EPS warning lamp OFF	Off
DPF W/L	Ignition switch ON	NOTE: This item is displayed, but cannot be monitored.	Off

COMBINATION METER

< ECU DIAGNOSIS INFORMATION >

Monitor Item	Condition		Value/Status	
LCD	Ignition switch LOCK or ACC	Engine start operation indicator lamp ON (CVT models)	B&P N	A
	Ignition switch ON	Engine start operation indicator lamp ON (CVT models)	B&P I	B
	Ignition switch LOCK or ACC	Engine start operation indicator lamp ON (M/T models)	C&P N	C
	Ignition switch ON	Engine start operation indicator lamp ON (M/T models)	C&P I	
	Ignition switch LOCK	During P position warning indication	SFT P	D
	Ignition switch LOCK	During Intelligent Key low battery warning indication	BATT	E
	Ignition switch ON	During take away warning indication	NO KY	
	Ignition switch ON	During ACC warning indication	LK WN	
SHIFT IND	Ignition switch ON	Shift position indicator P display	P	G
		Shift position indicator R display	R	
		Shift position indicator N display	N	
		Shift position indicator D display	D	
		Shift position indicator M1 display	M1	H
		Shift position indicator M2 display	M2	
		Shift position indicator M3 display	M3	I
		Shift position indicator M4 display	M4	
		Shift position indicator M5 display	M5	
		Shift position indicator M6 display	M6	
O/D OFF SW	Ignition switch ON	NOTE: This item is displayed, but cannot be monitored.	Off	K
M RANGE SW	Ignition switch ON	Selector lever in manual mode position	On	
		Other than the above	Off	
NM RANGE SW	Ignition switch ON	Selector lever in manual mode position	Off	L
		Other than the above	On	
AT SFT UP SW	Ignition switch ON	Selector lever in + position	On	M
		Other than the above	Off	
AT SFT DWN SW	Ignition switch ON	Selector lever in – position	On	WCS
		Other than the above	Off	
PKB SW	Ignition switch ON	Parking brake switch ON	On	O
		Parking brake switch OFF	Off	
BUCKLE SW	Ignition switch ON	Driver seat belt not fastened	On	P
		Driver seat belt fastened	Off	
BRAKE SW	Ignition switch ON	NOTE: This item is displayed, but cannot be monitored.	Off	
BRAKE OIL SW	Ignition switch ON	Brake fluid level switch ON	On	
		Brake fluid level switch OFF	Off	

COMBINATION METER

< ECU DIAGNOSIS INFORMATION >

Monitor Item	Condition		Value/Status
A/C AMP CONN	Ignition switch ON	Other than the following	On
		Receives A/C auto amp. connection recognition signal	Off
PASS BUCKLE SW	Ignition switch ON	NOTE: This item is displayed, but cannot be monitored.	Off
DISTANCE [km]	Ignition switch ON	—	Distance to empty calculated by combination meter
OUTSIDE TEMP [°C or °F]	Ignition switch ON	—	Input value of ambient sensor signal (CAN communication signal) NOTE: This may not match the indicated value on the information display.
FUEL LOW SIG	Ignition switch ON	During low fuel warning indication	On
		Other than above	Off
BUZZER	Ignition switch ON	Buzzer ON	On
		Buzzer OFF	Off
ASCD SPD BLNK	Ignition switch ON	Set vehicle speed indicator blinking	On
		Set vehicle speed indicator not blinking	Off
ASCD STATUS	Ignition switch ON	ASCD and speed limiter system OFF	Off
		ASCD system ON	ASCD
		ASCD set vehicle speed	CRUISE
ASCD REQ SPD [km/h or Off]	Ignition switch ON	While driving	Same value as ASCD or speed limiter set vehicle speed
TPMS PRESS L	Ignition switch ON	Low tire pressure warning display ON	On
		Low tire pressure warning display OFF	Off

NOTE:

Some items are not available according to vehicle specification.

TERMINAL LAYOUT

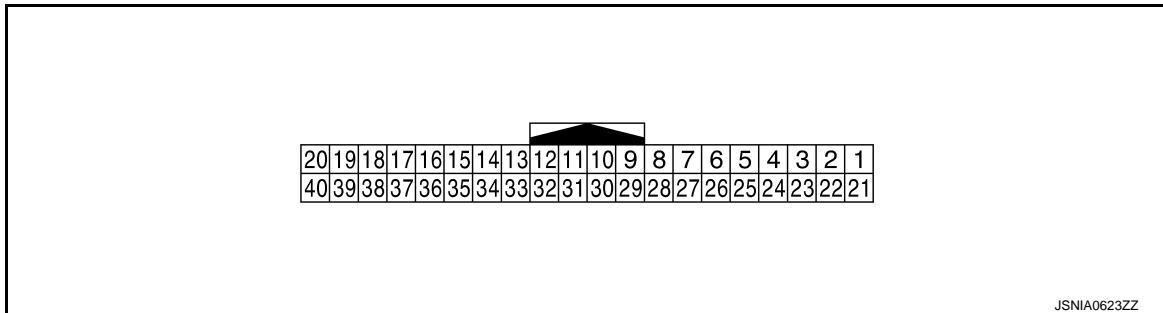

PHYSICAL VALUES

Terminal No. (Wire color)		Description		Condition		Value (Approx.)
+	-	Signal name	Input/Output			
1 (L)	—	CAN-H	—	—	—	—
2 (P)	—	CAN-L	—	—	—	—

COMBINATION METER

< ECU DIAGNOSIS INFORMATION >

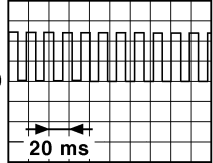
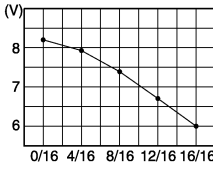
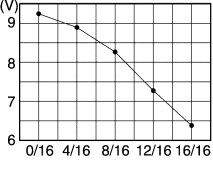
Terminal No. (Wire color)		Description		Condition		Value (Approx.)
+	-	Signal name	Input/ Output			
4 (V)	Ground	Vehicle speed signal (8-pulse)	Output	Ignition switch ON	Speedometer operated [When vehicle speed is ap- prox. 40 km/h (25 MPH)]	NOTE: The maximum voltage varies de- pending on the specification (destination unit).  <small>JSNIA0012GB</small>
6 (BR)	Ground	Fuel level sensor signal	Input	Ignition switch ON	—	2WD  <small>JSNIA3305ZZ</small>
						AWD  <small>JSNIA3721ZZ</small>
7 (R)	Ground	Air bag signal	Input	Ignition switch ON	Air bag warning lamp ON	4 V
					Air bag warning lamp OFF	0 V
8* (Y)	—	—	—	—	—	—
9 (O)	Ground	Seat belt buckle switch sig- nal (driver side)	Input	Engine idling	When driver seat belt is fas- tened.	12 V
					When driver seat belt is un- fastened.	0 V
10 (SB)	Ground	Parking brake switch signal	Input	Ignition switch ON	Parking brake applied.	0 V
					Parking brake released.	5 V
11 (G)	Ground	Brake fluid level switch sig- nal	Input	Ignition switch ON	Brake fluid level is normal	5 V
					Brake fluid level is less than LOW level	0 V

A
B
C
D
E
F
G
H
I
J
K
L
M
WCS
O
P

COMBINATION METER

< ECU DIAGNOSIS INFORMATION >

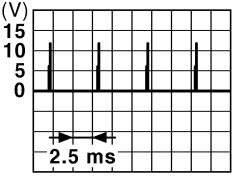
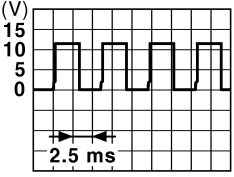
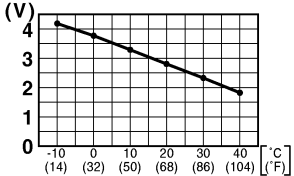
Terminal No. (Wire color)		Description		Condition	Value (Approx.)	
+	-	Signal name	Input/ Output			
13 (B)	Ground	Illumination control signal	Output	Ignition switch ON	<ul style="list-style-type: none"> Lighting switch 1ST When meter illumination is maximum 	
					<ul style="list-style-type: none"> Lighting switch 1ST When meter illumination is step 6 	
					<ul style="list-style-type: none"> Lighting switch 1ST When meter illumination is minimum 	12 V
14 (V)	Ground	Manual mode shift up signal	Input	Ignition switch ON	Selector lever UP operation	0 V
					Other than the above	12 V
15 (L)	Ground	ACC power supply	Input	Ignition switch ACC	—	Battery voltage
16 (O)	Ground	Manual mode shift down signal	Input	Ignition switch ON	Selector lever DOWN operation	0 V
					Other than the above	12 V
17 (W)	Ground	Washer level switch signal	Input	Ignition switch ON	Low washer fluid warning lamp ON	0 V
					Low washer fluid warning lamp OFF	12 V
18 (R)	Ground	Security signal	Input	Ignition switch ON	Security indicator lamp ON	0 V
					Security indicator lamp OFF	12 V
19 (GR)	Ground	Ambient sensor signal	Input	Ignition switch ON	Changes depending to ambient temperature.	
20 (LG)	Ground	Ambient sensor ground	—	Ignition switch ON	—	0 V
21 (B)	Ground	Ground	—	Ignition switch ON	—	0 V
22 (B)	Ground	Ground	—	Ignition switch ON	—	0 V

COMBINATION METER

< ECU DIAGNOSIS INFORMATION >

Terminal No. (Wire color)		Description		Condition		Value (Approx.)
+	-	Signal name	Input/ Output			
23 (B)	Ground	Ground	—	Ignition switch ON	—	0 V
24 (L)	Ground	Fuel level sensor ground	—	Ignition switch ON	—	0 V
25 (B)	Ground	VDC ground	—	Ignition switch ON	—	0 V
27 (LG)	Ground	Battery power supply	Input	Ignition switch OFF	—	Battery voltage
28 (GR)	Ground	Ignition signal	Input	Ignition switch ON	—	Battery voltage
29 (LG)	Ground	Seat belt buckle switch signal (passenger side)	Input	Ignition switch ON	• When getting in the passenger seat • When passenger seat belt is fastened	12 V
					• When getting in the passenger seat • When passenger seat belt is not fastened	0 V
31 (P)	Ground	A/C auto amp. connection recognition signal	Input	Ignition switch ON	—	5 V
36 (LG)	Ground	Manual mode signal	Input	Ignition switch ON	Selector manual mode position	0 V
					Other than the above	12 V
37 (Y)	Ground	Non-manual mode signal	Input	Ignition switch ON	Selector manual mode position	12 V
					Other than the above	0 V
38 (P)	Ground	Alternator signal	Input	Ignition switch ON	Charge warning lamp ON	2 V
					Charge warning lamp OFF	12 V

*: This harness is not used.

Fail-Safe

INFOID:000000009300391

FAIL-SAFE

The combination meter activates the fail-safe control if CAN communication with each unit is malfunctioning.

Function	Specifications
Speedometer	Reset to zero by suspending communication.
Tachometer	
Engine coolant temperature gauge	
Illumination control	When suspending communication, changes to nighttime mode.
Shift position indicator	When suspending communication, not indicate.

COMBINATION METER

< ECU DIAGNOSIS INFORMATION >

Function		Specifications
Information display	Instantaneous fuel consumption	<ul style="list-style-type: none"> When reception time of an abnormal signal is 2 seconds or less, the last received datum is used for calculation to indicate the result. When reception time of an abnormal signal is more than two seconds, the last result calculated during normal condition is indicated.
	Average fuel consumption	
	Possible driving distance	
	Torque distribution indicator	
	Low tire pressure warning	The display turns OFF by suspending communication.
Buzzer		The buzzer turns OFF by suspending communication.
Warning lamp/indicator lamp	ABS warning lamp	The lamp turns ON by suspending communication.
	Malfunction indicator lamp	
	VDC OFF indicator lamp	
	EPS warning lamp	
	AWD warning lamp	
	Brake warning lamp	
	VDC warning lamp	The lamp turns OFF by suspending communication.
	High beam indicator lamp	
	Turn signal indicator lamp	
	Door warning lamp	
	Tail lamp indicator lamp	
	Engine start operation indicator lamp	
	Shift P warning lamp	
	Oil pressure warning lamp	
	CRUISE indicator lamp	
	AWD mode indicator lamp (AWD)	
	AWD mode indicator lamp (AWD-V)	
	Key warning lamp	
	CVT indicator lamp	
Low tire pressure warning lamp	After blinking for 1 minute, the lamp remains ON.	

DTC Index

INFOID:000000009300392

Display contents of CONSULT	Diagnostic item is detected when...	Refer to
CAN COMM CIRCUIT [U1000]	When combination meter is not transmitting or receiving CAN communication signal for 2 seconds or more.	MWI-37. "Diagnosis Procedure"
CONTROL UNIT (CAN) [U1010]	When detecting error during the initial diagnosis of the CAN controller of combination meter.	MWI-38. "Diagnosis Procedure"
VEHICLE SPEED [B2205]	The abnormal vehicle speed signal is input from the ABS actuator and electric unit (control unit) for 2 seconds or more.	MWI-39. "Diagnosis Procedure"
ENGINE SPEED [B2267]	If ECM continuously transmits abnormal engine speed signals for 2 seconds or more.	MWI-40. "Diagnosis Procedure"
WATER TEMP [B2268]	If ECM continuously transmits abnormal engine coolant temperature signals for 60 seconds or more.	MWI-41. "Diagnosis Procedure"

BCM (BODY CONTROL MODULE)

< ECU DIAGNOSIS INFORMATION >

BCM (BODY CONTROL MODULE)

List of ECU Reference

INFOID:000000008273718

ECU		Reference
BCM	With intelligent key models	BCS-36, "Reference Value"
		BCS-57, "Fail-safe"
		BCS-58, "DTC Inspection Priority Chart"
		BCS-59, "DTC Index"
	Without intelligent key models	BCS-109, "Reference Value"
		BCS-122, "Fail-safe"
		BCS-123, "DTC Inspection Priority Chart"
	BCS-123, "DTC Index"	

A
B
C
D
E
F
G
H
I
J
K
L
M
O
P

WCS

WARNING CHIME SYSTEM

< WIRING DIAGRAM >

WIRING DIAGRAM

WARNING CHIME SYSTEM

Wiring Diagram

INFOID:000000008273719

For connector terminal arrangements, harness layouts, and alphabets in a  (option abbreviation; if not described in wiring diagram), refer to [GI-12. "Connector Information"](#).

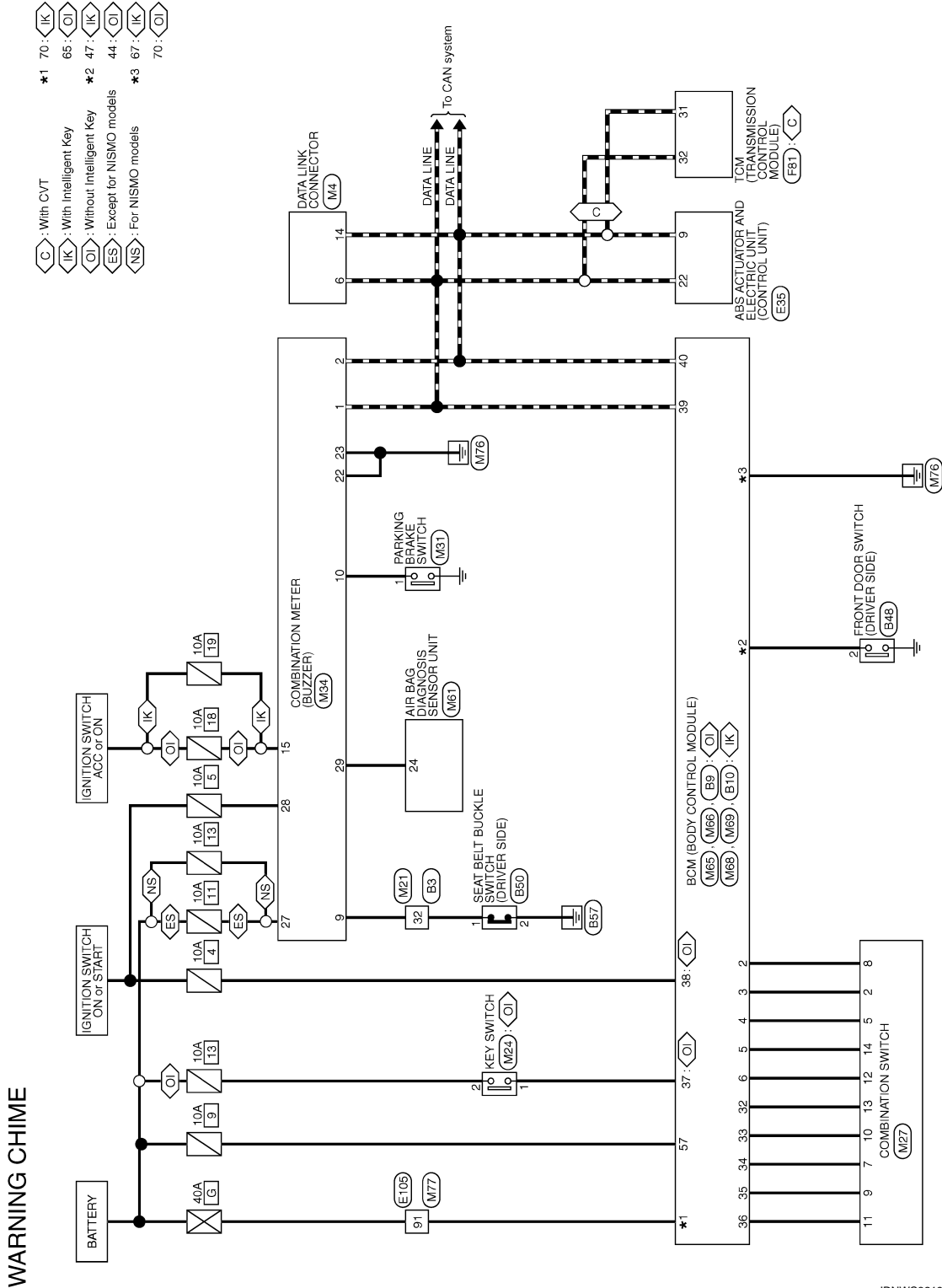

2012/12/12

JRNWC3219GB

DIAGNOSIS AND REPAIR WORKFLOW

< BASIC INSPECTION >

BASIC INSPECTION

DIAGNOSIS AND REPAIR WORKFLOW

Work Flow

INFOID:000000008273720

OVERALL SEQUENCE

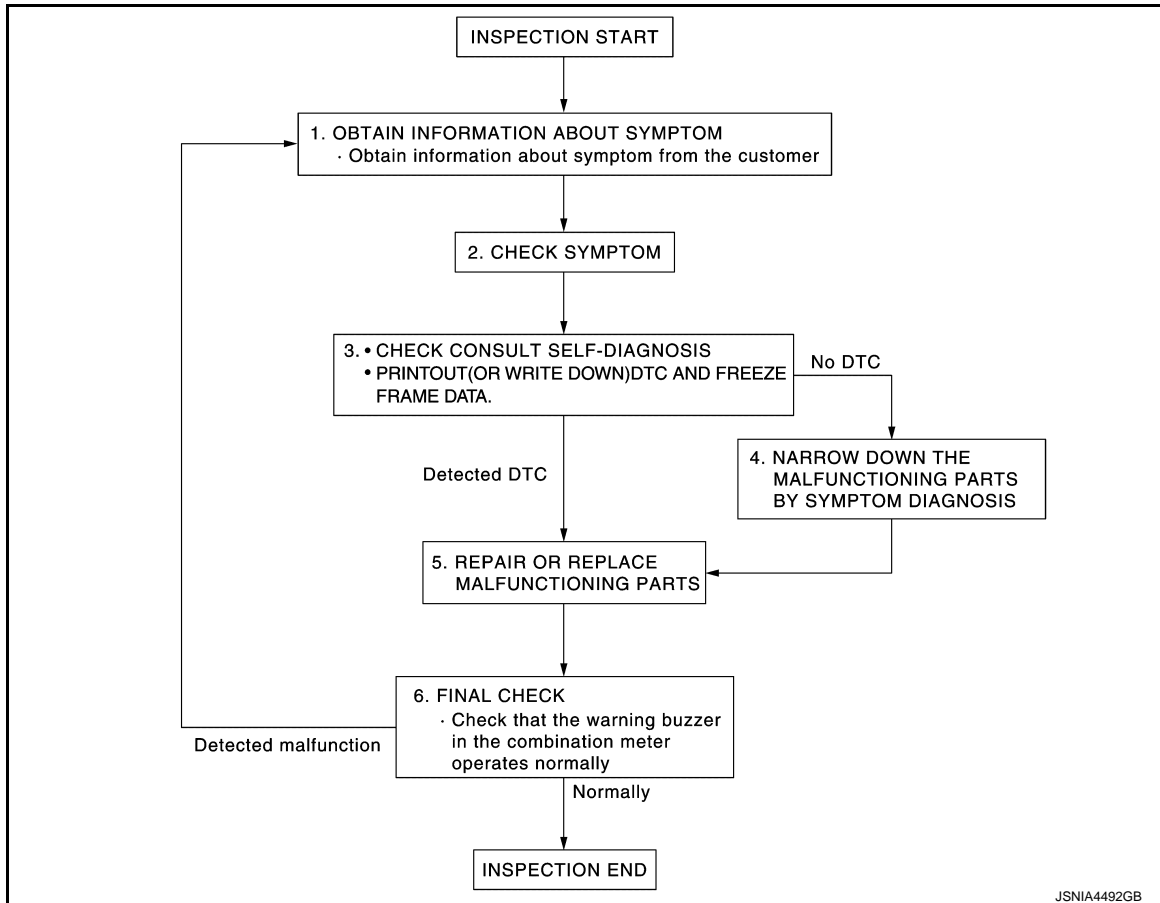

DETAILED FLOW

1.OBTAIN INFORMATION ABOUT SYMPTOM

Interview the customer to obtain as much information as possible about the conditions and environment under which the malfunction occurred.

>> GO TO 2.

2.CHECK SYMPTOM

- Check the symptom based on the information obtained from the customer.
- Check if any other malfunctions are present.

>> GO TO 3.

3.CHECK CONSULT SELF-DIAGNOSIS RESULTS

1. Connect CONSULT and perform self-diagnosis. Refer to [WCS-19, "BUZZER : CONSULT Function \(BCM - BUZZER\)"](#) (with intelligent key system) or [WCS-21, "BUZZER : CONSULT Function \(BCM - BUZZER\)"](#) (without intelligent key system).
2. When DTC is detected, follow the instructions below:
 - Record DTC and Freeze Frame Data.

Are self-diagnosis results normal?

YES >> GO TO 4.

DIAGNOSIS AND REPAIR WORKFLOW

< BASIC INSPECTION >

NO >> GO TO 5.

4.NARROW DOWN MALFUNCTIONING PARTS BY SYMPTOM DIAGNOSIS

Perform symptom diagnosis and narrow down the malfunctioning parts.

>> GO TO 5.

5.REPAIR OR REPLACE MALFUNCTIONING PARTS

Repair or replace malfunctioning parts.

NOTE:

If DTC is displayed, erase DTC after repairing or replacing malfunctioning parts.

>> GO TO 6.

6.FINAL CHECK

Check that the warning buzzer in the combination meter operates normally.

Does it operate normally?

YES >> INSPECTION END

NO >> GO TO 1.

POWER SUPPLY AND GROUND CIRCUIT

< DTC/CIRCUIT DIAGNOSIS >

DTC/CIRCUIT DIAGNOSIS

POWER SUPPLY AND GROUND CIRCUIT COMBINATION METER

COMBINATION METER : Diagnosis Procedure

INFOID:000000009203101

1. CHECK FUSE

Check for blown fuses.

Power source		Fuse No.
Battery	Except for NISMO models	11
	For NISMO models	13
Ignition switch ON or START		5
Ignition switch ACC or ON	Without intelligent key	18
	With intelligent key	19

Is the inspection result normal?

YES >> GO TO 2.

NO >> Be sure to eliminate cause of malfunction before installing new fuse.

2. CHECK POWER SUPPLY CIRCUIT

Check voltage between combination meter harness connector and ground.

Terminals		Ignition switch position	Voltage (Approx.)
(+)	(-)		
Combination meter		OFF ACC ON	Battery voltage
Connector	Terminal		
M34	27		
	15		
	28		

Is the inspection result normal?

YES >> GO TO 3.

NO >> Check harness between combination meter and fuse.

3. CHECK GROUND CIRCUIT

1. Turn ignition switch OFF.
2. Disconnect combination meter connector.
3. Check continuity between combination meter harness connector and ground.

Combination meter		Ground	Continuity
Connector	Terminal		
M34	21	Ground	Existed
	22		
	23		
	25		

Is the inspection result normal?

YES >> INSPECTION END

NO >> Repair harness or connector.

A
B
C
D
E
F
G
H
I
J
K
L
M
O
P

WCS

METER BUZZER CIRCUIT

< DTC/CIRCUIT DIAGNOSIS >

METER BUZZER CIRCUIT

Component Function Check

INFOID:000000008273722

1. CHECK OPERATION OF METER BUZZER

1. Select "BUZZER" of "BCM" on CONSULT.
2. Perform "LIGHT WARN ALM" of "Active Test".

Does meter buzzer beep?

- YES >> INSPECTION END
NO >> GO TO 2.

2. CHECK COMBINATION METER INPUT SIGNAL

Select the "Data Monitor" for the "METER/M&A" and check the "BUZZER" monitor value.

BUZZER

Under the condition of buzzer input : On

Except above : Off

Is the inspection result normal?

- YES >> Replace combination meter.
NO >> Replace BCM. Refer to [BCS-81, "Removal and Installation"](#) (WITH INTELLIGENT KEY SYSTEM)
or [BCS-142, "Removal and Installation"](#) (WITHOUT INTELLIGENT KEY SYSTEM).

Diagnosis Procedure

INFOID:000000008273723

1. CHECK POWER SUPPLY OF COMBINATION METER

Check power supply of combination meter. Refer to [WCS-35, "COMBINATION METER : Diagnosis Procedure"](#).

Is the inspection result normal?

- YES >> INSPECTION END
NO >> Repair power supply circuit of combination meter.

SEAT BELT BUCKLE SWITCH SIGNAL CIRCUIT

< DTC/CIRCUIT DIAGNOSIS >

SEAT BELT BUCKLE SWITCH SIGNAL CIRCUIT

Component Function Check

INFOID:000000008273724

1.CHECK COMBINATION METER INPUT SIGNAL

Select the "Data Monitor" for the "METER/M&A" and check the "BUCKLE SW" monitor value.

BUCKLE SW
When driver seat belt is fastened : Off
When driver seat belt is unfastened : On

>> INSPECTION END

Diagnosis Procedure

INFOID:000000008273725

1.CHECK SEAT BELT BUCKLE SWITCH (DRIVER SIDE) CIRCUIT

1. Turn ignition switch OFF.
2. Disconnect combination meter connector and seat belt buckle switch (driver side) connector.
3. Check continuity between combination meter harness connector and seat belt buckle switch (driver side) harness connector.

Combination meter		Seat belt buckle switch (driver side)		Continuity
Connector	Terminal	Connector	Terminal	
M34	9	B50	1	Existed

4. Check harness continuity between combination meter harness connector and ground.

Combination meter		Ground	Continuity
Connector	Terminal		
M34	9		Not existed

Is the inspection result normal?

- YES >> GO TO 2.
NO >> Repair harness or connector.

2.CHECK SEAT BELT BUCKLE SWITCH (DRIVER SIDE) GROUND CIRCUIT

Check harness continuity between seat belt buckle switch (driver side) harness connector and ground.

Seat belt buckle switch (driver side)		Ground	Continuity
Connector	Terminal		
B50	2		Existed

Is the inspection result normal?

- YES >> INSPECTION END
NO >> Repair harness or connector.

Component Inspection

INFOID:000000008273726

1.CHECK SEAT BELT BUCKLE SWITCH UNIT

1. Turn ignition switch OFF.
2. Disconnect the seat belt buckle switch (driver side) connector.
3. Check continuity between terminals.

A
B
C
D
E
F
G
H
I
J
K
L
M
O
P

WCS

SEAT BELT BUCKLE SWITCH SIGNAL CIRCUIT

< DTC/CIRCUIT DIAGNOSIS >

Terminal		Condition	Continuity
1	2	When driver seat belt is fastened	Not existed
		When driver seat belt is unfastened	Existed

Is the inspection result normal?

YES >> INSPECTION END

NO >> Replace the seat belt buckle (driver side). Refer to [SB-8. "SEAT BELT BUCKLE : Removal and Installation"](#).

PARKING BRAKE SWITCH SIGNAL CIRCUIT

< DTC/CIRCUIT DIAGNOSIS >

PARKING BRAKE SWITCH SIGNAL CIRCUIT

Diagnosis Procedure

INFOID:000000008273727

1. CHECK COMBINATION METER INPUT SIGNAL

1. Turn ignition switch ON.
2. Check the voltage between combination meter harness connector and ground.

(+)		(-)	Condition		Voltage (Approx.)
Combination meter		Ground			
Connector	Terminal				
M34	10		Ignition switch ON	When parking brake is applied	0 V
				When parking brake is released	12 V

Is the inspection result normal?

- YES >> INSPECTION END
NO >> GO TO 2.

2. CHECK PARKING BRAKE SWITCH SIGNAL CIRCUIT

1. Turn ignition switch OFF.
2. Disconnect combination meter connector and parking brake switch connector.
3. Check continuity between combination meter harness connector and parking brake switch harness connector.

Terminals				Continuity
Combination meter		Parking brake switch		
Connector	Terminal	Connector	Terminal	
M34	10	M31	1	Existed

4. Check continuity between combination meter harness connector and ground.

Terminals			Continuity
Combination meter		Ground	
Connector	Terminal		
M34	10		Not existed

Is the inspection result normal?

- YES >> INSPECTION END
NO >> Repair harness or connector.

Component Inspection

INFOID:000000008273728

1. CHECK PARKING BRAKE SWITCH

Check parking brake switch. Refer to [BRC-111, "Component Inspection"](#).

Is the inspection result normal?

- YES >> INSPECTION END.
NO >> Replace parking brake switch. Refer to [PB-5, "Exploded View"](#).

A
B
C
D
E
F
G
H
I
J
K
L
M
O
P

WCS

THE PARKING BRAKE RELEASE WARNING CONTINUES SOUNDING, OR DOES NOT SOUND

< SYMPTOM DIAGNOSIS >

SYMPTOM DIAGNOSIS

THE PARKING BRAKE RELEASE WARNING CONTINUES SOUNDING, OR DOES NOT SOUND

Description

INFOID:000000008273729

- The parking brake warning buzzer sounds continuously during vehicle travel though the parking brake is released.
- The parking brake warning buzzer does not sound at all even though driving the vehicle with the parking brake applied.

Diagnosis Procedure

INFOID:000000008273730

1. CHECK PARKING BRAKE WARNING LAMP

1. Start the engine.
2. Check the operation of the brake warning lamp by operating the parking brake.

When parking brake is applied : ON

When parking brake is released : OFF

Is the inspection result normal?

- YES >> Replace combination meter. Refer to [MWI-53. "Removal and Installation"](#)
NO >> GO TO 2.

2. CHECK PARKING BRAKE SWITCH SIGNAL CIRCUIT

Perform check for the parking brake switch signal circuit. Refer to [WCS-39. "Diagnosis Procedure"](#).

Is the inspection result normal?

- YES >> GO TO 3.
NO >> Repair harness or connector.

3. CHECK PARKING BRAKE SWITCH

Perform a unit check for the parking brake switch. Refer to [WCS-39. "Component Inspection"](#).

Is the inspection result normal?

- YES >> Replace combination meter. Refer to [MWI-53. "Removal and Installation"](#)
NO >> Replace parking brake switch. Refer to [PB-5. "Exploded View"](#).

THE LIGHT REMINDER WARNING DOES NOT SOUND

< SYMPTOM DIAGNOSIS >

THE LIGHT REMINDER WARNING DOES NOT SOUND

Description

INFOID:000000008273731

Light reminder warning chime does not sound even though headlamp is illuminated.

Diagnosis Procedure

INFOID:000000008273732

1. CHECK COMBINATION SWITCH (LIGHTING SWITCH) OPERATION

Check that the headlamps operate normally by operating the combination switch (lighting switch).

Do they operate normally?

YES >> GO TO 2.

NO >> Refer to [EXL-72, "WITH DAYTIME RUNNING LIGHT SYSTEM : Symptom Table"](#) (WITH DAYTIME RUNNING LIGHT SYSTEM) or [EXL-71, "WITHOUT DAYTIME RUNNING LIGHT SYSTEM : Symptom Table"](#) (WITHOUT DAYTIME RUNNING LIGHT SYSTEM).

2. CHECK DRIVER SIDE DOOR SWITCH SIGNAL CIRCUIT

Perform the check for the driver side door switch signal circuit. Refer to [DLK-71, "Diagnosis Procedure"](#) (WITH INTELLIGENT KEY SYSTEM) or [DLK-202, "Diagnosis Procedure"](#) (WITHOUT INTELLIGENT KEY SYSTEM).

Is the inspection result normal?

YES >> GO TO 3.

NO >> Repair harness or connector.

3. CHECK DRIVER SIDE DOOR SWITCH

Perform a unit check for the driver side door switch. Refer to [DLK-72, "Component Inspection"](#) (WITH INTELLIGENT KEY SYSTEM) or [DLK-203, "Component Inspection"](#) (WITHOUT INTELLIGENT KEY SYSTEM).

Is the inspection result normal?

YES >> Replace BCM. Refer to [BCS-81, "Removal and Installation"](#) (WITH INTELLIGENT KEY SYSTEM) or [BCS-142, "Removal and Installation"](#) (WITHOUT INTELLIGENT KEY SYSTEM).

NO >> Replace driver side door switch. Refer to [DLK-162, "Removal and Installation"](#) (WITH INTELLIGENT KEY SYSTEM) or [DLK-277, "Removal and Installation"](#) (WITHOUT INTELLIGENT KEY SYSTEM).

A
B
C
D
E
F
G
H
I
J
K
L
M
O
P

WCS

THE SEAT BELT WARNING CONTINUES SOUNDING, OR DOES NOT SOUND

< SYMPTOM DIAGNOSIS >

THE SEAT BELT WARNING CONTINUES SOUNDING, OR DOES NOT SOUND

Description

INFOID:000000008273733

- Seat belt warning does not sound.
- Seat belt warning sounds continuously.

Diagnosis Procedure

INFOID:000000008273734

1. CHECK SEAT BELT WARNING LAMP

1. Turn ignition switch ON.
2. Check the operation of the seat belt warning lamp in the combination meter.

Seat belt fastened : OFF
Seat belt not fastened : ON

Is the inspection result normal?

- YES >> GO TO 2.
NO >> GO TO 4.

2. CHECK BCM OUTPUT SIGNAL

Check if the seat belt warning chime is activated by performing BCM active test. Refer to [WCS-19, "BUZZER : CONSULT Function \(BCM - BUZZER\)"](#) (WITH INTELLIGENT KEY SYSTEM) or [WCS-21, "BUZZER : CONSULT Function \(BCM - BUZZER\)"](#) (WITHOUT INTELLIGENT KEY SYSTEM).

Is the inspection result normal?

- YES >> INSPECTION END
NO >> GO TO 3.

3. CHECK COMBINATION METER INPUT SIGNAL

Check if buzzer switches to proper condition (On/Off) on data monitor of combination meter. Refer to [WCS-14, "CONSULT Function"](#).

Buzzer active condition : On
Buzzer non-active condition : Off

Is the inspection result normal?

- YES >> Replace combination meter. Refer to [MWI-53, "Removal and Installation"](#).
NO >> Replace BCM. Refer to [BCS-81, "Removal and Installation"](#) (WITH INTELLIGENT KEY SYSTEM) or [BCS-142, "Removal and Installation"](#) (WITHOUT INTELLIGENT KEY SYSTEM).

4. CHECK SEAT BELT BUCKLE SWITCH (DRIVER SIDE) CIRCUIT

Perform the check for the seat belt buckle switch (driver side) circuit. Refer to [WCS-37, "Diagnosis Procedure"](#).

Is the inspection result normal?

- YES >> GO TO 5.
NO >> Repair harness or connector.

5. CHECK SEAT BELT BUCKLE SWITCH (DRIVER SIDE)

Perform a unit check for the seat belt buckle switch (driver side). Refer to [WCS-37, "Component Inspection"](#).

Is the inspection result normal?

- YES >> Replace combination meter. Refer to [MWI-53, "Removal and Installation"](#).
NO >> Replace seat belt buckle (driver side). Refer to [SB-8, "SEAT BELT BUCKLE : Removal and Installation"](#).

THE KEY WARNING DOES NOT SOUND (WITHOUT INTELLIGENT KEY)

< SYMPTOM DIAGNOSIS >

THE KEY WARNING DOES NOT SOUND (WITHOUT INTELLIGENT KEY)

Description

INFOID:000000008273735

The key warning chime does not sound, when all of the following conditions are fulfilled.

- Key inserted into the key cylinder (key switch signal ON).
- Ignition switch is in ACC or OFF (ignition switch signal OFF).
- Driver side door is open (driver side door switch ON)

Diagnosis Procedure

INFOID:000000008273736

1. CHECK BCM INPUT SIGNAL

1. Connect CONSULT.
2. Select the "Data Monitor" of "BCM (BUZZER)" and check the "KEY ON SW" monitor value. Refer to [WCS-19. "BUZZER : CONSULT Function \(BCM - BUZZER\)".](#)

Is the inspection result normal?

- YES >> Replace BCM. Refer to [BCS-142. "Removal and Installation".](#)
NO >> GO TO 2.

2. CHECK KEY SWITCH SIGNAL CIRCUIT

Check the key switch signal circuit. Refer to [DLK-206. "Diagnosis Procedure".](#)

Is the inspection result normal?

- YES >> Replace BCM. Refer to [BCS-142. "Removal and Installation".](#)
NO >> Check applicable parts, and repair or replace corresponding parts.

A
B
C
D
E
F
G
H
I
J
K
L
M
O
P

WCS