

CONTENTS

<b>MR16DDT</b>			
<b>PRECAUTION</b> .....	2	<b>FUEL TANK</b> .....	17
<b>PRECAUTIONS</b> .....	2	<b>2WD</b> .....	17
Precautions for Removing Battery Terminal .....	2	2WD : Exploded View .....	17
General Precautions .....	2	2WD : Removal and Installation .....	17
<b>PREPARATION</b> .....	3	2WD : Inspection .....	21
<b>PREPARATION</b> .....	3	<b>AWD</b> .....	21
Special Service Tool .....	3	AWD : Exploded View .....	21
Commercial Service Tools .....	3	AWD : Removal and Installation .....	22
<b>PERIODIC MAINTENANCE</b> .....	4	AWD : Inspection .....	23
<b>FUEL SYSTEM</b> .....	4	<b>EVAP CANISTER</b> .....	25
Inspection .....	4	<b>2WD</b> .....	25
Quick Connector .....	4	2WD : Hydraulic Layout .....	25
<b>REMOVAL AND INSTALLATION</b> .....	5	2WD : Exploded View .....	26
<b>FUEL LEVEL SENSOR UNIT, FUEL FILTER</b>		2WD : Removal and Installation .....	26
<b>AND FUEL PUMP ASSEMBLY</b> .....	5	2WD : Disassembly and Assembly .....	27
<b>2WD</b> .....	5	2WD : Inspection .....	27
2WD : Exploded View .....	5	<b>AWD</b> .....	27
2WD : Removal and Installation .....	6	AWD : Hydraulic Layout .....	27
2WD : Disassembly and Assembly .....	8	AWD : Exploded View .....	29
2WD : Inspection .....	9	AWD : Removal and Installation .....	29
<b>AWD</b> .....	9	AWD : Disassembly and Assembly .....	30
AWD : Exploded View .....	9	AWD : Inspection .....	30
AWD : Removal and Installation .....	10	<b>SERVICE DATA AND SPECIFICATIONS</b>	
AWD : Disassembly and Assembly .....	15	<b>(SDS)</b> .....	31
AWD : Inspection .....	16	<b>SERVICE DATA AND SPECIFICATIONS</b>	
		<b>(SDS)</b> .....	31
		Fuel Tank .....	31

## PRECAUTION

### PRECAUTIONS

#### Precautions for Removing Battery Terminal

INFOID:000000011463368

- When removing the 12V battery terminal, turn OFF the ignition switch and wait at least 30 seconds.

**NOTE:**

ECU may be active for several tens of seconds after the ignition switch is turned OFF. If the battery terminal is removed before ECU stops, then a DTC detection error or ECU data corruption may occur.

- For vehicles with the 2-batteries, be sure to connect the main battery and the sub battery before turning ON the ignition switch.

**NOTE:**

If the ignition switch is turned ON with any one of the terminals of main battery and sub battery disconnected, then DTC may be detected.

- After installing the 12V battery, always check "Self Diagnosis Result" of all ECUs and erase DTC.

**NOTE:**

The removal of 12V battery may cause a DTC detection error.

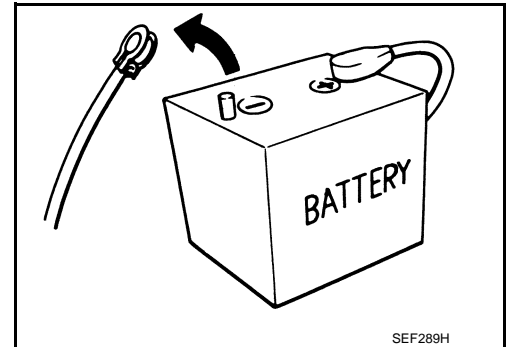

#### General Precautions

INFOID:000000011463369

**WARNING:**

When replacing fuel line parts, be sure to observe the following.

- Put a "CAUTION: FLAMMABLE" sign in the workshop.
- Be sure to work in a well ventilated area and furnish workshop with a CO2 fire extinguisher.
- Never smoke while servicing fuel system. Keep open flames and sparks away from the work area.

**CAUTION:**

- Use gasoline required by the regulations for octane number. Refer to [GI-28, "Fuel"](#).
- Before removing fuel line parts, perform out the following procedures:
  - Put drained fuel in an explosion-proof container and put the lid on securely. Keep the container in safe area.
  - Release fuel pressure from the fuel lines. Refer to [EC-162, "Work Procedure"](#).
  - Disconnect the battery cable from the negative terminal.
- Always replace O-ring and clamps with new ones.
- Never kink or twist tubes when they are being installed.
- Never tighten hose clamps excessively to avoid damaging hoses.
- After installing tubes, check there is no fuel leakage at connections in the following steps.
  - Apply fuel pressure to fuel lines with turning ignition switch "ON" (with engine stopped). Then check for fuel leakage at connections.
  - Start engine and rev it up and check for fuel leakage at connections.
- Use only a genuine NISSAN fuel filler cap as a replacement. If an incorrect fuel filler cap is used, the "MI" may come on.

# PREPARATION

< PREPARATION >

[MR16DDT ]

## PREPARATION

### PREPARATION

#### Special Service Tool

INFOID:000000011463370

A

FL

The actual shape of the TechMate tools may differ from those of the special service tools illustrated here.

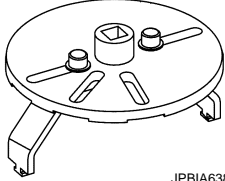
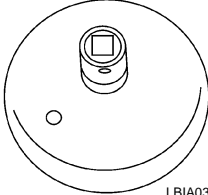
Tool number (TechMate No.) Tool name	Description
KV101207S0 ( — ) Unified fuel lock ring wrench  JPBIA6384ZZ	Removing and installing fuel tank lock ring
KV991J0090 (J-46214) Fuel tank lock ring wrench  LBIA0353E	

C

D

E

F

G

H

#### Commercial Service Tools

INFOID:000000011463371

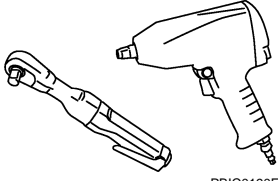
Tool name	Description
Power tool  PBIC0190E	Loosening bolts and nuts

I

J

K

L

M

N

O

P

## PERIODIC MAINTENANCE

### FUEL SYSTEM

#### Inspection

INFOID:000000011463372

Inspect fuel lines, fuel filler cap, and fuel tank for improper attachment, leakage, cracks, damage, loose connections, chafing or deterioration.

- A : Engine
- B : Fuel line
- C : Fuel tank

If necessary, repair or replace damaged parts.

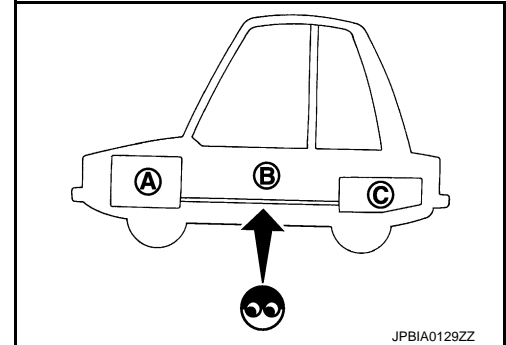

INFOID:000000011463373

#### Quick Connector

##### **CAUTION:**

- After connecting fuel tube quick connectors, check quick connectors are secure.
- Ensure that connector and resin tube never contact any adjacent parts.



# FUEL LEVEL SENSOR UNIT, FUEL FILTER AND FUEL PUMP ASSEMBLY

< REMOVAL AND INSTALLATION >

[MR16DDT ]

## 2WD : Removal and Installation

INFOID:000000011463375

### WARNING:

Read "General Precautions" when working on the fuel system. Refer to [FL-2, "General Precautions"](#).

### REMOVAL

1. Release the fuel pressure from the fuel lines. Refer to [EC-162, "Work Procedure"](#).
2. Check fuel level on a level ground. If the fuel level is 7/8 of the fuel tank (full or nearly full), draw appropriate amount of fuel from the fuel tank.

**Guideline** Draw approximately 25 liters (6-5/8 US gal, 5-1/4 Imp gal) from a full-tank condition.

- In the event of malfunction in fuel pump, insert a hose measuring 25 mm (0.98 in) in diameter into the filler opening to draw approximately 25 liters fuel.
3. Open fuel filler lid.
  4. Open filler cap and release the pressure inside fuel tank.
  5. Remove rear seat. Refer to [SE-29, "Exploded View"](#).
  6. Remove inspection hole cover.
  7. Disconnect harness connector (1) and quick connector (2).

3 : Fuel feed hose

4 : Fuel level sensor unit, fuel filter and fuel pump assembly

↶ : Vehicle front

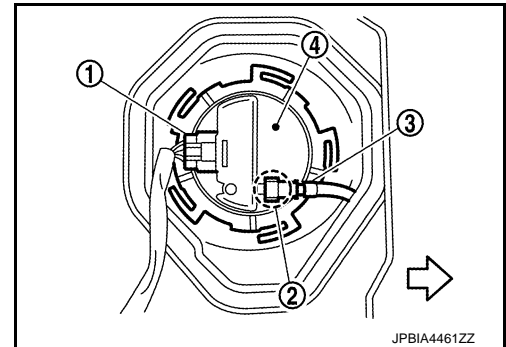

- Remove quick connector in the following procedures.
  - Pinch quick connector square-part (A) with your fingers, and pull out the quick connector (1) by hand.
  - If quick connector and tube on sender unit are stuck, push and pull several times until they move, and pull out.

### CAUTION:

- Quick connector can be removed when the tabs are completely depressed. Never twist it more than necessary.
- Never use any tools to disconnected quick connector.
- Keep resin tube away from heat. Be especially careful when welding near the resin tube.
- Prevent acid liquid such as battery electrolyte, etc. from getting on resin tube.
- Never bend or twist resin tube during installation and disconnection.
- To keep the connecting portion clean and to avoid damage and foreign materials, cover them completely with plastic bags (A) or something similar.
- Never insert plug, preventing damage on O-ring in quick connector.

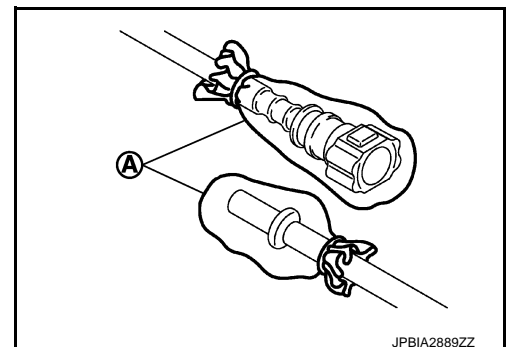
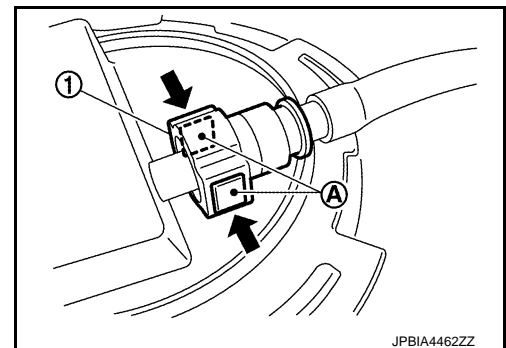

# FUEL LEVEL SENSOR UNIT, FUEL FILTER AND FUEL PUMP ASSEMBLY

## < REMOVAL AND INSTALLATION >

[MR16DDT ]

8. Remove lock ring for fuel level sensor unit, fuel filter and fuel pump assembly with lock ring wrench (A) by turning counter-clockwise.

**Tool number (A) : KV991J0090 (J-46214) (shown)**  
**: KV101207S0 ( — )**

### NOTE:

For reference when installing, put a matching mark on lock ring, fuel pump assembly and fuel tank.

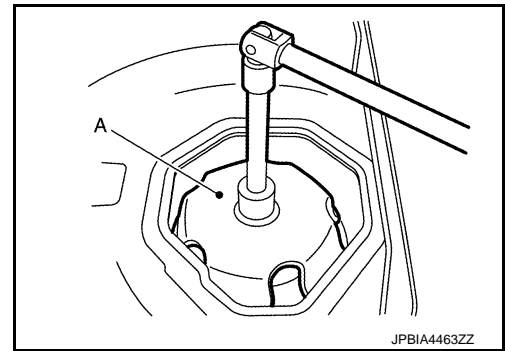

9. Raise fuel level sensor unit, fuel filter and fuel pump assembly (1).

### CAUTION:

- Never bend float arm during removal.
- Never pollute the inside by residue fuel. Draw out avoiding inclination by supporting with a cloth.
- Never cause impacts such by dropping when handling components.

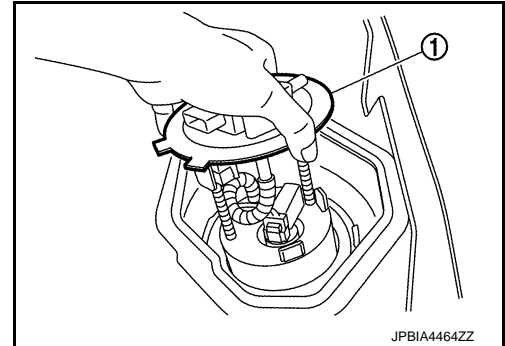

## INSTALLATION

Note to the following, and install in the reverse order of removal.

### CAUTION:

**Do not reuse O-rings.**

1. Install O-ring to fuel tank without twist.  
**CAUTION:**  
**Do not reuse O-ring.**
2. Install fuel level sensor unit, fuel filter and fuel pump assembly (1) with its matching mark (A) aligned with fuel tank matching mark (B) as shown in the figure.

↔ : Vehicle front

### CAUTION:

**Never bend float arm during installing.**

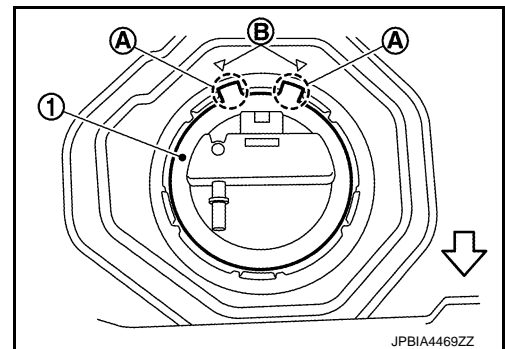

3. Install lock ring for fuel level sensor unit, fuel filter and fuel pump assembly with lock ring wrench (A) by turning clockwise.

**Tool number (A) : KV991J0090 (J-46214) (shown)**  
**: KV101207S0 ( — )**

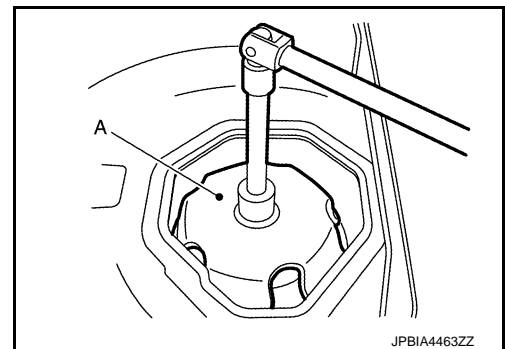

4. Connect quick connector of fuel feed tube as per following procedures.
  - a. Check the connection for damage or any foreign materials.
  - b. Align the connector with the tube, then insert the connector straight into the tube until a click sound is heard.

A  
FL  
C  
D  
E  
F  
G  
H  
I  
J  
K  
L  
M  
N  
O  
P

# FUEL LEVEL SENSOR UNIT, FUEL FILTER AND FUEL PUMP ASSEMBLY

## < REMOVAL AND INSTALLATION >

[MR16DDT ]

- c. After connecting, check that the connection is secure by following method.
- Visually confirm that the two tabs are connected to the connector.
  - Pull (A) the tube and the connector to check they are securely connected.

1 : Quick connector

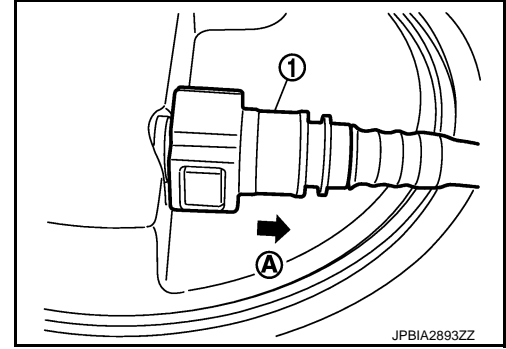

## 2WD : Disassembly and Assembly

INFOID:000000011463376

### DISASSEMBLY

1. Disconnect harness connector (A).

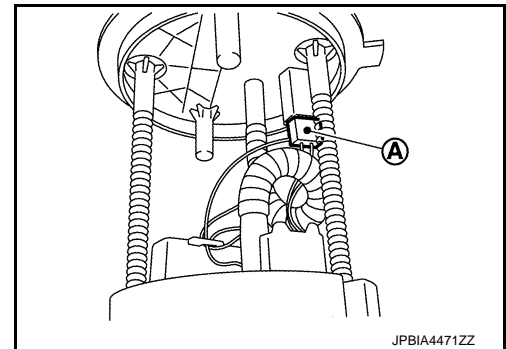

2. Press (A) with a flat-blade screwdriver or an equivalent to release lock and push out the fuel level sensor unit (1).

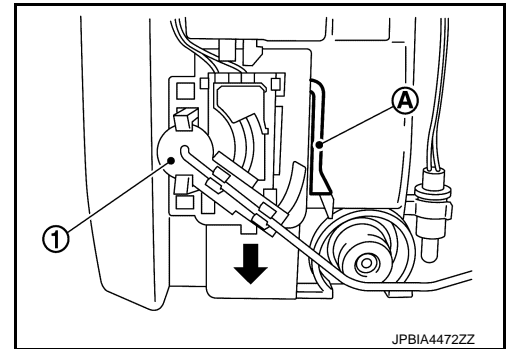

3. To remove the fuel level sensor unit (1), slide it in the direction (←) of the arrow with the lock release.

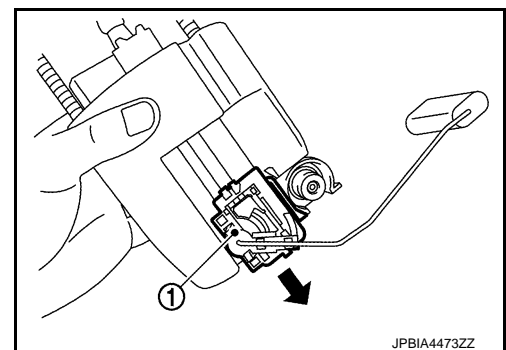

### ASSEMBLY

1. Check for damage of fuel level sensor unit installation position on the side of fuel filter and pump assembly.
2. Slide fuel level sensor unit until it aligns to installation groove, then insert it until stops.
  - After inserting, apply force in reverse direction (removal direction) to ensure it cannot be pulled out.
3. Connect harness connector.



# FUEL LEVEL SENSOR UNIT, FUEL FILTER AND FUEL PUMP ASSEMBLY

< REMOVAL AND INSTALLATION >

[MR16DDT ]

2WD : Inspection

INFOID:000000011463377

## INSPECTION AFTER INSTALLATION

Use the following procedure to check for fuel leakage.

1. Turn ignition switch "ON" (with engine stopped), then check connections for leakage by applying fuel pressure to fuel piping.
2. Start engine and let it idle and check there are no fuel leakage at the fuel system connections.

AWD

AWD : Exploded View

INFOID:000000011463378

## REMOVAL

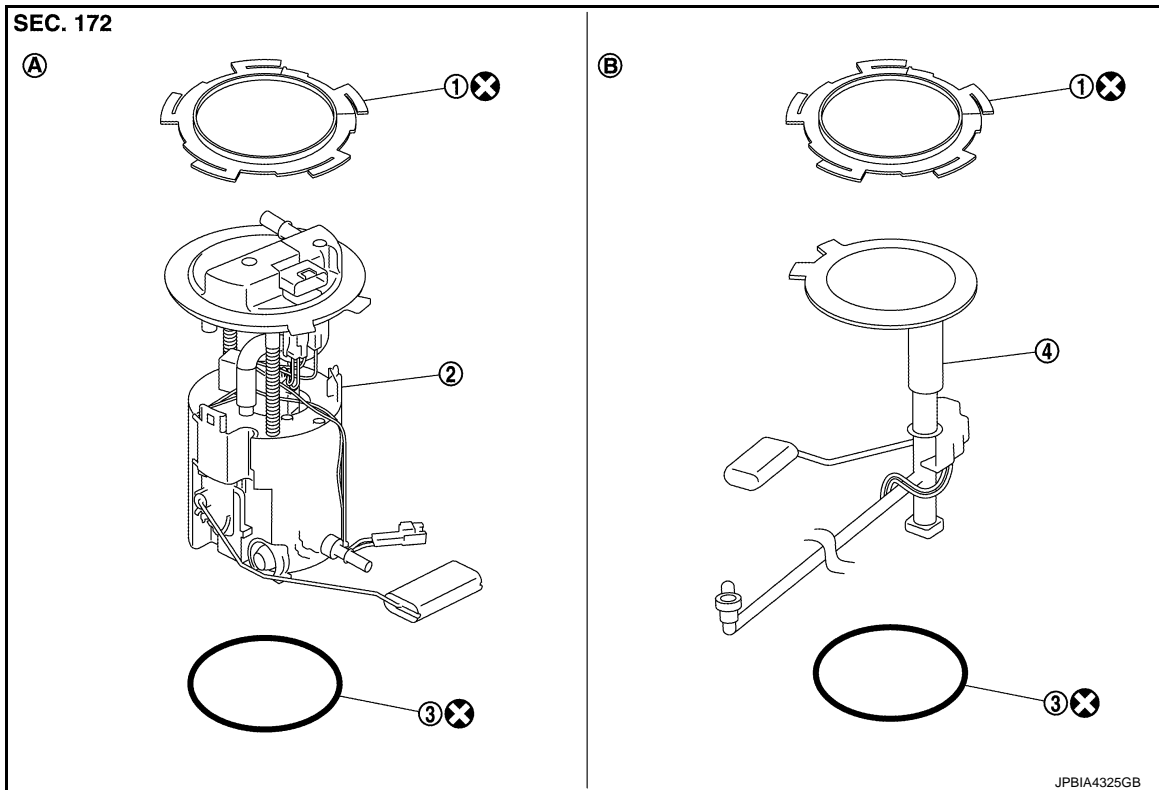

- |                                   |   |           |
|-----------------------------------|---|-----------|
| 1. Lock ring                      | 2. Fuel level sensor unit, fuel filter and fuel pump assembly | 3. O-ring |
| 4. Sub fuel level sensor assembly |   |           |
| A. Right side                     | B. Left side  |           |
- ⊗: Always replace after every disassembly.

## DISASSEMBLY

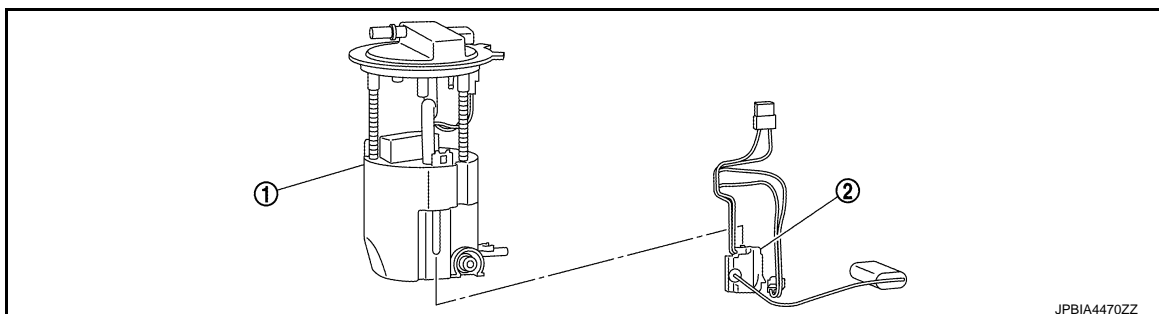

# FUEL LEVEL SENSOR UNIT, FUEL FILTER AND FUEL PUMP ASSEMBLY

< REMOVAL AND INSTALLATION >

[MR16DDT ]

1. Fuel filter and fuel pump assembly
2. Fuel level sensor unit

## CAUTION:

Sub fuel level sensor unit cannot be disassembled and should be replaced as a unit.

AWD : Removal and Installation

INFOID:000000011463379

## REMOVAL

Fuel Level Sensor Unit, Fuel Filter and Fuel Pump Assembly

## WARNING:

Read "General Precautions" before working on the fuel system. Refer to [FL-2, "General Precautions"](#).

1. Release the fuel pressure from the fuel lines. Refer to [EC-162, "Work Procedure"](#).
2. Check fuel level on a level ground. If the fuel level is 7/8 of the fuel tank (full or nearly full), draw appropriate amount of fuel from the fuel tank.

**Guideline** Draw approximately 25 liters (6-5/8 US gal, 5-1/4 Imp gal) from a full-tank condition.

- In the event of malfunction in fuel pump, insert a hose measuring 25 mm (0.98 in) in diameter into the filler opening to draw approximately 25 liters fuel.
3. Open fuel filler lid.
  4. Open filler cap and release the pressure inside fuel tank.
  5. Remove rear seat cushion. Refer to [SE-29, "Exploded View"](#).
  6. Remove inspection hole cover.
  7. Disconnect harness connector (1) and quick connector (2).

3 : Fuel feed hose

4 : Fuel level sensor unit, fuel filter and fuel pump.

↔ : Vehicle front

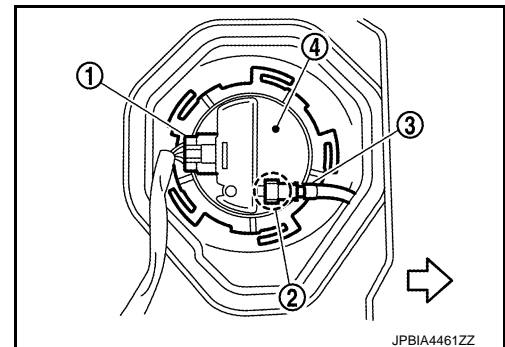

- Remove quick connector in the following procedures.
  - Pinch quick connector square-part (A) with your fingers, and pull out the quick connector (1) by hand.
  - If quick connector and tube on sender unit are stuck, push and pull several times until they move, and pull out.

## CAUTION:

- Quick connector can be removed when the tabs are completely depressed. Never twist it more than necessary.
- Never use any tools to disconnected quick connector.
- Keep resin tube away from heat. Be especially careful when welding near the resin tube.
- Prevent acid liquid such as battery electrolyte, etc. from getting on resin tube.
- Never bend or twist resin tube during installation and disconnection.

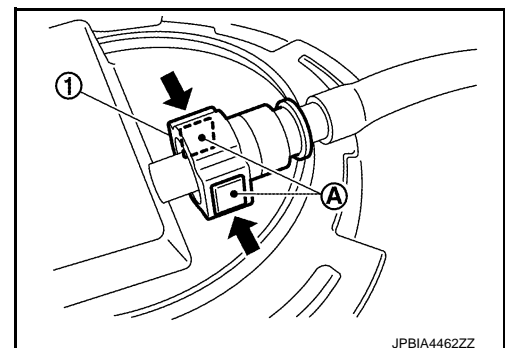

# FUEL LEVEL SENSOR UNIT, FUEL FILTER AND FUEL PUMP ASSEMBLY

< REMOVAL AND INSTALLATION >

[MR16DDT ]

- To keep the connecting portion clean and to avoid damage and foreign materials, cover them completely with plastic bags (A) or something similar.
- Never insert plug, preventing damage on O-ring in quick connector.

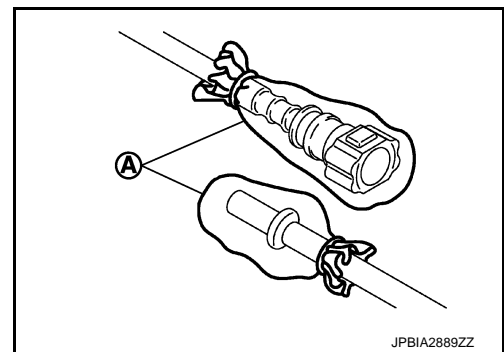

8. Remove lock ring for fuel level sensor unit, fuel filter and fuel pump assembly with lock ring wrench (A) by turning counter-clockwise.

**Tool number (A) : KV991J0090 (J-46214) (shown)**  
**: KV101207S0 ( — )**

**NOTE:**

For reference when installing, put a matching mark on lock ring, fuel pump assembly and fuel tank.

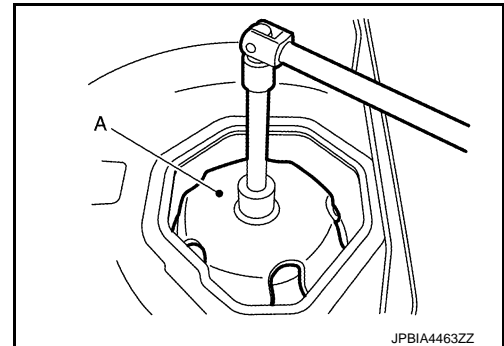

9. Raise fuel level sensor unit, fuel filter and fuel pump assembly (1).

**CAUTION:**

- Never bend float arm during removal.
- Never pollute the inside by residue fuel. Draw out avoiding inclination by supporting with a cloth.
- Never cause impacts such as by dropping when handling components.

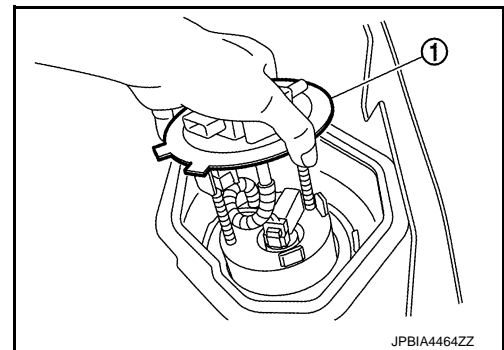

10. Separate fuel tube as per the following steps to remove fuel level sensor unit, fuel filter and fuel pump assembly.

- Pinch quick connector (A) square-part with your fingers, and pull out the quick connector by hand.
- If quick connector and tube on sender unit are stuck, push several times until they move, and pull out.

**NOTE:**

When separating the fuel tube, tie a gasoline-resistance rope to the tip of the fuel tube and leave the rope on the fuel tank side to easily pull the fuel tube for installation.

- Disconnect harness connector (B).

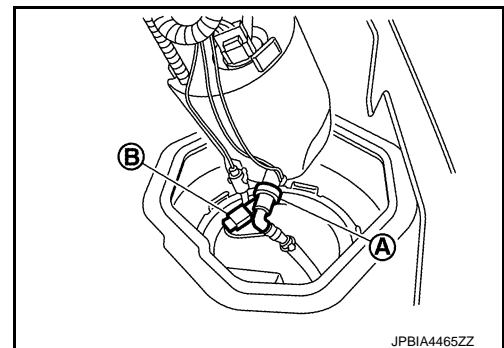

Sub Fuel Level Sensor Assembly

1. Remove fuel level sensor unit, fuel filter and fuel pump assembly.

A  
FL  
C  
D  
E  
F  
G  
H  
I  
J  
K  
L  
M  
N  
O  
P

# FUEL LEVEL SENSOR UNIT, FUEL FILTER AND FUEL PUMP ASSEMBLY

< REMOVAL AND INSTALLATION >

[MR16DDT ]

2. Remove lock ring for fuel level sensor unit, fuel filter and fuel pump assembly with lock ring wrench (A) by turning counter-clockwise.

**Tool number (A) : KV991J0090 (J-46214) (shown)**  
**: KV101207S0 ( — )**

**NOTE:**

For reference when installing, put a matching mark on lock ring, fuel pump assembly and fuel tank.

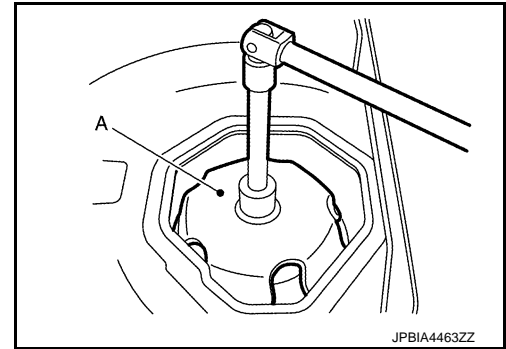

JPBIA4463ZZ

3. Remove sub fuel level sensor assembly (1).

**CAUTION:**

- Never disassemble a fuel tube (2) from sub fuel sensor assembly.
- Never bend float arm during removal.
- Never pollute the inside by residue fuel. Draw out avoiding inclination by supporting with a cloth.
- Never cause impacts such by dropping when handling components.

**NOTE:**

Tie a gasoline-resistance rope to a tip of the tube. Draw and leave the rope to the fuel tank side so that the rope can be the guide for installation.

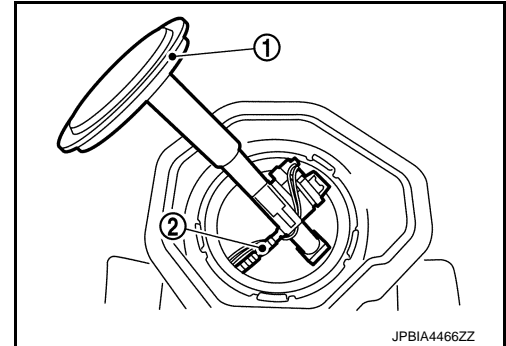

JPBIA4466ZZ

## INSTALLATION

Note the following, and install in the reverse order of removal.

**CAUTION:**

**Do not reuse O-rings.**

Sub Fuel Level Sensor Assembly

1. Install O-ring to fuel tank without any twist.

**CAUTION:**

**Do not reuse O-ring.**

2. Using the rope left on the fuel tank side at removal, run the fuel tube inside the fuel tank to install the sub fuel level sensor assembly to the fuel tank.

**CAUTION:**

- Never bend float arm during installation.
- To install, fuel tube (1) must run to the front (↔) of the vehicle to avoid the interference with the float arm (2), as shown in the figure.

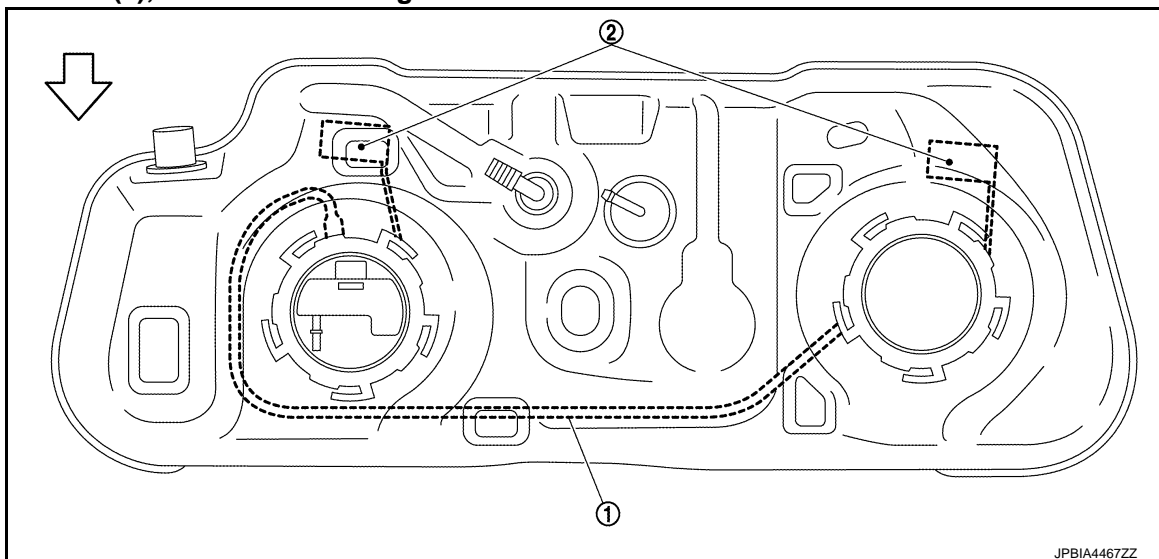

JPBIA4467ZZ

# FUEL LEVEL SENSOR UNIT, FUEL FILTER AND FUEL PUMP ASSEMBLY

## < REMOVAL AND INSTALLATION >

[MR16DDT ]

3. Install sub fuel level sensor assembly (1) with its matching mark (A) aligned with fuel tank matching mark (B) as shown in the figure.

← : Vehicle front

### NOTE:

- Figure shows fuel level sensor unit, fuel filter and fuel pump assembly side of fuel tank.
- For sub fuel level sensor assembly matching mark is located on the fuel tank of the vehicle rear side.

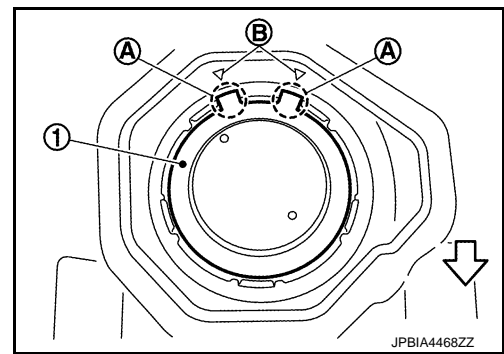

4. Install lock ring for sub fuel level sensor assembly with lock ring wrench (A) by turning clockwise.

**Tool number (A) : KV991J0090 (J-46214) (shown)**  
**: KV101207S0 ( — )**

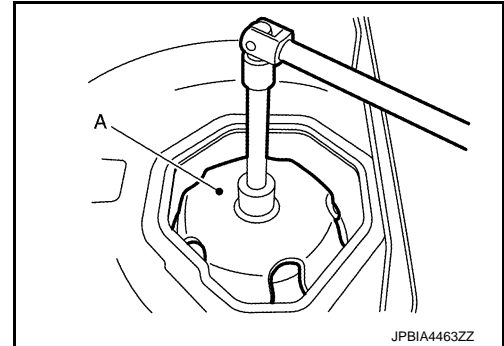

### Fuel Level Sensor Unit, Fuel Filter and Fuel Pump Assembly

1. Temporarily install the O-ring to the fuel level sensor unit, fuel filter and fuel pump assembly.
2. Connect the fuel tube as per the following steps.
  - Insert the quick connector (A) straight to the fuel level sensor unit, fuel filter and fuel pump assembly.
  - Judge a good fit from connecting sound and tactile feedback.
  - Pull the fuel tube by hand to check a secure fit.
3. Connect harness connector (B).

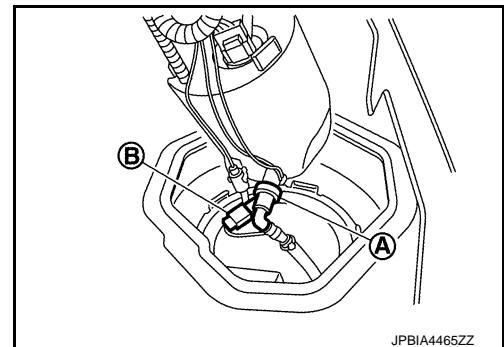

4. Insert the fuel level sensor unit, fuel filter and fuel pump assembly to the fuel tank.

### CAUTION:

- **Never bend float arm during installation.**
- **To install, fuel tube (1) must run to the front (←) of the vehicle to avoid the interference with the float arm (2), as shown in the figure.**

# FUEL LEVEL SENSOR UNIT, FUEL FILTER AND FUEL PUMP ASSEMBLY

< REMOVAL AND INSTALLATION >

[MR16DDT ]

- Through the clearance of the mounting part of the fuel level sensor unit and the fuel filter and fuel pump assembly, visually check that the fuel tube is placed on the vehicle front side of them.

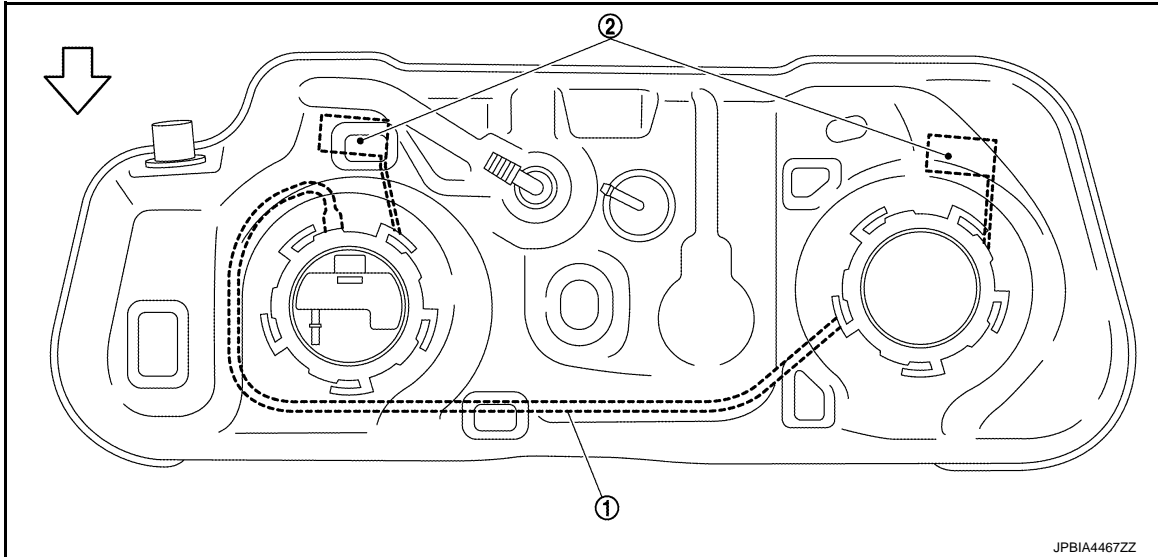

5. Install fuel level sensor unit, fuel filter and fuel pump assembly (1) with its matching mark (A) aligned with fuel tank matching mark (B) as shown in the figure.

← : Vehicle front

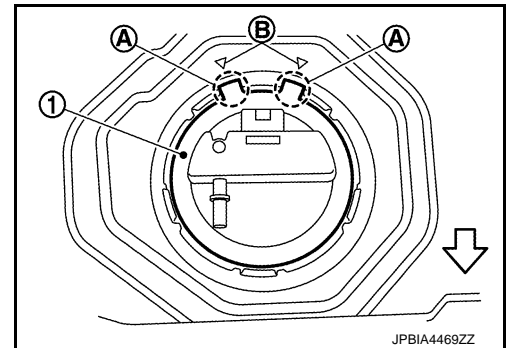

6. Install lock ring for sub fuel level sensor assembly with lock ring wrench (A) by turning clockwise.

**Tool number (A) : KV991J0090 (J-46214) (shown)**  
**: KV101207S0 ( — )**

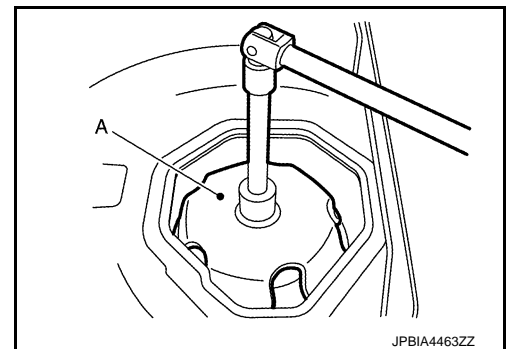

7. Connect quick connector of fuel feed tube as per following procedures.
- a. Check the connection for damage or any foreign materials.
  - b. Align the connector with the tube, then insert the connector straight into the tube until a “click” sound is heard.
  - c. After connecting, check that the connection is secured with following procedures.
    - Visually confirm that the two tabs are connected to the connector.

# FUEL LEVEL SENSOR UNIT, FUEL FILTER AND FUEL PUMP ASSEMBLY

## < REMOVAL AND INSTALLATION >

[MR16DDT ]

- Pull (A) the tube and the connector to check that they are securely connected.
8. Connect harness connector.

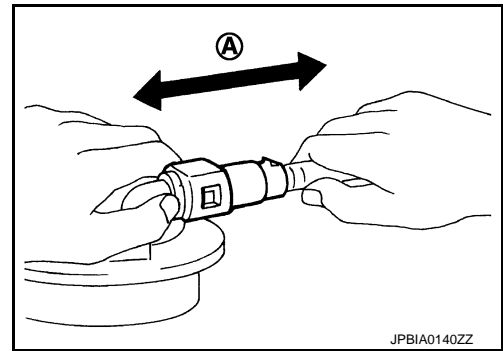

### Inspection Hole Cover

- Before installing inspection hole cover, check that the connecting part has no fuel leakage. Refer to [FL-9](#), "[2WD : Inspection](#)".
1. Install inspection hole covers with the front mark (arrow) facing front of vehicle.

## AWD : Disassembly and Assembly

INFOID:000000011463380

### DISASSEMBLY

#### CAUTION:

**Sub fuel level sensor unit cannot be disassembled and should be replaced as a unit.**

1. Disconnect harness connector (A).

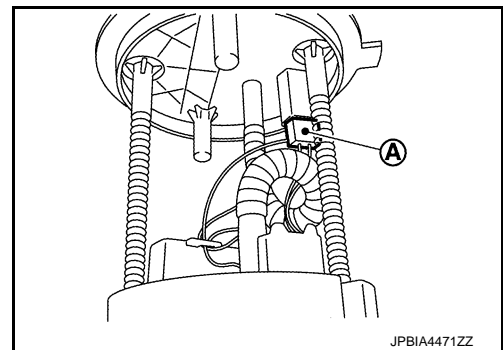

2. Press (A) with a flat-blade screwdriver or an equivalent to release lock and push out the fuel level sensor unit (1).

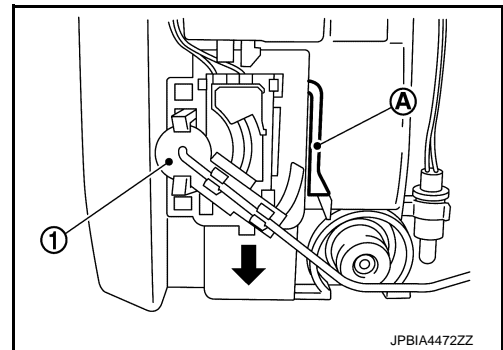

3. To remove the fuel level sensor unit (1), slide it in the direction (←) of the arrow with the lock release.

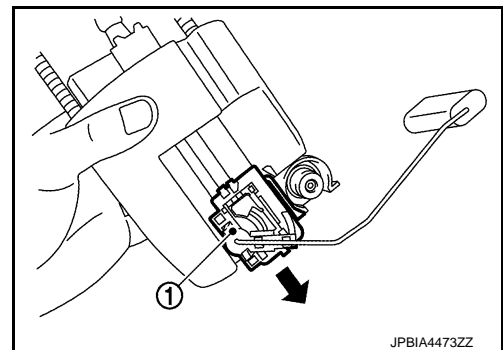

### ASSEMBLY

A  
FL  
C  
D  
E  
F  
G  
H  
I  
J  
K  
L  
M  
N  
O  
P

# FUEL LEVEL SENSOR UNIT, FUEL FILTER AND FUEL PUMP ASSEMBLY

< REMOVAL AND INSTALLATION >

[MR16DDT ]

1. Check for damage of fuel level sensor unit installation position on the side of fuel filter and pump assembly.
2. Slide fuel level sensor unit until it aligns to installation groove, then insert it until stops.
  - After inserting, apply force in reverse direction (removal direction) to ensure it cannot be pulled out.
3. Connect harness connector.

AWD : Inspection

INFOID:000000011463381

## INSPECTION AFTER INSTALLATION

Use the following procedure to check for fuel leakage.

1. Turn ignition switch "ON" (with engine stopped), then check connections for leakage by applying fuel pressure to fuel piping.
2. Start engine and let it idle and check there are no fuel leakage at the fuel system connections.



# FUEL TANK

< REMOVAL AND INSTALLATION >

[MR16DDT ]

## FUEL TANK

2WD

2WD : Exploded View

INFOID:000000011463382

A

FL

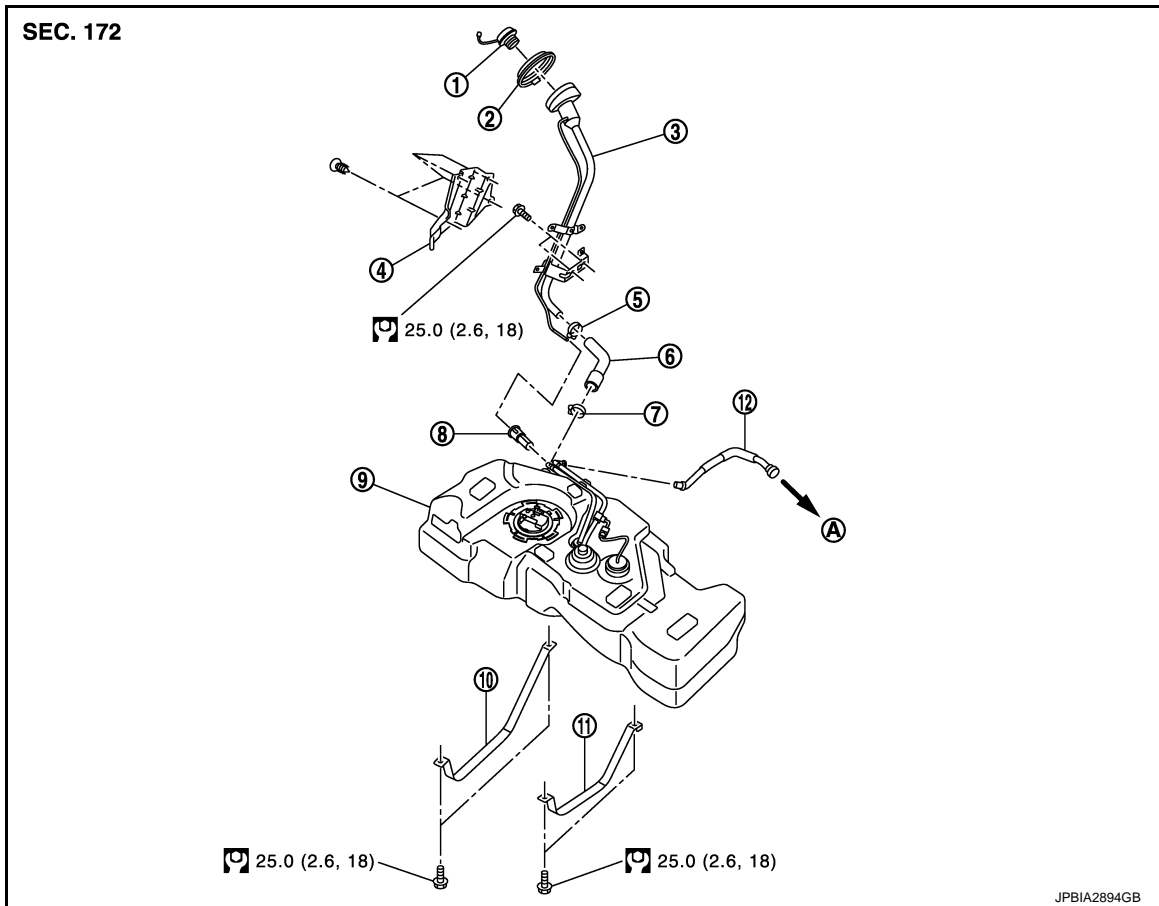

- |                                  |                                  |                     |
|----------------------------------|----------------------------------|---------------------|
| 1. Fuel filler cap               | 2. Grommet                       | 3. Fuel filler tube |
| 4. Cover                         | 5. Clamp                         | 6. Fuel filler hose |
| 7. Clamp                         | 8. EVAP canister protector       | 9. Fuel tank        |
| 10. Fuel tank mounting band (RH) | 11. Fuel tank mounting band (LH) | 12. Vent tube       |
- A. To EVAP canister

 : N·m (kg-m, ft-lb)

2WD : Removal and Installation

INFOID:000000011463383

### WARNING:

Be sure to read "General Precautions" when working on the fuel system. Refer to [FL-2, "General Precautions"](#).

### REMOVAL

- Drain fuel from fuel tank if necessary. Refer to [FL-6, "2WD : Removal and Installation"](#).
  - Perform work on level place.
1. Perform steps 2 to 7 of "REMOVAL" in "FUEL LEVEL SENSOR UNIT, FUEL FILTER AND FUEL PUMP ASSEMBLY" on fuel level sensor unit, fuel filter and fuel pump assembly. Refer to [FL-6, "2WD : Removal and Installation"](#).
  2. Remove center muffler. Refer to [EX-5, "Exploded View"](#).
  3. Remove insulator on vehicle side located above center and main mufflers.

# FUEL TANK

[MR16DDT ]

## < REMOVAL AND INSTALLATION >

4. Move parking brake cable (1) from the lower face of fuel tank. Then remove clips for parking brake cable.

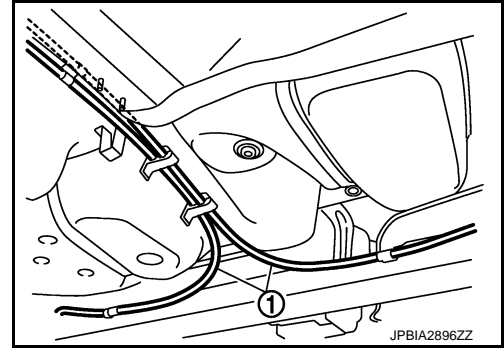

5. Disconnect fuel filler hose (4) at fuel tank side.

- 1 : Vent tube
- 2 : Fuel tank mounting band (RH)
- 3 : EVAP hose
- A : Quick connector

6. Disconnect EVAP hose and vent tube at the position shown in the figure.
- Instruction for quick connector of EVAP hose and vent tube, refer to the following:

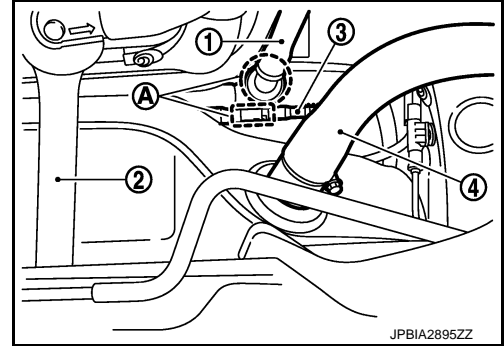

EVAP hose

### CAUTION:

- Quick connector (1) can be disconnected when the tabs (F) are depressed completely. Never twist it more than necessary.

- B : Connection (cross-section)
- D : To fuel tank
- E : To fuel filler tube
- G : Disconnection

- Never use any tools to disconnected quick connector.
- Keep resin tube (C) away from heat. Be especially careful when welding near the resin tube.
- Prevent acid liquid such as battery electrolyte, etc. from getting on resin tube.
- Never bend or twist resin tube during installation and disconnection.
- Never remove the remaining retainer (2) on hard tube (or the equivalent) (A) except when resin tube or retainer is replaced.
- When resin tube or hard tube (or the equivalent) is replaced, also replace retainer with new one.

Retainer color : Green

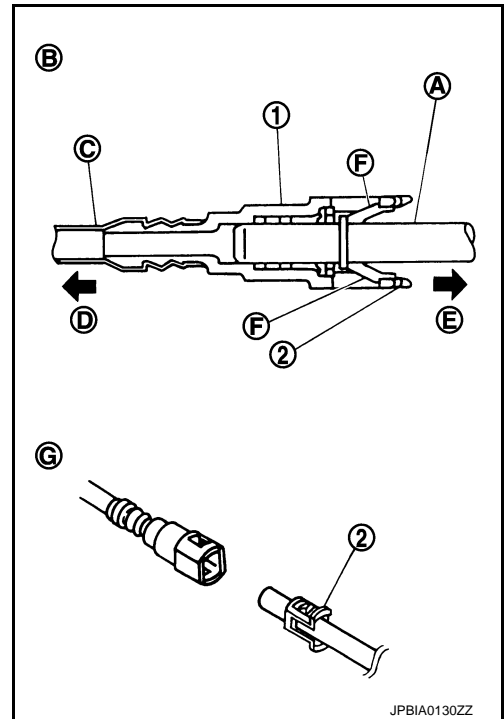

# FUEL TANK

[MR16DDT ]

## < REMOVAL AND INSTALLATION >

- To keep the connecting portion clean and to avoid damage and foreign materials, cover them completely with plastic bags (A) or something similar.
- Never insert plug, preventing damage on O-ring in quick connector.

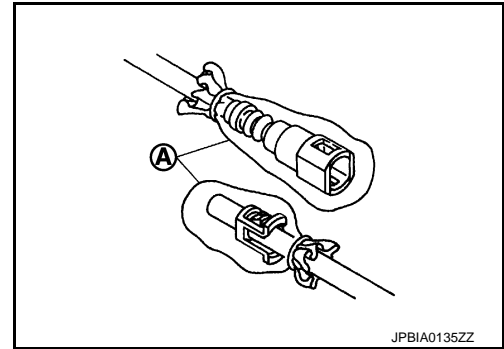

### Vent tube

- Remove quick connector in the following procedures.
- Pinch quick connector square-part (A) with your fingers, and pull out the quick connector (1) by hand.
- If quick connector and tube on vehicle are stuck, push and pull several times until they move, and pull out.

### CAUTION:

- The tube can be removed when the tabs are completely depressed. Never twist it more than necessary.
- Never use any tools to disconnect quick connector.
- Keep the resin tube away from heat. Be especially careful when welding near the tube.
- Prevent acid liquid such as battery electrolyte, etc. from getting on the resin tube.
- Never bend or twist resin tube during installation and disconnection.
- To keep the connecting portion clean and to avoid damage and foreign materials, cover them completely with plastic bags (A) or something similar.
- Never insert plug, preventing damage on O-ring in quick connector.

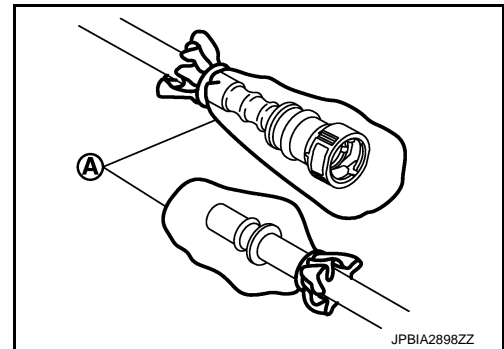
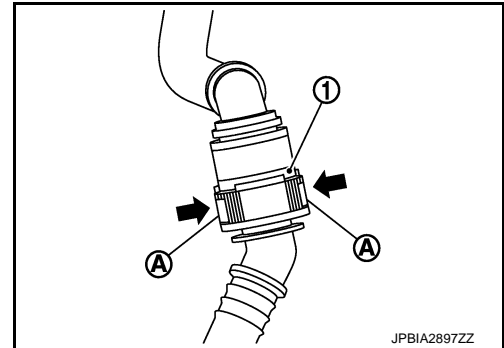

7. Support the center part of fuel tank (1) with transmission jack (A).

### CAUTION:

Securely support the fuel tank with a piece of wood (B).

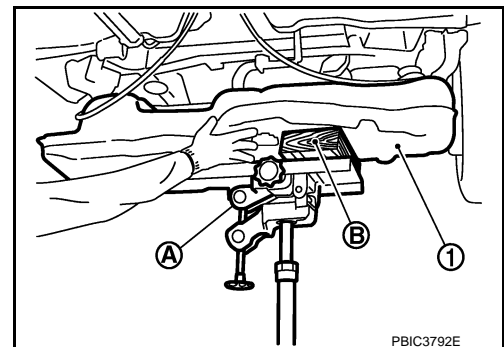

A  
FL  
C  
D  
E  
F  
G  
H  
I  
J  
K  
L  
M  
N  
O  
P

# FUEL TANK

## < REMOVAL AND INSTALLATION >

[MR16DDT ]

### 8. Remove canister filter (1).

- 2 : EVAP canister
- 3 : Fuel tank mounting band (RH)
- ⇐ : Vehicle front

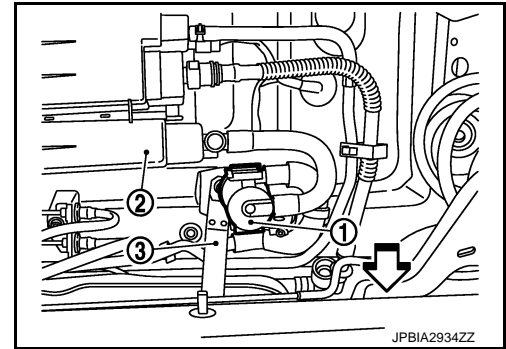

### 9. Remove fuel tank mounting bands (RH and LH).

### 10. Lower transmission jack carefully to remove fuel tank while holding it by hand.

#### **CAUTION:**

**Fuel tank may be in an unstable condition because of the shape of fuel tank bottom. Never rely on jack too much. Be sure to hold tank securely.**

## INSTALLATION

Note the following, and install in the reverse order of removal.

### Fuel Tank

#### 1. Temporarily tighten bolts [except (4)] in numerical order as shown in the figure.

- A : Under view
- ⇐ : Vehicle front

- 2. Tighten bolt (4) to specified torque, pressing fuel tank in the direction (⇐) shown in the figure.
- 3. Tighten bolts [except (4)] to specified torque in the reverse order as shown in the figure.

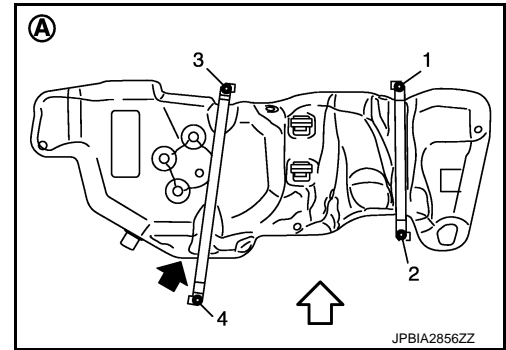

### Fuel Filler Hose

- Surely clamp fuel hose insert fuel filler hose to the length below.

**Fuel filler hose : 35 mm (1.38 in)**

**The other hose : 25 mm (0.98 in)**

- Be sure hose clamp is not placed on swelled area of fuel filler tube.
- Tighten the clamp band with the top mark (A) until the mark is on the bolt head flange.

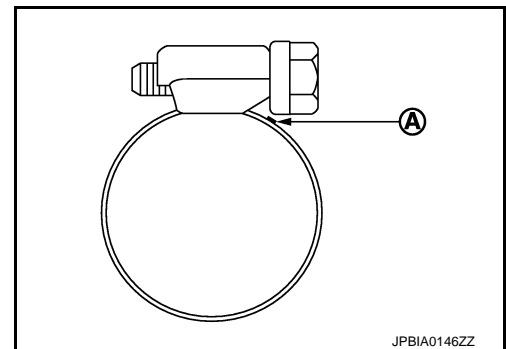

### EVAP Hose and Vent Tube

- 1. Check connections for damage or foreign material.
- 2. Align the matching side connection part with the center of shaft, and insert connector straight until it clicks.

# FUEL TANK

## < REMOVAL AND INSTALLATION >

[MR16DDT ]

- After connecting, pull out quick connector and centralized under floor piping by hand. Check connections are secure.

A : Pull

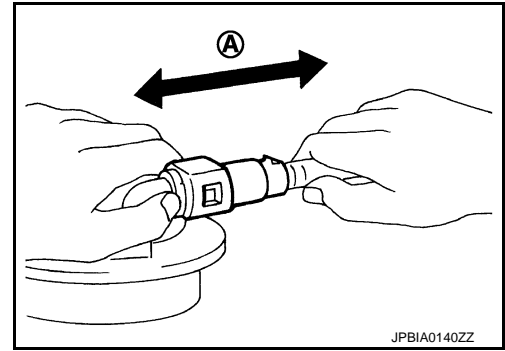

## 2WD : Inspection

INFOID:000000011463384

### INSPECTION AFTER INSTALLATION

Use the following procedure to check for fuel leakage.

- Turn ignition switch "ON" (with engine stopped), and check connections for leakage by applying fuel pressure to fuel piping.
- Start engine and rev it up and check there are no fuel leakage at the fuel system tube and hose connections.

## AWD

## AWD : Exploded View

INFOID:000000011463385

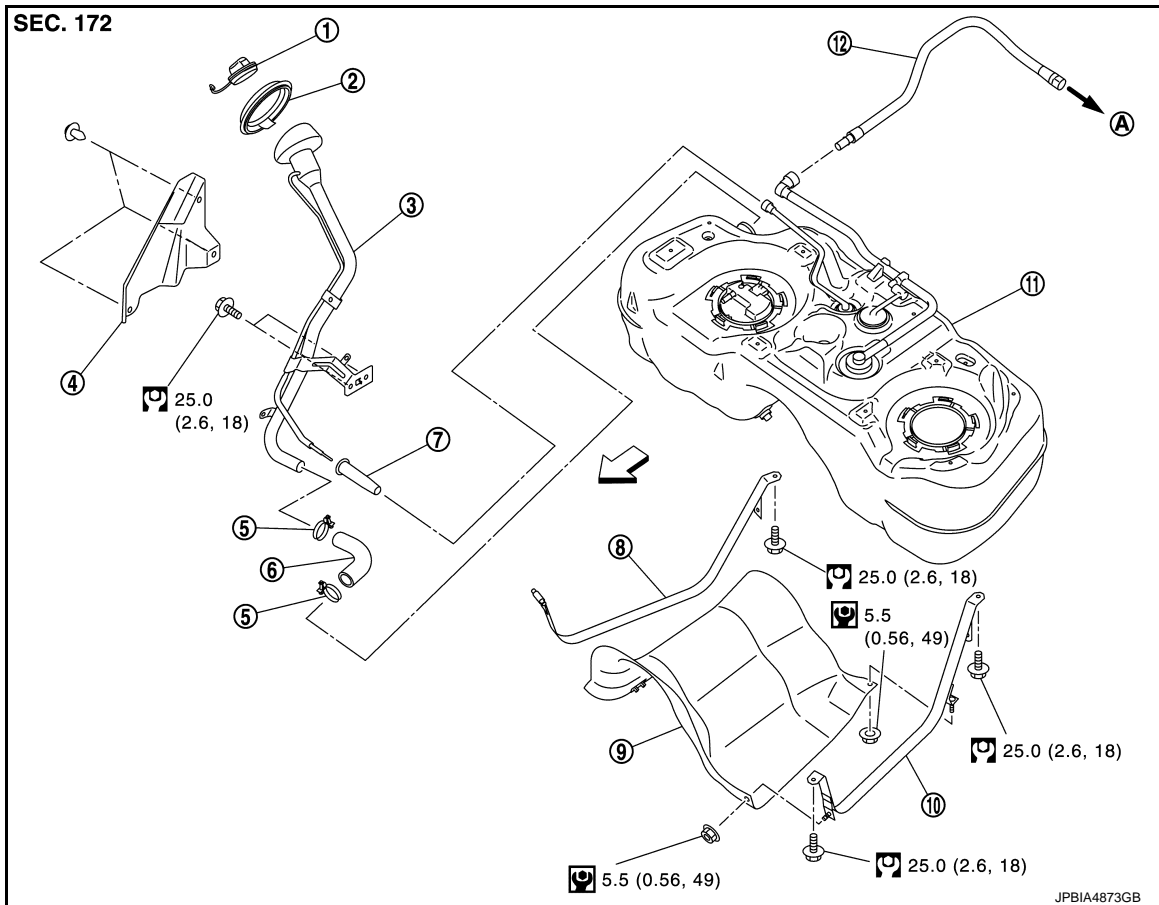

- |                        |                        |                     |
|------------------------|------------------------|---------------------|
| 1. Fuel filler cap     | 2. Grommet             | 3. Fuel filler tube |
| 4. Cover               | 5. Clamp               | 6. Fuel filler hose |
| 7. EVAP hose protector | 8. Fuel tank band (RH) | 9. Protector        |

# FUEL TANK

[MR16DDT ]

## < REMOVAL AND INSTALLATION >

10. Fuel tank band (LH)                      11. Fuel tank                      12. Vent tube  
A. To EVAP canister  
↳ Vehicle front  
🔧 : N·m (kg·m, ft·lb)  
🔧 : N·m (kg·m, in·lb)

## AWD : Removal and Installation

INFOID:000000011463386

### REMOVAL

#### **WARNING:**

Be sure to read “General Precautions” when working on the fuel system. Refer to [FL-2, "General Precautions"](#).

#### **CAUTION:**

- Because fuel tank forwardly inclines and becomes unstable when installing/removing, fuel should be drained if found the remaining quantity.
- Situate vehicle on a flat and solid surface.

1. Drain fuel from fuel tank if necessary.
2. Perform the steps 2 to 7 of “REMOVAL” in “ FUEL LEVEL SENSOR UNIT, FUEL FILTER AND FUEL PUMP ASSEMBLY”. Refer to [FL-10, "AWD : Removal and Installation"](#).
3. Remove center muffler. Refer to [EX-5, "Exploded View"](#).
4. Remove propeller shaft. Refer to [DLN-124, "Exploded View"](#).
5. Remove protector from fuel tank.
6. Remove fuel filler hose (3) at fuel tank side.

- 1 : Vent tube  
2 : EVAP hose  
↳ Vehicle front

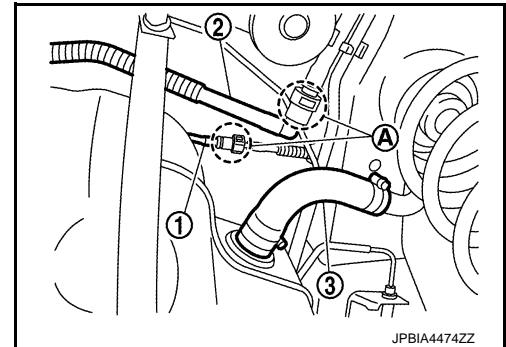

7. Disconnect vent hose connector (1).
8. Disconnect vent tube and EVAP hose at rear side of fuel tank.
  - Instruction for quick connector (A) of EVAP tube and vent hose. Refer to [FL-10, "AWD : Removal and Installation"](#).

9. Remove parking brake cable mounting bolts, and keep a service area. Refer to [PB-6, "Exploded View"](#).
10. Remove ABS harness connector from fuel tank mounting band.

11. Support left of fuel tank (1) with transmission jack (A), and then remove fuel tank band (RH) (2).

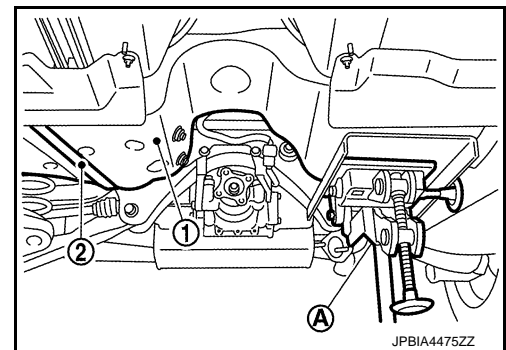

# FUEL TANK

[MR16DDT ]

## < REMOVAL AND INSTALLATION >

- Support right of fuel tank (1) with transmission jack (A), and then remove fuel tank band mounting bolts (LH).

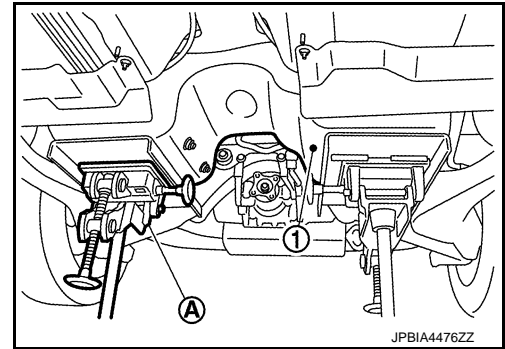

- Supporting with hands, descend transmission jack carefully, and remove fuel tank with fuel tank band (LH).

### CAUTION:

Fuel tank may be in an unstable condition because of the shape of fuel tank bottom. Never rely on jack too much. Be sure to hold tank securely.

## INSTALLATION

Note the following, and install in the reverse order of removal.

### Fuel Filler Hose

- Insert fuel filler hose to the length below.

: 35 mm (1.38 in)

- Be sure hose clamp is not placed on swelled area of fuel filler tube.
- Tighten the clamp band with the top mark (A) until the mark is on the bolt head flange.

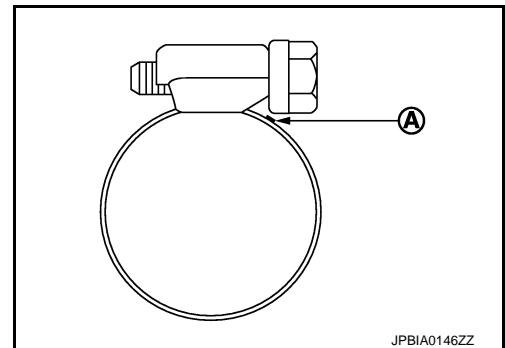

### EVAP Hose

- Check connections for damage or foreign material.
- Align the matching side connection part with the center of shaft, and insert connector straight until it clicks.
- After connecting, pull out quick connector and centralized under-floor piping by hand. Make sure connections are secure.

A : Pull

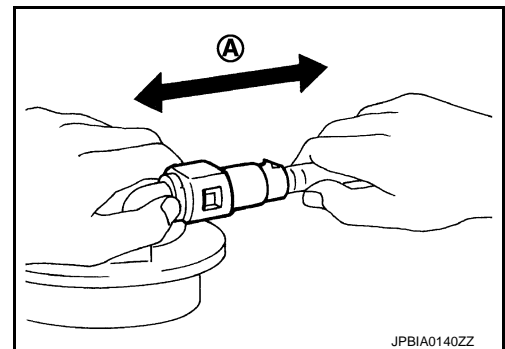

## AWD : Inspection

INFOID:000000011463387

## INSPECTION AFTER INSTALLATION

Use the following procedure to check for fuel leakage.

- Turn ignition switch "ON" (with engine stopped), and check connections for leakage by applying fuel pressure to fuel piping.

## FUEL TANK

< REMOVAL AND INSTALLATION >

[MR16DDT ]

2. Start engine and rev it up and check there are no fuel leakage at the fuel system tube and hose connections.



# EVAP CANISTER

< REMOVAL AND INSTALLATION >

[MR16DDT ]

## EVAP CANISTER

2WD

2WD : Hydraulic Layout

INFOID:000000011463388

EVAPORATIVE EMISSION LINE DRAWING

A

FL

C

D

E

F

G

H

I

J

K

L

M

N

O

P

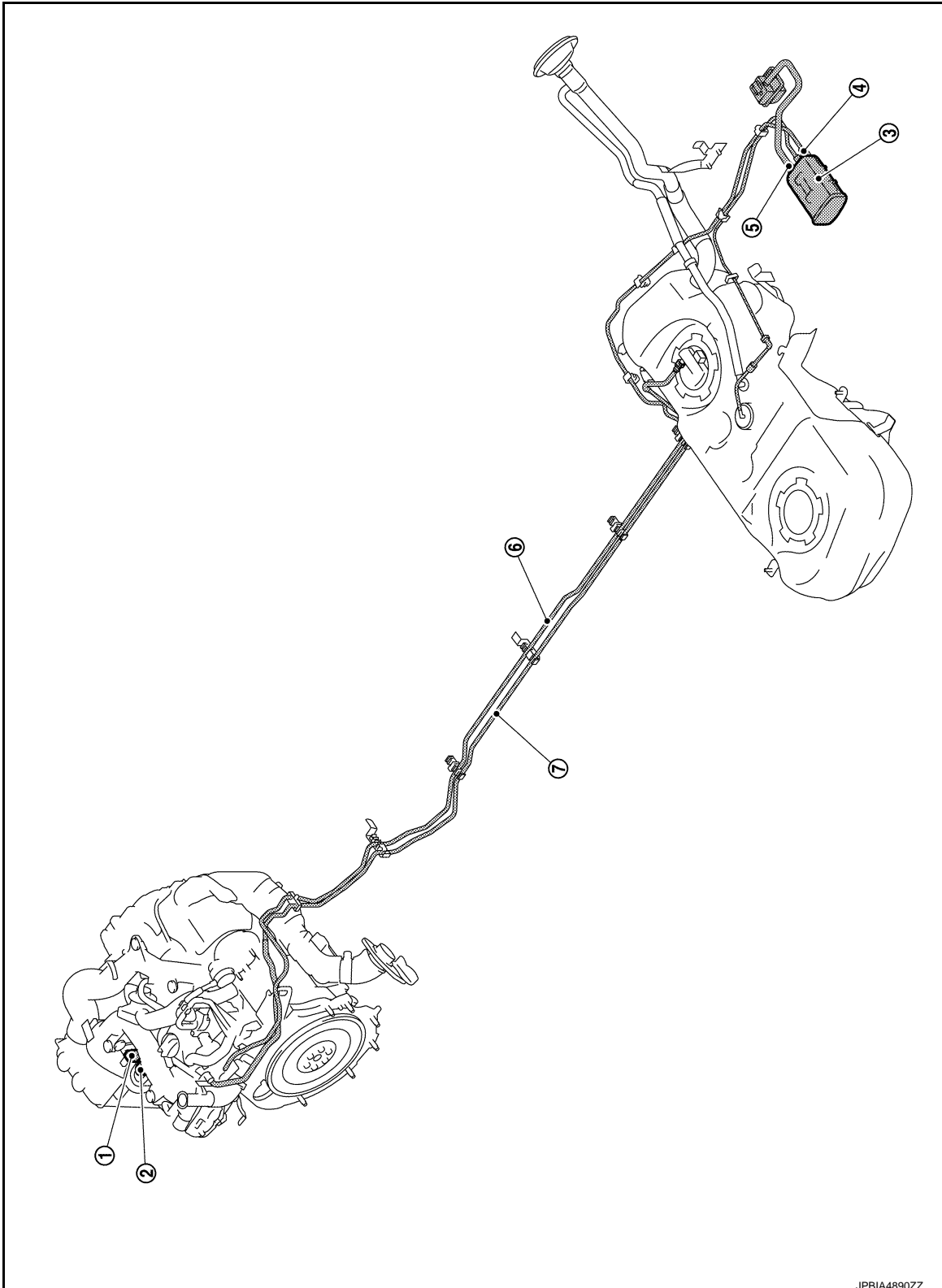

# EVAP CANISTER

## < REMOVAL AND INSTALLATION >

[MR16DDT ]

- |  |                                     |                  |
|--|-------------------------------------|------------------|
| 1. EVAP canister purge volume control solenoid valve | 2. EVAP service port                | 3. EVAP canister |
| 4. EVAP control pressure sensor                      | 5. EVAP canister vent control valve | 6. EAVP line     |
| 7. Fuel line   |                                     |                  |

### NOTE:

Do not use soapy water or any type of solvent while installing vacuum hose or purge hoses.

### 2WD : Exploded View

INFOID:000000011463389

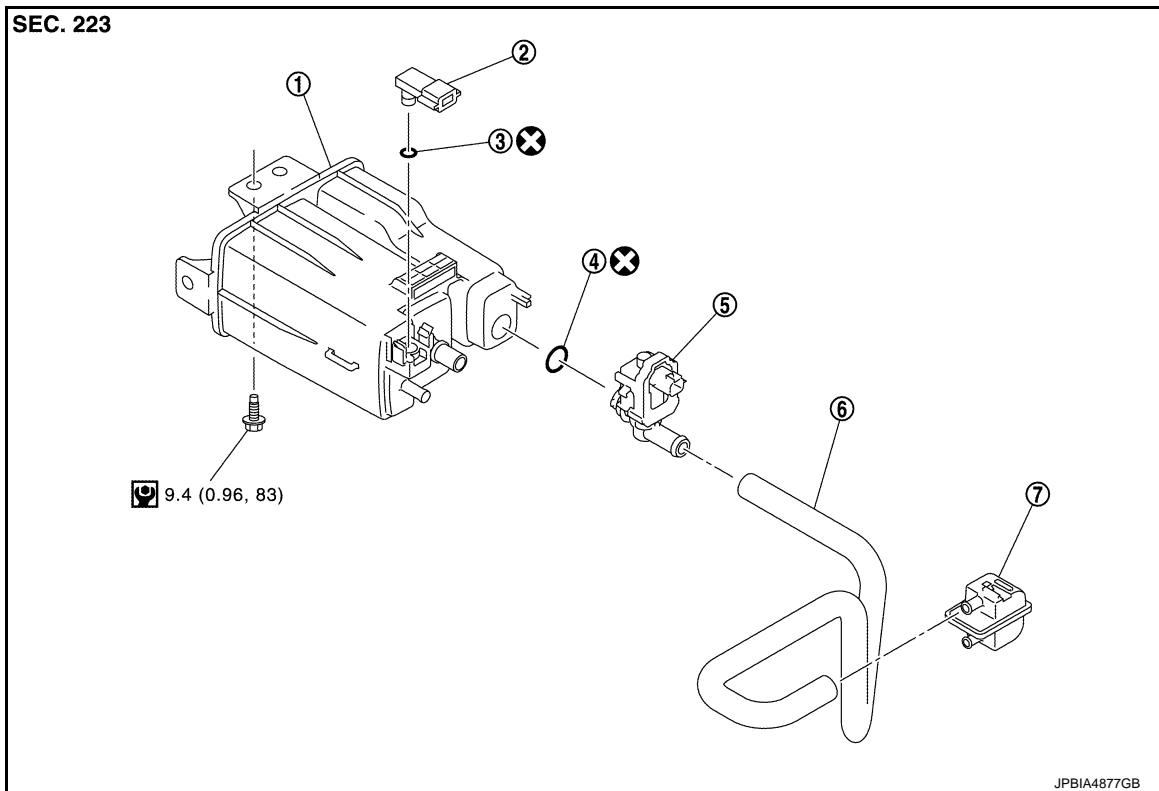

- |                    |                                     |                       |
|--------------------|-------------------------------------|-----------------------|
| 1. EVAP canister   | 2. EVAP control pressure sensor     | 3. O-ring             |
| 4. O-ring          | 5. EVAP canister vent control valve | 6. EVAP canister hose |
| 7. Canister filter |                                     |                       |

: N·m (kg·m, in·lb)

: Always replace after every disassembly.

### 2WD : Removal and Installation

INFOID:000000011463390

#### REMOVAL

1. Disconnect harness connectors (EVAP control pressure sensor and EVAP canister vent control valve) and EVAP canister hoses.
2. Remove EVAP canister fixing bolt.
3. Remove EVAP canister.

#### NOTE:

EVAP canister vent control valve and EVAP control pressure sensor can be removed without removing the EVAP canister.

#### INSTALLATION

#### CAUTION:

**Do not reuse O-rings.**

Install in the reverse order of removal.

# EVAP CANISTER

< REMOVAL AND INSTALLATION >

[MR16DDT ]

## NOTE:

Tighten EVAP canister fixing bolt to the specified torque.

## 2WD : Disassembly and Assembly

INFOID:0000000011463391

### DISASSEMBLY

1. Disengage the pawl and turn EVAP canister vent control valve counterclockwise.
  - Lock (A)
  - Unlock (B)
2. Remove the EVAP canister vent control valve.

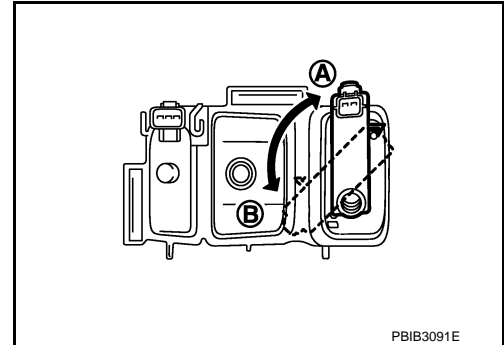

### ASSEMBLY

Assemble in the reverse order of disassembly.

## CAUTION:

**Always replace O-ring with a new one.**

## 2WD : Inspection

INFOID:0000000011463392

Check EVAP canister as per the following:

1. Block port (B).
2. Blow air into port (A) and check that it flows freely out of port (C).
3. Release blocked port (B).
4. Apply vacuum pressure to port (B) and check that vacuum pressure exists at the ports (A) and (C).
5. Block port (A) and (B).
6. Apply pressure to port (C) and check that there is no leakage.

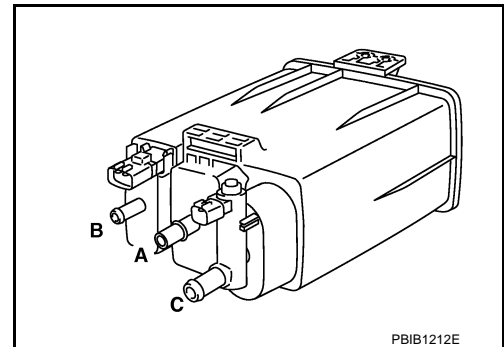

## AWD

## AWD : Hydraulic Layout

INFOID:0000000011463393

## EVAPORATIVE EMISSION LINE DRAWING

# EVAP CANISTER

< REMOVAL AND INSTALLATION >

[MR16DDT ]

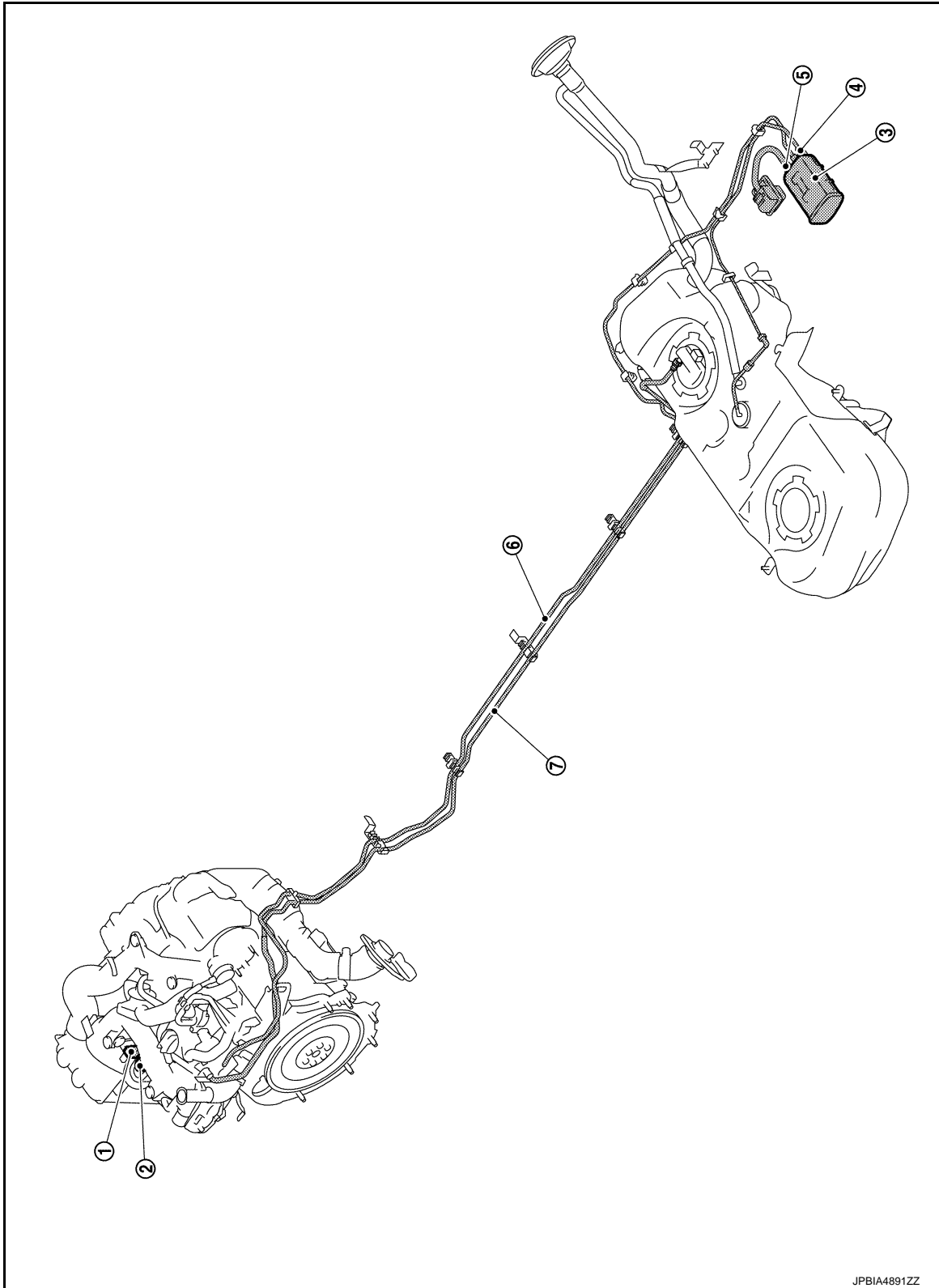

- |  |                                     |                  |
|--|-------------------------------------|------------------|
| 1. EVAP canister purge volume control solenoid valve | 2. EVAP service port                | 3. EVAP canister |
| 4. EVAP control pressure sensor                      | 5. EVAP canister vent control valve | 6. EAVP line     |
| 7. Fuel line   |                                     |                  |

**NOTE:**

Do not use soapy water or any type of solvent while installing vacuum hose or purge hoses.

# EVAP CANISTER

< REMOVAL AND INSTALLATION >

[MR16DDT ]

AWD : Exploded View

INFOID:000000011463394

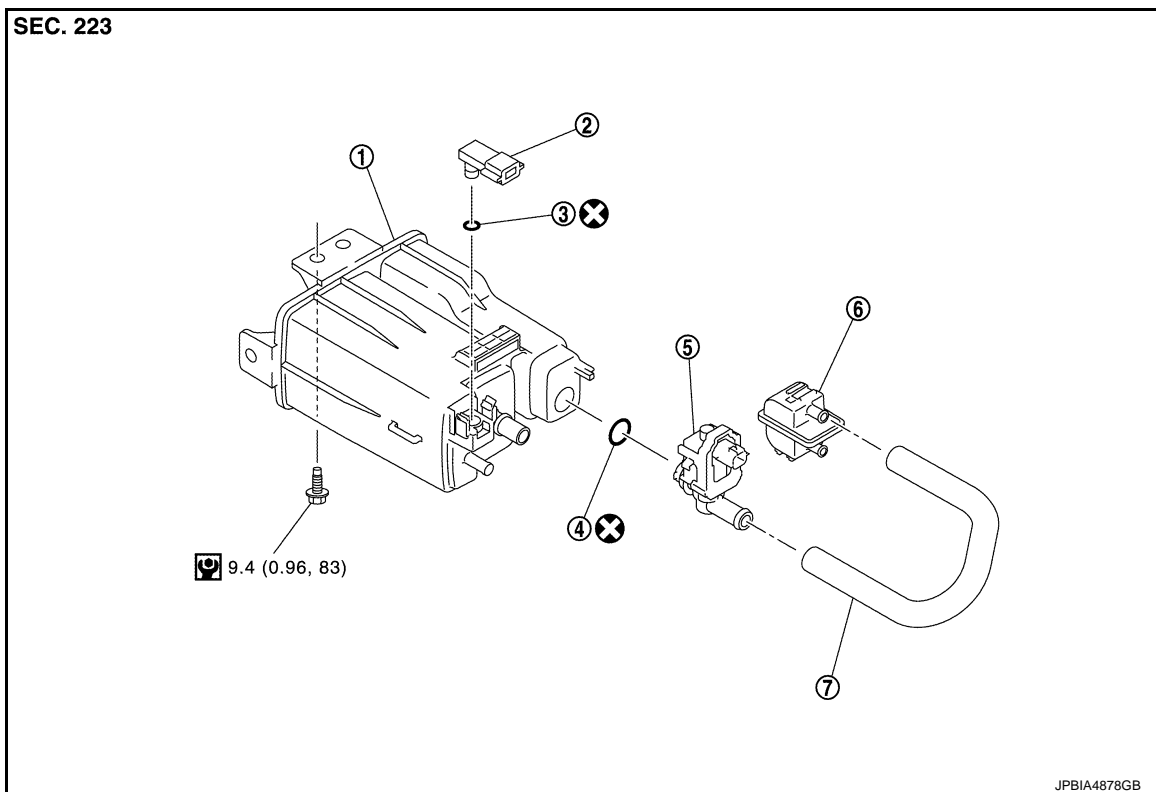

- |                       |                                     |                    |
|-----------------------|-------------------------------------|--------------------|
| 1. EVAP canister      | 2. EVAP control pressure sensor     | 3. O-ring          |
| 4. O-ring             | 5. EVAP canister vent control valve | 6. Canister filter |
| 7. EVAP canister hose |                                     |                    |

: N·m (kg·m, in·lb)

: Always replace after every disassembly.

AWD : Removal and Installation

INFOID:000000011463395

## REMOVAL

1. Remove rear stabilizer (1). Refer to [RSU-35, "Exploded View"](#).
2. EVAP canister
2. Disconnect harness connectors (EVAP control pressure sensor and EVAP canister vent control valve) and EVAP canister hoses.
3. Remove EVAP canister fixing bolt.
4. Remove EVAP canister.

### NOTE:

EVAP canister vent control valve and EVAP control pressure sensor can be removed without removing the EVAP canister.

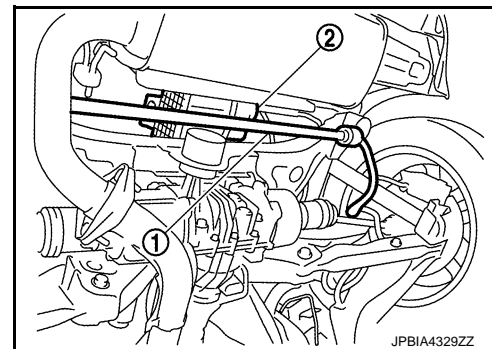

## INSTALLATION

### CAUTION:

**Do not reuse O-rings.**

Install in the reverse order of removal.

### NOTE:

Tighten EVAP canister fixing bolt to the specified torque.

# EVAP CANISTER

< REMOVAL AND INSTALLATION >

[MR16DDT ]

AWD : Disassembly and Assembly

INFOID:000000011463396

## DISASSEMBLY

1. Disengage the pawl and turn EVAP canister vent control valve counterclockwise.
  - Lock (A)
  - Unlock (B)
2. Remove the EVAP canister vent control valve.

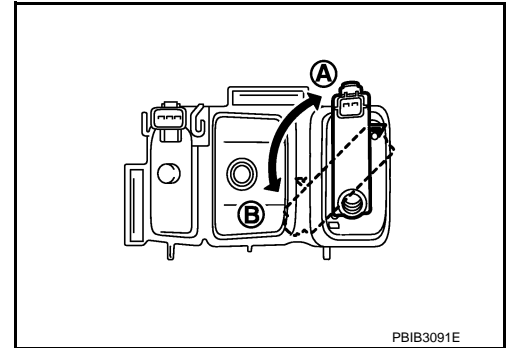

## ASSEMBLY

Assemble in the reverse order of disassembly.

### CAUTION:

**Always replace O-ring with a new one.**

AWD : Inspection

INFOID:000000011463397

Check EVAP canister as per the following:

1. Block port (B).
2. Blow air into port (A) and check that it flows freely out of port (C).
3. Release blocked port (B).
4. Apply vacuum pressure to port (B) and check that vacuum pressure exists at the ports (A) and (C).
5. Block port (A) and (B).
6. Apply pressure to port (C) and check that there is no leakage.

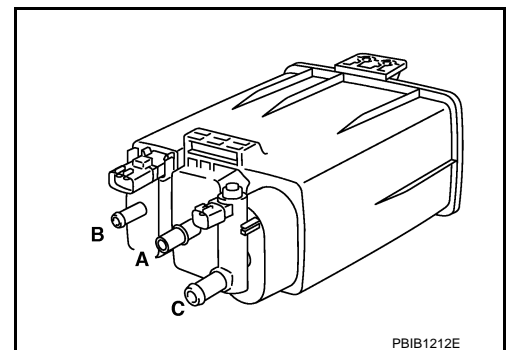

# SERVICE DATA AND SPECIFICATIONS (SDS)

< SERVICE DATA AND SPECIFICATIONS (SDS)

[MR16DDT ]

## SERVICE DATA AND SPECIFICATIONS (SDS)

### SERVICE DATA AND SPECIFICATIONS (SDS)

#### Fuel Tank

INFOID:000000011463398

A

FL

#### Standard and Limit

unit: ℓ (US gal, Imp gal)

Fuel tank capacity	2WD models	Approx. 50.0 (13-1/4, 11)
	AWD models	Approx. 45.0 (11-7/8, 9-7/8)
Fuel recommendation	Refer to <a href="#">GI-28</a>	

C

D

E

F

G

H

I

J

K

L

M

N

O

P