

A  
B  
C

# SECTION **PB**

## PARKING BRAKE SYSTEM

### CONTENTS

<p><b>PRECAUTION</b> ..... 2</p> <p><b>PRECAUTIONS</b> ..... 2</p> <p style="padding-left: 20px;">Precautions for Removing Battery Terminal .....2</p> <p><b>PREPARATION</b> ..... 3</p> <p><b>PREPARATION</b> ..... 3</p> <p style="padding-left: 20px;">Commercial Service Tool .....3</p> <p><b>PERIODIC MAINTENANCE</b> ..... 4</p> <p><b>PARKING BRAKE SYSTEM</b> ..... 4</p> <p style="padding-left: 20px;">Inspection and Adjustment .....4</p> <p><b>PARKING BRAKE SHOE</b> ..... 5</p> <p style="padding-left: 20px;">Adjustment .....5</p> <p><b>REMOVAL AND INSTALLATION</b> ..... 6</p>	<p><b>PARKING BRAKE CONTROL</b> ..... 6</p> <p style="padding-left: 20px;">Exploded View ..... 6</p> <p style="padding-left: 20px;">Removal and Installation ..... 7</p> <p style="padding-left: 20px;">Adjustment ..... 8</p> <p><b>PARKING BRAKE SHOE</b> ..... 9</p> <p style="padding-left: 20px;">Exploded View ..... 9</p> <p style="padding-left: 20px;">Removal and Installation ..... 9</p> <p style="padding-left: 20px;">Inspection and Adjustment .....11</p> <p><b>SERVICE DATA AND SPECIFICATIONS (SDS)</b> .....13</p> <p><b>SERVICE DATA AND SPECIFICATIONS (SDS)</b> .....13</p> <p style="padding-left: 20px;">Parking Drum Brake .....13</p> <p style="padding-left: 20px;">Parking Brake Control .....13</p>
---	--

A  
B  
C  
D  
E  
**PB**  
G  
H  
I  
J  
K  
L  
M  
N  
O  
P

# PRECAUTIONS

< PRECAUTION >

## PRECAUTION

### PRECAUTIONS

#### Precautions for Removing Battery Terminal

INFOID:000000011710423

- When removing the 12V battery terminal, turn OFF the ignition switch and wait at least 30 seconds.

**NOTE:**

ECU may be active for several tens of seconds after the ignition switch is turned OFF. If the battery terminal is removed before ECU stops, then a DTC detection error or ECU data corruption may occur.

- For vehicles with the 2-batteries, be sure to connect the main battery and the sub battery before turning ON the ignition switch.

**NOTE:**

If the ignition switch is turned ON with any one of the terminals of main battery and sub battery disconnected, then DTC may be detected.

- After installing the 12V battery, always check "Self Diagnosis Result" of all ECUs and erase DTC.

**NOTE:**

The removal of 12V battery may cause a DTC detection error.

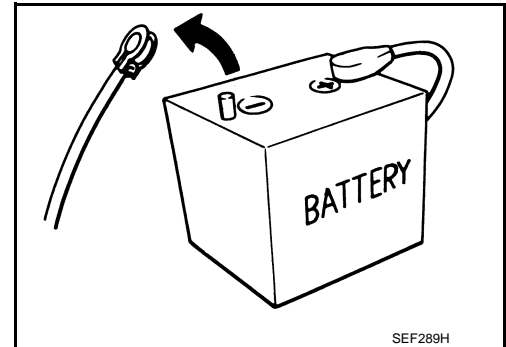

# PREPARATION

< PREPARATION >

## PREPARATION

### PREPARATION

#### Commercial Service Tool

INFOID:000000011460955

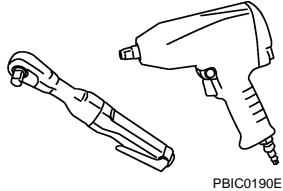
Tool name	Description
Power tool 	Loosening bolts and nuts

A

B

C

D

E

PB

G

H

I

J

K

L

M

N

O

P

# PARKING BRAKE SYSTEM

< PERIODIC MAINTENANCE >

## PERIODIC MAINTENANCE

### PARKING BRAKE SYSTEM

#### Inspection and Adjustment

INFOID:000000011460956

#### INSPECTION

##### Lever Stroke

1. Operate the parking brake lever with a force of 196 N (20 kg, 44 lb). Check that the lever stroke is within the specified number of notches. (Check it by listening to the clicks of the ratchet.)

**Number of notches** : Refer to [PB-13, "Parking Brake Control"](#).

2. When brake warning lamp turns ON, check that the lever stroke is within the specified number of notches. (Check it by listening to the clicks of the ratchet.)

**Number of notches** : Refer to [PB-13, "Parking Brake Control"](#).

##### Inspect Components

- Check each component for installation condition such as looseness.
- Check the parking brake lever assembly for bend, damage and cracks. Replace if necessary.
- Check the cables and equalizer for wear, damage and cracks. Replace if necessary.
- Check the parking brake switch, and replace it if necessary. Refer to [BRC-103, "Component Inspection"](#).

#### ADJUSTMENT

1. Remove rear tires with power tool.
2. Fix the disc rotor using wheel nut.
3. Remove the console mask. Refer to [IP-24, "Removal and Installation"](#).
4. Remove the adjusting hole plug from the disc rotor. Turn the adjuster (1) in the direction (A) as shown in the figure using a suitable tool until the disc rotor is locked.
5. Turn back the adjuster 7 notches from the locked position.
6. Rotate the disc rotor to check that there is no drag. Install the adjuster hole plug. Refer to [PB-11, "Inspection and Adjustment"](#).

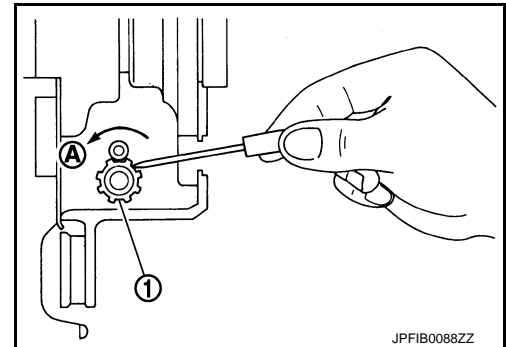

7. Adjust the cable with the following procedure.
  - a. Operate and maintain the parking brake lever with a force of 400 N (41 kg, 90 lb) for 15 minutes or more.
  - b. Adjust the parking brake lever stroke by turning the adjusting nut (1) with a socket wrench.

#### **CAUTION:**

**Make sure to securely depress the brake pedal.**

- c. Operate the parking brake lever with a force of 196 N (20 kg, 44lb). Check that the lever stroke is within the specified number of notches. (Check it by listening to the clicks of the ratchet.)

**Number of notches** : Refer to [PB-13, "Parking Brake Control"](#).

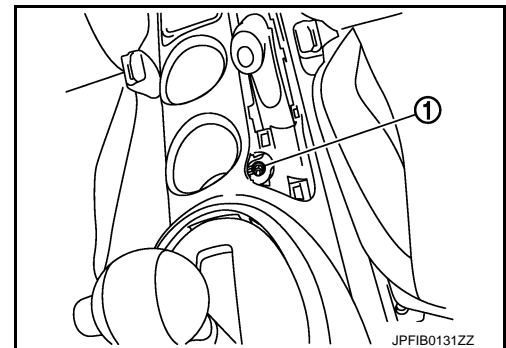

- d. Rotate the disc rotor to check that there is no drag. Refer to [PB-11, "Inspection and Adjustment"](#).

# PARKING BRAKE SHOE

< PERIODIC MAINTENANCE >

## PARKING BRAKE SHOE

### Adjustment

INFOID:000000011460957

1. Adjust parking brake lever stroke. Refer to [PB-4, "Inspection and Adjustment"](#).
2. Perform parking brake break-in (drag on) operation by driving vehicle under the following conditions:
  - Drive forward
  - Vehicle speed: Approx. 43 km/h (27 MPH) set (constant and forward)
  - Parking brake operating force: 125 N (12.8 kg, 28.1 lb) set contact
  - Time: Approx. 8 sec.

**CAUTION:**

**To prevent lining from getting too hot, allow a cool off period of approximately 5 minutes after every break-in operation.**

3. After the break-in procedure, check parking brake lever stroke of parking brake.

**CAUTION:**

**If it is out of the specification, adjust again. Refer to [PB-4, "Inspection and Adjustment"](#).**

A  
B  
C  
D  
E  
G  
H  
I  
J  
K  
L  
M  
N  
O  
P

PB

# PARKING BRAKE CONTROL

< REMOVAL AND INSTALLATION >

## REMOVAL AND INSTALLATION

### PARKING BRAKE CONTROL

Exploded View

INFOID:000000011460958

2WD

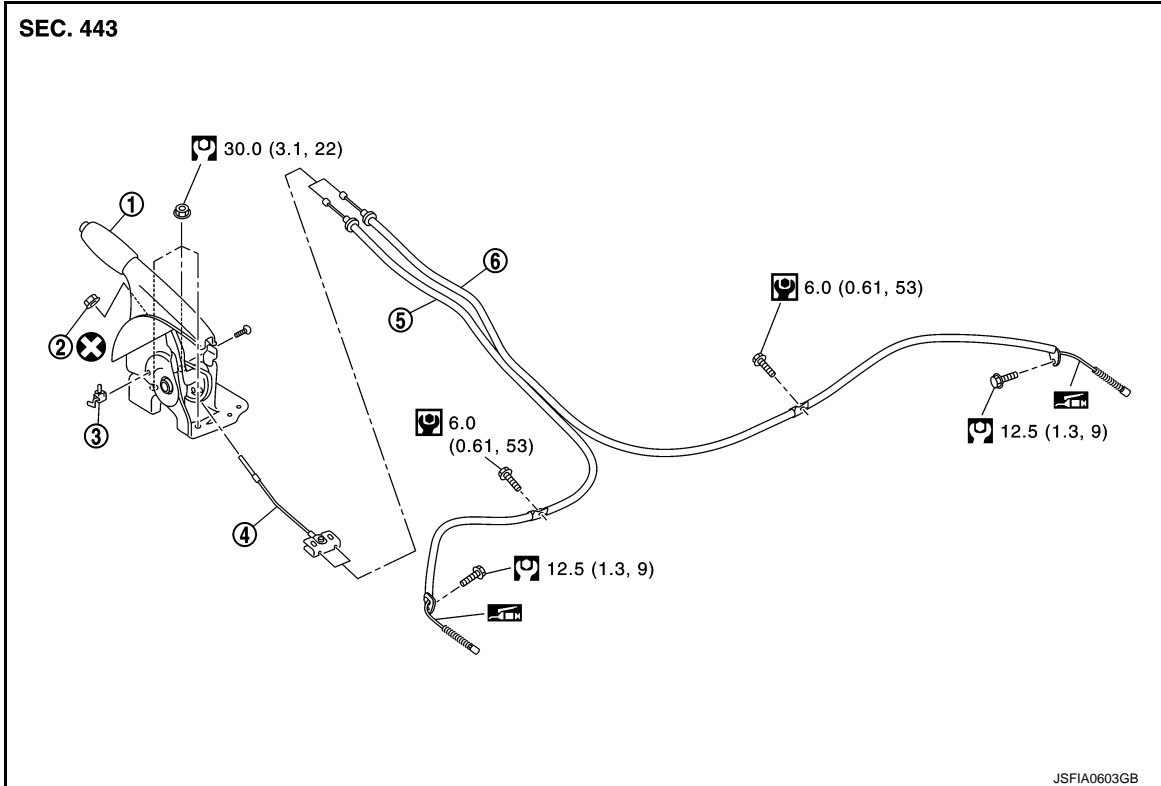

1. Parking brake lever assembly
4. Front cable

2. Adjusting nut
5. Rear cable (LH)
6. Rear cable (RH)

3. Parking brake switch

Apply multi-purpose grease.

: N-m (kg-m, ft-lb)

: N-m (kg-m, in-lb)

: Always replace after every disassembly.

AWD

# PARKING BRAKE CONTROL

## < REMOVAL AND INSTALLATION >

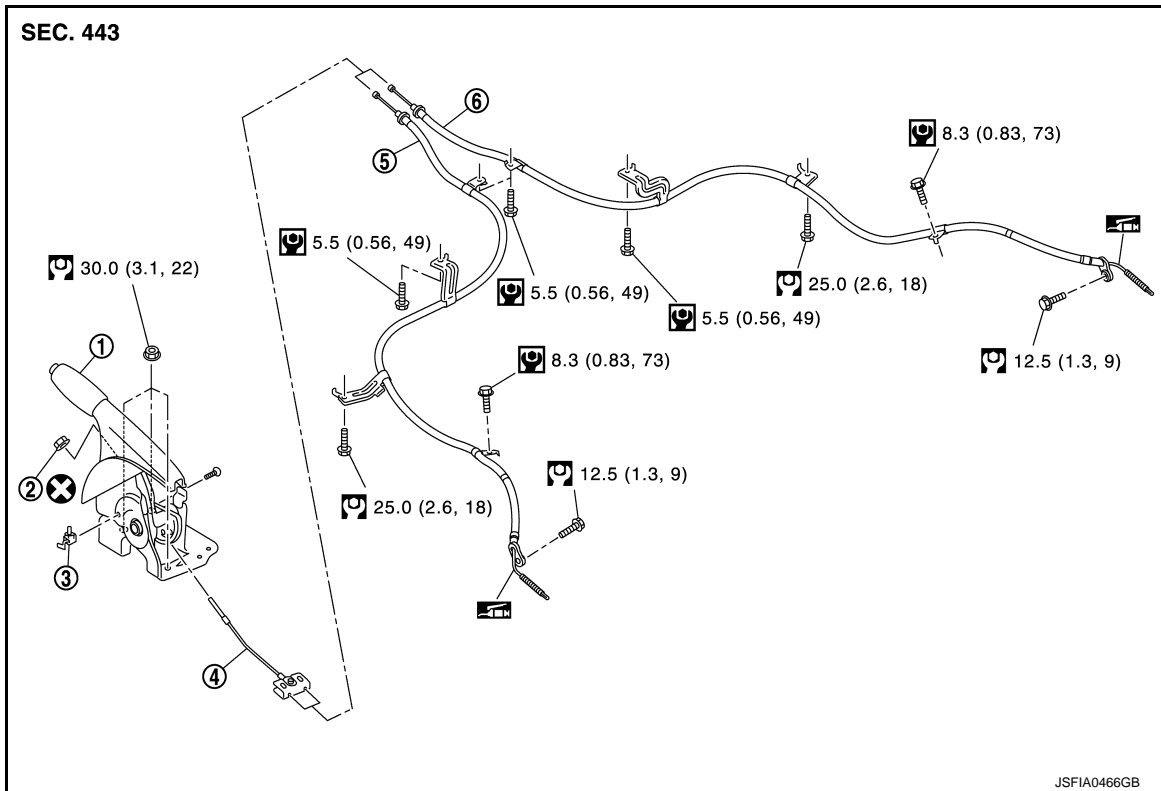

- |                                 |                    |                         |
|---------------------------------|--------------------|-------------------------|
| 1. Parking brake lever assembly | 2. Adjusting nut   | 3. Parking brake switch |
| 4. Front cable                  | 5. Rear cable (LH) | 6. Rear cable (RH)      |

: Apply multi-purpose grease.

: N·m (kg-m, ft-lb)

: N·m (kg-m, in-lb)

: Always replace after every disassembly.

## Removal and Installation

INFOID:000000011460959

### REMOVAL

1. Remove rear tires with power tool.
2. Remove the center console assembly. Refer to [IP-24, "Removal and Installation"](#).
3. Disconnect the parking brake switch harness connector.
4. Remove adjusting nut (1) and loosen front cable.
5. Remove the parking brake lever assembly.

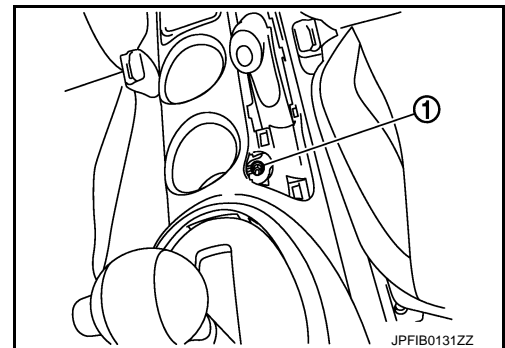

# PARKING BRAKE CONTROL

## < REMOVAL AND INSTALLATION >

6. Remove rear cable with the following procedure.
  - a. Pull equalizer (A) of the front cable (1) in a rearward direction.
  - b. Push the equalizer upward to remove the rear cable (2).
7. Remove center muffler and heat plate. Refer to [EX-10. "Removal and Installation"](#).
8. Remove brake shoe, and remove rear cable from toggle lever. Refer to [PB-9. "Exploded View"](#).
9. Remove rear cable mounting bolts, pull out rear cable from vehicle.
10. Press the pawl (1) to remove the rear cable from the vehicle.

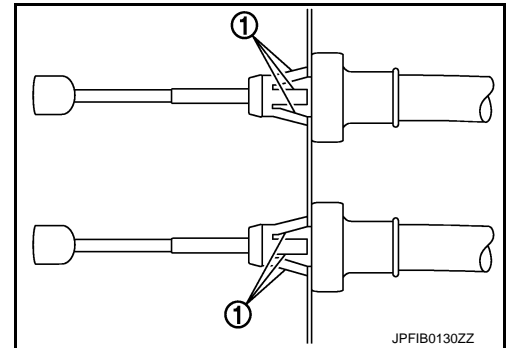
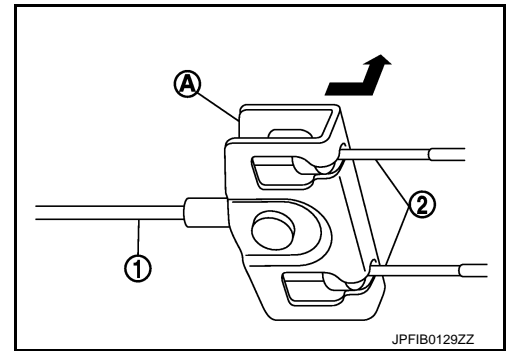

## INSTALLATION

Note the following, install in the reverse order of the removal.

- Never reuse adjusting nut.
- Perform adjustment after installation. Refer to [PB-4. "Inspection and Adjustment"](#).

## Adjustment

INFOID:0000000011460960

## ADJUSTMENT AFTER INSTALLATION

Adjust the parking brake lever stroke. Refer to [PB-4. "Inspection and Adjustment"](#).



# PARKING BRAKE SHOE

< REMOVAL AND INSTALLATION >

## PARKING BRAKE SHOE

Exploded View

INFOID:000000011460961

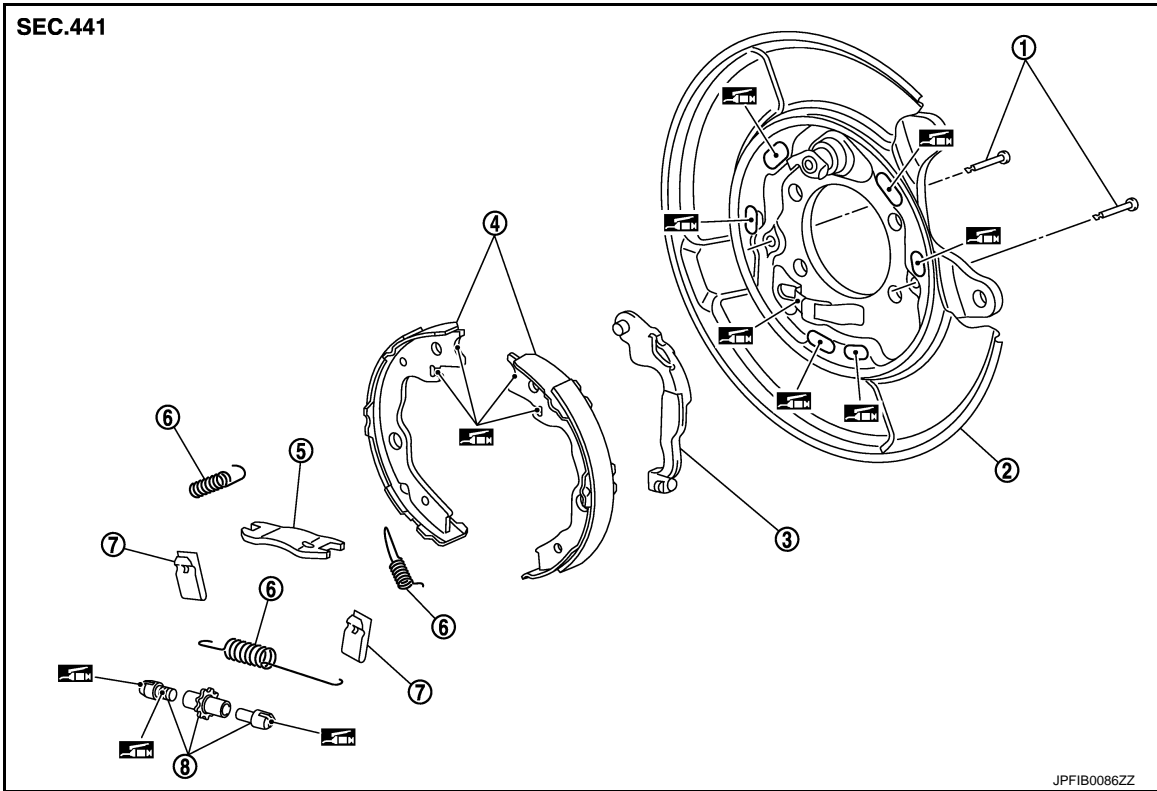

- |                       |                |                  |
|-----------------------|----------------|------------------|
| 1. Anti-rattle pin    | 2. Back plate  | 3. Toggle lever  |
| 4. Parking brake shoe | 5. Brake strut | 6. Return spring |
| 7. Spring             | 8. Adjuster    |                  |

: Apply PBC (Poly Butyl Cuprysil) grease or silicone-based grease.

## Removal and Installation

INFOID:000000011460962

### REMOVAL

#### **WARNING:**

Since dust covering the parking brake has an affect on human body, the dust must be removed with a dust collector. Never splatter the dust with an air blow gun.

1. Remove rear tires with power tool.
2. Remove disc rotor.
  - 2WD: Refer to [RAX-7, "Removal and Installation"](#).
  - AWD: Refer to [RAX-16, "Removal and Installation"](#).

#### **CAUTION:**

Parking brake completely in the released position.

# PARKING BRAKE SHOE

## < REMOVAL AND INSTALLATION >

3. Remove return spring (1) of the upper side.

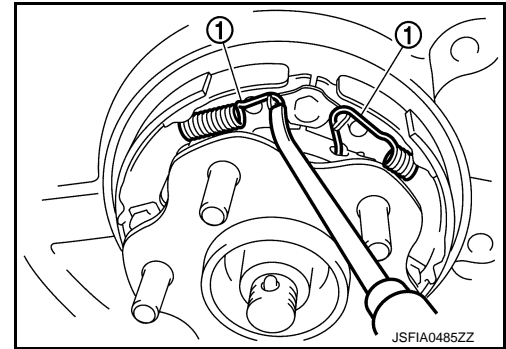

4. Remove return spring (1) of the lower side.

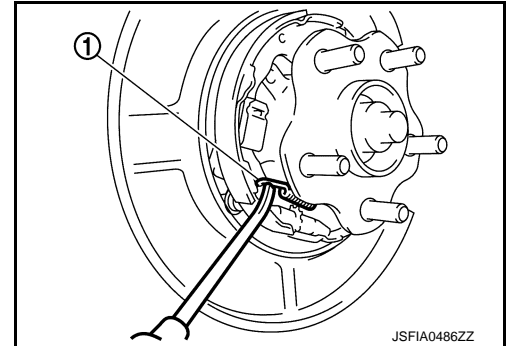

5. Remove spring (1).

**CAUTION:**

**Never drop the removed parts.**

6. Remove parking brake shoes, adjuster, brake strut and toggle lever.

**CAUTION:**

- The parking brake shoes for the front wheels are made of different materials from those for the rear wheels. Never misidentify them when removing.
- Never drop the removed parts.

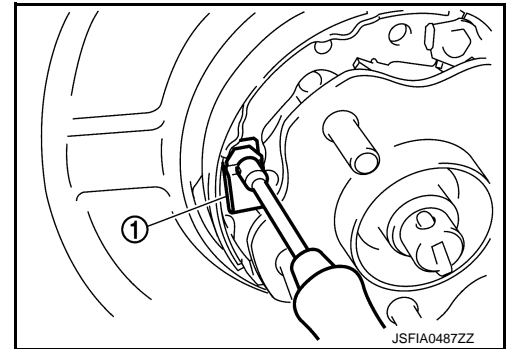

7. Press the rear cable spring (1) against spring tension to remove rear cable (3) from the clamp (A) of toggle lever (2).

**CAUTION:**

**Never bend rear cable.**

8. For the removal of back plate.

- 2WD: Refer to [RAX-7, "Removal and Installation"](#).
- AWD: Refer to [RAX-16, "Removal and Installation"](#).

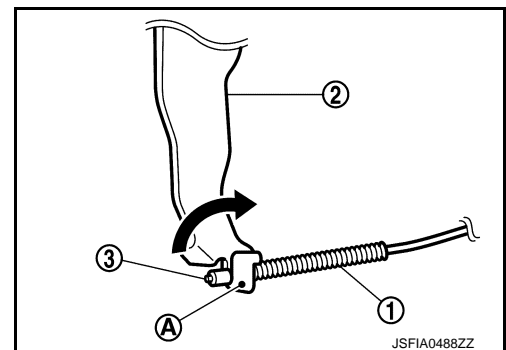

## INSTALLATION

Note the following, install in the reverse order of removal.

- Apply PBC (Poly Butyl Cuprysil) grease or silicone-based grease to the back plate and brake shoe.

**CAUTION:**

**The parking brake shoes for the front wheels are made of different materials from those for the rear wheels. Never misidentify them when removing and replacing.**

# PARKING BRAKE SHOE

## < REMOVAL AND INSTALLATION >

- Assemble adjusters so that threaded part is expanded when rotating it in the direction shown by arrow.

A : For right side brake

B : For left side brake

↔: Vehicle front

←: Adjuster expands

- Shorten adjuster by rotating it.
- When disassembling apply PBC (Poly Butyl Cuprysil) grease or silicone-based grease to threads.

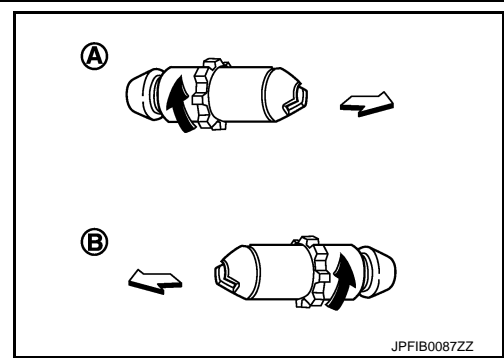

- Check that the component parts of the parking brake shoe are properly installed.
- Check brake shoe sliding surface and drum inner surface for grease. Wipe it off if it adhere on the surfaces.

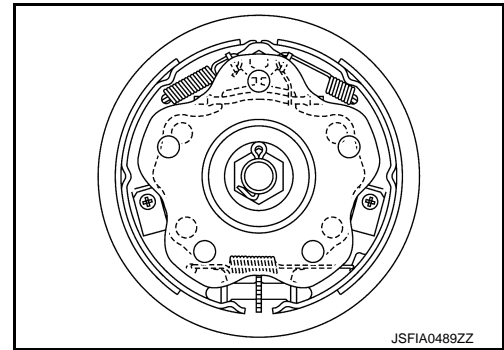

## Inspection and Adjustment

### INSPECTION AFTER REMOVAL

#### Lining Thickness Inspection

- Check thickness (A) of lining.

**A** : Refer to [PB-13, "Parking Drum Brake"](#).

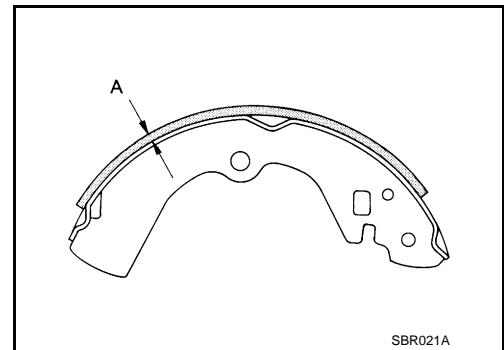

#### Drum Inner Diameter Inspection

- Check inner diameter (B) of drum.

**B** : Refer to [PB-13, "Parking Drum Brake"](#).

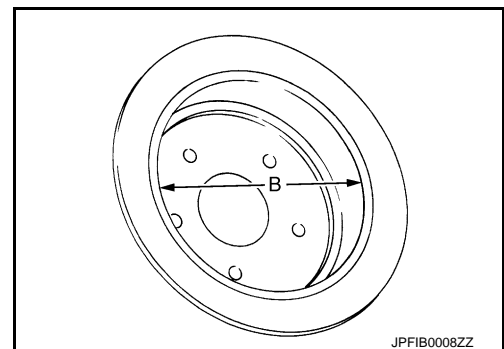

#### Other Inspections

Check the following items, and replace the parts if necessary.

- Lining for excessive wear, damage, and peeling.
- Brake shoe sliding surface for excessive wear and damage.
- Anti-rattle pin for excessive wear, damage and rust.
- Return spring and spring for settling, excessive wear, damage, and rust.

## PARKING BRAKE SHOE

### < REMOVAL AND INSTALLATION >

---

- Adjuster for smoothness.
- Toggle lever and brake strut for excessive wear, damage and rust.
- Visually check inside of the drum for excessive wear, cracks, and damage with a pair of vernier calipers.

### ADJUSTMENT AFTER INSTALLATION

1. Adjust the parking brake lever stroke. Refer to [PB-4, "Inspection and Adjustment"](#).
2. Rotate the disc rotor to check that there is no drag. Install the plug. If any drag is found, follow the procedure described below.
  - a. Adjust parking brake stroke again.
  - b. Check rear disc brake. Refer to [BR-67, "BRAKE CALIPER ASSEMBLY : Inspection"](#).
3. Adjust the parking brake shoe. Refer to [PB-5, "Adjustment"](#).

# SERVICE DATA AND SPECIFICATIONS (SDS)

< SERVICE DATA AND SPECIFICATIONS (SDS)

## SERVICE DATA AND SPECIFICATIONS (SDS)

### SERVICE DATA AND SPECIFICATIONS (SDS)

#### Parking Drum Brake

INFOID:0000000011460964

Unit: mm (in)

Item	Limit
Brake lining	1.5 (0.059)
Drum (disc of inner diameter)	173 (6.81)

#### Parking Brake Control

INFOID:0000000011460965

Item	Standard
Number of notches [under force of 196 N (20 kg, 44 lb)]	9 – 10 notches
Number of notches when brake warning lamp turns ON	1 notch

A  
B  
C  
D  
E  
PB  
G  
H  
I  
J  
K  
L  
M  
N  
O  
P