

SECTION **VTL**
VENTILATION SYSTEM

A
B
C
D
E
F
G
H
VTL
J
K
L
M
N
O
P

CONTENTS

PRECAUTION	2	FRONT DEFROSTER NOZZLE : Removal and Installation	10
PRECAUTIONS	2	CENTER VENTILATOR DUCT	10
Precaution for Supplemental Restraint System (SRS) "AIR BAG" and "SEAT BELT PRE-TENSIONER"	2	CENTER VENTILATOR DUCT : Removal and Installation	11
Precautions for Removing Battery Terminal	2	SIDE VENTILATOR DUCT	11
Precaution for Procedure without Cowl Top Cover.....	3	SIDE VENTILATOR DUCT : Removal and Installation	11
PREPARATION	4	REAR HEATER DUCT 1	11
PREPARATION	4	REAR HEATER DUCT 1 : Removal and Installation	11
Commercial Service Tool	4	REAR HEATER DUCT 2	12
SYSTEM DESCRIPTION	5	REAR HEATER DUCT 2 : Removal and Installation	12
VENTILATION SYSTEM	5	REAR HEATER DUCT 3	12
System Description	5	REAR HEATER DUCT 3 : Removal and Installation	12
REMOVAL AND INSTALLATION	7	FOOT DUCT	13
DUCT AND GRILLE	7	FOOT DUCT : Removal and Installation	13
Exploded View	7	BLOWER MOTOR	14
CENTER VENTILATOR GRILLE	8	Exploded View	14
CENTER VENTILATOR GRILLE : Removal and Installation	8	Removal and Installation	14
SIDE DEFROSTER NOZZLE	9	IN-CABIN MICROFILTER	16
SIDE DEFROSTER NOZZLE : Removal and Installation	9	Exploded View	16
SIDE VENTILATOR GRILLE	9	Removal and Installation	16
SIDE VENTILATOR GRILLE : Removal and Installation	9	Replacement	16
SIDE DEFROSTER GRILLE	10	SERVICE DATA AND SPECIFICATIONS (SDS)	17
SIDE DEFROSTER GRILLE : Removal and Installation	10	SERVICE DATA AND SPECIFICATIONS (SDS)	17
FRONT DEFROSTER NOZZLE	10	In-cabin microfilter	17

PRECAUTIONS

< PRECAUTION >

PRECAUTION

PRECAUTIONS

Precaution for Supplemental Restraint System (SRS) "AIR BAG" and "SEAT BELT PRE-TENSIONER"

INFOID:000000011460546

The Supplemental Restraint System such as "AIR BAG" and "SEAT BELT PRE-TENSIONER", used along with a front seat belt, helps to reduce the risk or severity of injury to the driver and front passenger for certain types of collision. This system includes seat belt switch inputs and dual stage front air bag modules. The SRS system uses the seat belt switches to determine the front air bag deployment, and may only deploy one front air bag, depending on the severity of a collision and whether the front occupants are belted or unbelted. Information necessary to service the system safely is included in the "SRS AIR BAG" and "SEAT BELT" of this Service Manual.

WARNING:

Always observe the following items for preventing accidental activation.

- To avoid rendering the SRS inoperative, which could increase the risk of personal injury or death in the event of a collision that would result in air bag inflation, all maintenance must be performed by an authorized NISSAN/INFINITI dealer.
- Improper maintenance, including incorrect removal and installation of the SRS, can lead to personal injury caused by unintentional activation of the system. For removal of Spiral Cable and Air Bag Module, see "SRS AIR BAG".
- Never use electrical test equipment on any circuit related to the SRS unless instructed to in this Service Manual. SRS wiring harnesses can be identified by yellow and/or orange harnesses or harness connectors.

PRECAUTIONS WHEN USING POWER TOOLS (AIR OR ELECTRIC) AND HAMMERS

WARNING:

Always observe the following items for preventing accidental activation.

- When working near the Air Bag Diagnosis Sensor Unit or other Air Bag System sensors with the ignition ON or engine running, never use air or electric power tools or strike near the sensor(s) with a hammer. Heavy vibration could activate the sensor(s) and deploy the air bag(s), possibly causing serious injury.
- When using air or electric power tools or hammers, always switch the ignition OFF, disconnect the battery, and wait at least 3 minutes before performing any service.

Precautions for Removing Battery Terminal

INFOID:000000011460547

- When removing the 12V battery terminal, turn OFF the ignition switch and wait at least 30 seconds.

NOTE:

ECU may be active for several tens of seconds after the ignition switch is turned OFF. If the battery terminal is removed before ECU stops, then a DTC detection error or ECU data corruption may occur.

- For vehicles with the 2-batteries, be sure to connect the main battery and the sub battery before turning ON the ignition switch.

NOTE:

If the ignition switch is turned ON with any one of the terminals of main battery and sub battery disconnected, then DTC may be detected.

- After installing the 12V battery, always check "Self Diagnosis Result" of all ECUs and erase DTC.

NOTE:

The removal of 12V battery may cause a DTC detection error.

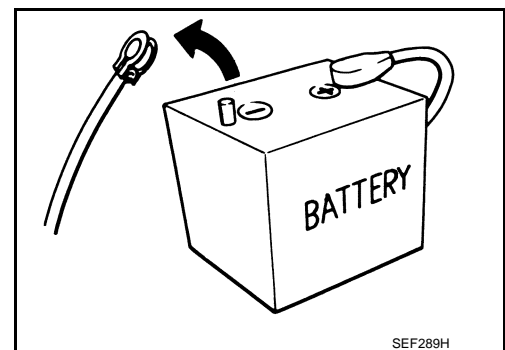

PRECAUTIONS

< PRECAUTION >

Precaution for Procedure without Cowl Top Cover

INFOID:000000011460548

When performing the procedure after removing cowl top cover, cover the lower end of windshield with urethane, etc to prevent damage to windshield.

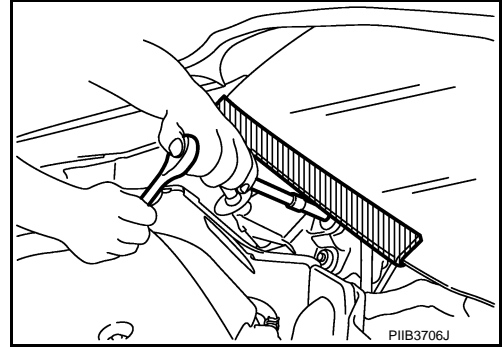

A
B
C
D
E
F
G
H
VTL
J
K
L
M
N
O
P

VTL

PREPARATION

< PREPARATION >

PREPARATION

PREPARATION

Commercial Service Tool

INFOID:000000011460549

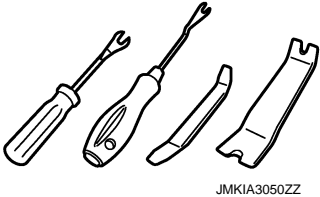
Tool name	Description
Remover tool  JMKIA3050ZZ	Remove clips, pawls and metal clips

VENTILATION SYSTEM

< SYSTEM DESCRIPTION >

SYSTEM DESCRIPTION

VENTILATION SYSTEM

System Description

INFOID:000000011460550

OUTLINE

Ventilation system is controlled by A/C auto amp. (AUTOMATIC AIR CONDITIONING) or A/C control (MANUAL AIR CONDITIONING). For details of air conditioner system, refer to [HAC-11. "System Description"](#) (AUTOMATIC AIR CONDITIONING), [HAC-105. "System Description"](#) (MANUAL AIR CONDITIONING).

AIR FLOW

Front

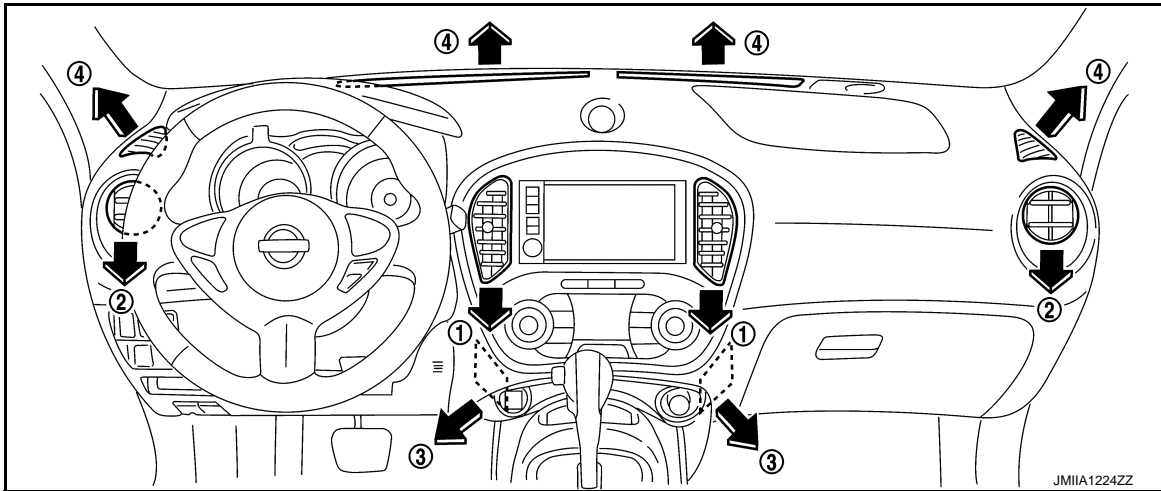

Rear

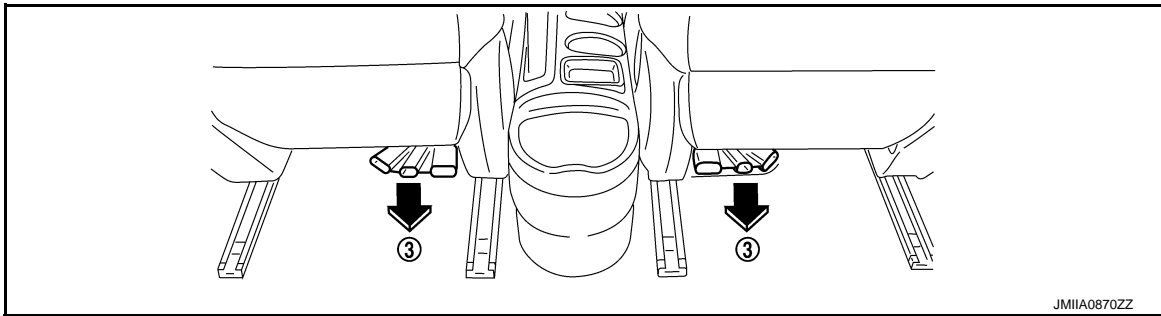

Models for Canada

x: Applicable

MODE/DEF position indication	AIR OUTLET				
	Ventilator		Foot		Defroster (4)
	Center (1)	Side (2)	Front (3)	Rear (3)	
	x	x	—	—	—
	x	x	x	x	—
	—	x	x	x	x
	—	x	x	x	x
	—	x	—	—	x

Models except for Canada





A
B
C
D
E
F
G
H
J
K
L
M
N
O
P

VTL

VENTILATION SYSTEM

< SYSTEM DESCRIPTION >

×: Applicable

MODE/DEF position indication	AIR OUTLET			
	Ventilator		Foot (3)	Defroster (4)
	Center (1)	Side (2)		
	×	×	—	—
	×	×	×	—
	—	×	×	×
	—	×	×	×
	—	×	—	×

DUCT AND GRILLE

< REMOVAL AND INSTALLATION >

REMOVAL AND INSTALLATION

DUCT AND GRILLE

Exploded View

INFOID:000000011460551

FRONT

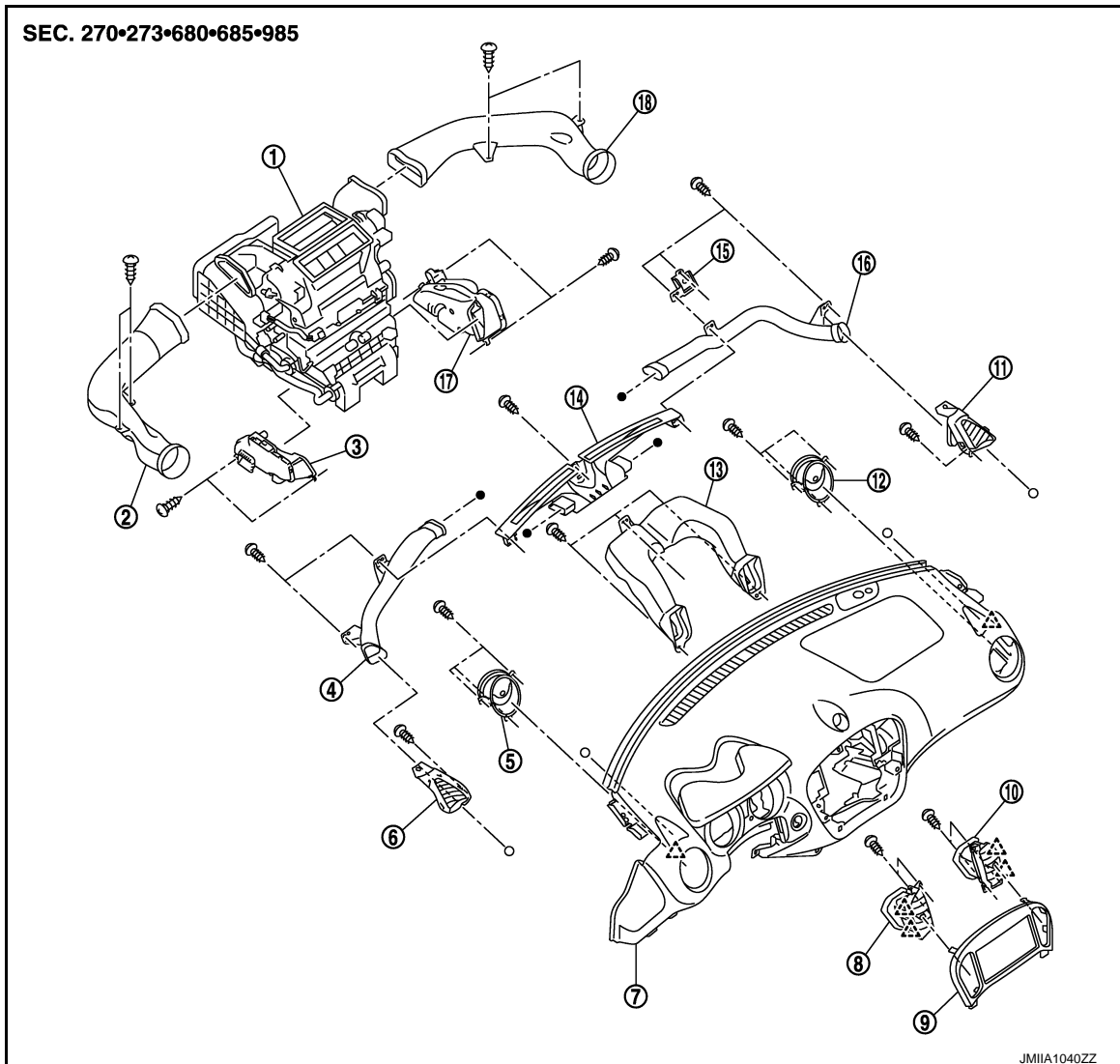

- | | | |
|---------------------------------|--------------------------------|-------------------------------|
| 1. A/C unit assembly | 2. Side ventilator duct LH | 3. Foot duct LH |
| 4. Side defroster nozzle LH | 5. Side ventilator grille LH | 6. Side defroster grille LH |
| 7. Instrument panel assembly | 8. Center ventilator grille LH | 9. Cluster lid C |
| 10. Center ventilator grille RH | 11. Side defroster grille RH | 12. Side ventilator grille RH |
| 13. Center ventilator duct | 14. Front defroster nozzle | 15. Instrument panel bracket |
| 16. Side defroster nozzle RH | 17. Foot duct RH | 18. Side ventilator duct RH |

△ : Pawl

●, ○ : Indicates that the part is connected at points with same symbol in actual vehicle

REAR

A
B
C
D
E
F
G
H
VTL
J
K
L
M
N
O
P

DUCT AND GRILLE

< REMOVAL AND INSTALLATION >

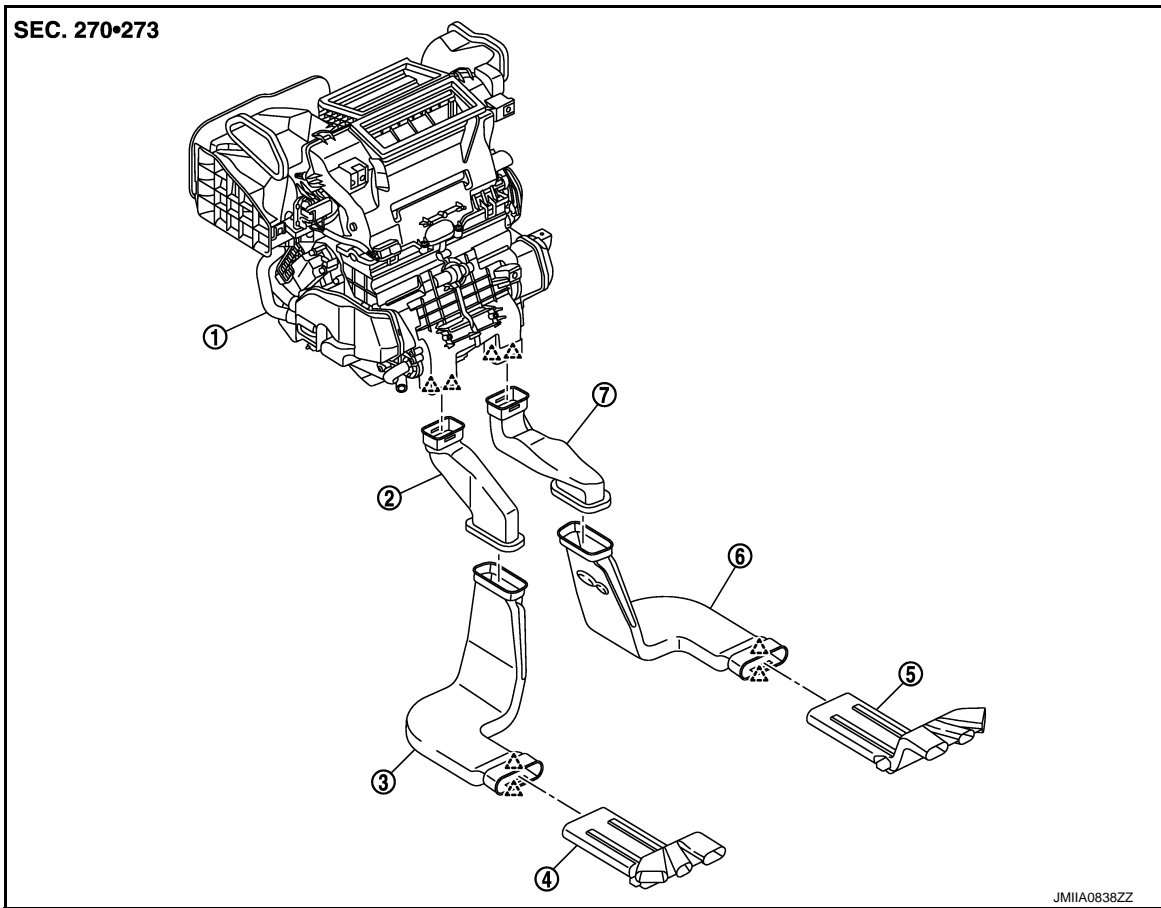

- | | | |
|---------------------------|---------------------------|---------------------------|
| 1. A/C unit assembly | 2. Rear heater duct 1 LH* | 3. Rear heater duct 2 LH* |
| 4. Rear heater duct 3 LH* | 5. Rear heater duct 1 RH* | 6. Rear heater duct 2 RH* |
| 7. Rear heater duct 3 RH* | | |

 : Pawl

*: Models for Canada only

CENTER VENTILATOR GRILLE

CENTER VENTILATOR GRILLE : Removal and Installation

INFOID:000000011460552

REMOVAL

1. Remove cluster lid C. Refer to [JP-13, "Removal and Installation"](#).
2. Remove fixing screws (A).

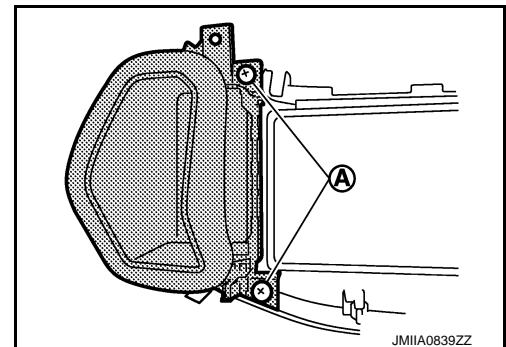

DUCT AND GRILLE

< REMOVAL AND INSTALLATION >

3. Disengage fixing pawls (A), and then remove center ventilator grille.

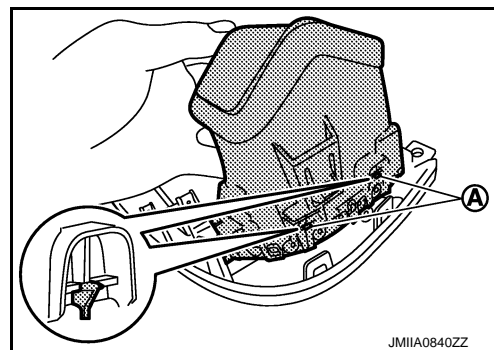

INSTALLATION

Install in the reverse order of removal.

SIDE DEFROSTER NOZZLE

SIDE DEFROSTER NOZZLE : Removal and Installation

INFOID:000000011460553

REMOVAL

Driver Side

1. Remove instrument panel assembly. Refer to [IP-13, "Removal and Installation"](#).
2. Remove fixing screws (A), and then remove side defroster nozzle.

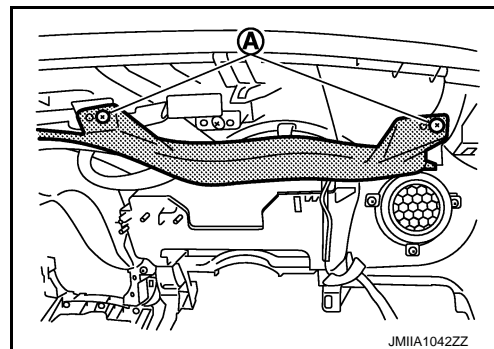

Passenger Side

1. Remove instrument panel assembly. Refer to [IP-13, "Removal and Installation"](#).
2. Remove fixing screws (A), and then remove instrument panel bracket (1).
3. Remove fixing screw (B), and then remove side defroster nozzle (2).

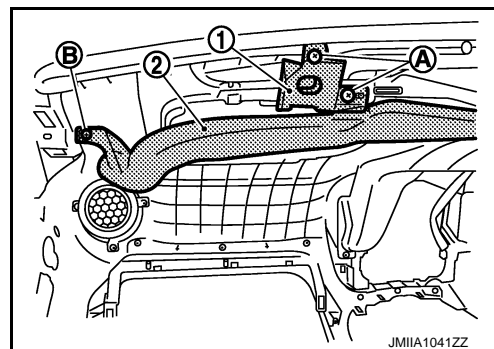

INSTALLATION

Install in the reverse order of removal.

SIDE VENTILATOR GRILLE

SIDE VENTILATOR GRILLE : Removal and Installation

INFOID:000000011460554

REMOVAL

1. Remove instrument panel assembly. Refer to [IP-13, "Removal and Installation"](#).

DUCT AND GRILLE

< REMOVAL AND INSTALLATION >

2. Remove fixing screws (A), and then remove side ventilator grille.

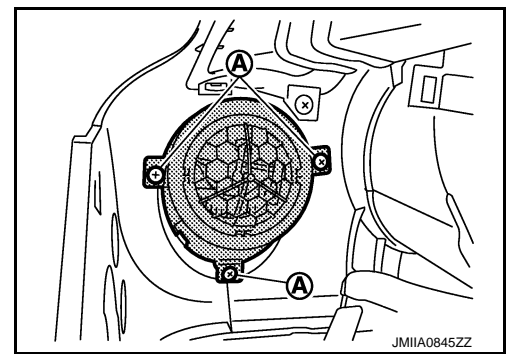

INSTALLATION

Install in the reverse order of removal.

SIDE DEFROSTER GRILLE

SIDE DEFROSTER GRILLE : Removal and Installation

INFOID:000000011460555

REMOVAL

1. Remove instrument panel assembly. Refer to [IP-13, "Removal and Installation"](#).
2. Remove side defroster nozzle. Refer to [VTL-9, "SIDE DEFROSTER NOZZLE : Removal and Installation"](#).
3. Remove fixing screw (A) and disengage fixing pawl (B), and then remove side defroster grille.

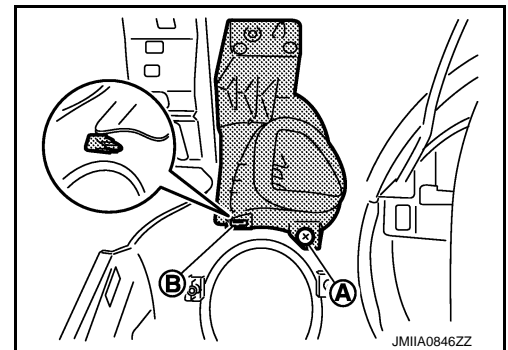

INSTALLATION

Install in the reverse order of removal.

FRONT DEFROSTER NOZZLE

FRONT DEFROSTER NOZZLE : Removal and Installation

INFOID:000000011460556

REMOVAL

1. Remove instrument panel assembly. Refer to [IP-13, "Removal and Installation"](#).
2. Remove side defroster nozzle. Refer to [VTL-9, "SIDE DEFROSTER NOZZLE : Removal and Installation"](#).
3. Remove fixing screw (A), and then remove front defroster nozzle.

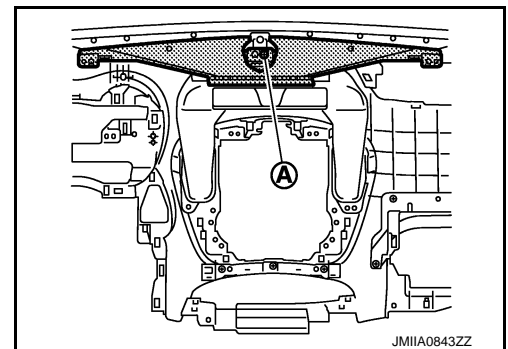

INSTALLATION

Install in the reverse order of removal.

CENTER VENTILATOR DUCT

DUCT AND GRILLE

< REMOVAL AND INSTALLATION >

CENTER VENTILATOR DUCT : Removal and Installation

INFOID:000000011460557

REMOVAL

1. Remove instrument panel assembly. Refer to [IP-13. "Removal and Installation"](#).
2. Remove side defroster nozzle LH and RH. Refer to [VTL-9. "SIDE DEFROSTER NOZZLE : Removal and Installation"](#).
3. Remove front defroster nozzle. Refer to [VTL-10. "FRONT DEFROSTER NOZZLE : Removal and Installation"](#).
4. Remove fixing screws (A), and then remove center ventilator duct.

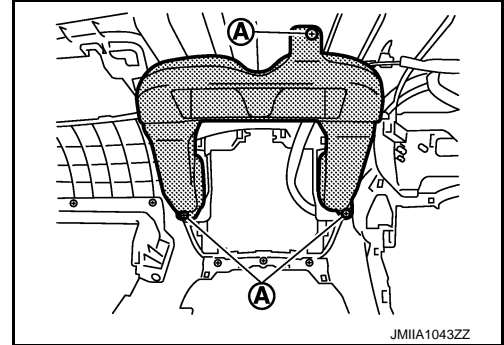

INSTALLATION

Install in the reverse order of removal.

SIDE VENTILATOR DUCT

SIDE VENTILATOR DUCT : Removal and Installation

INFOID:000000011460558

REMOVAL

1. Remove instrument panel assembly. Refer to [IP-13. "Removal and Installation"](#).
2. Remove fixing screws (A), and then remove side ventilator duct.

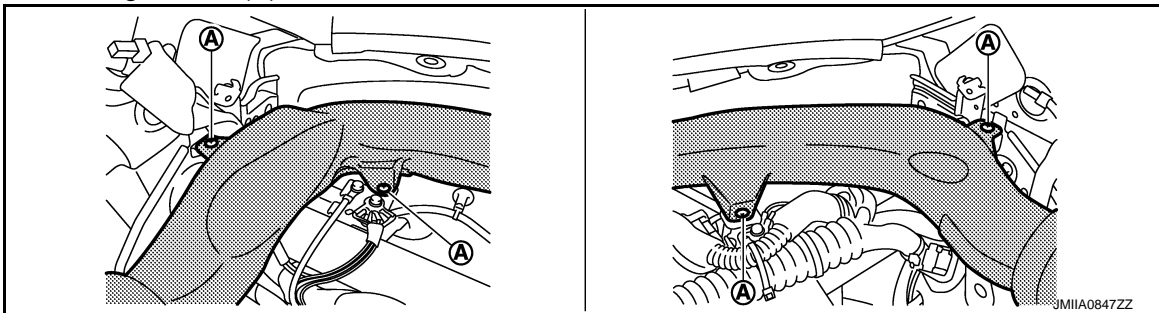

Driver side

Passenger side

INSTALLATION

Install in the reverse order of removal.

REAR HEATER DUCT 1

REAR HEATER DUCT 1 : Removal and Installation

INFOID:000000011460559

REMOVAL

1. Remove center console assembly. Refer to [IP-24. "Removal and Installation"](#).

A
B
C
D
E
F
G
H
VTL
J
K
L
M
N
O
P

DUCT AND GRILLE

< REMOVAL AND INSTALLATION >

2. Disengage fixing pawls, and then remove rear heater duct 1.
(Models for Canada only)

 : Pawl

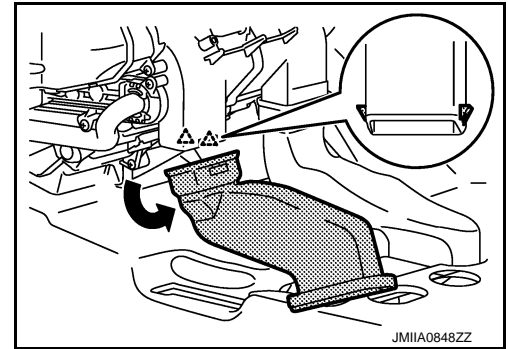

INSTALLATION

Install in the reverse order of removal.

REAR HEATER DUCT 2

REAR HEATER DUCT 2 : Removal and Installation

INFOID:000000011460560

REMOVAL

1. Remove center console assembly. Refer to [IP-24, "Removal and Installation"](#).
2. Remove front seat assembly. Refer to [SE-21, "Removal and Installation"](#).
3. Remove front kicking plate inner and rear kicking plate inner. Refer to [INT-19, "KICKING PLATE INNER : Removal and Installation"](#).
4. Remove center pillar lower garnish. Refer to [INT-22, "CENTER PILLAR LOWER GARNISH : Removal and Installation"](#).
5. Remove dash side finisher. Refer to [INT-21, "DASH SIDE FINISHER : Removal and Installation"](#).
6. Remove rear heater duct 2. (Models for Canada only)
 - Peel off floor carpet (1).
 - Remove rear heater duct 3 (2) from rear heater duct 2 (3).

 : Vehicle front

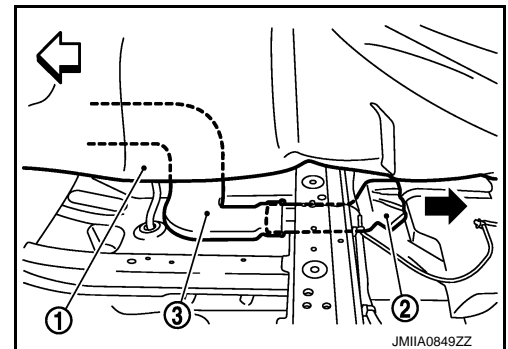

- Remove front floor spacer, and then remove rear heater duct 2 (2) from rear heater duct 1 (1).

 : Vehicle front

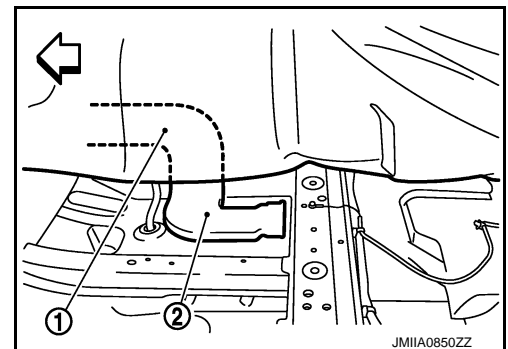

INSTALLATION

Install in the reverse order of removal.

REAR HEATER DUCT 3

REAR HEATER DUCT 3 : Removal and Installation

INFOID:000000011460561

REMOVAL

DUCT AND GRILLE

< REMOVAL AND INSTALLATION >

1. Remove center console assembly. Refer to [IP-24, "Removal and Installation"](#).
2. Remove front seat assembly. Refer to [SE-21, "Removal and Installation"](#).
3. Remove front kicking plate inner and rear kicking plate inner. Refer to [INT-19, "KICKING PLATE INNER : Removal and Installation"](#).
4. Remove center pillar lower garnish. Refer to [INT-22, "CENTER PILLAR LOWER GARNISH : Removal and Installation"](#).
5. Remove dash side finisher. Refer to [INT-21, "DASH SIDE FINISHER : Removal and Installation"](#).
6. Remove rear heater duct 3. (Models for Canada only)
 - Peel off floor carpet (1).
 - Remove rear floor spacer, and then remove rear heater duct 3 (2) from rear heater duct 2 (3).

↔ : Vehicle front

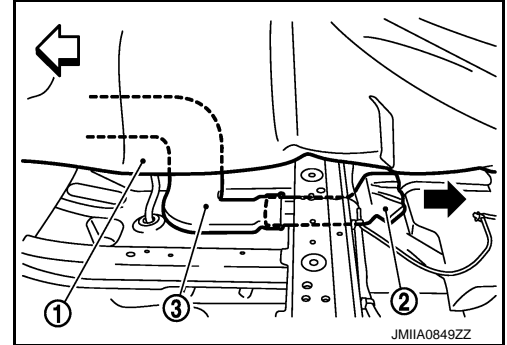

INSTALLATION

Install in the reverse order of removal.

FOOT DUCT

FOOT DUCT : Removal and Installation

INFOID:000000011460562

REMOVAL

Driver Side

1. Remove instrument lower panel LH. Refer to [IP-13, "Removal and Installation"](#).
2. Disconnect harness connector.
3. Remove harness connector fixing clamp.
4. Remove fixing screws, and then remove foot duct LH.

Passenger Side

1. Remove glove box assembly. Refer to [IP-13, "Removal and Installation"](#).
2. Remove fixing screws, and then remove foot duct RH.

INSTALLATION

Install in the reverse order of removal.

A
B
C
D
E
F
G
H
VTL
J
K
L
M
N
O
P

BLOWER MOTOR

< REMOVAL AND INSTALLATION >

BLOWER MOTOR

Exploded View

INFOID:000000011460563

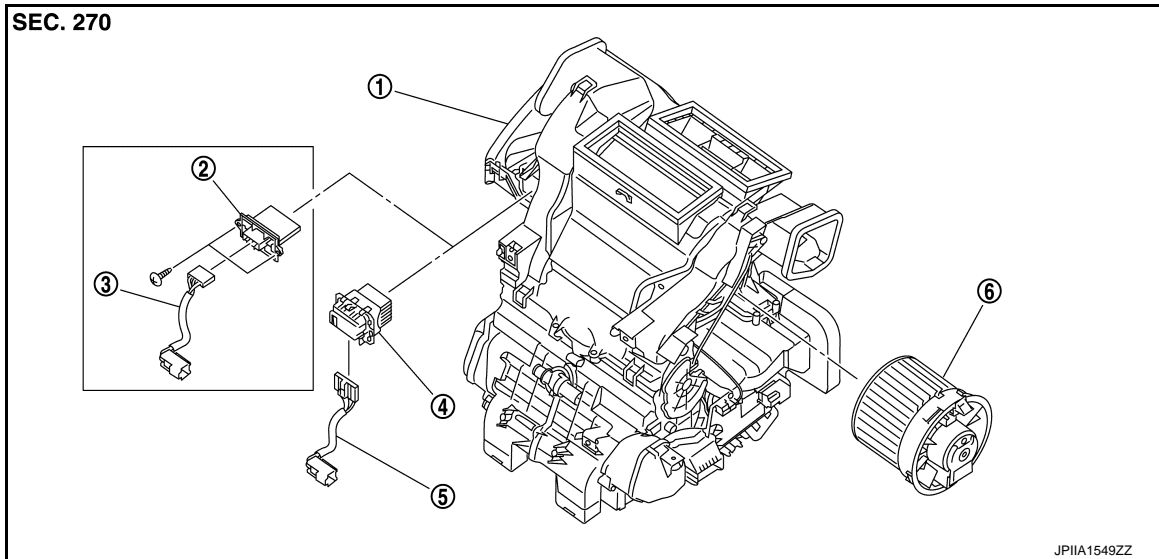

- | | | |
|-----------------------------------|--------------------------------------|------------------------------|
| 1. A/C unit assembly | 2. Blower fan resistor* ¹ | 3. Sub harness* ¹ |
| 4. Power transistor* ² | 5. Sub harness* ² | 6. Blower motor |

*1: Manual air conditioning

*2: Automatic air conditioning

Removal and Installation

INFOID:000000011460564

WARNING:

- Before servicing, turn ignition switch OFF, disconnect battery negative terminal and wait 3 minutes or more.
- Always work from the side of air bag module. Never work in front of it.
- Never use the air tools or the electric tools for servicing.

REMOVAL

1. Remove glove box assembly. Refer to [IP-13, "Removal and Installation"](#).
2. Disconnect blower motor harness connector (1) and front passenger air bag module harness connector (2).

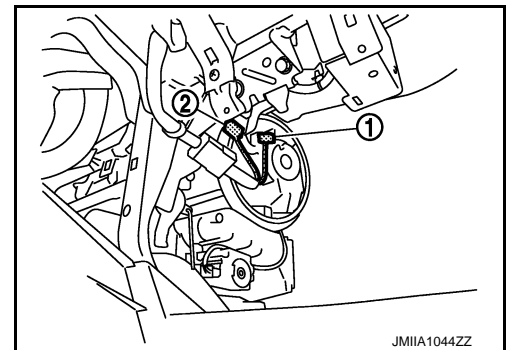

3. Remove front passenger air bag module. Refer to [SR-17, "Removal and Installation"](#).

BLOWER MOTOR

< REMOVAL AND INSTALLATION >

4. Press flange holding hook (A), and then turn blower motor (1) clockwise.

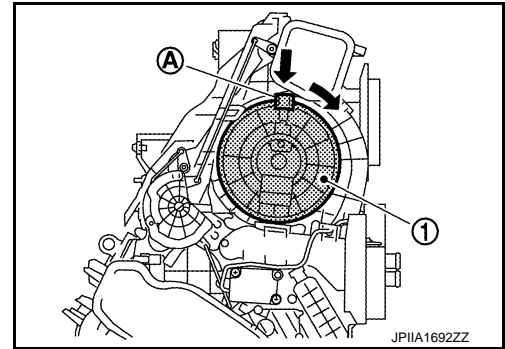

5. Pull outside, and then remove blower motor.

INSTALLATION

Note the following items, and then install in the reverse order of removal.

CAUTION:

- Never use the old mounting bolts after removal, replace with the new bolts.
- Never damage the harness while installing.
- If malfunction is detected by the air bag warning lamp, after repair or replacement of the malfunctioning parts, reset the memory using self-diagnosis or CONSULT. Refer to [SRC-10, "On Board Diagnosis Function"](#) or [SRC-15, "CONSULT Function"](#).
- After the work is completed, check that no system malfunction is detected by air bag warning lamp.

A
B
C
D
E
F
G
H
J
K
L
M
N
O
P

VTL

IN-CABIN MICROFILTER

< REMOVAL AND INSTALLATION >

IN-CABIN MICROFILTER

Exploded View

INFOID:000000011460565

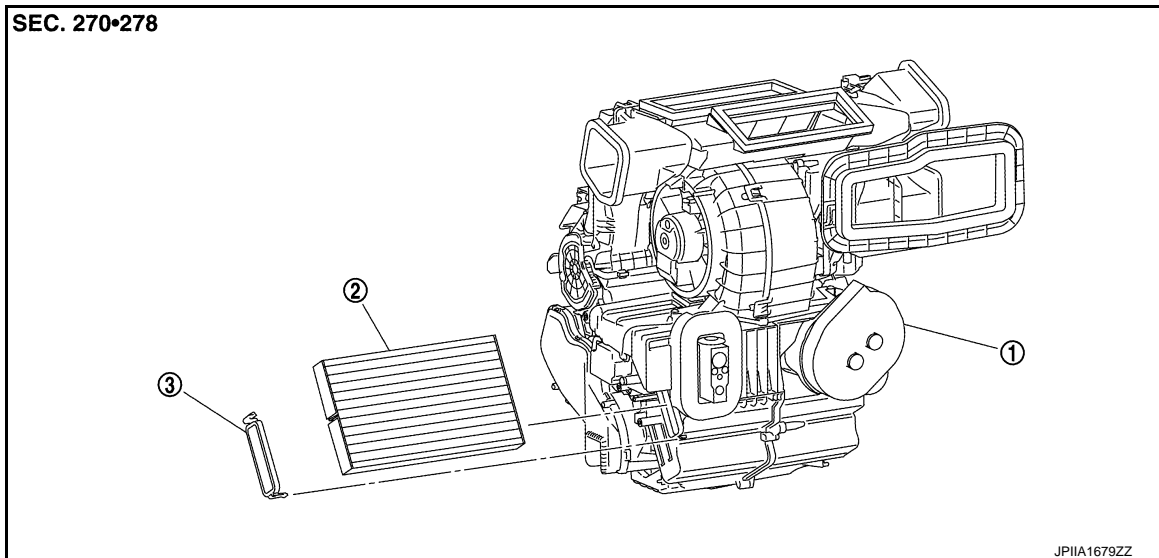

1. A/C unit assembly

2. In-cabin microfilter

3. Filter cover

Removal and Installation

INFOID:000000011460566

REMOVAL

1. Remove glove box assembly. Refer to [IP-13. "Removal and Installation"](#).
2. Remove filter cover (1), and then remove in-cabin microfilter (2).

CAUTION:

If the filter is deformed/damaged when removing, replace it with a new one. Deformed/damaged filter may deteriorate the dust collecting performance.

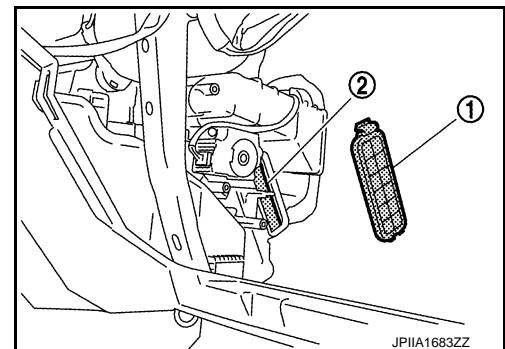

INSTALLATION

Note the following item, and then install in the reverse order of removal.

CAUTION:

When installing, handle the filter with extreme care to avoid deforming/damaging.

Replacement

INFOID:000000011460567

Replace In-cabin microfilter.

Refer to [VTL-17. "In-cabin microfilter"](#).

SERVICE DATA AND SPECIFICATIONS (SDS)

< SERVICE DATA AND SPECIFICATIONS (SDS)

SERVICE DATA AND SPECIFICATIONS (SDS)

SERVICE DATA AND SPECIFICATIONS (SDS)

In-cabin microfilter

INFOID:000000011460568

Replacement interval	MA-7. "Introduction of Periodic Maintenance"
----------------------	--

- A
- B
- C
- D
- E
- F
- G
- H
- VTL
- J
- K
- L
- M
- N
- O
- P