

A

ACC

C

SECTION ACC

ACCELERATOR CONTROL SYSTEM

CONTENTS

D

E

PRECAUTION 2	REMOVAL AND INSTALLATION 4	F
PRECAUTIONS 2	ACCELERATOR CONTROL SYSTEM 4	
Precautions for Removing Battery Terminal2	Exploded View 4	G
Precaution for Supplemental Restraint System (SRS) "AIR BAG" and "SEAT BELT PRE-TENSIONER"2	Removal and Installation 4	H
	Inspection 5	I

J

K

L

M

N

O

P

PRECAUTIONS

< PRECAUTION >

PRECAUTION

PRECAUTIONS

Precautions for Removing Battery Terminal

INFOID:000000012959279

When disconnecting the battery terminal, pay attention to the following.

- Always use a 12V battery as power source.
- Never disconnect battery terminal while engine is running.
- When removing the 12V battery terminal, turn OFF the ignition switch and wait at least 30 seconds.
- For vehicles with the engine listed below, remove the battery terminal after a lapse of the specified time:

D4D engine	: 20 minutes	YS23DDT	: 4 minutes
HRA2DDT	: 12 minutes	YS23DDTT	: 4 minutes
K9K engine	: 4 minutes	ZD30DDTi	: 60 seconds
M9R engine	: 4 minutes	ZD30DDTT	: 60 seconds
R9M engine	: 4 minutes		
V9X engine	: 4 minutes		
YD25DDTi	: 2 minutes		

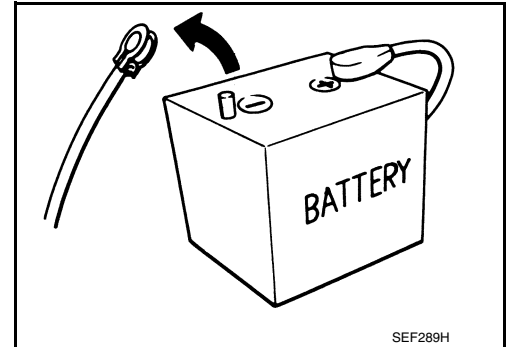

NOTE:

ECU may be active for several tens of seconds after the ignition switch is turned OFF. If the battery terminal is removed before ECU stops, then a DTC detection error or ECU data corruption may occur.

- After high-load driving, if the vehicle is equipped with the V9X engine, turn the ignition switch OFF and wait for at least 15 minutes to remove the battery terminal.

NOTE:

- Turbocharger cooling pump may operate in a few minutes after the ignition switch is turned OFF.
- Example of high-load driving
 - Driving for 30 minutes or more at 140 km/h (86 MPH) or more.
 - Driving for 30 minutes or more on a steep slope.
- For vehicles with the 2-batteries, be sure to connect the main battery and the sub battery before turning ON the ignition switch.

NOTE:

If the ignition switch is turned ON with any one of the terminals of main battery and sub battery disconnected, then DTC may be detected.

- After installing the 12V battery, always check "Self Diagnosis Result" of all ECUs and erase DTC.

NOTE:

The removal of 12V battery may cause a DTC detection error.

Precaution for Supplemental Restraint System (SRS) "AIR BAG" and "SEAT BELT PRE-TENSIONER"

INFOID:000000012199342

The Supplemental Restraint System such as "AIR BAG" and "SEAT BELT PRE-TENSIONER", used along with a front seat belt, helps to reduce the risk or severity of injury to the driver and front passenger for certain types of collision. This system includes seat belt switch inputs and dual stage front air bag modules. The SRS system uses the seat belt switches to determine the front air bag deployment, and may only deploy one front air bag, depending on the severity of a collision and whether the front occupants are belted or unbelted.

Information necessary to service the system safely is included in the "SRS AIR BAG" and "SEAT BELT" of this Service Manual.

WARNING:

Always observe the following items for preventing accidental activation.

- To avoid rendering the SRS inoperative, which could increase the risk of personal injury or death in the event of a collision that would result in air bag inflation, it is recommended that all maintenance and repair be performed by an authorized NISSAN/INFINITI dealer.
- Improper repair, including incorrect removal and installation of the SRS, can lead to personal injury caused by unintentional activation of the system. For removal of Spiral Cable and Air Bag Module, see "SRS AIR BAG".

PRECAUTIONS

< PRECAUTION >

- Never use electrical test equipment on any circuit related to the SRS unless instructed to in this Service Manual. SRS wiring harnesses can be identified by yellow and/or orange harnesses or harness connectors.

A

PRECAUTIONS WHEN USING POWER TOOLS (AIR OR ELECTRIC) AND HAMMERS

WARNING:

Always observe the following items for preventing accidental activation.

- When working near the Air Bag Diagnosis Sensor Unit or other Air Bag System sensors with the ignition ON or engine running, never use air or electric power tools or strike near the sensor(s) with a hammer. Heavy vibration could activate the sensor(s) and deploy the air bag(s), possibly causing serious injury.
- When using air or electric power tools or hammers, always switch the ignition OFF, disconnect the battery or batteries, and wait at least 3 minutes before performing any service.

ACC

C

D

E

F

G

H

I

J

K

L

M

N

O

P

ACCELERATOR CONTROL SYSTEM

< REMOVAL AND INSTALLATION >

REMOVAL AND INSTALLATION

ACCELERATOR CONTROL SYSTEM

Exploded View

INFOID:000000012199343

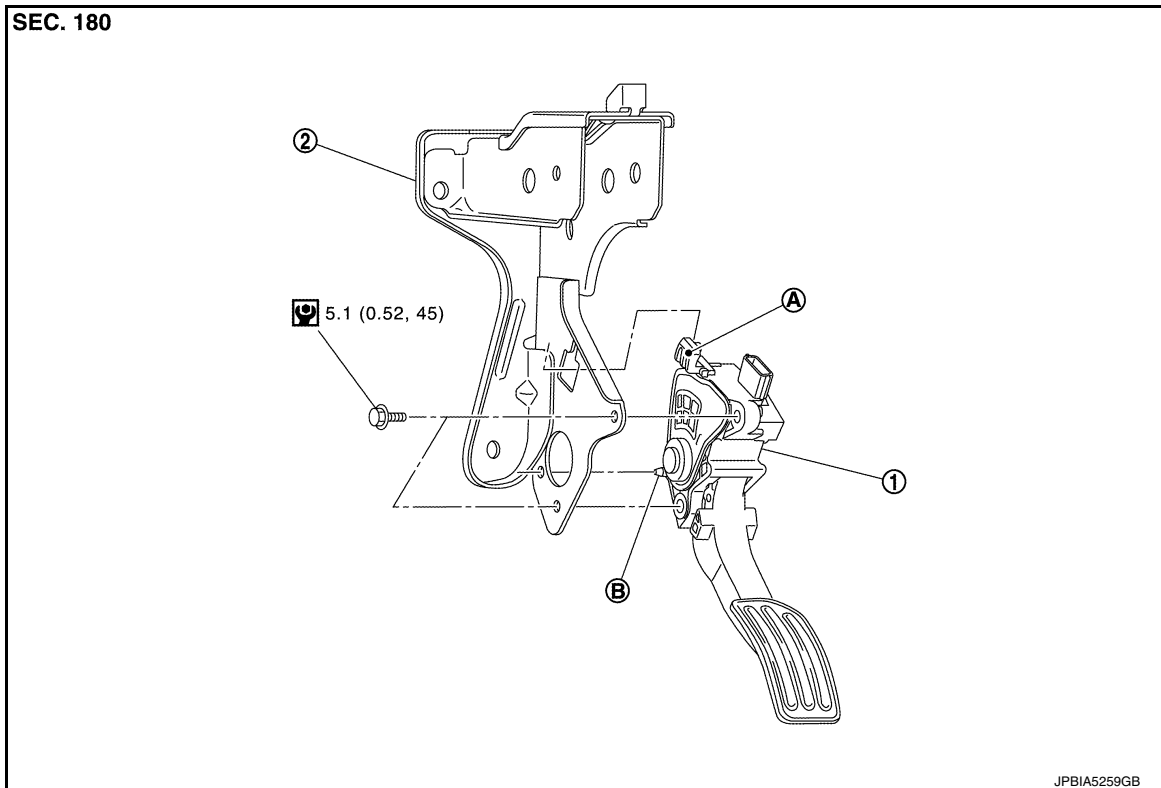

1. Accelerator pedal assembly 2. Brake pedal bracket
A. Locating hook B. Locating pin

: N·m (kg-m, in-lb)

Removal and Installation

INFOID:000000012199344

REMOVAL

1. Remove instrumentpanel lower cover driver side.
2. Disconnect accelerator pedal position sensor harness connector.
3. Loosen mounting bolts, and remove accelerator pedal assembly.

CAUTION:

- Never disassemble accelerator pedal assembly. Never remove accelerator pedal position sensor from accelerator pedal assembly.
- Avoid impact from dropping etc. during handling.
- Be careful to keep accelerator pedal assembly away from water.

INSTALLATION

Note the following, and install in the reverse order of removal.

- Insert the locating pin while inserting the locating hook in to the brake pedal bracket. Tighten mounting bolts to accelerator pedal assembly.

CAUTION:

Never squeeze the locating hook into the brake pedal bracket when inserting the locating pin into the hole on the brake pedal bracket side.

ACCELERATOR CONTROL SYSTEM

< REMOVAL AND INSTALLATION >

Inspection

INFOID:000000012199345

A

INSPECTION AFTER INSTALLATION

- Check accelerator pedal moves smoothly within the whole operation range when it is fully depressed and released.
- Check accelerator pedal securely returns to the fully released position.
- For the electrical inspection of accelerator pedal position sensor. Refer to [EC-518, "Component Inspection"](#), [EC-522, "Component Inspection"](#) and [EC-528, "Component Inspection"](#).

ACC

CAUTION:

When harness connector of accelerator pedal position sensor is disconnected, perform "ACCELERATOR PEDAL RELEASED POSITION LEARNING". Refer to following. Refer to [EC-160, "Work Procedure"](#).

C

D

E

F

G

H

I

J

K

L

M

N

O

P