

SECTION **CL**
CLUTCH

A
B
C

CL

CONTENTS

E

PRECAUTION	2	Removal and Installation	11	F
PRECAUTIONS	2	Inspection and Adjustment	12	
Precaution for Supplemental Restraint System (SRS) "AIR BAG" and "SEAT BELT PRE-TENSIONER"	2	CLUTCH MASTER CYLINDER	13	G
Precaution for Procedure without Cowl Top Cover.....	2	Exploded View	13	
Precautions for Removing Battery Terminal	2	Removal and Installation	13	
Service Notice or Precautions for Clutch	3	Inspection and Adjustment	14	H
PREPARATION	4	CLUTCH PIPING	15	
PREPARATION	4	Exploded View	15	I
Special Service Tools	4	Hydraulic Layout	15	
Commercial Service Tools	4	Removal and Installation	15	
SYMPTOM DIAGNOSIS	5	Inspection and Adjustment	16	J
NOISE, VIBRATION AND HARSHNESS (NVH) TROUBLESHOOTING	5	UNIT REMOVAL AND INSTALLATION	17	
NVH Troubleshooting Chart	5	CSC (CONCENTRIC SLAVE CYLINDER)	17	K
PERIODIC MAINTENANCE	6	Exploded View	17	
CLUTCH PEDAL	6	Removal and Installation	17	
Inspection and Adjustment	6	Inspection and Adjustment	17	
CLUTCH FLUID	8	CLUTCH DISC AND CLUTCH COVER	18	L
Inspection	8	Exploded View	18	
Draining	8	Removal and Installation	18	
Refilling	9	Inspection	19	M
Air Bleeding	10	SERVICE DATA AND SPECIFICATIONS (SDS)	21	N
REMOVAL AND INSTALLATION	11	SERVICE DATA AND SPECIFICATIONS (SDS)	21	
CLUTCH PEDAL	11	General Specifications	21	O
Exploded View	11	Clutch Pedal	21	
		Clutch Disc	21	
		Clutch Cover	21	P

PRECAUTIONS

< PRECAUTION >

PRECAUTION

PRECAUTIONS

Precaution for Supplemental Restraint System (SRS) "AIR BAG" and "SEAT BELT PRE-TENSIONER"

INFOID:000000012199536

The Supplemental Restraint System such as "AIR BAG" and "SEAT BELT PRE-TENSIONER", used along with a front seat belt, helps to reduce the risk or severity of injury to the driver and front passenger for certain types of collision. This system includes seat belt switch inputs and dual stage front air bag modules. The SRS system uses the seat belt switches to determine the front air bag deployment, and may only deploy one front air bag, depending on the severity of a collision and whether the front occupants are belted or unbelted. Information necessary to service the system safely is included in the "SRS AIR BAG" and "SEAT BELT" of this Service Manual.

WARNING:

Always observe the following items for preventing accidental activation.

- To avoid rendering the SRS inoperative, which could increase the risk of personal injury or death in the event of a collision that would result in air bag inflation, it is recommended that all maintenance and repair be performed by an authorized NISSAN/INFINITI dealer.
- Improper repair, including incorrect removal and installation of the SRS, can lead to personal injury caused by unintentional activation of the system. For removal of Spiral Cable and Air Bag Module, see "SRS AIR BAG".
- Never use electrical test equipment on any circuit related to the SRS unless instructed to in this Service Manual. SRS wiring harnesses can be identified by yellow and/or orange harnesses or harness connectors.

PRECAUTIONS WHEN USING POWER TOOLS (AIR OR ELECTRIC) AND HAMMERS

WARNING:

Always observe the following items for preventing accidental activation.

- When working near the Air Bag Diagnosis Sensor Unit or other Air Bag System sensors with the ignition ON or engine running, never use air or electric power tools or strike near the sensor(s) with a hammer. Heavy vibration could activate the sensor(s) and deploy the air bag(s), possibly causing serious injury.
- When using air or electric power tools or hammers, always switch the ignition OFF, disconnect the battery or batteries, and wait at least 3 minutes before performing any service.

Precaution for Procedure without Cowl Top Cover

INFOID:000000012199537

When performing the procedure after removing cowl top cover, cover the lower end of windshield with urethane, etc to prevent damage to windshield.

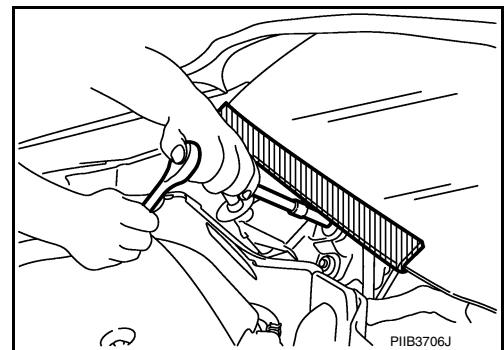

Precautions for Removing Battery Terminal

INFOID:000000012971758

When disconnecting the battery terminal, pay attention to the following.

- Always use a 12V battery as power source.
- Never disconnect battery terminal while engine is running.

PRECAUTIONS

< PRECAUTION >

- When removing the 12V battery terminal, turn OFF the ignition switch and wait at least 30 seconds.
- For vehicles with the engine listed below, remove the battery terminal after a lapse of the specified time:

D4D engine	: 20 minutes	YS23DDT	: 4 minutes
HRA2DDT	: 12 minutes	YS23DDTT	: 4 minutes
K9K engine	: 4 minutes	ZD30DDTi	: 60 seconds
M9R engine	: 4 minutes	ZD30DDTT	: 60 seconds
R9M engine	: 4 minutes		
V9X engine	: 4 minutes		
YD25DDTi	: 2 minutes		

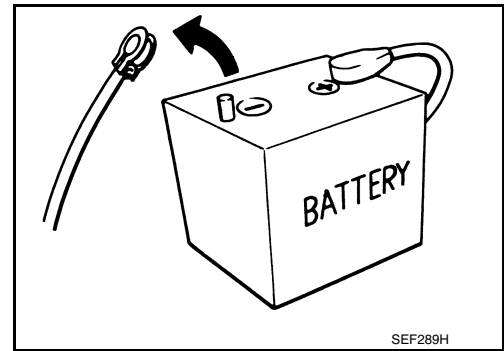

A
B
C
CL

NOTE:

ECU may be active for several tens of seconds after the ignition switch is turned OFF. If the battery terminal is removed before ECU stops, then a DTC detection error or ECU data corruption may occur.

- After high-load driving, if the vehicle is equipped with the V9X engine, turn the ignition switch OFF and wait for at least 15 minutes to remove the battery terminal.

NOTE:

- Turbocharger cooling pump may operate in a few minutes after the ignition switch is turned OFF.
- Example of high-load driving
 - Driving for 30 minutes or more at 140 km/h (86 MPH) or more.
 - Driving for 30 minutes or more on a steep slope.
- For vehicles with the 2-batteries, be sure to connect the main battery and the sub battery before turning ON the ignition switch.

NOTE:

If the ignition switch is turned ON with any one of the terminals of main battery and sub battery disconnected, then DTC may be detected.

- After installing the 12V battery, always check "Self Diagnosis Result" of all ECUs and erase DTC.

NOTE:

The removal of 12V battery may cause a DTC detection error.

Service Notice or Precautions for Clutch

INFOID:000000012199539

WARNING:

After cleaning clutch disc, wipe it with a dust collector. Never use compressed air.

CAUTION:

- Clutch fluid use refer to [MA-11, "Fluids and Lubricants"](#).
- Never reuse drained clutch fluid.
- Keep painted surface on the body or other parts free of clutch fluid. If it spills, wipe up immediately and wash the affected area with water.
- Never use mineral oils such as gasoline or kerosene. It will ruin the rubber parts of the hydraulic system.
- Never reuse CSC (Concentric Slave Cylinder). Because CSC slides back to the original position every time when removing transaxle assembly. At this timing, dust on the sliding parts may damage a seal of CSC and may cause clutch fluid leakage. Refer to [CL-17, "Removal and Installation"](#).
- Never disassemble clutch master cylinder and CSC.

E
F
G
H
I
J
K
L
M
N
O
P

PREPARATION

< PREPARATION >

PREPARATION

PREPARATION

Special Service Tools

INFOID:000000012199540

The actual shapes of TechMate tools may differ from those of special service tools illustrated here.

Tool number (TechMate No.) Tool name	Description
ST20050240 (—) Diaphragm adjusting wrench  ZZA0508D	Adjusting unevenness of diaphragm spring lever

Commercial Service Tools

INFOID:000000012199541

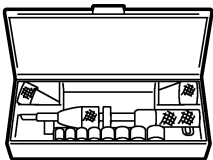
Tool name	Description
Clutch aligner  MCIB0404E	Installing clutch disc

NOISE, VIBRATION AND HARSHNESS (NVH) TROUBLESHOOTING

< SYMPTOM DIAGNOSIS >

SYMPTOM DIAGNOSIS

NOISE, VIBRATION AND HARSHNESS (NVH) TROUBLESHOOTING

NVH Troubleshooting Chart

INFOID:0000000012199542

Use the chart below to find the cause of the symptom. The numbers indicate the order of the inspection. If necessary, repair or replace these parts.

SYMPTOM		SUSPECTED PARTS (Possible cause)																
		CLUTCH PEDAL (Inspection and adjustment)	CLUTCH LINE (Air in line)	ENGINE MOUNTING (Loose)	CSC (Concentric Slave Cylinder) (Worn, dirty or damaged)	CLUTCH DISC (Out of true)	CLUTCH DISC (Runout is excessive)	CLUTCH DISC (Lining broken)	CLUTCH DISC (Dirty or burned)	CLUTCH DISC (Oily)	CLUTCH DISC (Worn out)	CLUTCH DISC (Hardened)	CLUTCH DISC (Lack of spline grease)	DIAPHRAGM SPRING (Damaged)	DIAPHRAGM SPRING (Out of tip alignment)	PRESSURE PLATE (Distortion)	FLYWHEEL (Distortion)	
Symptom	Clutch grabs/chatters			1				2				2	2	2			2	
	Clutch pedal spongy		1		2													
	Clutch noisy				1													
	Clutch slips	1								2	2			3		4	5	
	Clutch does not disengage	1	2		3	3	3	3	3	3			3	4	4	5		
Reference		CL-6	CL-10	EM-216 (Except for NISMO RS), EM-62 (For NISMO RS)	CL-17							CL-18					EM-227 (Except for NISMO RS), EM-123 (For NISMO RS)	

A
B
C
CL
E
F
G
H
I
J
K
L
M
N
O
P

CLUTCH PEDAL

< PERIODIC MAINTENANCE >

PERIODIC MAINTENANCE

CLUTCH PEDAL

Inspection and Adjustment

INFOID:000000012199543

INSPECTION

The Height of Clutch Pedal

1. Turn the floor carpet.
2. Check that the clutch pedal height "H₁" from the dash lower panel (1) is within the reference value.

Clutch pedal height "H₁" : Refer to [CL-21, "Clutch Pedal"](#).

3. Replace clutch pedal if the height is outside the reference value.

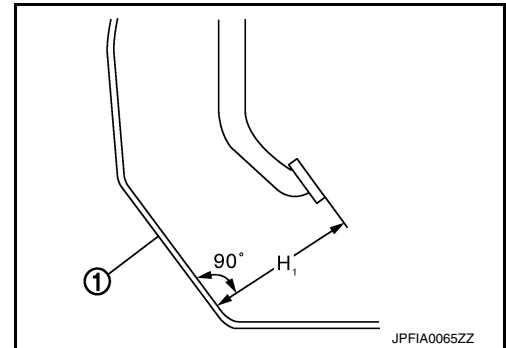

Clutch Pedal Height When Disengaging The Clutch

1. Securely engage the parking brake.
2. Turn the floor carpet.
3. Start the engine and run at idle.
4. Fully depress clutch pedal and shift to the 1st gear.

CAUTION:

Securely depress the brake pedal with shifter lever in 1st gear.

5. Gradually release the clutch pedal and check that the clutch pedal height "H₂" from the dash lower panel (1) is within the reference value with a scale immediately before the clutch is engaged.

Clutch pedal height at clutch disengagement "H₂" : Refer to [CL-21, "Clutch Pedal"](#).

NOTE:

Although the clutch pedal height differs according to whether the clutch gets disengaged or engaged, clutch-engaged case is regarded as clutch-disengaged case for easier inspection.

6. Replace clutch pedal if the height is outside the reference value.

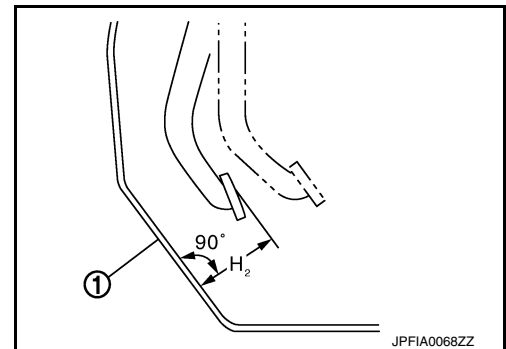

Clutch Pedal Play

1. Push the pedal pad by hand until a resistance can be felt and check that the play "A" on the upper surface of the pedal pad is within the reference value.

Clutch pedal play "A" : Refer to [CL-21, "Clutch Pedal"](#).

2. Replace clutch pedal if the play is outside the reference value.

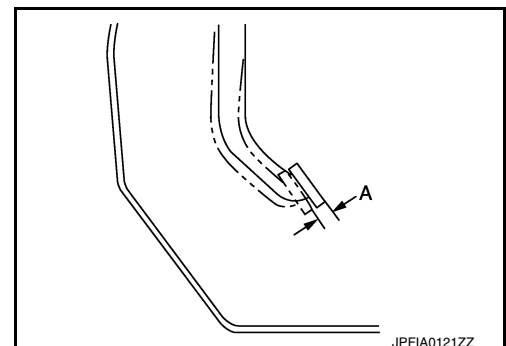

Position of Clutch Interlock Switch

CLUTCH PEDAL

< PERIODIC MAINTENANCE >

Check that the clearance "C" between the thread end of clutch interlock switch (1) and stopper rubber (2) is within the specified value while clutch pedal is fully depressed.

Clearance "C" : Refer to [CL-21, "Clutch Pedal"](#).

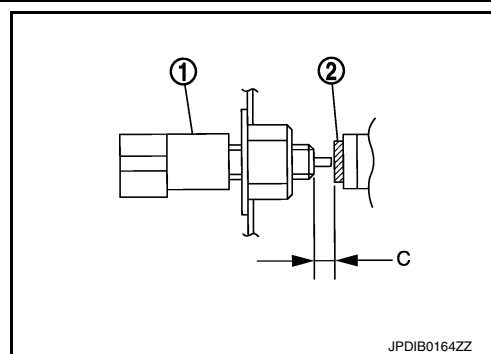

Position of Clutch Pedal Position Switch

Check that the clearance "A" between the thread end of clutch pedal position switch (1) and clutch pedal (2) is within the specified value while clutch pedal is fully released.

Clearance "A" : Refer to [CL-21, "Clutch Pedal"](#).

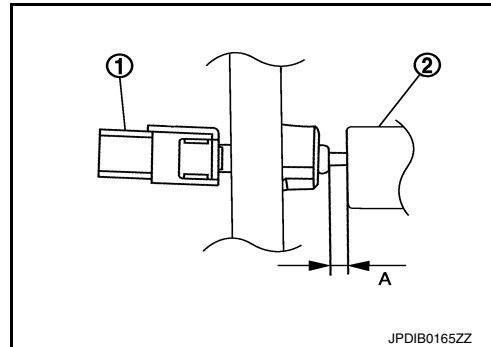

ADJUSTMENT

Position of Clutch Interlock Switch

1. Disconnect the clutch interlock switch connector.
2. Loosen the clutch interlock switch 45 degrees counterclockwise.
3. With the clutch pedal fully depressed, press into the clutch interlock switch (1) until it reaches the stopper rubber (2) and turn the switch clockwise by 45 degrees to secure it.

CAUTION:

The clearance "C" show in the figure must be within the specified value.

Clearance "C" : Refer to [CL-21, "Clutch Pedal"](#).

NOTE:

Fully depressed clutch pedal means a clutch pedal condition that the clutch pedal lever contacts the pedal stopper rubber.

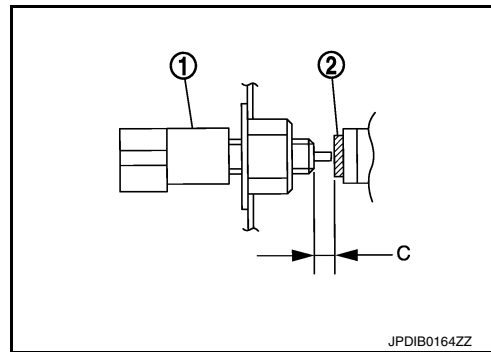

Position of Clutch Pedal Position Switch

1. Disconnect the clutch pedal position switch connector.
2. Loosen the clutch pedal position switch 45 degrees counterclockwise.
3. Press-fit the clutch pedal position switch (1) until the clutch pedal position switch hits the clutch pedal (2) 45 degrees clockwise while pulling the pedal pad slightly.

CAUTION:

The clearance "A" show in the figure must be within the specified value.

Clearance "A" : Refer to [CL-21, "Clutch Pedal"](#).

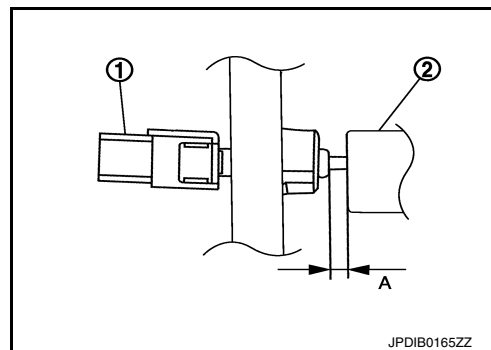

CLUTCH FLUID

< PERIODIC MAINTENANCE >

CLUTCH FLUID

Inspection

INFOID:000000012199544

FLUID LEAKAGE

- Check clutch line for cracks, deterioration or other damage. Replace any damaged parts.
- Check for fluid leakage by fully depressing clutch pedal while engine is running.

CAUTION:

If leakage occurs around joints, reinstall the joints or, if necessary, replace damaged parts.

FLUID LEVEL

- Check that the fluid level in the reservoir tank is within the specified range (MAX – MIN lines).
- Visually check for any clutch fluid leakage around the reservoir tank.
- Check the clutch system for any leakage if the fluid level is extremely low (lower than MIN).

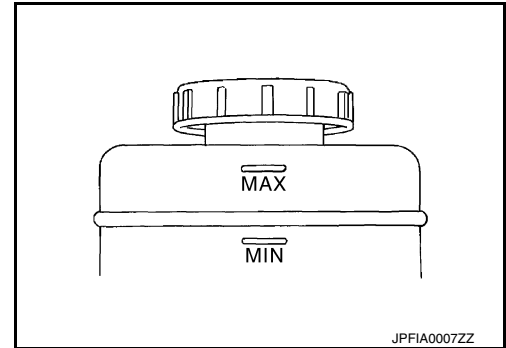

Draining

INFOID:000000012199545

CAUTION:

Keep painted surface on the body or other parts free of clutch fluid. If it spills, wipe up immediately and wash the affected area with water.

1. Connect a transparent vinyl hose to air bleeder of bleeding connector (1).

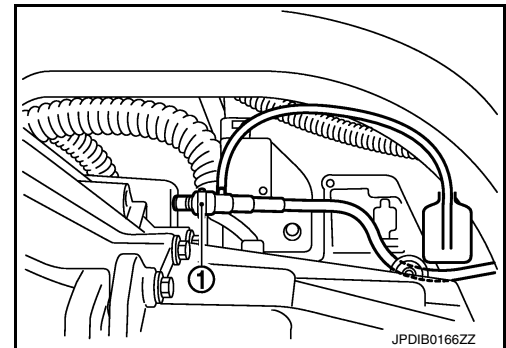

2. Press the lock pin (1) into the bleeding connector (2), and maintain the position.

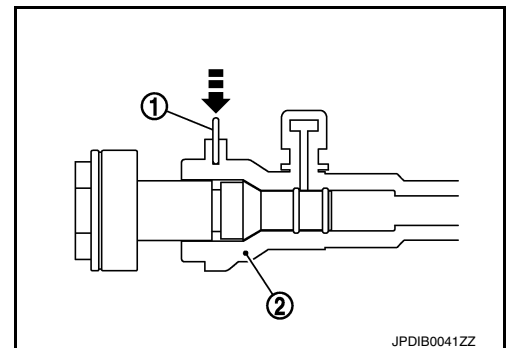

CLUTCH FLUID

< PERIODIC MAINTENANCE >

- Slide bleeding connector (1) in the direction of the arrow as shown in the figure.

2 : Clutch housing

Dimension "A" : 10 mm (0.39 in)

- Depress clutch pedal to gradually discharge clutch fluid.

CAUTION:

Since the inside of clutch tube is under hydraulic pressure, hold the tube to prevent it from getting disconnected.

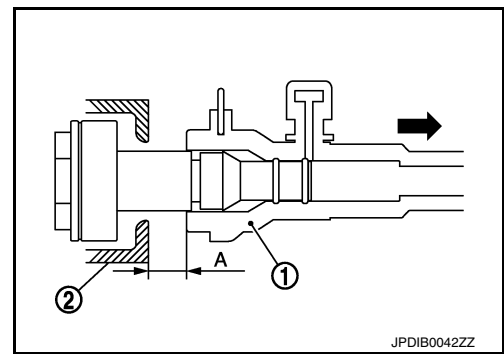

INFOID:000000012199546

Refilling

CAUTION:

Keep painted surface on the body or other parts free of clutch fluid. If it spills, wipe up immediately and wash the affected area with water.

- Check that there is no foreign material in reservoir tank, and then fill with new clutch fluid.

CAUTION:

Never reuse drained clutch fluid.

- Connect a transparent vinyl hose to air bleeder of bleeding connector (1).

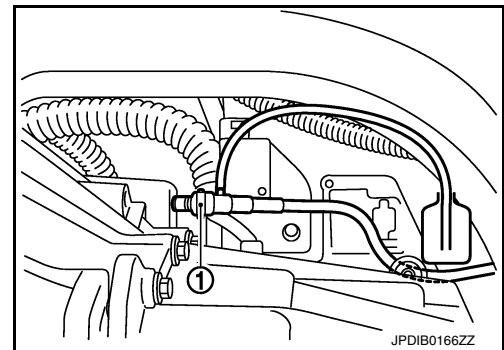

- Press the lock pin (1) into the bleeding connector (2), and maintain the position.

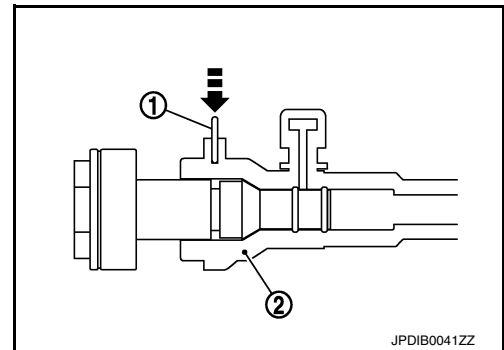

- Slide bleeding connector (1) in the direction of the arrow as shown in the figure.

2 : Clutch housing

Dimension "A" : 10 mm (0.39 in)

- Slowly depress clutch pedal to the full stroke position, and then release the pedal.

CAUTION:

Since the inside of clutch tube is under hydraulic pressure, hold the tube to prevent it from getting disconnected.

- Repeat step 5 at intervals of 2 or 3 seconds until new clutch fluid is discharged.

CAUTION:

Monitor clutch fluid level in reservoir tank so as not to empty the tank.

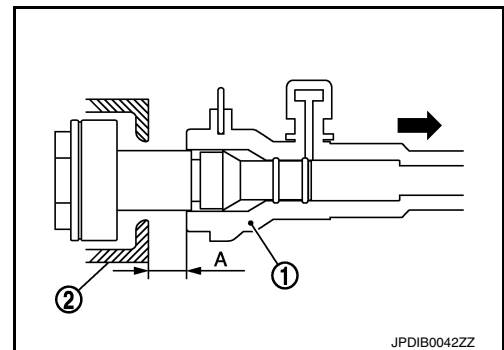

CLUTCH FLUID

< PERIODIC MAINTENANCE >

- Return clutch tube and lock pin in their original positions while clutch pedal is depressed.
- Perform the air bleeding. Refer to [CL-10, "Air Bleeding"](#).

Air Bleeding

INFOID:000000012199547

CAUTION:

- Monitor clutch fluid level in reservoir tank so as not to empty the tank.
- Keep painted surface on the body or other parts free of clutch fluid. If it spills, wipe up immediately and wash the affected area with water.

NOTE:

Do not use a vacuum assist or any other type of power bleeder on this system. Use of a vacuum assist or power bleeder will not purge all the air from the system.

- Fill reservoir tank with new clutch fluid.

CAUTION:

Never reuse drained clutch fluid.

- Connect a transparent vinyl hose to air bleeder of bleeding connector (1).
- "Depress" and "release" the clutch pedal slowly and fully 15 times at an interval of 2 to 3 seconds and release the clutch pedal.

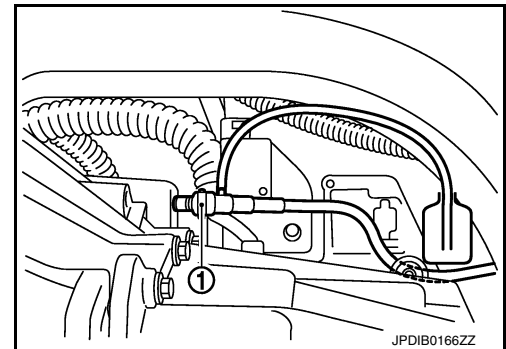

- Press the lock pin (1) into the bleeding connector (2), and maintain the position.

CAUTION:

Since the inside of clutch tube is under hydraulic pressure, hold the tube to prevent it from getting disconnected.

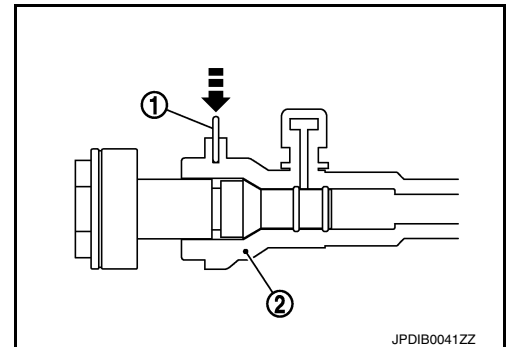

- Slide bleeding connector (1) in the direction of the arrow as shown in the figure.

2 : Clutch housing

Dimension "A" : 10 mm (0.39 in)

- Depress the clutch pedal soon and hold it, and then bleed the air from the piping.

CAUTION:

Since the inside of clutch tube is under hydraulic pressure, hold the tube to prevent it from getting disconnected.

- Return clutch tube and lock pin in their original positions.
- Release clutch pedal and wait for 5 seconds.
- Repeat steps 3 to 8 until no bubbles are observed in the clutch fluid.
- Check that the fluid level in the reservoir tank is within the specified range after air bleeding. Refer to [CL-8, "Inspection"](#).

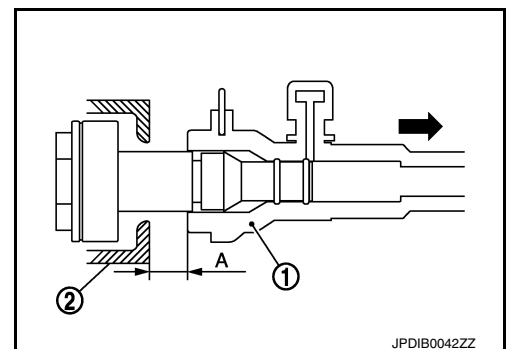

CLUTCH PEDAL

< REMOVAL AND INSTALLATION >

REMOVAL AND INSTALLATION

CLUTCH PEDAL

Exploded View

INFOID:000000012199548

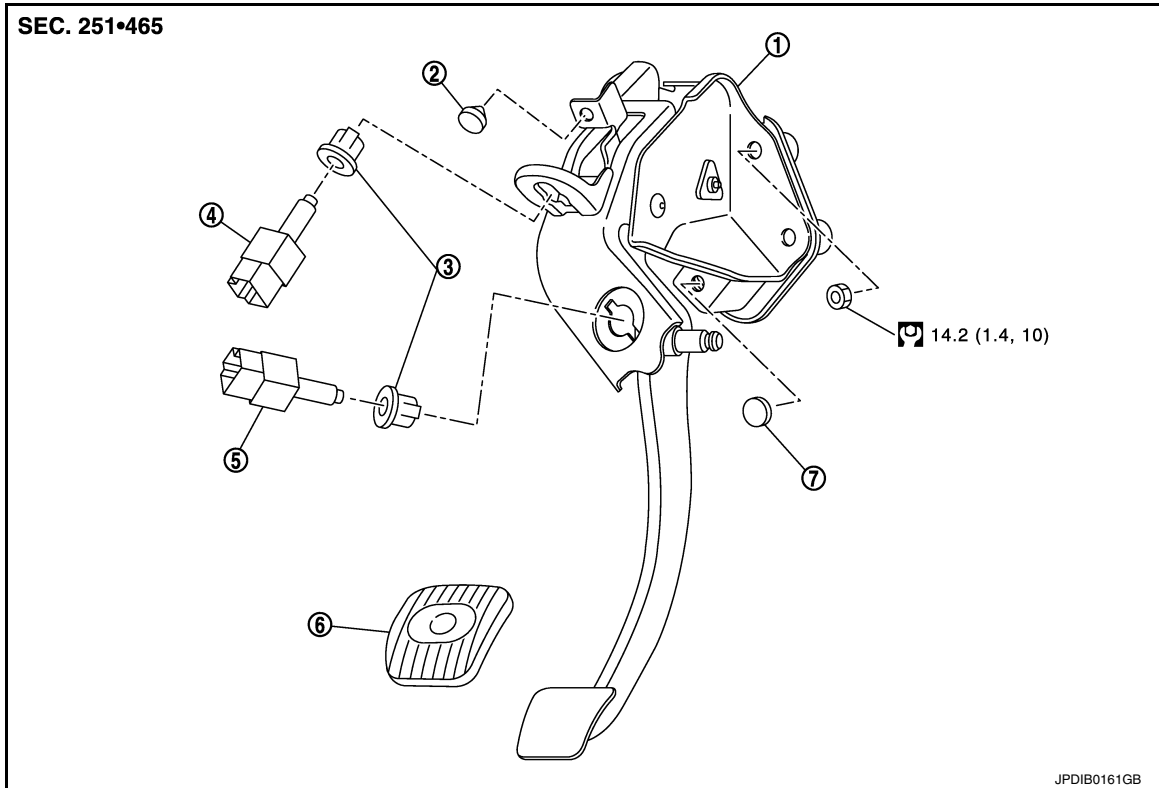

- | | | |
|----------------------------|---------------------------------|--------------|
| 1. Clutch pedal | 2. Stopper rubber | 3. Clip |
| 4. Clutch interlock switch | 5. Clutch pedal position switch | 6. Pedal pad |
| 7. Pedal stopper rubber | | |

: N·m (kg-m, ft-lb)

Removal and Installation

INFOID:000000012199549

REMOVAL

1. Remove instrument lower panel LH. Refer to [IP-13. "Removal and Installation"](#).
2. Disconnect clutch pedal position switch connector.
3. Disconnect clutch interlock switch connector.
4. Disconnect clip of harness from clutch pedal.
5. Remove master cylinder rod end from clutch pedal.
6. Remove clutch pedal position switch and clip from clutch pedal.
7. Remove clutch interlock switch and clip from clutch pedal.
8. Remove clutch pedal from the vehicle.
9. Remove pedal pad from clutch pedal.
10. Remove stopper rubber and pedal stopper rubber from clutch pedal, using a suitable remover.

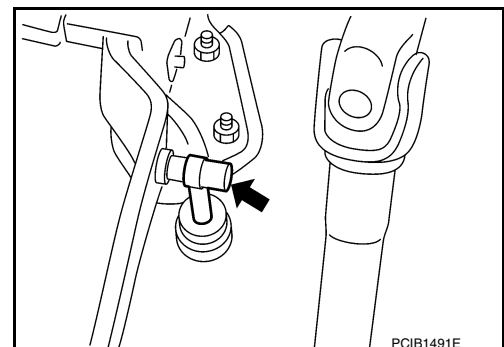

INSTALLATION

Revision: November 2015

CL-11

2016 JUKE

CLUTCH PEDAL

< REMOVAL AND INSTALLATION >

Note the following, and install in the reverse order of removal.

CAUTION:

Press master cylinder rod end into clutch pedal until it stops.

Inspection and Adjustment

INFOID:0000000012199550

INSPECTION AFTER REMOVAL

- Check clutch pedal for bend, damage, or a cracked weld. If bend, damage, or a cracked weld is found, replace clutch pedal.
- Check stopper rubber and pedal stopper rubber. If damage or deformation is found, replace stopper rubber and pedal stopper rubber.
- Check pedal pad. If wear or damage is found, replace pedal pad.

INSPECTION AFTER INSTALLATION

- Check the clutch pedal height, clutch pedal height at clutch disengagement, and clutch pedal play. Refer to [CL-6, "Inspection and Adjustment"](#).
- Check the clutch interlock switch position. Refer to [CL-6, "Inspection and Adjustment"](#).
- Check the clutch pedal position switch position. Refer to [CL-6, "Inspection and Adjustment"](#).

ADJUSTMENT AFTER INSTALLATION

- Adjust the clutch interlock switch position. Refer to [CL-6, "Inspection and Adjustment"](#).
- Adjust the clutch pedal position switch position. Refer to [CL-6, "Inspection and Adjustment"](#).

CLUTCH MASTER CYLINDER

< REMOVAL AND INSTALLATION >

CLUTCH MASTER CYLINDER

Exploded View

INFOID:000000012199551

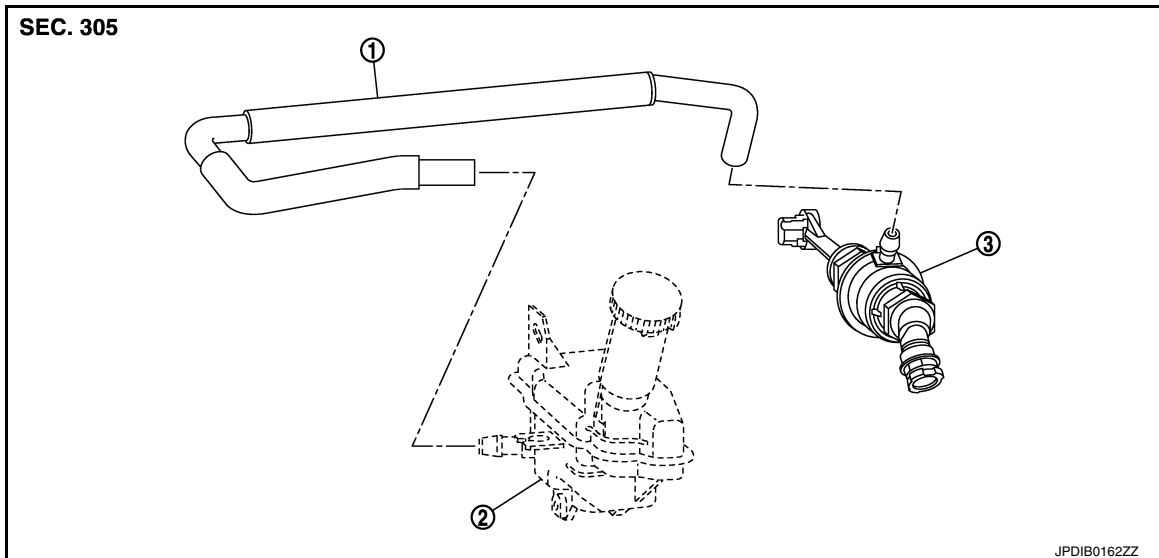

1. Reservoir hose
2. Reservoir tank
3. Master cylinder

Removal and Installation

INFOID:000000012199552

REMOVAL

CAUTION:

- Keep painted surface on the body or other parts free of clutch fluid. If it spills, wipe up immediately and wash the affected area with water.

- Never disassemble clutch master cylinder.

1. Drain clutch fluid. Refer to [CL-8, "Draining"](#).
2. Remove air cleaner case. Refer to [EM-192, "Removal and Installation"](#) (Except for NISMO RS), [EM-27, "Removal and Installation"](#) (For NISMO RS).
3. Remove reservoir hose from reservoir tank and master cylinder.
4. Remove master cylinder rod end (←) from clutch pedal.

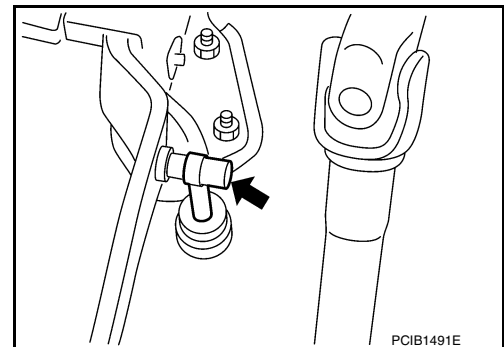

CLUTCH MASTER CYLINDER

< REMOVAL AND INSTALLATION >

5. Pull up the lock pin (1) from connector of master cylinder (2) and separate clutch tube (3).
6. Rotate master cylinder clockwise by 45 degrees, and then remove master cylinder from the vehicle.

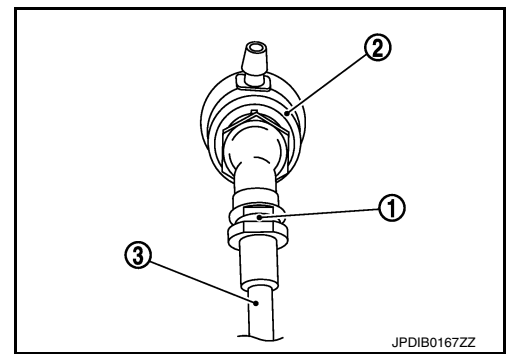

INSTALLATION

CAUTION:

Keep painted surface on the body or other parts free of clutch fluid. If it spills, wipe up immediately and wash the affected area with water.

1. Tilt master cylinder clockwise by 45 degrees (A) and insert it to the mounting hole. Rotate counterclockwise and secure it. At this time, nipple (1) is upward of the vehicle.

B : Mounting condition

2. Install master cylinder rod end to clutch pedal.

CAUTION:

Press master cylinder rod end into clutch pedal until it stops.

3. Install reservoir hose to reservoir tank and master cylinder.

CAUTION:

Set reservoir hose with painted mark facing upward.

4. Press down the lock pin into connector of master cylinder until it stops.
5. Install clutch tube into connector of master cylinder until it stops.
6. For the next step and after, install in the reverse order of removal.

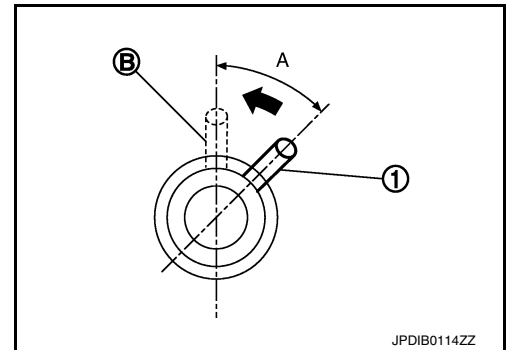

Inspection and Adjustment

INFOID:0000000012199553

INSPECTION AFTER INSTALLATION

- Check the fluid leakage and the fluid level. Refer to [CL-8, "Inspection"](#).
- Check the clutch pedal height, clutch pedal height at clutch disengagement, and clutch pedal play. Refer to [CL-6, "Inspection and Adjustment"](#).
- Check the clutch interlock switch position. Refer to [CL-6, "Inspection and Adjustment"](#).
- Check the clutch pedal position switch position. Refer to [CL-6, "Inspection and Adjustment"](#).

ADJUSTMENT AFTER INSTALLATION

- Adjust the clutch interlock switch position. Refer to [CL-6, "Inspection and Adjustment"](#).
- Adjust the clutch pedal position switch position. Refer to [CL-6, "Inspection and Adjustment"](#).
- Perform the air bleeding. Refer to [CL-10, "Air Bleeding"](#).

CLUTCH PIPING

< REMOVAL AND INSTALLATION >

CLUTCH PIPING

Exploded View

INFOID:000000012199554

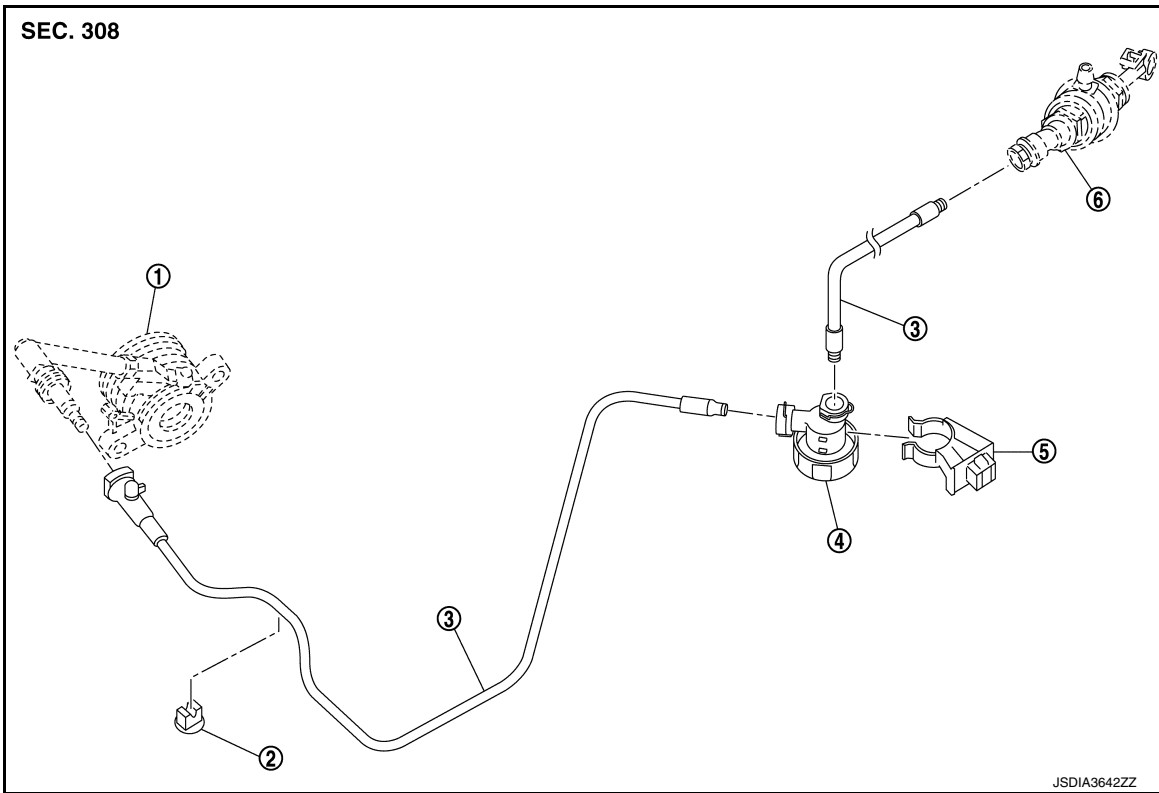

- | | | |
|------------------------------------|-------------------------------|--------------------|
| 1. CSC (Concentric Slave Cylinder) | 2. Clip (Except for NISMO RS) | 3. Clutch tube |
| 4. Clutch damper | 5. Bracket | 6. Master cylinder |

Hydraulic Layout

INFOID:000000012199555

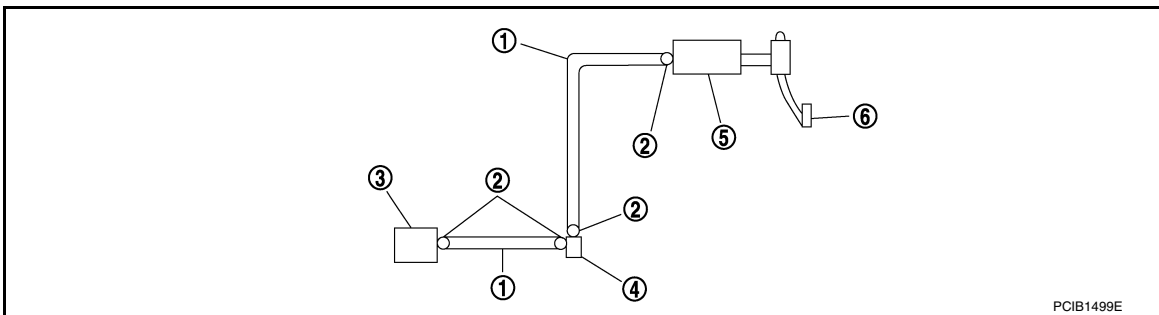

- | | | |
|------------------|--------------------|------------------------------------|
| 1. Clutch tube | 2. Lock pin | 3. CSC (Concentric Slave Cylinder) |
| 4. Clutch damper | 5. Master cylinder | 6. Clutch pedal |

Removal and Installation

INFOID:000000012199556

CAUTION:

Keep painted surface on the body or other parts free of clutch fluid. If it spills, wipe up immediately and wash the affected area with water.

REMOVAL

Note the following, and refer to [CL-15, "Exploded View"](#) for removal procedure.

- Drain clutch fluid. Refer to [CL-8, "Draining"](#).

CLUTCH PIPING

< REMOVAL AND INSTALLATION >

- Press the lock pin into the bleeding connector of the CSC, and then remove clutch tube from CSC.
- Pull the lock pins from the connectors of the clutch damper until the pins stop, and then remove clutch tubes from clutch damper.
- Pull the lock pin from the connector of the clutch master cylinder until the pin stop, and then remove clutch tube from clutch master cylinder.

INSTALLATION

Note the following, and refer to [CL-15, "Exploded View"](#) for installation procedure.

CAUTION:

Never damage clutch tube.

- Insert each clutch tube into the CSC bleeding connector, the clutch damper connector, and the clutch master cylinder connector until it contacts the end of each connector.
- Install each lock pin into the clutch damper connector and the clutch master cylinder connector until it contacts the end of each connector.

Inspection and Adjustment

INFOID:000000012199557

INSPECTION AFTER REMOVAL

- Check the clutch tube for cracks and damage. If the clutch tube has cracks or damage, replace it with a new one.
- Check the O-ring of the clutch tube for cracks and damage. If the O-ring of the clutch tube has cracks or damage, replace clutch tube with a new one.
- Check the clutch damper for cracks and damage. If the clutch damper has cracks or damage, replace it with a new one.

INSPECTION AFTER INSTALLATION

- Check the fluid leakage and the fluid level. Refer to [CL-8, "Inspection"](#).
- Check the clutch pedal height, clutch pedal height at clutch disengagement, and clutch pedal play. Refer to [CL-6, "Inspection and Adjustment"](#).

ADJUSTMENT AFTER INSTALLATION

Perform the air bleeding. Refer to [CL-10, "Air Bleeding"](#).

CSC (CONCENTRIC SLAVE CYLINDER)

< UNIT REMOVAL AND INSTALLATION >

UNIT REMOVAL AND INSTALLATION

CSC (CONCENTRIC SLAVE CYLINDER)

Exploded View

INFOID:0000000012199558

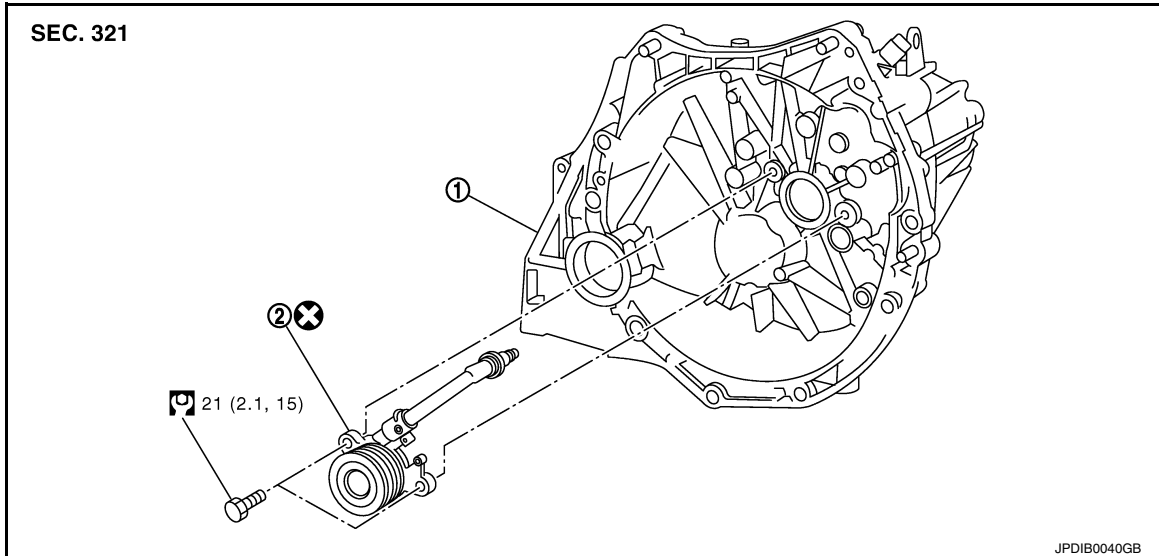

1. Transaxle assembly
2. CSC (Concentric Slave Cylinder)

⊗: Always replace after every disassembly.

⊞: N·m (kg-m, ft-lb)

Removal and Installation

INFOID:0000000012199559

CAUTION:

- Never reuse CSC (Concentric Slave Cylinder). Because CSC slides back to the original position every time when removing transaxle assembly. At this timing, dust on the sliding parts may damage a seal of CSC and may cause clutch fluid leakage.
- Never disassemble CSC.
- Keep painted surface on the body or other parts free of clutch fluid. If it spills, wipe up immediately and wash the affected area with water.

REMOVAL

1. Remove transaxle assembly. Refer to [TM-30. "Removal and Installation"](#) (RS6F94R), [TM-86. "Removal and Installation"](#) (RS6F52H).
2. Remove CSC from clutch housing.

INSTALLATION

1. Install CSC to clutch housing, and then tighten CSC mounting bolts to the specified torque.

CAUTION:

- Never reuse CSC.
- Never insert and operate CSC because piston and stopper of CSC components may fall off.

2. For the next step and after, install in the reverse order of removal.

Inspection and Adjustment

INFOID:0000000012199560

INSPECTION AFTER INSTALLATION

Check the fluid leakage and the fluid level. Refer to [CL-8. "Inspection"](#).

ADJUSTMENT AFTER INSTALLATION

Perform the air bleeding. Refer to [CL-10. "Air Bleeding"](#).

CLUTCH DISC AND CLUTCH COVER

< UNIT REMOVAL AND INSTALLATION >

CLUTCH DISC AND CLUTCH COVER

Exploded View

INFOID:000000012199561

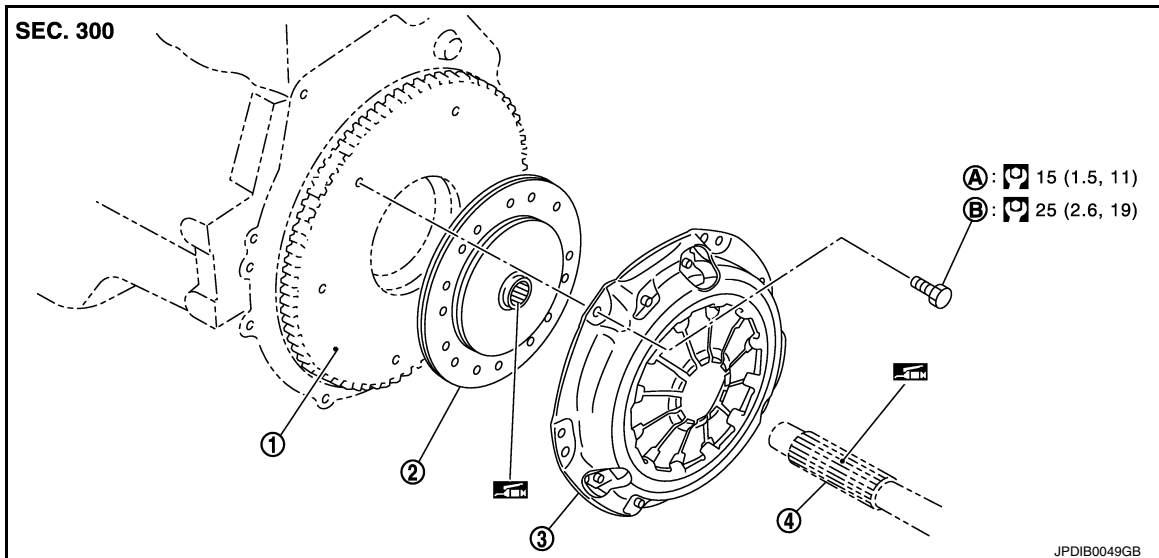

- | | | |
|----------------|----------------|-----------------|
| 1. Flywheel | 2. Clutch disc | 3. Clutch cover |
| 4. Input shaft | | |
| A. First step | B. Final step | |

: N·m (kg-m, ft-lb)

: Apply lithium-based grease including molybdenum disulphide.

Removal and Installation

INFOID:000000012199562

CAUTION:

- Never reuse CSC (Concentric Slave Cylinder). Because CSC slides back to the original position every time when removing transaxle assembly. At this timing, dust on the sliding parts may damage a seal of CSC and may cause clutch fluid leakage. Refer to [CL-17, "Removal and Installation"](#).
- Never bring any grease to the clutch disc facing, pressure plate surface and flywheel surface.
- Never clean clutch disc using solvent.

REMOVAL

1. Remove transaxle assembly. Refer to [TM-30, "Removal and Installation"](#) (RS6F94R), [TM-86, "Removal and Installation"](#) (RS6F52H).
2. Remove clutch cover mounting bolts while holding clutch cover.
CAUTION:
Never drop clutch disc.
3. Remove clutch cover and clutch disc.
CAUTION:
Never drop clutch disc.

INSTALLATION

1. Clean clutch disc and input shaft splines to remove grease and powder arisen from abrasion.

CLUTCH DISC AND CLUTCH COVER

< UNIT REMOVAL AND INSTALLATION >

- Apply recommended grease to clutch disc (1) and input shaft (2) splines (A).

CAUTION:

Be sure to apply grease to the points specified. Otherwise, noise, poor disengagement, or damage to the clutch may result. Excessive grease may cause slip or judder. And if it adheres to seal of CSC, it cause clutch fluid leakage. Wipe out excess grease. Wipe out any grease oozing from the parts.

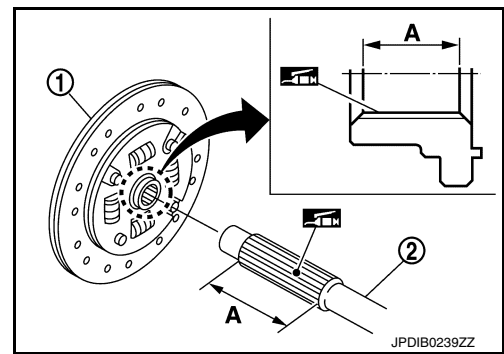

- Install clutch disc, using a clutch aligner (A) [Commercial service tool].
- Install clutch cover, and then temporarily tighten clutch cover mounting bolts.
- Tighten clutch cover mounting bolts to the specified torque evenly in two steps in the numerical order as shown in the figure.
- For the next step and after, install in the reverse order of removal.

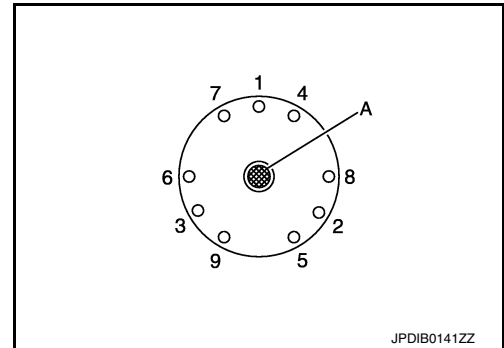

Inspection

INFOID:000000012199563

INSPECTION AFTER REMOVAL

Clutch Disc

- Measure circumferential runout relative to clutch disc center spline. If it is outside the specification, replace clutch disc.

Runout limit/diameter of the area to be measured : Refer to [CL-21, "Clutch Disc"](#).

- Measure backlash to clutch disc spline and input shaft spline at the circumference of clutch disc. If it is outside the specification, replace clutch disc.

Maximum allowable spline backlash (at outer edge of disc) : Refer to [CL-21, "Clutch Disc"](#).

- Measure the depth "A" to clutch disc facing rivet heads, using a calipers. If it exceeds the allowable wear limit, replace clutch disc.

Facing wear limit (depth to the rivet head) "A" : Refer to [CL-21, "Clutch Disc"](#).

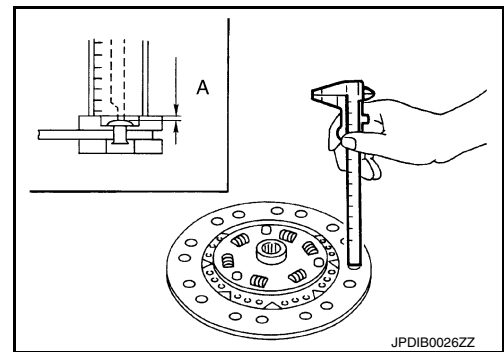
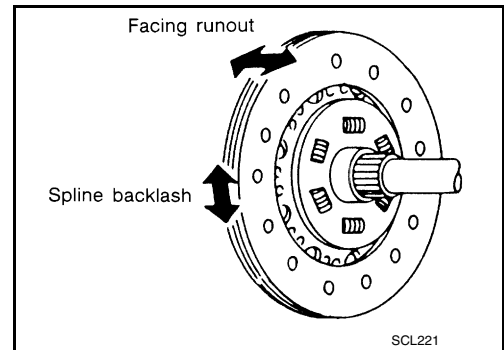

Clutch Cover

- Check clutch cover thrust ring for wear or breakage. If wear or breakage is found, replace clutch cover.

NOTE:

- Worn thrust ring will generate a beating noise when tapped at the rivet with a hammer.
- Broken thrust ring will make a clinking sound when cover is shaken up and down.
- If a trace of burn or discoloration is found on the clutch cover pressure plate to clutch disc contact surface, repair the surface with sandpaper. If surface is damaged or distorted, replace clutch cover.

CLUTCH DISC AND CLUTCH COVER

< UNIT REMOVAL AND INSTALLATION >

INSPECTION AFTER INSTALLATION

Clutch Cover

Check diaphragm spring lever claws for unevenness with the lever still on the vehicle. If they exceed the tolerance, adjust lever height, using the diaphragm adjusting wrench (A) [SST: ST20050240 (-)].

Tolerance for diaphragm spring lever unevenness : Refer to [CL-21, "Clutch Cover"](#).

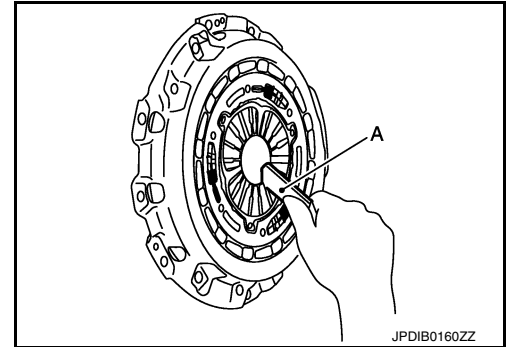

SERVICE DATA AND SPECIFICATIONS (SDS)

< SERVICE DATA AND SPECIFICATIONS (SDS)

SERVICE DATA AND SPECIFICATIONS (SDS)

SERVICE DATA AND SPECIFICATIONS (SDS)

General Specifications

INFOID:0000000012199564

Unit: mm (in)

Engine type	MR16DDT	
Transaxle type	RS6F94R	RS6F52H
Type of clutch control	Hydraulic	
Clutch disc	Facing size (Outer dia. × Inner dia. × Thickness) 230 × 155 × 3.2 (9.06 × 6.10 × 0.126)	
Recommended clutch fluid	Refer to MA-11. "Fluids and Lubricants" .	

Clutch Pedal

INFOID:0000000012199565

Unit: mm (in)

Engine type	MR16DDT	
Transaxle type	RS6F94R	RS6F52H
Clutch pedal height	169.7 – 179.7 (6.68 – 7.07)	
Clutch pedal height at clutch disengagement	80 (3.15) or more	
Clutch pedal play [Looseness at clutch pedal pin]	2 – 8 (0.08 – 0.31) [0 – 1.3 (0 – 0.051)]	
Clearance between stopper rubber and clutch interlock switch threaded end while clutch pedal is fully depressed.	0.74 – 1.96 (0.0291 – 0.0772)	
Clearance between clutch pedal and clutch pedal position switch threaded end while clutch pedal is fully released.	0.74 – 1.96 (0.0291 – 0.0772)	

Clutch Disc

INFOID:0000000012199566

Unit: mm (in)

Engine type	MR16DDT	
Transaxle type	RS6F94R	RS6F52H
Runout limit/diameter of the area to be measured	1.0 (0.039) / 220 (8.66) dia.	
Maximum allowable spline backlash (at outer edge of disc)	0.9 (0.035)	
Facing wear limit (depth to the rivet head)	0.35 (0.0138)	

Clutch Cover

INFOID:0000000012199567

Unit: mm (in)

Engine type	MR16DDT	
Transaxle type	RS6F94R	RS6F52H
Tolerance for diaphragm spring lever unevenness	0.7 (0.028) or less	