

SECTION DLK
DOOR & LOCK

A
B
C

CONTENTS

D
E

WITH INTELLIGENT KEY SYSTEM

PRECAUTION	6	BACK DOOR OPEN FUNCTION : System Description	16	F
PRECAUTIONS	6	REMOTE KEYLESS ENTRY FUNCTION	17	G
Precaution for Supplemental Restraint System (SRS) "AIR BAG" and "SEAT BELT PRE-TENSIONER"	6	REMOTE KEYLESS ENTRY FUNCTION : System Diagram	18	H
Precaution for Procedure without Cowl Top Cover.....	6	REMOTE KEYLESS ENTRY FUNCTION : System Description	18	
Precautions For Xenon Headlamp Service	6	KEY REMINDER FUNCTION	20	I
Precautions for Removing Battery Terminal	7	KEY REMINDER FUNCTION : System Diagram	20	
Work	7	KEY REMINDER FUNCTION : System Description	20	J
PREPARATION	8	WARNING FUNCTION	21	
PREPARATION	8	WARNING FUNCTION : System Description	21	
Special Service Tools	8	BACK DOOR OPENER SYSTEM	24	DLK
Commercial Service Tools	8	System Diagram	24	
SYSTEM DESCRIPTION	9	System Description	24	
COMPONENT PARTS	9	DIAGNOSIS SYSTEM (BCM)	25	L
Component Parts Location	9	COMMON ITEM	25	
Component Description	10	COMMON ITEM : CONSULT Function (BCM - COMMON ITEM)	25	M
SYSTEM (POWER DOOR LOCK SYSTEM)	11	DOOR LOCK	26	N
System Diagram	11	DOOR LOCK : CONSULT Function (BCM - DOOR LOCK)	26	
System Description	11	INTELLIGENT KEY	27	O
SYSTEM (INTELLIGENT KEY SYSTEM)	13	INTELLIGENT KEY : CONSULT Function (BCM - INTELLIGENT KEY)	28	
INTELLIGENT KEY SYSTEM	13	TRUNK	31	P
INTELLIGENT KEY SYSTEM : System Diagram.....	13	TRUNK : CONSULT Function (BCM - TRUNK)	31	
INTELLIGENT KEY SYSTEM : System Description	13	ECU DIAGNOSIS INFORMATION	32	
DOOR LOCK FUNCTION	14	BCM	32	
DOOR LOCK FUNCTION : System Diagram	14	List of ECU Reference	32	
DOOR LOCK FUNCTION : System Description	14	WIRING DIAGRAM	33	
BACK DOOR OPEN FUNCTION	16			
BACK DOOR OPEN FUNCTION : System Diagram	16			

DOOR & LOCK SYSTEM	33	REAR LH	70
Wiring Diagram	33	REAR LH : Component Function Check	70
BASIC INSPECTION	46	REAR LH : Diagnosis Procedure	70
DIAGNOSIS AND REPAIR WORK FLOW	46	REAR RH	71
Work Flow	46	REAR RH : Component Function Check	71
DTC/CIRCUIT DIAGNOSIS	49	REAR RH : Diagnosis Procedure	72
B2621 INSIDE ANTENNA	49	DOOR LOCK AND UNLOCK SWITCH	73
DTC Logic	49	Component Function Check	73
Diagnosis Procedure	49	Diagnosis Procedure	73
B2622 INSIDE ANTENNA	51	Component Inspection	74
DTC Logic	51	DOOR REQUEST SWITCH	75
Diagnosis Procedure	51	Component Function Check	75
B2626 OUTSIDE ANTENNA	53	Diagnosis Procedure	75
DTC Logic	53	Component Inspection	76
Diagnosis Procedure	53	DOOR SWITCH	77
B2627 OUTSIDE ANTENNA	55	Component Function Check	77
DTC Logic	55	Diagnosis Procedure	77
Diagnosis Procedure	55	Component Inspection	78
B2628 OUTSIDE ANTENNA	57	HAZARD FUNCTION	80
DTC Logic	57	Component Function Check	80
Diagnosis Procedure	57	Diagnosis Procedure	80
BACK DOOR OPENER ACTUATOR	59	INTELLIGENT KEY BATTERY	81
Component Function Check	59	Component Inspection	81
Diagnosis Procedure	59	INTELLIGENT KEY WARNING BUZZER	82
BACK DOOR OPENER SWITCH	61	Component Function Check	82
Component Function Check	61	Diagnosis Procedure	82
Diagnosis Procedure	61	Component Inspection	83
Component Inspection	62	KEY WARNING LAMP	84
BACK DOOR REQUEST SWITCH	63	Component Function Check	84
Component Function Check	63	Diagnosis Procedure	84
Diagnosis Procedure	63	REMOTE KEYLESS ENTRY RECEIVER	85
Component Inspection	64	Component Function Check	85
BUZZER (COMBINATION METER)	65	Diagnosis Procedure	85
Component Function Check	65	SHIFT P WARNING LAMP	87
Diagnosis Procedure	65	Component Function Check	87
DOOR KEY CYLINDER SWITCH	66	Diagnosis Procedure	87
Component Function Check	66	UNLOCK SENSOR	88
Diagnosis Procedure	66	Component Function Check	88
Component Inspection	67	Diagnosis Procedure	88
DOOR LOCK ACTUATOR	68	Component Inspection	89
DRIVER SIDE	68	SYMPTOM DIAGNOSIS	90
DRIVER SIDE : Component Function Check	68	DOOR DOES NOT LOCK/UNLOCK WITH	DOOR LOCK AND UNLOCK SWITCH
DRIVER SIDE : Diagnosis Procedure	68	ALL DOOR	90
PASSENGER SIDE	69	ALL DOOR : Description	90
PASSENGER SIDE :		ALL DOOR : Diagnosis Procedure	90
Component Function Check	69	DRIVER SIDE	90
PASSENGER SIDE : Diagnosis Procedure	69	DRIVER SIDE : Description	90

DRIVER SIDE : Diagnosis Procedure	90	VEHICLE SPEED SENSING AUTO LOCK OPERATION DOES NOT OPERATE	103	A
PASSENGER SIDE	90	Diagnosis Procedure	103	
PASSENGER SIDE : Description	91	IGN OFF INTERLOCK DOOR UNLOCK FUNCTION DOES NOT OPERATE	104	B
PASSENGER SIDE : Diagnosis Procedure	91	Diagnosis Procedure	104	
REAR LH	91	P RANGE INTERLOCK DOOR LOCK/UNLOCK FUNCTION DOES NOT OPERATE	105	C
REAR LH : Description	91	Diagnosis Procedure	105	
REAR LH : Diagnosis Procedure	91	HAZARD AND BUZZER REMINDER DOES NOT OPERATE	106	D
REAR RH	91	Diagnosis Procedure	106	
REAR RH : Description	91	KEY REMINDER FUNCTION DOES NOT OPERATE	108	E
REAR RH : Diagnosis Procedure	91	Diagnosis Procedure	108	F
DOOR DOES NOT LOCK/UNLOCK WITH DOOR REQUEST SWITCH	93	OFF POSITION WARNING DOES NOT OPERATE	109	G
ALL DOOR REQUEST SWITCHES	93	Diagnosis Procedure	109	
ALL DOOR REQUEST SWITCHES : Description	93	P POSITION WARNING DOES NOT OPERATE	110	H
ALL DOOR REQUEST SWITCHES : Diagnosis Procedure	93	Diagnosis Procedure	110	
DRIVER SIDE DOOR REQUEST SWITCH	93	ACC WARNING DOES NOT OPERATE	111	I
DRIVER SIDE DOOR REQUEST SWITCH : Description	94	Diagnosis Procedure	111	
DRIVER SIDE DOOR REQUEST SWITCH : Diagnosis Procedure	94	TAKE AWAY WARNING DOES NOT OPERATE	112	J
PASSENGER SIDE DOOR REQUEST SWITCH	94	Diagnosis Procedure	112	
PASSENGER SIDE DOOR REQUEST SWITCH : Description	94	INTELLIGENT KEY LOW BATTERY WARNING DOES NOT OPERATE	113	DLK
PASSENGER SIDE DOOR REQUEST SWITCH : Diagnosis Procedure	94	Diagnosis Procedure	113	
BACK DOOR REQUEST SWITCH	94	DOOR LOCK OPERATION WARNING DOES NOT OPERATE	114	L
BACK DOOR REQUEST SWITCH : Description	95	Diagnosis Procedure	114	
BACK DOOR REQUEST SWITCH : Diagnosis Procedure	95	KEY ID WARNING DOES NOT OPERATE	115	M
DOOR DOES NOT LOCK/UNLOCK WITH DOOR KEY CYLINDER OPERATION	96	Diagnosis Procedure	115	
Diagnosis Procedure	96	KEY WARNING LAMP DOES NOT ILLUMINATE	116	N
DOOR DOES NOT LOCK/UNLOCK WITH INTELLIGENT KEY	97	Diagnosis Procedure	116	
Diagnosis Procedure	97	UNLOCK LINK FUNCTION DOES NOT OPERATE	117	O
IGNITION POSITION WARNING FUNCTION DOES NOT OPERATE	99	Diagnosis Procedure	117	
Diagnosis Procedure	99	SQUEAK AND RATTLE TROUBLE DIAGNOSES	118	P
SELECTIVE UNLOCK FUNCTION DOES NOT OPERATE	100	Work Flow	118	
Diagnosis Procedure	100	Inspection Procedure	120	
BACK DOOR DOES NOT OPENED	101	Diagnostic Worksheet	122	
Diagnosis Procedure	101	REMOVAL AND INSTALLATION	124	
AUTO DOOR LOCK OPERATION DOES NOT OPERATE	102			
Diagnosis Procedure	102			

HOOD	124	BACK DOOR STRIKER	150
Exploded View	124	BACK DOOR STRIKER : Removal and Installation	150
HOOD ASSEMBLY	124	BACK DOOR HINGE	151
HOOD ASSEMBLY : Removal and Installation	124	BACK DOOR HINGE : Removal and Installation	151
HOOD ASSEMBLY : Adjustment	125	BACK DOOR STAY	151
HOOD HINGE	126	BACK DOOR STAY : Removal and Installation	151
HOOD HINGE : Removal and Installation	126	BACK DOOR STAY : Disposal	152
HOOD HINGE : Adjustment	127	BACK DOOR WEATHER-STRIP	152
HOOD SUPPORT ROD	129	BACK DOOR WEATHER-STRIP : Removal and Installation	152
HOOD SUPPORT ROD : Removal and Installation	129	HOOD LOCK	154
RADIATOR CORE SUPPORT	130	Exploded View	154
MR16DDT	130	HOOD LOCK	154
MR16DDT : Exploded View	130	HOOD LOCK : Removal and Installation	154
MR16DDT : Removal and Installation	130	HOOD LOCK CONTROL CABLE	155
FRONT FENDER	133	HOOD LOCK CONTROL CABLE : Removal and Installation	155
Exploded View	133	Inspection	155
Removal and Installation	133	FRONT DOOR LOCK	157
FRONT DOOR	135	Exploded View	157
Exploded View	135	DOOR LOCK	157
DOOR ASSEMBLY	135	DOOR LOCK : Removal and Installation	157
DOOR ASSEMBLY : Removal and Installation	135	INSIDE HANDLE	158
DOOR ASSEMBLY : Adjustment	137	INSIDE HANDLE : Removal and Installation	158
DOOR STRIKER	138	OUTSIDE HANDLE	158
DOOR STRIKER : Removal and Installation	138	OUTSIDE HANDLE : Removal and Installation	158
DOOR HINGE	138	REAR DOOR LOCK	161
DOOR HINGE : Removal and Installation	138	Exploded View	161
DOOR CHECK LINK	139	DOOR LOCK	161
DOOR CHECK LINK : Removal and Installation	139	DOOR LOCK : Removal and Installation	161
REAR DOOR	140	INSIDE HANDLE	162
Exploded View	140	INSIDE HANDLE : Removal and Installation	162
DOOR ASSEMBLY	140	OUTSIDE HANDLE	162
DOOR ASSEMBLY : Removal and Installation	140	OUTSIDE HANDLE : Removal and Installation	162
DOOR ASSEMBLY : Adjustment	142	BACK DOOR LOCK	164
DOOR STRIKER	143	Exploded View	164
DOOR STRIKER : Removal and Installation	143	DOOR LOCK	164
DOOR HINGE	143	DOOR LOCK : Removal and Installation	164
DOOR HINGE : Removal and Installation	143	EMERGENCY LEVER	164
DOOR CHECK LINK	144	EMERGENCY LEVER : Unlock procedures	164
DOOR CHECK LINK : Removal and Installation	144	FUEL FILLER LID OPENER	166
BACK DOOR	145	Exploded View	166
Exploded View	145	FUEL FILLER LID	166
BACK DOOR ASSEMBLY	145	FUEL FILLER LID : Removal and Installation	166
BACK DOOR ASSEMBLY : Removal and Installation	145		
BACK DOOR ASSEMBLY : Adjustment	148		

FUEL FILLER OPENER CABLE	167	OUTSIDE KEY ANTENNA	172	
FUEL FILLER OPENER CABLE : Removal and Installation	167	DRIVER SIDE	172	A
		DRIVER SIDE : Removal and Installation	172	
FUEL FILLER LID LOCK	167	PASSENGER SIDE	172	B
FUEL FILLER LID LOCK : Removal and Installation	168	PASSENGER SIDE : Removal and Installation ...	172	
DOOR SWITCH	169	REAR BUMPER	172	C
Exploded View	169	REAR BUMPER : Removal and Installation	172	
Removal and Installation	169	INTELLIGENT KEY WARNING BUZZER	173	D
INSIDE KEY ANTENNA	170	Removal and Installation	173	
INSTRUMENT CENTER	170	REMOTE KEYLESS ENTRY RECEIVER	174	E
INSTRUMENT CENTER : Removal and Installation	170	Removal and Installation	174	
LUGGAGE ROOM	170	INTELLIGENT KEY BATTERY	175	F
LUGGAGE ROOM : Exploded View	170	Removal and Installation	175	
LUGGAGE ROOM : Removal and Installation	170			G
				H
				I
				J

DLK

L
M
N
O
P

PRECAUTION

PRECAUTIONS

Precaution for Supplemental Restraint System (SRS) "AIR BAG" and "SEAT BELT PRE-TENSIONER"

INFOID:000000012196571

The Supplemental Restraint System such as "AIR BAG" and "SEAT BELT PRE-TENSIONER", used along with a front seat belt, helps to reduce the risk or severity of injury to the driver and front passenger for certain types of collision. This system includes seat belt switch inputs and dual stage front air bag modules. The SRS system uses the seat belt switches to determine the front air bag deployment, and may only deploy one front air bag, depending on the severity of a collision and whether the front occupants are belted or unbelted. Information necessary to service the system safely is included in the "SRS AIR BAG" and "SEAT BELT" of this Service Manual.

WARNING:

Always observe the following items for preventing accidental activation.

- To avoid rendering the SRS inoperative, which could increase the risk of personal injury or death in the event of a collision that would result in air bag inflation, it is recommended that all maintenance and repair be performed by an authorized NISSAN/INFINITI dealer.
- Improper repair, including incorrect removal and installation of the SRS, can lead to personal injury caused by unintentional activation of the system. For removal of Spiral Cable and Air Bag Module, see "SRS AIR BAG".
- Never use electrical test equipment on any circuit related to the SRS unless instructed to in this Service Manual. SRS wiring harnesses can be identified by yellow and/or orange harnesses or harness connectors.

PRECAUTIONS WHEN USING POWER TOOLS (AIR OR ELECTRIC) AND HAMMERS

WARNING:

Always observe the following items for preventing accidental activation.

- When working near the Air Bag Diagnosis Sensor Unit or other Air Bag System sensors with the ignition ON or engine running, never use air or electric power tools or strike near the sensor(s) with a hammer. Heavy vibration could activate the sensor(s) and deploy the air bag(s), possibly causing serious injury.
- When using air or electric power tools or hammers, always switch the ignition OFF, disconnect the battery or batteries, and wait at least 3 minutes before performing any service.

Precaution for Procedure without Cowl Top Cover

INFOID:000000012196572

When performing the procedure after removing cowl top cover, cover the lower end of windshield with urethane, etc to prevent damage to windshield.

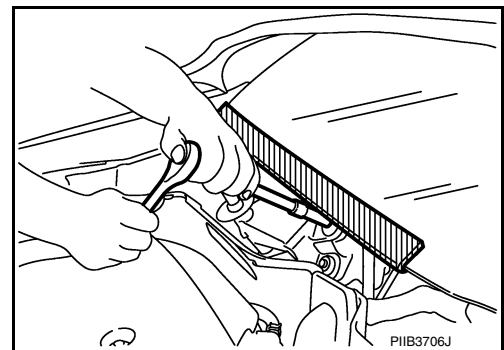

Precautions For Xenon Headlamp Service

INFOID:000000012196573

WARNING:

Comply with the following warnings to prevent any serious accident.

- Disconnect the battery cable (negative terminal) or the power supply fuse before installing, removing, or touching the xenon headlamp (bulb included). The xenon headlamp contains high-voltage generated parts.
- Never work with wet hands.
- Check the xenon headlamp ON-OFF status after assembling it to the vehicle. Never turn the xenon headlamp ON in other conditions. Connect the power supply to the vehicle-side connector.

PRECAUTIONS

[WITH INTELLIGENT KEY SYSTEM]

< PRECAUTION >

(Turning it ON outside the lamp case may cause fire or visual impairments.)

- Never touch the bulb glass immediately after turning it OFF. It is extremely hot.

CAUTION:

Comply with the following cautions to prevent any error and malfunction.

- Install the xenon bulb securely. (Insufficient bulb socket installation may melt the bulb, the connector, the housing, etc. by high-voltage leakage or corona discharge.)
- Never perform HID circuit inspection with a tester.
- Never touch the xenon bulb glass with hands. Never put oil and grease on it.
- Dispose of the used xenon bulb after packing it in thick vinyl without breaking it.
- Never wipe out dirt and contamination with organic solvent (thinner, gasoline, etc.).

Precautions for Removing Battery Terminal

INFOID:000000012831472

When disconnecting the battery terminal, pay attention to the following.

- Always use a 12V battery as power source.
- Never disconnect battery terminal while engine is running.
- When removing the 12V battery terminal, turn OFF the ignition switch and wait at least 30 seconds.
- For vehicles with the engine listed below, remove the battery terminal after a lapse of the specified time:

D4D engine	: 20 minutes	YS23DDT	: 4 minutes
HRA2DDT	: 12 minutes	YS23DDTT	: 4 minutes
K9K engine	: 4 minutes	ZD30DDTi	: 60 seconds
M9R engine	: 4 minutes	ZD30DDTT	: 60 seconds
R9M engine	: 4 minutes		
V9X engine	: 4 minutes		
YD25DDTi	: 2 minutes		

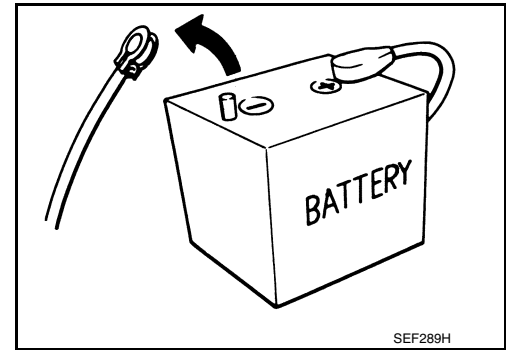

NOTE:

ECU may be active for several tens of seconds after the ignition switch is turned OFF. If the battery terminal is removed before ECU stops, then a DTC detection error or ECU data corruption may occur.

- After high-load driving, if the vehicle is equipped with the V9X engine, turn the ignition switch OFF and wait for at least 15 minutes to remove the battery terminal.

NOTE:

- Turbocharger cooling pump may operate in a few minutes after the ignition switch is turned OFF.
- Example of high-load driving
 - Driving for 30 minutes or more at 140 km/h (86 MPH) or more.
 - Driving for 30 minutes or more on a steep slope.
- For vehicles with the 2-batteries, be sure to connect the main battery and the sub battery before turning ON the ignition switch.

NOTE:

If the ignition switch is turned ON with any one of the terminals of main battery and sub battery disconnected, then DTC may be detected.

- After installing the 12V battery, always check "Self Diagnosis Result" of all ECUs and erase DTC.

NOTE:

The removal of 12V battery may cause a DTC detection error.

Work

INFOID:000000012196575

- After removing and installing the opening/closing parts, be sure to carry out fitting adjustments to check their operational.
- Check the lubrication level, damage, and wear of each part. If necessary, grease or replace it.

A
B
C
D
E
F
G
H
I
J
DLK
L
M
N
O
P

PREPARATION

< PREPARATION >

[WITH INTELLIGENT KEY SYSTEM]

PREPARATION

PREPARATION

Special Service Tools

INFOID:000000012196576

The actual shapes of Kent-Moore tools may differ from those of special service tools illustrated here.

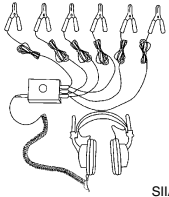
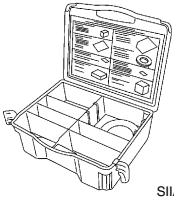
Tool number (Kent-Moore No.) Tool name	Description
<p>(J-39570) Chassis ear</p>  <p style="text-align: center;">SIIA0993E</p>	<p>Locates the noise</p>
<p>(J-50397) NISSAN Squeak and Rattle Kit</p>  <p style="text-align: center;">SIIA0994E</p>	<p>Repairs the cause of noise</p>

Commercial Service Tools

INFOID:000000012196577

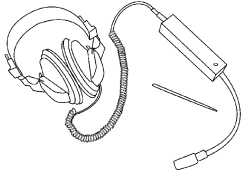
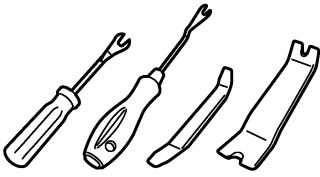
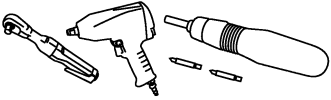
Tool name	Description
<p>Engine ear</p>  <p style="text-align: center;">SIIA0995E</p>	<p>Locates the noise</p>
<p>Remover tool</p>  <p style="text-align: center;">JMKIA3050ZZ</p>	<p>Removes clips, pawls and metal clips</p>
<p>Power tool</p>  <p style="text-align: center;">PIIB1407E</p>	<p>Loosening bolts, nuts and screws</p>

COMPONENT PARTS

< SYSTEM DESCRIPTION >

[WITH INTELLIGENT KEY SYSTEM]

SYSTEM DESCRIPTION

COMPONENT PARTS

Component Parts Location

INFOID:000000012196578

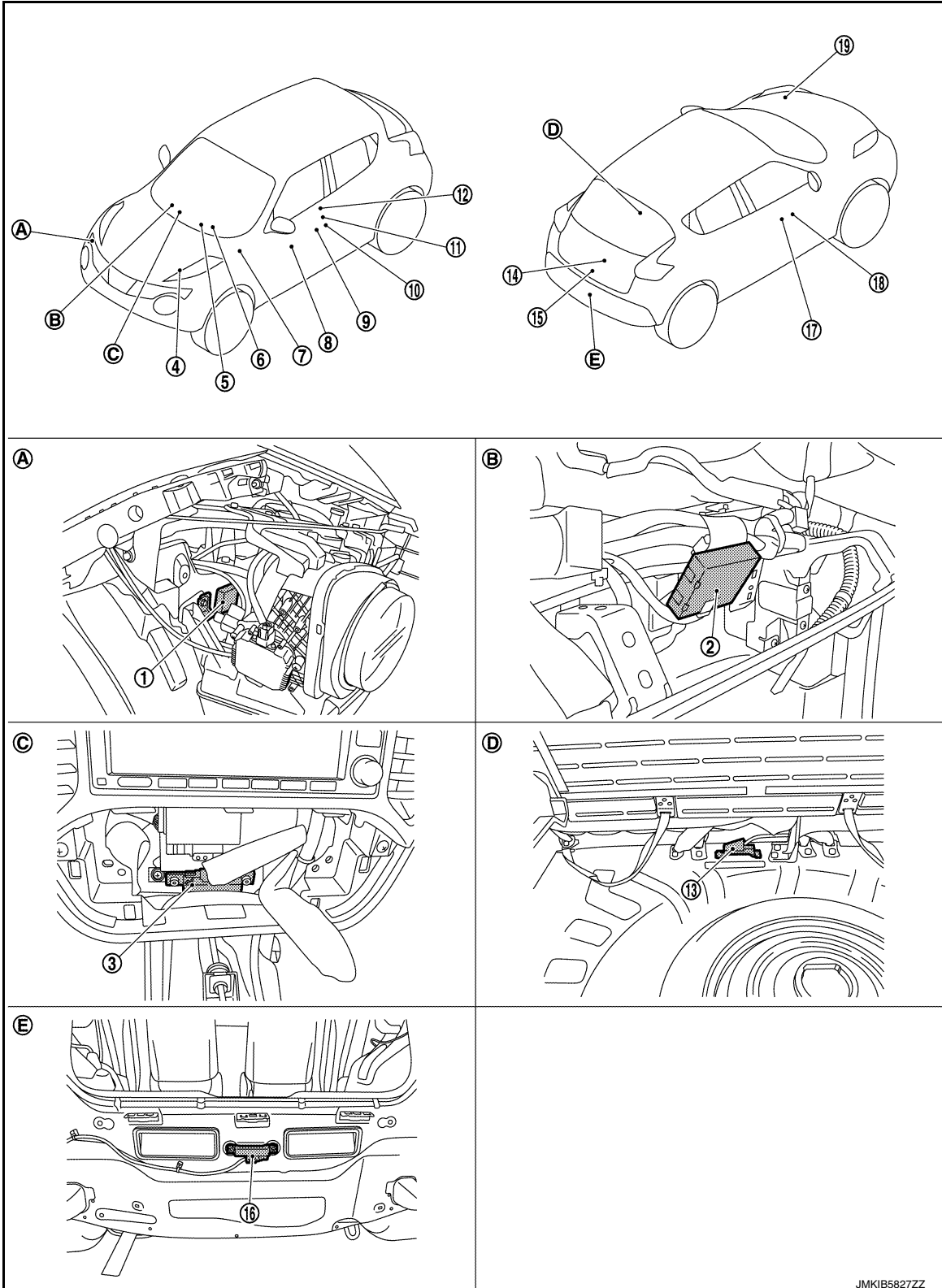

A
B
C
D
E
F
G
H
I
J
DLK
L
M
N
O
P

DLK

JMKIB5827ZZ

COMPONENT PARTS

< SYSTEM DESCRIPTION >

[WITH INTELLIGENT KEY SYSTEM]

- | | | |
|--|--|---|
| 1. Intelligent Key warning buzzer | 2. Remote keyless entry receiver | 3. Inside key antenna (instrument center) |
| 4. TCM
Refer to TM-156, "CVT CONTROL SYSTEM : Component Parts Location" | 5. Push-button ignition switch | 6. Combination meter |
| 7. BCM
Refer to BCS-5, "BODY CONTROL SYSTEM : Component Parts Location" | 8. Power window main switch | 9. Outside key antenna (driver side) |
| 10. Front door switch (driver side) | 11. Front door lock assembly (driver side) | 12. Front door request switch (driver side) |
| 13. Inside key antenna (luggage room) | 14. Back door request switch | 15. Back door lock assembly |
| 16. Outside antenna (rear bumper) | 17. Front door request switch (passenger side) | 18. Outside key antenna (passenger side) |
| 19. IPDM E/R
Refer to PCS-5, "Component Parts Location" | | |
| A. View with front bumper removed | B. View with instrument panel assembly removed | C. View with multi display unit removed |
| D. View with luggage room finisher removed | E. View with rear bumper removed | |

Component Description

INFOID:0000000012196579

Item	Function
BCM	Controls the door lock system.
Back door opener actuator	Opens the back door with the back door open signal from BCM.
Back door opener switch	Inputs back door opener switch operation signal to BCM.
Combination meter	<ul style="list-style-type: none"> Displays each operation method guide and warning for system malfunction. Performs operation method guide and warning with buzzer. Transmits vehicle sleep signal to CAN communication line.
Door lock actuator	<ul style="list-style-type: none"> Inputs locks/unlocks signal from BCM and locks/unlocks each door. Integrated in each door lock assembly.
Door lock and unlock switch	<ul style="list-style-type: none"> Transmits door lock/unlock operation to BCM. Integrated in the power window main switch and front power window switch (passenger side).
Door request switch	<ul style="list-style-type: none"> Transmits door lock/unlock operation to BCM. Integrated in the outside handle (driver side, passenger side and back door).
Door switch	Detects door open/close condition.
Inside key antenna	<ul style="list-style-type: none"> Detects whether Intelligent Key is inside the vehicle. Installed in the instrument center and luggage room.
Intelligent Key	<p>The following functions are available when having and carrying electronic ID.</p> <ul style="list-style-type: none"> Door lock/unlock Engine start Remote control entry function is available when operating on button.
Intelligent Key warning buzzer	Warns for an inappropriate operation.
IPDM E/R	Sounds horn via CAN communication between BCM.
Outside key antenna	<ul style="list-style-type: none"> Detects whether Intelligent Key is outside the vehicle. Integrated in the outside handle (driver side, passenger side and back door).
Push-button ignition switch	<ul style="list-style-type: none"> BCM transmits the change in the power supply position with the push-button ignition switch to IPDM E/R via CAN communication line. IPDM E/R transmits the power supply position status via CAN communication line to BCM. Immobilizer antenna amp checks Intelligent Key transponder.
Remote keyless entry receiver	Receives Intelligent Key operation and transmits to BCM.
TCM	Transmits shift position signal to BCM via CAN communication line

SYSTEM (POWER DOOR LOCK SYSTEM)

< SYSTEM DESCRIPTION >

[WITH INTELLIGENT KEY SYSTEM]

SYSTEM (POWER DOOR LOCK SYSTEM)

System Diagram

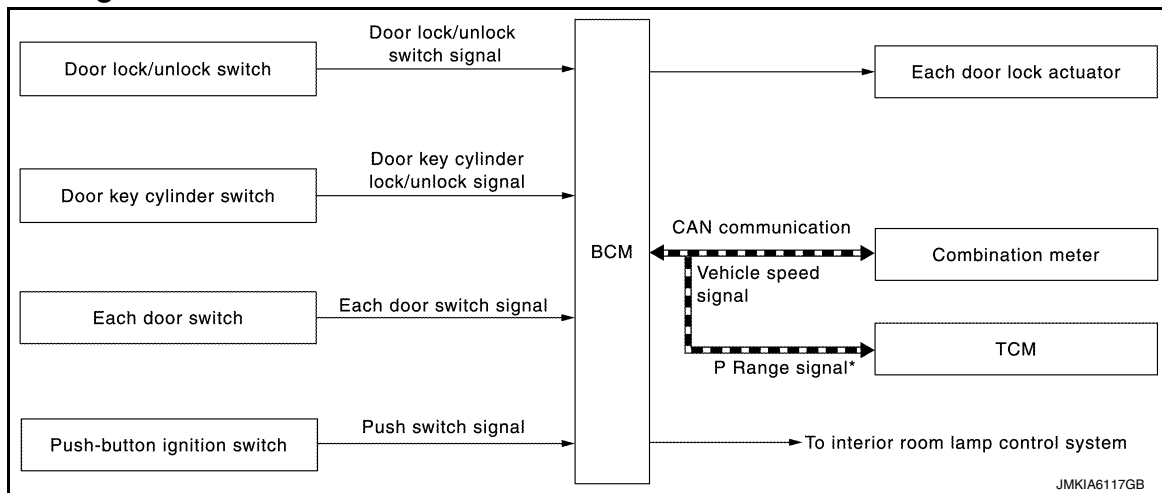

System Description

INFOID:000000012196581

DOOR LOCK FUNCTION

Door Lock and Unlock Switch

- The door lock and unlock switch (driver side) is build into power window main switch.
- Interlocked with the locking operation of door lock and unlock switch, door lock actuators of all doors are locked.
- Interlocked with the unlocking operation of door lock and unlock switch, door lock actuators of all doors actuator are unlocked.

Door Key Cylinder Switch

- With the mechanical key inserted in the door key cylinder on driver side, turning it to lock position, locks door lock actuator of all doors.
- With the mechanical key inserted in the door key cylinder on driver side, turning it to unlock position once unlocks the driver side door, turning it to unlock position again within 5 seconds after the first unlock operation unlocks all of the other doors actuator. (SELECTIVE UNLOCK OPERATION)

Selective unlock operation mode can be changed using CONSULT.

Refer to [DLK-26. "DOOR LOCK : CONSULT Function \(BCM - DOOR LOCK\)".](#)

IGNITION POSITION WARNING FUNCTION

When door lock and unlock switch are operated while driver side door is open and ignition position is ACC or ON, door locks once but immediately unlocks.

INTERIOR ROOM LAMP CONTROL FUNCTION

Interior room lamp is controlled according to door lock /unlock state, refer to [INL-6. "INTERIOR ROOM LAMP CONTROL SYSTEM : System Description".](#)

AUTOMATIC DOOR LOCK/UNLOCK FUNCTION (LOCK OPERATION)

The interlock door lock function is the function that locks all doors linked with the vehicle speed or shift position. It has 2 types as per the following items.

Vehicle Speed Sensing Auto Door Lock

All doors are locked when the vehicle speed reaches 24 km/h (15 MPH) or more.

BCM outputs the lock signal to all door lock actuators when it detects that the ignition switch is turned ON, all doors are closed and the vehicle speed received from the combination meter via CAN communication becomes 24 km/h (15 MPH) or more.

P Range Interlock Door Lock*

All doors are locked when shifting the selector lever from the P position to any position other than P.

BCM outputs the lock signal to all door lock actuators when it detects that the ignition switch is in the ON position and the shift signal received from the TCM via CAN communication is shifted from the P position to any position other than P.

SYSTEM (POWER DOOR LOCK SYSTEM)

[WITH INTELLIGENT KEY SYSTEM]

< SYSTEM DESCRIPTION >

Setting change of Automatic Door Lock/Unlock Function

The lock operation setting of the automatic door lock/unlock function can be changed.

NOTE:

P range interlock door lock can be selected for M/T models, but automatic door lock/unlock function does not operate.

With CONSULT

The ON/OFF switching of the automatic door lock function and the type selection of the automatic door lock/unlock function can be performed at the WORK SUPPORT setting of CONSULT.

Without CONSULT

The automatic door lock function ON/OFF can be switched by performing the following operation.

1. Close all doors (door switch OFF)
2. Ignition switch: OFF→ON
3. Press and hold the door lock and unlock switch for 5 seconds or more in the lock direction within 20 seconds after turning the ignition switch ON.
4. The switching complete when the hazard lamp blinks.

OFF → ON : 2 blinks

ON → OFF : 1 blink

*: This function does not operate on M/T models.

AUTOMATIC DOOR LOCK/UNLOCK FUNCTION (UNLOCK OPERATION)

The automatic door lock/unlock function is the function that unlocks all doors linked with the key position or shift position. It has 2 types as per the following items.

IGN OFF Interlock Door Unlock*¹

All doors are unlocked when the power supply position is changed from ON to OFF.

BCM outputs the unlock signal to all door lock actuators when it detects that the power supply position is changed from ignition switch ON to OFF.

P Range Interlock Door Unlock*²

All doors are unlocked when shifting the selector lever from any position other than the P to P position.

BCM outputs the unlock signal to all door lock actuators when it detects that the ignition switch is in the ON position and the shift signal received from TCM via CAN communication is shifted from any position other than the P to P position.

Setting change of Automatic Door Lock/Unlock Function

The unlock operation setting of the automatic door lock/unlock function can be changed.

NOTE:

P range interlock door lock can be selected for M/T models, but automatic door lock/unlock function does not operate.

With CONSULT

The ON/OFF switching of the automatic door lock/unlock function and the type selection of the automatic door lock/unlock function can be performed at the WORK SUPPORT setting of CONSULT. Refer to [DLK-26, "DOOR LOCK : CONSULT Function \(BCM - DOOR LOCK\)"](#).

Without CONSULT

The automatic door lock/unlock function ON/OFF can be switched by performing the following operation.

1. Close all doors below (door switch OFF)
2. Ignition switch: OFF→ON
3. Press and hold the door lock and unlock switch for 5 seconds or more in the unlock direction within 20 seconds after turning the power supply position ON.
4. The switching is complete when the hazard lamp blinks.

OFF → ON : 2 blinks

ON → OFF : 1 blink

*¹: This function is set to ON before delivery.

*²: This function does not operate on M/T models.

SYSTEM (INTELLIGENT KEY SYSTEM)

< SYSTEM DESCRIPTION >

[WITH INTELLIGENT KEY SYSTEM]

SYSTEM (INTELLIGENT KEY SYSTEM) INTELLIGENT KEY SYSTEM

INTELLIGENT KEY SYSTEM : System Diagram

INFOID:000000012196582

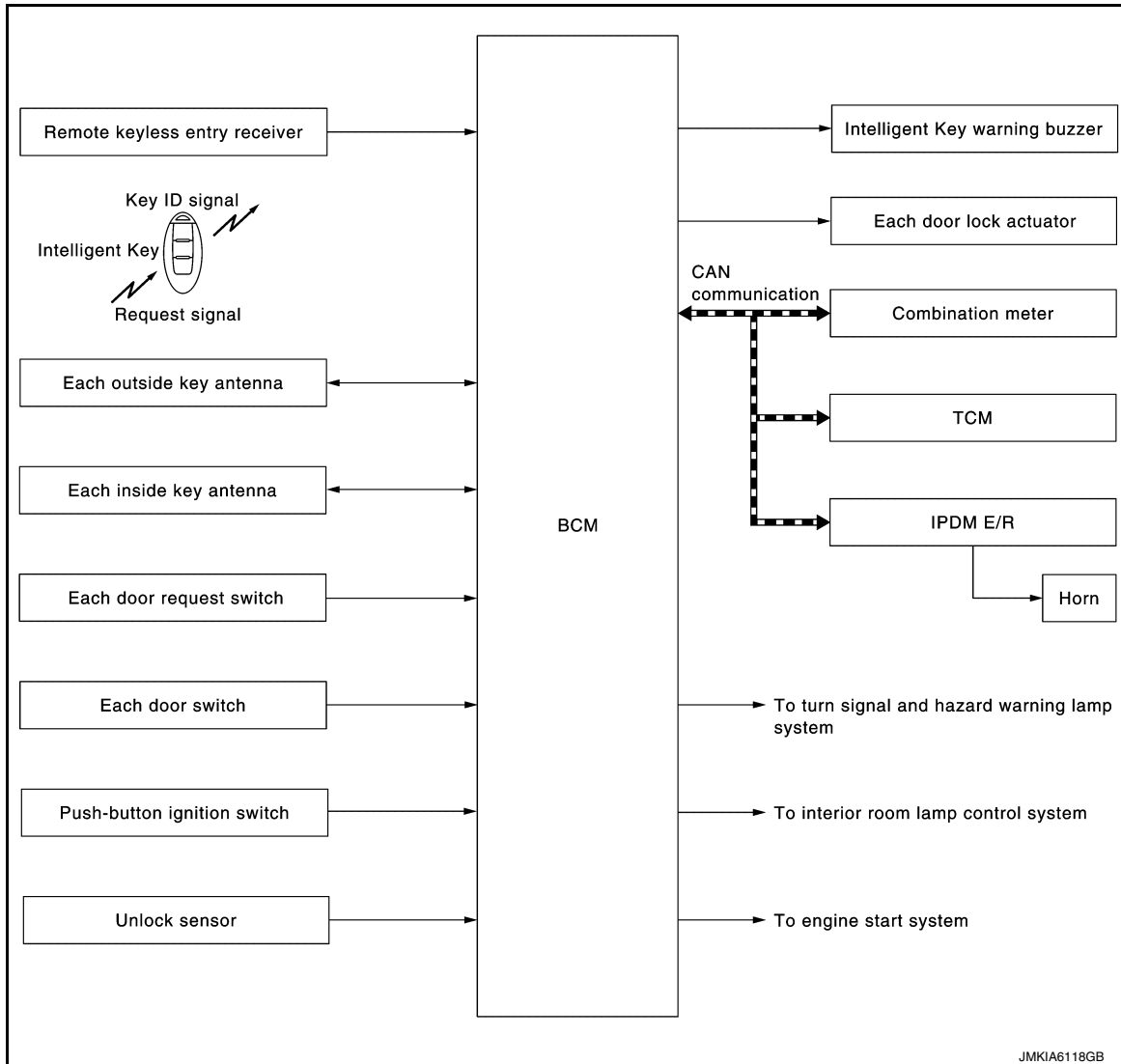

INTELLIGENT KEY SYSTEM : System Description

INFOID:000000012196583

- The Intelligent Key system is a system that makes it possible to lock and unlock the door locks (door lock/unlock function) by carrying the Intelligent Key, which operates based on the results of electronic ID verification using two-way communication between the Intelligent Key and the vehicle (BCM).

CAUTION:

The driver should always carry the Intelligent Key

- The settings for each function can be changed with CONSULT.
- If an Intelligent Key is lost, a new Intelligent Key can be registered. A maximum of 4 Intelligent Keys can be registered.
- It is possible to perform a diagnosis on the system and register an Intelligent Key with CONSULT.

Function	Description	Refer
Door lock	Lock/unlock can be performed by pressing the request switch	DLK-14
Remote keyless entry	Lock/unlock can be performed by pressing the remote controller button of the Intelligent Key	DLK-18
Key reminder	The key reminder buzzer sounds a warning if the door is locked with the key left inside the vehicle	DLK-20

A
B
C
D
E
F
G
H
I
J
K
L
M
N
O
P

DLK

SYSTEM (INTELLIGENT KEY SYSTEM)

< SYSTEM DESCRIPTION >

[WITH INTELLIGENT KEY SYSTEM]

Function	Description	Refer
Warning	If an action that does not meet the operating condition of the Intelligent Key system is taken, the buzzer sounds to inform the driver	DLK-21
Engine start	The engine can be turned on while carrying the Intelligent Key	SEC-10
Interior room lamp control	Interior room lamp is controlled according to door lock/unlock state	INL-6
Panic alarm	When Intelligent Key panic alarm button is pressed, horn sounds	SEC-16

DOOR LOCK FUNCTION

DOOR LOCK FUNCTION : System Diagram

INFOID:000000012196584

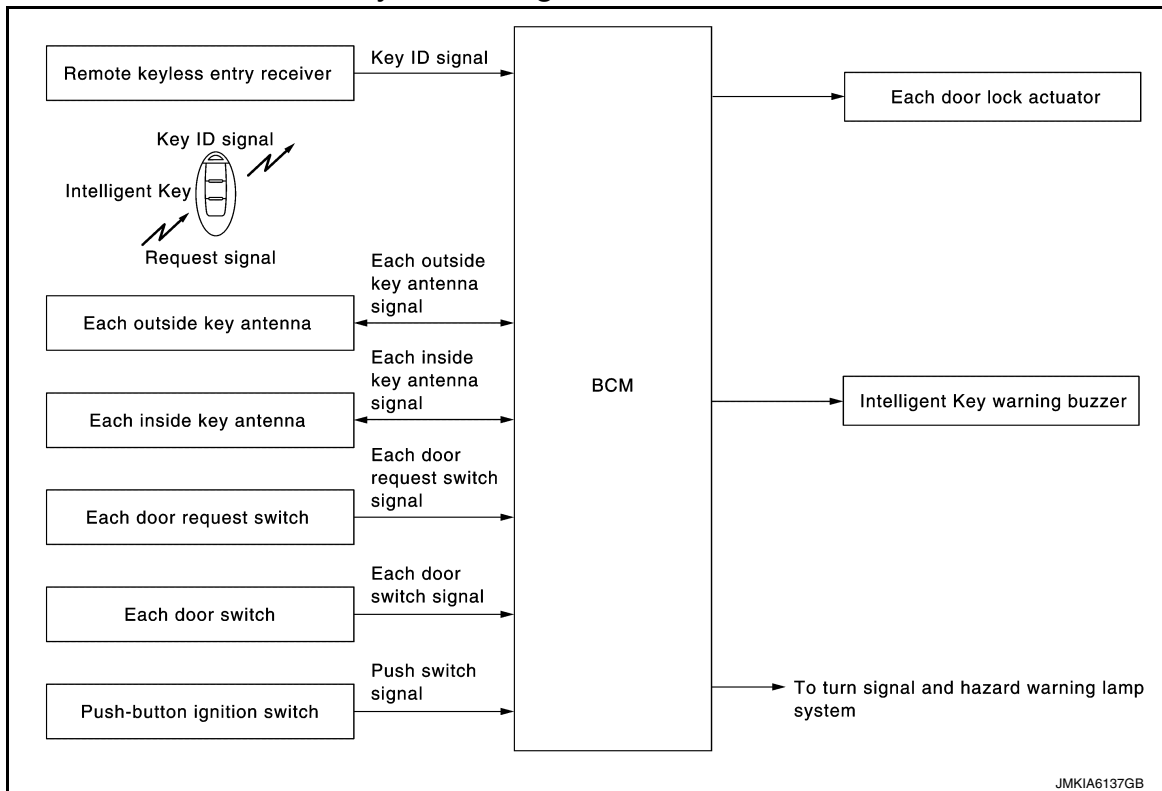

DOOR LOCK FUNCTION : System Description

INFOID:000000012196585

When pressing the door request switch, it is possible to lock and unlock the door by carrying the Intelligent Key.

OPERATION DESCRIPTION

- When the BCM detects that each door request switch is pressed, it activates the outside key antenna and inside key antenna corresponding to the pressed door request switch and transmits the request signal to the Intelligent Key. And then, check that the Intelligent Key is near the door.
- If the Intelligent Key is within the outside key antenna detection area, it receives the request signal and transmits the key ID signal to the BCM via remote keyless entry receiver.
- BCM receives the key ID signal and compares it with the registered key ID.
- BCM transmits door lock/unlock signal and operates each door lock actuator. At the same time, BCM blinks hazard warning lamp (lock: 2 times, unlock: 1 time) and sounds Intelligent Key buzzer (lock: 2 times, unlock: 1 time) as a reminder.

OPERATION CONDITION

If the following conditions are satisfied, door lock/unlock operation is performed if the door request switch is operated.

SYSTEM (INTELLIGENT KEY SYSTEM)

< SYSTEM DESCRIPTION >

[WITH INTELLIGENT KEY SYSTEM]

Each door request switch operation	Operation condition
Lock	<ul style="list-style-type: none"> All doors are closed Panic alarm is not activated P position warning is not activated Intelligent Key is outside the vehicle Intelligent Key is within outside key antenna detection area
Unlock	<ul style="list-style-type: none"> All doors are closed Panic alarm is not activated Intelligent Key is outside the vehicle Intelligent Key is within outside key antenna detection area *

*: Even with a registered Intelligent Key remaining inside the vehicle, door locks can be unlocked from outside of the vehicle with a spare Intelligent Key as long as key IDs are different.

OUTSIDE KEY ANTENNA DETECTION AREA

The outside key antenna detection area of door lock/unlock function is in the range of approximately 80 cm (31.50 in) surrounding the driver, passenger door handles (1) and back door handle (2). However, this operating range depends on the ambient conditions.

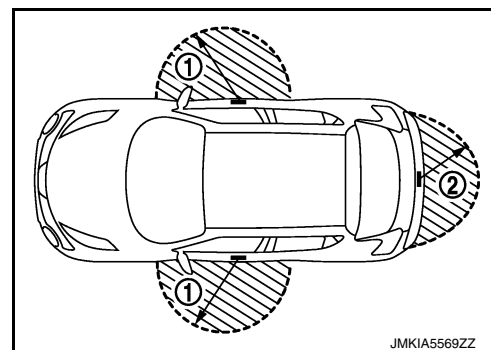

SELECTIVE UNLOCK FUNCTION

Lock Operation

When an LOCK signal is sent from door request switch (driver side, passenger side or back door), all doors are locked.

Unlock Operation

- When an UNLOCK signal from front door request switch (driver side) is transmitted, driver side door unlocks. When another UNLOCK signal is transmitted within 60 seconds, all door unlocks.
- When an UNLOCK signal from front door request switch (passenger side) is transmitted, passenger side door unlocks. When another UNLOCK signal is transmitted within 60 seconds, all door unlocks.
- When an UNLOCK signal from back door request switch is transmitted, back door unlocks. When another UNLOCK signal is transmitted within 60 seconds, all door unlocks.

How to Change Selective Unlock Operation Mode

Selective unlock operation mode can be changed using CONSULT.

Refer to [DLK-28, "INTELLIGENT KEY : CONSULT Function \(BCM - INTELLIGENT KEY\)"](#).

HAZARD AND BUZZER REMINDER FUNCTION

During lock, unlock, operation by each request switch, the hazard warning lamps and Intelligent Key warning buzzer will blink or honk as a reminder.

When doors are locked, unlocked by each request switch, BCM honks Intelligent Key warning buzzer as a reminder and blinks.

Operating Function of Hazard and Buzzer Reminder

Operation	Hazard warning lamp blinks	Intelligent Key warning buzzer honk
Unlock	Once	Once
Lock	Twice	Twice

Hazard and buzzer reminder does not operate if ignition switch ON position.

How to Change Hazard and Buzzer Reminder Operation Mode

Hazard and buzzer reminder operation mode can be changed using CONSULT.

Refer to [DLK-28, "INTELLIGENT KEY : CONSULT Function \(BCM - INTELLIGENT KEY\)"](#).

AUTO DOOR LOCK FUNCTION

SYSTEM (INTELLIGENT KEY SYSTEM)

[WITH INTELLIGENT KEY SYSTEM]

< SYSTEM DESCRIPTION >

After door is unlocked by door request switch operation and if 60 seconds or more passes without performing the following operation, all doors are automatically locked. However, operation check function does not activate.

Operating condition	<ul style="list-style-type: none"> • Door switch is ON (door is open) • Door is locked • Push switch is pressed
---------------------	--

How To Change Auto Door Lock Operation Mode

Auto door lock operation mode can be changed using CONSULT.

Refer to [DLK-28. "INTELLIGENT KEY : CONSULT Function \(BCM - INTELLIGENT KEY\)"](#).

LIST OF OPERATION RELATED PARTS

Parts marked with × are the parts related to operation.

Door lock function	Intelligent Key	Remote keyless entry receiver	Door switch	Door request switch	Door lock actuator	Inside key antenna	Outside key antenna	Intelligent Key warning buzzer	CAN communication system	BCM	Hazard warning lamp	Push-button ignition switch	Combination meter
Door lock/unlock function	×	×	×	×	×	×	×			×			
Hazard and buzzer reminder function								×	×	×	×		×
Selective unlock function	×			×	×	×	×			×			
Auto door lock function	×				×					×		×	

BACK DOOR OPEN FUNCTION

BACK DOOR OPEN FUNCTION : System Diagram

INFOID:000000012196586

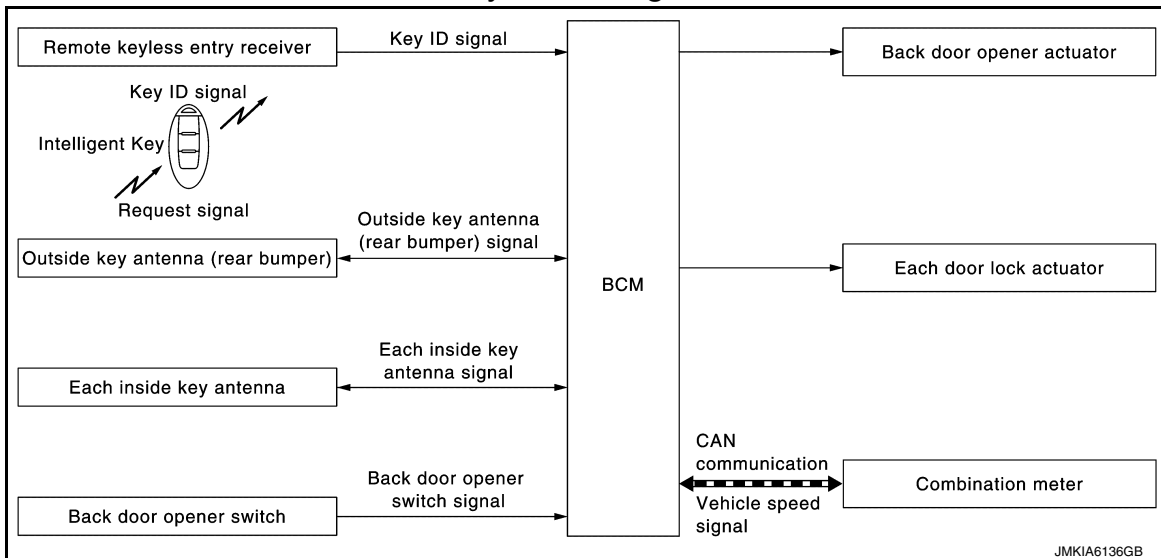

BACK DOOR OPEN FUNCTION : System Description

INFOID:000000012196587

While back door open in the permitted state, back door opens when back door opener switch is pressed after back door opener request switch is operated.

BACK DOOR OPEN

SYSTEM (INTELLIGENT KEY SYSTEM)

[WITH INTELLIGENT KEY SYSTEM]

< SYSTEM DESCRIPTION >

- When the BCM detects that back door opener switch is pressed, it starts the outside key antenna (rear bumper) and inside key antenna and transmits the request signal to the Intelligent Key. Then, check that the Intelligent Key is near the back door.
- If the Intelligent Key is within the outside key antenna detection area, it receives the request signal and transmits the key ID signal to the BCM via remote keyless entry receiver.
- BCM receives the key ID signal and compares it with the registered key ID.
- BCM opens back door, simultaneously unlocks all doors.

NOTE:

In selective unlock mode, only back door opens. All doors do not unlock.

OPERATION CONDITION

If the following conditions are satisfied, the back door can be opened.

Back door open function	Operation condition
Back door open operation	<ul style="list-style-type: none"> • Vehicle speed is less than 5 km/h (3 MPH) • 3 seconds or more after BCM outputs all doors lock signal • Intelligent Key is outside of vehicle • Intelligent Key is within outside key antenna detection area

OUTSIDE KEY ANTENNA DETECTION AREA

The outside key antenna detection area of back door open function is in the range of approximately 80 cm (31.50 in) surrounding the back door opener switch (1). However, this operating range depends on the ambient conditions.

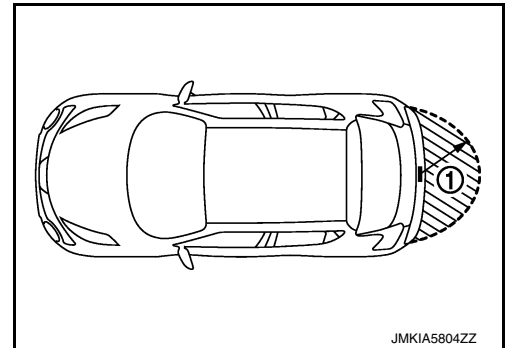

JMKIA5804ZZ

LIST OF OPERATION RELATED PARTS

Parts marked with × are the parts related to operation.

Door lock function	Intelligent Key	Remote keyless entry receiver	Back door opener actuator	Door lock actuator	Inside key antenna	Outside key antenna	CAN communication system	BCM	Back door opener switch	Combination meter
Back door open function	×	×	×	×	×	×	×	×	×	×

REMOTE KEYLESS ENTRY FUNCTION

A
B
C
D
E
F
G
H
I
J
L
M
N
O
P

DLK

SYSTEM (INTELLIGENT KEY SYSTEM)

< SYSTEM DESCRIPTION >

[WITH INTELLIGENT KEY SYSTEM]

REMOTE KEYLESS ENTRY FUNCTION : System Diagram

INFOID:000000012196588

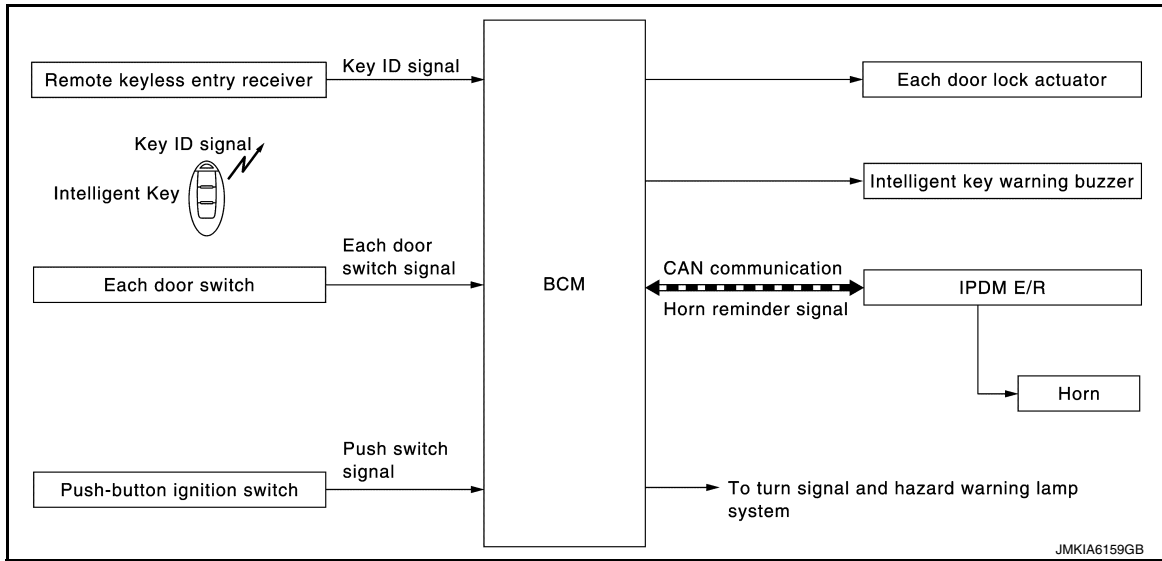

REMOTE KEYLESS ENTRY FUNCTION : System Description

INFOID:000000012196589

The Intelligent Key has the same functions as the remote control entry system. Therefore, it can be used in the same manner as the remote controller by operating the door lock/unlock button.

OPERATION

Remote keyless entry system controls operation of the following items.

- Door lock/unlock
- Selective unlock function
- Hazard reminder function
- Auto door lock

OPERATION AREA

To check that the Intelligent Key works normally, use within 1 m (3 ft) range of each doors, however the operable range may differ according to surroundings.

DOOR LOCK/UNLOCK FUNCTION

- When door lock/unlock button of the Intelligent Key is pressed, lock signal or unlock signal transmitted from Intelligent Key to BCM via remote keyless entry receiver.
- BCM receives the signal and compares it with the registered key ID to the vehicle.
- When BCM receives the door lock/unlock signal, it operates all door lock actuators and the hazard lamp (lock: 2 times, unlock: 1 time) and horn chirp signal to IPDM E/R at the same time as a reminder.
- IPDM E/R honks horn (lock: 1 times) as a reminder

OPERATION CONDITION

If the following condition are satisfied, remote keyless entry operation is performed when the Intelligent Key is operated.

Remote controller operation	Operation condition
Lock	<ul style="list-style-type: none"> • Panic alarm is not activated • P position warning is not activated
Unlock	Panic alarm is not activated

SELECTIVE UNLOCK FUNCTION

- When an LOCK signal is transmitted from Intelligent Key, all doors are locked.
- When an UNLOCK signal is transmitted from Intelligent Key once, driver side door is unlocked.
- Then, if an UNLOCK signal is transmitted from Intelligent Key again within 60 seconds, all other doors are unlocked.

How To Change Selective Unlock Operation Mode

Selective unlock operation mode can be changed using CONSULT.

SYSTEM (INTELLIGENT KEY SYSTEM)

< SYSTEM DESCRIPTION >

[WITH INTELLIGENT KEY SYSTEM]

Refer to [DLK-26. "DOOR LOCK : CONSULT Function \(BCM - DOOR LOCK\)"](#).

HAZARD AND HORN REMINDER FUNCTION

When doors are locked or unlocked by Intelligent Key, BCM blinks hazard warning lamps as a reminder and transmits horn chirp signal to IPDM E/R. IPDM E/R sounds horn as a reminder.

The hazard and horn reminder has a horn chirp mode (C mode) and a non-horn chirp mode (S mode).

Operating Function of Hazard and Horn Reminder

	C mode			S mode		
	Lock	Unlock	Back door open	Lock	Unlock	Back door open
Hazard warning lamp blinks	Twice	Once	—	Twice	—	—
Horn sound	Once	—	—	—	—	—

Hazard and horn reminder does not operate if ignition switch ON position.

How to change hazard and horn reminder mode

☑ With CONSULT

Refer to [DLK-28. "INTELLIGENT KEY : CONSULT Function \(BCM - INTELLIGENT KEY\)"](#).

⊗ Without CONSULT

When LOCK and UNLOCK signals are sent from the Intelligent Key for more than 2 seconds at the same time, the hazard and horn reminder mode is changed and hazard warning lamp blinks and horn sounds as per the following items:

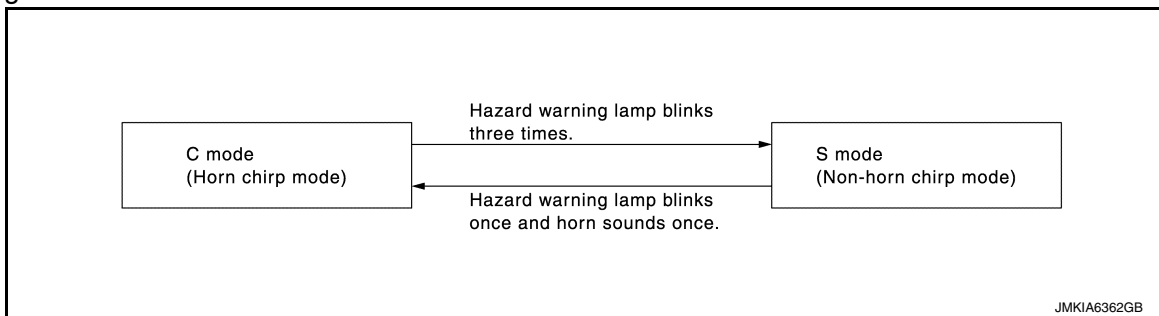

AUTO DOOR LOCK FUNCTION

After door is unlocked by Intelligent Key button operation and if 60 seconds or more passes without performing the following operation, all doors are locked. However, operation check function does not activate.

Operating condition	<ul style="list-style-type: none"> • Door switch is ON (door is open) • Door is locked • Push switch is pressed
---------------------	--

How To Change Auto Door Lock Operation Mode

Auto door lock operation mode can be changed using CONSULT.

Refer to [DLK-28. "INTELLIGENT KEY : CONSULT Function \(BCM - INTELLIGENT KEY\)"](#).

LIST OF OPERATION RELATED PARTS

Parts marked with × are the parts related to operation.

SYSTEM (INTELLIGENT KEY SYSTEM)

< SYSTEM DESCRIPTION >

[WITH INTELLIGENT KEY SYSTEM]

Remote keyless entry functions	Intelligent Key	Door switch	Door lock actuator	Push-button ignition switch	Intelligent Key warning buzzer	CAN communication system	BCM	Combination meter	Hazard warning lamp	Horn	IPDM E/R
Door lock/unlock function	x	x	x			x	x				
Hazard and horn reminder function	x				x	x	x	x	x	x	x
Selective unlock function	x	x	x			x	x				
Auto door lock function	x	x		x		x	x				

KEY REMINDER FUNCTION

KEY REMINDER FUNCTION : System Diagram

INFOID:000000012196590

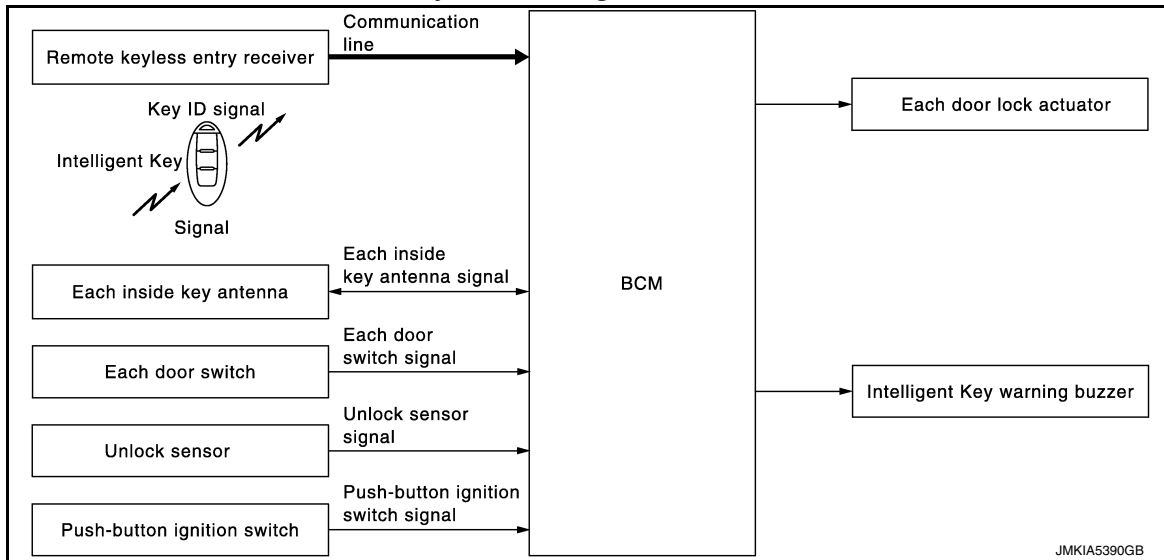

KEY REMINDER FUNCTION : System Description

INFOID:000000012196591

Key reminder is the function that prevents the key from being left in the vehicle. Key reminder has the following 3 functions.

Key remainder function	Operation condition	Operation
Driver side door closed*	Right after driver side door is closed under the following conditions <ul style="list-style-type: none"> Intelligent Key is inside the vehicle Driver side door is opened Driver side door is in unlock state 	All doors unlock
Door is open to closed	Right after all doors are closed under the following conditions <ul style="list-style-type: none"> Intelligent Key is inside the vehicle Any door is opened All doors are locked. 	<ul style="list-style-type: none"> All doors unlock Honk Intelligent Key warning buzzer
Back door is closed	Right after back door is closed under the following conditions <ul style="list-style-type: none"> Intelligent Key is inside the vehicle All doors (except back door) are closed All doors (except back door) are locked 	<ul style="list-style-type: none"> All doors unlock Back door can open with back door opener switch Honk Intelligent Key warning buzzer

SYSTEM (INTELLIGENT KEY SYSTEM)

[WITH INTELLIGENT KEY SYSTEM]

< SYSTEM DESCRIPTION >

*:If the door closing impact shocks the door lock knob, or contacts against baggage with the door lock knob might activate the door locks accidentally but unlock operation is perform in these cases.

CAUTION:

- The above function operates when the Intelligent Key is inside the vehicle. However, there may be times when the Intelligent Key cannot be detected, and this function does not operate when the Intelligent Key is on the instrument panel, rear parcel shelf, or in the glove box. Also, this system sometimes does not operate if the Intelligent Key is in the door pocket for the open door.

WARNING FUNCTION

WARNING FUNCTION : System Description

INFOID:000000012196592

OPERATION DESCRIPTION

The warning function are as per the following items and are given to the user as warning information and warnings using combinations of Intelligent Key warning buzzer, combination meter buzzer, KEY warning lamp, shift P warning lamp and engine start operation indicator lamp.

- Intelligent Key system malfunction
- OFF position warning
- P position warning
- ACC warning
- Take away warning
- Door lock operation warning
- Engine start information
- Intelligent Key low battery warning
- Key ID warning

OPERATION CONDITION

Operation condition of warning and information is as per the following table.

Warning/Information functions		Operation procedure
Intelligent Key system malfunction		A malfunction is detected on BCM and key warning lamp turns ON
OFF position warning	For internal	When condition A, B or condition C is satisfied <ul style="list-style-type: none"> • Condition A <ul style="list-style-type: none"> - Ignition switch: ACC position - Door switch (driver side): ON (Door is open) • Condition B <ul style="list-style-type: none"> - Turn ignition switch from ON to OFF while door is open • Condition C <ul style="list-style-type: none"> - Intelligent Key backside is contacted to ignition switch while brake pedal is depressed and ignition switch is LOCK or OFF (When the Intelligent Key battery is discharged) - Door switch (driver side): ON (Door is open)
	For external*	OFF position warning (For internal) is in active mode, driver side door is closed NOTE: OFF position warning (for external) operates only when driver door is closed after each of P position warning, ACC warning, and OFF position warning (internal) sounds.
P position warning*	For internal	<ul style="list-style-type: none"> • Shift position: Except P position • Engine is running to stopped (Ignition switch is ON to OFF)
	For external	<ul style="list-style-type: none"> • P position warning (For internal) operates • Door switch: ON to OFF (Door is open to close) • Intelligent Key cannot be detected inside the vehicle
ACC warning*		<ul style="list-style-type: none"> • After P position warning operates, or when ignition switch is turned ON immediately after P position warning operates • Ignition switch: ACC position

A
B
C
D
E
F
G
H
I
J
L
M
N
O
P

DLK

SYSTEM (INTELLIGENT KEY SYSTEM)

< SYSTEM DESCRIPTION >

[WITH INTELLIGENT KEY SYSTEM]

Warning/Information functions		Operation procedure
Take away warning	Door status changes from open to close	<ul style="list-style-type: none"> Ignition switch: Except LOCK position Door switch: ON to OFF (Door is open to close) Registered Intelligent Key is not detected inside the vehicle
	Door status is open	<ul style="list-style-type: none"> Door switch: ON (Door is open) Registered Intelligent Key is not detected inside the vehicle during Key ID verification for 5 seconds
	Push button-ignition switch operation	<ul style="list-style-type: none"> Ignition switch: Except LOCK position Press push-button ignition switch Registered Intelligent Key is not detected inside the vehicle
Door lock operation warning		When door lock operation is requested while door lock operating condition of door request switch not satisfied
Engine start information	Ignition switch is ON position	<ul style="list-style-type: none"> Ignition switch: ON position Shift position: P position* Engine is stopped
	Ignition switch is except ON position	<ul style="list-style-type: none"> Ignition switch: Except ON position Shift position: P position* Intelligent Key can be detected inside the vehicle
Intelligent Key low battery warning		BCM detects that Intelligent Key is low battery, after ignition switch is turned ON
Key ID warning		<ul style="list-style-type: none"> Push-button ignition switch is pressed Registered Intelligent Key is not detected inside the vehicle

*: M/T models do not apply.

WARNING METHOD

The following table shows the alarm or warning methods with chime.

Warning/Information functions		"KEY" warning lamp	Shift P warning lamp	Warning chime		Engine start operation indicator lamp
				Combination meter buzzer	Intelligent Key warning buzzer	
Intelligent Key system malfunction		Indicate	—	—	—	—
OFF position warning	For internal	—	—	Activate	—	—
	For external*	—	—	—	Activate	—
P position warning*	For internal	Blink (yellow)	Indicate	Activate	—	—
	For external		—	—	Active	—
ACC warning*		—	—	Activate	—	—
Take away warning	Door is open to close	Blink (yellow)	—	Activate	Activate	—
	Door is open		—	—	—	—
	Push-ignition switch operation		—	Activate	—	—
Door lock operation warning		—	—	—	Activate	—
Key ID warning		Blink (yellow)	—	—	—	—
Engine start information		—	—	—	—	Indicate
Intelligent Key low battery warning		Blink (green)	—	—	—	—

*: M/T models do not apply.

LIST OF OPERATION RELATED PARTS

Parts marked with × are the parts related to operation.

SYSTEM (INTELLIGENT KEY SYSTEM)

< SYSTEM DESCRIPTION >

[WITH INTELLIGENT KEY SYSTEM]

Warning function		Intelligent Key	Ignition switch	Door switch	Door request switch	Inside key antenna	Outside key antenna	Intelligent Key warning buzzer	Combination meter warning buzzer	CAN communication system	BCM	Shift P warning lamp	Engine start operation indicator lamp	"KEY" warning lamp
Intelligent Key system malfunction										×	×			×
OFF position warning	For internal			×					×	×	×			
	For external			×				×			×			
P position warning			×						×	×	×	×		×
ACC warning			×						×	×	×			
Take away warning	Door is open or close	×		×		×		×	×	×	×			×
	Door is open	×		×		×				×	×			×
	Push-button ignition switch operation	×	×			×			×	×	×			×
Door lock operation warning		×		×	×	×	×	×			×			
Key ID warning			×			×				×	×			×
Engine start information		×	×			×				×	×		×	
Steering lock information			×							×	×			
Intelligent Key low battery warning		×				×				×	×			×

A
B
C
D
E
F
G
H
I
J
L
M
N
O
P

DLK

BACK DOOR OPENER SYSTEM

[WITH INTELLIGENT KEY SYSTEM]

< SYSTEM DESCRIPTION >

BACK DOOR OPENER SYSTEM

System Diagram

INFOID:000000012196593

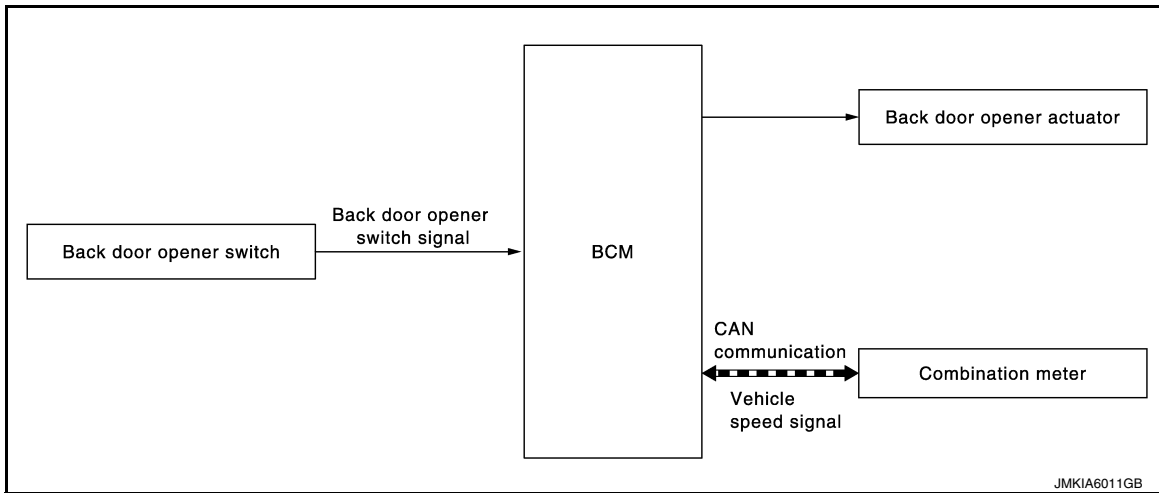

System Description

INFOID:000000012196594

BACK DOOR OPENER OPERATION

When back door opener switch is pressed, BCM operates back door opener actuator.

NOTE:

Back door opener actuator is not for locking the back door. The function is only to open the back door.

OPERATION CONDITION

If the following conditions are satisfied, back door opener operation is performed.

Back door opener switch operation	Operation condition
Back door open	<ul style="list-style-type: none"> When back door is unlocked using back door opener request switch (selective unlock mode), or after BCM outputs all doors unlock signal Vehicle speed is less than 5 km/h (3 MPH)

NOTE:

- When battery terminal is disconnected and reconnected during all doors unlock state, back door may not open.
- Regardless of door lock actuator state, BCM resets recognition of all doors unlock state approximately 30 seconds after battery terminal is disconnected and BCM recognizes that all doors are in lock state.
- When battery terminal is reconnected and back door does not open, have BCM recognize that all doors are in unlock state.

DIAGNOSIS SYSTEM (BCM)

[WITH INTELLIGENT KEY SYSTEM]

< SYSTEM DESCRIPTION >

DIAGNOSIS SYSTEM (BCM)

COMMON ITEM

COMMON ITEM : CONSULT Function (BCM - COMMON ITEM)

INFOID:000000012998445

APPLICATION ITEM

CONSULT performs the following functions via CAN communication with BCM.

Diagnosis mode	Function Description
Work Support	Changes the setting for each system function.
Self Diagnostic Result	Displays the diagnosis results judged by BCM.
CAN Diag Support Monitor	Monitors the reception status of CAN communication viewed from BCM.
Data Monitor	The BCM input/output signals are displayed.
Active Test	The signals used to activate each device are forcibly supplied from BCM.
Ecu Identification	The BCM part number is displayed.
Configuration	<ul style="list-style-type: none"> Read and save the vehicle specification. Write the vehicle specification when replacing BCM.

SYSTEM APPLICATION

BCM can perform the following functions for each system.

NOTE:

It can perform the diagnosis modes except the following for all sub system selection items.

×: Applicable item

System	Sub system selection item	Diagnosis mode		
		Work Support	Data Monitor	Active Test
Door lock	DOOR LOCK	×	×	×
Rear window defogger	REAR DEFOGGER		×	×
Warning chime	BUZZER		×	×
Interior room lamp timer	INT LAMP	×	×	×
Exterior lamp	HEAD LAMP	×	×	×
Wiper and washer	WIPER	×	×	×
Turn signal and hazard warning lamps	FLASHER	×	×	×
Air conditioning system	AIR CONDITONER		×	×*
<ul style="list-style-type: none"> Intelligent Key system Engine start system 	INTELLIGENT KEY	×	×	×
Combination switch	COMB SW		×	
Body control system	BCM	×		
NVIS - NATS	IMMU	×	×	×
Interior room lamp battery saver	BATTERY SAVER	×	×	×
Back door open	TRUNK		×	
Theft warning alarm	THEFT ALM	×	×	×
RAP	RETAINED PWR		×	
Signal buffer system	SIGNAL BUFFER		×	×
TPMS	AIR PRESSURE MONITOR	×	×	×

NOTE:

*: For models with automatic A/C, this diagnosis mode is not used.

FREEZE FRAME DATA (FFD)

The BCM records the following vehicle condition at the time a particular DTC is detected, and displays on CONSULT.

DIAGNOSIS SYSTEM (BCM)

[WITH INTELLIGENT KEY SYSTEM]

< SYSTEM DESCRIPTION >

CONSULT screen item	Indication/Unit	Description	
Vehicle Speed	km/h	Vehicle speed of the moment a particular DTC is detected	
Odo/Trip Meter	km	Total mileage (Odometer value) of the moment a particular DTC is detected	
Vehicle Condition	SLEEP>LOCK	Power position status of the moment a particular DTC is detected	While turning BCM status from low power consumption mode to normal mode (Power position is "LOCK"*.)
	SLEEP>OFF		While turning BCM status from low power consumption mode to normal mode (Power position is "OFF".)
	LOCK>ACC		While turning power position from "LOCK"* to "ACC"
	ACC>ON		While turning power position from "ACC" to "IGN"
	RUN>ACC		While turning power position from "RUN" to "ACC" (Vehicle is stopping and selector lever is except P position.)
	CRANK>RUN		While turning power position from "CRANKING" to "RUN" (From cranking up the engine to run it)
	RUN>URGENT		While turning power position from "RUN" to "ACC" (Emergency stop operation)
	ACC>OFF		While turning power position from "ACC" to "OFF"
	OFF>LOCK		While turning power position from "OFF" to "LOCK"*
	OFF>ACC		While turning power position from "OFF" to "ACC"
	ON>CRANK		While turning power position from "IGN" to "CRANKING"
	OFF>SLEEP		While turning BCM status from normal mode (Power position is "OFF".) to low power consumption mode
	LOCK>SLEEP		While turning BCM status from normal mode (Power position is "LOCK"*.) to low power consumption mode
	LOCK		Power position is "LOCK"*
	OFF		Power position is "OFF" (Ignition switch OFF)
	ACC		Power position is "ACC" (Ignition switch ACC)
	ON		Power position is "IGN" (Ignition switch ON with engine stopped)
	ENGINE RUN		Power position is "RUN" (Ignition switch ON with engine running)
CRANKING	Power position is "CRANKING" (At engine cranking)		
IGN Counter	0 - 39	The number of times that ignition switch is turned ON after DTC is detected <ul style="list-style-type: none"> • The number is 0 when a malfunction is detected now. • The number increases like 1 → 2 → 3...38 → 39 after returning to the normal condition whenever ignition switch OFF → ON. • The number is fixed to 39 until the self-diagnosis results are erased if it is over 39. 	

NOTE:

*: Power position shifts to "LOCK" from "OFF", when ignition switch is in the OFF position, selector lever is in the P position (A/T models and CVT models), and any of the following conditions are met.

- Closing door
- Opening door
- Door is locked using door request switch
- Door is locked using Intelligent Key

The power position shifts to "ACC" when the push-button ignition switch (push switch) is pushed at "LOCK".

DOOR LOCK

DOOR LOCK : CONSULT Function (BCM - DOOR LOCK)

INFOID:000000012196596

BCM CONSULT FUNCTION

CONSULT performs the following functions via CAN communication with BCM.

WORK SUPPORT

DIAGNOSIS SYSTEM (BCM)

[WITH INTELLIGENT KEY SYSTEM]

< SYSTEM DESCRIPTION >

Monitor item	Description
DOOR LOCK-UNLOCK SET	Anti-hijack function mode can be changed to operation with this mode <ul style="list-style-type: none"> • On: Operate • Off: Non-operation
AUTOMATIC DOOR LOCK SELECT	Automatic door lock function mode can be selected from the following in this mode <ul style="list-style-type: none"> • VH SPD: All doors are locked when vehicle speed more than 24km/h (15MPH) • P RANGE*: All doors are locked when shifting the selector lever from P position to other than the P position
AUTOMATIC DOOR UNLOCK SELECT	Automatic door unlock function mode can be selected from the following in the mode <ul style="list-style-type: none"> • MODE 1: All doors are unlocked when the power supply position is changed from ON to OFF • MODE 2*: All doors are unlocked when shifting the selector lever from any position other than the P to P position • MODE 3: Driver side door is unlocked when the power supply position is changed from ON to OFF • MODE 4*: Driver side door is unlocked when shifting the selector lever from any position other than the P to P position • MODE 5: This item is displayed, but cannot be monitored • MODE 6: This item is displayed, but cannot be monitored
AUTOMATIC LOCK/UNLOCK SET	Automatic door lock/unlock function mode can be selected from the following in this mode <ul style="list-style-type: none"> • Off: Non-operational • Unlock Only: Door unlock operation only • Lock Only: Door lock operation only • Lock/Unlock: Lock and unlock operation

*: P range interlock door lock can be selected for M/T models, but automatic door lock/unlock function does not operate.

DATA MONITOR

NOTE:

The following table includes information (items) inapplicable to this vehicle. For information (items) applicable to this vehicle, refer to CONSULT display items.

Monitor Item	Contents
REQ SW-DR	Indicated [On/Off] condition of door request switch (driver side)
REQ SW-AS	Indicated [On/Off] condition of door request switch (passenger side)
REQ SW-BD/TR	Indicated [On/Off] condition of back door request switch
DOOR SW-DR	Indicated [On/Off] condition of front door switch (driver side)
DOOR SW-AS	Indicated [On/Off] condition of front door switch (passenger side)
DOOR SW-RR	Indicated [On/Off] condition of rear door switch RH
DOOR SW-RL	Indicated [On/Off] condition of rear door switch LH
DOOR SW-BK	Indicated [On/Off] condition of back door switch
CDL LOCK SW	Indicated [On/Off] condition of lock signal from door lock unlock switch
CDL UNLOCK SW	Indicated [On/Off] condition of unlock signal from door lock unlock switch
KEY CYL LK-SW	Indicated [On/Off] condition of lock signal from door key cylinder
KEY CYL UN-SW	Indicated [On/Off] condition of unlock signal from door key cylinder

ACTIVE TEST

Test item	Description
DOOR LOCK	This test is able to check door lock/unlock operation <ul style="list-style-type: none"> • The all door lock actuators are locked when "ALL LOCK" on CONSULT screen is touched • The all door lock actuators are unlocked when "ALL UNLK" on CONSULT screen is touched • The door lock actuator (driver side) is unlocked when "DR UNLK" on CONSULT screen is touched • The door lock actuator (passenger side) is unlocked when "AS UNLK" on CONSULT screen is touched • The door lock actuator (other) is unlocked when "OTR ULK" on CONSULT screen is touched

INTELLIGENT KEY

DIAGNOSIS SYSTEM (BCM)

[WITH INTELLIGENT KEY SYSTEM]

< SYSTEM DESCRIPTION >

INTELLIGENT KEY : CONSULT Function (BCM - INTELLIGENT KEY)

INFOID:000000012196597

WORK SUPPORT

Monitor item	Description
INSIDE ANT DIAGNOSIS	This function allows inside key antenna self-diagnosis
LOCK/UNLOCK BY I-KEY	Door lock/unlock function by door request switch mode can be changed to operation in this mode <ul style="list-style-type: none">• On: Operate• Off: Non-operation
ENGINE START BY I-KEY	Engine start function mode can be changed to operation with this mode <ul style="list-style-type: none">• On: Operate• Off: Non-operation
TRUNK/GLASS HATCH OPEN	NOTE: This item is displayed, but cannot be monitored
HORN WITH KEYLESS LOCK	Horn reminder function mode by Intelligent Key button can be changed to operate (ON) or not operate (OFF) with this mode <ul style="list-style-type: none">• On: Operate• Off: Non-operation
PANIC ALARM SET	Panic alarm button pressing time on Intelligent Key remote control button can be selected from the following with this mode <ul style="list-style-type: none">• MODE 1: 0.5 sec• MODE 2: Non-operation• MODE 3: 1.5 sec
TRUNK OPEN DELAY	NOTE: This item is displayed, but cannot be monitored
LO- BATT OF KEY FOB WARN	Intelligent Key low battery warning mode can be changed to operation with this mode <ul style="list-style-type: none">• On: Operate• Off: Non-operation
ANTI KEY LOCK IN FUNCTI	Key reminder function mode can be changed to operation with this mode <ul style="list-style-type: none">• On: Operate• Off: Non-operation
HAZARD ANSWER BACK	Hazard reminder function mode by door request switch and Intelligent Key button can be selected from the following with this mode <ul style="list-style-type: none">• Lock Only: Door lock operation only• Unlock Only: Door unlock operation only• Lock/Unlock: Lock and unlock operation• Off: Non-operation
ANS BACK I-KEY LOCK	Buzzer reminder function (lock operation) mode by door request switch can be selected from the following with this mode <ul style="list-style-type: none">• Horn Chirp: Sound horn• Buzzer: Sound Intelligent Key warning buzzer• Off: Non-operation
ANS BACK I-KEY UNLOCK	Buzzer reminder function (unlock operation) mode by door request switch can be changed to operation with this mode <ul style="list-style-type: none">• On: Operate• Off: Non-operation
SHORT CRANKING OUTPUT	Starter motor can operate during the times below <ul style="list-style-type: none">• 70 msec• 100 msec• 200 msec

DIAGNOSIS SYSTEM (BCM)

[WITH INTELLIGENT KEY SYSTEM]

< SYSTEM DESCRIPTION >

Monitor item	Description
CONFIRM KEY FOB ID	It can be checked whether Intelligent Key ID code is registered or not in this mode
AUTO LOCK SET	Auto door lock operation time can be changed in this mode <ul style="list-style-type: none"> • MODE 1: OFF • MODE 2: 30 sec • MODE 3: 1 minute • MODE 4: 2 minutes • MODE 5: 3 minutes • MODE 6: 4 minutes • MODE 7: 5 minutes

SELF-DIAG RESULT

Refer to [BCS-62. "DTC Index"](#).

DATA MONITOR

NOTE:

The following table includes information (items) inapplicable to this vehicle. For information (items) applicable to this vehicle, refer to CONSULT display items.

Monitor Item	Condition
REQ SW -DR	Indicates [On/Off] condition of door request switch (driver side)
REQ SW -AS	Indicates [On/Off] condition of door request switch (passenger side)
REQ SW -BD/TR	Indicates [On/Off] condition of back door request switch
PUSH SW	Indicates [On/Off] condition of push-button ignition switch
CLUTCH SW*1	Indicates [On/Off] condition of clutch interlock switch
BRAKE SW 1	Indicates [On/Off]*2 condition of stop lamp switch power supply
BRAKE SW 2	Indicates [On/Off] condition of stop lamp switch
DETE/CANCL SW	Indicates [On/Off] condition of P position
SFT PN/N SW	Indicates [On/Off] condition of P or N position
UNLK SEN -DR	Indicates [On/Off] condition of driver door UNLOCK status
PUSH SW -IPDM	Indicates [On/Off] condition of push-button ignition switch
IGN RLY1 -F/B	Indicates [On/Off] condition of ignition relay 1
DETE SW -IPDM	Indicates [On/Off] condition of P position
SFT PN -IPDM	Indicates [On/Off] condition of P or N position
SFT P -MET	Indicates [On/Off] condition of P position
SFT N -MET	Indicates [On/Off] condition of N position
ENGINE STATE	Indicates [Stop/Stall/Crank/Run] condition of engine states
S/L LOCK-IPDM	NOTE: This item is displayed, but cannot be monitored
S/L UNLK-IPDM	NOTE: This item is displayed, but cannot be monitored
S/L RELAY-REQ	NOTE: This item is displayed, but cannot be monitored
VEH SPEED 1	Display the vehicle speed signal received from combination meter by numerical value [Km/h]
VEH SPEED 2	Display the vehicle speed signal received from ABS or VDC or TCM by numerical value [Km/h]
DOOR STAT-DR	Indicates [LOCK/READY/UNLK] condition of driver side door status
DOOR STAT-AS	Indicates [LOCK/READY/UNLK] condition of passenger side door status
ID OK FLAG	Indicates [Set/Reset] condition of key ID
PRMT ENG STRT	Indicates [Set/Reset] condition of engine start possibility
PRMT RKE STRT	NOTE: This item is displayed, but cannot be monitored

DIAGNOSIS SYSTEM (BCM)

[WITH INTELLIGENT KEY SYSTEM]

< SYSTEM DESCRIPTION >

Monitor Item	Condition
TRNK/HAT MNTR	NOTE: This item is displayed, but cannot be monitored
RKE-LOCK	Indicates [On/Off] condition of LOCK signal from Intelligent Key
RKE-UNLOCK	Indicates [On/Off] condition of UNLOCK signal from Intelligent Key
RKE-TR/BD	NOTE: This item is displayed, but cannot be monitored
RKE-PANIC	Indicates [On/Off] condition of PANIC button of Intelligent Key
RKE-MODE CHG	Indicates [On/Off] condition of MODE CHANGE signal from Intelligent Key
RKE OPE COUN1	When remote keyless entry receiver receives the signal transmitted while operating on Intelligent Key, the numerical value start changing
RKE OPE COUN2	NOTE: This item is displayed, but cannot be monitored

*1: It is displayed but does not operate on CVT models.

*2: OFF is displayed when brake pedal is depressed while brake switch power supply is OFF.

ACTIVE TEST

Test item	Description
OUTSIDE BUZZER	This test is able to check Intelligent Key warning buzzer operation <ul style="list-style-type: none"> • On: Operate • Off: Non-operation
INSIDE BUZZER	This test is able to check warning chime in combination meter operation <ul style="list-style-type: none"> • Take Out: Take away warning chime sounds when CONSULT screen is touched • Key: Key warning chime sounds when CONSULT screen is touched • Knob: OFF position warning chime sounds when CONSULT screen is touched • Off: Non-operation
INDICATOR	This test is able to check warning lamp operation <ul style="list-style-type: none"> • KEY ON: "KEY" Warning lamp illuminates when CONSULT screen is touched • KEY IND: "KEY" Warning lamp blinks when CONSULT screen is touched • Off: Non-operation
INT LAMP	This test is able to check interior room lamp operation <ul style="list-style-type: none"> • On: Operate • Off: Non-operation
LCD	This test is able to check meter display information <ul style="list-style-type: none"> • BP N: Engine start operation indicator lamp indicate when CONSULT screen is touched • BP I: Engine start operation indicator lamp indicate when CONSULT screen is touched • ID NG: This item is displayed, but cannot be monitored • ROTAT: This item is displayed, but cannot be monitored • SFT P: Shift P warning lamp indicate when CONSULT screen is touched • INSRT: This item is displayed, but cannot be monitored • BATT: Key warning lamp indicator when CONSULT screen is touched • NO KY: Key warning lamp indicator when CONSULT screen is touched • OUTKEY: Engine start operation indicator lamp indicate when CONSULT screen is touched • LK WN: Engine start operation indicator lamp indicate when CONSULT screen is touched
FLASHER	This test is able to check security hazard lamp operation The hazard lamps are activated after "LH/RH/Off" on CONSULT screen is touched
HORN	This test is able to check horn operation The horn is activated after "ON" on CONSULT screen is touched
P RANGE	This test is able to check CVT shift selector power supply <ul style="list-style-type: none"> • On: Operate • Off: Non-operation
ENGINE SW ILLUMI	This test is able to check push-ignition switch illumination operation Push-ignition switch illumination illuminates when "ON" on CONSULT screen is touched
PUSH SWITCH INDICATOR	This test is able to check LOCK indicator in push-ignition switch operation LOCK indicator in push-ignition switch illuminates when "ON" on CONSULT screen is touched

DIAGNOSIS SYSTEM (BCM)

[WITH INTELLIGENT KEY SYSTEM]

< SYSTEM DESCRIPTION >

Test item	Description
BATTERY SAVER	This test is able to check interior room lamp operation. The interior room lamp will be activated after "ON" on CONSULT screen is touched.
TRUNK/BACK DOOR	This test is able to check back door opener actuator open operation. This actuator opens when "Open" on CONSULT screen is touched.

TRUNK

TRUNK : CONSULT Function (BCM - TRUNK)

INFOID:000000012196598

DATA MONITOR

NOTE:

The following table includes information (items) inapplicable to this vehicle. For information (items) applicable to this vehicle, refer to CONSULT display items.

Monitor Item	Contents
PUSH SW	Indicates [On/Off] condition of push switch
UNLK SEN -DR	Indicates [On/Off] condition of unlock sensor
VEH SPEED 1	Indicates [Km/h] condition of vehicle speed signal from combination meter
TR/BD OPEN SW	Indicates [ON/OFF] condition of back door opener switch.
TRNK/HAT MNTR	NOTE: This item is displayed, but cannot be monitored
RKE-TR/BD	NOTE: This item is displayed, but cannot be monitored

A
B
C
D
E
F
G
H
I
J
L
M
N
O
P

DLK

ECU DIAGNOSIS INFORMATION

BCM

List of ECU Reference

INFOID:0000000012196599

ECU	Reference
BCM	BCS-39, "Reference Value"
	BCS-60, "Fail-safe"
	BCS-61, "DTC Inspection Priority Chart"
	BCS-62, "DTC Index"

DOOR & LOCK SYSTEM

[WITH INTELLIGENT KEY SYSTEM]

< WIRING DIAGRAM >

WIRING DIAGRAM

DOOR & LOCK SYSTEM

Wiring Diagram

INFOID:000000012196600

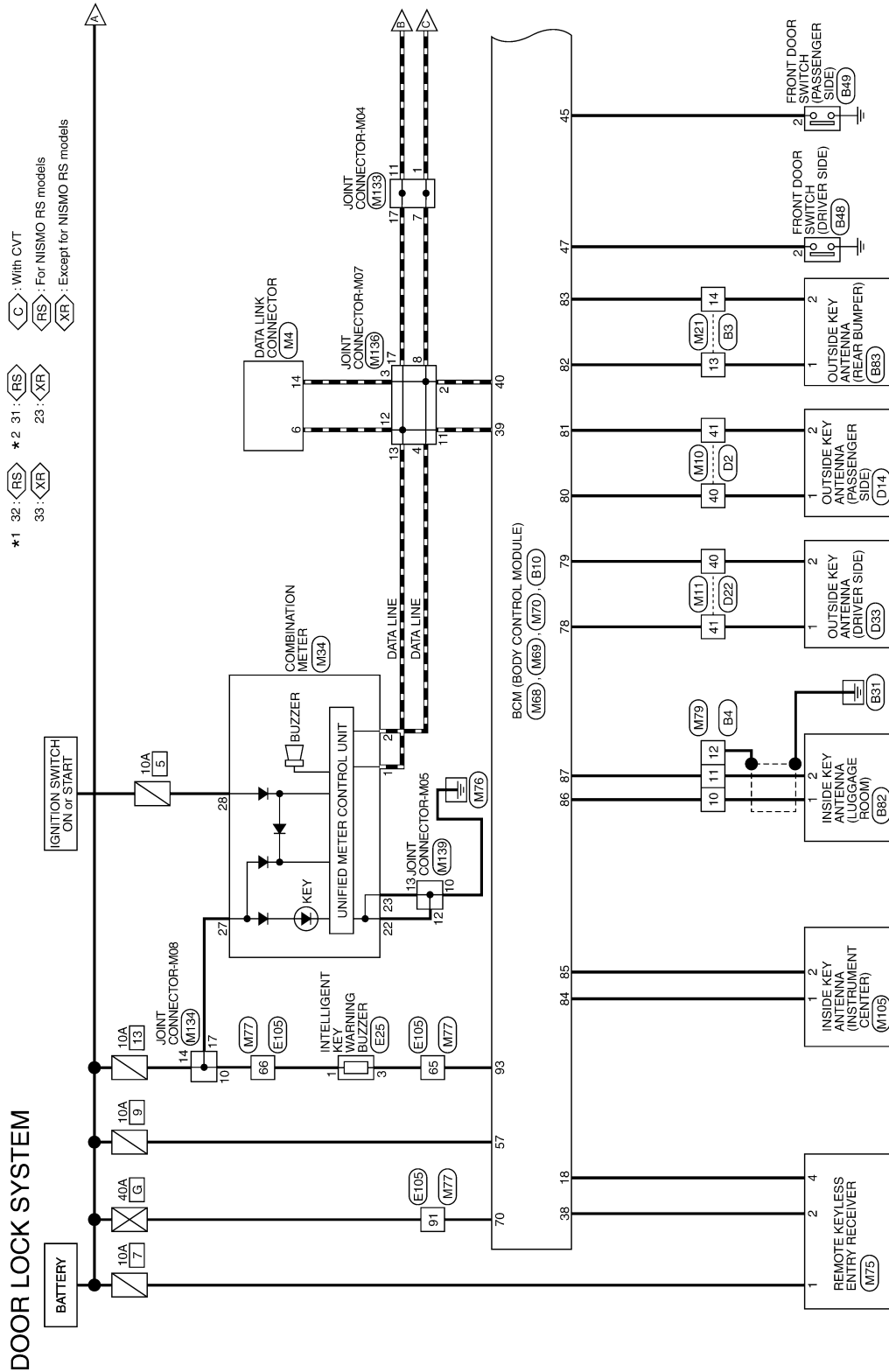

2015/08/18

JRKWF4404GB

A
B
C
D
E
F
G
H
I
J
K
L
M
N
O
P

DLK

DOOR & LOCK SYSTEM

< WIRING DIAGRAM >

[WITH INTELLIGENT KEY SYSTEM]

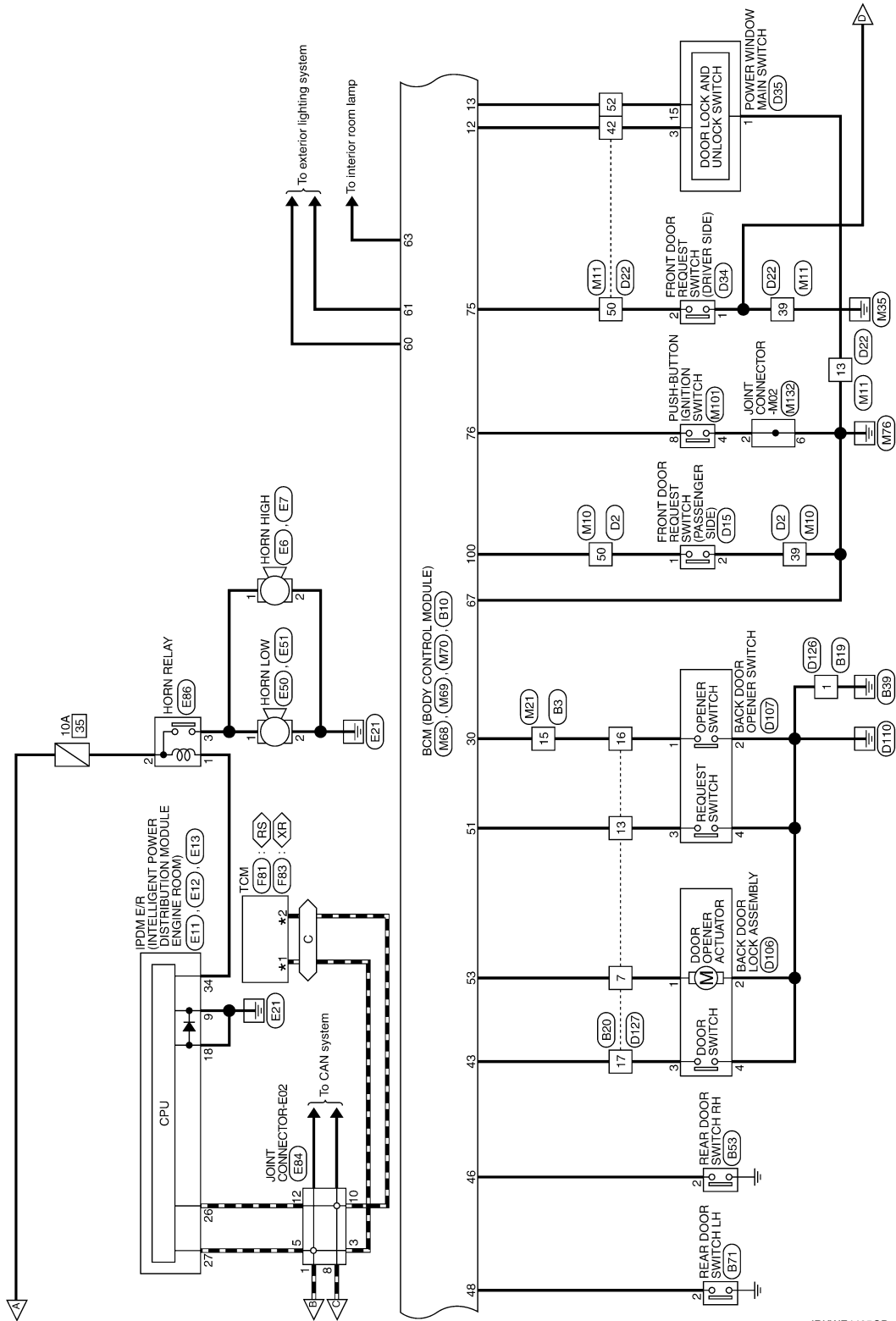

JRKWF4405GB

DOOR & LOCK SYSTEM

[WITH INTELLIGENT KEY SYSTEM]

< WIRING DIAGRAM >

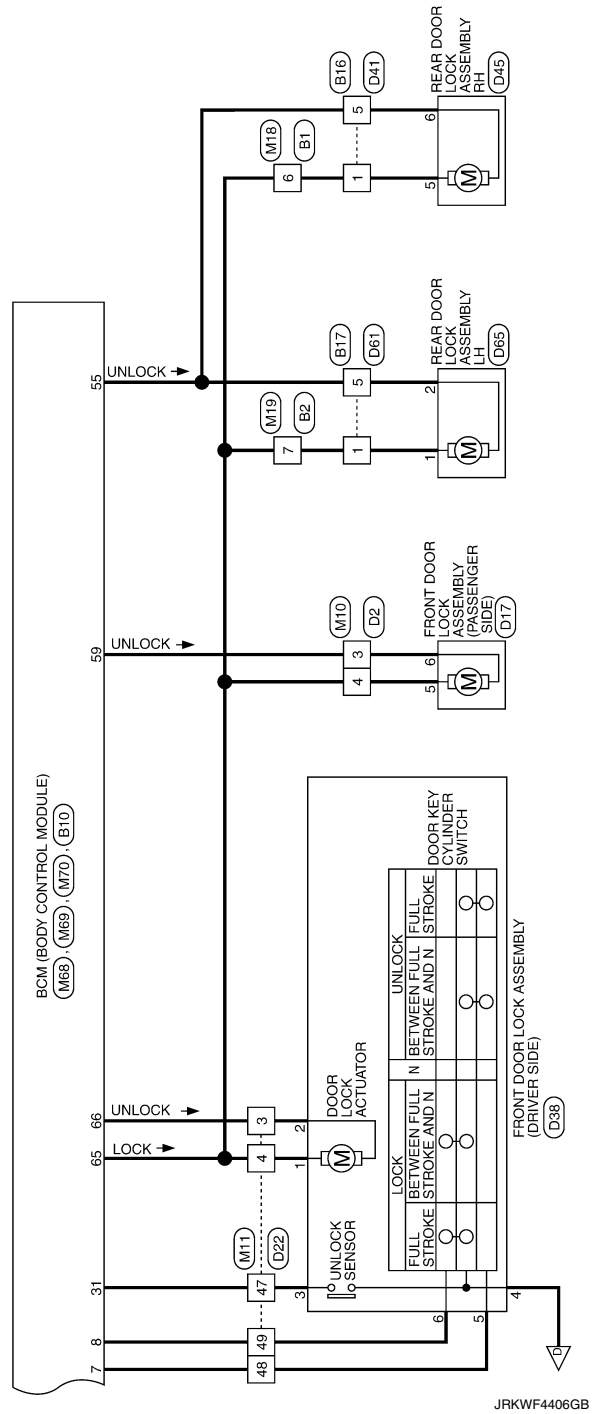

A
B
C
D
E
F
G
H
I
J
DLK
L
M
N
O
P

DOOR & LOCK SYSTEM

< WIRING DIAGRAM >

[WITH INTELLIGENT KEY SYSTEM]

DOOR LOCK SYSTEM

Connector No.	B31
Connector Name	WIRE TO WIRE
Connector Type	NS16PW-CS



Terminal No.	Color Of Wire	Signal Name [Specification]
1	P	-
2	GR	-
6	SB	-
10	W	-
11	L	-
12	R	-
13	GR	-
14	Y	-
15	LG	-
16	BR	-

Connector No.	B32
Connector Name	WIRE TO WIRE
Connector Type	NS16PW-CS

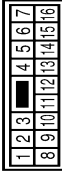

Terminal No.	Color Of Wire	Signal Name [Specification]
1	LG	-
2	L	-
4	Y	-
7	V	-
9	SB	-
10	V	-
11	Y	-
12	GR	-
13	R	-

14	P	-
15	L	-
16	G	-



Connector No.	B33
Connector Name	WIRE TO WIRE
Connector Type	TH132MW-NH



Terminal No.	Color Of Wire	Signal Name [Specification]
10	SHIELD	-
11	R	-
12	G	-
13	W	-
14	B	-
15	L	-
17	LG	-
18	W	-
19	Y	-
20	V	-
26	SHIELD	-
27	WT	-
28	R	-
29	W	-
30	B	-
32	R	-

Connector No.	B4
Connector Name	WIRE TO WIRE
Connector Type	TH132MW-NH



Terminal No.	Color Of Wire	Signal Name [Specification]
2	BR	-
3	GR	-
5	BR	-
6	L	-
10	V	-
11	LG	-
12	SHIELD	-

Connector No.	B10
Connector Name	BCM (BODY CONTROL MODULE)
Connector Type	FEAD5PB-FH6-SA



Terminal No.	Color Of Wire	Signal Name [Specification]
43	P	BACK DOORS SW
44	LG	REAR WIPER STOP POSITION
45	R	PASSENGER DOOR SW
46	LG	REAR RH DOOR SW
47	SB	DRIVER DOOR SW
48	BR	REAR LH DOOR SW
49	L	LUGGAGE LAMP OUTPUT
51	Y	BACK DOOR RECSW
53	GR	BK DOOR OPEN OUTPUT
54	P	REAR WIPER OUTPUT
55	G	RR DOOR LINK OUTPUT

Connector No.	B16
Connector Name	WIRE TO WIRE
Connector Type	NS10PW-CS

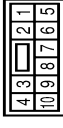

Terminal No.	Color Of Wire	Signal Name [Specification]
1	SB	-
4	BR	-
5	G	-
7	L	-
8	R	-
9	LG	-
10	Y	-

Connector No.	B17
Connector Name	WIRE TO WIRE
Connector Type	NS10PW-CS

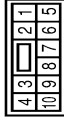

Terminal No.	Color Of Wire	Signal Name [Specification]
1	V	-
4	L	-
5	G	-
7	Y	-
8	GR	-
9	R	-
10	P	-

JRKWF4407GB

DOOR & LOCK SYSTEM

< WIRING DIAGRAM >

[WITH INTELLIGENT KEY SYSTEM]

DOOR LOCK SYSTEM

Connector No.	B19
Connector Name	WIRE TO WIRE
Connector Type	M023MB-P1-C



Terminal No.	Color Of Wire	Signal Name [Specification]
1	B	-
2	R	-

Connector No.	B20
Connector Name	WIRE TO WIRE
Connector Type	NH10MW-C510

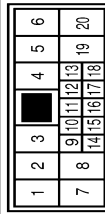

Terminal No.	Color Of Wire	Signal Name [Specification]
7	GR	-
8	LG	-
9	R	-
10	B	-
12	R	-
13	Y	-
14	SHIELD	-
15	W	-
16	L	-
17	P	-
18	GR	-

Connector No.	B48
Connector Name	FRONT DOOR SWITCH (DRIVER SIDE)
Connector Type	A03FW

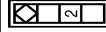

Terminal No.	Color Of Wire	Signal Name [Specification]
2	SB	-

Connector No.	B49
Connector Name	FRONT DOOR SWITCH (PASSENGER SIDE)
Connector Type	A03FW

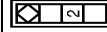

Terminal No.	2	Color Of Wire	R	Signal Name [Specification]	-
--------------	---	---------------	---	-----------------------------	---

Connector No.	B53
Connector Name	REAR DOOR SWITCH RH
Connector Type	A03FW

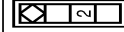

Terminal No.	2	Color Of Wire	LG	Signal Name [Specification]	-
--------------	---	---------------	----	-----------------------------	---

Connector No.	B71
Connector Name	REAR DOOR SWITCH LH
Connector Type	A03FW

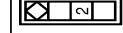

Terminal No.	2	Color Of Wire	BR	Signal Name [Specification]	-
--------------	---	---------------	----	-----------------------------	---

Connector No.	B82
Connector Name	INSIDE KEY ANTENNA (LUGGAGE ROOM)
Connector Type	RK02FL



Terminal No.	1	Color Of Wire	V	Signal Name [Specification]	-
2	LG	-	-	-	-

Connector No.	B83
Connector Name	OUTSIDE KEY ANTENNA (REAR BUMPER)
Connector Type	RK02FL



Terminal No.	Color Of Wire	Signal Name [Specification]
1	W	-
2	B	-

Connector No.	DZ
Connector Name	WIRE TO WIRE
Connector Type	TH40FW-C515

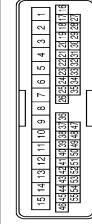

Terminal No.	Color Of Wire	Signal Name [Specification]
2	R	-
3	G	-
4	V	-
13	W	-
14	SB	-
15	L	-
16	GR	-
17	Y	-
18	W	-
19	R	-
24	R	-
25	G	-
38	G	-
39	B	-
40	LG	-
41	Y	-
43	P	-

A
B
C
D
E
F
G
H
I
J
K
L
M
N
O
P

DLK

DOOR & LOCK SYSTEM

[WITH INTELLIGENT KEY SYSTEM]

< WIRING DIAGRAM >

DOOR LOCK SYSTEM

44	V	-
45	W	-
46	BG	-
50	P	-

Connector No.	D14
Connector Name	OUTSIDE KEY ANTENNA (PASSENGER SIDE)
Connector Type	RK02MGT



Terminal No.	Color Of Wire	Signal Name [Specification]
1	LG	-
2	Y	-

Connector No.	D15
Connector Name	FRONT DOOR REQUEST SWITCH (PASSENGER SIDE)
Connector Type	RK02FGY



Terminal No.	Color Of Wire	Signal Name [Specification]
1	P	-
2	B	-

Connector No.	D17
Connector Name	FRONT DOOR LOCK ASSEMBLY (PASSENGER SIDE)
Connector Type	EG08CFY-BS

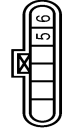

Terminal No.	Color Of Wire	Signal Name [Specification]
5	V	-
6	Y	-

Connector No.	D22
Connector Name	WIRE TO WIRE
Connector Type	TH4DFW-CS15

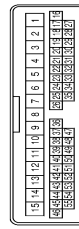

Terminal No.	Color Of Wire	Signal Name [Specification]
1	P	-
2	W	-
3	SB	-
4	V	-
7	G	-
8	BG	-
9	LG	-
10	Y	-
11	W	-
12	SB	-
13	B	-
14	L	-
15	P	-
16	LG	-
17	BR	-
18	P	-
19	V	-
24	G	-

45	R	-
48	G	-
49	Y	-
40	V	-
41	P	-
42	R	-
43	GR	-
44	W	-
45	Y	-
46	BG	-
47	G	-
48	L	-
49	R	-
50	LG	-
52	BR	-

Connector No.	D33
Connector Name	OUTSIDE KEY ANTENNA (DRIVER SIDE)
Connector Type	RK02MGT



Terminal No.	Color Of Wire	Signal Name [Specification]
1	P	-
2	V	-

Connector No.	D34
Connector Name	FRONT DOOR REQUEST SWITCH (DRIVER SIDE)
Connector Type	RK02FGY



Terminal No.	Color Of Wire	Signal Name [Specification]
2	LG	-

Connector No.	D35
Connector Name	POWER WINDOW MAIN SWITCH
Connector Type	NS16FW-CS

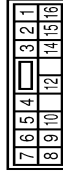

Terminal No.	Color Of Wire	Signal Name [Specification]
1	B	GROUND
2	SB	FRONT POWER WINDOW MOTOR (PASSENGER SIDE) DOWN SIGNAL
3	R	-
4	P	ENCODER SIGNAL 2
5	W	ENCODER SIGNAL 1
6	Y	REAR POWER WINDOW MOTOR RH DOWN SIGNAL
7	LG	REAR POWER WINDOW MOTOR LH DOWN SIGNAL
8	BG	REAR POWER WINDOW MOTOR RH UP SIGNAL
9	LG	REAR POWER WINDOW MOTOR LH UP SIGNAL
10	G	REAR POWER WINDOW MOTOR COMMON SUPPLY
11	SB	ENCODER SIGNAL 3
12	LG	ENCODER SIGNAL 4
13	LG	ENCODER SIGNAL 5
14	LG	ENCODER SIGNAL 6
15	BR	FRONT POWER WINDOW MOTOR (PASSENGER SIDE) UP SIGNAL
16	W	FRONT POWER WINDOW MOTOR (PASSENGER SIDE) UP SIGNAL

JRKWF4409GB

DOOR & LOCK SYSTEM

< WIRING DIAGRAM >

[WITH INTELLIGENT KEY SYSTEM]

DOOR LOCK SYSTEM

Connector No.	D107
Connector Name	BACK DOOR OPENER SWITCH
Connector Type	TK068WV-1V



Connector No.	D65
Connector Name	REAR DOOR LOCK ASSEMBLY LH
Connector Type	EG06CF-RS



Connector No.	D45
Connector Name	REAR DOOR LOCK ASSEMBLY RH
Connector Type	EG06CF-RS



Connector No.	D38
Connector Name	FRONT DOOR LOCK ASSEMBLY (DRIVER SIDE)
Connector Type	EG06CF-RS



Terminal No.	Color Of Wire	Signal Name [Specification]
1	L	-
2	B	-
3	SB	-
4	B	-
5	V	-
6	B	-

Connector No.	D106
Connector Name	BACK DOOR LOCK ASSEMBLY
Connector Type	NS04FV-CS

Connector No.	D61
Connector Name	WIRE TO WIRE
Connector Type	NS10MMW-CS

Connector No.	D41
Connector Name	WIRE TO WIRE
Connector Type	NS10MMW-CS

Connector No.	D126
Connector Name	WIRE TO WIRE
Connector Type	W02FB-LC

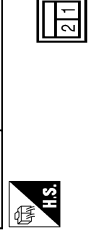

Terminal No.	Color Of Wire	Signal Name [Specification]
1	GR	-
2	B	-
3	P	-
4	B	-

Terminal No.	Color Of Wire	Signal Name [Specification]
1	L	-
2	G	-
3	LG	-
4	BR	-
5	V	-
6	Y	-

Terminal No.	Color Of Wire	Signal Name [Specification]
1	V	-
4	L	-
5	G	-
7	LG	-
8	GR	-
9	BR	-
10	Y	-

Terminal No.	Color Of Wire	Signal Name [Specification]
1	B	-
2	R	-

Terminal No.	Color Of Wire	Signal Name [Specification]
1	L	-
2	GR	-
3	B	-
4	B	-

Terminal No.	Color Of Wire	Signal Name [Specification]
1	L	-
2	L	-
3	L	-
4	L	-
5	G	-
6	LG	-
7	LG	-
8	GR	-
9	BR	-
10	Y	-

Terminal No.	Color Of Wire	Signal Name [Specification]
1	V	-
4	L	-
5	G	-
7	LG	-
8	GR	-
9	BR	-
10	Y	-

A
B
C
D
E
F
G
H
I
J
DLK
L
M
N
O
P

DOOR & LOCK SYSTEM

< WIRING DIAGRAM >

[WITH INTELLIGENT KEY SYSTEM]

DOOR LOCK SYSTEM

Connector No.	D127
Connector Name	WIRE TO WIRE
Connector Type	MS10FW-CS10

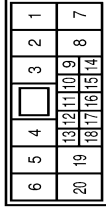

Terminal No.	Color Of Wire	Signal Name [Specification]
1	R	-
7	GR	-
8	LG	-
9	R	-
10	B	-
12	R	-
13	SB	-
14	B	-
15	Y	-
16	L	-
17	P	-
18	V	-

Connector No.	E6
Connector Name	HORN HIGH
Connector Type	PO11E-A



Terminal No.	1	Color Of Wire	G	Signal Name [Specification]
--------------	---	---------------	---	-----------------------------

Connector No.	E7
Connector Name	HORN HIGH
Connector Type	PO11E-A



Terminal No.	Color Of Wire	Signal Name [Specification]
2	GR	-

Connector No.	E11
Connector Name	POWER FOR INTELLIGENT POWER DISTRIBUTION MODULE ENGINE ROOM
Connector Type	MS06FB-LC



Terminal No.	9	Color Of Wire	BF	Signal Name [Specification]
10	L	-	-	-
14	R	-	-	-

Connector No.	E12
Connector Name	POWER FOR INTELLIGENT POWER DISTRIBUTION MODULE ENGINE ROOM
Connector Type	MS08EBC-CS

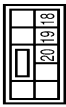

Terminal No.	Color Of Wire	Signal Name [Specification]
18	GR	-
19	R	- [Without front fog lamp]
19	W	- [With front fog lamp]
20	G	- [Without front fog lamp]
20	V	- [With front fog lamp]

Connector No.	E13
Connector Name	POWER FOR INTELLIGENT POWER DISTRIBUTION MODULE ENGINE ROOM
Connector Type	TH127FW-NH

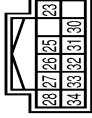

Terminal No.	Color Of Wire	Signal Name [Specification]
23	SB	-
25	BR	-
26	P	-
27	L	-
28	Y	-
30	V	-
31	Y	-
32	R	-
33	G	-
34	L	-

Connector No.	E25
Connector Name	INTELLIGENT KEY WARNING BUZZER
Connector Type	MS03EBA



Terminal No.	Color Of Wire	Signal Name [Specification]
1	R	-
3	L	-

Connector No.	E50
Connector Name	HORN LOW
Connector Type	PO11E-A



Terminal No.	1	Color Of Wire	G	Signal Name [Specification]
--------------	---	---------------	---	-----------------------------

Connector No.	E51
Connector Name	HORN LOW
Connector Type	PO11E-A



JRKWF4411GB

DOOR & LOCK SYSTEM

< WIRING DIAGRAM >

[WITH INTELLIGENT KEY SYSTEM]

DOOR LOCK SYSTEM

Terminal No.	Color Of Wire	Signal Name [Specification]
1	GR	-

Connector No.	E84
Connector Name	JOINT CONNECTOR-E02
Connector Type	A12FL



Terminal No.	Color Of Wire	Signal Name [Specification]
1	L	-
2	L	-
3	L	-
4	L	-
5	L	-
6	L	-
7	P	-
8	P	-
9	P	-
10	P	-
11	P	-
12	P	-

Connector No.	E86
Connector Name	HORN RELAY
Connector Type	Relay_24381_C90A



Terminal No.	Color Of Wire	Signal Name [Specification]
1	L	-
2	BR	-
3	G	-

Connector No.	E105
Connector Name	WIRE TO WIRE
Connector Type	TH883MW_CS16-TM4

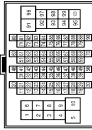

Terminal No.	Color Of Wire	Signal Name [Specification]
1	L	-
4	P	-
10	R	-
11	W	-
12	B	-
13	R	-
14	SHIELD	-
34	BE	-
35	R	-
36	B	-
37	P	-
52	R	-
53	BR	-
54	V	-
55	BE	-
56	Y	-
63	Y	-
64	V	-
65	LG	-
66	R	-
67	W	-
68	SB	-
70	BR	-
71	LG	-
72	V	-
73	L	-
76	R	-
78	B	-
79	W	-
80	L	-
83	Y	-
84	LG	-
85	P	-

88	BE	-
90	SHIELD	-
91	G	-
92	B	-
95	BR	-
96	P	-
97	GF	-
98	W	-
99	V	-
100	O	-

Connector No.	F81
Connector Name	TCM
Connector Type	RH40FB-R28-LRH

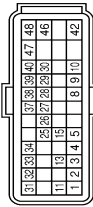

Terminal No.	Color Of Wire	Signal Name [Specification]
1	G	R RANGE SW
2	Y	N RANGE SW
3	W	D RANGE SW
4	B	P RANGE SW
5	BR	GRND
6	BR	CLCK (SEL 2)
8	GF	DATE (LO SEL 1)
10	W	P RANGE SW
11	L	CVT FLUID TEMPERATURE SENSOR
13	SB	SECONDARY PRESSURE SENSOR
15	P	SENSOR GROUND
25	Y	SENSOR POWER SUPPLY
26	LG	STEP MOTOR D
27	GR	STEP MOTOR C
28	V	STEP MOTOR B
29	BG	STEP MOTOR A
30	R	CAN-L
31	P	CAN-H
32	L	PRIMARY SPEED SENSOR
33	BG	SECONDARY SPEED SENSOR
34	R	LOCK-UP-SELECT SOLENOID VALVE
37	L	TORQUE CONVERTER CLUTCH SOLENOID VALVE
38	LG	SECONDARY PRESSURE SENSOR
39	G	STEP MOTOR D
40	W	STEP MOTOR C
41	B	STEP MOTOR B
42	B	STEP MOTOR A
43	B	CAN-L
44	P	CAN-H
45	V	PRIMARY SPEED SENSOR
46	GR	SECONDARY SPEED SENSOR
47	LG	LOCK-UP-SELECT SOLENOID VALVE
48	W	TORQUE CONVERTER CLUTCH SOLENOID VALVE

40	Y	LINE PRESSURE SOLENOID VALVE
42	B	GROUND
43	GR	IGNITION POWER SUPPLY
45	LG	BATTERY POWER SUPPLY (BACK-UP)
46	P	IGNITION POWER SUPPLY

Connector No.	F83
Connector Name	TCM
Connector Type	RH40FB-R28-LRH

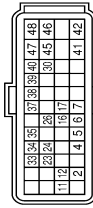

Terminal No.	Color Of Wire	Signal Name [Specification]
2	BR	-
4	W	D RANGE SW
5	LG	N RANGE SW
6	G	R RANGE SW
7	SB	SENSOR GROUND
11	Y	CVT FLUID TEMPERATURE SENSOR
12	SB	SECONDARY PRESSURE SENSOR
15	P	PRIMARY PRESSURE SENSOR
17	P	PRIMARY PRESSURE SENSOR
22	Y	IGNITION POWER SUPPLY
24	LG	LINE PRESSURE SOLENOID VALVE
30	Y	CAN-H
33	L	CAN-L
34	R	OUTPUT SPEED SENSOR
35	BG	PRIMARY SPEED SENSOR
37	L	SELECT SOLENOID VALVE
38	LG	TORQUE CONVERTER CLUTCH SOLENOID VALVE
39	G	SECONDARY PRESSURE SENSOR
40	W	PRIMARY PRESSURE SOLENOID VALVE
41	B	GROUND
42	B	GROUND
45	V	BATTERY POWER SUPPLY
46	GR	BATTERY POWER SUPPLY
47	LG	IGNITION POWER SUPPLY
48	W	IGNITION POWER SUPPLY

A
B
C
D
E
F
G
H
I
J
DLK
L
M
N
O
P

DOOR & LOCK SYSTEM

< WIRING DIAGRAM >

[WITH INTELLIGENT KEY SYSTEM]

DOOR LOCK SYSTEM

18	W	-
19	G	-
20	R	-
21	Y	-
27	SHIELD	-
28	V	-
30	LG	-
32	W	-

Connector No.	M34
Connector Name	COMBINATION METER
Connector Type	TH40FW-AH

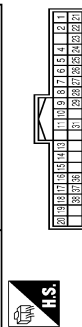

Terminal No.	Color Of Wire	Signal Name (Specification)
1	L	CAHH
2	P	CANH
4	Y	VEHICLE SPEED SIGNAL (8-PULSE)
5	G	PADDLE SHIFTER UP SWITCH SIGNAL
9	BR	FUEL LEVEL SENSOR SIGNAL
10	BR	AIR BAG SIGNAL
8	R	SEAT BELT BUCKLE SWITCH SIGNAL (DRIVER SIDE)
9	SB	PARKING BRAKE SWITCH SIGNAL
11	G	BRAKE FLUID LEVEL SWITCH SIGNAL
13	GR	ILLUMINATION CONTROL SIGNAL
14	R	MANUAL MODE SHIFT UP SIGNAL
15	L	ACC POWER SUPPLY
16	W	MANUAL MODE SHIFT DOWN SIGNAL
17	G	WASHER LEVEL SWITCH SIGNAL
18	R	SECURITY SIGNAL
19	GR	AMBIENT SENSOR SIGNAL
20	R	AMBIENT SENSOR GROUND
21	B	GROUND
22	B	GROUND
24	L	FUEL LEVEL SENSOR GROUND
25	B	VDC GROUND
26	V	PADDLE SHIFTER DOWN SWITCH SIGNAL
27	LG	BATTERY POWER SUPPLY

28	GR	IGNITION SIGNAL
29	V	PASSENGER SEAT BELT WARNING SIGNAL
30	Y	A/C AUTO AND MANUAL SIGNAL
31	Y	MANUAL LOCK SIGNAL
37	G	NON-BATTERY METER SIGNAL
38	P	ALTERNATOR SIGNAL

Connector No.	M68
Connector Name	BCM (BODY CONTROL MODULE)
Connector Type	TH40FB-AH



Terminal No.	Color Of Wire	Signal Name (Specification)
2	L	COMBI SW INPRF 5
3	GR	COMBI SW INPRF 4
4	BR	COMBI SW INPRF 3
5	G	COMBI SW INPRF 2
6	W	COMBI SW INPRF 1
7	L	KEY CYL UNLOCK SW
8	R	KEY CYL LOCK SW
9	R	STOP LAMP SW 1
10	GR	DOOR K & L UNLK SW LOCK
12	BR	DOOR K & L UNLK SW UNLOCK
13	GR	OPTICAL SENS
14	SB	REAR WINDOW DEF SW
15	W	OPTICAL SENS PWR SPLY
17	Y	RECEIVER GND
18	V	NATS ANT AMP
21	P	SECURITY IND LAMP CONT
23	R	DONGLE LINK
24	SB	NATS ANT AMP
25	LG	THERMO AMP
26	BR	A/E SW
27	Y	BLOWER FAN SW
28	LG	HAZARD SW
29	SB	BK DOOR OPENER SW
30	L	BK DOOR UNLK SENS
31	GR	COMBI SW OUTPUT 5
32	LG	COMBI SW OUTPUT 4
33	Y	COMBI SW OUTPUT 3
34	V	COMBI SW OUTPUT 2

35	R	COMBI SW OUTPUT 2
36	C	COMBI SW OUTPUT 1
37	SB	REAR BLMPRANT
38	SB	CONTR
39	P	CANL

Connector No.	M69
Connector Name	BCM (BODY CONTROL MODULE)
Connector Type	FEA09FW-FHAG-SA

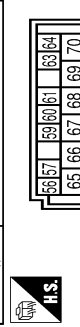

Terminal No.	Color Of Wire	Signal Name (Specification)
56	P	INT ROOM LAMP PWR SPLY
57	P	BAT(FUSE)
59	SB	PASS DOOR UNLK OUTPUT
60	V	TURN SIG RH OUTPUT
61	W	TURN SIG RH CONT
63	BR	INT ROOM LAMP CONT
64	R	REVERSE SW
65	R	ALL DOOR LOCK OUTPUT
66	SB	DR DOOR UNLK OUTPUT
67	SB	UNLK SENS
68	B	PWR PWR SPLY (IGN)
69	P	PWR PWR SPLY (BAT)
70	Y	BAT (F-L)

Connector No.	M70
Connector Name	BCM (BODY CONTROL MODULE)
Connector Type	TH40FW-AH



Terminal No.	Color Of Wire	Signal Name (Specification)
72	SB	A/C IND OUTPUT
75	LG	DR DOOR REQ SW
76	LG	PUSH SW
78	P	DRIVER DOOR ANT+
79	V	DRIVER DOOR ANT-
80	BR	PASS DOOR ANT+
81	G	PASS DOOR ANT-
82	W	REAR BLMPRANT+
83	B	REAR BLMPRANT-
84	BR	ROOM ANT+
85	GR	ROOM ANT-
86	V	ROOM ANT2+
87	LG	ROOM ANT2-
90	W	PUSH-BTN IGN SW ILL LAMP
91	V	A/C CONTIND
92	L	PUSH-BTN IGN SW ILL GND
93	SB	FUSE POWER SUPPLY
94	SB	SECURITY SIGNAL
97	SB	STARTER RELAY CONT
98	P	IGN RELAY (L/DR/L) CONT
99	R	IGN RELAY (R/B) CONT
100	P	PASS DOOR REQ SW
101	Y	CLUTCH INTERLOCK SW (FOR M/T MODELS)
101	Y	IGN SPLY NO2 (EXCEPT FOR M/T MODELS)
102	L	NEUTRAL SW (FOR M/T MODELS)
103	L	P/A POSITION (EXCEPT FOR M/T MODELS)
104	G	FR DEFROST SW
104	SB	CVT SHIF SELECT PWR SPLY
105	V	STOP LAMP SW 2
106	Y	BLWR RELAY CONT

A
B
C
D
E
F
G
H
I
J
DLK
L
M
N
O
P

DOOR & LOCK SYSTEM

< WIRING DIAGRAM >

[WITH INTELLIGENT KEY SYSTEM]

DOOR LOCK SYSTEM

Connector No.	M75
Connector Name	REMOTE KEYLESS ENTRY RECEIVER
Connector Type	TH12FW-NH



Terminal No.	Color Of Wire	Signal Name [Specification]
1	G	POWER
2	SB	SIGNAL
4	V	GND

Connector No.	M77
Connector Name	WIRE TO WIRE
Connector Type	TH12FW-CS16-TM4

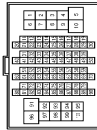

Terminal No.	Color Of Wire	Signal Name [Specification]
1	L	-
4	V	-
6	P	-
10	R	-
11	R	-
12	LG	-
13	V	-
14	SHIELD	-
34	LG	-
35	SB	-
36	B	-
37	P	-
52	R	-
53	L	-
54	SB	-
55	P	-
58	LG	-

69	G	-
72	V	-
82	W	-
84	LG	-
85	GR	-
86	V	-
67	V	-
68	R	-
70	V	-
71	R	-
72	GR	-
73	G	-
76	W	-
78	LG	-
79	V	-
80	LG	-
83	P	-
84	G	-
85	BR	-
86	LG	-
90	SHIELD	-
91	Y	-
92	BR	-
95	Y	-
96	L	-
97	GR	-
98	G	-
99	R	-
100	LG	-

Connector No.	M79
Connector Name	WIRE TO WIRE
Connector Type	TH12FW-NH

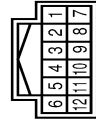

Terminal No.	Color Of Wire	Signal Name [Specification]
2	BR	-
3	W	-
5	BR	-
6	L	-
10	V	-

Connector No.	M81
Connector Name	PUSH-BUTTON IGNITION SWITCH
Connector Type	TK08FBR



Terminal No.	Color Of Wire	Signal Name [Specification]
3	G	-
4	B	-
5	W	-
6	R	-
7	V	-
8	LG	-

Connector No.	M105
Connector Name	IN-DEE KEY ANTENNA (INFLUENCE CENTER)
Connector Type	PK02FL



Connector No.	M132
Connector Name	JOINT CONNECTOR-M04
Connector Type	NM20FL-DC

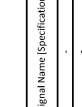

Terminal No.	Color Of Wire	Signal Name [Specification]
1	P	-
2	P	-
3	P	-
5	P	-
7	P	-
11	L	-
12	L	-

Connector No.	M132
Connector Name	JOINT CONNECTOR-M02
Connector Type	NM20FL-DC

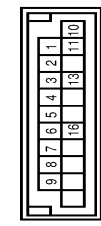

Terminal No.	Color Of Wire	Signal Name [Specification]
1	B	-
2	B	-
3	B	-
4	B	-
5	B	-
6	B	-
7	B	-
8	B	-
9	B	-
10	LG	-
11	LG	-
13	LG	-
15	LG	-

Connector No.	M132
Connector Name	JOINT CONNECTOR-M04
Connector Type	NM20FL-DC

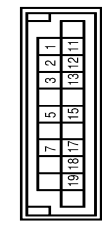

Terminal No.	Color Of Wire	Signal Name [Specification]
1	P	-
2	P	-
3	P	-
5	P	-
7	P	-
11	L	-
12	L	-

JRKWF4415GB

DOOR & LOCK SYSTEM

< WIRING DIAGRAM >

[WITH INTELLIGENT KEY SYSTEM]

DOOR LOCK SYSTEM

13	L	-
14	L	-
15	L	-
16	W	-
17	W	-
18	W	-
19	W	-

Connector No.	M134
Connector Name	JOINT CONNECTOR-M08
Connector Type	NI20FLDC

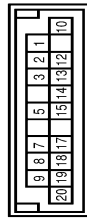

Terminal No.	Color Of Wire	Signal Name (Specification)
1	LG	-
2	LG	-
3	LG	-
5	LG	-
7	LG	-
8	LG	-
9	LG	-
10	Y	-
12	Y	-
14	Y	-
15	Y	-
17	LG	-
18	R	-
19	R	-
20	R	-

Connector No.	M136
Connector Name	JOINT CONNECTOR-M07
Connector Type	NI20FLDC

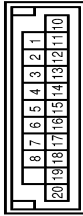

Terminal No.	Color Of Wire	Signal Name (Specification)
1	P	-
2	P	-
3	P	-
4	P	-
5	P	-
6	P	-
7	P	-
8	P	-
10	L	-
11	L	-
12	L	-
13	L	-
14	L	-
15	L	-
16	L	-
17	GR	-
18	GR	-
20	GR	-

A
B
C
D
E
F
G
H
I
J
K
L
M
N
O
P

DLK

JRKWF4416GB

DIAGNOSIS AND REPAIR WORK FLOW

< BASIC INSPECTION >

[WITH INTELLIGENT KEY SYSTEM]

BASIC INSPECTION

DIAGNOSIS AND REPAIR WORK FLOW

Work Flow

INFOID:000000012196601

OVERALL SEQUENCE

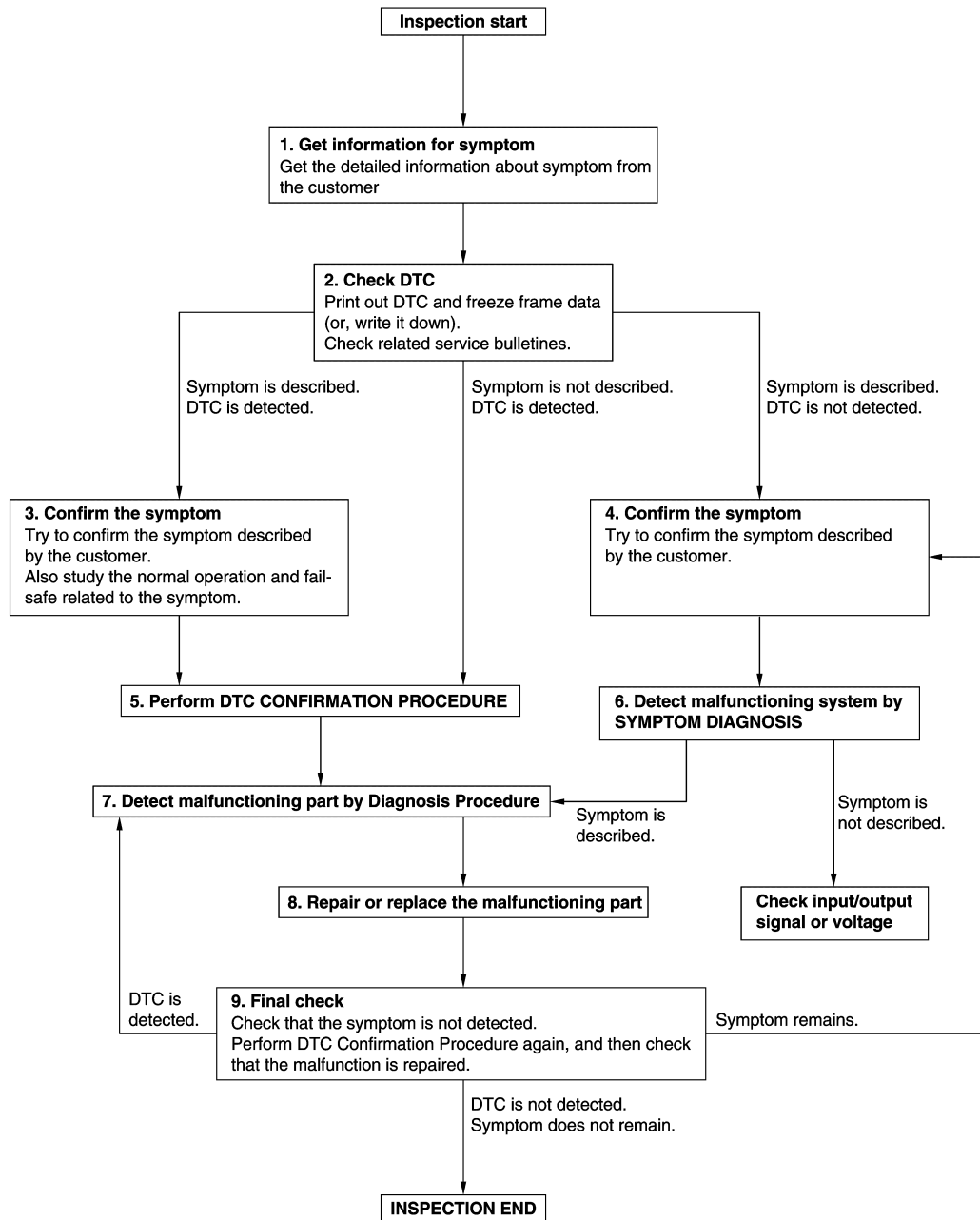

JMKIA8652GB

DETAILED FLOW

DIAGNOSIS AND REPAIR WORK FLOW

[WITH INTELLIGENT KEY SYSTEM]

< BASIC INSPECTION >

1. GET INFORMATION FOR SYMPTOM

1. Get detailed information from the customer about the symptom (the condition and the environment when the incident/malfunction occurs).
2. Check operation condition of the function that is malfunctioning.

>> GO TO 2.

2. CHECK DTC

1. Check DTC.
2. Perform the following procedure if DTC is detected.
 - Record DTC and freeze frame data (Print them out using CONSULT.)
 - Erase DTC.
 - Study the relationship between the cause detected by DTC and the symptom described by the customer.
3. Check related service bulletins for information.

Are any symptoms described and any DTC detected?

- Symptom is described, DTC is detected>>GO TO 3.
- Symptom is described, DTC is not detected>>GO TO 4.
- Symptom is not described, DTC is detected>>GO TO 5.

3. CONFIRM THE SYMPTOM

Try to confirm the symptom described by the customer.
Also study the normal operation and fail-safe related to the symptom.
Verify relation between the symptom and the condition when the symptom is detected.

>> GO TO 5.

4. CONFIRM THE SYMPTOM

Try to confirm the symptom described by the customer.
Verify relation between the symptom and the condition when the symptom is detected.

>> GO TO 6.

5. PERFORM DTC CONFIRMATION PROCEDURE

Perform DTC CONFIRMATION PROCEDURE for the detected DTC, and then check that DTC is detected again. At this time, always connect CONSULT to the vehicle, and check self diagnostic results in real time. If two or more DTCs are detected, refer to [BCS-61. "DTC Inspection Priority Chart"](#) (BCM), and determine trouble diagnosis order.

NOTE:

- Freeze frame data is useful if the DTC is not detected.
- Perform Component Function Check if DTC CONFIRMATION PROCEDURE is not included on Service Manual. This simplified check procedure is an effective alternative though DTC cannot be detected during this check.
If the result of Component Function Check is NG, it is the same as the detection of DTC by DTC CONFIRMATION PROCEDURE.

Is DTC detected?

- YES >> GO TO 7.
- NO >> Check according to [GI-45. "Intermittent Incident"](#).

6. DETECT MALFUNCTIONING SYSTEM BY SYMPTOM DIAGNOSIS

Detect malfunctioning system according to SYMPTOM DIAGNOSIS based on the confirmed symptom in step 4, and determine the trouble diagnosis order based on possible causes and symptom.

Is the symptom described?

- YES >> GO TO 7.
- NO >> Monitor input data from related sensors or check voltage of related module terminals using CONSULT.

7. DETECT MALFUNCTIONING PART BY DIAGNOSIS PROCEDURE

A
B
C
D
E
F
G
H
I
J
L
M
N
O
P

DLK

DIAGNOSIS AND REPAIR WORK FLOW

[WITH INTELLIGENT KEY SYSTEM]

< BASIC INSPECTION >

Inspect according to Diagnosis Procedure of the system.

Is malfunctioning part detected?

YES >> GO TO 8.

NO >> Check according to [GI-45. "Intermittent Incident"](#).

8. REPAIR OR REPLACE THE MALFUNCTIONING PART

1. Repair or replace the malfunctioning part.
2. Reconnect parts or connectors disconnected during Diagnosis Procedure again after repair and replacement.
3. Check DTC. If DTC is detected, erase it.

>> GO TO 9.

9. FINAL CHECK

When DTC is detected in step 2, perform DTC CONFIRMATION PROCEDURE again, and then check that the malfunction is repaired securely.

When symptom is described by the customer, refer to confirmed symptom in step 3 or 4, and check that the symptom is not detected.

Is DTC detected and does symptom remain?

YES-1 >> DTC is detected: GO TO 7.

YES-2 >> Symptom remains: GO TO 4.

NO >> Before returning the vehicle to the customer, always erase DTC.

B2621 INSIDE ANTENNA

< DTC/CIRCUIT DIAGNOSIS >

[WITH INTELLIGENT KEY SYSTEM]

DTC/CIRCUIT DIAGNOSIS

B2621 INSIDE ANTENNA

DTC Logic

INFOID:000000012196602

DTC DETECTION LOGIC

DTC	CONSULT display description	DTC detecting condition	Possible cause
B2621	INSIDE ANTENNA	An excessive high or low voltage from inside antenna (instrument center) is sent to BCM	<ul style="list-style-type: none"> Inside key antenna (instrument center) Harness or connector [Inside key antenna (instrument center) circuit is open or shorted]

DTC CONFIRMATION PROCEDURE

1. PERFORM DTC CONFIRMATION PROCEDURE

1. Select "INTELLIGENT KEY" of "BCM" using CONSULT.
2. Select "INSIDE ANT DIAGNOSIS" in "WORK SUPPORT" mode.
3. Perform inside key antenna ("INSIDE ANT DIAGNOSIS") on "WORK SUPPORT" of "INTELLIGENT KEY".
4. Check BCM for DTC.

Is inside key antenna DTC detected?

- YES >> Refer to [DLK-49. "Diagnosis Procedure"](#).
 NO >> Inside key antenna (instrument center) is OK.

Diagnosis Procedure

INFOID:000000012196603

1. CHECK INSIDE KEY ANTENNA INPUT SIGNAL 1

1. Turn ignition switch ON.
2. Check signal between BCM harness connector and ground using oscilloscope.

(+) BCM		(-)	Condition	Signal (Reference value)
Connector	Terminal			
M70	84 85	Ground	When Intelligent Key is in the antenna detection area	<p>JMKIA3839GB</p>
			When Intelligent Key is not in the antenna detection area	<p>JMKIA5951GB</p>

Is the inspection result normal?

- YES >> Replace BCM. Refer to [BCS-94. "Removal and Installation"](#).
 NO >> GO TO 2.

2. CHECK INSIDE KEY ANTENNA CIRCUIT

B2621 INSIDE ANTENNA

[WITH INTELLIGENT KEY SYSTEM]

< DTC/CIRCUIT DIAGNOSIS >

1. Turn ignition switch OFF.
2. Disconnect BCM connector and inside key antenna (instrument center) connector.
3. Check continuity between BCM harness connector and inside key antenna (instrument center) harness connector.

BCM		Inside key antenna (instrument center)		Continuity
Connector	Terminal	Connector	Terminal	
M70	84	M105	1	Existed
	85		2	

4. Check continuity between BCM harness connector and ground.

BCM		Ground	Continuity
Connector	Terminal		
M70	84		Not existed
	85		

Is the inspection result normal?

YES >> GO TO 3.

NO >> Repair or replace harness.

3. CHECK INSIDE KEY ANTENNA INPUT SIGNAL 2

1. Replace inside key antenna (instrument center). (New antenna or other antenna)
2. Connect BCM connector and inside key antenna (instrument center) connector.
3. Turn ignition switch ON.
4. Check signal between BCM harness connector and ground using oscilloscope.

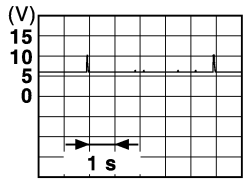
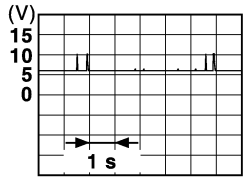
(+)		(-)	Condition	Signal (Reference value)
BCM				
Connector	Terminal			
M70	84	Ground	When Intelligent Key is in the antenna detection area	
	85		When Intelligent Key is not in the antenna detection area	

Is the inspection result normal?

YES >> Replace inside key antenna (instrument center).

NO >> Replace BCM. Refer to [BCS-94, "Removal and Installation"](#).

B2622 INSIDE ANTENNA

[WITH INTELLIGENT KEY SYSTEM]

< DTC/CIRCUIT DIAGNOSIS >

B2622 INSIDE ANTENNA

DTC Logic

INFOID:000000012196606

DTC DETECTION LOGIC

DTC	CONSULT display description	DTC detecting condition	Possible cause
B2622	INSIDE ANTENNA	An excessive high or low voltage from inside antenna (luggage room) is sent to BCM	<ul style="list-style-type: none"> Inside key antenna (luggage room) Harness or connector [Inside key antenna (luggage room) circuit is open or shorted]

DTC CONFIRMATION PROCEDURE

1. PERFORM DTC CONFIRMATION PROCEDURE

1. Select "INTELLIGENT KEY" of "BCM" using CONSULT.
2. Select "INSIDE ANT DIAGNOSIS" in "WORK SUPPORT" mode.
3. Perform inside key antenna ("INSIDE ANT DIAGNOSIS") on "WORK SUPPORT" of "INTELLIGENT KEY".
4. Check BCM for DTC.

Is inside key antenna DTC detected?

- YES >> Refer to [DLK-51, "Diagnosis Procedure"](#).
- NO >> Inside key antenna (luggage room) is OK.

Diagnosis Procedure

INFOID:000000012196607

1. CHECK INSIDE KEY ANTENNA INPUT SIGNAL 1

1. Turn ignition switch ON.
2. Check signal between BCM harness connector and ground using oscilloscope.

(+)		(-)	Condition	Signal (Reference value)
BCM				
Connector	Terminal			
M70	86	Ground	When Intelligent Key is in the antenna detection area	<p>JMKIA3839GB</p>
	87		When Intelligent Key is not in the antenna detection area	<p>JMKIA5951GB</p>

Is the inspection result normal?

- YES >> Replace BCM. Refer to [BCS-94, "Removal and Installation"](#).
- NO >> GO TO 2.

2. CHECK INSIDE KEY ANTENNA CIRCUIT

1. Turn ignition switch OFF.
2. Disconnect BCM connector and inside key antenna (luggage room) connector.

A
B
C
D
E
F
G
H
I
J
L
M
N
O
P

DLK

B2622 INSIDE ANTENNA

[WITH INTELLIGENT KEY SYSTEM]

< DTC/CIRCUIT DIAGNOSIS >

3. Check continuity between BCM harness connector and inside key antenna (luggage room) harness connector.

BCM		Inside key antenna (luggage room)		Continuity
Connector	Terminal	Connector	Terminal	
M70	86	B82	1	Existed
	87		2	

4. Check continuity between BCM harness connector and ground.

BCM		Ground	Continuity
Connector	Terminal		
M70	86		Not existed
	87		

Is the inspection result normal?

YES >> GO TO 3.

NO >> Repair or replace harness.

3. CHECK INSIDE KEY ANTENNA INPUT SIGNAL 2

1. Replace inside key antenna (luggage room). (New antenna or other antenna)
2. Connect BCM connector and inside key antenna (luggage room) connector.
3. Turn ignition switch ON.
4. Check signal between BCM harness connector and ground using oscilloscope.

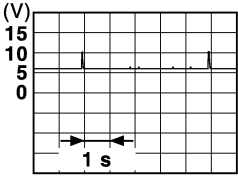
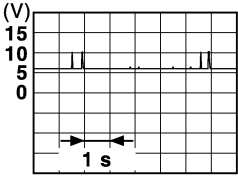
(+)		(-)	Condition	Signal (Reference value)
BCM				
Connector	Terminal			
M70	86	Ground	When Intelligent Key is in the antenna detection area	 <p style="text-align: right; font-size: small;">JMKIA3839GB</p>
	87		When Intelligent Key is not in the antenna detection area	 <p style="text-align: right; font-size: small;">JMKIA5951GB</p>

Is the inspection result normal?

YES >> Replace inside key antenna (luggage room).

NO >> Replace BCM. Refer to [BCS-94, "Removal and Installation"](#).

B2626 OUTSIDE ANTENNA

< DTC/CIRCUIT DIAGNOSIS >

[WITH INTELLIGENT KEY SYSTEM]

B2626 OUTSIDE ANTENNA

DTC Logic

INFOID:000000012196608

DTC DETECTION LOGIC

DTC	CONSULT display description	DTC detecting condition	Possible cause
B2626	OUTSIDE ANTENNA	An excessive high or low voltage from front door right outside key antenna is sent to BCM	<ul style="list-style-type: none"> Front door right outside key antenna Harness or connector [Front door right outside key antenna circuit is open or shorted]

DTC CONFIRMATION PROCEDURE

1. PERFORM DTC CONFIRMATION PROCEDURE

1. Disconnect outside key antenna (passenger side) connector.
2. Perform "INTELLIGENT KEY" Self Diagnostic Result.

Is outside key antenna DTC detected?

- YES >> Refer to [DLK-53, "Diagnosis Procedure"](#).
 NO >> Outside key antenna (passenger side) is OK.

Diagnosis Procedure

INFOID:000000012196609

1. CHECK OUTSIDE KEY ANTENNA INPUT SIGNAL 1

1. Turn ignition switch OFF.
2. Check signal between BCM harness connector and ground using oscilloscope.

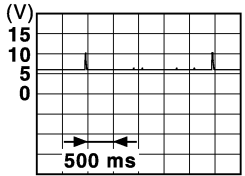
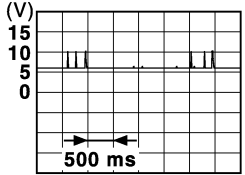
(+)		(-)	Condition	Signal (Reference value)
BCM				
Connector	Terminal			
M70	80	Ground	When Intelligent Key is in the antenna detection area (The distance between Intelligent Key and antenna: 80 cm or less)	 <p>JMKIA5955GB</p>
	81		When the driver door request switch is operated with ignition switch OFF	 <p>JMKIA5954GB</p>

Is the inspection result normal?

- YES >> Replace BCM. Refer to [BCS-94, "Removal and Installation"](#).
 NO >> GO TO 2.

2. CHECK OUTSIDE KEY ANTENNA CIRCUIT

1. Disconnect BCM connector and outside key antenna (passenger side) connector.
2. Check continuity between BCM harness connector and outside key antenna (passenger side) harness connector.

B2626 OUTSIDE ANTENNA

< DTC/CIRCUIT DIAGNOSIS >

[WITH INTELLIGENT KEY SYSTEM]

BCM		Outside key antenna (passenger side)		Continuity
Connector	Terminal	Connector	Terminal	
M70	80	D14	1	Existed
	81		2	

3. Check continuity between BCM harness connector and ground.

BCM		Ground	Continuity
Connector	Terminal		
M70	80		Not existed
	81		

Is the inspection result normal?

YES >> GO TO 3.

NO >> Repair or replace harness.

3. CHECK OUTSIDE KEY ANTENNA INPUT SIGNAL 2

1. Replace outside key antenna (passenger side). (New antenna or other antenna)
2. Connect BCM connector and outside key antenna (passenger side) connector.
3. Check signal between BCM harness connector and ground using oscilloscope.

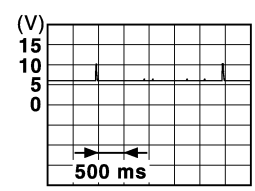
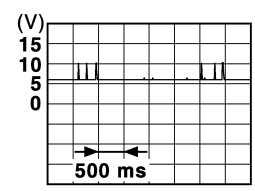
(+) BCM		(-)	Condition	Signal (Reference value)
Connector	Terminal			
M70	80	Ground	When Intelligent Key is in the antenna detection area (The distance between Intelligent Key and antenna: 80 cm or less)	
	81		When the driver door request switch is operated with ignition switch OFF	
			When Intelligent Key is not in the antenna detection area (The distance between Intelligent Key and antenna: Approx. 2 m)	

Is the inspection result normal?

YES >> Replace outside key antenna (passenger side).

NO >> Replace BCM. Refer to [BCS-94, "Removal and Installation"](#).

B2627 OUTSIDE ANTENNA

[WITH INTELLIGENT KEY SYSTEM]

< DTC/CIRCUIT DIAGNOSIS >

B2627 OUTSIDE ANTENNA

DTC Logic

INFOID:000000012196610

DTC DETECTION LOGIC

DTC	CONSULT display description	DTC detecting condition	Possible cause
B2627	OUTSIDE ANTENNA	An excessive high or low voltage from front door left outside key antenna is sent to BCM	<ul style="list-style-type: none"> Front door left outside key antenna Harness or connector [Front door left outside key antenna circuit is open or shorted]

DTC CONFIRMATION PROCEDURE

1. PERFORM DTC CONFIRMATION PROCEDURE

1. Disconnect outside key antenna (driver side) connector.
2. Perform "INTELLIGENT KEY" Self Diagnostic Result.

Is outside key antenna DTC detected?

- YES >> Refer to [DLK-55, "Diagnosis Procedure"](#).
 NO >> Outside key antenna (driver side) is OK.

Diagnosis Procedure

INFOID:000000012196611

1. CHECK OUTSIDE KEY ANTENNA INPUT SIGNAL 1

1. Turn ignition switch OFF.
2. Check signal between BCM harness connector and ground using oscilloscope.

(+)		(-)	Condition	Signal (Reference value)
BCM				
Connector	Terminal			
M70	78 79	Ground	When the driver door request switch is operated with ignition switch OFF	<p>JMKIA5955GB</p>
			When Intelligent Key is in the antenna detection area (The distance between Intelligent Key and antenna: 80 cm or less)	<p>JMKIA5955GB</p>
			When Intelligent Key is not in the antenna detection area (The distance between Intelligent Key and antenna: Approx. 2 m)	<p>JMKIA5954GB</p>

Is the inspection result normal?

- YES >> Replace BCM. Refer to [BCS-94, "Removal and Installation"](#).
 NO >> GO TO 2.

2. CHECK OUTSIDE KEY ANTENNA CIRCUIT

1. Disconnect BCM connector and outside key antenna (driver side) connector.
2. Check continuity between BCM harness connector and outside key antenna (driver side) harness connector.

A
B
C
D
E
F
G
H
I
J
L
M
N
O
P

DLK

B2627 OUTSIDE ANTENNA

< DTC/CIRCUIT DIAGNOSIS >

[WITH INTELLIGENT KEY SYSTEM]

BCM		Outside key antenna (driver side)		Continuity
Connector	Terminal	Connector	Terminal	
M70	78	D33	1	Existed
	79		2	

3. Check continuity between BCM harness connector and ground.

BCM		Ground	Continuity
Connector	Terminal		
M70	78		Not existed
	79		

Is the inspection result normal?

YES >> GO TO 3.

NO >> Repair or replace harness.

3. CHECK OUTSIDE KEY ANTENNA INPUT SIGNAL 2

1. Replace outside key antenna (driver side). (New antenna or other antenna)
2. Connect BCM connector and outside key antenna (driver side) connector.
3. Check signal between BCM harness connector and ground using oscilloscope.

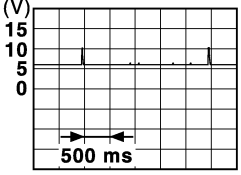
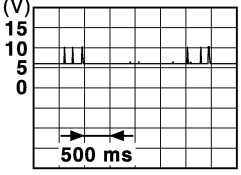
(+) BCM		(-)	Condition	Signal (Reference value)
Connector	Terminal			
M70	78	Ground	When Intelligent Key is in the antenna detection area (The distance between Intelligent Key and antenna: 80 cm or less)	
	79		When the driver door request switch is operated with ignition switch OFF	
			When Intelligent Key is not in the antenna detection area (The distance between Intelligent Key and antenna: Approx. 2 m)	

Is the inspection result normal?

YES >> Replace outside key antenna (driver side).

NO >> Replace BCM. Refer to [BCS-94, "Removal and Installation"](#).

B2628 OUTSIDE ANTENNA

[WITH INTELLIGENT KEY SYSTEM]

< DTC/CIRCUIT DIAGNOSIS >

B2628 OUTSIDE ANTENNA

DTC Logic

INFOID:000000012196612

DTC DETECTION LOGIC

DTC	CONSULT display description	DTC detecting condition	Possible cause
B2628	OUTSIDE ANTENNA	An excessive high or low voltage from outside key antenna (rear bumper) is sent to BCM	<ul style="list-style-type: none"> • Outside key antenna (rear bumper) • Harness or connector [Outside key antenna (rear bumper) circuit is open or shorted]

DTC CONFIRMATION PROCEDURE

1. PERFORM DTC CONFIRMATION PROCEDURE

1. Disconnect outside key antenna (rear bumper) connector.
2. Perform "INTELLIGENT KEY" Self Diagnostic Result.

Is outside key antenna DTC detected?

- YES >> Refer to [DLK-57, "Diagnosis Procedure"](#).
 NO >> Outside key antenna (rear bumper) is OK.

Diagnosis Procedure

INFOID:000000012196613

1. CHECK OUTSIDE KEY ANTENNA INPUT SIGNAL 1

1. Turn ignition switch OFF.
2. Check signal between BCM harness connector and ground using oscilloscope.

(+)		(-)	Condition	Signal (Reference value)
BCM				
Connector	Terminal			
M70	82 83	Ground	When the driver door request switch is operated with ignition switch OFF	<p>JMKIA5955GB</p>
			When Intelligent Key is in the antenna detection area (The distance between Intelligent Key and antenna: 80 cm or less)	<p>JMKIA5954GB</p>
			When Intelligent Key is not in the antenna detection area (The distance between Intelligent Key and antenna: Approx. 2 m)	<p>JMKIA5954GB</p>

Is the inspection result normal?

- YES >> Replace BCM. Refer to [BCS-94, "Removal and Installation"](#).
 NO >> GO TO 2.

2. CHECK OUTSIDE KEY ANTENNA CIRCUIT

1. Disconnect BCM connector and outside key antenna (rear bumper) connector.
2. Check continuity between BCM harness connector and outside key antenna (rear bumper) harness connector.

A
B
C
D
E
F
G
H
I
J
L
M
N
O
P

DLK

B2628 OUTSIDE ANTENNA

< DTC/CIRCUIT DIAGNOSIS >

[WITH INTELLIGENT KEY SYSTEM]

BCM		Outside key antenna (rear bumper)		Continuity
Connector	Terminal	Connector	Terminal	
M70	82	B83	1	Existed
	83		2	

3. Check continuity between BCM harness connector and ground.

BCM		Ground	Continuity
Connector	Terminal		
M70	82		Not existed
	83		

Is the inspection result normal?

YES >> GO TO 3.

NO >> Repair or replace harness.

3. CHECK OUTSIDE KEY ANTENNA INPUT SIGNAL 2

1. Replace outside key antenna (rear bumper). (New antenna or other antenna)
2. Connect BCM and outside key antenna (rear bumper) connector.
3. Check signal between BCM harness connector and ground using oscilloscope.

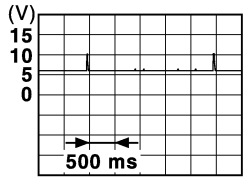
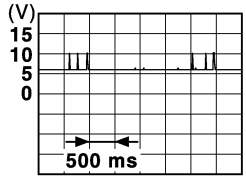
(+) BCM		(-)	Condition	Signal (Reference value)
Connector	Terminal			
M70	82	Ground	When Intelligent Key is in the antenna detection area (The distance between Intelligent Key and antenna: 80 cm or less)	 <p style="text-align: right; font-size: small;">JMKIA5955GB</p>
	83		When the driver door request switch is operated with ignition switch OFF	 <p style="text-align: right; font-size: small;">JMKIA5954GB</p>
			When Intelligent Key is not in the antenna detection area (The distance between Intelligent Key and antenna: Approx. 2 m)	

Is the inspection result normal?

YES >> Replace outside key antenna (rear bumper).

NO >> Replace BCM. Refer to [BCS-94, "Removal and Installation"](#).

BACK DOOR OPENER ACTUATOR

< DTC/CIRCUIT DIAGNOSIS >

[WITH INTELLIGENT KEY SYSTEM]

BACK DOOR OPENER ACTUATOR

Component Function Check

INFOID:000000012196614

1.CHECK FUNCTION

1. Select "INTELLIGENT KEY" of "BCM" using CONSULT.
2. Select "TRUNK/BACK DOOR" in "ACTIVE TEST" mode.
3. Check that the function operates normally according to the following conditions.

Monitor item		Status	
TRUNK/BACK DOOR	OPEN	Back door	OPEN

Is the inspection result normal?

- YES >> Back door opener actuator is OK.
NO >> Refer to [DLK-59. "Diagnosis Procedure"](#).

Diagnosis Procedure

INFOID:000000012196615

1.CHECK BACK DOOR OPENER ACTUATOR INPUT SIGNAL

1. Turn ignition switch OFF.
2. Disconnect back door lock assembly connector.
3. Check voltage between back door lock assembly harness connector and ground.

(+)		(-)	Condition		Voltage (Approx.)
Back door lock assembly					
Connector	Terminal	Ground	Back door opener switch	ON	12 V
D106	1				

Is the inspection result normal?

- YES >> GO TO 3.
NO >> GO TO 2.

2.CHECK BACK DOOR OPENER ACTUATOR CIRCUIT

1. Disconnect BCM connector.
2. Check continuity between BCM harness connector and back door lock assembly harness connector.

BCM		Back door lock assembly		Continuity
Connector	Terminal	Connector	Terminal	
B10	53	D106	1	Existed

3. Check continuity between BCM harness connector and ground.

BCM		Ground	Continuity
Connector	Terminal		
B10	53		Not existed

Is the inspection result normal?

- YES >> Replace BCM. Refer to [BCS-94. "Removal and Installation"](#).
NO >> Repair or replace harness.

3.CHECK BACK DOOR OPENER ACTUATOR GROUND CIRCUIT

Check continuity between back door lock assembly harness connector and ground.

A
B
C
D
E
F
G
H
I
J
L
M
N
O
P

DLK

BACK DOOR OPENER ACTUATOR

< DTC/CIRCUIT DIAGNOSIS >

[WITH INTELLIGENT KEY SYSTEM]

Back door lock assembly		Ground	Continuity
Connector	Terminal		Existed
D106	2		

Is the inspection normal?

- YES >> Replace back door lock assembly.
- NO >> Repair or replace harness.

BACK DOOR OPENER SWITCH

< DTC/CIRCUIT DIAGNOSIS >

[WITH INTELLIGENT KEY SYSTEM]

BACK DOOR OPENER SWITCH

Component Function Check

INFOID:000000012196616

1. CHECK FUNCTION

1. Select "TRUNK" of "BCM" using CONSULT.
2. Select "TR/BD OPEN SW" in "DATA MONITOR" mode.
3. Check that the function operates normally according to the following conditions.

Monitor item	Condition		Status
TR/BD OPEN SW	Back door opener switch	Pressed	ON
		Released	OFF

Is the inspection result normal?

- YES >> Back door opener switch is OK.
 NO >> Refer to [DLK-61, "Diagnosis Procedure"](#).

Diagnosis Procedure

INFOID:000000012196617

1. CHECK BACK DOOR OPENER SWITCH INPUT SIGNAL

1. Turn ignition switch OFF.
2. Disconnect back door opener switch connector.
3. Check signal between back door opener switch harness connector and ground using oscilloscope.

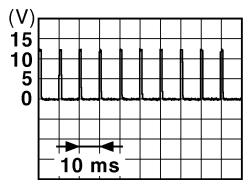
(+)		(-)	Signal (Reference value)
Connector	Terminal		
D107	1	Ground	 <p style="text-align: right;">JPMIA0012GB</p>

Is the inspection result normal?

- YES >> GO TO 3.
 NO >> GO TO 2.

2. CHECK BACK DOOR OPENER SWITCH CIRCUIT

1. Disconnect BCM connector.
2. Check continuity between BCM harness connector and back door opener switch harness connector.

BCM		Back door opener switch		Continuity
Connector	Terminal	Connector	Terminal	
M68	30	D107	1	Existed

3. Check continuity between BCM harness connector and ground.

BCM		Ground	Continuity
Connector	Terminal		
M68	30		Not existed

Is the inspection result normal?

- YES >> Replace BCM. Refer to [BCS-94, "Removal and Installation"](#).
 NO >> Repair or replace harness.

A
B
C
D
E
F
G
H
I
J
L
M
N
O
P

DLK

BACK DOOR OPENER SWITCH

< DTC/CIRCUIT DIAGNOSIS >

[WITH INTELLIGENT KEY SYSTEM]

3. CHECK BACK DOOR OPENER SWITCH GROUND CIRCUIT

Check continuity between back door opener switch harness connector and ground.

Back door opener switch		Ground	Continuity
Connector	Terminal		
D107	2		Existed

Is the inspection result normal?

YES >> GO TO 4.

NO >> Repair or replace harness.

4. CHECK BACK DOOR OPENER SWITCH

Refer to [DLK-62, "Component Inspection"](#).

Is the inspection result normal?

YES >> GO TO 5.

NO >> Replace back door opener switch.

5. CHECK INTERMITTENT INCIDENT

Refer to [GI-45, "Intermittent Incident"](#).

>> INSPECTION END

Component Inspection

INFOID:000000012196618

1. CHECK BACK DOOR OPENER SWITCH

1. Turn ignition switch OFF.
2. Disconnect back door opener switch connector.
3. Check continuity between back door opener switch terminals.

Back door opener switch		Condition	Continuity
Terminal			
1	2	Back door opener switch	Pressed Existed
			Released Not existed

Is the inspection result normal?

YES >> INSPECTION END

NO >> Replace back door opener switch.

BACK DOOR REQUEST SWITCH

< DTC/CIRCUIT DIAGNOSIS >

[WITH INTELLIGENT KEY SYSTEM]

BACK DOOR REQUEST SWITCH

Component Function Check

INFOID:000000012196619

1.CHECK FUNCTION

1. Select "INTELLIGENT KEY" of "BCM" using CONSULT.
2. Select "REQ SW-BD/TR" in "DATA MONITOR" mode.
3. Check that the function operates normally according to the following conditions.

Monitor item	Condition		Status
REQ SW-BD/TR	Back door request switch	Pressed	On
		Released	Off

Is the inspection result normal?

- YES >> Back door request switch is OK.
 NO >> Refer to [DLK-63, "Diagnosis Procedure"](#).

Diagnosis Procedure

INFOID:000000012196620

1.CHECK BACK DOOR REQUEST SWITCH INPUT SIGNAL

1. Turn ignition switch OFF.
2. Disconnect back door opener switch connector.
3. Check voltage between back door opener switch harness connector and ground.

(+)		(-)	Voltage (Approx.)
Back door opener switch			
Connector	Terminal	Ground	12 V
D107	3		

Is the inspection result normal?

- YES >> GO TO 3.
 NO >> GO TO 2.

2.CHECK BACK DOOR REQUEST SWITCH CIRCUIT

1. Disconnect BCM connector.
2. Check continuity between BCM harness connector and back door opener switch harness connector.

BCM		Back door opener switch		Continuity
Connector	Terminal	Connector	Terminal	
M68	51	D107	3	Existed

3. Check continuity between BCM harness connector and ground.

BCM		Ground	Continuity
Connector	Terminal		
M68	51		Not existed

Is the inspection result normal?

- YES >> Replace BCM. Refer to [BCS-94, "Removal and Installation"](#).
 NO >> Repair harness or connector.

3.CHECK BACK DOOR REQUEST SWITCH GROUND CIRCUIT

Check continuity between back door opener switch harness connector and ground.

Back door opener switch		Ground	Continuity
Connector	Terminal		
D107	4		Existed

A
B
C
D
E
F
G
H
I
J
L
M
N
O
P

DLK

BACK DOOR REQUEST SWITCH

[WITH INTELLIGENT KEY SYSTEM]

< DTC/CIRCUIT DIAGNOSIS >

Is the inspection result normal?

- YES >> GO TO 4.
- NO >> Repair or replace harness.

4.CHECK BACK DOOR REQUEST SWITCH

Refer to [DLK-64. "Component Inspection"](#).

Is the inspection result normal?

- YES >> GO TO 5.
- NO >> Replace back door opener switch.

5.CHECK INTERMITTENT INCIDENT

Refer to [GI-45. "Intermittent Incident"](#).

>> INSPECTION END

Component Inspection

INFOID:000000012196621

1.CHECK BACK DOOR REQUEST SWITCH

1. Turn ignition switch OFF.
2. Disconnect back door opener switch connector.
3. Check continuity between back door opener switch terminals.

Back door opener switch		Condition	Continuity
Terminal			
3	4	Back door request switch	Pressed Existed
			Released Not existed

Is the inspection result normal?

- YES >> INSPECTION END
- NO >> Replace back door opener switch.

BUZZER (COMBINATION METER)

< DTC/CIRCUIT DIAGNOSIS >

[WITH INTELLIGENT KEY SYSTEM]

BUZZER (COMBINATION METER)

Component Function Check

INFOID:000000012196622

1.CHECK FUNCTION

1. Select "INTELLIGENT KEY" of "BCM" using CONSULT.
2. Select "INSIDE BUZZER" in "ACTIVE TEST" mode.
3. Check that the function operates normally according to the following conditions.

Monitor item			Status	
INSIDE BUZZER	Take Out	ON	Take away warning	Buzzer sounds
		OFF		Buzzer does not sound
	Key	ON	OFF position warning	Buzzer sounds
		OFF		Buzzer does not sound

Is the inspection result normal?

- Yes >> Buzzer (combination meter) is OK.
No >> Refer to [DLK-65, "Diagnosis Procedure"](#).

Diagnosis Procedure

INFOID:000000012196623

1.CHECK METER BUZZER CIRCUIT

Refer to [WCS-40, "Component Function Check"](#).

Is the inspection result normal?

- Yes >> GO TO 2.
No >> Repair or replace the malfunctioning parts.

2.CHECK INTERMITTENT INCIDENT

Refer to [GI-45, "Intermittent Incident"](#).

>> INSPECTION END

DLK

DOOR KEY CYLINDER SWITCH

< DTC/CIRCUIT DIAGNOSIS >

[WITH INTELLIGENT KEY SYSTEM]

DOOR KEY CYLINDER SWITCH

Component Function Check

INFOID:000000012196624

1. CHECK FUNCTION

1. Select "DOOR LOCK" of "BCM" using CONSULT.
2. Select "KEY CYL LK SW", "KEY CYL UN-SW" in "DATA MONITOR" mode.
3. Check that the function operates normally according to the following conditions.

Monitor item	Condition	Status
KEY CYL LK-SW	Lock	ON
	Neutral / Unlock	OFF
KEY CYL UN-SW	Unlock	ON
	Neutral / Lock	OFF

Is the inspection result normal?

- YES >> Door key cylinder switch is OK.
 NO >> Refer to [DLK-66, "Diagnosis Procedure"](#).

Diagnosis Procedure

INFOID:000000012196625

1. CHECK DOOR KEY CYLINDER SWITCH INPUT SIGNAL

1. Turn ignition switch OFF.
2. Disconnect front door lock assembly (driver side) connector.
3. Check voltage between front door lock assembly (driver side) harness connector and ground.

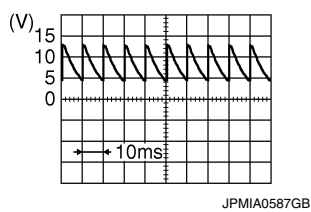
(+)		(-)	Voltage (V) (Approx.)
Connector	Terminal		
D38	5	Ground	 8.0 - 8.5 V
	6		

Is the inspection result normal?

- YES >> GO TO 3.
 NO >> GO TO 2.

2. CHECK DOOR KEY CYLINDER SWITCH SIGNAL CIRCUIT

1. Disconnect BCM connector.
2. Check continuity between BCM harness connector and front door lock assembly (driver side) harness connector.

BCM		Front door lock assembly (driver side)		Continuity
Connector	Terminal	Connector	Terminal	
M68	7	D38	5	Existed
	8		6	

3. Check continuity between BCM harness connector and ground.

DOOR KEY CYLINDER SWITCH

< DTC/CIRCUIT DIAGNOSIS >

[WITH INTELLIGENT KEY SYSTEM]

BCM		Ground	Continuity
Connector	Terminal		
M68	7		Continuity
	8		Not existed

Is the inspection result normal?

- YES >> Replace BCM. Refer to [BCS-94, "Removal and Installation"](#).
 NO >> Repair or replace harness.

3. CHECK DOOR KEY CYLINDER SWITCH GROUND CIRCUIT

Check continuity between front door lock assembly (driver side) harness connector and ground.

Front door lock assembly (driver side)		Ground	Continuity
Connector	Terminal		
D38	4		Existed

Is the inspection result normal?

- YES >> GO TO 4.
 NO >> Repair or replace harness.

4. CHECK DOOR KEY CYLINDER SWITCH

Refer to [DLK-67, "Component Inspection"](#).

Is the inspection result normal?

- YES >> GO TO 5.
 NO >> Replace front door lock assembly (driver side).

5. CHECK INTERMITTENT INCIDENT

Refer to [GI-45, "Intermittent Incident"](#).

>> INSPECTION END

Component Inspection

INFOID:0000000012196626

1. CHECK DOOR KEY CYLINDER SWITCH

1. Turn ignition switch OFF.
2. Disconnect front door lock assembly (driver side) terminal.
3. Check continuity between front door lock assembly (driver side) terminals.

Front door lock assembly (driver side)		Condition	Continuity
Terminal			
5	4	Driver side door key cylinder	Unlock
			Neutral / Lock
6			Lock
			Neutral / Unlock

Is the inspection result normal?

- YES >> INSPECTION END
 NO >> Replace front door lock assembly (driver side).

DOOR LOCK ACTUATOR

[WITH INTELLIGENT KEY SYSTEM]

< DTC/CIRCUIT DIAGNOSIS >

DOOR LOCK ACTUATOR DRIVER SIDE

DRIVER SIDE : Component Function Check

INFOID:000000012196627

1. CHECK FUNCTION

1. Select "DOOR LOCK" of "BCM" using CONSULT.
2. Select "DOOR LOCK" in "ACTIVE TEST" mode.
3. Check that the function operates normally according to the following conditions.

Monitor item		Status	
DOOR LOCK	ALL LOCK	Door lock actuators	LOCK
	ALL UNLK		UNLOCK

Is the inspection result normal?

YES >> Door lock actuator is OK.

NO >> Refer to [DLK-68, "DRIVER SIDE : Diagnosis Procedure"](#).

DRIVER SIDE : Diagnosis Procedure

INFOID:000000012196628

1. CHECK DOOR LOCK ACTUATOR INPUT SIGNAL

1. Turn ignition switch OFF.
2. Disconnect front door lock assembly (driver side) connector.
3. Check voltage between front door lock assembly (driver side) harness connector and ground.

(+)		(-)	Condition	Voltage (Approx.)
Connector	Terminal			
D38	2	Ground	Door lock and unlock switch	12 V
	1		Unlock Lock	

Is the inspection result normal?

YES >> Replace front door lock assembly (driver side).

NO >> GO TO 2.

2. CHECK DOOR LOCK ACTUATOR CIRCUIT

1. Disconnect BCM connector and all door lock assembly connector.
2. Check continuity between BCM harness connector and front door lock assembly (driver side) harness connector.

BCM		Front door lock assembly (driver side)		Continuity
Connector	Terminal	Connector	Terminal	
M69	65	D38	1	Existed
	66		2	

3. Check continuity between BCM harness connector and ground.

BCM		Ground	Continuity
Connector	Terminal		
M69	65		Not existed
	66		

Is the inspection result normal?

YES >> GO TO 3.

NO >> Repair or replace harness.

DOOR LOCK ACTUATOR

< DTC/CIRCUIT DIAGNOSIS >

[WITH INTELLIGENT KEY SYSTEM]

3.CHECK BCM OUTPUT SIGNAL

1. Connect BCM connector.
2. Check voltage between BCM harness connector and ground.

(+) BCM		(-)	Condition	Voltage (Approx.)
Connector	Terminal			
M69	66	Ground	Door lock and unlock switch	12 V
	65		Unlock Lock	

Is the inspection result normal?

YES >> Check for internal short of each door lock actuator.

NO >> Replace BCM. Refer to [BCS-94, "Removal and Installation"](#).

PASSENGER SIDE

PASSENGER SIDE : Component Function Check

INFOID:000000012196629

1.CHECK FUNCTION

1. Select "DOOR LOCK" of "BCM" using CONSULT.
2. Select "DOOR LOCK" in "ACTIVE TEST" mode.
3. Check that the function operates normally according to the following conditions.

Monitor item		Status	
DOOR LOCK	ALL LOCK	Door lock actuators	LOCK
	ALL UNLK		UNLOCK

Is the inspection result normal?

YES >> Door lock actuator is OK.

NO >> Refer to [DLK-68, "DRIVER SIDE : Diagnosis Procedure"](#).

PASSENGER SIDE : Diagnosis Procedure

INFOID:000000012196630

1.CHECK DOOR LOCK ACTUATOR INPUT SIGNAL

1. Turn ignition switch OFF.
2. Disconnect front door lock assembly (passenger side) connector.
3. Check voltage between front door lock assembly (passenger side) harness connector and ground.

(+) Front door lock assembly (passenger side)		(-)	Condition	Voltage (Approx.)
Connector	Terminal			
D17	6	Ground	Door lock and unlock switch	12 V
	5		Unlock Lock	

Is the inspection result normal?

YES >> Replace front door lock assembly (passenger side).

NO >> GO TO 2.

2.CHECK DOOR LOCK ACTUATOR CIRCUIT

1. Disconnect BCM connector and all door lock assembly connector.
2. Check continuity between BCM harness connector and front door lock assembly (passenger side) harness connector.

A
B
C
D
E
F
G
H
I
J
L
M
N
O
P

DLK

DOOR LOCK ACTUATOR

< DTC/CIRCUIT DIAGNOSIS >

[WITH INTELLIGENT KEY SYSTEM]

BCM		Front door lock assembly (passenger side)		Continuity
Connector	Terminal	Connector	Terminal	
M69	59	D17	6	Existed
	65		5	

3. Check continuity between BCM harness connector and ground.

BCM		Ground	Continuity
Connector	Terminal		
M69	59		Not existed
	65		

Is the inspection result normal?

- YES >> GO TO 3.
- NO >> Repair or replace harness.

3.CHECK BCM OUTPUT SIGNAL

1. Connect BCM connector.
2. Check voltage between BCM harness connector and ground.

(+)		(-)	Condition	Voltage (Approx.)	
BCM					
Connector	Terminal				
M69	59	Ground	Door lock and unlock switch	Unlock	12 V
	65			Lock	

Is the inspection result normal?

- YES >> Check for internal short of each door lock actuator.
- NO >> Replace BCM. Refer to [BCS-94, "Removal and Installation"](#).

REAR LH

REAR LH : Component Function Check

INFOID:000000012196631

1.CHECK FUNCTION

1. Select "DOOR LOCK" of "BCM" using CONSULT.
2. Select "DOOR LOCK" in "ACTIVE TEST" mode.
3. Check that the function operates normally according to the following conditions.

Monitor item		Status	
DOOR LOCK	ALL LOCK	Door lock actuators	LOCK
	ALL UNLK		UNLOCK

Is the inspection result normal?

- YES >> Door lock actuator is OK.
- NO >> Refer to [DLK-68, "DRIVER SIDE : Diagnosis Procedure"](#).

REAR LH : Diagnosis Procedure

INFOID:000000012196632

1.CHECK DOOR LOCK ACTUATOR INPUT SIGNAL

1. Turn ignition switch OFF.
2. Disconnect rear door lock assembly LH connector.
3. Check voltage between rear door lock assembly LH harness connector and ground.

DOOR LOCK ACTUATOR

[WITH INTELLIGENT KEY SYSTEM]

< DTC/CIRCUIT DIAGNOSIS >

(+)		(-)	Condition	Voltage (Approx.)
Rear door lock assembly LH				
Connector	Terminal			
D65	2	Ground	Door lock and unlock switch	Unlock
	1			Lock
12 V				

Is the inspection result normal?

YES >> Replace rear door lock assembly LH.

NO >> GO TO 2.

2. CHECK DOOR LOCK ACTUATOR CIRCUIT

1. Disconnect BCM connector and all door lock assembly connector.
2. Check continuity between BCM harness connector and rear door lock assembly LH harness connector.

BCM		Rear door lock assembly LH		Continuity
Connector	Terminal	Connector	Terminal	
B10	55	D65	2	Existed
M69	65		1	

3. Check continuity between BCM harness connector and ground.

BCM		Ground	Continuity
Connector	Terminal		
B10	55		Not existed
M69	65		

Is the inspection result normal?

YES >> GO TO 3.

NO >> Repair or replace harness.

3. CHECK BCM OUTPUT SIGNAL

1. Connect BCM connector.
2. Check voltage between BCM harness connector and ground.

(+)		(-)	Condition	Voltage (Approx.)
BCM				
Connector	Terminal			
B10	55	Ground	Door lock and unlock switch	Unlock
M69	65			Lock
12 V				

Is the inspection result normal?

YES >> Check for internal short of each door lock actuator.

NO >> Replace BCM. Refer to [BCS-94, "Removal and Installation"](#).

REAR RH

REAR RH : Component Function Check

INFOID:0000000012196633

1. CHECK FUNCTION

1. Select "DOOR LOCK" of "BCM" using CONSULT.
2. Select "DOOR LOCK" in "ACTIVE TEST" mode.
3. Check that the function operates normally according to the following conditions.

Monitor item	Status		
DOOR LOCK	ALL LOCK	Door lock actuators	LOCK
	ALL UNLK		UNLOCK

DOOR LOCK ACTUATOR

[WITH INTELLIGENT KEY SYSTEM]

< DTC/CIRCUIT DIAGNOSIS >

Is the inspection result normal?

YES >> Door lock actuator is OK.

NO >> Refer to [DLK-68, "DRIVER SIDE : Diagnosis Procedure"](#).

REAR RH : Diagnosis Procedure

INFOID:000000012196634

1. CHECK DOOR LOCK ACTUATOR INPUT SIGNAL

1. Turn ignition switch OFF.
2. Disconnect rear door lock assembly RH connector.
3. Check voltage between rear door lock assembly RH harness connector and ground.

(+)		(-)	Condition		Voltage (Approx.)
Rear door lock assembly RH					
Connector	Terminal	Ground	Door lock and unlock switch	Unlock	12 V
D45	6			Ground	
	5				

Is the inspection result normal?

YES >> Replace rear door lock assembly RH.

NO >> GO TO 2.

2. CHECK DOOR LOCK ACTUATOR CIRCUIT

1. Disconnect BCM connector and all door lock assembly connector.
2. Check continuity between BCM harness connector and rear door lock assembly RH harness connector.

BCM		Rear door lock assembly RH		Continuity
Connector	Terminal	Connector	Terminal	
B10	55	D45	6	Existed
M69	65		5	

3. Check continuity between BCM harness connector and ground.

BCM		Ground	Continuity
Connector	Terminal		
B10	55	Ground	Not existed
M69	65		

Is the inspection result normal?

YES >> GO TO 3.

NO >> Repair or replace harness.

3. CHECK BCM OUTPUT SIGNAL

1. Connect BCM connector.
2. Check voltage between BCM harness connector and ground.

(+)		(-)	Condition		Voltage (Approx.)
BCM					
Connector	Terminal	Ground	Door lock and unlock switch	Unlock	12 V
B10	55			Ground	
M69	65				

Is the inspection result normal?

YES >> Check for internal short of each door lock actuator.

NO >> Replace BCM. Refer to [BCS-94, "Removal and Installation"](#).

DOOR LOCK AND UNLOCK SWITCH

< DTC/CIRCUIT DIAGNOSIS >

[WITH INTELLIGENT KEY SYSTEM]

DOOR LOCK AND UNLOCK SWITCH

Component Function Check

INFOID:000000012196635

1. CHECK FUNCTION

1. Select "DOOR LOCK" of "BCM" using CONSULT.
2. Select "CDL LOCK SW", "CDL UNLOCK SW" in "DATA MONITOR" mode.
3. Check that the function operates normally according to the following conditions.

Monitor item	Condition	Status
CDL LOCK SW	Lock	ON
	Unlock	OFF
CDL UNLOCK SW	Lock	OFF
	Unlock	ON

Is the inspection result normal?

- YES >> Door lock and unlock switch is OK.
 NO >> Refer to [DLK-73, "Diagnosis Procedure"](#).

Diagnosis Procedure

INFOID:000000012196636

1. CHECK DOOR LOCK AND UNLOCK SWITCH INPUT SIGNAL

1. Turn ignition switch OFF.
2. Disconnect power window main switch connector.
3. Check signal between power window main switch harness connector and ground using oscilloscope.

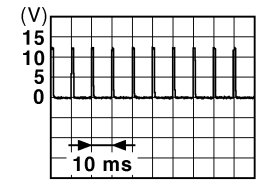
(+)		(-)	Signal (Reference value)
Power window main switch Connector	Terminal		
D35	3	Ground	 <p style="text-align: right; font-size: small;">JPMIA0012GB 1.0 - 1.5 V</p>
	15		

Is the inspection result normal?

- YES >> GO TO 3.
 NO >> GO TO 2.

2. CHECK DOOR LOCK AND UNLOCK SWITCH CIRCUIT

1. Disconnect BCM connector and power window main switch connector.
2. Check continuity between BCM harness connector and power window main switch harness connector.

BCM		Power window main switch		Continuity
Connector	Terminal	Connector	Terminal	
M68	12	D35	3	Existed
	13		15	

3. Check continuity between BCM harness connector and ground.

DOOR LOCK AND UNLOCK SWITCH

< DTC/CIRCUIT DIAGNOSIS >

[WITH INTELLIGENT KEY SYSTEM]

BCM		Ground	Continuity
Connector	Terminal		
M68	12		
	13		

Is the inspection result normal?

YES >> Replace BCM. Refer to [BCS-94, "Removal and Installation"](#).

NO >> Repair or replace harness.

3. CHECK DOOR LOCK AND UNLOCK SWITCH GROUND

Check continuity between power window main switch harness connector and ground.

Power window main switch		Ground	Continuity
Connector	Terminal		
D35	1		

Is the inspection result normal?

YES >> GO TO 4.

NO >> Repair or replace harness.

4. CHECK DOOR LOCK AND UNLOCK SWITCH

Refer to [DLK-74, "Component Inspection"](#).

Is the inspection result normal?

YES >> GO TO 5.

NO >> Replace power window main switch. Refer to [PWC-54, "Removal and Installation"](#).

5. CHECK INTERMITTENT INCIDENT

Refer to [GI-45, "Intermittent Incident"](#).

>> INSPECTION END

Component Inspection

INFOID:0000000012196637

1. CHECK DOOR LOCK AND UNLOCK SWITCH

1. Turn ignition switch OFF.
2. Disconnect power window main switch connector.
3. Check continuity between power window main switch terminals.

Power window main switch		Door lock and unlock switch	Condition	Continuity
Terminal				
3	1		LOCK	Existed
		UNLOCK	Not existed	
15		LOCK	Not existed	
		UNLOCK	Existed	

Is the inspection result normal?

YES >> INSPECTION END

NO >> Replace power window main switch.

DOOR REQUEST SWITCH

< DTC/CIRCUIT DIAGNOSIS >

[WITH INTELLIGENT KEY SYSTEM]

DOOR REQUEST SWITCH

Component Function Check

INFOID:000000012196638

1.CHECK FUNCTION

1. Select "INTELLIGENT KEY" of "BCM" using CONSULT.
2. Select "REQ SW-DR", "REQ SW-AS" in "DATA MONITOR" mode.
3. Check that the function operates normally according to the following conditions.

Monitor item	Condition		Status
REQ SW -DR	Driver side door request switch	Pressed	ON
		Released	OFF
REQ SW -AS	Passenger side door request switch	Pressed	ON
		Released	OFF

Is the inspection result normal?

- YES >> Front door request switch is OK.
 NO >> Refer to [DLK-75, "Diagnosis Procedure"](#).

Diagnosis Procedure

INFOID:000000012196639

1.CHECK DOOR REQUEST SWITCH INPUT SIGNAL

1. Turn ignition switch OFF.
2. Disconnect malfunctioning front door request switch connector.
3. Check voltage between malfunctioning front door request switch harness connector and ground.

(+)			(-)	Voltage (Approx.)
Front door request switch				
Connector	Terminal		Ground	12 V
Driver side	D34	2		
Passenger side	D15	1		

Is the inspection result normal?

- YES >> GO TO 3.
 NO >> GO TO 2.

2.CHECK DOOR REQUEST SWITCH CIRCUIT

1. Disconnect BCM connector.
2. Check continuity between malfunctioning front door request switch harness connector and BCM harness connector.

Front door request switch			BCM		Continuity
Connector	Terminal		Connector	Terminal	
Driver side	D34	2	M70	75	Existed
Passenger side	D15	1		100	

3. Check continuity between malfunctioning front door request switch harness connector and ground.

Front door request switch			Ground	Continuity
Connector	Terminal			
Driver side	D34	2		Not existed
Passenger side	D15	1		

Is the inspection result normal?

- YES >> Replace BCM. Refer to [BCS-94, "Removal and Installation"](#).
 NO >> Repair or replace harness.

DOOR REQUEST SWITCH

< DTC/CIRCUIT DIAGNOSIS >

[WITH INTELLIGENT KEY SYSTEM]

3. CHECK DOOR REQUEST SWITCH GROUND CIRCUIT

Check continuity between malfunctioning front door request switch harness connector and ground.

Front door request switch		Ground	Continuity
Connector	Terminal		
Driver side	D34	1	Existed
Passenger side	D15	2	

Is the inspection result normal?

YES >> GO TO 4.

NO >> Repair or replace harness.

4. CHECK DOOR REQUEST SWITCH

Refer to [DLK-76, "Component Inspection"](#).

Is the inspection result normal?

YES >> GO TO 5.

NO >> Replace malfunctioning front door request switch.

5. CHECK INTERMITTENT INCIDENT

Refer to [GI-45, "Intermittent Incident"](#).

>> INSPECTION END

Component Inspection

INFOID:0000000012196640

1. CHECK DOOR REQUEST SWITCH

1. Turn ignition switch OFF.
2. Disconnect malfunctioning front door request switch connector.
3. Check continuity between malfunctioning front door request switch terminals.

Front door request switch		Condition		Continuity
Terminal				
1	2	Door request switch	Pressed	Existed
			Released	Not existed

Is the inspection result normal?

YES >> INSPECTION END

NO >> Replace malfunctioning front door request switch.

DOOR SWITCH

< DTC/CIRCUIT DIAGNOSIS >

[WITH INTELLIGENT KEY SYSTEM]

DOOR SWITCH

Component Function Check

INFOID:000000012196641

1.CHECK FUNCTION

1. Select "DOOR LOCK" of "BCM" using CONSULT.
2. Select "DOOR SW-DR", "DOOR SW-AS", "DOOR SW-RL", "DOOR SW-RR", "DOOR SW-BK" in "DATA MONITOR" mode.
3. Check that the function operates normally according to the following conditions.

Monitor item	Condition		Status
DOOR SW-DR	Driver side door	Open	On
		Closed	Off
DOOR SW-AS	Passenger side door	Open	On
		Closed	Off
DOOR SW-RL	Rear door LH	Open	On
		Closed	Off
DOOR SW-RR	Rear door RH	Open	On
		Closed	Off
DOOR SW-BK	Back door	Open	On
		Closed	Off

Is the inspection result normal?

- YES >> Door switch is OK.
 NO >> Refer to [DLK-77. "Diagnosis Procedure"](#).

Diagnosis Procedure

INFOID:000000012196642

1.CHECK DOOR SWITCH INPUT SIGNAL

1. Turn ignition switch OFF.
2. Disconnect malfunctioning door switch connector.
3. Check signal between malfunctioning door switch harness connector and ground using oscilloscope.

DLK

(+)		Terminal	(-)	Signal (Reference value)
Door switch				
Connector				
Driver side	B48	2	Ground	
Passenger side	B49			
Rear LH	B71			
Rear RH	B53	3		
Back door	D106			

Is the inspection result normal?

- YES-1 >> Back door: GO TO 3.
 YES-2 >> Other door: GO TO 4.
 NO >> GO TO 2.

2.CHECK DOOR SWITCH CIRCUIT

1. Disconnect BCM connector.
2. Check continuity between door switch harness connector and BCM harness connector.

DOOR SWITCH

< DTC/CIRCUIT DIAGNOSIS >

[WITH INTELLIGENT KEY SYSTEM]

Door switch		BCM		Continuity
Connector	Terminal	Connector	Terminal	
Driver side	B48	B10	47	Existed
Passenger side	B49		45	
Rear LH	B71		48	
Rear RH	B53		46	
Back door	D106		43	
		2		
		3		

3. Check continuity between door switch harness connector and ground.

Door switch		Terminal	Ground	Continuity
Connector	Terminal			Continuity
Driver side	B48	2	Ground	Not existed
Passenger side	B49			
Rear LH	B71			
Rear RH	B53			
Back door	D106	3		

Is the inspection result normal?

YES >> Replace BCM. Refer to [BCS-94, "Removal and Installation"](#).

NO >> Repair or replace harness.

3.CHECK BACK DOOR LOCK ASSEMBLY CIRCUIT

Check continuity between back door lock assembly harness connector and ground.

Back door switch		Ground	Continuity
Connector	Terminal		Continuity
D106	4	Ground	Existed

Is the inspection result normal?

YES >> GO TO 4.

NO >> Repair or replace harness.

4.CHECK DOOR SWITCH

Refer to [DLK-78, "Component Inspection"](#).

Is the inspection result normal?

YES >> GO TO 5.

NO >> Replace malfunctioning door switch.

5.CHECK INTERMITTENT INCIDENT

Refer to [GI-45, "Intermittent Incident"](#).

>> INSPECTION END

Component Inspection

INFOID:0000000012196643

1.CHECK DOOR SWITCH

1. Turn ignition switch OFF.
2. Disconnect malfunctioning door switch connector.
3. Check continuity between door switch terminals.

DOOR SWITCH

< DTC/CIRCUIT DIAGNOSIS >

[WITH INTELLIGENT KEY SYSTEM]

Door switch			Condition	Continuity	
Terminal					
Driver side	2	Ground part of door switch	Door switch	Pressed	Existed
				Released	Not existed
Passenger side				Pressed	Existed
				Released	Not existed
Rear LH				Pressed	Existed
				Released	Not existed
Rear RH				Pressed	Existed
				Released	Not existed
Back door	3	4	Back door lock assembly	Lock	Existed
				Unlock	Not existed

Is the inspection result normal?

- YES >> INSPECTION END
- NO >> Replace malfunction door switch.

A
B
C
D
E
F
G
H
I
J
L
M
N
O
P

DLK

HAZARD FUNCTION

< DTC/CIRCUIT DIAGNOSIS >

[WITH INTELLIGENT KEY SYSTEM]

HAZARD FUNCTION

Component Function Check

INFOID:000000012196644

1.CHECK FUNCTION

1. Select "INTELLIGENT KEY" of "BCM" using CONSULT.
2. Select "FLASHER" in "ACTIVE TEST" mode.
3. Check that the function operates normally according to the following conditions.

Monitor item		Status	
FLASHER	LH	Front turn signal lamp LH	Turns ON
	RH	Front turn signal lamp RH	Turns ON
	OFF	Front turn signal lamp	Turns OFF

Is the inspection result normal?

- YES >> Hazard warning lamp circuit is OK.
NO >> Refer to [DLK-80, "Diagnosis Procedure"](#).

Diagnosis Procedure

INFOID:000000012196645

1.CHECK HAZARD SWITCH CIRCUIT

Refer to [EXL-77, "Component Function Check"](#).

Is the inspection result normal?

- YES >> GO TO 2.
NO >> Repair or replace the malfunctioning parts.

2.CHECK INTERMITTENT INCIDENT

Refer to [GI-45, "Intermittent Incident"](#).

>> INSPECTION END

INTELLIGENT KEY BATTERY

< DTC/CIRCUIT DIAGNOSIS >

[WITH INTELLIGENT KEY SYSTEM]

INTELLIGENT KEY BATTERY

Component Inspection

INFOID:000000012196646

1. CHECK INTELLIGENT KEY BATTERY

Check by connecting a resistance (approximately 300 Ω) so that the current value becomes about 10 mA.

Standard : Approx. 2.5 - 3.0 V

Is the measurement value within the specification?

- YES >> INSPECTION END
- NO >> Replace Intelligent Key battery.

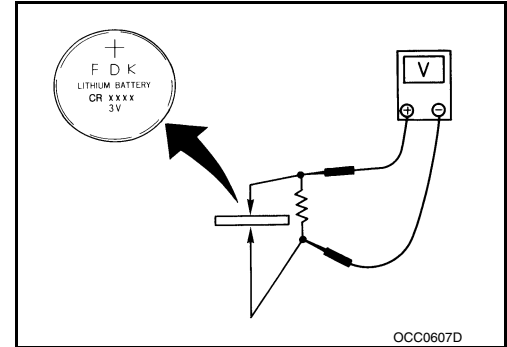

A
B
C
D
E
F
G
H
I
J
L
M
N
O
P

DLK

INTELLIGENT KEY WARNING BUZZER

< DTC/CIRCUIT DIAGNOSIS >

[WITH INTELLIGENT KEY SYSTEM]

INTELLIGENT KEY WARNING BUZZER

Component Function Check

INFOID:000000012196647

1.CHECK FUNCTION

1. Select "INTELLIGENT KEY" of "BCM" using CONSULT.
2. Select "OUTSIDE BUZZER" in "ACTIVE TEST" mode.
3. Check that the function operates normally according to the following conditions.

Monitor item		Status	
OUTSIDE BUZZER	ON	Outside warning buzzer	Buzzer sounds
	OFF		Buzzer does not sound

Is the inspection result normal?

- YES >> Intelligent Key warning buzzer is OK.
NO >> Refer to [DLK-82. "Diagnosis Procedure"](#).

Diagnosis Procedure

INFOID:000000012196648

1.CHECK FUSE

1. Turn ignition switch OFF.
2. Check 10 A fuse, [No. 13, located in fuse block (J/B)].

Is the inspection result normal?

- YES >> GO TO 2.
NO >> Replace the blown fuse after repairing the affected circuit if a fuse is blown.

2.CHECK INTELLIGENT KEY WARNING BUZZER POWER SUPPLY CIRCUIT

1. Disconnect Intelligent Key warning buzzer connector.
2. Check voltage between Intelligent Key warning buzzer harness connector and ground.

(+)		(-)	Voltage (Approx.)
Intelligent Key warning buzzer			
Connector	Terminal	Ground	Battery voltage
E25	1		

Is the inspection result normal?

- YES >> GO TO 3.
NO >> Repair or replace harness.

3.CHECK INTELLIGENT KEY WARNING BUZZER CIRCUIT

1. Disconnect BCM connector.
2. Check continuity between BCM harness connector and Intelligent Key warning buzzer harness connector.

BCM		Intelligent Key warning buzzer		Continuity
Connector	Terminal	Connector	Terminal	
M70	93	E25	3	Existed

3. Check continuity between BCM harness connector and ground.

BCM		Ground	Continuity
Connector	Terminal		
M70	93		Not existed

Is the inspection result normal?

- YES >> GO TO 4.
NO >> Repair or replace harness.

INTELLIGENT KEY WARNING BUZZER

< DTC/CIRCUIT DIAGNOSIS >

[WITH INTELLIGENT KEY SYSTEM]

4. CHECK INTELLIGENT KEY WARNING BUZZER

Refer to [DLK-83. "Component Inspection"](#).

Is the inspection result normal?

- YES >> Replace BCM. Refer to [BCS-94. "Removal and Installation"](#).
- NO >> Replace Intelligent Key warning buzzer.

Component Inspection

INFOID:000000012196649

1. CHECK INTELLIGENT KEY WARNING BUZZER

1. Turn ignition switch OFF.
2. Disconnect Intelligent Key warning buzzer connector.
3. Connect battery power supply directly to Intelligent Key warning buzzer terminals and check the operation.

Intelligent Key warning buzzer		Operation
Terminal		
(+)	(-)	Buzzer sounds
1	3	

Is the inspection result normal?

- YES >> INSPECTION END
- NO >> Replace Intelligent Key warning buzzer.

A
B
C
D
E
F
G
H
I
J
L
M
N
O
P

DLK

KEY WARNING LAMP

< DTC/CIRCUIT DIAGNOSIS >

[WITH INTELLIGENT KEY SYSTEM]

KEY WARNING LAMP

Component Function Check

INFOID:000000012196650

1.CHECK FUNCTION

1. Select "INTELLIGENT KEY" of "BCM" using CONSULT.
2. Select "INDICATOR" in "ACTIVE TEST" mode.
3. Check that the function operates normally according to the following conditions.

Monitor item		Status	
INDICATOR	KEY ON	Key warning lamp	Turns ON
	KEY IND		Blinks
	OFF		Turns OFF

Is the inspection result normal?

- YES >> Key warning lamp is OK.
NO >> Refer to [DLK-84, "Diagnosis Procedure"](#).

Diagnosis Procedure

INFOID:000000012196651

1.CHECK KEY WARNING LAMP

Refer to [MWI-21, "On Board Diagnosis Function"](#).

Is the inspection result normal?

- YES >> GO TO 2.
NO >> Repair or replace the malfunctioning parts.

2.CHECK INTERMITTENT INCIDENT

Refer to [GI-45, "Intermittent Incident"](#).

>> INSPECTION END

REMOTE KEYLESS ENTRY RECEIVER

[WITH INTELLIGENT KEY SYSTEM]

< DTC/CIRCUIT DIAGNOSIS >

REMOTE KEYLESS ENTRY RECEIVER

Component Function Check

INFOID:000000012196652

1.CHECK FUNCTION

1. Select "INTELLIGENT KEY" of "BCM" using CONSULT.
2. Select "RKE OPE COUN1" in "DATA MONITOR" mode.
3. Check that the function operates normally according to the following conditions.

Monitor item	Condition
RKE OPE COUN1	Checks whether value changes when operating Intelligent Key

Is the inspection result normal?

- YES >> Remote keyless entry receiver is OK.
NO >> Refer to [DLK-85. "Diagnosis Procedure"](#).

Diagnosis Procedure

INFOID:000000012196653

1.CHECK REMOTE KEYLESS ENTRY RECEIVER POWER SUPPLY

1. Turn ignition switch OFF.
2. Disconnect remote keyless entry receiver connector.
3. Check voltage between remote keyless entry receiver harness connector and ground.

(+)		(-)	Voltage
Connector	Terminal		
M75	1	Ground	Battery voltage

Is the inspection result normal?

- YES >> GO TO 3.
NO >> GO TO 2.

2.DETECT MALFUNCTIONING PART

Check the following.

- 10 A fuse (No. 7)
- Harness for open or short between remote keyless entry receiver and battery

Is the inspection result normal?

- YES >> GO TO 6.
NO >> Repair or replace the malfunctioning parts.

3.CHECK REMOTE KEYLESS ENTRY RECEIVER GROUND CIRCUIT

1. Disconnect BCM connector.
2. Check continuity between BCM harness connector and remote keyless entry receiver harness connector.

BCM		Remote keyless entry receiver		Continuity
Connector	Terminal	Connector	Terminal	
M68	18	M75	4	Existed

3. Check continuity between BCM harness connector and ground.

BCM		Ground	Continuity
Connector	Terminal		
M68	18		Existed

Is the inspection result normal?

- YES >> GO TO 4.
NO >> Repair or replace harness.

A
B
C
D
E
F
G
H
I
J
L
M
N
O
P

DLK

REMOTE KEYLESS ENTRY RECEIVER

[WITH INTELLIGENT KEY SYSTEM]

< DTC/CIRCUIT DIAGNOSIS >

4. CHECK REMOTE KEYLESS ENTRY RECEIVER OUTPUT SIGNAL

1. Reconnect BCM connector and remote keyless entry receiver connector.
2. Check signal between remote keyless entry receiver harness connector and ground using oscilloscope.

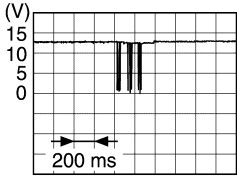
(+)		(-)	Condition	Signal (Reference value)
Remote keyless entry receiver Connector	Terminal			
M75	2	Ground	Waiting	12 V
			Press the Intelligent Key lock or unlock button	

JMMIA0572GB

Is the inspection result normal?

YES >> GO TO 5.

NO >> Replace remote keyless entry receiver.

5. CHECK REMOTE KEYLESS ENTRY RECEIVER CIRCUIT

1. Disconnect BCM connector and remote keyless entry receiver connector.
2. Check continuity between BCM harness connector and remote keyless entry receiver harness connector.

BCM		Remote keyless entry receiver		Continuity
Connector	Terminal	Connector	Terminal	
M68	38	M75	2	Existed

3. Check continuity between BCM harness connector and ground.

BCM		Ground	Continuity
Connector	Terminal		
M68	38		Not existed

Is the inspection result normal?

YES >> Replace BCM. Refer to [BCS-94. "Removal and Installation"](#).

NO >> Repair or replace harness.

6. CHECK INTERMITTENT INCIDENT

Refer to [GI-45. "Intermittent Incident"](#).

>> INSPECTION END

SHIFT P WARNING LAMP

< DTC/CIRCUIT DIAGNOSIS >

[WITH INTELLIGENT KEY SYSTEM]

SHIFT P WARNING LAMP

Component Function Check

INFOID:000000012196654

1.CHECK FUNCTION

1. Select "INTELLIGENT KEY" of "BCM" using CONSULT.
2. Select "LCD" in "ACTIVE TEST" mode.
3. Check that the function operates normally according to the following conditions.

Monitor item		Status	
LCD	SFT P	Shift P warning lamp	Turns ON

Is the inspection result normal?

- YES >> Shift P warning lamp is OK.
NO >> Refer to [DLK-87. "Diagnosis Procedure"](#).

Diagnosis Procedure

INFOID:000000012196655

1.CHECK SHIFT P WARNING LAMP

Refer to [MWI-21. "On Board Diagnosis Function"](#).

Is the inspection result normal?

- YES >> GO TO 2.
NO >> Repair or replace the malfunctioning parts.

2.CHECK INTERMITTENT INCIDENT

Refer to [GI-45. "Intermittent Incident"](#).

>> INSPECTION END

A
B
C
D
E
F
G
H
I
J
L
M
N
O
P

DLK

UNLOCK SENSOR

< DTC/CIRCUIT DIAGNOSIS >

[WITH INTELLIGENT KEY SYSTEM]

UNLOCK SENSOR

Component Function Check

INFOID:000000012196656

1.CHECK FUNCTION

1. Select "INTELLIGENT KEY" of "BCM" using CONSULT.
2. Select "UNLK SEN -DR" in "DATA MONITOR" mode.
3. Check that the function operates normally according to the following conditions.

Monitor item	Condition		Status
UNLK SEN -DR	Driver side door	Lock	OFF
		Unlock	ON

Is the inspection result normal?

- YES >> Unlock sensor is OK.
 NO >> Refer to [DLK-88. "Diagnosis Procedure"](#).

Diagnosis Procedure

INFOID:000000012196657

1.CHECK BCM OUTPUT SIGNAL

1. Turn ignition switch OFF.
2. Disconnect front door lock assembly (driver side) connector.
3. Check signal between front door lock assembly (driver side) harness connector and ground using oscilloscope.

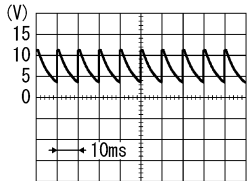
(+)		(-)	Signal (Reference value)
Connector	Terminal		
D38	3	Ground	 <p style="text-align: right;">PKIB4960J</p>

Is the inspection result normal?

- YES >> GO TO 3.
 NO >> GO TO 2.

2.CHECK UNLOCK SENSOR CIRCUIT

1. Disconnect BCM connector.
2. Check continuity between BCM harness connector and front door lock assembly (driver side) harness connector.

BCM		Front door lock assembly (driver side)		Continuity
Connector	Terminal	Connector	Terminal	
M68	31	D38	3	Existed

3. Check continuity between BCM harness connector and ground.

BCM		Ground	Continuity
Connector	Terminal		
M68	31		Not existed

Is the inspection result normal?

- YES >> Replace BCM. Refer to [BCS-94. "Removal and Installation"](#).

UNLOCK SENSOR

[WITH INTELLIGENT KEY SYSTEM]

< DTC/CIRCUIT DIAGNOSIS >

NO >> Repair or replace harness.

3.CHECK UNLOCK SENSOR GROUND CIRCUIT

Check continuity between front door lock assembly (driver side) harness connector and ground.

Front door lock assembly (driver side)		Ground	Continuity
Connector	Terminal		
D38	4		Existed

Is the inspection result normal?

YES >> GO TO 4.

NO >> Repair or replace harness.

4.CHECK UNLOCK SENSOR

Refer to [DLK-89. "Component Inspection"](#).

Is the inspection result normal?

YES >> GO TO 5.

NO >> Replace front door lock assembly (driver side).

5.CHECK INTERMITTENT INCIDENT

Refer to [GI-45. "Intermittent Incident"](#).

>> INSPECTION END

Component Inspection

INFOID:000000012196658

1.CHECK UNLOCK SENSOR

1. Turn ignition switch OFF.
2. Disconnect front door lock assembly (driver side) connector.
3. Check continuity between front door lock assembly (driver side) terminals.

Front door lock assembly (driver side)		Condition	Continuity
Terminal			
3	4	Driver side door	Unlock Existed
			Lock Not existed

Is the inspection result normal?

YES >> INSPECTION END

NO >> Replace front lock assembly (driver side).

A
B
C
D
E
F
G
H
I
J
L
M
N
O
P

DLK

SYMPTOM DIAGNOSIS

DOOR DOES NOT LOCK/UNLOCK WITH DOOR LOCK AND UNLOCK SWITCH

ALL DOOR

ALL DOOR : Description

INFOID:0000000012196659

All doors do not lock/unlock using door lock and unlock switch.

ALL DOOR : Diagnosis Procedure

INFOID:0000000012196660

1.CHECK DOOR LOCK AND UNLOCK SWITCH

Check door lock and unlock switch.

Refer to [DLK-73, "Component Function Check"](#).

Is the inspection result normal?

YES >> GO TO 2.

NO >> Repair or replace the malfunctioning parts.

2.CHECK DOOR LOCK ACTUATOR

Check front door lock assembly (driver side).

Refer to [DLK-68, "DRIVER SIDE : Component Function Check"](#).

Is the inspection result normal?

YES >> GO TO 3.

NO >> Repair or replace the malfunctioning parts.

3.REPLACE BCM

1. Replace BCM. Refer to [BCS-94, "Removal and Installation"](#).

2. Confirm the operation after replacement.

Is the result normal?

YES >> INSPECTION END

NO >> Check intermittent incident. Refer to [GI-45, "Intermittent Incident"](#).

DRIVER SIDE

DRIVER SIDE : Description

INFOID:0000000012196661

Driver side door does not lock/unlock using door lock and unlock switch.

DRIVER SIDE : Diagnosis Procedure

INFOID:0000000012196662

1.CHECK DOOR LOCK ACTUATOR

Check front door lock assembly (driver side).

Refer to [DLK-68, "DRIVER SIDE : Component Function Check"](#).

Is the inspection result normal?

YES >> GO TO 2.

NO >> Repair or replace the malfunctioning parts.

2.REPLACE BCM

1. Replace BCM. Refer to [BCS-94, "Removal and Installation"](#).

2. Confirm the operation after replacement.

Is the result normal?

YES >> INSPECTION END

NO >> Check intermittent incident. Refer to [GI-45, "Intermittent Incident"](#).

PASSENGER SIDE

DOOR DOES NOT LOCK/UNLOCK WITH DOOR LOCK AND UNLOCK SWITCH

< SYMPTOM DIAGNOSIS >

[WITH INTELLIGENT KEY SYSTEM]

PASSENGER SIDE : Description

INFOID:000000012196663

Passenger side door does not lock/unlock using door lock and unlock switch.

PASSENGER SIDE : Diagnosis Procedure

INFOID:000000012196664

1.CHECK DOOR LOCK ACTUATOR

Check front door lock assembly (passenger side).

Refer to [DLK-69, "PASSENGER SIDE : Component Function Check"](#).

Is the inspection result normal?

YES >> GO TO 2.

NO >> Repair or replace the malfunctioning parts.

2.REPLACE BCM

1. Replace BCM. Refer to [BCS-94, "Removal and Installation"](#).

2. Confirm the operation after replacement.

Is the result normal?

YES >> INSPECTION END

NO >> Check intermittent incident. Refer to [GI-45, "Intermittent Incident"](#).

REAR LH

REAR LH : Description

INFOID:000000012196665

Rear LH side door does not lock/unlock using door lock and unlock switch.

REAR LH : Diagnosis Procedure

INFOID:000000012196666

1.CHECK DOOR LOCK ACTUATOR

Check rear door lock assembly LH.

Refer to [DLK-70, "REAR LH : Component Function Check"](#).

Is the inspection result normal?

YES >> GO TO 2.

NO >> Repair or replace the malfunctioning parts.

2.REPLACE BCM

1. Replace BCM. Refer to [BCS-94, "Removal and Installation"](#).

2. Confirm the operation after replacement.

Is the result normal?

YES >> INSPECTION END

NO >> Check intermittent incident. Refer to [GI-45, "Intermittent Incident"](#).

REAR RH

REAR RH : Description

INFOID:000000012196667

Rear RH side door does not lock/unlock using door lock and unlock switch.

REAR RH : Diagnosis Procedure

INFOID:000000012196668

1.CHECK DOOR LOCK ACTUATOR

Check rear door lock assembly RH.

Refer to [DLK-71, "REAR RH : Component Function Check"](#).

Is the inspection result normal?

YES >> GO TO 2.

NO >> Repair or replace the malfunctioning parts.

2.REPLACE BCM

1. Replace BCM. Refer to [BCS-94, "Removal and Installation"](#).

A

B

C

D

E

F

G

H

I

J

DLK

L

M

N

O

P

DOOR DOES NOT LOCK/UNLOCK WITH DOOR LOCK AND UNLOCK SWITCH
[WITH INTELLIGENT KEY SYSTEM]

< SYMPTOM DIAGNOSIS >

2. Confirm the operation after replacement.

Is the result normal?

YES >> INSPECTION END

NO >> Check intermittent incident. Refer to [GI-45. "Intermittent Incident"](#).

DOOR DOES NOT LOCK/UNLOCK WITH DOOR REQUEST SWITCH

< SYMPTOM DIAGNOSIS >

[WITH INTELLIGENT KEY SYSTEM]

DOOR DOES NOT LOCK/UNLOCK WITH DOOR REQUEST SWITCH

ALL DOOR REQUEST SWITCHES

ALL DOOR REQUEST SWITCHES : Description

INFOID:0000000012196669

All doors do not lock/unlock using all door request switches.

ALL DOOR REQUEST SWITCHES : Diagnosis Procedure

INFOID:0000000012196670

1. CHECK REMOTE KEYLESS ENTRY FUNCTION

Check remote keyless entry function.

Does door lock/unlock with Intelligent Key button?

YES >> GO TO 2.

NO >> Refer to [DLK-18, "REMOTE KEYLESS ENTRY FUNCTION : System Description"](#).

2. CHECK "LOCK/UNLOCK BY I-KEY" SETTING IN "WORK SUPPORT"

1. Select "INTELLIGENT KEY" of "BCM" using CONSULT.

2. Select "LOCK/UNLOCK BY I-KEY" in "WORK SUPPORT" mode.

3. Check "LOCK/UNLOCK BY I-KEY" in "WORK SUPPORT".

Refer to [DLK-28, "INTELLIGENT KEY : CONSULT Function \(BCM - INTELLIGENT KEY\)"](#).

Is the inspection result normal?

YES >> GO TO 3.

NO >> Set "LOCK/UNLOCK BY I-KEY" in "WORK SUPPORT".

3. CHECK DOOR SWITCH

Check door switch.

Refer to [DLK-77, "Component Function Check"](#).

Is the inspection result normal?

YES >> GO TO 4.

NO >> Repair or replace the malfunctioning parts.

4. CHECK INSIDE KEY ANTENNA

Check inside key antenna.

• Instrument center: Refer to [DLK-49, "DTC Logic"](#).

• Luggage room: Refer to [DLK-51, "DTC Logic"](#).

Is the inspection result normal?

YES >> GO TO 5.

NO >> Repair or replace the malfunctioning parts.

5. CHECK OUTSIDE KEY ANTENNA

Check outside key antenna.

• Driver side: Refer to [DLK-55, "DTC Logic"](#).

• Passenger side: Refer to [DLK-53, "DTC Logic"](#).

• Rear bumper: Refer to [DLK-57, "DTC Logic"](#).

Is the inspection result normal?

YES >> GO TO 6.

NO >> Repair or replace the malfunctioning parts.

6. REPLACE BCM

1. Replace BCM. Refer to [BCS-94, "Removal and Installation"](#).

2. Confirm the operation after replacement.

Is the result normal?

YES >> INSPECTION END

NO >> Check intermittent incident. Refer to [GI-45, "Intermittent Incident"](#).

DRIVER SIDE DOOR REQUEST SWITCH

A
B
C
D
E
F
G
H
I
J
L
M
N
O
P

DLK

DOOR DOES NOT LOCK/UNLOCK WITH DOOR REQUEST SWITCH

< SYMPTOM DIAGNOSIS >

[WITH INTELLIGENT KEY SYSTEM]

DRIVER SIDE DOOR REQUEST SWITCH : Description

INFOID:000000012196671

All doors do not lock/unlock using driver side door request switch.

DRIVER SIDE DOOR REQUEST SWITCH : Diagnosis Procedure

INFOID:000000012196672

1.CHECK DRIVER SIDE DOOR REQUEST SWITCH

Check driver side door request switch.

Refer to [DLK-75, "Component Function Check"](#).

Is the inspection result normal?

YES >> GO TO 2.

NO >> Repair or replace the malfunctioning parts.

2.CHECK OUTSIDE KEY ANTENNA

Check outside key antenna (driver side).

Refer to [DLK-55, "DTC Logic"](#).

Is the inspection result normal?

YES >> GO TO 3.

NO >> Repair or replace the malfunctioning parts.

3.REPLACE BCM

1. Replace BCM. Refer to [BCS-94, "Removal and Installation"](#).

2. Confirm the operation after replacement.

Is the result normal?

YES >> INSPECTION END

NO >> Check intermittent incident. Refer to [GI-45, "Intermittent Incident"](#).

PASSENGER SIDE DOOR REQUEST SWITCH

PASSENGER SIDE DOOR REQUEST SWITCH : Description

INFOID:000000012196673

All doors do not lock/unlock using passenger side door request switch.

PASSENGER SIDE DOOR REQUEST SWITCH : Diagnosis Procedure

INFOID:000000012196674

1.CHECK PASSENGER SIDE DOOR REQUEST SWITCH

Check passenger side door request switch.

Refer to [DLK-75, "Component Function Check"](#).

Is the inspection result normal?

YES >> GO TO 2.

NO >> Repair or replace the malfunctioning parts.

2.CHECK OUTSIDE KEY ANTENNA

Check outside key antenna (passenger side).

Refer to [DLK-53, "DTC Logic"](#).

Is the inspection result normal?

YES >> GO TO 3.

NO >> Repair or replace the malfunctioning parts.

3.REPLACE BCM

1. Replace BCM. Refer to [BCS-94, "Removal and Installation"](#).

2. Confirm the operation after replacement.

Is the result normal?

YES >> INSPECTION END

NO >> Check intermittent incident. Refer to [GI-45, "Intermittent Incident"](#).

BACK DOOR REQUEST SWITCH

DOOR DOES NOT LOCK/UNLOCK WITH DOOR REQUEST SWITCH

< SYMPTOM DIAGNOSIS >

[WITH INTELLIGENT KEY SYSTEM]

BACK DOOR REQUEST SWITCH : Description

INFOID:000000012196675

All doors do not lock/unlock using back door request switch.

BACK DOOR REQUEST SWITCH : Diagnosis Procedure

INFOID:000000012196676

1. CHECK BACK DOOR REQUEST SWITCH

Check back door request switch.

Refer to [DLK-63, "Component Function Check"](#).

Is the inspection result normal?

YES >> GO TO 2.

NO >> Repair or replace the malfunctioning parts.

2. CHECK OUTSIDE KEY ANTENNA

Check outside key antenna (rear bumper).

Refer to [DLK-57, "DTC Logic"](#).

Is the inspection result normal?

YES >> GO TO 3.

NO >> Repair or replace the malfunctioning parts.

3. REPLACE BCM

1. Replace BCM. Refer to [BCS-94, "Removal and Installation"](#).

2. Confirm the operation after replacement.

Is the result normal?

YES >> INSPECTION END

NO >> Check intermittent incident. Refer to [GI-45, "Intermittent Incident"](#).

A
B
C
D
E
F
G
H
I
J
L
M
N
O
P

DLK

DOOR DOES NOT LOCK/UNLOCK WITH DOOR KEY CYLINDER OPERATION
< SYMPTOM DIAGNOSIS > **[WITH INTELLIGENT KEY SYSTEM]**

DOOR DOES NOT LOCK/UNLOCK WITH DOOR KEY CYLINDER OPERATION

Diagnosis Procedure

INFOID:000000012196677

1. CHECK POWER DOOR LOCK OPERATION

Check power door lock operation.

Does door lock/unlock with door lock and unlock switch?

YES >> GO TO 2.

NO >> Refer to [DLK-73, "Component Function Check"](#).

2. CHECK DOOR KEY CYLINDER SWITCH

Check door key cylinder switch.

Refer to [DLK-66, "Component Function Check"](#).

Is the inspection result normal?

YES >> GO TO 3.

NO >> Repair or replace the malfunctioning parts.

3. REPLACE BCM

1. Replace BCM. Refer to [BCS-94, "Removal and Installation"](#).

2. Confirm the operation after replacement.

Is the result normal?

YES >> INSPECTION END

NO >> Check intermittent incident. Refer to [GI-45, "Intermittent Incident"](#).

DOOR DOES NOT LOCK/UNLOCK WITH INTELLIGENT KEY

< SYMPTOM DIAGNOSIS >

[WITH INTELLIGENT KEY SYSTEM]

DOOR DOES NOT LOCK/UNLOCK WITH INTELLIGENT KEY

Diagnosis Procedure

INFOID:000000012196678

1.CHECK INTELLIGENT KEY

For Intelligent Key that cannot be used for door lock and unlock, check that the Intelligent Key belongs to the vehicle to be checked.

Does the Intelligent Key belong to the vehicle to be checked?

YES >> GO TO 2.

NO >> Check Intelligent Key button operation with registered Intelligent Key belonging to the vehicle.

2.CHECK INTELLIGENT KEY LOW BATTERY WARNING

Check that the Intelligent Key low battery warning is operated.

Is the Intelligent Key low battery warning operated?

YES >> GO TO 6.

NO-1 >> With another registered Intelligent Key: GO TO 3.

NO-2 >> Without another registered Intelligent Key: GO TO 4.

3.CHECK INTELLIGENT KEY BUTTON OPERATION

Check that door lock and unlock can be performed by operating the buttons of another registered Intelligent Key.

Can door lock and unlock be performed with another registered Intelligent Key?

YES >> GO TO 4.

NO >> GO TO 7.

4.CHECK ENGINE START

While depressing the brake pedal, contact the backside of the Intelligent Key that cannot be used to perform door lock and unlock operation to the push-button ignition switch. Operate the push-button ignition switch, and check that the vehicle is in START status.

Is the vehicle in START status?

YES >> GO TO 6.

NO >> GO TO 5.

5.CHECK INTELLIGENT KEY

Check the inside of the Intelligent Key for rust or corrosion by water. Simultaneously check the internal circuits for damage.

Is the vehicle in START status?

YES >> GO TO 6.

NO >> Replace Intelligent Key.

6.CHECK INTELLIGENT KEY BATTERY

Check the Intelligent Key battery.

Refer to [DLK-81, "Component Inspection"](#).

Is the inspection result normal?

YES >> GO TO 7.

NO >> Replace Intelligent Key battery.

7.CHECK POWER DOOR LOCK OPERATION

Check door lock/unlock using door lock and unlock switch.

Does door lock/unlock using door lock and unlock switch?

YES >> GO TO 8.

NO >> Refer to [DLK-90, "ALL DOOR : Diagnosis Procedure"](#).

8.CHECK REMOTE KEYLESS ENTRY RECEIVER

Check remote keyless entry receiver.

Refer to [DLK-85, "Component Function Check"](#).

A
B
C
D
E
F
G
H
I
J
L
M
N
O
P

DLK

DOOR DOES NOT LOCK/UNLOCK WITH INTELLIGENT KEY

< SYMPTOM DIAGNOSIS >

[WITH INTELLIGENT KEY SYSTEM]

Is the inspection result normal?

YES >> GO TO 9.

NO >> Repair or replace the malfunctioning parts.

9. CHECK DOOR SWITCH

Check door switch.

Refer to [DLK-77, "Component Function Check"](#).

Is the inspection result normal?

YES >> GO TO 10.

NO >> Repair or replace the malfunctioning parts.

10. REPLACE INTELLIGENT KEY

1. Replace Intelligent Key.
2. Confirm the operation after replacement.

Is the result normal?

YES >> INSPECTION END

NO >> Replace BCM. Refer to [BCS-94, "Removal and Installation"](#).

IGNITION POSITION WARNING FUNCTION DOES NOT OPERATE

< SYMPTOM DIAGNOSIS >

[WITH INTELLIGENT KEY SYSTEM]

IGNITION POSITION WARNING FUNCTION DOES NOT OPERATE

Diagnosis Procedure

INFOID:000000012196679

1. CHECK DTC WITH BCM

Check that DTC is not detected with BCM.

Is the inspection result normal?

YES >> GO TO 2.

NO >> Refer to [BCS-62, "DTC Index"](#).

2. CHECK POWER DOOR LOCK OPERATION

Check power door lock operation.

Does door lock/unlock with driver side door lock knob and door key cylinder?

YES >> GO TO 3.

NO >> Refer to [DLK-11, "System Description"](#).

3. CHECK DOOR SWITCH

Check door switch.

Refer to [DLK-77, "Component Function Check"](#).

Is the inspection result normal?

YES >> GO TO 4.

NO >> Repair or replace the malfunctioning parts.

4. REPLACE BCM

1. Replace BCM. Refer to [BCS-94, "Removal and Installation"](#).

2. Confirm the operation after replacement.

Is the result normal?

YES >> INSPECTION END

NO >> Check intermittent incident. Refer to [GI-45, "Intermittent Incident"](#).

A

B

C

D

E

F

G

H

I

J

DLK

L

M

N

O

P

SELECTIVE UNLOCK FUNCTION DOES NOT OPERATE

< SYMPTOM DIAGNOSIS >

[WITH INTELLIGENT KEY SYSTEM]

SELECTIVE UNLOCK FUNCTION DOES NOT OPERATE

Diagnosis Procedure

INFOID:000000012196680

1. CHECK "DOOR LOCK-UNLOCK SET" SETTING IN "WORK SUPPORT"

1. Select "DOOR LOCK" of "BCM" using CONSULT.
2. Select "DOOR LOCK-UNLOCK SET" in "WORK SUPPORT" mode.
3. Check "DOOR LOCK-UNLOCK SET" in "WORK SUPPORT"
Refer to [DLK-26, "DOOR LOCK : CONSULT Function \(BCM - DOOR LOCK\)"](#).

Is the inspection result normal?

- YES >> GO TO 2
NO >> Set "DOOR LOCK-UNLOCK SET" in "WORK SUPPORT".

2. REPLACE BCM

1. Replace BCM. Refer to [BCS-94, "Removal and Installation"](#).
2. Confirm the operation after replacement.

Is the result normal?

- YES >> INSPECTION END
NO >> Check intermittent incident. Refer to [GI-45, "Intermittent Incident"](#).

BACK DOOR DOES NOT OPENED

[WITH INTELLIGENT KEY SYSTEM]

< SYMPTOM DIAGNOSIS >

BACK DOOR DOES NOT OPENED

Diagnosis Procedure

INFOID:000000012196681

1.CHECK BACK DOOR OPENER SWITCH

Check back door opener switch.
Refer to [DLK-59, "Component Function Check"](#).

Is the inspection result normal?

- YES >> GO TO 2.
- NO >> Repair or replace the malfunctioning parts.

2.CHECK BACK DOOR OPENER ACTUATOR

Check back door opener actuator.
Refer to [DLK-59, "Component Function Check"](#).

Is the inspection result normal?

- YES >> GO TO 3.
- NO >> Repair or replace the malfunctioning parts.

3.CHECK VEHICLE SPEED SIGNAL

Check vehicle speed signal.
Refer to [MWI-33, "DTC Index"](#).

Is the inspection result normal?

- YES >> GO TO 4.
- NO >> Repair or replace the malfunctioning parts.

4.REPLACE BCM

1. Replace BCM. Refer to [BCS-94, "Removal and Installation"](#).
2. Confirm the operation after replacement.

Is the result normal?

- YES >> INSPECTION END
- NO >> Check intermittent incident. Refer to [GI-45, "Intermittent Incident"](#).

A
B
C
D
E
F
G
H
I
J
L
M
N
O
P

DLK

AUTO DOOR LOCK OPERATION DOES NOT OPERATE

< SYMPTOM DIAGNOSIS >

[WITH INTELLIGENT KEY SYSTEM]

AUTO DOOR LOCK OPERATION DOES NOT OPERATE

Diagnosis Procedure

INFOID:000000012196682

1. CHECK "AUTO LOCK SET" SETTING IN "WORK SUPPORT"

1. Select "INTELLIGENT KEY" of "BCM" using CONSULT.
2. Select "AUTO LOCK SET" in "WORK SUPPORT" mode.
3. Check "AUTO LOCK SET" in "WORK SUPPORT".

Refer to [DLK-28, "INTELLIGENT KEY : CONSULT Function \(BCM - INTELLIGENT KEY\)"](#).

Is the inspection result normal?

- YES >> GO TO 2.
NO >> Set "AUTO LOCK SET" setting in "WORK SUPPORT".

2. REPLACE BCM

1. Replace BCM. Refer to [BCS-94, "Removal and Installation"](#).
2. Confirm the operation after replacement.

Is the result normal?

- YES >> INSPECTION END
NO >> Check intermittent incident. Refer to [GI-45, "Intermittent Incident"](#).

VEHICLE SPEED SENSING AUTO LOCK OPERATION DOES NOT OPERATE
< SYMPTOM DIAGNOSIS > **[WITH INTELLIGENT KEY SYSTEM]**

VEHICLE SPEED SENSING AUTO LOCK OPERATION DOES NOT OPERATE

Diagnosis Procedure

INFOID:000000012196683

1.CHECK "AUTOMATIC LOCK/UNLOCK SELECT" SETTING IN "WORK SUPPORT"

1. Select "DOOR LOCK" of "BCM" using CONSULT.
2. Select "AUTOMATIC LOCK/UNLOCK SELECT" in "WORK SUPPORT" mode.
3. Check "AUTOMATIC LOCK/UNLOCK SELECT" in "WORK SUPPORT".
Refer to [DLK-26, "DOOR LOCK : CONSULT Function \(BCM - DOOR LOCK\)"](#).

Is the inspection result normal?

YES >> GO TO 2.

NO >> Set "AUTOMATIC LOCK/UNLOCK SELECT" in "WORK SUPPORT".

2.CHECK "AUTOMATIC DOOR LOCK SELECT" SETTING IN "WORK SUPPORT"

1. Select "DOOR LOCK" of "BCM" using CONSULT.
2. Select "AUTOMATIC DOOR LOCK SELECT" in "WORK SUPPORT" mode.
3. Check "AUTOMATIC DOOR LOCK SELECT" in "WORK SUPPORT".
Refer to [DLK-26, "DOOR LOCK : CONSULT Function \(BCM - DOOR LOCK\)"](#).

Is the inspection result normal?

YES >> GO TO 3.

NO >> Set "AUTOMATIC DOOR LOCK SELECT" in "WORK SUPPORT".

3.REPLACE BCM

1. Replace BCM. Refer to [BCS-94, "Removal and Installation"](#).
2. Confirm the operation after replacement.

Is the result normal?

YES >> INSPECTION END

NO >> Check intermittent incident. Refer to [GI-45, "Intermittent Incident"](#).

A
B
C
D
E
F
G
H
I
J
L
M
N
O
P

DLK

IGN OFF INTERLOCK DOOR UNLOCK FUNCTION DOES NOT OPERATE

< SYMPTOM DIAGNOSIS >

[WITH INTELLIGENT KEY SYSTEM]

IGN OFF INTERLOCK DOOR UNLOCK FUNCTION DOES NOT OPERATE

Diagnosis Procedure

INFOID:000000012196684

1. CHECK "AUTOMATIC LOCK/UNLOCK SELECT" SETTING IN "WORK SUPPORT"

1. Select "DOOR LOCK" of "BCM" using CONSULT.
2. Select "AUTOMATIC LOCK/UNLOCK SELECT" in "WORK SUPPORT" mode.
3. Check "AUTOMATIC LOCK/UNLOCK SELECT" in "WORK SUPPORT".
Refer to [DLK-26, "DOOR LOCK : CONSULT Function \(BCM - DOOR LOCK\)"](#).

Is the inspection result normal?

YES >> GO TO 2.

NO >> Set "AUTOMATIC LOCK/UNLOCK SELECT" in "WORK SUPPORT".

2. CHECK "AUTOMATIC DOOR UNLOCK SELECT" SETTING IN "WORK SUPPORT"

1. Select "DOOR LOCK" of "BCM" using CONSULT.
2. Select "AUTOMATIC DOOR UNLOCK SELECT" in "WORK SUPPORT" mode.
3. Check "AUTOMATIC DOOR UNLOCK SELECT" in "WORK SUPPORT".
Refer to [DLK-26, "DOOR LOCK : CONSULT Function \(BCM - DOOR LOCK\)"](#).

Is the inspection result normal?

YES >> GO TO 3.

NO >> Set "AUTOMATIC DOOR UNLOCK SELECT" in "WORK SUPPORT".

3. REPLACE BCM

1. Replace BCM. Refer to [BCS-94, "Removal and Installation"](#).
2. Confirm the operation after replacement.

Is the result normal?

YES >> INSPECTION END

NO >> Check intermittent incident. Refer to [GI-45, "Intermittent Incident"](#).

P RANGE INTERLOCK DOOR LOCK/UNLOCK FUNCTION DOES NOT OPERATE

< SYMPTOM DIAGNOSIS >

[WITH INTELLIGENT KEY SYSTEM]

P RANGE INTERLOCK DOOR LOCK/UNLOCK FUNCTION DOES NOT OPERATE

Diagnosis Procedure

INFOID:000000012196685

1. CHECK "AUTOMATIC LOCK/UNLOCK SELECT" SETTING IN "WORK SUPPORT"

1. Select "DOOR LOCK" of "BCM" using CONSULT.
2. Select "AUTOMATIC LOCK/UNLOCK SELECT" in "WORK SUPPORT" mode.
3. Check "AUTOMATIC LOCK/UNLOCK SELECT" in "WORK SUPPORT".
Refer to [DLK-26, "DOOR LOCK : CONSULT Function \(BCM - DOOR LOCK\)"](#).

Is the inspection result normal?

YES >> GO TO 2.

NO >> Set "AUTOMATIC LOCK/UNLOCK SELECT" in "WORK SUPPORT".

2. CHECK "AUTOMATIC DOOR LOCK SELECT" SETTING IN "WORK SUPPORT"

1. Select "DOOR LOCK" of "BCM" using CONSULT.
2. Select "AUTOMATIC DOOR LOCK SELECT" in "WORK SUPPORT" mode.
3. Check "AUTOMATIC DOOR LOCK SELECT" in "WORK SUPPORT".
Refer to [DLK-26, "DOOR LOCK : CONSULT Function \(BCM - DOOR LOCK\)"](#).

Is the inspection result normal?

YES >> GO TO 3.

NO >> Set "AUTOMATIC DOOR LOCK SELECT" in "WORK SUPPORT".

3. CHECK "AUTOMATIC DOOR UNLOCK SELECT" SETTING IN "WORK SUPPORT"

1. Select "DOOR LOCK" of "BCM" using CONSULT.
2. Select "AUTOMATIC DOOR UNLOCK SELECT" in "WORK SUPPORT" mode.
3. Check "AUTOMATIC DOOR UNLOCK SELECT" in "WORK SUPPORT".
Refer to [DLK-26, "DOOR LOCK : CONSULT Function \(BCM - DOOR LOCK\)"](#).

Is the inspection result normal?

YES >> GO TO 4.

NO >> Set "AUTOMATIC DOOR UNLOCK SELECT" in "WORK SUPPORT".

4. REPLACE BCM

1. Replace BCM. Refer to [BCS-94, "Removal and Installation"](#).
2. Confirm the operation after replacement.

Is the result normal?

YES >> INSPECTION END

NO >> Check intermittent incident. Refer to [GI-45, "Intermittent Incident"](#).

A
B
C
D
E
F
G
H
I
J
DLK
L
M
N
O
P

HAZARD AND BUZZER REMINDER DOES NOT OPERATE

< SYMPTOM DIAGNOSIS >

[WITH INTELLIGENT KEY SYSTEM]

HAZARD AND BUZZER REMINDER DOES NOT OPERATE

Diagnosis Procedure

INFOID:000000012196686

1. CHECK DTC WITH BCM AND COMBINATION METER

Check that DTC is not detected with BCM and combination meter.

Is the inspection result normal?

- YES >> GO TO 2.
- NO-1 >> Refer to [BCS-62, "DTC Index"](#). (BCM)
- NO-2 >> Refer to [MWI-33, "DTC Index"](#). (Combination meter)

2. CHECK "HAZARD ANSWER BACK" SETTING IN "WORK SUPPORT"

1. Select "INTELLIGENT KEY" of "BCM" using CONSULT.
2. Select "HAZARD ANSWER BACK" in "WORK SUPPORT" mode.
3. Check the "HAZARD ANSWER BACK" in "WORK SUPPORT".
Refer to [DLK-28, "INTELLIGENT KEY : CONSULT Function \(BCM - INTELLIGENT KEY\)"](#).

Is the inspection result normal?

- YES >> GO TO 3.
- NO >> Set "HAZARD ANSWER BACK" in "WORK SUPPORT".

3. CHECK "ANS BACK I-KEY LOCK" SETTING IN "WORK SUPPORT"

1. Select "INTELLIGENT KEY" of "BCM" using CONSULT.
2. Select "ANS BACK I-KEY LOCK" in "WORK SUPPORT" mode.
3. Check the "ANS BACK I-KEY LOCK" in "WORK SUPPORT".
Refer to [DLK-28, "INTELLIGENT KEY : CONSULT Function \(BCM - INTELLIGENT KEY\)"](#).

Is the inspection result normal?

- YES >> GO TO 4.
- NO >> Set "ANS BACK I-KEY LOCK" in "WORK SUPPORT".

4. CHECK "ANS BACK I-KEY UNLOCK" SETTING IN "WORK SUPPORT"

1. Select "INTELLIGENT KEY" of "BCM" using CONSULT.
2. Select "ANS BACK I-KEY UNLOCK" in "WORK SUPPORT" mode.
3. Check the "ANS BACK I-KEY UNLOCK" in "WORK SUPPORT".
Refer to [DLK-28, "INTELLIGENT KEY : CONSULT Function \(BCM - INTELLIGENT KEY\)"](#).

Is the inspection result normal?

- YES >> GO TO 5.
- NO >> Set "ANS BACK I-KEY UNLOCK" in "WORK SUPPORT".

5. CHECK HAZARD FUNCTION

Check hazard function.

Refer to [DLK-80, "Component Function Check"](#).

Is the inspection result normal?

- YES >> GO TO 6.
- NO >> Repair or replace the malfunctioning parts.

6. CHECK INTELLIGENT KEY WARNING BUZZER

Check Intelligent Key warning buzzer.

Refer to [DLK-82, "Component Function Check"](#).

Is the inspection result normal?

- YES >> GO TO 7.
- NO >> Repair or replace the malfunctioning parts.

7. REPLACE BCM

1. Replace BCM. Refer to [BCS-94, "Removal and Installation"](#).
2. Confirm the operation after replacement.

Is the result normal?

- YES >> INSPECTION END

HAZARD AND BUZZER REMINDER DOES NOT OPERATE

< SYMPTOM DIAGNOSIS >

[WITH INTELLIGENT KEY SYSTEM]

NO >> Check intermittent incident. Refer to [GI-45. "Intermittent Incident"](#).

A

B

C

D

E

F

G

H

I

J

DLK

L

M

N

O

P

KEY REMINDER FUNCTION DOES NOT OPERATE

< SYMPTOM DIAGNOSIS >

[WITH INTELLIGENT KEY SYSTEM]

KEY REMINDER FUNCTION DOES NOT OPERATE

Diagnosis Procedure

INFOID:000000012196687

1. CHECK DTC WITH BCM

Check that DTC is not detected with BCM.

Is the inspection result normal?

YES >> GO TO 2.

NO >> Refer to [BCS-62, "DTC Index"](#).

2. CHECK "ANTI KEY LOCK IN FUNCTI" SETTING IN "WORK SUPPORT"

1. Select "INTELLIGENT KEY" of "BCM" using CONSULT.

2. Select "ANTI KEY LOCK IN FUNCTI" in "WORK SUPPORT" mode.

3. Check "ANTI KEY LOCK IN FUNCTI" in "WORK SUPPORT".

Refer to [DLK-28, "INTELLIGENT KEY : CONSULT Function \(BCM - INTELLIGENT KEY\)"](#).

Is the inspection result normal?

YES >> GO TO 3.

NO >> Set "ANTI KEY LOCK IN FUNCTI" in "WORK SUPPORT".

3. CHECK DOOR SWITCH

Check door switch.

Refer to [DLK-77, "Component Function Check"](#).

Is the inspection result normal?

YES >> GO TO 4.

NO >> Repair or replace the malfunctioning parts.

4. CHECK INSIDE KEY ANTENNA

Check inside key antenna.

• Instrument center: Refer to [DLK-49, "DTC Logic"](#).

• Luggage room: Refer to [DLK-51, "DTC Logic"](#).

Is the inspection result normal?

YES >> GO TO 5.

NO >> Repair or replace the malfunctioning parts.

5. CHECK UNLOCK SENSOR

Check unlock sensor.

Refer to [DLK-88, "Component Function Check"](#).

Is the inspection result normal?

YES >> GO TO 6.

NO >> Repair or replace the malfunctioning parts.

6. REPLACE BCM

1. Replace BCM. Refer to [BCS-94, "Removal and Installation"](#).

2. Confirm the operation after replacement.

Is the result normal?

YES >> INSPECTION END

NO >> Check intermittent incident. Refer to [GI-45, "Intermittent Incident"](#).

OFF POSITION WARNING DOES NOT OPERATE

< SYMPTOM DIAGNOSIS >

[WITH INTELLIGENT KEY SYSTEM]

OFF POSITION WARNING DOES NOT OPERATE

Diagnosis Procedure

INFOID:000000012196688

1. CHECK DTC WITH BCM AND COMBINATION METER

Check that DTC is not detected with BCM and combination meter.

Is the inspection result normal?

YES >> GO TO 2.

NO-1 >> Refer to [BCS-62, "DTC Index"](#). (BCM)

NO-2 >> Refer to [MWI-33, "DTC Index"](#). (Combination meter)

2. CHECK DOOR SWITCH

Check front door switch (driver side).

Refer to [DLK-77, "Component Function Check"](#).

Is the inspection result normal?

YES >> GO TO 3.

NO >> Repair or replace the malfunctioning parts.

3. CHECK COMBINATION METER BUZZER

Check combination meter buzzer.

Refer to [WCS-40, "Component Function Check"](#).

Is the inspection result normal?

YES >> GO TO 4.

NO >> Repair or replace the malfunctioning parts.

4. CHECK INTELLIGENT KEY WARNING BUZZER

Check Intelligent Key warning buzzer.

Refer to [DLK-82, "Component Function Check"](#).

Is the inspection result normal?

YES >> GO TO 5.

NO >> Repair or replace the malfunctioning parts.

5. REPLACE BCM

1. Replace BCM. Refer to [BCS-94, "Removal and Installation"](#).

2. Confirm the operation after replacement.

Is the result normal?

YES >> INSPECTION END

NO >> Check intermittent incident. Refer to [GI-45, "Intermittent Incident"](#).

A
B
C
D
E
F
G
H
I
J
L
M
N
O
P

DLK

P POSITION WARNING DOES NOT OPERATE

< SYMPTOM DIAGNOSIS >

[WITH INTELLIGENT KEY SYSTEM]

P POSITION WARNING DOES NOT OPERATE

Diagnosis Procedure

INFOID:000000012196689

1. CHECK DTC WITH BCM, TCM AND COMBINATION METER

Check that DTC is not detected with BCM, TCM and combination meter.

Is the inspection result normal?

- YES >> GO TO 2.
- NO-1 >> Refer to [BCS-62, "DTC Index"](#). (BCM)
- NO-2 >> Refer to [TM-203, "DTC Index"](#). (TCM)
- NO-3 >> Refer to [MWI-33, "DTC Index"](#). (Combination meter)

2. CHECK COMBINATION METER BUZZER

Check combination meter buzzer.

Refer to [WCS-40, "Component Function Check"](#).

Is the inspection result normal?

- YES >> GO TO 3.
- NO >> Repair or replace the malfunctioning parts.

3. CHECK INTELLIGENT KEY WARNING BUZZER

Check Intelligent Key warning buzzer.

Refer to [DLK-82, "Component Function Check"](#).

Is the inspection result normal?

- YES >> GO TO 4.
- NO >> Repair or replace the malfunctioning parts.

4. CHECK DOOR SWITCH

Check front door switch (driver side).

Refer to [DLK-77, "Component Function Check"](#).

Is the inspection result normal?

- YES >> GO TO 5.
- NO >> Repair or replace the malfunctioning parts.

5. CHECK INSIDE KEY ANTENNA

Check inside key antenna.

- Instrument center: Refer to [DLK-49, "DTC Logic"](#).
- Luggage room: Refer to [DLK-51, "DTC Logic"](#).

Is the inspection result normal?

- YES >> GO TO 6.
- NO >> Repair or replace the malfunctioning parts.

6. CHECK KEY WARNING LAMP

Check key warning lamp.

Refer to [DLK-84, "Component Function Check"](#).

Is the inspection result normal?

- YES >> GO TO 7.
- NO >> Repair or replace the malfunctioning parts.

7. REPLACE BCM

1. Replace BCM. Refer to [BCS-94, "Removal and Installation"](#).
2. Confirm the operation after replacement.

Is the result normal?

- YES >> INSPECTION END
- NO >> Check intermittent incident. Refer to [GI-45, "Intermittent Incident"](#).

ACC WARNING DOES NOT OPERATE

< SYMPTOM DIAGNOSIS >

[WITH INTELLIGENT KEY SYSTEM]

ACC WARNING DOES NOT OPERATE

Diagnosis Procedure

INFOID:000000012196690

1. CHECK COMBINATION METER BUZZER

Check combination meter buzzer.

Refer to [WCS-40, "Component Function Check"](#).

Is the inspection result normal?

YES >> GO TO 2.

NO >> Repair or replace the malfunctioning parts.

2. REPLACE BCM

1. Replace BCM. Refer to [BCS-94, "Removal and Installation"](#).

2. Confirm the operation after replacement.

Is the result normal?

YES >> INSPECTION END

NO >> Check intermittent incident. Refer to [GI-45, "Intermittent Incident"](#).

A
B
C
D
E
F
G
H
I
J
DLK
L
M
N
O
P

TAKE AWAY WARNING DOES NOT OPERATE

< SYMPTOM DIAGNOSIS >

[WITH INTELLIGENT KEY SYSTEM]

TAKE AWAY WARNING DOES NOT OPERATE

Diagnosis Procedure

INFOID:000000012196691

1. CHECK DTC WITH BCM AND COMBINATION METER

Check that DTC is not detected with BCM and combination meter.

Is the inspection result normal?

- YES >> GO TO 2.
- NO-1 >> Refer to [BCS-62, "DTC Index"](#). (BCM)
- NO-2 >> Refer to [MWI-33, "DTC Index"](#). (Combination meter)

2. CHECK COMBINATION METER BUZZER

Check combination meter buzzer.

Refer to [WCS-40, "Component Function Check"](#).

Is the inspection result normal?

- YES >> GO TO 3.
- NO >> Repair or replace the malfunctioning parts.

3. CHECK KEY WARNING LAMP

Check key warning lamp.

Refer to [DLK-84, "Component Function Check"](#).

Is the inspection result normal?

- YES >> GO TO 4.
- NO >> Repair or replace the malfunctioning parts.

4. CHECK DOOR SWITCH

Check door switch.

Refer to [DLK-77, "Component Function Check"](#).

Is the inspection result normal?

- YES >> GO TO 5.
- NO >> Repair or replace the malfunctioning parts.

5. CHECK INTELLIGENT KEY WARNING BUZZER

Check Intelligent Key warning buzzer.

Refer to [DLK-82, "Component Function Check"](#).

Is the inspection result normal?

- YES >> GO TO 6.
- NO >> Repair or replace the malfunctioning parts.

6. CHECK INSIDE KEY ANTENNA

Check inside key antenna.

- Instrument center: Refer to [DLK-49, "DTC Logic"](#).
- Luggage room: Refer to [DLK-51, "DTC Logic"](#).

Is the inspection result normal?

- YES >> GO TO 7.
- NO >> Repair or replace the malfunctioning parts.

7. REPLACE BCM

1. Replace BCM. Refer to [BCS-94, "Removal and Installation"](#).

2. Confirm the operation after replacement.

Is the result normal?

- YES >> INSPECTION END
- NO >> Check intermittent incident. Refer to [GI-45, "Intermittent Incident"](#).

INTELLIGENT KEY LOW BATTERY WARNING DOES NOT OPERATE

< SYMPTOM DIAGNOSIS >

[WITH INTELLIGENT KEY SYSTEM]

INTELLIGENT KEY LOW BATTERY WARNING DOES NOT OPERATE

Diagnosis Procedure

INFOID:000000012196692

1. CHECK DTC WITH BCM AND COMBINATION METER

Check that DTC is not detected with BCM and combination meter.

Is the inspection result normal?

YES >> GO TO 2.

NO-1 >> Refer to [BCS-62, "DTC Index"](#). (BCM)

NO-2 >> Refer to [MWI-33, "DTC Index"](#). (Combination meter)

2. CHECK "LO- BATT OF KEY FOB WARN" SETTING IN "WORK SUPPORT"

1. Select "INTELLIGENT KEY" of "BCM".

2. Select "LO- BATT OF KEY FOB WARN" in "WORK SUPPORT" mode.

3. Check "LO- BATT OF KEY FOB WARN" in "WORK SUPPORT".

Refer to [DLK-28, "INTELLIGENT KEY : CONSULT Function \(BCM - INTELLIGENT KEY\)"](#).

Is the inspection result normal?

YES >> GO TO 3.

NO >> Set "LO- BATT OF KEY FOB WARN" in "WORK SUPPORT".

3. CHECK KEY WARNING LAMP

Check key warning lamp.

Refer to [DLK-84, "Component Function Check"](#).

Is the inspection result normal?

YES >> GO TO 4.

NO >> Repair or replace the malfunctioning parts.

4. CHECK INTELLIGENT KEY BATTERY

Check Intelligent Key battery.

Refer to [DLK-81, "Component Inspection"](#).

Is the inspection result normal?

YES >> GO TO 5.

NO >> Repair or replace the malfunctioning parts.

5. CHECK INSIDE KEY ANTENNA

Check inside key antenna.

• Instrument center: Refer to [DLK-49, "DTC Logic"](#).

• Luggage room: Refer to [DLK-51, "DTC Logic"](#).

Is the inspection result normal?

YES >> GO TO 6.

NO >> Repair or replace the malfunctioning parts.

6. REPLACE BCM

1. Replace BCM. Refer to [BCS-94, "Removal and Installation"](#).

2. Confirm the operation after replacement.

Is the result normal?

YES >> INSPECTION END

NO >> Check intermittent incident. Refer to [GI-45, "Intermittent Incident"](#).

A
B
C
D
E
F
G
H
I
J
DLK
L
M
N
O
P

DOOR LOCK OPERATION WARNING DOES NOT OPERATE

< SYMPTOM DIAGNOSIS >

[WITH INTELLIGENT KEY SYSTEM]

DOOR LOCK OPERATION WARNING DOES NOT OPERATE

Diagnosis Procedure

INFOID:000000012196693

1.CHECK DOOR LOCK FUNCTION

Check door lock function.

Does door lock/unlock using door request switch?

YES >> GO TO 2.

NO >> Refer to [DLK-75, "Component Function Check"](#).

2.CHECK INTELLIGENT KEY WARNING BUZZER

Check Intelligent Key warning buzzer.

Refer to [DLK-82, "Component Function Check"](#).

Is the inspection result normal?

YES >> GO TO 3.

NO >> Repair or replace the malfunctioning parts.

3.REPLACE BCM

1. Replace BCM. Refer to [BCS-94, "Removal and Installation"](#).

2. Confirm the operation after replacement.

Is the result normal?

YES >> INSPECTION END

NO >> Check intermittent incident. Refer to [GI-45, "Intermittent Incident"](#).

KEY ID WARNING DOES NOT OPERATE

< SYMPTOM DIAGNOSIS >

[WITH INTELLIGENT KEY SYSTEM]

KEY ID WARNING DOES NOT OPERATE

Diagnosis Procedure

INFOID:000000012196694

1. CHECK DTC WITH BCM AND COMBINATION METER

Check that DTC is not detected with BCM and combination meter.

Is the inspection result normal?

YES >> GO TO 2.

NO-1 >> Refer to [BCS-62, "DTC Index"](#). (BCM)

NO-2 >> Refer to [MWI-33, "DTC Index"](#). (Combination meter)

2. CHECK INTELLIGENT KEY BATTERY

Check Intelligent Key battery.

Refer to [DLK-81, "Component Inspection"](#).

Is the inspection result normal?

YES >> GO TO 3.

NO >> Repair or replace the malfunctioning parts.

3. CHECK INSIDE KEY ANTENNA

Check inside key antenna.

• Instrument center: Refer to [DLK-49, "DTC Logic"](#).

• Luggage room: Refer to [DLK-51, "DTC Logic"](#).

Is the inspection result normal?

YES >> GO TO 4.

NO >> Repair or replace the malfunctioning parts.

4. CHECK KEY WARNING LAMP

Check key warning lamp.

Refer to [DLK-84, "Component Function Check"](#).

Is the inspection result normal?

YES >> GO TO 5.

NO >> Repair or replace the malfunctioning parts.

5. REPLACE BCM

1. Replace BCM. Refer to [BCS-94, "Removal and Installation"](#).

2. Confirm the operation after replacement.

Is the result normal?

YES >> INSPECTION END

NO >> Check intermittent incident. Refer to [GI-45, "Intermittent Incident"](#).

A
B
C
D
E
F
G
H
I
J
L
M
N
O
P

DLK

KEY WARNING LAMP DOES NOT ILLUMINATE

< SYMPTOM DIAGNOSIS >

[WITH INTELLIGENT KEY SYSTEM]

KEY WARNING LAMP DOES NOT ILLUMINATE

Diagnosis Procedure

INFOID:000000012196695

1. CHECK KEY WARNING LAMP

Check key warning lamp.

Refer to [DLK-84, "Component Function Check"](#).

Is the inspection result normal?

YES >> GO TO 2.

NO >> Repair or replace the malfunctioning parts.

2. REPLACE BCM

1. Replace BCM. Refer to [BCS-94, "Removal and Installation"](#).

2. Confirm the operation after replacement.

Is the result normal?

YES >> INSPECTION END

NO >> Check intermittent incident. Refer to [GI-45, "Intermittent Incident"](#).

UNLOCK LINK FUNCTION DOES NOT OPERATE

< SYMPTOM DIAGNOSIS >

[WITH INTELLIGENT KEY SYSTEM]

UNLOCK LINK FUNCTION DOES NOT OPERATE

Diagnosis Procedure

INFOID:000000012196696

1. REPLACE BCM

1. Replace BCM. Refer to [BCS-94. "Removal and Installation"](#).
2. Confirm the operation after replacement.

Is the result normal?

YES >> INSPECTION END

NO >> Check intermittent incident. Refer to [GI-45. "Intermittent Incident"](#).

A
B
C
D
E
F
G
H
I
J
DLK
L
M
N
O
P

SQUEAK AND RATTLE TROUBLE DIAGNOSES

< SYMPTOM DIAGNOSIS >

[WITH INTELLIGENT KEY SYSTEM]

SQUEAK AND RATTLE TROUBLE DIAGNOSES

Work Flow

INFOID:000000012196697

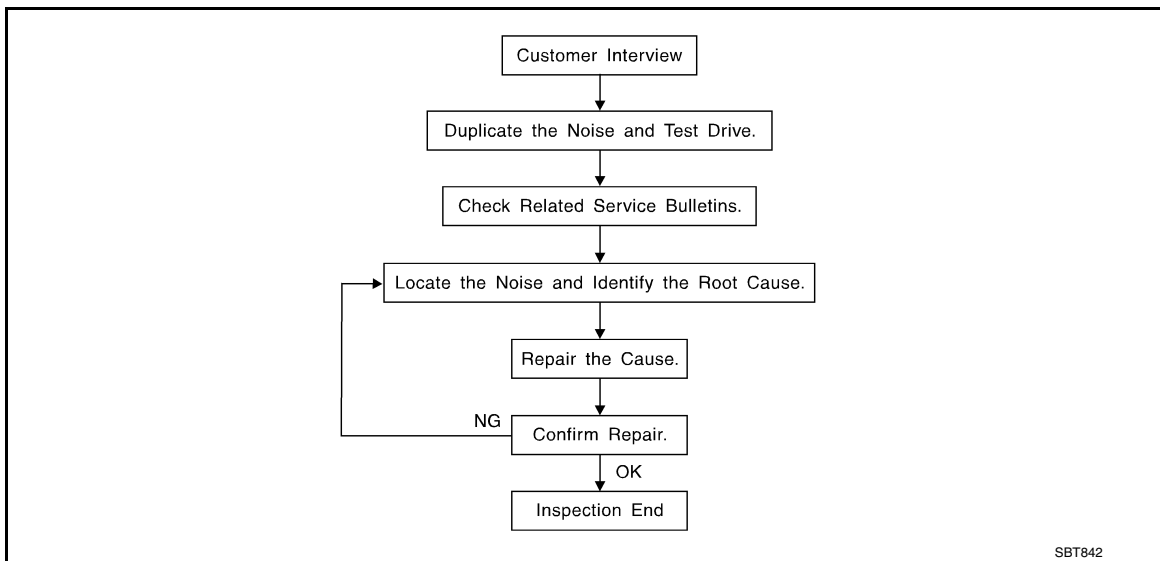

CUSTOMER INTERVIEW

Interview the customer if possible, to determine the conditions that exist when the noise occurs. Use the Diagnostic Worksheet during the interview to document the facts and conditions when the noise occurs and any of customer's comments; refer to [DLK-122, "Diagnostic Worksheet"](#). This information is necessary to duplicate the conditions that exist when the noise occurs.

- The customer may not be able to provide a detailed description or the location of the noise. Attempt to obtain all the facts and conditions that exist when the noise occurs (or does not occur).
- If there is more than one noise in the vehicle, perform a diagnosis and repair the noise that the customer is concerned about. This can be accomplished by performing a cruise test on the vehicle with the customer.
- After identifying the type of noise, isolate the noise in terms of its characteristics. The noise characteristics are provided so the customer, service adviser and technician are all speaking the same language when defining the noise.
- Squeak – (Like tennis shoes on a clean floor)
Squeak characteristics include the light contact/fast movement/brought on by road conditions/hard surfaces = higher pitch noise/softer surfaces = lower pitch noises/edge to surface = chirping
- Creak – (Like walking on an old wooden floor)
Creak characteristics include firm contact/slow movement/twisting with a rotational movement/pitch dependent on materials/often brought on by activity.
- Rattle – (Like shaking a baby rattle)
Rattle characteristics include the fast repeated contact/vibration or similar movement/loose parts/missing clip or fastener/incorrect clearance.
- Knock – (Like a knock on a door)
Knock characteristics include hollow sounding/sometimes repeating/often brought on by driver action.
- Tick – (Like a clock second hand)
Tick characteristics include gentle contacting of light materials/loose components/can be caused by driver action or road conditions.
- Thump – (Heavy, muffled knock noise)
Thump characteristics include softer knock/dead sound often brought on by activity.
- Buzz – (Like a bumblebee)
Buzz characteristics include high frequency rattle/firm contact.
- Often the degree of acceptable noise level will vary depending up on the person. A noise that a technician may judge as acceptable may be very irritating to the customer.
- Weather conditions, especially humidity and temperature, may have a great effect on noise level.

DUPLICATE THE NOISE AND TEST DRIVE

If possible, drive the vehicle with the customer until the noise is duplicated. Note any additional information on the Diagnostic Worksheet regarding the conditions or location of the noise. This information can be used to duplicate the same conditions when the repair is reconfirmed.

SQUEAK AND RATTLE TROUBLE DIAGNOSES

[WITH INTELLIGENT KEY SYSTEM]

< SYMPTOM DIAGNOSIS >

If the noise can be duplicated easily during the test drive, to help identify the source of the noise, try to duplicate the noise with the vehicle stopped by doing one or all of the following:

- 1) Close a door.
 - 2) Tap or push/pull around the area where the noise appears to be coming from.
 - 3) Rev the engine.
 - 4) Use a floor jack to recreate vehicle "twist".
 - 5) At idle, apply engine load (electrical load, half-clutch on M/T models, drive position on A/T models).
 - 6) Raise the vehicle on a hoist and hit a tire with a rubber hammer.
- Drive the vehicle and attempt to duplicate the conditions the customer states exist when the noise occurs.
 - If it is difficult to duplicate the noise, drive the vehicle slowly on an undulating or rough road to stress the vehicle body.

CHECK RELATED SERVICE BULLETINS

After verifying the customer concern or symptom, check ASIST for Technical Service Bulletins (TSBs) related to that concern or symptom.

If a TSB relates to the symptom, follow the procedure to repair the noise.

LOCATE THE NOISE AND IDENTIFY THE ROOT CAUSE

1. Narrow down the noise to a general area. To help pinpoint the source of the noise, use a listening tool (Chassis ear: J-39570, Engine ear and mechanics stethoscope).
2. Narrow down the noise to a more specific area and identify the cause of the noise by:
 - Removing the components in the area that is are suspected to be the cause of the noise.
Do not use too much force when removing clips and fasteners, otherwise clips and fastener can be broken or lost during the repair, resulting in the creation of new noise.
 - Tapping or pushing/pulling the component that is are suspected to be the cause of the noise.
Do not tap or push/pull the component with excessive force, otherwise the noise will be eliminated only temporarily.
 - Feeling for a vibration by hand by touching the component(s) that is are suspected to be the cause of the noise.
 - Placing a piece of paper between components that are suspected to be the cause of the noise.
 - Looking for loose components and contact marks.
Refer to [DLK-120. "Inspection Procedure"](#).

REPAIR THE CAUSE

- If the cause is a loose component, tighten the component securely.
- If the cause is insufficient clearance between components:
 - Separate components by repositioning or loosening and retightening the component, if possible.
 - Insulate components with a suitable insulator such as urethane pads, foam blocks, felt cloth tape or urethane tape. A Nissan Squeak and Rattle Kit (J-50397) is available through the authorized Nissan Parts Department.

CAUTION:

Never use excessive force as many components are constructed of plastic and may be damaged.

NOTE:

Always check with the Parts Department for the latest parts information.

The following materials are contained in the Nissan Squeak and Rattle Kit (J-50397) are listed on the inside cover of the kit; and can each be ordered separately as needed.

URETHANE PADS [1.5 mm (0.059 in) thick]

Insulates connectors, harness, etc.

76268-9E005: 100 × 135 mm (3.94 × 5.31 in)/76884-71L01: 60 × 85 mm (2.36 × 3.35 in)/76884-71L02: 15 × 25 mm (0.59 × 0.98 in)

INSULATOR (Foam blocks)

Insulates components from contact. Can be used to fill space behind a panel.

73982-9E000: 45 mm (1.77 in) thick, 50 × 50 mm (1.97 × 1.97 in)/73982-

50Y00: 10 mm (0.39 in) thick, 50 × 50 mm (1.97 × 1.97 in)

INSULATOR (Light foam block)

80845-71L00: 30 mm (1.18 in) thick, 30 × 50 mm (1.18 × 1.97 in)

FELT CLOTHTAPE

Used to insulate where movement does not occur. Ideal for instrument panel applications.

68370-4B000: 15 × 25 mm (0.59 × 0.98 in) pad/68239-13E00: 5 mm (0.20 in) wide tape roll

The following materials, not found in the kit, can also be used to repair squeaks and rattles.

UHMW (TEFLON) TAPE

SQUEAK AND RATTLE TROUBLE DIAGNOSES

[WITH INTELLIGENT KEY SYSTEM]

< SYMPTOM DIAGNOSIS >

Insulates where slight movement is present. Ideal for instrument panel applications.

SILICONE GREASE

Used in place of UHMW tape that is be visible or does not fit. Will only last a few months.

SILICONE SPRAY

Used when grease cannot be applied.

DUCT TAPE

Used to eliminate movement.

CONFIRM THE REPAIR

Confirm that the cause of a noise is repaired by test driving the vehicle. Operate the vehicle under the same conditions as when the noise originally occurred. Refer to the notes on the Diagnostic Worksheet.

Inspection Procedure

INFOID:000000012196698

Refer to Table of Contents for specific component removal and installation information.

INSTRUMENT PANEL

Most incidents are caused by contact and movement between:

1. The cluster lid A and instrument panel
2. Acrylic lens and combination meter housing
3. Instrument panel to front pillar garnish
4. Instrument panel to windshield
5. Instrument panel mounting pins
6. Wiring harnesses behind the combination meter
7. A/C defroster duct and duct joint

These incidents can usually be located by tapping or moving the components to duplicate the noise or by pressing on the components while driving to stop the noise. Most of these incidents can be repaired by applying felt cloth tape or silicon spray (in hard to reach areas). Urethane pads can be used to insulate wiring harness.

CAUTION:

Never use silicone spray to isolate a squeak or rattle. If the area is saturated with silicone, the recheck of repair becomes impossible.

CENTER CONSOLE

Components to pay attention to include:

1. Shifter assembly cover to finisher
2. A/C control unit and cluster lid C
3. Wiring harnesses behind audio and A/C control unit

The instrument panel repair and isolation procedures also apply to the center console.

DOORS

Pay attention to the following:

1. Finisher and inner panel making a slapping noise
2. Inside handle escutcheon to door finisher
3. Wiring harnesses tapping
4. Door striker out of alignment causing a popping noise on starts and stops

Tapping or moving the components or pressing on them while driving to duplicate the conditions can isolate many of these incidents. The areas can usually be insulated with felt cloth tape or insulator foam blocks from the Nissan Squeak and Rattle Kit (J-50397) to repair the noise.

TRUNK

Trunk noises are often caused by a loose jack or loose items put into the trunk by the customer.

In addition look for the following:

1. Trunk lid dumpers out of adjustment
2. Trunk lid striker out of adjustment
3. The trunk lid torsion bars knocking together
4. A loose license plate or bracket

SQUEAK AND RATTLE TROUBLE DIAGNOSES

[WITH INTELLIGENT KEY SYSTEM]

< SYMPTOM DIAGNOSIS >

Most of these incidents can be repaired by adjusting, securing or insulating the item(s) or component(s) causing the noise.

SUNROOF/HEADLINING

Noises in the sunroof/headlining area can often be traced to one of the following:

1. Sunroof lid, rail, linkage or seals making a rattle or light knocking noise
2. Sunvisor shaft shaking in the holder
3. Front or rear windshield touching headlining and squeaking

Again, pressing on the components to stop the noise while duplicating the conditions can isolate most of these incidents. Repairs usually consist of insulating with felt cloth tape.

SEATS

When isolating seat noise it's important to note the position the seats in and the load placed on the seat when the noise occurs. These conditions should be duplicated when verifying and isolating the cause of the noise.

Cause of seat noise include:

1. Headrest rods and holder
2. A squeak between the seat pad cushion and frame
3. The rear seatback lock and bracket

These noises can be isolated by moving or pressing on the suspected components while duplicating the conditions under which the noise occurs. Most of these incidents can be repaired by repositioning the component or applying urethane tape to the contact area.

UNDERHOOD

Some interior noise may be caused by components under the hood or on the engine wall. The noise is then transmitted into the passenger compartment.

Causes of transmitted underhood noise include:

1. Any component mounted to the engine wall
2. Components that pass through the engine wall
3. Engine wall mounts and connectors
4. Loose radiator mounting pins
5. Hood bumpers out of adjustment
6. Hood striker out of adjustment

These noises can be difficult to isolate since they cannot be reached from the interior of the vehicle. The best method is to secure, move or insulate one component at a time and test drive the vehicle. Also, engine RPM or load can be changed to isolate the noise. Repairs can usually be made by moving, adjusting, securing, or insulating the component causing the noise.

A
B
C
D
E
F
G
H
I
J
DLK
L
M
N
O
P

SQUEAK AND RATTLE TROUBLE DIAGNOSES

< SYMPTOM DIAGNOSIS >

[WITH INTELLIGENT KEY SYSTEM]

Diagnostic Worksheet

INFOID:000000012196699



SQUEAK & RATTLE DIAGNOSTIC WORKSHEET

Dear Nissan Customer:

We are concerned about your satisfaction with your Nissan vehicle. Repairing a squeak or rattle sometimes can be very difficult. To help us fix your Nissan right the first time, please take a moment to note the area of the vehicle where the squeak or rattle occurs and under what conditions. You may be asked to take a test drive with a service advisor or technician to ensure we confirm the noise you are hearing.

I. WHERE DOES THE NOISE COME FROM? (circle the area of the vehicle)

The illustrations are for reference only, and may not reflect the actual configuration of your vehicle.

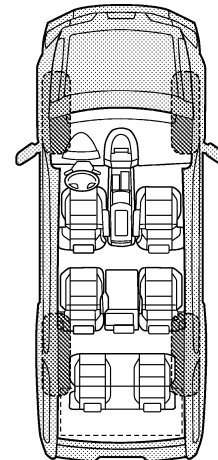
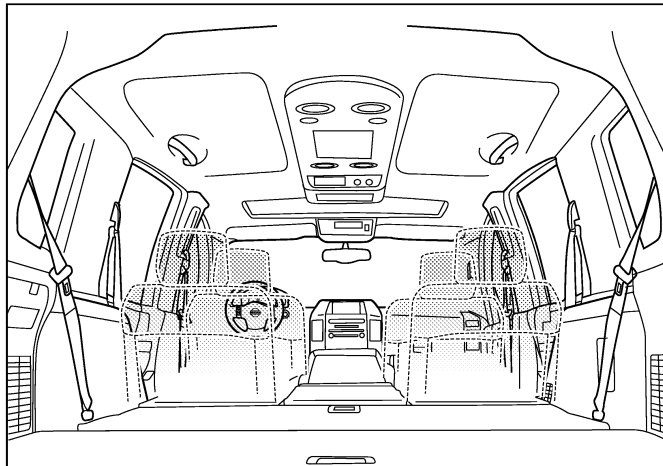
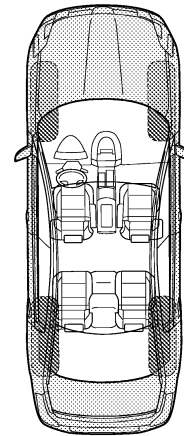
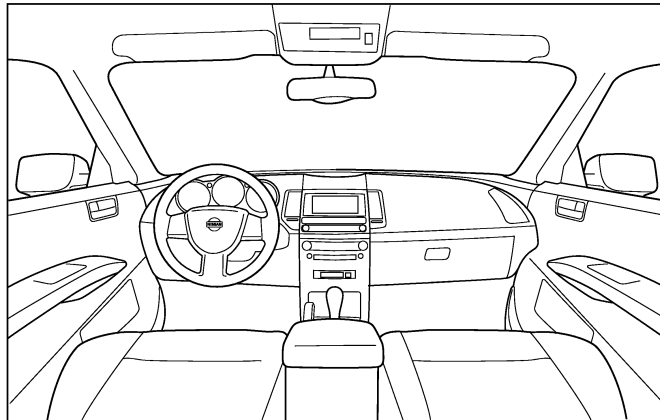

Continue to page 2 of the worksheet and briefly describe the location of the noise or rattle. In addition, please indicate the conditions which are present when the noise occurs.

PIIB8740E

SQUEAK AND RATTLE TROUBLE DIAGNOSES

< SYMPTOM DIAGNOSIS >

[WITH INTELLIGENT KEY SYSTEM]

SQUEAK & RATTLE DIAGNOSTIC WORKSHEET - page 2

Briefly describe the location where the noise occurs:

II. WHEN DOES IT OCCUR? (please check the boxes that apply)

- | | |
|---|--|
| <input type="checkbox"/> anytime | <input type="checkbox"/> after sitting out in the rain |
| <input type="checkbox"/> 1st time in the morning | <input type="checkbox"/> when it is raining or wet |
| <input type="checkbox"/> only when it is cold outside | <input type="checkbox"/> dry or dusty conditions |
| <input type="checkbox"/> only when it is hot outside | <input type="checkbox"/> other: |

III. WHEN DRIVING:

- through driveways
- over rough roads
- over speed bumps
- only about ____ mph
- on acceleration
- coming to a stop
- on turns: left, right or either (circle)
- with passengers or cargo
- other: _____
- after driving ____ miles or ____ minutes

IV. WHAT TYPE OF NOISE

- squeak (like tennis shoes on a clean floor)
- creak (like walking on an old wooden floor)
- rattle (like shaking a baby rattle)
- knock (like a knock at the door)
- tick (like a clock second hand)
- thump (heavy, muffled knock noise)
- buzz (like a bumble bee)

TO BE COMPLETED BY DEALERSHIP PERSONNEL

Test Drive Notes:

	YES	NO	Initials of person performing
Vehicle test driven with customer	<input type="checkbox"/>	<input type="checkbox"/>	_____
- Noise verified on test drive	<input type="checkbox"/>	<input type="checkbox"/>	_____
- Noise source located and repaired	<input type="checkbox"/>	<input type="checkbox"/>	_____
- Follow up test drive performed to confirm repair	<input type="checkbox"/>	<input type="checkbox"/>	_____

VIN: _____ Customer Name: _____
W.O.# _____ Date: _____

This form must be attached to Work Order

PIIB8742E

A
B
C
D
E
F
G
H
I
J
DLK
L
M
N
O
P

HOOD

< REMOVAL AND INSTALLATION >

[WITH INTELLIGENT KEY SYSTEM]

REMOVAL AND INSTALLATION

HOOD

Exploded View

INFOID:000000012196700

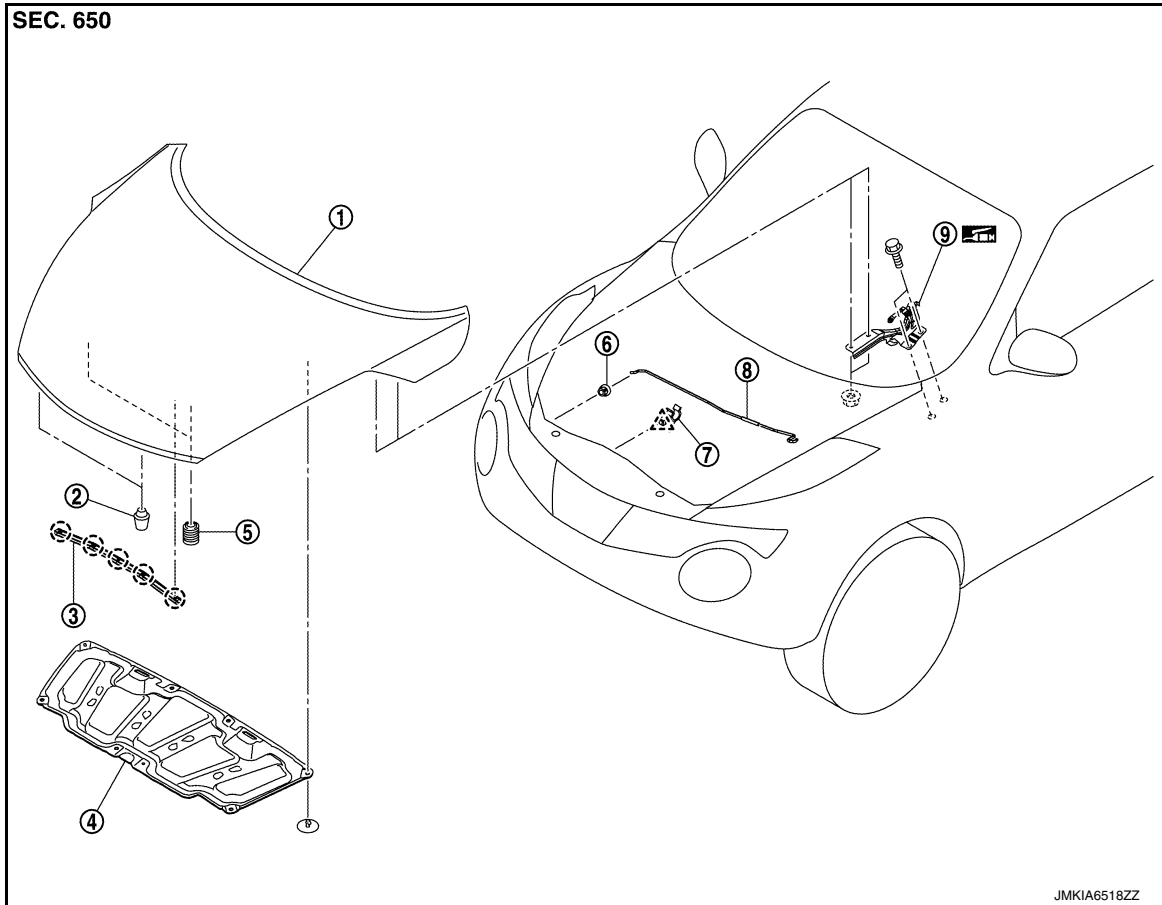

- | | | |
|-------------------|-----------------------|-----------------------|
| 1. Hood assembly | 2. Hood bumper rubber | 3. Radiator core seal |
| 4. Hood insulator | 5. Hood bumper rubber | 6. Grommet |
| 7. Clamp | 8. Hood support rod | 9. Hood hinge |

○ : Clip

△ : Pawl

▭ : Body grease

HOOD ASSEMBLY

HOOD ASSEMBLY : Removal and Installation

INFOID:000000012196701

CAUTION:

- Operate with two workers, because of its heavy weight.
- Use protective tape or shop cloth to protect from damage during removal and installation.

REMOVAL

1. Support hood assembly with the proper material to prevent it from falling.

WARNING:

Injury may occur if hood assembly is not supported by the proper material when removing hood assembly.

2. Remove hood hinge mounting nuts on the hood to remove the hood assembly.

HOOD

< REMOVAL AND INSTALLATION >

[WITH INTELLIGENT KEY SYSTEM]

INSTALLATION

Note the following items, and then install in the reverse order of removal.

CAUTION:

- After installation, apply touch-up paint (the body color) onto the heads of hood hinge mounting bolts and nuts.
- After installing, perform hood fitting adjustment. Refer to [DLK-125, "HOOD ASSEMBLY : Adjustment"](#).

HOOD ASSEMBLY : Adjustment

INFOID:000000012196702

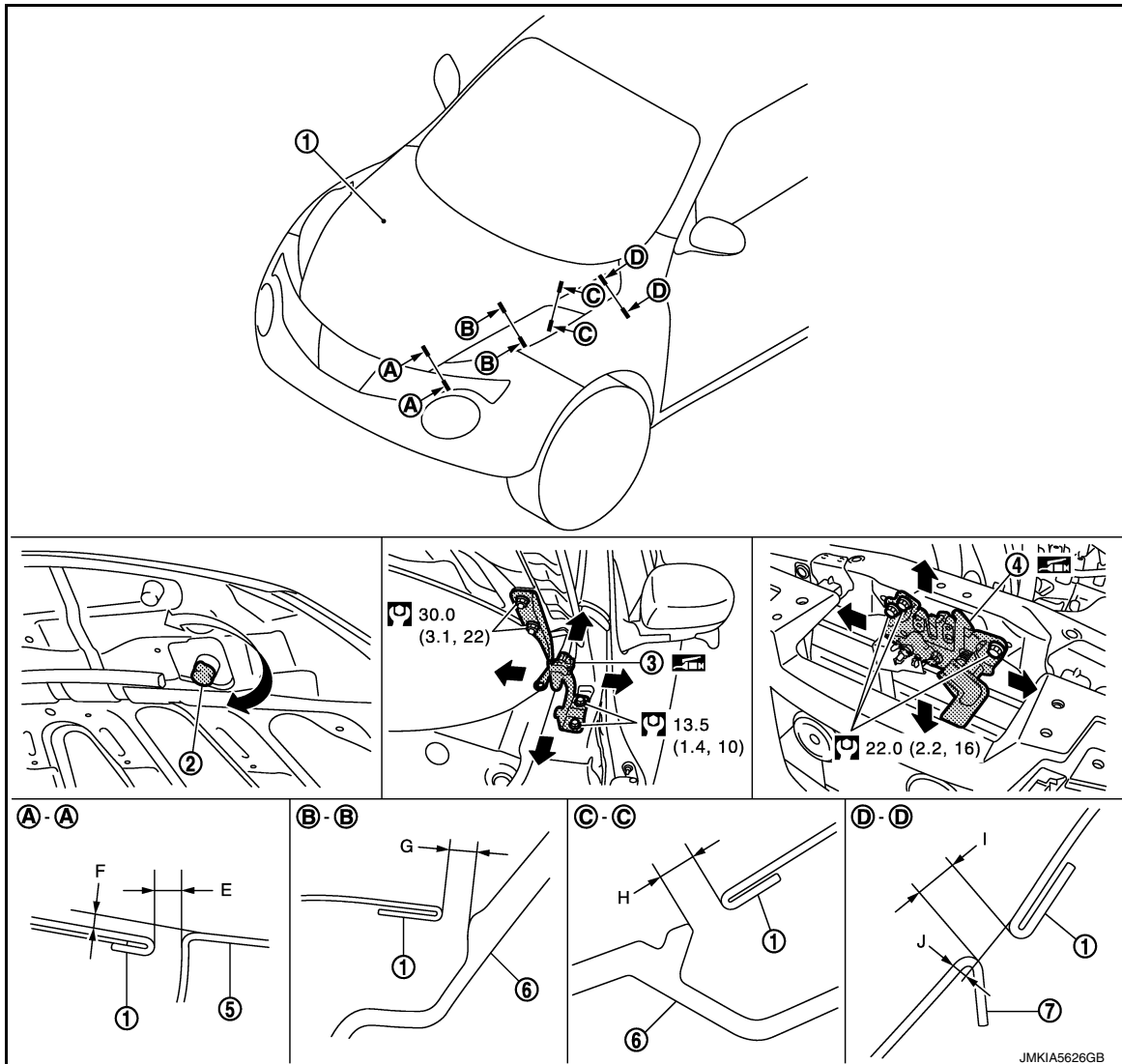

- | | | |
|-----------------------|------------------------|---------------------------|
| 1. Hood assembly | 2. Hood bumper rubber | 3. Hood hinge |
| 4. Hood lock assembly | 5. Front bumper fascia | 6. Front combination lamp |
| 7. Front fender | | |

: N·m (kg·m, ft·lb)

: Body grease

Check the clearance and the surface height between hood and each part by visually and touching. If the clearance and the surface height are out of specification, adjust them according to the procedures shown below.

HOOD

< REMOVAL AND INSTALLATION >

[WITH INTELLIGENT KEY SYSTEM]

Unit: mm (in)

Portion			Standard	Difference (RH/LH, MAX)	
Hood – Front bumper fascia	A – A	E	Clearance	2.0 – 6.0 (0.079 – 0.236)	< 2.5 (0.098)
		F	Surface height	(-2.0) – (+2.0) [(-0.079) – (+0.079)]	< 2.5 (0.098)
Hood – Front combination lamp	B – B	G	Clearance	2.0 – 6.0 (0.079 – 0.236)	< 2.5 (0.098)
Hood – Front combination lamp	C – C	H	Clearance	2.0 – 6.0 (0.079 – 0.236)	< 2.5 (0.098)
Hood – Front fender	D – D	I	Clearance	2.5 – 4.5 (0.098 – 0.177)	< 1.5 (0.059)
		J	Surface height	(-2.0) – (0.0) [(-0.079) – (0.000)]	< 1.5 (0.059)

FITTING ADJUSTMENT PROCEDURE

1. Remove front center grille. Refer to [EXT-26, "Removal and Installation"](#).
2. Remove hood lock assembly, and then adjust the surface height of hood assembly, front fender assembly, and front combination lamp according to the specified value, by rotating hood bumper rubber.
3. Position hood lock assembly and engage hood striker. Check hood lock assembly and hood striker for looseness.
4. Move hood lock assembly laterally until the center of hood striker and hood lock assembly are vertical when viewed from the front.
5. After adjustment, tighten lock bolts to the specified torque.
6. Open hood. Rotate bumper rubber counterclockwise between half a turn and three-quarters of a turn.
7. Check that secondary latch is securely engaged with secondary hood striker from the dead load of the hood assembly.
8. Check that primary latch is securely engaged with primary hood striker when hood assembly is closed [free-fall from approximately 200 mm (7.874 in) height].

CAUTION:

Never free-fall hood assembly from a height of 300 (11.811 in) mm or more.

9. Install front center grille. Refer to [EXT-26, "Removal and Installation"](#).

HOOD HINGE

HOOD HINGE : Removal and Installation

INFOID:000000012196703

REMOVAL

1. Remove hood assembly. Refer to [DLK-124, "HOOD ASSEMBLY : Removal and Installation"](#).
2. Remove front fender. Refer to [DLK-133, "Removal and Installation"](#).
3. Remove hood hinge mounting bolts, and then remove hood hinge.

INSTALLATION

Note the following items, and then install in the reverse order of removal.

CAUTION:

- After installation, perform hood hinge fitting adjustment. Refer to [DLK-127, "HOOD HINGE : Adjustment"](#).
- After installation, apply touch-up paint (the body color) onto the head of the hinge mounting bolts and nuts.

HOOD

< REMOVAL AND INSTALLATION >

[WITH INTELLIGENT KEY SYSTEM]

- Check hood hinge rotating part for poor lubrication. If necessary, apply grease.

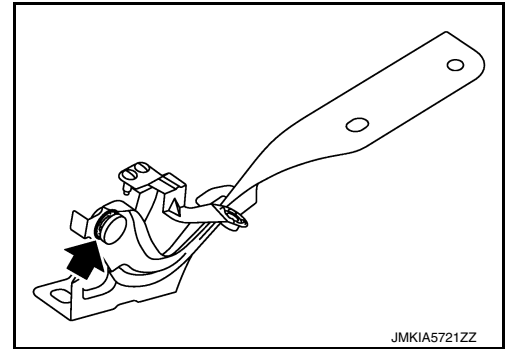

HOOD HINGE : Adjustment

INFOID:000000012196704

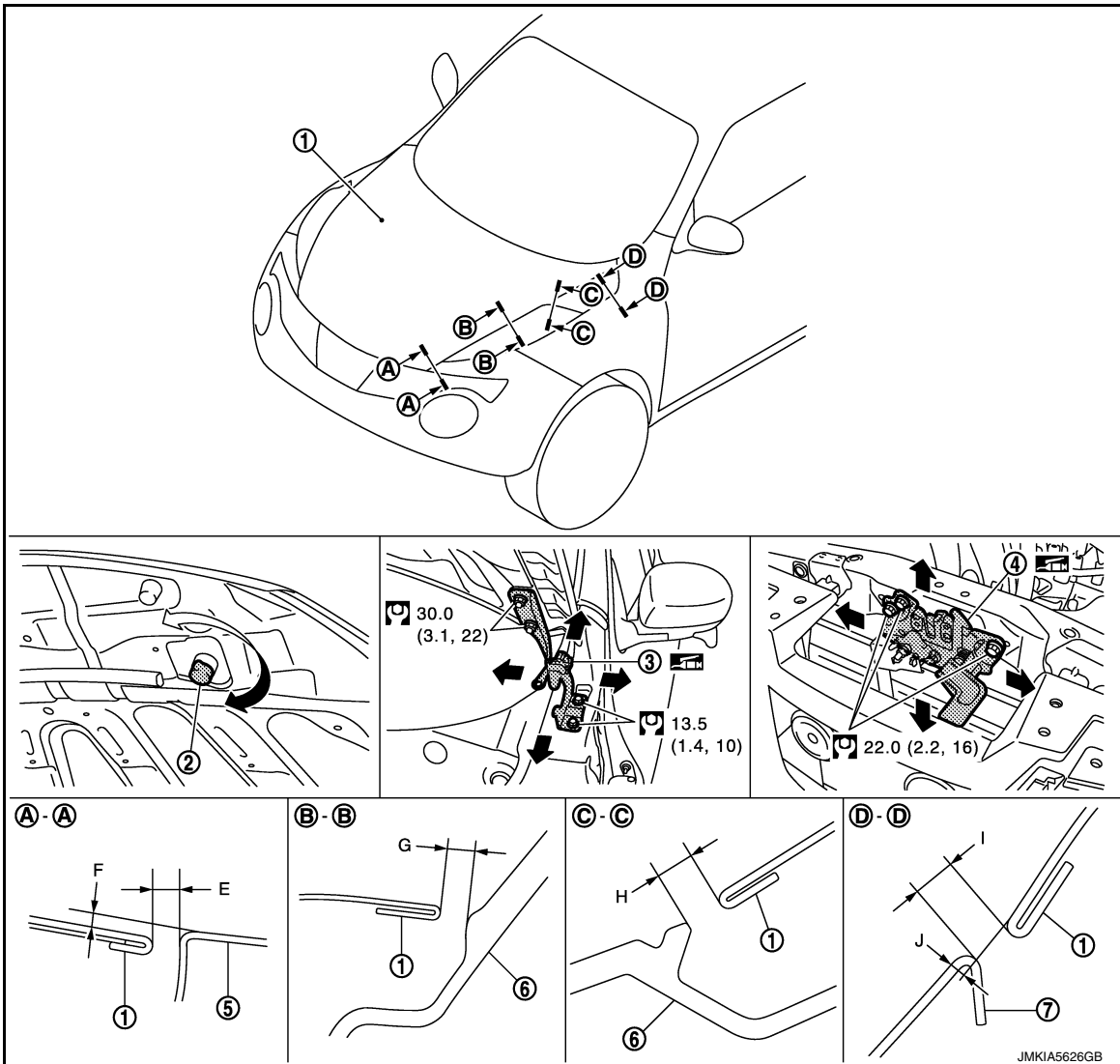

- | | | |
|-----------------------|------------------------|---------------------------|
| 1. Hood assembly | 2. Hood bumper rubber | 3. Hood hinge |
| 4. Hood lock assembly | 5. Front bumper fascia | 6. Front combination lamp |
| 7. Front fender | | |

: N·m (kg·m, ft·lb)

: Body grease

Check the clearance and the surface height between hood and each part by visually and touching.

A
B
C
D
E
F
G
H
I
J
DLK
L
M
N
O
P

HOOD

< REMOVAL AND INSTALLATION >

[WITH INTELLIGENT KEY SYSTEM]

If the clearance and the surface height are out of specification, adjust them according to the procedures shown below.

Unit: mm (in)

Portion			Standard	Difference (RH/LH, MAX)
Hood – Front bumper fascia	A – A	E	Clearance	2.0 – 6.0 (0.079 – 0.236)
		F	Surface height	(-2.0) – (+2.0) [(-0.079) – (+0.079)]
Hood – Front combination lamp	B – B	G	Clearance	2.0 – 6.0 (0.079 – 0.236)
Hood – Front combination lamp	C – C	H	Clearance	2.0 – 6.0 (0.079 – 0.236)
Hood – Front fender	D – D	I	Clearance	2.5 – 4.5 (0.098 – 0.177)
		J	Surface height	(-2.0) – (0.0) [(-0.079) – (0.000)]

1. Remove front center grille. Refer to [EXT-26, "Removal and Installation"](#).
2. Remove hood lock assembly.
3. Remove front bumper fascia. Refer to [EXT-17, "Removal and Installation"](#).
4. Remove front combination lamp (LH and RH). Refer to [EXL-100, "Removal and Installation"](#) (xenon type) or [EXL-211, "Removal and Installation"](#) (halogen type).
5. Remove front fender assembly (LH and RH). Refer to [DLK-133, "Removal and Installation"](#).
6. Loosen hood hinge mounting bolts.
7. Temporarily install front fender assembly (LH and RH), front combination lamp (LH and RH) and front bumper fascia.
8. Adjust the clearance of hood assembly, front fender assembly (LH and RH), front combination lamp (LH and RH) and front bumper fascia according to the specified value, by moving hood hinge (body side).
9. Temporarily tighten hood hinge (LH and RH).
10. Remove front bumper fascia, front combination lamp (LH and RH) and front fender assembly (LH and RH).
11. Tighten hood hinge (LH and RH) to the specified torque.
12. Install front fender assembly (LH and RH). Refer to [DLK-133, "Removal and Installation"](#).
13. Install front combination lamp (LH and RH). Refer to [EXL-100, "Removal and Installation"](#) (xenon type) or [EXL-211, "Removal and Installation"](#) (halogen type).
14. Install front bumper fascia. Refer to [EXT-17, "Removal and Installation"](#).
15. Adjust the surface height of hood assembly, front fender assembly, and front combination lamp according to the specified value, by rotating hood bumper rubber.
16. Position hood lock assembly and engage hood striker. Check hood lock assembly and hood striker for looseness.
17. Move hood lock assembly laterally until the center of hood striker and hood lock assembly are vertical when viewed from the front.
18. After adjustment, tighten lock bolts to the specified torque.
19. Open hood. Rotate bumper rubber counterclockwise between half a turn and three-quarters of a turn.
20. Check that secondary latch is securely engaged with secondary hood striker from the dead load of the hood assembly.
21. Check that primary latch is securely engaged with primary hood striker when hood assembly is closed [free-fall from approximately 200 mm (7.874 in) height].
CAUTION:
Never free-fall hood assembly from a height of 300 (11.811 in) mm or more.
22. Install front center grille. Refer to [EXT-26, "Removal and Installation"](#).
CAUTION:
After installation, apply touch-up paint (the body color) onto the heads of hood hinge mounting bolts and nuts.

HOOD

< REMOVAL AND INSTALLATION >

[WITH INTELLIGENT KEY SYSTEM]

HOOD SUPPORT ROD

HOOD SUPPORT ROD : Removal and Installation

INFOID:0000000012196705

REMOVAL

CAUTION:

Two workers are required to support the hood.

1. Support hood assembly with a suitable material to prevent it from falling.

WARNING:

Injury may occur if hood assembly is not supported by the proper material when removing hood assembly.

2. Pull hood support rod from grommet and remove.

INSTALLATION

Install in the reverse order of removal.

A
B
C
D
E
F
G
H
I
J
DLK
L
M
N
O
P

RADIATOR CORE SUPPORT

< REMOVAL AND INSTALLATION >

[WITH INTELLIGENT KEY SYSTEM]

RADIATOR CORE SUPPORT

MR16DDT

MR16DDT : Exploded View

INFOID:000000012196706

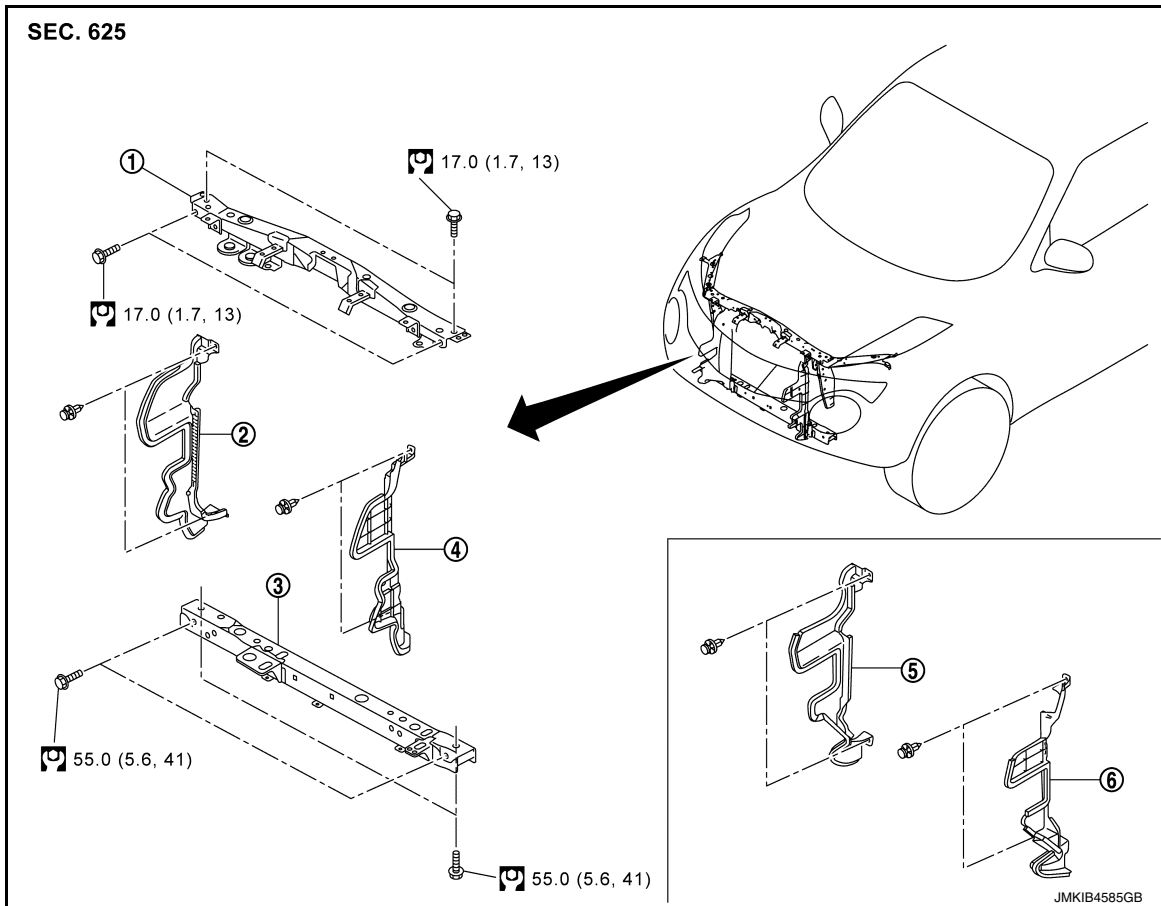

- | | | |
|--------------------------------|---------------------|--------------------------------|
| 1. Radiator core support upper | 2. Air guide (RH)*1 | 3. Radiator core support lower |
| 4. Air guide (LH)*1 | 5. Air guide (RH)*2 | 6. Air guide (LH)*2 |

 : N·m (kg-m, ft-lb)

*1: Except for NISMO/NISMO RS models

*2: For NISMO/NISMO RS models

MR16DDT : Removal and Installation

INFOID:000000012196707

RADIATOR CORE SUPPORT UPPER

Removal

1. Remove front bumper fascia. Refer to [EXT-17, "Removal and Installation"](#).
2. Remove front combination lamp (LH and RH). Refer to [EXL-100, "Removal and Installation"](#) (xenon type) or [EXL-211, "Removal and Installation"](#) (halogen type).
3. Remove headlamp (LH and RH). Refer to [EXL-96, "Removal and Installation"](#) (xenon type) or [EXL-207, "Removal and Installation"](#) (halogen type).
4. Disconnect crash zone sensor harness connector. Refer to [SR-24, "Removal and Installation"](#).
CAUTION:
Turn ignition switch OFF, disconnect battery negative terminal and then wait for at least 3 minutes.
5. Remove hood lock and hood lock cable fixing clip. Refer to [DLK-155, "HOOD LOCK CONTROL CABLE : Removal and Installation"](#).

RADIATOR CORE SUPPORT

< REMOVAL AND INSTALLATION >

[WITH INTELLIGENT KEY SYSTEM]

6. Remove horn bracket. Refer to [HRN-7, "Removal and Installation"](#).
7. Remove upper fixing clips (2) of air guide (LH and RH) (1).

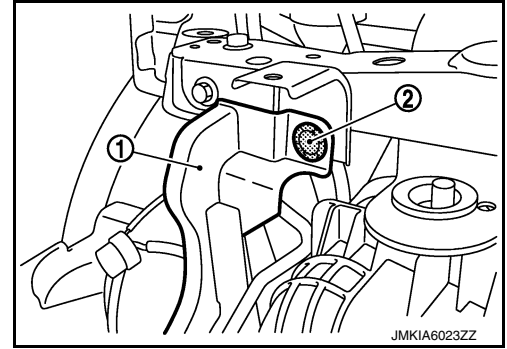

8. Remove hood support rod. Refer to [DLK-129, "HOOD SUPPORT ROD : Removal and Installation"](#).
9. Remove mounting bolts, and then remove radiator core support upper.

Installation

Install in the reverse order of removal.

RADIATOR CORE SUPPORT LOWER

Removal

1. Remove front bumper fascia. Refer to [EXT-17, "Removal and Installation"](#).
2. Remove lower fixing clips (2) of radiator side seal (LH and RH) (1).

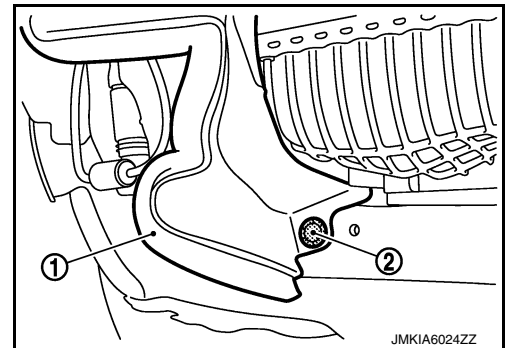

3. Using strings (A), hang inlet hose (1) and inlet hose (2) together with charge air cooler.

CAUTION:

Never damage inlet hoses and charge air cooler.

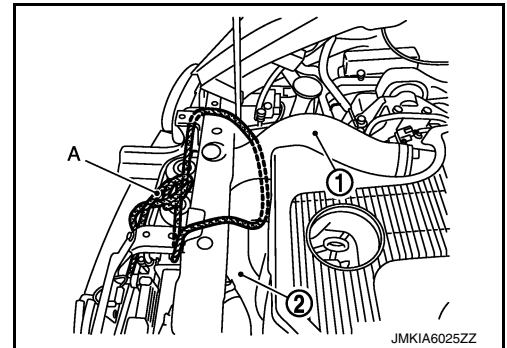

4. Support lower side radiator using a floor jack (A) and wooden blocks (B).

CAUTION:

Never damage radiator.

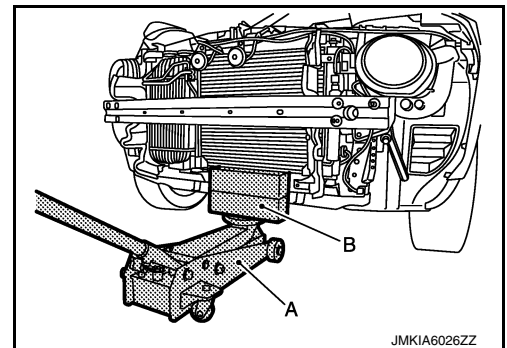

5. Remove mounting bolts, and then remove radiator core support lower.

RADIATOR CORE SUPPORT

< REMOVAL AND INSTALLATION >

[WITH INTELLIGENT KEY SYSTEM]

Installation

Install in the reverse order of removal.

FRONT FENDER

< REMOVAL AND INSTALLATION >

[WITH INTELLIGENT KEY SYSTEM]

FRONT FENDER

Exploded View

INFOID:000000012196708

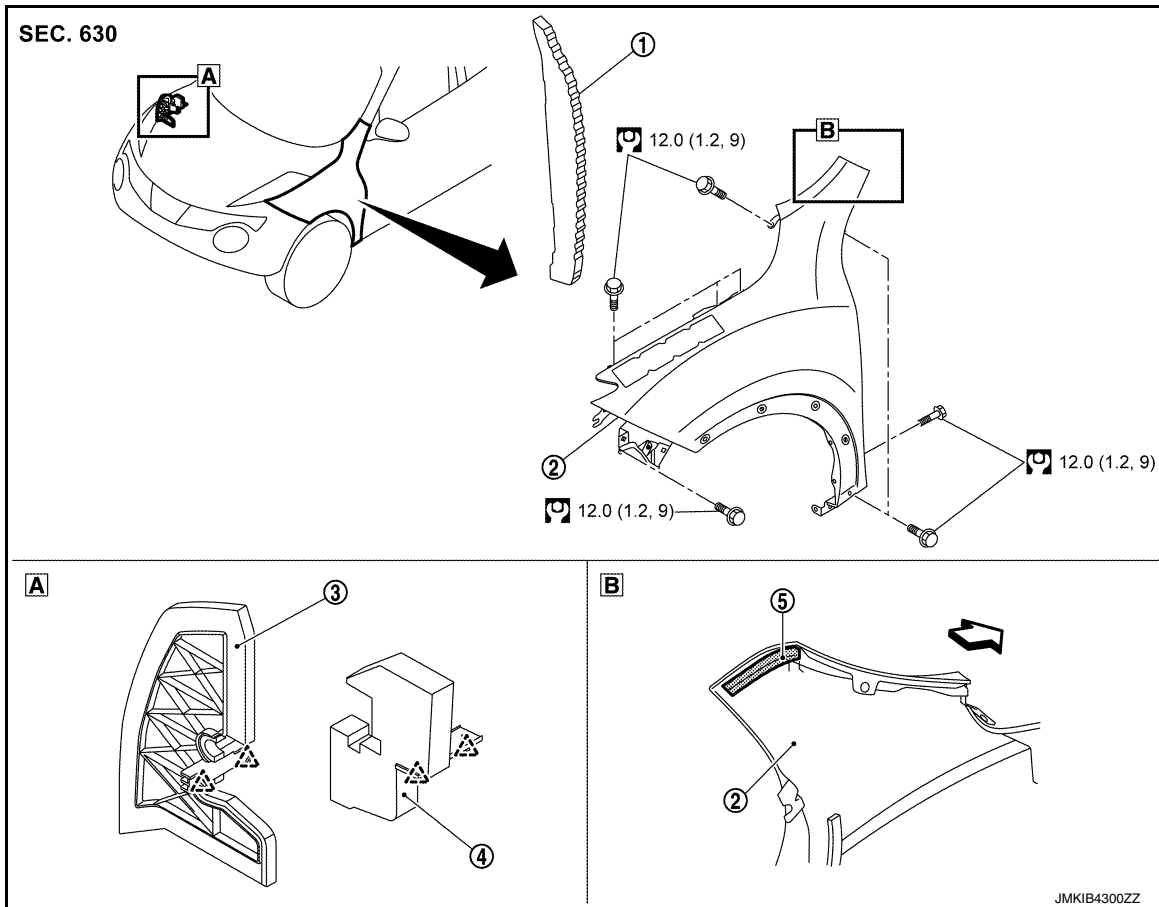

- 1. Front fender seal
- 2. Front fender assembly
- 3. Front fender upper insulator
- 4. Front fender seal
- 5. Front fender stiffener

↔ : Vehicle front

: N·m (kg-m, ft-lb)

Removal and Installation

INFOID:000000012196709

REMOVAL

1. Remove front fillet molding. Refer to [EXT-36, "FRONT FILLET MOLDING : Removal and Installation"](#).
2. Remove front bumper fascia assembly. Refer to [EXT-17, "Removal and Installation"](#).
3. Remove sill cover. Refer to [EXT-33, "Removal and Installation"](#).
4. Remove fender protector. Refer to [EXT-31, "Removal and Installation"](#).
5. Remove front fender cover. Refer to [EXT-31, "Exploded View"](#).
6. Remove front combination lamp. Refer to [EXL-100, "Removal and Installation"](#) (xenon type) or [EXL-211, "Removal and Installation"](#) (halogen type).
7. Remove mounting bolts of front fender assembly.

A
B
C
D
E
F
G
H
I
J

DLK

L
M
N
O
P

FRONT FENDER

< REMOVAL AND INSTALLATION >

[WITH INTELLIGENT KEY SYSTEM]

8. Remove front fender stiffener (2) from the vehicle body while carefully pulling upper portion of front fender (1) toward vehicle outside.

← : Vehicle front

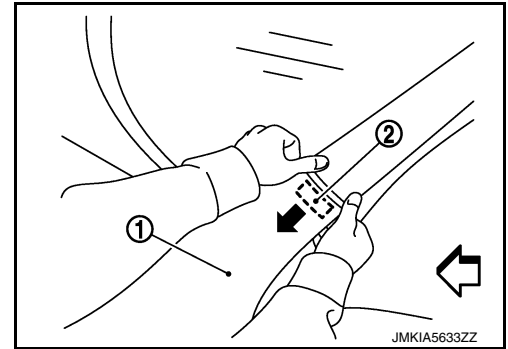

9. Remove front fender assembly.

CAUTION:

An viscous urethane foam is installed on the back surface of front fender. When removing the front fender, be careful to not deform the front fender while performing the procedure and removing the viscous urethane foam a little at a time.

INSTALLATION

Note the following items, and install in the reverse order of removal.

CAUTION:

- After installation, apply the touch-up paint (the body color) onto the head of front fender mounting bolts.
- After installation, adjust the following part.
- Hood assembly: Refer to [DLK-125, "HOOD ASSEMBLY : Adjustment"](#).
- Front door: Refer to [DLK-137, "DOOR ASSEMBLY : Adjustment"](#).

FRONT DOOR

< REMOVAL AND INSTALLATION >

[WITH INTELLIGENT KEY SYSTEM]

FRONT DOOR

Exploded View

INFOID:000000012196710

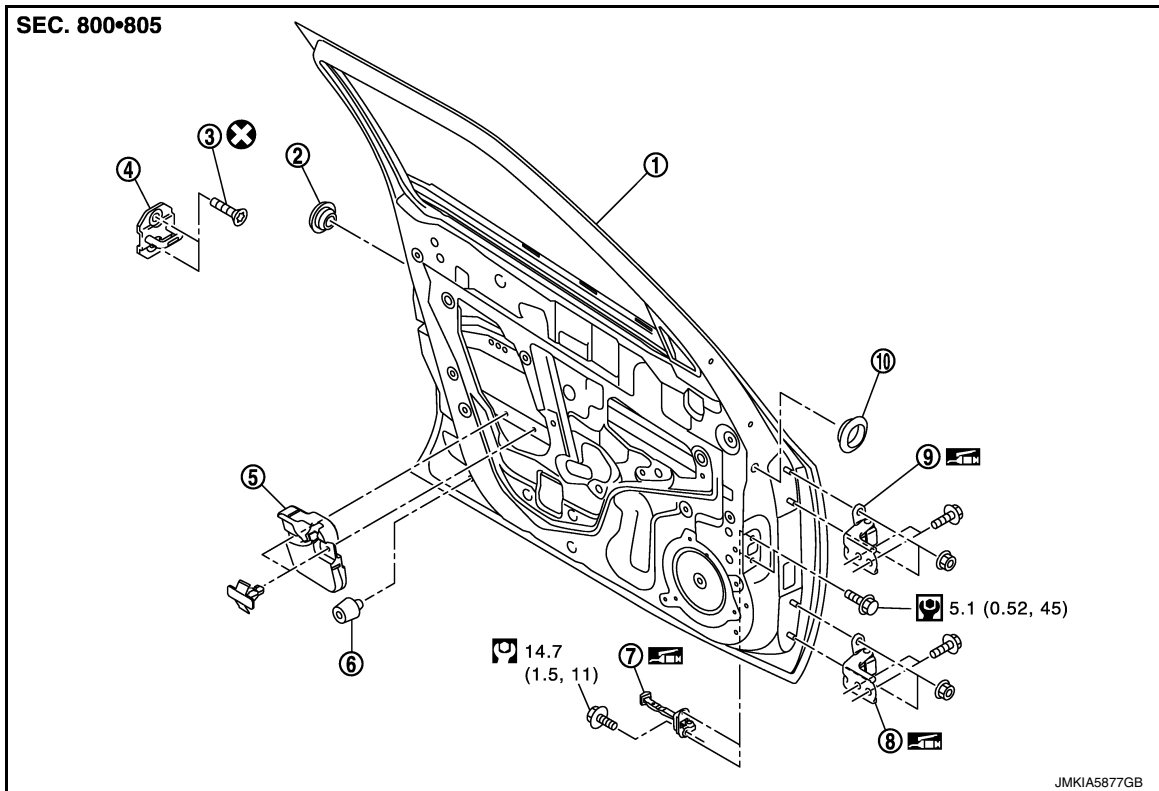

- | | | |
|---------------------|-----------------------|-----------------------|
| 1. Front door panel | 2. Grommet | 3. TORX bolt |
| 4. Door striker | 5. Door pad | 6. Bumper rubber |
| 7. Door check link | 8. Door hinge (lower) | 9. Door hinge (upper) |
| 10. Grommet | | |

: Always replace after every disassembly.

: N·m (kg-m, in-lb)

: N·m (kg-m, ft-lb)

: Body grease

DOOR ASSEMBLY

DOOR ASSEMBLY : Removal and Installation

INFOID:000000012196711

WARNING:

- Before servicing, turn ignition switch OFF, disconnect battery negative terminal and wait 3 minutes or more.
- Never use the air tools or electric tools for servicing.

CAUTION:

- Perform work with 2 workers, because of its heavy weight.
- When removing and installing front door assembly, support door with a jack and shop cloth to protect door and body.

REMOVAL

A
B
C
D
E
F
G
H
I
J
DLK
L
M
N
O
P

FRONT DOOR

< REMOVAL AND INSTALLATION >

[WITH INTELLIGENT KEY SYSTEM]

1. Disconnect front door harness connector.

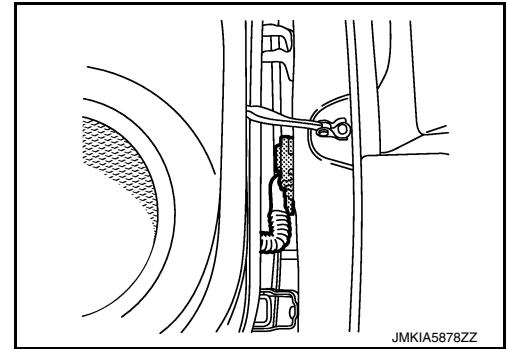

2. Remove mounting bolt of door check link on the vehicle.
3. Remove door hinge mounting bolts (door side), and then remove door assembly.

INSTALLATION

Note the following items, and install in the reverse order of removal.

CAUTION:

- Apply anticorrosive agent onto the mounting surface.
- Check front door open/close, lock/unlock operation after installation.
- Check door hinge rotating part for poor lubrication. If necessary, apply body grease.
- After installation, perform the fitting adjustment. Refer to [DLK-137, "DOOR ASSEMBLY : Adjustment"](#).
- After installation, apply touch-up paint (the body color) onto the head of door hinge mounting nuts.

FRONT DOOR

< REMOVAL AND INSTALLATION >

[WITH INTELLIGENT KEY SYSTEM]

DOOR ASSEMBLY : Adjustment

INFOID:000000012196712

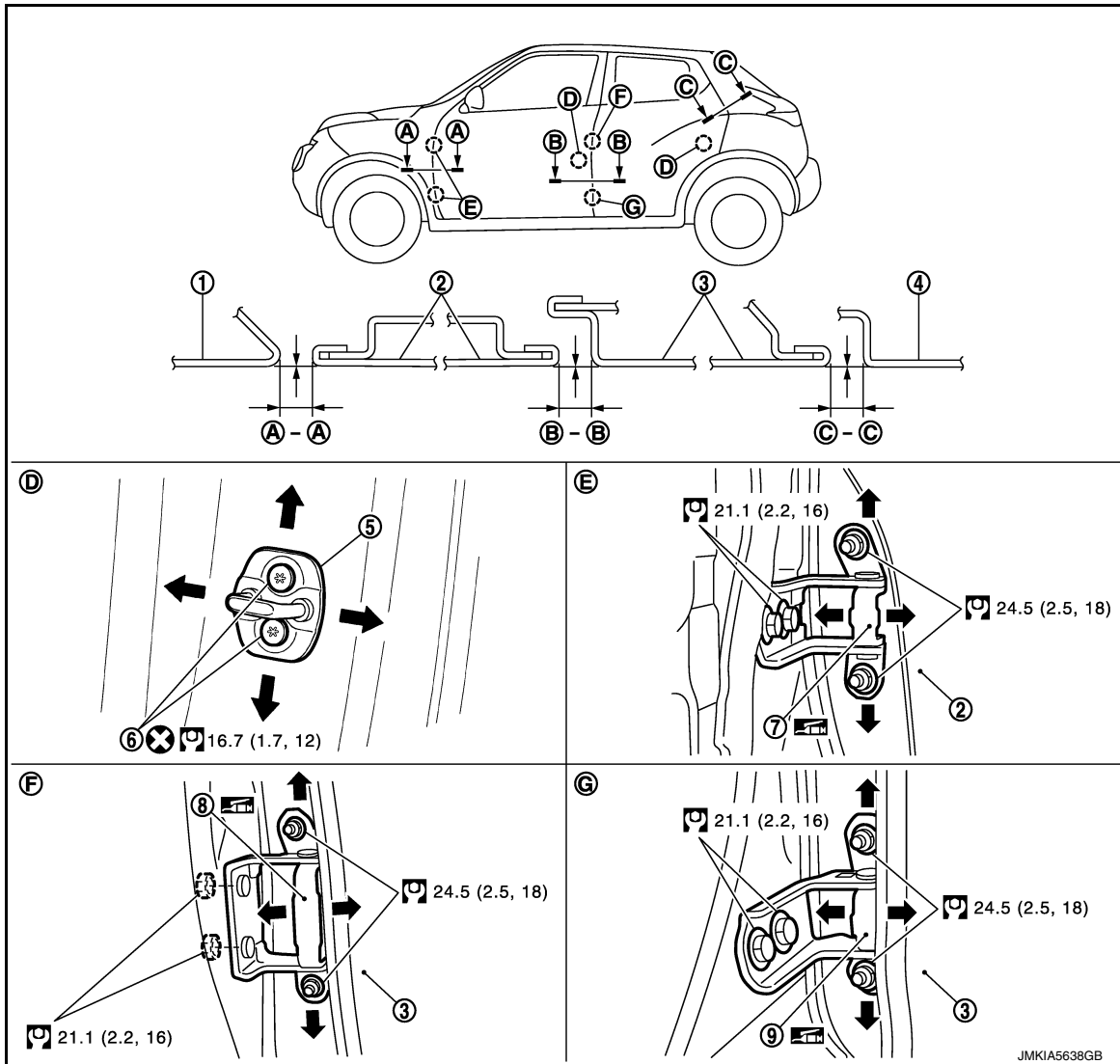

- | | | |
|---------------------|----------------------------|----------------------------|
| 1. Front fender | 2. Front door | 3. Rear door |
| 4. Body side outer | 5. Door striker | 6. TORX bolt |
| 7. Front door hinge | 8. Rear door hinge (upper) | 9. Rear door hinge (lower) |

⊗ : Always replace after every disassembly.

Ⓜ : N·m (kg·m, ft·lb)

🛢 : Body grease

Check the clearance and surface height between front door and each part by visually and touching. If the clearance and the surface height are out of specification, adjust them according to the procedures shown below.

Unit: mm (in)

Portion		Clearance	Surface height
Front fender – Front door	A – A	3.0 – 5.0 (0.118 – 0.197)	(-1.0) – (+1.0) [(-0.039) – (+0.039)]
Front door – Rear door	B – B	3.3 – 5.3 (0.130 – 0.209)	(-1.0) – (+1.0) [(-0.039) – (+0.039)]

FITTING ADJUSTMENT PROCEDURE

- Remove front fender. Refer to [DLK-133, "Removal and Installation"](#).
- Loosen door hinge mounting nuts on door side.

A
B
C
D
E
F
G
H
I
J
L
M
N
O
P

DLK

FRONT DOOR

< REMOVAL AND INSTALLATION >

[WITH INTELLIGENT KEY SYSTEM]

3. Adjust the surface height of front door according to the fitting standard dimension.
4. Temporarily tighten door hinge mounting nuts on door side.
5. Loosen door hinge mounting bolts on body side.
6. Raise front door at rear end to adjust clearance of the front door according to the fitting standard dimension.
7. After adjustment tighten bolts and nuts to the specified torque.
CAUTION:
 - After installation, apply touch-up paint (the body color) onto the head of hinge mounting bolts and nuts.
 - Check door hinge rotating part for poor lubrication. If necessary, apply body grease.
8. Install front fender. Refer to refer to [DLK-133, "Removal and Installation"](#).

DOOR STRIKER ADJUSTMENT

Adjust door striker so that it becomes parallel with door lock insertion direction.

DOOR STRIKER

DOOR STRIKER : Removal and Installation

INFOID:000000012196713

REMOVAL

Remove TORX bolts, and then remove door striker.

INSTALLATION

Note the following items, and install in the reverse order of removal.

CAUTION:

- Check front door open/close, lock/unlock operation after installation.
- After installation, be sure to perform the fitting adjustment. Refer to [DLK-137, "DOOR ASSEMBLY : Adjustment"](#).

DOOR HINGE

DOOR HINGE : Removal and Installation

INFOID:000000012196714

REMOVAL

CAUTION:

- Perform work with 2 workers, because of its heavy weight.
 - When removing and installing front door assembly, support door with a jack and shop cloth to protect door and body.
1. Remove front fender. Refer to [DLK-133, "Removal and Installation"](#).
 2. Remove front door assembly. Refer to [DLK-135, "DOOR ASSEMBLY : Removal and Installation"](#).
 3. Remove front door hinge mounting bolts (body side), and then remove front door hinge.

INSTALLATION

Note the following items, and install in the reverse order of removal.

CAUTION:

- Apply anticorrosive agent onto the mounting surface.
- Check front door open/close, lock/unlock operation after installation.
- After installation, perform the fitting adjustment. Refer to [DLK-137, "DOOR ASSEMBLY : Adjustment"](#).
- After installation, apply touch-up paint (the body color) onto the head of door hinge mounting nuts.

FRONT DOOR

< REMOVAL AND INSTALLATION >

[WITH INTELLIGENT KEY SYSTEM]

- Check door hinge rotating part for poor lubrication. If necessary, apply body grease.

← : Grease up point

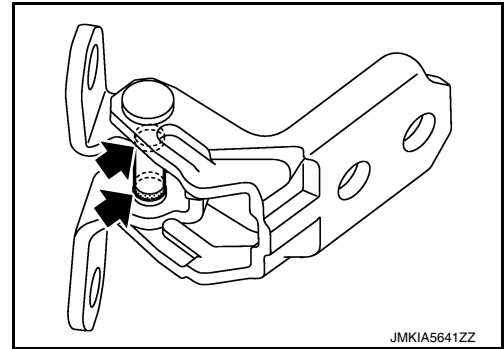

DOOR CHECK LINK

DOOR CHECK LINK : Removal and Installation

INFOID:000000012196715

REMOVAL

1. Fully close the front door window.
2. Remove front door finisher. Refer to [INT-13, "Removal and Installation"](#).
3. Disconnect harness connector of front door speaker.
4. Remove mounting bolts of front door speaker, and then remove front door speaker.
5. Remove mounting bolt of door check link on the vehicle.
6. Remove mounting bolts of door check link on door panel.
7. Take door check link (1) out from the hole of door panel (2).

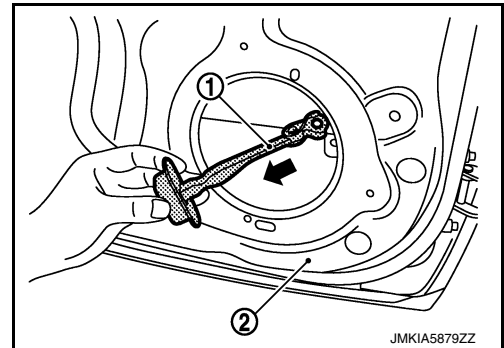

INSTALLATION

Note the following item, and install in the reverse order of removal.

CAUTION:

- Check front door open/close operation after installation.
- Check door check link rotating part for poor lubrication. If necessary, apply grease.

← : Grease up point

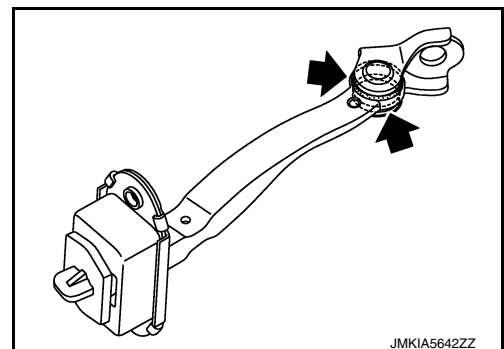

A
B
C
D
E
F
G
H
I
J
DLK
L
M
N
O
P

REAR DOOR

< REMOVAL AND INSTALLATION >

[WITH INTELLIGENT KEY SYSTEM]

REAR DOOR

Exploded View

INFOID:000000012196716

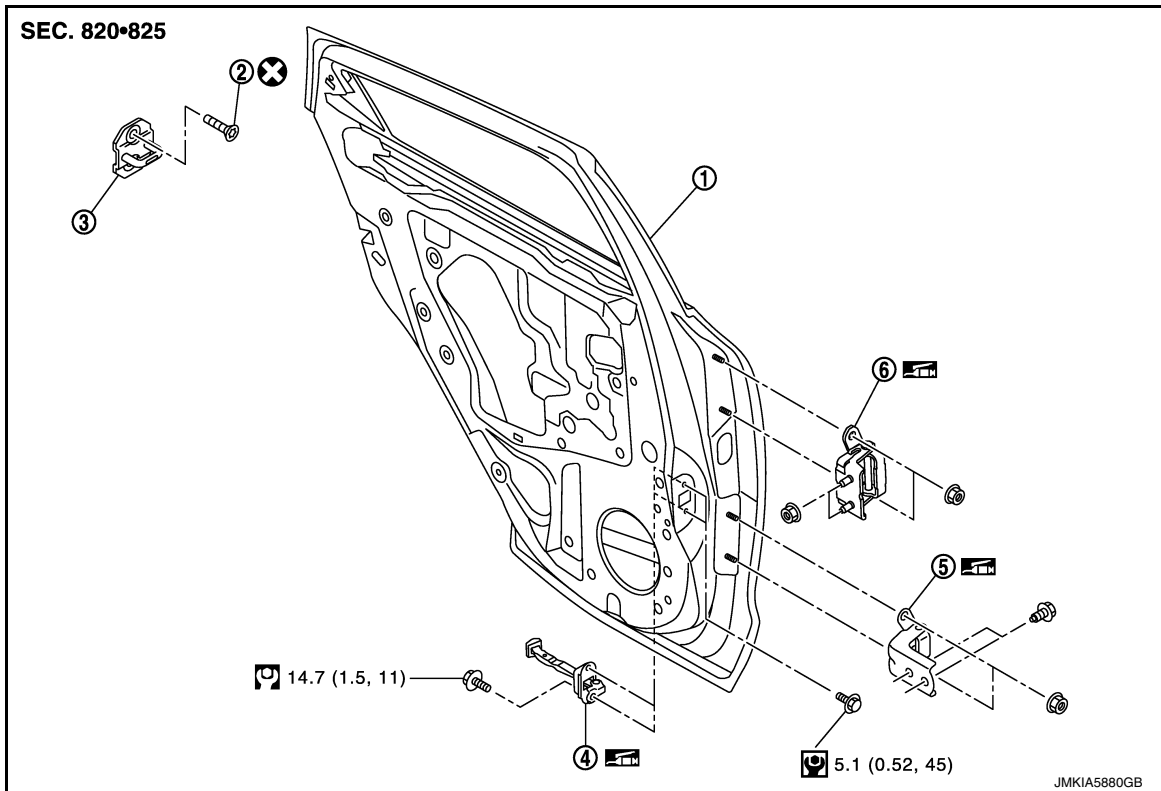

- | | | |
|--------------------|-----------------------|-----------------------|
| 1. Rear door panel | 2. TORX bolt | 3. Door striker |
| 4. Door check link | 5. Door hinge (lower) | 6. Door hinge (upper) |

⊗ : Always replace after every disassembly.

🔧 : N·m (kg-m, in-lb)

🔧 : N·m (kg-m, ft-lb)

🔧 : Body grease

DOOR ASSEMBLY

DOOR ASSEMBLY : Removal and Installation

INFOID:000000012196717

CAUTION:

- Perform work with 2 workers, because of it's heavy weight.
- When removing and installing rear door assembly, support door with a jack and shop cloth to protect door and body.

REMOVAL

REAR DOOR

< REMOVAL AND INSTALLATION >

[WITH INTELLIGENT KEY SYSTEM]

1. Remove rear door harness grommet (2) from body side outer (1), and then pull out rear door harness.

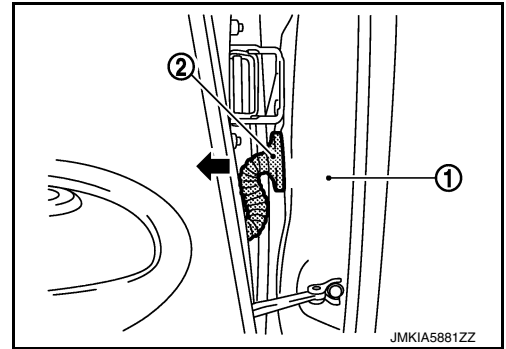

2. Disconnect rear door harness connector.



3. Remove mounting bolt of door check link on the vehicle.
4. Remove door hinge mounting bolts (door side), and then remove rear door assembly.

INSTALLATION

Note the following items, and install in the reverse order of removal.

CAUTION:

- Apply anticorrosive agent onto the mounting surface.
- Check rear door open/close, lock/unlock operation after installation.
- Check door hinge rotating part for poor lubrication. If necessary, apply body grease.
- After installation, perform the fitting adjustment. Refer to [DLK-142. "DOOR ASSEMBLY : Adjustment"](#).
- After installation, apply touch-up paint (the body color) onto the head of door hinge mounting nuts.

A
B
C
D
E
F
G
H
I
J
DLK
L
M
N
O
P

REAR DOOR

< REMOVAL AND INSTALLATION >

[WITH INTELLIGENT KEY SYSTEM]

DOOR ASSEMBLY : Adjustment

INFOID:000000012196718

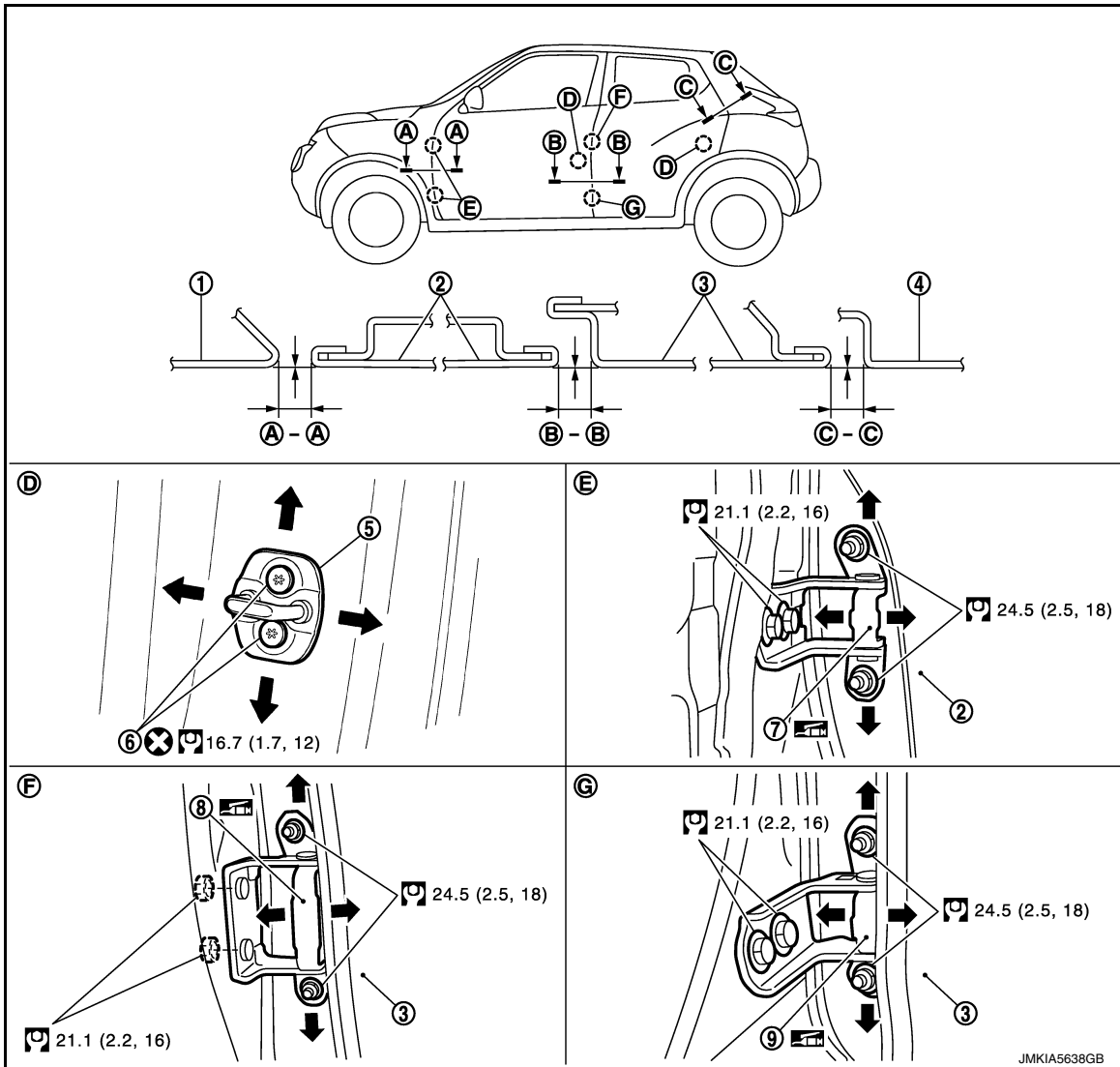

- | | | |
|---------------------|----------------------------|----------------------------|
| 1. Front fender | 2. Front door | 3. Rear door |
| 4. Body side outer | 5. Door striker | 6. TORX bolt |
| 7. Front door hinge | 8. Rear door hinge (upper) | 9. Rear door hinge (lower) |

⊗ : Always replace after every disassembly.

Ⓜ : N·m (kg·m, ft·lb)

🛢 : Body grease

Check the clearance and surface height between front door and each part by visually and touching. If the clearance and the surface height are out of specification, adjust them according to the procedures shown below.

Unit: mm (in)

Portion		Clearance	Surface height
Front door – Rear door	B – B	3.3 – 5.3 (0.130 – 0.209)	(-1.0) – (+1.0) [(-0.039) – (+0.039)]
Rear door – Body side outer	C – C	2.6 – 4.6 (0.102 – 0.181)	(-1.0) – (+1.0) [(-0.039) – (+0.039)]

FITTING ADJUSTMENT PROCEDURE

1. Remove center pillar lower garnish. Refer to [INT-22. "CENTER PILLAR LOWER GARNISH : Removal and Installation"](#).

REAR DOOR

< REMOVAL AND INSTALLATION >

[WITH INTELLIGENT KEY SYSTEM]

2. Loosen door hinge mounting nuts on door side.
3. Adjust the surface height of rear door according to the fitting standard dimension.
4. Temporarily tighten door hinge mounting nuts on door side.
5. Loosen door hinge mounting nuts and bolts on body side.
6. Raise rear door at rear end to adjust clearance of rear door according to the fitting standard dimension.
7. After adjustment tighten bolts and nuts to the specified torque.
CAUTION:
 - After installation, apply touch-up paint (the body color) onto the head of hinge mounting bolts and nuts.
 - Check door hinge rotating part for poor lubrication. If necessary, apply body grease.
8. Install center pillar lower garnish. Refer to [INT-22, "CENTER PILLAR LOWER GARNISH : Removal and Installation"](#).

DOOR STRIKER ADJUSTMENT

Adjust door striker so that it becomes parallel with door lock insertion direction.

DOOR STRIKER

DOOR STRIKER : Removal and Installation

INFOID:000000012196719

REMOVAL

Remove TORX bolts, and then remove door striker.

INSTALLATION

Note the following items, and install in the reverse order of removal.

CAUTION:

- Check rear door open/close, lock/unlock operation after installation.
- After installation, be sure to perform the fitting adjustment. Refer to [DLK-142, "DOOR ASSEMBLY : Adjustment"](#).

DOOR HINGE

DOOR HINGE : Removal and Installation

INFOID:000000012196720

CAUTION:

- Perform work with 2 workers, because of it's heavy weight.
- When removing and installing rear door assembly, support door with a jack and shop cloth to protect door and body.

REMOVAL

1. Remove rear door assembly. Refer to [DLK-140, "DOOR ASSEMBLY : Removal and Installation"](#).
2. Remove center pillar lower garnish. Refer to [INT-22, "CENTER PILLAR LOWER GARNISH : Removal and Installation"](#).
3. Remove rear door hinge mounting bolts and nuts (body side), and then remove door hinge.

INSTALLATION

Note the following items, and install in the reverse order of removal.

CAUTION:

- Apply anticorrosive agent onto the mounting surface.
- Check rear door open/close operation after installation.
- When removing and installing rear door assembly, perform the fitting adjustment. Refer to [DLK-142, "DOOR ASSEMBLY : Adjustment"](#).
- After installing, apply the touch-up paint (the body color) onto the head of door hinge mounting nuts.

REAR DOOR

< REMOVAL AND INSTALLATION >

[WITH INTELLIGENT KEY SYSTEM]

- Check door hinge rotating part for poor lubrication. If necessary, apply body grease.

← : Grease up point

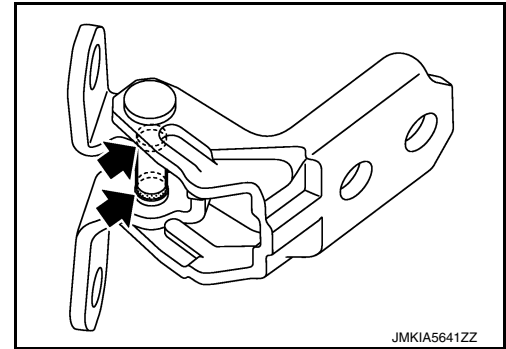

DOOR CHECK LINK

DOOR CHECK LINK : Removal and Installation

INFOID:000000012196721

REMOVAL

1. Fully close the rear door window.
2. Remove rear door finisher. Refer to [JNT-16, "Removal and Installation"](#).
3. Remove mounting bolts of rear door speaker, and then remove rear door speaker.
4. Disconnect harness connector of rear door speaker.
5. Remove mounting bolt of the check link on the vehicle.
6. Remove mounting bolts of the check link on door panel.
7. Take door check link (1) out from the hole of door panel (2).

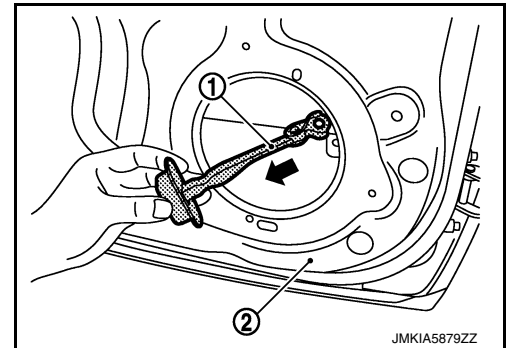

INSTALLATION

Note the following items, and install in the reverse order of removal.

CAUTION:

- Check rear door open/close operation after installation.
- Check door check link rotating part for poor lubrication. If necessary, apply grease.

← : Grease up point

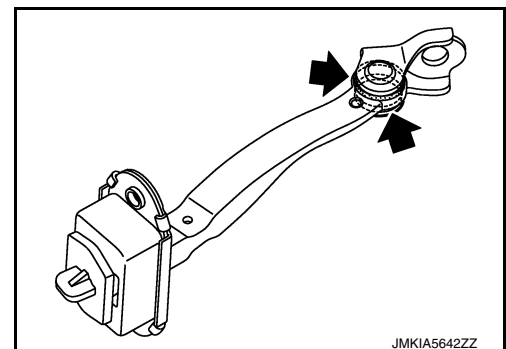

BACK DOOR

< REMOVAL AND INSTALLATION >

[WITH INTELLIGENT KEY SYSTEM]

BACK DOOR

Exploded View

INFOID:000000012196722

REMOVAL

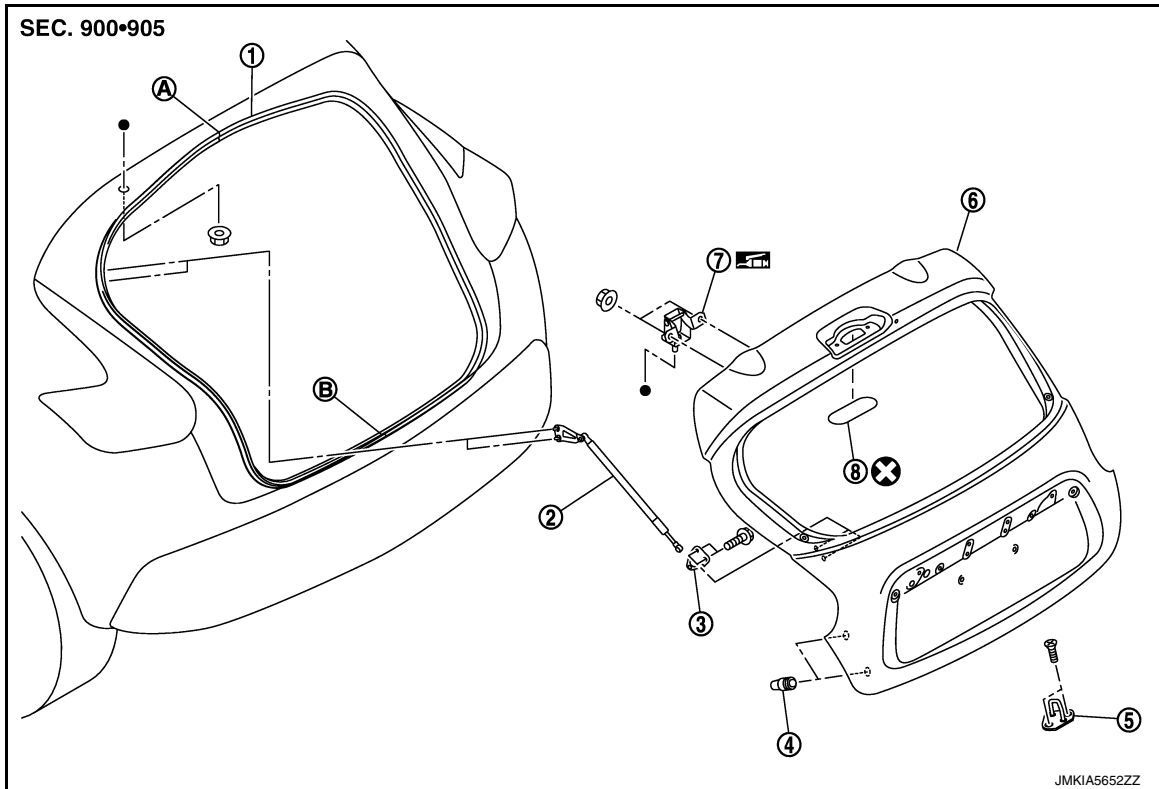

- | | | |
|----------------------------|----------------------|---------------------------------|
| 1. Back door weather-strip | 2. Back door stay | 3. Back door stay lower bracket |
| 4. Bumper rubber | 5. Back door striker | 6. Back door panel |
| 7. Back door hinge | 8. Hole cover | |
| A : Center mark | B : Seam | |

⊗ : Always replace after every disassembly.

☑ : Body grease

● : Indicates that the part is connected at points with same symbol in actual vehicle.

BACK DOOR ASSEMBLY

BACK DOOR ASSEMBLY : Removal and Installation

INFOID:000000012196723

CAUTION:

- Operate with two workers, because of its heavy weight.
- Use protective tape or shop cloth to protect from damage during removal and installation.

REMOVAL

1. Remove luggage side upper finisher (LH and RH). Refer to [INT-36. "LUGGAGE SIDE UPPER FINISHER : Removal and Installation"](#).

BACK DOOR

< REMOVAL AND INSTALLATION >

[WITH INTELLIGENT KEY SYSTEM]

2. Disconnect harness connector.

↔ : Vehicle front

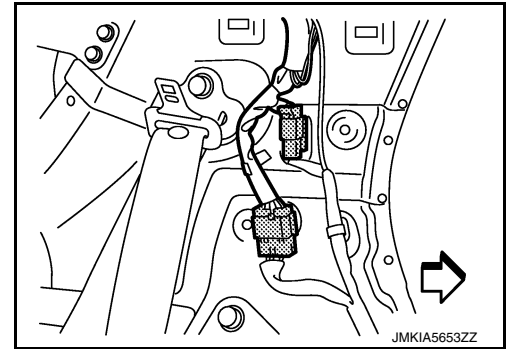

3. Remove rear washer hose (1) from hose mounting clip (A), and then disengage hose.

↔ : Vehicle front

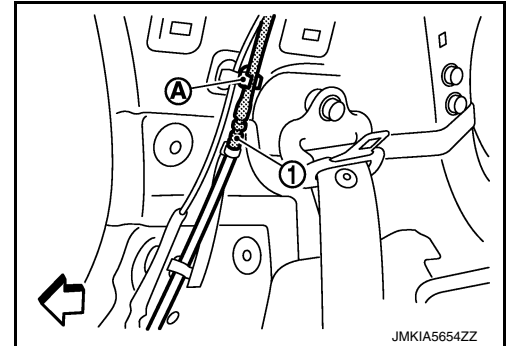

4. Remove center pillar upper garnish. Refer to [INT-22, "CENTER PILLAR UPPER GARNISH : Removal and Installation"](#).
5. Remove upper side of back door weather-strip. Refer to [DLK-152, "BACK DOOR WEATHER-STRIP : Removal and Installation"](#).
6. Remove rear assist grip (LH and RH) and mounting clips for rear portion of headlining, and then remove rear portion of headlining. Refer to [INT-27, "NORMAL ROOF : Exploded View"](#) or [INT-30, "SUNROOF : Removal and Installation"](#).
7. Remove ground harness mounting bolt (A) and harness fixing clips (B).

↔ : Vehicle front

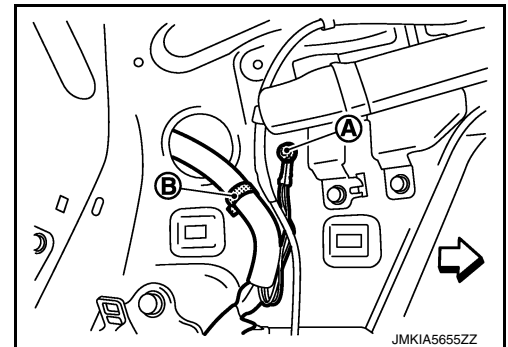

8. Remove grommet (1), and then pull out harness from roof panel (2).

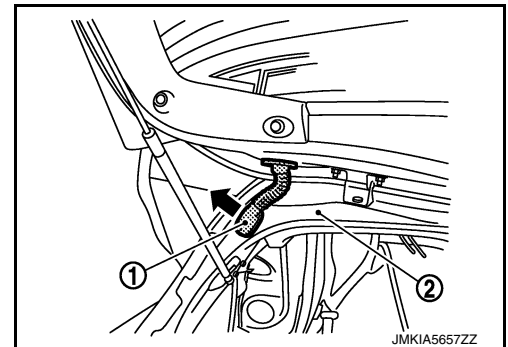

BACK DOOR

< REMOVAL AND INSTALLATION >

[WITH INTELLIGENT KEY SYSTEM]

9. Remove grommet (2), and then pull out harness and washer tube from roof panel (1).

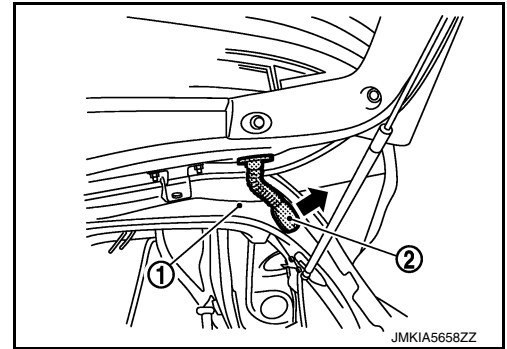

10. Support back door with the proper material to prevent it from falling.

WARNING:

Bodily injury may occur if no supporting rod is holding the back door open when removing the back door stay.

11. Remove back door stay (back door side). Refer to [DLK-151, "BACK DOOR STAY : Removal and Installation"](#).
12. Remove back door hinge mounting nuts on back door and remove back door assembly.

INSTALLATION

Note the following items, and install in the reverse order of removal.

CAUTION:

- Check back door hinge rotating part for poor lubrication. If necessary, apply body grease.
- After installation, check back door open/close, lock/unlock operation.
- After installation, perform the fitting adjustment. Refer to [DLK-148, "BACK DOOR ASSEMBLY : Adjustment"](#).

A
B
C
D
E
F
G
H
I
J
L
M
N
O
P

DLK

BACK DOOR

< REMOVAL AND INSTALLATION >

[WITH INTELLIGENT KEY SYSTEM]

BACK DOOR ASSEMBLY : Adjustment

INFOID:000000012196724

Except for NISMO/NISMO RS models

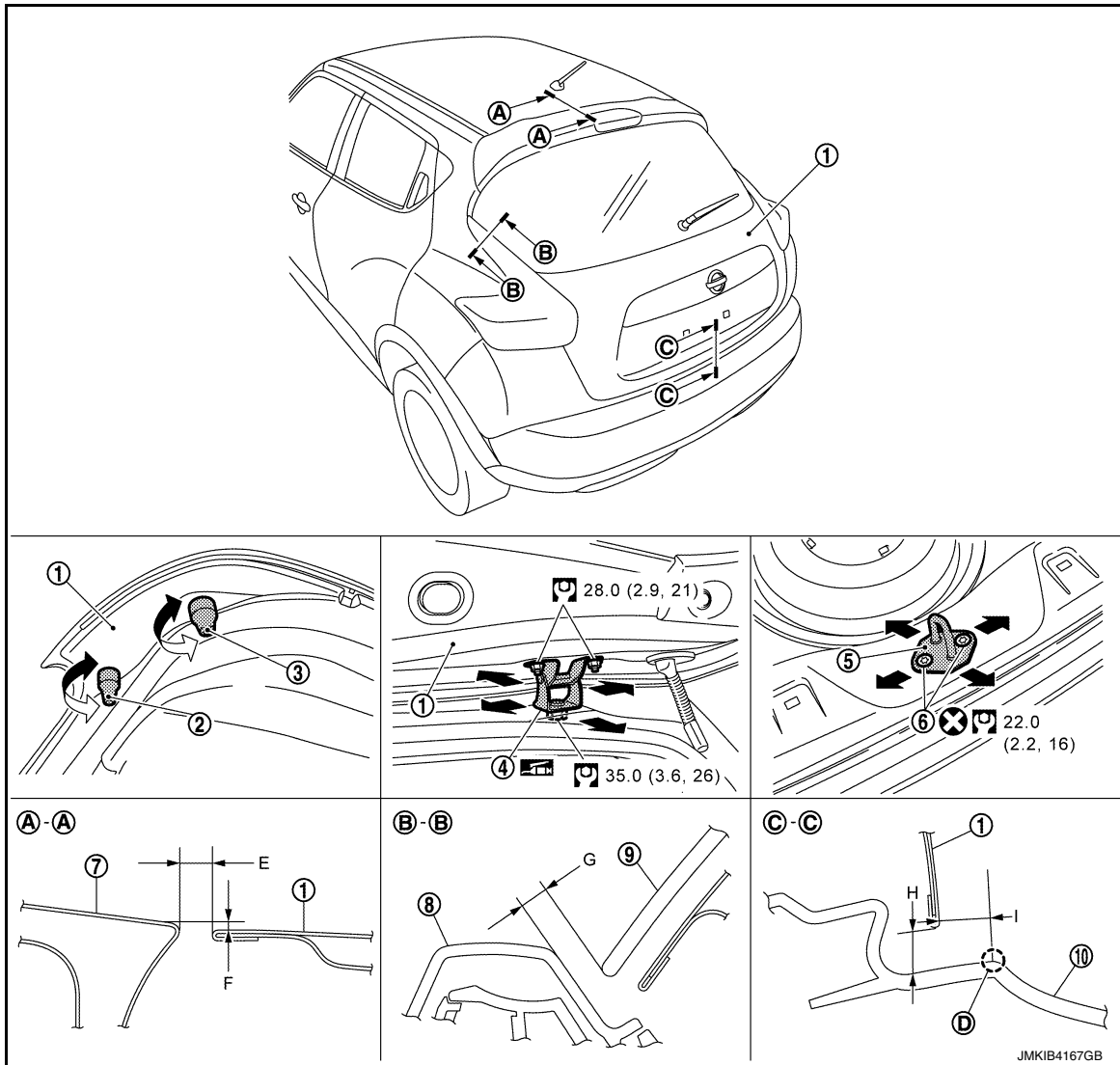

- | | | |
|-----------------------------|--------------------------|--------------------------|
| 1. Back door assembly | 2. Bumper rubber (upper) | 3. Bumper rubber (lower) |
| 4. Back door hinge | 5. Back door striker | 6. TORX bolt |
| 7. Roof panel | 8. Rear combination lamp | 9. Back door glass |
| 10. Rear bumper fascia | | |
| D. Rear bumper fascia R end | | |

: Always replace after every disassembly.

: N·m (kg·m, ft·lb)

: Body grease

BACK DOOR

< REMOVAL AND INSTALLATION >

[WITH INTELLIGENT KEY SYSTEM]

For NISMO/NISMO RS models

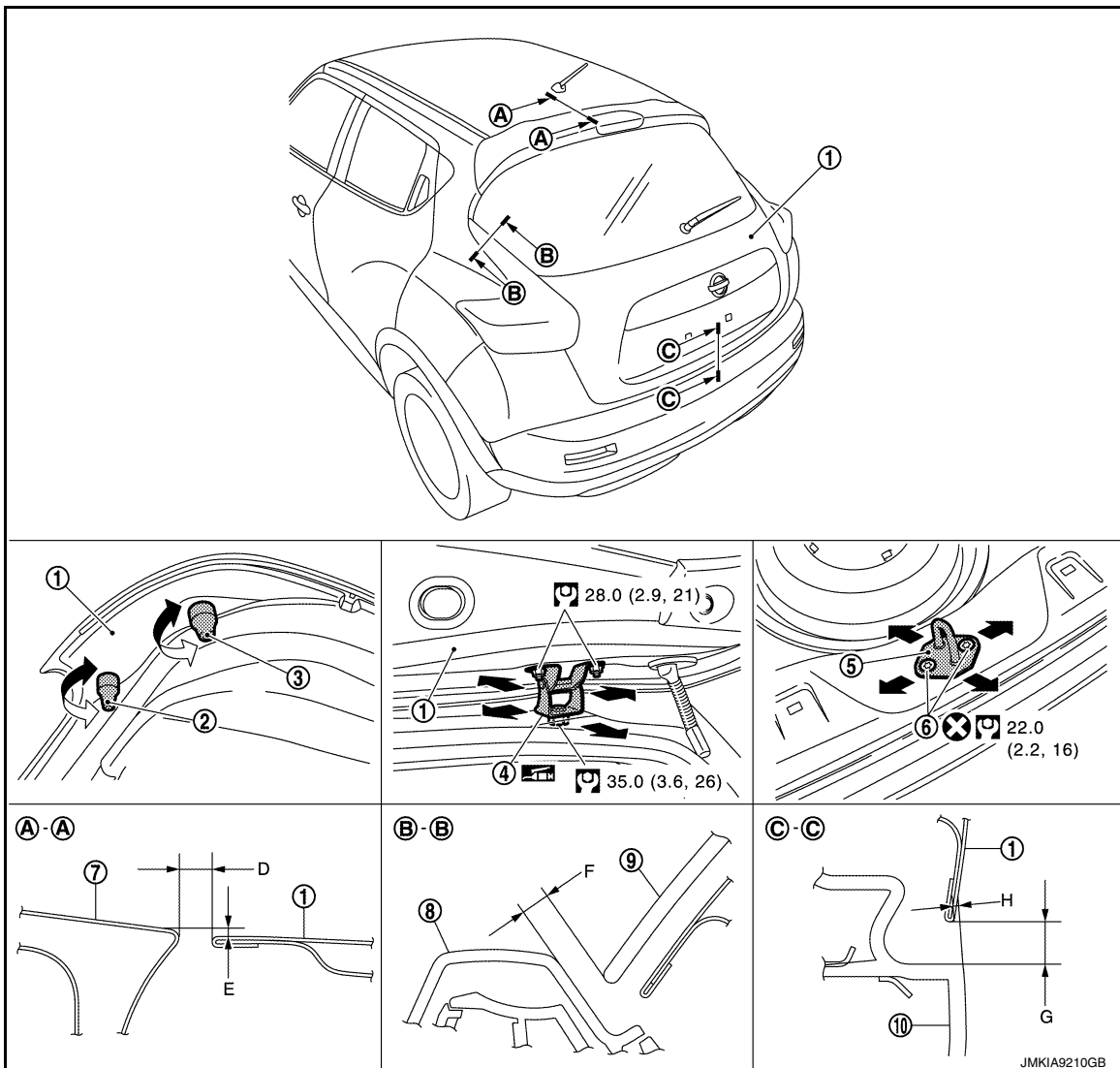

- | | | |
|------------------------|--------------------------|--------------------------|
| 1. Back door assembly | 2. Bumper rubber (upper) | 3. Bumper rubber (lower) |
| 4. Back door hinge | 5. Back door striker | 6. TORX bolt |
| 7. Roof panel | 8. Rear combination lamp | 9. Back door glass |
| 10. Rear bumper fascia | | |

⊗ : Always replace after every disassembly.

Ⓜ : N·m (kg·m, ft·lb)

🛢 : Body grease

Check the clearance and the surface height between back door and each part by seeing and touching. If the clearance and the surface height are out of specification, adjust them according to the procedures shown below.

Except for NISMO RS models

Unit: mm (in)

Portion			Standard	Difference (LH/RH, MAX)
Roof panel – Back door	A – A	E	Clearance	5.0 – 7.0 (0.197 – 0.276)
		F	Surface height	0.9 – 2.9 (0.035 – 0.114)

A
B
C
D
E
F
G
H
I
J
DLK

L
M
N
O
P

BACK DOOR

< REMOVAL AND INSTALLATION >

[WITH INTELLIGENT KEY SYSTEM]

Portion			Standard	Difference (LH/RH, MAX)	
Rear combination lamp – Back door glass	B – B	G	Clearance	2.8 – 7.2 (0.110 – 0.283)	<2.0 (0.079)
Rear bumper fascia – Back door	C – C	H	Clearance	6.0 – 10.0 (0.236 – 0.394)	—
		I	Surface height	9.1 – 12.6 (-0.358 – 0.496)	—

For NISMO RS models

Unit: mm (in)

Portion			Standard	Difference (LH/RH, MAX)	
Roof panel – Back door	A – A	D	Clearance	5.0 – 7.0 (0.197 – 0.276)	—
		E	Surface height	0.9 – 2.9 (0.035 – 0.114)	—
Rear combination lamp – Back door glass	B – B	F	Clearance	2.8 – 7.2 (0.110 – 0.283)	<2.0 (0.079)
Rear bumper fascia – Back door	C – C	G	Clearance	6.0 – 10.0 (0.236 – 0.394)	—
		H	Surface height	(-0.5) – (+3.0) [(-0.020) – (+0.118)]	—

FITTING ADJUSTMENT PROCEDURE

- Loosen back door striker mounting bolts.
- Loosen back door hinge mounting nuts (back door side).
- Adjust back door using back door striker and back door hinge to the specified value, as shown in the following table.
- After adjustment tighten back door striker mounting bolts and back door hinge mounting nuts (back door side) to the specified torque.
- Screw bumper rubber (upper) into the stopper position (A), and then loosen by a half turn.
- Screw bumper rubber (lower) into the end position of threads.

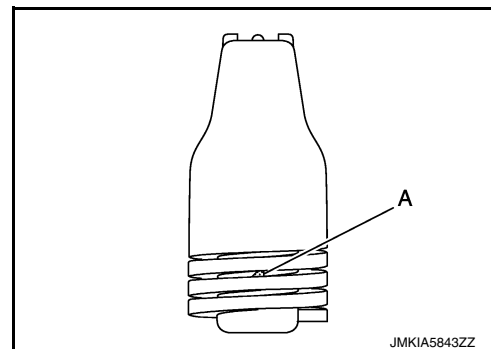

CAUTION:

- After installation, apply touch-up paint (the body color) onto the head of back door hinge mounting nuts.
- After adjusting, perform camera image calibration (with around view monitor). Refer to [AV-116, "CALIBRATING CAMERA IMAGE \(AROUND VIEW MONITOR\) : Work Procedure"](#)
- After adjusting, perform rear view camera adjustment (with rear view camera). Refer to [AV-56, "Adjustment"](#)

BACK DOOR STRIKER ADJUSTMENT

Adjust back door striker so that it becomes parallel with back door lock insertion direction.

BACK DOOR STRIKER

BACK DOOR STRIKER : Removal and Installation

INFOID:0000000012196725

REMOVAL

BACK DOOR

< REMOVAL AND INSTALLATION >

[WITH INTELLIGENT KEY SYSTEM]

1. Remove luggage rear plate. Refer to [INT-35, "LUGGAGE REAR PLATE : Removal and Installation"](#).
2. Remove TORX bolts, and then remove back door striker.

INSTALLATION

Note the following items, and install in the reverse order of removal.

CAUTION:

- After installation, check back door open/close, lock/unlock operation.
- After installation, perform the fitting adjustment. Refer to [DLK-148, "BACK DOOR ASSEMBLY : Adjustment"](#).

BACK DOOR HINGE

BACK DOOR HINGE : Removal and Installation

INFOID:000000012196726

REMOVAL

1. Remove back door assembly. Refer to [DLK-145, "BACK DOOR ASSEMBLY : Removal and Installation"](#).
2. Remove back door hinge mounting nuts (body side), and then remove back door hinge.

INSTALLATION

Note the following items, and install in the reverse order of removal.

CAUTION:

- After installation, check back door open/close, lock/unlock operation.
- After installation, perform the fitting adjustment. Refer to [DLK-148, "BACK DOOR ASSEMBLY : Adjustment"](#).
- Check back door hinge rotating part for poor lubrication. If necessary, apply body grease.

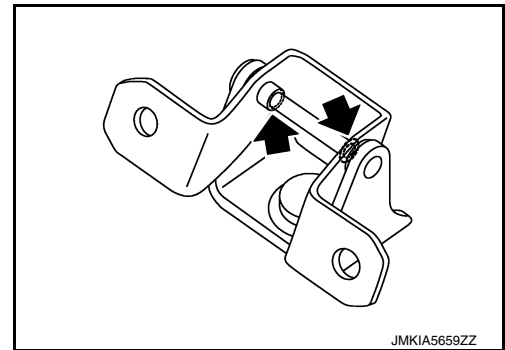

BACK DOOR STAY

BACK DOOR STAY : Removal and Installation

INFOID:000000012196727

REMOVAL

1. Remove luggage side upper finisher and rear pillar cap. Refer to [INT-36, "LUGGAGE SIDE UPPER FINISHER : Removal and Installation"](#).
2. Support the back door with the suitable material to prevent it from falling.

WARNING:

Bodily injury may occur if no supporting rod is holding the back door open when removing the back door stay.

3. Remove back door stay mounting bolts (body side).
4. Remove the metal clip (3) located on the connection between the back door stay (1) and the stud ball (2) (back door side) by using a flat-bladed screwdriver (A).

CAUTION:

Be careful not to damage painted surface.

5. Remove back door stay (back door side).

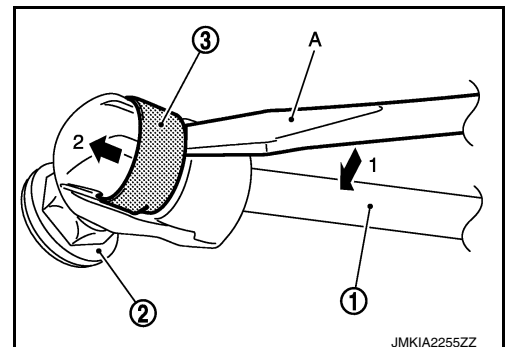

A
B
C
D
E
F
G
H
I
J
DLK

BACK DOOR

< REMOVAL AND INSTALLATION >

[WITH INTELLIGENT KEY SYSTEM]

6. Remove mounting bolts, and then remove back door stay lower bracket.

INSTALLATION

Note the following items, and install in the reverse order of removal.

CAUTION:

- Apply anticorrosive agent onto the mounting surface.
- After installation, check back door open/close, lock/unlock operation.

BACK DOOR STAY : Disposal

INFOID:000000012196728

1. Fix back door stay (1) using a vise (C).
2. Using hacksaw (A) slowly make 2 holes in the back door stay, in numerical order as shown in the figure.

CAUTION:

- When cutting a hole on back door stay, always cover a hacksaw using a shop cloth (B) to avoid scattering metal fragments or oil.
- Wear eye protection (safety glasses).
- Wear gloves.

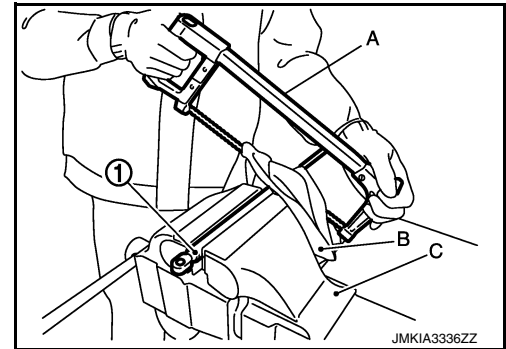

A: 20 mm (0.787 in)

B: Cut at the groove.

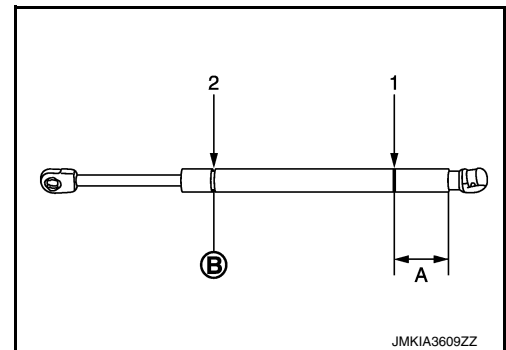

BACK DOOR WEATHER-STRIP

BACK DOOR WEATHER-STRIP : Removal and Installation

INFOID:000000012196729

REMOVAL

Pull up and remove engagement with body from weather-strip joint.

CAUTION:

Never pull strongly on weather-strip.

INSTALLATION

1. Working from the upper section, align weather-strip center mark with vehicle center position mark and install weather-strip onto the vehicle.
2. For the lower section, insert pad (A) into weather-strip (1), and then fix the connection point.

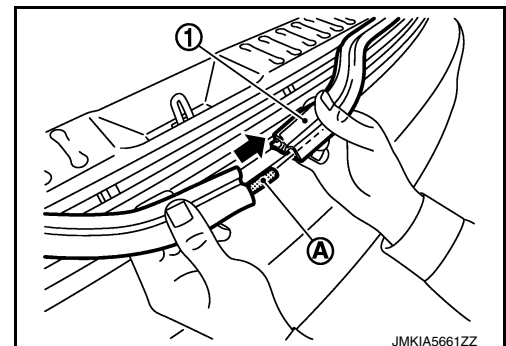

BACK DOOR

< REMOVAL AND INSTALLATION >

[WITH INTELLIGENT KEY SYSTEM]

3. Align the connecting point (B) of weather-strip (2) to the center (A) of striker (1), and then install as shown in the figure.

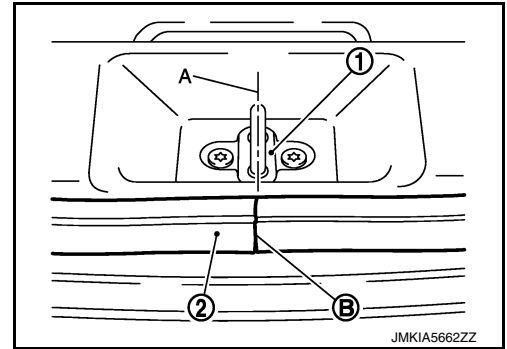

4. Pull weather-strip gently to ensure that there is no loose section.
NOTE:
Check that weather-strip fits tightly in each corner and luggage rear plate.

A
B
C
D
E
F
G
H
I
J
L
M
N
O
P

DLK

HOOD LOCK

< REMOVAL AND INSTALLATION >

[WITH INTELLIGENT KEY SYSTEM]

HOOD LOCK

Exploded View

INFOID:000000012196730

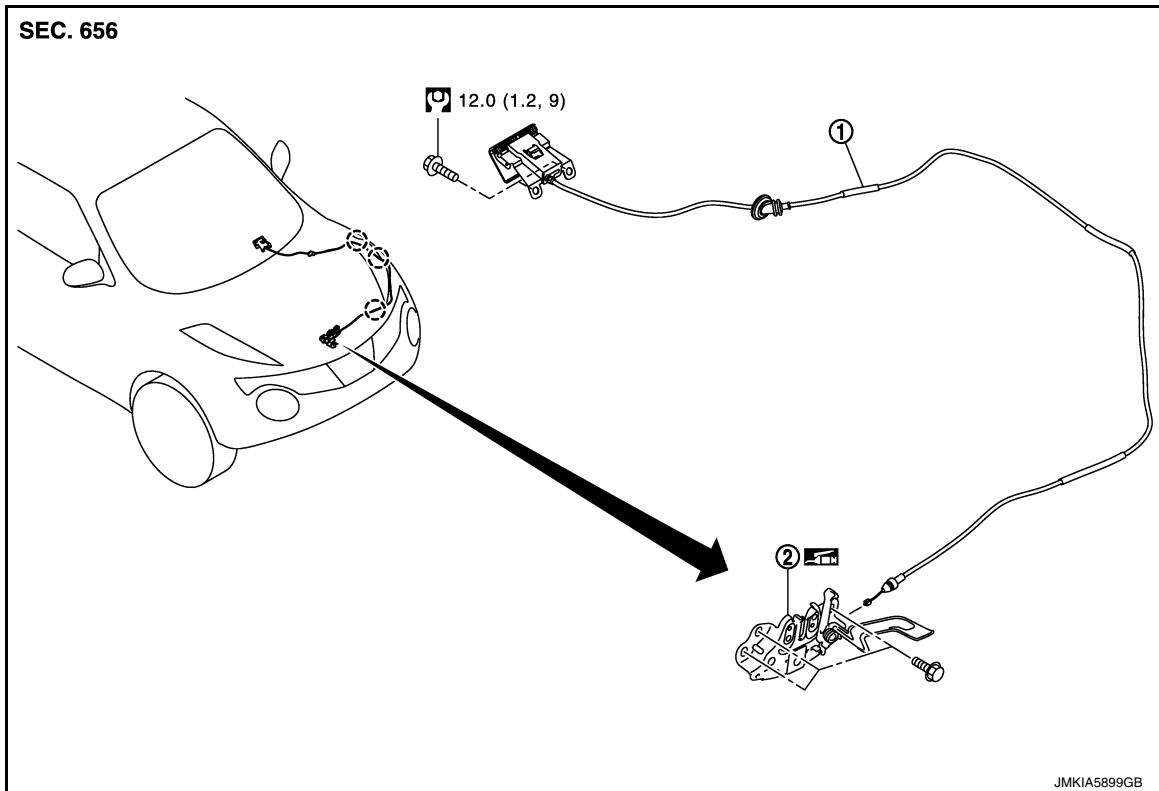

1. Hood lock control cable assembly 2. Hood lock assembly

 : Clip

 : N·m (kg-m, ft-lb)

 : Body grease

HOOD LOCK

HOOD LOCK : Removal and Installation

INFOID:000000012196731

REMOVAL

1. Remove front center grille. Refer to [EXT-26, "Removal and Installation"](#).
2. Remove crash zone sensor. Refer to [SR-24, "Removal and Installation"](#).
3. Remove hood lock assembly mounting bolts, and then remove hood lock assembly.
4. Disconnect hood lock control cable assembly (2) from hood lock assembly (1).

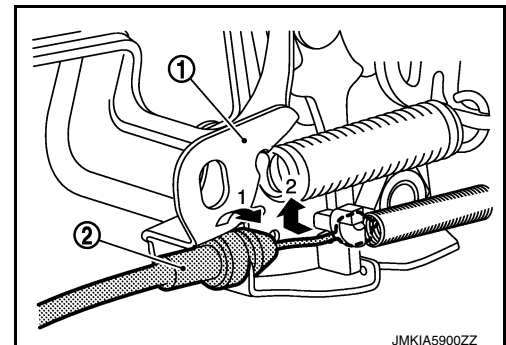

INSTALLATION

Revision: November 2015

DLK-154

2016 JUKE

HOOD LOCK

< REMOVAL AND INSTALLATION >

[WITH INTELLIGENT KEY SYSTEM]

Note the following items, and install in the reverse order of removal.

CAUTION:

- Check that hood lock control cable is properly engaged with hood lock.
- After installation, perform hood fitting adjustment. Refer to [DLK-125, "HOOD ASSEMBLY : Adjustment"](#).
- After installation, perform hood lock control inspection. Refer to [DLK-155, "Inspection"](#).

HOOD LOCK CONTROL CABLE

HOOD LOCK CONTROL CABLE : Removal and Installation

INFOID:0000000012196732

REMOVAL

1. Disconnect hood lock control cable assembly from hood lock assembly.
2. Remove fender protector (LH). Refer to [EXT-31, "Removal and Installation"](#).
3. Remove hood lock cable clip.
4. Remove hood lock control cable assembly of instrument lower panel (LH), and then remove fuel filler lid opener cable (2) from fuel filler lid opener lever (1).

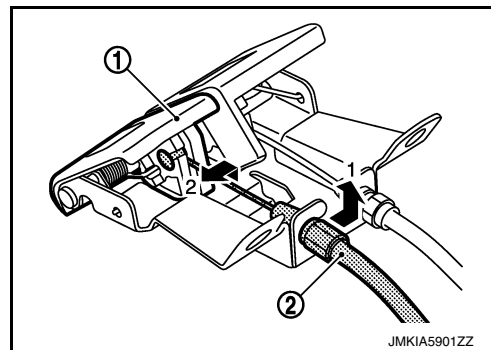

5. Remove grommet on the lower dash, and pull the hood lock control cable toward the passenger compartment.

CAUTION:

While pulling, never to damage (peeling) the outside of hood lock control cable.

INSTALLATION

Note the following items, and install in the reverse order of removal.

CAUTION:

- Never to bend cable too much, keeping the radius 100 mm (3.937 in) or more.
- Check that cable is not offset from the positioning grommet, and apply the sealant to the grommet (at * mark) properly.

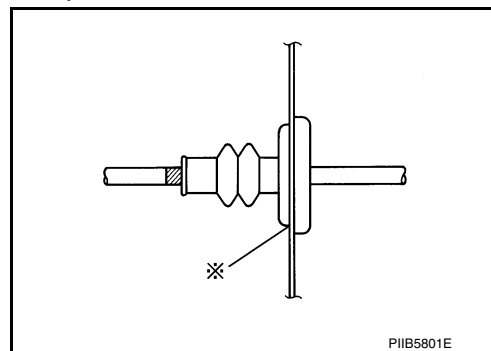

- Check that hood lock control cable is properly engaged with hood lock.
- After installation, perform hood fitting adjustment. Refer to [DLK-125, "HOOD ASSEMBLY : Adjustment"](#).
- After installation, perform hood lock control inspection. Refer to [DLK-155, "Inspection"](#).

Inspection

INFOID:0000000012196733

NOTE:

If the hood lock cable is bent or deformed, replace it.

1. Check that secondary latch is securely engaged with securely striker from the dead load of the hood assembly.

A
B
C
D
E
F
G
H
I
J
DLK
L
M
N
O
P

HOOD LOCK

< REMOVAL AND INSTALLATION >

[WITH INTELLIGENT KEY SYSTEM]

2. Check that primary latch is securely engaged with primary striker when hood assembly is closed [free-fall from approximately 200 mm (7.874 in) height].

CAUTION:

Never free-fall hood assembly from a height of 300 (11.811 in) mm or more.

3. While operating the hood opener carefully, check that the front end of the hood is lifted by approximately 20 mm (0.787 in) (A). Also, check that the hood opener returns to the original position.

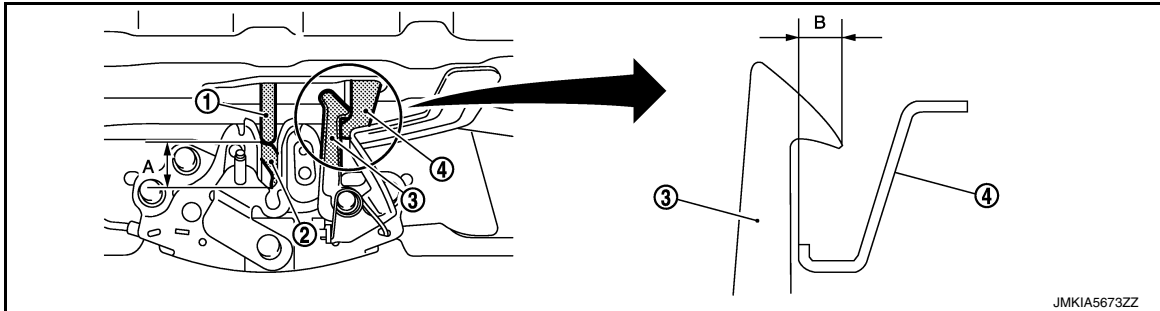

1. Primary striker
2. Primary latch
3. Secondary latch
4. Secondary striker

4. Check that secondary latch is properly engaged with secondary striker [6.8 mm (0.268 in)] (B).
5. Check the hood lock lubrication condition. If necessary, apply body grease to hood lock.

← : Grease up point

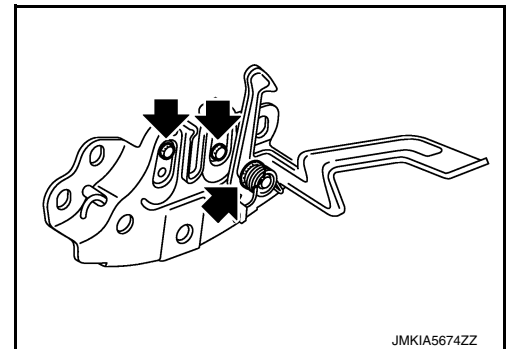

FRONT DOOR LOCK

< REMOVAL AND INSTALLATION >

[WITH INTELLIGENT KEY SYSTEM]

FRONT DOOR LOCK

Exploded View

INFOID:000000012196734

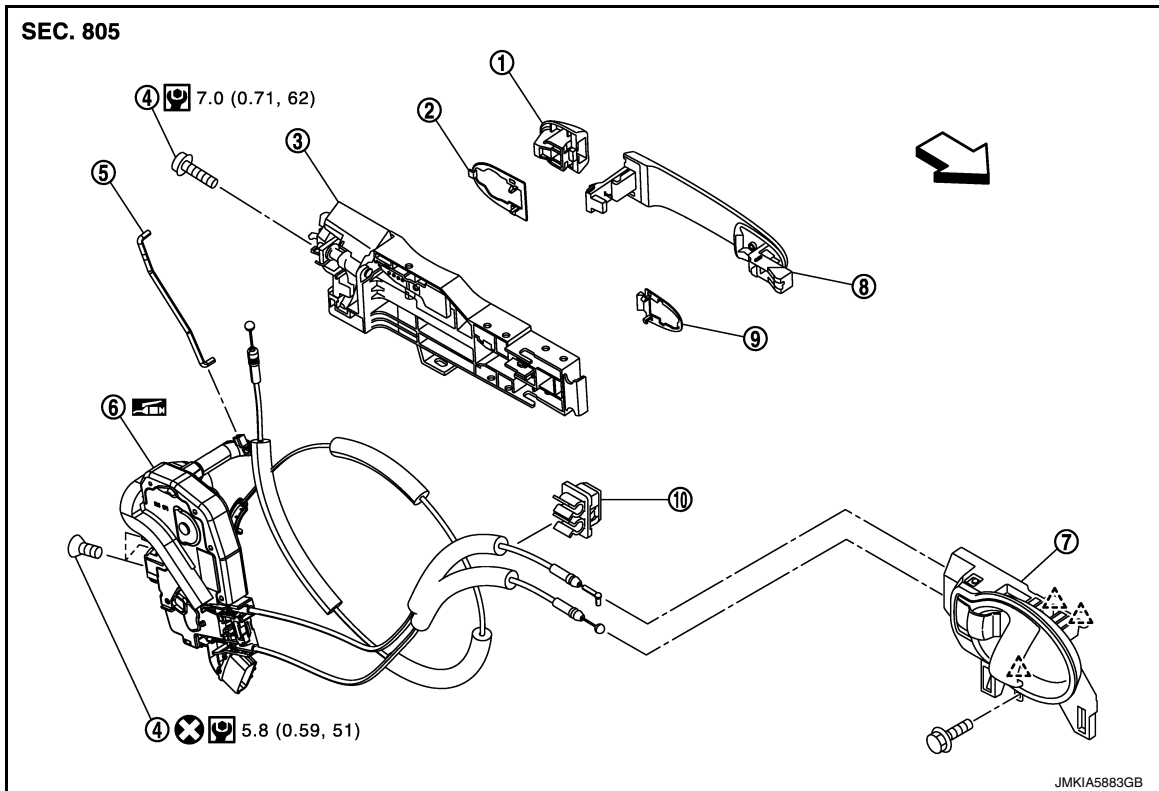

- | | | |
|---|--------------------------|---------------------------|
| 1. Door key cylinder assembly (driver side) | 2. Rear gasket | 3. Outside handle bracket |
| Outside handle escutcheon (passenger side) | | |
| 4. TORX bolt | 5. Key rod (driver side) | 6. Door lock assembly |
| 7. Inside handle | 8. Outside handle | 9. Front gasket |
| 10. Cable clip | | |

△ : Pawl

← : Vehicle front

⊗ : Always replace after every disassembly.

⊙ : N·m (kg-m, in-lb)

☑ : Body grease

DOOR LOCK

DOOR LOCK : Removal and Installation

INFOID:000000012196735

REMOVAL

1. Remove front door glass and front door lower sash (rear). Refer to [GW-17. "Removal and Installation"](#).
2. Remove inside handle. Refer to [DLK-158. "INSIDE HANDLE : Removal and Installation"](#).
3. Disengage inside handle cable and lock knob cable from cable clip.
4. Remove outside handle bracket. Refer to [DLK-158. "OUTSIDE HANDLE : Removal and Installation"](#).
5. Remove door lock assembly TORX bolts.
6. Disconnect door lock actuator connector, and then remove door lock assembly.

A
B
C
D
E
F
G
H
I
J
K
L
M
N
O
P

DLK

FRONT DOOR LOCK

< REMOVAL AND INSTALLATION >

[WITH INTELLIGENT KEY SYSTEM]

INSTALLATION

Note the following items, and install in the reverse order of removal.

CAUTION:

- Never reuse TORX bolt. Always replace it with a new one when it is removed.
- Check door open/close, lock/unlock operation after installation.
- Check door lock cable is properly engaged with outside handle bracket.
- Check door lock assembly for poor lubrication. Apply body grease to door lock if necessary.

← : Grease up point

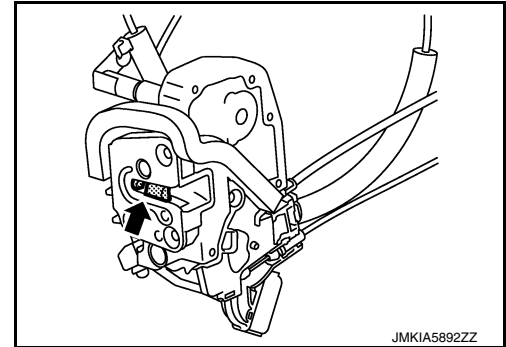

JMKIA5892ZZ

INSIDE HANDLE

INSIDE HANDLE : Removal and Installation

INFOID:000000012196736

REMOVAL

1. Remove front door finisher. Refer to [INT-13, "Removal and Installation"](#).
2. Remove inside handle mounting bolt (A).
3. Disengage inside handle (1) from door panel (2) while sliding inside handle toward vehicle rear, and then separate inside handle.

⇐ : Vehicle front

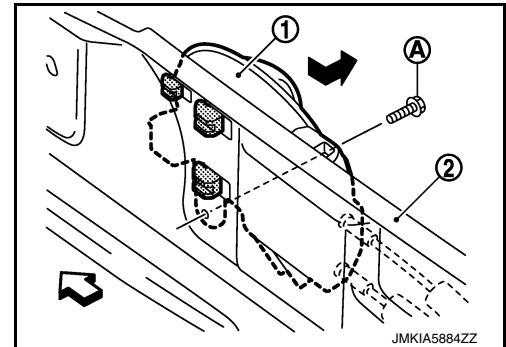

JMKIA5884ZZ

4. Disengage inside handle cable (3) and lock knob cable (2), and then remove inside handle (1).

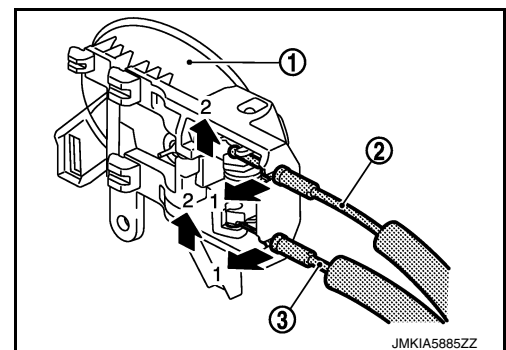

JMKIA5885ZZ

INSTALLATION

Note the following item, and install in the reverse order of removal.

CAUTION:

Check door open/close, lock/unlock operation after installation.

OUTSIDE HANDLE

OUTSIDE HANDLE : Removal and Installation

INFOID:000000012196737

REMOVAL

1. Fully close the front door glass.
2. Remove front door finisher. Refer to [INT-13, "Removal and Installation"](#).

FRONT DOOR LOCK

< REMOVAL AND INSTALLATION >

[WITH INTELLIGENT KEY SYSTEM]

3. Remove sealing screen.

NOTE:

Cut the butyl-tape so that some parts of the butyl-tape do not remain on the sealing screen, if the sealing screen is reused.

4. Disengage lock holder (1), and then separate key rod (3) from door lock assembly (2). (Driver side)

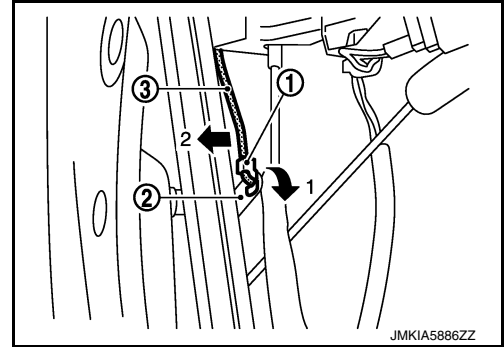

5. Disconnect harness connector of door antenna (1) and door request switch (2) and remove harness clamp (3).

← : Vehicle front

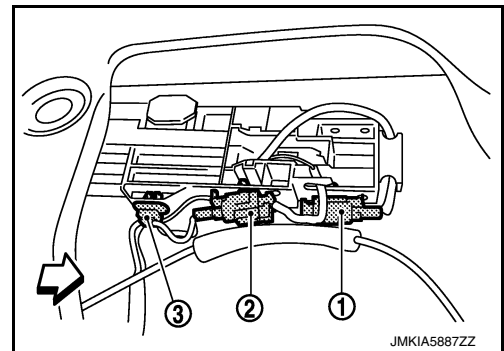

6. Remove grommet (1) of door side. Loosen, through grommet hole, TORX bolt (2) that fixes door lock cylinder. (For passenger side, TORX bolt fixes outside handle escutcheon.)

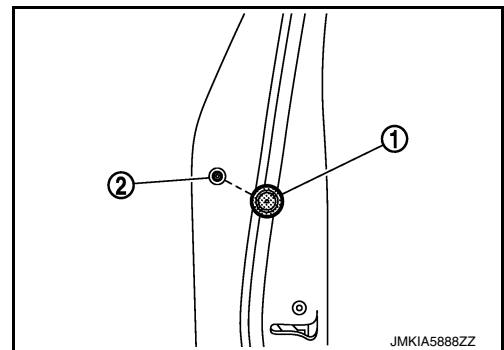

7. While pulling outside handle, remove door key cylinder assembly (driver side) or outside handle escutcheon (passenger side).

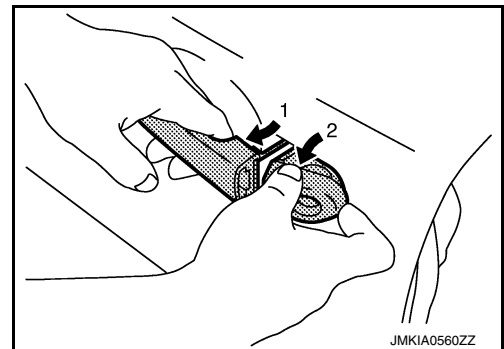

A
B
C
D
E
F
G
H
I
J
DLK
L
M
N
O
P

FRONT DOOR LOCK

< REMOVAL AND INSTALLATION >

[WITH INTELLIGENT KEY SYSTEM]

8. While pulling outside handle (1), slide toward rear of vehicle to remove outside handle.

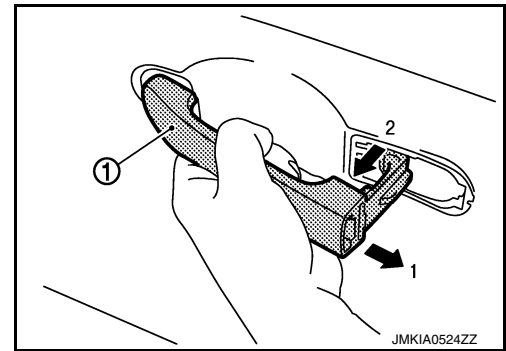

9. Remove front gasket (1) and rear gasket (2).

← : Vehicle front

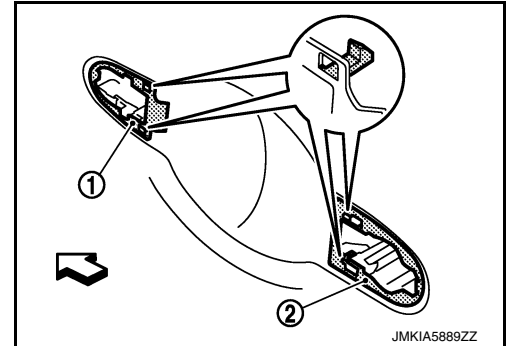

10. Slide outside handle bracket toward rear of vehicle to remove.

← : Vehicle front

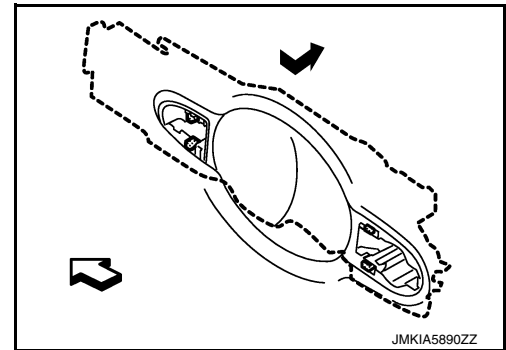

11. Disconnect outside handle cable (1) from outside handle bracket (2).

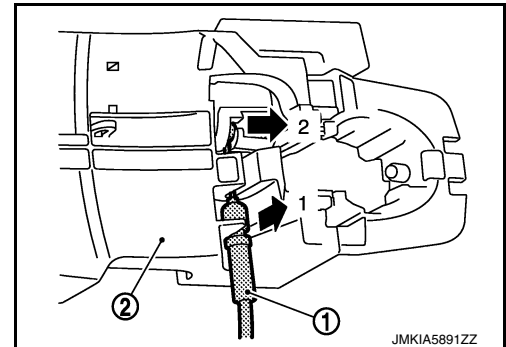

INSTALLATION

Note the following items, and install in the reverse order of removal.

CAUTION:

- When installing key rod, rotate key rod holder until a click is felt.
- Check that door lock cables are normally engaged with inside handle and outside handle.
- After installation, check door open/close, and lock/unlock operation.

REAR DOOR LOCK

< REMOVAL AND INSTALLATION >

[WITH INTELLIGENT KEY SYSTEM]

REAR DOOR LOCK

Exploded View

INFOID:000000012196738

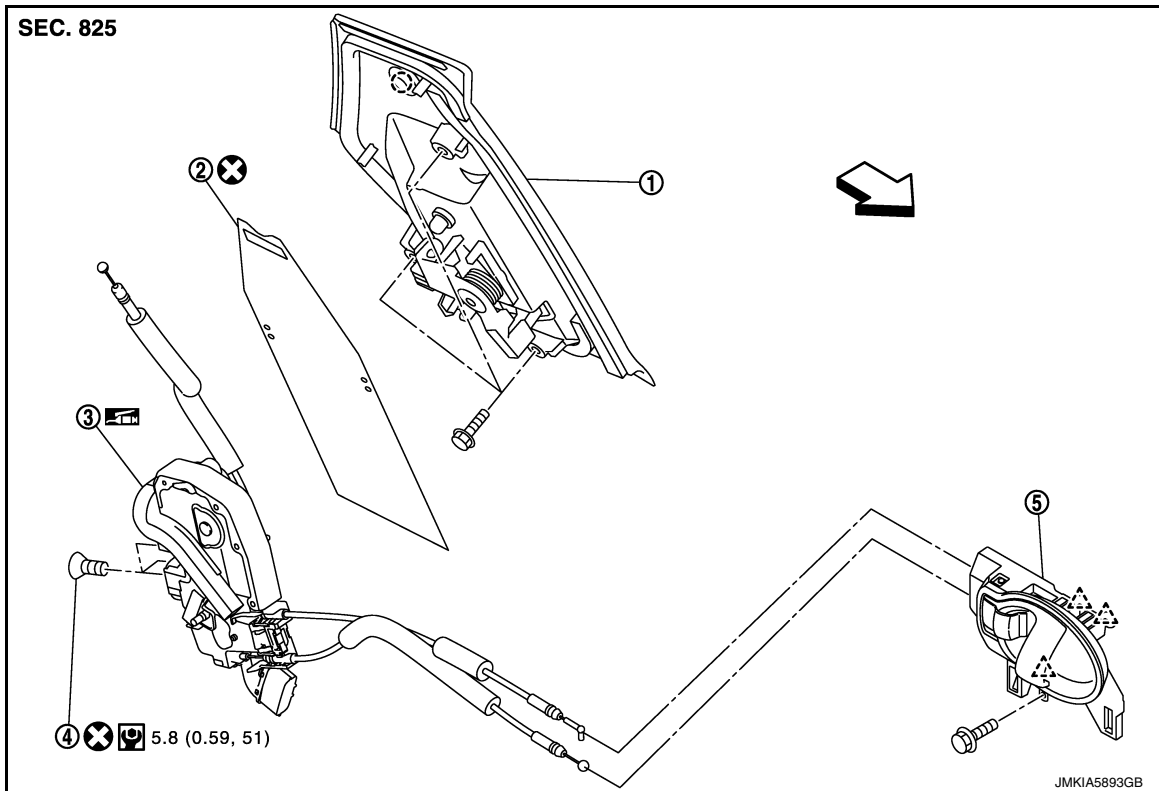

1. Outside handle assembly
2. Rear door sealing screen
3. Door lock assembly
4. TORX bolt
5. Inside handle

○ : Clip

△ : Pawl

← : Vehicle front

⊗ : Always replace after every disassembly.

Ⓜ : N·m (kg-m, in-lb)

Ⓜ : Body grease

DOOR LOCK

DOOR LOCK : Removal and Installation

INFOID:000000012196739

REMOVAL

1. Remove rear door glass and rear door lower sash (rear). Refer to [GW-21, "Removal and Installation"](#).
2. Remove inside handle. Refer to [DLK-162, "INSIDE HANDLE : Removal and Installation"](#).
3. Remove outside handle. Refer to [DLK-162, "OUTSIDE HANDLE : Removal and Installation"](#).
4. Remove door lock assembly TORX bolts.
5. Disconnect door lock actuator connector, and then remove door lock assembly.

INSTALLATION

Note the following items, and install in the reverse order of removal.

CAUTION:

- Never reuse TORX bolt. Always replace it with a new one when it is removed.
- Check door open/close, lock/unlock operation after installation.

A

B

C

D

E

F

G

H

I

J

DLK

L

M

N

O

P

REAR DOOR LOCK

< REMOVAL AND INSTALLATION >

[WITH INTELLIGENT KEY SYSTEM]

- Check door lock assembly for poor lubrication. Apply body grease to door lock if necessary.

← : Grease up point

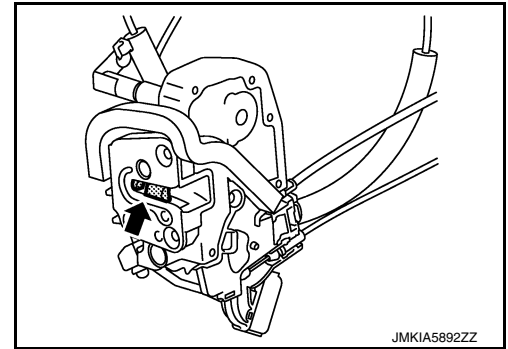

INSIDE HANDLE

INSIDE HANDLE : Removal and Installation

INFOID:000000012196740

REMOVAL

1. Remove rear door finisher. Refer to [INT-16. "Removal and Installation"](#).
2. Remove upper side of sealing screen.

NOTE:

Cut the butyl tape so that some parts of the butyl tape do not remain on the sealing screen, if the sealing screen is reused.

3. Remove inside handle mounting bolt (A).
4. Disengage inside handle (1) from door panel (2) while sliding inside handle toward vehicle rear, and then separate inside handle.

← : Vehicle front

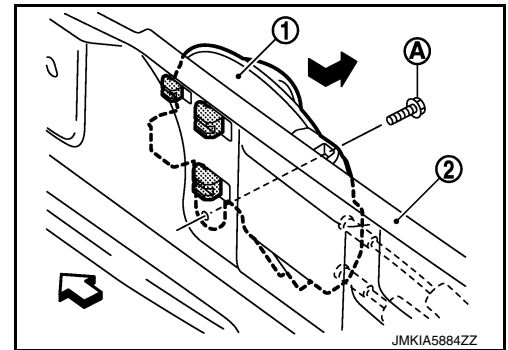

5. Disengage inside handle cable (3) and lock knob cable (2), and then remove inside handle (1).

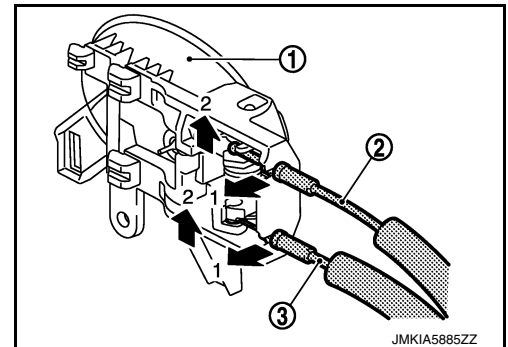

INSTALLATION

Note the following item, and install in the reverse order of removal.

CAUTION:

Check door open/close, lock/unlock operation after installation.

OUTSIDE HANDLE

OUTSIDE HANDLE : Removal and Installation

INFOID:000000012196741

REMOVAL

1. Remove rear door finisher and rear door corner cover inner. Refer to [INT-16. "Removal and Installation"](#).
2. Remove rear door sealing screen.

REAR DOOR LOCK

< REMOVAL AND INSTALLATION >

[WITH INTELLIGENT KEY SYSTEM]

3. Rotate stopper (1) upward.
4. Disengage outside handle cable (2), and then remove outside handle cable from outside handle assembly (3).

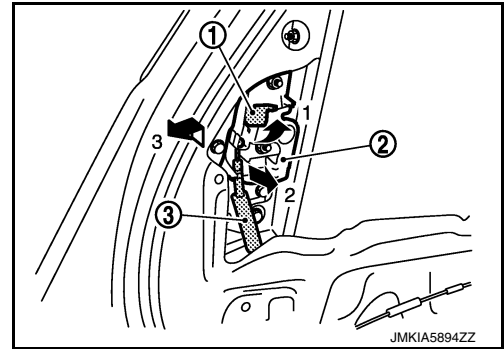

5. Remove outside handle assembly mounting bolts (A).

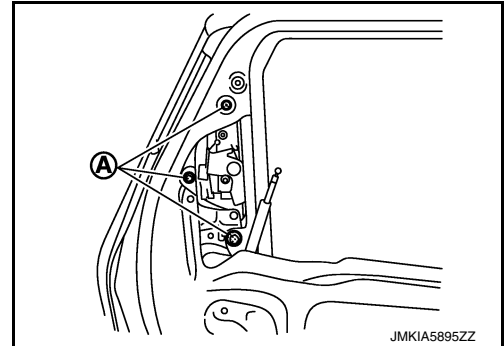

6. Disengage mounting clips using a remover tool (A), and then remove outside handle assembly.

CAUTION:

Apply protective tape (B) on the door panel to protect the painted surface from damage.

 : Clip

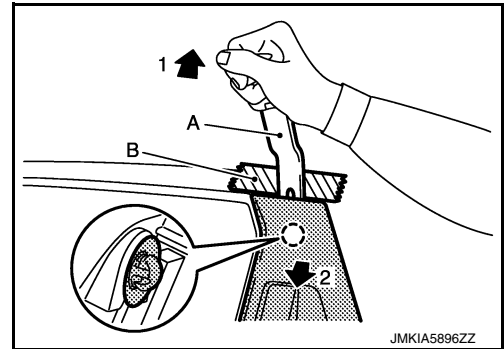

INSTALLATION

Note the following items, and install in the reverse order of removal.

CAUTION:

- Never reuse rear door sealing screen. Always replace it with a new one when it is removed.
- When installing rear door sealing screen, install it according to the following procedure.

- Put lower portion of rear door sealing screen (1) into inside of door panel (2).
- Perform positioning according to the following procedure, and then install rear door sealing screen.
- Align upper portion of rear door sealing screen to hole (A) of door panel as shown in the figure.
- Align hole of rear door sealing screen to edge (B) of door panel as shown in the figure.

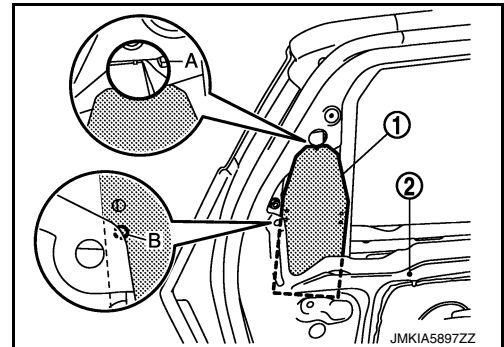

- Be careful to position outside handle cable normally when installing it. For details, refer to [DLK-161, "Exploded View"](#).
- Check door open/close, lock/unlock operation after installation.

BACK DOOR LOCK

< REMOVAL AND INSTALLATION >

[WITH INTELLIGENT KEY SYSTEM]

BACK DOOR LOCK

Exploded View

INFOID:000000012196742

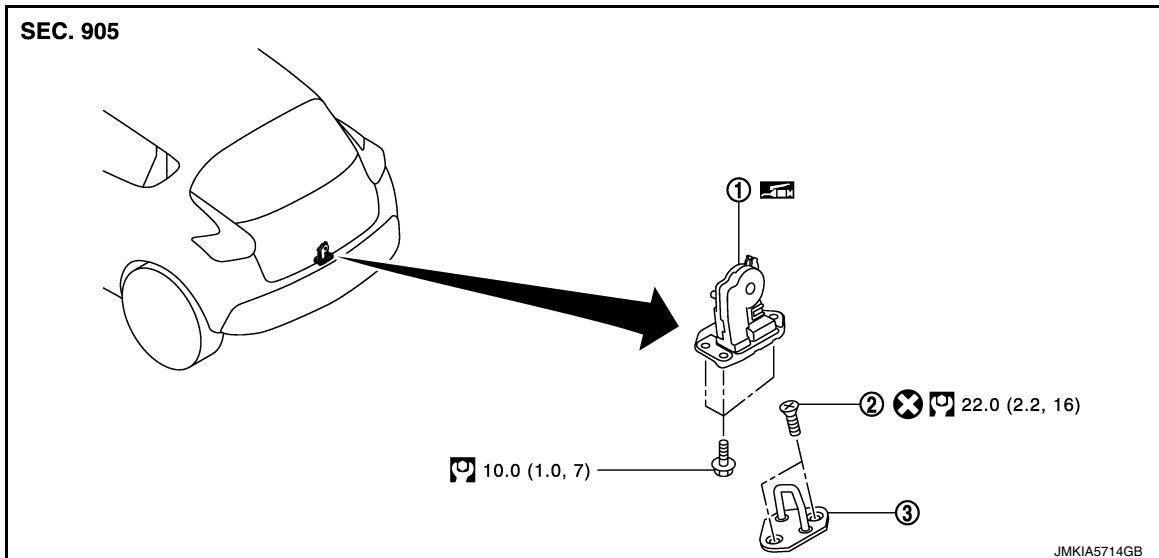

1. Back door lock assembly 2. TORX bolt 3. Back door striker

⊗ : Always replace after every disassembly.

Ⓜ : N·m (kg-m, ft-lb)

Ⓜ : Body grease

DOOR LOCK

DOOR LOCK : Removal and Installation

INFOID:000000012196743

REMOVAL

1. Remove the back door lower finisher. Refer to [INT-39, "BACK DOOR LOWER FINISHER : Removal and Installation"](#).
2. Remove back door lock assembly mounting bolts.
3. Disconnect back door lock connector, and then remove back door lock assembly.

INSTALLATION

Note the following item, and install in the reverse order of removal.

CAUTION:

After installation, check back door open/close, and lock/unlock operation.

EMERGENCY LEVER

EMERGENCY LEVER : Unlock procedures

INFOID:000000012196744

UNLOCK PROCEDURES

NOTE:

If back door lock cannot be unlocked due to a malfunction or battery discharge, follow the procedures to unlock back door.

1. Remove emergency lid. Refer to [INT-40, "EMERGENCY LID : Removal and Installation"](#).

BACK DOOR LOCK

< REMOVAL AND INSTALLATION >

[WITH INTELLIGENT KEY SYSTEM]

- From inside the vehicle, rotate emergency lever toward lower direction and unlock.

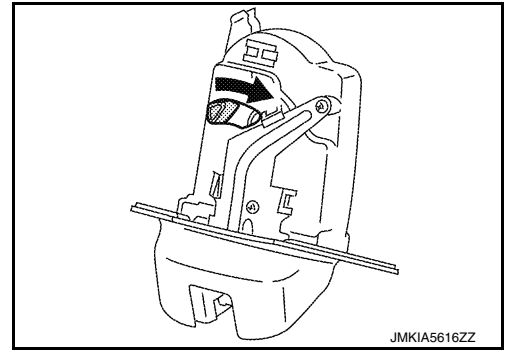

A
B
C
D
E
F
G
H
I
J
DLK
L
M
N
O
P

FUEL FILLER LID OPENER

< REMOVAL AND INSTALLATION >

[WITH INTELLIGENT KEY SYSTEM]

FUEL FILLER LID OPENER

Exploded View

INFOID:000000012196745

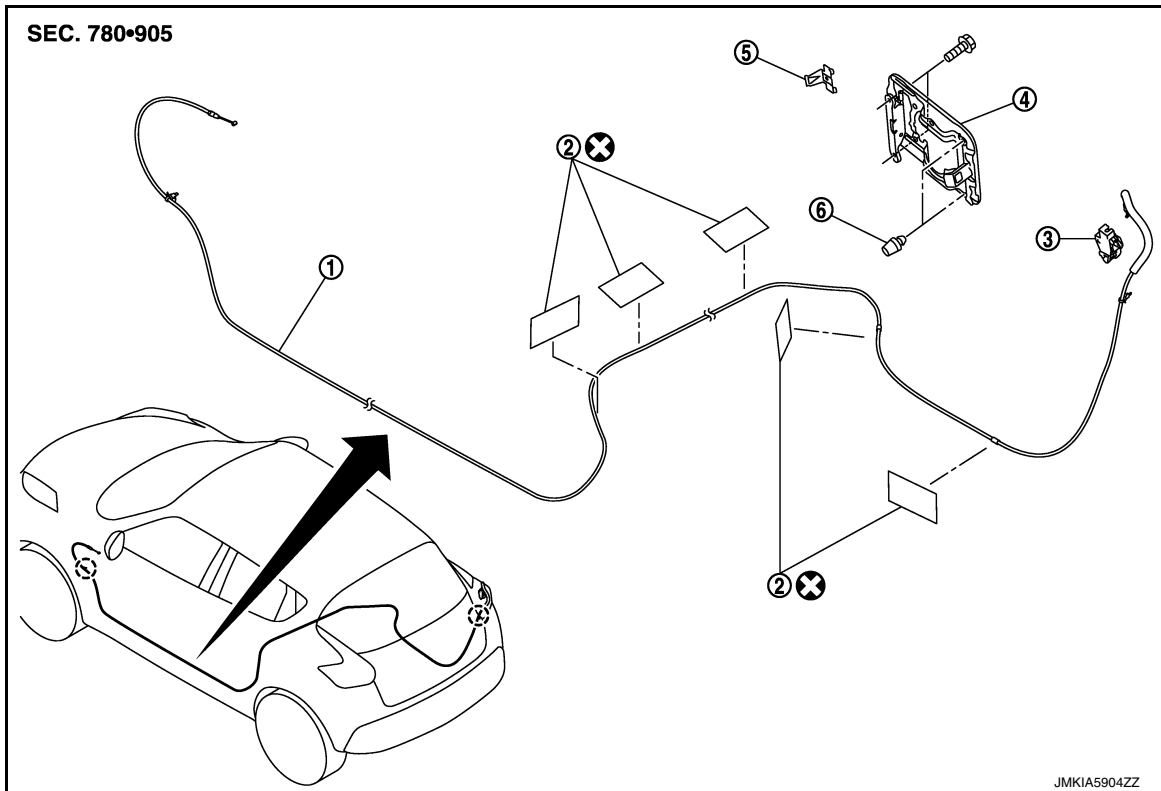

- | | | |
|---------------------------------|--------------------|----------------------------------|
| 1. Fuel filler lid opener cable | 2. Cable protector | 3. Fuel filler lid lock assembly |
| 4. Fuel filler lid assembly | 5. Spring | 6. Bumper rubber |

○ : Clip

⊗ : Always replace after every disassembly.

FUEL FILLER LID

FUEL FILLER LID : Removal and Installation

INFOID:000000012196746

REMOVAL

1. Fully open fuel filler lid.
2. Remove fuel mounting pin (1).

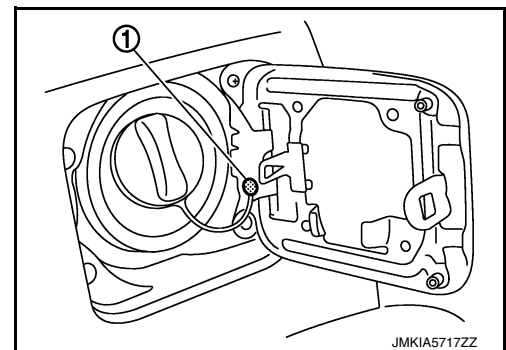

3. Remove mounting screws, and then remove fuel filler lid.

INSTALLATION

Note the following items, and install in the reverse order of removal.

FUEL FILLER LID OPENER

< REMOVAL AND INSTALLATION >

[WITH INTELLIGENT KEY SYSTEM]

CAUTION:

- After installation, check fuel filler lid assembly open/close, lock/unlock operation.
- After installation, apply the touch-up paint (the body color) onto the head of the mounting screws.

NOTE:

- The following table shows the specified values for checking normal installation status.
- Fitting adjustment cannot be performed.

Unit: mm (in)

	Clearance	Evenness
Fuel filler lid – Body side outer	2.0 – 4.0 (0.079 – 0.157)	(-1.0) – (+1.0) [(-0.039) – (+0.039)]

FUEL FILLER OPENER CABLE

FUEL FILLER OPENER CABLE : Removal and Installation

INFOID:000000012196747

REMOVAL

1. Remove hood lock control cable assembly from instrument lower panel (LH). Refer to [DLK-155, "HOOD LOCK CONTROL CABLE : Removal and Installation"](#).
2. Remove fuel filler lid opener cable (2) from fuel filler lid opener lever (1).

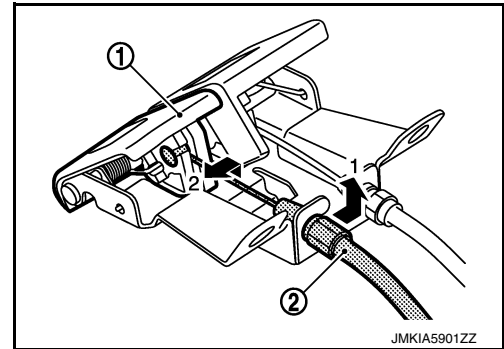

3. Remove front kicking plate inner (LH) and rear kicking plate inner (LH and RH). Refer to [INT-19, "KICKING PLATE INNER : Removal and Installation"](#).
4. Remove dash side finisher (LH). Refer to [INT-21, "DASH SIDE FINISHER : Removal and Installation"](#).
5. Remove center pillar lower garnish (LH). Refer to [INT-22, "CENTER PILLAR LOWER GARNISH : Removal and Installation"](#).
6. Remove luggage side lower finisher (RH). Refer to [INT-35, "LUGGAGE SIDE LOWER FINISHER : Removal and Installation"](#).
7. Remove fuel filler lid opener cable from fuel filler lid lock assembly. Refer to [DLK-168, "FUEL FILLER LID LOCK : Removal and Installation"](#).
8. Disengage each harness protector (1), and then remove fuel filler lid opener cable (2).

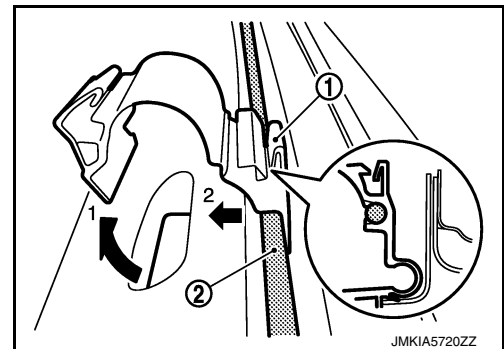

9. Remove fuel filler lid opener cable fixing clips, and then remove fuel filler lid opener cable.

INSTALLATION

Note the following item, and install in the reverse order of removal.

CAUTION:

After installation, check fuel filler lid assembly open/close, lock/unlock operation.

FUEL FILLER LID LOCK

FUEL FILLER LID OPENER

< REMOVAL AND INSTALLATION >

[WITH INTELLIGENT KEY SYSTEM]

FUEL FILLER LID LOCK : Removal and Installation

INFOID:000000012196748

REMOVAL

1. Fully open fuel filler lid.
2. Remove luggage side lower finisher (RH). Refer to [INT-35, "LUGGAGE SIDE LOWER FINISHER : Removal and Installation"](#).
3. Rotate and disengage fuel filler lid lock assembly, and then remove fuel filler lid lock assembly.

NOTE:

Operation is performed easily when rotating fuel filler lid lock from passenger room side.

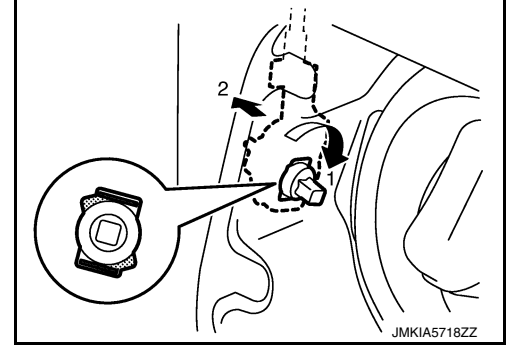

4. Disengage fuel filler lid opener cable (1). Remove fuel filler lid opener cable while pressing stopper pin (2).

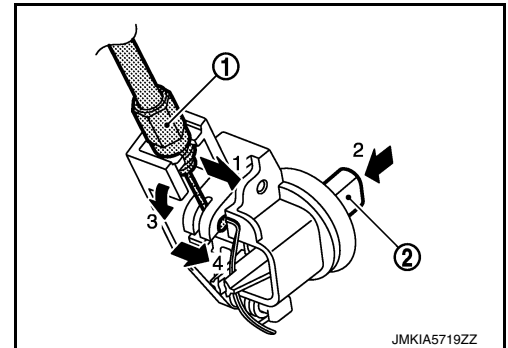

INSTALLATION

Note the following item, and install in the reverse order of removal.

CAUTION:

After installation, check fuel filler lid assembly open/close, lock/unlock operation.

DOOR SWITCH

< REMOVAL AND INSTALLATION >

[WITH INTELLIGENT KEY SYSTEM]

DOOR SWITCH

Exploded View

INFOID:000000012196749

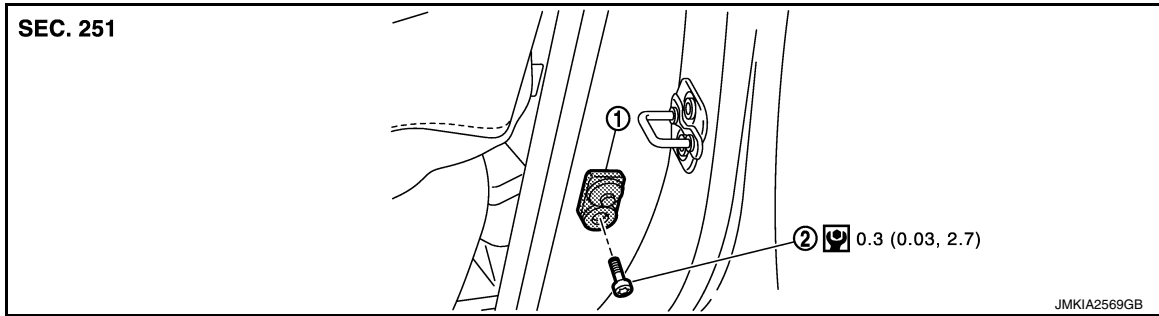

1. Door switch

2. TORX bolt

 : N·m (kg-m, in-lb)

Removal and Installation

INFOID:000000012196750

REMOVAL

Remove the TORX bolt (A), and then remove door switch (1).

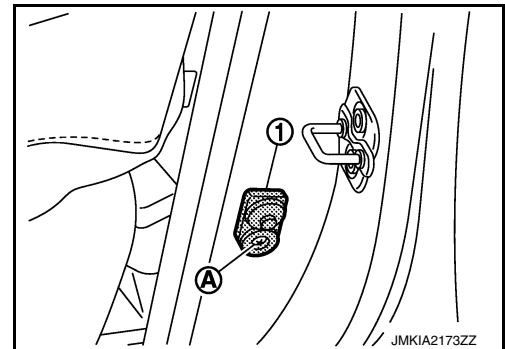

INSTALLATION

Install in the reverse order of removal.

A

B

C

D

E

F

G

H

I

J

DLK

L

M

N

O

P

INSIDE KEY ANTENNA

< REMOVAL AND INSTALLATION >

[WITH INTELLIGENT KEY SYSTEM]

INSIDE KEY ANTENNA INSTRUMENT CENTER

INSTRUMENT CENTER : Removal and Installation

INFOID:000000012196751

REMOVAL

1. Remove the multi display unit. Refer to [AV-231. "Removal and Installation"](#).
2. Remove the inside key antenna (instrument center) (1) mounting clip (A), and then remove inside key antenna (instrument center).

CAUTION:

Be careful not to drop mounting clip (A) into instrument panel.

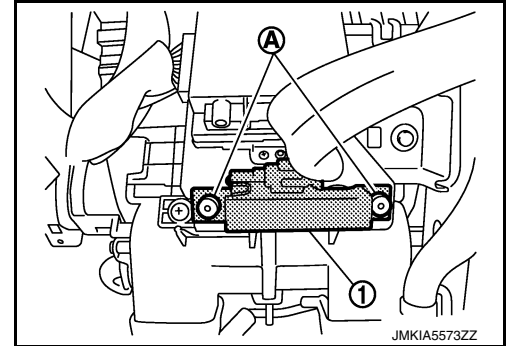

INSTALLATION

Install in the reverse order of removal.

LUGGAGE ROOM

LUGGAGE ROOM : Exploded View

INFOID:000000012196753

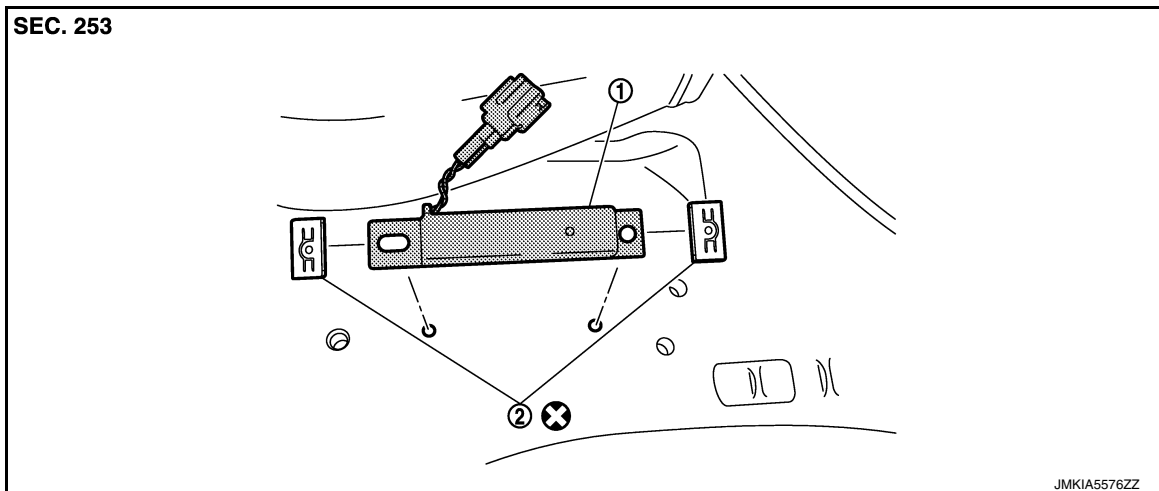

1. Inside key antenna (luggage room) 2. Clip

⊗ : Always replace after every disassembly.

LUGGAGE ROOM : Removal and Installation

INFOID:000000012196754

REMOVAL

1. Remove the luggage floor finisher. Refer to [INT-33. "Exploded View"](#).

INSIDE KEY ANTENNA

< REMOVAL AND INSTALLATION >

[WITH INTELLIGENT KEY SYSTEM]

2. Remove the inside key antenna (luggage room) (1) mounting clip RH (A).

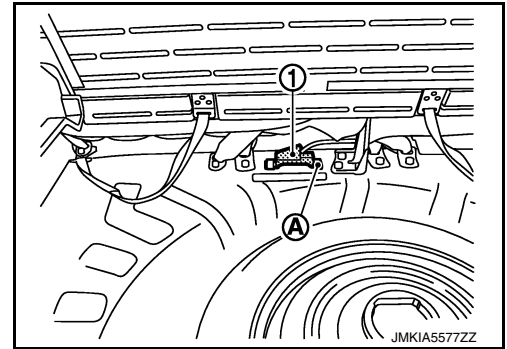

3. Disengage inside key antenna (luggage room) fixing clip using a flat-bladed screwdriver (A), and then pull out forward the inside key antenna (luggage room).

 : Pawl

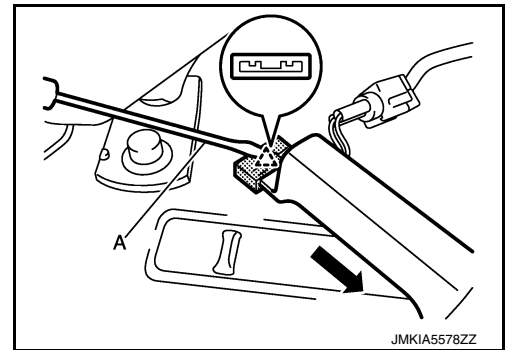

INSTALLATION

Install in the reverse order of removal.

CAUTION:

Visually check the clips for deformation and damage during installation.

Replace with new ones if necessary.

A
B
C
D
E
F
G
H
I
J
L
M
N
O
P

DLK

OUTSIDE KEY ANTENNA

< REMOVAL AND INSTALLATION >

[WITH INTELLIGENT KEY SYSTEM]

OUTSIDE KEY ANTENNA

DRIVER SIDE

DRIVER SIDE : Removal and Installation

INFOID:0000000012196755

REMOVAL

Remove the driver side outside handle. Refer to [DLK-158, "OUTSIDE HANDLE : Removal and Installation"](#).

INSTALLATION

Install in the reverse order of removal.

PASSENGER SIDE

PASSENGER SIDE : Removal and Installation

INFOID:0000000012196756

REMOVAL

Remove the passenger side outside handle. Refer to [DLK-158, "OUTSIDE HANDLE : Removal and Installation"](#).

INSTALLATION

Install in the reverse order of removal.

REAR BUMPER

REAR BUMPER : Removal and Installation

INFOID:0000000012196757

REMOVAL

1. Remove the rear bumper fascia. Refer to [EXT-23, "Removal and Installation"](#).
2. Remove the outside key antenna (rear bumper) (1) mounting clip (A), then remove outside key antenna (rear bumper).

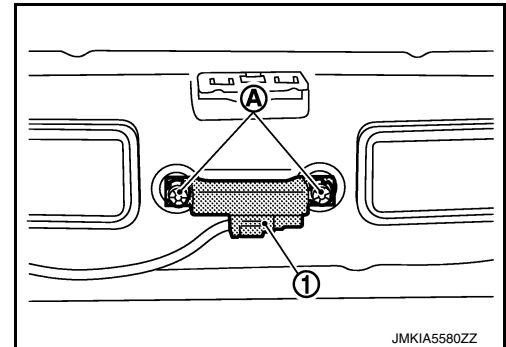

INSTALLATION

Install in the reverse order of removal.

INTELLIGENT KEY WARNING BUZZER

< REMOVAL AND INSTALLATION >

[WITH INTELLIGENT KEY SYSTEM]

INTELLIGENT KEY WARNING BUZZER

Removal and Installation

INFOID:000000012196758

REMOVAL

1. Remove the Intelligent Key warning buzzer (1) mounting bolt (A), and then remove the Intelligent Key warning buzzer.

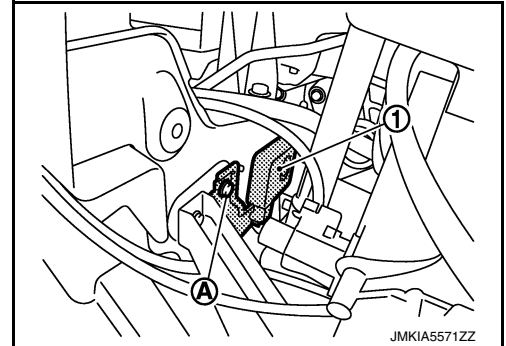

INSTALLATION

Install in the reverse order of removal.

A
B
C
D
E
F
G
H
I
J
L
M
N
O
P

DLK

REMOTE KEYLESS ENTRY RECEIVER

< REMOVAL AND INSTALLATION >

[WITH INTELLIGENT KEY SYSTEM]

REMOTE KEYLESS ENTRY RECEIVER

Removal and Installation

INFOID:000000012196759

REMOVAL

1. Remove the glove box assembly. Refer to [IP-13. "Removal and Installation"](#).
2. Remove the remote keyless entry receiver (1) mounting bolt (A), and then remove remote keyless entry receiver.

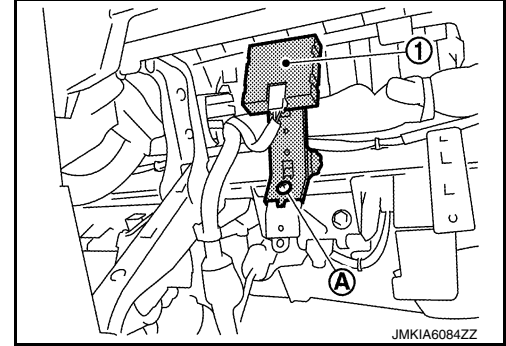

INSTALLATION

Install in the reverse order of removal.

INTELLIGENT KEY BATTERY

< REMOVAL AND INSTALLATION >

[WITH INTELLIGENT KEY SYSTEM]

INTELLIGENT KEY BATTERY

Removal and Installation

INFOID:000000012196760

1. Release the lock knob at the back of the Intelligent Key and remove the mechanical key.

2. Insert a remover tool (A) wrapped with a cloth into the slit of the corner and twist it to separate the upper part from the lower part.

CAUTION:

- Do not touch the circuit board or battery terminal.
- The key fob is water-resistant. However, if it does get wet, immediately wipe it dry.

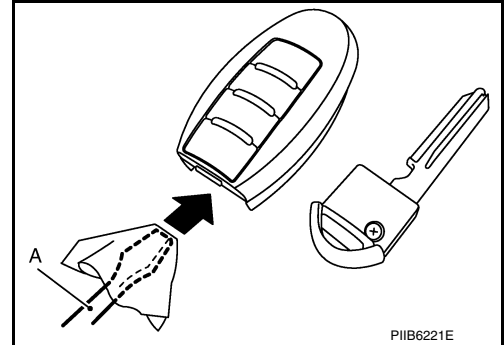

3. Replace the battery with new one.

Battery replacement

:Coin-type lithium battery (CR2025)

4. Align the tips of the upper and lower parts, and then push them together until it is securely closed.

CAUTION:

- When replacing battery, keep dirt, grease, and other foreign materials off the electrode contact area.
- After replacing the battery, check that all Intelligent Key functions work normally.

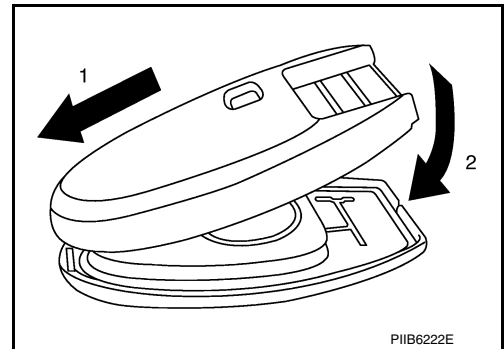

A
B
C
D
E
F
G
H
I
J
DLK
L
M
N
O
P