

SECTION **EXT**
EXTERIOR

A
B
C
D
E
F
G
H
I
J
EXT
L
M
N
O
P

CONTENTS

PRECAUTION	3	Exploded View	31
PRECAUTIONS	3	Removal and Installation	31
Precaution for Supplemental Restraint System (SRS) "AIR BAG" and "SEAT BELT PRE-TENSIONER"	3	SILL COVER	33
Precautions For Xenon Headlamp Service	3	Exploded View	33
Precaution for Procedure without Cowl Top Cover.....	4	Removal and Installation	33
Precautions for Removing Battery Terminal	4	FLOOR SIDE FAIRING	35
PREPARATION	5	Exploded View	35
PREPARATION	5	Removal and Installation	35
Special Service Tools	5	FILLET MOLDING	36
Commercial Service Tools	5	Exploded View	36
SYMPTOM DIAGNOSIS	6	FRONT FILLET MOLDING	36
SQUEAK AND RATTLE TROUBLE DIAGNOSES	6	FRONT FILLET MOLDING : Removal and Installation	36
Work Flow	6	REAR FILLET MOLDING	37
Inspection Procedure	8	REAR FILLET MOLDING : Removal and Installation	37
Diagnostic Worksheet	10	ROOF SIDE MOLDING	38
REMOVAL AND INSTALLATION	12	Exploded View	38
FRONT BUMPER	12	Removal and Installation	38
Exploded View	12	DOOR OUTSIDE MOLDING	41
Removal and Installation	17	Exploded View	41
REAR BUMPER	20	FRONT DOOR OUTSIDE MOLDING	41
Exploded View	20	FRONT DOOR OUTSIDE MOLDING : Removal and Installation	41
Removal and Installation	23	REAR DOOR OUTSIDE MOLDING	42
FRONT GRILLE	25	REAR DOOR OUTSIDE MOLDING : Removal and Installation	42
Exploded View	25	DOOR SASH TAPE	43
Removal and Installation	26	Exploded View	43
COWL TOP	29	FRONT DOOR SASH TAPE	43
Exploded View	29	FRONT DOOR SASH TAPE : Removal and Installation	43
Removal and Installation	30		
FENDER PROTECTOR	31		

REAR DOOR SASH TAPE	45	REAR SPOILER	49
REAR DOOR SASH TAPE : Removal and Instal- lation	45	Exploded View	49
REAR FENDER COVER	48	Removal and Installation	49
Exploded View	48	BACK DOOR FINISHER	51
Removal and Installation	48	Exploded View	51
		Removal and Installation	51

PRECAUTIONS

< PRECAUTION >

PRECAUTION

PRECAUTIONS

Precaution for Supplemental Restraint System (SRS) "AIR BAG" and "SEAT BELT PRE-TENSIONER"

INFOID:000000012199302

The Supplemental Restraint System such as "AIR BAG" and "SEAT BELT PRE-TENSIONER", used along with a front seat belt, helps to reduce the risk or severity of injury to the driver and front passenger for certain types of collision. This system includes seat belt switch inputs and dual stage front air bag modules. The SRS system uses the seat belt switches to determine the front air bag deployment, and may only deploy one front air bag, depending on the severity of a collision and whether the front occupants are belted or unbelted. Information necessary to service the system safely is included in the "SRS AIR BAG" and "SEAT BELT" of this Service Manual.

WARNING:

Always observe the following items for preventing accidental activation.

- To avoid rendering the SRS inoperative, which could increase the risk of personal injury or death in the event of a collision that would result in air bag inflation, it is recommended that all maintenance and repair be performed by an authorized NISSAN/INFINITI dealer.
- Improper repair, including incorrect removal and installation of the SRS, can lead to personal injury caused by unintentional activation of the system. For removal of Spiral Cable and Air Bag Module, see "SRS AIR BAG".
- Never use electrical test equipment on any circuit related to the SRS unless instructed to in this Service Manual. SRS wiring harnesses can be identified by yellow and/or orange harnesses or harness connectors.

PRECAUTIONS WHEN USING POWER TOOLS (AIR OR ELECTRIC) AND HAMMERS

WARNING:

Always observe the following items for preventing accidental activation.

- When working near the Air Bag Diagnosis Sensor Unit or other Air Bag System sensors with the ignition ON or engine running, never use air or electric power tools or strike near the sensor(s) with a hammer. Heavy vibration could activate the sensor(s) and deploy the air bag(s), possibly causing serious injury.
- When using air or electric power tools or hammers, always switch the ignition OFF, disconnect the battery or batteries, and wait at least 3 minutes before performing any service.

Precautions For Xenon Headlamp Service

INFOID:000000012996939

WARNING:

Comply with the following warnings to prevent any serious accident.

- Disconnect the battery cable (negative terminal) or the power supply fuse before installing, removing, or touching the xenon headlamp (bulb included). The xenon headlamp contains high-voltage generated parts.
- Never work with wet hands.
- Check the xenon headlamp ON-OFF status after assembling it to the vehicle. Never turn the xenon headlamp ON in other conditions. Connect the power supply to the vehicle-side connector. (Turning it ON outside the lamp case may cause fire or visual impairments.)
- Never touch the bulb glass immediately after turning it OFF. It is extremely hot.

CAUTION:

Comply with the following cautions to prevent any error and malfunction.

- Install the xenon bulb securely. (Insufficient bulb socket installation may melt the bulb, the connector, the housing, etc. by high-voltage leakage or corona discharge.)
- Never perform HID circuit inspection with a tester.
- Never touch the xenon bulb glass with hands. Never put oil and grease on it.
- Dispose of the used xenon bulb after packing it in thick vinyl without breaking it.
- Never wipe out dirt and contamination with organic solvent (thinner, gasoline, etc.).

A
B
C
D
E
F
G
H
I
J
EXT
L
M
N
O
P

PRECAUTIONS

< PRECAUTION >

Precaution for Procedure without Cowl Top Cover

INFOID:000000012199303

When performing the procedure after removing cowl top cover, cover the lower end of windshield with urethane, etc to prevent damage to windshield.

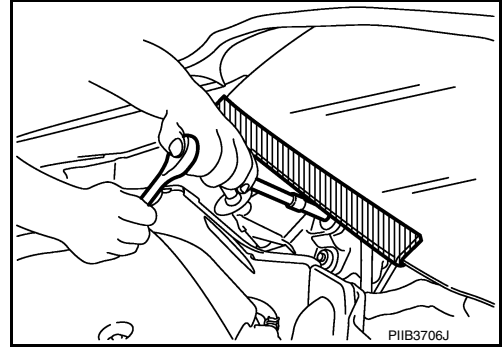

Precautions for Removing Battery Terminal

INFOID:000000012996941

When disconnecting the battery terminal, pay attention to the following.

- Always use a 12V battery as power source.
- Never disconnect battery terminal while engine is running.
- When removing the 12V battery terminal, turn OFF the ignition switch and wait at least 30 seconds.
- For vehicles with the engine listed below, remove the battery terminal after a lapse of the specified time:

D4D engine	: 20 minutes	YS23DDT	: 4 minutes
HRA2DDT	: 12 minutes	YS23DDTT	: 4 minutes
K9K engine	: 4 minutes	ZD30DDTi	: 60 seconds
M9R engine	: 4 minutes	ZD30DDTT	: 60 seconds
R9M engine	: 4 minutes		
V9X engine	: 4 minutes		
YD25DDTi	: 2 minutes		

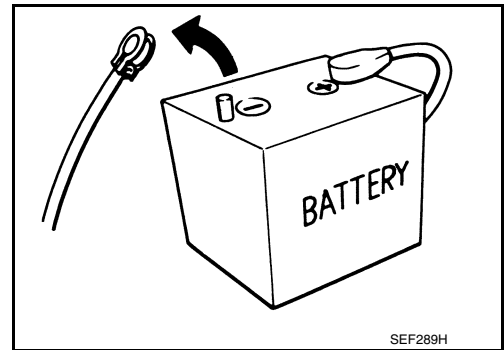

NOTE:

ECU may be active for several tens of seconds after the ignition switch is turned OFF. If the battery terminal is removed before ECU stops, then a DTC detection error or ECU data corruption may occur.

- After high-load driving, if the vehicle is equipped with the V9X engine, turn the ignition switch OFF and wait for at least 15 minutes to remove the battery terminal.

NOTE:

- Turbocharger cooling pump may operate in a few minutes after the ignition switch is turned OFF.
- Example of high-load driving
 - Driving for 30 minutes or more at 140 km/h (86 MPH) or more.
 - Driving for 30 minutes or more on a steep slope.
- For vehicles with the 2-batteries, be sure to connect the main battery and the sub battery before turning ON the ignition switch.

NOTE:

If the ignition switch is turned ON with any one of the terminals of main battery and sub battery disconnected, then DTC may be detected.

- After installing the 12V battery, always check "Self Diagnosis Result" of all ECUs and erase DTC.

NOTE:

The removal of 12V battery may cause a DTC detection error.

PREPARATION

< PREPARATION >

PREPARATION

PREPARATION

Special Service Tools

INFOID:000000012199305

The actual shapes of Kent-Moore tools may differ from those of special service tools illustrated here.

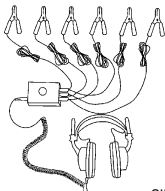
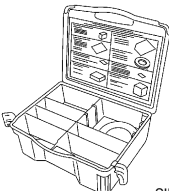
Tool number (Kent-Moore No.) Tool name	Description
<p>(J-39570) Chassis ear</p>  <p>SIIA0993E</p>	<p>Locates the noise</p>
<p>(J-50397) NISSAN Squeak and Rattle Kit</p>  <p>SIIA0994E</p>	<p>Repairs the cause of noise</p>

Commercial Service Tools

INFOID:000000012199306

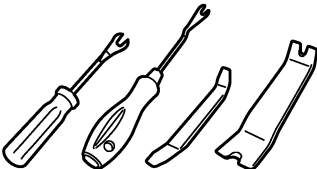
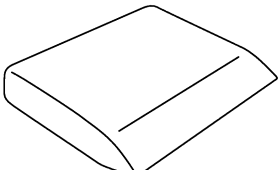
Tool name	Description
<p>Remover tool</p>  <p>JMKIA3050ZZ</p>	<p>Removes clips, pawls and metal clips</p>
<p>Squeegee</p>  <p>JMKIA5809ZZ</p>	<p>Paste up of the door sash tape</p>

A
B
C
D
E
F
G
H
I
J
EXT
L
M
N
O
P

SQUEAK AND RATTLE TROUBLE DIAGNOSES

< SYMPTOM DIAGNOSIS >

SYMPTOM DIAGNOSIS

SQUEAK AND RATTLE TROUBLE DIAGNOSES

Work Flow

INFOID:000000012199307

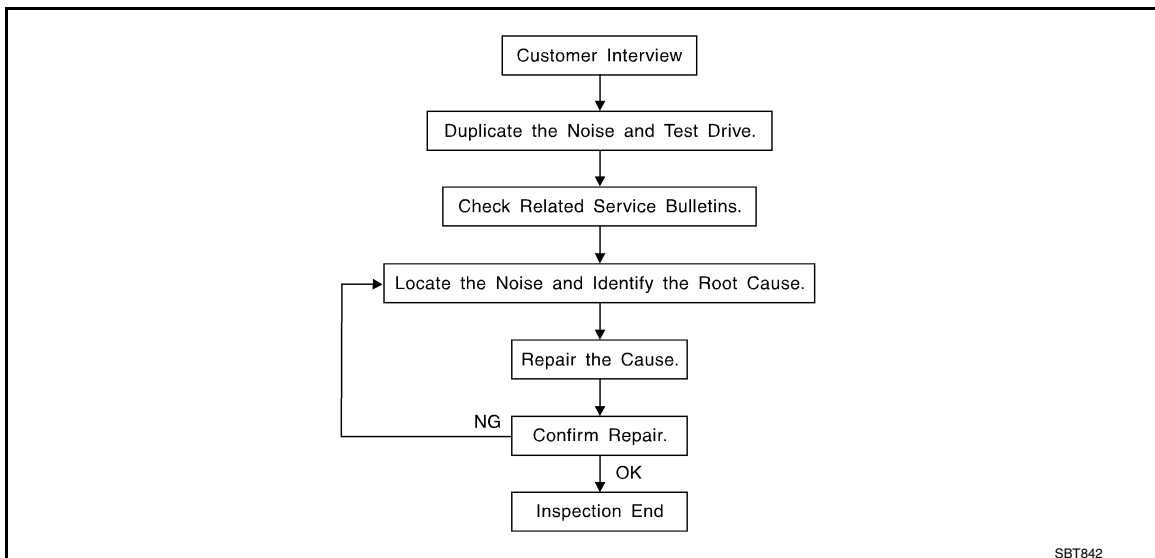

CUSTOMER INTERVIEW

Interview the customer if possible, to determine the conditions that exist when the noise occurs. Use the Diagnostic Worksheet during the interview to document the facts and conditions when the noise occurs and any customer comments. Refer to [EXT-10. "Diagnostic Worksheet"](#). This information is necessary to duplicate the conditions that exist when the noise occurs.

- The customer may not be able to provide a detailed description or the location of the noise. Attempt to obtain all the facts and conditions that exist when the noise occurs (or does not occur).
- If there is more than one noise in the vehicle, perform a diagnosis and repair the noise that the customer is concerned about. This can be accomplished by performing a test drive with the customer.
- After identifying the type of noise, isolate the noise in terms of its characteristics. The noise characteristics are provided so that the customer, service adviser, and technician use the same language when describing the noise.
- Squeak – (Like tennis shoes on a clean floor)
Squeak characteristics include the light contact / fast movement / brought on by road conditions / hard surfaces = high-pitched noise / softer surfaces = low-pitched noises / edge to surface = chirping
- Creak – (Like walking on an old wooden floor)
Creak characteristics include firm contact / slow movement/twisting with a rotational movement / pitch dependent on materials / often brought on by activity.
- Rattle – (Like shaking a baby rattle)
Rattle characteristics include fast repeated contact / vibration or similar movement / loose parts/missing clip or fastener / incorrect clearance.
- Knock – (Like a knock on a door)
Knock characteristics include hollow sounds / sometimes repeating / often brought on by driver action.
- Tick – (Like a clock second hand)
Tick characteristics include gentle contacting of light materials / loose components / can be caused by driver action or road conditions.
- Thump – (Heavy, muffled knock noise)
Thump characteristics include softer knock / dull sounds often brought on by activity.
- Buzz – (Like a bumblebee)
Buzz characteristics include high frequency rattle / firm contact.
- Often the degree of acceptable noise level varies depending upon the person. A noise that a technician may judge as acceptable may be very irritating to a customer.
- Weather conditions, especially humidity and temperature, may have a great effect on noise level.

DUPLICATE THE NOISE AND TEST DRIVE

SQUEAK AND RATTLE TROUBLE DIAGNOSES

< SYMPTOM DIAGNOSIS >

If possible, drive the vehicle with the customer until the noise is duplicated. Note any additional information on the Diagnostic Worksheet regarding the conditions or location of the noise. This information can be used to duplicate the same conditions when the repair is reconfirmed.

If the noise can be duplicated easily during the test drive, to help identify the source of the noise, try to duplicate the noise with the vehicle stopped by doing one or all of the following items:

- 1) Close a door.
 - 2) Tap or push/pull around the area where the noise appears to be coming from.
 - 3) Rev the engine.
 - 4) Use a floor jack to recreate vehicle "twist".
 - 5) At idle, apply engine load (electrical load, half-clutch on M/T models, drive position on A/T models).
 - 6) Raise the vehicle on a hoist and hit a tire with a rubber hammer.
- Drive the vehicle and attempt to duplicate the conditions the customer states exist when the noise occurs.
 - If it is difficult to duplicate the noise, drive the vehicle slowly on an undulating or rough road to stress the vehicle body.

CHECK RELATED SERVICE BULLETINS

After verifying the customer concern or symptom, check ASIST for Technical Service Bulletins (TSBs) related to the concern or symptom.

If a TSB relates to the symptom, follow the procedure to repair the noise.

LOCATE THE NOISE AND IDENTIFY THE ROOT CAUSE

1. Narrow down the noise to a general area. To help pinpoint the source of the noise, use a listening tool (Chassis ear: J-39570, engine ear, and mechanics stethoscope).
2. Narrow down the noise to a more specific area and identify the cause of the noise by:
 - Removing the component(s) in the area that is / are suspected to be the cause of the noise. Do not use too much force when removing clips and fasteners, otherwise clips and fasteners can be broken or lost during the repair, resulting in the creation of new noise.
 - Tapping or pushing/pulling the component(s) that is / are suspected to be the cause of the noise. Do not tap or push/pull the component(s) with excessive force, otherwise the noise is eliminated only temporarily.
 - Feeling for a vibration by hand by touching the component(s) that is / are suspected to be the cause of the noise.
 - Placing a piece of paper between components that are suspected to be the cause of the noise.
 - Looking for loose components and contact marks.
Refer to [EXT-8. "Inspection Procedure"](#).

REPAIR THE CAUSE

- If the cause is a loose component, tighten the component securely.
- If the cause is insufficient clearance between components:
 - Separate components by repositioning or loosening and retightening the components, if possible.
 - Insulate components with a suitable insulator such as urethane pads, foam blocks, felt cloth tape, or urethane tape. A NISSAN Squeak and Rattle Kit (J-50397) is available through the authorized NISSAN Parts Department.

CAUTION:

Never use excessive force as many components are constructed of plastic and may be damaged.

NOTE:

Always check with the Parts Department for the latest parts information.

The following materials are contained in the NISSAN Squeak and Rattle Kit (J-50397) are listed on the inside cover of the kit; and can each be ordered separately as needed.

URETHANE PADS [1.5 mm (0.059 in) thick]

Insulates connectors, harness, etc.

- 76268-9E005: 100 × 135 mm (3.937 × 5.315 in)
- 76884-71L01: 60 × 85 mm (2.362 × 3.346 in)
- 76884-71L02: 15 × 25 mm (0.591 × 0.984 in)

INSULATOR (Foam blocks)

Insulates components from contact. Can be used to fill space behind a panel.

- 73982-9E000: 45 mm (1.772 in) thick, 50 × 50 mm (1.969 × 1.969 in)
- 73982-50Y00: 10 mm (0.394 in) thick, 50 × 50 mm (1.969 × 1.969 in)

INSULATOR (Light foam block)

80845-71L00: 30 mm (1.181 in) thick, 30 × 50 mm (1.181 × 1.969 in)

FELT CLOTH TAPE

SQUEAK AND RATTLE TROUBLE DIAGNOSES

< SYMPTOM DIAGNOSIS >

Used to insulate where movement does not occur. Ideal for instrument panel applications.

- 68370-4B000: 15 × 25 mm (0.591 × 0.984 in) pad
- 68239-13E00: 5 mm (0.197 in) wide tape roll

The following materials, not found in the kit, can also be used to repair squeaks and rattles.

UHMW (TEFLON) TAPE

Insulates where slight movement is present. Ideal for instrument panel applications.

SILICONE GREASE

Used in place of UHMW tape that is visible or does not fit. Only lasts a few months.

SILICONE SPRAY

Used when grease cannot be applied.

DUCT TAPE

Used to eliminate movement.

CONFIRM THE REPAIR

After repair is complete, test drive the vehicle to confirm that the cause of noise is repaired by test driving the vehicle. Operate the vehicle under the same conditions as when the noise originally occurred. Refer to the notes on the Diagnostic Worksheet.

Inspection Procedure

INFOID:000000012199308

Refer to Table of Contents for specific component removal and installation information.

INSTRUMENT PANEL

Most incidents are caused by contact and movement between:

1. The cluster lid A and instrument panel
2. Acrylic lens and combination meter housing
3. Instrument panel to front pillar garnish
4. Instrument panel to windshield
5. Instrument panel mounting pins
6. Wiring harnesses behind the combination meter
7. A/C defroster duct and duct joint

These incidents can usually be located by tapping or moving the components to duplicate the noise or by pressing on the components while driving to stop the noise. Most of these incidents can be repaired by applying felt cloth tape or silicon spray (in hard to reach areas). Urethane pads can be used to insulate wiring harness.

CAUTION:

Never use silicone spray to isolate a squeak or rattle. If the area is saturated with silicone, the recheck of repair becomes impossible.

CENTER CONSOLE

Components to check include:

1. Shifter assembly cover to finisher
2. A/C control unit and cluster lid C
3. Wiring harnesses behind audio and A/C control unit

The instrument panel repair and isolation procedures also apply to the center console.

DOORS

Check the following items:

1. Finisher and inner panel making a slapping noise
2. Inside handle escutcheon connection to door finisher
3. Wiring harnesses tapping
4. Door striker out of alignment causing a popping noise on starts and stops

Tapping, moving the components, or pressing on them while driving to duplicate the conditions can isolate many of these incidents. The areas can usually be insulated with felt cloth tape or insulator foam blocks from the NISSAN Squeak and Rattle Kit (J-50397) to repair the noise.

TRUNK

Trunk noises are often caused by a loose jack or loose items put into the trunk by the customer.

In addition check for the following items:

SQUEAK AND RATTLE TROUBLE DIAGNOSES

< SYMPTOM DIAGNOSIS >

1. Trunk lid dumpers out of adjustment
2. Trunk lid striker out of adjustment
3. Trunk lid torsion bars knocking together
4. A loose license plate or bracket

Most of these incidents can be repaired by adjusting, securing, or insulating the item(s) or component(s) causing the noise.

SUNROOF/HEADLINING

Noises in the sunroof / headlining area can often be traced to one of the following items:

1. Sunroof lid, rail, linkage, or seals making a rattle or light knocking noise
2. Sunvisor shaft shaking in the holder
3. Front or rear windshield touching headlining and squeaking

Again, pressing on the components to stop the noise while duplicating the conditions can isolate most of these incidents. Repairs usually consist of insulating with felt cloth tape.

SEATS

When isolating seat noise it is important to note the position the seat is in and the load placed on the seat when the noise occurs. These conditions should be duplicated when verifying and isolating the cause of the noise.

Causes of seat noise include:

1. Headrest rods and holder
2. A squeak between the seat pad cushion and frame
3. The rear seatback lock and bracket

These noises can be isolated by moving or pressing on the suspected components while duplicating the conditions under which the noise occurs. Most of these incidents can be repaired by repositioning the component or applying urethane tape to the contact area.

UNDERHOOD

Some interior noise may be caused by components under the hood or on the engine wall. The noise is then transmitted into the passenger compartment.

Causes of transmitted underhood noise include:

1. Any component mounted to the engine wall
2. Components that pass through the engine wall
3. Engine wall mounts and connectors
4. Loose radiator mounting pins
5. Hood bumpers out of adjustment
6. Hood striker out of adjustment

These noises can be difficult to isolate since they cannot be reached from the interior of the vehicle. The best method is to secure, move, or insulate one component at a time and test drive the vehicle. Also, engine RPM or load can be changed to isolate the noise. Repairs can usually be made by moving, adjusting, securing, or insulating the component causing the noise.

A
B
C
D
E
F
G
H
I
J
L
M
N
O
P

EXT

SQUEAK AND RATTLE TROUBLE DIAGNOSES

< SYMPTOM DIAGNOSIS >

Diagnostic Worksheet

INFOID:000000012199309



SQUEAK & RATTLE DIAGNOSTIC WORKSHEET

Dear Nissan Customer:

We are concerned about your satisfaction with your Nissan vehicle. Repairing a squeak or rattle sometimes can be very difficult. To help us fix your Nissan right the first time, please take a moment to note the area of the vehicle where the squeak or rattle occurs and under what conditions. You may be asked to take a test drive with a service advisor or technician to ensure we confirm the noise you are hearing.

I. WHERE DOES THE NOISE COME FROM? (circle the area of the vehicle)

The illustrations are for reference only, and may not reflect the actual configuration of your vehicle.

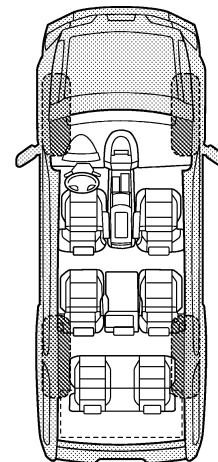
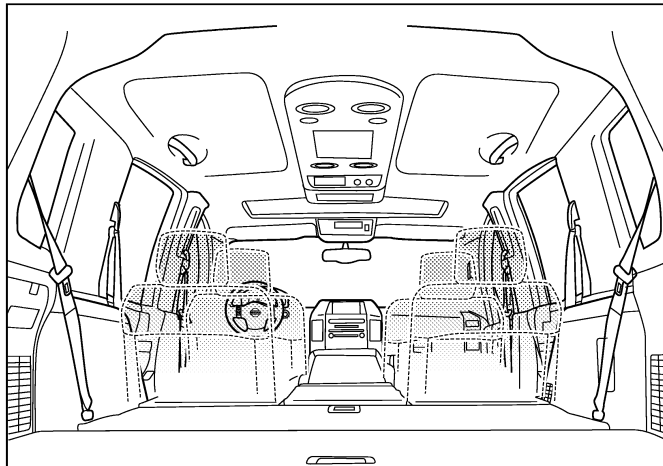
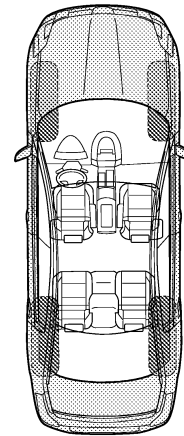
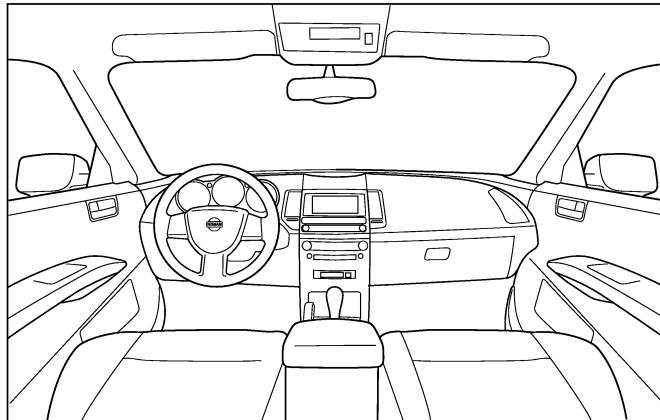

Continue to page 2 of the worksheet and briefly describe the location of the noise or rattle. In addition, please indicate the conditions which are present when the noise occurs.

PIIB8740E

SQUEAK AND RATTLE TROUBLE DIAGNOSES

< SYMPTOM DIAGNOSIS >

SQUEAK & RATTLE DIAGNOSTIC WORKSHEET - page 2

Briefly describe the location where the noise occurs:

II. WHEN DOES IT OCCUR? (please check the boxes that apply)

- | | |
|-------------------------------------------------------|--------------------------------------------------------|
| <input type="checkbox"/> anytime | <input type="checkbox"/> after sitting out in the rain |
| <input type="checkbox"/> 1st time in the morning | <input type="checkbox"/> when it is raining or wet |
| <input type="checkbox"/> only when it is cold outside | <input type="checkbox"/> dry or dusty conditions |
| <input type="checkbox"/> only when it is hot outside | <input type="checkbox"/> other: |

III. WHEN DRIVING:

- through driveways
- over rough roads
- over speed bumps
- only about ____ mph
- on acceleration
- coming to a stop
- on turns: left, right or either (circle)
- with passengers or cargo
- other: _____
- after driving ____ miles or ____ minutes

IV. WHAT TYPE OF NOISE

- squeak (like tennis shoes on a clean floor)
- creak (like walking on an old wooden floor)
- rattle (like shaking a baby rattle)
- knock (like a knock at the door)
- tick (like a clock second hand)
- thump (heavy, muffled knock noise)
- buzz (like a bumble bee)

TO BE COMPLETED BY DEALERSHIP PERSONNEL

Test Drive Notes:

	YES	NO	Initials of person performing
Vehicle test driven with customer	<input type="checkbox"/>	<input type="checkbox"/>	_____
- Noise verified on test drive	<input type="checkbox"/>	<input type="checkbox"/>	_____
- Noise source located and repaired	<input type="checkbox"/>	<input type="checkbox"/>	_____
- Follow up test drive performed to confirm repair	<input type="checkbox"/>	<input type="checkbox"/>	_____

VIN: _____ Customer Name: _____
W.O.# _____ Date: _____

This form must be attached to Work Order

PIIB8742E

A
B
C
D
E
F
G
H
I
J
EXT
L
M
N
O
P

FRONT BUMPER

< REMOVAL AND INSTALLATION >

REMOVAL AND INSTALLATION

FRONT BUMPER

Exploded View

INFOID:000000012199310

EXCEPT FOR NISMO AND NISMO RS

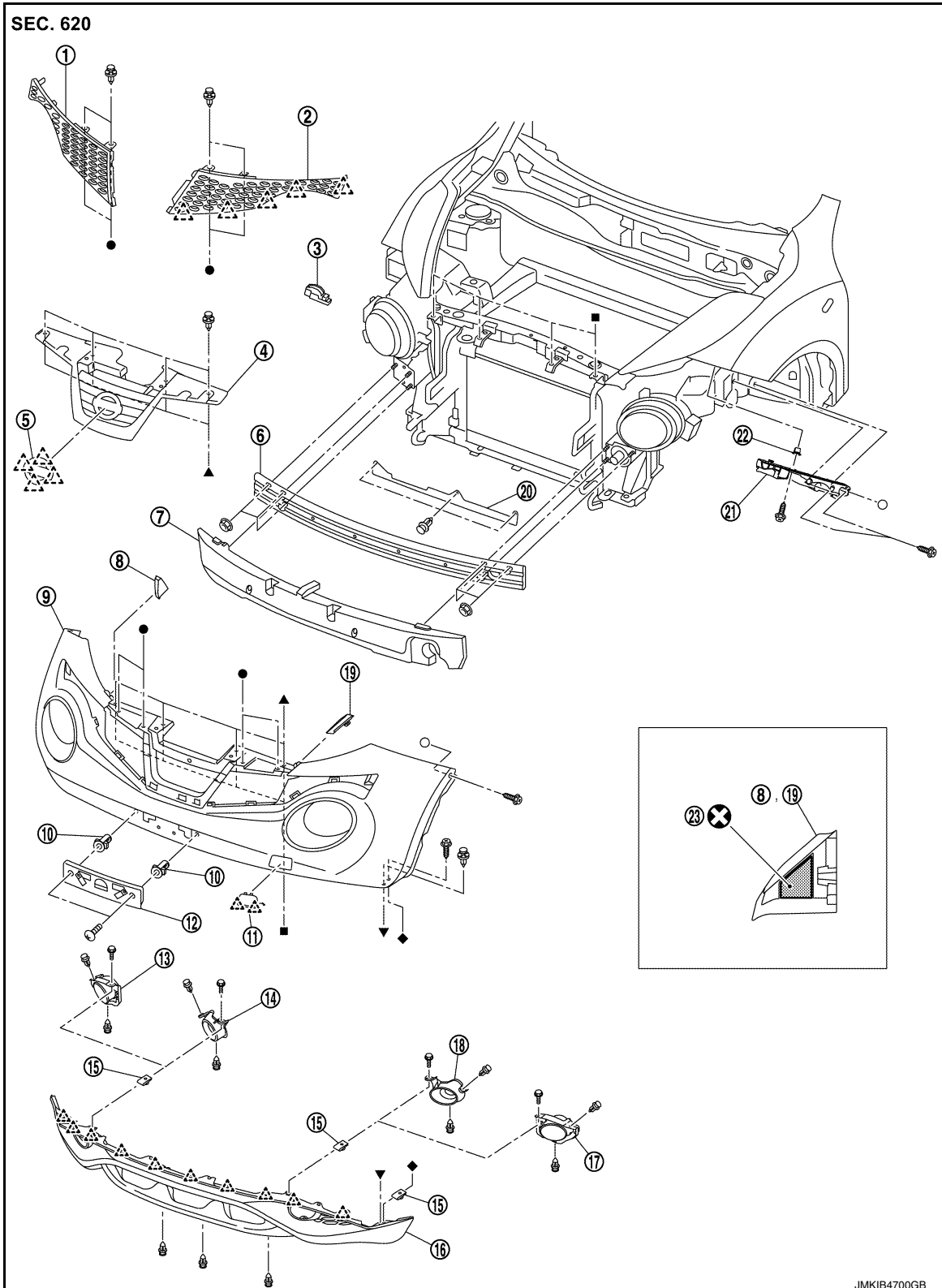

FRONT BUMPER

< REMOVAL AND INSTALLATION >

- | | | | |
|--------------------------------------------------------|--------------------------------------------------------|----------------------------------------------------|---|
| 1. Front side grille RH | 2. Front side grille LH | 3. Bumper side bracket RH | A |
| 4. Front center grille | 5. Emblem | 6. Bumper reinforcement | |
| 7. Bumper energy absorber | 8. Bumper end rubber RH | 9. Bumper fascia | |
| 10. Screw grommet | 11. Bumper bracket cover | 12. License plate bracket | B |
| 13. Front fog lamp bracket RH
(with front fog lamp) | 14. Bumper finisher RH
(without front fog lamp) | 15. U nut | |
| 16. Bumper fascia lower | 17. Front fog lamp bracket LH
(with front fog lamp) | 18. Bumper finisher LH
(without front fog lamp) | C |
| 19. Bumper end rubber LH | 20. Bumper retainer lower | 21. Bumper side bracket LH | |
| 22. Screw grommet | 23. Double-sided tape
[t: 1.2 mm (0.047 in)] | | D |

 : Pawl

 : Always replace after every disassembly.

●, ▲, ■, ▼, ◆, ○: Indicates that the part is connected at points with same symbol in actual vehicle.

NISMO

E

F

G

H

I

J

EXT

L

M

N

O

P

FRONT BUMPER

< REMOVAL AND INSTALLATION >

SEC. 620

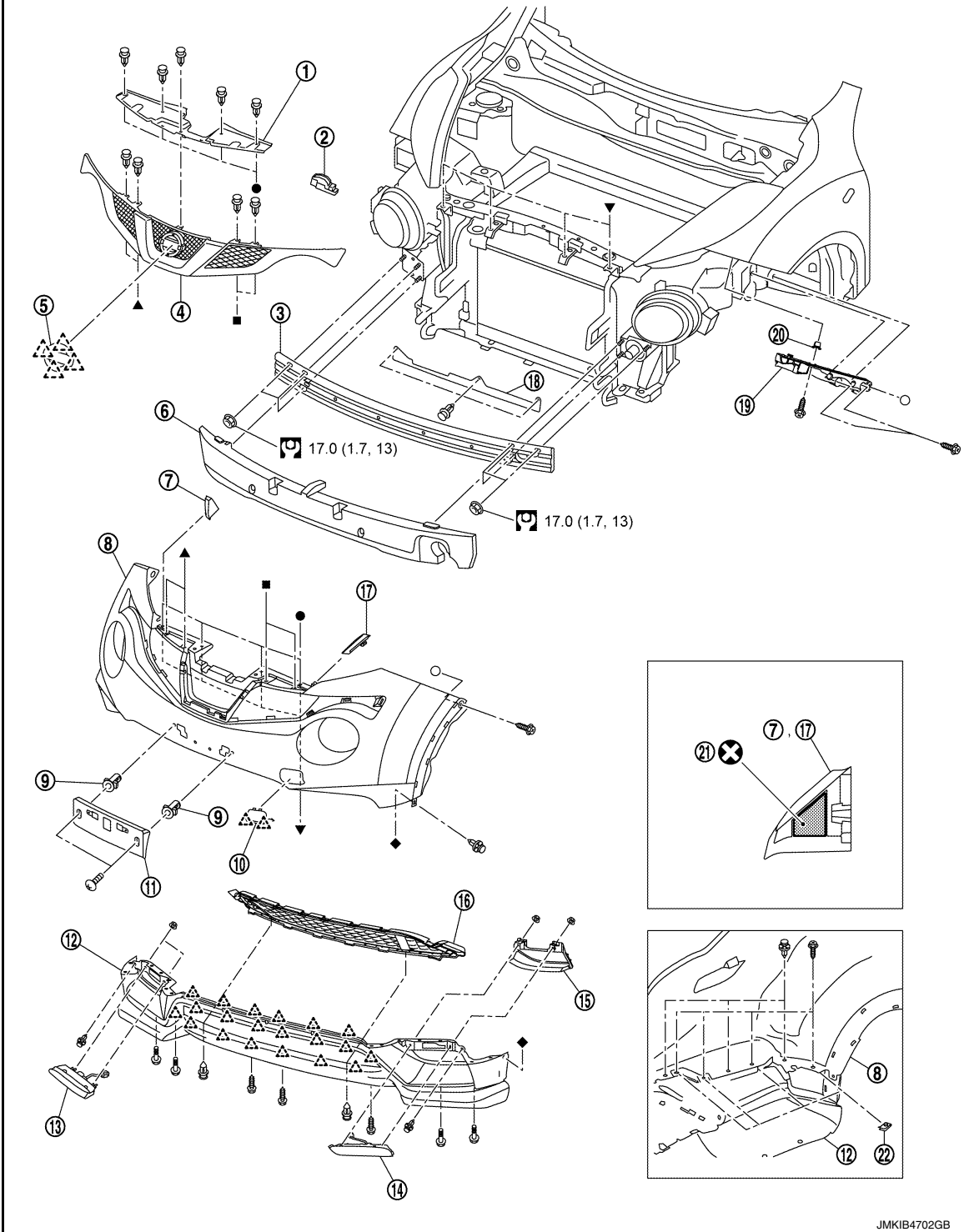

JMKIB4702GB

- | | | |
|------------------------------|------------------------------|---------------------------|
| 1. Front upper grille | 2. Bumper side bracket RH | 3. Bumper reinforcement |
| 4. Front grille | 5. Emblem | 6. Bumper energy absorber |
| 7. Bumper end rubber RH | 8. Bumper fascia | 9. Screw grommet |
| 10. Bumper bracket cover | 11. License plate bracket | 12. Bumper fascia lower |
| 13. Daytime running light RH | 14. Daytime running light LH | 15. Front bumper finisher |
| 16. Front bumper grille | 17. Bumper end rubber LH | 18. Bumper retainer lower |

FRONT BUMPER

< REMOVAL AND INSTALLATION >

19. Bumper side bracket LH

20. Screw grommet

21. Double-sided tape
[t: 1.2 mm (0.047 in)]

22. U nut

 : Pawl

 : Always replace after every disassembly.

 : N·m (kg-m, ft-lb)

●, ▲, ■, ▼, ◆, ○: Indicates that the part is connected at points with same symbol in actual vehicle.

NISMO RS

A
B
C
D
E
F
G
H
I
J
L
M
N
O
P

EXT

FRONT BUMPER

< REMOVAL AND INSTALLATION >

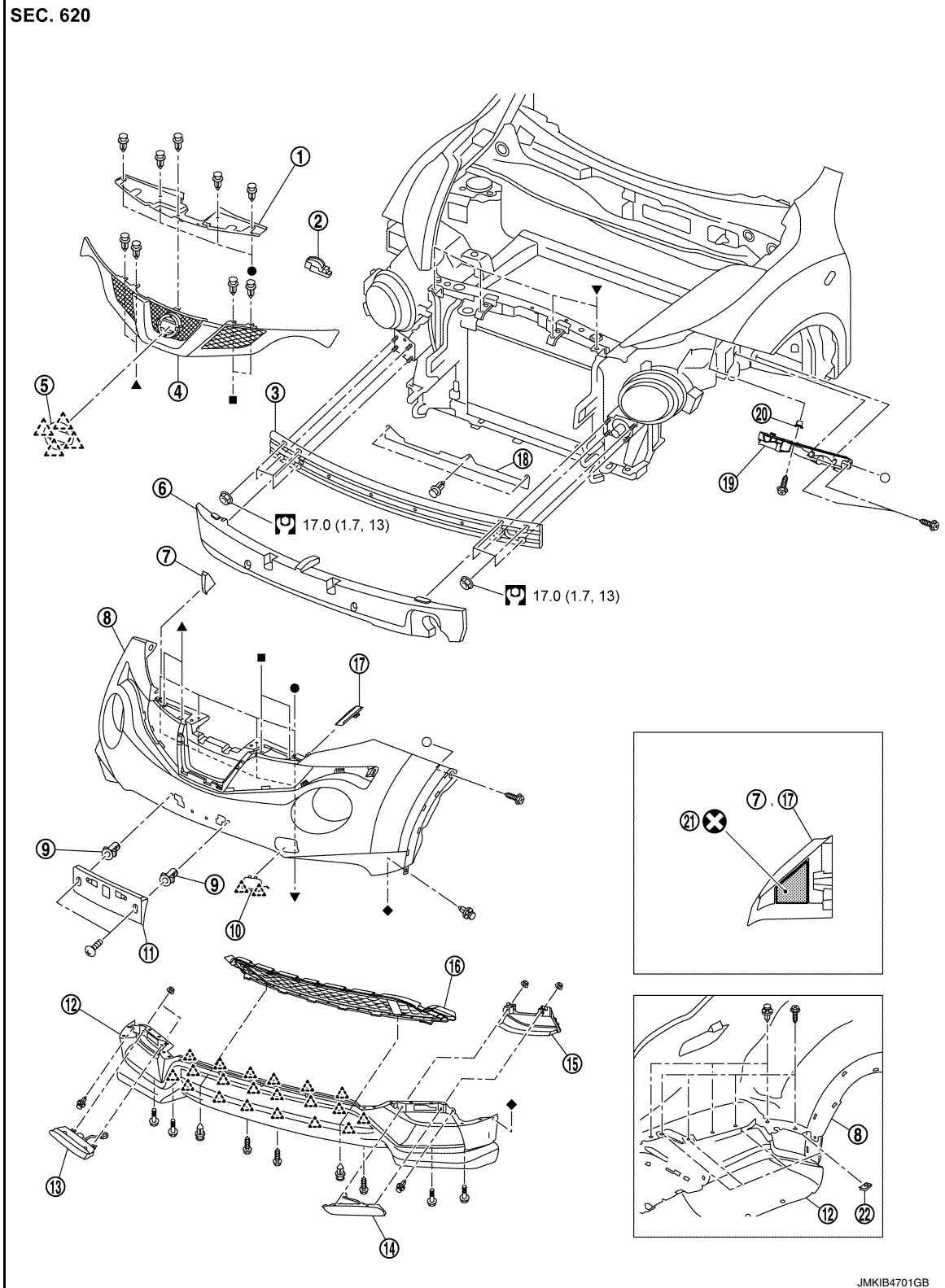

JMKIB4701GB

- | | | |
|------------------------------|------------------------------|---------------------------|
| 1. Front upper grille | 2. Bumper side bracket RH | 3. Bumper reinforcement |
| 4. Front grille | 5. Emblem | 6. Bumper energy absorber |
| 7. Bumper end rubber RH | 8. Bumper fascia | 9. Screw grommet |
| 10. Bumper bracket cover | 11. License plate bracket | 12. Bumper fascia lower |
| 13. Daytime running light RH | 14. Daytime running light LH | 15. Front bumper finisher |
| 16. Front bumper grille | 17. Bumper end rubber LH | 18. Bumper retainer lower |

FRONT BUMPER

< REMOVAL AND INSTALLATION >

19. Bumper side bracket LH 20. Screw grommet 21. Double-sided tape
[t: 1.2 mm (0.047 in)]

22. U nut

 : Pawl

 : Always replace after every disassembly.

 : N·m (kg-m, ft-lb)

●, ▲, ■, ▼, ◆, ○: Indicates that the part is connected at points with same symbol in actual vehicle.

Removal and Installation

INFOID:000000012199311

CAUTION:

Bumper fascia is made of resin. Never apply strong force to it, and be careful to prevent contact with oil.

REMOVAL

1. Fully open hood assembly.
2. Remove fixing clips (A) of bumper upper side.

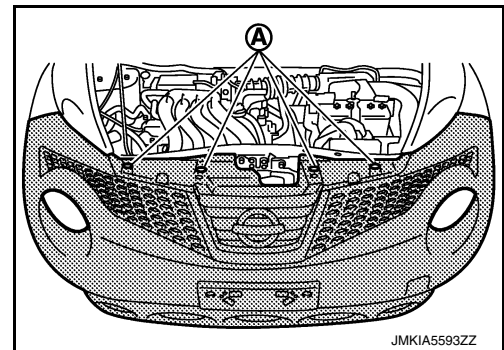

3. Remove front fillet molding front side. Refer to [EXT-36, "FRONT FILLET MOLDING : Removal and Installation"](#).
4. Remove bumper fascia fixing screws (A) (LH and RH).

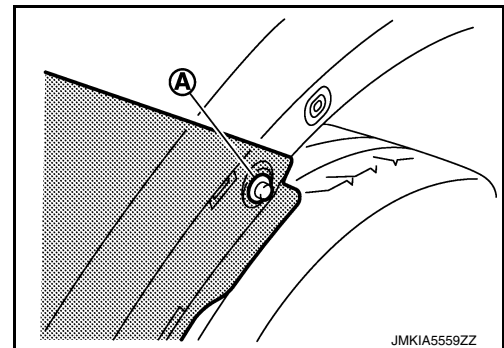

5. Remove air guide mounting bolts, and then remove air guide (LH and RH). Refer to [EXT-31, "Exploded View"](#).
6. Remove fixing clips of bumper lower side. (except for NISMO and NISMO RS)
7. Remove fixing screws of bumper lower side. (NISMO and NISMO RS)
8. Pull bumper fascia side toward the vehicle side to disengage the fitting of bumper side bracket and bumper fascia side according to the numerical order 1→3 as shown by the arrows in the figure.

FRONT BUMPER

< REMOVAL AND INSTALLATION >

- Except for NISMO and NISMO RS

CAUTION:

When removing bumper fascia assembly, 2 workers are required so as to prevent it from dropping.

 : Pawl

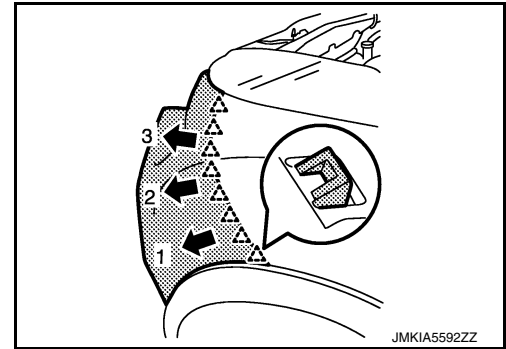

- NISMO and NISMO RS

CAUTION:

When removing bumper fascia assembly, 2 workers are required so as to prevent it from dropping.

 : Pawl

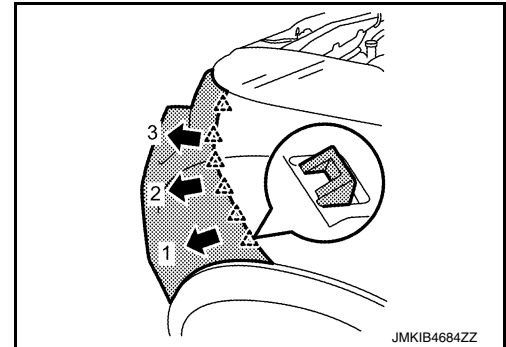

9. Disconnect front fog lamp harness connectors. (with front fog lamp)
10. Disconnect daytime running light harness connectors. (with daytime running light)
11. Remove bumper fascia assembly.
12. Remove the following parts after removing bumper fascia assembly.
 - Daytime running light (LH and RH). Refer to [EXL-101, "Removal and Installation"](#). (with daytime running light)
 - Front fog lamp (LH and RH). Refer to [EXL-102, "Removal and Installation"](#). (with front fog lamp)
 - Bumper finisher (LH and RH). (without front fog lamp)
 - Front grille. Refer to [EXT-26, "Removal and Installation"](#).
 - Bumper fascia lower.
 - Bumper end rubber (LH and RH).
 - Bumper bracket cover.
 - License plate bracket.
 - Front bumper finisher. (NISMO and NISMO RS)
 - Front bumper grille. (NISMO and NISMO RS)
13. Remove bumper energy absorber.
14. Remove bumper reinforcement mounting nuts, and then remove bumper reinforcement.
15. Remove bumper retainer lower fixing clips, and then remove bumper retainer lower.
16. Remove bumper side bracket fixing screws, and then remove bumper side bracket.

INSTALLATION

Note the following items, and then install in the reverse order of removal.

NOTE:

- The following table shows the specified values for checking normal installation status.
- Fitting adjustment cannot be performed.

FRONT BUMPER

< REMOVAL AND INSTALLATION >

Except for NISMO and NISMO RS

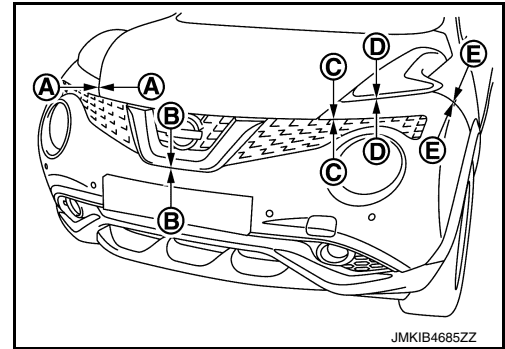

A
B
C
D
E
F
G
H

Portion		Clearance	Surface height difference
Bumper fascia assembly – Hood	A – A	2.0 – 6.0 mm (0.079 – 0.236 in)	(–2.5) – (+1.5) mm [(–0.098) – (+0.059) in]
Bumper fascia assembly – Front center grille	B – B	0.3 – 2.7 mm (0.012 – 0.106 in)	—
Bumper fascia assembly – Front side grille	C – C	0.3 – 2.7 mm (0.012 – 0.106 in)	—
Bumper fascia assembly – Front combination lamp	D – D	0.5 – 3.5 mm (0.020 – 0.138 in)	—
Bumper fascia assembly – Front fender	E – E	0.3 – 1.0 mm (0.012 – 0.039 in)	(–0.3) – (+1.7) mm [(–0.012) – (+0.067) in]

NISMO and NISMO RS

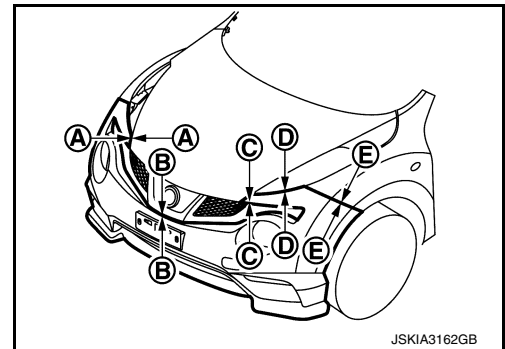

I
J
EXT
L

Portion		Clearance	Surface height difference
Bumper fascia assembly – Hood	A – A	2.0 – 6.0 mm (0.079 – 0.236 in)	(–2.0) – (+1.0) mm [(–0.079) – (+0.039) in]
Bumper fascia assembly – Front grille	B – B	0.3 – 2.7 mm (0.012 – 0.106 in)	—
	C – C	0.5 – 1.5 mm (0.020 – 0.059 in)	0.0 – 1.0 mm (0.000 – 0.039 in)
Bumper fascia assembly – Front combination lamp	D – D	0.5 – 3.5 mm (0.020 – 0.138 in)	—
Bumper fascia assembly – Front fender	E – E	0.3 – 1.0 mm (0.012 – 0.039 in)	(–0.3) – (+1.7) mm [(–0.012) – (+0.067) in]

M
N
O
P

REAR BUMPER

< REMOVAL AND INSTALLATION >

REAR BUMPER

Exploded View

INFOID:000000012199312

EXCEPT FOR NISMO AND NISMO RS

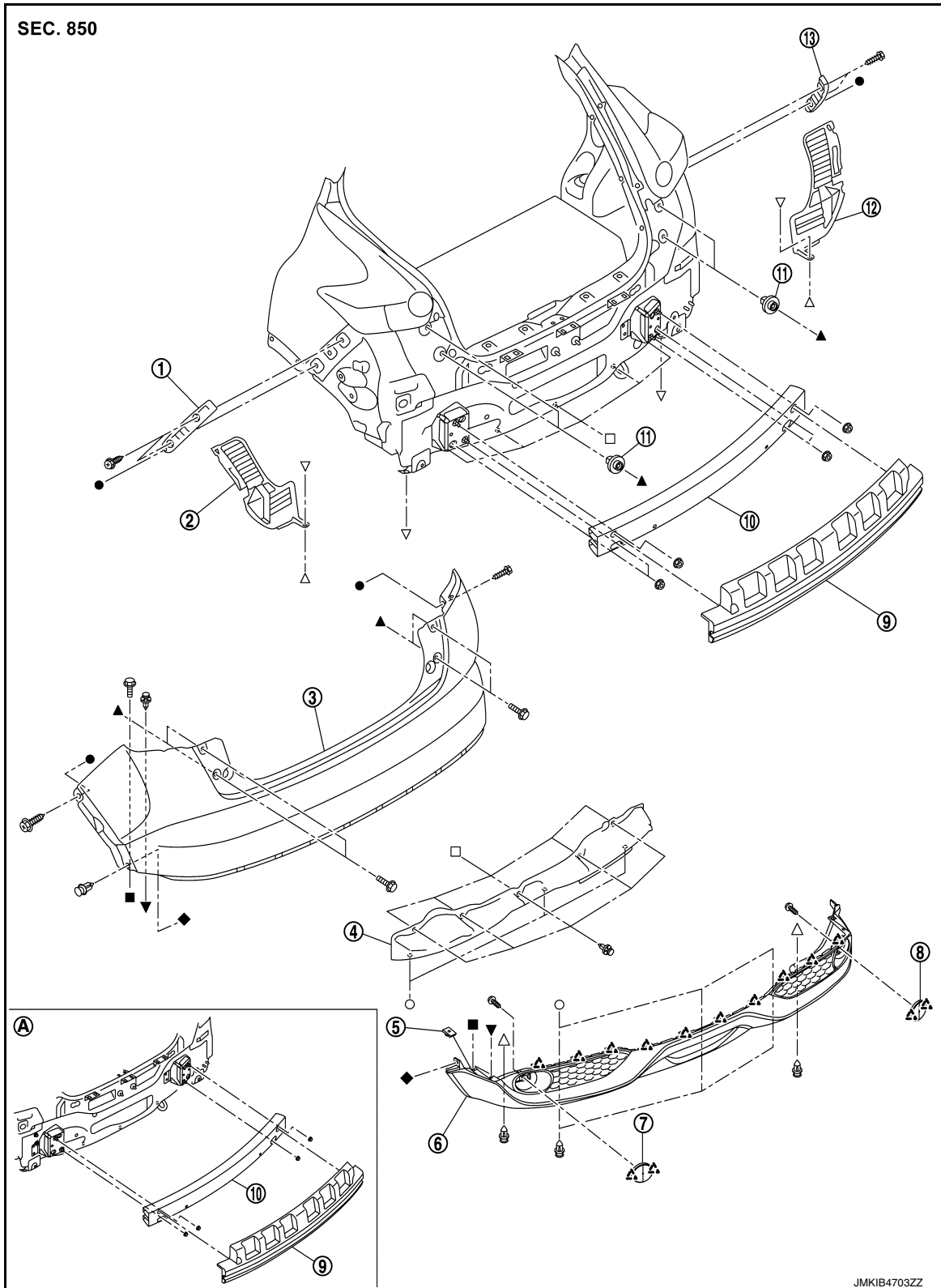

REAR BUMPER

< REMOVAL AND INSTALLATION >

- | | | |
|----------------------------|------------------------|---------------------------|
| 1. Bumper side bracket LH | 2. Bumper closing LH | 3. Bumper fascia assembly |
| 4. Rear panel lower | 5. U nut | 6. Bumper fascia lower |
| 7. Reflex reflector LH | 8. Reflex reflector RH | 9. Bumper energy absorber |
| 10. Bumper reinforcement | 11. Screw grommet | 12. Bumper closing RH |
| 13. Bumper side bracket RH | | |

A. : 4WD models

 : Pawl

●, ▲, ■, ▼, ◆, ○, △, □, ▽: Indicates that the part is connected at points with same symbol in actual vehicle.

NISMO AND NISMO RS

A

B

C

D

E

F

G

H

I

J

EXT

L

M

N

O

P

REAR BUMPER

< REMOVAL AND INSTALLATION >

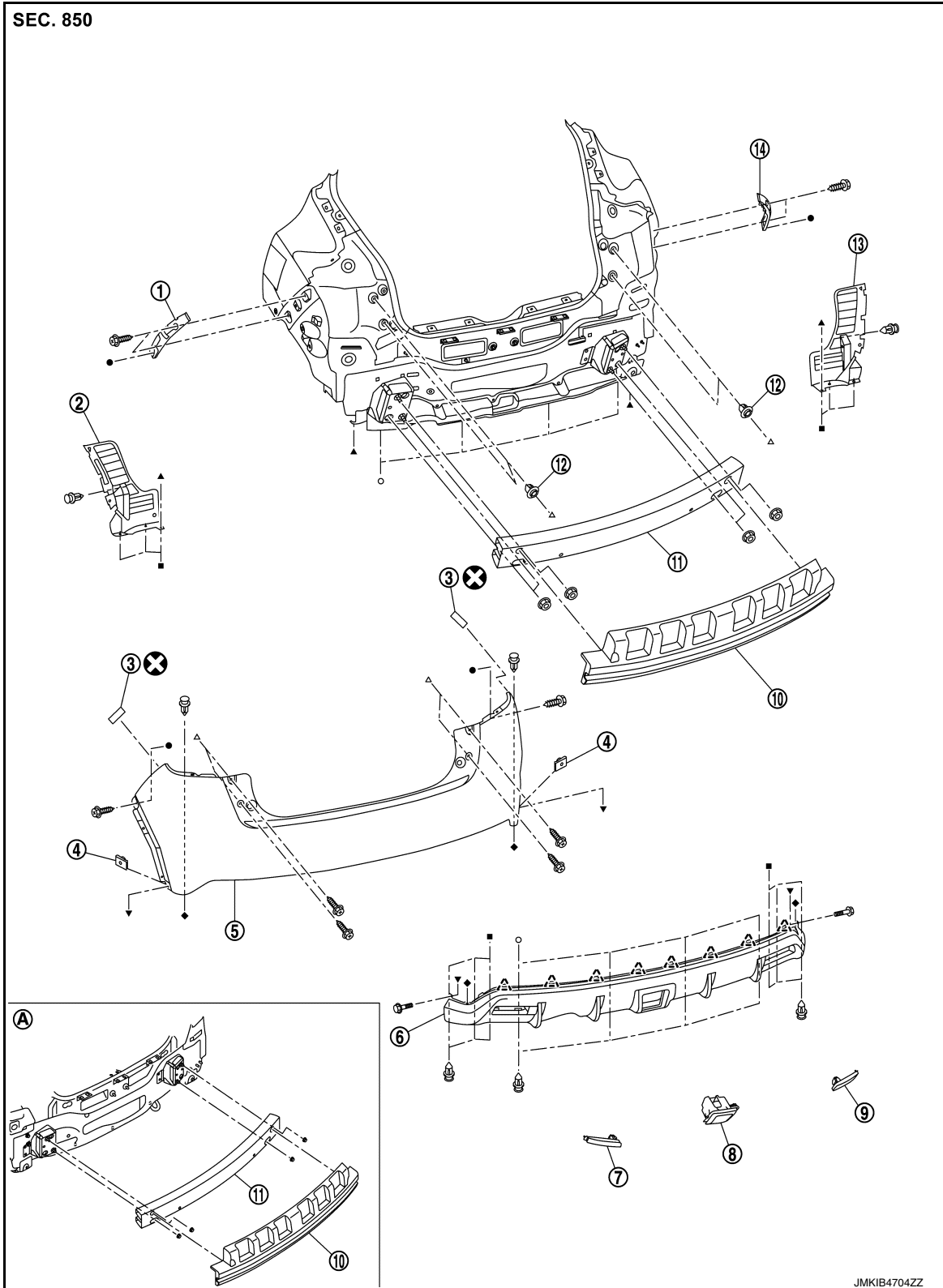

- | | | |
|----------------------------|--------------------------|------------------------|
| 1. Bumper side bracket LH | 2. Bumper closing LH | 3. Bumper spacer |
| 4. U nut | 5. Bumper fascia | 6. Bumper fascia lower |
| 7. Reflex reflector LH | 8. Rear fog lamp housing | 9. Reflex reflector RH |
| 10. Bumper energy absorber | 11. Bumper reinforcement | 12. Screw grommet |
| 13. Bumper closing RH | 14. Bumper stay RH | |
- A. : 4WD models

REAR BUMPER

< REMOVAL AND INSTALLATION >

 : Pawl

 : Always replace after every disassembly.

●, ▲, ■, ▼, ◆, ○, △: Indicates that the part is connected at points with same symbol in actual vehicle.

Removal and Installation

INFOID:000000012199313

CAUTION:

Bumper fascia is made of resin. Never apply strong force to it, and be careful to prevent contact with oil.

REMOVAL

1. Fully open back door.
2. Remove bumper fascia fixing screws of rear combination lamp lower side (LH and RH).
3. Remove rear fillet molding rear side. Refer to [EXT-37. "REAR FILLET MOLDING : Removal and Installation"](#).
4. Remove bumper closing (LH and RH).
5. Remove fixing clips of bumper lower side.
6. Remove bumper fascia fixing screws (A) (LH and RH).

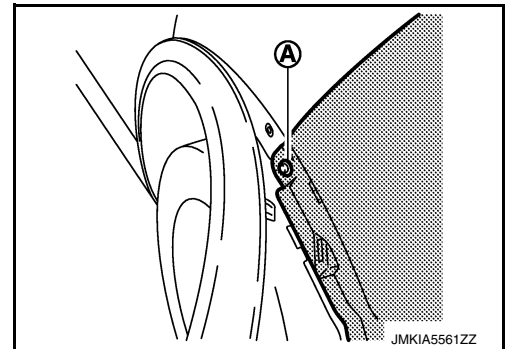

7. Pull bumper fascia side toward the vehicle side to disengage the fitting of bumper side bracket and bumper fascia side according to the numerical order 1→3 as shown by the arrows in the figure.

CAUTION:

When removing bumper fascia, 2 workers are required so as to prevent it from dropping.

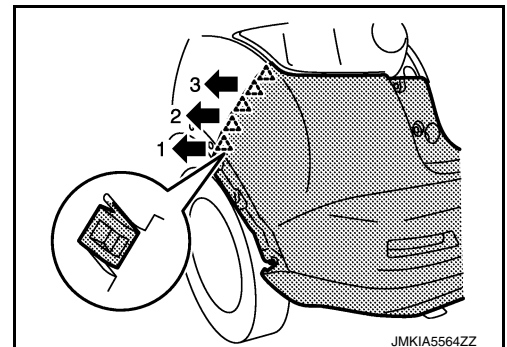

8. Remove bumper fascia.
9. Remove the following parts after removing bumper fascia.
 - Reflex reflector (LH and RH). Refer to [EXL-116. "Removal and Installation"](#).
 - Bumper fascia lower
 - Rear fog lamp housing (NISMO and NISMO RS). Refer to [EXL-115. "Removal and Installation"](#).
10. Remove bumper energy absorber.
11. Remove bumper reinforcement mounting nuts, and then remove bumper reinforcement.
12. Remove rear panel lower.
13. Remove bumper side bracket fixing screws, and then remove bumper side bracket (LH and RH).

INSTALLATION

Note the following items, and then install in the reverse order of removal.

NOTE:

- The following table shows the specified values for checking normal installation status.
- Fitting adjustment cannot be performed.

REAR BUMPER

< REMOVAL AND INSTALLATION >

Except for NISMO and NISMO RS

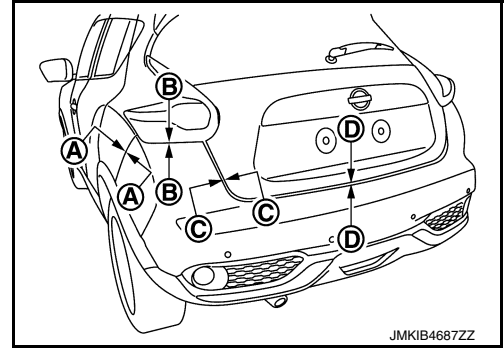

Portion		Clearance	Surface height difference
Bumper fascia assembly – Rear fender	A – A	0.3 – 1.1 mm (0.012 – 0.043 in)	(–0.3) – (+1.7) mm [(–0.012) – (+0.067) in]
Bumper fascia assembly – Rear combination lamp	B – B	0.2 – 2.8 mm (0.008 – 0.110 in)	—
Bumper fascia assembly – Back door	C – C	3.0 – 7.0 mm (0.118 – 0.276 in)	0.0 – 4.0 mm (0.000 – 0.157 in)
	D – D	6.0 – 10.0 mm (0.236 – 0.394 in)	—

NISMO and NISMO RS

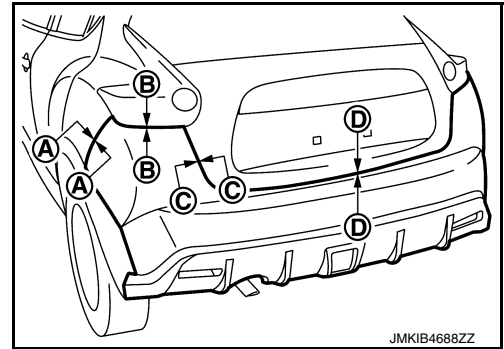

Portion		Clearance	Surface height difference
Bumper fascia assembly – Rear fender	A – A	0.0 – 1.0 mm (0.000 – 0.039 in)	(–0.3) – (+1.7) mm [(–0.012) – (+0.067) in]
Bumper fascia assembly – Rear combination lamp	B – B	0.2 – 3.0 mm (0.008 – 0.118 in)	—
Bumper fascia assembly – Back door	C – C	3.0 – 7.0 mm (0.118 – 0.276 in)	0.0 – 4.0 mm (0.000 – 0.157 in)
	D – D	6.0 – 10.0 mm (0.236 – 0.394 in)	0.0 – 4.0 mm (0.000 – 0.157 in)

FRONT GRILLE

< REMOVAL AND INSTALLATION >

FRONT GRILLE

Exploded View

INFOID:000000012199314

EXCEPT FOR NISMO AND NISMO RS

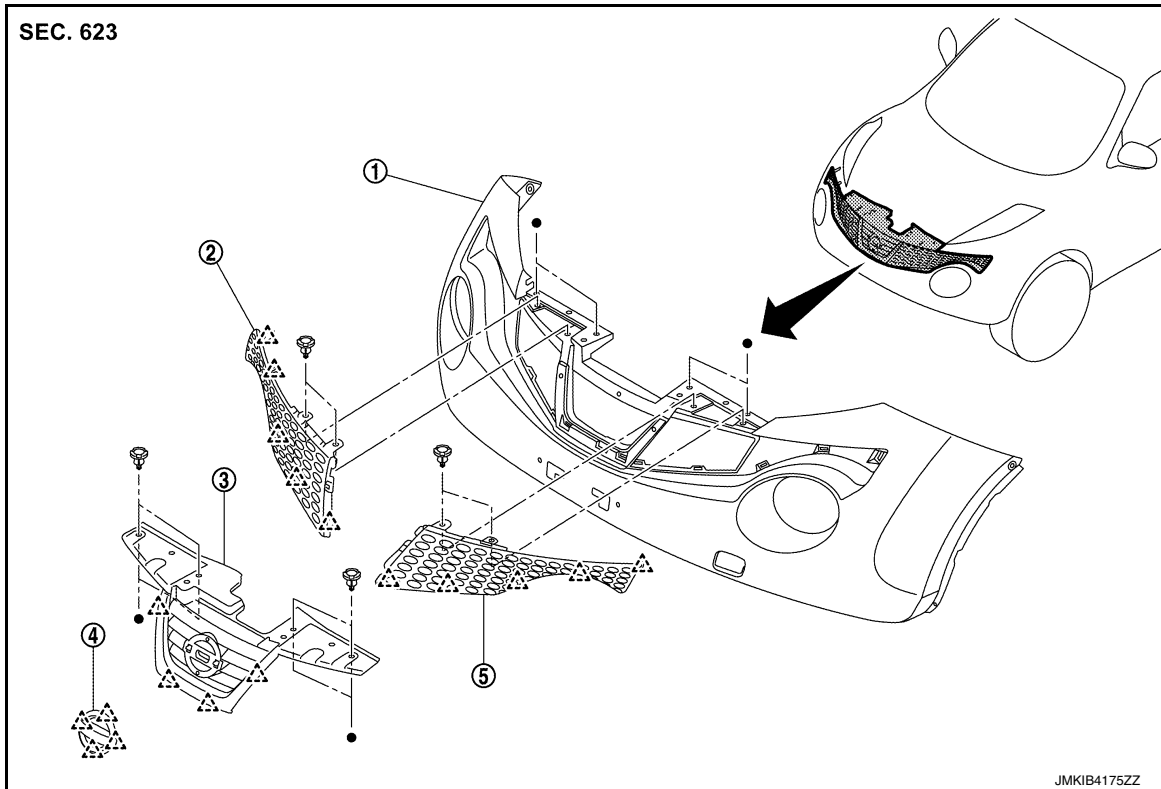

1. Bumper fascia

2. Front side grille RH

3. Front center grille

4. Emblem

5. Front side grille LH

△ : Pawl

● : Indicates that the part is connected at points with same symbol in actual vehicle.

NISMO AND NISMO RS

A
B
C
D
E
F
G
H
I
J

EXT

L
M
N
O
P

FRONT GRILLE

< REMOVAL AND INSTALLATION >

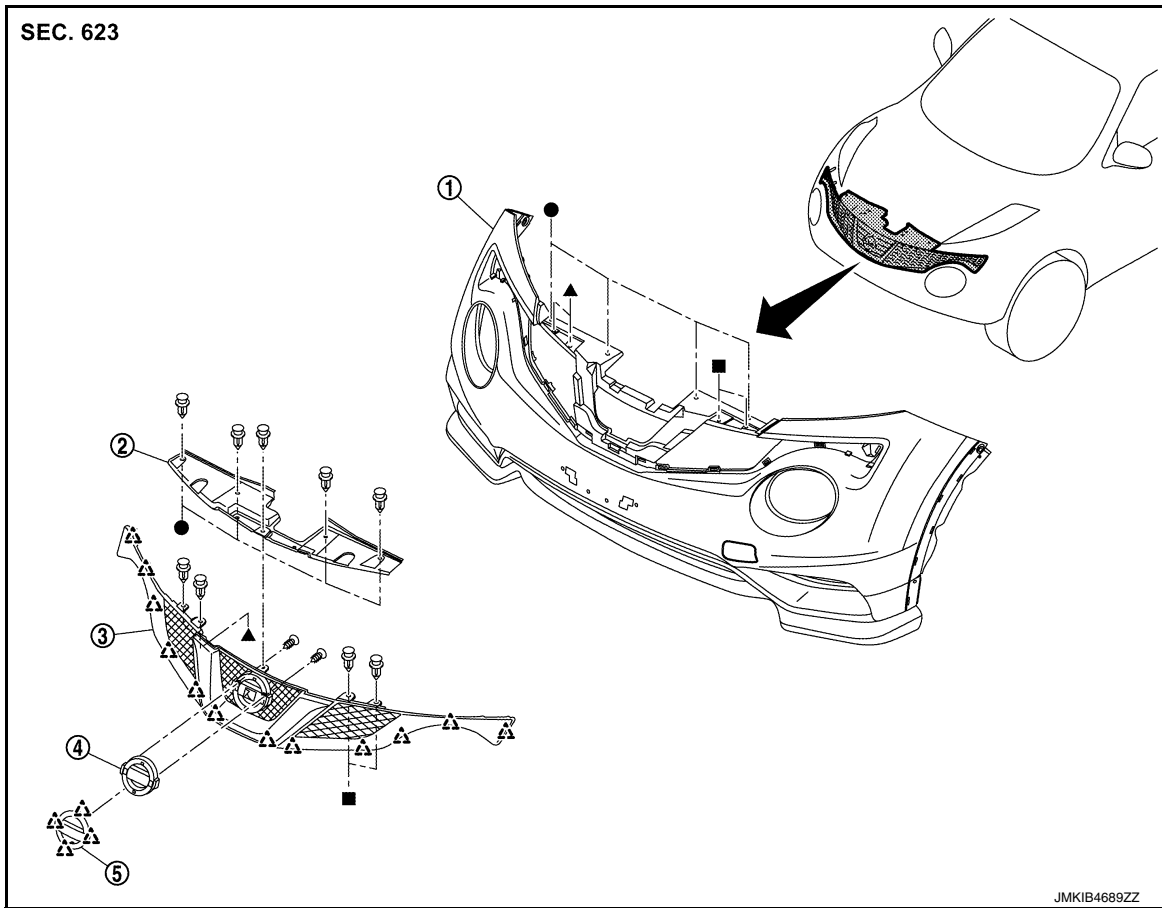

- | | | |
|------------------------|-----------------------|-----------------|
| 1. Bumper fascia | 2. Front upper grille | 3. Front grille |
| 4. Front grille emblem | 5. Emblem | |

△ : Pawl

●, ▲, ■: Indicates that the part is connected at points with same symbol in actual vehicle.

Removal and Installation

INFOID:000000012199315

REMOVAL

Except for NISMO and NISMO RS

1. Fully open hood assembly.
2. Remove front center grille upper fixing clips (A).
CAUTION:
Apply protective tape (B) around bumper fascia.

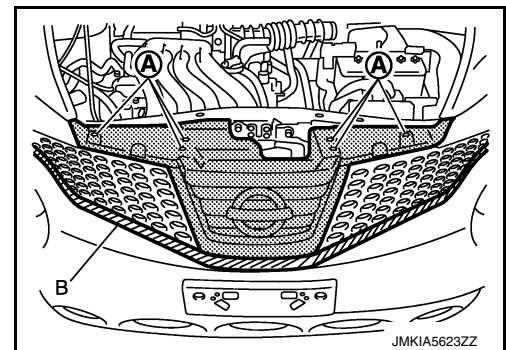

FRONT GRILLE

< REMOVAL AND INSTALLATION >

- Disengage fixing pawls from back side while pulling front center grille toward vehicle front, and then remove front center grille.

 : Pawl

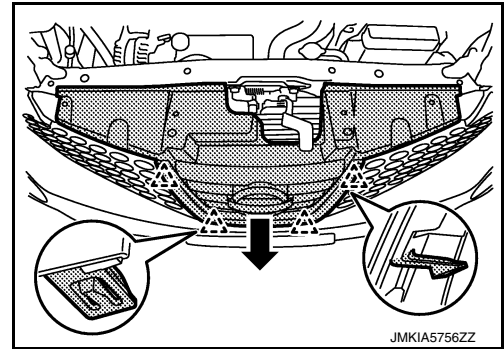

- Remove front side grille (LH and RH) upper fixing clips (A).
- Disengage fixing pawls from back side of front side grille, and then remove front side grille (LH and RH).

CAUTION:

Apply protective tape (B) around bumper fascia.

 : Pawl

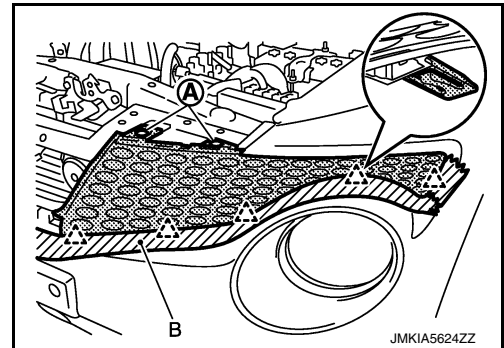

- Remove the following parts after removing front grille.
 - Emblem
 - Front camera (if equipped). Refer to [AV-191. "Removal and Installation"](#).

NISMO and NISMO RS

- Fully open hood assembly.
- Remove front upper grille fixing clips (A), and then remove front upper grille.

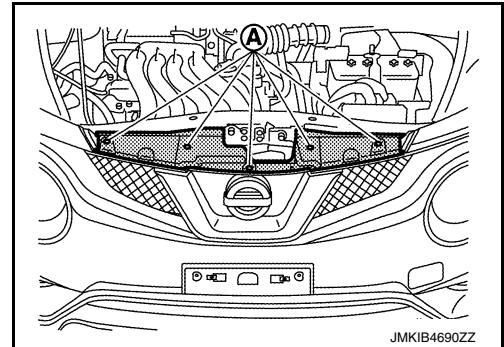

- Remove front grille fixing clips (A).

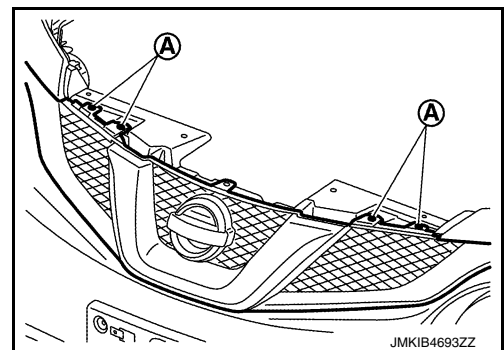

A
B
C
D
E
F
G
H
I
J
EXT
L
M
N
O
P

FRONT GRILLE

< REMOVAL AND INSTALLATION >

4. Disengage fixing pawls from back side of front grille, and then remove front grille.

CAUTION:

Apply protective tape (A) around bumper fascia.

 : Pawl

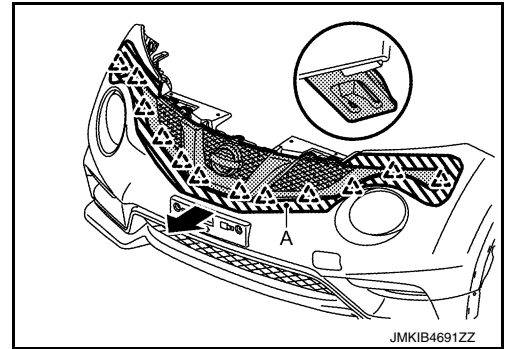

5. Remove the following parts after removing front grille.
 - Emblem
 - Front grille emblem
 - Front camera (if equipped). Refer to [AV-191, "Removal and Installation"](#).

INSTALLATION

Note the following item, and then install in the reverse order of removal.

NOTE:

Perform camera image calibration. Refer to [AV-116, "CALIBRATING CAMERA IMAGE \(AROUND VIEW MONITOR\) : Work Procedure"](#).

COWL TOP

< REMOVAL AND INSTALLATION >

COWL TOP

Exploded View

INFOID:000000012199316

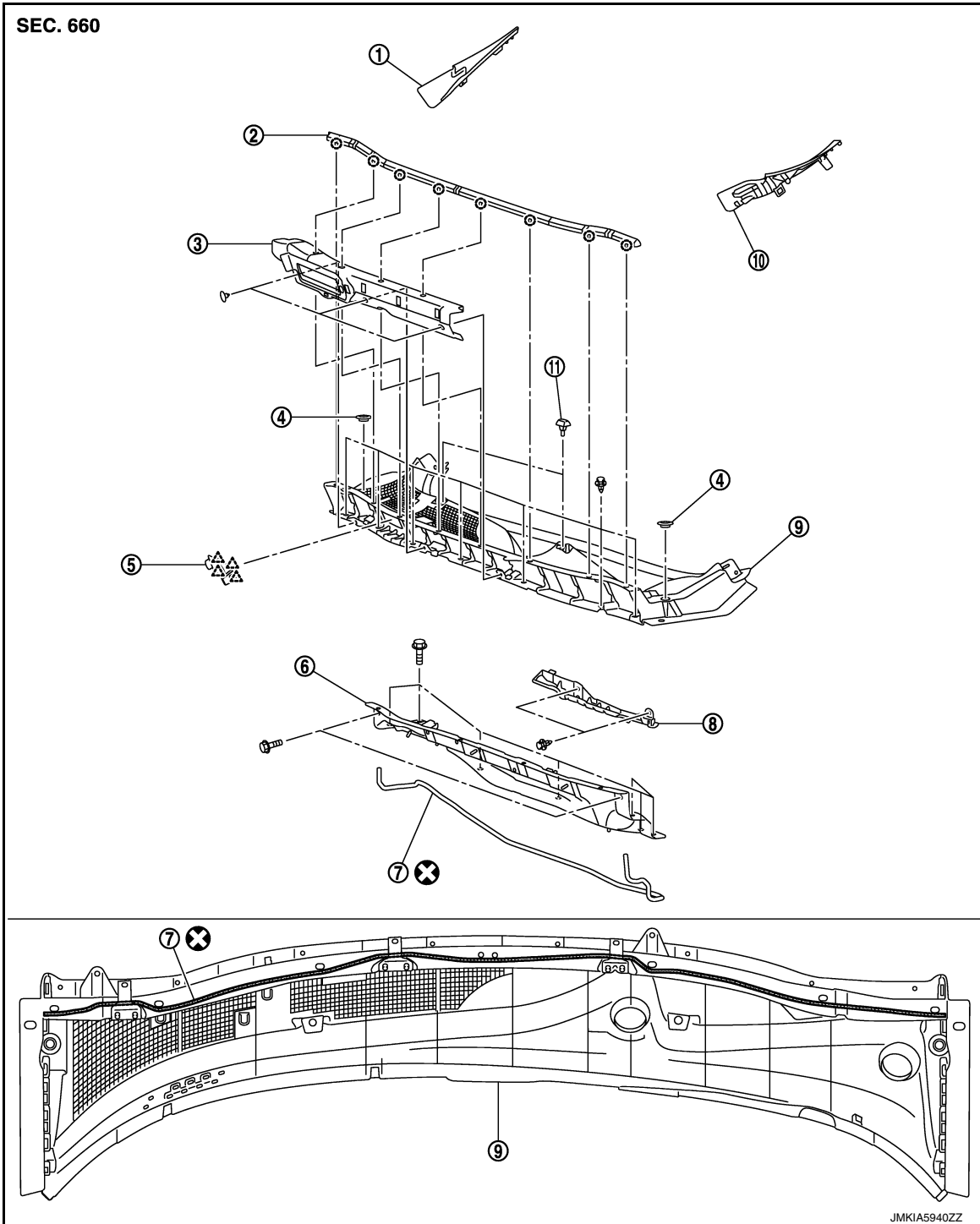

- | | | |
|------------------------------------|------------------------|-----------------------|
| 1. Front fender cover RH | 2. Cowl top cover seal | 3. Cowl top insulator |
| 4. Blind plug RH | 5. Cowl top cover cap | 6. Cowl top extension |
| 7. EPT seal [t: 3.0 mm (0.118 in)] | 8. Air intake cover | 9. Cowl top cover |
| 10. Front fender cover LH | 11. Washer nozzle | |

○ : Clip

A
B
C
D
E
F
G
H
I
J
EXT
L
M
N
O
P

COWL TOP

< REMOVAL AND INSTALLATION >

 : Pawl

 : Always replace after every disassembly.

Removal and Installation

INFOID:000000012199317

REMOVAL

1. Fully open hood assembly.
2. Remove front wiper arm (LH and RH). Refer to [WW-50, "Removal and Installation"](#).
3. Disconnect washer tube joint on cowl top cover RH.
4. Remove cowl top seal fixing clips, and then remove cowl top seal.
5. Remove cowl top insulator fixing clips, and then remove cowl top insulator.
6. Remove front fender cover (LH and RH).
7. Remove cowl top cover fixing clips.
8. Pull forward to release cowl top cover from windshield glass.

CAUTION:

When performing the procedure after removing cowl top cover, cover the lower end of windshield glass with urethane etc.

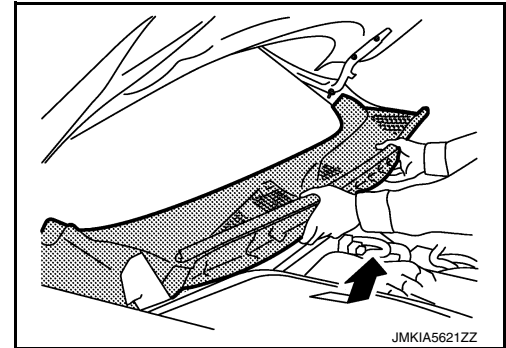

9. Remove cowl top cover.
10. Remove the following parts after removing cowl top cover.
 - EPT sealer
 - Washer tube
 - Washer nozzle (LH and RH). Refer to [WW-47, "Removal and Installation"](#).
11. Remove front wiper drive assembly. Refer to [WW-55, "Removal and Installation"](#).
12. Remove cowl top extension mounting bolts, and then remove cowl top extension.

INSTALLATION

Note the following items and then, install in the reverse order of removal.

CAUTION:

- Clean the joint between the cowl top cover and the windshield, and then install them.
- Replace the EPT sealer on the back surface with new EPT sealer when reusing the cowl top cover.
- Remove the EPT sealer remaining on the cowl top cover using a double-faced adhesive tape remove.
- To maintain adhesion, never wash the vehicle within 24 hours after installation.
- Perform the stop position adjustment at the installation of the front wiper arms. Refer to [WW-51, "Adjustment"](#).

FENDER PROTECTOR

< REMOVAL AND INSTALLATION >

FENDER PROTECTOR

Exploded View

INFOID:000000012199318

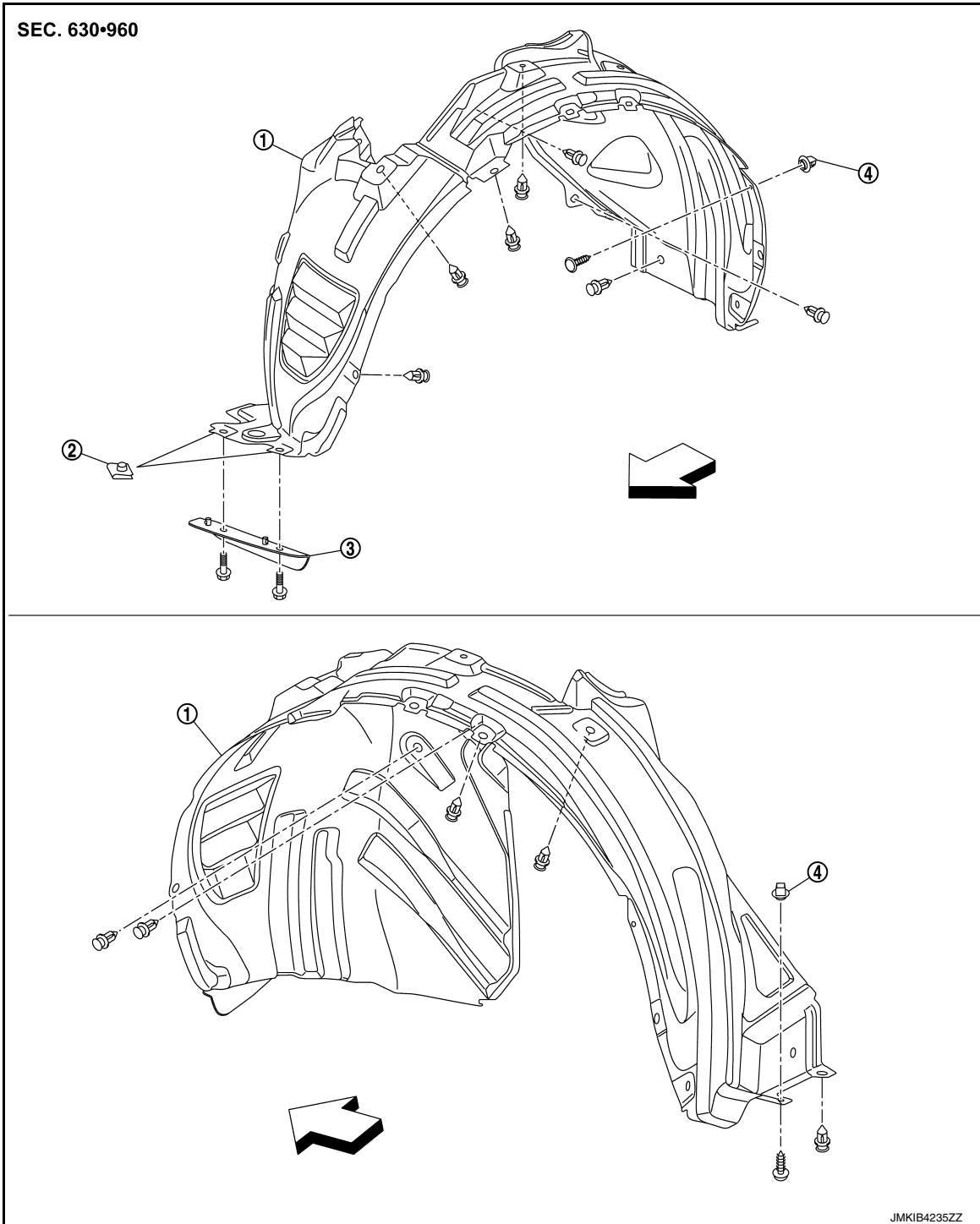

1. Fender protector

2. U nut

3. Air guide

4. Screw grommet

↔ : Vehicle front

Removal and Installation

INFOID:000000012199319

REMOVAL

Revision: November 2015

EXT-31

2016 JUKE

A
B
C
D
E
F
G
H
I
J
EXT
L
M
N
O
P

FENDER PROTECTOR

< REMOVAL AND INSTALLATION >

1. Remove front fillet molding. Refer to [EXT-36. "FRONT FILLET MOLDING : Removal and Installation"](#).
2. Remove air guide mounting bolts, and then remove air guide.
3. Remove front fender protector fixing screws and clips.
4. Remove front fender protector from wheel house.

INSTALLATION

Install in the reverse order of removal.

SILL COVER

< REMOVAL AND INSTALLATION >

SILL COVER

Exploded View

INFOID:000000012199320

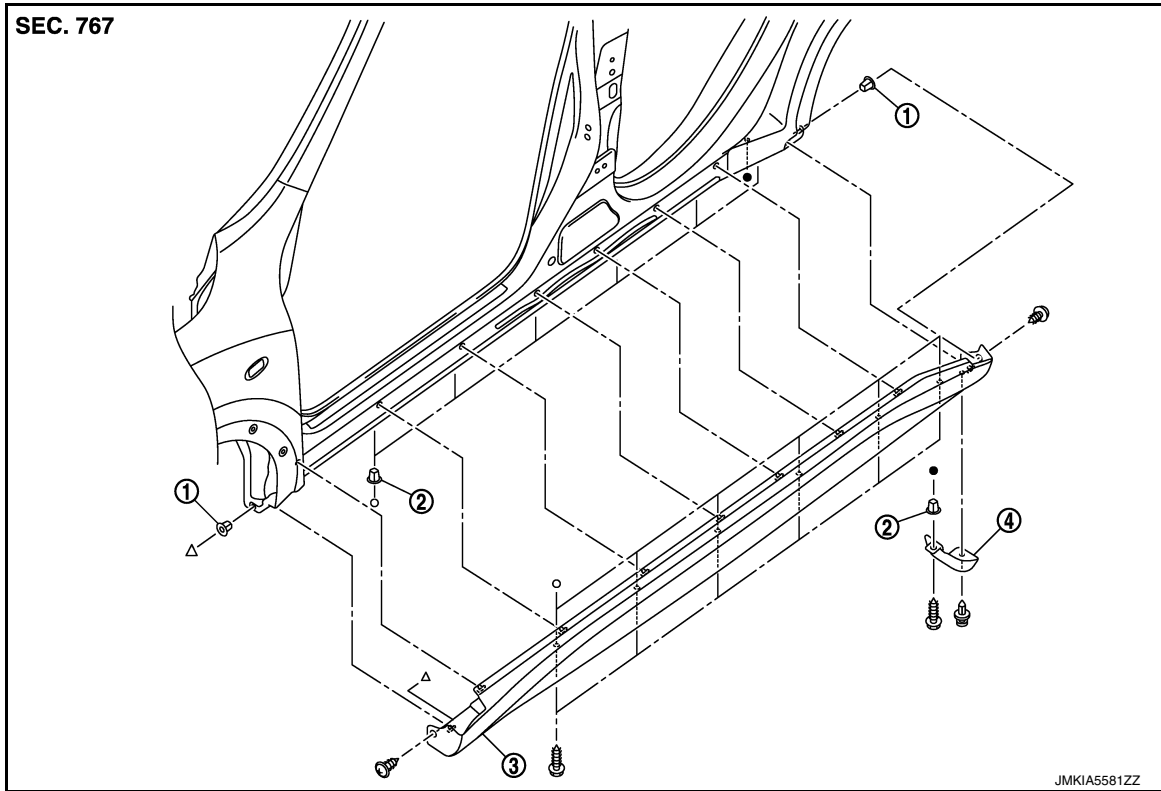

- 1. Screw grommet
- 2. Screw grommet
- 3. Sill cover
- 4. Wind deflector

●, ○, △: Indicates that the part is connected at points with same symbol in actual vehicle.

Removal and Installation

INFOID:000000012199321

REMOVAL

1. Remove sill cover front end fixing screw (A).

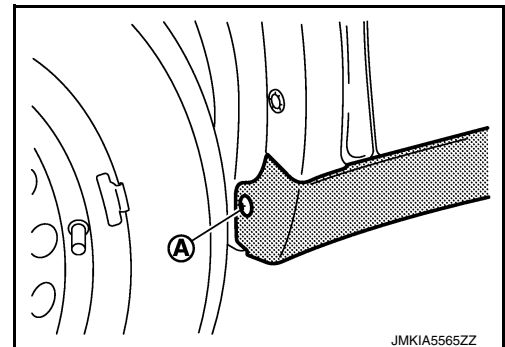

SILL COVER

< REMOVAL AND INSTALLATION >

2. Remove sill cover rear end fixing screw (A).

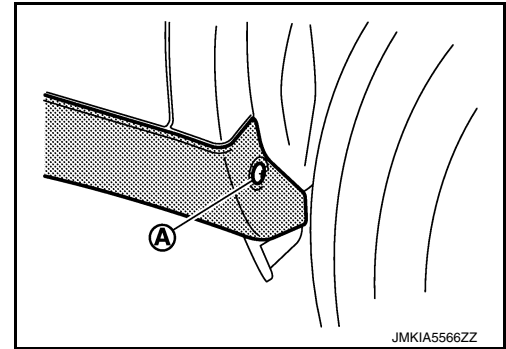

3. Remove sill cover lower side fixing screws.
4. Fully open front door and rear door.
5. Remove fixing clips from sill cover back side with a remover tool (A).

CAUTION:

Apply protective tape (B) on the body to protect the painted surface from damage.

 : Clip

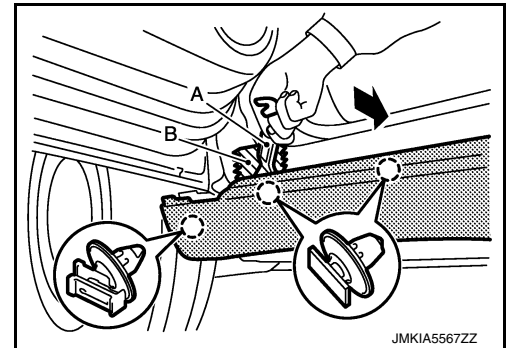

6. Remove sill cover from body side.

INSTALLATION

Note the following item, and then install in the reverse order of removal.

CAUTION:

When installing sill cover, check that clips are securely fitted in body panel holes, and then press clips in.

FLOOR SIDE FAIRING

< REMOVAL AND INSTALLATION >

FLOOR SIDE FAIRING

Exploded View

INFOID:000000012199322

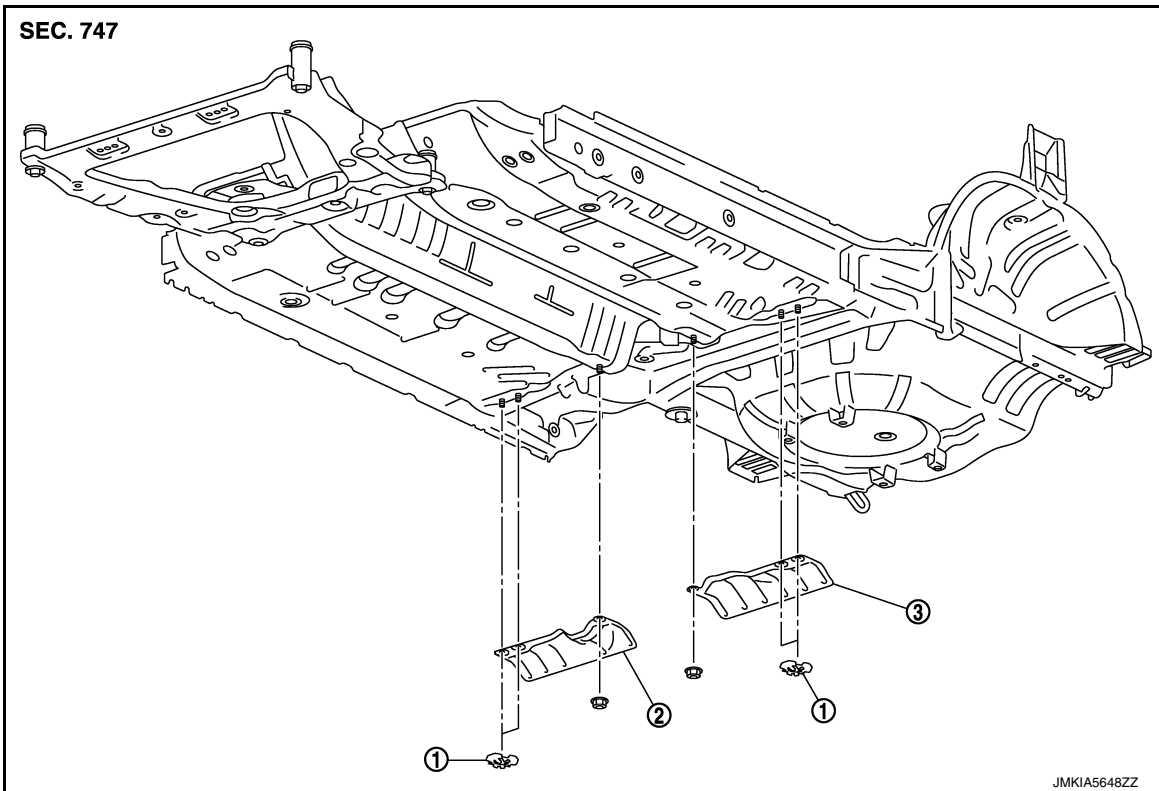

1. Push spring nut

2. Floor under cover RH

3. Floor under cover LH

Removal and Installation

INFOID:000000012199323

REMOVAL

FLOOR UNDER COVER

Remove floor under cover mounting nut and push spring nuts, and then remove floor under cover.

INSTALLATION

Install in the reverse order of removal.

A
B
C
D
E
F
G
H
I
J
L
M
N
O
P

EXT

FILLET MOLDING

< REMOVAL AND INSTALLATION >

FILLET MOLDING

Exploded View

INFOID:000000012199324

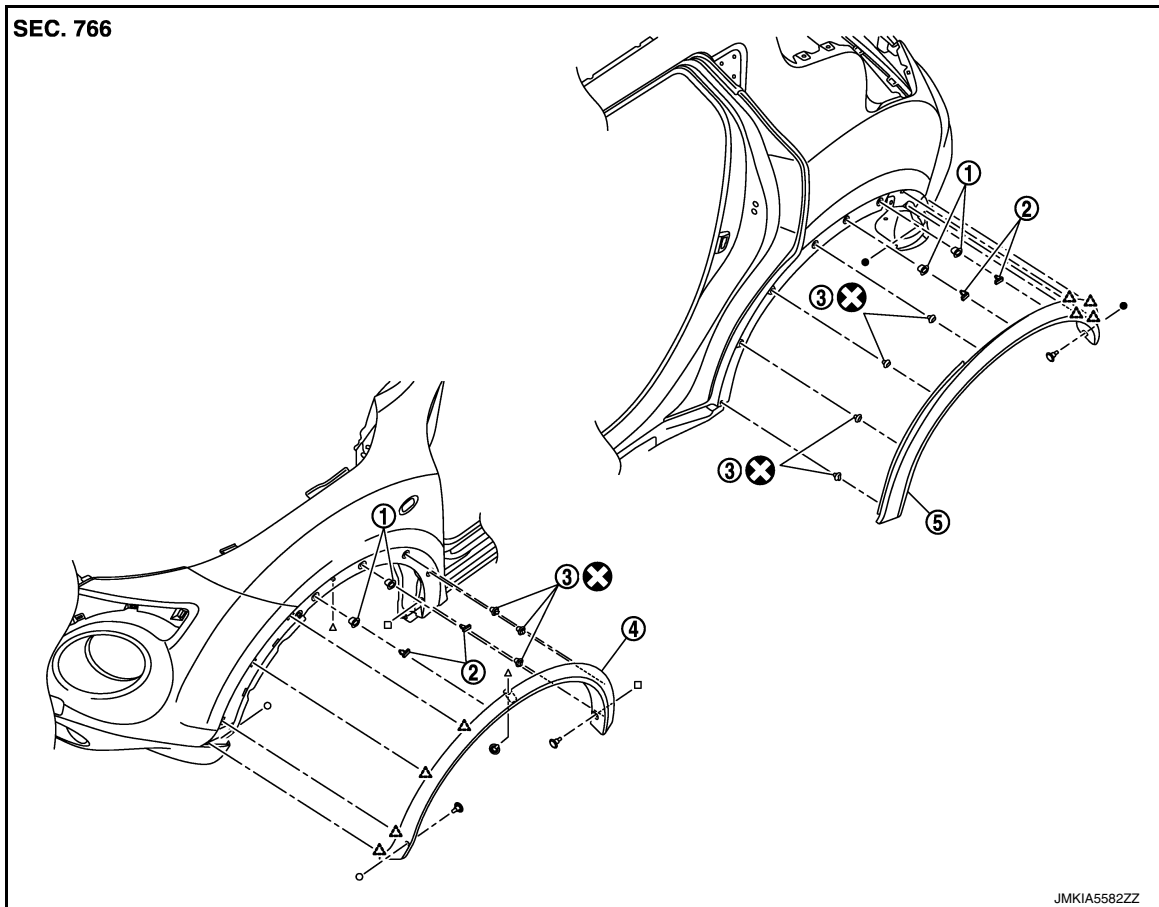

- | | | |
|-------------------------|------------------------|---------|
| 1. Grommet | 2. Clip | 3. Clip |
| 4. Front fillet molding | 5. Rear fillet molding | |

△ : Pawl

⊗ : Always replace after every disassembly.

●, ○, △, □: Indicates that the part is connected at points with same symbol in actual vehicle.

FRONT FILLET MOLDING

FRONT FILLET MOLDING : Removal and Installation

INFOID:000000012199325

REMOVAL

1. Remove front fillet molding fixing clips.
2. Remove front fillet molding front side fixing pawls.

CAUTION:

Never pull the front fillet molding strongly.

△ : Pawl

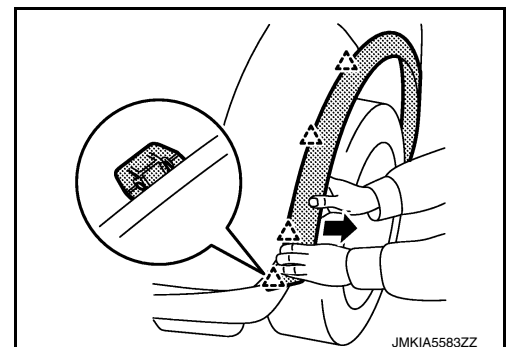

FILLET MOLDING

< REMOVAL AND INSTALLATION >

- Using remover tool (A), disengage the clips from front fillet molding by starting from front side.

CAUTION:

- Apply a protective tape (B) on the body to protect the painted surface from damage.
- Never pull the front fillet molding strongly.

 : Clip

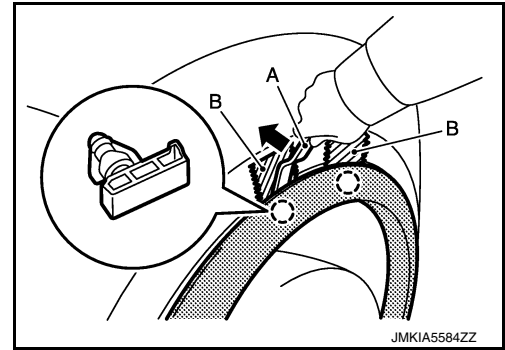

INSTALLATION

Note the following items, and then install in the reverse order of removal.

CAUTION:

- Always replace fillet molding fixing clips.
- When installing front fillet molding, check that blind clips and pawls are securely fitted in panel holes on body, and then press them in.

REAR FILLET MOLDING

REAR FILLET MOLDING : Removal and Installation

INFOID:0000000012199326

REMOVAL

- Remove rear fillet molding fixing clip from end of sill cover.
- Remove rear fillet molding rear side fixing pawls.

CAUTION:

Never pull the rear fillet molding strongly.

 : Pawl

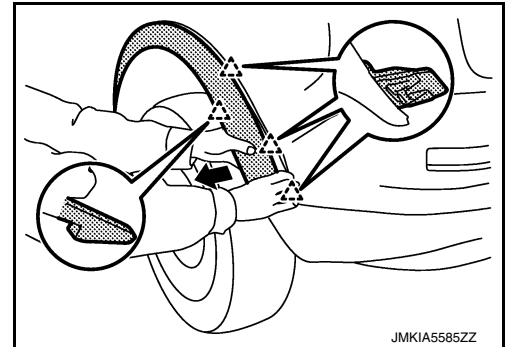

- Using remover tool (A), disengage the clips from rear fillet molding by starting from rear side.

CAUTION:

- Apply a protective tape (B) on the body to protect the painted surface from damage.
- Never pull the rear fillet molding strongly.

 : Clip

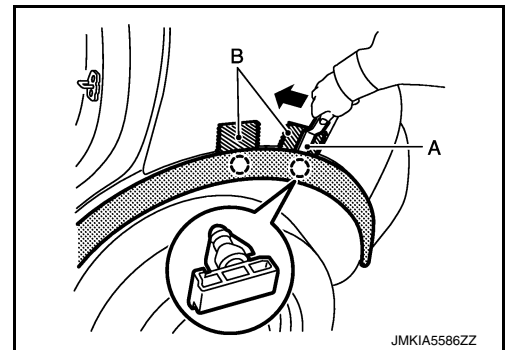

INSTALLATION

Note the following items, and then install in the reverse order of removal.

CAUTION:

- Always replace fillet molding fixing clips.
- When installing rear fillet molding, check that blind clips and pawls are securely fitted in panel holes on body, and then press them in.

ROOF SIDE MOLDING

< REMOVAL AND INSTALLATION >

ROOF SIDE MOLDING

Exploded View

INFOID:000000012199327

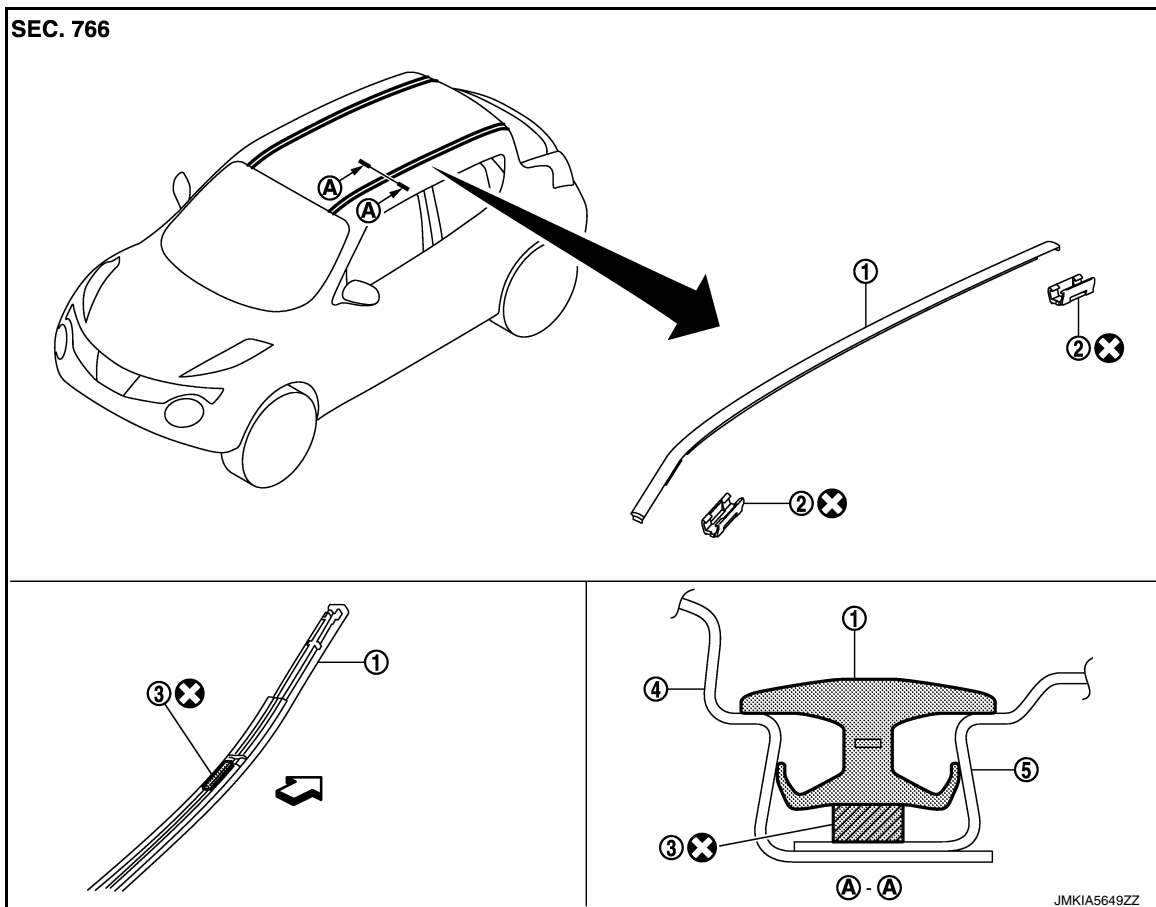

- 1. Roof side molding
- 2. Roof side molding clip
- 3. Double-sided tape [t: 2.5 mm (0.098 in)]

- 4. Body side outer panel
- 5. Roof panel

↔ : Vehicle front

⊗ : Always replace after every disassembly.

Removal and Installation

INFOID:000000012199328

REMOVAL

Roof Side Molding

1. Disengage roof side molding rear side fixing clip, using a remover tool (A).

CAUTION:

Apply protective tape (B) on body to protect the painted surface from damage.

○ : Clip

↔ : Vehicle front

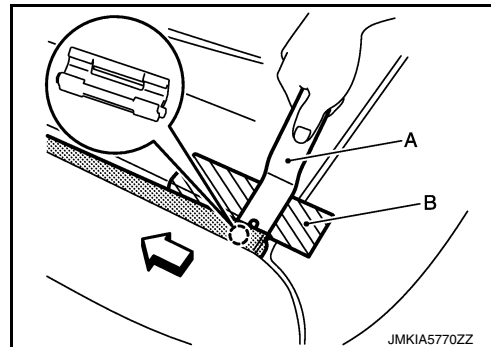

ROOF SIDE MOLDING

< REMOVAL AND INSTALLATION >

2. Pull up roof side molding from rear end to front end.

CAUTION:

Never pull the roof side molding strongly.

↔ : Vehicle front

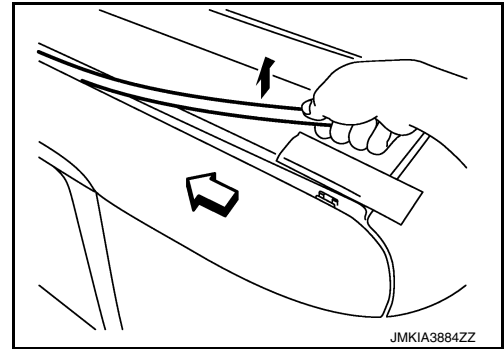

3. Disengage windshield molding and clip at the front end of roof side molding, and then remove while pulling out toward vehicle rear.

○ : Clip

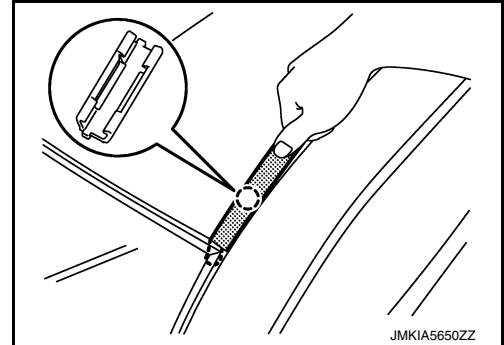

Roof Side Molding Clip

1. Remove roof side molding.
2. Heat adhesive tape interface using a dryer, and then peel roof side molding clips (body side) using long-nose pliers.

CAUTION:

Never damage the body.

INSTALLATION

Roof Side Molding

Note the following items, and then install in the reverse order of removal.

CAUTION:

- When installing roof side molding, check that roof side molding are securely in roof side molding clip, and press them in.
- Replace the double-sided tape on the back surface with new double-sided tape when reusing the roof side molding.
- Remove double-sided tape remaining on roof panel and back of roof side molding with a double-sided tape remover, after removing roof side molding.
- When installing, visually check the roof side molding and roof side molding clip, then replace them with new parts if they are damaged.

Roof Side Molding Clip

1. Clean tape removed surface with a shop cloth soaked in white gasoline or IPA.
2. Use two-part epoxy adhesive.

Adhesive : 3M-weld DP-100 or equivalent

3. Apply adhesive evenly to clip tape surface.

Thickness : Approximately 0.5 mm (0.020 in)

4. Position applied parts to the proper location, and then sufficiently press-fit until the adhesive protrudes to tape side.

Press-fit limit : 19.6 N× 2 seconds

A
B
C
D
E
F
G
H
I
J
L
M
N
O
P

EXT

ROOF SIDE MOLDING

< REMOVAL AND INSTALLATION >

5. Tape roof side molding clips after press fit, and temporarily hold it for specified time based on the following.

5 to 10°C (41 to 50°F)	: 1 hour or more
11 to 23°C (52 to 73°F)	: 30 minutes or more
24°C or more (75°F or more)	: 15 minutes or more

CAUTION:

- Use double-sided tape after hardening for roof side molding clips.
- Securely insert molding rear end cap onto roof rear end cutout (installation standard).
- When installing roof side molding of windshield glass portion, check that body side molding fastener is securely inserted and then press in.
- Never wash the vehicle within 24 hours so as to keep adhesive.

DOOR OUTSIDE MOLDING

< REMOVAL AND INSTALLATION >

DOOR OUTSIDE MOLDING

Exploded View

INFOID:000000012199329

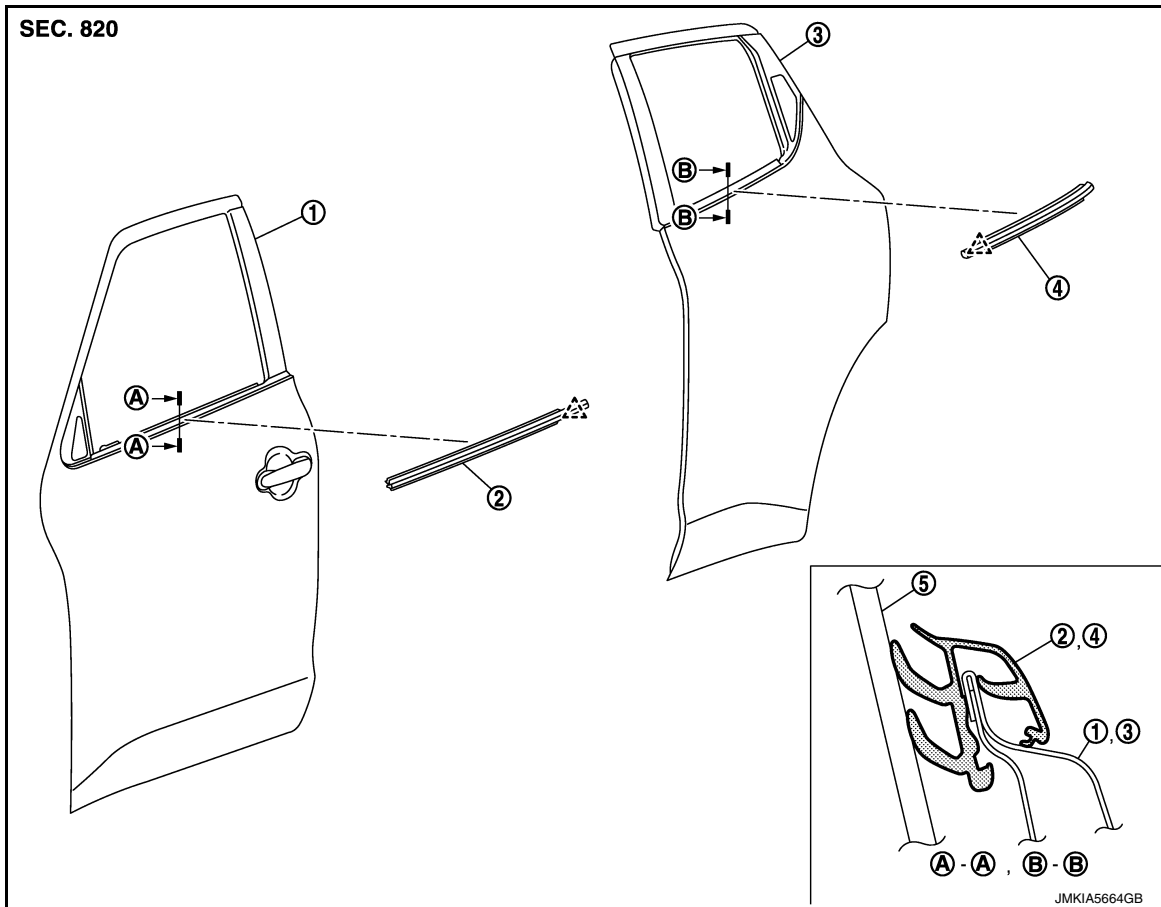

- | | | |
|------------------------------|-------------------------------|--------------------|
| 1. Front door panel | 2. Front door outside molding | 3. Rear door panel |
| 4. Rear door outside molding | 5. Door glass | |

 : Pawl

FRONT DOOR OUTSIDE MOLDING

FRONT DOOR OUTSIDE MOLDING : Removal and Installation

INFOID:000000012199330

REMOVAL

1. Fully open front door glass.
2. Twist door outside molding toward the outside of the vehicle, and then lift up and remove it while disengaging the pawls.

 : Pawl

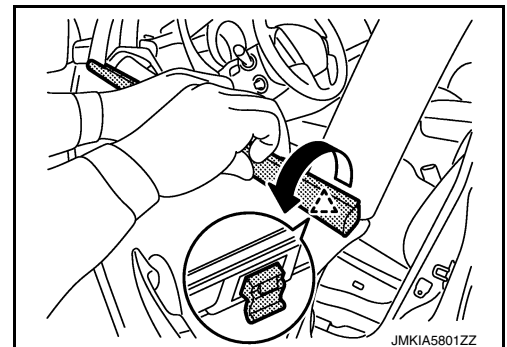

INSTALLATION

Note the following item, and then install in the reverse order of removal.

A
B
C
D
E
F
G
H
I
J

EXT

L

M

N

O

P

DOOR OUTSIDE MOLDING

< REMOVAL AND INSTALLATION >

CAUTION:

When installing front door outside molding, check that pawl (1) is accurately aligned with mounting hole (2), then press in.

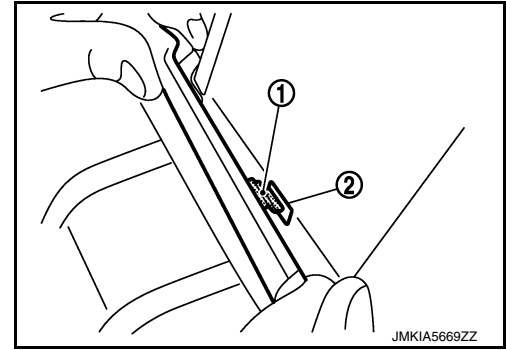

REAR DOOR OUTSIDE MOLDING

REAR DOOR OUTSIDE MOLDING : Removal and Installation

INFOID:0000000012199331

REMOVAL

1. Fully open rear door glass.
2. Twist rear door outside molding toward vehicle outside and remove molding while disengaging it from door panel.

 : Pawl

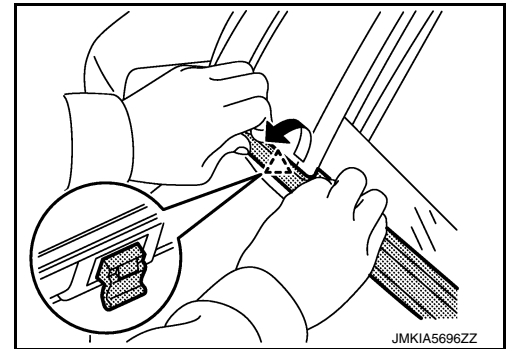

3. Slide rear door outside molding (1) toward vehicle front, and then pull molding out from rear door handle (2).

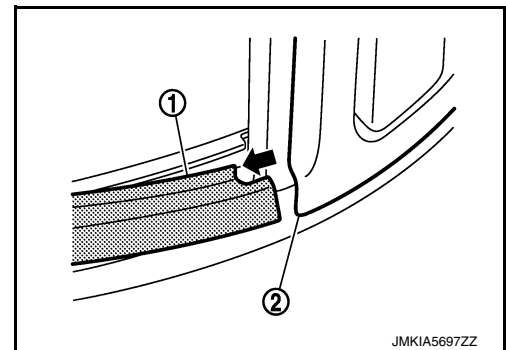

INSTALLATION

Note the following item, and then install in the reverse order of removal.

CAUTION:

When installing rear door outside molding, check that pawl (1) is accurately aligned with mounting hole (2), then press in.

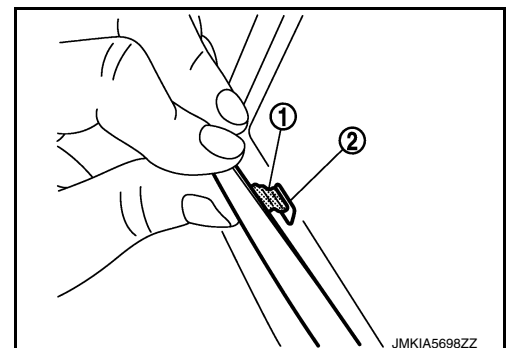

DOOR SASH TAPE

< REMOVAL AND INSTALLATION >

DOOR SASH TAPE

Exploded View

INFOID:000000012199332

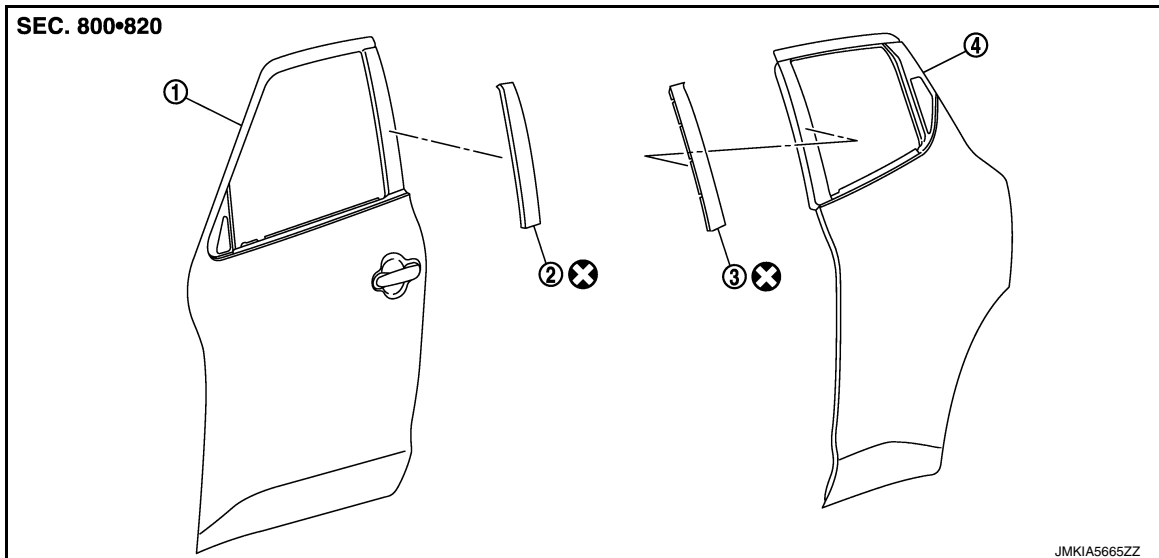

1. Front door panel
2. Front door sash tape
3. Rear door sash tape
4. Rear door panel

⊗ : Always replace after every disassembly.

FRONT DOOR SASH TAPE

FRONT DOOR SASH TAPE : Removal and Installation

INFOID:000000012199333

REMOVAL

1. Remove front door outside molding. Refer to [EXT-41. "FRONT DOOR OUTSIDE MOLDING : Removal and Installation"](#).
2. Heat front door sash tape surface using a dryer, and then peel front door sash tape.

CAUTION:

Never damage painted surface of door panel.

INSTALLATION

NOTE:

For installation position of front door sash tape, refer to the position as shown in the figure.

A
B
C
D
E
F
G
H
I
J
L
M
N
O
P

EXT

DOOR SASH TAPE

< REMOVAL AND INSTALLATION >

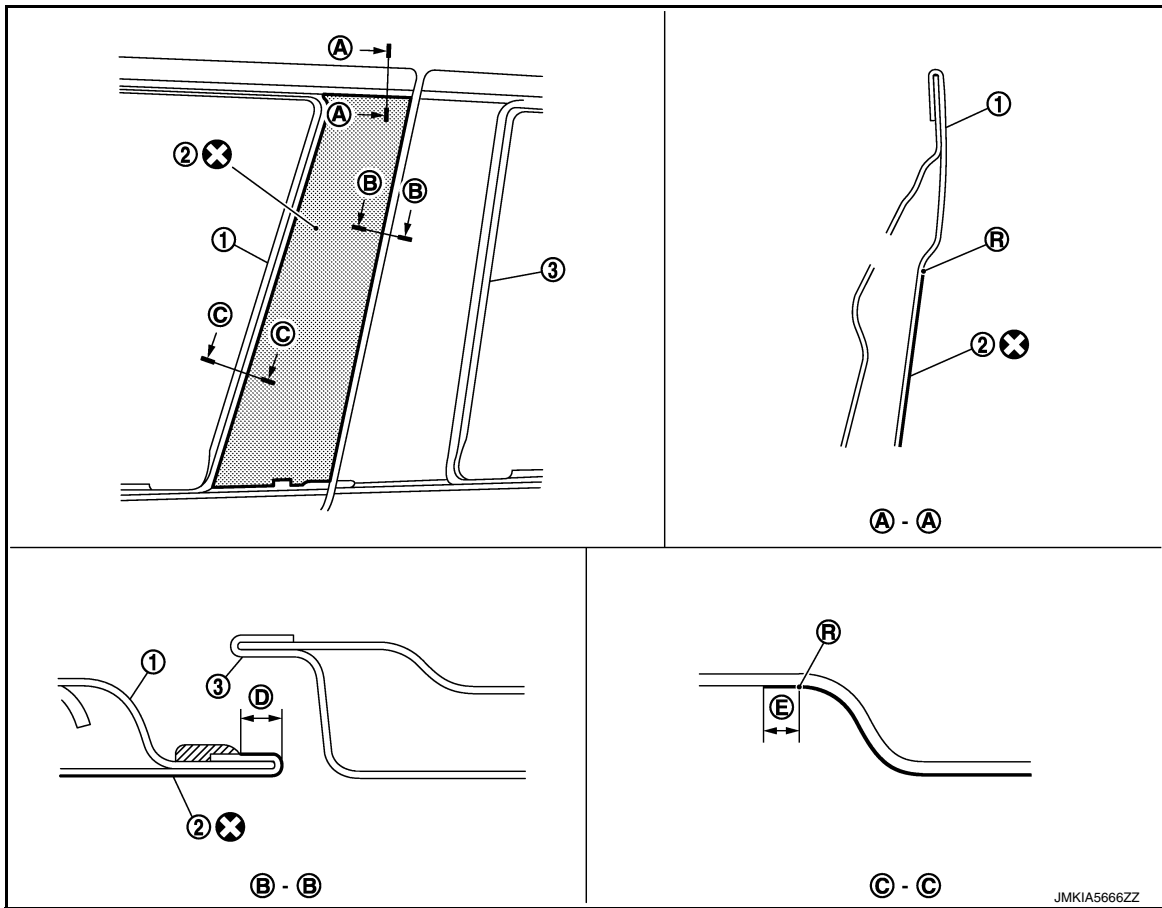

1. Front door panel

2. Front door sash tape

3. Rear door panel

R. Radius

⊗ : Always replace after every disassembly.

D : 2.0 mm (0.08 in)

E : 4.0 mm (0.16 in)

CAUTION:

- Degrease front door panel mounting surface for front door sash tape.
- Paint grain or dust on mounting surface of front door sash tape may spoil exterior appearance if it remains. Clean the mounting surface and check that no paint grain or dust remains, before starting the operation.
- Never reuse front door sash tape.

1. Affix front door sash tape align front door sash tape upper portion to front door outer upper end.

DOOR SASH TAPE

< REMOVAL AND INSTALLATION >

- Affix front door sash tape (2) to front door panel (3) by applying pressure using a squeegee (A) while peeling off release coated paper (1).

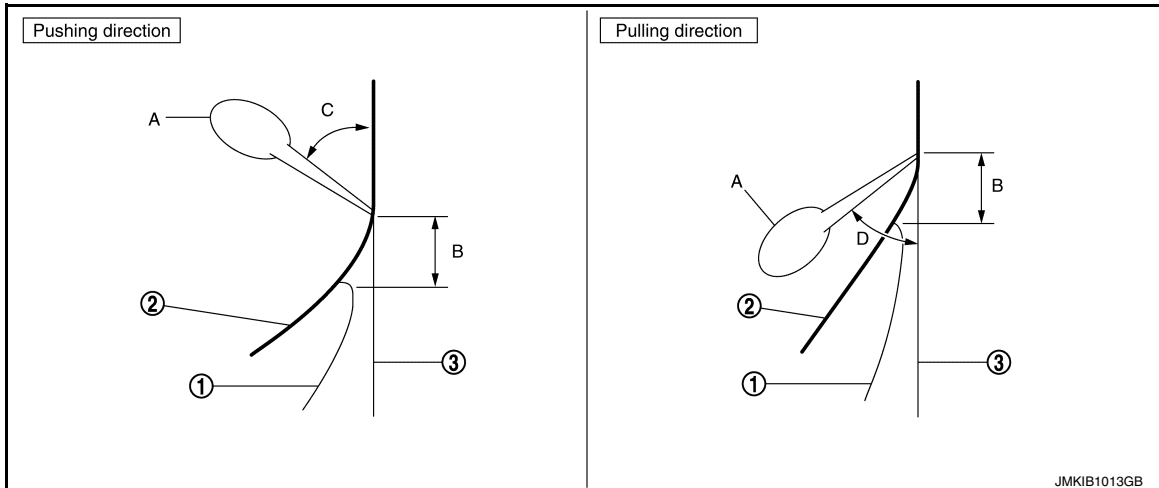

NOTE:

- Peel release coated paper at distance of 10 – 20 mm (0.394 – 0.787 in) ahead (B) of squeegee and affix front door sash tape.
 - To prevent any bubbles from forming, slightly lift the portion, not yet affixed using squeegee, so that portion does not contact with panel surface. Apply pressure and affix at a low and constant speed using squeegee tilted at 40 – 50° angle (pushing direction) (C) 30 – 45° angle (pulling direction) (D).
- For small radius portion of hemming part, gradually apply pressure and affix front door sash tape (1) using squeegee (A) in 1 – 3 steps.

CAUTION:

Never wash the vehicle within 24 hours so as to keep adhesive.

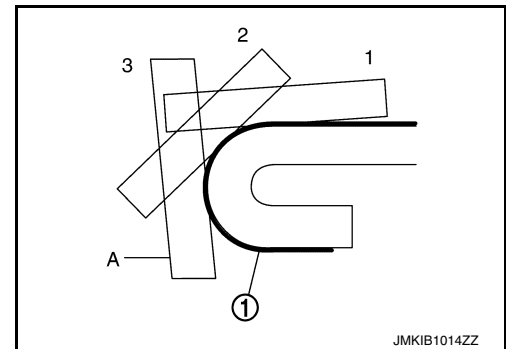

REAR DOOR SASH TAPE

REAR DOOR SASH TAPE : Removal and Installation

INFOID:000000012199334

REMOVAL

- Remove rear door outside molding. Refer to [EXT-42, "REAR DOOR OUTSIDE MOLDING : Removal and Installation"](#).
- Heat rear door sash tape surface using a dryer, and then peel rear door sash tape.

CAUTION:

Never damage painted surface of door panel.

INSTALLATION

NOTE:

For installation position of rear door sash tape, refer to the position as shown in the figure.

DOOR SASH TAPE

< REMOVAL AND INSTALLATION >

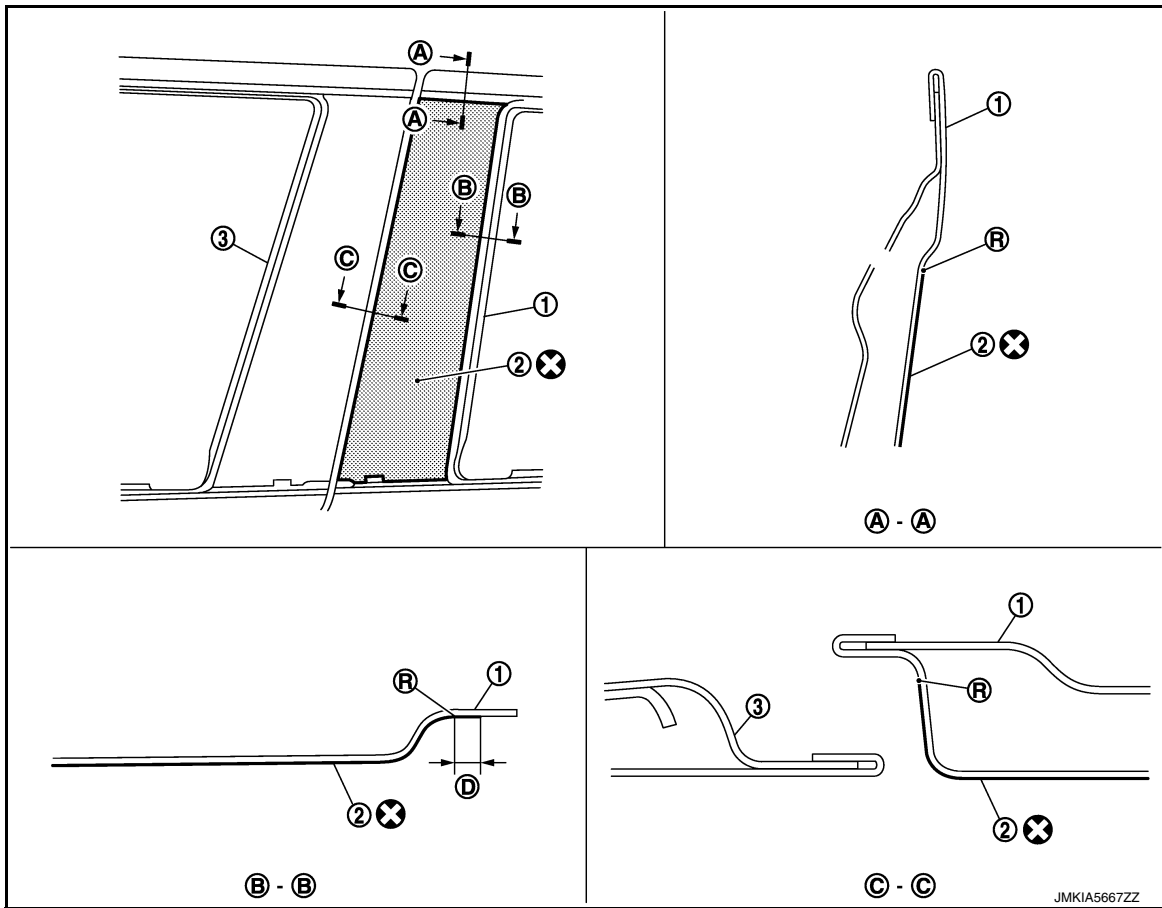

1. Rear door panel

2. Rear door sash tape

3. Front door panel

R. Radius

⊗ : Always replace after every disassembly.

D : 2.0 mm (0.08 in)

CAUTION:

- Degrease rear door panel mounting surface for rear door sash tape.
- Paint grain or dust on mounting surface of rear door sash tape may spoil exterior appearance if it remains. Clean the mounting surface and check that no paint grain or dust remains, before starting the operation.
- Never reuse rear door sash tape.

1. Affix rear door sash tape align rear door sash tape upper portion to rear door outer upper end.

DOOR SASH TAPE

< REMOVAL AND INSTALLATION >

2. Affix rear door sash tape (2) to rear door panel (3) by applying pressure using a squeegee (A) while peeling off release coated paper (1).

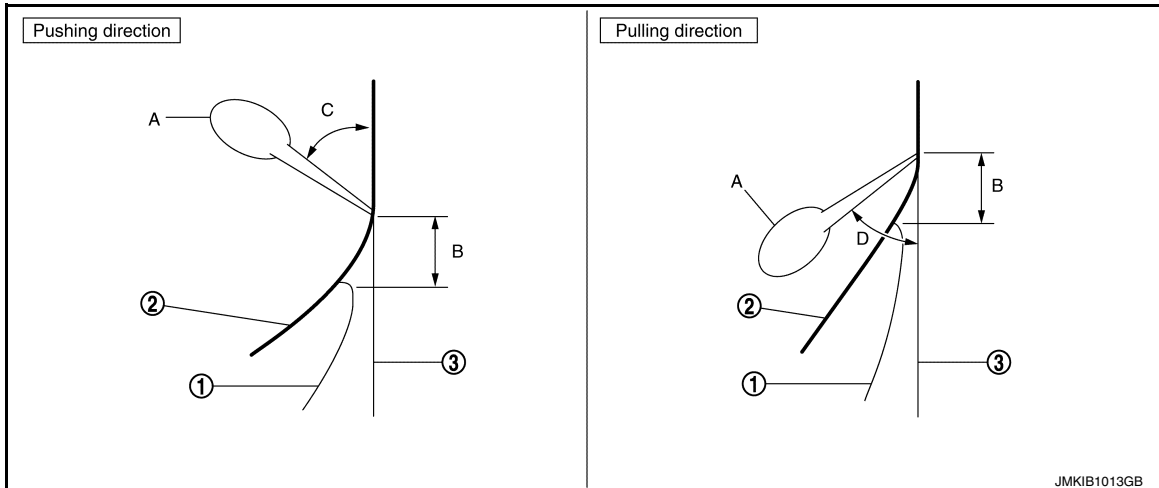

NOTE:

- Peel release coated paper at distance of 10 – 20 mm (0.394 – 0.787 in) ahead (B) of squeegee and affix rear door sash tape.
 - To prevent any bubbles from forming, slightly lift the portion, not yet affixed using squeegee, so that portion does not contact with panel surface. Apply pressure and affix at a low and constant speed using squeegee tilted at 40 – 50° angle (pushing direction) (C) 30 – 45° angle (pulling direction) (D).
3. For small radius portion of hemming part, gradually apply pressure and affix rear door sash tape (1) using squeegee (A) in 1 – 3 steps.

CAUTION:

Never wash the vehicle within 24 hours so as to keep adhesive.

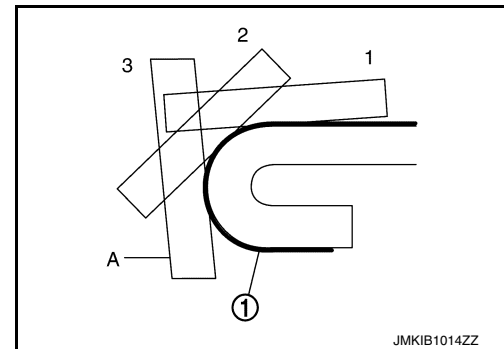

A
B
C
D
E
F
G
H
I
J
EXT
L
M
N
O
P

REAR FENDER COVER

< REMOVAL AND INSTALLATION >

REAR FENDER COVER

Exploded View

INFOID:000000012199335

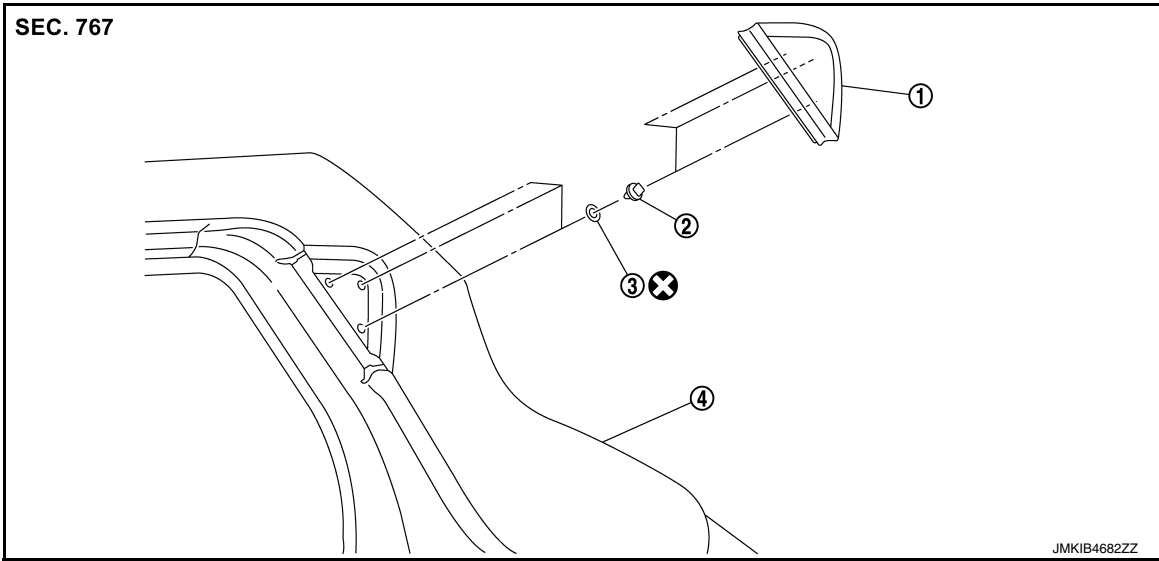

- 1. Rear fender cover
- 2. Clip
- 3. Seal packing
- 4. Rear fender

⊗ : Always replace after every disassembly.

Removal and Installation

INFOID:000000012199336

REMOVAL

Disengage rear fender cover fixing clips using a remover tool (A), and then remove rear fender cover.

CAUTION:

Apply protective tape (B) to the body side to protect from damage.

○ : Clip

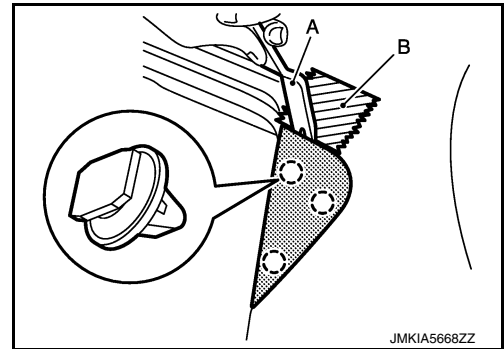

INSTALLATION

Note the following item, and install in the reverse order of removal.

CAUTION:

When installing rear fender cover, check that clips are securely fitted in body panel holes, and then press them it.

REAR SPOILER

< REMOVAL AND INSTALLATION >

REAR SPOILER

Exploded View

INFOID:000000012199337

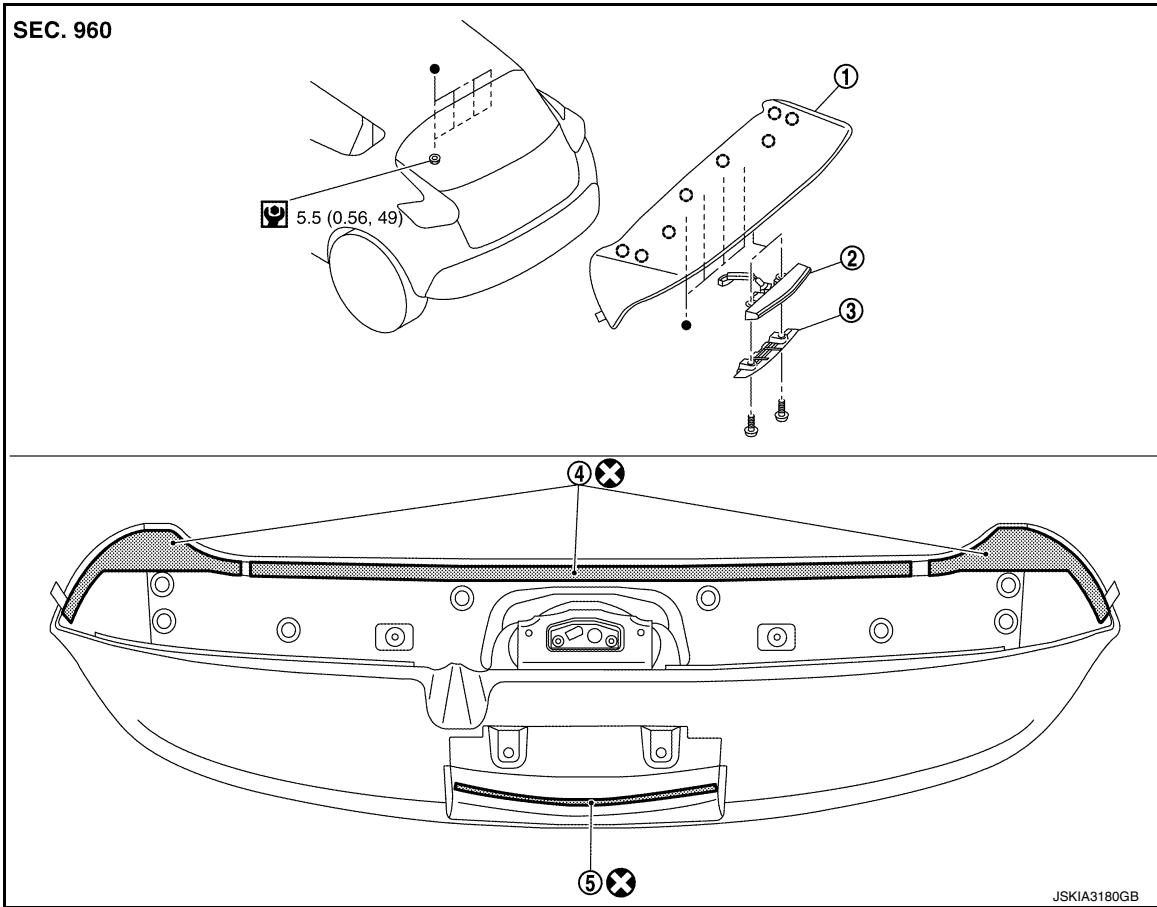

- | | | |
|------------------------------------------------|------------------------------------------------|---------------------------------|
| 1. Rear spoiler | 2. High-mounted stop lamp | 3. High-mounted stop lamp cover |
| 4. Double-sided tape
[t: 2.0 mm (0.079 in)] | 5. Double-sided tape
[t: 1.2 mm (0.047 in)] | |

○ : Clip

□ : N·m (kg-m, in-lb)

⊗ : Always replace after every disassembly.

● : Indicates that the part is connected at points with same symbol in actual vehicle.

Removal and Installation

INFOID:000000012199338

REMOVAL

1. Fully open back door.
2. Remove grommet of back door inside, and then remove rear spoiler mounting nuts.

A
B
C
D
E
F
G
H
I
J
EXT
L
M
N
O
P

REAR SPOILER

< REMOVAL AND INSTALLATION >

3. Apply protective tape (A) on body to protect the painted surface from damage.

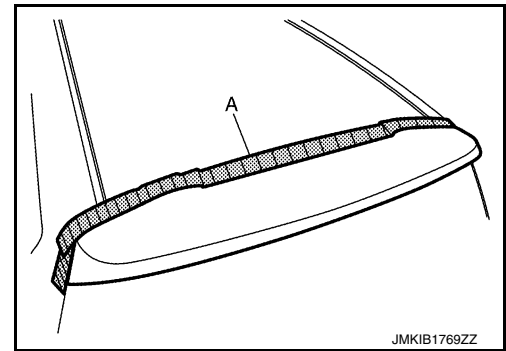

4. Insert a remover tool (A) between rear spoiler and back door panel, cut double-sided tape using a cutter (B) while lifting rear spoiler.

CAUTION:

Never damage the back door and rear spoiler.

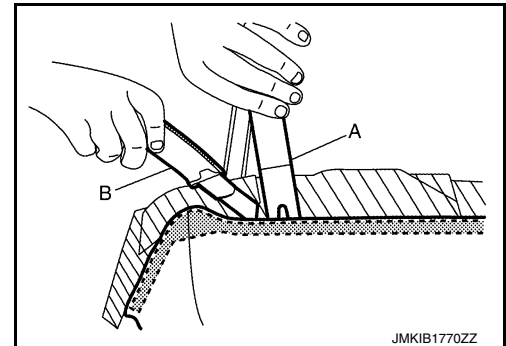

5. Remove rear spoiler fixing clips using a remover tool (A).

 : Clip

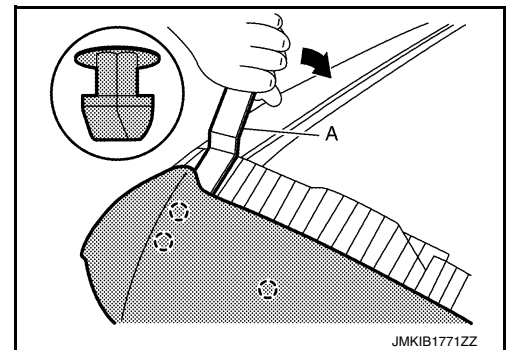

6. Disconnect high-mounted stop lamp harness connector, and then remove rear spoiler.
7. Remove high-mounted stop lamp after removing rear spoiler: Refer to [EXL-111. "Removal and Installation"](#).

INSTALLATION

Note the following items, and then install in the reverse order of removal.

CAUTION:

- Replace the double-sided tape on the back surface with new double-sided tape when reusing the rear spoiler.
- Remove double-sided tape remaining on back door assembly and back of rear spoiler with a double-sided tape remover, after removing rear spoiler.
- When installing, visually check the rear spoiler and clips, then replace them with new parts if they are damaged.
- When installing rear spoiler, check clips and bolts are securely in back door assembly holes, and press them in.
- Never wash the vehicle within 24 hours after installing so as to keep adhesive.

BACK DOOR FINISHER

< REMOVAL AND INSTALLATION >

BACK DOOR FINISHER

Exploded View

INFOID:000000012199339

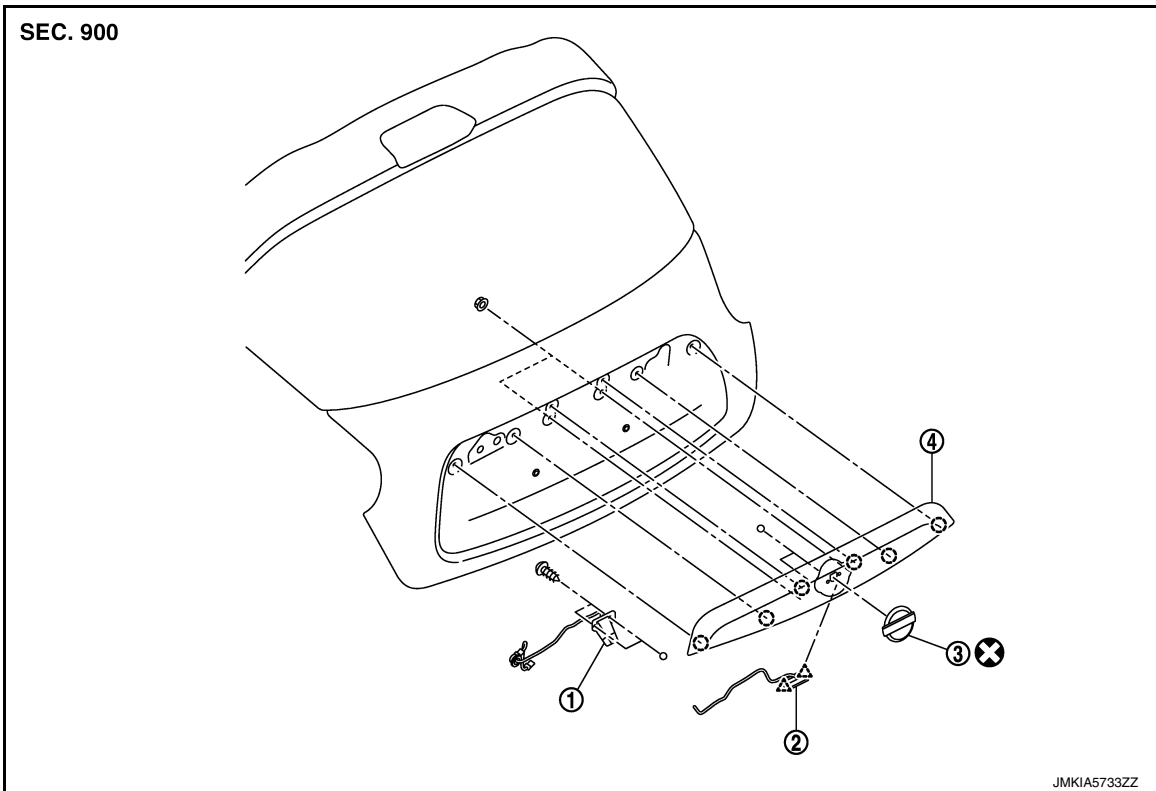

- 1. Rear view camera
- 2. Back door opener request switch
- 3. Emblem
- 4. Back door finisher

○ : Clip

△ : Pawl

⊗ : Always replace after every disassembly.

A
B
C
D
E
F
G
H
I
J

EXT

Removal and Installation

INFOID:000000012199340

REMOVAL

1. Remove back door lower finisher. Refer to [INT-39, "BACK DOOR LOWER FINISHER : Removal and Installation"](#).
2. Remove back door finisher mounting nuts.
3. Disconnect license lamp, back door opener request switch and rear view camera harness connectors.
4. Remove harness grommet.
5. Disengage back door finisher fixing clips using a remover tool (A).
6. Disengage back door finisher fixing clips at both ends of back door finisher from inside of back door.

CAUTION:

- Apply protect tape (B) on back door panel to protect the painted surface from damage.
- Never pull back door finisher strongly.

○ : Clip

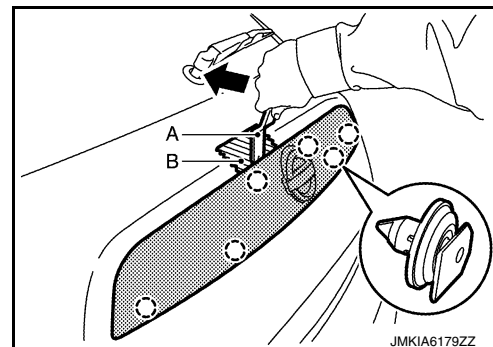

L
M
N
O
P

BACK DOOR FINISHER

< REMOVAL AND INSTALLATION >

INSTALLATION

Note the following item, and then install in the reverse order of removal.

CAUTION:

When installing back door finisher, check that clip are securely in body panel holes, and press them in.