

SECTION **HA**

HEATER & AIR CONDITIONING SYSTEM

A
B
C
D
E
F
G
H
HA
J
K
L
M
N
O
P

CONTENTS

PRECAUTION	3	CONDENSER	20
PRECAUTIONS	3	CONDENSER : Condenser	21
Precaution for Technicians Using Medical Electric.....	3	CONDENSER : Liquid Tank	21
High Voltage Precautions	3	Electric Compressor	21
Point to Be Checked Before Starting Maintenance		PTC Element Heater	23
Work	5	Heater Pump	24
Precautions for Removing Battery Terminal	6	Refrigerant and Compressor Oil	25
Precaution for Supplemental Restraint System		Heater Fluid	25
(SRS) "AIR BAG" and "SEAT BELT PRE-TEN-		High Voltage Warning Label	25
SIONER"	6	SYSTEM	27
Precaution for Procedure without Cowl Top Cover.....	7	REFRIGERATION SYSTEM	27
Precautions for Service Work of Cooler System	7	REFRIGERATION SYSTEM : System Diagram	27
Service Equipment	9	REFRIGERATION SYSTEM : System Description	
PREPARATION	12	27
PREPARATION	12	HEATING SYSTEM	28
Special Service Tool	12	HEATING SYSTEM : System Diagram	28
Commercial Service Tools	13	HEATING SYSTEM : System Description	28
Oil and Grease	15	BASIC INSPECTION	29
SYSTEM DESCRIPTION	16	DIAGNOSIS AND REPAIR WORK FLOW	29
DESCRIPTION	16	Flowchart of Trouble Diagnosis	29
Description	16	REFRIGERANT	31
Specification	16	Description	31
COMPONENT PARTS	18	Check Refrigerant Leakage	31
REFRIGERATION SYSTEM	18	Recycle Refrigerant	32
REFRIGERATION SYSTEM : Component Parts		Charge Refrigerant	33
Location	18	LUBRICANT	34
HEATING SYSTEM	18	Description	34
HEATING SYSTEM : Component Parts Location...	19	Inspection	34
A/C UNIT ASSEMBLY	19	Perform Lubricant Return Operation	34
A/C UNIT ASSEMBLY : A/C Unit	20	Lubricant Adjusting Procedure for Components	
A/C UNIT ASSEMBLY : Evaporator	20	Replacement Except Compressor	34
A/C UNIT ASSEMBLY : Expansion Valve	20	Lubricant Adjusting Procedure for Compressor	
A/C UNIT ASSEMBLY : Heater Core	20	Replacement	35
		PERFORMANCE TEST	37

Inspection	37	CONDENSER	56
SYMPTOM DIAGNOSIS	40	CONDENSER : Removal and Installation	56
REFRIGERATION SYSTEM SYMPTOMS	40	LIQUID TANK	58
Trouble Diagnosis For Unusual Pressure	40	LIQUID TANK : Removal and Installation	58
Symptom Table	40	REFRIGERANT PRESSURE SENSOR	59
NOISE	42	REFRIGERANT PRESSURE SENSOR : Removal and Installation	59
Symptom Table	42	A/C UNIT ASSEMBLY	60
PERIODIC MAINTENANCE	43	Exploded View	60
HEATER FLUID	43	A/C UNIT ASSEMBLY	62
Inspection	43	A/C UNIT ASSEMBLY : Removal and Installation...	62
Draining and Refilling	43	EVAPORATOR	64
DEGAS TANK CAP	45	EVAPORATOR : Removal and Installation	64
Degas Tank Cap Inspection	45	HEATER CORE	65
REMOVAL AND INSTALLATION	46	HEATER CORE : Removal and Installation	65
ELECTRIC COMPRESSOR	46	EXPANSION VALVE	66
Exploded View	46	Exploded View	66
Removal and Installation	46	Removal and Installation	66
Inspection	50	PTC ELEMENTS HEATER	68
COOLER PIPE AND HOSE	52	Exploded View	68
Exploded View	52	Removal and Installation	68
HIGH-PRESSURE FLEXIBLE HOSE	52	Inspection	73
HIGH-PRESSURE FLEXIBLE HOSE : Removal and Installation	52	HEATER PUMP	74
LOW-PRESSURE FLEXIBLE HOSE	53	Exploded View	74
LOW-PRESSURE FLEXIBLE HOSE : Removal and Installation	53	Removal and Installation	74
HIGH-PRESSURE PIPE	54	SERVICE DATA AND SPECIFICATIONS (SDS)	76
HIGH-PRESSURE PIPE : Removal and Installation	54	SERVICE DATA AND SPECIFICATIONS (SDS)	76
CONDENSER	56	Compressor	76
Exploded View	56	Lubricant	76
		Refrigerant	76
		Periodical Maintenance Specification	76

PRECAUTIONS

< PRECAUTION >

PRECAUTION

PRECAUTIONS

Precaution for Technicians Using Medical Electric

INFOID:000000007514029

OPERATION PROHIBITION

WARNING:

- Parts with strong magnet is used in this vehicle.
- Technicians using a medical electric device such as pacemaker must never perform operation on the vehicle, as magnetic field can affect the device function by approaching to such parts.

NORMAL CHARGE PRECAUTION

WARNING:

- If a technician uses a medical electric device such as an implantable cardiac pacemaker or an implantable cardioverter defibrillator, the possible effects on the devices must be checked with the device manufacturer before starting the charge operation.
- As radiated electromagnetic wave generated by on board charger at normal charge operation may effect medical electric devices, a technician using a medical electric device such as implantable cardiac pacemaker or an implantable cardioverter defibrillator must not enter the vehicle compartment (including luggage room) during normal charge operation.

PRECAUTION AT TELEMATICS SYSTEM OPERATION

WARNING:

- If a technician uses implantable cardiac pacemaker or implantable cardioverter defibrillator (ICD), avoid the device implanted part from approaching within approximately 220 mm (8.66 in) from interior/exterior antenna.
- The electromagnetic wave of TCU might affect the function of the implantable cardiac pacemaker or the implantable cardioverter defibrillator (ICD), when using the service, etc.
- If a technician uses other medical electric devices than implantable cardiac pacemaker or implantable cardioverter defibrillator (ICD), the electromagnetic wave of TCU might affect the function of the device. The possible effects on the devices must be checked with the device manufacturer before TCU use.

PRECAUTION AT INTELLIGENT KEY SYSTEM OPERATION

WARNING:

- If a technician uses implantable cardiac pacemaker or implantable cardioverter defibrillator (ICD), avoid the device implanted part from approaching within approximately 220 mm (8.66 in) from interior/exterior antenna.
- The electromagnetic wave of Intelligent Key might affect the function of the implantable cardiac pacemaker or the implantable cardioverter defibrillator (ICD), at door operation, at each request switch operation, or at engine starting.
- If a technician uses other medical electric devices than implantable cardiac pacemaker or implantable cardioverter defibrillator (ICD), the electromagnetic wave of Intelligent Key might affect the function of the device. The possible effects on the devices must be checked with the device manufacturer before Intelligent Key use.

High Voltage Precautions

INFOID:000000007080731

DANGER:



Since hybrid vehicles and electric vehicles contain a high voltage battery, there is the risk of electric shock, electric leakage, or similar accidents if the high voltage component and vehicle are handled incorrectly. Be sure to follow the correct work procedures when performing inspection and maintenance.

WARNING:

- Be sure to remove the service plug in order to disconnect the high voltage circuits before performing inspection or maintenance of high voltage system harnesses and parts.
- The removed service plug must always be carried in a pocket of the responsible worker or placed in the tool box during the procedure to prevent the plug from being connected by mistake.

PRECAUTIONS

< PRECAUTION >

- Be sure to wear insulated protective equipment before beginning work on the high voltage system.
- Never allow workers other than the responsible person to touch the vehicle containing high voltage parts. To keep others from touching the high voltage parts, these parts must be covered with an insulating sheet except when using them.

CAUTION:

Never bring the vehicle into the READY status with the service plug removed unless otherwise instructed in the Service Manual. A malfunction may occur if this is not observed.

HIGH VOLTAGE HARNESS AND EQUIPMENT IDENTIFICATION

All the high voltage harnesses and connectors are orange. The Li-ion battery and other high voltage devices include an orange high voltage label. Never touch these harnesses and high voltage parts.

HANDLING OF HIGH VOLTAGE HARNESS AND TERMINALS

Immediately insulate disconnected high voltage connectors and terminals with insulating tape.

REGULATIONS ON WORKERS WITH MEDICAL ELECTRONICS

WARNING:

The vehicle contains parts that contain powerful magnets. If a person who is wearing a heart pacemaker or other medical device is close to these parts, the medical device may be affected by the magnets. Such persons must not perform work on the vehicle.

PROHIBITED ITEMS TO CARRY DURING THE WORK

Hybrid vehicles and electric vehicles contain parts with high voltage and intense magnetic force. Never carry metal products and magnetic recording media (e.g. cash card, prepaid card) to repair/inspect high voltage parts. If this is not observed, the metal products may create a risk of short circuit and the magnetic recording media may lose their magnetic recording.

POSTING A SIGN OF "DANGER! HIGH VOLTAGE AREA. KEEP OUT"

PRECAUTIONS

< PRECAUTION >

Indicate "HIGH VOLTAGE. DO NOT TOUCH" on the vehicle under repair/inspection to call attention to other workers.

Person in charge: _____
DO NOT TOUCH! REPAIR IN PROGRESS. HIGH VOLTAGE DANGER:
DANGER: HIGH VOLTAGE REPAIR IN PROGRESS. DO NOT TOUCH! Person in charge: _____
Copy this page and put it after folding on the roof of the vehicle in service.

JSAIA1600GB

A
B
C
D
E
F
G
H
HA
J
K
L
M
N
O
P

Point to Be Checked Before Starting Maintenance Work

INFOID:000000007080586

The high voltage system may starts automatically. It is required to check that the timer air conditioner and timer charge (during EVSE connection) are not set before starting maintenance work.

NOTE:

If the timer air conditioner or timer charge (during EVSE connection) is set, the high voltage system starts automatically even when the power switch is in OFF state.

PRECAUTIONS

< PRECAUTION >

Precautions for Removing Battery Terminal

INFOID:000000007080595

- When removing the 12V battery terminal, turn OFF the power switch and wait at least 5 minutes.

NOTE:

ECU may be active for several minutes after the power switch is turned OFF. If the battery terminal is removed before ECU stops, then a DTC detection error or ECU data corruption may occur.

- Always disconnect the battery terminal within 60 minutes after turning OFF the power switch. Even when the power switch is OFF, the 12V battery automatic charge control may automatically start after a lapse of 60 minutes from power switch OFF.
- Disconnect 12V battery terminal according to the following steps.

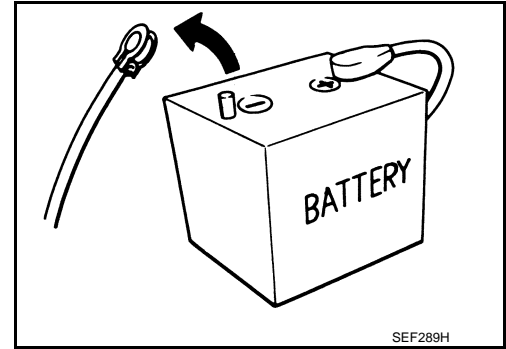

WORK PROCEDURE

1. Check that EVSE is not connected.

NOTE:

If EVSE is connected, the air conditioning system may be automatically activated by the timer A/C function.

2. Turn the power switch OFF → ON → OFF. Get out of the vehicle. Close all doors (including back door).
3. Check that the charge status indicator lamp does not blink and wait for 5 minutes or more.

NOTE:

If the battery is removed within 5 minutes after the power switch is turned OFF, plural DTCs may be detected.

4. Remove 12V battery terminal within 60 minutes after turning the power switch OFF → ON → OFF.

CAUTION:

- After all doors (including back door) are closed, if a door (including back door) is opened before battery terminals are disconnected, start over from Step 1.
- After turning the power switch OFF, if "Remote A/C" is activated by user operation, stop the air conditioner and start over from Step 1.

NOTE:

Once the power switch is turned ON → OFF, the 12V battery automatic charge control does not start for approximately 1 hour.

- For vehicles with the 2-batteries, be sure to connect the main battery and the sub battery before turning ON the power switch.

NOTE:

If the power switch is turned ON with any one of the terminals of main battery and sub battery disconnected, then DTC may be detected.

- After installing the 12V battery, always check "Self Diagnosis Result" of all ECUs and erase DTC.

NOTE:

The removal of 12V battery may cause a DTC detection error.

Precaution for Supplemental Restraint System (SRS) "AIR BAG" and "SEAT BELT PRE-TENSIONER"

INFOID:000000007080593

The Supplemental Restraint System such as "AIR BAG" and "SEAT BELT PRE-TENSIONER", used along with a front seat belt, helps to reduce the risk or severity of injury to the driver and front passenger for certain types of collision. This system includes seat belt switch inputs and dual stage front air bag modules. The SRS system uses the seat belt switches to determine the front air bag deployment, and may only deploy one front air bag, depending on the severity of a collision and whether the front occupants are belted or unbelted. Information necessary to service the system safely is included in the "SRS AIR BAG" and "SEAT BELT" of this Service Manual.

WARNING:

Always observe the following items for preventing accidental activation.

- To avoid rendering the SRS inoperative, which could increase the risk of personal injury or death in the event of a collision that would result in air bag inflation, all maintenance must be performed by an authorized NISSAN/INFINITI dealer.

PRECAUTIONS

< PRECAUTION >

- Improper maintenance, including incorrect removal and installation of the SRS, can lead to personal injury caused by unintentional activation of the system. For removal of Spiral Cable and Air Bag Module, see “SRS AIR BAG”.
- Never use electrical test equipment on any circuit related to the SRS unless instructed to in this Service Manual. SRS wiring harnesses can be identified by yellow and/or orange harnesses or harness connectors.

PRECAUTIONS WHEN USING POWER TOOLS (AIR OR ELECTRIC) AND HAMMERS

WARNING:

Always observe the following items for preventing accidental activation.

- When working near the Air Bag Diagnosis Sensor Unit or other Air Bag System sensors with the power switch ON, never use air or electric power tools or strike near the sensor(s) with a hammer. Heavy vibration could activate the sensor(s) and deploy the air bag(s), possibly causing serious injury.
- When using air or electric power tools or hammers, always switch the power switch OFF, disconnect the 12V battery, and wait at least 3 minutes before performing any service.

Precaution for Procedure without Cowl Top Cover

INFOID:000000007080594

When performing the procedure after removing cowl top cover, cover the lower end of windshield with urethane, etc to prevent damage to windshield.

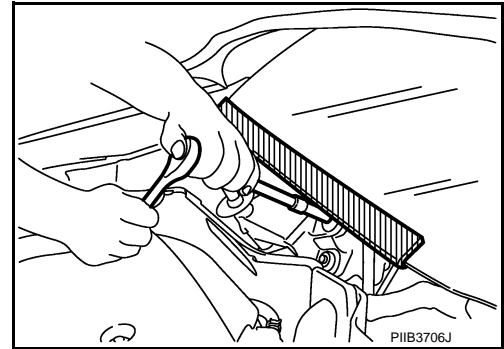

Precautions for Service Work of Cooler System

INFOID:000000007566291

GENERAL REFRIGERANT PRECAUTION

WARNING:

- Never breathe A/C refrigerant and lubricant vapor or mist. Exposure may irritate eyes, nose and throat. Remove HFC-134a (R-134a) from the A/C system, using certified service equipment meeting requirements of SAE J-2210 [HFC-134a (R-134a) recycling equipment], or J-2209 [HFC-134a (R-134a) recovery equipment]. Ventilate work area before resuming service if accidental system discharge occurs. Additional health and safety information may be obtained from refrigerant and lubricant manufacturers.
- Never release refrigerant into the air. Use approved recovery/recycling recharging equipment to capture the refrigerant each time an air conditioning system is discharged.
- Wear always eye and hand protection (goggles and gloves) when working with any refrigerant or air conditioning system.
- Never store or heat refrigerant containers above 52°C (126°F).
- Never heat a refrigerant container with an open flame; Place the bottom of the container in a warm pail of water if container warming is required.
- Never intentionally drop, puncture, or incinerate refrigerant containers.
- Keep refrigerant away from open flames: poisonous gas is produced if refrigerant burns.
- Refrigerant displaces oxygen, therefore be certain to work in well ventilated areas to prevent suffocation.
- Never pressure test or leakage test HFC-134a (R-134a) service equipment and/or vehicle air conditioning systems with compressed air during repair. Some mixtures of air and HFC-134a (R-134a) have been shown to be combustible at elevated pressures. These mixtures, if ignited, may cause injury or property damage. Additional health and safety information may be obtained from refrigerant manufacturers.

WORKING WITH HFC-134a (R-134a)

CAUTION:

PRECAUTIONS

< PRECAUTION >

- CFC-12 (R-12) refrigerant and HFC-134a (R-134a) refrigerant are not compatible. Compressor malfunction is likely to occur if the refrigerants are mixed, refer to “CONTAMINATED REFRIGERANT” below. To determine the purity of HFC-134a (R-134a) in the vehicle and recovery tank, use Refrigerant recovery/recycling recharging equipment and Refrigerant Identifier.
- Use only specified lubricant for the HFC-134a (R-134a) A/C system and HFC-134a (R-134a) components. Compressor malfunction is likely to occur if lubricant other than that specified is used.
- If rotary compressor oil (DH-PR), swash plate compressor oil (DH-PS), or CFC-12 compressor oil (mineral oil) is used, the insulation resistance may be reduced. Never use these oils.
- The specified HFC-134a (R-134a) lubricant rapidly absorbs moisture from the atmosphere. The following handling precautions must be observed:
 - Cap (seal) immediately the component to minimize the entry of moisture from the atmosphere when removing refrigerant components from a vehicle.
 - Never remove the caps (unseal) until just before connecting the components when installing refrigerant components to a vehicle. Connect all refrigerant loop components as quickly as possible to minimize the entry of moisture into system.
 - Use only the specified lubricant from a sealed container. Reseal immediately containers of lubricant. Lubricant becomes moisture saturated and should not be used without proper sealing.
 - Never allow lubricant to come in contact with styrene foam parts. Damage may result.

CONTAMINATED REFRIGERANT

Take appropriate steps shown below if a refrigerant other than pure HFC-134a (R-134a) is identified in a vehicle:

- Explain to the customer that environmental regulations prohibit the release of contaminated refrigerant into the atmosphere.
- Explain that recovery of the contaminated refrigerant could damage service equipment and refrigerant supply.
- Suggest the customer return the vehicle to the location of previous service where the contamination may have occurred.
- In case of repairing, recover the refrigerant using only **dedicated equipment and containers. Never recover contaminated refrigerant into the existing service equipment.** Contact a local refrigerant product retailer for available service if the facility does not have dedicated recovery equipment. This refrigerant must be disposed of in accordance with all federal and local regulations. In addition, replacement of all refrigerant system components on the vehicle is recommended.
- The air conditioner warranty is void if the vehicle is within the warranty period. Please contact Nissan Customer Affairs for further assistance.

REFRIGERANT CONNECTION

A new type refrigerant connection has been introduced to all refrigerant lines except the following location.

- Expansion valve to evaporator
- Refrigerant pressure sensor to liquid tank

WARNING:

Check that all refrigerant is discharged into the recycling equipment and the pressure in the system is less than atmospheric pressure. Then gradually loosen the discharge side hose fitting and remove it.

CAUTION:

Observe the following when replacing or cleaning refrigerant cycle components.

- To prevent fluorescent indicator from entering, prepare and use exclusive hose for EV (electric vehicle) and HEV (hybrid vehicle) when connecting recovery/recycling/recharging equipment.
- Store it in the same way as it is when mounted on the car when the compressor is removed. Failure to do so will cause lubricant to enter the low-pressure chamber.
- Use the torque wrench or the backup wrench when installing the piping.
- Plug immediately all openings to prevent entry of dust and moisture after disconnecting tubes.
- Connect the pipes at the final stage of the operation when installing an air conditioner in the vehicle. Never remove the seal caps of pipes and other components until just before required for connection.
- Allow components stored in cool areas to warm to working area temperature before removing seal caps. This prevents condensation from forming inside A/C components.
- Remove thoroughly moisture from the refrigeration system before charging the refrigerant.
- Replace always used O-rings.
- Apply lubricant to circle of the O-rings shown in illustration when connecting tube. Be careful not to apply lubricant to threaded portion.
- O-ring must be closely attached to the groove portion of tube.
- Be careful not to damage O-ring and tube when replacing the O-ring.

PRECAUTIONS

< PRECAUTION >

- Connect tube until a click can be heard. Then tighten the nut or bolt by hand. Check that the O-ring is installed to tube correctly.
- Perform leakage test and make sure that there is no leakage from connections after connecting line. Disconnect that line and replace the O-ring when the refrigerant leaking point is found. Then tighten connections of seal seat to the specified torque.

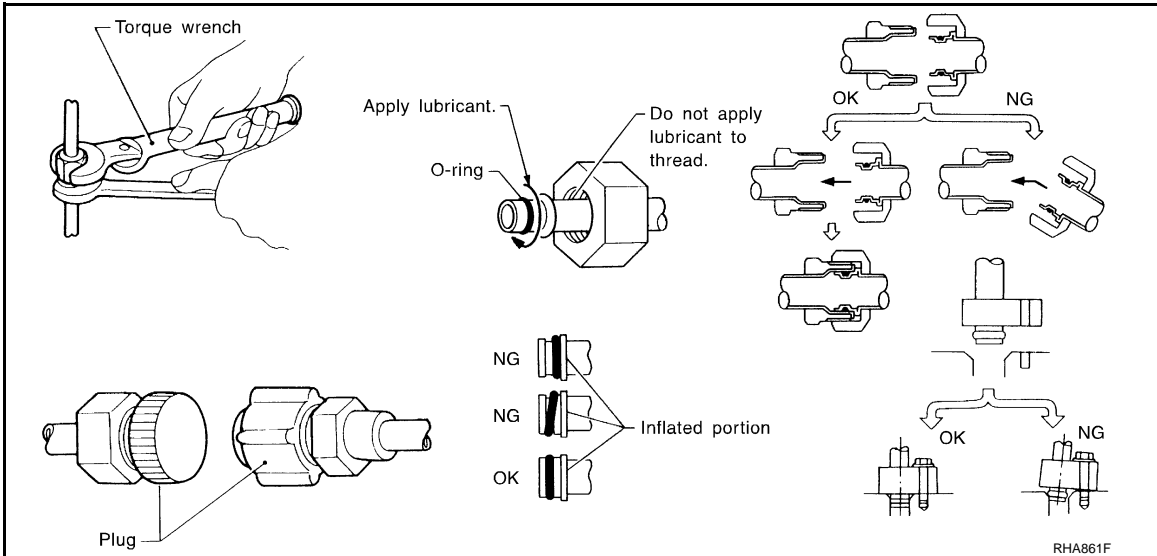

COMPRESSOR

CAUTION:

- Plug all openings to prevent moisture and foreign matter from entering.
- Store it in the same way as it is when mounted on the car when the compressor is removed.
- Follow "Maintenance of Lubricant Quantity in Compressor" exactly when replacing or repairing compressor. Refer to [HA-31, "Description"](#).

REFRIGERANT LEAKAGE DETECTING FLOURESCENT INDICATOR

CAUTION:

- Never use fluorescent indicators as these may reduce the insulation resistance.
- If a fluorescent indicator enters the refrigerant cycle, either wash the refrigerant cycle parts or replace the parts.

A/C IDENTIFICATION LABEL

Vehicles with factory installed A/C systems have this identification label on the underside of hood.

NOTE:

- Vehicles with factory installed fluorescent dye have a green label.
- Vehicles without factory installed fluorescent dye have a blue label.

Service Equipment

INFOID:000000007566292

RECOVERY/RECYCLING RECHARGING EQUIPMENT

Be certain to follow the manufacturer's instructions for machine operation and machine maintenance. Never introduce any refrigerant other than that specified into the machine.

VACUUM PUMP

PRECAUTIONS

< PRECAUTION >

The lubricant contained inside the vacuum pump is not compatible with the specified lubricant for HFC-134a (R-134a) A/C systems. The vent side of the vacuum pump is exposed to atmospheric pressure. So the vacuum pump lubricant may migrate out of the pump into the service hose. This is possible when the pump is switched OFF after evacuation (vacuuming) and hose is connected to it. To prevent this migration, use a manual valve placed near the hose-to-pump connection, as per the following.

- Vacuum pumps usually have a manual isolator valve as part of the pump. Close this valve to isolate the service hose from the pump.
- Use a hose equipped with a manual shut-off valve near the pump end for pumps without an isolator. Close the valve to isolate the hose from the pump.
- Disconnect the hose from the pump if the hose has an automatic shut-off valve. As long as the hose is connected, the valve is open and lubricating oil may migrate.

Some one-way valves open when vacuum is applied and close under no vacuum condition. Such valves may restrict the pump's ability to pull a deep vacuum and are not recommended.

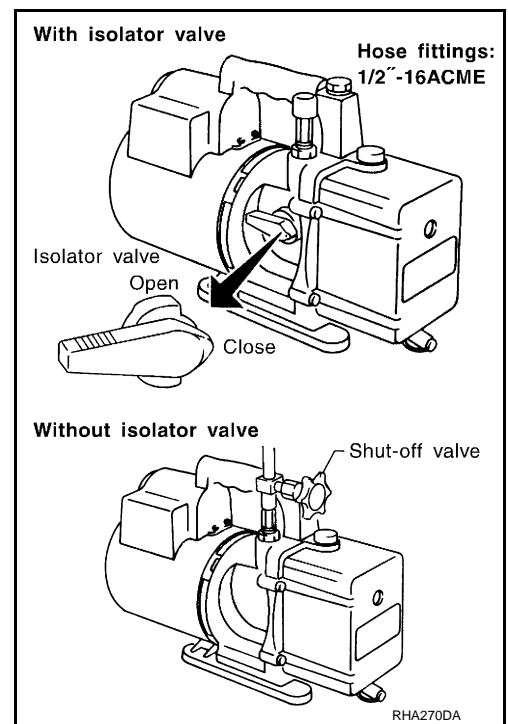

MANIFOLD GAUGE SET

Be certain that the gauge face indicates HFC-134a or R-134a. Be sure the gauge set has 1/2\"-16 ACME threaded connections for service hoses. Confirm the set has been used only with refrigerant HFC-134a (R-134a) and specified lubricants.

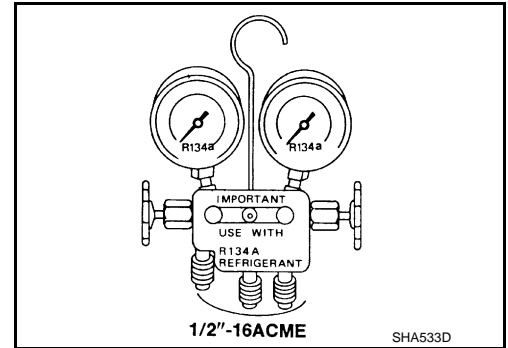

SERVICE HOSES

Be certain that the service hoses display the markings described (colored hose with black stripe). All hoses must equip positive shut-off devices (either manual or automatic) near the end of the hoses opposite to the manifold gauge.

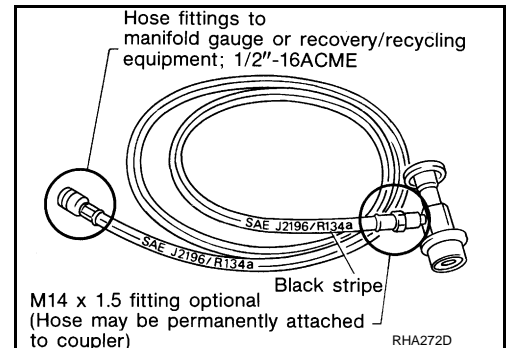

SERVICE COUPLERS

PRECAUTIONS

< PRECAUTION >

Never attempt to connect HFC-134a (R-134a) service couplers to the CFC-12 (R-12) A/C system. The HFC-134a (R-134a) couplers never properly connect to the CFC-12 (R-12) system. However, if an improper connection is attempted, discharging and contamination may occur.

Shut-off valve rotation	A/C service valve
Clockwise	Open
Counterclockwise	Close

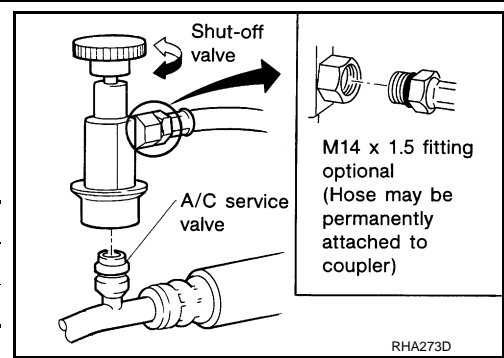

REFRIGERANT WEIGHT SCALE

Verify that no refrigerant other than HFC-134a (R-134a) and specified lubricants have been used with the scale. The hose fitting must be 1/2"-16 ACME if the scale controls refrigerant flow electronically.

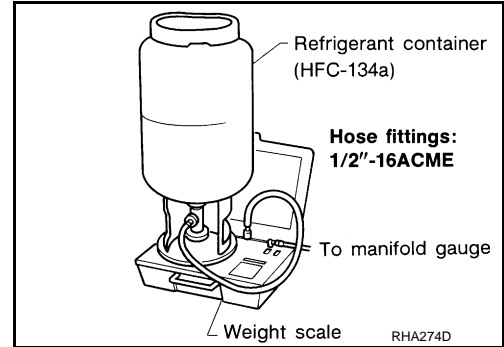

CHARGING CYLINDER

Using a charging cylinder is not recommended. Refrigerant may be vented into air from cylinder's top valve when filling the cylinder with refrigerant. Also, the accuracy of the cylinder is generally less than that of an electronic scale or of quality recycle/recharge equipment.

A
B
C
D
E
F
G
H
J
K
L
M
N
O
P

HA

PREPARATION

< PREPARATION >

PREPARATION

PREPARATION



Special Service Tool

INFOID:000000007063696

The actual shapes of Kent-Moore tools may differ from those of special service tools illustrated here.

HFC-134a (R-134a) Service Tool and Equipment

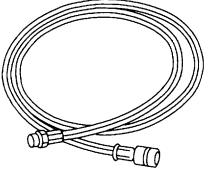
- Never mix HFC-134a (R-134a) refrigerant and/or its specified lubricant with CFC-12 (R-12) refrigerant and/or its lubricant.
- Separate and non-interchangeable service equipment must be used for handling each type of refrigerant/lubricant.
- Refrigerant container fittings, service hose fittings and service equipment fittings (equipment which handles refrigerant and/or lubricant) are different between CFC-12 (R-12) and HFC-134a (R-134a). This is to avoid mixed use of the refrigerants/lubricant.
- Never use adapters that convert one size fitting to another: refrigerant/lubricant contamination occurs and compressor malfunction may result.

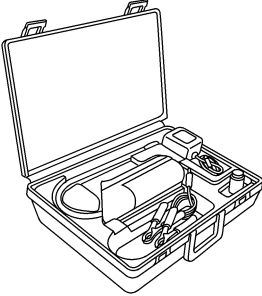
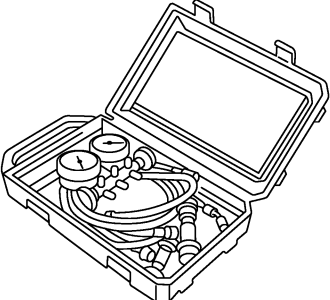
Tool name Tool number (Kent-Moore No.)	Description
<p>Service hoses</p> <ul style="list-style-type: none"> • High-pressure side hose (J-39501-72) • Low-pressure side hose (J-39502-72) • Utility hose (J-39476-72) 	 <p>Hose color:</p> <ul style="list-style-type: none"> • Low-pressure side hose: Blue with black stripe • High-pressure side hose: Red with black stripe • Utility hose: Yellow with black stripe or green with black stripe <p>Hose fitting to gauge: 1/2" -16 ACME</p>
<p>ACR5 A/C Service Center (ACR2005-NI)</p>	 <p>Function: Refrigerant recovery, recycling and recharging</p>
<p>(J-41995) Electrical leak detector</p>	 <p>Power supply: DC 12 V (Battery terminal)</p>
<p>Manifold gauge set (with hoses and couplers) (J-39183)</p>	 <p>Identification: The gauge face indicates HFC-134a (R-134a) Fitting size: Thread size: 1/2" -16 ACME</p>

PREPARATION

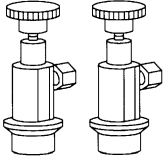
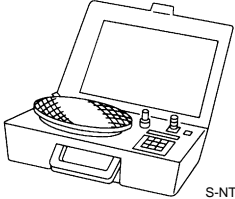
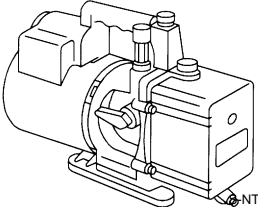

< PREPARATION >

Tool name Tool number (Kent-Moore No.)	Description
<p>Service couplers</p> <ul style="list-style-type: none"> • High-pressure side coupler (J-39500-20) • Low-pressure side coupler (J-39500-24)  <p style="text-align: center;">S-NT202</p>	<p>Hose fitting to service hose: M14 x 1.5 fitting is optional or permanently attached</p>
<p>Refrigerant weight scale (J-39650)</p>  <p style="text-align: center;">S-NT200</p>	<p>For measuring of refrigerant Fitting size: Thread size: 1/2" -16 ACME</p>
<p>Vacuum pump (Including the isolator valve) (J-39649)</p>  <p style="text-align: center;">S-NT203</p>	<p>Capacity:</p> <ul style="list-style-type: none"> • Air displacement: 4 CFM • Micron rating: 20 microns • Oil capacity: 482 mℓ (16.3 US fl oz, 17 Imp fl oz) <p>Fitting size: Thread size: 1/2" -16 ACME</p>

Commercial Service Tools

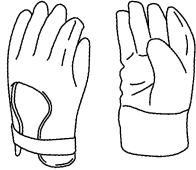

INFOID:000000006960766

HA

Tool name	Description
<p>Insulated gloves [Guaranteed insulation performance for 1000 V/300 A]</p>  <p style="text-align: center;">JMCIA0149ZZ</p>	<p>Removing and installing high voltage components</p>
<p>Leather gloves [Use leather gloves that can fasten the wrist tight]</p>  <p style="text-align: center;">JPCIA0066ZZ</p>	<ul style="list-style-type: none"> • Removing and installing high voltage components • Protect insulated gloves
<p>Insulated safety shoes</p>  <p style="text-align: center;">JPCIA0011ZZ</p>	<p>Removing and installing high voltage components</p>

PREPARATION

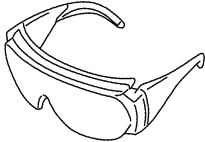
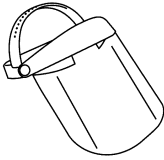
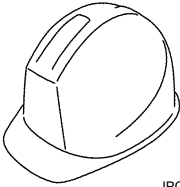
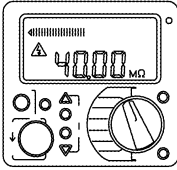
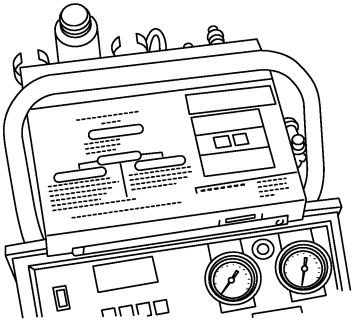
< PREPARATION >

Tool name	Description
<p>Safety glasses [ANSI Z87.1]</p>  <p>JPCIA0012ZZ</p>	<ul style="list-style-type: none"> • Removing and installing high voltage components • To protect eye from the spatter on the work to electric line
<p>Face shield</p>  <p>JPCIA0167ZZ</p>	<ul style="list-style-type: none"> • Removing and installing high voltage components • To protect face from the spatter on the work to electric line
<p>Insulated helmet</p>  <p>JPCIA0013ZZ</p>	<p>Removing and installing high voltage components</p>
<p>Insulation resistance tester (Multi tester)</p>  <p>JPCIA0014ZZ</p>	<p>Measuring insulation resistance, voltage, and resistance</p>
<p>Refrigerant identifier equipment</p>  <p>RJIA0197E</p>	<p>Checking for refrigerant purity and system contamination</p>
<p>Power tools</p>  <p>PIIB1407E</p>	<p>For loosening bolts, nuts, and screws</p>

PREPARATION

< PREPARATION >

Oil and Grease

INFOID:000000006960765

Name	Application	Note
Refrigerant can (HFC-134a)	Charging refrigerant	—
Compressor oil ND-OIL 11 KLH00-00040	Refilling compressor oil	—

A

B

C

D

E

F

G

H

HA

J

K

L

M

N

O

P

DESCRIPTION

< SYSTEM DESCRIPTION >

SYSTEM DESCRIPTION

DESCRIPTION

Description

INFOID:000000006997027

- This vehicle includes an ozone-safe full automatic air conditioning system.
- This system utilizes an A/C unit that combines the blower unit, heater unit, and cooling unit.
- It contains a sub-cool condenser in which the liquid tank is installed onto the condenser.
- An electric scroll compressor (with internal inverter) is used.
- A PTC element heater is used as the heat source for heating.
- Adopted an electric heater pump to circulate the water which warmed with a PTC element heater.

Specification

INFOID:000000006997028

COMPRESSOR

Item		Specification		
Compressor body	Model (manufacturer)	AES28AV3AA (Panasonic)		
	Compressor	Type	Scroll type	
		Displacement [cm ³ (cu in)/rpm]		28 (1.7)
		Oil	Name	ND-OIL 11 (ester oil)
			Capacity [m ℓ (US fl oz, Imp fl oz)]	150 (5.1, 5.3)
		Allowable speed range (rpm)		780 – 8,300
	Release valve opening pressure [kPa (kg/cm ² , psi)]		3,500 – 4,140 (35.7, 507.5) – (42.3, 600.3)	
	Motor	Type	DC brushless motor	
		Battery voltage (V)	345	
		Power consumption (kW)	2.1	

CONDENSER & LIQUID TANK

Item		Specification
Condenser	Type	Parallel flow type
	Width x Height x Thickness (core) [mm (in)]	615 (24.2) × 343 (13.5) × 16 (0.6)
	Frontal area (core) (m ²)	0.2
	Fin pitch [mm (in)]	1.4 (0.1)
	Heat discharge at wind speed 5 m/s [W (kcal/h)]	16,300 (14,015)
Liquid tank	Capacity [m ℓ (US fl oz, Imp fl oz)]	200 (6.8, 7.0)

REFRIGERANT PRESSURE SENSOR

Item	Specification
Type	Capacitance type

REFRIGERANT

Item	Specification
Name	HFC-134a
Capacity [kg (lb)]	0.4 (0.9)

A/C UNIT

DESCRIPTION

< SYSTEM DESCRIPTION >

Item		Specification	
Cooling unit	Cooling capacity at air flow 7 m ³ /min	[W (kcal/h)] 5,600 (4,816)	
	Evaporator	Type	Laminate type
		Height x Width x Thickness	[mm (in)] 225 (8.9) × 256.4 (10.1) × 39 (1.5)
		Fin pitch	[mm (in)] 2.6 (0.1)
Expansion valve type		Block-type external pressure equalization valve	
Heater unit	Heating capacity at air flow 5 m ³ /min	[W (kcal/h)] 5,350 (4,600)	
	Heater core	Type	Corrugated fin type
		Height x Width x Thickness	[mm (in)] 172.5 (6.8) × 218.5 (8.6) × 27 (1.1)
		Fin pitch	[mm (in)] 1.4 (0.1)
Blower motor	Fan	Type	Sirocco fan type
		Outer diameter × Width	[mm (in)] φ133 (5.2) × 85 (3.4)
	Motor	Type	Brushless motor type
		Power consumption	(W) 225

PTC ELEMENT HEATER

Item	Specification
Battery voltage	(V) 345
Output	[W (kcal/h)] 5,000 (4,299)
Capacity	[m ℓ (US fl oz, Imp fl oz)] 370 (12.5, 13.0)

HEATER PUMP

Item	Specification
Battery voltage	(V) 12
Allowable speed range	(rpm) 750 – 4,700
Maximum displacement	[cm ³ (cu in)/rpm] 12,000 (734.8)

A
B
C
D
E
F
G
H
HA
J
K
L
M
N
O
P

COMPONENT PARTS

< SYSTEM DESCRIPTION >

COMPONENT PARTS REFRIGERATION SYSTEM

REFRIGERATION SYSTEM : Component Parts Location

INFOID:000000006997029

COMPONENT PARTS LOCATION

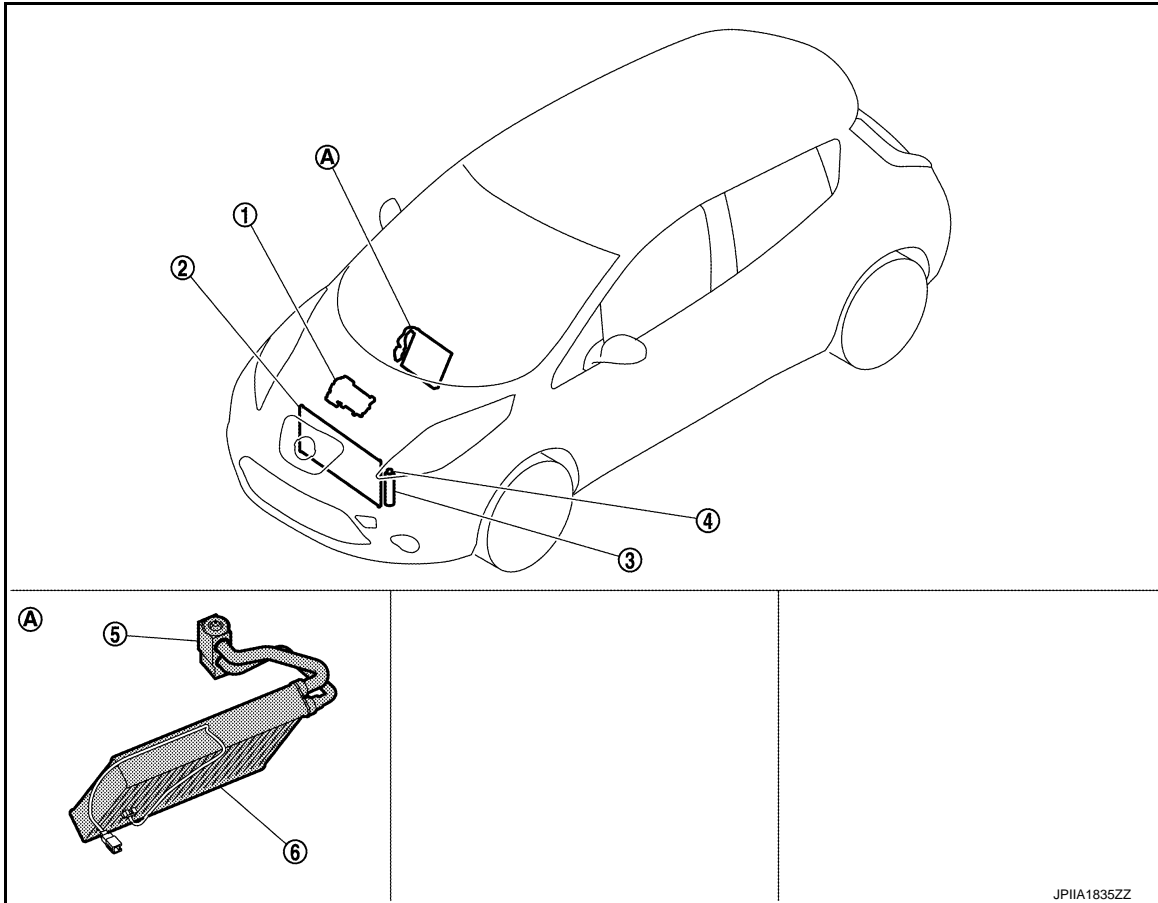

A. Built-in A/C unit assembly

COMPONENT PARTS DESCRIPTION

No.	Location	DESCRIPTION
1.	Electric compressor	Performs the intake, compression, and discharge of refrigerant, and circulates the refrigerant in the cooler cycle. Refer to HA-21, "Electric Compressor" .
2.	Condenser	Cools the high-temperature high-pressure refrigerant discharged from compressor to change it to the liquid refrigerant. Refer to HA-21, "CONDENSER : Condenser" .
3.	Liquid tank	Remove foreign materials from refrigerant that is discharged from condenser, and then temporarily collect the liquid refrigerant. Refer to HA-21, "CONDENSER : Liquid Tank" .
4.	Refrigerant pressure sensor	Refer to HAC-14, "Refrigerant Pressure Sensor" .
5.	Expansion valve	Turn the high-pressure liquid refrigerant to the misty low-pressure liquid refrigerant by squeezing action. Refer to HA-20, "A/C UNIT ASSEMBLY : Expansion Valve" .
6.	Evaporator	The misty liquid refrigerant causes evaporation and turns into gas by the air blown from blower motor. Cool the air by vaporization heat at this time. Refer to HA-20, "A/C UNIT ASSEMBLY : Evaporator" .

HEATING SYSTEM

COMPONENT PARTS

< SYSTEM DESCRIPTION >

HEATING SYSTEM : Component Parts Location

INFOID:000000006997031

COMPONENT PARTS LOCATION

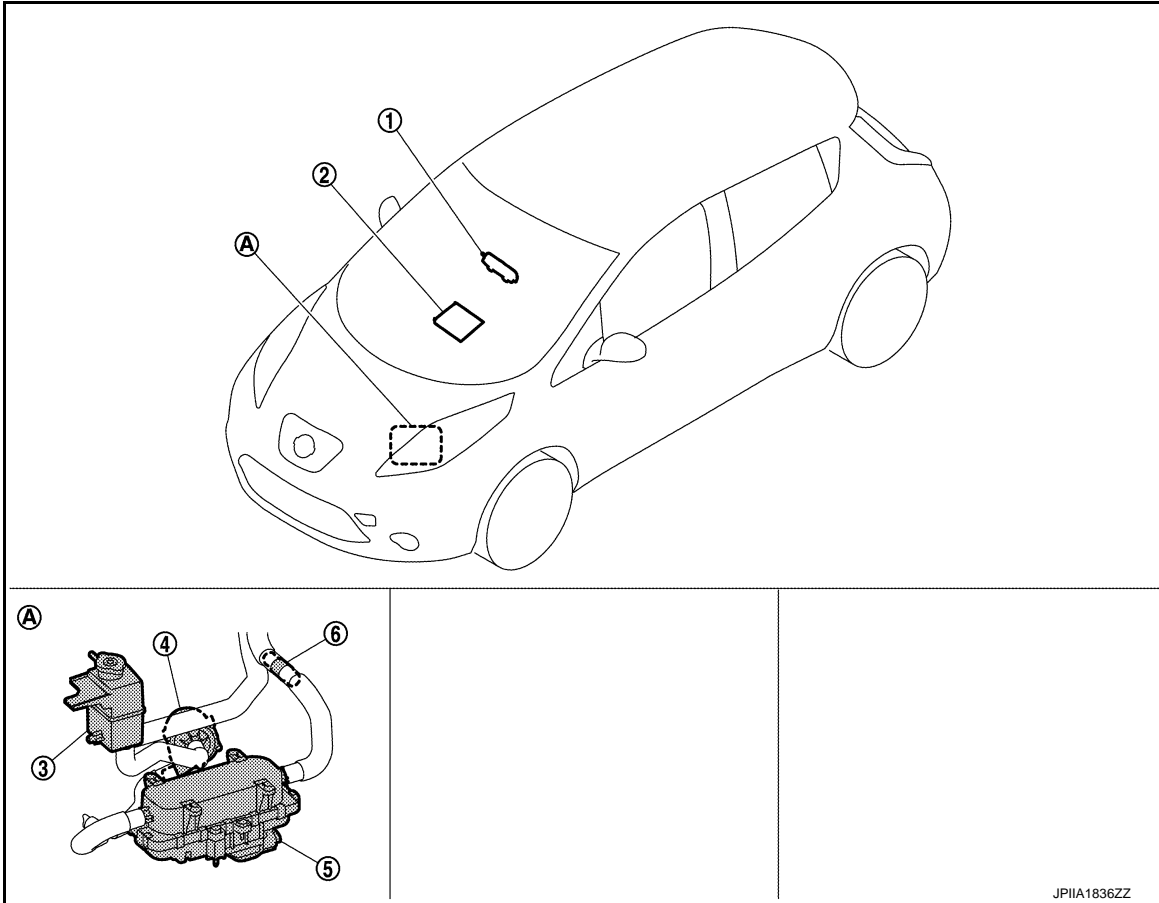

A. Left side of motor room

COMPONENT PARTS DESCRIPTION

No.	Location	DESCRIPTION
1.	A/C auto amp.	HAC-15, "AUTOMATIC AIR CONDITIONING SYSTEM : System Description"
2.	Heater core	HA-20, "A/C UNIT ASSEMBLY : Heater Core"
3.	Degas tank	Accumulates heater fluid and bleeds the air from fluid circuit.
4.	Heater pump	HA-24, "Heater Pump"
5.	PTC element heater	HA-23, "PTC Element Heater"
6.	Heater fluid temperature sensor	HAC-15, "AUTOMATIC AIR CONDITIONING SYSTEM : System Description"

A/C UNIT ASSEMBLY

COMPONENT PARTS

< SYSTEM DESCRIPTION >

A/C UNIT ASSEMBLY : A/C Unit

INFOID:000000006997033

This system utilizes an A/C unit that combines blower unit, heater unit, and cooling unit.

↔ : Vehicle front

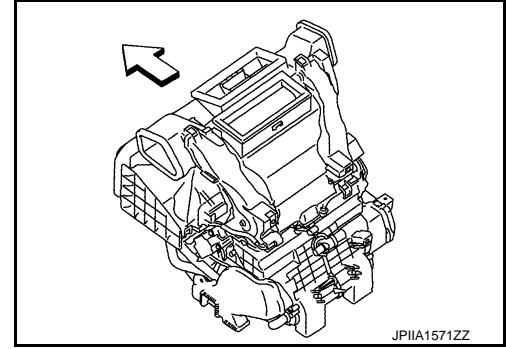

A/C UNIT ASSEMBLY : Evaporator

INFOID:000000006997034

A thin laminate pipeless evaporator is used.

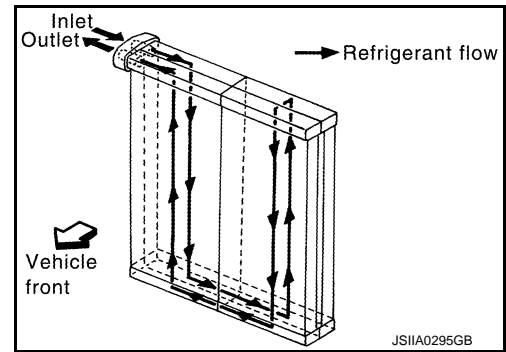

A/C UNIT ASSEMBLY : Expansion Valve

INFOID:000000006997035

The refrigerant temperature is detected by the temperature sensing part located in low-pressure refrigerant path inside expansion valve. The lift amount of high-pressure side ball valve is changed to regulate the refrigerant flow.

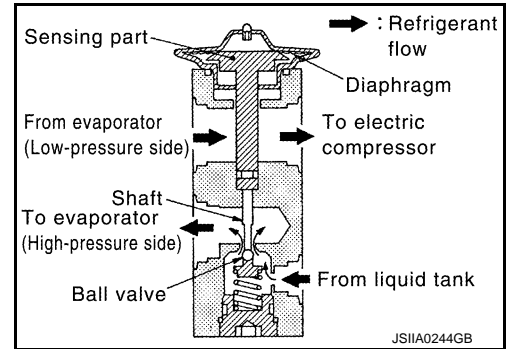

A/C UNIT ASSEMBLY : Heater Core

INFOID:000000006997036

An aluminum corrugated fin heater core is used.

↔ : Vehicle front

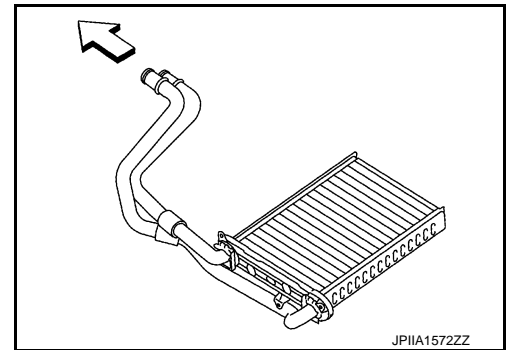

CONDENSER

COMPONENT PARTS

< SYSTEM DESCRIPTION >

CONDENSER : Condenser

INFOID:000000006997037

DESCRIPTION

A sub-cool condenser that combines a parallel-flow condenser and liquid tank in the sub-cool cycle is used.

STRUCTURE AND OPERATION

The sub-cool section is installed on the condenser, and the liquid refrigerant that exits the liquid tank is further cooled by the condenser sub-cool section, increasing the amount of heat that the liquid refrigerant can absorb and improving cooling performance.

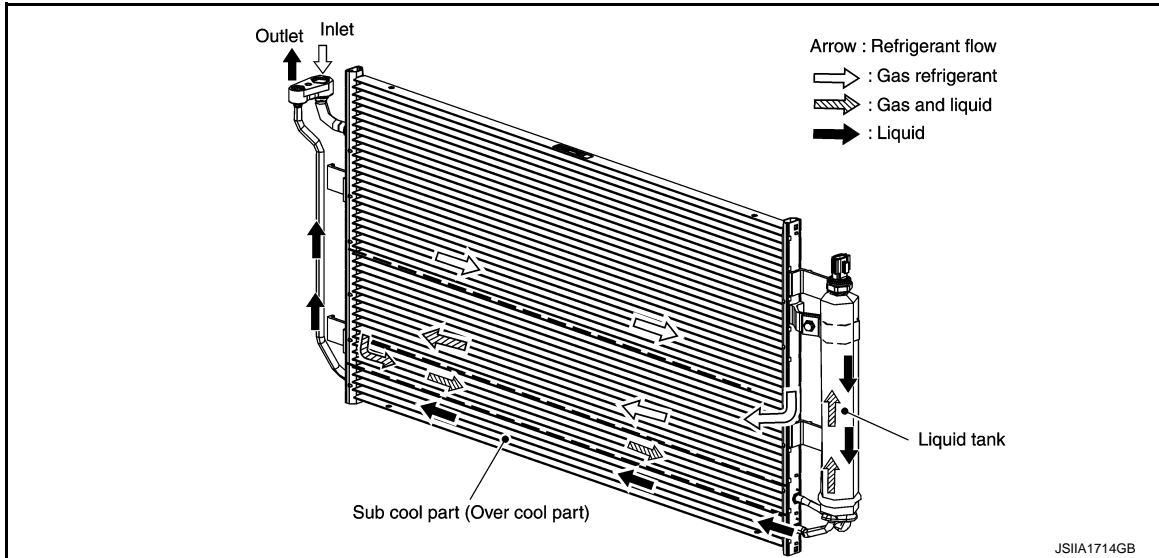

CONDENSER : Liquid Tank

INFOID:000000006997038

- A liquid tank compatible with HFC-134a refrigerant is used.
- A refrigerant pressure sensor for cooler cycle protection control and compressor speed control is installed on the liquid tank. For details, refer to [HAC-14, "Refrigerant Pressure Sensor"](#).

Electric Compressor

INFOID:000000006997039

- An electric scroll compressor is used.
- A 3-phase output inverter with IPM^{Note} is used.
- The inverter is adopted to IPM^{Note} for smaller size and improved reliability.

NOTE:

IPM (Intelligent Power Module) is the element which delivered power device equivalent to IGBT and the protection feature of the circuit to one package.

NOTE:

IGBT (Insulated Gate Bipolar Transistor) is a transistor which is suitable for high voltages and large currents and which can control large electrical power using a small gate voltage.

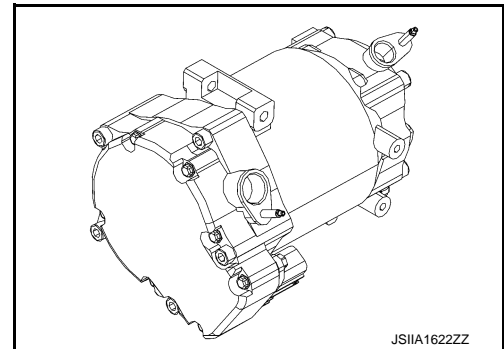

- The structure integrates the inverter, compressor, and motor, allowing compressor to operate at any speed.

COMPONENT PARTS

< SYSTEM DESCRIPTION >

- The inverter communicates with A/C auto amp., and uses PWM control^{Note} to control the motor speed via the drive circuit.

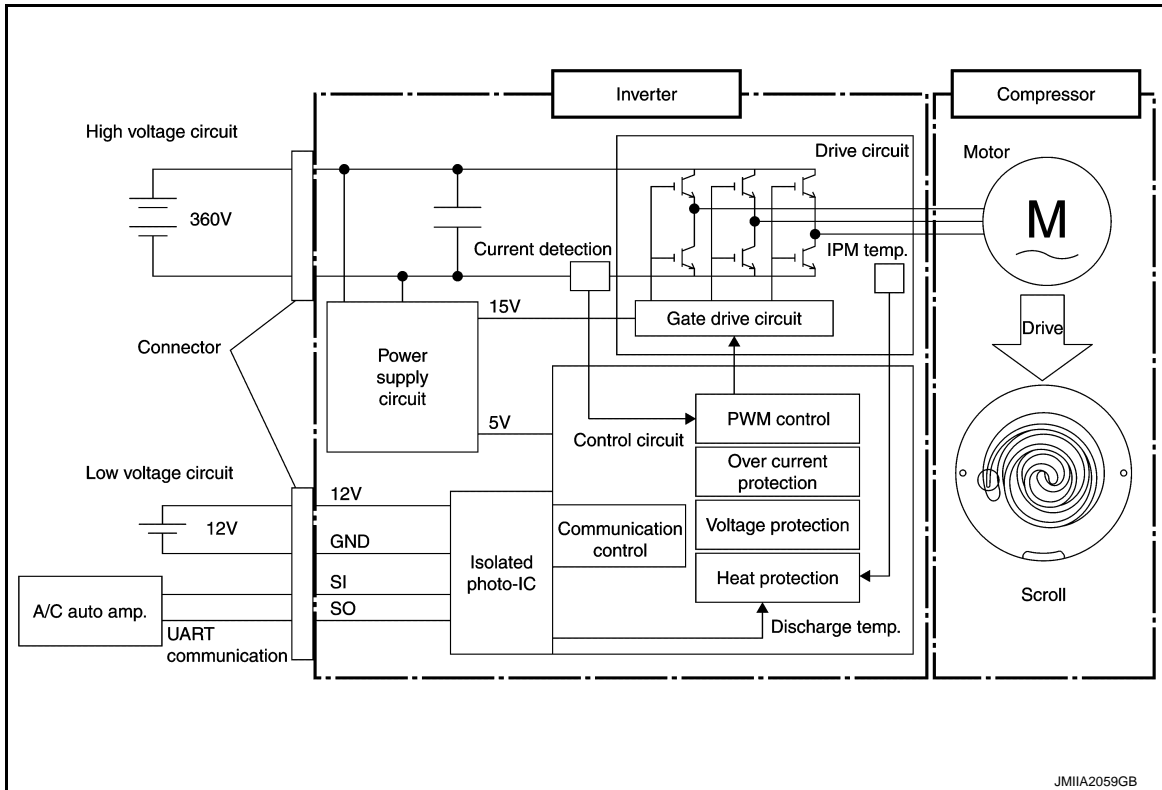

NOTE:

- PWM (Pulse Width Modulation) is a system that controls current and voltage by changing the duty ratio of a constant frequency pulse wave.
- PWM is used as the adjustment method of output voltage when inverter is used as a power supply for controlling motor speed.
- PWM changes voltage application time (pulse width) using a semiconductor element and controls motor speed.
- The IPM contains an internal protection circuit, and uses the inverter control circuit to monitor for an increase in motor drive circuit temperature in order to prevent circuit overheating.
- The motor uses a DC brushless motor, with speed control performed by the inverter drive circuit.

COMPONENT PARTS

< SYSTEM DESCRIPTION >

- A scroll-type compressor is used. The motor drive force is used to rotate the moveable scroll and perform refrigerant intake, compression, and discharge.

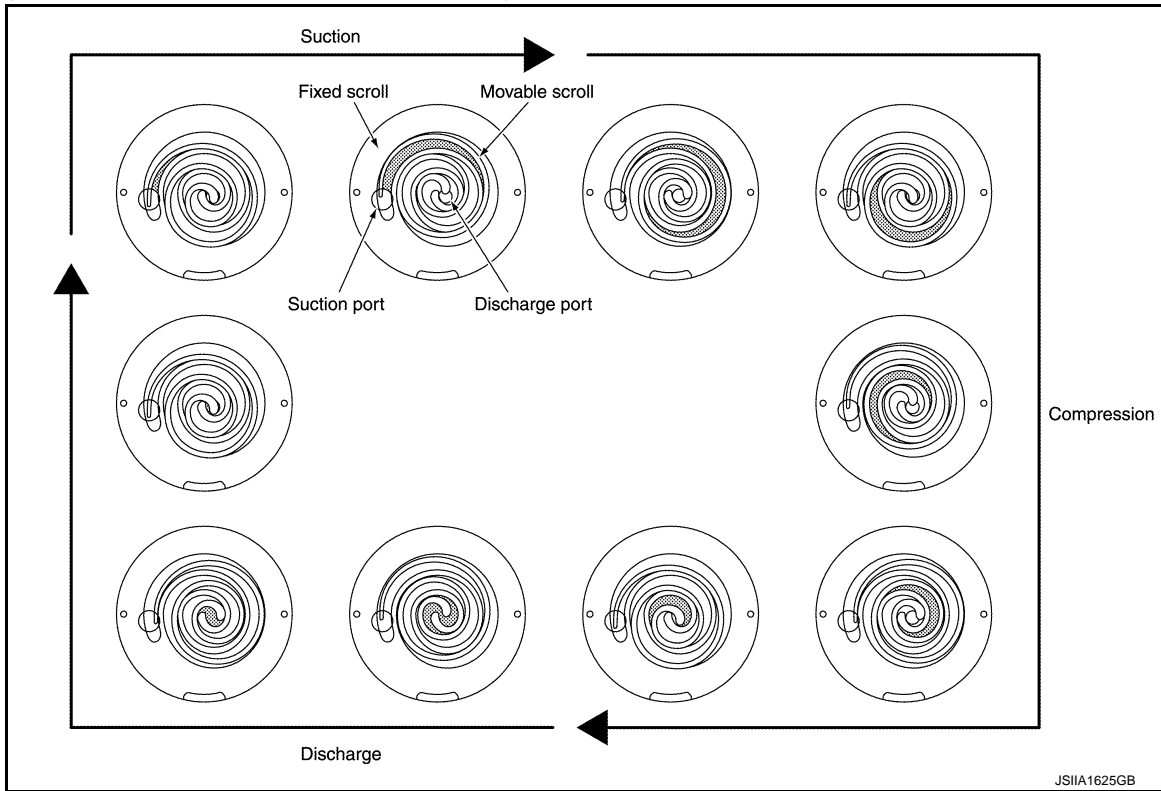

PTC Element Heater

INFOID:000000006997040

- A PTC element heater is used as the heat source for heating.
- An internal control circuit is installed for communication with A/C auto amp..
- Based on the signals from A/C auto amp., the microcomputer inside PTC element heater controls the heater output by PWM^{Note}.

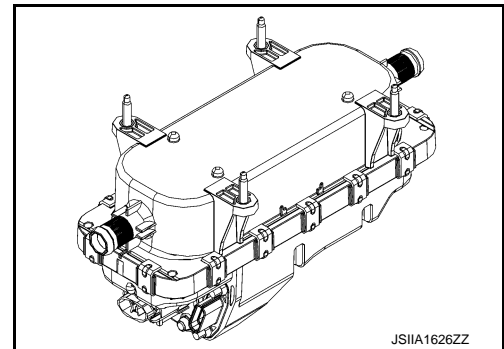

NOTE:

- PWM (Pulse Width Modulation) is a system that controls current and voltage by changing the duty ratio of a constant frequency pulse wave.
- PWM is used as the adjustment method of output voltage when inverter is used as a power supply for controlling motor speed.

COMPONENT PARTS

< SYSTEM DESCRIPTION >

- PWM changes voltage application time (pulse width) using a semiconductor element and controls PTC element heater.

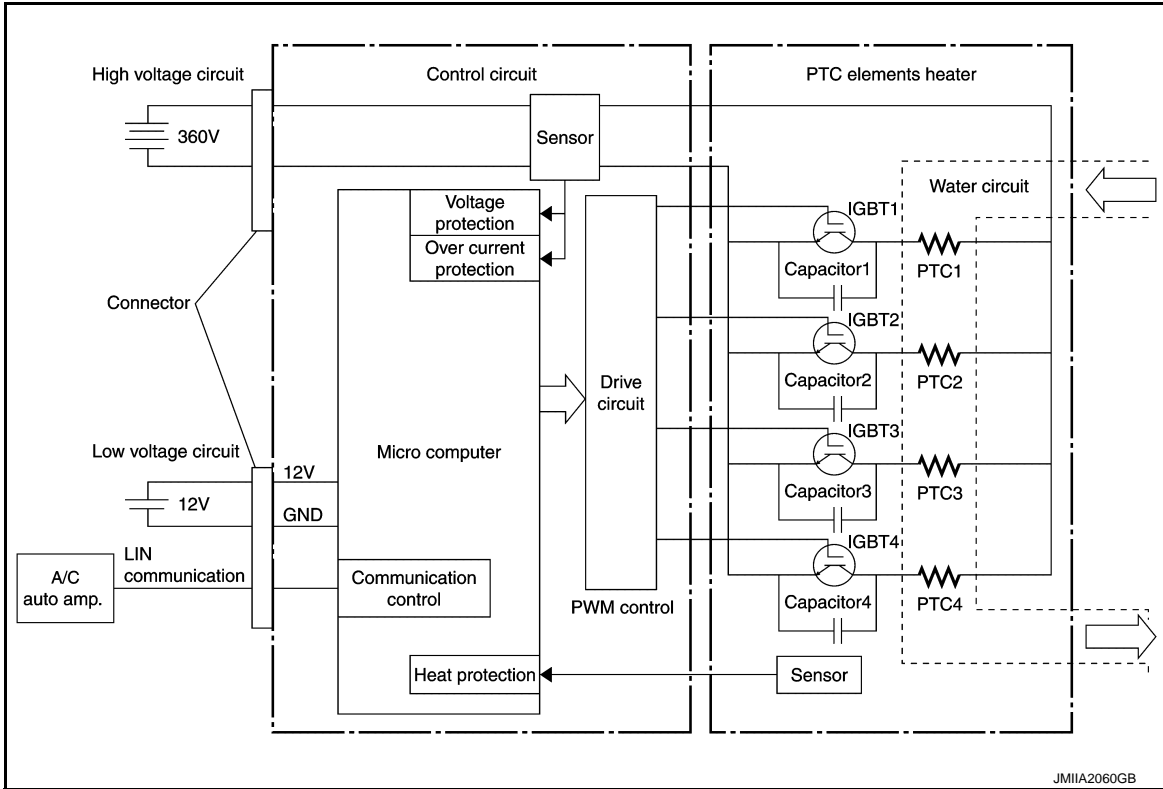

PTC ELEMENT

- PTC stands for "Positive Temperature Coefficient", and is a ceramic material with barium titanate as the primary component.
- When current is applied, it heats up. Upon reaching a certain temperature (Curie temperature) the resistance suddenly increases, limiting the current, and maintaining a constant amount of heating.

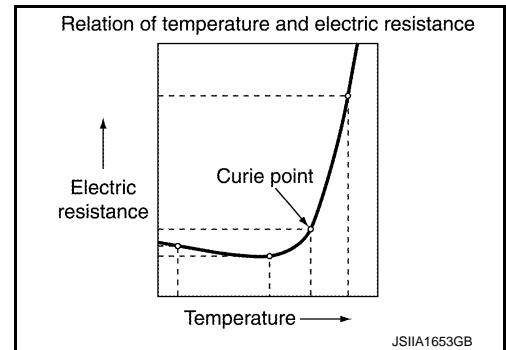

Heater Pump

INFOID:000000006997041

- Heater pump is used to circulate the water heated by PTC element heater.

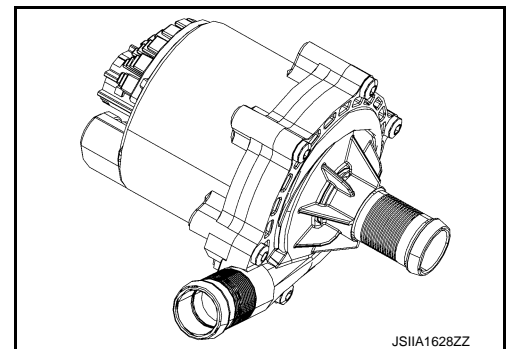

COMPONENT PARTS

< SYSTEM DESCRIPTION >

- The speed of heater pump is controlled based on the drive signal from A/C auto amp..

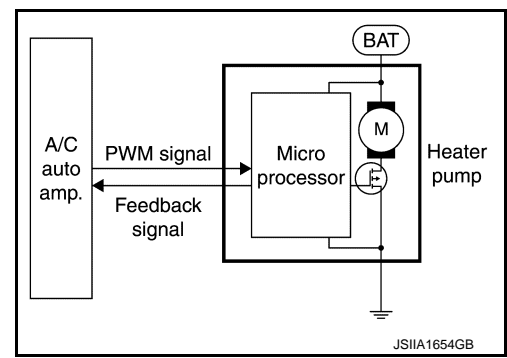

Refrigerant and Compressor Oil

INFOID:000000006997042

- The refrigerant is HFC-134a, which contains no chlorine (Cl), a substance which damages the ozone layer.
- The compressor oil is ND-OIL 11, an ester oil with high insulation performance, designed especially for electric compressors.

CAUTION:

The special electric compressor oil has different properties from the conventional HFC-134a compressor oil (PAG oil) and CFC-12 compressor oil (mineral oil). Be sure not to mix these oil types with compressor oil, as doing so may cause electric leakage.

NOTE:

- HFC: HydroFluoroCarbon
- CFC: ChloroFluoroCarbon

Heater Fluid

INFOID:000000006997043

- Water is used as the medium for transporting the heat generated by PTC element heater in the motor room into the vehicle interior.
- In order to protect the heater water path and prevent freezing, antifreeze^{Note} (Concentration 50%).

HA

NOTE:

The antifreeze used is the LLC which is used to cool conventional engines.

High Voltage Warning Label

INFOID:000000006997044

- High voltage warning label is stuck on each component parts below.
- When replacing component parts make sure to stick it on original position.

Electric Compressor

The label (A) is stuck on the compressor stay.

↔ : Application direction of the label

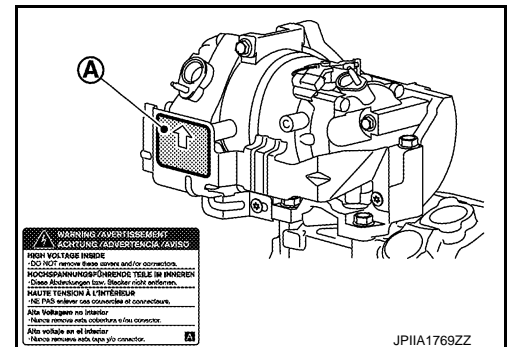

PTC Elements Heater

COMPONENT PARTS

< SYSTEM DESCRIPTION >

The label (A) is stuck on the body of PTC elements heater.

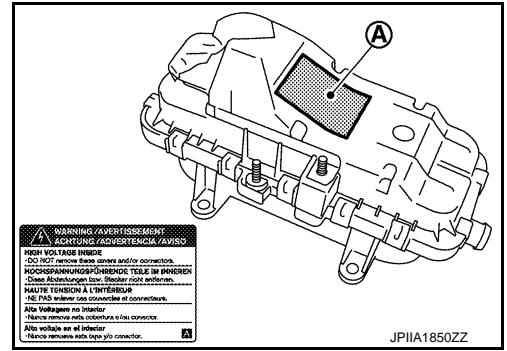

SYSTEM

< SYSTEM DESCRIPTION >

SYSTEM

REFRIGERATION SYSTEM

REFRIGERATION SYSTEM : System Diagram

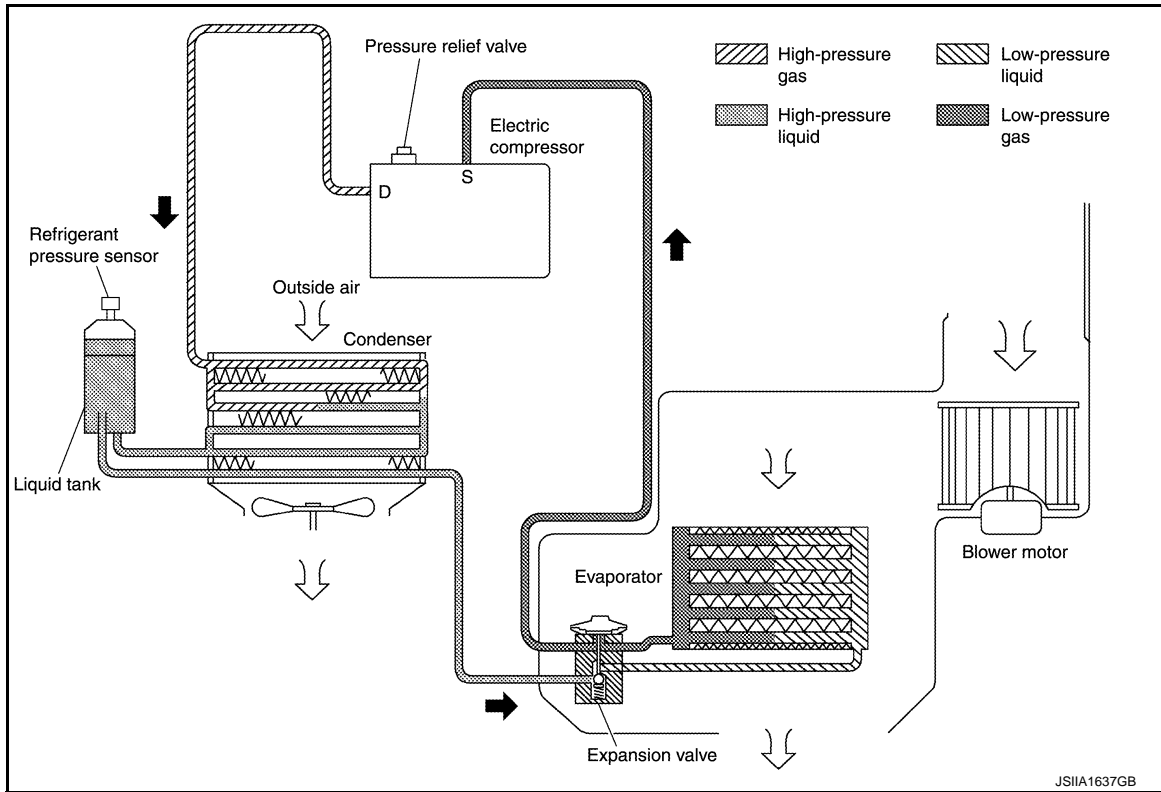

REFRIGERATION SYSTEM : System Description

INFOID:000000006997046

REFRIGERANT CYCLE

Refrigerant Flow

The basic path of refrigerant flow is through the electric compressor, condenser, liquid tank, and evaporator, and then it returns to the electric compressor. The vaporization of evaporator refrigerant is controlled by the expansion valve.

Evaporator Cryoprotective Protection Control

- If the air temperature after passing through the evaporator (detected by the intake sensor) is 1°C (34°F) or less, the A/C auto amp. sends a request for speed 0 rpm to the electric compressor.
- Based on this signal from the A/C auto amp., the electric compressor stops.

REFRIGERANT SYSTEM PROTECTION

Refrigerant Pressure Sensor

- The refrigerant system is protected from significant high pressure and low pressure by the refrigerant pressure sensor that is installed at the condenser outlet.
- The refrigerant pressure sensor outputs a signal to the VCM.
- If the A/C auto amp., judges that there is a malfunction (the conditions shown below) in the cooler cycle based on the refrigerant pressure sensor detection value sent from VCM via EV CAN communications, it stops operation of the electric compressor.

- Approximately 2,650 kPa (27.0 kg/cm², 384.3 psi) or more
- Approximately 140 kPa (1.4 kg/cm², 20.3 psi) or less

NOTE:

The values indicate gauge pressure.

Pressure Relief Valve

SYSTEM

< SYSTEM DESCRIPTION >

- The refrigerant system is protected from significant high pressure by the pressure relief valve that is installed in the electric compressor.
- If the pressure in the cooler cycle is excessively increased [3,500 kPa (35.7 kg/cm², 507.5 psi) - 4,140 kPa (42.2 kg/cm², 600.3 psi) or more], the pressure relief valve opens, releasing refrigerant into the atmosphere.

HEATING SYSTEM

HEATING SYSTEM : System Diagram

INFOID:000000006997047

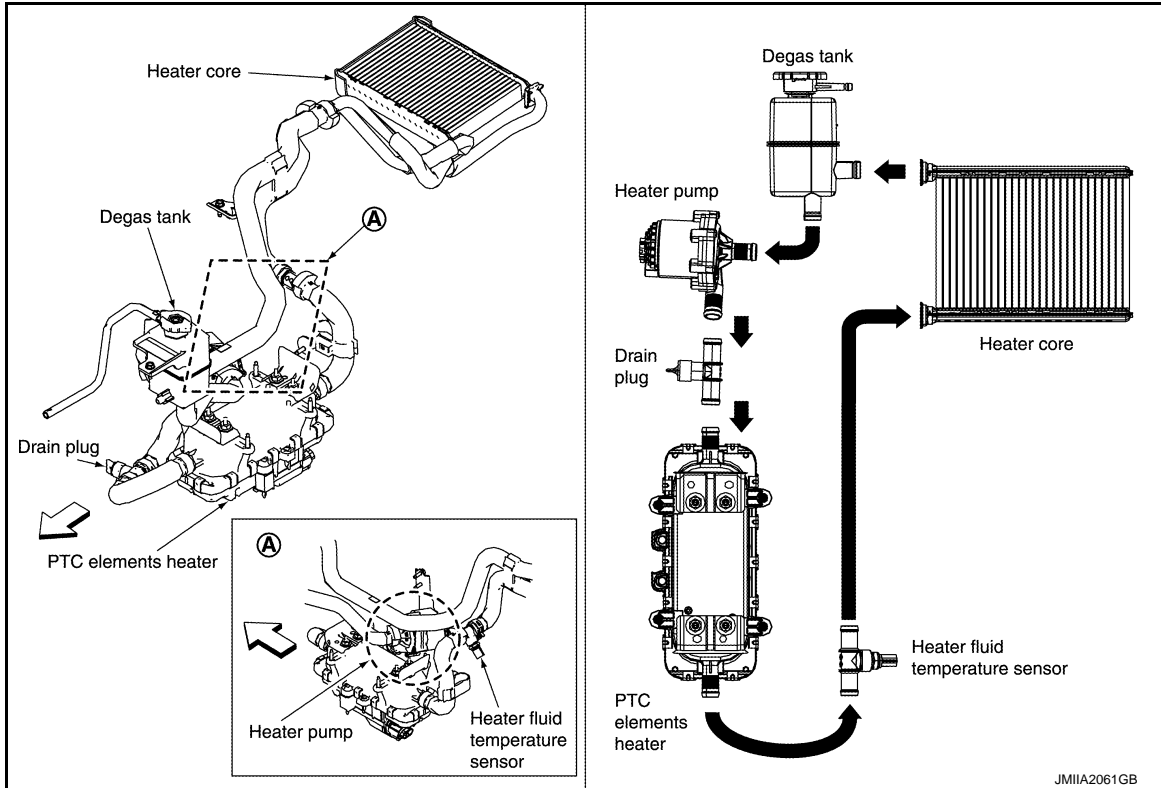

JMIIA2061GB

↶ : Vehicle front

HEATING SYSTEM : System Description

INFOID:000000006997048

HEATING CYCLE

Heater Fluid Flow

- The flow of heater fluid passes through the heater pump, PTC element heater, and heater core and then returns to the heater pump.
- The amount of heat generated by the PTC element heater is controlled by the A/C auto amp.

HEATING SYSTEM PROTECTION

- If the below conditions occur in the heating system, operation of the PTC heater is stopped in order to protect the system.
 - Heater fluid temperature sensor malfunction
 - Communications malfunction between A/C auto amp. and PTC element heater
 - Communications malfunction between A/C auto amp. and heater pump

DIAGNOSIS AND REPAIR WORK FLOW

< BASIC INSPECTION >

BASIC INSPECTION

DIAGNOSIS AND REPAIR WORK FLOW

Flowchart of Trouble Diagnosis

INFOID:000000006997049

DESCRIPTION OF TROUBLE DIAGNOSIS FLOWCHART

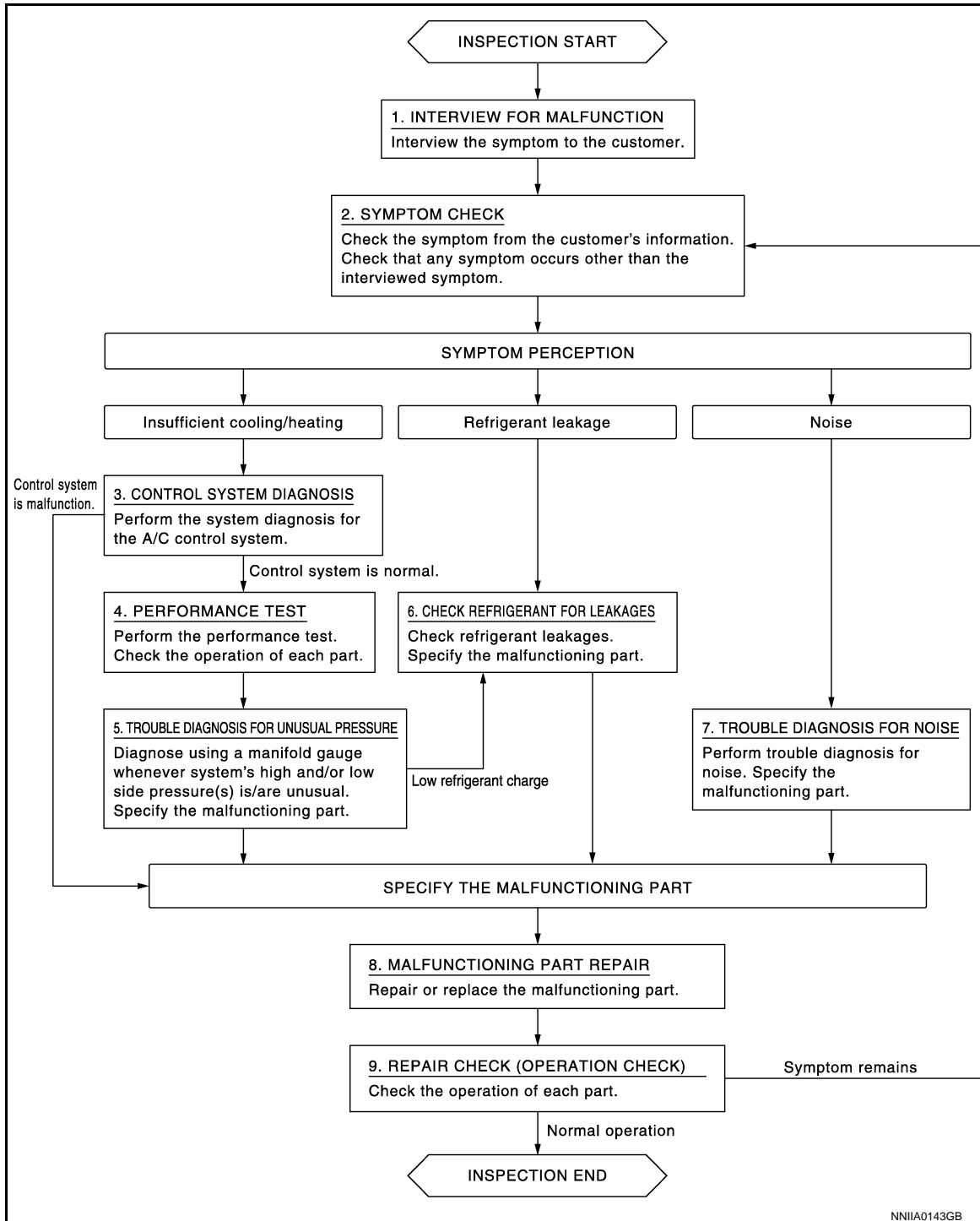

DETAILS OF TROUBLE DIAGNOSIS FLOWCHART

1. INTERVIEW FOR MALFUNCTION

Interview the customer to obtain the malfunction information.

A
B
C
D
E
F
G
H
HA
J
K
L
M
N
O
P

DIAGNOSIS AND REPAIR WORK FLOW

< BASIC INSPECTION >

>> GO TO 2.

2. SYMPTOM CHECK

Check the malfunction based on the information obtained from the customer. Check if any other malfunctions are present.

Insufficient cooling·Insufficient heating>>GO TO 3.

Coolant leakage>>GO TO 6.

Noise >> GO TO 7.

3. CONTROL SYSTEM DIAGNOSIS

Perform control system diagnosis. Refer to [HAC-52, "Work Flow"](#) in "HAC Heater·Air Conditioner Control System."

No malfunction detected>>GO TO 4.

Malfunctioning is detected>>GO TO 8.

4. PERFORMANCE TEST

Perform the performance inspection. Refer to [HA-37, "Inspection"](#).

>> GO TO 5.

5. TROUBLE DIAGNOSIS FOR UNUSUAL PRESSURE

Perform diagnosis based on the gauge pressure diagnosis table, and identify the location of the malfunction. Refer to [HA-40, "Symptom Table"](#).

Insufficient refrigerant>>GO TO 6.

Other than the above>>GO TO 8.

6. CHECK REFRIGERANT FOR LEAKAGE

Perform the refrigerant leakage check and identify the location of the leak. Refer to [HA-31, "Check Refrigerant Leakage"](#).

>> GO TO 8.

7. TROUBLE DIAGNOSIS FOR NOISE

Perform diagnosis based on the noise diagnosis table, and identify the location of the malfunction. Refer to [HA-42, "Symptom Table"](#).

>> GO TO 8.

8. MALFUNCTION PARTS REPAIR

Repair or replace malfunctioning part.

>> GO TO 9.

9. REPAIR CHECK (OPERATION CHECK)

Check operation and verify that the system is operating normally.

Is check result normal?

YES >> Trouble diagnosis is complete.

NO >> GO TO 2.

REFRIGERANT

< BASIC INSPECTION >

REFRIGERANT

Description

INFOID:000000006997050

CONNECTION OF SERVICE TOOLS AND EQUIPMENT

CAUTION:

To prevent fluorescent indicator from entering, prepare and use exclusive hose for EV (electric vehicle) and HEV (hybrid vehicle) when connecting recovery/recycling/recharging equipment.

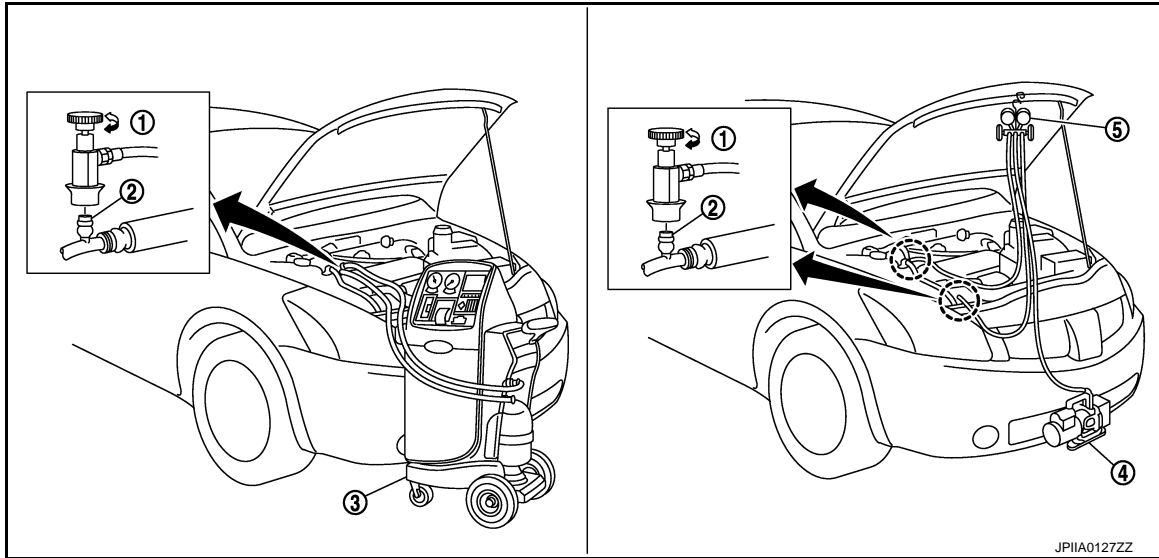

1. Shut-off valve
2. A/C service valve
3. Recovery/recycling/recharging equipment (for HFC-134a)
4. Vacuum pump
5. Manifold gauge

Check Refrigerant Leakage

INFOID:000000006997051

DETECTING LEAKAGES WITH FLUORESCENT INDICATOR

CAUTION:

Never use fluorescent indicators as these may reduce the insulation resistance.

CHECK REFRIGERANT LEAKAGE USING ELECTRICAL LEAK DETECTOR

CAUTION:

Be careful of the following items so that inaccurate checks or misidentifications are avoided.

- Never allow refrigerant vapor, shop chemical vapors, cigarette smoke, or others around the vehicle.
- Always check refrigerant leakage in a low air flow environment so that refrigerant may not disperse when leakage occurs.

1. Connect recovery/recycling/recharging equipment (for HFC-134a) or manifold gauge to A/C service valve.
2. Check that refrigerant gas pressure is 345 kPa (3.5 kg/cm², 50 psi) or more when temperature is 16°C (61°F) or more. When pressure is lower than the specified value, fully recover all refrigerant and then charge with refrigerant from the service can to the specified level.

NOTE:

Leakages may not be detected if refrigerant gas pressure is 345 kPa (3.5 kg/cm², 50 psi) or less when temperature is 16°C (61°F) or less.

3. Clean area where refrigerant leakage check is performed, and check refrigerant leakage along all surfaces of pipe connections and A/C system components using electrical leak detector probe.

CAUTION:

- Even when a leakage point has been found, always continue and complete checking along all pipe connections and A/C system components for additional leakage.
- When a leakage is detected, clean leakage area using compressed air and check again.
- When checking leakage of cooling unit inside, always clean inside of drain hose so that the probe surface may not be exposed to water or dirt.

REFRIGERANT

< BASIC INSPECTION >

NOTE:

- Always check leakage starting from high-pressure side and continue to low-pressure side.
 - When checking for leakage inside cooling unit, operate blower fan motor for 15 minutes or more at the maximum fan speed, and then insert electrical leak detector probe into drain hose and leave it inserted for 10 minutes or more.
 - When disconnecting shut-off valve that is connected to A/C service valve, always evacuate remaining refrigerant so that misidentification can be avoided.
4. Repair or replace parts where refrigerant leakage is detected. (Leakage is detected but leakage location is unknown. GO TO 5.)
 5. Start the vehicle and set A/C controller as shown below.
 - A/C switch: ON
 - Mode switch: Ventilation set
 - Intake switch: Recirculation set
 - Temperature setting: Full cold
 - Blower motor speed: Maximum speed set
 6. Operate A/C for 2 minutes or longer.
 7. Stop the A/C. Check again for refrigerant leakage. GO TO 3.

NOTE:

- Start refrigerant leakage check immediately after the A/C is stopped.
- When refrigerant circulation is stopped, pressure on the low-pressure side rises gradually, and after this, pressure on the high-pressure side falls gradually.
- The higher the pressure is, the easier it is to find the refrigerant leakage.

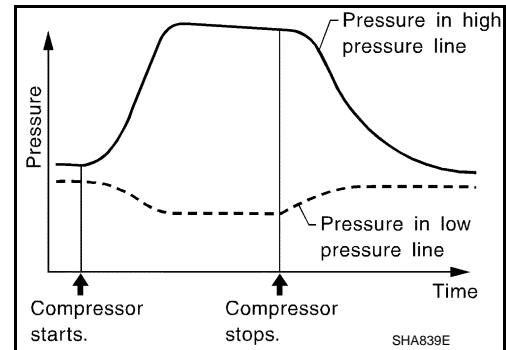

Recycle Refrigerant

INFOID:000000006997052

WARNING:

- Always use HFC-134a for refrigerant gas. If CFC-12 is accidentally charged, compressor is damaged due to insufficient lubrication.
 - Always observe and follow precautions described on refrigerant container. Incorrect handling may result in an explosion of refrigerant container, frostbite, or the loss of eyesight.
 - Never breathe refrigerant gas and lubricant vapor or mist. Exposure may irritate eyes, nose, or throat.
 - Never allow HFC-134a to be exposed to an open flame or others because it generates poisonous gas when in contact with high temperature objects. Keep workshop well ventilated.
 - To prevent fluorescent indicator from entering, prepare and use exclusive hose for EV (electric vehicle) and HEV (hybrid vehicle) when connecting recovery/recycling/recharging equipment.
1. Perform oil return operation. Refer to [HA-34, "Perform Lubricant Return Operation"](#). (If refrigerant or lubricant leakage is detected in a large amount, omit this step, and then GO TO 2.)

CAUTION:

Never perform lubricant return operation if a large amount of refrigerant or lubricant leakage is detected.

2. Check gauge pressure readings of recovery/recycling/recharging equipment (for HFC-134a). When remaining pressure exists, recycle refrigerant from high-pressure hose and low-pressure hose.

NOTE:

Follow manufacturer instructions for the handling or maintenance of the equipment. Never fill the equipment with non-specified refrigerant.

3. Remove A/C service valve cap from the vehicle.
4. Connect recovery/recycling/recharging equipment (for HFC-134a) to the A/C service valve.
5. Operate recovery/recycling/recharging equipment (for HFC-134a), and recycle refrigerant from the vehicle.
6. Evacuate air for 10 minutes or more to remove any remaining refrigerant integrated to compressor lubricant, etc.

REFRIGERANT

< BASIC INSPECTION >

7. Refrigerant recycle operation is complete.

Charge Refrigerant

INFOID:000000006997053

WARNING:

- Always use HFC-134a for refrigerant gas. If CFC-12 is accidentally charged, compressor is damaged due to insufficient lubrication.
- Always observe and follow precautions described on refrigerant container. Incorrect handling may result in an explosion of refrigerant container, frostbite, or the loss of eyesight.
- When charging with refrigerant gas, charge with the prescribed amount from a new service can.
- Never breathe refrigerant gas and lubricant vapor or mist. Exposure may irritate eyes, nose, or throat.
- Never allow HFC-134a to be exposed to an open flame or others because it generates poisonous gas when in contact with high temperature objects. Keep workshop well ventilated.
- To prevent fluorescent indicator from entering, prepare and use exclusive hose for EV (electric vehicle) and HEV (hybrid vehicle) when connecting recovery/recycling/recharging equipment.

1. Connect manifold gauge (for HFC-134a) to the service valve.
2. Connect vacuum pump to manifold gauge and operate the pump. Apply vacuum to the cooler cycle for approximately 25 minutes or longer.

CAUTION:

Evacuate air for 15 minutes or more if the parts are replaced.

3. Check the airtightness of A/C system for 25 minutes or more. If pressure raises more than the specified level, charge A/C system with approximately 200 g (0.4 lb) refrigerant and check that there is no refrigerant leakage. Refer to [HA-31, "Check Refrigerant Leakage"](#).

CAUTION:

Check the airtightness for 15 minutes or more if the parts are replaced.

4. If parts other than compressor were replaced, add compressor oil according to parts that were replaced. Refer to [HA-34, "Lubricant Adjusting Procedure for Components Replacement Except Compressor"](#).
5. Charge the A/C system from a service can with the specified amount of refrigerant.
6. Check that A/C system operates normally.
7. Disconnect the manifold gauge.
8. Install A/C service valve cap.
9. Refrigerant charge is complete.

LUBRICANT

< BASIC INSPECTION >

LUBRICANT

Description

INFOID:000000006997054

MAINTENANCE OF LUBRICANT LEVEL

The compressor lubricant is circulating in the system together with the refrigerant. It is necessary to fill compressor with lubricant when replacing A/C system parts or when a large amount of refrigerant leakage is detected. It is important to always maintain lubricant level within the specified level. Or otherwise, the following conditions may occur.

- Insufficient lubricant amount: Stuck compressor
- Excessive lubricant amount: Insufficient cooling (caused by insufficient heat exchange)

Specified lubricant ND-OIL 11 (special oil for electric compressors)

Inspection

INFOID:000000006997055

If there is a malfunction (abnormal noise from inside, cooling failure) in the compressor unit, check the compressor oil.

1. CHECK COMPRESSOR OIL

1. Remove electric compressor. [HA-46. "Exploded View"](#).
2. Refer to the diagram and judge the drained compressor oil.

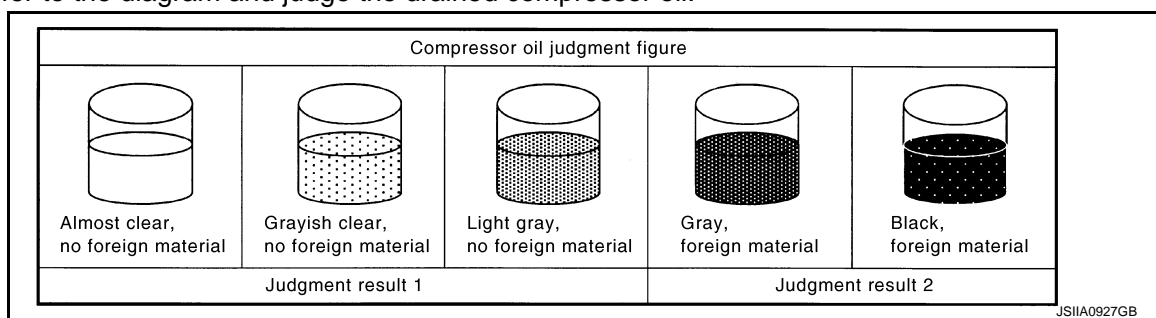

Judgment result 1:>>Replace only the compressor.

Judgment result 2:>>Replace compressor and liquid tank.

Perform Lubricant Return Operation

INFOID:000000006997056

CAUTION:

If a large amount of refrigerant or lubricant leakage is detected, never perform lubricant return operation.

1. Start the vehicle and set to the following conditions.
 - A/C switch: ON
 - Blower motor speed: Maximum speed set
 - Intake switch: Recirculation set
 - Temperature setting: Full cold
2. Perform lubricant return operation for approximately 10 minutes.
3. Stop A/C operation.
4. Oil return operation is complete.

Lubricant Adjusting Procedure for Components Replacement Except Compressor

INFOID:000000006997057

Fill with lubricant for the amount that is calculated according to the following conditions.

Example: Lubricant amount to be added when replacing evaporator and liquid tank [mℓ (US fl oz, Imp fl oz)] = 35 (1.2, 1.2) + 5 (0.2, 0.2) + α

LUBRICANT

< BASIC INSPECTION >

Item	Lubricant amount to be added to A/C system m ℓ (US fl oz, Imp fl oz)	
Replace evaporator	35 (1.2, 1.2)	
Replace condenser	15 (0.5, 0.5)	
Replace liquid tank	5 (0.2, 0.2)	
Refrigerant leakage is detected	Large amount leakage	30 (1.0, 1.0)
	Small amount leakage	—
Lubricant amount that is recycled together with refrigerant during recycle operation	α	

Lubricant Adjusting Procedure for Compressor Replacement

INFOID:000000006997058

1. Drain lubricant from removed compressor and measure lubricant amount.

- Turn the compressor so that it faces downward, and drain the compressor oil from the high-pressure port (A) and low-pressure port (B).
- Measure total amount of lubricant that is drained from removed compressor.

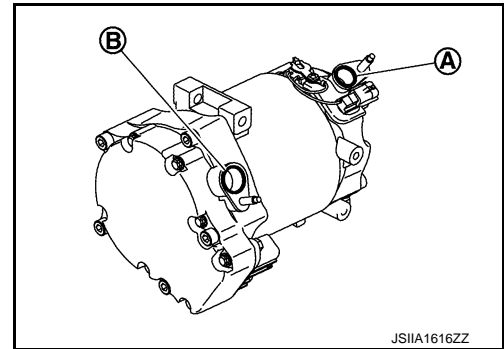

2. Drain lubricant from a new compressor that is calculated according to the following conditions.

Amount to be drained (A)

$$[m \ell \text{ (US fl oz, Imp fl oz)}] = F - (D + S + R + \alpha)$$

F : Lubricant amount that a new compressor contains [150 (5.1, 5.3)]

D : Lubricant amount that is drained from removed compressor

S : Lubricant amount that remains inside of removed compressor [20 (0.7, 0.7)]

R : Lubricant amount to be added according to components that are removed except compressor

α : Lubricant amount that is recycled together with refrigerant during recycle operation

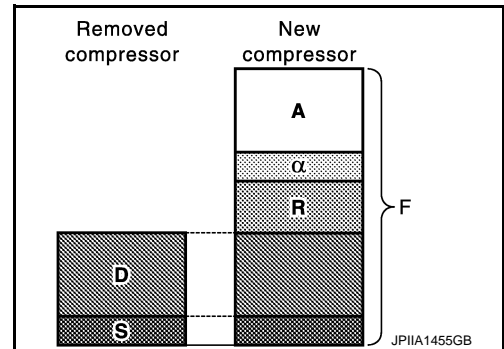

CAUTION:

If lubricant amount that is drained from removed compressor is less than 60 m ℓ (2.0 US fl oz, 2.1 Imp fl oz), perform calculation by setting "D" as 40 m ℓ (1.4 US fl oz, 1.4 Imp fl oz).

Item	Lubricant amount to be added to A/C system m ℓ (US fl oz, Imp fl oz)
Replace evaporator	35 (1.2, 1.2)
Replace condenser	15 (0.5, 0.5)
Replace liquid tank	5 (0.2, 0.2)

Example: Lubricant amount to be drained from a new compressor when replacing compressor and liquid tank [m ℓ (US fl oz, Imp fl oz)] [D = 60 (2.0, 2.1), α = 5 (0.2, 0.2)]
 $150 (5.1, 5.3) - [60 (2.0, 2.1) + 20 (0.7, 0.7) + 5 (0.2, 0.2) + 5 (0.2, 0.2)] = 60 (2.0, 2.1)$ from the new compressor.

LUBRICANT

< BASIC INSPECTION >

3. Install compressor and check the operation.

PERFORMANCE TEST

< BASIC INSPECTION >



PERFORMANCE TEST

Inspection

INFOID:000000006997059

INSPECTION PROCEDURE

1. Connect the manifold gauge.
2. Set the vehicle to the conditions shown below.

Test condition		
Surrounding condition		Indoors or in the shade (in a well-ventilated place)
Vehicle condition	Door	Closed
	Door glass	Full open
	Hood	Open
A/C condition	Temperature control switch or dial	Full cold
	A/C switch	ON
	Mode switch	 (Ventilation) set
	Intake switch	 (Recirculation) set
	 Blower motor speed	Maximum speed set

3. Maintain test condition until A/C system becomes stable. (Approximately 10 minutes)
4. Check that the characteristics for “intake temperature vs. discharge temperature” and “ambient temperature vs. pressure” are within the standard values.
5. When test results are within the specified value, inspection is complete.
If any of test result is out of the specified value, perform diagnosis by gauge pressure. Refer to [HA-40, "Trouble Diagnosis For Unusual Pressure"](#).

PERFORMANCE TEST

< BASIC INSPECTION >

INTAKE -DISCHARGE

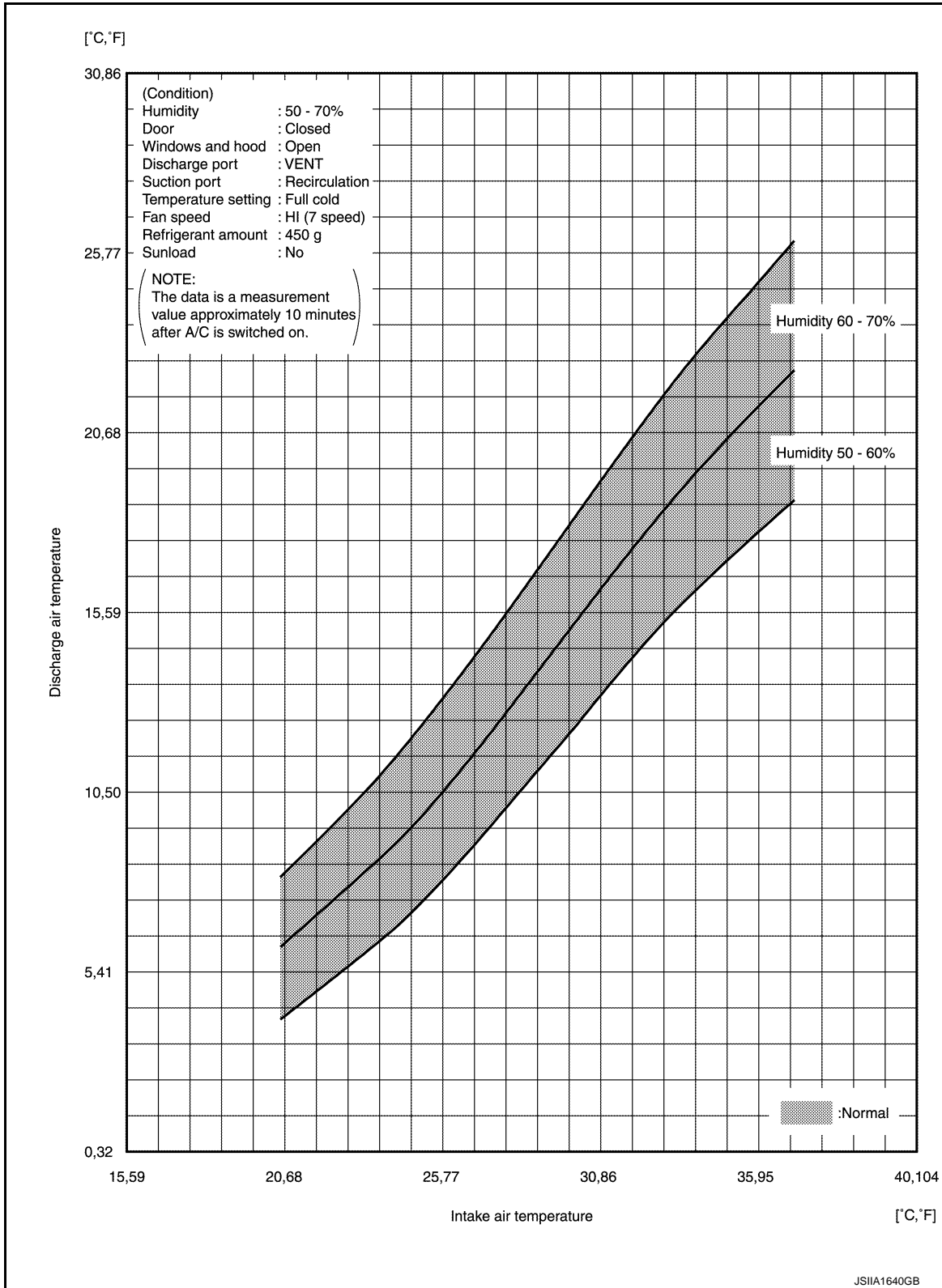

PERFORMANCE TEST

< BASIC INSPECTION >

AMBIENT TEMPERATURE-PRESSURE CHARACTERISTICS

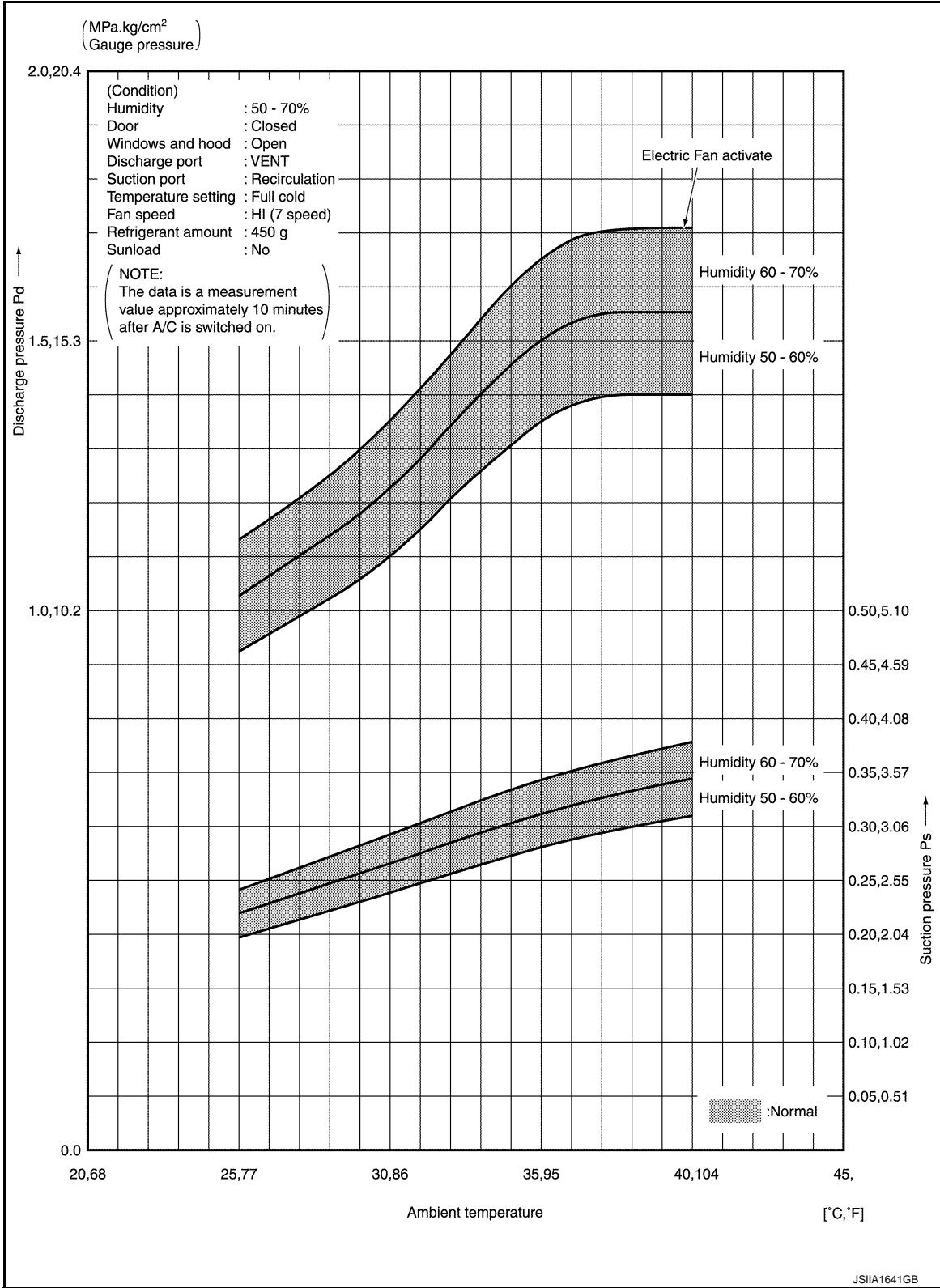

A
B
C
D
E
F
G
H
HA
J
K
L
M
N
O
P

REFRIGERATION SYSTEM SYMPTOMS

< SYMPTOM DIAGNOSIS >

SYMPTOM DIAGNOSIS

REFRIGERATION SYSTEM SYMPTOMS

Trouble Diagnosis For Unusual Pressure

INFOID:000000006997061

Diagnose using a manifold gauge whenever system's high and/or low side pressure(s) is/are unusual. The marker above the gauge scale in the following tables indicates the standard (usual) pressure range. Refer to above table (Ambient air temperature-to-operating pressure table) since the standard (usual) pressure, however, differs from vehicle to vehicle.

Symptom Table

INFOID:000000006997062

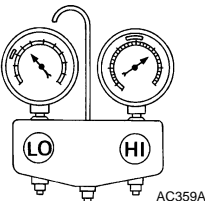
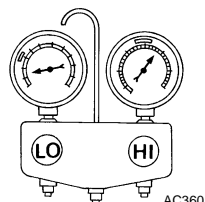
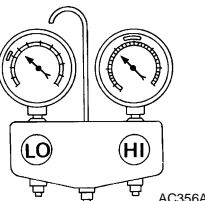
Gauge indication	Refrigerant cycle	Probable cause	Corrective action
<p>Both high- and low-pressure sides are too high.</p>  <p>AC359A</p>	<p>The pressure returns to normal soon after sprinkling water on condenser.</p>	<p>Overfilled refrigerant.</p>	<p>Collect all refrigerant, evacuate refrigerant cycle again, and then refill it with the specified amount of refrigerant.</p>
	<p>Air flow to condenser is insufficient.</p>	<p>Insufficient condenser cooling performance.</p> <ul style="list-style-type: none"> Poor fan rotation of radiator and condenser. Improper installation of air guide. Clogged or dirty condenser fins. 	<ul style="list-style-type: none"> Repair or replace malfunctioning parts. Clean and repair condenser fins.
	<p>When compressor is stopped, a high-pressure reading quickly drops by approximately 196 kPa (2 kg/cm², 28.4 psi). It then gradually decreases.</p>	<p>Air mixed in refrigerant cycle.</p>	<p>Collect all refrigerant, evacuate refrigerant cycle again, and then refill it with the specified amount of refrigerant.</p>
	<ul style="list-style-type: none"> Low-pressure pipe is cooler than the outlet of evaporator. Low-pressure pipe is frosted. 	<p>Expansion valve opened too much (excessive flow of refrigerant).</p>	<p>Replace expansion valve.</p>
<p>High-pressure side is excessively high and low-pressure side is too low.</p>  <p>AC360A</p>	<p>High-pressure pipe and upper side of condenser become hot, however, liquid tank does not become so hot.</p>	<p>Clogged or crushed high-pressure pipe located between compressor and condenser.</p>	<p>Repair or replace the malfunctioning parts.</p>
<p>High-pressure side is too low and low-pressure side is too high.</p>  <p>AC356A</p>	<ul style="list-style-type: none"> The readings of both sides become equal soon after compressor operation stops. There is no temperature difference between high- and low-pressure sides. 	<p>Malfunction in compressor system (insufficient compressor pressure operation).</p> <ul style="list-style-type: none"> Damage or breakage of valve. Malfunctioning gaskets. 	<p>Replace compressor.</p>

REFRIGERATION SYSTEM SYMPTOMS

< SYMPTOM DIAGNOSIS >

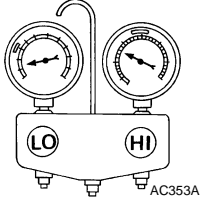
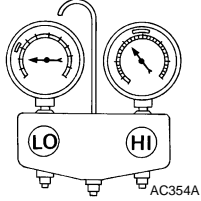
Gauge indication	Refrigerant cycle	Probable cause	Corrective action	
<p>Both high- and low-pressure sides are too low.</p>  <p style="text-align: right; font-size: small;">AC353A</p>	<ul style="list-style-type: none"> The area around evaporator outlet does not become cold. The area around evaporator inlet becomes frosted. 	<p>Clogged expansion valve.</p> <ul style="list-style-type: none"> Breakage of temperature sensor. Clogging by foreign material. 	<p>Eliminate foreign material from expansion valve, or replace it.</p>	A
	<ul style="list-style-type: none"> There is a temperature difference between the areas around outlet and inlet pipes of liquid tank. Liquid tank becomes frosted. 	<p>Malfunction in inner liquid tank (clogged strainer).</p>	<p>Replace liquid tank.</p>	B
	<p>Evaporator becomes frosted.</p>	<p>Clogged or crushed low-pressure pipe.</p>	<p>Repair or replace malfunctioning parts.</p>	C
	<p>Evaporator becomes frosted.</p>	<p>Malfunction in intake sensor.</p>	<p>Check intake sensor system. Refer to HAC-69, "Diagnosis Procedure".</p>	D
	<p>There is a small temperature difference between the high and low pressure pipes for refrigerant cycle.</p>	<ul style="list-style-type: none"> Shortage of refrigerant. Leakage of refrigerant. 	<ul style="list-style-type: none"> Check for leakage. Collect all refrigerant, evacuate refrigerant cycle again, and then refill it with the specified amount of refrigerant. 	E
<p>Low-pressure side sometimes becomes negative.</p>  <p style="text-align: right; font-size: small;">AC354A</p>	<ul style="list-style-type: none"> Sometimes the area around evaporator outlet does not become cold. Sometimes the area around evaporator inlet is frosted. 	<ul style="list-style-type: none"> Icing caused by the mixing of water in cooler cycle. Deteriorated dryer in liquid tank. 	<ul style="list-style-type: none"> Collect all refrigerant. Evacuate refrigerant cycle completely, and then refill it with the specified amount of refrigerant. At this time, always replace liquid tank. 	F

G

H

HA

J

K

L

M

N

O

P

NOISE

< SYMPTOM DIAGNOSIS >

NOISE

Symptom Table

INFOID:000000006997063

Symptom	Noise source	Probable cause	Corrective action
Unusual noise from compressor when A/C is ON.	Inside of compressor	Wear, breakage, or clogging of foreign material in inner parts.	Check compressor oil. Refer to HA-34, "Inspection" .
	Compressor body	Loosened compressor mounting bolts.	Check bolts for tightness. Refer to HA-46, "Exploded View" .
Unusual noise from cooler piping.	Cooler piping (pipe and flexible hose)	Improper installation of clip and bracket.	Check the installation condition of the cooler piping. Refer to HA-52, "Exploded View" .
Unusual noise from expansion valve when A/C is ON.	Expansion valve	Shortage of refrigerant.	<ul style="list-style-type: none"> • Check for leakage. • Collect all refrigerant, evacuate refrigerant cycle again, and then refill it with the specified amount of refrigerant.
		Wear, breakage, or clogging of foreign material in inner parts.	Eliminate foreign material from expansion valve, or replace it.

HEATER FLUID

< PERIODIC MAINTENANCE >

PERIODIC MAINTENANCE

HEATER FLUID

Inspection

INFOID:000000006960803

COOLANT AMOUNT INSPECTION

NOTE:

Heater system and high voltage cooling system share the reservoir tank. Refer to [HCO-11, "Inspection"](#).

LEAKAGE CHECK

- Apply pressure to the heater cycle using radiator cap tester (A) (commercial service tool). Check cycle for heater fluid leakage.

Maximum pressure : Refer to [HCO-27, "Radiator"](#).

CAUTION:

- Remove degas tank cap when heater fluid temperature is low.
 - Perform the inspection with the heater cycle filled with water.
 - Use hose adapter (B) (commercial service tool) between radiator cap tester (A) (commercial service tool) and the filler neck so that the degas tank filler neck is not deformed.
 - Be sure to observe the maximum pressure standards. Otherwise, Component parts may be damaged.
- If there is a malfunction, repair and replace applicable part.

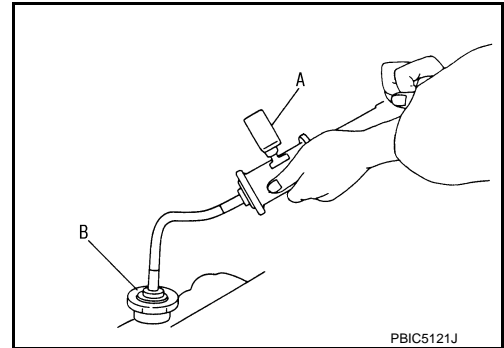

Draining and Refilling

INFOID:000000006960804

CAUTION:

- Never put additive such as waterleak preventive, since it may cause waterway clogging.
- When refilling use genuine NISSAN coolant or equivalent in its quality mixed with water (distilled or demineralized).
- Make sure not to dilute it with water.

DRAIN

CAUTION:

- Be sure to drain when heater fluid temperature is cold.
- This should be performed so that heater fluid never come in contact with surrounding parts.

1. Remove front under cover. Refer to [EXT-23, "FRONT UNDER COVER : Removal and Installation"](#).
2. Open the drain cock (1), and then remove degas tank cap and drain heater fluid.

↔ : Vehicle front

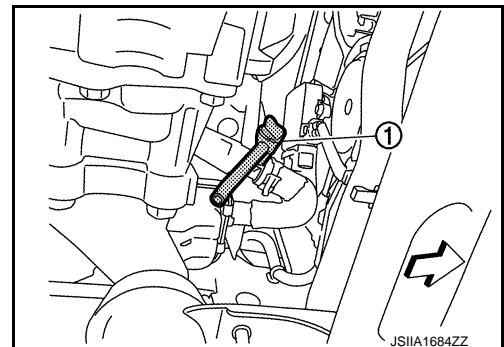

3. Remove reservoir tank and drain the heater fluid as per the following procedure.
 1. Remove radiator upper grille. Refer to [DLK-155, "RADIATOR UPPER GRILLE : Removal and Installation"](#).
 2. Remove reservoir tank hose and reservoir tank mounting bolts.
 3. Pull out the lower reservoir tank toward vehicle front. Remove insertion area and raise the tank for removal.

REFILLING

HEATER FLUID

< PERIODIC MAINTENANCE >

1. Install reservoir tank. (Install in the reverse order of removal.)
2. Close drain cock.
3. Check tightening of hose clamp.
4. Fill water to line (A) from degas tank cap.

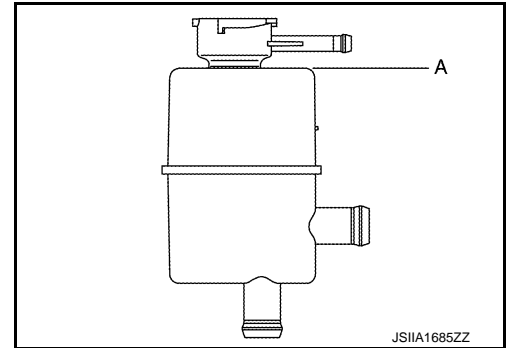

5. Set the vehicle to READY and operate heater pump.
6. When the degas tank level is low, open the degas tank cap and refill the tank with water to line (A).

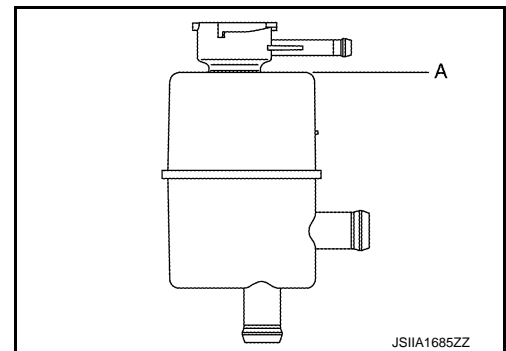

7. When the level is not lowered, close the degas tank cap and turn OFF the push start switch (stop the heater pump).

CAUTION:

If the heater pump is stopped with the degas tank open, heater fluid may be spilled.

8. Refill heater fluid to "MAX" line of reservoir tank.

CHECK WATER FLOW SOUND

CAUTION:

Prior to check, be sure to close windows, doors, and hood, and turn OFF audio system and other electrical loads.

1. Operate the heater pump for 1 minute.
2. Check if water flow sound can be heard from the instrument panel.
3. If water flow sound is heard, operate the heater pump until it cannot be heard.
4. When water flow sound cannot be heard, fill the reservoir tank up to "MAX" line.

CAUTION:

- Insufficient heater fluid may cause overheat, water flow sound of heater core, and malfunction of heater and defroster. Be sure to bleed air thoroughly.
- Never operate the heater pump without heater fluid.

DEGAS TANK CAP

< PERIODIC MAINTENANCE >

DEGAS TANK CAP

Degas Tank Cap Inspection

Visually check packing (A) of the degas tank cap for dirt and damage.

INFOID:000000006960805

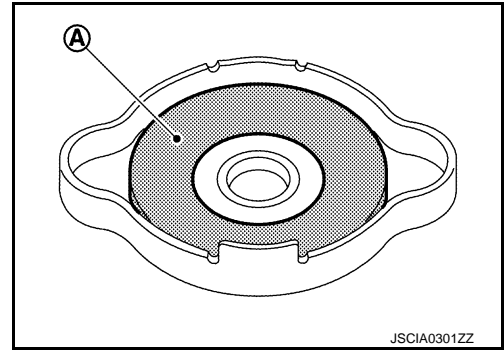

A
B
C
D
E
F
G
H
HA
J
K
L
M
N
O
P

HA

ELECTRIC COMPRESSOR

< REMOVAL AND INSTALLATION >

REMOVAL AND INSTALLATION

ELECTRIC COMPRESSOR

Exploded View

INFOID:000000006960806

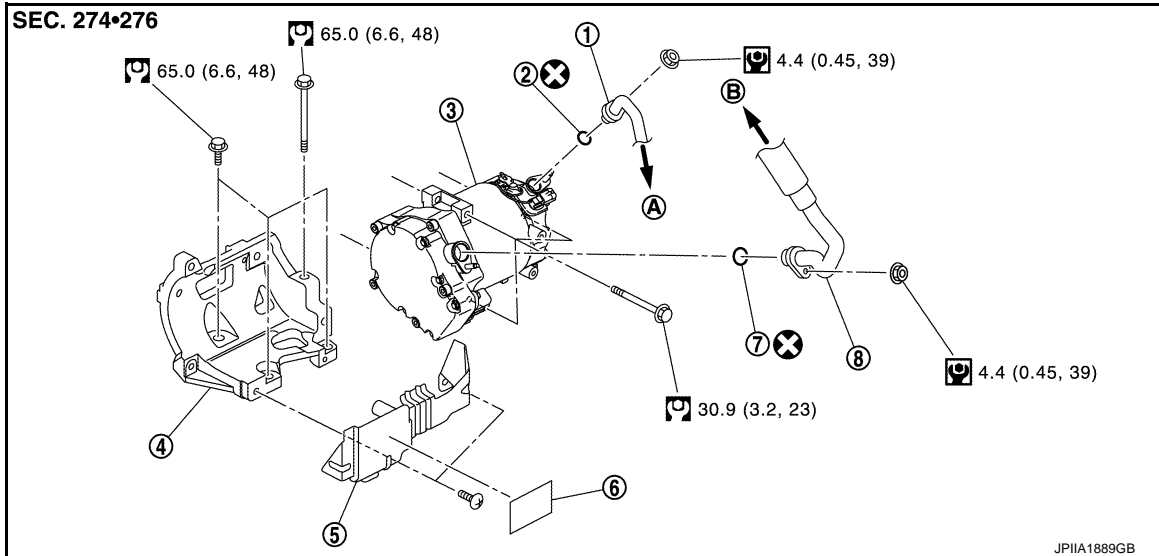

- | | | |
|--------------------------------|-------------------------------|-------------------------------|
| 1. High-pressure flexible hose | 2. O-ring | 3. Electric compressor |
| 4. Compressor bracket | 5. Compressor stay | 6. High voltage warning label |
| 7. O-ring | 8. Low-pressure flexible hose | |
| A. To condenser | B. To evaporator | |

⊗ : Always replace after every disassembly.

⊙ : N•m (kg-m in-lb)

⊙ : N•m (kg-m ft-lb)

Removal and Installation

INFOID:000000006960807

WARNING:

- Because EV (electric vehicle) and HEV (hybrid vehicle) contain a high voltage battery, there is the risk of electric shock, electric leakage, or similar accidents if the high voltage component and vehicle are handled incorrectly. Be sure to follow the correct work procedures when performing inspection and maintenance.
- Be sure to remove the service plug in order to disconnect the high voltage circuits before performing inspection or maintenance of high voltage system harnesses and parts.
- To prevent the removed service plug from being connected by mistake during the procedure, always carry it in your pocket or put it in the tool box.
- Be sure to wear insulating protective equipment consisting of glove, shoes, face shield and glasses before beginning work on the high voltage system.
- Clearly identify the persons responsible for high voltage work and ensure that other persons never touch the vehicle. When not working, cover high voltage parts with an insulating cover sheet or similar item to prevent other persons from contacting them.

CAUTION:

- There is the possibility of a malfunction occurring if the vehicle is changed to READY status while the service plug is removed. Therefore never change the vehicle to READY status unless instructed to do so in the Service Manual.
- Perform lubricant return operation before each refrigeration system disassembly. However, if a large amount of refrigerant or lubricant is detected, never perform lubricant return operation. Refer to [HA-34. "Perform Lubricant Return Operation"](#).

REMOVAL

ELECTRIC COMPRESSOR

< REMOVAL AND INSTALLATION >

WARNING:

Disconnect high voltage circuit. Refer to [GI-31, "How to Disconnect High Voltage"](#).

1. Check voltage in high voltage circuit. (Check that condenser are discharged.)
- a. Lift up the vehicle, and then remove Li-ion battery under covers.
 - Refer to [EVB-169, "Exploded View"](#). (Type 1: Without Li-ion battery heater)
 - Refer to [EVB-395, "Exploded View"](#). (Type 2: With Li-ion battery heater)
- b. Disconnect high voltage connector from front side of Li-ion battery.
 - Refer to [EVB-169, "Removal and Installation"](#). (Type 1: Without Li-ion battery heater)
 - Refer to [EVB-395, "Removal and Installation"](#). (Type 2: With Li-ion battery heater)
- c. Measure voltage between high voltage harness terminals.

DANGER:



Touching high voltage components without using the appropriate protective equipment will cause electrocution.



Standard

: 5 V or less

CAUTION:

For voltage measurements, use a tester which can measure to 500 V or higher.

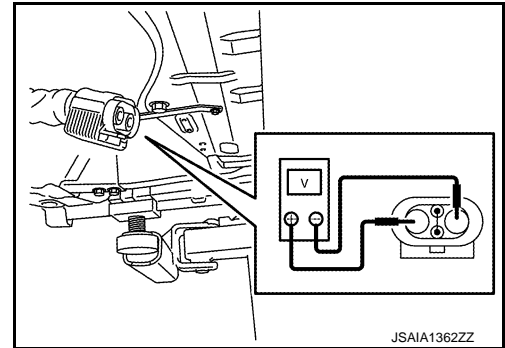

2. Use the refrigerant recovery equipment (for HFC-134a) and recover the refrigerant. [HA-32, "Recycle Refrigerant"](#).
3. Remove radiator upper grille. Refer to [DLK-155, "RADIATOR UPPER GRILLE : Removal and Installation"](#).
4. Remove mounting nut (A), and then disconnect low-pressure flexible hose (1) from electric compressor.

WARNING:



To prevent electric shock hazards, be sure to wear protective gear.



CAUTION:

- Cover the low pressure port of the electric compressor with a cap to prevent oil from spilling.
- To prevent the inclusion of foreign matter, use a cap or vinyl tape to seal off the pipe connection port from the atmosphere.

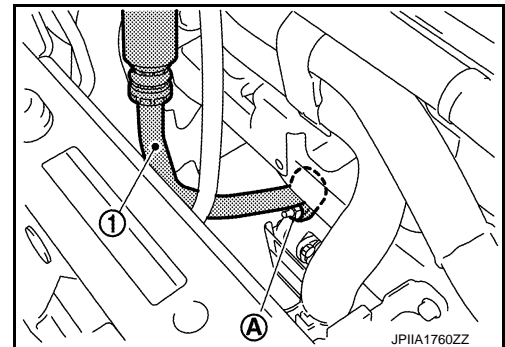

5. Remove mounting nut (A), and then disconnect high-pressure flexible hose (1) from electric compressor.

WARNING:



To prevent electric shock hazards, be sure to wear protective gear.



CAUTION:

- Cover the high pressure port of the electric compressor with a cap to prevent oil from spilling.
- To prevent the inclusion of foreign matter, use a cap or vinyl tape to seal off the pipe connection port from the atmosphere.

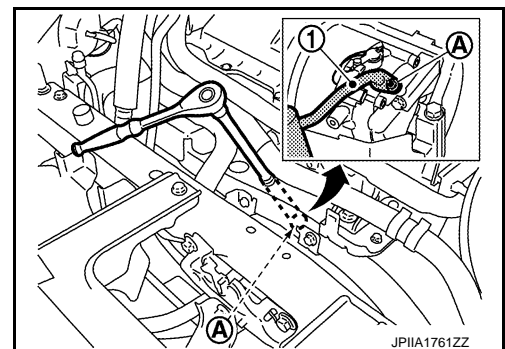

ELECTRIC COMPRESSOR

< REMOVAL AND INSTALLATION >

6. Disconnect quick charge port connectors (1) inside motor room.

← : Vehicle front

WARNING:

-  To prevent electric shock hazards, be sure to wear protective gear.



- To prevent electric shock hazards, immediately wrap insulating tape around disconnected high voltage connector terminals.

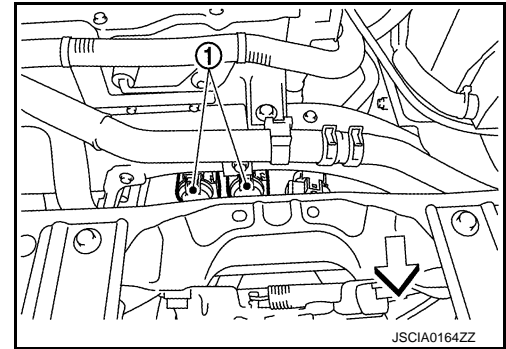

7. Disconnect normal charge port connector (1) inside motor room.

← : Vehicle front

WARNING:

-  To prevent electric shock hazards, be sure to wear protective gear.



- To prevent electric shock hazards, immediately wrap insulating tape around disconnected high voltage connector terminals.

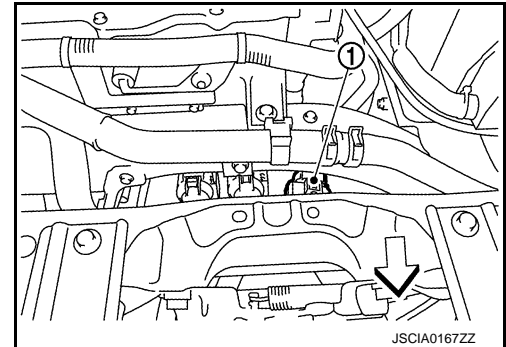

8. Move water hose to secure work space.

9. Remove front under cover. Refer to [EXT-23. "FRONT UNDER COVER : Removal and Installation"](#).

10. Remove front tire RH. Refer to [WT-47. "Removal and Installation"](#).

11. Remove fender protector. Refer to [EXT-21. "FENDER PROTECTOR : Removal and Installation"](#).

12. Remove mounting bolts (A), and then remove compressor stay (1).

WARNING:

-  To prevent electric shock hazards, be sure to wear protective gear.

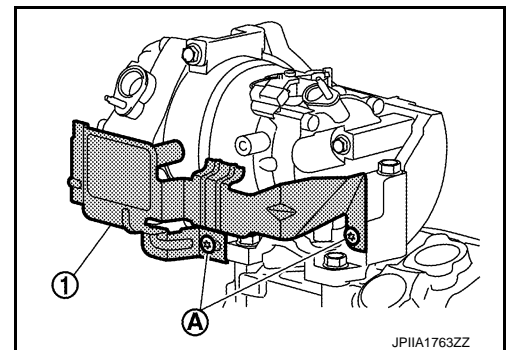

13. Disconnect high voltage harness connector (A).

WARNING:

-  To prevent electric shock hazards, be sure to wear protective gear.



- To prevent electric shock hazards, immediately wrap insulating tape around disconnected high voltage connector terminals.

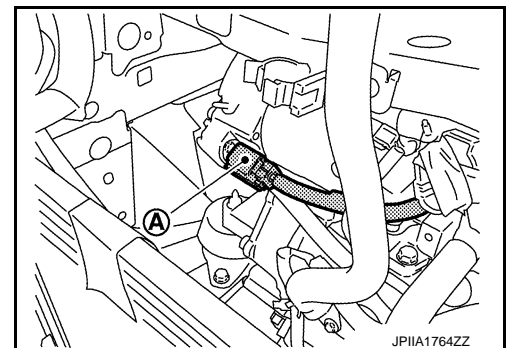

ELECTRIC COMPRESSOR

< REMOVAL AND INSTALLATION >

- Follow the procedure below and disconnect high voltage harness connector.

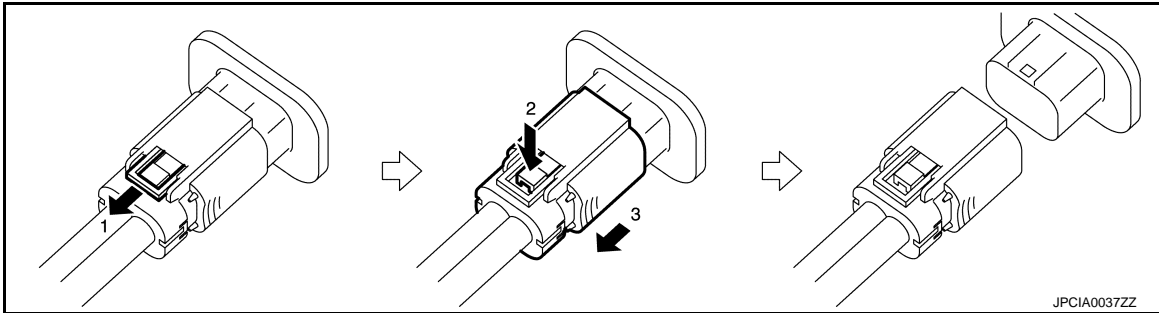

14. Disconnect low voltage harness connector (A).

WARNING:

 To prevent electric shock hazards, be sure to wear protective gear.

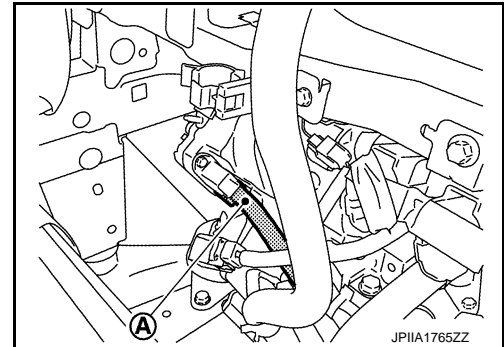

15. Remove mounting bolts (A) from electric compressor (1).

WARNING:

 To prevent electric shock hazards, be sure to wear protective gear.

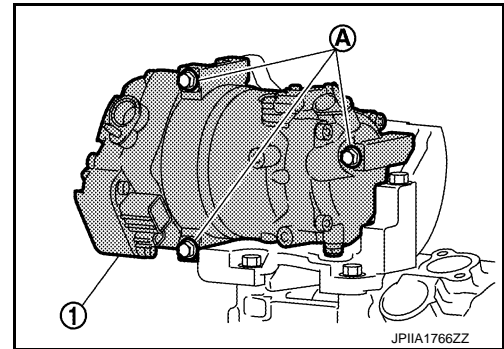

16. Remove electric compressor (1) from the vehicle.

WARNING:

 To prevent electric shock hazards, be sure to wear protective gear.

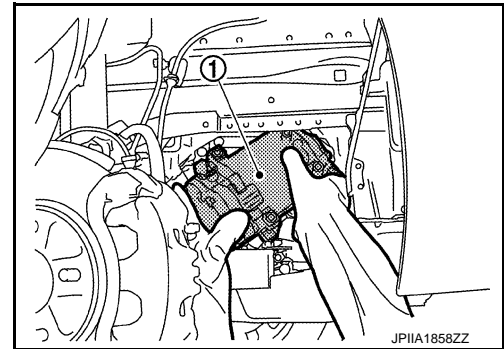

17. Remove mounting bolts (A), and then remove compressor bracket (1).

WARNING:

 To prevent electric shock hazards, be sure to wear protective gear.

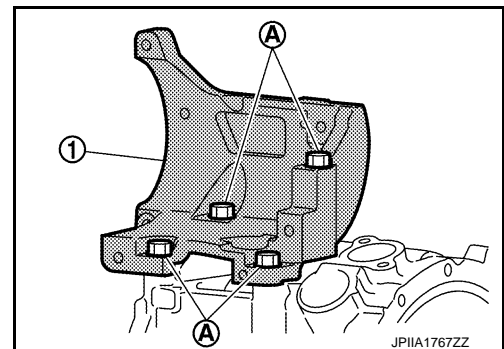

A
B
C
D
E
F
G
H
HA
J
K
L
M
N
O
P

ELECTRIC COMPRESSOR

< REMOVAL AND INSTALLATION >

INSTALLATION

Note the following items, and then install in the reverse order of removal.

WARNING:



To prevent electric shock hazards, be sure to wear protective gear.



CAUTION:

- Be sure to reinstall high voltage harness clips in their original positions. If a clip is damaged, replace it with a new clip before installing.
- Before installing the new compressor, adjust the compressor oil level. Refer to [HA-35, "Lubricant Adjusting Procedure for Compressor Replacement"](#).
- To prevent degradation in insulation performance, use special electric compressor oil as the compressor oil.
- In order to prevent conventional PAG oil from becoming mixed in, never reuse recovered compressor oil and instead always use new oil. The use of oil including the conventional PAG oil may degrade the performance of insulation.
- To prevent performance degradation, never use a fluorescent agent in order to detect refrigerant leakage. Also be careful that a fluorescent agent never enter the oil.
- To prevent leakage of refrigerant, replace the O-ring with a new one. Apply a coat of compressor oil to the O-ring prior to installation.
- Perform a check for refrigerant leakage when charging with refrigerant. Refer to [HA-31, "Check Refrigerant Leakage"](#).
- Set the vehicle to READY and operate the air conditioner for 1 minute or more with the vehicle parked to perform a break-in.

- If the compressor stay was replaced, first check that there is no dust or dirt on the surface of the compressor stay, then apply the new high voltage warning label at position (A), with the direction indicated by the arrow facing up.

↶ Application direction of the label

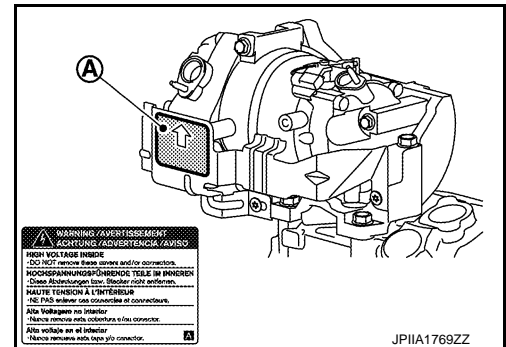

- Follow the procedure below and connect the high voltage harness connector.

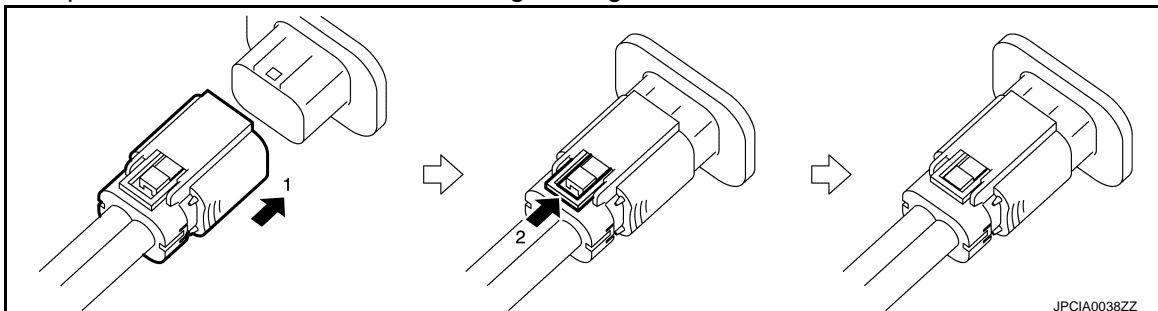

- After all parts are installed, be sure to check the equipotential. Refer to [HA-50, "Inspection"](#).

Inspection

INFOID:000000006960808

EQUIPOTENTIAL TEST

After installing the electric compressor, measure the resistance below.

- Between electric compressor (aluminum part) and body (ground bolt).
- Between electric compressor (aluminum part) and DC/DC-J/B (aluminum part).

ELECTRIC COMPRESSOR

< REMOVAL AND INSTALLATION >

WARNING:



To prevent electric shock hazards, be sure to wear protective gear.



Standard : Less than 0.1 Ω

If the result deviates from the standard value, check for paint, oil, dirt, or other substance adhering to the bolts or conductive mounting parts. If such substances are found, clean the surrounding area and remove foreign substances.

A
B
C
D
E
F
G
H
HA
J
K
L
M
N
O
P

HA

COOLER PIPE AND HOSE

< REMOVAL AND INSTALLATION >

COOLER PIPE AND HOSE

Exploded View

INFOID:000000006960809

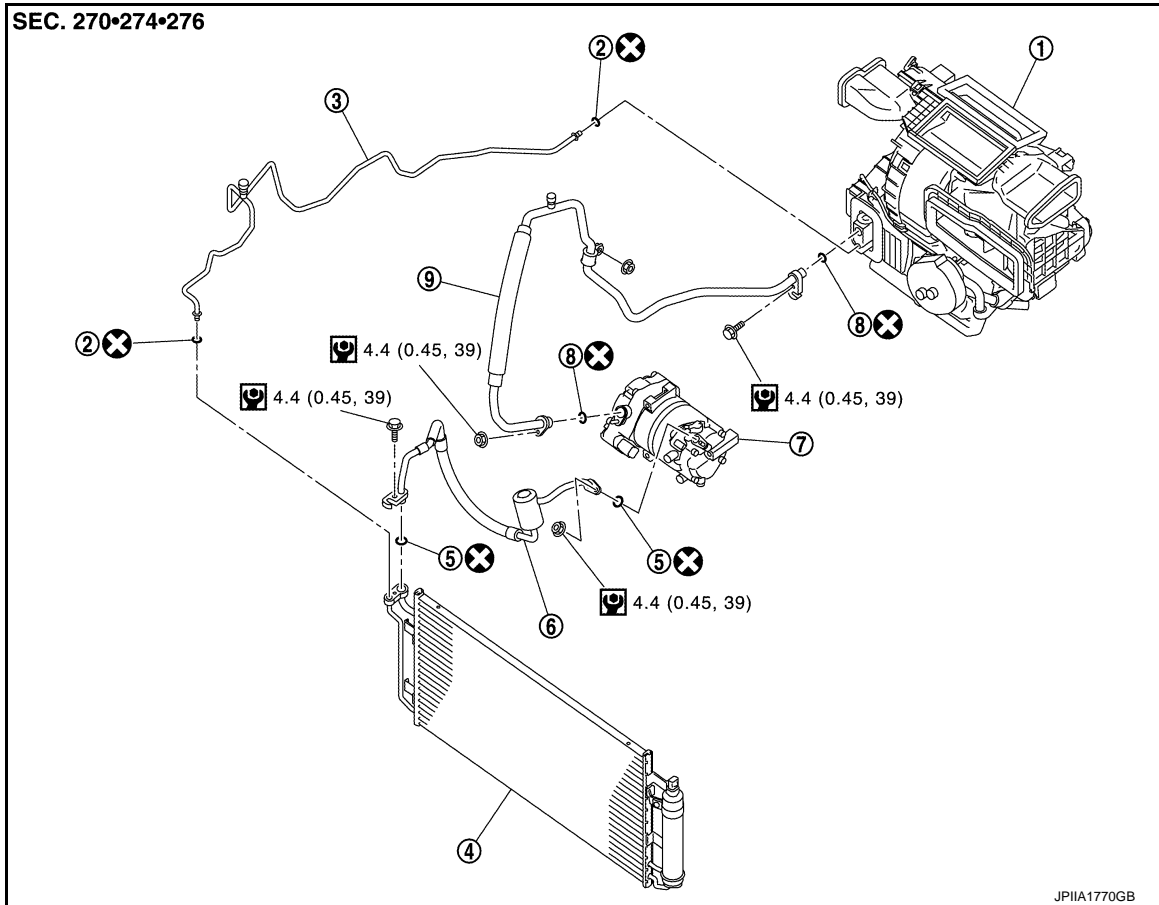

- | | | |
|------------------------|-----------|--------------------------------|
| 1. A/C unit assembly | 2. O-ring | 3. High-pressure pipe |
| 4. Condenser | 5. O-ring | 6. High-pressure flexible hose |
| 7. Electric compressor | 8. O-ring | 9. Low-pressure flexible hose |

⊗ : Always replace after every disassembly.

Ⓜ : N·m (kg-m in-lb)

HIGH-PRESSURE FLEXIBLE HOSE

HIGH-PRESSURE FLEXIBLE HOSE : Removal and Installation

INFOID:000000006960810

CAUTION:

Perform lubricant return operation before each refrigeration system disassembly. However, if a large amount of refrigerant or lubricant is detected, never perform lubricant return operation. Refer to [HA-34, "Perform Lubricant Return Operation"](#).

REMOVAL

1. Use the refrigerant recovery equipment (for HFC134a) and recover the refrigerant. Refer to [HA-32, "Recycle Refrigerant"](#).
2. Remove radiator upper grille. Refer to [DLK-155, "RADIATOR UPPER GRILLE : Removal and Installation"](#).
3. Remove washer tank inlet. Refer to [WW-47, "Removal and Installation"](#).

COOLER PIPE AND HOSE

< REMOVAL AND INSTALLATION >

4. Remove mounting bolt (A), and then disconnect high-pressure flexible hose (1) from condenser.

CAUTION:

To prevent the inclusion of foreign matter, use a cap or vinyl tape to seal off the connection ports of the pipe and condenser from the atmosphere.

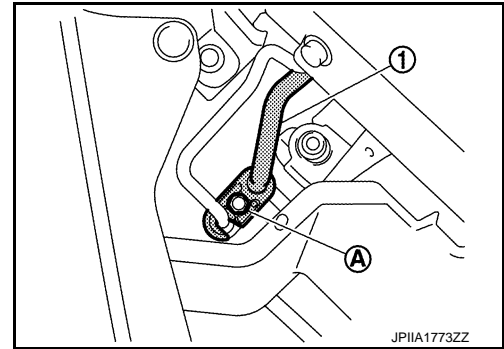

5. Remove mounting nut (A), and then disconnect high-pressure flexible hose (1) from electric compressor.

WARNING:

 To prevent electric shock hazards, be sure to wear protective gear.



CAUTION:

To prevent the inclusion of foreign matter, use a cap or vinyl tape to seal off the connection ports of the pipe and electric compressor from the atmosphere.

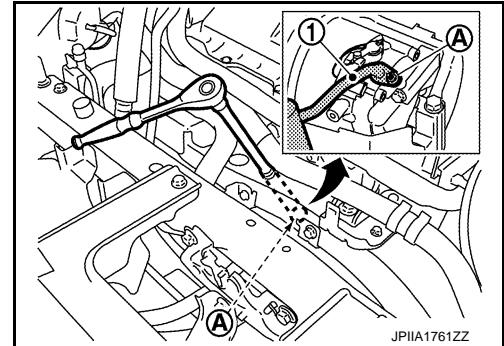

6. Disconnect high-pressure flexible hose from the vehicle.

INSTALLATION

Note the following items, and then install in the reverse order of removal.

CAUTION:

- To prevent degradation in insulation performance, use special electric compressor oil as the compressor oil.
- In order to prevent conventional PAG oil from becoming mixed in, never reuse recovered compressor oil and instead always use new oil. The use of oil including the conventional PAG oil may degrade the performance of insulation.
- To prevent performance degradation, never use a fluorescent agent in order to detect refrigerant leakage. Also be careful that a fluorescent agent never enter the oil.
- To prevent leakage of refrigerant, replace the O-ring with a new one. Apply a coat of compressor oil to the O-ring prior to installation.
- Perform a check for refrigerant leakage when charging with refrigerant. Refer to [HA-31, "Check Refrigerant Leakage"](#).

LOW-PRESSURE FLEXIBLE HOSE

LOW-PRESSURE FLEXIBLE HOSE : Removal and Installation

INFOID:000000006960811

CAUTION:

Perform lubricant return operation before each refrigeration system disassembly. However, if a large amount of refrigerant or lubricant is detected, never perform lubricant return operation. Refer to [HA-34, "Perform Lubricant Return Operation"](#).

REMOVAL

1. Use the refrigerant recovery equipment (for HFC134a) and recover the refrigerant. Refer to [HA-32, "Reycle Refrigerant"](#).
2. Remove cowl top extension. Refer to [EXT-19, "Removal and Installation"](#).
3. Remove radiator upper grille. Refer to [DLK-155, "RADIATOR UPPER GRILLE : Removal and Installation"](#).

COOLER PIPE AND HOSE

< REMOVAL AND INSTALLATION >

4. Remove mounting nut (A) from low-pressure flexible hose bracket (1).

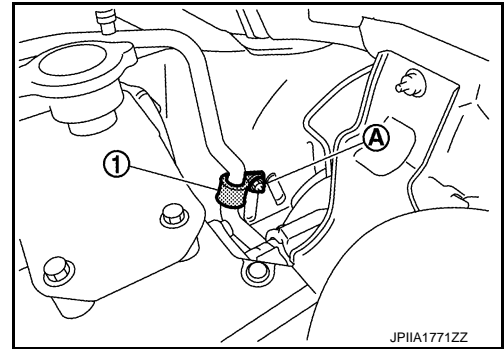

5. Remove mounting bolt (A), and then disconnect low-pressure flexible hose (1) from expansion valve.

CAUTION:

To prevent the inclusion of foreign matter, use a cap or vinyl tape to seal off the connection ports of the pipe and expansion valve from the atmosphere.

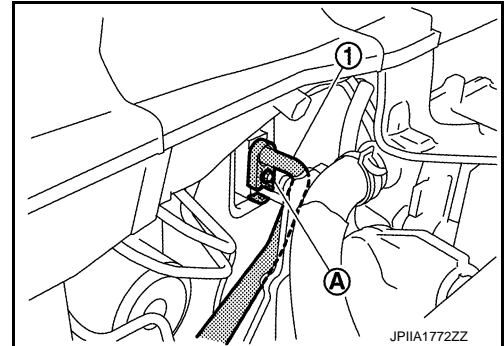

6. Remove mounting nut (A), and then disconnect low -pressure flexible hose (1) from electric compressor.

WARNING:

 To prevent electric shock hazards, be sure to wear protective gear.



CAUTION:

To prevent the inclusion of foreign matter, use a cap or vinyl tape to seal off the connection ports of the pipe and electric compressor from the atmosphere.

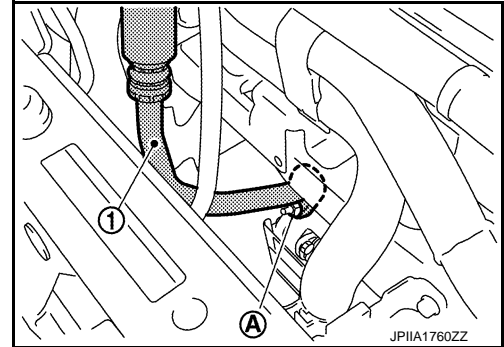

7. Disconnect low-pressure flexible hose from the vehicle.

INSTALLATION

Note the following items, and then install in the reverse order of removal.

CAUTION:

- To prevent degradation in insulation performance, use special electric compressor oil as the compressor oil.
- In order to prevent conventional PAG oil from becoming mixed in, never reuse recovered compressor oil and instead always use new oil. The use of oil including the conventional PAG oil may degrade the performance of insulation.
- To prevent performance degradation, never use a fluorescent agent in order to detect refrigerant leakage. Also be careful that a fluorescent agent never enter the oil.
- To prevent leakage of refrigerant, replace the O-ring with a new one. Apply a coat of compressor oil to the O-ring prior to installation.
- Perform a check for refrigerant leakage when charging with refrigerant. Refer to [HA-31, "Check Refrigerant Leakage"](#).

HIGH-PRESSURE PIPE

HIGH-PRESSURE PIPE : Removal and Installation

INFOID:000000006960812

CAUTION:

COOLER PIPE AND HOSE

< REMOVAL AND INSTALLATION >

Perform lubricant return operation before each refrigeration system disassembly. However, if a large amount of refrigerant or lubricant is detected, never perform lubricant return operation. Refer to [HA-34, "Perform Lubricant Return Operation"](#).

REMOVAL

1. Remove low-pressure flexible hose. Refer to [HA-53, "LOW-PRESSURE FLEXIBLE HOSE : Removal and Installation"](#).
2. Remove washer tank inlet. Refer to [WW-47, "Removal and Installation"](#).
3. Remove mounting bolt (A), and then disconnect high-pressure flexible hose (1) and high-pressure pipe (2) from condenser.

CAUTION:

To prevent the inclusion of foreign matter, use a cap or vinyl tape to seal off the connection ports of the pipe and condenser from the atmosphere.

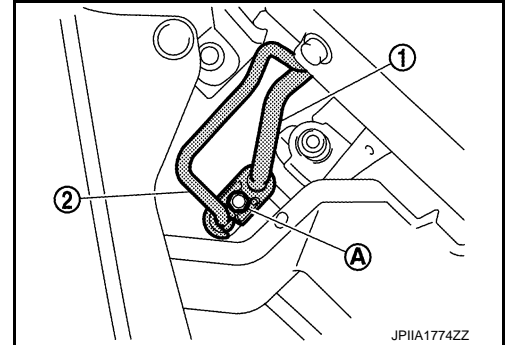

4. Disconnect high-pressure pipe from expansion valve.
CAUTION:
To prevent the inclusion of foreign matter, use a cap or vinyl tape to seal off the connection ports of the pipe and expansion valve from the atmosphere.
5. Remove cowl top extension. Refer to [EXT-19, "Removal and Installation"](#).
6. Move electric water pump 1 to secure work space. Refer to [HCO-23, "Exploded View"](#).
7. Disconnect high-pressure pipe from the vehicle.

INSTALLATION

Note the following items, and then install in the reverse order of removal.

CAUTION:

- To prevent degradation in insulation performance, use special electric compressor oil as the compressor oil.
- In order to prevent conventional PAG oil from becoming mixed in, never reuse recovered compressor oil and instead always use new oil. The use of oil including the conventional PAG oil may degrade the performance of insulation.
- To prevent performance degradation, never use a fluorescent agent in order to detect refrigerant leakage. Also be careful that a fluorescent agent never enter the oil.
- To prevent leakage of refrigerant, replace the O-ring with a new one. Apply a coat of compressor oil to the O-ring prior to installation.
- Perform a check for refrigerant leakage when charging with refrigerant. Refer to [HA-31, "Check Refrigerant Leakage"](#).

CONDENSER

< REMOVAL AND INSTALLATION >

CONDENSER

Exploded View

INFOID:000000006960813

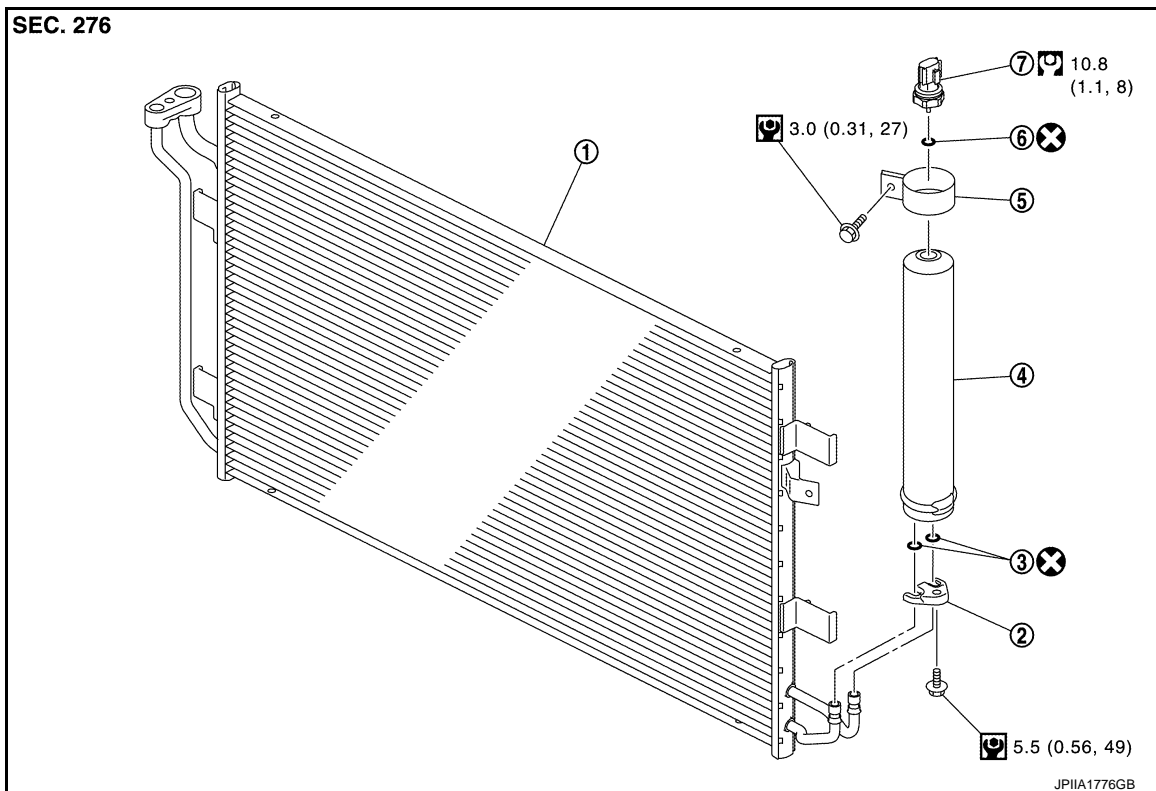

- | | | |
|--------------------------------|------------------------|-----------|
| 1. Condenser | 2. Bracket | 3. O-ring |
| 4. Liquid tank | 5. Liquid tank bracket | 6. O-ring |
| 7. Refrigerant pressure sensor | | |

⊗ : Always replace after every disassembly.

🔧 : N•m (kg-m in-lb)

🔧 : N•m (kg-m ft-lb)

CONDENSER

CONDENSER : Removal and Installation

INFOID:000000006960814

CAUTION:

Perform lubricant return operation before each refrigeration system disassembly. However, if a large amount of refrigerant or lubricant is detected, never perform lubricant return operation. Refer to [HA-34, "Perform Lubricant Return Operation"](#).

REMOVAL

1. Use the refrigerant recovery equipment (for HFC134a) and recover the refrigerant. Refer to [HA-32, "Recycle Refrigerant"](#).
2. Remove radiator upper grille. Refer to [DLK-155, "RADIATOR UPPER GRILLE : Removal and Installation"](#).
3. Remove washer tank inlet. Refer to [WW-47, "Removal and Installation"](#).

CONDENSER

< REMOVAL AND INSTALLATION >

4. Remove mounting bolt (A), and then disconnect high-pressure flexible hose (1) and high-pressure pipe (2) from condenser.

CAUTION:

To prevent the inclusion of foreign matter, use a cap or vinyl tape to seal off the connection ports of the pipe and condenser from the atmosphere.

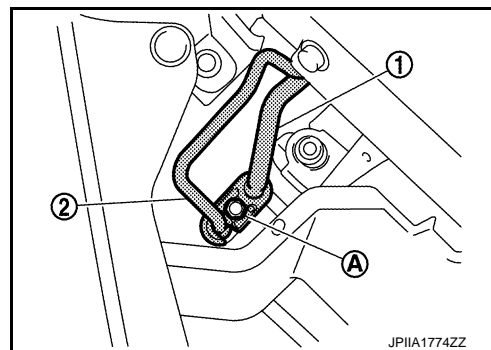

5. Remove charge port bracket. Refer to [DLK-155. "CHARGE PORT BRACKET : Removal and Installation"](#).
6. Remove radiator core support lower stay. Refer to [DLK-153. "RADIATOR CORE SUPPORT LOWER : Removal and Installation"](#).
7. Remove radiator core support upper. Refer to [DLK-151. "RADIATOR CORE SUPPORT UPPER : Removal and Installation"](#).
8. Disconnect refrigerant pressure sensor connector (A).

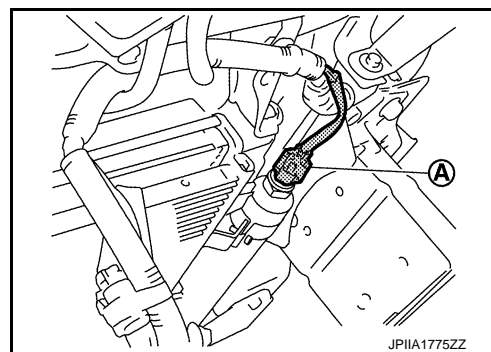

9. Lift the condenser upwards while pressing the tabs (1) on the right and left of the radiator to remove the condenser.

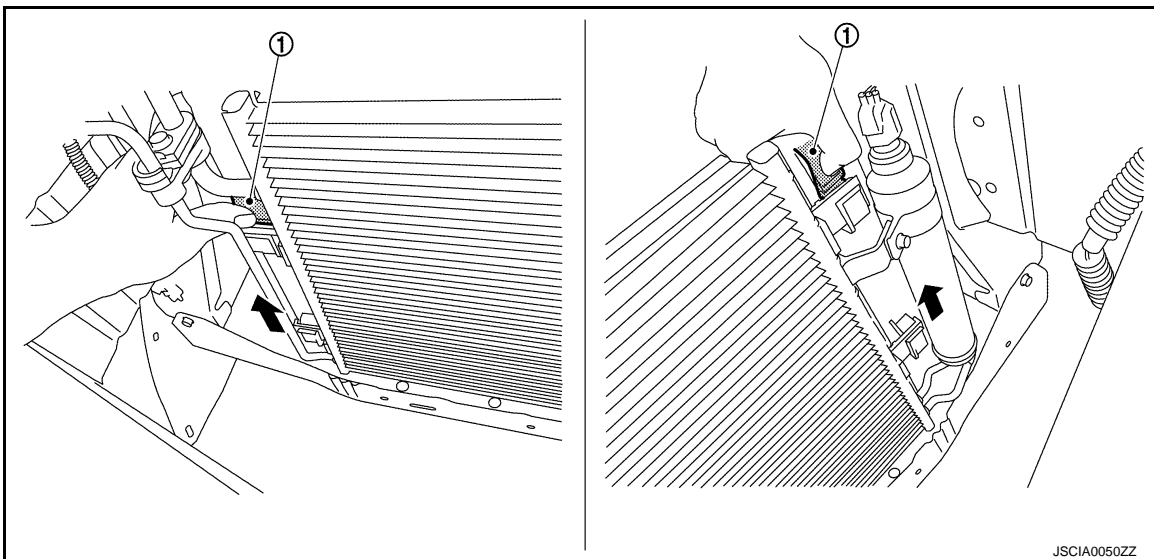

INSTALLATION

Note the following items, and then install in the reverse order of removal.

CAUTION:

A
B
C
D
E
F
G
H
HA
J
K
L
M
N
O
P

CONDENSER

< REMOVAL AND INSTALLATION >

- When installing the condenser, securely insert the mating part indicated by the arrow in the diagram.

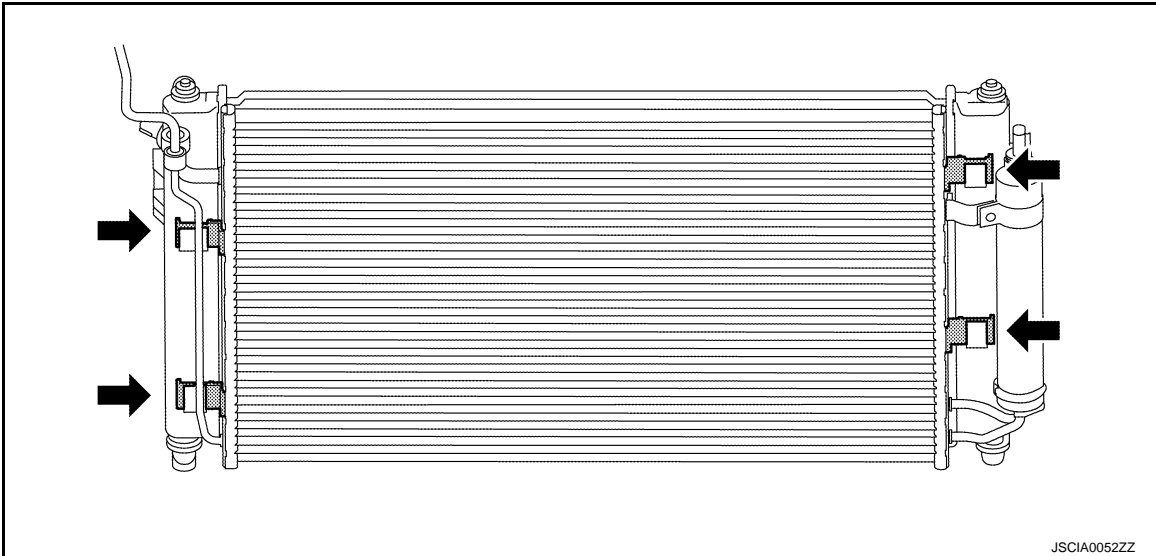

- To prevent degradation in insulation performance, use special electric compressor oil as the compressor oil.
- In order to prevent conventional PAG oil from becoming mixed in, never reuse recovered compressor oil and instead always use new oil. The use of oil including the conventional PAG oil may degrade the performance of insulation.
- To prevent performance degradation, never use a fluorescent agent in order to detect refrigerant leakage. Also be careful that a fluorescent agent never enter the oil.
- After installing a new condenser, adjust the compressor oil level. Refer to [HA-34, "Lubricant Adjusting Procedure for Components Replacement Except Compressor"](#).
- To prevent leakage of refrigerant, replace the O-ring with a new one. Apply a coat of compressor oil to the O-ring prior to installation.
- Perform a check for refrigerant leakage when charging with refrigerant. Refer to [HA-31, "Check Refrigerant Leakage"](#).

LIQUID TANK

LIQUID TANK : Removal and Installation

INFOID:000000006960815

CAUTION:

Perform lubricant return operation before each refrigeration system disassembly. However, if a large amount of refrigerant or lubricant is detected, never perform lubricant return operation. Refer to [HA-34, "Perform Lubricant Return Operation"](#).

REMOVAL

1. Use the refrigerant recovery equipment (for HFC134a) and recover the refrigerant. Refer to [HA-32, "Reycle Refrigerant"](#).
2. Disconnect refrigerant pressure sensor connector (A).

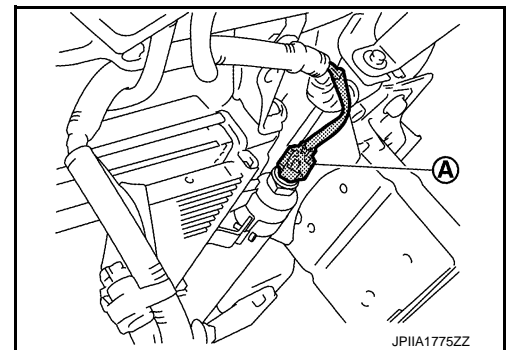

3. Clean around the liquid tank to remove any dirt or corrosion.

CONDENSER

< REMOVAL AND INSTALLATION >

4. Remove mounting bolts (A), and then remove liquid tank (1) from condenser.

CAUTION:

To prevent the inclusion of foreign matter, use a cap or vinyl tape to seal off the connection ports of the liquid tank and condenser from the atmosphere.

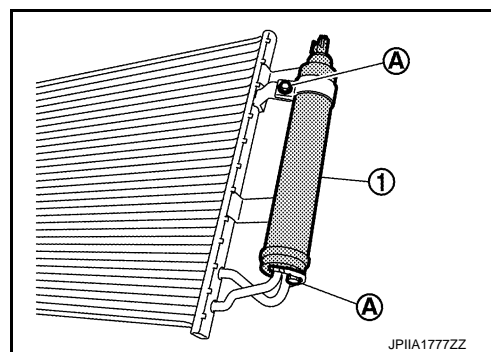

INSTALLATION

Note the following items, and then install in the reverse order of removal.

CAUTION:

- To prevent degradation in insulation performance, use special electric compressor oil as the compressor oil.
- In order to prevent conventional PAG oil from becoming mixed in, never reuse recovered compressor oil and instead always use new oil. The use of oil including the conventional PAG oil may degrade the performance of insulation.
- To prevent performance degradation, never use a fluorescent agent in order to detect refrigerant leakage. Also be careful that a fluorescent agent never enter the oil.
- After installing a new liquid tank, adjust the compressor oil level. Refer to [HA-34, "Lubricant Adjusting Procedure for Components Replacement Except Compressor"](#).
- To prevent leakage of refrigerant, replace the O-ring with a new one. Apply a coat of compressor oil to the O-ring prior to installation.
- Perform a check for refrigerant leakage when charging with refrigerant. Refer to [HA-31, "Check Refrigerant Leakage"](#).

REFRIGERANT PRESSURE SENSOR

REFRIGERANT PRESSURE SENSOR : Removal and Installation

INFOID:000000006960816

CAUTION:

Perform lubricant return operation before each refrigeration system disassembly. However, if a large amount of refrigerant or lubricant is detected, never perform lubricant return operation. Refer to [HA-34, "Perform Lubricant Return Operation"](#)

REMOVAL

1. Remove liquid tank. Refer to [HA-58, "LIQUID TANK : Removal and Installation"](#).
2. Use a vise (A) to fasten the liquid tank (1) in place, then use a spanner (B) and remove the refrigerant pressure sensor (2).

CAUTION:

- Wrap the liquid tank with shopcloth to prevent scratches.
- To prevent the inclusion of foreign matter, use a cap or vinyl tape to seal off the refrigerant pressure sensor mounting point on the liquid tank from the atmosphere.

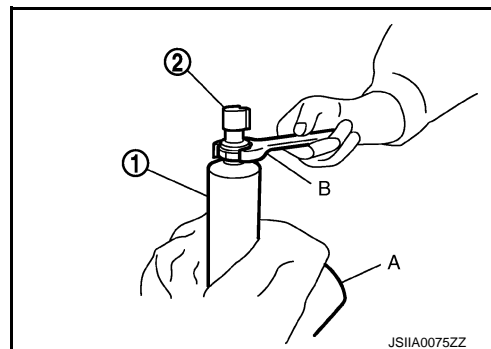

INSTALLATION

Note the following items, and then install in the reverse order of removal.

CAUTION:

- To prevent leakage of refrigerant, replace the O-ring with a new one. Apply a coat of compressor oil to the O-ring prior to installation.
- Perform a check for refrigerant leakage when charging with refrigerant. Refer to [HA-31, "Check Refrigerant Leakage"](#).

A/C UNIT ASSEMBLY

< REMOVAL AND INSTALLATION >

A/C UNIT ASSEMBLY

Exploded View

INFOID:000000006960817

REMOVAL

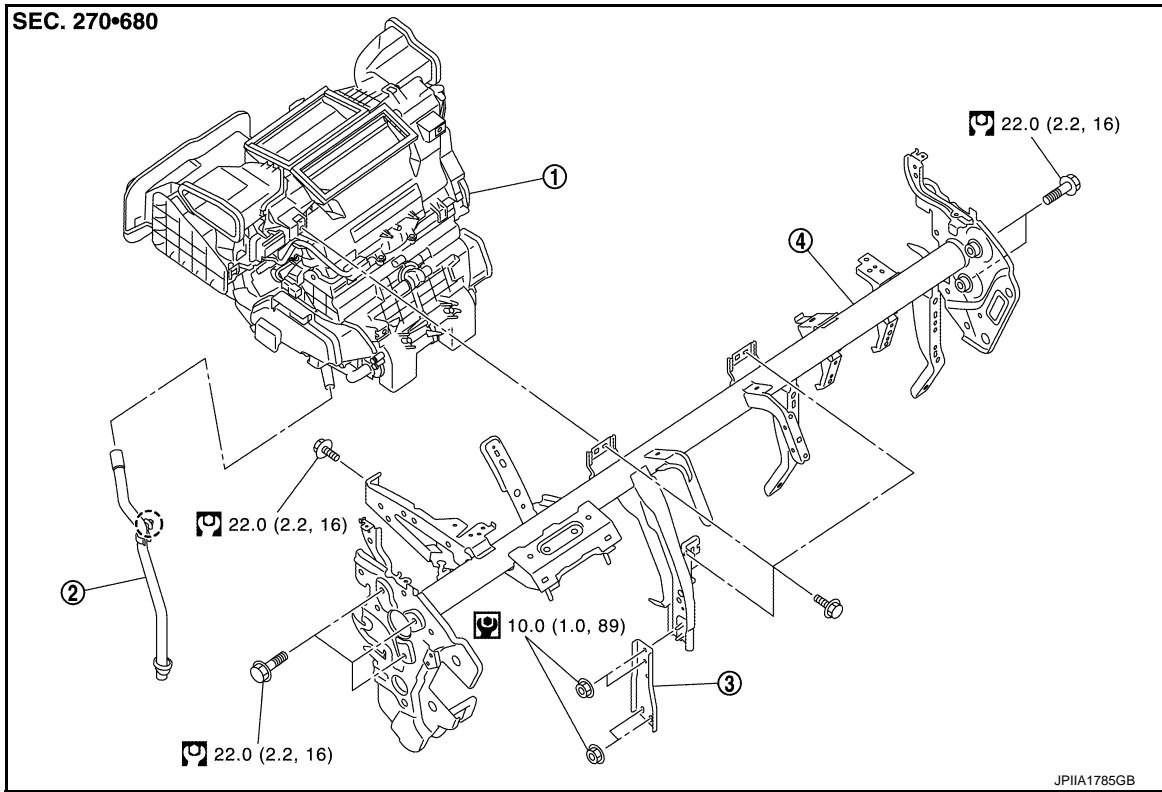

1. A/C unit assembly

2. Drain hose

3. Instrument stay

4. Steering member

○ : Clip

⊙ : N•m (kg-m in-lb)

⊙ : N•m (kg-m ft-lb)

DISASSEMBLY

A/C UNIT ASSEMBLY

< REMOVAL AND INSTALLATION >

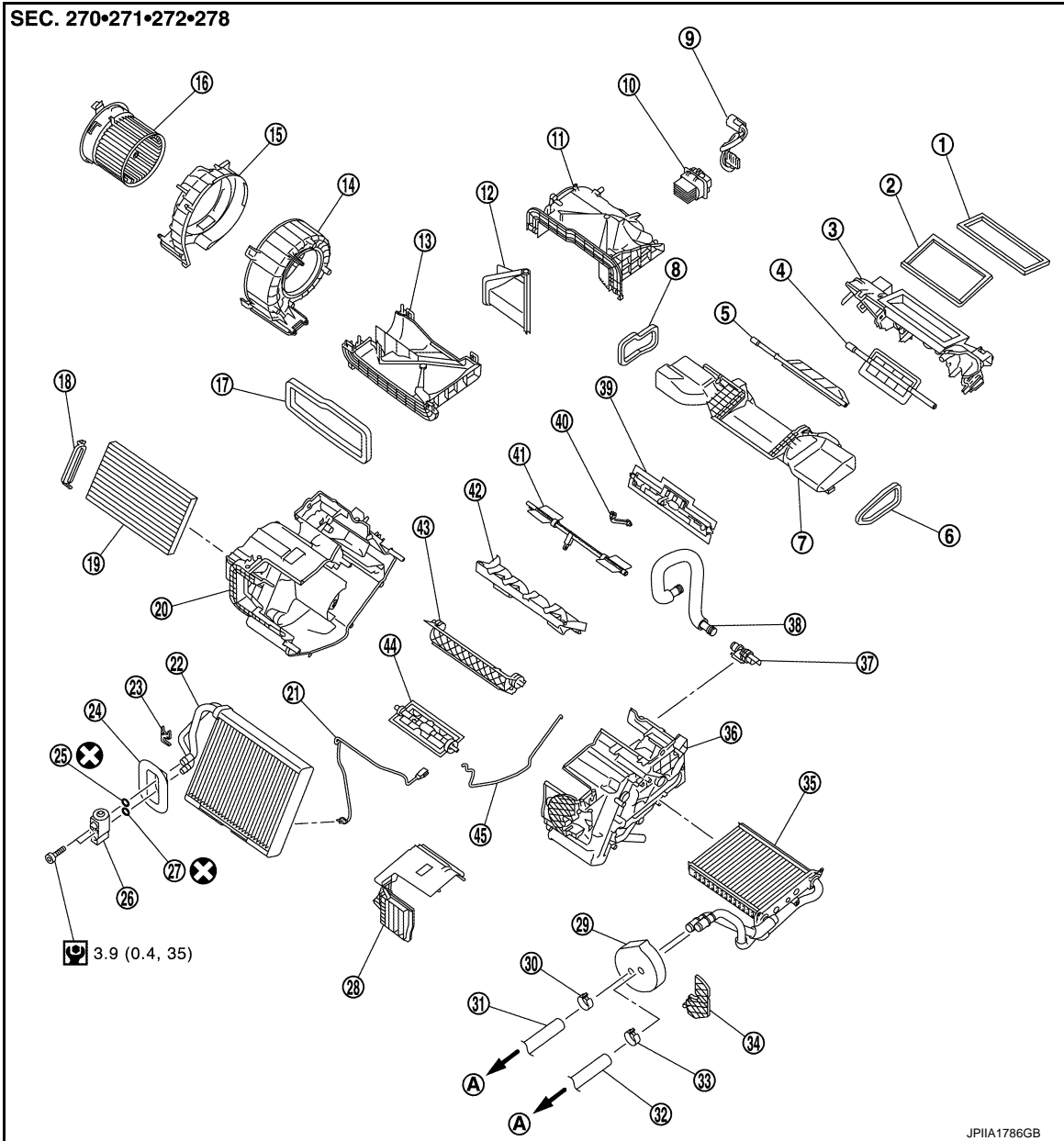

A
B
C
D
E
F
G
H
HA
J
K
L

HA

M
N
O
P

- | | | |
|--------------------------|---|-----------------------------|
| 1. Ventilator seal | 2. Defroster seal | 3. Upper attachment case |
| 4. Sub defroster door | 5. Center ventilator and defroster door | 6. Side ventilator seal LH |
| 7. Lower attachment case | 8. Side ventilator seal RH | 9. Sub harness |
| 10. Power transistor | 11. Upper intake case | 12. Intake door |
| 13. Lower intake case | 14. Blower case LH | 15. Blower case RH |
| 16. Blower motor | 17. Intake seal | 18. Filter cover |
| 19. In-cabin microfilter | 20. A/C unit case RH | 21. Intake sensor |
| 22. Evaporator | 23. Plate | 24. Expansion valve grommet |
| 25. O-ring | 26. Expansion valve | 27. O-ring |
| 28. Evaporator cover | 29. Heater pipe grommet | 30. Clamp |
| 31. Heater hose | 32. Heater hose | 33. Clamp |
| 34. Heater pipe support | 35. Heater core | 36. A/C unit case LH |
| 37. Aspirator | 38. Aspirator hose | 39. Foot door |
| 40. Foot door rod | 41. Side ventilator door | 42. Air mix door guide |
| 43. Upper air mix door | 44. Lower air mix door | 45. Case packing |
- A: To water outlet

A/C UNIT ASSEMBLY

< REMOVAL AND INSTALLATION >

⊗ : Always replace after every disassembly..

🔧 : N•m (kg-m in-lb)

A/C UNIT ASSEMBLY

A/C UNIT ASSEMBLY : Removal and Installation

INFOID:000000006960818

CAUTION:

Perform lubricant return operation before each refrigeration system disassembly. However, if a large amount of refrigerant or lubricant is detected, never perform lubricant return operation. Refer to [HA-34, "Perform Lubricant Return Operation"](#)

REMOVAL

1. Use the refrigerant recovery equipment (for HFC134a) and recover the refrigerant. Refer to [HA-32, "Recycle Refrigerant"](#).
2. Drain out heater fluid. Refer to [HA-43, "Draining and Refilling"](#).
3. Remove cowl top extension. Refer to [EXT-19, "Removal and Installation"](#).
4. Remove mounting bolt (A), and then disconnect low-pressure flexible hose (1) and high-pressure pipe (2) from expansion valve.

CAUTION:

To prevent the inclusion of foreign matter, use a cap or vinyl tape to seal off the connection ports of the pipe and expansion valve from the atmosphere.

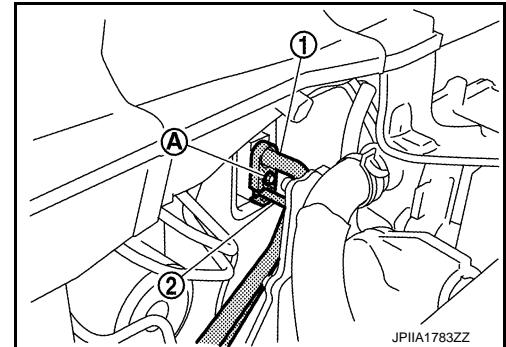

5. Remove fixing clamps, and then disconnect heater hoses (1).

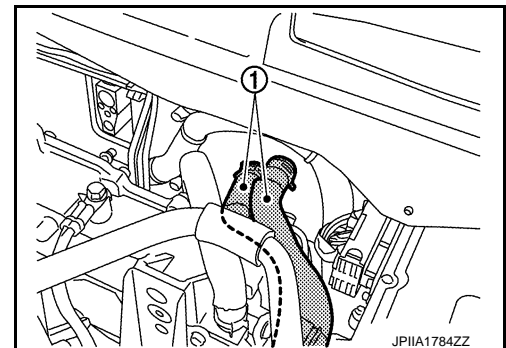

6. Remove instrument panel assembly. Refer to [IP-14, "Removal and Installation"](#).
7. Remove side ventilator duct. Refer to [VTL-17, "SIDE VENTILATOR DUCT : Removal and Installation"](#).
8. Disconnect drain hose (1).

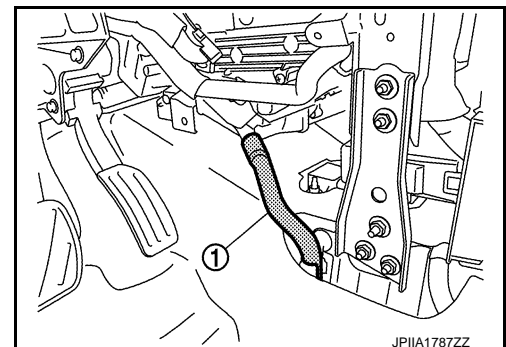

A/C UNIT ASSEMBLY

< REMOVAL AND INSTALLATION >

9. Remove mounting nuts (A), and then remove instrument stay (1).

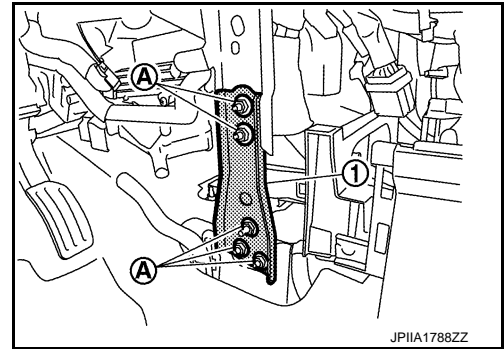

10. Remove fixing screws (A), and then remove fuse box (J/B) (1).

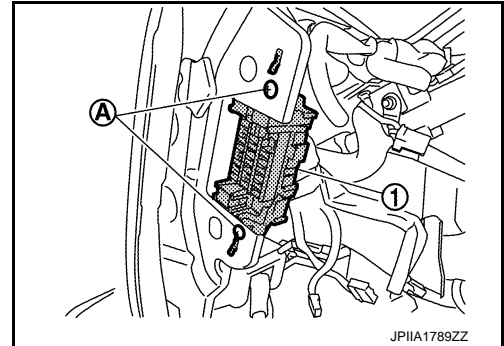

11. Remove mounting bolts (A) of ground wire from steering member.

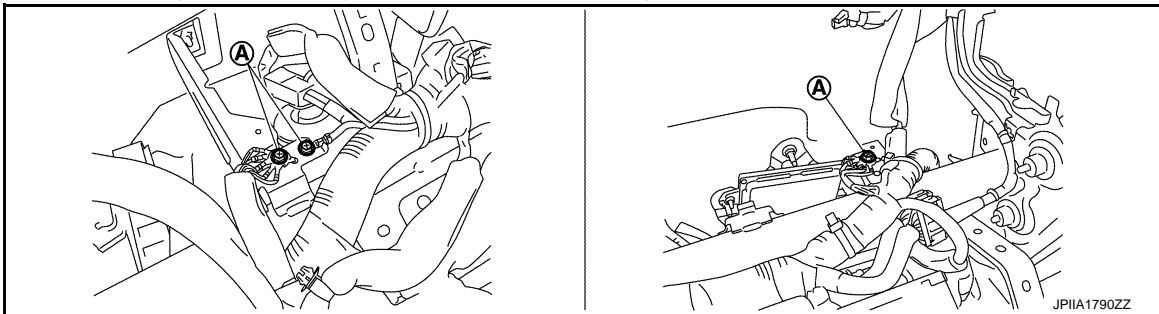

12. Remove all of harness connectors and mounting nuts necessary to allow steering column assembly to be moved. Refer to [ST-31. "Exploded View"](#) (With heated steering wheel) or [ST-53. "Exploded View"](#) (Without heated steering wheel).
13. Move steering column assembly to secure work space.
14. Remove all of harness connectors and clips necessary to allow steering member to be removed. Move main harness aside and secure work space so that steering member can be easily removed.

A/C UNIT ASSEMBLY

< REMOVAL AND INSTALLATION >

15. Remove mounting bolts (A) and (B), and then remove steering member (1) from the vehicle.

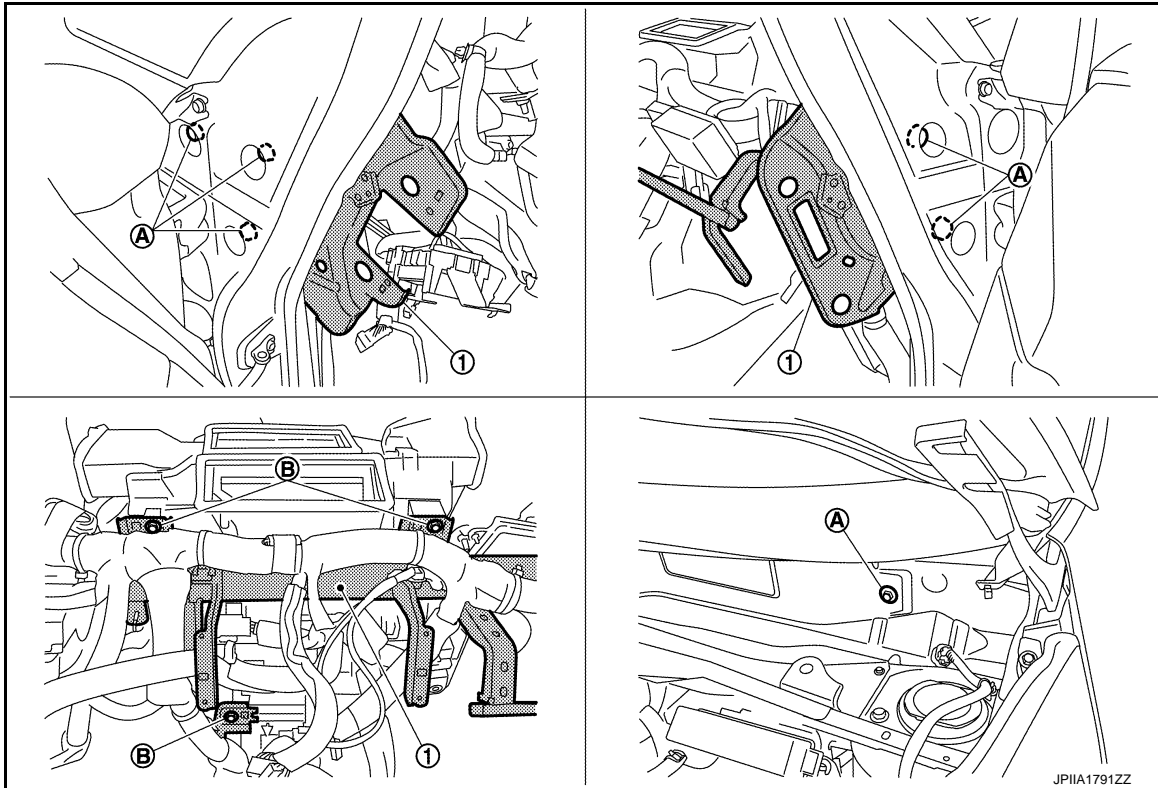

CAUTION:

When removing steering member, 2 workers are required to prevent it from dropping.

16. Remove A/C unit assembly from the vehicle.

INSTALLATION

Note the following items, and then install in the reverse order of removal.

CAUTION:

- To prevent degradation in insulation performance, use special electric compressor oil as the compressor oil.
- In order to prevent conventional PAG oil from becoming mixed in, never reuse recovered compressor oil and instead always use new oil. The use of oil including the conventional PAG oil may degrade the performance of insulation.
- To prevent performance degradation, never use a fluorescent agent in order to detect refrigerant leakage. Also be careful that a fluorescent agent never enter the oil.
- To prevent leakage of refrigerant, replace the O-ring with a new one. Apply a coat of compressor oil to the O-ring prior to installation.
- Perform a check for refrigerant leakage when charging with refrigerant. Refer to [HA-31, "Check Refrigerant Leakage"](#).

NOTE:

When adding heater fluid. Refer to [HA-43, "Draining and Refilling"](#).

EVAPORATOR

EVAPORATOR : Removal and Installation

INFOID:0000000006960819

REMOVAL

1. Remove A/C unit assembly. Refer to [HA-62, "A/C UNIT ASSEMBLY : Removal and Installation"](#).
2. Disassemble A/C unit assembly and remove evaporator assembly.
3. Remove expansion valve and intake sensor from evaporator assembly.

INSTALLATION

Note the following items, and then install in the reverse order of removal.

CAUTION:

A/C UNIT ASSEMBLY

< REMOVAL AND INSTALLATION >

- To prevent leakage of refrigerant, replace the O-ring with a new one. Apply a coat of compressor oil to the O-ring prior to installation.
- When installing the new evaporator, be sure to install the intake sensor in the same position as before it was removed.
- When removing or installing the intake sensor, be sure not to rotate the bracket insertion part. Failure to do this may cause damage to the evaporator.
- After installing a new evaporator, adjust the compressor oil level. Refer to [HA-34, "Lubricant Adjusting Procedure for Components Replacement Except Compressor"](#).

HEATER CORE

HEATER CORE : Removal and Installation

INFOID:000000006960820

REMOVAL

1. Remove A/C unit assembly. Refer to [HA-62, "A/C UNIT ASSEMBLY : Removal and Installation"](#).
2. Remove foot duct LH. Refer to [VTL-19, "FOOT DUCT : Removal and Installation"](#).
3. Remove heater pipe grommet and heater pipe support from A/C unit assembly.
4. Remove fixing screws, and then remove heater core from A/C unit assembly.

INSTALLATION

Install in the reverse order of removal.

A
B
C
D
E
F
G
H
J
K
L
M
N
O
P

HA

EXPANSION VALVE

< REMOVAL AND INSTALLATION >

EXPANSION VALVE

Exploded View

INFOID:000000006960821

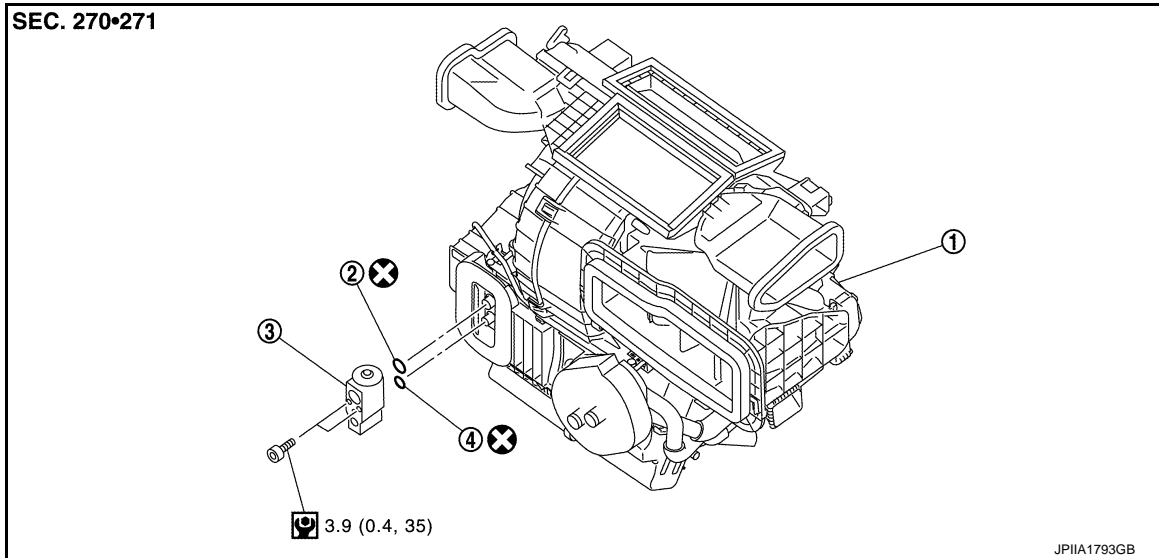

1. A/C unit assembly
2. O-ring
3. Expansion valve
4. O-ring

⊗ : Always replace after every disassembly.

Ⓜ : N•m (kg-m in-lb)

Removal and Installation

INFOID:000000006960822

CAUTION:

Perform lubricant return operation before each refrigeration system disassembly. However, if a large amount of refrigerant or lubricant is detected, never perform lubricant return operation. Refer to [HA-34, "Perform Lubricant Return Operation"](#).

REMOVAL

1. Use the refrigerant recovery equipment (for HFC134a) and recover the refrigerant. Refer to [HA-32, "Recycle Refrigerant"](#).

2. Remove mounting bolt (A), and then disconnect low-pressure flexible hose (1) and high-pressure pipe (2) from expansion valve.

CAUTION:

To prevent the inclusion of foreign matter, use a cap or vinyl tape to seal off the connection ports of the pipe and expansion valve from the atmosphere.

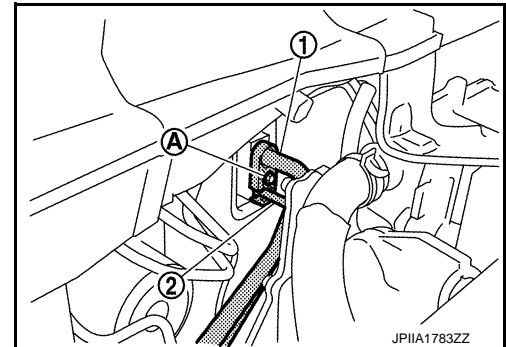

EXPANSION VALVE

< REMOVAL AND INSTALLATION >

3. Remove mounting bolts (A), and then remove expansion valve (1).

CAUTION:

To prevent the inclusion of foreign matter, use a cap or vinyl tape to seal off the connection ports of the expansion valve and evaporator from the atmosphere.

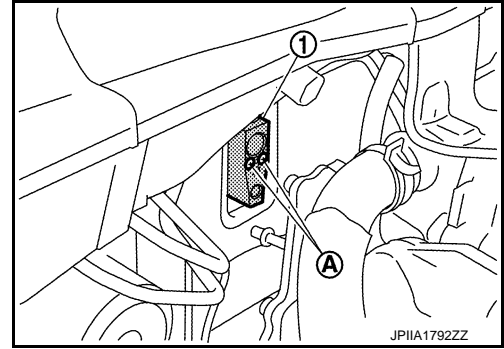

INSTALLATION

Note the following items, and then install in the reverse order of removal.

CAUTION:

- To prevent degradation in insulation performance, use special electric compressor oil as the compressor oil.
- In order to prevent conventional PAG oil from becoming mixed in, never reuse recovered compressor oil and instead always use new oil. The use of oil including the conventional PAG oil may degrade the performance of insulation.
- To prevent performance degradation, never use a fluorescent agent in order to detect refrigerant leakage. Also be careful that a fluorescent agent never enter the oil.
- To prevent leakage of refrigerant, replace the O-ring with a new one. Apply a coat of compressor oil to the O-ring prior to installation.
- Perform a check for refrigerant leakage when charging with refrigerant. Refer to [HA-31, "Check Refrigerant Leakage"](#).

A
B
C
D
E
F
G
H
HA
J
K
L
M
N
O
P

PTC ELEMENTS HEATER

< REMOVAL AND INSTALLATION >

PTC ELEMENTS HEATER

Exploded View

INFOID:000000006960823

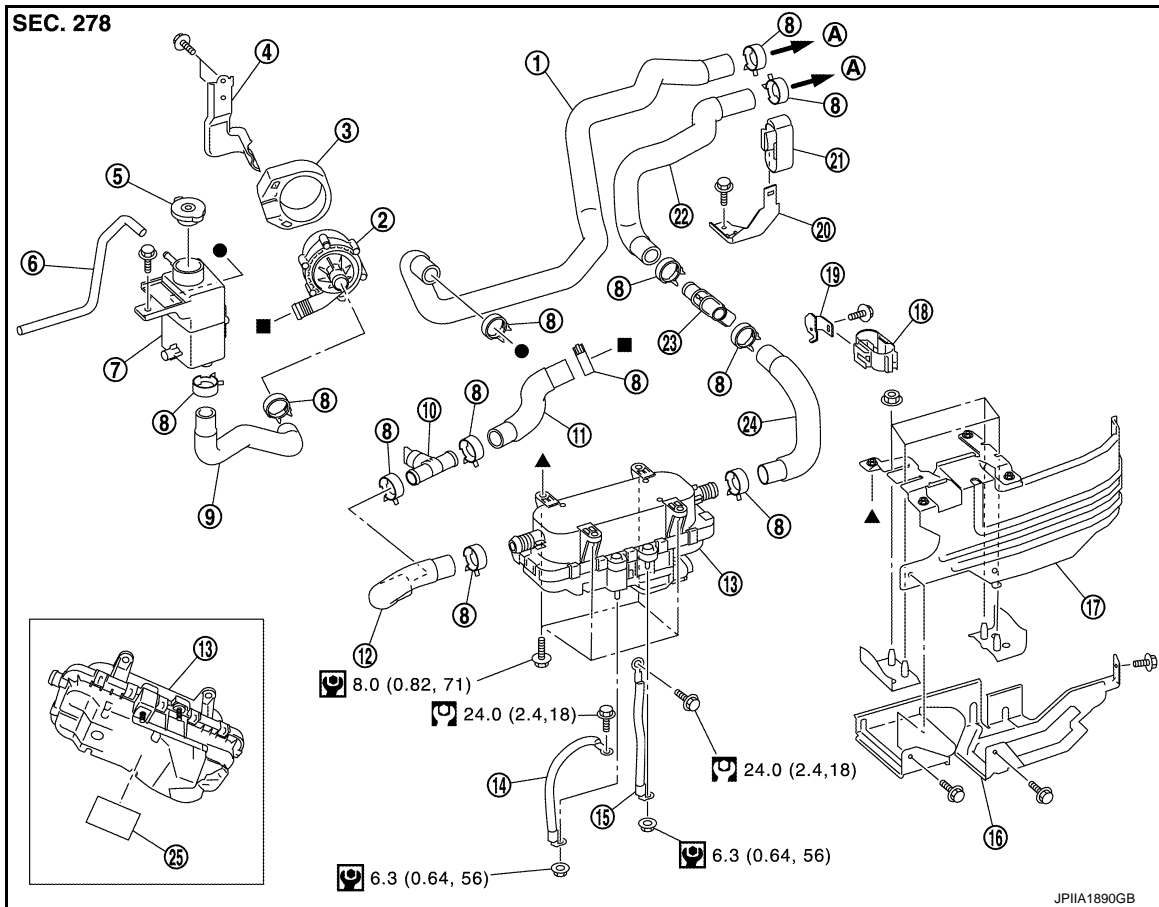

- | | | |
|-------------------------------------|---|----------------------|
| 1. Heater hose | 2. Heater pump | 3. Heater pump mount |
| 4. Heater pump bracket | 5. Degas tank cap | 6. Degas tank hose |
| 7. Degas tank (heater) | 8. Clamp | 9. Heater hose |
| 10. Drain cock | 11. Heater hose | 12. Heater hose |
| 13. PTC elements heater | 14. Bonding wire 1 | 15. Bonding wire 2 |
| 16. PTC elements heater lower cover | 17. PTC elements heater bracket | 18. Hose clip |
| 19. Bracket | 20. Bracket | 21. Hose clip |
| 22. Heater hose | 23. Sensor adapter
(Heater fluid temperature sensor) | 24. Heater hose |

25. High voltage warning label

A: To heater core

: N•m (kg-m in-lb)

: N•m (kg-m ft-lb)

●, ▲, ■: Indicates that the part is connected at points with same symbol in actual vehicle.

Removal and Installation

INFOID:000000006960824

WARNING:

- Because EV (electric vehicle) and HEV (hybrid vehicle) contain a high voltage battery, there is the risk of electric shock, electric leakage, or similar accidents if the high voltage component and vehicle are handled incorrectly. Be sure to follow the correct work procedures when performing inspection and maintenance.

PTC ELEMENTS HEATER

< REMOVAL AND INSTALLATION >

- Be sure to remove the service plug in order to disconnect the high voltage circuits before performing inspection or maintenance of high voltage system harnesses and parts.
- To prevent the removed service plug from being connected by mistake during the procedure, always carry it in your pocket or put it in the tool box.
- Be sure to wear insulating protective equipment consisting of glove, shoes, face shield and glasses before beginning work on the high voltage system.
- Clearly identify the persons responsible for high voltage work and ensure that other persons never touch the vehicle. When not working, cover high voltage parts with an insulating cover sheet or similar item to prevent other persons from contacting them.

CAUTION:

There is the possibility of a malfunction occurring if the vehicle is changed to READY status while the service plug is removed. Therefore never change the vehicle to READY status unless instructed to do so in the Service Manual.

REMOVAL

WARNING:

Disconnect high voltage circuit. Refer to [GI-31, "How to Disconnect High Voltage"](#).

1. Check voltage in high voltage circuit. (Check that condenser are discharged.)
 - a. Lift up the vehicle, and then remove Li-ion battery under covers.
 - Refer to [EVB-169, "Exploded View"](#). (Type 1: Without Li-ion battery heater)
 - Refer to [EVB-395, "Exploded View"](#). (Type 2: With Li-ion battery heater)
 - b. Disconnect high voltage connector from front side of Li-ion battery.
 - Refer to [EVB-169, "Removal and Installation"](#). (Type 1: Without Li-ion battery heater)
 - Refer to [EVB-395, "Removal and Installation"](#). (Type 2: With Li-ion battery heater)
 - c. Measure voltage between high voltage harness terminals.

DANGER:

 Touching high voltage components without using the appropriate protective equipment will cause electrocution.



Standard

: 5 V or less

CAUTION:

For voltage measurements, use a tester which can measure to 500 V or higher.

2. Remove front under cover. Refer to [EXT-23, "FRONT UNDER COVER : Removal and Installation"](#).
3. Drain out heater fluid. Refer to [HA-43, "Draining and Refilling"](#).
4. Remove front tire LH. Refer to [WT-47, "Removal and Installation"](#).
5. Remove front side of the front fender protector LH (1) and move to secure work space.

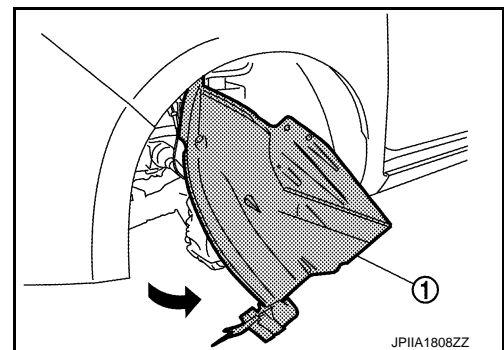
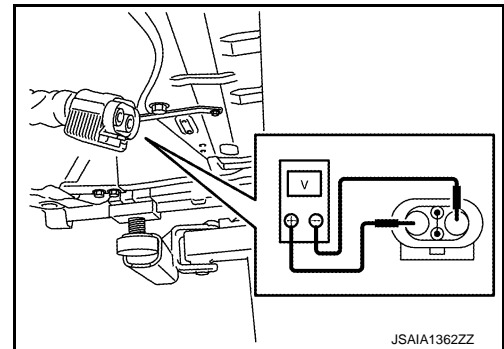

PTC ELEMENTS HEATER

< REMOVAL AND INSTALLATION >

6. Remove mounting bolts (A), and then remove PTC elements heater lower cover (1).

WARNING:

 To prevent electric shock hazards, be sure to wear protective gear.

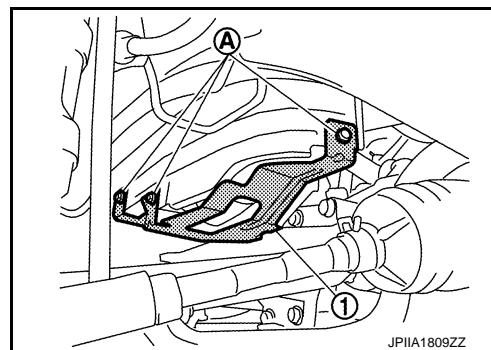

JPIIA1809ZZ

7. Disconnect high voltage harness connector (A) and low voltage harness connector (B) from PTC elements heater.

WARNING:

•  To prevent electric shock hazards, be sure to wear protective gear.



• To prevent electric shock hazards, immediately wrap insulating tape around disconnected high voltage connector terminals.

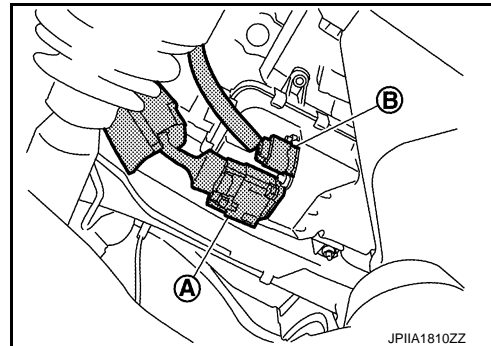

JPIIA1810ZZ

- Follow the procedure below and remove the high voltage harness connector.

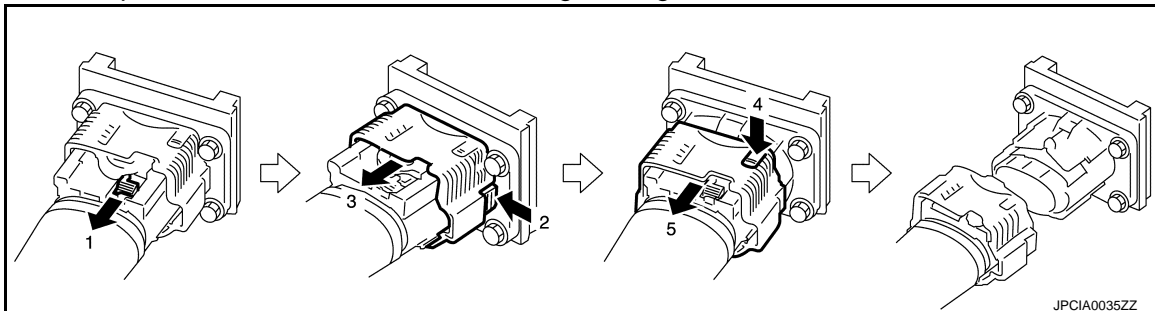

JPCIA0035ZZ

8. Remove fixing clamps, and then disconnect heater hoses (1).

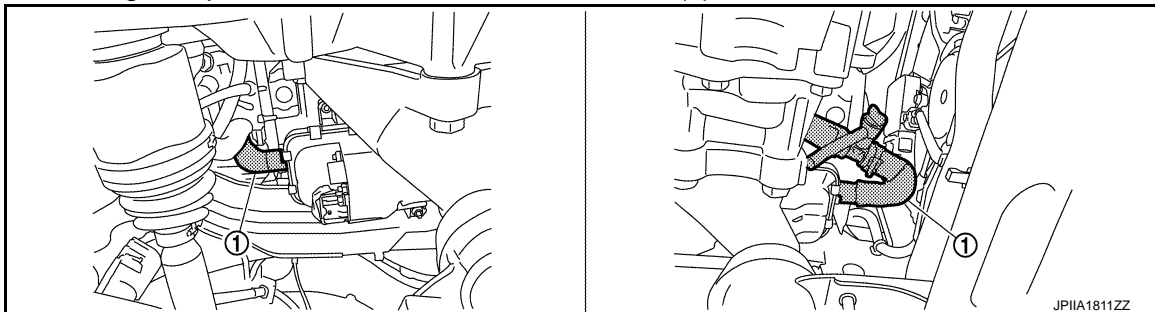

JPIIA1811ZZ

WARNING:

•  To prevent electric shock hazards, be sure to wear protective gear.



- When removing the PTC elements heater, be careful that the heater fluid never contact the high voltage harness connector.
- If heater fluid contacts the high voltage harness connector, immediately dry the high voltage connector completely with an air blow gun.

9. Remove 12 V battery. Refer to [PG-108, "Removal and Installation"](#).

PTC ELEMENTS HEATER

< REMOVAL AND INSTALLATION >

10. Remove mounting bolts (A), and then remove battery bracket (1).

WARNING:

 To prevent electric shock hazards, be sure to wear protective gear.

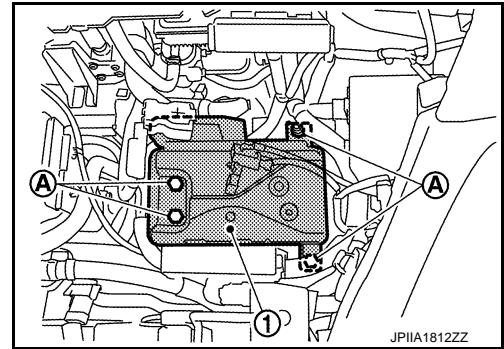

11. Remove bonding wire (1) mounting bolts (A).

WARNING:

 To prevent electric shock hazards, be sure to wear protective gear.

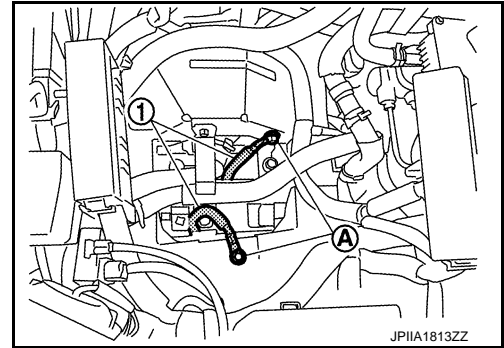

12. Remove PTC elements heater mounting nuts (A).

WARNING:

 Be sure to put on insulating protective gear before beginning work on the high voltage system.

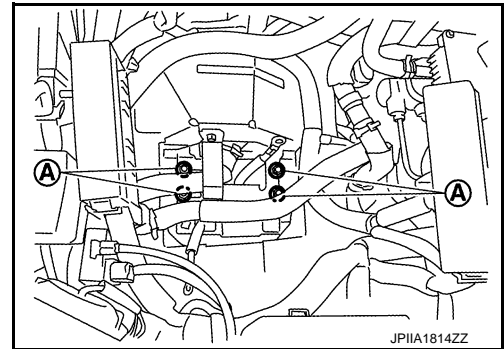

13. Remove PTC elements heater (1) from below the vehicle.

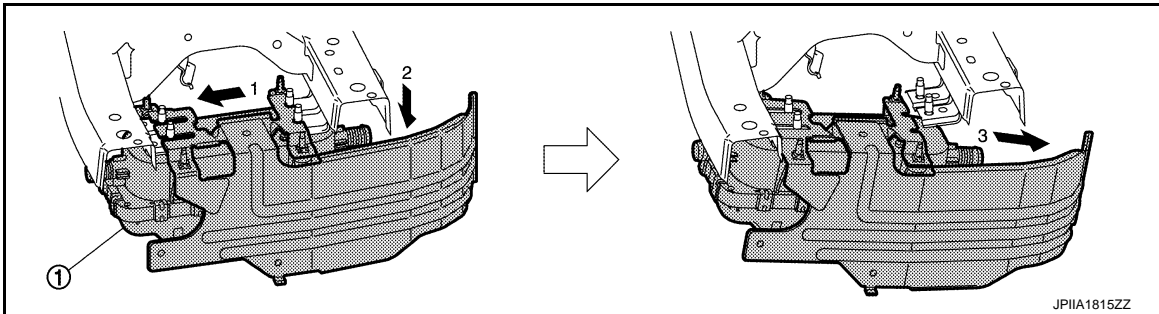

WARNING:

 To prevent electric shock hazards, be sure to wear protective gear.



A
B
C
D
E
F
G
H
HA
J
K
L
M
N
O
P

PTC ELEMENTS HEATER

< REMOVAL AND INSTALLATION >

14. Remove mounting bolts (A), and then remove PTC elements heater bracket (1).

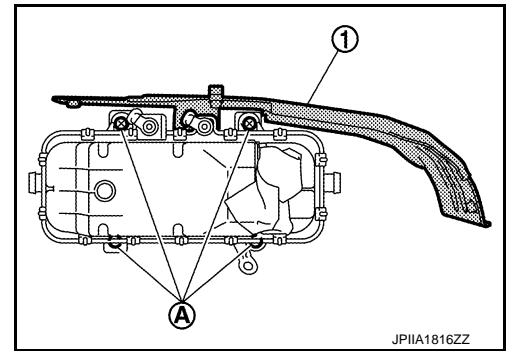

15. Remove mounting nuts (A), and then remove bonding wires (1).

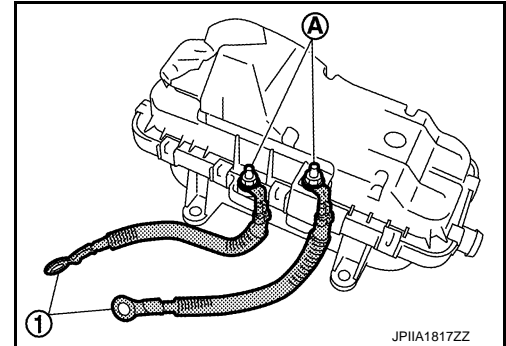

INSTALLATION

Note the following items, and then install in the reverse order of removal.

WARNING:



To prevent electric shock hazards, be sure to wear protective gear.



CAUTION:

Be sure to reinstall high voltage harness clips in their original positions. If a clip is damaged, replace it with a new clip before installing.

- If the PTC elements heater was replaced, first check that there is no dust or dirt on the surface of the PTC elements heater, then apply the new high voltage warning label at position (A).

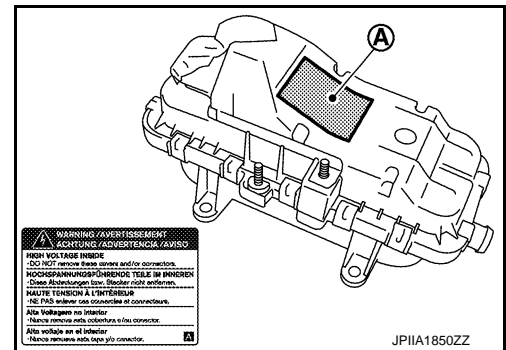

- Follow the procedure below and remove the PTC elements heater.

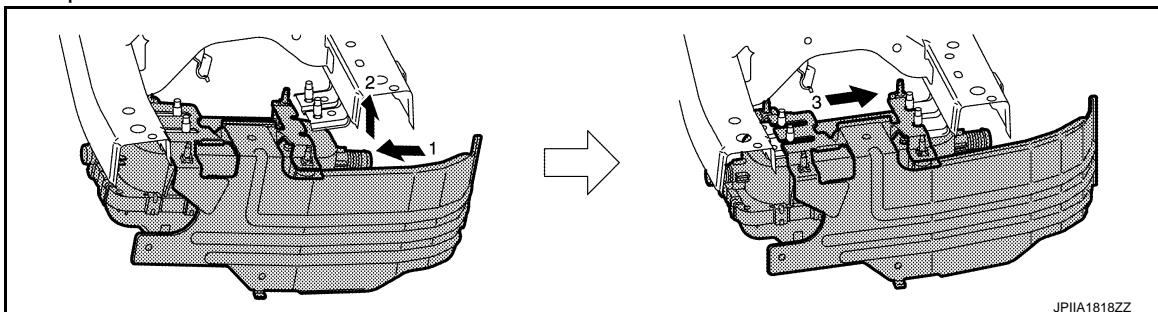

PTC ELEMENTS HEATER

< REMOVAL AND INSTALLATION >

- Follow the procedure below and connect the high voltage harness connector.

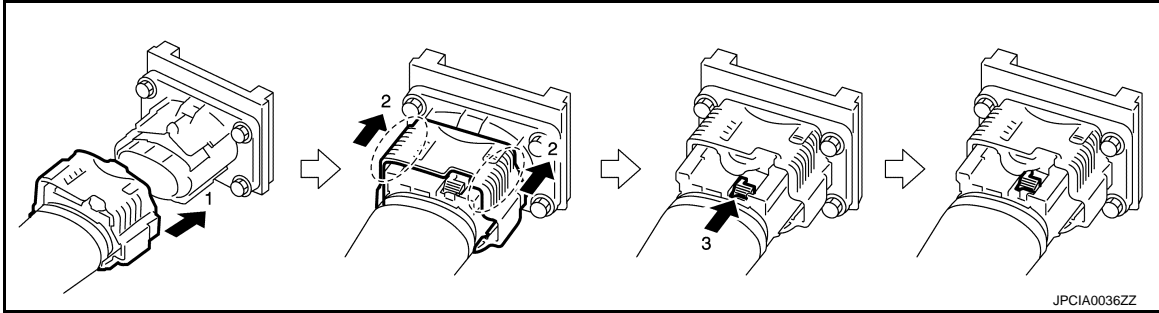

- After all parts are installed, be sure to check the equipotential. Refer to [HA-73. "Inspection"](#).

NOTE:

When adding heater fluid. Refer to [HA-43. "Draining and Refilling"](#).

Inspection

INFOID:000000006960825

EQUIPOTENTIAL TEST

After installing PTC elements heater, measure the resistance below.

- Between PTC elements heater (bonding wire stud bolt) and body (ground bolt).
- Between PTC elements heater (bonding wire stud bolt) and electric compressor (aluminum part).

WARNING:



To prevent electric shock hazards, be sure to wear protective gear.

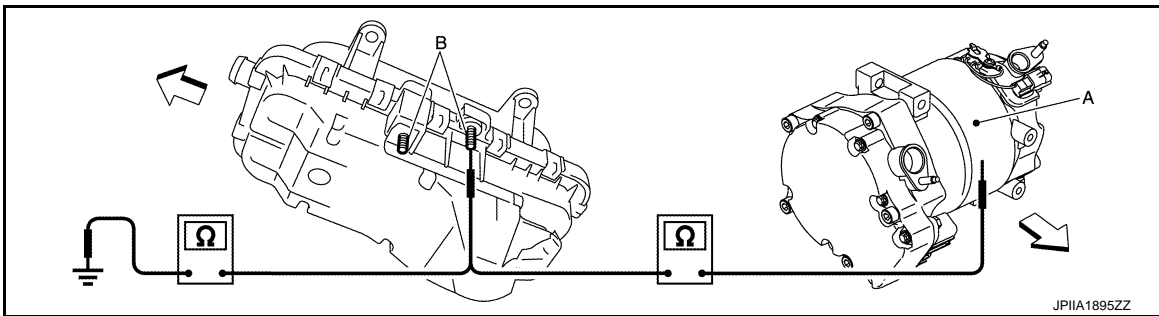

A : Electric compressor (aluminum part)

B : Bonding wire stud bolt

↔ : Vehicle front

Standard : Less than 0.1 Ω

If the result deviates from the standard value, check for paint, oil, dirt, or other substance adhering to the bolts or conductive mounting parts. If such substances are found, clean the surrounding area and remove the foreign substances.

A
B
C
D
E
F
G
H
J
K
L
M
N
O
P

HA

HEATER PUMP

< REMOVAL AND INSTALLATION >

HEATER PUMP

Exploded View

INFOID:000000006960826

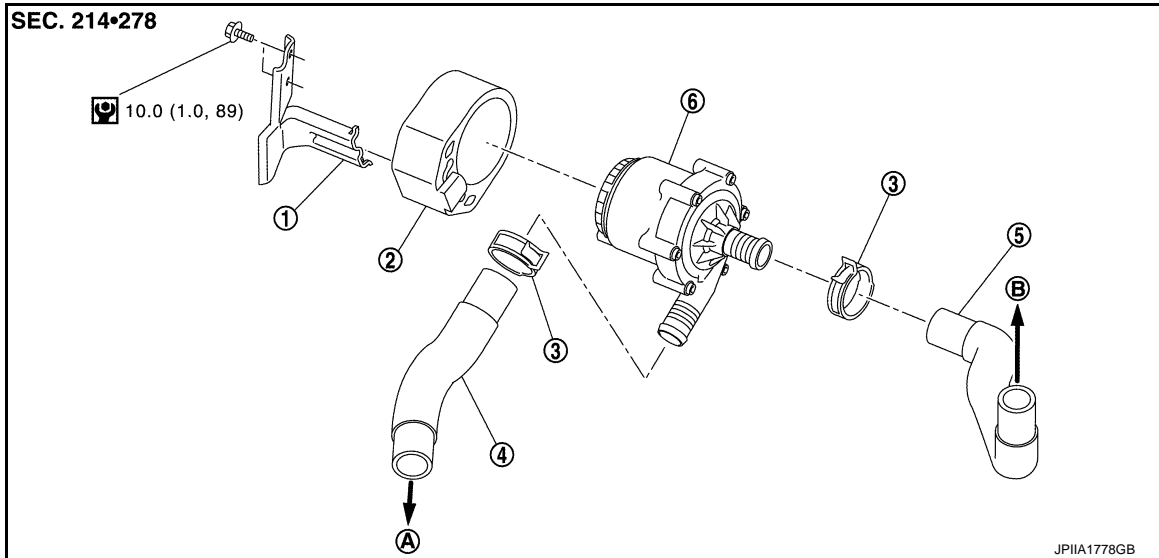

- | | | |
|---------------------------|----------------------|----------------|
| 1. Heater pump bracket | 2. Heater pump mount | 3. Clamp |
| 4. Heater hose | 5. Heater hose | 6. Heater pump |
| A: To PTC elements heater | B: To degas tank | |

 : N•m (kg-m in-lb)

Removal and Installation

INFOID:000000006960827

REMOVAL

1. Remove front under cover. Refer to [EXT-23, "FRONT UNDER COVER : Removal and Installation"](#).
2. Drain out heater fluid. Refer to [HA-43, "Draining and Refilling"](#).
3. Remove 12 V battery. Refer to [PG-108, "Removal and Installation"](#).
4. Remove mounting bolts (A), and then remove battery bracket (1).

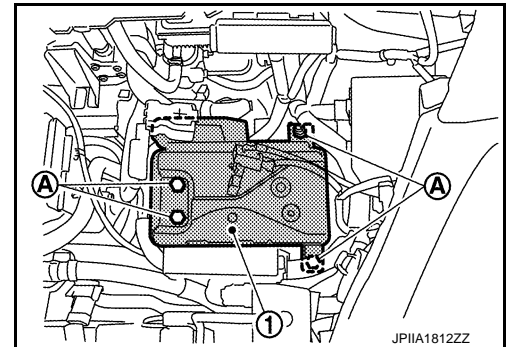

5. Move hoses (1) to secure work space.

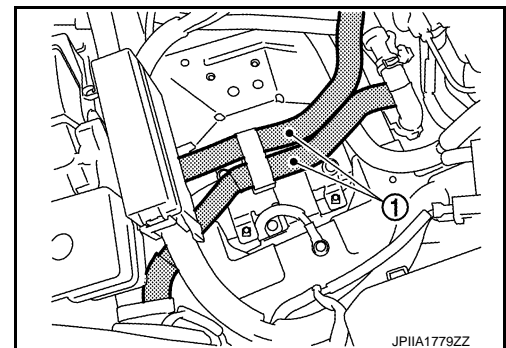

HEATER PUMP

< REMOVAL AND INSTALLATION >

6. Remove fixing hose clamp, and then disconnect heater hose (1) from heater pump (2).

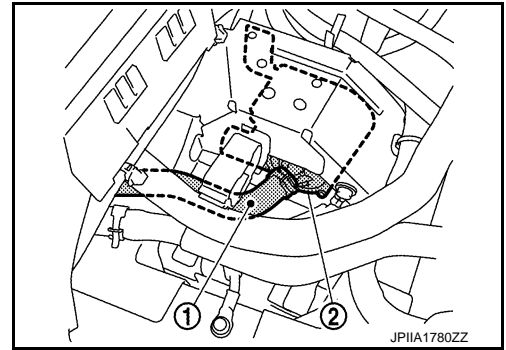

7. Remove fixing hose clamp, and then disconnect heater hose (1) from heater pump (2).

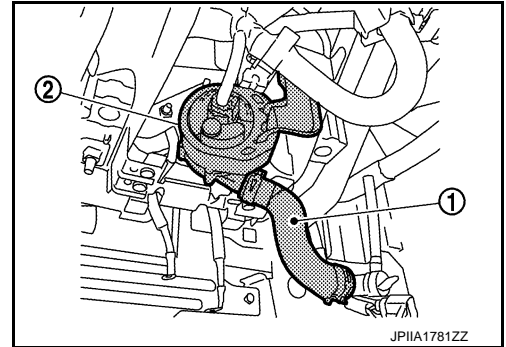

8. Disconnect heater pump connector.
9. Remove mounting bolts (A), and then remove heater pump (1).

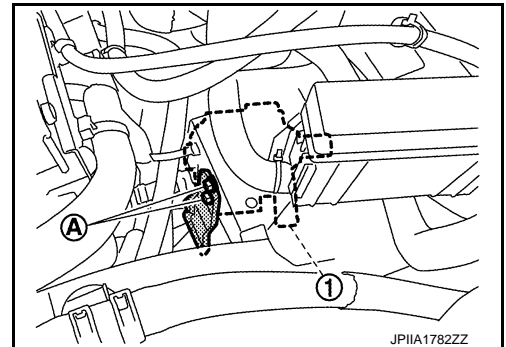

INSTALLATION

Note the following item, and then install in the reverse order of removal.

NOTE:

When adding heater fluid. Refer to [HA-43, "Draining and Refilling"](#).

A
B
C
D
E
F
G
H
HA
J
K
L
M
N
O
P

SERVICE DATA AND SPECIFICATIONS (SDS)

< SERVICE DATA AND SPECIFICATIONS (SDS)

SERVICE DATA AND SPECIFICATIONS (SDS)

SERVICE DATA AND SPECIFICATIONS (SDS)

Compressor

INFOID:000000006997070

Model (manufacturer)	AES28AV3AA (Panasonic)
Type	Electric drive scroll type (Include inverter)

Lubricant

INFOID:000000006997071

Name	ND-OIL11 (Exclusive use for electric compressor)
Capacity	m ℓ (US fl oz, Imp fl oz) 150 (5.1, 5.3)

Refrigerant

INFOID:000000006997072

Name	HFC-134a (R-134a)
Capacity	kg (lb) 0.4 (0.9)

Periodical Maintenance Specification

INFOID:000000006997073

HEATER FLUID CAPACITY (APPROXIMATE)

Heater fluid capacity [Exclude degas tank]	cm ³ (cu in)	1,830 (112.1)
Degas tank capacity	cm ³ (cu in)	403 (24.7)