

A
B
EVB

SECTION EVB

EV BATTERY SYSTEM

CONTENTS

<p style="text-align: center;">TYPE 1</p> <p>HOW TO USE THIS MANUAL14</p> <p>APPLICATION NOTICE14</p> <p style="padding-left: 20px;">How to Check Vehicle Type 14</p> <p>PRECAUTION15</p> <p>PRECAUTIONS15</p> <p style="padding-left: 20px;">Precaution for Technicians Using Medical Electric... 15</p> <p style="padding-left: 20px;">Point to Be Checked Before Starting Maintenance Work 15</p> <p style="padding-left: 20px;">Precaution for Supplemental Restraint System (SRS) "AIR BAG" and "SEAT BELT PRE-TENSIONER" 15</p> <p style="padding-left: 20px;">Precaution Necessary for Steering Wheel Rotation after 12V Battery Disconnect 16</p> <p style="padding-left: 20px;">Precaution for Procedure without Cowl Top Cover... 17</p> <p style="padding-left: 20px;">Precautions for Removing Battery Terminal 17</p> <p style="padding-left: 20px;">High Voltage Precautions 17</p> <p>PREPARATION20</p> <p>PREPARATION20</p> <p style="padding-left: 20px;">Special Service Tools20</p> <p style="padding-left: 20px;">Commercial Service Tools20</p> <p>SYSTEM DESCRIPTION25</p> <p>COMPONENT PARTS25</p> <p style="padding-left: 20px;">Component Parts Location25</p> <p style="padding-left: 20px;">Li-ion Battery26</p> <p style="padding-left: 20px;">Li-ion Battery Controller26</p> <p style="padding-left: 20px;">Module27</p> <p style="padding-left: 20px;">Battery Temperature Sensor28</p> <p style="padding-left: 20px;">Battery Junction Box28</p> <p style="padding-left: 20px;">Service Plug29</p> <p style="padding-left: 20px;">High Voltage Warning Label29</p> <p>SYSTEM31</p> <p style="padding-left: 20px;">System Description31</p>	<p style="padding-left: 20px;">Circuit Diagram34</p> <p>HANDLING PRECAUTION37</p> <p style="padding-left: 20px;">EV Battery System37</p> <p>DIAGNOSIS SYSTEM (LBC)38</p> <p style="padding-left: 20px;">CONSULT Function38</p> <p>ECU DIAGNOSIS INFORMATION40</p> <p>EV BATTERY SYSTEM40</p> <p style="padding-left: 20px;">Reference Value40</p> <p style="padding-left: 20px;">Fail-safe45</p> <p style="padding-left: 20px;">DTC Index50</p> <p>WIRING DIAGRAM55</p> <p>VCM55</p> <p style="padding-left: 20px;">Wiring Diagram55</p> <p>BASIC INSPECTION67</p> <p>DIAGNOSIS AND REPAIR WORK FLOW67</p> <p style="padding-left: 20px;">Work Flow67</p> <p style="padding-left: 20px;">Diagnostic Work Sheet68</p> <p>ADDITIONAL SERVICE WHEN REPLACING LI-ION BATTERY CONTROLLER70</p> <p style="padding-left: 20px;">Description70</p> <p style="padding-left: 20px;">Work Procedure70</p> <p>MODULE CHARGE BALANCE71</p> <p style="padding-left: 20px;">Description71</p> <p style="padding-left: 20px;">Work Procedure71</p> <p>DTC/CIRCUIT DIAGNOSIS73</p> <p>P0A0D HV SYSTEM INTERLOCK ERROR73</p> <p style="padding-left: 20px;">DTC Logic73</p> <p style="padding-left: 20px;">Diagnosis Procedure73</p> <p>P0A1F BATTERY ENERGY CONTROL MODULE75</p>
--	--

D
E
F
G
H
I
J
K
L
M
N
O
P

DTC Logic	75	DTC Logic	96
Diagnosis Procedure	75	Diagnosis Procedure	96
P3030 CELL CONTROLLER LIN	76	P30FE 12V BATTERY VOLTAGE	97
DTC Logic	76	DTC Logic	97
Diagnosis Procedure	76	Diagnosis Procedure	97
P3031-P303C CELL CONTROLLER ASIC	77	P318D COMMUNICATION ERROR	99
DTC Logic	77	DTC Logic	99
Diagnosis Procedure	77	Diagnosis Procedure	99
P303D-P3048 CELL CONTROLLER ASIC	78	P318E COMMUNICATION ERROR	100
DTC Logic	78	DTC Logic	100
Diagnosis Procedure	78	Diagnosis Procedure	100
P3049-P3054 CELL CONTROLLER ASIC		P3191 COMMUNICATION ERROR	101
VOLTAGE	79	DTC Logic	101
DTC Logic	79	Diagnosis Procedure	101
Diagnosis Procedure	79	P3196 COMMUNICATION ERROR	102
P3055-P3060 CELL CONTROLLER ASIC		DTC Logic	102
VOLTAGE	81	Diagnosis Procedure	102
DTC Logic	81	P3199 COMMUNICATION ERROR	103
Diagnosis Procedure	81	DTC Logic	103
P3061 CELL BATTERY VOLTAGE	83	Diagnosis Procedure	103
DTC Logic	83	P319C COMMUNICATION ERROR	104
Diagnosis Procedure	83	DTC Logic	104
P3062 BYPASS SWITCH	84	Diagnosis Procedure	104
DTC Logic	84	P31A4 CAN ERROR VCM	105
Diagnosis Procedure	84	DTC Logic	105
P308B-P3096 CELL CONTROLLER ASIC		Diagnosis Procedure	105
OPEN	85	P31A7 CAN ERROR INV/MC	106
DTC Logic	85	DTC Logic	106
Diagnosis Procedure	85	Diagnosis Procedure	106
P3097-P30A2 CELL CONTROLLER ASIC		P3300 TOTAL VOLTAGE OVER	107
OPEN	88	DTC Logic	107
DTC Logic	88	Diagnosis Procedure	107
Diagnosis Procedure	88	P3302-P330D CELL OVER VOLTAGE	108
P30F3 TOTAL VOLTAGE SENSOR	91	DTC Logic	108
DTC Logic	91	Diagnosis Procedure	108
Diagnosis Procedure	91	Component Inspection	110
P30F4 TOTAL VOLTAGE SENSOR	92	P330E-P3319 CELL OVER VOLTAGE	111
DTC Logic	92	DTC Logic	111
Diagnosis Procedure	92	Diagnosis Procedure	111
Component Inspection	93	Component Inspection	113
P30F5 TOTAL VOLTAGE SENSOR	94	P331A-P3325 CELL OVER VOLTAGE	114
DTC Logic	94	DTC Logic	114
Diagnosis Procedure	94	Diagnosis Procedure	114
P30FC OVER CURRENT	95	Component Inspection	116
DTC Logic	95	P3326-P3331 CELL OVER VOLTAGE	117
Diagnosis Procedure	95	DTC Logic	117
P30FD TOTAL VOLTAGE MONITOR		Diagnosis Procedure	117
SWITCH	96	Component Inspection	119

P3373 TOTAL VOLTAGE OVER DIS-CHARGE	120	Component Inspection	145
DTC Logic	120	P33E6 CELL VOLTAGE DEVIATION DIAG ...	146
Diagnosis Procedure	120	DTC Logic	146
P3375-P3380 CELL OVER DISCHARGE	121	Diagnosis Procedure	146
DTC Logic	121	P33E7 CELL CONTROLLER	150
Diagnosis Procedure	121	DTC Logic	150
Component Inspection	123	Diagnosis Procedure	150
P3381-P338C CELL OVER DISCHARGE	124	P33ED BATTERY PARALLEL DIAGNOSIS ..	151
DTC Logic	124	DTC Logic	151
Diagnosis Procedure	124	Diagnosis Procedure	151
Component Inspection	126	U1000 CAN COMM CIRCUIT	153
P338D-P3398 CELL OVER DISCHARGE	127	Description	153
DTC Logic	127	DTC Logic	153
Diagnosis Procedure	127	Diagnosis Procedure	153
Component Inspection	129	LI-ION BATTERY INSULATION RESIS-TANCE LOSS CHECK	154
P3399-P33A4 CELL OVER DISCHARGE	130	Component Inspection	154
DTC Logic	130	POWER SUPPLY AND GROUND CIRCUIT ..	164
Diagnosis Procedure	130	Diagnosis Procedure	164
Component Inspection	132	SYMPTOM DIAGNOSIS	167
P33D4 BATT GRADUAL CAPA LOSS DIAG ..	133	REDUCTION IN THE DRIVING RANGE	167
DTC Logic	133	Description	167
Diagnosis Procedure	133	Diagnosis Procedure	167
P33D5 CURRENT SENSOR	134	PERIODIC MAINTENANCE	168
DTC Logic	134	EV BATTERY USAGE REPORT	168
Diagnosis Procedure	134	Inspection	168
P33D6 CURRENT SENSOR	136	UNIT REMOVAL AND INSTALLATION ...	169
DTC Logic	136	LI-ION BATTERY	169
Diagnosis Procedure	136	Exploded View	169
P33D7, P33D9, P33DB, P33DD TEMPERA-TURE SENSOR	138	Removal and Installation	169
DTC Logic	138	Inspection	175
Diagnosis Procedure	138	UNIT DISASSEMBLY AND ASSEMBLY .	176
Component Inspection	139	LI-ION BATTERY	176
P33DF BAT VOLTAGE ISOLATION SEN	140	Exploded view	176
DTC Logic	140	BATTERY JUNCTION BOX	184
Diagnosis Procedure	140	BATTERY JUNCTION BOX : Disassembly and	
P33E0 BAT VOLTAGE ISOLATION SEN	141	Assembly	184
DTC Logic	141	BATTERY JUNCTION BOX : Inspection	190
Diagnosis Procedure	141	LI-ION BATTERY CONTROLLER	192
P33E1 BAT VOLTAGE ISOLATION SEN	142	LI-ION BATTERY CONTROLLER : Disassembly	
DTC Logic	142	and Assembly	192
Diagnosis Procedure	142	LI-ION BATTERY CONTROLLER : Inspection	196
P33E2 BATT PACK OVER TEMP	143	FRONT MODULE STACK	198
DTC Logic	143	FRONT MODULE STACK : Disassembly and As-	
Diagnosis Procedure	143	sembly	198
P33E4, P33E5 TEMPERATURE SENSOR	144	FRONT MODULE STACK : Inspection	206
DTC Logic	144		
Diagnosis Procedure	144		

A
B
EVB
D
E
F
G
H
I
J
K
L
M
N
O
P

REAR MODULE STACK	208	LI-ION BATTERY HEATER CONTROL SYSTEM	
REAR MODULE STACK : Disassembly and As-		: System Description	248
sembly	208	Circuit Diagram	250
REAR MODULE STACK : Inspection	222		
SERVICE DATA AND SPECIFICATIONS		HANDLING PRECAUTION	255
(SDS)	225	EV Battery System	255
SERVICE DATA AND SPECIFICATIONS		DIAGNOSIS SYSTEM (LBC)	256
(SDS)	225	CONSULT Function	256
Li-ion Battery	225	ECU DIAGNOSIS INFORMATION	258
TYPE 2		EV BATTERY SYSTEM	258
HOW TO USE THIS MANUAL	226	Reference Value	258
APPLICATION NOTICE	226	Fail-safe	263
How to Check Vehicle Type	226	DTC Index	268
PRECAUTION	227	WIRING DIAGRAM	274
PRECAUTIONS	227	VCM	274
Precaution for Technicians Using Medical Electric.	227	Wiring Diagram	274
Point to Be Checked Before Starting Maintenance		BASIC INSPECTION	286
Work	227	DIAGNOSIS AND REPAIR WORK FLOW	286
Precaution for Supplemental Restraint System		Work Flow	286
(SRS) "AIR BAG" and "SEAT BELT PRE-TEN-		Diagnostic Work Sheet	287
SIONER"	227	ADDITIONAL SERVICE WHEN REPLACING	
Precaution Necessary for Steering Wheel Rota-		LI-ION BATTERY CONTROLLER	289
tion after 12V Battery Disconnect	228	Description	289
Precaution for Procedure without Cowl Top Cover.	229	Work Procedure	289
Precautions for Removing Battery Terminal	229	MODULE CHARGE BALANCE	290
High Voltage Precautions	229	Description	290
PREPARATION	232	Work Procedure	290
PREPARATION	232	DTC/CIRCUIT DIAGNOSIS	292
Special Service Tools	232	P0A0D HV SYSTEM INTERLOCK ERROR	292
Commercial Service Tools	232	DTC Logic	292
SYSTEM DESCRIPTION	237	Diagnosis Procedure	292
COMPONENT PARTS	237	P0A1F BATTERY ENERGY CONTROL MOD-	294
Component Parts Location	237	ULE	294
Li-ion Battery	239	DTC Logic	294
Li-ion Battery Controller	239	Diagnosis Procedure	294
Module	240	P3030 CELL CONTROLLER LIN	295
Heater Relay Unit	241	DTC Logic	295
Li-ion Battery Heater	241	Diagnosis Procedure	295
Battery Temperature Sensor	242	P3031-P303C CELL CONTROLLER ASIC	296
Battery Junction Box	242	DTC Logic	296
Service Plug	243	Diagnosis Procedure	296
High Voltage Warning Label	243	P303D-P3048 CELL CONTROLLER ASIC	297
SYSTEM	245	DTC Logic	297
LI-ION BATTERY CONTROL SYSTEM	245	Diagnosis Procedure	297
LI-ION BATTERY CONTROL SYSTEM : System		P3049-P3054 CELL CONTROLLER ASIC	
Description	245	VOLTAGE	298
LI-ION BATTERY HEATER CONTROL SYSTEM	247		

DTC Logic	298	Diagnosis Procedure	320
Diagnosis Procedure	298		
P3055-P3060 CELL CONTROLLER ASIC		P3196 COMMUNICATION ERROR	321
VOLTAGE	300	DTC Logic	321
DTC Logic	300	Diagnosis Procedure	321
Diagnosis Procedure	300		
P3061 CELL BATTERY VOLTAGE	302	P3199 COMMUNICATION ERROR	322
DTC Logic	302	DTC Logic	322
Diagnosis Procedure	302	Diagnosis Procedure	322
P3062 BYPASS SWITCH	303	P319C COMMUNICATION ERROR	323
DTC Logic	303	DTC Logic	323
Diagnosis Procedure	303	Diagnosis Procedure	323
P308B-P3096 CELL CONTROLLER ASIC		P31A4 CAN ERROR VCM	324
OPEN	304	DTC Logic	324
DTC Logic	304	Diagnosis Procedure	324
Diagnosis Procedure	304		
		P31A7 CAN ERROR INV/MC	325
P3097-P30A2 CELL CONTROLLER ASIC		DTC Logic	325
OPEN	307	Diagnosis Procedure	325
DTC Logic	307		
Diagnosis Procedure	307	P3300 TOTAL VOLTAGE OVER	326
		DTC Logic	326
P30F3 TOTAL VOLTAGE SENSOR	310	Diagnosis Procedure	326
DTC Logic	310		
Diagnosis Procedure	310	P3302-P330D CELL OVER VOLTAGE	327
		DTC Logic	327
P30F4 TOTAL VOLTAGE SENSOR	311	Diagnosis Procedure	327
DTC Logic	311	Component Inspection	329
Diagnosis Procedure	311		
Component Inspection	312	P330E-P3319 CELL OVER VOLTAGE	330
		DTC Logic	330
P30F5 TOTAL VOLTAGE SENSOR	313	Diagnosis Procedure	330
DTC Logic	313	Component Inspection	332
Diagnosis Procedure	313		
		P331A-P3325 CELL OVER VOLTAGE	333
P30FC OVER CURRENT	314	DTC Logic	333
DTC Logic	314	Diagnosis Procedure	333
Diagnosis Procedure	314	Component Inspection	335
P30FD TOTAL VOLTAGE MONITOR		P3326-P3331 CELL OVER VOLTAGE	336
SWITCH	315	DTC Logic	336
DTC Logic	315	Diagnosis Procedure	336
Diagnosis Procedure	315	Component Inspection	338
P30FE 12V BATTERY VOLTAGE	316	P3373 TOTAL VOLTAGE OVER DIS-	
DTC Logic	316	CHARGE	339
Diagnosis Procedure	316	DTC Logic	339
		Diagnosis Procedure	339
P318D COMMUNICATION ERROR	318		
DTC Logic	318	P3375-P3380 CELL OVER DISCHARGE	340
Diagnosis Procedure	318	DTC Logic	340
		Diagnosis Procedure	340
P318E COMMUNICATION ERROR	319	Component Inspection	342
DTC Logic	319		
Diagnosis Procedure	319	P3381-P338C CELL OVER DISCHARGE	343
		DTC Logic	343
P3191 COMMUNICATION ERROR	320	Diagnosis Procedure	343
DTC Logic	320	Component Inspection	345
		P338D-P3398 CELL OVER DISCHARGE	346

A
B
EVB
D
E
F
G
H
I
J
K
L
M
N
O
P

DTC Logic	346	Diagnosis Procedure	372
Diagnosis Procedure	346		
Component Inspection	348		
P3399-P33A4 CELL OVER DISCHARGE	349	P33EE BATTERY HEATER CONTROL SYSTEM	374
DTC Logic	349	DTC Logic	374
Diagnosis Procedure	349	Diagnosis Procedure	374
Component Inspection	351		
P33D4 BATT GRADUAL CAPA LOSS DIAG. 352		U1000 CAN COMM CIRCUIT	376
DTC Logic	352	Description	376
Diagnosis Procedure	352	DTC Logic	376
		Diagnosis Procedure	376
P33D5 CURRENT SENSOR	353	LI-ION BATTERY INSULATION RESISTANCE LOSS CHECK	377
DTC Logic	353	Component Inspection	377
Diagnosis Procedure	353		
P33D6 CURRENT SENSOR	355	LI-ION BATTERY HEATER SYSTEM INSULATION RESISTANCE CHECK	387
DTC Logic	355	Diagnosis Procedure	387
Diagnosis Procedure	355		
P33D7, P33D9, P33DB, P33DD TEMPERATURE SENSOR	357	POWER SUPPLY AND GROUND CIRCUIT ...	390
DTC Logic	357	Diagnosis Procedure	390
Diagnosis Procedure	357		
Component Inspection	358	SYMPTOM DIAGNOSIS	393
P33DF BAT VOLTAGE ISOLATION SEN	359	REDUCTION IN THE DRIVING RANGE	393
DTC Logic	359	Description	393
Diagnosis Procedure	359	Diagnosis Procedure	393
P33E0 BAT VOLTAGE ISOLATION SEN	360	PERIODIC MAINTENANCE	394
DTC Logic	360	EV BATTERY USAGE REPORT	394
Diagnosis Procedure	360	Inspection	394
P33E1 BAT VOLTAGE ISOLATION SEN	361	UNIT REMOVAL AND INSTALLATION ...	395
DTC Logic	361	LI-ION BATTERY	395
Diagnosis Procedure	361	Exploded View	395
P33E2 BATT PACK OVER TEMP	362	Removal and Installation	395
DTC Logic	362	Inspection	401
Diagnosis Procedure	362	UNIT DISASSEMBLY AND ASSEMBLY ..	402
P33E4, P33E5 TEMPERATURE SENSOR	363	LI-ION BATTERY	402
DTC Logic	363	Exploded view	402
Diagnosis Procedure	363	BATTERY JUNCTION BOX	412
Component Inspection	364	BATTERY JUNCTION BOX : Disassembly and Assembly	412
P33E6 CELL VOLTAGE DEVIATION DIAG ..	365	BATTERY JUNCTION BOX : Inspection	417
DTC Logic	365	LI-ION BATTERY CONTROLLER	419
Diagnosis Procedure	365	LI-ION BATTERY CONTROLLER : Disassembly and Assembly	419
P33E7 CELL CONTROLLER	369	LI-ION BATTERY CONTROLLER : Inspection	424
DTC Logic	369	FRONT MODULE STACK	426
Diagnosis Procedure	369	FRONT MODULE STACK : Disassembly and Assembly	426
P33EA BATTERY HEATER RELAY	370	FRONT MODULE STACK : Inspection	433
DTC Logic	370	REAR MODULE STACK	435
Diagnosis Procedure	370		
P33ED BATTERY PARALLEL DIAGNOSIS ..	372		
DTC Logic	372		

REAR MODULE STACK : Disassembly and Assembly	435	SYSTEM	483	
REAR MODULE STACK : Inspection	447	System Description	483	A
HEATER RELAY UNIT	449	Circuit Diagram	486	
HEATER RELAY UNIT : Disassembly and Assembly	449	HANDLING PRECAUTION	489	B
HEATER RELAY UNIT : Inspection	454	EV Battery System	489	
HEATER UNIT	456	DIAGNOSIS SYSTEM (LBC)	490	EVB
HEATER UNIT : Disassembly and Assembly	456	CONSULT Function	490	
HEATER UNIT : Inspection	462	ECU DIAGNOSIS INFORMATION	492	
SERVICE DATA AND SPECIFICATIONS (SDS)	465	EV BATTERY SYSTEM	492	D
SERVICE DATA AND SPECIFICATIONS (SDS)	465	Reference Value	492	
Li-ion Battery	465	Fail-safe	497	E
TYPE 3		DTC Index	502	
HOW TO USE THIS MANUAL	466	WIRING DIAGRAM	507	
APPLICATION NOTICE	466	VCM	507	F
How to Check Vehicle Type	466	Wiring Diagram	507	
PRECAUTION	467	BASIC INSPECTION	519	G
PRECAUTIONS	467	DIAGNOSIS AND REPAIR WORK FLOW	519	
Precaution for Technicians Using Medical Electric. Point to Be Checked Before Starting Maintenance Work	467	Work Flow	519	H
Precaution for Supplemental Restraint System (SRS) "AIR BAG" and "SEAT BELT PRE-TENSIONER"	467	Diagnostic Work Sheet	520	
Precaution Necessary for Steering Wheel Rotation after 12V Battery Disconnect	468	ADDITIONAL SERVICE WHEN REPLACING LI-ION BATTERY CONTROLLER	522	I
Precaution for Procedure without Cowl Top Cover.	469	Description	522	
Precautions for Removing Battery Terminal	469	Work Procedure	522	J
High Voltage Precautions	469	MODULE CHARGE BALANCE	523	
PREPARATION	472	Description	523	K
PREPARATION	472	Work Procedure	523	
Special Service Tools	472	DTC/CIRCUIT DIAGNOSIS	525	L
Commercial Service Tools	473	P0A0D HV SYSTEM INTERLOCK ERROR ...	525	
Sealant or/and Lubricant	476	DTC Logic	525	M
SYSTEM DESCRIPTION	477	Diagnosis Procedure	525	
COMPONENT PARTS	477	P0A1F BATTERY ENERGY CONTROL MODULE	527	N
Component Parts Location	477	DTC Logic	527	
Li-ion Battery	478	Diagnosis Procedure	527	O
Li-ion Battery Controller	479	P3030 CELL CONTROLLER LIN	528	
Module	479	DTC Logic	528	P
Battery Current Sensor	480	Diagnosis Procedure	528	
Battery Temperature Sensor	481	P3031-P303C CELL CONTROLLER ASIC	529	
Battery Junction Box	481	DTC Logic	529	
Service Plug	481	Diagnosis Procedure	529	
High Voltage Warning Label	481	P303D-P3048 CELL CONTROLLER ASIC	530	
		DTC Logic	530	
		Diagnosis Procedure	530	
		P3049-P3054 CELL CONTROLLER ASIC VOLTAGE	531	

DTC Logic	531	Diagnosis Procedure	553
Diagnosis Procedure	531		
P3055-P3060 CELL CONTROLLER ASIC		P3196 COMMUNICATION ERROR	554
VOLTAGE	533	DTC Logic	554
DTC Logic	533	Diagnosis Procedure	554
Diagnosis Procedure	533	P3199 COMMUNICATION ERROR	555
P3061 CELL BATTERY VOLTAGE	535	DTC Logic	555
DTC Logic	535	Diagnosis Procedure	555
Diagnosis Procedure	535	P319C COMMUNICATION ERROR	556
P3062 BYPASS SWITCH	536	DTC Logic	556
DTC Logic	536	Diagnosis Procedure	556
Diagnosis Procedure	536	P31A4 CAN ERROR VCM	557
P308B-P3096 CELL CONTROLLER ASIC		DTC Logic	557
OPEN	537	Diagnosis Procedure	557
DTC Logic	537	P31A7 CAN ERROR INV/MC	558
Diagnosis Procedure	537	DTC Logic	558
P3097-P30A2 CELL CONTROLLER ASIC		Diagnosis Procedure	558
OPEN	540	P3300 TOTAL VOLTAGE OVER	559
DTC Logic	540	DTC Logic	559
Diagnosis Procedure	540	Diagnosis Procedure	559
P30F3 TOTAL VOLTAGE SENSOR	543	P3302-P330D CELL OVER VOLTAGE	560
DTC Logic	543	DTC Logic	560
Diagnosis Procedure	543	Diagnosis Procedure	560
P30F4 TOTAL VOLTAGE SENSOR	544	Component Inspection	563
DTC Logic	544	P330E-P3319 CELL OVER VOLTAGE	564
Diagnosis Procedure	544	DTC Logic	564
Component Inspection	545	Diagnosis Procedure	564
P30F5 TOTAL VOLTAGE SENSOR	546	Component Inspection	567
DTC Logic	546	P331A-P3325 CELL OVER VOLTAGE	568
Diagnosis Procedure	546	DTC Logic	568
P30FC OVER CURRENT	547	Diagnosis Procedure	568
DTC Logic	547	Component Inspection	570
Diagnosis Procedure	547	P3326-P3331 CELL OVER VOLTAGE	571
P30FD TOTAL VOLTAGE MONITOR		DTC Logic	571
SWITCH	548	Diagnosis Procedure	571
DTC Logic	548	Component Inspection	573
Diagnosis Procedure	548	P3373 TOTAL VOLTAGE OVER DIS-	
P30FE 12V BATTERY VOLTAGE	549	CHARGE	574
DTC Logic	549	DTC Logic	574
Diagnosis Procedure	549	Diagnosis Procedure	574
P318D COMMUNICATION ERROR	551	P3375-P3380 CELL OVER DISCHARGE	575
DTC Logic	551	DTC Logic	575
Diagnosis Procedure	551	Diagnosis Procedure	575
P318E COMMUNICATION ERROR	552	Component Inspection	578
DTC Logic	552	P3381-P338C CELL OVER DISCHARGE	579
Diagnosis Procedure	552	DTC Logic	579
P3191 COMMUNICATION ERROR	553	Diagnosis Procedure	579
DTC Logic	553	Component Inspection	582
		P338D-P3398 CELL OVER DISCHARGE	583

DTC Logic	583	DTC Logic	610	
Diagnosis Procedure	583	Diagnosis Procedure	610	A
Component Inspection	585			
P3399-P33A4 CELL OVER DISCHARGE	586	LI-ION BATTERY INSULATION RESIS-		
DTC Logic	586	TANCE LOSS CHECK	611	B
Diagnosis Procedure	586	Component Inspection	611	
Component Inspection	588	POWER SUPPLY AND GROUND CIRCUIT ..	621	
P33D4 BATT GRADUAL CAPA LOSS DIAG..	589	Diagnosis Procedure	621	EVB
DTC Logic	589	SYMPTOM DIAGNOSIS	624	
Diagnosis Procedure	589	REDUCTION IN THE DRIVING RANGE	624	D
P33D5 CURRENT SENSOR	590	Description	624	
DTC Logic	590	Diagnosis Procedure	624	E
Diagnosis Procedure	590	PERIODIC MAINTENANCE	625	
P33D6 CURRENT SENSOR	592	EV BATTERY USAGE REPORT	625	F
DTC Logic	592	Inspection	625	
Diagnosis Procedure	592	UNIT REMOVAL AND INSTALLATION ...	626	
P33D7, P33D9, P33DB, P33DD TEMPERA-		LI-ION BATTERY	626	G
TURE SENSOR	594	Exploded View	626	
DTC Logic	594	Removal and Installation	626	H
Diagnosis Procedure	594	Inspection	632	
Component Inspection	595	UNIT DISASSEMBLY AND ASSEMBLY .	634	
P33DF BAT VOLTAGE ISOLATION SEN	596	LI-ION BATTERY	634	I
DTC Logic	596	BATTERY PACK UPPER CASE	634	J
Diagnosis Procedure	596	BATTERY PACK UPPER CASE : Exploded View.	634	
P33E0 BAT VOLTAGE ISOLATION SEN	597	BATTERY PACK UPPER CASE : Removal and		
DTC Logic	597	Installation	635	
Diagnosis Procedure	597	LI-ION BATTERY CONTROLLER	644	K
P33E1 BAT VOLTAGE ISOLATION SEN	598	LI-ION BATTERY CONTROLLER : Exploded		
DTC Logic	598	View	645	
Diagnosis Procedure	598	LI-ION BATTERY CONTROLLER : Removal and		
P33E2 BATT PACK OVER TEMP	599	Installation	645	L
DTC Logic	599	BATTERY JUNCTION BOX AND BATTERY HAR-		
Diagnosis Procedure	599	NESS	647	M
P33E4, P33E5 TEMPERATURE SENSOR	600	BATTERY JUNCTION BOX AND BATTERY		
DTC Logic	600	HARNESS : Exploded View	648	
Diagnosis Procedure	600	BATTERY JUNCTION BOX AND BATTERY		
Component Inspection	601	HARNESS : Disassembly and Assembly	650	N
P33E6 CELL VOLTAGE DEVIATION DIAG ...	602	FRONT MODULE STACK	657	O
DTC Logic	602	FRONT MODULE STACK : Exploded View	657	
Diagnosis Procedure	602	FRONT MODULE STACK : Removal and Installa-		
P33E7 CELL CONTROLLER	607	tion	660	
DTC Logic	607	FRONT MODULE STACK : Disassembly and As-		
Diagnosis Procedure	607	sembly	665	P
P33ED BATTERY PARALLEL DIAGNOSIS ..	608	REAR MODULE STACK	670	
DTC Logic	608	REAR MODULE STACK : Exploded View	671	
Diagnosis Procedure	608	REAR MODULE STACK : Removal and Installa-		
U1000 CAN COMM CIRCUIT	610	tion	673	
Description	610			

REAR MODULE STACK : Disassembly and Assembly	680	LI-ION BATTERY HEATER CONTROL SYSTEM : System Description	714
Inspection	687	Circuit Diagram	716
SERVICE DATA AND SPECIFICATIONS (SDS)	691	HANDLING PRECAUTION	721
SERVICE DATA AND SPECIFICATIONS (SDS)	691	EV Battery System	721
Li-ion Battery	691	DIAGNOSIS SYSTEM (LBC)	722
TYPE 4		CONSULT Function	722
HOW TO USE THIS MANUAL	692	ECU DIAGNOSIS INFORMATION	724
APPLICATION NOTICE	692	EV BATTERY SYSTEM	724
How to Check Vehicle Type	692	Reference Value	724
PRECAUTION	693	Fail-safe	729
PRECAUTIONS	693	DTC Index	734
Precaution for Technicians Using Medical Electric Point to Be Checked Before Starting Maintenance Work	693	WIRING DIAGRAM	740
Precaution for Supplemental Restraint System (SRS) "AIR BAG" and "SEAT BELT PRE-TENSIONER"	693	VCM	740
Precaution Necessary for Steering Wheel Rotation after 12V Battery Disconnect	694	Wiring Diagram	740
Precaution for Procedure without Cowl Top Cover	695	BASIC INSPECTION	752
Precautions for Removing Battery Terminal	695	DIAGNOSIS AND REPAIR WORK FLOW	752
High Voltage Precautions	695	Work Flow	752
PREPARATION	698	Diagnostic Work Sheet	753
PREPARATION	698	ADDITIONAL SERVICE WHEN REPLACING LI-ION BATTERY CONTROLLER	755
Special Service Tools	698	Description	755
Commercial Service Tools	699	Work Procedure	755
Sealant or/and Lubricant	702	MODULE CHARGE BALANCE	756
SYSTEM DESCRIPTION	703	Description	756
COMPONENT PARTS	703	Work Procedure	756
Component Parts Location	703	DTC/CIRCUIT DIAGNOSIS	758
Li-ion Battery	705	P0A0D HV SYSTEM INTERLOCK ERROR	758
Li-ion Battery Controller	705	DTC Logic	758
Module	706	Diagnosis Procedure	758
Heater Relay Unit	707	P0A1F BATTERY ENERGY CONTROL MODULE	760
Li-ion Battery Heater	707	DTC Logic	760
Battery Current Sensor	708	Diagnosis Procedure	760
Battery Temperature Sensor	708	P3030 CELL CONTROLLER LIN	761
Battery Junction Box	709	DTC Logic	761
Service Plug	709	Diagnosis Procedure	761
High Voltage Warning Label	709	P3031-P303C CELL CONTROLLER ASIC	762
SYSTEM	711	DTC Logic	762
LI-ION BATTERY CONTROL SYSTEM	711	Diagnosis Procedure	762
LI-ION BATTERY CONTROL SYSTEM : System Description	711	P303D-P3048 CELL CONTROLLER ASIC	763
LI-ION BATTERY HEATER CONTROL SYSTEM	713	DTC Logic	763
		Diagnosis Procedure	763
		P3049-P3054 CELL CONTROLLER ASIC VOLTAGE	764

DTC Logic	764	Diagnosis Procedure	786
Diagnosis Procedure	764		
P3055-P3060 CELL CONTROLLER ASIC		P3196 COMMUNICATION ERROR	787
VOLTAGE	766	DTC Logic	787
DTC Logic	766	Diagnosis Procedure	787
Diagnosis Procedure	766		
P3061 CELL BATTERY VOLTAGE	768	P3199 COMMUNICATION ERROR	788
DTC Logic	768	DTC Logic	788
Diagnosis Procedure	768	Diagnosis Procedure	788
P3062 BYPASS SWITCH	769	P319C COMMUNICATION ERROR	789
DTC Logic	769	DTC Logic	789
Diagnosis Procedure	769	Diagnosis Procedure	789
P308B-P3096 CELL CONTROLLER ASIC		P31A4 CAN ERROR VCM	790
OPEN	770	DTC Logic	790
DTC Logic	770	Diagnosis Procedure	790
Diagnosis Procedure	770		
		P31A7 CAN ERROR INV/MC	791
P3097-P30A2 CELL CONTROLLER ASIC		DTC Logic	791
OPEN	773	Diagnosis Procedure	791
DTC Logic	773		
Diagnosis Procedure	773	P3300 TOTAL VOLTAGE OVER	792
		DTC Logic	792
P30F3 TOTAL VOLTAGE SENSOR	776	Diagnosis Procedure	792
DTC Logic	776		
Diagnosis Procedure	776	P3302-P330D CELL OVER VOLTAGE	793
		DTC Logic	793
P30F4 TOTAL VOLTAGE SENSOR	777	Diagnosis Procedure	793
DTC Logic	777	Component Inspection	796
Diagnosis Procedure	777		
Component Inspection	778	P330E-P3319 CELL OVER VOLTAGE	797
		DTC Logic	797
P30F5 TOTAL VOLTAGE SENSOR	779	Diagnosis Procedure	797
DTC Logic	779	Component Inspection	800
Diagnosis Procedure	779		
		P331A-P3325 CELL OVER VOLTAGE	801
P30FC OVER CURRENT	780	DTC Logic	801
DTC Logic	780	Diagnosis Procedure	801
Diagnosis Procedure	780	Component Inspection	803
P30FD TOTAL VOLTAGE MONITOR		P3326-P3331 CELL OVER VOLTAGE	804
SWITCH	781	DTC Logic	804
DTC Logic	781	Diagnosis Procedure	804
Diagnosis Procedure	781	Component Inspection	806
P30FE 12V BATTERY VOLTAGE	782	P3373 TOTAL VOLTAGE OVER DIS-	
DTC Logic	782	CHARGE	807
Diagnosis Procedure	782	DTC Logic	807
		Diagnosis Procedure	807
P318D COMMUNICATION ERROR	784		
DTC Logic	784	P3375-P3380 CELL OVER DISCHARGE	808
Diagnosis Procedure	784	DTC Logic	808
		Diagnosis Procedure	808
P318E COMMUNICATION ERROR	785	Component Inspection	811
DTC Logic	785		
Diagnosis Procedure	785	P3381-P338C CELL OVER DISCHARGE	812
		DTC Logic	812
P3191 COMMUNICATION ERROR	786	Diagnosis Procedure	812
DTC Logic	786	Component Inspection	815
		P338D-P3398 CELL OVER DISCHARGE	816

DTC Logic	816	Diagnosis Procedure	843
Diagnosis Procedure	816		
Component Inspection	818		
P3399-P33A4 CELL OVER DISCHARGE	819	P33EE BATTERY HEATER CONTROL SYSTEM	845
DTC Logic	819	DTC Logic	845
Diagnosis Procedure	819	Diagnosis Procedure	845
Component Inspection	821		
P33D4 BATT GRADUAL CAPA LOSS DIAG	822	U1000 CAN COMM CIRCUIT	847
DTC Logic	822	Description	847
Diagnosis Procedure	822	DTC Logic	847
		Diagnosis Procedure	847
P33D5 CURRENT SENSOR	823	LI-ION BATTERY INSULATION RESISTANCE LOSS CHECK	848
DTC Logic	823	Component Inspection	848
Diagnosis Procedure	823		
P33D6 CURRENT SENSOR	825	LI-ION BATTERY HEATER SYSTEM INSULATION RESISTANCE CHECK	858
DTC Logic	825	Diagnosis Procedure	858
Diagnosis Procedure	825		
P33D7, P33D9, P33DB, P33DD TEMPERATURE SENSOR	827	POWER SUPPLY AND GROUND CIRCUIT ...	861
DTC Logic	827	Diagnosis Procedure	861
Diagnosis Procedure	827		
Component Inspection	828	SYMPTOM DIAGNOSIS	864
P33DF BAT VOLTAGE ISOLATION SEN	829	REDUCTION IN THE DRIVING RANGE	864
DTC Logic	829	Description	864
Diagnosis Procedure	829	Diagnosis Procedure	864
P33E0 BAT VOLTAGE ISOLATION SEN	830	PERIODIC MAINTENANCE	865
DTC Logic	830	EV BATTERY USAGE REPORT	865
Diagnosis Procedure	830	Inspection	865
P33E1 BAT VOLTAGE ISOLATION SEN	831	UNIT REMOVAL AND INSTALLATION ...	866
DTC Logic	831	LI-ION BATTERY	866
Diagnosis Procedure	831	Exploded View	866
P33E2 BATT PACK OVER TEMP	832	Removal and Installation	866
DTC Logic	832	Inspection	872
Diagnosis Procedure	832	UNIT DISASSEMBLY AND ASSEMBLY ..	874
P33E4, P33E5 TEMPERATURE SENSOR	833	LI-ION BATTERY	874
DTC Logic	833	BATTERY PACK UPPER CASE	874
Diagnosis Procedure	833	BATTERY PACK UPPER CASE : Exploded View.	874
Component Inspection	834	BATTERY PACK UPPER CASE : Removal and Installation	875
P33E6 CELL VOLTAGE DEVIATION DIAG ..	835	LI-ION BATTERY CONTROLLER	884
DTC Logic	835	LI-ION BATTERY CONTROLLER : Exploded View	885
Diagnosis Procedure	835	LI-ION BATTERY CONTROLLER : Removal and Installation	885
P33E7 CELL CONTROLLER	840	BATTERY JUNCTION BOX AND BATTERY HARNESS	887
DTC Logic	840	BATTERY JUNCTION BOX AND BATTERY HARNESS : Exploded View	888
Diagnosis Procedure	840	BATTERY JUNCTION BOX AND BATTERY HARNESS : Disassembly and Assembly	890
P33EA BATTERY HEATER RELAY	841		
DTC Logic	841		
Diagnosis Procedure	841		
P33ED BATTERY PARALLEL DIAGNOSIS ..	843		
DTC Logic	843		

LI-ION BATTERY HEATER	897	REAR MODULE STACK	920	
LI-ION BATTERY HEATER : Exploded view	898	REAR MODULE STACK : Exploded View	921	A
LI-ION BATTERY HEATER : Disassembly and Assembly	899	REAR MODULE STACK : Removal and Installa- tion	923	
LI-ION BATTERY HEATER RELAY UNIT	903	REAR MODULE STACK : Disassembly and As- sembly	930	B
LI-ION BATTERY HEATER RELAY UNIT : Ex- ploded view	904	Inspection	938	
LI-ION BATTERY HEATER RELAY UNIT : Disas- sembly and Assembly	905	SERVICE DATA AND SPECIFICATIONS		EVB
FRONT MODULE STACK	906	(SDS)	941	
FRONT MODULE STACK : Exploded View	906	SERVICE DATA AND SPECIFICATIONS		D
FRONT MODULE STACK : Removal and Installa- tion	909	(SDS)	941	
FRONT MODULE STACK : Disassembly and As- sembly	915	Li-ion Battery	941	E
				F
				G
				H
				I
				J
				K
				L
				M
				N
				O
				P

APPLICATION NOTICE

< HOW TO USE THIS MANUAL >

[TYPE 1]

HOW TO USE THIS MANUAL

APPLICATION NOTICE

How to Check Vehicle Type

INFOID:000000007568801

Check the vehicle type to confirm the service information in EVB section.

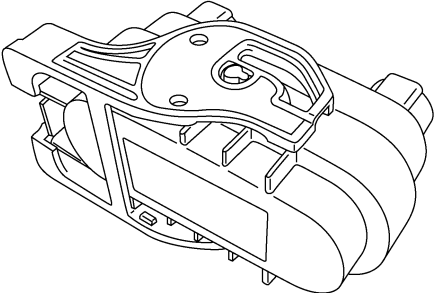
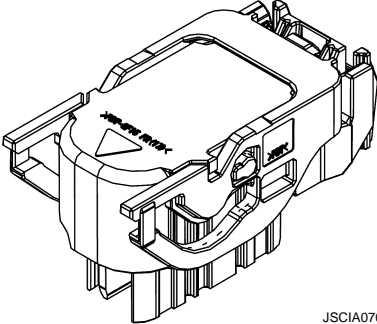
Service information	Vehicle type	Service plug type	
Type 1	Without Li-ion battery heater	Type A	 JSCIA0277ZZ
Type 2	With Li-ion battery heater		
Type 3	Without Li-ion battery heater	Type B	 JSCIA0706ZZ
Type 4	With Li-ion battery heater		

PRECAUTIONS

< PRECAUTION >

[TYPE 1]

PRECAUTION

PRECAUTIONS

Precaution for Technicians Using Medical Electric

INFOID:000000007405290

OPERATION PROHIBITION

WARNING:

- Parts with strong magnet is used in this vehicle.
- Technicians using a medical electric device such as pacemaker must never perform operation on the vehicle, as magnetic field can affect the device function by approaching to such parts.

NORMAL CHARGE PRECAUTION

WARNING:

- If a technician uses a medical electric device such as an implantable cardiac pacemaker or an implantable cardioverter defibrillator, the possible effects on the devices must be checked with the device manufacturer before starting the charge operation.
- As radiated electromagnetic wave generated by on board charger at normal charge operation may effect medical electric devices, a technician using a medical electric device such as implantable cardiac pacemaker or an implantable cardioverter defibrillator must not enter the vehicle compartment (including luggage room) during normal charge operation.

PRECAUTION AT TELEMATICS SYSTEM OPERATION

WARNING:

- If a technician uses implantable cardiac pacemaker or implantable cardioverter defibrillator (ICD), avoid the device implanted part from approaching within approximately 220 mm (8.66 in) from interior/exterior antenna.
- The electromagnetic wave of TCU might affect the function of the implantable cardiac pacemaker or the implantable cardioverter defibrillator (ICD), when using the service, etc.
- If a technician uses other medical electric devices than implantable cardiac pacemaker or implantable cardioverter defibrillator (ICD), the electromagnetic wave of TCU might affect the function of the device. The possible effects on the devices must be checked with the device manufacturer before TCU use.

PRECAUTION AT INTELLIGENT KEY SYSTEM OPERATION

WARNING:

- If a technician uses implantable cardiac pacemaker or implantable cardioverter defibrillator (ICD), avoid the device implanted part from approaching within approximately 220 mm (8.66 in) from interior/exterior antenna.
- The electromagnetic wave of Intelligent Key might affect the function of the implantable cardiac pacemaker or the implantable cardioverter defibrillator (ICD), at door operation, at each request switch operation, or at engine starting.
- If a technician uses other medical electric devices than implantable cardiac pacemaker or implantable cardioverter defibrillator (ICD), the electromagnetic wave of Intelligent Key might affect the function of the device. The possible effects on the devices must be checked with the device manufacturer before Intelligent Key use.

Point to Be Checked Before Starting Maintenance Work

INFOID:000000007081705

The high voltage system may starts automatically. It is required to check that the timer air conditioner and timer charge (during EVSE connection) are not set before starting maintenance work.

NOTE:

If the timer air conditioner or timer charge (during EVSE connection) is set, the high voltage system starts automatically even when the power switch is in OFF state.

Precaution for Supplemental Restraint System (SRS) "AIR BAG" and "SEAT BELT PRE-TENSIONER"

INFOID:000000007005864

The Supplemental Restraint System such as "AIR BAG" and "SEAT BELT PRE-TENSIONER", used along with a front seat belt, helps to reduce the risk or severity of injury to the driver and front passenger for certain types of collision. This system includes seat belt switch inputs and dual stage front air bag modules. The SRS

PRECAUTIONS

[TYPE 1]

< PRECAUTION >

system uses the seat belt switches to determine the front air bag deployment, and may only deploy one front air bag, depending on the severity of a collision and whether the front occupants are belted or unbelted. Information necessary to service the system safely is included in the "SRS AIR BAG" and "SEAT BELT" of this Service Manual.

WARNING:

Always observe the following items for preventing accidental activation.

- To avoid rendering the SRS inoperative, which could increase the risk of personal injury or death in the event of a collision that would result in air bag inflation, all maintenance must be performed by an authorized NISSAN/INFINITI dealer.
- Improper maintenance, including incorrect removal and installation of the SRS, can lead to personal injury caused by unintentional activation of the system. For removal of Spiral Cable and Air Bag Module, see "SRS AIR BAG".
- Never use electrical test equipment on any circuit related to the SRS unless instructed to in this Service Manual. SRS wiring harnesses can be identified by yellow and/or orange harnesses or harness connectors.

PRECAUTIONS WHEN USING POWER TOOLS (AIR OR ELECTRIC) AND HAMMERS

WARNING:

Always observe the following items for preventing accidental activation.

- When working near the Air Bag Diagnosis Sensor Unit or other Air Bag System sensors with the power switch ON, never use air or electric power tools or strike near the sensor(s) with a hammer. Heavy vibration could activate the sensor(s) and deploy the air bag(s), possibly causing serious injury.
- When using air or electric power tools or hammers, always switch the power switch OFF, disconnect the 12V battery, and wait at least 3 minutes before performing any service.

Precaution Necessary for Steering Wheel Rotation after 12V Battery Disconnect

INFOID:000000007405294

For vehicle with steering lock unit, if the 12V battery is disconnected or discharged, the steering wheel will lock and cannot be turned.

If turning the steering wheel is required with the 12V battery disconnected or discharged, follow the operation procedure below before starting the repair operation.

OPERATION PROCEDURE

1. Connect both 12V battery cables.

NOTE:

Supply power using jumper cables if 12V battery is discharged.

2. Turn the power switch to ACC position.
(At this time, the steering lock will be released.)
3. Disconnect both 12V battery cables. The steering lock will remain released with both 12V battery cables disconnected and the steering wheel can be turned.
4. Perform the necessary repair operation.
5. When the repair work is completed, re-connect both 12V battery cables. With the brake pedal released, turn the power switch from ACC position to ON position, then to LOCK position. (The steering wheel will lock when the power switch is turned to LOCK position.)
6. Perform All DTC Reading using CONSULT and delete DTC.

NOTE:

Multiple DTCs are detected when 12V battery cable is disconnected while power switch is in ACC position.

PRECAUTIONS

[TYPE 1]

< PRECAUTION >

Precaution for Procedure without Cowl Top Cover

INFOID:000000007005712

When performing the procedure after removing cowl top cover, cover the lower end of windshield with urethane, etc to prevent damage to windshield.

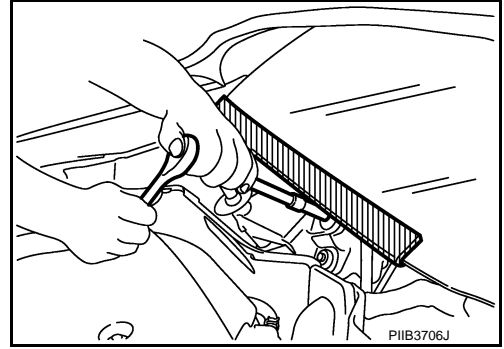

Precautions for Removing Battery Terminal

INFOID:000000007005861

- When removing the 12V battery terminal, turn OFF the power switch and wait at least 5 minutes.

NOTE:

ECU may be active for several minutes after the power switch is turned OFF. If the battery terminal is removed before ECU stops, then a DTC detection error or ECU data corruption may occur.

- Always disconnect the battery terminal within 60 minutes after turning OFF the power switch. Even when the power switch is OFF, the 12V battery automatic charge control may automatically start after a lapse of 60 minutes from power switch OFF.
- Disconnect 12V battery terminal according to the following steps.

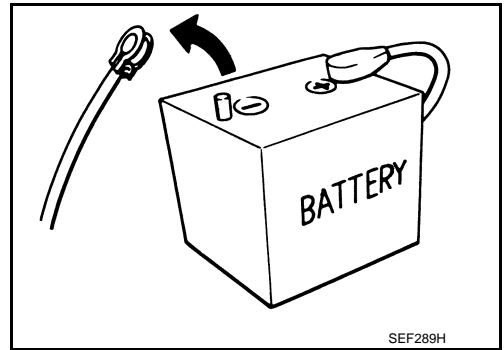

WORK PROCEDURE

1. Check that EVSE is not connected.

NOTE:

If EVSE is connected, the air conditioning system may be automatically activated by the timer A/C function.

2. Turn the power switch OFF → ON → OFF. Get out of the vehicle. Close all doors (including back door).
3. Check that the charge status indicator lamp does not blink and wait for 5 minutes or more.

NOTE:

If the battery is removed within 5 minutes after the power switch is turned OFF, plural DTCs may be detected.

4. Remove 12V battery terminal within 60 minutes after turning the power switch OFF → ON → OFF.

CAUTION:

- After all doors (including back door) are closed, if a door (including back door) is opened before battery terminals are disconnected, start over from Step 1.
- After turning the power switch OFF, if "Remote A/C" is activated by user operation, stop the air conditioner and start over from Step 1.

NOTE:

Once the power switch is turned ON → OFF, the 12V battery automatic charge control does not start for approximately 1 hour.

- For vehicles with the 2-batteries, be sure to connect the main battery and the sub battery before turning ON the power switch.

NOTE:

If the power switch is turned ON with any one of the terminals of main battery and sub battery disconnected, then DTC may be detected.

- After installing the 12V battery, always check "Self Diagnosis Result" of all ECUs and erase DTC.

NOTE:

The removal of 12V battery may cause a DTC detection error.

High Voltage Precautions

INFOID:000000007374286

DANGER:

A
B
EVB
D
E
F
G
H
I
J
K
L
M
N
O
P

PRECAUTIONS

< PRECAUTION >

[TYPE 1]



Since hybrid vehicles and electric vehicles contain a high voltage battery, there is the risk of electric shock, electric leakage, or similar accidents if the high voltage component and vehicle are handled incorrectly. Be sure to follow the correct work procedures when performing inspection and maintenance.

WARNING:

- Be sure to remove the service plug in order to disconnect the high voltage circuits before performing inspection or maintenance of high voltage system harnesses and parts.
- The removed service plug must always be carried in a pocket of the responsible worker or placed in the tool box during the procedure to prevent the plug from being connected by mistake.
- Be sure to wear insulated protective equipment before beginning work on the high voltage system.
- Never allow workers other than the responsible person to touch the vehicle containing high voltage parts. To keep others from touching the high voltage parts, these parts must be covered with an insulating sheet except when using them.

CAUTION:

Never bring the vehicle into the READY status with the service plug removed unless otherwise instructed in the Service Manual. A malfunction may occur if this is not observed.

HIGH VOLTAGE HARNESS AND EQUIPMENT IDENTIFICATION

All the high voltage harnesses and connectors are orange. The Li-ion battery and other high voltage devices include an orange high voltage label. Never touch these harnesses and high voltage parts.

HANDLING OF HIGH VOLTAGE HARNESS AND TERMINALS

Immediately insulate disconnected high voltage connectors and terminals with insulating tape.

REGULATIONS ON WORKERS WITH MEDICAL ELECTRONICS

WARNING:

The vehicle contains parts that contain powerful magnets. If a person who is wearing a heart pacemaker or other medical device is close to these parts, the medical device may be affected by the magnets. Such persons must not perform work on the vehicle.

PROHIBITED ITEMS TO CARRY DURING THE WORK

Hybrid vehicles and electric vehicles contain parts with high voltage and intense magnetic force. Never carry metal products and magnetic recording media (e.g. cash card, prepaid card) to repair/inspect high voltage parts. If this is not observed, the metal products may create a risk of short circuit and the magnetic recording media may lose their magnetic recording.

POSTING A SIGN OF “DANGER! HIGH VOLTAGE AREA. KEEP OUT”

PRECAUTIONS

< PRECAUTION >

[TYPE 1]

Indicate "HIGH VOLTAGE. DO NOT TOUCH" on the vehicle under repair/inspection to call attention to other workers.

Person in charge: _____
DO NOT TOUCH!
REPAIR IN PROGRESS.
HIGH VOLTAGE
DANGER:
DANGER:
HIGH VOLTAGE
REPAIR IN PROGRESS.
DO NOT TOUCH!
Person in charge: _____
Copy this page and put it after folding on the roof of the vehicle in service.
<small>JSAIA1600GB</small>

A
B
EVB
D
E
F
G
H
I
J
K
L
M
N
O
P

PREPARATION

< PREPARATION >

[TYPE 1]

PREPARATION

PREPARATION

Special Service Tools

INFOID:000000007063820

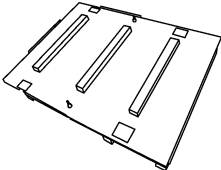
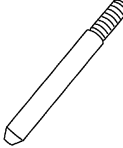
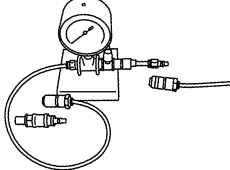
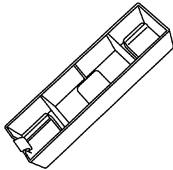
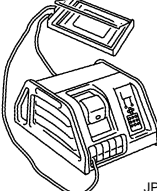
Tool name Tool number (Kent-Moore No.)	Description
Palette — (J-50583)	 <p>JPCIA0239ZZ</p> When removing/installing Li-ion battery.
Battery location guide pin KV99111300 (J-50306)	 <p>JPCIA0023ZZ</p> When installing Li-ion battery. 2 piece/set
Air leak checker KV99111400 (—)	 <p>JSCIA0257ZZ</p> When checking air leaks after disassembling/assembling Li-ion battery.
Module terminal cover KV99111500 (—)	 <p>JPCIA0069ZZ</p> Protect module terminals (for LEAF) 24 pieces/set
Module charge balancer — (J-50346)	 <p>JPCIA0070ZZ</p> Module voltage adjustment



Commercial Service Tools

INFOID:000000007063822

PREPARATION

< PREPARATION >

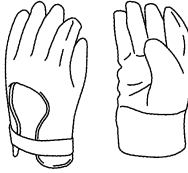
[TYPE 1]

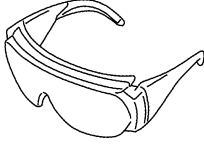
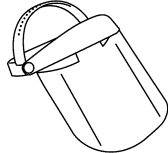
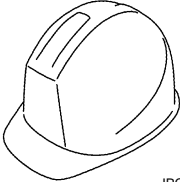
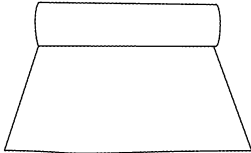
Tool name	Description	
<p>Insulated gloves</p>  <p>JMCIA0149ZZ</p>	<p>Removing and installing high voltage components [Guaranteed insulation performance for 1000V/ 300A]</p>	<p>A B EVB</p>
<p>Leather gloves</p>  <p>JPCIA0066ZZ</p>	<ul style="list-style-type: none"> • Removing and installing high voltage components • Protect insulated gloves [Use leather gloves that can fasten the wrist tight] 	<p>D E</p>
<p>Insulated safety shoes</p>  <p>JPCIA0011ZZ</p>	<p>Removing and installing high voltage components</p>	<p>F G H</p>
<p>Safety glasses</p>  <p>JPCIA0012ZZ</p>	<ul style="list-style-type: none"> • Removing and installing high voltage components • To protect eye from the spatter on the work to electric line [ANSI Z87.1] 	<p>I J</p>
<p>Face shield</p>  <p>JPCIA0167ZZ</p>	<ul style="list-style-type: none"> • Removing and installing high voltage components • To protect face from the spatter on the work to electric line 	<p>K L M</p>
<p>Insulated helmet</p>  <p>JPCIA0013ZZ</p>	<p>Removing and installing high voltage components</p>	<p>N O</p>
<p>Insulated rubber sheet</p>  <p>JPCIA0019ZZ</p>	<p>Removing and installing high voltage components</p>	<p>P</p>

PREPARATION

< PREPARATION >

[TYPE 1]

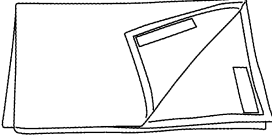
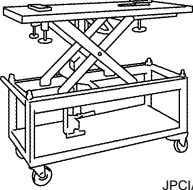
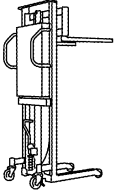
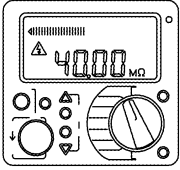
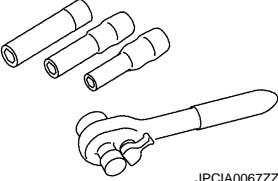
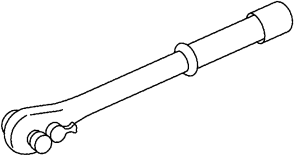
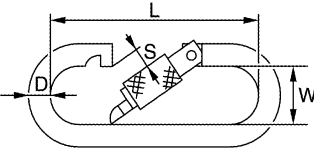
Tool name	Description
Insulated cover sheet  JPCIA0018ZZ	Removing and installing high voltage components
Battery lift table  JPCIA0024ZZ	Removing and installing Li-ion battery
Stacker  JPCIA0015ZZ	Removing and installing Li-ion battery
Insulation resistance tester (Multi tester)  JPCIA0014ZZ	Measuring insulation resistance, voltage, and resistance
Insulated hand tools  JPCIA0067ZZ	Removing and installing high voltage components
Insulated torque wrench  JPCIA0068ZZ	Removing and installing high voltage components
Carabineer [small]  JPCIA0016ZZ	Removing and installing battery module stack NOTE: <ul style="list-style-type: none"> • D: 8.0 mm (0.31 in) • L: 74.0 mm (2.91 in) • S: 10.0 mm (0.39 in) • W: 22.5 mm (0.89 in)

PREPARATION

< PREPARATION >

[TYPE 1]

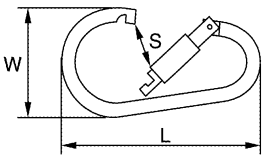
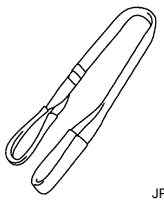
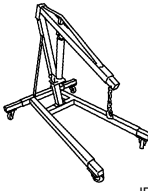
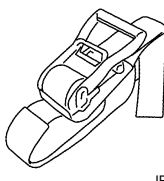
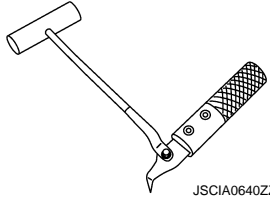
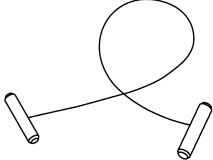
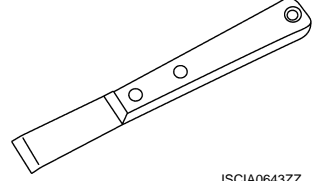
Tool name	Description
<p>Carabineer [large]</p>  <p style="text-align: right; font-size: small;">JPCIA0017ZZ</p>	<p>Removing and installing battery module stack</p> <p>NOTE:</p> <ul style="list-style-type: none"> • D: 14.0 mm (0.55 in) • L: 204.0 mm (8.03 in) • S: 47.0 mm (1.85 in) • W: 105.0 mm (4.13 in)
<p>Belt slinger</p>  <p style="text-align: right; font-size: small;">JPCIA0021ZZ</p>	<p>Removing and installing battery module stack</p> <p>NOTE:</p> <p>Length: 2.0 m (6.562 ft)</p>
<p>Mobile floor crane</p>  <p style="text-align: right; font-size: small;">JPCIA0020ZZ</p>	<p>Removing and installing battery module stack</p>
<p>Lashing belt</p>  <p style="text-align: right; font-size: small;">JPCIA0022ZZ</p>	<p>Removing and installing battery rear module stack</p>
<p>Windshield cutter [Gasket cutter]</p>  <p style="text-align: right; font-size: small;">JSCIA0640ZZ</p>	<p>Removing battery pack upper case (Cut the adhesive)</p>
<p>Piano wire with handles</p>  <p style="text-align: right; font-size: small;">JSCIA0641ZZ</p>	<p>Installing battery pack upper case (Cut the adhesive)</p> <p>NOTE:</p> <p>Wire size: ϕ 0.5 mm (0.02 in)</p>
<p>Scraper</p>  <p style="text-align: right; font-size: small;">JSCIA0643ZZ</p>	<p>Installing battery pack upper case (Smooth the adhesive)</p>

A
B
EVB
D
E
F
G
H
I
J
K
L
M
N
O
P

PREPARATION

< PREPARATION >

[TYPE 1]

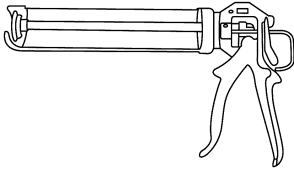
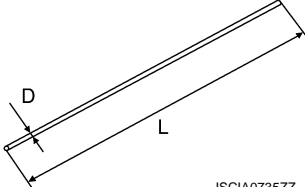
Tool name	Description
<p data-bbox="159 289 505 344">Tube presser [Gasket material applicator]</p>  <p data-bbox="789 415 873 432">JSCIA0639ZZ</p>	<p data-bbox="967 289 1308 344">Installing battery pack upper case (Apply the adhesive)</p>
<p data-bbox="159 554 256 579">Metal bar</p>  <p data-bbox="789 663 873 680">JSCIA0735ZZ</p>	<p data-bbox="967 512 1299 537">Assembling battery module stack</p> <p data-bbox="967 541 1039 567">NOTE:</p> <ul data-bbox="967 571 1182 625" style="list-style-type: none"><li data-bbox="967 571 1182 596">• D: ϕ 7 mm (0.28 in)<li data-bbox="967 600 1182 625">• L: 1 m (3.28 ft)

COMPONENT PARTS

< SYSTEM DESCRIPTION >

[TYPE 1]

SYSTEM DESCRIPTION

COMPONENT PARTS

Component Parts Location

INFOID:000000007005717

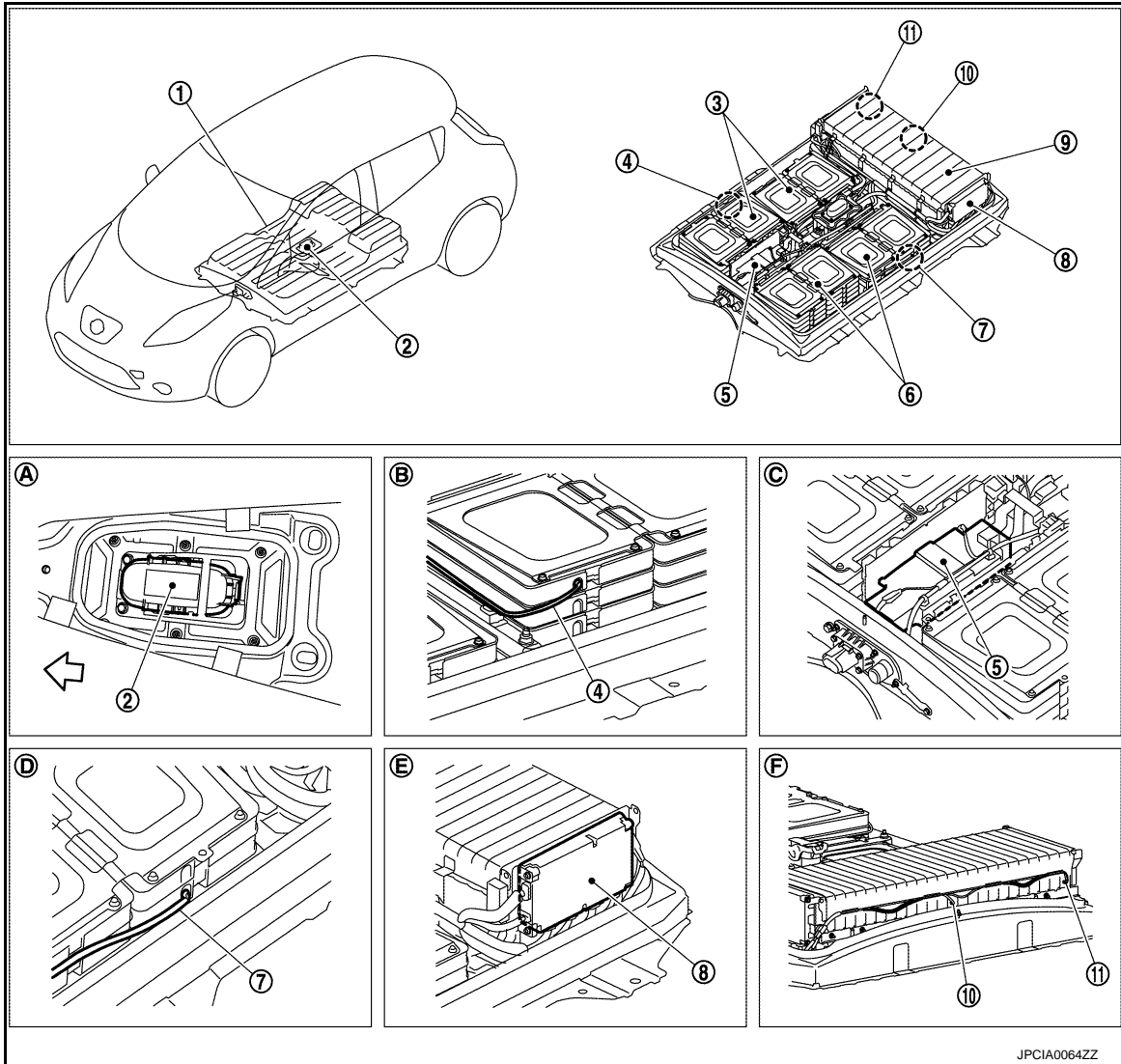

- A. Center of rear seat legroom B. Center of battery pack right side C. Center of battery pack front side
 D. Center of battery pack left side E. Back of battery pack left side F. Back of battery pack
 ⇐ : Vehicle front

No.	Component	Function
1.	Li-ion battery	EVB-26, "Li-ion Battery"
2.	Service plug	EVB-29, "Service Plug"
3.	Front module stack RH	EVB-27, "Module"
4.	Battery temperature sensor (Front RH)	EVB-28, "Battery Temperature Sensor"
5.	Battery junction box	EVB-28, "Battery Junction Box"
6.	Front module stack LH	EVB-27, "Module"
7.	Battery temperature sensor (Front LH)	EVB-28, "Battery Temperature Sensor"
8.	Li-ion battery controller	EVB-26, "Li-ion Battery Controller"

A
B
EVB
D
E
F
G
H
I
J
K
L
M

N
O
P

COMPONENT PARTS

< SYSTEM DESCRIPTION >

[TYPE 1]

No.	Component	Function
9.	Rear module stack	EVB-27. "Module"
10.	Battery temperature sensor (Rear center)	EVB-28. "Battery Temperature Sensor"
11.	Battery temperature sensor (Rear RH)	EVB-28. "Battery Temperature Sensor"

Li-ion Battery

INFOID:000000007005718

- A Li-ion battery with flat construction is placed under floor.
- The battery pack is equipped with necessary devices, such as Li-ion battery controller, battery junction box, and service plug in addition to a battery storing electricity.

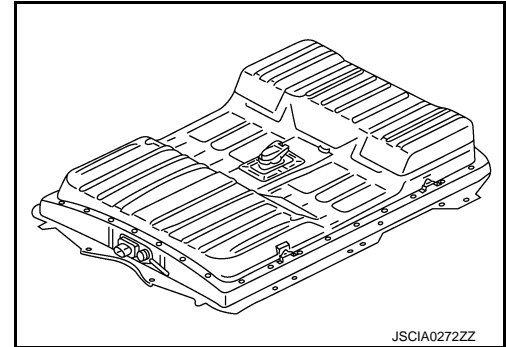

- Four cells are integrated into a single module. The Li-ion battery consists of 48 modules placed in series.

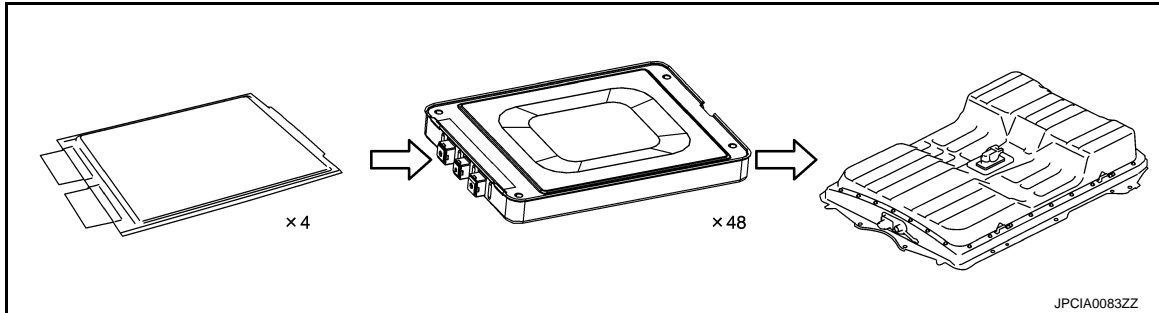

Li-ion Battery Controller

INFOID:000000007005719

- Li-ion battery controller (LBC) is included in the battery pack and installed on the left surface of the rear module stack.

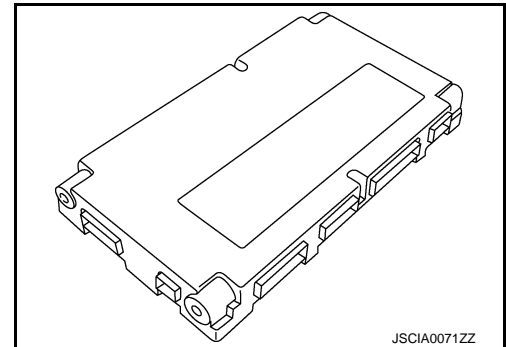

- The LBC is the core of battery control. Li-ion battery controller detects the voltage and current of the assembled battery, the temperature of each module, and the voltage of each cell to judge state of charge. LBC also calculates possible input/output values, meter indication values, and chargeable values, and send this data to VCM (Vehicle control module). VCM controls the vehicle, according to the battery state.

Main Role of Li-ion Battery Controller

1. Li-ion battery state check
 - State of charge
 - Possible output value
 - Possible input value
 - Temperature
2. Optimization of Li-ion battery voltage

COMPONENT PARTS

[TYPE 1]

< SYSTEM DESCRIPTION >

3. Prevention of overvoltage and overcurrent
4. Prevention of overheating
5. Detection of decrease in insulation resistance of high-voltage circuit
6. Detection of a fit of high voltage harness connector and service plug

Module

INFOID:000000007005720

- Four laminated cells are integrated into one module.
- The Li-ion battery is equipped with 48 modules.
- There are two kinds of modules, according to the location of positive and negative terminals.

Positive terminal : Red
 Negative terminal : Black

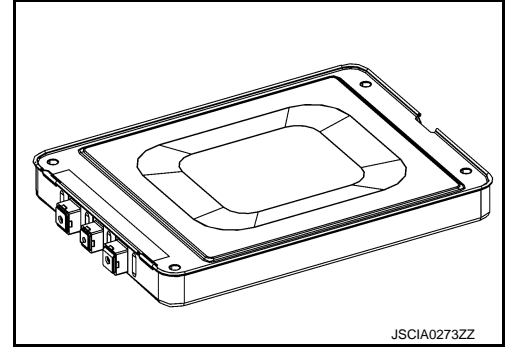

MODULE INTERNAL CIRCUIT

A module consists of two parallel-connected cells placed in series. The Li-ion battery has 48 modules placed in series in total. Ninety-six parallel-connected cell pairs are connected in series.

NOTE:

Cell voltage displayed on the data monitor of CONSULT means the potential difference between the upstream and the downstream of the parallel circuit.

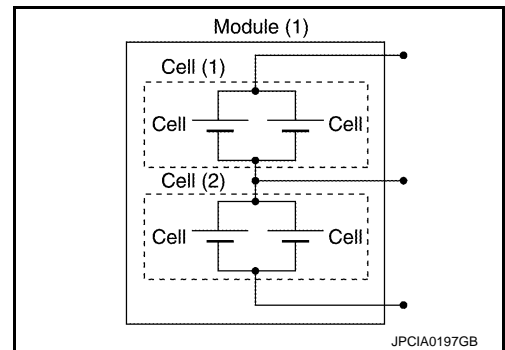

MODULE LAYOUT

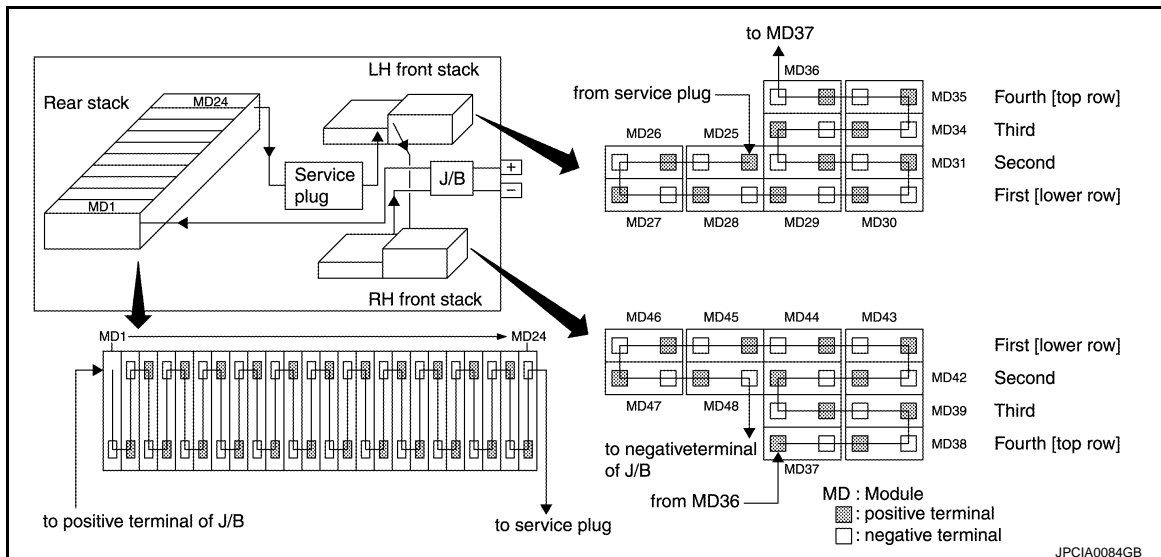

NOTE:

The highest potential is module (MD) 1 and the lowest is module (MD) 48.

CELL

A
B
EVB
D
E
F
G
H
I
J
K
L
M
N
O
P

COMPONENT PARTS

< SYSTEM DESCRIPTION >

[TYPE 1]

These are thin laminated cells with excellent cooling performance.

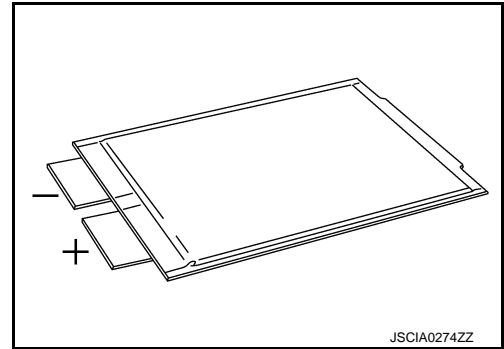

The Features of Laminated Cell

- Large surface area with excellent cooling performance reduces heat load to the battery and improves battery life.
- Light and thin structure increases flexibility in layout.

Battery Temperature Sensor

INFOID:000000007005721

- Four battery temperature sensors mounted in the battery pack measure the temperature.
- Right and left front module stacks have one battery temperature sensor, respectively, and the rear module stack has two.

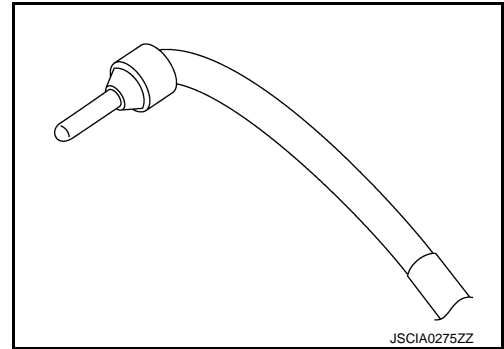

- The sensor uses a thermistor with a resistance value that varies according to changes in temperature. The electrical resistance of the thermistor decreases as the temperature increases.

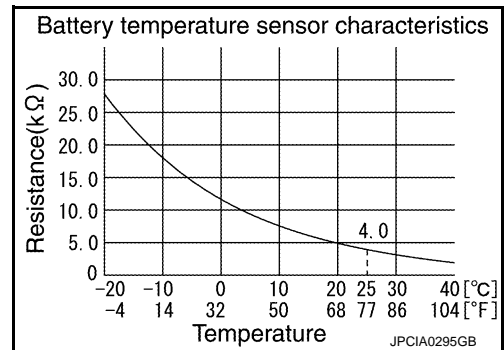

Battery Junction Box

INFOID:000000007005722

- The battery junction box is installed to the front side in the battery pack.
- The battery junction box includes:
 - System main relay to provide/interrupt DC current sent from Li-ion battery.
 - Pre-charge relay to protect the high voltage circuit from a high current immediately after power switch ON.
 - Current sensor to calculate battery capacity.
- Installed to both positive side and negative side, the system main relay provides DC current to each high voltage part. In addition, the system main relay provides DC current to the Li-ion battery during motor regeneration or charge.
- When an error occurs in the system, the system main relay is turned OFF and the Li-ion battery is interrupted for ensuring safety, based on a command from VCM (Vehicle control module).

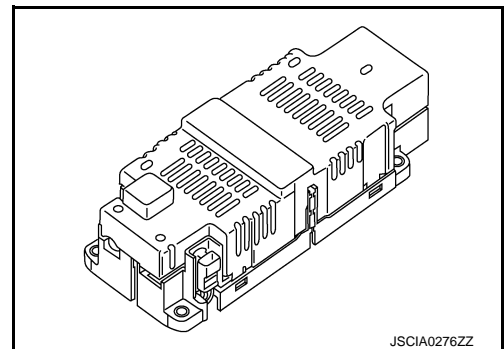

COMPONENT PARTS

< SYSTEM DESCRIPTION >

[TYPE 1]

Service Plug

INFOID:000000007005723

- The service plug is included in the Li-ion battery to securely disconnect the high voltage during high voltage part inspection and maintenance.
- The service plug is installed on the upper surface of the battery pack. The plug can be removed when the leg-room mounted service plug cover is removed.
- Always use insulating protective equipment when removing and installing service plug.

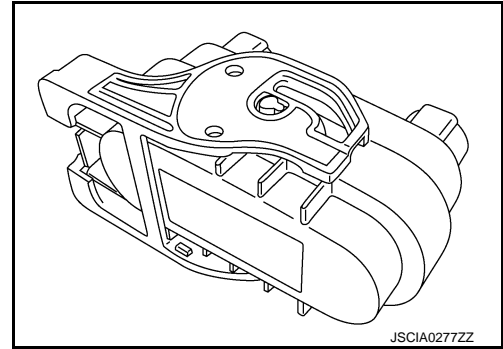

High Voltage Warning Label

INFOID:000000007005724

High voltage warning label is affixed to each of the following component parts.

After replacing a part, check that the part is affixed with a label. If the label is not affixed, be sure to affix the label in the original position.

Li-ion Battery

- The label (A) is affixed to the rear end of Li-ion battery.

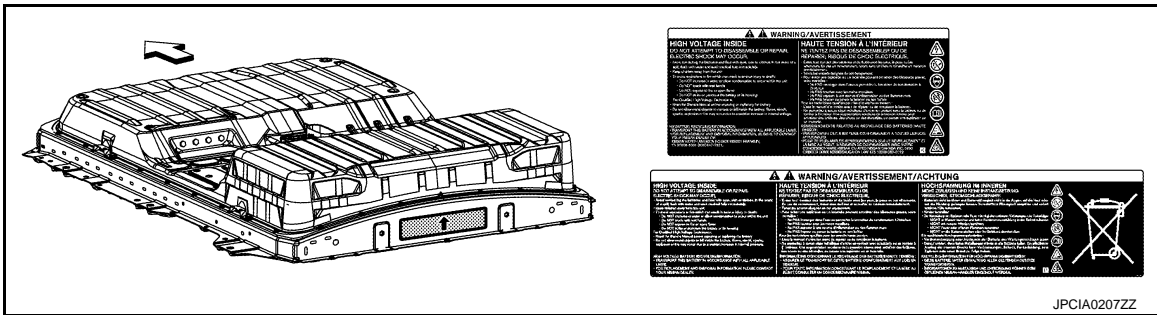

↶ : Vehicle front

← : Direction of the label

- The label (A) is affixed to the body panel near the high voltage harness connector.

↶ : Vehicle front

← : Direction of the label

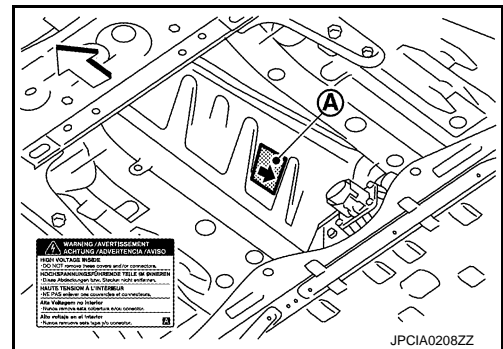

Li-ion Battery Controller

The label is affixed to the main body of controller.

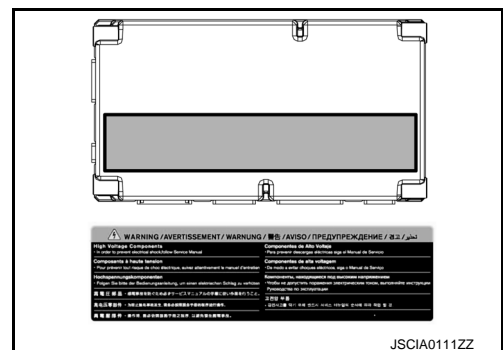

A
B
EVB
D
E
F
G
H
I
J
K
L
M
N
O
P

COMPONENT PARTS

[TYPE 1]

< SYSTEM DESCRIPTION >

Service Plug

The label is affixed to the inspection hole cover (1).

← : Direction of the label

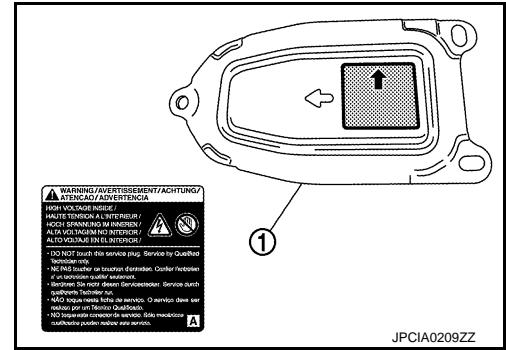

SYSTEM

System Description

INFOID:000000007005725

SYSTEM DIAGRAM

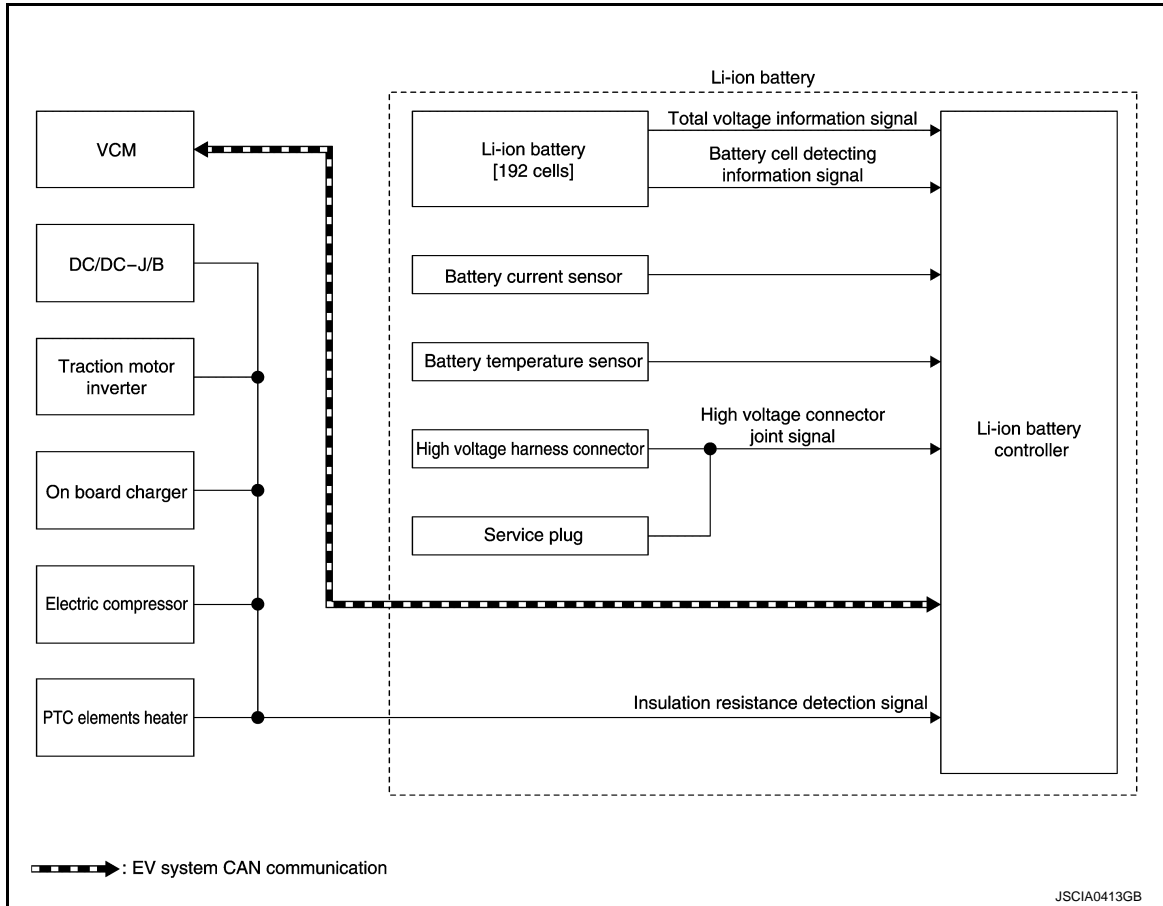

INPUT/OUTPUT SIGNAL ITEM

Input Signal Item

Transmit unit	Signal name	
VCM	EV system CAN	Target Li-ion battery remained energy signal

Output Signal Item

A
B
EVB
D
E
F
G
H
I
J
K
L
M
N
O
P

SYSTEM

< SYSTEM DESCRIPTION >

[TYPE 1]

Received unit	Signal name	
VCM	EV system CAN	High voltage discharge permit signal
		Li-ion battery main relay cut request signal
		Li-ion battery connector interlock signal
		Li-ion battery voltage signal
		Li-ion battery current signal
		Li-ion battery chargeable power signal
		Li-ion battery dischargeable power signal
		Li-ion battery chargeable completion signal
		Li-ion battery available charge signal
		Li-ion battery capacity signal
		Li-ion battery gradual capacity loss signal
		Insulation resistance signal

DESCRIPTION

The Li-ion battery controller (LBC) monitors the status of the inside of the Li-ion battery at all times and sends information, such as the charging status of Li-ion battery and possible power, to VCM (vehicle control module) via EV system CAN communication.

The Li-ion battery controller performs control as per the following.

- Monitors the battery state and transfers chargeable/dischargeable power to VCM to prevent an error, such as overvoltage, over discharge or excessive temperature rise in the battery.
- Detects an error (overvoltage, over discharge, overcurrent, or excessive temperature rise) immediately at the time of error occurrence and requests VCM to disconnect the system main relay to interrupt the discharge/charge line.
- Maintains the optimum battery state constantly with a cell capacity adjustment function to prevent a reduction in charging/discharging capacity caused by cell capacity variations.
- Detects the connector fit state with the function to detect the fit of the high voltage harness connector and transfers the detected state to VCM so that the vehicle does not start with an unsteady state.
- Detects the insulation resistance state with the function to detect the insulation resistance between high and low voltage and transfers the detected state to VCM so that the vehicle does not start with an unusual state.
- Estimates a battery charge state and low battery state, based on the data obtained with the battery state detection function, and reflects on the battery capacity meter.

BATTERY PROTECTION

The Li-ion battery has a voltage range capable of charge/discharge. If charged/discharged exceeding the range, excessive low capacity or malfunction may be caused. To prevent this, the Li-ion battery controller detects voltage of each cell and requests the control of charging/discharging energy to VCM so that the cell voltage stays within the voltage range.

Control item	Control	Operating condition
Overvoltage/overcurrent protection	Charging energy control	Gradual control of charging energy as the cell voltage approaches the upper limit of the voltage capable of charging.
	System main relay cut	Cell voltage exceeds the voltage judged as overvoltage and maintains the voltage for more than the specified time.
Over discharge protection	Discharging energy control	Gradual control of discharging energy as the cell voltage approaches the lower limit of the voltage capable of discharging.
	System main relay cut	Cell voltage exceeds the voltage judged as over discharge and maintains the voltage for more than the specified time.
Excessive temperature rise protection	Charging/discharging energy control	Gradual control of charging/discharging energy as Li-ion battery temperature approaches the upper limit of the temperature capable of use.
	System main relay cut	Li-ion battery temperature exceeds the temperature judged as excessive temperature rise and maintains the temperature for more than the specified time.

HOW TO ADJUST CELL CAPACITY

During cell capacity adjustment, the capacity of each cell is estimated based on the no-load voltage when the system starts, and the capacities are adjusted so that they are all at the target level. The voltage of each cell is detected inside the Li-ion battery controller. The bypass switches are then turned ON to discharge the cells that have excess capacity. In this way, capacity adjustment by the Li-ion battery controller allows the capacity of all cells to be fully utilized.

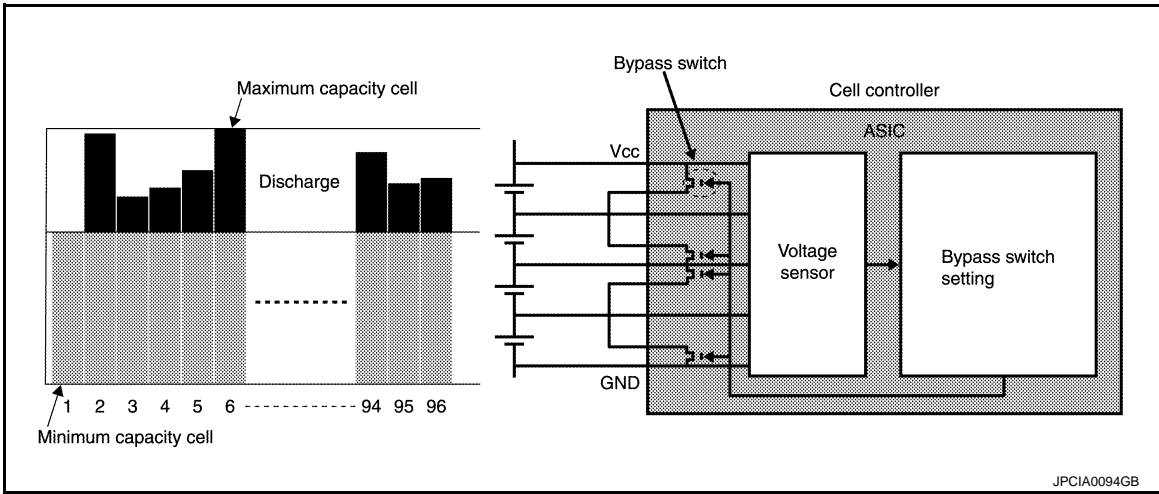

INSULATION RESISTANCE LOSS DETECTION FUNCTION

The insulation resistance detection circuit mounted inside the Li-ion battery controller measures the insulation resistance of each high voltage part and sends the measurement results to VCM via EV system CAN communication.

VCM judges abnormal insulation resistance in each high voltage part, based on the received insulation resistance value.

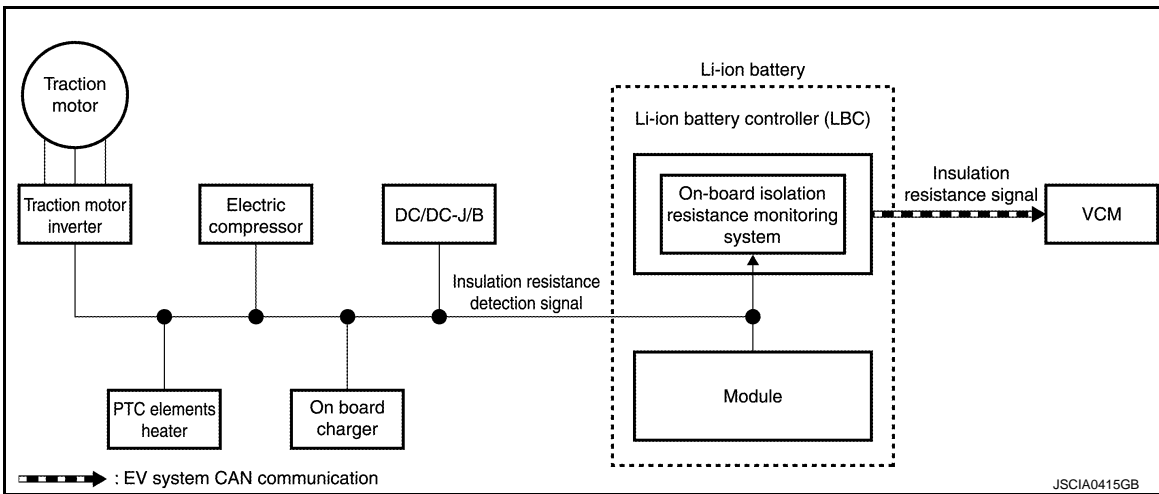

SYSTEM

< SYSTEM DESCRIPTION >

[TYPE 1]

Circuit Diagram

INFOID:000000007005726

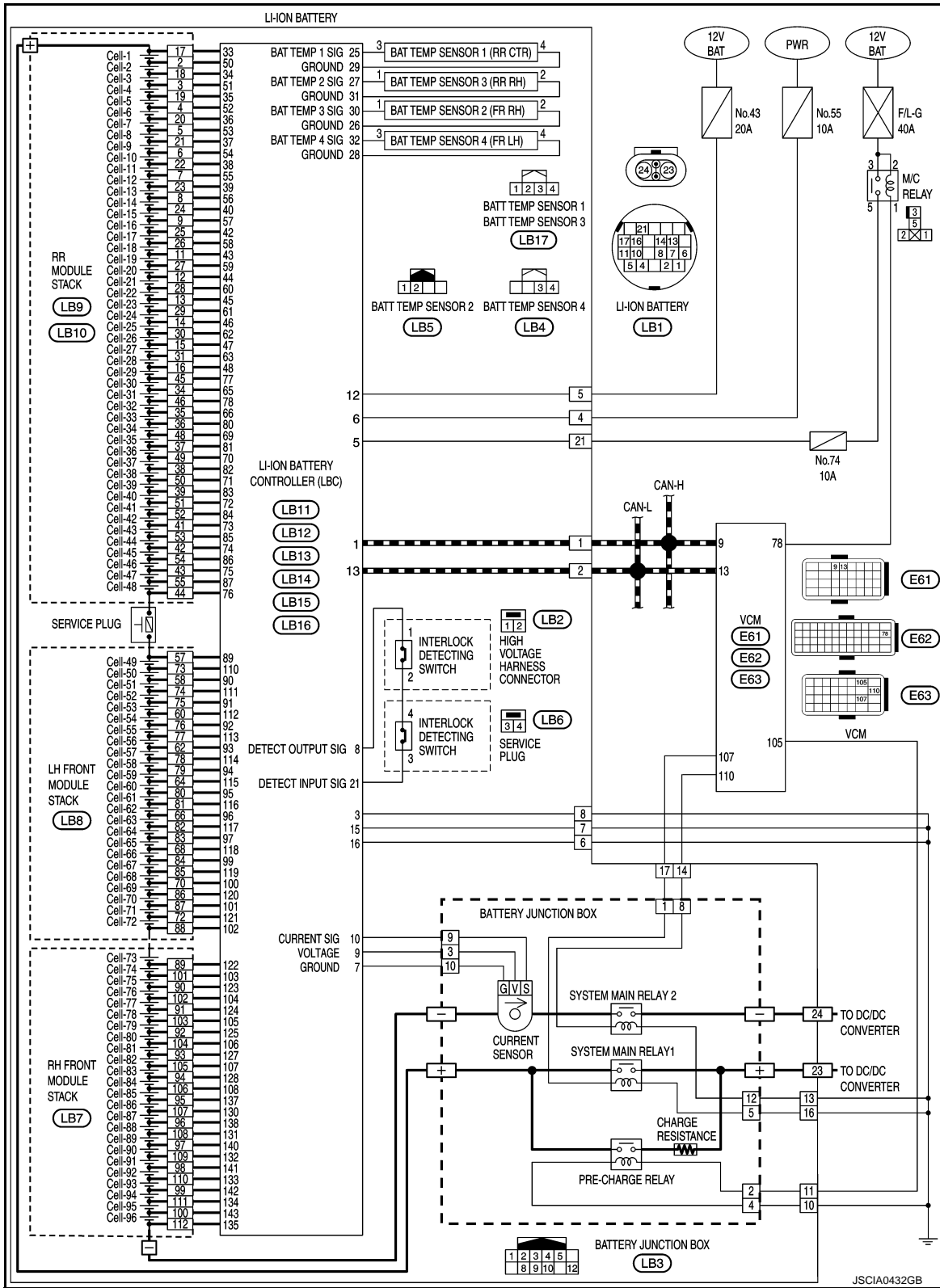

JSCIA0432GB

SYSTEM

< SYSTEM DESCRIPTION >

[TYPE 1]

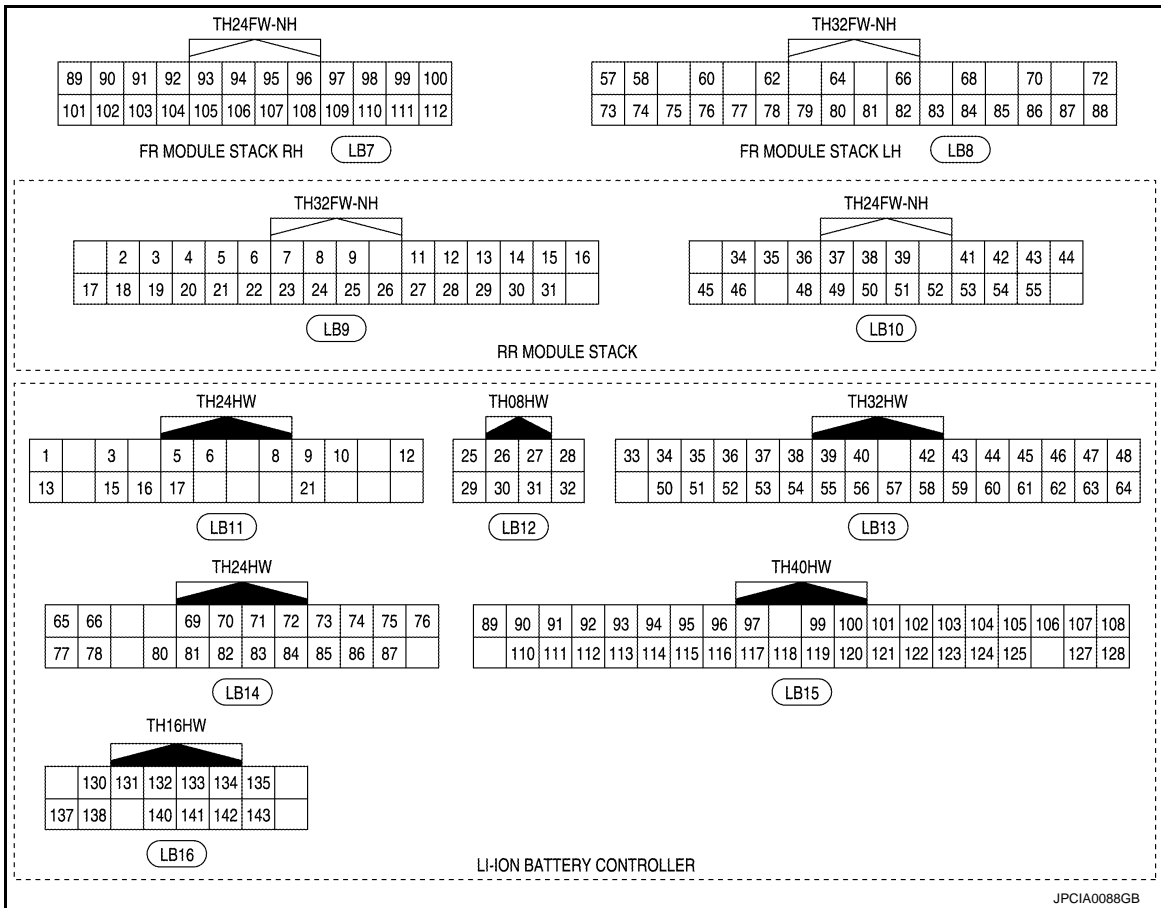

HARNESS LAYOUT

A
B
EVB
D
E
F
G
H
I
J
K
L
M
N
O
P

SYSTEM

< SYSTEM DESCRIPTION >

[TYPE 1]

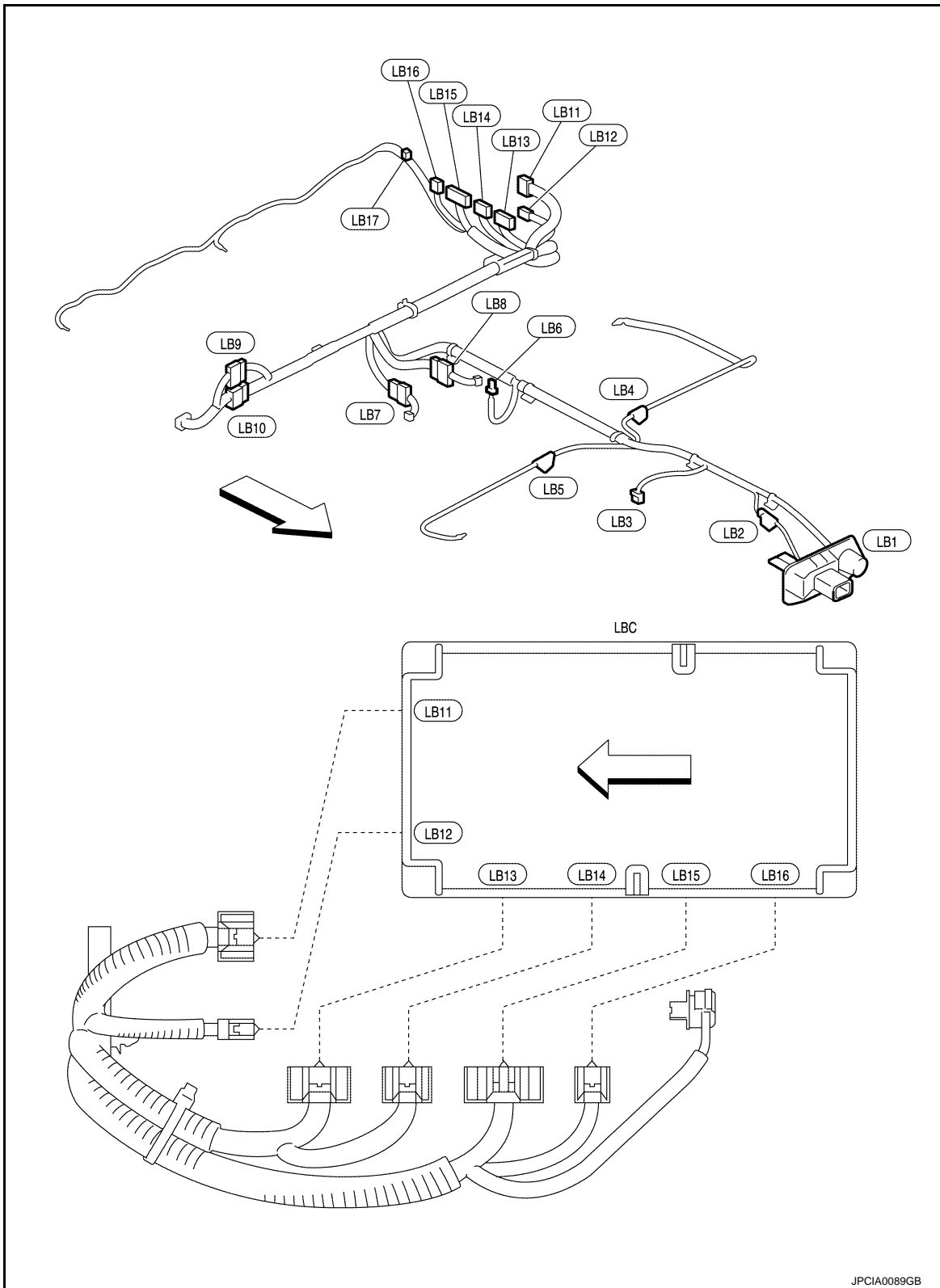

← : Vehicle front

HANDLING PRECAUTION

< SYSTEM DESCRIPTION >

[TYPE 1]

HANDLING PRECAUTION

EV Battery System

INFOID:000000007005727

- To improve the Li-ion battery life, never perform quick charge heavily.
- Use the method of nighttime normal charge or timer-controlled charge.
- Never perform rapid acceleration/deceleration.
- Never place EV battery in an area exposed to direct sunlight or under high temperature conditions.

PRECAUTIONS FOR STORAGE OF THE LI-ION BATTERY

- Apply insulating tape to the service plug and high voltage harness connector, and protect the terminals so that nothing contacts them.
- Store in a well-ventilated location that is not exposed to direct sunlight.
(Storing outdoors or unprotected is prohibited.)
- Never set directly on the floor.
- Lay an anti-static rubber sheet underneath the battery.
- Never invert the battery.
- Never stack batteries.
- Cover with an anti-static cover sheet.
- Put a caution display stating "CAUTION! HIGH VOLTAGE" on the insulated cover sheet.
- Put identification display showing the name of person in charge on the insulated cover sheet.
- Never allow water to contact the battery.
- Prevent other objects from falling onto the battery.

A

B

EVB

D

E

F

G

H

I

J

K

L

M

N

O

P

DIAGNOSIS SYSTEM (LBC)

< SYSTEM DESCRIPTION >

[TYPE 1]

DIAGNOSIS SYSTEM (LBC)

CONSULT Function

INFOID:000000007005728

APPLICATION ITEM

CONSULT performs the following functions via CAN communication with Li-ion battery controller (LBC).

Item	Function
ECU Identification	LBC parts number can be read.
Self-diagnostic Results	Self-diagnostic results and freeze frame data can be read and erased quickly.*
Data Monitor	Input/Output data in LBC can be read.
Work Support	This mode enables a technician to adjust some devices faster and more accurately by following the indications on the CONSULT.
CAN Diagnosis	Displays the CAN diagnosis results.
CAN Diagnosis Support Monitor	Displays the CAN communication status.

*: The following diagnosis information is cleared when the VCM memory is erased.

- Diagnostic trouble codes
- Freeze frame data

ECU IDENTIFICATION

Part number of LBC can be checked.

SELF-DIAGNOSTIC RESULTS

Self Diagnostic Item

Regarding items of DTC, refer to [EVB-50. "DTC Index"](#).

How to Erase DTC

1. Select "HV BAT" with CONSULT.
2. "SELF-DIAGNOSTIC RESULTS".
3. Touch "ERASE". (DTC in LBC will be erased.)

FREEZE FRAME DATA (FFD)

The following vehicle status is recorded when DTC is detected and is displayed on CONSULT.

Monitored item (Unit)	Remarks
DTC	Displays the DTC which caused FFD memory
BATT ELECTRIC CURRENT A	Displays the Li-ion battery current value
12V BATTERY VOLTAGE mV	Displays 12V battery power supply voltage
IR SEN SHORT PULSE mV	Displays the maximum to minimum difference of voltage magnitude of the on-board isolation resistance monitoring system
SERVICE PLUG INTERLOCK OPEN / CLOSE	Displays the OPEN/CLOSE state of the service plug
CELL VOLTAGE 01 - 96 mV	Displays each cell voltage
TOTAL BATTERY VOLTAGE V	Displays the total voltage of the Li-ion battery
BATTERY TEMPERATURE 1 °C	Displays the temperature calculated with a signal voltage from battery temperature 1 [Rear center]
BATTERY TEMPERATURE 2 °C	Displays the temperature calculated with a signal voltage from battery temperature 2 [Front RH]
BATTERY TEMPERATURE 3 °C	Displays the temperature calculated with a signal voltage from battery temperature 3 [Rear RH]
BATTERY TEMPERATURE 4 °C	Displays the temperature calculated with a signal voltage from battery temperature 4 [Front LH]

DATA MONITOR

DIAGNOSIS SYSTEM (LBC)

< SYSTEM DESCRIPTION >

[TYPE 1]

Monitored item	Unit	Remark
BATT ELECTRIC CURRENT	A	Displays the Li-ion battery current value
12V BATTERY VOLTAGE	mV	Displays 12V battery power supply voltage
IR SEN SHORT PULSE	mV	Displays the maximum to minimum difference of voltage magnitude of the on-board isolation resistance monitoring system
SERVICE PLUG INTERLOCK	OPEN / CLOSE	Displays the OPEN/CLOSE state of the service plug
CELL VOLTAGE 01 - 96	mV	Displays each cell voltage
TOTAL BATTERY VOLTAGE	V	Displays the total voltage of the Li-ion battery
MAXIMUM CELL VOLTAGE	mV	Displays the maximum cell voltage value
MINIMUM CELL VOLTAGE	mV	Displays the minimum cell voltage value
BATTERY TEMPERATURE 1	°C	Displays the temperature calculated with a signal voltage from battery temperature 1 [Rear center]
BATTERY TEMPERATURE 2	°C	Displays the temperature calculated with a signal voltage from battery temperature 2 [Front RH]
BATTERY TEMPERATURE 3	°C	Displays the temperature calculated with a signal voltage from battery temperature 3 [Rear RH]
BATTERY TEMPERATURE 4	°C	Displays the temperature calculated with a signal voltage from battery temperature 4 [Front LH]

WORK SUPPORT

Work item	Description	Usage
SAVE BATTERY INFORMATION DATA	Data saved in LBC is stored in CONSULT.	When Li-ion battery and LBC are replaced.
WRITE BATTERY INFORMATION DATA	The CONSULT-stored data can be written in LBC.	When Li-ion battery and LBC are replaced.
CLEAR BATTERY GRADUAL CAPACITY LOSS DATA	Battery capacity data stored in LBC can be erased.	When all modules of Li-ion battery are replaced.
CLEAR BATT CHARGE/DISCHARGE INFORMATION DATA	Battery charge/discharge data stored in LBC can be erased.	When all modules of Li-ion battery are replaced.
CELL VOLTAGE LOSS INSPECTION	This inspection identifies a cell of which cell voltage is on the decrease. If identified, this type of cell may be judged as an abnormal cell, unless it is replaced.	When checking voltage of all cells.

EV BATTERY SYSTEM

< ECU DIAGNOSIS INFORMATION >

[TYPE 1]

ECU DIAGNOSIS INFORMATION

EV BATTERY SYSTEM

Reference Value

INFOID:000000007005729

VALUE ON THE DIAGNOSIS TOOL

NOTE:

Specification data are reference values.

Monitor item	Condition		Values / Status
BATT ELECTRIC CURRENT	READY	Stop the vehicle	Approx. (-10) - (+20) A
12V BATTERY VOLTAGE	READY		Approx. 1,100 - 1,400 mV
IR SEN SHORT PULSE	READY		Approx. 4,100 - 4,300 mV
SERVICE PLUG INTER-LOCK	READY	Connect service plug	REQ
	READY	Disconnect service plug	NOT REQ
CELL VOLTAGE 01	READY	Total battery voltage 317 V	Approx. 3,200 - 3,400 mV
		Total battery voltage 393 V	Approx. 4,000 - 4,200 mV
CELL VOLTAGE 02	READY	Total battery voltage 317 V	Approx. 3,200 - 3,400 mV
		Total battery voltage 393 V	Approx. 4,000 - 4,200 mV
CELL VOLTAGE 03	READY	Total battery voltage 317 V	Approx. 3,200 - 3,400 mV
		Total battery voltage 393 V	Approx. 4,000 - 4,200 mV
CELL VOLTAGE 04	READY	Total battery voltage 317 V	Approx. 3,200 - 3,400 mV
		Total battery voltage 393 V	Approx. 4,000 - 4,200 mV
CELL VOLTAGE 05	READY	Total battery voltage 317 V	Approx. 3,200 - 3,400 mV
		Total battery voltage 393 V	Approx. 4,000 - 4,200 mV
CELL VOLTAGE 06	READY	Total battery voltage 317 V	Approx. 3,200 - 3,400 mV
		Total battery voltage 393 V	Approx. 4,000 - 4,200 mV
CELL VOLTAGE 07	READY	Total battery voltage 317 V	Approx. 3,200 - 3,400 mV
		Total battery voltage 393 V	Approx. 4,000 - 4,200 mV
CELL VOLTAGE 08	READY	Total battery voltage 317 V	Approx. 3,200 - 3,400 mV
		Total battery voltage 393 V	Approx. 4,000 - 4,200 mV
CELL VOLTAGE 09	READY	Total battery voltage 317 V	Approx. 3,200 - 3,400 mV
		Total battery voltage 393 V	Approx. 4,000 - 4,200 mV
CELL VOLTAGE 10	READY	Total battery voltage 317 V	Approx. 3,200 - 3,400 mV
		Total battery voltage 393 V	Approx. 4,000 - 4,200 mV
CELL VOLTAGE 11	READY	Total battery voltage 317 V	Approx. 3,200 - 3,400 mV
		Total battery voltage 393 V	Approx. 4,000 - 4,200 mV
CELL VOLTAGE 12	READY	Total battery voltage 317 V	Approx. 3,200 - 3,400 mV
		Total battery voltage 393 V	Approx. 4,000 - 4,200 mV
CELL VOLTAGE 13	READY	Total battery voltage 317 V	Approx. 3,200 - 3,400 mV
		Total battery voltage 393 V	Approx. 4,000 - 4,200 mV
CELL VOLTAGE 14	READY	Total battery voltage 317 V	Approx. 3,200 - 3,400 mV
		Total battery voltage 393 V	Approx. 4,000 - 4,200 mV
CELL VOLTAGE 15	READY	Total battery voltage 317 V	Approx. 3,200 - 3,400 mV
		Total battery voltage 393 V	Approx. 4,000 - 4,200 mV

EV BATTERY SYSTEM

< ECU DIAGNOSIS INFORMATION >

[TYPE 1]

Monitor item	Condition		Values / Status
CELL VOLTAGE 16	READY	Total battery voltage 317 V	Approx. 3,200 - 3,400 mV
		Total battery voltage 393 V	Approx. 4,000 - 4,200 mV
CELL VOLTAGE 17	READY	Total battery voltage 317 V	Approx. 3,200 - 3,400 mV
		Total battery voltage 393 V	Approx. 4,000 - 4,200 mV
CELL VOLTAGE 18	READY	Total battery voltage 317 V	Approx. 3,200 - 3,400 mV
		Total battery voltage 393 V	Approx. 4,000 - 4,200 mV
CELL VOLTAGE 19	READY	Total battery voltage 317 V	Approx. 3,200 - 3,400 mV
		Total battery voltage 393 V	Approx. 4,000 - 4,200 mV
CELL VOLTAGE 20	READY	Total battery voltage 317 V	Approx. 3,200 - 3,400 mV
		Total battery voltage 393 V	Approx. 4,000 - 4,200 mV
CELL VOLTAGE 21	READY	Total battery voltage 317 V	Approx. 3,200 - 3,400 mV
		Total battery voltage 393 V	Approx. 4,000 - 4,200 mV
CELL VOLTAGE 22	READY	Total battery voltage 317 V	Approx. 3,200 - 3,400 mV
		Total battery voltage 393 V	Approx. 4,000 - 4,200 mV
CELL VOLTAGE 23	READY	Total battery voltage 317 V	Approx. 3,200 - 3,400 mV
		Total battery voltage 393 V	Approx. 4,000 - 4,200 mV
CELL VOLTAGE 24	READY	Total battery voltage 317 V	Approx. 3,200 - 3,400 mV
		Total battery voltage 393 V	Approx. 4,000 - 4,200 mV
CELL VOLTAGE 25	READY	Total battery voltage 317 V	Approx. 3,200 - 3,400 mV
		Total battery voltage 393 V	Approx. 4,000 - 4,200 mV
CELL VOLTAGE 26	READY	Total battery voltage 317 V	Approx. 3,200 - 3,400 mV
		Total battery voltage 393 V	Approx. 4,000 - 4,200 mV
CELL VOLTAGE 27	READY	Total battery voltage 317 V	Approx. 3,200 - 3,400 mV
		Total battery voltage 393 V	Approx. 4,000 - 4,200 mV
CELL VOLTAGE 28	READY	Total battery voltage 317 V	Approx. 3,200 - 3,400 mV
		Total battery voltage 393 V	Approx. 4,000 - 4,200 mV
CELL VOLTAGE 29	READY	Total battery voltage 317 V	Approx. 3,200 - 3,400 mV
		Total battery voltage 393 V	Approx. 4,000 - 4,200 mV
CELL VOLTAGE 30	READY	Total battery voltage 317 V	Approx. 3,200 - 3,400 mV
		Total battery voltage 393 V	Approx. 4,000 - 4,200 mV
CELL VOLTAGE 31	READY	Total battery voltage 317 V	Approx. 3,200 - 3,400 mV
		Total battery voltage 393 V	Approx. 4,000 - 4,200 mV
CELL VOLTAGE 32	READY	Total battery voltage 317 V	Approx. 3,200 - 3,400 mV
		Total battery voltage 393 V	Approx. 4,000 - 4,200 mV
CELL VOLTAGE 33	READY	Total battery voltage 317 V	Approx. 3,200 - 3,400 mV
		Total battery voltage 393 V	Approx. 4,000 - 4,200 mV
CELL VOLTAGE 34	READY	Total battery voltage 317 V	Approx. 3,200 - 3,400 mV
		Total battery voltage 393 V	Approx. 4,000 - 4,200 mV
CELL VOLTAGE 35	READY	Total battery voltage 317 V	Approx. 3,200 - 3,400 mV
		Total battery voltage 393 V	Approx. 4,000 - 4,200 mV
CELL VOLTAGE 36	READY	Total battery voltage 317 V	Approx. 3,200 - 3,400 mV
		Total battery voltage 393 V	Approx. 4,000 - 4,200 mV
CELL VOLTAGE 37	READY	Total battery voltage 317 V	Approx. 3,200 - 3,400 mV
		Total battery voltage 393 V	Approx. 4,000 - 4,200 mV

A

B

EVB

D

E

F

G

H

I

J

K

L

M

N

O

P

EV BATTERY SYSTEM

< ECU DIAGNOSIS INFORMATION >

[TYPE 1]

Monitor item	Condition	Values / Status	
CELL VOLTAGE 38	READY	Total battery voltage 317 V	Approx. 3,200 - 3,400 mV
		Total battery voltage 393 V	Approx. 4,000 - 4,200 mV
CELL VOLTAGE 39	READY	Total battery voltage 317 V	Approx. 3,200 - 3,400 mV
		Total battery voltage 393 V	Approx. 4,000 - 4,200 mV
CELL VOLTAGE 40	READY	Total battery voltage 317 V	Approx. 3,200 - 3,400 mV
		Total battery voltage 393 V	Approx. 4,000 - 4,200 mV
CELL VOLTAGE 41	READY	Total battery voltage 317 V	Approx. 3,200 - 3,400 mV
		Total battery voltage 393 V	Approx. 4,000 - 4,200 mV
CELL VOLTAGE 42	READY	Total battery voltage 317 V	Approx. 3,200 - 3,400 mV
		Total battery voltage 393 V	Approx. 4,000 - 4,200 mV
CELL VOLTAGE 43	READY	Total battery voltage 317 V	Approx. 3,200 - 3,400 mV
		Total battery voltage 393 V	Approx. 4,000 - 4,200 mV
CELL VOLTAGE 44	READY	Total battery voltage 317 V	Approx. 3,200 - 3,400 mV
		Total battery voltage 393 V	Approx. 4,000 - 4,200 mV
CELL VOLTAGE 45	READY	Total battery voltage 317 V	Approx. 3,200 - 3,400 mV
		Total battery voltage 393 V	Approx. 4,000 - 4,200 mV
CELL VOLTAGE 46	READY	Total battery voltage 317 V	Approx. 3,200 - 3,400 mV
		Total battery voltage 393 V	Approx. 4,000 - 4,200 mV
CELL VOLTAGE 47	READY	Total battery voltage 317 V	Approx. 3,200 - 3,400 mV
		Total battery voltage 393 V	Approx. 4,000 - 4,200 mV
CELL VOLTAGE 48	READY	Total battery voltage 317 V	Approx. 3,200 - 3,400 mV
		Total battery voltage 393 V	Approx. 4,000 - 4,200 mV
CELL VOLTAGE 49	READY	Total battery voltage 317 V	Approx. 3,200 - 3,400 mV
		Total battery voltage 393 V	Approx. 4,000 - 4,200 mV
CELL VOLTAGE 50	READY	Total battery voltage 317 V	Approx. 3,200 - 3,400 mV
		Total battery voltage 393 V	Approx. 4,000 - 4,200 mV
CELL VOLTAGE 51	READY	Total battery voltage 317 V	Approx. 3,200 - 3,400 mV
		Total battery voltage 393 V	Approx. 4,000 - 4,200 mV
CELL VOLTAGE 52	READY	Total battery voltage 317 V	Approx. 3,200 - 3,400 mV
		Total battery voltage 393 V	Approx. 4,000 - 4,200 mV
CELL VOLTAGE 53	READY	Total battery voltage 317 V	Approx. 3,200 - 3,400 mV
		Total battery voltage 393 V	Approx. 4,000 - 4,200 mV
CELL VOLTAGE 54	READY	Total battery voltage 317 V	Approx. 3,200 - 3,400 mV
		Total battery voltage 393 V	Approx. 4,000 - 4,200 mV
CELL VOLTAGE 55	READY	Total battery voltage 317 V	Approx. 3,200 - 3,400 mV
		Total battery voltage 393 V	Approx. 4,000 - 4,200 mV
CELL VOLTAGE 56	READY	Total battery voltage 317 V	Approx. 3,200 - 3,400 mV
		Total battery voltage 393 V	Approx. 4,000 - 4,200 mV
CELL VOLTAGE 57	READY	Total battery voltage 317 V	Approx. 3,200 - 3,400 mV
		Total battery voltage 393 V	Approx. 4,000 - 4,200 mV
CELL VOLTAGE 58	READY	Total battery voltage 317 V	Approx. 3,200 - 3,400 mV
		Total battery voltage 393 V	Approx. 4,000 - 4,200 mV
CELL VOLTAGE 59	READY	Total battery voltage 317 V	Approx. 3,200 - 3,400 mV
		Total battery voltage 393 V	Approx. 4,000 - 4,200 mV

EV BATTERY SYSTEM

< ECU DIAGNOSIS INFORMATION >

[TYPE 1]

Monitor item	Condition		Values / Status
CELL VOLTAGE 60	READY	Total battery voltage 317 V	Approx. 3,200 - 3,400 mV
		Total battery voltage 393 V	Approx. 4,000 - 4,200 mV
CELL VOLTAGE 61	READY	Total battery voltage 317 V	Approx. 3,200 - 3,400 mV
		Total battery voltage 393 V	Approx. 4,000 - 4,200 mV
CELL VOLTAGE 62	READY	Total battery voltage 317 V	Approx. 3,200 - 3,400 mV
		Total battery voltage 393 V	Approx. 4,000 - 4,200 mV
CELL VOLTAGE 63	READY	Total battery voltage 317 V	Approx. 3,200 - 3,400 mV
		Total battery voltage 393 V	Approx. 4,000 - 4,200 mV
CELL VOLTAGE 64	READY	Total battery voltage 317 V	Approx. 3,200 - 3,400 mV
		Total battery voltage 393 V	Approx. 4,000 - 4,200 mV
CELL VOLTAGE 65	READY	Total battery voltage 317 V	Approx. 3,200 - 3,400 mV
		Total battery voltage 393 V	Approx. 4,000 - 4,200 mV
CELL VOLTAGE 66	READY	Total battery voltage 317 V	Approx. 3,200 - 3,400 mV
		Total battery voltage 393 V	Approx. 4,000 - 4,200 mV
CELL VOLTAGE 67	READY	Total battery voltage 317 V	Approx. 3,200 - 3,400 mV
		Total battery voltage 393 V	Approx. 4,000 - 4,200 mV
CELL VOLTAGE 68	READY	Total battery voltage 317 V	Approx. 3,200 - 3,400 mV
		Total battery voltage 393 V	Approx. 4,000 - 4,200 mV
CELL VOLTAGE 69	READY	Total battery voltage 317 V	Approx. 3,200 - 3,400 mV
		Total battery voltage 393 V	Approx. 4,000 - 4,200 mV
CELL VOLTAGE 70	READY	Total battery voltage 317 V	Approx. 3,200 - 3,400 mV
		Total battery voltage 393 V	Approx. 4,000 - 4,200 mV
CELL VOLTAGE 71	READY	Total battery voltage 317 V	Approx. 3,200 - 3,400 mV
		Total battery voltage 393 V	Approx. 4,000 - 4,200 mV
CELL VOLTAGE 72	READY	Total battery voltage 317 V	Approx. 3,200 - 3,400 mV
		Total battery voltage 393 V	Approx. 4,000 - 4,200 mV
CELL VOLTAGE 73	READY	Total battery voltage 317 V	Approx. 3,200 - 3,400 mV
		Total battery voltage 393 V	Approx. 4,000 - 4,200 mV
CELL VOLTAGE 74	READY	Total battery voltage 317 V	Approx. 3,200 - 3,400 mV
		Total battery voltage 393 V	Approx. 4,000 - 4,200 mV
CELL VOLTAGE 75	READY	Total battery voltage 317 V	Approx. 3,200 - 3,400 mV
		Total battery voltage 393 V	Approx. 4,000 - 4,200 mV
CELL VOLTAGE 76	READY	Total battery voltage 317 V	Approx. 3,200 - 3,400 mV
		Total battery voltage 393 V	Approx. 4,000 - 4,200 mV
CELL VOLTAGE 77	READY	Total battery voltage 317 V	Approx. 3,200 - 3,400 mV
		Total battery voltage 393 V	Approx. 4,000 - 4,200 mV
CELL VOLTAGE 78	READY	Total battery voltage 317 V	Approx. 3,200 - 3,400 mV
		Total battery voltage 393 V	Approx. 4,000 - 4,200 mV
CELL VOLTAGE 79	READY	Total battery voltage 317 V	Approx. 3,200 - 3,400 mV
		Total battery voltage 393 V	Approx. 4,000 - 4,200 mV
CELL VOLTAGE 80	READY	Total battery voltage 317 V	Approx. 3,200 - 3,400 mV
		Total battery voltage 393 V	Approx. 4,000 - 4,200 mV
CELL VOLTAGE 81	READY	Total battery voltage 317 V	Approx. 3,200 - 3,400 mV
		Total battery voltage 393 V	Approx. 4,000 - 4,200 mV

A

B

EVB

D

E

F

G

H

I

J

K

L

M

N

O

P

EV BATTERY SYSTEM

< ECU DIAGNOSIS INFORMATION >

[TYPE 1]

Monitor item	Condition		Values / Status
CELL VOLTAGE 82	READY	Total battery voltage 317 V	Approx. 3,200 - 3,400 mV
		Total battery voltage 393 V	Approx. 4,000 - 4,200 mV
CELL VOLTAGE 83	READY	Total battery voltage 317 V	Approx. 3,200 - 3,400 mV
		Total battery voltage 393 V	Approx. 4,000 - 4,200 mV
CELL VOLTAGE 84	READY	Total battery voltage 317 V	Approx. 3,200 - 3,400 mV
		Total battery voltage 393 V	Approx. 4,000 - 4,200 mV
CELL VOLTAGE 85	READY	Total battery voltage 317 V	Approx. 3,200 - 3,400 mV
		Total battery voltage 393 V	Approx. 4,000 - 4,200 mV
CELL VOLTAGE 86	READY	Total battery voltage 317 V	Approx. 3,200 - 3,400 mV
		Total battery voltage 393 V	Approx. 4,000 - 4,200 mV
CELL VOLTAGE 87	READY	Total battery voltage 317 V	Approx. 3,200 - 3,400 mV
		Total battery voltage 393 V	Approx. 4,000 - 4,200 mV
CELL VOLTAGE 88	READY	Total battery voltage 317 V	Approx. 3,200 - 3,400 mV
		Total battery voltage 393 V	Approx. 4,000 - 4,200 mV
CELL VOLTAGE 89	READY	Total battery voltage 317 V	Approx. 3,200 - 3,400 mV
		Total battery voltage 393 V	Approx. 4,000 - 4,200 mV
CELL VOLTAGE 90	READY	Total battery voltage 317 V	Approx. 3,200 - 3,400 mV
		Total battery voltage 393 V	Approx. 4,000 - 4,200 mV
CELL VOLTAGE 91	READY	Total battery voltage 317 V	Approx. 3,200 - 3,400 mV
		Total battery voltage 393 V	Approx. 4,000 - 4,200 mV
CELL VOLTAGE 92	READY	Total battery voltage 317 V	Approx. 3,200 - 3,400 mV
		Total battery voltage 393 V	Approx. 4,000 - 4,200 mV
CELL VOLTAGE 93	READY	Total battery voltage 317 V	Approx. 3,200 - 3,400 mV
		Total battery voltage 393 V	Approx. 4,000 - 4,200 mV
CELL VOLTAGE 94	READY	Total battery voltage 317 V	Approx. 3,200 - 3,400 mV
		Total battery voltage 393 V	Approx. 4,000 - 4,200 mV
CELL VOLTAGE 95	READY	Total battery voltage 317 V	Approx. 3,200 - 3,400 mV
		Total battery voltage 393 V	Approx. 4,000 - 4,200 mV
CELL VOLTAGE 96	READY	Total battery voltage 317 V	Approx. 3,200 - 3,400 mV
		Total battery voltage 393 V	Approx. 4,000 - 4,200 mV
TOTAL BATTERY VOLTAGE	READY		Approx. 240 - 420 V
MAXIMUM CELL VOLTAGE	READY	Total battery voltage 317 V	Approx. 3,300 - 3,500 mV
		Total battery voltage 393 V	Approx. 4,000 - 4,200 mV
MINIMUM CELL VOLTAGE	READY	Total battery voltage 317 V	Approx. 3,300 - 3,500 mV
		Total battery voltage 393 V	Approx. 4,000 - 4,200 mV
BATTERY TEMPERATURE 1	READY (Stop the vehicle)	Ambient temperature: 25°C (77°F)	20°C - 30°C (68°F - 86°F) [Equivalent to air temperature around rear module stack]
BATTERY TEMPERATURE 2	READY (Stop the vehicle)	Ambient temperature: 25°C (77°F)	20°C - 30°C (68°F - 86°F) [Equivalent to air temperature around front RH module stack]
BATTERY TEMPERATURE 3	READY (Stop the vehicle)	Ambient temperature: 25°C (77°F)	20°C - 30°C (68°F - 86°F) [Equivalent to air temperature around rear module stack]
BATTERY TEMPERATURE 4	READY (Stop the vehicle)	Ambient temperature: 25°C (77°F)	20°C - 30°C (68°F - 86°F) [Equivalent to air temperature around front LH module stack]

EV BATTERY SYSTEM

< ECU DIAGNOSIS INFORMATION >

[TYPE 1]

Fail-safe

INFOID:000000007005730

When Li-ion Battery Controller (LBC) detects a malfunction of the Li-ion battery, it enters the control mode that protects the battery by stopping or restricting the output/charging from/to the battery. The fail-safe mode differs depending on the contents of the detected malfunction.

FAIL-SAFE PATTERN

- Pattern A: No driving and Charge stop
- Pattern B: Driving output power limit, and Charge stop
- Pattern C: Driving output power limit, and Charge limit
- Pattern D: EV system warning lamp illuminate

FAIL-SAFE LIST

DTC	CONSULT screen items	Pattern			
		A	B	C	D
P0A0D	HV SYSTEM INTERLOCK ERROR				×
P0A1F	BATTERY ENERGY CONTROL MODULE	×	×		×
P3030	CELL CONT LIN		×		
P3031	CELL CONT ASIC1		×		
P3032	CELL CONT ASIC2		×		
P3033	CELL CONT ASIC3		×		
P3034	CELL CONT ASIC4		×		
P3035	CELL CONT ASIC5		×		
P3036	CELL CONT ASIC6		×		
P3037	CELL CONT ASIC7		×		
P3038	CELL CONT ASIC8		×		
P3039	CELL CONT ASIC9		×		
P303A	CELL CONT ASIC10		×		
P303B	CELL CONT ASIC11		×		
P303C	CELL CONT ASIC12		×		
P303D	CELL CONT ASIC13		×		
P303E	CELL CONT ASIC14		×		
P303F	CELL CONT ASIC15		×		
P3040	CELL CONT ASIC16		×		
P3041	CELL CONT ASIC17		×		
P3042	CELL CONT ASIC18		×		
P3043	CELL CONT ASIC19		×		
P3044	CELL CONT ASIC20		×		
P3045	CELL CONT ASIC21		×		
P3046	CELL CONT ASIC22		×		
P3047	CELL CONT ASIC23		×		
P3048	CELL CONT ASIC24		×		
P3049	CELL CONT ASIC1 VOLT		×		
P304A	CELL CONT ASIC2 VOLT		×		
P304B	CELL CONT ASIC3 VOLT		×		
P304C	CELL CONT ASIC4 VOLT		×		
P304D	CELL CONT ASIC5 VOLT		×		
P304E	CELL CONT ASIC6 VOLT		×		

EV BATTERY SYSTEM

< ECU DIAGNOSIS INFORMATION >

[TYPE 1]

DTC	CONSULT screen items	Pattern			
		A	B	C	D
P304F	CELL CONT ASIC7 VOLT		×		
P3050	CELL CONT ASIC8 VOLT		×		
P3051	CELL CONT ASIC9 VOLT		×		
P3052	CELL CONT ASIC10 VOLT		×		
P3053	CELL CONT ASIC11 VOLT		×		
P3054	CELL CONT ASIC12 VOLT		×		
P3055	CELL CONT ASIC13 VOLT		×		
P3056	CELL CONT ASIC14 VOLT		×		
P3057	CELL CONT ASIC15 VOLT		×		
P3058	CELL CONT ASIC16 VOLT		×		
P3059	CELL CONT ASIC17 VOLT		×		
P305A	CELL CONT ASIC18 VOLT		×		
P305B	CELL CONT ASIC19 VOLT		×		
P305C	CELL CONT ASIC20 VOLT		×		
P305D	CELL CONT ASIC21 VOLT		×		
P305E	CELL CONT ASIC22 VOLT		×		
P305F	CELL CONT ASIC23 VOLT		×		
P3060	CELL CONT ASIC24 VOLT		×		
P3061	CELL BATTERY VOLT				×
P3062	BYPASS SW				×
P308B	CELL CONT ASIC1 OPEN		×		
P308C	CELL CONT ASIC2 OPEN		×		
P308D	CELL CONT ASIC3 OPEN		×		
P308E	CELL CONT ASIC4 OPEN		×		
P308F	CELL CONT ASIC5 OPEN		×		
P3090	CELL CONT ASIC6 OPEN		×		
P3091	CELL CONT ASIC7 OPEN		×		
P3092	CELL CONT ASIC8 OPEN		×		
P3093	CELL CONT ASIC9 OPEN		×		
P3094	CELL CONT ASIC10 OPEN		×		
P3095	CELL CONT ASIC11 OPEN		×		
P3096	CELL CONT ASIC12 OPEN		×		
P3097	CELL CONT ASIC13 OPEN		×		
P3098	CELL CONT ASIC14 OPEN		×		
P3099	CELL CONT ASIC15 OPEN		×		
P309A	CELL CONT ASIC16 OPEN		×		
P309B	CELL CONT ASIC17 OPEN		×		
P309C	CELL CONT ASIC18 OPEN		×		
P309D	CELL CONT ASIC19 OPEN		×		
P309E	CELL CONT ASIC20 OPEN		×		
P309F	CELL CONT ASIC21 OPEN		×		
P30A0	CELL CONT ASIC22 OPEN		×		
P30A1	CELL CONT ASIC23 OPEN		×		

EV BATTERY SYSTEM

< ECU DIAGNOSIS INFORMATION >

[TYPE 1]

DTC	CONSULT screen items	Pattern				
		A	B	C	D	
P30A2	CELL CONT ASIC24 OPEN		×			A
P30F3	TOTAL VOLT SENSOR			×		B
P30F4	TOTAL VOLT SENSOR			×		
P30F5	TOTAL VOLT SENSOR			×		
P30FC	OVER CURRENT	×				EVB
P30FD	TOTAL VOLTAGE MONITOR SWITCH	No fail-safe				
P30FE	12V BATTERY VOLTAGE				×	D
P318D	COMMUNICATION ERROR				×	
P318E	COMMUNICATION ERROR				×	
P3191	COMMUNICATION ERROR	No fail-safe				E
P3196	COMMUNICATION ERROR	No fail-safe				
P3199	COMMUNICATION ERROR				×	F
P319C	COMMUNICATION ERROR	No fail-safe				
P31A4	CAN ERROR VCM				×	
P31A7	CAN ERROR INV/MC	No fail-safe				G
P3300	TOTAL VOLTAGE OVER	×				
P3302	CELL OVER VOLTAGE MODULE1	×				H
P3303	CELL OVER VOLTAGE MODULE2	×				
P3304	CELL OVER VOLTAGE MODULE3	×				
P3305	CELL OVER VOLTAGE MODULE4	×				I
P3306	CELL OVER VOLTAGE MODULE5	×				
P3307	CELL OVER VOLTAGE MODULE6	×				J
P3308	CELL OVER VOLTAGE MODULE7	×				
P3309	CELL OVER VOLTAGE MODULE8	×				
P330A	CELL OVER VOLTAGE MODULE9	×				K
P330B	CELL OVER VOLTAGE MODULE10	×				
P330C	CELL OVER VOLTAGE MODULE11	×				
P330D	CELL OVER VOLTAGE MODULE12	×				L
P330E	CELL OVER VOLTAGE MODULE13	×				
P330F	CELL OVER VOLTAGE MODULE14	×				M
P3310	CELL OVER VOLTAGE MODULE15	×				
P3311	CELL OVER VOLTAGE MODULE16	×				
P3312	CELL OVER VOLTAGE MODULE17	×				N
P3313	CELL OVER VOLTAGE MODULE18	×				
P3314	CELL OVER VOLTAGE MODULE19	×				O
P3315	CELL OVER VOLTAGE MODULE20	×				
P3316	CELL OVER VOLTAGE MODULE21	×				
P3317	CELL OVER VOLTAGE MODULE22	×				P
P3318	CELL OVER VOLTAGE MODULE23	×				
P3319	CELL OVER VOLTAGE MODULE24	×				
P331A	CELL OVER VOLTAGE MODULE25	×				
P331B	CELL OVER VOLTAGE MODULE26	×				
P331C	CELL OVER VOLTAGE MODULE27	×				

EV BATTERY SYSTEM

< ECU DIAGNOSIS INFORMATION >

[TYPE 1]

DTC	CONSULT screen items	Pattern			
		A	B	C	D
P331D	CELL OVER VOLTAGE MODULE28	×			
P331E	CELL OVER VOLTAGE MODULE29	×			
P331F	CELL OVER VOLTAGE MODULE30	×			
P3320	CELL OVER VOLTAGE MODULE31	×			
P3321	CELL OVER VOLTAGE MODULE32	×			
P3322	CELL OVER VOLTAGE MODULE33	×			
P3323	CELL OVER VOLTAGE MODULE34	×			
P3324	CELL OVER VOLTAGE MODULE35	×			
P3325	CELL OVER VOLTAGE MODULE36	×			
P3326	CELL OVER VOLTAGE MODULE37	×			
P3327	CELL OVER VOLTAGE MODULE38	×			
P3328	CELL OVER VOLTAGE MODULE39	×			
P3329	CELL OVER VOLTAGE MODULE40	×			
P332A	CELL OVER VOLTAGE MODULE41	×			
P332B	CELL OVER VOLTAGE MODULE42	×			
P332C	CELL OVER VOLTAGE MODULE43	×			
P332D	CELL OVER VOLTAGE MODULE44	×			
P332E	CELL OVER VOLTAGE MODULE45	×			
P332F	CELL OVER VOLTAGE MODULE46	×			
P3330	CELL OVER VOLTAGE MODULE47	×			
P3331	CELL OVER VOLTAGE MODULE48	×			
P3373	TOTAL VOLTAGE OVER DISCHARGE	×			
P3375	CELL OVER DISCHARGE MODULE1	×			
P3376	CELL OVER DISCHARGE MODULE2	×			
P3377	CELL OVER DISCHARGE MODULE3	×			
P3378	CELL OVER DISCHARGE MODULE4	×			
P3379	CELL OVER DISCHARGE MODULE5	×			
P337A	CELL OVER DISCHARGE MODULE6	×			
P337B	CELL OVER DISCHARGE MODULE7	×			
P337C	CELL OVER DISCHARGE MODULE8	×			
P337D	CELL OVER DISCHARGE MODULE9	×			
P337E	CELL OVER DISCHARGE MODULE10	×			
P337F	CELL OVER DISCHARGE MODULE11	×			
P3380	CELL OVER DISCHARGE MODULE12	×			
P3381	CELL OVER DISCHARGE MODULE13	×			
P3382	CELL OVER DISCHARGE MODULE14	×			
P3383	CELL OVER DISCHARGE MODULE15	×			
P3384	CELL OVER DISCHARGE MODULE16	×			
P3385	CELL OVER DISCHARGE MODULE17	×			
P3386	CELL OVER DISCHARGE MODULE18	×			
P3387	CELL OVER DISCHARGE MODULE19	×			
P3388	CELL OVER DISCHARGE MODULE20	×			
P3389	CELL OVER DISCHARGE MODULE21	×			

EV BATTERY SYSTEM

< ECU DIAGNOSIS INFORMATION >

[TYPE 1]

DTC	CONSULT screen items	Pattern				
		A	B	C	D	
P338A	CELL OVER DISCHARGE MODULE22	×				A
P338B	CELL OVER DISCHARGE MODULE23	×				B
P338C	CELL OVER DISCHARGE MODULE24	×				
P338D	CELL OVER DISCHARGE MODULE25	×				
P338E	CELL OVER DISCHARGE MODULE26	×				EVB
P338F	CELL OVER DISCHARGE MODULE27	×				
P3390	CELL OVER DISCHARGE MODULE28	×				
P3391	CELL OVER DISCHARGE MODULE29	×				D
P3392	CELL OVER DISCHARGE MODULE30	×				
P3393	CELL OVER DISCHARGE MODULE31	×				E
P3394	CELL OVER DISCHARGE MODULE32	×				
P3395	CELL OVER DISCHARGE MODULE33	×				
P3396	CELL OVER DISCHARGE MODULE34	×				F
P3397	CELL OVER DISCHARGE MODULE35	×				
P3398	CELL OVER DISCHARGE MODULE36	×				G
P3399	CELL OVER DISCHARGE MODULE37	×				
P339A	CELL OVER DISCHARGE MODULE38	×				
P339B	CELL OVER DISCHARGE MODULE39	×				H
P339C	CELL OVER DISCHARGE MODULE40	×				
P339D	CELL OVER DISCHARGE MODULE41	×				I
P339E	CELL OVER DISCHARGE MODULE42	×				
P339F	CELL OVER DISCHARGE MODULE43	×				J
P33A0	CELL OVER DISCHARGE MODULE44	×				
P33A1	CELL OVER DISCHARGE MODULE45	×				
P33A2	CELL OVER DISCHARGE MODULE46	×				K
P33A3	CELL OVER DISCHARGE MODULE47	×				
P33A4	CELL OVER DISCHARGE MODULE48	×				
P33D4	BATT GADUAL CAPA LOSS DIAG				×	L
P33D5	CURRENT SENSOR		×			
P33D6	CURRENT SENSOR		×			M
P33D7	TEMPERATURE SENSOR			No fail-safe		
P33D9	TEMPERATURE SENSOR			No fail-safe		
P33DB	TEMPERATURE SENSOR			No fail-safe		N
P33DD	TEMPERATURE SENSOR			No fail-safe		
P33DF	BATT VOLTAGE ISOLATION SEN				×	
P33E0	BATT VOLTAGE ISOLATION SEN				×	O
P33E1	BATT VOLTAGE ISOLATION SEN				×	
P33E2	BATT PACK OVER TEMP	×				P
P33E4	TEMPERATURE SENSOR			No fail-safe		
P33E5	TEMPERATURE SENSOR			No fail-safe		
P33E6	CELL VOLTAGE DEVIATION DIAG			×		
P33E7	CELL CONTROLLER				×	

EV BATTERY SYSTEM

< ECU DIAGNOSIS INFORMATION >

[TYPE 1]

DTC	CONSULT screen items	Pattern			
		A	B	C	D
P33ED	BATTERY PARALLEL DIAGNOSIS			×	
U1000	CAN COMM CIRCUIT				×

DTC Index

INFOID:000000007005731

×: Applicable —: Not applicable

DTC	CONSULT screen items	EV system warning lamp	Trip	Reference
P0A0D	HV SYSTEM INTERLOCK ERROR	×	1	EVB-73
P0A1F	BATTERY ENERGY CONTROL MODULE	×	1	EVB-75
P3030	CELL CONT LIN	×	1	EVB-76
P3031	CELL CONT ASIC1	×	1	EVB-77
P3032	CELL CONT ASIC2	×	1	EVB-77
P3033	CELL CONT ASIC3	×	1	EVB-77
P3034	CELL CONT ASIC4	×	1	EVB-77
P3035	CELL CONT ASIC5	×	1	EVB-77
P3036	CELL CONT ASIC6	×	1	EVB-77
P3037	CELL CONT ASIC7	×	1	EVB-77
P3038	CELL CONT ASIC8	×	1	EVB-77
P3039	CELL CONT ASIC9	×	1	EVB-77
P303A	CELL CONT ASIC10	×	1	EVB-77
P303B	CELL CONT ASIC11	×	1	EVB-77
P303C	CELL CONT ASIC12	×	1	EVB-77
P303D	CELL CONT ASIC13	×	1	EVB-78
P303E	CELL CONT ASIC14	×	1	EVB-78
P303F	CELL CONT ASIC15	×	1	EVB-78
P3040	CELL CONT ASIC16	×	1	EVB-78
P3041	CELL CONT ASIC17	×	1	EVB-78
P3042	CELL CONT ASIC18	×	1	EVB-78
P3043	CELL CONT ASIC19	×	1	EVB-78
P3044	CELL CONT ASIC20	×	1	EVB-78
P3045	CELL CONT ASIC21	×	1	EVB-78
P3046	CELL CONT ASIC22	×	1	EVB-78
P3047	CELL CONT ASIC23	×	1	EVB-78
P3048	CELL CONT ASIC24	×	1	EVB-78
P3049	CELL CONT ASIC1 VOLT	×	1	EVB-79
P304A	CELL CONT ASIC2 VOLT	×	1	EVB-79
P304B	CELL CONT ASIC3 VOLT	×	1	EVB-79
P304C	CELL CONT ASIC4 VOLT	×	1	EVB-79
P304D	CELL CONT ASIC5 VOLT	×	1	EVB-79
P304E	CELL CONT ASIC6 VOLT	×	1	EVB-79
P304F	CELL CONT ASIC7 VOLT	×	1	EVB-79
P3050	CELL CONT ASIC8 VOLT	×	1	EVB-79
P3051	CELL CONT ASIC9 VOLT	×	1	EVB-79

EV BATTERY SYSTEM

< ECU DIAGNOSIS INFORMATION >

[TYPE 1]

DTC	CONSULT screen items	EV system warning lamp	Trip	Reference
P3052	CELL CONT ASIC10 VOLT	×	1	EVB-79
P3053	CELL CONT ASIC11 VOLT	×	1	EVB-79
P3054	CELL CONT ASIC12 VOLT	×	1	EVB-79
P3055	CELL CONT ASIC13 VOLT	×	1	EVB-81
P3056	CELL CONT ASIC14 VOLT	×	1	EVB-81
P3057	CELL CONT ASIC15 VOLT	×	1	EVB-81
P3058	CELL CONT ASIC16 VOLT	×	1	EVB-81
P3059	CELL CONT ASIC17 VOLT	×	1	EVB-81
P305A	CELL CONT ASIC18 VOLT	×	1	EVB-81
P305B	CELL CONT ASIC19 VOLT	×	1	EVB-81
P305C	CELL CONT ASIC20 VOLT	×	1	EVB-81
P305D	CELL CONT ASIC21 VOLT	×	1	EVB-81
P305E	CELL CONT ASIC22 VOLT	×	1	EVB-81
P305F	CELL CONT ASIC23 VOLT	×	1	EVB-81
P3060	CELL CONT ASIC24 VOLT	×	1	EVB-81
P3061	CELL BATTERY VOLT	×	1	EVB-83
P3062	BYPASS SW	×	1	EVB-84
P308B	CELL CONT ASIC1 OPEN	×	1	EVB-85
P308C	CELL CONT ASIC2 OPEN	×	1	EVB-85
P308D	CELL CONT ASIC3 OPEN	×	1	EVB-85
P308E	CELL CONT ASIC4 OPEN	×	1	EVB-85
P308F	CELL CONT ASIC5 OPEN	×	1	EVB-85
P3090	CELL CONT ASIC6 OPEN	×	1	EVB-85
P3091	CELL CONT ASIC7 OPEN	×	1	EVB-85
P3092	CELL CONT ASIC8 OPEN	×	1	EVB-85
P3093	CELL CONT ASIC9 OPEN	×	1	EVB-85
P3094	CELL CONT ASIC10 OPEN	×	1	EVB-85
P3095	CELL CONT ASIC11 OPEN	×	1	EVB-85
P3096	CELL CONT ASIC12 OPEN	×	1	EVB-85
P3097	CELL CONT ASIC13 OPEN	×	1	EVB-88
P3098	CELL CONT ASIC14 OPEN	×	1	EVB-88
P3099	CELL CONT ASIC15 OPEN	×	1	EVB-88
P309A	CELL CONT ASIC16 OPEN	×	1	EVB-88
P309B	CELL CONT ASIC17 OPEN	×	1	EVB-88
P309C	CELL CONT ASIC18 OPEN	×	1	EVB-88
P309D	CELL CONT ASIC19 OPEN	×	1	EVB-88
P309E	CELL CONT ASIC20 OPEN	×	1	EVB-88
P309F	CELL CONT ASIC21 OPEN	×	1	EVB-88
P30A0	CELL CONT ASIC22 OPEN	×	1	EVB-88
P30A1	CELL CONT ASIC23 OPEN	×	1	EVB-88
P30A2	CELL CONT ASIC24 OPEN	×	1	EVB-88
P30F3	TOTAL VOLT SENSOR	×	1	EVB-91
P30F4	TOTAL VOLT SENSOR	×	1	EVB-92

A
B
EVB
D
E
F
G
H
I
J
K
L
M
N
O
P

EV BATTERY SYSTEM

< ECU DIAGNOSIS INFORMATION >

[TYPE 1]

DTC	CONSULT screen items	EV system warning lamp	Trip	Reference
P30F5	TOTAL VOLT SENSOR	×	1	EVB-94
P30FC	OVER CURRENT	×	1	EVB-95
P30FD	TOTAL VOLTAGE MONITOR SWITCH	—	1	EVB-96
P30FE	12V BATTERY VOLTAGE	×	1	EVB-97
P318D	COMMUNICATION ERROR	×	1	EVB-99
P318E	COMMUNICATION ERROR	×	1	EVB-100
P3191	COMMUNICATION ERROR	—	1	EVB-101
P3196	COMMUNICATION ERROR	—	1	EVB-102
P3199	COMMUNICATION ERROR	×	1	EVB-103
P319C	COMMUNICATION ERROR	—	1	EVB-104
P31A4	CAN ERROR VCM	×	1	EVB-105
P31A7	CAN ERROR INV/MC	—	1	EVB-106
P3300	TOTAL VOLTAGE OVER	×	1	EVB-107
P3302	CELL OVER VOLTAGE MODULE1	×	1	EVB-108
P3303	CELL OVER VOLTAGE MODULE2	×	1	EVB-108
P3304	CELL OVER VOLTAGE MODULE3	×	1	EVB-108
P3305	CELL OVER VOLTAGE MODULE4	×	1	EVB-108
P3306	CELL OVER VOLTAGE MODULE5	×	1	EVB-108
P3307	CELL OVER VOLTAGE MODULE6	×	1	EVB-108
P3308	CELL OVER VOLTAGE MODULE7	×	1	EVB-108
P3309	CELL OVER VOLTAGE MODULE8	×	1	EVB-108
P330A	CELL OVER VOLTAGE MODULE9	×	1	EVB-108
P330B	CELL OVER VOLTAGE MODULE10	×	1	EVB-108
P330C	CELL OVER VOLTAGE MODULE11	×	1	EVB-108
P330D	CELL OVER VOLTAGE MODULE12	×	1	EVB-108
P330E	CELL OVER VOLTAGE MODULE13	×	1	EVB-111
P330F	CELL OVER VOLTAGE MODULE14	×	1	EVB-111
P3310	CELL OVER VOLTAGE MODULE15	×	1	EVB-111
P3311	CELL OVER VOLTAGE MODULE16	×	1	EVB-111
P3312	CELL OVER VOLTAGE MODULE17	×	1	EVB-111
P3313	CELL OVER VOLTAGE MODULE18	×	1	EVB-111
P3314	CELL OVER VOLTAGE MODULE19	×	1	EVB-111
P3315	CELL OVER VOLTAGE MODULE20	×	1	EVB-111
P3316	CELL OVER VOLTAGE MODULE21	×	1	EVB-111
P3317	CELL OVER VOLTAGE MODULE22	×	1	EVB-111
P3318	CELL OVER VOLTAGE MODULE23	×	1	EVB-111
P3319	CELL OVER VOLTAGE MODULE24	×	1	EVB-111
P331A	CELL OVER VOLTAGE MODULE25	×	1	EVB-114
P331B	CELL OVER VOLTAGE MODULE26	×	1	EVB-114
P331C	CELL OVER VOLTAGE MODULE27	×	1	EVB-114
P331D	CELL OVER VOLTAGE MODULE28	×	1	EVB-114
P331E	CELL OVER VOLTAGE MODULE29	×	1	EVB-114
P331F	CELL OVER VOLTAGE MODULE30	×	1	EVB-114

EV BATTERY SYSTEM

< ECU DIAGNOSIS INFORMATION >

[TYPE 1]

DTC	CONSULT screen items	EV system warning lamp	Trip	Reference	
P3320	CELL OVER VOLTAGE MODULE31	×	1	EVB-114	A
P3321	CELL OVER VOLTAGE MODULE32	×	1	EVB-114	B
P3322	CELL OVER VOLTAGE MODULE33	×	1	EVB-114	
P3323	CELL OVER VOLTAGE MODULE34	×	1	EVB-114	
P3324	CELL OVER VOLTAGE MODULE35	×	1	EVB-114	EVB
P3325	CELL OVER VOLTAGE MODULE36	×	1	EVB-114	
P3326	CELL OVER VOLTAGE MODULE37	×	1	EVB-117	D
P3327	CELL OVER VOLTAGE MODULE38	×	1	EVB-117	
P3328	CELL OVER VOLTAGE MODULE39	×	1	EVB-117	
P3329	CELL OVER VOLTAGE MODULE40	×	1	EVB-117	E
P332A	CELL OVER VOLTAGE MODULE41	×	1	EVB-117	
P332B	CELL OVER VOLTAGE MODULE42	×	1	EVB-117	F
P332C	CELL OVER VOLTAGE MODULE43	×	1	EVB-117	
P332D	CELL OVER VOLTAGE MODULE44	×	1	EVB-117	
P332E	CELL OVER VOLTAGE MODULE45	×	1	EVB-117	G
P332F	CELL OVER VOLTAGE MODULE46	×	1	EVB-117	
P3330	CELL OVER VOLTAGE MODULE47	×	1	EVB-117	H
P3331	CELL OVER VOLTAGE MODULE48	×	1	EVB-117	
P3373	TOTAL VOLTAGE OVER DISCHARGE	×	1	EVB-120	
P3375	CELL OVER DISCHARGE MODULE1	×	1	EVB-121	I
P3376	CELL OVER DISCHARGE MODULE2	×	1	EVB-121	
P3377	CELL OVER DISCHARGE MODULE3	×	1	EVB-121	J
P3378	CELL OVER DISCHARGE MODULE4	×	1	EVB-121	
P3379	CELL OVER DISCHARGE MODULE5	×	1	EVB-121	
P337A	CELL OVER DISCHARGE MODULE6	×	1	EVB-121	K
P337B	CELL OVER DISCHARGE MODULE7	×	1	EVB-121	
P337C	CELL OVER DISCHARGE MODULE8	×	1	EVB-121	
P337D	CELL OVER DISCHARGE MODULE9	×	1	EVB-121	L
P337E	CELL OVER DISCHARGE MODULE10	×	1	EVB-121	
P337F	CELL OVER DISCHARGE MODULE11	×	1	EVB-121	M
P3380	CELL OVER DISCHARGE MODULE12	×	1	EVB-121	
P3381	CELL OVER DISCHARGE MODULE13	×	1	EVB-124	
P3382	CELL OVER DISCHARGE MODULE14	×	1	EVB-124	N
P3383	CELL OVER DISCHARGE MODULE15	×	1	EVB-124	
P3384	CELL OVER DISCHARGE MODULE16	×	1	EVB-124	O
P3385	CELL OVER DISCHARGE MODULE17	×	1	EVB-124	
P3386	CELL OVER DISCHARGE MODULE18	×	1	EVB-124	
P3387	CELL OVER DISCHARGE MODULE19	×	1	EVB-124	P
P3388	CELL OVER DISCHARGE MODULE20	×	1	EVB-124	
P3389	CELL OVER DISCHARGE MODULE21	×	1	EVB-124	
P338A	CELL OVER DISCHARGE MODULE22	×	1	EVB-124	
P338B	CELL OVER DISCHARGE MODULE23	×	1	EVB-124	
P338C	CELL OVER DISCHARGE MODULE24	×	1	EVB-124	

EV BATTERY SYSTEM

< ECU DIAGNOSIS INFORMATION >

[TYPE 1]

DTC	CONSULT screen items	EV system warning lamp	Trip	Reference
P338D	CELL OVER DISCHARGE MODULE25	×	1	EVB-127
P338E	CELL OVER DISCHARGE MODULE26	×	1	EVB-127
P338F	CELL OVER DISCHARGE MODULE27	×	1	EVB-127
P3390	CELL OVER DISCHARGE MODULE28	×	1	EVB-127
P3391	CELL OVER DISCHARGE MODULE29	×	1	EVB-127
P3392	CELL OVER DISCHARGE MODULE30	×	1	EVB-127
P3393	CELL OVER DISCHARGE MODULE31	×	1	EVB-127
P3394	CELL OVER DISCHARGE MODULE32	×	1	EVB-127
P3395	CELL OVER DISCHARGE MODULE33	×	1	EVB-127
P3396	CELL OVER DISCHARGE MODULE34	×	1	EVB-127
P3397	CELL OVER DISCHARGE MODULE35	×	1	EVB-127
P3398	CELL OVER DISCHARGE MODULE36	×	1	EVB-127
P3399	CELL OVER DISCHARGE MODULE37	×	1	EVB-130
P339A	CELL OVER DISCHARGE MODULE38	×	1	EVB-130
P339B	CELL OVER DISCHARGE MODULE39	×	1	EVB-130
P339C	CELL OVER DISCHARGE MODULE40	×	1	EVB-130
P339D	CELL OVER DISCHARGE MODULE41	×	1	EVB-130
P339E	CELL OVER DISCHARGE MODULE42	×	1	EVB-130
P339F	CELL OVER DISCHARGE MODULE43	×	1	EVB-130
P33A0	CELL OVER DISCHARGE MODULE44	×	1	EVB-130
P33A1	CELL OVER DISCHARGE MODULE45	×	1	EVB-130
P33A2	CELL OVER DISCHARGE MODULE46	×	1	EVB-130
P33A3	CELL OVER DISCHARGE MODULE47	×	1	EVB-130
P33A4	CELL OVER DISCHARGE MODULE48	×	1	EVB-130
P33D4	BATT GRADUAL CAPA LOSS DIAG	×	1	EVB-133
P33D5	CURRENT SENSOR	×	1	EVB-134
P33D6	CURRENT SENSOR	×	1	EVB-136
P33D7	TEMPERATURE SENSOR	—	1	EVB-138
P33D9	TEMPERATURE SENSOR	—	1	EVB-138
P33DB	TEMPERATURE SENSOR	—	1	EVB-138
P33DD	TEMPERATURE SENSOR	—	1	EVB-138
P33DF	BATT VOLTAGE ISOLATION SEN	×	1	EVB-140
P33E0	BATT VOLTAGE ISOLATION SEN	×	1	EVB-141
P33E1	BATT VOLTAGE ISOLATION SEN	×	1	EVB-142
P33E2	BATT PACK OVER TEMP	×	1	EVB-143
P33E4	TEMPERATURE SENSOR	—	1	EVB-144
P33E5	TEMPERATURE SENSOR	—	1	EVB-144
P33E6	CELL VOLTAGE DEVIATION DIAG	×	2	EVB-146
P33E7	CELL CONTROLLER	×	1	EVB-150
P33ED	BATTERY PARALLEL DIAGNOSIS	×	1	EVB-151
U1000	CAN COMM CIRCUIT	×	1	EVB-153

WIRING DIAGRAM

VCM

Wiring Diagram

INFOID:000000007563090

A

B

EVB

D

E

F

G

H

I

J

K

L

M

N

O

P

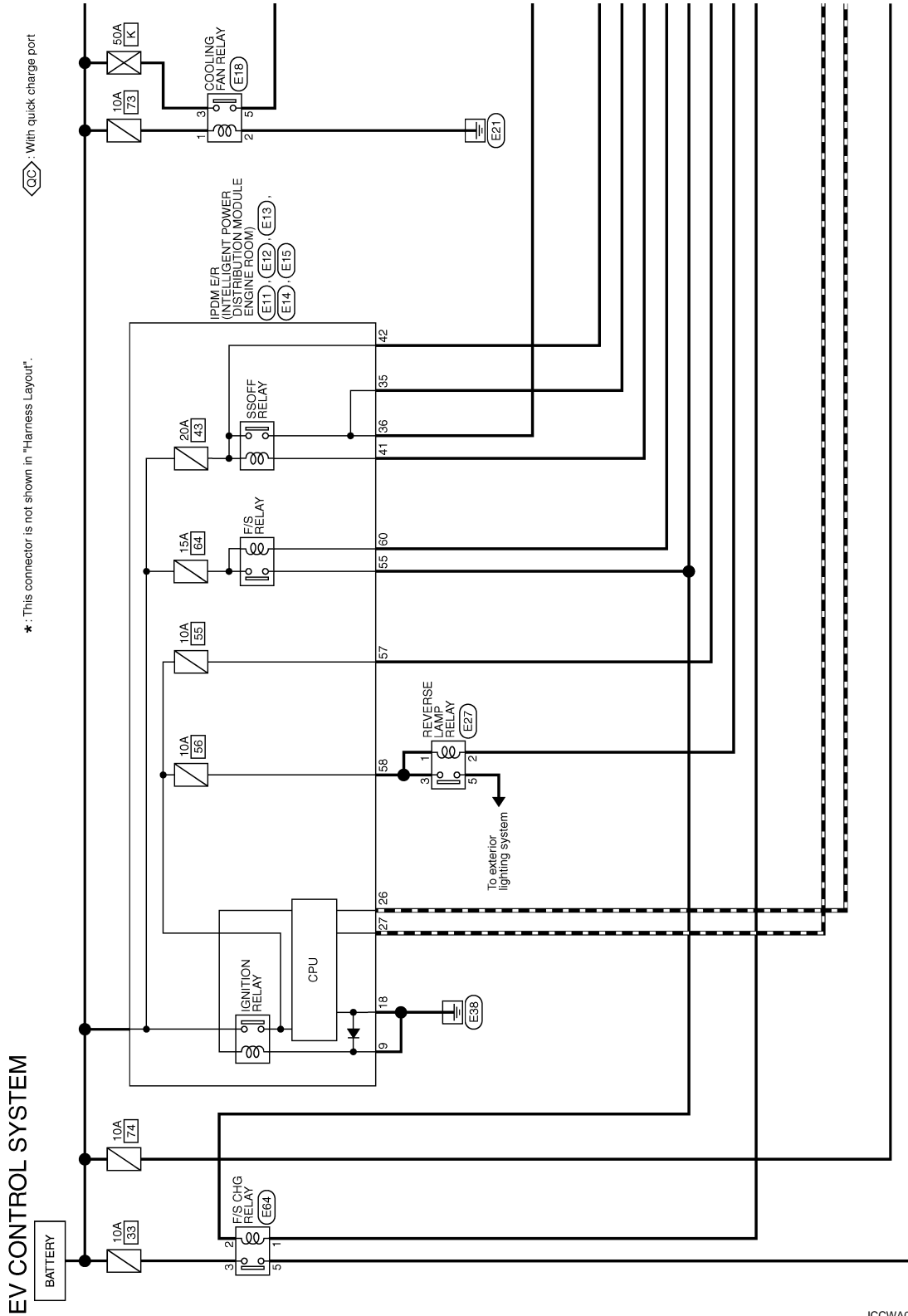

*: This connector is not shown in "Harness Layout".

□: With quick charge port

EV CONTROL SYSTEM

2010/10/29

JCCWA0029GB

VCM

< WIRING DIAGRAM >

[TYPE 1]

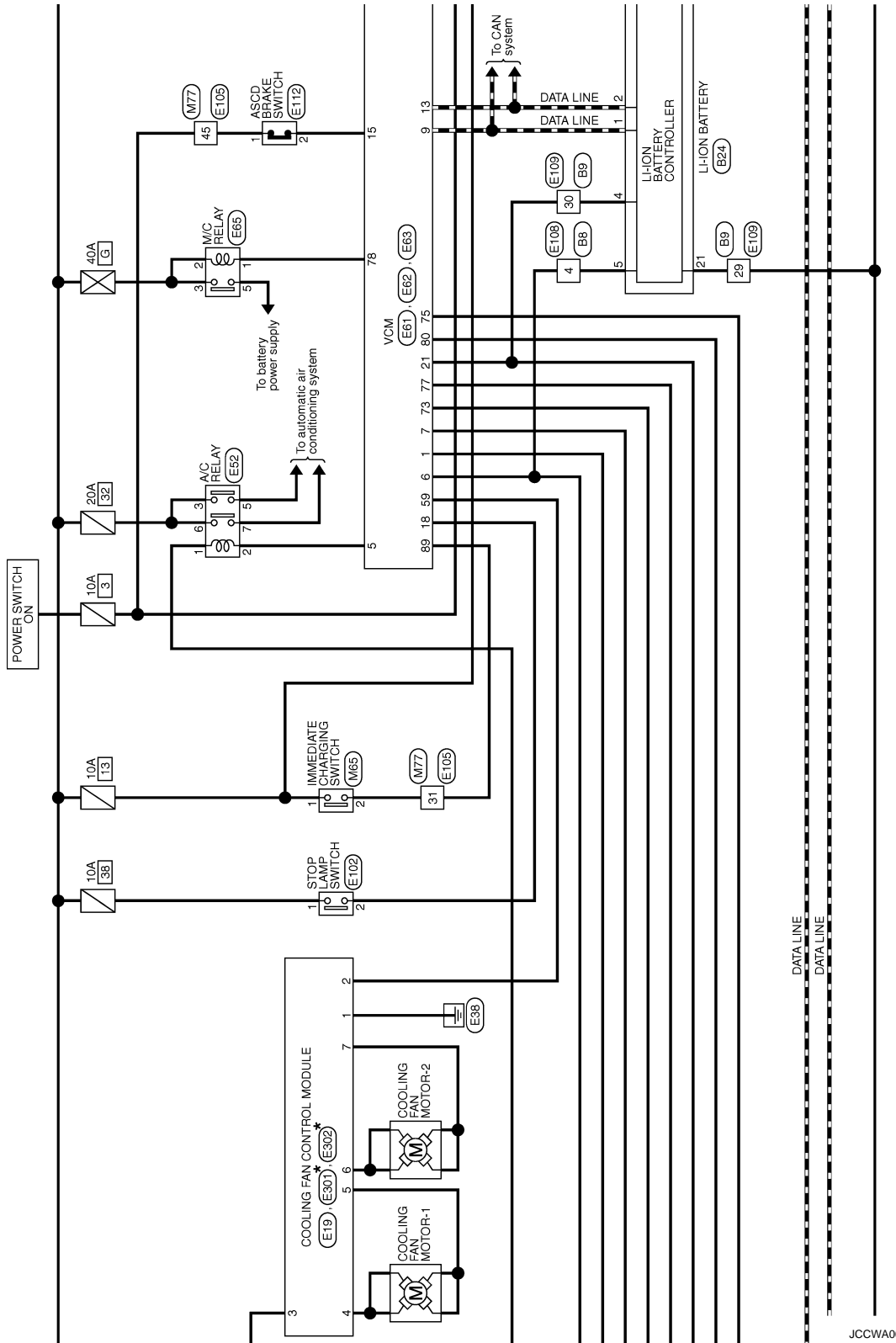

JCCWA0030GB

VCM

< WIRING DIAGRAM >

[TYPE 1]

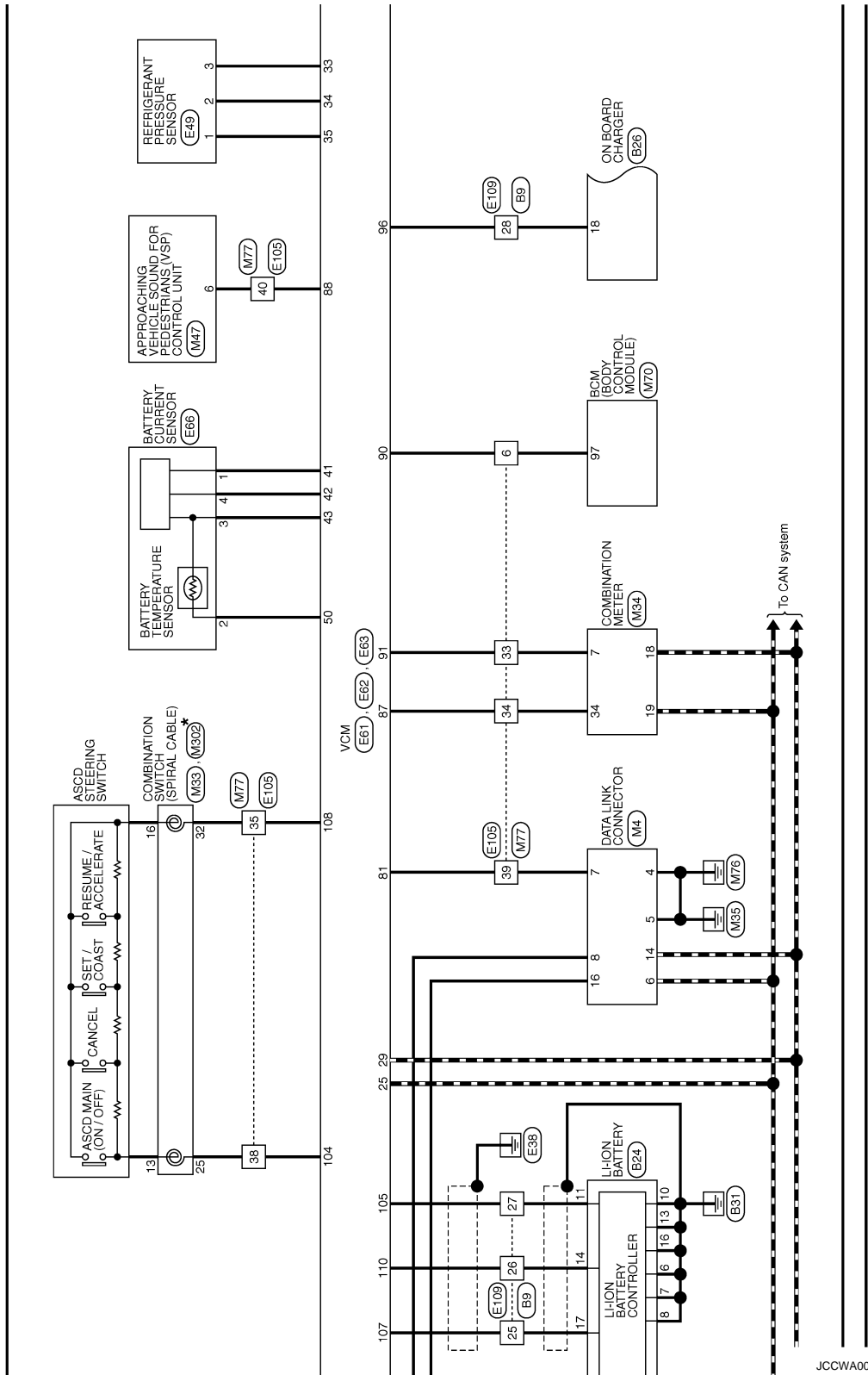

JCCWA0031GB

A
B
EVB
D
E
F
G
H
I
J
K
L
M
N
O
P

VCM

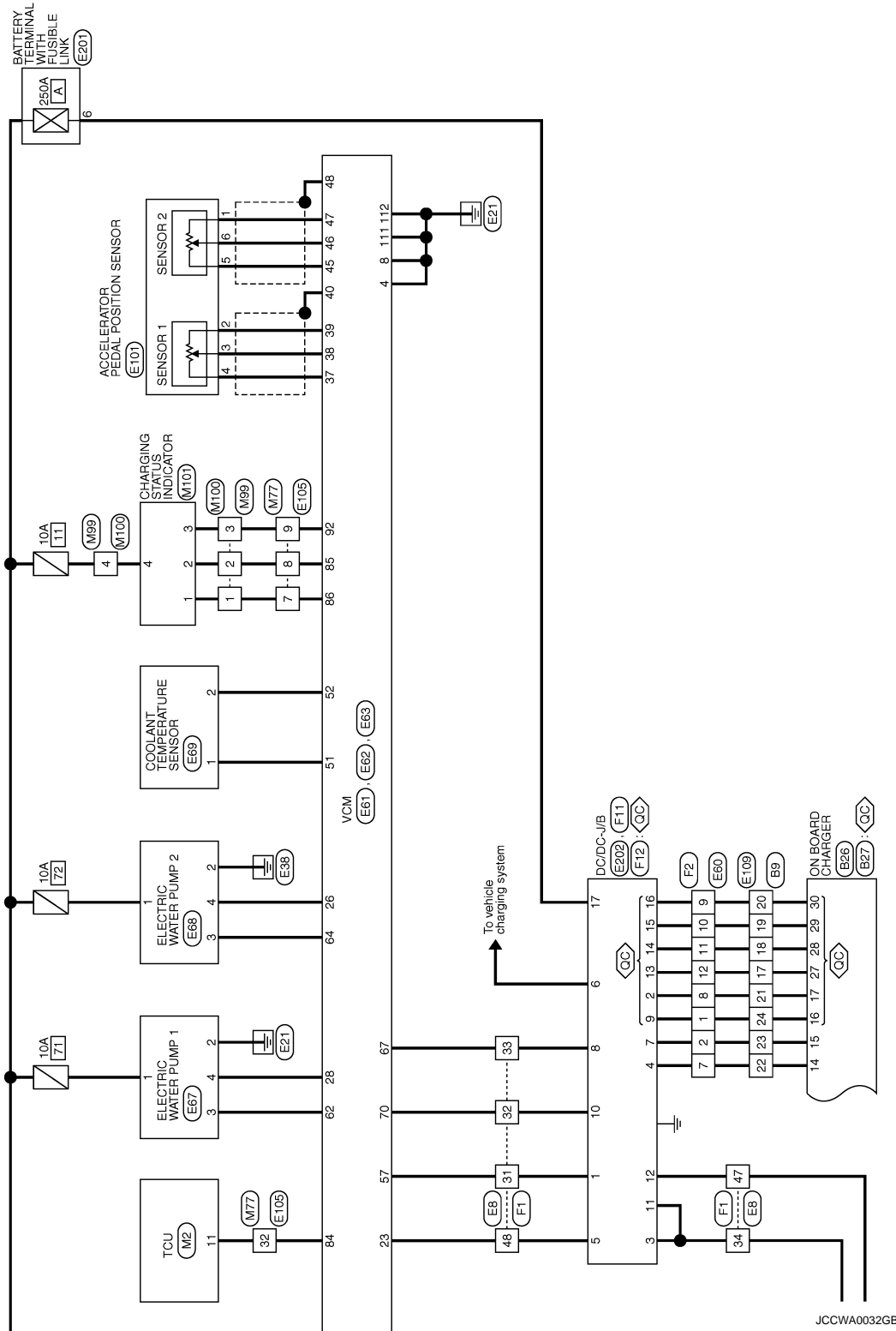

A
B
C
D
E
F
G
H
I
J
K
L
M
N
O
P

EVB

EV CONTROL SYSTEM

Connector No.	B8
Connector Name	WIRE TO WIRE
Connector Type	INSMFV-CS



Terminal No.	Color of Wire	Signal Name [Specification]
1	R	
2	L	
3	R	
4	R	

Connector No.	B9
Connector Name	WIRE TO WIRE
Connector Type	TH32FW-NH

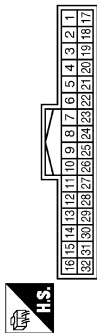

Terminal No.	Color of Wire	Signal Name [Specification]
1	W	
2	GR	
3	Y	
4	G	
5	BR	
6	L	
7	B	
8	P	
9	SB	
10	LG	
11	W	
17	R	
18	Y	
19	G	
20	V	
21	SB	
22	P	
23	LG	

24	L	
25	Y	
26	L	
27	G	
28	GR	
29	R	
30	R	
31	Y	

Connector No.	B24
Connector Name	LI-ION BATTERY
Connector Type	Yaaski 7283-8750-30

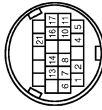

Terminal No.	Color of Wire	Signal Name [Specification]
1	L	EV CAN-H
2	G	EV CAN-L
4	R	IGN
5	R	BAT
6	B	GND3
7	B	GND2
8	B	GND1
10	B	PRE CHG GND
11	G	PRE CHG V
13	B	RLY2 GND
14	L	RLY2 V
16	B	RLY1 GND
17	Y	RLY1 V
21	R	CHG IGN

Connector No.	B26
Connector Name	ON BOARD CHARGER
Connector Type	RH12FB



Terminal No.	Color of Wire	Signal Name [Specification]
11	Y	BATTERY POWER SUPPLY
12	W	BATTERY POWER SUPPLY
13	V	POWER ON POWER SUPPLY
14	P	NORMAL CHARGE RELAY +
15	LG	NORMAL CHARGE RELAY -
16	L	QUICK CHARGE RELAY +
17	SB	QUICK CHARGE RELAY -
18	GR	EV ACTIVATION REQUEST SIGNAL
19	L	EV SYSTEM CAN-H
20	G	EV SYSTEM CAN-L
21	BR	PLUG IN SIGNAL
22	B	GROUND

Connector No.	B27
Connector Name	ON BOARD CHARGER
Connector Type	RH08FB



Terminal No.	Color of Wire	Signal Name [Specification]
25	W	QUICK CHARGE PORT TEMPERATURE SENSOR SIGNAL 1
26	GR	QUICK CHARGE PORT TEMPERATURE SENSOR SIGNAL 2
27	R	QUICK CHARGE VOLTAGE SENSOR SIGNAL-L
28	Y	SENSOR POWER SUPPLY/QUICK CHARGE VOLTAGE SENSOR
29	G	SENSOR GROUND/QUICK CHARGE VOLTAGE SENSOR
30	V	QUICK CHARGE VOLTAGE SENSOR SIGNAL-H

Connector No.	EB
Connector Name	WIRE TO WIRE
Connector Type	SAA38MB-RS10-S4ZZ

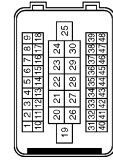

Terminal No.	Color of Wire	Signal Name [Specification]
--------------	---------------	-----------------------------

EV CONTROL SYSTEM

Connector No.	E11
Connector Name	ENGINE INTELLIGENT POWER DISTRIBUTION MODULE (ENGINE ROOM)
Connector Type	MS08FB-LC



Terminal No.	Color of Wire	Signal Name [Specification]
9	B	-
14	R	-

Connector No.	E12
Connector Name	ENGINE INTELLIGENT POWER DISTRIBUTION MODULE (ENGINE ROOM)
Connector Type	NS08FB-RCS

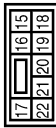

Terminal No.	Color of Wire	Signal Name [Specification]
18	B/W	-
19	W	-
20	V	-

Connector No.	E13
Connector Name	ENGINE INTELLIGENT POWER DISTRIBUTION MODULE (ENGINE ROOM)
Connector Type	TH12FW-NH



Terminal No.	Color of Wire	Signal Name [Specification]
25	R	-

Terminal No.	Color of Wire	Signal Name [Specification]
26	P	-
27	L	-
28	G	-
32	SB	-
34	W	-

Connector No.	E14
Connector Name	ENGINE INTELLIGENT POWER DISTRIBUTION MODULE (ENGINE ROOM)
Connector Type	NS12FBR-CS



Terminal No.	Color of Wire	Signal Name [Specification]
36	G	-
38	GR	-
39	V	-
41	W	-
42	R	-
43	O	-
44	LG	-
45	Y	-

Connector No.	E15
Connector Name	ENGINE INTELLIGENT POWER DISTRIBUTION MODULE (ENGINE ROOM)
Connector Type	NS16FW-CS



Terminal No.	Color of Wire	Signal Name [Specification]
49	Y	-
50	G	-
51	L	-
52	P	-
55	LG	-
57	R	-

Terminal No.	Color of Wire	Signal Name [Specification]
58	O	-
60	GR	-
61	Y	-
62	V	-

Connector No.	E18
Connector Name	COOLING FAN RELAY
Connector Type	Z3347_9F500



Terminal No.	Color of Wire	Signal Name [Specification]
1	G	-
2	B/Y	-
3	BR	-
5	R	-

Connector No.	E19
Connector Name	COOLING FAN CONTROL MODULE
Connector Type	SJZ01FGY-SNZZ



Terminal No.	Color of Wire	Signal Name [Specification]
1	B	GND
2	V	PWM SIG
3	R	PWM POWER

Connector No.	E27
Connector Name	REVERSE LAMP RELAY
Connector Type	MS20FL-M2-LC



Terminal No.	Color of Wire	Signal Name [Specification]
1	O	-
2	SB	-
3	O	-
5	G	-

Connector No.	E49
Connector Name	REFRIGERANT PRESSURE SENSOR
Connector Type	RK03FB



Terminal No.	Color of Wire	Signal Name [Specification]
1	BR	-
2	B	-
3	L	-

EV CONTROL SYSTEM

Connector No.	E52
Connector Name	A/C RELAY
Connector Type	M08FBR-R-LC



Terminal No.	Color of Wire	Signal Name [Specification]
1	GR	—
2	SB	—
3	R	—
4	V	—
5	R	—
6	R	—
7	W	—

Connector No.	E60
Connector Name	WIRE TO WIRE
Connector Type	RH12MB



Terminal No.	Color of Wire	Signal Name [Specification]
1	Y	—
2	G	—
3	L	—
4	G	—
5	L	—
6	G	—
7	L	—
8	SB	—
9	V	—
10	O	—
11	BR	—
12	LG	—

Connector No.	E61
Connector Name	VCM
Connector Type	RH24FGY-R26-R-RH



Terminal No.	Color of Wire	Signal Name [Specification]
1	G	POWER ON POWER SUPPLY
4	B/R	GROUND
5	SB	A/C RELAY
6	R	BATTERY POWER SUPPLY
7	W	SSDPF RELAY
8	B/R	GROUND
9	L	EV SYSTEM CAN-H
13	G	EV SYSTEM CAN-L
15	O	ASCD BRAKE SWITCH SIGNAL
18	SB	STOP LAMP SW SIGNAL
21	R	POWER ON POWER SUPPLY
23	P	HIGH VOLTAGE CABLE INTERLOCK
25	L	CAN-H
26	Y	WATER PUMP 2 SIGNAL
28	W	WATER PUMP 1 SIGNAL
29	P	CAN-L

Connector No.	E62
Connector Name	VCM
Connector Type	RH40FBR-R26-L-RH

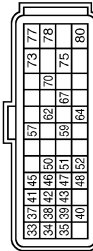

Terminal No.	Color of Wire	Signal Name [Specification]
33	L	SENSOR POWER SUPPLY (REFRIGERANT PRESSURE SENSOR)
34	B	REFRIGERANT PRESSURE SENSOR SIGNAL
35	BR	SENSOR GROUND (REFRIGERANT PRESSURE SENSOR)
37	W	SENSOR POWER SUPPLY (ACCELERATOR PEDAL POSITION SENSOR)
38	R	ACCELERATOR PEDAL POSITION SENSOR 1 SIGNAL
39	B	SENSOR GROUND (ACCELERATOR PEDAL POSITION SENSOR 1)

Terminal No.	Color of Wire	Signal Name [Specification]
40	SHIELD	—
41	R	SENSOR POWER SUPPLY (BATTERY CURRENT SENSOR)
42	Y	BATTERY CURRENT SENSOR SIGNAL
43	L	SENSOR GROUND (BATTERY CURRENT SENSOR)
44	W	SENSOR POWER SUPPLY (ACCELERATOR PEDAL POSITION SENSOR 2)
45	R	ACCELERATOR PEDAL POSITION SENSOR 2 SIGNAL
46	R	ACCELERATOR (ACCELERATOR PEDAL POSITION SENSOR 2)
47	B	SHIELD
48	SHIELD	—
50	L	BATTERY TEMPERATURE SENSOR SIGNAL
51	O	COOLANT TEMPERATURE SENSOR SIGNAL
52	W	SENSOR GROUND (COOLANT TEMPERATURE SENSOR)
57	LG	POWER VOLTAGE VARIABLE CONTROL SIGNAL
59	V	RADIATOR FAN CONTROL SIGNAL
62	G	WATER PUMP 1 ACTIVATION SIGNAL
64	R	WATER PUMP 2 ACTIVATION SIGNAL
67	Y	DC/DC CONVERTER TEMPERATURE SIGNAL
70	W	DC/DC CONVERTER ACTIVATION SIGNAL
72	GR	F/S RELAY
73	W	F/S CHG RELAY
77	LG	F/S RELAY POWER SUPPLY
78	G	M/C RELAY
80	SB	REVERSE LAMP RELAY

Connector No.	E63
Connector Name	VCM
Connector Type	RH42FEB-R26-L-RH

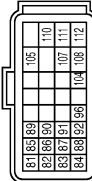

Terminal No.	Color of Wire	Signal Name [Specification]
81	GR	K-LINE
84	LG	EV SYSTEM ACTIVATION REQUEST SIGNAL
85	P	CHARGING STATUS INDICATOR 2
86	V	CHARGING STATUS INDICATOR 1
87	L	PLUG IN INDICATOR LAMP
88	Y	AVSP CONTROL SIGNAL
89	V	IMMEDIATE CHARGING SWITCH
90	W	STARTER RELAY CONT
91	O	ELECTRIC SHIFT WARNING SIGNAL
92	G	CHARGING STATUS INDICATOR 3
96	GR	EV SYSTEM ACTIVATION REQUEST SIGNAL
104	SB	ASCD STEERING SWITCH
106	L/O	PRE-CHARGE RELAY
107	W/L	SYSTEM MAIN RELAY 1

108	BR	ASCD STEERING SWITCH GROUND
110	L/Y	SYSTEM MAIN RELAY 2
111	B/R	GROUND
112	B/R	GROUND

Connector No.	E64
Connector Name	F/S CHG RELAY
Connector Type	MS02FL-M2-LC



Terminal No.	Color of Wire	Signal Name [Specification]
1	W	—
2	LG	—
3	W	—
5	V	—

Connector No.	E65
Connector Name	M/C RELAY
Connector Type	MS02FL-M2-LC



Terminal No.	Color of Wire	Signal Name [Specification]
1	G	—
2	R	—
3	R	—
5	W	—

EV CONTROL SYSTEM

Connector No.	E66
Connector Name	BATTERY CURRENT SENSOR
Connector Type	SAZ0MEGY



Terminal No.	Color of Wire	Signal Name [Specification]
1	R	-
2	L	-
3	L	-
4	Y	-

Connector No.	E67
Connector Name	ELECTRIC WATER PUMP 1
Connector Type	RSDHFG



Terminal No.	Color of Wire	Signal Name [Specification]
1	BR	-
2	B/Y	-
3	G	-
4	W	-

Connector No.	E68
Connector Name	ELECTRIC WATER PUMP 2
Connector Type	RSDHFG



Terminal No.	Color of Wire	Signal Name [Specification]
1	L	-
2	B/W	-
3	R	-
4	Y	-

Connector No.	E69
Connector Name	COOLANT TEMPERATURE SENSOR
Connector Type	ED2FGY-RS



Terminal No.	Color of Wire	Signal Name [Specification]
1	O	-
2	W	-

Connector No.	E101
Connector Name	ACCELERATOR PEDAL POSITION SENSOR
Connector Type	RHD6FB



Terminal No.	Color of Wire	Signal Name [Specification]
1	B	-
2	B	-
3	R	-
4	W	-
5	W	-
6	R	-

Connector No.	E102
Connector Name	STOP LAMP SWITCH
Connector Type	MM4FY-LC



Terminal No.	Color of Wire	Signal Name [Specification]
1	W	-
2	SB	-
3	LG	-
4	P	-

JCCWA0169GB

EV CONTROL SYSTEM

Connector No.	E103
Connector Name	WIRE TO WIRE
Connector Type	TH80MW-ZS16-TM4



Terminal No.	Color of Wire	Signal Name [Specification]
1	BR	
2	R	
3	GR	
4	LG	
5	W	
6	P	
7	V	
8	Y	
9	G	
10	R	
11	O	
12	W	
13	B	
14	Y	
15	BR	
16	LG	
17	L	
19	G	
20	V	
21	P	
22	LG	
23	GR	
24	L	
25	R	
26	SB	
27	B	
29	BR	
30	W	
31	V	
32	LG	
33	O	
34	L	
35	BR	
38	SB	
39	GR	
40	Y	
41	R	
42	W	
43	SB	

Connector No.	E108
Connector Name	WIRE TO WIRE
Connector Type	NS0MMW-GS

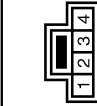

Terminal No.	Color of Wire	Signal Name [Specification]
1	W	
2	R	
3	L	
4	R	

Connector No.	E109
Connector Name	WIRE TO WIRE
Connector Type	TH432MW-NH



Terminal No.	Color of Wire	Signal Name [Specification]
1	W	
2	R	
3	Y	
4	G	
5	GR	
6	L	
7	O	
8	V	
9	SB	
10	LG	
11	L	
17	LG	
18	BR	
19	O	
20	V	
21	SB	
22	L	
23	G	

24	V	
25	W/L	
26	L/Y	
27	L/O	
28	GR	
29	P	
30	R	
31	W	

Connector No.	E112
Connector Name	ASCD BRAKE SWITCH
Connector Type	M02FBR-LC



Terminal No.	Color of Wire	Signal Name [Specification]
1	G	
2	O	

Connector No.	E201
Connector Name	BATTERY TERMINAL WITH FUSIBLE LINK
Connector Type	



Terminal No.	Color of Wire	Signal Name [Specification]
6	B/R	

A
B
EVB
D
E
F
G
H
I
J
K
L
M
N
O
P

EV CONTROL SYSTEM

Connector No.	E202
Connector Name	DC/DC-J/B
Connector Type	



Terminal No.	Color of Wire	Signal Name [Specification]
17	B/R	BATTERY POWER SUPPLY

Connector No.	E301
Connector Name	COOLING FAN CONTROL MODULE (COOLING FAN MOTOR-1)
Connector Type	6188-0259



Terminal No.	Color of Wire	Signal Name [Specification]
4	-	-
5	-	-

Connector No.	E302
Connector Name	COOLING FAN CONTROL MODULE (COOLING FAN MOTOR-2)
Connector Type	6188-0259



Terminal No.	Color of Wire	Signal Name [Specification]
6	-	-
7	-	-

Connector No.	F1
Connector Name	WIRE TO WIRE
Connector Type	SAA39FB-RS10-SLZ2

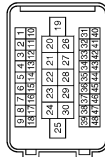

Terminal No.	Color of Wire	Signal Name [Specification]
1	Y	-
2	L	-
3	GR	-
4	LG	-
5	P	-
6	B	-
8	W	-
10	R	-
11	W	-
12	O	-
13	G	-
14	V	-
15	SB	-
16	LG	-
17	BR	-
18	Y	-
20	V	-
21	G	-
22	LG	-
23	B	-
26	SB	-
27	R	-
28	Y	-
29	W	-
30	P	-
31	L	-
32	W	-
34	R	-
35	G	-
36	LG	-
37	G	-
37	O	-
38	B	-
40	BR	-
41	O	-
42	SB	-
43	L	-

44	LG	-
47	V	-
48	P	-

Connector No.	F2
Connector Name	WIRE TO WIRE
Connector Type	RH12FB

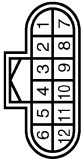

Terminal No.	Color of Wire	Signal Name [Specification]
1	L/W	-
2	LG	-
3	L	-
4	G	-
5	L	-
6	G	-
7	V	-
8	Y/V	-
9	V	-
10	O	-
11	R/Y	-
12	W/R	-

Connector No.	F11
Connector Name	DC/DC-J/B
Connector Type	RH12FB

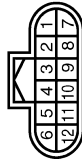

Terminal No.	Color of Wire	Signal Name [Specification]
1	L	-
2	Y/V	-
3	R	-
4	V	-
5	P	-

6	O	-
7	LG	-
8	Y	-
9	L/W	-
10	W	-
11	R	BATTERY POWER SUPPLY
12	V	QUICK CHARGE RELAY POWER SUPPLY

Connector No.	F12
Connector Name	DC/DC-J/B
Connector Type	RH04FB



Terminal No.	Color of Wire	Signal Name [Specification]
13	W/R	-
14	R/Y	-
15	O	-
16	V	-

Connector No.	M2
Connector Name	TCU
Connector Type	TH00FW-NH



Terminal No.	Color of Wire	Signal Name [Specification]
1	BR	BATTERY POWER SUPPLY
2	B	GROUND
3	G	ACC POWER SUPPLY
4	V	POWER SWITCH ON SIGNAL
9	L	EV SYSTEM CAN-H
10	G	EV SYSTEM CAN-L
11	LG	EV SYSTEM ACTIVATION REQUEST SIGNAL

A
B
EVB
D
E
F
G
H
I
J
K
L
M
N
O
P

EV CONTROL SYSTEM

Connector No.	M4
Connector Name	DATA LINK CONNECTOR
Connector Type	BD16FW

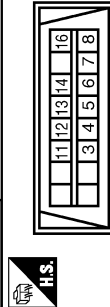

Connector No.	M34
Connector Name	COMBINATION METER
Connector Type	TH16FW-NH

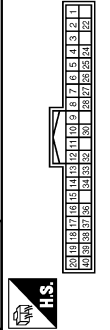

Connector No.	M47
Connector Name	VEHICLE SOUND FOR PEDESTRIANS (VSP) CONTROL UNIT
Connector Type	TH16FW-NH

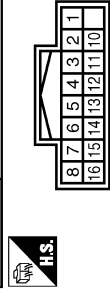

Connector No.	M70
Connector Name	BCM (BODY CONTROL MODULE)
Connector Type	TH16FW-NH

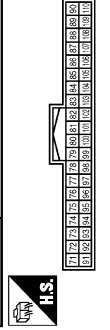

Terminal No.	Color of Wire	Signal Name [Specification]
3	LG	-
4	B	-
5	B	-
6	L	-
7	GR	-
8	G	-
11	SB	-
12	G	-
13	L	-
14	P	-
16	Y	-

Connector No.	M33
Connector Name	COMBINATION SWITCH (SPIRAL CABLE)
Connector Type	TK09FCY-1V



Terminal No.	Color of Wire	Signal Name [Specification]
1	LG	BATTERY POWER SUPPLY
2	R	BATTERY POWER SUPPLY (FOR UPPER METER)
3	GR	POWER SWITCH SUPPLY
4	BR	POWER SWITCH SUPPLY (FOR UPPER METER)
5	B	GROUND
6	B	GROUND
7	V	ELECTRIC SHIFT WARNING SIGNAL
8	Y	WASHER LEVEL SWITCH SIGNAL
9	G	PLUG IN SIGNAL
10	L	COMMUNICATION SIGNAL (METER → VSP)
11	P	COMMUNICATION SIGNAL (VSP → METER)
12	V	METER CONTROL SWITCH GROUND
13	LG	ENTER SWITCH SIGNAL
14	W	SELECT SWITCH SIGNAL
15	BR	TRIP RESET SWITCH SIGNAL
16	BR	ILLUMINATION CONTROL SWITCH SIGNAL
17	V	ILLUMINATION CONTROL SIGNAL (FOR UPPER METER)
18	P	CAN-L
19	L	CAN-H
20	V	SEAT BELT BUCKLE SWITCH SIGNAL (PASS/DRIVER SIDE)
22	GR	GROUND (FOR UPPER METER)
24	BR	ELECTRIC PARKING BRAKE CONTROL MODULE WARNING SIGNAL
25	SB	BRAKE FLUID LEVEL SWITCH SIGNAL
26	B	ILLUMINATION CONTROL SIGNAL
27	R	AIR BAG SIGNAL
28	R	SECURITY SIGNAL
30	GR	VEHICLE SPEED SIGNAL (3-PULSE)
32	W	COMMUNICATION SIGNAL (METER → UPPER)
33	LG	CLOCK SIGNAL
34	L	PLUG IN INDICATOR LAMP SIGNAL
38	V	LED HEADLAMP (RH) WARNING SIGNAL
39	LG	LED HEADLAMP (LH) WARNING SIGNAL
40	Y	SEAT BELT BUCKLE SWITCH SIGNAL (DRIVER SIDE)

Terminal No.	Color of Wire	Signal Name [Specification]
24	BR	-
25	LG	-
26	B	-
31	Y	-
32	SB	-
33	SHIELD	-
34	G	-

Terminal No.	Color of Wire	Signal Name [Specification]
1	B	GROUND
2	L	COMMUNICATION SIGNAL (METER → VSP)
3	SR	POWER SWITCH SIGNAL
4	P	COMMUNICATION SIGNAL (VSP → METER)
5	G	VSP OFF SWITCH SIGNAL
6	Y	CHARGE PULSE SIGNAL
7	L	VSP SPEAKER SIGNAL (-)
8	Y	VSP SPEAKER SIGNAL (+)
10	GR	K-LINE (CONSULT)
11	GR	POWER SWITCH SUPPLY
12	SB	STOP LAMP SWITCH SIGNAL
13	L	BATTERY POWER SUPPLY
14	LG	VSP OFF INDICATOR SIGNAL
15	R	STRAT UP SOUND SPEAKER SIGNAL (-)
16	W	STRAT UP SOUND SPEAKER SIGNAL (+)

Connector No.	M65
Connector Name	IMMEDIATE CHARGING SWITCH
Connector Type	TH06FCY-NH

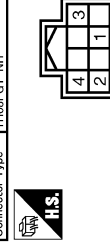

Terminal No.	Color of Wire	Signal Name [Specification]
75	LG	DR DOOR REQ SW
76	SB	POWER SW (PUSH SW)
78	B	DRIVER DOOR ANT-
79	V	DRIVER DOOR ANT+
80	LG	PASS DOOR ANT-
81	Y	PASS DOOR ANT+
82	W	REAR BMPR ANT-
83	B	REAR BMPR ANT+
84	BR	ROOM ANT 1-
85	Y	ROOM ANT 1+
86	G	ROOM ANT 2-
87	R	ROOM ANT 2+
88	V	LUGGAGE ROOM ANT+
89	LG	LUGGAGE ROOM ANT-
90	W	POWER SW ILL PWR
91	V	ACC / ON IND
92	B	POWER SW ILL GND CONT
93	GR	E-KEY WARN BUZZER
96	BR	ACC RELAY CONT
97	W	READY
98	G	IGN RELAY (BDM E/B) CONT
99	R	IGN RELAY (P/B) CONT
100	P	PASS DOOR REQ SW
102	R	P/N POSITION
104	LG	WAKE-UP
106	P	STOP LAMP SW 2

Terminal No.	Color of Wire	Signal Name [Specification]
1	Y	-
2	SB	-
3	W	ILLUMINATION +
4	B	ILLUMINATION -

EV CONTROL SYSTEM

Connector No.	M77
Connector Name	WIRE TO WIRE
Connector Type	TH80FW-CS16-TM4



Terminal No.	Color of Wire	Signal Name [Specification]
1	GR	-
2	V	-
3	GR	-
4	LG	-
6	W	-
7	V	-
8	P	-
9	SB	-
10	L	-
11	LG	-
12	W	-
13	R	-
14	Y	-
15	R	-
16	G	-
17	BR	-
19	G	-
20	G	-
21	P	-
22	LG	-
23	GR	-
24	L	-
25	Y	-
26	G	-
27	L	-
28	V	-
30	W	-
31	SB	-
32	LG	-
33	V	-
34	L	-
35	SB	-
38	LG	-
39	GR	-
40	Y	-
41	R	-
42	W	-
43	SB	-

44	GR	-
45	P	-
46	R	-
47	W	-
48	L	-
48	G	-
50	L	-
51	L	-
54	W	-
55	G	-
56	BR	-
57	P	-
58	R	-
60	Y	-
61	GR	-
62	SB	-
63	Y	-
64	G	-
65	V	-
66	P	-
67	Y	-
68	P	-
69	BR	-
71	Y	-
72	L	-
73	G	-
74	L	-
75	V	-
76	R	-
80	W	-
81	L	-
82	SB	-
83	R	-
84	BR	-
85	R	-
86	GR	-
88	R	-
88	W	-
90	SHIELD	-
91	Y	-
92	BR	-
93	W	-
94	P	-
95	V	-
96	P	-
97	G	-
98	R	-
99	LG	-

Connector No.	M99
Connector Name	WIRE TO WIRE
Connector Type	TH40FW-NH

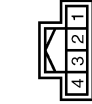

Terminal No.	Color of Wire	Signal Name [Specification]
1	V	-
2	P	-
3	SB	-
4	LG	-

Connector No.	M100
Connector Name	WIRE TO WIRE
Connector Type	TH60MP-NH



Terminal No.	Color of Wire	Signal Name [Specification]
1	V	-
2	P	-
3	SB	-
4	L	-

Connector No.	M101
Connector Name	CHARGING STATUS INDICATOR
Connector Type	TH40FW-NH



Terminal No.	Color of Wire	Signal Name [Specification]
1	V	-
2	P	-
3	SB	-
4	L	-

Connector No.	M302
Connector Name	COMBINATION SWITCH (SPIRAL CABLE)
Connector Type	TK08FGY



Terminal No.	Color of Wire	Signal Name [Specification]
13	R	-
14	W	-
15	L	-
16	B	-
17	BR	-
18	G	-
19	Y	-
20	Y	-

BASIC INSPECTION

DIAGNOSIS AND REPAIR WORK FLOW

Work Flow

INFOID:000000007005733

DETAILED FLOW

1.GET INFORMATION FOR SYMPTOM

Get the detailed information from the customer about the symptom (the condition and the environment when the incident/malfunction occurred) using the "Question sheet". (Refer to [EVB-68, "Diagnostic Work Sheet"](#).)

>> GO TO 2.

2.CHECK DTC IN VCM

1. Check DTC in VCM.
2. Check related service bulletins for information.

Are any DTCs detected?

- YES >> Check the DTC. Refer to [EVC-84, "DTC Index"](#).
NO >> GO TO 3.

3.CHECK DTC

1. Check DTC.
2. Perform the following procedure if DTC is displayed.
 - Record DTC and freeze frame data. (Print them out with CONSULT.)
 - Erase DTC.
 - Study the relationship between the cause detected by DTC and the symptom described by the customer. (Symptom Matrix Chart is useful. Refer to [EVC-355, "Symptom Index"](#).)
3. Check related service bulletins for information.

Are any symptoms described and any DTCs detected?

- Symptom is described, DTC is detected>>GO TO 4.
Symptom is described, DTC is not detected>>GO TO 5.
Symptom is not described, DTC is detected>>GO TO 6.

4.CONFIRM THE SYMPTOM

Try to confirm the symptom described by the customer.

Also study the normal operation and fail-safe related to the symptom. Refer to [EVC-355, "Symptom Index"](#) and [EVB-45, "Fail-safe"](#).

Diagnosis Work Sheet is useful to verify the incident.

Verify relation between the symptom and the condition when the symptom is detected.

>> GO TO 6.

5.CONFIRM THE SYMPTOM

Try to confirm the symptom described by the customer.

Also study the normal operation and fail-safe related to the symptom. Refer to [EVC-355, "Symptom Index"](#) and [EVB-45, "Fail-safe"](#).

Diagnosis Work Sheet is useful to verify the incident.

Verify relation between the symptom and the condition when the symptom is detected.

>> GO TO 7.

6.PERFORM DTC CONFIRMATION PROCEDURE

Perform DTC CONFIRMATION PROCEDURE for the displayed DTC, and then check that DTC is detected again.

NOTE:

- Freeze frame data is useful if the DTC is not detected.

DIAGNOSIS AND REPAIR WORK FLOW

[TYPE 1]

< BASIC INSPECTION >

- Perform Component Function Check if DTC CONFIRMATION PROCEDURE is not included on Service Manual. This simplified check procedure is an effective alternative though DTC cannot be detected during this check.
If the result of Component Function Check is NG, it is the same as the detection of DTC by DTC CONFIRMATION PROCEDURE.

Is DTC detected?

- YES >> GO TO 8.
- NO >> Check according to [GI-51, "Intermittent Incident"](#).

7. DETECT MALFUNCTIONING SYSTEM BY SYMPTOM TABLE

Detect malfunctioning system according to [EVC-355, "Symptom Index"](#) based on the confirmed symptom in step 4, and determine the trouble diagnosis order based on possible causes and symptoms.

Is the symptom described?

- YES >> GO TO 8.
- NO >> Monitor input data from related sensors using CONSULT.

8. DETECT MALFUNCTIONING PART BY DIAGNOSIS PROCEDURE

Inspect according to Diagnosis Procedure of the system.

Is a malfunctioning part detected?

- YES >> GO TO 9.
- NO >> Monitor input data from related sensors using CONSULT.

9. REPAIR OR REPLACE THE MALFUNCTIONING PART

1. Repair or replace the malfunctioning part.
2. Reconnect parts or connectors disconnected during Diagnosis Procedure again after repair and replacement.
3. Check DTC. If DTC is displayed, erase it.

>> GO TO 10.

10. FINAL CHECK

When DTC was detected in step 3, perform DTC CONFIRMATION PROCEDURE or Component Function Check again, and then check that the malfunction have been completely repaired.

When symptom was described from the customer, refer to confirmed symptom in step 4 or 5, and check that the symptom is not detected.

Is DTC detected and does symptom remain?

- YES-1 >> DTC is detected: GO TO 8.
- YES-2 >> Symptom remains: GO TO 5.
- NO >> Before returning the vehicle to the customer, always erase DTC.

Diagnostic Work Sheet

INFOID:000000007005734

DESCRIPTION

There are many operating conditions that lead to the malfunction of "EV battery system" components. A good grasp of such conditions can make troubleshooting faster and more accurate.

In general, each customer feels differently about symptoms. It is important to fully understand the symptoms or conditions for a customer complaint.

Utilize the diagnostic worksheet in order to organize all the information for troubleshooting.

NOTE:

Some conditions may cause a DTC to be detected.

KEY POINTS

- WHAT** Vehicle & motor model
- WHEN** Date, Frequencies
- WHERE**..... Road conditions
- HOW** Operating conditions,
Weather conditions,
Symptoms

JSCIA0412GB

WORKSHEET SAMPLE

DIAGNOSIS AND REPAIR WORK FLOW

< BASIC INSPECTION >

[TYPE 1]

Question Sheet					
Customer name MR/MS	Incident Date		VIN		
	Model & Year		In Service Date		
	Trans.		Mileage	km/mile	
Symptoms	<input type="checkbox"/> Does not to READY		<input type="checkbox"/> EV system warning lamp is on	<input type="checkbox"/> Power limitation indicator lamp is on	
	<input type="checkbox"/> Water leak*	<input type="checkbox"/> Noise*	<input type="checkbox"/> Vibration*	<input type="checkbox"/> Shock*	
	<input type="checkbox"/> Gear noise*	<input type="checkbox"/> Poor acceleration*		<input type="checkbox"/> Radio noise*	
	<input type="checkbox"/> Poor torque*		<input type="checkbox"/> Does not charge		
	<input type="checkbox"/> Other*		*: If applied, enter in detail		
	Detailed symptom				
Onomatopoeia					
Frequency	<input type="checkbox"/> All the time	<input type="checkbox"/> Once	<input type="checkbox"/> Sometimes (times a day)	<input type="checkbox"/> Other	
Charging condition	<input type="checkbox"/> Full	<input type="checkbox"/> Medium	<input type="checkbox"/> Low		
Weather conditions	<input type="checkbox"/> Not affected				
	Weather	<input type="checkbox"/> Fine	<input type="checkbox"/> Clouding	<input type="checkbox"/> Raining	
	Temp.	<input type="checkbox"/> Hot	<input type="checkbox"/> Warm	<input type="checkbox"/> Cool	
	Humidity	<input type="checkbox"/> High	<input type="checkbox"/> Middle	<input type="checkbox"/> Low	
Road conditions	<input type="checkbox"/> Not affected	<input type="checkbox"/> In town	<input type="checkbox"/> Freeway	<input type="checkbox"/> Off road (Up / Down)	
	<input type="checkbox"/> Deplorable road		<input type="checkbox"/> Flat road	<input type="checkbox"/> While turning (Right / Left)	
	<input type="checkbox"/> Bump		<input type="checkbox"/> Other		
Shift position	<input type="checkbox"/> Not affected				
	<input type="checkbox"/> P position	<input type="checkbox"/> R position	<input type="checkbox"/> N position	<input type="checkbox"/> D position	
Driving conditions	<input type="checkbox"/> ECO mode				
	<input type="checkbox"/> Not affected				
	<input type="checkbox"/> Power switch ON → OFF		<input type="checkbox"/> Power switch OFF → ON		
	<input type="checkbox"/> READY (stop the vehicle)		<input type="checkbox"/> While cruising		
	<input type="checkbox"/> While decelerating		<input type="checkbox"/> Just before stopping		
	<input type="checkbox"/> Just after stopping		<input type="checkbox"/> D position (stop the vehicle)		
<input type="checkbox"/> While recharging		<input type="checkbox"/> Other			
<input type="checkbox"/> Vehicle speed [km/h (MPH)]		<input type="checkbox"/> Accelerator pedal (/ 8)			
<input type="checkbox"/> Battery level (Low / Middle / High)					
Moments when mal-function disappears	<input type="checkbox"/> Disappears while driving		<input type="checkbox"/> Disappears when stopped		
	<input type="checkbox"/> Disappears with select operation		<input type="checkbox"/> Disappears when power switch is pushed OFF		
	<input type="checkbox"/> Disappears when battery charge is stopped		<input type="checkbox"/> Does not disappear		
<input type="checkbox"/> Other					
Other					

A
B
EVB
D
E
F
G
H
I
J
K
L
M
N
O
P

ADDITIONAL SERVICE WHEN REPLACING LI-ION BATTERY CONTROLLER

< BASIC INSPECTION >

[TYPE 1]

ADDITIONAL SERVICE WHEN REPLACING LI-ION BATTERY CONTROLLER

Description

INFOID:000000007005735

When a Li-ion Battery Controller (LBC) is replaced, it is necessary to save the battery information stored in LBC to the new LBC.

Whenever any of the following work is performed, make sure to perform the above operation.

- Replace LBC

Work Procedure

INFOID:000000007005736

1. SAVE THE LI-ION BATTERY CONTROLLER (LBC) INTERNAL INFORMATION

④ With CONSULT

1. Select "SAVE BATTERY INFORMATION DATA" in "WORK SUPPORT" mode.
2. Save the LBC internal information.

>> GO TO 2.

2. REPLACE LI-ION BATTERY OR LBC

Replace Li-ion battery or LBC. Refer to [EVB-169, "Removal and Installation"](#) (Li-ion battery) or [EVB-192, "LI-ION BATTERY CONTROLLER : Disassembly and Assembly"](#) (LBC).

>> GO TO 3.

3. WRITE THE LBC INTERNAL INFORMATION

④ With CONSULT

1. Select "WRITE BATTERY INFORMATION DATA" in "WORK SUPPORT" mode.
2. Write the information that has been read out before LBC replacement.

>> GO TO 4.

4. WRITE THE LBC INTERNAL INFORMATION TO VCM

Refer to "Li-ion Battery Registration Operation Manual."

>> END

MODULE CHARGE BALANCE

Description

INFOID:000000007005737

If a malfunction (e.g. abnormal voltage) occurs in a Li-ion battery cell, the module which includes the malfunctioning cell must be replaced. When replacing a module with a new one, its voltage is required to be adjusted to the adjusting voltage calculated from the maximum cell voltage of normal cells.

Work Procedure

INFOID:000000007005738

NOTE:

Voltage adjustment under low temperature conditions may require a long time. To prevent this from occurring, it is advisable to adjust voltage under room temperature conditions [20°C ± 10°C (68°F ± 18°F)].

1. CHECK ADJUSTMENT VOLTAGE VALUE

 With CONSULT

1. Power switch ON.
2. Select "DATA MONITOR" of "HV BAT".
3. Check "MAXIMUM CELL VOLTAGE".
4. Double the "MAXIMUM CELL VOLTAGE" and use that value as the module adjustment value.

Adjustment voltage value : MAXIMUM CELL VOLTAGE × 2

Example: 3.925 V (MAXIMUM CELL VOLTAGE) × 2 = 7.850 V (Adjustment voltage value)

>> GO TO 2.

2. CHECK MODULE VOLTAGE**CAUTION:**

For details on the module charge balancer operation, refer to the adjuster operation manual.

1. Set the new module to the module charge balancer.
2. Measure module voltage and compare it with "adjustment voltage value" confirmed in Step 1.

Module voltage is lower than adjustment voltage value >> GO TO 4.

Module voltage is higher than adjustment voltage value >> GO TO 3.

3. DISCHARGE OF MODULE VOLTAGE**CAUTION:**

For details on the module charge balancer operation, refer to the adjuster operation manual.

Discharge the module to 5.0 V using module charge balancer.

Discharge voltage : 5.0 V

>> GO TO 4.

4. ADJUST VOLTAGE WITH A MODULE CHARGE BALANCER**CAUTION:**

For details on the module charge balancer operation, refer to the adjuster operation manual.

1. Enter "adjustment voltage value" into module charge balancer.

Adjustment voltage value : MAXIMUM CELL VOLTAGE × 2

2. Start the voltage adjustment.

>> After module voltage adjustment, GO TO 5.

5. CHECK MODULE VOLTAGE

1. Remove the module from the module charge balancer.
2. Using a circuit tester, check that the module voltage is within the specified range.

Standard : Adjustment voltage value \pm 10 mV

>> GO TO 6.

6. CHECK CELL VOLTAGE

Ⓜ With CONSULT

1. After adjusting the voltage, install the module to the vehicle.
2. Select "DATA MONITOR" of "HV BAT".
3. Check "CELL VOLTAGE" of install module.
4. Check that the difference from the "MAXIMUM CELL VOLTAGE" confirmed in Step1 is within the specified range.

Standard : MAXIMUM CELL VOLTAGE \pm 33 mV

>> WORK END

P0A0D HV SYSTEM INTERLOCK ERROR

< DTC/CIRCUIT DIAGNOSIS >

[TYPE 1]

DTC/CIRCUIT DIAGNOSIS

P0A0D HV SYSTEM INTERLOCK ERROR

DTC Logic

INFOID:000000007005739

DTC DETECTION LOGIC

DTC	Trouble diagnosis name	DTC detecting condition	Possible causes
P0A0D	HV SYSTEM INTERLOCK ERROR	Self diagnosis program of Li-ion battery controller detects a malfunction in the CPU.	Li-ion battery controller

DTC CONFIRMATION PROCEDURE

1. PERFORM DTC CONFIRMATION PROCEDURE

④ With CONSULT

1. Power switch ON and wait for 10 seconds or more.
2. Select "Self Diagnostic Result" of "HV BAT".
3. Check DTC.

Is P0A1F detected?

- YES >> Refer to [EVB-73, "Diagnosis Procedure"](#).
NO >> INSPECTION END

Diagnosis Procedure

INFOID:000000007005740

WARNING:

- Because hybrid vehicles and electric vehicles contain a high voltage battery, there is the risk of electric shock, electric leakage, or similar accidents if the high voltage component and vehicle are handled incorrectly. Be sure to follow the correct work procedures when performing inspection and maintenance.
- Be sure to remove the service plug in order to disconnect the high voltage circuits before performing inspection or maintenance of high voltage system harnesses and parts.
- To prevent the removed service plug from being connected by mistake during the procedure, always carry it in your pocket or put it in the tool box.
- Be sure to wear insulating protective equipment consisting of glove, shoes, face shield and glasses before beginning work on the high voltage system.
- Clearly identify the persons responsible for high voltage work and ensure that other persons do not touch the vehicle. When not working, cover high voltage parts with an insulating cover sheet or similar item to prevent other persons from contacting them.
- Refer to [EVB-17, "High Voltage Precautions"](#).

CAUTION:

There is the possibility of a malfunction occurring if the vehicle is changed to READY status while the service plug is removed. Therefore do not change the vehicle to READY status unless instructed to do so in the Service Manual.

1. PRECONDITIONING

WARNING:

Disconnect high voltage. Refer to [GI-31, "How to Disconnect High Voltage"](#).

1. Remove Li-ion battery. Refer to [EVB-169, "Removal and Installation"](#).
2. Remove battery pack upper case. Refer to [EVB-184, "BATTERY JUNCTION BOX : Disassembly and Assembly"](#), see Step-1 to Step-3.

>> GO TO 2.

2. CHECK LI-ION BATTERY INTERLOCK DETECTION CIRCUIT FOR SHORT-1

1. Disconnect Li-ion battery controller (LBC) harness connector.
2. Disconnect interlock detecting switch (high voltage harness connector) harness connector.
3. Check the continuity between Li-ion battery controller harness connector and ground.

P0A0D HV SYSTEM INTERLOCK ERROR

[TYPE 1]

< DTC/CIRCUIT DIAGNOSIS >

LBC		—	Continuity
Connector	Terminal		
LB9	8	Ground	Not existed

Is the inspection result normal?

YES >> GO TO 3.

NO >> Replace Li-ion battery vehicle communication harness.

3. CHECK LI-ION BATTERY INTERLOCK DETECTIONING CIRCUIT FOR SHORT-2

1. Disconnect interlock detecting switch (service plug) harness connector.
2. Check the continuity between Li-ion battery controller harness connector and ground.

LBC		—	Continuity
Connector	Terminal		
LB9	21	Ground	Not existed

Is the inspection result normal?

YES >> GO TO 4.

NO >> Replace Li-ion battery vehicle communication harness.

4. CHECK LI-ION BATTERY INTERLOCK DETECTIONING CIRCUIT FOR SHORT-3

Check the continuity between interlock detecting switch (service plug) harness connector and ground.

Interlock detecting switch (Service plug)		—	Continuity
Connector	Terminal		
LB6	4	Ground	Not existed

Is the inspection result normal?

YES >> Replace Li-ion battery controller. Refer to [EVB-192. "LI-ION BATTERY CONTROLLER : Disassembly and Assembly"](#).

NO >> Replace Li-ion battery vehicle communication harness.

P0A1F BATTERY ENERGY CONTROL MODULE

< DTC/CIRCUIT DIAGNOSIS >

[TYPE 1]

P0A1F BATTERY ENERGY CONTROL MODULE

DTC Logic

INFOID:000000007005741

DTC DETECTION LOGIC

DTC	Trouble diagnosis name	DTC detecting condition	Possible causes
P0A1F	BATTERY ENERGY CONTROL MODULE	Self diagnosis program of Li-ion battery controller detects a malfunction in the CPU.	Li-ion battery controller

DTC CONFIRMATION PROCEDURE

1. PERFORM DTC CONFIRMATION PROCEDURE

④ With CONSULT

1. Power switch ON and wait for 10 seconds or more.
2. Select "Self Diagnostic Result" of "HV BAT".
3. Check DTC.

Is P0A1F detected?

- YES >> Refer to [EVB-75, "Diagnosis Procedure"](#).
NO >> INSPECTION END

Diagnosis Procedure

INFOID:000000007005742

When this DTC is detected, replace Li-ion battery controller. Refer to [EVB-192, "LI-ION BATTERY CONTROLLER : Disassembly and Assembly"](#).

P3030 CELL CONTROLLER LIN

< DTC/CIRCUIT DIAGNOSIS >

[TYPE 1]

P3030 CELL CONTROLLER LIN

DTC Logic

INFOID:000000007005743

DTC DETECTION LOGIC

DTC	Trouble diagnosis name	DTC detecting condition	Possible causes
P3030	CELL CONT LIN	A malfunction occurs with the communication function in Li-ion battery controller.	<ul style="list-style-type: none">• Li-ion battery controller• Module• Harness or connector

DTC CONFIRMATION PROCEDURE

1. PERFORM DTC CONFIRMATION PROCEDURE

④ With CONSULT

1. Power switch ON and wait for 10 seconds or more.
2. Select "Self Diagnostic Result" of "HV BAT".
3. Check DTC.

Is P3030 detected?

- YES >> Refer to [EVB-76, "Diagnosis Procedure"](#).
NO >> INSPECTION END

Diagnosis Procedure

INFOID:000000007005744

1. PERFORM THE SELF-DIAGNOSIS OF LI-ION BATTERY CONTROLLER

④ With CONSULT

1. Select "Self Diagnostic Result" of "HV BAT".
2. Check to see if "P30F3" is detected simultaneously with "P3030".

Is P30F3 detected?

- YES >> Replace Li-ion battery. Refer to [EVB-169, "Removal and Installation"](#).
NO >> Replace Li-ion battery controller. Refer to [EVB-192, "LI-ION BATTERY CONTROLLER : Disassembly and Assembly"](#).

P3031-P303C CELL CONTROLLER ASIC

< DTC/CIRCUIT DIAGNOSIS >

[TYPE 1]

P3031-P303C CELL CONTROLLER ASIC

DTC Logic

INFOID:000000007005745

DTC DETECTION LOGIC

DTC	Trouble diagnosis name	DTC detecting condition	Possible causes
P3031	CELL CONT ASIC1	A malfunction occurs with the communication function in Li-ion battery controller.	Li-ion battery controller
P3032	CELL CONT ASIC2		
P3033	CELL CONT ASIC3		
P3034	CELL CONT ASIC4		
P3035	CELL CONT ASIC5		
P3036	CELL CONT ASIC6		
P3037	CELL CONT ASIC7		
P3038	CELL CONT ASIC8		
P3039	CELL CONT ASIC9		
P303A	CELL CONT ASIC10		
P303B	CELL CONT ASIC11		
P303C	CELL CONT ASIC12		

EVB

DTC CONFIRMATION PROCEDURE

1. PERFORM DTC CONFIRMATION PROCEDURE

④ With CONSULT

1. Power switch ON and wait for 10 seconds or more.
2. Select "Self Diagnostic Result" of "HV BAT".
3. Check DTC.

Is any DTC detected?

- YES >> Refer to [EVB-77, "Diagnosis Procedure"](#).
NO >> INSPECTION END

Diagnosis Procedure

INFOID:000000007005746

1. PERFORM THE SELF-DIAGNOSIS OF LI-ION BATTERY CONTROLLER

④ With CONSULT

1. Select "Self Diagnostic Result" of "HV BAT".
2. Check to see if "P3030" is detected simultaneously with "P3031 -P303C".

Is P3030 detected?

- YES >> Perform diagnosis on the detected P3030. Refer to [EVB-76, "Diagnosis Procedure"](#).
NO >> Replace Li-ion battery controller. Refer to [EVB-192, "LI-ION BATTERY CONTROLLER : Disassembly and Assembly"](#).

P303D-P3048 CELL CONTROLLER ASIC

< DTC/CIRCUIT DIAGNOSIS >

[TYPE 1]

P303D-P3048 CELL CONTROLLER ASIC

DTC Logic

INFOID:000000007221009

DTC DETECTION LOGIC

DTC	Trouble diagnosis name	DTC detecting condition	Possible causes
P303D	CELL CONT ASIC13	A malfunction occurs with the communication function in Li-ion battery controller.	Li-ion battery controller
P303E	CELL CONT ASIC14		
P303F	CELL CONT ASIC15		
P3040	CELL CONT ASIC16		
P3041	CELL CONT ASIC17		
P3042	CELL CONT ASIC18		
P3043	CELL CONT ASIC19		
P3044	CELL CONT ASIC20		
P3045	CELL CONT ASIC21		
P3046	CELL CONT ASIC22		
P3047	CELL CONT ASIC23		
P3048	CELL CONT ASIC24		

DTC CONFIRMATION PROCEDURE

1. PERFORM DTC CONFIRMATION PROCEDURE

④ With CONSULT

1. Power switch ON and wait for 10 seconds or more.
2. Select "Self Diagnostic Result" of "HV BAT".
3. Check DTC.

Is any DTC detected?

- YES >> Refer to [EVB-78, "Diagnosis Procedure"](#).
NO >> INSPECTION END

Diagnosis Procedure

INFOID:000000007418361

1. PERFORM THE SELF-DIAGNOSIS OF LI-ION BATTERY CONTROLLER

④ With CONSULT

1. Select "Self Diagnostic Result" of "HV BAT".
2. Check to see if "P3030" is detected simultaneously with "P303D" -"P3048".

Is P3030 detected?

- YES >> Perform diagnosis on the detected P3030. Refer to [EVB-76, "Diagnosis Procedure"](#).
NO >> Replace Li-ion battery controller. Refer to [EVB-192, "LI-ION BATTERY CONTROLLER : Disassembly and Assembly"](#).

P3049-P3054 CELL CONTROLLER ASIC VOLTAGE

< DTC/CIRCUIT DIAGNOSIS >

[TYPE 1]

P3049-P3054 CELL CONTROLLER ASIC VOLTAGE

DTC Logic

INFOID:000000007005749

DTC DETECTION LOGIC

DTC	Trouble diagnosis name	DTC detecting condition	Possible causes
P3049	CELL CONT ASIC1 VOLT	The A/D converter in Li-ion battery controller is malfunctioning.	<ul style="list-style-type: none"> Li-ion battery controller Module Harness or connector
P304A	CELL CONT ASIC2 VOLT		
P304B	CELL CONT ASIC3 VOLT		
P304C	CELL CONT ASIC4 VOLT		
P304D	CELL CONT ASIC5 VOLT		
P304E	CELL CONT ASIC6 VOLT		
P304F	CELL CONT ASIC7 VOLT		
P3050	CELL CONT ASIC8 VOLT		
P3051	CELL CONT ASIC9 VOLT		
P3052	CELL CONT ASIC10 VOLT		
P3053	CELL CONT ASIC11 VOLT		
P3054	CELL CONT ASIC12 VOLT		

DTC CONFIRMATION PROCEDURE

1. PERFORM DTC CONFIRMATION PROCEDURE

☞ With CONSULT

- Power switch ON and wait for 10 seconds or more.
- Select "Self Diagnostic Result" of "HV BAT".
- Check DTC.

Is any DTC detected?

- YES >> Refer to [EVB-79, "Diagnosis Procedure"](#).
 NO >> INSPECTION END

Diagnosis Procedure

INFOID:000000007005750

1. PERFORM THE SELF-DIAGNOSIS OF LI-ION BATTERY CONTROLLER

☞ With CONSULT

- Select "Self Diagnostic Result" of "HV BAT".
- Check DTC.

Is any DTC detected?

YES-1 >> "P3302" - "P3331" are detected simultaneously.

- When "P3302" - "P330D" are detected simultaneously, perform the diagnosis procedure of "P3302" - "P330D". Refer to [EVB-108, "Diagnosis Procedure"](#).
- When "P330E" - "P3319" are detected simultaneously, perform the diagnosis procedure of "P330E" - "P3319". Refer to [EVB-111, "Diagnosis Procedure"](#).
- When "P331A" - "P3325" are detected simultaneously, perform the diagnosis procedure of "P331A" - "P3325". Refer to [EVB-114, "Diagnosis Procedure"](#).
- When "P3326" - "P3331" are detected simultaneously, perform the diagnosis procedure of "P3326" - "P3331". Refer to [EVB-117, "Diagnosis Procedure"](#).

YES-2 >> "P3375" - "P33A4" are detected simultaneously.

- When "P3375" - "P3380" are detected simultaneously, perform the diagnosis procedure of "P3375" - "P3380". Refer to [EVB-121, "Diagnosis Procedure"](#).
- When "P3381" - "P338C" are detected simultaneously, perform the diagnosis procedure of "P3381" - "P338C". Refer to [EVB-124, "Diagnosis Procedure"](#).
- When "P338D" - "P3398" are detected simultaneously, perform the diagnosis procedure of "P338D" - "P3398". Refer to [EVB-127, "Diagnosis Procedure"](#).

P3049-P3054 CELL CONTROLLER ASIC VOLTAGE

< DTC/CIRCUIT DIAGNOSIS >

[TYPE 1]

- When “P3399” - “P33A4” are detected simultaneously, perform the diagnosis procedure of “P3399” - “P33A4”. Refer to [EVB-130, "Diagnosis Procedure"](#).
- NO >> When only “P3049” - “P3054” are detected, replace Li-ion battery controller. Refer to [EVB-192, "LI-ION BATTERY CONTROLLER : Disassembly and Assembly"](#).

P3055-P3060 CELL CONTROLLER ASIC VOLTAGE

< DTC/CIRCUIT DIAGNOSIS >

[TYPE 1]

P3055-P3060 CELL CONTROLLER ASIC VOLTAGE

DTC Logic

INFOID:000000007221011

DTC DETECTION LOGIC

DTC	Trouble diagnosis name	DTC detecting condition	Possible causes
P3055	CELL CONT ASIC13 VOLT	The A/D converter in Li-ion battery controller is malfunctioning.	<ul style="list-style-type: none"> Li-ion battery controller Module Harness or connector
P3056	CELL CONT ASIC14 VOLT		
P3057	CELL CONT ASIC15 VOLT		
P3058	CELL CONT ASIC16 VOLT		
P3059	CELL CONT ASIC17 VOLT		
P305A	CELL CONT ASIC18 VOLT		
P305B	CELL CONT ASIC19 VOLT		
P305C	CELL CONT ASIC20 VOLT		
P305D	CELL CONT ASIC21 VOLT		
P305E	CELL CONT ASIC22 VOLT		
P305F	CELL CONT ASIC23 VOLT		
P3060	CELL CONT ASIC24 VOLT		

DTC CONFIRMATION PROCEDURE

1. PERFORM DTC CONFIRMATION PROCEDURE

☐ With CONSULT

- Power switch ON and wait for 10 seconds or more.
- Select "Self Diagnostic Result" of "HV BAT".
- Check DTC.

Is any DTC detected?

- YES >> Refer to [EV8-81, "Diagnosis Procedure"](#).
 NO >> INSPECTION END

Diagnosis Procedure

INFOID:000000007221012

1. PERFORM THE SELF-DIAGNOSIS OF LI-ION BATTERY CONTROLLER

☐ With CONSULT

- Select "Self Diagnostic Result" of "HV BAT".
- Check DTC.

Is any DTC detected?

YES-1 >> "P3302" - "P3331" are detected simultaneously.

- When "P3302" - "P330D" are detected simultaneously, perform the diagnosis procedure of "P3302" - "P330D". Refer to [EV8-108, "Diagnosis Procedure"](#).
- When "P330E" - "P3319" are detected simultaneously, perform the diagnosis procedure of "P330E" - "P3319". Refer to [EV8-111, "Diagnosis Procedure"](#).
- When "P331A" - "P3325" are detected simultaneously, perform the diagnosis procedure of "P331A" - "P3325". Refer to [EV8-114, "Diagnosis Procedure"](#).
- When "P3326" - "P3331" are detected simultaneously, perform the diagnosis procedure of "P3326" - "P3331". Refer to [EV8-117, "Diagnosis Procedure"](#).

YES-2 >> "P3375" - "P33A4" are detected simultaneously.

- When "P3375" - "P3380" are detected simultaneously, perform the diagnosis procedure of "P3375" - "P3380". Refer to [EV8-121, "Diagnosis Procedure"](#).
- When "P3381" - "P338C" are detected simultaneously, perform the diagnosis procedure of "P3381" - "P338C". Refer to [EV8-124, "Diagnosis Procedure"](#).
- When "P338D" - "P3398" are detected simultaneously, perform the diagnosis procedure of "P338D" - "P3398". Refer to [EV8-127, "Diagnosis Procedure"](#).

P3055-P3060 CELL CONTROLLER ASIC VOLTAGE

< DTC/CIRCUIT DIAGNOSIS >

[TYPE 1]

- When “P3399” - “P33A4” are detected simultaneously, perform the diagnosis procedure of “P3399” - “P33A4”. Refer to [EVB-130, "Diagnosis Procedure"](#).
- NO >> When only “P3055” - “P3060” are detected, replace Li-ion battery controller. Refer to [EVB-192, "LI-ION BATTERY CONTROLLER : Disassembly and Assembly"](#).

P3061 CELL BATTERY VOLTAGE

< DTC/CIRCUIT DIAGNOSIS >

[TYPE 1]

P3061 CELL BATTERY VOLTAGE

DTC Logic

INFOID:000000007005753

DTC DETECTION LOGIC

DTC	Trouble diagnosis name	DTC detecting condition	Possible causes
P3061	CELL BATTERY VOLT	An open circuit diagnosis detection circuit in Li-ion battery controller is malfunctioning.	Li-ion battery controller

DTC CONFIRMATION PROCEDURE

1. PERFORM DTC CONFIRMATION PROCEDURE

Ⓜ With CONSULT

1. Power switch ON and wait for 10 seconds or more.
2. Select "Self Diagnostic Result" of "HV BAT".
3. Check DTC.

Is P3061 detected?

- YES >> Refer to [EVB-83, "Diagnosis Procedure"](#).
NO >> INSPECTION END

Diagnosis Procedure

INFOID:000000007005754

When this DTC is detected, replace Li-ion battery controller. Refer to [EVB-192, "LI-ION BATTERY CONTROLLER : Disassembly and Assembly"](#).

P3062 BYPASS SWITCH

< DTC/CIRCUIT DIAGNOSIS >

[TYPE 1]

P3062 BYPASS SWITCH

DTC Logic

INFOID:000000007005755

DTC DETECTION LOGIC

DTC	Trouble diagnosis name	DTC detecting condition	Possible causes
P3062	BYPASS SW	A malfunction of the bypass switch in Li-ion battery controller is detected.	<ul style="list-style-type: none">• Li-ion battery controller• Module• Harness or connector

DTC DETECTION LOGIC

1. PERFORM DTC CONFIRMATION PROCEDURE

④ With CONSULT

1. Power switch ON and wait for 10 seconds or more.
2. Select "Self Diagnostic Result" of "HV BAT".
3. Check DTC.

Is P3062 detected?

- YES >> Refer to [EVB-84, "Diagnosis Procedure"](#).
NO >> INSPECTION END

Diagnosis Procedure

INFOID:000000007005756

1. PERFORM THE SELF-DIAGNOSIS OF LI-ION BATTERY CONTROLLER

④ With CONSULT

1. Select "Self Diagnostic Result" of "HV BAT".
2. Check to see if "P3375"- "P33A4" is detected simultaneously with "P3062".

Is P3375-P33A4 detected?

- YES >> • When "P3375" - "P3380" are detected simultaneously, perform the diagnosis procedure of "P3375" - "P3380". Refer to [EVB-121, "Diagnosis Procedure"](#).
• When "P3381" - "P338C" are detected simultaneously, perform the diagnosis procedure of "P3381" - "P338C". Refer to [EVB-124, "Diagnosis Procedure"](#).
• When "P338D" - "P3398" are detected simultaneously, perform the diagnosis procedure of "P338D" - "P3398". Refer to [EVB-127, "Diagnosis Procedure"](#).
• When "P3399" - "P33A4" are detected simultaneously, perform the diagnosis procedure of "P3399" - "P33A4". Refer to [EVB-130, "Diagnosis Procedure"](#).
NO >> Replace Li-ion battery controller. Refer to [EVB-192, "LI-ION BATTERY CONTROLLER : Disassembly and Assembly"](#).

P308B-P3096 CELL CONTROLLER ASIC OPEN

< DTC/CIRCUIT DIAGNOSIS >

[TYPE 1]

P308B-P3096 CELL CONTROLLER ASIC OPEN

DTC Logic

INFOID:000000007005757

DTC DETECTION LOGIC

DTC	Trouble diagnosis name	DTC detecting condition	Possible causes
P308B	CELL CONT ASIC1 OPEN	Self diagnosis program of Li-ion battery controller detects an open circuit in the cell voltage detection line.	<ul style="list-style-type: none"> Li-ion battery controller Harness or connector
P308C	CELL CONT ASIC2 OPEN		
P308D	CELL CONT ASIC3 OPEN		
P308E	CELL CONT ASIC4 OPEN		
P308F	CELL CONT ASIC5 OPEN		
P3090	CELL CONT ASIC6 OPEN		
P3091	CELL CONT ASIC7 OPEN		
P3092	CELL CONT ASIC8 OPEN		
P3093	CELL CONT ASIC9 OPEN		
P3094	CELL CONT ASIC10 OPEN		
P3095	CELL CONT ASIC11 OPEN		
P3096	CELL CONT ASIC12 OPEN		

DTC DETECTION LOGIC

1. PERFORM DTC CONFIRMATION PROCEDURE

Ⓜ With CONSULT

- Power switch ON and wait for 10 seconds or more.
- Select "Self Diagnostic Result" of "HV BAT".
- Check DTC.

Is P308B-P30A2 detected?

- YES >> Refer to [EVB-85, "Diagnosis Procedure"](#).
 NO >> INSPECTION END

Diagnosis Procedure

INFOID:000000007005758

WARNING:

- Because hybrid vehicles and electric vehicles contain a high voltage battery, there is the risk of electric shock, electric leakage, or similar accidents if the high voltage component and vehicle are handled incorrectly. Be sure to follow the correct work procedures when performing inspection and maintenance.
- Be sure to remove the service plug in order to disconnect the high voltage circuits before performing inspection or maintenance of high voltage system harnesses and parts.
- To prevent the removed service plug from being connected by mistake during the procedure, always carry it in your pocket or put it in the tool box.
- Be sure to wear insulating protective equipment consisting of glove, shoes, face shield and glasses before beginning work on the high voltage system.
- Clearly identify the persons responsible for high voltage work and ensure that other persons do not touch the vehicle. When not working, cover high voltage parts with an insulating cover sheet or similar item to prevent other persons from contacting them.
- Refer to [EVB-17, "High Voltage Precautions"](#).

CAUTION:

There is the possibility of a malfunction occurring if the vehicle is changed to READY status while the service plug is removed. Therefore do not change the vehicle to READY status unless instructed to do so in the Service Manual.

1. PERFORM THE SELF-DIAGNOSIS OF LI-ION BATTERY CONTROLLER

Ⓜ With CONSULT

- Select "Self Diagnostic Result" of "HV BAT".

P308B-P3096 CELL CONTROLLER ASIC OPEN

[TYPE 1]

< DTC/CIRCUIT DIAGNOSIS >

2. Check to see if “P3049”-“P3060” (CELL CONT ASIC VOLT related codes) or “P3375”-“P33A4” (CELL OVER DISCHARGE related codes) is detected simultaneously with “P308B”-“P3096”.

Is P3049-P3060 or P3375-P33A4 detected?

YES-1 >> “P3049”-“P3060” are detected simultaneously.

- When “P3049”-“P3054” are detected simultaneously, perform the diagnosis procedure of “P3049”-“P3054”. Refer to [EVB-121, "Diagnosis Procedure"](#).
- When “P3055”-“P3060” are detected simultaneously, perform the diagnosis procedure of “P3055”-“P3060”. Refer to [EVB-81, "Diagnosis Procedure"](#).

YES-2 >> “P3375”-“P33A4” are detected simultaneously.

- When “P3375”-“P3380” are detected simultaneously, perform the diagnosis procedure of “P3375”-“P3380”. Refer to [EVB-121, "Diagnosis Procedure"](#).
- When “P3381”-“P338C” are detected simultaneously, perform the diagnosis procedure of “P3381”-“P338C”. Refer to [EVB-124, "Diagnosis Procedure"](#).
- When “P338D”-“P3398” are detected simultaneously, perform the diagnosis procedure of “P338D”-“P3398”. Refer to [EVB-127, "Diagnosis Procedure"](#).
- When “P3399”-“P33A4” are detected simultaneously, perform the diagnosis procedure of “P3399”-“P33A4”. Refer to [EVB-130, "Diagnosis Procedure"](#).

NO >> GO TO 2.

2. PRECONDITIONING

WARNING:

Disconnect high voltage. Refer to [GI-31, "How to Disconnect High Voltage"](#).

1. Remove Li-ion battery. Refer to [EVB-169, "Removal and Installation"](#).
2. Remove battery pack upper case. Refer to [EVB-184, "BATTERY JUNCTION BOX : Disassembly and Assembly"](#), see Step-1 to Step-3.

>> GO TO 3.

3. CHECK CONNECTION STATUS

1. Power switch OFF.
2. Check connection status of Li-ion battery controller harness connector and module harness connector.

Is the inspection result normal?

YES >> GO TO 4.

NO >> Recover the connection status.

4. CHECK HARNESS BETWEEN LI-ION BATTERY CONTROLLER AND MODULE

1. Disconnect Li-ion battery controller harness connector and Module harness connector.
2. Refer to below table and continuity between Li-ion battery controller and Module, according to detected DTC.

DTC	Module No.	Module		Li-ion battery controller		Continuity
		Connector	Terminal	Connector	Terminal	
P308B	1	LB9	2	LB13	50	Existed
	2		3		51	
P308C	3	LB9	4	LB13	52	Existed
	4		5		53	
P308D	5	LB9	6	LB13	54	Existed
	6		7		55	
P308E	7	LB9	8	LB13	56	Existed
	8		9		57	
P308F	9	LB9	26	LB13	58	Existed
	10		27		59	
P3090	11	LB9	28	LB13	60	Existed
	12		29		61	

P308B-P3096 CELL CONTROLLER ASIC OPEN

< DTC/CIRCUIT DIAGNOSIS >

[TYPE 1]

DTC	Module No.	Module		Li-ion battery controller		Continuity
		Connector	Terminal	Connector	Terminal	
P3091	13	LB9	30	LB13	62	Existed
	14		31		63	
P3092	15	LB10	45	LB14	77	Existed
	16		46		78	
P3093	17	LB10	36	LB14	80	Existed
	18		37		81	
P3094	19	LB10	38	LB14	82	Existed
	20		39		83	
P3095	21	LB10	52	LB14	84	Existed
	22		53		85	
P3096	23	LB10	54	LB14	86	Existed
	24		55		87	

Is the inspection result normal?

- YES >> Replace Li-ion battery controller. Refer to [EVB-192. "LI-ION BATTERY CONTROLLER : Disassembly and Assembly"](#).
- NO >> Repair harness or connector.

A
B
EVB
D
E
F
G
H
I
J
K
L
M
N
O
P

P3097-P30A2 CELL CONTROLLER ASIC OPEN

< DTC/CIRCUIT DIAGNOSIS >

[TYPE 1]

P3097-P30A2 CELL CONTROLLER ASIC OPEN

DTC Logic

INFOID:000000007221013

DTC DETECTION LOGIC

DTC	Trouble diagnosis name	DTC detecting condition	Possible causes
P3097	CELL CONT ASIC13 OPEN	Self diagnosis program of Li-ion battery controller detects an open circuit in the cell voltage detection line.	<ul style="list-style-type: none"> • Li-ion battery controller • Harness or connector
P3098	CELL CONT ASIC14 OPEN		
P3099	CELL CONT ASIC15 OPEN		
P309A	CELL CONT ASIC16 OPEN		
P309B	CELL CONT ASIC17 OPEN		
P309C	CELL CONT ASIC18 OPEN		
P309D	CELL CONT ASIC19 OPEN		
P309E	CELL CONT ASIC20 OPEN		
P309F	CELL CONT ASIC21 OPEN		
P30A0	CELL CONT ASIC22 OPEN		
P30A1	CELL CONT ASIC23 OPEN		
P30A2	CELL CONT ASIC24 OPEN		

DTC DETECTION LOGIC

1. PERFORM DTC CONFIRMATION PROCEDURE

Ⓟ With CONSULT

1. Power switch ON and wait for 10 seconds or more.
2. Select "Self Diagnostic Result" of "HV BAT".
3. Check DTC.

Is P308B-P30A2 detected?

- YES >> Refer to [EVB-88, "Diagnosis Procedure"](#).
 NO >> INSPECTION END

Diagnosis Procedure

INFOID:000000007221014

WARNING:

- Because hybrid vehicles and electric vehicles contain a high voltage battery, there is the risk of electric shock, electric leakage, or similar accidents if the high voltage component and vehicle are handled incorrectly. Be sure to follow the correct work procedures when performing inspection and maintenance.
- Be sure to remove the service plug in order to disconnect the high voltage circuits before performing inspection or maintenance of high voltage system harnesses and parts.
- To prevent the removed service plug from being connected by mistake during the procedure, always carry it in your pocket or put it in the tool box.
- Be sure to wear insulating protective equipment consisting of glove, shoes, face shield and glasses before beginning work on the high voltage system.
- Clearly identify the persons responsible for high voltage work and ensure that other persons do not touch the vehicle. When not working, cover high voltage parts with an insulating cover sheet or similar item to prevent other persons from contacting them.
- Refer to [EVB-17, "High Voltage Precautions"](#).

CAUTION:

There is the possibility of a malfunction occurring if the vehicle is changed to READY status while the service plug is removed. Therefore do not change the vehicle to READY status unless instructed to do so in the Service Manual.

1. PERFORM THE SELF-DIAGNOSIS OF LI-ION BATTERY CONTROLLER

Ⓟ With CONSULT

1. Select "Self Diagnostic Result" mode of "HV BAT" using CONSULT.

P3097-P30A2 CELL CONTROLLER ASIC OPEN

[TYPE 1]

< DTC/CIRCUIT DIAGNOSIS >

- Check to see if "P3049"- "P3060" (CELL CONT ASIC VOLT related codes) or "P3375"- "P33A4" (CELL OVER DISCHARGE related codes) is detected simultaneously with "P3097"- "P30A2".

Is P3049-P3060 or P3375-P33A4 detected?

YES-1 >> "P3049"- "P3060" are detected simultaneously.

- When "P3049"- "P3054" are detected simultaneously, perform the diagnosis procedure of "P3049"- "P3054". Refer to [EVB-79, "Diagnosis Procedure"](#)
- When "P3055"- "P3060" are detected simultaneously, perform the diagnosis procedure of "P3055"- "P3060". Refer to [EVB-81, "Diagnosis Procedure"](#)

YES-2 >> "P3375"- "P33A4" are detected simultaneously.

- When "P3375"- "P3380" are detected simultaneously, perform the diagnosis procedure of "P3375"- "P3380". Refer to [EVB-121, "Diagnosis Procedure"](#).
- When "P3381"- "P338C" are detected simultaneously, perform the diagnosis procedure of "P3381"- "P338C". Refer to [EVB-124, "Diagnosis Procedure"](#).
- When "P338D"- "P3398" are detected simultaneously, perform the diagnosis procedure of "P338D"- "P3398". Refer to [EVB-127, "Diagnosis Procedure"](#).
- When "P3399"- "P33A4" are detected simultaneously, perform the diagnosis procedure of "P3399"- "P33A4". Refer to [EVB-130, "Diagnosis Procedure"](#)

NO >> GO TO 2.

2. PRECONDITIONING

WARNING:

Disconnect high voltage. Refer to [GI-31, "How to Disconnect High Voltage"](#).

- Remove Li-ion battery. Refer to [EVB-169, "Removal and Installation"](#).
- Remove battery pack upper case. Refer to [EVB-184, "BATTERY JUNCTION BOX : Disassembly and Assembly"](#), see Step-1 to Step-3.

>> GO TO 3.

3. CHECK CONNECTION STATUS

- Power switch OFF.
- Check connection status of Li-ion battery controller harness connector and module harness connector.

Is the inspection result normal?

YES >> GO TO 4.

NO >> Recover the connection status.

4. CHECK HARNESS BETWEEN LI-ION BATTERY CONTROLLER AND MODULE

- Disconnect Li-ion battery controller harness connector and Module harness connector.
- Refer to below table and continuity between Li-ion battery controller and Module, according to detected DTC.

DTC	Module No.	Module		Li-ion battery controller		Continuity
		Connector	Terminal	Connector	Terminal	
P3097	25	LB8	73	LB15	110	Existed
	26		74		111	
P3098	27	LB8	60	LB15	112	Existed
	28		77		113	
P3099	29	LB8	78	LB15	114	Existed
	30		64		115	
P309A	31	LB8	81	LB15	116	Existed
	32		82		117	
P309B	33	LB8	68	LB15	118	Existed
	34		85		119	
P309C	35	LB8	86	LB15	120	Existed
	36		72		121	

P3097-P30A2 CELL CONTROLLER ASIC OPEN

< DTC/CIRCUIT DIAGNOSIS >

[TYPE 1]

DTC	Module No.	Module		Li-ion battery controller		Continuity
		Connector	Terminal	Connector	Terminal	
P309D	37	LB7	89	LB15	122	Existed
	38		90		123	
P309E	39	LB7	91	LB15	124	Existed
	40		92		125	
P309F	41	LB7	93	LB15	127	Existed
	42		94		128	
P30A0	43	LB7	95	LB15	130	Existed
	44		96		138	
P30A1	45	LB7	97	LB15	140	Existed
	46		98		141	
P30A2	47	LB7	99	LB15	142	Existed
	48		100		143	

Is the inspection result normal?

YES >> Replace Li-ion battery controller. Refer to [EVB-192, "LI-ION BATTERY CONTROLLER : Disassembly and Assembly"](#).

NO >> Repair harness or connector.

P30F3 TOTAL VOLTAGE SENSOR

< DTC/CIRCUIT DIAGNOSIS >

[TYPE 1]

P30F3 TOTAL VOLTAGE SENSOR

DTC Logic

INFOID:000000007005761

DTC DETECTION LOGIC

DTC	Trouble diagnosis name	DTC detecting condition	Possible causes
P30F3	TOTAL VOLT SENSOR	A malfunction occurs with the communication function in Li-ion battery controller.	<ul style="list-style-type: none">• Li-ion battery controller• Module• Harness or connector

DTC CONFIRMATION PROCEDURE

1. PERFORM DTC CONFIRMATION PROCEDURE

④ With CONSULT

1. Power switch ON and wait for 10 seconds or more.
2. Select "Self Diagnostic Result" of "HV BAT".
3. Check DTC.

Is P30F3 detected?

- YES >> Refer to [EVB-91, "Diagnosis Procedure"](#).
NO >> INSPECTION END

Diagnosis Procedure

INFOID:000000007005762

1. PERFORM THE SELF-DIAGNOSIS OF LI-ION BATTERY CONTROLLER

④ With CONSULT

1. Select "Self Diagnostic Result" of "HV BAT".
2. Check to see if "P3030" is detected simultaneously with "P30F3".

Is any P3030 detected?

- YES >> Perform diagnosis on the detected "P3030". Refer to [EVB-76, "Diagnosis Procedure"](#).
NO >> Replace Li-ion battery controller. Refer to [EVB-192, "LI-ION BATTERY CONTROLLER : Disassembly and Assembly"](#).

P30F4 TOTAL VOLTAGE SENSOR

< DTC/CIRCUIT DIAGNOSIS >

[TYPE 1]

P30F4 TOTAL VOLTAGE SENSOR

DTC Logic

INFOID:000000007005763

DTC DETECTION LOGIC

DTC	Trouble diagnosis name	DTC detecting condition	Possible causes
P30F4	TOTAL VOLT SENSOR	When the voltage recognized by total voltage sensor in Li-ion battery controller is excessively high or low.	<ul style="list-style-type: none">• Li-ion battery controller• Bus bar between stack• Service plug (fuse)• Module

DTC CONFIRMATION PROCEDURE

1. PERFORM DTC CONFIRMATION PROCEDURE

④ With CONSULT

1. Power switch ON and wait for 10 seconds or more.
2. Select "Self Diagnostic Result" of "HV BAT".
3. Check DTC.

Is P30F4 detected?

- YES >> Refer to [EVB-92, "Diagnosis Procedure"](#).
NO >> INSPECTION END

Diagnosis Procedure

INFOID:000000007005764

WARNING:

- Because hybrid vehicles and electric vehicles contain a high voltage battery, there is the risk of electric shock, electric leakage, or similar accidents if the high voltage component and vehicle are handled incorrectly. Be sure to follow the correct work procedures when performing inspection and maintenance.
- Be sure to remove the service plug in order to disconnect the high voltage circuits before performing inspection or maintenance of high voltage system harnesses and parts.
- To prevent the removed service plug from being connected by mistake during the procedure, always carry it in your pocket or put it in the tool box.
- Be sure to wear insulating protective equipment consisting of glove, shoes, face shield and glasses before beginning work on the high voltage system.
- Clearly identify the persons responsible for high voltage work and ensure that other persons do not touch the vehicle. When not working, cover high voltage parts with an insulating cover sheet or similar item to prevent other persons from contacting them.
- Refer to [EVB-17, "High Voltage Precautions"](#).

CAUTION:

There is the possibility of a malfunction occurring if the vehicle is changed to READY status while the service plug is removed. Therefore do not change the vehicle to READY status unless instructed to do so in the Service Manual.

1. PERFORM THE SELF-DIAGNOSIS OF LI-ION BATTERY CONTROLLER

④ With CONSULT

1. Select "Self Diagnostic Result" mode of "HV BAT" using CONSULT.
2. Check if any DTC is detected in "Self Diagnostic Result".

Is any DTC detected?

- "P3030" is detected in addition to "P30F4" (Cannot be monitored)>>GO TO 3.
Just "P30F4" is detected>>GO TO 2.

2. CHECK FUSE

1. Power switch OFF.
2. Check fuse of service plug.

Is the inspection result normal?

- YES >> Replace Li-ion battery controller.
NO >> Replace service plug.

P30F4 TOTAL VOLTAGE SENSOR

< DTC/CIRCUIT DIAGNOSIS >

[TYPE 1]

3. PRECONDITIONING

WARNING:

Disconnect high voltage. Refer to [GI-31, "How to Disconnect High Voltage"](#).

1. Remove Li-ion battery. Refer to [EVB-169, "Removal and Installation"](#).
2. Remove battery pack upper case. Refer to [EVB-184, "BATTERY JUNCTION BOX : Disassembly and Assembly"](#), see Step-1 to Step-3.

>> GO TO 4.

4. CHECK CONNECTION STATUS STACK AND BUS BAR.

Check connection status between each stack and connection status of each bus bar.

Is the inspection result normal?

- YES >> GO TO 5.
 NO >> Recover the connection status.

5. CHECK MODULE VOLTAGE

Check the voltage of all modules.

Is the inspection result normal?

- YES >> Replace Li-ion battery controller. Refer to [EVB-192, "LI-ION BATTERY CONTROLLER : Disassembly and Assembly"](#).
 NO >> Replace the corresponding module. Refer to [EVB-176, "Exploded view"](#).

Component Inspection

INFOID:000000007005765

1. CHECK MODULE VOLTAGE

Check voltage of module.

- A : Positive terminal (Red)**
B : Negative terminal (Black)

Terminals		Voltage (Approx.)
(+)	(-)	
Module		5.0 - 8.5 V
Positive terminal (Red)	Negative terminal (Black)	

Is the inspection result normal?

- YES >> INSPECTION END
 NO >> Replace module. Refer to [EVB-198, "FRONT MODULE STACK : Disassembly and Assembly"](#) (Front module) or [EVB-208, "REAR MODULE STACK : Disassembly and Assembly"](#) (Rear module).

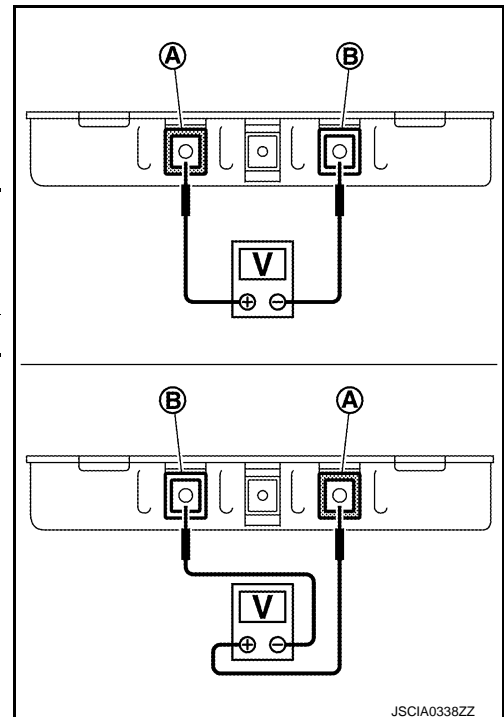

JSCIA0338ZZ

P30F5 TOTAL VOLTAGE SENSOR

< DTC/CIRCUIT DIAGNOSIS >

[TYPE 1]

P30F5 TOTAL VOLTAGE SENSOR

DTC Logic

INFOID:000000007005766

DTC DETECTION LOGIC

DTC	Trouble diagnosis name	DTC detecting condition	Possible causes
P30F5	TOTAL VOLT SENSOR	When the voltage recognized by total voltage sensor in Li-ion battery controller is excessively high or low.	<ul style="list-style-type: none">• Li-ion battery controller• Bus bar between stack• Service plug (fuse)• Module

DTC CONFIRMATION PROCEDURE

1. PERFORM DTC CONFIRMATION PROCEDURE

Ⓟ With CONSULT

1. Power switch ON and wait for 10 seconds or more.
2. Select "Self Diagnostic Result" of "HV BAT".
3. Check DTC.

Is P30F5 detected?

- YES >> Refer to [EVB-94, "Diagnosis Procedure"](#).
NO >> INSPECTION END

Diagnosis Procedure

INFOID:000000007005767

1. PERFORM THE SELF-DIAGNOSIS OF LI-ION BATTERY CONTROLLER

Ⓟ With CONSULT

1. Select "Self Diagnostic Result" of "HV BAT".
2. Check to see if "P30F4" is detected simultaneously with "P30F5".

Is any P30F4 detected?

- YES >> Perform diagnosis on the detected "P30F4". Refer to [EVB-92, "Diagnosis Procedure"](#).
NO >> Replace Li-ion battery controller. Refer to [EVB-192, "LI-ION BATTERY CONTROLLER : Disassembly and Assembly"](#).

P30FC OVER CURRENT

< DTC/CIRCUIT DIAGNOSIS >

[TYPE 1]

P30FC OVER CURRENT

DTC Logic

INFOID:000000007005768

DTC DETECTION LOGIC

DTC	Trouble diagnosis name	DTC detecting condition	Possible causes
P30FC	OVER CURRENT	When the temperature of the entire battery pack estimated from the current value is excessively high.	<ul style="list-style-type: none"> Battery current sensor Other systems malfunction

A

B

EVB

DTC CONFIRMATION PROCEDURE

1. PERFORM DTC CONFIRMATION PROCEDURE

④ With CONSULT

- Power switch ON and wait for 10 seconds or more.
- Select "Self Diagnostic Result" of "HV BAT".
- Check DTC.

Is P30FC detected?

- YES >> Refer to [EVB-95, "Diagnosis Procedure"](#).
 NO >> INSPECTION END

D

E

F

Diagnosis Procedure

INFOID:000000007005769

1. PERFORM THE SELF-DIAGNOSIS

④ With CONSULT

- Perform "All DTC Reading".
- Check "Self diagnostic result" of systems other than "HV BAT" to see if any DTC is detected.

Is any DTC detected?

- YES >> After performing trouble diagnosis of detected DTC, GO TO 2.
 NO >> GO TO 2.

2. CHECK BATTERY TEMPERATURE SENSOR

④ With CONSULT

Using FFD, check the values of four temperature sensors when DTC is detected.

Monitor item	Condition	Limit
Battery temperature sensor 1	Power switch ON	55°C (131°F) or less
Battery temperature sensor 2		
Battery temperature sensor 3		
Battery temperature sensor 4		

Is there temperature increase?

- Temperature increase is seen >> Replace Li-ion battery. Refer to [EVB-169, "Removal and Installation"](#).
 Temperature increase is not seen >> Replace battery junction box. Refer to [EVB-169, "Removal and Installation"](#).

G

H

I

J

K

L

M

N

O

P

P30FD TOTAL VOLTAGE MONITOR SWITCH

< DTC/CIRCUIT DIAGNOSIS >

[TYPE 1]

P30FD TOTAL VOLTAGE MONITOR SWITCH

DTC Logic

INFOID:000000007005770

DTC DETECTION LOGIC

DTC	Trouble diagnosis name	DTC detecting condition	Possible causes
P30FD	TOTAL VOLTAGE MONITOR SWITCH	<ul style="list-style-type: none">Total voltage detection switch in Li-ion battery controller is malfunctioning.Self diagnosis malfunction of total voltage detection circuit stop function in Li-ion battery controller.	<ul style="list-style-type: none">Li-ion battery controller

DTC CONFIRMATION PROCEDURE

1. PERFORM DTC CONFIRMATION PROCEDURE

Ⓢ With CONSULT

- Power switch ON and wait for 10 seconds or more.
- Select "Self Diagnostic Result" of "HV BAT".
- Check DTC.

Is P30FC detected?

- YES >> Refer to [EVB-96. "Diagnosis Procedure"](#).
NO >> INSPECTION END

Diagnosis Procedure

INFOID:000000007005771

When this DTC is detected, replace Li-ion battery controller. Refer to [EVB-192. "LI-ION BATTERY CONTROLLER : Disassembly and Assembly"](#).

P30FE 12V BATTERY VOLTAGE

[TYPE 1]

< DTC/CIRCUIT DIAGNOSIS >

P30FE 12V BATTERY VOLTAGE

DTC Logic

INFOID:000000007005772

DTC DETECTION LOGIC

DTC	Trouble diagnosis name	DTC detecting condition	Possible causes
P30FE	12V BATTERY VOLTAGE	12V battery voltage lowers to less than 9 V.	<ul style="list-style-type: none">• 12V battery• Harness

DTC CONFIRMATION PROCEDURE

1. PERFORM DTC CONFIRMATION PROCEDURE

 With CONSULT

1. Power switch ON and wait for 10 seconds or more.
2. Select "Self Diagnostic Result" of "HV BAT".
3. Check DTC.

Is P30FE detected?

- YES >> Refer to [EV9-97, "Diagnosis Procedure"](#).
NO >> INSPECTION END

Diagnosis Procedure

INFOID:000000007005773

WARNING:

- Because hybrid vehicles and electric vehicles contain a high voltage battery, there is the risk of electric shock, electric leakage, or similar accidents if the high voltage component and vehicle are handled incorrectly. Be sure to follow the correct work procedures when performing inspection and maintenance.
- Be sure to remove the service plug in order to disconnect the high voltage circuits before performing inspection or maintenance of high voltage system harnesses and parts.
- To prevent the removed service plug from being connected by mistake during the procedure, always carry it in your pocket or put it in the tool box.
- Be sure to wear insulating protective equipment consisting of glove, shoes, face shield and glasses before beginning work on the high voltage system.
- Clearly identify the persons responsible for high voltage work and ensure that other persons do not touch the vehicle. When not working, cover high voltage parts with an insulating cover sheet or similar item to prevent other persons from contacting them.
- Refer to [EV9-17, "High Voltage Precautions"](#).

CAUTION:

There is the possibility of a malfunction occurring if the vehicle is changed to READY status while the service plug is removed. Therefore do not change the vehicle to READY status unless instructed to do so in the Service Manual.

1. CHECK VOLTAGE OF 12 V BATTERY

Check the voltage of 12 V battery using circuit tester.

Is output more than 9 V?

- YES >> GO TO 2.
NO >> Replace 12 V battery. Refer to [PG-108, "Removal and Installation"](#).

2. CHECK FUSE

1. Power switch OFF.
2. Check 20A fuse [No.43].

NOTE:

Refer to [PG-87, "Fuse, Connector and Terminal Arrangement"](#) for fuse layout.

Is the inspection result normal?

- YES >> GO TO 3.
NO >> After eliminating the cause of flame cutting, replace the fuse.

3. CHECK LI-ION BATTERY POWER SUPPLY

P30FE 12V BATTERY VOLTAGE

[TYPE 1]

< DTC/CIRCUIT DIAGNOSIS >

1. Disconnect Li-ion battery vehicle communication harness connector.
2. Check voltage between Li-ion battery harness connector and ground.

+		-	Voltage
Li-ion battery			
Connector	Terminal		
B24	5	Ground	Battery voltage

Is the inspection result normal?

YES >> GO TO 4.

NO >> Repair harness or connector.

4. PRECONDITIONING

WARNING:

Disconnect high voltage. Refer to [GI-31, "How to Disconnect High Voltage"](#).

1. Remove Li-ion battery. Refer to [EVB-169, "Removal and Installation"](#).
2. Remove battery pack upper case. Refer to [EVB-184, "BATTERY JUNCTION BOX : Disassembly and Assembly"](#), see Step-1 to Step-3.

>> GO TO 5.

5. CHECK HARNESS BETWEEN LI-ION BATTERY AND LI-ION BATTERY CONTROLLER

1. Disconnect Li-ion battery harness connector and Li-ion battery controller harness connector.
2. Check continuity between Li-ion battery harness connector and Li-ion battery controller harness connector.

Li-ion battery		Li-ion battery controller		Continuity
Connector	Terminal	Connector	Terminal	
LB1	5	LB11	12	Existed

Is the inspection result normal?

YES >> Replace Li-ion battery controller. Refer to [EVB-192, "LI-ION BATTERY CONTROLLER : Disassembly and Assembly"](#).

NO >> Repair harness or connector.

P318D COMMUNICATION ERROR

< DTC/CIRCUIT DIAGNOSIS >

[TYPE 1]

P318D COMMUNICATION ERROR

DTC Logic

INFOID:000000007005774

DTC DETECTION LOGIC

DTC	Trouble diagnosis name	DTC detecting condition	Possible causes
P318D	COMMUNICATION ERROR	When no CAN communication signal is received continuously.	<ul style="list-style-type: none">• CAN communication line• Li-ion battery controller• VCM

DTC CONFIRMATION PROCEDURE

1. PERFORM DTC CONFIRMATION PROCEDURE

 With CONSULT

1. Power switch ON and wait for 10 seconds or more.
2. Select "Self Diagnostic Result" of "HV BAT".
3. Check DTC.

Is P318D detected?

- YES >> Refer to [EVB-99, "Diagnosis Procedure"](#).
NO >> INSPECTION END

Diagnosis Procedure

INFOID:000000007005775

For the diagnosis procedure, refer to [LAN-15, "Trouble Diagnosis Flow Chart"](#).

A
B
EVB
D
E
F
G
H
I
J
K
L
M
N
O
P

P318E COMMUNICATION ERROR

< DTC/CIRCUIT DIAGNOSIS >

[TYPE 1]

P318E COMMUNICATION ERROR

DTC Logic

INFOID:000000007005776

DTC DETECTION LOGIC

NOTE:

When the 12 V battery is removed within 5 minutes after turning the power switch OFF, "P318E", "P3191", and "P3196" may be simultaneously detected. This is not a malfunction.

DTC	Trouble diagnosis name	DTC detecting condition	Possible causes
P318E	COMMUNICATION ERROR	When no CAN communication signal is received from VCM continuously.	<ul style="list-style-type: none">• VCM• Li-ion battery controller• CAN communication line

DTC CONFIRMATION PROCEDURE

1. PERFORM DTC CONFIRMATION PROCEDURE

Ⓟ With CONSULT

1. Power switch OFF.
2. After turning the power switch OFF, get out of the vehicle and close all doors (including back door).
3. After turning the power switch OFF, wait for 5 minutes or more to remove the 12 V battery negative terminal. Refer to [EVB-17, "Precautions for Removing Battery Terminal"](#).
4. Connect 12 V battery negative terminal.
5. Power switch ON and wait for 10 seconds or more.
6. Select "Self Diagnostic Result" of "HV BAT".
7. Check DTC.

Is P318E detected?

- YES >> Refer to [EVB-100, "Diagnosis Procedure"](#).
NO >> INSPECTION END

Diagnosis Procedure

INFOID:000000007005777

1. PERFORM THE SELF-DIAGNOSIS

Ⓟ With CONSULT

1. Perform "All DTC Reading".
2. Check "Self diagnostic result" of systems other than "HV BAT" to see if "P318E" is detected.

Is P318E detected?

- YES >> Replace VCM. Refer to [EVC-377, "Removal and Installation"](#).
NO >> GO TO 2.

2. PREFORM THE SELF-DIAGNOSIS OF LI-ION BATTERY CONTROLLER

Ⓟ With CONSULT

1. Select "Self Diagnostic Result" of "HV BAT".
2. Check to see if "U1000" is detected simultaneously with "P318E".

Is U1000 detected?

- YES >> Replace Li-ion battery controller. Refer to [EVB-192, "LI-ION BATTERY CONTROLLER : Disassembly and Assembly"](#).
NO >> INSPECTION END

P3191 COMMUNICATION ERROR

< DTC/CIRCUIT DIAGNOSIS >

[TYPE 1]

P3191 COMMUNICATION ERROR

DTC Logic

INFOID:000000007005778

DTC DETECTION LOGIC

NOTE:

When the 12 V battery is removed within 5 minutes after turning the power switch OFF, "P318E", "P3191" and "P3196" may be simultaneously detected. This is not a malfunction.

DTC	Trouble diagnosis name	DTC detecting condition	Possible causes
P3191	COMMUNICATION ERROR	When no CAN communication signal is received from traction motor inverter continuously.	<ul style="list-style-type: none">• Traction motor inverter• Li-ion battery controller• CAN communication line

DTC CONFIRMATION PROCEDURE

1. PERFORM DTC CONFIRMATION PROCEDURE

Ⓜ With CONSULT

1. Power switch OFF.
2. After turning the power switch OFF, get out of the vehicle and close all doors (including back door).
3. After turning the power switch OFF, wait for 5 minutes or more to remove the 12 V battery negative terminal. Refer to [EVB-17, "Precautions for Removing Battery Terminal"](#).
4. Connect 12 V battery negative terminal.
5. Power switch ON and wait for 10 seconds or more.
6. Select "Self Diagnostic Result" of "HV BAT".
7. Check DTC.

Is P3191 detected?

- YES >> Refer to [EVB-101, "Diagnosis Procedure"](#).
NO >> INSPECTION END

Diagnosis Procedure

INFOID:000000007005779

1. PERFORM THE SELF-DIAGNOSIS

Ⓜ With CONSULT

1. Perform "All DTC Reading".
2. Check "Self diagnostic result" of systems other than "HV BAT" to see if "P3191" is detected.

Is P3191 detected?

- YES >> Replace traction motor inverter. Refer to [TMS-116, "Removal and Installation"](#)
NO >> GO TO 2.

2. PREFORM THE SELF-DIAGNOSIS OF LI-ION BATTERY CONTROLLER

Ⓜ With CONSULT

1. Select "Self Diagnostic Result" of "HV BAT".
2. Check to see if "U1000" is detected simultaneously with "P3191".

Is U1000 detected?

- YES >> Replace Li-ion battery controller. Refer to [EVB-192, "LI-ION BATTERY CONTROLLER : Disassembly and Assembly"](#).
NO >> INSPECTION END

P3196 COMMUNICATION ERROR

< DTC/CIRCUIT DIAGNOSIS >

[TYPE 1]

P3196 COMMUNICATION ERROR

DTC Logic

INFOID:000000007005780

DTC DETECTION LOGIC

NOTE:

When the 12 V battery is removed within 5 minutes after turning the power switch OFF, "P318E", "P3191" and "P3196" may be simultaneously detected. This is not a malfunction.

DTC	Trouble diagnosis name	DTC detecting condition	Possible causes
P3196	COMMUNICATION ERROR	When no CAN communication signal is received from on-board charger continuously.	<ul style="list-style-type: none">• On board charger• Li-ion battery controller• CAN communication line

DTC CONFIRMATION PROCEDURE

1. PERFORM DTC CONFIRMATION PROCEDURE

ⓐ With CONSULT

1. Power switch OFF.
2. After turning the power switch OFF, get out of the vehicle and close all doors (including back door).
3. After turning the power switch OFF, wait for 5 minutes or more to remove the 12 V battery negative terminal. Refer to [EVB-17, "Precautions for Removing Battery Terminal"](#).
4. Connect 12 V battery negative terminal.
5. Power switch ON and wait for 10 seconds or more.
6. Select "Self Diagnostic Result" of "HV BAT".
7. Check DTC.

Is P3196 detected?

- YES >> Refer to [EVB-102, "Diagnosis Procedure"](#).
NO >> INSPECTION END

Diagnosis Procedure

INFOID:000000007005781

1. PERFORM THE SELF-DIAGNOSIS

ⓐ With CONSULT

1. Perform "All DTC Reading".
2. Check "Self diagnostic result" of systems other than "HV BAT" to see if "P3196" is detected.

Is P3196 detected?

- YES >> Replace on board charger. Refer to [VC-112, "Removal and Installation"](#)
NO >> GO TO 2.

2. PREFORM THE SELF-DIAGNOSIS OF LI-ION BATTERY CONTROLLER

ⓐ With CONSULT

1. Select "Self Diagnostic Result" of "HV BAT".
2. Check to see if "U1000" is detected simultaneously with "P3196".

Is U1000 detected?

- YES >> Replace Li-ion battery controller. Refer to [EVB-192, "LI-ION BATTERY CONTROLLER : Disassembly and Assembly"](#).
NO >> INSPECTION END

P3199 COMMUNICATION ERROR

< DTC/CIRCUIT DIAGNOSIS >

[TYPE 1]

P3199 COMMUNICATION ERROR

DTC Logic

INFOID:000000007005782

DTC DETECTION LOGIC

DTC	Trouble diagnosis name	DTC detecting condition	Possible causes
P3199	COMMUNICATION ERROR	When a CRC error from VCM is detected.	<ul style="list-style-type: none">• VCM• Li-ion battery controller

DTC CONFIRMATION PROCEDURE

1. PERFORM DTC CONFIRMATION PROCEDURE

④ With CONSULT

1. Power switch ON and wait for 10 seconds or more.
2. Select "Self Diagnostic Result" of "HV BAT".
3. Check DTC.

Is P3199 detected?

- YES >> Refer to [EVB-103, "Diagnosis Procedure"](#).
NO >> INSPECTION END

Diagnosis Procedure

INFOID:000000007005783

When this DTC is detected, replace VCM. Refer to [EVC-377, "Removal and Installation"](#).

A
B
EVB
D
E
F
G
H
I
J
K
L
M
N
O
P

P319C COMMUNICATION ERROR

< DTC/CIRCUIT DIAGNOSIS >

[TYPE 1]

P319C COMMUNICATION ERROR

DTC Logic

INFOID:000000007005784

DTC DETECTION LOGIC

DTC	Trouble diagnosis name	DTC detecting condition	Possible causes
P319C	COMMUNICATION ER-ROR	When a CRC error from traction motor inverter is detected.	<ul style="list-style-type: none">• Traction motor inverter• Li-ion battery controller

DTC CONFIRMATION PROCEDURE

1. PERFORM DTC CONFIRMATION PROCEDURE

④ With CONSULT

1. Power switch ON and wait for 10 seconds or more.
2. Select "Self Diagnostic Result" of "HV BAT".
3. Check DTC.

Is P319C detected?

- YES >> Refer to [EVB-104, "Diagnosis Procedure"](#).
NO >> INSPECTION END

Diagnosis Procedure

INFOID:000000007005785

When this DTC is detected, replace traction motor inverter. Refer to [TMS-116, "Exploded View"](#).

P31A4 CAN ERROR VCM

< DTC/CIRCUIT DIAGNOSIS >

[TYPE 1]

P31A4 CAN ERROR VCM

DTC Logic

INFOID:000000007005786

DTC DETECTION LOGIC

DTC	Trouble diagnosis name	DTC detecting condition	Possible causes
P31A4	CAN ERROR VCM	If the CAN data from VCM has not change from the value which was previously received.	VCM

A

B

EVB

DTC CONFIRMATION PROCEDURE

1. PERFORM DTC CONFIRMATION PROCEDURE

 With CONSULT

1. Power switch ON and wait for 10 seconds or more.
2. Select "Self Diagnostic Result" of "HV BAT".
3. Check DTC.

Is P31A4 detected?

- YES >> Refer to [EVB-105, "Diagnosis Procedure"](#).
NO >> INSPECTION END

Diagnosis Procedure

INFOID:000000007005787

When this DTC is detected, replace VCM. Refer to [EVC-377, "Removal and Installation"](#).

D

E

F

G

H

I

J

K

L

M

N

O

P

P31A7 CAN ERROR INV/MC

< DTC/CIRCUIT DIAGNOSIS >

[TYPE 1]

P31A7 CAN ERROR INV/MC

DTC Logic

INFOID:000000007005788

DTC DETECTION LOGIC

DTC	Trouble diagnosis name	DTC detecting condition	Possible causes
P31A7	CAN ERROR INV/MC	If the CAN data from traction motor inverter has not change from the value which was previously received.	Traction motor inverter

DTC CONFIRMATION PROCEDURE

1. PERFORM DTC CONFIRMATION PROCEDURE

④ With CONSULT

1. Power switch ON and wait for 10 seconds or more.
2. Select "Self Diagnostic Result" of "HV BAT".
3. Check DTC.

Is P31A7 detected?

- YES >> Refer to [EVB-106, "Diagnosis Procedure"](#).
NO >> INSPECTION END

Diagnosis Procedure

INFOID:000000007005789

When this DTC is detected, replace traction motor inverter. Refer to [TMS-116, "Exploded View"](#).

P3300 TOTAL VOLTAGE OVER

< DTC/CIRCUIT DIAGNOSIS >

[TYPE 1]

P3300 TOTAL VOLTAGE OVER

DTC Logic

INFOID:000000007005790

DTC DETECTION LOGIC

DTC	Trouble diagnosis name	DTC detecting condition	Possible causes
P3300	TOTAL VOLTAGE OVER	When total voltage exceeds the allowable working voltage range.	<ul style="list-style-type: none">• Li-ion battery• Li-ion battery controller• VCM• Traction motor inverter

DTC CONFIRMATION PROCEDURE

1. PERFORM DTC CONFIRMATION PROCEDURE

④ With CONSULT

1. Power switch ON and wait for 10 seconds or more.
2. Select "Self Diagnostic Result" of "HV BAT".
3. Check DTC.

Is P3300 detected?

- YES >> Refer to [EVB-107, "Diagnosis Procedure"](#).
NO >> INSPECTION END

Diagnosis Procedure

INFOID:000000007005791

1. PERFORM THE SELF-DIAGNOSIS

④ With CONSULT

1. Perform "All DTC Reading".
2. Check "Self Diagnostic Result" of systems other than "HV BAT" to see if any DTC is detected.

Is any DTC detected?

- YES >> After performing trouble diagnosis of detected DTC, GO TO 2.
NO >> GO TO 2.

2. PERFORM THE SELF-DIAGNOSIS OF LI-ION BATTERY CONTROLLER

④ With CONSULT

1. Select "Self Diagnostic Result" of "HV BAT".
2. Check "Self Diagnostic Result" to see if "P3302"- "P3331" is detected.

Is P3302-P3331 detected?

- YES >> "P3302" - "P3331" are detected simultaneously.
- When "P3302" - "P330D" are detected simultaneously, perform the diagnosis procedure of "P3302" - "P330D". Refer to [EVB-108, "Diagnosis Procedure"](#).
 - When "P330E" - "P3319" are detected simultaneously, perform the diagnosis procedure of "P330E" - "P3319". Refer to [EVB-111, "Diagnosis Procedure"](#).
 - When "P331A" - "P3325" are detected simultaneously, perform the diagnosis procedure of "P331A" - "P3325". Refer to [EVB-114, "Diagnosis Procedure"](#).
 - When "P3326" - "P3331" are detected simultaneously, perform the diagnosis procedure of "P3326" - "P3331". Refer to [EVB-117, "Diagnosis Procedure"](#).
- NO >> Replace Li-ion battery controller. Refer to [EVB-192, "LI-ION BATTERY CONTROLLER : Disassembly and Assembly"](#).

P3302-P330D CELL OVER VOLTAGE

< DTC/CIRCUIT DIAGNOSIS >

[TYPE 1]

P3302-P330D CELL OVER VOLTAGE

DTC Logic

INFOID:000000007005792

DTC DETECTION LOGIC

DTC	Trouble diagnosis name	DTC detecting condition	Possible causes
P3302	CELL OVER VOLTAGE MODULE1	When cell voltage exceeds the allowable working voltage range.	<ul style="list-style-type: none">• Overcharge caused by traction motor inverter/VCM malfunction• Module• Li-ion battery controller• Bus bar• Harness or connector
P3303	CELL OVER VOLTAGE MODULE2		
P3304	CELL OVER VOLTAGE MODULE3		
P3305	CELL OVER VOLTAGE MODULE4		
P3306	CELL OVER VOLTAGE MODULE5		
P3307	CELL OVER VOLTAGE MODULE6		
P3308	CELL OVER VOLTAGE MODULE7		
P3309	CELL OVER VOLTAGE MODULE8		
P330A	CELL OVER VOLTAGE MODULE9		
P330B	CELL OVER VOLTAGE MODULE10		
P330C	CELL OVER VOLTAGE MODULE11		
P330D	CELL OVER VOLTAGE MODULE12		

DTC CONFIRMATION PROCEDURE

1. PERFORM DTC CONFIRMATION PROCEDURE

Ⓟ With CONSULT

1. Power switch ON and wait for 10 seconds or more.
2. Select "Self Diagnostic Result" of "HV BAT".
3. Check DTC.

Is any DTC detected?

- YES >> Refer to [EVB-108, "Diagnosis Procedure"](#).
NO >> INSPECTION END

Diagnosis Procedure

INFOID:000000007005793

WARNING:

- Because hybrid vehicles and electric vehicles contain a high voltage battery, there is the risk of electric shock, electric leakage, or similar accidents if the high voltage component and vehicle are handled incorrectly. Be sure to follow the correct work procedures when performing inspection and maintenance.
- Be sure to remove the service plug in order to disconnect the high voltage circuits before performing inspection or maintenance of high voltage system harnesses and parts.
- To prevent the removed service plug from being connected by mistake during the procedure, always carry it in your pocket or put it in the tool box.
- Be sure to wear insulating protective equipment consisting of glove, shoes, face shield and glasses before beginning work on the high voltage system.
- Clearly identify the persons responsible for high voltage work and ensure that other persons do not touch the vehicle. When not working, cover high voltage parts with an insulating cover sheet or similar item to prevent other persons from contacting them.
- Refer to [EVB-17, "High Voltage Precautions"](#).

CAUTION:

There is the possibility of a malfunction occurring if the vehicle is changed to READY status while the service plug is removed. Therefore do not change the vehicle to READY status unless instructed to do so in the Service Manual.

1. CHECK SELF-DIAGNOSIS RESULTS

Ⓟ With CONSULT

1. Perform "All DTC Reading" with CONSULT.

P3302-P330D CELL OVER VOLTAGE

< DTC/CIRCUIT DIAGNOSIS >

[TYPE 1]

2. Check systems other than "HV BAT" if any DTC is detected.

Is any DTC detected?

YES >> After performing trouble diagnosis of detected DTC, GO TO 2.

NO >> GO TO 2.

2. PRECONDITIONING

WARNING:

Disconnect high voltage. Refer to [GI-31, "How to Disconnect High Voltage"](#).

1. Remove Li-ion battery. Refer to [EVB-169, "Removal and Installation"](#).

2. Remove battery pack upper case. Refer to [EVB-184, "BATTERY JUNCTION BOX : Disassembly and Assembly"](#), see Step-1 to Step-3.

>> GO TO 3.

3. CHECK HARNESS BETWEEN MODULE AND LI-ION BATTERY CONTROLLER

1. Disconnect module harness connector and Li-ion battery controller harness connector.

2. Refer to below table and check the continuity between corresponding module and Li-ion battery controller.

DTC	Module No.	Module		Li-ion battery controller		Continuity
		Connector	Terminal	Connector	Terminal	
P3302	1	LB9	17	LB13	33	Existed
			2		50	
			18		34	
P3303	2	LB9	18	LB13	34	Existed
			3		51	
			19		35	
P3304	3	LB9	19	LB13	35	Existed
			4		52	
			20		36	
P3305	4	LB9	20	LB13	36	Existed
			5		53	
			21		37	
P3306	5	LB9	21	LB13	37	Existed
			6		54	
			22		38	
P3307	6	LB9	22	LB13	38	Existed
			7		55	
			23		39	
P3308	7	LB9	23	LB13	39	Existed
			8		56	
			24		40	
P3309	8	LB9	24	LB13	40	Existed
			9		57	
			25		42	
P330A	9	LB9	25	LB13	42	Existed
			26		58	
			11		43	

P3302-P330D CELL OVER VOLTAGE

[TYPE 1]

< DTC/CIRCUIT DIAGNOSIS >

DTC	Module No.	Module		Li-ion battery controller		Continuity
		Connector	Terminal	Connector	Terminal	
P330B	10	LB9	11	LB13	43	Existed
			27		59	
			12		44	
P330C	11	LB9	12	LB13	44	Existed
			28		60	
			13		45	
P330D	12	LB9	13	LB13	45	Existed
			29		61	
			14		46	

Is the inspection result normal?

YES >> GO TO 4.

NO >> Repair harness or connector.

4.CHECK MODULE VOLTAGE

Check voltage of corresponding module. Refer to [EVB-110, "Component Inspection"](#).

Is the inspection result normal?

YES >> Replace Li-ion battery controller. Refer to [EVB-192, "LI-ION BATTERY CONTROLLER : Disassembly and Assembly"](#).

NO >> Replace corresponding module. Refer to [EVB-176, "Exploded view"](#).

Component Inspection

INFOID:000000007592845

1.CHECK MODULE VOLTAGE

Check voltage of module.

A : Positive terminal (Red)

B : Negative terminal (Black)

Terminals		Voltage (Approx.)
(+)	(-)	
Module		5.0 - 8.5 V
Positive terminal (Red)	Negative terminal (Black)	

Is the inspection result normal?

YES >> INSPECTION END

NO >> Replace module. Refer to [EVB-198, "FRONT MODULE STACK : Disassembly and Assembly"](#) (Front module) or [EVB-208, "REAR MODULE STACK : Disassembly and Assembly"](#) (Rear module).

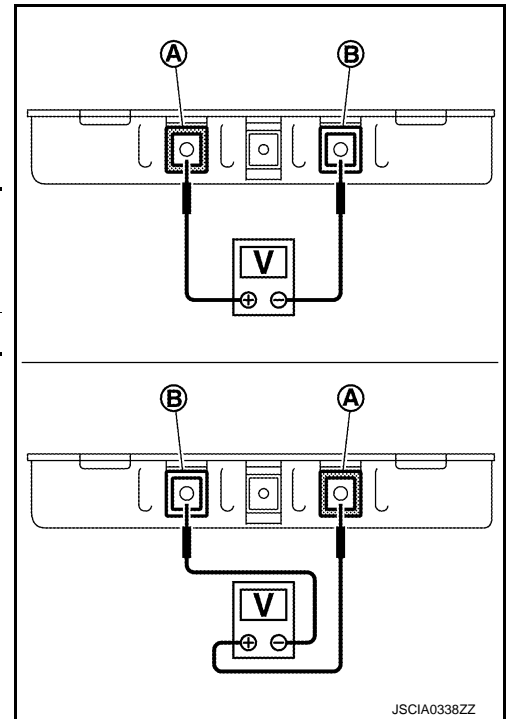

P330E-P3319 CELL OVER VOLTAGE

< DTC/CIRCUIT DIAGNOSIS >

[TYPE 1]

P330E-P3319 CELL OVER VOLTAGE

DTC Logic

INFOID:000000007221015

DTC DETECTION LOGIC

DTC	Trouble diagnosis name	DTC detecting condition	Possible causes
P330E	CELL OVER VOLTAGE MODULE13	When cell voltage exceeds the allowable working voltage range.	<ul style="list-style-type: none"> Overcharge caused by traction motor inverter/VCM malfunction Module Li-ion battery controller Bus bar Harness or connector
P330F	CELL OVER VOLTAGE MODULE14		
P3310	CELL OVER VOLTAGE MODULE15		
P3311	CELL OVER VOLTAGE MODULE16		
P3312	CELL OVER VOLTAGE MODULE17		
P3313	CELL OVER VOLTAGE MODULE18		
P3314	CELL OVER VOLTAGE MODULE19		
P3315	CELL OVER VOLTAGE MODULE20		
P3316	CELL OVER VOLTAGE MODULE21		
P3317	CELL OVER VOLTAGE MODULE22		
P3318	CELL OVER VOLTAGE MODULE23		
P3319	CELL OVER VOLTAGE MODULE24		

DTC CONFIRMATION PROCEDURE

1. PERFORM DTC CONFIRMATION PROCEDURE

④ With CONSULT

- Power switch ON and wait for 10 seconds or more.
- Select "Self Diagnostic Result" of "HV BAT".
- Check DTC.

Is any DTC detected?

- YES >> Refer to [EVB-117, "Diagnosis Procedure"](#).
- NO >> INSPECTION END

Diagnosis Procedure

INFOID:000000007221016

WARNING:

- Because hybrid vehicles and electric vehicles contain a high voltage battery, there is the risk of electric shock, electric leakage, or similar accidents if the high voltage component and vehicle are handled incorrectly. Be sure to follow the correct work procedures when performing inspection and maintenance.
- Be sure to remove the service plug in order to disconnect the high voltage circuits before performing inspection or maintenance of high voltage system harnesses and parts.
- To prevent the removed service plug from being connected by mistake during the procedure, always carry it in your pocket or put it in the tool box.
- Be sure to wear insulating protective equipment consisting of glove, shoes, face shield and glasses before beginning work on the high voltage system.
- Clearly identify the persons responsible for high voltage work and ensure that other persons do not touch the vehicle. When not working, cover high voltage parts with an insulating cover sheet or similar item to prevent other persons from contacting them.
- Refer to [EVB-17, "High Voltage Precautions"](#).

CAUTION:

There is the possibility of a malfunction occurring if the vehicle is changed to READY status while the service plug is removed. Therefore do not change the vehicle to READY status unless instructed to do so in the Service Manual.

1. CHECK SELF-DIAGNOSIS RESULTS

④ With CONSULT

- Perform "All DTC Reading" with CONSULT.

P330E-P3319 CELL OVER VOLTAGE

[TYPE 1]

< DTC/CIRCUIT DIAGNOSIS >

2. Check systems other than "HV BAT" if any DTC is detected.

Is any DTC detected?

YES >> After performing trouble diagnosis of detected DTC, GO TO 2.

NO >> GO TO 2.

2. PRECONDITIONING

WARNING:

Disconnect high voltage. Refer to [GI-31, "How to Disconnect High Voltage"](#).

1. Remove Li-ion battery. Refer to [EVB-169, "Removal and Installation"](#).

2. Remove battery pack upper case. Refer to [EVB-184, "BATTERY JUNCTION BOX : Disassembly and Assembly"](#), see Step-1 to Step-3.

>> GO TO 3.

3. CHECK HARNESS BETWEEN MODULE AND LI-ION BATTERY CONTROLLER

1. Disconnect module harness connector and Li-ion battery controller harness connector.

2. Refer to below table and check the continuity between corresponding module and Li-ion battery controller.

DTC	Module No.	Module		Li-ion battery controller		Continuity
		Connector	Terminal	Connector	Terminal	
P330E	13	LB9	14	LB13	46	Existed
			30		62	
			15		47	
P330F	14	LB9	15	LB13	47	Existed
			31		63	
			1		48	
P3310	15	LB9	1	LB13	48	Existed
		LB10	45	LB14	77	
			34		65	
P3311	16	LB10	34	LB14	65	Existed
			46		78	
			35		66	
P3312	17	LB10	35	LB14	66	Existed
			36		80	
			48		69	
P3313	18	LB10	48	LB14	69	Existed
			37		81	
			49		70	
P3314	19	LB10	49	LB14	70	Existed
			38		82	
			50		71	
P3315	20	LB10	50	LB14	71	Existed
			39		83	
			51		72	
P3316	21	LB10	51	LB14	72	Existed
			52		84	
			41		73	

P330E-P3319 CELL OVER VOLTAGE

< DTC/CIRCUIT DIAGNOSIS >

[TYPE 1]

DTC	Module No.	Module		Li-ion battery controller		Continuity
		Connector	Terminal	Connector	Terminal	
P3317	22	LB10	41	LB14	73	Existed
			53		85	
			42		74	
P3318	23	LB10	42	LB14	74	Existed
			54		86	
			43		75	
P3319	24	LB10	43	LB14	75	Existed
			55		87	
			44		76	

Is the inspection result normal?

YES >> GO TO 4.

NO >> Repair harness or connector.

4. CHECK MODULE VOLTAGE

Check voltage of corresponding module. Refer to [EVB-113, "Component Inspection"](#).

Is the inspection result normal?

YES >> Replace Li-ion battery controller. Refer to [EVB-192, "LI-ION BATTERY CONTROLLER : Disassembly and Assembly"](#).

NO >> Replace corresponding module. Refer to [EVB-176, "Exploded view"](#).

Component Inspection

INFOID:000000007592846

1. CHECK MODULE VOLTAGE

Check voltage of module.

A : Positive terminal (Red)

B : Negative terminal (Black)

Terminals		Voltage (Approx.)
(+)	(-)	
Module		5.0 - 8.5 V
Positive terminal (Red)	Negative terminal (Black)	

Is the inspection result normal?

YES >> INSPECTION END

NO >> Replace module. Refer to [EVB-198, "FRONT MODULE STACK : Disassembly and Assembly"](#) (Front module) or [EVB-208, "REAR MODULE STACK : Disassembly and Assembly"](#) (Rear module).

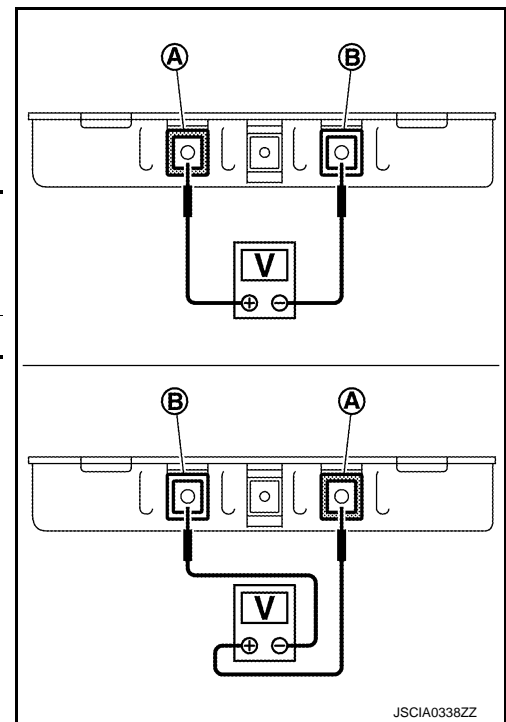

P331A-P3325 CELL OVER VOLTAGE

< DTC/CIRCUIT DIAGNOSIS >

[TYPE 1]

P331A-P3325 CELL OVER VOLTAGE

DTC Logic

INFOID:000000007221018

DTC DETECTION LOGIC

DTC	Trouble diagnosis name	DTC detecting condition	Possible causes
P331A	CELL OVER VOLTAGE MODULE25	When cell voltage exceeds the allowable working voltage range.	<ul style="list-style-type: none">• Overcharge caused by traction motor inverter/VCM malfunction• Module• Li-ion battery controller• Bus bar• Harness or connector
P331B	CELL OVER VOLTAGE MODULE26		
P331C	CELL OVER VOLTAGE MODULE27		
P331D	CELL OVER VOLTAGE MODULE28		
P331E	CELL OVER VOLTAGE MODULE29		
P331F	CELL OVER VOLTAGE MODULE30		
P3320	CELL OVER VOLTAGE MODULE31		
P3321	CELL OVER VOLTAGE MODULE32		
P3322	CELL OVER VOLTAGE MODULE33		
P3323	CELL OVER VOLTAGE MODULE34		
P3324	CELL OVER VOLTAGE MODULE35		
P3325	CELL OVER VOLTAGE MODULE36		

DTC CONFIRMATION PROCEDURE

1. PERFORM DTC CONFIRMATION PROCEDURE

Ⓟ With CONSULT

1. Power switch ON and wait for 10 seconds or more.
2. Select "Self Diagnostic Result" of "HV BAT".
3. Check DTC.

Is any DTC detected?

- YES >> Refer to [EVB-117, "Diagnosis Procedure"](#).
NO >> INSPECTION END

Diagnosis Procedure

INFOID:000000007221019

WARNING:

- Because hybrid vehicles and electric vehicles contain a high voltage battery, there is the risk of electric shock, electric leakage, or similar accidents if the high voltage component and vehicle are handled incorrectly. Be sure to follow the correct work procedures when performing inspection and maintenance.
- Be sure to remove the service plug in order to disconnect the high voltage circuits before performing inspection or maintenance of high voltage system harnesses and parts.
- To prevent the removed service plug from being connected by mistake during the procedure, always carry it in your pocket or put it in the tool box.
- Be sure to wear insulating protective equipment consisting of glove, shoes, face shield and glasses before beginning work on the high voltage system.
- Clearly identify the persons responsible for high voltage work and ensure that other persons do not touch the vehicle. When not working, cover high voltage parts with an insulating cover sheet or similar item to prevent other persons from contacting them.
- Refer to [EVB-17, "High Voltage Precautions"](#).

CAUTION:

There is the possibility of a malfunction occurring if the vehicle is changed to READY status while the service plug is removed. Therefore do not change the vehicle to READY status unless instructed to do so in the Service Manual.

1. CHECK SELF-DIAGNOSIS RESULTS

Ⓟ With CONSULT

1. Perform "All DTC Reading" with CONSULT.

P331A-P3325 CELL OVER VOLTAGE

< DTC/CIRCUIT DIAGNOSIS >

[TYPE 1]

2. Check "Self Diagnostic Result" of systems other than "HV BAT" if any DTC is detected.

Is any DTC detected?

YES >> After performing trouble diagnosis of detected DTC, GO TO 2.

NO >> GO TO 2.

2. PRECONDITIONING

WARNING:

Disconnect high voltage. Refer to [GI-31, "How to Disconnect High Voltage"](#).

1. Remove Li-ion battery. Refer to [EVV-169, "Removal and Installation"](#).

2. Remove battery pack upper case. Refer to [EVV-184, "BATTERY JUNCTION BOX : Disassembly and Assembly"](#), see Step-1 to Step-3.

>> GO TO 3.

3. CHECK HARNESS BETWEEN MODULE AND LI-ION BATTERY CONTROLLER

Ⓜ With CONSULT

1. Power switch OFF.

2. Identify the malfunctioning module based on detected DTC.

3. Disconnect module harness connector and Li-ion battery controller harness connector.

4. Refer to below table and check the continuity between corresponding module and Li-ion battery controller.

DTC	Module No.	Module		Li-ion battery controller		Continuity
		Connector	Terminal	Connector	Terminal	
P331A	25	LB8	57	LB15	89	Existed
			73		110	
			58		90	
P331B	26	LB8	58	LB15	90	Existed
			74		111	
			75		91	
P331C	27	LB8	75	LB15	91	Existed
			60		112	
			76		92	
P331D	28	LB8	76	LB15	92	Existed
			77		113	
			62		93	
P331E	29	LB8	62	LB15	93	Existed
			78		114	
			79		94	
P331F	30	LB8	79	LB15	94	Existed
			64		115	
			80		95	
P3320	31	LB8	80	LB15	95	Existed
			81		116	
			66		96	
P3321	32	LB8	66	LB15	96	Existed
			82		117	
			83		97	

P331A-P3325 CELL OVER VOLTAGE

[TYPE 1]

< DTC/CIRCUIT DIAGNOSIS >

DTC	Module No.	Module		Li-ion battery controller		Continuity
		Connector	Terminal	Connector	Terminal	
P3322	33	LB8	83	LB15	97	Existed
			68		118	
			84		99	
P3323	34	LB8	84	LB15	99	Existed
			85		119	
			70		100	
P3324	35	LB8	70	LB15	100	Existed
			86		120	
			87		101	
P3325	36	LB8	87	LB15	101	Existed
			72		121	
			88		102	

Is the inspection result normal?

YES >> GO TO 4.

NO >> Repair harness or connector.

4. CHECK MODULE VOLTAGE

Check voltage of corresponding module. Refer to [EVB-116, "Component Inspection"](#).

Is the inspection result normal?

YES >> Replace Li-ion battery controller. Refer to [EVB-192, "LI-ION BATTERY CONTROLLER : Disassembly and Assembly"](#).

NO >> Replace corresponding module. Refer to [EVB-176, "Exploded view"](#).

Component Inspection

INFOID:000000007592847

1. CHECK MODULE VOLTAGE

Check voltage of module.

A : Positive terminal (Red)

B : Negative terminal (Black)

Terminals		Voltage (Approx.)
(+)	(-)	
Module		5.0 - 8.5 V
Positive terminal (Red)	Negative terminal (Black)	

Is the inspection result normal?

YES >> INSPECTION END

NO >> Replace module. Refer to [EVB-198, "FRONT MODULE STACK : Disassembly and Assembly"](#) (Front module) or [EVB-208, "REAR MODULE STACK : Disassembly and Assembly"](#) (Rear module).

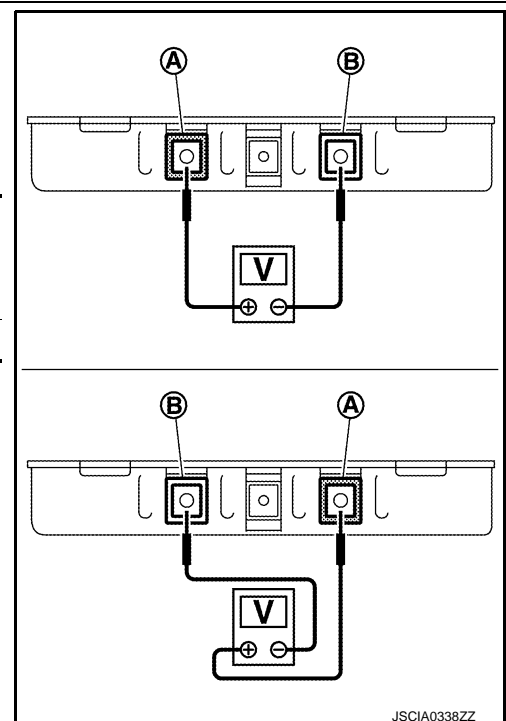

JSCIA0338ZZ

P3326-P3331 CELL OVER VOLTAGE

< DTC/CIRCUIT DIAGNOSIS >

[TYPE 1]

P3326-P3331 CELL OVER VOLTAGE

DTC Logic

INFOID:000000007221021

DTC DETECTION LOGIC

DTC	Trouble diagnosis name	DTC detecting condition	Possible causes
P3326	CELL OVER VOLTAGE MODULE37	When cell voltage exceeds the allowable working voltage range.	<ul style="list-style-type: none"> Overcharge caused by traction motor inverter/VCM malfunction Module Li-ion battery controller Bus bar Harness or connector
P3327	CELL OVER VOLTAGE MODULE38		
P3328	CELL OVER VOLTAGE MODULE39		
P3329	CELL OVER VOLTAGE MODULE40		
P332A	CELL OVER VOLTAGE MODULE41		
P332B	CELL OVER VOLTAGE MODULE42		
P332C	CELL OVER VOLTAGE MODULE43		
P332D	CELL OVER VOLTAGE MODULE44		
P332E	CELL OVER VOLTAGE MODULE45		
P332F	CELL OVER VOLTAGE MODULE46		
P3330	CELL OVER VOLTAGE MODULE47		
P3331	CELL OVER VOLTAGE MODULE48		

DTC CONFIRMATION PROCEDURE

1. PERFORM DTC CONFIRMATION PROCEDURE

④ With CONSULT

- Power switch ON and wait for 10 seconds or more.
- Select "Self Diagnostic Result" of "HV BAT".
- Check DTC.

Is any DTC detected?

- YES >> Refer to [EVB-117, "Diagnosis Procedure"](#).
 NO >> INSPECTION END

Diagnosis Procedure

INFOID:000000007221022

WARNING:

- Because hybrid vehicles and electric vehicles contain a high voltage battery, there is the risk of electric shock, electric leakage, or similar accidents if the high voltage component and vehicle are handled incorrectly. Be sure to follow the correct work procedures when performing inspection and maintenance.
- Be sure to remove the service plug in order to disconnect the high voltage circuits before performing inspection or maintenance of high voltage system harnesses and parts.
- To prevent the removed service plug from being connected by mistake during the procedure, always carry it in your pocket or put it in the tool box.
- Be sure to wear insulating protective equipment consisting of glove, shoes, face shield and glasses before beginning work on the high voltage system.
- Clearly identify the persons responsible for high voltage work and ensure that other persons do not touch the vehicle. When not working, cover high voltage parts with an insulating cover sheet or similar item to prevent other persons from contacting them.
- Refer to [EVB-17, "High Voltage Precautions"](#).

CAUTION:

There is the possibility of a malfunction occurring if the vehicle is changed to READY status while the service plug is removed. Therefore do not change the vehicle to READY status unless instructed to do so in the Service Manual.

1. CHECK SELF-DIAGNOSIS RESULTS

④ With CONSULT

- Perform "All DTC Reading" with CONSULT.

P3326-P3331 CELL OVER VOLTAGE

[TYPE 1]

< DTC/CIRCUIT DIAGNOSIS >

2. Check "Self Diagnostic Result" of systems other than "HV BAT" if any DTC is detected.

Is any DTC detected?

YES >> After performing trouble diagnosis of detected DTC, GO TO 2.

NO >> GO TO 2.

2. PRECONDITIONING

WARNING:

Disconnect high voltage. Refer to [GI-31, "How to Disconnect High Voltage"](#).

1. Remove Li-ion battery. Refer to [EV-169, "Removal and Installation"](#).

2. Remove battery pack upper case. Refer to [EV-184, "BATTERY JUNCTION BOX : Disassembly and Assembly"](#), see Step-1 to Step-3.

>> GO TO 3.

3. CHECK HARNESS BETWEEN MODULE AND LI-ION BATTERY CONTROLLER

Ⓟ With CONSULT

1. Power switch OFF.

2. Identify the malfunctioning module based on detected DTC.

3. Disconnect module harness connector and Li-ion battery controller harness connector.

4. Refer to below table and check the continuity between corresponding module and Li-ion battery controller.

DTC	Module No.	Module		Li-ion battery controller		Continuity
		Connector	Terminal	Connector	Terminal	
P3326	37	LB8	88	LB15	102	Existed
			LB7		89	
					101	
P3327	38	LB7	101	LB15	103	Existed
			90		123	
			102		104	
P3328	39	LB7	102	LB15	104	Existed
			91		124	
			103		105	
P3329	40	LB7	103	LB15	105	Existed
			92		125	
			104		106	
P332A	41	LB7	104	LB15	106	Existed
			93		127	
			105		107	
P332B	42	LB7	105	LB15	107	Existed
			94		128	
			106		108	
P332C	43	LB7	106	LB15	108	Existed
			95	LB16	137	
					107	
P332D	44	LB7	107	LB16	130	Existed
			96		138	
			108		131	

P3326-P3331 CELL OVER VOLTAGE

< DTC/CIRCUIT DIAGNOSIS >

[TYPE 1]

DTC	Module No.	Module		Li-ion battery controller		Continuity
		Connector	Terminal	Connector	Terminal	
P332E	45	LB7	108	LB16	131	Existed
			97		140	
			109		132	
P332F	46	LB7	109	LB16	132	Existed
			98		141	
			110		133	
P3330	47	LB7	110	LB16	133	Existed
			99		142	
			111		134	
P3331	48	LB7	111	LB16	134	Existed
			100		143	
			112		135	

Is the inspection result normal?

YES >> GO TO 4.

NO >> Repair harness or connector.

4.CHECK MODULE VOLTAGE

Check voltage of corresponding module. Refer to [EVb-119, "Component Inspection"](#).

Is the inspection result normal?

YES >> Replace Li-ion battery controller. Refer to [EVb-192, "LI-ION BATTERY CONTROLLER : Disassembly and Assembly"](#).

NO >> Replace corresponding module. Refer to [EVb-176, "Exploded view"](#).

Component Inspection

INFOID:000000007592848

1.CHECK MODULE VOLTAGE

Check voltage of module.

A : Positive terminal (Red)

B : Negative terminal (Black)

Terminals		Voltage (Approx.)
(+)	(-)	
Module		5.0 - 8.5 V
Positive terminal (Red)	Negative terminal (Black)	

Is the inspection result normal?

YES >> INSPECTION END

NO >> Replace module. Refer to [EVb-198, "FRONT MODULE STACK : Disassembly and Assembly"](#) (Front module) or [EVb-208, "REAR MODULE STACK : Disassembly and Assembly"](#) (Rear module).

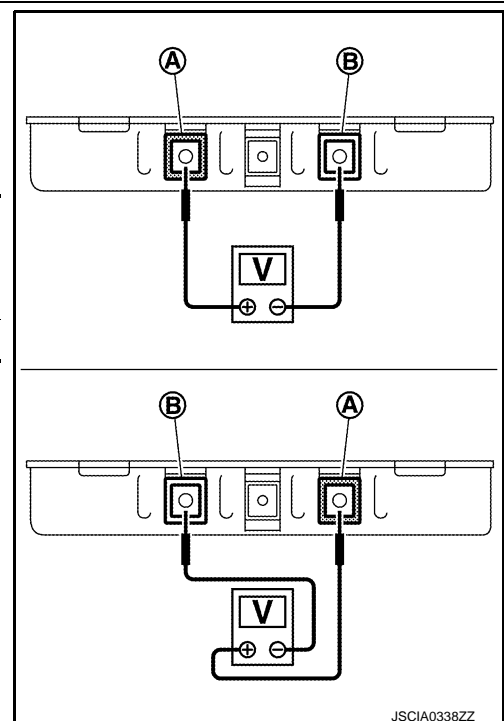

JSCIA0338ZZ

P3373 TOTAL VOLTAGE OVER DISCHARGE

< DTC/CIRCUIT DIAGNOSIS >

[TYPE 1]

P3373 TOTAL VOLTAGE OVER DISCHARGE

DTC Logic

INFOID:000000007005804

DTC DETECTION LOGIC

If DTC P3373 is displayed with DTC P30F4, first perform the trouble diagnosis for P30F4. Refer to [EVB-92, "DTC Logic"](#).

DTC	Trouble diagnosis name	DTC detecting condition	Possible causes
P3373	TOTAL VOLTAGE OVER DISCHARGE	When total voltage lowers below the allowable working voltage range.	<ul style="list-style-type: none">• Li-ion battery controller• Module• Bus bar• Service plug fuse• Overcharge caused by traction motor inverter/VCM malfunction• Harness or connector

DTC CONFIRMATION PROCEDURE

1. CHECK SELF-DIAGNOSIS RESULTS

Ⓟ With CONSULT

1. Power switch ON and wait for 10 seconds or more.
2. Select "Self Diagnostic Result" of "HV BAT".
3. Check DTC.

Is P3373 detected?

- YES >> Refer to [EVB-120, "Diagnosis Procedure"](#).
NO >> INSPECTION END

Diagnosis Procedure

INFOID:000000007005805

1. PERFORM THE SELF-DIAGNOSIS

Ⓟ With CONSULT

1. Perform "All DTC Reading".
2. Check "Self diagnostic result" of systems other than "HV BAT" to see if any DTC is detected.

Is any DTC detected?

- YES >> After performing trouble diagnosis of detected DTC, GO TO 2.
NO >> GO TO 2.

2. PERFORM THE SELF-DIAGNOSIS OF LI-ION BATTERY CONTROLLER

Ⓟ With CONSULT

1. Select "Self Diagnostic Result" of "HV BAT".
2. Check to see if "P3375"- "P33A4" is detected simultaneously with "P3373".

Is P3375-P33A4 detected?

- YES >>
 - When "P3375"- "P3380" are detected simultaneously, perform the diagnosis procedure of "P3375"- "P3380". Refer to [EVB-121, "Diagnosis Procedure"](#).
 - When "P3381"- "P338C" are detected simultaneously, perform the diagnosis procedure of "P3381"- "P338C". Refer to [EVB-124, "Diagnosis Procedure"](#).
 - When "P338D"- "P3398" are detected simultaneously, perform the diagnosis procedure of "P338D"- "P3398". Refer to [EVB-127, "Diagnosis Procedure"](#).
 - When "P3399"- "P33A4" are detected simultaneously, perform the diagnosis procedure of "P3399"- "P33A4". Refer to [EVB-130, "Diagnosis Procedure"](#).
- NO >> Replace Li-ion battery controller. Refer to [EVB-192, "LI-ION BATTERY CONTROLLER : Disassembly and Assembly"](#).

P3375-P3380 CELL OVER DISCHARGE

< DTC/CIRCUIT DIAGNOSIS >

[TYPE 1]

P3375-P3380 CELL OVER DISCHARGE

DTC Logic

INFOID:000000007005806

DTC DETECTION LOGIC

DTC	Trouble diagnosis name	DTC detecting condition	Possible causes
P3375	CELL OVER DISCHARGE MODULE1	When cell voltage lowers below the allowable working voltage range.	<ul style="list-style-type: none"> Overcharge caused by traction motor inverter/VCM malfunction Module Li-ion battery controller Bus bar Harness or connector
P3376	CELL OVER DISCHARGE MODULE2		
P3377	CELL OVER DISCHARGE MODULE3		
P3378	CELL OVER DISCHARGE MODULE4		
P3379	CELL OVER DISCHARGE MODULE5		
P337A	CELL OVER DISCHARGE MODULE6		
P337B	CELL OVER DISCHARGE MODULE7		
P337C	CELL OVER DISCHARGE MODULE8		
P337D	CELL OVER DISCHARGE MODULE9		
P337E	CELL OVER DISCHARGE MODULE10		
P337F	CELL OVER DISCHARGE MODULE11		
P3380	CELL OVER DISCHARGE MODULE12		

DTC CONFIRMATION PROCEDURE

1. PERFORM DTC CONFIRMATION PROCEDURE

④ With CONSULT

- Power switch ON and wait for 10 seconds or more.
- Select "Self Diagnostic Result" of "HV BAT".
- Check DTC.

Is any DTC detected?

- YES >> Refer to [EVB-121, "Diagnosis Procedure"](#).
- NO >> INSPECTION END

Diagnosis Procedure

INFOID:000000007005807

WARNING:

- Because hybrid vehicles and electric vehicles contain a high voltage battery, there is the risk of electric shock, electric leakage, or similar accidents if the high voltage component and vehicle are handled incorrectly. Be sure to follow the correct work procedures when performing inspection and maintenance.
- Be sure to remove the service plug in order to disconnect the high voltage circuits before performing inspection or maintenance of high voltage system harnesses and parts.
- To prevent the removed service plug from being connected by mistake during the procedure, always carry it in your pocket or put it in the tool box.
- Be sure to wear insulating protective equipment consisting of glove, shoes, face shield and glasses before beginning work on the high voltage system.
- Clearly identify the persons responsible for high voltage work and ensure that other persons do not touch the vehicle. When not working, cover high voltage parts with an insulating cover sheet or similar item to prevent other persons from contacting them.
- Refer to [EVB-17, "High Voltage Precautions"](#).

CAUTION:

There is the possibility of a malfunction occurring if the vehicle is changed to READY status while the service plug is removed. Therefore do not change the vehicle to READY status unless instructed to do so in the Service Manual.

1. CHECK SELF-DIAGNOSIS RESULTS

④ With CONSULT

- Perform "All DTC Reading" with CONSULT.

P3375-P3380 CELL OVER DISCHARGE

[TYPE 1]

< DTC/CIRCUIT DIAGNOSIS >

2. Check systems other than "HV BAT" if any DTC is detected.

Is any DTC detected?

YES >> After performing trouble diagnosis of detected DTC, GO TO 2.

NO >> GO TO 2.

2. PRECONDITIONING

WARNING:

Disconnect high voltage. Refer to [GI-31, "How to Disconnect High Voltage"](#).

1. Remove Li-ion battery. Refer to [EVB-169, "Removal and Installation"](#).

2. Remove battery pack upper case. Refer to [EVB-184, "BATTERY JUNCTION BOX : Disassembly and Assembly"](#), see Step-1 to Step-3.

>> GO TO 3.

3. CHECK HARNESS BETWEEN MODULE AND LI-ION BATTERY CONTROLLER

1. Disconnect module harness connector and Li-ion battery controller harness connector.

2. Refer to below table and check the continuity between corresponding module and Li-ion battery controller.

DTC	Module No.	Module		Li-ion battery controller		Continuity
		Connector	Terminal	Connector	Terminal	
P3375	1	LB9	17	LB13	33	Existed
			2		50	
			18		34	
P3376	2	LB9	18	LB13	34	Existed
			3		51	
			19		35	
P3377	3	LB9	19	LB13	35	Existed
			4		52	
			20		36	
P3378	4	LB9	20	LB13	36	Existed
			5		53	
			21		37	
P3379	5	LB9	21	LB13	37	Existed
			6		54	
			22		38	
P337A	6	LB9	22	LB13	38	Existed
			7		55	
			23		39	
P337B	7	LB9	23	LB13	39	Existed
			8		56	
			24		40	
P337C	8	LB9	24	LB13	40	Existed
			9		57	
			25		42	
P337D	9	LB9	25	LB13	42	Existed
			26		58	
			11		43	

P3375-P3380 CELL OVER DISCHARGE

< DTC/CIRCUIT DIAGNOSIS >

[TYPE 1]

DTC	Module No.	Module		Li-ion battery controller		Continuity
		Connector	Terminal	Connector	Terminal	
P337E	10	LB9	11	LB13	43	Existed
			27		59	
			12		44	
P330F	11	LB9	12	LB13	44	Existed
			28		60	
			13		45	
P3380	12	LB9	13	LB13	45	Existed
			29		61	
			14		46	

Is the inspection result normal?

YES >> GO TO 4.

NO >> Repair Harness or connector.

4. CHECK MODULE VOLTAGE

Check voltage of corresponding module. Refer to [EVB-123, "Component Inspection"](#).

Is the inspection result normal?

YES >> Replace Li-ion battery controller. Refer to [EVB-192, "LI-ION BATTERY CONTROLLER : Disassembly and Assembly"](#).

NO >> Replace corresponding module. Refer to [EVB-176, "Exploded view"](#).

Component Inspection

INFOID:000000007592849

1. CHECK MODULE VOLTAGE

Check voltage of module.

A : Positive terminal (Red)

B : Negative terminal (Black)

Terminals		Voltage (Approx.)
(+)	(-)	
Module		5.0 - 8.5 V
Positive terminal (Red)	Negative terminal (Black)	

Is the inspection result normal?

YES >> INSPECTION END

NO >> Replace module. Refer to [EVB-198, "FRONT MODULE STACK : Disassembly and Assembly"](#) (Front module) or [EVB-208, "REAR MODULE STACK : Disassembly and Assembly"](#) (Rear module).

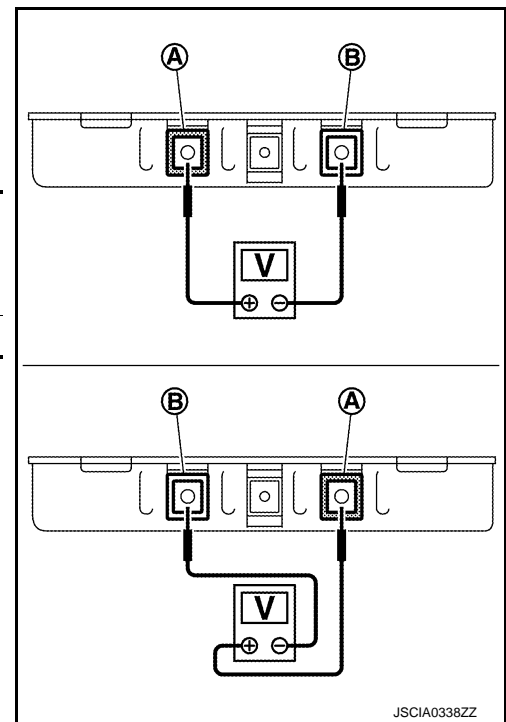

JSCIA0338ZZ

P3381-P338C CELL OVER DISCHARGE

< DTC/CIRCUIT DIAGNOSIS >

[TYPE 1]

P3381-P338C CELL OVER DISCHARGE

DTC Logic

INFOID:000000007221024

DTC DETECTION LOGIC

DTC	Trouble diagnosis name	DTC detecting condition	Possible causes
P3381	CELL OVER DISCHARGE MODULE13	When cell voltage lowers below the allowable working voltage range.	<ul style="list-style-type: none"> Overcharge caused by traction motor inverter/VCM malfunction Module Li-ion battery controller Bus bar Harness or connector
P3382	CELL OVER DISCHARGE MODULE14		
P3383	CELL OVER DISCHARGE MODULE15		
P3384	CELL OVER DISCHARGE MODULE16		
P3385	CELL OVER DISCHARGE MODULE17		
P3386	CELL OVER DISCHARGE MODULE18		
P3387	CELL OVER DISCHARGE MODULE19		
P3388	CELL OVER DISCHARGE MODULE20		
P3389	CELL OVER DISCHARGE MODULE21		
P338A	CELL OVER DISCHARGE MODULE22		
P338B	CELL OVER DISCHARGE MODULE23		
P338C	CELL OVER DISCHARGE MODULE24		

DTC CONFIRMATION PROCEDURE

1. PERFORM DTC CONFIRMATION PROCEDURE

Ⓜ With CONSULT

- Power switch ON and wait for 10 seconds or more.
- Select "Self Diagnostic Result" of "HV BAT".
- Check DTC.

Is any DTC detected?

- YES >> Refer to [EVB-130, "Diagnosis Procedure"](#).
- NO >> INSPECTION END

Diagnosis Procedure

INFOID:000000007221025

WARNING:

- Because hybrid vehicles and electric vehicles contain a high voltage battery, there is the risk of electric shock, electric leakage, or similar accidents if the high voltage component and vehicle are handled incorrectly. Be sure to follow the correct work procedures when performing inspection and maintenance.
- Be sure to remove the service plug in order to disconnect the high voltage circuits before performing inspection or maintenance of high voltage system harnesses and parts.
- To prevent the removed service plug from being connected by mistake during the procedure, always carry it in your pocket or put it in the tool box.
- Be sure to wear insulating protective equipment consisting of glove, shoes, face shield and glasses before beginning work on the high voltage system.
- Clearly identify the persons responsible for high voltage work and ensure that other persons do not touch the vehicle. When not working, cover high voltage parts with an insulating cover sheet or similar item to prevent other persons from contacting them.
- Refer to [EVB-17, "High Voltage Precautions"](#).

CAUTION:

There is the possibility of a malfunction occurring if the vehicle is changed to READY status while the service plug is removed. Therefore do not change the vehicle to READY status unless instructed to do so in the Service Manual.

1. CHECK SELF-DIAGNOSIS RESULTS

Ⓜ With CONSULT

- Perform "All DTC Reading" with CONSULT.

P3381-P338C CELL OVER DISCHARGE

[TYPE 1]

< DTC/CIRCUIT DIAGNOSIS >

2. Check systems other than "HV BAT" if any DTC is detected.

Is any DTC detected?

YES >> After performing trouble diagnosis of detected DTC, GO TO 2.

NO >> GO TO 2.

2. PRECONDITIONING

WARNING:

Disconnect high voltage circuit. Refer to [GI-31, "How to Disconnect High Voltage"](#).

1. Remove Li-ion battery. Refer to [EVb-169, "Removal and Installation"](#).

2. Remove battery pack upper case. Refer to [EVb-184, "BATTERY JUNCTION BOX : Disassembly and Assembly"](#), see Step-1 to Step-3.

>> GO TO 3.

3. CHECK HARNESS BETWEEN MODULE AND LI-ION BATTERY CONTROLLER

1. Disconnect module harness connector and Li-ion battery controller harness connector.

2. Refer to below table and check the continuity between corresponding module and Li-ion battery controller.

DTC	Module No.	Module		Li-ion battery controller		Continuity
		Connector	Terminal	Connector	Terminal	
P3381	13	LB9	14	LB13	46	Existed
			30		62	
			15		47	
P3382	14	LB9	15	LB13	47	Existed
			31		63	
			1		48	
P3383	15	LB9	1	LB13	48	Existed
		LB10	45	LB14	77	
			34		65	
P3384	16	LB10	34	LB14	65	Existed
			46		78	
			35		66	
P3385	17	LB10	35	LB14	66	Existed
			36		80	
			48		69	
P3386	18	LB10	48	LB14	69	Existed
			37		81	
			49		70	
P3387	19	LB10	49	LB14	70	Existed
			38		82	
			50		71	
P3388	20	LB10	50	LB14	71	Existed
			39		83	
			51		72	
P3389	21	LB10	51	LB14	72	Existed
			52		84	
			41		73	

P3381-P338C CELL OVER DISCHARGE

[TYPE 1]

< DTC/CIRCUIT DIAGNOSIS >

DTC	Module No.	Module		Li-ion battery controller		Continuity
		Connector	Terminal	Connector	Terminal	
P338A	22	LB10	41	LB14	73	Existed
			53		85	
			42		74	
P338B	23	LB10	42	LB14	74	Existed
			54		86	
			43		75	
P338C	24	LB10	43	LB14	75	Existed
			55		87	
			44		76	

Is the inspection result normal?

YES >> GO TO 4.

NO >> Repair Harness or connector.

4. CHECK MODULE VOLTAGE

Check voltage of corresponding module. Refer to [EVB-126, "Component Inspection"](#).

Is the inspection result normal?

YES >> Replace Li-ion battery controller. Refer to [EVB-192, "LI-ION BATTERY CONTROLLER : Disassembly and Assembly"](#).

NO >> Replace corresponding module. Refer to [EVB-176, "Exploded view"](#).

Component Inspection

INFOID:000000007592850

1. CHECK MODULE VOLTAGE

Check voltage of module.

A : Positive terminal (Red)

B : Negative terminal (Black)

Terminals		Voltage (Approx.)
(+)	(-)	
Module		5.0 - 8.5 V
Positive terminal (Red)	Negative terminal (Black)	

Is the inspection result normal?

YES >> INSPECTION END

NO >> Replace module. Refer to [EVB-198, "FRONT MODULE STACK : Disassembly and Assembly"](#) (Front module) or [EVB-208, "REAR MODULE STACK : Disassembly and Assembly"](#) (Rear module).

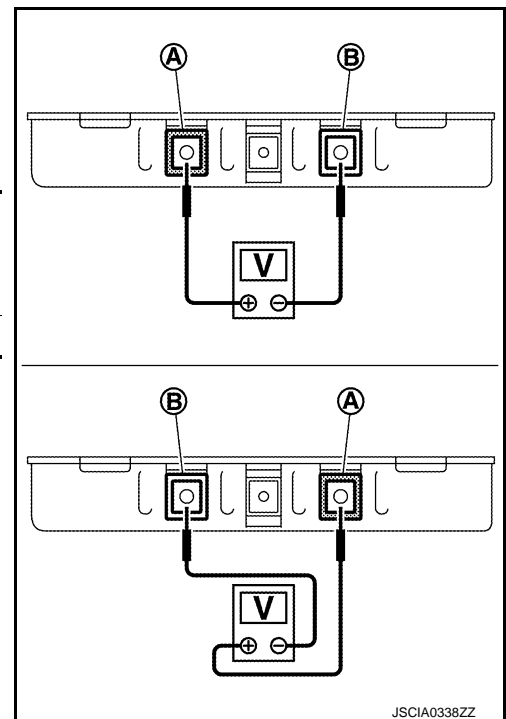

P338D-P3398 CELL OVER DISCHARGE

< DTC/CIRCUIT DIAGNOSIS >

[TYPE 1]

P338D-P3398 CELL OVER DISCHARGE

DTC Logic

INFOID:000000007221027

DTC DETECTION LOGIC

DTC	Trouble diagnosis name	DTC detecting condition	Possible causes
P338D	CELL OVER DISCHARGE MODULE25	When cell voltage lowers below the allowable working voltage range.	<ul style="list-style-type: none"> Overcharge caused by traction motor inverter/VCM malfunction Module Li-ion battery controller Bus bar Harness or connector
P338E	CELL OVER DISCHARGE MODULE26		
P338F	CELL OVER DISCHARGE MODULE27		
P3390	CELL OVER DISCHARGE MODULE28		
P3391	CELL OVER DISCHARGE MODULE29		
P3392	CELL OVER DISCHARGE MODULE30		
P3393	CELL OVER DISCHARGE MODULE31		
P3394	CELL OVER DISCHARGE MODULE32		
P3395	CELL OVER DISCHARGE MODULE33		
P3396	CELL OVER DISCHARGE MODULE34		
P3397	CELL OVER DISCHARGE MODULE35		
P3398	CELL OVER DISCHARGE MODULE36		

DTC CONFIRMATION PROCEDURE

1. PERFORM DTC CONFIRMATION PROCEDURE

Ⓜ With CONSULT

- Power switch ON and wait for 10 seconds or more.
- Select "Self Diagnostic Result" of "HV BAT".
- Check DTC.

Is any DTC detected?

- YES >> Refer to [EV B-130, "Diagnosis Procedure"](#).
 NO >> INSPECTION END

Diagnosis Procedure

INFOID:000000007221028

WARNING:

- Because hybrid vehicles and electric vehicles contain a high voltage battery, there is the risk of electric shock, electric leakage, or similar accidents if the high voltage component and vehicle are handled incorrectly. Be sure to follow the correct work procedures when performing inspection and maintenance.
- Be sure to remove the service plug in order to disconnect the high voltage circuits before performing inspection or maintenance of high voltage system harnesses and parts.
- To prevent the removed service plug from being connected by mistake during the procedure, always carry it in your pocket or put it in the tool box.
- Be sure to wear insulating protective equipment consisting of glove, shoes, face shield and glasses before beginning work on the high voltage system.
- Clearly identify the persons responsible for high voltage work and ensure that other persons do not touch the vehicle. When not working, cover high voltage parts with an insulating cover sheet or similar item to prevent other persons from contacting them.
- Refer to [EV B-17, "High Voltage Precautions"](#).

CAUTION:

There is the possibility of a malfunction occurring if the vehicle is changed to READY status while the service plug is removed. Therefore do not change the vehicle to READY status unless instructed to do so in the Service Manual.

1. CHECK SELF-DIAGNOSIS RESULTS

Ⓜ With CONSULT

- Perform "All DTC Reading" with CONSULT.

P338D-P3398 CELL OVER DISCHARGE

[TYPE 1]

< DTC/CIRCUIT DIAGNOSIS >

2. Check "Self Diagnostic Result" of systems other than "" if any DTC is detected.

Is any DTC detected?

- YES >> After performing trouble diagnosis of detected DTC, GO TO 2.
- NO >> GO TO 2.

2. PRECONDITIONING

WARNING:

Disconnect high voltage. Refer to [GI-31, "How to Disconnect High Voltage"](#).

1. Remove Li-ion battery. Refer to [EVB-169, "Removal and Installation"](#).
2. Remove battery pack upper case. Refer to [EVB-184, "BATTERY JUNCTION BOX : Disassembly and Assembly"](#), see Step-1 to Step-3.

>> GO TO 3.

3. CHECK HARNESS BETWEEN MODULE AND LI-ION BATTERY CONTROLLER

Ⓟ With CONSULT

1. Select "Self Diagnostic Result" mode of "HV BAT" using CONSULT.
2. Identify the malfunctioning module based on detected DTC.
3. Disconnect module harness connector and Li-ion battery controller harness connector.
4. Refer to below table and check the continuity between corresponding module and Li-ion battery controller.

DTC	Module No.	Module		Li-ion battery controller		Continuity
		Connector	Terminal	Connector	Terminal	
P338D	25	LB8	57	LB15	89	Existed
			73		110	
			58		90	
P338E	26	LB8	58	LB15	90	Existed
			74		111	
			75		91	
P338F	27	LB8	75	LB15	91	Existed
			60		112	
			76		92	
P3390	28	LB8	76	LB15	92	Existed
			77		113	
			62		93	
P3391	29	LB8	62	LB15	93	Existed
			78		114	
			79		94	
P3392	30	LB8	79	LB15	94	Existed
			64		115	
			80		95	
P3393	31	LB8	80	LB15	95	Existed
			81		116	
			66		96	
P3394	32	LB8	66	LB15	96	Existed
			82		117	
			83		97	

P338D-P3398 CELL OVER DISCHARGE

< DTC/CIRCUIT DIAGNOSIS >

[TYPE 1]

DTC	Module No.	Module		Li-ion battery controller		Continuity
		Connector	Terminal	Connector	Terminal	
P3395	33	LB8	83	LB15	97	Existed
			68		118	
			84		99	
P3396	34	LB8	84	LB15	99	Existed
			85		119	
			70		100	
P3397	35	LB8	70	LB15	100	Existed
			86		120	
			87		101	
P3398	36	LB8	87	LB15	101	Existed
			72		121	
			88		102	

Is the inspection result normal?

YES >> GO TO 4.

NO >> Repair Harness or connector.

4.CHECK MODULE VOLTAGE

Check voltage of corresponding module. Refer to [EVb-129, "Component Inspection"](#).

Is the inspection result normal?

YES >> Replace Li-ion battery controller. Refer to [EVb-192, "LI-ION BATTERY CONTROLLER : Disassembly and Assembly"](#).

NO >> Replace corresponding module. Refer to [EVb-176, "Exploded view"](#).

Component Inspection

INFOID:000000007592851

1.CHECK MODULE VOLTAGE

Check voltage of module.

A : Positive terminal (Red)

B : Negative terminal (Black)

Terminals		Voltage (Approx.)
(+)	(-)	
Module		5.0 - 8.5 V
Positive terminal (Red)	Negative terminal (Black)	

Is the inspection result normal?

YES >> INSPECTION END

NO >> Replace module. Refer to [EVb-198, "FRONT MODULE STACK : Disassembly and Assembly"](#) (Front module) or [EVb-208, "REAR MODULE STACK : Disassembly and Assembly"](#) (Rear module).

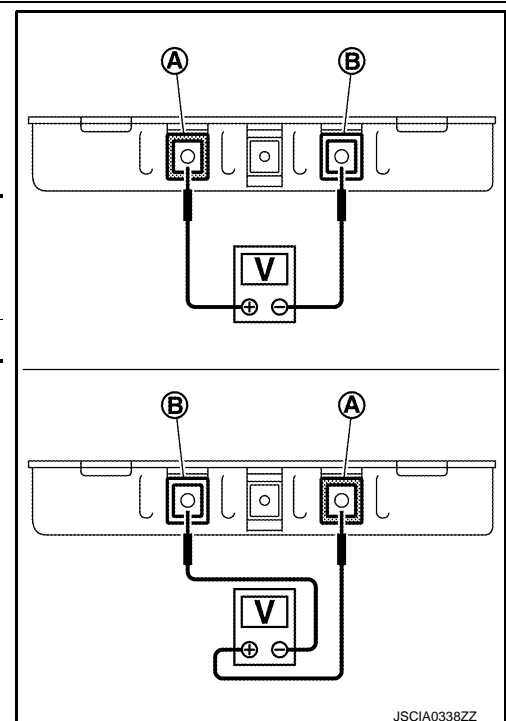

JSCIA0338ZZ

P3399-P33A4 CELL OVER DISCHARGE

< DTC/CIRCUIT DIAGNOSIS >

[TYPE 1]

P3399-P33A4 CELL OVER DISCHARGE

DTC Logic

INFOID:000000007221030

DTC DETECTION LOGIC

DTC	Trouble diagnosis name	DTC detecting condition	Possible causes
P3399	CELL OVER DISCHARGE MODULE37	When cell voltage lowers below the allowable working voltage range.	<ul style="list-style-type: none"> Overcharge caused by traction motor inverter/VCM malfunction Module Li-ion battery controller Bus bar Harness or connector
P339A	CELL OVER DISCHARGE MODULE38		
P339B	CELL OVER DISCHARGE MODULE39		
P339C	CELL OVER DISCHARGE MODULE40		
P339D	CELL OVER DISCHARGE MODULE41		
P339E	CELL OVER DISCHARGE MODULE42		
P339F	CELL OVER DISCHARGE MODULE43		
P33A0	CELL OVER DISCHARGE MODULE44		
P33A1	CELL OVER DISCHARGE MODULE45		
P33A2	CELL OVER DISCHARGE MODULE46		
P33A3	CELL OVER DISCHARGE MODULE47		
P33A4	CELL OVER DISCHARGE MODULE48		

DTC CONFIRMATION PROCEDURE

1. PERFORM DTC CONFIRMATION PROCEDURE

Ⓟ With CONSULT

- Power switch ON and wait for 10 seconds or more.
- Select "Self Diagnostic Result" of "HV BAT".
- Check DTC.

Is any DTC detected?

- YES >> Refer to [EVB-130, "Diagnosis Procedure"](#).
 NO >> INSPECTION END

Diagnosis Procedure

INFOID:000000007221031

WARNING:

- Because hybrid vehicles and electric vehicles contain a high voltage battery, there is the risk of electric shock, electric leakage, or similar accidents if the high voltage component and vehicle are handled incorrectly. Be sure to follow the correct work procedures when performing inspection and maintenance.
- Be sure to remove the service plug in order to disconnect the high voltage circuits before performing inspection or maintenance of high voltage system harnesses and parts.
- To prevent the removed service plug from being connected by mistake during the procedure, always carry it in your pocket or put it in the tool box.
- Be sure to wear insulating protective equipment consisting of glove, shoes, face shield and glasses before beginning work on the high voltage system.
- Clearly identify the persons responsible for high voltage work and ensure that other persons do not touch the vehicle. When not working, cover high voltage parts with an insulating cover sheet or similar item to prevent other persons from contacting them.
- Refer to [EVB-17, "High Voltage Precautions"](#).

CAUTION:

There is the possibility of a malfunction occurring if the vehicle is changed to READY status while the service plug is removed. Therefore do not change the vehicle to READY status unless instructed to do so in the Service Manual.

1. CHECK SELF-DIAGNOSIS RESULTS

Ⓟ With CONSULT

- Perform "All DTC Reading" with CONSULT.

P3399-P33A4 CELL OVER DISCHARGE

[TYPE 1]

< DTC/CIRCUIT DIAGNOSIS >

2. Check "Self Diagnostic Result" of systems other than "" if any DTC is detected.

Is any DTC detected?

- YES >> After performing trouble diagnosis of detected DTC, GO TO 2.
- NO >> GO TO 2.

2. PRECONDITIONING

WARNING:

Disconnect high voltage. Refer to [GI-31, "How to Disconnect High Voltage"](#).

1. Remove Li-ion battery. Refer to [EVB-169, "Removal and Installation"](#).
2. Remove battery pack upper case. Refer to [EVB-184, "BATTERY JUNCTION BOX : Disassembly and Assembly"](#), see Step-1 to Step-3.

>> GO TO 3.

3. CHECK HARNESS BETWEEN MODULE AND LI-ION BATTERY CONTROLLER

Ⓜ With CONSULT

1. Select "Self Diagnostic Result" mode of "HV BAT" using CONSULT.
2. Identify the malfunctioning module based on detected DTC.
3. Disconnect module harness connector and Li-ion battery controller harness connector.
4. Refer to below table and check the continuity between corresponding module and Li-ion battery controller.

DTC	Module No.	Module		Li-ion battery controller		Continuity
		Connector	Terminal	Connector	Terminal	
P3399	37	LB8	88	LB15	102	Existed
		LB7	89		122	
			101		103	
P339A	38	LB7	101	LB15	103	Existed
			90		123	
			102		104	
P339B	39	LB7	102	LB15	104	Existed
			91		124	
			103		105	
P339C	40	LB7	103	LB15	105	Existed
			92		125	
			104		106	
P339D	41	LB7	104	LB15	106	Existed
			93		127	
			105		107	
P339E	42	LB7	105	LB15	107	Existed
			94		128	
			106		108	
P339F	43	LB7	106	LB15	108	Existed
			95	LB16	137	
					107	
P33A0	44	LB7	107	LB16	130	Existed
			96		138	
			108		131	

P3399-P33A4 CELL OVER DISCHARGE

[TYPE 1]

< DTC/CIRCUIT DIAGNOSIS >

DTC	Module No.	Module		Li-ion battery controller		Continuity
		Connector	Terminal	Connector	Terminal	
P33A1	45	LB7	108	LB16	131	Existed
			97		140	
			109		132	
P33A2	46	LB7	109	LB16	132	Existed
			98		141	
			110		133	
P33A3	47	LB7	110	LB16	133	Existed
			99		142	
			111		134	
P33A4	48	LB7	111	LB16	134	Existed
			100		143	
			112		135	

Is the inspection result normal?

YES >> GO TO 4.

NO >> Repair Harness or connector.

4.CHECK MODULE VOLTAGE

Check voltage of corresponding module. Refer to [EVB-132, "Component Inspection"](#).

Is the inspection result normal?

YES >> Replace Li-ion battery controller. Refer to [EVB-192, "LI-ION BATTERY CONTROLLER : Disassembly and Assembly"](#).

NO >> Replace corresponding module. Refer to [EVB-176, "Exploded view"](#).

Component Inspection

INFOID:000000007592852

1.CHECK MODULE VOLTAGE

Check voltage of module.

A : Positive terminal (Red)

B : Negative terminal (Black)

Terminals		Voltage (Approx.)
(+)	(-)	
Module		5.0 - 8.5 V
Positive terminal (Red)	Negative terminal (Black)	

Is the inspection result normal?

YES >> INSPECTION END

NO >> Replace module. Refer to [EVB-198, "FRONT MODULE STACK : Disassembly and Assembly"](#) (Front module) or [EVB-208, "REAR MODULE STACK : Disassembly and Assembly"](#) (Rear module).

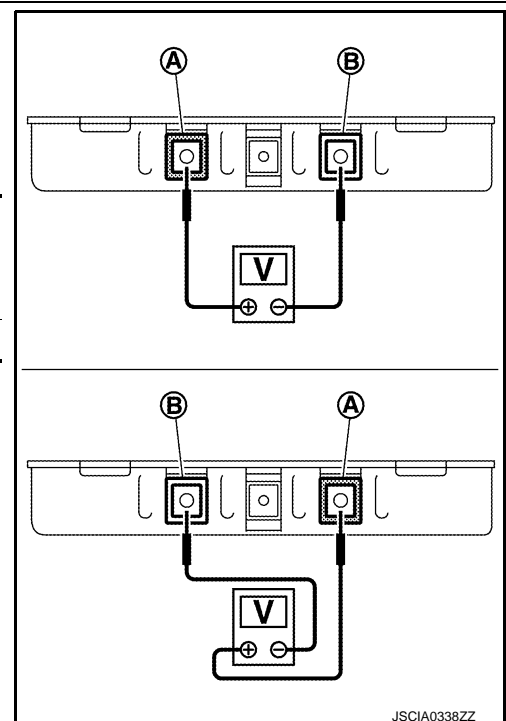

JSCIA0338ZZ

P33D4 BATT GRADUAL CAPA LOSS DIAG

< DTC/CIRCUIT DIAGNOSIS >

[TYPE 1]

P33D4 BATT GRADUAL CAPA LOSS DIAG

DTC Logic

INFOID:000000007005818

DTC DETECTION LOGIC

DTC	Trouble diagnosis name	DTC detecting condition	Possible causes
P33D4	BATT GRADUAL CAPA LOSS DIAG	When the battery charge lowers. (The internal resistance of the battery increases.)	Li-ion battery

A

B

EVB

DTC CONFIRMATION PROCEDURE

1. PERFORM DTC CONFIRMATION PROCEDURE

 With CONSULT

1. Power switch ON and wait for 10 seconds or more.
2. Select "Self Diagnostic Result" of "HV BAT".
3. Check DTC.

Is P33D4 detected?

- YES >> Refer to [EVB-133, "Diagnosis Procedure"](#).
NO >> INSPECTION END

Diagnosis Procedure

INFOID:000000007005819

When this DTC is detected, replace Li-ion battery. Refer to [EVB-169, "Removal and Installation"](#).

D

E

F

G

H

I

J

K

L

M

N

O

P

P33D5 CURRENT SENSOR

< DTC/CIRCUIT DIAGNOSIS >

[TYPE 1]

P33D5 CURRENT SENSOR

DTC Logic

INFOID:000000007005820

DTC DETECTION LOGIC

DTC	Trouble diagnosis name	DTC detecting condition	Possible causes
P33D5	CURRENT SENSOR	Deviation in characteristics of battery current sensor signal voltage. (Battery current sensor signal voltage is too high or too low.)	<ul style="list-style-type: none">• Li-ion battery controller• Current sensor• System main relay• Harness or connector

DTC CONFIRMATION PROCEDURE

1. PERFORM DTC CONFIRMATION PROCEDURE

④ With CONSULT

1. Power switch ON and wait for 10 seconds or more.
2. Select "Self Diagnostic Result" of "HV BAT".
3. Check DTC.

Is P33D5 detected?

- YES >> Refer to [EVB-134, "Diagnosis Procedure"](#).
NO >> INSPECTION END

Diagnosis Procedure

INFOID:000000007005821

WARNING:

- Because hybrid vehicles and electric vehicles contain a high voltage battery, there is the risk of electric shock, electric leakage, or similar accidents if the high voltage component and vehicle are handled incorrectly. Be sure to follow the correct work procedures when performing inspection and maintenance.
- Be sure to remove the service plug in order to disconnect the high voltage circuits before performing inspection or maintenance of high voltage system harnesses and parts.
- To prevent the removed service plug from being connected by mistake during the procedure, always carry it in your pocket or put it in the tool box.
- Be sure to wear insulating protective equipment consisting of glove, shoes, face shield and glasses before beginning work on the high voltage system.
- Clearly identify the persons responsible for high voltage work and ensure that other persons do not touch the vehicle. When not working, cover high voltage parts with an insulating cover sheet or similar item to prevent other persons from contacting them.
- Refer to [EVB-17, "High Voltage Precautions"](#).

CAUTION:

There is the possibility of a malfunction occurring if the vehicle is changed to READY status while the service plug is removed. Therefore do not change the vehicle to READY status unless instructed to do so in the Service Manual.

1. CHECK SELF-DIAGNOSIS RESULTS OF VCM

④ With CONSULT

1. Select "Self Diagnostic Result" mode of "EV/HEV" using CONSULT.
2. Check to see if "P0AA0", "P0AA1" or "P0AA4" is detected.

Is any DTC detected?

- YES >> Perform diagnosis on the detected DTC. Refer to [EVB-50, "DTC Index"](#).
NO >> GO TO 2.

2. PRECONDITIONING

WARNING:

Disconnect high voltage. Refer to [GI-31, "How to Disconnect High Voltage"](#).

1. Remove Li-ion battery. Refer to [EVB-169, "Removal and Installation"](#).
2. Remove battery pack upper case. Refer to [EVB-184, "BATTERY JUNCTION BOX : Disassembly and Assembly"](#), see Step-1 to Step-3.

P33D5 CURRENT SENSOR

< DTC/CIRCUIT DIAGNOSIS >

[TYPE 1]

>> GO TO 3.

3. CHECK CONNECTION STATUS

Check connection status of Li-ion battery controller harness connector and battery junction box (current sensor) harness connector.

Is the inspection result normal?

YES >> GO TO 4.

NO >> Recover the connection status.

4. CHECK HARNESS BETWEEN BATTERY JUNCTION BOX (CURRENT SENSOR) AND LI-ION BATTERY CONTROLLER

Check continuity between battery junction box (current sensor) harness connector and Li-ion battery controller harness connector.

Battery junction box (Current sensor)		Li-ion battery controller		Continuity
Connector	Terminal	Connector	Terminal	
LB3	9	LB11	10	Exited
	3		9	
	10		17	

Is the inspection result normal?

YES >> GO TO 5.

NO >> Repair Harness or connector.

5. CHECK CURRENT SENSOR

Check resistance of current sensor.

Battery junction box (Current sensor)			Resistance value
Connector	Terminal	Terminal	
LB3	9	10	1 k Ω –10 M Ω
	3	10	

Is the inspection result normal?

YES >> GO TO 6.

NO >> Replace current sensor.

6. CHECK LI-ION BATTERY CONTROLLER

Check resistance of Li-ion battery controller.

Li-ion battery controller			Resistance value
Connector	Terminal	Terminal	
LB11	10	17	Approx. 4.7 k Ω

Is the inspection result normal?

YES >> Replace battery junction box. Refer to [EVB-184, "BATTERY JUNCTION BOX : Disassembly and Assembly"](#).

NO >> Replace Li-ion battery controller. Refer to [EVB-192, "LI-ION BATTERY CONTROLLER : Disassembly and Assembly"](#).

P33D6 CURRENT SENSOR

< DTC/CIRCUIT DIAGNOSIS >

[TYPE 1]

P33D6 CURRENT SENSOR

DTC Logic

INFOID:000000007005822

DTC DETECTION LOGIC

DTC	Trouble diagnosis name	DTC detecting condition	Possible causes
P33D6	CURRENT SENSOR	Deviation from the specified voltage characteristics of battery current sensor.	Li-ion battery controller

DTC CONFIRMATION PROCEDURE

1. PERFORM DTC CONFIRMATION PROCEDURE

④ With CONSULT

1. Power switch ON and wait for 10 seconds or more.
2. Select "Self Diagnostic Result" of "HV BAT".
3. Check DTC.

Is P33D6 detected?

- YES >> Refer to [EVB-136, "Diagnosis Procedure"](#).
 NO >> INSPECTION END

Diagnosis Procedure

INFOID:000000007005823

WARNING:

- Because hybrid vehicles and electric vehicles contain a high voltage battery, there is the risk of electric shock, electric leakage, or similar accidents if the high voltage component and vehicle are handled incorrectly. Be sure to follow the correct work procedures when performing inspection and maintenance.
- Be sure to remove the service plug in order to disconnect the high voltage circuits before performing inspection or maintenance of high voltage system harnesses and parts.
- To prevent the removed service plug from being connected by mistake during the procedure, always carry it in your pocket or put it in the tool box.
- Be sure to wear insulating protective equipment consisting of glove, shoes, face shield and glasses before beginning work on the high voltage system.
- Clearly identify the persons responsible for high voltage work and ensure that other persons do not touch the vehicle. When not working, cover high voltage parts with an insulating cover sheet or similar item to prevent other persons from contacting them.
- Refer to [EVB-17, "High Voltage Precautions"](#).

CAUTION:

There is the possibility of a malfunction occurring if the vehicle is changed to READY status while the service plug is removed. Therefore do not change the vehicle to READY status unless instructed to do so in the Service Manual.

1. PRECONDITIONING

WARNING:

Disconnect high voltage. Refer to [GI-31, "How to Disconnect High Voltage"](#).

1. Remove Li-ion battery. Refer to [EVB-169, "Removal and Installation"](#).
2. Remove battery pack upper case. Refer to [EVB-184, "BATTERY JUNCTION BOX : Disassembly and Assembly"](#), see Step-1 to Step-3.

>> GO TO 2.

2. CHECK CURRENT SENSOR

1. Disconnect Li-ion battery controller harness connector.
2. Check the resistance of current sensor from Li-ion battery controller side.

Li-ion battery controller		Resistance value
Connector	Terminal	

P33D6 CURRENT SENSOR

< DTC/CIRCUIT DIAGNOSIS >

[TYPE 1]

LB11	10	9	1 kΩ–10 MΩ
	9	17	

A

Is the inspection result normal?

YES >> Replace Li-ion battery controller. Refer to [EVB-192, "LI-ION BATTERY CONTROLLER : Disassembly and Assembly"](#).

NO >> GO TO 3.

B

3. CHECK HARNESS BETWEEN LI-ION BATTERY CONTROLLER AND BATTERY JUNCTION BOX (CURRENT SENSOR)

EVB

1. Disconnect Battery junction box harness connector.
2. Check continuity between Li-ion battery controller and Battery junction box (current sensor).

D

Li-ion battery controller		Battery junction box (Current sensor)		Continuity
Connector	Terminal	Connector	Terminal	
LB11	10	LB3	9	Existed
	9		3	
	17		10	

E

F

Is the inspection result normal?

YES >> Replace battery junction box. Refer to [EVB-184, "BATTERY JUNCTION BOX : Disassembly and Assembly"](#).

NO >> Repair Harness or connector.

G

H

I

J

K

L

M

N

O

P

P33D7, P33D9, P33DB, P33DD TEMPERATURE SENSOR

< DTC/CIRCUIT DIAGNOSIS >

[TYPE 1]

P33D7, P33D9, P33DB, P33DD TEMPERATURE SENSOR

DTC Logic

INFOID:000000007005824

DTC DETECTION LOGIC

DTC	Trouble diagnosis name	DTC detecting condition	Possible causes
P33D7	TEMPERATURE SENSOR	Battery temperature sensor rear center signal voltage is too high or too low.	<ul style="list-style-type: none">• Battery temperature sensor 1• Li-ion battery controller• Harness or connector
P33D9		Battery temperature sensor front RH signal voltage is too high or too low.	
P33DB		Battery temperature sensor rear RH signal voltage is too high or too low.	
P33DD		Battery temperature sensor front LH signal voltage is too high or too low.	

DTC CONFIRMATION PROCEDURE

1. PERFORM DTC CONFIRMATION PROCEDURE

Ⓜ With CONSULT

1. Power switch ON and wait for 10 seconds or more.
2. Select "Self Diagnostic Result" of "HV BAT".
3. Check DTC.

Is any DTC detected?

- YES >> Refer to [EVB-138, "Diagnosis Procedure"](#).
NO >> INSPECTION END

Diagnosis Procedure

INFOID:000000007005825

WARNING:

- Because hybrid vehicles and electric vehicles contain a high voltage battery, there is the risk of electric shock, electric leakage, or similar accidents if the high voltage component and vehicle are handled incorrectly. Be sure to follow the correct work procedures when performing inspection and maintenance.
- Be sure to remove the service plug in order to disconnect the high voltage circuits before performing inspection or maintenance of high voltage system harnesses and parts.
- To prevent the removed service plug from being connected by mistake during the procedure, always carry it in your pocket or put it in the tool box.
- Be sure to wear insulating protective equipment consisting of glove, shoes, face shield and glasses before beginning work on the high voltage system.
- Clearly identify the persons responsible for high voltage work and ensure that other persons do not touch the vehicle. When not working, cover high voltage parts with an insulating cover sheet or similar item to prevent other persons from contacting them.
- Refer to [EVB-17, "High Voltage Precautions"](#).

CAUTION:

There is the possibility of a malfunction occurring if the vehicle is changed to READY status while the service plug is removed. Therefore do not change the vehicle to READY status unless instructed to do so in the Service Manual.

1. PRECONDITIONING

WARNING:

Disconnect high voltage. Refer to [GI-31, "How to Disconnect High Voltage"](#).

1. Remove Li-ion battery. Refer to [EVB-169, "Removal and Installation"](#).
2. Remove battery pack upper case. Refer to [EVB-184, "BATTERY JUNCTION BOX : Disassembly and Assembly"](#), see Step-1 to Step-3.

>> GO TO 2.

P33D7, P33D9, P33DB, P33DD TEMPERATURE SENSOR

< DTC/CIRCUIT DIAGNOSIS >

[TYPE 1]

2. CHECK HARNESS

1. Power switch OFF.
2. Check a connection state of harness connector of Li-ion battery controller.

Is the inspection result normal?

- YES >> GO TO 3.
NO >> Recover the connection status.

3. CHECK BATTERY TEMPERATURE SENSOR

Refer to [EVB-139. "Component Inspection"](#).

Is the inspection result normal?

- YES >> GO TO 4.
NO >> Replace battery temperature sensor.

4. CHECK HARNESS BETWEEN BATTERY TEMPERATURE SENSOR AND GROUND

1. Disconnect Li-ion battery controller harness connector.
2. Check continuity between battery temperature sensor harness connector and ground.

Battery temperature sensor	Connector	Terminal	—	Continuity
Rear center	LB17	3	Ground	No existed
Front RH	LB5	1		
Rear RH	LB17	1		
Front LH	LB4	3		

Is the inspection result normal?

- YES >> Replace Li-ion battery controller. Refer to [EVB-192. "LI-ION BATTERY CONTROLLER : Disassembly and Assembly"](#).
NO >> Repair harness or connector.

Component Inspection

INFOID:000000007005826

1. CHECK BATTERY TEMPERATURE SENSOR

1. Remove battery temperature sensor. Refer to [EVB-176. "Exploded view"](#).
2. Check resistance between battery temperature sensor terminals.

Battery temperature sensor	Terminals	Condition	Resistance (kΩ)	
Rear RH & Front RH	1 and 2	Temperature °C (°F)	10 (50)	Approx. 7.4
			25 (77)	Approx. 4.0
40 (104)	Approx. 2.3			
Rear center & Front LH	3 and 4			

Is the inspection result normal?

- YES >> INSPECTION END
NO >> Replace battery temperature sensor.

P33DF BAT VOLTAGE ISOLATION SEN

< DTC/CIRCUIT DIAGNOSIS >

[TYPE 1]

P33DF BAT VOLTAGE ISOLATION SEN

DTC Logic

INFOID:000000007005827

DTC DETECTION LOGIC

DTC	Trouble diagnosis name	DTC detecting condition	Possible causes
P33DF	BAT VOLTAGE ISOLATION SEN	Signal voltage of the on-board isolation resistance monitoring system is too high.	Li-ion battery controller

DTC CONFIRMATION PROCEDURE

1. PERFORM DTC CONFIRMATION PROCEDURE

④ With CONSULT

1. Power switch ON and wait for 10 seconds or more.
2. Select "Self Diagnostic Result" of "HV BAT".
3. Check DTC.

Is P33DF detected?

- YES >> Refer to [EVB-140, "Diagnosis Procedure"](#).
NO >> INSPECTION END

Diagnosis Procedure

INFOID:000000007005828

When this DTC is detected, replace Li-ion battery controller. Refer to [EVB-192, "LI-ION BATTERY CONTROLLER : Disassembly and Assembly"](#).

P33E0 BAT VOLTAGE ISOLATION SEN

< DTC/CIRCUIT DIAGNOSIS >

[TYPE 1]

P33E0 BAT VOLTAGE ISOLATION SEN

DTC Logic

INFOID:000000007005829

DTC DETECTION LOGIC

DTC	Trouble diagnosis name	DTC detecting condition	Possible causes
P33E0	BATTERY VOLTAGE ISOLATION SENSOR	Signal Voltage of the on-board isolation resistance monitoring system is too low.	Li-ion battery controller

A
B
EVB
D
E
F
G
H
I
J
K
L
M
N
O
P

DTC CONFIRMATION PROCEDURE

1. PERFORM DTC CONFIRMATION PROCEDURE

④ With CONSULT

1. Power switch ON and wait for 10 seconds or more.
2. Select "Self Diagnostic Result" of "HV BAT".
3. Check DTC.

Is P33E0 detected?

- YES >> Refer to [EVb-141, "Diagnosis Procedure"](#).
NO >> INSPECTION END

Diagnosis Procedure

INFOID:000000007005830

When this DTC is detected, replace Li-ion battery controller. Refer to [EVb-192, "LI-ION BATTERY CONTROLLER : Disassembly and Assembly"](#).

P33E1 BAT VOLTAGE ISOLATION SEN

< DTC/CIRCUIT DIAGNOSIS >

[TYPE 1]

P33E1 BAT VOLTAGE ISOLATION SEN

DTC Logic

INFOID:000000007005831

DTC DETECTION LOGIC

DTC	Trouble diagnosis name	DTC detecting condition	Possible causes
P33E1	BATTERY VOLTAGE ISOLATION SENSOR	Signal voltage of the on-board isolation resistance monitoring system exhibits no amplitude variation.	Li-ion battery controller

DTC CONFIRMATION PROCEDURE

1. PERFORM DTC CONFIRMATION PROCEDURE

④ With CONSULT

1. Power switch ON and wait for 10 seconds or more.
2. Select "Self Diagnostic Result" of "HV BAT".
3. Check DTC.

Is P33E1 detected?

- YES >> Refer to [EVB-142, "Diagnosis Procedure"](#).
NO >> INSPECTION END

Diagnosis Procedure

INFOID:000000007005832

When this DTC is detected, perform Li-ion battery insulation resistance loss check. Refer to [EVB-154, "Component Inspection"](#).

P33E2 BATT PACK OVER TEMP

< DTC/CIRCUIT DIAGNOSIS >

[TYPE 1]

P33E2 BATT PACK OVER TEMP

DTC Logic

INFOID:000000007005833

DTC DETECTION LOGIC

DTC	Trouble diagnosis name	DTC detecting condition	Possible causes
P33E2	BATTERY PACK OVER TEMPERATURE	When the battery (battery pack) temperature is excessively high.	Overcharge caused by traction motor inverter/VCM malfunction

DTC CONFIRMATION PROCEDURE

1. PERFORM DTC CONFIRMATION PROCEDURE

Ⓜ With CONSULT

1. Power switch ON and wait for 10 seconds or more.
2. Select "Self Diagnostic Result" of "HV BAT".
3. Check DTC.

Is P33E2 detected?

- YES >> Refer to [EVB-143, "Diagnosis Procedure"](#).
 NO >> INSPECTION END

Diagnosis Procedure

INFOID:000000007005834

1. PERFORM THE SELF-DIAGNOSIS OF LI-ION BATTERY CONTROLLER

Ⓜ With CONSULT

1. Select "Self Diagnostic Result" of "HV BAT".
2. Check to see if "P33E4" or "P33E5" is detected simultaneously with "P33E2".

Is P33E4 or P33E5 detected?

- YES >> Perform diagnosis on the detected "P33E4" or "P33E5". Refer to [EVB-144, "Diagnosis Procedure"](#).
 NO >> GO TO 2.

2. CHECK BATTERY TEMPERATURE SENSOR

Ⓜ With CONSULT

Using FREEZE FRAME DATA (FFD), check the values of four temperature sensors when DTC is detected.

Monitor item	Condition	Limit
Battery temperature sensor 1	Power switch ON	55°C (131°F) or less
Battery temperature sensor 2		
Battery temperature sensor 3		
Battery temperature sensor 4		

Is there temperature increase?

- Temperature increase is seen >> Replace Li-ion battery. Refer to [EVB-169, "Removal and Installation"](#).
 Temperature increase is not seen >> Replace battery temperature sensors. Refer to [EVB-169, "Removal and Installation"](#).

P33E4, P33E5 TEMPERATURE SENSOR

< DTC/CIRCUIT DIAGNOSIS >

[TYPE 1]

P33E4, P33E5 TEMPERATURE SENSOR

DTC Logic

INFOID:000000007005835

DTC DETECTION LOGIC

DTC	Trouble diagnosis name	DTC detecting condition	Possible causes
P33E4	TEMPERATURE SENSOR	Deviation in characteristics of Battery temperature sensor rear center or front RH.	Battery temperature sensor
P33E5		Deviation in characteristics of Battery temperature sensor rear RH or front LH.	

DTC CONFIRMATION PROCEDURE

1. PERFORM DTC CONFIRMATION PROCEDURE

Ⓟ With CONSULT

1. Power switch ON and wait for 10 seconds or more.
2. Select "Self Diagnostic Result" of "HV BAT".
3. Check DTC.

Is P33E4 or P33E5 DTC detected?

- YES >> Refer to [EVB-144, "Diagnosis Procedure"](#).
NO >> INSPECTION END

Diagnosis Procedure

INFOID:000000007005836

WARNING:

- Because hybrid vehicles and electric vehicles contain a high voltage battery, there is the risk of electric shock, electric leakage, or similar accidents if the high voltage component and vehicle are handled incorrectly. Be sure to follow the correct work procedures when performing inspection and maintenance.
- Be sure to remove the service plug in order to disconnect the high voltage circuits before performing inspection or maintenance of high voltage system harnesses and parts.
- To prevent the removed service plug from being connected by mistake during the procedure, always carry it in your pocket or put it in the tool box.
- Be sure to wear insulating protective equipment consisting of glove, shoes, face shield and glasses before beginning work on the high voltage system.
- Clearly identify the persons responsible for high voltage work and ensure that other persons do not touch the vehicle. When not working, cover high voltage parts with an insulating cover sheet or similar item to prevent other persons from contacting them.
- Refer to [EVB-17, "High Voltage Precautions"](#).

CAUTION:

There is the possibility of a malfunction occurring if the vehicle is changed to READY status while the service plug is removed. Therefore do not change the vehicle to READY status unless instructed to do so in the Service Manual.

1. PRECONDITIONING

WARNING:

Disconnect high voltage. Refer to [GI-31, "How to Disconnect High Voltage"](#).

1. Remove Li-ion battery. Refer to [EVB-169, "Removal and Installation"](#).
2. Remove battery pack upper case. Refer to [EVB-184, "BATTERY JUNCTION BOX : Disassembly and Assembly"](#), see Step-1 to Step-3.

>> GO TO 2.

2. CHECK BATTERY TEMPERATURE SENSOR

Refer to [EVB-145, "Component Inspection"](#).

Is the inspection result normal?

- YES >> Replace both battery temperature sensor.

P33E4, P33E5 TEMPERATURE SENSOR

[TYPE 1]

< DTC/CIRCUIT DIAGNOSIS >

NO >> Replace malfunction battery temperature sensor.

Component Inspection

INFOID:000000007592853

1. CHECK BATTERY TEMPERATURE SENSOR

1. Remove battery temperature sensor. Refer to [EVB-176. "Exploded view"](#).
2. Check resistance between battery temperature sensor terminals.

Battery temperature sensor	Terminals	Condition	Resistance (kΩ)
Rear RH & Front RH	1 and 2	Temperature °C (°F)	10 (50) Approx. 7.4
Rear center & Front LH	3 and 4		25 (77) Approx. 4.0
			40 (104) Approx. 2.3

Is the inspection result normal?

YES >> INSPECTION END

NO >> Replace battery temperature sensor.

A
B
EVB
D
E
F
G
H
I
J
K
L
M
N
O
P

P33E6 CELL VOLTAGE DEVIATION DIAG

< DTC/CIRCUIT DIAGNOSIS >

[TYPE 1]

P33E6 CELL VOLTAGE DEVIATION DIAG

DTC Logic

INFOID:000000007005838

DTC DETECTION LOGIC

DTC	Trouble diagnosis name	DTC detecting condition	Possible causes
P33E6	CELL VOLTAGE DEVIATION DIAG	With the power switch ON and no load condition, the difference between the maximum voltage and minimum voltage exceeds the allowable range.	<ul style="list-style-type: none">Li-ion battery controllerModule

DTC CONFIRMATION PROCEDURE

1. PERFORM DTC CONFIRMATION PROCEDURE

④ With CONSULT

- Turn power switch ON and wait for 10 seconds or more.
- Select "Self Diagnostic Result" of "HV BAT".
- Check DTC.

Is P33E6 detected?

- YES >> Refer to [EVB-146, "Diagnosis Procedure"](#).
NO >> INSPECTION END

Diagnosis Procedure

INFOID:000000007005839

WARNING:

- Because hybrid vehicles and electric vehicles contain a high voltage battery, there is the risk of electric shock, electric leakage, or similar accidents if the high voltage component and vehicle are handled incorrectly. Be sure to follow the correct work procedures when performing inspection and maintenance.
- Be sure to remove the service plug in order to disconnect the high voltage circuits before performing inspection or maintenance of high voltage system harnesses and parts.
- To prevent the removed service plug from being connected by mistake during the procedure, always carry it in your pocket or put it in the tool box.
- Be sure to wear insulating protective equipment before beginning work on the high voltage system.
- Clearly identify the persons responsible for high voltage work and ensure that other persons do not touch the vehicle. When not working, cover high voltage parts with an insulating cover sheet or similar item to prevent other persons from contacting them.
- Refer to [EVB-17, "High Voltage Precautions"](#).

CAUTION:

There is the possibility of a malfunction occurring if the vehicle is changed to READY status while the service plug is removed. Therefore do not change the vehicle to READY status unless instructed to do so in the Service Manual.

1. CHECK SELF-DIAGNOSIS RESULTS OF LI-ION BATTERY CONTROLLER

④ With CONSULT

- Select "Self Diagnostic Result" of "HV BAT".
- Check to see if "P0A1F", "P3062" or "P33ED" is detected simultaneously with "P33E6".

Is P0A1F, P3062 or P33ED detected?

- YES-1 >> When "P0A1F" or "P3062" are detected simultaneously, Replace Li-ion battery controller. Refer to [EVB-192, "LI-ION BATTERY CONTROLLER : Disassembly and Assembly"](#).
YES-2 >> When "P33ED" is detected simultaneously, perform the diagnosis procedure of "P33ED". Refer to [EVB-151, "Diagnosis Procedure"](#).
NO >> GO TO 2.

2. CHECK FREEZE FRAME DATA (FFD)

④ With CONSULT

- Check "FFD" when DTC is detected.
- Calculate the average value of cell voltage by dividing "TOTAL BATTERY VOLTAGE" by 96 (the number of cells).

P33E6 CELL VOLTAGE DEVIATION DIAG

< DTC/CIRCUIT DIAGNOSIS >

[TYPE 1]

Average cell voltage = "TOTAL BETTER VOLTAGE" ÷ 96 (the number of cells)

3. Identify the minimum cell voltage and the maximum cell voltage from 96 cells.
4. Calculate voltage according to the following expressions to compare voltage between A and B.

A = Maximum cell voltage – Average cell voltage

B = Average cell voltage – Minimum cell voltage

Which voltage is larger, A or B?

- A >> Replace module including a cell of the maximum cell voltage. Refer to [EVB-198, "FRONT MODULE STACK : Disassembly and Assembly"](#) (Front module stack) or [EVB-208, "REAR MODULE STACK : Disassembly and Assembly"](#) (Rear module stack). After replacing module, GO TO 3.
- B >> Replace module including a cell of the minimum cell voltage. Refer to [EVB-198, "FRONT MODULE STACK : Disassembly and Assembly"](#) (Front module stack) or [EVB-208, "REAR MODULE STACK : Disassembly and Assembly"](#) (Rear module stack). After replacing module, GO TO 3.

3.PERFORM CELL VOLTAGE LOSS INSPECTION

 With CONSULT

1. Select "WORK SUPPORT" of "HV BAT."
2. Select "CELL VOLTAGE LOSS INSPECTION." Touch "START."
3. Check "MINIMUM CELL VOLTAGE."

Is "MINIMUM CELL VOLTAGE" 3,712 mV or less?

- YES >> GO TO 5.
NO >> GO TO 4.

4.DISCHARGE OF LI-ION BATTERY

 With CONSULT

1. Set the vehicle to READY.
2. Set the vehicle, according to the following conditions.

A/C set temperature	: Full hot
A/C fan speed	: Maximum speed
A/C air outlet	:  Defroster
Headlamp	: High beam ON
Door glass	: Full open

3. Check "DATA MONITOR" and let the Li-ion battery discharge until the "MINIMUM CELL VOLTAGE" reaches 3,712 mV or less.

NOTE:

The guide line is to discharge until the Li-ion battery available charge gauge indicates 2 segments or less. For discharge time, refer to the following table.

Guideline for discharge time

The number of lighting segments of Li-ion battery available charge gauge	Time to 2 segments
12	Approx. 230 minute
11	Approx. 200 minute
10	Approx. 180 minute
9	Approx. 160 minute
8	Approx. 130 minute
7	Approx. 110 minute
6	Approx. 90 minute
5	Approx. 70 minute

P33E6 CELL VOLTAGE DEVIATION DIAG

[TYPE 1]

< DTC/CIRCUIT DIAGNOSIS >

The number of lighting segments of Li-ion battery available charge gauge	Time to 2 segments
4	Approx. 40 minute
3	Approx. 20 minute

>> GO TO 5.

5. CHECK CELL OF VOLTAGE LOSS

④ With CONSULT

1. Check that "MINIMUM CELL VOLTAGE" is 3,712 mV or less. Touch "START."
2. Check to see if a cell of which voltage is less than or equal to "CELL VOLTAGE LOSS JUDGMENT VALUE" is displayed.

Is a cell displayed?

YES >> Record applicable cell No. and then GO TO 6.

NO >> Check the minimum cell voltage on the data monitor and replace a module which includes the minimum cell voltage. Refer to [EVB-198, "FRONT MODULE STACK : Disassembly and Assembly"](#) (Front module stack) or [EVB-208, "REAR MODULE STACK : Disassembly and Assembly"](#) (Rear module stack).

6. PRECONDITIONING

WARNING:

Disconnect the high voltage. Refer to [GI-31, "How to Disconnect High Voltage"](#).

1. Remove Li-ion battery. Refer to [EVB-169, "Removal and Installation"](#).
2. Remove battery pack upper case. Refer to [EVB-169, "Exploded View"](#), see Step-1 to Step-3.

>> GO TO 2.

7. CHECK CONDENSATION

Check condensation in battery pack.

Is the inspection result normal?

YES >> GO TO 8.

NO >> Replace Li-ion battery. Refer to [EVB-169, "Removal and Installation"](#).

8. CHECK CONNECTORS AND FIXING BOLTS

Check connection state, damage and dust of following;

- Li-ion battery controller (LBC) harness connector
- Module harness connector
- Module terminal fixing bolt

Is the inspection result normal?

YES >> GO TO 9

NO >> Repair or replace error-detected parts.

9. CHECK MODULE VOLTAGE

Check module voltage within determined cell at step 3 and check the divergence of the voltage and cell voltage with "DATA MONITOR".

DANGER:

When check module voltage, be careful not to short.

Is Divergence within 40mV?

YES >> GO TO 10.

NO >> Replace Li-ion battery controller. Refer to [EVB-192, "LI-ION BATTERY CONTROLLER : Disassembly and Assembly"](#).

10. CHECK HARNESS BETWEEN LI-ION BATTERY CONTROLLER AND MODULE HARNESS CONNECTOR

1. Disconnect Li-ion battery controller harness connector and module harness connector.

P33E6 CELL VOLTAGE DEVIATION DIAG

[TYPE 1]

< DTC/CIRCUIT DIAGNOSIS >

2. Check the resistance Li-ion battery controller harness connector and module harness connector of the determined cell at step 3.

Terminal		Resistance value
Li-ion battery controller harness connector	Module harness connector	Approx. 0 Ω

3. Check the divergence of the resistance and the resistance of other cell harness.

Is the inspection result normal?

- YES >> Replace module within the determined cell at step 5.
NO >> Repair or replace harness or connectors.

A
B
EVB
D
E
F
G
H
I
J
K
L
M
N
O
P

P33E7 CELL CONTROLLER

< DTC/CIRCUIT DIAGNOSIS >

[TYPE 1]

P33E7 CELL CONTROLLER

DTC Logic

INFOID:000000007005840

DTC DETECTION LOGIC

DTC	Trouble diagnosis name	DTC detecting condition	Possible causes
P33E7	CELL CONTROLLER	The A/D converter in Li-ion battery controller is malfunctioning.	Li-ion battery controller

DTC CONFIRMATION PROCEDURE

1. PERFORM DTC CONFIRMATION PROCEDURE

④ With CONSULT

1. Power switch ON and wait for 10 seconds or more.
2. Select "Self Diagnostic Result" of "HV BAT".
3. Check DTC.

Is P33E7 detected?

- YES >> Refer to [EVB-150, "Diagnosis Procedure"](#).
NO >> INSPECTION END

Diagnosis Procedure

INFOID:000000007005841

When this DTC is detected, replace Li-ion battery controller. Refer to [EVB-192, "LI-ION BATTERY CONTROLLER : Disassembly and Assembly"](#).

P33ED BATTERY PARALLEL DIAGNOSIS

< DTC/CIRCUIT DIAGNOSIS >

[TYPE 1]

P33ED BATTERY PARALLEL DIAGNOSIS

DTC Logic

INFOID:000000007421455

DTC DETECTION LOGIC

DTC	Trouble diagnosis name	DTC detecting condition	Possible causes
P33ED	BATTERY PARALLEL DIAGNOSIS	When a sudden voltage fluctuation is detected in module.	Module

A

B

EVB

DTC CONFIRMATION PROCEDURE

1. CHECK LI-ION BATTERY AVAILABLE CHARGE GAUGE

Check the indication of the Li-ion battery available charge gauge.

NOTE:

Check 12 segments for lighting status.

Is the lighting status 1 Segment or none?

YES >> GO TO 3.

NO >> GO TO 2.

2. DISCHARGE OF LI-ION BATTERY

1. Set the vehicle to READY.
2. Set the vehicle, according to the following conditions.

A/C set temperature	: Full hot
A/C fan speed	: Maximum speed
A/C air outlet	:  Defroster
Headlamp	: High beam ON
Door glass	: Full open

3. Let the Li-ion battery discharge until the Li-ion battery available charge gauge shows segment 1 or below.

>> GO TO 3.

3. CHARGE OF LI-ION BATTERY

1. Charge the Li-ion battery by normal charge until the level reaches full charge.
2. After the completion of normal charge, check that the indication of the Li-ion battery available charge gauge shows 12 segments.

>> GO TO 4.

4. PERFORM DTC CONFIRMATION PROCEDURE

 With CONSULT

1. Power switch ON and wait for 10 seconds or more.
2. Select "Self Diagnostic Result" of "HV BAT".
3. Check DTC.

Is P33ED detected?

YES >> Refer to [EVb-151, "Diagnosis Procedure"](#).

NO >> INSPECTION END

Diagnosis Procedure

INFOID:000000007421456

1. CHECK DATA MONITOR OR FREEZE FRAME DATA (FFD)

 With CONSULT

1. Select "DATA MONITOR" or "FFD".
2. Check to see if there is a cell voltage which largely differ from the others.

Is there any abnormal cell?

P33ED BATTERY PARALLEL DIAGNOSIS

[TYPE 1]

< DTC/CIRCUIT DIAGNOSIS >

- YES >> Replace corresponding Module. Refer to [EVB-169. "Exploded View"](#).
NO >> GO TO 2.

2. DTC CONFIRMATION PROCEDURE OPERATION

1. If abnormal cell is not identified, perform DTC confirmation procedure. Refer to [EVB-151. "DTC Logic"](#).
2. Check cell voltage again using "DATA MONITOR" or "FFD" to identify malfunctioning cell.

>> Replace corresponding Module. Refer to [EVB-176. "Exploded view"](#).

U1000 CAN COMM CIRCUIT

< DTC/CIRCUIT DIAGNOSIS >

[TYPE 1]

U1000 CAN COMM CIRCUIT

Description

INFOID:000000007005844

CAN (Controller Area Network) is a serial communication line for real time applications. It is an on-vehicle multiplex communication line with high data communication speed and excellent error detection ability. Modern vehicle is equipped with many electronic control units, and each control unit shares information and links with other control units during operation (not independent). In CAN communication, control units are connected with 2 communication lines (CAN-H, CAN-L) allowing a high rate of information transmission with less wiring. Each control unit transmits/receives data but selectively reads the required data only.

CAN communication signal chart. Refer to [LAN-33. "CAN COMMUNICATION SYSTEM : CAN Communication Signal Chart"](#).

DTC Logic

INFOID:000000007005845

DTC DETECTION LOGIC

DTC	Trouble diagnosis name	DTC detecting condition	Possible causes
U1000	CAN COMM CIRCUIT	When no CAN communication signal is received continuously for 2 seconds or more.	CAN communication system

Diagnosis Procedure

INFOID:000000007005846

For the diagnosis procedure, refer to [LAN-15. "Trouble Diagnosis Flow Chart"](#).

A
B
EVB
D
E
F
G
H
I
J
K
L
M
N
O
P

LI-ION BATTERY INSULATION RESISTANCE LOSS CHECK

< DTC/CIRCUIT DIAGNOSIS >

[TYPE 1]

LI-ION BATTERY INSULATION RESISTANCE LOSS CHECK

Component Inspection

INFOID:000000007800479

WARNING:

- Because hybrid vehicles and electric vehicles contain a high voltage battery, there is the risk of electric shock, electric leakage, or similar accidents if the high voltage component and vehicle are handled incorrectly. Be sure to follow the correct work procedures when performing inspection and maintenance.
- Be sure to remove the service plug in order to disconnect the high voltage circuits before performing inspection or maintenance of high voltage system harnesses and parts.
- To prevent the removed service plug from being connected by mistake during the procedure, always carry it in your pocket or put it in the tool box.
- Be sure to wear insulating protective equipment consisting of glove, shoes, face shield and glasses before beginning work on the high voltage system.
- Clearly identify the persons responsible for high voltage work and ensure that other persons do not touch the vehicle. When not working, cover high voltage parts with an insulating cover sheet or similar item to prevent other persons from contacting them.
- Refer to [EVB-17, "High Voltage Precautions"](#).

CAUTION:

There is the possibility of a malfunction occurring if the vehicle is changed to READY status while the service plug is removed. Therefore do not change the vehicle to READY status unless instructed to do so in the Service Manual.

The following diagnosis procedure must be performed when "P0AA6 or P33E1" are detected and Li-ion battery is judged that its insulation resistance is dropping.

1. CHECK MAXIMUM CELL VOLTAGE

Ⓟ With CONSULT

1. Power switch ON.
2. Select "DATA MONITOR" of "HV BAT".
3. Record "MAXIMUM CELL VOLTAGE".

NOTE:

It is used, when replace a malfunction module.

>> GO TO 2

2. CHECK INSULATION OF FRONT MODULE STACK LH-1

CAUTION:

Check that high voltage harness and harness shield have no scratches and cracks. If any damage is found, replace damaged parts.

1. Remove Li-ion battery. Refer to [EVB-169, "Removal and Installation"](#).
2. Remove Li-ion battery controller. Refer to [EVB-192, "LI-ION BATTERY CONTROLLER : Disassembly and Assembly"](#).
3. Remove bus bar that connects front module stack LH and front module stack RH.
4. Measure voltages between positive terminal (A) of front module stack LH and battery pack ground, and between positive terminal (B) of front module stack LH and battery pack ground.

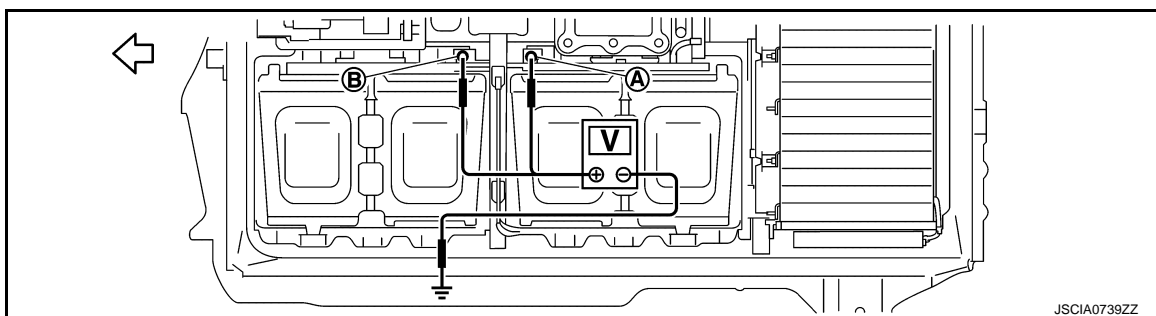

↩ : Battery pack front

LI-ION BATTERY INSULATION RESISTANCE LOSS CHECK

< DTC/CIRCUIT DIAGNOSIS >

[TYPE 1]

+	-	Voltage
Front module stack LH		
Terminal		
Ⓐ, Ⓑ	Battery pack ground	Approx. 0 V

Is the inspection result normal?

YES >> GO TO 8.

NO >> GO TO 3.

3. CHECK INSULATION OF FRONT MODULE STACK LH-2

1. Disconnect vehicle communication harness connector of front module stack LH.
2. Measure voltages between positive terminal Ⓐ of front module stack LH and battery pack ground, and between positive terminal Ⓑ of front module stack LH and battery pack ground.

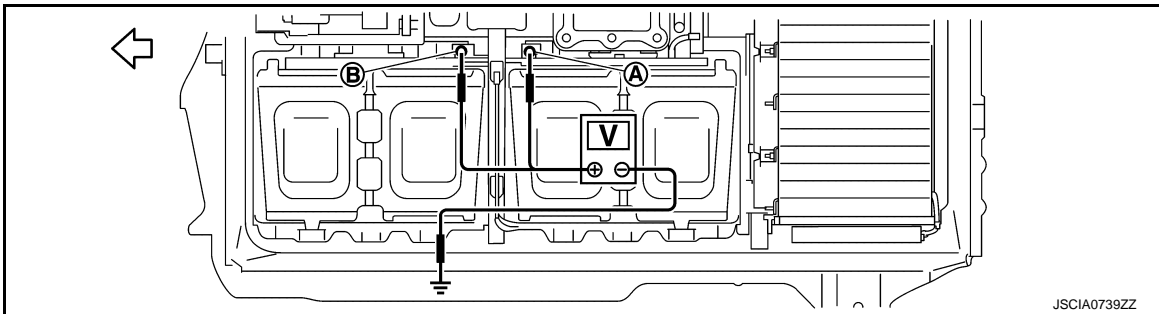

↩ : Battery pack front

+	-	Voltage
Front module stack LH		
Terminal		
Ⓐ, Ⓑ	Battery pack ground	Approx. 0 V

Is the inspection result normal?

YES >> Replace vehicle communication harness of front module stack LH and GO TO 8.

NO >> GO TO 4.

4. CHECK INSULATION OF FRONT MODULE STACK LH-3

1. Remove bus bar that connects service plug and front module stack LH.
2. Measure voltages between positive terminal Ⓐ of front module stack LH and battery pack ground, and between positive terminal Ⓑ of front module stack LH and battery pack ground.

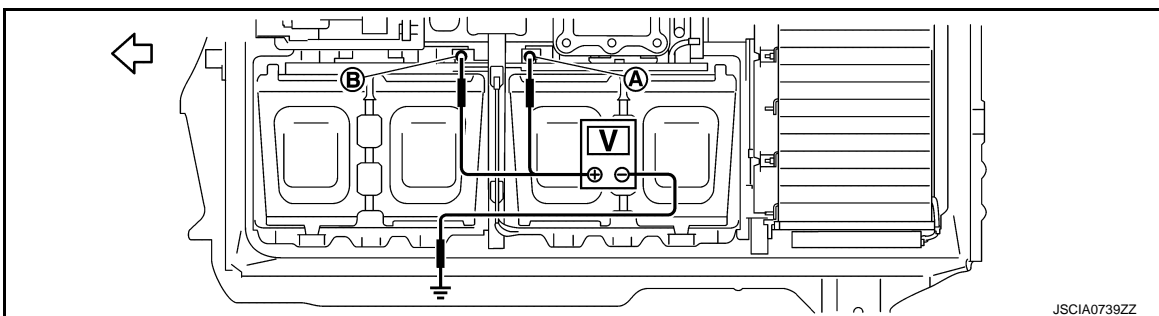

↩ : Battery pack front

LI-ION BATTERY INSULATION RESISTANCE LOSS CHECK

< DTC/CIRCUIT DIAGNOSIS >

[TYPE 1]

+	-	Voltage
Front module stack LH		
Terminal		
(A), (B)	Battery pack ground	Approx. 0 V

Is the inspection result normal?

- YES >> GO TO 5.
NO >> GO TO 6.

5. CHECK SERVICE PLUG SWITCH INSULATION RESISTANCE

- Remove bus bar that connects service plug and front module stack LH from service plug switch bracket.
- Using insulation resistance tester, measure insulation resistance between service plug switch terminal and service plug switch bracket.

WARNING:

Unlike the ordinary tester, the insulation resistance tester applies 500 V when measuring. If used incorrectly, there is the danger of electric shock. If used in the vehicle 12V system, there is the danger of damage to electronic devices. Read the insulation resistance tester instruction manual carefully and be sure to work safely.

CAUTION:

Be sure to set the insulation resistance tester to 500 V when performing this test. Using a setting higher than 500 V can result in damage to the component being inspected.

NOTE:

Check resistance without disassembling service plug switch and service plug switch bracket.

+	-	Resistance
Service plug switch terminal	Service plug switch bracket	1000 MΩ or more

Is the inspection result normal?

- YES >> Replace bus bar that connects service plug and front module stack LH and GO TO 8.
NO >> Replace service plug switch (Refer to [EVB-176, "Exploded view"](#).) and GO TO 8.

6. CHECK MODULE-1

- Remove front module stack LH. Refer to [EVB-198, "FRONT MODULE STACK : Disassembly and Assembly"](#).

NOTE:

Do not disassemble module stack.

- Measure voltages between terminal (A)/(B) of all modules in front module stack LH and module body.

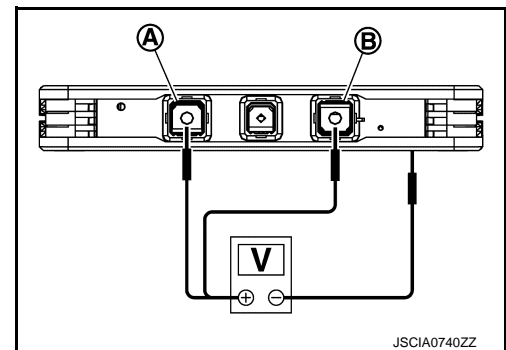

+	-	Voltage
Module		
Terminal		
(A)	Module body	Approx. 0 V
(B)		

Is the inspection result normal?

LI-ION BATTERY INSULATION RESISTANCE LOSS CHECK

[TYPE 1]

< DTC/CIRCUIT DIAGNOSIS >

- YES >> GO TO 7.
- NO >> Replace malfunctioning module (Refer to [EVB-198, "FRONT MODULE STACK : Disassembly and Assembly"](#).) and GO TO 8.

7. CHECK MODULE-2

Measure insulation resistance between terminal (A)/(B) of all modules in front module stack LH and module body.

WARNING:

Unlike the ordinary tester, the insulation resistance tester applies 500 V when measuring. If used incorrectly, there is the danger of electric shock. If used in the vehicle 12V system, there is the danger of damage to electronic devices. Read the insulation resistance tester instruction manual carefully and be sure to work safely.

CAUTION:

Be sure to set the insulation resistance tester to 500 V when performing this test. Using a setting higher than 500 V can result in damage to the component being inspected.

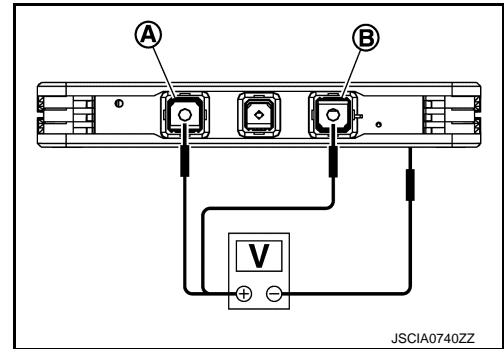

+		-	resistance
Module Terminal			
(A)	Module body	100 MΩ or more	
(B)			

Is the inspection result normal?

- YES >> Check insulation resistance of front module stack RH, because front module stack LH is normal. GO TO 8.
- NO >> Replace malfunctioning module (Refer to [EVB-198, "FRONT MODULE STACK : Disassembly and Assembly"](#).) and GO TO 8.

8. CHECK INSULATION OF FRONT MODULE STACK RH-1

1. Measure voltages between positive terminal (A) of front module stack RH and battery pack ground, and between positive terminal (B) of front module stack LH and battery pack ground.

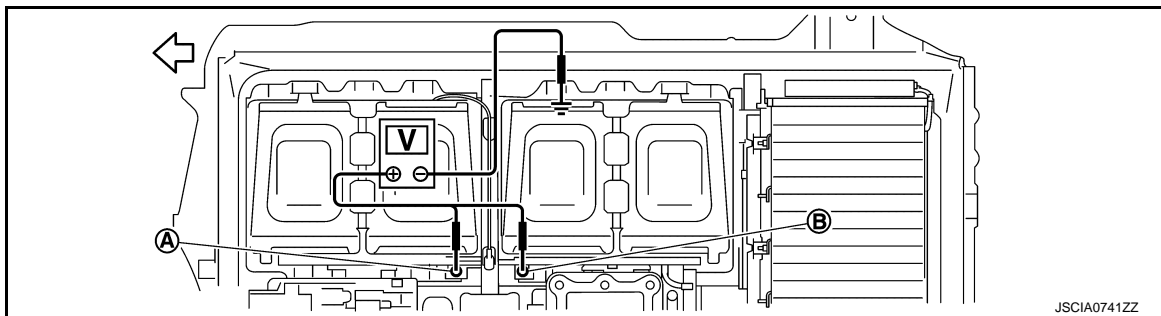

↩ : Battery pack front

+		-	Voltage
Front module stack RH Terminal			
(A), (B)	Battery pack ground	Approx. 0 V	

Is the inspection result normal?

- YES >> GO TO 14.
- NO >> GO TO 9.

LI-ION BATTERY INSULATION RESISTANCE LOSS CHECK

< DTC/CIRCUIT DIAGNOSIS >

[TYPE 1]

9. CHECK INSULATION OF FRONT MODULE STACK RH-2

1. Disconnect vehicle communication harness connector of front module stack RH.
2. Measure voltages between positive terminal (A) of front module stack RH and battery pack ground, and between positive terminal (B) of front module stack RH and battery pack ground.

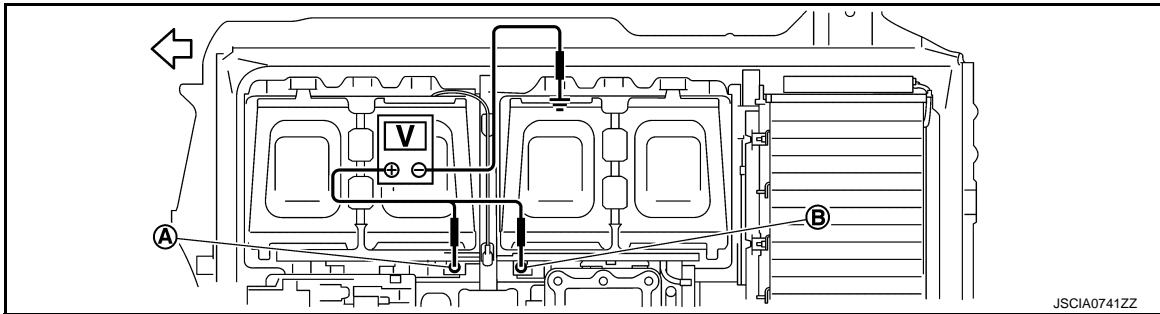

↩ : Battery pack front

+		
Front module stack RH	-	Voltage
Terminal		
(A), (B)	Battery pack ground	Approx. 0 V

Is the inspection result normal?

YES >> Replace vehicle communication harness of front module stack RH and GO TO 14.

NO >> GO TO 10.

10. CHECK INSULATION OF FRONT MODULE STACK RH-3

1. Remove bus bar that connects front module stack RH and battery junction box.
2. Measure voltages between positive terminal (A) of front module stack RH and battery pack ground, and between positive terminal (B) of front module stack RH and battery pack ground.

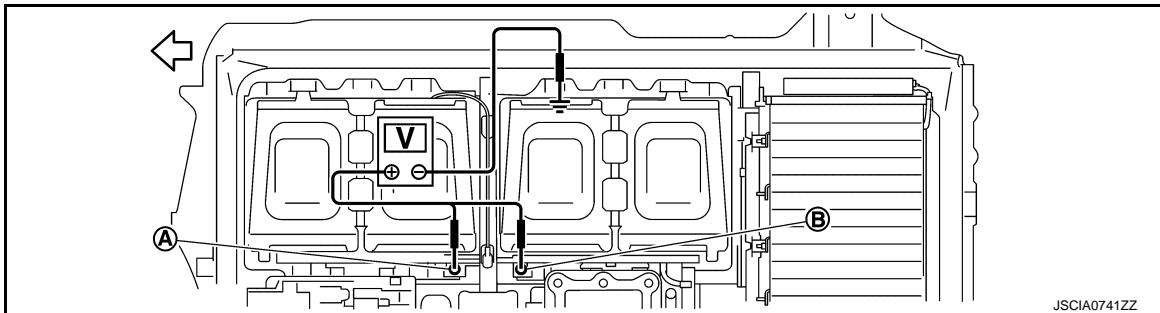

↩ : Battery pack front

+		
Front module stack RH	-	Voltage
Terminal		
(A), (B)	Battery pack ground	Approx. 0 V

Is the inspection result normal?

YES >> GO TO 11.

NO >> GO TO 12.

11. CHECK BATTERY JUNCTION BOX INSULATION RESISTANCE

LI-ION BATTERY INSULATION RESISTANCE LOSS CHECK

[TYPE 1]

< DTC/CIRCUIT DIAGNOSIS >

- Using insulation resistance tester, measure insulation resistance between high voltage terminal (A)/(B) of battery junction box and battery pack ground.

← : Battery pack front

WARNING:

Unlike the ordinary tester, the insulation resistance tester applies 500 V when measuring. If used incorrectly, there is the danger of electric shock. If used in the vehicle 12V system, there is the danger of damage to electronic devices. Read the insulation resistance tester instruction manual carefully and be sure to work safely.

CAUTION:

Be sure to set the insulation resistance tester to 500 V when performing this test. Using a setting higher than 500 V can result in damage to the component being inspected.

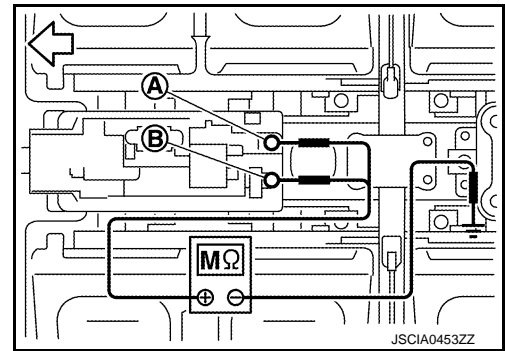

Battery junction box	—	Resistance
Terminal		
(A)	Battery pack ground	1000 MΩ or more
(B)		

Is the inspection result normal?

- YES >> Replace bus bar that connects front module stack RH and battery junction box and GO TO 14.
- NO >> Replace battery junction box (Refer to [EVB-184, "BATTERY JUNCTION BOX : Disassembly and Assembly"](#)) and GO TO 14.

12.CHECK MODULE-3

- Remove front module stack RH. Refer to [EVB-198, "FRONT MODULE STACK : Disassembly and Assembly"](#).

NOTE:

Do not disassemble module stack.

- Measure voltages between terminal (A)/(B) of all modules in front module stack RH and module body.

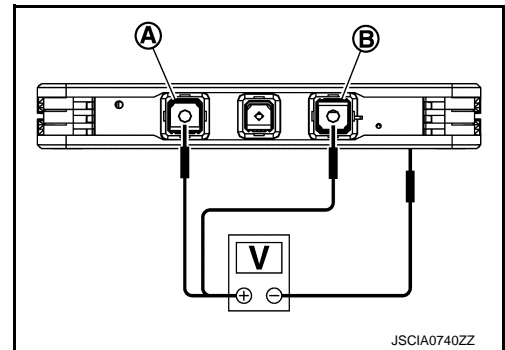

+	—	Voltage
Module Terminal		
(A)	Module body	Approx. 0 V
(B)		

Is the inspection result normal?

- YES >> GO TO 13.
- NO >> Replace malfunctioning module (Refer to [EVB-198, "FRONT MODULE STACK : Disassembly and Assembly"](#).) and GO TO 14.

13.CHECK MODULE-4

LI-ION BATTERY INSULATION RESISTANCE LOSS CHECK

[TYPE 1]

< DTC/CIRCUIT DIAGNOSIS >

Measure insulation resistance between terminal (A)/(B) of all modules in front module stack RH and module body.

WARNING:

Unlike the ordinary tester, the insulation resistance tester applies 500 V when measuring. If used incorrectly, there is the danger of electric shock. If used in the vehicle 12V system, there is the danger of damage to electronic devices. Read the insulation resistance tester instruction manual carefully and be sure to work safely.

CAUTION:

Be sure to set the insulation resistance tester to 500 V when performing this test. Using a setting higher than 500 V can result in damage to the component being inspected.

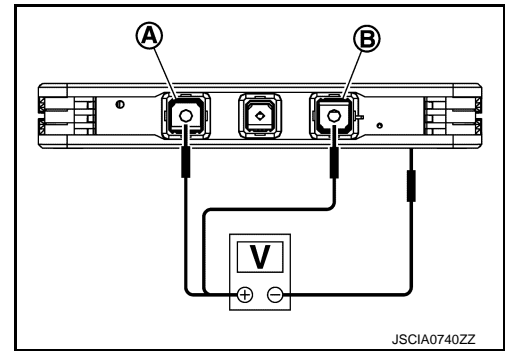

+	-	resistance
Module Terminal		
(A)	Module body	100 MΩ or more
(B)		

Is the inspection result normal?

YES >> Check insulation resistance of front module stack RH, because front module stack LH is normal.
GO TO 14.

NO >> Replace malfunctioning module (Refer to [EVB-198, "FRONT MODULE STACK : Disassembly and Assembly"](#).) and GO TO 14.

14. CHECK INSULATION OF REAR MODULE STACK-1

1. Measure voltages between positive terminal (A) of rear module stack and battery pack ground, and between positive terminal (B) of rear module stack and battery pack ground.

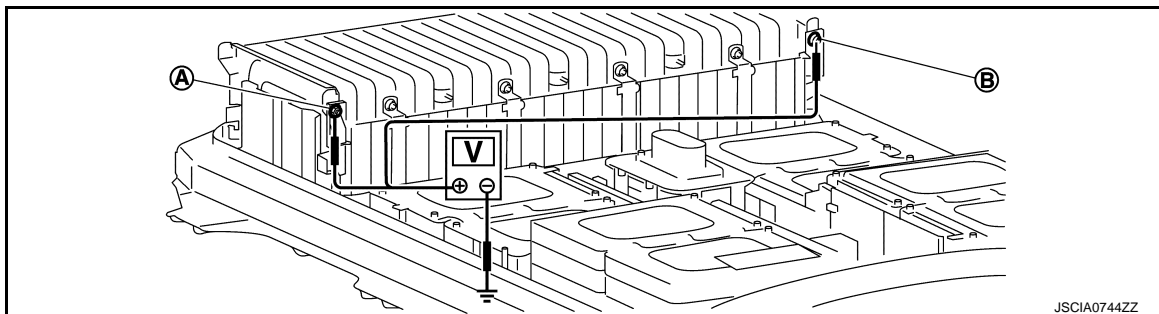

+	-	Voltage
Rear module stack Terminal		
(A), (B)	Battery pack ground	Approx. 0 V

Is the inspection result normal?

YES-1 >> Replace or repair of malfunctioning part is not-yet performed: Replace Li-ion battery controller.
Refer to [EVB-192, "LI-ION BATTERY CONTROLLER : Disassembly and Assembly"](#).

YES-2 >> Replace or repair of malfunctioning part is complete: INSPECTION END.

NO >> GO TO 15.

15. CHECK INSULATION OF REAR MODULE STACK-2

LI-ION BATTERY INSULATION RESISTANCE LOSS CHECK

< DTC/CIRCUIT DIAGNOSIS >

[TYPE 1]

1. Disconnect vehicle communication harness connector (A) of rear module stack.

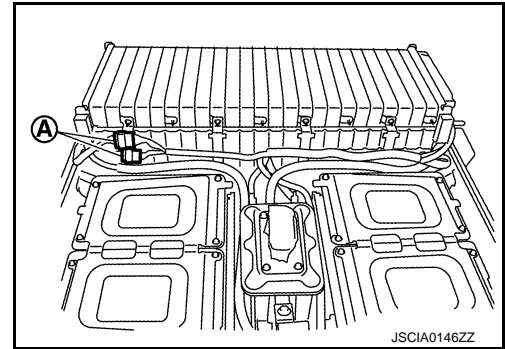

2. Measure voltages between positive terminal (A) of rear module stack and battery pack ground, and between positive terminal (B) of rear module stack and battery pack ground.

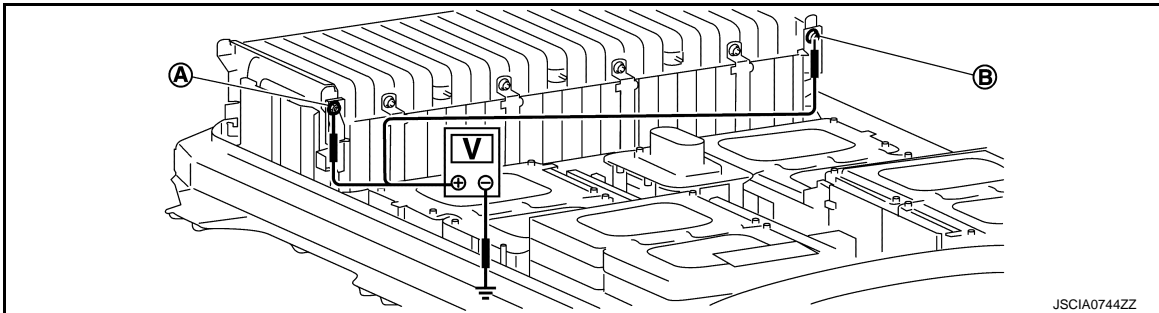

+		
Front module stack RH	-	Voltage
Terminal		
(A), (B)	Battery pack ground	Approx. 0 V

Is the inspection result normal?

YES >> Replace vehicle communication harness of rear module stack.

NO >> GO TO 16.

16.CHECK INSULATION OF FRONT MODULE STACK RH-3

1. Remove mounting nuts (A)/(B) and remove high voltage harness from rear module stack.

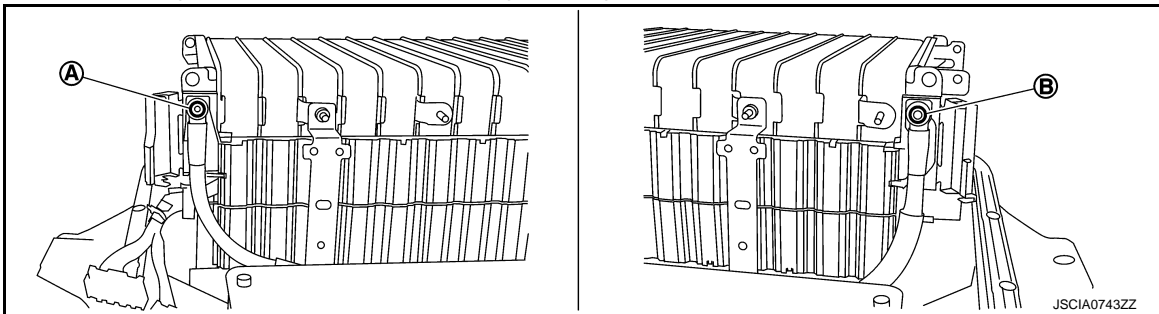

2. Measure voltages between positive terminal (A) of rear module stack and battery pack ground, and between positive terminal (B) of rear module stack and battery pack ground.

LI-ION BATTERY INSULATION RESISTANCE LOSS CHECK

< DTC/CIRCUIT DIAGNOSIS >

[TYPE 1]

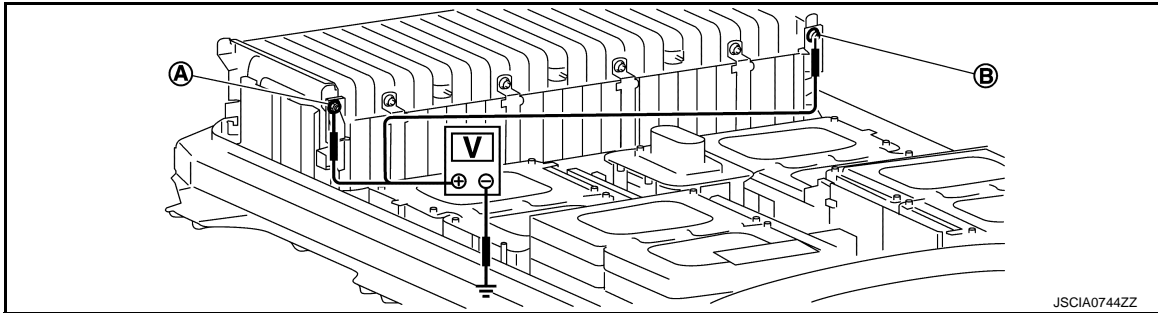

+	-	Voltage
Rear module stack		
Terminal		
(A), (B)	Battery pack ground	Approx. 0 V

Is the inspection result normal?

- YES >> .Replace high voltage harness.
 NO >> GO TO 17.

17.CHECK MODULE-5

- Remove rear module stack. Refer to [EVB-208, "REAR MODULE STACK : Disassembly and Assembly"](#).
NOTE:
 Do not disassemble module stack.
- Measure voltages between terminal (A)/(B) of all modules in rear module stack and module body.

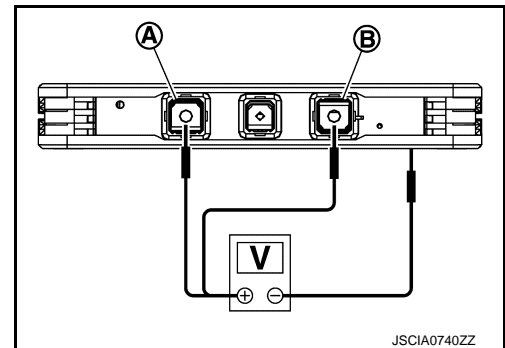

+	-	Voltage
Module		
Terminal		
(A)	Module body	Approx. 0 V
(B)		

Is the inspection result normal?

- YES >> GO TO 18.
 NO >> Replace malfunctioning module. Refer to [EVB-208, "REAR MODULE STACK : Disassembly and Assembly"](#).

18.CHECK MODULE-6

LI-ION BATTERY INSULATION RESISTANCE LOSS CHECK

[TYPE 1]

< DTC/CIRCUIT DIAGNOSIS >

Measure insulation resistance between terminal (A)/(B) of all modules in rear module stack and module body.

WARNING:

Unlike the ordinary tester, the insulation resistance tester applies 500 V when measuring. If used incorrectly, there is the danger of electric shock. If used in the vehicle 12V system, there is the danger of damage to electronic devices. Read the insulation resistance tester instruction manual carefully and be sure to work safely.

CAUTION:

Be sure to set the insulation resistance tester to 500 V when performing this test. Using a setting higher than 500 V can result in damage to the component being inspected.

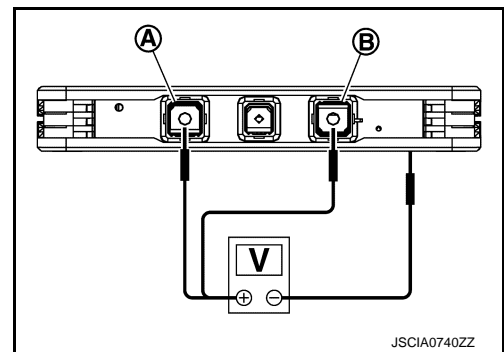

+	-	resistance
Module Terminal		
(A)	Module body	100 MΩ or more
(B)		

Is the inspection result normal?

- YES-1 >> Replace or repair of malfunctioning part is not-yet performed: Replace Li-ion battery controller. Refer to [EVB-192, "LI-ION BATTERY CONTROLLER : Disassembly and Assembly"](#).
- YES-2 >> Replace or repair of malfunctioning part is complete: INSPECTION END.
- NO >> Replace malfunctioning module. Refer to [EVB-208, "REAR MODULE STACK : Disassembly and Assembly"](#).

A
B
EVB
D
E
F
G
H
I
J
K
L
M
N
O
P

POWER SUPPLY AND GROUND CIRCUIT

< DTC/CIRCUIT DIAGNOSIS >

[TYPE 1]

POWER SUPPLY AND GROUND CIRCUIT

Diagnosis Procedure

INFOID:000000007005847

WARNING:

- Because hybrid vehicles and electric vehicles contain a high voltage battery, there is the risk of electric shock, electric leakage, or similar accidents if the high voltage component and vehicle are handled incorrectly. Be sure to follow the correct work procedures when performing inspection and maintenance.
- Be sure to remove the service plug in order to shut off the high voltage circuits before performing inspection or maintenance of high voltage system harnesses and parts.
- Be sure to put the removed service plug in your pocket and carry it with you so that another person does not accidentally connect it while work is in progress.
- Be sure to wear insulating protective gear consisting of glove, shoes and face shield before beginning work on the high voltage system.
- Clearly identify the persons responsible for high voltage work and ensure that other persons do not touch the vehicle. When not working, cover high voltage parts with an insulating cover sheet or similar item to prevent other persons from contacting them.
- Refer to [EVB-17, "High Voltage Precautions"](#).

CAUTION:

There is the possibility of a malfunction occurring if the vehicle is changed to READY status while the service plug is removed. Therefore do not change the vehicle to READY status unless instructed to do so in the Service Manual.

1. CHECK FUSE

Check that the following fuse is not fusing.

Power supply	Fuse No.
Battery	43
Power switch ON	55
	74

Is the fuse fusing?

YES >> Replace the fuse after repairing the applicable circuit.

NO >> GO TO 2.

2. CHECK LI-ION BATTERY CONTROLLER GROUND CIRCUIT

1. Turn power switch OFF.
2. Disconnect Li-ion battery vehicle communication harness connector.
3. Check the continuity between Li-ion battery vehicle communication harness connector and ground.

+		-	Continuity
Li-ion battery			
Connector	Terminal	Ground	Existed
B24	6		
	7		
	8		

Is the inspection result normal?

YES >> GO TO 3.

NO >> Repair or replace error-detected parts.

3. CHECK BATTERY POWER SUPPLY

Check the voltage between Li-ion battery vehicle communication harness connector and ground.

POWER SUPPLY AND GROUND CIRCUIT

< DTC/CIRCUIT DIAGNOSIS >

[TYPE 1]

+		-	Voltage
Li-ion battery			
Connector	Terminal		
B24	5	Ground	12V battery power supply

Is the inspection result normal?

YES >> GO TO 5.

NO >> GO TO 4.

4.CHECK BATTERY POWER SUPPLY CIRCUIT

1. Check the continuity between Li-ion battery vehicle communication harness connector and fuse terminal.

+		-	Continuity
Li-ion battery			
Connector	Terminal		
B24	5	No.43 fuse terminal	Existed

2. Also check harness for short to ground.

Is the inspection result normal?

YES >> Check power supply circuit for battery power supply.

NO >> Repair or replace error-detected parts.

5.CHECK IGNITION POWER SUPPLY

1. Turn power switch ON.
2. Check the voltage between Li-ion battery vehicle communication harness and ground.

+		-	Voltage (Approx.)
Li-ion battery			
Connector	Terminal		
B24	4	Ground	11 – 14 V
	21		

Is the inspection result normal?

YES >> GO TO 8.

NO >> GO TO 6.

6.CHECK IGNITION POWER SUPPLY CIRCUIT-1

1. Turn power switch OFF.
2. Disconnect IPDM E/R harness connector.
3. Check the continuity between Li-ion battery vehicle communication harness and IPDM E/R harness connector.

Li-ion battery		IPDM E/R		Continuity
Connector	Terminal	Connector	Terminal	
B24	4	E15	57	Existed

4. Also check harness for short to ground.

Is the inspection result normal?

YES >> GO TO 7.

NO >> Repair or replace error-detected parts.

7.CHECK IGNITION POWER SUPPLY CIRCUIT-2

1. Check the continuity between Li-ion battery vehicle communication harness and fuse terminal.

A
B
EVB
D
E
F
G
H
I
J
K
L
M
N
O
P

POWER SUPPLY AND GROUND CIRCUIT

< DTC/CIRCUIT DIAGNOSIS >

[TYPE 1]

Li-ion battery		—	Continuity
Connector	Terminal		
B24	21	No.74 fuse terminal	Existed

2. Also check harness for short to ground.

Is the inspection result normal?

YES >> Check power supply circuit for battery power supply.

NO >> Repair or replace error-detected parts.

8.PRECONDITIONING

WARNING:

Shut off high voltage circuit. Refer to [GI-31, "How to Disconnect High Voltage"](#).

1. Remove Li-ion battery. Refer to [EVB-169, "Removal and Installation"](#).

2. Remove battery pack upper case. Refer to [EVB-184, "BATTERY JUNCTION BOX : Disassembly and Assembly"](#), see Step-1 to Step-3.

>> GO TO 9.

9.CHECK HARNESS BETWEEN LI-ION BATTERY AND LI-ION BATTERY CONTROLLER

1. Check the continuity between Li-ion battery vehicle communication harness connector and Li-ion battery controller harness connector.

LBC		Li-ion battery		Continuity
Connector	Terminal	Connector	Terminal	
LB11	5	LB1	21	Existed
	6		4	
	21		5	
	3		8	
	15		7	
	16		6	

2. Also check harness for short to ground.

Is the inspection result normal?

YES >> INSPECTION END

NO >> Repair or replace error-detected parts.

REDUCTION IN THE DRIVING RANGE

< SYMPTOM DIAGNOSIS >

[TYPE 1]

SYMPTOM DIAGNOSIS

REDUCTION IN THE DRIVING RANGE

Description

INFOID:000000007374104

- The driving range is shorter than before.
- Sudden change (decrease/increase) in possible travel distance indicated on the combination meter.

Diagnosis Procedure

INFOID:000000007374105

1. CHECK LI-ION BATTERY AVAILABLE CHARGE GAUGE

Check the indication of the Li-ion battery available charge gauge.

NOTE:

Check 12 segments for lighting status.

Is the lighting status 1 Segment or none?

YES >> GO TO 3.

NO >> GO TO 2.

2. DISCHARGE OF LI-ION BATTERY

1. Set the vehicle to READY.
2. Set the vehicle, according to the following conditions.

A/C set temperature	: Full hot
A/C fan speed	: Maximum speed
A/C air outlet	:  Defroster
Headlamp	: High beam ON
Door glass	: Full open

3. Let the Li-ion battery discharge until the Li-ion battery available charge gauge shows Segment 1 or below.

>> GO TO 3.

3. CHARGE OF LI-ION BATTERY

1. Charge the Li-ion battery by normal charge until the level reaches full charge.
2. After the completion of normal charge, check that the indication of the Li-ion battery available charge gauge shows 12 segments.

>> GO TO 4.

4. PERFORM DTC CONFIRMATION PROCEDURE

 With CONSULT

1. Power switch ON and wait for 10 seconds or more.
2. Select "Self Diagnostic Result" of "HV BAT".
3. Check DTC.

Is any DTC detected?

YES >> Perform diagnosis on the detected DTC. Refer to [EVB-50. "DTC Index"](#).

NO >> INSPECTION END

PERIODIC MAINTENANCE

EV BATTERY USAGE REPORT

Inspection

INFOID:000000007462047

Generation of the EV battery usage report is one of the maintenance items.

This maintenance item generates a report that will help the customer understand the vehicle operating conditions needed to keep the Li-ion battery in the best possible condition.

For details about how to generate this report, please refer to EV battery usage report in the CONSULT III plus operation manual.

LI-ION BATTERY

< UNIT REMOVAL AND INSTALLATION >

[TYPE 1]

UNIT REMOVAL AND INSTALLATION

LI-ION BATTERY

Exploded View

INFOID:000000007005848

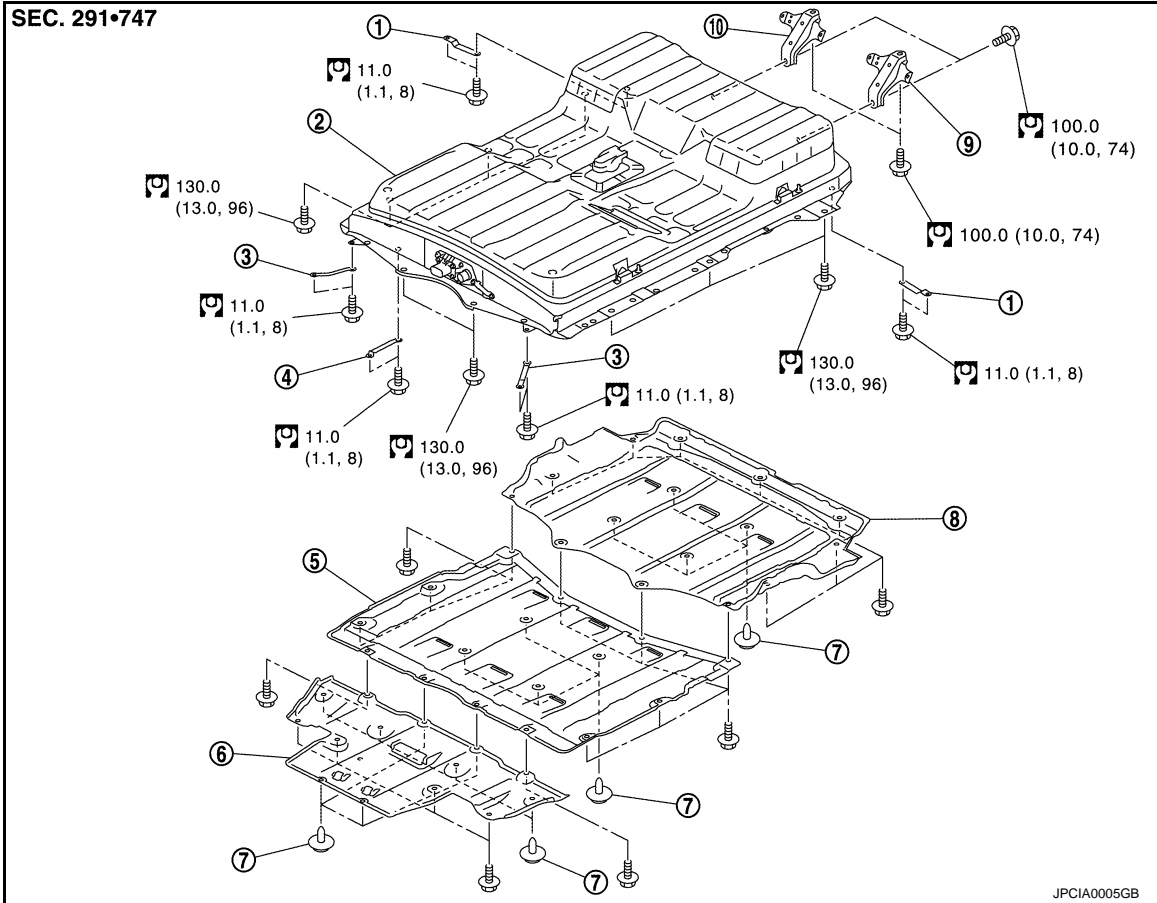

- | | | |
|---|--|---------------------------------------|
| 1. Bonding plate (Stamp No.6)
(August 2011 or later models, abolished) | 2. Li-ion battery | 3. Bonding plate (Stamp No.4) |
| 4. Bonding plate (Stamp No.2)
(August 2011 or later models, abolished) | 5. Li-ion battery under cover (center) | 6. Li-ion battery under cover (front) |
| 7. Clip | 8. Li-ion battery under cover (rear) | 9. Battery mounting bracket LH |
| 10. Battery mounting bracket RH | | |

: N·m (kg·m, ft·lb)

Removal and Installation

INFOID:000000007005849

WARNING:

- Because hybrid vehicles and electric vehicles contain a high voltage battery, there is the risk of electric shock, electric leakage, or similar accidents if the high voltage component and vehicle are handled incorrectly. Be sure to follow the correct work procedures when performing inspection and maintenance.
- Be sure to remove the service plug in order to disconnect the high voltage circuits before performing inspection or maintenance of high voltage system harnesses and parts.
- To prevent the removed service plug from being connected by mistake during the procedure, always carry it in your pocket or put it in the tool box.
- Be sure to wear insulating protective equipment consisting of glove, shoes, face shield and glasses before beginning work on the high voltage system.
- Refer to [EVB-17, "High Voltage Precautions"](#).

LI-ION BATTERY

< UNIT REMOVAL AND INSTALLATION >

[TYPE 1]

CAUTION:

There is the possibility of a malfunction occurring if the vehicle is changed to READY status while the service plug is removed. Therefore do not change the vehicle to READY status unless instructed to do so in the Service Manual.

REMOVAL

WARNING:

Perform high voltage system work preparation. Refer to [GI-31, "How to Disconnect High Voltage"](#).

1. Lift up the vehicle and remove the Li-ion battery under covers. Refer to [EVB-169, "Exploded View"](#).
2. Disconnect high voltage harness connector (A) from Li-ion battery.

WARNING:

-  To prevent electric shock hazards, be sure to wear protective gear.



-  To prevent electric shock hazards, immediately wrap insulating tape around disconnected high voltage harness connector and terminals.

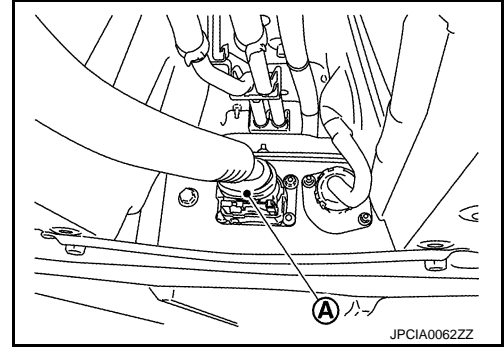

- Follow the procedure below to disconnect the high voltage harness connector.

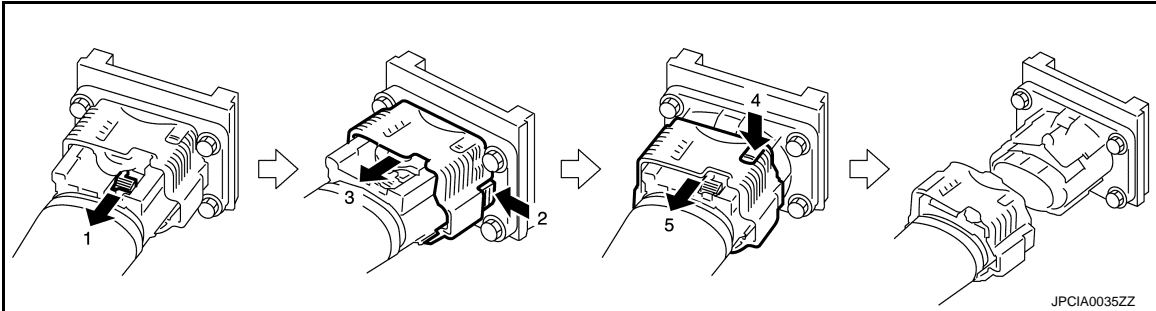

3. Disconnect the Li-ion battery vehicle communication harness connector (A) while turning it counterclockwise.

WARNING:

-  To prevent electric shock hazards, be sure to wear protective gear.

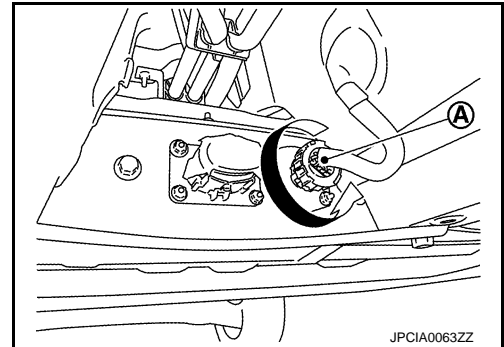

4. Remove the bonding plates.

1. Stamp No.2 (August 2011 or later models, abolished)
2. Stamp No.4
3. Stamp No.6 (August 2011 or later models, abolished)

← : Vehicle front

WARNING:

-  To prevent electric shock hazards, be sure to wear protective gear.

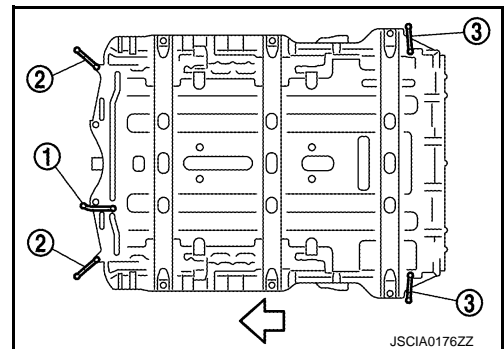

LI-ION BATTERY

< UNIT REMOVAL AND INSTALLATION >

[TYPE 1]



NOTE:

The bonding plate shape differs depending on the location of installation.

- Remove the Li-ion battery mounting bolts (A).

← : Vehicle front

WARNING:

 To prevent electric shock hazards, be sure to wear protective gear.



CAUTION:

Never remove the 4 bolts (B) shown in the figure.

- Set the pallet onto the lifter table.
 - Align center mark (A) of pallet (1) with center mark (B) of battery lift table (2).

C. Front

D. Side

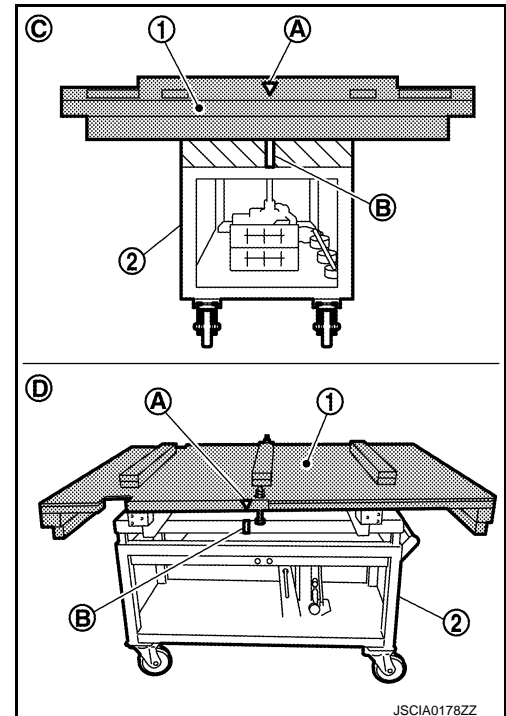
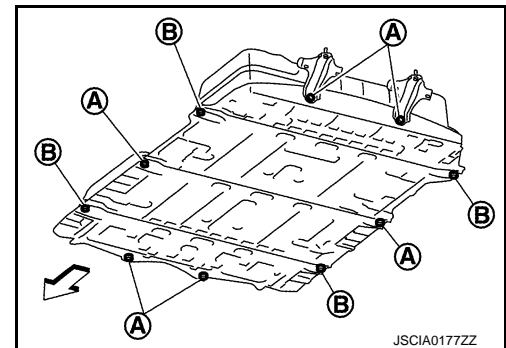

- Set the pallet (1) onto the Li-ion battery.

CAUTION:

Set the palette and Li-ion battery with transportation fixing bolts.

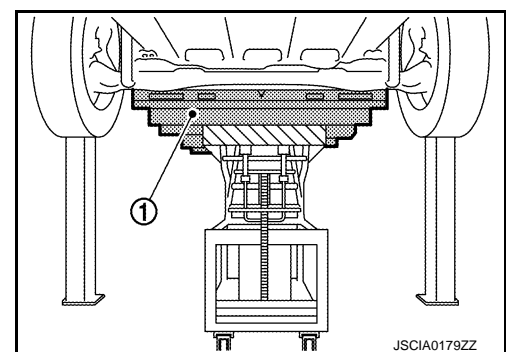

- Remove the Li-ion battery mounting bolts (4 bolts) (A).

A

B

EVB

D

E

F

G

H

I

J

K

L

M

N

O

P

LI-ION BATTERY

< UNIT REMOVAL AND INSTALLATION >

[TYPE 1]

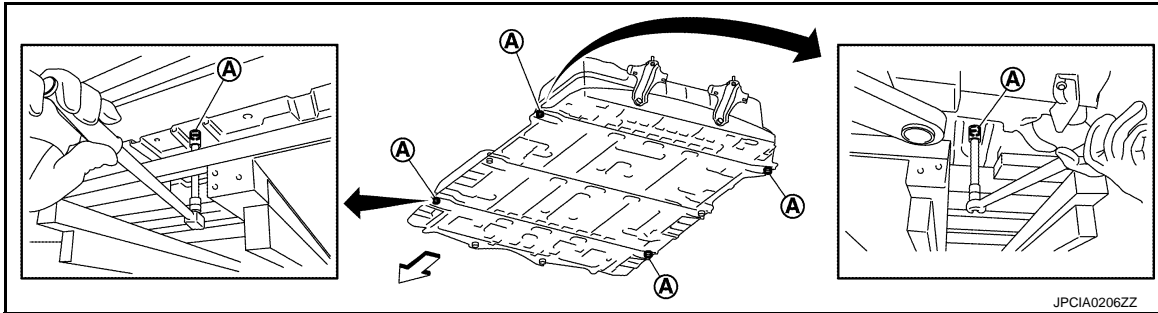

↔ : Vehicle front

WARNING:



To prevent electric shock hazards, be sure to wear protective gear.



9. Lower the pallet and remove the Li-ion battery (1) from the vehicle.

WARNING:



To prevent electric shock hazards, be sure to wear protective gear.

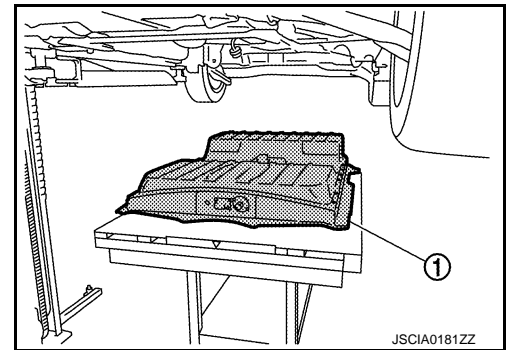

10. Move Li-ion battery from the lift table together with the pallet.

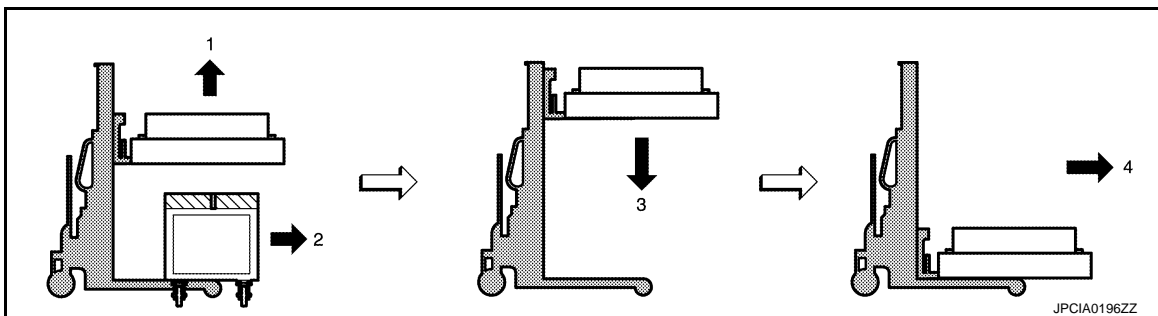

1. Lift Li-ion battery.
2. Move lift table.
3. Lower Li-ion battery.
4. Move Li-ion battery by operating stacker.

CAUTION:

To prevent stacker from falling, never move the stacker with the Li-ion battery lifted.

INSTALLATION

1. When replacing the Li-ion battery with a new one, perform the following procedure.
 - a. Enter the date of replacement on the EV battery traceability seal packaged with the new part.
 - b. Cut the EV battery traceability seal in two and affix each seal to the Li-ion battery and "Li-ion BATTERY REPLACEMENT RECORD".
 - c. Fill in the "Li-ion BATTERY REPLACEMENT RECORD".

LI-ION BATTERY

< UNIT REMOVAL AND INSTALLATION >

[TYPE 1]

2. Install 2 locating pins (1) at the positions on the vehicle body shown in the figure.

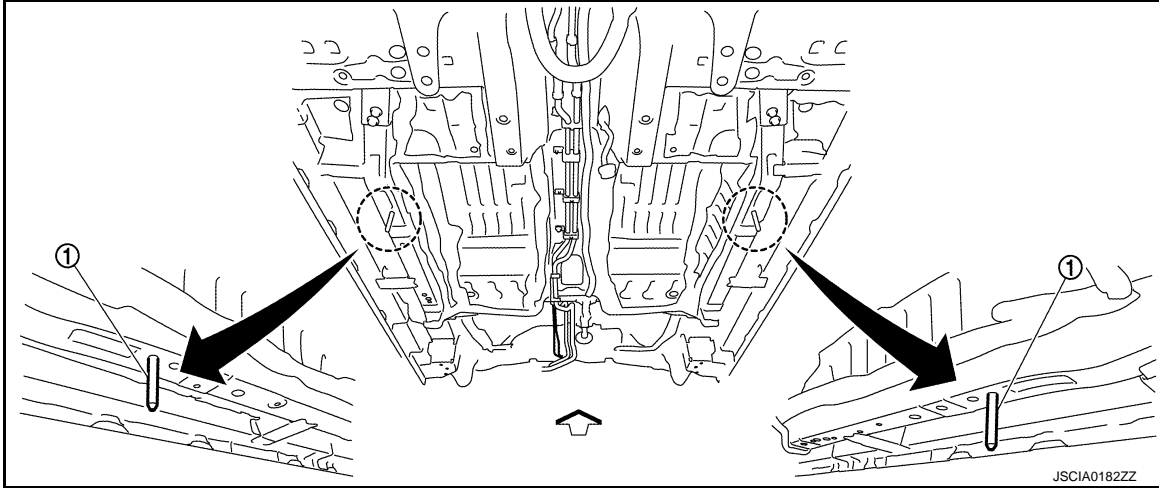

← : Vehicle front

3. Install the Li-ion battery onto the vehicle body.
 - Align the Li-ion battery (1) and the locating pin (2).

WARNING:

 To prevent electric shock hazards, be sure to wear protective gear.

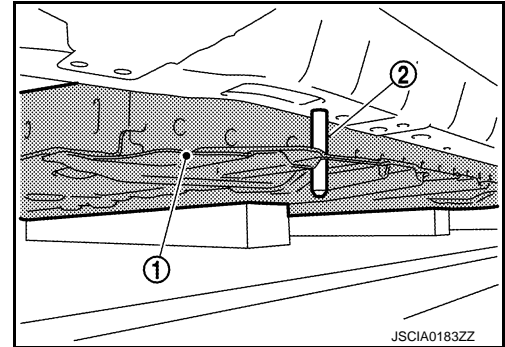

4. Tighten mounting bolts (4 bolts) (A) and remove pallet from Li-ion battery.

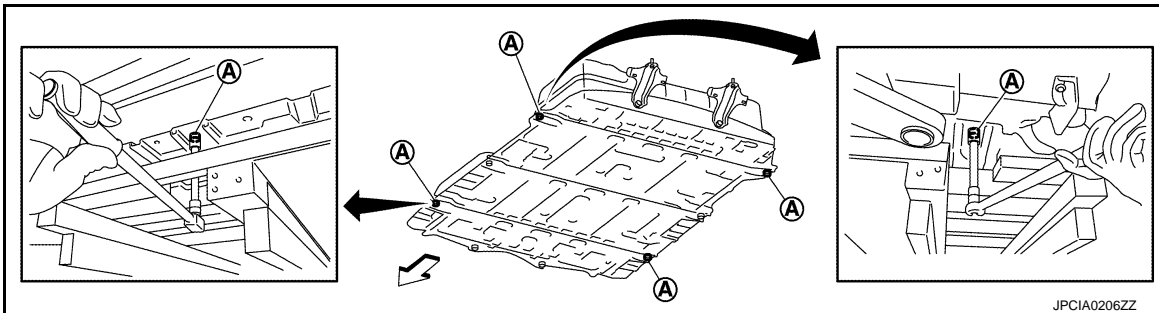

← : Vehicle front

WARNING:

 To prevent electric shock hazards, be sure to wear protective gear.



5. Remove the locating pins from the body.

A
B
EVB
D
E
F
G
H
I
J
K
L
M
N
O
P

LI-ION BATTERY

[TYPE 1]

< UNIT REMOVAL AND INSTALLATION >

- If the locating pins (1) are tight and cannot be removed, use a spanner to remove them.

WARNING:

 To prevent electric shock hazards, be sure to wear protective gear.

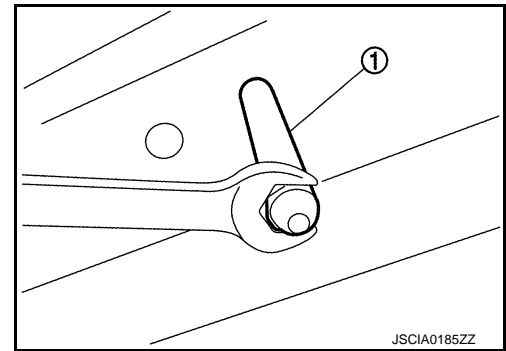

6. Install the Li-ion battery mounting bolts (A).

← : Vehicle front

WARNING:

 To prevent electric shock hazards, be sure to wear protective gear.

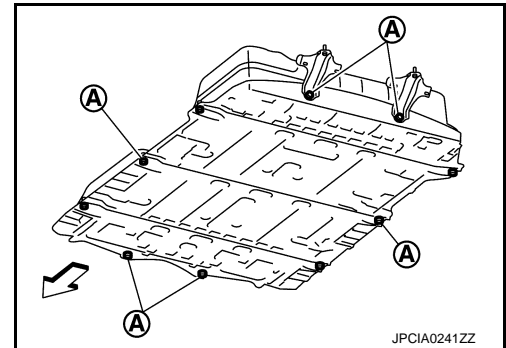

7. Check the stamp No. of the bonding plate, and install it at the position shown in the figure.

1. Stamp No.2 (August 2011 or later models, abolished)
2. Stamp No.4
3. Stamp No.6 (August 2011 or later models, abolished)

← : Vehicle front

WARNING:

 To prevent electric shock hazards, be sure to wear protective gear.

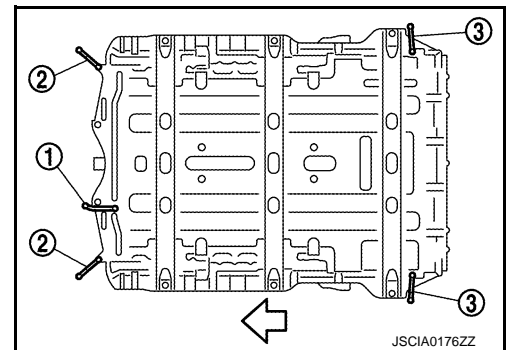

8. After installing the bonding plate, check the equipotential. Refer to [EVB-175, "Inspection"](#).

9. Turn the vehicle communication harness connector (A) clockwise to install.

WARNING:

 To prevent electric shock hazards, be sure to wear protective gear.

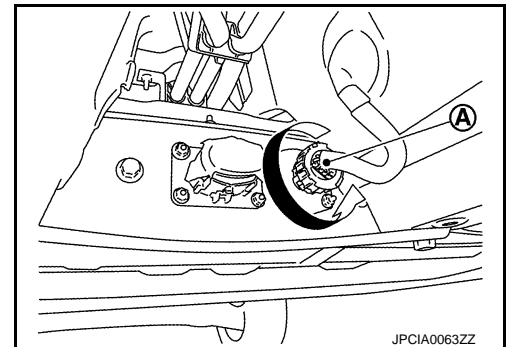

LI-ION BATTERY

< UNIT REMOVAL AND INSTALLATION >

[TYPE 1]

10. Install the high voltage harness connector (A).

WARNING:



To prevent electric shock hazards, be sure to wear protective gear.

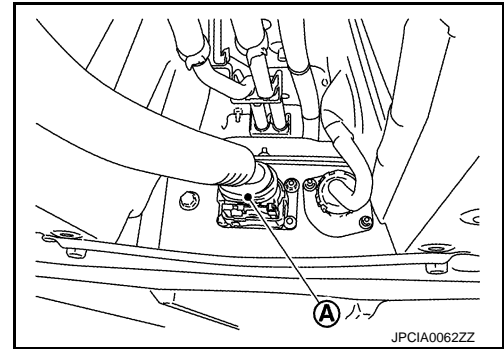

- Follow the procedure below to install the high voltage harness connector.

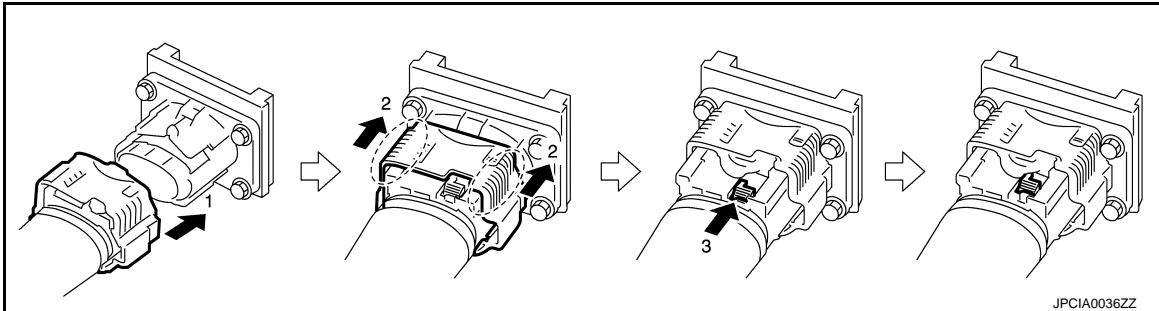

11. Install the Li-ion battery under covers. Refer to [EVB-169, "Exploded View"](#).

12. Install the service plug. Refer to [GI-31, "How to Disconnect High Voltage"](#).

Inspection

INFOID:000000007005850

EQUIPOTENTIAL TEST

After installing the Li-ion battery, measure the resistance between the body of the battery pack (A) and the vehicle body (B).

WARNING:



To prevent electric shock hazards, be sure to wear protective gear.



Standard : Less than 0.1 Ω

If the result deviates from the standard values, perform the below inspection and correct the abnormal location.

- Connection conditions of bonding plates
- Corrosion on bonding plate mounting surfaces
- Paint, oil, dust, or other substance on bonding plate mounting surfaces

LI-ION BATTERY

< UNIT DISASSEMBLY AND ASSEMBLY >

[TYPE 1]

UNIT DISASSEMBLY AND ASSEMBLY

LI-ION BATTERY

Exploded view

INFOID:000000007005851

LI-ION BATTERY



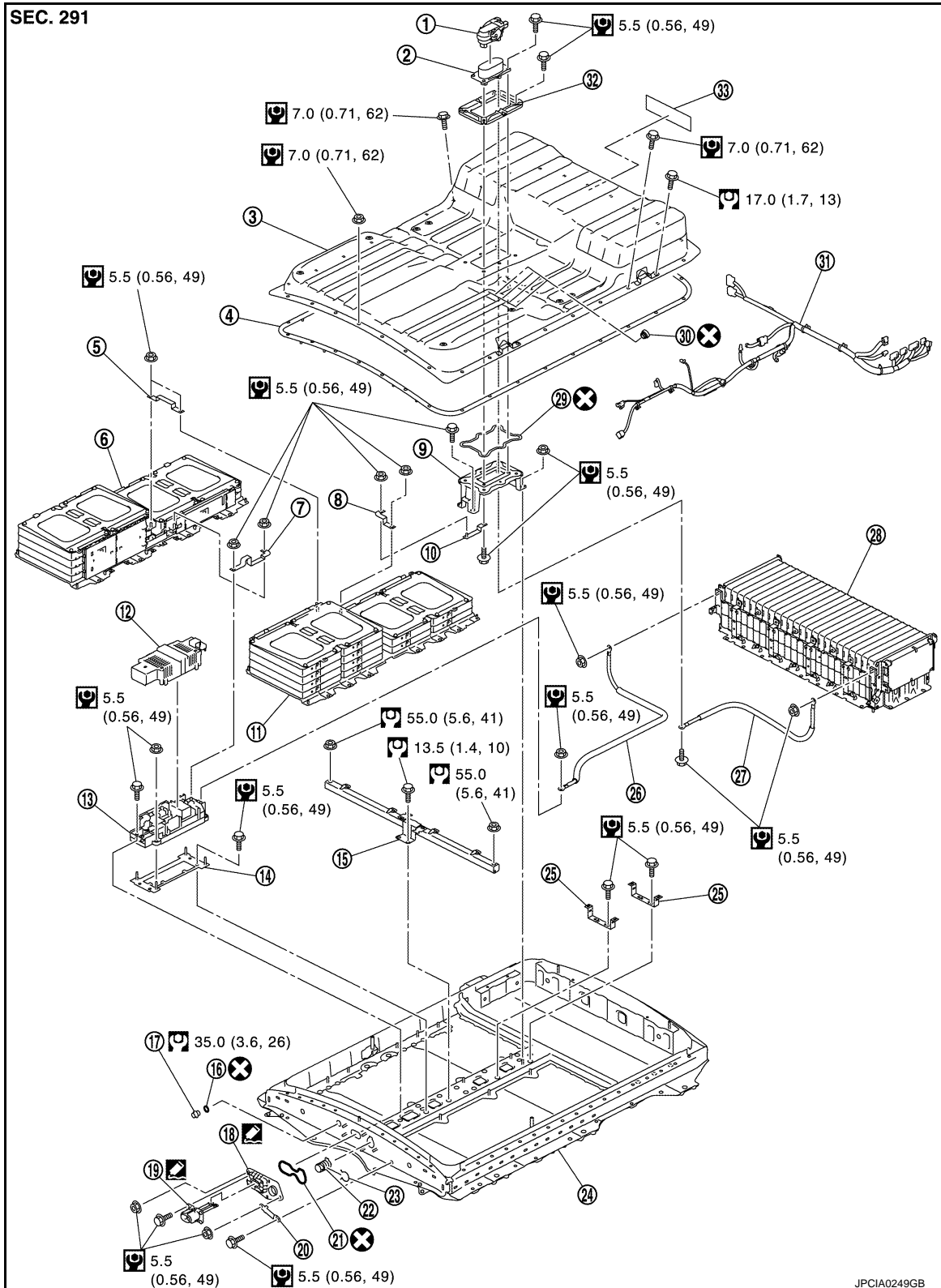

UP TO VIN: JN1AZ0CP*BT005462



LI-ION BATTERY

< UNIT DISASSEMBLY AND ASSEMBLY >

[TYPE 1]

1. Service plug	2. Service plug switch	3. Battery pack upper case	A
4. Seal	5. Bus bar	6. Front module stack RH	
7. Bus bar	8. Bus bar	9. Service plug switch bracket	
10. Bus bar	11. Front module stack LH	12. Battery junction box cover	B
13. Battery junction box	14. Battery junction box bracket	15. Battery member pipe	
16. Drain plug washer	17. Drain plug	18. Connector flange	
19. High voltage harness connector	20. Bonding plate	21. Seal	EVB
22. Vehicle communication harness connector	23. Snap ring	24. Battery pack lower case	
25. Harness bracket	26. High voltage harness	27. High voltage harness	D
28. Rear module stack	29. Seal	30. Breather	
31. Vehicle communication harness	32. Retainer	33. High voltage warning label	
 : Always replace every disassembly			E
 : Use Genuine RTV Silicone Sealant (Three Bond 1220G) or equivalent.			
 : N-m (kg-m, in-lb)			F
 : N-m (kg-m, ft-lb)			
			G
			H
			I
			J
			K
			L
			M
			N
			O
			P

LI-ION BATTERY

< UNIT DISASSEMBLY AND ASSEMBLY >

[TYPE 1]

FROM VIN: JN1AZ0CP*BT005463

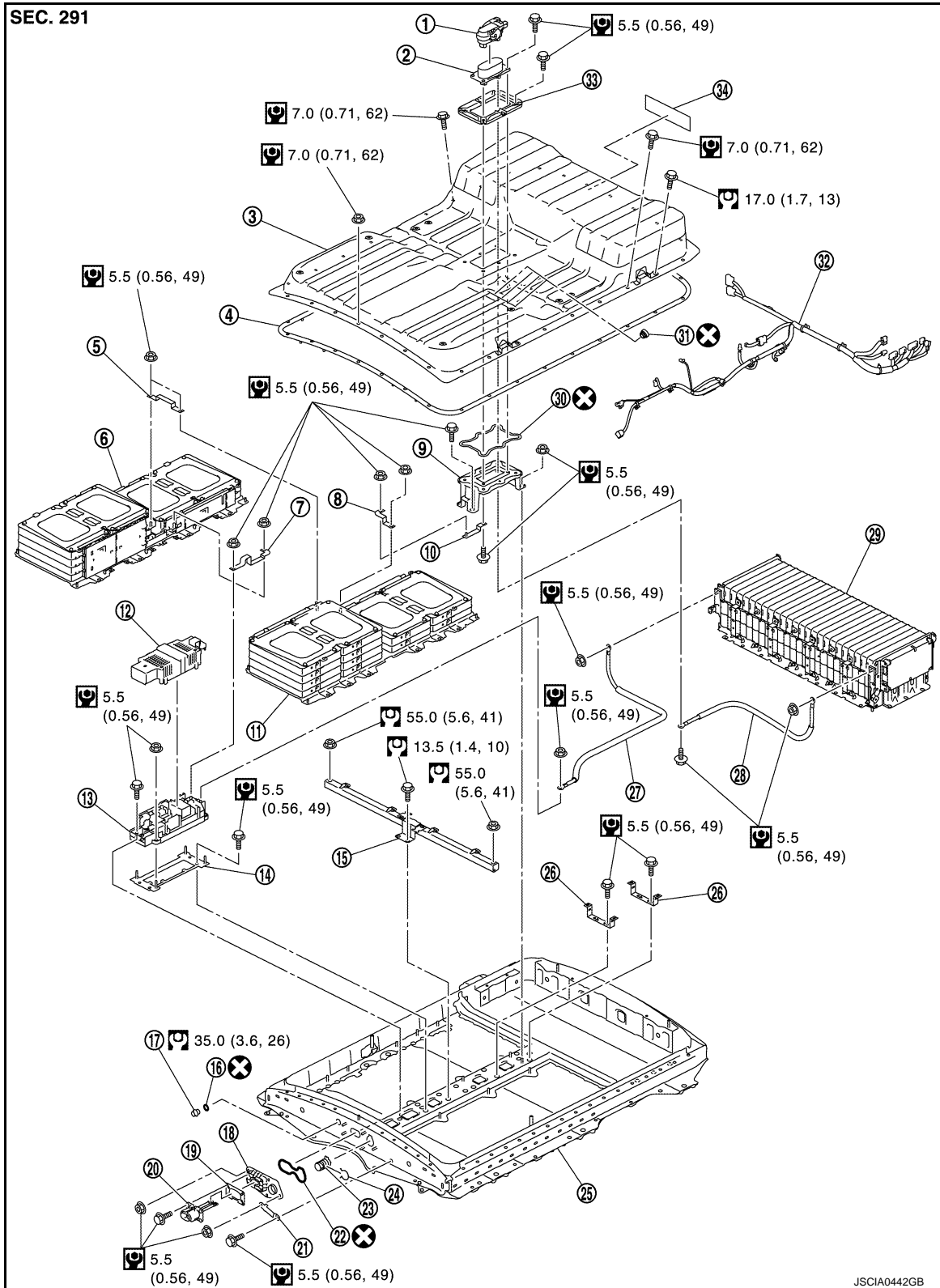

- | | | |
|--------------------------|----------------------------------|--------------------------------|
| 1. Service plug | 2. Service plug switch | 3. Battery pack upper case |
| 4. Seal | 5. Bus bar | 6. Front module stack RH |
| 7. Bus bar | 8. Bus bar | 9. Service plug switch bracket |
| 10. Bus bar | 11. Front module stack LH | 12. Battery junction box cover |
| 13. Battery junction box | 14. Battery junction box bracket | 15. Battery member pipe |
| 16. Drain plug washer | 17. Drain plug | 18. Connector flange |

LI-ION BATTERY

< UNIT DISASSEMBLY AND ASSEMBLY >

[TYPE 1]

- | | | |
|--------------------------------|---|--------------------------|
| 19. Plastic plate | 20. High voltage harness connector | 21. Bonding plate |
| 22. Seal | 23. Vehicle communication harness connector | 24. Snap ring |
| 25. Battery pack lower case | 26. Harness bracket | 27. High voltage harness |
| 28. High voltage harness | 29. Rear module stack | 30. Seal |
| 31. Breather*1 | 32. Vehicle communication harness | 33. Retainer |
| 34. High voltage warning label | | |

⊗ : Always replace every disassembly

🔧 : Use Genuine Liquid Gasket (Three Bond 1220G) or equivalent.

🔩 : N·m (kg-m, in-lb)

🔩 : N·m (kg-m, ft-lb)

*1 For models manufactured in January 2012 and later, the number of breathers is changed from four to two.

FRONT MODULE STACK

Removal

NOTE:

Figure indicates front RH.

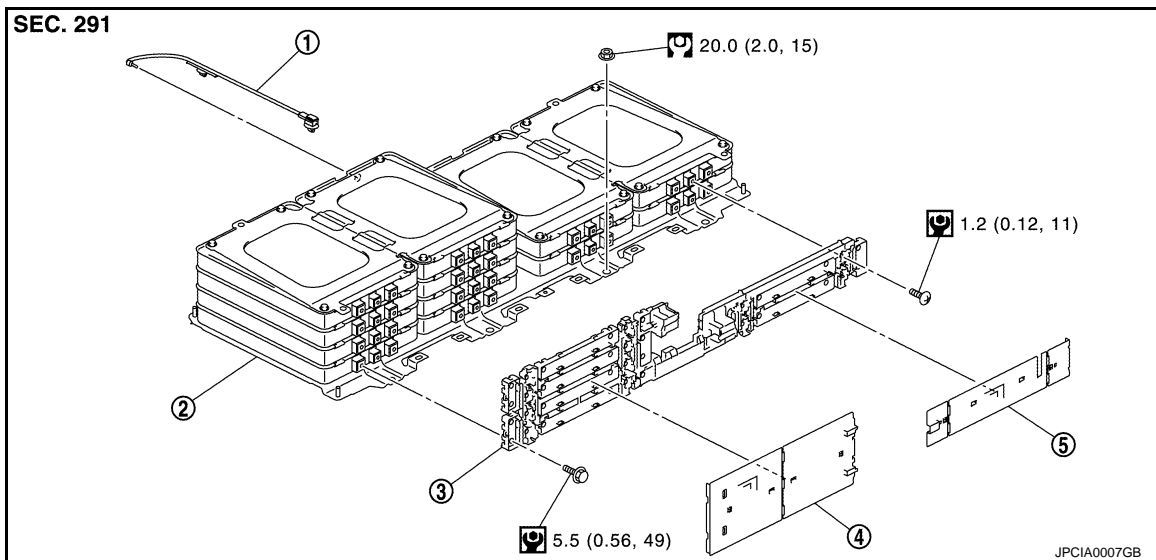

- | | | |
|--|-----------------------|------------|
| 1. Battery temperature sensor (RH front) | 2. Front module stack | 3. Bus bar |
| 4. Bus bar cover | 5. Bus bar cover | |

🔩 : N·m (kg-m, in-lb)

🔩 : N·m (kg-m, ft-lb)

Disassembly

NOTE:

Figure indicates front RH.

LI-ION BATTERY

< UNIT DISASSEMBLY AND ASSEMBLY >

[TYPE 1]

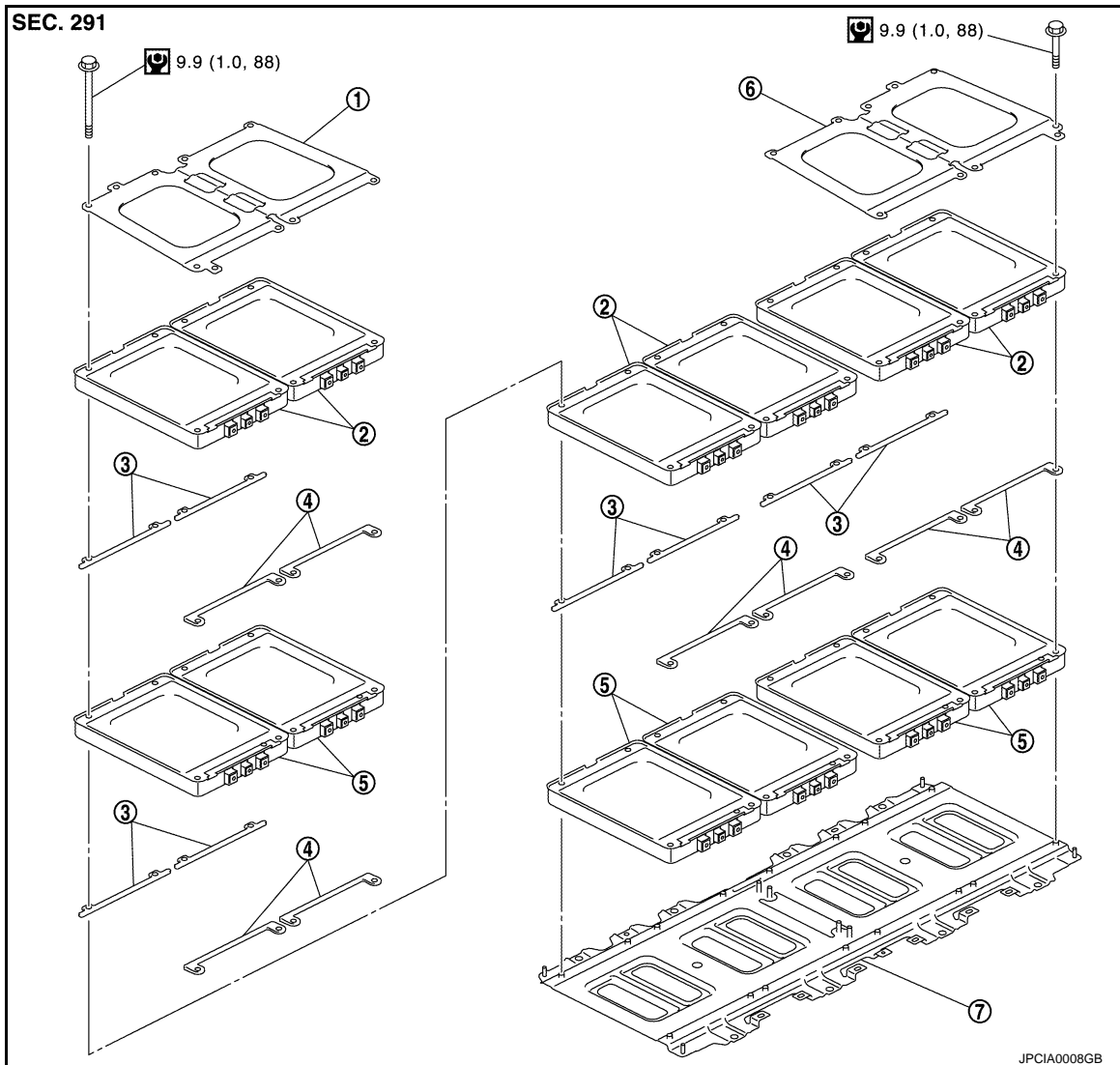

1. End plate (front)

2. Module B

3. Spacer (back side)

4. Spacer (terminal side)

5. Module A

6. End plate (rear)

7. Sub flame

 : N·m (kg·m, in·lb)

LI-ION BATTERY

< UNIT DISASSEMBLY AND ASSEMBLY >

[TYPE 1]

Module Layout

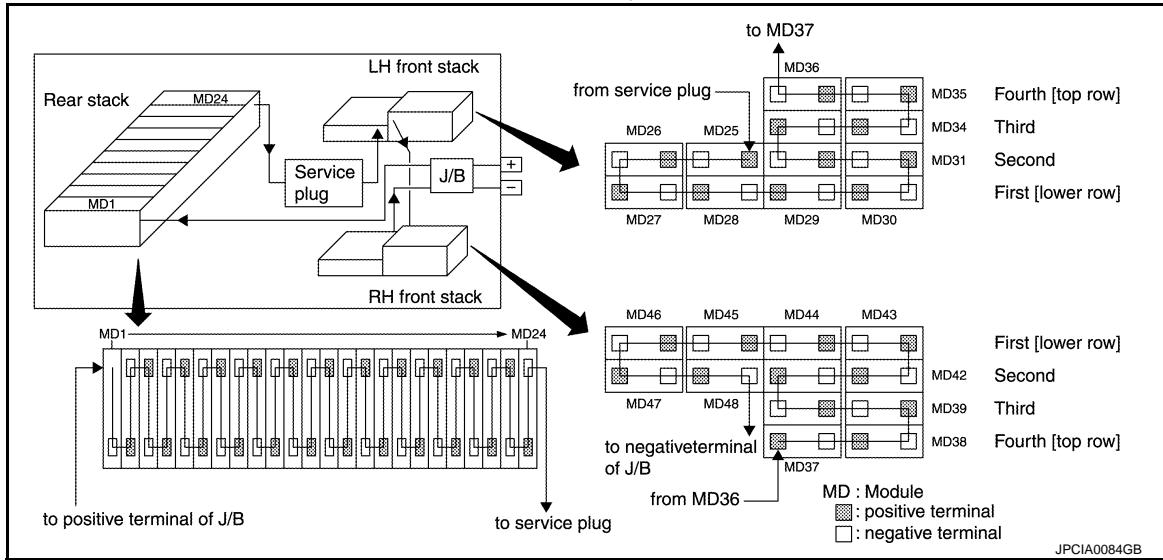

LH front module stack			RH front module stack		
Module No.	Module name	Cell No.	Module No.	Module name	Cell No.
MD25	Module B	49 & 50	MD37	Module B	73 & 74
MD26	Module B	51 & 52	MD38	Module B	75 & 76
MD27	Module A	53 & 54	MD39	Module A	77 & 78
MD28	Module A	55 & 56	MD40	Module A	79 & 80
MD29	Module A	57 & 58	MD41	Module B	81 & 82
MD30	Module A	59 & 60	MD42	Module B	83 & 84
MD31	Module B	61 & 62	MD43	Module A	85 & 86
MD32	Module B	63 & 64	MD44	Module A	87 & 88
MD33	Module A	65 & 66	MD45	Module A	89 & 90
MD34	Module A	67 & 68	MD46	Module A	91 & 92
MD35	Module B	69 & 70	MD47	Module B	93 & 94
MD36	Module B	71 & 72	MD48	Module B	95 & 96

Bus bar Layout

DANGER:

LI-ION BATTERY

< UNIT DISASSEMBLY AND ASSEMBLY >

[TYPE 1]



Because there is a danger of electric shock and fire, never contact bus bar in a wrong terminal.

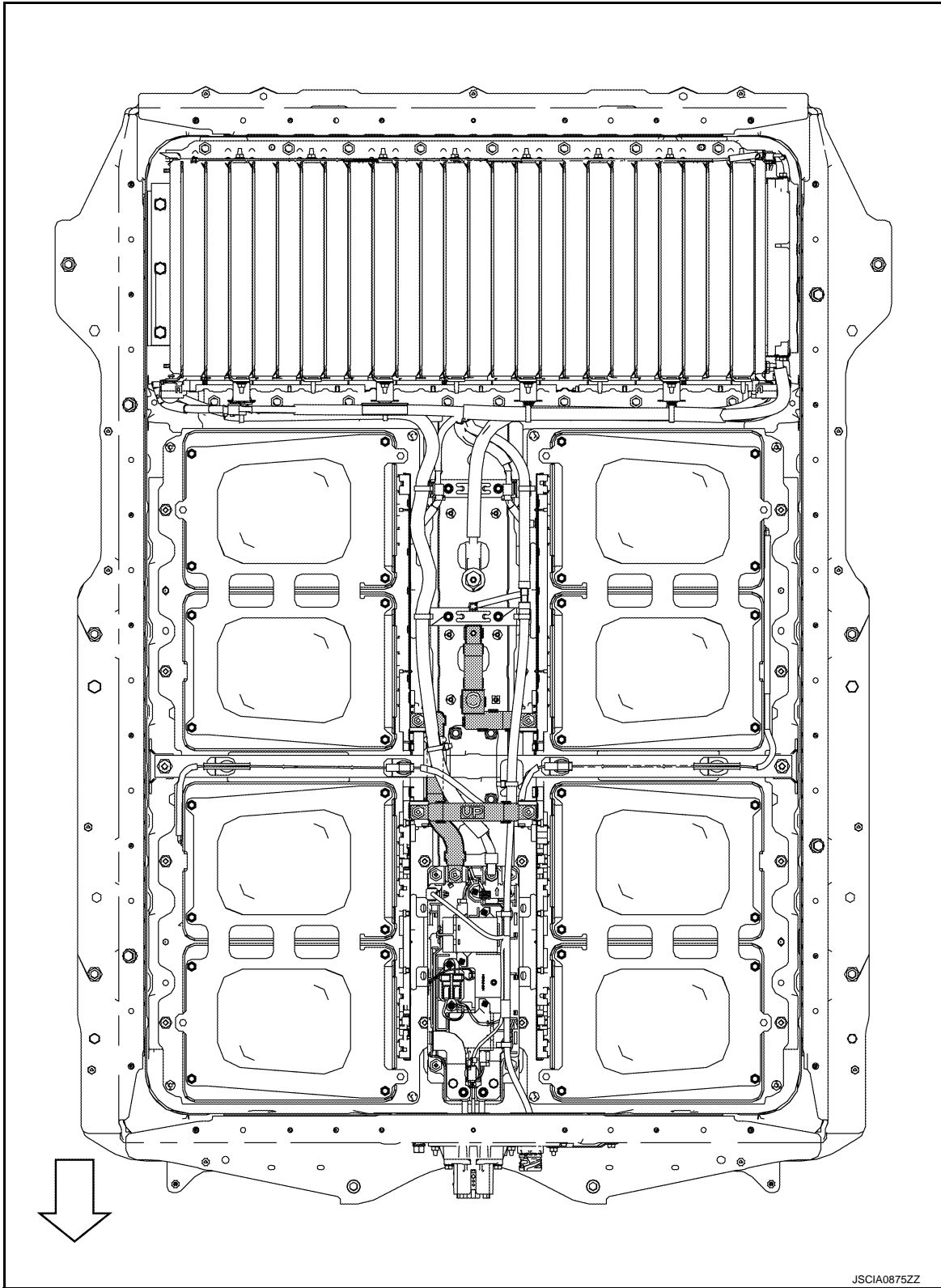

JSCIA0875ZZ

⇐ : Battery front

REAR MODULE STACK

Removal

LI-ION BATTERY

< UNIT DISASSEMBLY AND ASSEMBLY >

[TYPE 1]

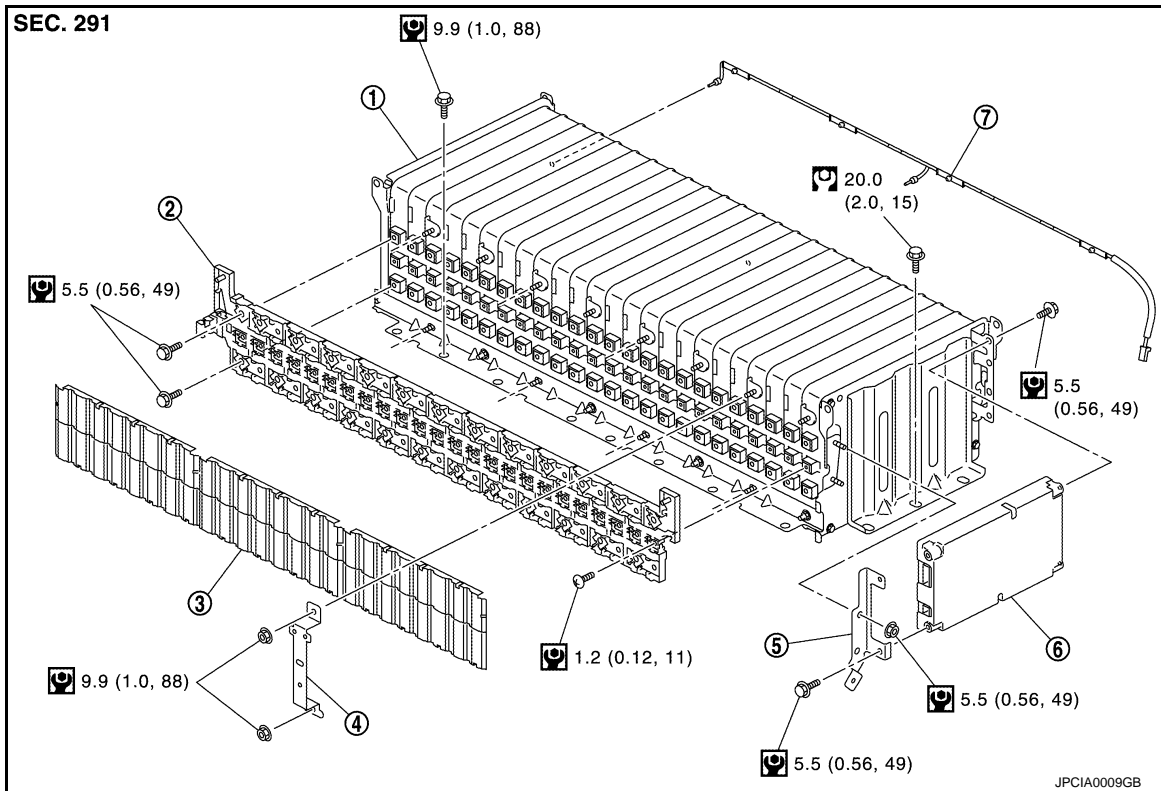

- 1. Rear module stack
- 2. Bus bar
- 3. Bus bar cover
- 4. Harness bracket
- 5. Control bracket
- 6. Li-ion battery controller
- 7. Battery temperature sensor (rear)

: N·m (kg·m, in·lb)

Disassembly

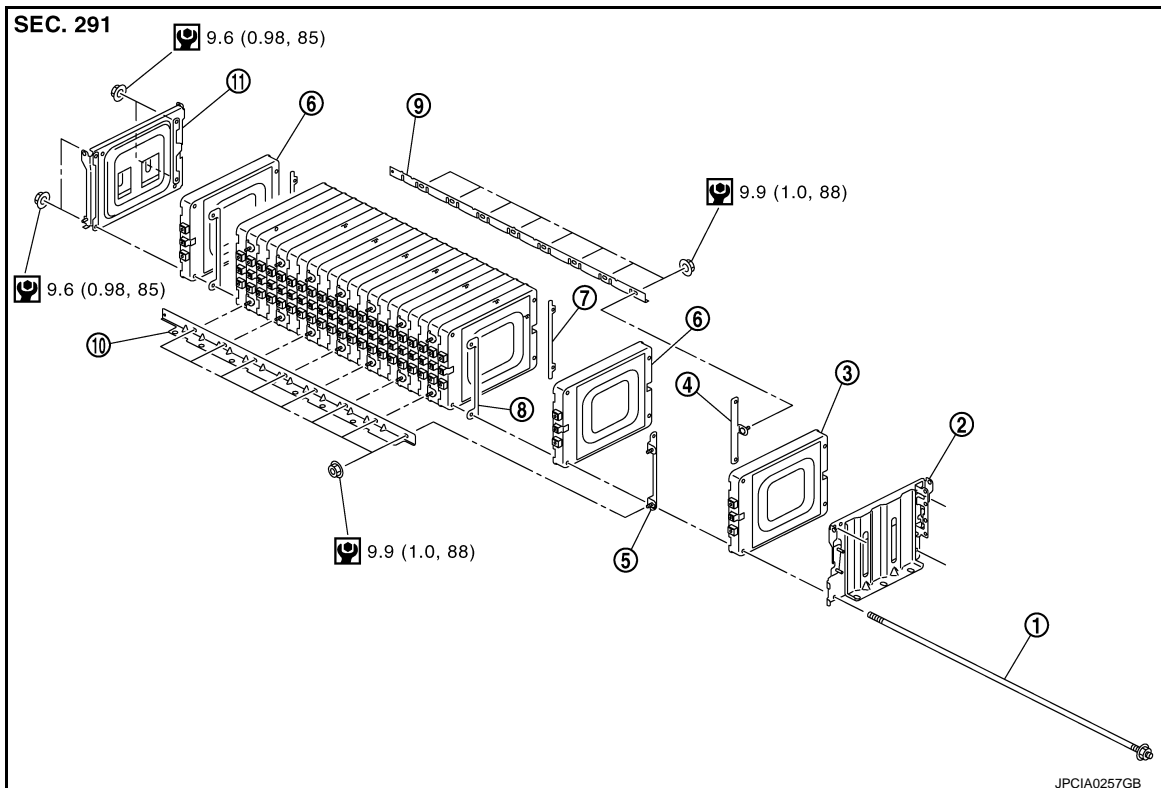

LI-ION BATTERY

< UNIT DISASSEMBLY AND ASSEMBLY >

[TYPE 1]

1. Through bolt
2. LH end plate
3. Module A
4. Mounting plate (back side)
5. Mounting plate (terminal side)
6. Module B
7. Support plate (back side)
8. Support plate (terminal side)
9. Rear stack member
10. Front stack member
11. RH end plate

 : N·m (kg·m, in·lb)

Module Layout

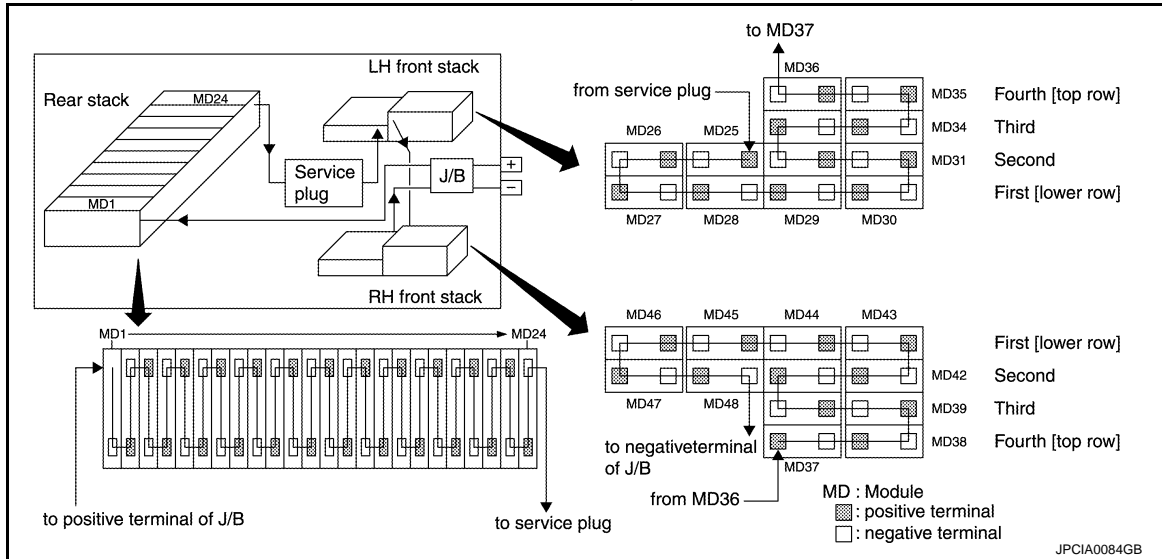

Rear module stack

Module No.	Module name	Cell No.	Module No.	Module name	Cell No.
MD1	Module B	1 & 2	MD13	Module B	25 & 26
MD2	Module A	3 & 4	MD14	Module A	27 & 28
MD3	Module B	5 & 6	MD15	Module B	29 & 30
MD4	Module A	7 & 8	MD16	Module A	31 & 32
MD5	Module B	9 & 10	MD17	Module B	33 & 34
MD6	Module A	11 & 12	MD18	Module A	35 & 36
MD7	Module B	13 & 14	MD19	Module B	37 & 38
MD8	Module A	15 & 16	MD20	Module A	39 & 40
MD9	Module B	17 & 18	MD21	Module B	41 & 42
MD10	Module A	19 & 20	MD22	Module A	43 & 44
MD11	Module B	21 & 22	MD23	Module B	45 & 46
MD12	Module A	23 & 24	MD24	Module A	47 & 48

BATTERY JUNCTION BOX

BATTERY JUNCTION BOX : Disassembly and Assembly

INFOID:000000007005852

DANGER:



Because hybrid vehicles and electric vehicles contain a high voltage battery, there is the risk of electric shock, electric leakage, or similar accidents if the high voltage component and vehicle are handled incorrectly. Be sure to follow the correct work procedures when performing inspection and maintenance.

WARNING:

- Be sure to remove the service plug in order to disconnect the high voltage circuits before performing inspection or maintenance of high voltage system harnesses and parts.

LI-ION BATTERY

< UNIT DISASSEMBLY AND ASSEMBLY >

[TYPE 1]

- To prevent the removed service plug from being connected by mistake during the procedure, always carry it in your pocket or put it in the tool box.
- Be sure to wear insulating protective equipment consisting of glove, shoes, face shield and glasses before beginning work on the high voltage system.
- Refer to [EVB-17, "High Voltage Precautions"](#).
- To prevent electric shock hazards, ignition, and damage to parts, always remove Li-ion battery controller before disassembling battery pack.

CAUTION:

There is the possibility of a malfunction occurring if the vehicle is changed to READY status while the service plug is removed. Therefore do not change the vehicle to READY status unless instructed to do so in the Service Manual.

WORK ENVIRONMENT FOR DISASSEMBLY OF LI-ION BATTERY

1. Must be an indoor environment.
 - The work environment must be able to be isolated from the outside by shutters or other means to prevent the intrusion of rain, snow, sand, and other substances.
 - The environment must prevent the entry of sweat during work, and also prevent condensation from occurring as a result of high temperature and humidity.
2. No entry of foreign materials.
 - In addition to being indoors, the environment must not permit the entry during disassembly work of metal powders, oil, or foreign substances resulting from causes such as servicing of other vehicles.
 - If there is any risk of the above, use a plastic curtain or other means to block off the work area, or take other necessary steps.
3. The floor must be dry.
 - The floor must not become wet as a result of causes such as vehicles entering when it is raining or snowing.
4. Work space
 - Space approximately the size of one vehicle must be secured as the disassembly space.
 - A sign indicating that disassembly is in progress or other measures must be taken so that persons other than the workers do not enter the work space.
5. Standard fire fighting equipment
 - Always place a standard fire fighting equipment in the disassembly work area.
 - Depending on type of fire (vehicle or battery) use standard fire fighting equipment (water or extinguisher).

DISASSEMBLY

1. Clean any contamination and dust from the battery pack.
2. Remove service plug retainer (1).

WARNING:



To prevent electric shock hazards, be sure to wear protective gear.

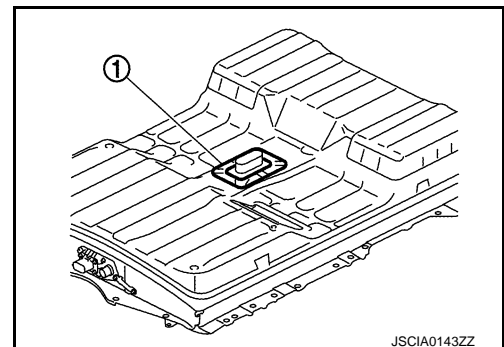

3. Remove mounting bolts (A), (B) and mounting nuts (C), then remove battery pack upper case.

LI-ION BATTERY

< UNIT DISASSEMBLY AND ASSEMBLY >

[TYPE 1]

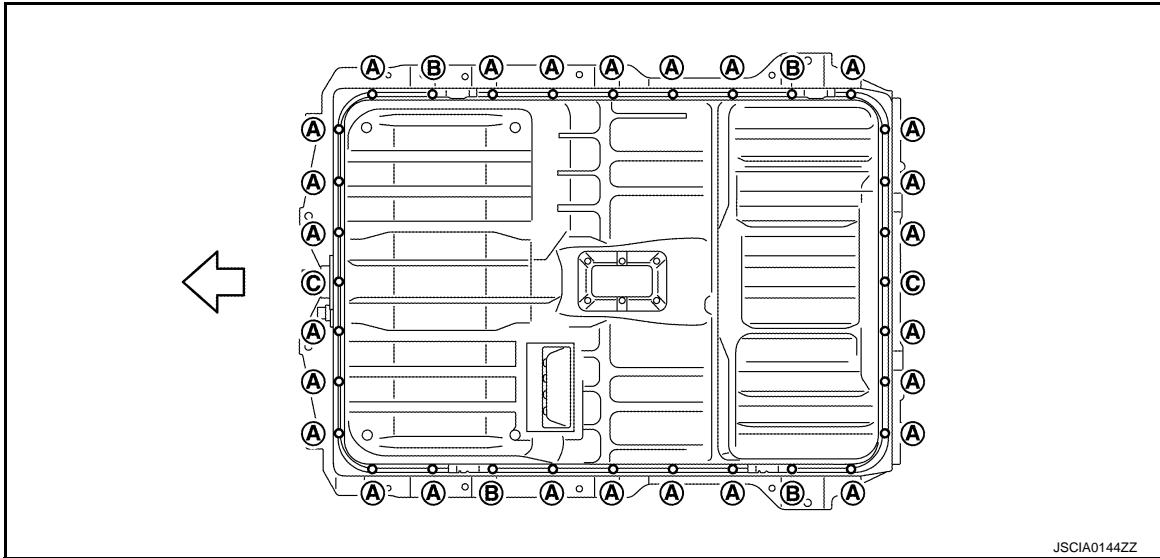

← : Vehicle front

WARNING:



To prevent electric shock hazards, be sure to wear protective gear.



4. Remove Li-ion battery controller. Refer to [EVB-192, "LI-ION BATTERY CONTROLLER : Disassembly and Assembly"](#).
5. Disengage pawls and remove battery junction box cover (1).

: Pawl

WARNING:



To prevent electric shock hazards, be sure to put on insulated protective gear and use insulated tools.

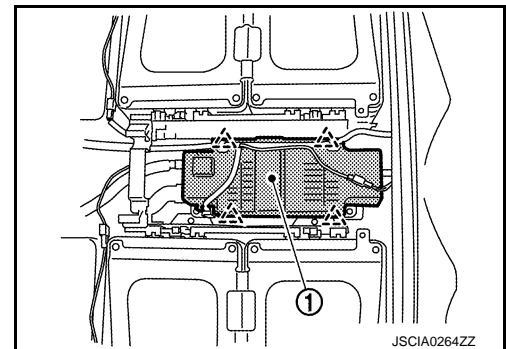

6. Remove terminal mounting nut (A) of high voltage harness connector.

DANGER:

- To prevent electric shock hazards, be sure to put on insulated protective gear and use insulated tools.



- To prevent electric shock hazards, immediately wrap insulating tape around disconnected high voltage harness connector and terminals.

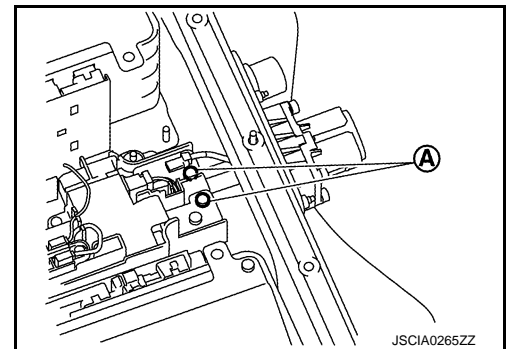

LI-ION BATTERY

< UNIT DISASSEMBLY AND ASSEMBLY >

[TYPE 1]

7. Remove mounting bolts (A), then disconnect high voltage harness connector (1) from battery pack.

WARNING:

 To prevent electric shock hazards, be sure to put on insulated protective gear and use insulated tools.

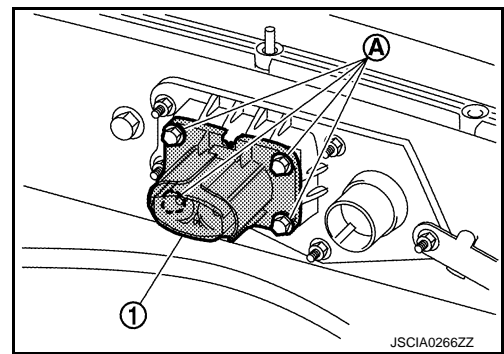

8. Remove mounting nuts (A), then remove high voltage harness (1) and bus bar (2) from battery junction box.

DANGER:

 To prevent electric shock hazards, be sure to put on insulated protective gear and use insulated tools.



 To prevent electric shock hazards, immediately wrap insulating tape around disconnected high voltage harness connector and terminals.

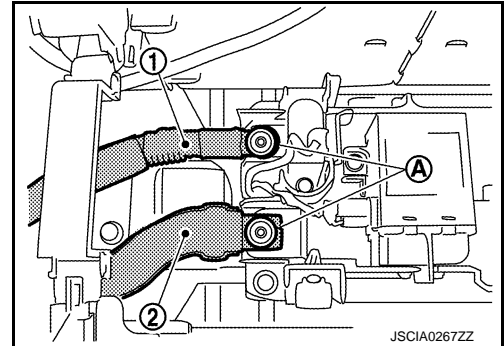

9. Remove mounting nuts (A) and remove battery junction box (1).

WARNING:

 To prevent electric shock hazards, be sure to put on insulated protective gear and use insulated tools.

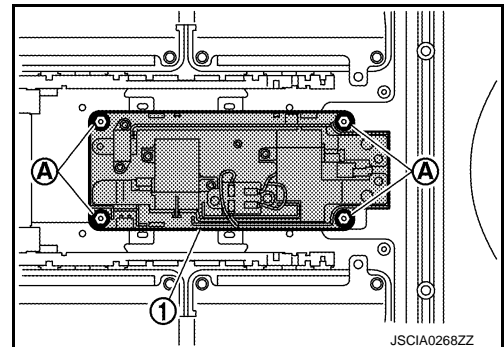

ASSEMBLY

1. Install battery junction box.

WARNING:

 To prevent electric shock hazards, be sure to put on insulated protective gear and use insulated tools.



2. Install high voltage harness connector.

WARNING:

 To prevent electric shock hazards, be sure to put on insulated protective gear and use insulated tools.



CAUTION:

- If the connection between high voltage harness connector and connector flange originally includes liquid gasket, apply liquid gasket to the connection as per the following steps.
- When replacing high voltage harness connector and connector flange with new ones, the application of liquid gasket is not required even if it is originally included.

A
B
EVB
D
E
F
G
H
I
J
K
L
M
N
O
P

LI-ION BATTERY

< UNIT DISASSEMBLY AND ASSEMBLY >

[TYPE 1]

HOW TO APPLY LIQUID GASKET

- a. Clean the bearing surface of high voltage harness connector and connector flange to remove dirt and dust.
- b. Install high voltage harness connector (1) to connector flange, then tighten bolts (A) to the specified torque.

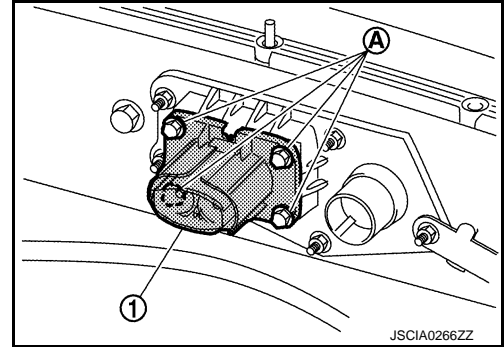

- c. Apply liquid gasket to the connection of high voltage harness connector and connector flange.

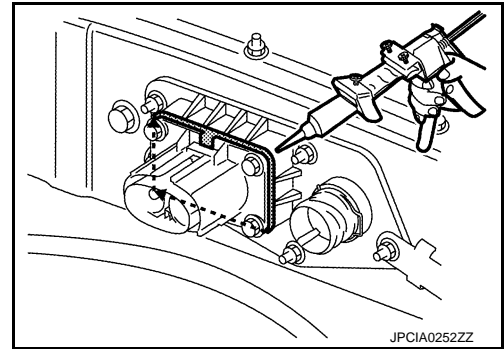

CAUTION:

Observe the following instructions to apply liquid gasket.

- Liquid gasket must be applied to the entire perimeter of the connection (A) of high voltage harness connector and connector flange.
- Liquid gasket must be applied in seamless manner. Never leave unevenness (B).
- Liquid gasket must be applied in the manner of filling the inside of rib (C) with liquid gasket.

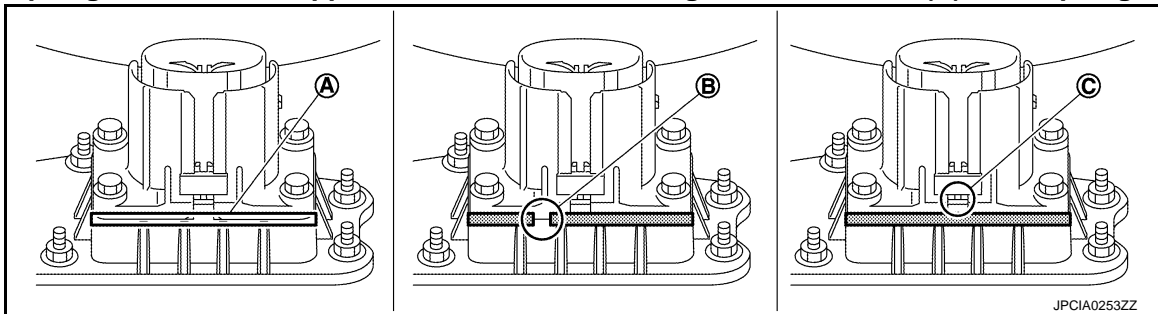

3. Install Li-ion battery controller. Refer to [EVB-192, "LI-ION BATTERY CONTROLLER : Disassembly and Assembly"](#).
4. Follow the procedure below and install battery pack upper case.

CAUTION:

Check seal before install battery pack upper case. Refer to [EVB-190, "BATTERY JUNCTION BOX : Inspection"](#).

- a. Tighten mounting nuts and bolts in the order from 1 to 28 as shown in the figure.

LI-ION BATTERY

< UNIT DISASSEMBLY AND ASSEMBLY >

[TYPE 1]

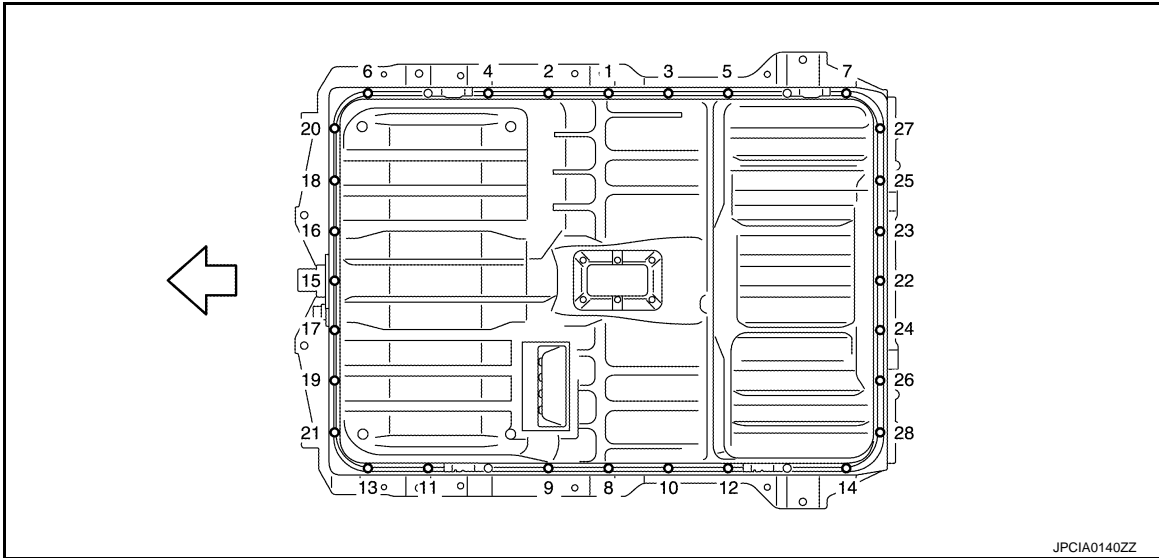

← : Vehicle front

WARNING:



To prevent electric shock hazards, be sure to wear protective gear.



b. Install ground bolt (A).

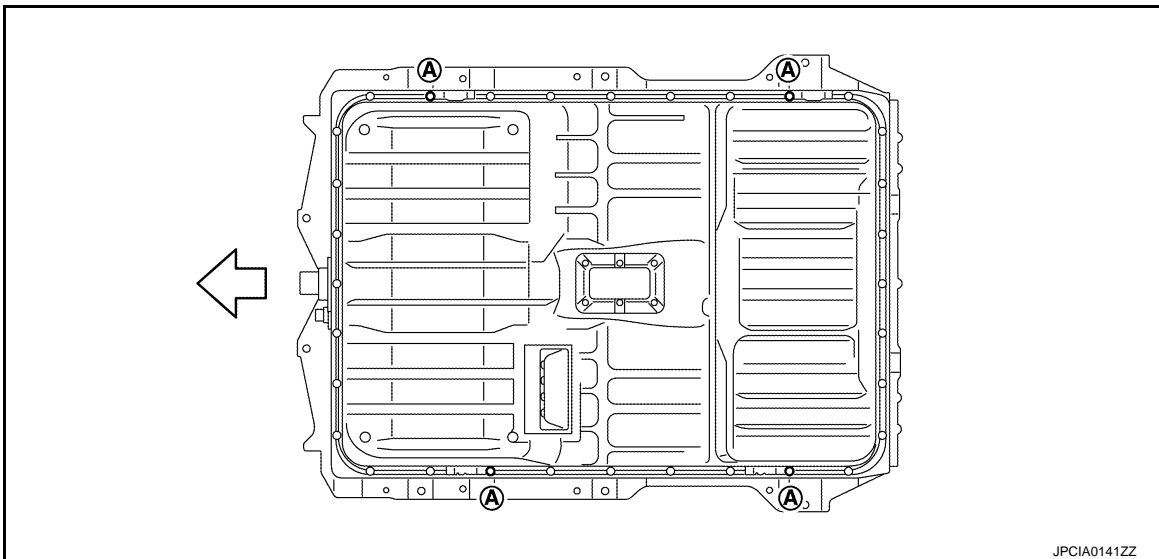

← : Vehicle front

WARNING:



To prevent electric shock hazards, be sure to wear protective gear.



A
B
EVB
D
E
F
G
H
I
J
K
L
M
N
O
P

LI-ION BATTERY

< UNIT DISASSEMBLY AND ASSEMBLY >

[TYPE 1]

5. Install service plug retainer (1).

WARNING:



To prevent electric shock hazards, be sure to wear protective gear.



CAUTION:

- Perform the "LI-ION BATTERY JUNCTION BOX DATA CLEAR" when battery junction box is replaced. Refer to [EVC-110, "Work Procedure"](#).
- Check the following items after installing battery pack: Refer to [EVB-190, "BATTERY JUNCTION BOX : Inspection"](#).

■AIR LEAK INSPECTION

■ELECTRIC EQUIPOTENTIAL TEST

BATTERY JUNCTION BOX : Inspection

INFOID:000000007005853

BATTERY PACK SEAL INSPECTION

- Visually check all lips (A) of seal (1) for damage. (e.g. scratches and cracks)
- Replace seal if its lips are damaged.

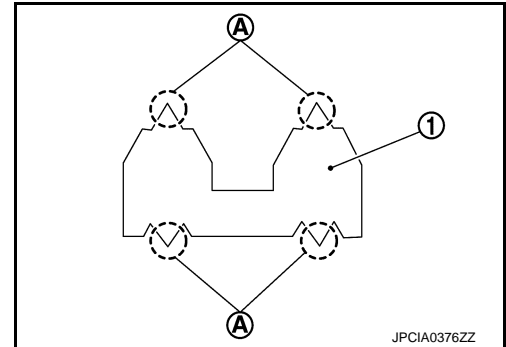

AIR LEAK INSPECTION

1. Remove drain plug and install adapter [SST: KV99111400] (A).

WARNING:



To prevent electric shock hazards, be sure to wear protective gear.

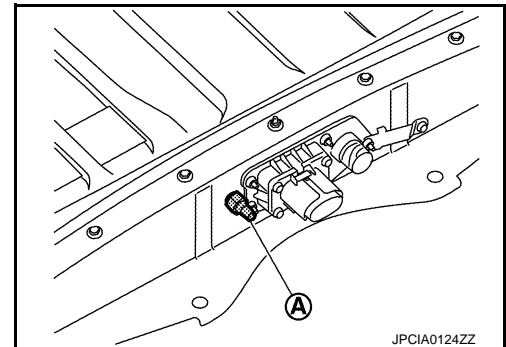

2. Install gauge [SST: KV99111400] (A).

WARNING:



To prevent electric shock hazards, be sure to wear protective gear.



CAUTION:

Handle the gauge carefully so that it will not drop.

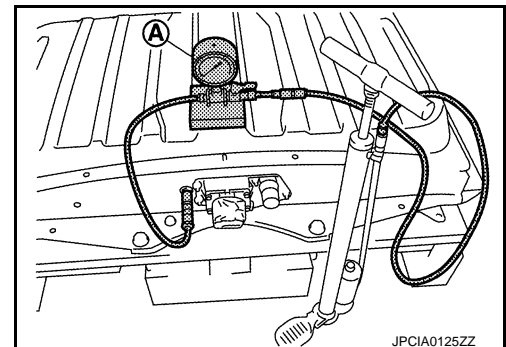

3. Install service plug to seal the battery pack.

DANGER:

LI-ION BATTERY

< UNIT DISASSEMBLY AND ASSEMBLY >

[TYPE 1]



To prevent electric shock hazards, be sure to wear protective gear.



4. Use vinyl tape (A) or similar means to seal the breather so that air does not enter it.
- Use the wide vinyl tape which can cover up breather at once.
 - Stick it so that tape is not wrinkled.

WARNING:



To prevent electric shock hazards, be sure to wear protective gear.

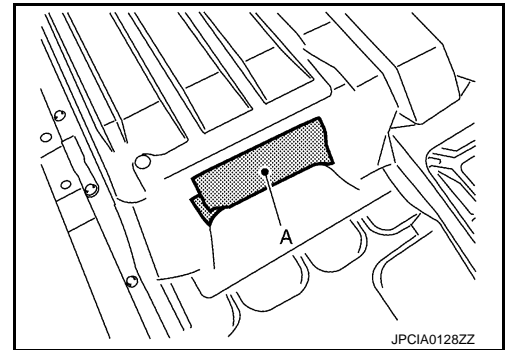

5. Perform air leak inspection by applying 1.6 kPa (0.0163 kg/cm², 0.23 psi) of pressure inside the battery pack for approximately 1 minute.

CAUTION:

- When applying pressure, operate the air pump slowly.
- Do not apply any pressure exceeding 2.0 kPa (0.0204 kg/cm², 0.29 psi).

Repair limit : 1.4 kPa (0.0143 kg/cm², 0.20 psi)

6. If the pressure drops below the limit value, use soapy water and check for leakage points.

WARNING:



To prevent electric shock hazards, be sure to wear protective gear.



CAUTION:

Never allow soapy water to contact the service plug and each connector terminals.

Electric Equipotential Test

After installing the battery pack, measure the resistance between the ground bolt mating surface (A) and the high voltage harness connector flange (B).

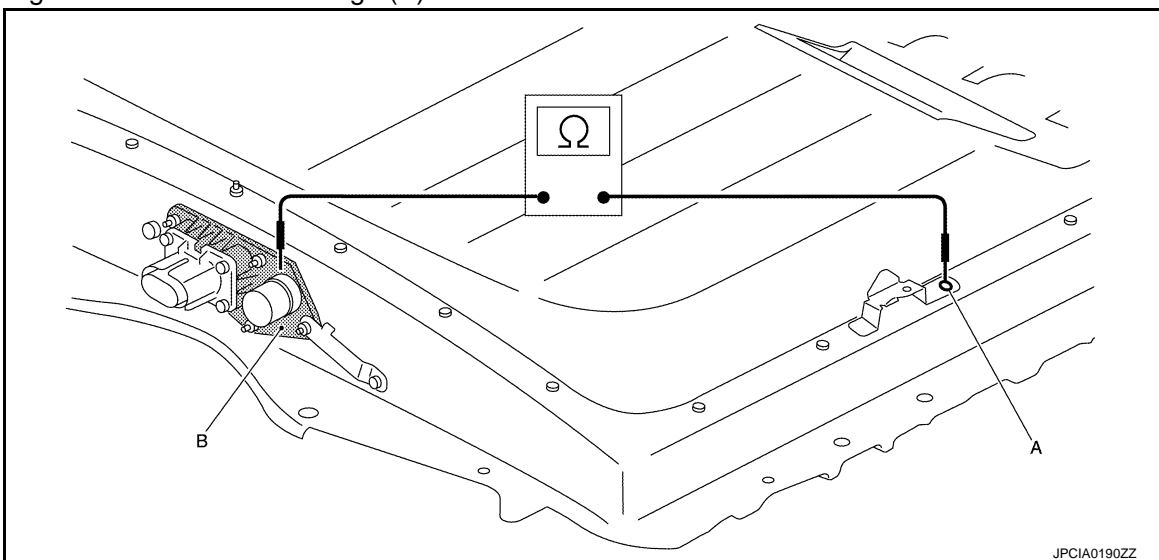

WARNING:

LI-ION BATTERY

< UNIT DISASSEMBLY AND ASSEMBLY >

[TYPE 1]



To prevent electric shock hazards, be sure to wear protective gear.



Standard : Less than 0.1 Ω

If the result deviates from the standard value, check the following items and repair malfunctioning parts

- Connection condition of ground bolts
- Rust on the mounting surface of ground bolts
- Paint, oil, and dust on the mounting surface of ground bolts

LI-ION BATTERY CONTROLLER

LI-ION BATTERY CONTROLLER : Disassembly and Assembly

INFOID:000000007005854

DANGER:



Because hybrid vehicles and electric vehicles contain a high voltage battery, there is the risk of electric shock, electric leakage, or similar accidents if the high voltage component and vehicle are handled incorrectly. Be sure to follow the correct work procedures when performing inspection and maintenance.

WARNING:

- Be sure to remove the service plug in order to disconnect the high voltage circuits before performing inspection or maintenance of high voltage system harnesses and parts.
- To prevent the removed service plug from being connected by mistake during the procedure, always carry it in your pocket or put it in the tool box.
- Be sure to wear insulating protective equipment consisting of glove, shoes, face shield and glasses before beginning work on the high voltage system.
- Refer to [EVB-17, "High Voltage Precautions"](#).
- To prevent electric shock hazards, ignition, and damage to parts, always remove Li-ion battery controller before disassembling battery pack.

CAUTION:

There is the possibility of a malfunction occurring if the vehicle is changed to READY status while the service plug is removed. Therefore do not change the vehicle to READY status unless instructed to do so in the Service Manual.

WORK ENVIRONMENT FOR DISASSEMBLY OF LI-ION BATTERY

1. Must be an indoor environment.
 - The work environment must be able to be isolated from the outside by shutters or other means to prevent the intrusion of rain, snow, sand, and other substances.
 - The environment must prevent the entry of sweat during work, and also prevent condensation from occurring as a result of high temperature and humidity.
2. No entry of foreign materials.
 - In addition to being indoors, the environment must not permit the entry during disassembly work of metal powders, oil, or foreign substances resulting from causes such as servicing of other vehicles.
 - If there is any risk of the above, use a plastic curtain or other means to block off the work area, or take other necessary steps.
3. The floor must be dry.
 - The floor must not become wet as a result of causes such as vehicles entering when it is raining or snowing.
4. Work space
 - Space approximately the size of one vehicle must be secured as the disassembly space.
 - A sign indicating that disassembly is in progress or other measures must be taken so that persons other than the workers do not enter the work space.
5. Standard fire fighting equipment
 - Always place a standard fire fighting equipment in the disassembly work area.
 - Depending on type of fire (vehicle or battery) use standard fire fighting equipment (water or extinguisher).

LI-ION BATTERY

< UNIT DISASSEMBLY AND ASSEMBLY >

[TYPE 1]

DISASSEMBLY

1. Clean any contamination and dust from the battery pack.
2. Remove service plug retainer (1).

WARNING:

 To prevent electric shock hazards, be sure to wear protective gear.

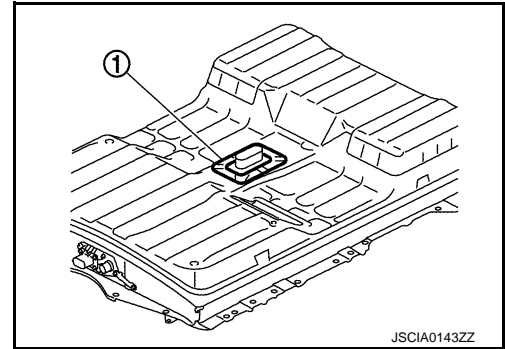

3. Remove mounting bolts (A), (B) and mounting nuts (C), then remove battery pack upper case.

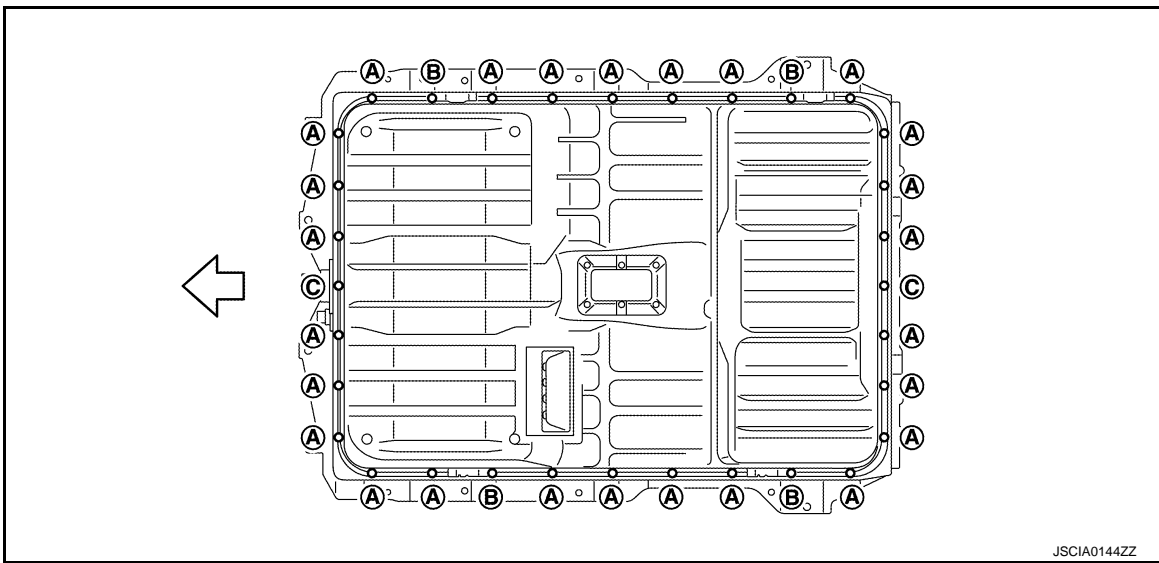

← : Vehicle front

WARNING:

 To prevent electric shock hazards, be sure to wear protective gear.



4. Disconnect Li-ion battery controller harness connector (A).

WARNING:

 To prevent electric shock hazards, be sure to wear protective gear.

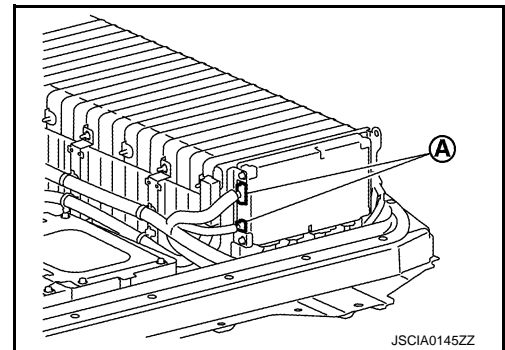

A
B
EVB
D
E
F
G
H
I
J
K
L
M
N
O
P

LI-ION BATTERY

< UNIT DISASSEMBLY AND ASSEMBLY >

[TYPE 1]

5. Remove Li-ion battery controller mounting bolts (A).

WARNING:

 To prevent electric shock hazards, be sure to put on insulated protective gear and use insulated tools.

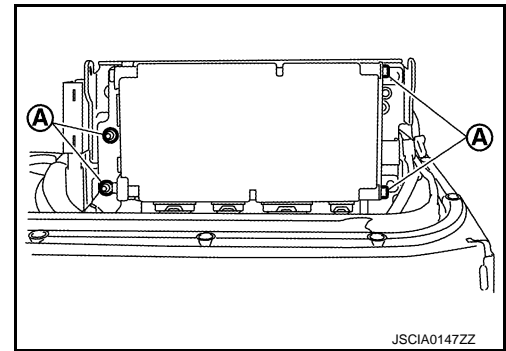

6. Remove harness connector (A) and harness clip, then remove Li-ion battery controller.

B : Low voltage harness connector

 : Vehicle front

WARNING:

-  To prevent electric shock hazards, be sure to wear protective gear.

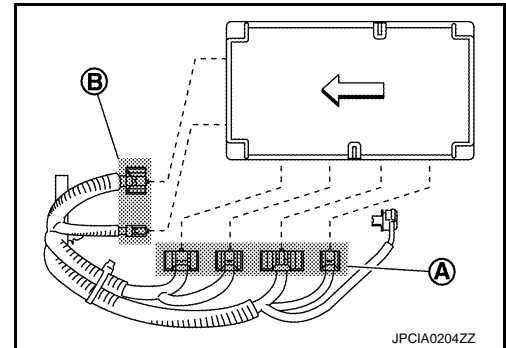

-  To prevent electric shock hazards, immediately wrap insulating tape around disconnected high voltage harness connector and terminals.

NOTE:

Remove together with controller bracket.

ASSEMBLY

Assemble in the reverse order of disassembly.

1. Install Li-ion battery controller.

WARNING:

-  To prevent electric shock hazards, be sure to put on insulated protective gear and use insulated tools.



- There are harness connector for high voltage (A) and low voltage (B) to a Li-ion battery controller. When the high voltage harness connector is inserted in the low voltage part, it causes smoking and the part damage. Be careful enough when install harness connector.

 : Vehicle front

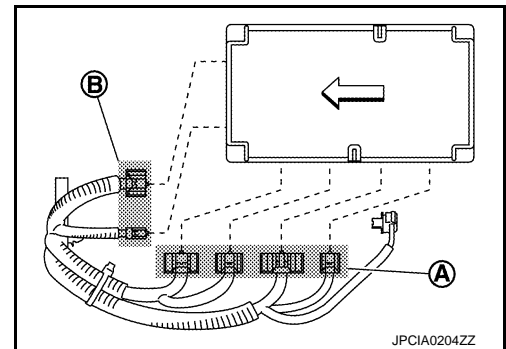

2. Follow the procedure below and install battery pack upper case.

CAUTION:

Check seal before install battery pack upper case. Refer to [EVB-196. "LI-ION BATTERY CONTROLLER : Inspection"](#).

- a. Tighten mounting nuts and bolts in the order from 1 to 28 as shown in the figure.

LI-ION BATTERY

< UNIT DISASSEMBLY AND ASSEMBLY >

[TYPE 1]

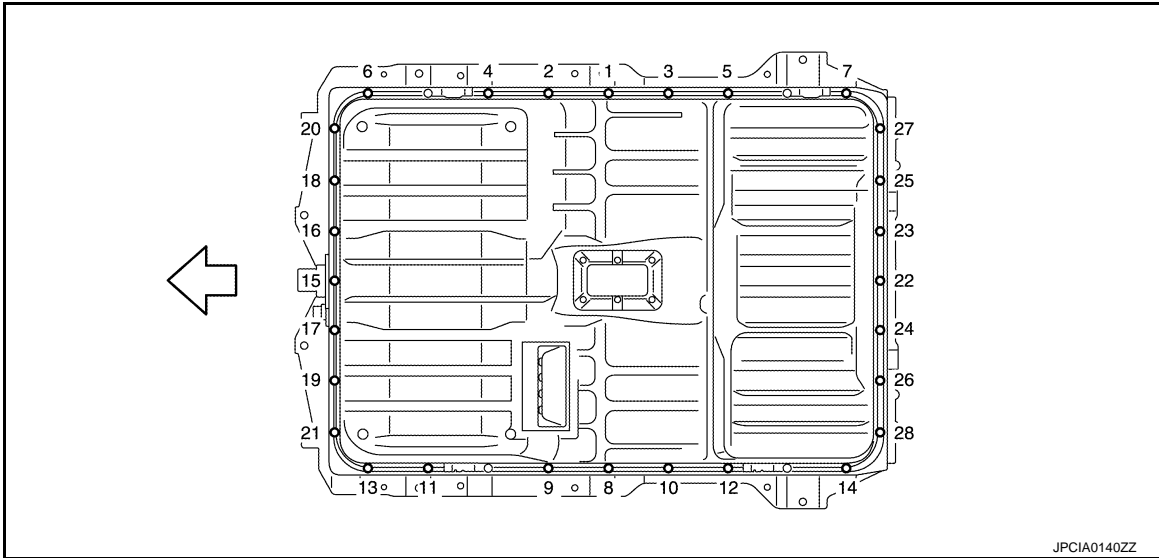

← : Vehicle front

WARNING:



To prevent electric shock hazards, be sure to wear protective gear.



b. Install ground bolt (A).

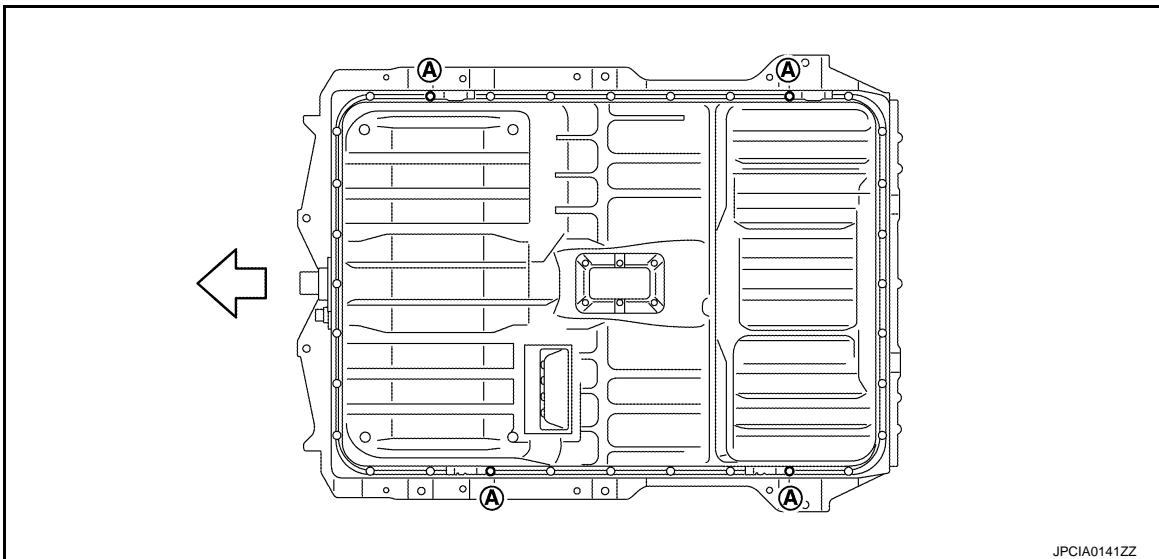

← : Vehicle front

WARNING:



To prevent electric shock hazards, be sure to wear protective gear.



A
B
EVB
D
E
F
G
H
I
J
K
L
M
N
O
P

LI-ION BATTERY

< UNIT DISASSEMBLY AND ASSEMBLY >

[TYPE 1]

3. Install service plug retainer (1).

WARNING:

 To prevent electric shock hazards, be sure to wear protective gear.



CAUTION:

- Perform the “ADDITIONAL SERVICE WHEN REPLACING LI-ION BATTERY CONTROLLER” when Li-ion battery controller is replaced. Refer to [EVB-70, "Work Procedure"](#).
- Check the following items after installing battery pack: Refer to [EVB-196, "LI-ION BATTERY CONTROLLER : Inspection"](#).

■AIR LEAK INSPECTION

■ELECTRIC EQUIPOTENTIAL TEST

LI-ION BATTERY CONTROLLER : Inspection

INFOID:000000007063698

BATTERY PACK SEAL INSPECTION

- Visually check all lips (A) of seal (1) for damage. (e.g. scratches and cracks)
- Replace seal if its lips are damaged.

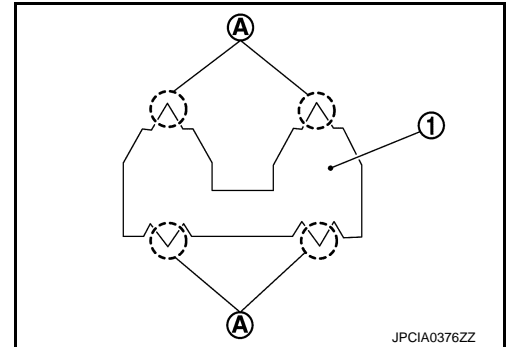

AIR LEAK INSPECTION

1. Remove drain plug and install adapter [SST: KV99111400] (A).

WARNING:

 To prevent electric shock hazards, be sure to wear protective gear.

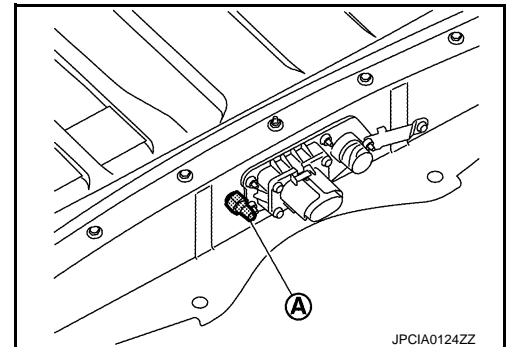

2. Install gauge [SST: KV99111400] (A).

WARNING:

 To prevent electric shock hazards, be sure to wear protective gear.



CAUTION:

Handle the gauge carefully so that it will not drop.

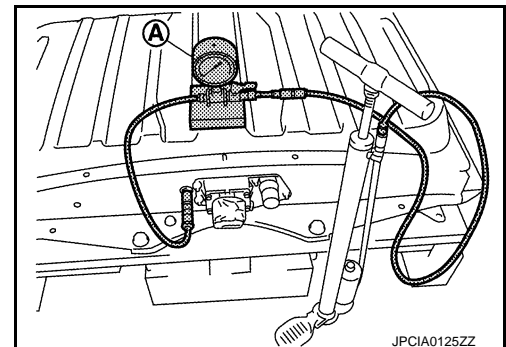

3. Install service plug to seal the battery pack.

DANGER:

LI-ION BATTERY

< UNIT DISASSEMBLY AND ASSEMBLY >

[TYPE 1]



To prevent electric shock hazards, be sure to wear protective gear.



4. Use vinyl tape (A) or similar means to seal the breather so that air does not enter it.
- Use the wide vinyl tape which can cover up breather at once.
 - Stick it so that tape is not wrinkled.

WARNING:



To prevent electric shock hazards, be sure to wear protective gear.

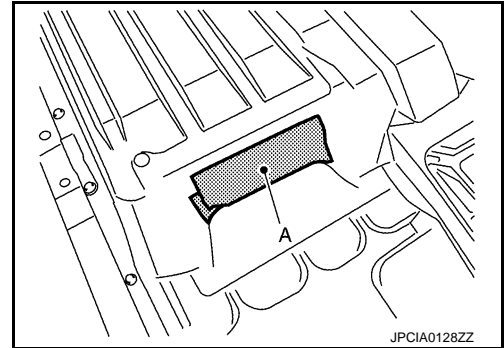

5. Perform air leak inspection by applying 1.6 kPa (0.0163 kg/cm², 0.23 psi) of pressure inside the battery pack for approximately 1 minute.

CAUTION:

- When applying pressure, operate the air pump slowly.
- Do not apply any pressure exceeding 2.0 kPa (0.0204 kg/cm², 0.29 psi).

Repair limit : 1.4 kPa (0.0143 kg/cm², 0.20 psi)

6. If the pressure drops below the limit value, use soapy water and check for leakage points.

WARNING:



To prevent electric shock hazards, be sure to wear protective gear.



CAUTION:

Never allow soapy water to contact the service plug and each connector terminals.

Electric Equipotential Test

After installing the battery pack, measure the resistance between the ground bolt mating surface (A) and the high voltage harness connector flange (B).

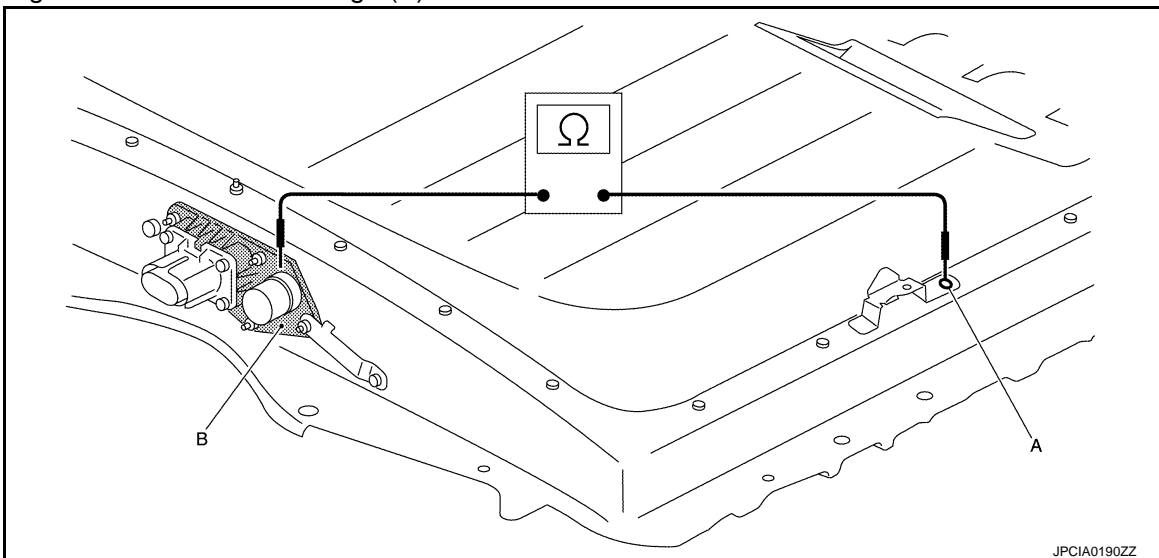

WARNING:

LI-ION BATTERY

< UNIT DISASSEMBLY AND ASSEMBLY >

[TYPE 1]



To prevent electric shock hazards, be sure to wear protective gear.



Standard : Less than 0.1 Ω

If the result deviates from the standard value, check the following items and repair malfunctioning parts

- Connection condition of ground bolts
- Rust on the mounting surface of ground bolts
- Paint, oil, and dust on the mounting surface of ground bolts

FRONT MODULE STACK

FRONT MODULE STACK : Disassembly and Assembly

INFOID:000000007005856

DANGER:



Because hybrid vehicles and electric vehicles contain a high voltage battery, there is the risk of electric shock, electric leakage, or similar accidents if the high voltage component and vehicle are handled incorrectly. Be sure to follow the correct work procedures when performing inspection and maintenance.

WARNING:

- Be sure to remove the service plug in order to disconnect the high voltage circuits before performing inspection or maintenance of high voltage system harnesses and parts.
- To prevent the removed service plug from being connected by mistake during the procedure, always carry it in your pocket or put it in the tool box.
- Be sure to wear insulating protective equipment consisting of glove, shoes, face shield and glasses before beginning work on the high voltage system.
- Refer to [EVB-17, "High Voltage Precautions"](#).
- To prevent electric shock hazards, ignition, and damage to parts, always remove Li-ion battery controller before disassembling battery pack.

CAUTION:

There is the possibility of a malfunction occurring if the vehicle is changed to READY status while the service plug is removed. Therefore do not change the vehicle to READY status unless instructed to do so in the Service Manual.

WORK ENVIRONMENT FOR DISASSEMBLY OF LI-ION BATTERY

1. Must be an indoor environment.
 - The work environment must be able to be isolated from the outside by shutters or other means to prevent the intrusion of rain, snow, sand, and other substances.
 - The environment must prevent the entry of sweat during work, and also prevent condensation from occurring as a result of high temperature and humidity.
2. No entry of foreign materials.
 - In addition to being indoors, the environment must not permit the entry during disassembly work of metal powders, oil, or foreign substances resulting from causes such as servicing of other vehicles.
 - If there is any risk of the above, use a plastic curtain or other means to block off the work area, or take other necessary steps.
3. The floor must be dry.
 - The floor must not become wet as a result of causes such as vehicles entering when it is raining or snowing.
4. Work space
 - Space approximately the size of one vehicle must be secured as the disassembly space.
 - A sign indicating that disassembly is in progress or other measures must be taken so that persons other than the workers do not enter the work space.
5. Standard fire fighting equipment
 - Always place a standard fire fighting equipment in the disassembly work area.
 - Depending on type of fire (vehicle or battery) use standard fire fighting equipment (water or extinguisher).

LI-ION BATTERY

< UNIT DISASSEMBLY AND ASSEMBLY >

[TYPE 1]

DISASSEMBLY

1. Remove battery pack upper case. Refer to [EVB-192, "LI-ION BATTERY CONTROLLER : Disassembly and Assembly"](#).
2. Remove Li-ion battery controller. Refer to [EVB-192, "LI-ION BATTERY CONTROLLER : Disassembly and Assembly"](#).
3. Remove battery junction box. Refer to [EVB-192, "LI-ION BATTERY CONTROLLER : Disassembly and Assembly"](#).

4. Remove bus bar (1) that connects service plug switch and left front module stack.

DANGER:

-  To prevent electric shock hazards, be sure to put on insulated protective gear and use insulated tools.



-  After removing, close bus bar cover.

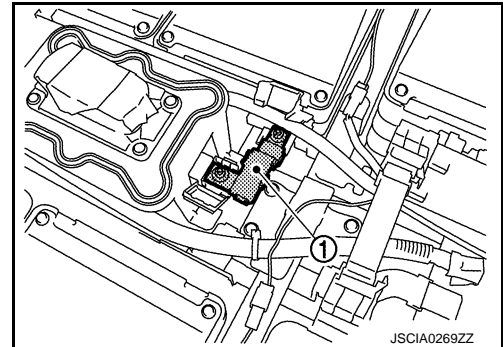

5. Remove mounting bolts (A) and nuts (B) of service plug switch bracket (1).

WARNING:

-  To prevent electric shock hazards, be sure to put on insulated protective gear and use insulated tools.

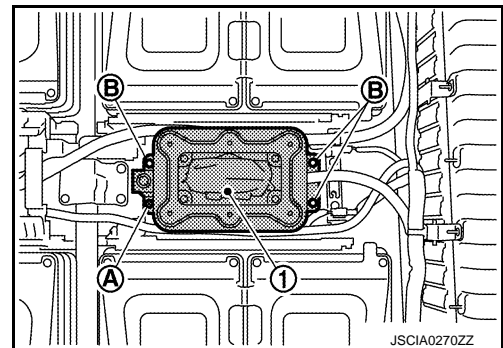

6. Disconnect high voltage harness (A) and connector (B) on reverse side of service plug switch bracket (1), then remove service plug switch bracket (1).

DANGER:

-  To prevent electric shock hazards, be sure to put on insulated protective gear and use insulated tools.



-  To prevent electric shock hazards, immediately wrap insulating tape around disconnected high voltage harness connector (high voltage terminal) and terminals.

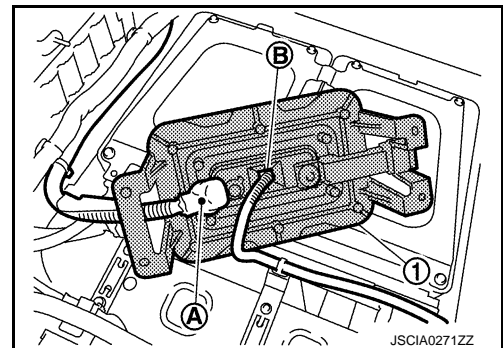

7. Remove harness bracket (1).

WARNING:

-  To prevent electric shock hazards, be sure to put on insulated protective gear and use insulated tools.

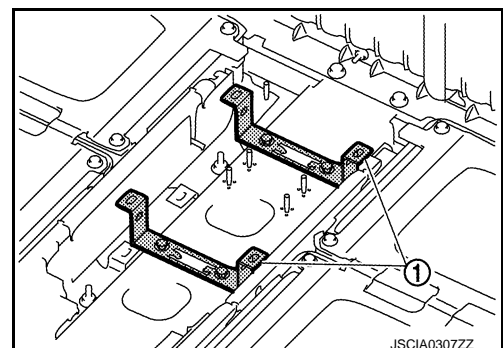

A

B

EVB

D

E

F

G

H

I

J

K

L

M

N

O

P

LI-ION BATTERY

< UNIT DISASSEMBLY AND ASSEMBLY >

[TYPE 1]

8. Remove bus bar (1) that connects left and right front module stacks.

← : Vehicle front

DANGER:

- ⚡ To prevent electric shock hazards, be sure to put on insulated protective gear and use insulated tools.



- ⚡ To prevent electric shock hazards, immediately wrap insulating tape around disconnected high voltage harness connector and terminals.

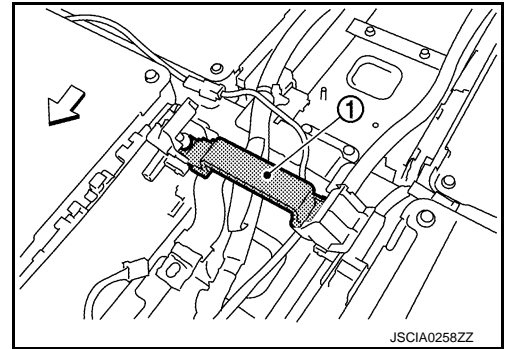

9. Remove battery temperature sensor (1) from module (2).

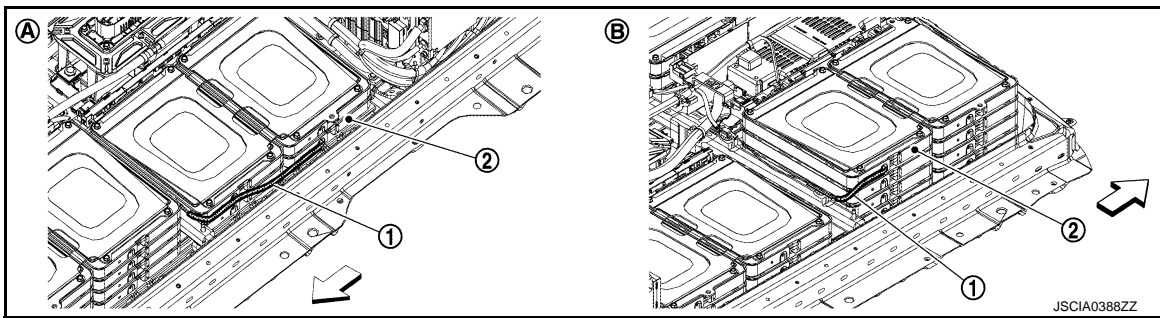

A. Front module stack LH

B. Front module stack RH

← : Vehicle front

WARNING:

- ⚡ To prevent electric shock hazards, be sure to put on insulated protective gear and use insulated tools.



10. Remove battery member pipe (1).

WARNING:

- ⚡ To prevent electric shock hazards, be sure to put on insulated protective gear and use insulated tools.

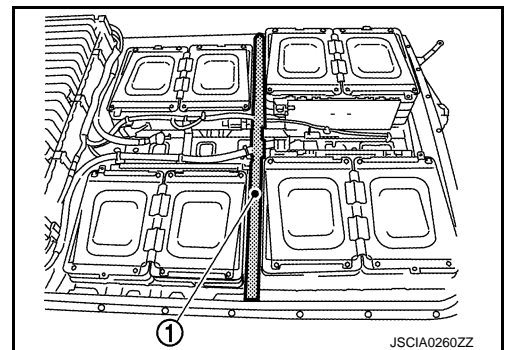

LI-ION BATTERY

< UNIT DISASSEMBLY AND ASSEMBLY >

[TYPE 1]

11. Remove vehicle communication harness connector.

- A. Front module stack LH side
- B. Front module stack RH side
- ← : Vehicle front

WARNING:

 To prevent electric shock hazards, be sure to wear protective gear.

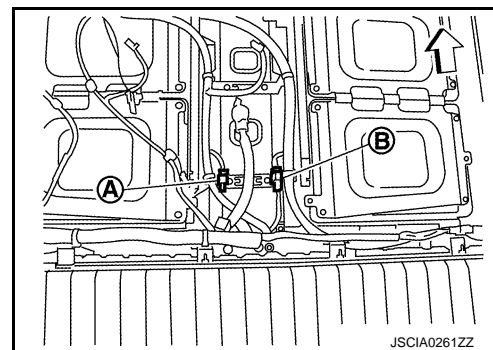

JSCIA0261ZZ

12. Remove front module stack mounting bolts (A).

- 1. Front module stack LH
- 2. Front module stack RH

WARNING:

 To prevent electric shock hazards, be sure to put on insulated protective gear and use insulated tools.

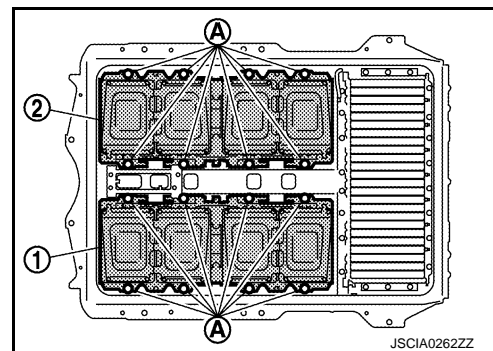

JSCIA0262ZZ

13. Follow the procedure below and remove front module stack from battery pack.

a. Attach a carabiner to the position (A) in the figure and connect a slinger belt to it.

WARNING:

 To prevent electric shock hazards, be sure to wear protective gear.

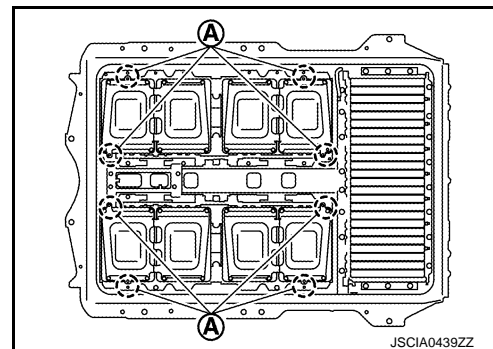

JSCIA0439ZZ

b. Use mobile floor crane (A) to lift up front module stack (1).

WARNING:

 To prevent electric shock hazards, be sure to wear protective gear.



 Be sure to place an insulating rubber sheet on the work bench.

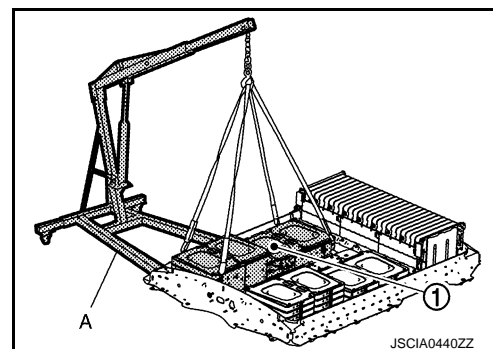

JSCIA0440ZZ

c. Move the battery pack and place work bench underneath front module stack.

WARNING:

 To prevent electric shock hazards, be sure to wear protective gear.



CAUTION:

LI-ION BATTERY

< UNIT DISASSEMBLY AND ASSEMBLY >

[TYPE 1]

Place removed battery pack upper case onto battery pack for storage.

d. Place front module stack (1) onto work bench.

WARNING:

-  To prevent electric shock hazards, be sure to wear protective gear.



-  Be sure to place an insulating rubber sheet on the work bench.

NOTE:

Figure indicates front module stack RH.

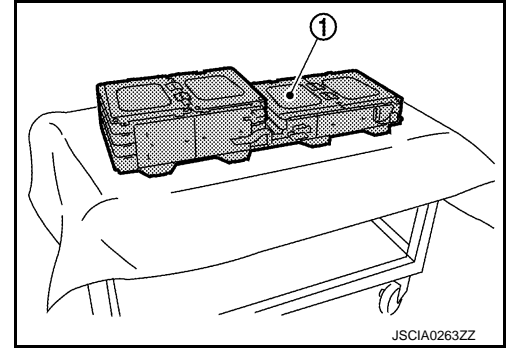

14. Follow the procedure below and remove bus bar from front module stack.

a. Remove bus bar (1).

DANGER:

-  To prevent electric shock hazards, be sure to put on insulated protective gear and use insulated tools.



-  To prevent electric shock hazards, immediately wrap insulating tape around disconnected high voltage harness connector and terminals.

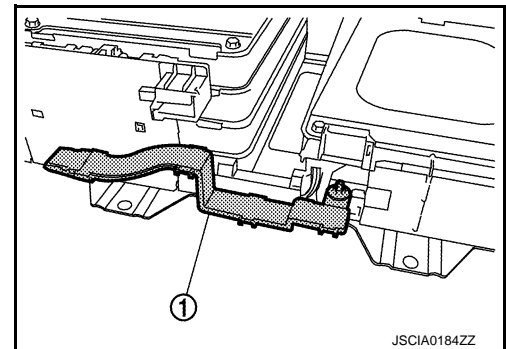

b. Remove bus bar cover and remove module terminal mounting bolts (A).

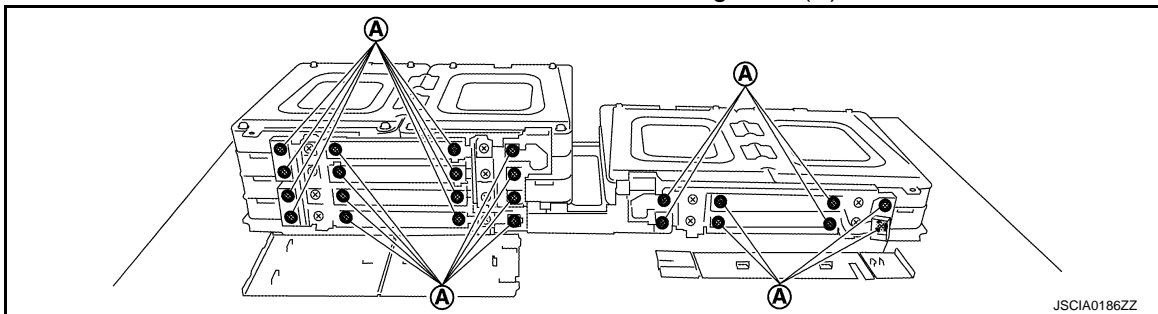

DANGER:

-  To prevent electric shock hazards, be sure to put on insulated protective gear and use insulated tools.



-  Work alone. Failure to do this may cause shock hazards.

LI-ION BATTERY

< UNIT DISASSEMBLY AND ASSEMBLY >

[TYPE 1]

- c. Remove voltage detection terminal mounting screws (A) and remove bus bar (1) from front module stack.

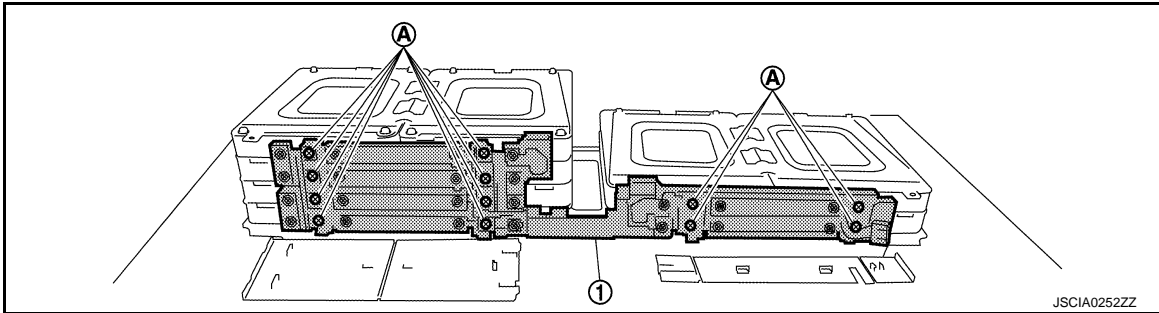

DANGER:

-  To prevent electric shock hazards, be sure to put on insulated protective gear and use insulated tools.



-  Work alone. Failure to do this may cause shock hazards.

- d. Attach module terminal covers [SST: KV99111500] (A) to all module terminals.

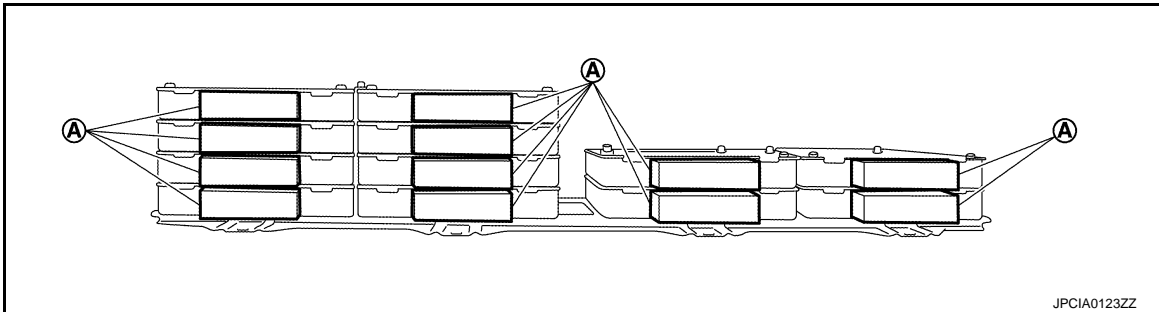

WARNING:

-  To prevent electric shock hazards, be sure to wear protective gear.



15. Remove end plate and disassembly front module stack.

WARNING:

-  To prevent electric shock hazards, be sure to put on insulated protective gear and use insulated tools.



ASSEMBLY

Note the following, assemble in the reverse order of disassembly.

DANGER:

-  There is the danger of electric shock caused by contact with the terminals. Be sure to wear insulated protective gear and use insulated tools.



-  Because there is a danger of electric shock and fire, never allow bus bar to contact a wrong terminal.

A
B
EVB
D
E
F
G
H
I
J
K
L
M
N
O
P

LI-ION BATTERY

< UNIT DISASSEMBLY AND ASSEMBLY >

[TYPE 1]

- If bus bar contacts a wrong terminal, the circuit becomes energized and a short may occur.
- Always keep the bus bar cover closed until immediately before the installation of bus bar.
- Since the correct installation position for the bus bar connected to both front module stacks is commonly-confused with the wrong position (B), install the bus bar to the correct position (A) with extreme caution.

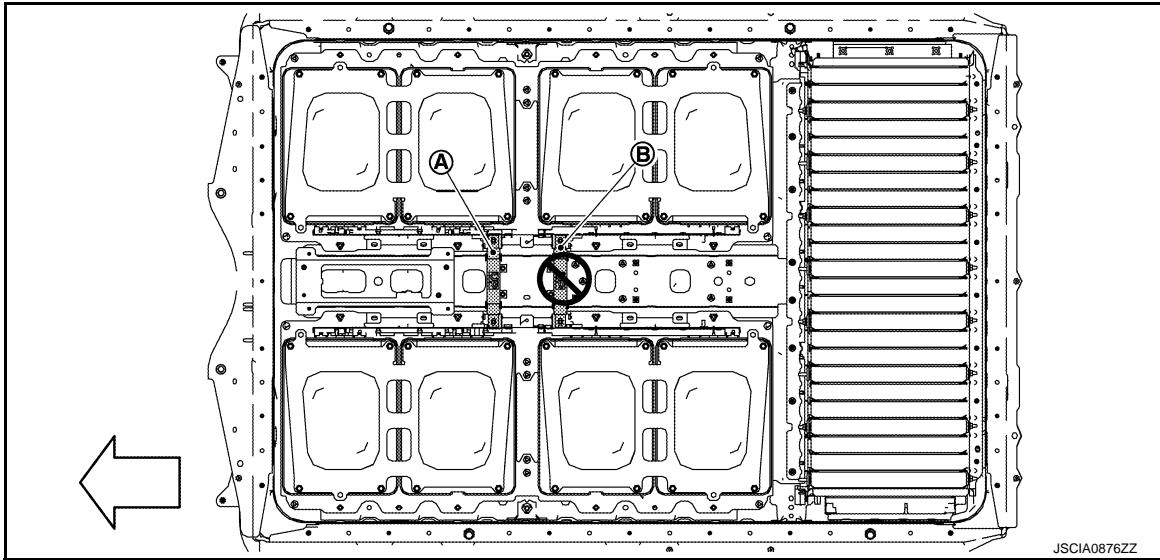

A. Correct position

B. Wrong position

⇐ : Battery front

WARNING:

Install Li-ion battery controller immediately before installing battery pack upper case.

CAUTION:

- Perform the "MODULE CHARGE BALANCE" when module is replaced. Refer to [EVB-71, "Work Procedure"](#).
- Check seal before install battery pack upper case. Refer to [EVB-206, "FRONT MODULE STACK : Inspection"](#).

EV Battery Traceability Seal

When replacing the module with a new one, perform the following procedure.

1. Enter the date of replacement on the EV battery traceability seal packaged with the new part.
2. Cut the EV battery traceability seal in two and affix each seal to the old module and "Li-ion BATTERY REPLACEMENT RECORD".
3. Fill in the "Li-ion BATTERY REPLACEMENT RECORD".

Front Module Stack

- Check that terminal of front module stack is arranged as shown in the figure.

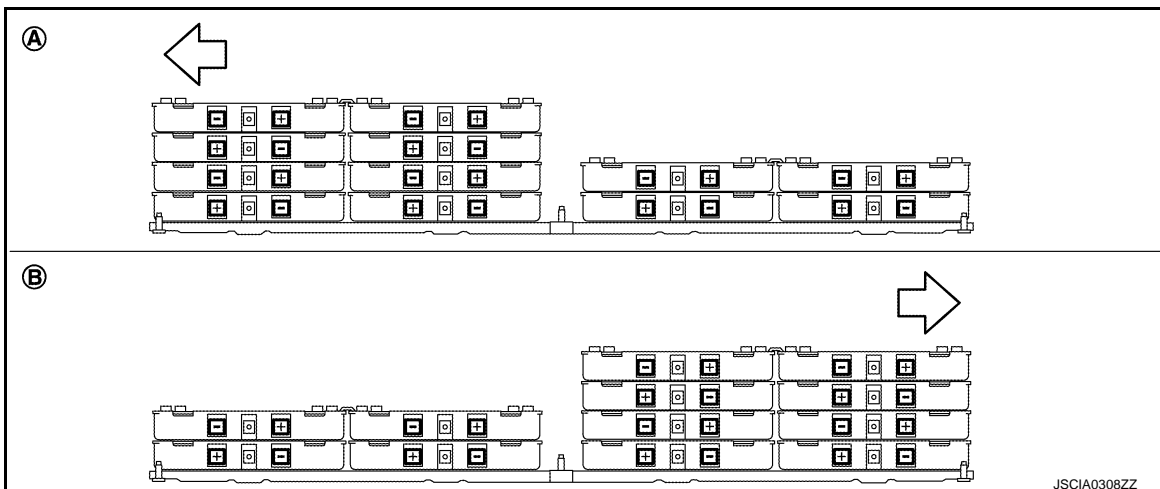

LI-ION BATTERY

< UNIT DISASSEMBLY AND ASSEMBLY >

[TYPE 1]

- A. Front module stack RH B. Front module stack LH

↔ : Vehicle front

- Tighten mounting bolts in numerical order as shown in the figure.

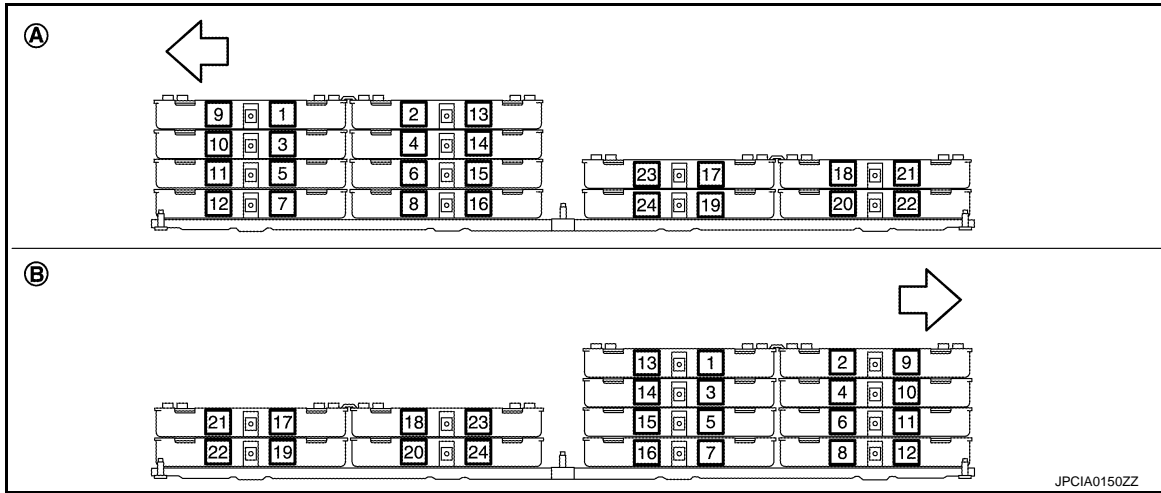

- A. Front module stack RH B. Front module stack LH

↔ : Vehicle front

DANGER:

-  To prevent electric shock hazards, be sure to put on insulated protective gear and use insulated tools.



-  Work alone. Failure to do this may cause shock hazards.

- Install end plate so that its carabiner mounting hole (A) is positioned as shown in the figure.

1. Front module stack RH

NOTE:

There are two kinds of end plates of which carabiner mounting hole location is different each other. The installation of improper end plate results in the carabiner mounting hole being placed inside. Accordingly, the front stack module cannot be lifted.

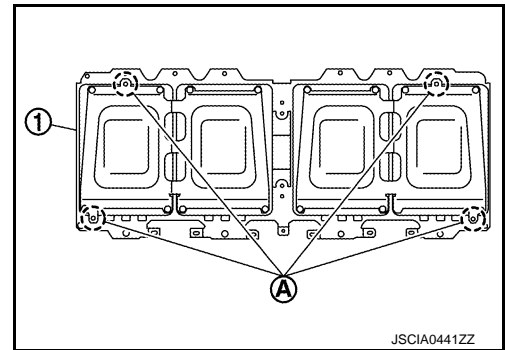

Battery Temperature Sensor

- Install battery temperature sensor (front) as shown in the figure.

LI-ION BATTERY

< UNIT DISASSEMBLY AND ASSEMBLY >

[TYPE 1]

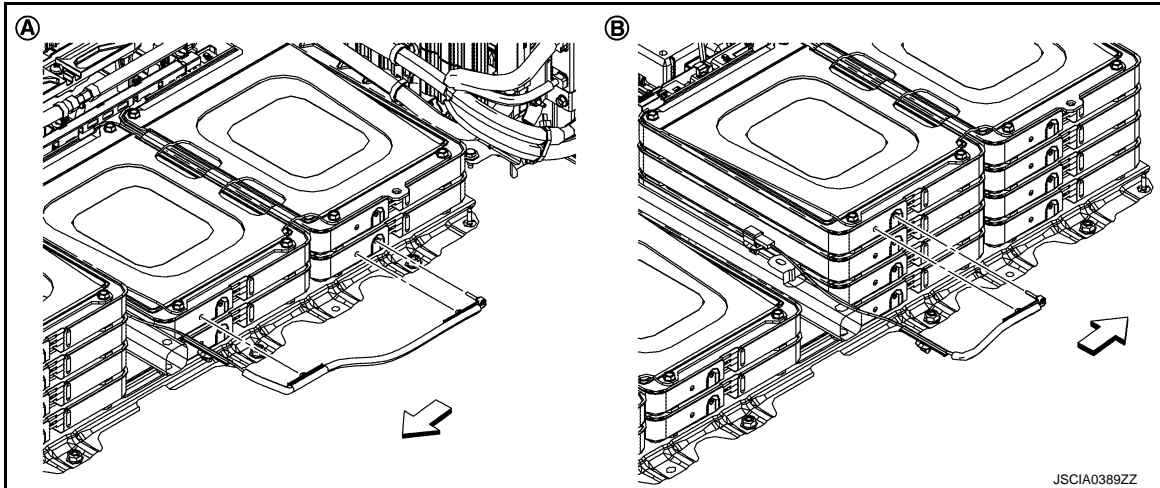

A. Front module stack LH

B. Front module stack RH

↔ : Vehicle front

- Insert a sensor (A) into module and fix with clip (B).

NOTE:

Do not fix with grommet (C).

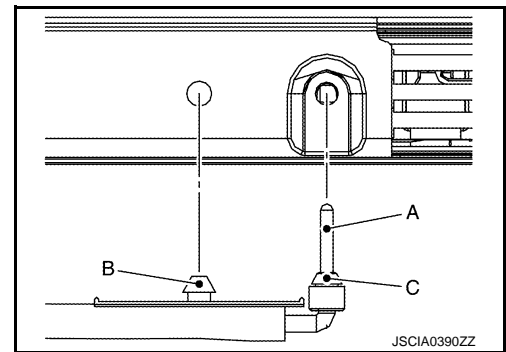

CAUTION:

- Check the following items after installing battery pack: Refer to [EVb-206, "FRONT MODULE STACK : Inspection"](#).

■AIR LEAK INSPECTION

■ELECTRIC EQUIPOTENTIAL TEST

FRONT MODULE STACK : Inspection

INFOID:000000007063699

BATTERY PACK SEAL INSPECTION

- Visually check all lips (A) of seal (1) for damage. (e.g. scratches and cracks)
- Replace seal if its lips are damaged.

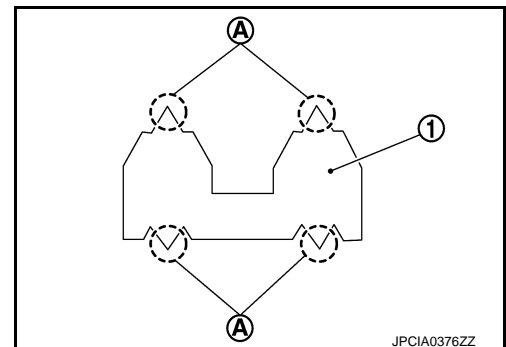

AIR LEAK INSPECTION

LI-ION BATTERY

< UNIT DISASSEMBLY AND ASSEMBLY >

[TYPE 1]

1. Remove drain plug and install adapter [SST: KV99111400] (A).

WARNING:

 To prevent electric shock hazards, be sure to wear protective gear.

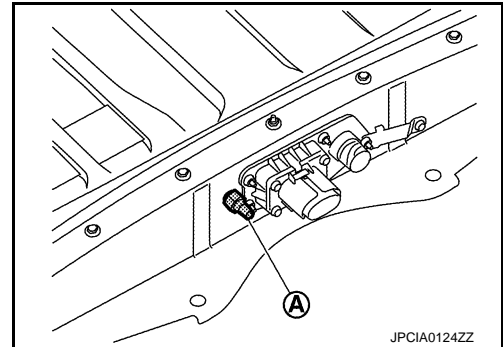

2. Install gauge [SST: KV99111400] (A).

WARNING:

 To prevent electric shock hazards, be sure to wear protective gear.



CAUTION:

Handle the gauge carefully so that it will not drop.

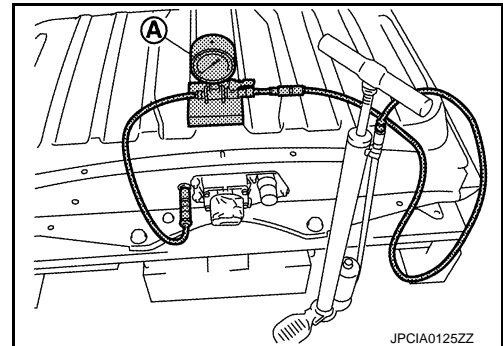

3. Install service plug to seal the battery pack.

DANGER:

 To prevent electric shock hazards, be sure to wear protective gear.



4. Use vinyl tape (A) or similar means to seal the breather so that air does not enter it.

- Use the wide vinyl tape which can cover up breather at once.
- Stick it so that tape is not wrinkled.

WARNING:

 To prevent electric shock hazards, be sure to wear protective gear.

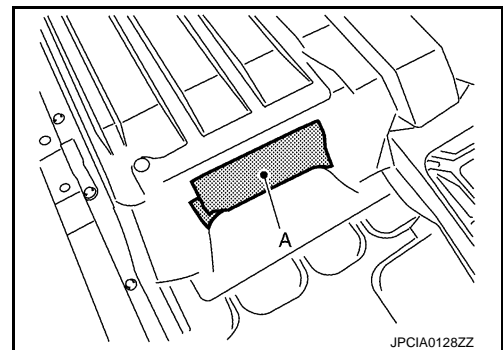

5. Perform air leak inspection by applying 1.6 kPa (0.0163 kg/cm², 0.23 psi) of pressure inside the battery pack for approximately 1 minute.

CAUTION:

- When applying pressure, operate the air pump slowly.
- Do not apply any pressure exceeding 2.0 kPa (0.0204 kg/cm², 0.29 psi).

Repair limit : 1.4 kPa (0.0143 kg/cm², 0.20 psi)

6. If the pressure drops below the limit value, use soapy water and check for leakage points.

WARNING:

 To prevent electric shock hazards, be sure to wear protective gear.



A
B
EVB
D
E
F
G
H
I
J
K
L
M
N
O
P

LI-ION BATTERY

< UNIT DISASSEMBLY AND ASSEMBLY >

[TYPE 1]

CAUTION:

Never allow soapy water to contact the service plug and each connector terminals.

Electric Equipotential Test

After installing the battery pack, measure the resistance between the ground bolt mating surface (A) and the high voltage harness connector flange (B).

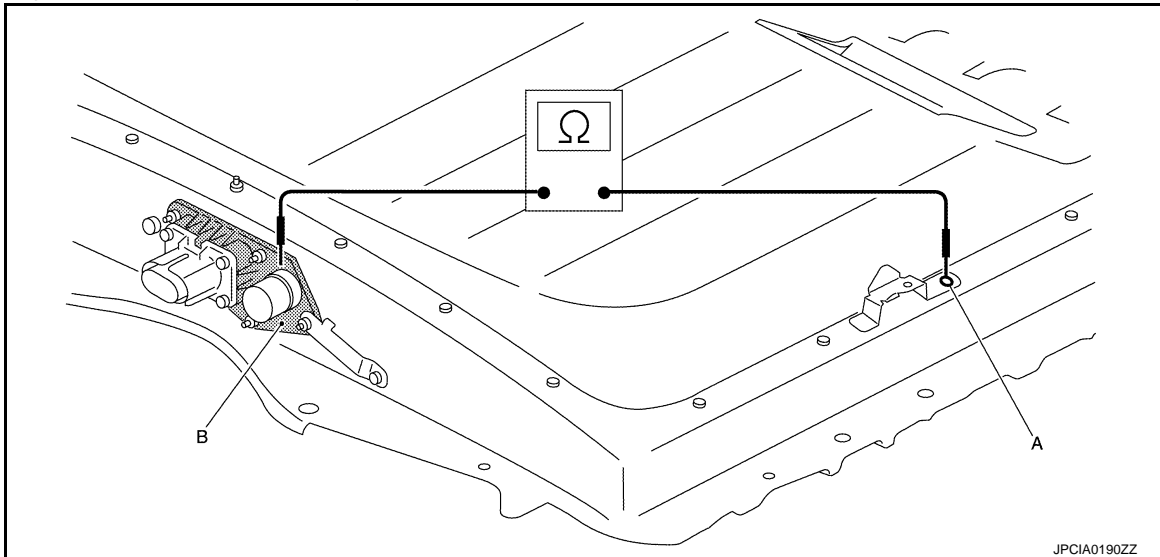

WARNING:



To prevent electric shock hazards, be sure to wear protective gear.



Standard : Less than 0.1 Ω

If the result deviates from the standard value, check the following items and repair malfunctioning parts

- Connection condition of ground bolts
- Rust on the mounting surface of ground bolts
- Paint, oil, and dust on the mounting surface of ground bolts

REAR MODULE STACK

REAR MODULE STACK : Disassembly and Assembly

INFOID:000000007005858

DANGER:



Because hybrid vehicles and electric vehicles contain a high voltage battery, there is the risk of electric shock, electric leakage, or similar accidents if the high voltage component and vehicle are handled incorrectly. Be sure to follow the correct work procedures when performing inspection and maintenance.

WARNING:

- Be sure to remove the service plug in order to disconnect the high voltage circuits before performing inspection or maintenance of high voltage system harnesses and parts.
- To prevent the removed service plug from being connected by mistake during the procedure, always carry it in your pocket or put it in the tool box.
- Be sure to wear insulating protective equipment consisting of glove, shoes, face shield and glasses before beginning work on the high voltage system.
- Refer to [EVB-17, "High Voltage Precautions"](#).
- To prevent electric shock hazards, ignition, and damage to parts, always remove Li-ion battery controller before disassembling battery pack.

CAUTION:

LI-ION BATTERY

< UNIT DISASSEMBLY AND ASSEMBLY >

[TYPE 1]

There is the possibility of a malfunction occurring if the vehicle is changed to READY status while the service plug is removed. Therefore do not change the vehicle to READY status unless instructed to do so in the Service Manual.

WORK ENVIRONMENT FOR DISASSEMBLY OF LI-ION BATTERY

1. Must be an indoor environment.
 - The work environment must be able to be isolated from the outside by shutters or other means to prevent the intrusion of rain, snow, sand, and other substances.
 - The environment must prevent the entry of sweat during work, and also prevent condensation from occurring as a result of high temperature and humidity.
2. No entry of foreign materials.
 - In addition to being indoors, the environment must not permit the entry during disassembly work of metal powders, oil, or foreign substances resulting from causes such as servicing of other vehicles.
 - If there is any risk of the above, use a plastic curtain or other means to block off the work area, or take other necessary steps.
3. The floor must be dry.
 - The floor must not become wet as a result of causes such as vehicles entering when it is raining or snowing.
4. Work space
 - Space approximately the size of one vehicle must be secured as the disassembly space.
 - A sign indicating that disassembly is in progress or other measures must be taken so that persons other than the workers do not enter the work space.
5. Standard fire fighting equipment
 - Always place a standard fire fighting equipment in the disassembly work area.
 - Depending on type of fire (vehicle or battery) use standard fire fighting equipment (water or extinguisher).

DISASSEMBLY

1. Clean any contamination and dust from the battery pack.
2. Remove service plug retainer (1).

WARNING:



To prevent electric shock hazards, be sure to wear protective gear.

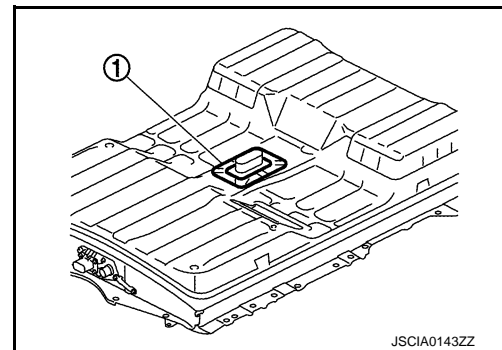

3. Remove mounting bolts (A), (B) and mounting nuts (C), then remove battery pack upper case.

LI-ION BATTERY

< UNIT DISASSEMBLY AND ASSEMBLY >

[TYPE 1]

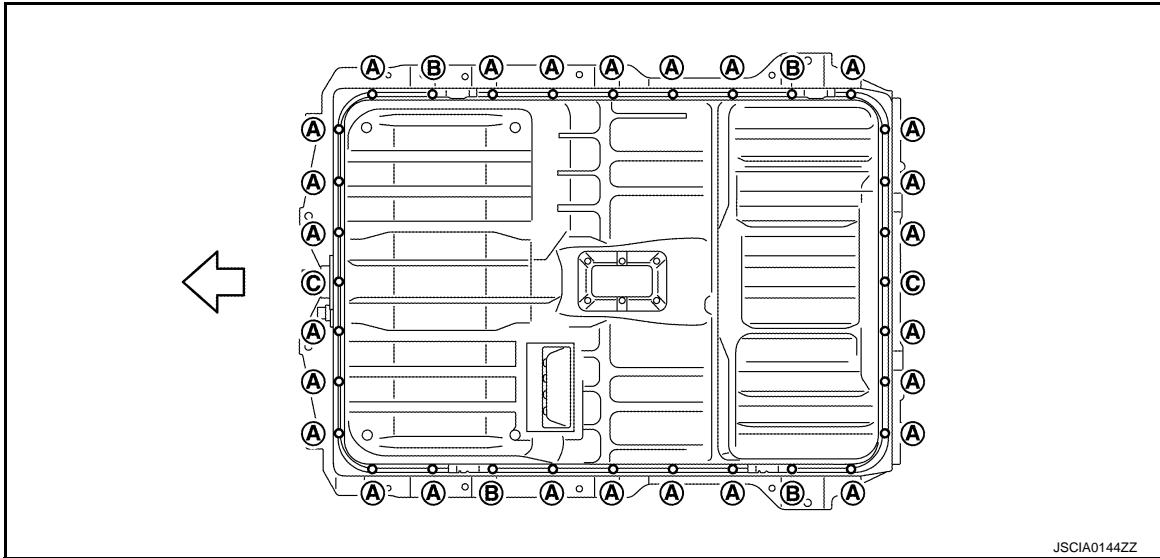

← : Vehicle front

WARNING:



To prevent electric shock hazards, be sure to wear protective gear.



- Remove Li-ion battery controller. Refer to [EVB-192, "LI-ION BATTERY CONTROLLER : Disassembly and Assembly"](#).
- Remove vehicle communication harness connector (A) on rear module stack.

WARNING:

-  To prevent electric shock hazards, be sure to put on insulated protective gear and use insulated tools.



-  To prevent electric shock hazards, immediately wrap insulating tape around disconnected high voltage harness connector and terminals.

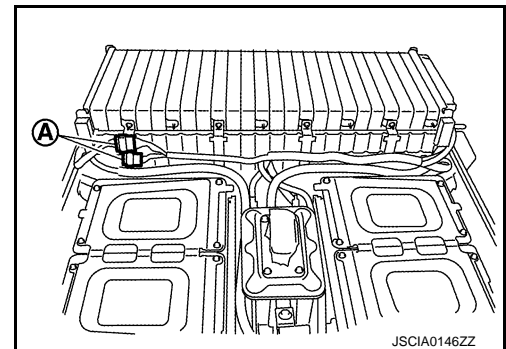

- Disconnect battery temperature sensor harness connector (A) from bracket.

WARNING:

-  To prevent electric shock hazards, be sure to put on insulated protective gear and use insulated tools.

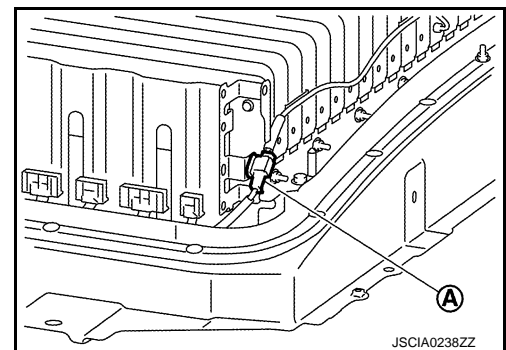

LI-ION BATTERY

< UNIT DISASSEMBLY AND ASSEMBLY >

[TYPE 1]

7. Remove harness clip (A) from harness bracket and move vehicle communication harness (1) to the position without the hindrance for work.

WARNING:

 To prevent electric shock hazards, be sure to put on insulated protective gear and use insulated tools.

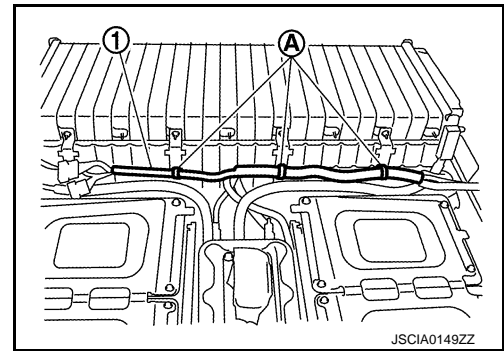

8. Remove mounting nuts (A) and remove high voltage harness from rear module stack.

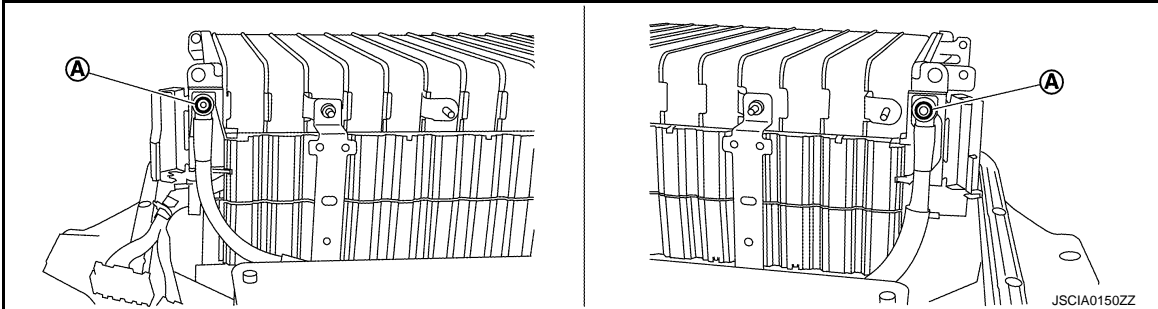

DANGER:

-  To prevent electric shock hazards, be sure to put on insulated protective gear and use insulated tools.



-  To prevent electric shock hazards, immediately wrap insulating tape around disconnected high voltage harness connector and terminals.

9. Remove rear module stack (1) mounting bolts (A).

WARNING:

 To prevent electric shock hazards, be sure to put on insulated protective gear and use insulated tools.

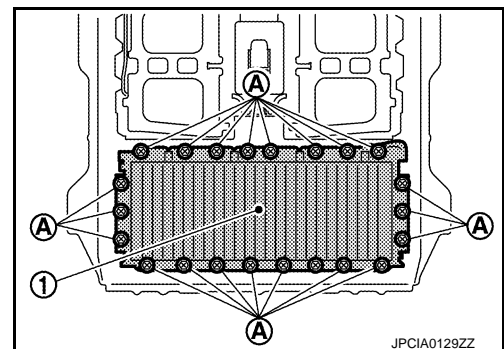

10. Follow the procedure below and remove rear module stack from battery pack.

- a. Attach a carabiner to the position (A) in the figure and connect a lashing belt to it.

WARNING:

 To prevent electric shock hazards, be sure to wear protective gear.

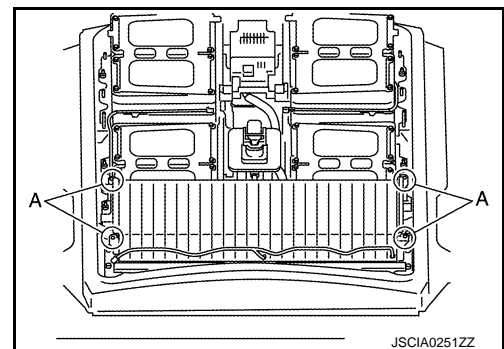

A
B
EVB
D
E
F
G
H
I
J
K
L
M
N
O
P

LI-ION BATTERY

< UNIT DISASSEMBLY AND ASSEMBLY >

[TYPE 1]

- b. Use mobile floor crane (A) to lift up rear module stack (1).

WARNING:

 To prevent electric shock hazards, be sure to wear protective gear.



CAUTION:

Do not move engine crane while rear module stack is hoisted up.

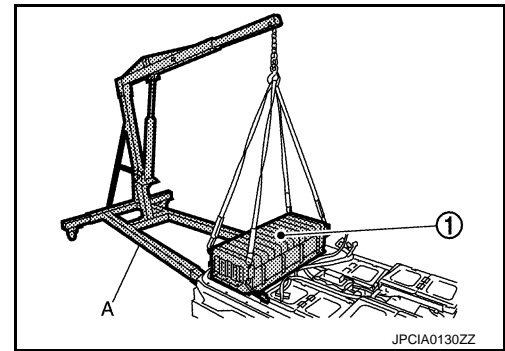

- c. Move the battery pack and place work bench underneath rear module stack.

WARNING:

 To prevent electric shock hazards, be sure to wear protective gear.



CAUTION:

Place removed battery pack upper case onto battery pack for storage.

- d. Place rear module stack onto work bench.

WARNING:

-  To prevent electric shock hazards, be sure to wear protective gear.



-  Be sure to place an insulating rubber sheet on the work bench.

11. Remove harness bracket (1) from rear module stack.

WARNING:

 To prevent electric shock hazards, be sure to put on insulated protective gear and use insulated tools.

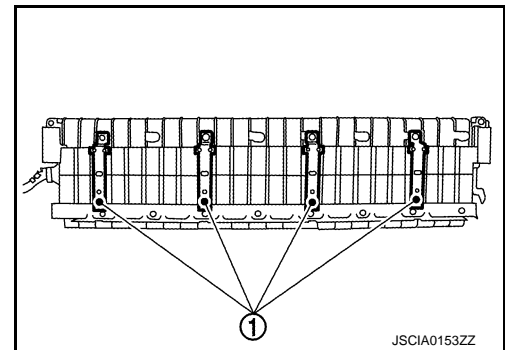

12. Follow the procedure below and remove bus bars from rear module stack.

- a. Remove central bus bar cover and remove module terminal mounting bolts (A).

DANGER:

-  To prevent electric shock hazards, be sure to put on insulated protective gear and use insulated tools.



-  Work alone. Failure to do this may cause shock hazards.

CAUTION:

Remove all bus bar covers at the same time, and do not remove module terminal mounting bolts.

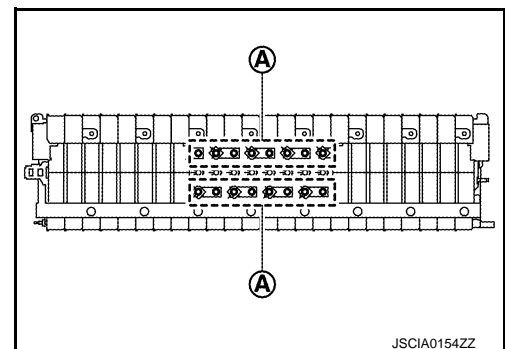

LI-ION BATTERY

< UNIT DISASSEMBLY AND ASSEMBLY >

[TYPE 1]

- b. Remove right-side bus bar cover and remove module terminal mounting bolts (A).

DANGER:

- ⚡ To prevent electric shock hazards, be sure to put on insulated protective gear and use insulated tools.



- ⚡ Work alone. Failure to do this may cause shock hazards.

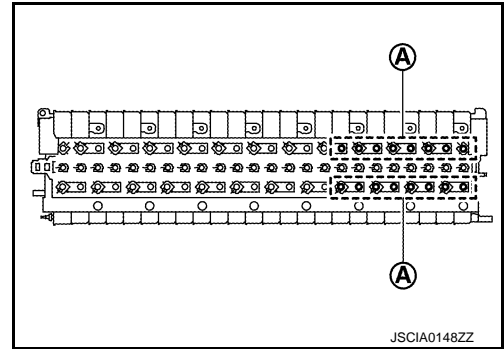

- c. Remove left-side bus bar cover and remove module terminal mounting bolts (A).

DANGER:

- ⚡ To prevent electric shock hazards, be sure to put on insulated protective gear and use insulated tools.



- ⚡ Work alone. Failure to do this may cause shock hazards.

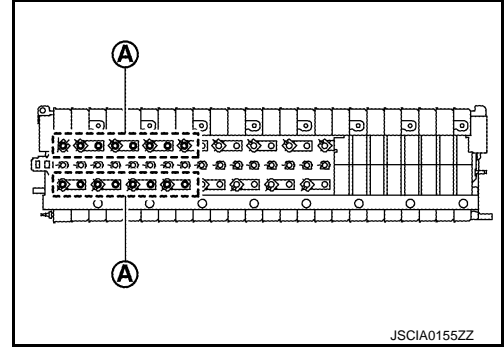

- d. Remove voltage detection terminal mounting screws (A), and then remove bus bar from rear module stack.

DANGER:

- ⚡ To prevent electric shock hazards, be sure to put on insulated protective gear and use insulated tools.



- ⚡ Work alone. Failure to do this may cause shock hazards.

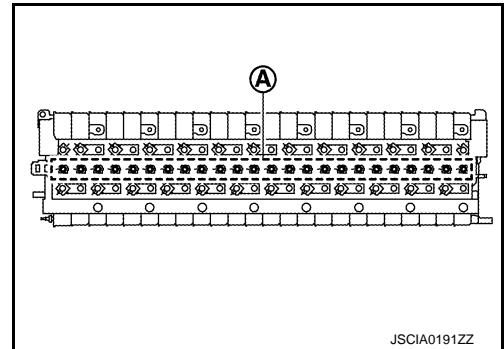

- e. Attach module terminal covers [SST: KV99111500] (A) to all module terminals.

WARNING:

- ⚡ To prevent electric shock hazards, be sure to wear protective gear.

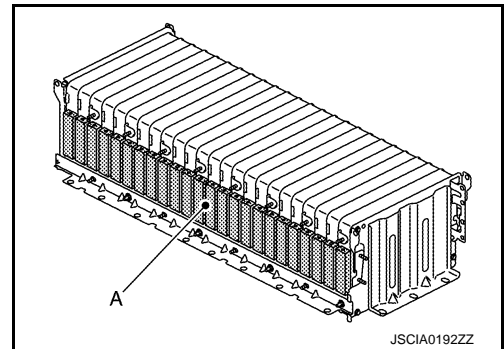

13. Remove battery temperature sensor (1) from rear module stack.

A
B
EVB
D
E
F
G
H
I
J
K
L
M
N
O
P

LI-ION BATTERY

< UNIT DISASSEMBLY AND ASSEMBLY >

[TYPE 1]

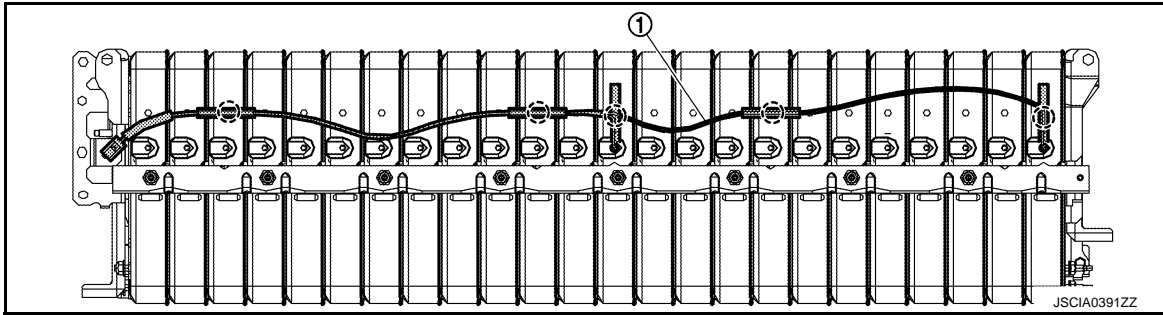

 : Clip

WARNING:

 To prevent electric shock hazards, be sure to put on insulated protective gear and use insulated tools.



14. Remove front stack member (1).

WARNING:

 To prevent electric shock hazards, be sure to put on insulated protective gear and use insulated tools.

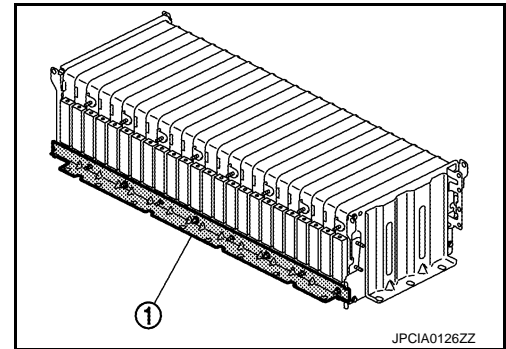

15. Remove rear stack member (1).

WARNING:

 To prevent electric shock hazards, be sure to put on insulated protective gear and use insulated tools.

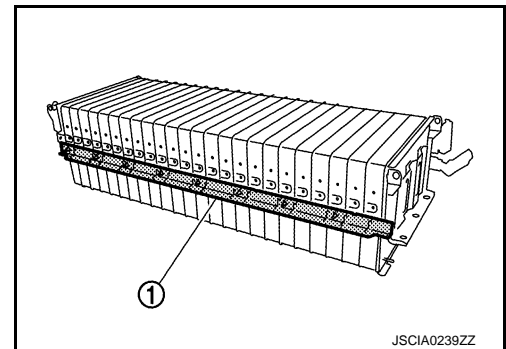

16. Use lashing belt (A) to fix rear module stack (1) in place.

WARNING:

 To prevent electric shock hazards, be sure to wear protective gear.

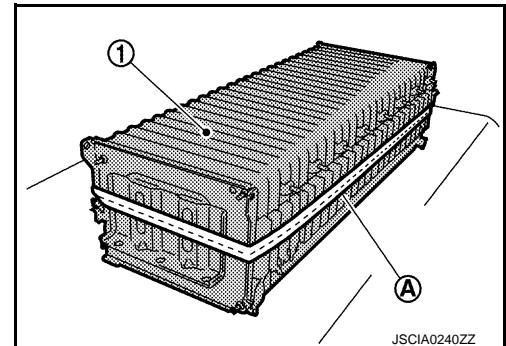

LI-ION BATTERY

< UNIT DISASSEMBLY AND ASSEMBLY >

[TYPE 1]

17. Remove through bolt mounting nut (A) (removal side, unfixed) and disassemble rear module stack (1), refer to following.

WARNING:

 To prevent electric shock hazards, be sure to put on insulated protective gear and use insulated tools.

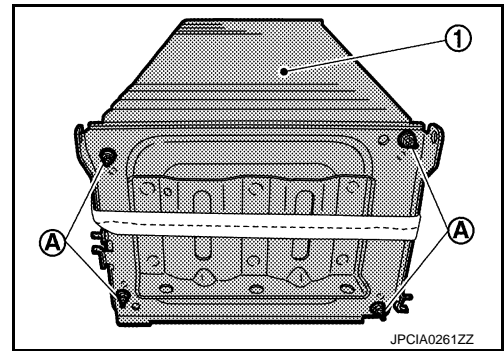

CAUTION:

- Never remove self-locking nut (fixed).

- A : Self-locking nut (fixed)
B : Mounting nut (removal side, unfixed)

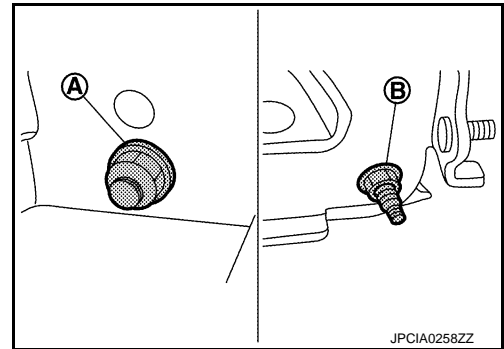

- Fix the tip of through bolt on the removal side to remove mounting nut.

NOTE:

When through bolt is removed, the spacer between the modules will fall out and it will be difficult to return it to its original position. Therefore pull the through bolt out only to the position necessary for the module that will be removed.

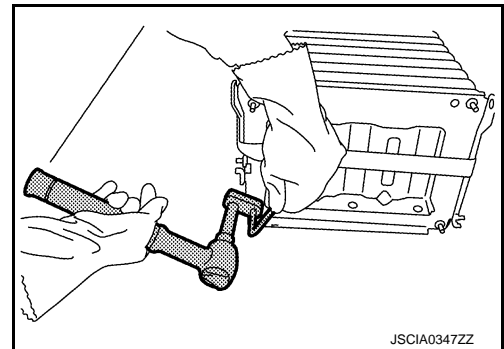

ASSEMBLY

CAUTION:

- Perform the “MODULE CHARGE BALANCE” when module is replaced. Refer to [EVB-71, "Work Procedure"](#).

1. When replacing the module with a new one, perform the following procedure.
 - a. Enter the date of replacement on the EV battery traceability seal packaged with the new part.
 - b. Cut the EV battery traceability seal in two and affix each seal to the module and “Li-ion BATTERY REPLACEMENT RECORD”.
 - c. Fill in the “Li-ion BATTERY REPLACEMENT RECORD”.
2. Follow procedure below and assemble rear module stack.
 - a. Assemble rear module stack, and provisionally fasten it in place with the through bolt.

WARNING:

 To prevent electric shock hazards, be sure to put on insulated protective gear and use insulated tools.



LI-ION BATTERY

< UNIT DISASSEMBLY AND ASSEMBLY >

[TYPE 1]

- Check that terminal of module is arranged as shown in the figure.

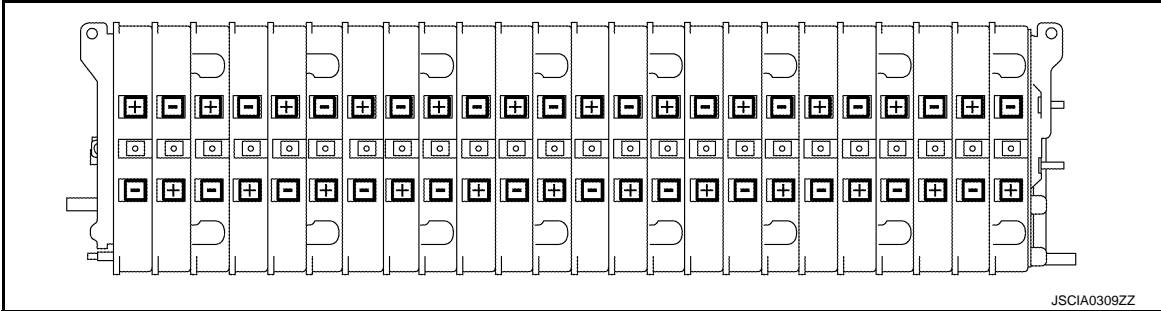

- Check that mounting plate (1) is located at position shown in the figure.

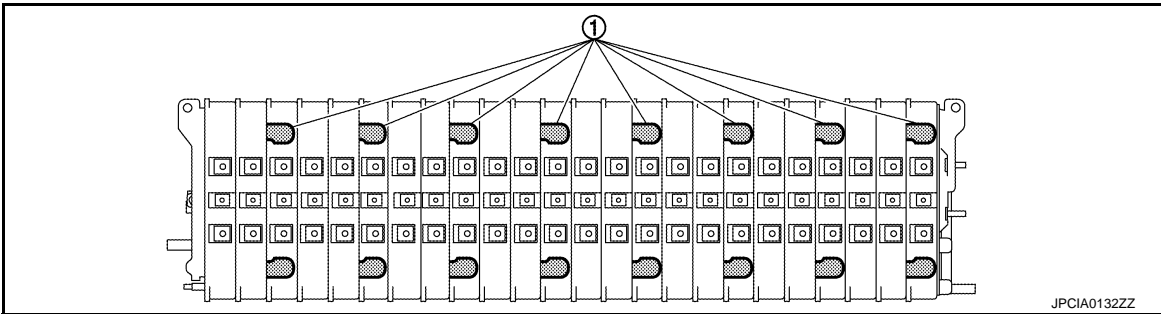

- b. Use lashing belt (A) and apply pressure to rear module stack (1).

WARNING:

 To prevent electric shock hazards, be sure to wear protective gear.

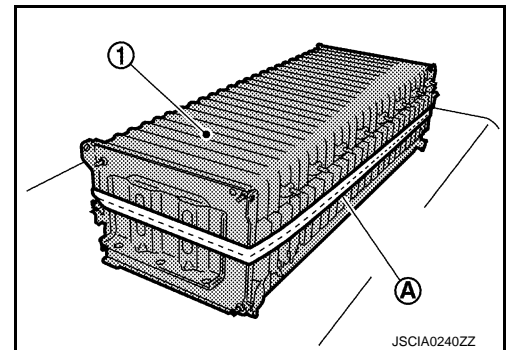

- c. Inspect the module installation condition, and correct it if it is incorrectly installed or a large distortion is found.

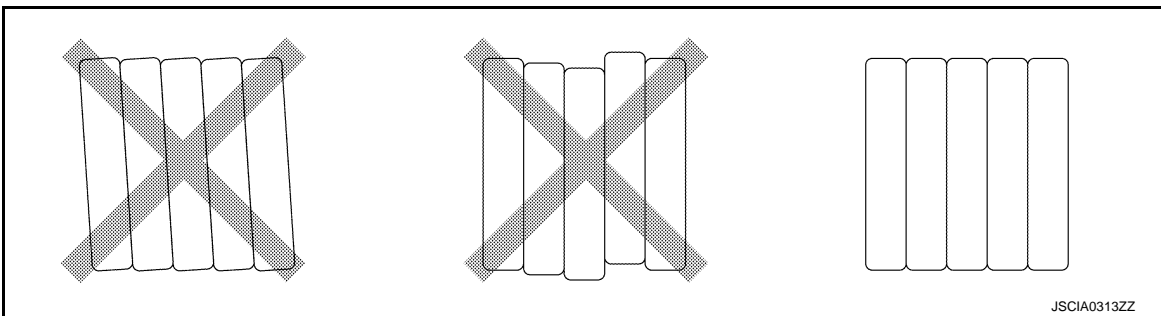

WARNING:

 To prevent electric shock hazards, be sure to put on insulated protective gear and use insulated tools.



- d. Tighten to the specified torque the mounting nuts (removal side, unfixed) for the through bolt that is attached tentatively.

LI-ION BATTERY

< UNIT DISASSEMBLY AND ASSEMBLY >

[TYPE 1]

- To tighten rear module stack, fix the tip of through bolt to tighten mounting nuts.

WARNING:

 To prevent electric shock hazards, be sure to put on insulated protective gear and use insulated tools.



CAUTION:

Never tighten self-locking nut (fixed). If tightened, replace through bolt and nut.

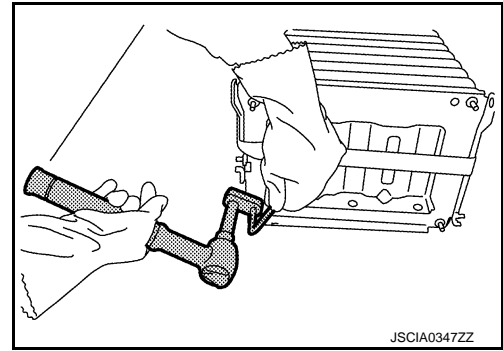

- Follow procedure below and assemble rear module member.
 - Temporarily install rear module stack member (1) to rear module stack.

WARNING:

 To prevent electric shock hazards, be sure to put on insulated protective gear and use insulated tools.

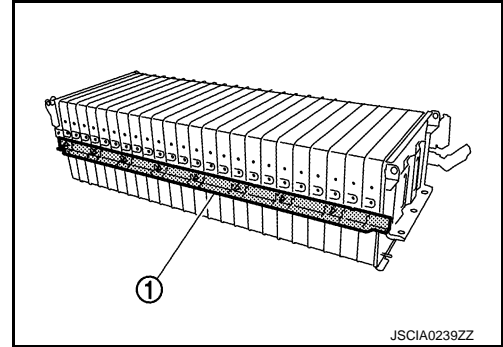

- Using the scale (A), inspect the module installation condition.

WARNING:

 To prevent electric shock hazards, be sure to wear protective gear.



- If the rear module stack is excessively distorted, loosen the through bolt of rear module stack and correct the condition.

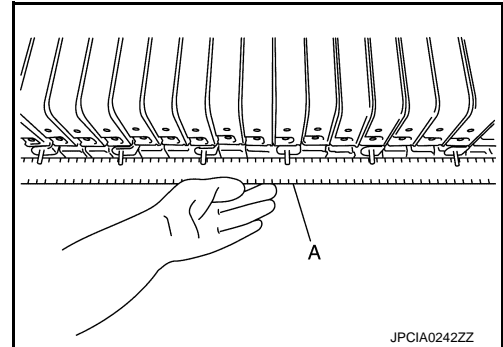

- Tighten to the specified torque the mounting nuts for the rear stack member.
- Install front stack member (1).

WARNING:

 To prevent electric shock hazards, be sure to put on insulated protective gear and use insulated tools.

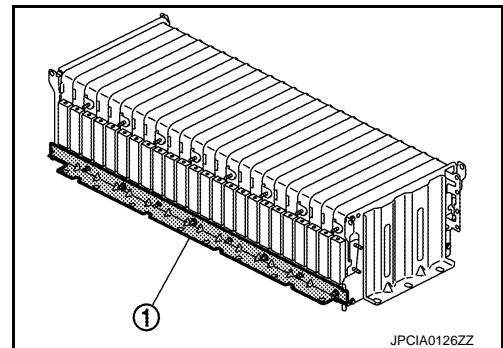

A
B
EVB
D
E
F
G
H
I
J
K
L
M
N
O
P

LI-ION BATTERY

< UNIT DISASSEMBLY AND ASSEMBLY >

[TYPE 1]

5. Install battery temperature sensor (rear) (1) in the figure.

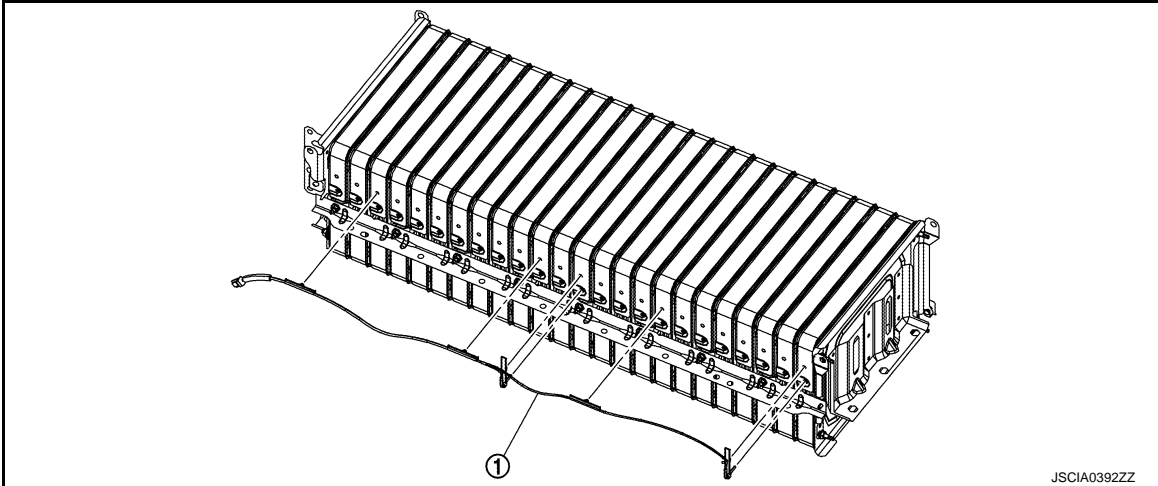

WARNING:



To prevent electric shock hazards, be sure to wear protective gear.



- Position module where sensor (1) will be installed so that it is aligned with concave part (A) of rear stack member.

 : Clip

- Position module where clip (2) will be installed so that it is aligned with concave part (B) of rear stack member.

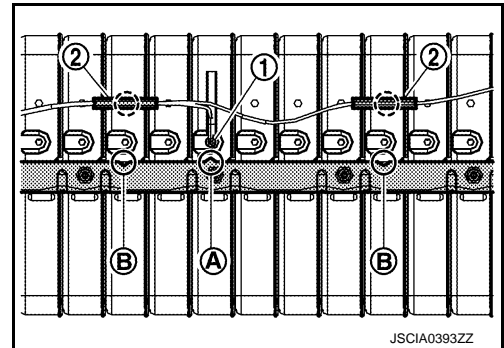

- Insert a sensor (A) in a module and fix by a clip (B). Do not fix in the grommet (C).

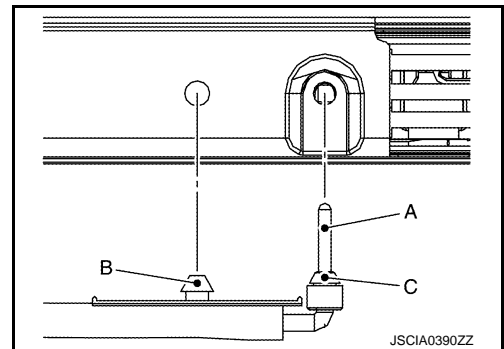

6. Remove module terminal cover [SST: KV99111500].

WARNING:



To prevent electric shock hazards, be sure to wear protective gear.



7. Follow the procedure below and install bus bars onto rear module stack.

a. Install bus bars onto rear module stack.

WARNING:

LI-ION BATTERY

< UNIT DISASSEMBLY AND ASSEMBLY >

[TYPE 1]



To prevent electric shock hazards, be sure to wear protective gear.



- b. Use an insulated torque driver (A) and tighten the voltage detection terminal mounting screws.

DANGER:



To prevent electric shock hazards, be sure to put on insulated protective gear and use insulated tools.



Work alone. Failure to do this may cause shock hazards.

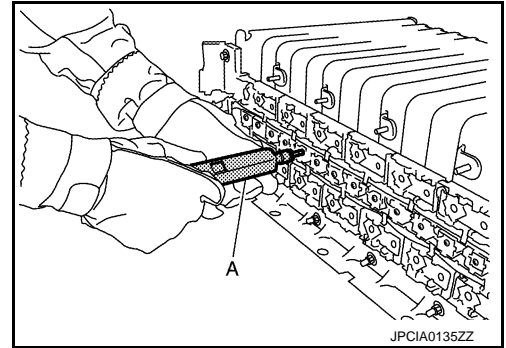

- c. Tighten module terminal mounting bolts in numerical order as shown in the figure.

- When bolts 1 – 16 have been tightened, install left side bus bar cover.
- When bolts 17 – 32 have been tightened, install right side bus bar cover.
- When bolts 33 – 48 have been tightened, install center bus bar cover.

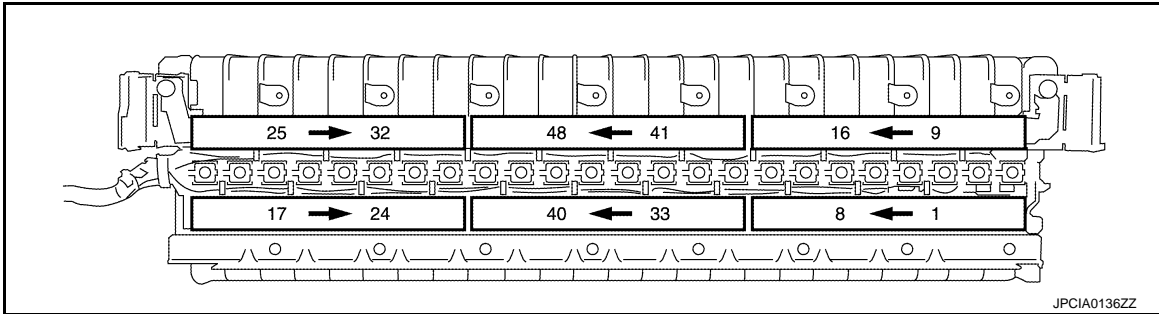

DANGER:



To prevent electric shock hazards, be sure to put on insulated protective gear and use insulated tools.



Work alone. Failure to do this may cause shock hazards.

- d. Install bus bar cover (1).

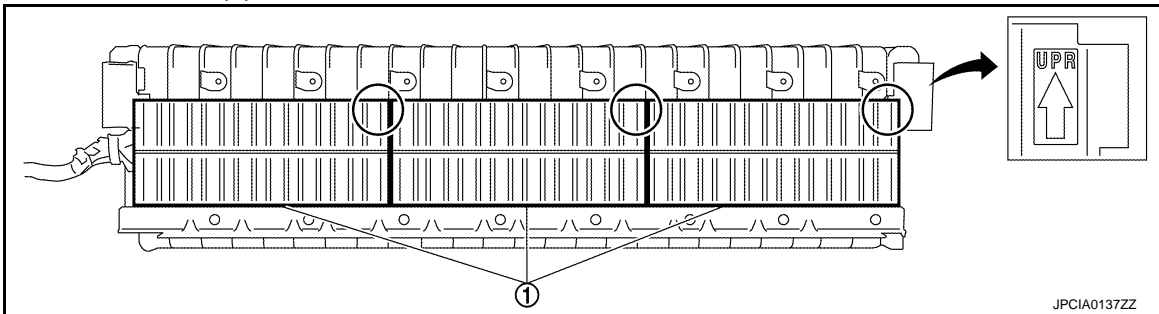

WARNING:



To prevent electric shock hazards, be sure to wear protective gear.



CAUTION:

- Be sure not to install with up/down sides facing in wrong directions.

A
B
EVB
D
E
F
G
H
I
J
K
L
M
N
O
P

LI-ION BATTERY

< UNIT DISASSEMBLY AND ASSEMBLY >

[TYPE 1]

- After installation, verify that the joined part does not disconnect.

8. Install harness bracket (1) at position of cut-out (A) in the figure.

WARNING:

 To prevent electric shock hazards, be sure to put on insulated protective gear and use insulated tools.

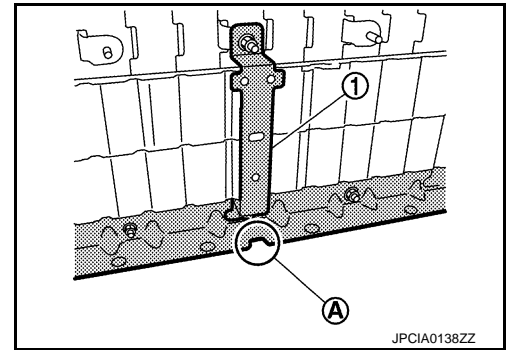

9. Follow procedure below and install rear module stack onto battery pack.

a. Use mobile floor crane (A) to lift up rear module stack (1).

WARNING:

 To prevent electric shock hazards, be sure to wear protective gear.



CAUTION:

Do not move engine crane while rear module stack is hoisted up.

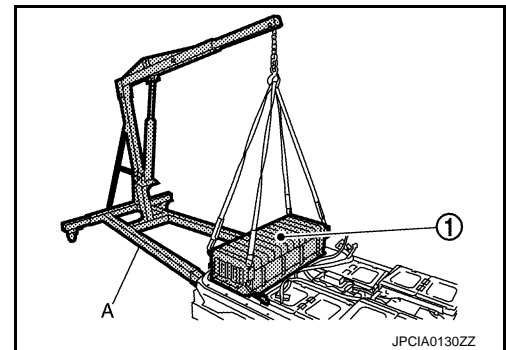

b. Move work bench so that battery pack is underneath rear module stack.

c. Install rear module stack onto battery pack.

WARNING:

 To prevent electric shock hazards, be sure to wear protective gear.



CAUTION:

Align position of locating pin.

10. Tighten rear module stack (1) mounting bolt (A).

WARNING:

 To prevent electric shock hazards, be sure to put on insulated protective gear and use insulated tools.

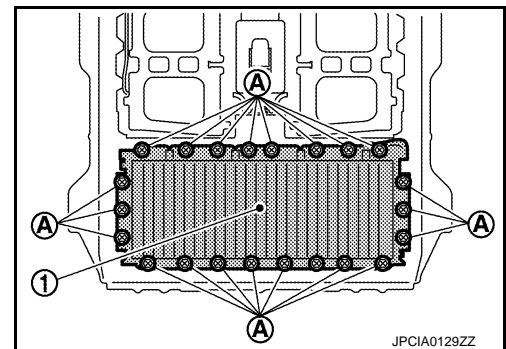

LI-ION BATTERY

< UNIT DISASSEMBLY AND ASSEMBLY >

[TYPE 1]

11. Tighten mounting nuts (A) and connect high voltage harness to rear module stack.

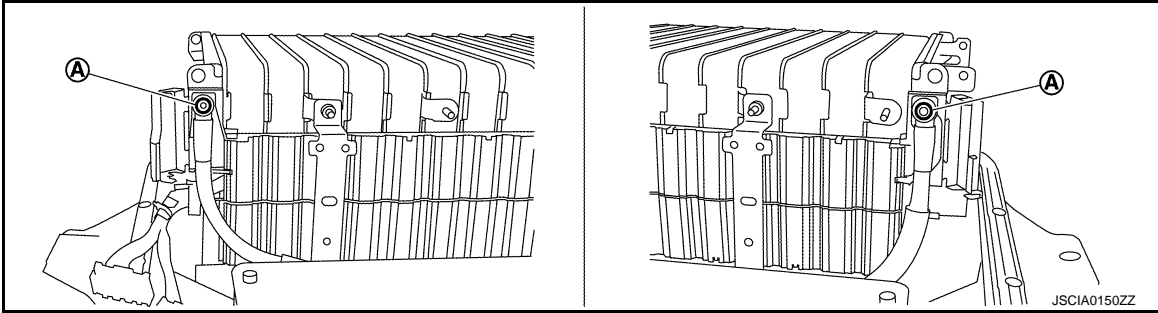

DANGER:

-  To prevent electric shock hazards, be sure to put on insulated protective gear and use insulated tools.



-  Be sure to close terminal cover.

12. Install vehicle communication harness.

WARNING:

-  To prevent electric shock hazards, be sure to wear protective gear.



13. Install Li-ion battery controller. Refer to [EVB-192. "LI-ION BATTERY CONTROLLER : Disassembly and Assembly"](#).

14. Follow the procedure below and install battery pack upper case.

CAUTION:

Check seal before install battery pack upper case. Refer to [EVB-222. "REAR MODULE STACK : Inspection"](#).

a. Tighten mounting nuts and bolts in the order from 1 to 28 as shown in the figure.

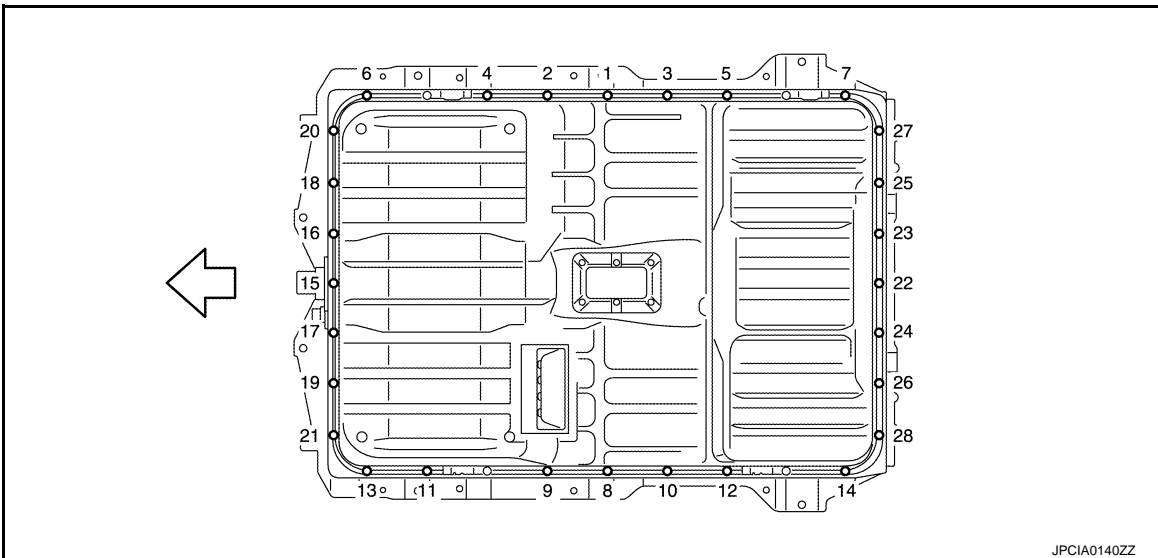

↔ : Vehicle front

WARNING:

-  To prevent electric shock hazards, be sure to wear protective gear.

LI-ION BATTERY

< UNIT DISASSEMBLY AND ASSEMBLY >

[TYPE 1]



b. Install ground bolt (A).

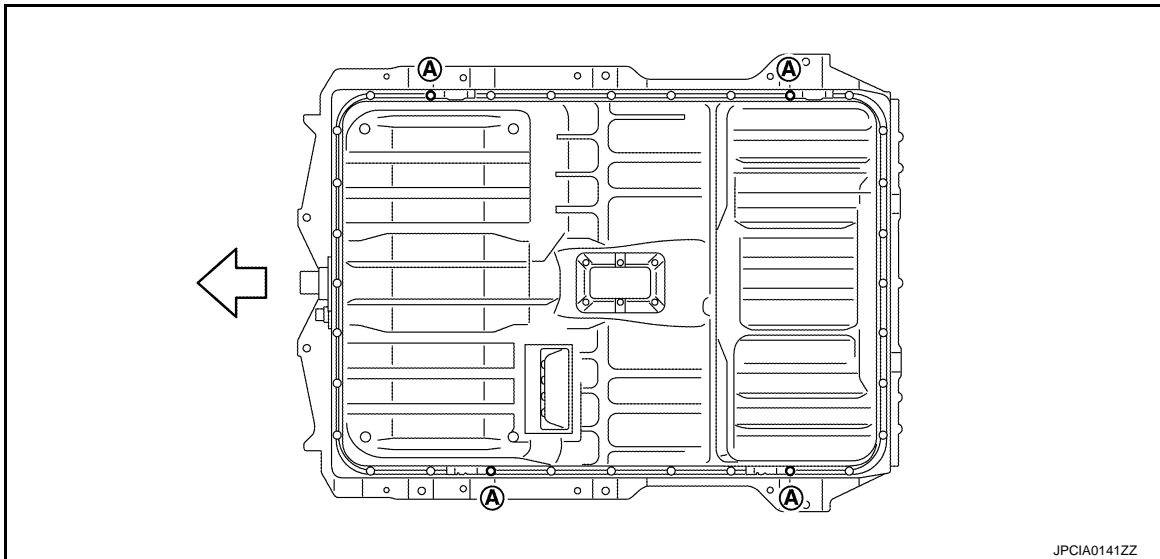

← : Vehicle front

WARNING:



To prevent electric shock hazards, be sure to wear protective gear.



15. Install service plug retainer (1).

WARNING:



To prevent electric shock hazards, be sure to wear protective gear.

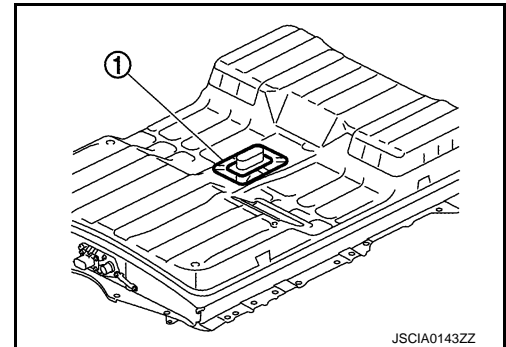

CAUTION:

• Check the following items after installing battery pack: Refer to [EVB-222, "REAR MODULE STACK : Inspection"](#).

- AIR LEAK INSPECTION
- ELECTRIC EQUIPOTENTIAL TEST

REAR MODULE STACK : Inspection

INFOID:000000007063700

BATTERY PACK SEAL INSPECTION

LI-ION BATTERY

[TYPE 1]

< UNIT DISASSEMBLY AND ASSEMBLY >

- Visually check all lips (A) of seal (1) for damage. (e.g. scratches and cracks)
- Replace seal if its lips are damaged.

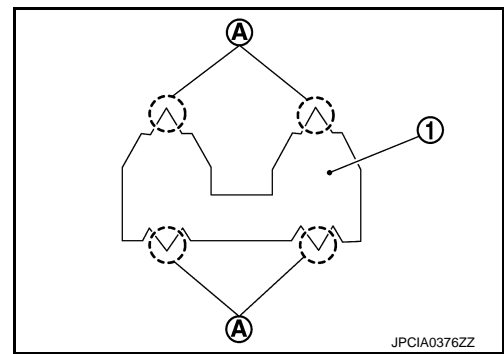

AIR LEAK INSPECTION

1. Remove drain plug and install adapter [SST: KV99111400] (A).

WARNING:



To prevent electric shock hazards, be sure to wear protective gear.

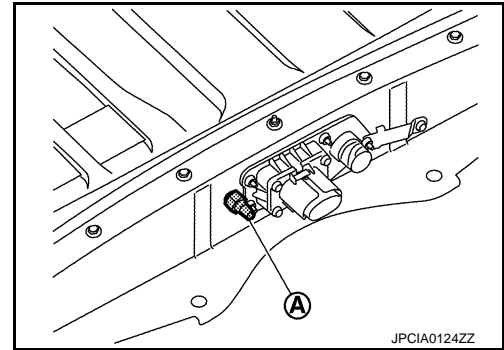

2. Install gauge [SST: KV99111400] (A).

WARNING:



To prevent electric shock hazards, be sure to wear protective gear.



CAUTION:

Handle the gauge carefully so that it will not drop.

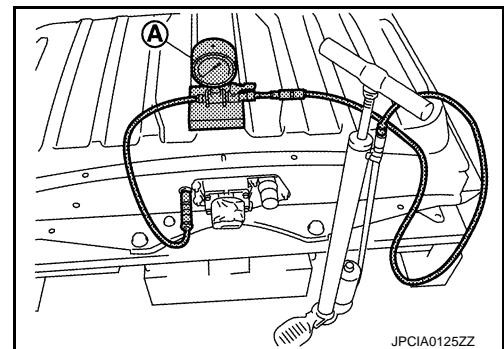

3. Install service plug to seal the battery pack.

DANGER:



To prevent electric shock hazards, be sure to wear protective gear.



4. Use vinyl tape (A) or similar means to seal the breather so that air does not enter it.

- Use the wide vinyl tape which can cover up breather at once.
- Stick it so that tape is not wrinkled.

WARNING:



To prevent electric shock hazards, be sure to wear protective gear.

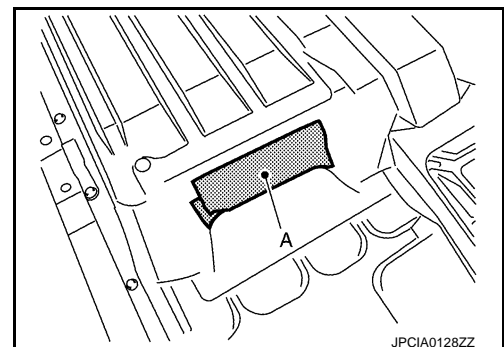

5. Perform air leak inspection by applying 1.6 kPa (0.0163 kg/cm², 0.23 psi) of pressure inside the battery pack for approximately 1 minute.

A
B
EVB
D
E
F
G
H
I
J
K
L
M
N
O
P

LI-ION BATTERY

< UNIT DISASSEMBLY AND ASSEMBLY >

[TYPE 1]

CAUTION:

- When applying pressure, operate the air pump slowly.
- Do not apply any pressure exceeding 2.0 kPa (0.0204 kg/cm², 0.29 psi).

Repair limit : 1.4 kPa (0.0143 kg/cm², 0.20 psi)

6. If the pressure drops below the limit value, use soapy water and check for leakage points.

WARNING:



To prevent electric shock hazards, be sure to wear protective gear.



CAUTION:

Never allow soapy water to contact the service plug and each connector terminals.

Electric Equipotential Test

After installing the battery pack, measure the resistance between the ground bolt mating surface (A) and the high voltage harness connector flange (B).

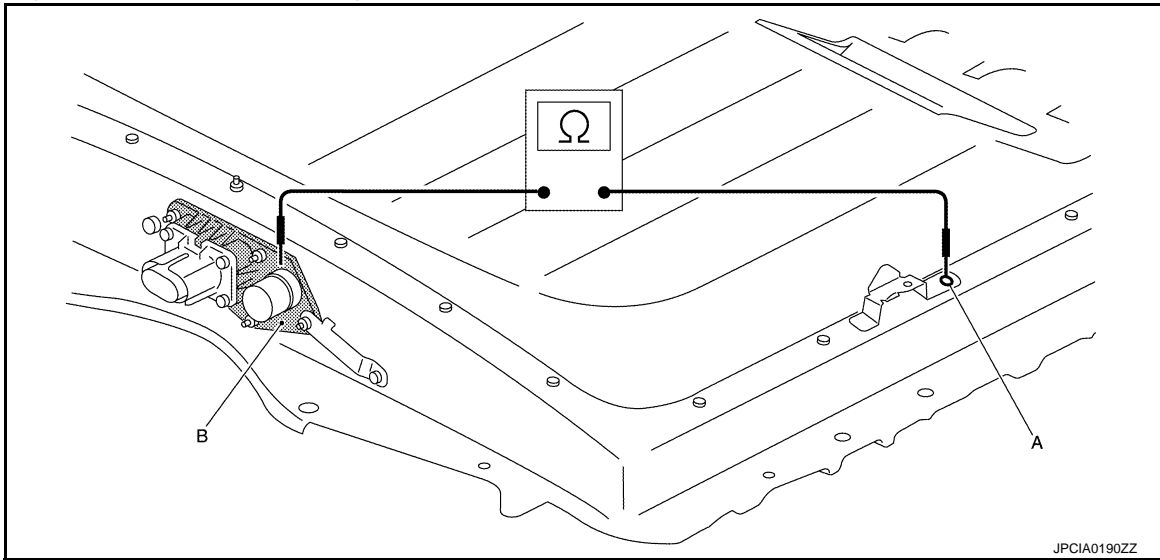

WARNING:



To prevent electric shock hazards, be sure to wear protective gear.



Standard : Less than 0.1 Ω

If the result deviates from the standard value, check the following items and repair malfunctioning parts

- Connection condition of ground bolts
- Rust on the mounting surface of ground bolts
- Paint, oil, and dust on the mounting surface of ground bolts

SERVICE DATA AND SPECIFICATIONS (SDS)

< SERVICE DATA AND SPECIFICATIONS (SDS)

[TYPE 1]

SERVICE DATA AND SPECIFICATIONS (SDS)

SERVICE DATA AND SPECIFICATIONS (SDS)

Li-ion Battery

INFOID:000000007005860

Items	Specification
Type	Li-ion battery
Structure	48 modules (192 cells)
Rated voltage (V)	Approx. 360
Battery capacity (kWh)	Approx. 24
Weight [kg (lb)]	Approx. 300 (661.5)

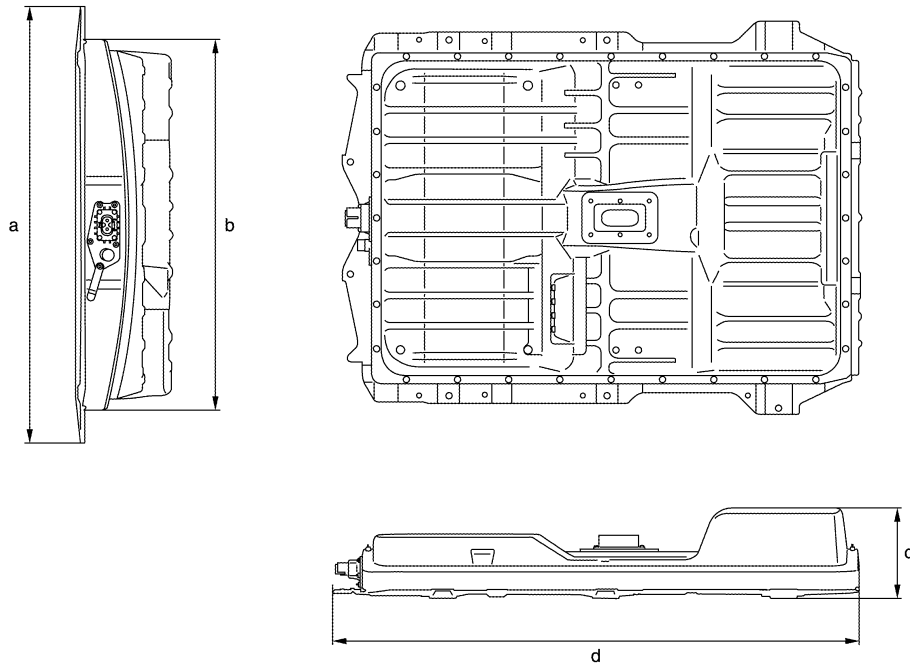

JPCIA0065ZZ

External dimension	Dimension	Unit	Value
"a"	[mm (in)]		1188.0 (46.77)
"b"	[mm (in)]		1007.0 (39.65)
"c"	[mm (in)]		264.9 (10.43)
"d"	[mm (in)]		1570.5 (61.83)

APPLICATION NOTICE

< HOW TO USE THIS MANUAL >

[TYPE 2]

HOW TO USE THIS MANUAL

APPLICATION NOTICE

How to Check Vehicle Type

INFOID:000000007568802

Check the vehicle type to confirm the service information in EVB section.

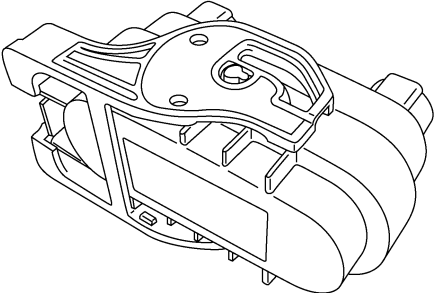
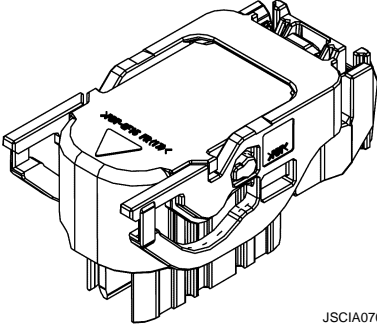
Service information	Vehicle type	Service plug type	
Type 1	Without Li-ion battery heater	Type A	 JSCIA0277ZZ
Type 2	With Li-ion battery heater		
Type 3	Without Li-ion battery heater	Type B	 JSCIA0706ZZ
Type 4	With Li-ion battery heater		

PRECAUTIONS

< PRECAUTION >

[TYPE 2]

PRECAUTION

PRECAUTIONS

Precaution for Technicians Using Medical Electric

INFOID:000000007405296

OPERATION PROHIBITION

WARNING:

- Parts with strong magnet is used in this vehicle.
- Technicians using a medical electric device such as pacemaker must never perform operation on the vehicle, as magnetic field can affect the device function by approaching to such parts.

NORMAL CHARGE PRECAUTION

WARNING:

- If a technician uses a medical electric device such as an implantable cardiac pacemaker or an implantable cardioverter defibrillator, the possible effects on the devices must be checked with the device manufacturer before starting the charge operation.
- As radiated electromagnetic wave generated by on board charger at normal charge operation may effect medical electric devices, a technician using a medical electric device such as implantable cardiac pacemaker or an implantable cardioverter defibrillator must not enter the vehicle compartment (including luggage room) during normal charge operation.

PRECAUTION AT TELEMATICS SYSTEM OPERATION

WARNING:

- If a technician uses implantable cardiac pacemaker or implantable cardioverter defibrillator (ICD), avoid the device implanted part from approaching within approximately 220 mm (8.66 in) from interior/exterior antenna.
- The electromagnetic wave of TCU might affect the function of the implantable cardiac pacemaker or the implantable cardioverter defibrillator (ICD), when using the service, etc.
- If a technician uses other medical electric devices than implantable cardiac pacemaker or implantable cardioverter defibrillator (ICD), the electromagnetic wave of TCU might affect the function of the device. The possible effects on the devices must be checked with the device manufacturer before TCU use.

PRECAUTION AT INTELLIGENT KEY SYSTEM OPERATION

WARNING:

- If a technician uses implantable cardiac pacemaker or implantable cardioverter defibrillator (ICD), avoid the device implanted part from approaching within approximately 220 mm (8.66 in) from interior/exterior antenna.
- The electromagnetic wave of Intelligent Key might affect the function of the implantable cardiac pacemaker or the implantable cardioverter defibrillator (ICD), at door operation, at each request switch operation, or at engine starting.
- If a technician uses other medical electric devices than implantable cardiac pacemaker or implantable cardioverter defibrillator (ICD), the electromagnetic wave of Intelligent Key might affect the function of the device. The possible effects on the devices must be checked with the device manufacturer before Intelligent Key use.

Point to Be Checked Before Starting Maintenance Work

INFOID:000000007321280

The high voltage system may starts automatically. It is required to check that the timer air conditioner and timer charge (during EVSE connection) are not set before starting maintenance work.

NOTE:

If the timer air conditioner or timer charge (during EVSE connection) is set, the high voltage system starts automatically even when the power switch is in OFF state.

Precaution for Supplemental Restraint System (SRS) "AIR BAG" and "SEAT BELT PRE-TENSIONER"

INFOID:000000007321281

The Supplemental Restraint System such as "AIR BAG" and "SEAT BELT PRE-TENSIONER", used along with a front seat belt, helps to reduce the risk or severity of injury to the driver and front passenger for certain types of collision. This system includes seat belt switch inputs and dual stage front air bag modules. The SRS

PRECAUTIONS

[TYPE 2]

< PRECAUTION >

system uses the seat belt switches to determine the front air bag deployment, and may only deploy one front air bag, depending on the severity of a collision and whether the front occupants are belted or unbelted. Information necessary to service the system safely is included in the "SRS AIR BAG" and "SEAT BELT" of this Service Manual.

WARNING:

Always observe the following items for preventing accidental activation.

- To avoid rendering the SRS inoperative, which could increase the risk of personal injury or death in the event of a collision that would result in air bag inflation, all maintenance must be performed by an authorized NISSAN/INFINITI dealer.
- Improper maintenance, including incorrect removal and installation of the SRS, can lead to personal injury caused by unintentional activation of the system. For removal of Spiral Cable and Air Bag Module, see "SRS AIR BAG".
- Never use electrical test equipment on any circuit related to the SRS unless instructed to in this Service Manual. SRS wiring harnesses can be identified by yellow and/or orange harnesses or harness connectors.

PRECAUTIONS WHEN USING POWER TOOLS (AIR OR ELECTRIC) AND HAMMERS

WARNING:

Always observe the following items for preventing accidental activation.

- When working near the Air Bag Diagnosis Sensor Unit or other Air Bag System sensors with the power switch ON, never use air or electric power tools or strike near the sensor(s) with a hammer. Heavy vibration could activate the sensor(s) and deploy the air bag(s), possibly causing serious injury.
- When using air or electric power tools or hammers, always switch the power switch OFF, disconnect the 12V battery, and wait at least 3 minutes before performing any service.

Precaution Necessary for Steering Wheel Rotation after 12V Battery Disconnect

INFOID:000000007405297

For vehicle with steering lock unit, if the 12V battery is disconnected or discharged, the steering wheel will lock and cannot be turned.

If turning the steering wheel is required with the 12V battery disconnected or discharged, follow the operation procedure below before starting the repair operation.

OPERATION PROCEDURE

1. Connect both 12V battery cables.

NOTE:

Supply power using jumper cables if 12V battery is discharged.

2. Turn the power switch to ACC position.
(At this time, the steering lock will be released.)
3. Disconnect both 12V battery cables. The steering lock will remain released with both 12V battery cables disconnected and the steering wheel can be turned.
4. Perform the necessary repair operation.
5. When the repair work is completed, re-connect both 12V battery cables. With the brake pedal released, turn the power switch from ACC position to ON position, then to LOCK position. (The steering wheel will lock when the power switch is turned to LOCK position.)
6. Perform All DTC Reading using CONSULT and delete DTC.

NOTE:

Multiple DTCs are detected when 12V battery cable is disconnected while power switch is in ACC position.

PRECAUTIONS

< PRECAUTION >

[TYPE 2]

Precaution for Procedure without Cowl Top Cover

INFOID:000000007321284

When performing the procedure after removing cowl top cover, cover the lower end of windshield with urethane, etc to prevent damage to windshield.

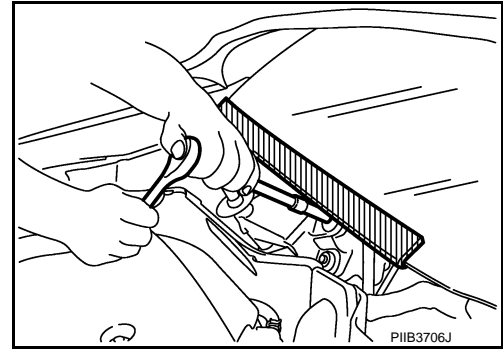

Precautions for Removing Battery Terminal

INFOID:000000007321285

- When removing the 12V battery terminal, turn OFF the power switch and wait at least 5 minutes.

NOTE:

ECU may be active for several minutes after the power switch is turned OFF. If the battery terminal is removed before ECU stops, then a DTC detection error or ECU data corruption may occur.

- Always disconnect the battery terminal within 60 minutes after turning OFF the power switch. Even when the power switch is OFF, the 12V battery automatic charge control may automatically start after a lapse of 60 minutes from power switch OFF.
- Disconnect 12V battery terminal according to the following steps.

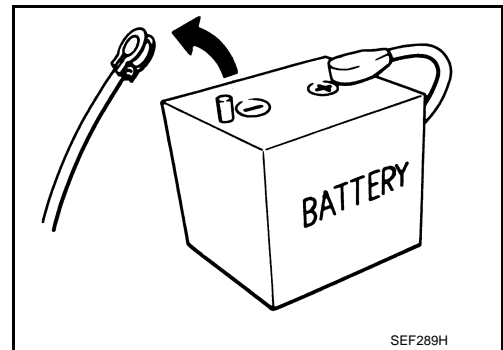

WORK PROCEDURE

1. Check that EVSE is not connected.

NOTE:

If EVSE is connected, the air conditioning system may be automatically activated by the timer A/C function.

2. Turn the power switch OFF → ON → OFF. Get out of the vehicle. Close all doors (including back door).
3. Check that the charge status indicator lamp does not blink and wait for 5 minutes or more.

NOTE:

If the battery is removed within 5 minutes after the power switch is turned OFF, plural DTCs may be detected.

4. Remove 12V battery terminal within 60 minutes after turning the power switch OFF → ON → OFF.

CAUTION:

- After all doors (including back door) are closed, if a door (including back door) is opened before battery terminals are disconnected, start over from Step 1.
- After turning the power switch OFF, if "Remote A/C" is activated by user operation, stop the air conditioner and start over from Step 1.

NOTE:

Once the power switch is turned ON → OFF, the 12V battery automatic charge control does not start for approximately 1 hour.

- For vehicles with the 2-batteries, be sure to connect the main battery and the sub battery before turning ON the power switch.

NOTE:

If the power switch is turned ON with any one of the terminals of main battery and sub battery disconnected, then DTC may be detected.

- After installing the 12V battery, always check "Self Diagnosis Result" of all ECUs and erase DTC.

NOTE:

The removal of 12V battery may cause a DTC detection error.

High Voltage Precautions

INFOID:000000007321286

DANGER:

A
B
EVB
D
E
F
G
H
I
J
K
L
M
N
O
P

PRECAUTIONS

< PRECAUTION >

[TYPE 2]



Since hybrid vehicles and electric vehicles contain a high voltage battery, there is the risk of electric shock, electric leakage, or similar accidents if the high voltage component and vehicle are handled incorrectly. Be sure to follow the correct work procedures when performing inspection and maintenance.

WARNING:

- Be sure to remove the service plug in order to disconnect the high voltage circuits before performing inspection or maintenance of high voltage system harnesses and parts.
- The removed service plug must always be carried in a pocket of the responsible worker or placed in the tool box during the procedure to prevent the plug from being connected by mistake.
- Be sure to wear insulated protective equipment before beginning work on the high voltage system.
- Never allow workers other than the responsible person to touch the vehicle containing high voltage parts. To keep others from touching the high voltage parts, these parts must be covered with an insulating sheet except when using them.

CAUTION:

Never bring the vehicle into the READY status with the service plug removed unless otherwise instructed in the Service Manual. A malfunction may occur if this is not observed.

HIGH VOLTAGE HARNESS AND EQUIPMENT IDENTIFICATION

All the high voltage harnesses and connectors are orange. The Li-ion battery and other high voltage devices include an orange high voltage label. Never touch these harnesses and high voltage parts.

HANDLING OF HIGH VOLTAGE HARNESS AND TERMINALS

Immediately insulate disconnected high voltage connectors and terminals with insulating tape.

REGULATIONS ON WORKERS WITH MEDICAL ELECTRONICS

WARNING:

The vehicle contains parts that contain powerful magnets. If a person who is wearing a heart pacemaker or other medical device is close to these parts, the medical device may be affected by the magnets. Such persons must not perform work on the vehicle.

PROHIBITED ITEMS TO CARRY DURING THE WORK

Hybrid vehicles and electric vehicles contain parts with high voltage and intense magnetic force. Never carry metal products and magnetic recording media (e.g. cash card, prepaid card) to repair/inspect high voltage parts. If this is not observed, the metal products may create a risk of short circuit and the magnetic recording media may lose their magnetic recording.

POSTING A SIGN OF “DANGER! HIGH VOLTAGE AREA. KEEP OUT”

PRECAUTIONS

< PRECAUTION >

[TYPE 2]

Indicate "HIGH VOLTAGE. DO NOT TOUCH" on the vehicle under repair/inspection to call attention to other workers.

A
B
EVB
D
E
F
G
H
I
J
K
L
M
N
O
P

CAUTION:
HIGH VOLTAGE. DO NOT TOUCH DURING OPERATION.

Person in charge: _____

CAUTION:
HIGH VOLTAGE. DO NOT TOUCH DURING OPERATION.

Person in charge: _____

Copy this page and put it after folding on the roof of the vehicle in service.

JSAIA0091GB

PREPARATION

< PREPARATION >

[TYPE 2]

PREPARATION

PREPARATION

Special Service Tools

INFOID:000000007321287

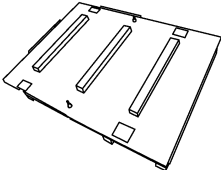
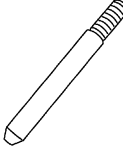
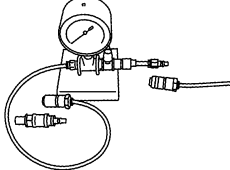
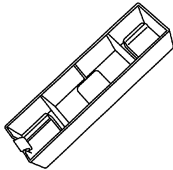
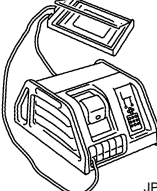
Tool name Tool number (Kent-Moore No.)	Description
<p>Palette — (J-50583)</p>  <p>JPCIA0239ZZ</p>	<p>When removing/installing Li-ion battery.</p>
<p>Battery location guide pin KV99111300 (J-50306)</p>  <p>JPCIA0023ZZ</p>	<p>When installing Li-ion battery. 2 piece/set</p>
<p>Air leak checker KV99111400 (—)</p>  <p>JSCIA0257ZZ</p>	<p>When checking air leaks after disassembling/assembling Li-ion battery.</p>
<p>Module terminal cover KV99111500 (—)</p>  <p>JPCIA0069ZZ</p>	<p>Protect module terminals (for LEAF) 24 pieces/set</p>
<p>Module charge balancer — (J-50346)</p>  <p>JPCIA0070ZZ</p>	<p>Module voltage adjustment</p>



Commercial Service Tools

INFOID:000000007321289

PREPARATION

< PREPARATION >

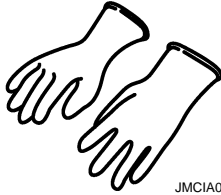
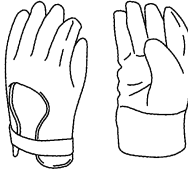
[TYPE 2]

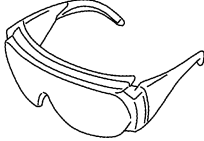
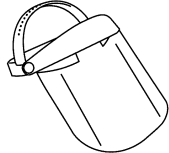
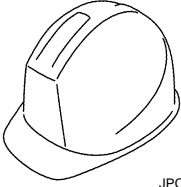
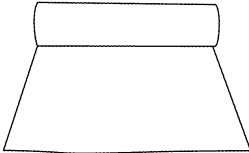
Tool name	Description
<p>Insulated gloves</p>  <p style="text-align: center; font-size: small;">JMCIA0149ZZ</p>	<p>Removing and installing high voltage components [Guaranteed insulation performance for 1000V/ 300A]</p>
<p>Leather gloves</p>  <p style="text-align: center; font-size: small;">JPCIA0066ZZ</p>	<ul style="list-style-type: none"> • Removing and installing high voltage components • Protect insulated gloves [Use leather gloves that can fasten the wrist tight]
<p>Insulated safety shoes</p>  <p style="text-align: center; font-size: small;">JPCIA0011ZZ</p>	<p>Removing and installing high voltage components</p>
<p>Safety glasses</p>  <p style="text-align: center; font-size: small;">JPCIA0012ZZ</p>	<ul style="list-style-type: none"> • Removing and installing high voltage components • To protect eye from the spatter on the work to electric line [ANSI Z87.1]
<p>Face shield</p>  <p style="text-align: center; font-size: small;">JPCIA0167ZZ</p>	<ul style="list-style-type: none"> • Removing and installing high voltage components • To protect face from the spatter on the work to electric line
<p>Insulated helmet</p>  <p style="text-align: center; font-size: small;">JPCIA0013ZZ</p>	<p>Removing and installing high voltage components</p>
<p>Insulated rubber sheet</p>  <p style="text-align: center; font-size: small;">JPCIA0019ZZ</p>	<p>Removing and installing high voltage components</p>

A
B
EVB

D
E
F
G
H

I
J
K
L
M

N
O
P

PREPARATION

< PREPARATION >

[TYPE 2]

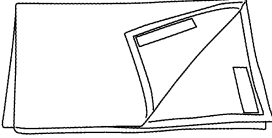
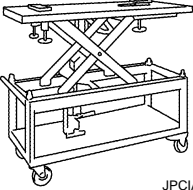
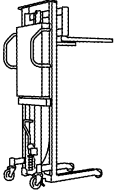
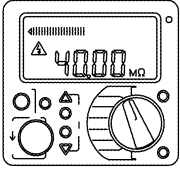
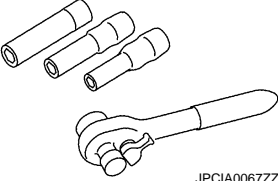
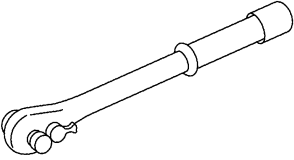
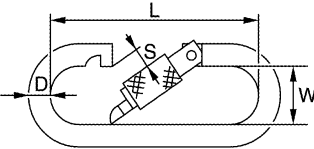
Tool name	Description
<p>Insulated cover sheet</p>  <p style="text-align: right; font-size: small;">JPCIA0018ZZ</p>	<p>Removing and installing high voltage components</p>
<p>Battery lift table</p>  <p style="text-align: right; font-size: small;">JPCIA0024ZZ</p>	<p>Removing and installing Li-ion battery</p>
<p>Stacker</p>  <p style="text-align: right; font-size: small;">JPCIA0015ZZ</p>	<p>Removing and installing Li-ion battery</p>
<p>Insulation resistance tester (Multi tester)</p>  <p style="text-align: right; font-size: small;">JPCIA0014ZZ</p>	<p>Measuring insulation resistance, voltage, and resistance</p>
<p>Insulated hand tools</p>  <p style="text-align: right; font-size: small;">JPCIA0067ZZ</p>	<p>Removing and installing high voltage components</p>
<p>Insulated torque wrench</p>  <p style="text-align: right; font-size: small;">JPCIA0068ZZ</p>	<p>Removing and installing high voltage components</p>
<p>Carabineer [small]</p>  <p style="text-align: right; font-size: small;">JPCIA0016ZZ</p>	<p>Removing and installing battery module stack</p> <p>NOTE:</p> <ul style="list-style-type: none"> • D: 8.0 mm (0.31 in) • L: 74.0 mm (2.91 in) • S: 10.0 mm (0.39 in) • W: 22.5 mm (0.89 in)

PREPARATION

< PREPARATION >

[TYPE 2]

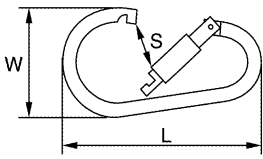
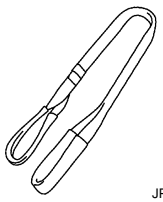
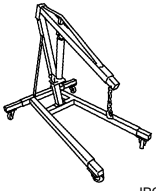
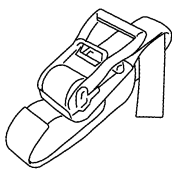
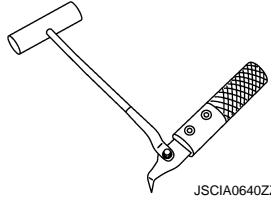
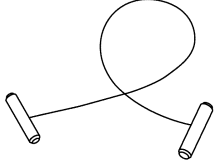
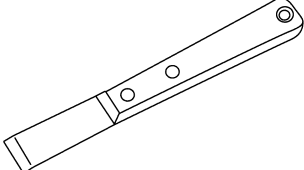
Tool name	Description	
<p>Carabineer [large]</p>  <p>JPCIA0017ZZ</p>	<p>Removing and installing battery module stack</p> <p>NOTE:</p> <ul style="list-style-type: none"> • D: 14.0 mm (0.55 in) • L: 204.0 mm (8.03 in) • S: 47.0 mm (1.85 in) • W: 105.0 mm (4.13 in) 	<p>A</p> <p>B</p> <p>EVB</p>
<p>Belt slinger</p>  <p>JPCIA0021ZZ</p>	<p>Removing and installing battery module stack</p> <p>NOTE:</p> <p>Length: 2.0 m (6.562 ft)</p>	<p>D</p> <p>E</p>
<p>Mobile floor crane</p>  <p>JPCIA0020ZZ</p>	<p>Removing and installing battery module stack</p>	<p>F</p> <p>G</p> <p>H</p>
<p>Lashing belt</p>  <p>JPCIA0022ZZ</p>	<p>Removing and installing battery rear module stack</p>	<p>I</p> <p>J</p>
<p>Windshield cutter [Gasket cutter]</p>  <p>JSCIA0640ZZ</p>	<p>Removing battery pack upper case (Cut the adhesive)</p>	<p>K</p> <p>L</p>
<p>Piano wire with handles</p>  <p>JSCIA0641ZZ</p>	<p>Installing battery pack upper case (Cut the adhesive)</p> <p>NOTE:</p> <p>Wire size: ϕ 0.5 mm (0.02 in)</p>	<p>M</p> <p>N</p> <p>O</p>
<p>Scraper</p>  <p>JSCIA0643ZZ</p>	<p>Installing battery pack upper case (Smooth the adhesive)</p>	<p>P</p>

PREPARATION

< PREPARATION >

[TYPE 2]

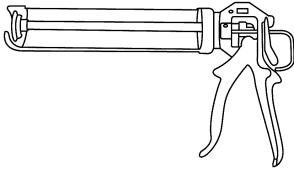
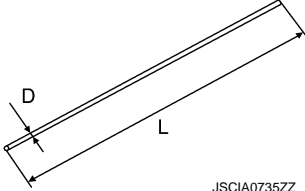
Tool name	Description
<p data-bbox="159 289 505 342">Tube presser [Gasket material applicator]</p>  <p data-bbox="789 415 873 432">JSCIA0639ZZ</p>	<p data-bbox="967 289 1308 342">Installing battery pack upper case (Apply the adhesive)</p>
<p data-bbox="159 556 256 579">Metal bar</p>  <p data-bbox="789 667 873 684">JSCIA0735ZZ</p>	<p data-bbox="967 514 1299 537">Assembling battery module stack</p> <p data-bbox="967 541 1039 564">NOTE:</p> <ul data-bbox="967 569 1182 621" style="list-style-type: none"><li data-bbox="967 569 1182 592">• D: ϕ 7 mm (0.28 in)<li data-bbox="967 596 1136 621">• L: 1 m (3.28 ft)

COMPONENT PARTS

< SYSTEM DESCRIPTION >

[TYPE 2]

SYSTEM DESCRIPTION

COMPONENT PARTS

Component Parts Location

INFOID:000000007592225

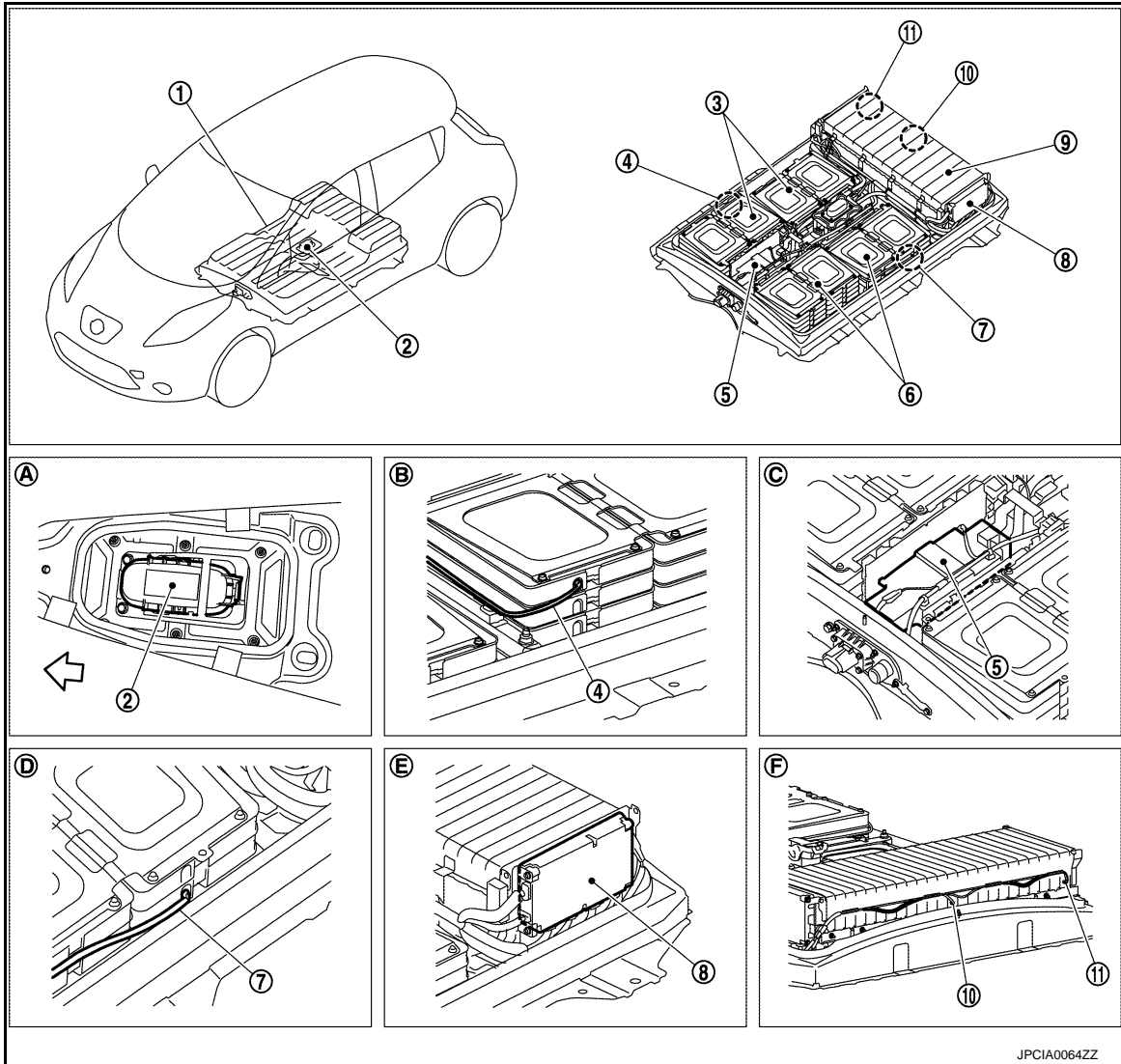

- A. Center of rear seat legroom
 - B. Center of battery pack right side
 - C. Center of battery pack front side
 - D. Center of battery pack left side
 - E. Back of battery pack left side
 - F. Back of battery pack
- ↶ : Vehicle front

No.	Component	Function
1.	Li-ion battery	EVB-239, "Li-ion Battery"
2.	Service plug	EVB-243, "Service Plug"
3.	Front module stack RH	EVB-240, "Module"
4.	Battery temperature sensor (Front RH)	EVB-242, "Battery Temperature Sensor"
5.	Battery junction box	EVB-242, "Battery Junction Box"
6.	Front module stack LH	EVB-240, "Module"
7.	Battery temperature sensor (Front LH)	EVB-242, "Battery Temperature Sensor"
8.	Li-ion battery controller	EVB-239, "Li-ion Battery Controller"

A
B
EVB
D
E
F
G
H
I
J
K
L
M

N
O
P

COMPONENT PARTS

< SYSTEM DESCRIPTION >

[TYPE 2]

No.	Component	Function
9.	Rear module stack	EVB-240, "Module"
10.	Battery temperature sensor (Rear center)	EVB-242, "Battery Temperature Sensor"
11.	Battery temperature sensor (Rear RH)	EVB-242, "Battery Temperature Sensor"

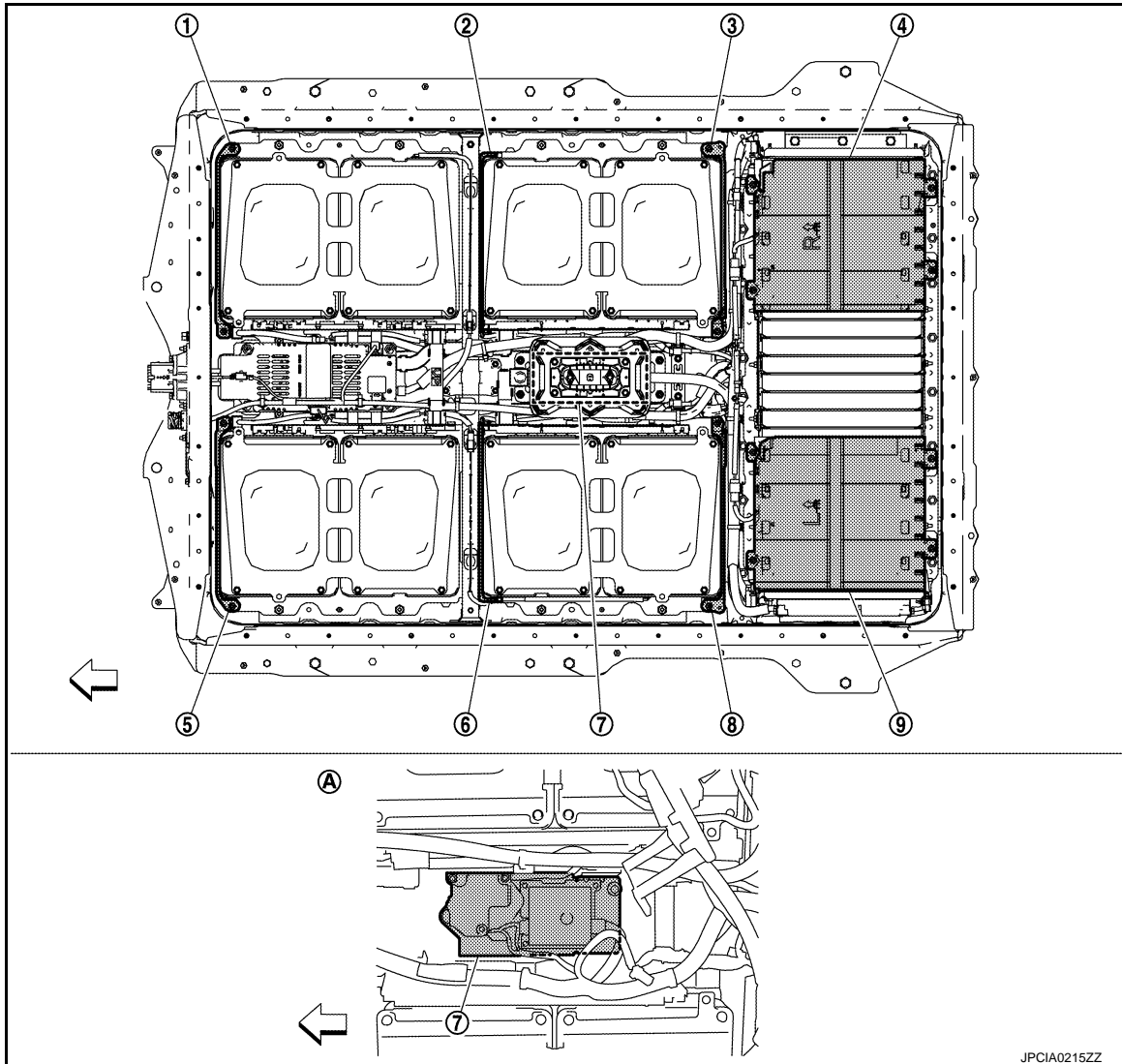

A. Under the service plug

↶ : Vehicle front

No.	Component	Function
1.	Li-ion battery heater RH 1	EVB-241, "Li-ion Battery Heater"
2.	Li-ion battery heater RH 2	EVB-241, "Li-ion Battery Heater"
3.	Li-ion battery heater RH 3	EVB-241, "Li-ion Battery Heater"
4.	Li-ion battery heater RR 2	EVB-241, "Li-ion Battery Heater"
5.	Li-ion battery heater LH 1	EVB-241, "Li-ion Battery Heater"
6.	Li-ion battery heater LH 2	EVB-241, "Li-ion Battery Heater"
7.	Heater relay unit	EVB-241, "Heater Relay Unit"
8.	Li-ion battery heater LH 3	EVB-241, "Li-ion Battery Heater"
9.	Li-ion battery heater RR 2	EVB-241, "Li-ion Battery Heater"

COMPONENT PARTS

< SYSTEM DESCRIPTION >

[TYPE 2]

Li-ion Battery

INFOID:000000007592226

- A Li-ion battery with flat construction is placed under floor.
- The battery pack is equipped with necessary devices, such as Li-ion battery controller, battery junction box, and service plug in addition to a battery storing electricity.

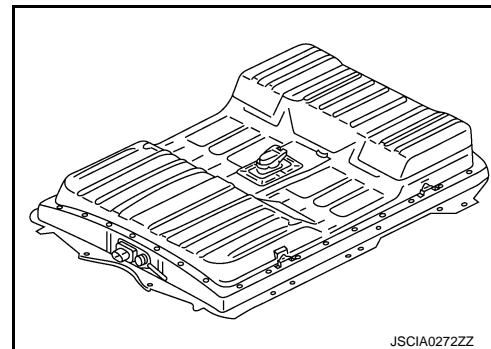

- Four cells are integrated into a single module. The Li-ion battery consists of 48 modules placed in series.

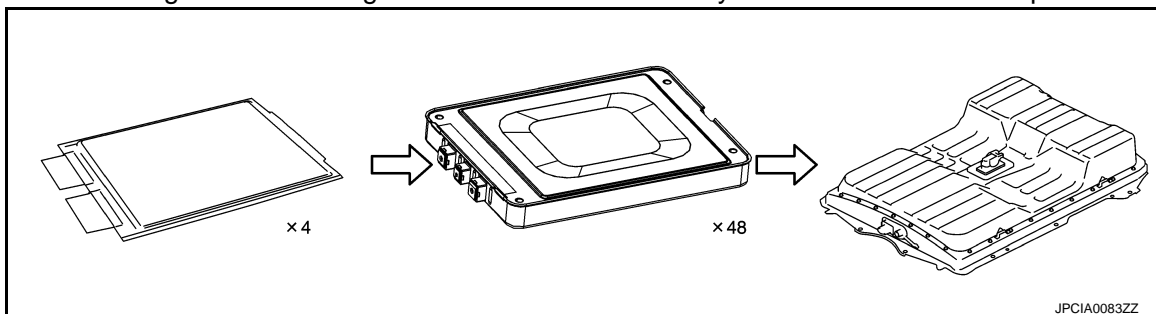

Li-ion Battery Controller

INFOID:000000007592227

- Li-ion battery controller (LBC) is included in the battery pack and installed on the left surface of the rear module stack.

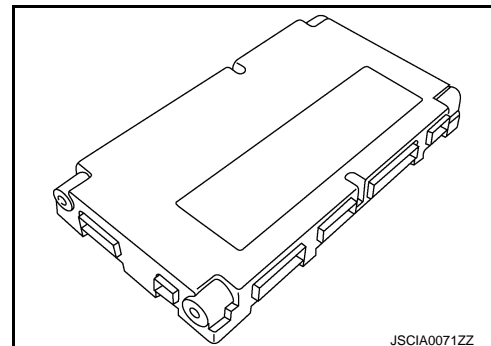

- The LBC is the core of battery control. Li-ion battery controller detects the voltage and current of the assembled battery, the temperature of each module, and the voltage of each cell to judge state of charge. LBC also calculates possible input/output values, meter indication values, and chargeable values, and send this data to VCM (Vehicle control module). VCM controls the vehicle, according to the battery state.

Main Role of Li-ion Battery Controller

1. Li-ion battery state check
 - State of charge
 - Possible output value
 - Possible input value
 - Temperature
2. Optimization of Li-ion battery voltage
3. Prevention of overvoltage and overcurrent
4. Prevention of overheating
5. Detection of decrease in insulation resistance of high-voltage circuit
6. Detection of a fit of high voltage harness connector and service plug

COMPONENT PARTS

< SYSTEM DESCRIPTION >

[TYPE 2]

Module

INFOID:000000007592228

- Four laminated cells are integrated into one module.
- The Li-ion battery is equipped with 48 modules.
- There are two kinds of modules, according to the location of positive and negative terminals.

Positive terminal : Red
 Negative terminal : Black

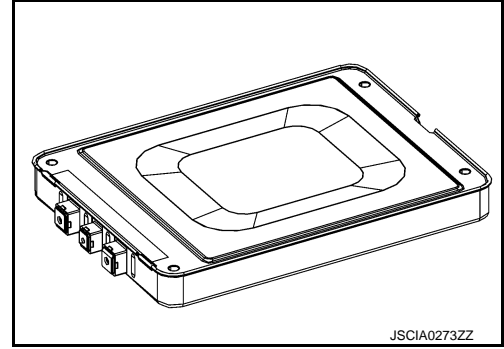

MODULE INTERNAL CIRCUIT

A module consists of two parallel-connected cells placed in series. The Li-ion battery has 48 modules placed in series in total. Ninety-six parallel-connected cell pairs are connected in series.

NOTE:

Cell voltage displayed on the data monitor of CONSULT means the potential difference between the upstream and the downstream of the parallel circuit.

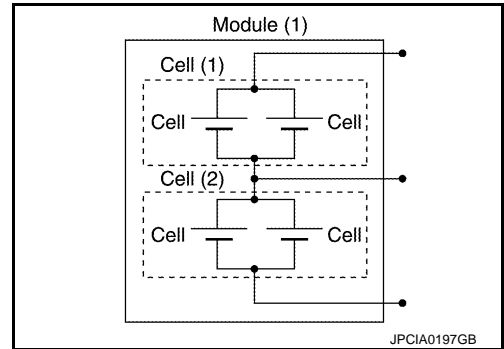

MODULE LAYOUT

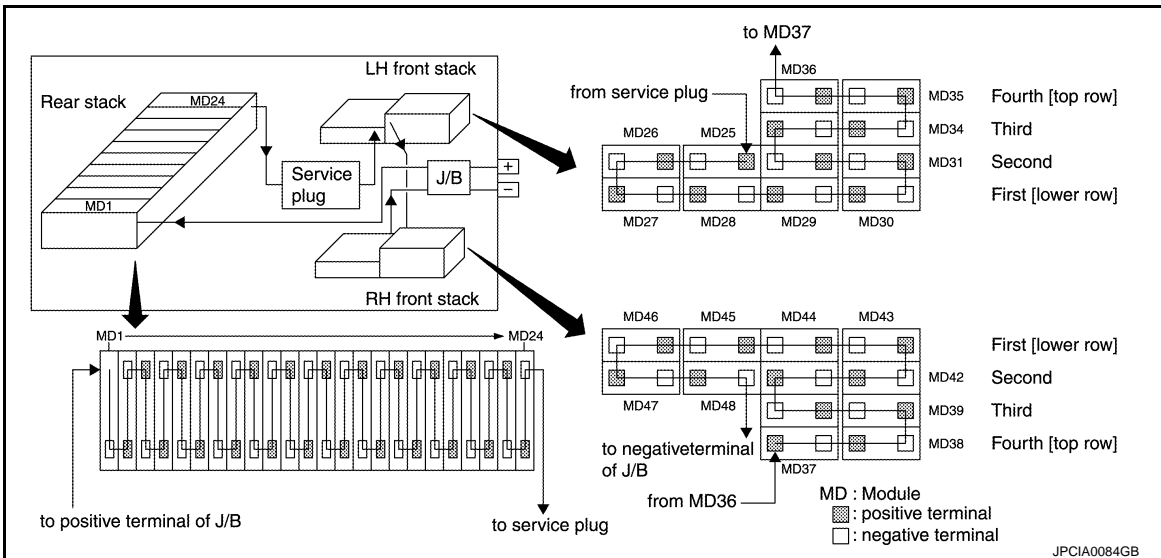

NOTE:

The highest potential is module (MD) 1 and the lowest is module (MD) 48.

CELL

COMPONENT PARTS

< SYSTEM DESCRIPTION >

[TYPE 2]

These are thin laminated cells with excellent cooling performance.

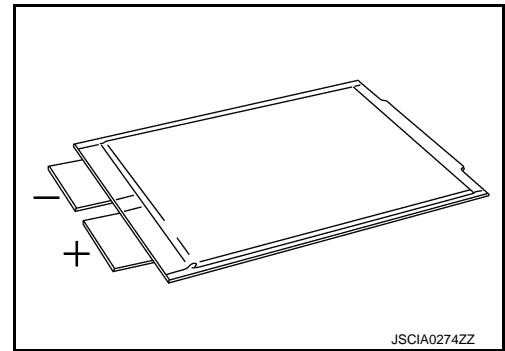

The Features of Laminated Cell

- Large surface area with excellent cooling performance reduces heat load to the battery and improves battery life.
- Light and thin structure increases flexibility in layout.

Heater Relay Unit

INFOID:000000007374102

- The heater relay unit is installed in the battery pack (under the service plug).
- When receiving a relay control signal from LBC (Li-ion battery controller), the heater relay unit turns ON the built-in relay and supplies high-voltage power to each Li-ion battery heater.

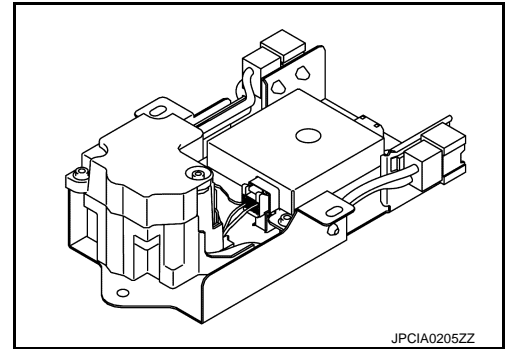

Li-ion Battery Heater

INFOID:000000007374103

- Li-ion battery heater is installed in the battery pack.
- High voltage power is supplied from the heater relay unit.
- Each Li-ion battery heater is connected in parallel.

FRONT LI-ION BATTERY HEATER

- Three front Li-ion battery heaters are installed to each front module stack.

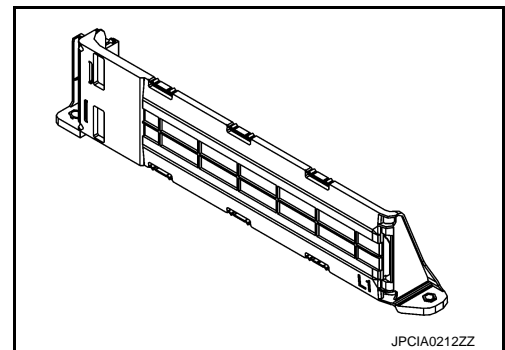

REAR LI-ION BATTERY HEATER

A
B
EVB
D
E
F
G
H
I
J
K
L
M
N
O
P

COMPONENT PARTS

[TYPE 2]

< SYSTEM DESCRIPTION >

- Two rear Li-ion battery heaters are installed to the rear module stack.

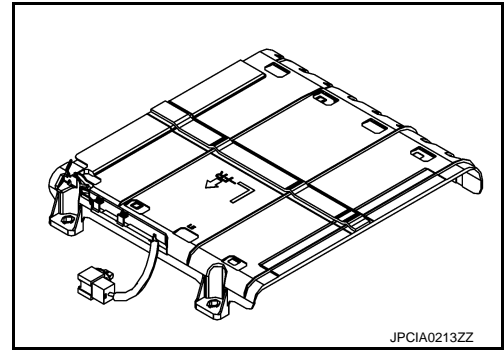

INFOID:000000007592229

Battery Temperature Sensor

- Four battery temperature sensors mounted in the battery pack measure the temperature.
- Right and left front module stacks have one battery temperature sensor, respectively, and the rear module stack has two.

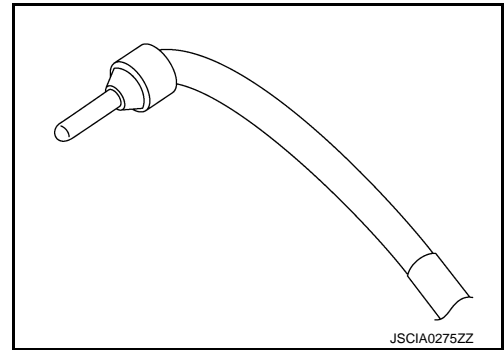

- The sensor uses a thermistor with a resistance value that varies according to changes in temperature. The electrical resistance of the thermistor decreases as the temperature increases.

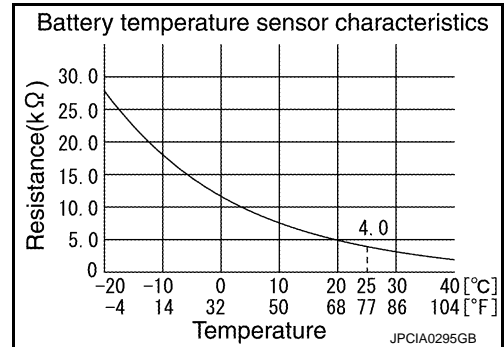

INFOID:000000007592230

Battery Junction Box

- The battery junction box is installed to the front side in the battery pack.
- The battery junction box includes:
 - System main relay to provide/interrupt DC current sent from Li-ion battery.
 - Pre-charge relay to protect the high voltage circuit from a high current immediately after power switch ON.
 - Current sensor to calculate battery capacity.
- Installed to both positive side and negative side, the system main relay provides DC current to each high voltage part. In addition, the system main relay provides DC current to the Li-ion battery during motor regeneration or charge.
- When an error occurs in the system, the system main relay is turned OFF and the Li-ion battery is interrupted for ensuring safety, based on a command from VCM (Vehicle control module).

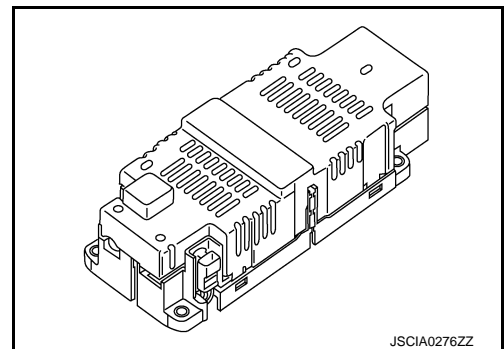

COMPONENT PARTS

< SYSTEM DESCRIPTION >

[TYPE 2]

Service Plug

INFOID:000000007592231

- The service plug is included in the Li-ion battery to securely disconnect the high voltage during high voltage part inspection and maintenance.
- The service plug is installed on the upper surface of the battery pack. The plug can be removed when the leg-room mounted service plug cover is removed.
- Always use insulating protective equipment when removing and installing service plug.

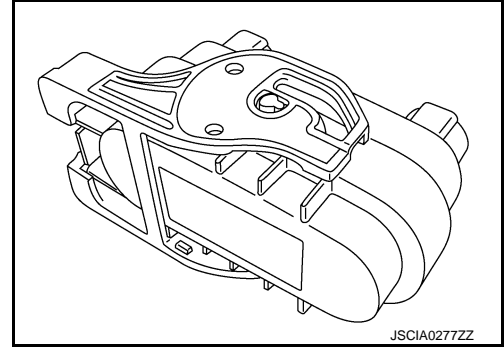

High Voltage Warning Label

INFOID:0000000007592232

High voltage warning label is affixed to each of the following component parts.

After replacing a part, check that the part is affixed with a label. If the label is not affixed, be sure to affix the label in the original position.

Li-ion Battery

- The label (A) is affixed to the rear end of Li-ion battery.

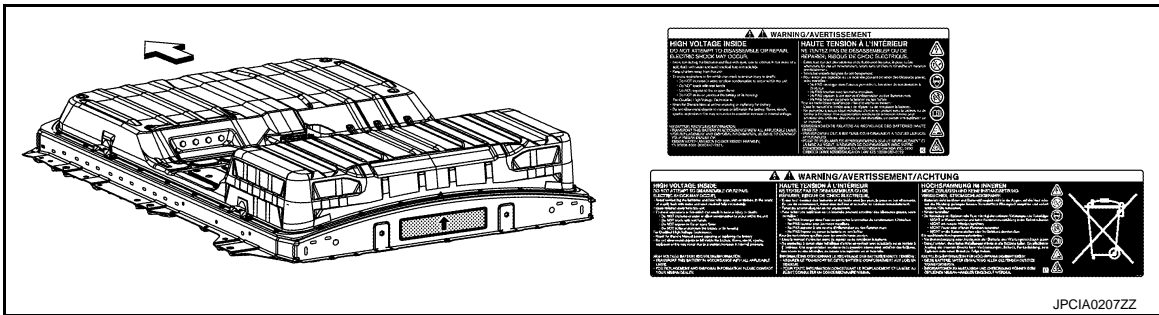

↶ : Vehicle front

← : Direction of the label

- The label (A) is affixed to the body panel near the high voltage harness connector.

↶ : Vehicle front

← : Direction of the label

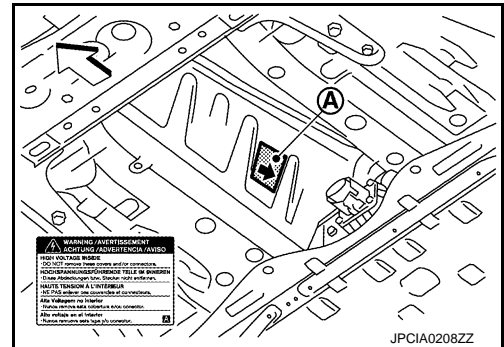

Li-ion Battery Controller

The label is affixed to the main body of controller.

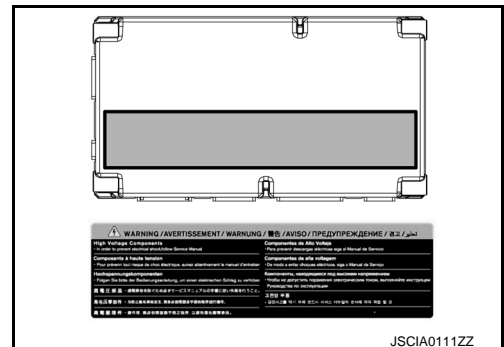

A
B
EVB
D
E
F
G
H
I
J
K
L
M
N
O
P

COMPONENT PARTS

[TYPE 2]

< SYSTEM DESCRIPTION >

Service Plug

The label is affixed to the inspection hole cover (1).

← : Direction of the label

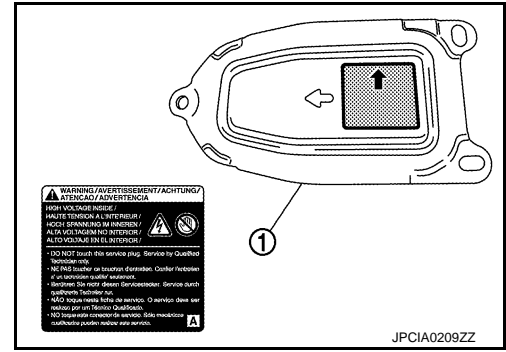

SYSTEM

LI-ION BATTERY CONTROL SYSTEM

LI-ION BATTERY CONTROL SYSTEM : System Description

INFOID:000000007592271

SYSTEM DIAGRAM

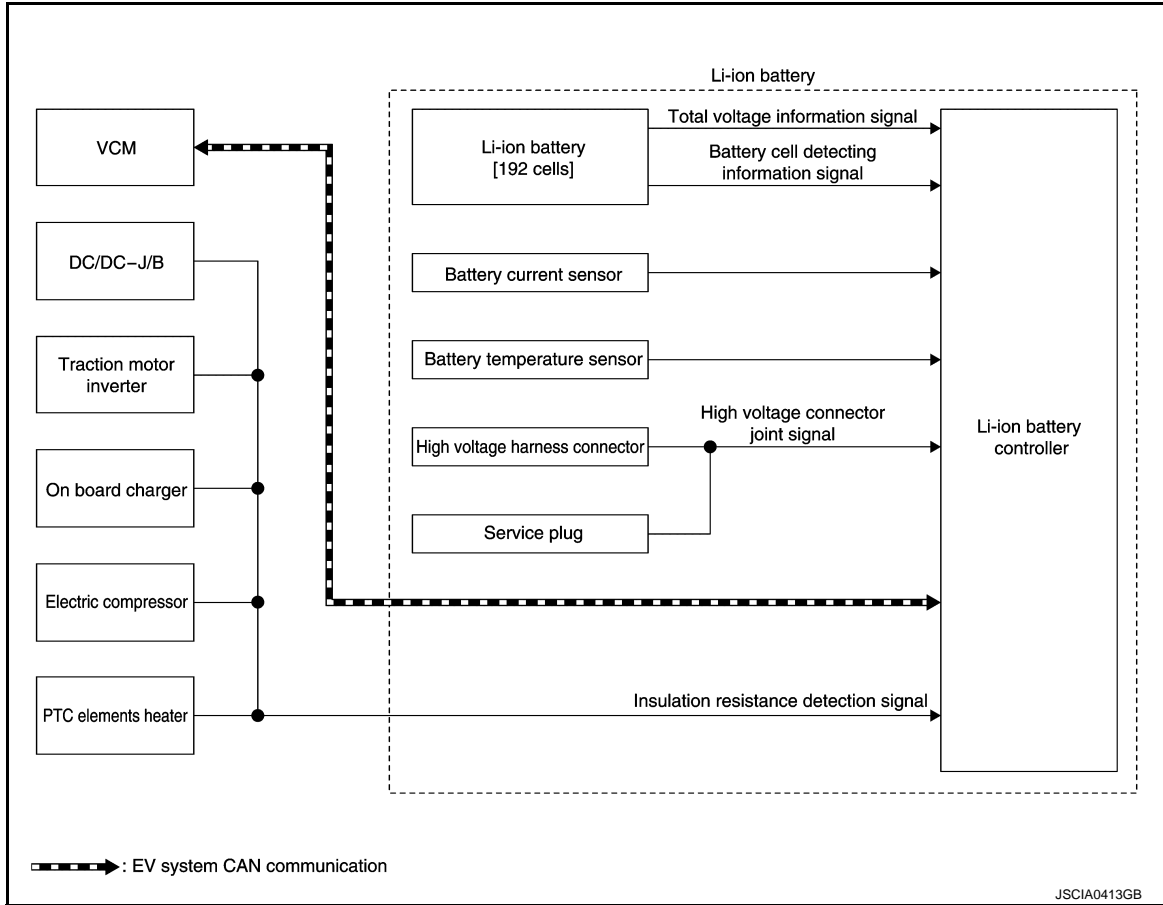

INPUT/OUTPUT SIGNAL ITEM

Input Signal Item

Transmit unit	Signal name	
VCM	EV system CAN	Target Li-ion battery remained energy signal

Output Signal Item

A
B
C
D
E
F
G
H
I
J
K
L
M
N
O
P

EVB

SYSTEM

< SYSTEM DESCRIPTION >

[TYPE 2]

Received unit	Signal name	
VCM	EV system CAN	High voltage discharge permit signal
		Li-ion battery main relay cut request signal
		Li-ion battery connector interlock signal
		Li-ion battery voltage signal
		Li-ion battery current signal
		Li-ion battery chargeable power signal
		Li-ion battery dischargeable power signal
		Li-ion battery chargeable completion signal
		Li-ion battery available charge signal
		Li-ion battery capacity signal
		Li-ion battery gradual capacity loss signal
		Insulation resistance signal

DESCRIPTION

The Li-ion battery controller (LBC) monitors the status of the inside of the Li-ion battery at all times and sends information, such as the charging status of Li-ion battery and possible power, to VCM (vehicle control module) via EV system CAN communication.

The Li-ion battery controller performs control as per the following.

- Monitors the battery state and transfers chargeable/dischargeable power to VCM to prevent an error, such as overvoltage, over discharge or excessive temperature rise in the battery.
- Detects an error (overvoltage, over discharge, overcurrent, or excessive temperature rise) immediately at the time of error occurrence and requests VCM to disconnect the system main relay to interrupt the discharge/charge line.
- Maintains the optimum battery state constantly with a cell capacity adjustment function to prevent a reduction in charging/discharging capacity caused by cell capacity variations.
- Detects the connector fit state with the function to detect the fit of the high voltage harness connector and transfers the detected state to VCM so that the vehicle does not start with an unsteady state.
- Detects the insulation resistance state with the function to detect the insulation resistance between high and low voltage and transfers the detected state to VCM so that the vehicle does not start with an unusual state.
- Estimates a battery charge state and low battery state, based on the data obtained with the battery state detection function, and reflects on the battery capacity meter.

BATTERY PROTECTION

The Li-ion battery has a voltage range capable of charge/discharge. If charged/discharged exceeding the range, excessive low capacity or malfunction may be caused. To prevent this, the Li-ion battery controller detects voltage of each cell and requests the control of charging/discharging energy to VCM so that the cell voltage stays within the voltage range.

Control item	Control	Operating condition
Overvoltage/overcurrent protection	Charging energy control	Gradual control of charging energy as the cell voltage approaches the upper limit of the voltage capable of charging.
	System main relay cut	Cell voltage exceeds the voltage judged as overvoltage and maintains the voltage for more than the specified time.
Over discharge protection	Discharging energy control	Gradual control of discharging energy as the cell voltage approaches the lower limit of the voltage capable of discharging.
	System main relay cut	Cell voltage exceeds the voltage judged as over discharge and maintains the voltage for more than the specified time.
Excessive temperature rise protection	Charging/discharging energy control	Gradual control of charging/discharging energy as Li-ion battery temperature approaches the upper limit of the temperature capable of use.
	System main relay cut	Li-ion battery temperature exceeds the temperature judged as excessive temperature rise and maintains the temperature for more than the specified time.

SYSTEM

< SYSTEM DESCRIPTION >

[TYPE 2]

HOW TO ADJUST CELL CAPACITY

During cell capacity adjustment, the capacity of each cell is estimated based on the no-load voltage when the system starts, and the capacities are adjusted so that they are all at the target level. The voltage of each cell is detected inside the Li-ion battery controller. The bypass switches are then turned ON to discharge the cells that have excess capacity. In this way, capacity adjustment by the Li-ion battery controller allows the capacity of all cells to be fully utilized.

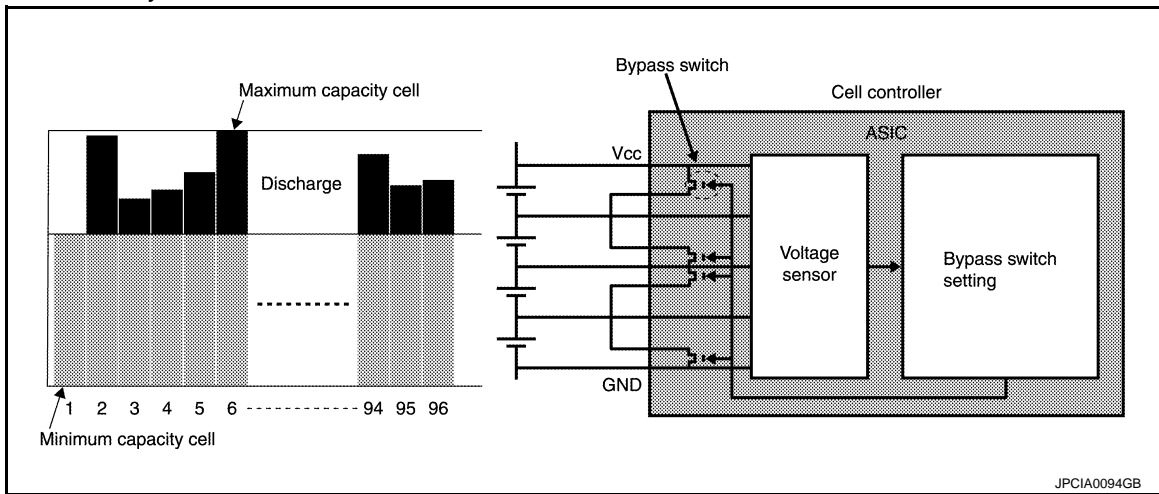

INSULATION RESISTANCE LOSS DETECTION FUNCTION

The insulation resistance detection circuit mounted inside the Li-ion battery controller measures the insulation resistance of each high voltage part and sends the measurement results to VCM via EV system CAN communication.

VCM judges abnormal insulation resistance in each high voltage part, based on the received insulation resistance value.

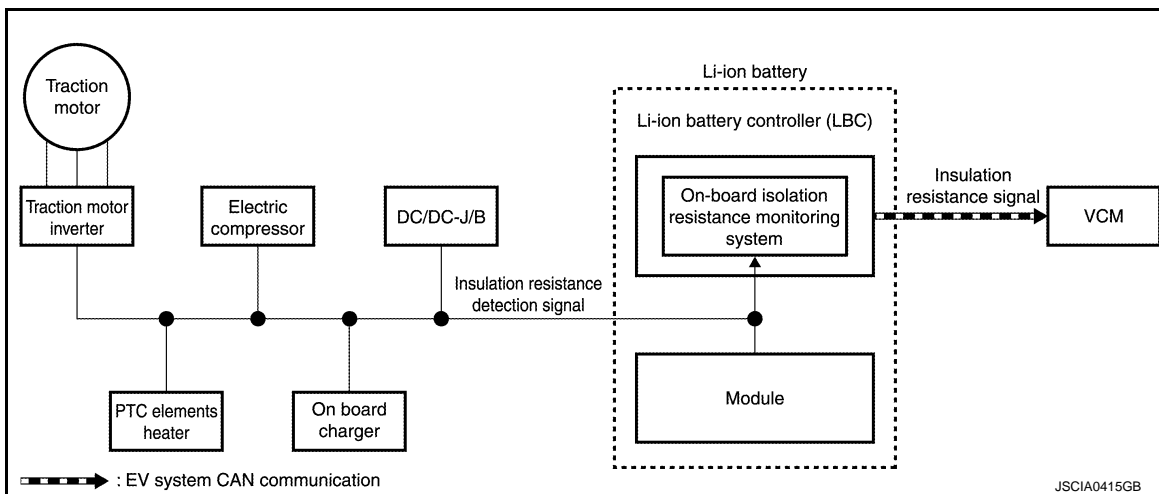

LI-ION BATTERY HEATER CONTROL SYSTEM

LI-ION BATTERY HEATER CONTROL SYSTEM : System Description

INFOID:000000007411148

SYSTEM DIAGRAM

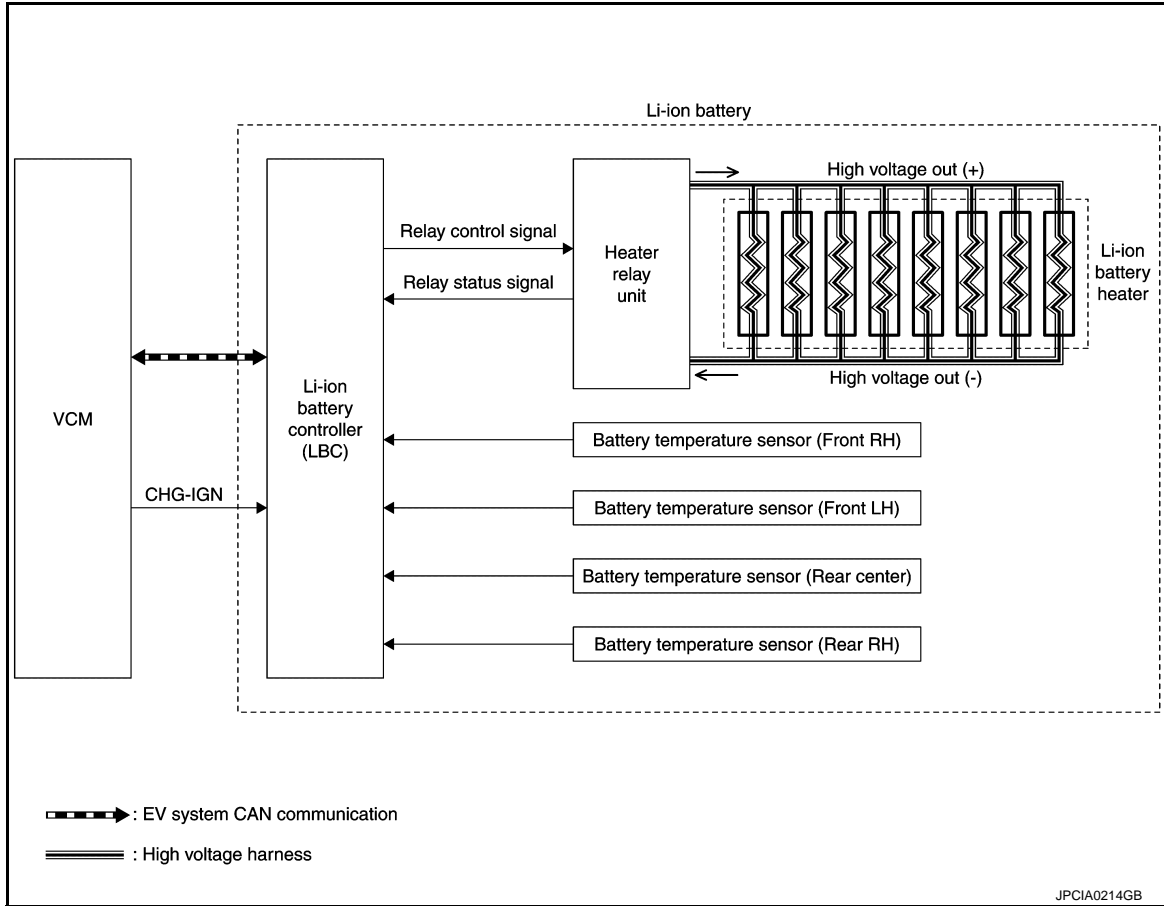

INPUT/OUTPUT SIGNAL ITEM

Input Signal Item

Transmit unit	Signal name	
VCM	EV system CAN communication	Keep SOC request signal

Output Signal Item

Receive unit	Signal name	
VCM	EV system CAN communication	Next start time signal

DESCRIPTION

- When the temperature decreases [approximately -20°C (-4°F)] extremely in the battery pack, the Li-ion battery heater control system automatically activates the Li-ion battery heater to warm the inside of the battery pack for protecting Li-ion battery from freezing and preventing the decline in battery output. In addition, when the temperature in the battery pack is restored [approximately -10°C (14°F)], the Li-ion battery heater stops.
- The Li-ion battery controller (LBC) detects a temperature in the battery pack, according to a signal transmitted from the battery temperature sensor installed to the battery pack and judges the activation of the Li-ion battery heater.
- When the relay built in the heater relay unit turns ON, high voltage power is supplied to each Li-ion battery heater.
- LBC detects the ON/OFF status of the relay built in to heater relay unit.
- Even when the power switch is OFF, VCM periodically activates LBC to protect Li-ion battery from freezing.

SYSTEM

[TYPE 2]

< SYSTEM DESCRIPTION >

- When the temperature in Li-ion battery pack is low with no necessity of Li-ion battery heater operation, LBC estimates the time that Li-ion battery may freeze and transmits a next start time signal to VCM via EV system CAN communication to prepare for starting the Li-ion battery heater next time.
- When receiving a next start time signal via EV system CAN communication, VCM transmits a start request signal (CHG-IGN) to LBC after a lapse of the set time. When receiving a start request signal (CHG-IGN), LBC activates the Li-ion battery heater.

When EVSE is connected (normal charge)

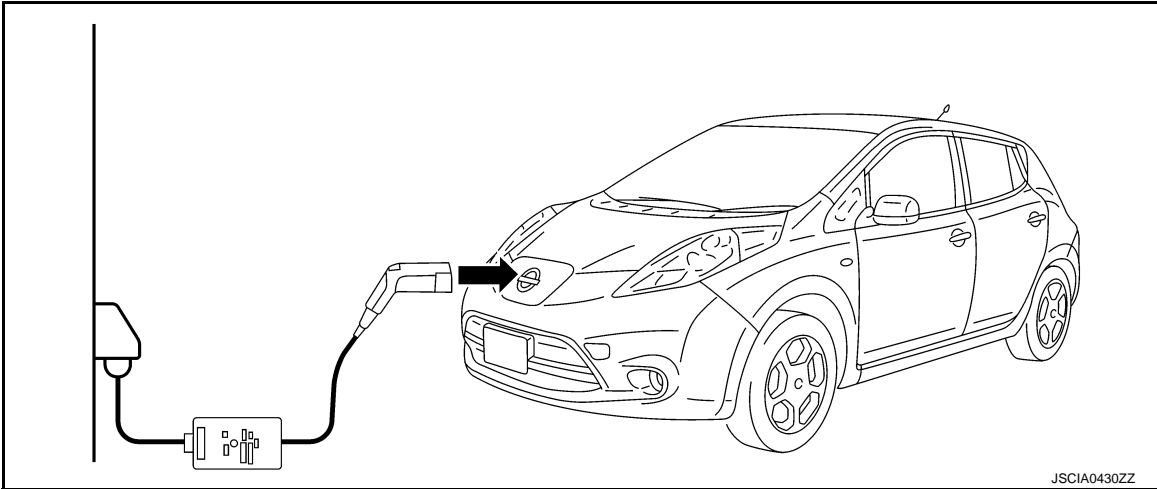

- When the temperature in the battery pack is low outside the timer charge set time, VCM transmits a keep SOC request signal to LBC via EV system CAN communication. In this case Li-ion battery is not charged, and only Li-ion battery heater is activated.
- When timer charge starts at the set time, Li-ion batter is charged, and the Li-ion battery heater is activated.

When EVSE is not connected (normal charge)

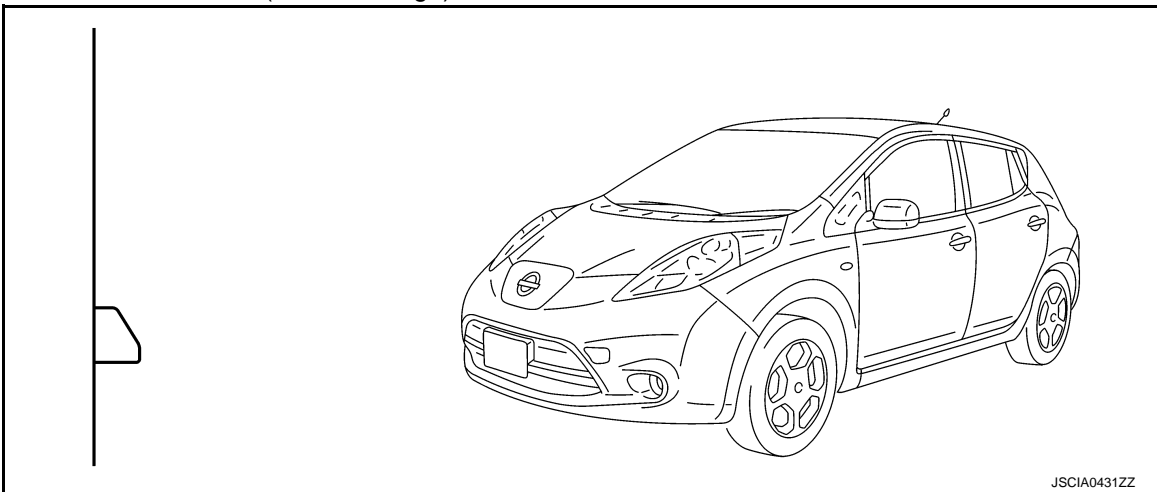

- When the charge level of the Li-ion battery is low during the Li-ion battery heater operation, LBC stops the Li-ion battery heater operation even if the temperature in the battery pack is insufficient.

A
B
EVB
D
E
F
G
H
I
J
K
L
M
N
O
P

SYSTEM

< SYSTEM DESCRIPTION >

[TYPE 2]

Circuit Diagram

INFOID:000000007411149

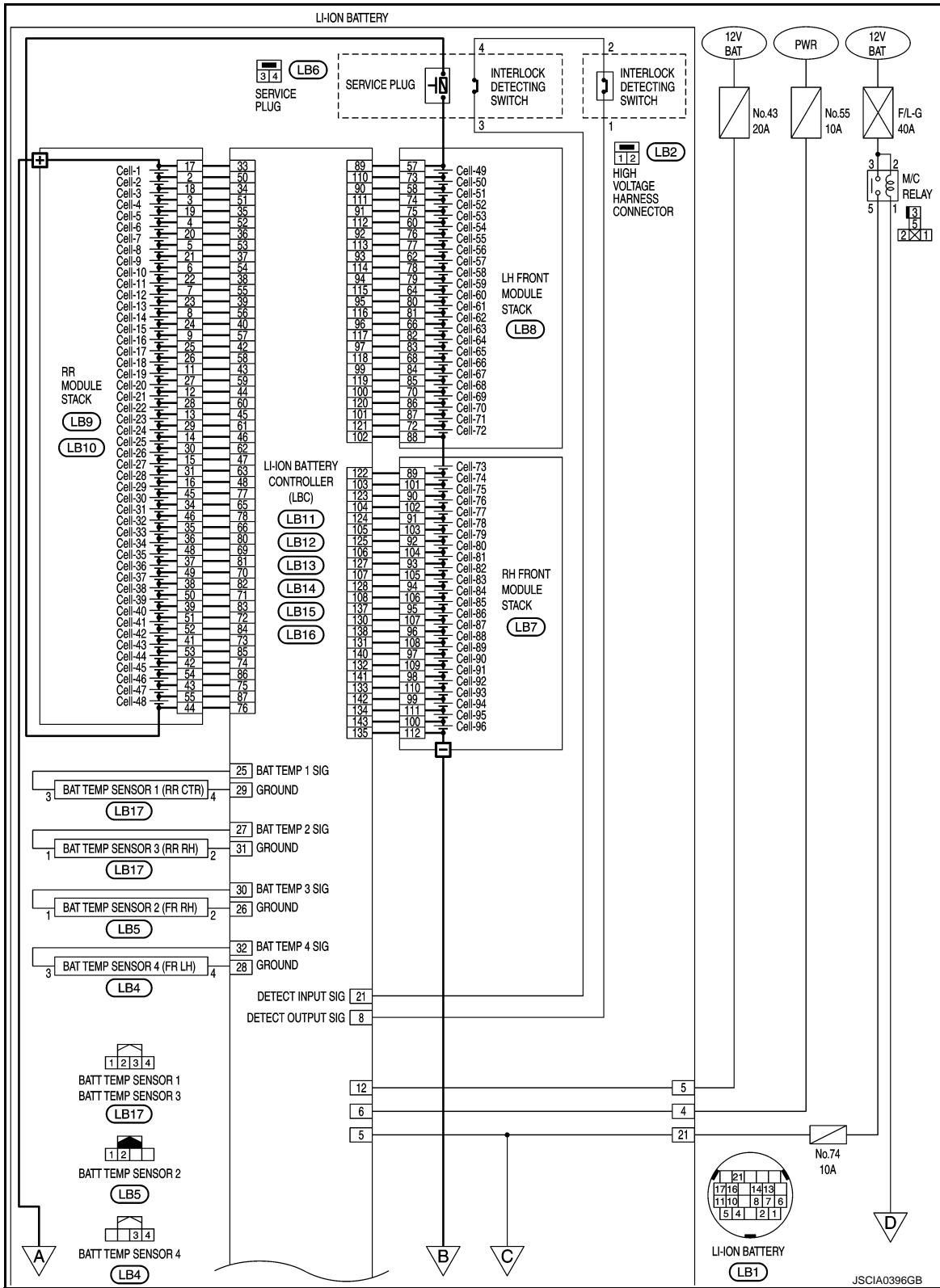

SYSTEM

< SYSTEM DESCRIPTION >

[TYPE 2]

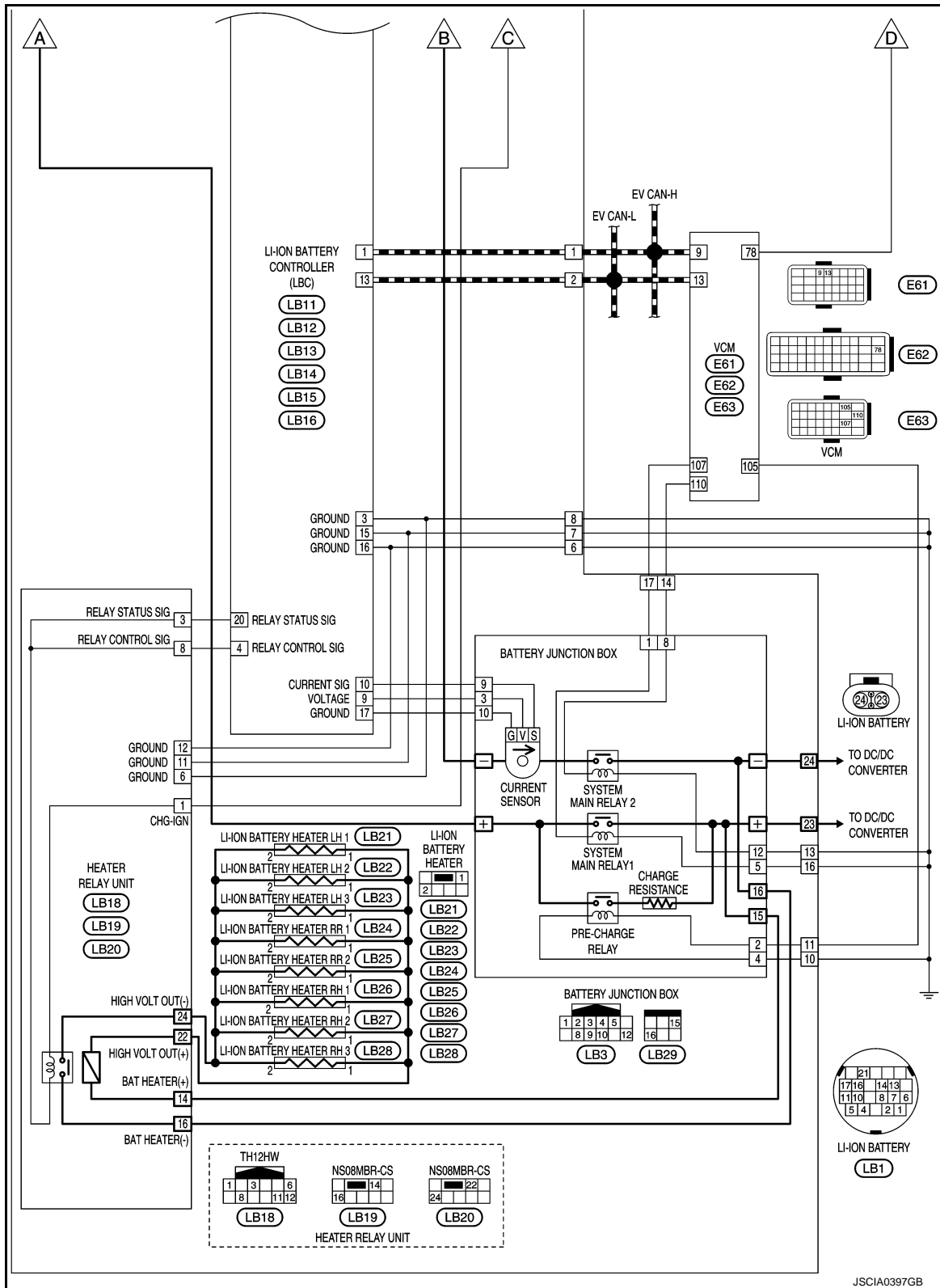

JSCIA0397GB

A
B
C
D
E
F
G
H
I
J
K
L
M
N
O
P

EVB

SYSTEM

< SYSTEM DESCRIPTION >

[TYPE 2]

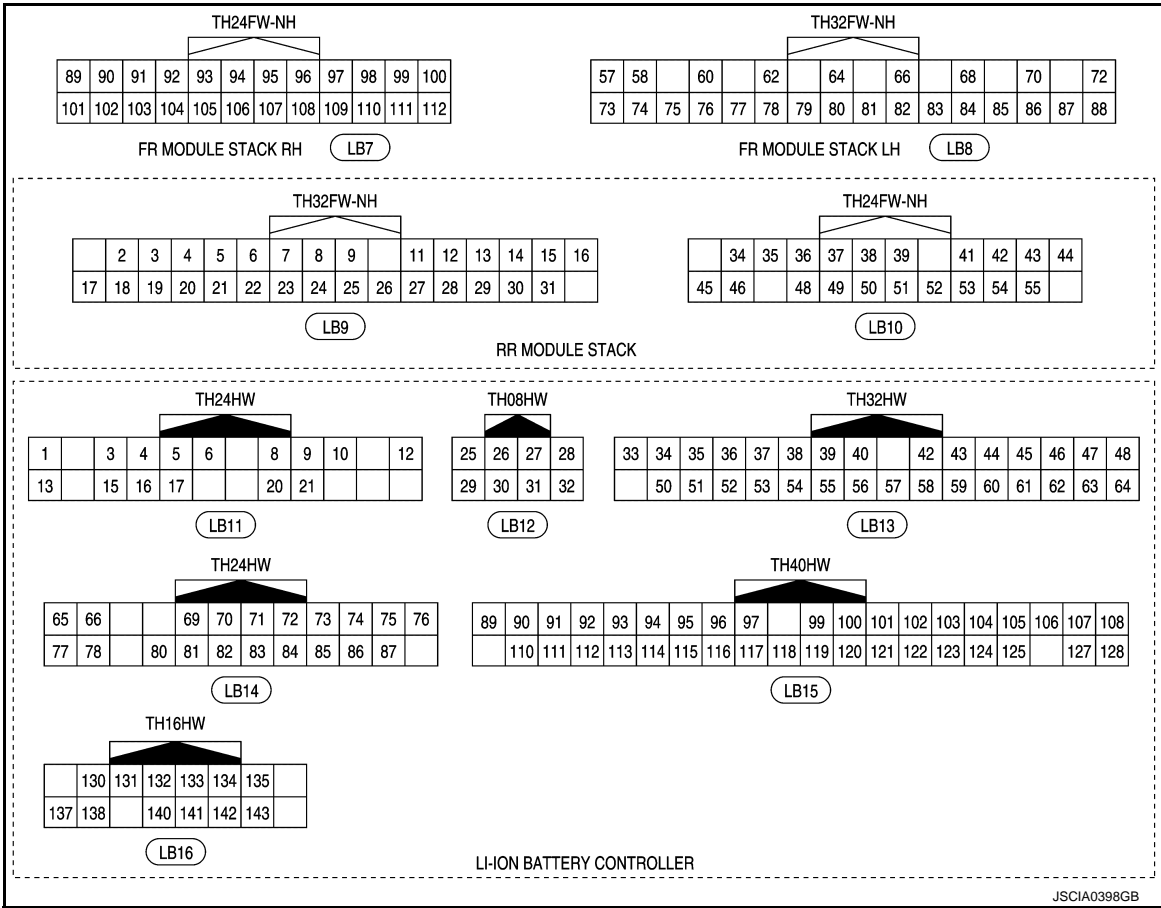

HARNESS LAYOUT

SYSTEM

< SYSTEM DESCRIPTION >

[TYPE 2]

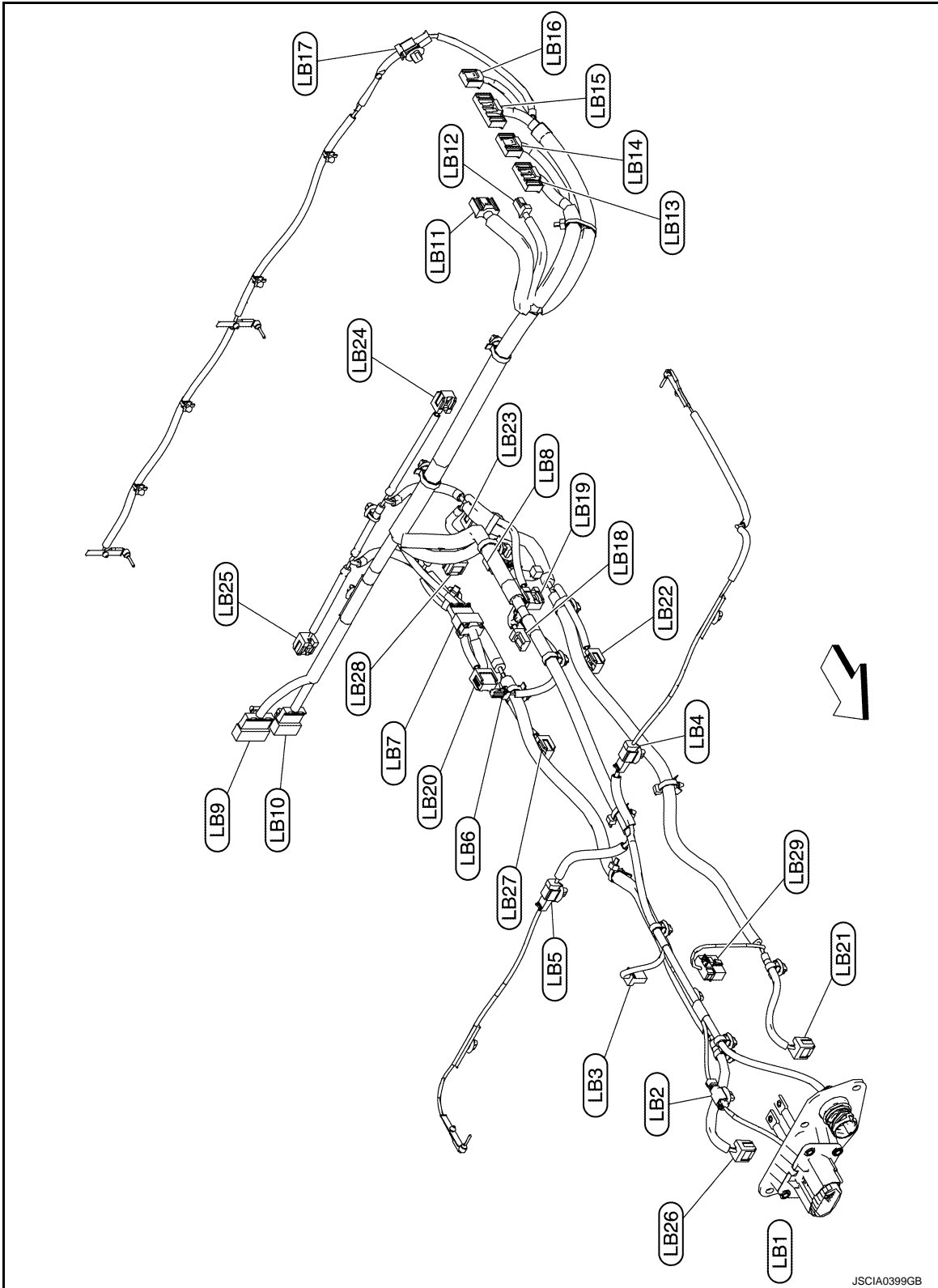

A

B

EVB

D

E

F

G

H

I

J

K

L

M

N

O

P

↶ : Vehicle front

SYSTEM

< SYSTEM DESCRIPTION >

[TYPE 2]

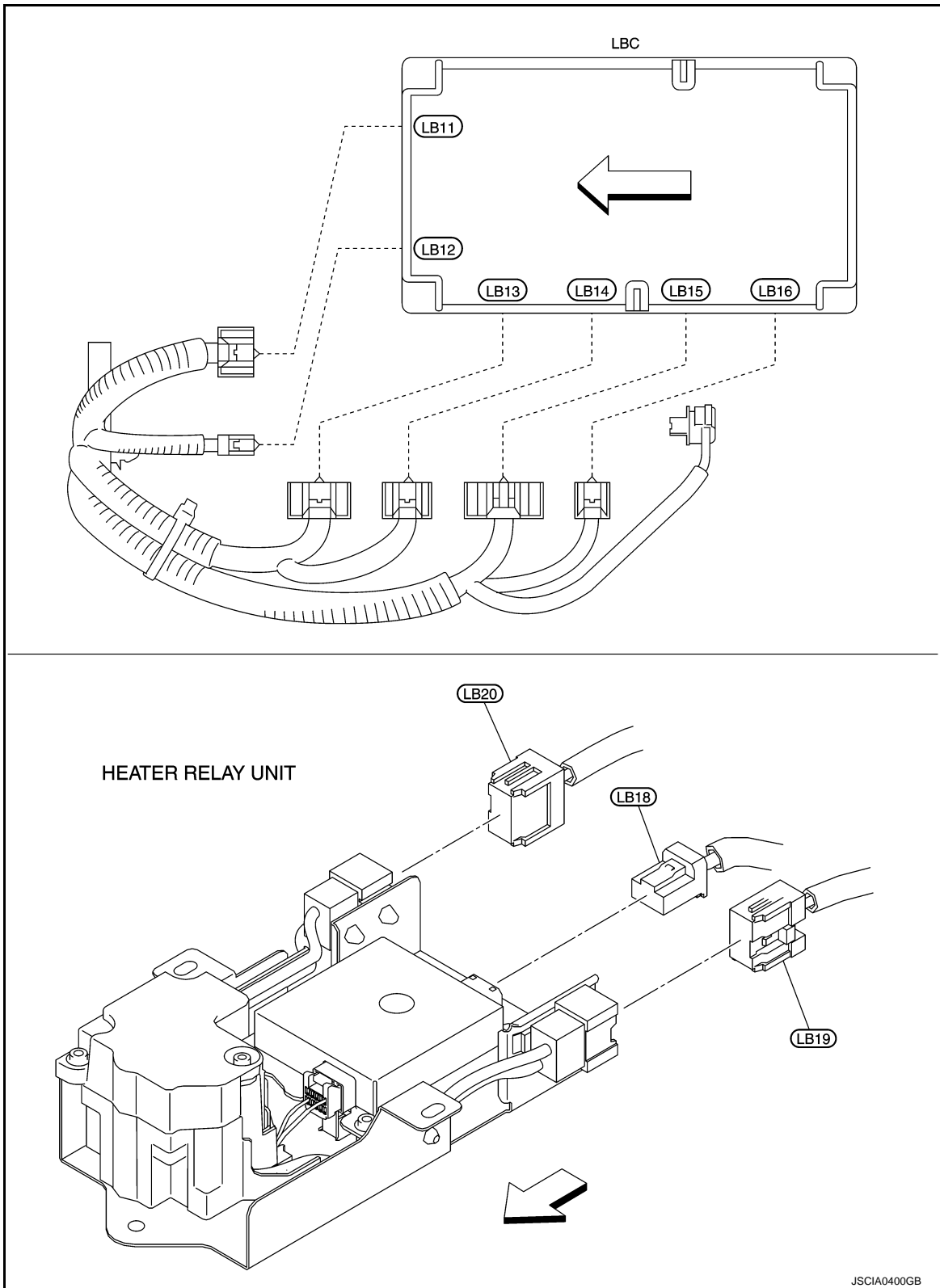

← : Vehicle front

HANDLING PRECAUTION

< SYSTEM DESCRIPTION >

[TYPE 2]

HANDLING PRECAUTION

EV Battery System

INFOID:000000007592274

- To improve the Li-ion battery life, never perform quick charge heavily.
- Use the method of nighttime normal charge or timer-controlled charge.
- Never perform rapid acceleration/deceleration.
- Never place EV battery in an area exposed to direct sunlight or under high temperature conditions.

PRECAUTIONS FOR STORAGE OF THE LI-ION BATTERY

- Apply insulating tape to the service plug and high voltage harness connector, and protect the terminals so that nothing contacts them.
- Store in a well-ventilated location that is not exposed to direct sunlight.
(Storing outdoors or unprotected is prohibited.)
- Never set directly on the floor.
- Lay an anti-static rubber sheet underneath the battery.
- Never invert the battery.
- Never stack batteries.
- Cover with an anti-static cover sheet.
- Put a caution display stating "CAUTION! HIGH VOLTAGE" on the insulated cover sheet.
- Put identification display showing the name of person in charge on the insulated cover sheet.
- Never allow water to contact the battery.
- Prevent other objects from falling onto the battery.

A

B

EVB

D

E

F

G

H

I

J

K

L

M

N

O

P

DIAGNOSIS SYSTEM (LBC)

< SYSTEM DESCRIPTION >

[TYPE 2]

DIAGNOSIS SYSTEM (LBC)

CONSULT Function

INFOID:000000007592275

APPLICATION ITEM

CONSULT performs the following functions via CAN communication with Li-ion battery controller (LBC).

Item	Function
ECU Identification	LBC parts number can be read.
Self-diagnostic Results	Self-diagnostic results and freeze frame data can be read and erased quickly.*
Data Monitor	Input/Output data in LBC can be read.
Active Test	Activates the actuator via LBC.
Work Support	This mode enables a technician to adjust some devices faster and more accurately by following the indications on the CONSULT.
CAN Diagnosis	Displays the CAN diagnosis results.
CAN Diagnosis Support Monitor	Displays the CAN communication status.

*: The following diagnosis information is cleared when the VCM memory is erased.

- Diagnostic trouble codes
- Freeze frame data

ECU IDENTIFICATION

Part number of LBC can be checked.

SELF-DIAGNOSTIC RESULTS

Self Diagnostic Item

Regarding items of DTC, refer to [EVB-268. "DTC Index"](#).

How to Erase DTC

1. Select "HV BAT" with CONSULT.
2. "SELF-DIAGNOSTIC RESULTS".
3. Touch "ERASE". (DTC in LBC will be erased.)

FREEZE FRAME DATA (FFD)

The following vehicle status is recorded when DTC is detected and is displayed on CONSULT.

Monitored item (Unit)	Remarks	
DTC	Displays the DTC which caused FFD memory	
BATT ELECTRIC CURRENT	A	Displays the Li-ion battery current value
12V BATTERY VOLTAGE	mV	Displays 12V battery power supply voltage
IR SEN SHORT PULSE	mV	Displays the maximum to minimum difference of voltage magnitude of the on-board isolation resistance monitoring system
SERVICE PLUG INTERLOCK	OPEN / CLOSE	Displays the OPEN/CLOSE state of the service plug
CELL VOLTAGE 01 - 96	mV	Displays each cell voltage
TOTAL BATTERY VOLTAGE	V	Displays the total voltage of the Li-ion battery
BATTERY TEMPERATURE 1	°C	Displays the temperature calculated with a signal voltage from battery temperature 1 [Rear center]
BATTERY TEMPERATURE 2	°C	Displays the temperature calculated with a signal voltage from battery temperature 2 [Front RH]
BATTERY TEMPERATURE 3	°C	Displays the temperature calculated with a signal voltage from battery temperature 3 [Rear RH]
BATTERY TEMPERATURE 4	°C	Displays the temperature calculated with a signal voltage from battery temperature 4 [Front LH]

DIAGNOSIS SYSTEM (LBC)

< SYSTEM DESCRIPTION >

[TYPE 2]

DATA MONITOR

Monitored item	Unit	Remark
BATT ELECTRIC CURRENT	A	Displays the Li-ion battery current value
12V BATTERY VOLTAGE	mV	Displays 12V battery power supply voltage
IR SEN SHORT PULSE	mV	Displays the maximum to minimum difference of voltage magnitude of the on-board isolation resistance monitoring system
SERVICE PLUG INTERLOCK	OPEN / CLOSE	Displays the OPEN/CLOSE state of the service plug
CELL VOLTAGE 01 - 96	mV	Displays each cell voltage
TOTAL BATTERY VOLTAGE	V	Displays the total voltage of the Li-ion battery
MAXIMUM CELL VOLTAGE	mV	Displays the maximum cell voltage value
MINIMUM CELL VOLTAGE	mV	Displays the minimum cell voltage value
BATTERY TEMPERATURE 1	°C	Displays the temperature calculated with a signal voltage from battery temperature 1 [Rear center]
BATTERY TEMPERATURE 2	°C	Displays the temperature calculated with a signal voltage from battery temperature 2 [Front RH]
BATTERY TEMPERATURE 3	°C	Displays the temperature calculated with a signal voltage from battery temperature 3 [Rear RH]
BATTERY TEMPERATURE 4	°C	Displays the temperature calculated with a signal voltage from battery temperature 4 [Front LH]

ACTIVE TEST

Test item	Operation item	Operation status
HEATER RELAY UNIT	On	Turns ON the relay built into the heater relay unit to supply high voltage power to the Li-ion battery heater.
	Off	Turns OFF the relay built into the heater relay unit to stop high voltage power supply to the Li-ion battery heater.

WORK SUPPORT

Work item	Description	Usage
SAVE BATTERY INFORMATION DATA	Data saved in LBC is stored in CONSULT.	When Li-ion battery and LBC are replaced.
WRITE BATTERY INFORMATION DATA	The CONSULT-stored data can be written in LBC.	When Li-ion battery and LBC are replaced.
CLEAR BATTERY GRADUAL CAPACITY LOSS DATA	Battery capacity data stored in LBC can be erased.	When all modules of Li-ion battery are replaced.
CLEAR BATT CHARGE/DISCHARGE INFORMATION DATA	Battery charge/discharge data stored in LBC can be erased.	When all modules of Li-ion battery are replaced.
CELL VOLTAGE LOSS INSPECTION	This inspection identifies a cell of which cell voltage is on the decrease. If identified, this type of cell may be judged as an abnormal cell, unless it is replaced.	When checking voltage of all cells.

EV BATTERY SYSTEM

< ECU DIAGNOSIS INFORMATION >

[TYPE 2]

ECU DIAGNOSIS INFORMATION

EV BATTERY SYSTEM

Reference Value

INFOID:000000007592276

VALUE ON THE DIAGNOSIS TOOL

NOTE:

Specification data are reference values.

Monitor item	Condition		Values / Status
BATT ELECTRIC CURRENT	READY	Stop the vehicle	Approx. (-10) - (+20) A
12V BATTERY VOLTAGE	READY		Approx. 1,100 - 1,400 mV
IR SEN SHORT PULSE	READY		Approx. 4,100 - 4,300 mV
SERVICE PLUG INTER-LOCK	READY	Connect service plug	REQ
	READY	Disconnect service plug	NOT REQ
CELL VOLTAGE 01	READY	Total battery voltage 317 V	Approx. 3,200 - 3,400 mV
		Total battery voltage 393 V	Approx. 4,000 - 4,200 mV
CELL VOLTAGE 02	READY	Total battery voltage 317 V	Approx. 3,200 - 3,400 mV
		Total battery voltage 393 V	Approx. 4,000 - 4,200 mV
CELL VOLTAGE 03	READY	Total battery voltage 317 V	Approx. 3,200 - 3,400 mV
		Total battery voltage 393 V	Approx. 4,000 - 4,200 mV
CELL VOLTAGE 04	READY	Total battery voltage 317 V	Approx. 3,200 - 3,400 mV
		Total battery voltage 393 V	Approx. 4,000 - 4,200 mV
CELL VOLTAGE 05	READY	Total battery voltage 317 V	Approx. 3,200 - 3,400 mV
		Total battery voltage 393 V	Approx. 4,000 - 4,200 mV
CELL VOLTAGE 06	READY	Total battery voltage 317 V	Approx. 3,200 - 3,400 mV
		Total battery voltage 393 V	Approx. 4,000 - 4,200 mV
CELL VOLTAGE 07	READY	Total battery voltage 317 V	Approx. 3,200 - 3,400 mV
		Total battery voltage 393 V	Approx. 4,000 - 4,200 mV
CELL VOLTAGE 08	READY	Total battery voltage 317 V	Approx. 3,200 - 3,400 mV
		Total battery voltage 393 V	Approx. 4,000 - 4,200 mV
CELL VOLTAGE 09	READY	Total battery voltage 317 V	Approx. 3,200 - 3,400 mV
		Total battery voltage 393 V	Approx. 4,000 - 4,200 mV
CELL VOLTAGE 10	READY	Total battery voltage 317 V	Approx. 3,200 - 3,400 mV
		Total battery voltage 393 V	Approx. 4,000 - 4,200 mV
CELL VOLTAGE 11	READY	Total battery voltage 317 V	Approx. 3,200 - 3,400 mV
		Total battery voltage 393 V	Approx. 4,000 - 4,200 mV
CELL VOLTAGE 12	READY	Total battery voltage 317 V	Approx. 3,200 - 3,400 mV
		Total battery voltage 393 V	Approx. 4,000 - 4,200 mV
CELL VOLTAGE 13	READY	Total battery voltage 317 V	Approx. 3,200 - 3,400 mV
		Total battery voltage 393 V	Approx. 4,000 - 4,200 mV
CELL VOLTAGE 14	READY	Total battery voltage 317 V	Approx. 3,200 - 3,400 mV
		Total battery voltage 393 V	Approx. 4,000 - 4,200 mV
CELL VOLTAGE 15	READY	Total battery voltage 317 V	Approx. 3,200 - 3,400 mV
		Total battery voltage 393 V	Approx. 4,000 - 4,200 mV

EV BATTERY SYSTEM

< ECU DIAGNOSIS INFORMATION >

[TYPE 2]

Monitor item	Condition		Values / Status
CELL VOLTAGE 16	READY	Total battery voltage 317 V	Approx. 3,200 - 3,400 mV
		Total battery voltage 393 V	Approx. 4,000 - 4,200 mV
CELL VOLTAGE 17	READY	Total battery voltage 317 V	Approx. 3,200 - 3,400 mV
		Total battery voltage 393 V	Approx. 4,000 - 4,200 mV
CELL VOLTAGE 18	READY	Total battery voltage 317 V	Approx. 3,200 - 3,400 mV
		Total battery voltage 393 V	Approx. 4,000 - 4,200 mV
CELL VOLTAGE 19	READY	Total battery voltage 317 V	Approx. 3,200 - 3,400 mV
		Total battery voltage 393 V	Approx. 4,000 - 4,200 mV
CELL VOLTAGE 20	READY	Total battery voltage 317 V	Approx. 3,200 - 3,400 mV
		Total battery voltage 393 V	Approx. 4,000 - 4,200 mV
CELL VOLTAGE 21	READY	Total battery voltage 317 V	Approx. 3,200 - 3,400 mV
		Total battery voltage 393 V	Approx. 4,000 - 4,200 mV
CELL VOLTAGE 22	READY	Total battery voltage 317 V	Approx. 3,200 - 3,400 mV
		Total battery voltage 393 V	Approx. 4,000 - 4,200 mV
CELL VOLTAGE 23	READY	Total battery voltage 317 V	Approx. 3,200 - 3,400 mV
		Total battery voltage 393 V	Approx. 4,000 - 4,200 mV
CELL VOLTAGE 24	READY	Total battery voltage 317 V	Approx. 3,200 - 3,400 mV
		Total battery voltage 393 V	Approx. 4,000 - 4,200 mV
CELL VOLTAGE 25	READY	Total battery voltage 317 V	Approx. 3,200 - 3,400 mV
		Total battery voltage 393 V	Approx. 4,000 - 4,200 mV
CELL VOLTAGE 26	READY	Total battery voltage 317 V	Approx. 3,200 - 3,400 mV
		Total battery voltage 393 V	Approx. 4,000 - 4,200 mV
CELL VOLTAGE 27	READY	Total battery voltage 317 V	Approx. 3,200 - 3,400 mV
		Total battery voltage 393 V	Approx. 4,000 - 4,200 mV
CELL VOLTAGE 28	READY	Total battery voltage 317 V	Approx. 3,200 - 3,400 mV
		Total battery voltage 393 V	Approx. 4,000 - 4,200 mV
CELL VOLTAGE 29	READY	Total battery voltage 317 V	Approx. 3,200 - 3,400 mV
		Total battery voltage 393 V	Approx. 4,000 - 4,200 mV
CELL VOLTAGE 30	READY	Total battery voltage 317 V	Approx. 3,200 - 3,400 mV
		Total battery voltage 393 V	Approx. 4,000 - 4,200 mV
CELL VOLTAGE 31	READY	Total battery voltage 317 V	Approx. 3,200 - 3,400 mV
		Total battery voltage 393 V	Approx. 4,000 - 4,200 mV
CELL VOLTAGE 32	READY	Total battery voltage 317 V	Approx. 3,200 - 3,400 mV
		Total battery voltage 393 V	Approx. 4,000 - 4,200 mV
CELL VOLTAGE 33	READY	Total battery voltage 317 V	Approx. 3,200 - 3,400 mV
		Total battery voltage 393 V	Approx. 4,000 - 4,200 mV
CELL VOLTAGE 34	READY	Total battery voltage 317 V	Approx. 3,200 - 3,400 mV
		Total battery voltage 393 V	Approx. 4,000 - 4,200 mV
CELL VOLTAGE 35	READY	Total battery voltage 317 V	Approx. 3,200 - 3,400 mV
		Total battery voltage 393 V	Approx. 4,000 - 4,200 mV
CELL VOLTAGE 36	READY	Total battery voltage 317 V	Approx. 3,200 - 3,400 mV
		Total battery voltage 393 V	Approx. 4,000 - 4,200 mV
CELL VOLTAGE 37	READY	Total battery voltage 317 V	Approx. 3,200 - 3,400 mV
		Total battery voltage 393 V	Approx. 4,000 - 4,200 mV

A

B

EVB

D

E

F

G

H

I

J

K

L

M

N

O

P

EV BATTERY SYSTEM

< ECU DIAGNOSIS INFORMATION >

[TYPE 2]

Monitor item	Condition	Values / Status	
CELL VOLTAGE 38	READY	Total battery voltage 317 V	Approx. 3,200 - 3,400 mV
		Total battery voltage 393 V	Approx. 4,000 - 4,200 mV
CELL VOLTAGE 39	READY	Total battery voltage 317 V	Approx. 3,200 - 3,400 mV
		Total battery voltage 393 V	Approx. 4,000 - 4,200 mV
CELL VOLTAGE 40	READY	Total battery voltage 317 V	Approx. 3,200 - 3,400 mV
		Total battery voltage 393 V	Approx. 4,000 - 4,200 mV
CELL VOLTAGE 41	READY	Total battery voltage 317 V	Approx. 3,200 - 3,400 mV
		Total battery voltage 393 V	Approx. 4,000 - 4,200 mV
CELL VOLTAGE 42	READY	Total battery voltage 317 V	Approx. 3,200 - 3,400 mV
		Total battery voltage 393 V	Approx. 4,000 - 4,200 mV
CELL VOLTAGE 43	READY	Total battery voltage 317 V	Approx. 3,200 - 3,400 mV
		Total battery voltage 393 V	Approx. 4,000 - 4,200 mV
CELL VOLTAGE 44	READY	Total battery voltage 317 V	Approx. 3,200 - 3,400 mV
		Total battery voltage 393 V	Approx. 4,000 - 4,200 mV
CELL VOLTAGE 45	READY	Total battery voltage 317 V	Approx. 3,200 - 3,400 mV
		Total battery voltage 393 V	Approx. 4,000 - 4,200 mV
CELL VOLTAGE 46	READY	Total battery voltage 317 V	Approx. 3,200 - 3,400 mV
		Total battery voltage 393 V	Approx. 4,000 - 4,200 mV
CELL VOLTAGE 47	READY	Total battery voltage 317 V	Approx. 3,200 - 3,400 mV
		Total battery voltage 393 V	Approx. 4,000 - 4,200 mV
CELL VOLTAGE 48	READY	Total battery voltage 317 V	Approx. 3,200 - 3,400 mV
		Total battery voltage 393 V	Approx. 4,000 - 4,200 mV
CELL VOLTAGE 49	READY	Total battery voltage 317 V	Approx. 3,200 - 3,400 mV
		Total battery voltage 393 V	Approx. 4,000 - 4,200 mV
CELL VOLTAGE 50	READY	Total battery voltage 317 V	Approx. 3,200 - 3,400 mV
		Total battery voltage 393 V	Approx. 4,000 - 4,200 mV
CELL VOLTAGE 51	READY	Total battery voltage 317 V	Approx. 3,200 - 3,400 mV
		Total battery voltage 393 V	Approx. 4,000 - 4,200 mV
CELL VOLTAGE 52	READY	Total battery voltage 317 V	Approx. 3,200 - 3,400 mV
		Total battery voltage 393 V	Approx. 4,000 - 4,200 mV
CELL VOLTAGE 53	READY	Total battery voltage 317 V	Approx. 3,200 - 3,400 mV
		Total battery voltage 393 V	Approx. 4,000 - 4,200 mV
CELL VOLTAGE 54	READY	Total battery voltage 317 V	Approx. 3,200 - 3,400 mV
		Total battery voltage 393 V	Approx. 4,000 - 4,200 mV
CELL VOLTAGE 55	READY	Total battery voltage 317 V	Approx. 3,200 - 3,400 mV
		Total battery voltage 393 V	Approx. 4,000 - 4,200 mV
CELL VOLTAGE 56	READY	Total battery voltage 317 V	Approx. 3,200 - 3,400 mV
		Total battery voltage 393 V	Approx. 4,000 - 4,200 mV
CELL VOLTAGE 57	READY	Total battery voltage 317 V	Approx. 3,200 - 3,400 mV
		Total battery voltage 393 V	Approx. 4,000 - 4,200 mV
CELL VOLTAGE 58	READY	Total battery voltage 317 V	Approx. 3,200 - 3,400 mV
		Total battery voltage 393 V	Approx. 4,000 - 4,200 mV
CELL VOLTAGE 59	READY	Total battery voltage 317 V	Approx. 3,200 - 3,400 mV
		Total battery voltage 393 V	Approx. 4,000 - 4,200 mV

EV BATTERY SYSTEM

< ECU DIAGNOSIS INFORMATION >

[TYPE 2]

Monitor item	Condition		Values / Status
CELL VOLTAGE 60	READY	Total battery voltage 317 V	Approx. 3,200 - 3,400 mV
		Total battery voltage 393 V	Approx. 4,000 - 4,200 mV
CELL VOLTAGE 61	READY	Total battery voltage 317 V	Approx. 3,200 - 3,400 mV
		Total battery voltage 393 V	Approx. 4,000 - 4,200 mV
CELL VOLTAGE 62	READY	Total battery voltage 317 V	Approx. 3,200 - 3,400 mV
		Total battery voltage 393 V	Approx. 4,000 - 4,200 mV
CELL VOLTAGE 63	READY	Total battery voltage 317 V	Approx. 3,200 - 3,400 mV
		Total battery voltage 393 V	Approx. 4,000 - 4,200 mV
CELL VOLTAGE 64	READY	Total battery voltage 317 V	Approx. 3,200 - 3,400 mV
		Total battery voltage 393 V	Approx. 4,000 - 4,200 mV
CELL VOLTAGE 65	READY	Total battery voltage 317 V	Approx. 3,200 - 3,400 mV
		Total battery voltage 393 V	Approx. 4,000 - 4,200 mV
CELL VOLTAGE 66	READY	Total battery voltage 317 V	Approx. 3,200 - 3,400 mV
		Total battery voltage 393 V	Approx. 4,000 - 4,200 mV
CELL VOLTAGE 67	READY	Total battery voltage 317 V	Approx. 3,200 - 3,400 mV
		Total battery voltage 393 V	Approx. 4,000 - 4,200 mV
CELL VOLTAGE 68	READY	Total battery voltage 317 V	Approx. 3,200 - 3,400 mV
		Total battery voltage 393 V	Approx. 4,000 - 4,200 mV
CELL VOLTAGE 69	READY	Total battery voltage 317 V	Approx. 3,200 - 3,400 mV
		Total battery voltage 393 V	Approx. 4,000 - 4,200 mV
CELL VOLTAGE 70	READY	Total battery voltage 317 V	Approx. 3,200 - 3,400 mV
		Total battery voltage 393 V	Approx. 4,000 - 4,200 mV
CELL VOLTAGE 71	READY	Total battery voltage 317 V	Approx. 3,200 - 3,400 mV
		Total battery voltage 393 V	Approx. 4,000 - 4,200 mV
CELL VOLTAGE 72	READY	Total battery voltage 317 V	Approx. 3,200 - 3,400 mV
		Total battery voltage 393 V	Approx. 4,000 - 4,200 mV
CELL VOLTAGE 73	READY	Total battery voltage 317 V	Approx. 3,200 - 3,400 mV
		Total battery voltage 393 V	Approx. 4,000 - 4,200 mV
CELL VOLTAGE 74	READY	Total battery voltage 317 V	Approx. 3,200 - 3,400 mV
		Total battery voltage 393 V	Approx. 4,000 - 4,200 mV
CELL VOLTAGE 75	READY	Total battery voltage 317 V	Approx. 3,200 - 3,400 mV
		Total battery voltage 393 V	Approx. 4,000 - 4,200 mV
CELL VOLTAGE 76	READY	Total battery voltage 317 V	Approx. 3,200 - 3,400 mV
		Total battery voltage 393 V	Approx. 4,000 - 4,200 mV
CELL VOLTAGE 77	READY	Total battery voltage 317 V	Approx. 3,200 - 3,400 mV
		Total battery voltage 393 V	Approx. 4,000 - 4,200 mV
CELL VOLTAGE 78	READY	Total battery voltage 317 V	Approx. 3,200 - 3,400 mV
		Total battery voltage 393 V	Approx. 4,000 - 4,200 mV
CELL VOLTAGE 79	READY	Total battery voltage 317 V	Approx. 3,200 - 3,400 mV
		Total battery voltage 393 V	Approx. 4,000 - 4,200 mV
CELL VOLTAGE 80	READY	Total battery voltage 317 V	Approx. 3,200 - 3,400 mV
		Total battery voltage 393 V	Approx. 4,000 - 4,200 mV
CELL VOLTAGE 81	READY	Total battery voltage 317 V	Approx. 3,200 - 3,400 mV
		Total battery voltage 393 V	Approx. 4,000 - 4,200 mV

A

B

EVB

D

E

F

G

H

I

J

K

L

M

N

O

P

EV BATTERY SYSTEM

< ECU DIAGNOSIS INFORMATION >

[TYPE 2]

Monitor item	Condition		Values / Status
CELL VOLTAGE 82	READY	Total battery voltage 317 V	Approx. 3,200 - 3,400 mV
		Total battery voltage 393 V	Approx. 4,000 - 4,200 mV
CELL VOLTAGE 83	READY	Total battery voltage 317 V	Approx. 3,200 - 3,400 mV
		Total battery voltage 393 V	Approx. 4,000 - 4,200 mV
CELL VOLTAGE 84	READY	Total battery voltage 317 V	Approx. 3,200 - 3,400 mV
		Total battery voltage 393 V	Approx. 4,000 - 4,200 mV
CELL VOLTAGE 85	READY	Total battery voltage 317 V	Approx. 3,200 - 3,400 mV
		Total battery voltage 393 V	Approx. 4,000 - 4,200 mV
CELL VOLTAGE 86	READY	Total battery voltage 317 V	Approx. 3,200 - 3,400 mV
		Total battery voltage 393 V	Approx. 4,000 - 4,200 mV
CELL VOLTAGE 87	READY	Total battery voltage 317 V	Approx. 3,200 - 3,400 mV
		Total battery voltage 393 V	Approx. 4,000 - 4,200 mV
CELL VOLTAGE 88	READY	Total battery voltage 317 V	Approx. 3,200 - 3,400 mV
		Total battery voltage 393 V	Approx. 4,000 - 4,200 mV
CELL VOLTAGE 89	READY	Total battery voltage 317 V	Approx. 3,200 - 3,400 mV
		Total battery voltage 393 V	Approx. 4,000 - 4,200 mV
CELL VOLTAGE 90	READY	Total battery voltage 317 V	Approx. 3,200 - 3,400 mV
		Total battery voltage 393 V	Approx. 4,000 - 4,200 mV
CELL VOLTAGE 91	READY	Total battery voltage 317 V	Approx. 3,200 - 3,400 mV
		Total battery voltage 393 V	Approx. 4,000 - 4,200 mV
CELL VOLTAGE 92	READY	Total battery voltage 317 V	Approx. 3,200 - 3,400 mV
		Total battery voltage 393 V	Approx. 4,000 - 4,200 mV
CELL VOLTAGE 93	READY	Total battery voltage 317 V	Approx. 3,200 - 3,400 mV
		Total battery voltage 393 V	Approx. 4,000 - 4,200 mV
CELL VOLTAGE 94	READY	Total battery voltage 317 V	Approx. 3,200 - 3,400 mV
		Total battery voltage 393 V	Approx. 4,000 - 4,200 mV
CELL VOLTAGE 95	READY	Total battery voltage 317 V	Approx. 3,200 - 3,400 mV
		Total battery voltage 393 V	Approx. 4,000 - 4,200 mV
CELL VOLTAGE 96	READY	Total battery voltage 317 V	Approx. 3,200 - 3,400 mV
		Total battery voltage 393 V	Approx. 4,000 - 4,200 mV
TOTAL BATTERY VOLTAGE	READY		Approx. 240 - 420 V
MAXIMUM CELL VOLTAGE	READY	Total battery voltage 317 V	Approx. 3,300 - 3,500 mV
		Total battery voltage 393 V	Approx. 4,000 - 4,200 mV
MINIMUM CELL VOLTAGE	READY	Total battery voltage 317 V	Approx. 3,300 - 3,500 mV
		Total battery voltage 393 V	Approx. 4,000 - 4,200 mV
BATTERY TEMPERATURE 1	READY (Stop the vehicle)	Ambient temperature: 25°C (77°F)	20°C - 30°C (68°F - 86°F) [Equivalent to air temperature around rear module stack]
BATTERY TEMPERATURE 2	READY (Stop the vehicle)	Ambient temperature: 25°C (77°F)	20°C - 30°C (68°F - 86°F) [Equivalent to air temperature around front RH module stack]
BATTERY TEMPERATURE 3	READY (Stop the vehicle)	Ambient temperature: 25°C (77°F)	20°C - 30°C (68°F - 86°F) [Equivalent to air temperature around rear module stack]
BATTERY TEMPERATURE 4	READY (Stop the vehicle)	Ambient temperature: 25°C (77°F)	20°C - 30°C (68°F - 86°F) [Equivalent to air temperature around front LH module stack]

EV BATTERY SYSTEM

< ECU DIAGNOSIS INFORMATION >

[TYPE 2]

Fail-safe

INFOID:000000007605331

When Li-ion Battery Controller (LBC) detects a malfunction of the Li-ion battery, it enters the control mode that protects the battery by stopping or restricting the output/charging from/to the battery. The fail-safe mode differs depending on the contents of the detected malfunction.

FAIL-SAFE PATTERN

- Pattern A: No driving and Charge stop
- Pattern B: Driving output power limit, and Charge stop
- Pattern C: Driving output power limit, and Charge limit
- Pattern D: EV system warning lamp illuminate

FAIL-SAFE LIST

DTC	CONSULT screen items	Pattern			
		A	B	C	D
P0A0D	HV SYSTEM INTERLOCK ERROR				×
P0A1F	BATTERY ENERGY CONTROL MODULE	×	×		×
P3030	CELL CONT LIN		×		
P3031	CELL CONT ASIC1		×		
P3032	CELL CONT ASIC2		×		
P3033	CELL CONT ASIC3		×		
P3034	CELL CONT ASIC4		×		
P3035	CELL CONT ASIC5		×		
P3036	CELL CONT ASIC6		×		
P3037	CELL CONT ASIC7		×		
P3038	CELL CONT ASIC8		×		
P3039	CELL CONT ASIC9		×		
P303A	CELL CONT ASIC10		×		
P303B	CELL CONT ASIC11		×		
P303C	CELL CONT ASIC12		×		
P303D	CELL CONT ASIC13		×		
P303E	CELL CONT ASIC14		×		
P303F	CELL CONT ASIC15		×		
P3040	CELL CONT ASIC16		×		
P3041	CELL CONT ASIC17		×		
P3042	CELL CONT ASIC18		×		
P3043	CELL CONT ASIC19		×		
P3044	CELL CONT ASIC20		×		
P3045	CELL CONT ASIC21		×		
P3046	CELL CONT ASIC22		×		
P3047	CELL CONT ASIC23		×		
P3048	CELL CONT ASIC24		×		
P3049	CELL CONT ASIC1 VOLT		×		
P304A	CELL CONT ASIC2 VOLT		×		
P304B	CELL CONT ASIC3 VOLT		×		
P304C	CELL CONT ASIC4 VOLT		×		
P304D	CELL CONT ASIC5 VOLT		×		
P304E	CELL CONT ASIC6 VOLT		×		

EV BATTERY SYSTEM

< ECU DIAGNOSIS INFORMATION >

[TYPE 2]

DTC	CONSULT screen items	Pattern			
		A	B	C	D
P304F	CELL CONT ASIC7 VOLT		×		
P3050	CELL CONT ASIC8 VOLT		×		
P3051	CELL CONT ASIC9 VOLT		×		
P3052	CELL CONT ASIC10 VOLT		×		
P3053	CELL CONT ASIC11 VOLT		×		
P3054	CELL CONT ASIC12 VOLT		×		
P3055	CELL CONT ASIC13 VOLT		×		
P3056	CELL CONT ASIC14 VOLT		×		
P3057	CELL CONT ASIC15 VOLT		×		
P3058	CELL CONT ASIC16 VOLT		×		
P3059	CELL CONT ASIC17 VOLT		×		
P305A	CELL CONT ASIC18 VOLT		×		
P305B	CELL CONT ASIC19 VOLT		×		
P305C	CELL CONT ASIC20 VOLT		×		
P305D	CELL CONT ASIC21 VOLT		×		
P305E	CELL CONT ASIC22 VOLT		×		
P305F	CELL CONT ASIC23 VOLT		×		
P3060	CELL CONT ASIC24 VOLT		×		
P3061	CELL BATTERY VOLT				×
P3062	BYPASS SW				×
P308B	CELL CONT ASIC1 OPEN		×		
P308C	CELL CONT ASIC2 OPEN		×		
P308D	CELL CONT ASIC3 OPEN		×		
P308E	CELL CONT ASIC4 OPEN		×		
P308F	CELL CONT ASIC5 OPEN		×		
P3090	CELL CONT ASIC6 OPEN		×		
P3091	CELL CONT ASIC7 OPEN		×		
P3092	CELL CONT ASIC8 OPEN		×		
P3093	CELL CONT ASIC9 OPEN		×		
P3094	CELL CONT ASIC10 OPEN		×		
P3095	CELL CONT ASIC11 OPEN		×		
P3096	CELL CONT ASIC12 OPEN		×		
P3097	CELL CONT ASIC13 OPEN		×		
P3098	CELL CONT ASIC14 OPEN		×		
P3099	CELL CONT ASIC15 OPEN		×		
P309A	CELL CONT ASIC16 OPEN		×		
P309B	CELL CONT ASIC17 OPEN		×		
P309C	CELL CONT ASIC18 OPEN		×		
P309D	CELL CONT ASIC19 OPEN		×		
P309E	CELL CONT ASIC20 OPEN		×		
P309F	CELL CONT ASIC21 OPEN		×		
P30A0	CELL CONT ASIC22 OPEN		×		
P30A1	CELL CONT ASIC23 OPEN		×		

EV BATTERY SYSTEM

< ECU DIAGNOSIS INFORMATION >

[TYPE 2]

DTC	CONSULT screen items	Pattern				
		A	B	C	D	
P30A2	CELL CONT ASIC24 OPEN		×			A
P30F3	TOTAL VOLT SENSOR			×		B
P30F4	TOTAL VOLT SENSOR			×		
P30F5	TOTAL VOLT SENSOR			×		
P30FC	OVER CURRENT	×				EVB
P30FD	TOTAL VOLTAGE MONITOR SWITCH	No fail-safe				
P30FE	12V BATTERY VOLTAGE				×	D
P318D	COMMUNICATION ERROR				×	
P318E	COMMUNICATION ERROR				×	
P3191	COMMUNICATION ERROR	No fail-safe				E
P3196	COMMUNICATION ERROR	No fail-safe				
P3199	COMMUNICATION ERROR				×	F
P319C	COMMUNICATION ERROR	No fail-safe				
P31A4	CAN ERROR VCM				×	
P31A7	CAN ERROR INV/MC	No fail-safe				G
P3300	TOTAL VOLTAGE OVER	×				
P3302	CELL OVER VOLTAGE MODULE1	×				H
P3303	CELL OVER VOLTAGE MODULE2	×				
P3304	CELL OVER VOLTAGE MODULE3	×				
P3305	CELL OVER VOLTAGE MODULE4	×				I
P3306	CELL OVER VOLTAGE MODULE5	×				
P3307	CELL OVER VOLTAGE MODULE6	×				
P3308	CELL OVER VOLTAGE MODULE7	×				J
P3309	CELL OVER VOLTAGE MODULE8	×				
P330A	CELL OVER VOLTAGE MODULE9	×				K
P330B	CELL OVER VOLTAGE MODULE10	×				
P330C	CELL OVER VOLTAGE MODULE11	×				
P330D	CELL OVER VOLTAGE MODULE12	×				L
P330E	CELL OVER VOLTAGE MODULE13	×				
P330F	CELL OVER VOLTAGE MODULE14	×				M
P3310	CELL OVER VOLTAGE MODULE15	×				
P3311	CELL OVER VOLTAGE MODULE16	×				
P3312	CELL OVER VOLTAGE MODULE17	×				N
P3313	CELL OVER VOLTAGE MODULE18	×				
P3314	CELL OVER VOLTAGE MODULE19	×				
P3315	CELL OVER VOLTAGE MODULE20	×				O
P3316	CELL OVER VOLTAGE MODULE21	×				
P3317	CELL OVER VOLTAGE MODULE22	×				P
P3318	CELL OVER VOLTAGE MODULE23	×				
P3319	CELL OVER VOLTAGE MODULE24	×				
P331A	CELL OVER VOLTAGE MODULE25	×				
P331B	CELL OVER VOLTAGE MODULE26	×				
P331C	CELL OVER VOLTAGE MODULE27	×				

EV BATTERY SYSTEM

< ECU DIAGNOSIS INFORMATION >

[TYPE 2]

DTC	CONSULT screen items	Pattern			
		A	B	C	D
P331D	CELL OVER VOLTAGE MODULE28	×			
P331E	CELL OVER VOLTAGE MODULE29	×			
P331F	CELL OVER VOLTAGE MODULE30	×			
P3320	CELL OVER VOLTAGE MODULE31	×			
P3321	CELL OVER VOLTAGE MODULE32	×			
P3322	CELL OVER VOLTAGE MODULE33	×			
P3323	CELL OVER VOLTAGE MODULE34	×			
P3324	CELL OVER VOLTAGE MODULE35	×			
P3325	CELL OVER VOLTAGE MODULE36	×			
P3326	CELL OVER VOLTAGE MODULE37	×			
P3327	CELL OVER VOLTAGE MODULE38	×			
P3328	CELL OVER VOLTAGE MODULE39	×			
P3329	CELL OVER VOLTAGE MODULE40	×			
P332A	CELL OVER VOLTAGE MODULE41	×			
P332B	CELL OVER VOLTAGE MODULE42	×			
P332C	CELL OVER VOLTAGE MODULE43	×			
P332D	CELL OVER VOLTAGE MODULE44	×			
P332E	CELL OVER VOLTAGE MODULE45	×			
P332F	CELL OVER VOLTAGE MODULE46	×			
P3330	CELL OVER VOLTAGE MODULE47	×			
P3331	CELL OVER VOLTAGE MODULE48	×			
P3373	TOTAL VOLTAGE OVER DISCHARGE	×			
P3375	CELL OVER DISCHARGE MODULE1	×			
P3376	CELL OVER DISCHARGE MODULE2	×			
P3377	CELL OVER DISCHARGE MODULE3	×			
P3378	CELL OVER DISCHARGE MODULE4	×			
P3379	CELL OVER DISCHARGE MODULE5	×			
P337A	CELL OVER DISCHARGE MODULE6	×			
P337B	CELL OVER DISCHARGE MODULE7	×			
P337C	CELL OVER DISCHARGE MODULE8	×			
P337D	CELL OVER DISCHARGE MODULE9	×			
P337E	CELL OVER DISCHARGE MODULE10	×			
P337F	CELL OVER DISCHARGE MODULE11	×			
P3380	CELL OVER DISCHARGE MODULE12	×			
P3381	CELL OVER DISCHARGE MODULE13	×			
P3382	CELL OVER DISCHARGE MODULE14	×			
P3383	CELL OVER DISCHARGE MODULE15	×			
P3384	CELL OVER DISCHARGE MODULE16	×			
P3385	CELL OVER DISCHARGE MODULE17	×			
P3386	CELL OVER DISCHARGE MODULE18	×			
P3387	CELL OVER DISCHARGE MODULE19	×			
P3388	CELL OVER DISCHARGE MODULE20	×			
P3389	CELL OVER DISCHARGE MODULE21	×			

EV BATTERY SYSTEM

< ECU DIAGNOSIS INFORMATION >

[TYPE 2]

DTC	CONSULT screen items	Pattern				
		A	B	C	D	
P338A	CELL OVER DISCHARGE MODULE22	×				A
P338B	CELL OVER DISCHARGE MODULE23	×				B
P338C	CELL OVER DISCHARGE MODULE24	×				
P338D	CELL OVER DISCHARGE MODULE25	×				
P338E	CELL OVER DISCHARGE MODULE26	×				EVB
P338F	CELL OVER DISCHARGE MODULE27	×				
P3390	CELL OVER DISCHARGE MODULE28	×				D
P3391	CELL OVER DISCHARGE MODULE29	×				
P3392	CELL OVER DISCHARGE MODULE30	×				
P3393	CELL OVER DISCHARGE MODULE31	×				E
P3394	CELL OVER DISCHARGE MODULE32	×				
P3395	CELL OVER DISCHARGE MODULE33	×				F
P3396	CELL OVER DISCHARGE MODULE34	×				
P3397	CELL OVER DISCHARGE MODULE35	×				
P3398	CELL OVER DISCHARGE MODULE36	×				G
P3399	CELL OVER DISCHARGE MODULE37	×				
P339A	CELL OVER DISCHARGE MODULE38	×				H
P339B	CELL OVER DISCHARGE MODULE39	×				
P339C	CELL OVER DISCHARGE MODULE40	×				I
P339D	CELL OVER DISCHARGE MODULE41	×				
P339E	CELL OVER DISCHARGE MODULE42	×				J
P339F	CELL OVER DISCHARGE MODULE43	×				
P33A0	CELL OVER DISCHARGE MODULE44	×				K
P33A1	CELL OVER DISCHARGE MODULE45	×				
P33A2	CELL OVER DISCHARGE MODULE46	×				L
P33A3	CELL OVER DISCHARGE MODULE47	×				
P33A4	CELL OVER DISCHARGE MODULE48	×				M
P33D4	BATT GRADUAL CAPA LOSS DIAG				×	
P33D5	CURRENT SENSOR		×			N
P33D6	CURRENT SENSOR		×			
P33D7	TEMPERATURE SENSOR			No fail-safe		O
P33D9	TEMPERATURE SENSOR			No fail-safe		
P33DB	TEMPERATURE SENSOR			No fail-safe		P
P33DD	TEMPERATURE SENSOR			No fail-safe		
P33DF	BATT VOLTAGE ISOLATION SEN				×	
P33E0	BATT VOLTAGE ISOLATION SEN				×	
P33E1	BATT VOLTAGE ISOLATION SEN				×	
P33E2	BATT PACK OVER TEMP	×				
P33E4	TEMPERATURE SENSOR			No fail-safe		
P33E5	TEMPERATURE SENSOR			No fail-safe		
P33E6	CELL VOLTAGE DEVIATION DIAG			×		
P33E7	CELL CONTROLLER				×	
P33EA	BATTERY HEATER RELAY				×	

EV BATTERY SYSTEM

< ECU DIAGNOSIS INFORMATION >

[TYPE 2]

DTC	CONSULT screen items	Pattern			
		A	B	C	D
P33ED	BATTERY PARALLEL DIAGNOSIS			×	
P33EE	BATTERY HEATER CONTROL SYSTEM				×
U1000	CAN COMM CIRCUIT				×

DTC Index

INFOID:000000007605332

×: Applicable —: Not applicable

DTC	CONSULT screen items	EV system warning lamp	Trip	Reference
P0A0D	HV SYSTEM INTERLOCK ERROR	×	1	EVB-292
P0A1F	BATTERY ENERGY CONTROL MODULE	×	1	EVB-294
P3030	CELL CONT LIN	×	1	EVB-295
P3031	CELL CONT ASIC1	×	1	EVB-296
P3032	CELL CONT ASIC2	×	1	EVB-296
P3033	CELL CONT ASIC3	×	1	EVB-296
P3034	CELL CONT ASIC4	×	1	EVB-296
P3035	CELL CONT ASIC5	×	1	EVB-296
P3036	CELL CONT ASIC6	×	1	EVB-296
P3037	CELL CONT ASIC7	×	1	EVB-296
P3038	CELL CONT ASIC8	×	1	EVB-296
P3039	CELL CONT ASIC9	×	1	EVB-296
P303A	CELL CONT ASIC10	×	1	EVB-296
P303B	CELL CONT ASIC11	×	1	EVB-296
P303C	CELL CONT ASIC12	×	1	EVB-296
P303D	CELL CONT ASIC13	×	1	EVB-297
P303E	CELL CONT ASIC14	×	1	EVB-297
P303F	CELL CONT ASIC15	×	1	EVB-297
P3040	CELL CONT ASIC16	×	1	EVB-297
P3041	CELL CONT ASIC17	×	1	EVB-297
P3042	CELL CONT ASIC18	×	1	EVB-297
P3043	CELL CONT ASIC19	×	1	EVB-297
P3044	CELL CONT ASIC20	×	1	EVB-297
P3045	CELL CONT ASIC21	×	1	EVB-297
P3046	CELL CONT ASIC22	×	1	EVB-297
P3047	CELL CONT ASIC23	×	1	EVB-297
P3048	CELL CONT ASIC24	×	1	EVB-297
P3049	CELL CONT ASIC1 VOLT	×	1	EVB-298
P304A	CELL CONT ASIC2 VOLT	×	1	EVB-298
P304B	CELL CONT ASIC3 VOLT	×	1	EVB-298
P304C	CELL CONT ASIC4 VOLT	×	1	EVB-298
P304D	CELL CONT ASIC5 VOLT	×	1	EVB-298
P304E	CELL CONT ASIC6 VOLT	×	1	EVB-298
P304F	CELL CONT ASIC7 VOLT	×	1	EVB-298
P3050	CELL CONT ASIC8 VOLT	×	1	EVB-298

EV BATTERY SYSTEM

< ECU DIAGNOSIS INFORMATION >

[TYPE 2]

DTC	CONSULT screen items	EV system warning lamp	Trip	Reference	
P3051	CELL CONT ASIC9 VOLT	×	1	EVB-298	A
P3052	CELL CONT ASIC10 VOLT	×	1	EVB-298	B
P3053	CELL CONT ASIC11 VOLT	×	1	EVB-298	
P3054	CELL CONT ASIC12 VOLT	×	1	EVB-298	EVB
P3055	CELL CONT ASIC13 VOLT	×	1	EVB-300	
P3056	CELL CONT ASIC14 VOLT	×	1	EVB-300	
P3057	CELL CONT ASIC15 VOLT	×	1	EVB-300	D
P3058	CELL CONT ASIC16 VOLT	×	1	EVB-300	
P3059	CELL CONT ASIC17 VOLT	×	1	EVB-300	
P305A	CELL CONT ASIC18 VOLT	×	1	EVB-300	E
P305B	CELL CONT ASIC19 VOLT	×	1	EVB-300	
P305C	CELL CONT ASIC20 VOLT	×	1	EVB-300	F
P305D	CELL CONT ASIC21 VOLT	×	1	EVB-300	
P305E	CELL CONT ASIC22 VOLT	×	1	EVB-300	
P305F	CELL CONT ASIC23 VOLT	×	1	EVB-300	G
P3060	CELL CONT ASIC24 VOLT	×	1	EVB-300	
P3061	CELL BATTERY VOLT	×	1	EVB-302	H
P3062	BYPASS SW	×	1	EVB-303	
P308B	CELL CONT ASIC1 OPEN	×	1	EVB-304	
P308C	CELL CONT ASIC2 OPEN	×	1	EVB-304	I
P308D	CELL CONT ASIC3 OPEN	×	1	EVB-304	
P308E	CELL CONT ASIC4 OPEN	×	1	EVB-304	J
P308F	CELL CONT ASIC5 OPEN	×	1	EVB-304	
P3090	CELL CONT ASIC6 OPEN	×	1	EVB-304	
P3091	CELL CONT ASIC7 OPEN	×	1	EVB-304	K
P3092	CELL CONT ASIC8 OPEN	×	1	EVB-304	
P3093	CELL CONT ASIC9 OPEN	×	1	EVB-304	L
P3094	CELL CONT ASIC10 OPEN	×	1	EVB-304	
P3095	CELL CONT ASIC11 OPEN	×	1	EVB-304	
P3096	CELL CONT ASIC12 OPEN	×	1	EVB-304	M
P3097	CELL CONT ASIC13 OPEN	×	1	EVB-307	
P3098	CELL CONT ASIC14 OPEN	×	1	EVB-307	
P3099	CELL CONT ASIC15 OPEN	×	1	EVB-307	N
P309A	CELL CONT ASIC16 OPEN	×	1	EVB-307	
P309B	CELL CONT ASIC17 OPEN	×	1	EVB-307	O
P309C	CELL CONT ASIC18 OPEN	×	1	EVB-307	
P309D	CELL CONT ASIC19 OPEN	×	1	EVB-307	
P309E	CELL CONT ASIC20 OPEN	×	1	EVB-307	P
P309F	CELL CONT ASIC21 OPEN	×	1	EVB-307	
P30A0	CELL CONT ASIC22 OPEN	×	1	EVB-307	
P30A1	CELL CONT ASIC23 OPEN	×	1	EVB-307	
P30A2	CELL CONT ASIC24 OPEN	×	1	EVB-307	
P30F3	TOTAL VOLT SENSOR	×	1	EVB-310	

EV BATTERY SYSTEM

< ECU DIAGNOSIS INFORMATION >

[TYPE 2]

DTC	CONSULT screen items	EV system warning lamp	Trip	Reference
P30F4	TOTAL VOLT SENSOR	×	1	EVB-311
P30F5	TOTAL VOLT SENSOR	×	1	EVB-313
P30FC	OVER CURRENT	×	1	EVB-314
P30FD	TOTAL VOLTAGE MONITOR SWITCH	—	1	EVB-315
P30FE	12V BATTERY VOLTAGE	×	1	EVB-316
P318D	COMMUNICATION ERROR	×	1	EVB-318
P318E	COMMUNICATION ERROR	×	1	EVB-319
P3191	COMMUNICATION ERROR	—	1	EVB-320
P3196	COMMUNICATION ERROR	—	1	EVB-321
P3199	COMMUNICATION ERROR	×	1	EVB-322
P319C	COMMUNICATION ERROR	—	1	EVB-323
P31A4	CAN ERROR VCM	×	1	EVB-324
P31A7	CAN ERROR INV/MC	—	1	EVB-325
P3300	TOTAL VOLTAGE OVER	×	1	EVB-326
P3302	CELL OVER VOLTAGE MODULE1	×	1	EVB-327
P3303	CELL OVER VOLTAGE MODULE2	×	1	EVB-327
P3304	CELL OVER VOLTAGE MODULE3	×	1	EVB-327
P3305	CELL OVER VOLTAGE MODULE4	×	1	EVB-327
P3306	CELL OVER VOLTAGE MODULE5	×	1	EVB-327
P3307	CELL OVER VOLTAGE MODULE6	×	1	EVB-327
P3308	CELL OVER VOLTAGE MODULE7	×	1	EVB-327
P3309	CELL OVER VOLTAGE MODULE8	×	1	EVB-327
P330A	CELL OVER VOLTAGE MODULE9	×	1	EVB-327
P330B	CELL OVER VOLTAGE MODULE10	×	1	EVB-327
P330C	CELL OVER VOLTAGE MODULE11	×	1	EVB-327
P330D	CELL OVER VOLTAGE MODULE12	×	1	EVB-327
P330E	CELL OVER VOLTAGE MODULE13	×	1	EVB-330
P330F	CELL OVER VOLTAGE MODULE14	×	1	EVB-330
P3310	CELL OVER VOLTAGE MODULE15	×	1	EVB-330
P3311	CELL OVER VOLTAGE MODULE16	×	1	EVB-330
P3312	CELL OVER VOLTAGE MODULE17	×	1	EVB-330
P3313	CELL OVER VOLTAGE MODULE18	×	1	EVB-330
P3314	CELL OVER VOLTAGE MODULE19	×	1	EVB-330
P3315	CELL OVER VOLTAGE MODULE20	×	1	EVB-330
P3316	CELL OVER VOLTAGE MODULE21	×	1	EVB-330
P3317	CELL OVER VOLTAGE MODULE22	×	1	EVB-330
P3318	CELL OVER VOLTAGE MODULE23	×	1	EVB-330
P3319	CELL OVER VOLTAGE MODULE24	×	1	EVB-330
P331A	CELL OVER VOLTAGE MODULE25	×	1	EVB-333
P331B	CELL OVER VOLTAGE MODULE26	×	1	EVB-333
P331C	CELL OVER VOLTAGE MODULE27	×	1	EVB-333
P331D	CELL OVER VOLTAGE MODULE28	×	1	EVB-333
P331E	CELL OVER VOLTAGE MODULE29	×	1	EVB-333

EV BATTERY SYSTEM

< ECU DIAGNOSIS INFORMATION >

[TYPE 2]

DTC	CONSULT screen items	EV system warning lamp	Trip	Reference	
P331F	CELL OVER VOLTAGE MODULE30	×	1	EVB-333	A
P3320	CELL OVER VOLTAGE MODULE31	×	1	EVB-333	B
P3321	CELL OVER VOLTAGE MODULE32	×	1	EVB-333	
P3322	CELL OVER VOLTAGE MODULE33	×	1	EVB-333	EVB
P3323	CELL OVER VOLTAGE MODULE34	×	1	EVB-333	
P3324	CELL OVER VOLTAGE MODULE35	×	1	EVB-333	
P3325	CELL OVER VOLTAGE MODULE36	×	1	EVB-333	D
P3326	CELL OVER VOLTAGE MODULE37	×	1	EVB-336	
P3327	CELL OVER VOLTAGE MODULE38	×	1	EVB-336	
P3328	CELL OVER VOLTAGE MODULE39	×	1	EVB-336	E
P3329	CELL OVER VOLTAGE MODULE40	×	1	EVB-336	
P332A	CELL OVER VOLTAGE MODULE41	×	1	EVB-336	F
P332B	CELL OVER VOLTAGE MODULE42	×	1	EVB-336	
P332C	CELL OVER VOLTAGE MODULE43	×	1	EVB-336	
P332D	CELL OVER VOLTAGE MODULE44	×	1	EVB-336	G
P332E	CELL OVER VOLTAGE MODULE45	×	1	EVB-336	
P332F	CELL OVER VOLTAGE MODULE46	×	1	EVB-336	H
P3330	CELL OVER VOLTAGE MODULE47	×	1	EVB-336	
P3331	CELL OVER VOLTAGE MODULE48	×	1	EVB-336	
P3373	TOTAL VOLTAGE OVER DISCHARGE	×	1	EVB-339	I
P3375	CELL OVER DISCHARGE MODULE1	×	1	EVB-340	
P3376	CELL OVER DISCHARGE MODULE2	×	1	EVB-340	J
P3377	CELL OVER DISCHARGE MODULE3	×	1	EVB-340	
P3378	CELL OVER DISCHARGE MODULE4	×	1	EVB-340	
P3379	CELL OVER DISCHARGE MODULE5	×	1	EVB-340	K
P337A	CELL OVER DISCHARGE MODULE6	×	1	EVB-340	
P337B	CELL OVER DISCHARGE MODULE7	×	1	EVB-340	L
P337C	CELL OVER DISCHARGE MODULE8	×	1	EVB-340	
P337D	CELL OVER DISCHARGE MODULE9	×	1	EVB-340	
P337E	CELL OVER DISCHARGE MODULE10	×	1	EVB-340	M
P337F	CELL OVER DISCHARGE MODULE11	×	1	EVB-340	
P3380	CELL OVER DISCHARGE MODULE12	×	1	EVB-340	
P3381	CELL OVER DISCHARGE MODULE13	×	1	EVB-343	N
P3382	CELL OVER DISCHARGE MODULE14	×	1	EVB-343	
P3383	CELL OVER DISCHARGE MODULE15	×	1	EVB-343	O
P3384	CELL OVER DISCHARGE MODULE16	×	1	EVB-343	
P3385	CELL OVER DISCHARGE MODULE17	×	1	EVB-343	
P3386	CELL OVER DISCHARGE MODULE18	×	1	EVB-343	P
P3387	CELL OVER DISCHARGE MODULE19	×	1	EVB-343	
P3388	CELL OVER DISCHARGE MODULE20	×	1	EVB-343	
P3389	CELL OVER DISCHARGE MODULE21	×	1	EVB-343	
P338A	CELL OVER DISCHARGE MODULE22	×	1	EVB-343	
P338B	CELL OVER DISCHARGE MODULE23	×	1	EVB-343	

EV BATTERY SYSTEM

< ECU DIAGNOSIS INFORMATION >

[TYPE 2]

DTC	CONSULT screen items	EV system warning lamp	Trip	Reference
P338C	CELL OVER DISCHARGE MODULE24	×	1	EVB-343
P338D	CELL OVER DISCHARGE MODULE25	×	1	EVB-346
P338E	CELL OVER DISCHARGE MODULE26	×	1	EVB-346
P338F	CELL OVER DISCHARGE MODULE27	×	1	EVB-346
P3390	CELL OVER DISCHARGE MODULE28	×	1	EVB-346
P3391	CELL OVER DISCHARGE MODULE29	×	1	EVB-346
P3392	CELL OVER DISCHARGE MODULE30	×	1	EVB-346
P3393	CELL OVER DISCHARGE MODULE31	×	1	EVB-346
P3394	CELL OVER DISCHARGE MODULE32	×	1	EVB-346
P3395	CELL OVER DISCHARGE MODULE33	×	1	EVB-346
P3396	CELL OVER DISCHARGE MODULE34	×	1	EVB-346
P3397	CELL OVER DISCHARGE MODULE35	×	1	EVB-346
P3398	CELL OVER DISCHARGE MODULE36	×	1	EVB-346
P3399	CELL OVER DISCHARGE MODULE37	×	1	EVB-349
P339A	CELL OVER DISCHARGE MODULE38	×	1	EVB-349
P339B	CELL OVER DISCHARGE MODULE39	×	1	EVB-349
P339C	CELL OVER DISCHARGE MODULE40	×	1	EVB-349
P339D	CELL OVER DISCHARGE MODULE41	×	1	EVB-349
P339E	CELL OVER DISCHARGE MODULE42	×	1	EVB-349
P339F	CELL OVER DISCHARGE MODULE43	×	1	EVB-349
P33A0	CELL OVER DISCHARGE MODULE44	×	1	EVB-349
P33A1	CELL OVER DISCHARGE MODULE45	×	1	EVB-349
P33A2	CELL OVER DISCHARGE MODULE46	×	1	EVB-349
P33A3	CELL OVER DISCHARGE MODULE47	×	1	EVB-349
P33A4	CELL OVER DISCHARGE MODULE48	×	1	EVB-349
P33D4	BATT GRADUAL CAPA LOSS DIAG	×	1	EVB-352
P33D5	CURRENT SENSOR	×	1	EVB-353
P33D6	CURRENT SENSOR	×	1	EVB-355
P33D7	TEMPERATURE SENSOR	—	1	EVB-357
P33D9	TEMPERATURE SENSOR	—	1	EVB-357
P33DB	TEMPERATURE SENSOR	—	1	EVB-357
P33DD	TEMPERATURE SENSOR	—	1	EVB-357
P33DF	BATT VOLTAGE ISOLATION SEN	×	1	EVB-359
P33E0	BATT VOLTAGE ISOLATION SEN	×	1	EVB-360
P33E1	BATT VOLTAGE ISOLATION SEN	×	1	EVB-361
P33E2	BATT PACK OVER TEMP	×	1	EVB-362
P33E4	TEMPERATURE SENSOR	—	1	EVB-363
P33E5	TEMPERATURE SENSOR	—	1	EVB-363
P33E6	CELL VOLTAGE DEVIATION DIAG	×	2	EVB-365
P33E7	CELL CONTROLLER	×	1	EVB-369
P33EA	BATTERY HEATER RELAY	×	1	EVB-370
P33ED	BATTERY PARALLEL DIAGNOSIS	×	1	EVB-372

EV BATTERY SYSTEM

< ECU DIAGNOSIS INFORMATION >

[TYPE 2]

DTC	CONSULT screen items	EV system warning lamp	Trip	Reference
P33EE	BATTERY HEATER CONTROL SYSTEM	×	1	EVB-374
U1000	CAN COMM CIRCUIT	×	1	EVB-376

A

B

EVB

D

E

F

G

H

I

J

K

L

M

N

O

P

WIRING DIAGRAM

VCM

Wiring Diagram

INFOID:000000007592279

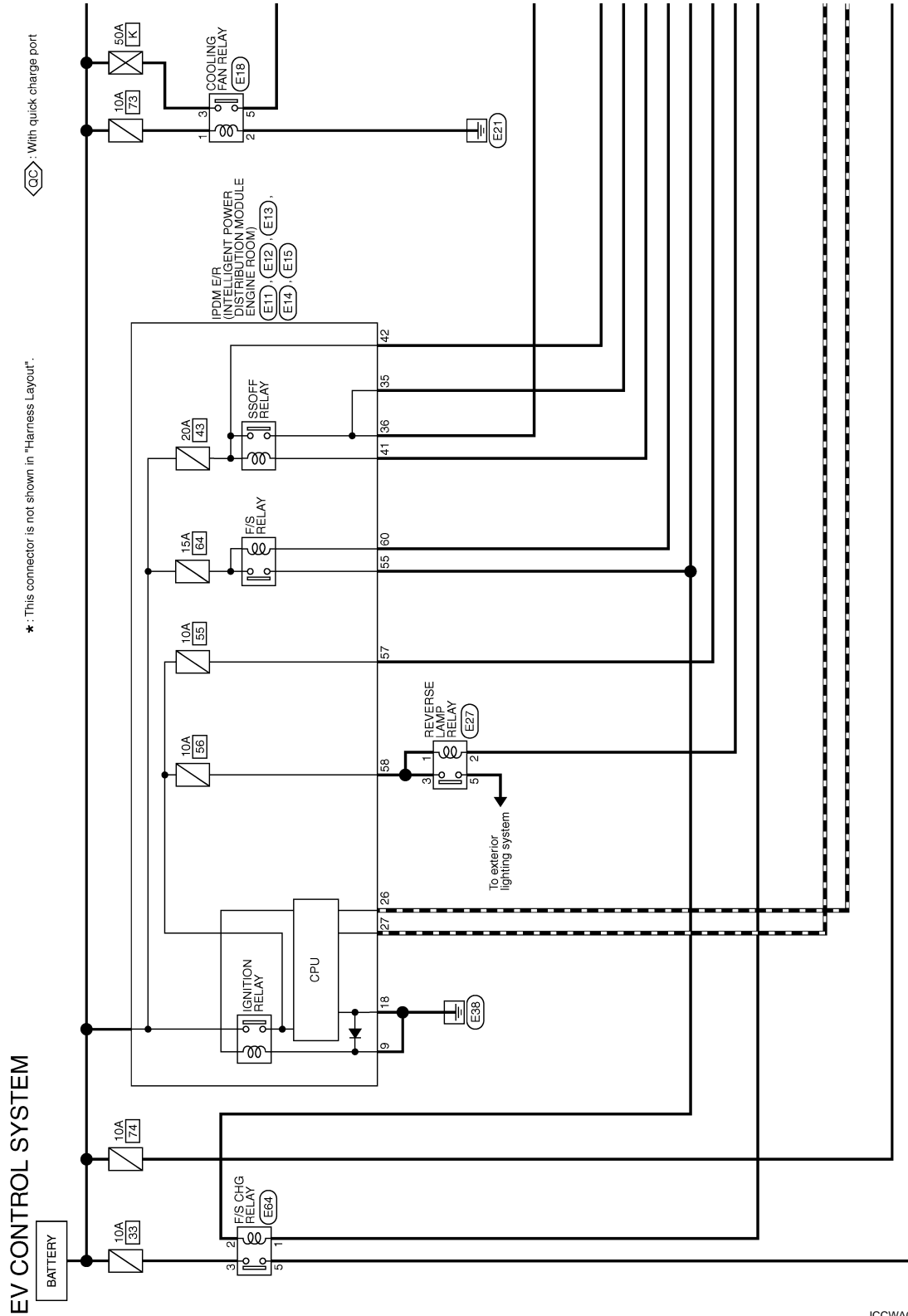

VCM

< WIRING DIAGRAM >

[TYPE 2]

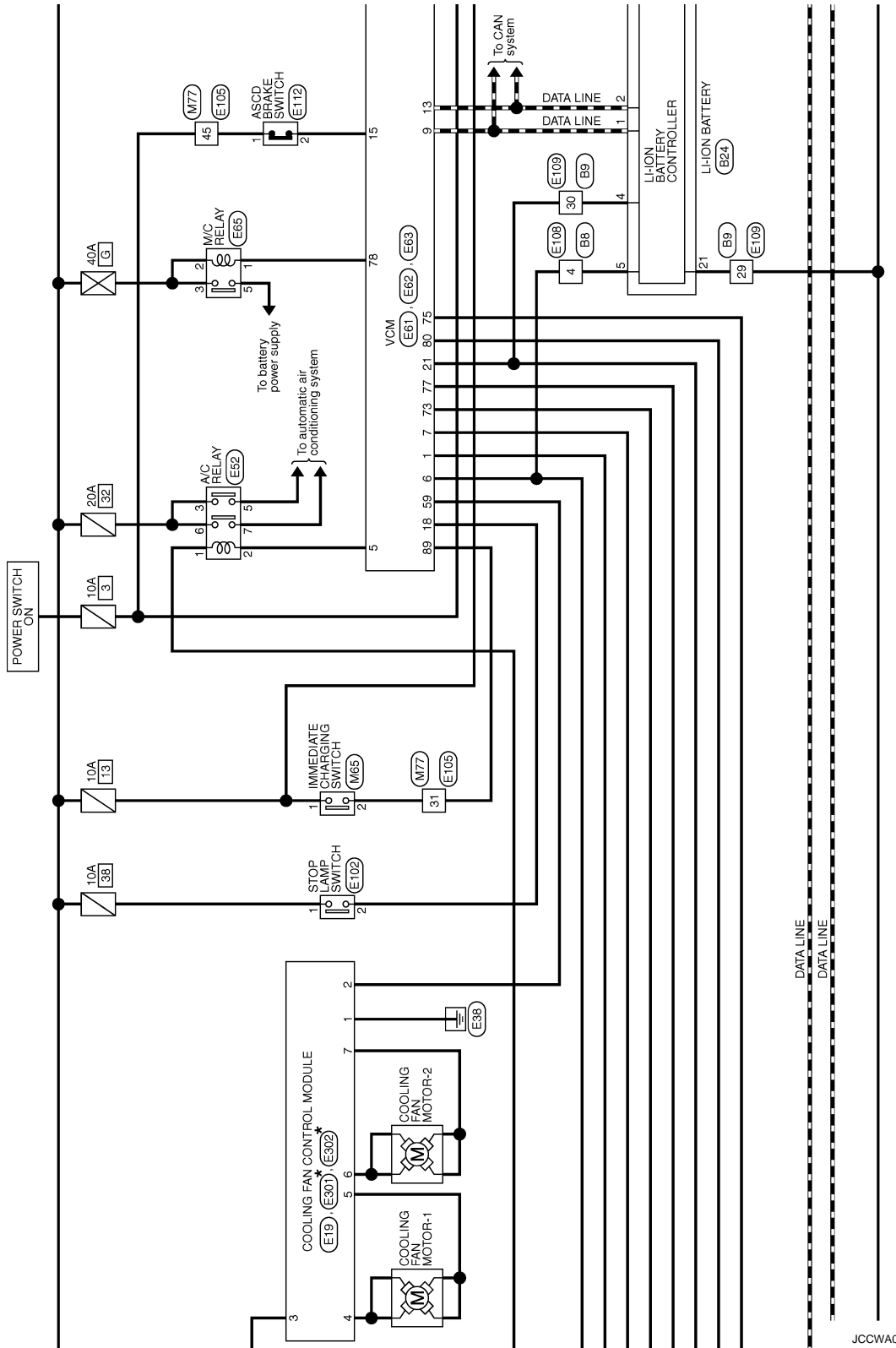

JCCWA0030GB

A
B
EVB
D
E
F
G
H
I
J
K
L
M
N
O
P

VCM

< WIRING DIAGRAM >

[TYPE 2]

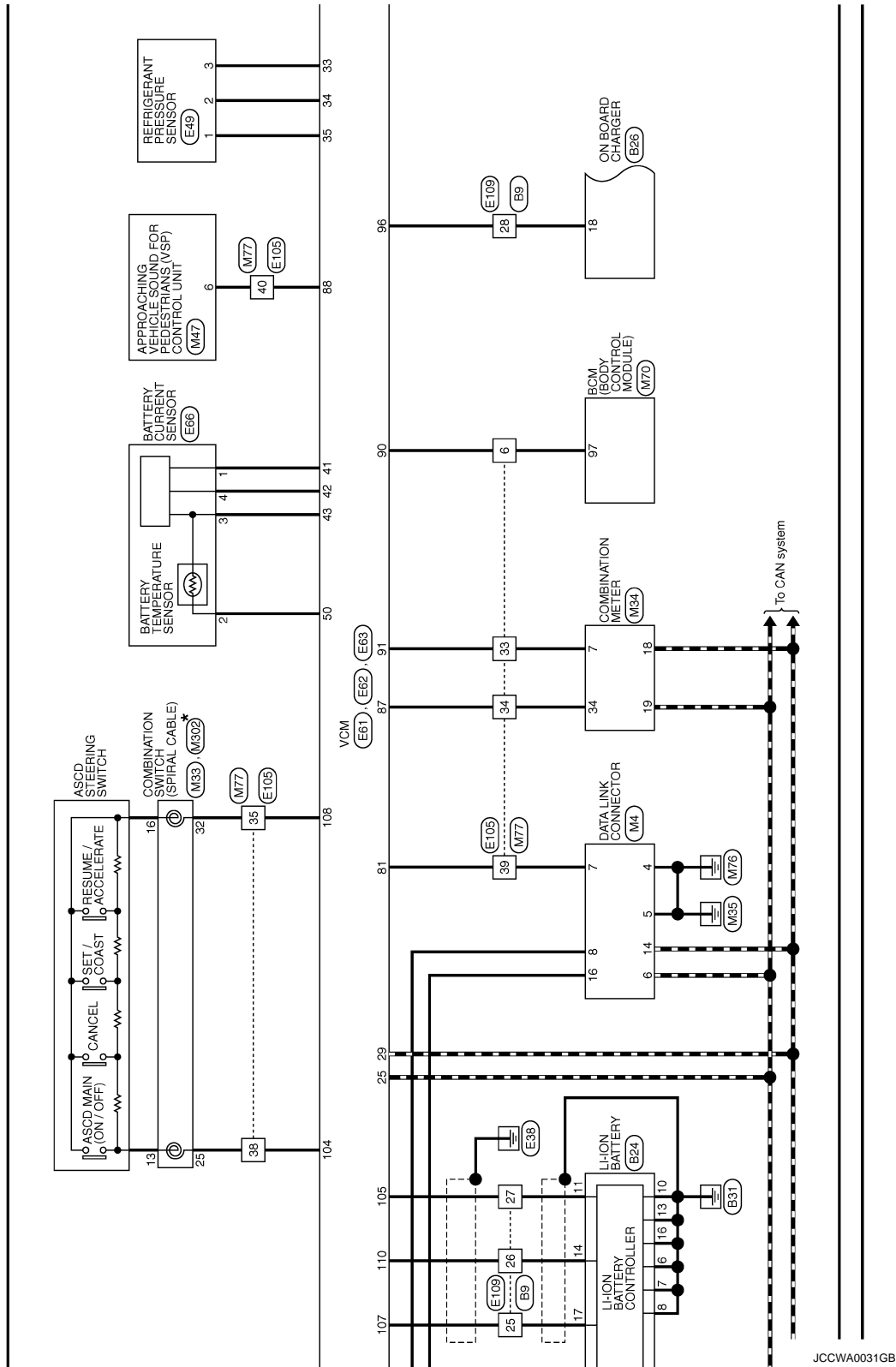

JCCWA0031GB

VCM

< WIRING DIAGRAM >

[TYPE 2]

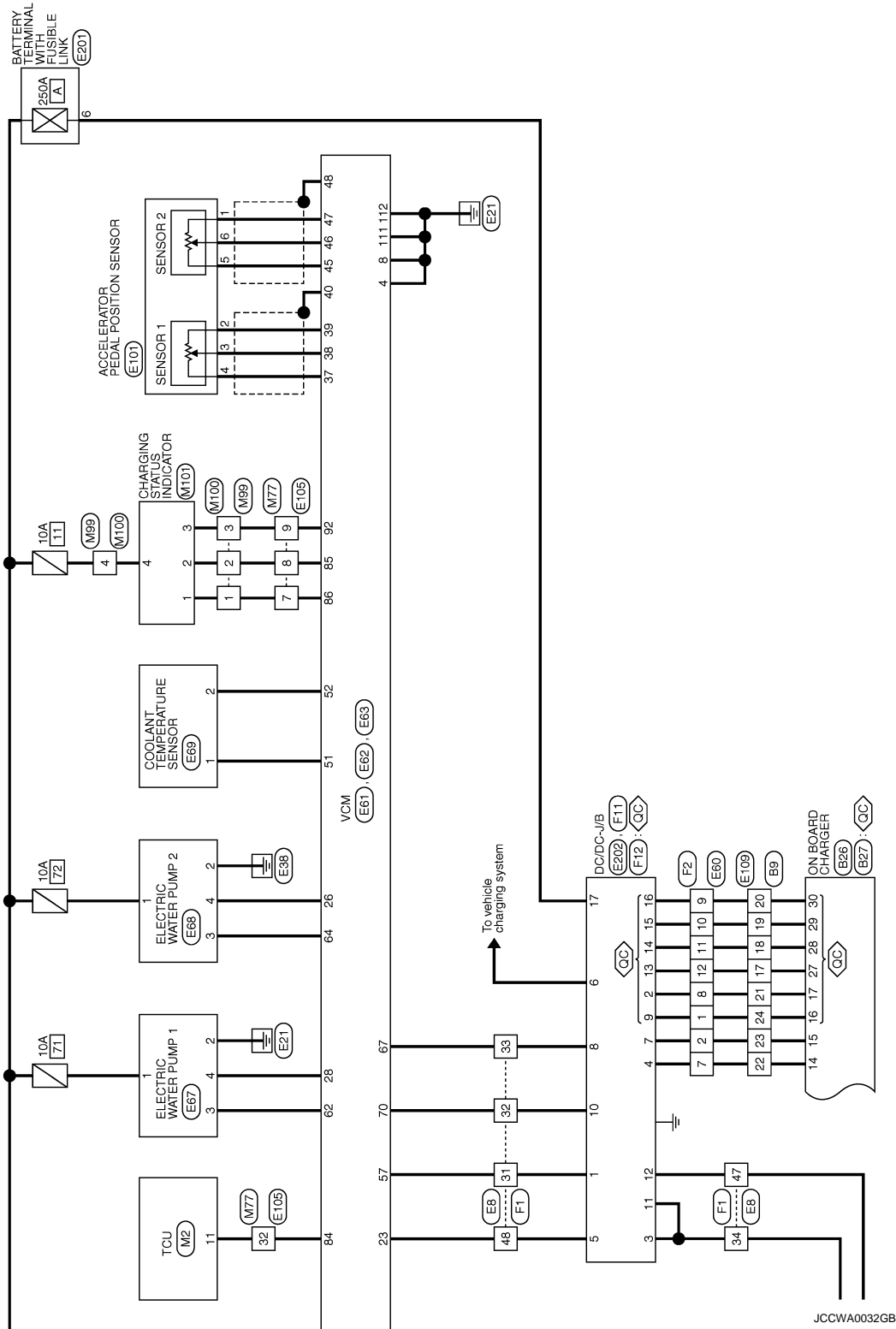

JCCWA0032GB

A
B
EVB
D
E
F
G
H
I
J
K
L
M
N
O
P

EV CONTROL SYSTEM

Connector No.	B8
Connector Name	WIRE TO WIRE
Connector Type	MS04W-GS



Terminal No.	Color of Wire	Signal Name [Specification]
1	R	-
2	L	-
3	R	-
4	R	-

Connector No.	B9
Connector Name	WIRE TO WIRE
Connector Type	TH32PW-BH

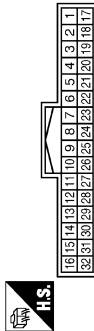

Terminal No.	Color of Wire	Signal Name [Specification]
1	W	-
2	GR	-
3	Y	-
4	G	-
5	BR	-
6	L	-
7	B	-
8	P	-
9	SB	-
10	LG	-
11	W	-
17	R	-
18	Y	-
19	G	-
20	V	-
21	SB	-
22	P	-
23	LG	-

24	L	-
25	Y	-
26	L	-
27	G	-
28	GR	-
29	R	-
30	R	-
31	Y	-

Connector No.	B24
Connector Name	LI-ION BATTERY
Connector Type	Yazaki: 7283-8750-30

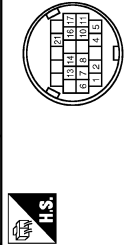

Terminal No.	Color of Wire	Signal Name [Specification]
1	L	EV CAN-H
2	G	EV CAN-L
4	R	IGN
5	R	BAT
6	B	GND3
7	B	GND2
8	B	GND1
10	B	PRE CHG V
11	G	PRE CHG V
13	B	RLY2 GND
14	L	RLY2 V
16	B	RLY1 GND
17	Y	RLY1 V
21	R	CHG IGN

Connector No.	B26
Connector Name	ON BOARD CHARGER
Connector Type	RH12FB

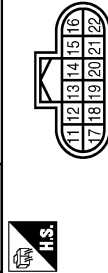

Terminal No.	Color of Wire	Signal Name [Specification]
11	Y	BATTERY POWER SUPPLY
12	W	BATTERY POWER SUPPLY
13	V	POWER ON POWER SUPPLY
14	P	NORMAL CHARGE RELAY +
15	LG	NORMAL CHARGE RELAY -
16	L	QUICK CHARGE RELAY +
17	SB	QUICK CHARGE RELAY -
18	GR	EV ACTIVATION REQUEST SIGNAL
19	L	EV SYSTEM CAN-H
20	G	EV SYSTEM CAN-L
21	BR	PLUG IN SIGNAL
22	B	GROUND

Connector No.	B27
Connector Name	ON BOARD CHARGER
Connector Type	RR48FB



Terminal No.	Color of Wire	Signal Name [Specification]
25	W	QUICK CHARGE PORT TEMPERATURE SENSOR SIGNAL 1
26	GR	QUICK CHARGE PORT TEMPERATURE SENSOR SIGNAL 2
27	R	QUICK CHARGE VOLTAGE SENSOR SIGNAL-L
28	Y	SENSOR POWER SUPPLY QUICK CHARGE VOLTAGE SENSOR
29	G	SENSOR GROUND QUICK CHARGE VOLTAGE SENSOR
30	V	QUICK CHARGE VOLTAGE SENSOR SIGNAL-H

Connector No.	E8
Connector Name	WIRE TO WIRE
Connector Type	SAASMB-RS10-SJ22

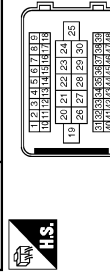

Terminal No.	Color of Wire	Signal Name [Specification]
--------------	---------------	-----------------------------

1	Y	-
2	L	-
3	GR	-
4	LG	-
5	P	-
6	B	-
8	BR	-
10	B	-
11	W	-
12	O	-
13	G	-
14	V	-
15	SB	-
16	R	-
17	L	-
18	LG	-
20	V	-
21	G	-
22	Y	-
23	B/R	-
24	V	-
26	V	-
27	B	-
28	B/R	-
29	W	-
30	B/R	-
31	LG	-
32	W	-
33	Y	-
34	P	-
35	P	-
36	R	-
37	G	-
38	B/R	-
40	BR	-
41	G	-
42	SB	-
43	L	-
44	O	-
47	V	-
48	P	-

A
B
EVB
D
E
F
G
H
I
J
K
L
M
N
O
P

EV CONTROL SYSTEM

Connector No.	E11
Connector Name	FROM E/R INTELLIGENT POWER DISTRIBUTION MODULE (ENGINE ROOM)
Connector Type	MS08FB-LC



Terminal No.	Color of Wire	Signal Name [Specification]
9	B	
14	R	

Connector No.	E12
Connector Name	FROM E/R INTELLIGENT POWER DISTRIBUTION MODULE (ENGINE ROOM)
Connector Type	MS08FB-CS



Terminal No.	Color of Wire	Signal Name [Specification]
18	B/W	
19	W	
20	V	

Connector No.	E13
Connector Name	FROM E/R INTELLIGENT POWER DISTRIBUTION MODULE (ENGINE ROOM)
Connector Type	TH12FW-NH



Terminal No.	Color of Wire	Signal Name [Specification]
25	R	

26	P	
27	L	
28	G	
32	SB	
34	W	

Connector No.	E14
Connector Name	FROM E/R INTELLIGENT POWER DISTRIBUTION MODULE (ENGINE ROOM)
Connector Type	NS12FBR-CS



Terminal No.	Color of Wire	Signal Name [Specification]
35	G	
36	GR	
38	V	
39	L	
41	W	
42	R	
43	O	
44	LG	
45	Y	

Connector No.	E15
Connector Name	FROM E/R INTELLIGENT POWER DISTRIBUTION MODULE (ENGINE ROOM)
Connector Type	NS16FW-CS



Terminal No.	Color of Wire	Signal Name [Specification]
49	Y	
50	G	
51	L	
52	P	
55	LG	
57	R	

58	O	
60	GR	
61	Y	
62	V	

Connector No.	E18
Connector Name	COOLING FAN RELAY
Connector Type	Z4347_9F900



Terminal No.	Color of Wire	Signal Name [Specification]
1	G	
2	B/Y	
3	BR	
5	R	

Connector No.	E19
Connector Name	COOLING FAN CONTROL MODULE
Connector Type	SJZ01FGY-SNZ2



Terminal No.	Color of Wire	Signal Name [Specification]
1	B	
2	V	GND
3	R	PWM SIG
		PWM POWER

Connector No.	E27
Connector Name	REVERSE LAMP RELAY
Connector Type	MS02FL-MZ-LC



Terminal No.	Color of Wire	Signal Name [Specification]
1	O	
2	SB	
3	O	
5	G	

Connector No.	E49
Connector Name	REFRIGERANT PRESSURE SENSOR
Connector Type	RK03FB



Terminal No.	Color of Wire	Signal Name [Specification]
2	BR	
3	L	

EV CONTROL SYSTEM

Connector No.	E52
Connector Name	A/C RELAY
Connector Type	M08FBR-R-LC



Terminal No.	Color of Wire	Signal Name [Specification]
1	GR	-
2	SB	-
3	R	-
4	R	-
5	V	-
6	R	-
7	W	-

Connector No.	E60
Connector Name	WIRE TO WIRE
Connector Type	RH12MB

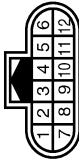

Terminal No.	Color of Wire	Signal Name [Specification]
1	Y	-
2	G	-
3	L	-
4	G	-
5	L	-
6	G	-
7	L	-
8	SB	-
9	V	-
10	O	-
11	BR	-
12	LG	-

Connector No.	E61
Connector Name	VCM
Connector Type	RH24FGV-R28-R-RH

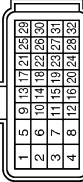

Terminal No.	Color of Wire	Signal Name [Specification]
1	G	POWER ON POWER SUPPLY
4	B/R	GROUND
5	SB	A/C RELAY
6	R	BATTERY POWER SUPPLY
7	W	SSOFF RELAY
8	B/R	GROUND
9	L	EV SYSTEM CAN-H
13	G	EV SYSTEM CAN-L
15	O	ASCD BRAKE SWITCH SIGNAL
16	SB	STOP LAMP SW SIGNAL
21	R	POWER ON POWER SUPPLY
23	P	HIGH VOLTAGE CABLE INTERLOCK
25	L	CAN-H
26	Y	WATER PUMP 2 SIGNAL
28	W	WATER PUMP 1 SIGNAL
29	P	CAN-L

Connector No.	E62
Connector Name	VCM
Connector Type	RH40FBR-R28-L-RH



Terminal No.	Color of Wire	Signal Name [Specification]
33	L	SENSOR POWER SUPPLY (REFRIGERANT PRESSURE SENSOR)
34	BR	REFRIGERANT PRESSURE SENSOR SIGNAL
35	BR	SENSOR GROUND (REFRIGERANT PRESSURE SENSOR)
37	W	SENSOR POWER SUPPLY (ACCELERATOR PEDAL POSITION SENSOR)
38	R	ACCELERATOR PEDAL POSITION SENSOR 1 SIGNAL
39	B	SENSOR GROUND (ACCELERATOR PEDAL POSITION SENSOR 1)

Terminal No.	Color of Wire	Signal Name [Specification]
40	SHIELD	-
41	R	SENSOR POWER SUPPLY (BATTERY CURRENT SENSOR)
42	Y	BATTERY CURRENT SENSOR SIGNAL
43	L	SENSOR GROUND (BATTERY CURRENT SENSOR)
45	W	SENSOR POWER SUPPLY (ACCELERATOR PEDAL POSITION SENSOR 2)
46	R	ACCELERATOR PEDAL POSITION SENSOR 2 SIGNAL
47	B	SENSOR GROUND (ACCELERATOR PEDAL POSITION SENSOR 2)
48	SHIELD	-
50	L	BATTERY TEMPERATURE SENSOR SIGNAL
51	O	COOLANT TEMPERATURE SENSOR SIGNAL
52	W	SENSOR GROUND (COOLANT TEMPERATURE SENSOR)
57	LG	POWER VOLTAGE VARIABLE CONTROL SIGNAL
59	V	RADIATOR FAN CONTROL SIGNAL
62	G	WATER PUMP 1 ACTIVATION SIGNAL
64	R	WATER PUMP 2 ACTIVATION SIGNAL
67	Y	DC/DC CONVERTER TEMPERATURE SIGNAL
70	W	DC/DC CONVERTER ACTIVATION SIGNAL
73	GR	F/S RELAY
75	W	F/S CHG RELAY
77	LG	F/S RELAY POWER SUPPLY
78	G	M/C RELAY
80	SB	REVERSE LAMP RELAY

Connector No.	E63
Connector Name	VCM
Connector Type	RH24FBR-R28-L-RH

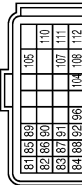

Terminal No.	Color of Wire	Signal Name [Specification]
81	GR	K-LINE
84	LG	EV SYSTEM ACTIVATION REQUEST SIGNAL
85	P	CHARGING STATUS INDICATOR 2
86	V	CHARGING STATUS INDICATOR 1
87	L	PLUG IN INDICATOR LAMP
88	Y	AVSP CONTROL SIGNAL
89	V	IMMEDIATE CHARGING SWITCH
90	W	STARTER RELAY CONT
91	O	ELECTRIC SHIF WARNING SIGNAL
92	G	CHARGING STATUS INDICATOR 3
96	GR	EV SYSTEM ACTIVATION REQUEST SIGNAL
104	SB	ASCD STEERING SWITCH
105	L/O	PRE-CHARGE RELAY
107	W/L	SYSTEM MAIN RELAY 1

108	BR	ASCD STTERING SWICH GROUND
110	L/Y	SYSTEM MAIN RELAY 2
111	B/R	GROUND
112	B/R	GROUND

Connector No.	E64
Connector Name	F/S CHG RELAY
Connector Type	MS02FL-M2-LC



Terminal No.	Color of Wire	Signal Name [Specification]
1	W	-
2	LG	-
3	W	-
5	V	-

Connector No.	E65
Connector Name	M/C RELAY
Connector Type	MS02FL-M2-LC



Terminal No.	Color of Wire	Signal Name [Specification]
1	G	-
2	R	-
3	R	-
5	W	-

A

B

EVB

D

E

F

G

H

I

J

K

L

M

N

O

P

EV CONTROL SYSTEM

Connector No.	EB6
Connector Name	BATTERY CURRENT SENSOR
Connector Type	SAZ04FGY



Terminal No.	Color of Wire	Signal Name [Specification]
1	R	-
2	L	-
3	L	-
4	Y	-

Connector No.	EB7
Connector Name	ELECTRIC WATER PUMP 1
Connector Type	RSDHFG



Terminal No.	Color of Wire	Signal Name [Specification]
1	BR	-
2	BY	-
3	G	-
4	W	-

Connector No.	EB8
Connector Name	ELECTRIC WATER PUMP 2
Connector Type	RSDHFG



Terminal No.	Color of Wire	Signal Name [Specification]
1	L	-
2	B/W	-
3	R	-
4	Y	-



Connector No.	EB9
Connector Name	COOLANT TEMPERATURE SENSOR
Connector Type	EDZFGY-RS



Terminal No.	Color of Wire	Signal Name [Specification]
1	O	-
2	W	-



Connector No.	EI01
Connector Name	ACCELERATOR PEDAL POSITION SENSOR
Connector Type	RHD0FB



Terminal No.	Color of Wire	Signal Name [Specification]
1	B	-
2	B	-
3	R	-
4	W	-
5	W	-
6	R	-

Connector No.	EI02
Connector Name	STOP LAMP SWITCH
Connector Type	JM04FW-LC



Terminal No.	Color of Wire	Signal Name [Specification]
1	W	-
2	SR	-
3	LG	-
4	P	-

EV CONTROL SYSTEM

Connector No.	E105
Connector Name	WIRE TO WIRE
Connector Type	TH80MM-DS16-TM4



Terminal No.	Color of Wire	Signal Name [Specification]
1	BR	-
2	R	-
3	GR	-
4	LG	-
6	W	-
7	V	-
8	P	-
9	G	-
10	R	-
11	O	-
12	W	-
13	B	-
14	Y	-
15	BR	-
16	LG	-
17	L	-
19	G	-
20	V	-
21	P	-
22	LG	-
23	GR	-
24	L	-
25	R	-
26	SB	-
27	B	-
28	BR	-
29	W	-
30	W	-
31	V	-
32	LG	-
33	O	-
34	L	-
35	BR	-
38	SB	-
39	GR	-
40	Y	-
41	R	-
42	W	-
43	SB	-

Connector No.	E108
Connector Name	WIRE TO WIRE
Connector Type	NS5MMH-CS



Terminal No.	Color of Wire	Signal Name [Specification]
1	W	-
2	R	-
3	L	-
4	R	-

Connector No.	E109
Connector Name	WIRE TO WIRE
Connector Type	TH62MM-NH

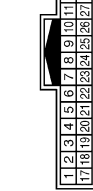

Terminal No.	Color of Wire	Signal Name [Specification]
1	W	-
2	R	-
3	Y	-
4	G	-
5	BR	-
6	L	-
7	O	-
8	V	-
9	SB	-
10	LG	-
11	L	-
17	LG	-
18	BR	-
19	O	-
20	V	-
21	SB	-
22	L	-
23	G	-

24	Y	-
25	W/L	-
26	L/Y	-
27	L/O	-
28	GR	-
29	P	-
30	R	-
31	W	-

Connector No.	E112
Connector Name	ASC'D BRAKE SWITCH
Connector Type	MD2FER-LC



Terminal No.	Color of Wire	Signal Name [Specification]
1	G	-
2	O	-

Connector No.	E201
Connector Name	BATTERY TERMINAL WITH FUSIBLE LINK
Connector Type	-



Terminal No.	Color of Wire	Signal Name [Specification]
6	B/R	-

JCCWA0170GB

EV CONTROL SYSTEM

Connector No.	E202
Connector Name	DC/DC-J/B
Connector Type	-



Terminal No.	Color of Wire	Signal Name [Specification]
17	B/R	BATTERY POWER SUPPLY

Connector No.	E301
Connector Name	COOLING FAN CONTROL MODULE (COOLING FAN MOTOR-1)
Connector Type	6188-0299



Terminal No.	Color of Wire	Signal Name [Specification]
4	-	-
5	-	-

Connector No.	E302
Connector Name	COOLING FAN CONTROL MODULE (COOLING FAN MOTOR-2)
Connector Type	6188-0299



Terminal No.	Color of Wire	Signal Name [Specification]
6	-	-
7	-	-

Connector No.	F1
Connector Name	WIRE TO WIRE
Connector Type	SA33PF-RS10-SJ22

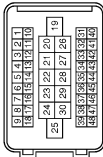

Terminal No.	Color of Wire	Signal Name [Specification]
1	Y	-
2	L	-
3	GR	-
4	LG	-
5	P	-
6	B	-
8	W	-
10	R	-
11	W	-
12	O	-
13	G	-
14	V	-
15	SB	-
16	LG	-
17	BR	-
18	Y	-
20	V	-
21	G	-
22	LG	-
23	B	-
26	SB	-
27	R	-
28	Y	-
29	W	-
30	P	-
31	L	-
32	W	-
33	Y	-
34	R	-
35	G	-
36	LG	-
37	O	-
37	O	- [With quick charge port]
37	O	- [Without quick charge port]
38	B	-
40	BR	-
41	O	-
42	SB	-
43	L	-

44	LG	-
47	V	-
48	P	-

Connector No.	F2
Connector Name	WIRE TO WIRE
Connector Type	RH1ZFB

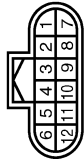

Terminal No.	Color of Wire	Signal Name [Specification]
1	L/W	-
2	LG	-
3	L	-
4	G	-
5	L	-
6	G	-
7	V	-
8	Y/V	-
9	V	-
10	O	-
11	R/Y	-
12	W/R	-

Connector No.	F11
Connector Name	DC/DC-J/B
Connector Type	RH1ZFB

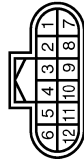

Terminal No.	Color of Wire	Signal Name [Specification]
1	L	-
2	Y/V	-
3	R	-
4	V	-
5	P	-

6	O	-
7	LG	-
8	Y	-
9	L/W	-
10	W	-
11	R	BATTERY POWER SUPPLY
12	V	QUICK CHARGE RELAY POWER SUPPLY

Connector No.	F12
Connector Name	DC/DC-J/B
Connector Type	RH04FB



Terminal No.	Color of Wire	Signal Name [Specification]
13	W/R	-
14	R/Y	-
15	O	-
16	V	-

Connector No.	M2
Connector Name	TCU
Connector Type	TH06PW-RH

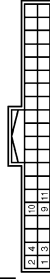

Terminal No.	Color of Wire	Signal Name [Specification]
1	BR	BATTERY POWER SUPPLY
2	B	GROUND
3	G	ACC POWER SUPPLY
4	V	POWER SWITCH ON SIGNAL
9	L	EV SYSTEM CAN-H
10	G	EV SYSTEM CAN-L
11	LG	EV SYSTEM ACTIVATION REQUEST SIGNAL

EV CONTROL SYSTEM

Connector No.	M4
Connector Name	DATA LINK CONNECTOR
Connector Type	BD18EV

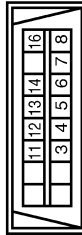

Terminal No.	Color of Wire	Signal Name [Specification]
3	LG	-
4	B	-
5	B	-
6	L	-
7	GR	-
8	G	-
11	SB	-
12	G	-
13	L	-
14	P	-
16	Y	-

Connector No.	M33
Connector Name	COMBINATION SWITCH (SPIRAL CABLE)
Connector Type	TK08FGY-1V



Terminal No.	Color of Wire	Signal Name [Specification]
24	BR	-
25	LG	-
26	B	-
31	Y	-
32	SB	-
33	SHIELD	-
34	G	-

Connector No.	M34
Connector Name	COMBINATION METER
Connector Type	TH40FPV-NH



Terminal No.	Color of Wire	Signal Name [Specification]
1	LG	BATTERY POWER SUPPLY
2	R	BATTERY POWER SUPPLY (FOR UPPER METER)
3	GR	POWER SWITCH SUPPLY
4	BR	POWER SWITCH SUPPLY (FOR UPPER METER)
5	B	GROUND
6	V	GROUND
7	B	ELECTRIC SHIFT WARNING SIGNAL
8	Y	WASHER LEVEL SWITCH SIGNAL
9	G	PLUG IN SIGNAL
10	L	COMMUNICATION SIGNAL (METER → VSP)
11	P	COMMUNICATION SIGNAL (VSP → METER)
12	V	METER CONTROL SWITCH GROUND
13	LG	ENTER SWITCH SIGNAL
14	W	TRIP RESET SWITCH SIGNAL
15	BR	ILLUMINATION CONTROL SWITCH SIGNAL
16	BR	ILLUMINATION CONTROL SIGNAL (FOR UPPER METER)
17	V	CAN-L
18	P	CAN-H
19	L	SEAT BELT BUCKLE SWITCH SIGNAL (PASSENGER SIDE)
22	GR	GROUND (FOR UPPER METER)
24	BR	ELECTRIC PARKING BRAKE CONTROL MODULE WARNING SIGNAL
25	SB	BRAKE FLUID LEVEL SWITCH SIGNAL
26	B	ILLUMINATION CONTROL SIGNAL
27	R	AIR BAG SIGNAL
28	R	SECURITY SIGNAL
30	GR	VEHICLE SPEED SIGNAL (3-PULSE)
32	W	COMMUNICATION SIGNAL (METER → UPPER)
33	LG	CLOCK SIGNAL
34	L	PLUG IN INDICATOR LAMP SIGNAL
38	V	LED HEADLAMP (RH) WARNING SIGNAL
39	LG	LED HEADLAMP (LH) WARNING SIGNAL
40	Y	SEAT BELT BUCKLE SWITCH SIGNAL (DRIVER SIDE)

Connector No.	M47
Connector Name	APPROACHING VEHICLE SOUND FOR PEDESTRIANS (VSP) CONTROL UNIT
Connector Type	TH18FV-NH



Terminal No.	Color of Wire	Signal Name [Specification]
1	B	GROUND
2	L	COMMUNICATION SIGNAL (METER → VSP)
3	SB	POWER SWITCH SIGNAL
4	P	COMMUNICATION SIGNAL (VSP → METER)
5	G	VSP OFF SWITCH SIGNAL
6	Y	CHARGE PULSE SIGNAL
7	L	VSP SPEAKER SIGNAL (-)
8	Y	VSP SPEAKER SIGNAL (+)
10	GR	R-LINE (CONSULT)
11	GR	POWER SWITCH SUPPLY
12	SB	STOP LAMP SWITCH SIGNAL
13	L	BATTERY POWER SUPPLY
14	LG	VSP OFF INDICATOR SIGNAL
15	R	STRAT UP SOUND SPEAKER SIGNAL (-)
16	W	STRAT UP SOUND SPEAKER SIGNAL (+)

Connector No.	M85
Connector Name	IMMEDIATE CHARGING SWITCH
Connector Type	TH08FGY-NH

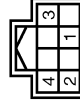

Terminal No.	Color of Wire	Signal Name [Specification]
1	Y	-
2	SB	-
3	W	ILLUMINATION +
4	B	ILLUMINATION -

Connector No.	M70
Connector Name	BGM (BODY CONTROL MODULE)
Connector Type	TH40FPV-NH



Terminal No.	Color of Wire	Signal Name [Specification]
75	LG	DR DOOR REQ SW
76	SB	POWER SW (PUSH SW)
78	P	DRIVER DOOR ANT+
79	V	DRIVER DOOR ANT-
80	LG	PASS DOOR ANT+
81	Y	PASS DOOR ANT-
82	W	REAR BEMR ANT+
83	B	REAR BEMR ANT-
84	BR	ROOM ANT 1+
85	Y	ROOM ANT 1-
86	G	ROOM ANT 2+
87	R	ROOM ANT 2-
88	V	LUGGAGE ROOM ANT-
89	LG	LUGGAGE ROOM ANT-
90	W	POWER SW ILL PWR
91	V	ACC 7 ON IND
92	B	POWER SW ILL GND CONT
93	GR	I-KEY WARN BUZZER
96	BR	ACC RELAY COAT
97	W	READY
98	G	IGN RELAY (IPDM F/R) CONT
99	R	IGN RELAY (F/B) CONT
100	P	PASS DOOR REQ SW
102	R	PAN POSITION
104	LG	WAKE-UP
106	P	STOP LAMP SW 2

EV CONTROL SYSTEM

Connector No.	M77
Connector Name	WIRE TO WIRE
Connector Type	TH8DFV-CST6-TM4

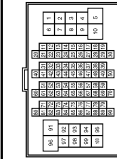

Terminal No.	Color of Wire	Signal Name [Specification]
1	GR	
2	V	
3	GR	
4	LG	
5	W	
6	W	
7	V	
8	P	
9	SB	
10	L	
11	LG	
12	W	
13	R	
14	Y	
15	R	
16	G	
17	BR	
19	G	
20	G	
21	P	
22	LG	
23	GR	
24	L	
25	Y	
26	G	
27	L	
29	V	
30	W	
31	SB	
32	LG	
33	V	
34	L	
35	SB	
38	LG	
39	GR	
40	Y	
41	R	
42	W	
43	SB	

Connector No.	M89
Connector Name	WIRE TO WIRE
Connector Type	TH8DFV-NH



Terminal No.	Color of Wire	Signal Name [Specification]
1	V	
2	P	
3	SB	
4	LG	

Terminal No.	Color of Wire	Signal Name [Specification]
1	V	
2	P	
3	SB	
4	L	

Connector No.	M302
Connector Name	COMBINATION SWITCH (SPIRAL CABLE)
Connector Type	TK08FGY



Terminal No.	Color of Wire	Signal Name [Specification]
13	R	
14	W	
15	L	
16	B	
17	BR	
18	G	
19	Y	
20	Y	

Connector No.	M100
Connector Name	WIRE TO WIRE
Connector Type	TH0AMW-NH



Terminal No.	Color of Wire	Signal Name [Specification]
1	V	
2	P	
3	SB	
4	L	

Connector No.	M101
Connector Name	CHARGING STATUS INDICATOR
Connector Type	TH8DFV-NH



44	GR	
45	P	
46	R	
47	W	
48	L	
49	G	
50	L	
51	L	
54	W	
55	G	
56	BR	
57	P	
58	R	
60	Y	
61	GR	
62	SB	
63	Y	
64	G	
65	V	
66	P	
67	Y	
68	P	
69	BR	
71	Y	
72	L	
73	G	
74	L	
75	V	
76	R	
80	W	
81	L	
82	SB	
83	R	
84	BR	
85	R	
86	GR	
88	R	
89	W	
90	SHIELD	
91	Y	
92	BR	
93	W	
94	P	
95	V	
96	P	
97	G	
98	R	
99	LG	

A
B
EVB
D
E
F
G
H
I
J
K
L
M
N
O
P

BASIC INSPECTION

DIAGNOSIS AND REPAIR WORK FLOW

Work Flow

INFOID:000000007592288

DETAILED FLOW

1.GET INFORMATION FOR SYMPTOM

Get the detailed information from the customer about the symptom (the condition and the environment when the incident/malfunction occurred) using the "Question sheet". (Refer to [EVB-287, "Diagnostic Work Sheet"](#).)

>> GO TO 2.

2.CHECK DTC IN VCM

1. Check DTC in VCM.
2. Check related service bulletins for information.

Are any DTCs detected?

- YES >> Check the DTC. Refer to [EVC-84, "DTC Index"](#).
NO >> GO TO 3.

3.CHECK DTC

1. Check DTC.
2. Perform the following procedure if DTC is displayed.
 - Record DTC and freeze frame data. (Print them out with CONSULT.)
 - Erase DTC.
 - Study the relationship between the cause detected by DTC and the symptom described by the customer. (Symptom Matrix Chart is useful. Refer to [EVC-355, "Symptom Index"](#).)
3. Check related service bulletins for information.

Are any symptoms described and any DTCs detected?

- Symptom is described, DTC is detected>>GO TO 4.
Symptom is described, DTC is not detected>>GO TO 5.
Symptom is not described, DTC is detected>>GO TO 6.

4.CONFIRM THE SYMPTOM

Try to confirm the symptom described by the customer.
Also study the normal operation and fail-safe related to the symptom. Refer to [EVC-355, "Symptom Index"](#) and [EVB-263, "Fail-safe"](#).

Diagnosis Work Sheet is useful to verify the incident.

Verify relation between the symptom and the condition when the symptom is detected.

>> GO TO 6.

5.CONFIRM THE SYMPTOM

Try to confirm the symptom described by the customer.
Also study the normal operation and fail-safe related to the symptom. Refer to [EVC-355, "Symptom Index"](#) and [EVB-263, "Fail-safe"](#).

Diagnosis Work Sheet is useful to verify the incident.

Verify relation between the symptom and the condition when the symptom is detected.

>> GO TO 7.

6.PERFORM DTC CONFIRMATION PROCEDURE

Perform DTC CONFIRMATION PROCEDURE for the displayed DTC, and then check that DTC is detected again.

NOTE:

- Freeze frame data is useful if the DTC is not detected.

DIAGNOSIS AND REPAIR WORK FLOW

[TYPE 2]

< BASIC INSPECTION >

- Perform Component Function Check if DTC CONFIRMATION PROCEDURE is not included on Service Manual. This simplified check procedure is an effective alternative though DTC cannot be detected during this check.
If the result of Component Function Check is NG, it is the same as the detection of DTC by DTC CONFIRMATION PROCEDURE.

Is DTC detected?

- YES >> GO TO 8.
- NO >> Check according to [GI-51, "Intermittent Incident"](#).

7. DETECT MALFUNCTIONING SYSTEM BY SYMPTOM TABLE

Detect malfunctioning system according to [EVC-355, "Symptom Index"](#) based on the confirmed symptom in step 4, and determine the trouble diagnosis order based on possible causes and symptoms.

Is the symptom described?

- YES >> GO TO 8.
- NO >> Monitor input data from related sensors using CONSULT.

8. DETECT MALFUNCTIONING PART BY DIAGNOSIS PROCEDURE

Inspect according to Diagnosis Procedure of the system.

Is a malfunctioning part detected?

- YES >> GO TO 9.
- NO >> Monitor input data from related sensors using CONSULT.

9. REPAIR OR REPLACE THE MALFUNCTIONING PART

1. Repair or replace the malfunctioning part.
2. Reconnect parts or connectors disconnected during Diagnosis Procedure again after repair and replacement.
3. Check DTC. If DTC is displayed, erase it.

>> GO TO 10.

10. FINAL CHECK

When DTC was detected in step 3, perform DTC CONFIRMATION PROCEDURE or Component Function Check again, and then check that the malfunction have been completely repaired.

When symptom was described from the customer, refer to confirmed symptom in step 4 or 5, and check that the symptom is not detected.

Is DTC detected and does symptom remain?

- YES-1 >> DTC is detected: GO TO 8.
- YES-2 >> Symptom remains: GO TO 5.
- NO >> Before returning the vehicle to the customer, always erase DTC.

Diagnostic Work Sheet

INFOID:000000007592289

DESCRIPTION

There are many operating conditions that lead to the malfunction of "EV battery system" components. A good grasp of such conditions can make troubleshooting faster and more accurate.

In general, each customer feels differently about symptoms. It is important to fully understand the symptoms or conditions for a customer complaint.

Utilize the diagnostic worksheet in order to organize all the information for troubleshooting.

NOTE:

Some conditions may cause a DTC to be detected.

KEY POINTS

- WHAT** Vehicle & motor model
- WHEN** Date, Frequencies
- WHERE**..... Road conditions
- HOW** Operating conditions,
Weather conditions,
Symptoms

JSCIA0412GB

WORKSHEET SAMPLE

DIAGNOSIS AND REPAIR WORK FLOW

< BASIC INSPECTION >

[TYPE 2]

Question Sheet

Customer name MR/MS	Incident Date	VIN		
	Model & Year	In Service Date		
	Trans.	Mileage	km/mile	
Symptoms	<input type="checkbox"/> Does not to READY <input type="checkbox"/> EV system warning lamp is on <input type="checkbox"/> Power limitation indicator lamp is on			
	<input type="checkbox"/> Water leak* <input type="checkbox"/> Noise* <input type="checkbox"/> Vibration* <input type="checkbox"/> Shock* <input type="checkbox"/> Gear noise*			
	<input type="checkbox"/> Non driving* <input type="checkbox"/> Poor acceleration* <input type="checkbox"/> Poor torque* <input type="checkbox"/> Radio noise*			
	<input type="checkbox"/> Does not charge <input type="checkbox"/> Other* *: If applied, enter in detail			
	Detailed symptom			
	Onomatopoeia			
Frequency	<input type="checkbox"/> All the time <input type="checkbox"/> Once <input type="checkbox"/> Sometimes (times a day) <input type="checkbox"/> Other			
Charging condition	<input type="checkbox"/> Full <input type="checkbox"/> Medium <input type="checkbox"/> Low			
Weather conditions	<input type="checkbox"/> Not affected			
	Weather	<input type="checkbox"/> Fine <input type="checkbox"/> Clouding <input type="checkbox"/> Raining <input type="checkbox"/> Snowing <input type="checkbox"/> Other ()		
	Temp.	<input type="checkbox"/> Hot <input type="checkbox"/> Warm <input type="checkbox"/> Cool <input type="checkbox"/> Cold <input type="checkbox"/> Temp. [Approx. °C (°F)]		
	Humidity	<input type="checkbox"/> High <input type="checkbox"/> Middle <input type="checkbox"/> Low <input type="checkbox"/> Humidity (Approx. %)		
Road conditions	<input type="checkbox"/> Not affected <input type="checkbox"/> In town <input type="checkbox"/> Freeway <input type="checkbox"/> Off road (Up / Down) <input type="checkbox"/> Deplorable road			
	<input type="checkbox"/> Flat road <input type="checkbox"/> While turning (Right / Left) <input type="checkbox"/> Bump			
	<input type="checkbox"/> Other			
Shift position	<input type="checkbox"/> Not affected			
	<input type="checkbox"/> P position <input type="checkbox"/> R position <input type="checkbox"/> N position <input type="checkbox"/> D position <input type="checkbox"/> ECO mode			
Driving conditions	<input type="checkbox"/> Not affected			
	<input type="checkbox"/> Power switch ON → OFF <input type="checkbox"/> Power switch OFF → ON <input type="checkbox"/> READY (stop the vehicle)			
	<input type="checkbox"/> While cruising <input type="checkbox"/> While decelerating <input type="checkbox"/> Just before stopping <input type="checkbox"/> Just after stopping <input type="checkbox"/> D position (stop the vehicle)			
	<input type="checkbox"/> While recharging <input type="checkbox"/> Other			
	<input type="checkbox"/> Vehicle speed [km/h (MPH)] <input type="checkbox"/> Accelerator pedal (/ 8)			
	<input type="checkbox"/> Battery level (Low / Middle / High)			
Moments when mal-function disappears	<input type="checkbox"/> Disappears while driving <input type="checkbox"/> Disappears when stopped <input type="checkbox"/> Disappears with select operation			
	<input type="checkbox"/> Disappears when power switch is pushed OFF <input type="checkbox"/> Disappears when battery charge is stopped <input type="checkbox"/> Does not disappear			
	<input type="checkbox"/> Other			
Other				

ADDITIONAL SERVICE WHEN REPLACING LI-ION BATTERY CONTROLLER

< BASIC INSPECTION >

[TYPE 2]

ADDITIONAL SERVICE WHEN REPLACING LI-ION BATTERY CONTROLLER

Description

INFOID:000000007592290

When a Li-ion Battery Controller (LBC) is replaced, it is necessary to save the battery information stored in LBC to the new LBC.

Whenever any of the following work is performed, make sure to perform the above operation.

- Replace LBC

Work Procedure

INFOID:000000007592291

1. SAVE THE LI-ION BATTERY CONTROLLER (LBC) INTERNAL INFORMATION

Ⓜ With CONSULT

1. Select "SAVE BATTERY INFORMATION DATA" in "WORK SUPPORT" mode.
2. Save the LBC internal information.

>> GO TO 2.

2. REPLACE LI-ION BATTERY OR LBC

Replace Li-ion battery or LBC. Refer to [EVB-395, "Removal and Installation"](#) (Li-ion battery) or [EVB-419, "LI-ION BATTERY CONTROLLER : Disassembly and Assembly"](#) (LBC).

>> GO TO 3.

3. WRITE THE LBC INTERNAL INFORMATION

Ⓜ With CONSULT

1. Select "WRITE BATTERY INFORMATION DATA" in "WORK SUPPORT" mode.
2. Write the information that has been read out before LBC replacement.

>> GO TO 4.

4. WRITE THE LBC INTERNAL INFORMATION TO VCM

Refer to "Li-ion Battery Registration Operation Manual."

>> END

A
B
EVB
D
E
F
G
H
I
J
K
L
M
N
O
P

MODULE CHARGE BALANCE

Description

INFOID:000000007592292

If a malfunction (e.g. abnormal voltage) occurs in a Li-ion battery cell, the module which includes the malfunctioning cell must be replaced. When replacing a module with a new one, its voltage is required to be adjusted to the adjusting voltage calculated from the maximum cell voltage of normal cells.

Work Procedure

INFOID:000000007592293

NOTE:

Voltage adjustment under low temperature conditions may require a long time. To prevent this from occurring, it is advisable to adjust voltage under room temperature conditions [20°C ± 10°C (68°F ± 18°F)].

1. CHECK ADJUSTMENT VOLTAGE VALUE

 With CONSULT

1. Power switch ON.
2. Select "DATA MONITOR" of "HV BAT".
3. Check "MAXIMUM CELL VOLTAGE".
4. Double the "MAXIMUM CELL VOLTAGE" and use that value as the module adjustment value.

Adjustment voltage value : MAXIMUM CELL VOLTAGE × 2

Example: 3.925 V (MAXIMUM CELL VOLTAGE) × 2 = 7.850 V (Adjustment voltage value)

>> GO TO 2.

2. CHECK MODULE VOLTAGE

CAUTION:

For details on the module charge balancer operation, refer to the adjuster operation manual.

1. Set the new module to the module charge balancer.
2. Measure module voltage and compare it with "adjustment voltage value" confirmed in Step 1.

Module voltage is lower than adjustment voltage value >> GO TO 4.

Module voltage is higher than adjustment voltage value >> GO TO 3.

3. DISCHARGE OF MODULE VOLTAGE

CAUTION:

For details on the module charge balancer operation, refer to the adjuster operation manual.

Discharge the module to 5.0 V using module charge balancer.

Discharge voltage : 5.0 V

>> GO TO 4.

4. ADJUST VOLTAGE WITH A MODULE CHARGE BALANCER

CAUTION:

For details on the module charge balancer operation, refer to the adjuster operation manual.

1. Enter "adjustment voltage value" into module charge balancer.

Adjustment voltage value : MAXIMUM CELL VOLTAGE × 2

2. Start the voltage adjustment.

>> After module voltage adjustment, GO TO 5.

5. CHECK MODULE VOLTAGE

1. Remove the module from the module charge balancer.
2. Using a circuit tester, check that the module voltage is within the specified range.

MODULE CHARGE BALANCE

< BASIC INSPECTION >

[TYPE 2]

Standard : Adjustment voltage value ± 10 mV

A

>> GO TO 6.

6.CHECK CELL VOLTAGE

B

Ⓜ With CONSULT

1. After adjusting the voltage, install the module to the vehicle.
2. Select "DATA MONITOR" of "HV BAT".
3. Check "CELL VOLTAGE" of install module.
4. Check that the difference from the "MAXIMUM CELL VOLTAGE" confirmed in Step1 is within the specified range.

EVB

D

Standard : MAXIMUM CELL VOLTAGE ± 33 mV

E

>> WORK END

F

G

H

I

J

K

L

M

N

O

P

P0A0D HV SYSTEM INTERLOCK ERROR

< DTC/CIRCUIT DIAGNOSIS >

[TYPE 2]

DTC/CIRCUIT DIAGNOSIS

P0A0D HV SYSTEM INTERLOCK ERROR

DTC Logic

INFOID:000000007592299

DTC DETECTION LOGIC

DTC	Trouble diagnosis name	DTC detecting condition	Possible causes
P0A0D	HV SYSTEM INTERLOCK ERROR	Self diagnosis program of Li-ion battery controller detects a malfunction in the CPU.	Li-ion battery controller

DTC CONFIRMATION PROCEDURE

1. PERFORM DTC CONFIRMATION PROCEDURE

④ With CONSULT

1. Power switch ON and wait for 10 seconds or more.
2. Select "Self Diagnostic Result" of "HV BAT".
3. Check DTC.

Is P0A1F detected?

- YES >> Refer to [EVB-292, "Diagnosis Procedure"](#).
NO >> INSPECTION END

Diagnosis Procedure

INFOID:000000007592300

WARNING:

- Because hybrid vehicles and electric vehicles contain a high voltage battery, there is the risk of electric shock, electric leakage, or similar accidents if the high voltage component and vehicle are handled incorrectly. Be sure to follow the correct work procedures when performing inspection and maintenance.
- Be sure to remove the service plug in order to disconnect the high voltage circuits before performing inspection or maintenance of high voltage system harnesses and parts.
- To prevent the removed service plug from being connected by mistake during the procedure, always carry it in your pocket or put it in the tool box.
- Be sure to wear insulating protective equipment consisting of glove, shoes, face shield and glasses before beginning work on the high voltage system.
- Clearly identify the persons responsible for high voltage work and ensure that other persons do not touch the vehicle. When not working, cover high voltage parts with an insulating cover sheet or similar item to prevent other persons from contacting them.
- Refer to [EVB-229, "High Voltage Precautions"](#).

CAUTION:

There is the possibility of a malfunction occurring if the vehicle is changed to READY status while the service plug is removed. Therefore do not change the vehicle to READY status unless instructed to do so in the Service Manual.

1. PRECONDITIONING

WARNING:

Disconnect high voltage. Refer to [GI-31, "How to Disconnect High Voltage"](#).

1. Remove Li-ion battery. Refer to [EVB-395, "Removal and Installation"](#).
2. Remove battery pack upper case. Refer to [EVB-412, "BATTERY JUNCTION BOX : Disassembly and Assembly"](#), see Step-1 to Step-3.

>> GO TO 2.

2. CHECK LI-ION BATTERY INTERLOCK DETECTIONING CIRCUIT FOR SHORT-1

1. Disconnect Li-ion battery controller (LBC) harness connector.
2. Disconnect interlock detecting switch (high voltage harness connector) harness connector.
3. Check the continuity between Li-ion battery controller harness connector and ground.

P0A0D HV SYSTEM INTERLOCK ERROR

< DTC/CIRCUIT DIAGNOSIS >

[TYPE 2]

LBC		—	Continuity
Connector	Terminal		
LB9	8	Ground	Not existed

Is the inspection result normal?

YES >> GO TO 3.

NO >> Replace Li-ion battery vehicle communication harness.

3. CHECK LI-ION BATTERY INTERLOCK DETECTIONING CIRCUIT FOR SHORT-2

1. Disconnect interlock detecting switch (service plug) harness connector.
2. Check the continuity between Li-ion battery controller harness connector and ground.

LBC		—	Continuity
Connector	Terminal		
LB9	21	Ground	Not existed

Is the inspection result normal?

YES >> GO TO 4.

NO >> Replace Li-ion battery vehicle communication harness.

4. CHECK LI-ION BATTERY INTERLOCK DETECTIONING CIRCUIT FOR SHORT-3

Check the continuity between interlock detecting switch (service plug) harness connector and ground.

Interlock detecting switch (Service plug)		—	Continuity
Connector	Terminal		
LB6	4	Ground	Not existed

Is the inspection result normal?

YES >> Replace Li-ion battery controller. Refer to [EVB-419, "LI-ION BATTERY CONTROLLER : Disassembly and Assembly"](#).

NO >> Replace Li-ion battery vehicle communication harness.

A
B
EVB
D
E
F
G
H
I
J
K
L
M
N
O
P

P0A1F BATTERY ENERGY CONTROL MODULE

< DTC/CIRCUIT DIAGNOSIS >

[TYPE 2]

P0A1F BATTERY ENERGY CONTROL MODULE

DTC Logic

INFOID:000000007592349

DTC DETECTION LOGIC

DTC	Trouble diagnosis name	DTC detecting condition	Possible causes
P0A1F	BATTERY ENERGY CONTROL MODULE	Self diagnosis program of Li-ion battery controller detects a malfunction in the CPU.	Li-ion battery controller

DTC CONFIRMATION PROCEDURE

1. PERFORM DTC CONFIRMATION PROCEDURE

④ With CONSULT

1. Power switch ON and wait for 10 seconds or more.
2. Select "Self Diagnostic Result" of "HV BAT".
3. Check DTC.

Is P0A1F detected?

- YES >> Refer to [EVB-294, "Diagnosis Procedure"](#).
NO >> INSPECTION END

Diagnosis Procedure

INFOID:000000007592350

When this DTC is detected, replace Li-ion battery controller. Refer to [EVB-419, "LI-ION BATTERY CONTROLLER : Disassembly and Assembly"](#).

P3030 CELL CONTROLLER LIN

< DTC/CIRCUIT DIAGNOSIS >

[TYPE 2]

P3030 CELL CONTROLLER LIN

DTC Logic

INFOID:000000007592351

DTC DETECTION LOGIC

DTC	Trouble diagnosis name	DTC detecting condition	Possible causes
P3030	CELL CONT LIN	A malfunction occurs with the communication function in Li-ion battery controller.	<ul style="list-style-type: none">• Li-ion battery controller• Module• Harness or connector

DTC CONFIRMATION PROCEDURE

1. PERFORM DTC CONFIRMATION PROCEDURE

④ With CONSULT

1. Power switch ON and wait for 10 seconds or more.
2. Select "Self Diagnostic Result" of "HV BAT".
3. Check DTC.

Is P3030 detected?

- YES >> Refer to [EVB-295, "Diagnosis Procedure"](#).
NO >> INSPECTION END

Diagnosis Procedure

INFOID:000000007592352

1. PERFORM THE SELF-DIAGNOSIS OF LI-ION BATTERY CONTROLLER

④ With CONSULT

1. Select "Self Diagnostic Result" of "HV BAT".
2. Check to see if "P30F3" is detected simultaneously with "P3030".

Is P30F3 detected?

- YES >> Replace Li-ion battery. Refer to [EVB-395, "Removal and Installation"](#).
NO >> Replace Li-ion battery controller. Refer to [EVB-419, "LI-ION BATTERY CONTROLLER : Disassembly and Assembly"](#).

P3031-P303C CELL CONTROLLER ASIC

< DTC/CIRCUIT DIAGNOSIS >

[TYPE 2]

P3031-P303C CELL CONTROLLER ASIC

DTC Logic

INFOID:000000007592353

DTC DETECTION LOGIC

DTC	Trouble diagnosis name	DTC detecting condition	Possible causes
P3031	CELL CONT ASIC1	A malfunction occurs with the communication function in Li-ion battery controller.	Li-ion battery controller
P3032	CELL CONT ASIC2		
P3033	CELL CONT ASIC3		
P3034	CELL CONT ASIC4		
P3035	CELL CONT ASIC5		
P3036	CELL CONT ASIC6		
P3037	CELL CONT ASIC7		
P3038	CELL CONT ASIC8		
P3039	CELL CONT ASIC9		
P303A	CELL CONT ASIC10		
P303B	CELL CONT ASIC11		
P303C	CELL CONT ASIC12		

DTC CONFIRMATION PROCEDURE

1. PERFORM DTC CONFIRMATION PROCEDURE

④ With CONSULT

1. Power switch ON and wait for 10 seconds or more.
2. Select "Self Diagnostic Result" of "HV BAT".
3. Check DTC.

Is any DTC detected?

- YES >> Refer to [EVB-296, "Diagnosis Procedure"](#).
NO >> INSPECTION END

Diagnosis Procedure

INFOID:000000007592354

1. PERFORM THE SELF-DIAGNOSIS OF LI-ION BATTERY CONTROLLER

④ With CONSULT

1. Select "Self Diagnostic Result" of "HV BAT".
2. Check to see if "P3030" is detected simultaneously with "P3031 -P303C".

Is P3030 detected?

- YES >> Perform diagnosis on the detected P3030. Refer to [EVB-295, "Diagnosis Procedure"](#).
NO >> Replace Li-ion battery controller. Refer to [EVB-419, "LI-ION BATTERY CONTROLLER : Disassembly and Assembly"](#).

P303D-P3048 CELL CONTROLLER ASIC

< DTC/CIRCUIT DIAGNOSIS >

[TYPE 2]

P303D-P3048 CELL CONTROLLER ASIC

DTC Logic

INFOID:000000007592355

DTC DETECTION LOGIC

DTC	Trouble diagnosis name	DTC detecting condition	Possible causes
P303D	CELL CONT ASIC13	A malfunction occurs with the communication function in Li-ion battery controller.	Li-ion battery controller
P303E	CELL CONT ASIC14		
P303F	CELL CONT ASIC15		
P3040	CELL CONT ASIC16		
P3041	CELL CONT ASIC17		
P3042	CELL CONT ASIC18		
P3043	CELL CONT ASIC19		
P3044	CELL CONT ASIC20		
P3045	CELL CONT ASIC21		
P3046	CELL CONT ASIC22		
P3047	CELL CONT ASIC23		
P3048	CELL CONT ASIC24		

A
B
C
D
E
F
G
H
I
J
K
L
M
N
O
P

EVB

DTC CONFIRMATION PROCEDURE

1. PERFORM DTC CONFIRMATION PROCEDURE

④ With CONSULT

1. Power switch ON and wait for 10 seconds or more.
2. Select "Self Diagnostic Result" of "HV BAT".
3. Check DTC.

Is any DTC detected?

- YES >> Refer to [EVB-297, "Diagnosis Procedure"](#).
- NO >> INSPECTION END

Diagnosis Procedure

INFOID:000000007592356

1. PERFORM THE SELF-DIAGNOSIS OF LI-ION BATTERY CONTROLLER

④ With CONSULT

1. Select "Self Diagnostic Result" of "HV BAT".
2. Check to see if "P3030" is detected simultaneously with "P303D" -"P3048".

Is P3030 detected?

- YES >> Perform diagnosis on the detected P3030. Refer to [EVB-295, "Diagnosis Procedure"](#).
- NO >> Replace Li-ion battery controller. Refer to [EVB-419, "LI-ION BATTERY CONTROLLER : Disassembly and Assembly"](#).

P3049-P3054 CELL CONTROLLER ASIC VOLTAGE

< DTC/CIRCUIT DIAGNOSIS >

[TYPE 2]

P3049-P3054 CELL CONTROLLER ASIC VOLTAGE

DTC Logic

INFOID:000000007592357

DTC DETECTION LOGIC

DTC	Trouble diagnosis name	DTC detecting condition	Possible causes
P3049	CELL CONT ASIC1 VOLT	The A/D converter in Li-ion battery controller is malfunctioning.	<ul style="list-style-type: none">• Li-ion battery controller• Module• Harness or connector
P304A	CELL CONT ASIC2 VOLT		
P304B	CELL CONT ASIC3 VOLT		
P304C	CELL CONT ASIC4 VOLT		
P304D	CELL CONT ASIC5 VOLT		
P304E	CELL CONT ASIC6 VOLT		
P304F	CELL CONT ASIC7 VOLT		
P3050	CELL CONT ASIC8 VOLT		
P3051	CELL CONT ASIC9 VOLT		
P3052	CELL CONT ASIC10 VOLT		
P3053	CELL CONT ASIC11 VOLT		
P3054	CELL CONT ASIC12 VOLT		

DTC CONFIRMATION PROCEDURE

1. PERFORM DTC CONFIRMATION PROCEDURE

④ With CONSULT

1. Power switch ON and wait for 10 seconds or more.
2. Select "Self Diagnostic Result" of "HV BAT".
3. Check DTC.

Is any DTC detected?

- YES >> Refer to [EVB-298, "Diagnosis Procedure"](#).
NO >> INSPECTION END

Diagnosis Procedure

INFOID:000000007592358

1. PERFORM THE SELF-DIAGNOSIS OF LI-ION BATTERY CONTROLLER

④ With CONSULT

1. Select "Self Diagnostic Result" of "HV BAT".
2. Check DTC.

Is any DTC detected?

YES-1 >> "P3302" - "P3331" are detected simultaneously.

- When "P3302" - "P330D" are detected simultaneously, perform the diagnosis procedure of "P3302" - "P330D". Refer to [EVB-327, "Diagnosis Procedure"](#).
- When "P330E" - "P3319" are detected simultaneously, perform the diagnosis procedure of "P330E" - "P3319". Refer to [EVB-330, "Diagnosis Procedure"](#).
- When "P331A" - "P3325" are detected simultaneously, perform the diagnosis procedure of "P331A" - "P3325". Refer to [EVB-333, "Diagnosis Procedure"](#).
- When "P3326" - "P3331" are detected simultaneously, perform the diagnosis procedure of "P3326" - "P3331". Refer to [EVB-336, "Diagnosis Procedure"](#).

YES-2 >> "P3375" - "P33A4" are detected simultaneously.

- When "P3375" - "P3380" are detected simultaneously, perform the diagnosis procedure of "P3375" - "P3380". Refer to [EVB-340, "Diagnosis Procedure"](#).
- When "P3381" - "P338C" are detected simultaneously, perform the diagnosis procedure of "P3381" - "P338C". Refer to [EVB-343, "Diagnosis Procedure"](#).
- When "P338D" - "P3398" are detected simultaneously, perform the diagnosis procedure of "P338D" - "P3398". Refer to [EVB-346, "Diagnosis Procedure"](#).

P3049-P3054 CELL CONTROLLER ASIC VOLTAGE

< DTC/CIRCUIT DIAGNOSIS >

[TYPE 2]

- When "P3399" - "P33A4" are detected simultaneously, perform the diagnosis procedure of "P3399" - "P33A4". Refer to [EVB-349, "Diagnosis Procedure"](#).
- NO >> When only "P3049" - "P3054" are detected, replace Li-ion battery controller. Refer to [EVB-419, "LI-ION BATTERY CONTROLLER : Disassembly and Assembly"](#).

A

B

EVB

D

E

F

G

H

I

J

K

L

M

N

O

P

P3055-P3060 CELL CONTROLLER ASIC VOLTAGE

< DTC/CIRCUIT DIAGNOSIS >

[TYPE 2]

P3055-P3060 CELL CONTROLLER ASIC VOLTAGE

DTC Logic

INFOID:000000007592359

DTC DETECTION LOGIC

DTC	Trouble diagnosis name	DTC detecting condition	Possible causes
P3055	CELL CONT ASIC13 VOLT	The A/D converter in Li-ion battery controller is malfunctioning.	<ul style="list-style-type: none">• Li-ion battery controller• Module• Harness or connector
P3056	CELL CONT ASIC14 VOLT		
P3057	CELL CONT ASIC15 VOLT		
P3058	CELL CONT ASIC16 VOLT		
P3059	CELL CONT ASIC17 VOLT		
P305A	CELL CONT ASIC18 VOLT		
P305B	CELL CONT ASIC19 VOLT		
P305C	CELL CONT ASIC20 VOLT		
P305D	CELL CONT ASIC21 VOLT		
P305E	CELL CONT ASIC22 VOLT		
P305F	CELL CONT ASIC23 VOLT		
P3060	CELL CONT ASIC24 VOLT		

DTC CONFIRMATION PROCEDURE

1. PERFORM DTC CONFIRMATION PROCEDURE

④ With CONSULT

1. Power switch ON and wait for 10 seconds or more.
2. Select "Self Diagnostic Result" of "HV BAT".
3. Check DTC.

Is any DTC detected?

- YES >> Refer to [EVB-300, "Diagnosis Procedure"](#).
NO >> INSPECTION END

Diagnosis Procedure

INFOID:000000007592360

1. PERFORM THE SELF-DIAGNOSIS OF LI-ION BATTERY CONTROLLER

④ With CONSULT

1. Select "Self Diagnostic Result" of "HV BAT".
2. Check DTC.

Is any DTC detected?

YES-1 >> "P3302" - "P3331" are detected simultaneously.

- When "P3302" - "P330D" are detected simultaneously, perform the diagnosis procedure of "P3302" - "P330D". Refer to [EVB-327, "Diagnosis Procedure"](#).
- When "P330E" - "P3319" are detected simultaneously, perform the diagnosis procedure of "P330E" - "P3319". Refer to [EVB-330, "Diagnosis Procedure"](#).
- When "P331A" - "P3325" are detected simultaneously, perform the diagnosis procedure of "P331A" - "P3325". Refer to [EVB-333, "Diagnosis Procedure"](#).
- When "P3326" - "P3331" are detected simultaneously, perform the diagnosis procedure of "P3326" - "P3331". Refer to [EVB-336, "Diagnosis Procedure"](#).

YES-2 >> "P3375" - "P33A4" are detected simultaneously.

- When "P3375" - "P3380" are detected simultaneously, perform the diagnosis procedure of "P3375" - "P3380". Refer to [EVB-340, "Diagnosis Procedure"](#).
- When "P3381" - "P338C" are detected simultaneously, perform the diagnosis procedure of "P3381" - "P338C". Refer to [EVB-343, "Diagnosis Procedure"](#).
- When "P338D" - "P3398" are detected simultaneously, perform the diagnosis procedure of "P338D" - "P3398". Refer to [EVB-346, "Diagnosis Procedure"](#).

P3055-P3060 CELL CONTROLLER ASIC VOLTAGE

< DTC/CIRCUIT DIAGNOSIS >

[TYPE 2]

- When “P3399” - “P33A4” are detected simultaneously, perform the diagnosis procedure of “P3399” - “P33A4”. Refer to [EVB-349, "Diagnosis Procedure"](#).
- NO >> When only “P3055” - “P3060” are detected, replace Li-ion battery controller. Refer to [EVB-419, "LI-ION BATTERY CONTROLLER : Disassembly and Assembly"](#).

A

B

EVB

D

E

F

G

H

I

J

K

L

M

N

O

P

P3061 CELL BATTERY VOLTAGE

< DTC/CIRCUIT DIAGNOSIS >

[TYPE 2]

P3061 CELL BATTERY VOLTAGE

DTC Logic

INFOID:000000007592361

DTC DETECTION LOGIC

DTC	Trouble diagnosis name	DTC detecting condition	Possible causes
P3061	CELL BATTERY VOLT	An open circuit diagnosis detection circuit in Li-ion battery controller is malfunctioning.	Li-ion battery controller

DTC CONFIRMATION PROCEDURE

1. PERFORM DTC CONFIRMATION PROCEDURE

④ With CONSULT

1. Power switch ON and wait for 10 seconds or more.
2. Select "Self Diagnostic Result" of "HV BAT".
3. Check DTC.

Is P3061 detected?

- YES >> Refer to [EVB-302, "Diagnosis Procedure"](#).
NO >> INSPECTION END

Diagnosis Procedure

INFOID:000000007592362

When this DTC is detected, replace Li-ion battery controller. Refer to [EVB-419, "LI-ION BATTERY CONTROLLER : Disassembly and Assembly"](#).

P3062 BYPASS SWITCH

< DTC/CIRCUIT DIAGNOSIS >

[TYPE 2]

P3062 BYPASS SWITCH

DTC Logic

INFOID:000000007592363

DTC DETECTION LOGIC

DTC	Trouble diagnosis name	DTC detecting condition	Possible causes
P3062	BYPASS SW	A malfunction of the bypass switch in Li-ion battery controller is detected.	<ul style="list-style-type: none">• Li-ion battery controller• Module• Harness or connector

DTC DETECTION LOGIC

1.PERFORM DTC CONFIRMATION PROCEDURE

④ With CONSULT

1. Power switch ON and wait for 10 seconds or more.
2. Select "Self Diagnostic Result" of "HV BAT".
3. Check DTC.

Is P3062 detected?

- YES >> Refer to [EVB-303, "Diagnosis Procedure"](#).
NO >> INSPECTION END

Diagnosis Procedure

INFOID:000000007592364

1.PERFORM THE SELF-DIAGNOSIS OF LI-ION BATTERY CONTROLLER

④ With CONSULT

1. Select "Self Diagnostic Result" of "HV BAT".
2. Check to see if "P3375"- "P33A4" is detected simultaneously with "P3062".

Is P3375-P33A4 detected?

- YES >> • When "P3375" - "P3380" are detected simultaneously, perform the diagnosis procedure of "P3375" - "P3380". Refer to [EVB-340, "Diagnosis Procedure"](#).
• When "P3381" - "P338C" are detected simultaneously, perform the diagnosis procedure of "P3381" - "P338C". Refer to [EVB-343, "Diagnosis Procedure"](#).
• When "P338D" - "P3398" are detected simultaneously, perform the diagnosis procedure of "P338D" - "P3398". Refer to [EVB-346, "Diagnosis Procedure"](#).
• When "P3399" - "P33A4" are detected simultaneously, perform the diagnosis procedure of "P3399" - "P33A4". Refer to [EVB-349, "Diagnosis Procedure"](#).
- NO >> Replace Li-ion battery controller. Refer to [EVB-419, "LI-ION BATTERY CONTROLLER : Disassembly and Assembly"](#).

P308B-P3096 CELL CONTROLLER ASIC OPEN

< DTC/CIRCUIT DIAGNOSIS >

[TYPE 2]

P308B-P3096 CELL CONTROLLER ASIC OPEN

DTC Logic

INFOID:000000007592365

DTC DETECTION LOGIC

DTC	Trouble diagnosis name	DTC detecting condition	Possible causes
P308B	CELL CONT ASIC1 OPEN	Self diagnosis program of Li-ion battery controller detects an open circuit in the cell voltage detection line.	<ul style="list-style-type: none"> • Li-ion battery controller • Harness or connector
P308C	CELL CONT ASIC2 OPEN		
P308D	CELL CONT ASIC3 OPEN		
P308E	CELL CONT ASIC4 OPEN		
P308F	CELL CONT ASIC5 OPEN		
P3090	CELL CONT ASIC6 OPEN		
P3091	CELL CONT ASIC7 OPEN		
P3092	CELL CONT ASIC8 OPEN		
P3093	CELL CONT ASIC9 OPEN		
P3094	CELL CONT ASIC10 OPEN		
P3095	CELL CONT ASIC11 OPEN		
P3096	CELL CONT ASIC12 OPEN		

DTC DETECTION LOGIC

1. PERFORM DTC CONFIRMATION PROCEDURE

Ⓟ With CONSULT

1. Power switch ON and wait for 10 seconds or more.
2. Select "Self Diagnostic Result" of "HV BAT".
3. Check DTC.

Is P308B-P30A2 detected?

- YES >> Refer to [EVB-304, "Diagnosis Procedure"](#).
 NO >> INSPECTION END

Diagnosis Procedure

INFOID:000000007592366

WARNING:

- Because hybrid vehicles and electric vehicles contain a high voltage battery, there is the risk of electric shock, electric leakage, or similar accidents if the high voltage component and vehicle are handled incorrectly. Be sure to follow the correct work procedures when performing inspection and maintenance.
- Be sure to remove the service plug in order to disconnect the high voltage circuits before performing inspection or maintenance of high voltage system harnesses and parts.
- To prevent the removed service plug from being connected by mistake during the procedure, always carry it in your pocket or put it in the tool box.
- Be sure to wear insulating protective equipment consisting of glove, shoes, face shield and glasses before beginning work on the high voltage system.
- Clearly identify the persons responsible for high voltage work and ensure that other persons do not touch the vehicle. When not working, cover high voltage parts with an insulating cover sheet or similar item to prevent other persons from contacting them.
- Refer to [EVB-229, "High Voltage Precautions"](#).

CAUTION:

There is the possibility of a malfunction occurring if the vehicle is changed to READY status while the service plug is removed. Therefore do not change the vehicle to READY status unless instructed to do so in the Service Manual.

1. PERFORM THE SELF-DIAGNOSIS OF LI-ION BATTERY CONTROLLER

Ⓟ With CONSULT

1. Select "Self Diagnostic Result" of "HV BAT".

P308B-P3096 CELL CONTROLLER ASIC OPEN

< DTC/CIRCUIT DIAGNOSIS >

[TYPE 2]

2. Check to see if “P3049”-“P3060” (CELL CONT ASIC VOLT related codes) or “P3375”-“P33A4” (CELL OVER DISCHARGE related codes) is detected simultaneously with “P308B”-“P3096”.

Is P3049-P3060 or P3375-P33A4 detected?

YES-1 >> “P3049”-“P3060” are detected simultaneously.

- When “P3049”-“P3054” are detected simultaneously, perform the diagnosis procedure of “P3049”-“P3054”. Refer to [EVB-298, "Diagnosis Procedure"](#).
- When “P3055”-“P3060” are detected simultaneously, perform the diagnosis procedure of “P3055”-“P3060”. Refer to [EVB-300, "Diagnosis Procedure"](#).

YES-2 >> “P3375”-“P33A4” are detected simultaneously.

- When “P3375”-“P3380” are detected simultaneously, perform the diagnosis procedure of “P3375”-“P3380”. Refer to [EVB-340, "Diagnosis Procedure"](#).
- When “P3381”-“P338C” are detected simultaneously, perform the diagnosis procedure of “P3381”-“P338C”. Refer to [EVB-343, "Diagnosis Procedure"](#).
- When “P338D”-“P3398” are detected simultaneously, perform the diagnosis procedure of “P338D”-“P3398”. Refer to [EVB-346, "Diagnosis Procedure"](#).
- When “P3399”-“P33A4” are detected simultaneously, perform the diagnosis procedure of “P3399”-“P33A4”. Refer to [EVB-349, "Diagnosis Procedure"](#).

NO >> GO TO 2.

2. PRECONDITIONING

WARNING:

Disconnect high voltage. Refer to [GI-31, "How to Disconnect High Voltage"](#).

1. Remove Li-ion battery. Refer to [EVB-395, "Removal and Installation"](#).
2. Remove battery pack upper case. Refer to [EVB-412, "BATTERY JUNCTION BOX : Disassembly and Assembly"](#), see Step-1 to Step-3.

>> GO TO 3.

3. CHECK CONNECTION STATUS

1. Power switch OFF.
2. Check connection status of Li-ion battery controller harness connector and module harness connector.

Is the inspection result normal?

YES >> GO TO 4.

NO >> Recover the connection status.

4. CHECK HARNESS BETWEEN LI-ION BATTERY CONTROLLER AND MODULE

1. Disconnect Li-ion battery controller harness connector and Module harness connector.
2. Refer to below table and continuity between Li-ion battery controller and Module, according to detected DTC.

DTC	Module No.	Module		Li-ion battery controller		Continuity
		Connector	Terminal	Connector	Terminal	
P308B	1	LB9	2	LB13	50	Existed
	2		3		51	
P308C	3	LB9	4	LB13	52	Existed
	4		5		53	
P308D	5	LB9	6	LB13	54	Existed
	6		7		55	
P308E	7	LB9	8	LB13	56	Existed
	8		9		57	
P308F	9	LB9	26	LB13	58	Existed
	10		27		59	
P3090	11	LB9	28	LB13	60	Existed
	12		29		61	

P308B-P3096 CELL CONTROLLER ASIC OPEN

< DTC/CIRCUIT DIAGNOSIS >

[TYPE 2]

DTC	Module No.	Module		Li-ion battery controller		Continuity
		Connector	Terminal	Connector	Terminal	
P3091	13	LB9	30	LB13	62	Existed
	14		31		63	
P3092	15	LB10	45	LB14	77	Existed
	16		46		78	
P3093	17	LB10	36	LB14	80	Existed
	18		37		81	
P3094	19	LB10	38	LB14	82	Existed
	20		39		83	
P3095	21	LB10	52	LB14	84	Existed
	22		53		85	
P3096	23	LB10	54	LB14	86	Existed
	24		55		87	

Is the inspection result normal?

- YES >> Replace Li-ion battery controller. Refer to [EVB-419, "LI-ION BATTERY CONTROLLER : Disassembly and Assembly"](#).
- NO >> Repair harness or connector.

P3097-P30A2 CELL CONTROLLER ASIC OPEN

< DTC/CIRCUIT DIAGNOSIS >

[TYPE 2]

P3097-P30A2 CELL CONTROLLER ASIC OPEN

DTC Logic

INFOID:000000007592367

DTC DETECTION LOGIC

DTC	Trouble diagnosis name	DTC detecting condition	Possible causes
P3097	CELL CONT ASIC13 OPEN	Self diagnosis program of Li-ion battery controller detects an open circuit in the cell voltage detection line.	<ul style="list-style-type: none"> Li-ion battery controller Harness or connector
P3098	CELL CONT ASIC14 OPEN		
P3099	CELL CONT ASIC15 OPEN		
P309A	CELL CONT ASIC16 OPEN		
P309B	CELL CONT ASIC17 OPEN		
P309C	CELL CONT ASIC18 OPEN		
P309D	CELL CONT ASIC19 OPEN		
P309E	CELL CONT ASIC20 OPEN		
P309F	CELL CONT ASIC21 OPEN		
P30A0	CELL CONT ASIC22 OPEN		
P30A1	CELL CONT ASIC23 OPEN		
P30A2	CELL CONT ASIC24 OPEN		

DTC DETECTION LOGIC

1. PERFORM DTC CONFIRMATION PROCEDURE

Ⓜ With CONSULT

- Power switch ON and wait for 10 seconds or more.
- Select "Self Diagnostic Result" of "HV BAT".
- Check DTC.

Is P308B-P30A2 detected?

- YES >> Refer to [EVB-307, "Diagnosis Procedure"](#).
 NO >> INSPECTION END

Diagnosis Procedure

INFOID:000000007592368

WARNING:

- Because hybrid vehicles and electric vehicles contain a high voltage battery, there is the risk of electric shock, electric leakage, or similar accidents if the high voltage component and vehicle are handled incorrectly. Be sure to follow the correct work procedures when performing inspection and maintenance.
- Be sure to remove the service plug in order to disconnect the high voltage circuits before performing inspection or maintenance of high voltage system harnesses and parts.
- To prevent the removed service plug from being connected by mistake during the procedure, always carry it in your pocket or put it in the tool box.
- Be sure to wear insulating protective equipment consisting of glove, shoes, face shield and glasses before beginning work on the high voltage system.
- Clearly identify the persons responsible for high voltage work and ensure that other persons do not touch the vehicle. When not working, cover high voltage parts with an insulating cover sheet or similar item to prevent other persons from contacting them.
- Refer to [EVB-229, "High Voltage Precautions"](#).

CAUTION:

There is the possibility of a malfunction occurring if the vehicle is changed to READY status while the service plug is removed. Therefore do not change the vehicle to READY status unless instructed to do so in the Service Manual.

1. PERFORM THE SELF-DIAGNOSIS OF LI-ION BATTERY CONTROLLER

Ⓜ With CONSULT

- Select "Self Diagnostic Result" mode of "HV BAT" using CONSULT.

P3097-P30A2 CELL CONTROLLER ASIC OPEN

[TYPE 2]

< DTC/CIRCUIT DIAGNOSIS >

2. Check to see if “P3049”-“P3060” (CELL CONT ASIC VOLT related codes) or “P3375”-“P33A4” (CELL OVER DISCHARGE related codes) is detected simultaneously with “P3097”-“P30A2”.

Is P3049-P3060 or P3375-P33A4 detected?

YES-1 >> “P3049”-“P3060” are detected simultaneously.

- When “P3049”-“P3054” are detected simultaneously, perform the diagnosis procedure of “P3049”-“P3054”. Refer to [EVB-298, "Diagnosis Procedure"](#)
- When “P3055”-“P3060” are detected simultaneously, perform the diagnosis procedure of “P3055”-“P3060”. Refer to [EVB-300, "Diagnosis Procedure"](#)

YES-2 >> “P3375”-“P33A4” are detected simultaneously.

- When “P3375”-“P3380” are detected simultaneously, perform the diagnosis procedure of “P3375”-“P3380”. Refer to [EVB-340, "Diagnosis Procedure"](#).
- When “P3381”-“P338C” are detected simultaneously, perform the diagnosis procedure of “P3381”-“P338C”. Refer to [EVB-343, "Diagnosis Procedure"](#).
- When “P338D”-“P3398” are detected simultaneously, perform the diagnosis procedure of “P338D”-“P3398”. Refer to [EVB-346, "Diagnosis Procedure"](#).
- When “P3399”-“P33A4” are detected simultaneously, perform the diagnosis procedure of “P3399”-“P33A4”. Refer to [EVB-349, "Diagnosis Procedure"](#)

NO >> GO TO 2.

2. PRECONDITIONING

WARNING:

Disconnect high voltage. Refer to [GI-31, "How to Disconnect High Voltage"](#).

1. Remove Li-ion battery. Refer to [EVB-395, "Removal and Installation"](#).
2. Remove battery pack upper case. Refer to [EVB-412, "BATTERY JUNCTION BOX : Disassembly and Assembly"](#), see Step-1 to Step-3.

>> GO TO 3.

3. CHECK CONNECTION STATUS

1. Power switch OFF.
2. Check connection status of Li-ion battery controller harness connector and module harness connector.

Is the inspection result normal?

YES >> GO TO 4.

NO >> Recover the connection status.

4. CHECK HARNESS BETWEEN LI-ION BATTERY CONTROLLER AND MODULE

1. Disconnect Li-ion battery controller harness connector and Module harness connector.
2. Refer to below table and continuity between Li-ion battery controller and Module, according to detected DTC.

DTC	Module No.	Module		Li-ion battery controller		Continuity
		Connector	Terminal	Connector	Terminal	
P3097	25	LB8	73	LB15	110	Existed
	26		74		111	
P3098	27	LB8	60	LB15	112	Existed
	28		77		113	
P3099	29	LB8	78	LB15	114	Existed
	30		64		115	
P309A	31	LB8	81	LB15	116	Existed
	32		82		117	
P309B	33	LB8	68	LB15	118	Existed
	34		85		119	
P309C	35	LB8	86	LB15	120	Existed
	36		72		121	

P3097-P30A2 CELL CONTROLLER ASIC OPEN

< DTC/CIRCUIT DIAGNOSIS >

[TYPE 2]

DTC	Module No.	Module		Li-ion battery controller		Continuity
		Connector	Terminal	Connector	Terminal	
P309D	37	LB7	89	LB15	122	Existed
	38		90		123	
P309E	39	LB7	91	LB15	124	Existed
	40		92		125	
P309F	41	LB7	93	LB15	127	Existed
	42		94		128	
P30A0	43	LB7	95	LB15	130	Existed
	44		96		138	
P30A1	45	LB7	97	LB15	140	Existed
	46		98		141	
P30A2	47	LB7	99	LB15	142	Existed
	48		100		143	

Is the inspection result normal?

- YES >> Replace Li-ion battery controller. Refer to [EVB-419, "LI-ION BATTERY CONTROLLER : Disassembly and Assembly"](#).
- NO >> Repair harness or connector.

A
B
EVB
D
E
F
G
H
I
J
K
L
M
N
O
P

P30F3 TOTAL VOLTAGE SENSOR

< DTC/CIRCUIT DIAGNOSIS >

[TYPE 2]

P30F3 TOTAL VOLTAGE SENSOR

DTC Logic

INFOID:000000007592369

DTC DETECTION LOGIC

DTC	Trouble diagnosis name	DTC detecting condition	Possible causes
P30F3	TOTAL VOLT SENSOR	A malfunction occurs with the communication function in Li-ion battery controller.	<ul style="list-style-type: none">• Li-ion battery controller• Module• Harness or connector

DTC CONFIRMATION PROCEDURE

1. PERFORM DTC CONFIRMATION PROCEDURE

④ With CONSULT

1. Power switch ON and wait for 10 seconds or more.
2. Select "Self Diagnostic Result" of "HV BAT".
3. Check DTC.

Is P30F3 detected?

- YES >> Refer to [EVB-310, "Diagnosis Procedure"](#).
NO >> INSPECTION END

Diagnosis Procedure

INFOID:000000007592370

1. PERFORM THE SELF-DIAGNOSIS OF LI-ION BATTERY CONTROLLER

④ With CONSULT

1. Select "Self Diagnostic Result" of "HV BAT".
2. Check to see if "P3030" is detected simultaneously with "P30F3".

Is any P3030 detected?

- YES >> Perform diagnosis on the detected "P3030". Refer to [EVB-295, "Diagnosis Procedure"](#).
NO >> Replace Li-ion battery controller. Refer to [EVB-419, "LI-ION BATTERY CONTROLLER : Disassembly and Assembly"](#).

P30F4 TOTAL VOLTAGE SENSOR

< DTC/CIRCUIT DIAGNOSIS >

[TYPE 2]

P30F4 TOTAL VOLTAGE SENSOR

DTC Logic

INFOID:000000007592979

DTC DETECTION LOGIC

DTC	Trouble diagnosis name	DTC detecting condition	Possible causes
P30F4	TOTAL VOLT SENSOR	When the voltage recognized by total voltage sensor in Li-ion battery controller is excessively high or low.	<ul style="list-style-type: none">• Li-ion battery controller• Bus bar between stack• Service plug (fuse)• Module

DTC CONFIRMATION PROCEDURE

1. PERFORM DTC CONFIRMATION PROCEDURE

④ With CONSULT

1. Power switch ON and wait for 10 seconds or more.
2. Select "Self Diagnostic Result" of "HV BAT".
3. Check DTC.

Is P30F4 detected?

- YES >> Refer to [EVB-311, "Diagnosis Procedure"](#).
NO >> INSPECTION END

Diagnosis Procedure

INFOID:000000007592980

WARNING:

- Because hybrid vehicles and electric vehicles contain a high voltage battery, there is the risk of electric shock, electric leakage, or similar accidents if the high voltage component and vehicle are handled incorrectly. Be sure to follow the correct work procedures when performing inspection and maintenance.
- Be sure to remove the service plug in order to disconnect the high voltage circuits before performing inspection or maintenance of high voltage system harnesses and parts.
- To prevent the removed service plug from being connected by mistake during the procedure, always carry it in your pocket or put it in the tool box.
- Be sure to wear insulating protective equipment consisting of glove, shoes, face shield and glasses before beginning work on the high voltage system.
- Clearly identify the persons responsible for high voltage work and ensure that other persons do not touch the vehicle. When not working, cover high voltage parts with an insulating cover sheet or similar item to prevent other persons from contacting them.
- Refer to [EVB-229, "High Voltage Precautions"](#).

CAUTION:

There is the possibility of a malfunction occurring if the vehicle is changed to READY status while the service plug is removed. Therefore do not change the vehicle to READY status unless instructed to do so in the Service Manual.

1. PERFORM THE SELF-DIAGNOSIS OF LI-ION BATTERY CONTROLLER

④ With CONSULT

1. Select "Self Diagnostic Result" mode of "HV BAT" using CONSULT.
2. Check if any DTC is detected in "Self Diagnostic Result".

Is any DTC detected?

- "P3030" is detected in addition to "P30F4" (Cannot be monitored)>>GO TO 3.
Just "P30F4" is detected>>GO TO 2.

2. CHECK FUSE

1. Power switch OFF.
2. Check fuse of service plug.

Is the inspection result normal?

- YES >> Replace Li-ion battery controller.
NO >> Replace service plug.

P30F4 TOTAL VOLTAGE SENSOR

[TYPE 2]

< DTC/CIRCUIT DIAGNOSIS >

3. PRECONDITIONING

WARNING:

Disconnect high voltage. Refer to [GI-31, "How to Disconnect High Voltage"](#).

1. Remove Li-ion battery. Refer to [EVB-395, "Removal and Installation"](#).
2. Remove battery pack upper case. Refer to [EVB-412, "BATTERY JUNCTION BOX : Disassembly and Assembly"](#), see Step-1 to Step-3.

>> GO TO 4.

4. CHECK CONNECTION STATUS STACK AND BUS BAR.

Check connection status between each stack and connection status of each bus bar.

Is the inspection result normal?

YES >> GO TO 5.

NO >> Recover the connection status.

5. CHECK MODULE VOLTAGE

Check the voltage of all modules.

Is the inspection result normal?

YES >> Replace Li-ion battery controller. Refer to [EVB-419, "LI-ION BATTERY CONTROLLER : Disassembly and Assembly"](#).

NO >> Replace the corresponding module. Refer to [EVB-402, "Exploded view"](#).

Component Inspection

INFOID:000000007592981

1. CHECK MODULE VOLTAGE

Check voltage of module.

A : Positive terminal (Red)

B : Negative terminal (Black)

Terminals		Voltage (Approx.)
(+)	(-)	
Module		5.0 - 8.5 V
Positive terminal (Red)	Negative terminal (Black)	

Is the inspection result normal?

YES >> INSPECTION END

NO >> Replace module. Refer to [EVB-426, "FRONT MODULE STACK : Disassembly and Assembly"](#) (Front module) or [EVB-435, "REAR MODULE STACK : Disassembly and Assembly"](#) (Rear module).

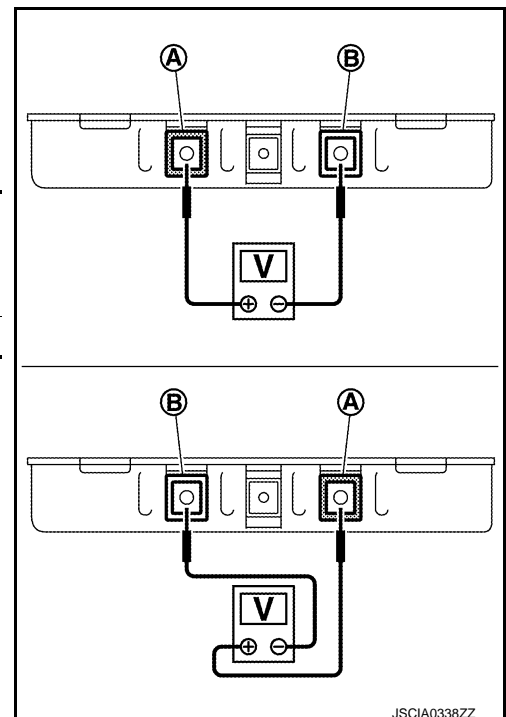

P30F5 TOTAL VOLTAGE SENSOR

< DTC/CIRCUIT DIAGNOSIS >

[TYPE 2]

P30F5 TOTAL VOLTAGE SENSOR

DTC Logic

INFOID:000000007592375

DTC DETECTION LOGIC

DTC	Trouble diagnosis name	DTC detecting condition	Possible causes
P30F5	TOTAL VOLT SENSOR	When the voltage recognized by total voltage sensor in Li-ion battery controller is excessively high or low.	<ul style="list-style-type: none">• Li-ion battery controller• Bus bar between stack• Service plug (fuse)• Module

DTC CONFIRMATION PROCEDURE

1. PERFORM DTC CONFIRMATION PROCEDURE

④ With CONSULT

1. Power switch ON and wait for 10 seconds or more.
2. Select "Self Diagnostic Result" of "HV BAT".
3. Check DTC.

Is P30F5 detected?

- YES >> Refer to [EVB-313, "Diagnosis Procedure"](#).
NO >> INSPECTION END

Diagnosis Procedure

INFOID:000000007592376

1. PERFORM THE SELF-DIAGNOSIS OF LI-ION BATTERY CONTROLLER

④ With CONSULT

1. Select "Self Diagnostic Result" of "HV BAT".
2. Check to see if "P30F4" is detected simultaneously with "P30F5".

Is any P30F4 detected?

- YES >> Perform diagnosis on the detected "P30F4". Refer to [EVB-311, "Diagnosis Procedure"](#).
NO >> Replace Li-ion battery controller. Refer to [EVB-419, "LI-ION BATTERY CONTROLLER : Disassembly and Assembly"](#).

P30FC OVER CURRENT

[TYPE 2]

< DTC/CIRCUIT DIAGNOSIS >

P30FC OVER CURRENT

DTC Logic

INFOID:000000007592377

DTC DETECTION LOGIC

DTC	Trouble diagnosis name	DTC detecting condition	Possible causes
P30FC	OVER CURRENT	When the temperature of the entire battery pack estimated from the current value is excessively high.	<ul style="list-style-type: none">Battery current sensorOther systems malfunction

DTC CONFIRMATION PROCEDURE

1.PERFORM DTC CONFIRMATION PROCEDURE

④With CONSULT

- Power switch ON and wait for 10 seconds or more.
- Select "Self Diagnostic Result" of "HV BAT".
- Check DTC.

Is P30FC detected?

- YES >> Refer to [EVB-314, "Diagnosis Procedure"](#).
NO >> INSPECTION END

Diagnosis Procedure

INFOID:000000007592378

1.PERFORM THE SELF-DIAGNOSIS

④With CONSULT

- Perform "All DTC Reading".
- Check "Self diagnostic result" of systems other than "HV BAT" to see if any DTC is detected.

Is any DTC detected?

- YES >> After performing trouble diagnosis of detected DTC, GO TO 2.
NO >> GO TO 2.

2.CHECK BATTERY TEMPERATURE SENSOR

④With CONSULT

Using FFD, check the values of four temperature sensors when DTC is detected.

Monitor item	Condition	Limit
Battery temperature sensor 1	Power switch ON	55°C (131°F) or less
Battery temperature sensor 2		
Battery temperature sensor 3		
Battery temperature sensor 4		

Is there temperature increase?

- Temperature increase is seen>>Replace Li-ion battery. Refer to [EVB-395, "Removal and Installation"](#).
Temperature increase is not seen>>Replace battery junction box. Refer to [EVB-412, "BATTERY JUNCTION BOX : Disassembly and Assembly"](#).

P30FD TOTAL VOLTAGE MONITOR SWITCH

< DTC/CIRCUIT DIAGNOSIS >

[TYPE 2]

P30FD TOTAL VOLTAGE MONITOR SWITCH

DTC Logic

INFOID:000000007592379

DTC DETECTION LOGIC

DTC	Trouble diagnosis name	DTC detecting condition	Possible causes
P30FD	TOTAL VOLTAGE MONITOR SWITCH	<ul style="list-style-type: none">Total voltage detection switch in Li-ion battery controller is malfunctioning.Self diagnosis malfunction of total voltage detection circuit stop function in Li-ion battery controller.	<ul style="list-style-type: none">Li-ion battery controller

DTC CONFIRMATION PROCEDURE

1. PERFORM DTC CONFIRMATION PROCEDURE

Ⓜ With CONSULT

- Power switch ON and wait for 10 seconds or more.
- Select "Self Diagnostic Result" of "HV BAT".
- Check DTC.

Is P30FC detected?

- YES >> Refer to [EVB-315, "Diagnosis Procedure"](#).
NO >> INSPECTION END

Diagnosis Procedure

INFOID:000000007592380

When this DTC is detected, replace Li-ion battery controller. Refer to [EVB-419, "LI-ION BATTERY CONTROLLER : Disassembly and Assembly"](#).

P30FE 12V BATTERY VOLTAGE

< DTC/CIRCUIT DIAGNOSIS >

[TYPE 2]

P30FE 12V BATTERY VOLTAGE

DTC Logic

INFOID:000000007592429

DTC DETECTION LOGIC

DTC	Trouble diagnosis name	DTC detecting condition	Possible causes
P30FE	12V BATTERY VOLTAGE	12V battery voltage lowers to less than 9 V.	<ul style="list-style-type: none">• 12V battery• Harness

DTC CONFIRMATION PROCEDURE

1. PERFORM DTC CONFIRMATION PROCEDURE

Ⓜ With CONSULT

1. Power switch ON and wait for 10 seconds or more.
2. Select "Self Diagnostic Result" of "HV BAT".
3. Check DTC.

Is P30FE detected?

- YES >> Refer to [EVB-316, "Diagnosis Procedure"](#).
NO >> INSPECTION END

Diagnosis Procedure

INFOID:000000007592430

WARNING:

- Because hybrid vehicles and electric vehicles contain a high voltage battery, there is the risk of electric shock, electric leakage, or similar accidents if the high voltage component and vehicle are handled incorrectly. Be sure to follow the correct work procedures when performing inspection and maintenance.
- Be sure to remove the service plug in order to disconnect the high voltage circuits before performing inspection or maintenance of high voltage system harnesses and parts.
- To prevent the removed service plug from being connected by mistake during the procedure, always carry it in your pocket or put it in the tool box.
- Be sure to wear insulating protective equipment consisting of glove, shoes, face shield and glasses before beginning work on the high voltage system.
- Clearly identify the persons responsible for high voltage work and ensure that other persons do not touch the vehicle. When not working, cover high voltage parts with an insulating cover sheet or similar item to prevent other persons from contacting them.
- Refer to [EVB-229, "High Voltage Precautions"](#).

CAUTION:

There is the possibility of a malfunction occurring if the vehicle is changed to READY status while the service plug is removed. Therefore do not change the vehicle to READY status unless instructed to do so in the Service Manual.

1. CHECK VOLTAGE OF 12 V BATTERY

Check the voltage of 12 V battery using circuit tester.

Is output more than 9 V?

- YES >> GO TO 2.
NO >> Replace 12 V battery. Refer to [PG-108, "Removal and Installation"](#).

2. CHECK FUSE

1. Power switch OFF.
2. Check 20A fuse [No.43].

NOTE:

Refer to [PG-87, "Fuse, Connector and Terminal Arrangement"](#) for fuse layout.

Is the inspection result normal?

- YES >> GO TO 3.
NO >> After eliminating the cause of flame cutting, replace the fuse.

3. CHECK LI-ION BATTERY POWER SUPPLY

P30FE 12V BATTERY VOLTAGE

[TYPE 2]

< DTC/CIRCUIT DIAGNOSIS >

1. Disconnect Li-ion battery vehicle communication harness connector.
2. Check voltage between Li-ion battery harness connector and ground.

+		-	Voltage
Li-ion battery			
Connector	Terminal	Ground	Battery voltage
B24	5		

Is the inspection result normal?

YES >> GO TO 4.

NO >> Repair harness or connector.

4. PRECONDITIONING

WARNING:

Disconnect high voltage. Refer to [GI-31, "How to Disconnect High Voltage"](#).

1. Remove Li-ion battery. Refer to [EVB-395, "Removal and Installation"](#).
2. Remove battery pack upper case. Refer to [EVB-412, "BATTERY JUNCTION BOX : Disassembly and Assembly"](#), see Step-1 to Step-3.

>> GO TO 5.

5. CHECK HARNESS BETWEEN LI-ION BATTERY AND LI-ION BATTERY CONTROLLER

1. Disconnect Li-ion battery harness connector and Li-ion battery controller harness connector.
2. Check continuity between Li-ion battery harness connector and Li-ion battery controller harness connector.

Li-ion battery		Li-ion battery controller		Continuity
Connector	Terminal	Connector	Terminal	
LB1	5	LB11	12	Existed

Is the inspection result normal?

YES >> Replace Li-ion battery controller. Refer to [EVB-192, "LI-ION BATTERY CONTROLLER : Disassembly and Assembly"](#).

NO >> Repair harness or connector.

P318D COMMUNICATION ERROR

< DTC/CIRCUIT DIAGNOSIS >

[TYPE 2]

P318D COMMUNICATION ERROR

DTC Logic

INFOID:000000007592431

DTC DETECTION LOGIC

DTC	Trouble diagnosis name	DTC detecting condition	Possible causes
P318D	COMMUNICATION ERROR	When no CAN communication signal is received continuously.	<ul style="list-style-type: none">• CAN communication line• Li-ion battery controller• VCM

DTC CONFIRMATION PROCEDURE

1. PERFORM DTC CONFIRMATION PROCEDURE

④ With CONSULT

1. Power switch ON and wait for 10 seconds or more.
2. Select "Self Diagnostic Result" of "HV BAT".
3. Check DTC.

Is P318D detected?

YES >> Refer to [EVB-318, "Diagnosis Procedure"](#).

NO >> INSPECTION END

Diagnosis Procedure

INFOID:000000007592432

For the diagnosis procedure, refer to [LAN-15, "Trouble Diagnosis Flow Chart"](#).

P318E COMMUNICATION ERROR

< DTC/CIRCUIT DIAGNOSIS >

[TYPE 2]

P318E COMMUNICATION ERROR

DTC Logic

INFOID:000000007592433

DTC DETECTION LOGIC

NOTE:

When the 12 V battery is removed within 5 minutes after turning the power switch OFF, "P318E", "P3191", and "P3196" may be simultaneously detected. This is not a malfunction.

DTC	Trouble diagnosis name	DTC detecting condition	Possible causes
P318E	COMMUNICATION ERROR	When no CAN communication signal is received from VCM continuously.	<ul style="list-style-type: none">• VCM• Li-ion battery controller• CAN communication line

DTC CONFIRMATION PROCEDURE

1. PERFORM DTC CONFIRMATION PROCEDURE

Ⓜ With CONSULT

1. Power switch OFF.
2. After turning the power switch OFF, get out of the vehicle and close all doors (including back door).
3. After turning the power switch OFF, wait for 5 minutes or more to remove the 12 V battery negative terminal. Refer to [EVB-229, "Precautions for Removing Battery Terminal"](#).
4. Connect 12 V battery negative terminal.
5. Power switch ON and wait for 10 seconds or more.
6. Select "Self Diagnostic Result" of "HV BAT".
7. Check DTC.

Is P318E detected?

- YES >> Refer to [EVB-319, "Diagnosis Procedure"](#).
NO >> INSPECTION END

Diagnosis Procedure

INFOID:000000007592434

1. PERFORM THE SELF-DIAGNOSIS

Ⓜ With CONSULT

1. Perform "All DTC Reading".
2. Check "Self diagnostic result" of systems other than "HV BAT" to see if "P318E" is detected.

Is P318E detected?

- YES >> Replace VCM. Refer to [EVC-377, "Removal and Installation"](#).
NO >> GO TO 2.

2. PERFORM THE SELF-DIAGNOSIS OF LI-ION BATTERY CONTROLLER

Ⓜ With CONSULT

1. Select "Self Diagnostic Result" of "HV BAT".
2. Check to see if "U1000" is detected simultaneously with "P318E".

Is U1000 detected?

- YES >> Replace Li-ion battery controller. Refer to [EVB-419, "LI-ION BATTERY CONTROLLER : Disassembly and Assembly"](#).
NO >> INSPECTION END

P3191 COMMUNICATION ERROR

< DTC/CIRCUIT DIAGNOSIS >

[TYPE 2]

P3191 COMMUNICATION ERROR

DTC Logic

INFOID:000000007592435

DTC DETECTION LOGIC

NOTE:

When the 12 V battery is removed within 5 minutes after turning the power switch OFF, "P318E", "P3191" and "P3196" may be simultaneously detected. This is not a malfunction.

DTC	Trouble diagnosis name	DTC detecting condition	Possible causes
P3191	COMMUNICATION ERROR	When no CAN communication signal is received from traction motor inverter continuously.	<ul style="list-style-type: none">• Traction motor inverter• Li-ion battery controller• CAN communication line

DTC CONFIRMATION PROCEDURE

1. PERFORM DTC CONFIRMATION PROCEDURE

Ⓜ With CONSULT

1. Power switch OFF.
2. After turning the power switch OFF, get out of the vehicle and close all doors (including back door).
3. After turning the power switch OFF, wait for 5 minutes or more to remove the 12 V battery negative terminal. Refer to [EVB-229, "Precautions for Removing Battery Terminal"](#).
4. Connect 12 V battery negative terminal.
5. Power switch ON and wait for 10 seconds or more.
6. Select "Self Diagnostic Result" of "HV BAT".
7. Check DTC.

Is P3191 detected?

- YES >> Refer to [EVB-320, "Diagnosis Procedure"](#).
NO >> INSPECTION END

Diagnosis Procedure

INFOID:000000007592436

1. PERFORM THE SELF-DIAGNOSIS

Ⓜ With CONSULT

1. Perform "All DTC Reading".
2. Check "Self diagnostic result" of systems other than "HV BAT" to see if "P3191" is detected.

Is P3191 detected?

- YES >> Replace traction motor inverter. Refer to [TMS-116, "Removal and Installation"](#)
NO >> GO TO 2.

2. PREFORM THE SELF-DIAGNOSIS OF LI-ION BATTERY CONTROLLER

Ⓜ With CONSULT

1. Select "Self Diagnostic Result" of "HV BAT".
2. Check to see if "U1000" is detected simultaneously with "P3191".

Is U1000 detected?

- YES >> Replace Li-ion battery controller. Refer to [EVB-419, "LI-ION BATTERY CONTROLLER : Disassembly and Assembly"](#).
NO >> INSPECTION END

P3196 COMMUNICATION ERROR

< DTC/CIRCUIT DIAGNOSIS >

[TYPE 2]

P3196 COMMUNICATION ERROR

DTC Logic

INFOID:000000007592437

DTC DETECTION LOGIC

NOTE:

When the 12 V battery is removed within 5 minutes after turning the power switch OFF, "P318E", "P3191" and "P3196" may be simultaneously detected. This is not a malfunction.

DTC	Trouble diagnosis name	DTC detecting condition	Possible causes
P3196	COMMUNICATION ERROR	When no CAN communication signal is received from on-board charger continuously.	<ul style="list-style-type: none">• On board charger• Li-ion battery controller• CAN communication line

DTC CONFIRMATION PROCEDURE

1. PERFORM DTC CONFIRMATION PROCEDURE

Ⓜ With CONSULT

1. Power switch OFF.
2. After turning the power switch OFF, get out of the vehicle and close all doors (including back door).
3. After turning the power switch OFF, wait for 5 minutes or more to remove the 12 V battery negative terminal. Refer to [EVB-229, "Precautions for Removing Battery Terminal"](#).
4. Connect 12 V battery negative terminal.
5. Power switch ON and wait for 10 seconds or more.
6. Select "Self Diagnostic Result" of "HV BAT".
7. Check DTC.

Is P3196 detected?

- YES >> Refer to [EVB-321, "Diagnosis Procedure"](#).
NO >> INSPECTION END

Diagnosis Procedure

INFOID:000000007592438

1. PERFORM THE SELF-DIAGNOSIS

Ⓜ With CONSULT

1. Perform "All DTC Reading".
2. Check "Self diagnostic result" of systems other than "HV BAT" to see if "P3196" is detected.

Is P3196 detected?

- YES >> Replace on board charger. Refer to [VC-112, "Removal and Installation"](#).
NO >> GO TO 2.

2. PERFORM THE SELF-DIAGNOSIS OF LI-ION BATTERY CONTROLLER

Ⓜ With CONSULT

1. Select "Self Diagnostic Result" of "HV BAT".
2. Check to see if "U1000" is detected simultaneously with "P3196".

Is U1000 detected?

- YES >> Replace Li-ion battery controller. Refer to [EVB-419, "LI-ION BATTERY CONTROLLER : Disassembly and Assembly"](#).
NO >> INSPECTION END

P3199 COMMUNICATION ERROR

< DTC/CIRCUIT DIAGNOSIS >

[TYPE 2]

P3199 COMMUNICATION ERROR

DTC Logic

INFOID:000000007592439

DTC DETECTION LOGIC

DTC	Trouble diagnosis name	DTC detecting condition	Possible causes
P3199	COMMUNICATION ERROR	When a CRC error from VCM is detected.	<ul style="list-style-type: none">• VCM• Li-ion battery controller

DTC CONFIRMATION PROCEDURE

1. PERFORM DTC CONFIRMATION PROCEDURE

④ With CONSULT

1. Power switch ON and wait for 10 seconds or more.
2. Select "Self Diagnostic Result" of "HV BAT".
3. Check DTC.

Is P3199 detected?

- YES >> Refer to [EVB-322, "Diagnosis Procedure"](#).
NO >> INSPECTION END

Diagnosis Procedure

INFOID:000000007592440

When this DTC is detected, replace VCM. Refer to [EVC-377, "Removal and Installation"](#).

P319C COMMUNICATION ERROR

< DTC/CIRCUIT DIAGNOSIS >

[TYPE 2]

P319C COMMUNICATION ERROR

DTC Logic

INFOID:000000007592441

DTC DETECTION LOGIC

DTC	Trouble diagnosis name	DTC detecting condition	Possible causes
P319C	COMMUNICATION ERROR	When a CRC error from traction motor inverter is detected.	<ul style="list-style-type: none">• Traction motor inverter• Li-ion battery controller

A

B

EVB

DTC CONFIRMATION PROCEDURE

1. PERFORM DTC CONFIRMATION PROCEDURE

④ With CONSULT

1. Power switch ON and wait for 10 seconds or more.
2. Select "Self Diagnostic Result" of "HV BAT".
3. Check DTC.

Is P319C detected?

- YES >> Refer to [EVB-323, "Diagnosis Procedure"](#).
NO >> INSPECTION END

Diagnosis Procedure

INFOID:000000007592442

When this DTC is detected, replace traction motor inverter. Refer to [TMS-116, "Exploded View"](#).

D

E

F

G

H

I

J

K

L

M

N

O

P

P31A4 CAN ERROR VCM

< DTC/CIRCUIT DIAGNOSIS >

[TYPE 2]

P31A4 CAN ERROR VCM

DTC Logic

INFOID:000000007592444

DTC DETECTION LOGIC

DTC	Trouble diagnosis name	DTC detecting condition	Possible causes
P31A4	CAN ERROR VCM	If the CAN data from VCM has not change from the value which was previously received.	VCM

DTC CONFIRMATION PROCEDURE

1. PERFORM DTC CONFIRMATION PROCEDURE

④ With CONSULT

1. Power switch ON and wait for 10 seconds or more.
2. Select "Self Diagnostic Result" of "HV BAT".
3. Check DTC.

Is P31A4 detected?

- YES >> Refer to [EVB-324, "Diagnosis Procedure"](#).
NO >> INSPECTION END

Diagnosis Procedure

INFOID:000000007592445

When this DTC is detected, replace VCM. Refer to [EVC-377, "Removal and Installation"](#).

P31A7 CAN ERROR INV/MC

< DTC/CIRCUIT DIAGNOSIS >

[TYPE 2]

P31A7 CAN ERROR INV/MC

DTC Logic

INFOID:000000007592446

DTC DETECTION LOGIC

DTC	Trouble diagnosis name	DTC detecting condition	Possible causes
P31A7	CAN ERROR INV/MC	If the CAN data from traction motor inverter has not change from the value which was previously received.	Traction motor inverter

A
B
EVB
D
E
F
G
H
I
J
K
L
M
N
O
P

DTC CONFIRMATION PROCEDURE

1. PERFORM DTC CONFIRMATION PROCEDURE

 With CONSULT

1. Power switch ON and wait for 10 seconds or more.
2. Select "Self Diagnostic Result" of "HV BAT".
3. Check DTC.

Is P31A7 detected?

- YES >> Refer to [EVB-325, "Diagnosis Procedure"](#).
- NO >> INSPECTION END

Diagnosis Procedure

INFOID:000000007592447

When this DTC is detected, replace traction motor inverter. Refer to [TMS-116, "Exploded View"](#).

P3300 TOTAL VOLTAGE OVER

< DTC/CIRCUIT DIAGNOSIS >

[TYPE 2]

P3300 TOTAL VOLTAGE OVER

DTC Logic

INFOID:000000007592448

DTC DETECTION LOGIC

DTC	Trouble diagnosis name	DTC detecting condition	Possible causes
P3300	TOTAL VOLTAGE OVER	When total voltage exceeds the allowable working voltage range.	<ul style="list-style-type: none">• Li-ion battery• Li-ion battery controller• VCM• Traction motor inverter

DTC CONFIRMATION PROCEDURE

1. PERFORM DTC CONFIRMATION PROCEDURE

Ⓟ With CONSULT

1. Power switch ON and wait for 10 seconds or more.
2. Select "Self Diagnostic Result" of "HV BAT".
3. Check DTC.

Is P3300 detected?

- YES >> Refer to [EVB-326, "Diagnosis Procedure"](#).
NO >> INSPECTION END

Diagnosis Procedure

INFOID:000000007592449

1. PERFORM THE SELF-DIAGNOSIS

Ⓟ With CONSULT

1. Perform "All DTC Reading".
2. Check "Self Diagnostic Result" of systems other than "HV BAT" to see if any DTC is detected.

Is any DTC detected?

- YES >> After performing trouble diagnosis of detected DTC, GO TO 2.
NO >> GO TO 2.

2. PERFORM THE SELF-DIAGNOSIS OF LI-ION BATTERY CONTROLLER

Ⓟ With CONSULT

1. Select "Self Diagnostic Result" of "HV BAT".
2. Check "Self Diagnostic Result" to see if "P3302"- "P3331" is detected.

Is P3302-P3331 detected?

- YES >> "P3302" - "P3331" are detected simultaneously.
- When "P3302" - "P330D" are detected simultaneously, perform the diagnosis procedure of "P3302" - "P330D". Refer to [EVB-327, "Diagnosis Procedure"](#).
 - When "P330E" - "P3319" are detected simultaneously, perform the diagnosis procedure of "P330E" - "P3319". Refer to [EVB-330, "Diagnosis Procedure"](#).
 - When "P331A" - "P3325" are detected simultaneously, perform the diagnosis procedure of "P331A" - "P3325". Refer to [EVB-333, "Diagnosis Procedure"](#).
 - When "P3326" - "P3331" are detected simultaneously, perform the diagnosis procedure of "P3326" - "P3331". Refer to [EVB-336, "Diagnosis Procedure"](#).
- NO >> Replace Li-ion battery controller. Refer to [EVB-419, "LI-ION BATTERY CONTROLLER : Disassembly and Assembly"](#).

P3302-P330D CELL OVER VOLTAGE

< DTC/CIRCUIT DIAGNOSIS >

[TYPE 2]

P3302-P330D CELL OVER VOLTAGE

DTC Logic

INFOID:000000007592450

DTC DETECTION LOGIC

DTC	Trouble diagnosis name	DTC detecting condition	Possible causes
P3302	CELL OVER VOLTAGE MODULE1	When cell voltage exceeds the allowable working voltage range.	<ul style="list-style-type: none"> Overcharge caused by traction motor inverter/VCM malfunction Module Li-ion battery controller Bus bar Harness or connector
P3303	CELL OVER VOLTAGE MODULE2		
P3304	CELL OVER VOLTAGE MODULE3		
P3305	CELL OVER VOLTAGE MODULE4		
P3306	CELL OVER VOLTAGE MODULE5		
P3307	CELL OVER VOLTAGE MODULE6		
P3308	CELL OVER VOLTAGE MODULE7		
P3309	CELL OVER VOLTAGE MODULE8		
P330A	CELL OVER VOLTAGE MODULE9		
P330B	CELL OVER VOLTAGE MODULE10		
P330C	CELL OVER VOLTAGE MODULE11		
P330D	CELL OVER VOLTAGE MODULE12		

DTC CONFIRMATION PROCEDURE

1. PERFORM DTC CONFIRMATION PROCEDURE

④ With CONSULT

- Power switch ON and wait for 10 seconds or more.
- Select "Self Diagnostic Result" of "HV BAT".
- Check DTC.

Is any DTC detected?

- YES >> Refer to [EV3-327, "Diagnosis Procedure"](#).
 NO >> INSPECTION END

Diagnosis Procedure

INFOID:000000007592451

WARNING:

- Because hybrid vehicles and electric vehicles contain a high voltage battery, there is the risk of electric shock, electric leakage, or similar accidents if the high voltage component and vehicle are handled incorrectly. Be sure to follow the correct work procedures when performing inspection and maintenance.
- Be sure to remove the service plug in order to disconnect the high voltage circuits before performing inspection or maintenance of high voltage system harnesses and parts.
- To prevent the removed service plug from being connected by mistake during the procedure, always carry it in your pocket or put it in the tool box.
- Be sure to wear insulating protective equipment consisting of glove, shoes, face shield and glasses before beginning work on the high voltage system.
- Clearly identify the persons responsible for high voltage work and ensure that other persons do not touch the vehicle. When not working, cover high voltage parts with an insulating cover sheet or similar item to prevent other persons from contacting them.
- Refer to [EV3-229, "High Voltage Precautions"](#).

CAUTION:

There is the possibility of a malfunction occurring if the vehicle is changed to READY status while the service plug is removed. Therefore do not change the vehicle to READY status unless instructed to do so in the Service Manual.

1. CHECK SELF-DIAGNOSIS RESULTS

④ With CONSULT

- Perform "All DTC Reading" with CONSULT.

P3302-P330D CELL OVER VOLTAGE

[TYPE 2]

< DTC/CIRCUIT DIAGNOSIS >

2. Check systems other than "HV BAT" if any DTC is detected.

Is any DTC detected?

YES >> After performing trouble diagnosis of detected DTC, GO TO 2.

NO >> GO TO 2.

2. PRECONDITIONING

WARNING:

Disconnect high voltage. Refer to [GI-31, "How to Disconnect High Voltage"](#).

1. Remove Li-ion battery. Refer to [EVB-395, "Removal and Installation"](#).

2. Remove battery pack upper case. Refer to [EVB-412, "BATTERY JUNCTION BOX : Disassembly and Assembly"](#), see Step-1 to Step-3.

>> GO TO 3.

3. CHECK HARNESS BETWEEN MODULE AND LI-ION BATTERY CONTROLLER

1. Disconnect module harness connector and Li-ion battery controller harness connector.

2. Refer to below table and check the continuity between corresponding module and Li-ion battery controller.

DTC	Module No.	Module		Li-ion battery controller		Continuity
		Connector	Terminal	Connector	Terminal	
P3302	1	LB9	17	LB13	33	Existed
			2		50	
			18		34	
P3303	2	LB9	18	LB13	34	Existed
			3		51	
			19		35	
P3304	3	LB9	19	LB13	35	Existed
			4		52	
			20		36	
P3305	4	LB9	20	LB13	36	Existed
			5		53	
			21		37	
P3306	5	LB9	21	LB13	37	Existed
			6		54	
			22		38	
P3307	6	LB9	22	LB13	38	Existed
			7		55	
			23		39	
P3308	7	LB9	23	LB13	39	Existed
			8		56	
			24		40	
P3309	8	LB9	24	LB13	40	Existed
			9		57	
			25		42	
P330A	9	LB9	25	LB13	42	Existed
			26		58	
			11		43	

P3302-P330D CELL OVER VOLTAGE

< DTC/CIRCUIT DIAGNOSIS >

[TYPE 2]

DTC	Module No.	Module		Li-ion battery controller		Continuity
		Connector	Terminal	Connector	Terminal	
P330B	10	LB9	11	LB13	43	Existed
			27		59	
			12		44	
P330C	11	LB9	12	LB13	44	Existed
			28		60	
			13		45	
P330D	12	LB9	13	LB13	45	Existed
			29		61	
			14		46	

Is the inspection result normal?

YES >> GO TO 4.

NO >> Repair harness or connector.

4.CHECK MODULE VOLTAGE

Check voltage of corresponding module. Refer to [EVB-329, "Component Inspection"](#).

Is the inspection result normal?

YES >> Replace Li-ion battery controller. Refer to [EVB-419, "LI-ION BATTERY CONTROLLER : Disassembly and Assembly"](#).

NO >> Replace corresponding module. Refer to [EVB-402, "Exploded view"](#).

Component Inspection

INFOID:000000007592452

1.CHECK MODULE VOLTAGE

Check voltage of module.

A : Positive terminal (Red)

B : Negative terminal (Black)

Terminals		Voltage (Approx.)
(+)	(-)	
Module		5.0 - 8.5 V
Positive terminal (Red)	Negative terminal (Black)	

Is the inspection result normal?

YES >> INSPECTION END

NO >> Replace module. Refer to [EVB-426, "FRONT MODULE STACK : Disassembly and Assembly"](#) (Front module) or [EVB-435, "REAR MODULE STACK : Disassembly and Assembly"](#) (Rear module).

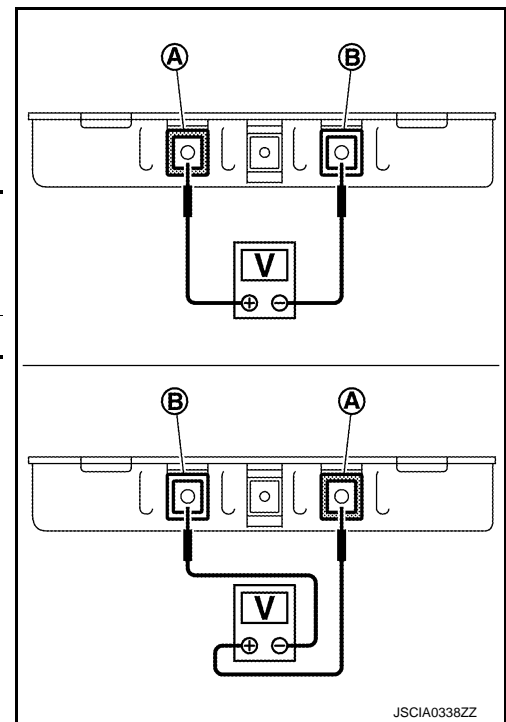

JSCIA0338ZZ

P330E-P3319 CELL OVER VOLTAGE

< DTC/CIRCUIT DIAGNOSIS >

[TYPE 2]

P330E-P3319 CELL OVER VOLTAGE

DTC Logic

INFOID:000000007592982

DTC DETECTION LOGIC

DTC	Trouble diagnosis name	DTC detecting condition	Possible causes
P330E	CELL OVER VOLTAGE MODULE13	When cell voltage exceeds the allowable working voltage range.	<ul style="list-style-type: none">• Overcharge caused by traction motor inverter/VCM malfunction• Module• Li-ion battery controller• Bus bar• Harness or connector
P330F	CELL OVER VOLTAGE MODULE14		
P3310	CELL OVER VOLTAGE MODULE15		
P3311	CELL OVER VOLTAGE MODULE16		
P3312	CELL OVER VOLTAGE MODULE17		
P3313	CELL OVER VOLTAGE MODULE18		
P3314	CELL OVER VOLTAGE MODULE19		
P3315	CELL OVER VOLTAGE MODULE20		
P3316	CELL OVER VOLTAGE MODULE21		
P3317	CELL OVER VOLTAGE MODULE22		
P3318	CELL OVER VOLTAGE MODULE23		
P3319	CELL OVER VOLTAGE MODULE24		

DTC CONFIRMATION PROCEDURE

1. PERFORM DTC CONFIRMATION PROCEDURE

Ⓟ With CONSULT

1. Power switch ON and wait for 10 seconds or more.
2. Select "Self Diagnostic Result" of "HV BAT".
3. Check DTC.

Is any DTC detected?

- YES >> Refer to [EVB-336, "Diagnosis Procedure"](#).
NO >> INSPECTION END

Diagnosis Procedure

INFOID:000000007592983

WARNING:

- Because hybrid vehicles and electric vehicles contain a high voltage battery, there is the risk of electric shock, electric leakage, or similar accidents if the high voltage component and vehicle are handled incorrectly. Be sure to follow the correct work procedures when performing inspection and maintenance.
- Be sure to remove the service plug in order to disconnect the high voltage circuits before performing inspection or maintenance of high voltage system harnesses and parts.
- To prevent the removed service plug from being connected by mistake during the procedure, always carry it in your pocket or put it in the tool box.
- Be sure to wear insulating protective equipment consisting of glove, shoes, face shield and glasses before beginning work on the high voltage system.
- Clearly identify the persons responsible for high voltage work and ensure that other persons do not touch the vehicle. When not working, cover high voltage parts with an insulating cover sheet or similar item to prevent other persons from contacting them.
- Refer to [EVB-229, "High Voltage Precautions"](#).

CAUTION:

There is the possibility of a malfunction occurring if the vehicle is changed to READY status while the service plug is removed. Therefore do not change the vehicle to READY status unless instructed to do so in the Service Manual.

1. CHECK SELF-DIAGNOSIS RESULTS

Ⓟ With CONSULT

1. Perform "All DTC Reading" with CONSULT.

P330E-P3319 CELL OVER VOLTAGE

< DTC/CIRCUIT DIAGNOSIS >

[TYPE 2]

2. Check systems other than "HV BAT" if any DTC is detected.

Is any DTC detected?

YES >> After performing trouble diagnosis of detected DTC, GO TO 2.

NO >> GO TO 2.

2. PRECONDITIONING

WARNING:

Disconnect high voltage. Refer to [GI-31, "How to Disconnect High Voltage"](#).

1. Remove Li-ion battery. Refer to [EVb-395, "Removal and Installation"](#).

2. Remove battery pack upper case. Refer to [EVb-412, "BATTERY JUNCTION BOX : Disassembly and Assembly"](#), see Step-1 to Step-3.

>> GO TO 3.

3. CHECK HARNESS BETWEEN MODULE AND LI-ION BATTERY CONTROLLER

1. Disconnect module harness connector and Li-ion battery controller harness connector.

2. Refer to below table and check the continuity between corresponding module and Li-ion battery controller.

DTC	Module No.	Module		Li-ion battery controller		Continuity
		Connector	Terminal	Connector	Terminal	
P330E	13	LB9	14	LB13	46	Existed
			30		62	
			15		47	
P330F	14	LB9	15	LB13	47	Existed
			31		63	
			1		48	
P3310	15	LB9	1	LB13	48	Existed
		LB10	45	LB14	77	
			34		65	
P3311	16	LB10	34	LB14	65	Existed
			46		78	
			35		66	
P3312	17	LB10	35	LB14	66	Existed
			36		80	
			48		69	
P3313	18	LB10	48	LB14	69	Existed
			37		81	
			49		70	
P3314	19	LB10	49	LB14	70	Existed
			38		82	
			50		71	
P3315	20	LB10	50	LB14	71	Existed
			39		83	
			51		72	
P3316	21	LB10	51	LB14	72	Existed
			52		84	
			41		73	

P330E-P3319 CELL OVER VOLTAGE

[TYPE 2]

< DTC/CIRCUIT DIAGNOSIS >

DTC	Module No.	Module		Li-ion battery controller		Continuity
		Connector	Terminal	Connector	Terminal	
P3317	22	LB10	41	LB14	73	Existed
			53		85	
			42		74	
P3318	23	LB10	42	LB14	74	Existed
			54		86	
			43		75	
P3319	24	LB10	43	LB14	75	Existed
			55		87	
			44		76	

Is the inspection result normal?

YES >> GO TO 4.

NO >> Repair harness or connector.

4. CHECK MODULE VOLTAGE

Check voltage of corresponding module. Refer to [EVB-332, "Component Inspection"](#).

Is the inspection result normal?

YES >> Replace Li-ion battery controller. Refer to [EVB-419, "LI-ION BATTERY CONTROLLER : Disassembly and Assembly"](#).

NO >> Replace corresponding module. Refer to [EVB-402, "Exploded view"](#).

Component Inspection

INFOID:000000007592984

1. CHECK MODULE VOLTAGE

Check voltage of module.

A : Positive terminal (Red)

B : Negative terminal (Black)

Terminals		Voltage (Approx.)
(+)	(-)	
Module		5.0 - 8.5 V
Positive terminal (Red)	Negative terminal (Black)	

Is the inspection result normal?

YES >> INSPECTION END

NO >> Replace module. Refer to [EVB-426, "FRONT MODULE STACK : Disassembly and Assembly"](#) (Front module) or [EVB-435, "REAR MODULE STACK : Disassembly and Assembly"](#) (Rear module).

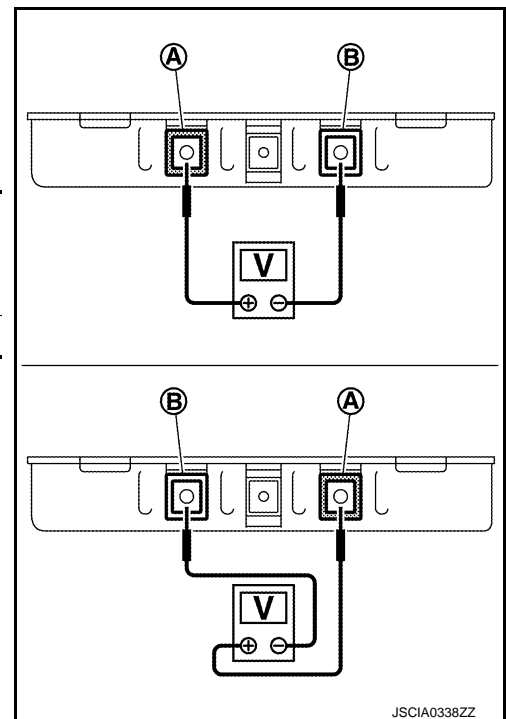

P331A-P3325 CELL OVER VOLTAGE

< DTC/CIRCUIT DIAGNOSIS >

[TYPE 2]

P331A-P3325 CELL OVER VOLTAGE

DTC Logic

INFOID:000000007592985

DTC DETECTION LOGIC

DTC	Trouble diagnosis name	DTC detecting condition	Possible causes
P331A	CELL OVER VOLTAGE MODULE25	When cell voltage exceeds the allowable working voltage range.	<ul style="list-style-type: none">• Overcharge caused by traction motor inverter/VCM malfunction• Module• Li-ion battery controller• Bus bar• Harness or connector
P331B	CELL OVER VOLTAGE MODULE26		
P331C	CELL OVER VOLTAGE MODULE27		
P331D	CELL OVER VOLTAGE MODULE28		
P331E	CELL OVER VOLTAGE MODULE29		
P331F	CELL OVER VOLTAGE MODULE30		
P3320	CELL OVER VOLTAGE MODULE31		
P3321	CELL OVER VOLTAGE MODULE32		
P3322	CELL OVER VOLTAGE MODULE33		
P3323	CELL OVER VOLTAGE MODULE34		
P3324	CELL OVER VOLTAGE MODULE35		
P3325	CELL OVER VOLTAGE MODULE36		

DTC CONFIRMATION PROCEDURE

1. PERFORM DTC CONFIRMATION PROCEDURE

④ With CONSULT

1. Power switch ON and wait for 10 seconds or more.
2. Select "Self Diagnostic Result" of "HV BAT".
3. Check DTC.

Is any DTC detected?

- YES >> Refer to [EV3-336, "Diagnosis Procedure"](#).
NO >> INSPECTION END

Diagnosis Procedure

INFOID:000000007592986

WARNING:

- Because hybrid vehicles and electric vehicles contain a high voltage battery, there is the risk of electric shock, electric leakage, or similar accidents if the high voltage component and vehicle are handled incorrectly. Be sure to follow the correct work procedures when performing inspection and maintenance.
- Be sure to remove the service plug in order to disconnect the high voltage circuits before performing inspection or maintenance of high voltage system harnesses and parts.
- To prevent the removed service plug from being connected by mistake during the procedure, always carry it in your pocket or put it in the tool box.
- Be sure to wear insulating protective equipment consisting of glove, shoes, face shield and glasses before beginning work on the high voltage system.
- Clearly identify the persons responsible for high voltage work and ensure that other persons do not touch the vehicle. When not working, cover high voltage parts with an insulating cover sheet or similar item to prevent other persons from contacting them.
- Refer to [EV3-229, "High Voltage Precautions"](#).

CAUTION:

There is the possibility of a malfunction occurring if the vehicle is changed to READY status while the service plug is removed. Therefore do not change the vehicle to READY status unless instructed to do so in the Service Manual.

1. CHECK SELF-DIAGNOSIS RESULTS

④ With CONSULT

1. Perform "All DTC Reading" with CONSULT.

P331A-P3325 CELL OVER VOLTAGE

[TYPE 2]

< DTC/CIRCUIT DIAGNOSIS >

2. Check "Self Diagnostic Result" of systems other than "HV BAT" if any DTC is detected.

Is any DTC detected?

YES >> After performing trouble diagnosis of detected DTC, GO TO 2.

NO >> GO TO 2.

2. PRECONDITIONING

WARNING:

Disconnect high voltage. Refer to [GI-31, "How to Disconnect High Voltage"](#).

1. Remove Li-ion battery. Refer to [EVB-395, "Removal and Installation"](#).

2. Remove battery pack upper case. Refer to [EVB-412, "BATTERY JUNCTION BOX : Disassembly and Assembly"](#), see Step-1 to Step-3.

>> GO TO 3.

3. CHECK HARNESS BETWEEN MODULE AND LI-ION BATTERY CONTROLLER

Ⓟ With CONSULT

1. Power switch OFF.

2. Identify the malfunctioning module based on detected DTC.

3. Disconnect module harness connector and Li-ion battery controller harness connector.

4. Refer to below table and check the continuity between corresponding module and Li-ion battery controller.

DTC	Module No.	Module		Li-ion battery controller		Continuity
		Connector	Terminal	Connector	Terminal	
P331A	25	LB8	57	LB15	89	Existed
			73		110	
			58		90	
P331B	26	LB8	58	LB15	90	Existed
			74		111	
			75		91	
P331C	27	LB8	75	LB15	91	Existed
			60		112	
			76		92	
P331D	28	LB8	76	LB15	92	Existed
			77		113	
			62		93	
P331E	29	LB8	62	LB15	93	Existed
			78		114	
			79		94	
P331F	30	LB8	79	LB15	94	Existed
			64		115	
			80		95	
P3320	31	LB8	80	LB15	95	Existed
			81		116	
			66		96	
P3321	32	LB8	66	LB15	96	Existed
			82		117	
			83		97	

P331A-P3325 CELL OVER VOLTAGE

< DTC/CIRCUIT DIAGNOSIS >

[TYPE 2]

DTC	Module No.	Module		Li-ion battery controller		Continuity
		Connector	Terminal	Connector	Terminal	
P3322	33	LB8	83	LB15	97	Existed
			68		118	
			84		99	
P3323	34	LB8	84	LB15	99	Existed
			85		119	
			70		100	
P3324	35	LB8	70	LB15	100	Existed
			86		120	
			87		101	
P3325	36	LB8	87	LB15	101	Existed
			72		121	
			88		102	

Is the inspection result normal?

YES >> GO TO 4.

NO >> Repair harness or connector.

4.CHECK MODULE VOLTAGE

Check voltage of corresponding module. Refer to [EVB-335, "Component Inspection"](#).

Is the inspection result normal?

YES >> Replace Li-ion battery controller. Refer to [EVB-419, "LI-ION BATTERY CONTROLLER : Disassembly and Assembly"](#).

NO >> Replace corresponding module. Refer to [EVB-402, "Exploded view"](#).

Component Inspection

INFOID:000000007592987

1.CHECK MODULE VOLTAGE

Check voltage of module.

A : Positive terminal (Red)

B : Negative terminal (Black)

Terminals		Voltage (Approx.)
(+)	(-)	
Module		5.0 - 8.5 V
Positive terminal (Red)	Negative terminal (Black)	

Is the inspection result normal?

YES >> INSPECTION END

NO >> Replace module. Refer to [EVB-426, "FRONT MODULE STACK : Disassembly and Assembly"](#) (Front module) or [EVB-435, "REAR MODULE STACK : Disassembly and Assembly"](#) (Rear module).

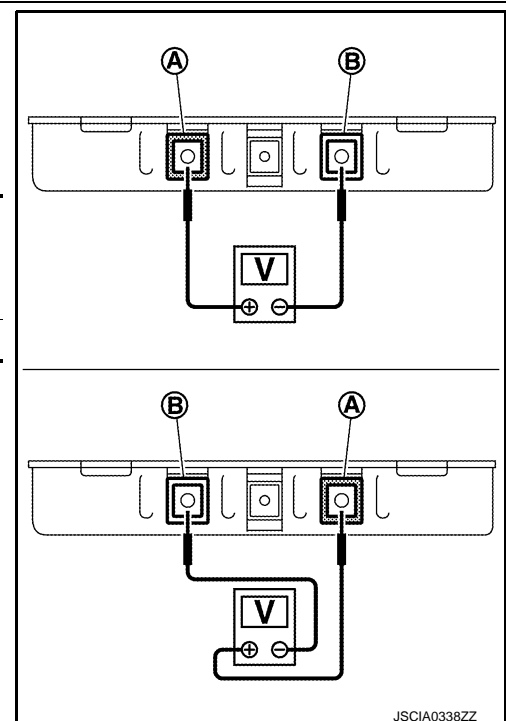

JSCIA0338ZZ

P3326-P3331 CELL OVER VOLTAGE

< DTC/CIRCUIT DIAGNOSIS >

[TYPE 2]

P3326-P3331 CELL OVER VOLTAGE

DTC Logic

INFOID:000000007592994

DTC DETECTION LOGIC

DTC	Trouble diagnosis name	DTC detecting condition	Possible causes
P3326	CELL OVER VOLTAGE MODULE37	When cell voltage exceeds the allowable working voltage range.	<ul style="list-style-type: none"> Overcharge caused by traction motor inverter/VCM malfunction Module Li-ion battery controller Bus bar Harness or connector
P3327	CELL OVER VOLTAGE MODULE38		
P3328	CELL OVER VOLTAGE MODULE39		
P3329	CELL OVER VOLTAGE MODULE40		
P332A	CELL OVER VOLTAGE MODULE41		
P332B	CELL OVER VOLTAGE MODULE42		
P332C	CELL OVER VOLTAGE MODULE43		
P332D	CELL OVER VOLTAGE MODULE44		
P332E	CELL OVER VOLTAGE MODULE45		
P332F	CELL OVER VOLTAGE MODULE46		
P3330	CELL OVER VOLTAGE MODULE47		
P3331	CELL OVER VOLTAGE MODULE48		

DTC CONFIRMATION PROCEDURE

1. PERFORM DTC CONFIRMATION PROCEDURE

Ⓟ With CONSULT

- Power switch ON and wait for 10 seconds or more.
- Select "Self Diagnostic Result" of "HV BAT".
- Check DTC.

Is any DTC detected?

- YES >> Refer to [EVB-336, "Diagnosis Procedure"](#).
- NO >> INSPECTION END

Diagnosis Procedure

INFOID:000000007592995

WARNING:

- Because hybrid vehicles and electric vehicles contain a high voltage battery, there is the risk of electric shock, electric leakage, or similar accidents if the high voltage component and vehicle are handled incorrectly. Be sure to follow the correct work procedures when performing inspection and maintenance.
- Be sure to remove the service plug in order to disconnect the high voltage circuits before performing inspection or maintenance of high voltage system harnesses and parts.
- To prevent the removed service plug from being connected by mistake during the procedure, always carry it in your pocket or put it in the tool box.
- Be sure to wear insulating protective equipment consisting of glove, shoes, face shield and glasses before beginning work on the high voltage system.
- Clearly identify the persons responsible for high voltage work and ensure that other persons do not touch the vehicle. When not working, cover high voltage parts with an insulating cover sheet or similar item to prevent other persons from contacting them.
- Refer to [EVB-229, "High Voltage Precautions"](#).

CAUTION:

There is the possibility of a malfunction occurring if the vehicle is changed to READY status while the service plug is removed. Therefore do not change the vehicle to READY status unless instructed to do so in the Service Manual.

1. CHECK SELF-DIAGNOSIS RESULTS

Ⓟ With CONSULT

- Perform "All DTC Reading" with CONSULT.

P3326-P3331 CELL OVER VOLTAGE

< DTC/CIRCUIT DIAGNOSIS >

[TYPE 2]

2. Check "Self Diagnostic Result" of systems other than "HV BAT" if any DTC is detected.

Is any DTC detected?

YES >> After performing trouble diagnosis of detected DTC, GO TO 2.

NO >> GO TO 2.

2. PRECONDITIONING

WARNING:

Disconnect high voltage. Refer to [GI-31, "How to Disconnect High Voltage"](#).

1. Remove Li-ion battery. Refer to [EVB-395, "Removal and Installation"](#).

2. Remove battery pack upper case. Refer to [EVB-412, "BATTERY JUNCTION BOX : Disassembly and Assembly"](#), see Step-1 to Step-3.

>> GO TO 3.

3. CHECK HARNESS BETWEEN MODULE AND LI-ION BATTERY CONTROLLER

Ⓜ With CONSULT

1. Power switch OFF.

2. Identify the malfunctioning module based on detected DTC.

3. Disconnect module harness connector and Li-ion battery controller harness connector.

4. Refer to below table and check the continuity between corresponding module and Li-ion battery controller.

DTC	Module No.	Module		Li-ion battery controller		Continuity	
		Connector	Terminal	Connector	Terminal		
P3326	37	LB8	88	LB15	102	Existed	
			LB7		89		122
					101		103
P3327	38	LB7	101	LB15	103	Existed	
					90		123
					102		104
P3328	39	LB7	102	LB15	104	Existed	
					91		124
					103		105
P3329	40	LB7	103	LB15	105	Existed	
					92		125
					104		106
P332A	41	LB7	104	LB15	106	Existed	
					93		127
					105		107
P332B	42	LB7	105	LB15	107	Existed	
					94		128
					106		108
P332C	43	LB7	106	LB15	108	Existed	
				95	LB16		137
				107			130
P332D	44	LB7	107	LB16	130	Existed	
					96		138
					108		131

P3326-P3331 CELL OVER VOLTAGE

< DTC/CIRCUIT DIAGNOSIS >

[TYPE 2]

DTC	Module No.	Module		Li-ion battery controller		Continuity
		Connector	Terminal	Connector	Terminal	
P332E	45	LB7	108	LB16	131	Existed
			97		140	
			109		132	
P332F	46	LB7	109	LB16	132	Existed
			98		141	
			110		133	
P3330	47	LB7	110	LB16	133	Existed
			99		142	
			111		134	
P3331	48	LB7	111	LB16	134	Existed
			100		143	
			112		135	

Is the inspection result normal?

YES >> GO TO 4.

NO >> Repair harness or connector.

4. CHECK MODULE VOLTAGE

Check voltage of corresponding module. Refer to [EVB-338, "Component Inspection"](#).

Is the inspection result normal?

YES >> Replace Li-ion battery controller. Refer to [EVB-419, "LI-ION BATTERY CONTROLLER : Disassembly and Assembly"](#).

NO >> Replace corresponding module. Refer to [EVB-402, "Exploded view"](#).

Component Inspection

INFOID:000000007592996

1. CHECK MODULE VOLTAGE

Check voltage of module.

A : Positive terminal (Red)

B : Negative terminal (Black)

Terminals		Voltage (Approx.)
(+)	(-)	
Module		5.0 - 8.5 V
Positive terminal (Red)	Negative terminal (Black)	

Is the inspection result normal?

YES >> INSPECTION END

NO >> Replace module. Refer to [EVB-426, "FRONT MODULE STACK : Disassembly and Assembly"](#) (Front module) or [EVB-435, "REAR MODULE STACK : Disassembly and Assembly"](#) (Rear module).

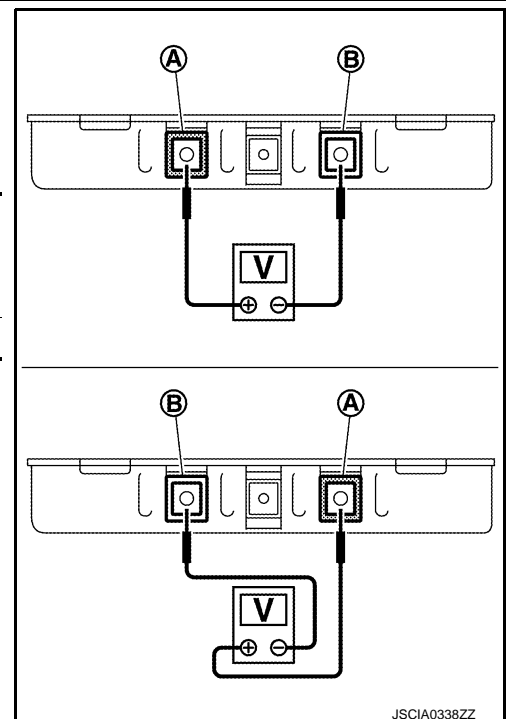

JSCIA0338ZZ

P3373 TOTAL VOLTAGE OVER DISCHARGE

< DTC/CIRCUIT DIAGNOSIS >

[TYPE 2]

P3373 TOTAL VOLTAGE OVER DISCHARGE

DTC Logic

INFOID:000000007592463

DTC DETECTION LOGIC

If DTC P3373 is displayed with DTC P30F4, first perform the trouble diagnosis for P30F4. Refer to [EVB-311, "DTC Logic"](#).

DTC	Trouble diagnosis name	DTC detecting condition	Possible causes
P3373	TOTAL VOLTAGE OVER DISCHARGE	When total voltage lowers below the allowable working voltage range.	<ul style="list-style-type: none">• Li-ion battery controller• Module• Bus bar• Service plug fuse• Overcharge caused by traction motor inverter/VCM malfunction• Harness or connector

DTC CONFIRMATION PROCEDURE

1. CHECK SELF-DIAGNOSIS RESULTS

④ With CONSULT

1. Power switch ON and wait for 10 seconds or more.
2. Select "Self Diagnostic Result" of "HV BAT".
3. Check DTC.

Is P3373 detected?

- YES >> Refer to [EVB-339, "Diagnosis Procedure"](#).
NO >> INSPECTION END

Diagnosis Procedure

INFOID:000000007592464

1. PERFORM THE SELF-DIAGNOSIS

④ With CONSULT

1. Perform "All DTC Reading".
2. Check "Self diagnostic result" of systems other than "HV BAT" to see if any DTC is detected.

Is any DTC detected?

- YES >> After performing trouble diagnosis of detected DTC, GO TO 2.
NO >> GO TO 2.

2. PERFORM THE SELF-DIAGNOSIS OF LI-ION BATTERY CONTROLLER

④ With CONSULT

1. Select "Self Diagnostic Result" of "HV BAT".
2. Check to see if "P3375"- "P33A4" is detected simultaneously with "P3373".

Is P3375-P33A4 detected?

- YES >> • When "P3375"- "P3380" are detected simultaneously, perform the diagnosis procedure of "P3375"- "P3380". Refer to [EVB-340, "Diagnosis Procedure"](#).
• When "P3381"- "P338C" are detected simultaneously, perform the diagnosis procedure of "P3381"- "P338C". Refer to [EVB-343, "Diagnosis Procedure"](#).
• When "P338D"- "P3398" are detected simultaneously, perform the diagnosis procedure of "P338D"- "P3398". Refer to [EVB-346, "Diagnosis Procedure"](#).
• When "P3399"- "P33A4" are detected simultaneously, perform the diagnosis procedure of "P3399"- "P33A4". Refer to [EVB-349, "Diagnosis Procedure"](#).
- NO >> Replace Li-ion battery controller. Refer to [EVB-419, "LI-ION BATTERY CONTROLLER : Disassembly and Assembly"](#).

P3375-P3380 CELL OVER DISCHARGE

< DTC/CIRCUIT DIAGNOSIS >

[TYPE 2]

P3375-P3380 CELL OVER DISCHARGE

DTC Logic

INFOID:000000007592997

DTC DETECTION LOGIC

DTC	Trouble diagnosis name	DTC detecting condition	Possible causes
P3375	CELL OVER DISCHARGE MODULE1	When cell voltage lowers below the allowable working voltage range.	<ul style="list-style-type: none">• Overcharge caused by traction motor inverter/VCM malfunction• Module• Li-ion battery controller• Bus bar• Harness or connector
P3376	CELL OVER DISCHARGE MODULE2		
P3377	CELL OVER DISCHARGE MODULE3		
P3378	CELL OVER DISCHARGE MODULE4		
P3379	CELL OVER DISCHARGE MODULE5		
P337A	CELL OVER DISCHARGE MODULE6		
P337B	CELL OVER DISCHARGE MODULE7		
P337C	CELL OVER DISCHARGE MODULE8		
P337D	CELL OVER DISCHARGE MODULE9		
P337E	CELL OVER DISCHARGE MODULE10		
P337F	CELL OVER DISCHARGE MODULE11		
P3380	CELL OVER DISCHARGE MODULE12		

DTC CONFIRMATION PROCEDURE

1. PERFORM DTC CONFIRMATION PROCEDURE

Ⓜ With CONSULT

1. Power switch ON and wait for 10 seconds or more.
2. Select "Self Diagnostic Result" of "HV BAT".
3. Check DTC.

Is any DTC detected?

- YES >> Refer to [EVB-340, "Diagnosis Procedure"](#).
NO >> INSPECTION END

Diagnosis Procedure

INFOID:000000007592998

WARNING:

- Because hybrid vehicles and electric vehicles contain a high voltage battery, there is the risk of electric shock, electric leakage, or similar accidents if the high voltage component and vehicle are handled incorrectly. Be sure to follow the correct work procedures when performing inspection and maintenance.
- Be sure to remove the service plug in order to disconnect the high voltage circuits before performing inspection or maintenance of high voltage system harnesses and parts.
- To prevent the removed service plug from being connected by mistake during the procedure, always carry it in your pocket or put it in the tool box.
- Be sure to wear insulating protective equipment consisting of glove, shoes, face shield and glasses before beginning work on the high voltage system.
- Clearly identify the persons responsible for high voltage work and ensure that other persons do not touch the vehicle. When not working, cover high voltage parts with an insulating cover sheet or similar item to prevent other persons from contacting them.
- Refer to [EVB-229, "High Voltage Precautions"](#).

CAUTION:

There is the possibility of a malfunction occurring if the vehicle is changed to READY status while the service plug is removed. Therefore do not change the vehicle to READY status unless instructed to do so in the Service Manual.

1. CHECK SELF-DIAGNOSIS RESULTS

Ⓜ With CONSULT

1. Perform "All DTC Reading" with CONSULT.

P3375-P3380 CELL OVER DISCHARGE

[TYPE 2]

< DTC/CIRCUIT DIAGNOSIS >

2. Check systems other than "HV BAT" if any DTC is detected.

Is any DTC detected?

- YES >> After performing trouble diagnosis of detected DTC, GO TO 2.
- NO >> GO TO 2.

2. PRECONDITIONING

WARNING:

Disconnect high voltage. Refer to [GI-31, "How to Disconnect High Voltage"](#).

1. Remove Li-ion battery. Refer to [EVb-395, "Removal and Installation"](#).
2. Remove battery pack upper case. Refer to [EVb-412, "BATTERY JUNCTION BOX : Disassembly and Assembly"](#), see Step-1 to Step-3.

>> GO TO 3.

3. CHECK HARNESS BETWEEN MODULE AND LI-ION BATTERY CONTROLLER

1. Disconnect module harness connector and Li-ion battery controller harness connector.
2. Refer to below table and check the continuity between corresponding module and Li-ion battery controller.

DTC	Module No.	Module		Li-ion battery controller		Continuity
		Connector	Terminal	Connector	Terminal	
P3375	1	LB9	17	LB13	33	Existed
			2		50	
			18		34	
P3376	2	LB9	18	LB13	34	Existed
			3		51	
			19		35	
P3377	3	LB9	19	LB13	35	Existed
			4		52	
			20		36	
P3378	4	LB9	20	LB13	36	Existed
			5		53	
			21		37	
P3379	5	LB9	21	LB13	37	Existed
			6		54	
			22		38	
P337A	6	LB9	22	LB13	38	Existed
			7		55	
			23		39	
P337B	7	LB9	23	LB13	39	Existed
			8		56	
			24		40	
P337C	8	LB9	24	LB13	40	Existed
			9		57	
			25		42	
P337D	9	LB9	25	LB13	42	Existed
			26		58	
			11		43	

P3375-P3380 CELL OVER DISCHARGE

[TYPE 2]

< DTC/CIRCUIT DIAGNOSIS >

DTC	Module No.	Module		Li-ion battery controller		Continuity
		Connector	Terminal	Connector	Terminal	
P337E	10	LB9	11	LB13	43	Existed
			27		59	
			12		44	
P330F	11	LB9	12	LB13	44	Existed
			28		60	
			13		45	
P3380	12	LB9	13	LB13	45	Existed
			29		61	
			14		46	

Is the inspection result normal?

YES >> GO TO 4.

NO >> Repair Harness or connector.

4. CHECK MODULE VOLTAGE

Check voltage of corresponding module. Refer to [EVB-342, "Component Inspection"](#).

Is the inspection result normal?

YES >> Replace Li-ion battery controller. Refer to [EVB-419, "LI-ION BATTERY CONTROLLER : Disassembly and Assembly"](#).

NO >> Replace corresponding module. Refer to [EVB-402, "Exploded view"](#).

Component Inspection

INFOID:000000007592999

1. CHECK MODULE VOLTAGE

Check voltage of module.

A : Positive terminal (Red)

B : Negative terminal (Black)

Terminals		Voltage (Approx.)
(+)	(-)	
Module		5.0 - 8.5 V
Positive terminal (Red)	Negative terminal (Black)	

Is the inspection result normal?

YES >> INSPECTION END

NO >> Replace module. Refer to [EVB-426, "FRONT MODULE STACK : Disassembly and Assembly"](#) (Front module) or [EVB-435, "REAR MODULE STACK : Disassembly and Assembly"](#) (Rear module).

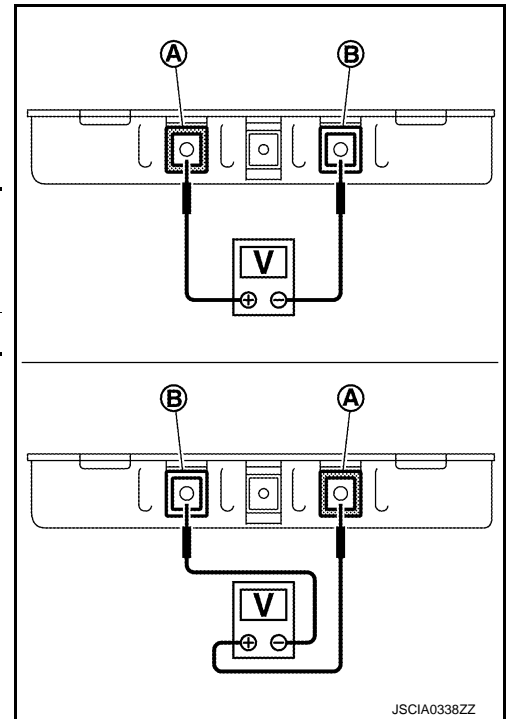

P3381-P338C CELL OVER DISCHARGE

< DTC/CIRCUIT DIAGNOSIS >

[TYPE 2]

P3381-P338C CELL OVER DISCHARGE

DTC Logic

INFOID:000000007593000

DTC DETECTION LOGIC

DTC	Trouble diagnosis name	DTC detecting condition	Possible causes
P3381	CELL OVER DISCHARGE MODULE13	When cell voltage lowers below the allowable working voltage range.	<ul style="list-style-type: none"> Overcharge caused by traction motor inverter/VCM malfunction Module Li-ion battery controller Bus bar Harness or connector
P3382	CELL OVER DISCHARGE MODULE14		
P3383	CELL OVER DISCHARGE MODULE15		
P3384	CELL OVER DISCHARGE MODULE16		
P3385	CELL OVER DISCHARGE MODULE17		
P3386	CELL OVER DISCHARGE MODULE18		
P3387	CELL OVER DISCHARGE MODULE19		
P3388	CELL OVER DISCHARGE MODULE20		
P3389	CELL OVER DISCHARGE MODULE21		
P338A	CELL OVER DISCHARGE MODULE22		
P338B	CELL OVER DISCHARGE MODULE23		
P338C	CELL OVER DISCHARGE MODULE24		

DTC CONFIRMATION PROCEDURE

1. PERFORM DTC CONFIRMATION PROCEDURE

Ⓜ With CONSULT

- Power switch ON and wait for 10 seconds or more.
- Select "Self Diagnostic Result" of "HV BAT".
- Check DTC.

Is any DTC detected?

- YES >> Refer to [EV3-349, "Diagnosis Procedure"](#).
- NO >> INSPECTION END

Diagnosis Procedure

INFOID:000000007593001

WARNING:

- Because hybrid vehicles and electric vehicles contain a high voltage battery, there is the risk of electric shock, electric leakage, or similar accidents if the high voltage component and vehicle are handled incorrectly. Be sure to follow the correct work procedures when performing inspection and maintenance.
- Be sure to remove the service plug in order to disconnect the high voltage circuits before performing inspection or maintenance of high voltage system harnesses and parts.
- To prevent the removed service plug from being connected by mistake during the procedure, always carry it in your pocket or put it in the tool box.
- Be sure to wear insulating protective equipment consisting of glove, shoes, face shield and glasses before beginning work on the high voltage system.
- Clearly identify the persons responsible for high voltage work and ensure that other persons do not touch the vehicle. When not working, cover high voltage parts with an insulating cover sheet or similar item to prevent other persons from contacting them.
- Refer to [EV3-229, "High Voltage Precautions"](#).

CAUTION:

There is the possibility of a malfunction occurring if the vehicle is changed to READY status while the service plug is removed. Therefore do not change the vehicle to READY status unless instructed to do so in the Service Manual.

1. CHECK SELF-DIAGNOSIS RESULTS

Ⓜ With CONSULT

- Perform "All DTC Reading" with CONSULT.

P3381-P338C CELL OVER DISCHARGE

[TYPE 2]

< DTC/CIRCUIT DIAGNOSIS >

2. Check systems other than "HV BAT" if any DTC is detected.

Is any DTC detected?

YES >> After performing trouble diagnosis of detected DTC, GO TO 2.

NO >> GO TO 2.

2. PRECONDITIONING

WARNING:

Disconnect high voltage circuit. Refer to [GI-31, "How to Disconnect High Voltage"](#).

1. Remove Li-ion battery. Refer to [EV-395, "Removal and Installation"](#).

2. Remove battery pack upper case. Refer to [EV-412, "BATTERY JUNCTION BOX : Disassembly and Assembly"](#), see Step-1 to Step-3.

>> GO TO 3.

3. CHECK HARNESS BETWEEN MODULE AND LI-ION BATTERY CONTROLLER

1. Disconnect module harness connector and Li-ion battery controller harness connector.

2. Refer to below table and check the continuity between corresponding module and Li-ion battery controller.

DTC	Module No.	Module		Li-ion battery controller		Continuity
		Connector	Terminal	Connector	Terminal	
P3381	13	LB9	14	LB13	46	Existed
			30		62	
			15		47	
P3382	14	LB9	15	LB13	47	Existed
			31		63	
			1		48	
P3383	15	LB9	1	LB13	48	Existed
		LB10	45	LB14	77	
			34		65	
P3384	16	LB10	34	LB14	65	Existed
			46		78	
			35		66	
P3385	17	LB10	35	LB14	66	Existed
			36		80	
			48		69	
P3386	18	LB10	48	LB14	69	Existed
			37		81	
			49		70	
P3387	19	LB10	49	LB14	70	Existed
			38		82	
			50		71	
P3388	20	LB10	50	LB14	71	Existed
			39		83	
			51		72	
P3389	21	LB10	51	LB14	72	Existed
			52		84	
			41		73	

P3381-P338C CELL OVER DISCHARGE

< DTC/CIRCUIT DIAGNOSIS >

[TYPE 2]

DTC	Module No.	Module		Li-ion battery controller		Continuity
		Connector	Terminal	Connector	Terminal	
P338A	22	LB10	41	LB14	73	Existed
			53		85	
			42		74	
P338B	23	LB10	42	LB14	74	Existed
			54		86	
			43		75	
P338C	24	LB10	43	LB14	75	Existed
			55		87	
			44		76	

Is the inspection result normal?

YES >> GO TO 4.

NO >> Repair Harness or connector.

4. CHECK MODULE VOLTAGE

Check voltage of corresponding module. Refer to [EVB-345, "Component Inspection"](#).

Is the inspection result normal?

YES >> Replace Li-ion battery controller. Refer to [EVB-419, "LI-ION BATTERY CONTROLLER : Disassembly and Assembly"](#).

NO >> Replace corresponding module. Refer to [EVB-395, "Exploded View"](#).

Component Inspection

INFOID:000000007593002

1. CHECK MODULE VOLTAGE

Check voltage of module.

A : Positive terminal (Red)

B : Negative terminal (Black)

Terminals		Voltage (Approx.)
(+)	(-)	
Module		5.0 - 8.5 V
Positive terminal (Red)	Negative terminal (Black)	

Is the inspection result normal?

YES >> INSPECTION END

NO >> Replace module. Refer to [EVB-426, "FRONT MODULE STACK : Disassembly and Assembly"](#) (Front module) or [EVB-435, "REAR MODULE STACK : Disassembly and Assembly"](#) (Rear module).

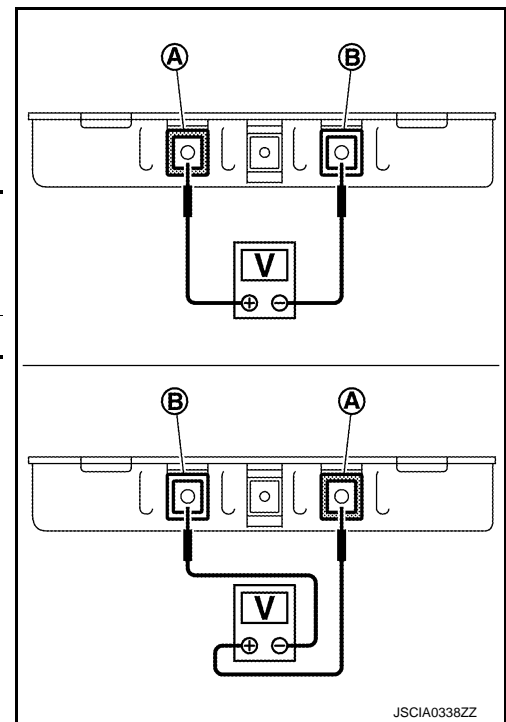

JSCIA0338ZZ

P338D-P3398 CELL OVER DISCHARGE

< DTC/CIRCUIT DIAGNOSIS >

[TYPE 2]

P338D-P3398 CELL OVER DISCHARGE

DTC Logic

INFOID:000000007593003

DTC DETECTION LOGIC

DTC	Trouble diagnosis name	DTC detecting condition	Possible causes
P338D	CELL OVER DISCHARGE MODULE25	When cell voltage lowers below the allowable working voltage range.	<ul style="list-style-type: none"> • Overcharge caused by traction motor inverter/VCM malfunction • Module • Li-ion battery controller • Bus bar • Harness or connector
P338E	CELL OVER DISCHARGE MODULE26		
P338F	CELL OVER DISCHARGE MODULE27		
P3390	CELL OVER DISCHARGE MODULE28		
P3391	CELL OVER DISCHARGE MODULE29		
P3392	CELL OVER DISCHARGE MODULE30		
P3393	CELL OVER DISCHARGE MODULE31		
P3394	CELL OVER DISCHARGE MODULE32		
P3395	CELL OVER DISCHARGE MODULE33		
P3396	CELL OVER DISCHARGE MODULE34		
P3397	CELL OVER DISCHARGE MODULE35		
P3398	CELL OVER DISCHARGE MODULE36		

DTC CONFIRMATION PROCEDURE

1. PERFORM DTC CONFIRMATION PROCEDURE

Ⓟ With CONSULT

1. Power switch ON and wait for 10 seconds or more.
2. Select "Self Diagnostic Result" of "HV BAT".
3. Check DTC.

Is any DTC detected?

- YES >> Refer to [EVB-349, "Diagnosis Procedure"](#).
- NO >> INSPECTION END

Diagnosis Procedure

INFOID:000000007593004

WARNING:

- Because hybrid vehicles and electric vehicles contain a high voltage battery, there is the risk of electric shock, electric leakage, or similar accidents if the high voltage component and vehicle are handled incorrectly. Be sure to follow the correct work procedures when performing inspection and maintenance.
- Be sure to remove the service plug in order to disconnect the high voltage circuits before performing inspection or maintenance of high voltage system harnesses and parts.
- To prevent the removed service plug from being connected by mistake during the procedure, always carry it in your pocket or put it in the tool box.
- Be sure to wear insulating protective equipment consisting of glove, shoes, face shield and glasses before beginning work on the high voltage system.
- Clearly identify the persons responsible for high voltage work and ensure that other persons do not touch the vehicle. When not working, cover high voltage parts with an insulating cover sheet or similar item to prevent other persons from contacting them.
- Refer to [EVB-229, "High Voltage Precautions"](#).

CAUTION:

There is the possibility of a malfunction occurring if the vehicle is changed to READY status while the service plug is removed. Therefore do not change the vehicle to READY status unless instructed to do so in the Service Manual.

1. CHECK SELF-DIAGNOSIS RESULTS

Ⓟ With CONSULT

1. Perform "All DTC Reading" with CONSULT.

P338D-P3398 CELL OVER DISCHARGE

[TYPE 2]

< DTC/CIRCUIT DIAGNOSIS >

2. Check "Self Diagnostic Result" of systems other than "" if any DTC is detected.

Is any DTC detected?

- YES >> After performing trouble diagnosis of detected DTC, GO TO 2.
- NO >> GO TO 2.

2. PRECONDITIONING

WARNING:

Disconnect high voltage. Refer to [GI-31, "How to Disconnect High Voltage"](#).

1. Remove Li-ion battery. Refer to [EVB-395, "Removal and Installation"](#).
2. Remove battery pack upper case. Refer to [EVB-412, "BATTERY JUNCTION BOX : Disassembly and Assembly"](#), see Step-1 to Step-3.

>> GO TO 3.

3. CHECK HARNESS BETWEEN MODULE AND LI-ION BATTERY CONTROLLER

Ⓜ With CONSULT

1. Select "Self Diagnostic Result" mode of "HV BAT" using CONSULT.
2. Identify the malfunctioning module based on detected DTC.
3. Disconnect module harness connector and Li-ion battery controller harness connector.
4. Refer to below table and check the continuity between corresponding module and Li-ion battery controller.

DTC	Module No.	Module		Li-ion battery controller		Continuity
		Connector	Terminal	Connector	Terminal	
P338D	25	LB8	57	LB15	89	Existed
			73		110	
			58		90	
P338E	26	LB8	58	LB15	90	Existed
			74		111	
			75		91	
P338F	27	LB8	75	LB15	91	Existed
			60		112	
			76		92	
P3390	28	LB8	76	LB15	92	Existed
			77		113	
			62		93	
P3391	29	LB8	62	LB15	93	Existed
			78		114	
			79		94	
P3392	30	LB8	79	LB15	94	Existed
			64		115	
			80		95	
P3393	31	LB8	80	LB15	95	Existed
			81		116	
			66		96	
P3394	32	LB8	66	LB15	96	Existed
			82		117	
			83		97	

P338D-P3398 CELL OVER DISCHARGE

[TYPE 2]

< DTC/CIRCUIT DIAGNOSIS >

DTC	Module No.	Module		Li-ion battery controller		Continuity
		Connector	Terminal	Connector	Terminal	
P3395	33	LB8	83	LB15	97	Existed
			68		118	
			84		99	
P3396	34	LB8	84	LB15	99	Existed
			85		119	
			70		100	
P3397	35	LB8	70	LB15	100	Existed
			86		120	
			87		101	
P3398	36	LB8	87	LB15	101	Existed
			72		121	
			88		102	

Is the inspection result normal?

YES >> GO TO 4.

NO >> Repair Harness or connector.

4. CHECK MODULE VOLTAGE

Check voltage of corresponding module. Refer to [EVB-348, "Component Inspection"](#).

Is the inspection result normal?

YES >> Replace Li-ion battery controller. Refer to [EVB-419, "LI-ION BATTERY CONTROLLER : Disassembly and Assembly"](#).

NO >> Replace corresponding module. Refer to [EVB-402, "Exploded view"](#).

Component Inspection

INFOID:000000007593005

1. CHECK MODULE VOLTAGE

Check voltage of module.

A : Positive terminal (Red)

B : Negative terminal (Black)

Terminals		Voltage (Approx.)
(+)	(-)	
Module		5.0 - 8.5 V
Positive terminal (Red)	Negative terminal (Black)	

Is the inspection result normal?

YES >> INSPECTION END

NO >> Replace module. Refer to [EVB-426, "FRONT MODULE STACK : Disassembly and Assembly"](#) (Front module) or [EVB-435, "REAR MODULE STACK : Disassembly and Assembly"](#) (Rear module).

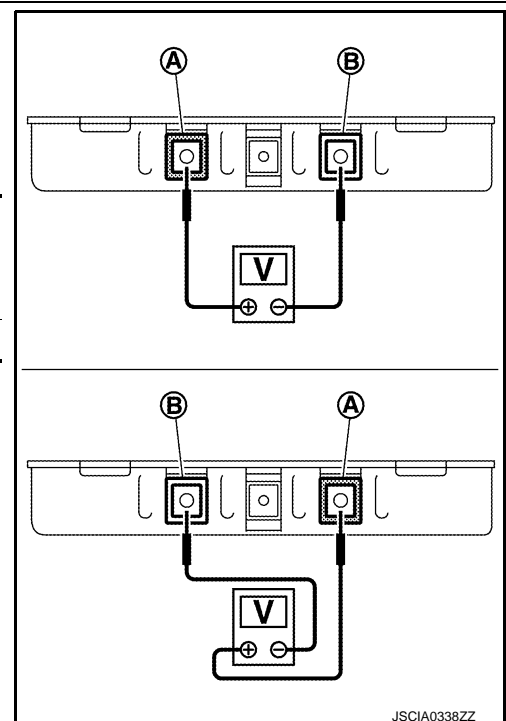

P3399-P33A4 CELL OVER DISCHARGE

< DTC/CIRCUIT DIAGNOSIS >

[TYPE 2]

P3399-P33A4 CELL OVER DISCHARGE

DTC Logic

INFOID:000000007593006

DTC DETECTION LOGIC

DTC	Trouble diagnosis name	DTC detecting condition	Possible causes
P3399	CELL OVER DISCHARGE MODULE37	When cell voltage lowers below the allowable working voltage range.	<ul style="list-style-type: none"> Overcharge caused by traction motor inverter/VCM malfunction Module Li-ion battery controller Bus bar Harness or connector
P339A	CELL OVER DISCHARGE MODULE38		
P339B	CELL OVER DISCHARGE MODULE39		
P339C	CELL OVER DISCHARGE MODULE40		
P339D	CELL OVER DISCHARGE MODULE41		
P339E	CELL OVER DISCHARGE MODULE42		
P339F	CELL OVER DISCHARGE MODULE43		
P33A0	CELL OVER DISCHARGE MODULE44		
P33A1	CELL OVER DISCHARGE MODULE45		
P33A2	CELL OVER DISCHARGE MODULE46		
P33A3	CELL OVER DISCHARGE MODULE47		
P33A4	CELL OVER DISCHARGE MODULE48		

DTC CONFIRMATION PROCEDURE

1. PERFORM DTC CONFIRMATION PROCEDURE

④ With CONSULT

- Power switch ON and wait for 10 seconds or more.
- Select "Self Diagnostic Result" of "HV BAT".
- Check DTC.

Is any DTC detected?

- YES >> Refer to [EVB-349, "Diagnosis Procedure"](#).
 NO >> INSPECTION END

Diagnosis Procedure

INFOID:000000007593007

WARNING:

- Because hybrid vehicles and electric vehicles contain a high voltage battery, there is the risk of electric shock, electric leakage, or similar accidents if the high voltage component and vehicle are handled incorrectly. Be sure to follow the correct work procedures when performing inspection and maintenance.
- Be sure to remove the service plug in order to disconnect the high voltage circuits before performing inspection or maintenance of high voltage system harnesses and parts.
- To prevent the removed service plug from being connected by mistake during the procedure, always carry it in your pocket or put it in the tool box.
- Be sure to wear insulating protective equipment consisting of glove, shoes, face shield and glasses before beginning work on the high voltage system.
- Clearly identify the persons responsible for high voltage work and ensure that other persons do not touch the vehicle. When not working, cover high voltage parts with an insulating cover sheet or similar item to prevent other persons from contacting them.
- Refer to [EVB-229, "High Voltage Precautions"](#).

CAUTION:

There is the possibility of a malfunction occurring if the vehicle is changed to READY status while the service plug is removed. Therefore do not change the vehicle to READY status unless instructed to do so in the Service Manual.

1. CHECK SELF-DIAGNOSIS RESULTS

④ With CONSULT

- Perform "All DTC Reading" with CONSULT.

P3399-P33A4 CELL OVER DISCHARGE

[TYPE 2]

< DTC/CIRCUIT DIAGNOSIS >

2. Check "Self Diagnostic Result" of systems other than "" if any DTC is detected.

Is any DTC detected?

- YES >> After performing trouble diagnosis of detected DTC, GO TO 2.
- NO >> GO TO 2.

2. PRECONDITIONING

WARNING:

Disconnect high voltage. Refer to [GI-31, "How to Disconnect High Voltage"](#).

1. Remove Li-ion battery. Refer to [EVB-395, "Removal and Installation"](#).
2. Remove battery pack upper case. Refer to [EVB-412, "BATTERY JUNCTION BOX : Disassembly and Assembly"](#), see Step-1 to Step-3.

>> GO TO 3.

3. CHECK HARNESS BETWEEN MODULE AND LI-ION BATTERY CONTROLLER

Ⓟ With CONSULT

1. Select "Self Diagnostic Result" mode of "HV BAT" using CONSULT.
2. Identify the malfunctioning module based on detected DTC.
3. Disconnect module harness connector and Li-ion battery controller harness connector.
4. Refer to below table and check the continuity between corresponding module and Li-ion battery controller.

DTC	Module No.	Module		Li-ion battery controller		Continuity
		Connector	Terminal	Connector	Terminal	
P3399	37	LB8	88	LB15	102	Existed
			LB7		89	
					101	
P339A	38	LB7	101	LB15	103	Existed
			90		123	
			102		104	
P339B	39	LB7	102	LB15	104	Existed
			91		124	
			103		105	
P339C	40	LB7	103	LB15	105	Existed
			92		125	
			104		106	
P339D	41	LB7	104	LB15	106	Existed
			93		127	
			105		107	
P339E	42	LB7	105	LB15	107	Existed
			94		128	
			106		108	
P339F	43	LB7	106	LB15	108	Existed
			95	LB16	137	
					107	
P33A0	44	LB7	107	LB16	130	Existed
			96		138	
			108		131	

P3399-P33A4 CELL OVER DISCHARGE

< DTC/CIRCUIT DIAGNOSIS >

[TYPE 2]

DTC	Module No.	Module		Li-ion battery controller		Continuity
		Connector	Terminal	Connector	Terminal	
P33A1	45	LB7	108	LB16	131	Existed
			97		140	
			109		132	
P33A2	46	LB7	109	LB16	132	Existed
			98		141	
			110		133	
P33A3	47	LB7	110	LB16	133	Existed
			99		142	
			111		134	
P33A4	48	LB7	111	LB16	134	Existed
			100		143	
			112		135	

Is the inspection result normal?

YES >> GO TO 4.

NO >> Repair Harness or connector.

4.CHECK MODULE VOLTAGE

Check voltage of corresponding module. Refer to [EVb-351, "Component Inspection"](#).

Is the inspection result normal?

YES >> Replace Li-ion battery controller. Refer to [EVb-419, "LI-ION BATTERY CONTROLLER : Disassembly and Assembly"](#).

NO >> Replace corresponding module. Refer to [EVb-402, "Exploded view"](#).

Component Inspection

INFOID:000000007593008

1.CHECK MODULE VOLTAGE

Check voltage of module.

A : Positive terminal (Red)

B : Negative terminal (Black)

Terminals		Voltage (Approx.)
(+)	(-)	
Module		5.0 - 8.5 V
Positive terminal (Red)	Negative terminal (Black)	

Is the inspection result normal?

YES >> INSPECTION END

NO >> Replace module. Refer to [EVb-426, "FRONT MODULE STACK : Disassembly and Assembly"](#) (Front module) or [EVb-435, "REAR MODULE STACK : Disassembly and Assembly"](#) (Rear module).

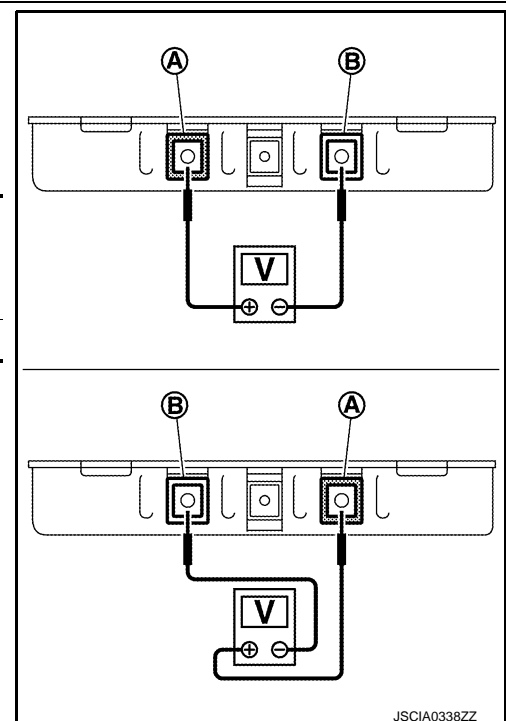

JSCIA0338ZZ

P33D4 BATT GRADUAL CAPA LOSS DIAG

< DTC/CIRCUIT DIAGNOSIS >

[TYPE 2]

P33D4 BATT GRADUAL CAPA LOSS DIAG

DTC Logic

INFOID:000000007592477

DTC DETECTION LOGIC

DTC	Trouble diagnosis name	DTC detecting condition	Possible causes
P33D4	BATT GRADUAL CAPA LOSS DIAG	When the battery charge lowers. (The internal resistance of the battery increases.)	Li-ion battery

DTC CONFIRMATION PROCEDURE

1. PERFORM DTC CONFIRMATION PROCEDURE

④ With CONSULT

1. Power switch ON and wait for 10 seconds or more.
2. Select "Self Diagnostic Result" of "HV BAT".
3. Check DTC.

Is P33D4 detected?

- YES >> Refer to [EVB-352, "Diagnosis Procedure"](#).
NO >> INSPECTION END

Diagnosis Procedure

INFOID:000000007592478

When this DTC is detected, replace Li-ion battery. Refer to [EVB-395, "Removal and Installation"](#).

P33D5 CURRENT SENSOR

< DTC/CIRCUIT DIAGNOSIS >

[TYPE 2]

P33D5 CURRENT SENSOR

DTC Logic

INFOID:000000007592479

DTC DETECTION LOGIC

DTC	Trouble diagnosis name	DTC detecting condition	Possible causes
P33D5	CURRENT SENSOR	Deviation in characteristics of battery current sensor signal voltage. (Battery current sensor signal voltage is too high or too low.)	<ul style="list-style-type: none">• Li-ion battery controller• Current sensor• System main relay• Harness or connector

DTC CONFIRMATION PROCEDURE

1. PERFORM DTC CONFIRMATION PROCEDURE

④ With CONSULT

1. Power switch ON and wait for 10 seconds or more.
2. Select "Self Diagnostic Result" of "HV BAT".
3. Check DTC.

Is P33D5 detected?

- YES >> Refer to [EV B-353, "Diagnosis Procedure"](#).
NO >> INSPECTION END

Diagnosis Procedure

INFOID:000000007592480

WARNING:

- Because hybrid vehicles and electric vehicles contain a high voltage battery, there is the risk of electric shock, electric leakage, or similar accidents if the high voltage component and vehicle are handled incorrectly. Be sure to follow the correct work procedures when performing inspection and maintenance.
- Be sure to remove the service plug in order to disconnect the high voltage circuits before performing inspection or maintenance of high voltage system harnesses and parts.
- To prevent the removed service plug from being connected by mistake during the procedure, always carry it in your pocket or put it in the tool box.
- Be sure to wear insulating protective equipment consisting of glove, shoes, face shield and glasses before beginning work on the high voltage system.
- Clearly identify the persons responsible for high voltage work and ensure that other persons do not touch the vehicle. When not working, cover high voltage parts with an insulating cover sheet or similar item to prevent other persons from contacting them.
- Refer to [EV B-229, "High Voltage Precautions"](#).

CAUTION:

There is the possibility of a malfunction occurring if the vehicle is changed to READY status while the service plug is removed. Therefore do not change the vehicle to READY status unless instructed to do so in the Service Manual.

1. CHECK SELF-DIAGNOSIS RESULTS OF VCM

④ With CONSULT

1. Select "Self Diagnostic Result" mode of "EV/HEV" using CONSULT.
2. Check to see if "P0AA0", "P0AA1" or "P0AA4" is detected.

Is any DTC detected?

- YES >> Perform diagnosis on the detected DTC. Refer to [EV B-268, "DTC Index"](#).
NO >> GO TO 2.

2. PRECONDITIONING

WARNING:

Disconnect high voltage. Refer to [GI-31, "How to Disconnect High Voltage"](#).

1. Remove Li-ion battery. Refer to [EV B-395, "Removal and Installation"](#).
2. Remove battery pack upper case. Refer to [EV B-412, "BATTERY JUNCTION BOX : Disassembly and Assembly"](#), see Step-1 to Step-3.

P33D5 CURRENT SENSOR

< DTC/CIRCUIT DIAGNOSIS >

[TYPE 2]

>> GO TO 3.

3.CHECK CONNECTION STATUS

Check connection status of Li-ion battery controller harness connector and battery junction box (current sensor) harness connector.

Is the inspection result normal?

YES >> GO TO 4.

NO >> Recover the connection status.

4.CHECK HARNESS BETWEEN BATTERY JUNCTION BOX (CURRENT SENSOR) AND LI-ION BATTERY CONTROLLER

Check continuity between battery junction box (current sensor) harness connector and Li-ion battery controller harness connector.

Battery junction box (Current sensor)		Li-ion battery controller		Continuity
Connector	Terminal	Connector	Terminal	
LB3	9	LB11	10	Exited
	3		9	
	10		17	

Is the inspection result normal?

YES >> GO TO 5.

NO >> Repair Harness or connector.

5.CHECK CURRENT SENSOR

Check resistance of current sensor.

Battery junction box (Current sensor)			Resistance value
Connector	Terminal	Terminal	
LB3	9	10	1 k Ω –10 M Ω
	3	10	

Is the inspection result normal?

YES >> GO TO 6.

NO >> Replace current sensor.

6.CHECK LI-ION BATTERY CONTROLLER

Check resistance of Li-ion battery controller.

Li-ion battery controller			Resistance value
Connector	Terminal	Terminal	
LB11	10	17	Approx. 4.7 k Ω

Is the inspection result normal?

YES >> Replace battery junction box. Refer to [EVB-412, "BATTERY JUNCTION BOX : Disassembly and Assembly"](#).

NO >> Replace Li-ion battery controller. Refer to [EVB-419, "LI-ION BATTERY CONTROLLER : Disassembly and Assembly"](#).

P33D6 CURRENT SENSOR

< DTC/CIRCUIT DIAGNOSIS >

[TYPE 2]

P33D6 CURRENT SENSOR

DTC Logic

INFOID:000000007592481

DTC DETECTION LOGIC

DTC	Trouble diagnosis name	DTC detecting condition	Possible causes
P33D6	CURRENT SENSOR	Deviation from the specified voltage characteristics of battery current sensor.	Li-ion battery controller

A
B
EVB

DTC CONFIRMATION PROCEDURE

1. PERFORM DTC CONFIRMATION PROCEDURE

④ With CONSULT

1. Power switch ON and wait for 10 seconds or more.
2. Select "Self Diagnostic Result" of "HV BAT".
3. Check DTC.

Is P33D6 detected?

- YES >> Refer to [EV3-355, "Diagnosis Procedure"](#).
 NO >> INSPECTION END

Diagnosis Procedure

INFOID:000000007592482

WARNING:

- Because hybrid vehicles and electric vehicles contain a high voltage battery, there is the risk of electric shock, electric leakage, or similar accidents if the high voltage component and vehicle are handled incorrectly. Be sure to follow the correct work procedures when performing inspection and maintenance.
- Be sure to remove the service plug in order to disconnect the high voltage circuits before performing inspection or maintenance of high voltage system harnesses and parts.
- To prevent the removed service plug from being connected by mistake during the procedure, always carry it in your pocket or put it in the tool box.
- Be sure to wear insulating protective equipment consisting of glove, shoes, face shield and glasses before beginning work on the high voltage system.
- Clearly identify the persons responsible for high voltage work and ensure that other persons do not touch the vehicle. When not working, cover high voltage parts with an insulating cover sheet or similar item to prevent other persons from contacting them.
- Refer to [EV3-229, "High Voltage Precautions"](#).

CAUTION:

There is the possibility of a malfunction occurring if the vehicle is changed to READY status while the service plug is removed. Therefore do not change the vehicle to READY status unless instructed to do so in the Service Manual.

1. PRECONDITIONING

WARNING:

Disconnect high voltage. Refer to [GI-31, "How to Disconnect High Voltage"](#).

1. Remove Li-ion battery. Refer to [EV3-395, "Removal and Installation"](#).
2. Remove battery pack upper case. Refer to [EV3-412, "BATTERY JUNCTION BOX : Disassembly and Assembly"](#), see Step-1 to Step-3.

>> GO TO 2.

2. CHECK CURRENT SENSOR

1. Disconnect Li-ion battery controller harness connector.
2. Check the resistance of current sensor from Li-ion battery controller side.

Li-ion battery controller		Resistance value
Connector	Terminal	

D
E
F
G
H
I
J
K
L
M
N
O
P

P33D6 CURRENT SENSOR

< DTC/CIRCUIT DIAGNOSIS >

[TYPE 2]

LB11	10	9	1 kΩ–10 MΩ
	9	17	

Is the inspection result normal?

YES >> Replace Li-ion battery controller. Refer to [EVB-419, "LI-ION BATTERY CONTROLLER : Disassembly and Assembly"](#).

NO >> GO TO 3.

3. CHECK HARNESS BETWEEN LI-ION BATTERY CONTROLLER AND BATTERY JUNCTION BOX (CURRENT SENSOR)

1. Disconnect Battery junction box harness connector.
2. Check continuity between Li-ion battery controller and Battery junction box (current sensor).

Li-ion battery controller		Battery junction box (Current sensor)		Continuity
Connector	Terminal	Connector	Terminal	
LB11	10	LB3	9	Existed
	9		3	
	17		10	

Is the inspection result normal?

YES >> Replace battery junction box. Refer to [EVB-412, "BATTERY JUNCTION BOX : Disassembly and Assembly"](#).

NO >> Repair Harness or connector.

P33D7, P33D9, P33DB, P33DD TEMPERATURE SENSOR

< DTC/CIRCUIT DIAGNOSIS >

[TYPE 2]

P33D7, P33D9, P33DB, P33DD TEMPERATURE SENSOR

DTC Logic

INFOID:000000007593009

DTC DETECTION LOGIC

DTC	Trouble diagnosis name	DTC detecting condition	Possible causes
P33D7	TEMPERATURE SENSOR	Battery temperature sensor rear center signal voltage is too high or too low.	<ul style="list-style-type: none"> Battery temperature sensor 1 Li-ion battery controller Harness or connector
P33D9		Battery temperature sensor front RH signal voltage is too high or too low.	
P33DB		Battery temperature sensor rear RH signal voltage is too high or too low.	
P33DD		Battery temperature sensor front LH signal voltage is too high or too low.	

DTC CONFIRMATION PROCEDURE

1. PERFORM DTC CONFIRMATION PROCEDURE

Ⓜ With CONSULT

- Power switch ON and wait for 10 seconds or more.
- Select "Self Diagnostic Result" of "HV BAT".
- Check DTC.

Is any DTC detected?

- YES >> Refer to [EV3-357, "Diagnosis Procedure"](#).
 NO >> INSPECTION END

Diagnosis Procedure

INFOID:000000007593010

WARNING:

- Because hybrid vehicles and electric vehicles contain a high voltage battery, there is the risk of electric shock, electric leakage, or similar accidents if the high voltage component and vehicle are handled incorrectly. Be sure to follow the correct work procedures when performing inspection and maintenance.
- Be sure to remove the service plug in order to disconnect the high voltage circuits before performing inspection or maintenance of high voltage system harnesses and parts.
- To prevent the removed service plug from being connected by mistake during the procedure, always carry it in your pocket or put it in the tool box.
- Be sure to wear insulating protective equipment consisting of glove, shoes, face shield and glasses before beginning work on the high voltage system.
- Clearly identify the persons responsible for high voltage work and ensure that other persons do not touch the vehicle. When not working, cover high voltage parts with an insulating cover sheet or similar item to prevent other persons from contacting them.
- Refer to [EV3-229, "High Voltage Precautions"](#).

CAUTION:

There is the possibility of a malfunction occurring if the vehicle is changed to READY status while the service plug is removed. Therefore do not change the vehicle to READY status unless instructed to do so in the Service Manual.

1. PRECONDITIONING

WARNING:

Disconnect high voltage. Refer to [GI-31, "How to Disconnect High Voltage"](#).

- Remove Li-ion battery. Refer to [EV3-395, "Removal and Installation"](#).
- Remove battery pack upper case. Refer to [EV3-412, "BATTERY JUNCTION BOX : Disassembly and Assembly"](#), see Step-1 to Step-3.

>> GO TO 2.

P33D7, P33D9, P33DB, P33DD TEMPERATURE SENSOR

< DTC/CIRCUIT DIAGNOSIS >

[TYPE 2]

2.CHECK HARNESS

1. Power switch OFF.
2. Check a connection state of harness connector of Li-ion battery controller.

Is the inspection result normal?

- YES >> GO TO 3.
NO >> Recover the connection status.

3.CHECK BATTERY TEMPERATURE SENSOR

Refer to [EVB-358. "Component Inspection"](#).

Is the inspection result normal?

- YES >> GO TO 4.
NO >> Replace battery temperature sensor.

4.CHECK HARNESS BETWEEN BATTERY TEMPERATURE SENSOR AND GROUND

1. Disconnect Li-ion battery controller harness connector.
2. Check continuity between battery temperature sensor harness connector and ground.

Battery temperature sensor	Connector	Terminal	—	Continuity
Rear center	LB17	3	Ground	No existed
Front RH	LB5	1		
Rear RH	LB17	1		
Front LH	LB4	3		

Is the inspection result normal?

- YES >> Replace Li-ion battery controller. Refer to [EVB-419. "LI-ION BATTERY CONTROLLER : Disassembly and Assembly"](#).
NO >> Repair harness or connector.

Component Inspection

INFOID:000000007593011

1.CHECK BATTERY TEMPERATURE SENSOR

1. Remove battery temperature sensor. Refer to [EVB-402. "Exploded view"](#).
2. Check resistance between battery temperature sensor terminals.

Battery temperature sensor	Terminals	Condition	Resistance (kΩ)
Rear RH & Front RH	1 and 2	Temperature °C (°F)	10 (50) Approx. 7.4
Rear center & Front LH	3 and 4		25 (77) Approx. 4.0
			40 (104) Approx. 2.3

Is the inspection result normal?

- YES >> INSPECTION END
NO >> Replace battery temperature sensor.

P33DF BAT VOLTAGE ISOLATION SEN

< DTC/CIRCUIT DIAGNOSIS >

[TYPE 2]

P33DF BAT VOLTAGE ISOLATION SEN

DTC Logic

INFOID:000000007592486

DTC DETECTION LOGIC

DTC	Trouble diagnosis name	DTC detecting condition	Possible causes
P33DF	BAT VOLTAGE ISOLATION SEN	Signal voltage of the on-board isolation resistance monitoring system is too high.	Li-ion battery controller

EVB

DTC CONFIRMATION PROCEDURE

1. PERFORM DTC CONFIRMATION PROCEDURE

④ With CONSULT

1. Power switch ON and wait for 10 seconds or more.
2. Select "Self Diagnostic Result" of "HV BAT".
3. Check DTC.

Is P33DF detected?

- YES >> Refer to [EVB-359, "Diagnosis Procedure"](#).
NO >> INSPECTION END

Diagnosis Procedure

INFOID:000000007592487

When this DTC is detected, replace Li-ion battery controller. Refer to [EVB-419, "LI-ION BATTERY CONTROLLER : Disassembly and Assembly"](#).

A
B
D
E
F
G
H
I
J
K
L
M
N
O
P

P33E0 BAT VOLTAGE ISOLATION SEN

< DTC/CIRCUIT DIAGNOSIS >

[TYPE 2]

P33E0 BAT VOLTAGE ISOLATION SEN

DTC Logic

INFOID:000000007592492

DTC DETECTION LOGIC

DTC	Trouble diagnosis name	DTC detecting condition	Possible causes
P33E0	BATTERY VOLTAGE ISOLATION SENSOR	Signal Voltage of the on-board isolation resistance monitoring system is too low.	Li-ion battery controller

DTC CONFIRMATION PROCEDURE

1. PERFORM DTC CONFIRMATION PROCEDURE

④ With CONSULT

1. Power switch ON and wait for 10 seconds or more.
2. Select "Self Diagnostic Result" of "HV BAT".
3. Check DTC.

Is P33E0 detected?

- YES >> Refer to [EVB-360, "Diagnosis Procedure"](#).
NO >> INSPECTION END

Diagnosis Procedure

INFOID:000000007592493

When this DTC is detected, replace Li-ion battery controller. Refer to [EVB-419, "LI-ION BATTERY CONTROLLER : Disassembly and Assembly"](#).

P33E1 BAT VOLTAGE ISOLATION SEN

< DTC/CIRCUIT DIAGNOSIS >

[TYPE 2]

P33E1 BAT VOLTAGE ISOLATION SEN

DTC Logic

INFOID:000000007592604

DTC DETECTION LOGIC

DTC	Trouble diagnosis name	DTC detecting condition	Possible causes
P33E1	BATTERY VOLTAGE ISOLATION SENSOR	Signal voltage of the on-board isolation resistance monitoring system exhibits no amplitude variation.	Li-ion battery controller

A
B
EVB
D
E
F
G
H
I
J
K
L
M
N
O
P

DTC CONFIRMATION PROCEDURE

1. PERFORM DTC CONFIRMATION PROCEDURE

④ With CONSULT

1. Power switch ON and wait for 10 seconds or more.
2. Select "Self Diagnostic Result" of "HV BAT".
3. Check DTC.

Is P33E1 detected?

- YES >> Refer to [EVB-361, "Diagnosis Procedure"](#).
- NO >> INSPECTION END

Diagnosis Procedure

INFOID:000000007592605

When this DTC is detected, perform Li-ion battery insulation resistance loss check. Refer to [EVB-377, "Component Inspection"](#).

P33E2 BATT PACK OVER TEMP

< DTC/CIRCUIT DIAGNOSIS >

[TYPE 2]

P33E2 BATT PACK OVER TEMP

DTC Logic

INFOID:000000007592606

DTC DETECTION LOGIC

DTC	Trouble diagnosis name	DTC detecting condition	Possible causes
P33E2	BATTERY PACK OVER TEMPERATURE	When the battery (battery pack) temperature is excessively high.	Overcharge caused by traction motor inverter/VCM malfunction

DTC CONFIRMATION PROCEDURE

1. PERFORM DTC CONFIRMATION PROCEDURE

Ⓟ With CONSULT

1. Power switch ON and wait for 10 seconds or more.
2. Select "Self Diagnostic Result" of "HV BAT".
3. Check DTC.

Is P33E2 detected?

YES >> Refer to [EVB-362, "Diagnosis Procedure"](#).

NO >> INSPECTION END

Diagnosis Procedure

INFOID:000000007592607

1. PERFORM THE SELF-DIAGNOSIS OF LI-ION BATTERY CONTROLLER

Ⓟ With CONSULT

1. Select "Self Diagnostic Result" of "HV BAT".
2. Check to see if "P33E4" or "P33E5" is detected simultaneously with "P33E2".

Is P33E4 or P33E5 detected?

YES >> Perform diagnosis on the detected "P33E4" or "P33E5". Refer to [EVB-363, "Diagnosis Procedure"](#).

NO >> GO TO 2.

2. CHECK BATTERY TEMPERATURE SENSOR

Ⓟ With CONSULT

Using FREEZE FRAME DATA (FFD), check the values of four temperature sensors when DTC is detected.

Monitor item	Condition	Limit
Battery temperature sensor 1	Power switch ON	55°C (131°F) or less
Battery temperature sensor 2		
Battery temperature sensor 3		
Battery temperature sensor 4		

Is there temperature increase?

Temperature increase is seen>>Replace Li-ion battery. Refer to [EVB-395, "Removal and Installation"](#).

Temperature increase is not seen>>Replace battery temperature sensors. Refer to [EVB-176, "Exploded view"](#).

P33E4, P33E5 TEMPERATURE SENSOR

< DTC/CIRCUIT DIAGNOSIS >

[TYPE 2]

P33E4, P33E5 TEMPERATURE SENSOR

DTC Logic

INFOID:000000007593013

DTC DETECTION LOGIC

DTC	Trouble diagnosis name	DTC detecting condition	Possible causes
P33E4	TEMPERATURE SENSOR	Deviation in characteristics of Battery temperature sensor rear center or front RH.	Battery temperature sensor
P33E5		Deviation in characteristics of Battery temperature sensor rear RH or front LH.	

DTC CONFIRMATION PROCEDURE

1. PERFORM DTC CONFIRMATION PROCEDURE

Ⓜ With CONSULT

1. Power switch ON and wait for 10 seconds or more.
2. Select "Self Diagnostic Result" of "HV BAT".
3. Check DTC.

Is P33E4 or P33E5 DTC detected?

- YES >> Refer to [EVB-363, "Diagnosis Procedure"](#).
NO >> INSPECTION END

Diagnosis Procedure

INFOID:000000007593014

WARNING:

- Because hybrid vehicles and electric vehicles contain a high voltage battery, there is the risk of electric shock, electric leakage, or similar accidents if the high voltage component and vehicle are handled incorrectly. Be sure to follow the correct work procedures when performing inspection and maintenance.
- Be sure to remove the service plug in order to disconnect the high voltage circuits before performing inspection or maintenance of high voltage system harnesses and parts.
- To prevent the removed service plug from being connected by mistake during the procedure, always carry it in your pocket or put it in the tool box.
- Be sure to wear insulating protective equipment consisting of glove, shoes, face shield and glasses before beginning work on the high voltage system.
- Clearly identify the persons responsible for high voltage work and ensure that other persons do not touch the vehicle. When not working, cover high voltage parts with an insulating cover sheet or similar item to prevent other persons from contacting them.
- Refer to [EVB-229, "High Voltage Precautions"](#).

CAUTION:

There is the possibility of a malfunction occurring if the vehicle is changed to READY status while the service plug is removed. Therefore do not change the vehicle to READY status unless instructed to do so in the Service Manual.

1. PRECONDITIONING

WARNING:

Disconnect high voltage. Refer to [GI-31, "How to Disconnect High Voltage"](#).

1. Remove Li-ion battery. Refer to [EVB-395, "Removal and Installation"](#).
2. Remove battery pack upper case. Refer to [EVB-412, "BATTERY JUNCTION BOX : Disassembly and Assembly"](#), see Step-1 to Step-3.

>> GO TO 2.

2. CHECK BATTERY TEMPERATURE SENSOR

Refer to [EVB-364, "Component Inspection"](#).

Is the inspection result normal?

- YES >> Replace both battery temperature sensor.

P33E4, P33E5 TEMPERATURE SENSOR

[TYPE 2]

< DTC/CIRCUIT DIAGNOSIS >

NO >> Replace malfunction battery temperature sensor.

Component Inspection

INFOID:000000007593015

1. CHECK BATTERY TEMPERATURE SENSOR

1. Remove battery temperature sensor. Refer to [EVB-402, "Exploded view"](#).
2. Check resistance between battery temperature sensor terminals.

Battery temperature sensor	Terminals	Condition	Resistance (k Ω)
Rear RH & Front RH	1 and 2	Temperature °C (°F)	10 (50) Approx. 7.4
Rear center & Front LH	3 and 4		25 (77) Approx. 4.0
			40 (104) Approx. 2.3

Is the inspection result normal?

YES >> INSPECTION END

NO >> Replace battery temperature sensor.

P33E6 CELL VOLTAGE DEVIATION DIAG

< DTC/CIRCUIT DIAGNOSIS >

[TYPE 2]

P33E6 CELL VOLTAGE DEVIATION DIAG

DTC Logic

INFOID:000000007592611

DTC DETECTION LOGIC

DTC	Trouble diagnosis name	DTC detecting condition	Possible causes
P33E6	CELL VOLTAGE DEVIATION DIAG	With the power switch ON and no load condition, the difference between the maximum voltage and minimum voltage exceeds the allowable range.	<ul style="list-style-type: none">Li-ion battery controllerModule

DTC CONFIRMATION PROCEDURE

1. PERFORM DTC CONFIRMATION PROCEDURE

④ With CONSULT

- Turn power switch ON and wait for 10 seconds or more.
- Select "Self Diagnostic Result" of "HV BAT".
- Check DTC.

Is P33E6 detected?

- YES >> Refer to [EVB-365, "Diagnosis Procedure"](#).
NO >> INSPECTION END

Diagnosis Procedure

INFOID:000000007592612

WARNING:

- Because hybrid vehicles and electric vehicles contain a high voltage battery, there is the risk of electric shock, electric leakage, or similar accidents if the high voltage component and vehicle are handled incorrectly. Be sure to follow the correct work procedures when performing inspection and maintenance.
- Be sure to remove the service plug in order to disconnect the high voltage circuits before performing inspection or maintenance of high voltage system harnesses and parts.
- To prevent the removed service plug from being connected by mistake during the procedure, always carry it in your pocket or put it in the tool box.
- Be sure to wear insulating protective equipment before beginning work on the high voltage system.
- Clearly identify the persons responsible for high voltage work and ensure that other persons do not touch the vehicle. When not working, cover high voltage parts with an insulating cover sheet or similar item to prevent other persons from contacting them.
- Refer to [EVB-229, "High Voltage Precautions"](#).

CAUTION:

There is the possibility of a malfunction occurring if the vehicle is changed to READY status while the service plug is removed. Therefore do not change the vehicle to READY status unless instructed to do so in the Service Manual.

1. CHECK SELF-DIAGNOSIS RESULTS OF LI-ION BATTERY CONTROLLER

④ With CONSULT

- Select "Self Diagnostic Result" of "HV BAT".
- Check to see if "P0A1F", "P3062" or "P33ED" is detected simultaneously with "P33E6".

Is P0A1F, P3062 or P33ED detected?

- YES-1 >> When "P0A1F" or "P3062" are detected simultaneously, Replace Li-ion battery controller. Refer to [EVB-419, "LI-ION BATTERY CONTROLLER : Disassembly and Assembly"](#).
YES-2 >> When "P33ED" is detected simultaneously, perform the diagnosis procedure of "P33ED". Refer to [EVB-372, "Diagnosis Procedure"](#).
NO >> GO TO 2.

2. CHECK FREEZE FRAME DATA (FFD)

④ With CONSULT

- Check "FFD" when DTC is detected.
- Calculate the average value of cell voltage by dividing "TOTAL BATTERY VOLTAGE" by 96 (the number of cells).

P33E6 CELL VOLTAGE DEVIATION DIAG

< DTC/CIRCUIT DIAGNOSIS >

[TYPE 2]

Average cell voltage = "TOTAL BETTER VOLTAGE" ÷ 96 (the number of cells)

- Identify the minimum cell voltage and the maximum cell voltage from 96 cells.
- Calculate voltage according to the following expressions to compare voltage between A and B.

A = Maximum cell voltage – Average cell voltage

B = Average cell voltage – Minimum cell voltage

Which voltage is larger, A or B?

- A >> Replace module including a cell of the maximum cell voltage. Refer to [EVB-426, "FRONT MODULE STACK : Disassembly and Assembly"](#) (Front module stack) or [EVB-435, "REAR MODULE STACK : Disassembly and Assembly"](#) (Rear module stack). After replacing module, GO TO 3.
- B >> Replace module including a cell of the minimum cell voltage. Refer to [EVB-426, "FRONT MODULE STACK : Disassembly and Assembly"](#) (Front module stack) or [EVB-435, "REAR MODULE STACK : Disassembly and Assembly"](#) (Rear module stack). After replacing module, GO TO 3.

3.PERFORM CELL VOLTAGE LOSS INSPECTION

Ⓟ With CONSULT

- Select "WORK SUPPORT" of "HV BAT."
- Select "CELL VOLTAGE LOSS INSPECTION." Touch "START."
- Check "MINIMUM CELL VOLTAGE."

Is "MINIMUM CELL VOLTAGE" 3,712 mV or less?

YES >> GO TO 5.

NO >> GO TO 4.

4.DISCHARGE OF LI-ION BATTERY

Ⓟ With CONSULT

- Set the vehicle to READY.
- Set the vehicle, according to the following conditions.

A/C set temperature	: Full hot
A/C fan speed	: Maximum speed
A/C air outlet	:  Defroster
Headlamp	: High beam ON
Door glass	: Full open

- Check "DATA MONITOR" and let the Li-ion battery discharge until the "MINIMUM CELL VOLTAGE" reaches 3,712 mV or less.

NOTE:

The guide line is to discharge until the Li-ion battery available charge gauge indicates 2 segments or less. For discharge time, refer to the following table.

Guideline for discharge time

The number of lighting segments of Li-ion battery available charge gauge	Time to 2 segments
12	Approx. 230 minute
11	Approx. 200 minute
10	Approx. 180 minute
9	Approx. 160 minute
8	Approx. 130 minute
7	Approx. 110 minute
6	Approx. 90 minute
5	Approx. 70 minute

P33E6 CELL VOLTAGE DEVIATION DIAG

< DTC/CIRCUIT DIAGNOSIS >

[TYPE 2]

The number of lighting segments of Li-ion battery available charge gauge	Time to 2 segments
4	Approx. 40 minute
3	Approx. 20 minute

>> GO TO 5.

5. CHECK CELL OF VOLTAGE LOSS

④ With CONSULT

1. Check that "MINIMUM CELL VOLTAGE" is 3,712 mV or less. Touch "START."
2. Check to see if a cell of which voltage is less than or equal to "CELL VOLTAGE LOSS JUDGMENT VALUE" is displayed.

Is a cell displayed?

- YES >> Record applicable cell No. and then GO TO 6.
NO >> Check the minimum cell voltage on the data monitor and replace a module which includes the minimum cell voltage. Refer to [EVB-426, "FRONT MODULE STACK : Disassembly and Assembly"](#) (Front module stack) or [EVB-435, "REAR MODULE STACK : Disassembly and Assembly"](#) (Rear module stack).

6. PRECONDITIONING

WARNING:

Disconnect the high voltage. Refer to [GI-31, "How to Disconnect High Voltage"](#).

1. Remove Li-ion battery. Refer to [EVB-395, "Removal and Installation"](#).
2. Remove battery pack upper case. Refer to [EVB-395, "Exploded View"](#), see Step-1 to Step-3.

>> GO TO 2.

7. CHECK CONDENSATION

Check condensation in battery pack.

Is the inspection result normal?

- YES >> GO TO 8.
NO >> Replace Li-ion battery. Refer to [EVB-395, "Removal and Installation"](#).

8. CHECK CONNECTORS AND FIXING BOLTS

Check connection state, damage and dust of following;

- Li-ion battery controller (LBC) harness connector
- Module harness connector
- Module terminal fixing bolt

Is the inspection result normal?

- YES >> GO TO 9
NO >> Repair or replace error-detected parts.

9. CHECK MODULE VOLTAGE

Check module voltage within determined cell at step 3 and check the divergence of the voltage and cell voltage with "DATA MONITOR".

DANGER:

When check module voltage, be careful not to short.

Is Divergence within 40mV?

- YES >> GO TO 10.
NO >> Replace Li-ion battery controller. Refer to [EVB-419, "LI-ION BATTERY CONTROLLER : Disassembly and Assembly"](#).

10. CHECK HARNESS BETWEEN LI-ION BATTERY CONTROLLER AND MODULE HARNESS CONNECTOR

1. Disconnect Li-ion battery controller harness connector and module harness connector.

P33E6 CELL VOLTAGE DEVIATION DIAG

< DTC/CIRCUIT DIAGNOSIS >

[TYPE 2]

2. Check the resistance Li-ion battery controller harness connector and module harness connector of the determined cell at step 3.

Terminal		Resistance value
Li-ion battery controller harness connector	Module harness connector	Approx. 0 Ω

3. Check the divergence of the resistance and the resistance of other cell harness.

Is the inspection result normal?

- YES >> Replace module within the determined cell at step 5.
NO >> Repair or replace harness or connectors.

P33E7 CELL CONTROLLER

< DTC/CIRCUIT DIAGNOSIS >

[TYPE 2]

P33E7 CELL CONTROLLER

DTC Logic

INFOID:000000007592613

DTC DETECTION LOGIC

DTC	Trouble diagnosis name	DTC detecting condition	Possible causes
P33E7	CELL CONTROLLER	The A/D converter in Li-ion battery controller is malfunctioning.	Li-ion battery controller

A
B
EVB
D
E
F
G
H
I
J
K
L
M
N
O
P

DTC CONFIRMATION PROCEDURE

1. PERFORM DTC CONFIRMATION PROCEDURE

④ With CONSULT

1. Power switch ON and wait for 10 seconds or more.
2. Select "Self Diagnostic Result" of "HV BAT".
3. Check DTC.

Is P33E7 detected?

- YES >> Refer to [EVB-369, "Diagnosis Procedure"](#).
NO >> INSPECTION END

Diagnosis Procedure

INFOID:000000007592614

When this DTC is detected, replace Li-ion battery controller. Refer to [EVB-419, "LI-ION BATTERY CONTROLLER : Disassembly and Assembly"](#).

P33EA BATTERY HEATER RELAY

< DTC/CIRCUIT DIAGNOSIS >

[TYPE 2]

P33EA BATTERY HEATER RELAY

DTC Logic

INFOID:000000007374108

DTC DETECTION LOGIC

DTC	Trouble diagnosis name	DTC detecting condition	Possible causes
P33EA	BATTERY HEATER RELAY	Li-ion battery controller judges that the status of a relay control signal transmitted from Li-ion battery controller and that of a relay status signal transmitted from heater relay unit do not match.	<ul style="list-style-type: none">• Li-ion battery controller• Heater relay unit• Harness or connector

NOTE:

- The Li-ion battery controller transmits a relay control signal to the heater relay unit and turns ON/OFF the relay built-in the heater relay unit.
- The heater relay unit turns ON/OFF the built-in relay, according to a relay control signal transmitted from the Li-ion battery controller, and transmits a relay status signal (the ON/OFF status of the built-in relay) to the Li-ion battery controller.

DTC CONFIRMATION PROCEDURE

1. PERFORM DTC CONFIRMATION PROCEDURE-1

Ⓜ With CONSULT

1. Select "ACTIVE TEST" of "HV BAT."
2. Select "HEATER RELAY UNIT." Touch "START."

>> GO TO 2.

2. PERFORM DTC CONFIRMATION PROCEDURE-2

Ⓜ With CONSULT

1. Select "Self Diagnostic Result" of "HV BAT".
2. Check DTC.

Is P33EE detected?

- YES >> Refer to [EVB-370, "Diagnosis Procedure"](#).
- NO >> INSPECTION END

Diagnosis Procedure

INFOID:000000007374109

WARNING:

- Because hybrid vehicles and electric vehicles contain a high voltage battery, there is the risk of electric shock, electric leakage, or similar accidents if the high voltage component and vehicle are handled incorrectly. Be sure to follow the correct work procedures when performing inspection and maintenance.
- Be sure to remove the service plug in order to shut off the high voltage circuits before performing inspection or maintenance of high voltage system harnesses and parts.
- To prevent the removed service plug from being connected by mistake during the procedure, always carry it in your pocket or put it in the tool box.
- Be sure to wear insulating protective equipment consisting of glove, shoes, face shield and glasses before beginning work on the high voltage system.
- Clearly identify the persons responsible for high voltage work and ensure that other persons do not touch the vehicle. When not working, cover high voltage parts with an insulating cover sheet or similar item to prevent other persons from contacting them.
- Refer to [EVB-17, "High Voltage Precautions"](#).

CAUTION:

There is the possibility of a malfunction occurring if the vehicle is changed to READY status while the service plug is removed. Therefore do not change the vehicle to READY status unless instructed to do so in the Service Manual.

1. PRECONDITIONING

WARNING:

P33EA BATTERY HEATER RELAY

< DTC/CIRCUIT DIAGNOSIS >

[TYPE 2]

Shut off high voltage circuit. Refer to [GI-31, "How to Disconnect High Voltage"](#).

1. Remove Li-ion battery. Refer to [EVB-395, "Removal and Installation"](#).
2. Remove battery pack upper case. Refer to [EVB-412, "BATTERY JUNCTION BOX : Disassembly and Assembly"](#), see Step-1 to Step-3.

>> GO TO 2.

2. CHECK CONTINUITY LI-ION BATTERY CONTROLLER AND HEATER RELAY UNIT

1. Remove service plug switch bracket. Refer to [EVB-449, "HEATER RELAY UNIT : Disassembly and Assembly"](#).
2. Disconnect li-ion battery controller harness connector and heater relay unit harness connector.
3. Check continuity li-ion battery controller harness connector and heater relay unit harness connector.

Lli-ion battery controller		Heater relay unit		Continuity
Connector	Terminal	Connector	Terminal	
LB11	20	LB18	3	Existed
	4		8	

Is the inspection result normal?

YES >> GO TO 3.

NO >> Repair harness or connector.

3. CHECK CONTINUITY LI-ION BATTERY AND HEATER RELAY UNIT

Check continuity li-ion battery harness connector and heater relay unit harness connector.

Li-ion battery		Heater relay unit		Continuity
Connector	Terminal	Connector	Terminal	
LB1	21	LB18	1	Existed

Is the inspection result normal?

YES >> GO TO 4.

NO >> Repair harness or connector.

4. CHECK CONTINUITY HEATER RELAY UNIT AND LI-ION BATTERY CONTROLLER

Check continuity heater relay unit harness connector and li-ion battery controller harness connector.

Heater relay unit		Li-ion battery controller		Continuity
Connector	Terminal	Connector	Terminal	
LB18	6	LB11	3	Existed
	11		15	
	12		16	

Is the inspection result normal?

YES >> Replace to shown in the below.

- Li-ion battery controller. Refer to [EVB-419, "LI-ION BATTERY CONTROLLER : Disassembly and Assembly"](#).
- Heater relay unit. Refer to [EVB-449, "HEATER RELAY UNIT : Disassembly and Assembly"](#).

NO >> Repair harness or connector.

P33ED BATTERY PARALLEL DIAGNOSIS

< DTC/CIRCUIT DIAGNOSIS >

[TYPE 2]

P33ED BATTERY PARALLEL DIAGNOSIS

DTC Logic

INFOID:000000007592615

DTC DETECTION LOGIC

DTC	Trouble diagnosis name	DTC detecting condition	Possible causes
P33ED	BATTERY PARALLEL DIAGNOSIS	When a sudden voltage fluctuation is detected in module.	Module

DTC CONFIRMATION PROCEDURE

1. CHECK LI-ION BATTERY AVAILABLE CHARGE GAUGE

Check the indication of the Li-ion battery available charge gauge.

NOTE:

Check 12 segments for lighting status.

Is the lighting status 1 Segment or none?

YES >> GO TO 3.

NO >> GO TO 2.

2. DISCHARGE OF LI-ION BATTERY

1. Set the vehicle to READY.
2. Set the vehicle, according to the following conditions.

A/C set temperature	: Full hot
A/C fan speed	: Maximum speed
A/C air outlet	:  Defroster
Headlamp	: High beam ON
Door glass	: Full open

3. Let the Li-ion battery discharge until the Li-ion battery available charge gauge shows segment 1 or below.

>> GO TO 3.

3. CHARGE OF LI-ION BATTERY

1. Charge the Li-ion battery by normal charge until the level reaches full charge.
2. After the completion of normal charge, check that the indication of the Li-ion battery available charge gauge shows 12 segments.

>> GO TO 4.

4. PERFORM DTC CONFIRMATION PROCEDURE

Ⓟ With CONSULT

1. Power switch ON and wait for 10 seconds or more.
2. Select "Self Diagnostic Result" of "HV BAT".
3. Check DTC.

Is P33ED detected?

YES >> Refer to [EVB-372, "Diagnosis Procedure"](#).

NO >> INSPECTION END

Diagnosis Procedure

INFOID:000000007592616

1. CHECK DATA MONITOR OR FREEZE FRAME DATA (FFD)

Ⓟ With CONSULT

1. Select "DATA MONITOR" or "FFD".
2. Check to see if there is a cell voltage which largely differ from the others.

Is there any abnormal cell?

P33ED BATTERY PARALLEL DIAGNOSIS

[TYPE 2]

< DTC/CIRCUIT DIAGNOSIS >

- YES >> Replace corresponding Module. Refer to [EVB-402. "Exploded view"](#).
NO >> GO TO 2.

A

2. DTC CONFIRMATION PROCEDURE OPERATION

1. If abnormal cell is not identified, perform DTC confirmation procedure. Refer to [EVB-372. "DTC Logic"](#).
2. Check cell voltage again using "DATA MONITOR" or "FFD" to identify malfunctioning cell.

B

- >> Replace corresponding Module. Refer to [EVB-402. "Exploded view"](#).

EVB

D

E

F

G

H

I

J

K

L

M

N

O

P

P33EE BATTERY HEATER CONTROL SYSTEM

< DTC/CIRCUIT DIAGNOSIS >

[TYPE 2]

P33EE BATTERY HEATER CONTROL SYSTEM

DTC Logic

INFOID:000000007374110

DTC DETECTION LOGIC

DTC	Trouble diagnosis name	DTC detecting condition	Possible causes
P33EE	BATTERY HEATER CONTROL SYSTEM	Under extremely low temperatures that Li-ion battery heater activates, Li-ion battery controller judges that the temperature of Li-ion battery is still low after a lapse of specified time.	<ul style="list-style-type: none">• Li-ion battery controller• Heater relay unit• Li-ion battery heater• Harness or connector

Diagnosis Procedure

INFOID:000000007605387

WARNING:

- Because hybrid vehicles and electric vehicles contain a high voltage battery, there is the risk of electric shock, electric leakage, or similar accidents if the high voltage component and vehicle are handled incorrectly. Be sure to follow the correct work procedures when performing inspection and maintenance.
- Be sure to remove the service plug in order to disconnect the high voltage circuits before performing inspection or maintenance of high voltage system harnesses and parts.
- To prevent the removed service plug from being connected by mistake during the procedure, always carry it in your pocket or put it in the tool box.
- Be sure to wear insulating protective equipment before beginning work on the high voltage system.
- Clearly identify the persons responsible for high voltage work and ensure that other persons do not touch the vehicle. When not working, cover high voltage parts with an insulating cover sheet or similar item to prevent other persons from contacting them.
- Refer to [EVB-229, "High Voltage Precautions"](#).

CAUTION:

There is the possibility of a malfunction occurring if the vehicle is changed to READY status while the service plug is removed. Therefore do not change the vehicle to READY status unless instructed to do so in the Service Manual.

1. PRECONDITIONING

WARNING:

Disconnect the high voltage. Refer to [GI-31, "How to Disconnect High Voltage"](#).

1. Remove Li-ion battery. Refer to [EVB-395, "Removal and Installation"](#).
2. Remove battery pack upper case. Refer to [EVB-412, "BATTERY JUNCTION BOX : Disassembly and Assembly"](#), see Step-1 to Step-3.

>> GO TO 2.

2. CHECK INSTALLATION CONDITION OF LI-ION BATTERY HEATER

Check the main body of Li-ion battery heater for installation condition.

Is the inspection result normal?

YES >> GO TO 3.

NO >> Tighten the mounting nut of the Li-ion battery heater to the specified torque. Refer to [EVB-402, "Exploded view"](#).

3. CHECK CONNECTION STATUS OF LI-ION BATTERY HEATER CONNECTOR

Check the connection status of the Li-ion battery heater connector.

Is the inspection result normal?

YES >> GO TO 4.

NO >> Restore the connection status of the Li-ion battery heater connector.

4. CHECK RESISTANCE OF LI-ION BATTERY HEATER

Check resistance of Li-ion battery heater.

P33EE BATTERY HEATER CONTROL SYSTEM

< DTC/CIRCUIT DIAGNOSIS >

[TYPE 2]

Li-ion battery heater		Resistance	
Item	Terminal		
LH 1	1	2	Less than 5,269 Ω
LH 2			
LH 3			
RH 1			
RH 2			
RH 3			
RR 1	1	2	Less than 1,265 Ω
RR 2			

Is the inspection result normal?

YES >> GO TO 5.

NO >> Replace applicable Li-ion battery heater. Refer to [EVB-456. "HEATER UNIT : Disassembly and Assembly"](#).

5. CHECK CONTINUITY OF LI-ION BATTERY HEATER AND HEATER RELAY UNIT

1. Disconnect Li-ion battery heater and heater relay unit harness connector harness connector.
2. Check continuity Li-ion battery heater and heater relay unit harness connector harness connector.

Li-ion battery heater			Heater relay unit		Continuity
Item	Connector	Terminal	Connector	Terminal	
LH 1	LB21	1	LB20	22	Existed
		2		24	
LH 2	LB22	1	LB20	22	Existed
		2		24	
LH 3	LB23	1	LB20	22	Existed
		2		24	
RH 1	LB26	1	LB20	22	Existed
		2		24	
RH 2	LB27	1	LB20	22	Existed
		2		24	
RH 3	LB28	1	LB20	22	Existed
		2		24	
RR 1	LB24	1	LB20	22	Existed
		2		24	
RR 2	LB25	1	LB20	22	Existed
		2		24	

Is the inspection result normal?

YES >> Replace heater relay unit. Refer to [EVB-456. "HEATER UNIT : Disassembly and Assembly"](#).

NO >> Repair harness or connector.

U1000 CAN COMM CIRCUIT

< DTC/CIRCUIT DIAGNOSIS >

[TYPE 2]

U1000 CAN COMM CIRCUIT

Description

INFOID:000000007592617

CAN (Controller Area Network) is a serial communication line for real time applications. It is an on-vehicle multiplex communication line with high data communication speed and excellent error detection ability. Modern vehicle is equipped with many electronic control units, and each control unit shares information and links with other control units during operation (not independent). In CAN communication, control units are connected with 2 communication lines (CAN-H, CAN-L) allowing a high rate of information transmission with less wiring. Each control unit transmits/receives data but selectively reads the required data only.

CAN communication signal chart. Refer to [LAN-33, "CAN COMMUNICATION SYSTEM : CAN Communication Signal Chart"](#).

DTC Logic

INFOID:000000007592618

DTC DETECTION LOGIC

DTC	Trouble diagnosis name	DTC detecting condition	Possible causes
U1000	CAN COMM CIRCUIT	When no CAN communication signal is received continuously for 2 seconds or more.	CAN communication system

Diagnosis Procedure

INFOID:000000007592619

For the diagnosis procedure, refer to [LAN-15, "Trouble Diagnosis Flow Chart"](#).

LI-ION BATTERY INSULATION RESISTANCE LOSS CHECK

< DTC/CIRCUIT DIAGNOSIS >

[TYPE 2]

LI-ION BATTERY INSULATION RESISTANCE LOSS CHECK

Component Inspection

INFOID:000000007805128

WARNING:

- Because hybrid vehicles and electric vehicles contain a high voltage battery, there is the risk of electric shock, electric leakage, or similar accidents if the high voltage component and vehicle are handled incorrectly. Be sure to follow the correct work procedures when performing inspection and maintenance.
- Be sure to remove the service plug in order to disconnect the high voltage circuits before performing inspection or maintenance of high voltage system harnesses and parts.
- To prevent the removed service plug from being connected by mistake during the procedure, always carry it in your pocket or put it in the tool box.
- Be sure to wear insulating protective equipment consisting of glove, shoes, face shield and glasses before beginning work on the high voltage system.
- Clearly identify the persons responsible for high voltage work and ensure that other persons do not touch the vehicle. When not working, cover high voltage parts with an insulating cover sheet or similar item to prevent other persons from contacting them.
- Refer to [EVB-229, "High Voltage Precautions"](#).

CAUTION:

There is the possibility of a malfunction occurring if the vehicle is changed to READY status while the service plug is removed. Therefore do not change the vehicle to READY status unless instructed to do so in the Service Manual.

The following diagnosis procedure must be performed when "P0AA6 or P33E1" are detected and Li-ion battery is judged that its insulation resistance is dropping.

1. CHECK MAXIMUM CELL VOLTAGE

Ⓜ With CONSULT

1. Power switch ON.
2. Select "DATA MONITOR" of "HV BAT".
3. Record "MAXIMUM CELL VOLTAGE".

NOTE:

It is used, when replace a malfunction module.

>> GO TO 2

2. CHECK INSULATION OF FRONT MODULE STACK LH-1

CAUTION:

Check that high voltage harness and harness shield have no scratches and cracks. If any damage is found, replace damaged parts.

1. Remove Li-ion battery. Refer to [EVB-395, "Removal and Installation"](#).
2. Remove Li-ion battery controller. Refer to [EVB-419, "LI-ION BATTERY CONTROLLER : Disassembly and Assembly"](#).
3. Remove bus bar that connects front module stack LH and front module stack RH.
4. Measure voltages between positive terminal Ⓐ of front module stack LH and battery pack ground, and between positive terminal Ⓑ of front module stack LH and battery pack ground.

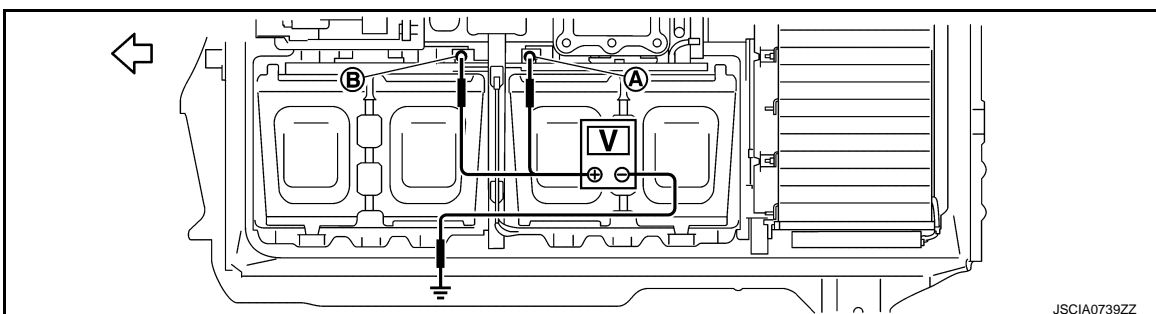

← : Battery pack front

LI-ION BATTERY INSULATION RESISTANCE LOSS CHECK

< DTC/CIRCUIT DIAGNOSIS >

[TYPE 2]

+	-	Voltage
Front module stack LH		
Terminal		
Ⓐ, Ⓑ	Battery pack ground	Approx. 0 V

Is the inspection result normal?

- YES >> GO TO 8.
- NO >> GO TO 3.

3. CHECK INSULATION OF FRONT MODULE STACK LH-2

1. Disconnect vehicle communication harness connector of front module stack LH.
2. Measure voltages between positive terminal Ⓐ of front module stack LH and battery pack ground, and between positive terminal Ⓑ of front module stack LH and battery pack ground.

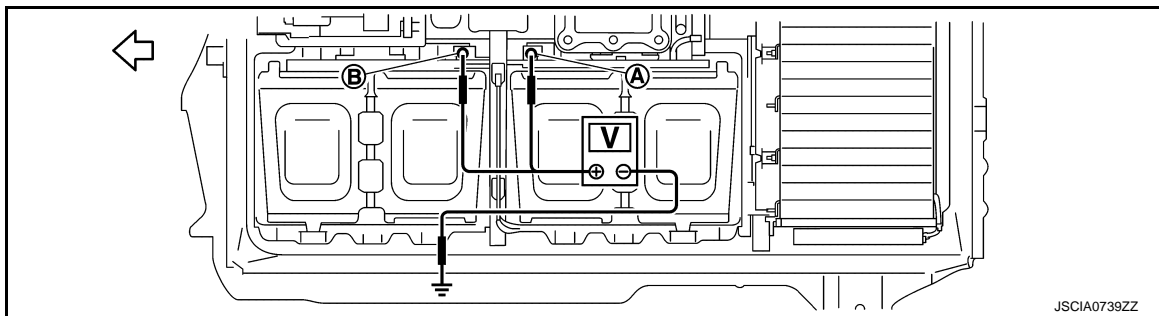

↖ : Battery pack front

+	-	Voltage
Front module stack LH		
Terminal		
Ⓐ, Ⓑ	Battery pack ground	Approx. 0 V

Is the inspection result normal?

- YES >> Replace vehicle communication harness of front module stack LH and GO TO 8.
- NO >> GO TO 4.

4. CHECK INSULATION OF FRONT MODULE STACK LH-3

1. Remove bus bar that connects service plug and front module stack LH.
2. Measure voltages between positive terminal Ⓐ of front module stack LH and battery pack ground, and between positive terminal Ⓑ of front module stack LH and battery pack ground.

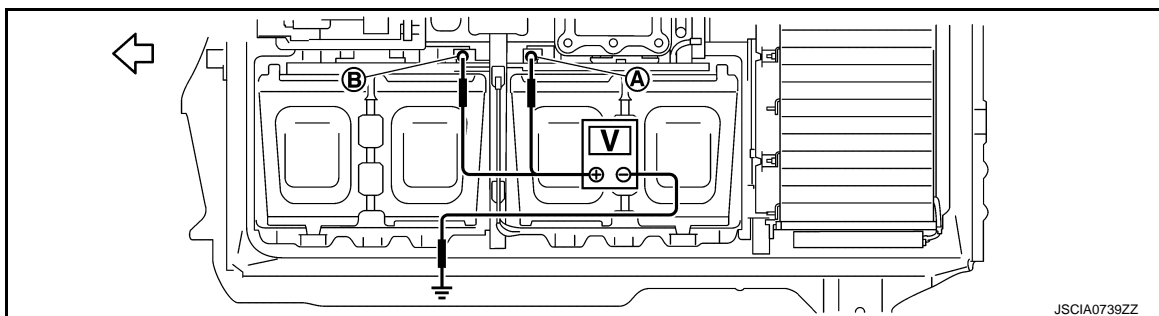

↖ : Battery pack front

LI-ION BATTERY INSULATION RESISTANCE LOSS CHECK

< DTC/CIRCUIT DIAGNOSIS >

[TYPE 2]

+	-	Voltage
Front module stack LH		
Terminal		
(A), (B)	Battery pack ground	Approx. 0 V

Is the inspection result normal?

- YES >> GO TO 5.
- NO >> GO TO 6.

5. CHECK SERVICE PLUG SWITCH INSULATION RESISTANCE

1. Remove bus bar that connects service plug and front module stack LH from service plug switch bracket.
2. Using insulation resistance tester, measure insulation resistance between service plug switch terminal and service plug switch bracket.

WARNING:

Unlike the ordinary tester, the insulation resistance tester applies 500 V when measuring. If used incorrectly, there is the danger of electric shock. If used in the vehicle 12V system, there is the danger of damage to electronic devices. Read the insulation resistance tester instruction manual carefully and be sure to work safely.

CAUTION:

Be sure to set the insulation resistance tester to 500 V when performing this test. Using a setting higher than 500 V can result in damage to the component being inspected.

NOTE:

Check resistance without disassembling service plug switch and service plug switch bracket.

+	-	Resistance
Service plug switch terminal	Service plug switch bracket	1000 MΩ or more

Is the inspection result normal?

- YES >> Replace bus bar that connects service plug and front module stack LH and GO TO 8.
- NO >> Replace service plug switch (Refer to [EVB-402. "Exploded view"](#).) and GO TO 8.

6. CHECK MODULE-1

1. Remove front module stack LH. Refer to [EVB-426. "FRONT MODULE STACK : Disassembly and Assembly"](#).

NOTE:

Do not disassemble module stack.

2. Measure voltages between terminal (A)/(B) of all modules in front module stack LH and module body.

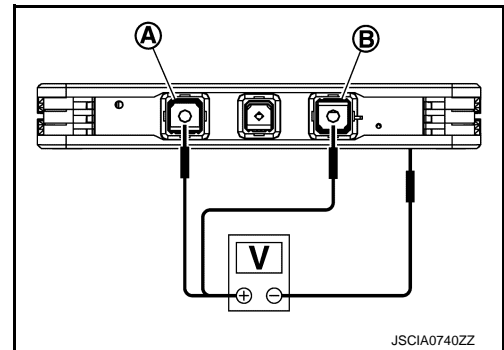

+	-	Voltage
Module		
Terminal		
(A)	Module body	Approx. 0 V
(B)		

Is the inspection result normal?

LI-ION BATTERY INSULATION RESISTANCE LOSS CHECK

[TYPE 2]

< DTC/CIRCUIT DIAGNOSIS >

- YES >> GO TO 7.
 NO >> Replace malfunctioning module (Refer to [EVB-426, "FRONT MODULE STACK : Disassembly and Assembly"](#).) and GO TO 8.

7. CHECK MODULE-2

Measure insulation resistance between terminal (A)/(B) of all modules in front module stack LH and module body.

WARNING:

Unlike the ordinary tester, the insulation resistance tester applies 500 V when measuring. If used incorrectly, there is the danger of electric shock. If used in the vehicle 12V system, there is the danger of damage to electronic devices. Read the insulation resistance tester instruction manual carefully and be sure to work safely.

CAUTION:

Be sure to set the insulation resistance tester to 500 V when performing this test. Using a setting higher than 500 V can result in damage to the component being inspected.

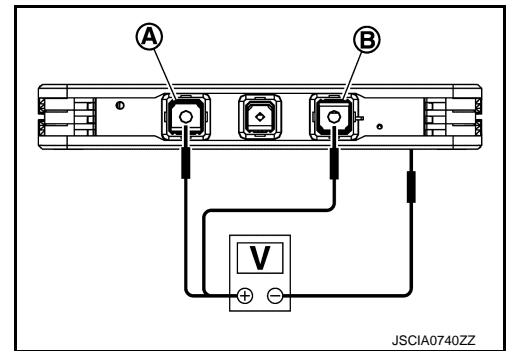

+	-	resistance
Module Terminal		
(A)	Module body	100 MΩ or more
(B)		

Is the inspection result normal?

- YES >> Check insulation resistance of front module stack RH, because front module stack LH is normal. GO TO 8.
 NO >> Replace malfunctioning module (Refer to [EVB-426, "FRONT MODULE STACK : Disassembly and Assembly"](#).) and GO TO 8.

8. CHECK INSULATION OF FRONT MODULE STACK RH-1

1. Measure voltages between positive terminal (A) of front module stack RH and battery pack ground, and between positive terminal (B) of front module stack LH and battery pack ground.

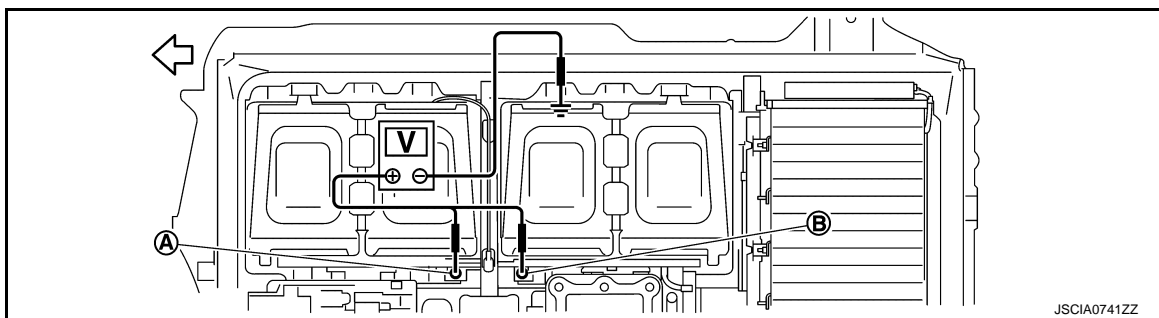

↩ : Battery pack front

+	-	Voltage
Front module stack RH Terminal		
(A), (B)	Battery pack ground	Approx. 0 V

Is the inspection result normal?

- YES >> GO TO 14.
 NO >> GO TO 9.

LI-ION BATTERY INSULATION RESISTANCE LOSS CHECK

< DTC/CIRCUIT DIAGNOSIS >

[TYPE 2]

9. CHECK INSULATION OF FRONT MODULE STACK RH-2

1. Disconnect vehicle communication harness connector of front module stack RH.
2. Measure voltages between positive terminal (A) of front module stack RH and battery pack ground, and between positive terminal (B) of front module stack RH and battery pack ground.

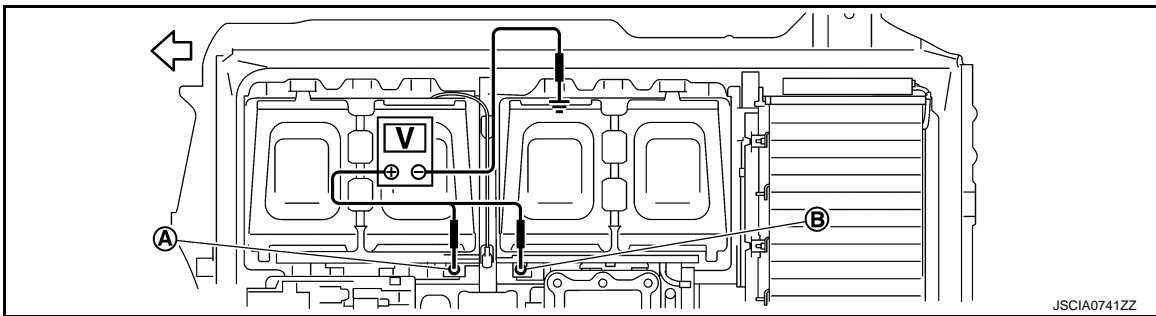

↶ : Battery pack front

+		
Front module stack RH	-	Voltage
Terminal		
(A), (B)	Battery pack ground	Approx. 0 V

Is the inspection result normal?

YES >> Replace vehicle communication harness of front module stack RH and GO TO 14.

NO >> GO TO 10.

10. CHECK INSULATION OF FRONT MODULE STACK RH-3

1. Remove bus bar that connects front module stack RH and battery junction box.
2. Measure voltages between positive terminal (A) of front module stack RH and battery pack ground, and between positive terminal (B) of front module stack RH and battery pack ground.

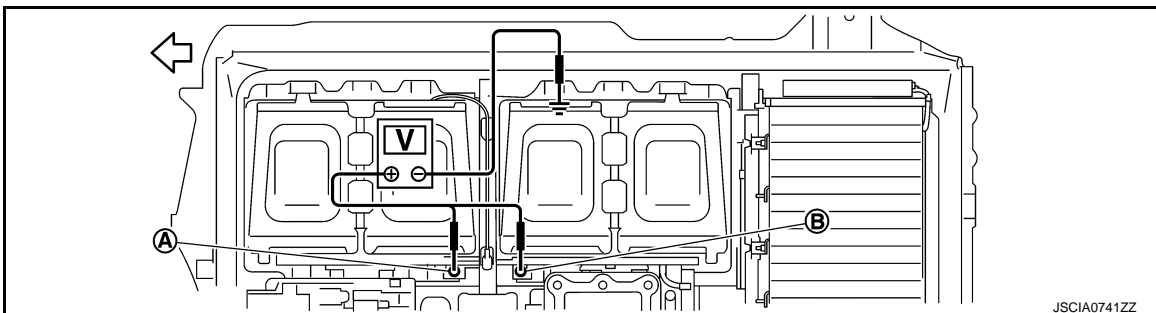

↶ : Battery pack front

+		
Front module stack RH	-	Voltage
Terminal		
(A), (B)	Battery pack ground	Approx. 0 V

Is the inspection result normal?

YES >> GO TO 11.

NO >> GO TO 12.

11. CHECK BATTERY JUNCTION BOX INSULATION RESISTANCE

LI-ION BATTERY INSULATION RESISTANCE LOSS CHECK

[TYPE 2]

< DTC/CIRCUIT DIAGNOSIS >

- Using insulation resistance tester, measure insulation resistance between high voltage terminal (A)/(B) of battery junction box and battery pack ground.

← : Battery pack front

WARNING:

Unlike the ordinary tester, the insulation resistance tester applies 500 V when measuring. If used incorrectly, there is the danger of electric shock. If used in the vehicle 12V system, there is the danger of damage to electronic devices. Read the insulation resistance tester instruction manual carefully and be sure to work safely.

CAUTION:

Be sure to set the insulation resistance tester to 500 V when performing this test. Using a setting higher than 500 V can result in damage to the component being inspected.

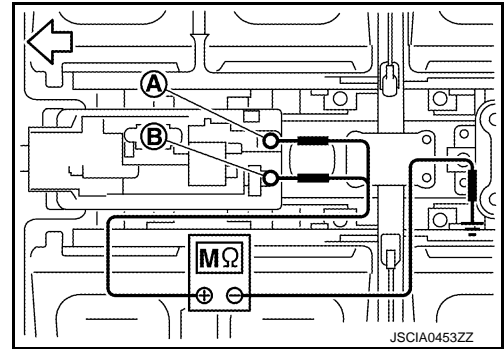

Battery junction box	—	Resistance
Terminal		
(A)	Battery pack ground	1000 MΩ or more
(B)		

Is the inspection result normal?

- YES >> Replace bus bar that connects front module stack RH and battery junction box and GO TO 14.
 NO >> Replace battery junction box (Refer to [EVB-412, "BATTERY JUNCTION BOX : Disassembly and Assembly"](#)) and GO TO 14.

12.CHECK MODULE-3

- Remove front module stack RH. Refer to [EVB-426, "FRONT MODULE STACK : Disassembly and Assembly"](#).

NOTE:

Do not disassemble module stack.

- Measure voltages between terminal (A)/(B) of all modules in front module stack RH and module body.

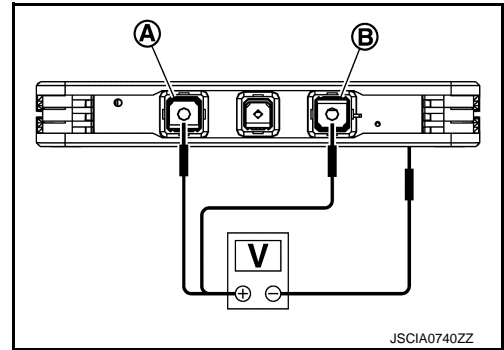

+	-	Voltage
Module		
Terminal	Module body	Approx. 0 V
(A)		
(B)		

Is the inspection result normal?

- YES >> GO TO 13.
 NO >> Replace malfunctioning module (Refer to [EVB-426, "FRONT MODULE STACK : Disassembly and Assembly"](#).) and GO TO 14.

13.CHECK MODULE-4

LI-ION BATTERY INSULATION RESISTANCE LOSS CHECK

< DTC/CIRCUIT DIAGNOSIS >

[TYPE 2]

Measure insulation resistance between terminal (A)/(B) of all modules in front module stack RH and module body.

WARNING:

Unlike the ordinary tester, the insulation resistance tester applies 500 V when measuring. If used incorrectly, there is the danger of electric shock. If used in the vehicle 12V system, there is the danger of damage to electronic devices. Read the insulation resistance tester instruction manual carefully and be sure to work safely.

CAUTION:

Be sure to set the insulation resistance tester to 500 V when performing this test. Using a setting higher than 500 V can result in damage to the component being inspected.

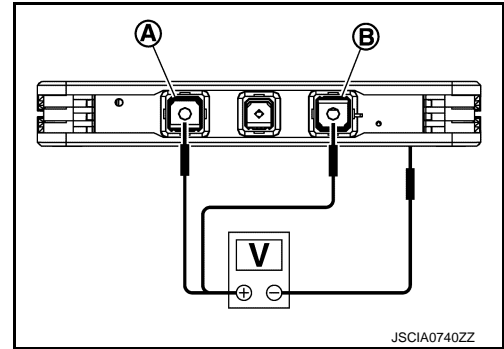

+	-	resistance
Module		
Terminal	Module body	100 MΩ or more
(A)		
(B)		

Is the inspection result normal?

- YES >> Check insulation resistance of front module stack RH, because front module stack LH is normal. GO TO 14.
- NO >> Replace malfunctioning module (Refer to [EVB-426, "FRONT MODULE STACK : Disassembly and Assembly"](#).) and GO TO 14.

14. CHECK INSULATION OF REAR MODULE STACK-1

1. Measure voltages between positive terminal (A) of rear module stack and battery pack ground, and between positive terminal (B) of rear module stack and battery pack ground.

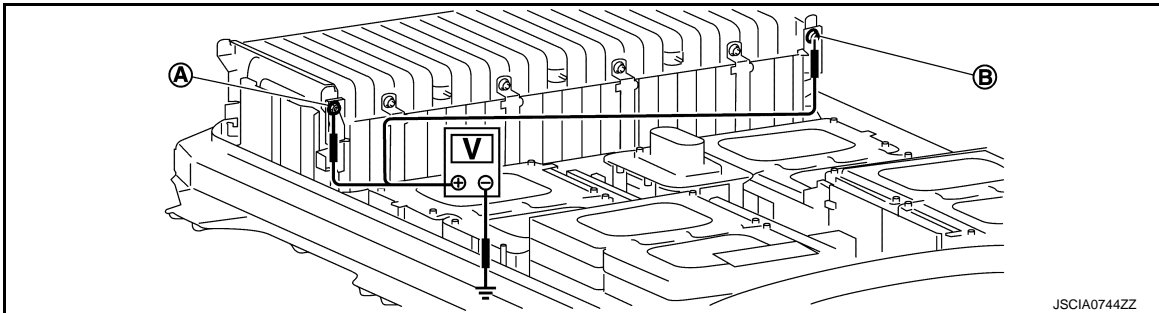

+	-	Voltage
Rear module stack		
Terminal	Battery pack ground	Approx. 0 V
(A), (B)		

Is the inspection result normal?

- YES-1 >> Replace or repair of malfunctioning part is not-yet performed: Replace Li-ion battery controller. Refer to [EVB-419, "LI-ION BATTERY CONTROLLER : Disassembly and Assembly"](#).
- YES-2 >> Replace or repair of malfunctioning part is complete: INSPECTION END.
- NO >> GO TO 15.

15. CHECK INSULATION OF REAR MODULE STACK-2

LI-ION BATTERY INSULATION RESISTANCE LOSS CHECK

< DTC/CIRCUIT DIAGNOSIS >

[TYPE 2]

1. Disconnect vehicle communication harness connector (A) of rear module stack.

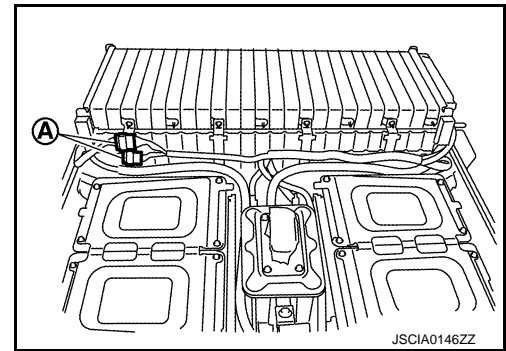

2. Measure voltages between positive terminal (A) of rear module stack and battery pack ground, and between positive terminal (B) of rear module stack and battery pack ground.

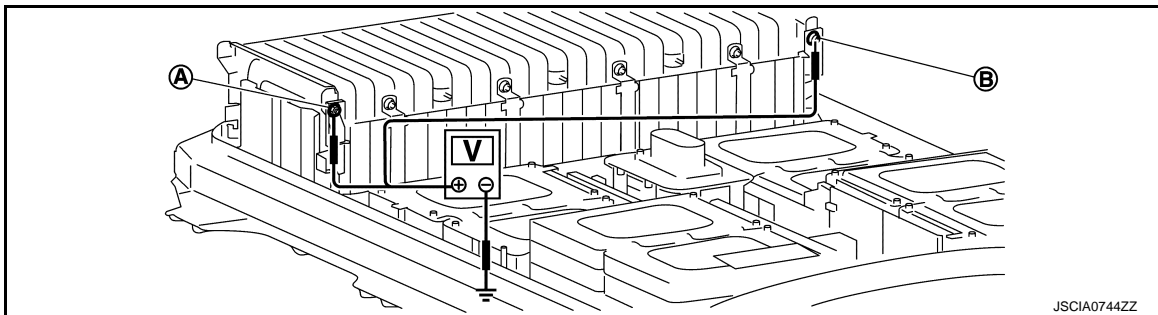

+		
Front module stack RH	-	Voltage
Terminal		
(A), (B)	Battery pack ground	Approx. 0 V

Is the inspection result normal?

- YES >> Replace vehicle communication harness of rear module stack.
 NO >> GO TO 16.

16. CHECK INSULATION OF FRONT MODULE STACK RH-3

1. Remove mounting nuts (A)/(B) and remove high voltage harness from rear module stack.

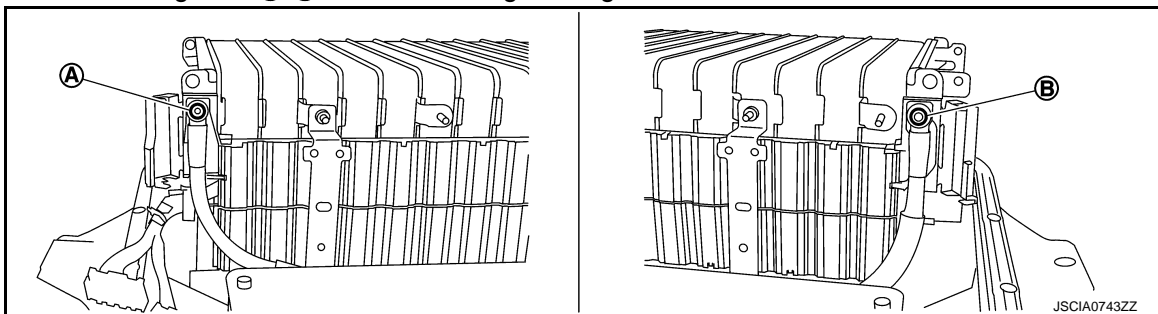

2. Measure voltages between positive terminal (A) of rear module stack and battery pack ground, and between positive terminal (B) of rear module stack and battery pack ground.

LI-ION BATTERY INSULATION RESISTANCE LOSS CHECK

< DTC/CIRCUIT DIAGNOSIS >

[TYPE 2]

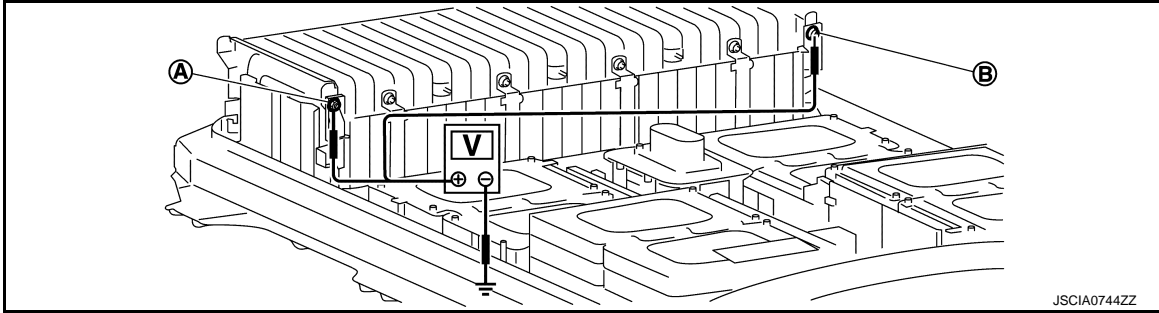

+		-	Voltage
Rear module stack			
Terminal			
(A), (B)	Battery pack ground	Approx. 0 V	

Is the inspection result normal?

- YES >> .Replace high voltage harness.
- NO >> GO TO 17.

17.CHECK MODULE-5

1. Remove rear module stack. Refer to [EVb-435. "REAR MODULE STACK : Disassembly and Assembly"](#).

NOTE:

Do not disassemble module stack.

2. Measure voltages between terminal (A)/(B) of all modules in rear module stack and module body.

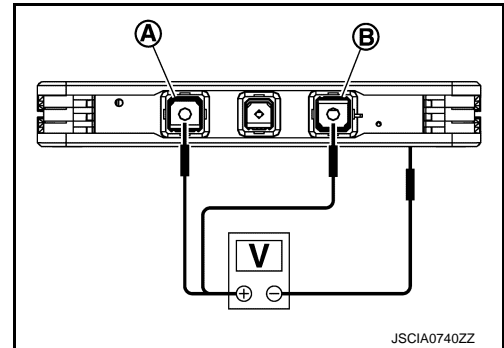

+		-	Voltage
Module			
Terminal			
(A)	Module body	Approx. 0 V	
(B)			

Is the inspection result normal?

- YES >> GO TO 18.
- NO >> Replace malfunctioning module. Refer to [EVb-435. "REAR MODULE STACK : Disassembly and Assembly"](#).

18.CHECK MODULE-6

A
B
EVB
D
E
F
G
H
I
J
K
L
M
N
O
P

LI-ION BATTERY INSULATION RESISTANCE LOSS CHECK

[TYPE 2]

< DTC/CIRCUIT DIAGNOSIS >

Measure insulation resistance between terminal (A)/(B) of all modules in rear module stack and module body.

WARNING:

Unlike the ordinary tester, the insulation resistance tester applies 500 V when measuring. If used incorrectly, there is the danger of electric shock. If used in the vehicle 12V system, there is the danger of damage to electronic devices. Read the insulation resistance tester instruction manual carefully and be sure to work safely.

CAUTION:

Be sure to set the insulation resistance tester to 500 V when performing this test. Using a setting higher than 500 V can result in damage to the component being inspected.

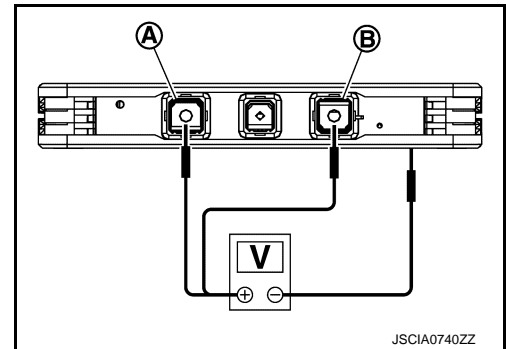

+	-	resistance
Module Terminal		
(A)	Module body	100 MΩ or more
(B)		

Is the inspection result normal?

- YES-1 >> Replace or repair of malfunctioning part is not-yet performed: Replace Li-ion battery controller. Refer to [EVB-419, "LI-ION BATTERY CONTROLLER : Disassembly and Assembly"](#).
- YES-2 >> Replace or repair of malfunctioning part is complete: INSPECTION END.
- NO >> Replace malfunctioning module. Refer to [EVB-435, "REAR MODULE STACK : Disassembly and Assembly"](#).

LI-ION BATTERY HEATER SYSTEM INSULATION RESISTANCE CHECK

< DTC/CIRCUIT DIAGNOSIS >

[TYPE 2]

LI-ION BATTERY HEATER SYSTEM INSULATION RESISTANCE CHECK

Diagnosis Procedure

INFOID:000000007575724

WARNING:

- Because hybrid vehicles and electric vehicles contain a high voltage battery, there is the risk of electric shock, electric leakage, or similar accidents if the high voltage component and vehicle are handled incorrectly. Be sure to follow the correct work procedures when performing inspection and maintenance.
- Be sure to remove the service plug in order to disconnect the high voltage circuits before performing inspection or maintenance of high voltage system harnesses and parts.
- To prevent the removed service plug from being connected by mistake during the procedure, always carry it in your pocket or put it in the tool box.
- Be sure to wear insulating protective equipment before beginning work on the high voltage system.
- Clearly identify the persons responsible for high voltage work and ensure that other persons do not touch the vehicle. When not working, cover high voltage parts with an insulating cover sheet or similar item to prevent other persons from contacting them.
- Refer to [EVB-229, "High Voltage Precautions"](#).

CAUTION:

There is the possibility of a malfunction occurring if the vehicle is changed to READY status while the service plug is removed. Therefore do not change the vehicle to READY status unless instructed to do so in the Service Manual.

1. PRECONDITIONING

WARNING:

Disconnect the high voltage. Refer to [GI-31, "How to Disconnect High Voltage"](#).

1. Remove Li-ion battery. Refer to [EVB-395, "Removal and Installation"](#).
2. Remove battery pack upper case. Refer to [EVB-412, "BATTERY JUNCTION BOX : Disassembly and Assembly"](#), see Step-1 to Step-3.

>> GO TO 2.

2. CHECK HIGH VOLTAGE HARNESS

Check the harness shield between the heater relay unit and the Li-ion battery heater for scratches and cracks.

Is the inspection result normal?

YES >> GO TO 3.

NO >> Repair or replace error-detected parts and Li-ion battery controller.

3. CHECK HEATER RELAY UNIT INSULATION RESISTANCE

WARNING:

Unlike the ordinary tester, the insulation resistance tester applies 500 V when measuring. If used incorrectly, there is the danger of electric shock. If used in the vehicle 12 V system, there is the danger of damage to electronic devices. Read the insulation resistance tester instruction manual carefully and be sure to work safely.

1. Disconnect high voltage harness connector from heater relay unit.

NOTE:

Check the heater relay with it installed on the battery pack.

2. Use 500 V range of insulation resistance tester to measure insulation resistance. Wait for 30 seconds until the value becomes stable.

CAUTION:

Be sure to set the insulation resistance tester to 500 V when performing this test. Using a setting higher than 500 V can result in damage to the component being inspected.

LI-ION BATTERY HEATER SYSTEM INSULATION RESISTANCE CHECK

< DTC/CIRCUIT DIAGNOSIS >

[TYPE 2]

Heater relay unit	Ground	Resistance
Terminal		
14	Battery pack lower case	1000 MΩ or more
16		
22		
24		

Is the inspection result normal?

YES >> GO TO 4.

NO >> Replace heater relay unit and Li-ion battery controller.

4. CHECK LI-ION BATTERY HEATER

WARNING:

Unlike the ordinary tester, the insulation resistance tester applies 500 V when measuring. If used incorrectly, there is the danger of electric shock. If used in the vehicle 12 V system, there is the danger of damage to electronic devices. Read the insulation resistance tester instruction manual carefully and be sure to work safely.

1. Disconnect high voltage harness connector from Li-ion battery heater.

NOTE:

Check the heater relay with it installed on the battery pack.

2. Use 500 V range of insulation resistance tester to measure insulation resistance. Wait for 30 seconds until the value becomes stable.

CAUTION:

Be sure to set the insulation resistance tester to 500 V when performing this test. Using a setting higher than 500 V can result in damage to the component being inspected.

Li-ion battery heater			Ground	Resistance
Item	Connector	Terminal		
LH1	LB21	1	Battery pack lower case	1000 MΩ or more
		2		
LH2	LB21	1		1000 MΩ or more
		2		
LH3	LB21	1		1000 MΩ or more
		2		
RH1	LB26	1		1000 MΩ or more
		2		
RH2	LB27	1		1000 MΩ or more
		2		
RH3	LB28	1		1000 MΩ or more
		2		
RR1	LB24	1		1000 MΩ or more
		2		
RR2	LB25	1		1000 MΩ or more
		2		

Is the inspection result normal?

YES >> GO TO 5.

NO >> Replace corresponding Li-ion battery heater and Li-ion battery controller.

5. CHECK HIGH VOLTAGE HARNESS INSULATION RESISTANCE

WARNING:

LI-ION BATTERY HEATER SYSTEM INSULATION RESISTANCE CHECK

< DTC/CIRCUIT DIAGNOSIS >

[TYPE 2]

Unlike the ordinary tester, the insulation resistance tester applies 500 V when measuring. If used incorrectly, there is the danger of electric shock. If used in the vehicle 12 V system, there is the danger of damage to electronic devices. Read the insulation resistance tester instruction manual carefully and be sure to work safely.

1. Use 500 V range of insulation resistance tester to measure insulation resistance. Wait for 30 seconds until the value becomes stable.

CAUTION:

Be sure to set the insulation resistance tester to 500V when performing this test. Using a setting higher than 500 V can result in damage to the component being inspected.

High voltage harness		Ground	Resistance
Connector	Terminal		
LB20	22	Battery pack lower case	1000 MΩ or more
	24		

Is the inspection result normal?

- YES >> INSPECTION END.
- NO >> Replace high voltage harness.

A
B
D
E
F
G
H
I
J
K
L
M
N
O
P

EVB

POWER SUPPLY AND GROUND CIRCUIT

< DTC/CIRCUIT DIAGNOSIS >

[TYPE 2]

POWER SUPPLY AND GROUND CIRCUIT

Diagnosis Procedure

INFOID:000000007592620

WARNING:

- Because hybrid vehicles and electric vehicles contain a high voltage battery, there is the risk of electric shock, electric leakage, or similar accidents if the high voltage component and vehicle are handled incorrectly. Be sure to follow the correct work procedures when performing inspection and maintenance.
- Be sure to remove the service plug in order to shut off the high voltage circuits before performing inspection or maintenance of high voltage system harnesses and parts.
- Be sure to put the removed service plug in your pocket and carry it with you so that another person does not accidentally connect it while work is in progress.
- Be sure to wear insulating protective gear consisting of glove, shoes and face shield before beginning work on the high voltage system.
- Clearly identify the persons responsible for high voltage work and ensure that other persons do not touch the vehicle. When not working, cover high voltage parts with an insulating cover sheet or similar item to prevent other persons from contacting them.
- Refer to [EVB-229, "High Voltage Precautions"](#).

CAUTION:

There is the possibility of a malfunction occurring if the vehicle is changed to READY status while the service plug is removed. Therefore do not change the vehicle to READY status unless instructed to do so in the Service Manual.

1. CHECK FUSE

Check that the following fuse is not fusing.

Power supply	Fuse No.
Battery	43
Power switch ON	55
	74

Is the fuse fusing?

YES >> Replace the fuse after repairing the applicable circuit.

NO >> GO TO 2.

2. CHECK LI-ION BATTERY CONTROLLER GROUND CIRCUIT

1. Turn power switch OFF.
2. Disconnect Li-ion battery vehicle communication harness connector.
3. Check the continuity between Li-ion battery vehicle communication harness connector and ground.

+		-	Continuity
Li-ion battery			
Connector	Terminal	Ground	Existed
B24	6		
	7		
	8		

Is the inspection result normal?

YES >> GO TO 3.

NO >> Repair or replace error-detected parts.

3. CHECK BATTERY POWER SUPPLY

Check the voltage between Li-ion battery vehicle communication harness connector and ground.

POWER SUPPLY AND GROUND CIRCUIT

< DTC/CIRCUIT DIAGNOSIS >

[TYPE 2]

+		-	Voltage
Li-ion battery			
Connector	Terminal		
B24	5	Ground	12V battery power supply

Is the inspection result normal?

YES >> GO TO 5.

NO >> GO TO 4.

4.CHECK BATTERY POWER SUPPLY CIRCUIT

1. Check the continuity between Li-ion battery vehicle communication harness connector and fuse terminal.

+		-	Continuity
Li-ion battery			
Connector	Terminal		
B24	5	No.43 fuse terminal	Existed

2. Also check harness for short to ground.

Is the inspection result normal?

YES >> Check power supply circuit for battery power supply.

NO >> Repair or replace error-detected parts.

5.CHECK IGNITION POWER SUPPLY

1. Turn power switch ON.
2. Check the voltage between Li-ion battery vehicle communication harness and ground.

+		-	Voltage (Approx.)
Li-ion battery			
Connector	Terminal		
B24	4	Ground	11 – 14 V
	21		

Is the inspection result normal?

YES >> GO TO 8.

NO >> GO TO 6.

6.CHECK IGNITION POWER SUPPLY CIRCUIT-1

1. Turn power switch OFF.
2. Disconnect IPDM E/R harness connector.
3. Check the continuity between Li-ion battery vehicle communication harness and IPDM E/R harness connector.

Li-ion battery		IPDM E/R		Continuity
Connector	Terminal	Connector	Terminal	
B24	4	E15	57	Existed

4. Also check harness for short to ground.

Is the inspection result normal?

YES >> GO TO 7.

NO >> Repair or replace error-detected parts.

7.CHECK IGNITION POWER SUPPLY CIRCUIT-2

1. Check the continuity between Li-ion battery vehicle communication harness and fuse terminal.

POWER SUPPLY AND GROUND CIRCUIT

< DTC/CIRCUIT DIAGNOSIS >

[TYPE 2]

Li-ion battery		—	Continuity
Connector	Terminal		
B24	21	No.74 fuse terminal	Existed

2. Also check harness for short to ground.

Is the inspection result normal?

YES >> Check power supply circuit for battery power supply.

NO >> Repair or replace error-detected parts.

8.PRECONDITIONING

WARNING:

Shut off high voltage circuit. Refer to [GI-31, "How to Disconnect High Voltage"](#).

1. Remove Li-ion battery. Refer to [EVB-395, "Removal and Installation"](#).

2. Remove battery pack upper case. Refer to [EVB-412, "BATTERY JUNCTION BOX : Disassembly and Assembly"](#), see Step-1 to Step-3.

>> GO TO 9.

9.CHECK HARNESS BETWEEN LI-ION BATTERY AND LI-ION BATTERY CONTROLLER

1. Check the continuity between Li-ion battery vehicle communication harness connector and Li-ion battery controller harness connector.

LBC		Li-ion battery		Continuity
Connector	Terminal	Connector	Terminal	
LB11	5	LB1	21	Existed
	6		4	
	21		5	
	3		8	
	15		7	
	16		6	

2. Also check harness for short to ground.

Is the inspection result normal?

YES >> INSPECTION END

NO >> Repair or replace error-detected parts.

REDUCTION IN THE DRIVING RANGE

< SYMPTOM DIAGNOSIS >

[TYPE 2]

SYMPTOM DIAGNOSIS

REDUCTION IN THE DRIVING RANGE

Description

INFOID:000000007592296

- The driving range is shorter than before.
- Sudden change (decrease/increase) in possible travel distance indicated on the combination meter.

Diagnosis Procedure

INFOID:000000007592297

1. CHECK LI-ION BATTERY AVAILABLE CHARGE GAUGE

Check the indication of the Li-ion battery available charge gauge.

NOTE:

Check 12 segments for lighting status.

Is the lighting status 1 Segment or none?

YES >> GO TO 3.

NO >> GO TO 2.

2. DISCHARGE OF LI-ION BATTERY

1. Set the vehicle to READY.
2. Set the vehicle, according to the following conditions.

A/C set temperature	: Full hot
A/C fan speed	: Maximum speed
A/C air outlet	:  Defroster
Headlamp	: High beam ON
Door glass	: Full open

3. Let the Li-ion battery discharge until the Li-ion battery available charge gauge shows Segment 1 or below.

>> GO TO 3.

3. CHARGE OF LI-ION BATTERY

1. Charge the Li-ion battery by normal charge until the level reaches full charge.
2. After the completion of normal charge, check that the indication of the Li-ion battery available charge gauge shows 12 segments.

>> GO TO 4.

4. PERFORM DTC CONFIRMATION PROCEDURE

 With CONSULT

1. Power switch ON and wait for 10 seconds or more.
2. Select "Self Diagnostic Result" of "HV BAT".
3. Check DTC.

Is any DTC detected?

YES >> Perform diagnosis on the detected DTC. Refer to [EVB-268, "DTC Index"](#).

NO >> INSPECTION END

EV BATTERY USAGE REPORT

< PERIODIC MAINTENANCE >

[TYPE 2]

PERIODIC MAINTENANCE

EV BATTERY USAGE REPORT

Inspection

INFOID:000000007592298

Generation of the EV battery usage report is one of the maintenance items.

This maintenance item generates a report that will help the customer understand the vehicle operating conditions needed to keep the Li-ion battery in the best possible condition.

For details about how to generate this report, please refer to EV battery usage report in the CONSULT III plus operation manual.

LI-ION BATTERY

< UNIT REMOVAL AND INSTALLATION >

[TYPE 2]

UNIT REMOVAL AND INSTALLATION

LI-ION BATTERY

Exploded View

INFOID:000000007321450

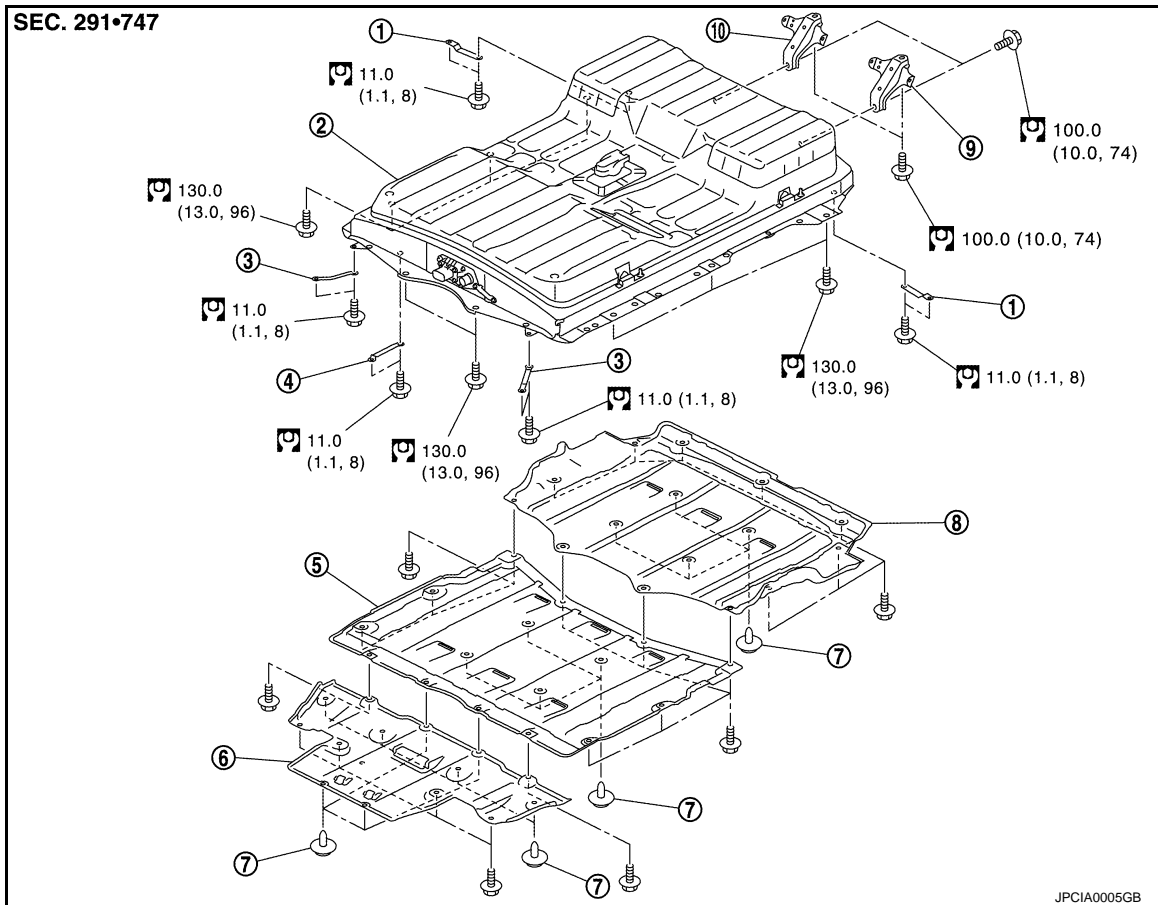

- | | | |
|---|--|---------------------------------------|
| 1. Bonding plate (Stamp No.6)
(August 2011 or later models, abolished) | 2. Li-ion battery | 3. Bonding plate (Stamp No.4) |
| 4. Bonding plate (Stamp No.2)
(August 2011 or later models, abolished) | 5. Li-ion battery under cover (center) | 6. Li-ion battery under cover (front) |
| 7. Clip | 8. Li-ion battery under cover (rear) | 9. Battery mounting bracket LH |
| 10. Battery mounting bracket RH | | |

 : N·m (kg·m, ft·lb)

Removal and Installation

INFOID:000000007321451

WARNING:

- Because hybrid vehicles and electric vehicles contain a high voltage battery, there is the risk of electric shock, electric leakage, or similar accidents if the high voltage component and vehicle are handled incorrectly. Be sure to follow the correct work procedures when performing inspection and maintenance.
- Be sure to remove the service plug in order to disconnect the high voltage circuits before performing inspection or maintenance of high voltage system harnesses and parts.
- To prevent the removed service plug from being connected by mistake during the procedure, always carry it in your pocket or put it in the tool box.
- Be sure to wear insulating protective equipment consisting of glove, shoes, face shield and glasses before beginning work on the high voltage system.
- Refer to [EVB-229, "High Voltage Precautions"](#).

LI-ION BATTERY

< UNIT REMOVAL AND INSTALLATION >

[TYPE 2]

CAUTION:

There is the possibility of a malfunction occurring if the vehicle is changed to READY status while the service plug is removed. Therefore do not change the vehicle to READY status unless instructed to do so in the Service Manual.

REMOVAL

WARNING:

Perform high voltage system work preparation. Refer to [GI-31, "How to Disconnect High Voltage"](#).

1. Lift up the vehicle and remove the Li-ion battery under covers. Refer to [EVB-395, "Exploded View"](#).
2. Disconnect high voltage harness connector (A) from Li-ion battery.

WARNING:

-  To prevent electric shock hazards, be sure to wear protective gear.



-  To prevent electric shock hazards, immediately wrap insulating tape around disconnected high voltage harness connector and terminals.

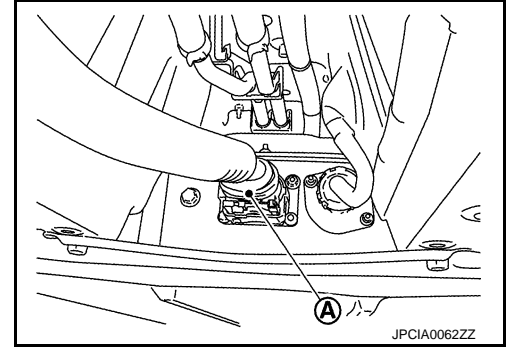

- Follow the procedure below to disconnect the high voltage harness connector.

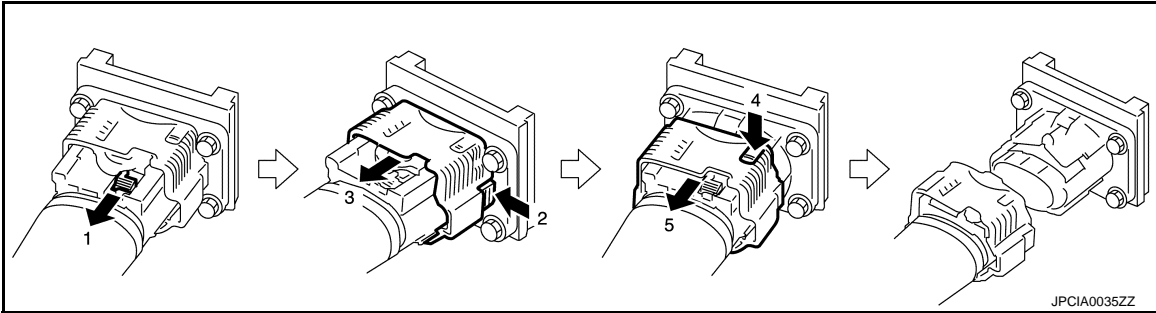

3. Disconnect the Li-ion battery vehicle communication harness connector (A) while turning it counterclockwise.

WARNING:

-  To prevent electric shock hazards, be sure to wear protective gear.

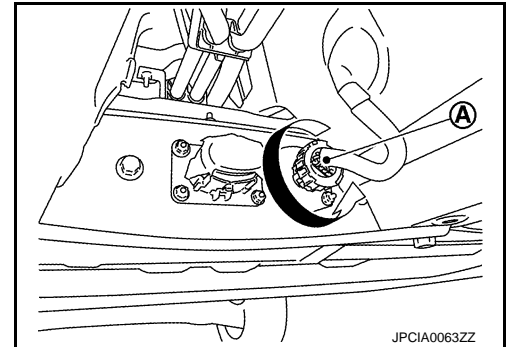

4. Remove the bonding plates.

1. Stamp No.2 (August 2011 or later models, abolished)
2. Stamp No.4
3. Stamp No.6 (August 2011 or later models, abolished)

← : Vehicle front

WARNING:

-  To prevent electric shock hazards, be sure to wear protective gear.

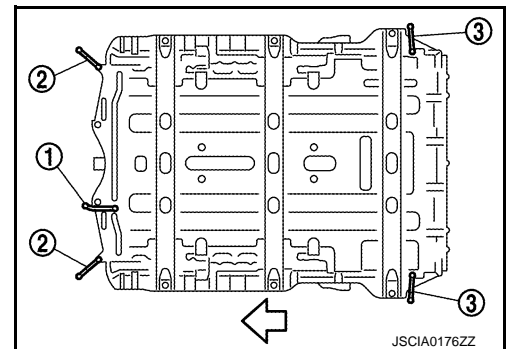

LI-ION BATTERY

< UNIT REMOVAL AND INSTALLATION >

[TYPE 2]



NOTE:

The bonding plate shape differs depending on the location of installation.

- Remove the Li-ion battery mounting bolts (A).

← : Vehicle front

WARNING:

 To prevent electric shock hazards, be sure to wear protective gear.



CAUTION:

Never remove the 4 bolts (B) shown in the figure.

- Set the pallet onto the lifter table.
 - Align center mark (A) of pallet (1) with center mark (B) of battery lift table (2).

C. Front

D. Side

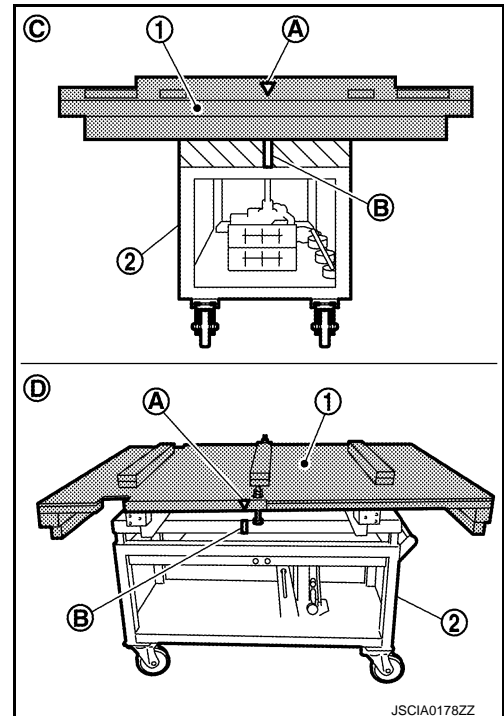
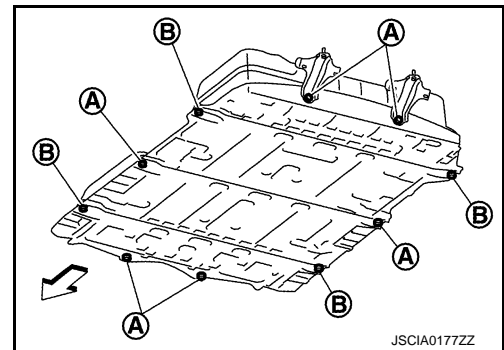

- Set the pallet (1) onto the Li-ion battery.

CAUTION:

Set the palette and Li-ion battery with transportation fixing bolts.

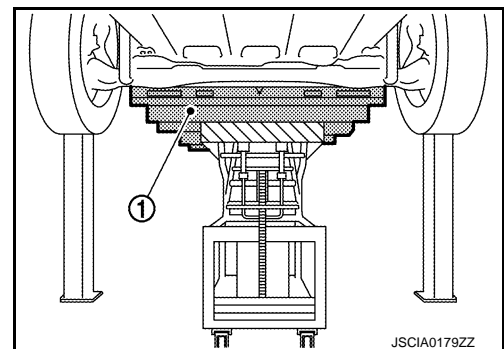

- Remove the Li-ion battery mounting bolts (4 bolts) (A).

A

B

EVB

D

E

F

G

H

I

J

K

L

M

N

O

P

LI-ION BATTERY

< UNIT REMOVAL AND INSTALLATION >

[TYPE 2]

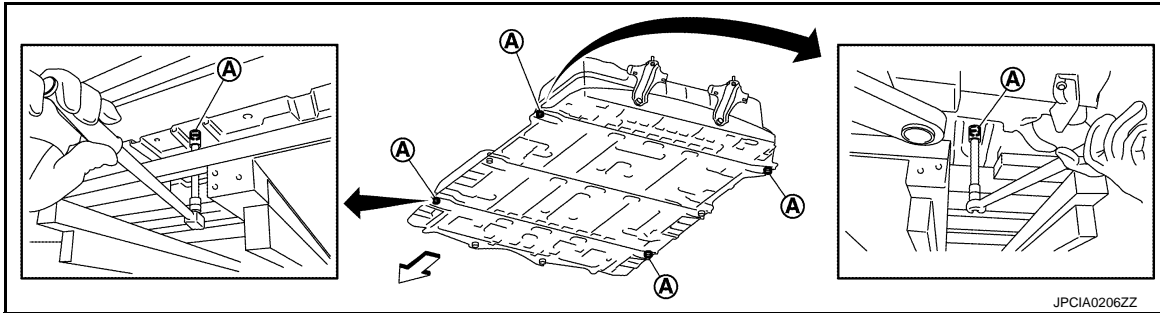

↔ : Vehicle front

WARNING:



To prevent electric shock hazards, be sure to wear protective gear.



9. Lower the pallet and remove the Li-ion battery (1) from the vehicle.

WARNING:



To prevent electric shock hazards, be sure to wear protective gear.

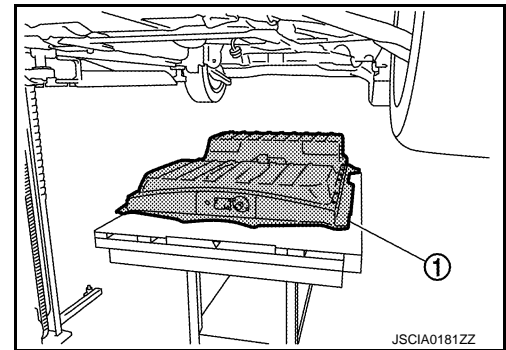

10. Move Li-ion battery from the lift table together with the pallet.

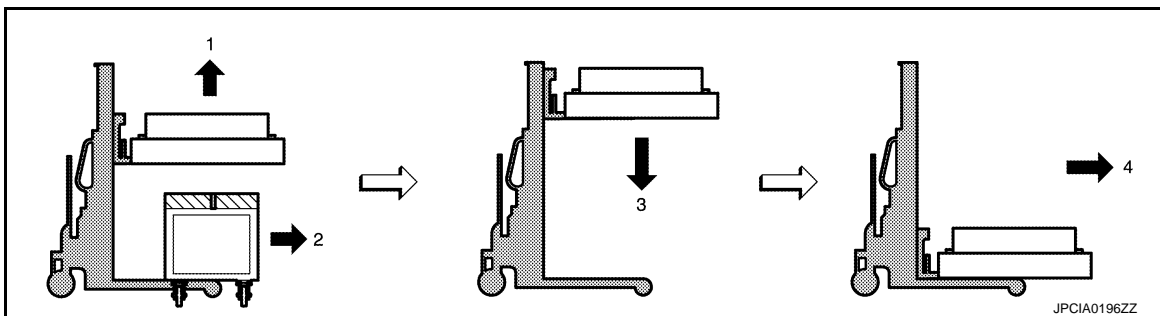

1. Lift Li-ion battery.
2. Move lift table.
3. Lower Li-ion battery.
4. Move Li-ion battery by operating stacker.

CAUTION:

To prevent stacker from falling, never move the stacker with the Li-ion battery lifted.

INSTALLATION

1. When replacing the Li-ion battery with a new one, perform the following procedure.
 - a. Enter the date of replacement on the EV battery traceability seal packaged with the new part.
 - b. Cut the EV battery traceability seal in two and affix each seal to the Li-ion battery and "Li-ion BATTERY REPLACEMENT RECORD".
 - c. Fill in the "Li-ion BATTERY REPLACEMENT RECORD".

LI-ION BATTERY

< UNIT REMOVAL AND INSTALLATION >

[TYPE 2]

2. Install 2 locating pins (1) at the positions on the vehicle body shown in the figure.

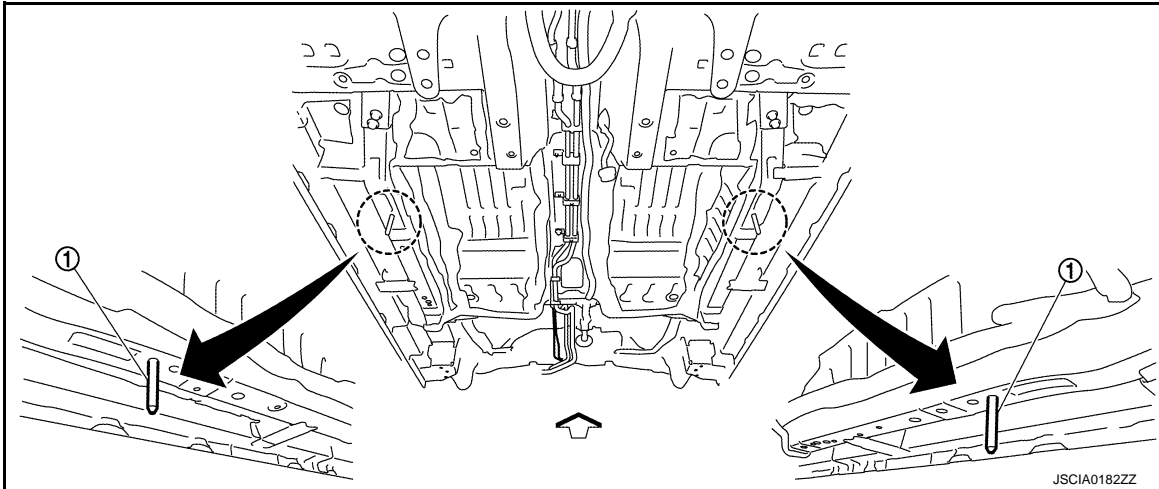

← : Vehicle front

3. Install the Li-ion battery onto the vehicle body.
 - Align the Li-ion battery (1) and the locating pin (2).

WARNING:

 To prevent electric shock hazards, be sure to wear protective gear.

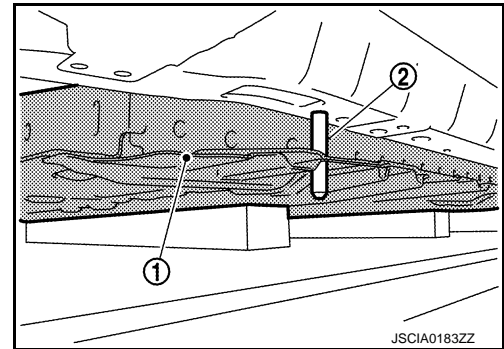

4. Tighten mounting bolts (4 bolts) (A) and remove pallet from Li-ion battery.

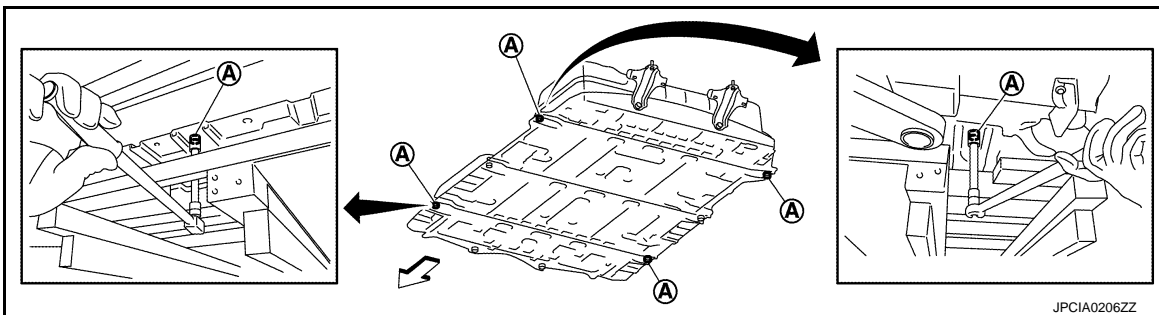

← : Vehicle front

WARNING:

 To prevent electric shock hazards, be sure to wear protective gear.



5. Remove the locating pins from the body.

A
B
EVB
D
E
F
G
H
I
J
K
L
M
N
O
P

LI-ION BATTERY

< UNIT REMOVAL AND INSTALLATION >

[TYPE 2]

- If the locating pins (1) are tight and cannot be removed, use a spanner to remove them.

WARNING:

 To prevent electric shock hazards, be sure to wear protective gear.

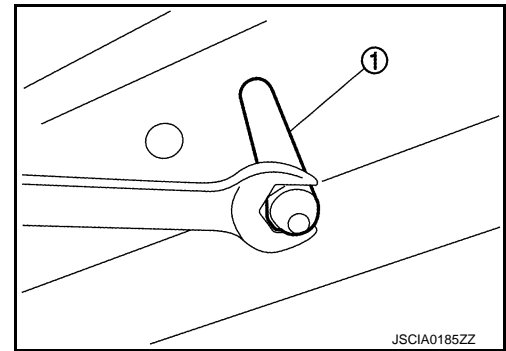

6. Install the Li-ion battery mounting bolts (A).

 : Vehicle front

WARNING:

 To prevent electric shock hazards, be sure to wear protective gear.

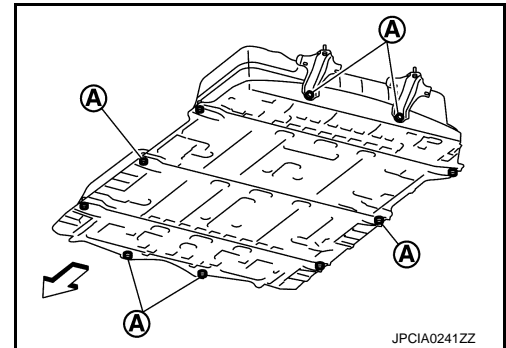

7. Check the stamp No. of the bonding plate, and install it at the position shown in the figure.

1. Stamp No.2 (August 2011 or later models, abolished)
2. Stamp No.4
3. Stamp No.6 (August 2011 or later models, abolished)

 : Vehicle front

WARNING:

 To prevent electric shock hazards, be sure to wear protective gear.

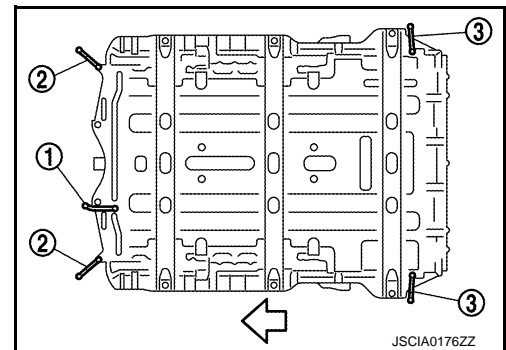

8. After installing the bonding plate, check the equipotential. Refer to [EVB-401, "Inspection"](#).

9. Turn the vehicle communication harness connector (A) clockwise to install.

WARNING:

 To prevent electric shock hazards, be sure to wear protective gear.

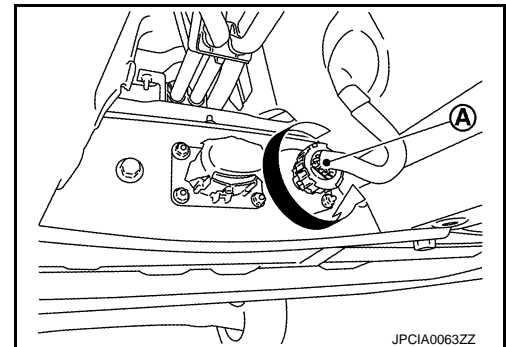

LI-ION BATTERY

< UNIT REMOVAL AND INSTALLATION >

[TYPE 2]

10. Install the high voltage harness connector (A).

WARNING:



To prevent electric shock hazards, be sure to wear protective gear.

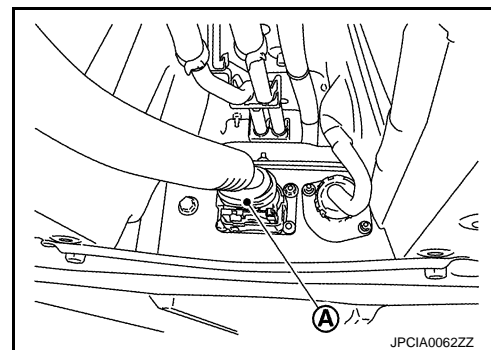

- Follow the procedure below to install the high voltage harness connector.

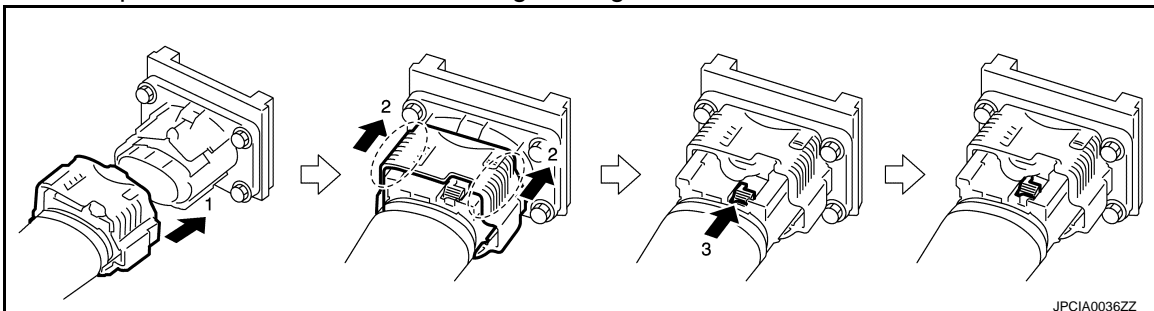

11. Install the Li-ion battery under covers. Refer to [EVB-395, "Exploded View"](#).

12. Install the service plug. Refer to [GI-31, "How to Disconnect High Voltage"](#).

Inspection

INFOID:000000007321452

EQUIPOTENTIAL TEST

After installing the Li-ion battery, measure the resistance between the body of the battery pack (A) and the vehicle body (B).

WARNING:



To prevent electric shock hazards, be sure to wear protective gear.



Standard : Less than 0.1 Ω

If the result deviates from the standard values, perform the below inspection and correct the abnormal location.

- Connection conditions of bonding plates
- Corrosion on bonding plate mounting surfaces
- Paint, oil, dust, or other substance on bonding plate mounting surfaces

LI-ION BATTERY

< UNIT DISASSEMBLY AND ASSEMBLY >

[TYPE 2]

UNIT DISASSEMBLY AND ASSEMBLY

LI-ION BATTERY

Exploded view

INFOID:000000007341787

LI-ION BATTERY



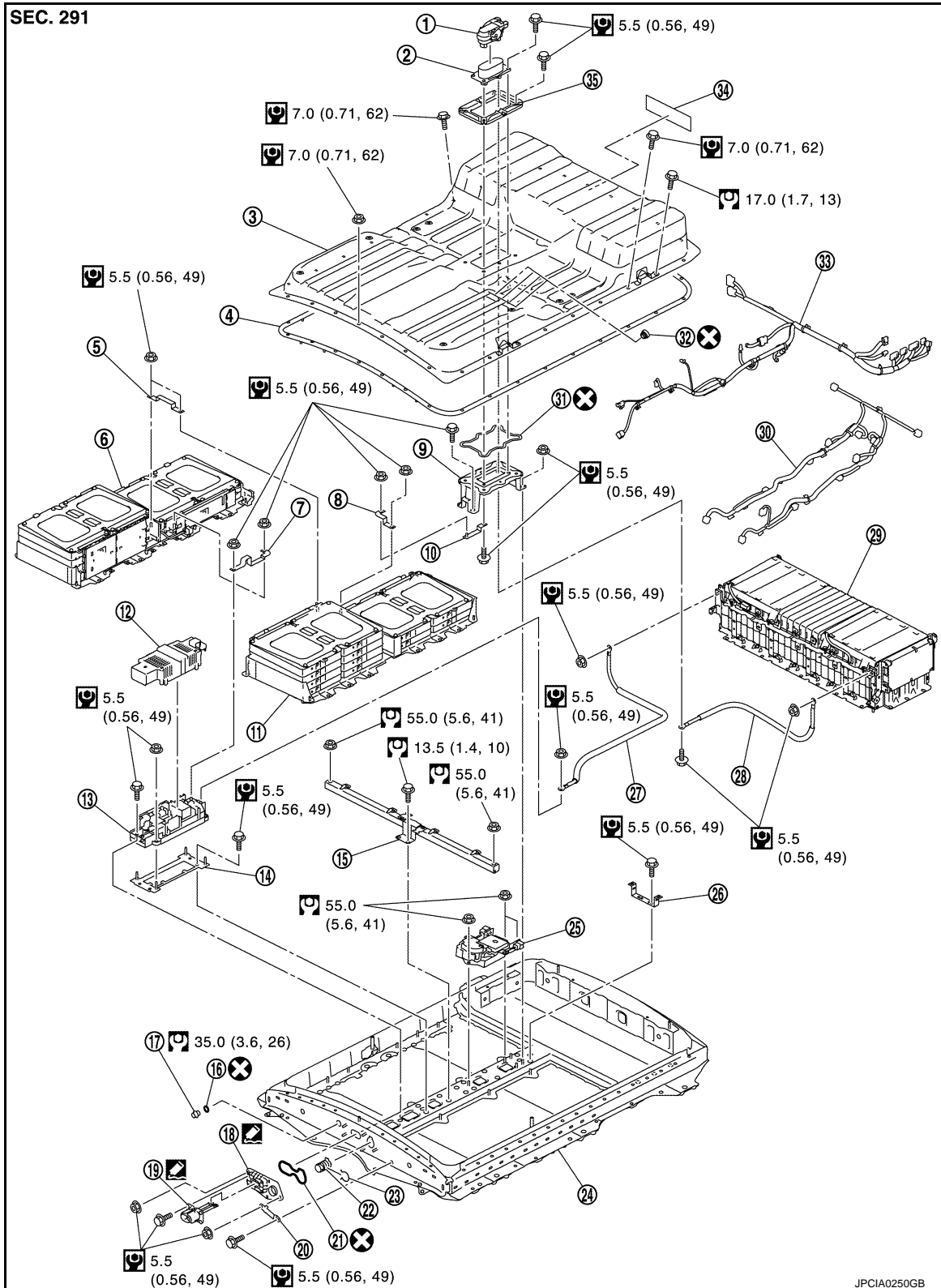

UP TO VIN: JN1AZ0CP*BT005462



LI-ION BATTERY

< UNIT DISASSEMBLY AND ASSEMBLY >

[TYPE 2]

1. Service plug	2. Service plug switch	3. Battery pack upper case	A
4. Seal	5. Bus bar	6. Front module stack RH	
7. Bus bar	8. Bus bar	9. Service plug switch bracket	
10. Bus bar	11. Front module stack LH	12. Battery junction box cover	B
13. Battery junction box	14. Battery junction box bracket	15. Battery member pipe	
16. Drain plug washer	17. Drain plug	18. Connector flange	
19. High voltage harness connector	20. Bonding plate	21. Seal	EVB
22. Vehicle communication harness connector	23. Snap ring	24. Battery pack lower case	
25. Heater relay unit	26. Harness bracket	27. High voltage harness	D
28. High voltage harness	29. Rear module stack	30. Li-ion battery heater harness	
31. Seal	32. Breather	33. Vehicle communication harness	
34. High voltage warning label	35. Retainer		E
 : Always replace every disassembly			
 : Use Genuine Liquid Gasket (Three Bond 1220G) or equivalent.			F
 : N·m (kg-m, in-lb)			
 : N·m (kg-m, ft-lb)			G
			H
			I
			J
			K
			L
			M
			N
			O
			P

LI-ION BATTERY

< UNIT DISASSEMBLY AND ASSEMBLY >

[TYPE 2]

FROM VIN: JN1AZ0CP*BT005463

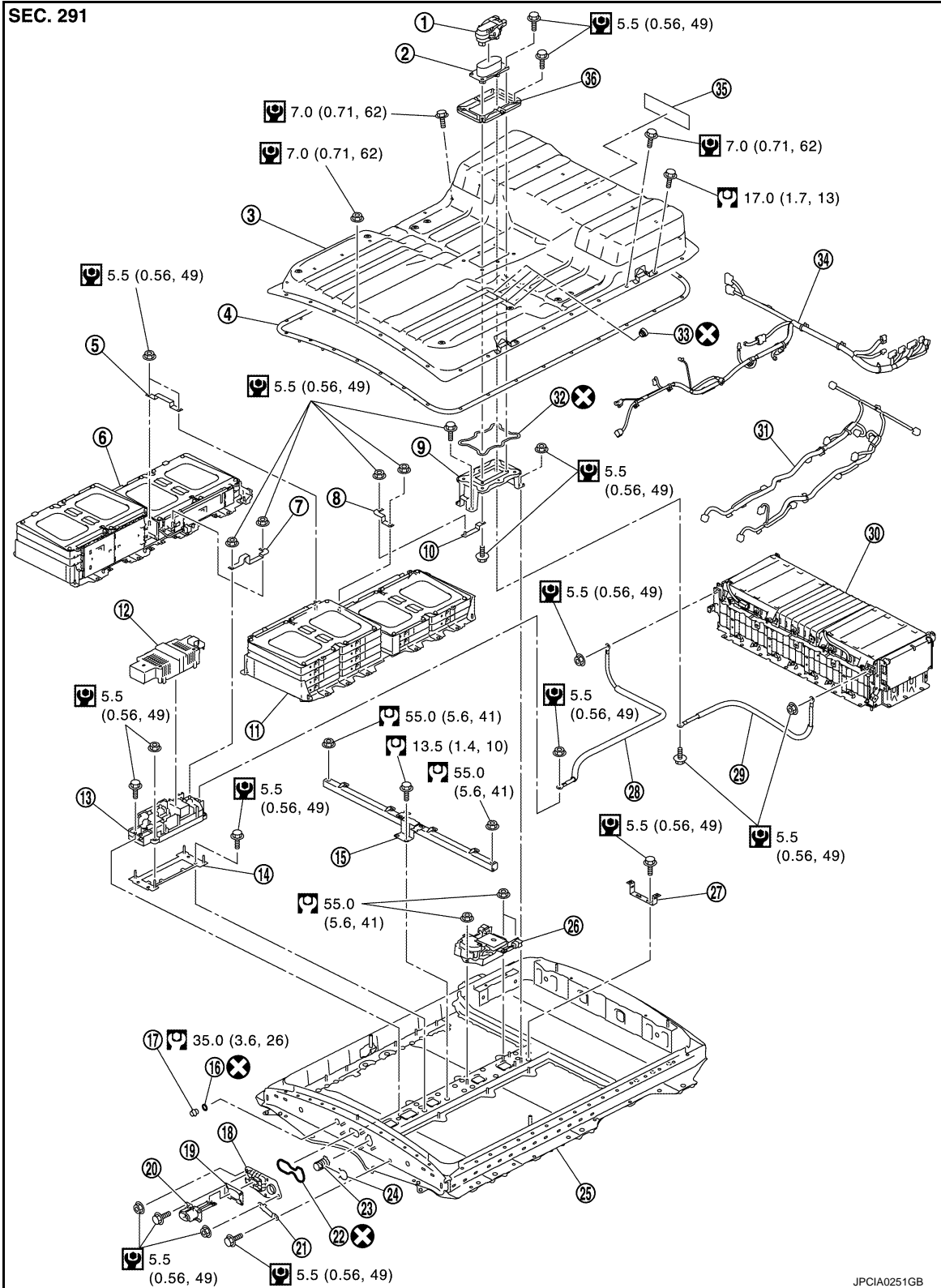

- | | | |
|--------------------------|----------------------------------|--------------------------------|
| 1. Service plug | 2. Service plug switch | 3. Battery pack upper case |
| 4. Seal | 5. Bus bar | 6. Front module stack RH |
| 7. Bus bar | 8. Bus bar | 9. Service plug switch bracket |
| 10. Bus bar | 11. Front module stack LH | 12. Battery junction box cover |
| 13. Battery junction box | 14. Battery junction box bracket | 15. Battery member pipe |
| 16. Drain plug washer | 17. Drain plug | 18. Connector flange |

LI-ION BATTERY

< UNIT DISASSEMBLY AND ASSEMBLY >

[TYPE 2]

- | | | |
|-----------------------------------|---|----------------------------|
| 19. Plastic plate | 20. High voltage harness connector | 21. Bonding plate |
| 22. Seal | 23. Vehicle communication harness connector | 24. Snap ring |
| 25. Battery pack lower case | 26. Heater relay unit | 27. Harness bracket |
| 28. High voltage harness | 29. High voltage harness | 30. Rear module stack |
| 31. Li-ion battery heater harness | 32. Seal | 33. Breather* ¹ |
| 34. Vehicle communication harness | 35. High voltage warning label | 36. Retainer |

⊗ : Always replace every disassembly

🔧 : Use Genuine Liquid Gasket (Three Bond 1220G) or equivalent.

🔩 : N·m (kg·m, in·lb)

🔩 : N·m (kg·m, ft·lb)

*1 For models manufactured in January 2012 and later, the number of breathers is changed from four to two.

FRONT MODULE STACK

Removal

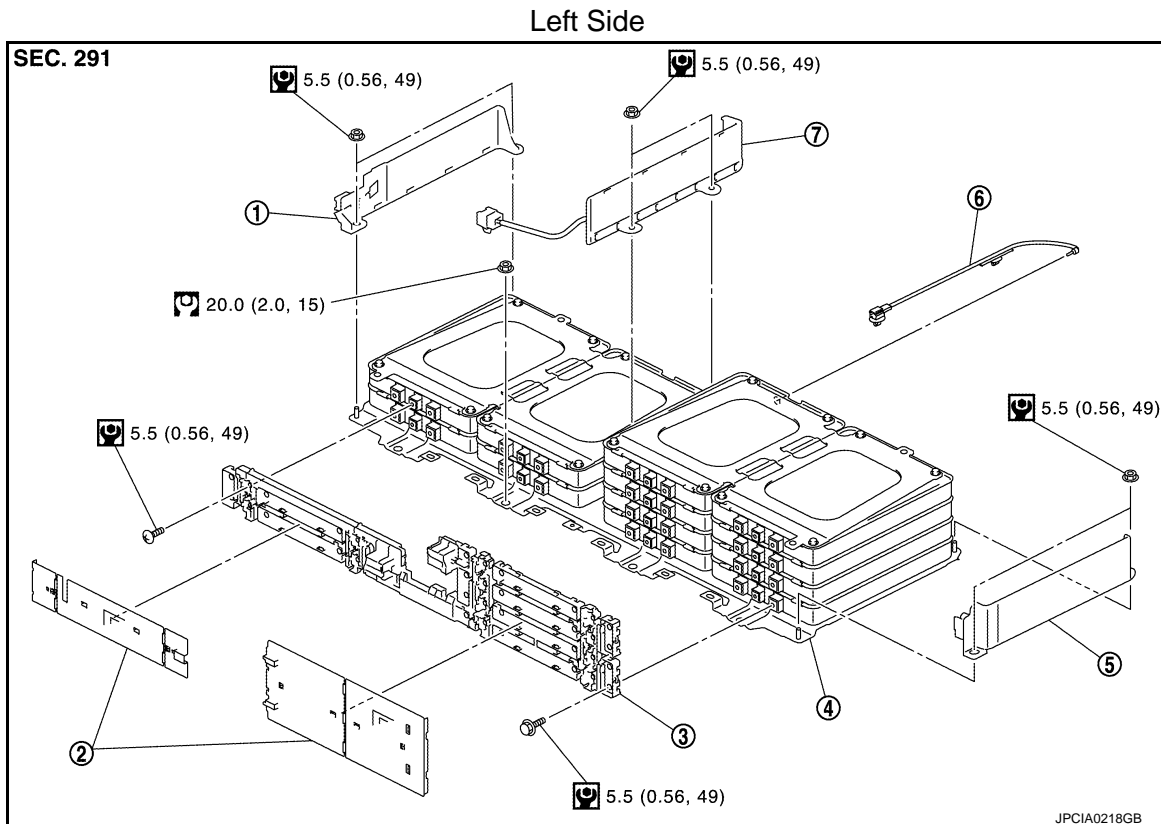

- | | | |
|------------------------------|------------------------------|--|
| 1. Li-ion battery heater LH3 | 2. Bus bar cover | 3. Bus bar |
| 4. Front module stack LH | 5. Li-ion battery heater LH1 | 6. Battery temperature sensor (LH front) |
| 7. Li-ion battery heater LH2 | | |

🔩 : N·m (kg·m, in·lb)

🔩 : N·m (kg·m, ft·lb)

LI-ION BATTERY

< UNIT DISASSEMBLY AND ASSEMBLY >

[TYPE 2]

Right Side

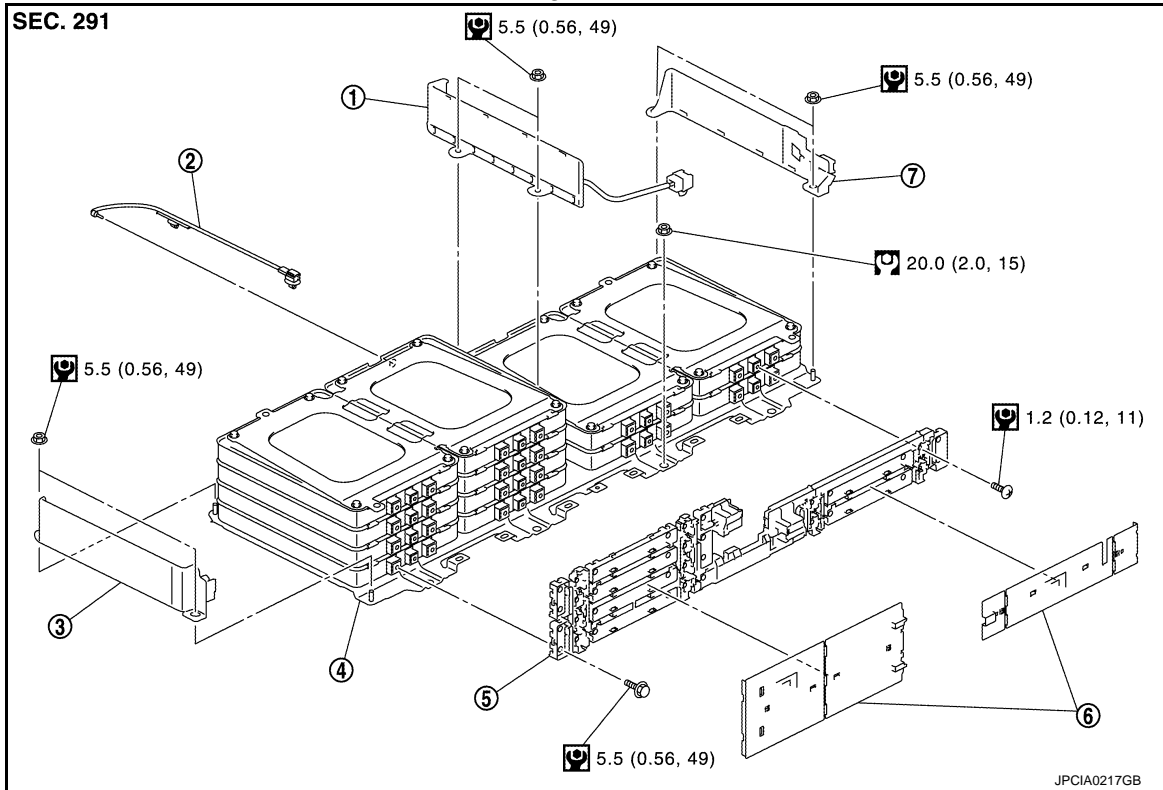

- | | | |
|------------------------------|--|------------------------------|
| 1. Li-ion battery heater RH2 | 2. Battery temperature sensor (RH front) | 3. Li-ion battery heater RH1 |
| 4. Front module stack RH | 5. Bus bar | 6. Bus bar cover |
| 7. Li-ion battery heater RH3 | | |

: N-m (kg-m, in-lb)

: N-m (kg-m, ft-lb)

Disassembly

NOTE:

Figure indicates front RH.

LI-ION BATTERY

< UNIT DISASSEMBLY AND ASSEMBLY >

[TYPE 2]

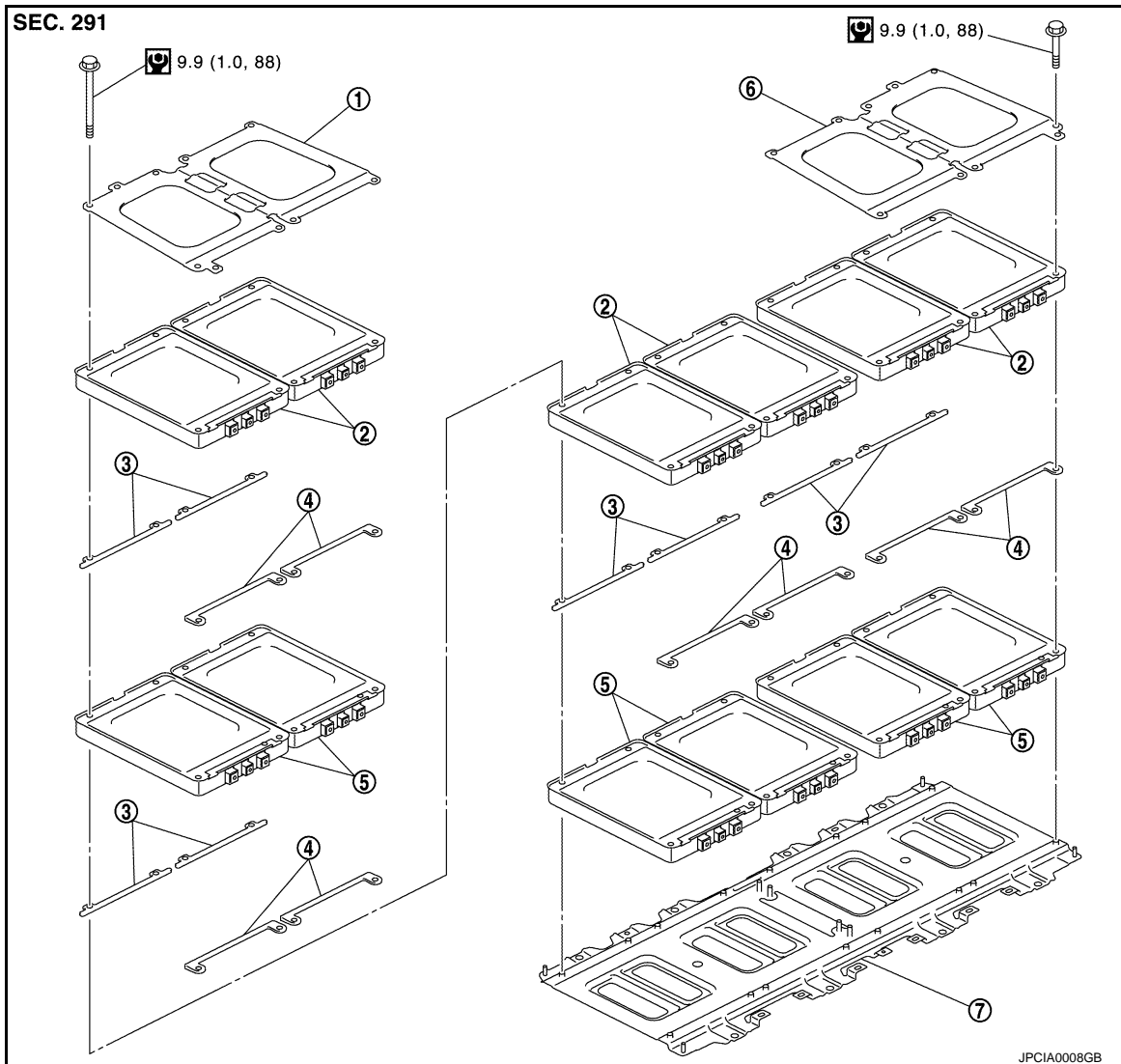

- | | | |
|---------------------------|-------------|-----------------------|
| 1. End plate (front) | 2. Module B | 3. Spacer (back side) |
| 4. Spacer (terminal side) | 5. Module A | 6. End plate (rear) |
| 7. Sub flame | | |

 : N·m (kg·m, in·lb)

A
B
EVB
D
E
F
G
H
I
J
K
L
M
N
O
P

LI-ION BATTERY

< UNIT DISASSEMBLY AND ASSEMBLY >

[TYPE 2]

Module Layout

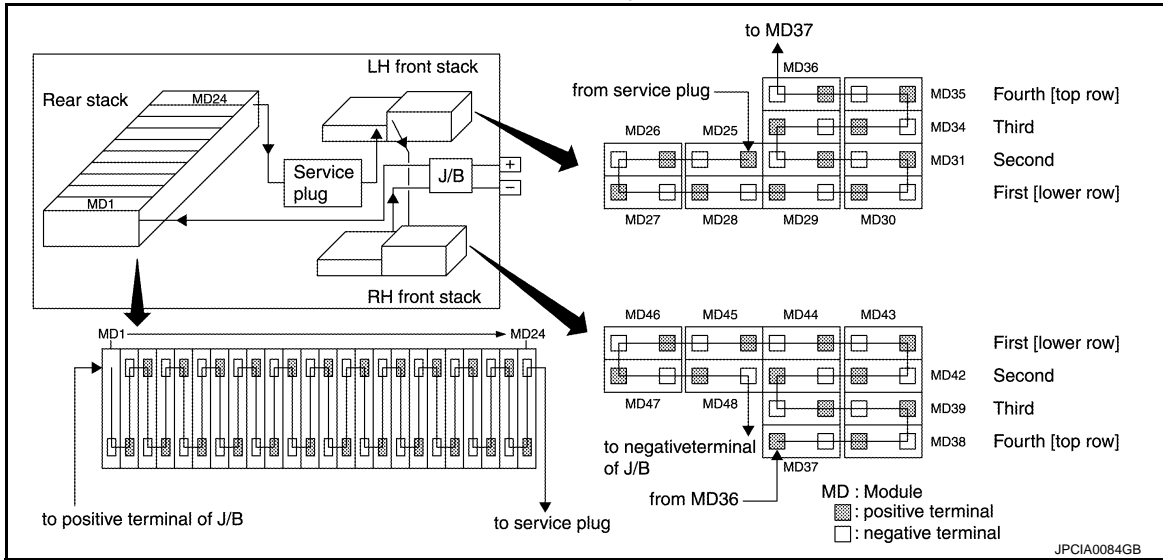

LH front module stack			RH front module stack		
Module No.	Module name	Cell No.	Module No.	Module name	Cell No.
MD25	Module B	49 & 50	MD37	Module B	73 & 74
MD26	Module B	51 & 52	MD38	Module B	75 & 76
MD27	Module A	53 & 54	MD39	Module A	77 & 78
MD28	Module A	55 & 56	MD40	Module A	79 & 80
MD29	Module A	57 & 58	MD41	Module B	81 & 82
MD30	Module A	59 & 60	MD42	Module B	83 & 84
MD31	Module B	61 & 62	MD43	Module A	85 & 86
MD32	Module B	63 & 64	MD44	Module A	87 & 88
MD33	Module A	65 & 66	MD45	Module A	89 & 90
MD34	Module A	67 & 68	MD46	Module A	91 & 92
MD35	Module B	69 & 70	MD47	Module B	93 & 94
MD36	Module B	71 & 72	MD48	Module B	95 & 96

Bus bar Layout

DANGER:

LI-ION BATTERY

< UNIT DISASSEMBLY AND ASSEMBLY >

[TYPE 2]



Because there is a danger of electric shock and fire, never contact bus bar in a wrong terminal.

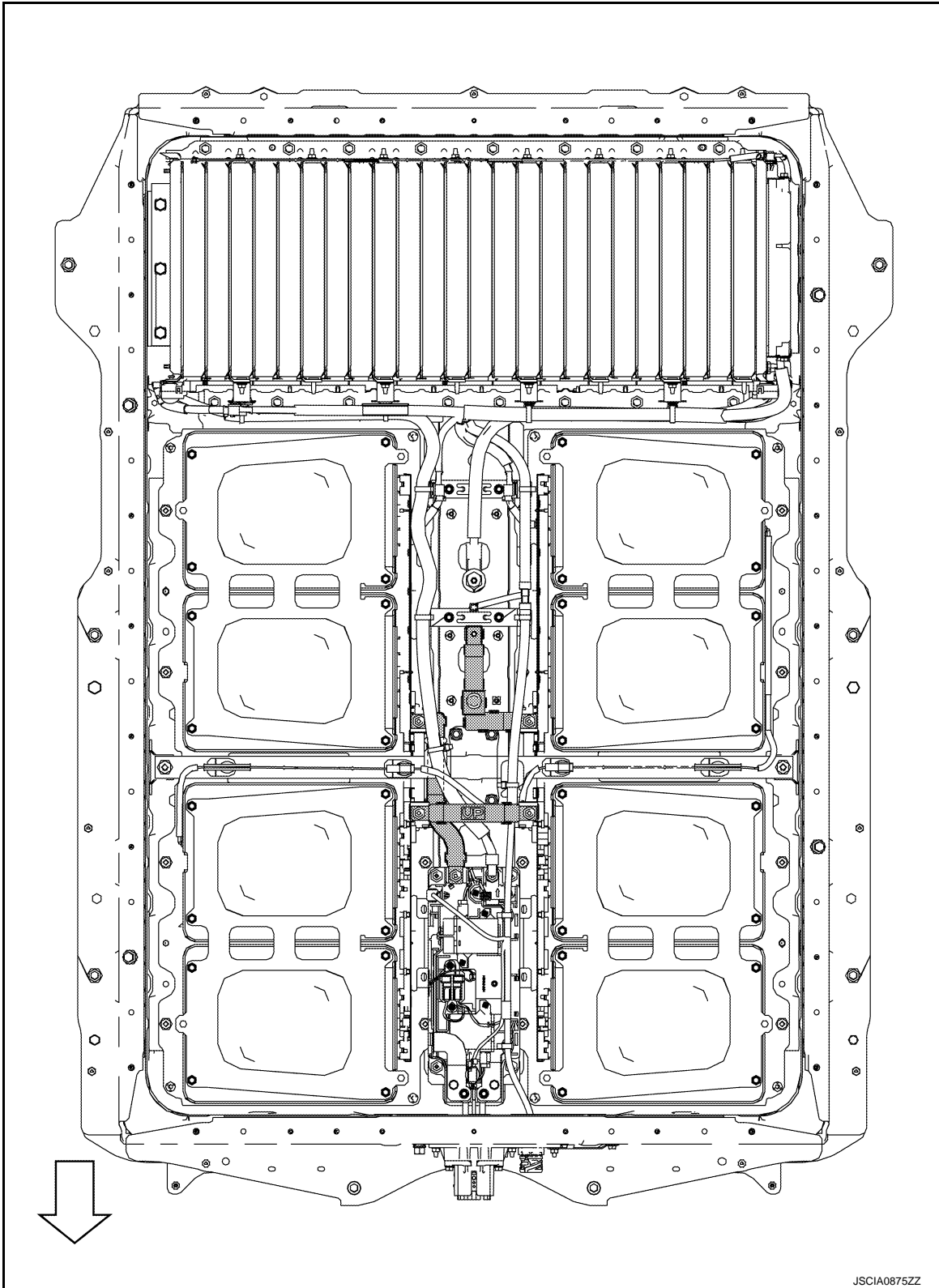

A
B
EVB
D
E
F
G
H
I
J
K
L
M
N
O
P

⇐ : Battery front

REAR MODULE STACK

Removal

LI-ION BATTERY

< UNIT DISASSEMBLY AND ASSEMBLY >

[TYPE 2]

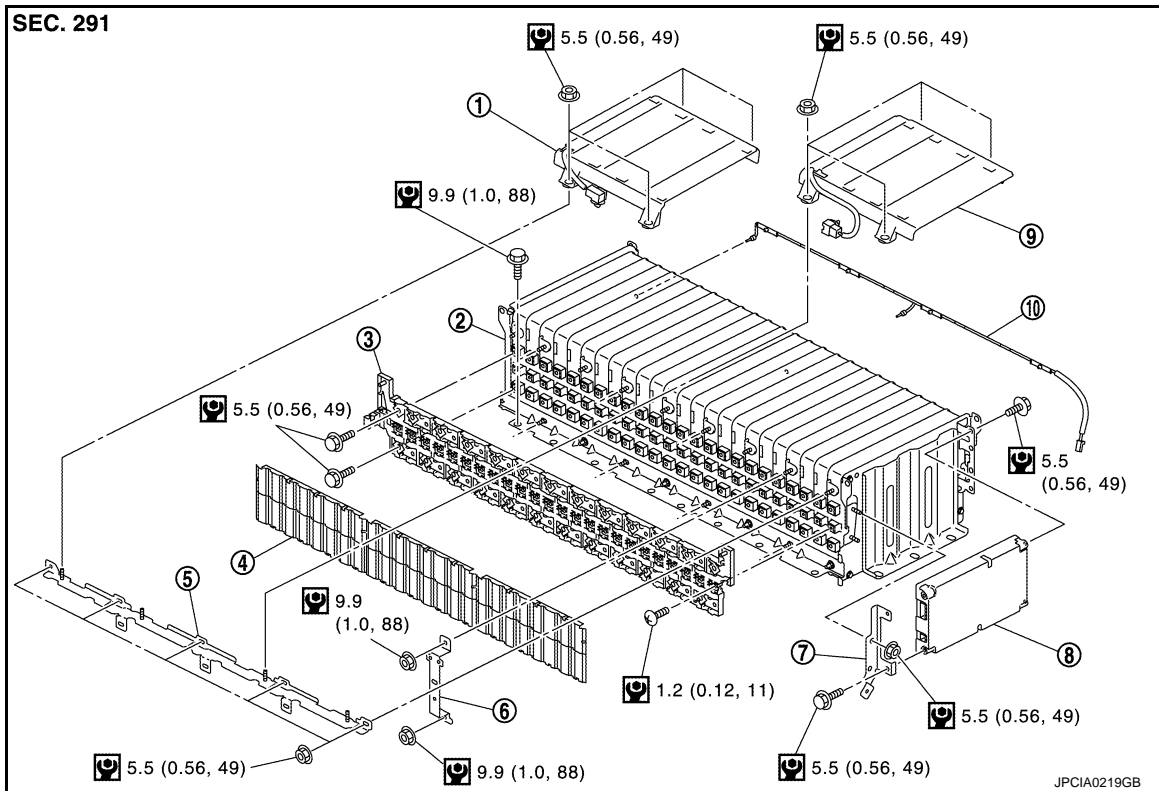

- | | | |
|---------------------------------------|------------------------------|------------------------------|
| 1. Li-ion battery heater RR2 | 2. Rear module stack | 3. Bus bar |
| 4. Bus bar cover | 5. Heater harness bracket | 6. Harness bracket |
| 7. Control bracket | 8. Li-ion battery controller | 9. Li-ion battery heater RR1 |
| 10. Battery temperature sensor (rear) | | |

: N-m (kg-m, in-lb)

Disassembly

LI-ION BATTERY

< UNIT DISASSEMBLY AND ASSEMBLY >

[TYPE 2]

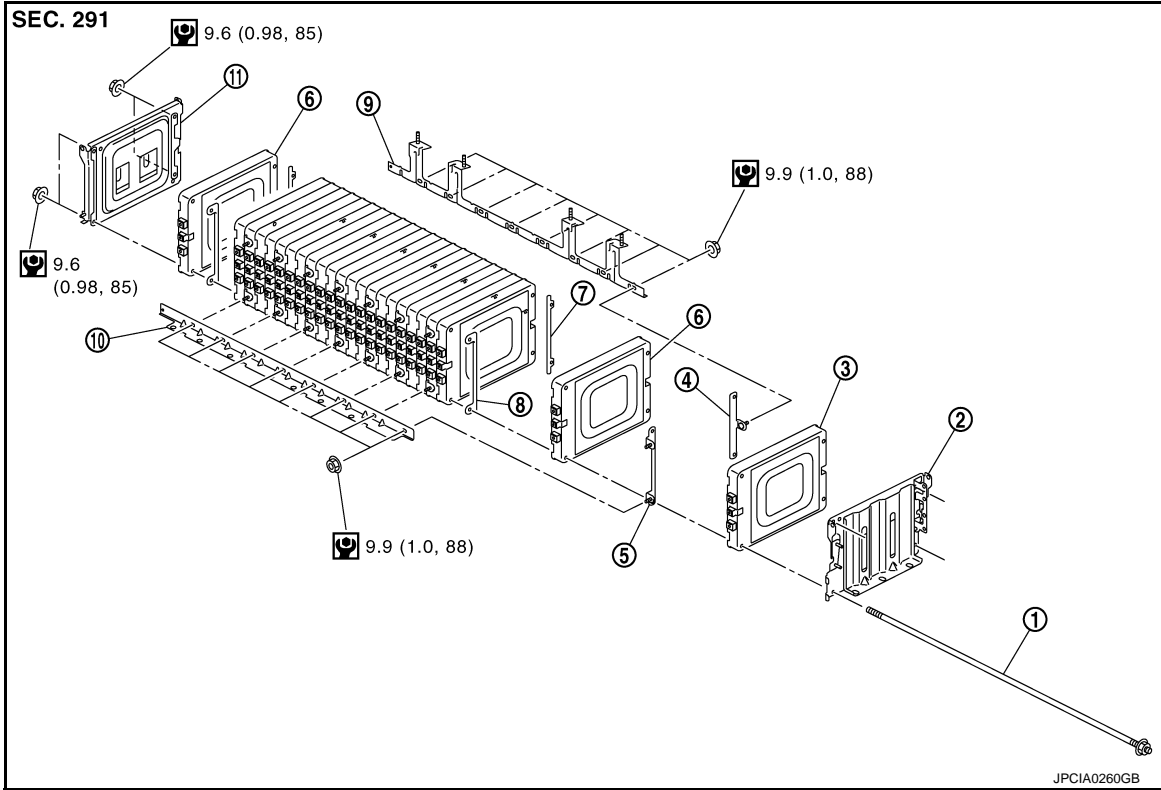

- 1. Through bolt
- 2. LH end plate
- 3. Module A
- 4. Mounting plate (back side)
- 5. Mounting plate (terminal side)
- 6. Module B
- 7. Support plate (back side)
- 8. Support plate (terminal side)
- 9. Rear stack member
- 10. Front stack member
- 11. RH end plate

: N-m (kg-m, in-lb)

Module Layout

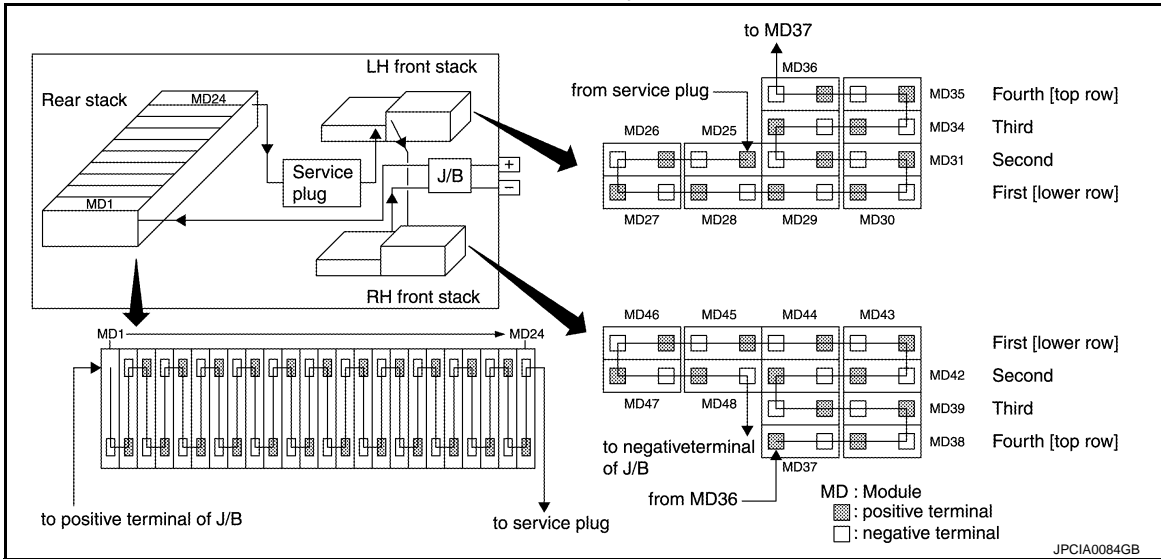

Rear module stack

Module No.	Module name	Cell No.	Module No.	Module name	Cell No.
MD1	Module B	1 & 2	MD13	Module B	25 & 26
MD2	Module A	3 & 4	MD14	Module A	27 & 28

A
B
EVB
D
E
F
G
H
I
J
K
L
M
N
O
P

LI-ION BATTERY

< UNIT DISASSEMBLY AND ASSEMBLY >

[TYPE 2]

Rear module stack

Module No.	Module name	Cell No.	Module No.	Module name	Cell No.
MD3	Module B	5 & 6	MD15	Module B	29 & 30
MD4	Module A	7 & 8	MD16	Module A	31 & 32
MD5	Module B	9 & 10	MD17	Module B	33 & 34
MD6	Module A	11 & 12	MD18	Module A	35 & 36
MD7	Module B	13 & 14	MD19	Module B	37 & 38
MD8	Module A	15 & 16	MD20	Module A	39 & 40
MD9	Module B	17 & 18	MD21	Module B	41 & 42
MD10	Module A	19 & 20	MD22	Module A	43 & 44
MD11	Module B	21 & 22	MD23	Module B	45 & 46
MD12	Module A	23 & 24	MD24	Module A	47 & 48

BATTERY JUNCTION BOX

BATTERY JUNCTION BOX : Disassembly and Assembly

INFOID:000000007341788

DANGER:



Because hybrid vehicles and electric vehicles contain a high voltage battery, there is the risk of electric shock, electric leakage, or similar accidents if the high voltage component and vehicle are handled incorrectly. Be sure to follow the correct work procedures when performing inspection and maintenance.

WARNING:

- Be sure to remove the service plug in order to disconnect the high voltage circuits before performing inspection or maintenance of high voltage system harnesses and parts.
- To prevent the removed service plug from being connected by mistake during the procedure, always carry it in your pocket or put it in the tool box.
- Be sure to wear insulating protective equipment consisting of glove, shoes, face shield and glasses before beginning work on the high voltage system.
- Refer to [EVB-229, "High Voltage Precautions"](#).
- To prevent electric shock hazards, ignition, and damage to parts, always remove Li-ion battery controller before disassembling battery pack.

CAUTION:

There is the possibility of a malfunction occurring if the vehicle is changed to READY status while the service plug is removed. Therefore do not change the vehicle to READY status unless instructed to do so in the Service Manual.

WORK ENVIRONMENT FOR DISASSEMBLY OF LI-ION BATTERY

1. Must be an indoor environment.
 - The work environment must be able to be isolated from the outside by shutters or other means to prevent the intrusion of rain, snow, sand, and other substances.
 - The environment must prevent the entry of sweat during work, and also prevent condensation from occurring as a result of high temperature and humidity.
2. No entry of foreign materials.
 - In addition to being indoors, the environment must not permit the entry during disassembly work of metal powders, oil, or foreign substances resulting from causes such as servicing of other vehicles.
 - If there is any risk of the above, use a plastic curtain or other means to block off the work area, or take other necessary steps.
3. The floor must be dry.
 - The floor must not become wet as a result of causes such as vehicles entering when it is raining or snowing.
4. Work space
 - Space approximately the size of one vehicle must be secured as the disassembly space.
 - A sign indicating that disassembly is in progress or other measures must be taken so that persons other than the workers do not enter the work space.

LI-ION BATTERY

< UNIT DISASSEMBLY AND ASSEMBLY >

[TYPE 2]

- Standard fire fighting equipment
 - Always place a standard fire fighting equipment in the disassembly work area.
 - Depending on type of fire (vehicle or battery) use standard fire fighting equipment (water or extinguisher).

DISASSEMBLY

- Clean any contamination and dust from the battery pack.
- Remove service plug retainer (1).

WARNING:



To prevent electric shock hazards, be sure to wear protective gear.

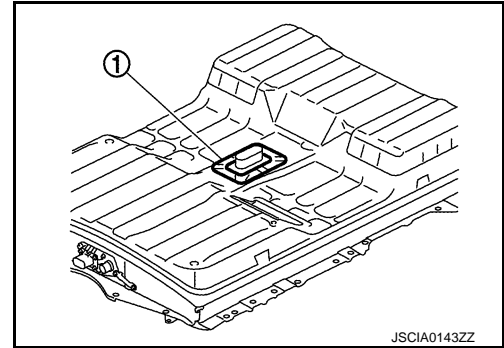

- Remove mounting bolts (A), (B) and mounting nuts (C), then remove battery pack upper case.

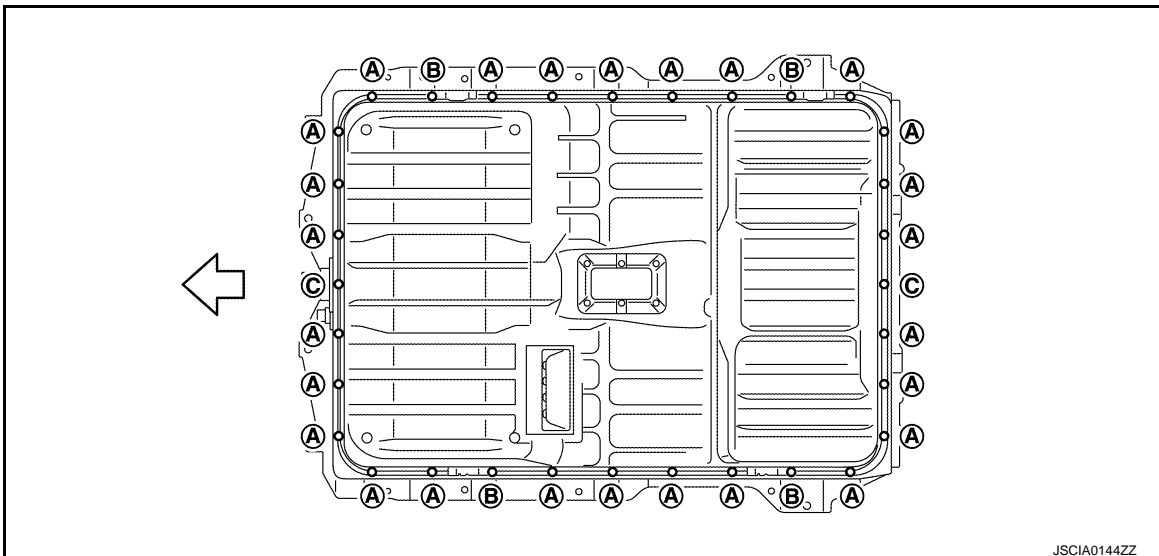

← : Vehicle front

WARNING:



To prevent electric shock hazards, be sure to wear protective gear.



- Remove Li-ion battery controller. Refer to [EVB-419, "LI-ION BATTERY CONTROLLER : Disassembly and Assembly"](#).

LI-ION BATTERY

< UNIT DISASSEMBLY AND ASSEMBLY >

[TYPE 2]

5. Disengage pawls and remove battery junction box cover (1).

 : Pawl

WARNING:

 To prevent electric shock hazards, be sure to put on insulated protective gear and use insulated tools.

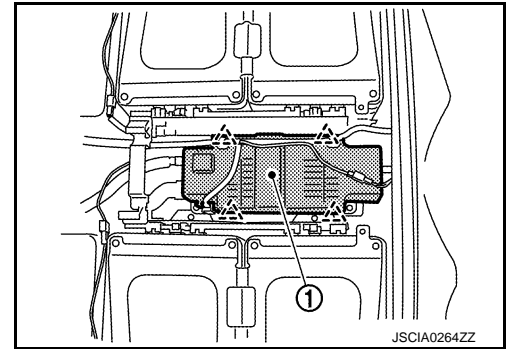

6. Remove terminal mounting nut (A) of high voltage harness connector.

DANGER:

 To prevent electric shock hazards, be sure to put on insulated protective gear and use insulated tools.



 To prevent electric shock hazards, immediately wrap insulating tape around disconnected high voltage harness connector (high voltage terminal) and terminals.

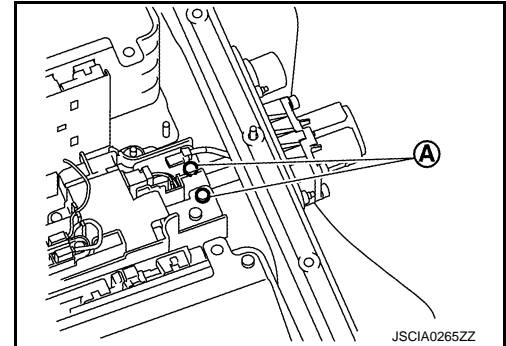

7. Remove mounting bolts (A), then disconnect high voltage harness connector (1) from battery pack.

WARNING:

 To prevent electric shock hazards, be sure to put on insulated protective gear and use insulated tools.

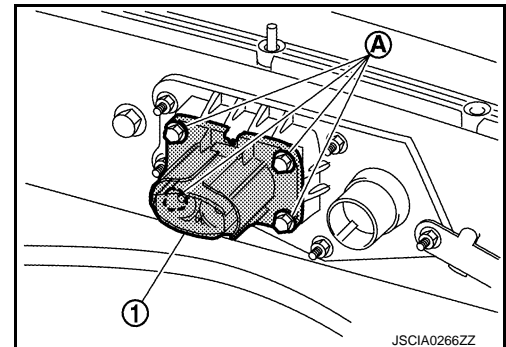

8. Remove mounting nuts (A), then remove high voltage harness (1) and bus bar (2) from battery junction box.

DANGER:

 To prevent electric shock hazards, be sure to put on insulated protective gear and use insulated tools.



 To prevent electric shock hazards, immediately wrap insulating tape around disconnected high voltage harness connector (high voltage terminal) and terminals.

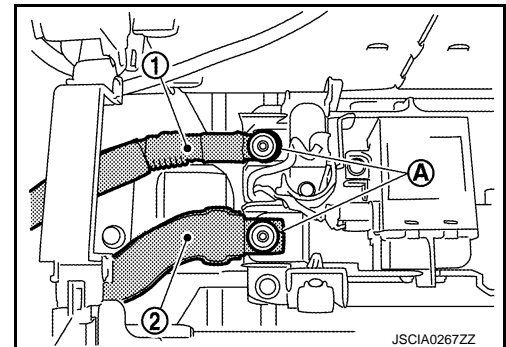

LI-ION BATTERY

[TYPE 2]

< UNIT DISASSEMBLY AND ASSEMBLY >

9. Remove mounting nuts (A) and remove battery junction box (1).

WARNING:



To prevent electric shock hazards, be sure to put on insulated protective gear and use insulated tools.

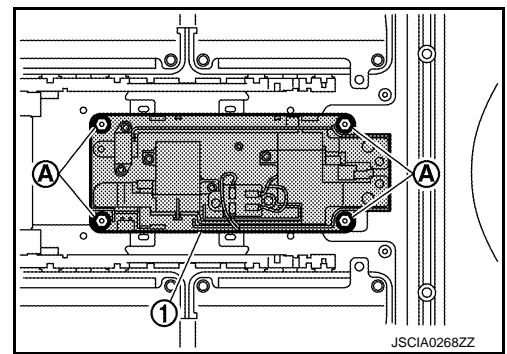

A
B
EVB

ASSEMBLY

1. Install battery junction box.

WARNING:



To prevent electric shock hazards, be sure to put on insulated protective gear and use insulated tools.



2. Install high voltage harness connector.

WARNING:



To prevent electric shock hazards, be sure to put on insulated protective gear and use insulated tools.



CAUTION:

- If the connection between high voltage harness connector and connector flange originally includes liquid gasket, apply liquid gasket to the connection as per the following steps.
- When replacing high voltage harness connector and connector flange with new ones, the application of liquid gasket is not required even if it is originally included.

HOW TO APPLY LIQUID GASKET

- a. Clean the bearing surface of high voltage harness connector and connector flange to remove dirt and dust.
- b. Install high voltage harness connector (1) to connector flange, then tighten bolts (A) to the specified torque.

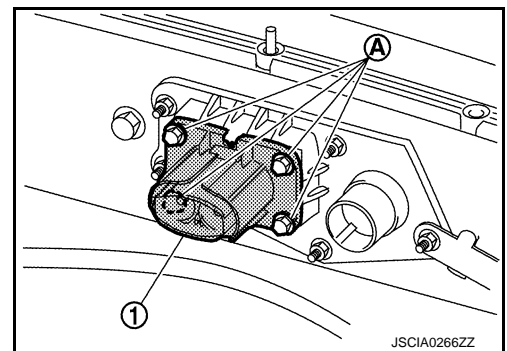

D
E
F
G
H
I
J
K
L
M
N
O
P

LI-ION BATTERY

< UNIT DISASSEMBLY AND ASSEMBLY >

[TYPE 2]

- c. Apply liquid gasket to the connection of high voltage harness connector and connector flange.

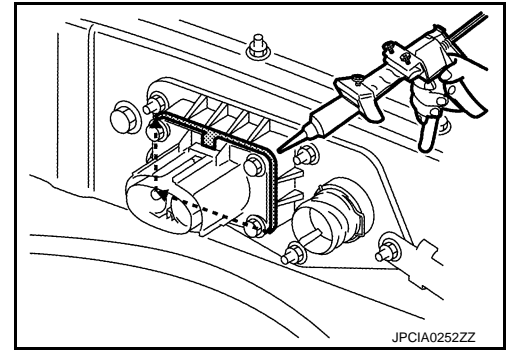

CAUTION:

Observe the following instructions to apply liquid gasket.

- Liquid gasket must be applied to the entire perimeter of the connection (A) of high voltage harness connector and connector flange.
- Liquid gasket must be applied in seamless manner. Never leave unevenness (B).
- Liquid gasket must be applied in the manner of filling the inside of rib (C) with liquid gasket.

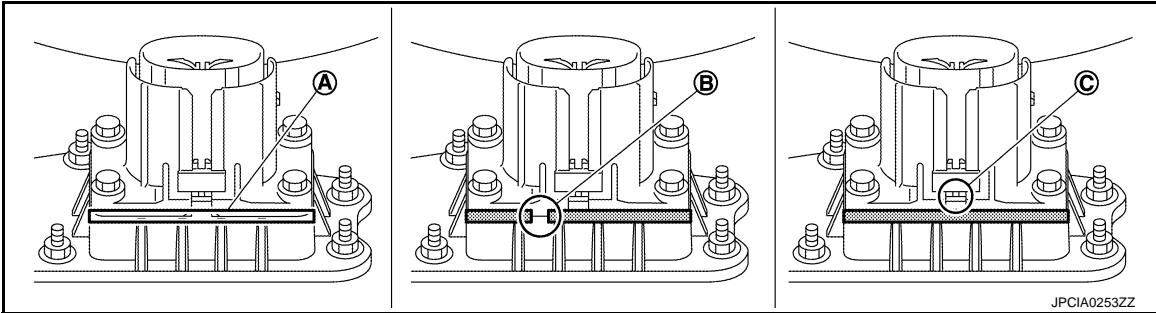

3. Install Li-ion battery controller. Refer to [EVB-419, "LI-ION BATTERY CONTROLLER : Disassembly and Assembly"](#).
4. Follow the procedure below and install battery pack upper case.

CAUTION:

Check seal before install battery pack upper case. Refer to [EVB-417, "BATTERY JUNCTION BOX : Inspection"](#).

- a. Tighten mounting nuts and bolts in the order from 1 to 28 as shown in the figure.

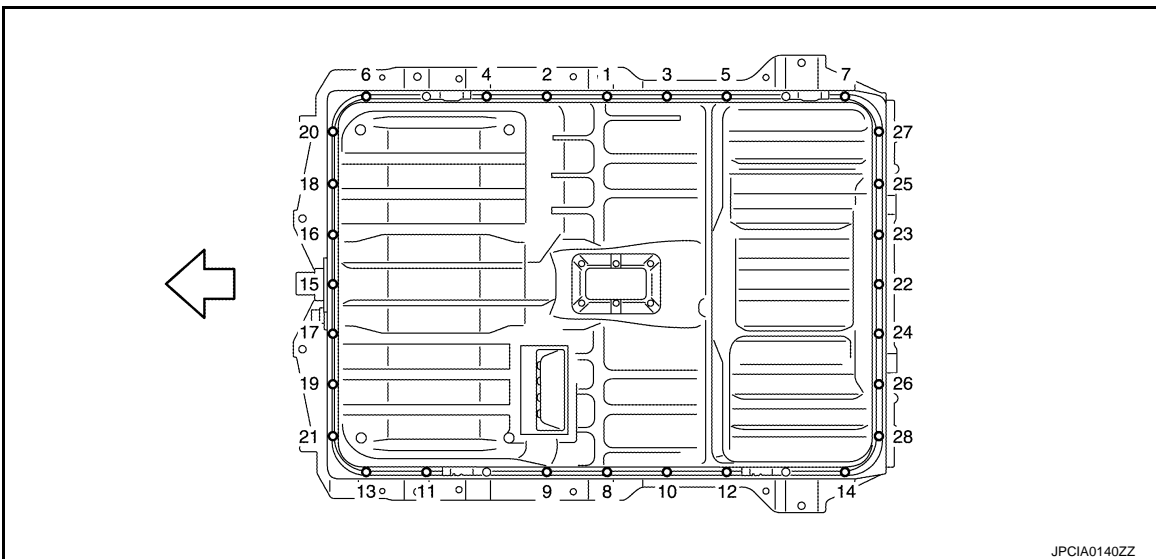

← : Vehicle front

WARNING:

LI-ION BATTERY

< UNIT DISASSEMBLY AND ASSEMBLY >

[TYPE 2]



To prevent electric shock hazards, be sure to wear protective gear.



b. Install ground bolt (A).

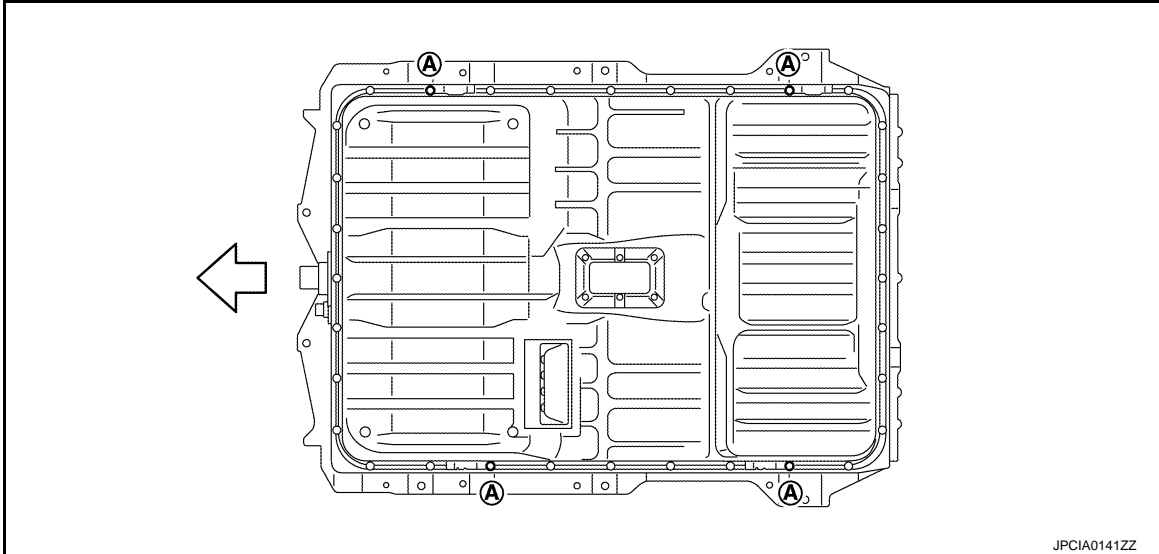

← : Vehicle front

WARNING:



To prevent electric shock hazards, be sure to wear protective gear.



5. Install service plug retainer (1).

WARNING:



To prevent electric shock hazards, be sure to wear protective gear.

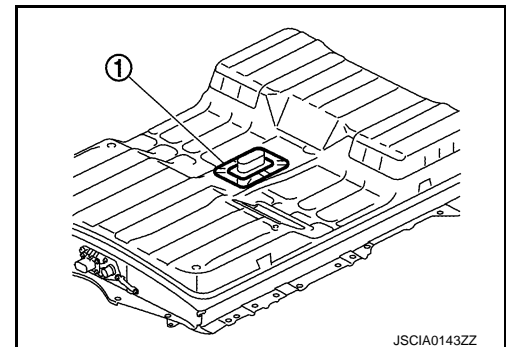

CAUTION:

- Perform the “LI-ION BATTERY JUNCTION BOX DATA CLEAR” when battery junction box is replaced. Refer to [EVC-110, "Work Procedure"](#).
- Check the following items after installing battery pack: Refer to [EVB-417, "BATTERY JUNCTION BOX : Inspection"](#).

■AIR LEAK INSPECTION

■ELECTRIC EQUIPOTENTIAL TEST

BATTERY JUNCTION BOX : Inspection

INFOID:000000007479184

BATTERY PACK SEAL INSPECTION

LI-ION BATTERY

< UNIT DISASSEMBLY AND ASSEMBLY >

[TYPE 2]

- Visually check all lips (A) of seal (1) for damage. (e.g. scratches and cracks)
- Replace seal if its lips are damaged.

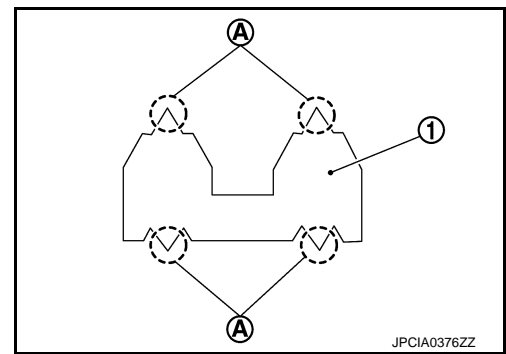

AIR LEAK INSPECTION

1. Remove drain plug and install adapter [SST: KV99111400] (A).

WARNING:

 To prevent electric shock hazards, be sure to wear protective gear.

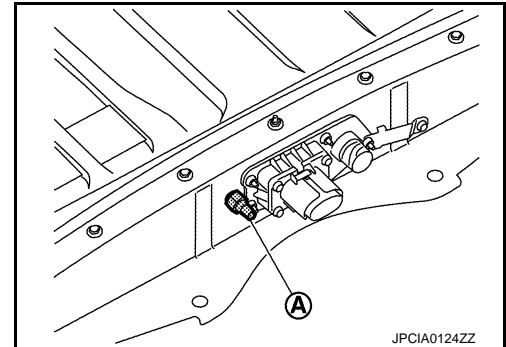

2. Install gauge [SST: KV99111400] (A).

WARNING:

 To prevent electric shock hazards, be sure to wear protective gear.



CAUTION:

Handle the gauge carefully so that it will not drop.

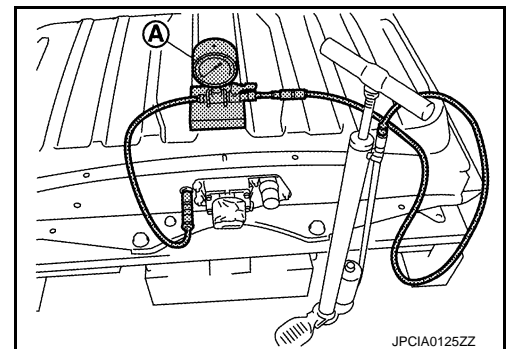

3. Install service plug to seal the battery pack.

DANGER:

 To prevent electric shock hazards, be sure to wear protective gear.



4. Use vinyl tape (A) or similar means to seal the breather so that air does not enter it.

- Use the wide vinyl tape which can cover up breather at once.
- Stick it so that tape is not wrinkled.

WARNING:

 To prevent electric shock hazards, be sure to wear protective gear.

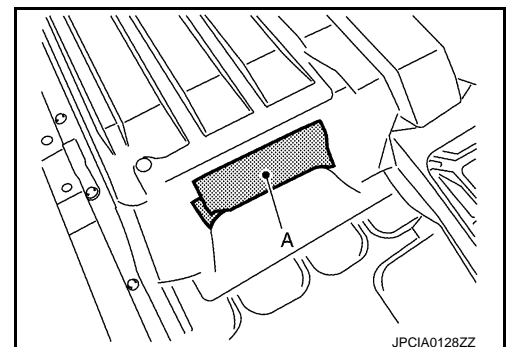

5. Perform air leak inspection by applying 1.6 kPa (0.0163 kg/cm², 0.23 psi) of pressure inside the battery pack for approximately 1 minute.

LI-ION BATTERY

< UNIT DISASSEMBLY AND ASSEMBLY >

[TYPE 2]

CAUTION:

- When applying pressure, operate the air pump slowly.
- Do not apply any pressure exceeding 2.0 kPa (0.0204 kg/cm², 0.29 psi).

Repair limit : 1.4 kPa (0.0143 kg/cm², 0.20 psi)

6. If the pressure drops below the limit value, use soapy water and check for leakage points.

WARNING:



To prevent electric shock hazards, be sure to wear protective gear.



CAUTION:

Never allow soapy water to contact the service plug and each connector terminals.

Electric Equipotential Test

After installing the battery pack, measure the resistance between the ground bolt mating surface (A) and the high voltage harness connector flange (B).

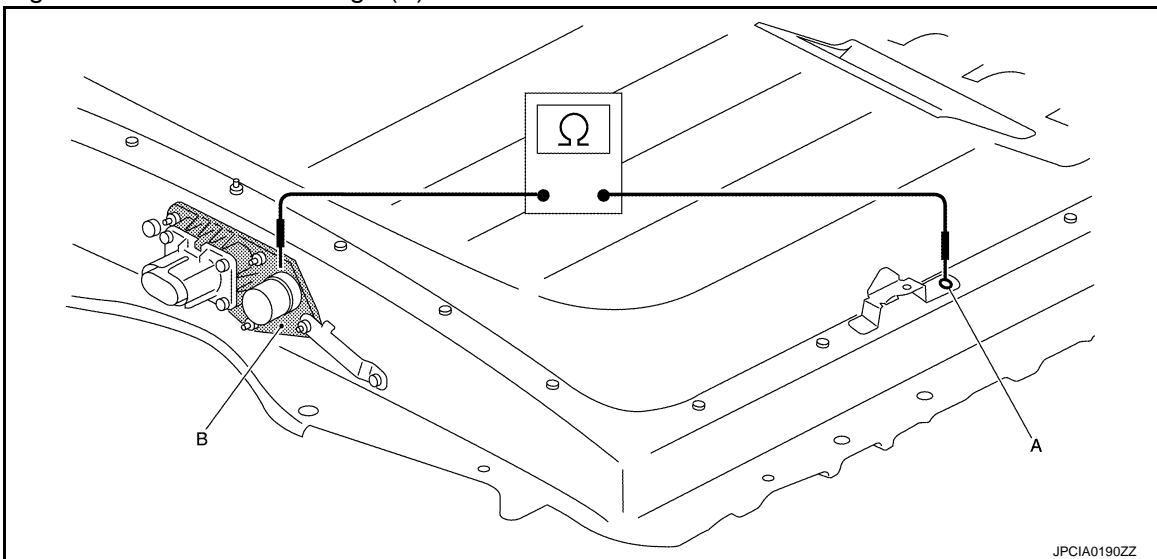

WARNING:



To prevent electric shock hazards, be sure to wear protective gear.



Standard : Less than 0.1 Ω

If the result deviates from the standard value, check the following items and repair malfunctioning parts

- Connection condition of ground bolts
- Rust on the mounting surface of ground bolts
- Paint, oil, and dust on the mounting surface of ground bolts

LI-ION BATTERY CONTROLLER

LI-ION BATTERY CONTROLLER : Disassembly and Assembly

INFOID:000000007341790

DANGER:



Because hybrid vehicles and electric vehicles contain a high voltage battery, there is the risk of electric shock, electric leakage, or similar accidents if the high voltage component and vehicle are handled incorrectly. Be sure to follow the correct work procedures when performing inspection and maintenance.

LI-ION BATTERY

< UNIT DISASSEMBLY AND ASSEMBLY >

[TYPE 2]

WARNING:

- Be sure to remove the service plug in order to disconnect the high voltage circuits before performing inspection or maintenance of high voltage system harnesses and parts.
- To prevent the removed service plug from being connected by mistake during the procedure, always carry it in your pocket or put it in the tool box.
- Be sure to wear insulating protective equipment consisting of glove, shoes, face shield and glasses before beginning work on the high voltage system.
- Refer to [EVb-229, "High Voltage Precautions"](#).
- To prevent electric shock hazards, ignition, and damage to parts, always remove Li-ion battery controller before disassembling battery pack.

CAUTION:

There is the possibility of a malfunction occurring if the vehicle is changed to READY status while the service plug is removed. Therefore do not change the vehicle to READY status unless instructed to do so in the Service Manual.

WORK ENVIRONMENT FOR DISASSEMBLY OF LI-ION BATTERY

1. Must be an indoor environment.
 - The work environment must be able to be isolated from the outside by shutters or other means to prevent the intrusion of rain, snow, sand, and other substances.
 - The environment must prevent the entry of sweat during work, and also prevent condensation from occurring as a result of high temperature and humidity.
2. No entry of foreign materials.
 - In addition to being indoors, the environment must not permit the entry during disassembly work of metal powders, oil, or foreign substances resulting from causes such as servicing of other vehicles.
 - If there is any risk of the above, use a plastic curtain or other means to block off the work area, or take other necessary steps.
3. The floor must be dry.
 - The floor must not become wet as a result of causes such as vehicles entering when it is raining or snowing.
4. Work space
 - Space approximately the size of one vehicle must be secured as the disassembly space.
 - A sign indicating that disassembly is in progress or other measures must be taken so that persons other than the workers do not enter the work space.
5. Standard fire fighting equipment
 - Always place a standard fire fighting equipment in the disassembly work area.
 - Depending on type of fire (vehicle or battery) use standard fire fighting equipment (water or extinguisher).

DISASSEMBLY

1. Clean any contamination and dust from the battery pack.
2. Remove service plug retainer (1).

WARNING:



To prevent electric shock hazards, be sure to wear protective gear.

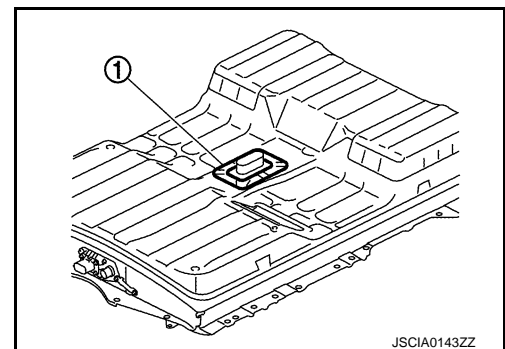

3. Remove mounting bolts (A), (B) and mounting nuts (C), then remove battery pack upper case.

LI-ION BATTERY

< UNIT DISASSEMBLY AND ASSEMBLY >

[TYPE 2]

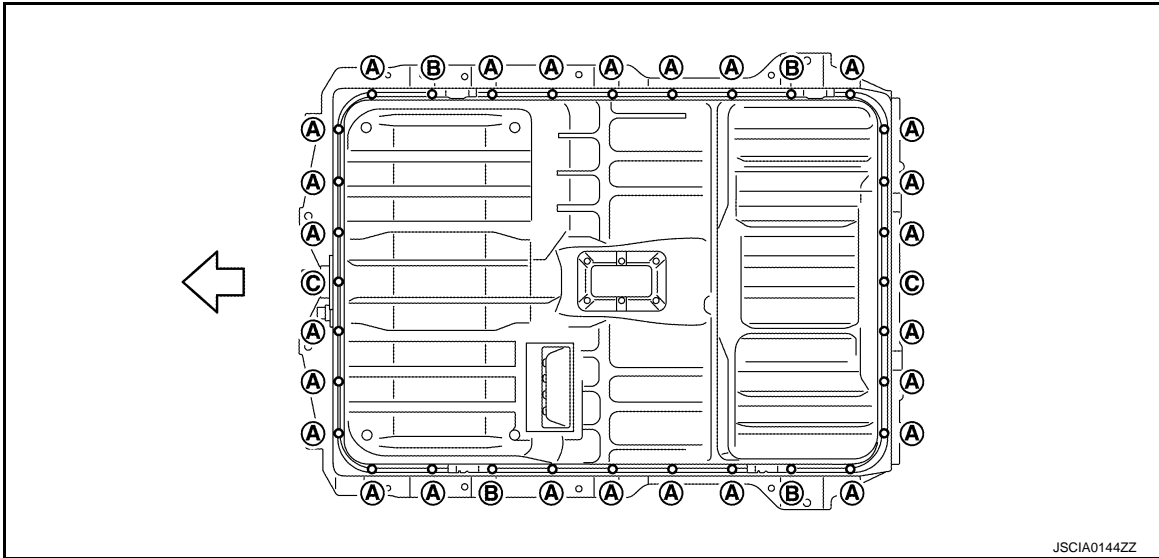

← : Vehicle front

WARNING:



To prevent electric shock hazards, be sure to wear protective gear.



4. Disconnect Li-ion battery controller harness connector (A).

WARNING:



To prevent electric shock hazards, be sure to wear protective gear.

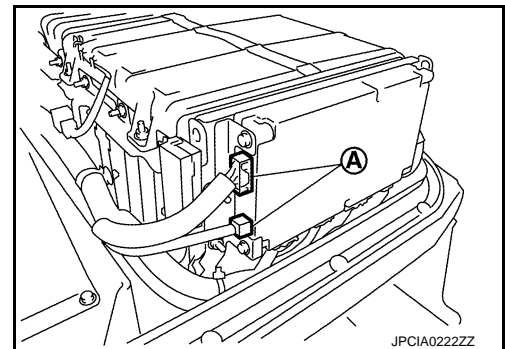

5. Remove Li-ion battery controller mounting bolts (A).

WARNING:



To prevent electric shock hazards, be sure to put on insulated protective gear and use insulated tools.

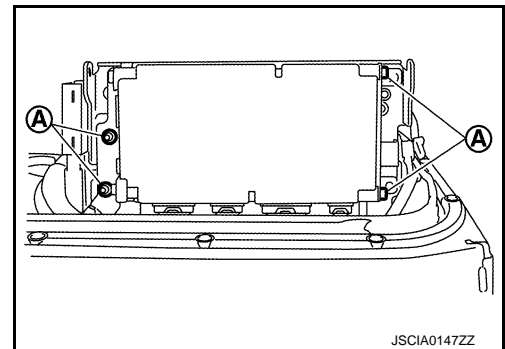

A
B
EVB
D
E
F
G
H
I
J
K
L
M
N
O
P

LI-ION BATTERY

[TYPE 2]

< UNIT DISASSEMBLY AND ASSEMBLY >

6. Remove harness connector (A) and harness clip, then remove Li-ion battery controller.

B : Low voltage harness connector

← : Vehicle front

WARNING:

-  To prevent electric shock hazards, be sure to wear protective gear.



-  To prevent electric shock hazards, immediately wrap insulating tape around disconnected high voltage harness connector and terminals.

NOTE:

Remove together with controller bracket.

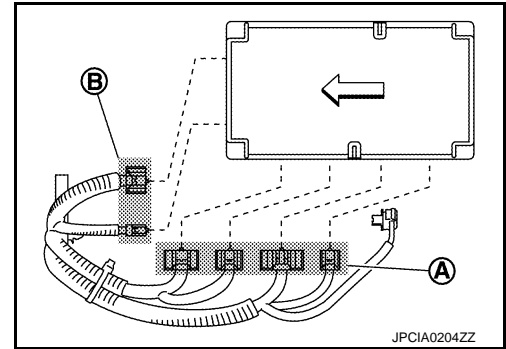

ASSEMBLY

Assemble in the reverse order of disassembly.

1. Install Li-ion battery controller.

WARNING:

-  To prevent electric shock hazards, be sure to put on insulated protective gear and use insulated tools.



- There are harness connector for high voltage (A) and low voltage (B) to a Li-ion battery controller. When the high voltage harness connector is inserted in the low voltage part, it causes smoking and the part damage. Be careful enough when install harness connector.

← : Vehicle front

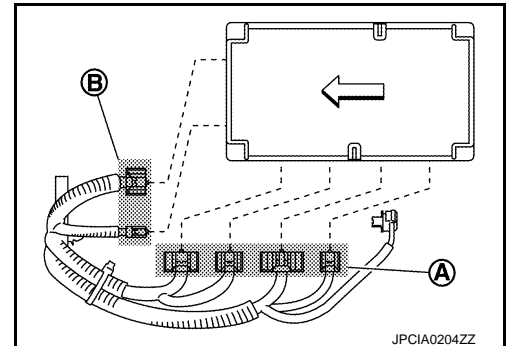

2. Follow the procedure below and install battery pack upper case.

CAUTION:

Check seal before install battery pack upper case. Refer to [EVB-424, "LI-ION BATTERY CONTROL-
LER : Inspection"](#).

- a. Tighten mounting nuts and bolts in the order from 1 to 28 as shown in the figure.

LI-ION BATTERY

< UNIT DISASSEMBLY AND ASSEMBLY >

[TYPE 2]

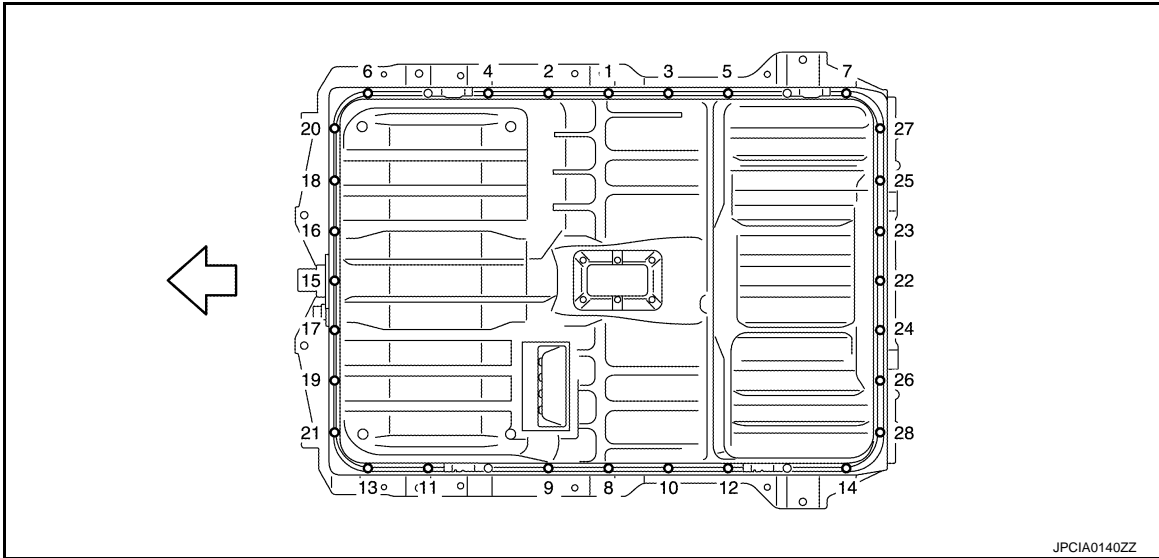

JPCIA0140ZZ

← : Vehicle front

WARNING:



To prevent electric shock hazards, be sure to wear protective gear.



b. Install ground bolt (A).

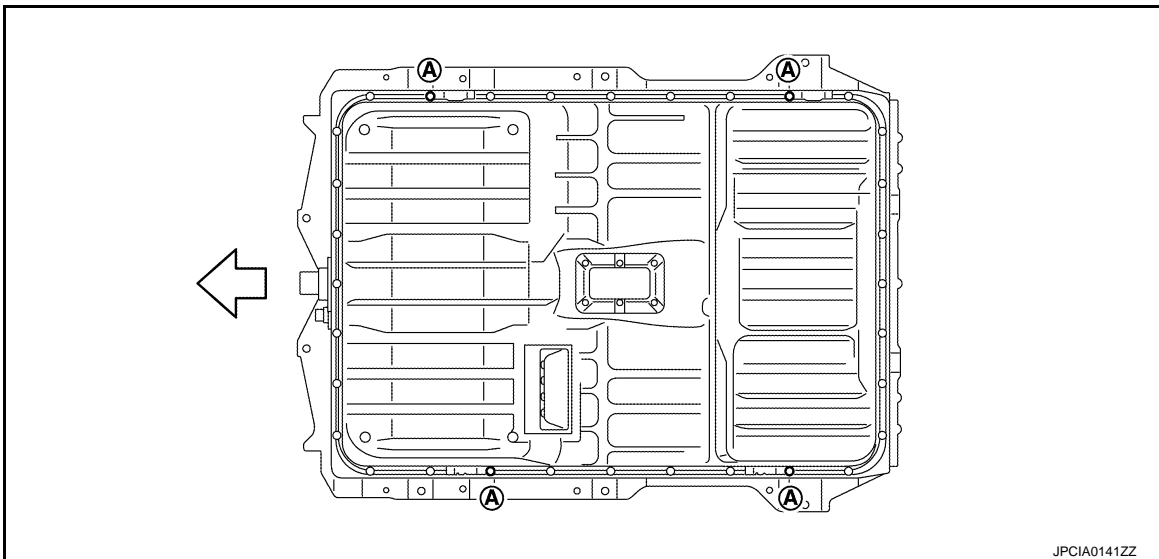

JPCIA0141ZZ

← : Vehicle front

WARNING:



To prevent electric shock hazards, be sure to wear protective gear.



A
B
EVB
D
E
F
G
H
I
J
K
L
M
N
O
P

LI-ION BATTERY

< UNIT DISASSEMBLY AND ASSEMBLY >

[TYPE 2]

3. Install service plug retainer (1).

WARNING:



To prevent electric shock hazards, be sure to wear protective gear.

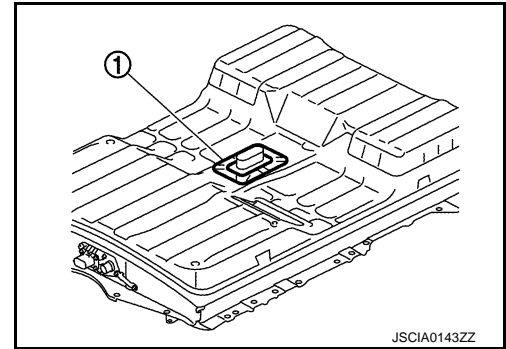

CAUTION:

- Perform the “ADDITIONAL SERVICE WHEN REPLACING LI-ION BATTERY CONTROLLER” when Li-ion battery controller is replaced. Refer to [EVB-289, "Work Procedure"](#).
- Check the following items after installing battery pack: Refer to [EVB-424, "LI-ION BATTERY CONTROLLER : Inspection"](#).

■AIR LEAK INSPECTION

■ELECTRIC EQUIPOTENTIAL TEST

LI-ION BATTERY CONTROLLER : Inspection

INFOID:000000007479185

BATTERY PACK SEAL INSPECTION

- Visually check all lips (A) of seal (1) for damage. (e.g. scratches and cracks)
- Replace seal if its lips are damaged.

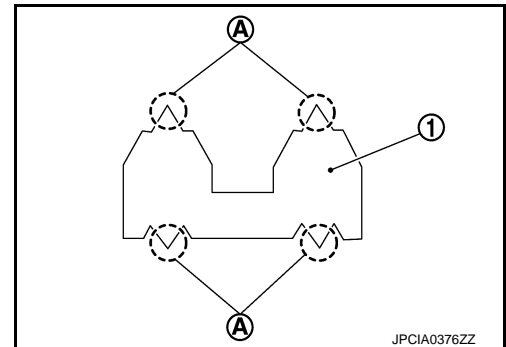

AIR LEAK INSPECTION

1. Remove drain plug and install adapter [SST: KV99111400] (A).

WARNING:



To prevent electric shock hazards, be sure to wear protective gear.

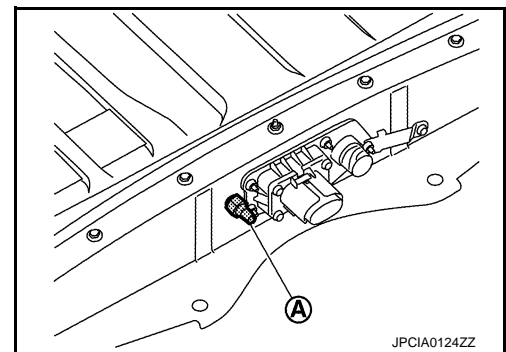

2. Install gauge [SST: KV99111400] (A).

WARNING:



To prevent electric shock hazards, be sure to wear protective gear.



CAUTION:

Handle the gauge carefully so that it will not drop.

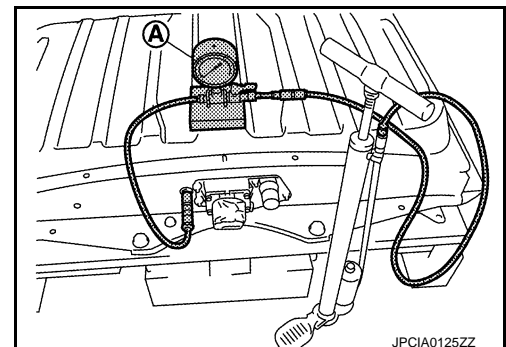

LI-ION BATTERY

< UNIT DISASSEMBLY AND ASSEMBLY >

[TYPE 2]

3. Install service plug to seal the battery pack.

DANGER:



To prevent electric shock hazards, be sure to wear protective gear.



4. Use vinyl tape (A) or similar means to seal the breather so that air does not enter it.

- Use the wide vinyl tape which can cover up breather at once.
- Stick it so that tape is not wrinkled.

WARNING:



To prevent electric shock hazards, be sure to wear protective gear.

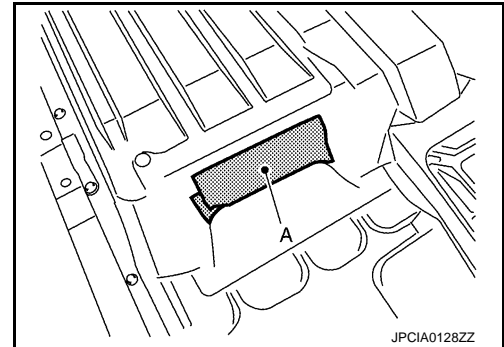

5. Perform air leak inspection by applying 1.6 kPa (0.0163 kg/cm², 0.23 psi) of pressure inside the battery pack for approximately 1 minute.

CAUTION:

- When applying pressure, operate the air pump slowly.
- Do not apply any pressure exceeding 2.0 kPa (0.0204 kg/cm², 0.29 psi).

Repair limit : 1.4 kPa (0.0143 kg/cm², 0.20 psi)

6. If the pressure drops below the limit value, use soapy water and check for leakage points.

WARNING:



To prevent electric shock hazards, be sure to wear protective gear.



CAUTION:

Never allow soapy water to contact the service plug and each connector terminals.

Electric Equipotential Test

After installing the battery pack, measure the resistance between the ground bolt mating surface (A) and the high voltage harness connector flange (B).

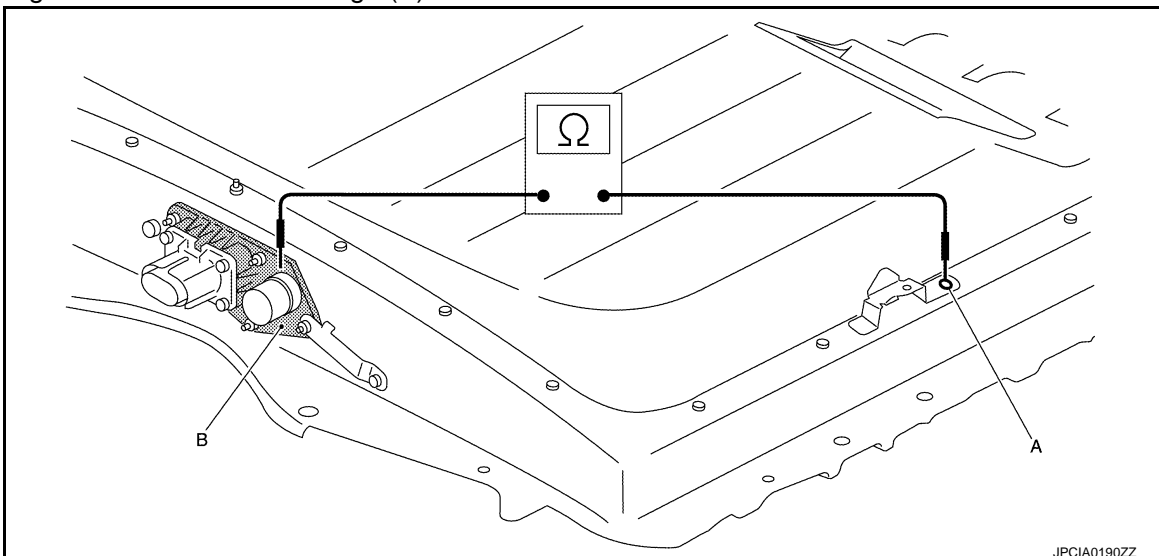

A

B

EVB

D

E

F

G

H

I

J

K

L

M

N

O

P

LI-ION BATTERY

< UNIT DISASSEMBLY AND ASSEMBLY >

[TYPE 2]

WARNING:



To prevent electric shock hazards, be sure to wear protective gear.



Standard : Less than 0.1 Ω

If the result deviates from the standard value, check the following items and repair malfunctioning parts

- Connection condition of ground bolts
- Rust on the mounting surface of ground bolts
- Paint, oil, and dust on the mounting surface of ground bolts

FRONT MODULE STACK

FRONT MODULE STACK : Disassembly and Assembly

INFOID:000000007341792

DANGER:



Because hybrid vehicles and electric vehicles contain a high voltage battery, there is the risk of electric shock, electric leakage, or similar accidents if the high voltage component and vehicle are handled incorrectly. Be sure to follow the correct work procedures when performing inspection and maintenance.

WARNING:

- Be sure to remove the service plug in order to disconnect the high voltage circuits before performing inspection or maintenance of high voltage system harnesses and parts.
- To prevent the removed service plug from being connected by mistake during the procedure, always carry it in your pocket or put it in the tool box.
- Be sure to wear insulating protective equipment consisting of glove, shoes, face shield and glasses before beginning work on the high voltage system.
- Refer to [EVB-229, "High Voltage Precautions"](#).
- To prevent electric shock hazards, ignition, and damage to parts, always remove Li-ion battery controller before disassembling battery pack.

CAUTION:

There is the possibility of a malfunction occurring if the vehicle is changed to READY status while the service plug is removed. Therefore do not change the vehicle to READY status unless instructed to do so in the Service Manual.

WORK ENVIRONMENT FOR DISASSEMBLY OF LI-ION BATTERY

1. Must be an indoor environment.
 - The work environment must be able to be isolated from the outside by shutters or other means to prevent the intrusion of rain, snow, sand, and other substances.
 - The environment must prevent the entry of sweat during work, and also prevent condensation from occurring as a result of high temperature and humidity.
2. No entry of foreign materials.
 - In addition to being indoors, the environment must not permit the entry during disassembly work of metal powders, oil, or foreign substances resulting from causes such as servicing of other vehicles.
 - If there is any risk of the above, use a plastic curtain or other means to block off the work area, or take other necessary steps.
3. The floor must be dry.
 - The floor must not become wet as a result of causes such as vehicles entering when it is raining or snowing.
4. Work space
 - Space approximately the size of one vehicle must be secured as the disassembly space.
 - A sign indicating that disassembly is in progress or other measures must be taken so that persons other than the workers do not enter the work space.
5. Standard fire fighting equipment
 - Always place a standard fire fighting equipment in the disassembly work area.
 - Depending on type of fire (vehicle or battery) use standard fire fighting equipment (water or extinguisher).

LI-ION BATTERY

< UNIT DISASSEMBLY AND ASSEMBLY >

[TYPE 2]

DISASSEMBLY

1. Remove battery pack upper case. Refer to [EVB-419, "LI-ION BATTERY CONTROLLER : Disassembly and Assembly"](#).
2. Remove Li-ion battery controller. Refer to [EVB-419, "LI-ION BATTERY CONTROLLER : Disassembly and Assembly"](#).
3. Remove battery junction box. Refer to [EVB-412, "BATTERY JUNCTION BOX : Disassembly and Assembly"](#).
4. Remove service plug switch and heater relay unit. Refer to [EVB-449, "HEATER RELAY UNIT : Disassembly and Assembly"](#).
5. Remove Li-ion battery heater (front). Refer to [EVB-456, "HEATER UNIT : Disassembly and Assembly"](#).
6. Remove bus bar (1) that connects left and right front module stacks.

⇐ : Vehicle front

DANGER:

-  To prevent electric shock hazards, be sure to put on insulated protective gear and use insulated tools.



-  To prevent electric shock hazards, immediately wrap insulating tape around disconnected high voltage harness connector and terminals.

7. Remove battery temperature sensor (1) from module (2).

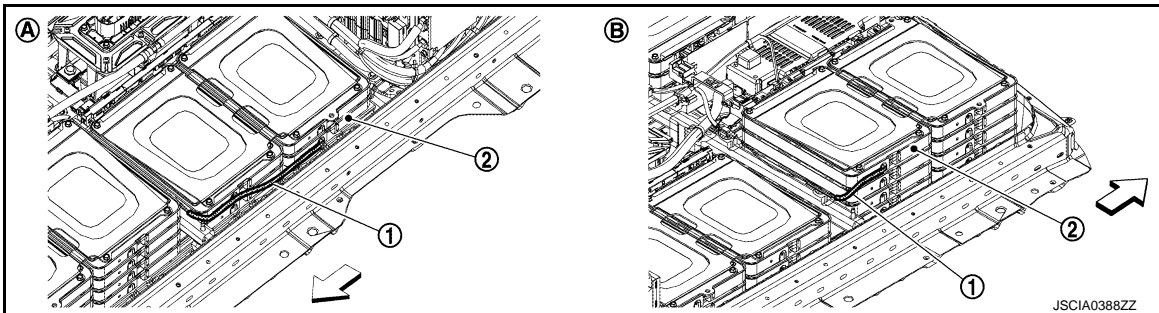
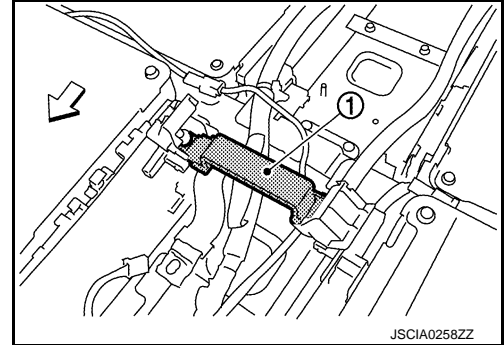

A. Front module stack LH

B. Front module stack RH

⇐ : Vehicle front

WARNING:

-  To prevent electric shock hazards, be sure to put on insulated protective gear and use insulated tools.



LI-ION BATTERY

< UNIT DISASSEMBLY AND ASSEMBLY >

[TYPE 2]

9. Remove vehicle communication harness connector.

- A. Front module stack LH side
- B. Front module stack RH side
- ← : Vehicle front

WARNING:

-  To prevent electric shock hazards, be sure to put on insulated protective gear and use insulated tools.



-  To prevent electric shock hazards, immediately wrap insulating tape around disconnected high voltage harness connector and terminals.

10. Remove front module stack mounting bolts (A).

- 1. Front module stack LH
- 2. Front module stack RH

WARNING:

-  To prevent electric shock hazards, be sure to put on insulated protective gear and use insulated tools.

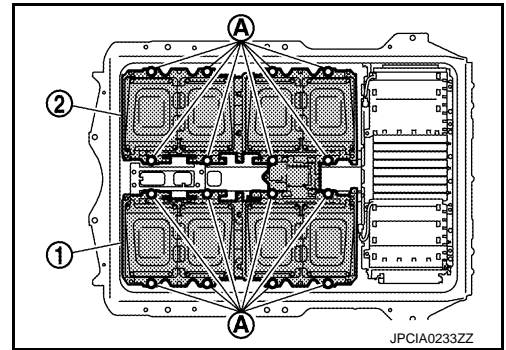
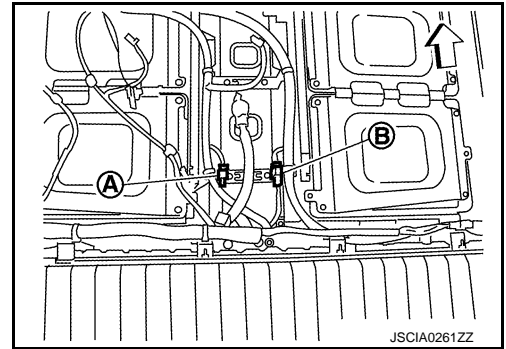

11. Follow the procedure below and remove front module stack from battery pack.

a. Attach a carabiner to the position (A) in the figure and connect a slinger belt to it.

WARNING:

-  To prevent electric shock hazards, be sure to wear protective gear.

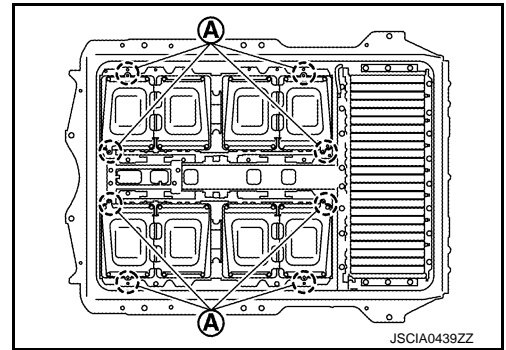

b. Use mobile floor crane (A) to lift up front module stack (1).

WARNING:

-  To prevent electric shock hazards, be sure to wear protective gear.



-  Be sure to place an insulating rubber sheet on the work bench.

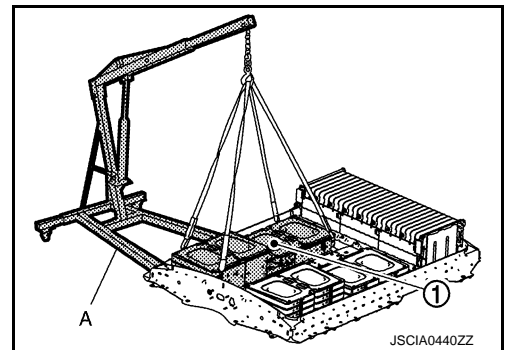

c. Move the battery pack and place work bench underneath front module stack.

WARNING:

-  To prevent electric shock hazards, be sure to wear protective gear.

LI-ION BATTERY

< UNIT DISASSEMBLY AND ASSEMBLY >

[TYPE 2]



CAUTION:

Place removed battery pack upper case onto battery pack for storage.

d. Place front module stack (1) onto work bench.

WARNING:

-  To prevent electric shock hazards, be sure to wear protective gear.



-  Be sure to place an insulating rubber sheet on the work bench.

NOTE:

Figure indicates front module stack RH.

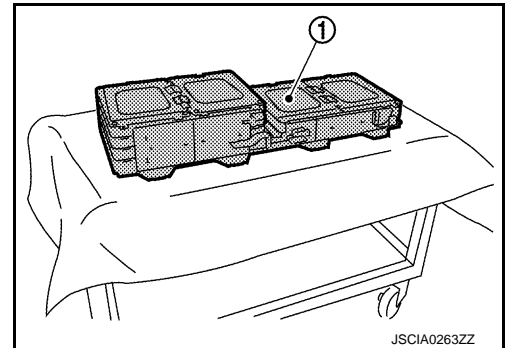

12. Follow the procedure below and remove bus bar from front module stack.

a. Remove bus bar (1).

DANGER:

-  To prevent electric shock hazards, be sure to put on insulated protective gear and use insulated tools.



-  To prevent electric shock hazards, immediately wrap insulating tape around disconnected high voltage harness connector (high voltage terminal) and terminals.

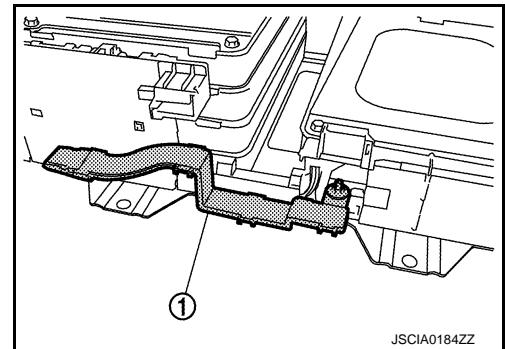

b. Remove bus bar cover and remove module terminal mounting bolts (A).

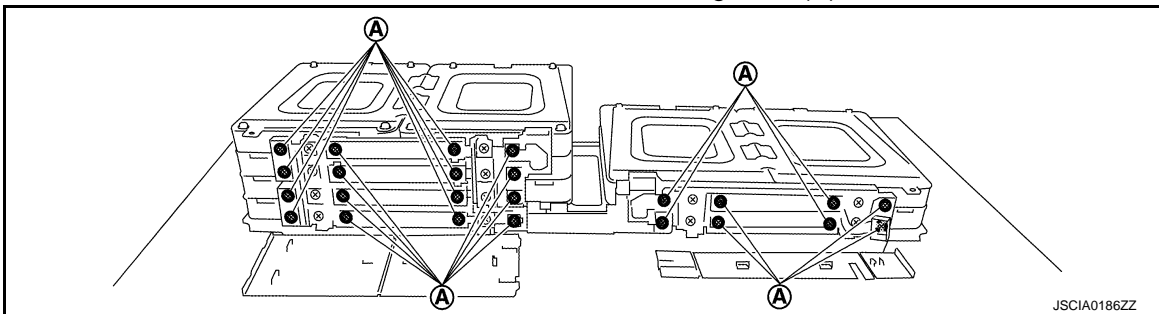

DANGER:

-  To prevent electric shock hazards, be sure to put on insulated protective gear and use insulated tools.



-  Work alone. Failure to do this may cause shock hazards.

A
B
EVB
D
E
F
G
H
I
J
K
L
M
N
O
P

LI-ION BATTERY

< UNIT DISASSEMBLY AND ASSEMBLY >

[TYPE 2]

c. Remove voltage detection terminal mounting screws (A) and remove bus bar (1) from front module stack.

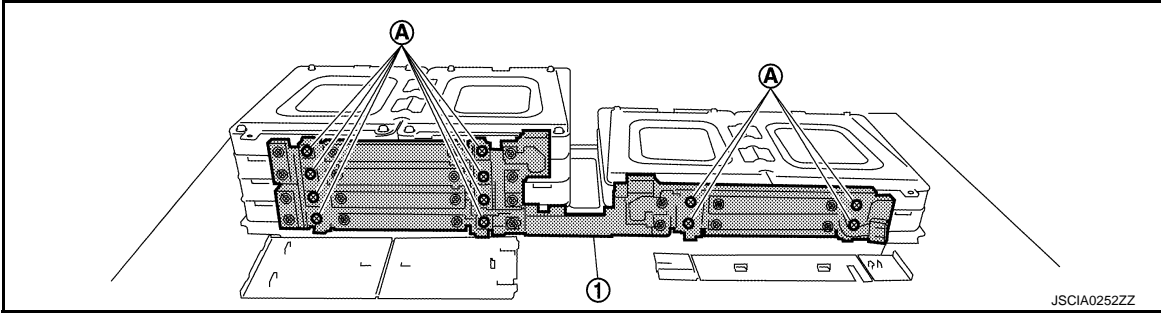

DANGER:

-  To prevent electric shock hazards, be sure to put on insulated protective gear and use insulated tools.



-  Work alone. Failure to do this may cause shock hazards.

d. Attach module terminal covers [SST: KV99111500] (A) to all module terminals.

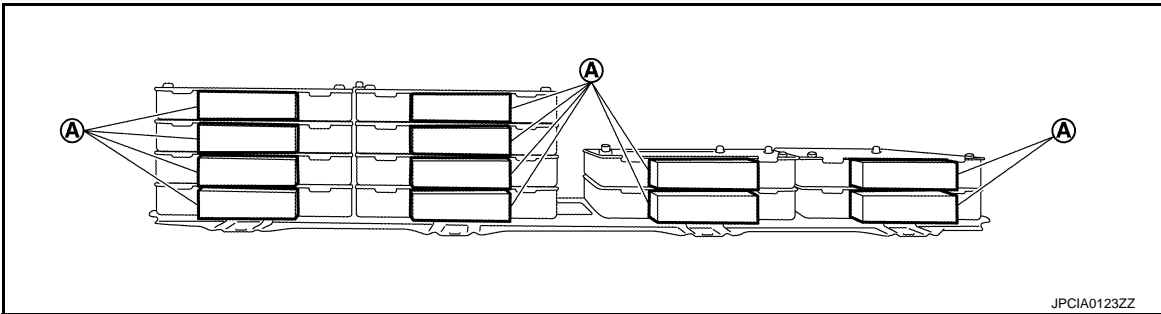

WARNING:

-  To prevent electric shock hazards, be sure to wear protective gear.



13. Remove end plate and disassembly front module stack.

WARNING:

-  To prevent electric shock hazards, be sure to put on insulated protective gear and use insulated tools.



ASSEMBLY

Note the following, assemble in the reverse order of disassembly.

DANGER:

-  There is the danger of electric shock caused by contact with the terminals. Be sure to wear insulated protective gear and use insulated tools.



-  Because there is a danger of electric shock and fire, never allow bus bar to contact a wrong terminal.

LI-ION BATTERY

< UNIT DISASSEMBLY AND ASSEMBLY >

[TYPE 2]

- If bus bar contacts a wrong terminal, the circuit becomes energized and a short may occur.
- Always keep the bus bar cover closed until immediately before the installation of bus bar.
- Since the correct installation position for the bus bar connected to both front module stacks is commonly-confused with the wrong position (B), install the bus bar to the correct position (A) with extreme caution.

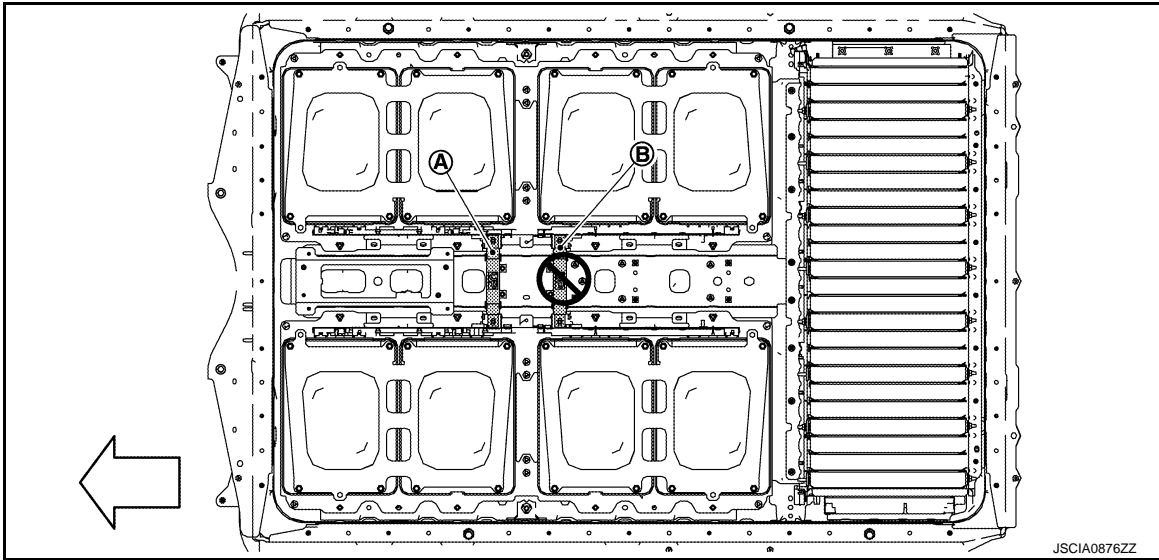

A. Correct position

B. Wrong position

← : Battery front

WARNING:

Install Li-ion battery controller immediately before installing battery pack upper case.

CAUTION:

- Perform the "MODULE CHARGE BALANCE" when module is replaced. Refer to [EVB-290, "Work Procedure"](#).
- Check seal before install battery pack upper case. Refer to [EVB-433, "FRONT MODULE STACK : Inspection"](#).

EV Battery Traceability Seal

When replacing the module with a new one, perform the following procedure.

1. Enter the date of replacement on the EV battery traceability seal packaged with the new part.
2. Cut the EV battery traceability seal in two and affix each seal to the old module and "Li-ion BATTERY REPLACEMENT RECORD".
3. Fill in the "Li-ion BATTERY REPLACEMENT RECORD".

Front Module Stack

- Check that terminal of front module stack is arranged as shown in the figure.

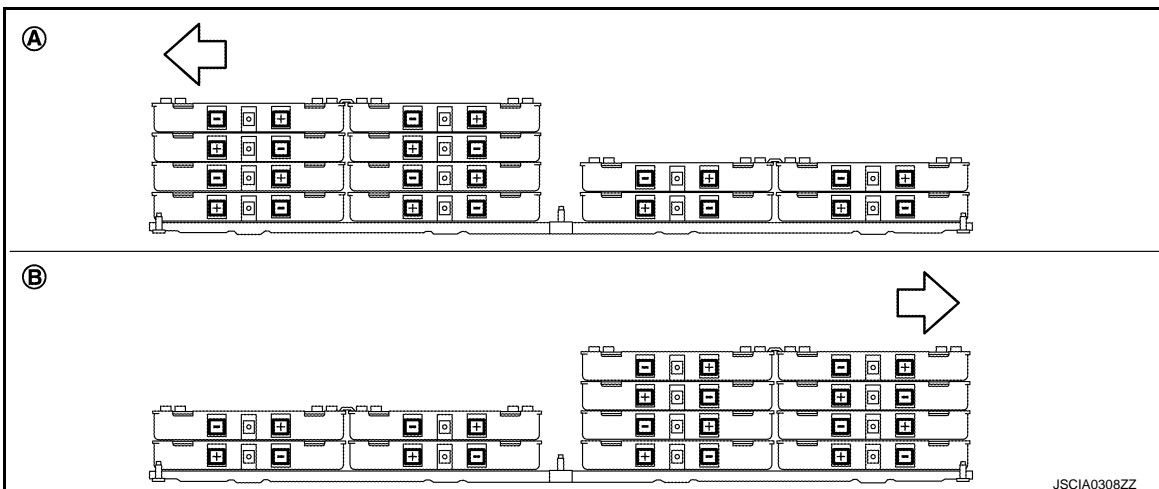

LI-ION BATTERY

< UNIT DISASSEMBLY AND ASSEMBLY >

[TYPE 2]

A. Front module stack RH B. Front module stack LH

↔ : Vehicle front

- Tighten mounting bolts in numerical order as shown in the figure.

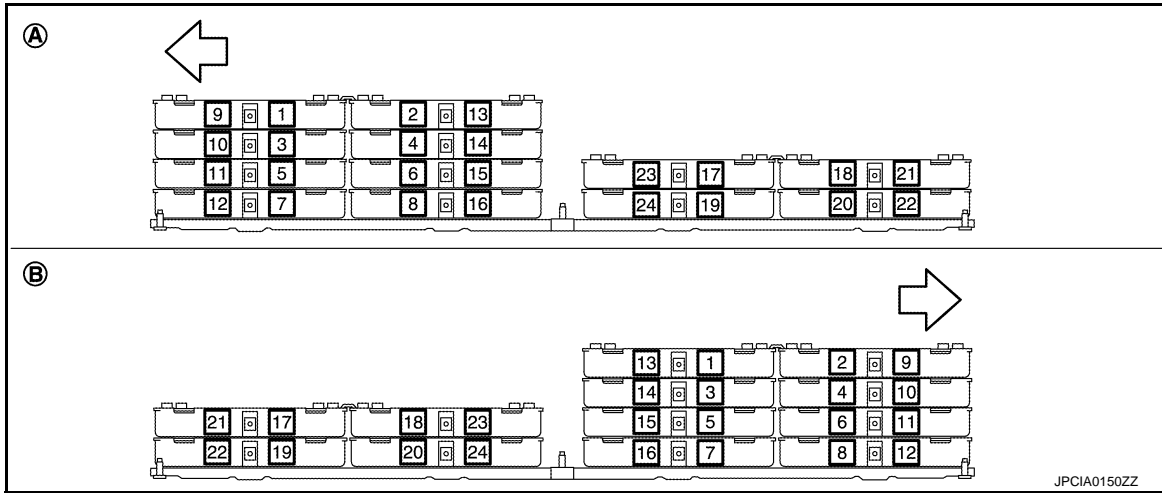

A. Front module stack RH B. Front module stack LH

↔ : Vehicle front

DANGER:

- To prevent electric shock hazards, be sure to put on insulated protective gear and use insulated tools.



- **Work alone. Failure to do this may cause shock hazards.**
- Install end plate so that its carabiner mounting hole (A) is positioned as shown in the figure.

1. Front module stack RH

NOTE:

There are two kinds of end plates of which carabiner mounting hole location is different each other. The installation of improper end plate results in the carabiner mounting hole being placed inside. Accordingly, the front stack module cannot be lifted.

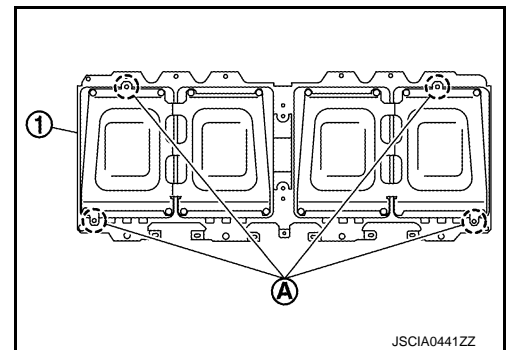

Battery Temperature Sensor

- Install battery temperature sensor (front) as shown in the figure.

LI-ION BATTERY

< UNIT DISASSEMBLY AND ASSEMBLY >

[TYPE 2]

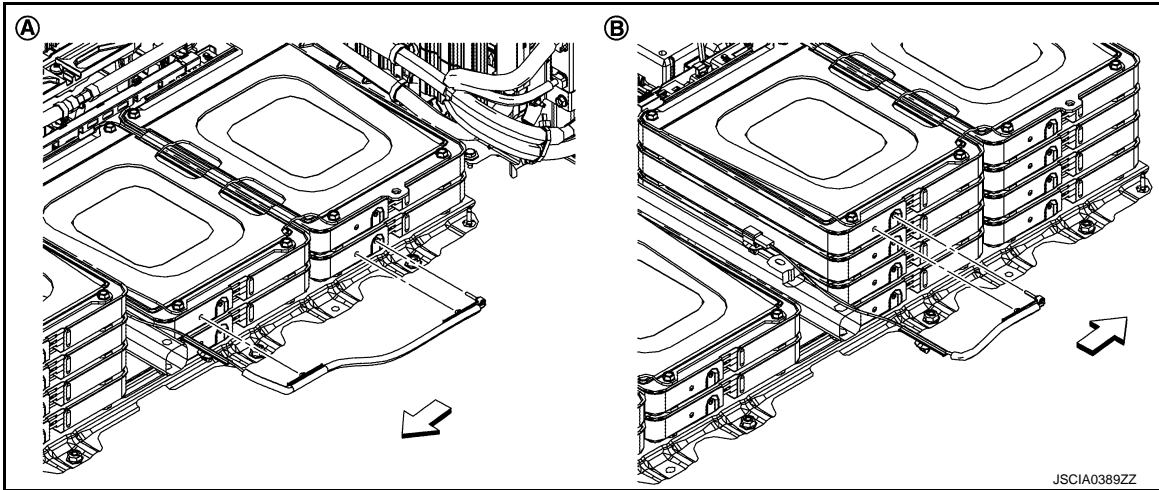

A. Front module stack LH

B. Front module stack RH

↶ : Vehicle front

- Insert a sensor (A) into module and fix with clip (B).

NOTE:

Do not fix with grommet (C).

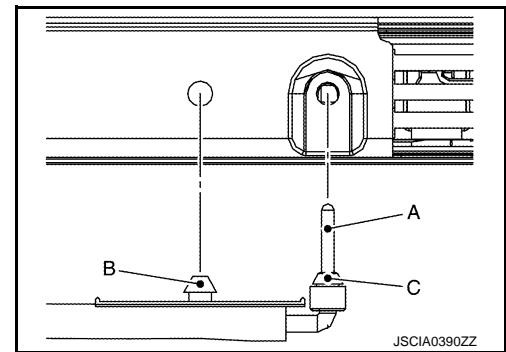

CAUTION:

- Check the following items after installing battery pack: Refer to [EVB-433, "FRONT MODULE STACK : Inspection"](#).

■AIR LEAK INSPECTION

■ELECTRIC EQUIPOTENTIAL TEST

FRONT MODULE STACK : Inspection

INFOID:000000007479186

BATTERY PACK SEAL INSPECTION

- Visually check all lips (A) of seal (1) for damage. (e.g. scratches and cracks)
- Replace seal if its lips are damaged.

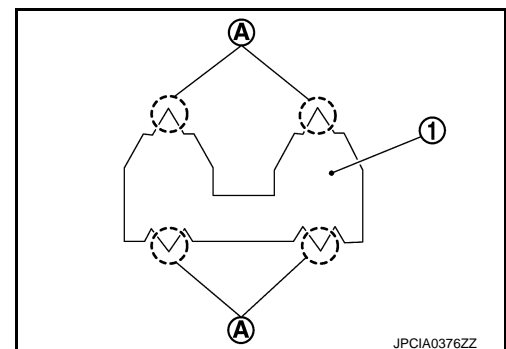

AIR LEAK INSPECTION

LI-ION BATTERY

< UNIT DISASSEMBLY AND ASSEMBLY >

[TYPE 2]

1. Remove drain plug and install adapter [SST: KV99111400] (A).

WARNING:

 To prevent electric shock hazards, be sure to wear protective gear.

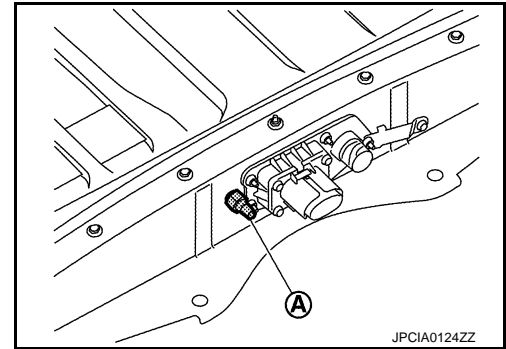

2. Install gauge [SST: KV99111400] (A).

WARNING:

 To prevent electric shock hazards, be sure to wear protective gear.



CAUTION:

Handle the gauge carefully so that it will not drop.

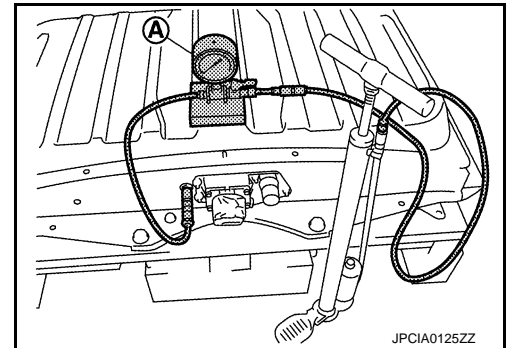

3. Install service plug to seal the battery pack.

DANGER:

 To prevent electric shock hazards, be sure to wear protective gear.



4. Use vinyl tape (A) or similar means to seal the breather so that air does not enter it.

- Use the wide vinyl tape which can cover up breather at once.
- Stick it so that tape is not wrinkled.

WARNING:

 To prevent electric shock hazards, be sure to wear protective gear.

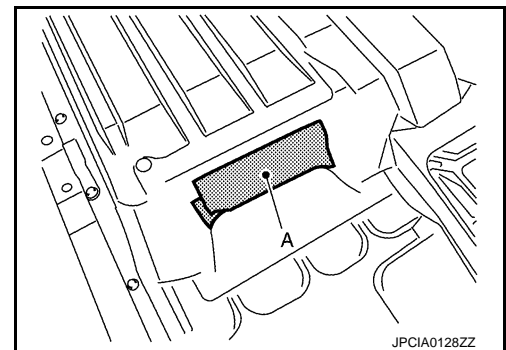

5. Perform air leak inspection by applying 1.6 kPa (0.0163 kg/cm², 0.23 psi) of pressure inside the battery pack for approximately 1 minute.

CAUTION:

- When applying pressure, operate the air pump slowly.
- Do not apply any pressure exceeding 2.0 kPa (0.0204 kg/cm², 0.29 psi).

Repair limit : 1.4 kPa (0.0143 kg/cm², 0.20 psi)

6. If the pressure drops below the limit value, use soapy water and check for leakage points.

WARNING:

 To prevent electric shock hazards, be sure to wear protective gear.



LI-ION BATTERY

< UNIT DISASSEMBLY AND ASSEMBLY >

[TYPE 2]

CAUTION:

Never allow soapy water to contact the service plug and each connector terminals.

Electric Equipotential Test

After installing the battery pack, measure the resistance between the ground bolt mating surface (A) and the high voltage harness connector flange (B).

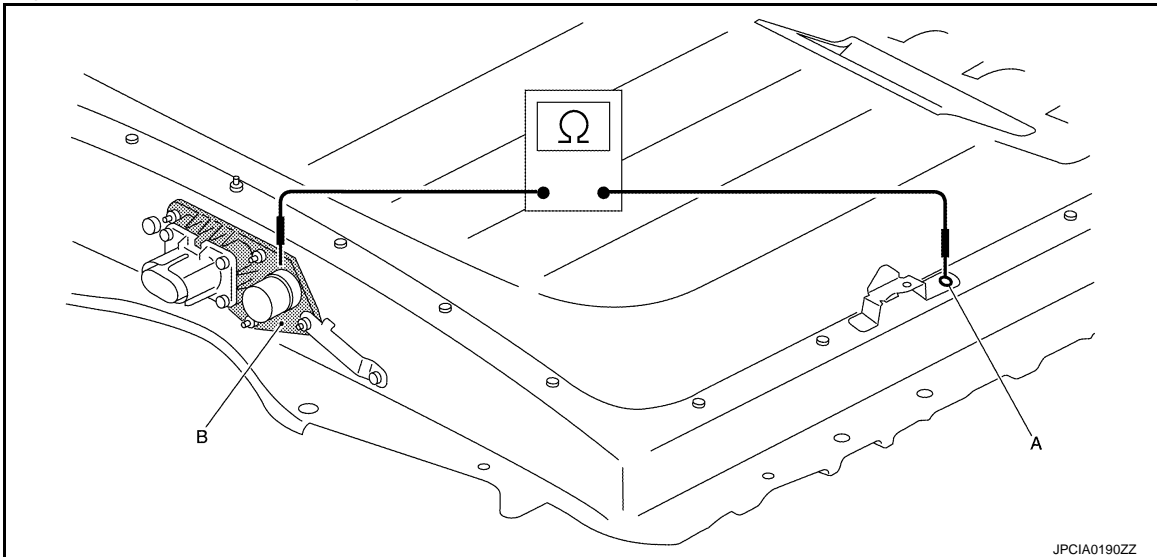

WARNING:



To prevent electric shock hazards, be sure to wear protective gear.



Standard : Less than 0.1 Ω

If the result deviates from the standard value, check the following items and repair malfunctioning parts

- Connection condition of ground bolts
- Rust on the mounting surface of ground bolts
- Paint, oil, and dust on the mounting surface of ground bolts

REAR MODULE STACK

REAR MODULE STACK : Disassembly and Assembly

INFOID:000000007341794

DANGER:



Because hybrid vehicles and electric vehicles contain a high voltage battery, there is the risk of electric shock, electric leakage, or similar accidents if the high voltage component and vehicle are handled incorrectly. Be sure to follow the correct work procedures when performing inspection and maintenance.

WARNING:

- Be sure to remove the service plug in order to disconnect the high voltage circuits before performing inspection or maintenance of high voltage system harnesses and parts.
- To prevent the removed service plug from being connected by mistake during the procedure, always carry it in your pocket or put it in the tool box.
- Be sure to wear insulating protective equipment consisting of glove, shoes, face shield and glasses before beginning work on the high voltage system.
- Refer to [EVB-229, "High Voltage Precautions"](#).
- To prevent electric shock hazards, ignition, and damage to parts, always remove Li-ion battery controller before disassembling battery pack.

CAUTION:

LI-ION BATTERY

< UNIT DISASSEMBLY AND ASSEMBLY >

[TYPE 2]

There is the possibility of a malfunction occurring if the vehicle is changed to READY status while the service plug is removed. Therefore do not change the vehicle to READY status unless instructed to do so in the Service Manual.

WORK ENVIRONMENT FOR DISASSEMBLY OF LI-ION BATTERY

1. Must be an indoor environment.
 - The work environment must be able to be isolated from the outside by shutters or other means to prevent the intrusion of rain, snow, sand, and other substances.
 - The environment must prevent the entry of sweat during work, and also prevent condensation from occurring as a result of high temperature and humidity.
2. No entry of foreign materials.
 - In addition to being indoors, the environment must not permit the entry during disassembly work of metal powders, oil, or foreign substances resulting from causes such as servicing of other vehicles.
 - If there is any risk of the above, use a plastic curtain or other means to block off the work area, or take other necessary steps.
3. The floor must be dry.
 - The floor must not become wet as a result of causes such as vehicles entering when it is raining or snowing.
4. Work space
 - Space approximately the size of one vehicle must be secured as the disassembly space.
 - A sign indicating that disassembly is in progress or other measures must be taken so that persons other than the workers do not enter the work space.
5. Standard fire fighting equipment
 - Always place a standard fire fighting equipment in the disassembly work area.
 - Depending on type of fire (vehicle or battery) use standard fire fighting equipment (water or extinguisher).

DISASSEMBLY

1. Remove battery pack upper case. Refer to [EVB-419. "LI-ION BATTERY CONTROLLER : Disassembly and Assembly"](#).
2. Remove Li-ion battery controller. Refer to [EVB-419. "LI-ION BATTERY CONTROLLER : Disassembly and Assembly"](#).
3. Remove Li-ion battery heater (rear). Refer to [EVB-456. "HEATER UNIT : Disassembly and Assembly"](#).
4. Remove vehicle communication harness connector (A) on rear module stack.

WARNING:

-  To prevent electric shock hazards, be sure to put on insulated protective gear and use insulated tools.



-  To prevent electric shock hazards, immediately wrap insulating tape around disconnected high voltage harness connector (high voltage terminal) and terminals.

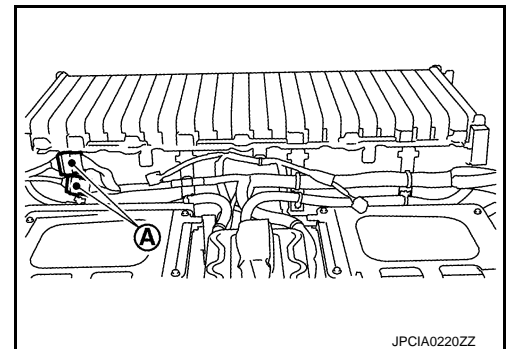

6. Disconnect battery temperature sensor harness connector (A) from bracket.

WARNING:

-  To prevent electric shock hazards, be sure to put on insulated protective gear and use insulated tools.

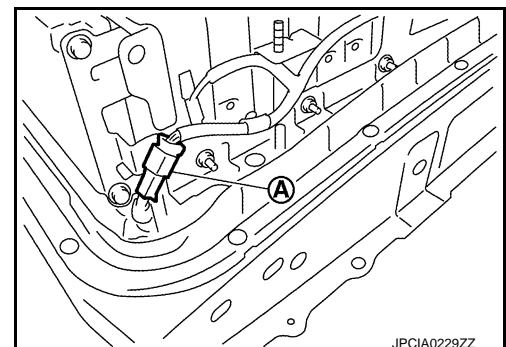

LI-ION BATTERY

< UNIT DISASSEMBLY AND ASSEMBLY >

[TYPE 2]

7. Remove harness clip (A) from harness bracket and move harness (1) to the position without the hindrance for work.

WARNING:

 To prevent electric shock hazards, be sure to put on insulated protective gear and use insulated tools.

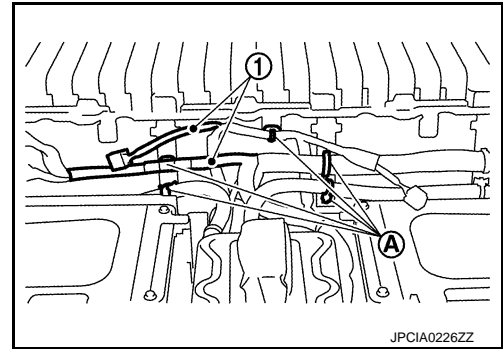

8. Remove mounting nuts (A) and remove high voltage harness from rear module stack.

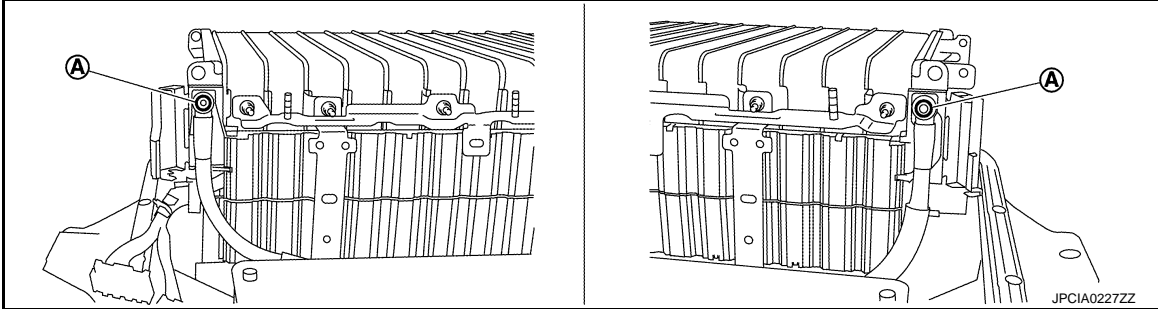

DANGER:

-  To prevent electric shock hazards, be sure to put on insulated protective gear and use insulated tools.



-  To prevent electric shock hazards, immediately wrap insulating tape around disconnected high voltage connector (high voltage terminal) and terminals.

9. Remove rear module stack (1) mounting bolts (A).

WARNING:

 To prevent electric shock hazards, be sure to put on insulated protective gear and use insulated tools.

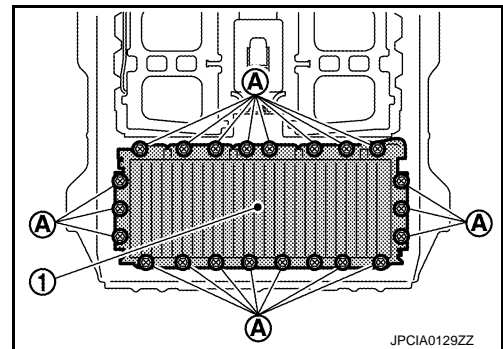

10. Follow the procedure below and remove rear module stack from battery pack.

- a. Attach a carabiner to the position (A) in the figure and connect a lashing belt to it.

WARNING:

 To prevent electric shock hazards, be sure to wear protective gear.

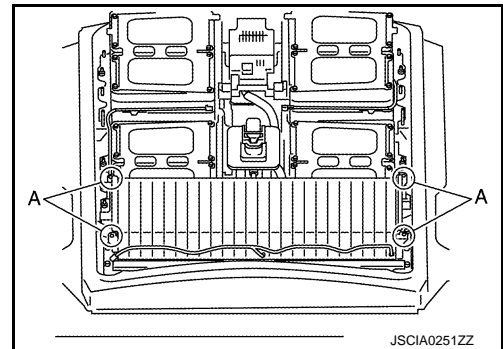

A
B
EVB
D
E
F
G
H
I
J
K
L
M
N
O
P

LI-ION BATTERY

< UNIT DISASSEMBLY AND ASSEMBLY >

[TYPE 2]

- b. Use mobile floor crane (A) to lift up rear module stack (1).

WARNING:



To prevent electric shock hazards, be sure to wear protective gear.



CAUTION:

Do not move mobile floor crane while rear module stack is hoisted up.

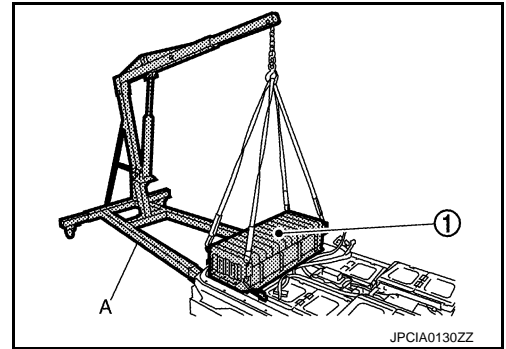

- c. Move the battery pack and place work bench underneath rear module stack.

WARNING:



To prevent electric shock hazards, be sure to wear protective gear.



CAUTION:

Place removed battery pack upper case onto battery pack for storage.

- d. Place rear module stack onto work bench.

WARNING:



To prevent electric shock hazards, be sure to wear protective gear.



Be sure to place an insulating rubber sheet on the work bench.

11. Remove heater harness bracket (1) from rear module stack.

WARNING:



To prevent electric shock hazards, be sure to put on insulated protective gear and use insulated tools.

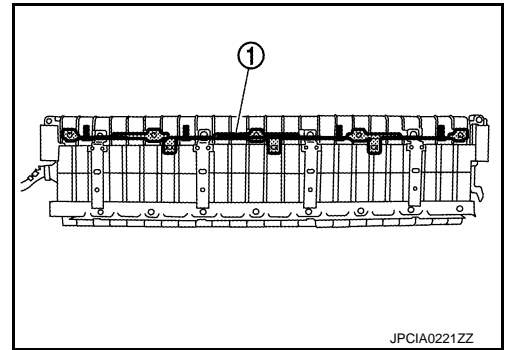

12. Remove harness bracket (1) from rear module stack.

WARNING:



To prevent electric shock hazards, be sure to put on insulated protective gear and use insulated tools.

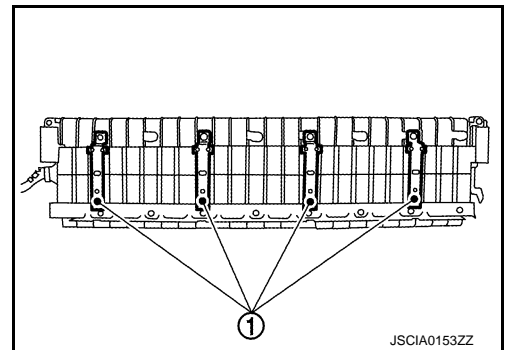

13. Follow the procedure below and remove bus bars from rear module stack.

LI-ION BATTERY

[TYPE 2]

< UNIT DISASSEMBLY AND ASSEMBLY >

- a. Remove central bus bar cover and remove module terminal mounting bolts (A).

DANGER:

- ⚡ To prevent electric shock hazards, be sure to put on insulated protective gear and use insulated tools.



- ⚡ Work alone. Failure to do this may cause shock hazards.

CAUTION:

Remove all bus bar covers at the same time, and do not remove module terminal mounting bolts.

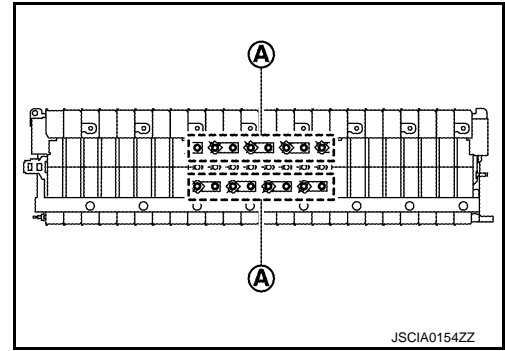

- b. Remove right-side bus bar cover and remove module terminal mounting bolts (A).

DANGER:

- ⚡ To prevent electric shock hazards, be sure to put on insulated protective gear and use insulated tools.



- ⚡ Work alone. Failure to do this may cause shock hazards.

WARNING:

This work must not be performed by more than 1 person.

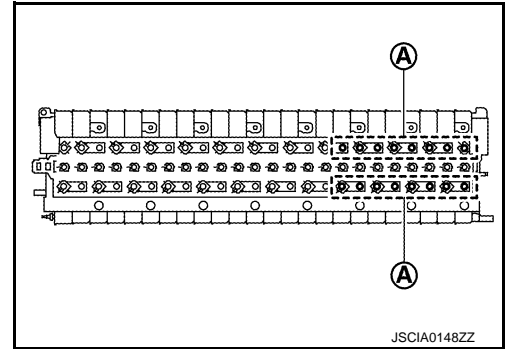

- c. Remove left-side bus bar cover and remove module terminal mounting bolts (A).

DANGER:

- ⚡ To prevent electric shock hazards, be sure to put on insulated protective gear and use insulated tools.



- ⚡ Work alone. Failure to do this may cause shock hazards.

WARNING:

This work must not be performed by more than 1 person.

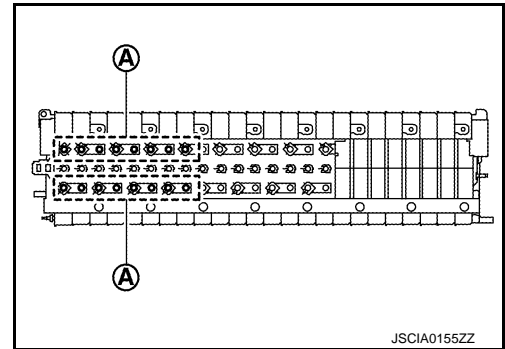

- d. Remove voltage detection terminal mounting screws (A), and then remove bus bar from rear module stack.

DANGER:

- ⚡ To prevent electric shock hazards, be sure to put on insulated protective gear and use insulated tools.



- ⚡ Work alone. Failure to do this may cause shock hazards.

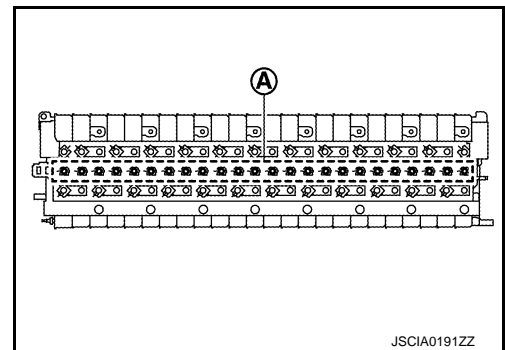

A
B
EVB
D
E
F
G
H
I
J
K
L
M
N
O
P

LI-ION BATTERY

< UNIT DISASSEMBLY AND ASSEMBLY >

[TYPE 2]

- e. Attach module terminal covers [SST: KV99111500] (A) to all module terminals.

WARNING:



To prevent electric shock hazards, be sure to wear protective gear.

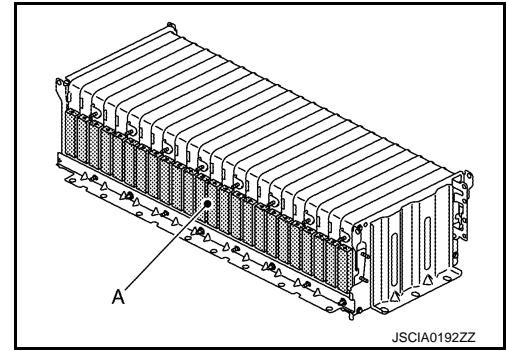

14. Remove battery temperature sensor (1) from rear module stack.

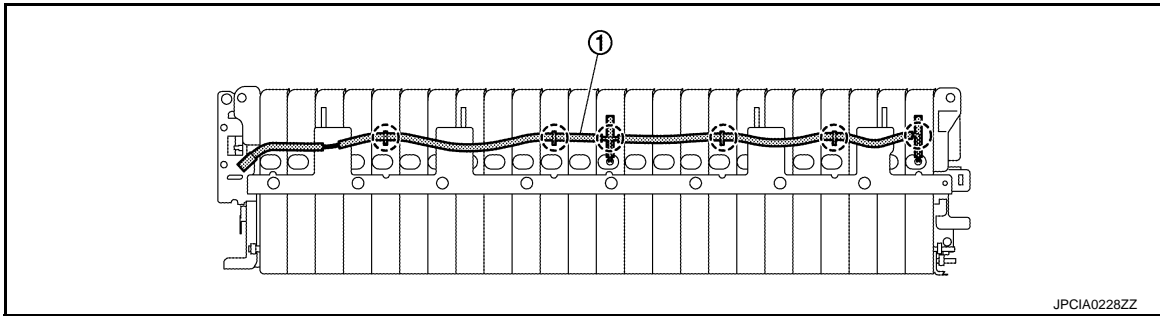

: Clip

WARNING:



To prevent electric shock hazards, be sure to put on insulated protective gear and use insulated tools.



15. Remove front stack member (1).

WARNING:



To prevent electric shock hazards, be sure to put on insulated protective gear and use insulated tools.

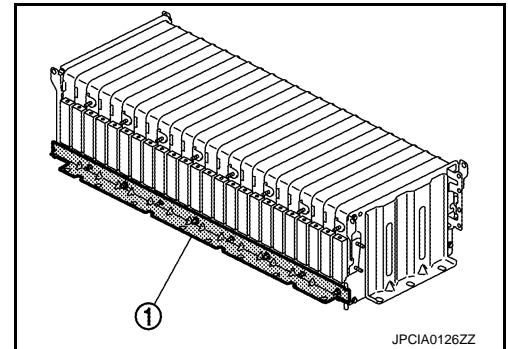

16. Remove rear stack member (1).

WARNING:



To prevent electric shock hazards, be sure to put on insulated protective gear and use insulated tools.

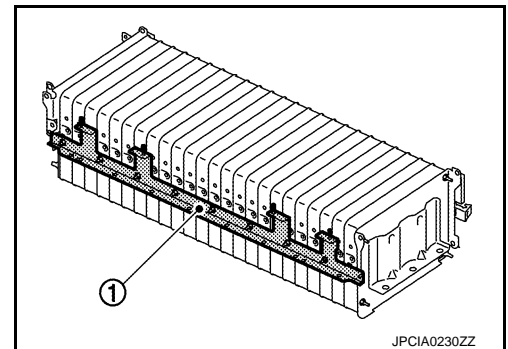

LI-ION BATTERY

< UNIT DISASSEMBLY AND ASSEMBLY >

[TYPE 2]

17. Use lashing belt (A) to fix rear module stack (1) in place.

WARNING:



To prevent electric shock hazards, be sure to wear protective gear.

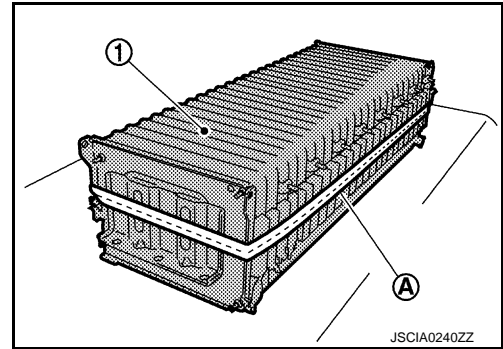

18. Remove through bolt mounting nut (A) (removal side, unfixed) and disassemble rear module stack (1), refer to following.

WARNING:



To prevent electric shock hazards, be sure to put on insulated protective gear and use insulated tools.

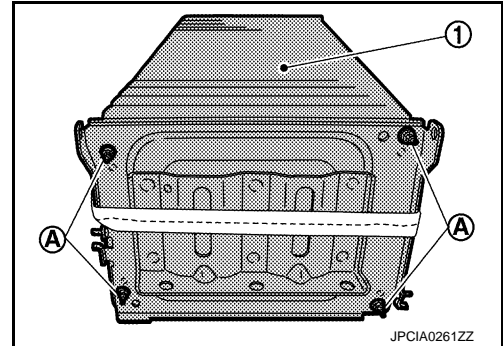

CAUTION:

• Never remove self-locking nut (fixed).

- A : Self-locking nut (fixed)
- B : Mounting nut (removal side, unfixed)

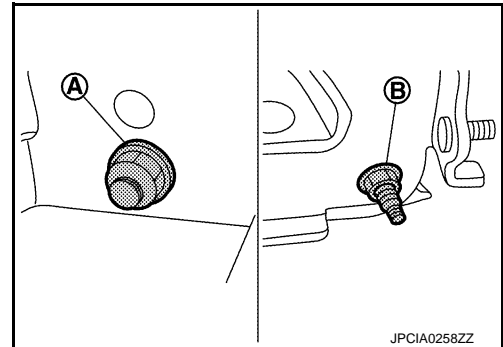

• Fix the tip of through bolt on the removal side to remove mounting nut.

NOTE:

When through bolt is removed, the spacer between the modules will fall out and it will be difficult to return it to its original position. Therefore pull the through bolt out only to the position necessary for the module that will be removed.

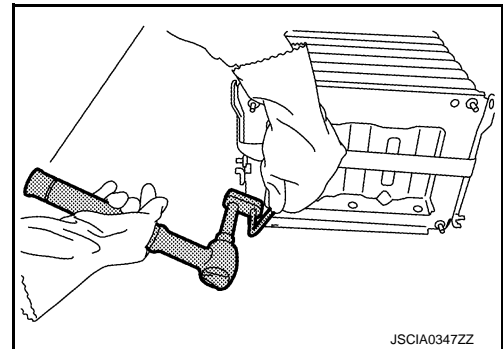

ASSEMBLY

CAUTION:

• Perform the "MODULE CHARGE BALANCE" when module is replaced. Refer to [EVb-290, "Work Procedure"](#).

1. When replacing the module with a new one, perform the following procedure.
 - a. Enter the date of replacement on the EV battery traceability seal packaged with the new part.
 - b. Cut the EV battery traceability seal in two and affix each seal to the old module and "Li-ion BATTERY REPLACEMENT RECORD".
 - c. Fill in the "Li-ion BATTERY REPLACEMENT RECORD".

A
B
EVB
D
E
F
G
H
I
J
K
L
M
N
O
P

LI-ION BATTERY

< UNIT DISASSEMBLY AND ASSEMBLY >

[TYPE 2]

2. Follow procedure below and assemble rear module stack.
 - a. Assemble rear module stack, and provisionally fasten it in place with the through bolt.

WARNING:



To prevent electric shock hazards, be sure to put on insulated protective gear and use insulated tools.



- Check that terminal of module is arranged as shown in the figure.

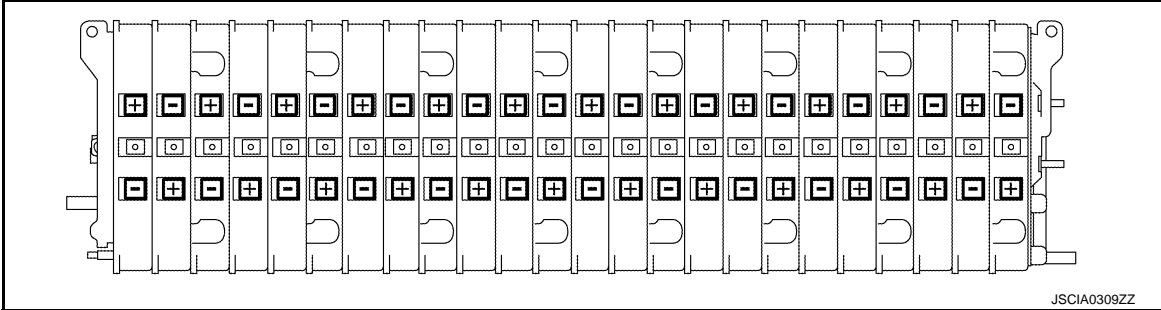

- Check that mounting plate (1) is located at position shown in the figure.

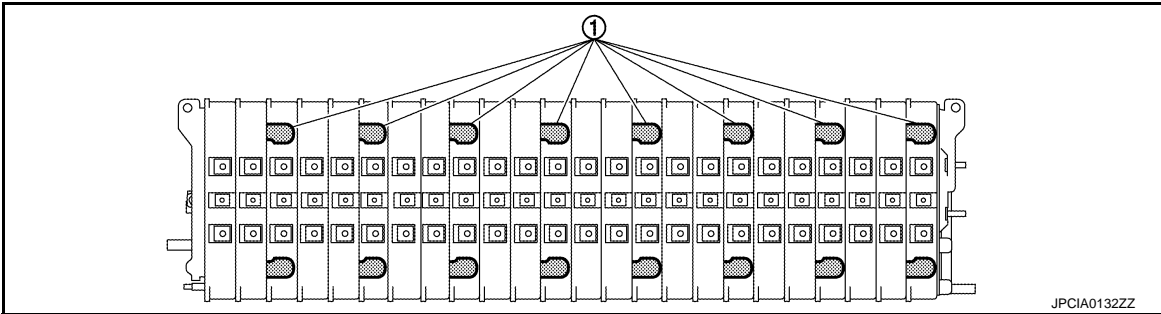

- b. Use lashing belt (A) and apply pressure to rear module stack (1).

WARNING:



To prevent electric shock hazards, be sure to wear protective gear.

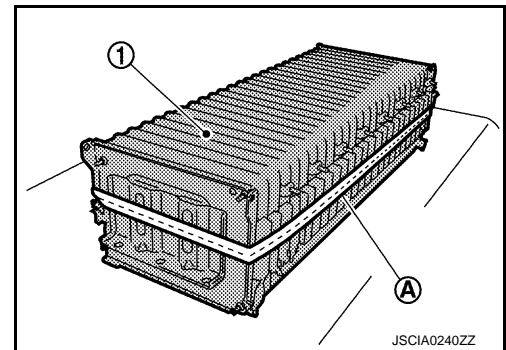

- c. Inspect the module installation condition, and correct it if it is incorrectly installed or a large distortion is found.

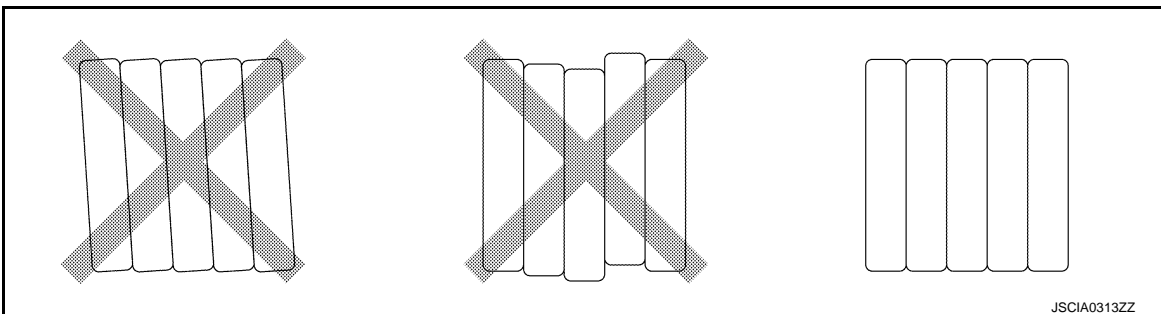

WARNING:



To prevent electric shock hazards, be sure to put on insulated protective gear and use insulated tools.

LI-ION BATTERY

< UNIT DISASSEMBLY AND ASSEMBLY >

[TYPE 2]



- d. Tighten to the specified torque the mounting nuts (removal side, unfixed) for the through bolt that is attached tentatively.
- To tighten rear module stack, fix the tip of through bolt to tighten mounting nuts.

WARNING:

 To prevent electric shock hazards, be sure to put on insulated protective gear and use insulated tools.



CAUTION:

Never tighten self-locking nut (fixed). If tightened, replace through bolt and nut.

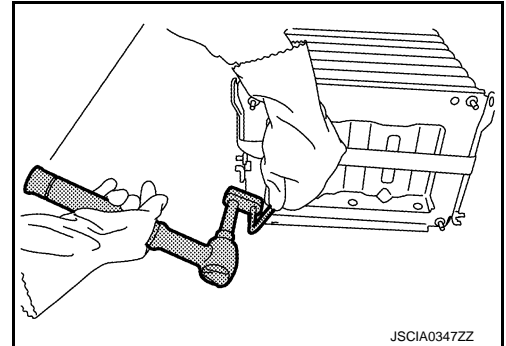

3. Follow procedure below and assemble rear module member.
- a. Temporarily install rear module stack member (1) to rear module stack.

WARNING:

 To prevent electric shock hazards, be sure to put on insulated protective gear and use insulated tools.

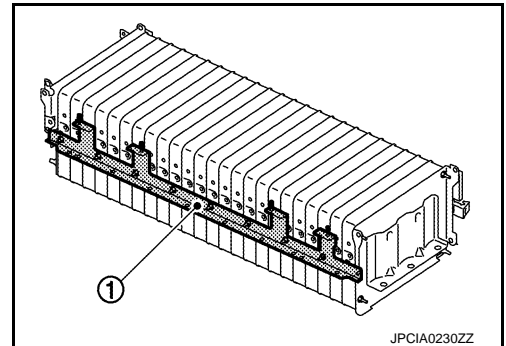

- b. Using the scale (A), inspect the module installation condition.

WARNING:

 To prevent electric shock hazards, be sure to wear protective gear.



- If the rear module stack is excessively distorted, loosen the through bolt of rear module stack and correct the condition.

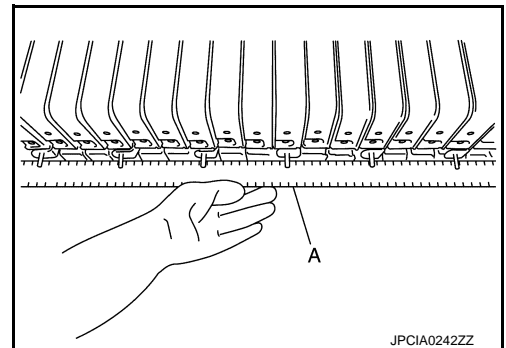

- c. Tighten to the specified torque the mounting nuts for the rear stack member.
4. Install front stack member (1).

WARNING:

 To prevent electric shock hazards, be sure to put on insulated protective gear and use insulated tools.

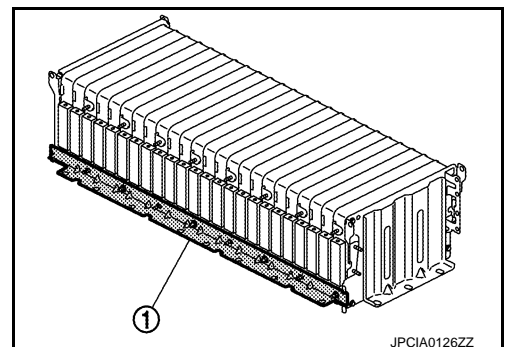

A
B
EVB
D
E
F
G
H
I
J
K
L
M
N
O
P

LI-ION BATTERY

< UNIT DISASSEMBLY AND ASSEMBLY >

[TYPE 2]

5. Install battery temperature sensor (rear) (1) in the figure.

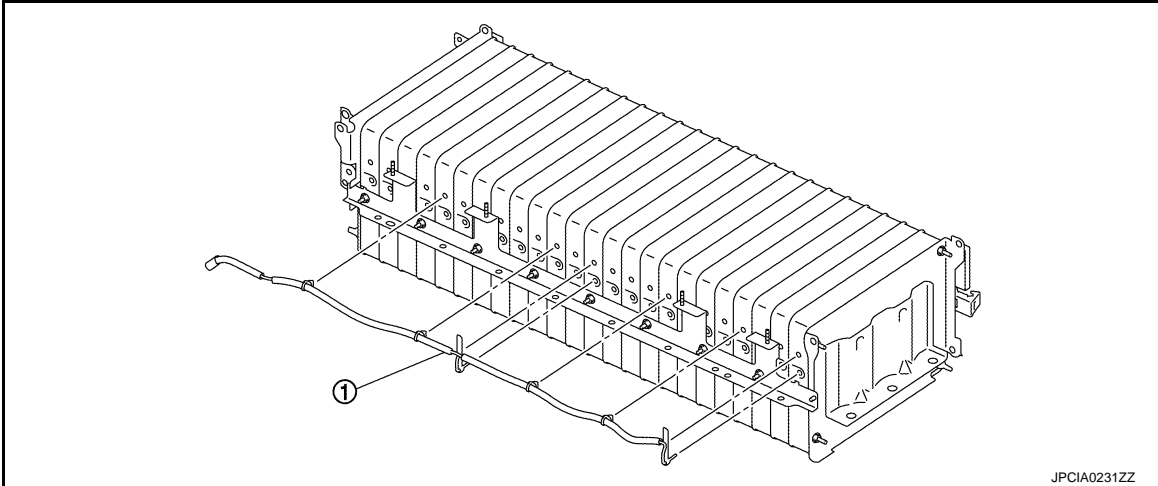

WARNING:



To prevent electric shock hazards, be sure to wear protective gear.



- Position module where sensor (1) will be installed so that it is aligned with concave part (A) of rear stack member.

 : Clip

- Position module where clip (2) will be installed so that it is aligned with concave part (B) of rear stack member.

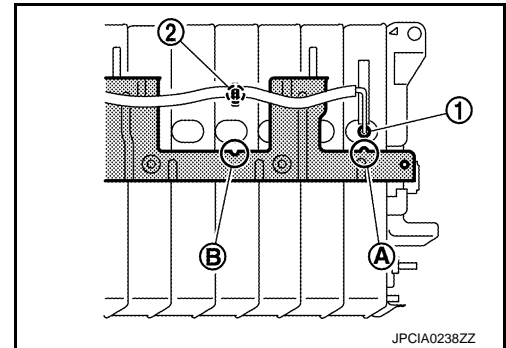

- Insert a sensor (A) in a module and fix by a clip (B). Do not fix in the grommet (C).

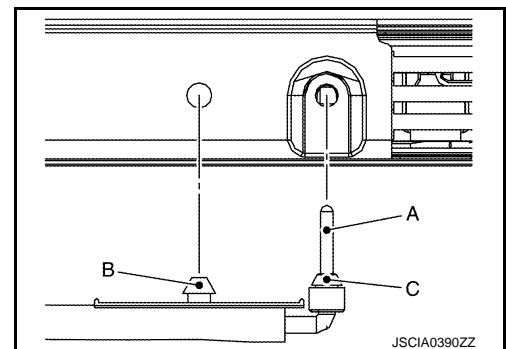

6. Remove module terminal cover [SST: KV99111500].

WARNING:



To prevent electric shock hazards, be sure to wear protective gear.



7. Follow the procedure below and install bus bars onto rear module stack.

a. Install bus bars onto rear module stack.

WARNING:

LI-ION BATTERY

< UNIT DISASSEMBLY AND ASSEMBLY >

[TYPE 2]



To prevent electric shock hazards, be sure to wear protective gear.



- b. Use an insulated torque driver (A) and tighten the voltage detection terminal mounting screws.

DANGER:



To prevent electric shock hazards, be sure to put on insulated protective gear and use insulated tools.



Work alone. Failure to do this may cause shock hazards.

- c. Tighten module terminal mounting bolts in numerical order as shown in the figure.
- When bolts 1 – 16 have been tightened, install right side bus bar cover.
 - When bolts 17 – 32 have been tightened, install left side bus bar cover.
 - When bolts 33 – 48 have been tightened, install center bus bar cover.

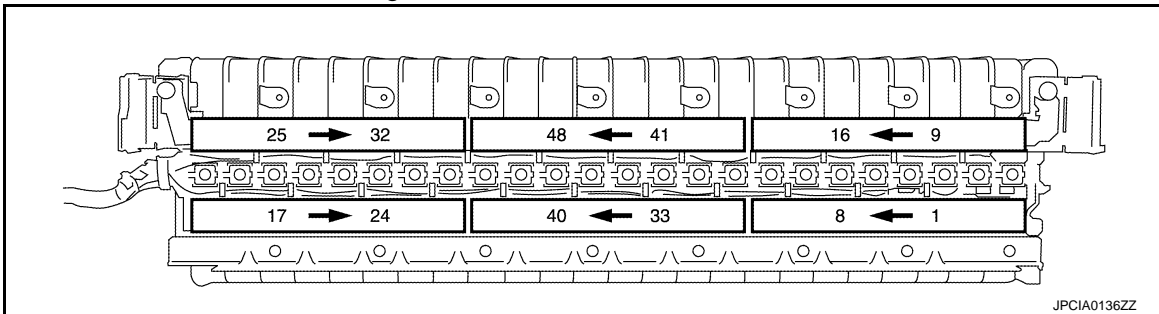

DANGER:



To prevent electric shock hazards, be sure to put on insulated protective gear and use insulated tools.



Work alone. Failure to do this may cause shock hazards.

- d. Install bus bar cover (1).

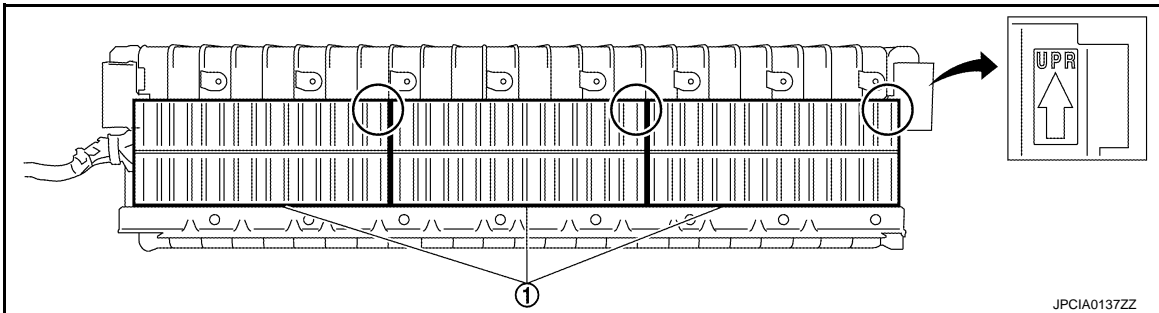

WARNING:



To prevent electric shock hazards, be sure to wear protective gear.



CAUTION:

Be sure not to install with up/down sides facing in wrong directions.

A
B
EVB
D
E
F
G
H
I
J
K
L
M
N
O
P

LI-ION BATTERY

< UNIT DISASSEMBLY AND ASSEMBLY >

[TYPE 2]

- After installation, verify that the joined part does not disconnect.

8. Install harness bracket (1) at position of cut-out (A) in the figure.

WARNING:



To prevent electric shock hazards, be sure to put on insulated protective gear and use insulated tools.

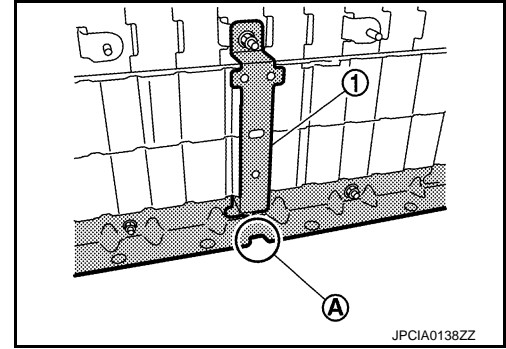

JPCIA0138ZZ

9. Install heater harness bracket (1).

WARNING:



To prevent electric shock hazards, be sure to put on insulated protective gear and use insulated tools.

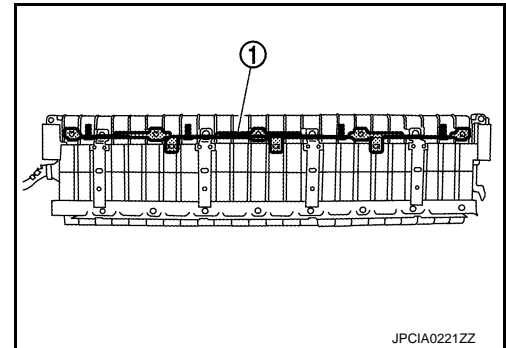

JPCIA0221ZZ

10. Follow procedure below and install rear module stack onto battery pack.

a. Use mobile floor crane (A) to lift up rear module stack (1).

WARNING:



To prevent electric shock hazards, be sure to wear protective gear.



CAUTION:

Do not move mobile floor crane while rear module stack is hoisted up.

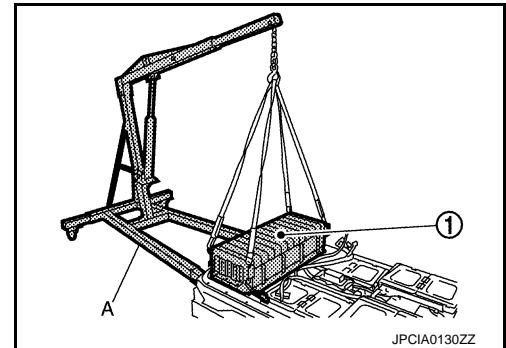

JPCIA0130ZZ

b. Move work bench so that battery pack is underneath rear module stack.

c. Install rear module stack onto battery pack.

WARNING:



To prevent electric shock hazards, be sure to wear protective gear.



CAUTION:

Align position of locating pin.

LI-ION BATTERY

< UNIT DISASSEMBLY AND ASSEMBLY >

[TYPE 2]

11. Tighten rear module stack (1) mounting bolt (A).

WARNING:



To prevent electric shock hazards, be sure to put on insulated protective gear and use insulated tools.

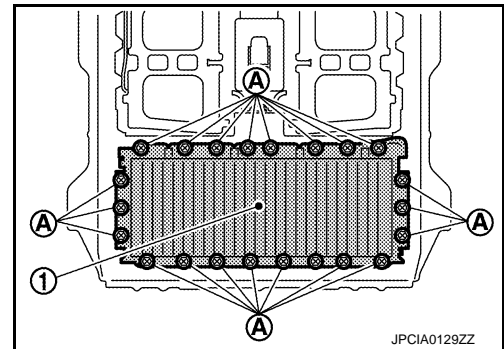

12. Tighten mounting nuts (A) and connect high voltage harness to rear module stack.

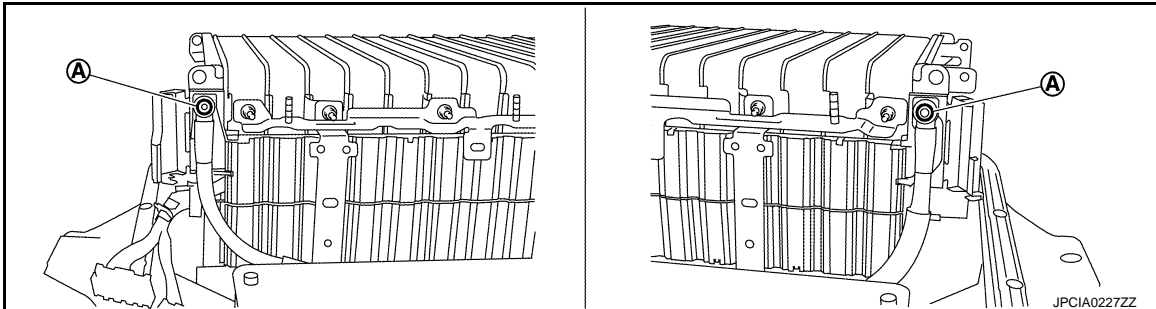

DANGER:



- To prevent electric shock hazards, be sure to put on insulated protective gear and use insulated tools.



- Be sure to close terminal cover.

13. Install vehicle communication harness.

WARNING:



- To prevent electric shock hazards, be sure to wear protective gear.



14. Install Li-ion battery heater (rear). Refer to [EVB-456, "HEATER UNIT : Disassembly and Assembly"](#).
15. Install Li-ion battery controller. Refer to [EVB-419, "LI-ION BATTERY CONTROLLER : Disassembly and Assembly"](#).
16. Install battery pack upper case. Refer to [EVB-419, "LI-ION BATTERY CONTROLLER : Disassembly and Assembly"](#).

CAUTION:

- Check seal before install battery pack upper case. Refer to [EVB-447, "REAR MODULE STACK : Inspection"](#).
- Check the following items after installing battery pack: Refer to [EVB-447, "REAR MODULE STACK : Inspection"](#).
 - AIR LEAK INSPECTION
 - ELECTRIC EQUIPOTENTIAL TEST

REAR MODULE STACK : Inspection

INFOID:000000007479187

BATTERY PACK SEAL INSPECTION

LI-ION BATTERY

[TYPE 2]

< UNIT DISASSEMBLY AND ASSEMBLY >

- Visually check all lips (A) of seal (1) for damage. (e.g. scratches and cracks)
- Replace seal if its lips are damaged.

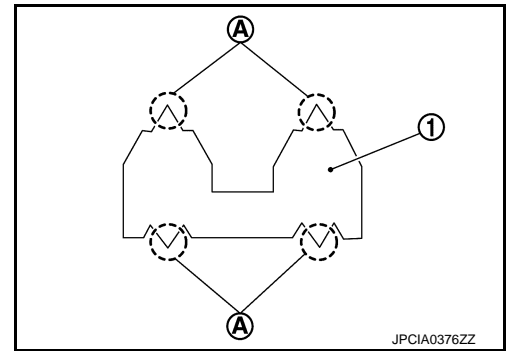

AIR LEAK INSPECTION

1. Remove drain plug and install adapter [SST: KV99111400] (A).

WARNING:

 To prevent electric shock hazards, be sure to wear protective gear.

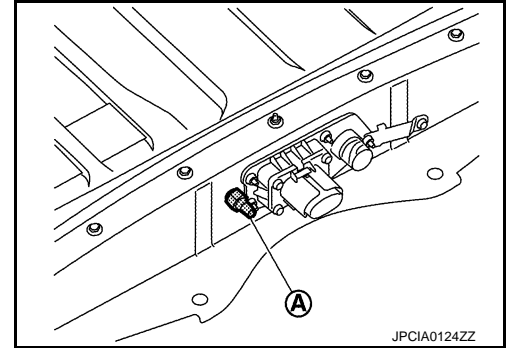

2. Install gauge [SST: KV99111400] (A).

WARNING:

 To prevent electric shock hazards, be sure to wear protective gear.



CAUTION:

Handle the gauge carefully so that it will not drop.

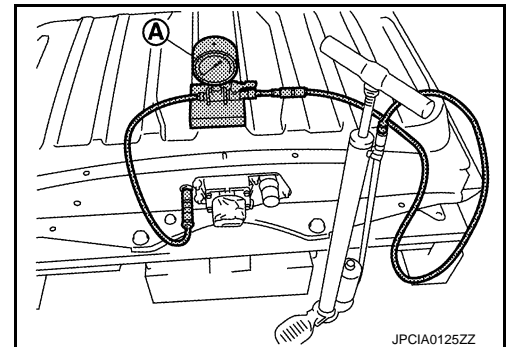

3. Install service plug to seal the battery pack.

DANGER:

 To prevent electric shock hazards, be sure to wear protective gear.



4. Use vinyl tape (A) or similar means to seal the breather so that air does not enter it.

- Use the wide vinyl tape which can cover up breather at once.
- Stick it so that tape is not wrinkled.

WARNING:

 To prevent electric shock hazards, be sure to wear protective gear.

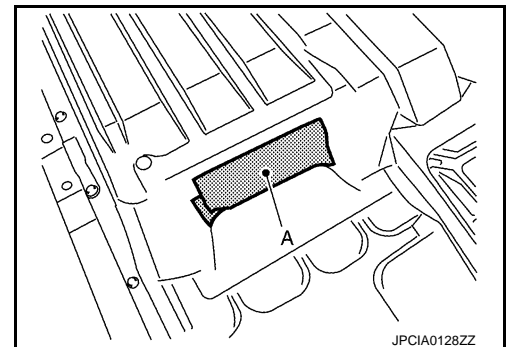

5. Perform air leak inspection by applying 1.6 kPa (0.0163 kg/cm², 0.23 psi) of pressure inside the battery pack for approximately 1 minute.

LI-ION BATTERY

< UNIT DISASSEMBLY AND ASSEMBLY >

[TYPE 2]

CAUTION:

- When applying pressure, operate the air pump slowly.
- Do not apply any pressure exceeding 2.0 kPa (0.0204 kg/cm², 0.29 psi).

Repair limit : 1.4 kPa (0.0143 kg/cm², 0.20 psi)

6. If the pressure drops below the limit value, use soapy water and check for leakage points.

WARNING:



To prevent electric shock hazards, be sure to wear protective gear.



CAUTION:

Never allow soapy water to contact the service plug and each connector terminals.

Electric Equipotential Test

After installing the battery pack, measure the resistance between the ground bolt mating surface (A) and the high voltage harness connector flange (B).

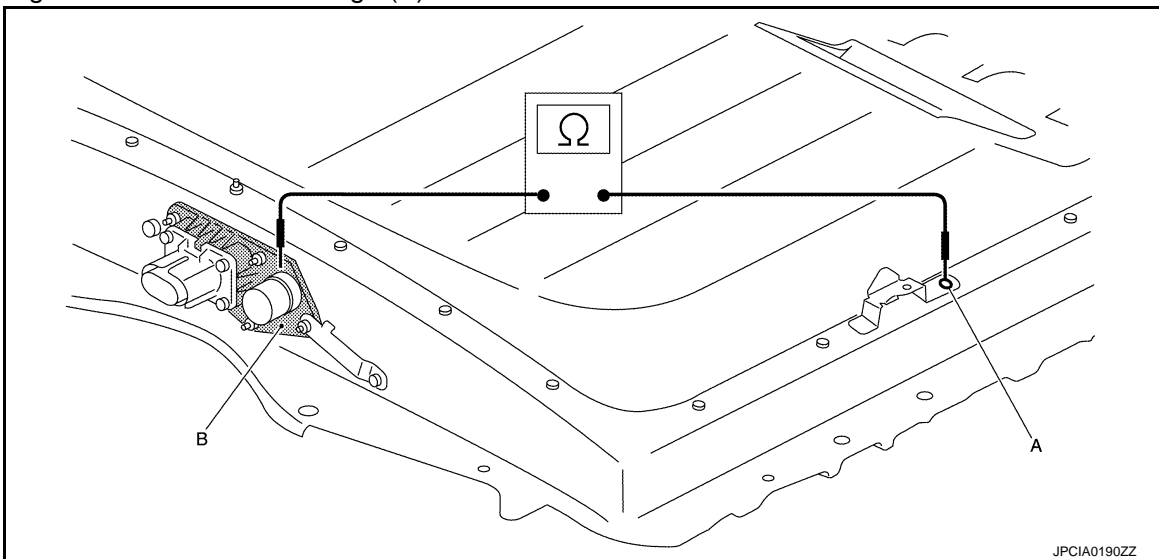

WARNING:



To prevent electric shock hazards, be sure to wear protective gear.



Standard : Less than 0.1 Ω

If the result deviates from the standard value, check the following items and repair malfunctioning parts

- Connection condition of ground bolts
- Rust on the mounting surface of ground bolts
- Paint, oil, and dust on the mounting surface of ground bolts

HEATER RELAY UNIT

HEATER RELAY UNIT : Disassembly and Assembly

INFOID:000000007341796

DANGER:



Because hybrid vehicles and electric vehicles contain a high voltage battery, there is the risk of electric shock, electric leakage, or similar accidents if the high voltage component and vehicle are handled incorrectly. Be sure to follow the correct work procedures when performing inspection and maintenance.

LI-ION BATTERY

< UNIT DISASSEMBLY AND ASSEMBLY >

[TYPE 2]

WARNING:

- Be sure to remove the service plug in order to disconnect the high voltage circuits before performing inspection or maintenance of high voltage system harnesses and parts.
- To prevent the removed service plug from being connected by mistake during the procedure, always carry it in your pocket or put it in the tool box.
- Be sure to wear insulating protective equipment consisting of glove, shoes, face shield and glasses before beginning work on the high voltage system.
- Refer to [EVb-229, "High Voltage Precautions"](#).
- To prevent electric shock hazards, ignition, and damage to parts, always remove Li-ion battery controller before disassembling battery pack.

CAUTION:

There is the possibility of a malfunction occurring if the vehicle is changed to READY status while the service plug is removed. Therefore do not change the vehicle to READY status unless instructed to do so in the Service Manual.

WORK ENVIRONMENT FOR DISASSEMBLY OF LI-ION BATTERY

1. Must be an indoor environment.
 - The work environment must be able to be isolated from the outside by shutters or other means to prevent the intrusion of rain, snow, sand, and other substances.
 - The environment must prevent the entry of sweat during work, and also prevent condensation from occurring as a result of high temperature and humidity.
2. No entry of foreign materials.
 - In addition to being indoors, the environment must not permit the entry during disassembly work of metal powders, oil, or foreign substances resulting from causes such as servicing of other vehicles.
 - If there is any risk of the above, use a plastic curtain or other means to block off the work area, or take other necessary steps.
3. The floor must be dry.
 - The floor must not become wet as a result of causes such as vehicles entering when it is raining or snowing.
4. Work space
 - Space approximately the size of one vehicle must be secured as the disassembly space.
 - A sign indicating that disassembly is in progress or other measures must be taken so that persons other than the workers do not enter the work space.
5. Standard fire fighting equipment
 - Always place a standard fire fighting equipment in the disassembly work area.
 - Depending on type of fire (vehicle or battery) use standard fire fighting equipment (water or extinguisher).

DISASSEMBLY

1. Clean any contamination and dust from the battery pack.
2. Remove service plug retainer (1).

WARNING:



To prevent electric shock hazards, be sure to wear protective gear.

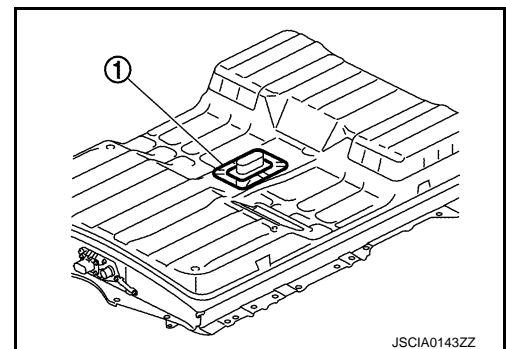

3. Remove mounting bolts (A), (B) and mounting nuts (C), then remove battery pack upper case.

LI-ION BATTERY

< UNIT DISASSEMBLY AND ASSEMBLY >

[TYPE 2]

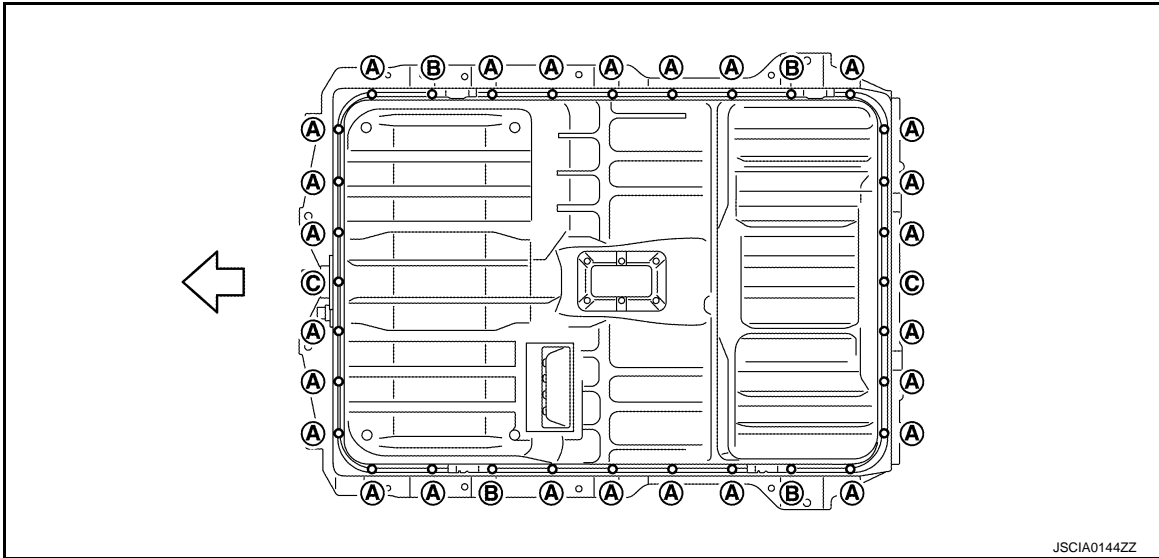

← : Vehicle front

WARNING:



To prevent electric shock hazards, be sure to wear protective gear.



- Remove Li-ion battery controller. Refer to [EVB-419, "LI-ION BATTERY CONTROLLER : Disassembly and Assembly"](#).
- Remove bus bar (1) that connects service plug switch and left front module stack.

DANGER:



To prevent electric shock hazards, be sure to put on insulated protective gear and use insulated tools.

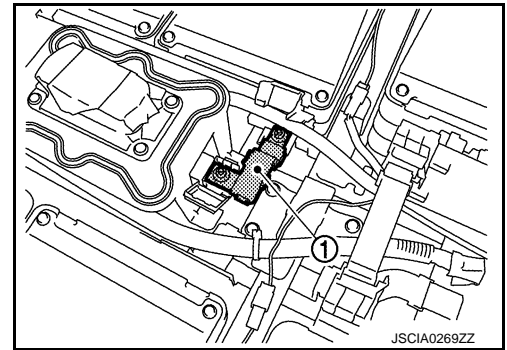

WARNING:

After removing, close bus bar cover.

- Remove mounting bolts (A) and nuts (B) of service plug switch bracket (1).

WARNING:



To prevent electric shock hazards, be sure to put on insulated protective gear and use insulated tools.

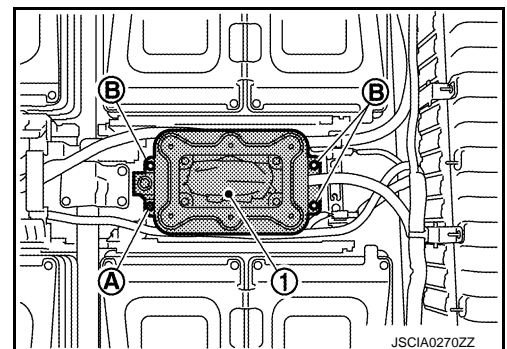

A
B
EVB
D
E
F
G
H
I
J
K
L
M
N
O
P

LI-ION BATTERY

< UNIT DISASSEMBLY AND ASSEMBLY >

[TYPE 2]

7. Disconnect high voltage harness (A) and connector (B) on reverse side of service plug switch bracket, then remove service plug switch bracket (1).

DANGER:

- ⚡ To prevent electric shock hazards, be sure to put on insulated protective gear and use insulated tools.



- ⚡ To prevent electric shock hazards, immediately wrap insulating tape around disconnected high voltage harness connector (high voltage terminal) and terminals.

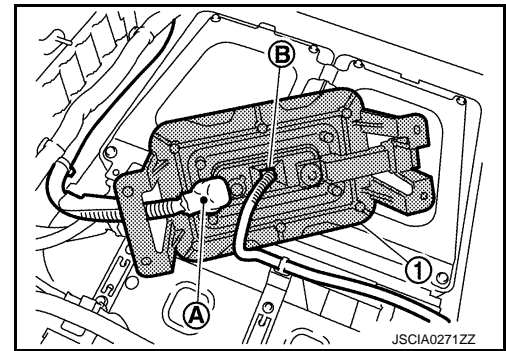

8. Disconnect heater relay harness connector (A) and heater harness connector (B) and then remove harness clips (C).

WARNING:

- ⚡ To prevent electric shock hazards, be sure to put on insulated protective gear and use insulated tools.

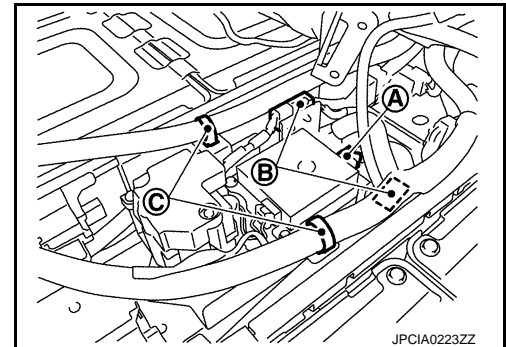

9. Remove mounting nuts (A) and then remove heater relay unit (1).

WARNING:

- ⚡ To prevent electric shock hazards, be sure to put on insulated protective gear and use insulated tools.

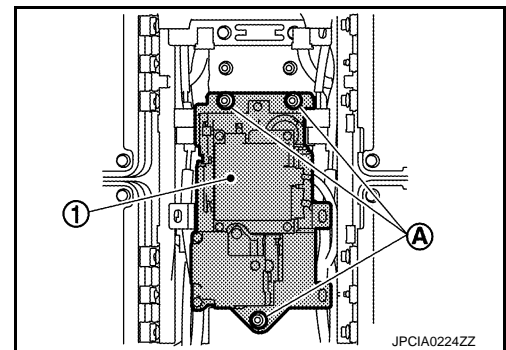

10. Remove harness bracket (1).

WARNING:

- ⚡ To prevent electric shock hazards, be sure to put on insulated protective gear and use insulated tools.

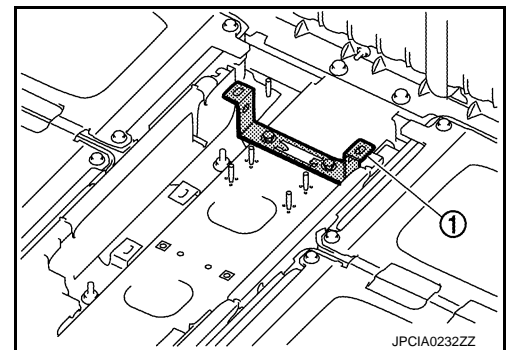

ASSEMBLY

Assemble in the reverse order of disassembly.

1. Install heater relay unit.

WARNING:

- ⚡ To prevent electric shock hazards, be sure to put on insulated protective gear and use insulated tools.

LI-ION BATTERY

< UNIT DISASSEMBLY AND ASSEMBLY >

[TYPE 2]



2. Install service plug switch bracket.

WARNING:



To prevent electric shock hazards, be sure to put on insulated protective gear and use insulated tools.



3. Install Li-ion battery controller. Refer to [EVB-419, "LI-ION BATTERY CONTROLLER : Disassembly and Assembly"](#).
4. Follow the procedure below and install battery pack upper case.

CAUTION:

Check seal before install battery pack upper case. Refer to [EVB-454, "HEATER RELAY UNIT : Inspection"](#).

- a. Tighten mounting nuts and bolts in the order from 1 to 28 as shown in the figure.

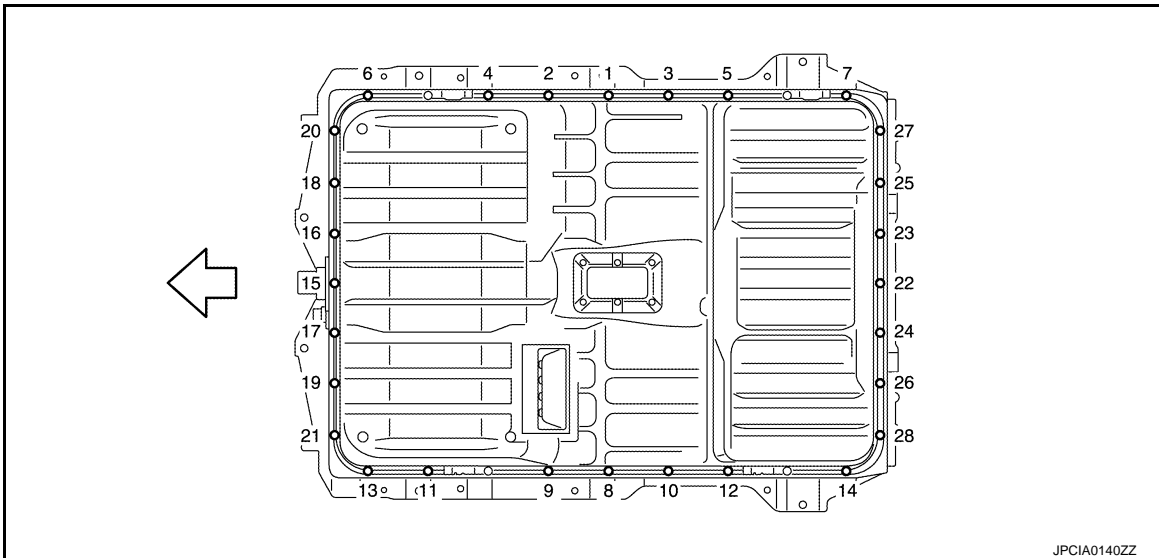

← : Vehicle front

WARNING:



To prevent electric shock hazards, be sure to wear protective gear.



- b. Install ground bolt (A).

LI-ION BATTERY

< UNIT DISASSEMBLY AND ASSEMBLY >

[TYPE 2]

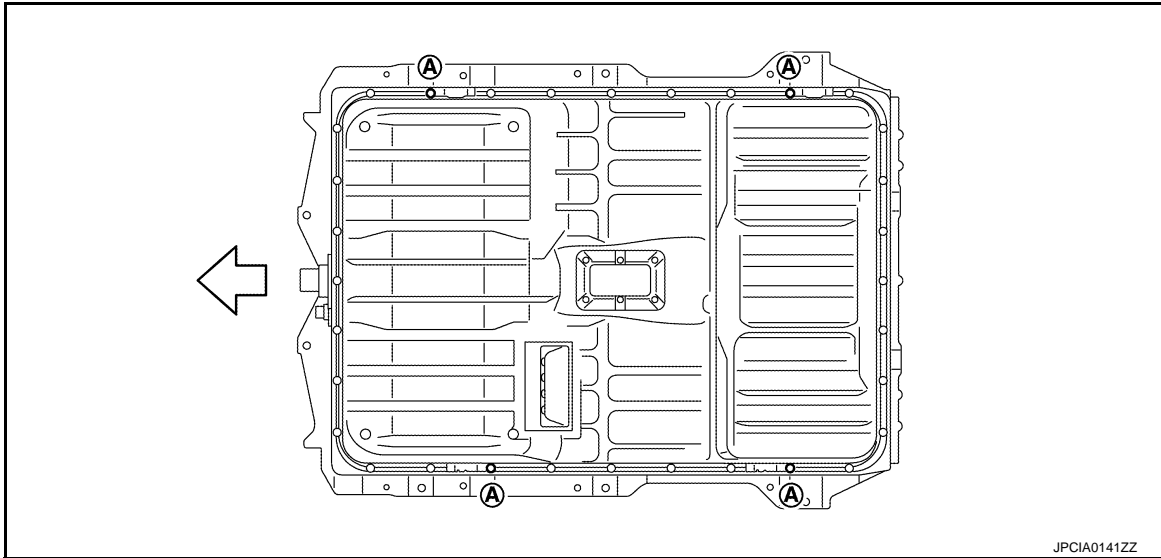

← : Vehicle front

WARNING:



To prevent electric shock hazards, be sure to wear protective gear.



5. Install service plug retainer (1).

WARNING:



To prevent electric shock hazards, be sure to wear protective gear.

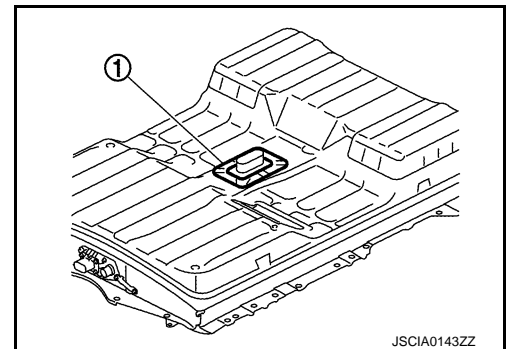

CAUTION:

• Check the following items after installing battery pack: Refer to [EVB-454, "HEATER RELAY UNIT : Inspection"](#).

■AIR LEAK INSPECTION

■ELECTRIC EQUIPOTENTIAL TEST

HEATER RELAY UNIT : Inspection

INFOID:000000007479188

BATTERY PACK SEAL INSPECTION

- Visually check all lips (A) of seal (1) for damage. (e.g. scratches and cracks)
- Replace seal if its lips are damaged.

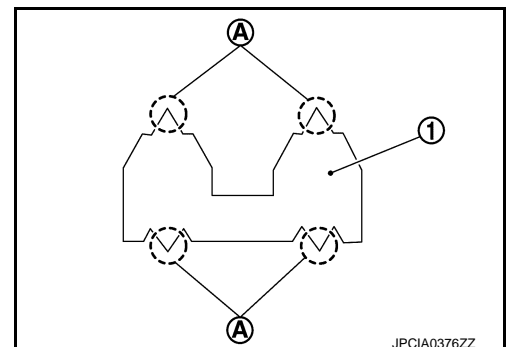

LI-ION BATTERY

< UNIT DISASSEMBLY AND ASSEMBLY >

[TYPE 2]

AIR LEAK INSPECTION

1. Remove drain plug and install adapter [SST: KV99111400] (A).

WARNING:

 To prevent electric shock hazards, be sure to wear protective gear.

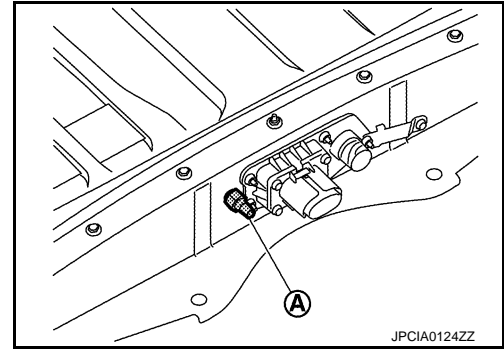

2. Install gauge [SST: KV99111400] (A).

WARNING:

 To prevent electric shock hazards, be sure to wear protective gear.



CAUTION:

Handle the gauge carefully so that it will not drop.

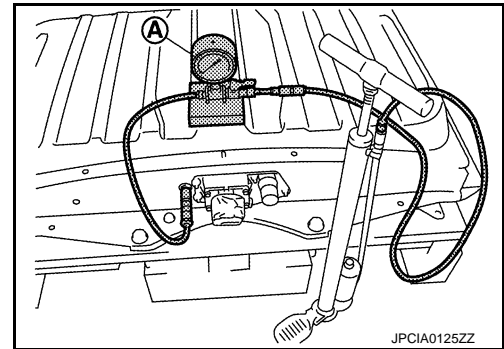

3. Install service plug to seal the battery pack.

DANGER:

 To prevent electric shock hazards, be sure to wear protective gear.



4. Use vinyl tape (A) or similar means to seal the breather so that air does not enter it.
- Use the wide vinyl tape which can cover up breather at once.
 - Stick it so that tape is not wrinkled.

WARNING:

 To prevent electric shock hazards, be sure to wear protective gear.

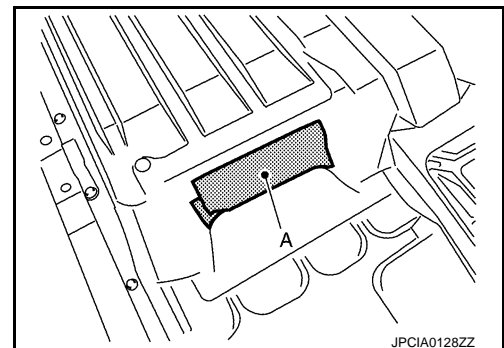

5. Perform air leak inspection by applying 1.6 kPa (0.0163 kg/cm², 0.23 psi) of pressure inside the battery pack for approximately 1 minute.

CAUTION:

- When applying pressure, operate the air pump slowly.
- Do not apply any pressure exceeding 2.0 kPa (0.0204 kg/cm², 0.29 psi).

Repair limit : 1.4 kPa (0.0143 kg/cm², 0.20 psi)

6. If the pressure drops below the limit value, use soapy water and check for leakage points.

WARNING:

 To prevent electric shock hazards, be sure to wear protective gear.

A
B
EVB
D
E
F
G
H
I
J
K
L
M
N
O
P

LI-ION BATTERY

< UNIT DISASSEMBLY AND ASSEMBLY >

[TYPE 2]



CAUTION:

Never allow soapy water to contact the service plug and each connector terminals.

Electric Equipotential Test

After installing the battery pack, measure the resistance between the ground bolt mating surface (A) and the high voltage harness connector flange (B).

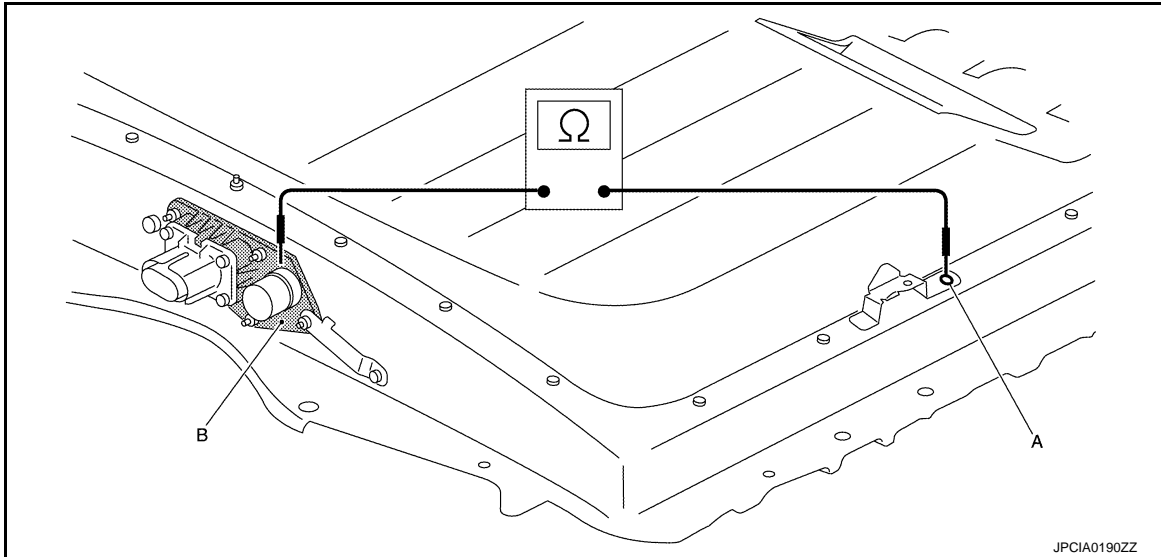

WARNING:



To prevent electric shock hazards, be sure to wear protective gear.



Standard : Less than 0.1 Ω

If the result deviates from the standard value, check the following items and repair malfunctioning parts

- Connection condition of ground bolts
- Rust on the mounting surface of ground bolts
- Paint, oil, and dust on the mounting surface of ground bolts

HEATER UNIT

HEATER UNIT : Disassembly and Assembly

INFOID:000000007341798

DANGER:



Because hybrid vehicles and electric vehicles contain a high voltage battery, there is the risk of electric shock, electric leakage, or similar accidents if the high voltage component and vehicle are handled incorrectly. Be sure to follow the correct work procedures when performing inspection and maintenance.

WARNING:

- Be sure to remove the service plug in order to disconnect the high voltage circuits before performing inspection or maintenance of high voltage system harnesses and parts.
- To prevent the removed service plug from being connected by mistake during the procedure, always carry it in your pocket or put it in the tool box.
- Be sure to wear insulating protective equipment consisting of glove, shoes, face shield and glasses before beginning work on the high voltage system.
- Refer to [EVB-229, "High Voltage Precautions"](#).
- To prevent electric shock hazards, ignition, and damage to parts, always remove Li-ion battery controller before disassembling battery pack.

LI-ION BATTERY

< UNIT DISASSEMBLY AND ASSEMBLY >

[TYPE 2]

CAUTION:

There is the possibility of a malfunction occurring if the vehicle is changed to READY status while the service plug is removed. Therefore do not change the vehicle to READY status unless instructed to do so in the Service Manual.

WORK ENVIRONMENT FOR DISASSEMBLY OF LI-ION BATTERY

1. Must be an indoor environment.
 - The work environment must be able to be isolated from the outside by shutters or other means to prevent the intrusion of rain, snow, sand, and other substances.
 - The environment must prevent the entry of sweat during work, and also prevent condensation from occurring as a result of high temperature and humidity.
2. No entry of foreign materials.
 - In addition to being indoors, the environment must not permit the entry during disassembly work of metal powders, oil, or foreign substances resulting from causes such as servicing of other vehicles.
 - If there is any risk of the above, use a plastic curtain or other means to block off the work area, or take other necessary steps.
3. The floor must be dry.
 - The floor must not become wet as a result of causes such as vehicles entering when it is raining or snowing.
4. Work space
 - Space approximately the size of one vehicle must be secured as the disassembly space.
 - A sign indicating that disassembly is in progress or other measures must be taken so that persons other than the workers do not enter the work space.
5. Standard fire fighting equipment
 - Always place a standard fire fighting equipment in the disassembly work area.
 - Depending on type of fire (vehicle or battery) use standard fire fighting equipment (water or extinguisher).

DISASSEMBLY

Li-Ion Battery Heater (Front)

1. Clean any contamination and dust from the battery pack.
2. Remove service plug retainer (1).

WARNING:



To prevent electric shock hazards, be sure to wear protective gear.

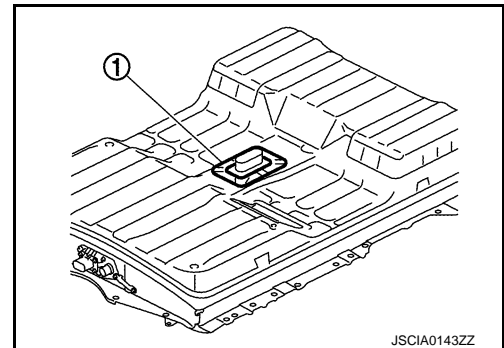

3. Remove mounting bolts (A), (B) and mounting nuts (C), then remove battery pack upper case.

LI-ION BATTERY

< UNIT DISASSEMBLY AND ASSEMBLY >

[TYPE 2]

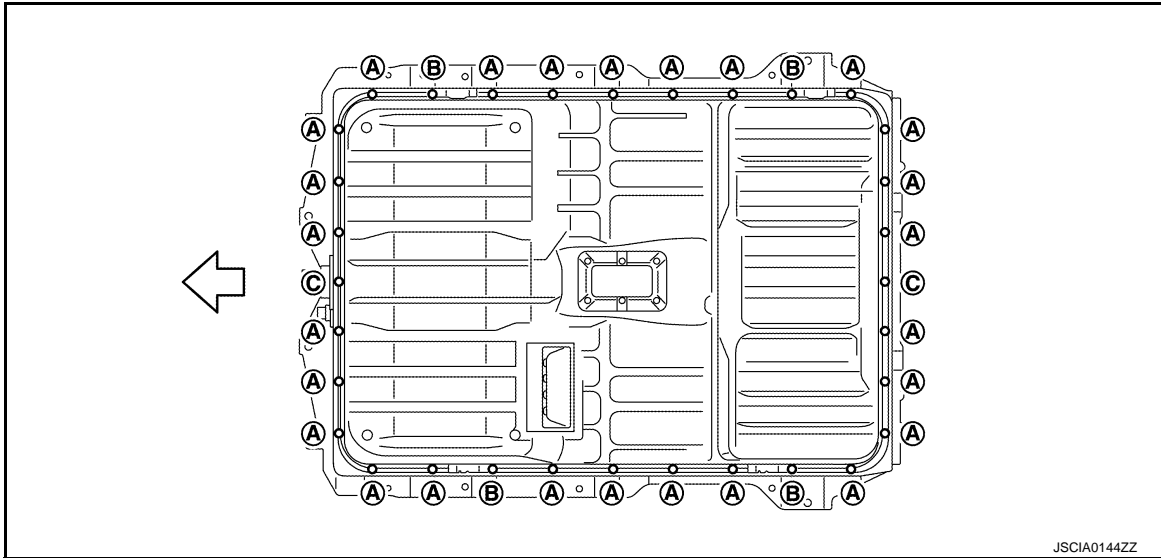

← : Vehicle front

WARNING:



To prevent electric shock hazards, be sure to wear protective gear.



4. Remove Li-ion battery controller. Refer to [EVB-419, "LI-ION BATTERY CONTROLLER : Disassembly and Assembly"](#).
5. Remove high voltage harness connector clips and vehicle communication harness connector clips.

WARNING:



To prevent electric shock hazards, be sure to put on insulated protective gear and use insulated tools.



6. Remove battery member pipe (1).

WARNING:



To prevent electric shock hazards, be sure to put on insulated protective gear and use insulated tools.

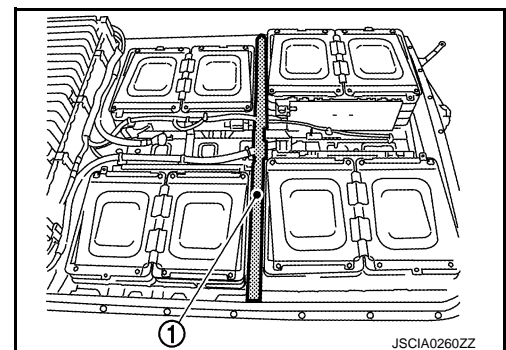

LI-ION BATTERY

< UNIT DISASSEMBLY AND ASSEMBLY >

[TYPE 2]

7. Disconnect Li-ion battery heater (front) harness connectors (A).

WARNING:



To prevent electric shock hazards, be sure to put on insulated protective gear and use insulated tools.

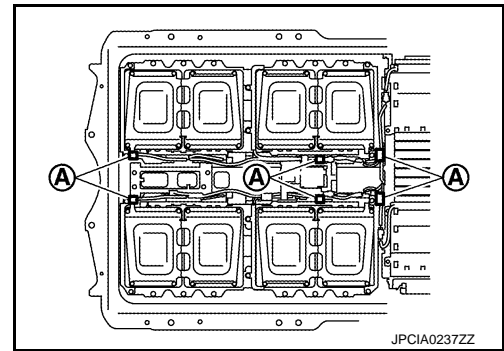

8. Remove mounting nuts (A) and then remove Li-ion battery heater (front).

1. Li-ion battery heater RH1
2. Li-ion battery heater RH2
3. Li-ion battery heater RH3
4. Li-ion battery heater LH1
5. Li-ion battery heater LH2
6. Li-ion battery heater LH3

WARNING:



To prevent electric shock hazards, be sure to put on insulated protective gear and use insulated tools.

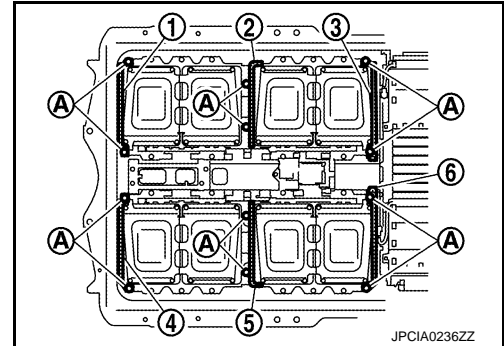

Li-Ion Battery Heater (Rear)

1. Clean any contamination and dust from the battery pack.
2. Remove service plug retainer (1).

WARNING:



To prevent electric shock hazards, be sure to wear protective gear.

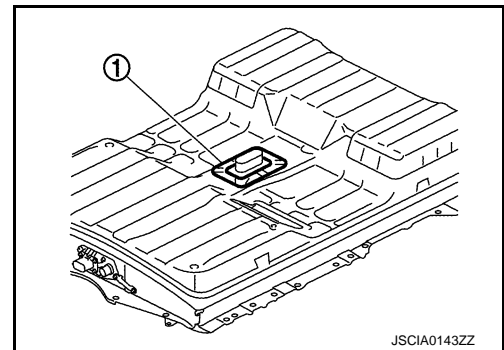

3. Remove mounting bolts (A), (B) and mounting nuts (C), then remove battery pack upper case.

A
B
EVB
D
E
F
G
H
I
J
K
L
M
N
O
P

LI-ION BATTERY

< UNIT DISASSEMBLY AND ASSEMBLY >

[TYPE 2]

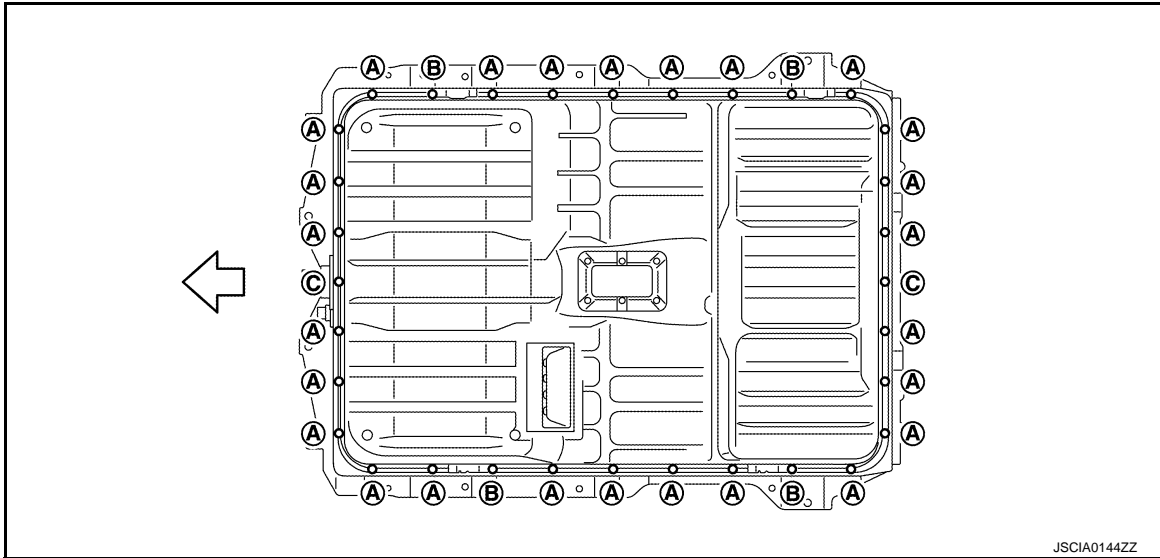

↔ : Vehicle front

WARNING:



To prevent electric shock hazards, be sure to wear protective gear.



4. Disconnect rear module stack heater harness connectors (A).

1. Li-ion battery heater RR2
2. Li-ion battery heater RR1

WARNING:



To prevent electric shock hazards, be sure to put on insulated protective gear and use insulated tools.

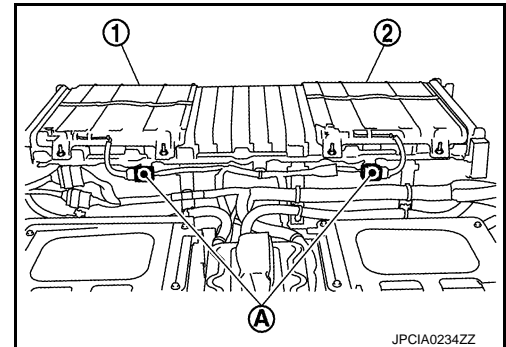

JPCIA0234ZZ

5. Remove mounting nuts (A) and then remove Li-ion battery heater (rear).

1. Li-ion battery heater RR2
2. Li-ion battery heater RR1

WARNING:



To prevent electric shock hazards, be sure to put on insulated protective gear and use insulated tools.

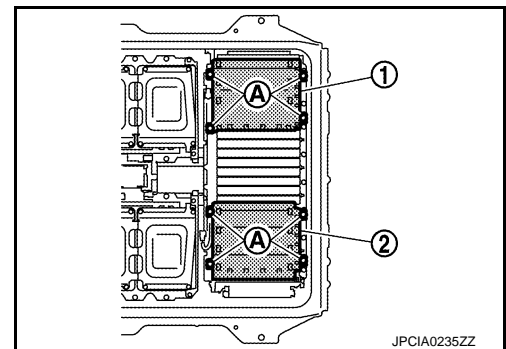

JPCIA0235ZZ

ASSEMBLY

Li-Ion Battery Heater (Front & Rear)
Assemble in the reverse order of disassembly.

1. Install Li-ion battery heater (front & rear)

WARNING:

LI-ION BATTERY

< UNIT DISASSEMBLY AND ASSEMBLY >

[TYPE 2]



To prevent electric shock hazards, be sure to put on insulated protective gear and use insulated tools.



2. Install Li-ion battery controller. Refer to [EVB-419, "LI-ION BATTERY CONTROLLER : Disassembly and Assembly"](#).
3. Follow the procedure below and install battery pack upper case.
CAUTION:
Check seal before install battery pack upper case. Refer to [EVB-462, "HEATER UNIT : Inspection"](#).
- a. Tighten mounting nuts and bolts in the order from 1 to 28 as shown in the figure.

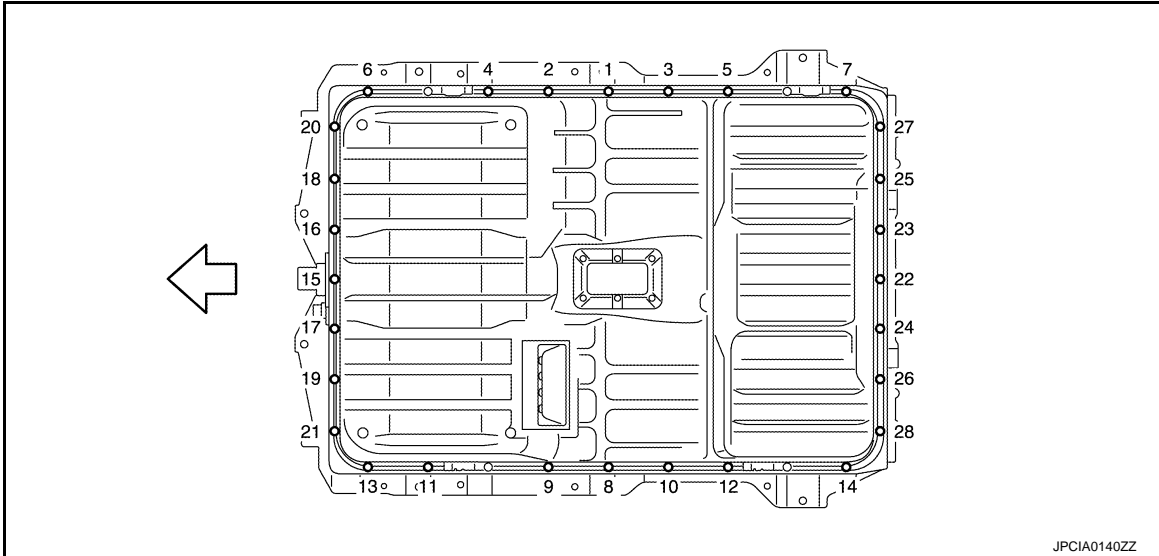

← : Vehicle front

WARNING:



To prevent electric shock hazards, be sure to wear protective gear.



- b. Install ground bolt (A).

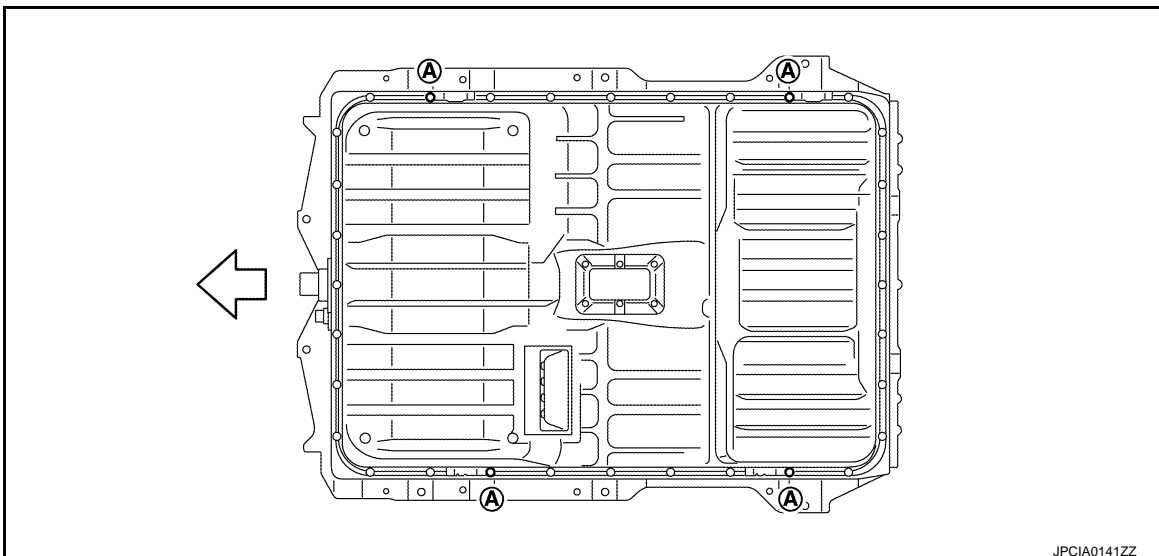

LI-ION BATTERY

< UNIT DISASSEMBLY AND ASSEMBLY >

[TYPE 2]

↶ : Vehicle front

WARNING:



To prevent electric shock hazards, be sure to wear protective gear.



4. Install service plug retainer (1).

WARNING:



To prevent electric shock hazards, be sure to wear protective gear.

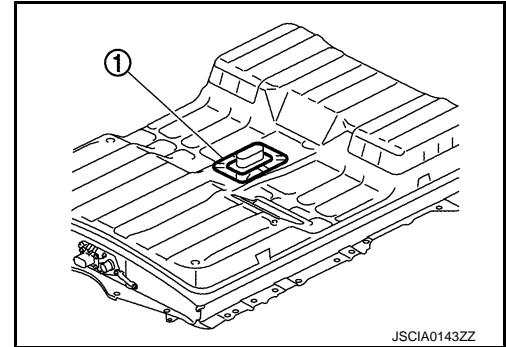

WARNING:



To prevent electric shock hazards, be sure to put on insulated protective gear and use insulated tools.



CAUTION:

• Check the following items after installing battery pack: Refer to [EVB-462, "HEATER UNIT : Inspection"](#).

- AIR LEAK INSPECTION
- ELECTRIC EQUIPOTENTIAL TEST

HEATER UNIT : Inspection

INFOID:000000007479189

BATTERY PACK SEAL INSPECTION

- Visually check all lips (A) of seal (1) for damage. (e.g. scratches and cracks)
- Replace seal if its lips are damaged.

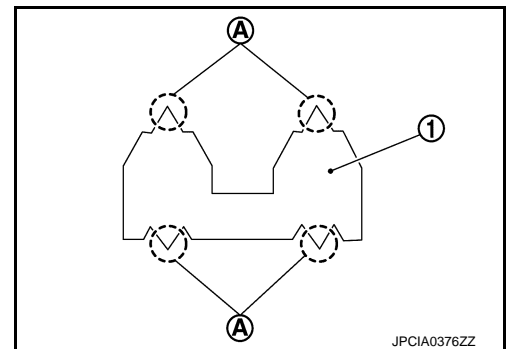

AIR LEAK INSPECTION

LI-ION BATTERY

< UNIT DISASSEMBLY AND ASSEMBLY >

[TYPE 2]

1. Remove drain plug and install adapter [SST: KV99111400] (A).

WARNING:

 To prevent electric shock hazards, be sure to wear protective gear.

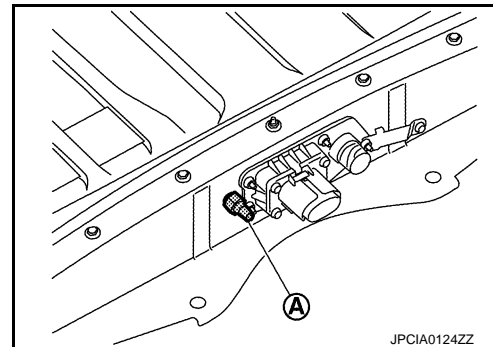

2. Install gauge [SST: KV99111400] (A).

WARNING:

 To prevent electric shock hazards, be sure to wear protective gear.



CAUTION:

Handle the gauge carefully so that it will not drop.

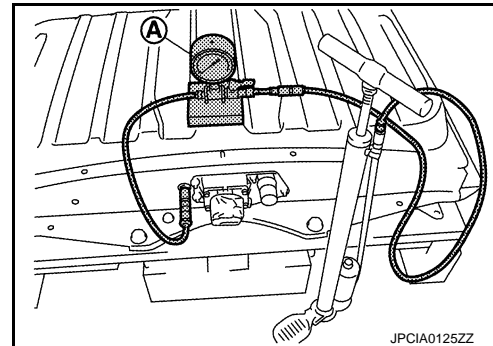

3. Install service plug to seal the battery pack.

DANGER:

 To prevent electric shock hazards, be sure to wear protective gear.



4. Use vinyl tape (A) or similar means to seal the breather so that air does not enter it.

- Use the wide vinyl tape which can cover up breather at once.
- Stick it so that tape is not wrinkled.

WARNING:

 To prevent electric shock hazards, be sure to wear protective gear.

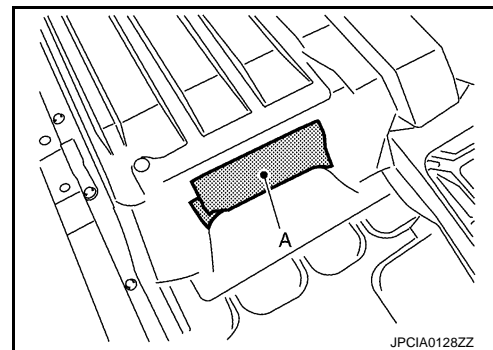

5. Perform air leak inspection by applying 1.6 kPa (0.0163 kg/cm², 0.23 psi) of pressure inside the battery pack for approximately 1 minute.

CAUTION:

- When applying pressure, operate the air pump slowly.
- Do not apply any pressure exceeding 2.0 kPa (0.0204 kg/cm², 0.29 psi).

Repair limit : 1.4 kPa (0.0143 kg/cm², 0.20 psi)

6. If the pressure drops below the limit value, use soapy water and check for leakage points.

WARNING:

 To prevent electric shock hazards, be sure to wear protective gear.



A
B
EVB
D
E
F
G
H
I
J
K
L
M
N
O
P

LI-ION BATTERY

< UNIT DISASSEMBLY AND ASSEMBLY >

[TYPE 2]

CAUTION:

Never allow soapy water to contact the service plug and each connector terminals.

Electric Equipotential Test

After installing the battery pack, measure the resistance between the ground bolt mating surface (A) and the high voltage harness connector flange (B).

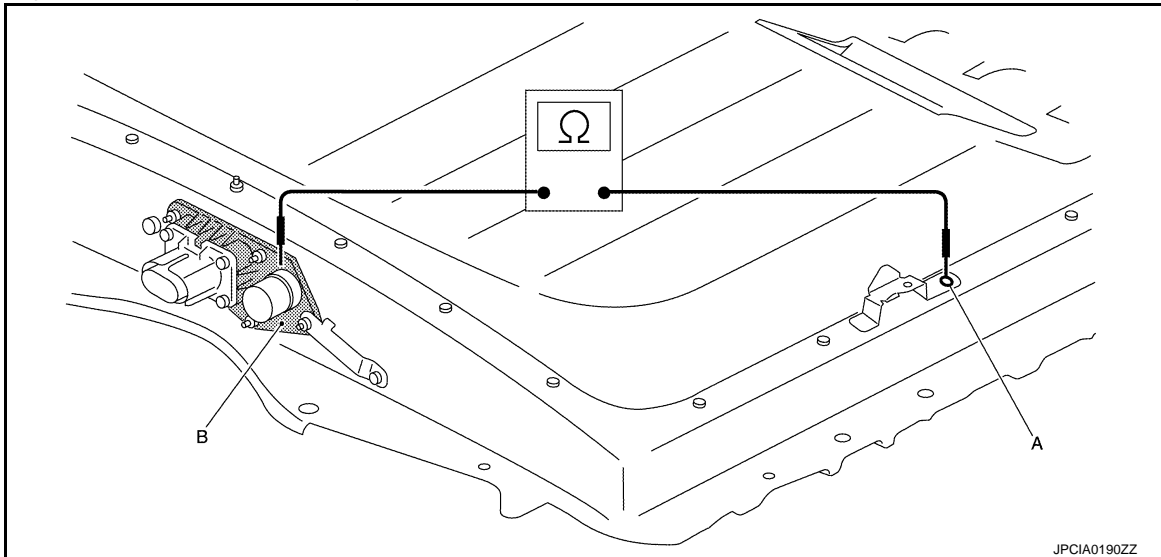

WARNING:



To prevent electric shock hazards, be sure to wear protective gear.



Standard : Less than 0.1 Ω

If the result deviates from the standard value, check the following items and repair malfunctioning parts

- Connection condition of ground bolts
- Rust on the mounting surface of ground bolts
- Paint, oil, and dust on the mounting surface of ground bolts

SERVICE DATA AND SPECIFICATIONS (SDS)

< SERVICE DATA AND SPECIFICATIONS (SDS)

[TYPE 2]

SERVICE DATA AND SPECIFICATIONS (SDS)

SERVICE DATA AND SPECIFICATIONS (SDS)

Li-ion Battery

INFOID:000000007321465

Items	Specification
Type	Li-ion battery
Structure	48 modules (192 cells)
Rated voltage (V)	Approx. 360
Battery capacity (kWh)	Approx. 24
Weight [kg (lb)]	Approx. 300 (661.5)

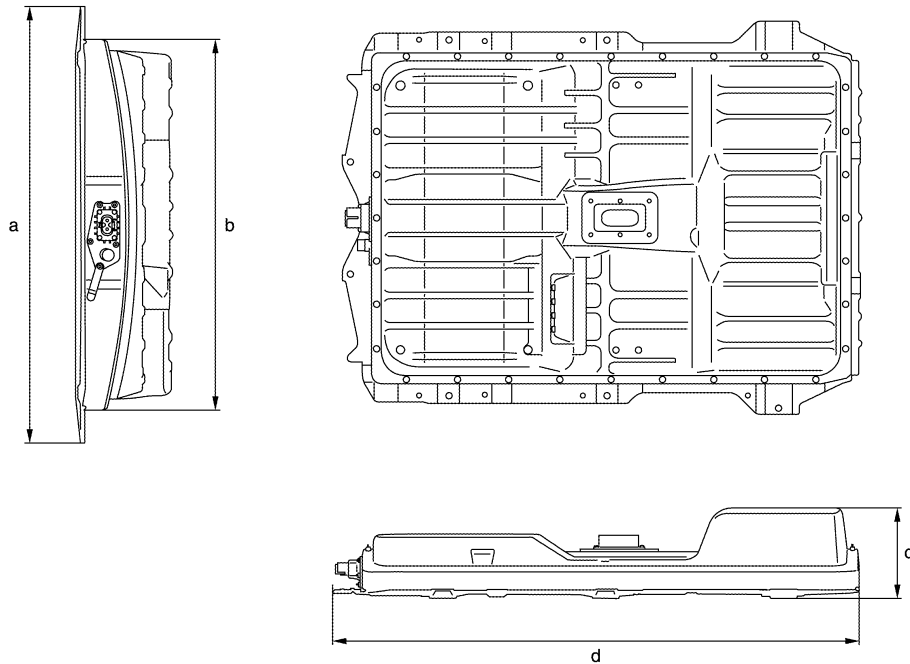

JPCIA0065ZZ

External dimension	Dimension	Unit	Value
"a"	[mm (in)]	1188.0 (46.77)	
"b"	[mm (in)]	1007.0 (39.65)	
"c"	[mm (in)]	264.9 (10.43)	
"d"	[mm (in)]	1570.5 (61.83)	

APPLICATION NOTICE

< HOW TO USE THIS MANUAL >

[TYPE 3]

HOW TO USE THIS MANUAL

APPLICATION NOTICE

How to Check Vehicle Type

INFOID:0000000011104156

Check the vehicle type to confirm the service information in EVB section.

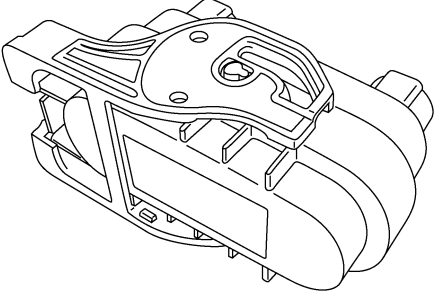
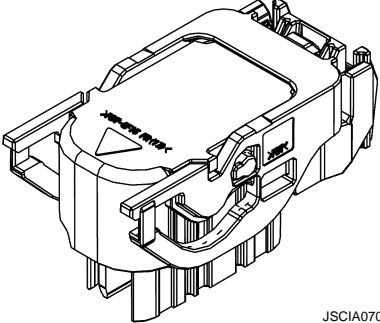
Service information	Vehicle type	Service plug type	
Type 1	Without Li-ion battery heater	Type A	 <p>JSCIA0277ZZ</p>
Type 2	With Li-ion battery heater		
Type 3	Without Li-ion battery heater	Type B	 <p>JSCIA0706ZZ</p>
Type 4	With Li-ion battery heater		

PRECAUTIONS

< PRECAUTION >

[TYPE 3]

PRECAUTION

PRECAUTIONS

Precaution for Technicians Using Medical Electric

INFOID:000000011104157

OPERATION PROHIBITION

WARNING:

- Parts with strong magnet is used in this vehicle.
- Technicians using a medical electric device such as pacemaker must never perform operation on the vehicle, as magnetic field can affect the device function by approaching to such parts.

NORMAL CHARGE PRECAUTION

WARNING:

- If a technician uses a medical electric device such as an implantable cardiac pacemaker or an implantable cardioverter defibrillator, the possible effects on the devices must be checked with the device manufacturer before starting the charge operation.
- As radiated electromagnetic wave generated by on board charger at normal charge operation may effect medical electric devices, a technician using a medical electric device such as implantable cardiac pacemaker or an implantable cardioverter defibrillator must not enter the vehicle compartment (including luggage room) during normal charge operation.

PRECAUTION AT TELEMATICS SYSTEM OPERATION

WARNING:

- If a technician uses implantable cardiac pacemaker or implantable cardioverter defibrillator (ICD), avoid the device implanted part from approaching within approximately 220 mm (8.66 in) from interior/exterior antenna.
- The electromagnetic wave of TCU might affect the function of the implantable cardiac pacemaker or the implantable cardioverter defibrillator (ICD), when using the service, etc.
- If a technician uses other medical electric devices than implantable cardiac pacemaker or implantable cardioverter defibrillator (ICD), the electromagnetic wave of TCU might affect the function of the device. The possible effects on the devices must be checked with the device manufacturer before TCU use.

PRECAUTION AT INTELLIGENT KEY SYSTEM OPERATION

WARNING:

- If a technician uses implantable cardiac pacemaker or implantable cardioverter defibrillator (ICD), avoid the device implanted part from approaching within approximately 220 mm (8.66 in) from interior/exterior antenna.
- The electromagnetic wave of Intelligent Key might affect the function of the implantable cardiac pacemaker or the implantable cardioverter defibrillator (ICD), at door operation, at each request switch operation, or at engine starting.
- If a technician uses other medical electric devices than implantable cardiac pacemaker or implantable cardioverter defibrillator (ICD), the electromagnetic wave of Intelligent Key might affect the function of the device. The possible effects on the devices must be checked with the device manufacturer before Intelligent Key use.

Point to Be Checked Before Starting Maintenance Work

INFOID:000000011104158

The high voltage system may starts automatically. It is required to check that the timer air conditioner and timer charge (during EVSE connection) are not set before starting maintenance work.

NOTE:

If the timer air conditioner or timer charge (during EVSE connection) is set, the high voltage system starts automatically even when the power switch is in OFF state.

Precaution for Supplemental Restraint System (SRS) "AIR BAG" and "SEAT BELT PRE-TENSIONER"

INFOID:000000011104159

The Supplemental Restraint System such as "AIR BAG" and "SEAT BELT PRE-TENSIONER", used along with a front seat belt, helps to reduce the risk or severity of injury to the driver and front passenger for certain types of collision. This system includes seat belt switch inputs and dual stage front air bag modules. The SRS

PRECAUTIONS

[TYPE 3]

< PRECAUTION >

system uses the seat belt switches to determine the front air bag deployment, and may only deploy one front air bag, depending on the severity of a collision and whether the front occupants are belted or unbelted. Information necessary to service the system safely is included in the "SRS AIR BAG" and "SEAT BELT" of this Service Manual.

WARNING:

Always observe the following items for preventing accidental activation.

- To avoid rendering the SRS inoperative, which could increase the risk of personal injury or death in the event of a collision that would result in air bag inflation, all maintenance must be performed by an authorized NISSAN/INFINITI dealer.
- Improper maintenance, including incorrect removal and installation of the SRS, can lead to personal injury caused by unintentional activation of the system. For removal of Spiral Cable and Air Bag Module, see "SRS AIR BAG".
- Never use electrical test equipment on any circuit related to the SRS unless instructed to in this Service Manual. SRS wiring harnesses can be identified by yellow and/or orange harnesses or harness connectors.

PRECAUTIONS WHEN USING POWER TOOLS (AIR OR ELECTRIC) AND HAMMERS

WARNING:

Always observe the following items for preventing accidental activation.

- When working near the Air Bag Diagnosis Sensor Unit or other Air Bag System sensors with the power switch ON, never use air or electric power tools or strike near the sensor(s) with a hammer. Heavy vibration could activate the sensor(s) and deploy the air bag(s), possibly causing serious injury.
- When using air or electric power tools or hammers, always switch the power switch OFF, disconnect the 12V battery, and wait at least 3 minutes before performing any service.

Precaution Necessary for Steering Wheel Rotation after 12V Battery Disconnect

INFOID:000000011104160

For vehicle with steering lock unit, if the 12V battery is disconnected or discharged, the steering wheel will lock and cannot be turned.

If turning the steering wheel is required with the 12V battery disconnected or discharged, follow the operation procedure below before starting the repair operation.

OPERATION PROCEDURE

1. Connect both 12V battery cables.

NOTE:

Supply power using jumper cables if 12V battery is discharged.

2. Turn the power switch to ACC position.
(At this time, the steering lock will be released.)
3. Disconnect both 12V battery cables. The steering lock will remain released with both 12V battery cables disconnected and the steering wheel can be turned.
4. Perform the necessary repair operation.
5. When the repair work is completed, re-connect both 12V battery cables. With the brake pedal released, turn the power switch from ACC position to ON position, then to LOCK position. (The steering wheel will lock when the power switch is turned to LOCK position.)
6. Perform All DTC Reading using CONSULT and delete DTC.

NOTE:

Multiple DTCs are detected when 12V battery cable is disconnected while power switch is in ACC position.

PRECAUTIONS

[TYPE 3]

< PRECAUTION >

Precaution for Procedure without Cowl Top Cover

INFOID:000000011104161

When performing the procedure after removing cowl top cover, cover the lower end of windshield with urethane, etc to prevent damage to windshield.

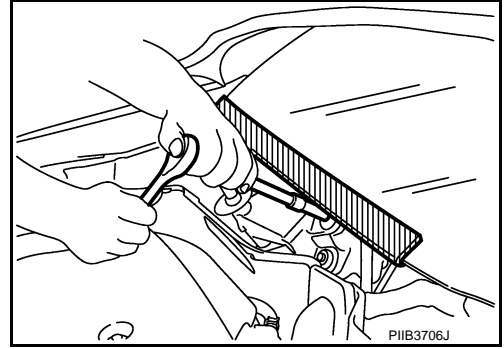

Precautions for Removing Battery Terminal

INFOID:000000011104162

- When removing the 12V battery terminal, turn OFF the power switch and wait at least 5 minutes.

NOTE:

ECU may be active for several minutes after the power switch is turned OFF. If the battery terminal is removed before ECU stops, then a DTC detection error or ECU data corruption may occur.

- Always disconnect the battery terminal within 60 minutes after turning OFF the power switch. Even when the power switch is OFF, the 12V battery automatic charge control may automatically start after a lapse of 60 minutes from power switch OFF.
- Disconnect 12V battery terminal according to the following steps.

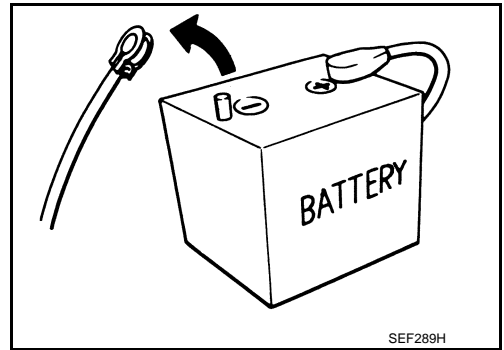

WORK PROCEDURE

1. Check that EVSE is not connected.

NOTE:

If EVSE is connected, the air conditioning system may be automatically activated by the timer A/C function.

2. Turn the power switch OFF → ON → OFF. Get out of the vehicle. Close all doors (including back door).
3. Check that the charge status indicator lamp does not blink and wait for 5 minutes or more.

NOTE:

If the battery is removed within 5 minutes after the power switch is turned OFF, plural DTCs may be detected.

4. Remove 12V battery terminal within 60 minutes after turning the power switch OFF → ON → OFF.

CAUTION:

- After all doors (including back door) are closed, if a door (including back door) is opened before battery terminals are disconnected, start over from Step 1.
- After turning the power switch OFF, if "Remote A/C" is activated by user operation, stop the air conditioner and start over from Step 1.

NOTE:

Once the power switch is turned ON → OFF, the 12V battery automatic charge control does not start for approximately 1 hour.

- For vehicles with the 2-batteries, be sure to connect the main battery and the sub battery before turning ON the power switch.

NOTE:

If the power switch is turned ON with any one of the terminals of main battery and sub battery disconnected, then DTC may be detected.

- After installing the 12V battery, always check "Self Diagnosis Result" of all ECUs and erase DTC.

NOTE:

The removal of 12V battery may cause a DTC detection error.

High Voltage Precautions

INFOID:000000011104163

DANGER:

A
B
EVB
D
E
F
G
H
I
J
K
L
M
N
O
P

PRECAUTIONS

< PRECAUTION >

[TYPE 3]



Since hybrid vehicles and electric vehicles contain a high voltage battery, there is the risk of electric shock, electric leakage, or similar accidents if the high voltage component and vehicle are handled incorrectly. Be sure to follow the correct work procedures when performing inspection and maintenance.

WARNING:

- Be sure to remove the service plug in order to disconnect the high voltage circuits before performing inspection or maintenance of high voltage system harnesses and parts.
- The removed service plug must always be carried in a pocket of the responsible worker or placed in the tool box during the procedure to prevent the plug from being connected by mistake.
- Be sure to wear insulated protective equipment before beginning work on the high voltage system.
- Never allow workers other than the responsible person to touch the vehicle containing high voltage parts. To keep others from touching the high voltage parts, these parts must be covered with an insulating sheet except when using them.

CAUTION:

Never bring the vehicle into the READY status with the service plug removed unless otherwise instructed in the Service Manual. A malfunction may occur if this is not observed.

HIGH VOLTAGE HARNESS AND EQUIPMENT IDENTIFICATION

All the high voltage harnesses and connectors are orange. The Li-ion battery and other high voltage devices include an orange high voltage label. Never touch these harnesses and high voltage parts.

HANDLING OF HIGH VOLTAGE HARNESS AND TERMINALS

Immediately insulate disconnected high voltage connectors and terminals with insulating tape.

REGULATIONS ON WORKERS WITH MEDICAL ELECTRONICS

WARNING:

The vehicle contains parts that contain powerful magnets. If a person who is wearing a heart pacemaker or other medical device is close to these parts, the medical device may be affected by the magnets. Such persons must not perform work on the vehicle.

PROHIBITED ITEMS TO CARRY DURING THE WORK

Hybrid vehicles and electric vehicles contain parts with high voltage and intense magnetic force. Never carry metal products and magnetic recording media (e.g. cash card, prepaid card) to repair/inspect high voltage parts. If this is not observed, the metal products may create a risk of short circuit and the magnetic recording media may lose their magnetic recording.

POSTING A SIGN OF “DANGER! HIGH VOLTAGE AREA. KEEP OUT”

PRECAUTIONS

< PRECAUTION >

[TYPE 3]

Indicate "HIGH VOLTAGE. DO NOT TOUCH" on the vehicle under repair/inspection to call attention to other workers.

Person in charge: _____
DO NOT TOUCH!
REPAIR IN PROGRESS.
HIGH VOLTAGE
DANGER:
DANGER:
HIGH VOLTAGE
REPAIR IN PROGRESS.
DO NOT TOUCH!
Person in charge: _____
Copy this page and put it after folding on the roof of the vehicle in service.
<small>JSAIA1600GB</small>

A
B
EVB
D
E
F
G
H
I
J
K
L
M
N
O
P

PREPARATION

< PREPARATION >

[TYPE 3]

PREPARATION

PREPARATION

Special Service Tools

INFOID:000000011192811

The actual shape of the tools may differ from those illustrated here.

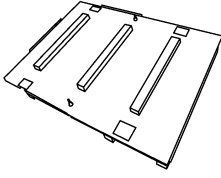
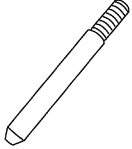
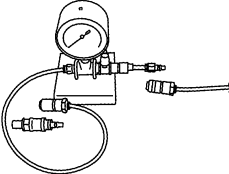
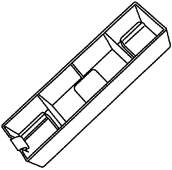
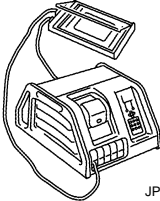
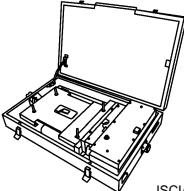
Tool number (TechMate No.) Tool name	Description
— (J-50583) Palette  JPCIA0239ZZ	When removing/installing Li-ion battery.
KV99111300 (J-50306) Battery location guide pin  JPCIA0023ZZ	When installing Li-ion battery. 2 piece/set
KV99111400 (—) Air leak tester  JSCIA0257ZZ	When checking air leaks after disassembling/assembling Li-ion battery.
KV99111500 (—) Module terminal cover  JPCIA0069ZZ	Protect module terminals (for LEAF) 24 pieces/set
— (J-50346) Module charge balancer  JPCIA0070ZZ	Module voltage adjustment
— (J-51031) Module charge balancer module box  JSCIA0726ZZ	Module voltage adjustment Use with the module charge balancer (J-50346).



PREPARATION

< PREPARATION >

[TYPE 3]

Commercial Service Tools

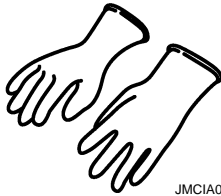
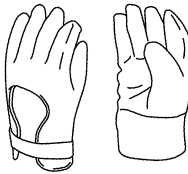
INFOID:000000011192812

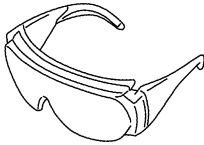
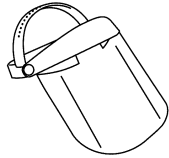
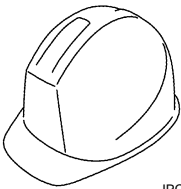
Tool name	Description
<p>Insulated gloves</p>  <p>JMCIA0149ZZ</p>	<p>Removing and installing high voltage components [Guaranteed insulation performance for 1000V/ 300A]</p>
<p>Leather gloves</p>  <p>JPCIA0066ZZ</p>	<ul style="list-style-type: none"> • Removing and installing high voltage components • Protect insulated gloves [Use leather gloves that can fasten the wrist tight]
<p>Insulated safety shoes</p>  <p>JPCIA0011ZZ</p>	<p>Removing and installing high voltage components</p>
<p>Safety glasses</p>  <p>JPCIA0012ZZ</p>	<ul style="list-style-type: none"> • Removing and installing high voltage components • To protect eye from the spatter on the work to electric line [ANSI Z87.1]
<p>Face shield</p>  <p>JPCIA0167ZZ</p>	<ul style="list-style-type: none"> • Removing and installing high voltage components • To protect face from the spatter on the work to electric line
<p>Insulated helmet</p>  <p>JPCIA0013ZZ</p>	<p>Removing and installing high voltage components</p>

A
B
EVB
D
E
F
G
H
I
J
K
L
M
N
O
P

PREPARATION

< PREPARATION >

[TYPE 3]

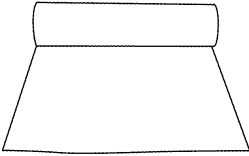
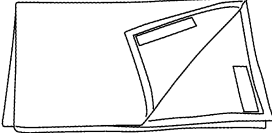
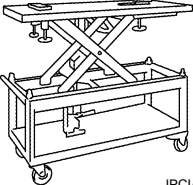
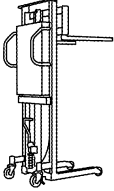
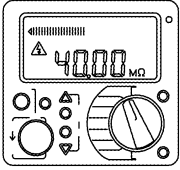
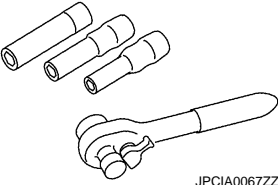
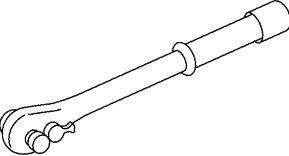
Tool name	Description
<p>Insulated rubber sheet</p>  <p style="text-align: right; font-size: small;">JPCIA0019ZZ</p>	<p>Removing and installing high voltage components</p>
<p>Insulated cover sheet</p>  <p style="text-align: right; font-size: small;">JPCIA0018ZZ</p>	<p>Removing and installing high voltage components</p>
<p>Battery lift table</p>  <p style="text-align: right; font-size: small;">JPCIA0024ZZ</p>	<p>Removing and installing Li-ion battery</p>
<p>Stacker</p>  <p style="text-align: right; font-size: small;">JPCIA0015ZZ</p>	<p>Removing and installing Li-ion battery</p>
<p>Insulation resistance tester (Multi tester)</p>  <p style="text-align: right; font-size: small;">JPCIA0014ZZ</p>	<p>Measuring insulation resistance, voltage, and resistance</p>
<p>Insulated hand tools</p>  <p style="text-align: right; font-size: small;">JPCIA0067ZZ</p>	<p>Removing and installing high voltage components</p>
<p>Insulated torque wrench</p>  <p style="text-align: right; font-size: small;">JPCIA0068ZZ</p>	<p>Removing and installing high voltage components</p>

PREPARATION

< PREPARATION >

[TYPE 3]

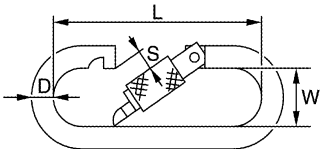
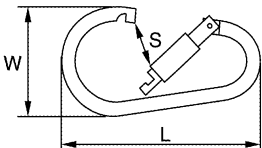
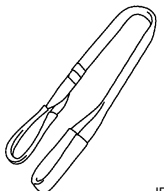
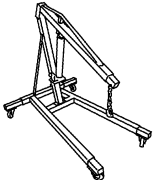
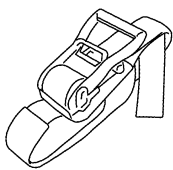
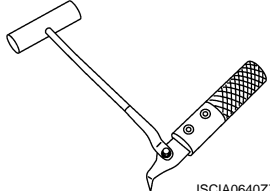
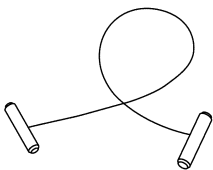
Tool name	Description
<p>Carabineer [small]</p>  <p style="text-align: center;">JPCIA0016ZZ</p>	<ul style="list-style-type: none"> • Removing and installing battery module stack • Installing battery pack upper case <p>NOTE:</p> <ul style="list-style-type: none"> • D: 8.0 mm (0.31 in) • L: 74.0 mm (2.91 in) • S: 10.0 mm (0.39 in) • W: 22.5 mm (0.89 in)
<p>Carabineer [large]</p>  <p style="text-align: center;">JPCIA0017ZZ</p>	<p>Removing and installing battery module stack</p> <p>NOTE:</p> <ul style="list-style-type: none"> • D: 14.0 mm (0.55 in) • L: 204.0 mm (8.03 in) • S: 47.0 mm (1.85 in) • W: 105.0 mm (4.13 in)
<p>Belt slinger</p>  <p style="text-align: center;">JPCIA0021ZZ</p>	<p>Removing and installing battery module stack</p> <p>NOTE:</p> <p>Length: 2.0 m (6.562 ft)</p>
<p>Mobile floor crane</p>  <p style="text-align: center;">JPCIA0020ZZ</p>	<p>Removing and installing battery module stack</p>
<p>Lashing belt</p>  <p style="text-align: center;">JPCIA0022ZZ</p>	<p>Removing and installing battery rear module stack</p>
<p>Windshield cutter [Gasket cutter]</p>  <p style="text-align: center;">JSCIA0640ZZ</p>	<p>Removing battery pack upper case (Cut the adhesive)</p>
<p>Piano wire with handles</p>  <p style="text-align: center;">JSCIA0641ZZ</p>	<p>Installing battery pack upper case (Cut the adhesive)</p> <p>NOTE:</p> <p>Wire size: ϕ 0.5 mm (0.02 in)</p>

A
B
EVB
D
E
F
G
H
I
J
K
L
M
N
O
P

PREPARATION

< PREPARATION >

[TYPE 3]

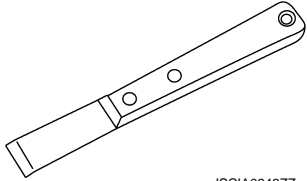
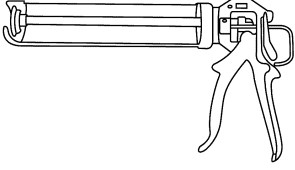
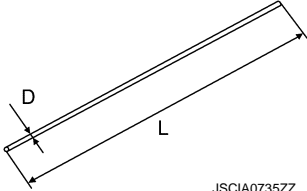
Tool name	Description
<p>Scraper</p> <div style="text-align: center;">  <p>JSCIA0643ZZ</p> </div>	<p>Installing battery pack upper case (Smooth the adhesive)</p>
<p>Tube presser [Gasket material applicator]</p> <div style="text-align: center;">  <p>JSCIA0639ZZ</p> </div>	<p>Installing battery pack upper case (Apply the adhesive)</p>
<p>Metal bar</p> <div style="text-align: center;">  <p>JSCIA0735ZZ</p> </div>	<p>Assembling battery module stack NOTE:</p> <ul style="list-style-type: none"> • D: ϕ 7 mm (0.28 in) • L: 1 m (3.28 ft)

Sealant or/and Lubricant

INFOID:000000011192813

Tool name Tool number	Description
<p>Adhesive 999MP-57302NP</p>	<p>Installing battery pack upper case</p>
<p>Dam rubber KA390-0059U</p>	
<p>Primer (Adhesive primer) 999MP-43533PP</p>	
<p>Primer sufacer (anti-corrosion praimer) —</p>	

COMPONENT PARTS

< SYSTEM DESCRIPTION >

[TYPE 3]

SYSTEM DESCRIPTION

COMPONENT PARTS

Component Parts Location

INFOID:000000011104166

A

B

EVB

D

E

F

G

H

I

J

K

L

M

N

O

P

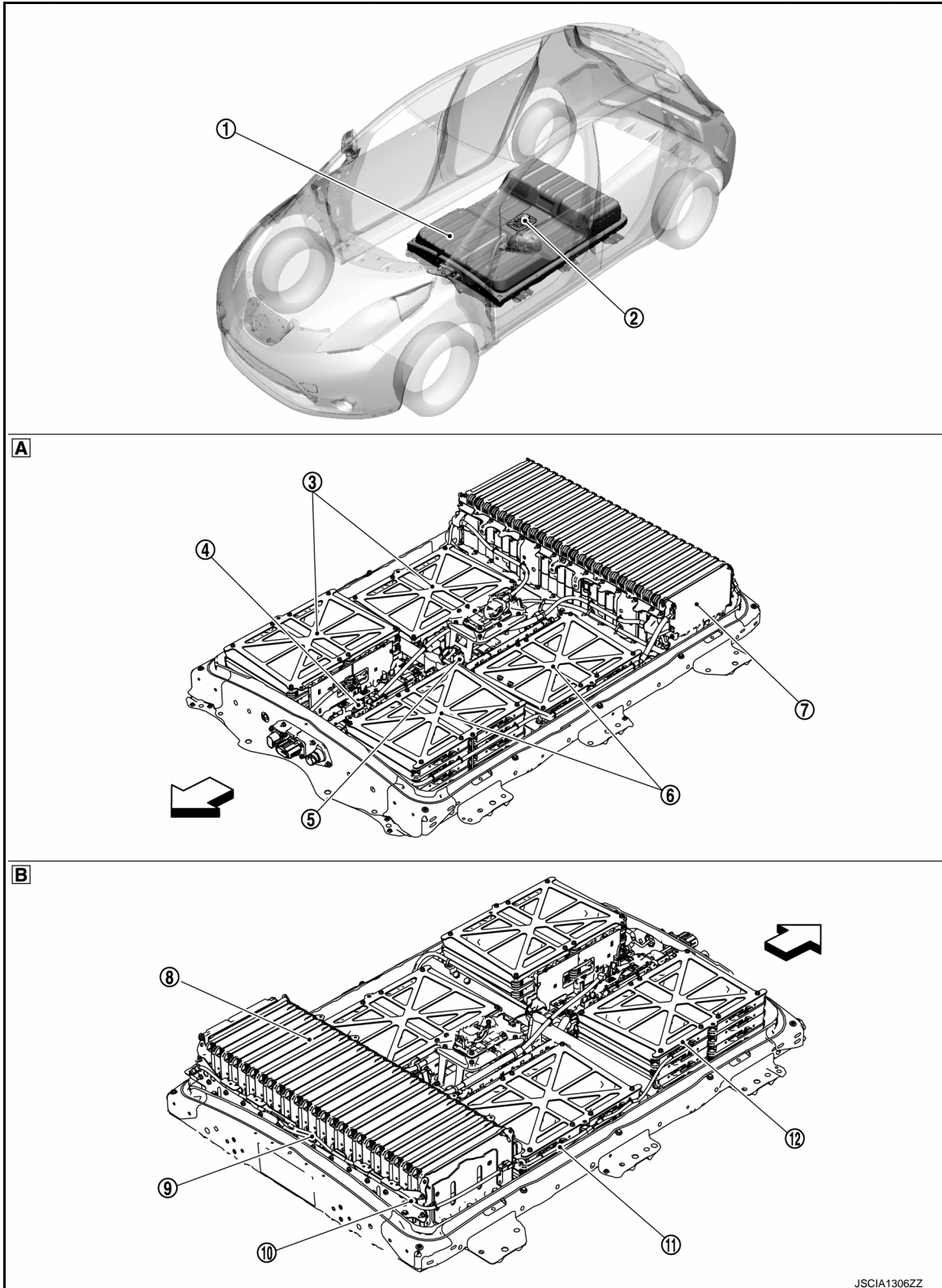

JSCIA1306ZZ

COMPONENT PARTS

< SYSTEM DESCRIPTION >

[TYPE 3]

A. Front of battery pack

B. Back of battery pack

↶ : Vehicle front

No.	Component	Function
1.	Li-ion battery	EVB-478, "Li-ion Battery"
2.	Service plug	EVB-481, "Service Plug"
3.	Front module stack RH	EVB-479, "Module"
4.	Battery junction box	EVB-481, "Battery Junction Box"
5.	Battery current sensor	EVB-480, "Battery Current Sensor"
6.	Front module stack LH	EVB-479, "Module"
7.	Li-ion battery controller	EVB-479, "Li-ion Battery Controller"
8.	Rear module stack	EVB-479, "Module"
9.	Battery temperature sensor 1	EVB-481, "Battery Temperature Sensor"
10.	Battery temperature sensor 3	EVB-481, "Battery Temperature Sensor"
11.	Battery temperature sensor 4	EVB-481, "Battery Temperature Sensor"
12.	Battery temperature sensor 2	EVB-481, "Battery Temperature Sensor"

Li-ion Battery

INFOID:000000011104167

- A Li-ion battery with flat construction is placed under floor.
- The battery pack is equipped with necessary devices, such as Li-ion battery controller, battery junction box, and service plug in addition to a battery storing electricity.

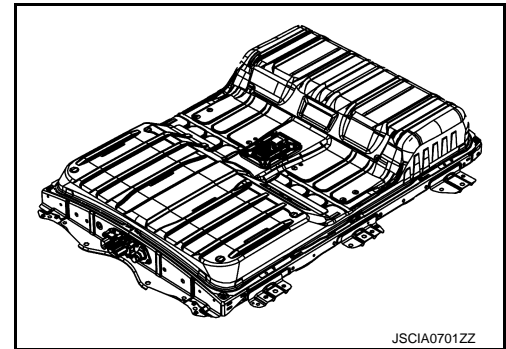

- Four cells are integrated into a single module. The Li-ion battery consists of 48 modules placed in series.

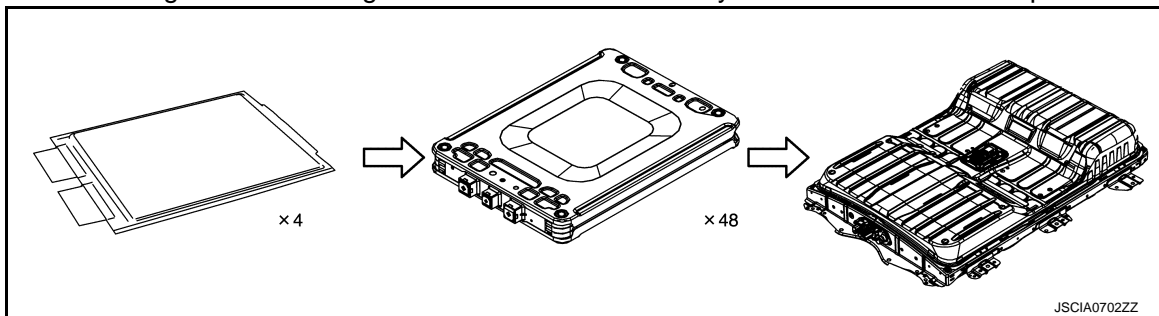

COMPONENT PARTS

< SYSTEM DESCRIPTION >

[TYPE 3]

Li-ion Battery Controller

INFOID:0000000011104168

- Li-ion battery controller (LBC) is included in the battery pack and installed on the left surface of the rear module stack.

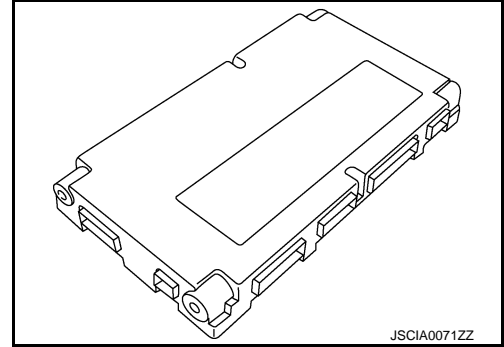

- The LBC is the core of battery control. Li-ion battery controller detects the voltage and current of the assembled battery, the temperature of each module, and the voltage of each cell to judge state of charge. LBC also calculates possible input/output values, meter indication values, and chargeable values, and send this data to VCM (Vehicle control module). VCM controls the vehicle, according to the battery state.

Main Role of Li-ion Battery Controller

1. Li-ion battery state check
 - State of charge
 - Possible output value
 - Possible input value
 - Temperature
2. Optimization of Li-ion battery voltage
3. Prevention of overvoltage and overcurrent
4. Prevention of overheat
5. Detection of decrease in insulation resistance of high-voltage circuit
6. Detection of a fit of high voltage harness connector and service plug

Module

INFOID:0000000011104169

- Four laminated cells are integrated into one module.
- The Li-ion battery is equipped with 48 modules.
- There are two kinds of modules, according to the location of positive and negative terminals.

Positive terminal : Red
Negative terminal : Black

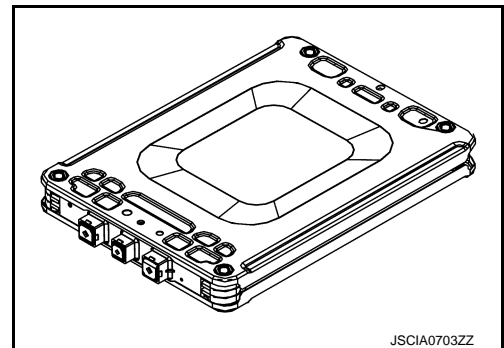

MODULE INTERNAL CIRCUIT

A module consists of two parallel-connected cells placed in series. The Li-ion battery has 48 modules placed in series in total. Ninety-six parallel-connected cell pairs are connected in series.

NOTE:

Cell voltage displayed on the data monitor of CONSULT means the potential difference between the upstream and the downstream of the parallel circuit.

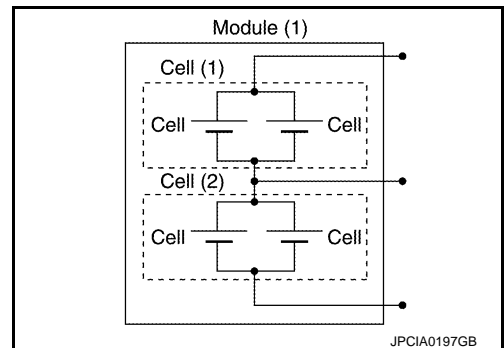

COMPONENT PARTS

< SYSTEM DESCRIPTION >

[TYPE 3]

MODULE LAYOUT

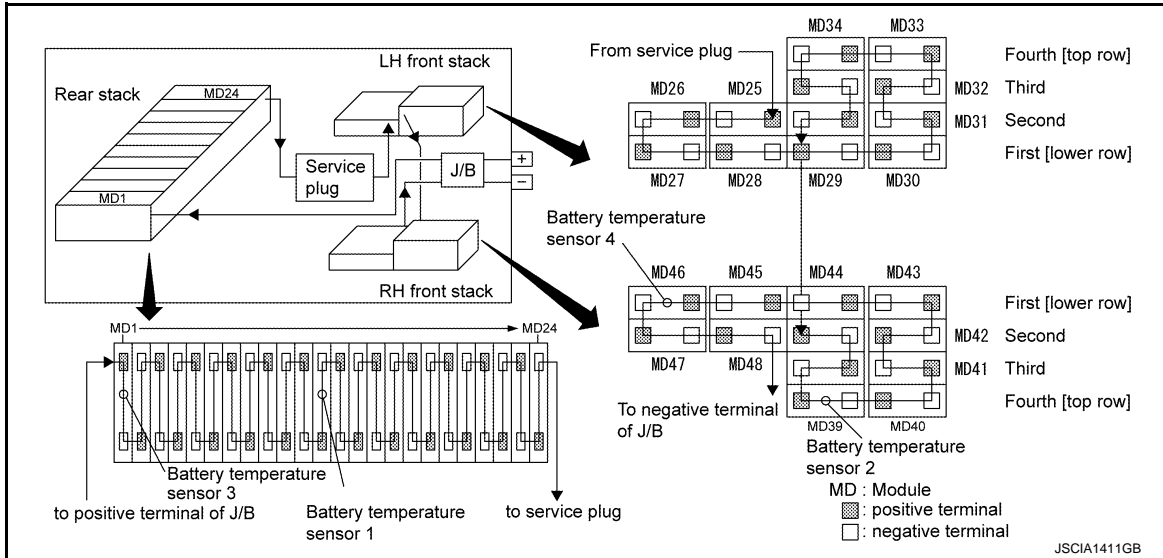

NOTE:

The highest potential is module (MD) 1 and the lowest is module (MD) 48.

CELL

These are thin laminated cells with excellent cooling performance.

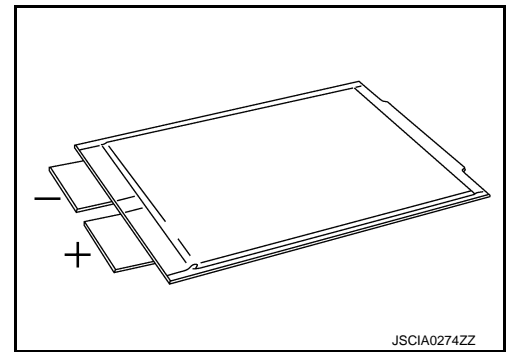

The Features of Laminated Cell

- Large surface area with excellent cooling performance reduces heat load to the battery and improves battery life.
- Light and thin structure increases flexibility in layout.

Battery Current Sensor

INFOID:000000011195530

- The battery current sensor is installed to bus bar between battery junction box and rear module stack.
- This sensor measures charge/discharge current sent to Li-ion battery and transmits a current signal to Li-ion battery controller (LBC).
- Li-ion Battery controller (LBC) measures remaining battery level according to charge/discharge current and sends the data to VCM.

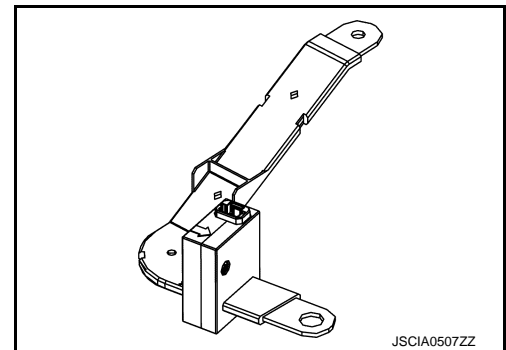

COMPONENT PARTS

< SYSTEM DESCRIPTION >

[TYPE 3]

Battery Temperature Sensor

INFOID:000000011104170

- Four battery temperature sensors mounted in the battery pack measure the temperature.
- Right and left front module stacks have one battery temperature sensor, respectively, and the rear module stack has two.

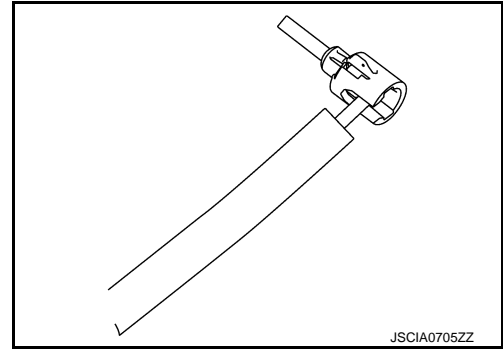

- The sensor uses a thermistor with a resistance value that varies according to changes in temperature. The electrical resistance of the thermistor decreases as the temperature increases.

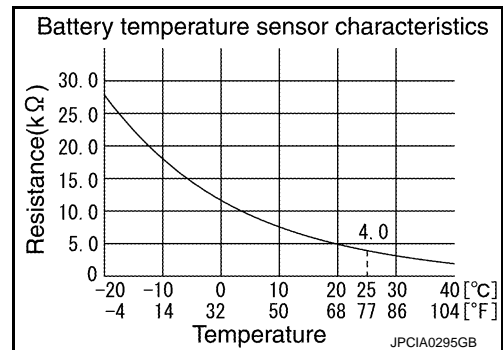

Battery Junction Box

INFOID:000000011104171

- The battery junction box is installed to the front side in the battery pack.
- The battery junction box includes:
 - System main relay to provide/interrupt DC current sent from Li-ion battery.
 - Pre-charge relay to protect the high voltage circuit from a high current immediately after power switch ON.
- Installed to both positive side and negative side, the system main relay provides DC current to each high voltage part. In addition, the system main relay provides DC current to the Li-ion battery during motor regeneration or charge.
- When an error occurs in the system, the system main relay is turned OFF and the Li-ion battery is interrupted for ensuring safety, based on a command from VCM (Vehicle control module).

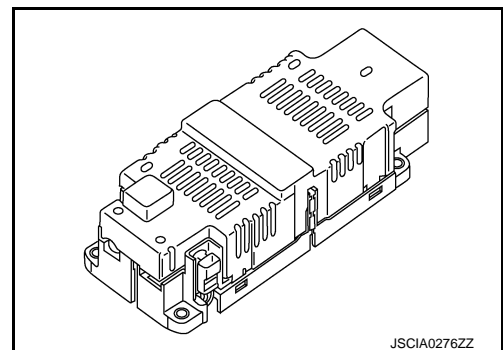

Service Plug

INFOID:000000011104172

- The service plug is included in the Li-ion battery to securely disconnect the high voltage during high voltage part inspection and maintenance.
- The service plug is installed on the upper surface of the battery pack. The plug can be removed when the leg-room mounted service plug cover is removed.
- Always use insulating protective equipment when removing and installing service plug.

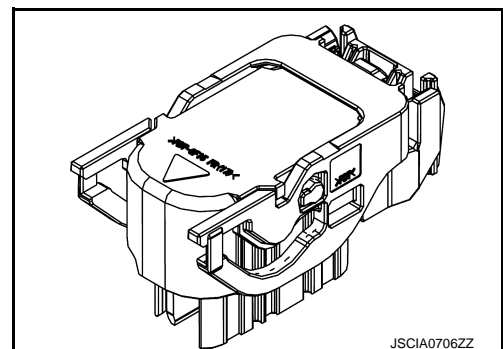

High Voltage Warning Label

INFOID:000000011104173

High voltage warning label is affixed to each of the following component parts.

A
B
EVB
D
E
F
G
H
I
J
K
L
M
N
O
P

COMPONENT PARTS

[TYPE 3]

< SYSTEM DESCRIPTION >

After replacing a part, check that the part is affixed with a label. If the label is not affixed, be sure to affix the label in the original position.

Li-ion Battery

- The label (A) is affixed to the rear end of Li-ion battery.

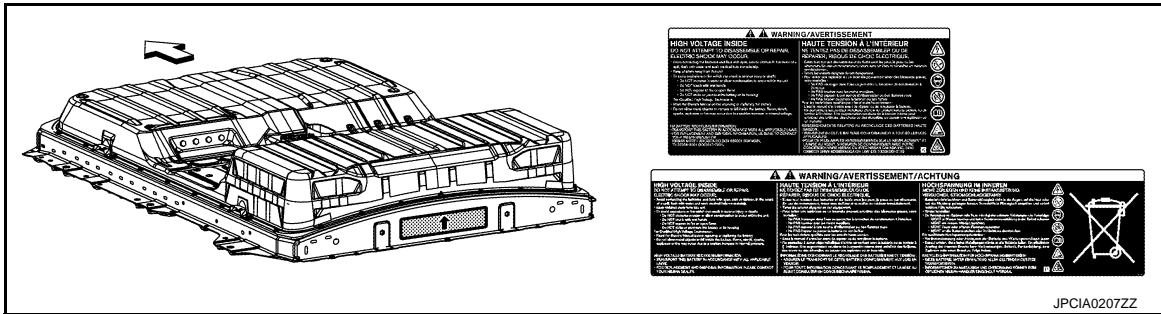

↔ : Vehicle front

← : Direction of the label

- The label (A) is affixed to the body panel near the high voltage harness connector.

↔ : Vehicle front

← : Direction of the label

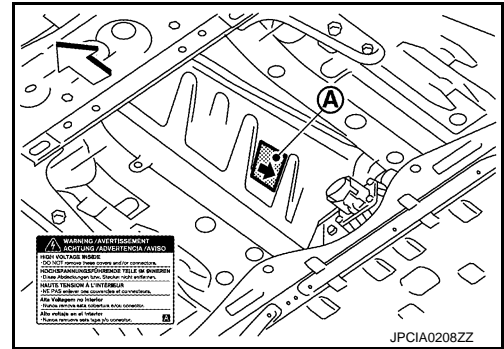

Li-ion Battery Controller

The label is affixed to the main body of controller.

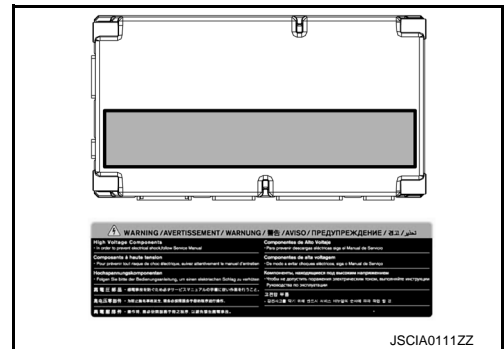

Service Plug

The label is affixed to the inspection hole cover (1).

← : Direction of the label

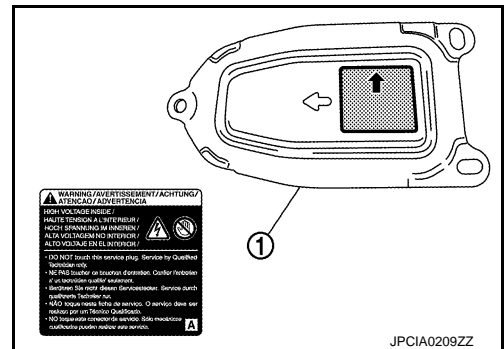

SYSTEM

System Description

INFOID:000000011104174

SYSTEM DIAGRAM

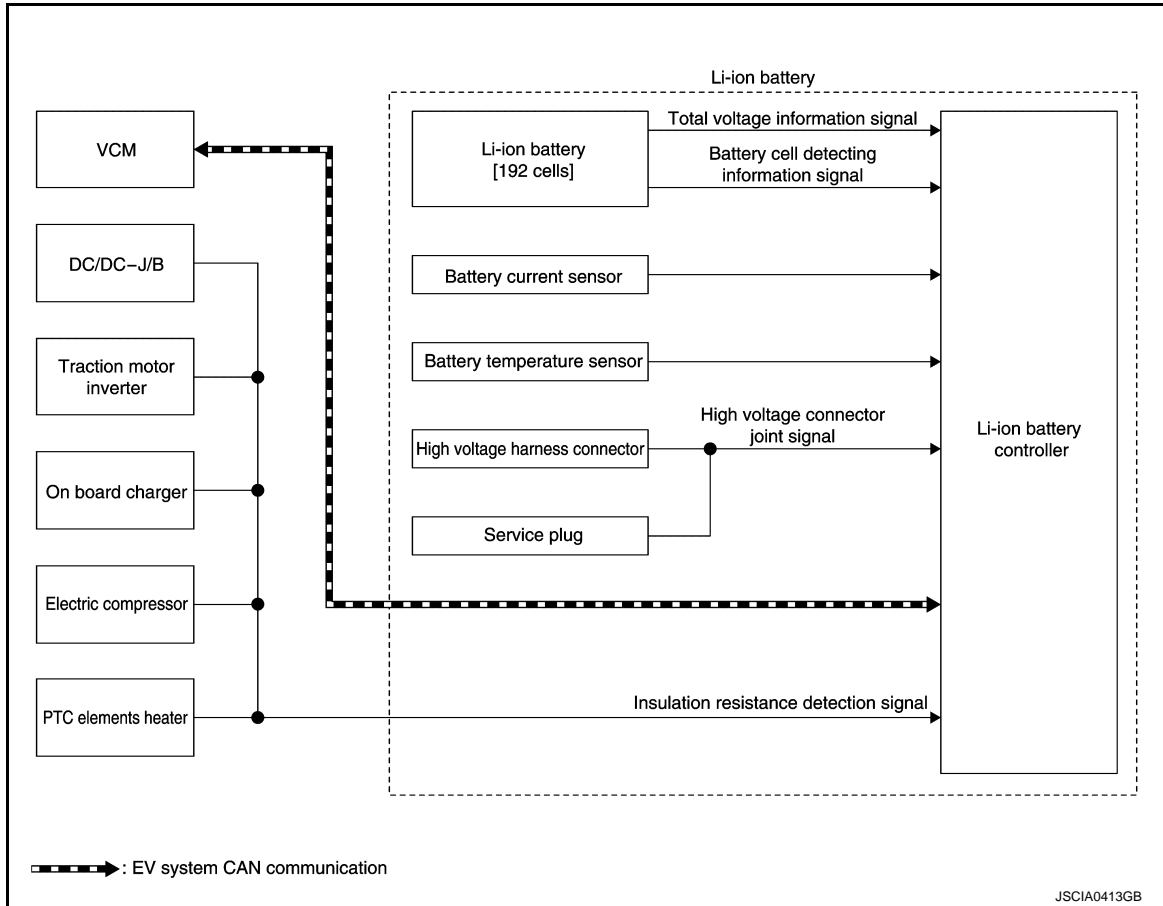

INPUT/OUTPUT SIGNAL ITEM

Input Signal Item

Transmit unit	Signal name	
VCM	EV system CAN	Target Li-ion battery remained energy signal

Output Signal Item

A
B
EVB
D
E
F
G
H
I
J
K
L
M
N
O
P

SYSTEM

< SYSTEM DESCRIPTION >

[TYPE 3]

Received unit	Signal name	
VCM	EV system CAN	High voltage discharge permit signal
		Li-ion battery main relay cut request signal
		Li-ion battery connector interlock signal
		Li-ion battery voltage signal
		Li-ion battery current signal
		Li-ion battery chargeable power signal
		Li-ion battery dischargeable power signal
		Li-ion battery chargeable completion signal
		Li-ion battery available charge signal
		Li-ion battery capacity signal
		Li-ion battery gradual capacity loss signal
		Insulation resistance signal

DESCRIPTION

The Li-ion battery controller (LBC) monitors the status of the inside of the Li-ion battery at all times and sends information, such as the charging status of Li-ion battery and possible power, to VCM (vehicle control module) via EV system CAN communication.

The Li-ion battery controller performs control as per the following.

- Monitors the battery state and transfers chargeable/dischargeable power to VCM to prevent an error, such as overvoltage, over discharge or excessive temperature rise in the battery.
- Detects an error (overvoltage, over discharge, overcurrent, or excessive temperature rise) immediately at the time of error occurrence and requests VCM to disconnect the system main relay to interrupt the discharge/charge line.
- Maintains the optimum battery state constantly with a cell capacity adjustment function to prevent a reduction in charging/discharging capacity caused by cell capacity variations.
- Detects the connector fit state with the function to detect the fit of the high voltage harness connector and transfers the detected state to VCM so that the vehicle does not start with an unsteady state.
- Detects the insulation resistance state with the function to detect the insulation resistance between high and low voltage and transfers the detected state to VCM so that the vehicle does not start with an unusual state.
- Estimates a battery charge state and low battery state, based on the data obtained with the battery state detection function, and reflects on the battery capacity meter.

BATTERY PROTECTION

The Li-ion battery has a voltage range capable of charge/discharge. If charged/discharged exceeding the range, excessive low capacity or malfunction may be caused. To prevent this, the Li-ion battery controller detects voltage of each cell and requests the control of charging/discharging energy to VCM so that the cell voltage stays within the voltage range.

Control item	Control	Operating condition
Overvoltage/overcurrent protection	Charging energy control	Gradual control of charging energy as the cell voltage approaches the upper limit of the voltage capable of charging.
	System main relay cut	Cell voltage exceeds the voltage judged as overvoltage and maintains the voltage for more than the specified time.
Over discharge protection	Discharging energy control	Gradual control of discharging energy as the cell voltage approaches the lower limit of the voltage capable of discharging.
	System main relay cut	Cell voltage exceeds the voltage judged as over discharge and maintains the voltage for more than the specified time.
Excessive temperature rise protection	Charging/discharging energy control	Gradual control of charging/discharging energy as Li-ion battery temperature approaches the upper limit of the temperature capable of use.
	System main relay cut	Li-ion battery temperature exceeds the temperature judged as excessive temperature rise and maintains the temperature for more than the specified time.

HOW TO ADJUST CELL CAPACITY

During cell capacity adjustment, the capacity of each cell is estimated based on the no-load voltage when the system starts, and the capacities are adjusted so that they are all at the target level. The voltage of each cell is detected inside the Li-ion battery controller. The bypass switches are then turned ON to discharge the cells that have excess capacity. In this way, capacity adjustment by the Li-ion battery controller allows the capacity of all cells to be fully utilized.

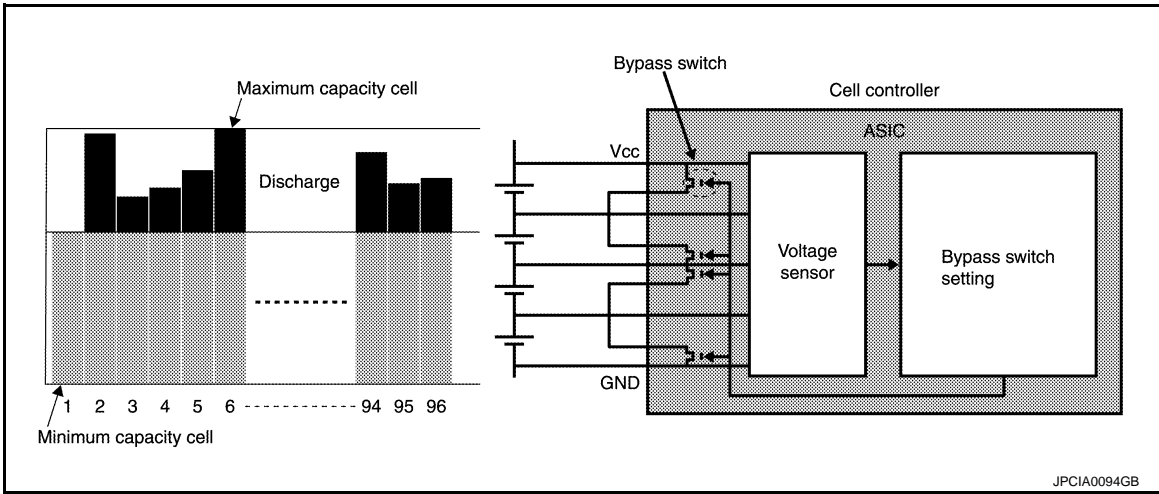

INSULATION RESISTANCE LOSS DETECTION FUNCTION

The insulation resistance detection circuit mounted inside the Li-ion battery controller measures the insulation resistance of each high voltage part and sends the measurement results to VCM via EV system CAN communication.

VCM judges abnormal insulation resistance in each high voltage part, based on the received insulation resistance value.

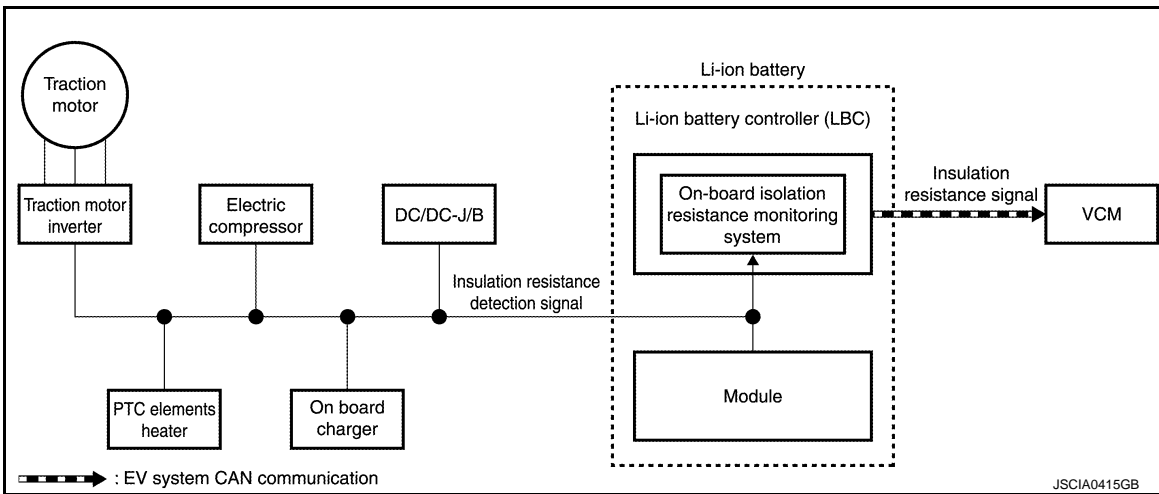

SYSTEM

< SYSTEM DESCRIPTION >

[TYPE 3]

Circuit Diagram

INFOID:000000011104175

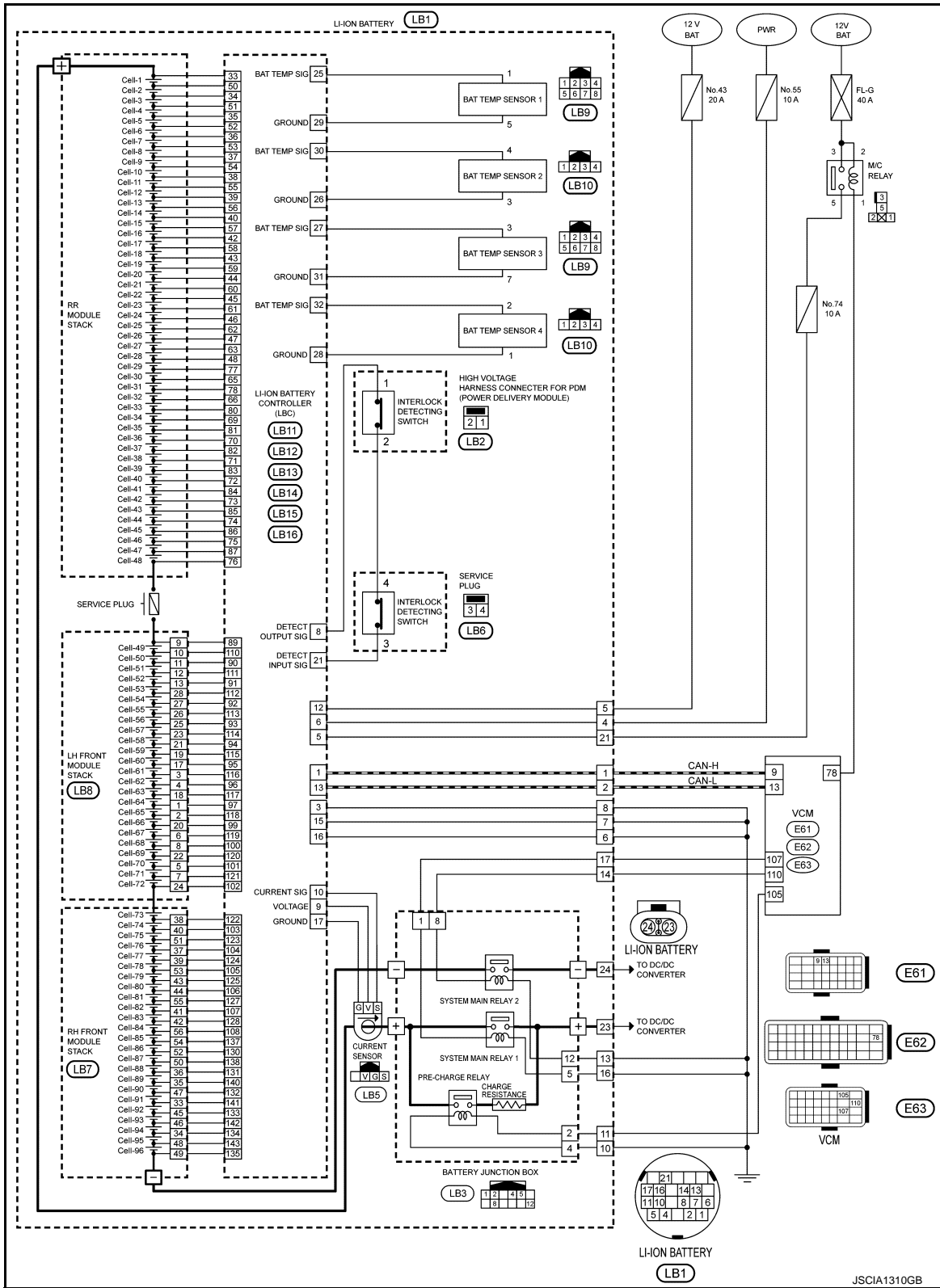

JSCIA1310GB

SYSTEM

< SYSTEM DESCRIPTION >

[TYPE 3]

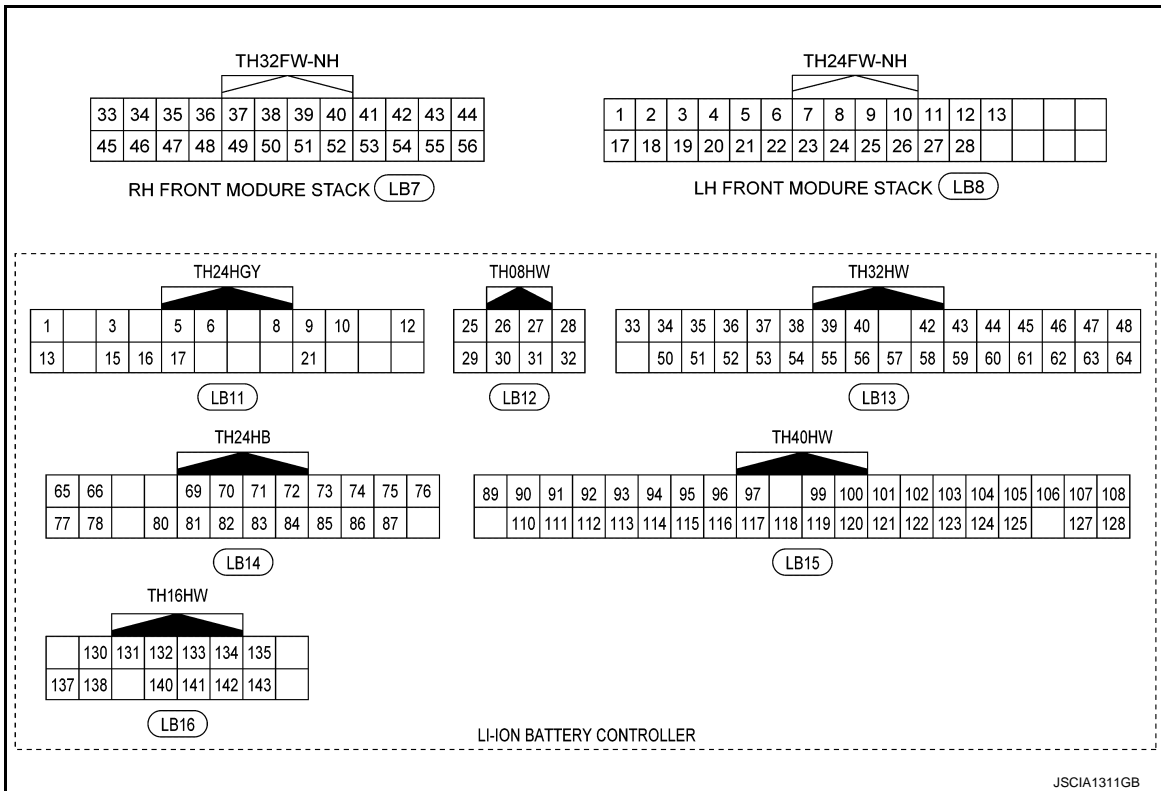

HARNESS LAYOUT

A
B
EVB
D
E
F
G
H
I
J
K
L
M
N
O
P

SYSTEM

< SYSTEM DESCRIPTION >

[TYPE 3]

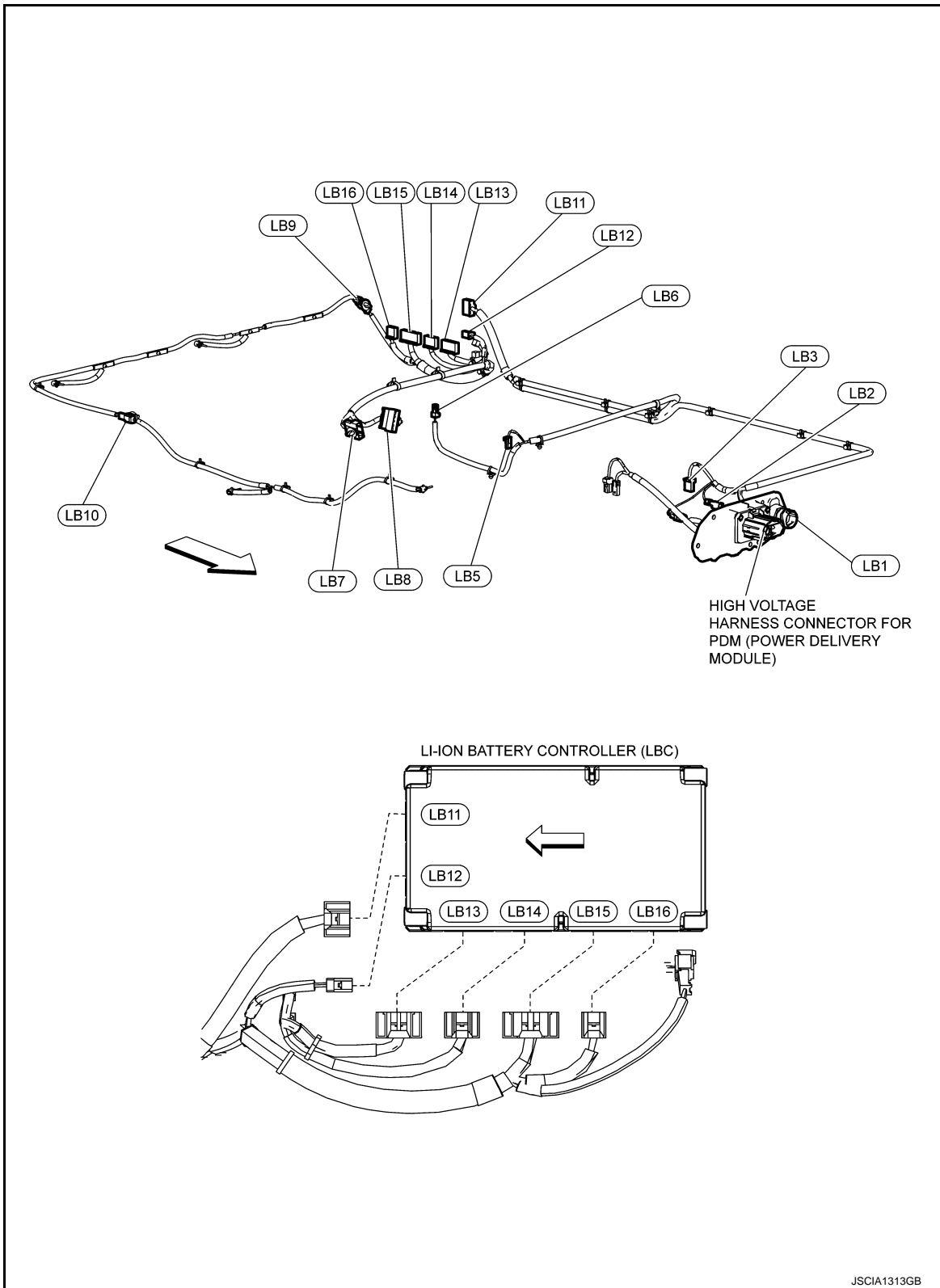

← : Vehicle front

HANDLING PRECAUTION

< SYSTEM DESCRIPTION >

[TYPE 3]

HANDLING PRECAUTION

EV Battery System

INFOID:0000000011104176

- To improve the Li-ion battery life, never perform quick charge heavily.
- Use the method of nighttime normal charge or timer-controlled charge.
- Never perform rapid acceleration/deceleration.
- Never place EV battery in an area exposed to direct sunlight or under high temperature conditions.

PRECAUTIONS FOR STORAGE OF THE LI-ION BATTERY

- Apply insulating tape to the service plug and high voltage harness connector, and protect the terminals so that nothing contacts them.
- Store in a well-ventilated location that is not exposed to direct sunlight.
(Storing outdoors or unprotected is prohibited.)
- Never set directly on the floor.
- Lay an anti-static rubber sheet underneath the battery.
- Never invert the battery.
- Never stack batteries.
- Cover with an anti-static cover sheet.
- Put a caution display stating "CAUTION! HIGH VOLTAGE" on the insulated cover sheet.
- Put identification display showing the name of person in charge on the insulated cover sheet.
- Never allow water to contact the battery.
- Prevent other objects from falling onto the battery.

A

B

EVB

D

E

F

G

H

I

J

K

L

M

N

O

P

DIAGNOSIS SYSTEM (LBC)

< SYSTEM DESCRIPTION >

[TYPE 3]

DIAGNOSIS SYSTEM (LBC)

CONSULT Function

INFOID:000000011104177

APPLICATION ITEM

CONSULT performs the following functions via CAN communication with Li-ion battery controller (LBC).

Item	Function
ECU Identification	LBC parts number can be read.
Self-diagnostic Results	Self-diagnostic results and freeze frame data can be read and erased quickly.*
Data Monitor	Input/Output data in LBC can be read.
Work Support	This mode enables a technician to adjust some devices faster and more accurately by following the indications on the CONSULT.
CAN Diagnosis	Displays the CAN diagnosis results.
CAN Diagnosis Support Monitor	Displays the CAN communication status.

*: The following diagnosis information is cleared when the VCM memory is erased.

- Diagnostic trouble codes
- Freeze frame data

ECU IDENTIFICATION

Part number of LBC can be checked.

SELF-DIAGNOSTIC RESULTS

Self Diagnostic Item

Regarding items of DTC, refer to [EVB-502. "DTC Index"](#).

How to Erase DTC

1. Select "HV BAT" with CONSULT.
2. "SELF-DIAGNOSTIC RESULTS".
3. Touch "ERASE". (DTC in LBC will be erased.)

FREEZE FRAME DATA (FFD)

The following vehicle status is recorded when DTC is detected and is displayed on CONSULT.

Monitored item (Unit)	Remarks	
DTC	Displays the DTC which caused FFD memory	
BATT ELECTRIC CURRENT	A	Displays the Li-ion battery current value
12V BATTERY VOLTAGE	mV	Displays 12V battery power supply voltage
IR SEN SHORT PULSE	mV	Displays the maximum to minimum difference of voltage magnitude of the on-board isolation resistance monitoring system
SERVICE PLUG INTERLOCK	OPEN / CLOSE	Displays the OPEN/CLOSE state of the service plug
CELL VOLTAGE 01 - 96	mV	Displays each cell voltage
TOTAL BATTERY VOLTAGE	V	Displays the total voltage of the Li-ion battery
BATTERY TEMPERATURE 1	°C	Displays the temperature calculated with a signal voltage from battery temperature 1
BATTERY TEMPERATURE 2	°C	Displays the temperature calculated with a signal voltage from battery temperature 2
BATTERY TEMPERATURE 3	°C	Displays the temperature calculated with a signal voltage from battery temperature 3
BATTERY TEMPERATURE 4	°C	Displays the temperature calculated with a signal voltage from battery temperature 4

DATA MONITOR

DIAGNOSIS SYSTEM (LBC)

< SYSTEM DESCRIPTION >

[TYPE 3]

Monitored item	Unit	Remark
BATT ELECTRIC CURRENT	A	Displays the Li-ion battery current value
12V BATTERY VOLTAGE	mV	Displays 12V battery power supply voltage
IR SEN SHORT PULSE	mV	Displays the maximum to minimum difference of voltage magnitude of the on-board isolation resistance monitoring system
SERVICE PLUG INTERLOCK	OPEN / CLOSE	Displays the OPEN/CLOSE state of the service plug
CELL VOLTAGE 01 - 96	mV	Displays each cell voltage
TOTAL BATTERY VOLTAGE	V	Displays the total voltage of the Li-ion battery
MAXIMUM CELL VOLTAGE	mV	Displays the maximum cell voltage value
MINIMUM CELL VOLTAGE	mV	Displays the minimum cell voltage value
BATTERY TEMPERATURE 1	°C	Displays the temperature calculated with a signal voltage from battery temperature 1
BATTERY TEMPERATURE 2	°C	Displays the temperature calculated with a signal voltage from battery temperature 2
BATTERY TEMPERATURE 3	°C	Displays the temperature calculated with a signal voltage from battery temperature 3
BATTERY TEMPERATURE 4	°C	Displays the temperature calculated with a signal voltage from battery temperature 4

WORK SUPPORT

Work item	Description	Usage
SAVE BATTERY INFORMATION DATA	Data saved in LBC is stored in CONSULT.	When Li-ion battery and LBC are replaced.
WRITE BATTERY INFORMATION DATA	The CONSULT-stored data can be written in LBC.	When Li-ion battery and LBC are replaced.
CLEAR BATTERY GRADUAL CAPACITY LOSS DATA	Battery capacity data stored in LBC can be erased.	When all modules of Li-ion battery are replaced.
CLEAR BATT CHARGE/DISCHARGE INFORMATION DATA	Battery charge/discharge data stored in LBC can be erased.	When all modules of Li-ion battery are replaced.
CELL VOLTAGE LOSS INSPECTION	This inspection identifies a cell of which cell voltage is on the decrease. If identified, this type of cell may be judged as an abnormal cell, unless it is replaced.	When checking voltage of all cells.

EV BATTERY SYSTEM

< ECU DIAGNOSIS INFORMATION >

[TYPE 3]

ECU DIAGNOSIS INFORMATION

EV BATTERY SYSTEM

Reference Value

INFOID:0000000011104178

VALUE ON THE DIAGNOSIS TOOL

NOTE:

Specification data are reference values.

Monitor item	Condition		Values / Status
BATT ELECTRIC CURRENT	READY	Stop the vehicle	Approx. (-10) - (+20) A
12V BATTERY VOLTAGE	READY		Approx. 1,100 - 1,400 mV
IR SEN SHORT PULSE	READY		Approx. 4,100 - 4,300 mV
SERVICE PLUG INTER-LOCK	READY	Connect service plug	REQ
	READY	Disconnect service plug	NOT REQ
CELL VOLTAGE 01	READY	Total battery voltage 317 V	Approx. 3,200 - 3,400 mV
		Total battery voltage 393 V	Approx. 4,000 - 4,200 mV
CELL VOLTAGE 02	READY	Total battery voltage 317 V	Approx. 3,200 - 3,400 mV
		Total battery voltage 393 V	Approx. 4,000 - 4,200 mV
CELL VOLTAGE 03	READY	Total battery voltage 317 V	Approx. 3,200 - 3,400 mV
		Total battery voltage 393 V	Approx. 4,000 - 4,200 mV
CELL VOLTAGE 04	READY	Total battery voltage 317 V	Approx. 3,200 - 3,400 mV
		Total battery voltage 393 V	Approx. 4,000 - 4,200 mV
CELL VOLTAGE 05	READY	Total battery voltage 317 V	Approx. 3,200 - 3,400 mV
		Total battery voltage 393 V	Approx. 4,000 - 4,200 mV
CELL VOLTAGE 06	READY	Total battery voltage 317 V	Approx. 3,200 - 3,400 mV
		Total battery voltage 393 V	Approx. 4,000 - 4,200 mV
CELL VOLTAGE 07	READY	Total battery voltage 317 V	Approx. 3,200 - 3,400 mV
		Total battery voltage 393 V	Approx. 4,000 - 4,200 mV
CELL VOLTAGE 08	READY	Total battery voltage 317 V	Approx. 3,200 - 3,400 mV
		Total battery voltage 393 V	Approx. 4,000 - 4,200 mV
CELL VOLTAGE 09	READY	Total battery voltage 317 V	Approx. 3,200 - 3,400 mV
		Total battery voltage 393 V	Approx. 4,000 - 4,200 mV
CELL VOLTAGE 10	READY	Total battery voltage 317 V	Approx. 3,200 - 3,400 mV
		Total battery voltage 393 V	Approx. 4,000 - 4,200 mV
CELL VOLTAGE 11	READY	Total battery voltage 317 V	Approx. 3,200 - 3,400 mV
		Total battery voltage 393 V	Approx. 4,000 - 4,200 mV
CELL VOLTAGE 12	READY	Total battery voltage 317 V	Approx. 3,200 - 3,400 mV
		Total battery voltage 393 V	Approx. 4,000 - 4,200 mV
CELL VOLTAGE 13	READY	Total battery voltage 317 V	Approx. 3,200 - 3,400 mV
		Total battery voltage 393 V	Approx. 4,000 - 4,200 mV
CELL VOLTAGE 14	READY	Total battery voltage 317 V	Approx. 3,200 - 3,400 mV
		Total battery voltage 393 V	Approx. 4,000 - 4,200 mV
CELL VOLTAGE 15	READY	Total battery voltage 317 V	Approx. 3,200 - 3,400 mV
		Total battery voltage 393 V	Approx. 4,000 - 4,200 mV

EV BATTERY SYSTEM

< ECU DIAGNOSIS INFORMATION >

[TYPE 3]

Monitor item	Condition		Values / Status
CELL VOLTAGE 16	READY	Total battery voltage 317 V	Approx. 3,200 - 3,400 mV
		Total battery voltage 393 V	Approx. 4,000 - 4,200 mV
CELL VOLTAGE 17	READY	Total battery voltage 317 V	Approx. 3,200 - 3,400 mV
		Total battery voltage 393 V	Approx. 4,000 - 4,200 mV
CELL VOLTAGE 18	READY	Total battery voltage 317 V	Approx. 3,200 - 3,400 mV
		Total battery voltage 393 V	Approx. 4,000 - 4,200 mV
CELL VOLTAGE 19	READY	Total battery voltage 317 V	Approx. 3,200 - 3,400 mV
		Total battery voltage 393 V	Approx. 4,000 - 4,200 mV
CELL VOLTAGE 20	READY	Total battery voltage 317 V	Approx. 3,200 - 3,400 mV
		Total battery voltage 393 V	Approx. 4,000 - 4,200 mV
CELL VOLTAGE 21	READY	Total battery voltage 317 V	Approx. 3,200 - 3,400 mV
		Total battery voltage 393 V	Approx. 4,000 - 4,200 mV
CELL VOLTAGE 22	READY	Total battery voltage 317 V	Approx. 3,200 - 3,400 mV
		Total battery voltage 393 V	Approx. 4,000 - 4,200 mV
CELL VOLTAGE 23	READY	Total battery voltage 317 V	Approx. 3,200 - 3,400 mV
		Total battery voltage 393 V	Approx. 4,000 - 4,200 mV
CELL VOLTAGE 24	READY	Total battery voltage 317 V	Approx. 3,200 - 3,400 mV
		Total battery voltage 393 V	Approx. 4,000 - 4,200 mV
CELL VOLTAGE 25	READY	Total battery voltage 317 V	Approx. 3,200 - 3,400 mV
		Total battery voltage 393 V	Approx. 4,000 - 4,200 mV
CELL VOLTAGE 26	READY	Total battery voltage 317 V	Approx. 3,200 - 3,400 mV
		Total battery voltage 393 V	Approx. 4,000 - 4,200 mV
CELL VOLTAGE 27	READY	Total battery voltage 317 V	Approx. 3,200 - 3,400 mV
		Total battery voltage 393 V	Approx. 4,000 - 4,200 mV
CELL VOLTAGE 28	READY	Total battery voltage 317 V	Approx. 3,200 - 3,400 mV
		Total battery voltage 393 V	Approx. 4,000 - 4,200 mV
CELL VOLTAGE 29	READY	Total battery voltage 317 V	Approx. 3,200 - 3,400 mV
		Total battery voltage 393 V	Approx. 4,000 - 4,200 mV
CELL VOLTAGE 30	READY	Total battery voltage 317 V	Approx. 3,200 - 3,400 mV
		Total battery voltage 393 V	Approx. 4,000 - 4,200 mV
CELL VOLTAGE 31	READY	Total battery voltage 317 V	Approx. 3,200 - 3,400 mV
		Total battery voltage 393 V	Approx. 4,000 - 4,200 mV
CELL VOLTAGE 32	READY	Total battery voltage 317 V	Approx. 3,200 - 3,400 mV
		Total battery voltage 393 V	Approx. 4,000 - 4,200 mV
CELL VOLTAGE 33	READY	Total battery voltage 317 V	Approx. 3,200 - 3,400 mV
		Total battery voltage 393 V	Approx. 4,000 - 4,200 mV
CELL VOLTAGE 34	READY	Total battery voltage 317 V	Approx. 3,200 - 3,400 mV
		Total battery voltage 393 V	Approx. 4,000 - 4,200 mV
CELL VOLTAGE 35	READY	Total battery voltage 317 V	Approx. 3,200 - 3,400 mV
		Total battery voltage 393 V	Approx. 4,000 - 4,200 mV
CELL VOLTAGE 36	READY	Total battery voltage 317 V	Approx. 3,200 - 3,400 mV
		Total battery voltage 393 V	Approx. 4,000 - 4,200 mV
CELL VOLTAGE 37	READY	Total battery voltage 317 V	Approx. 3,200 - 3,400 mV
		Total battery voltage 393 V	Approx. 4,000 - 4,200 mV

A

B

EVB

D

E

F

G

H

I

J

K

L

M

N

O

P

EV BATTERY SYSTEM

< ECU DIAGNOSIS INFORMATION >

[TYPE 3]

Monitor item	Condition	Values / Status	
CELL VOLTAGE 38	READY	Total battery voltage 317 V	Approx. 3,200 - 3,400 mV
		Total battery voltage 393 V	Approx. 4,000 - 4,200 mV
CELL VOLTAGE 39	READY	Total battery voltage 317 V	Approx. 3,200 - 3,400 mV
		Total battery voltage 393 V	Approx. 4,000 - 4,200 mV
CELL VOLTAGE 40	READY	Total battery voltage 317 V	Approx. 3,200 - 3,400 mV
		Total battery voltage 393 V	Approx. 4,000 - 4,200 mV
CELL VOLTAGE 41	READY	Total battery voltage 317 V	Approx. 3,200 - 3,400 mV
		Total battery voltage 393 V	Approx. 4,000 - 4,200 mV
CELL VOLTAGE 42	READY	Total battery voltage 317 V	Approx. 3,200 - 3,400 mV
		Total battery voltage 393 V	Approx. 4,000 - 4,200 mV
CELL VOLTAGE 43	READY	Total battery voltage 317 V	Approx. 3,200 - 3,400 mV
		Total battery voltage 393 V	Approx. 4,000 - 4,200 mV
CELL VOLTAGE 44	READY	Total battery voltage 317 V	Approx. 3,200 - 3,400 mV
		Total battery voltage 393 V	Approx. 4,000 - 4,200 mV
CELL VOLTAGE 45	READY	Total battery voltage 317 V	Approx. 3,200 - 3,400 mV
		Total battery voltage 393 V	Approx. 4,000 - 4,200 mV
CELL VOLTAGE 46	READY	Total battery voltage 317 V	Approx. 3,200 - 3,400 mV
		Total battery voltage 393 V	Approx. 4,000 - 4,200 mV
CELL VOLTAGE 47	READY	Total battery voltage 317 V	Approx. 3,200 - 3,400 mV
		Total battery voltage 393 V	Approx. 4,000 - 4,200 mV
CELL VOLTAGE 48	READY	Total battery voltage 317 V	Approx. 3,200 - 3,400 mV
		Total battery voltage 393 V	Approx. 4,000 - 4,200 mV
CELL VOLTAGE 49	READY	Total battery voltage 317 V	Approx. 3,200 - 3,400 mV
		Total battery voltage 393 V	Approx. 4,000 - 4,200 mV
CELL VOLTAGE 50	READY	Total battery voltage 317 V	Approx. 3,200 - 3,400 mV
		Total battery voltage 393 V	Approx. 4,000 - 4,200 mV
CELL VOLTAGE 51	READY	Total battery voltage 317 V	Approx. 3,200 - 3,400 mV
		Total battery voltage 393 V	Approx. 4,000 - 4,200 mV
CELL VOLTAGE 52	READY	Total battery voltage 317 V	Approx. 3,200 - 3,400 mV
		Total battery voltage 393 V	Approx. 4,000 - 4,200 mV
CELL VOLTAGE 53	READY	Total battery voltage 317 V	Approx. 3,200 - 3,400 mV
		Total battery voltage 393 V	Approx. 4,000 - 4,200 mV
CELL VOLTAGE 54	READY	Total battery voltage 317 V	Approx. 3,200 - 3,400 mV
		Total battery voltage 393 V	Approx. 4,000 - 4,200 mV
CELL VOLTAGE 55	READY	Total battery voltage 317 V	Approx. 3,200 - 3,400 mV
		Total battery voltage 393 V	Approx. 4,000 - 4,200 mV
CELL VOLTAGE 56	READY	Total battery voltage 317 V	Approx. 3,200 - 3,400 mV
		Total battery voltage 393 V	Approx. 4,000 - 4,200 mV
CELL VOLTAGE 57	READY	Total battery voltage 317 V	Approx. 3,200 - 3,400 mV
		Total battery voltage 393 V	Approx. 4,000 - 4,200 mV
CELL VOLTAGE 58	READY	Total battery voltage 317 V	Approx. 3,200 - 3,400 mV
		Total battery voltage 393 V	Approx. 4,000 - 4,200 mV
CELL VOLTAGE 59	READY	Total battery voltage 317 V	Approx. 3,200 - 3,400 mV
		Total battery voltage 393 V	Approx. 4,000 - 4,200 mV

EV BATTERY SYSTEM

< ECU DIAGNOSIS INFORMATION >

[TYPE 3]

Monitor item	Condition		Values / Status
CELL VOLTAGE 60	READY	Total battery voltage 317 V	Approx. 3,200 - 3,400 mV
		Total battery voltage 393 V	Approx. 4,000 - 4,200 mV
CELL VOLTAGE 61	READY	Total battery voltage 317 V	Approx. 3,200 - 3,400 mV
		Total battery voltage 393 V	Approx. 4,000 - 4,200 mV
CELL VOLTAGE 62	READY	Total battery voltage 317 V	Approx. 3,200 - 3,400 mV
		Total battery voltage 393 V	Approx. 4,000 - 4,200 mV
CELL VOLTAGE 63	READY	Total battery voltage 317 V	Approx. 3,200 - 3,400 mV
		Total battery voltage 393 V	Approx. 4,000 - 4,200 mV
CELL VOLTAGE 64	READY	Total battery voltage 317 V	Approx. 3,200 - 3,400 mV
		Total battery voltage 393 V	Approx. 4,000 - 4,200 mV
CELL VOLTAGE 65	READY	Total battery voltage 317 V	Approx. 3,200 - 3,400 mV
		Total battery voltage 393 V	Approx. 4,000 - 4,200 mV
CELL VOLTAGE 66	READY	Total battery voltage 317 V	Approx. 3,200 - 3,400 mV
		Total battery voltage 393 V	Approx. 4,000 - 4,200 mV
CELL VOLTAGE 67	READY	Total battery voltage 317 V	Approx. 3,200 - 3,400 mV
		Total battery voltage 393 V	Approx. 4,000 - 4,200 mV
CELL VOLTAGE 68	READY	Total battery voltage 317 V	Approx. 3,200 - 3,400 mV
		Total battery voltage 393 V	Approx. 4,000 - 4,200 mV
CELL VOLTAGE 69	READY	Total battery voltage 317 V	Approx. 3,200 - 3,400 mV
		Total battery voltage 393 V	Approx. 4,000 - 4,200 mV
CELL VOLTAGE 70	READY	Total battery voltage 317 V	Approx. 3,200 - 3,400 mV
		Total battery voltage 393 V	Approx. 4,000 - 4,200 mV
CELL VOLTAGE 71	READY	Total battery voltage 317 V	Approx. 3,200 - 3,400 mV
		Total battery voltage 393 V	Approx. 4,000 - 4,200 mV
CELL VOLTAGE 72	READY	Total battery voltage 317 V	Approx. 3,200 - 3,400 mV
		Total battery voltage 393 V	Approx. 4,000 - 4,200 mV
CELL VOLTAGE 73	READY	Total battery voltage 317 V	Approx. 3,200 - 3,400 mV
		Total battery voltage 393 V	Approx. 4,000 - 4,200 mV
CELL VOLTAGE 74	READY	Total battery voltage 317 V	Approx. 3,200 - 3,400 mV
		Total battery voltage 393 V	Approx. 4,000 - 4,200 mV
CELL VOLTAGE 75	READY	Total battery voltage 317 V	Approx. 3,200 - 3,400 mV
		Total battery voltage 393 V	Approx. 4,000 - 4,200 mV
CELL VOLTAGE 76	READY	Total battery voltage 317 V	Approx. 3,200 - 3,400 mV
		Total battery voltage 393 V	Approx. 4,000 - 4,200 mV
CELL VOLTAGE 77	READY	Total battery voltage 317 V	Approx. 3,200 - 3,400 mV
		Total battery voltage 393 V	Approx. 4,000 - 4,200 mV
CELL VOLTAGE 78	READY	Total battery voltage 317 V	Approx. 3,200 - 3,400 mV
		Total battery voltage 393 V	Approx. 4,000 - 4,200 mV
CELL VOLTAGE 79	READY	Total battery voltage 317 V	Approx. 3,200 - 3,400 mV
		Total battery voltage 393 V	Approx. 4,000 - 4,200 mV
CELL VOLTAGE 80	READY	Total battery voltage 317 V	Approx. 3,200 - 3,400 mV
		Total battery voltage 393 V	Approx. 4,000 - 4,200 mV
CELL VOLTAGE 81	READY	Total battery voltage 317 V	Approx. 3,200 - 3,400 mV
		Total battery voltage 393 V	Approx. 4,000 - 4,200 mV

A

B

EVB

D

E

F

G

H

I

J

K

L

M

N

O

P

EV BATTERY SYSTEM

< ECU DIAGNOSIS INFORMATION >

[TYPE 3]

Monitor item	Condition		Values / Status
CELL VOLTAGE 82	READY	Total battery voltage 317 V	Approx. 3,200 - 3,400 mV
		Total battery voltage 393 V	Approx. 4,000 - 4,200 mV
CELL VOLTAGE 83	READY	Total battery voltage 317 V	Approx. 3,200 - 3,400 mV
		Total battery voltage 393 V	Approx. 4,000 - 4,200 mV
CELL VOLTAGE 84	READY	Total battery voltage 317 V	Approx. 3,200 - 3,400 mV
		Total battery voltage 393 V	Approx. 4,000 - 4,200 mV
CELL VOLTAGE 85	READY	Total battery voltage 317 V	Approx. 3,200 - 3,400 mV
		Total battery voltage 393 V	Approx. 4,000 - 4,200 mV
CELL VOLTAGE 86	READY	Total battery voltage 317 V	Approx. 3,200 - 3,400 mV
		Total battery voltage 393 V	Approx. 4,000 - 4,200 mV
CELL VOLTAGE 87	READY	Total battery voltage 317 V	Approx. 3,200 - 3,400 mV
		Total battery voltage 393 V	Approx. 4,000 - 4,200 mV
CELL VOLTAGE 88	READY	Total battery voltage 317 V	Approx. 3,200 - 3,400 mV
		Total battery voltage 393 V	Approx. 4,000 - 4,200 mV
CELL VOLTAGE 89	READY	Total battery voltage 317 V	Approx. 3,200 - 3,400 mV
		Total battery voltage 393 V	Approx. 4,000 - 4,200 mV
CELL VOLTAGE 90	READY	Total battery voltage 317 V	Approx. 3,200 - 3,400 mV
		Total battery voltage 393 V	Approx. 4,000 - 4,200 mV
CELL VOLTAGE 91	READY	Total battery voltage 317 V	Approx. 3,200 - 3,400 mV
		Total battery voltage 393 V	Approx. 4,000 - 4,200 mV
CELL VOLTAGE 92	READY	Total battery voltage 317 V	Approx. 3,200 - 3,400 mV
		Total battery voltage 393 V	Approx. 4,000 - 4,200 mV
CELL VOLTAGE 93	READY	Total battery voltage 317 V	Approx. 3,200 - 3,400 mV
		Total battery voltage 393 V	Approx. 4,000 - 4,200 mV
CELL VOLTAGE 94	READY	Total battery voltage 317 V	Approx. 3,200 - 3,400 mV
		Total battery voltage 393 V	Approx. 4,000 - 4,200 mV
CELL VOLTAGE 95	READY	Total battery voltage 317 V	Approx. 3,200 - 3,400 mV
		Total battery voltage 393 V	Approx. 4,000 - 4,200 mV
CELL VOLTAGE 96	READY	Total battery voltage 317 V	Approx. 3,200 - 3,400 mV
		Total battery voltage 393 V	Approx. 4,000 - 4,200 mV
TOTAL BATTERY VOLTAGE	READY		Approx. 240 - 420 V
MAXIMUM CELL VOLTAGE	READY	Total battery voltage 317 V	Approx. 3,300 - 3,500 mV
		Total battery voltage 393 V	Approx. 4,000 - 4,200 mV
MINIMUM CELL VOLTAGE	READY	Total battery voltage 317 V	Approx. 3,300 - 3,500 mV
		Total battery voltage 393 V	Approx. 4,000 - 4,200 mV
BATTERY TEMPERATURE 1	READY (Stop the vehicle)	Ambient temperature: 25°C (77°F)	20°C - 30°C (68°F - 86°F) [Equivalent to air temperature around rear module stack]
BATTERY TEMPERATURE 2	READY (Stop the vehicle)	Ambient temperature: 25°C (77°F)	20°C - 30°C (68°F - 86°F) [Equivalent to air temperature around front RH module stack]
BATTERY TEMPERATURE 3	READY (Stop the vehicle)	Ambient temperature: 25°C (77°F)	20°C - 30°C (68°F - 86°F) [Equivalent to air temperature around rear module stack]
BATTERY TEMPERATURE 4	READY (Stop the vehicle)	Ambient temperature: 25°C (77°F)	20°C - 30°C (68°F - 86°F) [Equivalent to air temperature around front RH module stack]

EV BATTERY SYSTEM

< ECU DIAGNOSIS INFORMATION >

[TYPE 3]

Fail-safe

INFOID:0000000011104179

When Li-ion Battery Controller (LBC) detects a malfunction of the Li-ion battery, it enters the control mode that protects the battery by stopping or restricting the output/charging from/to the battery. The fail-safe mode differs depending on the contents of the detected malfunction.

FAIL-SAFE PATTERN

- Pattern A: No driving and Charge stop
- Pattern B: Driving output power limit, and Charge stop
- Pattern C: Driving output power limit, and Charge limit
- Pattern D: EV system warning lamp illuminate

FAIL-SAFE LIST

DTC	CONSULT screen items	Pattern			
		A	B	C	D
P0A0D	HV SYSTEM INTERLOCK ERROR				×
P0A1F	BATTERY ENERGY CONTROL MODULE	×	×		×
P3030	CELL CONT LIN		×		
P3031	CELL CONT ASIC1		×		
P3032	CELL CONT ASIC2		×		
P3033	CELL CONT ASIC3		×		
P3034	CELL CONT ASIC4		×		
P3035	CELL CONT ASIC5		×		
P3036	CELL CONT ASIC6		×		
P3037	CELL CONT ASIC7		×		
P3038	CELL CONT ASIC8		×		
P3039	CELL CONT ASIC9		×		
P303A	CELL CONT ASIC10		×		
P303B	CELL CONT ASIC11		×		
P303C	CELL CONT ASIC12		×		
P303D	CELL CONT ASIC13		×		
P303E	CELL CONT ASIC14		×		
P303F	CELL CONT ASIC15		×		
P3040	CELL CONT ASIC16		×		
P3041	CELL CONT ASIC17		×		
P3042	CELL CONT ASIC18		×		
P3043	CELL CONT ASIC19		×		
P3044	CELL CONT ASIC20		×		
P3045	CELL CONT ASIC21		×		
P3046	CELL CONT ASIC22		×		
P3047	CELL CONT ASIC23		×		
P3048	CELL CONT ASIC24		×		
P3049	CELL CONT ASIC1 VOLT		×		
P304A	CELL CONT ASIC2 VOLT		×		
P304B	CELL CONT ASIC3 VOLT		×		
P304C	CELL CONT ASIC4 VOLT		×		
P304D	CELL CONT ASIC5 VOLT		×		
P304E	CELL CONT ASIC6 VOLT		×		

EV BATTERY SYSTEM

< ECU DIAGNOSIS INFORMATION >

[TYPE 3]

DTC	CONSULT screen items	Pattern			
		A	B	C	D
P304F	CELL CONT ASIC7 VOLT		×		
P3050	CELL CONT ASIC8 VOLT		×		
P3051	CELL CONT ASIC9 VOLT		×		
P3052	CELL CONT ASIC10 VOLT		×		
P3053	CELL CONT ASIC11 VOLT		×		
P3054	CELL CONT ASIC12 VOLT		×		
P3055	CELL CONT ASIC13 VOLT		×		
P3056	CELL CONT ASIC14 VOLT		×		
P3057	CELL CONT ASIC15 VOLT		×		
P3058	CELL CONT ASIC16 VOLT		×		
P3059	CELL CONT ASIC17 VOLT		×		
P305A	CELL CONT ASIC18 VOLT		×		
P305B	CELL CONT ASIC19 VOLT		×		
P305C	CELL CONT ASIC20 VOLT		×		
P305D	CELL CONT ASIC21 VOLT		×		
P305E	CELL CONT ASIC22 VOLT		×		
P305F	CELL CONT ASIC23 VOLT		×		
P3060	CELL CONT ASIC24 VOLT		×		
P3061	CELL BATTERY VOLT				×
P3062	BYPASS SW				×
P308B	CELL CONT ASIC1 OPEN		×		
P308C	CELL CONT ASIC2 OPEN		×		
P308D	CELL CONT ASIC3 OPEN		×		
P308E	CELL CONT ASIC4 OPEN		×		
P308F	CELL CONT ASIC5 OPEN		×		
P3090	CELL CONT ASIC6 OPEN		×		
P3091	CELL CONT ASIC7 OPEN		×		
P3092	CELL CONT ASIC8 OPEN		×		
P3093	CELL CONT ASIC9 OPEN		×		
P3094	CELL CONT ASIC10 OPEN		×		
P3095	CELL CONT ASIC11 OPEN		×		
P3096	CELL CONT ASIC12 OPEN		×		
P3097	CELL CONT ASIC13 OPEN		×		
P3098	CELL CONT ASIC14 OPEN		×		
P3099	CELL CONT ASIC15 OPEN		×		
P309A	CELL CONT ASIC16 OPEN		×		
P309B	CELL CONT ASIC17 OPEN		×		
P309C	CELL CONT ASIC18 OPEN		×		
P309D	CELL CONT ASIC19 OPEN		×		
P309E	CELL CONT ASIC20 OPEN		×		
P309F	CELL CONT ASIC21 OPEN		×		
P30A0	CELL CONT ASIC22 OPEN		×		
P30A1	CELL CONT ASIC23 OPEN		×		

EV BATTERY SYSTEM

< ECU DIAGNOSIS INFORMATION >

[TYPE 3]

DTC	CONSULT screen items	Pattern				
		A	B	C	D	
P30A2	CELL CONT ASIC24 OPEN		×			A
P30F3	TOTAL VOLT SENSOR			×		B
P30F4	TOTAL VOLT SENSOR			×		
P30F5	TOTAL VOLT SENSOR			×		
P30FC	OVER CURRENT	×				EVB
P30FD	TOTAL VOLTAGE MONITOR SWITCH	No fail-safe				
P30FE	12V BATTERY VOLTAGE				×	D
P318D	COMMUNICATION ERROR				×	
P318E	COMMUNICATION ERROR				×	
P3191	COMMUNICATION ERROR	No fail-safe				E
P3196	COMMUNICATION ERROR	No fail-safe				
P3199	COMMUNICATION ERROR				×	F
P319C	COMMUNICATION ERROR	No fail-safe				
P31A4	CAN ERROR VCM				×	
P31A7	CAN ERROR INV/MC	No fail-safe				G
P3300	TOTAL VOLTAGE OVER	×				
P3302	CELL OVER VOLTAGE MODULE1	×				H
P3303	CELL OVER VOLTAGE MODULE2	×				
P3304	CELL OVER VOLTAGE MODULE3	×				
P3305	CELL OVER VOLTAGE MODULE4	×				I
P3306	CELL OVER VOLTAGE MODULE5	×				
P3307	CELL OVER VOLTAGE MODULE6	×				J
P3308	CELL OVER VOLTAGE MODULE7	×				
P3309	CELL OVER VOLTAGE MODULE8	×				
P330A	CELL OVER VOLTAGE MODULE9	×				K
P330B	CELL OVER VOLTAGE MODULE10	×				
P330C	CELL OVER VOLTAGE MODULE11	×				
P330D	CELL OVER VOLTAGE MODULE12	×				L
P330E	CELL OVER VOLTAGE MODULE13	×				
P330F	CELL OVER VOLTAGE MODULE14	×				M
P3310	CELL OVER VOLTAGE MODULE15	×				
P3311	CELL OVER VOLTAGE MODULE16	×				
P3312	CELL OVER VOLTAGE MODULE17	×				N
P3313	CELL OVER VOLTAGE MODULE18	×				
P3314	CELL OVER VOLTAGE MODULE19	×				
P3315	CELL OVER VOLTAGE MODULE20	×				O
P3316	CELL OVER VOLTAGE MODULE21	×				
P3317	CELL OVER VOLTAGE MODULE22	×				P
P3318	CELL OVER VOLTAGE MODULE23	×				
P3319	CELL OVER VOLTAGE MODULE24	×				
P331A	CELL OVER VOLTAGE MODULE25	×				
P331B	CELL OVER VOLTAGE MODULE26	×				
P331C	CELL OVER VOLTAGE MODULE27	×				

EV BATTERY SYSTEM

< ECU DIAGNOSIS INFORMATION >

[TYPE 3]

DTC	CONSULT screen items	Pattern			
		A	B	C	D
P331D	CELL OVER VOLTAGE MODULE28	×			
P331E	CELL OVER VOLTAGE MODULE29	×			
P331F	CELL OVER VOLTAGE MODULE30	×			
P3320	CELL OVER VOLTAGE MODULE31	×			
P3321	CELL OVER VOLTAGE MODULE32	×			
P3322	CELL OVER VOLTAGE MODULE33	×			
P3323	CELL OVER VOLTAGE MODULE34	×			
P3324	CELL OVER VOLTAGE MODULE35	×			
P3325	CELL OVER VOLTAGE MODULE36	×			
P3326	CELL OVER VOLTAGE MODULE37	×			
P3327	CELL OVER VOLTAGE MODULE38	×			
P3328	CELL OVER VOLTAGE MODULE39	×			
P3329	CELL OVER VOLTAGE MODULE40	×			
P332A	CELL OVER VOLTAGE MODULE41	×			
P332B	CELL OVER VOLTAGE MODULE42	×			
P332C	CELL OVER VOLTAGE MODULE43	×			
P332D	CELL OVER VOLTAGE MODULE44	×			
P332E	CELL OVER VOLTAGE MODULE45	×			
P332F	CELL OVER VOLTAGE MODULE46	×			
P3330	CELL OVER VOLTAGE MODULE47	×			
P3331	CELL OVER VOLTAGE MODULE48	×			
P3373	TOTAL VOLTAGE OVER DISCHARGE	×			
P3375	CELL OVER DISCHARGE MODULE1	×			
P3376	CELL OVER DISCHARGE MODULE2	×			
P3377	CELL OVER DISCHARGE MODULE3	×			
P3378	CELL OVER DISCHARGE MODULE4	×			
P3379	CELL OVER DISCHARGE MODULE5	×			
P337A	CELL OVER DISCHARGE MODULE6	×			
P337B	CELL OVER DISCHARGE MODULE7	×			
P337C	CELL OVER DISCHARGE MODULE8	×			
P337D	CELL OVER DISCHARGE MODULE9	×			
P337E	CELL OVER DISCHARGE MODULE10	×			
P337F	CELL OVER DISCHARGE MODULE11	×			
P3380	CELL OVER DISCHARGE MODULE12	×			
P3381	CELL OVER DISCHARGE MODULE13	×			
P3382	CELL OVER DISCHARGE MODULE14	×			
P3383	CELL OVER DISCHARGE MODULE15	×			
P3384	CELL OVER DISCHARGE MODULE16	×			
P3385	CELL OVER DISCHARGE MODULE17	×			
P3386	CELL OVER DISCHARGE MODULE18	×			
P3387	CELL OVER DISCHARGE MODULE19	×			
P3388	CELL OVER DISCHARGE MODULE20	×			
P3389	CELL OVER DISCHARGE MODULE21	×			

EV BATTERY SYSTEM

< ECU DIAGNOSIS INFORMATION >

[TYPE 3]

DTC	CONSULT screen items	Pattern				
		A	B	C	D	
P338A	CELL OVER DISCHARGE MODULE22	×				A
P338B	CELL OVER DISCHARGE MODULE23	×				B
P338C	CELL OVER DISCHARGE MODULE24	×				
P338D	CELL OVER DISCHARGE MODULE25	×				
P338E	CELL OVER DISCHARGE MODULE26	×				EVB
P338F	CELL OVER DISCHARGE MODULE27	×				
P3390	CELL OVER DISCHARGE MODULE28	×				
P3391	CELL OVER DISCHARGE MODULE29	×				D
P3392	CELL OVER DISCHARGE MODULE30	×				
P3393	CELL OVER DISCHARGE MODULE31	×				E
P3394	CELL OVER DISCHARGE MODULE32	×				
P3395	CELL OVER DISCHARGE MODULE33	×				F
P3396	CELL OVER DISCHARGE MODULE34	×				
P3397	CELL OVER DISCHARGE MODULE35	×				
P3398	CELL OVER DISCHARGE MODULE36	×				G
P3399	CELL OVER DISCHARGE MODULE37	×				
P339A	CELL OVER DISCHARGE MODULE38	×				H
P339B	CELL OVER DISCHARGE MODULE39	×				
P339C	CELL OVER DISCHARGE MODULE40	×				
P339D	CELL OVER DISCHARGE MODULE41	×				I
P339E	CELL OVER DISCHARGE MODULE42	×				
P339F	CELL OVER DISCHARGE MODULE43	×				J
P33A0	CELL OVER DISCHARGE MODULE44	×				
P33A1	CELL OVER DISCHARGE MODULE45	×				
P33A2	CELL OVER DISCHARGE MODULE46	×				K
P33A3	CELL OVER DISCHARGE MODULE47	×				
P33A4	CELL OVER DISCHARGE MODULE48	×				
P33D4	BATT GADUAL CAPA LOSS DIAG				×	L
P33D5	CURRENT SENSOR		×			
P33D6	CURRENT SENSOR		×			M
P33D7	TEMPERATURE SENSOR			No fail-safe		
P33D9	TEMPERATURE SENSOR			No fail-safe		
P33DB	TEMPERATURE SENSOR			No fail-safe		N
P33DD	TEMPERATURE SENSOR			No fail-safe		
P33DF	BATT VOLTAGE ISOLATION SEN				×	O
P33E0	BATT VOLTAGE ISOLATION SEN				×	
P33E1	BATT VOLTAGE ISOLATION SEN				×	
P33E2	BATT PACK OVER TEMP	×				P
P33E4	TEMPERATURE SENSOR			No fail-safe		
P33E5	TEMPERATURE SENSOR			No fail-safe		
P33E6	CELL VOLTAGE DEVIATION DIAG			×		
P33E7	CELL CONTROLLER				×	

EV BATTERY SYSTEM

< ECU DIAGNOSIS INFORMATION >

[TYPE 3]

DTC	CONSULT screen items	Pattern			
		A	B	C	D
P33ED	BATTERY PARALLEL DIAGNOSIS			×	
U1000	CAN COMM CIRCUIT				×

DTC Index

INFOID:0000000011104180

×: Applicable —: Not applicable

DTC	CONSULT screen items	EV system warning lamp	Trip	Reference
P0A0D	HV SYSTEM INTERLOCK ERROR	×	1	EVB-525
P0A1F	BATTERY ENERGY CONTROL MODULE	×	1	EVB-527
P3030	CELL CONT LIN	×	1	EVB-528
P3031	CELL CONT ASIC1	×	1	EVB-529
P3032	CELL CONT ASIC2	×	1	EVB-529
P3033	CELL CONT ASIC3	×	1	EVB-529
P3034	CELL CONT ASIC4	×	1	EVB-529
P3035	CELL CONT ASIC5	×	1	EVB-529
P3036	CELL CONT ASIC6	×	1	EVB-529
P3037	CELL CONT ASIC7	×	1	EVB-529
P3038	CELL CONT ASIC8	×	1	EVB-529
P3039	CELL CONT ASIC9	×	1	EVB-529
P303A	CELL CONT ASIC10	×	1	EVB-529
P303B	CELL CONT ASIC11	×	1	EVB-529
P303C	CELL CONT ASIC12	×	1	EVB-529
P303D	CELL CONT ASIC13	×	1	EVB-530
P303E	CELL CONT ASIC14	×	1	EVB-530
P303F	CELL CONT ASIC15	×	1	EVB-530
P3040	CELL CONT ASIC16	×	1	EVB-530
P3041	CELL CONT ASIC17	×	1	EVB-530
P3042	CELL CONT ASIC18	×	1	EVB-530
P3043	CELL CONT ASIC19	×	1	EVB-530
P3044	CELL CONT ASIC20	×	1	EVB-530
P3045	CELL CONT ASIC21	×	1	EVB-530
P3046	CELL CONT ASIC22	×	1	EVB-530
P3047	CELL CONT ASIC23	×	1	EVB-530
P3048	CELL CONT ASIC24	×	1	EVB-530
P3049	CELL CONT ASIC1 VOLT	×	1	EVB-531
P304A	CELL CONT ASIC2 VOLT	×	1	EVB-531
P304B	CELL CONT ASIC3 VOLT	×	1	EVB-531
P304C	CELL CONT ASIC4 VOLT	×	1	EVB-531
P304D	CELL CONT ASIC5 VOLT	×	1	EVB-531
P304E	CELL CONT ASIC6 VOLT	×	1	EVB-531
P304F	CELL CONT ASIC7 VOLT	×	1	EVB-531
P3050	CELL CONT ASIC8 VOLT	×	1	EVB-531
P3051	CELL CONT ASIC9 VOLT	×	1	EVB-531

EV BATTERY SYSTEM

< ECU DIAGNOSIS INFORMATION >

[TYPE 3]

DTC	CONSULT screen items	EV system warning lamp	Trip	Reference	
P3052	CELL CONT ASIC10 VOLT	×	1	EVB-531	A
P3053	CELL CONT ASIC11 VOLT	×	1	EVB-531	B
P3054	CELL CONT ASIC12 VOLT	×	1	EVB-531	
P3055	CELL CONT ASIC13 VOLT	×	1	EVB-533	EVB
P3056	CELL CONT ASIC14 VOLT	×	1	EVB-533	
P3057	CELL CONT ASIC15 VOLT	×	1	EVB-533	
P3058	CELL CONT ASIC16 VOLT	×	1	EVB-533	D
P3059	CELL CONT ASIC17 VOLT	×	1	EVB-533	
P305A	CELL CONT ASIC18 VOLT	×	1	EVB-533	
P305B	CELL CONT ASIC19 VOLT	×	1	EVB-533	E
P305C	CELL CONT ASIC20 VOLT	×	1	EVB-533	
P305D	CELL CONT ASIC21 VOLT	×	1	EVB-533	F
P305E	CELL CONT ASIC22 VOLT	×	1	EVB-533	
P305F	CELL CONT ASIC23 VOLT	×	1	EVB-533	
P3060	CELL CONT ASIC24 VOLT	×	1	EVB-533	G
P3061	CELL BATTERY VOLT	×	1	EVB-535	
P3062	BYPASS SW	×	1	EVB-536	H
P308B	CELL CONT ASIC1 OPEN	×	1	EVB-537	
P308C	CELL CONT ASIC2 OPEN	×	1	EVB-537	
P308D	CELL CONT ASIC3 OPEN	×	1	EVB-537	I
P308E	CELL CONT ASIC4 OPEN	×	1	EVB-537	
P308F	CELL CONT ASIC5 OPEN	×	1	EVB-537	J
P3090	CELL CONT ASIC6 OPEN	×	1	EVB-537	
P3091	CELL CONT ASIC7 OPEN	×	1	EVB-537	
P3092	CELL CONT ASIC8 OPEN	×	1	EVB-537	K
P3093	CELL CONT ASIC9 OPEN	×	1	EVB-537	
P3094	CELL CONT ASIC10 OPEN	×	1	EVB-537	L
P3095	CELL CONT ASIC11 OPEN	×	1	EVB-537	
P3096	CELL CONT ASIC12 OPEN	×	1	EVB-537	
P3097	CELL CONT ASIC13 OPEN	×	1	EVB-540	M
P3098	CELL CONT ASIC14 OPEN	×	1	EVB-540	
P3099	CELL CONT ASIC15 OPEN	×	1	EVB-540	
P309A	CELL CONT ASIC16 OPEN	×	1	EVB-540	N
P309B	CELL CONT ASIC17 OPEN	×	1	EVB-540	
P309C	CELL CONT ASIC18 OPEN	×	1	EVB-540	O
P309D	CELL CONT ASIC19 OPEN	×	1	EVB-540	
P309E	CELL CONT ASIC20 OPEN	×	1	EVB-540	P
P309F	CELL CONT ASIC21 OPEN	×	1	EVB-540	
P30A0	CELL CONT ASIC22 OPEN	×	1	EVB-540	
P30A1	CELL CONT ASIC23 OPEN	×	1	EVB-540	
P30A2	CELL CONT ASIC24 OPEN	×	1	EVB-540	
P30F3	TOTAL VOLT SENSOR	×	1	EVB-543	
P30F4	TOTAL VOLT SENSOR	×	1	EVB-544	

EV BATTERY SYSTEM

< ECU DIAGNOSIS INFORMATION >

[TYPE 3]

DTC	CONSULT screen items	EV system warning lamp	Trip	Reference
P30F5	TOTAL VOLT SENSOR	×	1	EVB-546
P30FC	OVER CURRENT	×	1	EVB-547
P30FD	TOTAL VOLTAGE MONITOR SWITCH	—	1	EVB-548
P30FE	12V BATTERY VOLTAGE	×	1	EVB-549
P318D	COMMUNICATION ERROR	×	1	EVB-551
P318E	COMMUNICATION ERROR	×	1	EVB-552
P3191	COMMUNICATION ERROR	—	1	EVB-553
P3196	COMMUNICATION ERROR	—	1	EVB-554
P3199	COMMUNICATION ERROR	×	1	EVB-555
P319C	COMMUNICATION ERROR	—	1	EVB-556
P31A4	CAN ERROR VCM	×	1	EVB-557
P31A7	CAN ERROR INV/MC	—	1	EVB-558
P3300	TOTAL VOLTAGE OVER	×	1	EVB-559
P3302	CELL OVER VOLTAGE MODULE1	×	1	EVB-560
P3303	CELL OVER VOLTAGE MODULE2	×	1	EVB-560
P3304	CELL OVER VOLTAGE MODULE3	×	1	EVB-560
P3305	CELL OVER VOLTAGE MODULE4	×	1	EVB-560
P3306	CELL OVER VOLTAGE MODULE5	×	1	EVB-560
P3307	CELL OVER VOLTAGE MODULE6	×	1	EVB-560
P3308	CELL OVER VOLTAGE MODULE7	×	1	EVB-560
P3309	CELL OVER VOLTAGE MODULE8	×	1	EVB-560
P330A	CELL OVER VOLTAGE MODULE9	×	1	EVB-560
P330B	CELL OVER VOLTAGE MODULE10	×	1	EVB-560
P330C	CELL OVER VOLTAGE MODULE11	×	1	EVB-560
P330D	CELL OVER VOLTAGE MODULE12	×	1	EVB-560
P330E	CELL OVER VOLTAGE MODULE13	×	1	EVB-564
P330F	CELL OVER VOLTAGE MODULE14	×	1	EVB-564
P3310	CELL OVER VOLTAGE MODULE15	×	1	EVB-564
P3311	CELL OVER VOLTAGE MODULE16	×	1	EVB-564
P3312	CELL OVER VOLTAGE MODULE17	×	1	EVB-564
P3313	CELL OVER VOLTAGE MODULE18	×	1	EVB-564
P3314	CELL OVER VOLTAGE MODULE19	×	1	EVB-564
P3315	CELL OVER VOLTAGE MODULE20	×	1	EVB-564
P3316	CELL OVER VOLTAGE MODULE21	×	1	EVB-564
P3317	CELL OVER VOLTAGE MODULE22	×	1	EVB-564
P3318	CELL OVER VOLTAGE MODULE23	×	1	EVB-564
P3319	CELL OVER VOLTAGE MODULE24	×	1	EVB-564
P331A	CELL OVER VOLTAGE MODULE25	×	1	EVB-568
P331B	CELL OVER VOLTAGE MODULE26	×	1	EVB-568
P331C	CELL OVER VOLTAGE MODULE27	×	1	EVB-568
P331D	CELL OVER VOLTAGE MODULE28	×	1	EVB-568
P331E	CELL OVER VOLTAGE MODULE29	×	1	EVB-568
P331F	CELL OVER VOLTAGE MODULE30	×	1	EVB-568

EV BATTERY SYSTEM

< ECU DIAGNOSIS INFORMATION >

[TYPE 3]

DTC	CONSULT screen items	EV system warning lamp	Trip	Reference	
P3320	CELL OVER VOLTAGE MODULE31	×	1	EVB-568	A
P3321	CELL OVER VOLTAGE MODULE32	×	1	EVB-568	B
P3322	CELL OVER VOLTAGE MODULE33	×	1	EVB-568	
P3323	CELL OVER VOLTAGE MODULE34	×	1	EVB-568	
P3324	CELL OVER VOLTAGE MODULE35	×	1	EVB-568	EVB
P3325	CELL OVER VOLTAGE MODULE36	×	1	EVB-568	
P3326	CELL OVER VOLTAGE MODULE37	×	1	EVB-571	D
P3327	CELL OVER VOLTAGE MODULE38	×	1	EVB-571	
P3328	CELL OVER VOLTAGE MODULE39	×	1	EVB-571	
P3329	CELL OVER VOLTAGE MODULE40	×	1	EVB-571	E
P332A	CELL OVER VOLTAGE MODULE41	×	1	EVB-571	
P332B	CELL OVER VOLTAGE MODULE42	×	1	EVB-571	F
P332C	CELL OVER VOLTAGE MODULE43	×	1	EVB-571	
P332D	CELL OVER VOLTAGE MODULE44	×	1	EVB-571	
P332E	CELL OVER VOLTAGE MODULE45	×	1	EVB-571	G
P332F	CELL OVER VOLTAGE MODULE46	×	1	EVB-571	
P3330	CELL OVER VOLTAGE MODULE47	×	1	EVB-571	H
P3331	CELL OVER VOLTAGE MODULE48	×	1	EVB-571	
P3373	TOTAL VOLTAGE OVER DISCHARGE	×	1	EVB-574	
P3375	CELL OVER DISCHARGE MODULE1	×	1	EVB-575	I
P3376	CELL OVER DISCHARGE MODULE2	×	1	EVB-575	
P3377	CELL OVER DISCHARGE MODULE3	×	1	EVB-575	J
P3378	CELL OVER DISCHARGE MODULE4	×	1	EVB-575	
P3379	CELL OVER DISCHARGE MODULE5	×	1	EVB-575	
P337A	CELL OVER DISCHARGE MODULE6	×	1	EVB-575	K
P337B	CELL OVER DISCHARGE MODULE7	×	1	EVB-575	
P337C	CELL OVER DISCHARGE MODULE8	×	1	EVB-575	
P337D	CELL OVER DISCHARGE MODULE9	×	1	EVB-575	L
P337E	CELL OVER DISCHARGE MODULE10	×	1	EVB-575	
P337F	CELL OVER DISCHARGE MODULE11	×	1	EVB-575	M
P3380	CELL OVER DISCHARGE MODULE12	×	1	EVB-575	
P3381	CELL OVER DISCHARGE MODULE13	×	1	EVB-579	
P3382	CELL OVER DISCHARGE MODULE14	×	1	EVB-579	N
P3383	CELL OVER DISCHARGE MODULE15	×	1	EVB-579	
P3384	CELL OVER DISCHARGE MODULE16	×	1	EVB-579	O
P3385	CELL OVER DISCHARGE MODULE17	×	1	EVB-579	
P3386	CELL OVER DISCHARGE MODULE18	×	1	EVB-579	
P3387	CELL OVER DISCHARGE MODULE19	×	1	EVB-579	P
P3388	CELL OVER DISCHARGE MODULE20	×	1	EVB-579	
P3389	CELL OVER DISCHARGE MODULE21	×	1	EVB-579	
P338A	CELL OVER DISCHARGE MODULE22	×	1	EVB-579	
P338B	CELL OVER DISCHARGE MODULE23	×	1	EVB-579	
P338C	CELL OVER DISCHARGE MODULE24	×	1	EVB-579	

EV BATTERY SYSTEM

< ECU DIAGNOSIS INFORMATION >

[TYPE 3]

DTC	CONSULT screen items	EV system warning lamp	Trip	Reference
P338D	CELL OVER DISCHARGE MODULE25	×	1	EVB-583
P338E	CELL OVER DISCHARGE MODULE26	×	1	EVB-583
P338F	CELL OVER DISCHARGE MODULE27	×	1	EVB-583
P3390	CELL OVER DISCHARGE MODULE28	×	1	EVB-583
P3391	CELL OVER DISCHARGE MODULE29	×	1	EVB-583
P3392	CELL OVER DISCHARGE MODULE30	×	1	EVB-583
P3393	CELL OVER DISCHARGE MODULE31	×	1	EVB-583
P3394	CELL OVER DISCHARGE MODULE32	×	1	EVB-583
P3395	CELL OVER DISCHARGE MODULE33	×	1	EVB-583
P3396	CELL OVER DISCHARGE MODULE34	×	1	EVB-583
P3397	CELL OVER DISCHARGE MODULE35	×	1	EVB-583
P3398	CELL OVER DISCHARGE MODULE36	×	1	EVB-583
P3399	CELL OVER DISCHARGE MODULE37	×	1	EVB-586
P339A	CELL OVER DISCHARGE MODULE38	×	1	EVB-586
P339B	CELL OVER DISCHARGE MODULE39	×	1	EVB-586
P339C	CELL OVER DISCHARGE MODULE40	×	1	EVB-586
P339D	CELL OVER DISCHARGE MODULE41	×	1	EVB-586
P339E	CELL OVER DISCHARGE MODULE42	×	1	EVB-586
P339F	CELL OVER DISCHARGE MODULE43	×	1	EVB-586
P33A0	CELL OVER DISCHARGE MODULE44	×	1	EVB-586
P33A1	CELL OVER DISCHARGE MODULE45	×	1	EVB-586
P33A2	CELL OVER DISCHARGE MODULE46	×	1	EVB-586
P33A3	CELL OVER DISCHARGE MODULE47	×	1	EVB-586
P33A4	CELL OVER DISCHARGE MODULE48	×	1	EVB-586
P33D4	BATT GRADUAL CAPA LOSS DIAG	×	1	EVB-589
P33D5	CURRENT SENSOR	×	1	EVB-590
P33D6	CURRENT SENSOR	×	1	EVB-592
P33D7	TEMPERATURE SENSOR	—	1	EVB-594
P33D9	TEMPERATURE SENSOR	—	1	EVB-594
P33DB	TEMPERATURE SENSOR	—	1	EVB-594
P33DD	TEMPERATURE SENSOR	—	1	EVB-594
P33DF	BATT VOLTAGE ISOLATION SEN	×	1	EVB-596
P33E0	BATT VOLTAGE ISOLATION SEN	×	1	EVB-597
P33E1	BATT VOLTAGE ISOLATION SEN	×	1	EVB-598
P33E2	BATT PACK OVER TEMP	×	1	EVB-599
P33E4	TEMPERATURE SENSOR	—	1	EVB-600
P33E5	TEMPERATURE SENSOR	—	1	EVB-600
P33E6	CELL VOLTAGE DEVIATION DIAG	×	2	EVB-602
P33E7	CELL CONTROLLER	×	1	EVB-607
P33ED	BATTERY PARALLEL DIAGNOSIS	×	1	EVB-608
U1000	CAN COMM CIRCUIT	×	1	EVB-610

WIRING DIAGRAM

VCM

Wiring Diagram

INFOID:000000011195533

A

B

EVB

D

E

F

G

H

I

J

K

L

M

N

O

P

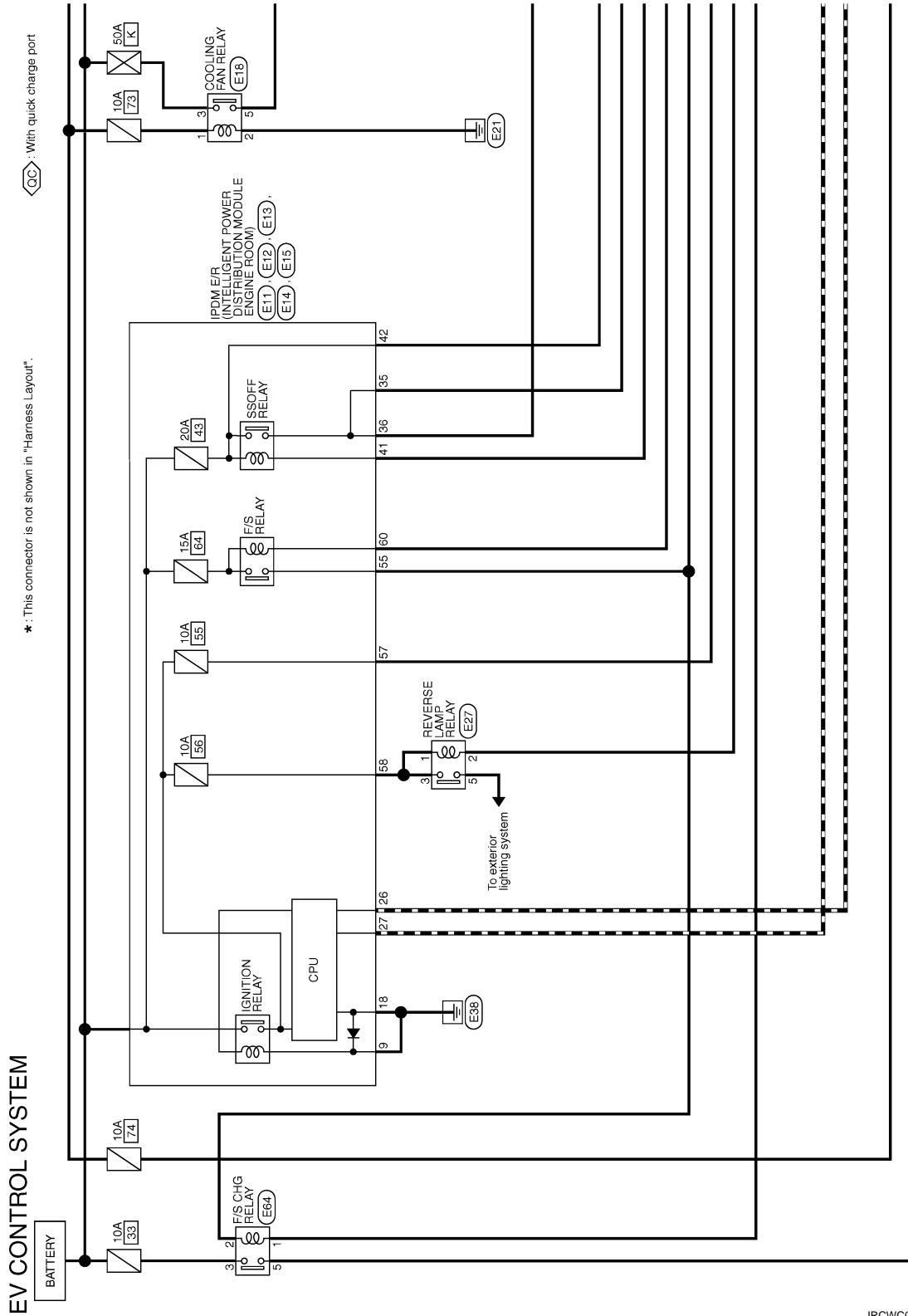

2012/11/15

JRCWC0085GB

VCM

< WIRING DIAGRAM >

[TYPE 3]

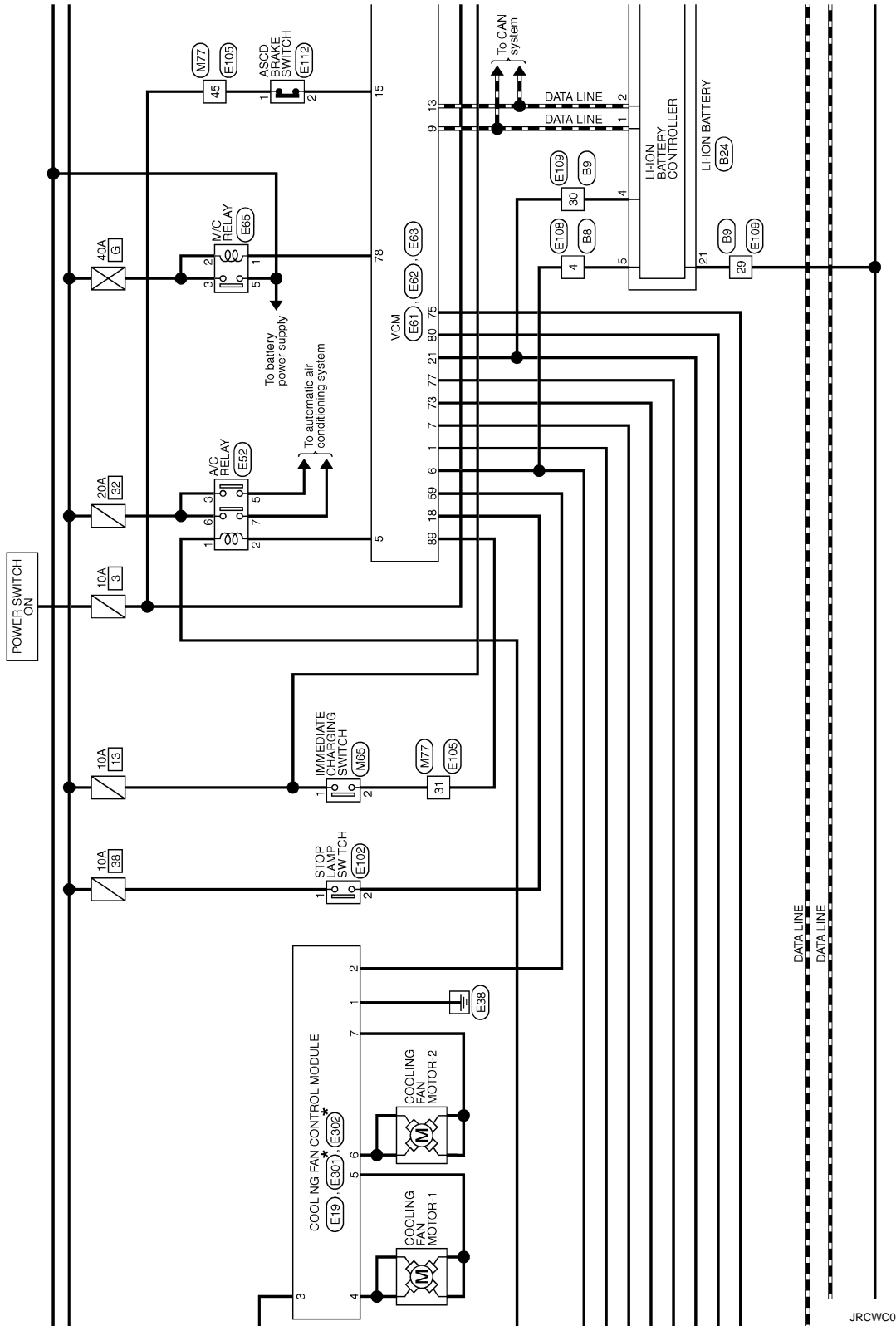

JRCWC0086GB

VCM

< WIRING DIAGRAM >

[TYPE 3]

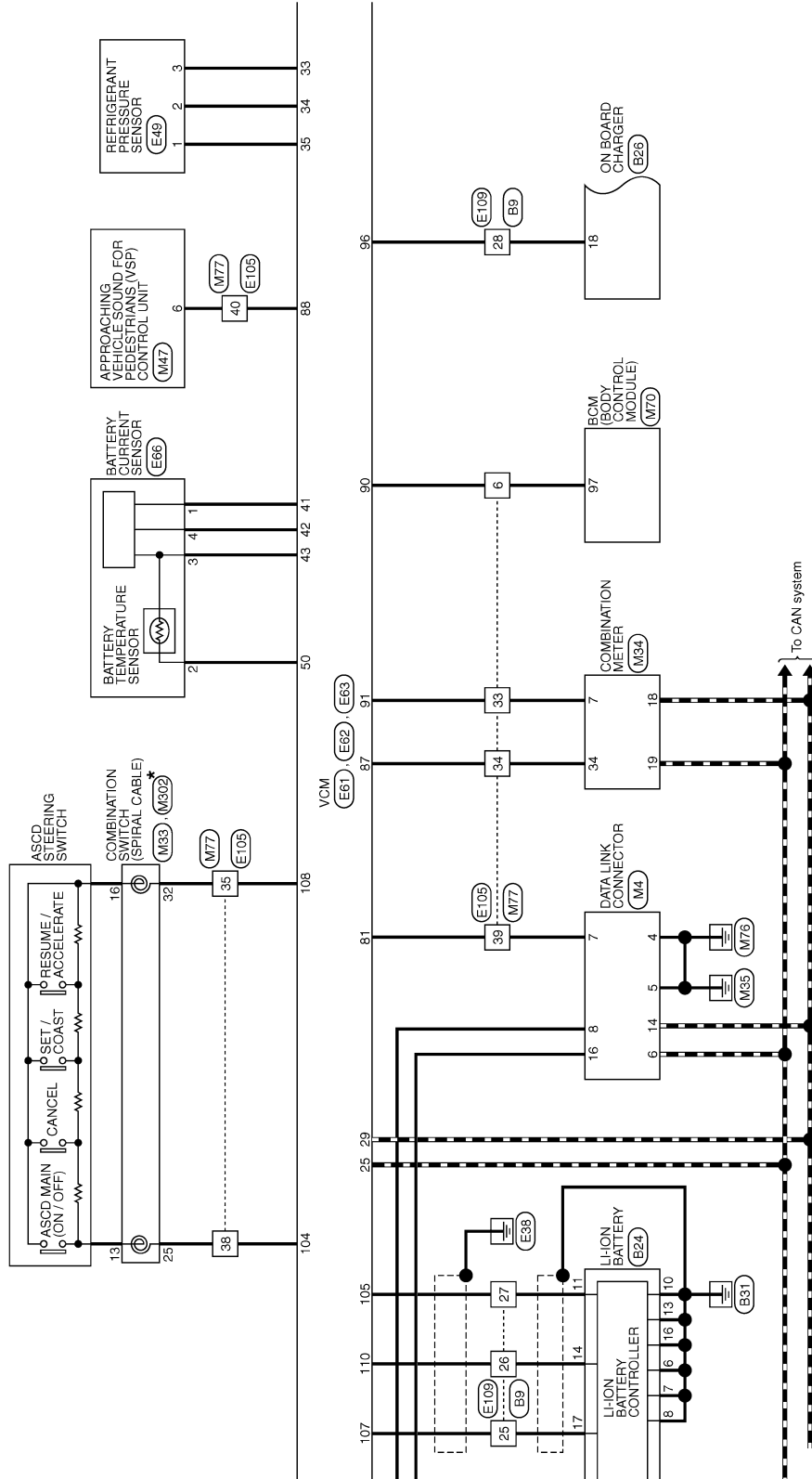

JRCWC0087GB

A
B
C
D
E
F
G
H
I
J
K
L
M
N
O
P

EVB

VCM

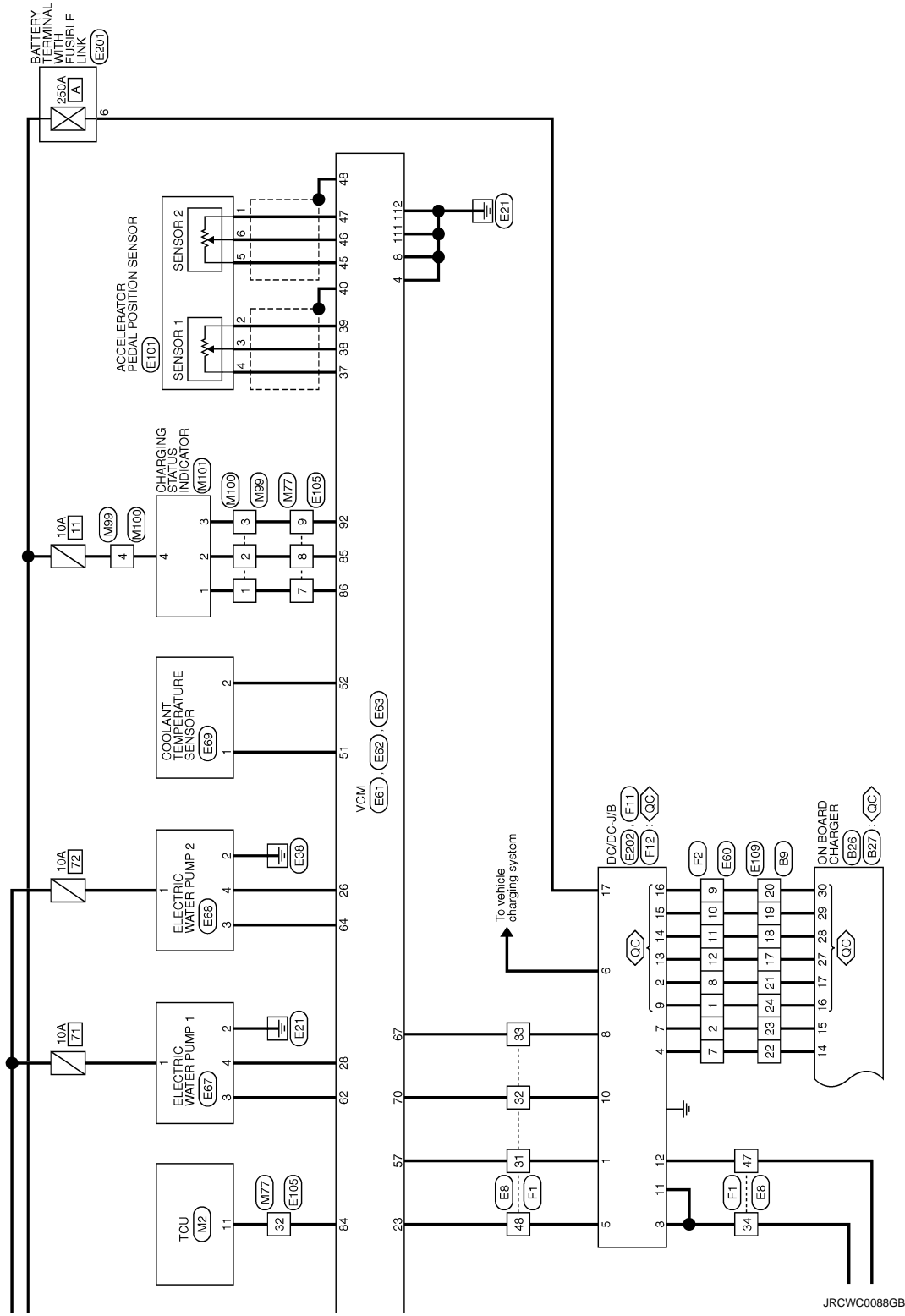

JRCWC0088GB

EV CONTROL SYSTEM

Connector No.	B8
Connector Name	WIRE TO WIRE
Connector Type	INSMFV-CS



Terminal No.	Color of Wire	Signal Name [Specification]
1	R	
2	L	
3	R	
4	R	

Connector No.	B9
Connector Name	WIRE TO WIRE
Connector Type	TH32FW-NH

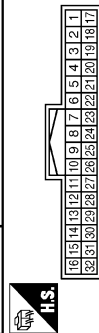

Terminal No.	Color of Wire	Signal Name [Specification]
1	W	
2	GR	
3	Y	
4	G	
5	BR	
6	L	
7	B	
8	P	
9	SB	
10	LG	
11	W	
17	Y	
18	Y	
19	G	
20	V	
21	SB	
22	P	
23	LG	

24	L	
25	Y	
26	L	
27	G	
28	GR	
29	R	
30	R	
31	Y	

Connector No.	B24
Connector Name	LI-ION BATTERY
Connector Type	Yaaski 7283-8750-30

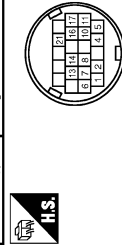

Terminal No.	Color of Wire	Signal Name [Specification]
1	L	EV CAN-H
2	G	EV CAN-L
4	R	IGN
5	R	BAT
6	B	GND3
7	B	GND2
8	B	GND1
10	B	PRE CHG GND
11	G	PRE CHG V
13	B	RLY2 GND
14	L	RLY2 V
16	B	RLY1 GND
17	Y	RLY1 V
21	R	CHG IGN

Connector No.	B26
Connector Name	ON BOARD CHARGER
Connector Type	RH12FB

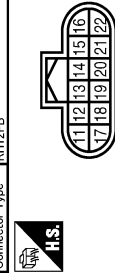

Terminal No.	Color of Wire	Signal Name [Specification]
11	Y	BATTERY POWER SUPPLY
12	W	BATTERY POWER SUPPLY
13	V	POWER ON POWER SUPPLY
14	P	NORMAL CHARGE RELAY +
15	LG	NORMAL CHARGE RELAY -
16	L	QUICK CHARGE RELAY +
17	SB	QUICK CHARGE RELAY -
18	GR	EV ACTIVATION REQUEST SIGNAL
19	L	EV SYSTEM CAN-H
20	G	EV SYSTEM CAN-L
21	BR	PLUG IN SIGNAL
22	B	GROUND

Connector No.	B27
Connector Name	ON BOARD CHARGER
Connector Type	RH08FB

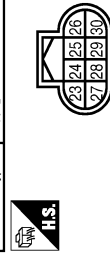

Terminal No.	Color of Wire	Signal Name [Specification]
25	W	QUICK CHARGE PORT TEMPERATURE SENSOR SIGNAL 1
26	GR	QUICK CHARGE PORT TEMPERATURE SENSOR SIGNAL 2
27	R	QUICK CHARGE VOLTAGE SENSOR SIGNAL-L
28	Y	SENSOR POWER SUPPLY/QUICK CHARGE VOLTAGE SENSOR
29	G	SENSOR GROUND/QUICK CHARGE VOLTAGE SENSOR
30	V	QUICK CHARGE VOLTAGE SENSOR SIGNAL-H

Connector No.	EB
Connector Name	WIRE TO WIRE
Connector Type	SAA38MB-RS10-S4ZZ

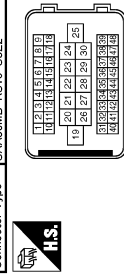

Terminal No.	Color of Wire	Signal Name [Specification]
--------------	---------------	-----------------------------

EV CONTROL SYSTEM

Connector No.	E11
Connector Name	ENGINE ROOM INTELLIGENT POWER DISTRIBUTION MODULE
Connector Type	MS08FB-LC



Terminal No.	Color of Wire	Signal Name [Specification]
9	B	-
14	R	-

Connector No.	E12
Connector Name	ENGINE ROOM INTELLIGENT POWER DISTRIBUTION MODULE
Connector Type	NS08FB-RCS



Terminal No.	Color of Wire	Signal Name [Specification]
18	B/W	-
19	W	-
20	V	-

Connector No.	E13
Connector Name	ENGINE ROOM INTELLIGENT POWER DISTRIBUTION MODULE
Connector Type	TH12FW-NH



Terminal No.	Color of Wire	Signal Name [Specification]
25	R	-

26	P	-
27	L	-
28	G	-
32	SB	-
34	W	-

Connector No.	E14
Connector Name	ENGINE ROOM INTELLIGENT POWER DISTRIBUTION MODULE
Connector Type	NS12FBR-CS

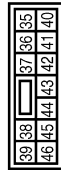

Terminal No.	Color of Wire	Signal Name [Specification]
36	G	-
38	GR	-
39	V	-
41	L	-
42	R	-
43	O	-
44	LG	-
45	Y	-

Connector No.	E15
Connector Name	ENGINE ROOM INTELLIGENT POWER DISTRIBUTION MODULE
Connector Type	NS16FW-CS



Terminal No.	Color of Wire	Signal Name [Specification]
49	Y	-
50	G	-
51	L	-
52	P	-
55	LG	-
57	R	-

58	O	-
60	GR	-
61	Y	-
62	V	-

Connector No.	E18
Connector Name	COOLING FAN RELAY
Connector Type	Z3347_9F500



Terminal No.	Color of Wire	Signal Name [Specification]
1	G	-
2	B/Y	-
3	BR	-
5	R	-

Connector No.	E19
Connector Name	COOLING FAN CONTROL MODULE
Connector Type	SJZ01FGY-SNZ2

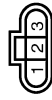

Terminal No.	Color of Wire	Signal Name [Specification]
1	B	GND
2	V	PWM SIG
3	R	PWM POWER

Connector No.	E27
Connector Name	REVERSE LAMP RELAY
Connector Type	MS20FL-M2-LC



Terminal No.	Color of Wire	Signal Name [Specification]
1	O	-
2	SB	-
3	O	-
5	G	-

Connector No.	E49
Connector Name	REFRIGERANT PRESSURE SENSOR
Connector Type	PK03FB



Terminal No.	Color of Wire	Signal Name [Specification]
1	BR	-
2	B	-
3	L	-

EV CONTROL SYSTEM

Connector No.	E52
Connector Name	A/C RELAY
Connector Type	M08FBR-R-LC



Terminal No.	Color of Wire	Signal Name [Specification]
1	GR	WIRE TO WIRE
2	SB	
3	R	
4	V	
5	R	
6	R	
7	W	

Connector No.	E60
Connector Name	WIRE TO WIRE
Connector Type	RH12MB

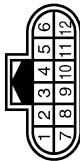

Terminal No.	Color of Wire	Signal Name [Specification]
1	Y	
2	G	
3	L	
4	G	
5	L	
6	G	
7	L	
8	SB	
9	V	
10	O	
11	BR	
12	LG	

Connector No.	E61
Connector Name	VCM
Connector Type	RH24FGY-R26-R-RH



Terminal No.	Color of Wire	Signal Name [Specification]
1	G	POWER ON POWER SUPPLY
4	B/R	GROUND
5	SB	A/C RELAY
6	R	BATTERY POWER SUPPLY
7	W	SSDPF RELAY
8	B/R	GROUND
9	L	EV SYSTEM CAN-H
13	G	EV SYSTEM CAN-L
15	O	ASCD BRAKE SWITCH SIGNAL
18	SB	STOP LAMP SW SIGNAL
21	R	POWER ON POWER SUPPLY
23	P	HIGH VOLTAGE CABLE INTERLOCK
25	L	CAN-H
26	Y	WATER PUMP 2 SIGNAL
28	W	WATER PUMP 1 SIGNAL
29	P	CAN-L

Connector No.	E62
Connector Name	VCM
Connector Type	RH40FBR-R26-L-RH

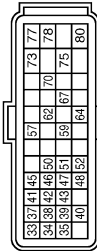

Terminal No.	Color of Wire	Signal Name [Specification]
33	L	SENSOR POWER SUPPLY (REFRIGERANT PRESSURE SENSOR)
34	B	REFRIGERANT PRESSURE SENSOR SIGNAL
35	BR	SENSOR GROUND (REFRIGERANT PRESSURE SENSOR)
37	W	SENSOR POWER SUPPLY (ACCELERATOR PEDAL POSITION SENSOR)
38	R	ACCELERATOR PEDAL POSITION SENSOR 1 SIGNAL
39	B	SENSOR GROUND (ACCELERATOR PEDAL POSITION SENSOR 1)

Terminal No.	Color of Wire	Signal Name [Specification]
40	SHIELD	
41	R	SENSOR POWER SUPPLY (BATTERY CURRENT SENSOR)
42	Y	BATTERY CURRENT SENSOR SIGNAL
43	L	SENSOR GROUND (BATTERY CURRENT SENSOR)
44	W	SENSOR POWER SUPPLY (ACCELERATOR PEDAL POSITION SENSOR 2)
45	R	ACCELERATOR PEDAL POSITION SENSOR 2 SIGNAL
46	R	ACCELERATOR PEDAL POSITION SENSOR 2 SIGNAL
47	B	SENSOR GROUND (ACCELERATOR PEDAL POSITION SENSOR 2)
48	SHIELD	
50	L	BATTERY TEMPERATURE SENSOR SIGNAL
51	O	COOLANT TEMPERATURE SENSOR SIGNAL
52	W	SENSOR GROUND (COOLANT TEMPERATURE SENSOR)
57	LG	POWER VOLTAGE VARIABLE CONTROL SIGNAL
59	V	RADIATOR FAN CONTROL SIGNAL
62	G	WATER PUMP 1 ACTIVATION SIGNAL
64	R	WATER PUMP 2 ACTIVATION SIGNAL
67	Y	DC/DC CONVERTER TEMPERATURE SIGNAL
70	W	DC/DC CONVERTER ACTIVATION SIGNAL
73	GR	F/S RELAY
75	W	F/S CHG RELAY
77	LG	F/S RELAY POWER SUPPLY
78	G	M/C RELAY
80	SB	REVERSE LAMP RELAY

Connector No.	E63
Connector Name	VCM
Connector Type	RH4ZFB-R26-L-RH

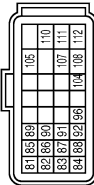

Terminal No.	Color of Wire	Signal Name [Specification]
81	GR	K-LINE
84	LG	EV SYSTEM ACTIVATION REQUEST SIGNAL
85	P	CHARGING STATUS INDICATOR 2
86	V	CHARGING STATUS INDICATOR 1
87	L	PLUG IN INDICATOR LAMP
88	Y	AVSP CONTROL SIGNAL
89	V	IMMEDIATE CHARGING SWITCH
90	W	STARTER RELAY CONT
91	O	ELECTRIC SHIFT WARNING SIGNAL
92	G	CHARGING STATUS INDICATOR 3
96	GR	EV SYSTEM ACTIVATION REQUEST SIGNAL
104	SB	ASCD STEERING SWITCH
106	L/O	PRE-CHARGE RELAY
107	W/L	SYSTEM MAIN RELAY 1

108	BR	ASCD STEERING SWITCH GROUND
110	L/Y	SYSTEM MAIN RELAY 2
111	B/R	GROUND
112	B/R	GROUND

Connector No.	E64
Connector Name	F/S CHG RELAY
Connector Type	MS02FL-M2-LC



Terminal No.	Color of Wire	Signal Name [Specification]
1	W	
2	LG	
3	W	
5	V	

Connector No.	E65
Connector Name	M/C RELAY
Connector Type	MS02FL-M2-LC



Terminal No.	Color of Wire	Signal Name [Specification]
1	G	
2	R	
3	R	
5	W	

EV CONTROL SYSTEM

Connector No.	E66
Connector Name	BATTERY CURRENT SENSOR
Connector Type	SAZ0MEGY



Terminal No.	Color of Wire	Signal Name [Specification]
1	R	-
2	L	-
3	L	-
4	Y	-

Connector No.	E67
Connector Name	ELECTRIC WATER PUMP 1
Connector Type	RSDHFG



Terminal No.	Color of Wire	Signal Name [Specification]
1	BR	-
2	B/Y	-
3	G	-
4	W	-

Connector No.	E68
Connector Name	ELECTRIC WATER PUMP 2
Connector Type	RSDHFG



Terminal No.	Color of Wire	Signal Name [Specification]
1	L	-
2	B/W	-
3	R	-
4	Y	-



Connector No.	E69
Connector Name	COOLANT TEMPERATURE SENSOR
Connector Type	ED2FGY-RS



Terminal No.	Color of Wire	Signal Name [Specification]
1	O	-
2	W	-



Connector No.	E101
Connector Name	ACCELERATOR PEDAL POSITION SENSOR
Connector Type	RHD6FB



Terminal No.	Color of Wire	Signal Name [Specification]
1	B	-
2	B	-
3	R	-
4	W	-
5	W	-
6	R	-

Connector No.	E102
Connector Name	STOP LAMP SWITCH
Connector Type	MM4FY-LC



Terminal No.	Color of Wire	Signal Name [Specification]
1	W	-
2	SB	-
3	LG	-
4	P	-

EV CONTROL SYSTEM

Connector No.	E109
Connector Name	WIRE TO WIRE
Connector Type	TH80MW-ZS16-TM4



Terminal No.	Color of Wire	Signal Name [Specification]
1	BR	
2	R	
3	GR	
4	LG	
5	W	
6	P	
7	V	
8	Y	
9	G	
10	R	
11	O	
12	W	
13	B	
14	Y	
15	BR	
16	LG	
17	L	
19	G	
20	V	
21	P	
22	LG	
23	GR	
24	L	
25	R	
26	SB	
27	B	
29	BR	
30	W	
31	V	
32	LG	
33	O	
34	L	
35	BR	
38	SB	
39	GR	
40	Y	
41	R	
42	W	
43	SB	

Connector No.	E108
Connector Name	WIRE TO WIRE
Connector Type	NS0MMW-GS



Terminal No.	Color of Wire	Signal Name [Specification]
1	W	
2	R	
3	L	
4	R	

Connector No.	E109
Connector Name	WIRE TO WIRE
Connector Type	TH432MW-NH



Terminal No.	Color of Wire	Signal Name [Specification]
1	W	
2	R	
3	Y	
4	G	
5	GR	
6	L	
7	O	
8	V	
9	SB	
10	LG	
11	L	
17	LG	
18	BR	
19	O	
20	V	
21	SB	
22	L	
23	G	

24	V	
25	W/L	
26	L/Y	
27	L/O	
28	GR	
29	P	
30	R	
31	W	

Connector No.	E112
Connector Name	ASCD BRAKE SWITCH
Connector Type	M02FER-LC



Terminal No.	Color of Wire	Signal Name [Specification]
1	G	
2	O	

Connector No.	E201
Connector Name	BATTERY TERMINAL WITH FUSIBLE LINK
Connector Type	



Terminal No.	Color of Wire	Signal Name [Specification]
6	B/R	

A
B
EVB
D
E
F
G
H
I
J
K
L
M
N
O
P

EV CONTROL SYSTEM

Connector No.	E202
Connector Name	DC/DC-J/B
Connector Type	



Terminal No.	Color of Wire	Signal Name [Specification]
17	B/R	BATTERY POWER SUPPLY

Connector No.	E301
Connector Name	COOLING FAN CONTROL MODULE (COOLING FAN MOTOR-1)
Connector Type	6188-0259



Terminal No.	Color of Wire	Signal Name [Specification]
4	-	-
5	-	-

Connector No.	E302
Connector Name	COOLING FAN CONTROL MODULE (COOLING FAN MOTOR-2)
Connector Type	6188-0259



Terminal No.	Color of Wire	Signal Name [Specification]
6	-	-
7	-	-

Connector No.	F1
Connector Name	WIRE TO WIRE
Connector Type	SAA39EB-RS10-SLZ2

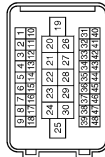

Terminal No.	Color of Wire	Signal Name [Specification]
1	Y	-
2	L	-
3	GR	-
4	LG	-
5	P	-
6	B	-
8	W	-
10	R	-
11	W	-
12	O	-
13	G	-
14	V	-
15	SB	-
16	LG	-
17	BR	-
18	Y	-
20	V	-
21	G	-
22	LG	-
23	B	-
26	SB	-
27	R	-
28	Y	-
29	W	-
30	P	-
31	L	-
32	W	-
34	R	-
35	G	-
36	LG	-
37	G	-
37	O	- [With quick charge port]
38	B	- [Without quick charge port]
40	BR	-
41	O	-
42	SB	-
43	L	-

44	LG	-
47	V	-
48	P	-

Connector No.	F2
Connector Name	WIRE TO WIRE
Connector Type	RH12FB

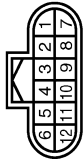

Terminal No.	Color of Wire	Signal Name [Specification]
1	L/W	-
2	LG	-
3	L	-
4	G	-
5	L	-
6	G	-
7	V	-
8	Y/V	-
9	V	-
10	O	-
11	R/Y	-
12	W/R	-

Connector No.	F11
Connector Name	DC/DC-J/B
Connector Type	RH12EB

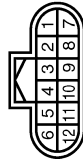

Terminal No.	Color of Wire	Signal Name [Specification]
1	L	-
2	Y/V	-
3	R	-
4	V	-
5	P	-

6	O	-
7	LG	-
8	Y	-
9	L/W	-
10	W	-
11	R	BATTERY POWER SUPPLY
12	V	QUICK CHARGE RELAY POWER SUPPLY

Connector No.	F12
Connector Name	DC/DC-J/B
Connector Type	RH04FB



Terminal No.	Color of Wire	Signal Name [Specification]
13	W/R	-
14	R/Y	-
15	O	-
16	V	-

Connector No.	M2
Connector Name	TCU
Connector Type	TH00FW-NH

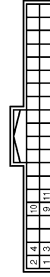

Terminal No.	Color of Wire	Signal Name [Specification]
1	BR	BATTERY POWER SUPPLY
2	B	GROUND
3	G	ACC POWER SUPPLY
4	V	POWER SWITCH ON SIGNAL
9	L	EV SYSTEM CAN-H
10	G	EV SYSTEM CAN-L
11	LG	EV SYSTEM ACTIVATION REQUEST SIGNAL

EV CONTROL SYSTEM

Connector No.	M4
Connector Name	DATA LINK CONNECTOR
Connector Type	BD16FW

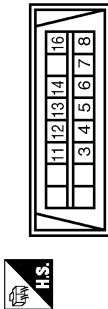

Connector No.	M34
Connector Name	COMBINATION METER
Connector Type	TH16FW-NH

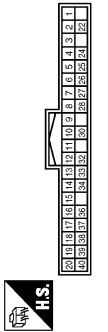

Connector No.	M47
Connector Name	VEHICLE SOUND FOR PEDESTRIANS (VSP) CONTROL UNIT
Connector Type	TH16FW-NH

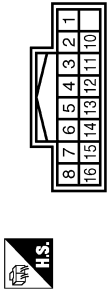

Connector No.	M70
Connector Name	BCM (BODY CONTROL MODULE)
Connector Type	TH16FW-NH

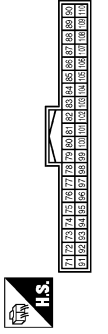

Terminal No.	Color of Wire	Signal Name [Specification]
3	LG	-
4	B	-
5	B	-
6	L	-
7	GR	-
8	G	-
11	SB	-
12	G	-
13	L	-
14	P	-
16	Y	-

Connector No.	M33
Connector Name	COMBINATION SWITCH (SPIRAL CABLE)
Connector Type	TK09FCY-1V

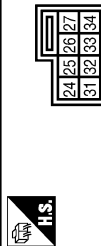

Terminal No.	Color of Wire	Signal Name [Specification]
1	LG	BATTERY POWER SUPPLY
2	R	BATTERY POWER SUPPLY (FOR UPPER METER)
3	GR	POWER SWITCH SUPPLY
4	BR	POWER SWITCH SUPPLY (FOR UPPER METER)
5	B	GROUND
6	B	GROUND
7	V	ELECTRIC SHIFT WARNING SIGNAL
8	Y	WASHER LEVEL SWITCH SIGNAL
9	G	PLUG IN SIGNAL
10	L	COMMUNICATION SIGNAL (METER → VSP)
11	P	COMMUNICATION SIGNAL (VSP → METER)
12	V	METER CONTROL SWITCH GROUND
13	LG	ENTER SWITCH SIGNAL
14	W	SELECT SWITCH SIGNAL
15	BR	TRIP RESET SWITCH SIGNAL
16	BR	ILLUMINATION CONTROL SWITCH SIGNAL
17	V	ILLUMINATION CONTROL SIGNAL (FOR UPPER METER)
18	P	CAN-L
19	L	CAN-H
20	V	SEAT BELT BUCKLE SWITCH SIGNAL (PASSenger SIDE)
22	GR	GROUND (FOR UPPER METER)
24	BR	ELECTRIC PARKING BRAKE CONTROL SWITCH SIGNAL
25	SB	BRAKE FLUID LEVEL SWITCH SIGNAL
26	B	ILLUMINATION CONTROL SIGNAL
27	R	AIR BAG SIGNAL
28	R	SECURITY SIGNAL
30	GR	VEHICLE SPEED SIGNAL (3-PULSE)
32	W	COMMUNICATION SIGNAL (METER → UPPER)
33	LG	CLOCK SIGNAL
34	L	PLUG IN INDICATOR LAMP SIGNAL
38	V	LED HEADLAMP (RH) WARNING SIGNAL
39	LG	LED HEADLAMP (LH) WARNING SIGNAL
40	Y	SEAT BELT BUCKLE SWITCH SIGNAL (DRIVER SIDE)

Terminal No.	Color of Wire	Signal Name [Specification]
24	BR	-
25	LG	-
26	B	-
31	Y	-
32	SB	-
33	SHIELD	-
34	G	-

Terminal No.	Color of Wire	Signal Name [Specification]
1	B	GROUND
2	L	COMMUNICATION SIGNAL (METER → VSP)
3	SR	POWER SWITCH SIGNAL
4	P	COMMUNICATION SIGNAL (VSP → METER)
5	G	VSP OFF SWITCH SIGNAL
6	Y	CHARGE PULSE SIGNAL
7	L	VSP SPEAKER SIGNAL (-)
8	Y	VSP SPEAKER SIGNAL (+)
10	GR	K-LINE (CONSULT)
11	GR	POWER SWITCH SUPPLY
12	SB	STOP LAMP SWITCH SIGNAL
13	L	BATTERY POWER SUPPLY
14	LG	VSP OFF INDICATOR SIGNAL
15	R	STRAUT UP SOUND SPEAKER SIGNAL (-)
16	W	STRAUT UP SOUND SPEAKER SIGNAL (+)

Connector No.	M65
Connector Name	IMMEDIATE CHARGING SWITCH
Connector Type	TH06FCY-NH



Terminal No.	Color of Wire	Signal Name [Specification]
1	Y	-
2	SB	-
3	W	ILLUMINATION +
4	B	ILLUMINATION -

Terminal No.	Color of Wire	Signal Name [Specification]
75	LG	DR DOOR REQ SW
76	SB	POWER SW (PUSH SW)
78	B	DRIVER DOOR ANT-
79	V	DRIVER DOOR ANT+
80	LG	PASS DOOR ANT-
81	Y	PASS DOOR ANT+
82	W	REAR BMPR ANT-
83	B	REAR BMPR ANT+
84	BR	ROOM ANT 1-
85	Y	ROOM ANT 1+
86	G	ROOM ANT 2-
87	R	ROOM ANT 2+
88	V	LUGGAGE ROOM ANT+
89	LG	LUGGAGE ROOM ANT-
90	W	POWER SW ILL PWR
91	V	ACC / ON IND
92	B	POWER SW ILL GND CONT
93	GR	E-KEY WARN BUZZER
96	BR	ACC RELAY CONT
97	W	READY
98	G	IGN RELAY (BDM E/B) CONT
99	R	IGN RELAY (P/B) CONT
100	P	PASS DOOR REQ SW
102	R	P/N POSITION
104	LG	WAKE-UP
106	P	STOP LAMP SW 2

EV CONTROL SYSTEM

Connector No.	M77
Connector Name	WIRE TO WIRE
Connector Type	TH80FW-CS16-TM4



Terminal No.	Color of Wire	Signal Name [Specification]
1	GR	-
2	V	-
3	GR	-
4	LG	-
6	W	-
7	V	-
8	P	-
9	SB	-
10	L	-
11	LG	-
12	W	-
13	R	-
14	Y	-
15	R	-
16	G	-
17	BR	-
19	G	-
20	G	-
21	P	-
22	LG	-
23	GR	-
24	L	-
25	Y	-
26	G	-
27	L	-
28	V	-
29	W	-
30	W	-
31	SB	-
32	LG	-
33	V	-
34	L	-
35	SB	-
38	LG	-
39	GR	-
40	Y	-
41	R	-
42	W	-
43	SB	-

44	GR	-
45	P	-
46	R	-
47	W	-
48	L	-
48	G	-
50	L	-
51	L	-
54	W	-
55	G	-
56	BR	-
57	P	-
58	R	-
60	Y	-
61	GR	-
62	SB	-
63	Y	-
64	G	-
65	V	-
66	P	-
67	Y	-
68	P	-
69	BR	-
71	Y	-
72	L	-
73	G	-
74	L	-
75	V	-
76	R	-
80	W	-
81	L	-
82	SB	-
83	R	-
84	BR	-
85	R	-
86	GR	-
88	R	-
88	W	-
90	SHIELD	-
91	Y	-
92	BR	-
93	W	-
94	P	-
95	V	-
96	P	-
97	G	-
98	R	-
99	LG	-

Connector No.	M99
Connector Name	WIRE TO WIRE
Connector Type	TH40FW-NH



Terminal No.	Color of Wire	Signal Name [Specification]
1	V	-
2	P	-
3	SB	-
4	LG	-

Connector No.	M100
Connector Name	WIRE TO WIRE
Connector Type	TH60MP-NH



Terminal No.	Color of Wire	Signal Name [Specification]
1	V	-
2	P	-
3	SB	-
4	L	-

Connector No.	M101
Connector Name	CHARGING STATUS INDICATOR
Connector Type	TH40FW-NH



Terminal No.	Color of Wire	Signal Name [Specification]
1	V	-
2	P	-
3	SB	-
4	L	-

Connector No.	M302
Connector Name	COMBINATION SWITCH (SPIRAL CABLE)
Connector Type	TK08FGY



Terminal No.	Color of Wire	Signal Name [Specification]
13	R	-
14	W	-
15	L	-
16	B	-
17	BR	-
18	G	-
19	Y	-
20	Y	-

DIAGNOSIS AND REPAIR WORK FLOW

< BASIC INSPECTION >

[TYPE 3]

BASIC INSPECTION

DIAGNOSIS AND REPAIR WORK FLOW

Work Flow

INFOID:000000011104182

DETAILED FLOW

1.GET INFORMATION FOR SYMPTOM

Get the detailed information from the customer about the symptom (the condition and the environment when the incident/malfunction occurred) using the "Question sheet". (Refer to [EVB-520, "Diagnostic Work Sheet"](#).)

>> GO TO 2.

2.CHECK DTC IN VCM

1. Check DTC in VCM.
2. Check related service bulletins for information.

Are any DTCs detected?

- YES >> Check the DTC. Refer to [EVC-84, "DTC Index"](#).
NO >> GO TO 3.

3.CHECK DTC

1. Check DTC.
2. Perform the following procedure if DTC is displayed.
 - Record DTC and freeze frame data. (Print them out with CONSULT.)
 - Erase DTC.
 - Study the relationship between the cause detected by DTC and the symptom described by the customer. (Symptom Matrix Chart is useful. Refer to [EVC-355, "Symptom Index"](#).)
3. Check related service bulletins for information.

Are any symptoms described and any DTCs detected?

- Symptom is described, DTC is detected>>GO TO 4.
Symptom is described, DTC is not detected>>GO TO 5.
Symptom is not described, DTC is detected>>GO TO 6.

4.CONFIRM THE SYMPTOM

Try to confirm the symptom described by the customer.

Also study the normal operation and fail-safe related to the symptom. Refer to [EVC-355, "Symptom Index"](#) and [EVB-497, "Fail-safe"](#).

Diagnosis Work Sheet is useful to verify the incident.

Verify relation between the symptom and the condition when the symptom is detected.

>> GO TO 6.

5.CONFIRM THE SYMPTOM

Try to confirm the symptom described by the customer.

Also study the normal operation and fail-safe related to the symptom. Refer to [EVC-355, "Symptom Index"](#) and [EVB-497, "Fail-safe"](#).

Diagnosis Work Sheet is useful to verify the incident.

Verify relation between the symptom and the condition when the symptom is detected.

>> GO TO 7.

6.PERFORM DTC CONFIRMATION PROCEDURE

Perform DTC CONFIRMATION PROCEDURE for the displayed DTC, and then check that DTC is detected again.

NOTE:

- Freeze frame data is useful if the DTC is not detected.

DIAGNOSIS AND REPAIR WORK FLOW

[TYPE 3]

< BASIC INSPECTION >

- Perform Component Function Check if DTC CONFIRMATION PROCEDURE is not included on Service Manual. This simplified check procedure is an effective alternative though DTC cannot be detected during this check.
If the result of Component Function Check is NG, it is the same as the detection of DTC by DTC CONFIRMATION PROCEDURE.

Is DTC detected?

- YES >> GO TO 8.
- NO >> Check according to [GI-51, "Intermittent Incident"](#).

7. DETECT MALFUNCTIONING SYSTEM BY SYMPTOM TABLE

Detect malfunctioning system according to [EVC-355, "Symptom Index"](#) based on the confirmed symptom in step 4, and determine the trouble diagnosis order based on possible causes and symptoms.

Is the symptom described?

- YES >> GO TO 8.
- NO >> Monitor input data from related sensors using CONSULT.

8. DETECT MALFUNCTIONING PART BY DIAGNOSIS PROCEDURE

Inspect according to Diagnosis Procedure of the system.

Is a malfunctioning part detected?

- YES >> GO TO 9.
- NO >> Monitor input data from related sensors using CONSULT.

9. REPAIR OR REPLACE THE MALFUNCTIONING PART

1. Repair or replace the malfunctioning part.
2. Reconnect parts or connectors disconnected during Diagnosis Procedure again after repair and replacement.
3. Check DTC. If DTC is displayed, erase it.

>> GO TO 10.

10. FINAL CHECK

When DTC was detected in step 3, perform DTC CONFIRMATION PROCEDURE or Component Function Check again, and then check that the malfunction have been completely repaired.

When symptom was described from the customer, refer to confirmed symptom in step 4 or 5, and check that the symptom is not detected.

Is DTC detected and does symptom remain?

- YES-1 >> DTC is detected: GO TO 8.
- YES-2 >> Symptom remains: GO TO 5.
- NO >> Before returning the vehicle to the customer, always erase DTC.

Diagnostic Work Sheet

INFOID:000000011104183

DESCRIPTION

There are many operating conditions that lead to the malfunction of "EV battery system" components. A good grasp of such conditions can make troubleshooting faster and more accurate.

In general, each customer feels differently about symptoms. It is important to fully understand the symptoms or conditions for a customer complaint.

Utilize the diagnostic worksheet in order to organize all the information for troubleshooting.

NOTE:

Some conditions may cause a DTC to be detected.

KEY POINTS

- WHAT** Vehicle & motor model
- WHEN** Date, Frequencies
- WHERE**..... Road conditions
- HOW** Operating conditions,
Weather conditions,
Symptoms

JSCIA0412GB

WORKSHEET SAMPLE

DIAGNOSIS AND REPAIR WORK FLOW

< BASIC INSPECTION >

[TYPE 3]

Question Sheet					
Customer name MR/MS	Incident Date		VIN		
	Model & Year		In Service Date		
	Trans.		Mileage	km/mile	
Symptoms	<input type="checkbox"/> Does not to READY		<input type="checkbox"/> EV system warning lamp is on		
	<input type="checkbox"/> Power limitation indicator lamp is on				
	<input type="checkbox"/> Water leak*	<input type="checkbox"/> Noise*	<input type="checkbox"/> Vibration*	<input type="checkbox"/> Shock*	<input type="checkbox"/> Gear noise*
	<input type="checkbox"/> Non driving*	<input type="checkbox"/> Poor acceleration*	<input type="checkbox"/> Poor torque*	<input type="checkbox"/> Radio noise*	
	<input type="checkbox"/> Does not charge	<input type="checkbox"/> Other*	*: If applied, enter in detail		
	Detailed symptom				
Onomatopoeia					
Frequency	<input type="checkbox"/> All the time	<input type="checkbox"/> Once	<input type="checkbox"/> Sometimes (times a day)	<input type="checkbox"/> Other	
Charging condition	<input type="checkbox"/> Full	<input type="checkbox"/> Medium	<input type="checkbox"/> Low		
Weather conditions	<input type="checkbox"/> Not affected				
	Weather	<input type="checkbox"/> Fine	<input type="checkbox"/> Clouding	<input type="checkbox"/> Raining	
		<input type="checkbox"/> Snowing	<input type="checkbox"/> Other ()		
	Temp.	<input type="checkbox"/> Hot	<input type="checkbox"/> Warm	<input type="checkbox"/> Cool	
	<input type="checkbox"/> Cold	<input type="checkbox"/> Temp. [Approx. °C (°F)]			
Humidity	<input type="checkbox"/> High	<input type="checkbox"/> Middle	<input type="checkbox"/> Low	<input type="checkbox"/> Humidity (Approx. %)	
Road conditions	<input type="checkbox"/> Not affected	<input type="checkbox"/> In town	<input type="checkbox"/> Freeway	<input type="checkbox"/> Off road (Up / Down)	
	<input type="checkbox"/> Deplorable road				
	<input type="checkbox"/> Flat road	<input type="checkbox"/> While turning (Right / Left)	<input type="checkbox"/> Bump		
	<input type="checkbox"/> Other				
Shift position	<input type="checkbox"/> Not affected				
	<input type="checkbox"/> P position	<input type="checkbox"/> R position	<input type="checkbox"/> N position	<input type="checkbox"/> D position	
	<input type="checkbox"/> ECO mode				
Driving conditions	<input type="checkbox"/> Not affected				
	<input type="checkbox"/> Power switch ON → OFF		<input type="checkbox"/> Power switch OFF → ON		
	<input type="checkbox"/> READY (stop the vehicle)				
	<input type="checkbox"/> While cruising	<input type="checkbox"/> While decelerating	<input type="checkbox"/> Just before stopping	<input type="checkbox"/> Just after stopping	
	<input type="checkbox"/> D position (stop the vehicle)				
	<input type="checkbox"/> While recharging		<input type="checkbox"/> Other		
<input type="checkbox"/> Vehicle speed [km/h (MPH)]		<input type="checkbox"/> Accelerator pedal (/ 8)			
<input type="checkbox"/> Battery level (Low / Middle / High)					
Moments when malfunction disappears	<input type="checkbox"/> Disappears while driving		<input type="checkbox"/> Disappears when stopped		
	<input type="checkbox"/> Disappears with select operation				
	<input type="checkbox"/> Disappears when power switch is pushed OFF	<input type="checkbox"/> Disappears when battery charge is stopped	<input type="checkbox"/> Does not disappear		
<input type="checkbox"/> Other					
Other					

A
B
EVB
D
E
F
G
H
I
J
K
L
M
N
O
P

ADDITIONAL SERVICE WHEN REPLACING LI-ION BATTERY CONTROLLER

< BASIC INSPECTION >

[TYPE 3]

ADDITIONAL SERVICE WHEN REPLACING LI-ION BATTERY CONTROLLER

Description

INFOID:000000011104184

When only Li-ion Battery Controller (LBC) is replaced, it is necessary to save the battery information stored in LBC to the new LBC.

Work Procedure

INFOID:000000011104185

1. SAVE THE LI-ION BATTERY CONTROLLER (LBC) INTERNAL INFORMATION

Ⓜ With CONSULT

1. Select "SAVE BATTERY INFORMATION DATA" in "WORK SUPPORT" mode.
2. Save the LBC internal information.

>> GO TO 2.

2. REPLACE LI-ION BATTERY OR LBC

Replace LBC. Refer to [EVB-645, "LI-ION BATTERY CONTROLLER : Removal and Installation"](#).

>> GO TO 3.

3. WRITE THE LBC INTERNAL INFORMATION

Ⓜ With CONSULT

1. Select "WRITE BATTERY INFORMATION DATA" in "WORK SUPPORT" mode.
2. Write the information that has been read out before LBC replacement.

>> GO TO 4.

4. WRITE THE LBC INTERNAL INFORMATION TO VCM

Refer to "Li-ion Battery Registration Operation Manual."

>> END

MODULE CHARGE BALANCE

Description

INFOID:0000000011104186

If a malfunction (e.g. abnormal voltage) occurs in a Li-ion battery cell, the module which includes the malfunctioning cell must be replaced. When replacing a module with a new one, its voltage is required to be adjusted to the adjusting voltage calculated from the maximum cell voltage of normal cells.

Work Procedure

INFOID:0000000011104187

NOTE:

Voltage adjustment under low temperature conditions may require a long time. To prevent this from occurring, it is advisable to adjust voltage under room temperature conditions [20°C ± 10°C (68°F ± 18°F)].

1. CHECK ADJUSTMENT VOLTAGE VALUE

 With CONSULT

1. Power switch ON.
2. Select "DATA MONITOR" of "HV BAT".
3. Check "MAXIMUM CELL VOLTAGE".
4. Double the "MAXIMUM CELL VOLTAGE" and use that value as the module adjustment value.

Adjustment voltage value : MAXIMUM CELL VOLTAGE × 2

Example: 3.925 V (MAXIMUM CELL VOLTAGE) × 2 = 7.850 V (Adjustment voltage value)

>> GO TO 2.

2. CHECK MODULE VOLTAGE**CAUTION:**

For details on the module charge balancer operation, refer to the adjuster operation manual.

1. Set the new module to the module charge balancer.
2. Measure module voltage and compare it with "adjustment voltage value" confirmed in Step 1.

Module voltage is lower than adjustment voltage value >> GO TO 4.

Module voltage is higher than adjustment voltage value >> GO TO 3.

3. DISCHARGE OF MODULE VOLTAGE**CAUTION:**

For details on the module charge balancer operation, refer to the adjuster operation manual.

Discharge the module to 5.0 V using module charge balancer.

Discharge voltage : 5.0 V

>> GO TO 4.

4. ADJUST VOLTAGE WITH A MODULE CHARGE BALANCER**CAUTION:**

For details on the module charge balancer operation, refer to the adjuster operation manual.

1. Enter "adjustment voltage value" into module charge balancer.

Adjustment voltage value : MAXIMUM CELL VOLTAGE × 2

2. Start the voltage adjustment.

>> After module voltage adjustment, GO TO 5.

5. CHECK MODULE VOLTAGE

1. Remove the module from the module charge balancer.
2. Using a circuit tester, check that the module voltage is within the specified range.

Standard : Adjustment voltage value \pm 10 mV

>> GO TO 6.

6. CHECK CELL VOLTAGE

Ⓜ With CONSULT

1. After adjusting the voltage, install the module to the vehicle.
2. Select "DATA MONITOR" of "HV BAT".
3. Check "CELL VOLTAGE" of install module.
4. Check that the difference from the "MAXIMUM CELL VOLTAGE" confirmed in Step1 is within the specified range.

Standard : MAXIMUM CELL VOLTAGE \pm 33 mV

>> WORK END

P0A0D HV SYSTEM INTERLOCK ERROR

< DTC/CIRCUIT DIAGNOSIS >

[TYPE 3]

DTC/CIRCUIT DIAGNOSIS

P0A0D HV SYSTEM INTERLOCK ERROR

DTC Logic

INFOID:0000000011104190

DTC DETECTION LOGIC

DTC	Trouble diagnosis name	DTC detecting condition	Possible causes
P0A0D	HV SYSTEM INTERLOCK ERROR	Self diagnosis program of Li-ion battery controller detects a malfunction in the CPU.	Li-ion battery controller

DTC CONFIRMATION PROCEDURE

1. PERFORM DTC CONFIRMATION PROCEDURE

④ With CONSULT

1. Power switch ON and wait for 10 seconds or more.
2. Select "Self Diagnostic Result" of "HV BAT".
3. Check DTC.

Is P0A1F detected?

- YES >> Refer to [EVB-525, "Diagnosis Procedure"](#).
NO >> INSPECTION END

Diagnosis Procedure

INFOID:0000000011104191

WARNING:

- Because hybrid vehicles and electric vehicles contain a high voltage battery, there is the risk of electric shock, electric leakage, or similar accidents if the high voltage component and vehicle are handled incorrectly. Be sure to follow the correct work procedures when performing inspection and maintenance.
- Be sure to remove the service plug in order to disconnect the high voltage circuits before performing inspection or maintenance of high voltage system harnesses and parts.
- To prevent the removed service plug from being connected by mistake during the procedure, always carry it in your pocket or put it in the tool box.
- Be sure to wear insulating protective equipment consisting of glove, shoes, face shield and glasses before beginning work on the high voltage system.
- Clearly identify the persons responsible for high voltage work and ensure that other persons do not touch the vehicle. When not working, cover high voltage parts with an insulating cover sheet or similar item to prevent other persons from contacting them.
- Refer to [EVB-469, "High Voltage Precautions"](#).

CAUTION:

There is the possibility of a malfunction occurring if the vehicle is changed to READY status while the service plug is removed. Therefore do not change the vehicle to READY status unless instructed to do so in the Service Manual.

1. PRECONDITIONING

WARNING:

Disconnect high voltage. Refer to [GI-31, "How to Disconnect High Voltage"](#).

1. Remove Li-ion battery. Refer to [EVB-626, "Removal and Installation"](#).
2. Remove battery pack upper case. Refer to [EVB-635, "BATTERY PACK UPPER CASE : Removal and Installation"](#).

>> GO TO 2.

2. CHECK LI-ION BATTERY INTERLOCK DETECTION CIRCUIT FOR SHORT-1

1. Disconnect Li-ion battery controller (LBC) harness connector.
2. Disconnect interlock detecting switch (high voltage harness connector) harness connector.
3. Check the continuity between Li-ion battery controller harness connector and ground.

POA0D HV SYSTEM INTERLOCK ERROR

[TYPE 3]

< DTC/CIRCUIT DIAGNOSIS >

LBC		—	Continuity
Connector	Terminal		
LB11	8	Ground	Not existed

Is the inspection result normal?

YES >> GO TO 3.

NO >> Replace Li-ion battery vehicle communication harness.

3. CHECK LI-ION BATTERY INTERLOCK DETECTIONING CIRCUIT FOR SHORT-2

1. Disconnect interlock detecting switch (service plug) harness connector.
2. Check the continuity between Li-ion battery controller harness connector and ground.

LBC		—	Continuity
Connector	Terminal		
LB11	21	Ground	Not existed

Is the inspection result normal?

YES >> GO TO 4.

NO >> Replace Li-ion battery vehicle communication harness.

4. CHECK LI-ION BATTERY INTERLOCK DETECTIONING CIRCUIT FOR SHORT-3

Check the continuity between interlock detecting switch (service plug) harness connector and ground.

Interlock detecting switch (Service plug)		—	Continuity
Connector	Terminal		
LB6	4	Ground	Not existed

Is the inspection result normal?

YES >> Replace Li-ion battery controller. Refer to [EVB-645, "LI-ION BATTERY CONTROLLER : Removal and Installation"](#).

NO >> Replace Li-ion battery vehicle communication harness.

P0A1F BATTERY ENERGY CONTROL MODULE

< DTC/CIRCUIT DIAGNOSIS >

[TYPE 3]

P0A1F BATTERY ENERGY CONTROL MODULE

DTC Logic

INFOID:0000000011104192

DTC DETECTION LOGIC

DTC	Trouble diagnosis name	DTC detecting condition	Possible causes
P0A1F	BATTERY ENERGY CONTROL MODULE	Self diagnosis program of Li-ion battery controller detects a malfunction in the CPU.	Li-ion battery controller

A

B

EVB

DTC CONFIRMATION PROCEDURE

1. PERFORM DTC CONFIRMATION PROCEDURE

④ With CONSULT

1. Power switch ON and wait for 10 seconds or more.
2. Select "Self Diagnostic Result" of "HV BAT".
3. Check DTC.

Is P0A1F detected?

- YES >> Refer to [EVB-527, "Diagnosis Procedure"](#).
NO >> INSPECTION END

Diagnosis Procedure

INFOID:0000000011104193

When this DTC is detected, replace Li-ion battery controller. Refer to [EVB-645, "LI-ION BATTERY CONTROLLER : Removal and Installation"](#).

D

E

F

G

H

I

J

K

L

M

N

O

P

P3030 CELL CONTROLLER LIN

< DTC/CIRCUIT DIAGNOSIS >

[TYPE 3]

P3030 CELL CONTROLLER LIN

DTC Logic

INFOID:000000011104194

DTC DETECTION LOGIC

DTC	Trouble diagnosis name	DTC detecting condition	Possible causes
P3030	CELL CONT LIN	A malfunction occurs with the communication function in Li-ion battery controller.	<ul style="list-style-type: none">• Li-ion battery controller• Module• Harness or connector

DTC CONFIRMATION PROCEDURE

1. PERFORM DTC CONFIRMATION PROCEDURE

④ With CONSULT

1. Power switch ON and wait for 10 seconds or more.
2. Select "Self Diagnostic Result" of "HV BAT".
3. Check DTC.

Is P3030 detected?

- YES >> Refer to [EVB-528, "Diagnosis Procedure"](#).
NO >> INSPECTION END

Diagnosis Procedure

INFOID:000000011104195

1. PERFORM THE SELF-DIAGNOSIS OF LI-ION BATTERY CONTROLLER

④ With CONSULT

1. Select "Self Diagnostic Result" of "HV BAT".
2. Check to see if "P30F3" is detected simultaneously with "P3030".

Is P30F3 detected?

- YES >> Replace Li-ion battery. Refer to [EVB-626, "Removal and Installation"](#).
NO >> Replace Li-ion battery controller. Refer to [EVB-645, "LI-ION BATTERY CONTROLLER : Removal and Installation"](#).

P3031-P303C CELL CONTROLLER ASIC

< DTC/CIRCUIT DIAGNOSIS >

[TYPE 3]

P3031-P303C CELL CONTROLLER ASIC

DTC Logic

INFOID:0000000011104196

DTC DETECTION LOGIC

DTC	Trouble diagnosis name	DTC detecting condition	Possible causes
P3031	CELL CONT ASIC1	A malfunction occurs with the communication function in Li-ion battery controller.	Li-ion battery controller
P3032	CELL CONT ASIC2		
P3033	CELL CONT ASIC3		
P3034	CELL CONT ASIC4		
P3035	CELL CONT ASIC5		
P3036	CELL CONT ASIC6		
P3037	CELL CONT ASIC7		
P3038	CELL CONT ASIC8		
P3039	CELL CONT ASIC9		
P303A	CELL CONT ASIC10		
P303B	CELL CONT ASIC11		
P303C	CELL CONT ASIC12		

A

B

EVB

D

E

F

G

DTC CONFIRMATION PROCEDURE

1. PERFORM DTC CONFIRMATION PROCEDURE

④ With CONSULT

1. Power switch ON and wait for 10 seconds or more.
2. Select "Self Diagnostic Result" of "HV BAT".
3. Check DTC.

Is any DTC detected?

- YES >> Refer to [EVB-529, "Diagnosis Procedure"](#).
 NO >> INSPECTION END

H

I

J

Diagnosis Procedure

INFOID:0000000011104197

1. PERFORM THE SELF-DIAGNOSIS OF LI-ION BATTERY CONTROLLER

④ With CONSULT

1. Select "Self Diagnostic Result" of "HV BAT".
2. Check to see if "P3030" is detected simultaneously with "P3031 -P303C".

Is P3030 detected?

- YES >> Perform diagnosis on the detected P3030. Refer to [EVB-528, "Diagnosis Procedure"](#).
 NO >> Replace Li-ion battery controller. Refer to [EVB-645, "LI-ION BATTERY CONTROLLER : Removal and Installation"](#).

K

L

M

N

O

P

P303D-P3048 CELL CONTROLLER ASIC

< DTC/CIRCUIT DIAGNOSIS >

[TYPE 3]

P303D-P3048 CELL CONTROLLER ASIC

DTC Logic

INFOID:000000011104198

DTC DETECTION LOGIC

DTC	Trouble diagnosis name	DTC detecting condition	Possible causes
P303D	CELL CONT ASIC13	A malfunction occurs with the communication function in Li-ion battery controller.	Li-ion battery controller
P303E	CELL CONT ASIC14		
P303F	CELL CONT ASIC15		
P3040	CELL CONT ASIC16		
P3041	CELL CONT ASIC17		
P3042	CELL CONT ASIC18		
P3043	CELL CONT ASIC19		
P3044	CELL CONT ASIC20		
P3045	CELL CONT ASIC21		
P3046	CELL CONT ASIC22		
P3047	CELL CONT ASIC23		
P3048	CELL CONT ASIC24		

DTC CONFIRMATION PROCEDURE

1. PERFORM DTC CONFIRMATION PROCEDURE

④ With CONSULT

1. Power switch ON and wait for 10 seconds or more.
2. Select "Self Diagnostic Result" of "HV BAT".
3. Check DTC.

Is any DTC detected?

- YES >> Refer to [EVB-530, "Diagnosis Procedure"](#).
NO >> INSPECTION END

Diagnosis Procedure

INFOID:000000011104199

1. PERFORM THE SELF-DIAGNOSIS OF LI-ION BATTERY CONTROLLER

④ With CONSULT

1. Select "Self Diagnostic Result" of "HV BAT".
2. Check to see if "P3030" is detected simultaneously with "P303D" -"P3048".

Is P3030 detected?

- YES >> Perform diagnosis on the detected P3030. Refer to [EVB-528, "Diagnosis Procedure"](#).
NO >> Replace Li-ion battery controller. Refer to [EVB-645, "LI-ION BATTERY CONTROLLER : Removal and Installation"](#).

P3049-P3054 CELL CONTROLLER ASIC VOLTAGE

< DTC/CIRCUIT DIAGNOSIS >

[TYPE 3]

P3049-P3054 CELL CONTROLLER ASIC VOLTAGE

DTC Logic

INFOID:0000000011104200

DTC DETECTION LOGIC

DTC	Trouble diagnosis name	DTC detecting condition	Possible causes
P3049	CELL CONT ASIC1 VOLT	The A/D converter in Li-ion battery controller is malfunctioning.	<ul style="list-style-type: none"> Li-ion battery controller Module Harness or connector
P304A	CELL CONT ASIC2 VOLT		
P304B	CELL CONT ASIC3 VOLT		
P304C	CELL CONT ASIC4 VOLT		
P304D	CELL CONT ASIC5 VOLT		
P304E	CELL CONT ASIC6 VOLT		
P304F	CELL CONT ASIC7 VOLT		
P3050	CELL CONT ASIC8 VOLT		
P3051	CELL CONT ASIC9 VOLT		
P3052	CELL CONT ASIC10 VOLT		
P3053	CELL CONT ASIC11 VOLT		
P3054	CELL CONT ASIC12 VOLT		

DTC CONFIRMATION PROCEDURE

1. PERFORM DTC CONFIRMATION PROCEDURE

☐ With CONSULT

- Power switch ON and wait for 10 seconds or more.
- Select "Self Diagnostic Result" of "HV BAT".
- Check DTC.

Is any DTC detected?

- YES >> Refer to [EV5-531, "Diagnosis Procedure"](#).
 NO >> INSPECTION END

Diagnosis Procedure

INFOID:0000000011104201

1. PERFORM THE SELF-DIAGNOSIS OF LI-ION BATTERY CONTROLLER

☐ With CONSULT

- Select "Self Diagnostic Result" of "HV BAT".
- Check DTC.

Is any DTC detected?

YES-1 >> "P3302" - "P3331" are detected simultaneously.

- When "P3302" - "P330D" are detected simultaneously, perform the diagnosis procedure of "P3302" - "P330D". Refer to [EV5-560, "Diagnosis Procedure"](#).
- When "P330E" - "P3319" are detected simultaneously, perform the diagnosis procedure of "P330E" - "P3319". Refer to [EV5-564, "Diagnosis Procedure"](#).
- When "P331A" - "P3325" are detected simultaneously, perform the diagnosis procedure of "P331A" - "P3325". Refer to [EV5-568, "Diagnosis Procedure"](#).
- When "P3326" - "P3331" are detected simultaneously, perform the diagnosis procedure of "P3326" - "P3331". Refer to [EV5-571, "Diagnosis Procedure"](#).

YES-2 >> "P3375" - "P33A4" are detected simultaneously.

- When "P3375" - "P3380" are detected simultaneously, perform the diagnosis procedure of "P3375" - "P3380". Refer to [EV5-575, "Diagnosis Procedure"](#).
- When "P3381" - "P338C" are detected simultaneously, perform the diagnosis procedure of "P3381" - "P338C". Refer to [EV5-579, "Diagnosis Procedure"](#).
- When "P338D" - "P3398" are detected simultaneously, perform the diagnosis procedure of "P338D" - "P3398". Refer to [EV5-583, "Diagnosis Procedure"](#).

P3049-P3054 CELL CONTROLLER ASIC VOLTAGE

< DTC/CIRCUIT DIAGNOSIS >

[TYPE 3]

- When “P3399” - “P33A4” are detected simultaneously, perform the diagnosis procedure of “P3399” - “P33A4”. Refer to [EVB-586, "Diagnosis Procedure"](#).
- NO >> When only “P3049” - “P3054” are detected, replace Li-ion battery controller. Refer to [EVB-645, "LI-ION BATTERY CONTROLLER : Removal and Installation"](#).

P3055-P3060 CELL CONTROLLER ASIC VOLTAGE

< DTC/CIRCUIT DIAGNOSIS >

[TYPE 3]

P3055-P3060 CELL CONTROLLER ASIC VOLTAGE

DTC Logic

INFOID:0000000011104202

DTC DETECTION LOGIC

DTC	Trouble diagnosis name	DTC detecting condition	Possible causes
P3055	CELL CONT ASIC13 VOLT	The A/D converter in Li-ion battery controller is malfunctioning.	<ul style="list-style-type: none"> Li-ion battery controller Module Harness or connector
P3056	CELL CONT ASIC14 VOLT		
P3057	CELL CONT ASIC15 VOLT		
P3058	CELL CONT ASIC16 VOLT		
P3059	CELL CONT ASIC17 VOLT		
P305A	CELL CONT ASIC18 VOLT		
P305B	CELL CONT ASIC19 VOLT		
P305C	CELL CONT ASIC20 VOLT		
P305D	CELL CONT ASIC21 VOLT		
P305E	CELL CONT ASIC22 VOLT		
P305F	CELL CONT ASIC23 VOLT		
P3060	CELL CONT ASIC24 VOLT		

DTC CONFIRMATION PROCEDURE

1. PERFORM DTC CONFIRMATION PROCEDURE

☐ With CONSULT

- Power switch ON and wait for 10 seconds or more.
- Select "Self Diagnostic Result" of "HV BAT".
- Check DTC.

Is any DTC detected?

- YES >> Refer to [EV5-533, "Diagnosis Procedure"](#).
 NO >> INSPECTION END

Diagnosis Procedure

INFOID:0000000011104203

1. PERFORM THE SELF-DIAGNOSIS OF LI-ION BATTERY CONTROLLER

☐ With CONSULT

- Select "Self Diagnostic Result" of "HV BAT".
- Check DTC.

Is any DTC detected?

YES-1 >> "P3302" - "P3331" are detected simultaneously.

- When "P3302" - "P330D" are detected simultaneously, perform the diagnosis procedure of "P3302" - "P330D". Refer to [EV5-560, "Diagnosis Procedure"](#).
- When "P330E" - "P3319" are detected simultaneously, perform the diagnosis procedure of "P330E" - "P3319". Refer to [EV5-564, "Diagnosis Procedure"](#).
- When "P331A" - "P3325" are detected simultaneously, perform the diagnosis procedure of "P331A" - "P3325". Refer to [EV5-568, "Diagnosis Procedure"](#).
- When "P3326" - "P3331" are detected simultaneously, perform the diagnosis procedure of "P3326" - "P3331". Refer to [EV5-571, "Diagnosis Procedure"](#).

YES-2 >> "P3375" - "P33A4" are detected simultaneously.

- When "P3375" - "P3380" are detected simultaneously, perform the diagnosis procedure of "P3375" - "P3380". Refer to [EV5-575, "Diagnosis Procedure"](#).
- When "P3381" - "P338C" are detected simultaneously, perform the diagnosis procedure of "P3381" - "P338C". Refer to [EV5-579, "Diagnosis Procedure"](#).
- When "P338D" - "P3398" are detected simultaneously, perform the diagnosis procedure of "P338D" - "P3398". Refer to [EV5-583, "Diagnosis Procedure"](#).

P3055-P3060 CELL CONTROLLER ASIC VOLTAGE

< DTC/CIRCUIT DIAGNOSIS >

[TYPE 3]

- When “P3399” - “P33A4” are detected simultaneously, perform the diagnosis procedure of “P3399” - “P33A4”. Refer to [EVB-586, "Diagnosis Procedure"](#).
- NO >> When only “P3055” - “P3060” are detected, replace Li-ion battery controller. Refer to [EVB-645, "LI-ION BATTERY CONTROLLER : Removal and Installation"](#).

P3061 CELL BATTERY VOLTAGE

< DTC/CIRCUIT DIAGNOSIS >

[TYPE 3]

P3061 CELL BATTERY VOLTAGE

DTC Logic

INFOID:0000000011104204

DTC DETECTION LOGIC

DTC	Trouble diagnosis name	DTC detecting condition	Possible causes
P3061	CELL BATTERY VOLT	An open circuit diagnosis detection circuit in Li-ion battery controller is malfunctioning.	Li-ion battery controller

DTC CONFIRMATION PROCEDURE

1. PERFORM DTC CONFIRMATION PROCEDURE

Ⓜ With CONSULT

1. Power switch ON and wait for 10 seconds or more.
2. Select "Self Diagnostic Result" of "HV BAT".
3. Check DTC.

Is P3061 detected?

- YES >> Refer to [EVB-535, "Diagnosis Procedure"](#).
NO >> INSPECTION END

Diagnosis Procedure

INFOID:0000000011104205

When this DTC is detected, replace Li-ion battery controller. Refer to [EVB-645, "LI-ION BATTERY CONTROLLER : Removal and Installation"](#).

P3062 BYPASS SWITCH

< DTC/CIRCUIT DIAGNOSIS >

[TYPE 3]

P3062 BYPASS SWITCH

DTC Logic

INFOID:000000011104206

DTC DETECTION LOGIC

DTC	Trouble diagnosis name	DTC detecting condition	Possible causes
P3062	BYPASS SW	A malfunction of the bypass switch in Li-ion battery controller is detected.	<ul style="list-style-type: none">• Li-ion battery controller• Module• Harness or connector

DTC DETECTION LOGIC

1. PERFORM DTC CONFIRMATION PROCEDURE

④ With CONSULT

1. Power switch ON and wait for 10 seconds or more.
2. Select "Self Diagnostic Result" of "HV BAT".
3. Check DTC.

Is P3062 detected?

- YES >> Refer to [EVB-536, "Diagnosis Procedure"](#).
NO >> INSPECTION END

Diagnosis Procedure

INFOID:000000011104207

1. PERFORM THE SELF-DIAGNOSIS OF LI-ION BATTERY CONTROLLER

④ With CONSULT

1. Select "Self Diagnostic Result" of "HV BAT".
2. Check to see if "P3375"- "P33A4" is detected simultaneously with "P3062".

Is P3375-P33A4 detected?

- YES >> • When "P3375" - "P3380" are detected simultaneously, perform the diagnosis procedure of "P3375" - "P3380". Refer to [EVB-575, "Diagnosis Procedure"](#).
• When "P3381" - "P338C" are detected simultaneously, perform the diagnosis procedure of "P3381" - "P338C". Refer to [EVB-579, "Diagnosis Procedure"](#).
• When "P338D" - "P3398" are detected simultaneously, perform the diagnosis procedure of "P338D" - "P3398". Refer to [EVB-583, "Diagnosis Procedure"](#).
• When "P3399" - "P33A4" are detected simultaneously, perform the diagnosis procedure of "P3399" - "P33A4". Refer to [EVB-586, "Diagnosis Procedure"](#).
NO >> Replace Li-ion battery controller. Refer to [EVB-645, "LI-ION BATTERY CONTROLLER : Removal and Installation"](#).

P308B-P3096 CELL CONTROLLER ASIC OPEN

< DTC/CIRCUIT DIAGNOSIS >

[TYPE 3]

P308B-P3096 CELL CONTROLLER ASIC OPEN

DTC Logic

INFOID:0000000011104208

DTC DETECTION LOGIC

DTC	Trouble diagnosis name	DTC detecting condition	Possible causes
P308B	CELL CONT ASIC1 OPEN	Self diagnosis program of Li-ion battery controller detects an open circuit in the cell voltage detection line.	<ul style="list-style-type: none"> Li-ion battery controller Harness or connector
P308C	CELL CONT ASIC2 OPEN		
P308D	CELL CONT ASIC3 OPEN		
P308E	CELL CONT ASIC4 OPEN		
P308F	CELL CONT ASIC5 OPEN		
P3090	CELL CONT ASIC6 OPEN		
P3091	CELL CONT ASIC7 OPEN		
P3092	CELL CONT ASIC8 OPEN		
P3093	CELL CONT ASIC9 OPEN		
P3094	CELL CONT ASIC10 OPEN		
P3095	CELL CONT ASIC11 OPEN		
P3096	CELL CONT ASIC12 OPEN		

DTC DETECTION LOGIC

1. PERFORM DTC CONFIRMATION PROCEDURE

Ⓜ With CONSULT

- Power switch ON and wait for 10 seconds or more.
- Select "Self Diagnostic Result" of "HV BAT".
- Check DTC.

Is P308B-P30A2 detected?

- YES >> Refer to [EV B-537, "Diagnosis Procedure"](#).
 NO >> INSPECTION END

Diagnosis Procedure

INFOID:0000000011104209

WARNING:

- Because hybrid vehicles and electric vehicles contain a high voltage battery, there is the risk of electric shock, electric leakage, or similar accidents if the high voltage component and vehicle are handled incorrectly. Be sure to follow the correct work procedures when performing inspection and maintenance.
- Be sure to remove the service plug in order to disconnect the high voltage circuits before performing inspection or maintenance of high voltage system harnesses and parts.
- To prevent the removed service plug from being connected by mistake during the procedure, always carry it in your pocket or put it in the tool box.
- Be sure to wear insulating protective equipment consisting of glove, shoes, face shield and glasses before beginning work on the high voltage system.
- Clearly identify the persons responsible for high voltage work and ensure that other persons do not touch the vehicle. When not working, cover high voltage parts with an insulating cover sheet or similar item to prevent other persons from contacting them.
- Refer to [EV B-469, "High Voltage Precautions"](#).

CAUTION:

There is the possibility of a malfunction occurring if the vehicle is changed to READY status while the service plug is removed. Therefore do not change the vehicle to READY status unless instructed to do so in the Service Manual.

1. PERFORM THE SELF-DIAGNOSIS OF LI-ION BATTERY CONTROLLER

Ⓜ With CONSULT

- Select "Self Diagnostic Result" of "HV BAT".

P308B-P3096 CELL CONTROLLER ASIC OPEN

[TYPE 3]

< DTC/CIRCUIT DIAGNOSIS >

2. Check to see if "P3049"- "P3060" (CELL CONT ASIC VOLT related codes) or "P3375"- "P33A4" (CELL OVER DISCHARGE related codes) is detected simultaneously with "P308B"- "P3096".

Is P3049-P3060 or P3375-P33A4 detected?

YES-1 >> "P3049"- "P3060" are detected simultaneously.

- When "P3049"- "P3054" are detected simultaneously, perform the diagnosis procedure of "P3049"- "P3054". Refer to [EVB-575, "Diagnosis Procedure"](#).
- When "P3055"- "P3060" are detected simultaneously, perform the diagnosis procedure of "P3055"- "P3060". Refer to [EVB-533, "Diagnosis Procedure"](#).

YES-2 >> "P3375"- "P33A4" are detected simultaneously.

- When "P3375"- "P3380" are detected simultaneously, perform the diagnosis procedure of "P3375"- "P3380". Refer to [EVB-575, "Diagnosis Procedure"](#).
- When "P3381"- "P338C" are detected simultaneously, perform the diagnosis procedure of "P3381"- "P338C". Refer to [EVB-579, "Diagnosis Procedure"](#).
- When "P338D"- "P3398" are detected simultaneously, perform the diagnosis procedure of "P338D"- "P3398". Refer to [EVB-583, "Diagnosis Procedure"](#).
- When "P3399"- "P33A4" are detected simultaneously, perform the diagnosis procedure of "P3399"- "P33A4". Refer to [EVB-586, "Diagnosis Procedure"](#).

NO >> GO TO 2.

2. PRECONDITIONING

WARNING:

Disconnect high voltage. Refer to [GI-31, "How to Disconnect High Voltage"](#).

1. Remove Li-ion battery. Refer to [EVB-626, "Removal and Installation"](#).
2. Remove battery pack upper case. Refer to [EVB-635, "BATTERY PACK UPPER CASE : Removal and Installation"](#).

>> GO TO 3.

3. CHECK CONNECTION STATUS

1. Power switch OFF.
2. Check connection status of Li-ion battery controller harness connector and module harness connector.

Is the inspection result normal?

YES >> GO TO 4.

NO >> Recover the connection status.

4. CHECK HARNESS BETWEEN LI-ION BATTERY CONTROLLER AND MODULE

1. Disconnect Li-ion battery controller harness connector and voltage detection terminal of bus bar.
2. Refer to below table and continuity between Li-ion battery controller (A) and voltage detection terminal (B) of bus bar, according to detected DTC.

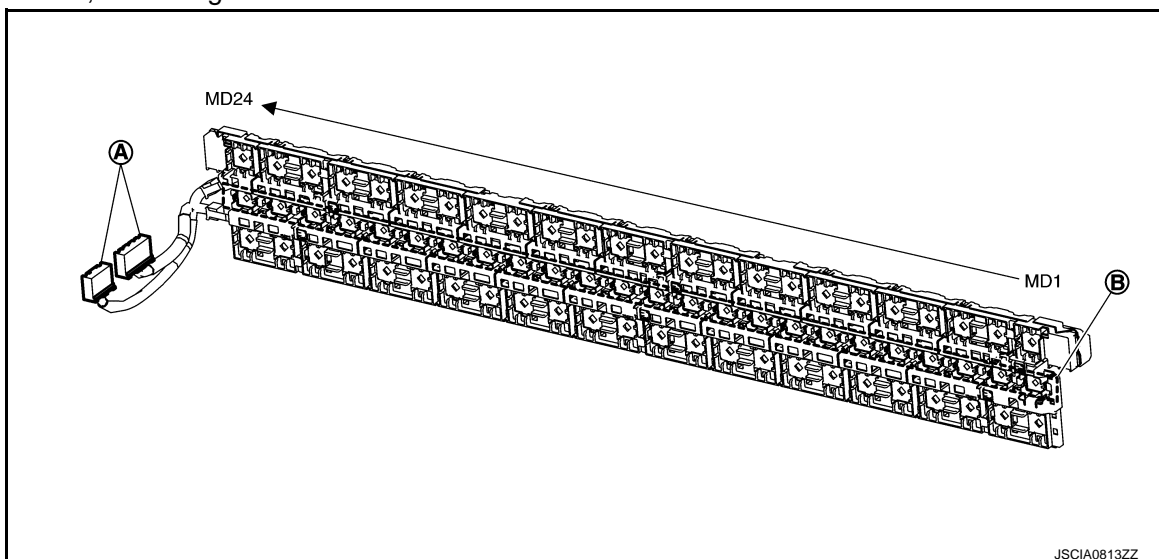

P308B-P3096 CELL CONTROLLER ASIC OPEN

< DTC/CIRCUIT DIAGNOSIS >

[TYPE 3]

DTC	Module No.		Li-ion battery controller		Continuity
			Connector	Terminal	
P308B	1	Voltage detection terminal of bus bar	LB13	50	Existed
	2			51	
P308C	3		LB13	52	Existed
	4			53	
P308D	5		LB13	54	Existed
	6			55	
P308E	7		LB13	56	Existed
	8			57	
P308F	9		LB13	58	Existed
	10			59	
P3090	11		LB13	60	Existed
	12			61	
P3091	13		LB13	62	Existed
	14			63	
P3092	15		LB14	77	Existed
	16			78	
P3093	17		LB14	80	Existed
	18			81	
P3094	19		LB14	82	Existed
	20			83	
P3095	21		LB14	84	Existed
	22			85	
P3096	23		LB14	86	Existed
	24			87	

Is the inspection result normal?

YES >> Replace Li-ion battery controller. Refer to [EVB-645, "LI-ION BATTERY CONTROLLER : Removal and Installation"](#).

NO >> Repair harness or connector.

A
B
EVB
D
E
F
G
H
I
J
K
L
M
N
O
P

P3097-P30A2 CELL CONTROLLER ASIC OPEN

< DTC/CIRCUIT DIAGNOSIS >

[TYPE 3]

P3097-P30A2 CELL CONTROLLER ASIC OPEN

DTC Logic

INFOID:000000011104210

DTC DETECTION LOGIC

DTC	Trouble diagnosis name	DTC detecting condition	Possible causes
P3097	CELL CONT ASIC13 OPEN	Self diagnosis program of Li-ion battery controller detects an open circuit in the cell voltage detection line.	<ul style="list-style-type: none">• Li-ion battery controller• Harness or connector
P3098	CELL CONT ASIC14 OPEN		
P3099	CELL CONT ASIC15 OPEN		
P309A	CELL CONT ASIC16 OPEN		
P309B	CELL CONT ASIC17 OPEN		
P309C	CELL CONT ASIC18 OPEN		
P309D	CELL CONT ASIC19 OPEN		
P309E	CELL CONT ASIC20 OPEN		
P309F	CELL CONT ASIC21 OPEN		
P30A0	CELL CONT ASIC22 OPEN		
P30A1	CELL CONT ASIC23 OPEN		
P30A2	CELL CONT ASIC24 OPEN		

DTC DETECTION LOGIC

1. PERFORM DTC CONFIRMATION PROCEDURE

④ With CONSULT

1. Power switch ON and wait for 10 seconds or more.
2. Select "Self Diagnostic Result" of "HV BAT".
3. Check DTC.

Is P308B-P30A2 detected?

- YES >> Refer to [EVB-540, "Diagnosis Procedure"](#).
NO >> INSPECTION END

Diagnosis Procedure

INFOID:000000011104211

WARNING:

- Because hybrid vehicles and electric vehicles contain a high voltage battery, there is the risk of electric shock, electric leakage, or similar accidents if the high voltage component and vehicle are handled incorrectly. Be sure to follow the correct work procedures when performing inspection and maintenance.
- Be sure to remove the service plug in order to disconnect the high voltage circuits before performing inspection or maintenance of high voltage system harnesses and parts.
- To prevent the removed service plug from being connected by mistake during the procedure, always carry it in your pocket or put it in the tool box.
- Be sure to wear insulating protective equipment consisting of glove, shoes, face shield and glasses before beginning work on the high voltage system.
- Clearly identify the persons responsible for high voltage work and ensure that other persons do not touch the vehicle. When not working, cover high voltage parts with an insulating cover sheet or similar item to prevent other persons from contacting them.
- Refer to [EVB-469, "High Voltage Precautions"](#).

CAUTION:

There is the possibility of a malfunction occurring if the vehicle is changed to READY status while the service plug is removed. Therefore do not change the vehicle to READY status unless instructed to do so in the Service Manual.

1. PERFORM THE SELF-DIAGNOSIS OF LI-ION BATTERY CONTROLLER

④ With CONSULT

1. Select "Self Diagnostic Result" mode of "HV BAT" using CONSULT.

P3097-P30A2 CELL CONTROLLER ASIC OPEN

[TYPE 3]

< DTC/CIRCUIT DIAGNOSIS >

- Check to see if "P3049"- "P3060" (CELL CONT ASIC VOLT related codes) or "P3375"- "P33A4" (CELL OVER DISCHARGE related codes) is detected simultaneously with "P3097"- "P30A2".

Is P3049-P3060 or P3375-P33A4 detected?

YES-1 >> "P3049"- "P3060" are detected simultaneously.

- When "P3049"- "P3054" are detected simultaneously, perform the diagnosis procedure of "P3049"- "P3054". Refer to [EVB-531, "Diagnosis Procedure"](#)
- When "P3055"- "P3060" are detected simultaneously, perform the diagnosis procedure of "P3055"- "P3060". Refer to [EVB-533, "Diagnosis Procedure"](#)

YES-2 >> "P3375"- "P33A4" are detected simultaneously.

- When "P3375"- "P3380" are detected simultaneously, perform the diagnosis procedure of "P3375"- "P3380". Refer to [EVB-575, "Diagnosis Procedure"](#).
- When "P3381"- "P338C" are detected simultaneously, perform the diagnosis procedure of "P3381"- "P338C". Refer to [EVB-579, "Diagnosis Procedure"](#).
- When "P338D"- "P3398" are detected simultaneously, perform the diagnosis procedure of "P338D"- "P3398". Refer to [EVB-583, "Diagnosis Procedure"](#).
- When "P3399"- "P33A4" are detected simultaneously, perform the diagnosis procedure of "P3399"- "P33A4". Refer to [EVB-586, "Diagnosis Procedure"](#)

NO >> GO TO 2.

2. PRECONDITIONING

WARNING:

Disconnect high voltage. Refer to [GI-31, "How to Disconnect High Voltage"](#).

- Remove Li-ion battery. Refer to [EVB-626, "Removal and Installation"](#).
- Remove battery pack upper case. Refer to [EVB-635, "BATTERY PACK UPPER CASE : Removal and Installation"](#).

>> GO TO 3.

3. CHECK CONNECTION STATUS

- Power switch OFF.
- Check connection status of Li-ion battery controller harness connector and module harness connector.

Is the inspection result normal?

YES >> GO TO 4.

NO >> Recover the connection status.

4. CHECK HARNESS BETWEEN LI-ION BATTERY CONTROLLER AND MODULE

- Disconnect Li-ion battery controller harness connector and Module harness connector.
- Refer to below table and continuity between Li-ion battery controller and Module, according to detected DTC.

DTC	Module No.	Module		Li-ion battery controller		Continuity
		Connector	Terminal	Connector	Terminal	
P3097	25	LB8	73	LB15	110	Existed
	26		74		111	
P3098	27	LB8	60	LB15	112	Existed
	28		77		113	
P3099	29	LB8	78	LB15	114	Existed
	30		64		115	
P309A	31	LB8	81	LB15	116	Existed
	32		82		117	
P309B	33	LB8	68	LB15	118	Existed
	34		85		119	
P309C	35	LB8	86	LB15	120	Existed
	36		72		121	

P3097-P30A2 CELL CONTROLLER ASIC OPEN

< DTC/CIRCUIT DIAGNOSIS >

[TYPE 3]

DTC	Module No.	Module		Li-ion battery controller		Continuity
		Connector	Terminal	Connector	Terminal	
P309D	37	LB7	89	LB15	122	Existed
	38		90		123	
P309E	39	LB7	91	LB15	124	Existed
	40		92		125	
P309F	41	LB7	93	LB15	127	Existed
	42		94		128	
P30A0	43	LB7	95	LB15	130	Existed
	44		96		138	
P30A1	45	LB7	97	LB15	140	Existed
	46		98		141	
P30A2	47	LB7	99	LB15	142	Existed
	48		100		143	

Is the inspection result normal?

YES >> Replace Li-ion battery controller. Refer to [EVB-645, "LI-ION BATTERY CONTROLLER : Removal and Installation"](#).

NO >> Repair harness or connector.

P30F3 TOTAL VOLTAGE SENSOR

< DTC/CIRCUIT DIAGNOSIS >

[TYPE 3]

P30F3 TOTAL VOLTAGE SENSOR

DTC Logic

INFOID:0000000011104212

DTC DETECTION LOGIC

DTC	Trouble diagnosis name	DTC detecting condition	Possible causes
P30F3	TOTAL VOLT SENSOR	A malfunction occurs with the communication function in Li-ion battery controller.	<ul style="list-style-type: none">• Li-ion battery controller• Module• Harness or connector

DTC CONFIRMATION PROCEDURE

1. PERFORM DTC CONFIRMATION PROCEDURE

④ With CONSULT

1. Power switch ON and wait for 10 seconds or more.
2. Select "Self Diagnostic Result" of "HV BAT".
3. Check DTC.

Is P30F3 detected?

- YES >> Refer to [EVB-543, "Diagnosis Procedure"](#).
NO >> INSPECTION END

Diagnosis Procedure

INFOID:0000000011104213

1. PERFORM THE SELF-DIAGNOSIS OF LI-ION BATTERY CONTROLLER

④ With CONSULT

1. Select "Self Diagnostic Result" of "HV BAT".
2. Check to see if "P3030" is detected simultaneously with "P30F3".

Is any P3030 detected?

- YES >> Perform diagnosis on the detected "P3030". Refer to [EVB-528, "Diagnosis Procedure"](#).
NO >> Replace Li-ion battery controller. Refer to [EVB-645, "LI-ION BATTERY CONTROLLER : Removal and Installation"](#).

P30F4 TOTAL VOLTAGE SENSOR

< DTC/CIRCUIT DIAGNOSIS >

[TYPE 3]

P30F4 TOTAL VOLTAGE SENSOR

DTC Logic

INFOID:0000000011104214

DTC DETECTION LOGIC

DTC	Trouble diagnosis name	DTC detecting condition	Possible causes
P30F4	TOTAL VOLT SENSOR	When the voltage recognized by total voltage sensor in Li-ion battery controller is excessively high or low.	<ul style="list-style-type: none">• Li-ion battery controller• Bus bar between stack• Service plug (fuse)• Module

DTC CONFIRMATION PROCEDURE

1. PERFORM DTC CONFIRMATION PROCEDURE

④ With CONSULT

1. Power switch ON and wait for 10 seconds or more.
2. Select "Self Diagnostic Result" of "HV BAT".
3. Check DTC.

Is P30F4 detected?

- YES >> Refer to [EVB-544, "Diagnosis Procedure"](#).
NO >> INSPECTION END

Diagnosis Procedure

INFOID:0000000011104215

WARNING:

- Because hybrid vehicles and electric vehicles contain a high voltage battery, there is the risk of electric shock, electric leakage, or similar accidents if the high voltage component and vehicle are handled incorrectly. Be sure to follow the correct work procedures when performing inspection and maintenance.
- Be sure to remove the service plug in order to disconnect the high voltage circuits before performing inspection or maintenance of high voltage system harnesses and parts.
- To prevent the removed service plug from being connected by mistake during the procedure, always carry it in your pocket or put it in the tool box.
- Be sure to wear insulating protective equipment consisting of glove, shoes, face shield and glasses before beginning work on the high voltage system.
- Clearly identify the persons responsible for high voltage work and ensure that other persons do not touch the vehicle. When not working, cover high voltage parts with an insulating cover sheet or similar item to prevent other persons from contacting them.
- Refer to [EVB-469, "High Voltage Precautions"](#).

CAUTION:

There is the possibility of a malfunction occurring if the vehicle is changed to READY status while the service plug is removed. Therefore do not change the vehicle to READY status unless instructed to do so in the Service Manual.

1. PERFORM THE SELF-DIAGNOSIS OF LI-ION BATTERY CONTROLLER

④ With CONSULT

1. Select "Self Diagnostic Result" mode of "HV BAT" using CONSULT.
2. Check if any DTC is detected in "Self Diagnostic Result".

Is any DTC detected?

- "P3030" is detected in addition to "P30F4" (Cannot be monitored)>>GO TO 3.
Just "P30F4" is detected>>GO TO 2.

2. CHECK FUSE

1. Power switch OFF.
2. Check fuse of service plug.

Is the inspection result normal?

- YES >> Replace Li-ion battery controller.
NO >> Replace service plug.

P30F4 TOTAL VOLTAGE SENSOR

< DTC/CIRCUIT DIAGNOSIS >

[TYPE 3]

3. PRECONDITIONING

WARNING:

Disconnect high voltage. Refer to [GI-31, "How to Disconnect High Voltage"](#).

1. Remove Li-ion battery. Refer to [EVb-626, "Removal and Installation"](#).
2. Remove battery pack upper case. Refer to [EVb-635, "BATTERY PACK UPPER CASE : Removal and Installation"](#).

>> GO TO 4.

4. CHECK CONNECTION STATUS STACK AND BUS BAR.

Check connection status between each stack and connection status of each bus bar.

Is the inspection result normal?

- YES >> GO TO 5.
NO >> Recover the connection status.

5. CHECK MODULE VOLTAGE

Check the voltage of all modules.

Is the inspection result normal?

- YES >> Replace Li-ion battery controller. Refer to [EVb-645, "LI-ION BATTERY CONTROLLER : Removal and Installation"](#).
- NO >> Replace the corresponding module. Refer to [EVb-665, "FRONT MODULE STACK : Disassembly and Assembly"](#) (Front module) or [EVb-680, "REAR MODULE STACK : Disassembly and Assembly"](#) (Rear module).

Component Inspection

INFOID:0000000011104216

1. CHECK MODULE VOLTAGE

Check voltage of module.

- A : Positive terminal (Red)**
B : Negative terminal (Black)

Terminals		Voltage (Approx.)
(+)	(-)	
Module		5.0 - 8.5 V
Positive terminal (Red)	Negative terminal (Black)	

Is the inspection result normal?

- YES >> INSPECTION END
NO >> Replace module. Refer to [EVb-665, "FRONT MODULE STACK : Disassembly and Assembly"](#) (Front module) or [EVb-680, "REAR MODULE STACK : Disassembly and Assembly"](#) (Rear module).

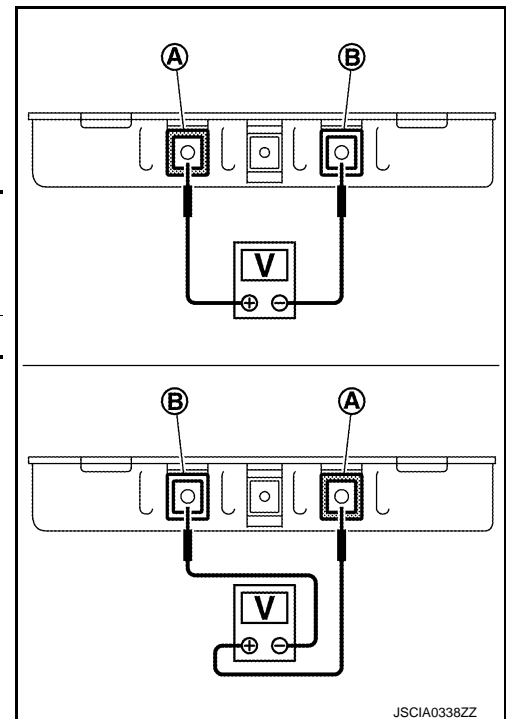

P30F5 TOTAL VOLTAGE SENSOR

< DTC/CIRCUIT DIAGNOSIS >

[TYPE 3]

P30F5 TOTAL VOLTAGE SENSOR

DTC Logic

INFOID:0000000011104217

DTC DETECTION LOGIC

DTC	Trouble diagnosis name	DTC detecting condition	Possible causes
P30F5	TOTAL VOLT SENSOR	When the voltage recognized by total voltage sensor in Li-ion battery controller is excessively high or low.	<ul style="list-style-type: none">• Li-ion battery controller• Bus bar between stack• Service plug (fuse)• Module

DTC CONFIRMATION PROCEDURE

1. PERFORM DTC CONFIRMATION PROCEDURE

Ⓟ With CONSULT

1. Power switch ON and wait for 10 seconds or more.
2. Select "Self Diagnostic Result" of "HV BAT".
3. Check DTC.

Is P30F5 detected?

- YES >> Refer to [EVB-546, "Diagnosis Procedure"](#).
NO >> INSPECTION END

Diagnosis Procedure

INFOID:0000000011104218

1. PERFORM THE SELF-DIAGNOSIS OF LI-ION BATTERY CONTROLLER

Ⓟ With CONSULT

1. Select "Self Diagnostic Result" of "HV BAT".
2. Check to see if "P30F4" is detected simultaneously with "P30F5".

Is any P30F4 detected?

- YES >> Perform diagnosis on the detected "P30F4". Refer to [EVB-544, "Diagnosis Procedure"](#).
NO >> Replace Li-ion battery controller. Refer to [EVB-645, "LI-ION BATTERY CONTROLLER : Removal and Installation"](#).

P30FC OVER CURRENT

< DTC/CIRCUIT DIAGNOSIS >

[TYPE 3]

P30FC OVER CURRENT

DTC Logic

INFOID:0000000011104219

DTC DETECTION LOGIC

DTC	Trouble diagnosis name	DTC detecting condition	Possible causes
P30FC	OVER CURRENT	When the temperature of the entire battery pack estimated from the current value is excessively high.	<ul style="list-style-type: none"> Battery current sensor Other systems malfunction

A
B

EVB

DTC CONFIRMATION PROCEDURE

1. PERFORM DTC CONFIRMATION PROCEDURE

④ With CONSULT

- Power switch ON and wait for 10 seconds or more.
- Select "Self Diagnostic Result" of "HV BAT".
- Check DTC.

Is P30FC detected?

- YES >> Refer to [EV B-547, "Diagnosis Procedure"](#).
 NO >> INSPECTION END

D
E
F

Diagnosis Procedure

INFOID:0000000011104220

1. PERFORM THE SELF-DIAGNOSIS

④ With CONSULT

- Perform "All DTC Reading".
- Check "Self diagnostic result" of systems other than "HV BAT" to see if any DTC is detected.

Is any DTC detected?

- YES >> After performing trouble diagnosis of detected DTC, GO TO 2.
 NO >> GO TO 2.

2. CHECK BATTERY TEMPERATURE SENSOR

④ With CONSULT

Using FFD, check the values of four temperature sensors when DTC is detected.

Monitor item	Condition	Limit
Battery temperature sensor 1	Power switch ON	55°C (131°F) or less
Battery temperature sensor 2		
Battery temperature sensor 3		
Battery temperature sensor 4		

G
H
I
J
K

Is there temperature increase?

- Temperature increase is seen >> Replace Li-ion battery. Refer to [EV B-626, "Removal and Installation"](#).
 Temperature increase is not seen >> Replace battery junction box. Refer to [EV B-645, "LI-ION BATTERY CONTROLLER : Removal and Installation"](#).

L
M
N
O
P

P30FD TOTAL VOLTAGE MONITOR SWITCH

< DTC/CIRCUIT DIAGNOSIS >

[TYPE 3]

P30FD TOTAL VOLTAGE MONITOR SWITCH

DTC Logic

INFOID:000000011104221

DTC DETECTION LOGIC

DTC	Trouble diagnosis name	DTC detecting condition	Possible causes
P30FD	TOTAL VOLTAGE MONITOR SWITCH	<ul style="list-style-type: none">Total voltage detection switch in Li-ion battery controller is malfunctioning.Self diagnosis malfunction of total voltage detection circuit stop function in Li-ion battery controller.	<ul style="list-style-type: none">Li-ion battery controller

DTC CONFIRMATION PROCEDURE

1. PERFORM DTC CONFIRMATION PROCEDURE

Ⓢ With CONSULT

- Power switch ON and wait for 10 seconds or more.
- Select "Self Diagnostic Result" of "HV BAT".
- Check DTC.

Is P30FC detected?

- YES >> Refer to [EVB-548. "Diagnosis Procedure"](#).
NO >> INSPECTION END

Diagnosis Procedure

INFOID:000000011104222

When this DTC is detected, replace Li-ion battery controller. Refer to [EVB-645. "LI-ION BATTERY CONTROLLER : Removal and Installation"](#).

P30FE 12V BATTERY VOLTAGE

< DTC/CIRCUIT DIAGNOSIS >

[TYPE 3]

P30FE 12V BATTERY VOLTAGE

DTC Logic

INFOID:0000000011104223

DTC DETECTION LOGIC

DTC	Trouble diagnosis name	DTC detecting condition	Possible causes
P30FE	12V BATTERY VOLTAGE	12V battery voltage lowers to less than 9 V.	<ul style="list-style-type: none">• 12V battery• Harness

DTC CONFIRMATION PROCEDURE

1. PERFORM DTC CONFIRMATION PROCEDURE

 With CONSULT

1. Power switch ON and wait for 10 seconds or more.
2. Select "Self Diagnostic Result" of "HV BAT".
3. Check DTC.

Is P30FE detected?

- YES >> Refer to [EV5-549, "Diagnosis Procedure"](#).
NO >> INSPECTION END

Diagnosis Procedure

INFOID:0000000011104224

WARNING:

- Because hybrid vehicles and electric vehicles contain a high voltage battery, there is the risk of electric shock, electric leakage, or similar accidents if the high voltage component and vehicle are handled incorrectly. Be sure to follow the correct work procedures when performing inspection and maintenance.
- Be sure to remove the service plug in order to disconnect the high voltage circuits before performing inspection or maintenance of high voltage system harnesses and parts.
- To prevent the removed service plug from being connected by mistake during the procedure, always carry it in your pocket or put it in the tool box.
- Be sure to wear insulating protective equipment consisting of glove, shoes, face shield and glasses before beginning work on the high voltage system.
- Clearly identify the persons responsible for high voltage work and ensure that other persons do not touch the vehicle. When not working, cover high voltage parts with an insulating cover sheet or similar item to prevent other persons from contacting them.
- Refer to [EV5-469, "High Voltage Precautions"](#).

CAUTION:

There is the possibility of a malfunction occurring if the vehicle is changed to READY status while the service plug is removed. Therefore do not change the vehicle to READY status unless instructed to do so in the Service Manual.

1. CHECK VOLTAGE OF 12 V BATTERY

Check the voltage of 12 V battery using circuit tester.

Is output more than 9 V?

- YES >> GO TO 2.
NO >> Replace 12 V battery. Refer to [PG-108, "Removal and Installation"](#).

2. CHECK FUSE

1. Power switch OFF.
2. Check 20A fuse [No.43].

NOTE:

Refer to [PG-87, "Fuse, Connector and Terminal Arrangement"](#) for fuse layout.

Is the inspection result normal?

- YES >> GO TO 3.
NO >> After eliminating the cause of flame cutting, replace the fuse.

3. CHECK LI-ION BATTERY POWER SUPPLY

P30FE 12V BATTERY VOLTAGE

[TYPE 3]

< DTC/CIRCUIT DIAGNOSIS >

1. Disconnect Li-ion battery vehicle communication harness connector.
2. Check voltage between Li-ion battery harness connector and ground.

+		-	Voltage
Li-ion battery			
Connector	Terminal		
B24	5	Ground	Battery voltage

Is the inspection result normal?

YES >> GO TO 4.

NO >> Repair harness or connector.

4. PRECONDITIONING

WARNING:

Disconnect high voltage. Refer to [GI-31, "How to Disconnect High Voltage"](#).

1. Remove Li-ion battery. Refer to [EVB-626, "Removal and Installation"](#).
2. Remove battery pack upper case. Refer to [EVB-635, "BATTERY PACK UPPER CASE : Removal and Installation"](#).

>> GO TO 5.

5. CHECK HARNESS BETWEEN LI-ION BATTERY AND LI-ION BATTERY CONTROLLER

1. Disconnect Li-ion battery harness connector and Li-ion battery controller harness connector.
2. Check continuity between Li-ion battery harness connector and Li-ion battery controller harness connector.

Li-ion battery		Li-ion battery controller		Continuity
Connector	Terminal	Connector	Terminal	
LB1	5	LB11	12	Existed

Is the inspection result normal?

YES >> Replace Li-ion battery controller. Refer to [EVB-645, "LI-ION BATTERY CONTROLLER : Removal and Installation"](#).

NO >> Repair harness or connector.

P318D COMMUNICATION ERROR

< DTC/CIRCUIT DIAGNOSIS >

[TYPE 3]

P318D COMMUNICATION ERROR

DTC Logic

INFOID:0000000011104225

DTC DETECTION LOGIC

DTC	Trouble diagnosis name	DTC detecting condition	Possible causes
P318D	COMMUNICATION ERROR	When no CAN communication signal is received continuously.	<ul style="list-style-type: none">• CAN communication line• Li-ion battery controller• VCM

EVB

DTC CONFIRMATION PROCEDURE

1. PERFORM DTC CONFIRMATION PROCEDURE

④ With CONSULT

1. Power switch ON and wait for 10 seconds or more.
2. Select "Self Diagnostic Result" of "HV BAT".
3. Check DTC.

Is P318D detected?

- YES >> Refer to [EVB-551, "Diagnosis Procedure"](#).
NO >> INSPECTION END

Diagnosis Procedure

INFOID:0000000011104226

For the diagnosis procedure, refer to [LAN-15, "Trouble Diagnosis Flow Chart"](#).

P318E COMMUNICATION ERROR

[TYPE 3]

< DTC/CIRCUIT DIAGNOSIS >

P318E COMMUNICATION ERROR

DTC Logic

INFOID:000000011104227

DTC DETECTION LOGIC

NOTE:

When the 12 V battery is removed within 5 minutes after turning the power switch OFF, "P318E", "P3191", and "P3196" may be simultaneously detected. This is not a malfunction.

DTC	Trouble diagnosis name	DTC detecting condition	Possible causes
P318E	COMMUNICATION ERROR	When no CAN communication signal is received from VCM continuously.	<ul style="list-style-type: none">• VCM• Li-ion battery controller• CAN communication line

DTC CONFIRMATION PROCEDURE

1. PERFORM DTC CONFIRMATION PROCEDURE

ⓐ With CONSULT

1. Power switch OFF.
2. After turning the power switch OFF, get out of the vehicle and close all doors (including back door).
3. After turning the power switch OFF, wait for 5 minutes or more to remove the 12 V battery negative terminal. Refer to [EVB-469, "Precautions for Removing Battery Terminal"](#).
4. Connect 12 V battery negative terminal.
5. Power switch ON and wait for 10 seconds or more.
6. Select "Self Diagnostic Result" of "HV BAT".
7. Check DTC.

Is P318E detected?

- YES >> Refer to [EVB-552, "Diagnosis Procedure"](#).
NO >> INSPECTION END

Diagnosis Procedure

INFOID:000000011104228

1. PERFORM THE SELF-DIAGNOSIS

ⓐ With CONSULT

1. Perform "All DTC Reading".
2. Check "Self diagnostic result" of systems other than "HV BAT" to see if "P318E" is detected.

Is P318E detected?

- YES >> Replace VCM. Refer to [EVC-377, "Removal and Installation"](#).
NO >> GO TO 2.

2. PREFORM THE SELF-DIAGNOSIS OF LI-ION BATTERY CONTROLLER

ⓐ With CONSULT

1. Select "Self Diagnostic Result" of "HV BAT".
2. Check to see if "U1000" is detected simultaneously with "P318E".

Is U1000 detected?

- YES >> Replace Li-ion battery controller. Refer to [EVB-645, "LI-ION BATTERY CONTROLLER : Removal and Installation"](#).
NO >> INSPECTION END

P3191 COMMUNICATION ERROR

< DTC/CIRCUIT DIAGNOSIS >

[TYPE 3]

P3191 COMMUNICATION ERROR

DTC Logic

INFOID:0000000011104229

DTC DETECTION LOGIC

NOTE:

When the 12 V battery is removed within 5 minutes after turning the power switch OFF, "P318E", "P3191" and "P3196" may be simultaneously detected. This is not a malfunction.

DTC	Trouble diagnosis name	DTC detecting condition	Possible causes
P3191	COMMUNICATION ERROR	When no CAN communication signal is received from traction motor inverter continuously.	<ul style="list-style-type: none">• Traction motor inverter• Li-ion battery controller• CAN communication line

DTC CONFIRMATION PROCEDURE

1. PERFORM DTC CONFIRMATION PROCEDURE

Ⓜ With CONSULT

1. Power switch OFF.
2. After turning the power switch OFF, get out of the vehicle and close all doors (including back door).
3. After turning the power switch OFF, wait for 5 minutes or more to remove the 12 V battery negative terminal. Refer to [EVb-469, "Precautions for Removing Battery Terminal"](#).
4. Connect 12 V battery negative terminal.
5. Power switch ON and wait for 10 seconds or more.
6. Select "Self Diagnostic Result" of "HV BAT".
7. Check DTC.

Is P3191 detected?

- YES >> Refer to [EVb-553, "Diagnosis Procedure"](#).
NO >> INSPECTION END

Diagnosis Procedure

INFOID:0000000011104230

1. PERFORM THE SELF-DIAGNOSIS

Ⓜ With CONSULT

1. Perform "All DTC Reading".
2. Check "Self diagnostic result" of systems other than "HV BAT" to see if "P3191" is detected.

Is P3191 detected?

- YES >> Replace traction motor inverter. Refer to [TMS-116, "Removal and Installation"](#)
NO >> GO TO 2.

2. PERFORM THE SELF-DIAGNOSIS OF LI-ION BATTERY CONTROLLER

Ⓜ With CONSULT

1. Select "Self Diagnostic Result" of "HV BAT".
2. Check to see if "U1000" is detected simultaneously with "P3191".

Is U1000 detected?

- YES >> Replace Li-ion battery controller. Refer to [EVb-645, "LI-ION BATTERY CONTROLLER : Removal and Installation"](#).
NO >> INSPECTION END

P3196 COMMUNICATION ERROR

< DTC/CIRCUIT DIAGNOSIS >

[TYPE 3]

P3196 COMMUNICATION ERROR

DTC Logic

INFOID:0000000011104231

DTC DETECTION LOGIC

NOTE:

When the 12 V battery is removed within 5 minutes after turning the power switch OFF, "P318E", "P3191" and "P3196" may be simultaneously detected. This is not a malfunction.

DTC	Trouble diagnosis name	DTC detecting condition	Possible causes
P3196	COMMUNICATION ERROR	When no CAN communication signal is received from on-board charger continuously.	<ul style="list-style-type: none">• On board charger• Li-ion battery controller• CAN communication line

DTC CONFIRMATION PROCEDURE

1. PERFORM DTC CONFIRMATION PROCEDURE

ⓐ With CONSULT

1. Power switch OFF.
2. After turning the power switch OFF, get out of the vehicle and close all doors (including back door).
3. After turning the power switch OFF, wait for 5 minutes or more to remove the 12 V battery negative terminal. Refer to [EVB-469, "Precautions for Removing Battery Terminal"](#).
4. Connect 12 V battery negative terminal.
5. Power switch ON and wait for 10 seconds or more.
6. Select "Self Diagnostic Result" of "HV BAT".
7. Check DTC.

Is P3196 detected?

- YES >> Refer to [EVB-554, "Diagnosis Procedure"](#).
NO >> INSPECTION END

Diagnosis Procedure

INFOID:0000000011104232

1. PERFORM THE SELF-DIAGNOSIS

ⓐ With CONSULT

1. Perform "All DTC Reading".
2. Check "Self diagnostic result" of systems other than "HV BAT" to see if "P3196" is detected.

Is P3196 detected?

- YES >> Replace on board charger. Refer to [VC-112, "Removal and Installation"](#)
NO >> GO TO 2.

2. PREFORM THE SELF-DIAGNOSIS OF LI-ION BATTERY CONTROLLER

ⓐ With CONSULT

1. Select "Self Diagnostic Result" of "HV BAT".
2. Check to see if "U1000" is detected simultaneously with "P3196".

Is U1000 detected?

- YES >> Replace Li-ion battery controller. Refer to [EVB-645, "LI-ION BATTERY CONTROLLER : Removal and Installation"](#).
NO >> INSPECTION END

P3199 COMMUNICATION ERROR

< DTC/CIRCUIT DIAGNOSIS >

[TYPE 3]

P3199 COMMUNICATION ERROR

DTC Logic

INFOID:0000000011104233

DTC DETECTION LOGIC

DTC	Trouble diagnosis name	DTC detecting condition	Possible causes
P3199	COMMUNICATION ERROR	When a CRC error from VCM is detected.	<ul style="list-style-type: none">• VCM• Li-ion battery controller

A

B

EVB

DTC CONFIRMATION PROCEDURE

1. PERFORM DTC CONFIRMATION PROCEDURE

 With CONSULT

1. Power switch ON and wait for 10 seconds or more.
2. Select "Self Diagnostic Result" of "HV BAT".
3. Check DTC.

Is P3199 detected?

- YES >> Refer to [EVB-555, "Diagnosis Procedure"](#).
NO >> INSPECTION END

Diagnosis Procedure

INFOID:0000000011104234

When this DTC is detected, replace VCM. Refer to [EVC-377, "Removal and Installation"](#).

D

E

F

G

H

I

J

K

L

M

N

O

P

P319C COMMUNICATION ERROR

< DTC/CIRCUIT DIAGNOSIS >

[TYPE 3]

P319C COMMUNICATION ERROR

DTC Logic

INFOID:000000011104235

DTC DETECTION LOGIC

DTC	Trouble diagnosis name	DTC detecting condition	Possible causes
P319C	COMMUNICATION ER-ROR	When a CRC error from traction motor inverter is detected.	<ul style="list-style-type: none">• Traction motor inverter• Li-ion battery controller

DTC CONFIRMATION PROCEDURE

1. PERFORM DTC CONFIRMATION PROCEDURE

④ With CONSULT

1. Power switch ON and wait for 10 seconds or more.
2. Select "Self Diagnostic Result" of "HV BAT".
3. Check DTC.

Is P319C detected?

- YES >> Refer to [EVB-556, "Diagnosis Procedure"](#).
NO >> INSPECTION END

Diagnosis Procedure

INFOID:000000011104236

When this DTC is detected, replace traction motor inverter. Refer to [TMS-116, "Exploded View"](#).

P31A4 CAN ERROR VCM

< DTC/CIRCUIT DIAGNOSIS >

[TYPE 3]

P31A4 CAN ERROR VCM

DTC Logic

INFOID:0000000011104237

DTC DETECTION LOGIC

DTC	Trouble diagnosis name	DTC detecting condition	Possible causes
P31A4	CAN ERROR VCM	If the CAN data from VCM has not change from the value which was previously received.	VCM

A

B

EVB

DTC CONFIRMATION PROCEDURE

1. PERFORM DTC CONFIRMATION PROCEDURE

 With CONSULT

1. Power switch ON and wait for 10 seconds or more.
2. Select "Self Diagnostic Result" of "HV BAT".
3. Check DTC.

Is P31A4 detected?

- YES >> Refer to [EVB-557, "Diagnosis Procedure"](#).
NO >> INSPECTION END

Diagnosis Procedure

INFOID:0000000011104238

When this DTC is detected, replace VCM. Refer to [EVC-377, "Removal and Installation"](#).

D

E

F

G

H

I

J

K

L

M

N

O

P

P31A7 CAN ERROR INV/MC

< DTC/CIRCUIT DIAGNOSIS >

[TYPE 3]

P31A7 CAN ERROR INV/MC

DTC Logic

INFOID:000000011104239

DTC DETECTION LOGIC

DTC	Trouble diagnosis name	DTC detecting condition	Possible causes
P31A7	CAN ERROR INV/MC	If the CAN data from traction motor inverter has not change from the value which was previously received.	Traction motor inverter

DTC CONFIRMATION PROCEDURE

1. PERFORM DTC CONFIRMATION PROCEDURE

④ With CONSULT

1. Power switch ON and wait for 10 seconds or more.
2. Select "Self Diagnostic Result" of "HV BAT".
3. Check DTC.

Is P31A7 detected?

- YES >> Refer to [EVB-558, "Diagnosis Procedure"](#).
NO >> INSPECTION END

Diagnosis Procedure

INFOID:000000011104240

When this DTC is detected, replace traction motor inverter. Refer to [TMS-116, "Exploded View"](#).

P3300 TOTAL VOLTAGE OVER

< DTC/CIRCUIT DIAGNOSIS >

[TYPE 3]

P3300 TOTAL VOLTAGE OVER

DTC Logic

INFOID:0000000011104241

DTC DETECTION LOGIC

DTC	Trouble diagnosis name	DTC detecting condition	Possible causes
P3300	TOTAL VOLTAGE OVER	When total voltage exceeds the allowable working voltage range.	<ul style="list-style-type: none">• Li-ion battery• Li-ion battery controller• VCM• Traction motor inverter

DTC CONFIRMATION PROCEDURE

1. PERFORM DTC CONFIRMATION PROCEDURE

④ With CONSULT

1. Power switch ON and wait for 10 seconds or more.
2. Select "Self Diagnostic Result" of "HV BAT".
3. Check DTC.

Is P3300 detected?

- YES >> Refer to [EVB-559, "Diagnosis Procedure"](#).
NO >> INSPECTION END

Diagnosis Procedure

INFOID:0000000011104242

1. PERFORM THE SELF-DIAGNOSIS

④ With CONSULT

1. Perform "All DTC Reading".
2. Check "Self Diagnostic Result" of systems other than "HV BAT" to see if any DTC is detected.

Is any DTC detected?

- YES >> After performing trouble diagnosis of detected DTC, GO TO 2.
NO >> GO TO 2.

2. PERFORM THE SELF-DIAGNOSIS OF LI-ION BATTERY CONTROLLER

④ With CONSULT

1. Select "Self Diagnostic Result" of "HV BAT".
2. Check "Self Diagnostic Result" to see if "P3302"- "P3331" is detected.

Is P3302-P3331 detected?

- YES >> "P3302" - "P3331" are detected simultaneously.
- When "P3302" - "P330D" are detected simultaneously, perform the diagnosis procedure of "P3302" - "P330D". Refer to [EVB-560, "Diagnosis Procedure"](#).
 - When "P330E" - "P3319" are detected simultaneously, perform the diagnosis procedure of "P330E" - "P3319". Refer to [EVB-564, "Diagnosis Procedure"](#).
 - When "P331A" - "P3325" are detected simultaneously, perform the diagnosis procedure of "P331A" - "P3325". Refer to [EVB-568, "Diagnosis Procedure"](#).
 - When "P3326" - "P3331" are detected simultaneously, perform the diagnosis procedure of "P3326" - "P3331". Refer to [EVB-571, "Diagnosis Procedure"](#).
- NO >> Replace Li-ion battery controller. Refer to [EVB-645, "LI-ION BATTERY CONTROLLER : Removal and Installation"](#).

P3302-P330D CELL OVER VOLTAGE

< DTC/CIRCUIT DIAGNOSIS >

[TYPE 3]

P3302-P330D CELL OVER VOLTAGE

DTC Logic

INFOID:000000011104243

DTC DETECTION LOGIC

DTC	Trouble diagnosis name	DTC detecting condition	Possible causes
P3302	CELL OVER VOLTAGE MODULE1	When cell voltage exceeds the allowable working voltage range.	<ul style="list-style-type: none">• Overcharge caused by traction motor inverter/VCM malfunction• Module• Li-ion battery controller• Bus bar• Harness or connector
P3303	CELL OVER VOLTAGE MODULE2		
P3304	CELL OVER VOLTAGE MODULE3		
P3305	CELL OVER VOLTAGE MODULE4		
P3306	CELL OVER VOLTAGE MODULE5		
P3307	CELL OVER VOLTAGE MODULE6		
P3308	CELL OVER VOLTAGE MODULE7		
P3309	CELL OVER VOLTAGE MODULE8		
P330A	CELL OVER VOLTAGE MODULE9		
P330B	CELL OVER VOLTAGE MODULE10		
P330C	CELL OVER VOLTAGE MODULE11		
P330D	CELL OVER VOLTAGE MODULE12		

DTC CONFIRMATION PROCEDURE

1. PERFORM DTC CONFIRMATION PROCEDURE

Ⓟ With CONSULT

1. Power switch ON and wait for 10 seconds or more.
2. Select "Self Diagnostic Result" of "HV BAT".
3. Check DTC.

Is any DTC detected?

- YES >> Refer to [EVB-560, "Diagnosis Procedure"](#).
NO >> INSPECTION END

Diagnosis Procedure

INFOID:000000011104244

WARNING:

- Because hybrid vehicles and electric vehicles contain a high voltage battery, there is the risk of electric shock, electric leakage, or similar accidents if the high voltage component and vehicle are handled incorrectly. Be sure to follow the correct work procedures when performing inspection and maintenance.
- Be sure to remove the service plug in order to disconnect the high voltage circuits before performing inspection or maintenance of high voltage system harnesses and parts.
- To prevent the removed service plug from being connected by mistake during the procedure, always carry it in your pocket or put it in the tool box.
- Be sure to wear insulating protective equipment consisting of glove, shoes, face shield and glasses before beginning work on the high voltage system.
- Clearly identify the persons responsible for high voltage work and ensure that other persons do not touch the vehicle. When not working, cover high voltage parts with an insulating cover sheet or similar item to prevent other persons from contacting them.
- Refer to [EVB-469, "High Voltage Precautions"](#).

CAUTION:

There is the possibility of a malfunction occurring if the vehicle is changed to READY status while the service plug is removed. Therefore do not change the vehicle to READY status unless instructed to do so in the Service Manual.

1. CHECK SELF-DIAGNOSIS RESULTS

Ⓟ With CONSULT

1. Perform "All DTC Reading" with CONSULT.

P3302-P330D CELL OVER VOLTAGE

[TYPE 3]

< DTC/CIRCUIT DIAGNOSIS >

2. Check systems other than "HV BAT" if any DTC is detected.

Is any DTC detected?

- YES >> After performing trouble diagnosis of detected DTC, GO TO 2.
- NO >> GO TO 2.

2. PRECONDITIONING

WARNING:

Disconnect high voltage. Refer to [GI-31, "How to Disconnect High Voltage"](#).

1. Remove Li-ion battery. Refer to [EVB-626, "Removal and Installation"](#).
2. Remove battery pack upper case. Refer to [EVB-635, "BATTERY PACK UPPER CASE : Removal and Installation"](#).

>> GO TO 3.

3. CHECK HARNESS BETWEEN MODULE AND LI-ION BATTERY CONTROLLER

1. Disconnect voltage detection terminal of bus bar and Li-ion battery controller harness connector.
2. Refer to below table and check the continuity between Li-ion battery controller (A) and corresponding bus bar (B).

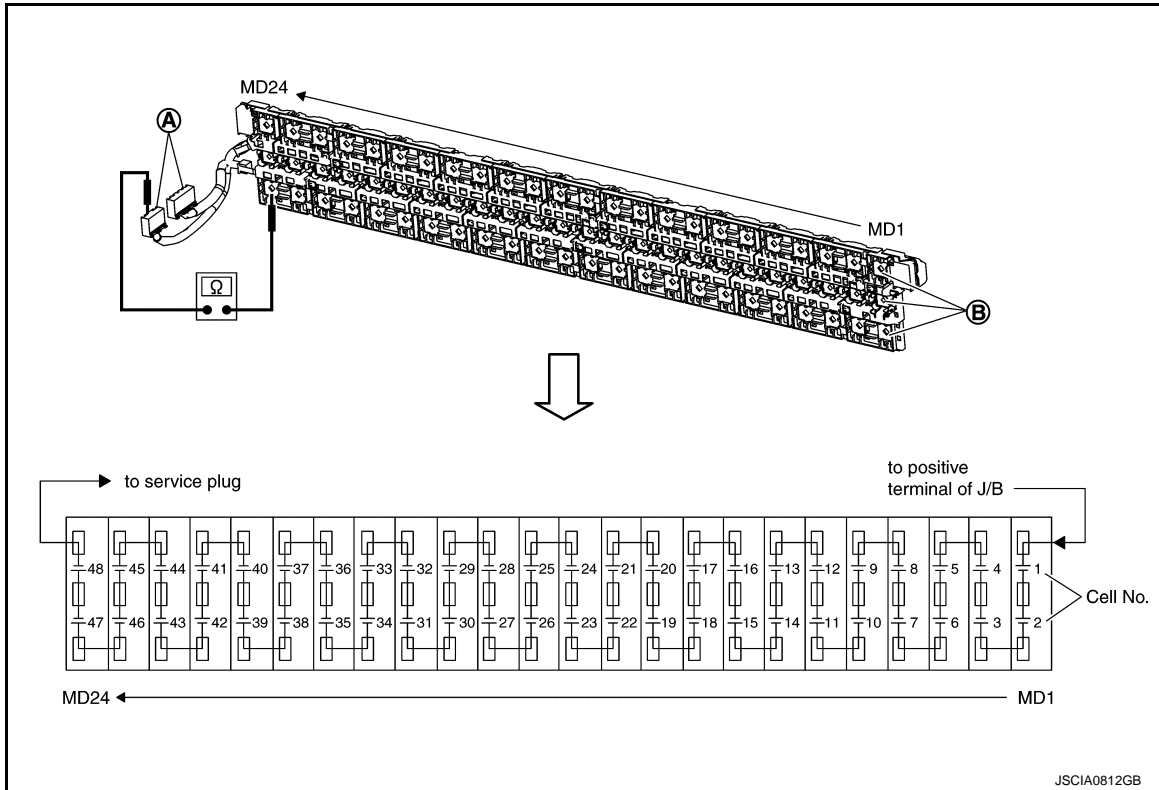

P3302-P330D CELL OVER VOLTAGE

< DTC/CIRCUIT DIAGNOSIS >

[TYPE 3]

DTC	Module No.		Li-ion battery controller		Continuity
			Connector	Terminal	
P3302	1	Bus bar	LB13	33	Existed
				50	
				34	
P3303	2		LB13	34	Existed
				51	
				35	
P3304	3		LB13	35	Existed
				52	
				36	
P3305	4		LB13	36	Existed
				53	
				37	
P3306	5	LB13	37	Existed	
			54		
			38		
P3307	6	LB13	38	Existed	
			55		
			39		
P3308	7	LB13	39	Existed	
			56		
			40		
P3309	8	LB13	40	Existed	
			57		
			42		
P330A	9	LB13	42	Existed	
			58		
			43		
P330B	10	LB13	43	Existed	
			59		
			44		
P330C	11	LB13	44	Existed	
			60		
			45		
P330D	12	LB13	45	Existed	
			61		
			46		

Is the inspection result normal?

YES >> GO TO 4.

NO >> Repair harness or connector.

4. CHECK MODULE VOLTAGE

Check voltage of corresponding module. Refer to [EVb-563, "Component Inspection"](#).

Is the inspection result normal?

P3302-P330D CELL OVER VOLTAGE

[TYPE 3]

< DTC/CIRCUIT DIAGNOSIS >

- YES >> Replace Li-ion battery controller. Refer to [EVB-645, "LI-ION BATTERY CONTROLLER : Removal and Installation"](#).
- NO >> Replace corresponding module. Refer to [EVB-680, "REAR MODULE STACK : Disassembly and Assembly"](#).

Component Inspection

INFOID:000000011104245

1. CHECK MODULE VOLTAGE

Check voltage of module.

- A : Positive terminal (Red)**
- B : Negative terminal (Black)**

Terminals		Voltage (Approx.)
(+)	(-)	
Module		5.0 - 8.5 V
Positive terminal (Red)	Negative terminal (Black)	

Is the inspection result normal?

- YES >> INSPECTION END
- NO >> Replace module. Refer to [EVB-665, "FRONT MODULE STACK : Disassembly and Assembly"](#) (Front module) or [EVB-680, "REAR MODULE STACK : Disassembly and Assembly"](#) (Rear module).

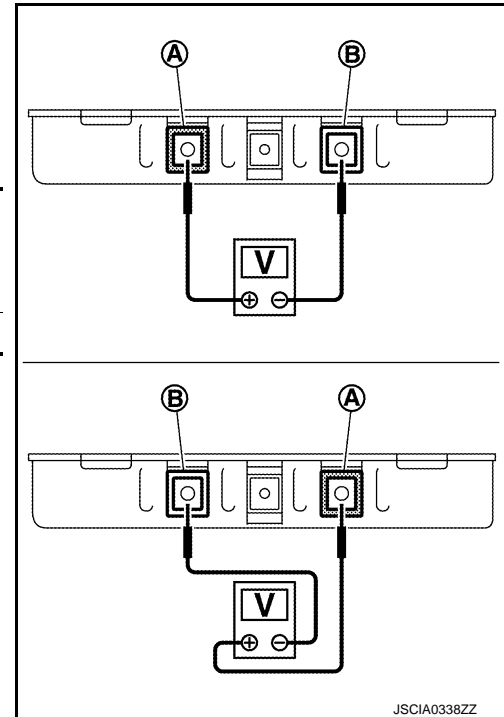

EVB

D

E

F

G

H

I

J

K

L

M

N

O

P

P330E-P3319 CELL OVER VOLTAGE

< DTC/CIRCUIT DIAGNOSIS >

[TYPE 3]

P330E-P3319 CELL OVER VOLTAGE

DTC Logic

INFOID:000000011104246

DTC DETECTION LOGIC

DTC	Trouble diagnosis name	DTC detecting condition	Possible causes
P330E	CELL OVER VOLTAGE MODULE13	When cell voltage exceeds the allowable working voltage range.	<ul style="list-style-type: none"> Overcharge caused by traction motor inverter/VCM malfunction Module Li-ion battery controller Bus bar Harness or connector
P330F	CELL OVER VOLTAGE MODULE14		
P3310	CELL OVER VOLTAGE MODULE15		
P3311	CELL OVER VOLTAGE MODULE16		
P3312	CELL OVER VOLTAGE MODULE17		
P3313	CELL OVER VOLTAGE MODULE18		
P3314	CELL OVER VOLTAGE MODULE19		
P3315	CELL OVER VOLTAGE MODULE20		
P3316	CELL OVER VOLTAGE MODULE21		
P3317	CELL OVER VOLTAGE MODULE22		
P3318	CELL OVER VOLTAGE MODULE23		
P3319	CELL OVER VOLTAGE MODULE24		

DTC CONFIRMATION PROCEDURE

1. PERFORM DTC CONFIRMATION PROCEDURE

Ⓜ With CONSULT

- Power switch ON and wait for 10 seconds or more.
- Select "Self Diagnostic Result" of "HV BAT".
- Check DTC.

Is any DTC detected?

- YES >> Refer to [EVB-571, "Diagnosis Procedure"](#).
- NO >> INSPECTION END

Diagnosis Procedure

INFOID:000000011104247

WARNING:

- Because hybrid vehicles and electric vehicles contain a high voltage battery, there is the risk of electric shock, electric leakage, or similar accidents if the high voltage component and vehicle are handled incorrectly. Be sure to follow the correct work procedures when performing inspection and maintenance.
- Be sure to remove the service plug in order to disconnect the high voltage circuits before performing inspection or maintenance of high voltage system harnesses and parts.
- To prevent the removed service plug from being connected by mistake during the procedure, always carry it in your pocket or put it in the tool box.
- Be sure to wear insulating protective equipment consisting of glove, shoes, face shield and glasses before beginning work on the high voltage system.
- Clearly identify the persons responsible for high voltage work and ensure that other persons do not touch the vehicle. When not working, cover high voltage parts with an insulating cover sheet or similar item to prevent other persons from contacting them.
- Refer to [EVB-469, "High Voltage Precautions"](#).

CAUTION:

There is the possibility of a malfunction occurring if the vehicle is changed to READY status while the service plug is removed. Therefore do not change the vehicle to READY status unless instructed to do so in the Service Manual.

1. CHECK SELF-DIAGNOSIS RESULTS

Ⓜ With CONSULT

- Perform "All DTC Reading" with CONSULT.

P330E-P3319 CELL OVER VOLTAGE

[TYPE 3]

< DTC/CIRCUIT DIAGNOSIS >

2. Check systems other than "HV BAT" if any DTC is detected.

Is any DTC detected?

- YES >> After performing trouble diagnosis of detected DTC, GO TO 2.
- NO >> GO TO 2.

2. PRECONDITIONING

WARNING:

Disconnect high voltage. Refer to [GI-31, "How to Disconnect High Voltage"](#).

1. Remove Li-ion battery. Refer to [EVB-626, "Removal and Installation"](#).
2. Remove battery pack upper case. Refer to [EVB-635, "BATTERY PACK UPPER CASE : Removal and Installation"](#).

>> GO TO 3.

3. CHECK HARNESS BETWEEN MODULE AND LI-ION BATTERY CONTROLLER

1. Disconnect voltage detection terminal of bus bar and Li-ion battery controller harness connector.
2. Refer to below table and check the continuity between Li-ion battery controller (A) and corresponding bus bar (B).

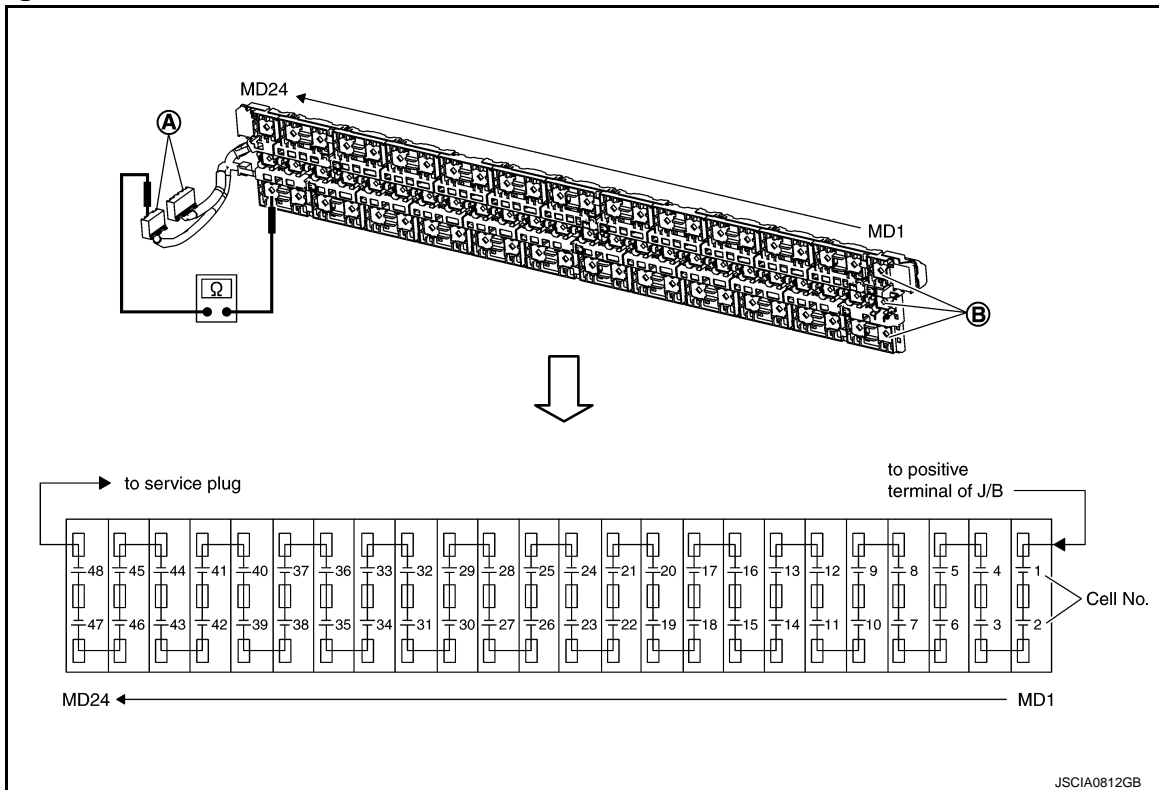

P330E-P3319 CELL OVER VOLTAGE

< DTC/CIRCUIT DIAGNOSIS >

[TYPE 3]

DTC	Module No.		Li-ion battery controller		Continuity
			Connector	Terminal	
P330E	13	Bus bar	LB13	46	Existed
				62	
				47	
P330F	14		LB13	47	Existed
				63	
				48	
P3310	15		LB13	48	Existed
			LB14	77	
P3311	16		LB14	65	Existed
				78	
				66	
P3312	17		LB14	66	Existed
				80	
				69	
P3313	18		LB14	69	Existed
				81	
				70	
P3314	19		LB14	70	Existed
				82	
				71	
P3315	20		LB14	71	Existed
				83	
				72	
P3316	21		LB14	72	Existed
		84			
		73			
P3317	22	LB14	73	Existed	
			85		
			74		
P3318	23	LB14	74	Existed	
			86		
			75		
P3319	24	LB14	75	Existed	
			87		
			76		

Is the inspection result normal?

YES >> GO TO 4.

NO >> Repair harness or connector.

4. CHECK MODULE VOLTAGE

Check voltage of corresponding module. Refer to [EVb-567, "Component Inspection"](#).

Is the inspection result normal?

P330E-P3319 CELL OVER VOLTAGE

[TYPE 3]

< DTC/CIRCUIT DIAGNOSIS >

- YES >> Replace Li-ion battery controller. Refer to [EVB-645. "LI-ION BATTERY CONTROLLER : Removal and Installation"](#).
- NO >> Replace corresponding module. Refer to [EVB-660. "FRONT MODULE STACK : Removal and Installation"](#).

Component Inspection

INFOID:000000011104248

1. CHECK MODULE VOLTAGE

Check voltage of module.

- A : Positive terminal (Red)**
- B : Negative terminal (Black)**

Terminals		Voltage (Approx.)
(+)	(-)	
Module		5.0 - 8.5 V
Positive terminal (Red)	Negative terminal (Black)	

Is the inspection result normal?

- YES >> INSPECTION END
- NO >> Replace module. Refer to [EVB-665. "FRONT MODULE STACK : Disassembly and Assembly"](#) (Front module) or [EVB-680. "REAR MODULE STACK : Disassembly and Assembly"](#) (Rear module).

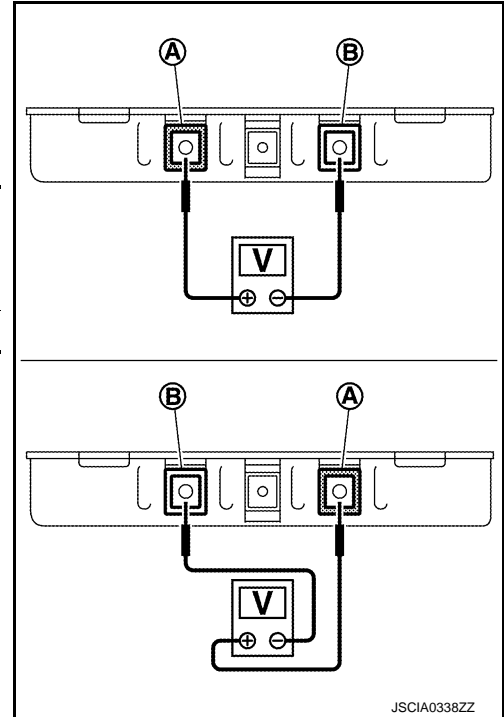

JSCIA0338ZZ

EVB

D

E

F

G

H

I

J

K

L

M

N

O

P

P331A-P3325 CELL OVER VOLTAGE

< DTC/CIRCUIT DIAGNOSIS >

[TYPE 3]

P331A-P3325 CELL OVER VOLTAGE

DTC Logic

INFOID:000000011104249

DTC DETECTION LOGIC

DTC	Trouble diagnosis name	DTC detecting condition	Possible causes
P331A	CELL OVER VOLTAGE MODULE25	When cell voltage exceeds the allowable working voltage range.	<ul style="list-style-type: none">• Overcharge caused by traction motor inverter/VCM malfunction• Module• Li-ion battery controller• Bus bar• Harness or connector
P331B	CELL OVER VOLTAGE MODULE26		
P331C	CELL OVER VOLTAGE MODULE27		
P331D	CELL OVER VOLTAGE MODULE28		
P331E	CELL OVER VOLTAGE MODULE29		
P331F	CELL OVER VOLTAGE MODULE30		
P3320	CELL OVER VOLTAGE MODULE31		
P3321	CELL OVER VOLTAGE MODULE32		
P3322	CELL OVER VOLTAGE MODULE33		
P3323	CELL OVER VOLTAGE MODULE34		
P3324	CELL OVER VOLTAGE MODULE35		
P3325	CELL OVER VOLTAGE MODULE36		

DTC CONFIRMATION PROCEDURE

1. PERFORM DTC CONFIRMATION PROCEDURE

Ⓟ With CONSULT

1. Power switch ON and wait for 10 seconds or more.
2. Select "Self Diagnostic Result" of "HV BAT".
3. Check DTC.

Is any DTC detected?

- YES >> Refer to [EVB-571, "Diagnosis Procedure"](#).
NO >> INSPECTION END

Diagnosis Procedure

INFOID:000000011104250

WARNING:

- Because hybrid vehicles and electric vehicles contain a high voltage battery, there is the risk of electric shock, electric leakage, or similar accidents if the high voltage component and vehicle are handled incorrectly. Be sure to follow the correct work procedures when performing inspection and maintenance.
- Be sure to remove the service plug in order to disconnect the high voltage circuits before performing inspection or maintenance of high voltage system harnesses and parts.
- To prevent the removed service plug from being connected by mistake during the procedure, always carry it in your pocket or put it in the tool box.
- Be sure to wear insulating protective equipment consisting of glove, shoes, face shield and glasses before beginning work on the high voltage system.
- Clearly identify the persons responsible for high voltage work and ensure that other persons do not touch the vehicle. When not working, cover high voltage parts with an insulating cover sheet or similar item to prevent other persons from contacting them.
- Refer to [EVB-469, "High Voltage Precautions"](#).

CAUTION:

There is the possibility of a malfunction occurring if the vehicle is changed to READY status while the service plug is removed. Therefore do not change the vehicle to READY status unless instructed to do so in the Service Manual.

1. CHECK SELF-DIAGNOSIS RESULTS

Ⓟ With CONSULT

1. Perform "All DTC Reading" with CONSULT.

P331A-P3325 CELL OVER VOLTAGE

< DTC/CIRCUIT DIAGNOSIS >

[TYPE 3]

2. Check "Self Diagnostic Result" of systems other than "HV BAT" if any DTC is detected.

Is any DTC detected?

YES >> After performing trouble diagnosis of detected DTC, GO TO 2.

NO >> GO TO 2.

2. PRECONDITIONING

WARNING:

Disconnect high voltage. Refer to [GI-31, "How to Disconnect High Voltage"](#).

1. Remove Li-ion battery. Refer to [EVB-626, "Removal and Installation"](#).

2. Remove battery pack upper case. Refer to [EVB-635, "BATTERY PACK UPPER CASE : Removal and Installation"](#).

>> GO TO 3.

3. CHECK HARNESS BETWEEN MODULE AND LI-ION BATTERY CONTROLLER

Ⓜ With CONSULT

1. Power switch OFF.

2. Identify the malfunctioning module based on detected DTC.

3. Disconnect module harness connector and Li-ion battery controller harness connector.

4. Refer to below table and check the continuity between corresponding module and Li-ion battery controller.

DTC	Module No.	Module		Li-ion battery controller		Continuity
		Connector	Terminal	Connector	Terminal	
P331A	25	LB8	57	LB15	89	Existed
			73		110	
			58		90	
P331B	26	LB8	58	LB15	90	Existed
			74		111	
			75		91	
P331C	27	LB8	75	LB15	91	Existed
			60		112	
			76		92	
P331D	28	LB8	76	LB15	92	Existed
			77		113	
			62		93	
P331E	29	LB8	62	LB15	93	Existed
			78		114	
			79		94	
P331F	30	LB8	79	LB15	94	Existed
			64		115	
			80		95	
P3320	31	LB8	80	LB15	95	Existed
			81		116	
			66		96	
P3321	32	LB8	66	LB15	96	Existed
			82		117	
			83		97	

P331A-P3325 CELL OVER VOLTAGE

< DTC/CIRCUIT DIAGNOSIS >

[TYPE 3]

DTC	Module No.	Module		Li-ion battery controller		Continuity
		Connector	Terminal	Connector	Terminal	
P3322	33	LB8	83	LB15	97	Existed
			68		118	
			84		99	
P3323	34	LB8	84	LB15	99	Existed
			85		119	
			70		100	
P3324	35	LB8	70	LB15	100	Existed
			86		120	
			87		101	
P3325	36	LB8	87	LB15	101	Existed
			72		121	
			88		102	

Is the inspection result normal?

YES >> GO TO 4.

NO >> Repair harness or connector.

4. CHECK MODULE VOLTAGE

Check voltage of corresponding module. Refer to [EVB-570, "Component Inspection"](#).

Is the inspection result normal?

YES >> Replace Li-ion battery controller. Refer to [EVB-645, "LI-ION BATTERY CONTROLLER : Removal and Installation"](#).

NO >> Replace corresponding module. Refer to [EVB-665, "FRONT MODULE STACK : Disassembly and Assembly"](#).

Component Inspection

INFOID:000000011104251

1. CHECK MODULE VOLTAGE

Check voltage of module.

A : Positive terminal (Red)

B : Negative terminal (Black)

Terminals		Voltage (Approx.)
(+)	(-)	
Module		5.0 - 8.5 V
Positive terminal (Red)	Negative terminal (Black)	

Is the inspection result normal?

YES >> INSPECTION END

NO >> Replace module. Refer to [EVB-665, "FRONT MODULE STACK : Disassembly and Assembly"](#) (Front module) or [EVB-680, "REAR MODULE STACK : Disassembly and Assembly"](#) (Rear module).

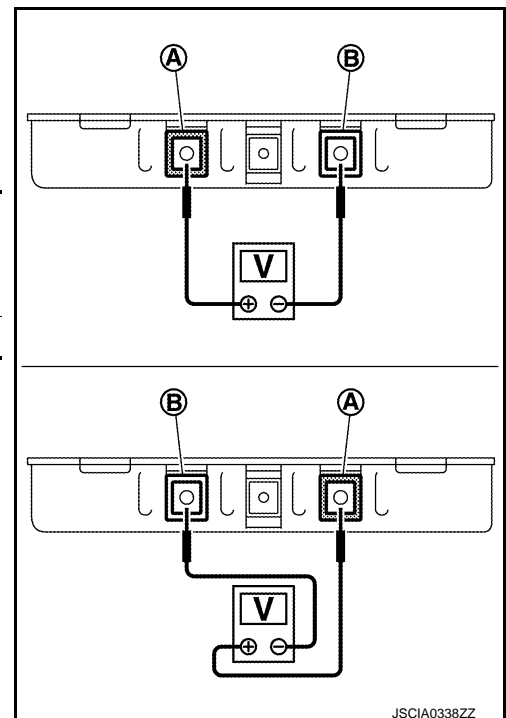

JSCIA0338ZZ

P3326-P3331 CELL OVER VOLTAGE

< DTC/CIRCUIT DIAGNOSIS >

[TYPE 3]

P3326-P3331 CELL OVER VOLTAGE

DTC Logic

INFOID:0000000011104252

DTC DETECTION LOGIC

DTC	Trouble diagnosis name	DTC detecting condition	Possible causes
P3326	CELL OVER VOLTAGE MODULE37	When cell voltage exceeds the allowable working voltage range.	<ul style="list-style-type: none">• Overcharge caused by traction motor inverter/VCM malfunction• Module• Li-ion battery controller• Bus bar• Harness or connector
P3327	CELL OVER VOLTAGE MODULE38		
P3328	CELL OVER VOLTAGE MODULE39		
P3329	CELL OVER VOLTAGE MODULE40		
P332A	CELL OVER VOLTAGE MODULE41		
P332B	CELL OVER VOLTAGE MODULE42		
P332C	CELL OVER VOLTAGE MODULE43		
P332D	CELL OVER VOLTAGE MODULE44		
P332E	CELL OVER VOLTAGE MODULE45		
P332F	CELL OVER VOLTAGE MODULE46		
P3330	CELL OVER VOLTAGE MODULE47		
P3331	CELL OVER VOLTAGE MODULE48		

DTC CONFIRMATION PROCEDURE

1. PERFORM DTC CONFIRMATION PROCEDURE

④ With CONSULT

1. Power switch ON and wait for 10 seconds or more.
2. Select "Self Diagnostic Result" of "HV BAT".
3. Check DTC.

Is any DTC detected?

- YES >> Refer to [EVB-571, "Diagnosis Procedure"](#).
NO >> INSPECTION END

Diagnosis Procedure

INFOID:0000000011104253

WARNING:

- Because hybrid vehicles and electric vehicles contain a high voltage battery, there is the risk of electric shock, electric leakage, or similar accidents if the high voltage component and vehicle are handled incorrectly. Be sure to follow the correct work procedures when performing inspection and maintenance.
- Be sure to remove the service plug in order to disconnect the high voltage circuits before performing inspection or maintenance of high voltage system harnesses and parts.
- To prevent the removed service plug from being connected by mistake during the procedure, always carry it in your pocket or put it in the tool box.
- Be sure to wear insulating protective equipment consisting of glove, shoes, face shield and glasses before beginning work on the high voltage system.
- Clearly identify the persons responsible for high voltage work and ensure that other persons do not touch the vehicle. When not working, cover high voltage parts with an insulating cover sheet or similar item to prevent other persons from contacting them.
- Refer to [EVB-469, "High Voltage Precautions"](#).

CAUTION:

There is the possibility of a malfunction occurring if the vehicle is changed to READY status while the service plug is removed. Therefore do not change the vehicle to READY status unless instructed to do so in the Service Manual.

1. CHECK SELF-DIAGNOSIS RESULTS

④ With CONSULT

1. Perform "All DTC Reading" with CONSULT.

P3326-P3331 CELL OVER VOLTAGE

[TYPE 3]

< DTC/CIRCUIT DIAGNOSIS >

2. Check "Self Diagnostic Result" of systems other than "HV BAT" if any DTC is detected.

Is any DTC detected?

YES >> After performing trouble diagnosis of detected DTC, GO TO 2.

NO >> GO TO 2.

2. PRECONDITIONING

WARNING:

Disconnect high voltage. Refer to [GI-31, "How to Disconnect High Voltage"](#).

1. Remove Li-ion battery. Refer to [EVB-626, "Removal and Installation"](#).

2. Remove battery pack upper case. Refer to [EVB-635, "BATTERY PACK UPPER CASE : Removal and Installation"](#).

>> GO TO 3.

3. CHECK HARNESS BETWEEN MODULE AND LI-ION BATTERY CONTROLLER

Ⓟ With CONSULT

1. Power switch OFF.

2. Identify the malfunctioning module based on detected DTC.

3. Disconnect module harness connector and Li-ion battery controller harness connector.

4. Refer to below table and check the continuity between corresponding module and Li-ion battery controller.

DTC	Module No.	Module		Li-ion battery controller		Continuity	
		Connector	Terminal	Connector	Terminal		
P3326	37	LB8	88	LB15	102	Existed	
			LB7		89		122
					101		103
P3327	38	LB7	101	LB15	103	Existed	
					90		123
					102		104
P3328	39	LB7	102	LB15	104	Existed	
					91		124
					103		105
P3329	40	LB7	103	LB15	105	Existed	
					92		125
					104		106
P332A	41	LB7	104	LB15	106	Existed	
					93		127
					105		107
P332B	42	LB7	105	LB15	107	Existed	
					94		128
					106		108
P332C	43	LB7	106	LB15	108	Existed	
				95	LB16		137
				107			130
P332D	44	LB7	107	LB16	130	Existed	
					96		138
					108		131

P3326-P3331 CELL OVER VOLTAGE

< DTC/CIRCUIT DIAGNOSIS >

[TYPE 3]

DTC	Module No.	Module		Li-ion battery controller		Continuity
		Connector	Terminal	Connector	Terminal	
P332E	45	LB7	108	LB16	131	Existed
			97		140	
			109		132	
P332F	46	LB7	109	LB16	132	Existed
			98		141	
			110		133	
P3330	47	LB7	110	LB16	133	Existed
			99		142	
			111		134	
P3331	48	LB7	111	LB16	134	Existed
			100		143	
			112		135	

Is the inspection result normal?

YES >> GO TO 4.

NO >> Repair harness or connector.

4.CHECK MODULE VOLTAGE

Check voltage of corresponding module. Refer to [EVB-573, "Component Inspection"](#).

Is the inspection result normal?

YES >> Replace Li-ion battery controller. Refer to [EVB-645, "LI-ION BATTERY CONTROLLER : Removal and Installation"](#).

NO >> Replace corresponding module. Refer to [EVB-665, "FRONT MODULE STACK : Disassembly and Assembly"](#).

Component Inspection

INFOID:000000011104254

1.CHECK MODULE VOLTAGE

Check voltage of module.

A : Positive terminal (Red)

B : Negative terminal (Black)

Terminals		Voltage (Approx.)
(+)	(-)	
Module		5.0 - 8.5 V
Positive terminal (Red)	Negative terminal (Black)	

Is the inspection result normal?

YES >> INSPECTION END

NO >> Replace module. Refer to [EVB-665, "FRONT MODULE STACK : Disassembly and Assembly"](#) (Front module) or [EVB-680, "REAR MODULE STACK : Disassembly and Assembly"](#) (Rear module).

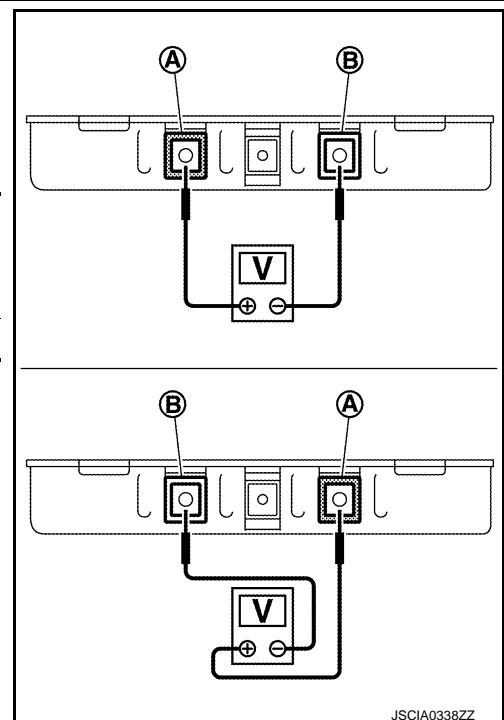

JSCIA0338ZZ

P3373 TOTAL VOLTAGE OVER DISCHARGE

< DTC/CIRCUIT DIAGNOSIS >

[TYPE 3]

P3373 TOTAL VOLTAGE OVER DISCHARGE

DTC Logic

INFOID:0000000011104255

DTC DETECTION LOGIC

If DTC P3373 is displayed with DTC P30F4, first perform the trouble diagnosis for P30F4. Refer to [EVB-544](#), "[DTC Logic](#)".

DTC	Trouble diagnosis name	DTC detecting condition	Possible causes
P3373	TOTAL VOLTAGE OVER DISCHARGE	When total voltage lowers below the allowable working voltage range.	<ul style="list-style-type: none">• Li-ion battery controller• Module• Bus bar• Service plug fuse• Overcharge caused by traction motor inverter/VCM malfunction• Harness or connector

DTC CONFIRMATION PROCEDURE

1. CHECK SELF-DIAGNOSIS RESULTS

Ⓟ With CONSULT

1. Power switch ON and wait for 10 seconds or more.
2. Select "Self Diagnostic Result" of "HV BAT".
3. Check DTC.

Is P3373 detected?

- YES >> Refer to [EVB-574](#), "[Diagnosis Procedure](#)".
NO >> INSPECTION END

Diagnosis Procedure

INFOID:0000000011104256

1. PERFORM THE SELF-DIAGNOSIS

Ⓟ With CONSULT

1. Perform "All DTC Reading".
2. Check "Self diagnostic result" of systems other than "HV BAT" to see if any DTC is detected.

Is any DTC detected?

- YES >> After performing trouble diagnosis of detected DTC, GO TO 2.
NO >> GO TO 2.

2. PERFORM THE SELF-DIAGNOSIS OF LI-ION BATTERY CONTROLLER

Ⓟ With CONSULT

1. Select "Self Diagnostic Result" of "HV BAT".
2. Check to see if "P3375"- "P33A4" is detected simultaneously with "P3373".

Is P3375-P33A4 detected?

- YES >> • When "P3375"- "P3380" are detected simultaneously, perform the diagnosis procedure of "P3375"- "P3380". Refer to [EVB-575](#), "[Diagnosis Procedure](#)".
• When "P3381"- "P338C" are detected simultaneously, perform the diagnosis procedure of "P3381"- "P338C". Refer to [EVB-579](#), "[Diagnosis Procedure](#)".
• When "P338D"- "P3398" are detected simultaneously, perform the diagnosis procedure of "P338D"- "P3398". Refer to [EVB-583](#), "[Diagnosis Procedure](#)".
• When "P3399"- "P33A4" are detected simultaneously, perform the diagnosis procedure of "P3399"- "P33A4". Refer to [EVB-586](#), "[Diagnosis Procedure](#)".
- NO >> Replace Li-ion battery controller. Refer to [EVB-645](#), "[LI-ION BATTERY CONTROLLER : Removal and Installation](#)".

P3375-P3380 CELL OVER DISCHARGE

< DTC/CIRCUIT DIAGNOSIS >

[TYPE 3]

P3375-P3380 CELL OVER DISCHARGE

DTC Logic

INFOID:000000011104257

DTC DETECTION LOGIC

DTC	Trouble diagnosis name	DTC detecting condition	Possible causes
P3375	CELL OVER DISCHARGE MODULE1	When cell voltage lowers below the allowable working voltage range.	<ul style="list-style-type: none"> Overcharge caused by traction motor inverter/VCM malfunction Module Li-ion battery controller Bus bar Harness or connector
P3376	CELL OVER DISCHARGE MODULE2		
P3377	CELL OVER DISCHARGE MODULE3		
P3378	CELL OVER DISCHARGE MODULE4		
P3379	CELL OVER DISCHARGE MODULE5		
P337A	CELL OVER DISCHARGE MODULE6		
P337B	CELL OVER DISCHARGE MODULE7		
P337C	CELL OVER DISCHARGE MODULE8		
P337D	CELL OVER DISCHARGE MODULE9		
P337E	CELL OVER DISCHARGE MODULE10		
P337F	CELL OVER DISCHARGE MODULE11		
P3380	CELL OVER DISCHARGE MODULE12		

DTC CONFIRMATION PROCEDURE

1. PERFORM DTC CONFIRMATION PROCEDURE

Ⓜ With CONSULT

- Power switch ON and wait for 10 seconds or more.
- Select "Self Diagnostic Result" of "HV BAT".
- Check DTC.

Is any DTC detected?

- YES >> Refer to [EV B-575, "Diagnosis Procedure"](#).
- NO >> INSPECTION END

Diagnosis Procedure

INFOID:000000011104258

WARNING:

- Because hybrid vehicles and electric vehicles contain a high voltage battery, there is the risk of electric shock, electric leakage, or similar accidents if the high voltage component and vehicle are handled incorrectly. Be sure to follow the correct work procedures when performing inspection and maintenance.
- Be sure to remove the service plug in order to disconnect the high voltage circuits before performing inspection or maintenance of high voltage system harnesses and parts.
- To prevent the removed service plug from being connected by mistake during the procedure, always carry it in your pocket or put it in the tool box.
- Be sure to wear insulating protective equipment consisting of glove, shoes, face shield and glasses before beginning work on the high voltage system.
- Clearly identify the persons responsible for high voltage work and ensure that other persons do not touch the vehicle. When not working, cover high voltage parts with an insulating cover sheet or similar item to prevent other persons from contacting them.
- Refer to [EV B-469, "High Voltage Precautions"](#).

CAUTION:

There is the possibility of a malfunction occurring if the vehicle is changed to READY status while the service plug is removed. Therefore do not change the vehicle to READY status unless instructed to do so in the Service Manual.

1. CHECK SELF-DIAGNOSIS RESULTS

Ⓜ With CONSULT

- Perform "All DTC Reading" with CONSULT.

P3375-P3380 CELL OVER DISCHARGE

[TYPE 3]

< DTC/CIRCUIT DIAGNOSIS >

2. Check systems other than "HV BAT" if any DTC is detected.

Is any DTC detected?

YES >> After performing trouble diagnosis of detected DTC, GO TO 2.

NO >> GO TO 2.

2. PRECONDITIONING

WARNING:

Disconnect high voltage. Refer to [GI-31, "How to Disconnect High Voltage"](#).

1. Remove Li-ion battery. Refer to [EVB-626, "Removal and Installation"](#).

2. Remove battery pack upper case. Refer to [EVB-635, "BATTERY PACK UPPER CASE : Removal and Installation"](#).

>> GO TO 3.

3. CHECK HARNESS BETWEEN MODULE AND LI-ION BATTERY CONTROLLER

1. Disconnect voltage detection terminal of bus bar and Li-ion battery controller harness connector.

2. Refer to below table and check the continuity between Li-ion battery controller (A) and corresponding bus bar (B).

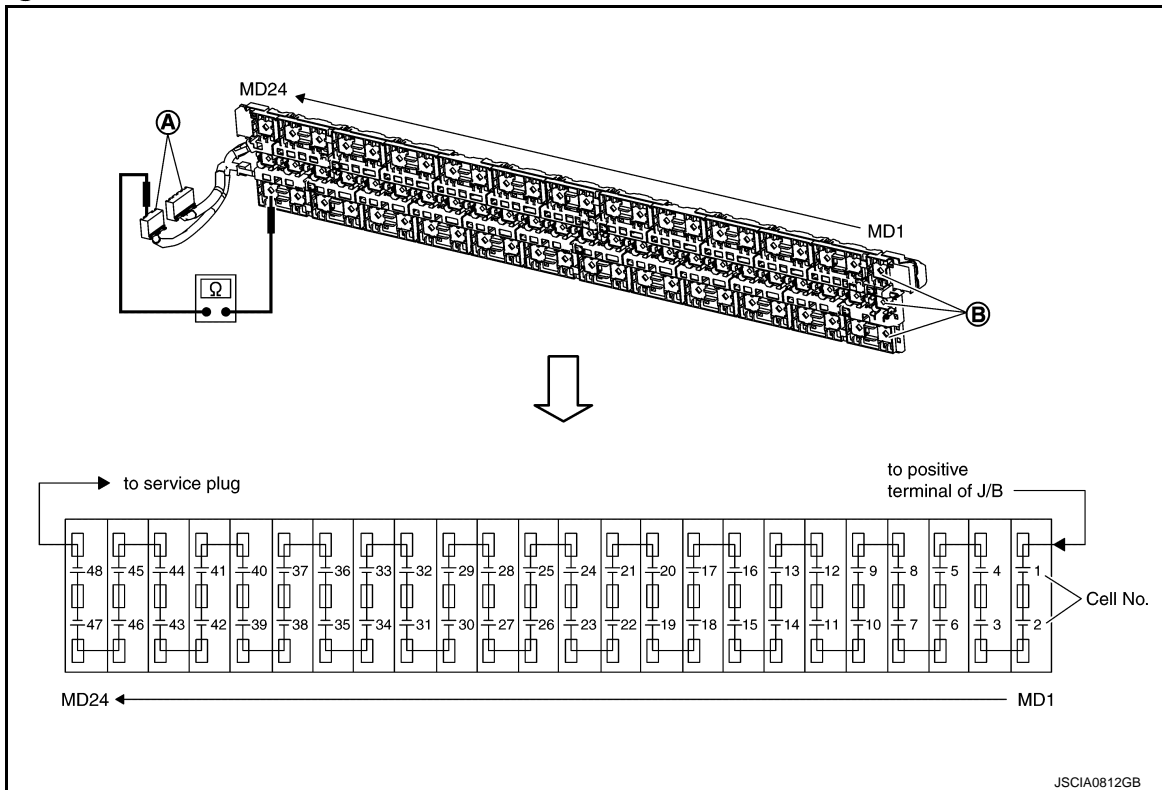

P3375-P3380 CELL OVER DISCHARGE

< DTC/CIRCUIT DIAGNOSIS >

[TYPE 3]

DTC	Module No.		Li-ion battery controller		Continuity
			Connector	Terminal	
P3375	1	Bus bar	LB13	33	Existed
				50	
				34	
P3376	2		LB13	34	Existed
				51	
				35	
P3377	3		LB13	35	Existed
				52	
				36	
P3378	4		LB13	36	Existed
				53	
				37	
P3379	5	LB13	37	Existed	
			54		
			38		
P337A	6	LB13	38	Existed	
			55		
			39		
P337B	7	LB13	39	Existed	
			56		
			40		
P337C	8	LB13	40	Existed	
			57		
			42		
P337D	9	LB13	42	Existed	
			58		
			43		
P337E	10	LB13	43	Existed	
			59		
			44		
P330F	11	LB13	44	Existed	
			60		
			45		
P3380	12	LB13	45	Existed	
			61		
			46		

A
B
EVB
D
E
F
G
H
I
J
K
L
M
N
O
P

Is the inspection result normal?

YES >> GO TO 4.

NO >> Repair Harness or connector.

4. CHECK MODULE VOLTAGE

Check voltage of corresponding module. Refer to [EVB-578, "Component Inspection"](#).

Is the inspection result normal?

P3375-P3380 CELL OVER DISCHARGE

[TYPE 3]

< DTC/CIRCUIT DIAGNOSIS >

- YES >> Replace Li-ion battery controller. Refer to [EVB-645. "LI-ION BATTERY CONTROLLER : Removal and Installation"](#).
- NO >> Replace corresponding module. Refer to [EVB-680. "REAR MODULE STACK : Disassembly and Assembly"](#).

Component Inspection

INFOID:000000011104259

1. CHECK MODULE VOLTAGE

Check voltage of module.

- A : Positive terminal (Red)**
- B : Negative terminal (Black)**

Terminals		Voltage (Approx.)
(+)	(-)	
Module		5.0 - 8.5 V
Positive terminal (Red)	Negative terminal (Black)	

Is the inspection result normal?

- YES >> INSPECTION END
- NO >> Replace module. Refer to [EVB-665. "FRONT MODULE STACK : Disassembly and Assembly"](#) (Front module) or [EVB-680. "REAR MODULE STACK : Disassembly and Assembly"](#) (Rear module).

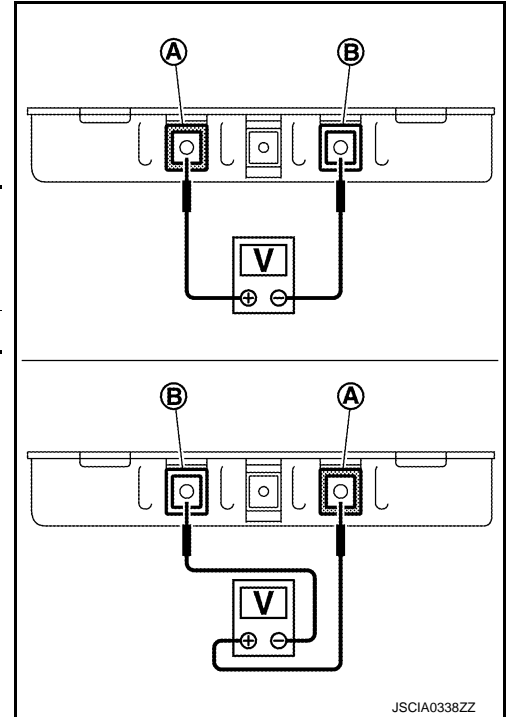

P3381-P338C CELL OVER DISCHARGE

< DTC/CIRCUIT DIAGNOSIS >

[TYPE 3]

P3381-P338C CELL OVER DISCHARGE

DTC Logic

INFOID:000000011104260

DTC DETECTION LOGIC

DTC	Trouble diagnosis name	DTC detecting condition	Possible causes
P3381	CELL OVER DISCHARGE MODULE13	When cell voltage lowers below the allowable working voltage range.	<ul style="list-style-type: none"> Overcharge caused by traction motor inverter/VCM malfunction Module Li-ion battery controller Bus bar Harness or connector
P3382	CELL OVER DISCHARGE MODULE14		
P3383	CELL OVER DISCHARGE MODULE15		
P3384	CELL OVER DISCHARGE MODULE16		
P3385	CELL OVER DISCHARGE MODULE17		
P3386	CELL OVER DISCHARGE MODULE18		
P3387	CELL OVER DISCHARGE MODULE19		
P3388	CELL OVER DISCHARGE MODULE20		
P3389	CELL OVER DISCHARGE MODULE21		
P338A	CELL OVER DISCHARGE MODULE22		
P338B	CELL OVER DISCHARGE MODULE23		
P338C	CELL OVER DISCHARGE MODULE24		

DTC CONFIRMATION PROCEDURE

1. PERFORM DTC CONFIRMATION PROCEDURE

Ⓜ With CONSULT

- Power switch ON and wait for 10 seconds or more.
- Select "Self Diagnostic Result" of "HV BAT".
- Check DTC.

Is any DTC detected?

- YES >> Refer to [EV B-586, "Diagnosis Procedure"](#).
 NO >> INSPECTION END

Diagnosis Procedure

INFOID:000000011104261

WARNING:

- Because hybrid vehicles and electric vehicles contain a high voltage battery, there is the risk of electric shock, electric leakage, or similar accidents if the high voltage component and vehicle are handled incorrectly. Be sure to follow the correct work procedures when performing inspection and maintenance.
- Be sure to remove the service plug in order to disconnect the high voltage circuits before performing inspection or maintenance of high voltage system harnesses and parts.
- To prevent the removed service plug from being connected by mistake during the procedure, always carry it in your pocket or put it in the tool box.
- Be sure to wear insulating protective equipment consisting of glove, shoes, face shield and glasses before beginning work on the high voltage system.
- Clearly identify the persons responsible for high voltage work and ensure that other persons do not touch the vehicle. When not working, cover high voltage parts with an insulating cover sheet or similar item to prevent other persons from contacting them.
- Refer to [EV B-469, "High Voltage Precautions"](#).

CAUTION:

There is the possibility of a malfunction occurring if the vehicle is changed to READY status while the service plug is removed. Therefore do not change the vehicle to READY status unless instructed to do so in the Service Manual.

1. CHECK SELF-DIAGNOSIS RESULTS

Ⓜ With CONSULT

- Perform "All DTC Reading" with CONSULT.

P3381-P338C CELL OVER DISCHARGE

[TYPE 3]

< DTC/CIRCUIT DIAGNOSIS >

2. Check systems other than "HV BAT" if any DTC is detected.

Is any DTC detected?

YES >> After performing trouble diagnosis of detected DTC, GO TO 2.

NO >> GO TO 2.

2. PRECONDITIONING

WARNING:

Disconnect high voltage circuit. Refer to [GI-31, "How to Disconnect High Voltage"](#).

1. Remove Li-ion battery. Refer to [EVB-626, "Removal and Installation"](#).

2. Remove battery pack upper case. Refer to [EVB-635, "BATTERY PACK UPPER CASE : Removal and Installation"](#).

>> GO TO 3.

3. CHECK HARNESS BETWEEN MODULE AND LI-ION BATTERY CONTROLLER

1. Disconnect voltage detection terminal of bus bar and Li-ion battery controller harness connector.

2. Refer to below table and check the continuity between Li-ion battery controller (A) and corresponding bus bar (B).

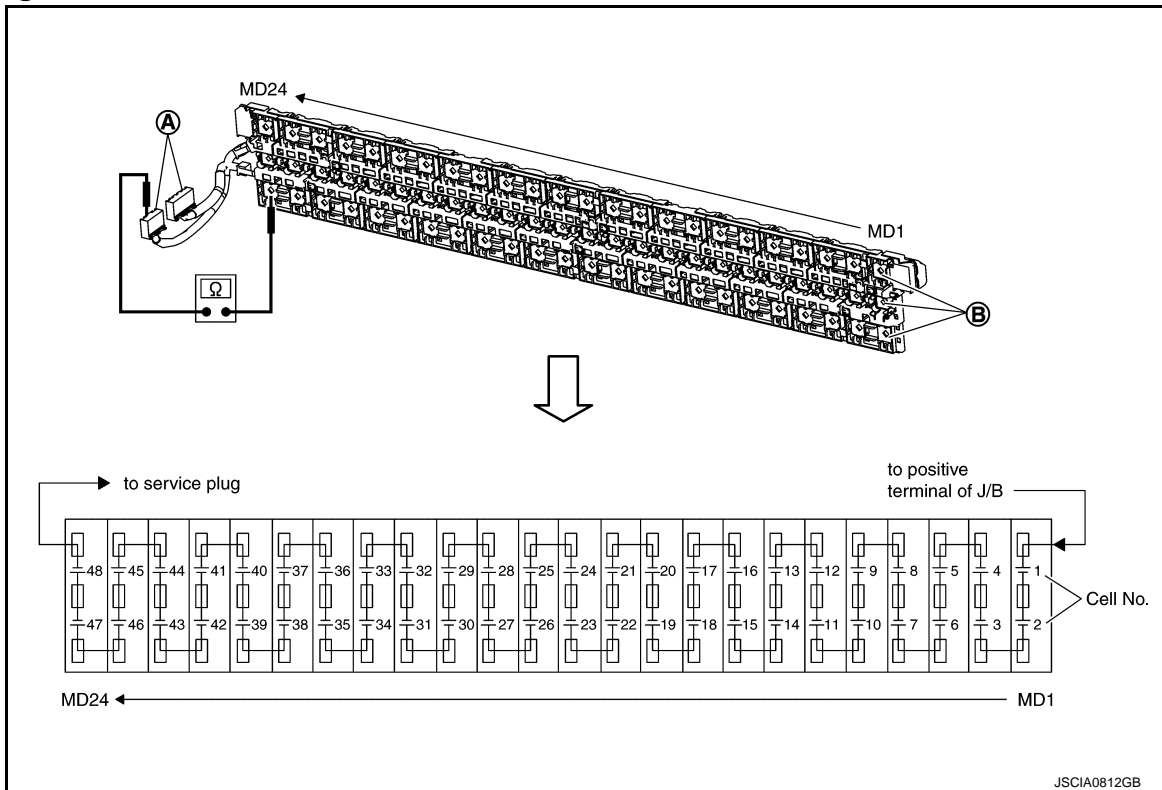

P3381-P338C CELL OVER DISCHARGE

< DTC/CIRCUIT DIAGNOSIS >

[TYPE 3]

DTC	Module No.		Li-ion battery controller		Continuity
			Connector	Terminal	
P3381	13		LB13	46	Existed
				62	
				47	
P3382	14		LB13	47	Existed
				63	
				48	
P3383	15		LB13	48	Existed
			LB14	77	
				65	
P3384	16		LB14	65	Existed
				78	
				66	
P3385	17		LB14	66	Existed
				80	
				69	
P3386	18	Bus bar	LB14	69	Existed
				81	
				70	
P3387	19		LB14	70	Existed
				82	
				71	
P3388	20		LB14	71	Existed
				83	
				72	
P3389	21		LB14	72	Existed
				84	
				73	
P338A	22		LB14	73	Existed
				85	
				74	
P338B	23		LB14	74	Existed
				86	
				75	
P338C	24		LB14	75	Existed
				87	
				76	

A
B
EVB
D
E
F
G
H
I
J
K
L
M
N
O
P

Is the inspection result normal?

YES >> GO TO 4.

NO >> Repair Harness or connector.

4. CHECK MODULE VOLTAGE

Check voltage of corresponding module. Refer to [EVB-582, "Component Inspection"](#).

Is the inspection result normal?

P3381-P338C CELL OVER DISCHARGE

[TYPE 3]

< DTC/CIRCUIT DIAGNOSIS >

- YES >> Replace Li-ion battery controller. Refer to [EVB-645. "LI-ION BATTERY CONTROLLER : Removal and Installation"](#).
- NO >> Replace corresponding module. Refer to [EVB-680. "REAR MODULE STACK : Disassembly and Assembly"](#).

Component Inspection

INFOID:000000011104262

1. CHECK MODULE VOLTAGE

Check voltage of module.

- A : Positive terminal (Red)**
B : Negative terminal (Black)

Terminals		Voltage (Approx.)
(+)	(-)	
Module		5.0 - 8.5 V
Positive terminal (Red)	Negative terminal (Black)	

Is the inspection result normal?

- YES >> INSPECTION END
- NO >> Replace module. Refer to [EVB-665. "FRONT MODULE STACK : Disassembly and Assembly"](#) (Front module) or [EVB-680. "REAR MODULE STACK : Disassembly and Assembly"](#) (Rear module).

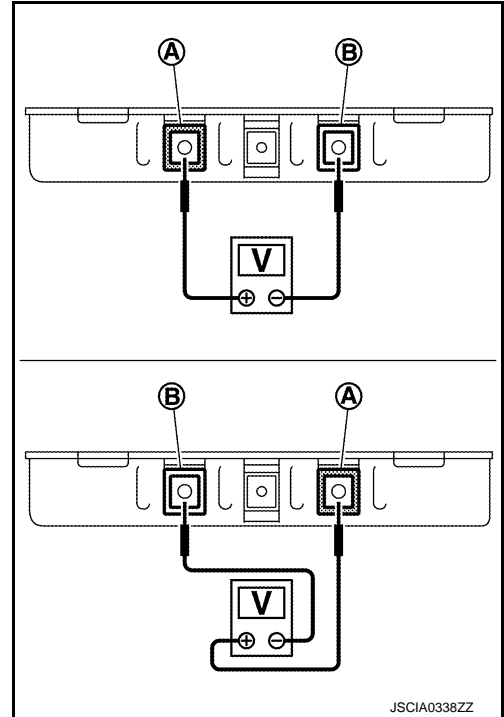

P338D-P3398 CELL OVER DISCHARGE

< DTC/CIRCUIT DIAGNOSIS >

[TYPE 3]

P338D-P3398 CELL OVER DISCHARGE

DTC Logic

INFOID:000000011104263

DTC DETECTION LOGIC

DTC	Trouble diagnosis name	DTC detecting condition	Possible causes
P338D	CELL OVER DISCHARGE MODULE25	When cell voltage lowers below the allowable working voltage range.	<ul style="list-style-type: none"> Overcharge caused by traction motor inverter/VCM malfunction Module Li-ion battery controller Bus bar Harness or connector
P338E	CELL OVER DISCHARGE MODULE26		
P338F	CELL OVER DISCHARGE MODULE27		
P3390	CELL OVER DISCHARGE MODULE28		
P3391	CELL OVER DISCHARGE MODULE29		
P3392	CELL OVER DISCHARGE MODULE30		
P3393	CELL OVER DISCHARGE MODULE31		
P3394	CELL OVER DISCHARGE MODULE32		
P3395	CELL OVER DISCHARGE MODULE33		
P3396	CELL OVER DISCHARGE MODULE34		
P3397	CELL OVER DISCHARGE MODULE35		
P3398	CELL OVER DISCHARGE MODULE36		

DTC CONFIRMATION PROCEDURE

1. PERFORM DTC CONFIRMATION PROCEDURE

Ⓜ With CONSULT

- Power switch ON and wait for 10 seconds or more.
- Select "Self Diagnostic Result" of "HV BAT".
- Check DTC.

Is any DTC detected?

- YES >> Refer to [EV B-586, "Diagnosis Procedure"](#).
- NO >> INSPECTION END

Diagnosis Procedure

INFOID:000000011104264

WARNING:

- Because hybrid vehicles and electric vehicles contain a high voltage battery, there is the risk of electric shock, electric leakage, or similar accidents if the high voltage component and vehicle are handled incorrectly. Be sure to follow the correct work procedures when performing inspection and maintenance.
- Be sure to remove the service plug in order to disconnect the high voltage circuits before performing inspection or maintenance of high voltage system harnesses and parts.
- To prevent the removed service plug from being connected by mistake during the procedure, always carry it in your pocket or put it in the tool box.
- Be sure to wear insulating protective equipment consisting of glove, shoes, face shield and glasses before beginning work on the high voltage system.
- Clearly identify the persons responsible for high voltage work and ensure that other persons do not touch the vehicle. When not working, cover high voltage parts with an insulating cover sheet or similar item to prevent other persons from contacting them.
- Refer to [EV B-469, "High Voltage Precautions"](#).

CAUTION:

There is the possibility of a malfunction occurring if the vehicle is changed to READY status while the service plug is removed. Therefore do not change the vehicle to READY status unless instructed to do so in the Service Manual.

1. CHECK SELF-DIAGNOSIS RESULTS

Ⓜ With CONSULT

- Perform "All DTC Reading" with CONSULT.

P338D-P3398 CELL OVER DISCHARGE

[TYPE 3]

< DTC/CIRCUIT DIAGNOSIS >

2. Check "Self Diagnostic Result" of systems other than "" if any DTC is detected.

Is any DTC detected?

- YES >> After performing trouble diagnosis of detected DTC, GO TO 2.
- NO >> GO TO 2.

2. PRECONDITIONING

WARNING:

Disconnect high voltage. Refer to [GI-31, "How to Disconnect High Voltage"](#).

1. Remove Li-ion battery. Refer to [EVB-626, "Removal and Installation"](#).
2. Remove battery pack upper case. Refer to [EVB-635, "BATTERY PACK UPPER CASE : Removal and Installation"](#).

>> GO TO 3.

3. CHECK HARNESS BETWEEN MODULE AND LI-ION BATTERY CONTROLLER

Ⓟ With CONSULT

1. Select "Self Diagnostic Result" mode of "HV BAT" using CONSULT.
2. Identify the malfunctioning module based on detected DTC.
3. Disconnect module harness connector and Li-ion battery controller harness connector.
4. Refer to below table and check the continuity between corresponding module and Li-ion battery controller.

DTC	Module No.	Module		Li-ion battery controller		Continuity
		Connector	Terminal	Connector	Terminal	
P338D	25	LB8	57	LB15	89	Existed
			73		110	
			58		90	
P338E	26	LB8	58	LB15	90	Existed
			74		111	
			75		91	
P338F	27	LB8	75	LB15	91	Existed
			60		112	
			76		92	
P3390	28	LB8	76	LB15	92	Existed
			77		113	
			62		93	
P3391	29	LB8	62	LB15	93	Existed
			78		114	
			79		94	
P3392	30	LB8	79	LB15	94	Existed
			64		115	
			80		95	
P3393	31	LB8	80	LB15	95	Existed
			81		116	
			66		96	
P3394	32	LB8	66	LB15	96	Existed
			82		117	
			83		97	

P338D-P3398 CELL OVER DISCHARGE

< DTC/CIRCUIT DIAGNOSIS >

[TYPE 3]

DTC	Module No.	Module		Li-ion battery controller		Continuity
		Connector	Terminal	Connector	Terminal	
P3395	33	LB8	83	LB15	97	Existed
			68		118	
			84		99	
P3396	34	LB8	84	LB15	99	Existed
			85		119	
			70		100	
P3397	35	LB8	70	LB15	100	Existed
			86		120	
			87		101	
P3398	36	LB8	87	LB15	101	Existed
			72		121	
			88		102	

Is the inspection result normal?

YES >> GO TO 4.

NO >> Repair Harness or connector.

4.CHECK MODULE VOLTAGE

Check voltage of corresponding module. Refer to [EVB-585, "Component Inspection"](#).

Is the inspection result normal?

YES >> Replace Li-ion battery controller. Refer to [EVB-645, "LI-ION BATTERY CONTROLLER : Removal and Installation"](#).

NO >> Replace corresponding module. Refer to [EVB-665, "FRONT MODULE STACK : Disassembly and Assembly"](#).

Component Inspection

INFOID:000000011104265

1.CHECK MODULE VOLTAGE

Check voltage of module.

A : Positive terminal (Red)

B : Negative terminal (Black)

Terminals		Voltage (Approx.)
(+)	(-)	
Module		5.0 - 8.5 V
Positive terminal (Red)	Negative terminal (Black)	

Is the inspection result normal?

YES >> INSPECTION END

NO >> Replace module. Refer to [EVB-665, "FRONT MODULE STACK : Disassembly and Assembly"](#) (Front module) or [EVB-680, "REAR MODULE STACK : Disassembly and Assembly"](#) (Rear module).

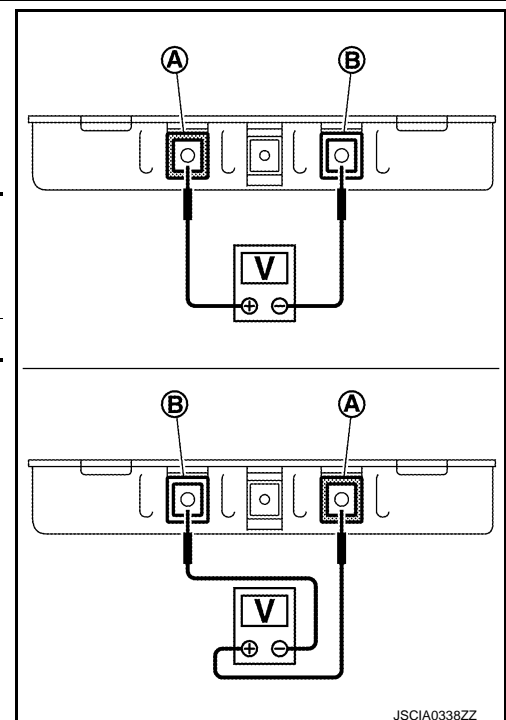

JSCIA0338ZZ

P3399-P33A4 CELL OVER DISCHARGE

< DTC/CIRCUIT DIAGNOSIS >

[TYPE 3]

P3399-P33A4 CELL OVER DISCHARGE

DTC Logic

INFOID:000000011104266

DTC DETECTION LOGIC

DTC	Trouble diagnosis name	DTC detecting condition	Possible causes
P3399	CELL OVER DISCHARGE MODULE37	When cell voltage lowers below the allowable working voltage range.	<ul style="list-style-type: none"> Overcharge caused by traction motor inverter/VCM malfunction Module Li-ion battery controller Bus bar Harness or connector
P339A	CELL OVER DISCHARGE MODULE38		
P339B	CELL OVER DISCHARGE MODULE39		
P339C	CELL OVER DISCHARGE MODULE40		
P339D	CELL OVER DISCHARGE MODULE41		
P339E	CELL OVER DISCHARGE MODULE42		
P339F	CELL OVER DISCHARGE MODULE43		
P33A0	CELL OVER DISCHARGE MODULE44		
P33A1	CELL OVER DISCHARGE MODULE45		
P33A2	CELL OVER DISCHARGE MODULE46		
P33A3	CELL OVER DISCHARGE MODULE47		
P33A4	CELL OVER DISCHARGE MODULE48		

DTC CONFIRMATION PROCEDURE

1. PERFORM DTC CONFIRMATION PROCEDURE

Ⓟ With CONSULT

- Power switch ON and wait for 10 seconds or more.
- Select "Self Diagnostic Result" of "HV BAT".
- Check DTC.

Is any DTC detected?

- YES >> Refer to [EVB-586, "Diagnosis Procedure"](#).
 NO >> INSPECTION END

Diagnosis Procedure

INFOID:000000011104267

WARNING:

- Because hybrid vehicles and electric vehicles contain a high voltage battery, there is the risk of electric shock, electric leakage, or similar accidents if the high voltage component and vehicle are handled incorrectly. Be sure to follow the correct work procedures when performing inspection and maintenance.
- Be sure to remove the service plug in order to disconnect the high voltage circuits before performing inspection or maintenance of high voltage system harnesses and parts.
- To prevent the removed service plug from being connected by mistake during the procedure, always carry it in your pocket or put it in the tool box.
- Be sure to wear insulating protective equipment consisting of glove, shoes, face shield and glasses before beginning work on the high voltage system.
- Clearly identify the persons responsible for high voltage work and ensure that other persons do not touch the vehicle. When not working, cover high voltage parts with an insulating cover sheet or similar item to prevent other persons from contacting them.
- Refer to [EVB-469, "High Voltage Precautions"](#).

CAUTION:

There is the possibility of a malfunction occurring if the vehicle is changed to READY status while the service plug is removed. Therefore do not change the vehicle to READY status unless instructed to do so in the Service Manual.

1. CHECK SELF-DIAGNOSIS RESULTS

Ⓟ With CONSULT

- Perform "All DTC Reading" with CONSULT.

P3399-P33A4 CELL OVER DISCHARGE

[TYPE 3]

< DTC/CIRCUIT DIAGNOSIS >

2. Check "Self Diagnostic Result" of systems other than "" if any DTC is detected.

Is any DTC detected?

- YES >> After performing trouble diagnosis of detected DTC, GO TO 2.
- NO >> GO TO 2.

2. PRECONDITIONING

WARNING:

Disconnect high voltage. Refer to [GI-31, "How to Disconnect High Voltage"](#).

1. Remove Li-ion battery. Refer to [EVB-626, "Removal and Installation"](#).
2. Remove battery pack upper case. Refer to [EVB-635, "BATTERY PACK UPPER CASE : Removal and Installation"](#).

>> GO TO 3.

3. CHECK HARNESS BETWEEN MODULE AND LI-ION BATTERY CONTROLLER

Ⓜ With CONSULT

1. Select "Self Diagnostic Result" mode of "HV BAT" using CONSULT.
2. Identify the malfunctioning module based on detected DTC.
3. Disconnect module harness connector and Li-ion battery controller harness connector.
4. Refer to below table and check the continuity between corresponding module and Li-ion battery controller.

DTC	Module No.	Module		Li-ion battery controller		Continuity
		Connector	Terminal	Connector	Terminal	
P3399	37	LB8	88	LB15	102	Existed
			LB7		89	
					101	
P339A	38	LB7	101	LB15	103	Existed
			90		123	
			102		104	
P339B	39	LB7	102	LB15	104	Existed
			91		124	
			103		105	
P339C	40	LB7	103	LB15	105	Existed
			92		125	
			104		106	
P339D	41	LB7	104	LB15	106	Existed
			93		127	
			105		107	
P339E	42	LB7	105	LB15	107	Existed
			94		128	
			106		108	
P339F	43	LB7	106	LB15	108	Existed
			95	LB16	137	
					107	
P33A0	44	LB7	107	LB16	130	Existed
			96		138	
			108		131	

P3399-P33A4 CELL OVER DISCHARGE

[TYPE 3]

< DTC/CIRCUIT DIAGNOSIS >

DTC	Module No.	Module		Li-ion battery controller		Continuity
		Connector	Terminal	Connector	Terminal	
P33A1	45	LB7	108	LB16	131	Existed
			97		140	
			109		132	
P33A2	46	LB7	109	LB16	132	Existed
			98		141	
			110		133	
P33A3	47	LB7	110	LB16	133	Existed
			99		142	
			111		134	
P33A4	48	LB7	111	LB16	134	Existed
			100		143	
			112		135	

Is the inspection result normal?

YES >> GO TO 4.

NO >> Repair Harness or connector.

4. CHECK MODULE VOLTAGE

Check voltage of corresponding module. Refer to [EVB-588, "Component Inspection"](#).

Is the inspection result normal?

YES >> Replace Li-ion battery controller. Refer to [EVB-645, "LI-ION BATTERY CONTROLLER : Removal and Installation"](#).

NO >> Replace corresponding module. Refer to [EVB-665, "FRONT MODULE STACK : Disassembly and Assembly"](#).

Component Inspection

INFOID:000000011104268

1. CHECK MODULE VOLTAGE

Check voltage of module.

A : Positive terminal (Red)

B : Negative terminal (Black)

Terminals		Voltage (Approx.)
(+)	(-)	
Module		5.0 - 8.5 V
Positive terminal (Red)	Negative terminal (Black)	

Is the inspection result normal?

YES >> INSPECTION END

NO >> Replace module. Refer to [EVB-665, "FRONT MODULE STACK : Disassembly and Assembly"](#) (Front module) or [EVB-680, "REAR MODULE STACK : Disassembly and Assembly"](#) (Rear module).

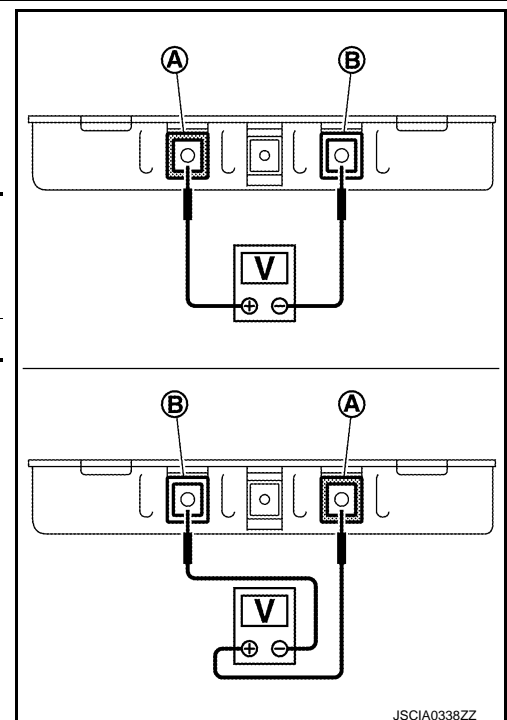

JSCIA0338ZZ

P33D4 BATT GRADUAL CAPA LOSS DIAG

< DTC/CIRCUIT DIAGNOSIS >

[TYPE 3]

P33D4 BATT GRADUAL CAPA LOSS DIAG

DTC Logic

INFOID:0000000011104269

DTC DETECTION LOGIC

DTC	Trouble diagnosis name	DTC detecting condition	Possible causes
P33D4	BATT GRADUAL CAPA LOSS DIAG	When the battery charge lowers. (The internal resistance of the battery increases.)	Li-ion battery

A

B

EVB

DTC CONFIRMATION PROCEDURE

1. PERFORM DTC CONFIRMATION PROCEDURE

 With CONSULT

1. Power switch ON and wait for 10 seconds or more.
2. Select "Self Diagnostic Result" of "HV BAT".
3. Check DTC.

Is P33D4 detected?

- YES >> Refer to [EVB-589, "Diagnosis Procedure"](#).
NO >> INSPECTION END

Diagnosis Procedure

INFOID:0000000011104270

When this DTC is detected, replace Li-ion battery. Refer to [EVB-626, "Removal and Installation"](#).

D

E

F

G

H

I

J

K

L

M

N

O

P

P33D5 CURRENT SENSOR

< DTC/CIRCUIT DIAGNOSIS >

[TYPE 3]

P33D5 CURRENT SENSOR

DTC Logic

INFOID:0000000011104271

DTC DETECTION LOGIC

DTC	Trouble diagnosis name	DTC detecting condition	Possible causes
P33D5	CURRENT SENSOR	Deviation in characteristics of battery current sensor signal voltage. (Battery current sensor signal voltage is too high or too low.)	<ul style="list-style-type: none">• Li-ion battery controller• Current sensor• System main relay• Harness or connector

DTC CONFIRMATION PROCEDURE

1. PERFORM DTC CONFIRMATION PROCEDURE

Ⓜ With CONSULT

1. Power switch ON and wait for 10 seconds or more.
2. Select "Self Diagnostic Result" of "HV BAT".
3. Check DTC.

Is P33D5 detected?

- YES >> Refer to [EVB-590, "Diagnosis Procedure"](#).
NO >> INSPECTION END

Diagnosis Procedure

INFOID:0000000011104272

WARNING:

- Because hybrid vehicles and electric vehicles contain a high voltage battery, there is the risk of electric shock, electric leakage, or similar accidents if the high voltage component and vehicle are handled incorrectly. Be sure to follow the correct work procedures when performing inspection and maintenance.
- Be sure to remove the service plug in order to disconnect the high voltage circuits before performing inspection or maintenance of high voltage system harnesses and parts.
- To prevent the removed service plug from being connected by mistake during the procedure, always carry it in your pocket or put it in the tool box.
- Be sure to wear insulating protective equipment consisting of glove, shoes, face shield and glasses before beginning work on the high voltage system.
- Clearly identify the persons responsible for high voltage work and ensure that other persons do not touch the vehicle. When not working, cover high voltage parts with an insulating cover sheet or similar item to prevent other persons from contacting them.
- Refer to [EVB-469, "High Voltage Precautions"](#).

CAUTION:

There is the possibility of a malfunction occurring if the vehicle is changed to READY status while the service plug is removed. Therefore do not change the vehicle to READY status unless instructed to do so in the Service Manual.

1. CHECK SELF-DIAGNOSIS RESULTS OF VCM

Ⓜ With CONSULT

1. Select "Self Diagnostic Result" mode of "EV/HEV" using CONSULT.
2. Check to see if "P0AA0", "P0AA1" or "P0AA4" is detected.

Is any DTC detected?

- YES >> Perform diagnosis on the detected DTC. Refer to [EVB-502, "DTC Index"](#).
NO >> GO TO 2.

2. PRECONDITIONING

WARNING:

Disconnect high voltage. Refer to [GI-31, "How to Disconnect High Voltage"](#).

1. Remove Li-ion battery. Refer to [EVB-626, "Removal and Installation"](#).
2. Remove battery pack upper case. Refer to [EVB-635, "BATTERY PACK UPPER CASE : Removal and Installation"](#).

P33D5 CURRENT SENSOR

< DTC/CIRCUIT DIAGNOSIS >

[TYPE 3]

>> GO TO 3.

3. CHECK CONNECTION STATUS

Check connection status of Li-ion battery controller harness connector and current sensor harness connector.

Is the inspection result normal?

YES >> GO TO 4.

NO >> Recover the connection status.

4. CHECK HARNESS BETWEEN CURRENT SENSOR AND LI-ION BATTERY CONTROLLER

Check continuity between current sensor harness connector and Li-ion battery controller harness connector.

Current sensor		Li-ion battery controller		Continuity
Connector	Terminal	Connector	Terminal	
LB5	S	LB11	10	Exited
	V		9	
	G		17	

Is the inspection result normal?

YES >> GO TO 5.

NO >> Repair Harness or connector.

5. CHECK CURRENT SENSOR

Check resistance of current sensor.

Current sensor			Resistance value
Connector	Terminal	Terminal	
LB5	S	G	1 k Ω –10 M Ω
	V	G	

Is the inspection result normal?

YES >> GO TO 6.

NO >> Replace current sensor.

6. CHECK LI-ION BATTERY CONTROLLER

Check resistance of Li-ion battery controller.

Li-ion battery controller			Resistance value
Connector	Terminal	Terminal	
LB11	10	17	Approx. 4.7 k Ω

Is the inspection result normal?

YES >> Replace current sensor. Refer to [EVB-648, "BATTERY JUNCTION BOX AND BATTERY HARNESS : Exploded View"](#).

NO >> Replace Li-ion battery controller. Refer to [EVB-645, "LI-ION BATTERY CONTROLLER : Removal and Installation"](#).

P33D6 CURRENT SENSOR

< DTC/CIRCUIT DIAGNOSIS >

[TYPE 3]

P33D6 CURRENT SENSOR

DTC Logic

INFOID:000000011104273

DTC DETECTION LOGIC

DTC	Trouble diagnosis name	DTC detecting condition	Possible causes
P33D6	CURRENT SENSOR	Deviation from the specified voltage characteristics of battery current sensor.	Li-ion battery controller

DTC CONFIRMATION PROCEDURE

1. PERFORM DTC CONFIRMATION PROCEDURE

④ With CONSULT

1. Power switch ON and wait for 10 seconds or more.
2. Select "Self Diagnostic Result" of "HV BAT".
3. Check DTC.

Is P33D6 detected?

- YES >> Refer to [EVB-592, "Diagnosis Procedure"](#).
 NO >> INSPECTION END

Diagnosis Procedure

INFOID:000000011104274

WARNING:

- Because hybrid vehicles and electric vehicles contain a high voltage battery, there is the risk of electric shock, electric leakage, or similar accidents if the high voltage component and vehicle are handled incorrectly. Be sure to follow the correct work procedures when performing inspection and maintenance.
- Be sure to remove the service plug in order to disconnect the high voltage circuits before performing inspection or maintenance of high voltage system harnesses and parts.
- To prevent the removed service plug from being connected by mistake during the procedure, always carry it in your pocket or put it in the tool box.
- Be sure to wear insulating protective equipment consisting of glove, shoes, face shield and glasses before beginning work on the high voltage system.
- Clearly identify the persons responsible for high voltage work and ensure that other persons do not touch the vehicle. When not working, cover high voltage parts with an insulating cover sheet or similar item to prevent other persons from contacting them.
- Refer to [EVB-469, "High Voltage Precautions"](#).

CAUTION:

There is the possibility of a malfunction occurring if the vehicle is changed to READY status while the service plug is removed. Therefore do not change the vehicle to READY status unless instructed to do so in the Service Manual.

1. PRECONDITIONING

WARNING:

Disconnect high voltage. Refer to [GI-31, "How to Disconnect High Voltage"](#).

1. Remove Li-ion battery. Refer to [EVB-626, "Removal and Installation"](#).
2. Remove battery pack upper case. Refer to [EVB-635, "BATTERY PACK UPPER CASE : Removal and Installation"](#).

>> GO TO 2.

2. CHECK CURRENT SENSOR

1. Disconnect Li-ion battery controller harness connector.
2. Check the resistance of current sensor from Li-ion battery controller side.

Li-ion battery controller		Resistance value
Connector	Terminal	

P33D6 CURRENT SENSOR

< DTC/CIRCUIT DIAGNOSIS >

[TYPE 3]

LB11	10	9	1 kΩ–10 MΩ
	9	17	

Is the inspection result normal?

YES >> Replace Li-ion battery controller. Refer to [EVB-645. "LI-ION BATTERY CONTROLLER : Removal and Installation"](#).

NO >> GO TO 3.

3. CHECK HARNESS BETWEEN LI-ION BATTERY CONTROLLER AND CURRENT SENSOR

1. Disconnect current sensor harness connector.
2. Check continuity between Li-ion battery controller and current sensor.

Li-ion battery controller		Current sensor		Continuity
Connector	Terminal	Connector	Terminal	
LB11	10	LB5	S	Existed
	9		V	
	17		G	

Is the inspection result normal?

YES >> Replace current sensor. Refer to [EVB-648. "BATTERY JUNCTION BOX AND BATTERY HARNESS : Exploded View"](#).

NO >> Repair Harness or connector.

A
B
C
D
E
F
G
H
I
J
K
L
M
N
O
P

EVB

P33D7, P33D9, P33DB, P33DD TEMPERATURE SENSOR

< DTC/CIRCUIT DIAGNOSIS >

[TYPE 3]

P33D7, P33D9, P33DB, P33DD TEMPERATURE SENSOR

DTC Logic

INFOID:000000011104275

DTC DETECTION LOGIC

DTC	Trouble diagnosis name	DTC detecting condition	Possible causes
P33D7	TEMPERATURE SENSOR	Battery temperature sensor 1 signal voltage is too high or too low.	<ul style="list-style-type: none">• Battery temperature sensor 1• Li-ion battery controller• Harness or connector
P33D9		Battery temperature sensor 2 signal voltage is too high or too low.	
P33DB		Battery temperature sensor 3 signal voltage is too high or too low.	
P33DD		Battery temperature sensor 4 signal voltage is too high or too low.	

DTC CONFIRMATION PROCEDURE

1. PERFORM DTC CONFIRMATION PROCEDURE

Ⓟ With CONSULT

1. Power switch ON and wait for 10 seconds or more.
2. Select "Self Diagnostic Result" of "HV BAT".
3. Check DTC.

Is any DTC detected?

- YES >> Refer to [EVB-594, "Diagnosis Procedure"](#).
NO >> INSPECTION END

Diagnosis Procedure

INFOID:000000011104276

WARNING:

- Because hybrid vehicles and electric vehicles contain a high voltage battery, there is the risk of electric shock, electric leakage, or similar accidents if the high voltage component and vehicle are handled incorrectly. Be sure to follow the correct work procedures when performing inspection and maintenance.
- Be sure to remove the service plug in order to disconnect the high voltage circuits before performing inspection or maintenance of high voltage system harnesses and parts.
- To prevent the removed service plug from being connected by mistake during the procedure, always carry it in your pocket or put it in the tool box.
- Be sure to wear insulating protective equipment consisting of glove, shoes, face shield and glasses before beginning work on the high voltage system.
- Clearly identify the persons responsible for high voltage work and ensure that other persons do not touch the vehicle. When not working, cover high voltage parts with an insulating cover sheet or similar item to prevent other persons from contacting them.
- Refer to [EVB-469, "High Voltage Precautions"](#).

CAUTION:

There is the possibility of a malfunction occurring if the vehicle is changed to READY status while the service plug is removed. Therefore do not change the vehicle to READY status unless instructed to do so in the Service Manual.

1. PRECONDITIONING

WARNING:

Disconnect high voltage. Refer to [GI-31, "How to Disconnect High Voltage"](#).

1. Remove Li-ion battery. Refer to [EVB-626, "Removal and Installation"](#).
2. Remove battery pack upper case. Refer to [EVB-635, "BATTERY PACK UPPER CASE : Removal and Installation"](#).

>> GO TO 2.

P33D7, P33D9, P33DB, P33DD TEMPERATURE SENSOR

< DTC/CIRCUIT DIAGNOSIS >

[TYPE 3]

2.CHECK HARNESS

1. Power switch OFF.
2. Check a connection state of harness connector of Li-ion battery controller.

Is the inspection result normal?

- YES >> GO TO 3.
NO >> Recover the connection status.

3.CHECK BATTERY TEMPERATURE SENSOR

Refer to [EVB-595. "Component Inspection"](#).

Is the inspection result normal?

- YES >> GO TO 4.
NO >> Replace battery temperature sensor.

4.CHECK HARNESS BETWEEN BATTERY TEMPERATURE SENSOR AND GROUND

1. Disconnect Li-ion battery controller harness connector.
2. Check continuity between battery temperature sensor harness connector and ground.

Battery temperature sensor	Connector	Terminal	—	Continuity
1	LB9	1	Ground	No existed
2	LB10	4		
3	LB9	3		
4	LB10	2		

Is the inspection result normal?

- YES >> Replace Li-ion battery controller. Refer to [EVB-645. "LI-ION BATTERY CONTROLLER : Removal and Installation"](#).
NO >> Repair harness or connector.

Component Inspection

INFOID:0000000011104277

1.CHECK BATTERY TEMPERATURE SENSOR

1. Remove battery temperature sensor. Refer to [EVB-665. "FRONT MODULE STACK : Disassembly and Assembly"](#) (Front module) or [EVB-680. "REAR MODULE STACK : Disassembly and Assembly"](#) (Rear module).
2. Check resistance between battery temperature sensor terminals.

Battery temperature sensor	Terminals	Condition	Resistance (kΩ)
1	1 and 5	Temperature °C (°F)	10 (50) Approx. 7.4
2	3 and 4		25 (77) Approx. 4.0
3	3 and 7		40 (104) Approx. 2.3
4	1 and 2		

Is the inspection result normal?

- YES >> INSPECTION END
NO >> Replace battery temperature sensor.

P33DF BAT VOLTAGE ISOLATION SEN

< DTC/CIRCUIT DIAGNOSIS >

[TYPE 3]

P33DF BAT VOLTAGE ISOLATION SEN

DTC Logic

INFOID:000000011104278

DTC DETECTION LOGIC

DTC	Trouble diagnosis name	DTC detecting condition	Possible causes
P33DF	BAT VOLTAGE ISOLATION SEN	Signal voltage of the on-board isolation resistance monitoring system is too high.	Li-ion battery controller

DTC CONFIRMATION PROCEDURE

1. PERFORM DTC CONFIRMATION PROCEDURE

④ With CONSULT

1. Power switch ON and wait for 10 seconds or more.
2. Select "Self Diagnostic Result" of "HV BAT".
3. Check DTC.

Is P33DF detected?

- YES >> Refer to [EVB-596, "Diagnosis Procedure"](#).
NO >> INSPECTION END

Diagnosis Procedure

INFOID:000000011104279

When this DTC is detected, replace Li-ion battery controller. Refer to [EVB-645, "LI-ION BATTERY CONTROLLER : Removal and Installation"](#).

P33E0 BAT VOLTAGE ISOLATION SEN

< DTC/CIRCUIT DIAGNOSIS >

[TYPE 3]

P33E0 BAT VOLTAGE ISOLATION SEN

DTC Logic

INFOID:0000000011104280

DTC DETECTION LOGIC

DTC	Trouble diagnosis name	DTC detecting condition	Possible causes
P33E0	BATTERY VOLTAGE ISOLATION SENSOR	Signal Voltage of the on-board isolation resistance monitoring system is too low.	Li-ion battery controller

A

B

EVB

DTC CONFIRMATION PROCEDURE

1. PERFORM DTC CONFIRMATION PROCEDURE

④ With CONSULT

1. Power switch ON and wait for 10 seconds or more.
2. Select "Self Diagnostic Result" of "HV BAT".
3. Check DTC.

Is P33E0 detected?

- YES >> Refer to [EVB-597, "Diagnosis Procedure"](#).
NO >> INSPECTION END

Diagnosis Procedure

INFOID:0000000011104281

When this DTC is detected, replace Li-ion battery controller. Refer to [EVB-645, "LI-ION BATTERY CONTROLLER : Removal and Installation"](#).

D

E

F

G

H

I

J

K

L

M

N

O

P

P33E1 BAT VOLTAGE ISOLATION SEN

< DTC/CIRCUIT DIAGNOSIS >

[TYPE 3]

P33E1 BAT VOLTAGE ISOLATION SEN

DTC Logic

INFOID:000000011104282

DTC DETECTION LOGIC

DTC	Trouble diagnosis name	DTC detecting condition	Possible causes
P33E1	BATTERY VOLTAGE ISOLATION SENSOR	Signal voltage of the on-board isolation resistance monitoring system exhibits no amplitude variation.	Li-ion battery controller

DTC CONFIRMATION PROCEDURE

1. PERFORM DTC CONFIRMATION PROCEDURE

④ With CONSULT

1. Power switch ON and wait for 10 seconds or more.
2. Select "Self Diagnostic Result" of "HV BAT".
3. Check DTC.

Is P33E1 detected?

- YES >> Refer to [EVB-598, "Diagnosis Procedure"](#).
NO >> INSPECTION END

Diagnosis Procedure

INFOID:000000011104283

When this DTC is detected, perform Li-ion battery insulation resistance loss check. Refer to [EVB-611, "Component Inspection"](#).

P33E2 BATT PACK OVER TEMP

< DTC/CIRCUIT DIAGNOSIS >

[TYPE 3]

P33E2 BATT PACK OVER TEMP

DTC Logic

INFOID:0000000011104284

DTC DETECTION LOGIC

DTC	Trouble diagnosis name	DTC detecting condition	Possible causes
P33E2	BATTERY PACK OVER TEMPERATURE	When the battery (battery pack) temperature is excessively high.	Overcharge caused by traction motor inverter/VCM malfunction

DTC CONFIRMATION PROCEDURE

1. PERFORM DTC CONFIRMATION PROCEDURE

Ⓜ With CONSULT

1. Power switch ON and wait for 10 seconds or more.
2. Select "Self Diagnostic Result" of "HV BAT".
3. Check DTC.

Is P33E2 detected?

- YES >> Refer to [EVB-599, "Diagnosis Procedure"](#).
 NO >> INSPECTION END

Diagnosis Procedure

INFOID:0000000011104285

1. PERFORM THE SELF-DIAGNOSIS OF LI-ION BATTERY CONTROLLER

Ⓜ With CONSULT

1. Select "Self Diagnostic Result" of "HV BAT".
2. Check to see if "P33E4" or "P33E5" is detected simultaneously with "P33E2".

Is P33E4 or P33E5 detected?

- YES >> Perform diagnosis on the detected "P33E4" or "P33E5". Refer to [EVB-600, "Diagnosis Procedure"](#).
 NO >> GO TO 2.

2. CHECK BATTERY TEMPERATURE SENSOR

Ⓜ With CONSULT

Using FREEZE FRAME DATA (FFD), check the values of four temperature sensors when DTC is detected.

Monitor item	Condition	Limit
Battery temperature sensor 1	Power switch ON	55°C (131°F) or less
Battery temperature sensor 2		
Battery temperature sensor 3		
Battery temperature sensor 4		

Is there temperature increase?

- Temperature increase is seen >> Replace Li-ion battery. Refer to [EVB-645, "LI-ION BATTERY CONTROLLER : Removal and Installation"](#).
 Temperature increase is not seen >> Replace battery temperature sensors. Refer to [EVB-634, "BATTERY PACK UPPER CASE : Exploded View"](#).

P33E4, P33E5 TEMPERATURE SENSOR

< DTC/CIRCUIT DIAGNOSIS >

[TYPE 3]

P33E4, P33E5 TEMPERATURE SENSOR

DTC Logic

INFOID:000000011104286

DTC DETECTION LOGIC

DTC	Trouble diagnosis name	DTC detecting condition	Possible causes
P33E4	TEMPERATURE SENSOR	Deviation in characteristics of Battery temperature sensor rear center or front RH.	Battery temperature sensor
P33E5		Deviation in characteristics of Battery temperature sensor rear RH or front LH.	

DTC CONFIRMATION PROCEDURE

1. PERFORM DTC CONFIRMATION PROCEDURE

Ⓟ With CONSULT

1. Power switch ON and wait for 10 seconds or more.
2. Select "Self Diagnostic Result" of "HV BAT".
3. Check DTC.

Is P33E4 or P33E5 DTC detected?

- YES >> Refer to [EVB-600, "Diagnosis Procedure"](#).
NO >> INSPECTION END

Diagnosis Procedure

INFOID:000000011104287

WARNING:

- Because hybrid vehicles and electric vehicles contain a high voltage battery, there is the risk of electric shock, electric leakage, or similar accidents if the high voltage component and vehicle are handled incorrectly. Be sure to follow the correct work procedures when performing inspection and maintenance.
- Be sure to remove the service plug in order to disconnect the high voltage circuits before performing inspection or maintenance of high voltage system harnesses and parts.
- To prevent the removed service plug from being connected by mistake during the procedure, always carry it in your pocket or put it in the tool box.
- Be sure to wear insulating protective equipment consisting of glove, shoes, face shield and glasses before beginning work on the high voltage system.
- Clearly identify the persons responsible for high voltage work and ensure that other persons do not touch the vehicle. When not working, cover high voltage parts with an insulating cover sheet or similar item to prevent other persons from contacting them.
- Refer to [EVB-469, "High Voltage Precautions"](#).

CAUTION:

There is the possibility of a malfunction occurring if the vehicle is changed to READY status while the service plug is removed. Therefore do not change the vehicle to READY status unless instructed to do so in the Service Manual.

1. PRECONDITIONING

WARNING:

Disconnect high voltage. Refer to [GI-31, "How to Disconnect High Voltage"](#).

1. Remove Li-ion battery. Refer to [EVB-626, "Removal and Installation"](#).
2. Remove battery pack upper case. Refer to [EVB-645, "LI-ION BATTERY CONTROLLER : Removal and Installation"](#).

>> GO TO 2.

2. CHECK BATTERY TEMPERATURE SENSOR

Refer to [EVB-601, "Component Inspection"](#).

Is the inspection result normal?

- YES >> Replace both battery temperature sensor.

P33E4, P33E5 TEMPERATURE SENSOR

[TYPE 3]

< DTC/CIRCUIT DIAGNOSIS >

NO >> Replace malfunction battery temperature sensor.

Component Inspection

INFOID:0000000011104288

1. CHECK BATTERY TEMPERATURE SENSOR

1. Remove battery temperature sensor. Refer to [EVB-665, "FRONT MODULE STACK : Disassembly and Assembly"](#) (Front module) or [EVB-680, "REAR MODULE STACK : Disassembly and Assembly"](#) (Rear module).
2. Check resistance between battery temperature sensor terminals.

Battery temperature sensor	Terminals	Condition	Resistance (kΩ)	
1	1 and 5	Temperature °C (°F)	Approx. 7.4	
2	3 and 4			10 (50)
3	3 and 7		25 (77)	Approx. 4.0
4	1 and 2		40 (104)	Approx. 2.3

Is the inspection result normal?

YES >> INSPECTION END

NO >> Replace battery temperature sensor.

A
B
EVB
D
E
F
G
H
I
J
K
L
M
N
O
P

P33E6 CELL VOLTAGE DEVIATION DIAG

< DTC/CIRCUIT DIAGNOSIS >

[TYPE 3]

P33E6 CELL VOLTAGE DEVIATION DIAG

DTC Logic

INFOID:000000011104289

DTC DETECTION LOGIC

DTC	Trouble diagnosis name	DTC detecting condition	Possible causes
P33E6	CELL VOLTAGE DEVIATION DIAG	With the power switch ON and no load condition, the difference between the maximum voltage and minimum voltage exceeds the allowable range.	<ul style="list-style-type: none">Li-ion battery controllerModule

DTC CONFIRMATION PROCEDURE

1. PERFORM DTC CONFIRMATION PROCEDURE

④ With CONSULT

- Turn power switch ON and wait for 10 seconds or more.
- Select "Self Diagnostic Result" of "HV BAT".
- Check DTC.

Is P33E6 detected?

- YES >> Refer to [EVB-602, "Diagnosis Procedure"](#).
NO >> INSPECTION END

Diagnosis Procedure

INFOID:000000011104290

WARNING:

- Because hybrid vehicles and electric vehicles contain a high voltage battery, there is the risk of electric shock, electric leakage, or similar accidents if the high voltage component and vehicle are handled incorrectly. Be sure to follow the correct work procedures when performing inspection and maintenance.
- Be sure to remove the service plug in order to disconnect the high voltage circuits before performing inspection or maintenance of high voltage system harnesses and parts.
- To prevent the removed service plug from being connected by mistake during the procedure, always carry it in your pocket or put it in the tool box.
- Be sure to wear insulating protective equipment before beginning work on the high voltage system.
- Clearly identify the persons responsible for high voltage work and ensure that other persons do not touch the vehicle. When not working, cover high voltage parts with an insulating cover sheet or similar item to prevent other persons from contacting them.
- Refer to [EVB-469, "High Voltage Precautions"](#).

CAUTION:

There is the possibility of a malfunction occurring if the vehicle is changed to READY status while the service plug is removed. Therefore do not change the vehicle to READY status unless instructed to do so in the Service Manual.

1. CHECK SELF-DIAGNOSIS RESULTS OF LI-ION BATTERY CONTROLLER

④ With CONSULT

- Select "Self Diagnostic Result" of "HV BAT".
- Check to see if "P0A1F", "P3062" or "P33ED" is detected simultaneously with "P33E6".

Is P0A1F, P3062 or P33ED detected?

- YES-1 >> When "P0A1F" or "P3062" are detected simultaneously, Replace Li-ion battery controller. Refer to [EVB-626, "Removal and Installation"](#).
YES-2 >> When "P33ED" is detected simultaneously, perform the diagnosis procedure of "P33ED". Refer to [EVB-608, "Diagnosis Procedure"](#).
NO >> GO TO 2.

2. CHECK FREEZE FRAME DATA (FFD)

④ With CONSULT

- Check "FFD" when DTC is detected.
- Calculate the average value of cell voltage by dividing "TOTAL BATTERY VOLTAGE" by 96 (the number of cells).

P33E6 CELL VOLTAGE DEVIATION DIAG

< DTC/CIRCUIT DIAGNOSIS >

[TYPE 3]

Average cell voltage = "TOTAL BETTER VOLTAGE" ÷ 96 (the number of cells)

3. Identify the minimum cell voltage and the maximum cell voltage from 96 cells.
4. Calculate voltage according to the following expressions to compare voltage between A and B.

A = Maximum cell voltage – Average cell voltage

B = Average cell voltage – Minimum cell voltage

Which voltage is larger, A or B?

- A >> Replace module including a cell of the maximum cell voltage. Refer to [EVB-657, "FRONT MODULE STACK : Exploded View"](#) (Front module stack) or [EVB-671, "REAR MODULE STACK : Exploded View"](#) (Rear module stack). After replacing module, GO TO 3.
- B >> Replace module including a cell of the minimum cell voltage. Refer to [EVB-657, "FRONT MODULE STACK : Exploded View"](#) (Front module stack) or [EVB-671, "REAR MODULE STACK : Exploded View"](#) (Rear module stack). After replacing module, GO TO 3.

3.PERFORM CELL VOLTAGE LOSS INSPECTION

 With CONSULT

1. Select "WORK SUPPORT" of "HV BAT."
2. Select "CELL VOLTAGE LOSS INSPECTION." Touch "START."
3. Check "MINIMUM CELL VOLTAGE."

Is "MINIMUM CELL VOLTAGE" 3,712 mV or less?

- YES >> GO TO 5.
NO >> GO TO 4.

4.DISCHARGE OF LI-ION BATTERY

 With CONSULT

1. Set the vehicle to READY.
2. Set the vehicle, according to the following conditions.

A/C set temperature	: Full hot
A/C fan speed	: Maximum speed
A/C air outlet	:  Defroster
Headlamp	: High beam ON
Door glass	: Full open

3. Check "DATA MONITOR" and let the Li-ion battery discharge until the "MINIMUM CELL VOLTAGE" reaches 3,712 mV or less.

NOTE:

The guide line is to discharge until the Li-ion battery available charge gauge indicates 2 segments or less. For discharge time, refer to the following table.

Guideline for discharge time

The number of lighting segments of Li-ion battery available charge gauge	Time to 2 segments
12	Approx. 230 minute
11	Approx. 200 minute
10	Approx. 180 minute
9	Approx. 160 minute
8	Approx. 130 minute
7	Approx. 110 minute
6	Approx. 90 minute
5	Approx. 70 minute

P33E6 CELL VOLTAGE DEVIATION DIAG

[TYPE 3]

< DTC/CIRCUIT DIAGNOSIS >

The number of lighting segments of Li-ion battery available charge gauge	Time to 2 segments
4	Approx. 40 minute
3	Approx. 20 minute

>> GO TO 5.

5. CHECK CELL OF VOLTAGE LOSS

④ With CONSULT

1. Check that "MINIMUM CELL VOLTAGE" is 3,712 mV or less. Touch "START."
2. Check to see if a cell of which voltage is less than or equal to "CELL VOLTAGE LOSS JUDGMENT VALUE" is displayed.

Is a cell displayed?

YES >> Record applicable cell No. and then GO TO 6.

NO >> Check the minimum cell voltage on the data monitor and replace a module which includes the minimum cell voltage. Refer to [EVB-657, "FRONT MODULE STACK : Exploded View"](#) (Front module stack) or [EVB-671, "REAR MODULE STACK : Exploded View"](#) (Rear module stack).

6. PRECONDITIONING

WARNING:

Disconnect high voltage circuit. Refer to [GI-31, "How to Disconnect High Voltage"](#).

1. Remove Li-ion battery. Refer to [EVB-626, "Removal and Installation"](#).
2. Remove battery pack upper case. Refer to [EVB-635, "BATTERY PACK UPPER CASE : Removal and Installation"](#).

>> GO TO 7.

7. CHECK CONDENSATION

Check condensation in battery pack.

Is the inspection result normal?

YES >> GO TO 8.

NO >> Replace Li-ion battery. Refer to [EVB-626, "Removal and Installation"](#).

8. CHECK CONNECTORS AND FIXING BOLTS

Check connection state, damage and dust of following;

- Li-ion battery controller (LBC) harness connector
- Module harness connector
- Module terminal fixing bolt

Is the inspection result normal?

YES >> GO TO 9

NO >> Repair or replace error-detected parts.

9. CHECK MODULE VOLTAGE

Check module voltage within determined cell at step 5 and check the divergence of the voltage and cell voltage with "DATA MONITOR".

DANGER:

When check module voltage, be careful not to short.

Is Divergence within 40mV?

YES-1 >> When the determined cell at step 5 is in front module stack.: GO TO 10.

YES-2 >> When the determined cell at step 5 is in rear module stack.: GO TO 12.

NO >> Replace Li-ion battery controller. Refer to [EVB-645, "LI-ION BATTERY CONTROLLER : Removal and Installation"](#).

10. CHECK HARNESS BETWEEN LI-ION BATTERY CONTROLLER AND MODULE HARNESS CONNECTOR

P33E6 CELL VOLTAGE DEVIATION DIAG

[TYPE 3]

< DTC/CIRCUIT DIAGNOSIS >

1. Disconnect Li-ion battery controller harness connector and module harness connector.
2. Check the resistance Li-ion battery controller harness connector and module harness connector of the determined cell at step 5.

Terminal		Resistance value
Li-ion battery controller harness connector	Module harness connector	Approx. 0 Ω

3. Check the divergence of the resistance and the resistance of other cell harness.

Is the inspection result normal?

- YES >> GO TO 11
 NO >> Repair or replace harness or connectors.

11. CHECK HARNESS BETWEEN MODULE HARNESS CONNECTOR AND BUS BAR

1. Check the resistance module harness connector (A) and bus bar (B) of the determined cell at step 5.

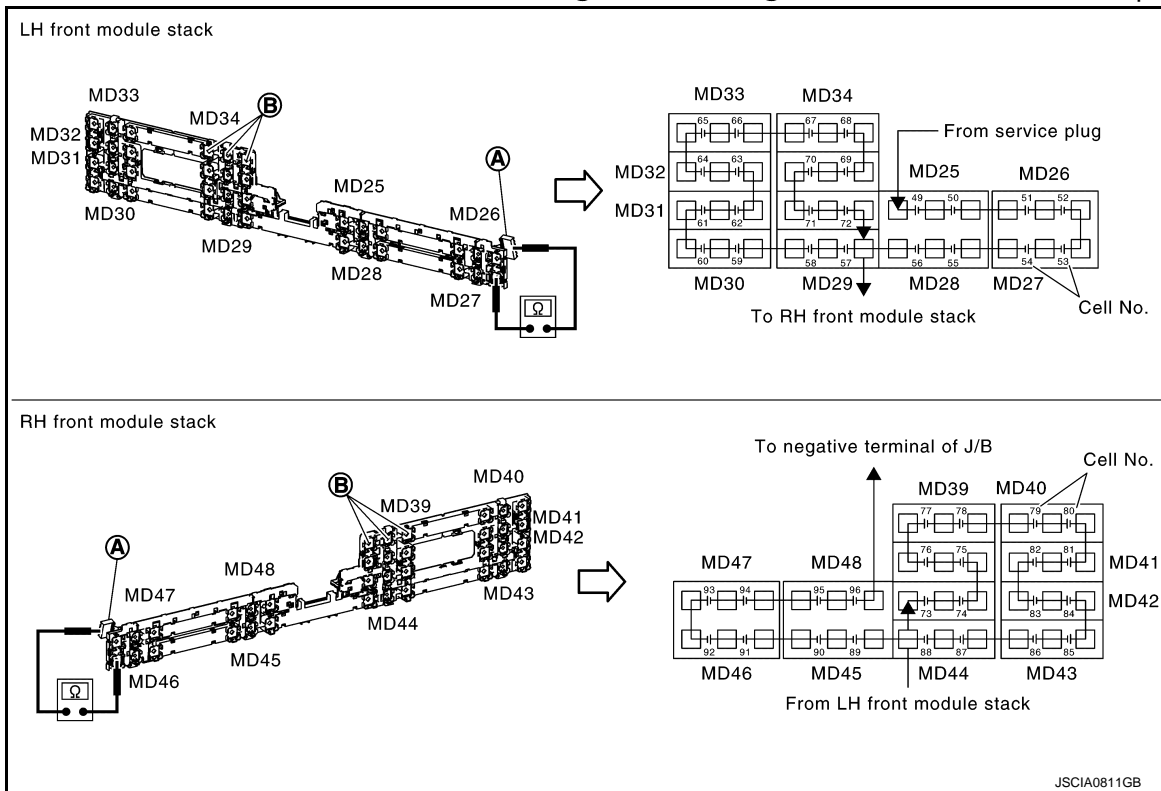

Terminal		Resistance value
Module harness connector	Bus bar	Approx. 0 Ω

2. Check the divergence of the resistance and the resistance of other cell harness.

Is the inspection result normal?

- YES >> Replace module within the determined cell at step 5.
 NO >> Repair or replace harness or connectors.

12. CHECK HARNESS BETWEEN LI-ION BATTERY CONTROLLER AND BUS BAR

P33E6 CELL VOLTAGE DEVIATION DIAG

[TYPE 3]

< DTC/CIRCUIT DIAGNOSIS >

1. Check the resistance Li-ion battery controller harness connector (A) and bus bar (B) of the determined cell at step 5.

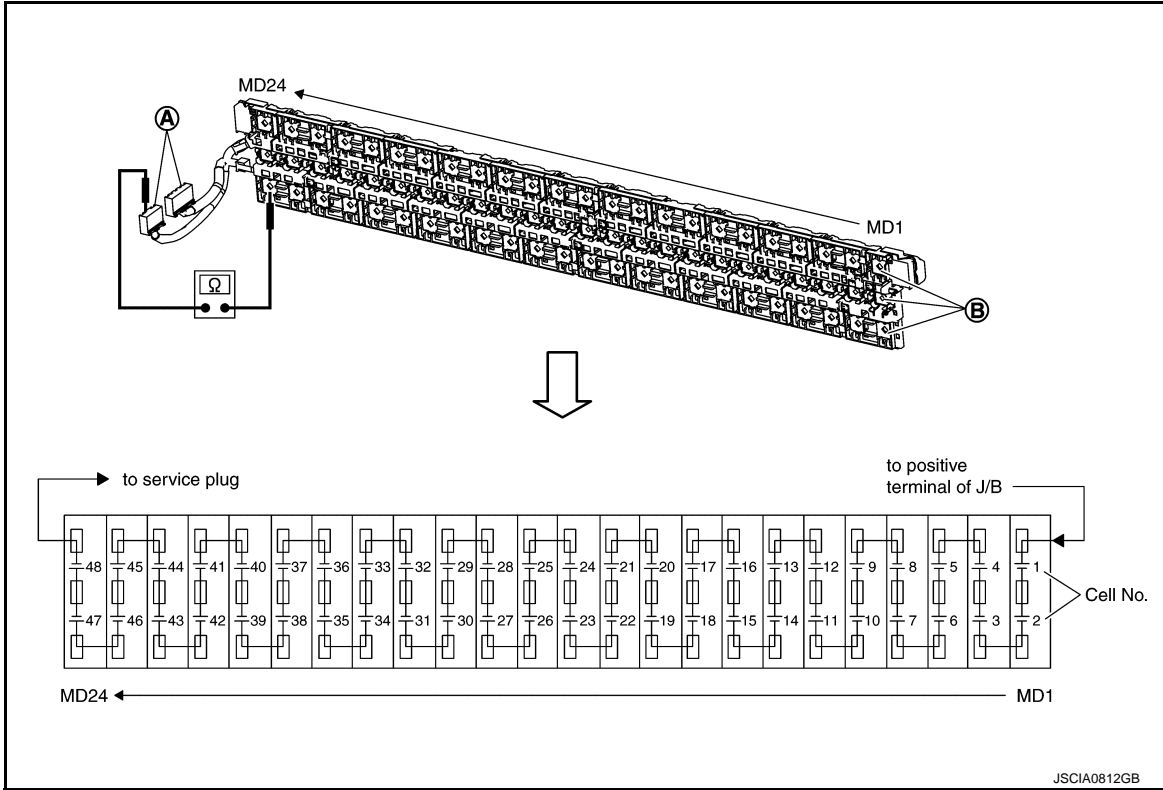

Terminal		Resistance value
Li-ion battery controller harness connector	Bus bar	Approx. 0 Ω

2. Check the divergence of the resistance and the resistance of other cell harness.

Is the inspection result normal?

- YES >> Replace module within the determined cell at step 5.
- NO >> Repair or replace harness or connectors.

P33E7 CELL CONTROLLER

< DTC/CIRCUIT DIAGNOSIS >

[TYPE 3]

P33E7 CELL CONTROLLER

DTC Logic

INFOID:0000000011104291

DTC DETECTION LOGIC

DTC	Trouble diagnosis name	DTC detecting condition	Possible causes
P33E7	CELL CONTROLLER	The A/D converter in Li-ion battery controller is malfunctioning.	Li-ion battery controller

EVB

DTC CONFIRMATION PROCEDURE

1. PERFORM DTC CONFIRMATION PROCEDURE

④ With CONSULT

1. Power switch ON and wait for 10 seconds or more.
2. Select "Self Diagnostic Result" of "HV BAT".
3. Check DTC.

Is P33E7 detected?

- YES >> Refer to [EVB-607, "Diagnosis Procedure"](#).
NO >> INSPECTION END

Diagnosis Procedure

INFOID:0000000011104292

When this DTC is detected, replace Li-ion battery controller. Refer to [EVB-645, "LI-ION BATTERY CONTROLLER : Removal and Installation"](#).

A
B
D
E
F
G
H
I
J
K
L
M
N
O
P

P33ED BATTERY PARALLEL DIAGNOSIS

< DTC/CIRCUIT DIAGNOSIS >

[TYPE 3]

P33ED BATTERY PARALLEL DIAGNOSIS

DTC Logic

INFOID:000000011104293

DTC DETECTION LOGIC

DTC	Trouble diagnosis name	DTC detecting condition	Possible causes
P33ED	BATTERY PARALLEL DIAGNOSIS	When a sudden voltage fluctuation is detected in module.	Module

DTC CONFIRMATION PROCEDURE

1. CHECK LI-ION BATTERY AVAILABLE CHARGE GAUGE

Check the indication of the Li-ion battery available charge gauge.

NOTE:

Check 12 segments for lighting status.

Is the lighting status 1 Segment or none?

YES >> GO TO 3.

NO >> GO TO 2.

2. DISCHARGE OF LI-ION BATTERY

1. Set the vehicle to READY.
2. Set the vehicle, according to the following conditions.

A/C set temperature	: Full hot
A/C fan speed	: Maximum speed
A/C air outlet	:  Defroster
Headlamp	: High beam ON
Door glass	: Full open

3. Let the Li-ion battery discharge until the Li-ion battery available charge gauge shows segment 1 or below.

>> GO TO 3.

3. CHARGE OF LI-ION BATTERY

1. Charge the Li-ion battery by normal charge until the level reaches full charge.
2. After the completion of normal charge, check that the indication of the Li-ion battery available charge gauge shows 12 segments.

>> GO TO 4.

4. PERFORM DTC CONFIRMATION PROCEDURE

Ⓟ With CONSULT

1. Power switch ON and wait for 10 seconds or more.
2. Select "Self Diagnostic Result" of "HV BAT".
3. Check DTC.

Is P33ED detected?

YES >> Refer to [EVB-608, "Diagnosis Procedure"](#).

NO >> INSPECTION END

Diagnosis Procedure

INFOID:000000011104294

1. CHECK DATA MONITOR OR FREEZE FRAME DATA (FFD)

Ⓟ With CONSULT

1. Select "DATA MONITOR" or "FFD".
2. Check to see if there is a cell voltage which largely differ from the others.

Is there any abnormal cell?

P33ED BATTERY PARALLEL DIAGNOSIS

[TYPE 3]

< DTC/CIRCUIT DIAGNOSIS >

- YES >> Replace corresponding Module. Refer to [EVB-657, "FRONT MODULE STACK : Exploded View"](#).
NO >> GO TO 2.

A

2. DTC CONFIRMATION PROCEDURE OPERATION

1. If abnormal cell is not identified, perform DTC confirmation procedure. Refer to [EVB-608, "DTC Logic"](#).
2. Check cell voltage again using "DATA MONITOR" or "FFD" to identify malfunctioning cell.

B

>> Replace corresponding Module. Refer to [EVB-657, "FRONT MODULE STACK : Exploded View"](#).

EVB

D

E

F

G

H

I

J

K

L

M

N

O

P

U1000 CAN COMM CIRCUIT

< DTC/CIRCUIT DIAGNOSIS >

[TYPE 3]

U1000 CAN COMM CIRCUIT

Description

INFOID:000000011104295

CAN (Controller Area Network) is a serial communication line for real time applications. It is an on-vehicle multiplex communication line with high data communication speed and excellent error detection ability. Modern vehicle is equipped with many electronic control units, and each control unit shares information and links with other control units during operation (not independent). In CAN communication, control units are connected with 2 communication lines (CAN-H, CAN-L) allowing a high rate of information transmission with less wiring. Each control unit transmits/receives data but selectively reads the required data only.

CAN communication signal chart. Refer to [LAN-33, "CAN COMMUNICATION SYSTEM : CAN Communication Signal Chart"](#).

DTC Logic

INFOID:000000011104296

DTC DETECTION LOGIC

DTC	Trouble diagnosis name	DTC detecting condition	Possible causes
U1000	CAN COMM CIRCUIT	When no CAN communication signal is received continuously for 2 seconds or more.	CAN communication system

Diagnosis Procedure

INFOID:000000011104297

For the diagnosis procedure, refer to [LAN-15, "Trouble Diagnosis Flow Chart"](#).

LI-ION BATTERY INSULATION RESISTANCE LOSS CHECK

< DTC/CIRCUIT DIAGNOSIS >

[TYPE 3]

LI-ION BATTERY INSULATION RESISTANCE LOSS CHECK

Component Inspection

INFOID:000000011104298

WARNING:

- Because hybrid vehicles and electric vehicles contain a high voltage battery, there is the risk of electric shock, electric leakage, or similar accidents if the high voltage component and vehicle are handled incorrectly. Be sure to follow the correct work procedures when performing inspection and maintenance.
- Be sure to remove the service plug in order to disconnect the high voltage circuits before performing inspection or maintenance of high voltage system harnesses and parts.
- To prevent the removed service plug from being connected by mistake during the procedure, always carry it in your pocket or put it in the tool box.
- Be sure to wear insulating protective equipment consisting of glove, shoes, face shield and glasses before beginning work on the high voltage system.
- Clearly identify the persons responsible for high voltage work and ensure that other persons do not touch the vehicle. When not working, cover high voltage parts with an insulating cover sheet or similar item to prevent other persons from contacting them.
- Refer to [EV B-469, "High Voltage Precautions"](#).

CAUTION:

There is the possibility of a malfunction occurring if the vehicle is changed to READY status while the service plug is removed. Therefore do not change the vehicle to READY status unless instructed to do so in the Service Manual.

The following diagnosis procedure must be performed when "P0AA6 or P33E1" are detected and Li-ion battery is judged that its insulation resistance is dropping.

1. CHECK MAXIMUM CELL VOLTAGE

Ⓜ With CONSULT

1. Power switch ON.
2. Select "DATA MONITOR" of "HV BAT".
3. Record "MAXIMUM CELL VOLTAGE".

NOTE:

It is used, when replace a malfunction module.

>> GO TO 2

2. CHECK INSULATION OF FRONT MODULE STACK LH-1

CAUTION:

Check that high voltage harness and harness shield have no scratches and cracks. If any damage is found, replace damaged parts.

1. Remove Li-ion battery. Refer to [EV B-626, "Removal and Installation"](#).
2. Remove Li-ion battery controller. Refer to [EV B-645, "LI-ION BATTERY CONTROLLER : Removal and Installation"](#).
3. Remove bus bar that connects front module stack LH and front module stack RH.
4. Measure voltages between positive terminal Ⓐ of front module stack LH and battery pack ground, and between positive terminal Ⓑ of front module stack LH and battery pack ground.

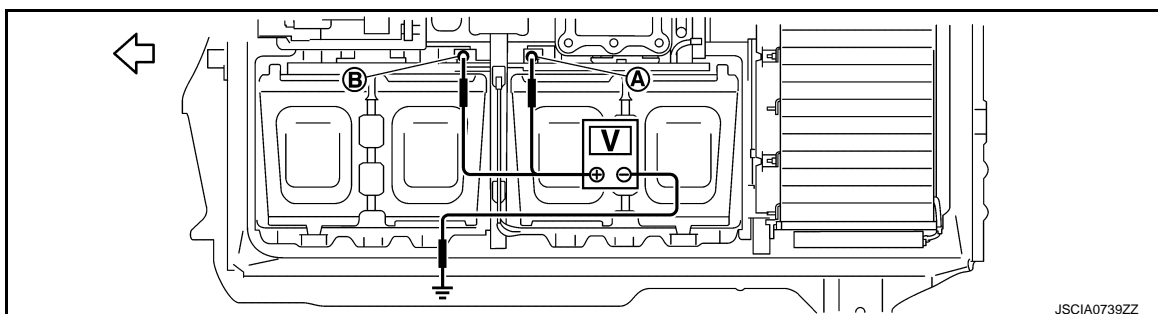

← : Battery pack front

LI-ION BATTERY INSULATION RESISTANCE LOSS CHECK

< DTC/CIRCUIT DIAGNOSIS >

[TYPE 3]

+	-	Voltage
Front module stack LH		
Terminal		
Ⓐ, Ⓑ	Battery pack ground	Approx. 0 V

Is the inspection result normal?

YES >> GO TO 8.

NO >> GO TO 3.

3. CHECK INSULATION OF FRONT MODULE STACK LH-2

1. Disconnect vehicle communication harness connector of front module stack LH.
2. Measure voltages between positive terminal Ⓐ of front module stack LH and battery pack ground, and between positive terminal Ⓑ of front module stack LH and battery pack ground.

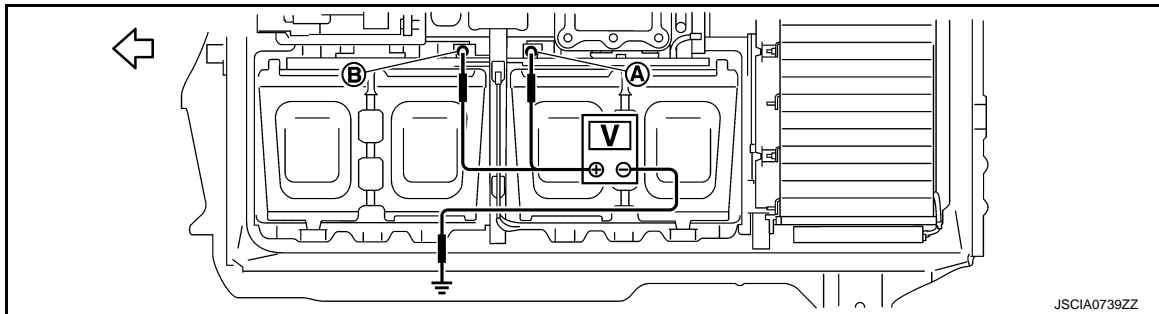

↖ : Battery pack front

+	-	Voltage
Front module stack LH		
Terminal		
Ⓐ, Ⓑ	Battery pack ground	Approx. 0 V

Is the inspection result normal?

YES >> Replace vehicle communication harness of front module stack LH and GO TO 8.

NO >> GO TO 4.

4. CHECK INSULATION OF FRONT MODULE STACK LH-3

1. Remove bus bar that connects service plug and front module stack LH.
2. Measure voltages between positive terminal Ⓐ of front module stack LH and battery pack ground, and between positive terminal Ⓑ of front module stack LH and battery pack ground.

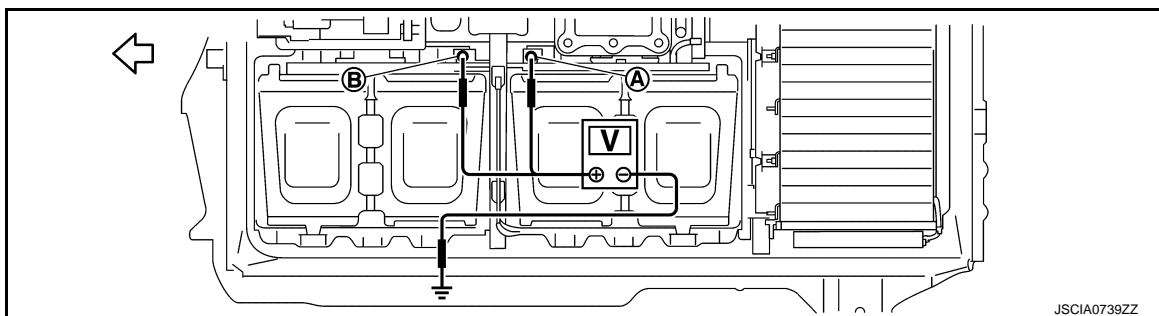

↖ : Battery pack front

LI-ION BATTERY INSULATION RESISTANCE LOSS CHECK

< DTC/CIRCUIT DIAGNOSIS >

[TYPE 3]

+	-	Voltage
Front module stack LH		
Terminal		
Ⓐ, Ⓑ	Battery pack ground	Approx. 0 V

Is the inspection result normal?

- YES >> GO TO 5.
- NO >> GO TO 6.

5. CHECK SERVICE PLUG SWITCH INSULATION RESISTANCE

1. Remove bus bar that connects service plug and front module stack LH from service plug switch bracket.
2. Using insulation resistance tester, measure insulation resistance between service plug switch terminal and service plug switch bracket.

WARNING:

Unlike the ordinary tester, the insulation resistance tester applies 500 V when measuring. If used incorrectly, there is the danger of electric shock. If used in the vehicle 12V system, there is the danger of damage to electronic devices. Read the insulation resistance tester instruction manual carefully and be sure to work safely.

CAUTION:

Be sure to set the insulation resistance tester to 500 V when performing this test. Using a setting higher than 500 V can result in damage to the component being inspected.

NOTE:

Check resistance without disassembling service plug switch and service plug switch bracket.

+	-	Resistance
Service plug switch terminal	Service plug switch bracket	1000 MΩ or more

Is the inspection result normal?

- YES >> Replace bus bar that connects service plug and front module stack LH and GO TO 8.
- NO >> Replace service plug switch (Refer to [EVB-648, "BATTERY JUNCTION BOX AND BATTERY HARNESS : Exploded View"](#).) and GO TO 8.

6. CHECK MODULE-1

1. Remove front module stack LH. Refer to [EVB-660, "FRONT MODULE STACK : Removal and Installation"](#).

NOTE:

Do not disassemble module stack.

2. Measure voltages between terminal Ⓐ/Ⓑ of all modules in front module stack LH and module body.

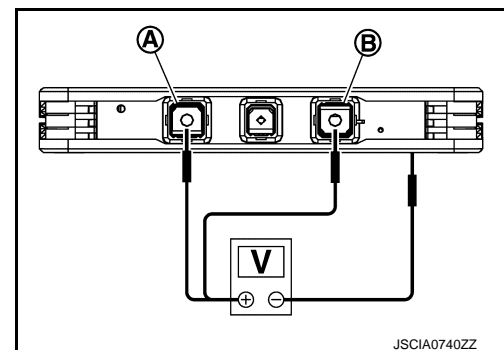

+	-	Voltage
Module		
Terminal		
Ⓐ	Module body	Approx. 0 V
Ⓑ		

LI-ION BATTERY INSULATION RESISTANCE LOSS CHECK

[TYPE 3]

< DTC/CIRCUIT DIAGNOSIS >

Is the inspection result normal?

YES >> GO TO 7.

NO >> Replace malfunctioning module (Refer to [EVB-665. "FRONT MODULE STACK : Disassembly and Assembly".](#)) and GO TO 8.

7. CHECK MODULE-2

Measure insulation resistance between terminal (A)/(B) of all modules in front module stack LH and module body.

WARNING:

Unlike the ordinary tester, the insulation resistance tester applies 500 V when measuring. If used incorrectly, there is the danger of electric shock. If used in the vehicle 12V system, there is the danger of damage to electronic devices. Read the insulation resistance tester instruction manual carefully and be sure to work safely.

CAUTION:

Be sure to set the insulation resistance tester to 500 V when performing this test. Using a setting higher than 500 V can result in damage to the component being inspected.

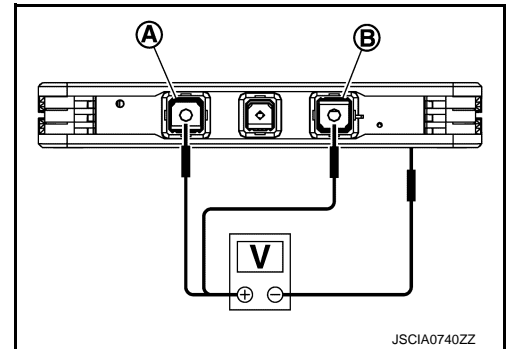

JSCIA0740ZZ

+	-	resistance
Module		
Terminal	Module body	100 MΩ or more
(A)		
(B)		

Is the inspection result normal?

YES >> Check insulation resistance of front module stack RH, because front module stack LH is normal. GO TO 8.

NO >> Replace malfunctioning module (Refer to [EVB-665. "FRONT MODULE STACK : Disassembly and Assembly".](#)) and GO TO 8.

8. CHECK INSULATION OF FRONT MODULE STACK RH-1

1. Measure voltages between positive terminal (A) of front module stack RH and battery pack ground, and between positive terminal (B) of front module stack LH and battery pack ground.

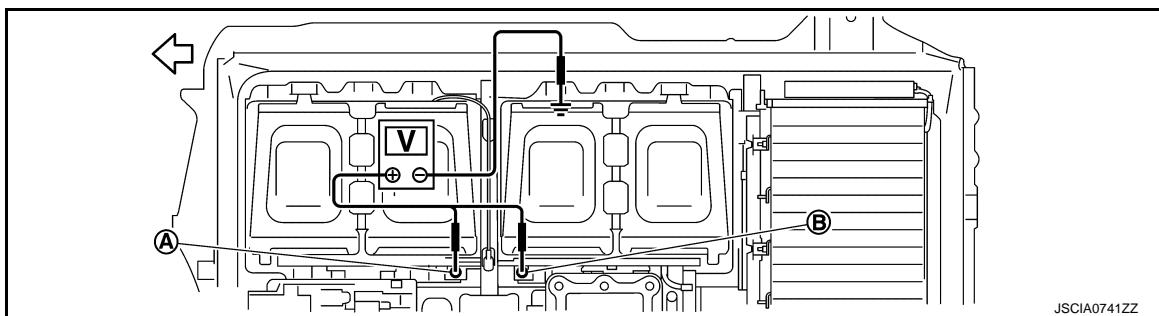

JSCIA0741ZZ

↶ : Battery pack front

+	-	Voltage
Front module stack RH		
Terminal		
(A), (B)	Battery pack ground	Approx. 0 V

Is the inspection result normal?

YES >> GO TO 14.

LI-ION BATTERY INSULATION RESISTANCE LOSS CHECK

[TYPE 3]

< DTC/CIRCUIT DIAGNOSIS >

NO >> GO TO 9.

9. CHECK INSULATION OF FRONT MODULE STACK RH-2

1. Disconnect vehicle communication harness connector of front module stack RH.
2. Measure voltages between positive terminal (A) of front module stack RH and battery pack ground, and between positive terminal (B) of front module stack RH and battery pack ground.

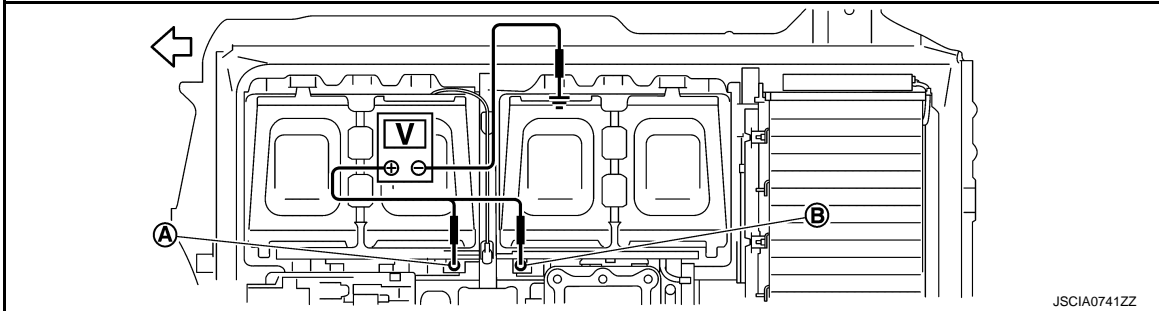

← : Battery pack front

+		
Front module stack RH	-	Voltage
Terminal		
(A), (B)	Battery pack ground	Approx. 0 V

Is the inspection result normal?

- YES >> Replace vehicle communication harness of front module stack RH and GO TO 14.
 NO >> GO TO 10.

10. CHECK INSULATION OF FRONT MODULE STACK RH-3

1. Remove bus bar that connects front module stack RH and battery junction box.
2. Measure voltages between positive terminal (A) of front module stack RH and battery pack ground, and between positive terminal (B) of front module stack RH and battery pack ground.

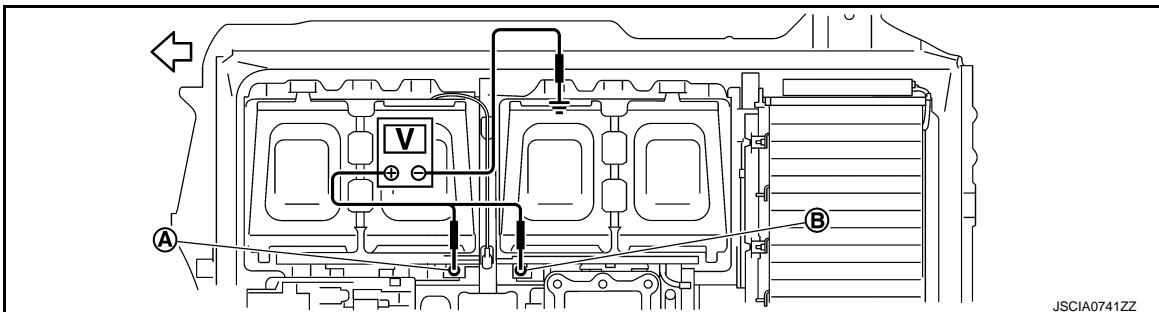

← : Battery pack front

+		
Front module stack RH	-	Voltage
Terminal		
(A), (B)	Battery pack ground	Approx. 0 V

Is the inspection result normal?

- YES >> GO TO 11.
 NO >> GO TO 12.

A
B
EVB
D
E
F
G
H
I
J
K
L
M
N
O
P

LI-ION BATTERY INSULATION RESISTANCE LOSS CHECK

< DTC/CIRCUIT DIAGNOSIS >

[TYPE 3]

11. CHECK BATTERY JUNCTION BOX INSULATION RESISTANCE

- Using insulation resistance tester, measure insulation resistance between high voltage terminal (A)/(B) of battery junction box and battery pack ground.

← : Battery pack front

WARNING:

Unlike the ordinary tester, the insulation resistance tester applies 500 V when measuring. If used incorrectly, there is the danger of electric shock. If used in the vehicle 12V system, there is the danger of damage to electronic devices. Read the insulation resistance tester instruction manual carefully and be sure to work safely.

CAUTION:

Be sure to set the insulation resistance tester to 500 V when performing this test. Using a setting higher than 500 V can result in damage to the component being inspected.

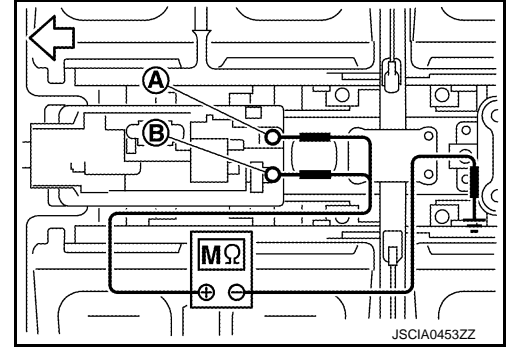

Battery junction box	—	Resistance
Terminal		
(A)	Battery pack ground	1000 MΩ or more
(B)		

Is the inspection result normal?

- YES >> Replace bus bar that connects front module stack RH and battery junction box and GO TO 14.
 NO >> Replace battery junction box (Refer to [EVB-650, "BATTERY JUNCTION BOX AND BATTERY HARNESS : Disassembly and Assembly"](#)) and GO TO 14.

12. CHECK MODULE-3

- Remove front module stack RH. Refer to [EVB-660, "FRONT MODULE STACK : Removal and Installation"](#).

NOTE:

Do not disassemble module stack.

- Measure voltages between terminal (A)/(B) of all modules in front module stack RH and module body.

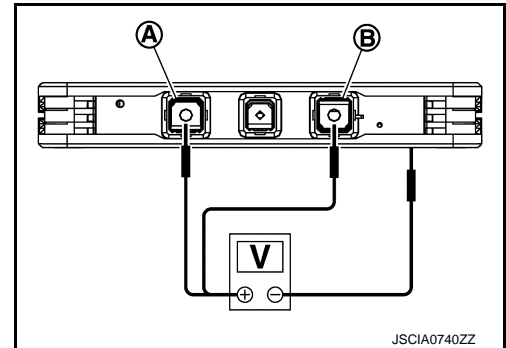

+	—	Voltage
Module		
Terminal		
(A)	Module body	Approx. 0 V
(B)		

Is the inspection result normal?

- YES >> GO TO 13.
 NO >> Replace malfunctioning module (Refer to [EVB-665, "FRONT MODULE STACK : Disassembly and Assembly"](#).) and GO TO 14.

LI-ION BATTERY INSULATION RESISTANCE LOSS CHECK

< DTC/CIRCUIT DIAGNOSIS >

[TYPE 3]

13.CHECK MODULE-4

Measure insulation resistance between terminal (A)/(B) of all modules in front module stack RH and module body.

WARNING:

Unlike the ordinary tester, the insulation resistance tester applies 500 V when measuring. If used incorrectly, there is the danger of electric shock. If used in the vehicle 12V system, there is the danger of damage to electronic devices. Read the insulation resistance tester instruction manual carefully and be sure to work safely.

CAUTION:

Be sure to set the insulation resistance tester to 500 V when performing this test. Using a setting higher than 500 V can result in damage to the component being inspected.

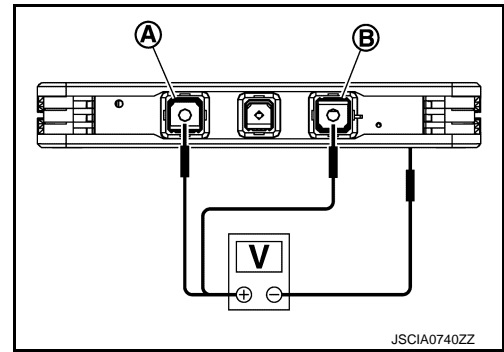

+	-	resistance
Module Terminal		
(A)	Module body	100 MΩ or more
(B)		

Is the inspection result normal?

- YES >> Check insulation resistance of front module stack RH, because front module stack LH is normal. GO TO 14.
- NO >> Replace malfunctioning module (Refer to [EVB-665, "FRONT MODULE STACK : Disassembly and Assembly"](#).) and GO TO 14.

14.CHECK INSULATION OF REAR MODULE STACK-1

1. Measure voltages between positive terminal (A) of rear module stack and battery pack ground, and between positive terminal (B) of rear module stack and battery pack ground.

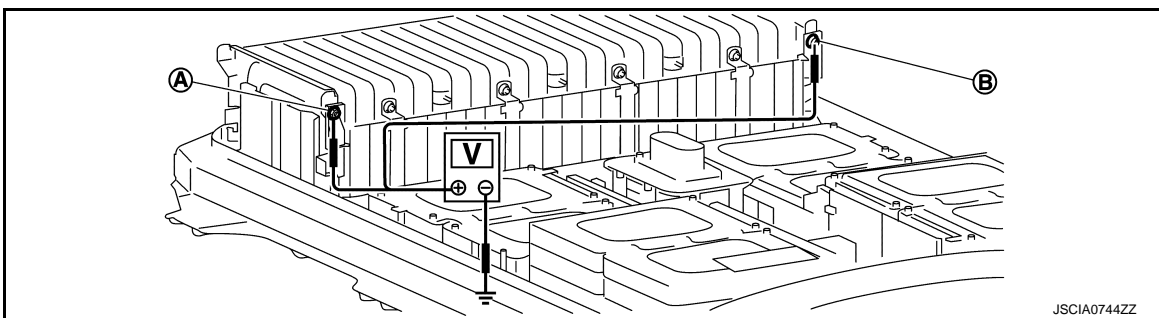

+	-	Voltage
Rear module stack Terminal		
(A), (B)	Battery pack ground	Approx. 0 V

Is the inspection result normal?

- YES-1 >> Replace or repair of malfunctioning part is not-yet performed: Replace Li-ion battery controller. Refer to [EVB-645, "LI-ION BATTERY CONTROLLER : Removal and Installation"](#).
- YES-2 >> Replace or repair of malfunctioning part is complete: INSPECTION END.
- NO >> GO TO 15.

15.CHECK INSULATION OF REAR MODULE STACK-2

LI-ION BATTERY INSULATION RESISTANCE LOSS CHECK

< DTC/CIRCUIT DIAGNOSIS >

[TYPE 3]

1. Disconnect vehicle communication harness connector (A) of rear module stack.

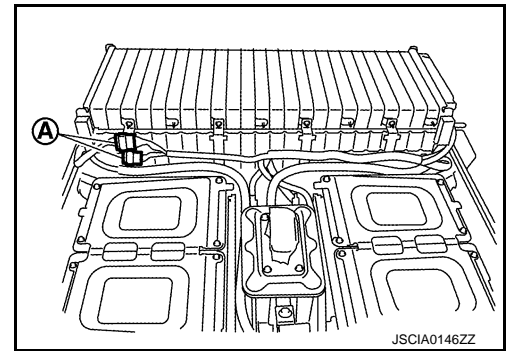

2. Measure voltages between positive terminal (A) of rear module stack and battery pack ground, and between positive terminal (B) of rear module stack and battery pack ground.

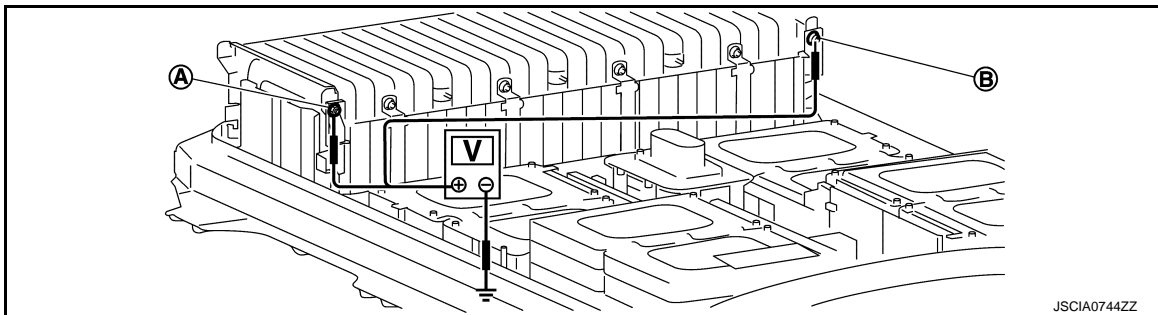

+		
Front module stack RH	-	Voltage
Terminal		
(A), (B)	Battery pack ground	Approx. 0 V

Is the inspection result normal?

- YES >> Replace vehicle communication harness of rear module stack.
 NO >> GO TO 16.

16. CHECK INSULATION OF FRONT MODULE STACK RH-3

1. Remove mounting nuts (A)/(B) and remove high voltage harness from rear module stack.

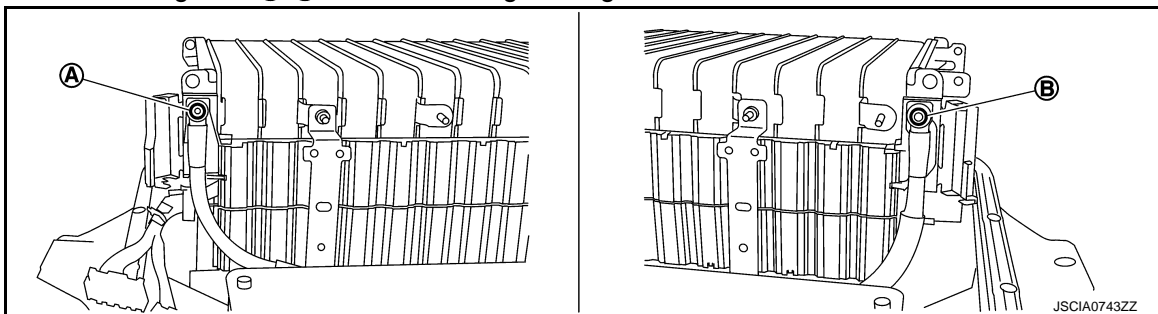

2. Measure voltages between positive terminal (A) of rear module stack and battery pack ground, and between positive terminal (B) of rear module stack and battery pack ground.

LI-ION BATTERY INSULATION RESISTANCE LOSS CHECK

< DTC/CIRCUIT DIAGNOSIS >

[TYPE 3]

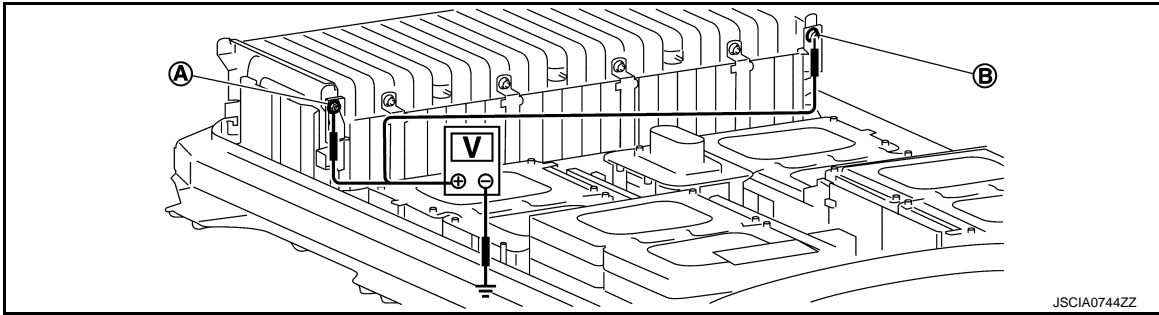

+	-	Voltage
Rear module stack		
Terminal		
(A), (B)	Battery pack ground	Approx. 0 V

Is the inspection result normal?

- YES >> .Replace high voltage harness.
- NO >> GO TO 17.

17.CHECK MODULE-5

1. Remove rear module stack. Refer to [EV6-680, "REAR MODULE STACK : Disassembly and Assembly"](#).

NOTE:

Do not disassemble module stack.

2. Measure voltages between terminal (A)/(B) of all modules in rear module stack and module body.

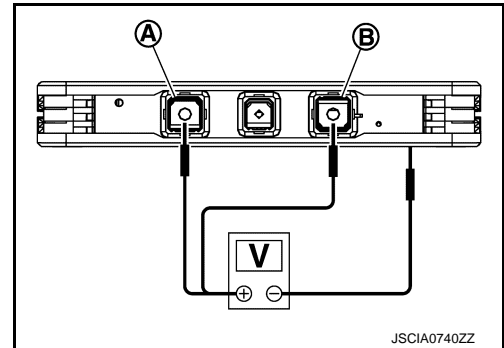

+	-	Voltage
Module		
Terminal		
(A)	Module body	Approx. 0 V
(B)		

Is the inspection result normal?

- YES >> GO TO 18.
- NO >> Replace malfunctioning module. Refer to [EV6-680, "REAR MODULE STACK : Disassembly and Assembly"](#).

18.CHECK MODULE-6

A
B
EVB
D
E
F
G
H
I
J
K
L
M
N
O
P

LI-ION BATTERY INSULATION RESISTANCE LOSS CHECK

[TYPE 3]

< DTC/CIRCUIT DIAGNOSIS >

Measure insulation resistance between terminal (A)/(B) of all modules in rear module stack and module body.

WARNING:

Unlike the ordinary tester, the insulation resistance tester applies 500 V when measuring. If used incorrectly, there is the danger of electric shock. If used in the vehicle 12V system, there is the danger of damage to electronic devices. Read the insulation resistance tester instruction manual carefully and be sure to work safely.

CAUTION:

Be sure to set the insulation resistance tester to 500 V when performing this test. Using a setting higher than 500 V can result in damage to the component being inspected.

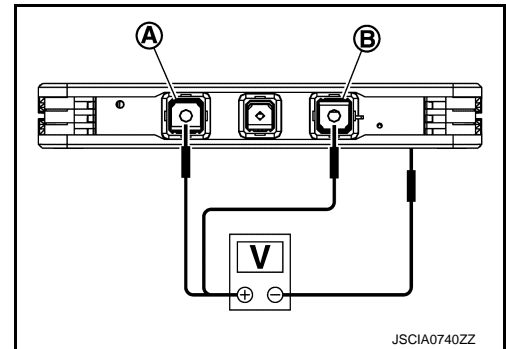

+	-	resistance
Module		
Terminal		
(A)	Module body	100 MΩ or more
(B)		

Is the inspection result normal?

- YES-1 >> Replace or repair of malfunctioning part is not-yet performed: Replace Li-ion battery controller. Refer to [EVB-645, "LI-ION BATTERY CONTROLLER : Removal and Installation"](#).
- YES-2 >> Replace or repair of malfunctioning part is complete: INSPECTION END.
- NO >> Replace malfunctioning module. Refer to [EVB-680, "REAR MODULE STACK : Disassembly and Assembly"](#).

POWER SUPPLY AND GROUND CIRCUIT

< DTC/CIRCUIT DIAGNOSIS >

[TYPE 3]

POWER SUPPLY AND GROUND CIRCUIT

Diagnosis Procedure

INFOID:0000000011104299

WARNING:

- Because hybrid vehicles and electric vehicles contain a high voltage battery, there is the risk of electric shock, electric leakage, or similar accidents if the high voltage component and vehicle are handled incorrectly. Be sure to follow the correct work procedures when performing inspection and maintenance.
- Be sure to remove the service plug in order to shut off the high voltage circuits before performing inspection or maintenance of high voltage system harnesses and parts.
- Be sure to put the removed service plug in your pocket and carry it with you so that another person does not accidentally connect it while work is in progress.
- Be sure to wear insulating protective gear consisting of glove, shoes and face shield before beginning work on the high voltage system.
- Clearly identify the persons responsible for high voltage work and ensure that other persons do not touch the vehicle. When not working, cover high voltage parts with an insulating cover sheet or similar item to prevent other persons from contacting them.
- Refer to [EVB-469, "High Voltage Precautions"](#).

CAUTION:

There is the possibility of a malfunction occurring if the vehicle is changed to READY status while the service plug is removed. Therefore do not change the vehicle to READY status unless instructed to do so in the Service Manual.

1. CHECK FUSE

Check that the following fuse is not fusing.

Power supply	Fuse No.
Battery	43
Power switch ON	55
	74

Is the fuse fusing?

YES >> Replace the fuse after repairing the applicable circuit.

NO >> GO TO 2.

2. CHECK LI-ION BATTERY CONTROLLER GROUND CIRCUIT

1. Turn power switch OFF.
2. Disconnect Li-ion battery vehicle communication harness connector.
3. Check the continuity between Li-ion battery vehicle communication harness connector and ground.

+		-	Continuity
Li-ion battery			
Connector	Terminal	Ground	Existed
B24	6		
	7		
	8		

Is the inspection result normal?

YES >> GO TO 3.

NO >> Repair or replace error-detected parts.

3. CHECK BATTERY POWER SUPPLY

Check the voltage between Li-ion battery vehicle communication harness connector and ground.

POWER SUPPLY AND GROUND CIRCUIT

[TYPE 3]

< DTC/CIRCUIT DIAGNOSIS >

+		-	Voltage
Li-ion battery			
Connector	Terminal		
B24	5	Ground	12V battery power supply

Is the inspection result normal?

YES >> GO TO 5.

NO >> GO TO 4.

4.CHECK BATTERY POWER SUPPLY CIRCUIT

1. Check the continuity between Li-ion battery vehicle communication harness connector and fuse terminal.

+		-	Continuity
Li-ion battery			
Connector	Terminal		
B24	5	No.43 fuse terminal	Existed

2. Also check harness for short to ground.

Is the inspection result normal?

YES >> Check power supply circuit for battery power supply.

NO >> Repair or replace error-detected parts.

5.CHECK IGNITION POWER SUPPLY

1. Turn power switch ON.
2. Check the voltage between Li-ion battery vehicle communication harness and ground.

+		-	Voltage (Approx.)
Li-ion battery			
Connector	Terminal		
B24	4	Ground	11 – 14 V
	21		

Is the inspection result normal?

YES >> GO TO 8.

NO >> GO TO 6.

6.CHECK IGNITION POWER SUPPLY CIRCUIT-1

1. Turn power switch OFF.
2. Disconnect IPDM E/R harness connector.
3. Check the continuity between Li-ion battery vehicle communication harness and IPDM E/R harness connector.

Li-ion battery		IPDM E/R		Continuity
Connector	Terminal	Connector	Terminal	
B24	4	E15	57	Existed

4. Also check harness for short to ground.

Is the inspection result normal?

YES >> GO TO 7.

NO >> Repair or replace error-detected parts.

7.CHECK IGNITION POWER SUPPLY CIRCUIT-2

1. Check the continuity between Li-ion battery vehicle communication harness and fuse terminal.

POWER SUPPLY AND GROUND CIRCUIT

< DTC/CIRCUIT DIAGNOSIS >

[TYPE 3]

Li-ion battery		—	Continuity
Connector	Terminal		
B24	21	No.74 fuse terminal	Existed

2. Also check harness for short to ground.

Is the inspection result normal?

YES >> Check power supply circuit for battery power supply.

NO >> Repair or replace error-detected parts.

8. PRECONDITIONING

WARNING:

Shut off high voltage circuit. Refer to [GI-31, "How to Disconnect High Voltage"](#).

1. Remove Li-ion battery. Refer to [EV6-626, "Removal and Installation"](#).

2. Remove battery pack upper case. Refer to [EV6-635, "BATTERY PACK UPPER CASE : Removal and Installation"](#).

>> GO TO 9.

9. CHECK HARNESS BETWEEN LI-ION BATTERY AND LI-ION BATTERY CONTROLLER

1. Check the continuity between Li-ion battery vehicle communication harness connector and Li-ion battery controller harness connector.

LBC		Li-ion battery		Continuity
Connector	Terminal	Connector	Terminal	
LB11	5	LB1	21	Existed
	6		4	
	21		5	
	3		8	
	15		7	
	16		6	

2. Also check harness for short to ground.

Is the inspection result normal?

YES >> INSPECTION END

NO >> Repair or replace error-detected parts.

REDUCTION IN THE DRIVING RANGE

[TYPE 3]

< SYMPTOM DIAGNOSIS >

SYMPTOM DIAGNOSIS

REDUCTION IN THE DRIVING RANGE

Description

INFOID:0000000011104300

- The driving range is shorter than before.
- Sudden change (decrease/increase) in possible travel distance indicated on the combination meter.

Diagnosis Procedure

INFOID:0000000011104301

1. CHECK LI-ION BATTERY AVAILABLE CHARGE GAUGE

Check the indication of the Li-ion battery available charge gauge.

NOTE:

Check 12 segments for lighting status.

Is the lighting status 1 Segment or none?

YES >> GO TO 3.

NO >> GO TO 2.

2. DISCHARGE OF LI-ION BATTERY

1. Set the vehicle to READY.
2. Set the vehicle, according to the following conditions.

A/C set temperature	: Full hot
A/C fan speed	: Maximum speed
A/C air outlet	:  Defroster
Headlamp	: High beam ON
Door glass	: Full open

3. Let the Li-ion battery discharge until the Li-ion battery available charge gauge shows Segment 1 or below.

>> GO TO 3.

3. CHARGE OF LI-ION BATTERY

1. Charge the Li-ion battery by normal charge until the level reaches full charge.
2. After the completion of normal charge, check that the indication of the Li-ion battery available charge gauge shows 12 segments.

>> GO TO 4.

4. PERFORM DTC CONFIRMATION PROCEDURE

 With CONSULT

1. Power switch ON and wait for 10 seconds or more.
2. Select "Self Diagnostic Result" of "HV BAT".
3. Check DTC.

Is any DTC detected?

YES >> Perform diagnosis on the detected DTC. Refer to [EVB-502. "DTC Index"](#).

NO >> INSPECTION END

EV BATTERY USAGE REPORT

< PERIODIC MAINTENANCE >

[TYPE 3]

PERIODIC MAINTENANCE

EV BATTERY USAGE REPORT

Inspection

INFOID:000000011104302

Generation of the EV battery usage report is one of the maintenance items.

This maintenance item generates a report that will help the customer understand the vehicle operating conditions needed to keep the Li-ion battery in the best possible condition.

For details about how to generate this report, please refer to EV battery usage report in the CONSULT III plus operation manual.

A

B

EVB

D

E

F

G

H

I

J

K

L

M

N

O

P

LI-ION BATTERY

< UNIT REMOVAL AND INSTALLATION >

[TYPE 3]

UNIT REMOVAL AND INSTALLATION

LI-ION BATTERY

Exploded View

INFOID:000000011192167

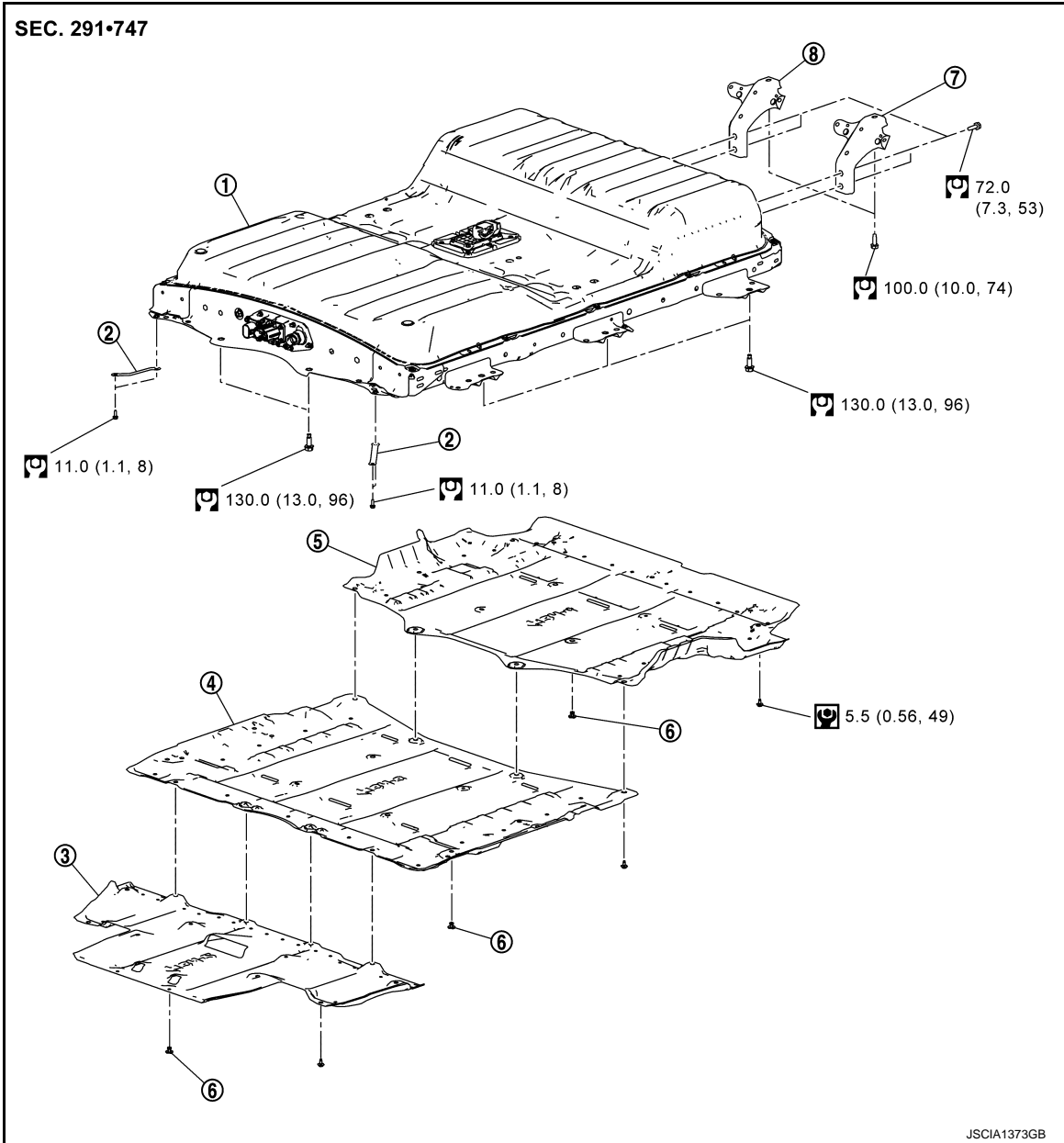

- ① Li-ion battery
- ② Bonding plate (stamped No. 4.)
- ③ Li-ion battery undercover (front)
- ④ Li-ion battery undercover (center)
- ⑤ Li-ion battery undercover (rear)
- ⑥ Clip
- ⑦ Battery mounting bracket (left)
- ⑧ Battery mounting bracket (right)

 : N·m (kg·m ft·lb)

 : N·m (kg·m, in·lb)

Removal and Installation

INFOID:000000011192168

DANGER:

LI-ION BATTERY

< UNIT REMOVAL AND INSTALLATION >

[TYPE 3]

 Because hybrid vehicles and electric vehicles contain a high voltage battery, there is a risk of electric shock, electric leakage, or similar accidents if the vehicle is handled incorrectly. Be sure to follow the correct work procedures when performing inspection and maintenance.

WARNING:

- Be sure to remove the service plug in order to shut off the high voltage circuits before performing inspection or maintenance of high voltage system harnesses and parts.
- Be sure to put the removed service plug in pocket and carry it or store it in a tool box or other container so that another person does not accidentally connect it while work is in progress.
- Be sure to put on insulating protective gear before beginning work on the high voltage system.
- Clearly identify the persons responsible for high voltage work and ensure that other persons do not touch the vehicle. When not working, cover high voltage components with an anti-static cover sheet or similar item to prevent contact with other persons.
- Refer to [EVB-469, "High Voltage Precautions"](#).

CAUTION:

There is the possibility of a malfunction occurring if the vehicle is changed to READY status while the service plug is removed. Therefore do not change the vehicle to READY status unless instructed to do so in the Service Manual.

REMOVAL

WARNING:

Prepare for work on the high-voltage system. Refer to [GI-31, "How to Disconnect High Voltage"](#).

1. Lift up the vehicle and remove the Li-ion battery undercover. Refer to [EVB-626, "Exploded View"](#).
2. Remove the harness clamp (A) and disconnect the Li-ion battery high-voltage harness connector (B).

DANGER:

-  There is the danger of electric shock caused by contact with the terminals. Be sure to wear insulated protective gear.



-  Because there is the danger of electric shock, immediately insulate disconnected high voltage connectors and terminals with insulating tape.

- Follow the procedure below to disconnect the high-voltage harness connector.

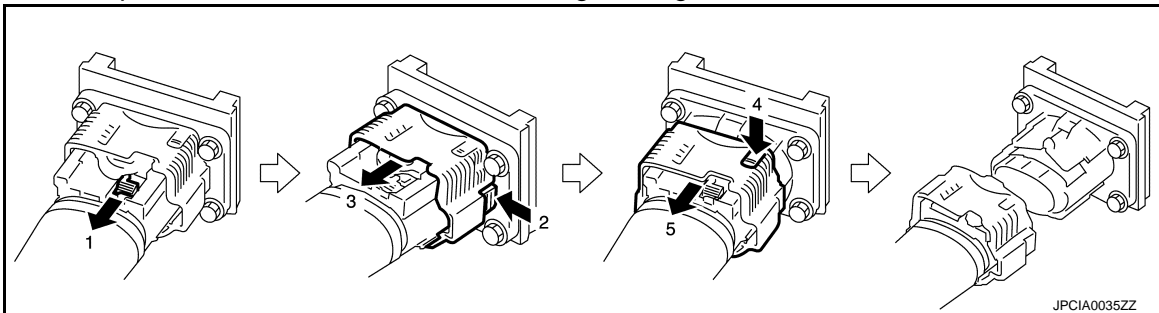

3. Disconnect the Li-ion battery vehicle communications connector (A) while rotating it in the counterclockwise direction.

WARNING:

-  To prevent electric shock, wear insulated protective gear.

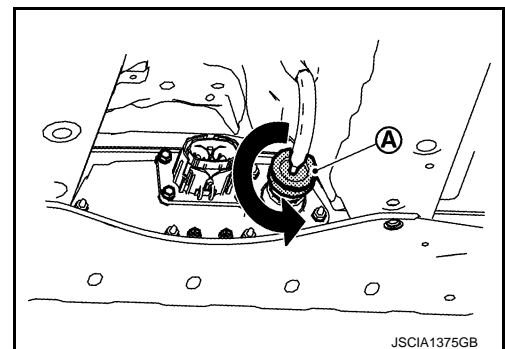
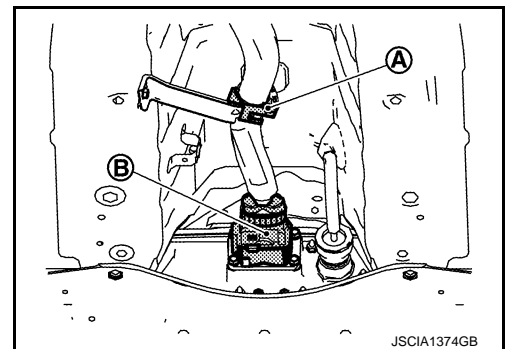

LI-ION BATTERY

< UNIT REMOVAL AND INSTALLATION >

[TYPE 3]

4. Remove bonding plate ①.

WARNING:



To prevent electric shock, wear insulated protective gear.

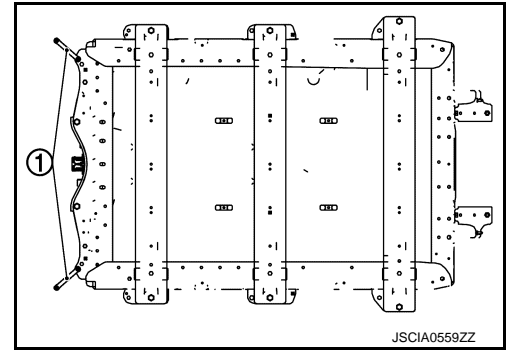

5. Remove Li-ion battery mounting bolts ①.

WARNING:



To prevent electric shock, wear insulated protective gear.



CAUTION:

Do not remove the 4 bolts shown by ② in the figure.

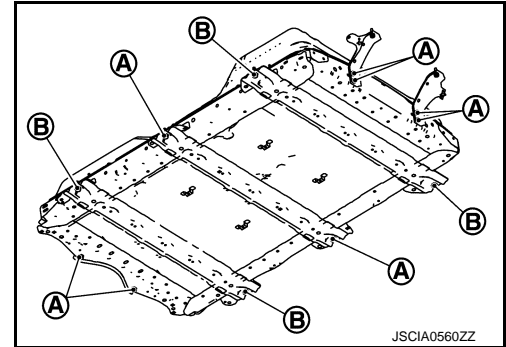

6. Set the pallet [SST: — (J-50583)] onto the lift table.
- Align the pallet ① center mark ① and the lift table ② center mark ②.

- ③ Front
- ④ Side

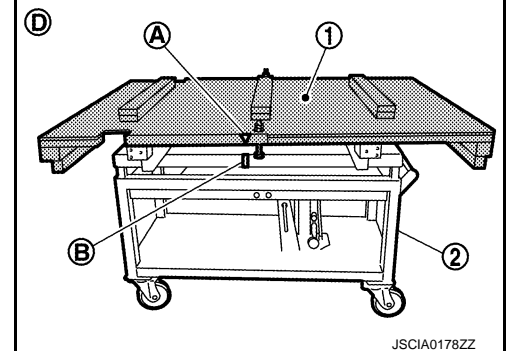
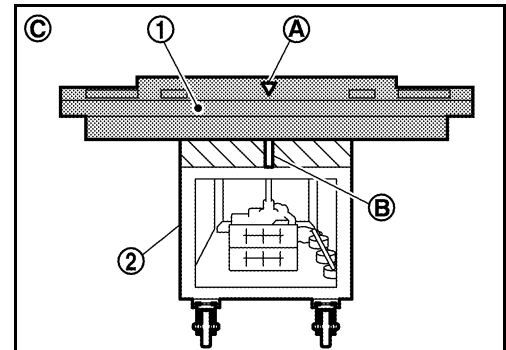

7. Set the pallet ① onto the Li-ion battery.

CAUTION:

For preventing the battery from falling, fasten the pallet and battery with transport fastening bolts.

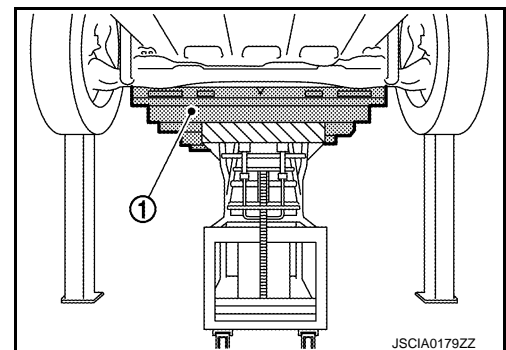

LI-ION BATTERY

< UNIT REMOVAL AND INSTALLATION >

[TYPE 3]

8. Remove the Li-ion battery mounting bolts (4 bolts) (A).

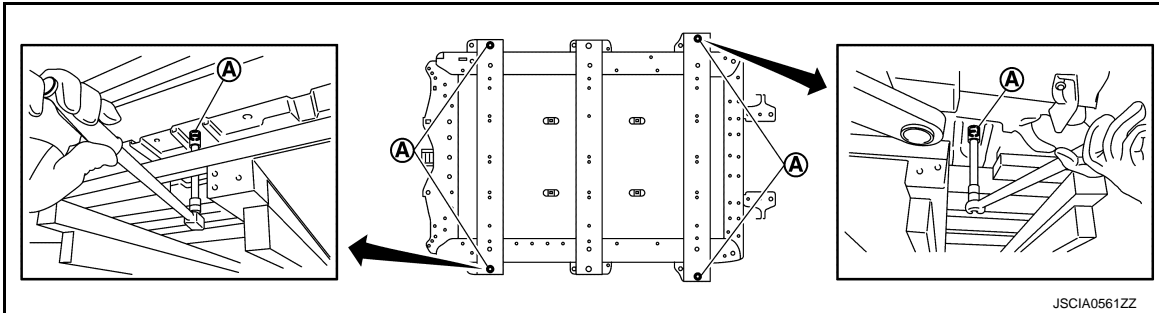

WARNING:

 To prevent electric shock, wear insulated protective gear.



9. Lower the pallet, and remove the Li-ion battery (1) from the vehicle.

WARNING:

 To prevent electric shock, wear insulated protective gear.

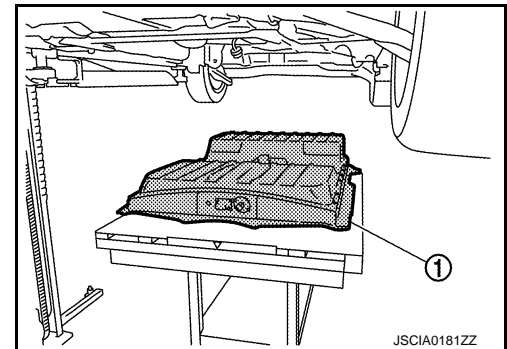

10. Lower the Li-ion battery from the lift table together with the pallet.

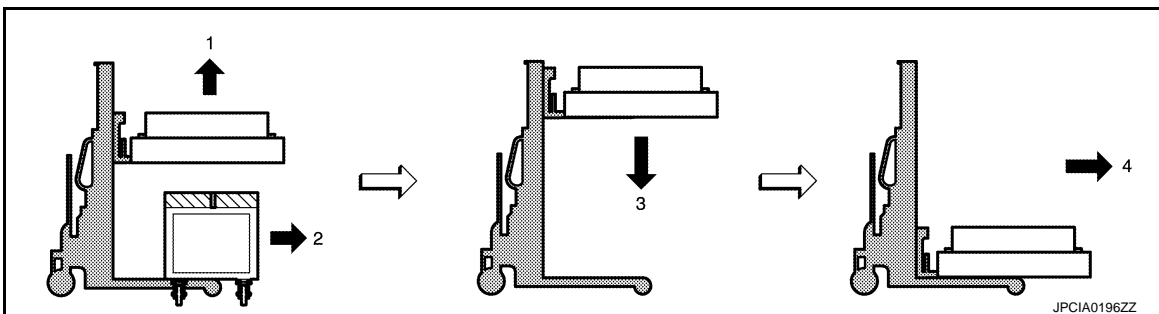

1. Lift up the Li-ion battery.
2. Move the lift table.
3. Lower the Li-ion battery.
4. Operate the stacker and move the Li-ion battery.

CAUTION:

Because there is the danger of tipping over, do not move the stacker while the Li-ion battery is lifted up.

INSTALLATION

1. When replacing the Li-ion battery with a new battery, perform the work listed below.
 - a. Enter the date of the (replacement) work on the EV battery tracking identification seal that is packaged together with the new part.
 - b. Cut the EV battery tracking identification seal into 2 pieces and apply them to the body of the replaced (old) Li-ion battery and to the "Li-ion battery replacement history record".
 - c. Enter the necessary information in the "Li-ion battery replacement history record".

A
B
EVB
D
E
F
G
H
I
J
K
L
M
N
O
P

LI-ION BATTERY

< UNIT REMOVAL AND INSTALLATION >

[TYPE 3]

2. Install the locating pin ① [SST: KV99111300 (J-50306)] in the position on the body as shown in the figure.

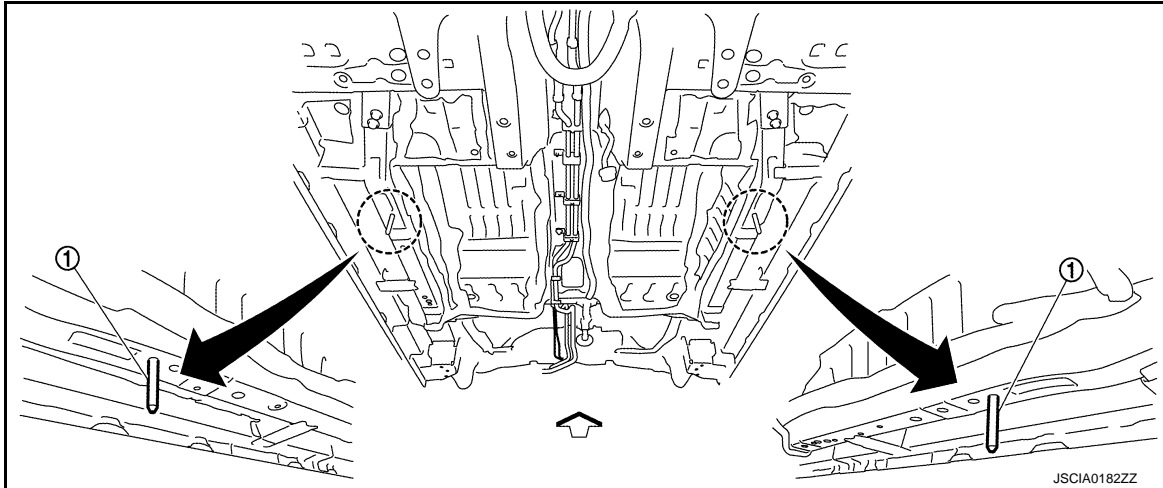

← : Vehicle front

3. Install the Li-ion battery onto the vehicle body.
 - Align the Li-ion battery ① and the locating pin ②.

WARNING:



To prevent electric shock, wear insulated protective gear.

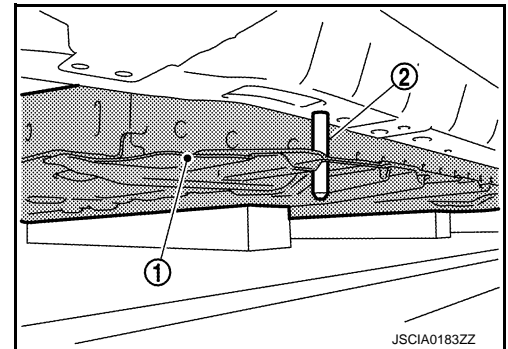

4. Tighten the Li-ion battery mounting bolts (4 bolts) ①, then remove the pallet.

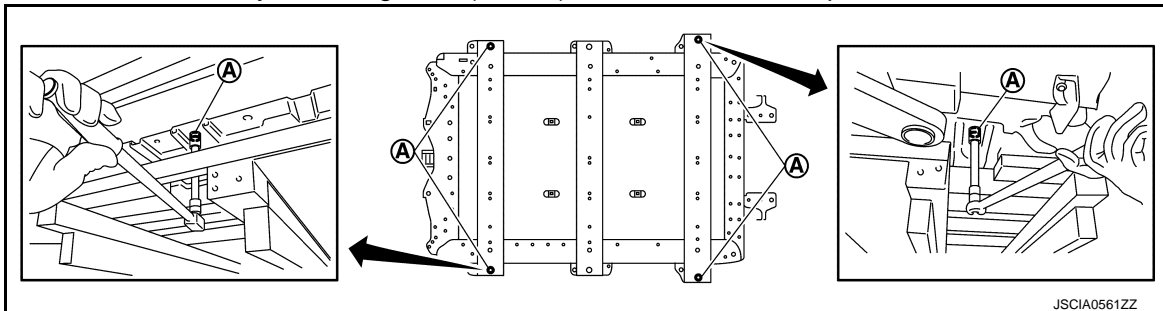

WARNING:



To prevent electric shock, wear insulated protective gear.



5. Remove the locating pin from the body.

LI-ION BATTERY

< UNIT REMOVAL AND INSTALLATION >

[TYPE 3]

- If the locating pin ① is stuck and cannot be removed, remove it using a wrench.

WARNING:



To prevent electric shock, wear insulated protective gear.

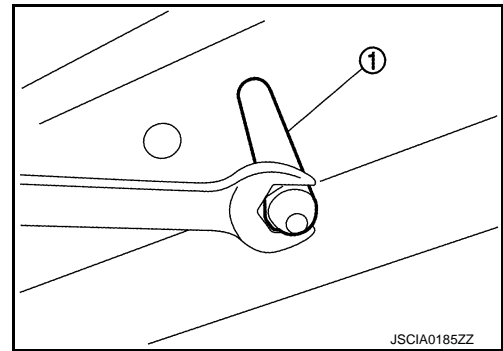

6. Install the Li-ion battery mounting bolts ①.

WARNING:



To prevent electric shock, wear insulated protective gear.

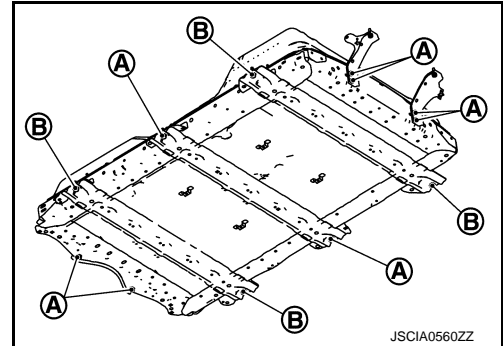

7. Install the bonding plate ①.

WARNING:



To prevent electric shock, wear insulated protective gear.

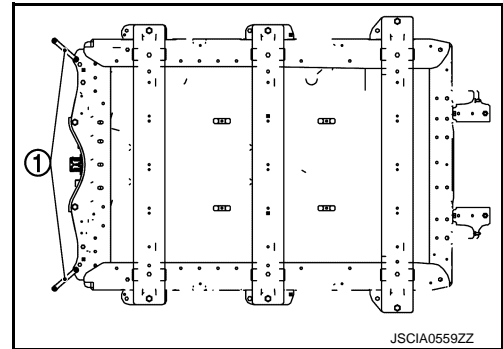

8. After installing the bonding plate, perform an electric equipotential test. [EV6-632, "Inspection"](#).

9. Rotate the vehicle communications connector ① clockwise to connect it.

WARNING:



To prevent electric shock, wear insulated protective gear.

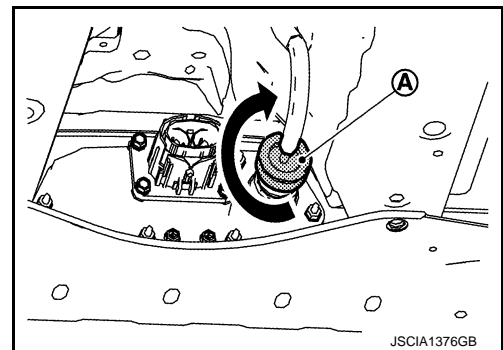

A
B
EVB
D
E
F
G
H
I
J
K
L
M
N
O
P

LI-ION BATTERY

< UNIT REMOVAL AND INSTALLATION >

[TYPE 3]

10. Install the high-voltage harness connector (B) and install the harness clamp (A).

WARNING:



To prevent electric shock, wear insulated protective gear.

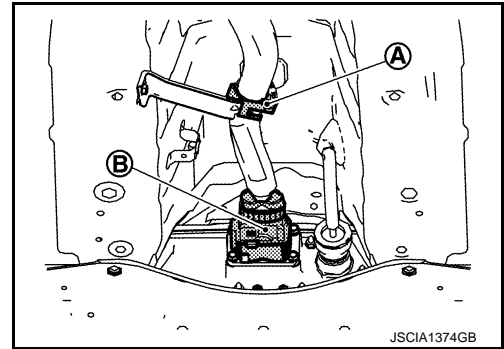

- Connect the high-voltage harness connector by the following procedure.

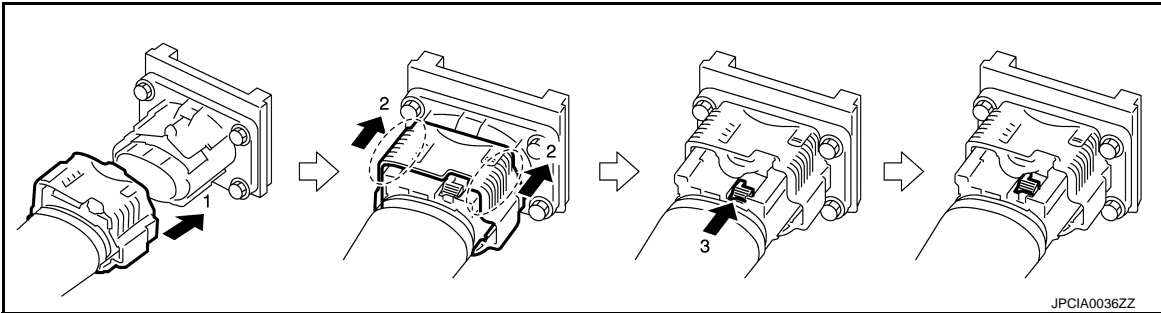

11. Install the Li-ion battery undercover.
12. Install the service plug Refer to [GI-31, "How to Disconnect High Voltage"](#).

Inspection

INFOID:000000011192169

ELECTRIC EQUIPOTENTIAL TEST

After installing the Li-ion battery, measure the resistance between the battery pack ground bolt (A) and the body ground.

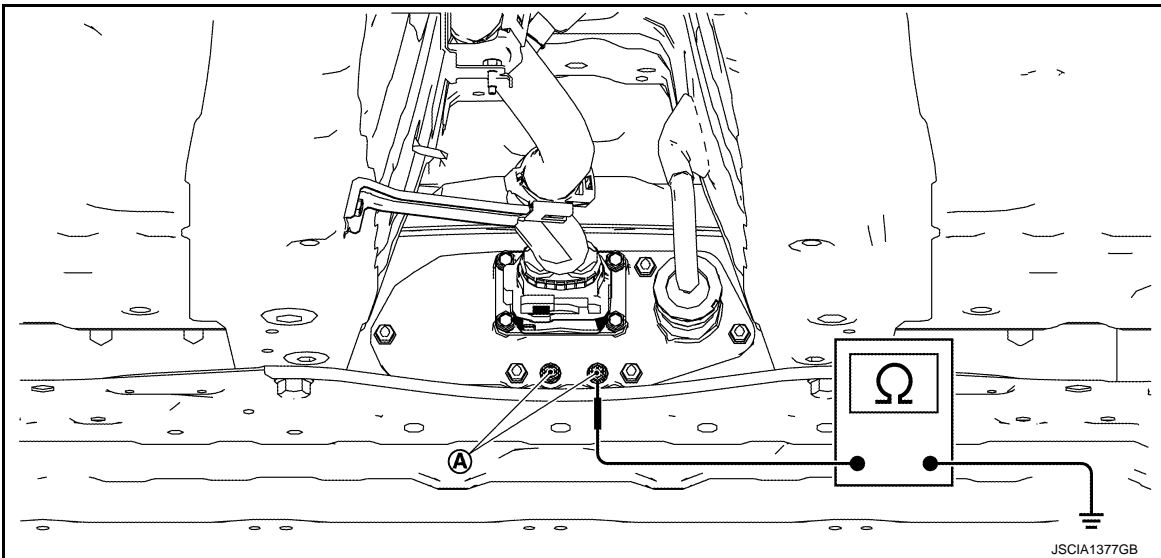

WARNING:



To prevent electric shock, wear insulated protective gear.



Standard : Less than 0.1Ω

If the result deviates from the standard value, check the following and correct the malfunction location.

LI-ION BATTERY

< UNIT REMOVAL AND INSTALLATION >

[TYPE 3]

- Conditions of bonding plate connection
- Corrosion on bonding plate mounting surface
- Presence of paint, oil, dirt, or other substance on the bonding plate mounting surface

A

B

EVB

D

E

F

G

H

I

J

K

L

M

N

O

P

LI-ION BATTERY

< UNIT DISASSEMBLY AND ASSEMBLY >

[TYPE 3]

UNIT DISASSEMBLY AND ASSEMBLY

LI-ION BATTERY

BATTERY PACK UPPER CASE

BATTERY PACK UPPER CASE : Exploded View

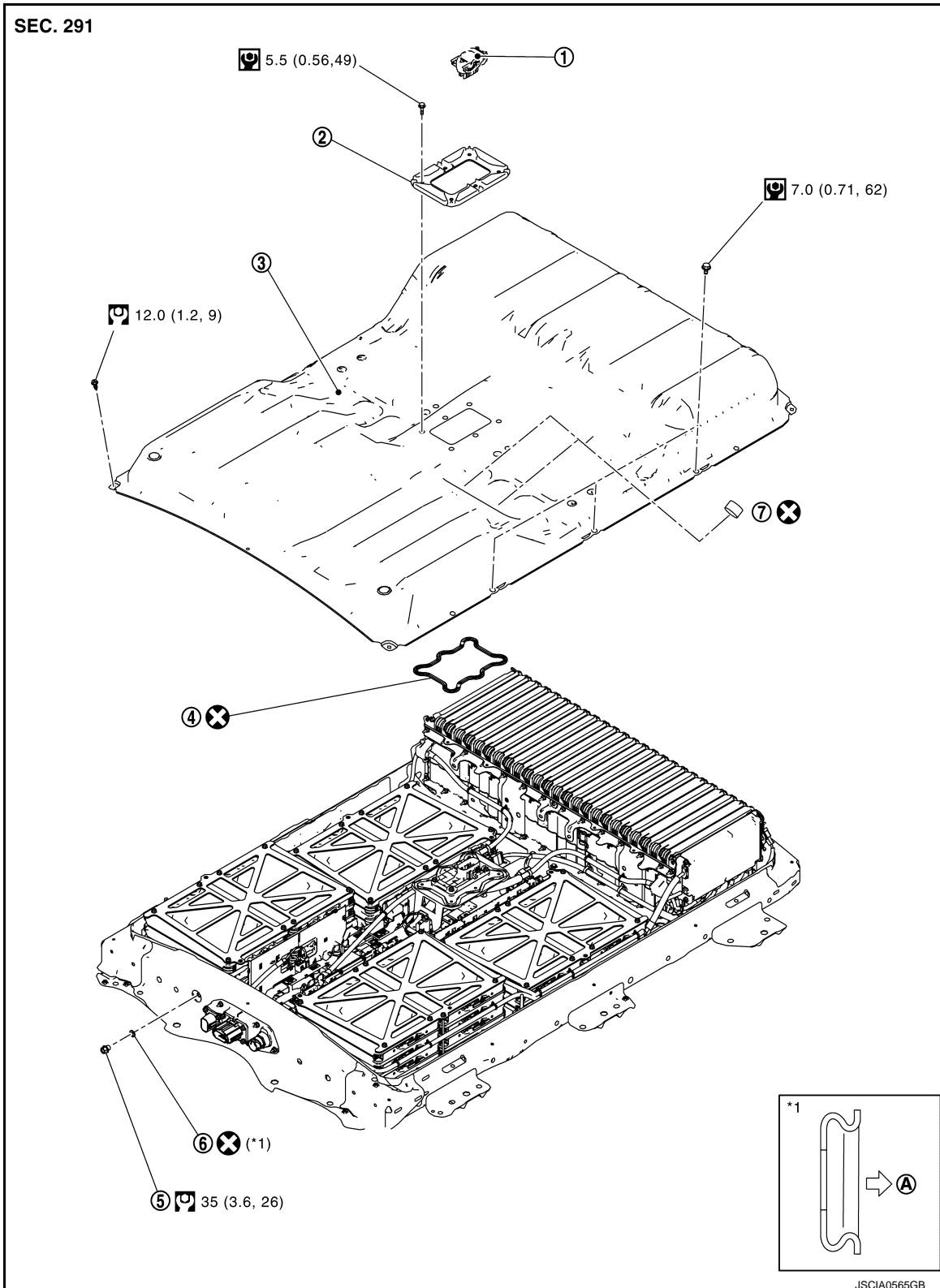

INFOID:000000011192170



LI-ION BATTERY

< UNIT DISASSEMBLY AND ASSEMBLY >

[TYPE 3]

- | | | |
|--------------------------|-------------------------|---------------------------|
| ① Service plug | ② Service plug retainer | ③ Battery pack upper case |
| ④ Seal | ⑤ Plug | ⑥ Plug washer |
| ⑦ Breather | | |
| Ⓐ Battery pack case side | | |
-  : Always replace after every disassembly.
-  : N-m (kg-m, in-lb)
-  : N-m (kg-m, ft-lb)

A
B
D

EVB

BATTERY PACK UPPER CASE : Removal and Installation

INFOID:000000011192171

DANGER:

 Since hybrid vehicles and electric vehicles contain a high voltage battery, there is the risk of electric shock, electric leakage, or similar accidents if the high voltage component and vehicle are handled incorrectly. Be sure to follow the correct work procedures when performing inspection and maintenance.

WARNING:

- Be sure to remove the service plug in order to shut off the high voltage circuits before performing inspection or maintenance of high voltage system harnesses and parts.
- Be sure to put the removed service plug in pocket and carry it or store it in a tool box or other container so that another person does not accidentally connect it while work is in progress.
- Be sure to put on insulating protective gear before beginning work on the high voltage system.
- Clearly identify the persons responsible for high voltage work and ensure that other persons do not touch the vehicle. When not working, cover high voltage components with an anti-static cover sheet or similar item to prevent contact with other persons.
- Refer to [EVB-469, "High Voltage Precautions"](#).
- If the battery pack is to be disassembled, be sure to remove the Li-ion battery controller for preventing electric shock, fire, and damage to parts.

CAUTION:

There is the possibility of a malfunction occurring if the vehicle is changed to READY status while the service plug is removed. Therefore do not change the vehicle to READY status unless instructed to do so in the Service Manual.

ENVIRONMENT FOR LI-ION BATTERY DISASSEMBLY WORK

1. Must be an indoor environment.
 - The environment must utilize a shutter or other means to shut out the outside environment and prevent rain, snow, dust, or other substances from entering.
 - The environment must not cause the intrusion of sweat during work, or cause condensation to occur due to high temperature or humidity.
2. Metal powder, grease, and other foreign substances must not enter.
 - The indoor environment must also prevent metal powder, grease, and other foreign substances from entering due to maintenance performed on other vehicles and other sources during disassembly work.
 - If there is a risk of the above substances entering, take appropriate countermeasures, such as use of a vinyl curtain or an equivalent to shut out the outside environment.
3. The floor must be dry.
 - The floor must not be wet as a result of factors such as vehicle entry during rain or snow.
4. Work space
 - The work space must be approximately the size of one entire vehicle.
 - Take appropriate countermeasures so that persons other than the operator do not enter the work space, such as by placing signs indicating that disassembly work is in progress.
5. Standard fire fighting equipment
 - Always place a standard fire fighting equipment in the disassembly work area.
 - Depending on type of fire (vehicle or battery) use standard fire fighting equipment (water or extinguisher).

REMOVAL

LI-ION BATTERY

< UNIT DISASSEMBLY AND ASSEMBLY >

[TYPE 3]

1. Clean any dust or dirt adhered to the battery pack.
2. Remove the service plug retainer ①.

WARNING:

 To prevent electric shock, wear insulated protective gear and use insulated tools.

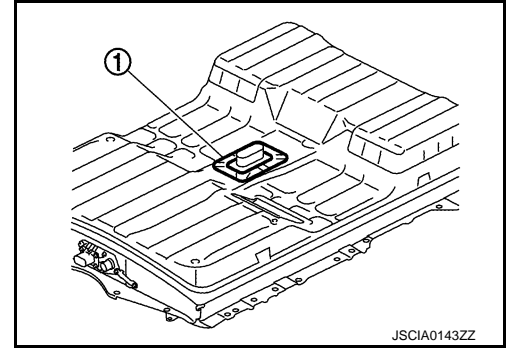

3. Remove the battery pack upper case mounting bolts ① and ground bolts ②.

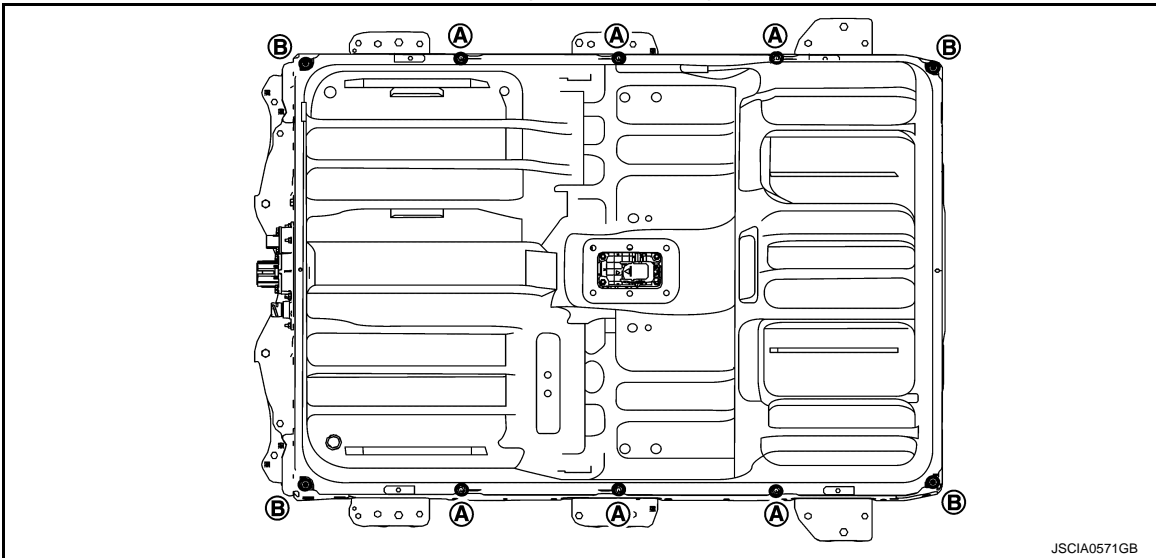

WARNING:

 To prevent electric shock, wear insulated protective gear and use insulated tools.



4. Cut the battery pack upper case adhesive according to the following procedure.

WARNING:

 To prevent electric shock, wear insulated protective gear.



- a. Prepare a windshield cutter.

NOTE:

- Sharpen the blade of the windshield cutter ①.
- Apply a tape ② for preventing damage to the battery pack.

③ : 38 mm (1.50 in)

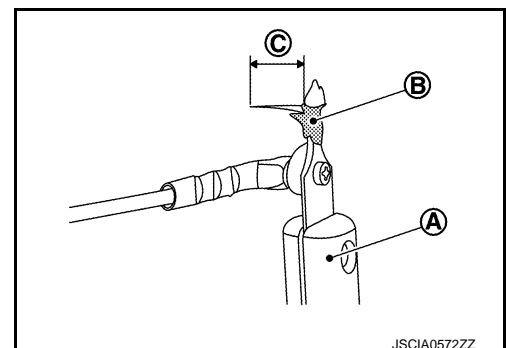

LI-ION BATTERY

< UNIT DISASSEMBLY AND ASSEMBLY >

[TYPE 3]

b. Use the windshield cutter and cut the adhesive in the order from 1 to 4 as shown in the figure.

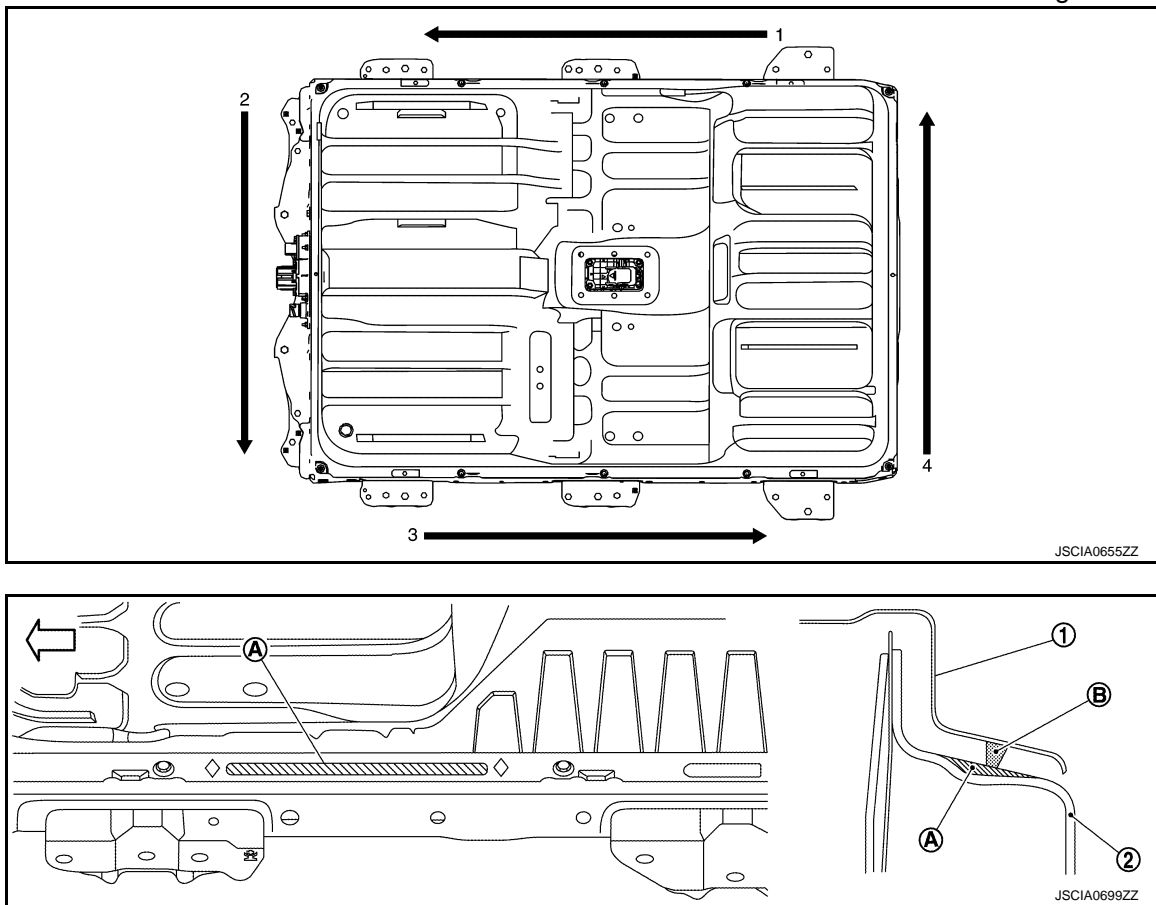

- ① Battery pack upper case
- ② Battery pack lower case
- Ⓐ Paint sealant
- Ⓑ Adhesive
- ◇ : Paint sealant mark
- ↶ : Battery front

CAUTION:

- When cutting the adhesive, be careful to avoid scratching the battery pack coating to the maximum extent possible.
- The paint sealant is set between the paint sealant marks stamped on the battery pack upper case (between ◇ to ◇). Therefore be careful not to damage the paint sealant when cutting the adhesive.
- Because the paint sealant functions to release pressure from inside the battery pack, if the paint sealant is damaged beyond the limit, the battery pack lower case must be replaced. If the paint sealant damage is less than the limit, repair by applying primer (adhesive primer: 999MP-43533PP).

Paint sealant damage limit:

Continuous length of undamaged section: : 210 mm (8.27 in) or more

NOTE:

- Because there is no clearance at the embossed part, cut the adhesive there last.

LI-ION BATTERY

< UNIT DISASSEMBLY AND ASSEMBLY >

[TYPE 3]

- Set the windshield cutter (A) at an angle of 90° to the surface of the battery case.

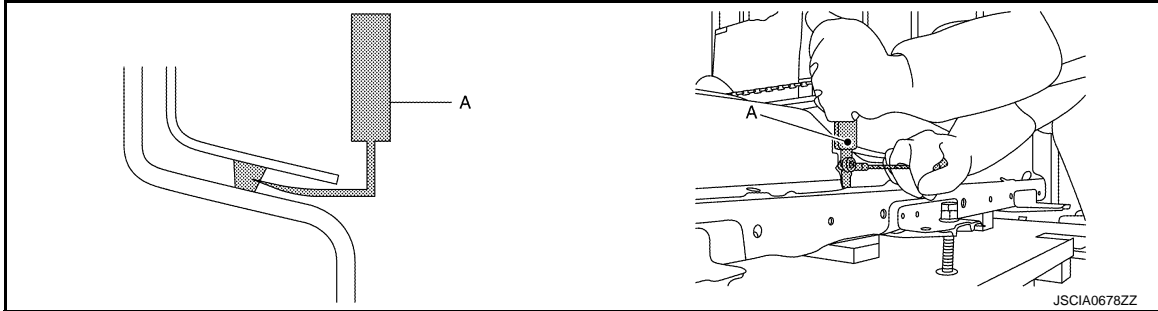

- Hold the windshield cutter facing toward the grip, and cut the adhesive while holding the blade level.

- c. Use piano wire (A) to cut the adhesive at the battery pack corners.

CAUTION:

When cutting the adhesive, be careful to avoid scratching the battery pack coating and paint sealant to the maximum extent possible.

NOTE:

Press the piano wire against the adhesive at the battery pack corner, and pull it in alternate directions for cutting of adhesive.

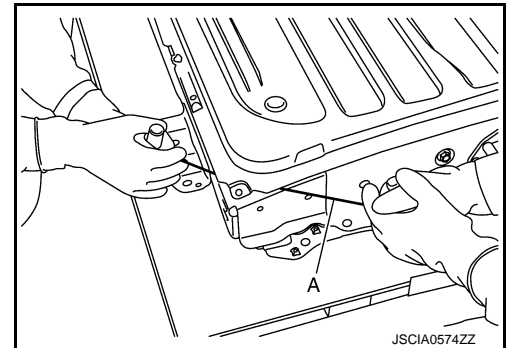

- d. Use the windshield cutter (A) for cutting adhesive at the embossed locations.



- i. Insert a plastic remover tool (B) into the embossed locations to open a clearance.

CAUTION:

Do not press the remover tool farther in than necessary. Doing so may deform the battery pack upper case.

- ii. Tilt the windshield cutter blade at an angle and cut the adhesive at the embossed locations.

CAUTION:

When cutting the adhesive, be careful to avoid scratching the battery pack coating to the maximum extent possible.

5. Remove the battery pack upper case.

WARNING:



To prevent electric shock, wear insulated protective gear.



CAUTION:

- Check that the adhesive is fully cut before removing. Use of excessive force during removal may deform the battery pack upper case.
- When removing the battery pack upper case, be careful that cutting particles do not enter the battery pack.

LI-ION BATTERY

< UNIT DISASSEMBLY AND ASSEMBLY >

[TYPE 3]

- If adhesive cutting particles enter the battery pack, clean (use of air blow is prohibited) when assembling so that no particles remain on the battery module, bus bar, and high-voltage harness.
- Operation must be performed by 2 persons. Be careful that the battery pack upper case does not contact the battery module.

INSTALLATION

1. To remove remaining adhesive on the battery pack upper case and battery pack lower case (A), use a scraper (B), and cut so that the surface is smooth, leaving approximately 1 – 2 mm (0.04 – 0.08 in) (C) of adhesive behind.

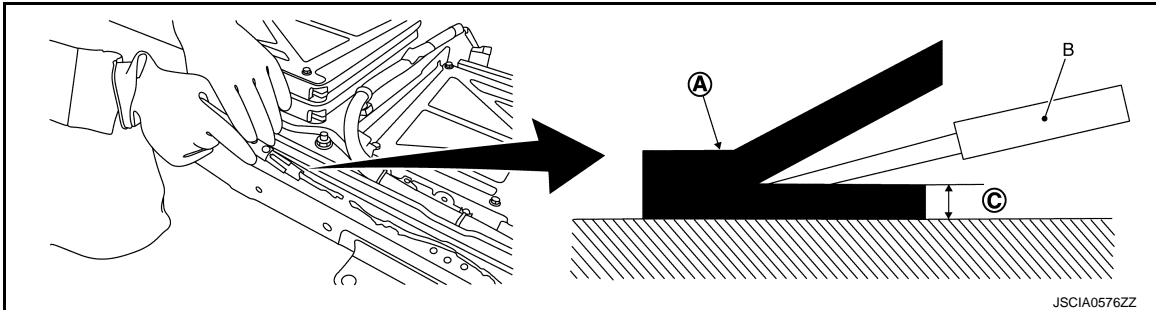

CAUTION:

- Because airtightness leakage is likely to occur, cut the seal in such a way that burrs are not produced.
- Be careful not to damage the paint sealant.
- If the paint sealant on a straight section is damaged in excess of the limit, the battery pack lower case must be replaced. If the paint sealant damage is less than the limit, repair by applying primer (adhesive primer: 999MP-43533PP).

Paint sealant damage limit:

Continuous length of undamaged section: : 210 mm (8.27 in) or more

- If the paint sealant damage on a corner is damaged, repair by applying primer (adhesive primer: 999MP-43533PP).

NOTE:

- Leave 1 – 2 mm (0.04 – 0.08 in) of adhesive so that the battery pack coating surface and paint sealant are not damaged.
- Sharpen the blade of the scraper.

2. Repair scratches to the battery pack upper case by the following procedure.

- a. Protect the seal with masking tape (A).

NOTE:

If primer surfacer (anti-corrosion primer) contacts the seal, the adhesive strength is reduced.

- b. Spray primer surfacer (anti-corrosion primer) (B) into the cracks in the battery pack upper case.

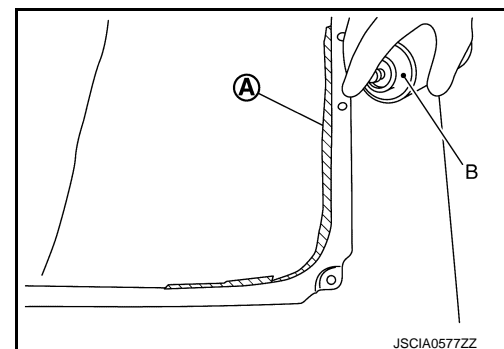

LI-ION BATTERY

< UNIT DISASSEMBLY AND ASSEMBLY >

[TYPE 3]

3. Install a carabiner (A) onto the bracket of the battery pack upper case.

NOTE:

This is to provide a handle for use after the adhesive is applied and prevent adhesive from adhering to the operator's hands.

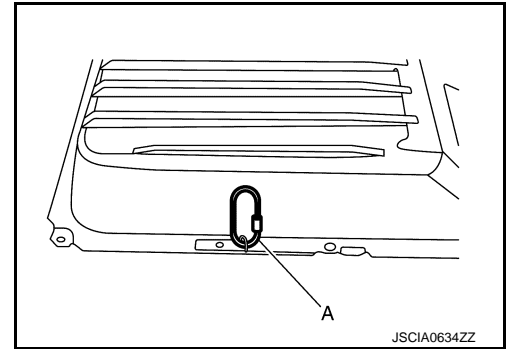

4. Apply dam rubber (KA390-0059U) (B) on the inside of the old adhesive (A) on the battery pack lower case.

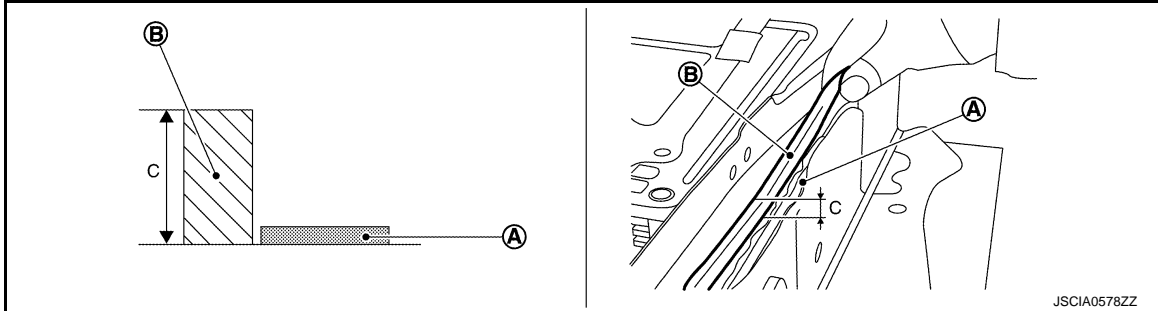

C : 10 mm (0.39 in)

WARNING:



To prevent electric shock, wear insulated protective gear.



CAUTION:

If dam rubber is already applied there, replace it with new dam rubber.

NOTE:

Apply the dam rubber so that adhesive does not enter the inner side. If the adhesive enters the inner side, then the next time the battery pack is disassembled, the windshield cutter may not be able to reach the adhesive and removing the battery pack upper case may be difficult.

5. Apply adhesive (999MP-57302NP) to the battery pack lower case as shown in the figure.

WARNING:



To prevent electric shock, wear insulated protective gear.



LI-ION BATTERY

< UNIT DISASSEMBLY AND ASSEMBLY >

[TYPE 3]

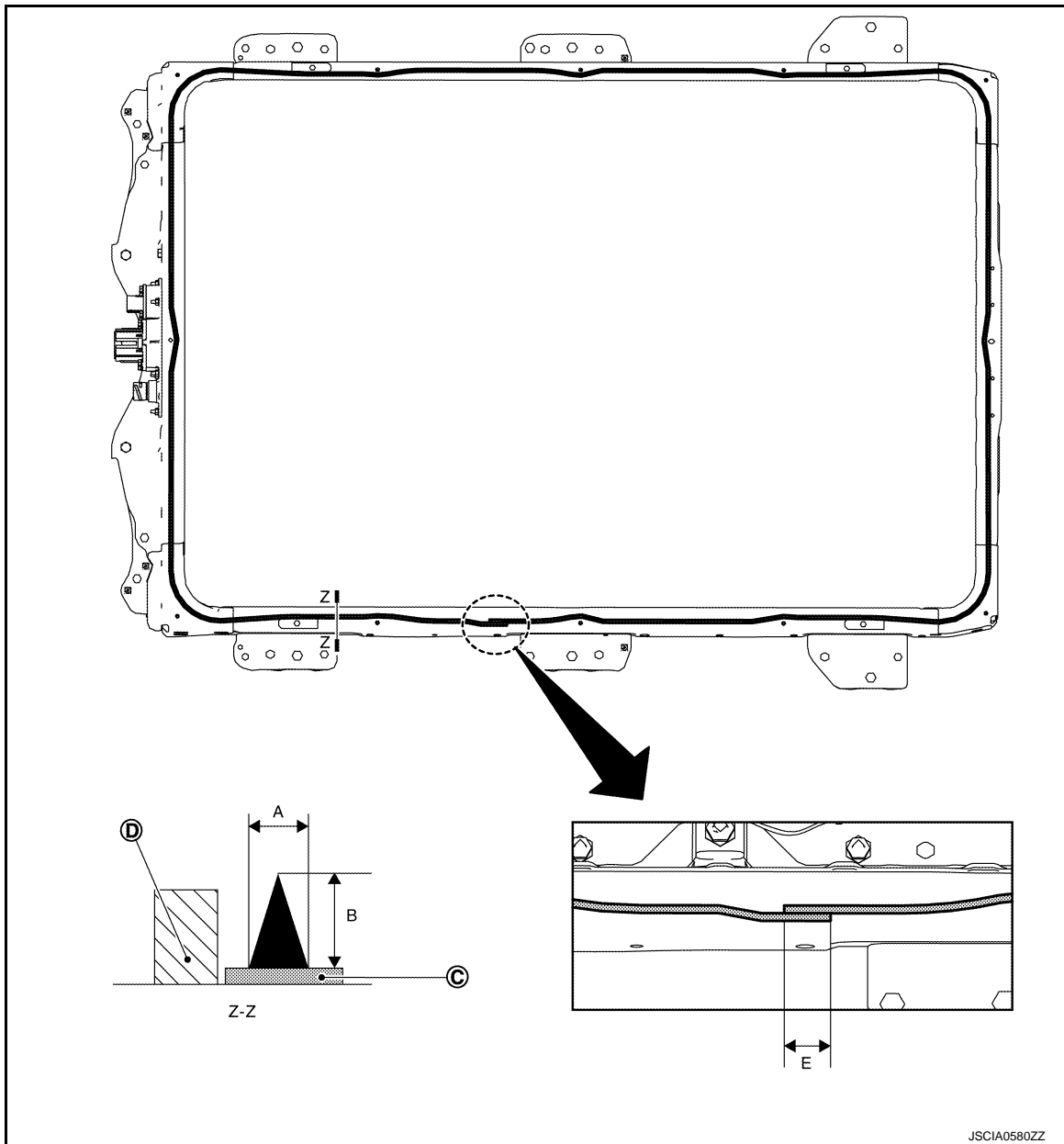

A : 5 mm (0.20 in)

B : 10 mm (0.39 in)

© : Old adhesive

Ⓓ : Dam rubber

E : 50 mm (1.97 in) or more

CAUTION:

- Because there is a risk of airtightness leakage, apply the adhesive so that there are no seams or overlaps.
- Complete installation of the battery pack upper case before the adhesive surface hardens. The adhesive begins to harden in as little as 12 minutes. [Humidity: 80%, Temperature: 35°C (95°F)]
- Before installing the battery pack upper case, check that there are no locations of insufficient adhesive. If there is insufficient adhesive, correct the location. (If the adhesive height is lower than the height of the dam rubber, then the amount of adhesive is insufficient.)
- Do not apply too much adhesive as doing so may make work difficult the next time the battery pack upper case is removed.

NOTE:

LI-ION BATTERY

< UNIT DISASSEMBLY AND ASSEMBLY >

[TYPE 3]

- For applying the adhesive in a triangle, cut the end of the nozzle as shown in the figure.

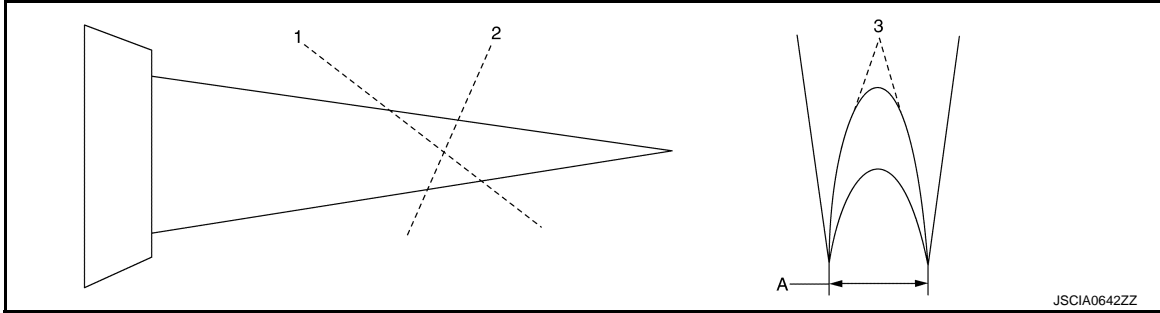

Nozzle inner diameter (A) : Approx. 5 mm (0.20 in)

6. Grasp the carabiner installed in Step 3, and install the battery pack upper case while visually aligning the alignment holes on the battery pack upper case and battery pack lower case (A).

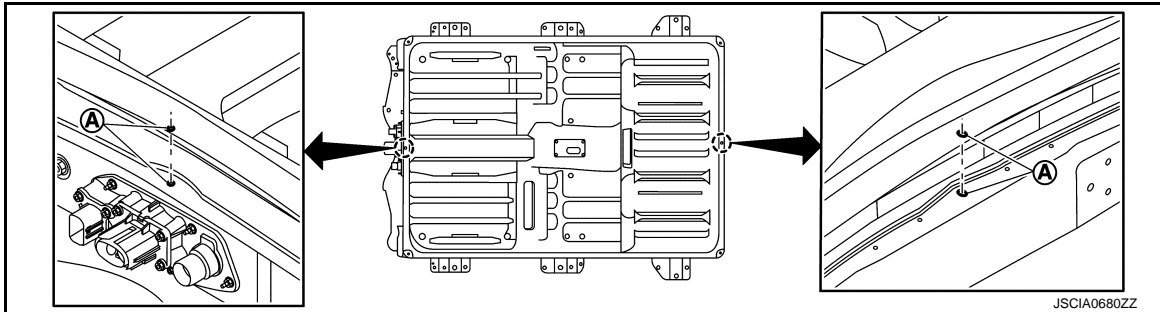

WARNING:



To prevent electric shock, wear insulated protective gear.



CAUTION:

- Operation must be performed by 2 persons. Be careful that the battery pack upper case does not contact the battery module.
- Moving the upper case after it is installed makes airtightness leakage more likely. Therefore, position the upper case carefully.

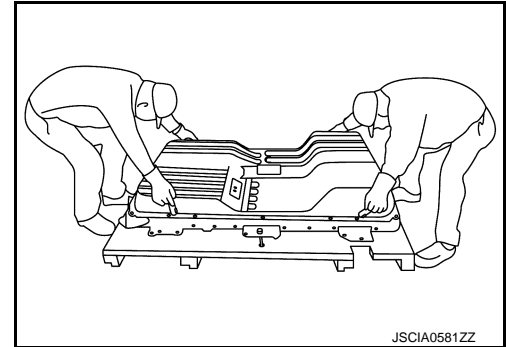

LI-ION BATTERY

< UNIT DISASSEMBLY AND ASSEMBLY >

[TYPE 3]

7. Tighten the mounting bolts in the order from 1 to 6 as shown in the figure.

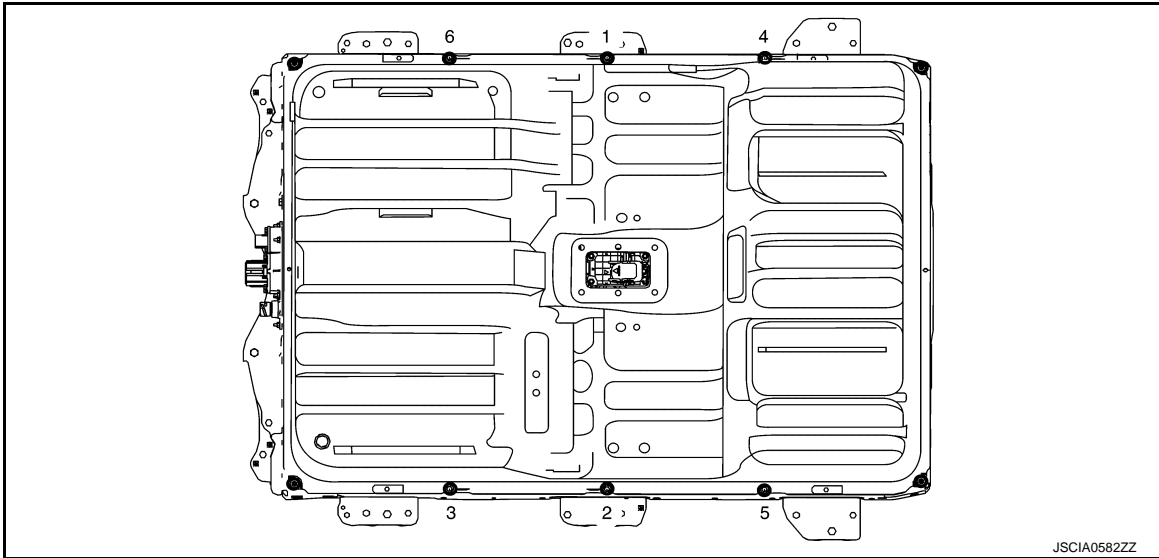

WARNING:

 To prevent electric shock, wear insulated protective gear and use insulated tools.



8. Install the ground bolt (A).

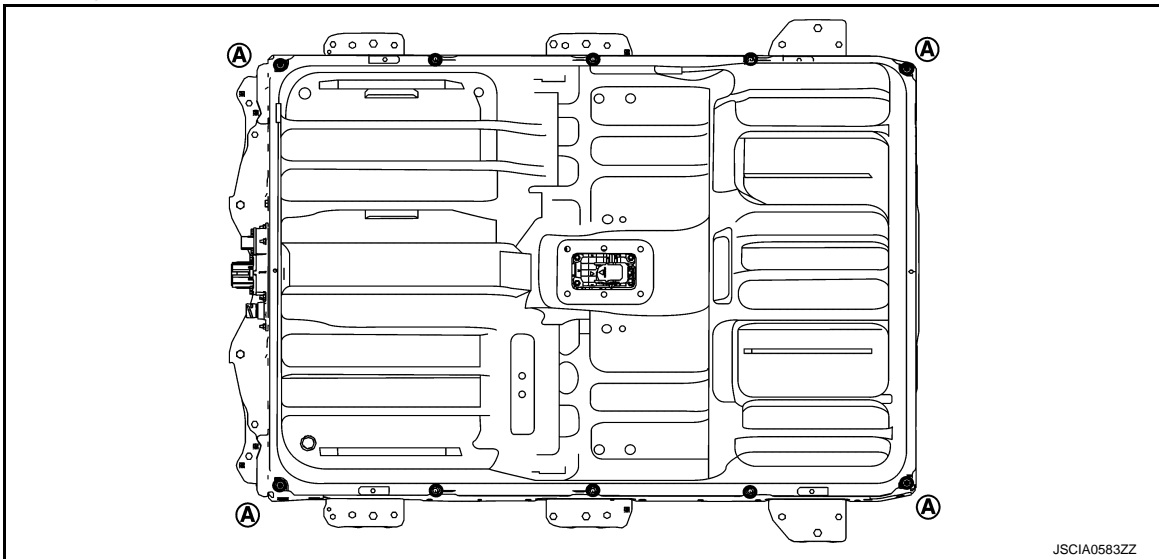

WARNING:

 To prevent electric shock, wear insulated protective gear and use insulated tools.



A
B
EVB
D
E
F
G
H
I
J
K
L
M
N
O
P

LI-ION BATTERY

< UNIT DISASSEMBLY AND ASSEMBLY >

[TYPE 3]

9. Install the service plug retainer ①.

WARNING:



To prevent electric shock, wear insulated protective gear and use insulated tools.

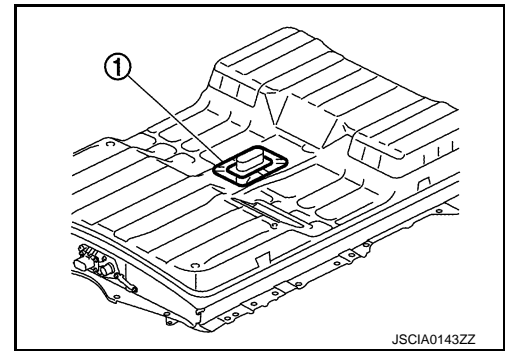

10. Perform a battery pack air leak inspection. Refer to [EVB-687, "Inspection"](#).

CAUTION:

If air leakage occurs, remove the battery pack upper case and wipe off the adhesive, then apply new dam rubber and apply adhesive again. (Proceed to Step 4.)

11. Spray primer surfacer (anti-corrosion primer) (A) into cracks in the periphery of the battery pack adhesive.

WARNING:



To prevent electric shock, wear insulated protective gear.

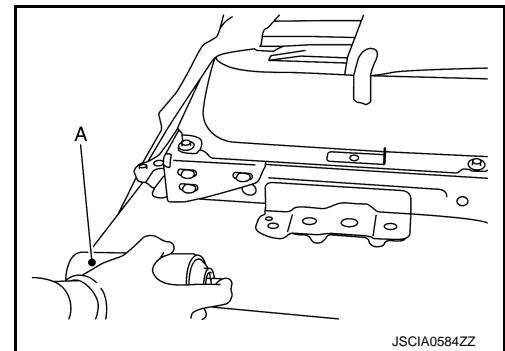

CAUTION:

- After the battery pack is assembled, it can be installed into the vehicle. However the battery pack must not be subjected to any external force (such as high-pressure washing or parking in a location which strains the vehicle body) for approximately 3 hours after installation.
- Be sure to reinstall the high voltage harness clips in their original positions. If a clip is damaged, replace it with a new clip before installing.
- After assembling the battery pack, perform an electric equipotential test.
- Check the following items after installing battery pack: Refer to [EVB-687, "Inspection"](#).

■AIR LEAK INSPECTION

■ELECTRIC EQUIPOTENTIAL TEST

LI-ION BATTERY CONTROLLER

LI-ION BATTERY

< UNIT DISASSEMBLY AND ASSEMBLY >

[TYPE 3]

LI-ION BATTERY CONTROLLER : Exploded View

INFOID:000000011192172

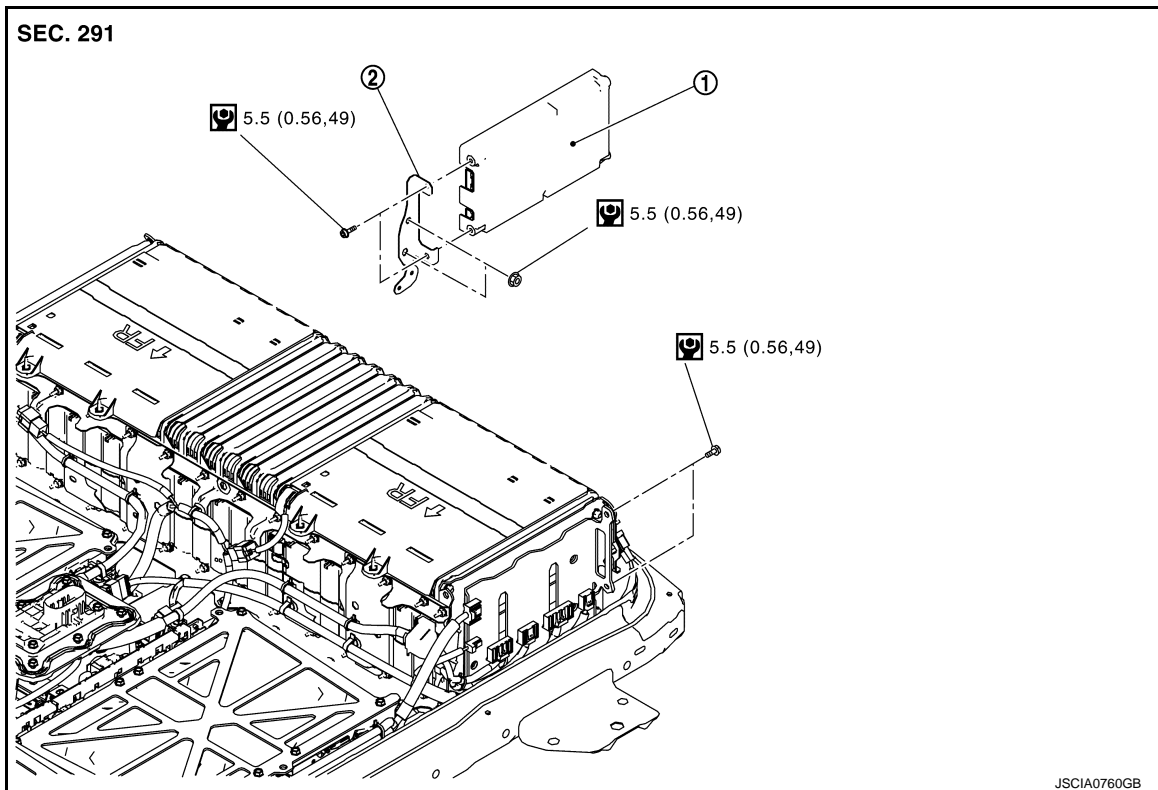

① Li-ion battery controller

② Controller bracket

🔩 : N·m (kg-m, in-lb)

LI-ION BATTERY CONTROLLER : Removal and Installation

INFOID:000000011192173

DANGER:



Since hybrid vehicles and electric vehicles contain a high voltage battery, there is the risk of electric shock, electric leakage, or similar accidents if the high voltage component and vehicle are handled incorrectly. Be sure to follow the correct work procedures when performing inspection and maintenance.

WARNING:

- Be sure to remove the service plug in order to shut off the high voltage circuits before performing inspection or maintenance of high voltage system harnesses and parts.
- Be sure to put the removed service plug in pocket and carry it or store it in a tool box or other container so that another person does not accidentally connect it while work is in progress.
- Be sure to put on insulating protective gear before beginning work on the high voltage system.
- Clearly identify the persons responsible for high voltage work and ensure that other persons do not touch the vehicle. When not working, cover high voltage components with an anti-static cover sheet or similar item to prevent contact with other persons.
- Refer to [EV6-469, "High Voltage Precautions"](#).
- If the battery pack is to be disassembled, be sure to remove the Li-ion battery controller for preventing electric shock, fire, and damage to parts.

CAUTION:

There is the possibility of a malfunction occurring if the vehicle is changed to READY status while the service plug is removed. Therefore do not change the vehicle to READY status unless instructed to do so in the Service Manual.

ENVIRONMENT FOR LI-ION BATTERY DISASSEMBLY WORK

1. Must be an indoor environment.

LI-ION BATTERY

< UNIT DISASSEMBLY AND ASSEMBLY >

[TYPE 3]

- The environment must utilize a shutter or other means to shut out the outside environment and prevent rain, snow, dust, or other substances from entering.
 - The environment must not cause the intrusion of sweat during work, or cause condensation to occur due to high temperature or humidity.
2. Metal powder, grease, and other foreign substances must not enter.
 - The indoor environment must also prevent metal powder, grease, and other foreign substances from entering due to maintenance performed on other vehicles and other sources during disassembly work.
 - If there is a risk of the above substances entering, take appropriate countermeasures, such as use of a vinyl curtain or an equivalent to shut out the outside environment.
 3. The floor must be dry.
 - The floor must not be wet as a result of factors such as vehicle entry during rain or snow.
 4. Work space
 - The work space must be approximately the size of one entire vehicle.
 - Take appropriate countermeasures so that persons other than the operator do not enter the work space, such as by placing signs indicating that disassembly work is in progress.
 5. Standard fire fighting equipment
 - Always place a standard fire fighting equipment in the disassembly work area.
 - Depending on type of fire (vehicle or battery) use standard fire fighting equipment (water or extinguisher).

REMOVAL

1. Remove the battery pack upper case. Refer to [EVB-635, "BATTERY PACK UPPER CASE : Removal and Installation"](#).

2. Disconnect the low-voltage harness connector (A) of the Li-ion battery controller.

WARNING:



To prevent electric shock, wear insulated protective gear.

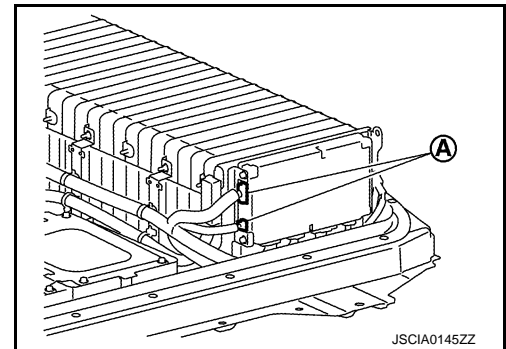

3. Remove the Li-ion battery controller mounting nuts (A), then remove the mounting bolts (B).

WARNING:



To prevent electric shock, wear insulated protective gear and use insulated tools.

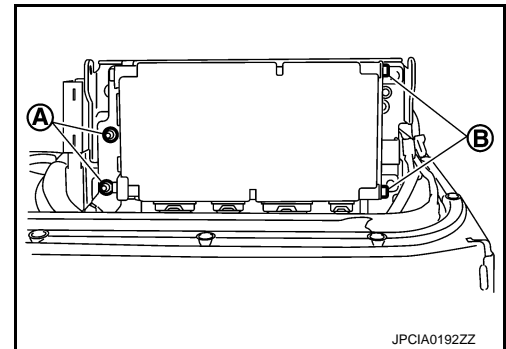

4. Disconnect the high-voltage harness connector (A), then remove the Li-ion battery controller.

(B) : Low-voltage harness connector

← : Battery front

WARNING:



To prevent electric shock, wear insulated protective gear.

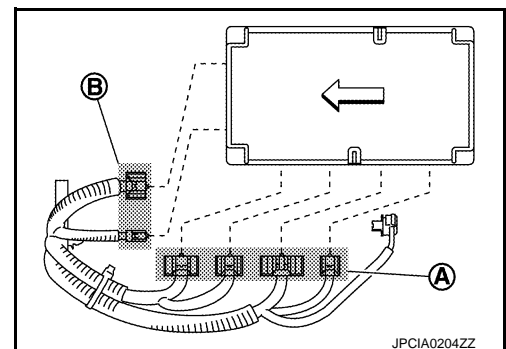

LI-ION BATTERY

< UNIT DISASSEMBLY AND ASSEMBLY >

[TYPE 3]



- ⚠ Because there is a risk of electric shock, immediately protect the terminals of the disconnected high-voltage harness connector with insulating tape so that they are not exposed.

INSTALLATION

1. Install the Li-ion battery controller.

WARNING:

- ⚠ To prevent electric shock, wear insulated protective gear and use insulated tools.



- The Li-ion battery controller includes 2 harness connectors: a high-voltage connector (A) and a low-voltage connector (B). If the high-voltage harness connector is inserted at the low-voltage point, smoking and component damage may occur. Be very careful not to insert the connectors at the wrong points.

← : Battery front

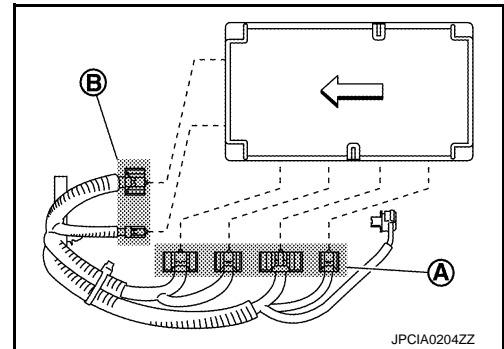

2. Install the battery pack upper case. Refer to [EVB-635, "BATTERY PACK UPPER CASE : Removal and Installation"](#).

CAUTION:

- Be sure to reinstall the high voltage harness clips in their original positions. If a clip is damaged, replace it with a new clip before installing.
- Check the following items after installing battery pack: Refer to [EVB-687, "Inspection"](#).

■AIR LEAK INSPECTION

■ELECTRIC EQUIPOTENTIAL TEST

BATTERY JUNCTION BOX AND BATTERY HARNESS

LI-ION BATTERY

< UNIT DISASSEMBLY AND ASSEMBLY >

[TYPE 3]

BATTERY JUNCTION BOX AND BATTERY HARNESS : Exploded View

INFOID:000000011192817

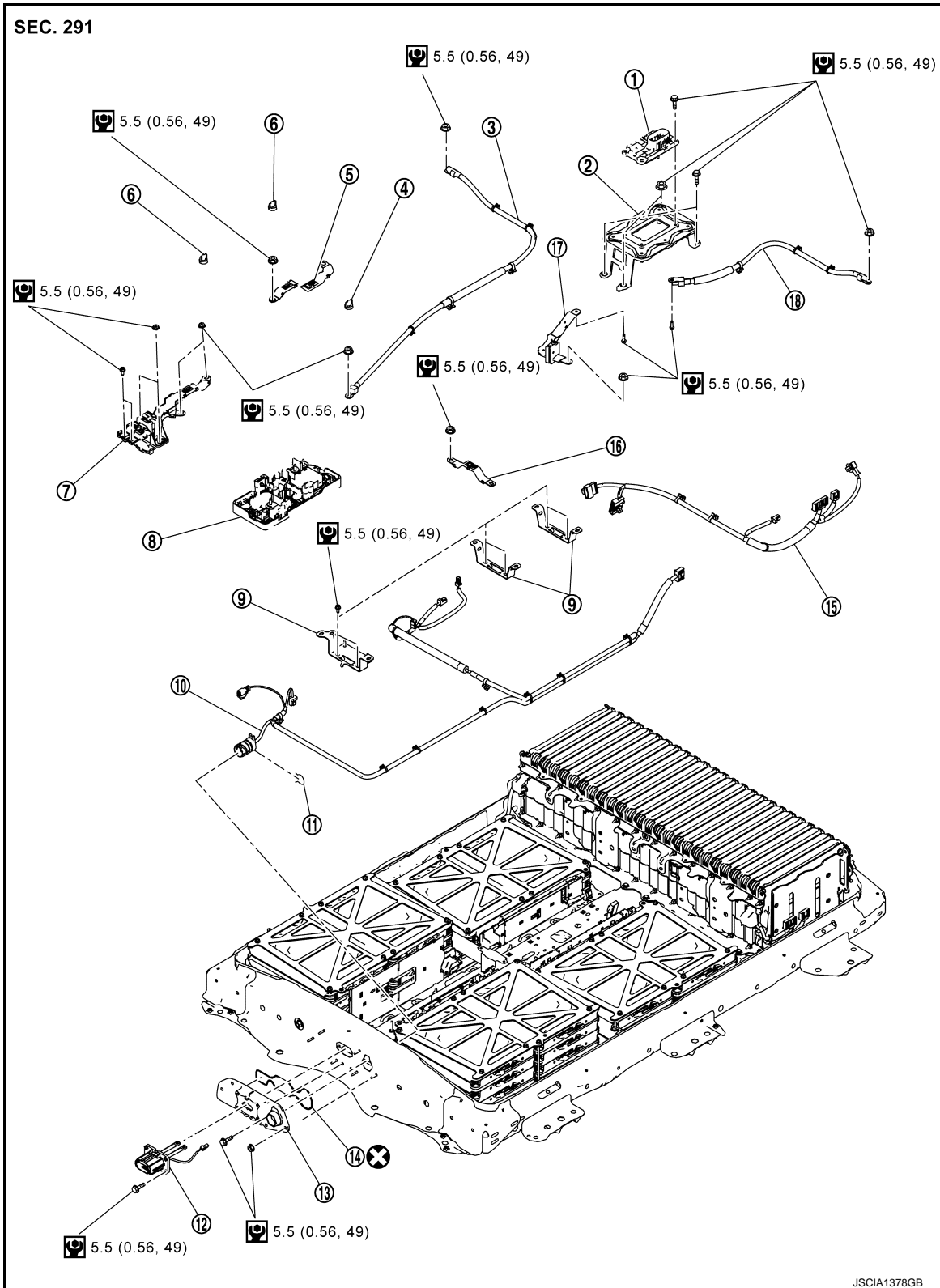

- | | | |
|--|-------------------------------|----------------------------------|
| ① Service plug switch | ② Service plug switch bracket | ③ High-voltage battery harness |
| ④ Bus bar nut cap | ⑤ Bus bar | ⑥ Bus bar nut cap |
| ⑦ Bus bar (integrated with noise filter) | ⑧ Battery junction box | ⑨ Harness bracket |
| ⑩ Vehicle communications harness | ⑪ Snap ring | ⑫ High-voltage harness connector |

LI-ION BATTERY

< UNIT DISASSEMBLY AND ASSEMBLY >

[TYPE 3]

⑬ Connector flange

⑭ Seal

⑮ Voltage detection harness

⑯ Bus bar

⑰ Battery current sensor (integrated with bus bar)

⑱ High-voltage battery harness

 : Always replace after every disassembly.

 : N·m (kg·m, in·lb)

A

B

Bus bar Layout

EVB

DANGER:

D

E

F

G

H

I

J

K

L

M

N

O

P

LI-ION BATTERY

< UNIT DISASSEMBLY AND ASSEMBLY >

[TYPE 3]



Because there is a danger of electric shock and fire, never contact bus bar in a wrong terminal.

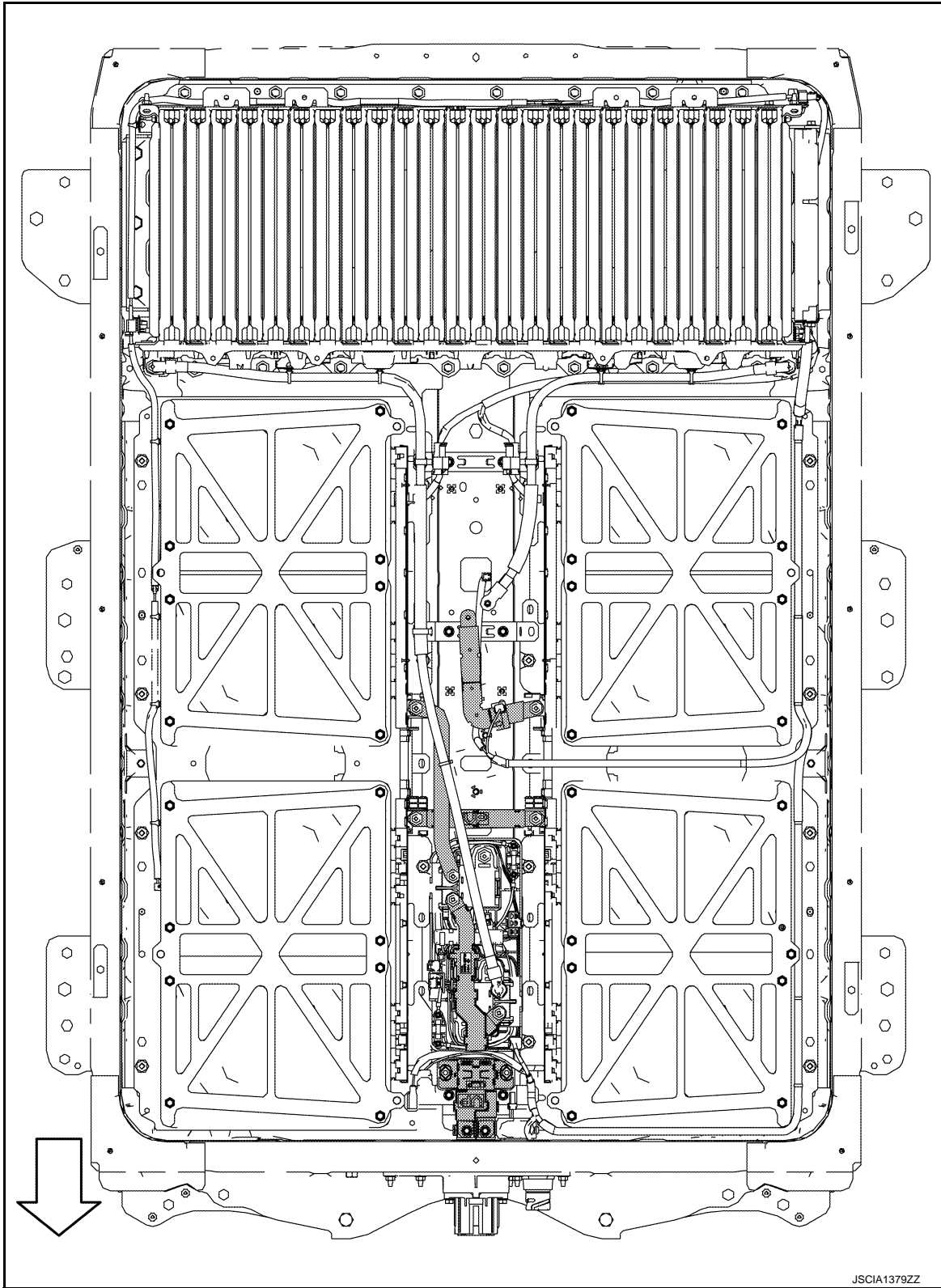

⇩ : Battery front

BATTERY JUNCTION BOX AND BATTERY HARNESS : Disassembly and Assembly

INFOID:000000011192818

DANGER:

LI-ION BATTERY

< UNIT DISASSEMBLY AND ASSEMBLY >

[TYPE 3]



Because hybrid vehicles and electric vehicles contain a high voltage battery, there is a risk of electric shock, electric leakage, or similar accidents if the vehicle is handled incorrectly. Be sure to follow the correct work procedures when performing inspection and maintenance.

WARNING:

- Be sure to remove the service plug in order to shut off the high voltage circuits before performing inspection or maintenance of high voltage system harnesses and parts.
- Be sure to put the removed service plug in pocket and carry it or store it in a tool box or other container so that another person does not accidentally connect it while work is in progress.
- Be sure to put on insulating protective gear before beginning work on the high voltage system.
- Clearly identify the persons responsible for high voltage work and ensure that other persons do not touch the vehicle. When not working, cover high voltage components with an anti-static cover sheet or similar item to prevent contact with other persons.
- Refer to [EVB-469, "High Voltage Precautions"](#).
- If the battery pack is to be disassembled, be sure to remove the Li-ion battery controller for preventing electric shock, fire, and damage to parts.

CAUTION:

There is the possibility of a malfunction occurring if the vehicle is changed to READY status while the service plug is removed. Therefore do not change the vehicle to READY status unless instructed to do so in the Service Manual.

ENVIRONMENT FOR LI-ION BATTERY DISASSEMBLY WORK

1. Must be an indoor environment.
 - The environment must utilize a shutter or other means to shut out the outside environment and prevent rain, snow, dust, or other substances from entering.
 - The environment must not cause the intrusion of sweat during work, or cause condensation to occur due to high temperature or humidity.
2. Metal powder, grease, and other foreign substances must not enter.
 - The indoor environment must also prevent metal powder, grease, and other foreign substances from entering due to maintenance performed on other vehicles and other sources during disassembly work.
 - If there is a risk of the above substances entering, take appropriate countermeasures, such as use of a vinyl curtain or an equivalent to shut out the outside environment.
3. The floor must be dry.
 - The floor must not be wet as a result of factors such as vehicle entry during rain or snow.
4. Work space
 - The work space must be approximately the size of one entire vehicle.
 - Take appropriate countermeasures so that persons other than the operator do not enter the work space, such as by placing signs indicating that disassembly work is in progress.
5. Standard fire fighting equipment
 - Always place a standard fire fighting equipment in the disassembly work area.
 - Depending on type of fire (vehicle or battery) use standard fire fighting equipment (water or extinguisher).

DISASSEMBLY

1. Remove the battery pack upper case. [EVB-635, "BATTERY PACK UPPER CASE : Removal and Installation"](#).
2. Remove Li-ion battery controller. Refer to [EVB-645, "LI-ION BATTERY CONTROLLER : Removal and Installation"](#).
3. Disconnect the high-voltage harness engagement detection switch harness connector (A).

WARNING:



To prevent electric shock, wear insulated protective gear.

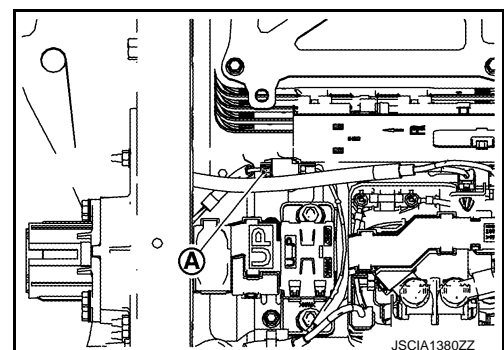

LI-ION BATTERY

< UNIT DISASSEMBLY AND ASSEMBLY >

[TYPE 3]

4. Open the bus bar cover and remove the high-voltage harness connector terminal mounting bolt (A).

DANGER:

- ⚡ There is the danger of electric shock caused by contact with the terminals. Be sure to wear insulated protective gear and use insulated tools.



- ⚡ Because of the danger of electric shock, be sure to close the bus bar cover after removing the bus bar.

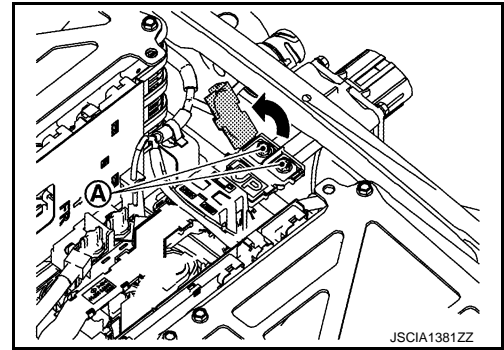

JSCIA1381ZZ

5. Remove the mounting bolt (A) and disconnect the high-voltage harness connector from the connector flange.

WARNING:

- ⚡ To prevent electric shock, wear insulated protective gear and use insulated tools.

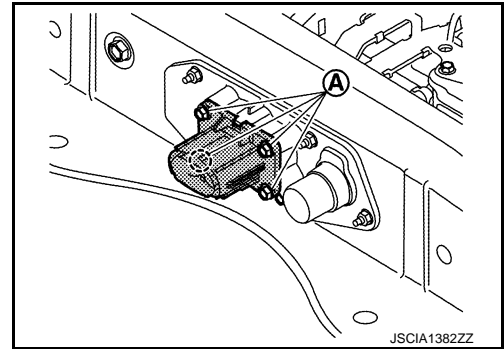

JSCIA1382ZZ

8. Disconnect the vehicle communications harness connector (A) from the junction box, and remove the connector clips (B).

WARNING:

- ⚡ To prevent electric shock, wear insulated protective gear and use insulated tools.

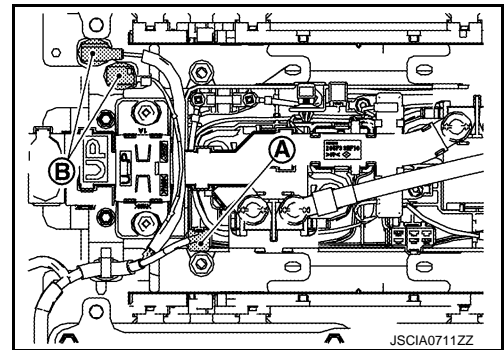
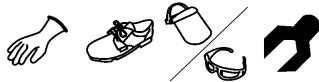

JSCIA0711ZZ

9. Remove the bus bar nut caps (A).

WARNING:

- ⚡ To prevent electric shock, wear insulated protective gear and use insulated tools.

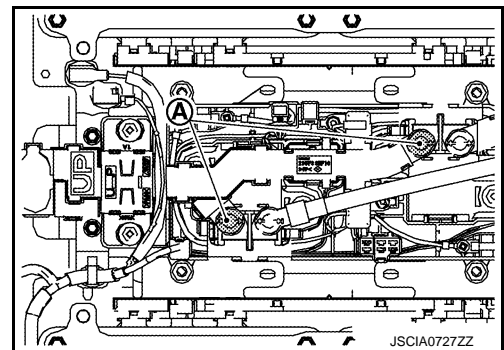

JSCIA0727ZZ

LI-ION BATTERY

< UNIT DISASSEMBLY AND ASSEMBLY >

[TYPE 3]

10. Remove the bus bar mounting nuts (A) and (B), and remove the bus bar (integrated with noise filter) (1).

WARNING:

 To prevent electric shock, wear insulated protective gear and use insulated tools.

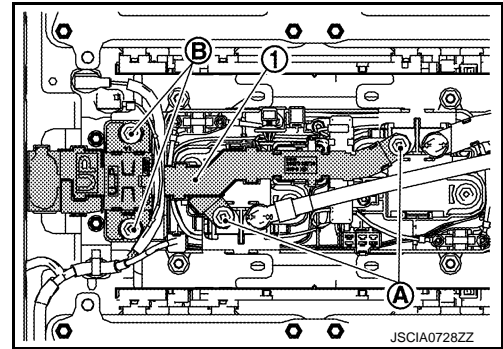

11. Remove the harness clips, then remove the battery member pipe (1).

WARNING:

 To prevent electric shock, wear insulated protective gear and use insulated tools.



NOTE:

The right-side mounting hole is larger for facilitating removal of the battery member pipe. Lifting up the left side first makes removal easier.

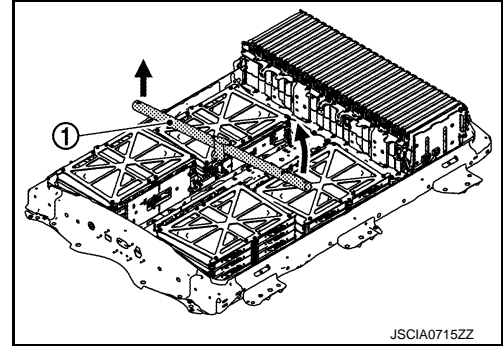

12. Remove the bus bar nut cap (1) and remove the high-voltage harness nut cap (2), then open the bus bar cover (3).

WARNING:

 To prevent electric shock, wear insulated protective gear.

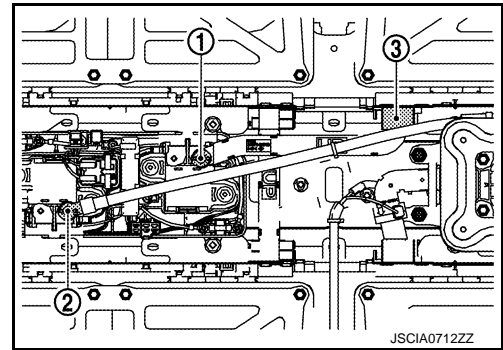

13. Remove the mounting nuts (A), and remove the bus bar (1) and high-voltage harness (2).

DANGER:

 There is the danger of electric shock caused by contact with the terminals. Be sure to wear insulated protective gear and use insulated tools.



 Because there is a risk of electric shock, immediately protect the terminals of the disconnected high-voltage harness connector (high-voltage terminals) with insulating tape so that they are not exposed.

 Because of the danger of electric shock, be sure to close the bus bar cover after removing the bus bar.

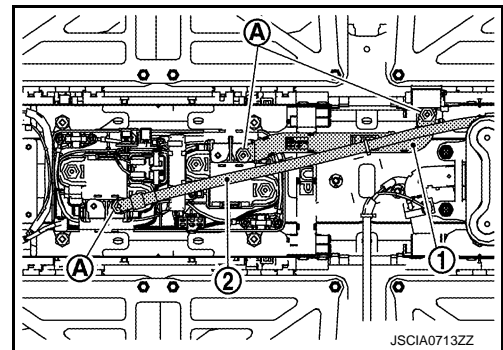

A
B
EVB
D
E
F
G
H
I
J
K
L
M
N
O
P

LI-ION BATTERY

< UNIT DISASSEMBLY AND ASSEMBLY >

[TYPE 3]

14. Remove the mounting nuts (A) and remove the junction box (1).

WARNING:

 To prevent electric shock, wear insulated protective gear and use insulated tools.

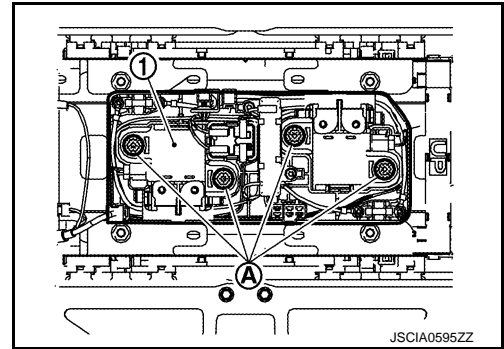

15. Disconnect the current sensor harness connector (1).

WARNING:

 To prevent electric shock, wear insulated protective gear and use insulated tools.

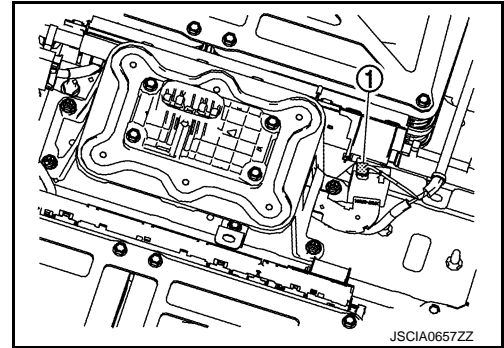

16. Remove the bus bar mounting nut which connects the current sensor and left front module stack (A).

DANGER:

-  There is the danger of electric shock caused by contact with the terminals. Be sure to wear insulated protective gear and use insulated tools.



-  Because of the danger of electric shock, be sure to close the bus bar cover after removing the bus bar.

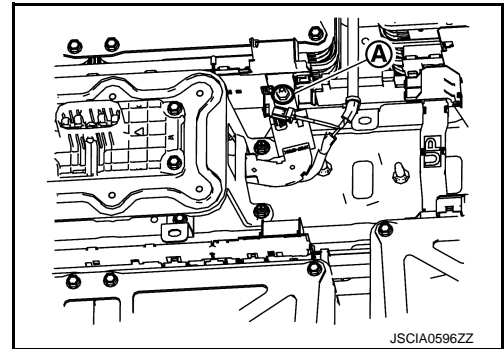

17. Remove the service plug switch bracket (1) mounting bolts (A) and mounting nuts (B).

WARNING:

 To prevent electric shock, wear insulated protective gear and use insulated tools.

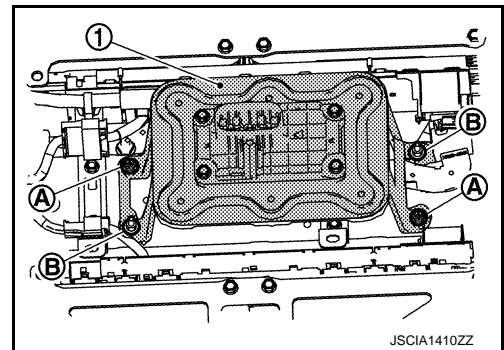

LI-ION BATTERY

< UNIT DISASSEMBLY AND ASSEMBLY >

[TYPE 3]

18. Invert the service plug switch bracket and remove the high-voltage harness mounting bolt ①, current sensor mounting bolt ②, and the connector ③, then remove the service plug switch bracket ④.

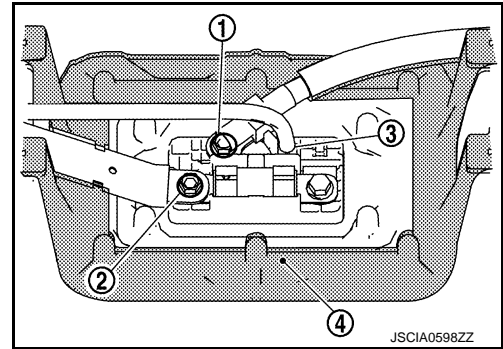

DANGER:

- ⚠ There is the danger of electric shock caused by contact with the terminals. Be sure to wear insulated protective gear and use insulated tools.



- ⚠ Because there is a risk of electric shock, immediately protect the terminals of the disconnected high-voltage harness connector (high-voltage terminals) with insulating tape so that they are not exposed.

19. Remove the mounting nuts ①, then remove high-voltage harness ① and ②.

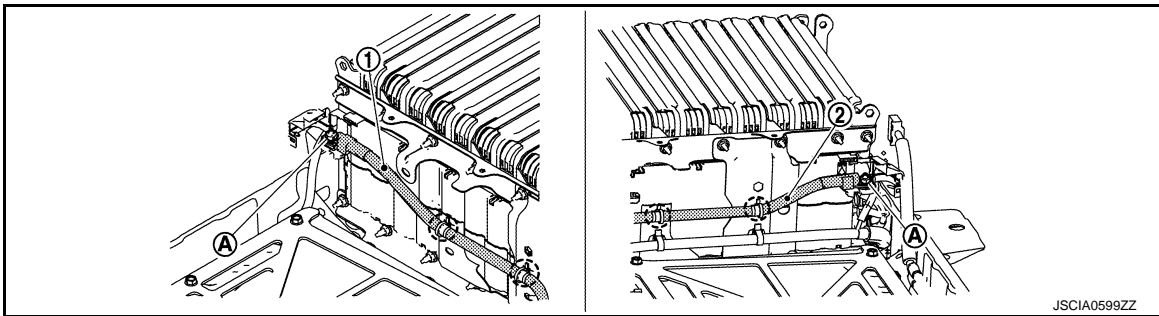

○ : Harness clip

DANGER:

- ⚠ There is the danger of electric shock caused by contact with the terminals. Be sure to wear insulated protective gear and use insulated tools.



- ⚠ Because of the danger of electric shock, be sure to close the bus bar cover after removing the bus bar.

20. Remove the vehicle communications harness and voltage detection harness.

A
B
EVB
D
E
F
G
H
I
J
K
L
M
N
O
P

LI-ION BATTERY

< UNIT DISASSEMBLY AND ASSEMBLY >

[TYPE 3]

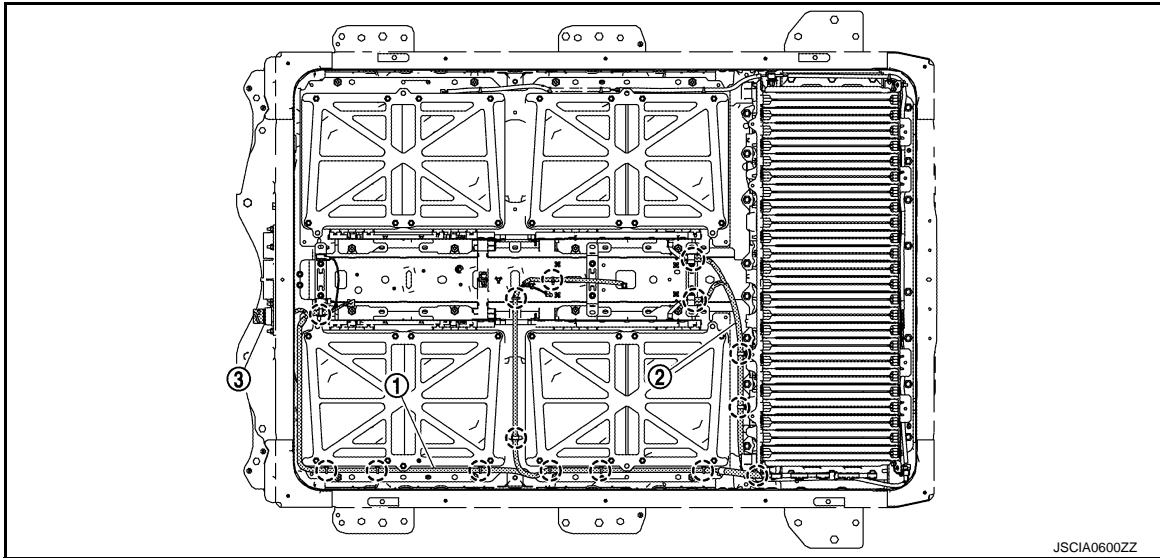

- ① Vehicle communications harness ② Voltage detection harness ③ Snap ring

○ : Harness clip

WARNING:



To prevent electric shock, wear insulated protective gear and use insulated tools.

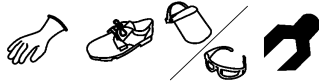

ASSEMBLY

Note the following items, and disassembly in the reverse order of disassembly.

DANGER:

-  There is the danger of electric shock caused by contact with the terminals. Be sure to wear insulated protective gear and use insulated tools.



-  Because there is a danger of electric shock and fire, never allow bus bar to contact a wrong terminal.
 - If bus bar contacts a wrong terminal, the circuit becomes energized and a short may occur.
 - Always keep the bus bar cover closed until immediately before the installation of bus bar.
 - Since the correct installation position for the bus bar connected to both front module stacks is commonly-confused with the wrong position (B), install the bus bar to the correct position (A) with extreme caution.

LI-ION BATTERY

< UNIT DISASSEMBLY AND ASSEMBLY >

[TYPE 3]

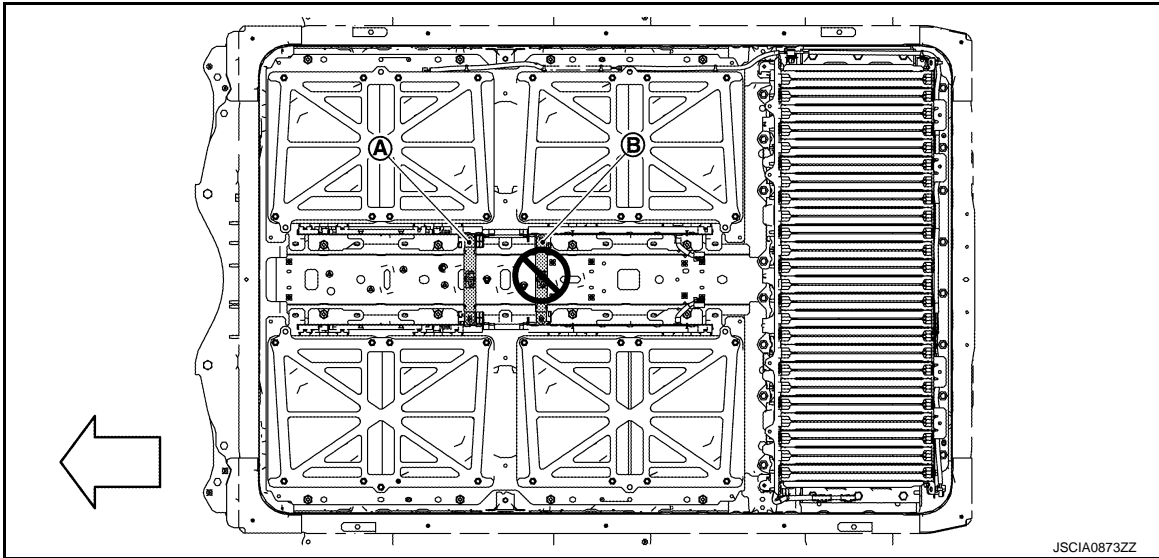

(A) Correct position

(B) Wrong position

← : Battery front

WARNING:

Install the Li-ion battery controller immediately before installing the battery pack upper case. Refer to [EVB-635, "BATTERY PACK UPPER CASE : Removal and Installation"](#).

CAUTION:

- Perform the "LI-ION BATTERY JUNCTION BOX DATA CLEAR" when battery junction box is replaced. Refer to [EVC-110, "Work Procedure"](#).
- Be sure to reinstall the high voltage harness clips in their original positions. If a clip is damaged, replace it with a new clip before installing.
- Check the following items after installing battery pack: Refer to [EVB-687, "Inspection"](#).

■ AIR LEAK INSPECTION

■ ELECTRIC EQUIPOTENTIAL TEST

FRONT MODULE STACK

FRONT MODULE STACK : Exploded View

INFOID:000000011192180

REMOVAL AND INSTALLATION

LI-ION BATTERY

< UNIT DISASSEMBLY AND ASSEMBLY >

[TYPE 3]

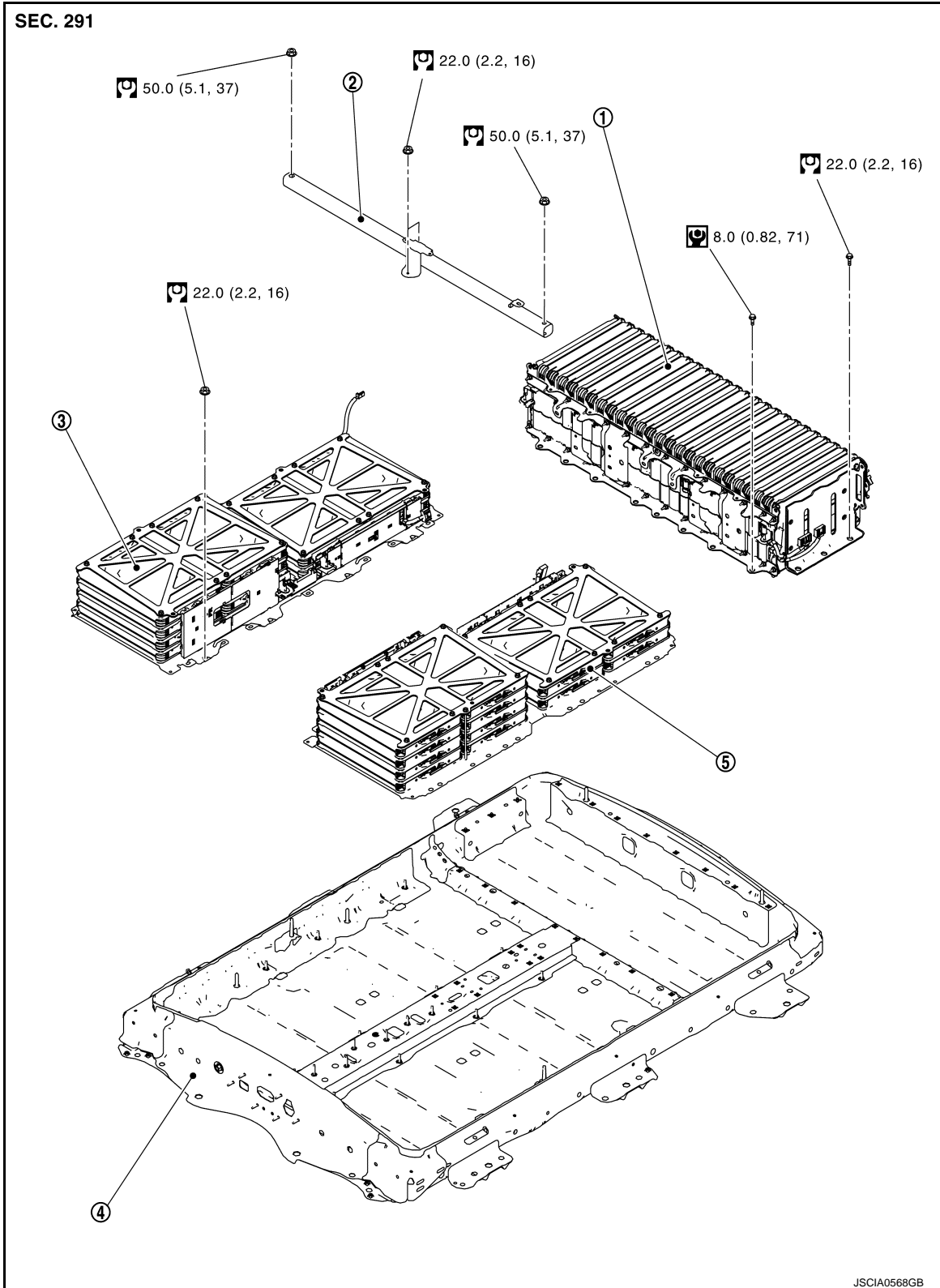

① Rear module stack

② Battery member pipe

③ Front module stack RH

④ Battery pack lower case

⑤ Front module stack LH

: N·m (kg·m, in·lb)

: N·m (kg·m, ft·lb)

LI-ION BATTERY

< UNIT DISASSEMBLY AND ASSEMBLY >

[TYPE 3]

DISASSEMBLY AND ASSEMBLY

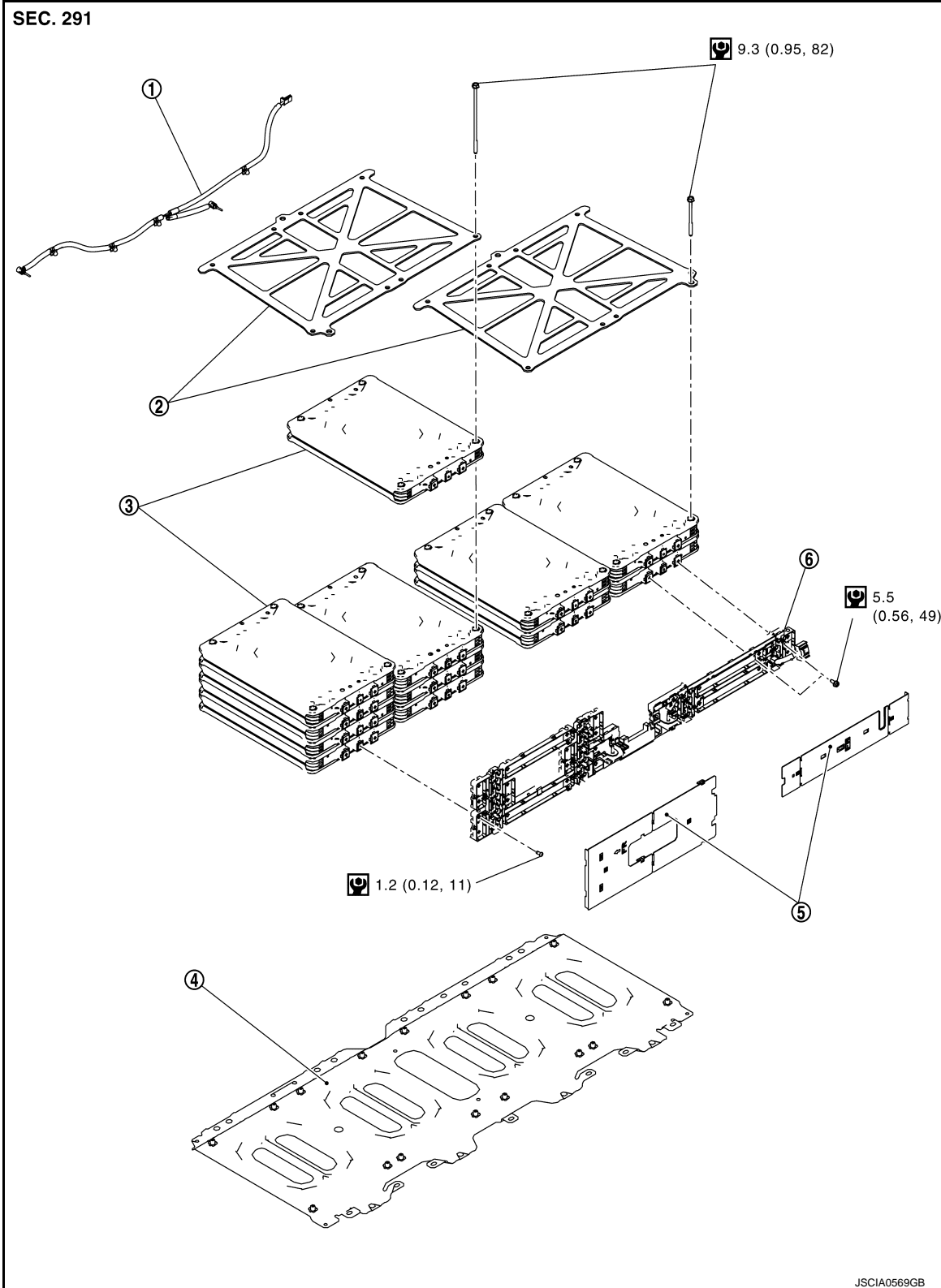

- ① Battery temperature sensor harness (front)
- ② End plate
- ③ Module
- ④ Sub frame
- ⑤ Bus bar cover
- ⑥ Bus bar module

: N·m (kg·m, in·lb)

A
B
EVB
D
E
F
G
H
I
J
K
L
M
N
O
P

LI-ION BATTERY

< UNIT DISASSEMBLY AND ASSEMBLY >

[TYPE 3]

NOTE:

The figure shows the right front.

Module layout

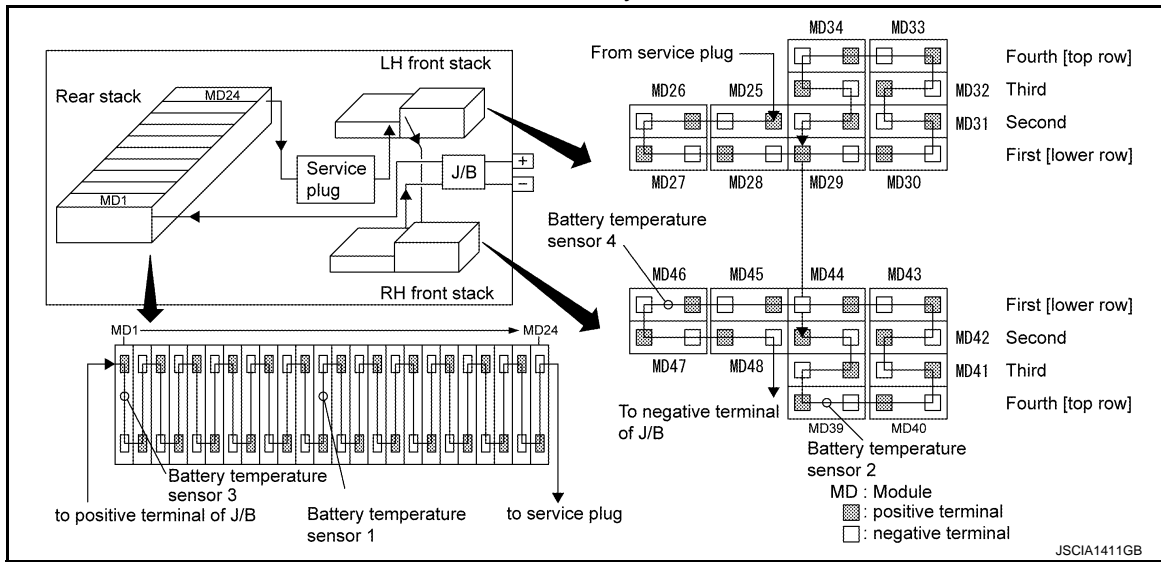

Left front module stack			Right front module stack		
Module No.	Module name	Cell No.	Module No.	Module name	Cell No.
MD25	Module A	49 & 50	MD37	Module A	73 & 74
MD26	Module A	51 & 52	MD38	Module A	75 & 76
MD27	Module A	53 & 54	MD39	Module A	77 & 78
MD28	Module A	55 & 56	MD40	Module A	79 & 80
MD29	Module A	57 & 58	MD41	Module A	81 & 82
MD30	Module A	59 & 60	MD42	Module A	83 & 84
MD31	Module A	61 & 62	MD43	Module A	85 & 86
MD32	Module A	63 & 64	MD44	Module A	87 & 88
MD33	Module A	65 & 66	MD45	Module A	89 & 90
MD34	Module A	67 & 68	MD46	Module A	91 & 92
MD35	Module A	69 & 70	MD47	Module A	93 & 94
MD36	Module A	71 & 72	MD48	Module A	95 & 96

FRONT MODULE STACK : Removal and Installation

INFOID:000000011192816

DANGER:



Because hybrid vehicles and electric vehicles contain a high voltage battery, there is a risk of electric shock, electric leakage, or similar accidents if the vehicle is handled incorrectly. Be sure to follow the correct work procedures when performing inspection and maintenance.

WARNING:

- Be sure to remove the service plug in order to shut off the high voltage circuits before performing inspection or maintenance of high voltage system harnesses and parts.
- Be sure to put the removed service plug in pocket and carry it or store it in a tool box or other container so that another person does not accidentally connect it while work is in progress.
- Be sure to put on insulating protective gear before beginning work on the high voltage system.
- Clearly identify the persons responsible for high voltage work and ensure that other persons do not touch the vehicle. When not working, cover high voltage components with an anti-static cover sheet or similar item to prevent contact with other persons.
- Refer to [EVB-469, "High Voltage Precautions"](#).

LI-ION BATTERY

< UNIT DISASSEMBLY AND ASSEMBLY >

[TYPE 3]

- If the battery pack is to be disassembled, be sure to remove the Li-ion battery controller for preventing electric shock, fire, and damage to parts.

CAUTION:

There is the possibility of a malfunction occurring if the vehicle is changed to READY status while the service plug is removed. Therefore do not change the vehicle to READY status unless instructed to do so in the Service Manual.

ENVIRONMENT FOR LI-ION BATTERY DISASSEMBLY WORK

1. Must be an indoor environment.
 - The environment must utilize a shutter or other means to shut out the outside environment and prevent rain, snow, dust, or other substances from entering.
 - The environment must not cause the intrusion of sweat during work, or cause condensation to occur due to high temperature or humidity.
2. Metal powder, grease, and other foreign substances must not enter.
 - The indoor environment must also prevent metal powder, grease, and other foreign substances from entering due to maintenance performed on other vehicles and other sources during disassembly work.
 - If there is a risk of the above substances entering, take appropriate countermeasures, such as use of a vinyl curtain or an equivalent to shut out the outside environment.
3. The floor must be dry.
 - The floor must not be wet as a result of factors such as vehicle entry during rain or snow.
4. Work space
 - The work space must be approximately the size of one entire vehicle.
 - Take appropriate countermeasures so that persons other than the operator do not enter the work space, such as by placing signs indicating that disassembly work is in progress.
5. Standard fire fighting equipment
 - Always place a standard fire fighting equipment in the disassembly work area.
 - Depending on type of fire (vehicle or battery) use standard fire fighting equipment (water or extinguisher).

REMOVAL

1. Remove the battery pack upper case. [EVB-635. "BATTERY PACK UPPER CASE : Removal and Installation"](#).
2. Remove Li-ion battery controller. Refer to [EVB-645. "LI-ION BATTERY CONTROLLER : Removal and Installation"](#).
3. Remove the following. [EVB-650. "BATTERY JUNCTION BOX AND BATTERY HARNESS : Disassembly and Assembly"](#).
 - Battery junction box
 - Service plug switch bracket
 - All high-voltage battery harnesses
 - Vehicle communications harness
 - Voltage detection harness
4. Remove the mounting nuts (A), then remove the bus bar ① which connects the left and right front module stacks.

← : Battery front

DANGER:

-  There is the danger of electric shock caused by contact with the terminals. Be sure to wear insulated protective gear and use insulated tools.



-  Because there is a danger of electric shock, be sure to close the bus bar cover after removing the bus bar.

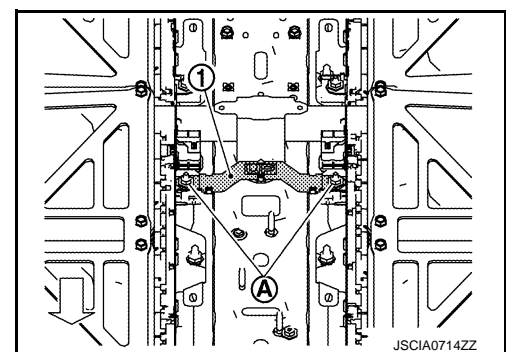

LI-ION BATTERY

< UNIT DISASSEMBLY AND ASSEMBLY >

[TYPE 3]

5. Disconnect the harness connector ① between the battery temperature sensor harness (front) and the battery temperature sensor harness (rear).

WARNING:



To prevent electric shock, wear insulated protective gear.

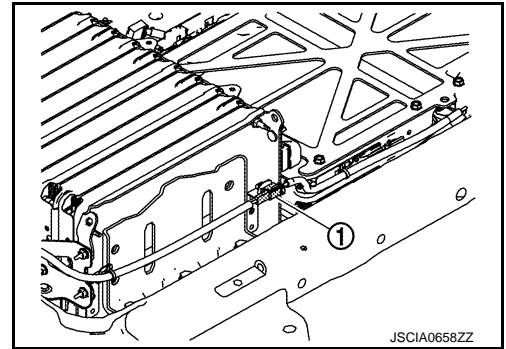

JSCIA0658ZZ

6. Remove the battery temperature sensor harness (front) ① from the right front module stack.

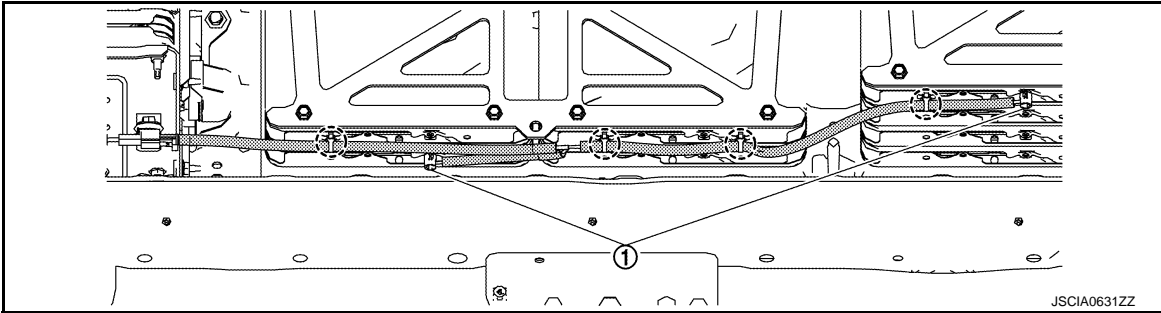

JSCIA0631ZZ

○ : Harness clip

WARNING:



To prevent electric shock, wear insulated protective gear and use insulated tools.



7. Remove the battery member pipe ①.

WARNING:



To prevent electric shock, wear insulated protective gear and use insulated tools.



NOTE:

The right-side mounting hole is larger for facilitating removal of the battery member pipe. Lifting up the left side first makes removal easier.

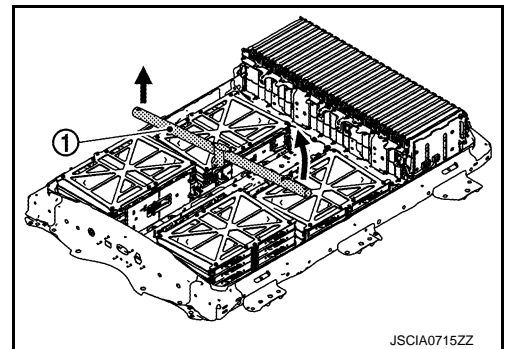

JSCIA0715ZZ

LI-ION BATTERY

< UNIT DISASSEMBLY AND ASSEMBLY >

[TYPE 3]

8. Remove the front module stack mounting nuts (A).

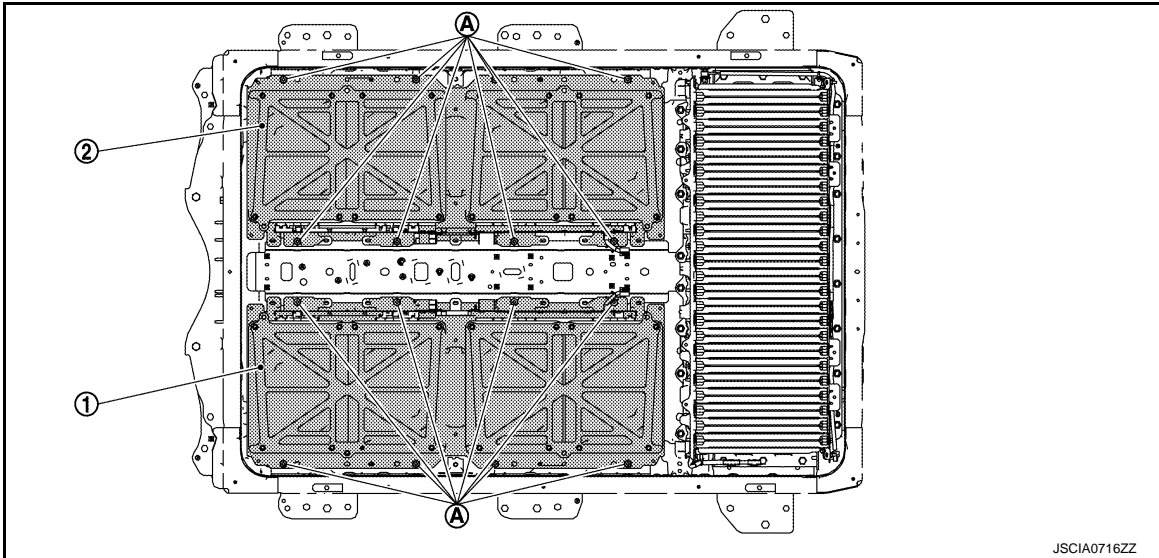

- ① Front module stack LH ② Front module stack RH

WARNING:



To prevent electric shock, wear insulated protective gear and use insulated tools.



9. Follow the procedure below and remove the front module stack from the battery pack.
a. Attach a carabiner at position (A) as shown in the figure, and attach a sling belt to it.

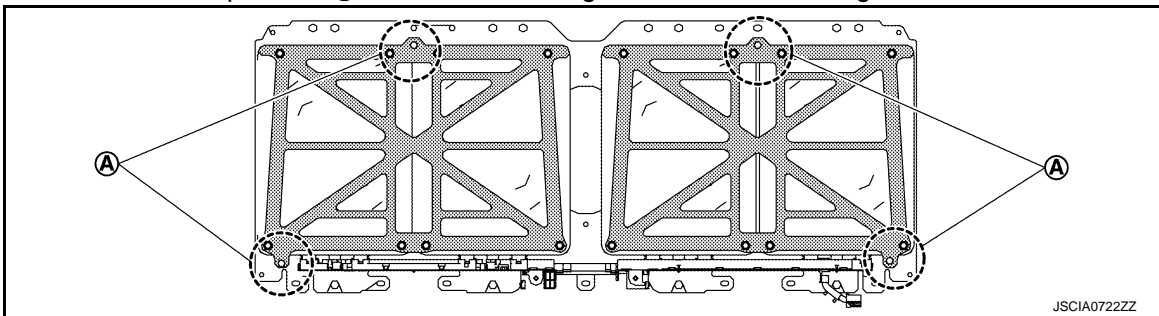

WARNING:



To prevent electric shock, wear insulated protective gear.



- b. Use the engine frame (A) and lift up the front module stack.

WARNING:



To prevent electric shock, wear insulated protective gear.



CAUTION:

Do not move the engine crane when the front module stack is lifted up.

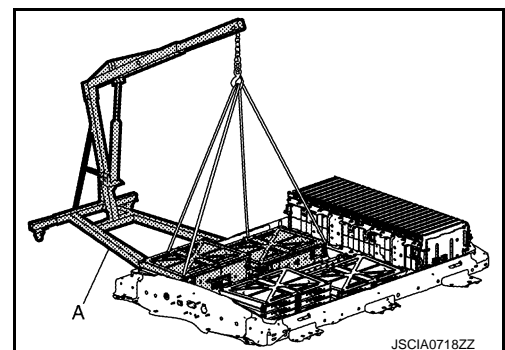

A
B
EVB
D
E
F
G
H
I
J
K
L
M
N
O
P

LI-ION BATTERY

< UNIT DISASSEMBLY AND ASSEMBLY >

[TYPE 3]

c. Move the battery pack and place the workbench below the front module stack.

WARNING:

 To prevent electric shock, wear insulated protective gear.



CAUTION:

Place the removed battery pack upper case onto the battery pack for storage.

d. Place the front module stack onto the workbench.

WARNING:

•  To prevent electric shock, wear insulated protective gear.



•  Because there is a risk of electric shock, lay an anti-static rubber sheet on the workbench.

NOTE:

The figure shows the front module stack RH.

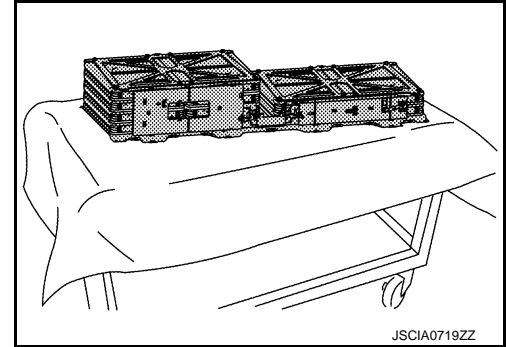

INSTALLATION

Note the following items, and disassembly in the reverse order of disassembly.

DANGER:

•  There is the danger of electric shock caused by contact with the terminals. Be sure to wear insulated protective gear and use insulated tools.



•  Because there is a danger of electric shock and fire, never allow bus bar to contact a wrong terminal.

- If bus bar contacts a wrong terminal, the circuit becomes energized and a short may occur.
- Always keep the bus bar cover closed until immediately before the installation of bus bar.
- Since the correct installation position for the bus bar connected to both front module stacks is commonly-confused with the wrong position (B), install the bus bar to the correct position (A) with extreme caution.

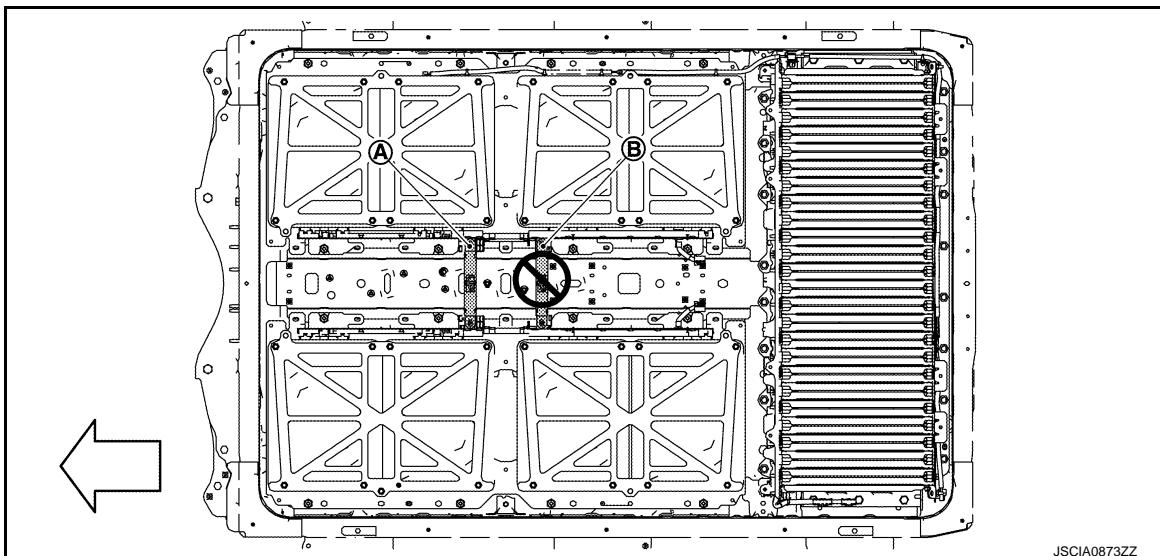

LI-ION BATTERY

< UNIT DISASSEMBLY AND ASSEMBLY >

[TYPE 3]

(A) Correct position

(B) Wrong position

↶ : Battery front

WARNING:

Install the Li-ion battery controller immediately before installing the battery pack upper case. Refer to [EVB-635, "BATTERY PACK UPPER CASE : Removal and Installation"](#).

EV Battery Tracking Identification Seal

When replacing the Li-ion battery with a new battery, perform the following operation.

1. Enter the date of the (replacement) work on the EV battery tracking identification seal that is packaged together with the new part.
2. Cut the EV battery tracking identification tool into 2 pieces and apply them to the body of the replaced (old) Li-ion battery and to the "Li-ion battery replacement history record".
3. Enter the necessary information in the "Li-ion battery replacement history record".

Battery Temperature Sensor Harness (Front)

Install the battery temperature sensor harness (front) onto the front module stack RH.

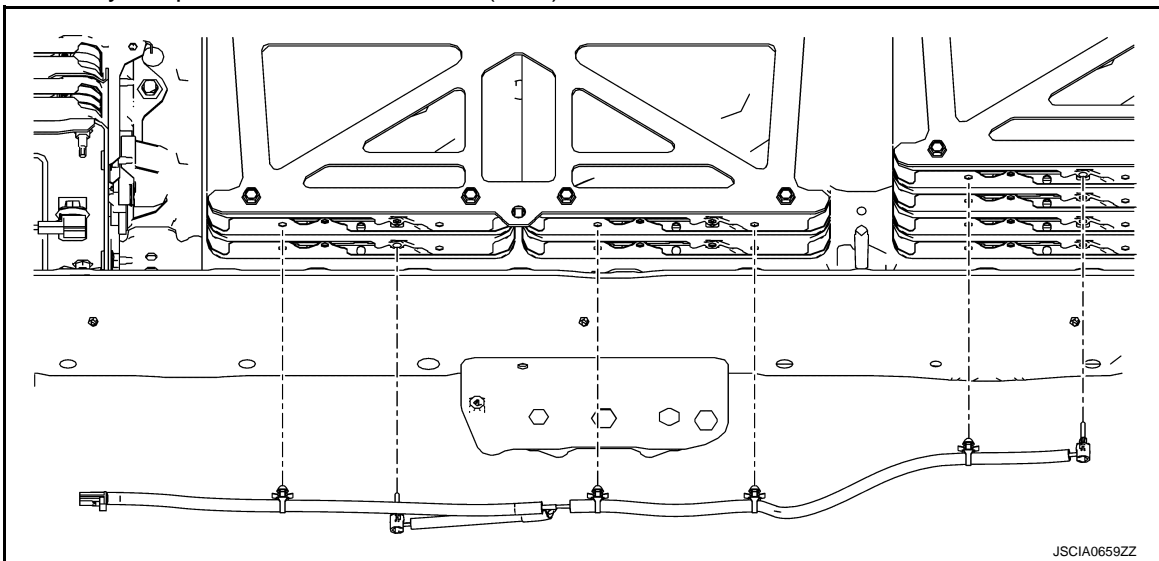

CAUTION:

- Be sure to reinstall the high voltage harness clips in their original positions. If a clip is damaged, replace it with a new clip before installing.
- Check the following items after installing battery pack: Refer to [EVB-687, "Inspection"](#).
 - AIR LEAK INSPECTION
 - ELECTRIC EQUIPOTENTIAL TEST

NOTE:

Install the battery temperature sensor onto module No. MD39 and MD46.

FRONT MODULE STACK : Disassembly and Assembly

INFOID:000000011192182

DANGER:

 Since hybrid vehicles and electric vehicles contain a high voltage battery, there is the risk of electric shock, electric leakage, or similar accidents if the high voltage component and vehicle are handled incorrectly. Be sure to follow the correct work procedures when performing inspection and maintenance.

WARNING:

- Be sure to remove the service plug in order to shut off the high voltage circuits before performing inspection or maintenance of high voltage system harnesses and parts.
- Be sure to put the removed service plug in pocket and carry it or store it in a tool box or other container so that another person does not accidentally connect it while work is in progress.
- Be sure to put on insulating protective gear before beginning work on the high voltage system.

LI-ION BATTERY

< UNIT DISASSEMBLY AND ASSEMBLY >

[TYPE 3]

- Clearly identify the persons responsible for high voltage work and ensure that other persons do not touch the vehicle. When not working, cover high voltage components with an anti-static cover sheet or similar item to prevent contact with other persons.
- Refer to [EVB-469, "High Voltage Precautions"](#).
- If the battery pack is to be disassembled, be sure to remove the Li-ion battery controller for preventing electric shock, fire, and damage to parts.

CAUTION:

There is the possibility of a malfunction occurring if the vehicle is changed to READY status while the service plug is removed. Therefore do not change the vehicle to READY status unless instructed to do so in the Service Manual.

ENVIRONMENT FOR LI-ION BATTERY DISASSEMBLY WORK

1. Must be an indoor environment.
 - The environment must utilize a shutter or other means to shut out the outside environment and prevent rain, snow, dust, or other substances from entering.
 - The environment must not cause the intrusion of sweat during work, or cause condensation to occur due to high temperature or humidity.
2. Metal powder, grease, and other foreign substances must not enter.
 - The indoor environment must also prevent metal powder, grease, and other foreign substances from entering due to maintenance performed on other vehicles and other sources during disassembly work.
 - If there is a risk of the above substances entering, take appropriate countermeasures, such as use of a vinyl curtain or an equivalent to shut out the outside environment.
3. The floor must be dry.
 - The floor must not be wet as a result of factors such as vehicle entry during rain or snow.
4. Work space
 - The work space must be approximately the size of one entire vehicle.
 - Take appropriate countermeasures so that persons other than the operator do not enter the work space, such as by placing signs indicating that disassembly work is in progress.
5. Standard fire fighting equipment
 - Always place a standard fire fighting equipment in the disassembly work area.
 - Depending on type of fire (vehicle or battery) use standard fire fighting equipment (water or extinguisher).

DISASSEMBLY

1. Follow the procedure below and remove the bus bar module from the front module stack.
 - a. Remove the bus bar cover, then remove the module terminal mounting bolts (A).

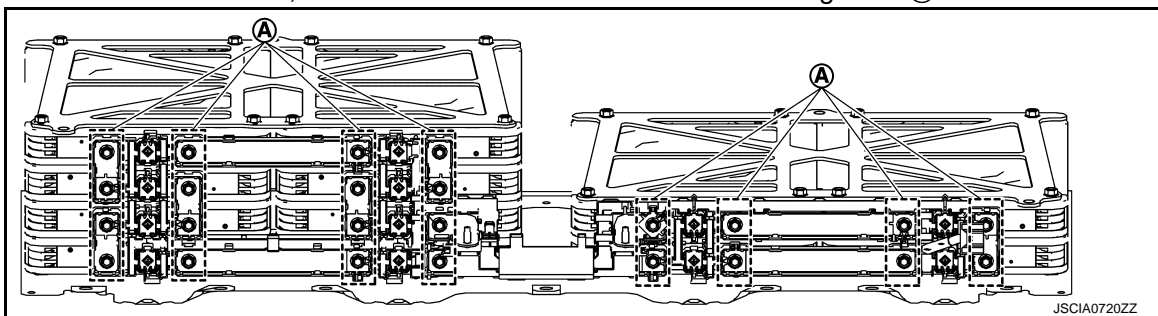

DANGER:

-  There is the danger of electric shock caused by contact with the terminals. Be sure to wear insulated protective gear and use insulated tools.



-  This work must not be performed by multiple operators because there is a risk of electric shock if the operators contact one another.

LI-ION BATTERY

< UNIT DISASSEMBLY AND ASSEMBLY >

[TYPE 3]

- b. Remove the voltage detection terminal mounting screws (A), then remove the bus bar module (1) from the front module stack.

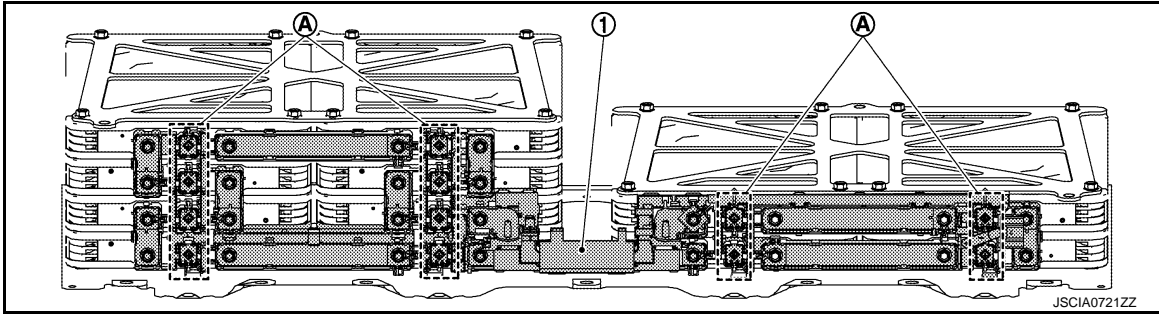

DANGER:

- ⚡ There is the danger of electric shock caused by contact with the terminals. Be sure to wear insulated protective gear and use insulated tools.



- ⚡ This work must not be performed by multiple operators because there is a risk of electric shock if the operators contact one another.

- c. Install a module terminal cover [SST: KV99111500 (—)] (A) onto all module terminals.

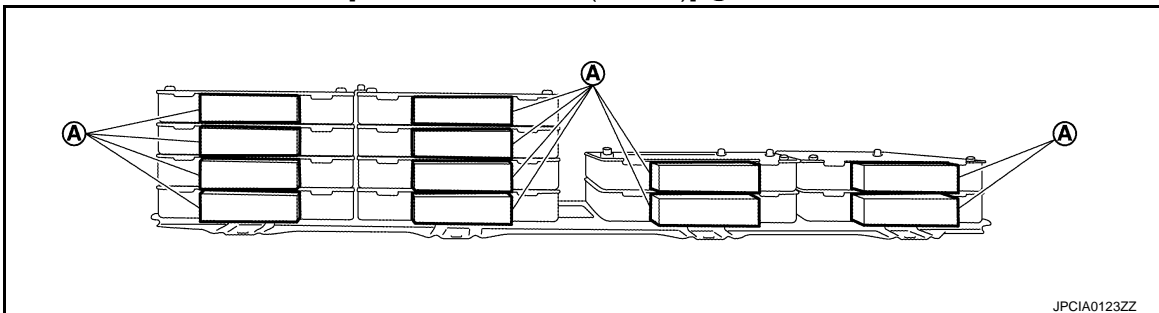

WARNING:

- ⚡ To prevent electric shock, wear insulated protective gear.



2. Remove the end plate and disassemble the front module stack.

WARNING:

- ⚡ To prevent electric shock, wear insulated protective gear and use insulated tools.



ASSEMBLY

- When replacing the Li-ion battery with a new battery, perform the following operation.
 - Enter the date of the (replacement) work on the EV battery tracking identification seal that is packaged together with the new part.
 - Cut the EV battery tracking identification tool into 2 pieces and apply them to the body of the replaced (old) Li-ion battery and to the "Li-ion battery replacement history record".
 - Enter the necessary information in the "Li-ion battery replacement history record".
- Follow the procedure below to assemble the front module stack.

DANGER:

A
B
EVB
D
E
F
G
H
I
J
K
L
M
N
O
P

LI-ION BATTERY

< UNIT DISASSEMBLY AND ASSEMBLY >

[TYPE 3]



There is the danger of electric shock caused by contact with the terminals. Be sure to wear insulated protective gear and use insulated tools.



a. Assemble the module so that the module terminals are arranged as shown in the figure.

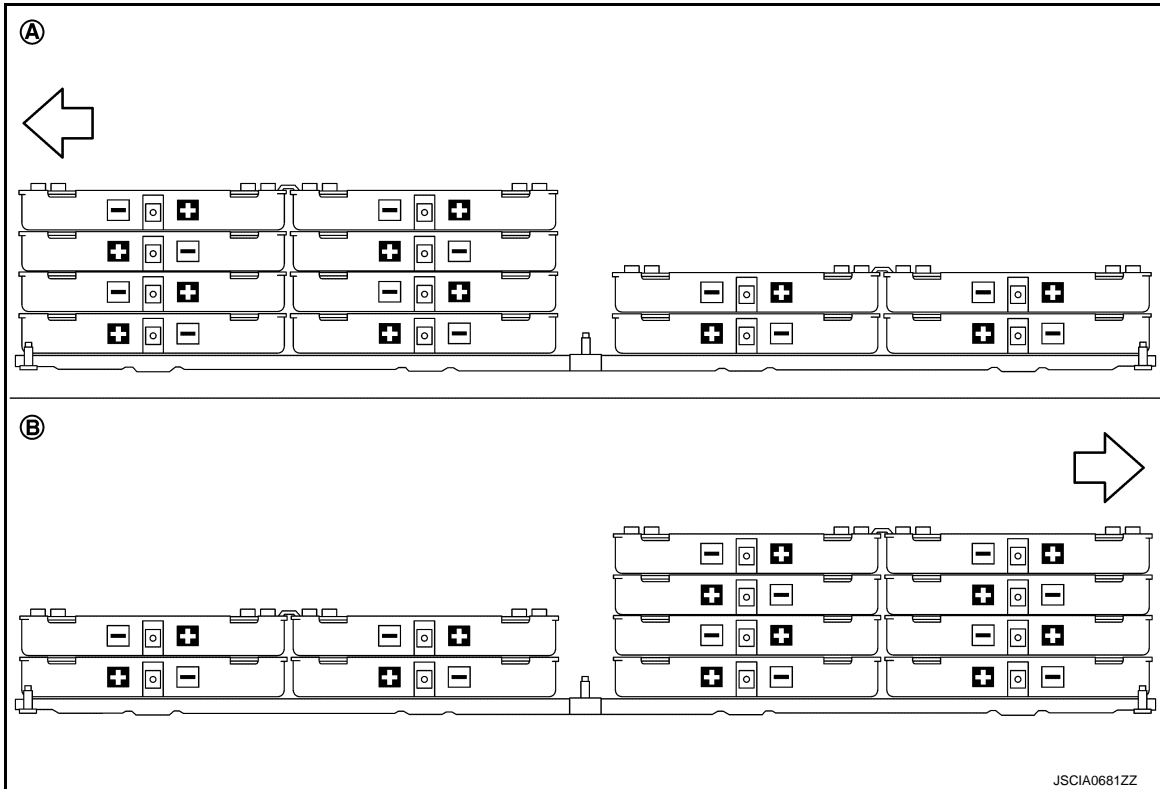

(A) Right module stack

(B) Left module stack

← : Battery front

WARNING:



Be careful of the directions of the + terminal and – terminal when assembling the module. If the polarity is incorrect, there is a risk of electric shock, fire, and component damage.

NOTE:

- To identify the module + terminal and – terminal, refer to the figure.

- + terminal identification color (A) : Red
- terminal identification color (B) : Black

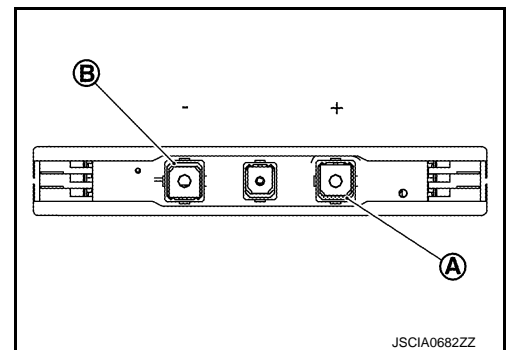

LI-ION BATTERY

< UNIT DISASSEMBLY AND ASSEMBLY >

[TYPE 3]

- Install the module while aligning the position of the module collar ①.

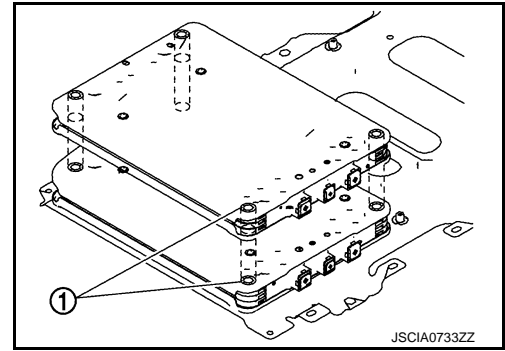

- b. Install so that the end plate carabiner installation holes (A) are in the positions shown in the figure.

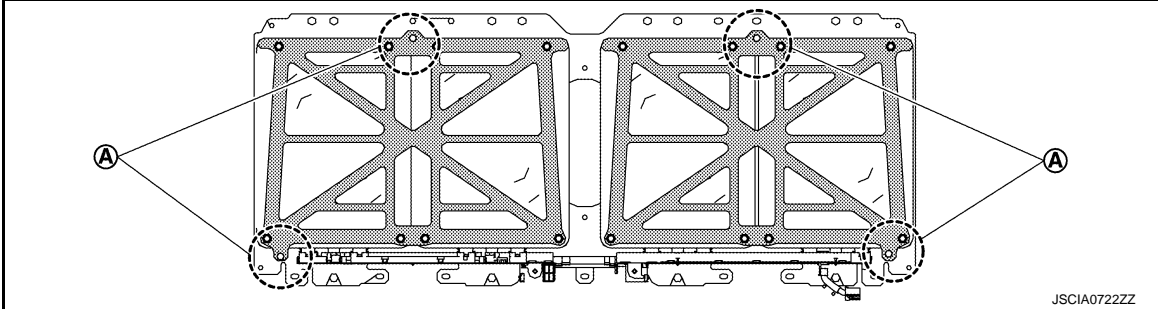

NOTE:

There are 2 end plates, each with different carabiner installation hole positions. If they are installed reversed, the carabiner installation hole is positioned on the inside and lifting up is not possible.

- c. Install the mounting bolts (A) at opposite corners for each module, then insert $\phi 7$ mm (0.28 in) metal bars (B) into the empty bolt holes and perform centering of the module collar position.

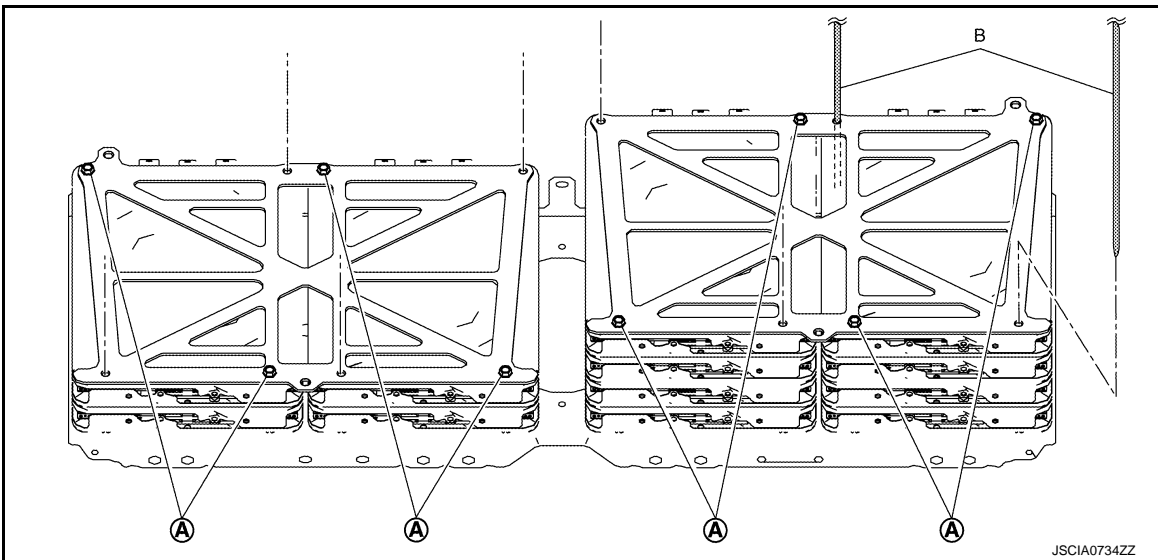

CAUTION:

If the collar position is incorrect, there is a risk of the bolts loosening because they are not supported by the collar between the modules.

- d. Tighten the mounting bolt to the specified torque.
3. Follow the following procedure and install the bus bar module onto the front module stack.

LI-ION BATTERY

< UNIT DISASSEMBLY AND ASSEMBLY >

[TYPE 3]

- a. Install the bus bar module ①, then use an insulated torque driver to tighten the voltage detection terminal mounting screws ②.

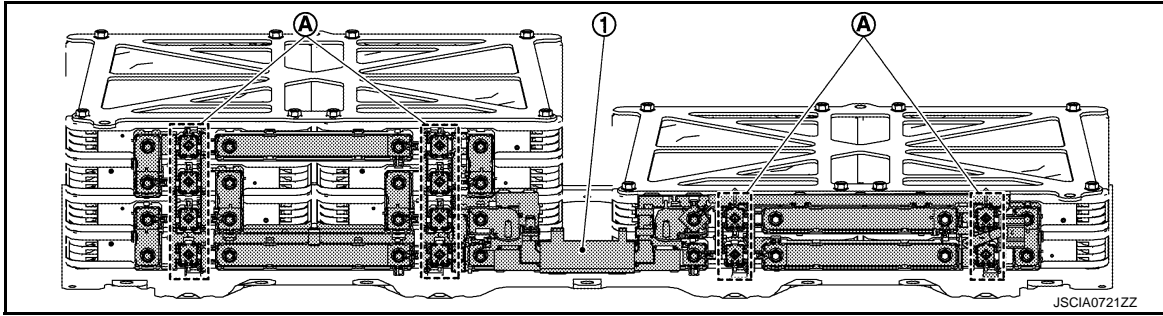

DANGER:

- ⚡ There is the danger of electric shock caused by contact with the terminals. Be sure to wear insulated protective gear and use insulated tools.



- ⚡ This work must not be performed by multiple operators because there is a risk of electric shock if the operators contact one another.

- b. Tighten the module terminal mounting bolts in numerical order as shown in the figure.

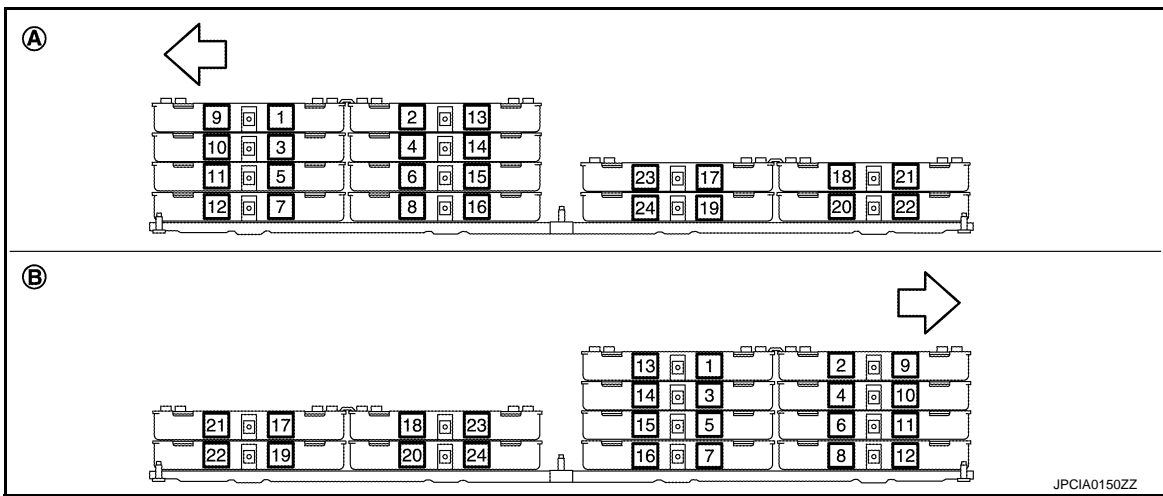

Ⓐ Right module stack

Ⓑ Left module stack

← : Battery front

DANGER:

- ⚡ There is the danger of electric shock caused by contact with the terminals. Be sure to wear insulated protective gear and use insulated tools.



- ⚡ This work must not be performed by multiple operators because there is a risk of electric shock if the operators contact one another.

- c. Install the bus bar cover.

REAR MODULE STACK

LI-ION BATTERY

< UNIT DISASSEMBLY AND ASSEMBLY >

[TYPE 3]

INFOID:000000011192183

REAR MODULE STACK : Exploded View

REMOVAL AND INSTALLATION

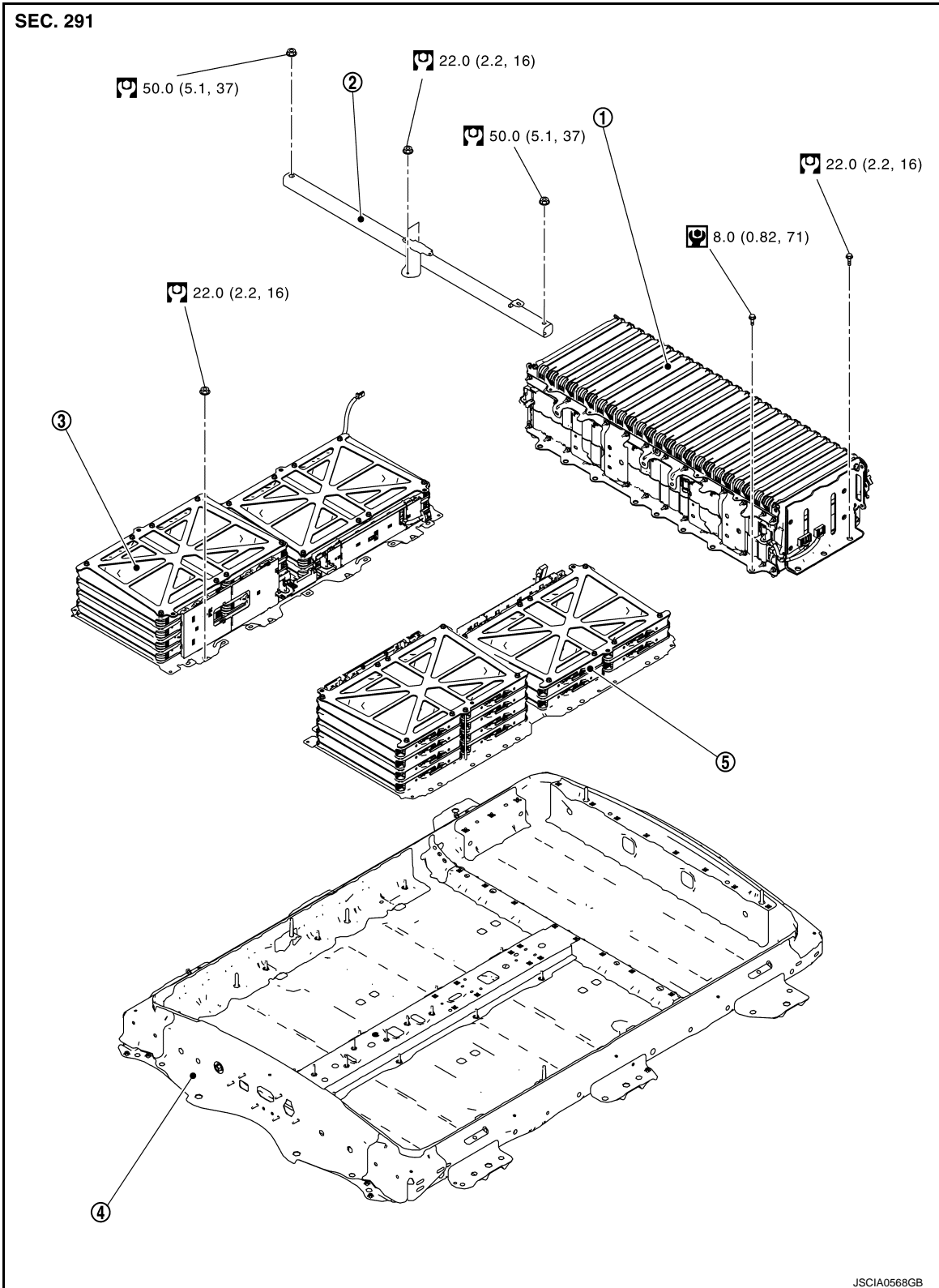

- ① Rear module stack
- ② Battery member pipe
- ③ Front module stack RH
- ④ Battery pack lower case
- ⑤ Front module stack LH

A
B
EVB
D
E
F
G
H
I
J
K
L
M
N
O
P

LI-ION BATTERY

< UNIT DISASSEMBLY AND ASSEMBLY >

[TYPE 3]

 : N·m (kg·m, in·lb)

 : N·m (kg·m, ft·lb)

DISASSEMBLY AND ASSEMBLY

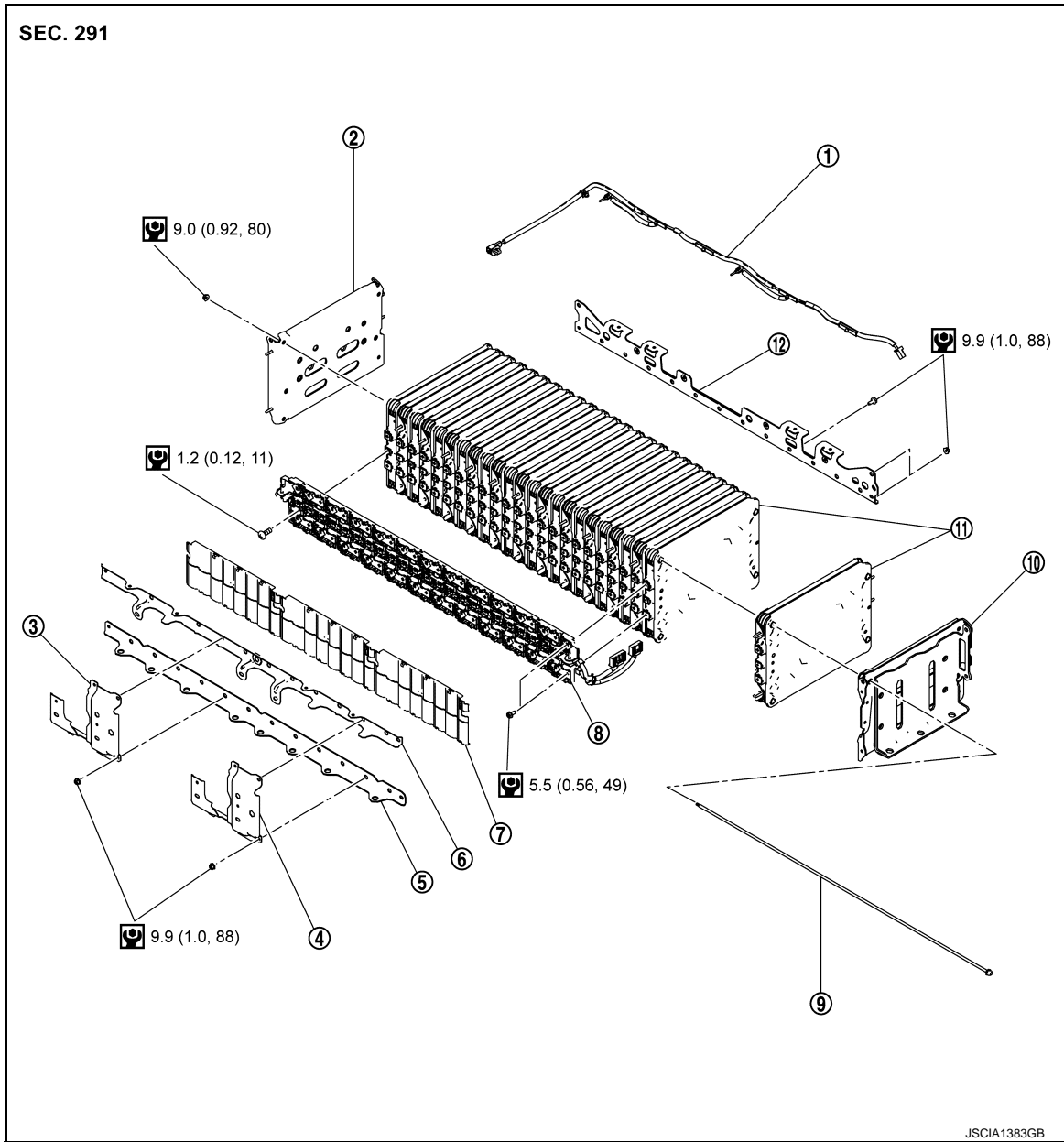

- | | | |
|---|----------------------|---------------------|
| ① Battery temperature sensor harness (rear) | ② Right end plate | ③ Harness bracket |
| ④ Harness bracket | ⑤ Front stack member | ⑥ Harness bracket |
| ⑦ Bus bar cover | ⑧ Bus bar module | ⑨ Through-bolt |
| ⑩ Left end plate | ⑪ Module | ⑫ Rear stack member |

 : N·m (kg·m, in·lb)

LI-ION BATTERY

< UNIT DISASSEMBLY AND ASSEMBLY >

[TYPE 3]

Module layout

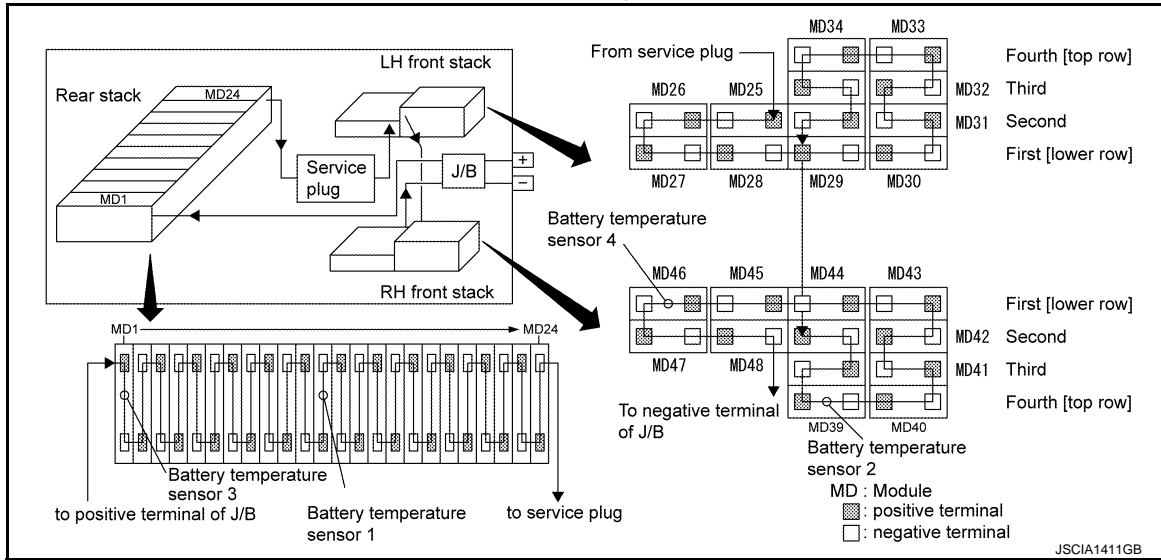

Rear module stack

Module No.	Module name	Cell No.	Module No.	Module name	Cell No.
MD1	Module A	1 & 2	MD13	Module A	25 & 26
MD2	Module B	3 & 4	MD14	Module B	27 & 28
MD3	Module A	5 & 6	MD15	Module A	29 & 30
MD4	Module B	7 & 8	MD16	Module B	31 & 32
MD5	Module A	9 & 10	MD17	Module A	33 & 34
MD6	Module B	11 & 12	MD18	Module B	35 & 36
MD7	Module A	13 & 14	MD19	Module A	37 & 38
MD8	Module B	15 & 16	MD20	Module B	39 & 40
MD9	Module A	17 & 18	MD21	Module A	41 & 42
MD10	Module B	19 & 20	MD22	Module B	43 & 44
MD11	Module A	21 & 22	MD23	Module A	45 & 46
MD12	Module B	23 & 24	MD24	Module B	47 & 48

NOTE:

- Module A: No bracket
- Module B: With bracket

REAR MODULE STACK : Removal and Installation

INFOID:000000011192815

DANGER:



Because hybrid vehicles and electric vehicles contain a high voltage battery, there is a risk of electric shock, electric leakage, or similar accidents if the vehicle is handled incorrectly. Be sure to follow the correct work procedures when performing inspection and maintenance.

WARNING:

- Be sure to remove the service plug in order to shut off the high voltage circuits before performing inspection or maintenance of high voltage system harnesses and parts.
- Be sure to put the removed service plug in pocket and carry it or store it in a tool box or other container so that another person does not accidentally connect it while work is in progress.
- Be sure to put on insulating protective gear before beginning work on the high voltage system.
- Clearly identify the persons responsible for high voltage work and ensure that other persons do not touch the vehicle. When not working, cover high voltage components with an anti-static cover sheet or similar item to prevent contact with other persons.
- Refer to [EVB-469, "High Voltage Precautions"](#).

LI-ION BATTERY

< UNIT DISASSEMBLY AND ASSEMBLY >

[TYPE 3]

- If the battery pack is to be disassembled, be sure to remove the Li-ion battery controller for preventing electric shock, fire, and damage to parts.

CAUTION:

There is the possibility of a malfunction occurring if the vehicle is changed to READY status while the service plug is removed. Therefore do not change the vehicle to READY status unless instructed to do so in the Service Manual.

ENVIRONMENT FOR LI-ION BATTERY DISASSEMBLY WORK

1. Must be an indoor environment.
 - The environment must utilize a shutter or other means to shut out the outside environment and prevent rain, snow, dust, or other substances from entering.
 - The environment must not cause the intrusion of sweat during work, or cause condensation to occur due to high temperature or humidity.
2. Metal powder, grease, and other foreign substances must not enter.
 - The indoor environment must also prevent metal powder, grease, and other foreign substances from entering due to maintenance performed on other vehicles and other sources during disassembly work.
 - If there is a risk of the above substances entering, take appropriate countermeasures, such as use of a vinyl curtain or an equivalent to shut out the outside environment.
3. The floor must be dry.
 - The floor must not be wet as a result of factors such as vehicle entry during rain or snow.
4. Work space
 - The work space must be approximately the size of one entire vehicle.
 - Take appropriate countermeasures so that persons other than the operator do not enter the work space, such as by placing signs indicating that disassembly work is in progress.
5. Standard fire fighting equipment
 - Always place a standard fire fighting equipment in the disassembly work area.
 - Depending on type of fire (vehicle or battery) use standard fire fighting equipment (water or extinguisher).

REMOVAL

1. Remove the battery pack upper case. Refer to [EVB-635. "BATTERY PACK UPPER CASE : Removal and Installation"](#).
2. Remove Li-ion battery controller. Refer to [EVB-645. "LI-ION BATTERY CONTROLLER : Removal and Installation"](#).
3. Disconnect the harness connector ① between the battery temperature sensor harness (front) and the battery temperature sensor harness (rear).

WARNING:



To prevent electric shock, wear insulated protective gear.

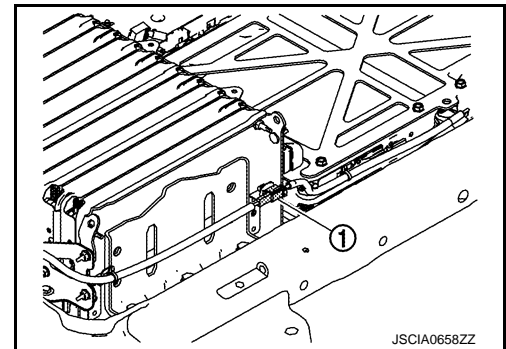

JSCIA0658ZZ

LI-ION BATTERY

< UNIT DISASSEMBLY AND ASSEMBLY >

[TYPE 3]

4. Disconnect the connector, and then remove the battery temperature sensor harness (rear).

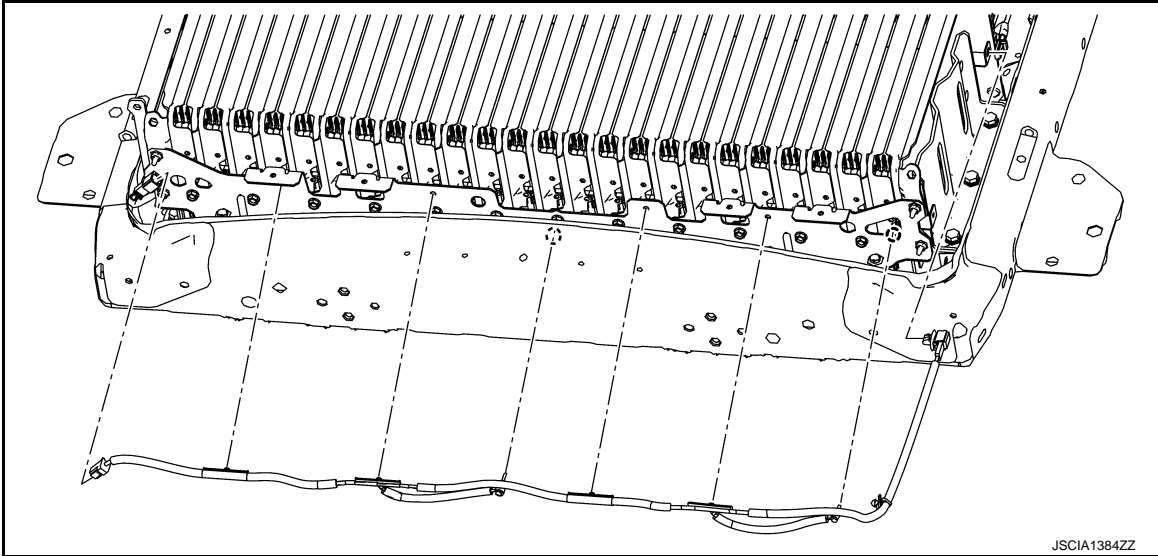

WARNING:



To prevent electric shock, wear insulated protective gear and use insulated tools.



5. Remove the harness clips of the voltage detection harness ① from the harness bracket, and move them to a location where they do not inhibit with work.

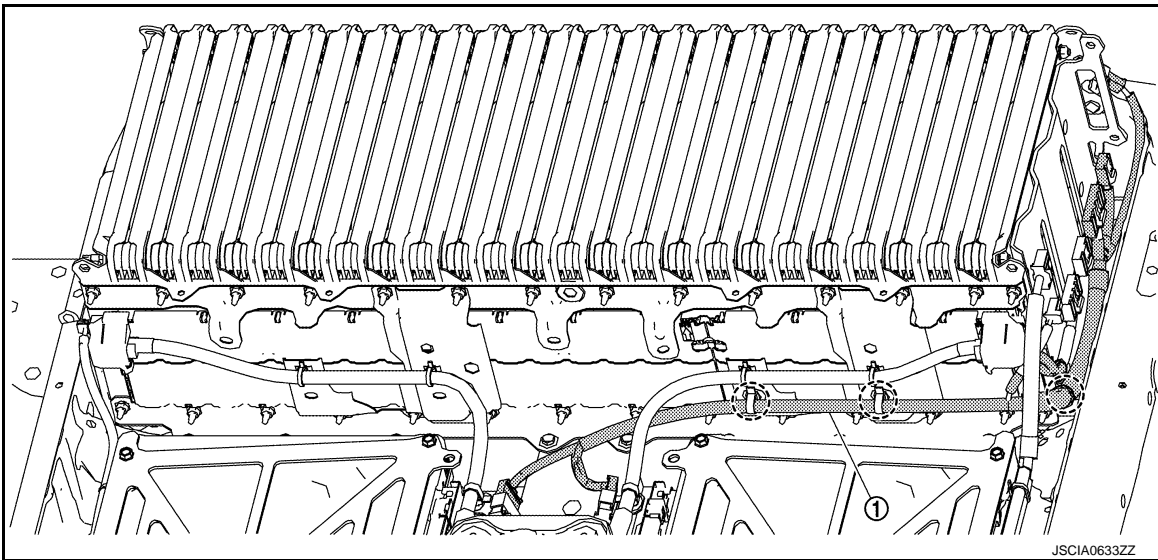

○ : Harness clip

WARNING:



To prevent electric shock, wear insulated protective gear and use insulated tools.



6. Remove the mounting nuts ① and remove the high-voltage harness ①, ② from the rear module stack.

A
B
EVB
D
E
F
G
H
I
J
K
L
M
N
O
P

LI-ION BATTERY

< UNIT DISASSEMBLY AND ASSEMBLY >

[TYPE 3]

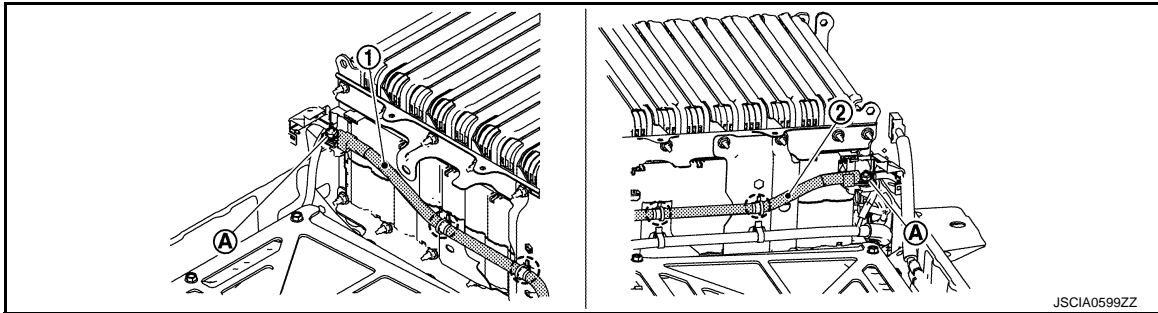

○ : Harness clip

DANGER:

-  There is the danger of electric shock caused by contact with the terminals. Be sure to wear insulated protective gear and use insulated tools.



-  Because there is a risk of electric shock, immediately protect the disconnected high-voltage terminals with insulating tape so that they are not exposed.

7. Remove the rear module stack ① mounting bolts (A).

WARNING:

-  To prevent electric shock, wear insulated protective gear and use insulated tools.

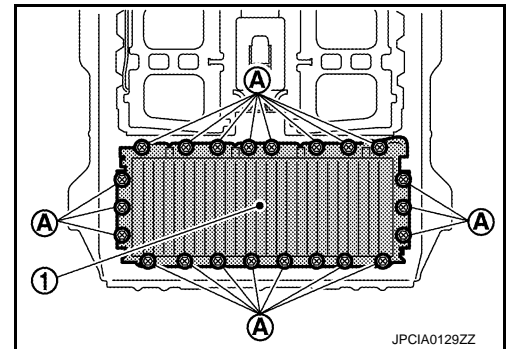
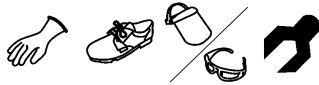

8. Follow the procedure below and remove the rear module stack from the battery pack.

- a. Attach a carabiner to position (A) as shown in the figure and connect a lashing belt to it.

WARNING:

-  To prevent electric shock, wear insulated protective gear.

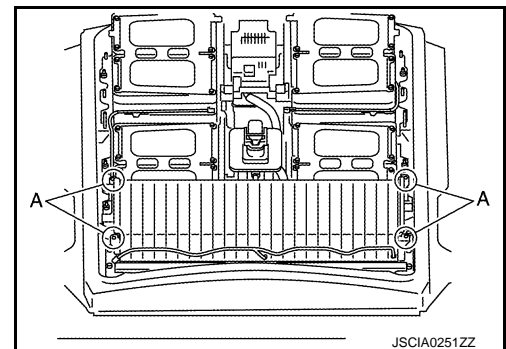

LI-ION BATTERY

< UNIT DISASSEMBLY AND ASSEMBLY >

[TYPE 3]

- b. Use the engine frame (A) and lift up the rear module stack ①.

WARNING:



To prevent electric shock, wear insulated protective gear.



CAUTION:

Do not move the engine crane when the rear module stack is lifted up.

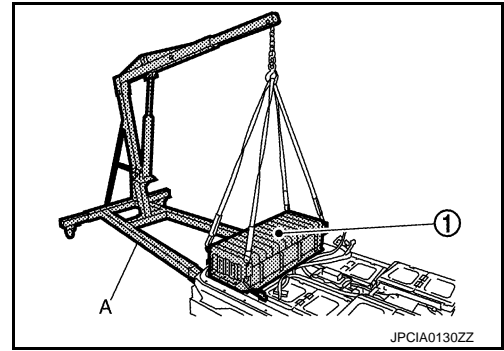

- c. Move the battery pack and place the workbench below the rear module stack.

WARNING:



To prevent electric shock, wear insulated protective gear.



CAUTION:

Place the removed battery pack upper case onto the battery pack for storage.

- d. Place the rear module stack onto the workbench.

WARNING:



To prevent electric shock, wear insulated protective gear.



Because there is a risk of electric shock, lay an anti-static rubber sheet on the workbench.

INSTALLATION

1. When replacing the Li-ion battery with a new battery, perform the following operation.

- Enter the date of the (replacement) work on the EV battery tracking identification seal that is packaged together with the new part.
 - Cut the EV battery tracking identification tool into 2 pieces and apply them to the body of the replaced (old) Li-ion battery and to the "Li-ion battery replacement history record".
 - Enter the necessary information in the "Li-ion battery replacement history record".
2. Follow the following procedure and install the rear module stack onto the battery pack.

- a. Use the engine frame (A) and lift up the rear module stack ①.

WARNING:



To prevent electric shock, wear insulated protective gear.



CAUTION:

Do not move the engine crane when the rear module stack is lifted up.

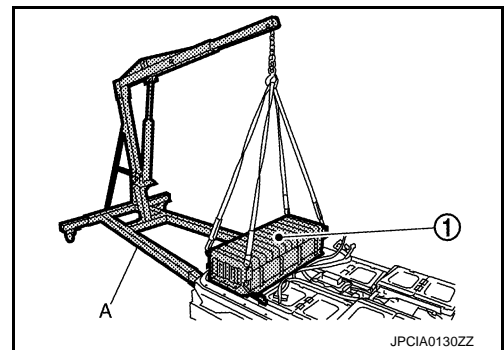

- Move the workbench and place the battery pack below the rear module stack.
- Mount the rear module stack onto the battery pack.

WARNING:



To prevent electric shock, wear insulated protective gear.

A

B

EVB

D

E

F

G

H

I

J

K

L

M

N

O

P

LI-ION BATTERY

< UNIT DISASSEMBLY AND ASSEMBLY >

[TYPE 3]



CAUTION:

Be sure to align the locating pin position.

3. Tighten the rear module stack ① mounting bolts ④.

WARNING:



To prevent electric shock, wear insulated protective gear and use insulated tools.

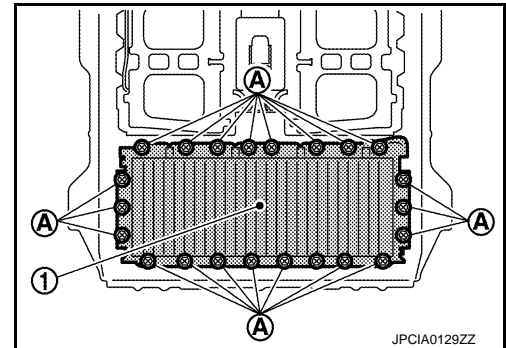
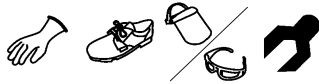

4. Tighten the mounting nuts ④, and then install the high-voltage harness ①, ② onto the rear module stack.

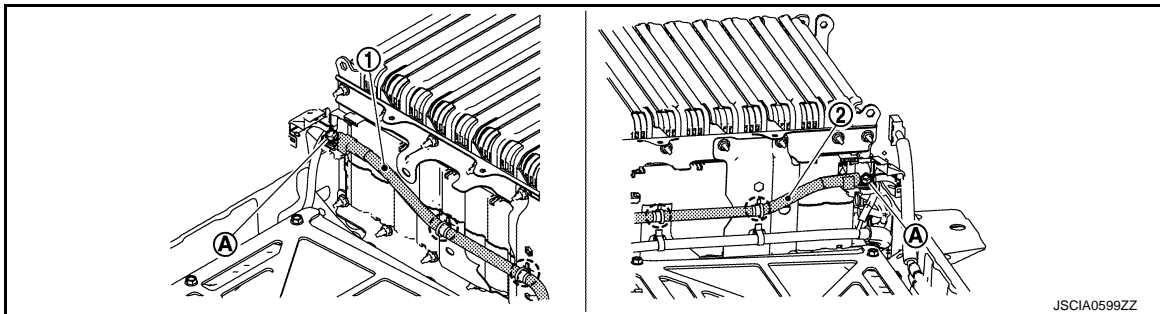

○ : Harness clip

DANGER:

-  There is the danger of electric shock caused by contact with the terminals. Be sure to wear insulated protective gear and use insulated tools.



-  Because there is a risk of electric shock, immediately protect the disconnected high-voltage terminals with insulating tape so that they are not exposed.

5. Install the voltage detection harness ①.

LI-ION BATTERY

< UNIT DISASSEMBLY AND ASSEMBLY >

[TYPE 3]

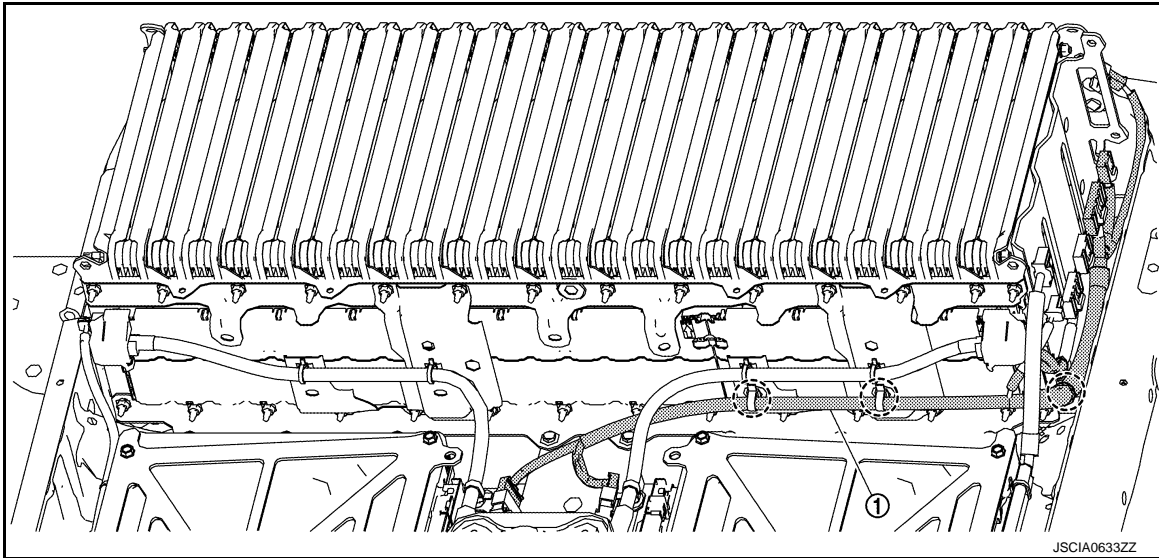

 : Harness clip

WARNING:

 To prevent electric shock, wear insulated protective gear.



6. Install the battery temperature sensor harness (rear).

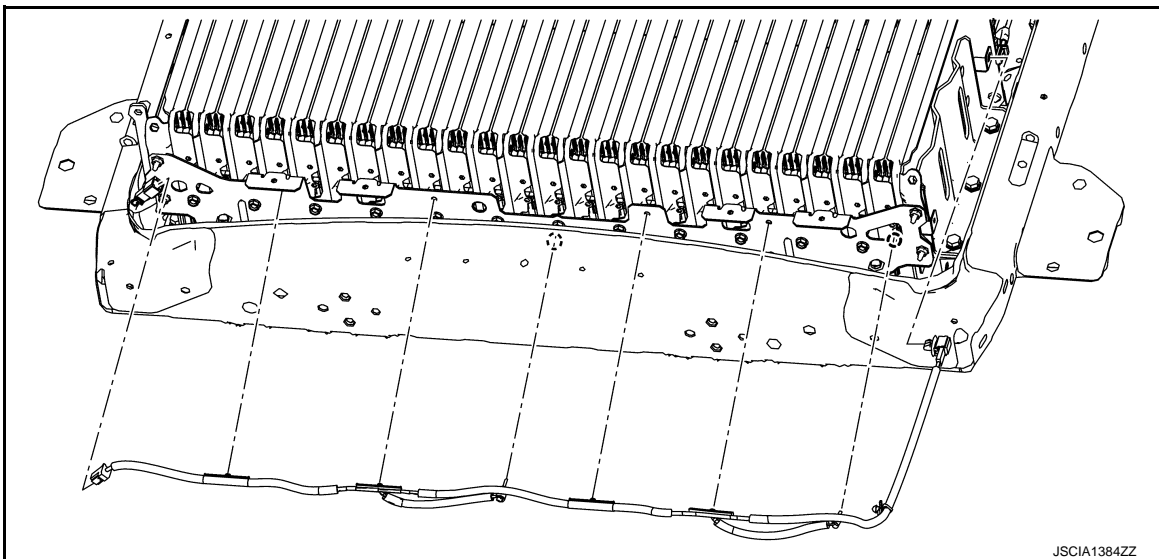

WARNING:

 To prevent electric shock, wear insulated protective gear and use insulated tools.



NOTE:

Install the battery temperature sensor onto module No. MD1 and MD12.

A
B
EVB
D
E
F
G
H
I
J
K
L
M
N
O
P

LI-ION BATTERY

< UNIT DISASSEMBLY AND ASSEMBLY >

[TYPE 3]

7. Connect the harness connector ① between the battery temperature sensor harness (front) and battery temperature sensor harness (rear).

WARNING:



To prevent electric shock, wear insulated protective gear.

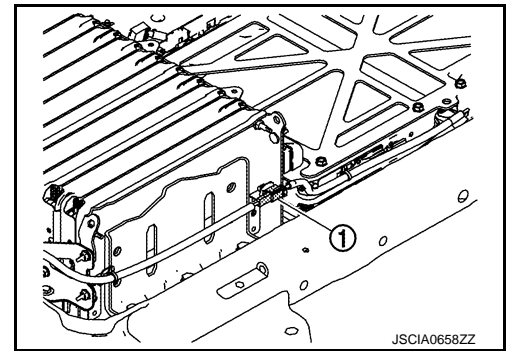

8. Install the Li-ion battery controller. Refer to [EVB-645. "LI-ION BATTERY CONTROLLER : Removal and Installation"](#).
9. Install the battery pack upper case. Refer to [EVB-635. "BATTERY PACK UPPER CASE : Removal and Installation"](#).

CAUTION:

- Be sure to reinstall the high voltage harness clips in their original positions. If a clip is damaged, replace it with a new clip before installing.
- Check the following items after installing battery pack: Refer to [EVB-687. "Inspection"](#).

■AIR LEAK INSPECTION

■ELECTRIC EQUIPOTENTIAL TEST

REAR MODULE STACK : Disassembly and Assembly

INFOID:000000011192185

DANGER:



Since hybrid vehicles and electric vehicles contain a high voltage battery, there is the risk of electric shock, electric leakage, or similar accidents if the high voltage component and vehicle are handled incorrectly. Be sure to follow the correct work procedures when performing inspection and maintenance.

WARNING:

- Be sure to remove the service plug for shutting off high voltage circuits before performing inspection or maintenance of high voltage system harnesses and parts.
- Be sure to put the removed service plug in pocket and carry it or store it in a tool box or other container so that another person does not accidentally connect it while work is in progress.
- Be sure to put on insulating protective gear before beginning work on the high voltage system.
- Clearly identify the persons responsible for high voltage work and ensure that other persons do not touch the vehicle. When not working, cover high voltage components with an anti-static cover sheet or similar item to prevent contact with other persons.
- Refer to [EVB-469. "High Voltage Precautions"](#).
- If the battery pack is to be disassembled, be sure to remove the Li-ion battery controller for preventing electric shock, fire, and damage to parts.

CAUTION:

There is the possibility of a malfunction occurring if the vehicle is changed to READY status while the service plug is removed. Therefore do not change the vehicle to READY status unless instructed to do so in the Service Manual.

ENVIRONMENT FOR LI-ION BATTERY DISASSEMBLY WORK

1. Must be an indoor environment.
 - The environment must utilize a shutter or other means to shut out the outside environment and prevent rain, snow, dust, or other substances from entering.
 - The environment must not cause the intrusion of sweat during work, or cause condensation to occur due to high temperature or humidity.
2. Metal powder, grease, and other foreign substances must not enter.
 - The indoor environment must also prevent metal powder, grease, and other foreign substances from entering due to maintenance performed on other vehicles and other sources during disassembly work.
 - If there is a risk of the above substances entering, take appropriate countermeasures, such as use of a vinyl curtain or an equivalent to shut out the outside environment.
3. The floor must be dry.

LI-ION BATTERY

< UNIT DISASSEMBLY AND ASSEMBLY >

[TYPE 3]

- The floor must not be wet as a result of factors such as vehicle entry during rain or snow.
4. Work space
 - The work space must be approximately the size of one entire vehicle.
 - Take appropriate countermeasures so that persons other than the operator do not enter the work space, such as by placing signs indicating that disassembly work is in progress.
 5. Standard fire fighting equipment
 - Always place a standard fire fighting equipment in the disassembly work area.
 - Depending on type of fire (vehicle or battery) use standard fire fighting equipment (water or extinguisher).

DISASSEMBLY

1. Remove harness bracket ①, ② and ③ from the rear module stack.

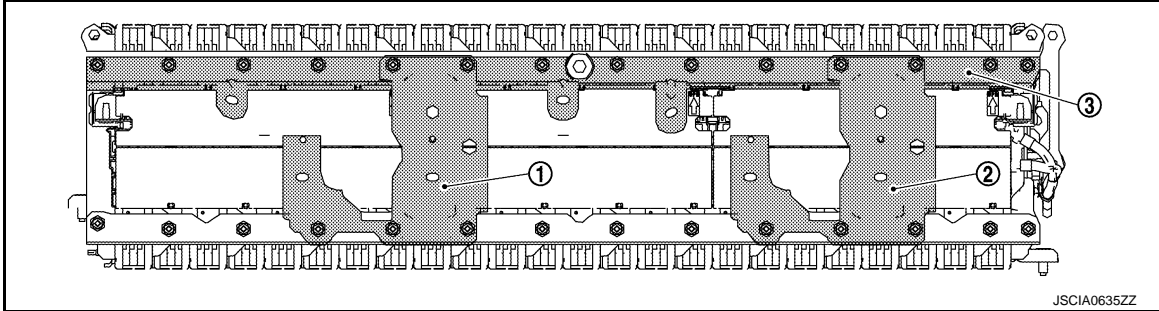

WARNING:



To prevent electric shock, wear insulated protective gear and use insulated tools.



2. Follow the following procedure and remove the bus bar from the rear module stack.
 - a. Remove the center bus bar cover, then remove the module terminal mounting bolts (A).

DANGER:

- There is the danger of electric shock caused by contact with the terminals. Be sure to wear insulated protective gear and use insulated tools.



- This work must not be performed by multiple operators because there is a risk of electric shock if the operators contact one another.

CAUTION:

Do not remove all bus bar covers and all module terminal mounting bolts at the same time.

- b. Remove the left-side bus bar cover, then remove the module terminal mounting bolts (A).

DANGER:

- There is the danger of electric shock caused by contact with the terminals. Be sure to wear insulated protective gear and use insulated tools.



- This work must not be performed by multiple operators because there is a risk of electric shock if the operators contact one another.

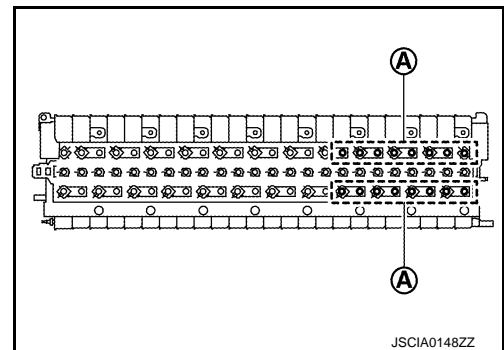
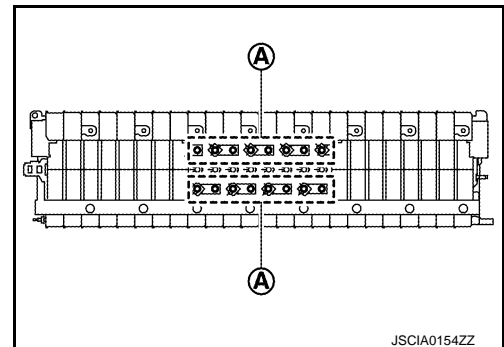

LI-ION BATTERY

< UNIT DISASSEMBLY AND ASSEMBLY >

[TYPE 3]

- c. Remove the right-side bus bar cover, then remove the module terminal mounting bolts (A).

DANGER:

- ⚡ There is the danger of electric shock caused by contact with the terminals. Be sure to wear insulated protective gear and use insulated tools.



- ⚡ This work must not be performed by multiple operators because there is a risk of electric shock if the operators contact one another.

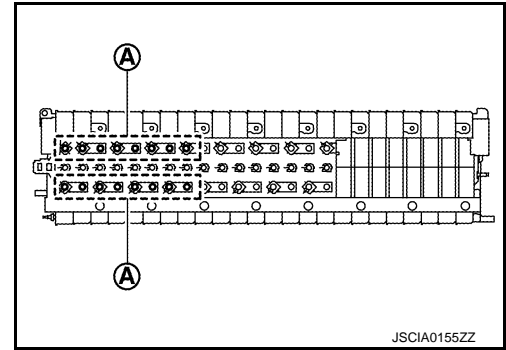

- d. Remove the voltage detection terminal mounting screws (A), then remove the bus bar from the rear module stack.

DANGER:

- ⚡ There is the danger of electric shock caused by contact with the terminals. Be sure to wear insulated protective gear and use insulated tools.



- ⚡ This work must not be performed by multiple operators because there is a risk of electric shock if the operators contact one another.

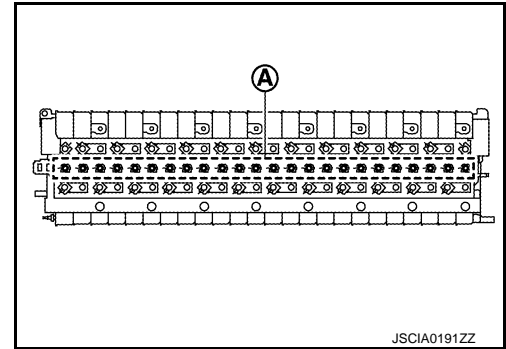

- e. Install a module terminal cover [SST: KV99111500 (—)] (A) onto all module terminals.

WARNING:

- ⚡ To prevent electric shock, wear insulated protective gear.



NOTE:

- Because "module B" interferes with the bracket and cover, cut the module terminal cover at the position shown in the figure.

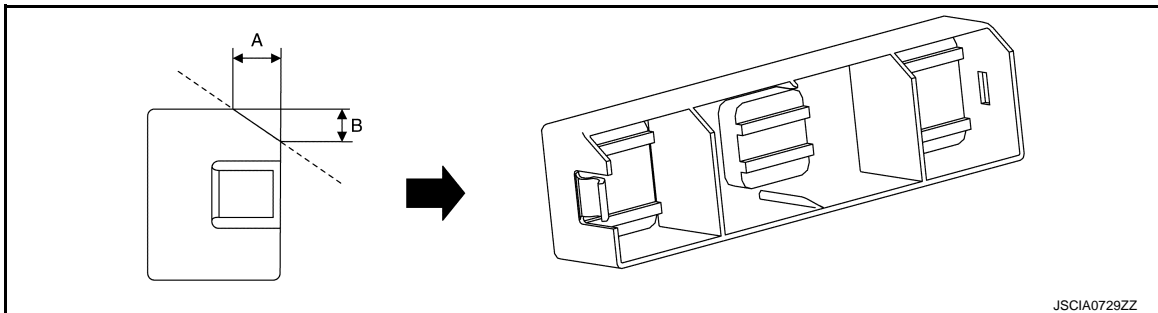
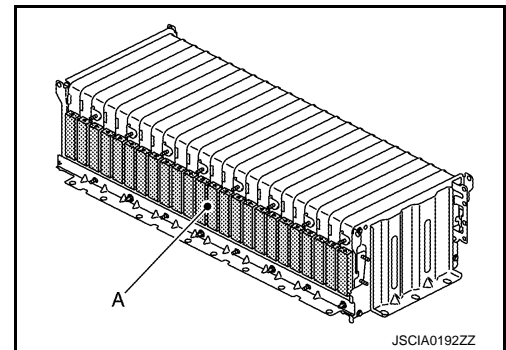

A : 7 mm (0.28 in)

B : 5 mm (0.20 in)

LI-ION BATTERY

< UNIT DISASSEMBLY AND ASSEMBLY >

[TYPE 3]

3. Remove the front stack member ①.

WARNING:

 To prevent electric shock, wear insulated protective gear and use insulated tools.

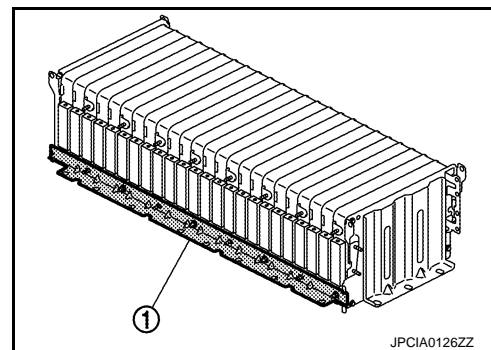

4. Remove the rear stack member ①.

WARNING:

 To prevent electric shock, wear insulated protective gear and use insulated tools.

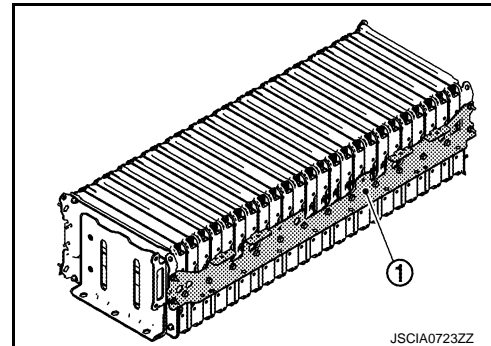

5. Fasten the rear module stack ① with a lashing belt ②.

WARNING:

 To prevent electric shock, wear insulated protective gear.

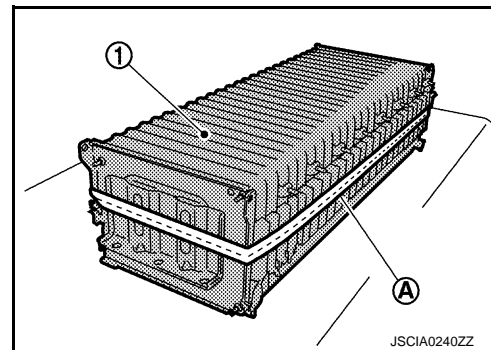

6. Remove the through bolt ② mounting nut, then disassemble the rear module stack ①.

WARNING:

 To prevent electric shock, wear insulated protective gear and use insulated tools.

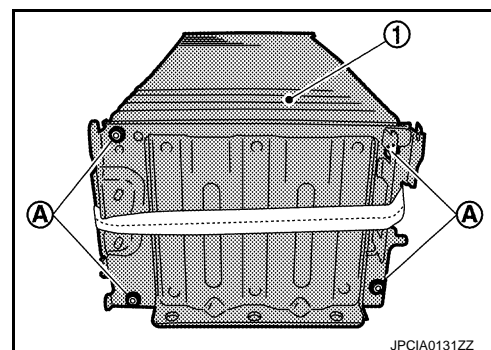

ASSEMBLY

- When replacing the Li-ion battery with a new battery, perform the following operation.
 - Enter the date of the (replacement) work on the EV battery tracking identification seal that is packaged together with the new part.
 - Cut the EV battery tracking identification tool into 2 pieces and apply them to the body of the replaced (old) Li-ion battery and to the "Li-ion battery replacement history record".
 - Enter the necessary information in the "Li-ion battery replacement history record".
- Follow the procedure below to assemble the rear module.

WARNING:

A
B
EVB
D
E
F
G
H
I
J
K
L
M
N
O
P

LI-ION BATTERY

< UNIT DISASSEMBLY AND ASSEMBLY >

[TYPE 3]

 To prevent electric shock, wear insulated protective gear and use insulated tools.



a. Assemble the rear module so that the module terminals are arranged as shown in the figure.

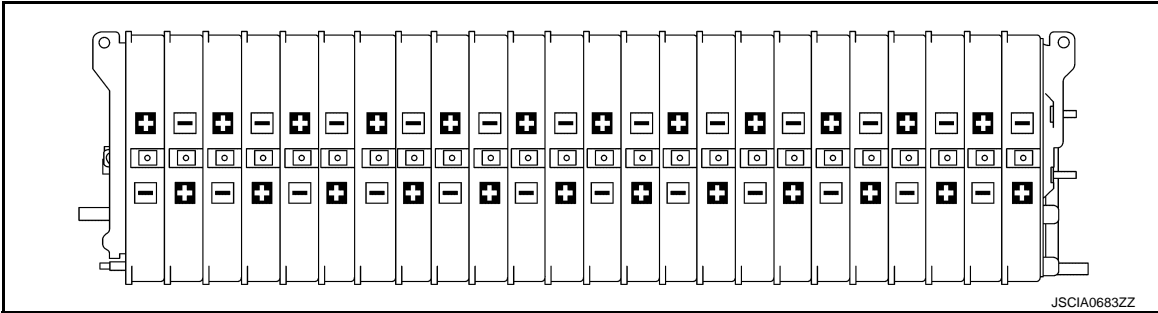

WARNING:

 Be careful of the directions of the + terminal and – terminal when assembling the module. If the polarity is incorrect, there is a risk of electric shock, fire, and component damage.

NOTE:

- To identify the module + terminal and – terminal, refer to the figure.

- + terminal identification color (A) : Red
- terminal identification color (B) : Black

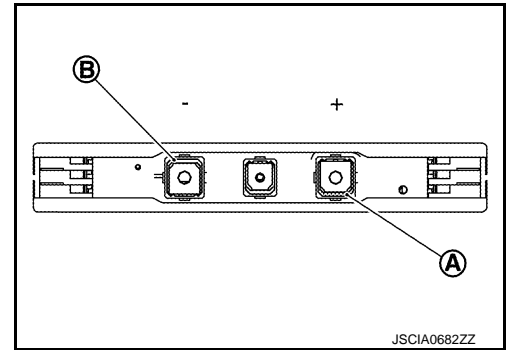

b. Use a lashing belt (A) and apply pressure to the rear module stack (1).

WARNING:

 To prevent electric shock, wear insulated protective gear.

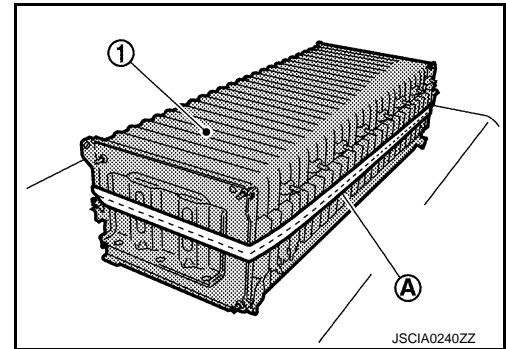

c. Inspect the module installation condition, and correct it if it is skewed or a large distortion is found.

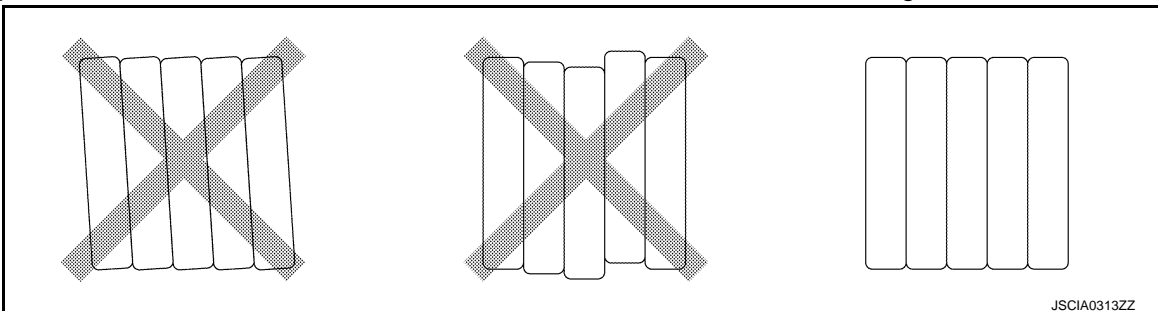

WARNING:

 To prevent electric shock, wear insulated protective gear and use insulated tools.

LI-ION BATTERY

< UNIT DISASSEMBLY AND ASSEMBLY >

[TYPE 3]



- d. Install the 2 through-bolts ② at opposite corners of the module, then insert $\phi 7$ mm (0.28 in) metal bars (A) into the bolt holes and tighten the mounting nuts to the prescribed torque.

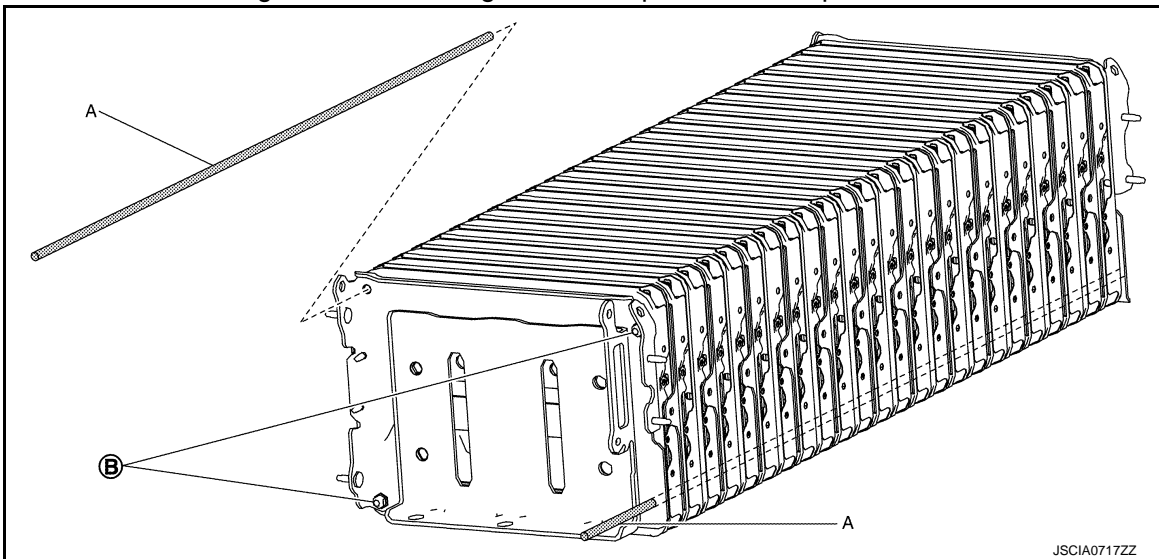

CAUTION:

If the collar position is incorrect, there is a risk of the bolts loosening because they are not supported by the collar between the modules.

- e. Install the remaining 2 through-bolts, and tighten the mounting nuts to the prescribed torque.
- When installing, hold the end of the through bolt stationary and tighten the installation nut.

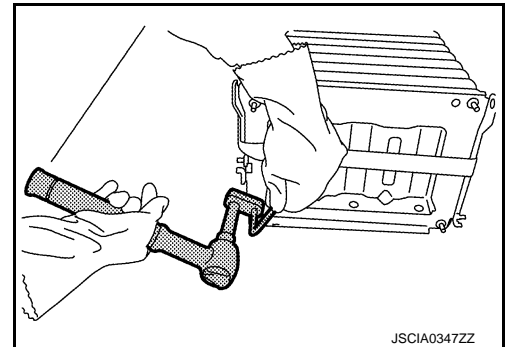

3. Install the rear stack member ①.

WARNING:

 To prevent electric shock, wear insulated protective gear and use insulated tools.

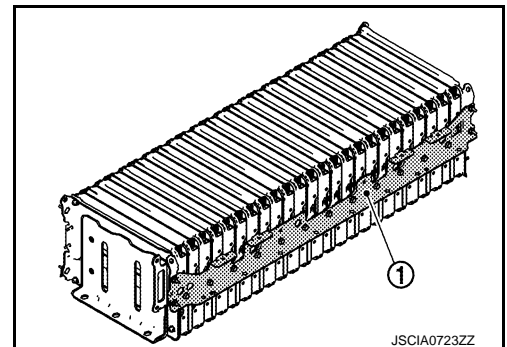

A
B
EVB
D
E
F
G
H
I
J
K
L
M
N
O
P

LI-ION BATTERY

< UNIT DISASSEMBLY AND ASSEMBLY >

[TYPE 3]

4. Install the front stack member ①.

WARNING:



To prevent electric shock, wear insulated protective gear and use insulated tools.

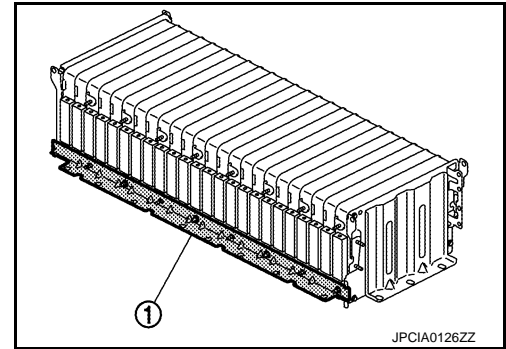

5. Remove the module terminal cover [SST: KV99111500 (—)] (A).

WARNING:



To prevent electric shock, wear insulated protective gear.

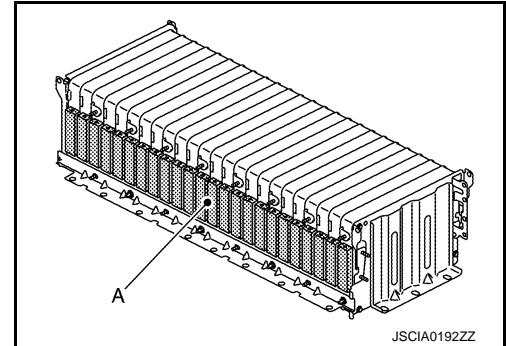

6. Follow the procedure below and install the bus bar module onto the rear module stack.

- a. Install the bus bar module onto the rear module stack.

WARNING:



To prevent electric shock, wear insulated protective gear.



- b. Use an insulated torque driver (A) and tighten the voltage detection terminal mounting screws to the prescribed torque.

DANGER:



- There is the danger of electric shock caused by contact with the terminals. Be sure to wear insulated protective gear and use insulated tools.



- This work must not be performed by multiple operators because there is a risk of electric shock if the operators contact one another.

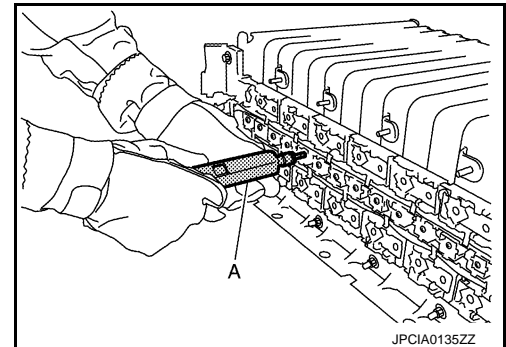

- c. Tighten the module terminal mounting bolts in numerical order as shown in the figure.

- When tightening of 1 – 16 is completed, install the left-side bus bar cover.
- When tightening of 17 – 32 is completed, install the right-side bus bar cover.
- When tightening of 33 – 48 is completed, install the center bus bar cover.

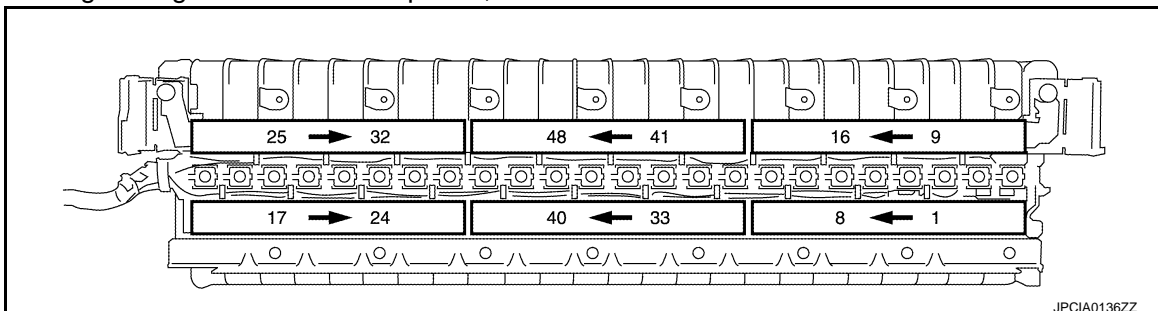

DANGER:

LI-ION BATTERY

< UNIT DISASSEMBLY AND ASSEMBLY >

[TYPE 3]

- ⚠ There is the danger of electric shock caused by contact with the terminals. Be sure to wear insulated protective gear and use insulated tools.



- ⚠ This work must not be performed by multiple operators because there is a risk of electric shock if the operators contact one another.

d. Install the bus bar cover ①.

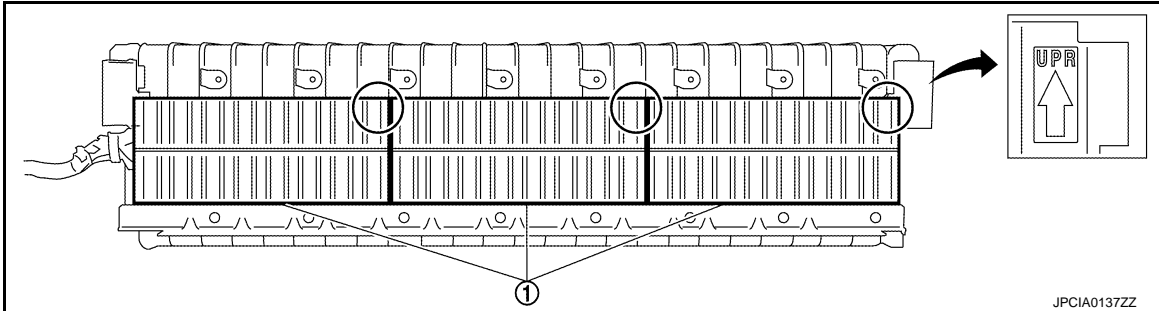

WARNING:

- ⚠ To prevent electric shock, wear insulated protective gear.



CAUTION:

- Be careful not to install with the top and bottom facing in the wrong directions.
- After installation, check that the mating is not skewed.

7. Install the harness bracket ①, ② and ③ to the rear module stack.

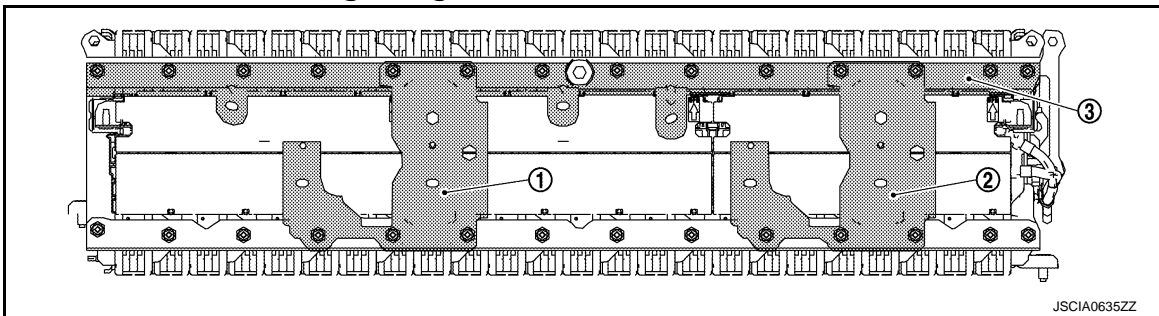

WARNING:

- ⚠ To prevent electric shock, wear insulated protective gear and use insulated tools.



CAUTION:

- Be sure to reinstall the high voltage harness clips in their original positions. If a clip is damaged, replace it with a new clip before installing.
- Check the following items after installing battery pack: Refer to [EV6-687, "Inspection"](#).

- AIR LEAK INSPECTION
- ELECTRIC EQUIPOTENTIAL TEST

Inspection

INFOID:000000011192186

AIR LEAK INSPECTION

LI-ION BATTERY

< UNIT DISASSEMBLY AND ASSEMBLY >

[TYPE 3]

1. Use vinyl tape or similar means (A) for preventing air leakage from the harness connectors.
 - Use wide vinyl tape that is capable of covering all of the harness connector with one strip.
 - Apply carefully so that no wrinkles in the tape occur.

WARNING:



To prevent electric shock, wear insulated protective gear.

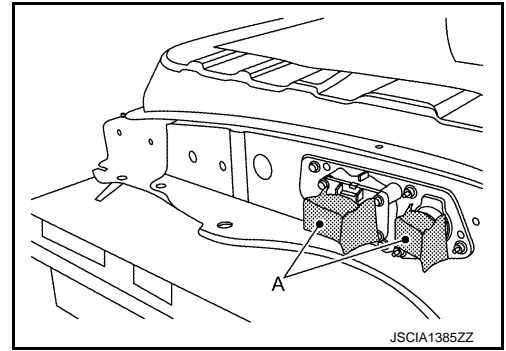

2. Use vinyl tape or similar means (A) to prevent air leakage from the breather.
 - Use wide vinyl tape that is capable of covering all of the breather with one strip.
 - Apply carefully so that no wrinkles in the tape occur.

WARNING:



To prevent electric shock, wear insulated protective gear.

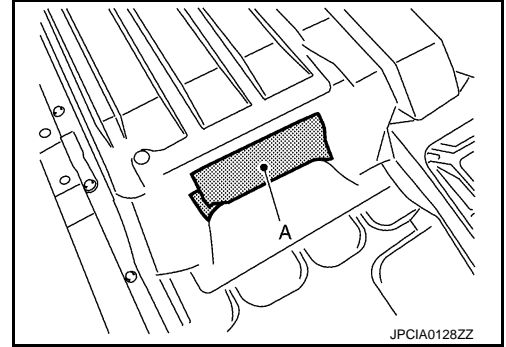

3. Remove the plug and install the adapter (A) of the air leak tester [SST: KV99111400 (—)].

WARNING:



To prevent electric shock, wear insulated protective gear.

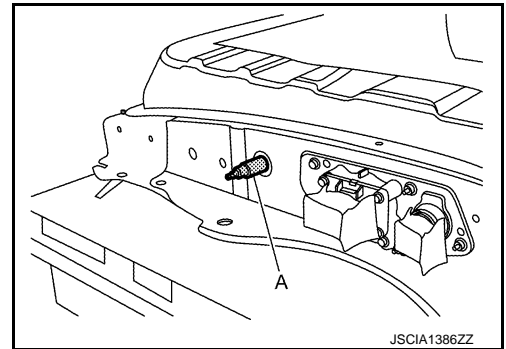

4. Install the gauge (A) of the air leak tester [SST: KV99111400 (—)].

WARNING:



To prevent electric shock, wear insulated protective gear.



CAUTION:

The gauge is a precision instrument. Be careful not to drop it when handling it.

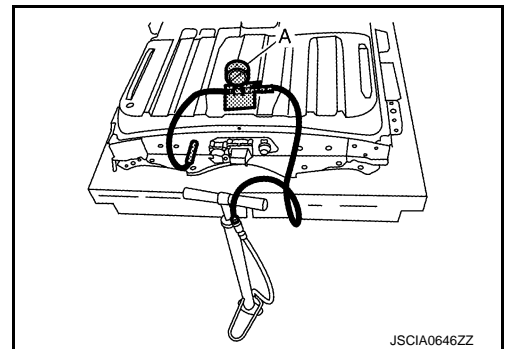

5. Install the service plug.

DANGER:



There is the danger of electric shock caused by contact with the terminals. Be sure to wear insulated protective gear.



NOTE:

LI-ION BATTERY

< UNIT DISASSEMBLY AND ASSEMBLY >

[TYPE 3]

Because the service plug location is open, install the service plug for sealing the case.

6. Follow the procedure below to check the battery case pressure.

WARNING:



To prevent electric shock, wear insulated protective gear.



- a. Open the cock (A) on the air leak tester.

CAUTION:

Do not operate the pump before opening the cock on the air leak tester. Doing so may damage the gauge. If the pump is operated before the cock is opened, first disconnect the air pump hose to release the pressure.

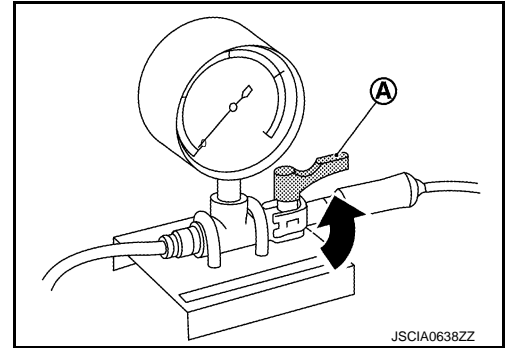

- b. Operate the air pump slowly and apply the specified inspection pressure inside the battery pack. If the gauge pressure does not rise, or if the gauge reading fluctuates, check for the location of air leakage.

Specified inspection pressure : 1.6 kPa (0.016 bar, 0.0163 kg/cm², 0.232 psi)

CAUTION:

- Operate the air pump carefully when applying pressure. If pressure is applied suddenly to the gauge, the gauge may be damaged.
- Do not apply pressure of 2.0 kPa (0.0204 kg/cm²) or more to the battery case or air leak tester.

- c. Close the cock and wait for 1 minute.
d. Check that the air leak tester reading remains at or above the limit value.

Repair limit : 1.4 kPa (0.014 bar, 0.0142 kg/cm², 0.203 psi)

- e. If the pressure is below the limit value, check for the locations of air leakage.

NOTE:

Check for air leakage from the sound of air escaping when pressure is applied.

ELECTRIC EQUIPOTENTIAL TEST

LI-ION BATTERY

< UNIT DISASSEMBLY AND ASSEMBLY >

[TYPE 3]

After assembling the Li-ion battery pack, remove the battery pack upper case ground bolt (A), then measure the resistance between the high-voltage harness connector flange ground bolts (B) and the ground bolt seat (location of coating peeling) (C).

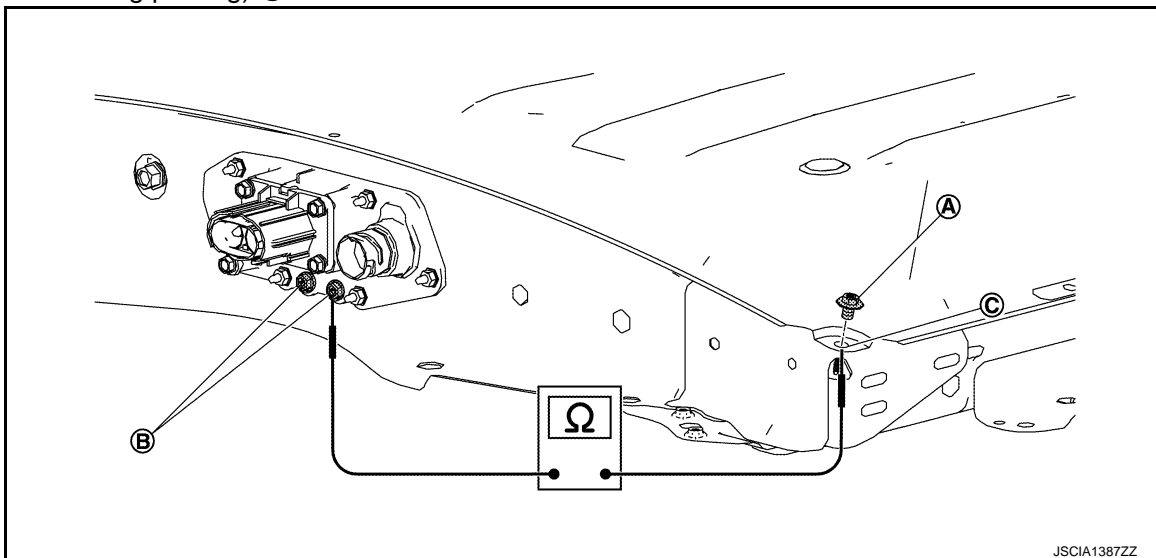

WARNING:



To prevent electric shock, wear insulated protective gear.



Standard : Less than 0.1Ω

If the result deviates from the standard value, check the following and correct the malfunction location.

- Ground bolt connection condition
- Corrosion on ground bolt mounting surface
- Presence of paint, oil, dirt, or other substance on ground bolt mounting surface

SERVICE DATA AND SPECIFICATIONS (SDS)

< SERVICE DATA AND SPECIFICATIONS (SDS)

[TYPE 3]

SERVICE DATA AND SPECIFICATIONS (SDS)

SERVICE DATA AND SPECIFICATIONS (SDS)

Li-ion Battery

INFOID:000000011192814

Items	Specification
Type	Li-ion battery
Structure	48 modules (192 cells)
Rated voltage (V)	Approx. 360
Battery capacity (kWh)	Approx. 24
Weight [kg (lb)]	Approx. 273 (602)

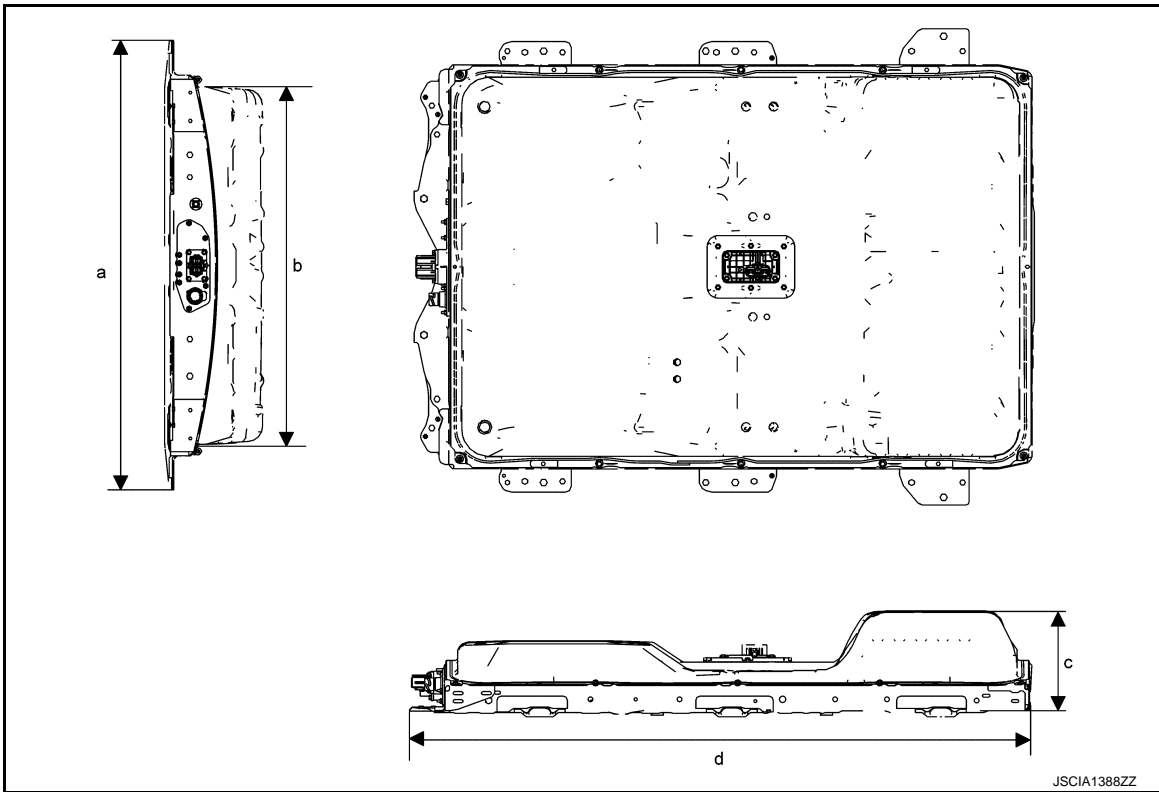

External dimension	"a"	[mm (in)]	1188 (46.77)
	"b"	[mm (in)]	1007 (39.65)
	"c"	[mm (in)]	264 (10.39)
	"d"	[mm (in)]	1547 (60.90)

A
B
EVB
D
E
F
G
H
I
J
K
L
M
N
O
P

APPLICATION NOTICE

< HOW TO USE THIS MANUAL >

[TYPE 4]

HOW TO USE THIS MANUAL

APPLICATION NOTICE

How to Check Vehicle Type

INFOID:0000000011104318

Check the vehicle type to confirm the service information in EVB section.

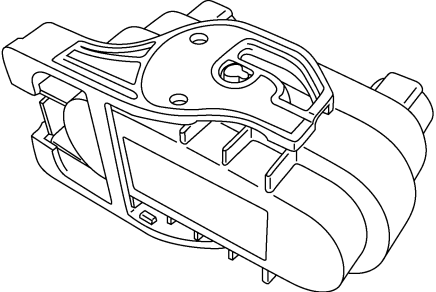
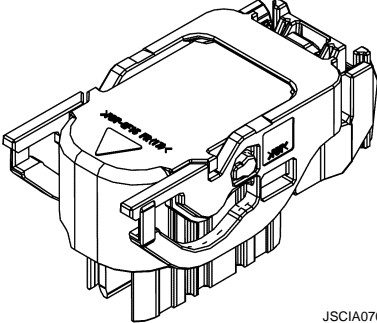
Service information	Vehicle type	Service plug type	
Type 1	Without Li-ion battery heater	Type A	 <p>JSCIA0277ZZ</p>
Type 2	With Li-ion battery heater		
Type 3	Without Li-ion battery heater	Type B	 <p>JSCIA0706ZZ</p>
Type 4	With Li-ion battery heater		

PRECAUTIONS

< PRECAUTION >

[TYPE 4]

PRECAUTION

PRECAUTIONS

Precaution for Technicians Using Medical Electric

INFOID:000000011104319

OPERATION PROHIBITION

WARNING:

- Parts with strong magnet is used in this vehicle.
- Technicians using a medical electric device such as pacemaker must never perform operation on the vehicle, as magnetic field can affect the device function by approaching to such parts.

NORMAL CHARGE PRECAUTION

WARNING:

- If a technician uses a medical electric device such as an implantable cardiac pacemaker or an implantable cardioverter defibrillator, the possible effects on the devices must be checked with the device manufacturer before starting the charge operation.
- As radiated electromagnetic wave generated by on board charger at normal charge operation may effect medical electric devices, a technician using a medical electric device such as implantable cardiac pacemaker or an implantable cardioverter defibrillator must not enter the vehicle compartment (including luggage room) during normal charge operation.

PRECAUTION AT TELEMATICS SYSTEM OPERATION

WARNING:

- If a technician uses implantable cardiac pacemaker or implantable cardioverter defibrillator (ICD), avoid the device implanted part from approaching within approximately 220 mm (8.66 in) from interior/exterior antenna.
- The electromagnetic wave of TCU might affect the function of the implantable cardiac pacemaker or the implantable cardioverter defibrillator (ICD), when using the service, etc.
- If a technician uses other medical electric devices than implantable cardiac pacemaker or implantable cardioverter defibrillator (ICD), the electromagnetic wave of TCU might affect the function of the device. The possible effects on the devices must be checked with the device manufacturer before TCU use.

PRECAUTION AT INTELLIGENT KEY SYSTEM OPERATION

WARNING:

- If a technician uses implantable cardiac pacemaker or implantable cardioverter defibrillator (ICD), avoid the device implanted part from approaching within approximately 220 mm (8.66 in) from interior/exterior antenna.
- The electromagnetic wave of Intelligent Key might affect the function of the implantable cardiac pacemaker or the implantable cardioverter defibrillator (ICD), at door operation, at each request switch operation, or at engine starting.
- If a technician uses other medical electric devices than implantable cardiac pacemaker or implantable cardioverter defibrillator (ICD), the electromagnetic wave of Intelligent Key might affect the function of the device. The possible effects on the devices must be checked with the device manufacturer before Intelligent Key use.

Point to Be Checked Before Starting Maintenance Work

INFOID:000000011104320

The high voltage system may starts automatically. It is required to check that the timer air conditioner and timer charge (during EVSE connection) are not set before starting maintenance work.

NOTE:

If the timer air conditioner or timer charge (during EVSE connection) is set, the high voltage system starts automatically even when the power switch is in OFF state.

Precaution for Supplemental Restraint System (SRS) "AIR BAG" and "SEAT BELT PRE-TENSIONER"

INFOID:000000011104321

The Supplemental Restraint System such as "AIR BAG" and "SEAT BELT PRE-TENSIONER", used along with a front seat belt, helps to reduce the risk or severity of injury to the driver and front passenger for certain types of collision. This system includes seat belt switch inputs and dual stage front air bag modules. The SRS

PRECAUTIONS

[TYPE 4]

< PRECAUTION >

system uses the seat belt switches to determine the front air bag deployment, and may only deploy one front air bag, depending on the severity of a collision and whether the front occupants are belted or unbelted. Information necessary to service the system safely is included in the "SRS AIR BAG" and "SEAT BELT" of this Service Manual.

WARNING:

Always observe the following items for preventing accidental activation.

- To avoid rendering the SRS inoperative, which could increase the risk of personal injury or death in the event of a collision that would result in air bag inflation, all maintenance must be performed by an authorized NISSAN/INFINITI dealer.
- Improper maintenance, including incorrect removal and installation of the SRS, can lead to personal injury caused by unintentional activation of the system. For removal of Spiral Cable and Air Bag Module, see "SRS AIR BAG".
- Never use electrical test equipment on any circuit related to the SRS unless instructed to in this Service Manual. SRS wiring harnesses can be identified by yellow and/or orange harnesses or harness connectors.

PRECAUTIONS WHEN USING POWER TOOLS (AIR OR ELECTRIC) AND HAMMERS

WARNING:

Always observe the following items for preventing accidental activation.

- When working near the Air Bag Diagnosis Sensor Unit or other Air Bag System sensors with the power switch ON, never use air or electric power tools or strike near the sensor(s) with a hammer. Heavy vibration could activate the sensor(s) and deploy the air bag(s), possibly causing serious injury.
- When using air or electric power tools or hammers, always switch the power switch OFF, disconnect the 12V battery, and wait at least 3 minutes before performing any service.

Precaution Necessary for Steering Wheel Rotation after 12V Battery Disconnect

INFOID:000000011104322

For vehicle with steering lock unit, if the 12V battery is disconnected or discharged, the steering wheel will lock and cannot be turned.

If turning the steering wheel is required with the 12V battery disconnected or discharged, follow the operation procedure below before starting the repair operation.

OPERATION PROCEDURE

1. Connect both 12V battery cables.

NOTE:

Supply power using jumper cables if 12V battery is discharged.

2. Turn the power switch to ACC position.
(At this time, the steering lock will be released.)
3. Disconnect both 12V battery cables. The steering lock will remain released with both 12V battery cables disconnected and the steering wheel can be turned.
4. Perform the necessary repair operation.
5. When the repair work is completed, re-connect both 12V battery cables. With the brake pedal released, turn the power switch from ACC position to ON position, then to LOCK position. (The steering wheel will lock when the power switch is turned to LOCK position.)
6. Perform All DTC Reading using CONSULT and delete DTC.

NOTE:

Multiple DTCs are detected when 12V battery cable is disconnected while power switch is in ACC position.

PRECAUTIONS

[TYPE 4]

< PRECAUTION >

Precaution for Procedure without Cowl Top Cover

INFOID:000000011104323

When performing the procedure after removing cowl top cover, cover the lower end of windshield with urethane, etc to prevent damage to windshield.

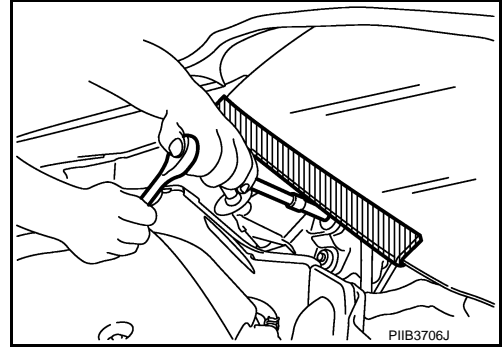

Precautions for Removing Battery Terminal

INFOID:000000011104324

- When removing the 12V battery terminal, turn OFF the power switch and wait at least 5 minutes.

NOTE:

ECU may be active for several minutes after the power switch is turned OFF. If the battery terminal is removed before ECU stops, then a DTC detection error or ECU data corruption may occur.

- Always disconnect the battery terminal within 60 minutes after turning OFF the power switch. Even when the power switch is OFF, the 12V battery automatic charge control may automatically start after a lapse of 60 minutes from power switch OFF.
- Disconnect 12V battery terminal according to the following steps.

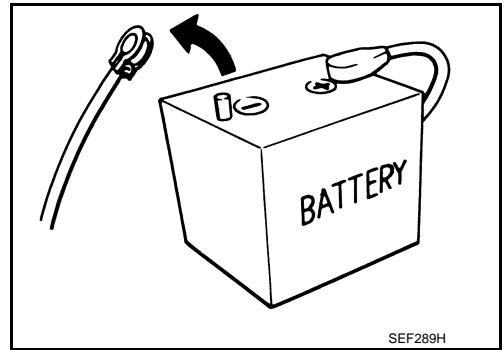

WORK PROCEDURE

1. Check that EVSE is not connected.

NOTE:

If EVSE is connected, the air conditioning system may be automatically activated by the timer A/C function.

2. Turn the power switch OFF → ON → OFF. Get out of the vehicle. Close all doors (including back door).
3. Check that the charge status indicator lamp does not blink and wait for 5 minutes or more.

NOTE:

If the battery is removed within 5 minutes after the power switch is turned OFF, plural DTCs may be detected.

4. Remove 12V battery terminal within 60 minutes after turning the power switch OFF → ON → OFF.

CAUTION:

- After all doors (including back door) are closed, if a door (including back door) is opened before battery terminals are disconnected, start over from Step 1.
- After turning the power switch OFF, if "Remote A/C" is activated by user operation, stop the air conditioner and start over from Step 1.

NOTE:

Once the power switch is turned ON → OFF, the 12V battery automatic charge control does not start for approximately 1 hour.

- For vehicles with the 2-batteries, be sure to connect the main battery and the sub battery before turning ON the power switch.

NOTE:

If the power switch is turned ON with any one of the terminals of main battery and sub battery disconnected, then DTC may be detected.

- After installing the 12V battery, always check "Self Diagnosis Result" of all ECUs and erase DTC.

NOTE:

The removal of 12V battery may cause a DTC detection error.

High Voltage Precautions

INFOID:000000011104325

DANGER:

PRECAUTIONS

< PRECAUTION >

[TYPE 4]



Since hybrid vehicles and electric vehicles contain a high voltage battery, there is the risk of electric shock, electric leakage, or similar accidents if the high voltage component and vehicle are handled incorrectly. Be sure to follow the correct work procedures when performing inspection and maintenance.

WARNING:

- Be sure to remove the service plug in order to disconnect the high voltage circuits before performing inspection or maintenance of high voltage system harnesses and parts.
- The removed service plug must always be carried in a pocket of the responsible worker or placed in the tool box during the procedure to prevent the plug from being connected by mistake.
- Be sure to wear insulated protective equipment before beginning work on the high voltage system.
- Never allow workers other than the responsible person to touch the vehicle containing high voltage parts. To keep others from touching the high voltage parts, these parts must be covered with an insulating sheet except when using them.

CAUTION:

Never bring the vehicle into the READY status with the service plug removed unless otherwise instructed in the Service Manual. A malfunction may occur if this is not observed.

HIGH VOLTAGE HARNESS AND EQUIPMENT IDENTIFICATION

All the high voltage harnesses and connectors are orange. The Li-ion battery and other high voltage devices include an orange high voltage label. Never touch these harnesses and high voltage parts.

HANDLING OF HIGH VOLTAGE HARNESS AND TERMINALS

Immediately insulate disconnected high voltage connectors and terminals with insulating tape.

REGULATIONS ON WORKERS WITH MEDICAL ELECTRONICS

WARNING:

The vehicle contains parts that contain powerful magnets. If a person who is wearing a heart pacemaker or other medical device is close to these parts, the medical device may be affected by the magnets. Such persons must not perform work on the vehicle.

PROHIBITED ITEMS TO CARRY DURING THE WORK

Hybrid vehicles and electric vehicles contain parts with high voltage and intense magnetic force. Never carry metal products and magnetic recording media (e.g. cash card, prepaid card) to repair/inspect high voltage parts. If this is not observed, the metal products may create a risk of short circuit and the magnetic recording media may lose their magnetic recording.

POSTING A SIGN OF “DANGER! HIGH VOLTAGE AREA. KEEP OUT”

PRECAUTIONS

< PRECAUTION >

[TYPE 4]

Indicate "HIGH VOLTAGE. DO NOT TOUCH" on the vehicle under repair/inspection to call attention to other workers.

A
B
EVB
D
E
F
G
H
I
J
K
L
M
N
O
P

Person in charge: _____

**CAUTION:
HIGH VOLTAGE. DO
NOT TOUCH DURING
OPERATION.**

**CAUTION:
HIGH VOLTAGE. DO
NOT TOUCH DURING
OPERATION.**

Person in charge: _____

Copy this page and put it after folding on the roof of the vehicle in service.

JSAIA0091GB

PREPARATION

< PREPARATION >

[TYPE 4]

PREPARATION

PREPARATION

Special Service Tools

INFOID:000000011191805

The actual shape of the tools may differ from those illustrated here.

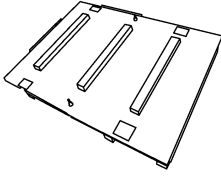
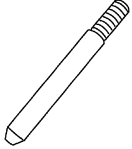
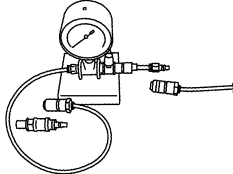
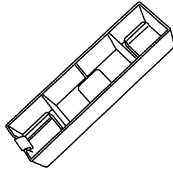
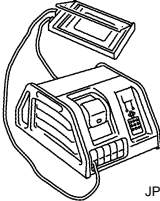
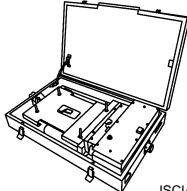
Tool number (TechMate No.) Tool name	Description
— (J-50583) Palette  JPCIA0239ZZ	When removing/installing Li-ion battery.
KV99111300 (J-50306) Battery location guide pin  JPCIA0023ZZ	When installing Li-ion battery. 2 piece/set
KV99111400 (—) Air leak tester  JSCIA0257ZZ	When checking air leaks after disassembling/assembling Li-ion battery.
KV99111500 (—) Module terminal cover  JPCIA0069ZZ	Protect module terminals (for LEAF) 24 pieces/set
— (J-50346) Module charge balancer  JPCIA0070ZZ	Module voltage adjustment
— (J-51031) Module charge balancer module box  JSCIA0726ZZ	Module voltage adjustment Use with the module charge balancer (J-50346).



PREPARATION

< PREPARATION >

[TYPE 4]

Commercial Service Tools

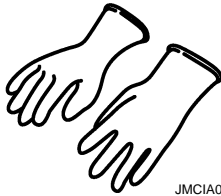
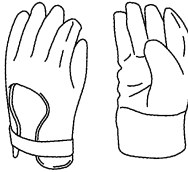
INFOID:000000011191806

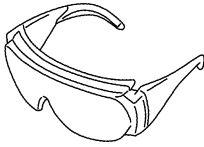
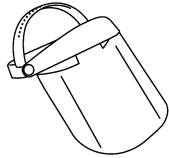
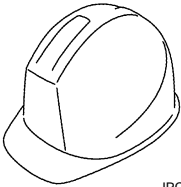
Tool name	Description
<p>Insulated gloves</p>  <p>JMCIA0149ZZ</p>	<p>Removing and installing high voltage components [Guaranteed insulation performance for 1000V/ 300A]</p>
<p>Leather gloves</p>  <p>JPCIA0066ZZ</p>	<ul style="list-style-type: none"> • Removing and installing high voltage components • Protect insulated gloves [Use leather gloves that can fasten the wrist tight]
<p>Insulated safety shoes</p>  <p>JPCIA0011ZZ</p>	<p>Removing and installing high voltage components</p>
<p>Safety glasses</p>  <p>JPCIA0012ZZ</p>	<ul style="list-style-type: none"> • Removing and installing high voltage components • To protect eye from the spatter on the work to electric line [ANSI Z87.1]
<p>Face shield</p>  <p>JPCIA0167ZZ</p>	<ul style="list-style-type: none"> • Removing and installing high voltage components • To protect face from the spatter on the work to electric line
<p>Insulated helmet</p>  <p>JPCIA0013ZZ</p>	<p>Removing and installing high voltage components</p>

A
B
C
D
E
F
G
H
I
J
K
L
M
N
O
P

EVB

PREPARATION

< PREPARATION >

[TYPE 4]

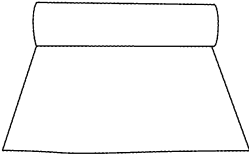
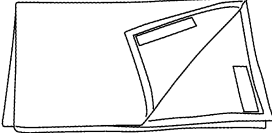
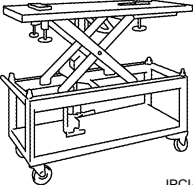
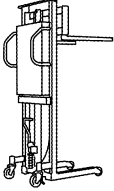
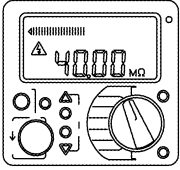
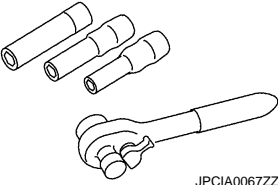
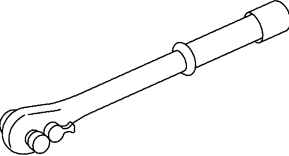
Tool name	Description
<p>Insulated rubber sheet</p>  <p style="text-align: right; font-size: small;">JPCIA0019ZZ</p>	<p>Removing and installing high voltage components</p>
<p>Insulated cover sheet</p>  <p style="text-align: right; font-size: small;">JPCIA0018ZZ</p>	<p>Removing and installing high voltage components</p>
<p>Battery lift table</p>  <p style="text-align: right; font-size: small;">JPCIA0024ZZ</p>	<p>Removing and installing Li-ion battery</p>
<p>Stacker</p>  <p style="text-align: right; font-size: small;">JPCIA0015ZZ</p>	<p>Removing and installing Li-ion battery</p>
<p>Insulation resistance tester (Multi tester)</p>  <p style="text-align: right; font-size: small;">JPCIA0014ZZ</p>	<p>Measuring insulation resistance, voltage, and resistance</p>
<p>Insulated hand tools</p>  <p style="text-align: right; font-size: small;">JPCIA0067ZZ</p>	<p>Removing and installing high voltage components</p>
<p>Insulated torque wrench</p>  <p style="text-align: right; font-size: small;">JPCIA0068ZZ</p>	<p>Removing and installing high voltage components</p>

PREPARATION

< PREPARATION >

[TYPE 4]

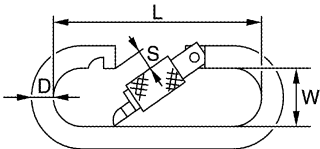
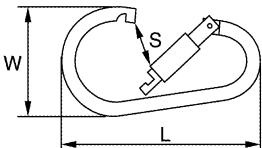
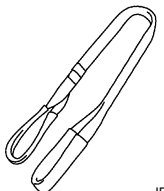
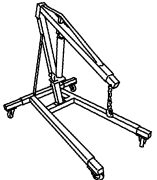
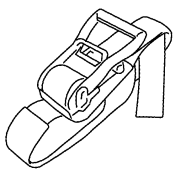
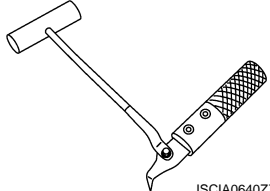
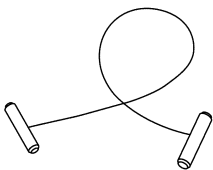
Tool name	Description
<p>Carabineer [small]</p>  <p style="text-align: center;">JPCIA0016ZZ</p>	<ul style="list-style-type: none"> • Removing and installing battery module stack • Installing battery pack upper case <p>NOTE:</p> <ul style="list-style-type: none"> • D: 8.0 mm (0.31 in) • L: 74.0 mm (2.91 in) • S: 10.0 mm (0.39 in) • W: 22.5 mm (0.89 in)
<p>Carabineer [large]</p>  <p style="text-align: center;">JPCIA0017ZZ</p>	<p>Removing and installing battery module stack</p> <p>NOTE:</p> <ul style="list-style-type: none"> • D: 14.0 mm (0.55 in) • L: 204.0 mm (8.03 in) • S: 47.0 mm (1.85 in) • W: 105.0 mm (4.13 in)
<p>Belt slinger</p>  <p style="text-align: center;">JPCIA0021ZZ</p>	<p>Removing and installing battery module stack</p> <p>NOTE:</p> <p>Length: 2.0 m (6.562 ft)</p>
<p>Mobile floor crane</p>  <p style="text-align: center;">JPCIA0020ZZ</p>	<p>Removing and installing battery module stack</p>
<p>Lashing belt</p>  <p style="text-align: center;">JPCIA0022ZZ</p>	<p>Removing and installing battery rear module stack</p>
<p>Windshield cutter [Gasket cutter]</p>  <p style="text-align: center;">JSCIA0640ZZ</p>	<p>Removing battery pack upper case (Cut the adhesive)</p>
<p>Piano wire with handles</p>  <p style="text-align: center;">JSCIA0641ZZ</p>	<p>Installing battery pack upper case (Cut the adhesive)</p> <p>NOTE:</p> <p>Wire size: ϕ 0.5 mm (0.02 in)</p>

A
B
EVB
D
E
F
G
H
I
J
K
L
M
N
O
P

PREPARATION

< PREPARATION >

[TYPE 4]

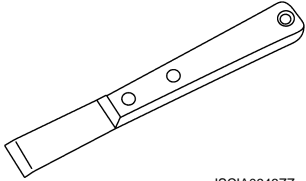
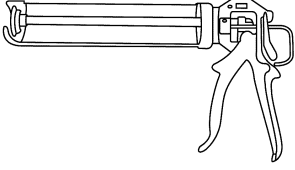
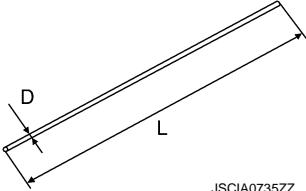
Tool name	Description
<p>Scraper</p> <div style="text-align: center;">  <p>JSCIA0643ZZ</p> </div>	<p>Installing battery pack upper case (Smooth the adhesive)</p>
<p>Tube presser [Gasket material applicator]</p> <div style="text-align: center;">  <p>JSCIA0639ZZ</p> </div>	<p>Installing battery pack upper case (Apply the adhesive)</p>
<p>Metal bar</p> <div style="text-align: center;">  <p>JSCIA0735ZZ</p> </div>	<p>Assembling battery module stack NOTE:</p> <ul style="list-style-type: none"> • D: ϕ 7 mm (0.28 in) • L: 1 m (3.28 ft)

Sealant or/and Lubricant

INFOID:000000011191807

Tool name Tool number	Description
<p>Adhesive 999MP-57302NP</p>	<p>Installing battery pack upper case</p>
<p>Dam rubber KA390-0059U</p>	
<p>Primer (Adhesive primer) 999MP-43533PP</p>	
<p>Primer sufacer (anti-corrosion praimer) —</p>	

COMPONENT PARTS

< SYSTEM DESCRIPTION >

[TYPE 4]

SYSTEM DESCRIPTION

COMPONENT PARTS

Component Parts Location

INFOID:000000011104328

A

B

EVB

D

E

F

G

H

I

J

K

L

M

N

O

P

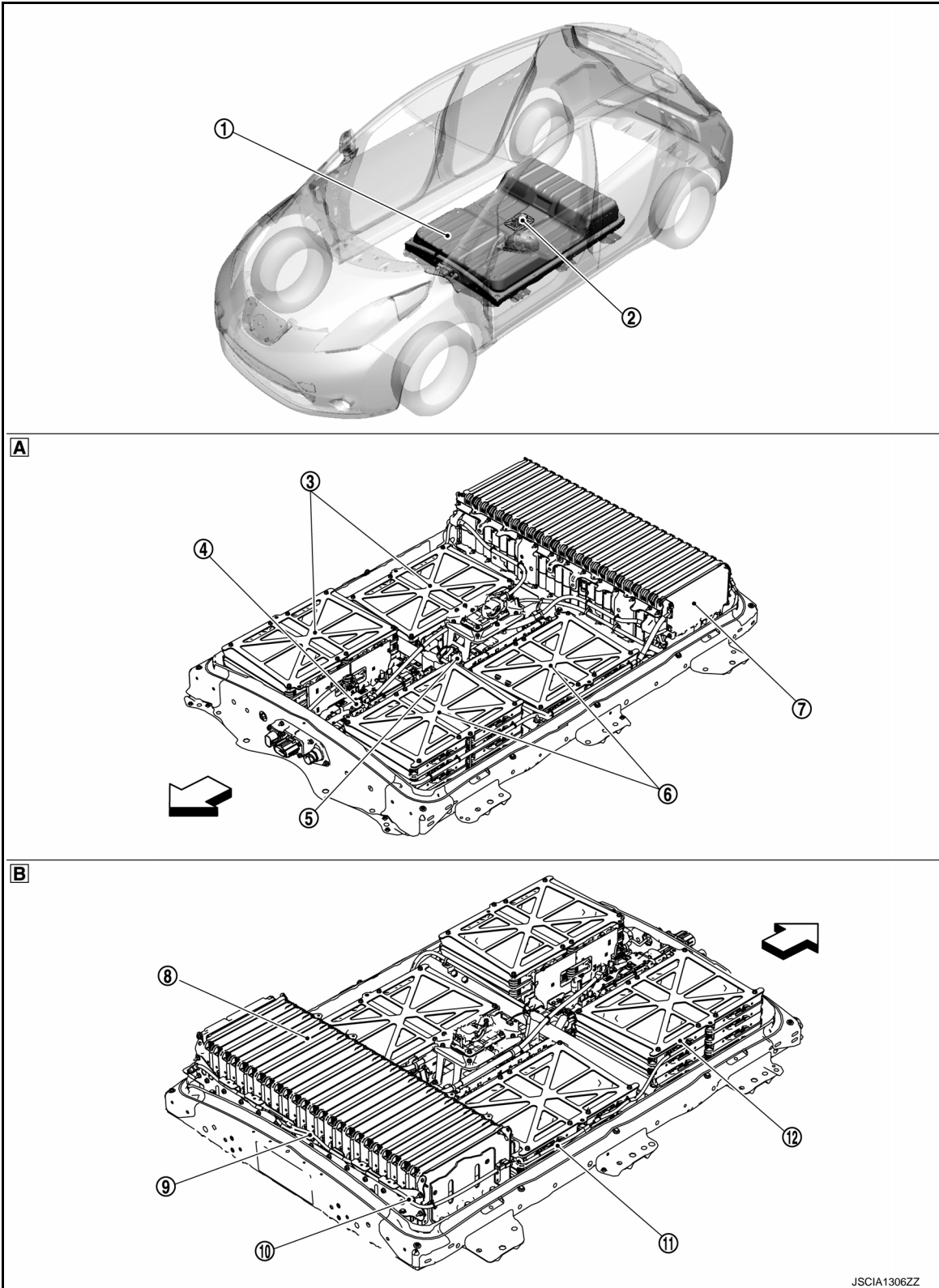

JSCIA1306ZZ

COMPONENT PARTS

[TYPE 4]

< SYSTEM DESCRIPTION >

A. Front of battery pack

B. Back of battery pack

← : Vehicle front

No.	Component	Function
1.	Li-ion battery	EVB-705, "Li-ion Battery"
2.	Service plug	EVB-709, "Service Plug"
3.	Front module stack RH	EVB-706, "Module"
4.	Battery junction box	EVB-709, "Battery Junction Box"
5.	Battery current sensor	EVB-708, "Battery Current Sensor"
6.	Front module stack LH	EVB-706, "Module"
7.	Li-ion battery controller	EVB-705, "Li-ion Battery Controller"
8.	Rear module stack	EVB-706, "Module"
9.	Battery temperature sensor 1	EVB-708, "Battery Temperature Sensor"
10.	Battery temperature sensor 3	EVB-708, "Battery Temperature Sensor"
11.	Battery temperature sensor 4	EVB-708, "Battery Temperature Sensor"
12.	Battery temperature sensor 2	EVB-708, "Battery Temperature Sensor"

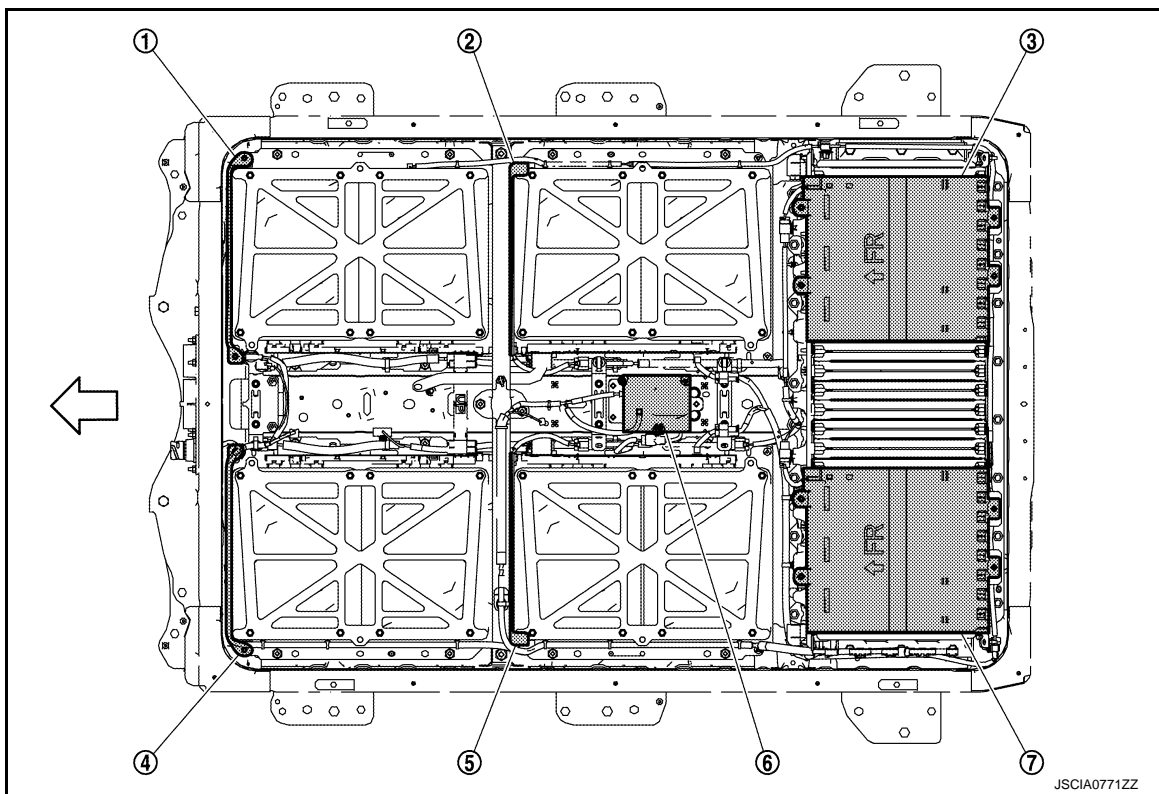

← : Vehicle front

No.	Component	Function
1.	Li-ion battery heater RH 1	EVB-707, "Li-ion Battery Heater"
2.	Li-ion battery heater RH 2	EVB-707, "Li-ion Battery Heater"
3.	Li-ion battery heater RR 2	EVB-707, "Li-ion Battery Heater"
4.	Li-ion battery heater LH 1	EVB-707, "Li-ion Battery Heater"
5.	Li-ion battery heater LH 2	EVB-707, "Li-ion Battery Heater"

COMPONENT PARTS

< SYSTEM DESCRIPTION >

[TYPE 4]

No.	Component	Function
6.	Heater relay unit	EVB-707, "Heater Relay Unit"
7.	Li-ion battery heater RR 1	EVB-707, "Li-ion Battery Heater"

Li-ion Battery

INFOID:000000011104329

- A Li-ion battery with flat construction is placed under floor.
- The battery pack is equipped with necessary devices, such as Li-ion battery controller, battery junction box, and service plug in addition to a battery storing electricity.

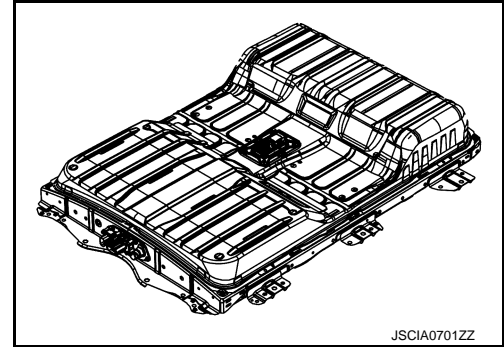

- Four cells are integrated into a single module. The Li-ion battery consists of 48 modules placed in series.

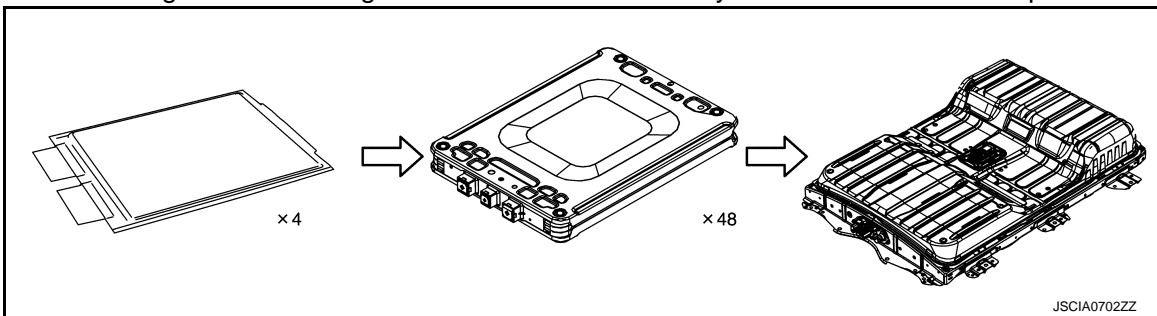

Li-ion Battery Controller

INFOID:000000011104330

- Li-ion battery controller (LBC) is included in the battery pack and installed on the left surface of the rear module stack.

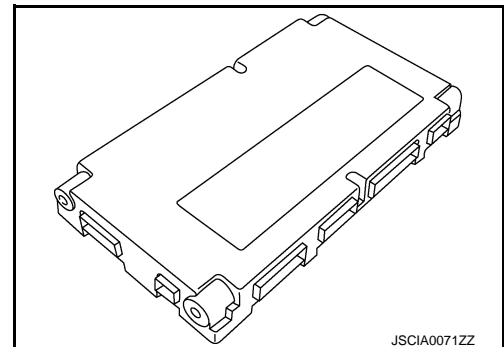

- The LBC is the core of battery control. Li-ion battery controller detects the voltage and current of the assembled battery, the temperature of each module, and the voltage of each cell to judge state of charge. LBC also calculates possible input/output values, meter indication values, and chargeable values, and send this data to VCM (Vehicle control module). VCM controls the vehicle, according to the battery state.

Main Role of Li-ion Battery Controller

1. Li-ion battery state check
 - State of charge
 - Possible output value
 - Possible input value
 - Temperature
2. Optimization of Li-ion battery voltage
3. Prevention of overvoltage and overcurrent

COMPONENT PARTS

[TYPE 4]

< SYSTEM DESCRIPTION >

4. Prevention of overheat
5. Detection of decrease in insulation resistance of high-voltage circuit
6. Detection of a fit of high voltage harness connector and service plug

Module

INFOID:000000011104331

- Four laminated cells are integrated into one module.
- The Li-ion battery is equipped with 48 modules.
- There are two kinds of modules, according to the location of positive and negative terminals.

Positive terminal : Red
 Negative terminal : Black

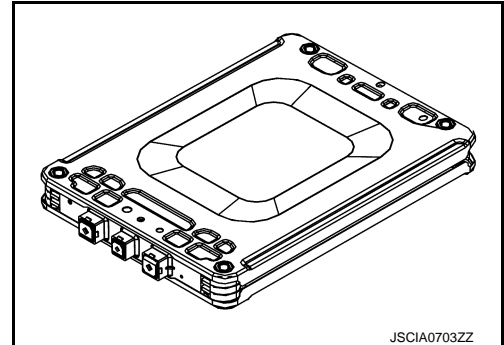

MODULE INTERNAL CIRCUIT

A module consists of two parallel-connected cells placed in series. The Li-ion battery has 48 modules placed in series in total. Ninety-six parallel-connected cell pairs are connected in series.

NOTE:

Cell voltage displayed on the data monitor of CONSULT means the potential difference between the upstream and the downstream of the parallel circuit.

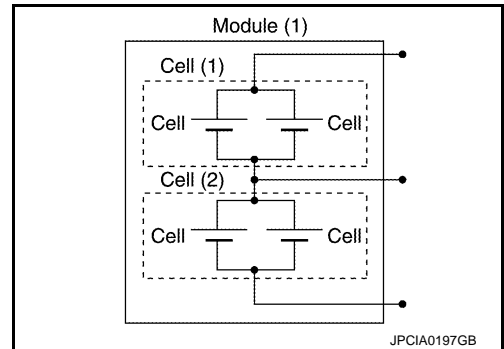

MODULE LAYOUT

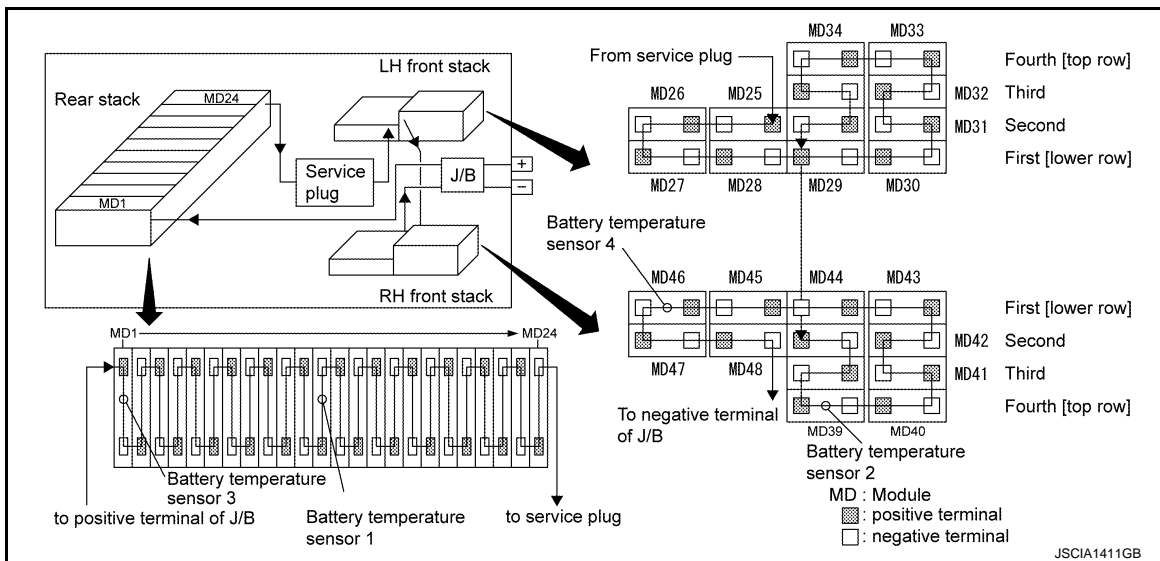

NOTE:

The highest potential is module (MD) 1 and the lowest is module (MD) 48.

CELL

COMPONENT PARTS

< SYSTEM DESCRIPTION >

[TYPE 4]

These are thin laminated cells with excellent cooling performance.

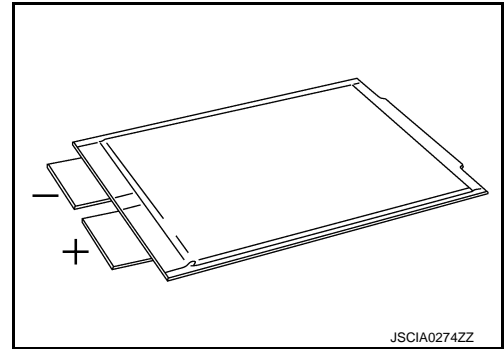

The Features of Laminated Cell

- Large surface area with excellent cooling performance reduces heat load to the battery and improves battery life.
- Light and thin structure increases flexibility in layout.

Heater Relay Unit

INFOID:000000011104332

- The heater relay unit is installed in the battery pack (under the service plug).
- When receiving a relay control signal from LBC (Li-ion battery controller), the heater relay unit turns ON the built-in relay and supplies high-voltage power to each Li-ion battery heater.

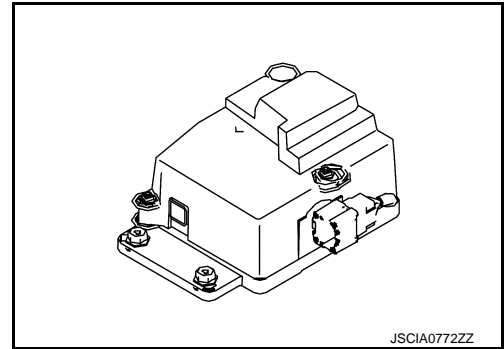

Li-ion Battery Heater

INFOID:000000011104333

- Li-ion battery heater is installed in the battery pack.
- High voltage power is supplied from the heater relay unit.
- Each Li-ion battery heater is connected in parallel.

FRONT LI-ION BATTERY HEATER

- Two front Li-ion battery heaters are installed to each front module stack.

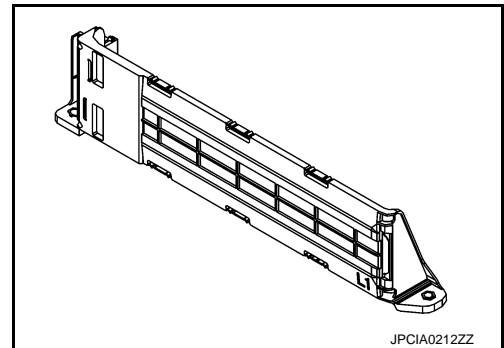

REAR LI-ION BATTERY HEATER

A
B
EVB
D
E
F
G
H
I
J
K
L
M
N
O
P

COMPONENT PARTS

[TYPE 4]

< SYSTEM DESCRIPTION >

- Two rear Li-ion battery heaters are installed to the rear module stack.

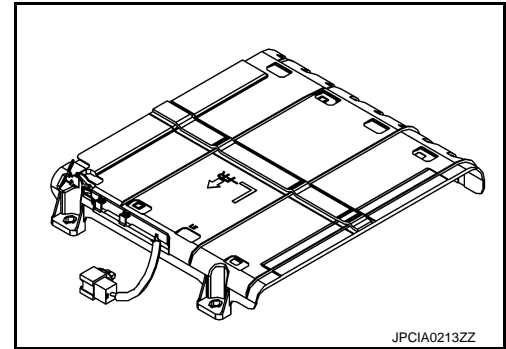

INFOID:000000011199169

Battery Current Sensor

- The battery current sensor is installed to bus bar between battery junction box and rear module stack.
- This sensor measures charge/discharge current sent to Li-ion battery and transmits a current signal to Li-ion battery controller (LBC).
- Li-ion Battery controller (LBC) measures remaining battery level according to charge/discharge current and sends the data to VCM.

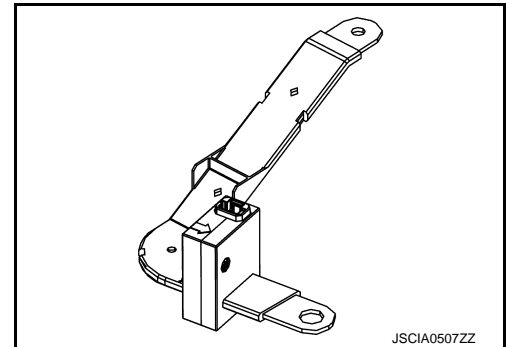

INFOID:000000011104334

Battery Temperature Sensor

- Four battery temperature sensors mounted in the battery pack measure the temperature.
- Right and left front module stacks have one battery temperature sensor, respectively, and the rear module stack has two.

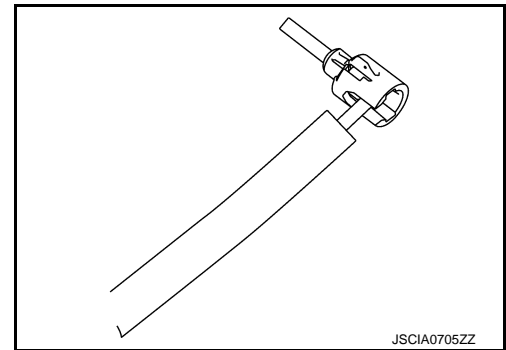

- The sensor uses a thermistor with a resistance value that varies according to changes in temperature. The electrical resistance of the thermistor decreases as the temperature increases.

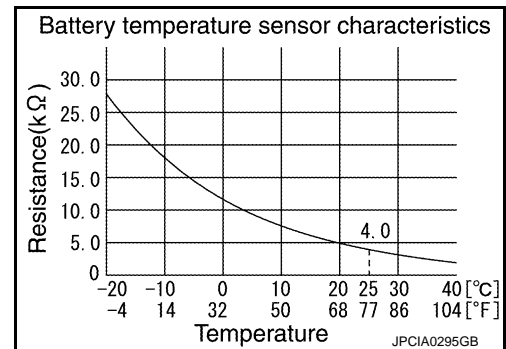

COMPONENT PARTS

< SYSTEM DESCRIPTION >

[TYPE 4]

Battery Junction Box

INFOID:000000011104335

- The battery junction box is installed to the front side in the battery pack.
- The battery junction box includes:
 - System main relay to provide/interrupt DC current sent from Li-ion battery.
 - Pre-charge relay to protect the high voltage circuit from a high current immediately after power switch ON.
- Installed to both positive side and negative side, the system main relay provides DC current to each high voltage part. In addition, the system main relay provides DC current to the Li-ion battery during motor regeneration or charge.
- When an error occurs in the system, the system main relay is turned OFF and the Li-ion battery is interrupted for ensuring safety, based on a command from VCM (Vehicle control module).

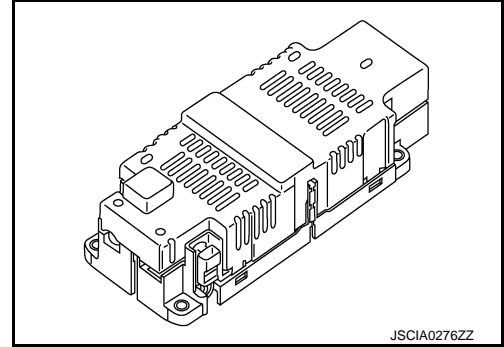

A

B

EVB

D

E

Service Plug

INFOID:000000011104336

- The service plug is included in the Li-ion battery to securely disconnect the high voltage during high voltage part inspection and maintenance.
- The service plug is installed on the upper surface of the battery pack. The plug can be removed when the leg-room mounted service plug cover is removed.
- Always use insulating protective equipment when removing and installing service plug.

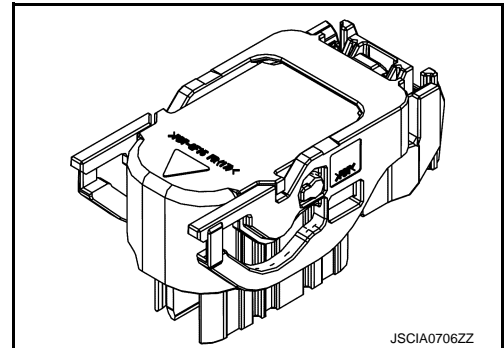

F

G

H

I

High Voltage Warning Label

INFOID:000000011104337

High voltage warning label is affixed to each of the following component parts.

After replacing a part, check that the part is affixed with a label. If the label is not affixed, be sure to affix the label in the original position.

Li-ion Battery

- The label (A) is affixed to the rear end of Li-ion battery.

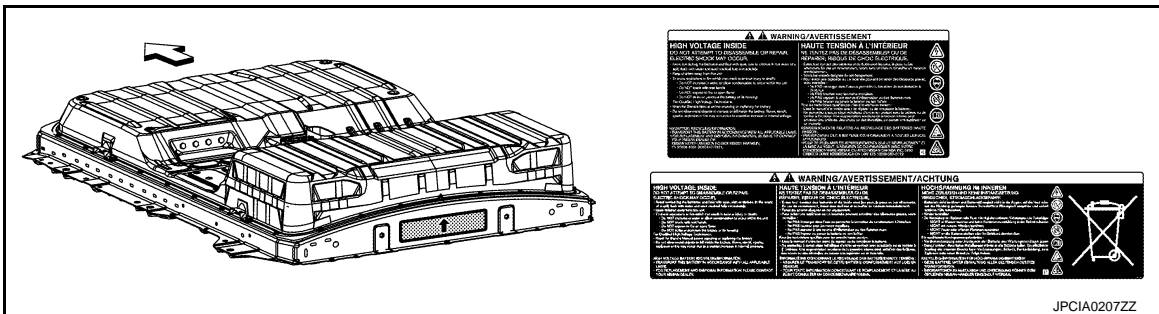

↩ : Vehicle front

← : Direction of the label

J

K

L

M

N

O

P

COMPONENT PARTS

[TYPE 4]

< SYSTEM DESCRIPTION >

- The label (A) is affixed to the body panel near the high voltage harness connector.

↔ : Vehicle front

← : Direction of the label

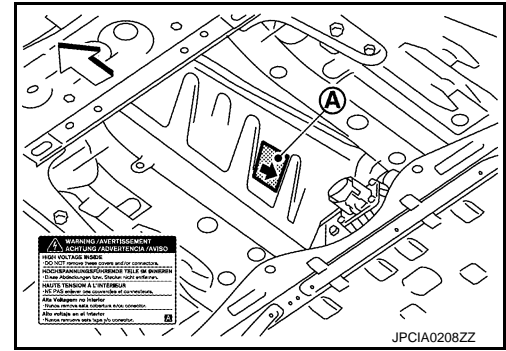

Li-ion Battery Controller

The label is affixed to the main body of controller.

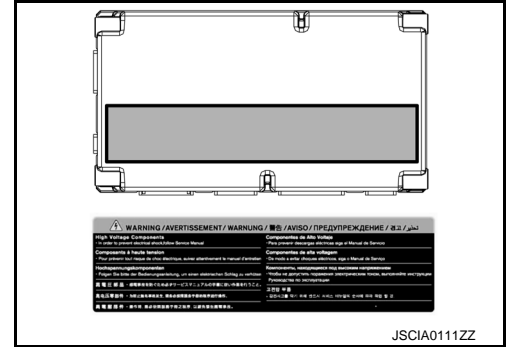

Service Plug

The label is affixed to the inspection hole cover (1).

← : Direction of the label

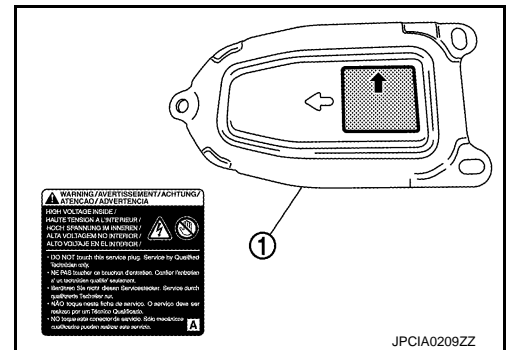

SYSTEM

LI-ION BATTERY CONTROL SYSTEM

LI-ION BATTERY CONTROL SYSTEM : System Description

INFOID:000000011104338

SYSTEM DIAGRAM

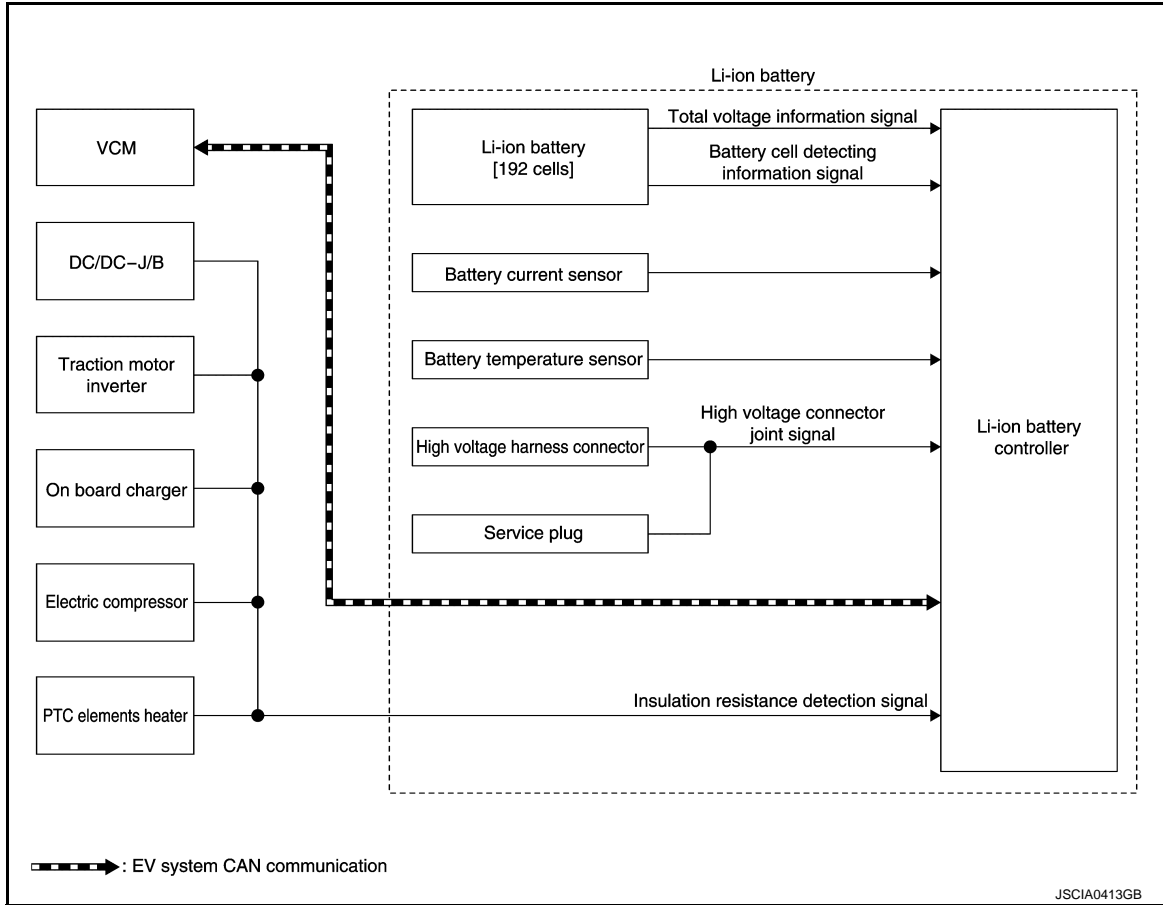

INPUT/OUTPUT SIGNAL ITEM

Input Signal Item

Transmit unit	Signal name	
VCM	EV system CAN	Target Li-ion battery remained energy signal

Output Signal Item

A
B
C
D
E
F
G
H
I
J
K
L
M
N
O
P

EVB

SYSTEM

< SYSTEM DESCRIPTION >

[TYPE 4]

Received unit	Signal name
VCM	High voltage discharge permit signal
	Li-ion battery main relay cut request signal
	Li-ion battery connector interlock signal
	Li-ion battery voltage signal
	Li-ion battery current signal
	Li-ion battery chargeable power signal
	Li-ion battery dischargeable power signal
	Li-ion battery chargeable completion signal
	Li-ion battery available charge signal
	Li-ion battery capacity signal
	Li-ion battery gradual capacity loss signal
	Insulation resistance signal

DESCRIPTION

The Li-ion battery controller (LBC) monitors the status of the inside of the Li-ion battery at all times and sends information, such as the charging status of Li-ion battery and possible power, to VCM (vehicle control module) via EV system CAN communication.

The Li-ion battery controller performs control as per the following.

- Monitors the battery state and transfers chargeable/dischargeable power to VCM to prevent an error, such as overvoltage, over discharge or excessive temperature rise in the battery.
- Detects an error (overvoltage, over discharge, overcurrent, or excessive temperature rise) immediately at the time of error occurrence and requests VCM to disconnect the system main relay to interrupt the discharge/charge line.
- Maintains the optimum battery state constantly with a cell capacity adjustment function to prevent a reduction in charging/discharging capacity caused by cell capacity variations.
- Detects the connector fit state with the function to detect the fit of the high voltage harness connector and transfers the detected state to VCM so that the vehicle does not start with an unsteady state.
- Detects the insulation resistance state with the function to detect the insulation resistance between high and low voltage and transfers the detected state to VCM so that the vehicle does not start with an unusual state.
- Estimates a battery charge state and low battery state, based on the data obtained with the battery state detection function, and reflects on the battery capacity meter.

BATTERY PROTECTION

The Li-ion battery has a voltage range capable of charge/discharge. If charged/discharged exceeding the range, excessive low capacity or malfunction may be caused. To prevent this, the Li-ion battery controller detects voltage of each cell and requests the control of charging/discharging energy to VCM so that the cell voltage stays within the voltage range.

Control item	Control	Operating condition
Overvoltage/overcurrent protection	Charging energy control	Gradual control of charging energy as the cell voltage approaches the upper limit of the voltage capable of charging.
	System main relay cut	Cell voltage exceeds the voltage judged as overvoltage and maintains the voltage for more than the specified time.
Over discharge protection	Discharging energy control	Gradual control of discharging energy as the cell voltage approaches the lower limit of the voltage capable of discharging.
	System main relay cut	Cell voltage exceeds the voltage judged as over discharge and maintains the voltage for more than the specified time.
Excessive temperature rise protection	Charging/discharging energy control	Gradual control of charging/discharging energy as Li-ion battery temperature approaches the upper limit of the temperature capable of use.
	System main relay cut	Li-ion battery temperature exceeds the temperature judged as excessive temperature rise and maintains the temperature for more than the specified time.

HOW TO ADJUST CELL CAPACITY

During cell capacity adjustment, the capacity of each cell is estimated based on the no-load voltage when the system starts, and the capacities are adjusted so that they are all at the target level. The voltage of each cell is detected inside the Li-ion battery controller. The bypass switches are then turned ON to discharge the cells that have excess capacity. In this way, capacity adjustment by the Li-ion battery controller allows the capacity of all cells to be fully utilized.

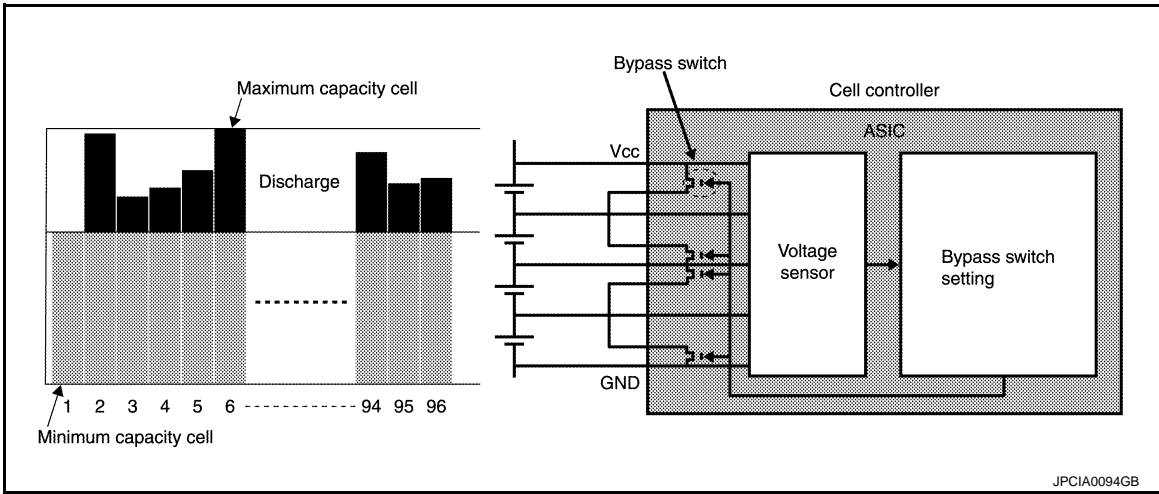

INSULATION RESISTANCE LOSS DETECTION FUNCTION

The insulation resistance detection circuit mounted inside the Li-ion battery controller measures the insulation resistance of each high voltage part and sends the measurement results to VCM via EV system CAN communication.

VCM judges abnormal insulation resistance in each high voltage part, based on the received insulation resistance value.

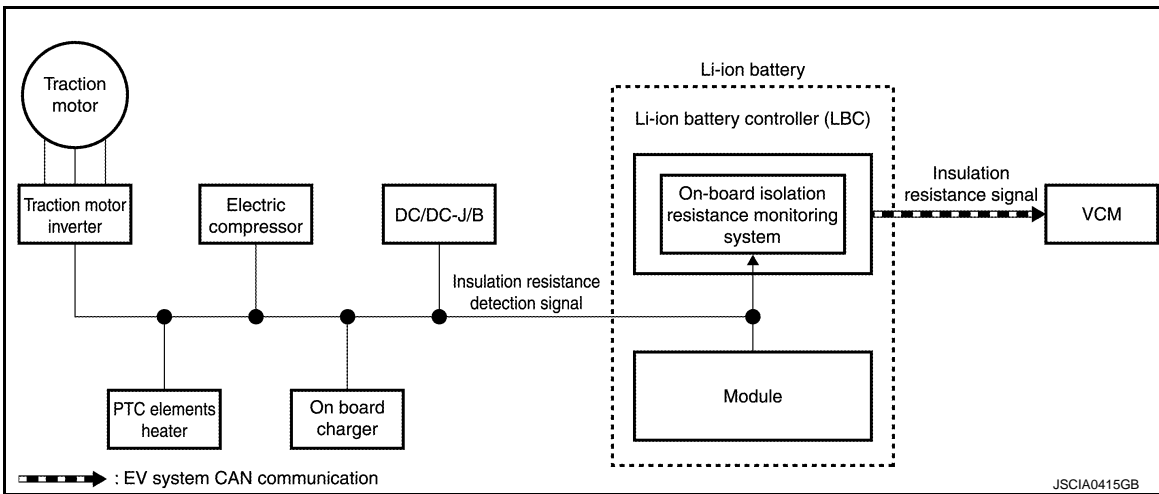

LI-ION BATTERY HEATER CONTROL SYSTEM

A
B
EVB
D
E
F
G
H
I
J
K
L
M
N
O
P

LI-ION BATTERY HEATER CONTROL SYSTEM : System Description

INFOID:000000011104339

SYSTEM DIAGRAM

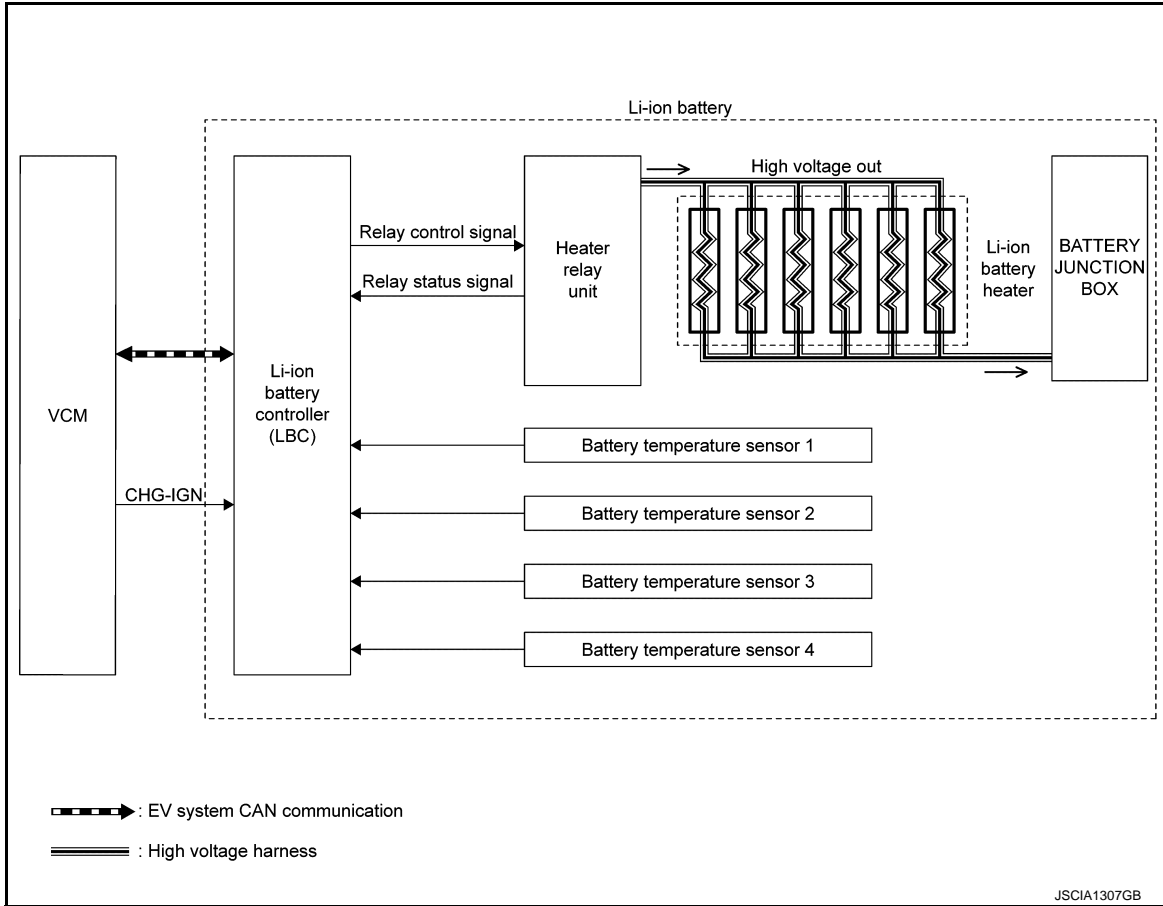

INPUT/OUTPUT SIGNAL ITEM

Input Signal Item

Transmit unit	Signal name	
VCM	EV system CAN communication	Keep SOC request signal

Output Signal Item

Receive unit	Signal name	
VCM	EV system CAN communication	Next start time signal

DESCRIPTION

- When the temperature decreases [approximately -20°C (-4°F)] extremely in the battery pack, the Li-ion battery heater control system automatically activates the Li-ion battery heater to warm the inside of the battery pack for protecting Li-ion battery from freezing and preventing the decline in battery output. In addition, when the temperature in the battery pack is restored [approximately -10°C (14°F)], the Li-ion battery heater stops.
- The Li-ion battery controller (LBC) detects a temperature in the battery pack, according to a signal transmitted from the battery temperature sensor installed to the battery pack and judges the activation of the Li-ion battery heater.
- When the relay built in the heater relay unit turns ON, high voltage power is supplied to each Li-ion battery heater.
- LBC detects the ON/OFF status of the relay built in to heater relay unit.
- Even when the power switch is OFF, VCM periodically activates LBC to protect Li-ion battery from freezing.

SYSTEM

[TYPE 4]

< SYSTEM DESCRIPTION >

- When the temperature in Li-ion battery pack is low with no necessity of Li-ion battery heater operation, LBC estimates the time that Li-ion battery may freeze and transmits a next start time signal to VCM via EV system CAN communication to prepare for starting the Li-ion battery heater next time.
- When receiving a next start time signal via EV system CAN communication, VCM transmits a start request signal (CHG-IGN) to LBC after a lapse of the set time. When receiving a start request signal (CHG-IGN), LBC activates the Li-ion battery heater.

When EVSE is connected (normal charge)

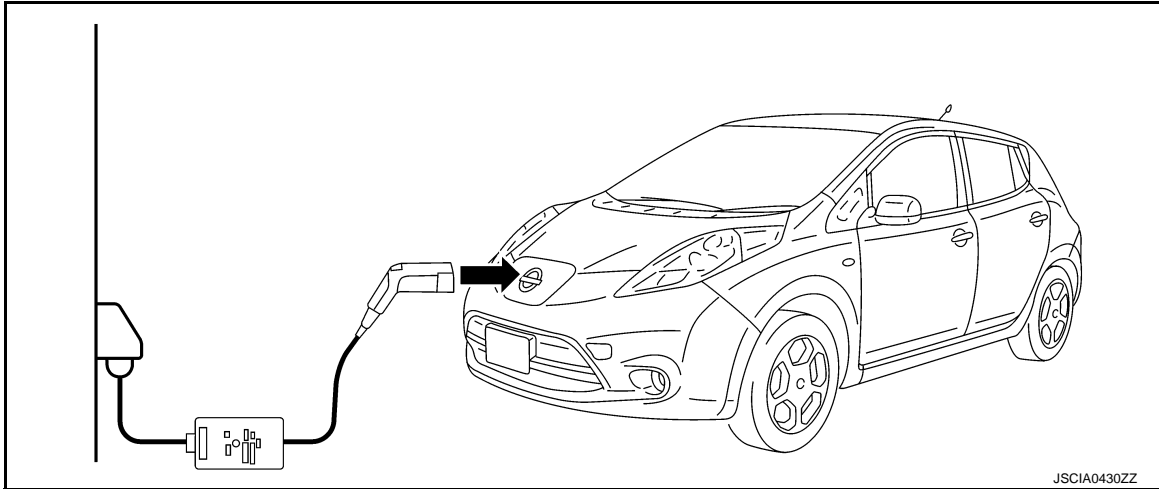

- When the temperature in the battery pack is low outside the timer charge set time, VCM transmits a keep SOC request signal to LBC via EV system CAN communication. In this case Li-ion battery is not charged, and only Li-ion battery heater is activated.
- When timer charge starts at the set time, Li-ion batter is charged, and the Li-ion battery heater is activated.

When EVSE is not connected (normal charge)

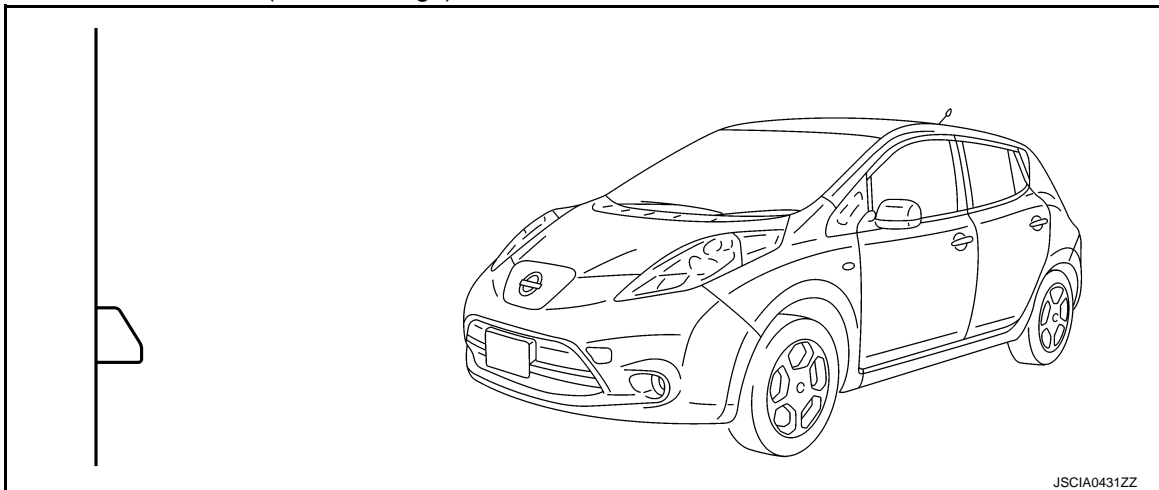

- When the charge level of the Li-ion battery is low during the Li-ion battery heater operation, LBC stops the Li-ion battery heater operation even if the temperature in the battery pack is insufficient.

A
B
C
D
E
F
G
H
I
J
K
L
M
N
O
P

EVB

SYSTEM

< SYSTEM DESCRIPTION >

[TYPE 4]

Circuit Diagram

INFOID:000000011104340

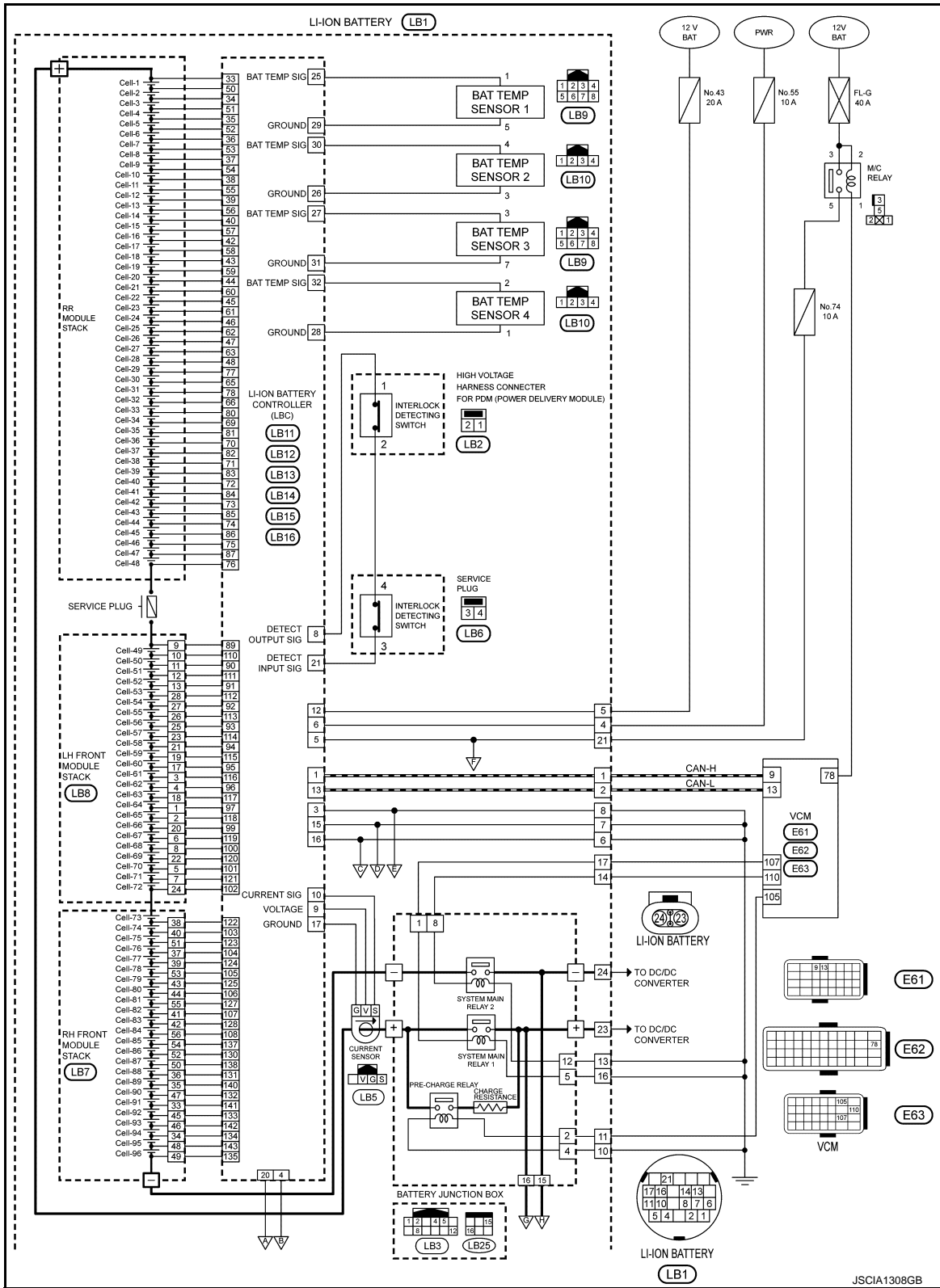

JSCIA1308GB

SYSTEM

< SYSTEM DESCRIPTION >

[TYPE 4]

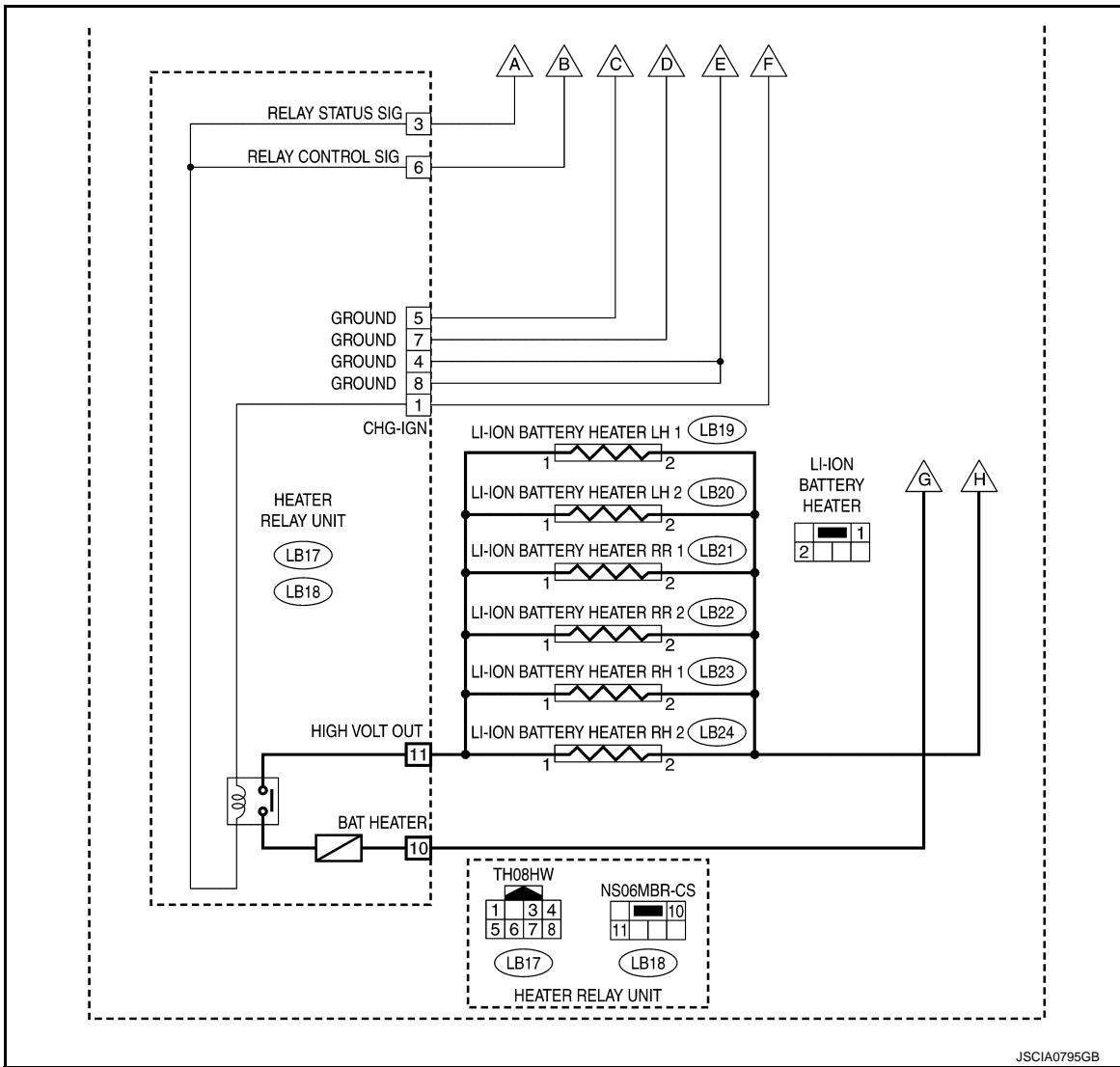

A

B

EVB

D

E

F

G

H

I

J

K

L

M

N

O

P

SYSTEM

< SYSTEM DESCRIPTION >

[TYPE 4]

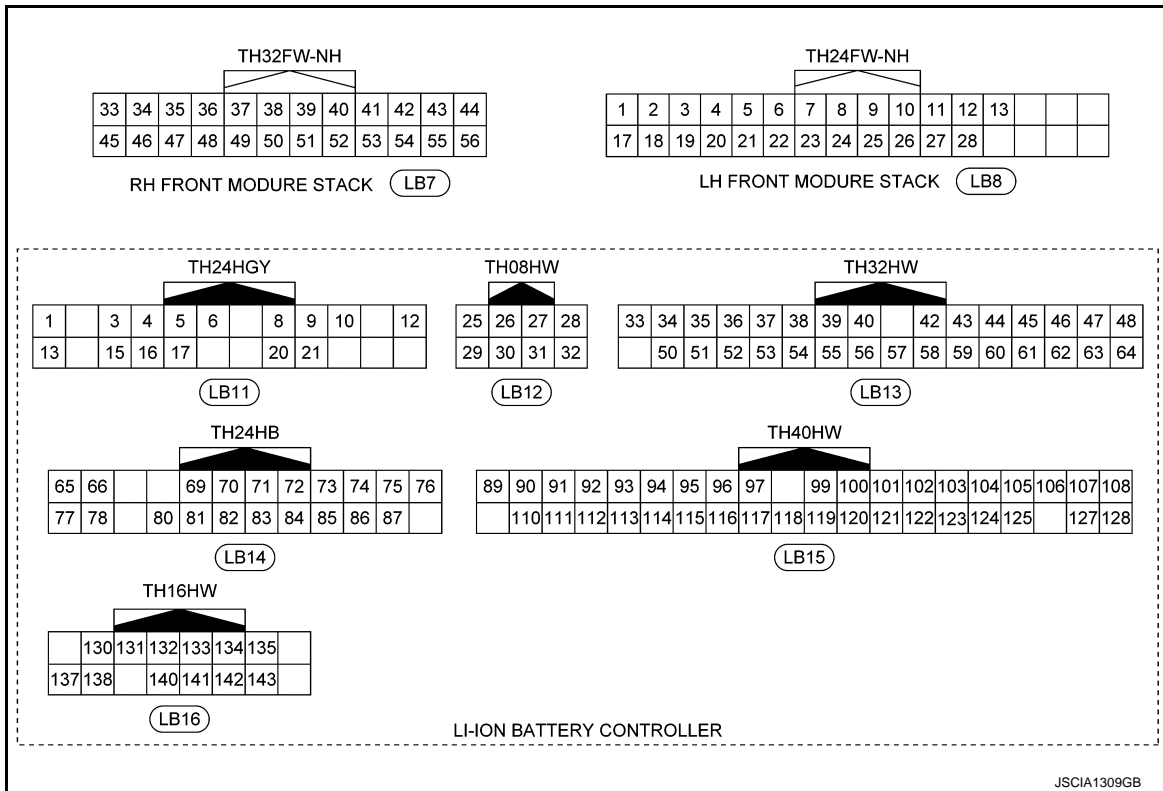

HARNESS LAYOUT

SYSTEM

< SYSTEM DESCRIPTION >

[TYPE 4]

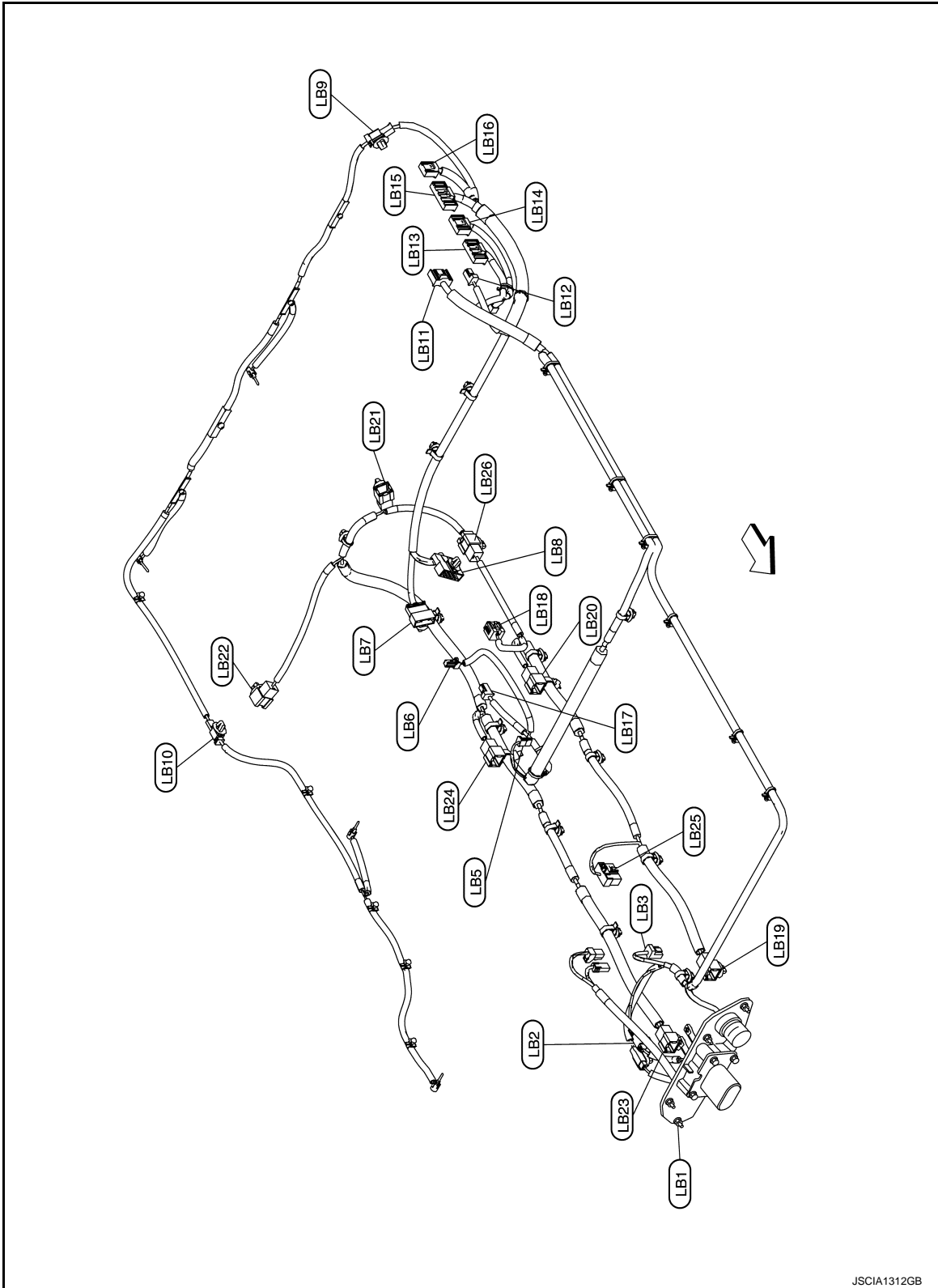

↖ : Vehicle front

A
B
EVB
D
E
F
G
H
I
J
K
L
M
N
O
P

SYSTEM

< SYSTEM DESCRIPTION >

[TYPE 4]

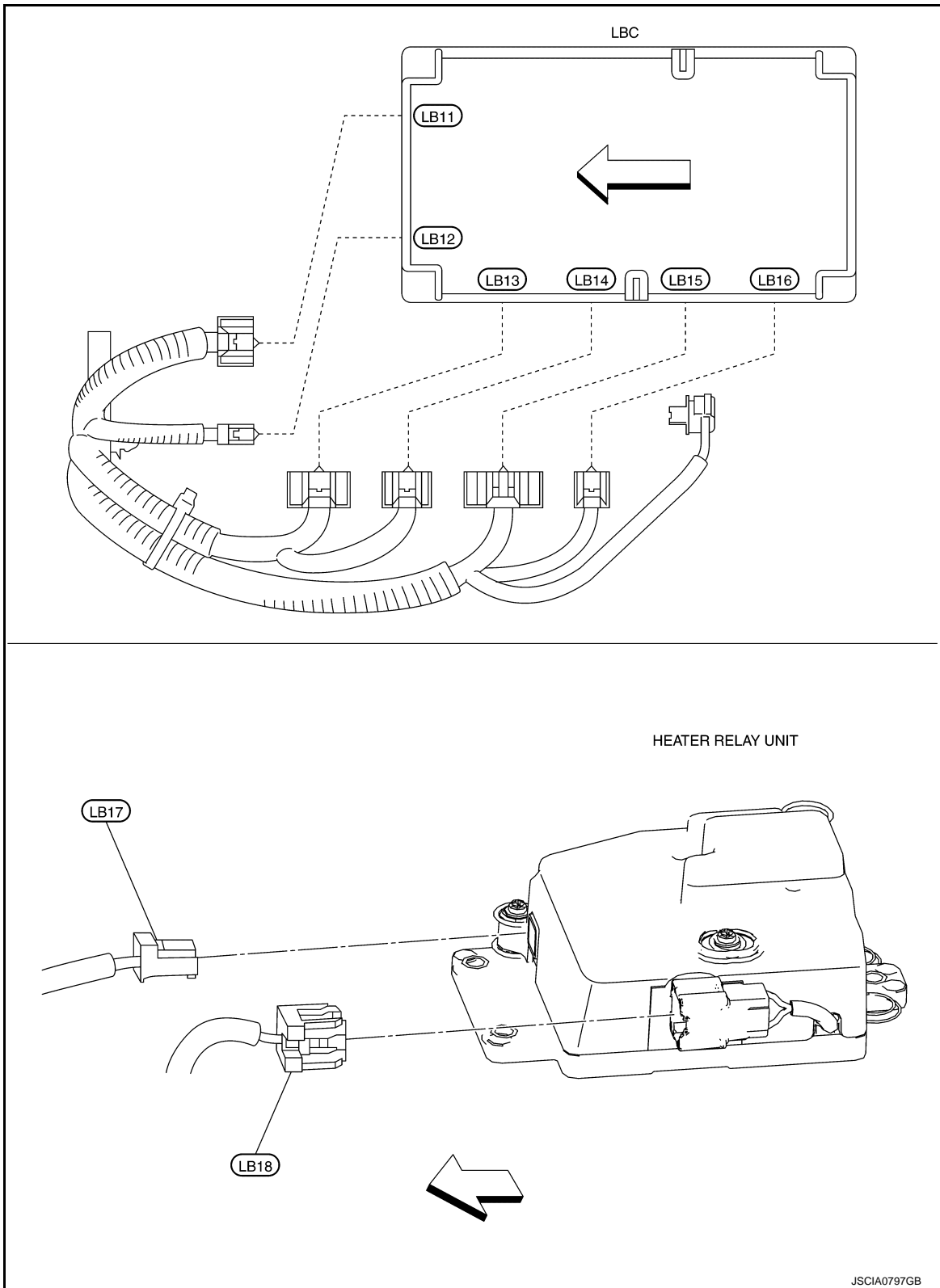

← : Vehicle front

HANDLING PRECAUTION

< SYSTEM DESCRIPTION >

[TYPE 4]

HANDLING PRECAUTION

EV Battery System

INFOID:0000000011104341

- To improve the Li-ion battery life, never perform quick charge heavily.
- Use the method of nighttime normal charge or timer-controlled charge.
- Never perform rapid acceleration/deceleration.
- Never place EV battery in an area exposed to direct sunlight or under high temperature conditions.

PRECAUTIONS FOR STORAGE OF THE LI-ION BATTERY

- Apply insulating tape to the service plug and high voltage harness connector, and protect the terminals so that nothing contacts them.
- Store in a well-ventilated location that is not exposed to direct sunlight.
(Storing outdoors or unprotected is prohibited.)
- Never set directly on the floor.
- Lay an anti-static rubber sheet underneath the battery.
- Never invert the battery.
- Never stack batteries.
- Cover with an anti-static cover sheet.
- Put a caution display stating "CAUTION! HIGH VOLTAGE" on the insulated cover sheet.
- Put identification display showing the name of person in charge on the insulated cover sheet.
- Never allow water to contact the battery.
- Prevent other objects from falling onto the battery.

A

B

EVB

D

E

F

G

H

I

J

K

L

M

N

O

P

DIAGNOSIS SYSTEM (LBC)

< SYSTEM DESCRIPTION >

[TYPE 4]

DIAGNOSIS SYSTEM (LBC)

CONSULT Function

INFOID:000000011104342

APPLICATION ITEM

CONSULT performs the following functions via CAN communication with Li-ion battery controller (LBC).

Item	Function
ECU Identification	LBC parts number can be read.
Self-diagnostic Results	Self-diagnostic results and freeze frame data can be read and erased quickly.*
Data Monitor	Input/Output data in LBC can be read.
Active Test	Activates the actuator via LBC.
Work Support	This mode enables a technician to adjust some devices faster and more accurately by following the indications on the CONSULT.
CAN Diagnosis	Displays the CAN diagnosis results.
CAN Diagnosis Support Monitor	Displays the CAN communication status.

*: The following diagnosis information is cleared when the VCM memory is erased.

- Diagnostic trouble codes
- Freeze frame data

ECU IDENTIFICATION

Part number of LBC can be checked.

SELF-DIAGNOSTIC RESULTS

Self Diagnostic Item

Regarding items of DTC, refer to [EVB-734, "DTC Index"](#).

How to Erase DTC

1. Select "HV BAT" with CONSULT.
2. "SELF-DIAGNOSTIC RESULTS".
3. Touch "ERASE". (DTC in LBC will be erased.)

FREEZE FRAME DATA (FFD)

The following vehicle status is recorded when DTC is detected and is displayed on CONSULT.

Monitored item (Unit)	Remarks
DTC	Displays the DTC which caused FFD memory
BATT ELECTRIC CURRENT A	Displays the Li-ion battery current value
12V BATTERY VOLTAGE mV	Displays 12V battery power supply voltage
IR SEN SHORT PULSE mV	Displays the maximum to minimum difference of voltage magnitude of the on-board isolation resistance monitoring system
SERVICE PLUG INTERLOCK OPEN / CLOSE	Displays the OPEN/CLOSE state of the service plug
CELL VOLTAGE 01 - 96 mV	Displays each cell voltage
TOTAL BATTERY VOLTAGE V	Displays the total voltage of the Li-ion battery
BATTERY TEMPERATURE 1 °C	Displays the temperature calculated with a signal voltage from battery temperature 1
BATTERY TEMPERATURE 2 °C	Displays the temperature calculated with a signal voltage from battery temperature 2
BATTERY TEMPERATURE 3 °C	Displays the temperature calculated with a signal voltage from battery temperature 3
BATTERY TEMPERATURE 4 °C	Displays the temperature calculated with a signal voltage from battery temperature 4

DIAGNOSIS SYSTEM (LBC)

< SYSTEM DESCRIPTION >

[TYPE 4]

DATA MONITOR

Monitored item	Unit	Remark
BATT ELECTRIC CURRENT	A	Displays the Li-ion battery current value
12V BATTERY VOLTAGE	mV	Displays 12V battery power supply voltage
IR SEN SHORT PULSE	mV	Displays the maximum to minimum difference of voltage magnitude of the on-board isolation resistance monitoring system
SERVICE PLUG INTERLOCK	OPEN / CLOSE	Displays the OPEN/CLOSE state of the service plug
CELL VOLTAGE 01 - 96	mV	Displays each cell voltage
TOTAL BATTERY VOLTAGE	V	Displays the total voltage of the Li-ion battery
MAXIMUM CELL VOLTAGE	mV	Displays the maximum cell voltage value
MINIMUM CELL VOLTAGE	mV	Displays the minimum cell voltage value
BATTERY TEMPERATURE 1	°C	Displays the temperature calculated with a signal voltage from battery temperature 1
BATTERY TEMPERATURE 2	°C	Displays the temperature calculated with a signal voltage from battery temperature 2
BATTERY TEMPERATURE 3	°C	Displays the temperature calculated with a signal voltage from battery temperature 3
BATTERY TEMPERATURE 4	°C	Displays the temperature calculated with a signal voltage from battery temperature 4

ACTIVE TEST

Test item	Operation item	Operation status
HEATER RELAY UNIT	On	Turns ON the relay built into the heater relay unit to supply high voltage power to the Li-ion battery heater.
	Off	Turns OFF the relay built into the heater relay unit to stop high voltage power supply to the Li-ion battery heater.

WORK SUPPORT

Work item	Description	Usage
SAVE BATTERY INFORMATION DATA	Data saved in LBC is stored in CONSULT.	When Li-ion battery and LBC are replaced.
WRITE BATTERY INFORMATION DATA	The CONSULT-stored data can be written in LBC.	When Li-ion battery and LBC are replaced.
CLEAR BATTERY GRADUAL CAPACITY LOSS DATA	Battery capacity data stored in LBC can be erased.	When all modules of Li-ion battery are replaced.
CLEAR BATT CHARGE/DISCHARGE INFORMATION DATA	Battery charge/discharge data stored in LBC can be erased.	When all modules of Li-ion battery are replaced.
CELL VOLTAGE LOSS INSPECTION	This inspection identifies a cell of which cell voltage is on the decrease. If identified, this type of cell may be judged as an abnormal cell, unless it is replaced.	When checking voltage of all cells.

EV BATTERY SYSTEM

< ECU DIAGNOSIS INFORMATION >

[TYPE 4]

ECU DIAGNOSIS INFORMATION

EV BATTERY SYSTEM

Reference Value

INFOID:0000000011104343

VALUE ON THE DIAGNOSIS TOOL

NOTE:

Specification data are reference values.

Monitor item	Condition		Values / Status
BATT ELECTRIC CURRENT	READY	Stop the vehicle	Approx. (-10) - (+20) A
12V BATTERY VOLTAGE	READY		Approx. 1,100 - 1,400 mV
IR SEN SHORT PULSE	READY		Approx. 4,100 - 4,300 mV
SERVICE PLUG INTER-LOCK	READY	Connect service plug	REQ
	READY	Disconnect service plug	NOT REQ
CELL VOLTAGE 01	READY	Total battery voltage 317 V	Approx. 3,200 - 3,400 mV
		Total battery voltage 393 V	Approx. 4,000 - 4,200 mV
CELL VOLTAGE 02	READY	Total battery voltage 317 V	Approx. 3,200 - 3,400 mV
		Total battery voltage 393 V	Approx. 4,000 - 4,200 mV
CELL VOLTAGE 03	READY	Total battery voltage 317 V	Approx. 3,200 - 3,400 mV
		Total battery voltage 393 V	Approx. 4,000 - 4,200 mV
CELL VOLTAGE 04	READY	Total battery voltage 317 V	Approx. 3,200 - 3,400 mV
		Total battery voltage 393 V	Approx. 4,000 - 4,200 mV
CELL VOLTAGE 05	READY	Total battery voltage 317 V	Approx. 3,200 - 3,400 mV
		Total battery voltage 393 V	Approx. 4,000 - 4,200 mV
CELL VOLTAGE 06	READY	Total battery voltage 317 V	Approx. 3,200 - 3,400 mV
		Total battery voltage 393 V	Approx. 4,000 - 4,200 mV
CELL VOLTAGE 07	READY	Total battery voltage 317 V	Approx. 3,200 - 3,400 mV
		Total battery voltage 393 V	Approx. 4,000 - 4,200 mV
CELL VOLTAGE 08	READY	Total battery voltage 317 V	Approx. 3,200 - 3,400 mV
		Total battery voltage 393 V	Approx. 4,000 - 4,200 mV
CELL VOLTAGE 09	READY	Total battery voltage 317 V	Approx. 3,200 - 3,400 mV
		Total battery voltage 393 V	Approx. 4,000 - 4,200 mV
CELL VOLTAGE 10	READY	Total battery voltage 317 V	Approx. 3,200 - 3,400 mV
		Total battery voltage 393 V	Approx. 4,000 - 4,200 mV
CELL VOLTAGE 11	READY	Total battery voltage 317 V	Approx. 3,200 - 3,400 mV
		Total battery voltage 393 V	Approx. 4,000 - 4,200 mV
CELL VOLTAGE 12	READY	Total battery voltage 317 V	Approx. 3,200 - 3,400 mV
		Total battery voltage 393 V	Approx. 4,000 - 4,200 mV
CELL VOLTAGE 13	READY	Total battery voltage 317 V	Approx. 3,200 - 3,400 mV
		Total battery voltage 393 V	Approx. 4,000 - 4,200 mV
CELL VOLTAGE 14	READY	Total battery voltage 317 V	Approx. 3,200 - 3,400 mV
		Total battery voltage 393 V	Approx. 4,000 - 4,200 mV
CELL VOLTAGE 15	READY	Total battery voltage 317 V	Approx. 3,200 - 3,400 mV
		Total battery voltage 393 V	Approx. 4,000 - 4,200 mV

EV BATTERY SYSTEM

< ECU DIAGNOSIS INFORMATION >

[TYPE 4]

Monitor item	Condition		Values / Status
CELL VOLTAGE 16	READY	Total battery voltage 317 V	Approx. 3,200 - 3,400 mV
		Total battery voltage 393 V	Approx. 4,000 - 4,200 mV
CELL VOLTAGE 17	READY	Total battery voltage 317 V	Approx. 3,200 - 3,400 mV
		Total battery voltage 393 V	Approx. 4,000 - 4,200 mV
CELL VOLTAGE 18	READY	Total battery voltage 317 V	Approx. 3,200 - 3,400 mV
		Total battery voltage 393 V	Approx. 4,000 - 4,200 mV
CELL VOLTAGE 19	READY	Total battery voltage 317 V	Approx. 3,200 - 3,400 mV
		Total battery voltage 393 V	Approx. 4,000 - 4,200 mV
CELL VOLTAGE 20	READY	Total battery voltage 317 V	Approx. 3,200 - 3,400 mV
		Total battery voltage 393 V	Approx. 4,000 - 4,200 mV
CELL VOLTAGE 21	READY	Total battery voltage 317 V	Approx. 3,200 - 3,400 mV
		Total battery voltage 393 V	Approx. 4,000 - 4,200 mV
CELL VOLTAGE 22	READY	Total battery voltage 317 V	Approx. 3,200 - 3,400 mV
		Total battery voltage 393 V	Approx. 4,000 - 4,200 mV
CELL VOLTAGE 23	READY	Total battery voltage 317 V	Approx. 3,200 - 3,400 mV
		Total battery voltage 393 V	Approx. 4,000 - 4,200 mV
CELL VOLTAGE 24	READY	Total battery voltage 317 V	Approx. 3,200 - 3,400 mV
		Total battery voltage 393 V	Approx. 4,000 - 4,200 mV
CELL VOLTAGE 25	READY	Total battery voltage 317 V	Approx. 3,200 - 3,400 mV
		Total battery voltage 393 V	Approx. 4,000 - 4,200 mV
CELL VOLTAGE 26	READY	Total battery voltage 317 V	Approx. 3,200 - 3,400 mV
		Total battery voltage 393 V	Approx. 4,000 - 4,200 mV
CELL VOLTAGE 27	READY	Total battery voltage 317 V	Approx. 3,200 - 3,400 mV
		Total battery voltage 393 V	Approx. 4,000 - 4,200 mV
CELL VOLTAGE 28	READY	Total battery voltage 317 V	Approx. 3,200 - 3,400 mV
		Total battery voltage 393 V	Approx. 4,000 - 4,200 mV
CELL VOLTAGE 29	READY	Total battery voltage 317 V	Approx. 3,200 - 3,400 mV
		Total battery voltage 393 V	Approx. 4,000 - 4,200 mV
CELL VOLTAGE 30	READY	Total battery voltage 317 V	Approx. 3,200 - 3,400 mV
		Total battery voltage 393 V	Approx. 4,000 - 4,200 mV
CELL VOLTAGE 31	READY	Total battery voltage 317 V	Approx. 3,200 - 3,400 mV
		Total battery voltage 393 V	Approx. 4,000 - 4,200 mV
CELL VOLTAGE 32	READY	Total battery voltage 317 V	Approx. 3,200 - 3,400 mV
		Total battery voltage 393 V	Approx. 4,000 - 4,200 mV
CELL VOLTAGE 33	READY	Total battery voltage 317 V	Approx. 3,200 - 3,400 mV
		Total battery voltage 393 V	Approx. 4,000 - 4,200 mV
CELL VOLTAGE 34	READY	Total battery voltage 317 V	Approx. 3,200 - 3,400 mV
		Total battery voltage 393 V	Approx. 4,000 - 4,200 mV
CELL VOLTAGE 35	READY	Total battery voltage 317 V	Approx. 3,200 - 3,400 mV
		Total battery voltage 393 V	Approx. 4,000 - 4,200 mV
CELL VOLTAGE 36	READY	Total battery voltage 317 V	Approx. 3,200 - 3,400 mV
		Total battery voltage 393 V	Approx. 4,000 - 4,200 mV
CELL VOLTAGE 37	READY	Total battery voltage 317 V	Approx. 3,200 - 3,400 mV
		Total battery voltage 393 V	Approx. 4,000 - 4,200 mV

A

B

EVB

D

E

F

G

H

I

J

K

L

M

N

O

P

EV BATTERY SYSTEM

< ECU DIAGNOSIS INFORMATION >

[TYPE 4]

Monitor item	Condition	Values / Status	
CELL VOLTAGE 38	READY	Total battery voltage 317 V	Approx. 3,200 - 3,400 mV
		Total battery voltage 393 V	Approx. 4,000 - 4,200 mV
CELL VOLTAGE 39	READY	Total battery voltage 317 V	Approx. 3,200 - 3,400 mV
		Total battery voltage 393 V	Approx. 4,000 - 4,200 mV
CELL VOLTAGE 40	READY	Total battery voltage 317 V	Approx. 3,200 - 3,400 mV
		Total battery voltage 393 V	Approx. 4,000 - 4,200 mV
CELL VOLTAGE 41	READY	Total battery voltage 317 V	Approx. 3,200 - 3,400 mV
		Total battery voltage 393 V	Approx. 4,000 - 4,200 mV
CELL VOLTAGE 42	READY	Total battery voltage 317 V	Approx. 3,200 - 3,400 mV
		Total battery voltage 393 V	Approx. 4,000 - 4,200 mV
CELL VOLTAGE 43	READY	Total battery voltage 317 V	Approx. 3,200 - 3,400 mV
		Total battery voltage 393 V	Approx. 4,000 - 4,200 mV
CELL VOLTAGE 44	READY	Total battery voltage 317 V	Approx. 3,200 - 3,400 mV
		Total battery voltage 393 V	Approx. 4,000 - 4,200 mV
CELL VOLTAGE 45	READY	Total battery voltage 317 V	Approx. 3,200 - 3,400 mV
		Total battery voltage 393 V	Approx. 4,000 - 4,200 mV
CELL VOLTAGE 46	READY	Total battery voltage 317 V	Approx. 3,200 - 3,400 mV
		Total battery voltage 393 V	Approx. 4,000 - 4,200 mV
CELL VOLTAGE 47	READY	Total battery voltage 317 V	Approx. 3,200 - 3,400 mV
		Total battery voltage 393 V	Approx. 4,000 - 4,200 mV
CELL VOLTAGE 48	READY	Total battery voltage 317 V	Approx. 3,200 - 3,400 mV
		Total battery voltage 393 V	Approx. 4,000 - 4,200 mV
CELL VOLTAGE 49	READY	Total battery voltage 317 V	Approx. 3,200 - 3,400 mV
		Total battery voltage 393 V	Approx. 4,000 - 4,200 mV
CELL VOLTAGE 50	READY	Total battery voltage 317 V	Approx. 3,200 - 3,400 mV
		Total battery voltage 393 V	Approx. 4,000 - 4,200 mV
CELL VOLTAGE 51	READY	Total battery voltage 317 V	Approx. 3,200 - 3,400 mV
		Total battery voltage 393 V	Approx. 4,000 - 4,200 mV
CELL VOLTAGE 52	READY	Total battery voltage 317 V	Approx. 3,200 - 3,400 mV
		Total battery voltage 393 V	Approx. 4,000 - 4,200 mV
CELL VOLTAGE 53	READY	Total battery voltage 317 V	Approx. 3,200 - 3,400 mV
		Total battery voltage 393 V	Approx. 4,000 - 4,200 mV
CELL VOLTAGE 54	READY	Total battery voltage 317 V	Approx. 3,200 - 3,400 mV
		Total battery voltage 393 V	Approx. 4,000 - 4,200 mV
CELL VOLTAGE 55	READY	Total battery voltage 317 V	Approx. 3,200 - 3,400 mV
		Total battery voltage 393 V	Approx. 4,000 - 4,200 mV
CELL VOLTAGE 56	READY	Total battery voltage 317 V	Approx. 3,200 - 3,400 mV
		Total battery voltage 393 V	Approx. 4,000 - 4,200 mV
CELL VOLTAGE 57	READY	Total battery voltage 317 V	Approx. 3,200 - 3,400 mV
		Total battery voltage 393 V	Approx. 4,000 - 4,200 mV
CELL VOLTAGE 58	READY	Total battery voltage 317 V	Approx. 3,200 - 3,400 mV
		Total battery voltage 393 V	Approx. 4,000 - 4,200 mV
CELL VOLTAGE 59	READY	Total battery voltage 317 V	Approx. 3,200 - 3,400 mV
		Total battery voltage 393 V	Approx. 4,000 - 4,200 mV

EV BATTERY SYSTEM

< ECU DIAGNOSIS INFORMATION >

[TYPE 4]

Monitor item	Condition		Values / Status
CELL VOLTAGE 60	READY	Total battery voltage 317 V	Approx. 3,200 - 3,400 mV
		Total battery voltage 393 V	Approx. 4,000 - 4,200 mV
CELL VOLTAGE 61	READY	Total battery voltage 317 V	Approx. 3,200 - 3,400 mV
		Total battery voltage 393 V	Approx. 4,000 - 4,200 mV
CELL VOLTAGE 62	READY	Total battery voltage 317 V	Approx. 3,200 - 3,400 mV
		Total battery voltage 393 V	Approx. 4,000 - 4,200 mV
CELL VOLTAGE 63	READY	Total battery voltage 317 V	Approx. 3,200 - 3,400 mV
		Total battery voltage 393 V	Approx. 4,000 - 4,200 mV
CELL VOLTAGE 64	READY	Total battery voltage 317 V	Approx. 3,200 - 3,400 mV
		Total battery voltage 393 V	Approx. 4,000 - 4,200 mV
CELL VOLTAGE 65	READY	Total battery voltage 317 V	Approx. 3,200 - 3,400 mV
		Total battery voltage 393 V	Approx. 4,000 - 4,200 mV
CELL VOLTAGE 66	READY	Total battery voltage 317 V	Approx. 3,200 - 3,400 mV
		Total battery voltage 393 V	Approx. 4,000 - 4,200 mV
CELL VOLTAGE 67	READY	Total battery voltage 317 V	Approx. 3,200 - 3,400 mV
		Total battery voltage 393 V	Approx. 4,000 - 4,200 mV
CELL VOLTAGE 68	READY	Total battery voltage 317 V	Approx. 3,200 - 3,400 mV
		Total battery voltage 393 V	Approx. 4,000 - 4,200 mV
CELL VOLTAGE 69	READY	Total battery voltage 317 V	Approx. 3,200 - 3,400 mV
		Total battery voltage 393 V	Approx. 4,000 - 4,200 mV
CELL VOLTAGE 70	READY	Total battery voltage 317 V	Approx. 3,200 - 3,400 mV
		Total battery voltage 393 V	Approx. 4,000 - 4,200 mV
CELL VOLTAGE 71	READY	Total battery voltage 317 V	Approx. 3,200 - 3,400 mV
		Total battery voltage 393 V	Approx. 4,000 - 4,200 mV
CELL VOLTAGE 72	READY	Total battery voltage 317 V	Approx. 3,200 - 3,400 mV
		Total battery voltage 393 V	Approx. 4,000 - 4,200 mV
CELL VOLTAGE 73	READY	Total battery voltage 317 V	Approx. 3,200 - 3,400 mV
		Total battery voltage 393 V	Approx. 4,000 - 4,200 mV
CELL VOLTAGE 74	READY	Total battery voltage 317 V	Approx. 3,200 - 3,400 mV
		Total battery voltage 393 V	Approx. 4,000 - 4,200 mV
CELL VOLTAGE 75	READY	Total battery voltage 317 V	Approx. 3,200 - 3,400 mV
		Total battery voltage 393 V	Approx. 4,000 - 4,200 mV
CELL VOLTAGE 76	READY	Total battery voltage 317 V	Approx. 3,200 - 3,400 mV
		Total battery voltage 393 V	Approx. 4,000 - 4,200 mV
CELL VOLTAGE 77	READY	Total battery voltage 317 V	Approx. 3,200 - 3,400 mV
		Total battery voltage 393 V	Approx. 4,000 - 4,200 mV
CELL VOLTAGE 78	READY	Total battery voltage 317 V	Approx. 3,200 - 3,400 mV
		Total battery voltage 393 V	Approx. 4,000 - 4,200 mV
CELL VOLTAGE 79	READY	Total battery voltage 317 V	Approx. 3,200 - 3,400 mV
		Total battery voltage 393 V	Approx. 4,000 - 4,200 mV
CELL VOLTAGE 80	READY	Total battery voltage 317 V	Approx. 3,200 - 3,400 mV
		Total battery voltage 393 V	Approx. 4,000 - 4,200 mV
CELL VOLTAGE 81	READY	Total battery voltage 317 V	Approx. 3,200 - 3,400 mV
		Total battery voltage 393 V	Approx. 4,000 - 4,200 mV

A

B

EVB

D

E

F

G

H

I

J

K

L

M

N

O

P

EV BATTERY SYSTEM

< ECU DIAGNOSIS INFORMATION >

[TYPE 4]

Monitor item	Condition		Values / Status
CELL VOLTAGE 82	READY	Total battery voltage 317 V	Approx. 3,200 - 3,400 mV
		Total battery voltage 393 V	Approx. 4,000 - 4,200 mV
CELL VOLTAGE 83	READY	Total battery voltage 317 V	Approx. 3,200 - 3,400 mV
		Total battery voltage 393 V	Approx. 4,000 - 4,200 mV
CELL VOLTAGE 84	READY	Total battery voltage 317 V	Approx. 3,200 - 3,400 mV
		Total battery voltage 393 V	Approx. 4,000 - 4,200 mV
CELL VOLTAGE 85	READY	Total battery voltage 317 V	Approx. 3,200 - 3,400 mV
		Total battery voltage 393 V	Approx. 4,000 - 4,200 mV
CELL VOLTAGE 86	READY	Total battery voltage 317 V	Approx. 3,200 - 3,400 mV
		Total battery voltage 393 V	Approx. 4,000 - 4,200 mV
CELL VOLTAGE 87	READY	Total battery voltage 317 V	Approx. 3,200 - 3,400 mV
		Total battery voltage 393 V	Approx. 4,000 - 4,200 mV
CELL VOLTAGE 88	READY	Total battery voltage 317 V	Approx. 3,200 - 3,400 mV
		Total battery voltage 393 V	Approx. 4,000 - 4,200 mV
CELL VOLTAGE 89	READY	Total battery voltage 317 V	Approx. 3,200 - 3,400 mV
		Total battery voltage 393 V	Approx. 4,000 - 4,200 mV
CELL VOLTAGE 90	READY	Total battery voltage 317 V	Approx. 3,200 - 3,400 mV
		Total battery voltage 393 V	Approx. 4,000 - 4,200 mV
CELL VOLTAGE 91	READY	Total battery voltage 317 V	Approx. 3,200 - 3,400 mV
		Total battery voltage 393 V	Approx. 4,000 - 4,200 mV
CELL VOLTAGE 92	READY	Total battery voltage 317 V	Approx. 3,200 - 3,400 mV
		Total battery voltage 393 V	Approx. 4,000 - 4,200 mV
CELL VOLTAGE 93	READY	Total battery voltage 317 V	Approx. 3,200 - 3,400 mV
		Total battery voltage 393 V	Approx. 4,000 - 4,200 mV
CELL VOLTAGE 94	READY	Total battery voltage 317 V	Approx. 3,200 - 3,400 mV
		Total battery voltage 393 V	Approx. 4,000 - 4,200 mV
CELL VOLTAGE 95	READY	Total battery voltage 317 V	Approx. 3,200 - 3,400 mV
		Total battery voltage 393 V	Approx. 4,000 - 4,200 mV
CELL VOLTAGE 96	READY	Total battery voltage 317 V	Approx. 3,200 - 3,400 mV
		Total battery voltage 393 V	Approx. 4,000 - 4,200 mV
TOTAL BATTERY VOLTAGE	READY		Approx. 240 - 420 V
MAXIMUM CELL VOLTAGE	READY	Total battery voltage 317 V	Approx. 3,300 - 3,500 mV
		Total battery voltage 393 V	Approx. 4,000 - 4,200 mV
MINIMUM CELL VOLTAGE	READY	Total battery voltage 317 V	Approx. 3,300 - 3,500 mV
		Total battery voltage 393 V	Approx. 4,000 - 4,200 mV
BATTERY TEMPERATURE 1	READY (Stop the vehicle)	Ambient temperature: 25°C (77°F)	20°C - 30°C (68°F - 86°F) [Equivalent to air temperature around rear module stack]
BATTERY TEMPERATURE 2	READY (Stop the vehicle)	Ambient temperature: 25°C (77°F)	20°C - 30°C (68°F - 86°F) [Equivalent to air temperature around front RH module stack]
BATTERY TEMPERATURE 3	READY (Stop the vehicle)	Ambient temperature: 25°C (77°F)	20°C - 30°C (68°F - 86°F) [Equivalent to air temperature around rear module stack]
BATTERY TEMPERATURE 4	READY (Stop the vehicle)	Ambient temperature: 25°C (77°F)	20°C - 30°C (68°F - 86°F) [Equivalent to air temperature around front RH module stack]

EV BATTERY SYSTEM

< ECU DIAGNOSIS INFORMATION >

[TYPE 4]

Fail-safe

INFOID:000000011104344

When Li-ion Battery Controller (LBC) detects a malfunction of the Li-ion battery, it enters the control mode that protects the battery by stopping or restricting the output/charging from/to the battery. The fail-safe mode differs depending on the contents of the detected malfunction.

FAIL-SAFE PATTERN

- Pattern A: No driving and Charge stop
- Pattern B: Driving output power limit, and Charge stop
- Pattern C: Driving output power limit, and Charge limit
- Pattern D: EV system warning lamp illuminate

FAIL-SAFE LIST

DTC	CONSULT screen items	Pattern			
		A	B	C	D
P0A0D	HV SYSTEM INTERLOCK ERROR				×
P0A1F	BATTERY ENERGY CONTROL MODULE	×	×		×
P3030	CELL CONT LIN		×		
P3031	CELL CONT ASIC1		×		
P3032	CELL CONT ASIC2		×		
P3033	CELL CONT ASIC3		×		
P3034	CELL CONT ASIC4		×		
P3035	CELL CONT ASIC5		×		
P3036	CELL CONT ASIC6		×		
P3037	CELL CONT ASIC7		×		
P3038	CELL CONT ASIC8		×		
P3039	CELL CONT ASIC9		×		
P303A	CELL CONT ASIC10		×		
P303B	CELL CONT ASIC11		×		
P303C	CELL CONT ASIC12		×		
P303D	CELL CONT ASIC13		×		
P303E	CELL CONT ASIC14		×		
P303F	CELL CONT ASIC15		×		
P3040	CELL CONT ASIC16		×		
P3041	CELL CONT ASIC17		×		
P3042	CELL CONT ASIC18		×		
P3043	CELL CONT ASIC19		×		
P3044	CELL CONT ASIC20		×		
P3045	CELL CONT ASIC21		×		
P3046	CELL CONT ASIC22		×		
P3047	CELL CONT ASIC23		×		
P3048	CELL CONT ASIC24		×		
P3049	CELL CONT ASIC1 VOLT		×		
P304A	CELL CONT ASIC2 VOLT		×		
P304B	CELL CONT ASIC3 VOLT		×		
P304C	CELL CONT ASIC4 VOLT		×		
P304D	CELL CONT ASIC5 VOLT		×		
P304E	CELL CONT ASIC6 VOLT		×		

EV BATTERY SYSTEM

< ECU DIAGNOSIS INFORMATION >

[TYPE 4]

DTC	CONSULT screen items	Pattern			
		A	B	C	D
P304F	CELL CONT ASIC7 VOLT		×		
P3050	CELL CONT ASIC8 VOLT		×		
P3051	CELL CONT ASIC9 VOLT		×		
P3052	CELL CONT ASIC10 VOLT		×		
P3053	CELL CONT ASIC11 VOLT		×		
P3054	CELL CONT ASIC12 VOLT		×		
P3055	CELL CONT ASIC13 VOLT		×		
P3056	CELL CONT ASIC14 VOLT		×		
P3057	CELL CONT ASIC15 VOLT		×		
P3058	CELL CONT ASIC16 VOLT		×		
P3059	CELL CONT ASIC17 VOLT		×		
P305A	CELL CONT ASIC18 VOLT		×		
P305B	CELL CONT ASIC19 VOLT		×		
P305C	CELL CONT ASIC20 VOLT		×		
P305D	CELL CONT ASIC21 VOLT		×		
P305E	CELL CONT ASIC22 VOLT		×		
P305F	CELL CONT ASIC23 VOLT		×		
P3060	CELL CONT ASIC24 VOLT		×		
P3061	CELL BATTERY VOLT				×
P3062	BYPASS SW				×
P308B	CELL CONT ASIC1 OPEN		×		
P308C	CELL CONT ASIC2 OPEN		×		
P308D	CELL CONT ASIC3 OPEN		×		
P308E	CELL CONT ASIC4 OPEN		×		
P308F	CELL CONT ASIC5 OPEN		×		
P3090	CELL CONT ASIC6 OPEN		×		
P3091	CELL CONT ASIC7 OPEN		×		
P3092	CELL CONT ASIC8 OPEN		×		
P3093	CELL CONT ASIC9 OPEN		×		
P3094	CELL CONT ASIC10 OPEN		×		
P3095	CELL CONT ASIC11 OPEN		×		
P3096	CELL CONT ASIC12 OPEN		×		
P3097	CELL CONT ASIC13 OPEN		×		
P3098	CELL CONT ASIC14 OPEN		×		
P3099	CELL CONT ASIC15 OPEN		×		
P309A	CELL CONT ASIC16 OPEN		×		
P309B	CELL CONT ASIC17 OPEN		×		
P309C	CELL CONT ASIC18 OPEN		×		
P309D	CELL CONT ASIC19 OPEN		×		
P309E	CELL CONT ASIC20 OPEN		×		
P309F	CELL CONT ASIC21 OPEN		×		
P30A0	CELL CONT ASIC22 OPEN		×		
P30A1	CELL CONT ASIC23 OPEN		×		

EV BATTERY SYSTEM

< ECU DIAGNOSIS INFORMATION >

[TYPE 4]

DTC	CONSULT screen items	Pattern				
		A	B	C	D	
P30A2	CELL CONT ASIC24 OPEN		×			A
P30F3	TOTAL VOLT SENSOR			×		B
P30F4	TOTAL VOLT SENSOR			×		
P30F5	TOTAL VOLT SENSOR			×		
P30FC	OVER CURRENT	×				EVB
P30FD	TOTAL VOLTAGE MONITOR SWITCH	No fail-safe				
P30FE	12V BATTERY VOLTAGE				×	D
P318D	COMMUNICATION ERROR				×	
P318E	COMMUNICATION ERROR				×	
P3191	COMMUNICATION ERROR	No fail-safe				E
P3196	COMMUNICATION ERROR	No fail-safe				
P3199	COMMUNICATION ERROR				×	F
P319C	COMMUNICATION ERROR	No fail-safe				
P31A4	CAN ERROR VCM				×	
P31A7	CAN ERROR INV/MC	No fail-safe				G
P3300	TOTAL VOLTAGE OVER	×				
P3302	CELL OVER VOLTAGE MODULE1	×				H
P3303	CELL OVER VOLTAGE MODULE2	×				
P3304	CELL OVER VOLTAGE MODULE3	×				
P3305	CELL OVER VOLTAGE MODULE4	×				I
P3306	CELL OVER VOLTAGE MODULE5	×				
P3307	CELL OVER VOLTAGE MODULE6	×				
P3308	CELL OVER VOLTAGE MODULE7	×				J
P3309	CELL OVER VOLTAGE MODULE8	×				
P330A	CELL OVER VOLTAGE MODULE9	×				K
P330B	CELL OVER VOLTAGE MODULE10	×				
P330C	CELL OVER VOLTAGE MODULE11	×				
P330D	CELL OVER VOLTAGE MODULE12	×				L
P330E	CELL OVER VOLTAGE MODULE13	×				
P330F	CELL OVER VOLTAGE MODULE14	×				M
P3310	CELL OVER VOLTAGE MODULE15	×				
P3311	CELL OVER VOLTAGE MODULE16	×				
P3312	CELL OVER VOLTAGE MODULE17	×				N
P3313	CELL OVER VOLTAGE MODULE18	×				
P3314	CELL OVER VOLTAGE MODULE19	×				
P3315	CELL OVER VOLTAGE MODULE20	×				O
P3316	CELL OVER VOLTAGE MODULE21	×				
P3317	CELL OVER VOLTAGE MODULE22	×				P
P3318	CELL OVER VOLTAGE MODULE23	×				
P3319	CELL OVER VOLTAGE MODULE24	×				
P331A	CELL OVER VOLTAGE MODULE25	×				
P331B	CELL OVER VOLTAGE MODULE26	×				
P331C	CELL OVER VOLTAGE MODULE27	×				

EV BATTERY SYSTEM

< ECU DIAGNOSIS INFORMATION >

[TYPE 4]

DTC	CONSULT screen items	Pattern			
		A	B	C	D
P331D	CELL OVER VOLTAGE MODULE28	×			
P331E	CELL OVER VOLTAGE MODULE29	×			
P331F	CELL OVER VOLTAGE MODULE30	×			
P3320	CELL OVER VOLTAGE MODULE31	×			
P3321	CELL OVER VOLTAGE MODULE32	×			
P3322	CELL OVER VOLTAGE MODULE33	×			
P3323	CELL OVER VOLTAGE MODULE34	×			
P3324	CELL OVER VOLTAGE MODULE35	×			
P3325	CELL OVER VOLTAGE MODULE36	×			
P3326	CELL OVER VOLTAGE MODULE37	×			
P3327	CELL OVER VOLTAGE MODULE38	×			
P3328	CELL OVER VOLTAGE MODULE39	×			
P3329	CELL OVER VOLTAGE MODULE40	×			
P332A	CELL OVER VOLTAGE MODULE41	×			
P332B	CELL OVER VOLTAGE MODULE42	×			
P332C	CELL OVER VOLTAGE MODULE43	×			
P332D	CELL OVER VOLTAGE MODULE44	×			
P332E	CELL OVER VOLTAGE MODULE45	×			
P332F	CELL OVER VOLTAGE MODULE46	×			
P3330	CELL OVER VOLTAGE MODULE47	×			
P3331	CELL OVER VOLTAGE MODULE48	×			
P3373	TOTAL VOLTAGE OVER DISCHARGE	×			
P3375	CELL OVER DISCHARGE MODULE1	×			
P3376	CELL OVER DISCHARGE MODULE2	×			
P3377	CELL OVER DISCHARGE MODULE3	×			
P3378	CELL OVER DISCHARGE MODULE4	×			
P3379	CELL OVER DISCHARGE MODULE5	×			
P337A	CELL OVER DISCHARGE MODULE6	×			
P337B	CELL OVER DISCHARGE MODULE7	×			
P337C	CELL OVER DISCHARGE MODULE8	×			
P337D	CELL OVER DISCHARGE MODULE9	×			
P337E	CELL OVER DISCHARGE MODULE10	×			
P337F	CELL OVER DISCHARGE MODULE11	×			
P3380	CELL OVER DISCHARGE MODULE12	×			
P3381	CELL OVER DISCHARGE MODULE13	×			
P3382	CELL OVER DISCHARGE MODULE14	×			
P3383	CELL OVER DISCHARGE MODULE15	×			
P3384	CELL OVER DISCHARGE MODULE16	×			
P3385	CELL OVER DISCHARGE MODULE17	×			
P3386	CELL OVER DISCHARGE MODULE18	×			
P3387	CELL OVER DISCHARGE MODULE19	×			
P3388	CELL OVER DISCHARGE MODULE20	×			
P3389	CELL OVER DISCHARGE MODULE21	×			

EV BATTERY SYSTEM

< ECU DIAGNOSIS INFORMATION >

[TYPE 4]

DTC	CONSULT screen items	Pattern				
		A	B	C	D	
P338A	CELL OVER DISCHARGE MODULE22	×				A
P338B	CELL OVER DISCHARGE MODULE23	×				B
P338C	CELL OVER DISCHARGE MODULE24	×				
P338D	CELL OVER DISCHARGE MODULE25	×				
P338E	CELL OVER DISCHARGE MODULE26	×				EVB
P338F	CELL OVER DISCHARGE MODULE27	×				
P3390	CELL OVER DISCHARGE MODULE28	×				D
P3391	CELL OVER DISCHARGE MODULE29	×				
P3392	CELL OVER DISCHARGE MODULE30	×				
P3393	CELL OVER DISCHARGE MODULE31	×				E
P3394	CELL OVER DISCHARGE MODULE32	×				
P3395	CELL OVER DISCHARGE MODULE33	×				F
P3396	CELL OVER DISCHARGE MODULE34	×				
P3397	CELL OVER DISCHARGE MODULE35	×				
P3398	CELL OVER DISCHARGE MODULE36	×				G
P3399	CELL OVER DISCHARGE MODULE37	×				
P339A	CELL OVER DISCHARGE MODULE38	×				H
P339B	CELL OVER DISCHARGE MODULE39	×				
P339C	CELL OVER DISCHARGE MODULE40	×				I
P339D	CELL OVER DISCHARGE MODULE41	×				
P339E	CELL OVER DISCHARGE MODULE42	×				J
P339F	CELL OVER DISCHARGE MODULE43	×				
P33A0	CELL OVER DISCHARGE MODULE44	×				K
P33A1	CELL OVER DISCHARGE MODULE45	×				
P33A2	CELL OVER DISCHARGE MODULE46	×				L
P33A3	CELL OVER DISCHARGE MODULE47	×				
P33A4	CELL OVER DISCHARGE MODULE48	×				M
P33D4	BATT GRADUAL CAPA LOSS DIAG				×	
P33D5	CURRENT SENSOR		×			N
P33D6	CURRENT SENSOR		×			
P33D7	TEMPERATURE SENSOR			No fail-safe		
P33D9	TEMPERATURE SENSOR			No fail-safe		
P33DB	TEMPERATURE SENSOR			No fail-safe		O
P33DD	TEMPERATURE SENSOR			No fail-safe		
P33DF	BATT VOLTAGE ISOLATION SEN				×	
P33E0	BATT VOLTAGE ISOLATION SEN				×	P
P33E1	BATT VOLTAGE ISOLATION SEN				×	
P33E2	BATT PACK OVER TEMP	×				
P33E4	TEMPERATURE SENSOR			No fail-safe		
P33E5	TEMPERATURE SENSOR			No fail-safe		
P33E6	CELL VOLTAGE DEVIATION DIAG			×		
P33E7	CELL CONTROLLER				×	
P33EA	BATTERY HEATER RELAY				×	

EV BATTERY SYSTEM

< ECU DIAGNOSIS INFORMATION >

[TYPE 4]

DTC	CONSULT screen items	Pattern			
		A	B	C	D
P33ED	BATTERY PARALLEL DIAGNOSIS			×	
P33EE	BATTERY HEATER CONTROL SYSTEM				×
U1000	CAN COMM CIRCUIT				×

DTC Index

INFOID:0000000011104345

×: Applicable —: Not applicable

DTC	CONSULT screen items	EV system warning lamp	Trip	Reference
P0A0D	HV SYSTEM INTERLOCK ERROR	×	1	EVB-758
P0A1F	BATTERY ENERGY CONTROL MODULE	×	1	EVB-760
P3030	CELL CONT LIN	×	1	EVB-761
P3031	CELL CONT ASIC1	×	1	EVB-762
P3032	CELL CONT ASIC2	×	1	EVB-762
P3033	CELL CONT ASIC3	×	1	EVB-762
P3034	CELL CONT ASIC4	×	1	EVB-762
P3035	CELL CONT ASIC5	×	1	EVB-762
P3036	CELL CONT ASIC6	×	1	EVB-762
P3037	CELL CONT ASIC7	×	1	EVB-762
P3038	CELL CONT ASIC8	×	1	EVB-762
P3039	CELL CONT ASIC9	×	1	EVB-762
P303A	CELL CONT ASIC10	×	1	EVB-762
P303B	CELL CONT ASIC11	×	1	EVB-762
P303C	CELL CONT ASIC12	×	1	EVB-762
P303D	CELL CONT ASIC13	×	1	EVB-763
P303E	CELL CONT ASIC14	×	1	EVB-763
P303F	CELL CONT ASIC15	×	1	EVB-763
P3040	CELL CONT ASIC16	×	1	EVB-763
P3041	CELL CONT ASIC17	×	1	EVB-763
P3042	CELL CONT ASIC18	×	1	EVB-763
P3043	CELL CONT ASIC19	×	1	EVB-763
P3044	CELL CONT ASIC20	×	1	EVB-763
P3045	CELL CONT ASIC21	×	1	EVB-763
P3046	CELL CONT ASIC22	×	1	EVB-763
P3047	CELL CONT ASIC23	×	1	EVB-763
P3048	CELL CONT ASIC24	×	1	EVB-763
P3049	CELL CONT ASIC1 VOLT	×	1	EVB-764
P304A	CELL CONT ASIC2 VOLT	×	1	EVB-764
P304B	CELL CONT ASIC3 VOLT	×	1	EVB-764
P304C	CELL CONT ASIC4 VOLT	×	1	EVB-764
P304D	CELL CONT ASIC5 VOLT	×	1	EVB-764
P304E	CELL CONT ASIC6 VOLT	×	1	EVB-764
P304F	CELL CONT ASIC7 VOLT	×	1	EVB-764
P3050	CELL CONT ASIC8 VOLT	×	1	EVB-764

EV BATTERY SYSTEM

< ECU DIAGNOSIS INFORMATION >

[TYPE 4]

DTC	CONSULT screen items	EV system warning lamp	Trip	Reference	
P3051	CELL CONT ASIC9 VOLT	×	1	EVB-764	A
P3052	CELL CONT ASIC10 VOLT	×	1	EVB-764	B
P3053	CELL CONT ASIC11 VOLT	×	1	EVB-764	
P3054	CELL CONT ASIC12 VOLT	×	1	EVB-764	EVB
P3055	CELL CONT ASIC13 VOLT	×	1	EVB-766	
P3056	CELL CONT ASIC14 VOLT	×	1	EVB-766	
P3057	CELL CONT ASIC15 VOLT	×	1	EVB-766	D
P3058	CELL CONT ASIC16 VOLT	×	1	EVB-766	
P3059	CELL CONT ASIC17 VOLT	×	1	EVB-766	
P305A	CELL CONT ASIC18 VOLT	×	1	EVB-766	E
P305B	CELL CONT ASIC19 VOLT	×	1	EVB-766	
P305C	CELL CONT ASIC20 VOLT	×	1	EVB-766	F
P305D	CELL CONT ASIC21 VOLT	×	1	EVB-766	
P305E	CELL CONT ASIC22 VOLT	×	1	EVB-766	
P305F	CELL CONT ASIC23 VOLT	×	1	EVB-766	G
P3060	CELL CONT ASIC24 VOLT	×	1	EVB-766	
P3061	CELL BATTERY VOLT	×	1	EVB-768	H
P3062	BYPASS SW	×	1	EVB-769	
P308B	CELL CONT ASIC1 OPEN	×	1	EVB-770	
P308C	CELL CONT ASIC2 OPEN	×	1	EVB-770	I
P308D	CELL CONT ASIC3 OPEN	×	1	EVB-770	
P308E	CELL CONT ASIC4 OPEN	×	1	EVB-770	
P308F	CELL CONT ASIC5 OPEN	×	1	EVB-770	J
P3090	CELL CONT ASIC6 OPEN	×	1	EVB-770	
P3091	CELL CONT ASIC7 OPEN	×	1	EVB-770	K
P3092	CELL CONT ASIC8 OPEN	×	1	EVB-770	
P3093	CELL CONT ASIC9 OPEN	×	1	EVB-770	
P3094	CELL CONT ASIC10 OPEN	×	1	EVB-770	L
P3095	CELL CONT ASIC11 OPEN	×	1	EVB-770	
P3096	CELL CONT ASIC12 OPEN	×	1	EVB-770	M
P3097	CELL CONT ASIC13 OPEN	×	1	EVB-773	
P3098	CELL CONT ASIC14 OPEN	×	1	EVB-773	
P3099	CELL CONT ASIC15 OPEN	×	1	EVB-773	N
P309A	CELL CONT ASIC16 OPEN	×	1	EVB-773	
P309B	CELL CONT ASIC17 OPEN	×	1	EVB-773	O
P309C	CELL CONT ASIC18 OPEN	×	1	EVB-773	
P309D	CELL CONT ASIC19 OPEN	×	1	EVB-773	
P309E	CELL CONT ASIC20 OPEN	×	1	EVB-773	P
P309F	CELL CONT ASIC21 OPEN	×	1	EVB-773	
P30A0	CELL CONT ASIC22 OPEN	×	1	EVB-773	
P30A1	CELL CONT ASIC23 OPEN	×	1	EVB-773	
P30A2	CELL CONT ASIC24 OPEN	×	1	EVB-773	
P30F3	TOTAL VOLT SENSOR	×	1	EVB-776	

EV BATTERY SYSTEM

< ECU DIAGNOSIS INFORMATION >

[TYPE 4]

DTC	CONSULT screen items	EV system warning lamp	Trip	Reference
P30F4	TOTAL VOLT SENSOR	×	1	EVB-777
P30F5	TOTAL VOLT SENSOR	×	1	EVB-779
P30FC	OVER CURRENT	×	1	EVB-780
P30FD	TOTAL VOLTAGE MONITOR SWITCH	—	1	EVB-781
P30FE	12V BATTERY VOLTAGE	×	1	EVB-782
P318D	COMMUNICATION ERROR	×	1	EVB-784
P318E	COMMUNICATION ERROR	×	1	EVB-785
P3191	COMMUNICATION ERROR	—	1	EVB-786
P3196	COMMUNICATION ERROR	—	1	EVB-787
P3199	COMMUNICATION ERROR	×	1	EVB-788
P319C	COMMUNICATION ERROR	—	1	EVB-789
P31A4	CAN ERROR VCM	×	1	EVB-790
P31A7	CAN ERROR INV/MC	—	1	EVB-791
P3300	TOTAL VOLTAGE OVER	×	1	EVB-792
P3302	CELL OVER VOLTAGE MODULE1	×	1	EVB-793
P3303	CELL OVER VOLTAGE MODULE2	×	1	EVB-793
P3304	CELL OVER VOLTAGE MODULE3	×	1	EVB-793
P3305	CELL OVER VOLTAGE MODULE4	×	1	EVB-793
P3306	CELL OVER VOLTAGE MODULE5	×	1	EVB-793
P3307	CELL OVER VOLTAGE MODULE6	×	1	EVB-793
P3308	CELL OVER VOLTAGE MODULE7	×	1	EVB-793
P3309	CELL OVER VOLTAGE MODULE8	×	1	EVB-793
P330A	CELL OVER VOLTAGE MODULE9	×	1	EVB-793
P330B	CELL OVER VOLTAGE MODULE10	×	1	EVB-793
P330C	CELL OVER VOLTAGE MODULE11	×	1	EVB-793
P330D	CELL OVER VOLTAGE MODULE12	×	1	EVB-793
P330E	CELL OVER VOLTAGE MODULE13	×	1	EVB-797
P330F	CELL OVER VOLTAGE MODULE14	×	1	EVB-797
P3310	CELL OVER VOLTAGE MODULE15	×	1	EVB-797
P3311	CELL OVER VOLTAGE MODULE16	×	1	EVB-797
P3312	CELL OVER VOLTAGE MODULE17	×	1	EVB-797
P3313	CELL OVER VOLTAGE MODULE18	×	1	EVB-797
P3314	CELL OVER VOLTAGE MODULE19	×	1	EVB-797
P3315	CELL OVER VOLTAGE MODULE20	×	1	EVB-797
P3316	CELL OVER VOLTAGE MODULE21	×	1	EVB-797
P3317	CELL OVER VOLTAGE MODULE22	×	1	EVB-797
P3318	CELL OVER VOLTAGE MODULE23	×	1	EVB-797
P3319	CELL OVER VOLTAGE MODULE24	×	1	EVB-797
P331A	CELL OVER VOLTAGE MODULE25	×	1	EVB-801
P331B	CELL OVER VOLTAGE MODULE26	×	1	EVB-801
P331C	CELL OVER VOLTAGE MODULE27	×	1	EVB-801
P331D	CELL OVER VOLTAGE MODULE28	×	1	EVB-801
P331E	CELL OVER VOLTAGE MODULE29	×	1	EVB-801

EV BATTERY SYSTEM

< ECU DIAGNOSIS INFORMATION >

[TYPE 4]

DTC	CONSULT screen items	EV system warning lamp	Trip	Reference
P331F	CELL OVER VOLTAGE MODULE30	×	1	EVB-801
P3320	CELL OVER VOLTAGE MODULE31	×	1	EVB-801
P3321	CELL OVER VOLTAGE MODULE32	×	1	EVB-801
P3322	CELL OVER VOLTAGE MODULE33	×	1	EVB-801
P3323	CELL OVER VOLTAGE MODULE34	×	1	EVB-801
P3324	CELL OVER VOLTAGE MODULE35	×	1	EVB-801
P3325	CELL OVER VOLTAGE MODULE36	×	1	EVB-801
P3326	CELL OVER VOLTAGE MODULE37	×	1	EVB-804
P3327	CELL OVER VOLTAGE MODULE38	×	1	EVB-804
P3328	CELL OVER VOLTAGE MODULE39	×	1	EVB-804
P3329	CELL OVER VOLTAGE MODULE40	×	1	EVB-804
P332A	CELL OVER VOLTAGE MODULE41	×	1	EVB-804
P332B	CELL OVER VOLTAGE MODULE42	×	1	EVB-804
P332C	CELL OVER VOLTAGE MODULE43	×	1	EVB-804
P332D	CELL OVER VOLTAGE MODULE44	×	1	EVB-804
P332E	CELL OVER VOLTAGE MODULE45	×	1	EVB-804
P332F	CELL OVER VOLTAGE MODULE46	×	1	EVB-804
P3330	CELL OVER VOLTAGE MODULE47	×	1	EVB-804
P3331	CELL OVER VOLTAGE MODULE48	×	1	EVB-804
P3373	TOTAL VOLTAGE OVER DISCHARGE	×	1	EVB-807
P3375	CELL OVER DISCHARGE MODULE1	×	1	EVB-808
P3376	CELL OVER DISCHARGE MODULE2	×	1	EVB-808
P3377	CELL OVER DISCHARGE MODULE3	×	1	EVB-808
P3378	CELL OVER DISCHARGE MODULE4	×	1	EVB-808
P3379	CELL OVER DISCHARGE MODULE5	×	1	EVB-808
P337A	CELL OVER DISCHARGE MODULE6	×	1	EVB-808
P337B	CELL OVER DISCHARGE MODULE7	×	1	EVB-808
P337C	CELL OVER DISCHARGE MODULE8	×	1	EVB-808
P337D	CELL OVER DISCHARGE MODULE9	×	1	EVB-808
P337E	CELL OVER DISCHARGE MODULE10	×	1	EVB-808
P337F	CELL OVER DISCHARGE MODULE11	×	1	EVB-808
P3380	CELL OVER DISCHARGE MODULE12	×	1	EVB-808
P3381	CELL OVER DISCHARGE MODULE13	×	1	EVB-812
P3382	CELL OVER DISCHARGE MODULE14	×	1	EVB-812
P3383	CELL OVER DISCHARGE MODULE15	×	1	EVB-812
P3384	CELL OVER DISCHARGE MODULE16	×	1	EVB-812
P3385	CELL OVER DISCHARGE MODULE17	×	1	EVB-812
P3386	CELL OVER DISCHARGE MODULE18	×	1	EVB-812
P3387	CELL OVER DISCHARGE MODULE19	×	1	EVB-812
P3388	CELL OVER DISCHARGE MODULE20	×	1	EVB-812
P3389	CELL OVER DISCHARGE MODULE21	×	1	EVB-812
P338A	CELL OVER DISCHARGE MODULE22	×	1	EVB-812
P338B	CELL OVER DISCHARGE MODULE23	×	1	EVB-812

A

B

EVB

D

E

F

G

H

I

J

K

L

M

N

O

P

EV BATTERY SYSTEM

< ECU DIAGNOSIS INFORMATION >

[TYPE 4]

DTC	CONSULT screen items	EV system warning lamp	Trip	Reference
P338C	CELL OVER DISCHARGE MODULE24	×	1	EVB-812
P338D	CELL OVER DISCHARGE MODULE25	×	1	EVB-816
P338E	CELL OVER DISCHARGE MODULE26	×	1	EVB-816
P338F	CELL OVER DISCHARGE MODULE27	×	1	EVB-816
P3390	CELL OVER DISCHARGE MODULE28	×	1	EVB-816
P3391	CELL OVER DISCHARGE MODULE29	×	1	EVB-816
P3392	CELL OVER DISCHARGE MODULE30	×	1	EVB-816
P3393	CELL OVER DISCHARGE MODULE31	×	1	EVB-816
P3394	CELL OVER DISCHARGE MODULE32	×	1	EVB-816
P3395	CELL OVER DISCHARGE MODULE33	×	1	EVB-816
P3396	CELL OVER DISCHARGE MODULE34	×	1	EVB-816
P3397	CELL OVER DISCHARGE MODULE35	×	1	EVB-816
P3398	CELL OVER DISCHARGE MODULE36	×	1	EVB-816
P3399	CELL OVER DISCHARGE MODULE37	×	1	EVB-819
P339A	CELL OVER DISCHARGE MODULE38	×	1	EVB-819
P339B	CELL OVER DISCHARGE MODULE39	×	1	EVB-819
P339C	CELL OVER DISCHARGE MODULE40	×	1	EVB-819
P339D	CELL OVER DISCHARGE MODULE41	×	1	EVB-819
P339E	CELL OVER DISCHARGE MODULE42	×	1	EVB-819
P339F	CELL OVER DISCHARGE MODULE43	×	1	EVB-819
P33A0	CELL OVER DISCHARGE MODULE44	×	1	EVB-819
P33A1	CELL OVER DISCHARGE MODULE45	×	1	EVB-819
P33A2	CELL OVER DISCHARGE MODULE46	×	1	EVB-819
P33A3	CELL OVER DISCHARGE MODULE47	×	1	EVB-819
P33A4	CELL OVER DISCHARGE MODULE48	×	1	EVB-819
P33D4	BATT GRADUAL CAPA LOSS DIAG	×	1	EVB-822
P33D5	CURRENT SENSOR	×	1	EVB-823
P33D6	CURRENT SENSOR	×	1	EVB-825
P33D7	TEMPERATURE SENSOR	—	1	EVB-827
P33D9	TEMPERATURE SENSOR	—	1	EVB-827
P33DB	TEMPERATURE SENSOR	—	1	EVB-827
P33DD	TEMPERATURE SENSOR	—	1	EVB-827
P33DF	BATT VOLTAGE ISOLATION SEN	×	1	EVB-829
P33E0	BATT VOLTAGE ISOLATION SEN	×	1	EVB-830
P33E1	BATT VOLTAGE ISOLATION SEN	×	1	EVB-831
P33E2	BATT PACK OVER TEMP	×	1	EVB-832
P33E4	TEMPERATURE SENSOR	—	1	EVB-833
P33E5	TEMPERATURE SENSOR	—	1	EVB-833
P33E6	CELL VOLTAGE DEVIATION DIAG	×	2	EVB-835
P33E7	CELL CONTROLLER	×	1	EVB-840
P33EA	BATTERY HEATER RELAY	×	1	EVB-841
P33ED	BATTERY PARALLEL DIAGNOSIS	×	1	EVB-843

EV BATTERY SYSTEM

< ECU DIAGNOSIS INFORMATION >

[TYPE 4]

DTC	CONSULT screen items	EV system warning lamp	Trip	Reference
P33EE	BATTERY HEATER CONTROL SYSTEM	×	1	EVB-845
U1000	CAN COMM CIRCUIT	×	1	EVB-847

A

B

EVB

D

E

F

G

H

I

J

K

L

M

N

O

P

WIRING DIAGRAM

VCM

Wiring Diagram

INFOID:000000011199172

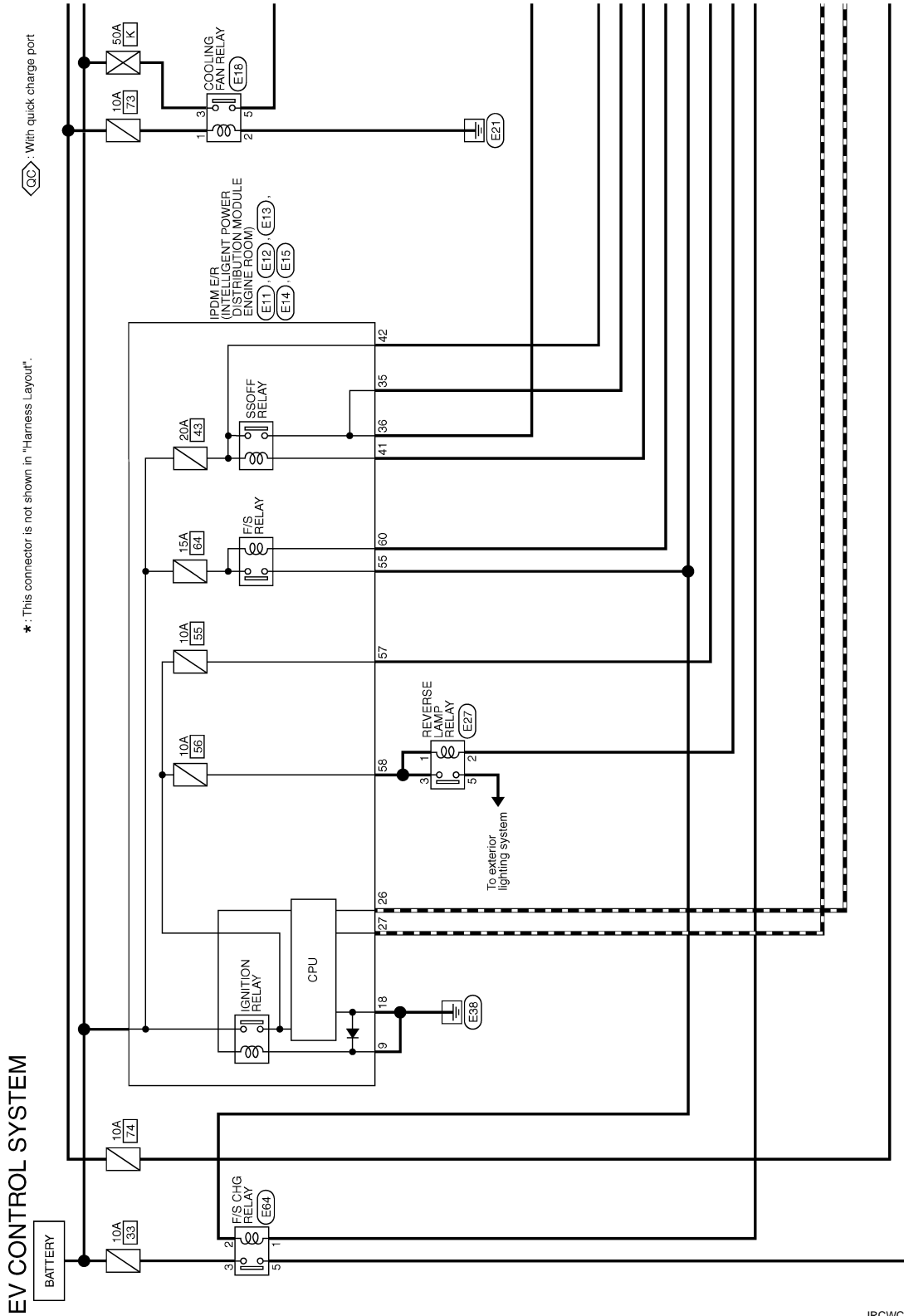

2012/11/15

JRCWC0085GB

VCM

< WIRING DIAGRAM >

[TYPE 4]

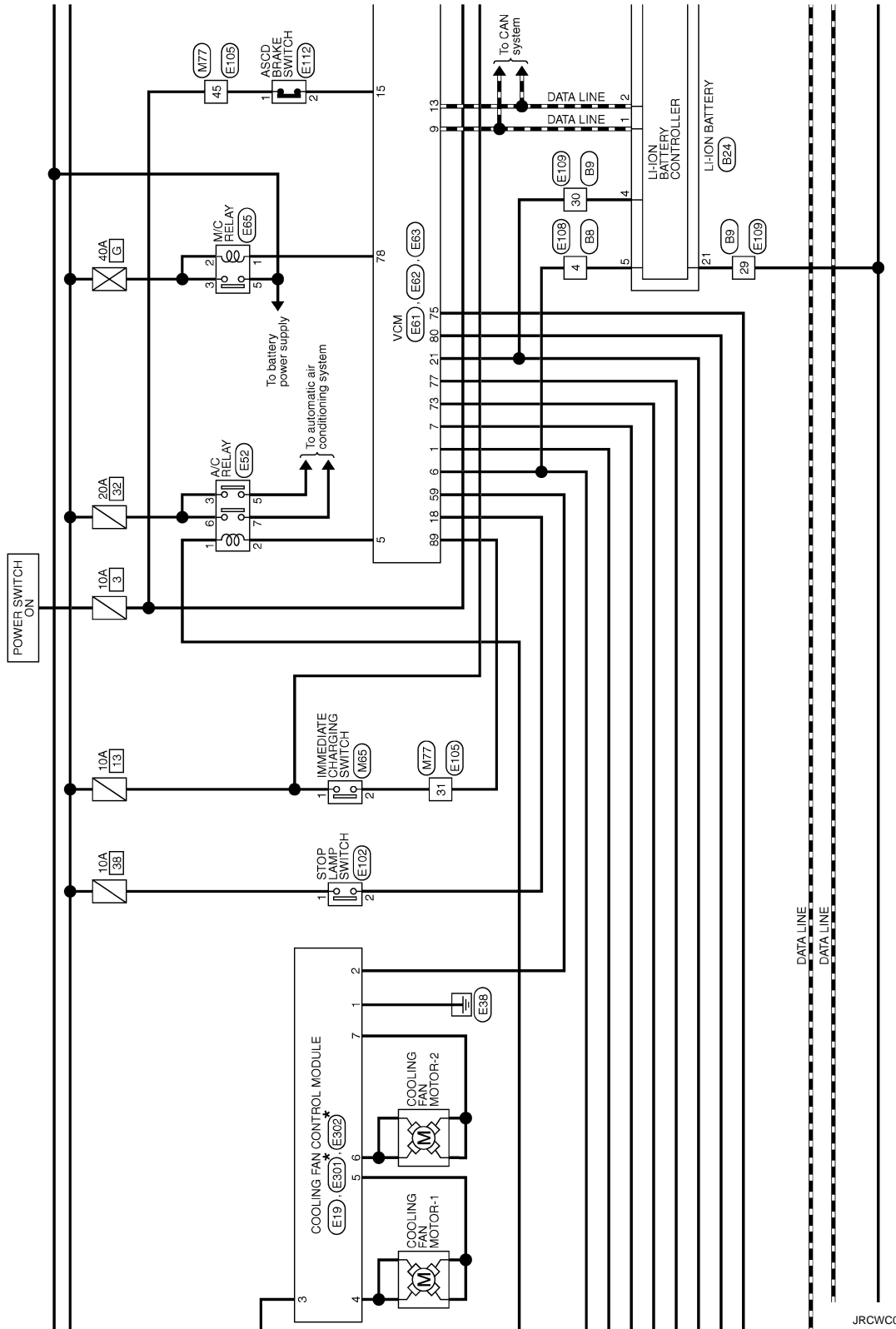

JRCWC0086GB

A
B
C
D
E
F
G
H
I
J
K
L
M
N
O
P

EVB

VCM

< WIRING DIAGRAM >

[TYPE 4]

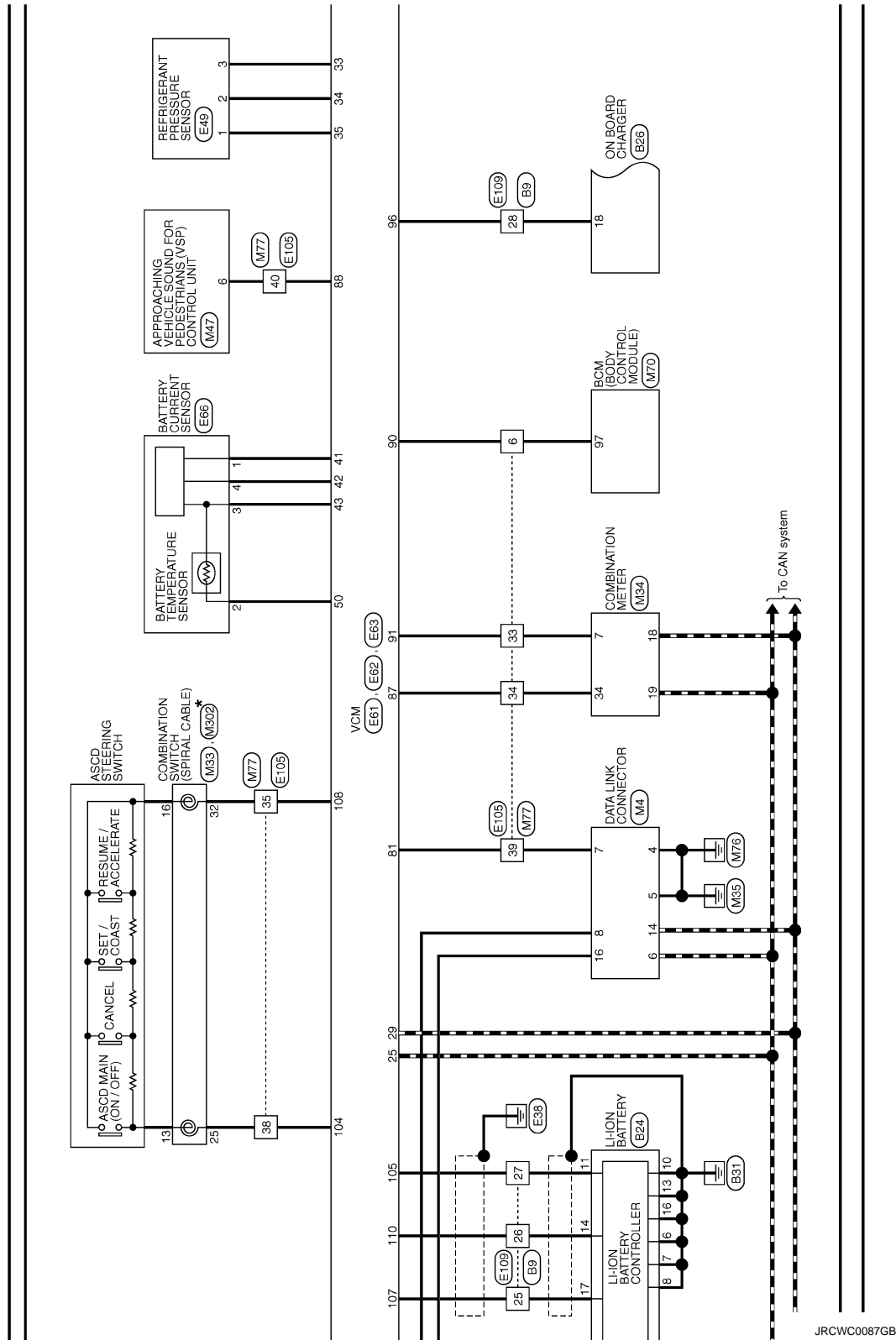

JRCWC0087GB

VCM

< WIRING DIAGRAM >

[TYPE 4]

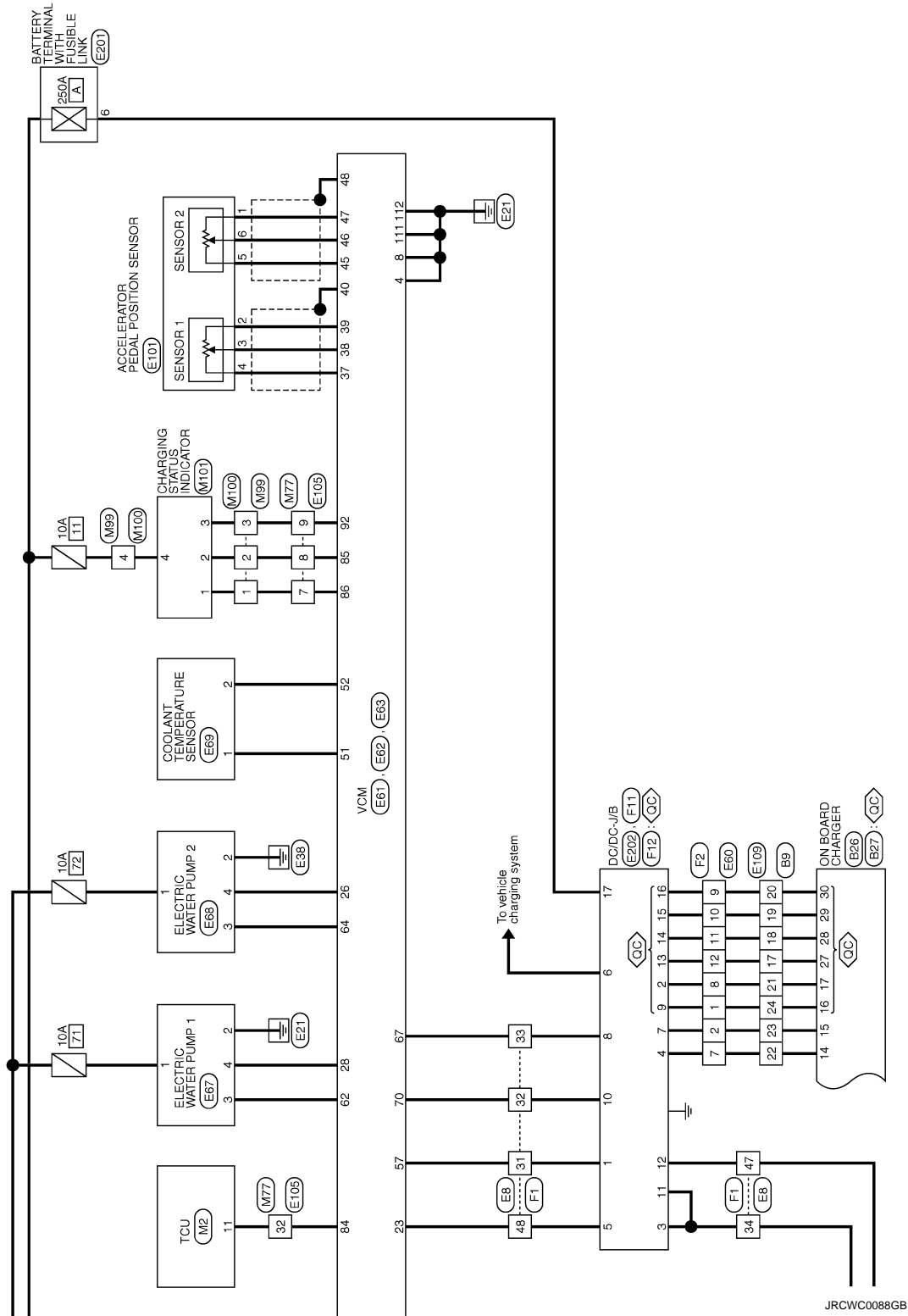

A

B

EVB

D

E

F

G

H

I

J

K

L

M

N

O

P

EV CONTROL SYSTEM

Connector No.	B8
Connector Name	WIRE TO WIRE
Connector Type	MS04W-GS



Terminal No.	Color of Wire	Signal Name [Specification]
1	R	
2	L	
3	R	
4	R	

Connector No.	B9
Connector Name	WIRE TO WIRE
Connector Type	TH32PW-BH

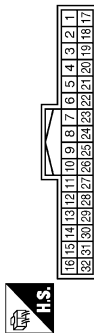

Terminal No.	Color of Wire	Signal Name [Specification]
1	W	
2	GR	
3	Y	
4	G	
5	BR	
6	L	
7	B	
8	P	
9	SB	
10	LG	
11	W	
17	R	
18	Y	
19	G	
20	V	
21	SB	
22	P	
23	LG	

24	L	
25	Y	
26	L	
27	G	
28	GR	
29	R	
30	R	
31	Y	

Connector No.	B24
Connector Name	LI-ION BATTERY
Connector Type	Yazaki: 7283-8750-30

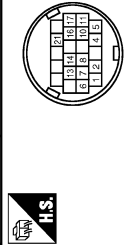

Terminal No.	Color of Wire	Signal Name [Specification]
1	L	EV CAN-H
2	G	EV CAN-L
4	R	IGN
5	R	BAT
6	B	GND3
7	B	GND2
8	B	GND1
10	B	PRE CHG V
11	G	PRE CHG V
13	B	RLY2 GND
14	L	RLY2 V
16	B	RLY1 GND
17	Y	RLY1 V
21	R	CHG IGN

Connector No.	B26
Connector Name	ON BOARD CHARGER
Connector Type	RH12FB

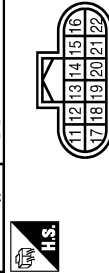

Terminal No.	Color of Wire	Signal Name [Specification]
11	Y	BATTERY POWER SUPPLY
12	W	BATTERY POWER SUPPLY
13	V	POWER ON POWER SUPPLY
14	P	NORMAL CHARGE RELAY +
15	LG	NORMAL CHARGE RELAY -
16	L	QUICK CHARGE RELAY +
17	SB	QUICK CHARGE RELAY -
18	GR	EV ACTIVATION REQUEST SIGNAL
19	L	EV SYSTEM CAN-H
20	G	EV SYSTEM CAN-L
21	BR	PLUG IN SIGNAL
22	B	GROUND

Connector No.	B27
Connector Name	ON BOARD CHARGER
Connector Type	RR08FB



Terminal No.	Color of Wire	Signal Name [Specification]
25	W	QUICK CHARGE PORT TEMPERATURE SENSOR SIGNAL 1
26	GR	QUICK CHARGE PORT TEMPERATURE SENSOR SIGNAL 2
27	R	QUICK CHARGE VOLTAGE SENSOR SIGNAL-L
28	Y	SENSOR POWER SUPPLY QUICK CHARGE VOLTAGE SENSOR
29	G	SENSOR GROUND QUICK CHARGE VOLTAGE SENSOR
30	V	QUICK CHARGE VOLTAGE SENSOR SIGNAL-H

Connector No.	E8
Connector Name	WIRE TO WIRE
Connector Type	SAASMB-RS10-SJ22

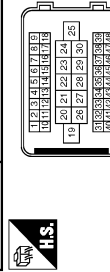

Terminal No.	Color of Wire	Signal Name [Specification]
--------------	---------------	-----------------------------

1	Y	
2	L	
3	GR	
4	LG	
5	P	
6	B	
8	BR	
10	B	
11	W	
12	O	
13	G	
14	V	
15	SB	
16	R	
17	L	
18	LG	
20	V	
21	G	
22	Y	
23	B/R	
26	V	
27	B	
28	B/R	
29	W	
30	B/R	
31	LG	
32	W	
33	Y	
34	P	
35	P	
36	R	
37	G	
38	B/R	
40	BR	
41	G	
42	SB	
43	L	
44	O	
47	V	
48	P	

A
B
EVB
D
E
F
G
H
I
J
K
L
M
N
O
P

EV CONTROL SYSTEM

Connector No.	E11
Connector Name	FROM E/R INTELLIGENT POWER DISTRIBUTION MODULE (ENGINE ROOM)
Connector Type	MS08FB-LC



Terminal No.	Color of Wire	Signal Name [Specification]
9	B	
14	R	

Connector No.	E12
Connector Name	FROM E/R INTELLIGENT POWER DISTRIBUTION MODULE (ENGINE ROOM)
Connector Type	MS08FB-CS



Terminal No.	Color of Wire	Signal Name [Specification]
18	B/W	
19	W	
20	V	

Connector No.	E13
Connector Name	FROM E/R INTELLIGENT POWER DISTRIBUTION MODULE (ENGINE ROOM)
Connector Type	TH12FW-NH

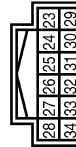

Terminal No.	Color of Wire	Signal Name [Specification]
25	R	

26	P	
27	L	
28	G	
32	SB	
34	W	

Connector No.	E14
Connector Name	FROM E/R INTELLIGENT POWER DISTRIBUTION MODULE (ENGINE ROOM)
Connector Type	NS12FBR-CS



Terminal No.	Color of Wire	Signal Name [Specification]
35	G	
36	GR	
38	V	
39	L	
41	W	
42	R	
43	O	
44	LG	
45	Y	

Connector No.	E15
Connector Name	FROM E/R INTELLIGENT POWER DISTRIBUTION MODULE (ENGINE ROOM)
Connector Type	NS16FW-CS



Terminal No.	Color of Wire	Signal Name [Specification]
49	Y	
50	G	
51	L	
52	P	
55	LG	
57	R	

58	O	
60	GR	
61	Y	
62	V	

Connector No.	E18
Connector Name	COOLING FAN RELAY
Connector Type	Z4347_9F900



Terminal No.	Color of Wire	Signal Name [Specification]
1	G	
2	B/Y	
3	BR	
5	R	

Connector No.	E19
Connector Name	COOLING FAN CONTROL MODULE
Connector Type	SJZ01FGY-SNZ2



Terminal No.	Color of Wire	Signal Name [Specification]
1	B	
2	V	GND
3	R	PWM SIG
		PWM POWER

Connector No.	E27
Connector Name	REVERSE LAMP RELAY
Connector Type	MS02FL-MZ-LC



Terminal No.	Color of Wire	Signal Name [Specification]
1	O	
2	SB	
3	O	
5	G	

Connector No.	E49
Connector Name	REFRIGERANT PRESSURE SENSOR
Connector Type	RK03FB



Terminal No.	Color of Wire	Signal Name [Specification]
2	BR	
3	L	

EV CONTROL SYSTEM

Connector No.	E52
Connector Name	A/C RELAY
Connector Type	M08FBR-R-LC



Terminal No.	Color of Wire	Signal Name [Specification]
1	GR	-
2	SB	-
3	R	-
4	R	-
5	V	-
6	R	-
7	W	-

Connector No.	E60
Connector Name	WIRE TO WIRE
Connector Type	RH12MB

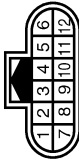

Terminal No.	Color of Wire	Signal Name [Specification]
1	Y	-
2	G	-
3	L	-
4	G	-
5	L	-
6	G	-
7	L	-
8	SB	-
9	V	-
10	O	-
11	BR	-
12	LG	-

Connector No.	E61
Connector Name	VCM
Connector Type	RH24FGV-R28-R-RH

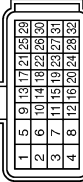

Terminal No.	Color of Wire	Signal Name [Specification]
1	G	POWER ON POWER SUPPLY
4	B/R	GROUND
5	SB	A/C RELAY
6	R	BATTERY POWER SUPPLY
7	W	SSOFF RELAY
8	B/R	GROUND
9	L	EV SYSTEM CAN-H
10	G	EV SYSTEM CAN-L
13	O	ASCD BRAKE SWITCH SIGNAL
16	SB	STOP LAMP SW SIGNAL
21	R	POWER ON POWER SUPPLY
23	P	HIGH VOLTAGE CABLE INTERLOCK
25	L	CAN-H
26	Y	WATER PUMP 2 SIGNAL
28	W	WATER PUMP 1 SIGNAL
29	P	CAN-L

Connector No.	E62
Connector Name	VCM
Connector Type	RH40FBR-R28-L-RH



Terminal No.	Color of Wire	Signal Name [Specification]
33	L	SENSOR POWER SUPPLY (REFRIGERANT PRESSURE SENSOR)
34	BR	REFRIGERANT PRESSURE SENSOR SIGNAL
35	BR	SENSOR GROUND (REFRIGERANT PRESSURE SENSOR)
37	W	SENSOR POWER SUPPLY (ACCELERATOR PEDAL POSITION SENSOR)
38	R	ACCELERATOR PEDAL POSITION SENSOR 1 SIGNAL
39	B	SENSOR GROUND (ACCELERATOR PEDAL POSITION SENSOR 1)

Terminal No.	Color of Wire	Signal Name [Specification]
40	SHIELD	-
41	R	SENSOR POWER SUPPLY (BATTERY CURRENT SENSOR)
42	Y	BATTERY CURRENT SENSOR SIGNAL
43	L	SENSOR GROUND (BATTERY CURRENT SENSOR)
45	W	SENSOR POWER SUPPLY (ACCELERATOR PEDAL POSITION SENSOR 2)
46	R	ACCELERATOR PEDAL POSITION SENSOR 2 SIGNAL
47	B	SENSOR GROUND (ACCELERATOR PEDAL POSITION SENSOR 2)
48	SHIELD	-
50	L	BATTERY TEMPERATURE SENSOR SIGNAL
51	O	COOLANT TEMPERATURE SENSOR SIGNAL
52	W	SENSOR GROUND (COOLANT TEMPERATURE SENSOR)
57	LG	POWER VOLTAGE VARIABLE CONTROL SIGNAL
59	V	RADIATOR FAN CONTROL SIGNAL
62	G	WATER PUMP 1 ACTIVATION SIGNAL
64	R	WATER PUMP 2 ACTIVATION SIGNAL
67	Y	DC/DC CONVERTER TEMPERATURE SIGNAL
70	W	DC/DC CONVERTER ACTIVATION SIGNAL
73	GR	F/S RELAY
75	W	F/S CHG RELAY
77	LG	F/S RELAY POWER SUPPLY
78	G	M/C RELAY
80	SB	REVERSE LAMP RELAY

Connector No.	E63
Connector Name	VCM
Connector Type	RH24FBR-R28-L-RH



Terminal No.	Color of Wire	Signal Name [Specification]
81	GR	K-LINE
84	LG	EV SYSTEM ACTIVATION REQUEST SIGNAL
85	P	CHARGING STATUS INDICATOR 2
86	V	CHARGING STATUS INDICATOR 1
87	L	PLUG IN INDICATOR LAMP
88	Y	AVSP CONTROL SIGNAL
89	V	IMMEDIATE CHARGING SWITCH
90	W	STARTER RELAY CONT
91	O	ELECTRIC SHIF WARNING SIGNAL
92	G	CHARGING STATUS INDICATOR 3
96	GR	EV SYSTEM ACTIVATION REQUEST SIGNAL
104	SB	ASCD STEERING SWITCH
105	L/O	PRE-CHARGE RELAY
107	W/L	SYSTEM MAIN RELAY 1

108	BR	ASCD STTERING SWICH GROUND
110	L/Y	SYSTEM MAIN RELAY 2
111	B/R	GROUND
112	B/R	GROUND

Connector No.	E64
Connector Name	F/S CHG RELAY
Connector Type	MS02FL-M2-LC



Terminal No.	Color of Wire	Signal Name [Specification]
1	W	-
2	LG	-
3	W	-
5	V	-

Connector No.	E65
Connector Name	M/C RELAY
Connector Type	MS02FL-M2-LC



Terminal No.	Color of Wire	Signal Name [Specification]
1	G	-
2	R	-
3	R	-
5	W	-

A
B
C
D
E
F
G
H
I
J
K
L
M
N
O
P

EVB

EV CONTROL SYSTEM

Connector No.	EB6
Connector Name	BATTERY CURRENT SENSOR
Connector Type	SAZ04FGY



Terminal No.	Color of Wire	Signal Name [Specification]
1	R	-
2	L	-
3	L	-
4	Y	-

Connector No.	EB7
Connector Name	ELECTRIC WATER PUMP 1
Connector Type	RSDMFG



Terminal No.	Color of Wire	Signal Name [Specification]
1	BR	-
2	B/Y	-
3	G	-
4	W	-

Connector No.	EB8
Connector Name	ELECTRIC WATER PUMP 2
Connector Type	RSDMFG



Terminal No.	Color of Wire	Signal Name [Specification]
1	L	-
2	B/W	-
3	R	-
4	Y	-

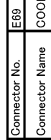

Connector No.	EB9
Connector Name	COOLANT TEMPERATURE SENSOR
Connector Type	EDZFGY-RS



Terminal No.	Color of Wire	Signal Name [Specification]
1	O	-
2	W	-



Connector No.	EI01
Connector Name	ACCELERATOR PEDAL POSITION SENSOR
Connector Type	RHD0FB



Terminal No.	Color of Wire	Signal Name [Specification]
1	B	-
2	B	-
3	R	-
4	W	-
5	W	-
6	R	-

Connector No.	EI02
Connector Name	STOP LAMP SWITCH
Connector Type	JM04FW-LC



Terminal No.	Color of Wire	Signal Name [Specification]
1	W	-
2	SR	-
3	LG	-
4	P	-

EV CONTROL SYSTEM

Connector No.	E105
Connector Name	WIRE TO WIRE
Connector Type	TH80MH-GS16-TM4



Terminal No.	Color of Wire	Signal Name [Specification]
1	BR	-
2	R	-
3	GR	-
4	LG	-
6	W	-
7	V	-
8	P	-
9	G	-
10	R	-
11	O	-
12	W	-
13	B	-
14	Y	-
15	BR	-
16	LG	-
17	L	-
19	G	-
20	V	-
21	P	-
22	LG	-
23	GR	-
24	L	-
25	R	-
26	SB	-
27	B	-
28	BR	-
29	W	-
31	V	-
32	LG	-
33	O	-
34	L	-
35	BR	-
38	SB	-
39	GR	-
40	Y	-
41	R	-
42	W	-
43	SB	-

Connector No.	E108
Connector Name	WIRE TO WIRE
Connector Type	NS5MMH-GS



Terminal No.	Color of Wire	Signal Name [Specification]
1	W	-
2	R	-
3	L	-
4	R	-

Connector No.	E109
Connector Name	WIRE TO WIRE
Connector Type	TH82MH-NH

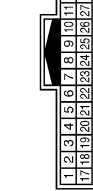

Terminal No.	Color of Wire	Signal Name [Specification]
1	W	-
2	R	-
3	Y	-
4	G	-
5	BR	-
6	L	-
7	O	-
8	V	-
9	SB	-
10	LG	-
11	L	-
17	LG	-
18	BR	-
19	O	-
20	V	-
21	SB	-
22	L	-
23	G	-

24	Y	-
25	W/L	-
26	L/Y	-
27	L/O	-
28	GR	-
29	P	-
30	R	-
31	W	-

Connector No.	E112
Connector Name	ASC'D BRAKE SWITCH
Connector Type	MD2FER-LC



Terminal No.	Color of Wire	Signal Name [Specification]
1	G	-
2	O	-

Connector No.	E201
Connector Name	BATTERY TERMINAL WITH FUSIBLE LINK
Connector Type	-



Terminal No.	Color of Wire	Signal Name [Specification]
6	B/R	-

EV CONTROL SYSTEM

Connector No.	E202
Connector Name	DC/DC-J/B
Connector Type	-



Terminal No.	Color of Wire	Signal Name [Specification]
17	B/R	BATTERY POWER SUPPLY

Connector No.	E301
Connector Name	COOLING FAN CONTROL MODULE (COOLING FAN MOTOR-1)
Connector Type	6188-0299



Terminal No.	Color of Wire	Signal Name [Specification]
4	-	-
5	-	-

Connector No.	E302
Connector Name	COOLING FAN CONTROL MODULE (COOLING FAN MOTOR-2)
Connector Type	6188-0299



Terminal No.	Color of Wire	Signal Name [Specification]
6	-	-
7	-	-

Connector No.	F1
Connector Name	WIRE TO WIRE
Connector Type	SA33PEF-RS10-SJ22

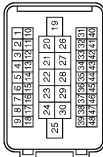

Terminal No.	Color of Wire	Signal Name [Specification]
1	Y	-
2	L	-
3	GR	-
4	LG	-
5	P	-
6	B	-
8	W	-
10	R	-
11	W	-
12	O	-
13	G	-
14	V	-
15	SB	-
16	LG	-
17	BR	-
18	Y	-
20	V	-
21	G	-
22	LG	-
23	B	-
26	SB	-
27	R	-
28	Y	-
29	W	-
30	P	-
31	L	-
32	W	-
33	Y	-
34	R	-
35	G	-
36	LG	-
37	O	-
37	O	- [With quick charge port]
37	O	- [Without quick charge port]
38	B	-
40	BR	-
41	O	-
42	SB	-
43	L	-

44	LG	-
47	V	-
48	P	-

Connector No.	F2
Connector Name	WIRE TO WIRE
Connector Type	RH1ZFB



Terminal No.	Color of Wire	Signal Name [Specification]
1	L/W	-
2	LG	-
3	L	-
4	G	-
5	L	-
6	G	-
7	V	-
8	Y/V	-
9	V	-
10	O	-
11	R/Y	-
12	W/R	-

Connector No.	F11
Connector Name	DC/DC-J/B
Connector Type	RH1ZFB

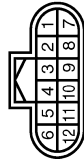

Terminal No.	Color of Wire	Signal Name [Specification]
1	L	-
2	Y/V	-
3	R	-
4	V	-
5	P	-

6	O	-
7	LG	-
8	Y	-
9	L/W	-
10	W	-
11	R	-
12	V	BATTERY CHARGE RELAY POWER SUPPLY

Connector No.	F12
Connector Name	DC/DC-J/B
Connector Type	RH04FB



Terminal No.	Color of Wire	Signal Name [Specification]
13	W/R	-
14	R/Y	-
15	O	-
16	V	-

Connector No.	M2
Connector Name	TCU
Connector Type	TH06PW-RH

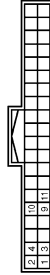

Terminal No.	Color of Wire	Signal Name [Specification]
1	BR	BATTERY POWER SUPPLY
2	B	GROUND
3	G	ACC POWER SUPPLY
4	V	POWER SWITCH ON SIGNAL
9	L	EV SYSTEM CAN-H
10	G	EV SYSTEM CAN-L
11	LG	EV SYSTEM ACTIVATION REQUEST SIGNAL

A
B
EVB
D
E
F
G
H
I
J
K
L
M
N
O
P

EV CONTROL SYSTEM

Connector No.	M4
Connector Name	DATA LINK CONNECTOR
Connector Type	BD18EV

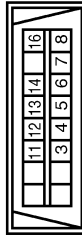

Terminal No.	Color of Wire	Signal Name [Specification]
3	LG	-
4	B	-
5	B	-
6	L	-
7	GR	-
8	G	-
11	SB	-
12	G	-
13	L	-
14	P	-
16	Y	-

Connector No.	M33
Connector Name	COMBINATION SWITCH (SPIRAL CABLE)
Connector Type	TK08FGY-1V



Terminal No.	Color of Wire	Signal Name [Specification]
24	BR	-
25	LG	-
26	B	-
31	Y	-
32	SB	-
33	SHIELD	-
34	G	-

Connector No.	M34
Connector Name	COMBINATION METER
Connector Type	TH40FPV-NH



Terminal No.	Color of Wire	Signal Name [Specification]
1	LG	BATTERY POWER SUPPLY
2	R	BATTERY POWER SUPPLY (FOR UPPER METER)
3	GR	POWER SWITCH SUPPLY
4	L	POWER SWITCH SUPPLY (FOR UPPER METER)
5	B	GROUND
6	B	GROUND
7	V	ELECTRIC SHIFT WARNING SIGNAL
8	Y	WASHER LEVEL SWITCH SIGNAL
9	G	PLUG IN SIGNAL
10	L	COMMUNICATION SIGNAL (METER → VSP)
11	P	COMMUNICATION SIGNAL (VSP → METER)
12	V	METER CONTROL SWITCH GROUND
13	LG	ENTER SWITCH SIGNAL
14	W	TRIP RESET SWITCH SIGNAL
15	BR	ILLUMINATION CONTROL SWITCH SIGNAL
17	V	ILLUMINATION CONTROL SIGNAL (FOR UPPER METER)
18	P	CAN-L
19	L	CAN-H
20	V	SEAT BELT BUCKLE SWITCH SIGNAL (PASSENGER SIDE)
22	GR	GROUND (FOR UPPER METER)
24	BR	ELECTRIC PARKING BRAKE CONTROL MODULE WARNING SIGNAL
25	SB	BRAKE FLUID LEVEL SWITCH SIGNAL
26	B	ILLUMINATION CONTROL SIGNAL
27	R	AIR BAG SIGNAL
28	R	SECURITY SIGNAL
30	GR	VEHICLE SPEED SIGNAL (3-PULSE)
32	W	COMMUNICATION SIGNAL (METER → UPPER)
33	LG	CLOCK SIGNAL
34	L	PLUG IN INDICATOR LAMP SIGNAL
38	V	LED HEADLAMP (RH) WARNING SIGNAL
39	LG	LED HEADLAMP (LH) WARNING SIGNAL
40	Y	SEAT BELT BUCKLE SWITCH SIGNAL (DRIVER SIDE)

Connector No.	M47
Connector Name	APPROACHING VEHICLE SOUND FOR PEDESTRIANS (VSP) CONTROL UNIT
Connector Type	TH18FV-NH

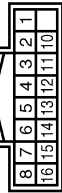

Terminal No.	Color of Wire	Signal Name [Specification]
1	B	GROUND
2	L	COMMUNICATION SIGNAL (METER → VSP)
3	SB	POWER SWITCH SIGNAL
4	P	COMMUNICATION SIGNAL (VSP → METER)
5	G	VSP OFF SWITCH SIGNAL
6	Y	CHARGE PULSE SIGNAL
7	L	VSP SPEAKER SIGNAL (-)
8	Y	VSP SPEAKER SIGNAL (+)
10	GR	R-LINE (CONSULT)
11	GR	POWER SWITCH SUPPLY
12	SB	STOP LAMP SWITCH SIGNAL
13	L	BATTERY POWER SUPPLY
14	LG	VSP OFF INDICATOR SIGNAL
15	R	STRAT UP SOUND SPEAKER SIGNAL (-)
16	W	STRAT UP SOUND SPEAKER SIGNAL (+)

Connector No.	M85
Connector Name	IMMEDIATE CHARGING SWITCH
Connector Type	TH08FGY-NH

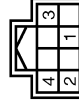

Terminal No.	Color of Wire	Signal Name [Specification]
1	Y	-
2	SB	-
3	W	ILLUMINATION +
4	B	ILLUMINATION -

Connector No.	M70
Connector Name	BGM (BODY CONTROL MODULE)
Connector Type	TH40FPV-NH

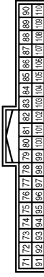

Terminal No.	Color of Wire	Signal Name [Specification]
75	LG	DR DOOR REQ SW
76	SB	POWER SW (PUSH SW)
78	P	DRIVER DOOR ANT+
79	V	DRIVER DOOR ANT-
80	LG	PASS DOOR ANT+
81	Y	PASS DOOR ANT-
82	W	REAR BEMR ANT+
83	B	REAR BEMR ANT-
84	BR	ROOM ANT 1+
85	Y	ROOM ANT 1-
86	G	ROOM ANT 2+
87	R	ROOM ANT 2-
88	V	LUGGAGE ROOM ANT-
89	LG	LUGGAGE ROOM ANT-
90	W	POWER SW ILL PWR
91	V	ACC 7 ON IND
92	B	POWER SW ILL GND CONT
93	GR	I-KEY WARN BUZZER
96	BR	ACC RELAY COAT
97	W	READY
98	G	IGN RELAY (IPDM F/R) CONT
99	R	IGN RELAY (F/B) CONT
100	P	PASS DOOR REQ SW
102	R	PAN POSITION
104	LG	WAKE UP
106	P	STOP LAMP SW 2

A
B
EVB
D
E
F
G
H
I
J
K
L
M
N
O
P

EV CONTROL SYSTEM

Connector No.	M77
Connector Name	WIRE TO WIRE
Connector Type	TH8DFV-CST6-TM4

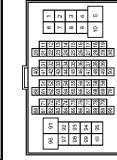

Terminal No.	Color of Wire	Signal Name [Specification]
1	GR	
2	V	
3	GR	
4	LG	
5	W	
6	W	
7	V	
8	P	
9	SB	
10	L	
11	LG	
12	W	
13	R	
14	Y	
15	R	
16	G	
17	BR	
19	G	
20	G	
21	P	
22	LG	
23	GR	
24	L	
25	Y	
26	G	
27	L	
29	V	
30	W	
31	SB	
32	LG	
33	V	
34	L	
35	SB	
38	LG	
39	GR	
40	Y	
41	R	
42	W	
43	SB	

44	GR	
45	P	
46	R	
47	W	
48	L	
49	G	
50	L	
51	L	
54	W	
55	G	
56	BR	
57	P	
58	R	
60	Y	
61	GR	
62	SB	
63	Y	
64	G	
65	V	
66	P	
67	Y	
68	P	
69	BR	
71	Y	
72	L	
73	G	
74	L	
75	V	
76	R	
80	W	
81	L	
82	SB	
83	R	
84	BR	
85	R	
86	GR	
88	R	
89	W	
90	SHIELD	
91	Y	
92	BR	
93	W	
94	P	
95	V	
96	P	
97	G	
98	R	
99	LG	

Connector No.	M89
Connector Name	WIRE TO WIRE
Connector Type	TH8DFV-NH



Terminal No.	Color of Wire	Signal Name [Specification]
1	V	
2	P	
3	SB	
4	LG	

Connector No.	M100
Connector Name	WIRE TO WIRE
Connector Type	TH8DMW-NH



Terminal No.	Color of Wire	Signal Name [Specification]
1	V	
2	P	
3	SB	
4	L	

Connector No.	M101
Connector Name	CHARGING STATUS INDICATOR
Connector Type	TH8DFV-NH



Terminal No.	Color of Wire	Signal Name [Specification]
1	V	
2	P	
3	SB	
4	L	

Connector No.	M302
Connector Name	COMBINATION SWITCH (SPIRAL CABLE)
Connector Type	TK08FGY



Terminal No.	Color of Wire	Signal Name [Specification]
13	R	
14	W	
15	L	
16	B	
17	BR	
18	G	
19	Y	
20	Y	

BASIC INSPECTION

DIAGNOSIS AND REPAIR WORK FLOW

Work Flow

INFOID:000000011104347

DETAILED FLOW

1.GET INFORMATION FOR SYMPTOM

Get the detailed information from the customer about the symptom (the condition and the environment when the incident/malfunction occurred) using the "Question sheet". (Refer to [EVB-753, "Diagnostic Work Sheet"](#).)

>> GO TO 2.

2.CHECK DTC IN VCM

1. Check DTC in VCM.
2. Check related service bulletins for information.

Are any DTCs detected?

- YES >> Check the DTC. Refer to [EVC-84, "DTC Index"](#).
NO >> GO TO 3.

3.CHECK DTC

1. Check DTC.
2. Perform the following procedure if DTC is displayed.
 - Record DTC and freeze frame data. (Print them out with CONSULT.)
 - Erase DTC.
 - Study the relationship between the cause detected by DTC and the symptom described by the customer. (Symptom Matrix Chart is useful. Refer to [EVC-355, "Symptom Index"](#).)
3. Check related service bulletins for information.

Are any symptoms described and any DTCs detected?

- Symptom is described, DTC is detected>>GO TO 4.
Symptom is described, DTC is not detected>>GO TO 5.
Symptom is not described, DTC is detected>>GO TO 6.

4.CONFIRM THE SYMPTOM

Try to confirm the symptom described by the customer.
Also study the normal operation and fail-safe related to the symptom. Refer to [EVC-355, "Symptom Index"](#) and [EVB-729, "Fail-safe"](#).

Diagnosis Work Sheet is useful to verify the incident.

Verify relation between the symptom and the condition when the symptom is detected.

>> GO TO 6.

5.CONFIRM THE SYMPTOM

Try to confirm the symptom described by the customer.
Also study the normal operation and fail-safe related to the symptom. Refer to [EVC-355, "Symptom Index"](#) and [EVB-729, "Fail-safe"](#).

Diagnosis Work Sheet is useful to verify the incident.

Verify relation between the symptom and the condition when the symptom is detected.

>> GO TO 7.

6.PERFORM DTC CONFIRMATION PROCEDURE

Perform DTC CONFIRMATION PROCEDURE for the displayed DTC, and then check that DTC is detected again.

NOTE:

- Freeze frame data is useful if the DTC is not detected.

DIAGNOSIS AND REPAIR WORK FLOW

[TYPE 4]

< BASIC INSPECTION >

- Perform Component Function Check if DTC CONFIRMATION PROCEDURE is not included on Service Manual. This simplified check procedure is an effective alternative though DTC cannot be detected during this check.
If the result of Component Function Check is NG, it is the same as the detection of DTC by DTC CONFIRMATION PROCEDURE.

Is DTC detected?

- YES >> GO TO 8.
- NO >> Check according to [GI-51, "Intermittent Incident"](#).

7. DETECT MALFUNCTIONING SYSTEM BY SYMPTOM TABLE

Detect malfunctioning system according to [EVC-355, "Symptom Index"](#) based on the confirmed symptom in step 4, and determine the trouble diagnosis order based on possible causes and symptoms.

Is the symptom described?

- YES >> GO TO 8.
- NO >> Monitor input data from related sensors using CONSULT.

8. DETECT MALFUNCTIONING PART BY DIAGNOSIS PROCEDURE

Inspect according to Diagnosis Procedure of the system.

Is a malfunctioning part detected?

- YES >> GO TO 9.
- NO >> Monitor input data from related sensors using CONSULT.

9. REPAIR OR REPLACE THE MALFUNCTIONING PART

1. Repair or replace the malfunctioning part.
2. Reconnect parts or connectors disconnected during Diagnosis Procedure again after repair and replacement.
3. Check DTC. If DTC is displayed, erase it.

>> GO TO 10.

10. FINAL CHECK

When DTC was detected in step 3, perform DTC CONFIRMATION PROCEDURE or Component Function Check again, and then check that the malfunction have been completely repaired.

When symptom was described from the customer, refer to confirmed symptom in step 4 or 5, and check that the symptom is not detected.

Is DTC detected and does symptom remain?

- YES-1 >> DTC is detected: GO TO 8.
- YES-2 >> Symptom remains: GO TO 5.
- NO >> Before returning the vehicle to the customer, always erase DTC.

Diagnostic Work Sheet

INFOID:000000011104348

DESCRIPTION

There are many operating conditions that lead to the malfunction of "EV battery system" components. A good grasp of such conditions can make troubleshooting faster and more accurate.

In general, each customer feels differently about symptoms. It is important to fully understand the symptoms or conditions for a customer complaint.

Utilize the diagnostic worksheet in order to organize all the information for troubleshooting.

NOTE:

Some conditions may cause a DTC to be detected.

KEY POINTS

- WHAT** Vehicle & motor model
- WHEN** Date, Frequencies
- WHERE**..... Road conditions
- HOW** Operating conditions,
Weather conditions,
Symptoms

JSCIA0412GB

WORKSHEET SAMPLE

DIAGNOSIS AND REPAIR WORK FLOW

< BASIC INSPECTION >

[TYPE 4]

Question Sheet

Customer name MR/MS	Incident Date	VIN		
	Model & Year	In Service Date		
	Trans.	Mileage	km/mile	
Symptoms	<input type="checkbox"/> Does not to READY <input type="checkbox"/> EV system warning lamp is on <input type="checkbox"/> Power limitation indicator lamp is on			
	<input type="checkbox"/> Water leak* <input type="checkbox"/> Noise* <input type="checkbox"/> Vibration* <input type="checkbox"/> Shock* <input type="checkbox"/> Gear noise*			
	<input type="checkbox"/> Non driving* <input type="checkbox"/> Poor acceleration* <input type="checkbox"/> Poor torque* <input type="checkbox"/> Radio noise*			
	<input type="checkbox"/> Does not charge <input type="checkbox"/> Other* *: If applied, enter in detail			
	Detailed symptom			
	Onomatopoeia			
Frequency	<input type="checkbox"/> All the time <input type="checkbox"/> Once <input type="checkbox"/> Sometimes (times a day) <input type="checkbox"/> Other			
Charging condition	<input type="checkbox"/> Full <input type="checkbox"/> Medium <input type="checkbox"/> Low			
Weather conditions	<input type="checkbox"/> Not affected			
	Weather	<input type="checkbox"/> Fine <input type="checkbox"/> Clouding <input type="checkbox"/> Raining <input type="checkbox"/> Snowing <input type="checkbox"/> Other ()		
	Temp.	<input type="checkbox"/> Hot <input type="checkbox"/> Warm <input type="checkbox"/> Cool <input type="checkbox"/> Cold <input type="checkbox"/> Temp. [Approx. °C (°F)]		
	Humidity	<input type="checkbox"/> High <input type="checkbox"/> Middle <input type="checkbox"/> Low <input type="checkbox"/> Humidity (Approx. %)		
Road conditions	<input type="checkbox"/> Not affected <input type="checkbox"/> In town <input type="checkbox"/> Freeway <input type="checkbox"/> Off road (Up / Down) <input type="checkbox"/> Deplorable road			
	<input type="checkbox"/> Flat road <input type="checkbox"/> While turning (Right / Left) <input type="checkbox"/> Bump			
	<input type="checkbox"/> Other			
Shift position	<input type="checkbox"/> Not affected			
	<input type="checkbox"/> P position <input type="checkbox"/> R position <input type="checkbox"/> N position <input type="checkbox"/> D position <input type="checkbox"/> ECO mode			
Driving conditions	<input type="checkbox"/> Not affected			
	<input type="checkbox"/> Power switch ON → OFF <input type="checkbox"/> Power switch OFF → ON <input type="checkbox"/> READY (stop the vehicle)			
	<input type="checkbox"/> While cruising <input type="checkbox"/> While decelerating <input type="checkbox"/> Just before stopping <input type="checkbox"/> Just after stopping <input type="checkbox"/> D position (stop the vehicle)			
	<input type="checkbox"/> While recharging <input type="checkbox"/> Other			
	<input type="checkbox"/> Vehicle speed [km/h (MPH)] <input type="checkbox"/> Accelerator pedal (/ 8)			
	<input type="checkbox"/> Battery level (Low / Middle / High)			
Moments when mal-function disappears	<input type="checkbox"/> Disappears while driving <input type="checkbox"/> Disappears when stopped <input type="checkbox"/> Disappears with select operation			
	<input type="checkbox"/> Disappears when power switch is pushed OFF <input type="checkbox"/> Disappears when battery charge is stopped <input type="checkbox"/> Does not disappear			
	<input type="checkbox"/> Other			
Other				

ADDITIONAL SERVICE WHEN REPLACING LI-ION BATTERY CONTROLLER

< BASIC INSPECTION >

[TYPE 4]

ADDITIONAL SERVICE WHEN REPLACING LI-ION BATTERY CONTROLLER

Description

INFOID:0000000011104349

When only Li-ion Battery Controller (LBC) is replaced, it is necessary to save the battery information stored in LBC to the new LBC.

Work Procedure

INFOID:0000000011104350

1. SAVE THE LI-ION BATTERY CONTROLLER (LBC) INTERNAL INFORMATION

Ⓜ With CONSULT

1. Select "SAVE BATTERY INFORMATION DATA" in "WORK SUPPORT" mode.
2. Save the LBC internal information.

>> GO TO 2.

2. REPLACE LI-ION BATTERY OR LBC

Replace LBC. Refer to [EV8-885, "LI-ION BATTERY CONTROLLER : Removal and Installation"](#).

>> GO TO 3.

3. WRITE THE LBC INTERNAL INFORMATION

Ⓜ With CONSULT

1. Select "WRITE BATTERY INFORMATION DATA" in "WORK SUPPORT" mode.
2. Write the information that has been read out before LBC replacement.

>> GO TO 4.

4. WRITE THE LBC INTERNAL INFORMATION TO VCM

Refer to "Li-ion Battery Registration Operation Manual."

>> END

A
B
EVB
D
E
F
G
H
I
J
K
L
M
N
O
P

MODULE CHARGE BALANCE

Description

INFOID:000000011104351

If a malfunction (e.g. abnormal voltage) occurs in a Li-ion battery cell, the module which includes the malfunctioning cell must be replaced. When replacing a module with a new one, its voltage is required to be adjusted to the adjusting voltage calculated from the maximum cell voltage of normal cells.

Work Procedure

INFOID:000000011104352

NOTE:

Voltage adjustment under low temperature conditions may require a long time. To prevent this from occurring, it is advisable to adjust voltage under room temperature conditions [20°C ± 10°C (68°F ± 18°F)].

1. CHECK ADJUSTMENT VOLTAGE VALUE

 With CONSULT

1. Power switch ON.
2. Select "DATA MONITOR" of "HV BAT".
3. Check "MAXIMUM CELL VOLTAGE".
4. Double the "MAXIMUM CELL VOLTAGE" and use that value as the module adjustment value.

Adjustment voltage value : MAXIMUM CELL VOLTAGE × 2

Example: 3.925 V (MAXIMUM CELL VOLTAGE) × 2 = 7.850 V (Adjustment voltage value)

>> GO TO 2.

2. CHECK MODULE VOLTAGE

CAUTION:

For details on the module charge balancer operation, refer to the adjuster operation manual.

1. Set the new module to the module charge balancer.
2. Measure module voltage and compare it with "adjustment voltage value" confirmed in Step 1.

Module voltage is lower than adjustment voltage value >> GO TO 4.

Module voltage is higher than adjustment voltage value >> GO TO 3.

3. DISCHARGE OF MODULE VOLTAGE

CAUTION:

For details on the module charge balancer operation, refer to the adjuster operation manual.

Discharge the module to 5.0 V using module charge balancer.

Discharge voltage : 5.0 V

>> GO TO 4.

4. ADJUST VOLTAGE WITH A MODULE CHARGE BALANCER

CAUTION:

For details on the module charge balancer operation, refer to the adjuster operation manual.

1. Enter "adjustment voltage value" into module charge balancer.

Adjustment voltage value : MAXIMUM CELL VOLTAGE × 2

2. Start the voltage adjustment.

>> After module voltage adjustment, GO TO 5.

5. CHECK MODULE VOLTAGE

1. Remove the module from the module charge balancer.
2. Using a circuit tester, check that the module voltage is within the specified range.

MODULE CHARGE BALANCE

< BASIC INSPECTION >

[TYPE 4]

Standard : Adjustment voltage value ± 10 mV

A

>> GO TO 6.

6. CHECK CELL VOLTAGE

B

Ⓜ With CONSULT

1. After adjusting the voltage, install the module to the vehicle.
2. Select "DATA MONITOR" of "HV BAT".
3. Check "CELL VOLTAGE" of install module.
4. Check that the difference from the "MAXIMUM CELL VOLTAGE" confirmed in Step1 is within the specified range.

EVB

D

Standard : MAXIMUM CELL VOLTAGE ± 33 mV

E

>> WORK END

F

G

H

I

J

K

L

M

N

O

P

P0A0D HV SYSTEM INTERLOCK ERROR

< DTC/CIRCUIT DIAGNOSIS >

[TYPE 4]

DTC/CIRCUIT DIAGNOSIS

P0A0D HV SYSTEM INTERLOCK ERROR

DTC Logic

INFOID:0000000011104355

DTC DETECTION LOGIC

DTC	Trouble diagnosis name	DTC detecting condition	Possible causes
P0A0D	HV SYSTEM INTERLOCK ERROR	Self diagnosis program of Li-ion battery controller detects a malfunction in the CPU.	Li-ion battery controller

DTC CONFIRMATION PROCEDURE

1. PERFORM DTC CONFIRMATION PROCEDURE

④ With CONSULT

1. Power switch ON and wait for 10 seconds or more.
2. Select "Self Diagnostic Result" of "HV BAT".
3. Check DTC.

Is P0A1F detected?

- YES >> Refer to [EVB-758, "Diagnosis Procedure"](#).
NO >> INSPECTION END

Diagnosis Procedure

INFOID:0000000011104356

WARNING:

- Because hybrid vehicles and electric vehicles contain a high voltage battery, there is the risk of electric shock, electric leakage, or similar accidents if the high voltage component and vehicle are handled incorrectly. Be sure to follow the correct work procedures when performing inspection and maintenance.
- Be sure to remove the service plug in order to disconnect the high voltage circuits before performing inspection or maintenance of high voltage system harnesses and parts.
- To prevent the removed service plug from being connected by mistake during the procedure, always carry it in your pocket or put it in the tool box.
- Be sure to wear insulating protective equipment consisting of glove, shoes, face shield and glasses before beginning work on the high voltage system.
- Clearly identify the persons responsible for high voltage work and ensure that other persons do not touch the vehicle. When not working, cover high voltage parts with an insulating cover sheet or similar item to prevent other persons from contacting them.
- Refer to [EVB-695, "High Voltage Precautions"](#).

CAUTION:

There is the possibility of a malfunction occurring if the vehicle is changed to READY status while the service plug is removed. Therefore do not change the vehicle to READY status unless instructed to do so in the Service Manual.

1. PRECONDITIONING

WARNING:

Disconnect high voltage. Refer to [GI-31, "How to Disconnect High Voltage"](#).

1. Remove Li-ion battery. Refer to [EVB-866, "Removal and Installation"](#).
2. Remove battery pack upper case. Refer to [EVB-875, "BATTERY PACK UPPER CASE : Removal and Installation"](#).

>> GO TO 2.

2. CHECK LI-ION BATTERY INTERLOCK DETECTION CIRCUIT FOR SHORT-1

1. Disconnect Li-ion battery controller (LBC) harness connector.
2. Disconnect interlock detecting switch (high voltage harness connector) harness connector.
3. Check the continuity between Li-ion battery controller harness connector and ground.

P0A0D HV SYSTEM INTERLOCK ERROR

< DTC/CIRCUIT DIAGNOSIS >

[TYPE 4]

LBC		—	Continuity
Connector	Terminal		
LB11	8	Ground	Not existed

Is the inspection result normal?

YES >> GO TO 3.

NO >> Replace Li-ion battery vehicle communication harness.

3. CHECK LI-ION BATTERY INTERLOCK DETECTIONING CIRCUIT FOR SHORT-2

1. Disconnect interlock detecting switch (service plug) harness connector.
2. Check the continuity between Li-ion battery controller harness connector and ground.

LBC		—	Continuity
Connector	Terminal		
LB11	21	Ground	Not existed

Is the inspection result normal?

YES >> GO TO 4.

NO >> Replace Li-ion battery vehicle communication harness.

4. CHECK LI-ION BATTERY INTERLOCK DETECTIONING CIRCUIT FOR SHORT-3

Check the continuity between interlock detecting switch (service plug) harness connector and ground.

Interlock detecting switch (Service plug)		—	Continuity
Connector	Terminal		
LB6	4	Ground	Not existed

Is the inspection result normal?

YES >> Replace Li-ion battery controller. Refer to [EVB-885, "LI-ION BATTERY CONTROLLER : Removal and Installation"](#).

NO >> Replace Li-ion battery vehicle communication harness.

A
B
EVB
D
E
F
G
H
I
J
K
L
M
N
O
P

P0A1F BATTERY ENERGY CONTROL MODULE

< DTC/CIRCUIT DIAGNOSIS >

[TYPE 4]

P0A1F BATTERY ENERGY CONTROL MODULE

DTC Logic

INFOID:000000011104357

DTC DETECTION LOGIC

DTC	Trouble diagnosis name	DTC detecting condition	Possible causes
P0A1F	BATTERY ENERGY CONTROL MODULE	Self diagnosis program of Li-ion battery controller detects a malfunction in the CPU.	Li-ion battery controller

DTC CONFIRMATION PROCEDURE

1. PERFORM DTC CONFIRMATION PROCEDURE

Ⓜ With CONSULT

1. Power switch ON and wait for 10 seconds or more.
2. Select "Self Diagnostic Result" of "HV BAT".
3. Check DTC.

Is P0A1F detected?

- YES >> Refer to [EVB-760, "Diagnosis Procedure"](#).
NO >> INSPECTION END

Diagnosis Procedure

INFOID:000000011104358

When this DTC is detected, replace Li-ion battery controller. Refer to [EVB-885, "LI-ION BATTERY CONTROLLER : Removal and Installation"](#).

P3030 CELL CONTROLLER LIN

< DTC/CIRCUIT DIAGNOSIS >

[TYPE 4]

P3030 CELL CONTROLLER LIN

DTC Logic

INFOID:0000000011104359

DTC DETECTION LOGIC

DTC	Trouble diagnosis name	DTC detecting condition	Possible causes
P3030	CELL CONT LIN	A malfunction occurs with the communication function in Li-ion battery controller.	<ul style="list-style-type: none">• Li-ion battery controller• Module• Harness or connector

DTC CONFIRMATION PROCEDURE

1. PERFORM DTC CONFIRMATION PROCEDURE

④ With CONSULT

1. Power switch ON and wait for 10 seconds or more.
2. Select "Self Diagnostic Result" of "HV BAT".
3. Check DTC.

Is P3030 detected?

- YES >> Refer to [EVB-761, "Diagnosis Procedure"](#).
NO >> INSPECTION END

Diagnosis Procedure

INFOID:0000000011104360

1. PERFORM THE SELF-DIAGNOSIS OF LI-ION BATTERY CONTROLLER

④ With CONSULT

1. Select "Self Diagnostic Result" of "HV BAT".
2. Check to see if "P30F3" is detected simultaneously with "P3030".

Is P30F3 detected?

- YES >> Replace Li-ion battery. Refer to [EVB-866, "Removal and Installation"](#).
NO >> Replace Li-ion battery controller. Refer to [EVB-885, "LI-ION BATTERY CONTROLLER : Removal and Installation"](#).

P3031-P303C CELL CONTROLLER ASIC

< DTC/CIRCUIT DIAGNOSIS >

[TYPE 4]

P3031-P303C CELL CONTROLLER ASIC

DTC Logic

INFOID:000000011104361

DTC DETECTION LOGIC

DTC	Trouble diagnosis name	DTC detecting condition	Possible causes
P3031	CELL CONT ASIC1	A malfunction occurs with the communication function in Li-ion battery controller.	Li-ion battery controller
P3032	CELL CONT ASIC2		
P3033	CELL CONT ASIC3		
P3034	CELL CONT ASIC4		
P3035	CELL CONT ASIC5		
P3036	CELL CONT ASIC6		
P3037	CELL CONT ASIC7		
P3038	CELL CONT ASIC8		
P3039	CELL CONT ASIC9		
P303A	CELL CONT ASIC10		
P303B	CELL CONT ASIC11		
P303C	CELL CONT ASIC12		

DTC CONFIRMATION PROCEDURE

1. PERFORM DTC CONFIRMATION PROCEDURE

④ With CONSULT

1. Power switch ON and wait for 10 seconds or more.
2. Select "Self Diagnostic Result" of "HV BAT".
3. Check DTC.

Is any DTC detected?

- YES >> Refer to [EVB-762, "Diagnosis Procedure"](#).
NO >> INSPECTION END

Diagnosis Procedure

INFOID:000000011104362

1. PERFORM THE SELF-DIAGNOSIS OF LI-ION BATTERY CONTROLLER

④ With CONSULT

1. Select "Self Diagnostic Result" of "HV BAT".
2. Check to see if "P3030" is detected simultaneously with "P3031 -P303C".

Is P3030 detected?

- YES >> Perform diagnosis on the detected P3030. Refer to [EVB-761, "Diagnosis Procedure"](#).
NO >> Replace Li-ion battery controller. Refer to [EVB-885, "LI-ION BATTERY CONTROLLER : Removal and Installation"](#).

P303D-P3048 CELL CONTROLLER ASIC

< DTC/CIRCUIT DIAGNOSIS >

[TYPE 4]

P303D-P3048 CELL CONTROLLER ASIC

DTC Logic

INFOID:0000000011104363

DTC DETECTION LOGIC

DTC	Trouble diagnosis name	DTC detecting condition	Possible causes
P303D	CELL CONT ASIC13	A malfunction occurs with the communication function in Li-ion battery controller.	Li-ion battery controller
P303E	CELL CONT ASIC14		
P303F	CELL CONT ASIC15		
P3040	CELL CONT ASIC16		
P3041	CELL CONT ASIC17		
P3042	CELL CONT ASIC18		
P3043	CELL CONT ASIC19		
P3044	CELL CONT ASIC20		
P3045	CELL CONT ASIC21		
P3046	CELL CONT ASIC22		
P3047	CELL CONT ASIC23		
P3048	CELL CONT ASIC24		

A

B

EVB

D

E

F

G

DTC CONFIRMATION PROCEDURE

1. PERFORM DTC CONFIRMATION PROCEDURE

④ With CONSULT

1. Power switch ON and wait for 10 seconds or more.
2. Select "Self Diagnostic Result" of "HV BAT".
3. Check DTC.

Is any DTC detected?

- YES >> Refer to [EVB-763, "Diagnosis Procedure"](#).
NO >> INSPECTION END

H

I

J

Diagnosis Procedure

INFOID:0000000011104364

1. PERFORM THE SELF-DIAGNOSIS OF LI-ION BATTERY CONTROLLER

④ With CONSULT

1. Select "Self Diagnostic Result" of "HV BAT".
2. Check to see if "P3030" is detected simultaneously with "P303D" -"P3048".

Is P3030 detected?

- YES >> Perform diagnosis on the detected P3030. Refer to [EVB-761, "Diagnosis Procedure"](#).
NO >> Replace Li-ion battery controller. Refer to [EVB-885, "LI-ION BATTERY CONTROLLER : Removal and Installation"](#).

K

L

M

N

O

P

P3049-P3054 CELL CONTROLLER ASIC VOLTAGE

< DTC/CIRCUIT DIAGNOSIS >

[TYPE 4]

P3049-P3054 CELL CONTROLLER ASIC VOLTAGE

DTC Logic

INFOID:0000000011104365

DTC DETECTION LOGIC

DTC	Trouble diagnosis name	DTC detecting condition	Possible causes
P3049	CELL CONT ASIC1 VOLT	The A/D converter in Li-ion battery controller is malfunctioning.	<ul style="list-style-type: none">• Li-ion battery controller• Module• Harness or connector
P304A	CELL CONT ASIC2 VOLT		
P304B	CELL CONT ASIC3 VOLT		
P304C	CELL CONT ASIC4 VOLT		
P304D	CELL CONT ASIC5 VOLT		
P304E	CELL CONT ASIC6 VOLT		
P304F	CELL CONT ASIC7 VOLT		
P3050	CELL CONT ASIC8 VOLT		
P3051	CELL CONT ASIC9 VOLT		
P3052	CELL CONT ASIC10 VOLT		
P3053	CELL CONT ASIC11 VOLT		
P3054	CELL CONT ASIC12 VOLT		

DTC CONFIRMATION PROCEDURE

1. PERFORM DTC CONFIRMATION PROCEDURE

④ With CONSULT

1. Power switch ON and wait for 10 seconds or more.
2. Select "Self Diagnostic Result" of "HV BAT".
3. Check DTC.

Is any DTC detected?

- YES >> Refer to [EVB-764, "Diagnosis Procedure"](#).
NO >> INSPECTION END

Diagnosis Procedure

INFOID:0000000011104366

1. PERFORM THE SELF-DIAGNOSIS OF LI-ION BATTERY CONTROLLER

④ With CONSULT

1. Select "Self Diagnostic Result" of "HV BAT".
2. Check DTC.

Is any DTC detected?

YES-1 >> "P3302" - "P3331" are detected simultaneously.

- When "P3302" - "P330D" are detected simultaneously, perform the diagnosis procedure of "P3302" - "P330D". Refer to [EVB-793, "Diagnosis Procedure"](#).
- When "P330E" - "P3319" are detected simultaneously, perform the diagnosis procedure of "P330E" - "P3319". Refer to [EVB-797, "Diagnosis Procedure"](#).
- When "P331A" - "P3325" are detected simultaneously, perform the diagnosis procedure of "P331A" - "P3325". Refer to [EVB-801, "Diagnosis Procedure"](#).
- When "P3326" - "P3331" are detected simultaneously, perform the diagnosis procedure of "P3326" - "P3331". Refer to [EVB-804, "Diagnosis Procedure"](#).

YES-2 >> "P3375" - "P33A4" are detected simultaneously.

- When "P3375" - "P3380" are detected simultaneously, perform the diagnosis procedure of "P3375" - "P3380". Refer to [EVB-808, "Diagnosis Procedure"](#).
- When "P3381" - "P338C" are detected simultaneously, perform the diagnosis procedure of "P3381" - "P338C". Refer to [EVB-812, "Diagnosis Procedure"](#).
- When "P338D" - "P3398" are detected simultaneously, perform the diagnosis procedure of "P338D" - "P3398". Refer to [EVB-816, "Diagnosis Procedure"](#).

P3049-P3054 CELL CONTROLLER ASIC VOLTAGE

< DTC/CIRCUIT DIAGNOSIS >

[TYPE 4]

- When “P3399” - “P33A4” are detected simultaneously, perform the diagnosis procedure of “P3399” - “P33A4”. Refer to [EVB-819, "Diagnosis Procedure"](#).
- NO >> When only “P3049” - “P3054” are detected, replace Li-ion battery controller. Refer to [EVB-885, "LI-ION BATTERY CONTROLLER : Removal and Installation"](#).

A

B

EVB

D

E

F

G

H

I

J

K

L

M

N

O

P

P3055-P3060 CELL CONTROLLER ASIC VOLTAGE

< DTC/CIRCUIT DIAGNOSIS >

[TYPE 4]

P3055-P3060 CELL CONTROLLER ASIC VOLTAGE

DTC Logic

INFOID:000000011104367

DTC DETECTION LOGIC

DTC	Trouble diagnosis name	DTC detecting condition	Possible causes
P3055	CELL CONT ASIC13 VOLT	The A/D converter in Li-ion battery controller is malfunctioning.	<ul style="list-style-type: none">• Li-ion battery controller• Module• Harness or connector
P3056	CELL CONT ASIC14 VOLT		
P3057	CELL CONT ASIC15 VOLT		
P3058	CELL CONT ASIC16 VOLT		
P3059	CELL CONT ASIC17 VOLT		
P305A	CELL CONT ASIC18 VOLT		
P305B	CELL CONT ASIC19 VOLT		
P305C	CELL CONT ASIC20 VOLT		
P305D	CELL CONT ASIC21 VOLT		
P305E	CELL CONT ASIC22 VOLT		
P305F	CELL CONT ASIC23 VOLT		
P3060	CELL CONT ASIC24 VOLT		

DTC CONFIRMATION PROCEDURE

1. PERFORM DTC CONFIRMATION PROCEDURE

④ With CONSULT

1. Power switch ON and wait for 10 seconds or more.
2. Select "Self Diagnostic Result" of "HV BAT".
3. Check DTC.

Is any DTC detected?

- YES >> Refer to [EVB-766, "Diagnosis Procedure"](#).
NO >> INSPECTION END

Diagnosis Procedure

INFOID:000000011104368

1. PERFORM THE SELF-DIAGNOSIS OF LI-ION BATTERY CONTROLLER

④ With CONSULT

1. Select "Self Diagnostic Result" of "HV BAT".
2. Check DTC.

Is any DTC detected?

YES-1 >> "P3302" - "P3331" are detected simultaneously.

- When "P3302" - "P330D" are detected simultaneously, perform the diagnosis procedure of "P3302" - "P330D". Refer to [EVB-793, "Diagnosis Procedure"](#).
- When "P330E" - "P3319" are detected simultaneously, perform the diagnosis procedure of "P330E" - "P3319". Refer to [EVB-797, "Diagnosis Procedure"](#).
- When "P331A" - "P3325" are detected simultaneously, perform the diagnosis procedure of "P331A" - "P3325". Refer to [EVB-801, "Diagnosis Procedure"](#).
- When "P3326" - "P3331" are detected simultaneously, perform the diagnosis procedure of "P3326" - "P3331". Refer to [EVB-804, "Diagnosis Procedure"](#).

YES-2 >> "P3375" - "P33A4" are detected simultaneously.

- When "P3375" - "P3380" are detected simultaneously, perform the diagnosis procedure of "P3375" - "P3380". Refer to [EVB-808, "Diagnosis Procedure"](#).
- When "P3381" - "P338C" are detected simultaneously, perform the diagnosis procedure of "P3381" - "P338C". Refer to [EVB-812, "Diagnosis Procedure"](#).
- When "P338D" - "P3398" are detected simultaneously, perform the diagnosis procedure of "P338D" - "P3398". Refer to [EVB-816, "Diagnosis Procedure"](#).

P3055-P3060 CELL CONTROLLER ASIC VOLTAGE

< DTC/CIRCUIT DIAGNOSIS >

[TYPE 4]

- When “P3399” - “P33A4” are detected simultaneously, perform the diagnosis procedure of “P3399” - “P33A4”. Refer to [EVB-819, "Diagnosis Procedure"](#).
- NO >> When only “P3055” - “P3060” are detected, replace Li-ion battery controller. Refer to [EVB-885, "LI-ION BATTERY CONTROLLER : Removal and Installation"](#).

A

B

EVB

D

E

F

G

H

I

J

K

L

M

N

O

P

P3061 CELL BATTERY VOLTAGE

< DTC/CIRCUIT DIAGNOSIS >

[TYPE 4]

P3061 CELL BATTERY VOLTAGE

DTC Logic

INFOID:000000011104369

DTC DETECTION LOGIC

DTC	Trouble diagnosis name	DTC detecting condition	Possible causes
P3061	CELL BATTERY VOLT	An open circuit diagnosis detection circuit in Li-ion battery controller is malfunctioning.	Li-ion battery controller

DTC CONFIRMATION PROCEDURE

1. PERFORM DTC CONFIRMATION PROCEDURE

Ⓜ With CONSULT

1. Power switch ON and wait for 10 seconds or more.
2. Select "Self Diagnostic Result" of "HV BAT".
3. Check DTC.

Is P3061 detected?

- YES >> Refer to [EVB-768, "Diagnosis Procedure"](#).
NO >> INSPECTION END

Diagnosis Procedure

INFOID:000000011104370

When this DTC is detected, replace Li-ion battery controller. Refer to [EVB-885, "LI-ION BATTERY CONTROLLER : Removal and Installation"](#).

P3062 BYPASS SWITCH

< DTC/CIRCUIT DIAGNOSIS >

[TYPE 4]

P3062 BYPASS SWITCH

DTC Logic

INFOID:0000000011104371

DTC DETECTION LOGIC

DTC	Trouble diagnosis name	DTC detecting condition	Possible causes
P3062	BYPASS SW	A malfunction of the bypass switch in Li-ion battery controller is detected.	<ul style="list-style-type: none">• Li-ion battery controller• Module• Harness or connector

DTC DETECTION LOGIC

1. PERFORM DTC CONFIRMATION PROCEDURE

④ With CONSULT

1. Power switch ON and wait for 10 seconds or more.
2. Select "Self Diagnostic Result" of "HV BAT".
3. Check DTC.

Is P3062 detected?

- YES >> Refer to [EVB-769, "Diagnosis Procedure"](#).
NO >> INSPECTION END

Diagnosis Procedure

INFOID:0000000011104372

1. PERFORM THE SELF-DIAGNOSIS OF LI-ION BATTERY CONTROLLER

④ With CONSULT

1. Select "Self Diagnostic Result" of "HV BAT".
2. Check to see if "P3375"- "P33A4" is detected simultaneously with "P3062".

Is P3375-P33A4 detected?

- YES >> • When "P3375" - "P3380" are detected simultaneously, perform the diagnosis procedure of "P3375" - "P3380". Refer to [EVB-808, "Diagnosis Procedure"](#).
• When "P3381" - "P338C" are detected simultaneously, perform the diagnosis procedure of "P3381" - "P338C". Refer to [EVB-812, "Diagnosis Procedure"](#).
• When "P338D" - "P3398" are detected simultaneously, perform the diagnosis procedure of "P338D" - "P3398". Refer to [EVB-816, "Diagnosis Procedure"](#).
• When "P3399" - "P33A4" are detected simultaneously, perform the diagnosis procedure of "P3399" - "P33A4". Refer to [EVB-819, "Diagnosis Procedure"](#).
- NO >> Replace Li-ion battery controller. Refer to [EVB-885, "LI-ION BATTERY CONTROLLER : Removal and Installation"](#).

P308B-P3096 CELL CONTROLLER ASIC OPEN

< DTC/CIRCUIT DIAGNOSIS >

[TYPE 4]

P308B-P3096 CELL CONTROLLER ASIC OPEN

DTC Logic

INFOID:000000011104373

DTC DETECTION LOGIC

DTC	Trouble diagnosis name	DTC detecting condition	Possible causes
P308B	CELL CONT ASIC1 OPEN	Self diagnosis program of Li-ion battery controller detects an open circuit in the cell voltage detection line.	<ul style="list-style-type: none"> • Li-ion battery controller • Harness or connector
P308C	CELL CONT ASIC2 OPEN		
P308D	CELL CONT ASIC3 OPEN		
P308E	CELL CONT ASIC4 OPEN		
P308F	CELL CONT ASIC5 OPEN		
P3090	CELL CONT ASIC6 OPEN		
P3091	CELL CONT ASIC7 OPEN		
P3092	CELL CONT ASIC8 OPEN		
P3093	CELL CONT ASIC9 OPEN		
P3094	CELL CONT ASIC10 OPEN		
P3095	CELL CONT ASIC11 OPEN		
P3096	CELL CONT ASIC12 OPEN		

DTC DETECTION LOGIC

1. PERFORM DTC CONFIRMATION PROCEDURE

Ⓟ With CONSULT

1. Power switch ON and wait for 10 seconds or more.
2. Select "Self Diagnostic Result" of "HV BAT".
3. Check DTC.

Is P308B-P30A2 detected?

- YES >> Refer to [EVB-770, "Diagnosis Procedure"](#).
 NO >> INSPECTION END

Diagnosis Procedure

INFOID:000000011104374

WARNING:

- Because hybrid vehicles and electric vehicles contain a high voltage battery, there is the risk of electric shock, electric leakage, or similar accidents if the high voltage component and vehicle are handled incorrectly. Be sure to follow the correct work procedures when performing inspection and maintenance.
- Be sure to remove the service plug in order to disconnect the high voltage circuits before performing inspection or maintenance of high voltage system harnesses and parts.
- To prevent the removed service plug from being connected by mistake during the procedure, always carry it in your pocket or put it in the tool box.
- Be sure to wear insulating protective equipment consisting of glove, shoes, face shield and glasses before beginning work on the high voltage system.
- Clearly identify the persons responsible for high voltage work and ensure that other persons do not touch the vehicle. When not working, cover high voltage parts with an insulating cover sheet or similar item to prevent other persons from contacting them.
- Refer to [EVB-695, "High Voltage Precautions"](#).

CAUTION:

There is the possibility of a malfunction occurring if the vehicle is changed to READY status while the service plug is removed. Therefore do not change the vehicle to READY status unless instructed to do so in the Service Manual.

1. PERFORM THE SELF-DIAGNOSIS OF LI-ION BATTERY CONTROLLER

Ⓟ With CONSULT

1. Select "Self Diagnostic Result" of "HV BAT".

P308B-P3096 CELL CONTROLLER ASIC OPEN

[TYPE 4]

< DTC/CIRCUIT DIAGNOSIS >

2. Check to see if "P3049"- "P3060" (CELL CONT ASIC VOLT related codes) or "P3375"- "P33A4" (CELL OVER DISCHARGE related codes) is detected simultaneously with "P308B"- "P3096".

Is P3049-P3060 or P3375-P33A4 detected?

YES-1 >> "P3049"- "P3060" are detected simultaneously.

- When "P3049"- "P3054" are detected simultaneously, perform the diagnosis procedure of "P3049"- "P3054". Refer to [EVB-764, "Diagnosis Procedure"](#).
- When "P3055"- "P3060" are detected simultaneously, perform the diagnosis procedure of "P3055"- "P3060". Refer to [EVB-766, "Diagnosis Procedure"](#).

YES-2 >> "P3375"- "P33A4" are detected simultaneously.

- When "P3375"- "P3380" are detected simultaneously, perform the diagnosis procedure of "P3375"- "P3380". Refer to [EVB-808, "Diagnosis Procedure"](#).
- When "P3381"- "P338C" are detected simultaneously, perform the diagnosis procedure of "P3381"- "P338C". Refer to [EVB-812, "Diagnosis Procedure"](#).
- When "P338D"- "P3398" are detected simultaneously, perform the diagnosis procedure of "P338D"- "P3398". Refer to [EVB-816, "Diagnosis Procedure"](#).
- When "P3399"- "P33A4" are detected simultaneously, perform the diagnosis procedure of "P3399"- "P33A4". Refer to [EVB-819, "Diagnosis Procedure"](#).

NO >> GO TO 2.

2. PRECONDITIONING

WARNING:

Disconnect high voltage. Refer to [GI-31, "How to Disconnect High Voltage"](#).

1. Remove Li-ion battery. Refer to [EVB-866, "Removal and Installation"](#).
2. Remove battery pack upper case. Refer to [EVB-875, "BATTERY PACK UPPER CASE : Removal and Installation"](#).

>> GO TO 3.

3. CHECK CONNECTION STATUS

1. Power switch OFF.
2. Check connection status of Li-ion battery controller harness connector and module harness connector.

Is the inspection result normal?

YES >> GO TO 4.

NO >> Recover the connection status.

4. CHECK HARNESS BETWEEN LI-ION BATTERY CONTROLLER AND MODULE

1. Disconnect Li-ion battery controller harness connector and voltage detection terminal of bus bar.
2. Refer to below table and continuity between Li-ion battery controller (A) and voltage detection terminal (B) of bus bar, according to detected DTC.

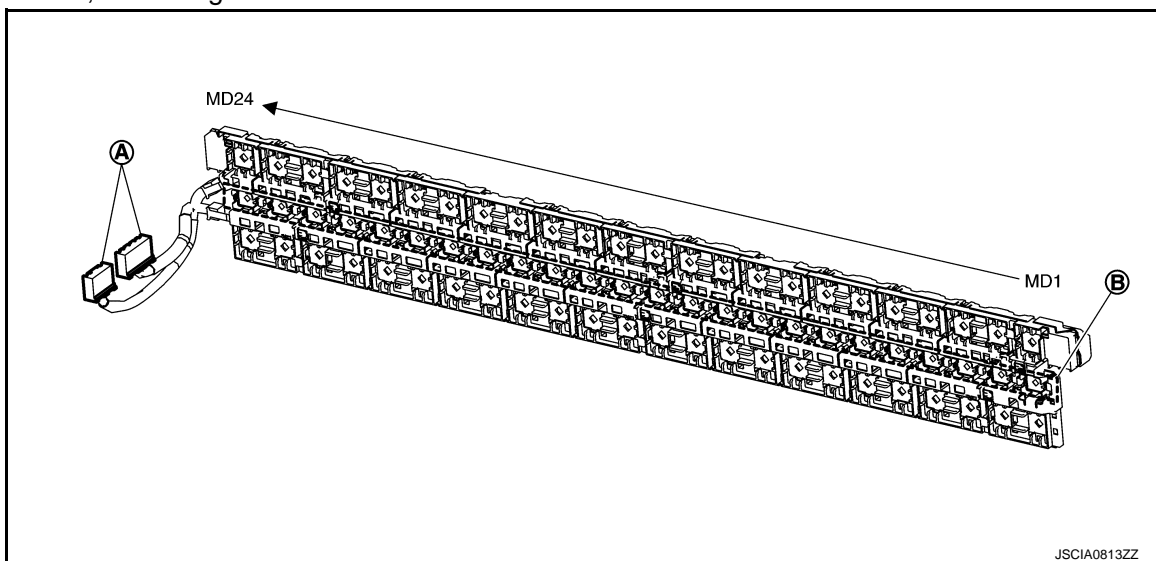

P308B-P3096 CELL CONTROLLER ASIC OPEN

< DTC/CIRCUIT DIAGNOSIS >

[TYPE 4]

DTC	Module No.		Li-ion battery controller		Continuity
			Connector	Terminal	
P308B	1	Voltage detection terminal of bus bar	LB13	50	Existed
	2			51	
P308C	3		LB13	52	Existed
	4			53	
P308D	5		LB13	54	Existed
	6			55	
P308E	7		LB13	56	Existed
	8			57	
P308F	9		LB13	58	Existed
	10			59	
P3090	11		LB13	60	Existed
	12			61	
P3091	13		LB13	62	Existed
	14			63	
P3092	15		LB14	77	Existed
	16			78	
P3093	17		LB14	80	Existed
	18			81	
P3094	19		LB14	82	Existed
	20			83	
P3095	21		LB14	84	Existed
	22			85	
P3096	23		LB14	86	Existed
	24			87	

Is the inspection result normal?

YES >> Replace Li-ion battery controller. Refer to [EVB-885, "LI-ION BATTERY CONTROLLER : Removal and Installation"](#).

NO >> Repair harness or connector.

P3097-P30A2 CELL CONTROLLER ASIC OPEN

< DTC/CIRCUIT DIAGNOSIS >

[TYPE 4]

P3097-P30A2 CELL CONTROLLER ASIC OPEN

DTC Logic

INFOID:0000000011104375

DTC DETECTION LOGIC

DTC	Trouble diagnosis name	DTC detecting condition	Possible causes
P3097	CELL CONT ASIC13 OPEN	Self diagnosis program of Li-ion battery controller detects an open circuit in the cell voltage detection line.	<ul style="list-style-type: none"> Li-ion battery controller Harness or connector
P3098	CELL CONT ASIC14 OPEN		
P3099	CELL CONT ASIC15 OPEN		
P309A	CELL CONT ASIC16 OPEN		
P309B	CELL CONT ASIC17 OPEN		
P309C	CELL CONT ASIC18 OPEN		
P309D	CELL CONT ASIC19 OPEN		
P309E	CELL CONT ASIC20 OPEN		
P309F	CELL CONT ASIC21 OPEN		
P30A0	CELL CONT ASIC22 OPEN		
P30A1	CELL CONT ASIC23 OPEN		
P30A2	CELL CONT ASIC24 OPEN		

DTC DETECTION LOGIC

1. PERFORM DTC CONFIRMATION PROCEDURE

Ⓜ With CONSULT

- Power switch ON and wait for 10 seconds or more.
- Select "Self Diagnostic Result" of "HV BAT".
- Check DTC.

Is P308B-P30A2 detected?

- YES >> Refer to [EVB-773, "Diagnosis Procedure"](#).
 NO >> INSPECTION END

Diagnosis Procedure

INFOID:0000000011104376

WARNING:

- Because hybrid vehicles and electric vehicles contain a high voltage battery, there is the risk of electric shock, electric leakage, or similar accidents if the high voltage component and vehicle are handled incorrectly. Be sure to follow the correct work procedures when performing inspection and maintenance.
- Be sure to remove the service plug in order to disconnect the high voltage circuits before performing inspection or maintenance of high voltage system harnesses and parts.
- To prevent the removed service plug from being connected by mistake during the procedure, always carry it in your pocket or put it in the tool box.
- Be sure to wear insulating protective equipment consisting of glove, shoes, face shield and glasses before beginning work on the high voltage system.
- Clearly identify the persons responsible for high voltage work and ensure that other persons do not touch the vehicle. When not working, cover high voltage parts with an insulating cover sheet or similar item to prevent other persons from contacting them.
- Refer to [EVB-695, "High Voltage Precautions"](#).

CAUTION:

There is the possibility of a malfunction occurring if the vehicle is changed to READY status while the service plug is removed. Therefore do not change the vehicle to READY status unless instructed to do so in the Service Manual.

1. PERFORM THE SELF-DIAGNOSIS OF LI-ION BATTERY CONTROLLER

Ⓜ With CONSULT

- Select "Self Diagnostic Result" mode of "HV BAT" using CONSULT.

P3097-P30A2 CELL CONTROLLER ASIC OPEN

[TYPE 4]

< DTC/CIRCUIT DIAGNOSIS >

- Check to see if "P3049"- "P3060" (CELL CONT ASIC VOLT related codes) or "P3375"- "P33A4" (CELL OVER DISCHARGE related codes) is detected simultaneously with "P3097"- "P30A2".

Is P3049-P3060 or P3375-P33A4 detected?

YES-1 >> "P3049"- "P3060" are detected simultaneously.

- When "P3049"- "P3054" are detected simultaneously, perform the diagnosis procedure of "P3049"- "P3054". Refer to [EVB-764, "Diagnosis Procedure"](#)
- When "P3055"- "P3060" are detected simultaneously, perform the diagnosis procedure of "P3055"- "P3060". Refer to [EVB-766, "Diagnosis Procedure"](#)

YES-2 >> "P3375"- "P33A4" are detected simultaneously.

- When "P3375"- "P3380" are detected simultaneously, perform the diagnosis procedure of "P3375"- "P3380". Refer to [EVB-808, "Diagnosis Procedure"](#).
- When "P3381"- "P338C" are detected simultaneously, perform the diagnosis procedure of "P3381"- "P338C". Refer to [EVB-812, "Diagnosis Procedure"](#).
- When "P338D"- "P3398" are detected simultaneously, perform the diagnosis procedure of "P338D"- "P3398". Refer to [EVB-816, "Diagnosis Procedure"](#).
- When "P3399"- "P33A4" are detected simultaneously, perform the diagnosis procedure of "P3399"- "P33A4". Refer to [EVB-819, "Diagnosis Procedure"](#)

NO >> GO TO 2.

2. PRECONDITIONING

WARNING:

Disconnect high voltage. Refer to [GI-31, "How to Disconnect High Voltage"](#).

- Remove Li-ion battery. Refer to [EVB-866, "Removal and Installation"](#).
- Remove battery pack upper case. Refer to [EVB-875, "BATTERY PACK UPPER CASE : Removal and Installation"](#).

>> GO TO 3.

3. CHECK CONNECTION STATUS

- Power switch OFF.
- Check connection status of Li-ion battery controller harness connector and module harness connector.

Is the inspection result normal?

YES >> GO TO 4.

NO >> Recover the connection status.

4. CHECK HARNESS BETWEEN LI-ION BATTERY CONTROLLER AND MODULE

- Disconnect Li-ion battery controller harness connector and Module harness connector.
- Refer to below table and continuity between Li-ion battery controller and Module, according to detected DTC.

DTC	Module No.	Module		Li-ion battery controller		Continuity
		Connector	Terminal	Connector	Terminal	
P3097	25	LB8	73	LB15	110	Existed
	26		74		111	
P3098	27	LB8	60	LB15	112	Existed
	28		77		113	
P3099	29	LB8	78	LB15	114	Existed
	30		64		115	
P309A	31	LB8	81	LB15	116	Existed
	32		82		117	
P309B	33	LB8	68	LB15	118	Existed
	34		85		119	
P309C	35	LB8	86	LB15	120	Existed
	36		72		121	

P3097-P30A2 CELL CONTROLLER ASIC OPEN

< DTC/CIRCUIT DIAGNOSIS >

[TYPE 4]

DTC	Module No.	Module		Li-ion battery controller		Continuity
		Connector	Terminal	Connector	Terminal	
P309D	37	LB7	89	LB15	122	Existed
	38		90		123	
P309E	39	LB7	91	LB15	124	Existed
	40		92		125	
P309F	41	LB7	93	LB15	127	Existed
	42		94		128	
P30A0	43	LB7	95	LB15	130	Existed
	44		96		138	
P30A1	45	LB7	97	LB15	140	Existed
	46		98		141	
P30A2	47	LB7	99	LB15	142	Existed
	48		100		143	

Is the inspection result normal?

- YES >> Replace Li-ion battery controller. Refer to [EVB-885. "LI-ION BATTERY CONTROLLER : Removal and Installation"](#).
- NO >> Repair harness or connector.

A
B
EVB
D
E
F
G
H
I
J
K
L
M
N
O
P

P30F3 TOTAL VOLTAGE SENSOR

< DTC/CIRCUIT DIAGNOSIS >

[TYPE 4]

P30F3 TOTAL VOLTAGE SENSOR

DTC Logic

INFOID:000000011104377

DTC DETECTION LOGIC

DTC	Trouble diagnosis name	DTC detecting condition	Possible causes
P30F3	TOTAL VOLT SENSOR	A malfunction occurs with the communication function in Li-ion battery controller.	<ul style="list-style-type: none">• Li-ion battery controller• Module• Harness or connector

DTC CONFIRMATION PROCEDURE

1. PERFORM DTC CONFIRMATION PROCEDURE

④ With CONSULT

1. Power switch ON and wait for 10 seconds or more.
2. Select "Self Diagnostic Result" of "HV BAT".
3. Check DTC.

Is P30F3 detected?

- YES >> Refer to [EVB-776, "Diagnosis Procedure"](#).
NO >> INSPECTION END

Diagnosis Procedure

INFOID:000000011104378

1. PERFORM THE SELF-DIAGNOSIS OF LI-ION BATTERY CONTROLLER

④ With CONSULT

1. Select "Self Diagnostic Result" of "HV BAT".
2. Check to see if "P3030" is detected simultaneously with "P30F3".

Is any P3030 detected?

- YES >> Perform diagnosis on the detected "P3030". Refer to [EVB-761, "Diagnosis Procedure"](#).
NO >> Replace Li-ion battery controller. Refer to [EVB-885, "LI-ION BATTERY CONTROLLER : Removal and Installation"](#).

P30F4 TOTAL VOLTAGE SENSOR

< DTC/CIRCUIT DIAGNOSIS >

[TYPE 4]

P30F4 TOTAL VOLTAGE SENSOR

DTC Logic

INFOID:0000000011104379

DTC DETECTION LOGIC

DTC	Trouble diagnosis name	DTC detecting condition	Possible causes
P30F4	TOTAL VOLT SENSOR	When the voltage recognized by total voltage sensor in Li-ion battery controller is excessively high or low.	<ul style="list-style-type: none">• Li-ion battery controller• Bus bar between stack• Service plug (fuse)• Module

DTC CONFIRMATION PROCEDURE

1. PERFORM DTC CONFIRMATION PROCEDURE

④ With CONSULT

1. Power switch ON and wait for 10 seconds or more.
2. Select "Self Diagnostic Result" of "HV BAT".
3. Check DTC.

Is P30F4 detected?

- YES >> Refer to [EVB-777, "Diagnosis Procedure"](#).
NO >> INSPECTION END

Diagnosis Procedure

INFOID:0000000011104380

WARNING:

- Because hybrid vehicles and electric vehicles contain a high voltage battery, there is the risk of electric shock, electric leakage, or similar accidents if the high voltage component and vehicle are handled incorrectly. Be sure to follow the correct work procedures when performing inspection and maintenance.
- Be sure to remove the service plug in order to disconnect the high voltage circuits before performing inspection or maintenance of high voltage system harnesses and parts.
- To prevent the removed service plug from being connected by mistake during the procedure, always carry it in your pocket or put it in the tool box.
- Be sure to wear insulating protective equipment consisting of glove, shoes, face shield and glasses before beginning work on the high voltage system.
- Clearly identify the persons responsible for high voltage work and ensure that other persons do not touch the vehicle. When not working, cover high voltage parts with an insulating cover sheet or similar item to prevent other persons from contacting them.
- Refer to [EVB-695, "High Voltage Precautions"](#).

CAUTION:

There is the possibility of a malfunction occurring if the vehicle is changed to READY status while the service plug is removed. Therefore do not change the vehicle to READY status unless instructed to do so in the Service Manual.

1. PERFORM THE SELF-DIAGNOSIS OF LI-ION BATTERY CONTROLLER

④ With CONSULT

1. Select "Self Diagnostic Result" mode of "HV BAT" using CONSULT.
2. Check if any DTC is detected in "Self Diagnostic Result".

Is any DTC detected?

- "P3030" is detected in addition to "P30F4" (Cannot be monitored)>>GO TO 3.
Just "P30F4" is detected>>GO TO 2.

2. CHECK FUSE

1. Power switch OFF.
2. Check fuse of service plug.

Is the inspection result normal?

- YES >> Replace Li-ion battery controller.
NO >> Replace service plug.

P30F4 TOTAL VOLTAGE SENSOR

[TYPE 4]

< DTC/CIRCUIT DIAGNOSIS >

3. PRECONDITIONING

WARNING:

Disconnect high voltage. Refer to [GI-31, "How to Disconnect High Voltage"](#).

1. Remove Li-ion battery. Refer to [EVB-866, "Removal and Installation"](#).
2. Remove battery pack upper case. Refer to [EVB-875, "BATTERY PACK UPPER CASE : Removal and Installation"](#).

>> GO TO 4.

4. CHECK CONNECTION STATUS STACK AND BUS BAR.

Check connection status between each stack and connection status of each bus bar.

Is the inspection result normal?

- YES >> GO TO 5.
NO >> Recover the connection status.

5. CHECK MODULE VOLTAGE

Check the voltage of all modules.

Is the inspection result normal?

- YES >> Replace Li-ion battery controller. Refer to [EVB-885, "LI-ION BATTERY CONTROLLER : Removal and Installation"](#).
NO >> Replace the corresponding module. Refer to [EVB-915, "FRONT MODULE STACK : Disassembly and Assembly"](#) (Front module) or [EVB-930, "REAR MODULE STACK : Disassembly and Assembly"](#) (Rear module).

Component Inspection

INFOID:000000011104381

1. CHECK MODULE VOLTAGE

Check voltage of module.

- A : Positive terminal (Red)**
B : Negative terminal (Black)

Terminals		Voltage (Approx.)
(+)	(-)	
Module		5.0 - 8.5 V
Positive terminal (Red)	Negative terminal (Black)	

Is the inspection result normal?

- YES >> INSPECTION END
NO >> Replace module. Refer to [EVB-915, "FRONT MODULE STACK : Disassembly and Assembly"](#) (Front module) or [EVB-930, "REAR MODULE STACK : Disassembly and Assembly"](#) (Rear module).

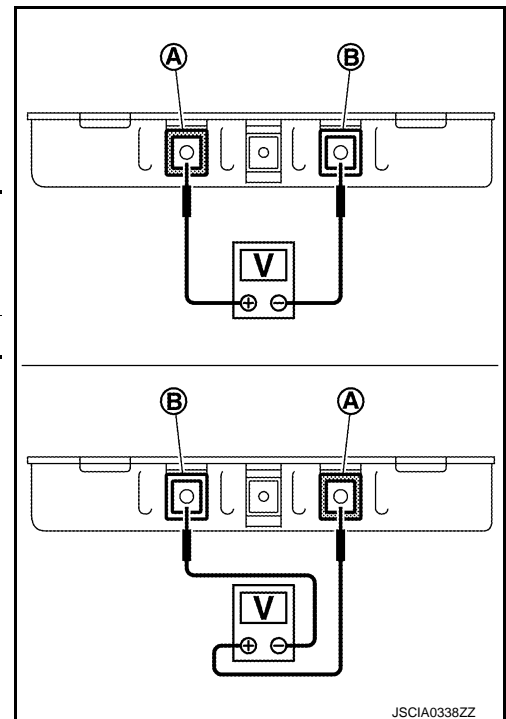

P30F5 TOTAL VOLTAGE SENSOR

< DTC/CIRCUIT DIAGNOSIS >

[TYPE 4]

P30F5 TOTAL VOLTAGE SENSOR

DTC Logic

INFOID:0000000011104382

DTC DETECTION LOGIC

DTC	Trouble diagnosis name	DTC detecting condition	Possible causes
P30F5	TOTAL VOLT SENSOR	When the voltage recognized by total voltage sensor in Li-ion battery controller is excessively high or low.	<ul style="list-style-type: none">• Li-ion battery controller• Bus bar between stack• Service plug (fuse)• Module

DTC CONFIRMATION PROCEDURE

1. PERFORM DTC CONFIRMATION PROCEDURE

④ With CONSULT

1. Power switch ON and wait for 10 seconds or more.
2. Select "Self Diagnostic Result" of "HV BAT".
3. Check DTC.

Is P30F5 detected?

- YES >> Refer to [EVB-779, "Diagnosis Procedure"](#).
NO >> INSPECTION END

Diagnosis Procedure

INFOID:0000000011104383

1. PERFORM THE SELF-DIAGNOSIS OF LI-ION BATTERY CONTROLLER

④ With CONSULT

1. Select "Self Diagnostic Result" of "HV BAT".
2. Check to see if "P30F4" is detected simultaneously with "P30F5".

Is any P30F4 detected?

- YES >> Perform diagnosis on the detected "P30F4". Refer to [EVB-777, "Diagnosis Procedure"](#).
NO >> Replace Li-ion battery controller. Refer to [EVB-885, "LI-ION BATTERY CONTROLLER : Removal and Installation"](#).

P30FC OVER CURRENT

[TYPE 4]

< DTC/CIRCUIT DIAGNOSIS >

P30FC OVER CURRENT

DTC Logic

INFOID:000000011104384

DTC DETECTION LOGIC

DTC	Trouble diagnosis name	DTC detecting condition	Possible causes
P30FC	OVER CURRENT	When the temperature of the entire battery pack estimated from the current value is excessively high.	<ul style="list-style-type: none">Battery current sensorOther systems malfunction

DTC CONFIRMATION PROCEDURE

1. PERFORM DTC CONFIRMATION PROCEDURE

④ With CONSULT

- Power switch ON and wait for 10 seconds or more.
- Select "Self Diagnostic Result" of "HV BAT".
- Check DTC.

Is P30FC detected?

- YES >> Refer to [EVB-780, "Diagnosis Procedure"](#).
NO >> INSPECTION END

Diagnosis Procedure

INFOID:000000011104385

1. PERFORM THE SELF-DIAGNOSIS

④ With CONSULT

- Perform "All DTC Reading".
- Check "Self diagnostic result" of systems other than "HV BAT" to see if any DTC is detected.

Is any DTC detected?

- YES >> After performing trouble diagnosis of detected DTC, GO TO 2.
NO >> GO TO 2.

2. CHECK BATTERY TEMPERATURE SENSOR

④ With CONSULT

Using FFD, check the values of four temperature sensors when DTC is detected.

Monitor item	Condition	Limit
Battery temperature sensor 1	Power switch ON	55°C (131°F) or less
Battery temperature sensor 2		
Battery temperature sensor 3		
Battery temperature sensor 4		

Is there temperature increase?

- Temperature increase is seen>>Replace Li-ion battery. Refer to [EVB-866, "Removal and Installation"](#).
Temperature increase is not seen>>Replace battery junction box. Refer to [EVB-890, "BATTERY JUNCTION BOX AND BATTERY HARNESS : Disassembly and Assembly"](#).

P30FD TOTAL VOLTAGE MONITOR SWITCH

< DTC/CIRCUIT DIAGNOSIS >

[TYPE 4]

P30FD TOTAL VOLTAGE MONITOR SWITCH

DTC Logic

INFOID:0000000011104386

DTC DETECTION LOGIC

DTC	Trouble diagnosis name	DTC detecting condition	Possible causes
P30FD	TOTAL VOLTAGE MONITOR SWITCH	<ul style="list-style-type: none">Total voltage detection switch in Li-ion battery controller is malfunctioning.Self diagnosis malfunction of total voltage detection circuit stop function in Li-ion battery controller.	<ul style="list-style-type: none">Li-ion battery controller

DTC CONFIRMATION PROCEDURE

1. PERFORM DTC CONFIRMATION PROCEDURE

Ⓜ With CONSULT

- Power switch ON and wait for 10 seconds or more.
- Select "Self Diagnostic Result" of "HV BAT".
- Check DTC.

Is P30FC detected?

- YES >> Refer to [EVB-781, "Diagnosis Procedure"](#).
NO >> INSPECTION END

Diagnosis Procedure

INFOID:0000000011104387

When this DTC is detected, replace Li-ion battery controller. Refer to [EVB-885, "LI-ION BATTERY CONTROLLER : Removal and Installation"](#).

P30FE 12V BATTERY VOLTAGE

< DTC/CIRCUIT DIAGNOSIS >

[TYPE 4]

P30FE 12V BATTERY VOLTAGE

DTC Logic

INFOID:000000011104388

DTC DETECTION LOGIC

DTC	Trouble diagnosis name	DTC detecting condition	Possible causes
P30FE	12V BATTERY VOLTAGE	12V battery voltage lowers to less than 9 V.	<ul style="list-style-type: none">• 12V battery• Harness

DTC CONFIRMATION PROCEDURE

1. PERFORM DTC CONFIRMATION PROCEDURE

Ⓜ With CONSULT

1. Power switch ON and wait for 10 seconds or more.
2. Select "Self Diagnostic Result" of "HV BAT".
3. Check DTC.

Is P30FE detected?

- YES >> Refer to [EVB-782, "Diagnosis Procedure"](#).
NO >> INSPECTION END

Diagnosis Procedure

INFOID:000000011104389

WARNING:

- Because hybrid vehicles and electric vehicles contain a high voltage battery, there is the risk of electric shock, electric leakage, or similar accidents if the high voltage component and vehicle are handled incorrectly. Be sure to follow the correct work procedures when performing inspection and maintenance.
- Be sure to remove the service plug in order to disconnect the high voltage circuits before performing inspection or maintenance of high voltage system harnesses and parts.
- To prevent the removed service plug from being connected by mistake during the procedure, always carry it in your pocket or put it in the tool box.
- Be sure to wear insulating protective equipment consisting of glove, shoes, face shield and glasses before beginning work on the high voltage system.
- Clearly identify the persons responsible for high voltage work and ensure that other persons do not touch the vehicle. When not working, cover high voltage parts with an insulating cover sheet or similar item to prevent other persons from contacting them.
- Refer to [EVB-695, "High Voltage Precautions"](#).

CAUTION:

There is the possibility of a malfunction occurring if the vehicle is changed to READY status while the service plug is removed. Therefore do not change the vehicle to READY status unless instructed to do so in the Service Manual.

1. CHECK VOLTAGE OF 12 V BATTERY

Check the voltage of 12 V battery using circuit tester.

Is output more than 9 V?

- YES >> GO TO 2.
NO >> Replace 12 V battery. Refer to [PG-108, "Removal and Installation"](#).

2. CHECK FUSE

1. Power switch OFF.
2. Check 20A fuse [No.43].

NOTE:

Refer to [PG-87, "Fuse, Connector and Terminal Arrangement"](#) for fuse layout.

Is the inspection result normal?

- YES >> GO TO 3.
NO >> After eliminating the cause of flame cutting, replace the fuse.

3. CHECK LI-ION BATTERY POWER SUPPLY

P30FE 12V BATTERY VOLTAGE

[TYPE 4]

< DTC/CIRCUIT DIAGNOSIS >

1. Disconnect Li-ion battery vehicle communication harness connector.
2. Check voltage between Li-ion battery harness connector and ground.

+		-	Voltage
Li-ion battery			
Connector	Terminal		
B24	5	Ground	Battery voltage

Is the inspection result normal?

YES >> GO TO 4.

NO >> Repair harness or connector.

4. PRECONDITIONING

WARNING:

Disconnect high voltage. Refer to [GI-31, "How to Disconnect High Voltage"](#).

1. Remove Li-ion battery. Refer to [EVB-866, "Removal and Installation"](#).
2. Remove battery pack upper case. Refer to [EVB-875, "BATTERY PACK UPPER CASE : Removal and Installation"](#).

>> GO TO 5.

5. CHECK HARNESS BETWEEN LI-ION BATTERY AND LI-ION BATTERY CONTROLLER

1. Disconnect Li-ion battery harness connector and Li-ion battery controller harness connector.
2. Check continuity between Li-ion battery harness connector and Li-ion battery controller harness connector.

Li-ion battery		Li-ion battery controller		Continuity
Connector	Terminal	Connector	Terminal	
LB1	5	LB11	12	Existed

Is the inspection result normal?

YES >> Replace Li-ion battery controller. Refer to [EVB-885, "LI-ION BATTERY CONTROLLER : Removal and Installation"](#).

NO >> Repair harness or connector.

P318D COMMUNICATION ERROR

< DTC/CIRCUIT DIAGNOSIS >

[TYPE 4]

P318D COMMUNICATION ERROR

DTC Logic

INFOID:000000011104390

DTC DETECTION LOGIC

DTC	Trouble diagnosis name	DTC detecting condition	Possible causes
P318D	COMMUNICATION ERROR	When no CAN communication signal is received continuously.	<ul style="list-style-type: none">• CAN communication line• Li-ion battery controller• VCM

DTC CONFIRMATION PROCEDURE

1. PERFORM DTC CONFIRMATION PROCEDURE

④ With CONSULT

1. Power switch ON and wait for 10 seconds or more.
2. Select "Self Diagnostic Result" of "HV BAT".
3. Check DTC.

Is P318D detected?

- YES >> Refer to [EVB-784, "Diagnosis Procedure"](#).
NO >> INSPECTION END

Diagnosis Procedure

INFOID:000000011104391

For the diagnosis procedure, refer to [LAN-15, "Trouble Diagnosis Flow Chart"](#).

P318E COMMUNICATION ERROR

< DTC/CIRCUIT DIAGNOSIS >

[TYPE 4]

P318E COMMUNICATION ERROR

DTC Logic

INFOID:0000000011104392

DTC DETECTION LOGIC

NOTE:

When the 12 V battery is removed within 5 minutes after turning the power switch OFF, "P318E", "P3191", and "P3196" may be simultaneously detected. This is not a malfunction.

DTC	Trouble diagnosis name	DTC detecting condition	Possible causes
P318E	COMMUNICATION ERROR	When no CAN communication signal is received from VCM continuously.	<ul style="list-style-type: none">• VCM• Li-ion battery controller• CAN communication line

DTC CONFIRMATION PROCEDURE

1. PERFORM DTC CONFIRMATION PROCEDURE

Ⓜ With CONSULT

1. Power switch OFF.
2. After turning the power switch OFF, get out of the vehicle and close all doors (including back door).
3. After turning the power switch OFF, wait for 5 minutes or more to remove the 12 V battery negative terminal. Refer to [EVB-695, "Precautions for Removing Battery Terminal"](#).
4. Connect 12 V battery negative terminal.
5. Power switch ON and wait for 10 seconds or more.
6. Select "Self Diagnostic Result" of "HV BAT".
7. Check DTC.

Is P318E detected?

- YES >> Refer to [EVB-785, "Diagnosis Procedure"](#).
NO >> INSPECTION END

Diagnosis Procedure

INFOID:0000000011104393

1. PERFORM THE SELF-DIAGNOSIS

Ⓜ With CONSULT

1. Perform "All DTC Reading".
2. Check "Self diagnostic result" of systems other than "HV BAT" to see if "P318E" is detected.

Is P318E detected?

- YES >> Replace VCM. Refer to [EVC-377, "Removal and Installation"](#).
NO >> GO TO 2.

2. PERFORM THE SELF-DIAGNOSIS OF LI-ION BATTERY CONTROLLER

Ⓜ With CONSULT

1. Select "Self Diagnostic Result" of "HV BAT".
2. Check to see if "U1000" is detected simultaneously with "P318E".

Is U1000 detected?

- YES >> Replace Li-ion battery controller. Refer to [EVB-885, "LI-ION BATTERY CONTROLLER : Removal and Installation"](#).
NO >> INSPECTION END

P3191 COMMUNICATION ERROR

< DTC/CIRCUIT DIAGNOSIS >

[TYPE 4]

P3191 COMMUNICATION ERROR

DTC Logic

INFOID:000000011104394

DTC DETECTION LOGIC

NOTE:

When the 12 V battery is removed within 5 minutes after turning the power switch OFF, "P318E", "P3191" and "P3196" may be simultaneously detected. This is not a malfunction.

DTC	Trouble diagnosis name	DTC detecting condition	Possible causes
P3191	COMMUNICATION ERROR	When no CAN communication signal is received from traction motor inverter continuously.	<ul style="list-style-type: none">• Traction motor inverter• Li-ion battery controller• CAN communication line

DTC CONFIRMATION PROCEDURE

1. PERFORM DTC CONFIRMATION PROCEDURE

Ⓜ With CONSULT

1. Power switch OFF.
2. After turning the power switch OFF, get out of the vehicle and close all doors (including back door).
3. After turning the power switch OFF, wait for 5 minutes or more to remove the 12 V battery negative terminal. Refer to [EVB-695, "Precautions for Removing Battery Terminal"](#).
4. Connect 12 V battery negative terminal.
5. Power switch ON and wait for 10 seconds or more.
6. Select "Self Diagnostic Result" of "HV BAT".
7. Check DTC.

Is P3191 detected?

- YES >> Refer to [EVB-786, "Diagnosis Procedure"](#).
NO >> INSPECTION END

Diagnosis Procedure

INFOID:000000011104395

1. PERFORM THE SELF-DIAGNOSIS

Ⓜ With CONSULT

1. Perform "All DTC Reading".
2. Check "Self diagnostic result" of systems other than "HV BAT" to see if "P3191" is detected.

Is P3191 detected?

- YES >> Replace traction motor inverter. Refer to [TMS-116, "Removal and Installation"](#)
NO >> GO TO 2.

2. PREFORM THE SELF-DIAGNOSIS OF LI-ION BATTERY CONTROLLER

Ⓜ With CONSULT

1. Select "Self Diagnostic Result" of "HV BAT".
2. Check to see if "U1000" is detected simultaneously with "P3191".

Is U1000 detected?

- YES >> Replace Li-ion battery controller. Refer to [EVB-885, "LI-ION BATTERY CONTROLLER : Removal and Installation"](#).
NO >> INSPECTION END

P3196 COMMUNICATION ERROR

< DTC/CIRCUIT DIAGNOSIS >

[TYPE 4]

P3196 COMMUNICATION ERROR

DTC Logic

INFOID:0000000011104396

DTC DETECTION LOGIC

NOTE:

When the 12 V battery is removed within 5 minutes after turning the power switch OFF, "P318E", "P3191" and "P3196" may be simultaneously detected. This is not a malfunction.

DTC	Trouble diagnosis name	DTC detecting condition	Possible causes
P3196	COMMUNICATION ERROR	When no CAN communication signal is received from on-board charger continuously.	<ul style="list-style-type: none">• On board charger• Li-ion battery controller• CAN communication line

DTC CONFIRMATION PROCEDURE

1. PERFORM DTC CONFIRMATION PROCEDURE

Ⓜ With CONSULT

1. Power switch OFF.
2. After turning the power switch OFF, get out of the vehicle and close all doors (including back door).
3. After turning the power switch OFF, wait for 5 minutes or more to remove the 12 V battery negative terminal. Refer to [EVB-695, "Precautions for Removing Battery Terminal"](#).
4. Connect 12 V battery negative terminal.
5. Power switch ON and wait for 10 seconds or more.
6. Select "Self Diagnostic Result" of "HV BAT".
7. Check DTC.

Is P3196 detected?

- YES >> Refer to [EVB-787, "Diagnosis Procedure"](#).
NO >> INSPECTION END

Diagnosis Procedure

INFOID:0000000011104397

1. PERFORM THE SELF-DIAGNOSIS

Ⓜ With CONSULT

1. Perform "All DTC Reading".
2. Check "Self diagnostic result" of systems other than "HV BAT" to see if "P3196" is detected.

Is P3196 detected?

- YES >> Replace on board charger. Refer to [VC-112, "Removal and Installation"](#).
NO >> GO TO 2.

2. PREFORM THE SELF-DIAGNOSIS OF LI-ION BATTERY CONTROLLER

Ⓜ With CONSULT

1. Select "Self Diagnostic Result" of "HV BAT".
2. Check to see if "U1000" is detected simultaneously with "P3196".

Is U1000 detected?

- YES >> Replace Li-ion battery controller. Refer to [EVB-885, "LI-ION BATTERY CONTROLLER : Removal and Installation"](#).
NO >> INSPECTION END

P3199 COMMUNICATION ERROR

< DTC/CIRCUIT DIAGNOSIS >

[TYPE 4]

P3199 COMMUNICATION ERROR

DTC Logic

INFOID:000000011104398

DTC DETECTION LOGIC

DTC	Trouble diagnosis name	DTC detecting condition	Possible causes
P3199	COMMUNICATION ERROR	When a CRC error from VCM is detected.	<ul style="list-style-type: none">• VCM• Li-ion battery controller

DTC CONFIRMATION PROCEDURE

1. PERFORM DTC CONFIRMATION PROCEDURE

④ With CONSULT

1. Power switch ON and wait for 10 seconds or more.
2. Select "Self Diagnostic Result" of "HV BAT".
3. Check DTC.

Is P3199 detected?

- YES >> Refer to [EVB-788, "Diagnosis Procedure"](#).
NO >> INSPECTION END

Diagnosis Procedure

INFOID:000000011104399

When this DTC is detected, replace VCM. Refer to [EVC-377, "Removal and Installation"](#).

P319C COMMUNICATION ERROR

< DTC/CIRCUIT DIAGNOSIS >

[TYPE 4]

P319C COMMUNICATION ERROR

DTC Logic

INFOID:0000000011104400

DTC DETECTION LOGIC

DTC	Trouble diagnosis name	DTC detecting condition	Possible causes
P319C	COMMUNICATION ERROR	When a CRC error from traction motor inverter is detected.	<ul style="list-style-type: none">• Traction motor inverter• Li-ion battery controller

EVB

DTC CONFIRMATION PROCEDURE

1. PERFORM DTC CONFIRMATION PROCEDURE

④ With CONSULT

1. Power switch ON and wait for 10 seconds or more.
2. Select "Self Diagnostic Result" of "HV BAT".
3. Check DTC.

Is P319C detected?

- YES >> Refer to [EVB-789, "Diagnosis Procedure"](#).
NO >> INSPECTION END

Diagnosis Procedure

INFOID:0000000011104401

When this DTC is detected, replace traction motor inverter. Refer to [TMS-116, "Exploded View"](#).

A
B
D
E
F
G
H
I
J
K
L
M
N
O
P

P31A4 CAN ERROR VCM

< DTC/CIRCUIT DIAGNOSIS >

[TYPE 4]

P31A4 CAN ERROR VCM

DTC Logic

INFOID:000000011104402

DTC DETECTION LOGIC

DTC	Trouble diagnosis name	DTC detecting condition	Possible causes
P31A4	CAN ERROR VCM	If the CAN data from VCM has not change from the value which was previously received.	VCM

DTC CONFIRMATION PROCEDURE

1. PERFORM DTC CONFIRMATION PROCEDURE

④ With CONSULT

1. Power switch ON and wait for 10 seconds or more.
2. Select "Self Diagnostic Result" of "HV BAT".
3. Check DTC.

Is P31A4 detected?

- YES >> Refer to [EVB-790, "Diagnosis Procedure"](#).
NO >> INSPECTION END

Diagnosis Procedure

INFOID:000000011104403

When this DTC is detected, replace VCM. Refer to [EVC-377, "Removal and Installation"](#).

P31A7 CAN ERROR INV/MC

< DTC/CIRCUIT DIAGNOSIS >

[TYPE 4]

P31A7 CAN ERROR INV/MC

DTC Logic

INFOID:0000000011104404

DTC DETECTION LOGIC

DTC	Trouble diagnosis name	DTC detecting condition	Possible causes
P31A7	CAN ERROR INV/MC	If the CAN data from traction motor inverter has not change from the value which was previously received.	Traction motor inverter

A
B
EVB
D
E
F
G
H
I
J
K
L
M
N
O
P

DTC CONFIRMATION PROCEDURE

1. PERFORM DTC CONFIRMATION PROCEDURE

 With CONSULT

1. Power switch ON and wait for 10 seconds or more.
2. Select "Self Diagnostic Result" of "HV BAT".
3. Check DTC.

Is P31A7 detected?

- YES >> Refer to [EVB-791, "Diagnosis Procedure"](#).
NO >> INSPECTION END

Diagnosis Procedure

INFOID:0000000011104405

When this DTC is detected, replace traction motor inverter. Refer to [TMS-116, "Exploded View"](#).

P3300 TOTAL VOLTAGE OVER

< DTC/CIRCUIT DIAGNOSIS >

[TYPE 4]

P3300 TOTAL VOLTAGE OVER

DTC Logic

INFOID:0000000011104406

DTC DETECTION LOGIC

DTC	Trouble diagnosis name	DTC detecting condition	Possible causes
P3300	TOTAL VOLTAGE OVER	When total voltage exceeds the allowable working voltage range.	<ul style="list-style-type: none">• Li-ion battery• Li-ion battery controller• VCM• Traction motor inverter

DTC CONFIRMATION PROCEDURE

1. PERFORM DTC CONFIRMATION PROCEDURE

Ⓟ With CONSULT

1. Power switch ON and wait for 10 seconds or more.
2. Select "Self Diagnostic Result" of "HV BAT".
3. Check DTC.

Is P3300 detected?

- YES >> Refer to [EVB-792, "Diagnosis Procedure"](#).
NO >> INSPECTION END

Diagnosis Procedure

INFOID:0000000011104407

1. PERFORM THE SELF-DIAGNOSIS

Ⓟ With CONSULT

1. Perform "All DTC Reading".
2. Check "Self Diagnostic Result" of systems other than "HV BAT" to see if any DTC is detected.

Is any DTC detected?

- YES >> After performing trouble diagnosis of detected DTC, GO TO 2.
NO >> GO TO 2.

2. PERFORM THE SELF-DIAGNOSIS OF LI-ION BATTERY CONTROLLER

Ⓟ With CONSULT

1. Select "Self Diagnostic Result" of "HV BAT".
2. Check "Self Diagnostic Result" to see if "P3302"- "P3331" is detected.

Is P3302-P3331 detected?

- YES >> "P3302" - "P3331" are detected simultaneously.
- When "P3302" - "P330D" are detected simultaneously, perform the diagnosis procedure of "P3302" - "P330D". Refer to [EVB-793, "Diagnosis Procedure"](#).
 - When "P330E" - "P3319" are detected simultaneously, perform the diagnosis procedure of "P330E" - "P3319". Refer to [EVB-797, "Diagnosis Procedure"](#).
 - When "P331A" - "P3325" are detected simultaneously, perform the diagnosis procedure of "P331A" - "P3325". Refer to [EVB-801, "Diagnosis Procedure"](#).
 - When "P3326" - "P3331" are detected simultaneously, perform the diagnosis procedure of "P3326" - "P3331". Refer to [EVB-804, "Diagnosis Procedure"](#).
- NO >> Replace Li-ion battery controller. Refer to [EVB-885, "LI-ION BATTERY CONTROLLER : Removal and Installation"](#).

P3302-P330D CELL OVER VOLTAGE

< DTC/CIRCUIT DIAGNOSIS >

[TYPE 4]

P3302-P330D CELL OVER VOLTAGE

DTC Logic

INFOID:000000011104408

DTC DETECTION LOGIC

DTC	Trouble diagnosis name	DTC detecting condition	Possible causes
P3302	CELL OVER VOLTAGE MODULE1	When cell voltage exceeds the allowable working voltage range.	<ul style="list-style-type: none">• Overcharge caused by traction motor inverter/VCM malfunction• Module• Li-ion battery controller• Bus bar• Harness or connector
P3303	CELL OVER VOLTAGE MODULE2		
P3304	CELL OVER VOLTAGE MODULE3		
P3305	CELL OVER VOLTAGE MODULE4		
P3306	CELL OVER VOLTAGE MODULE5		
P3307	CELL OVER VOLTAGE MODULE6		
P3308	CELL OVER VOLTAGE MODULE7		
P3309	CELL OVER VOLTAGE MODULE8		
P330A	CELL OVER VOLTAGE MODULE9		
P330B	CELL OVER VOLTAGE MODULE10		
P330C	CELL OVER VOLTAGE MODULE11		
P330D	CELL OVER VOLTAGE MODULE12		

DTC CONFIRMATION PROCEDURE

1. PERFORM DTC CONFIRMATION PROCEDURE

④ With CONSULT

1. Power switch ON and wait for 10 seconds or more.
2. Select "Self Diagnostic Result" of "HV BAT".
3. Check DTC.

Is any DTC detected?

- YES >> Refer to [EVb-793, "Diagnosis Procedure"](#).
NO >> INSPECTION END

Diagnosis Procedure

INFOID:000000011104409

WARNING:

- Because hybrid vehicles and electric vehicles contain a high voltage battery, there is the risk of electric shock, electric leakage, or similar accidents if the high voltage component and vehicle are handled incorrectly. Be sure to follow the correct work procedures when performing inspection and maintenance.
- Be sure to remove the service plug in order to disconnect the high voltage circuits before performing inspection or maintenance of high voltage system harnesses and parts.
- To prevent the removed service plug from being connected by mistake during the procedure, always carry it in your pocket or put it in the tool box.
- Be sure to wear insulating protective equipment consisting of glove, shoes, face shield and glasses before beginning work on the high voltage system.
- Clearly identify the persons responsible for high voltage work and ensure that other persons do not touch the vehicle. When not working, cover high voltage parts with an insulating cover sheet or similar item to prevent other persons from contacting them.
- Refer to [EVb-695, "High Voltage Precautions"](#).

CAUTION:

There is the possibility of a malfunction occurring if the vehicle is changed to READY status while the service plug is removed. Therefore do not change the vehicle to READY status unless instructed to do so in the Service Manual.

1. CHECK SELF-DIAGNOSIS RESULTS

④ With CONSULT

1. Perform "All DTC Reading" with CONSULT.

P3302-P330D CELL OVER VOLTAGE

[TYPE 4]

< DTC/CIRCUIT DIAGNOSIS >

2. Check systems other than "HV BAT" if any DTC is detected.

Is any DTC detected?

YES >> After performing trouble diagnosis of detected DTC, GO TO 2.

NO >> GO TO 2.

2. PRECONDITIONING

WARNING:

Disconnect high voltage. Refer to [GI-31, "How to Disconnect High Voltage"](#).

1. Remove Li-ion battery. Refer to [EVB-866, "Removal and Installation"](#).

2. Remove battery pack upper case. Refer to [EVB-875, "BATTERY PACK UPPER CASE : Removal and Installation"](#).

>> GO TO 3.

3. CHECK HARNESS BETWEEN MODULE AND LI-ION BATTERY CONTROLLER

1. Disconnect voltage detection terminal of bus bar and Li-ion battery controller harness connector.

2. Refer to below table and check the continuity between Li-ion battery controller (A) and corresponding bus bar (B).

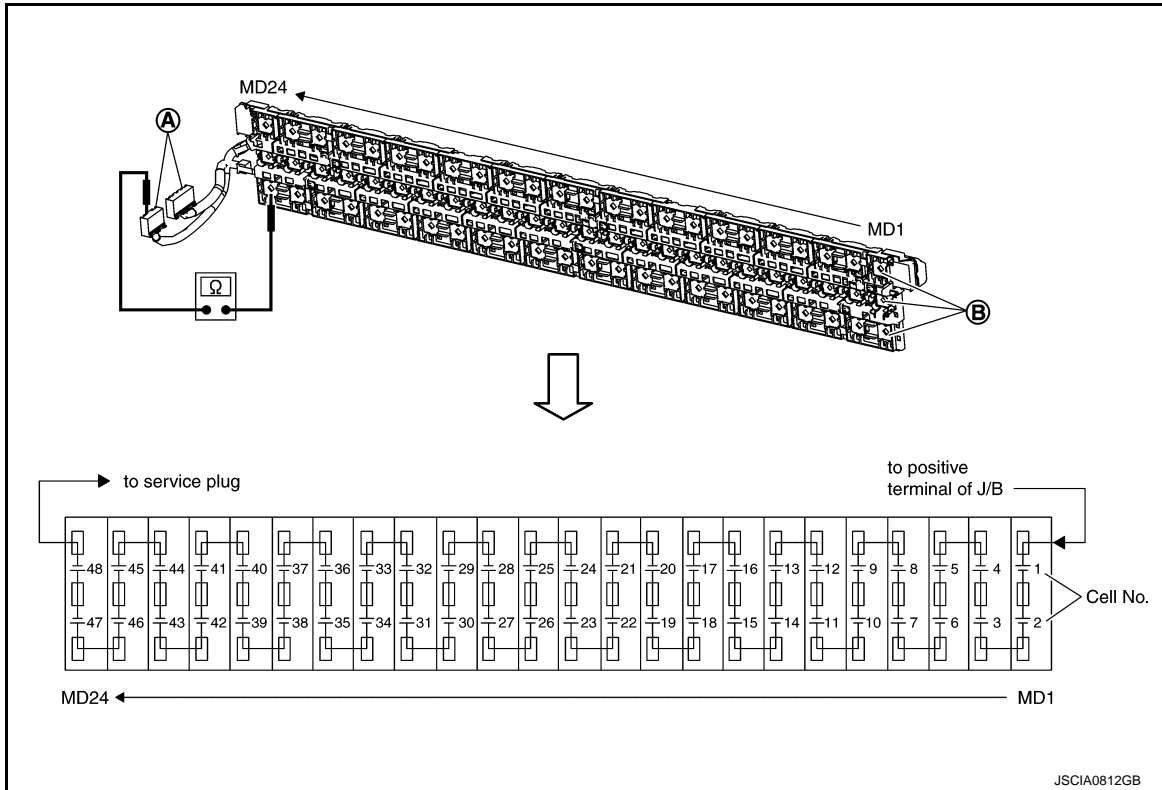

P3302-P330D CELL OVER VOLTAGE

< DTC/CIRCUIT DIAGNOSIS >

[TYPE 4]

DTC	Module No.		Li-ion battery controller		Continuity
			Connector	Terminal	
P3302	1	Bus bar	LB13	33	Existed
				50	
				34	
P3303	2		LB13	34	Existed
				51	
				35	
P3304	3		LB13	35	Existed
				52	
				36	
P3305	4		LB13	36	Existed
				53	
				37	
P3306	5	LB13	37	Existed	
			54		
			38		
P3307	6	LB13	38	Existed	
			55		
			39		
P3308	7	LB13	39	Existed	
			56		
			40		
P3309	8	LB13	40	Existed	
			57		
			42		
P330A	9	LB13	42	Existed	
			58		
			43		
P330B	10	LB13	43	Existed	
			59		
			44		
P330C	11	LB13	44	Existed	
			60		
			45		
P330D	12	LB13	45	Existed	
			61		
			46		

Is the inspection result normal?

YES >> GO TO 4.

NO >> Repair harness or connector.

4. CHECK MODULE VOLTAGE

Check voltage of corresponding module. Refer to [EVB-796, "Component Inspection"](#).

Is the inspection result normal?

A
B
EVB
D
E
F
G
H
I
J
K
L
M
N
O
P

P3302-P330D CELL OVER VOLTAGE

[TYPE 4]

< DTC/CIRCUIT DIAGNOSIS >

- YES >> Replace Li-ion battery controller. Refer to [EVB-885. "LI-ION BATTERY CONTROLLER : Removal and Installation"](#).
- NO >> Replace corresponding module. Refer to [EVB-930. "REAR MODULE STACK : Disassembly and Assembly"](#).

Component Inspection

INFOID:000000011104410

1. CHECK MODULE VOLTAGE

Check voltage of module.

- A : Positive terminal (Red)**
B : Negative terminal (Black)

Terminals		Voltage (Approx.)
(+)	(-)	
Module		5.0 - 8.5 V
Positive terminal (Red)	Negative terminal (Black)	

Is the inspection result normal?

- YES >> INSPECTION END
- NO >> Replace module. Refer to [EVB-915. "FRONT MODULE STACK : Disassembly and Assembly"](#) (Front module) or [EVB-930. "REAR MODULE STACK : Disassembly and Assembly"](#) (Rear module).

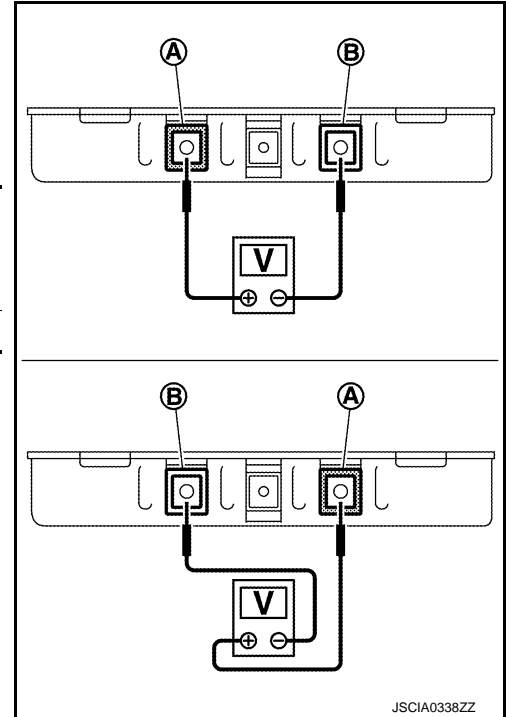

P330E-P3319 CELL OVER VOLTAGE

< DTC/CIRCUIT DIAGNOSIS >

[TYPE 4]

P330E-P3319 CELL OVER VOLTAGE

DTC Logic

INFOID:000000011104411

DTC DETECTION LOGIC

DTC	Trouble diagnosis name	DTC detecting condition	Possible causes
P330E	CELL OVER VOLTAGE MODULE13	When cell voltage exceeds the allowable working voltage range.	<ul style="list-style-type: none"> Overcharge caused by traction motor inverter/VCM malfunction Module Li-ion battery controller Bus bar Harness or connector
P330F	CELL OVER VOLTAGE MODULE14		
P3310	CELL OVER VOLTAGE MODULE15		
P3311	CELL OVER VOLTAGE MODULE16		
P3312	CELL OVER VOLTAGE MODULE17		
P3313	CELL OVER VOLTAGE MODULE18		
P3314	CELL OVER VOLTAGE MODULE19		
P3315	CELL OVER VOLTAGE MODULE20		
P3316	CELL OVER VOLTAGE MODULE21		
P3317	CELL OVER VOLTAGE MODULE22		
P3318	CELL OVER VOLTAGE MODULE23		
P3319	CELL OVER VOLTAGE MODULE24		

DTC CONFIRMATION PROCEDURE

1. PERFORM DTC CONFIRMATION PROCEDURE

④ With CONSULT

- Power switch ON and wait for 10 seconds or more.
- Select "Self Diagnostic Result" of "HV BAT".
- Check DTC.

Is any DTC detected?

- YES >> Refer to [EV8-804, "Diagnosis Procedure"](#).
- NO >> INSPECTION END

Diagnosis Procedure

INFOID:000000011104412

WARNING:

- Because hybrid vehicles and electric vehicles contain a high voltage battery, there is the risk of electric shock, electric leakage, or similar accidents if the high voltage component and vehicle are handled incorrectly. Be sure to follow the correct work procedures when performing inspection and maintenance.
- Be sure to remove the service plug in order to disconnect the high voltage circuits before performing inspection or maintenance of high voltage system harnesses and parts.
- To prevent the removed service plug from being connected by mistake during the procedure, always carry it in your pocket or put it in the tool box.
- Be sure to wear insulating protective equipment consisting of glove, shoes, face shield and glasses before beginning work on the high voltage system.
- Clearly identify the persons responsible for high voltage work and ensure that other persons do not touch the vehicle. When not working, cover high voltage parts with an insulating cover sheet or similar item to prevent other persons from contacting them.
- Refer to [EV8-695, "High Voltage Precautions"](#).

CAUTION:

There is the possibility of a malfunction occurring if the vehicle is changed to READY status while the service plug is removed. Therefore do not change the vehicle to READY status unless instructed to do so in the Service Manual.

1. CHECK SELF-DIAGNOSIS RESULTS

④ With CONSULT

- Perform "All DTC Reading" with CONSULT.

P330E-P3319 CELL OVER VOLTAGE

[TYPE 4]

< DTC/CIRCUIT DIAGNOSIS >

2. Check systems other than "HV BAT" if any DTC is detected.

Is any DTC detected?

YES >> After performing trouble diagnosis of detected DTC, GO TO 2.

NO >> GO TO 2.

2. PRECONDITIONING

WARNING:

Disconnect high voltage. Refer to [GI-31, "How to Disconnect High Voltage"](#).

1. Remove Li-ion battery. Refer to [EVB-866, "Removal and Installation"](#).

2. Remove battery pack upper case. Refer to [EVB-875, "BATTERY PACK UPPER CASE : Removal and Installation"](#).

>> GO TO 3.

3. CHECK HARNESS BETWEEN MODULE AND LI-ION BATTERY CONTROLLER

1. Disconnect voltage detection terminal of bus bar and Li-ion battery controller harness connector.

2. Refer to below table and check the continuity between Li-ion battery controller (A) and corresponding bus bar (B).

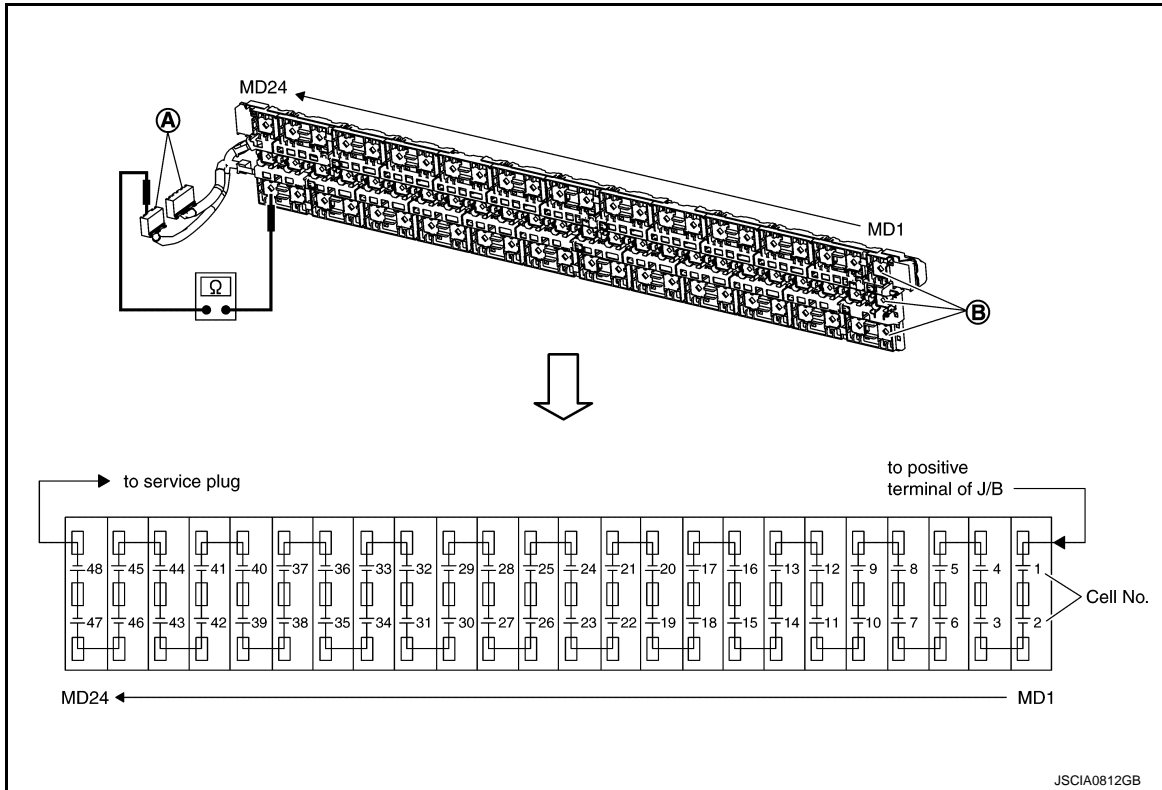

P330E-P3319 CELL OVER VOLTAGE

< DTC/CIRCUIT DIAGNOSIS >

[TYPE 4]

DTC	Module No.		Li-ion battery controller		Continuity
			Connector	Terminal	
P330E	13		LB13	46	Existed
				62	
				47	
P330F	14		LB13	47	Existed
				63	
				48	
P3310	15		LB13	48	Existed
			LB14	77	
				65	
P3311	16		LB14	65	Existed
				78	
				66	
P3312	17		LB14	66	Existed
				80	
				69	
P3313	18	Bus bar	LB14	69	Existed
				81	
				70	
P3314	19		LB14	70	Existed
				82	
				71	
P3315	20		LB14	71	Existed
				83	
				72	
P3316	21		LB14	72	Existed
				84	
				73	
P3317	22		LB14	73	Existed
				85	
				74	
P3318	23		LB14	74	Existed
				86	
				75	
P3319	24		LB14	75	Existed
				87	
				76	

A
B
EVB
D
E
F
G
H
I
J
K
L
M
N
O
P

Is the inspection result normal?

YES >> GO TO 4.

NO >> Repair harness or connector.

4. CHECK MODULE VOLTAGE

Check voltage of corresponding module. Refer to [EVB-800, "Component Inspection"](#).

Is the inspection result normal?

P330E-P3319 CELL OVER VOLTAGE

[TYPE 4]

< DTC/CIRCUIT DIAGNOSIS >

- YES >> Replace Li-ion battery controller. Refer to [EVB-885. "LI-ION BATTERY CONTROLLER : Removal and Installation"](#).
- NO >> Replace corresponding module. Refer to [EVB-930. "REAR MODULE STACK : Disassembly and Assembly"](#).

Component Inspection

INFOID:000000011104413

1. CHECK MODULE VOLTAGE

Check voltage of module.

- A : Positive terminal (Red)**
B : Negative terminal (Black)

Terminals		Voltage (Approx.)
(+)	(-)	
Module		5.0 - 8.5 V
Positive terminal (Red)	Negative terminal (Black)	

Is the inspection result normal?

- YES >> INSPECTION END
- NO >> Replace module. Refer to [EVB-915. "FRONT MODULE STACK : Disassembly and Assembly"](#) (Front module) or [EVB-930. "REAR MODULE STACK : Disassembly and Assembly"](#) (Rear module).

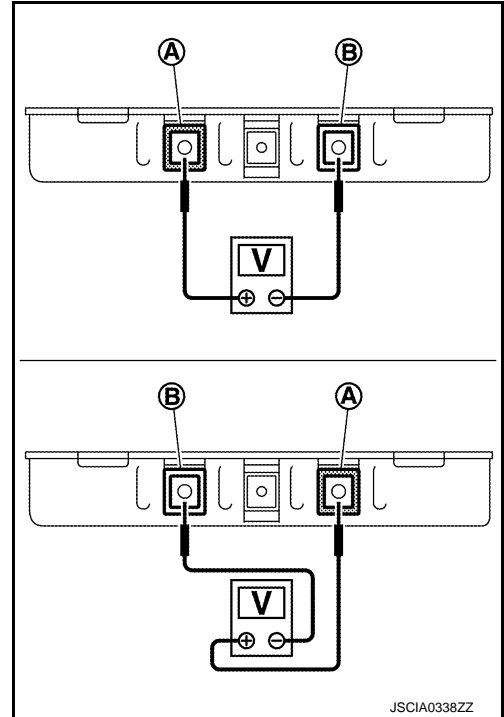

P331A-P3325 CELL OVER VOLTAGE

< DTC/CIRCUIT DIAGNOSIS >

[TYPE 4]

P331A-P3325 CELL OVER VOLTAGE

DTC Logic

INFOID:000000011104414

DTC DETECTION LOGIC

DTC	Trouble diagnosis name	DTC detecting condition	Possible causes
P331A	CELL OVER VOLTAGE MODULE25	When cell voltage exceeds the allowable working voltage range.	<ul style="list-style-type: none"> Overcharge caused by traction motor inverter/VCM malfunction Module Li-ion battery controller Bus bar Harness or connector
P331B	CELL OVER VOLTAGE MODULE26		
P331C	CELL OVER VOLTAGE MODULE27		
P331D	CELL OVER VOLTAGE MODULE28		
P331E	CELL OVER VOLTAGE MODULE29		
P331F	CELL OVER VOLTAGE MODULE30		
P3320	CELL OVER VOLTAGE MODULE31		
P3321	CELL OVER VOLTAGE MODULE32		
P3322	CELL OVER VOLTAGE MODULE33		
P3323	CELL OVER VOLTAGE MODULE34		
P3324	CELL OVER VOLTAGE MODULE35		
P3325	CELL OVER VOLTAGE MODULE36		

DTC CONFIRMATION PROCEDURE

1. PERFORM DTC CONFIRMATION PROCEDURE

④ With CONSULT

- Power switch ON and wait for 10 seconds or more.
- Select "Self Diagnostic Result" of "HV BAT".
- Check DTC.

Is any DTC detected?

- YES >> Refer to [EVB-804, "Diagnosis Procedure"](#).
 NO >> INSPECTION END

Diagnosis Procedure

INFOID:000000011104415

WARNING:

- Because hybrid vehicles and electric vehicles contain a high voltage battery, there is the risk of electric shock, electric leakage, or similar accidents if the high voltage component and vehicle are handled incorrectly. Be sure to follow the correct work procedures when performing inspection and maintenance.
- Be sure to remove the service plug in order to disconnect the high voltage circuits before performing inspection or maintenance of high voltage system harnesses and parts.
- To prevent the removed service plug from being connected by mistake during the procedure, always carry it in your pocket or put it in the tool box.
- Be sure to wear insulating protective equipment consisting of glove, shoes, face shield and glasses before beginning work on the high voltage system.
- Clearly identify the persons responsible for high voltage work and ensure that other persons do not touch the vehicle. When not working, cover high voltage parts with an insulating cover sheet or similar item to prevent other persons from contacting them.
- Refer to [EVB-695, "High Voltage Precautions"](#).

CAUTION:

There is the possibility of a malfunction occurring if the vehicle is changed to READY status while the service plug is removed. Therefore do not change the vehicle to READY status unless instructed to do so in the Service Manual.

1. CHECK SELF-DIAGNOSIS RESULTS

④ With CONSULT

- Perform "All DTC Reading" with CONSULT.

P331A-P3325 CELL OVER VOLTAGE

[TYPE 4]

< DTC/CIRCUIT DIAGNOSIS >

2. Check "Self Diagnostic Result" of systems other than "HV BAT" if any DTC is detected.

Is any DTC detected?

YES >> After performing trouble diagnosis of detected DTC, GO TO 2.

NO >> GO TO 2.

2. PRECONDITIONING

WARNING:

Disconnect high voltage. Refer to [GI-31, "How to Disconnect High Voltage"](#).

1. Remove Li-ion battery. Refer to [EVB-866, "Removal and Installation"](#).

2. Remove battery pack upper case. Refer to [EVB-875, "BATTERY PACK UPPER CASE : Removal and Installation"](#).

>> GO TO 3.

3. CHECK HARNESS BETWEEN MODULE AND LI-ION BATTERY CONTROLLER

Ⓟ With CONSULT

1. Power switch OFF.

2. Identify the malfunctioning module based on detected DTC.

3. Disconnect module harness connector and Li-ion battery controller harness connector.

4. Refer to below table and check the continuity between corresponding module and Li-ion battery controller.

DTC	Module No.	Module		Li-ion battery controller		Continuity
		Connector	Terminal	Connector	Terminal	
P331A	25	LB8	57	LB15	89	Existed
			73		110	
			58		90	
P331B	26	LB8	58	LB15	90	Existed
			74		111	
			75		91	
P331C	27	LB8	75	LB15	91	Existed
			60		112	
			76		92	
P331D	28	LB8	76	LB15	92	Existed
			77		113	
			62		93	
P331E	29	LB8	62	LB15	93	Existed
			78		114	
			79		94	
P331F	30	LB8	79	LB15	94	Existed
			64		115	
			80		95	
P3320	31	LB8	80	LB15	95	Existed
			81		116	
			66		96	
P3321	32	LB8	66	LB15	96	Existed
			82		117	
			83		97	

P331A-P3325 CELL OVER VOLTAGE

< DTC/CIRCUIT DIAGNOSIS >

[TYPE 4]

DTC	Module No.	Module		Li-ion battery controller		Continuity
		Connector	Terminal	Connector	Terminal	
P3322	33	LB8	83	LB15	97	Existed
			68		118	
			84		99	
P3323	34	LB8	84	LB15	99	Existed
			85		119	
			70		100	
P3324	35	LB8	70	LB15	100	Existed
			86		120	
			87		101	
P3325	36	LB8	87	LB15	101	Existed
			72		121	
			88		102	

Is the inspection result normal?

YES >> GO TO 4.

NO >> Repair harness or connector.

4. CHECK MODULE VOLTAGE

Check voltage of corresponding module. Refer to [EV8-803, "Component Inspection"](#).

Is the inspection result normal?

YES >> Replace Li-ion battery controller. Refer to [EV8-885, "LI-ION BATTERY CONTROLLER : Removal and Installation"](#).

NO >> Replace corresponding module. Refer to [EV8-915, "FRONT MODULE STACK : Disassembly and Assembly"](#).

Component Inspection

INFOID:000000011104416

1. CHECK MODULE VOLTAGE

Check voltage of module.

A : Positive terminal (Red)

B : Negative terminal (Black)

Terminals		Voltage (Approx.)
(+)	(-)	
Module		5.0 - 8.5 V
Positive terminal (Red)	Negative terminal (Black)	

Is the inspection result normal?

YES >> INSPECTION END

NO >> Replace module. Refer to [EV8-915, "FRONT MODULE STACK : Disassembly and Assembly"](#) (Front module) or [EV8-930, "REAR MODULE STACK : Disassembly and Assembly"](#) (Rear module).

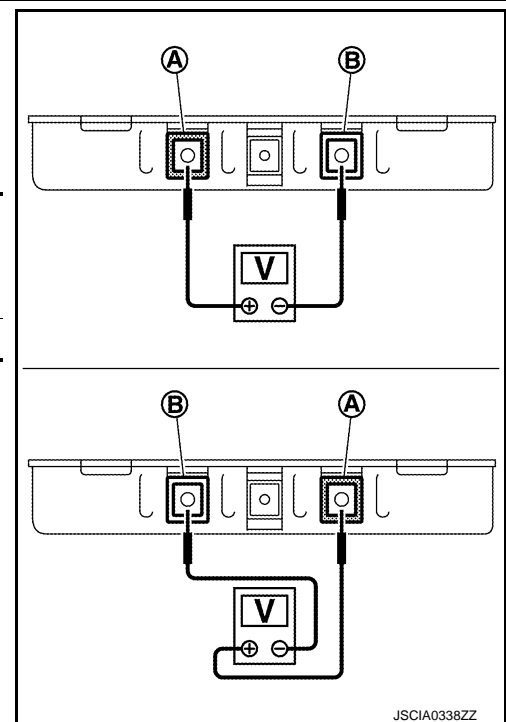

JSCIA0338ZZ

P3326-P3331 CELL OVER VOLTAGE

< DTC/CIRCUIT DIAGNOSIS >

[TYPE 4]

P3326-P3331 CELL OVER VOLTAGE

DTC Logic

INFOID:000000011104417

DTC DETECTION LOGIC

DTC	Trouble diagnosis name	DTC detecting condition	Possible causes
P3326	CELL OVER VOLTAGE MODULE37	When cell voltage exceeds the allowable working voltage range.	<ul style="list-style-type: none"> • Overcharge caused by traction motor inverter/VCM malfunction • Module • Li-ion battery controller • Bus bar • Harness or connector
P3327	CELL OVER VOLTAGE MODULE38		
P3328	CELL OVER VOLTAGE MODULE39		
P3329	CELL OVER VOLTAGE MODULE40		
P332A	CELL OVER VOLTAGE MODULE41		
P332B	CELL OVER VOLTAGE MODULE42		
P332C	CELL OVER VOLTAGE MODULE43		
P332D	CELL OVER VOLTAGE MODULE44		
P332E	CELL OVER VOLTAGE MODULE45		
P332F	CELL OVER VOLTAGE MODULE46		
P3330	CELL OVER VOLTAGE MODULE47		
P3331	CELL OVER VOLTAGE MODULE48		

DTC CONFIRMATION PROCEDURE

1. PERFORM DTC CONFIRMATION PROCEDURE

Ⓟ With CONSULT

1. Power switch ON and wait for 10 seconds or more.
2. Select "Self Diagnostic Result" of "HV BAT".
3. Check DTC.

Is any DTC detected?

- YES >> Refer to [EVB-804, "Diagnosis Procedure"](#).
 NO >> INSPECTION END

Diagnosis Procedure

INFOID:000000011104418

WARNING:

- Because hybrid vehicles and electric vehicles contain a high voltage battery, there is the risk of electric shock, electric leakage, or similar accidents if the high voltage component and vehicle are handled incorrectly. Be sure to follow the correct work procedures when performing inspection and maintenance.
- Be sure to remove the service plug in order to disconnect the high voltage circuits before performing inspection or maintenance of high voltage system harnesses and parts.
- To prevent the removed service plug from being connected by mistake during the procedure, always carry it in your pocket or put it in the tool box.
- Be sure to wear insulating protective equipment consisting of glove, shoes, face shield and glasses before beginning work on the high voltage system.
- Clearly identify the persons responsible for high voltage work and ensure that other persons do not touch the vehicle. When not working, cover high voltage parts with an insulating cover sheet or similar item to prevent other persons from contacting them.
- Refer to [EVB-695, "High Voltage Precautions"](#).

CAUTION:

There is the possibility of a malfunction occurring if the vehicle is changed to READY status while the service plug is removed. Therefore do not change the vehicle to READY status unless instructed to do so in the Service Manual.

1. CHECK SELF-DIAGNOSIS RESULTS

Ⓟ With CONSULT

1. Perform "All DTC Reading" with CONSULT.

P3326-P3331 CELL OVER VOLTAGE

< DTC/CIRCUIT DIAGNOSIS >

[TYPE 4]

2. Check "Self Diagnostic Result" of systems other than "HV BAT" if any DTC is detected.

Is any DTC detected?

YES >> After performing trouble diagnosis of detected DTC, GO TO 2.

NO >> GO TO 2.

2. PRECONDITIONING

WARNING:

Disconnect high voltage. Refer to [GI-31, "How to Disconnect High Voltage"](#).

1. Remove Li-ion battery. Refer to [EVB-866, "Removal and Installation"](#).

2. Remove battery pack upper case. Refer to [EVB-875, "BATTERY PACK UPPER CASE : Removal and Installation"](#).

>> GO TO 3.

3. CHECK HARNESS BETWEEN MODULE AND LI-ION BATTERY CONTROLLER

Ⓜ With CONSULT

1. Power switch OFF.

2. Identify the malfunctioning module based on detected DTC.

3. Disconnect module harness connector and Li-ion battery controller harness connector.

4. Refer to below table and check the continuity between corresponding module and Li-ion battery controller.

DTC	Module No.	Module		Li-ion battery controller		Continuity
		Connector	Terminal	Connector	Terminal	
P3326	37	LB8	88	LB15	102	Existed
			LB7		89	
					101	
P3327	38	LB7	101	LB15	103	Existed
			90		123	
			102		104	
P3328	39	LB7	102	LB15	104	Existed
			91		124	
			103		105	
P3329	40	LB7	103	LB15	105	Existed
			92		125	
			104		106	
P332A	41	LB7	104	LB15	106	Existed
			93		127	
			105		107	
P332B	42	LB7	105	LB15	107	Existed
			94		128	
			106		108	
P332C	43	LB7	106	LB15	108	Existed
			95	LB16	137	
					107	
P332D	44	LB7	107	LB16	130	Existed
			96		138	
			108		131	

P3326-P3331 CELL OVER VOLTAGE

< DTC/CIRCUIT DIAGNOSIS >

[TYPE 4]

DTC	Module No.	Module		Li-ion battery controller		Continuity
		Connector	Terminal	Connector	Terminal	
P332E	45	LB7	108	LB16	131	Existed
			97		140	
			109		132	
P332F	46	LB7	109	LB16	132	Existed
			98		141	
			110		133	
P3330	47	LB7	110	LB16	133	Existed
			99		142	
			111		134	
P3331	48	LB7	111	LB16	134	Existed
			100		143	
			112		135	

Is the inspection result normal?

YES >> GO TO 4.

NO >> Repair harness or connector.

4. CHECK MODULE VOLTAGE

Check voltage of corresponding module. Refer to [EVB-806, "Component Inspection"](#).

Is the inspection result normal?

YES >> Replace Li-ion battery controller. Refer to [EVB-885, "LI-ION BATTERY CONTROLLER : Removal and Installation"](#).

NO >> Replace corresponding module. Refer to [EVB-915, "FRONT MODULE STACK : Disassembly and Assembly"](#).

Component Inspection

INFOID:000000011104419

1. CHECK MODULE VOLTAGE

Check voltage of module.

A : Positive terminal (Red)

B : Negative terminal (Black)

Terminals		Voltage (Approx.)
(+)	(-)	
Module		5.0 - 8.5 V
Positive terminal (Red)	Negative terminal (Black)	

Is the inspection result normal?

YES >> INSPECTION END

NO >> Replace module. Refer to [EVB-915, "FRONT MODULE STACK : Disassembly and Assembly"](#) (Front module) or [EVB-930, "REAR MODULE STACK : Disassembly and Assembly"](#) (Rear module).

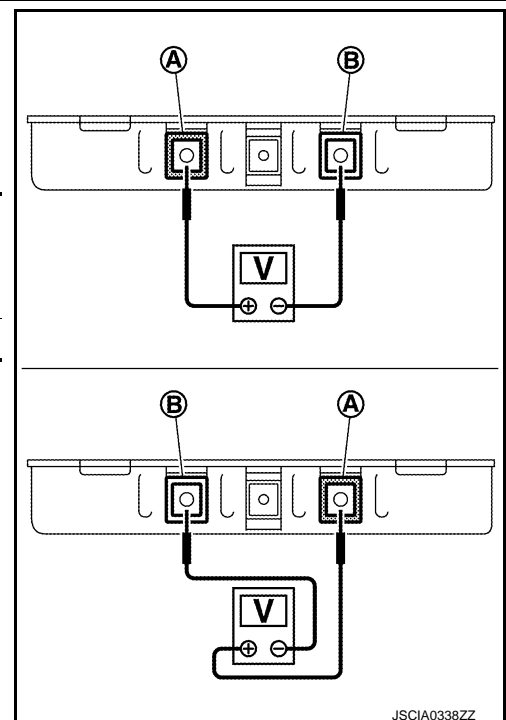

JSCIA0338ZZ

P3373 TOTAL VOLTAGE OVER DISCHARGE

< DTC/CIRCUIT DIAGNOSIS >

[TYPE 4]

P3373 TOTAL VOLTAGE OVER DISCHARGE

DTC Logic

INFOID:0000000011104420

DTC DETECTION LOGIC

If DTC P3373 is displayed with DTC P30F4, first perform the trouble diagnosis for P30F4. Refer to [EVB-777, "DTC Logic"](#).

DTC	Trouble diagnosis name	DTC detecting condition	Possible causes
P3373	TOTAL VOLTAGE OVER DISCHARGE	When total voltage lowers below the allowable working voltage range.	<ul style="list-style-type: none">• Li-ion battery controller• Module• Bus bar• Service plug fuse• Overcharge caused by traction motor inverter/VCM malfunction• Harness or connector

DTC CONFIRMATION PROCEDURE

1. CHECK SELF-DIAGNOSIS RESULTS

④ With CONSULT

1. Power switch ON and wait for 10 seconds or more.
2. Select "Self Diagnostic Result" of "HV BAT".
3. Check DTC.

Is P3373 detected?

- YES >> Refer to [EVB-807, "Diagnosis Procedure"](#).
NO >> INSPECTION END

Diagnosis Procedure

INFOID:0000000011104421

1. PERFORM THE SELF-DIAGNOSIS

④ With CONSULT

1. Perform "All DTC Reading".
2. Check "Self diagnostic result" of systems other than "HV BAT" to see if any DTC is detected.

Is any DTC detected?

- YES >> After performing trouble diagnosis of detected DTC, GO TO 2.
NO >> GO TO 2.

2. PERFORM THE SELF-DIAGNOSIS OF LI-ION BATTERY CONTROLLER

④ With CONSULT

1. Select "Self Diagnostic Result" of "HV BAT".
2. Check to see if "P3375"- "P33A4" is detected simultaneously with "P3373".

Is P3375-P33A4 detected?

- YES >>
 - When "P3375"- "P3380" are detected simultaneously, perform the diagnosis procedure of "P3375"- "P3380". Refer to [EVB-808, "Diagnosis Procedure"](#).
 - When "P3381"- "P338C" are detected simultaneously, perform the diagnosis procedure of "P3381"- "P338C". Refer to [EVB-812, "Diagnosis Procedure"](#).
 - When "P338D"- "P3398" are detected simultaneously, perform the diagnosis procedure of "P338D"- "P3398". Refer to [EVB-816, "Diagnosis Procedure"](#).
 - When "P3399"- "P33A4" are detected simultaneously, perform the diagnosis procedure of "P3399"- "P33A4". Refer to [EVB-819, "Diagnosis Procedure"](#).
- NO >> Replace Li-ion battery controller. Refer to [EVB-885, "LI-ION BATTERY CONTROLLER : Removal and Installation"](#).

P3375-P3380 CELL OVER DISCHARGE

< DTC/CIRCUIT DIAGNOSIS >

[TYPE 4]

P3375-P3380 CELL OVER DISCHARGE

DTC Logic

INFOID:000000011104422

DTC DETECTION LOGIC

DTC	Trouble diagnosis name	DTC detecting condition	Possible causes
P3375	CELL OVER DISCHARGE MODULE1	When cell voltage lowers below the allowable working voltage range.	<ul style="list-style-type: none">• Overcharge caused by traction motor inverter/VCM malfunction• Module• Li-ion battery controller• Bus bar• Harness or connector
P3376	CELL OVER DISCHARGE MODULE2		
P3377	CELL OVER DISCHARGE MODULE3		
P3378	CELL OVER DISCHARGE MODULE4		
P3379	CELL OVER DISCHARGE MODULE5		
P337A	CELL OVER DISCHARGE MODULE6		
P337B	CELL OVER DISCHARGE MODULE7		
P337C	CELL OVER DISCHARGE MODULE8		
P337D	CELL OVER DISCHARGE MODULE9		
P337E	CELL OVER DISCHARGE MODULE10		
P337F	CELL OVER DISCHARGE MODULE11		
P3380	CELL OVER DISCHARGE MODULE12		

DTC CONFIRMATION PROCEDURE

1. PERFORM DTC CONFIRMATION PROCEDURE

Ⓟ With CONSULT

1. Power switch ON and wait for 10 seconds or more.
2. Select "Self Diagnostic Result" of "HV BAT".
3. Check DTC.

Is any DTC detected?

- YES >> Refer to [EVB-808, "Diagnosis Procedure"](#).
NO >> INSPECTION END

Diagnosis Procedure

INFOID:000000011104423

WARNING:

- Because hybrid vehicles and electric vehicles contain a high voltage battery, there is the risk of electric shock, electric leakage, or similar accidents if the high voltage component and vehicle are handled incorrectly. Be sure to follow the correct work procedures when performing inspection and maintenance.
- Be sure to remove the service plug in order to disconnect the high voltage circuits before performing inspection or maintenance of high voltage system harnesses and parts.
- To prevent the removed service plug from being connected by mistake during the procedure, always carry it in your pocket or put it in the tool box.
- Be sure to wear insulating protective equipment consisting of glove, shoes, face shield and glasses before beginning work on the high voltage system.
- Clearly identify the persons responsible for high voltage work and ensure that other persons do not touch the vehicle. When not working, cover high voltage parts with an insulating cover sheet or similar item to prevent other persons from contacting them.
- Refer to [EVB-695, "High Voltage Precautions"](#).

CAUTION:

There is the possibility of a malfunction occurring if the vehicle is changed to READY status while the service plug is removed. Therefore do not change the vehicle to READY status unless instructed to do so in the Service Manual.

1. CHECK SELF-DIAGNOSIS RESULTS

Ⓟ With CONSULT

1. Perform "All DTC Reading" with CONSULT.

P3375-P3380 CELL OVER DISCHARGE

[TYPE 4]

< DTC/CIRCUIT DIAGNOSIS >

2. Check systems other than "HV BAT" if any DTC is detected.

Is any DTC detected?

- YES >> After performing trouble diagnosis of detected DTC, GO TO 2.
- NO >> GO TO 2.

2. PRECONDITIONING

WARNING:

Disconnect high voltage. Refer to [GI-31, "How to Disconnect High Voltage"](#).

1. Remove Li-ion battery. Refer to [EV-866, "Removal and Installation"](#).
2. Remove battery pack upper case. Refer to [EV-875, "BATTERY PACK UPPER CASE : Removal and Installation"](#).

>> GO TO 3.

3. CHECK HARNESS BETWEEN MODULE AND LI-ION BATTERY CONTROLLER

1. Disconnect voltage detection terminal of bus bar and Li-ion battery controller harness connector.
2. Refer to below table and check the continuity between Li-ion battery controller (A) and corresponding bus bar (B).

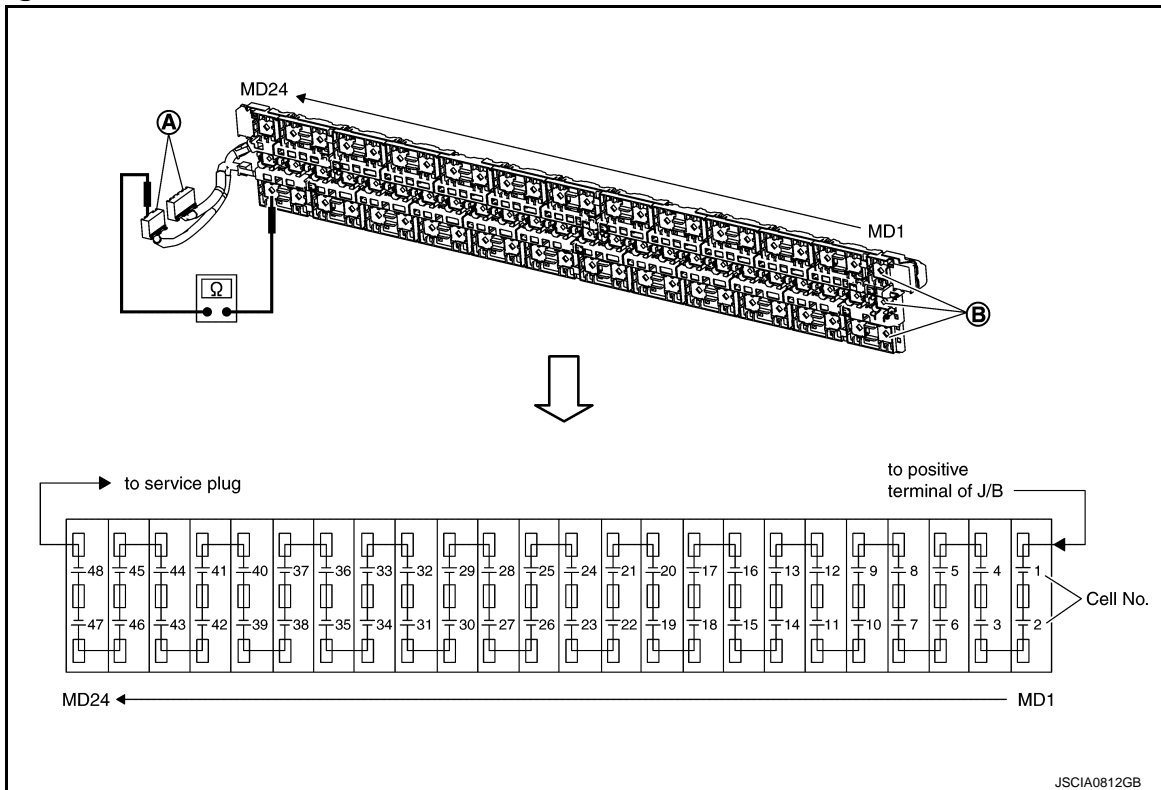

P3375-P3380 CELL OVER DISCHARGE

< DTC/CIRCUIT DIAGNOSIS >

[TYPE 4]

DTC	Module No.		Li-ion battery controller		Continuity
			Connector	Terminal	
P3375	1	Bus bar	LB13	33	Existed
				50	
				34	
P3376	2		LB13	34	Existed
				51	
				35	
P3377	3		LB13	35	Existed
				52	
				36	
P3378	4		LB13	36	Existed
				53	
				37	
P3379	5	LB13	37	Existed	
			54		
			38		
P337A	6	LB13	38	Existed	
			55		
			39		
P337B	7	LB13	39	Existed	
			56		
			40		
P337C	8	LB13	40	Existed	
			57		
			42		
P337D	9	LB13	42	Existed	
			58		
			43		
P337E	10	LB13	43	Existed	
			59		
			44		
P330F	11	LB13	44	Existed	
			60		
			45		
P3380	12	LB13	45	Existed	
			61		
			46		

Is the inspection result normal?

YES >> GO TO 4.

NO >> Repair Harness or connector.

4. CHECK MODULE VOLTAGE

Check voltage of corresponding module. Refer to [EV8-811, "Component Inspection"](#).

Is the inspection result normal?

P3375-P3380 CELL OVER DISCHARGE

[TYPE 4]

< DTC/CIRCUIT DIAGNOSIS >

- YES >> Replace Li-ion battery controller. Refer to [EVB-885, "LI-ION BATTERY CONTROLLER : Removal and Installation"](#).
- NO >> Replace corresponding module. Refer to [EVB-930, "REAR MODULE STACK : Disassembly and Assembly"](#).

Component Inspection

INFOID:000000011104424

1. CHECK MODULE VOLTAGE

Check voltage of module.

- A : Positive terminal (Red)**
- B : Negative terminal (Black)**

Terminals		Voltage (Approx.)
(+)	(-)	
Module		5.0 - 8.5 V
Positive terminal (Red)	Negative terminal (Black)	

Is the inspection result normal?

- YES >> INSPECTION END
- NO >> Replace module. Refer to [EVB-915, "FRONT MODULE STACK : Disassembly and Assembly"](#) (Front module) or [EVB-930, "REAR MODULE STACK : Disassembly and Assembly"](#) (Rear module).

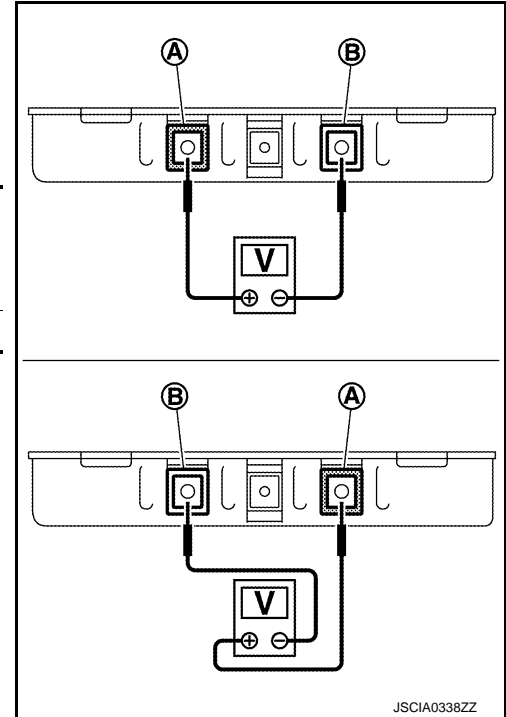

JSCIA0338ZZ

EVB

D

E

F

G

H

I

J

K

L

M

N

O

P

P3381-P338C CELL OVER DISCHARGE

< DTC/CIRCUIT DIAGNOSIS >

[TYPE 4]

P3381-P338C CELL OVER DISCHARGE

DTC Logic

INFOID:000000011104425

DTC DETECTION LOGIC

DTC	Trouble diagnosis name	DTC detecting condition	Possible causes
P3381	CELL OVER DISCHARGE MODULE13	When cell voltage lowers below the allowable working voltage range.	<ul style="list-style-type: none"> • Overcharge caused by traction motor inverter/VCM malfunction • Module • Li-ion battery controller • Bus bar • Harness or connector
P3382	CELL OVER DISCHARGE MODULE14		
P3383	CELL OVER DISCHARGE MODULE15		
P3384	CELL OVER DISCHARGE MODULE16		
P3385	CELL OVER DISCHARGE MODULE17		
P3386	CELL OVER DISCHARGE MODULE18		
P3387	CELL OVER DISCHARGE MODULE19		
P3388	CELL OVER DISCHARGE MODULE20		
P3389	CELL OVER DISCHARGE MODULE21		
P338A	CELL OVER DISCHARGE MODULE22		
P338B	CELL OVER DISCHARGE MODULE23		
P338C	CELL OVER DISCHARGE MODULE24		

DTC CONFIRMATION PROCEDURE

1. PERFORM DTC CONFIRMATION PROCEDURE

Ⓟ With CONSULT

1. Power switch ON and wait for 10 seconds or more.
2. Select "Self Diagnostic Result" of "HV BAT".
3. Check DTC.

Is any DTC detected?

- YES >> Refer to [EVB-819, "Diagnosis Procedure"](#).
 NO >> INSPECTION END

Diagnosis Procedure

INFOID:000000011104426

WARNING:

- Because hybrid vehicles and electric vehicles contain a high voltage battery, there is the risk of electric shock, electric leakage, or similar accidents if the high voltage component and vehicle are handled incorrectly. Be sure to follow the correct work procedures when performing inspection and maintenance.
- Be sure to remove the service plug in order to disconnect the high voltage circuits before performing inspection or maintenance of high voltage system harnesses and parts.
- To prevent the removed service plug from being connected by mistake during the procedure, always carry it in your pocket or put it in the tool box.
- Be sure to wear insulating protective equipment consisting of glove, shoes, face shield and glasses before beginning work on the high voltage system.
- Clearly identify the persons responsible for high voltage work and ensure that other persons do not touch the vehicle. When not working, cover high voltage parts with an insulating cover sheet or similar item to prevent other persons from contacting them.
- Refer to [EVB-695, "High Voltage Precautions"](#).

CAUTION:

There is the possibility of a malfunction occurring if the vehicle is changed to READY status while the service plug is removed. Therefore do not change the vehicle to READY status unless instructed to do so in the Service Manual.

1. CHECK SELF-DIAGNOSIS RESULTS

Ⓟ With CONSULT

1. Perform "All DTC Reading" with CONSULT.

P3381-P338C CELL OVER DISCHARGE

[TYPE 4]

< DTC/CIRCUIT DIAGNOSIS >

2. Check systems other than "HV BAT" if any DTC is detected.

Is any DTC detected?

- YES >> After performing trouble diagnosis of detected DTC, GO TO 2.
- NO >> GO TO 2.

2. PRECONDITIONING

WARNING:

Disconnect high voltage circuit. Refer to [GI-31, "How to Disconnect High Voltage"](#).

1. Remove Li-ion battery. Refer to [EV8-866, "Removal and Installation"](#).
2. Remove battery pack upper case. Refer to [EV8-875, "BATTERY PACK UPPER CASE : Removal and Installation"](#).

>> GO TO 3.

3. CHECK HARNESS BETWEEN MODULE AND LI-ION BATTERY CONTROLLER

1. Disconnect voltage detection terminal of bus bar and Li-ion battery controller harness connector.
2. Refer to below table and check the continuity between Li-ion battery controller (A) and corresponding bus bar (B).

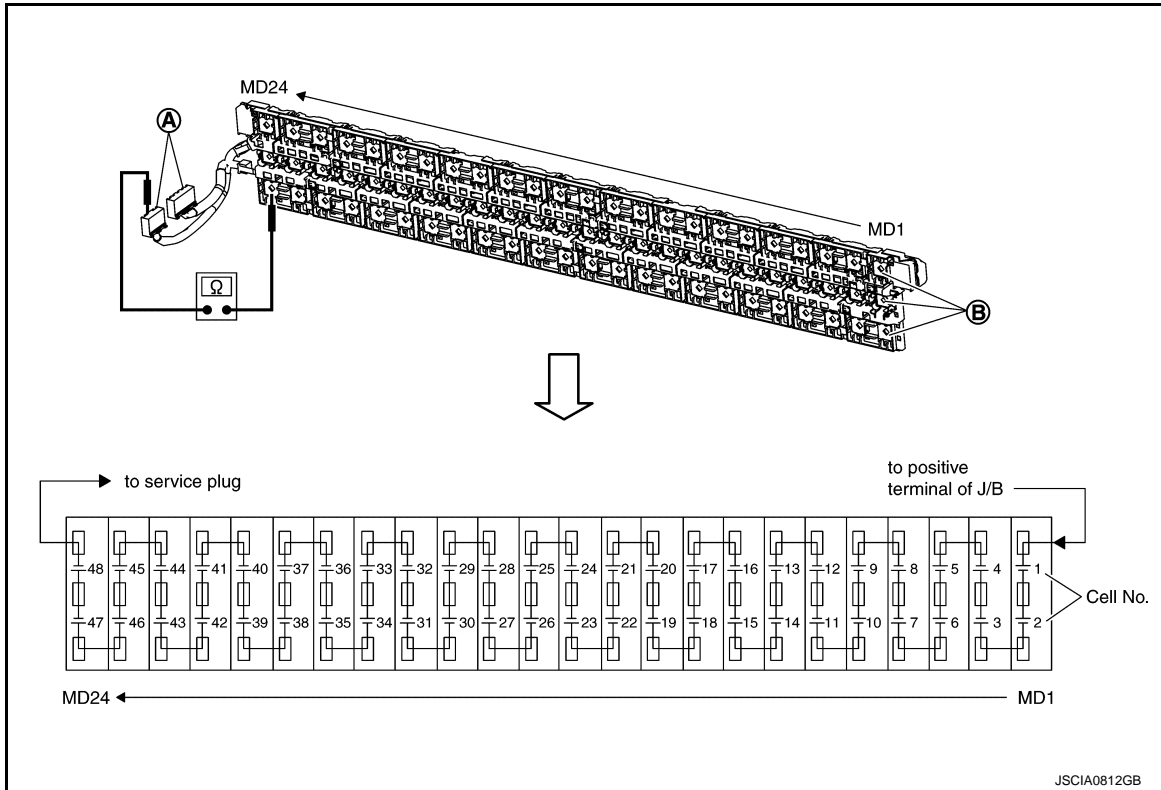

P3381-P338C CELL OVER DISCHARGE

< DTC/CIRCUIT DIAGNOSIS >

[TYPE 4]

DTC	Module No.		Li-ion battery controller		Continuity
			Connector	Terminal	
P3381	13	Bus bar	LB13	46	Existed
				62	
				47	
P3382	14		LB13	47	Existed
				63	
				48	
P3383	15		LB13	48	Existed
			LB14	77	
P3384	16		LB14	65	Existed
				78	
				66	
P3385	17		LB14	66	Existed
				80	
				69	
P3386	18		LB14	69	Existed
				81	
				70	
P3387	19		LB14	70	Existed
				82	
				71	
P3388	20		LB14	71	Existed
				83	
				72	
P3389	21		LB14	72	Existed
		84			
		73			
P338A	22	LB14	73	Existed	
			85		
			74		
P338B	23	LB14	74	Existed	
			86		
			75		
P338C	24	LB14	75	Existed	
			87		
			76		

Is the inspection result normal?

YES >> GO TO 4.

NO >> Repair Harness or connector.

4. CHECK MODULE VOLTAGE

Check voltage of corresponding module. Refer to [EV8-815, "Component Inspection"](#).

Is the inspection result normal?

P3381-P338C CELL OVER DISCHARGE

[TYPE 4]

< DTC/CIRCUIT DIAGNOSIS >

- YES >> Replace Li-ion battery controller. Refer to [EVB-885, "LI-ION BATTERY CONTROLLER : Removal and Installation"](#).
- NO >> Replace corresponding module. Refer to [EVB-930, "REAR MODULE STACK : Disassembly and Assembly"](#).

Component Inspection

INFOID:000000011104427

1. CHECK MODULE VOLTAGE

Check voltage of module.

- A : Positive terminal (Red)**
- B : Negative terminal (Black)**

Terminals		Voltage (Approx.)
(+)	(-)	
Module		5.0 - 8.5 V
Positive terminal (Red)	Negative terminal (Black)	

Is the inspection result normal?

- YES >> INSPECTION END
- NO >> Replace module. Refer to [EVB-915, "FRONT MODULE STACK : Disassembly and Assembly"](#) (Front module) or [EVB-930, "REAR MODULE STACK : Disassembly and Assembly"](#) (Rear module).

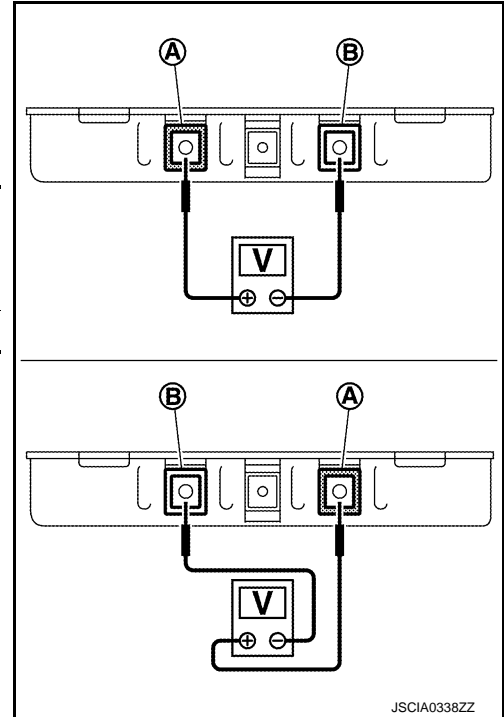

A
B
EVB
D
E
F
G
H
I
J
K
L
M
N
O
P

P338D-P3398 CELL OVER DISCHARGE

< DTC/CIRCUIT DIAGNOSIS >

[TYPE 4]

P338D-P3398 CELL OVER DISCHARGE

DTC Logic

INFOID:000000011104428

DTC DETECTION LOGIC

DTC	Trouble diagnosis name	DTC detecting condition	Possible causes
P338D	CELL OVER DISCHARGE MODULE25	When cell voltage lowers below the allowable working voltage range.	<ul style="list-style-type: none"> Overcharge caused by traction motor inverter/VCM malfunction Module Li-ion battery controller Bus bar Harness or connector
P338E	CELL OVER DISCHARGE MODULE26		
P338F	CELL OVER DISCHARGE MODULE27		
P3390	CELL OVER DISCHARGE MODULE28		
P3391	CELL OVER DISCHARGE MODULE29		
P3392	CELL OVER DISCHARGE MODULE30		
P3393	CELL OVER DISCHARGE MODULE31		
P3394	CELL OVER DISCHARGE MODULE32		
P3395	CELL OVER DISCHARGE MODULE33		
P3396	CELL OVER DISCHARGE MODULE34		
P3397	CELL OVER DISCHARGE MODULE35		
P3398	CELL OVER DISCHARGE MODULE36		

DTC CONFIRMATION PROCEDURE

1. PERFORM DTC CONFIRMATION PROCEDURE

Ⓟ With CONSULT

- Power switch ON and wait for 10 seconds or more.
- Select "Self Diagnostic Result" of "HV BAT".
- Check DTC.

Is any DTC detected?

- YES >> Refer to [EVB-819, "Diagnosis Procedure"](#).
- NO >> INSPECTION END

Diagnosis Procedure

INFOID:000000011104429

WARNING:

- Because hybrid vehicles and electric vehicles contain a high voltage battery, there is the risk of electric shock, electric leakage, or similar accidents if the high voltage component and vehicle are handled incorrectly. Be sure to follow the correct work procedures when performing inspection and maintenance.
- Be sure to remove the service plug in order to disconnect the high voltage circuits before performing inspection or maintenance of high voltage system harnesses and parts.
- To prevent the removed service plug from being connected by mistake during the procedure, always carry it in your pocket or put it in the tool box.
- Be sure to wear insulating protective equipment consisting of glove, shoes, face shield and glasses before beginning work on the high voltage system.
- Clearly identify the persons responsible for high voltage work and ensure that other persons do not touch the vehicle. When not working, cover high voltage parts with an insulating cover sheet or similar item to prevent other persons from contacting them.
- Refer to [EVB-695, "High Voltage Precautions"](#).

CAUTION:

There is the possibility of a malfunction occurring if the vehicle is changed to READY status while the service plug is removed. Therefore do not change the vehicle to READY status unless instructed to do so in the Service Manual.

1. CHECK SELF-DIAGNOSIS RESULTS

Ⓟ With CONSULT

- Perform "All DTC Reading" with CONSULT.

P338D-P3398 CELL OVER DISCHARGE

[TYPE 4]

< DTC/CIRCUIT DIAGNOSIS >

2. Check "Self Diagnostic Result" of systems other than "" if any DTC is detected.

Is any DTC detected?

- YES >> After performing trouble diagnosis of detected DTC, GO TO 2.
- NO >> GO TO 2.

2. PRECONDITIONING

WARNING:

Disconnect high voltage. Refer to [GI-31, "How to Disconnect High Voltage"](#).

1. Remove Li-ion battery. Refer to [EVB-866, "Removal and Installation"](#).
2. Remove battery pack upper case. Refer to [EVB-875, "BATTERY PACK UPPER CASE : Removal and Installation"](#).

>> GO TO 3.

3. CHECK HARNESS BETWEEN MODULE AND LI-ION BATTERY CONTROLLER

Ⓜ With CONSULT

1. Select "Self Diagnostic Result" mode of "HV BAT" using CONSULT.
2. Identify the malfunctioning module based on detected DTC.
3. Disconnect module harness connector and Li-ion battery controller harness connector.
4. Refer to below table and check the continuity between corresponding module and Li-ion battery controller.

DTC	Module No.	Module		Li-ion battery controller		Continuity
		Connector	Terminal	Connector	Terminal	
P338D	25	LB8	57	LB15	89	Existed
			73		110	
			58		90	
P338E	26	LB8	58	LB15	90	Existed
			74		111	
			75		91	
P338F	27	LB8	75	LB15	91	Existed
			60		112	
			76		92	
P3390	28	LB8	76	LB15	92	Existed
			77		113	
			62		93	
P3391	29	LB8	62	LB15	93	Existed
			78		114	
			79		94	
P3392	30	LB8	79	LB15	94	Existed
			64		115	
			80		95	
P3393	31	LB8	80	LB15	95	Existed
			81		116	
			66		96	
P3394	32	LB8	66	LB15	96	Existed
			82		117	
			83		97	

P338D-P3398 CELL OVER DISCHARGE

[TYPE 4]

< DTC/CIRCUIT DIAGNOSIS >

DTC	Module No.	Module		Li-ion battery controller		Continuity
		Connector	Terminal	Connector	Terminal	
P3395	33	LB8	83	LB15	97	Existed
			68		118	
			84		99	
P3396	34	LB8	84	LB15	99	Existed
			85		119	
			70		100	
P3397	35	LB8	70	LB15	100	Existed
			86		120	
			87		101	
P3398	36	LB8	87	LB15	101	Existed
			72		121	
			88		102	

Is the inspection result normal?

YES >> GO TO 4.

NO >> Repair Harness or connector.

4.CHECK MODULE VOLTAGE

Check voltage of corresponding module. Refer to [EVB-818, "Component Inspection"](#).

Is the inspection result normal?

YES >> Replace Li-ion battery controller. Refer to [EVB-885, "LI-ION BATTERY CONTROLLER : Removal and Installation"](#).

NO >> Replace corresponding module. Refer to [EVB-915, "FRONT MODULE STACK : Disassembly and Assembly"](#).

Component Inspection

INFOID:000000011104430

1.CHECK MODULE VOLTAGE

Check voltage of module.

A : Positive terminal (Red)

B : Negative terminal (Black)

Terminals		Voltage (Approx.)
(+)	(-)	
Module		5.0 - 8.5 V
Positive terminal (Red)	Negative terminal (Black)	

Is the inspection result normal?

YES >> INSPECTION END

NO >> Replace module. Refer to [EVB-915, "FRONT MODULE STACK : Disassembly and Assembly"](#) (Front module) or [EVB-930, "REAR MODULE STACK : Disassembly and Assembly"](#) (Rear module).

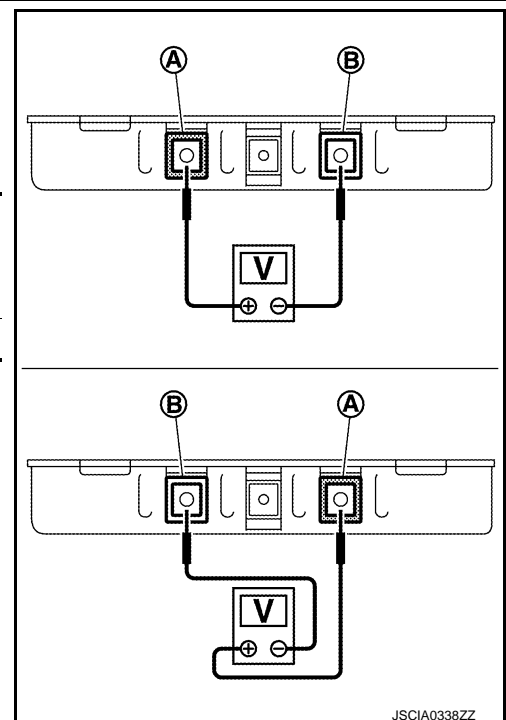

JSCIA0338ZZ

P3399-P33A4 CELL OVER DISCHARGE

< DTC/CIRCUIT DIAGNOSIS >

[TYPE 4]

P3399-P33A4 CELL OVER DISCHARGE

DTC Logic

INFOID:000000011104431

DTC DETECTION LOGIC

DTC	Trouble diagnosis name	DTC detecting condition	Possible causes
P3399	CELL OVER DISCHARGE MODULE37	When cell voltage lowers below the allowable working voltage range.	<ul style="list-style-type: none"> Overcharge caused by traction motor inverter/VCM malfunction Module Li-ion battery controller Bus bar Harness or connector
P339A	CELL OVER DISCHARGE MODULE38		
P339B	CELL OVER DISCHARGE MODULE39		
P339C	CELL OVER DISCHARGE MODULE40		
P339D	CELL OVER DISCHARGE MODULE41		
P339E	CELL OVER DISCHARGE MODULE42		
P339F	CELL OVER DISCHARGE MODULE43		
P33A0	CELL OVER DISCHARGE MODULE44		
P33A1	CELL OVER DISCHARGE MODULE45		
P33A2	CELL OVER DISCHARGE MODULE46		
P33A3	CELL OVER DISCHARGE MODULE47		
P33A4	CELL OVER DISCHARGE MODULE48		

DTC CONFIRMATION PROCEDURE

1. PERFORM DTC CONFIRMATION PROCEDURE

Ⓜ With CONSULT

- Power switch ON and wait for 10 seconds or more.
- Select "Self Diagnostic Result" of "HV BAT".
- Check DTC.

Is any DTC detected?

- YES >> Refer to [EVB-819, "Diagnosis Procedure"](#).
- NO >> INSPECTION END

Diagnosis Procedure

INFOID:000000011104432

WARNING:

- Because hybrid vehicles and electric vehicles contain a high voltage battery, there is the risk of electric shock, electric leakage, or similar accidents if the high voltage component and vehicle are handled incorrectly. Be sure to follow the correct work procedures when performing inspection and maintenance.
- Be sure to remove the service plug in order to disconnect the high voltage circuits before performing inspection or maintenance of high voltage system harnesses and parts.
- To prevent the removed service plug from being connected by mistake during the procedure, always carry it in your pocket or put it in the tool box.
- Be sure to wear insulating protective equipment consisting of glove, shoes, face shield and glasses before beginning work on the high voltage system.
- Clearly identify the persons responsible for high voltage work and ensure that other persons do not touch the vehicle. When not working, cover high voltage parts with an insulating cover sheet or similar item to prevent other persons from contacting them.
- Refer to [EVB-695, "High Voltage Precautions"](#).

CAUTION:

There is the possibility of a malfunction occurring if the vehicle is changed to READY status while the service plug is removed. Therefore do not change the vehicle to READY status unless instructed to do so in the Service Manual.

1. CHECK SELF-DIAGNOSIS RESULTS

Ⓜ With CONSULT

- Perform "All DTC Reading" with CONSULT.

P3399-P33A4 CELL OVER DISCHARGE

[TYPE 4]

< DTC/CIRCUIT DIAGNOSIS >

2. Check "Self Diagnostic Result" of systems other than "" if any DTC is detected.

Is any DTC detected?

YES >> After performing trouble diagnosis of detected DTC, GO TO 2.

NO >> GO TO 2.

2. PRECONDITIONING

WARNING:

Disconnect high voltage. Refer to [GI-31, "How to Disconnect High Voltage"](#).

1. Remove Li-ion battery. Refer to [EVB-866, "Removal and Installation"](#).

2. Remove battery pack upper case. Refer to [EVB-875, "BATTERY PACK UPPER CASE : Removal and Installation"](#).

>> GO TO 3.

3. CHECK HARNESS BETWEEN MODULE AND LI-ION BATTERY CONTROLLER

Ⓟ With CONSULT

1. Select "Self Diagnostic Result" mode of "HV BAT" using CONSULT.

2. Identify the malfunctioning module based on detected DTC.

3. Disconnect module harness connector and Li-ion battery controller harness connector.

4. Refer to below table and check the continuity between corresponding module and Li-ion battery controller.

DTC	Module No.	Module		Li-ion battery controller		Continuity	
		Connector	Terminal	Connector	Terminal		
P3399	37	LB8	88	LB15	102	Existed	
			LB7		89		122
					101		103
P339A	38	LB7	101	LB15	103	Existed	
					90		123
					102		104
P339B	39	LB7	102	LB15	104	Existed	
					91		124
					103		105
P339C	40	LB7	103	LB15	105	Existed	
					92		125
					104		106
P339D	41	LB7	104	LB15	106	Existed	
					93		127
					105		107
P339E	42	LB7	105	LB15	107	Existed	
					94		128
					106		108
P339F	43	LB7	106	LB15	108	Existed	
				95	LB16		137
				107			130
P33A0	44	LB7	107	LB16	130	Existed	
					96		138
					108		131

P3399-P33A4 CELL OVER DISCHARGE

< DTC/CIRCUIT DIAGNOSIS >

[TYPE 4]

DTC	Module No.	Module		Li-ion battery controller		Continuity
		Connector	Terminal	Connector	Terminal	
P33A1	45	LB7	108	LB16	131	Existed
			97		140	
			109		132	
P33A2	46	LB7	109	LB16	132	Existed
			98		141	
			110		133	
P33A3	47	LB7	110	LB16	133	Existed
			99		142	
			111		134	
P33A4	48	LB7	111	LB16	134	Existed
			100		143	
			112		135	

Is the inspection result normal?

YES >> GO TO 4.

NO >> Repair Harness or connector.

4.CHECK MODULE VOLTAGE

Check voltage of corresponding module. Refer to [EVB-821, "Component Inspection"](#).

Is the inspection result normal?

YES >> Replace Li-ion battery controller. Refer to [EVB-885, "LI-ION BATTERY CONTROLLER : Removal and Installation"](#).

NO >> Replace corresponding module. Refer to [EVB-915, "FRONT MODULE STACK : Disassembly and Assembly"](#).

Component Inspection

INFOID:000000011104433

1.CHECK MODULE VOLTAGE

Check voltage of module.

A : Positive terminal (Red)

B : Negative terminal (Black)

Terminals		Voltage (Approx.)
(+)	(-)	
Module		5.0 - 8.5 V
Positive terminal (Red)	Negative terminal (Black)	

Is the inspection result normal?

YES >> INSPECTION END

NO >> Replace module. Refer to [EVB-915, "FRONT MODULE STACK : Disassembly and Assembly"](#) (Front module) or [EVB-930, "REAR MODULE STACK : Disassembly and Assembly"](#) (Rear module).

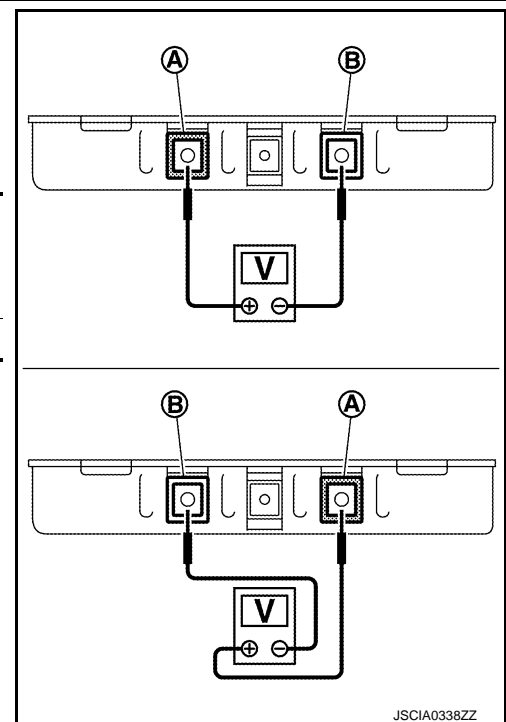

JSCIA0338ZZ

P33D4 BATT GRADUAL CAPA LOSS DIAG

< DTC/CIRCUIT DIAGNOSIS >

[TYPE 4]

P33D4 BATT GRADUAL CAPA LOSS DIAG

DTC Logic

INFOID:000000011104434

DTC DETECTION LOGIC

DTC	Trouble diagnosis name	DTC detecting condition	Possible causes
P33D4	BATT GRADUAL CAPA LOSS DIAG	When the battery charge lowers. (The internal resistance of the battery increases.)	Li-ion battery

DTC CONFIRMATION PROCEDURE

1. PERFORM DTC CONFIRMATION PROCEDURE

④ With CONSULT

1. Power switch ON and wait for 10 seconds or more.
2. Select "Self Diagnostic Result" of "HV BAT".
3. Check DTC.

Is P33D4 detected?

- YES >> Refer to [EVB-822, "Diagnosis Procedure"](#).
NO >> INSPECTION END

Diagnosis Procedure

INFOID:000000011104435

When this DTC is detected, replace Li-ion battery. Refer to [EVB-866, "Removal and Installation"](#).

P33D5 CURRENT SENSOR

< DTC/CIRCUIT DIAGNOSIS >

[TYPE 4]

P33D5 CURRENT SENSOR

DTC Logic

INFOID:0000000011104436

DTC DETECTION LOGIC

DTC	Trouble diagnosis name	DTC detecting condition	Possible causes
P33D5	CURRENT SENSOR	Deviation in characteristics of battery current sensor signal voltage. (Battery current sensor signal voltage is too high or too low.)	<ul style="list-style-type: none">• Li-ion battery controller• Current sensor• System main relay• Harness or connector

DTC CONFIRMATION PROCEDURE

1. PERFORM DTC CONFIRMATION PROCEDURE

④ With CONSULT

1. Power switch ON and wait for 10 seconds or more.
2. Select "Self Diagnostic Result" of "HV BAT".
3. Check DTC.

Is P33D5 detected?

- YES >> Refer to [EVB-823, "Diagnosis Procedure"](#).
NO >> INSPECTION END

Diagnosis Procedure

INFOID:0000000011104437

WARNING:

- Because hybrid vehicles and electric vehicles contain a high voltage battery, there is the risk of electric shock, electric leakage, or similar accidents if the high voltage component and vehicle are handled incorrectly. Be sure to follow the correct work procedures when performing inspection and maintenance.
- Be sure to remove the service plug in order to disconnect the high voltage circuits before performing inspection or maintenance of high voltage system harnesses and parts.
- To prevent the removed service plug from being connected by mistake during the procedure, always carry it in your pocket or put it in the tool box.
- Be sure to wear insulating protective equipment consisting of glove, shoes, face shield and glasses before beginning work on the high voltage system.
- Clearly identify the persons responsible for high voltage work and ensure that other persons do not touch the vehicle. When not working, cover high voltage parts with an insulating cover sheet or similar item to prevent other persons from contacting them.
- Refer to [EVB-695, "High Voltage Precautions"](#).

CAUTION:

There is the possibility of a malfunction occurring if the vehicle is changed to READY status while the service plug is removed. Therefore do not change the vehicle to READY status unless instructed to do so in the Service Manual.

1. CHECK SELF-DIAGNOSIS RESULTS OF VCM

④ With CONSULT

1. Select "Self Diagnostic Result" mode of "EV/HEV" using CONSULT.
2. Check to see if "P0AA0", "P0AA1" or "P0AA4" is detected.

Is any DTC detected?

- YES >> Perform diagnosis on the detected DTC. Refer to [EVB-734, "DTC Index"](#).
NO >> GO TO 2.

2. PRECONDITIONING

WARNING:

Disconnect high voltage. Refer to [GI-31, "How to Disconnect High Voltage"](#).

1. Remove Li-ion battery. Refer to [EVB-866, "Removal and Installation"](#).
2. Remove battery pack upper case. Refer to [EVB-875, "BATTERY PACK UPPER CASE : Removal and Installation"](#).

P33D5 CURRENT SENSOR

< DTC/CIRCUIT DIAGNOSIS >

[TYPE 4]

>> GO TO 3.

3. CHECK CONNECTION STATUS

Check connection status of Li-ion battery controller harness connector and current sensor harness connector.

Is the inspection result normal?

YES >> GO TO 4.

NO >> Recover the connection status.

4. CHECK HARNESS BETWEEN CURRENT SENSOR AND LI-ION BATTERY CONTROLLER

Check continuity between current sensor harness connector and Li-ion battery controller harness connector.

Current sensor		Li-ion battery controller		Continuity
Connector	Terminal	Connector	Terminal	
LB5	S	LB11	10	Exited
	V		9	
	G		17	

Is the inspection result normal?

YES >> GO TO 5.

NO >> Repair Harness or connector.

5. CHECK CURRENT SENSOR

Check resistance of current sensor.

Current sensor			Resistance value
Connector	Terminal	Terminal	
LB5	S	G	1 k Ω –10 M Ω
	V	G	

Is the inspection result normal?

YES >> GO TO 6.

NO >> Replace current sensor.

6. CHECK LI-ION BATTERY CONTROLLER

Check resistance of Li-ion battery controller.

Li-ion battery controller			Resistance value
Connector	Terminal	Terminal	
LB11	10	17	Approx. 4.7 k Ω

Is the inspection result normal?

YES >> Replace current sensor. Refer to [EVB-888, "BATTERY JUNCTION BOX AND BATTERY HARNESS : Exploded View"](#).

NO >> Replace Li-ion battery controller. Refer to [EVB-885, "LI-ION BATTERY CONTROLLER : Removal and Installation"](#).

P33D6 CURRENT SENSOR

< DTC/CIRCUIT DIAGNOSIS >

[TYPE 4]

P33D6 CURRENT SENSOR

DTC Logic

INFOID:0000000011104438

DTC DETECTION LOGIC

DTC	Trouble diagnosis name	DTC detecting condition	Possible causes
P33D6	CURRENT SENSOR	Deviation from the specified voltage characteristics of battery current sensor.	Li-ion battery controller

DTC CONFIRMATION PROCEDURE

1. PERFORM DTC CONFIRMATION PROCEDURE

④ With CONSULT

1. Power switch ON and wait for 10 seconds or more.
2. Select "Self Diagnostic Result" of "HV BAT".
3. Check DTC.

Is P33D6 detected?

- YES >> Refer to [EV8-825, "Diagnosis Procedure"](#).
 NO >> INSPECTION END

Diagnosis Procedure

INFOID:0000000011104439

WARNING:

- Because hybrid vehicles and electric vehicles contain a high voltage battery, there is the risk of electric shock, electric leakage, or similar accidents if the high voltage component and vehicle are handled incorrectly. Be sure to follow the correct work procedures when performing inspection and maintenance.
- Be sure to remove the service plug in order to disconnect the high voltage circuits before performing inspection or maintenance of high voltage system harnesses and parts.
- To prevent the removed service plug from being connected by mistake during the procedure, always carry it in your pocket or put it in the tool box.
- Be sure to wear insulating protective equipment consisting of glove, shoes, face shield and glasses before beginning work on the high voltage system.
- Clearly identify the persons responsible for high voltage work and ensure that other persons do not touch the vehicle. When not working, cover high voltage parts with an insulating cover sheet or similar item to prevent other persons from contacting them.
- Refer to [EV8-695, "High Voltage Precautions"](#).

CAUTION:

There is the possibility of a malfunction occurring if the vehicle is changed to READY status while the service plug is removed. Therefore do not change the vehicle to READY status unless instructed to do so in the Service Manual.

1. PRECONDITIONING

WARNING:

Disconnect high voltage. Refer to [GI-31, "How to Disconnect High Voltage"](#).

1. Remove Li-ion battery. Refer to [EV8-866, "Removal and Installation"](#).
2. Remove battery pack upper case. Refer to [EV8-875, "BATTERY PACK UPPER CASE : Removal and Installation"](#).

>> GO TO 2.

2. CHECK CURRENT SENSOR

1. Disconnect Li-ion battery controller harness connector.
2. Check the resistance of current sensor from Li-ion battery controller side.

Li-ion battery controller		Resistance value
Connector	Terminal	

P33D6 CURRENT SENSOR

< DTC/CIRCUIT DIAGNOSIS >

[TYPE 4]

LB11	10	9	1 kΩ–10 MΩ
	9	17	

Is the inspection result normal?

YES >> Replace Li-ion battery controller. Refer to [EVB-885. "LI-ION BATTERY CONTROLLER : Removal and Installation"](#).

NO >> GO TO 3.

3. CHECK HARNESS BETWEEN LI-ION BATTERY CONTROLLER AND CURRENT SENSOR

1. Disconnect current sensor harness connector.
2. Check continuity between Li-ion battery controller and current sensor.

Li-ion battery controller		Current sensor		Continuity
Connector	Terminal	Connector	Terminal	
LB11	10	LB5	S	Existed
	9		V	
	17		G	

Is the inspection result normal?

YES >> Replace current sensor. Refer to [EVB-888. "BATTERY JUNCTION BOX AND BATTERY HARNESS : Exploded View"](#).

NO >> Repair Harness or connector.

P33D7, P33D9, P33DB, P33DD TEMPERATURE SENSOR

< DTC/CIRCUIT DIAGNOSIS >

[TYPE 4]

P33D7, P33D9, P33DB, P33DD TEMPERATURE SENSOR

DTC Logic

INFOID:000000011104440

DTC DETECTION LOGIC

DTC	Trouble diagnosis name	DTC detecting condition	Possible causes
P33D7	TEMPERATURE SENSOR	Battery temperature sensor 1 signal voltage is too high or too low.	<ul style="list-style-type: none"> Battery temperature sensor 1 Li-ion battery controller Harness or connector
P33D9		Battery temperature sensor 2 signal voltage is too high or too low.	
P33DB		Battery temperature sensor 3 signal voltage is too high or too low.	
P33DD		Battery temperature sensor 4 signal voltage is too high or too low.	

DTC CONFIRMATION PROCEDURE

1. PERFORM DTC CONFIRMATION PROCEDURE

Ⓜ With CONSULT

- Power switch ON and wait for 10 seconds or more.
- Select "Self Diagnostic Result" of "HV BAT".
- Check DTC.

Is any DTC detected?

- YES >> Refer to [EV8-827, "Diagnosis Procedure"](#).
 NO >> INSPECTION END

Diagnosis Procedure

INFOID:000000011104441

WARNING:

- Because hybrid vehicles and electric vehicles contain a high voltage battery, there is the risk of electric shock, electric leakage, or similar accidents if the high voltage component and vehicle are handled incorrectly. Be sure to follow the correct work procedures when performing inspection and maintenance.
- Be sure to remove the service plug in order to disconnect the high voltage circuits before performing inspection or maintenance of high voltage system harnesses and parts.
- To prevent the removed service plug from being connected by mistake during the procedure, always carry it in your pocket or put it in the tool box.
- Be sure to wear insulating protective equipment consisting of glove, shoes, face shield and glasses before beginning work on the high voltage system.
- Clearly identify the persons responsible for high voltage work and ensure that other persons do not touch the vehicle. When not working, cover high voltage parts with an insulating cover sheet or similar item to prevent other persons from contacting them.
- Refer to [EV8-695, "High Voltage Precautions"](#).

CAUTION:

There is the possibility of a malfunction occurring if the vehicle is changed to READY status while the service plug is removed. Therefore do not change the vehicle to READY status unless instructed to do so in the Service Manual.

1. PRECONDITIONING

WARNING:

Disconnect high voltage. Refer to [GI-31, "How to Disconnect High Voltage"](#).

- Remove Li-ion battery. Refer to [EV8-866, "Removal and Installation"](#).
- Remove battery pack upper case. Refer to [EV8-875, "BATTERY PACK UPPER CASE : Removal and Installation"](#).

>> GO TO 2.

P33D7, P33D9, P33DB, P33DD TEMPERATURE SENSOR

< DTC/CIRCUIT DIAGNOSIS >

[TYPE 4]

2.CHECK HARNESS

1. Power switch OFF.
2. Check a connection state of harness connector of Li-ion battery controller.

Is the inspection result normal?

- YES >> GO TO 3.
NO >> Recover the connection status.

3.CHECK BATTERY TEMPERATURE SENSOR

Refer to [EVB-828. "Component Inspection"](#).

Is the inspection result normal?

- YES >> GO TO 4.
NO >> Replace battery temperature sensor.

4.CHECK HARNESS BETWEEN BATTERY TEMPERATURE SENSOR AND GROUND

1. Disconnect Li-ion battery controller harness connector.
2. Check continuity between battery temperature sensor harness connector and ground.

Battery temperature sensor	Connector	Terminal	—	Continuity
1	LB9	1	Ground	No existed
2	LB10	4		
3	LB9	3		
4	LB10	2		

Is the inspection result normal?

- YES >> Replace Li-ion battery controller. Refer to [EVB-885. "LI-ION BATTERY CONTROLLER : Removal and Installation"](#).
NO >> Repair harness or connector.

Component Inspection

INFOID:0000000011104442

1.CHECK BATTERY TEMPERATURE SENSOR

1. Remove battery temperature sensor. Refer to [EVB-915. "FRONT MODULE STACK : Disassembly and Assembly"](#) (Front module) or [EVB-930. "REAR MODULE STACK : Disassembly and Assembly"](#) (Rear module).
2. Check resistance between battery temperature sensor terminals.

Battery temperature sensor	Terminals	Condition	Resistance (kΩ)
1	1 and 5	Temperature °C (°F)	10 (50) Approx. 7.4
2	3 and 4		
3	3 and 7		25 (77) Approx. 4.0
4	1 and 2		40 (104) Approx. 2.3

Is the inspection result normal?

- YES >> INSPECTION END
NO >> Replace battery temperature sensor.

P33DF BAT VOLTAGE ISOLATION SEN

< DTC/CIRCUIT DIAGNOSIS >

[TYPE 4]

P33DF BAT VOLTAGE ISOLATION SEN

DTC Logic

INFOID:0000000011104443

DTC DETECTION LOGIC

DTC	Trouble diagnosis name	DTC detecting condition	Possible causes
P33DF	BAT VOLTAGE ISOLATION SEN	Signal voltage of the on-board isolation resistance monitoring system is too high.	Li-ion battery controller

EVB

DTC CONFIRMATION PROCEDURE

1. PERFORM DTC CONFIRMATION PROCEDURE

④ With CONSULT

1. Power switch ON and wait for 10 seconds or more.
2. Select "Self Diagnostic Result" of "HV BAT".
3. Check DTC.

Is P33DF detected?

- YES >> Refer to [EVB-829, "Diagnosis Procedure"](#).
NO >> INSPECTION END

Diagnosis Procedure

INFOID:0000000011104444

When this DTC is detected, replace Li-ion battery controller. Refer to [EVB-885, "LI-ION BATTERY CONTROLLER : Removal and Installation"](#).

A
B
D
E
F
G
H
I
J
K
L
M
N
O
P

P33E0 BAT VOLTAGE ISOLATION SEN

< DTC/CIRCUIT DIAGNOSIS >

[TYPE 4]

P33E0 BAT VOLTAGE ISOLATION SEN

DTC Logic

INFOID:000000011104445

DTC DETECTION LOGIC

DTC	Trouble diagnosis name	DTC detecting condition	Possible causes
P33E0	BATTERY VOLTAGE ISOLATION SENSOR	Signal Voltage of the on-board isolation resistance monitoring system is too low.	Li-ion battery controller

DTC CONFIRMATION PROCEDURE

1. PERFORM DTC CONFIRMATION PROCEDURE

④ With CONSULT

1. Power switch ON and wait for 10 seconds or more.
2. Select "Self Diagnostic Result" of "HV BAT".
3. Check DTC.

Is P33E0 detected?

- YES >> Refer to [EVB-830, "Diagnosis Procedure"](#).
NO >> INSPECTION END

Diagnosis Procedure

INFOID:000000011104446

When this DTC is detected, replace Li-ion battery controller. Refer to [EVB-885, "LI-ION BATTERY CONTROLLER : Removal and Installation"](#).

P33E1 BAT VOLTAGE ISOLATION SEN

< DTC/CIRCUIT DIAGNOSIS >

[TYPE 4]

P33E1 BAT VOLTAGE ISOLATION SEN

DTC Logic

INFOID:0000000011104447

DTC DETECTION LOGIC

DTC	Trouble diagnosis name	DTC detecting condition	Possible causes
P33E1	BATTERY VOLTAGE ISOLATION SENSOR	Signal voltage of the on-board isolation resistance monitoring system exhibits no amplitude variation.	Li-ion battery controller

A
B
EVB
D
E
F
G
H
I
J
K
L
M
N
O
P

DTC CONFIRMATION PROCEDURE

1. PERFORM DTC CONFIRMATION PROCEDURE

④ With CONSULT

1. Power switch ON and wait for 10 seconds or more.
2. Select "Self Diagnostic Result" of "HV BAT".
3. Check DTC.

Is P33E1 detected?

- YES >> Refer to [EVB-831, "Diagnosis Procedure"](#).
NO >> INSPECTION END

Diagnosis Procedure

INFOID:0000000011104448

When this DTC is detected, perform Li-ion battery insulation resistance loss check. Refer to [EVB-848, "Component Inspection"](#).

P33E2 BATT PACK OVER TEMP

< DTC/CIRCUIT DIAGNOSIS >

[TYPE 4]

P33E2 BATT PACK OVER TEMP

DTC Logic

INFOID:000000011104449

DTC DETECTION LOGIC

DTC	Trouble diagnosis name	DTC detecting condition	Possible causes
P33E2	BATTERY PACK OVER TEMPERATURE	When the battery (battery pack) temperature is excessively high.	Overcharge caused by traction motor inverter/VCM malfunction

DTC CONFIRMATION PROCEDURE

1. PERFORM DTC CONFIRMATION PROCEDURE

Ⓟ With CONSULT

1. Power switch ON and wait for 10 seconds or more.
2. Select "Self Diagnostic Result" of "HV BAT".
3. Check DTC.

Is P33E2 detected?

YES >> Refer to [EVB-832, "Diagnosis Procedure"](#).

NO >> INSPECTION END

Diagnosis Procedure

INFOID:000000011104450

1. PERFORM THE SELF-DIAGNOSIS OF LI-ION BATTERY CONTROLLER

Ⓟ With CONSULT

1. Select "Self Diagnostic Result" of "HV BAT".
2. Check to see if "P33E4" or "P33E5" is detected simultaneously with "P33E2".

Is P33E4 or P33E5 detected?

YES >> Perform diagnosis on the detected "P33E4" or "P33E5". Refer to [EVB-833, "Diagnosis Procedure"](#).

NO >> GO TO 2.

2. CHECK BATTERY TEMPERATURE SENSOR

Ⓟ With CONSULT

Using FREEZE FRAME DATA (FFD), check the values of four temperature sensors when DTC is detected.

Monitor item	Condition	Limit
Battery temperature sensor 1	Power switch ON	55°C (131°F) or less
Battery temperature sensor 2		
Battery temperature sensor 3		
Battery temperature sensor 4		

Is there temperature increase?

Temperature increase is seen>>Replace Li-ion battery. Refer to [EVB-866, "Removal and Installation"](#).

Temperature increase is not seen>>Replace battery temperature sensors. Refer to [EVB-915, "FRONT MODULE STACK : Disassembly and Assembly"](#) (Front module) or [EVB-930, "REAR MODULE STACK : Disassembly and Assembly"](#) (Rear module).

P33E4, P33E5 TEMPERATURE SENSOR

< DTC/CIRCUIT DIAGNOSIS >

[TYPE 4]

P33E4, P33E5 TEMPERATURE SENSOR

DTC Logic

INFOID:000000011104451

DTC DETECTION LOGIC

DTC	Trouble diagnosis name	DTC detecting condition	Possible causes
P33E4	TEMPERATURE SENSOR	Deviation in characteristics of Battery temperature sensor rear center or front RH.	Battery temperature sensor
P33E5		Deviation in characteristics of Battery temperature sensor rear RH or front LH.	

DTC CONFIRMATION PROCEDURE

1. PERFORM DTC CONFIRMATION PROCEDURE

Ⓜ With CONSULT

1. Power switch ON and wait for 10 seconds or more.
2. Select "Self Diagnostic Result" of "HV BAT".
3. Check DTC.

Is P33E4 or P33E5 DTC detected?

- YES >> Refer to [EVB-833. "Diagnosis Procedure"](#).
NO >> INSPECTION END

Diagnosis Procedure

INFOID:000000011104452

WARNING:

- Because hybrid vehicles and electric vehicles contain a high voltage battery, there is the risk of electric shock, electric leakage, or similar accidents if the high voltage component and vehicle are handled incorrectly. Be sure to follow the correct work procedures when performing inspection and maintenance.
- Be sure to remove the service plug in order to disconnect the high voltage circuits before performing inspection or maintenance of high voltage system harnesses and parts.
- To prevent the removed service plug from being connected by mistake during the procedure, always carry it in your pocket or put it in the tool box.
- Be sure to wear insulating protective equipment consisting of glove, shoes, face shield and glasses before beginning work on the high voltage system.
- Clearly identify the persons responsible for high voltage work and ensure that other persons do not touch the vehicle. When not working, cover high voltage parts with an insulating cover sheet or similar item to prevent other persons from contacting them.
- Refer to [EVB-695. "High Voltage Precautions"](#).

CAUTION:

There is the possibility of a malfunction occurring if the vehicle is changed to READY status while the service plug is removed. Therefore do not change the vehicle to READY status unless instructed to do so in the Service Manual.

1. PRECONDITIONING

WARNING:

Disconnect high voltage. Refer to [GI-31. "How to Disconnect High Voltage"](#).

1. Remove Li-ion battery. Refer to [EVB-866. "Removal and Installation"](#).
2. Remove battery pack upper case. Refer to [EVB-875. "BATTERY PACK UPPER CASE : Removal and Installation"](#).

>> GO TO 2.

2. CHECK BATTERY TEMPERATURE SENSOR

Refer to [EVB-834. "Component Inspection"](#).

Is the inspection result normal?

- YES >> Replace both battery temperature sensor.

P33E4, P33E5 TEMPERATURE SENSOR

[TYPE 4]

< DTC/CIRCUIT DIAGNOSIS >

NO >> Replace malfunction battery temperature sensor.

Component Inspection

INFOID:000000011104453

1. CHECK BATTERY TEMPERATURE SENSOR

1. Remove battery temperature sensor. Refer to [EVB-915. "FRONT MODULE STACK : Disassembly and Assembly"](#) (Front module) or [EVB-930. "REAR MODULE STACK : Disassembly and Assembly"](#) (Rear module).
2. Check resistance between battery temperature sensor terminals.

Battery temperature sensor	Terminals	Condition		Resistance (kΩ)
1	1 and 5	Temperature °C (°F)	10 (50)	Approx. 7.4
2	3 and 4		25 (77)	Approx. 4.0
3	3 and 7		40 (104)	Approx. 2.3
4	1 and 2			

Is the inspection result normal?

YES >> INSPECTION END

NO >> Replace battery temperature sensor.

P33E6 CELL VOLTAGE DEVIATION DIAG

< DTC/CIRCUIT DIAGNOSIS >

[TYPE 4]

P33E6 CELL VOLTAGE DEVIATION DIAG

DTC Logic

INFOID:000000011104454

DTC DETECTION LOGIC

DTC	Trouble diagnosis name	DTC detecting condition	Possible causes
P33E6	CELL VOLTAGE DEVIATION DIAG	With the power switch ON and no load condition, the difference between the maximum voltage and minimum voltage exceeds the allowable range.	<ul style="list-style-type: none">Li-ion battery controllerModule

DTC CONFIRMATION PROCEDURE

1. PERFORM DTC CONFIRMATION PROCEDURE

④ With CONSULT

- Turn power switch ON and wait for 10 seconds or more.
- Select "Self Diagnostic Result" of "HV BAT".
- Check DTC.

Is P33E6 detected?

- YES >> Refer to [EVB-835, "Diagnosis Procedure"](#).
NO >> INSPECTION END

Diagnosis Procedure

INFOID:000000011104455

WARNING:

- Because hybrid vehicles and electric vehicles contain a high voltage battery, there is the risk of electric shock, electric leakage, or similar accidents if the high voltage component and vehicle are handled incorrectly. Be sure to follow the correct work procedures when performing inspection and maintenance.
- Be sure to remove the service plug in order to disconnect the high voltage circuits before performing inspection or maintenance of high voltage system harnesses and parts.
- To prevent the removed service plug from being connected by mistake during the procedure, always carry it in your pocket or put it in the tool box.
- Be sure to wear insulating protective equipment before beginning work on the high voltage system.
- Clearly identify the persons responsible for high voltage work and ensure that other persons do not touch the vehicle. When not working, cover high voltage parts with an insulating cover sheet or similar item to prevent other persons from contacting them.
- Refer to [EVB-695, "High Voltage Precautions"](#).

CAUTION:

There is the possibility of a malfunction occurring if the vehicle is changed to READY status while the service plug is removed. Therefore do not change the vehicle to READY status unless instructed to do so in the Service Manual.

1. CHECK SELF-DIAGNOSIS RESULTS OF LI-ION BATTERY CONTROLLER

④ With CONSULT

- Select "Self Diagnostic Result" of "HV BAT".
- Check to see if "P0A1F", "P3062" or "P33ED" is detected simultaneously with "P33E6".

Is P0A1F, P3062 or P33ED detected?

- YES-1 >> When "P0A1F" or "P3062" are detected simultaneously, Replace Li-ion battery controller. Refer to [EVB-885, "LI-ION BATTERY CONTROLLER : Removal and Installation"](#).
YES-2 >> When "P33ED" is detected simultaneously, perform the diagnosis procedure of "P33ED". Refer to [EVB-843, "Diagnosis Procedure"](#).
NO >> GO TO 2.

2. CHECK FREEZE FRAME DATA (FFD)

④ With CONSULT

- Check "FFD" when DTC is detected.
- Calculate the average value of cell voltage by dividing "TOTAL BATTERY VOLTAGE" by 96 (the number of cells).

P33E6 CELL VOLTAGE DEVIATION DIAG

< DTC/CIRCUIT DIAGNOSIS >

[TYPE 4]

Average cell voltage = "TOTAL BETTER VOLTAGE" ÷ 96 (the number of cells)

3. Identify the minimum cell voltage and the maximum cell voltage from 96 cells.
4. Calculate voltage according to the following expressions to compare voltage between A and B.

A = Maximum cell voltage – Average cell voltage

B = Average cell voltage – Minimum cell voltage

Which voltage is larger, A or B?

- A >> Replace module including a cell of the maximum cell voltage. Refer to [EVB-915, "FRONT MODULE STACK : Disassembly and Assembly"](#) (Front module stack) or [EVB-930, "REAR MODULE STACK : Disassembly and Assembly"](#) (Rear module stack). After replacing module, GO TO 3.
- B >> Replace module including a cell of the minimum cell voltage. Refer to [EVB-915, "FRONT MODULE STACK : Disassembly and Assembly"](#) (Front module stack) or [EVB-930, "REAR MODULE STACK : Disassembly and Assembly"](#) (Rear module stack). After replacing module, GO TO 3.

3.PERFORM CELL VOLTAGE LOSS INSPECTION

Ⓟ With CONSULT

1. Select "WORK SUPPORT" of "HV BAT."
2. Select "CELL VOLTAGE LOSS INSPECTION." Touch "START."
3. Check "MINIMUM CELL VOLTAGE."

Is "MINIMUM CELL VOLTAGE" 3,712 mV or less?

YES >> GO TO 5.

NO >> GO TO 4.

4.DISCHARGE OF LI-ION BATTERY

Ⓟ With CONSULT

1. Set the vehicle to READY.
2. Set the vehicle, according to the following conditions.

A/C set temperature	: Full hot
A/C fan speed	: Maximum speed
A/C air outlet	:  Defroster
Headlamp	: High beam ON
Door glass	: Full open

3. Check "DATA MONITOR" and let the Li-ion battery discharge until the "MINIMUM CELL VOLTAGE" reaches 3,712 mV or less.

NOTE:

The guide line is to discharge until the Li-ion battery available charge gauge indicates 2 segments or less. For discharge time, refer to the following table.

Guideline for discharge time

The number of lighting segments of Li-ion battery available charge gauge	Time to 2 segments
12	Approx. 230 minute
11	Approx. 200 minute
10	Approx. 180 minute
9	Approx. 160 minute
8	Approx. 130 minute
7	Approx. 110 minute
6	Approx. 90 minute
5	Approx. 70 minute

P33E6 CELL VOLTAGE DEVIATION DIAG

< DTC/CIRCUIT DIAGNOSIS >

[TYPE 4]

The number of lighting segments of Li-ion battery available charge gauge	Time to 2 segments
4	Approx. 40 minute
3	Approx. 20 minute

>> GO TO 5.

5. CHECK CELL OF VOLTAGE LOSS

④ With CONSULT

1. Check that "MINIMUM CELL VOLTAGE" is 3,712 mV or less. Touch "START."
2. Check to see if a cell of which voltage is less than or equal to "CELL VOLTAGE LOSS JUDGMENT VALUE" is displayed.

Is a cell displayed?

YES >> Record applicable cell No. and then GO TO 6.

NO >> Check the minimum cell voltage on the data monitor and replace a module which includes the minimum cell voltage. Refer to [EVB-915, "FRONT MODULE STACK : Disassembly and Assembly"](#) (Front module stack) or [EVB-930, "REAR MODULE STACK : Disassembly and Assembly"](#) (Rear module stack).

6. PRECONDITIONING

WARNING:

Disconnect high voltage circuit. Refer to [GI-31, "How to Disconnect High Voltage"](#).

1. Remove Li-ion battery. Refer to [EVB-866, "Removal and Installation"](#).
2. Remove battery pack upper case. Refer to [EVB-875, "BATTERY PACK UPPER CASE : Removal and Installation"](#).

>> GO TO 7.

7. CHECK CONDENSATION

Check condensation in battery pack.

Is the inspection result normal?

YES >> GO TO 8.

NO >> Replace Li-ion battery. Refer to [EVB-866, "Removal and Installation"](#).

8. CHECK CONNECTORS AND FIXING BOLTS

Check connection state, damage and dust of following;

- Li-ion battery controller (LBC) harness connector
- Module harness connector
- Module terminal fixing bolt

Is the inspection result normal?

YES >> GO TO 9

NO >> Repair or replace error-detected parts.

9. CHECK MODULE VOLTAGE

Check module voltage within determined cell at step 5 and check the divergence of the voltage and cell voltage with "DATA MONITOR".

DANGER:

When check module voltage, be careful not to short.

Is Divergence within 40mV?

YES-1 >> When the determined cell at step 5 is in front module stack.: GO TO 10.

YES-2 >> When the determined cell at step 5 is in rear module stack.: GO TO 12.

NO >> Replace Li-ion battery controller. Refer to [EVB-885, "LI-ION BATTERY CONTROLLER : Removal and Installation"](#).

10. CHECK HARNESS BETWEEN LI-ION BATTERY CONTROLLER AND MODULE HARNESS CONNEC-

P33E6 CELL VOLTAGE DEVIATION DIAG

[TYPE 4]

< DTC/CIRCUIT DIAGNOSIS >

TOR

1. Disconnect Li-ion battery controller harness connector and module harness connector.
2. Check the resistance Li-ion battery controller harness connector and module harness connector of the determined cell at step 5.

Terminal		Resistance value
Li-ion battery controller harness connector	Module harness connector	Approx. 0 Ω

3. Check the divergence of the resistance and the resistance of other cell harness.

Is the inspection result normal?

YES >> GO TO 11

NO >> Repair or replace harness or connectors.

11. CHECK HARNESS BETWEEN MODULE HARNESS CONNECTOR AND BUS BAR

1. Check the resistance module harness connector (A) and bus bar (B) of the determined cell at step 5.

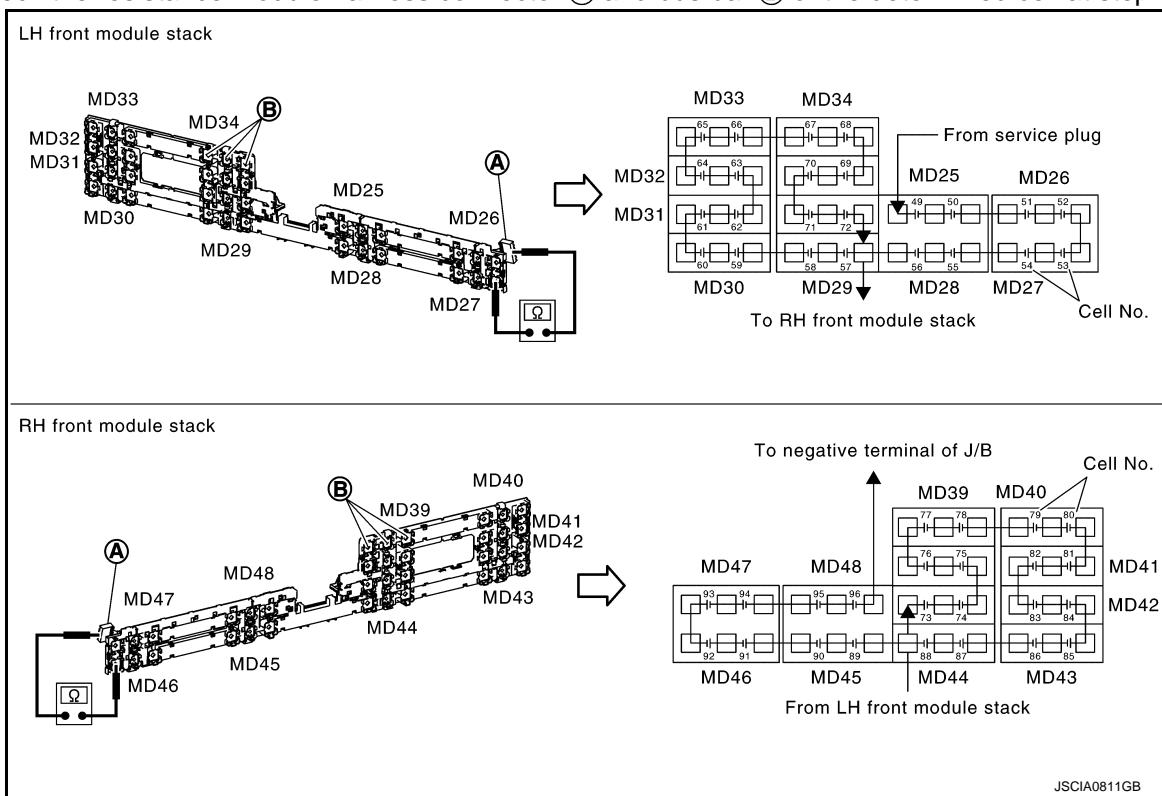

Terminal		Resistance value
Module harness connector	Bus bar	Approx. 0 Ω

2. Check the divergence of the resistance and the resistance of other cell harness.

Is the inspection result normal?

YES >> Replace module within the determined cell at step 5.

NO >> Repair or replace harness or connectors.

12. CHECK HARNESS BETWEEN LI-ION BATTERY CONTROLLER AND BUS BAR

P33E6 CELL VOLTAGE DEVIATION DIAG

[TYPE 4]

< DTC/CIRCUIT DIAGNOSIS >

1. Check the resistance Li-ion battery controller harness connector (A) and bus bar (B) of the determined cell at step 5.

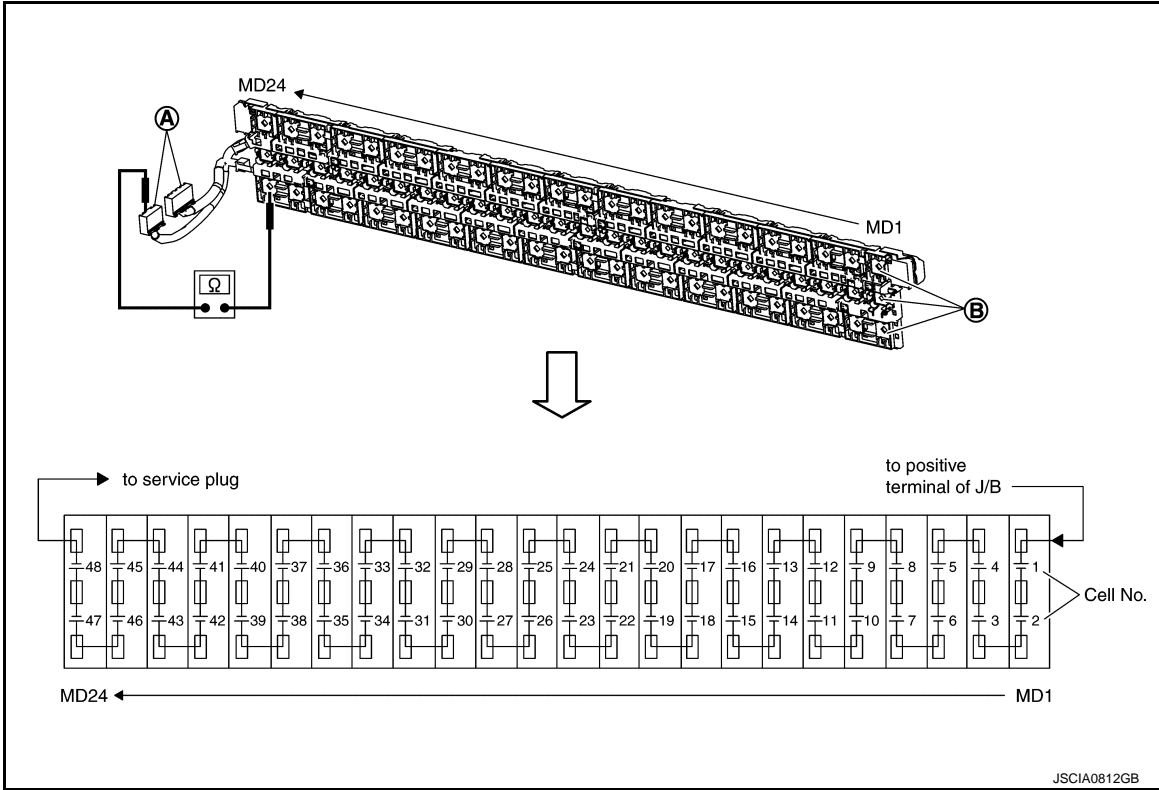

Terminal		Resistance value
Li-ion battery controller harness connector	Bus bar	Approx. 0 Ω

2. Check the divergence of the resistance and the resistance of other cell harness.

Is the inspection result normal?

- YES >> Replace module within the determined cell at step 5.
- NO >> Repair or replace harness or connectors.

A
B
EVB
D
E
F
G
H
I
J
K
L
M
N
O
P

P33E7 CELL CONTROLLER

< DTC/CIRCUIT DIAGNOSIS >

[TYPE 4]

P33E7 CELL CONTROLLER

DTC Logic

INFOID:000000011104456

DTC DETECTION LOGIC

DTC	Trouble diagnosis name	DTC detecting condition	Possible causes
P33E7	CELL CONTROLLER	The A/D converter in Li-ion battery controller is malfunctioning.	Li-ion battery controller

DTC CONFIRMATION PROCEDURE

1. PERFORM DTC CONFIRMATION PROCEDURE

④ With CONSULT

1. Power switch ON and wait for 10 seconds or more.
2. Select "Self Diagnostic Result" of "HV BAT".
3. Check DTC.

Is P33E7 detected?

- YES >> Refer to [EVB-840, "Diagnosis Procedure"](#).
NO >> INSPECTION END

Diagnosis Procedure

INFOID:000000011104457

When this DTC is detected, replace Li-ion battery controller. Refer to [EVB-885, "LI-ION BATTERY CONTROLLER : Removal and Installation"](#).

P33EA BATTERY HEATER RELAY

< DTC/CIRCUIT DIAGNOSIS >

[TYPE 4]

P33EA BATTERY HEATER RELAY

DTC Logic

INFOID:0000000011104458

DTC DETECTION LOGIC

DTC	Trouble diagnosis name	DTC detecting condition	Possible causes
P33EA	BATTERY HEATER RELAY	Li-ion battery controller judges that the status of a relay control signal transmitted from Li-ion battery controller and that of a relay status signal transmitted from heater relay unit do not match.	<ul style="list-style-type: none">Li-ion battery controllerHeater relay unitHarness or connector

NOTE:

- The Li-ion battery controller transmits a relay control signal to the heater relay unit and turns ON/OFF the relay built-in the heater relay unit.
- The heater relay unit turns ON/OFF the built-in relay, according to a relay control signal transmitted from the Li-ion battery controller, and transmits a relay status signal (the ON/OFF status of the built-in relay) to the Li-ion battery controller.

DTC CONFIRMATION PROCEDURE

1. PERFORM DTC CONFIRMATION PROCEDURE-1

④ With CONSULT

- Select "ACTIVE TEST" of "HV BAT."
- Select "HEATER RELAY UNIT." Touch "START."

>> GO TO 2.

2. PERFORM DTC CONFIRMATION PROCEDURE-2

④ With CONSULT

- Select "Self Diagnostic Result" of "HV BAT".
- Check DTC.

Is P33EE detected?

- YES >> Refer to [EV8-841, "Diagnosis Procedure"](#).
- NO >> INSPECTION END

Diagnosis Procedure

INFOID:0000000011104459

WARNING:

- Because hybrid vehicles and electric vehicles contain a high voltage battery, there is the risk of electric shock, electric leakage, or similar accidents if the high voltage component and vehicle are handled incorrectly. Be sure to follow the correct work procedures when performing inspection and maintenance.
- Be sure to remove the service plug in order to shut off the high voltage circuits before performing inspection or maintenance of high voltage system harnesses and parts.
- To prevent the removed service plug from being connected by mistake during the procedure, always carry it in your pocket or put it in the tool box.
- Be sure to wear insulating protective equipment consisting of glove, shoes, face shield and glasses before beginning work on the high voltage system.
- Clearly identify the persons responsible for high voltage work and ensure that other persons do not touch the vehicle. When not working, cover high voltage parts with an insulating cover sheet or similar item to prevent other persons from contacting them.
- Refer to [EV8-469, "High Voltage Precautions"](#).

CAUTION:

There is the possibility of a malfunction occurring if the vehicle is changed to READY status while the service plug is removed. Therefore do not change the vehicle to READY status unless instructed to do so in the Service Manual.

1. PRECONDITIONING

WARNING:

P33EA BATTERY HEATER RELAY

[TYPE 4]

< DTC/CIRCUIT DIAGNOSIS >

Shut off high voltage circuit. Refer to [GI-31, "How to Disconnect High Voltage"](#).

1. Remove Li-ion battery. Refer to [EVB-866, "Removal and Installation"](#).
2. Remove battery pack upper case. Refer to [EVB-875, "BATTERY PACK UPPER CASE : Removal and Installation"](#).

>> GO TO 2.

2.CHECK CONTINUITY LI-ION BATTERY CONTROLLER AND HEATER RELAY UNIT

1. Remove service plug switch bracket. Refer to [EVB-874, "BATTERY PACK UPPER CASE : Exploded View"](#).
2. Disconnect li-ion battery controller harness connector and heater relay unit harness connector.
3. Check continuity li-ion battery controller harness connector and heater relay unit harness connector.

Li-ion battery controller		Heater relay unit		Continuity
Connector	Terminal	Connector	Terminal	
LB11	20	LB17	3	Existed
	4		6	

Is the inspection result normal?

YES >> GO TO 3.

NO >> Repair harness or connector.

3.CHECK CONTINUITY LI-ION BATTERY AND HEATER RELAY UNIT

Check continuity li-ion battery harness connector and heater relay unit harness connector.

Li-ion battery		Heater relay unit		Continuity
Connector	Terminal	Connector	Terminal	
LB1	21	LB17	1	Existed

Is the inspection result normal?

YES >> GO TO 4.

NO >> Repair harness or connector.

4.CHECK CONTINUITY HEATER RELAY UNIT AND LI-ION BATTERY CONTROLLER

Check continuity heater relay unit harness connector and li-ion battery controller harness connector.

Heater relay unit		Li-ion battery controller		Continuity
Connector	Terminal	Connector	Terminal	
LB17	4	LB11	3	Existed
	8		15	
	7		16	
	5			

Is the inspection result normal?

YES >> Replace to shown in the below.

- Li-ion battery controller. Refer to [EVB-885, "LI-ION BATTERY CONTROLLER : Removal and Installation"](#).
- Heater relay unit. Refer to [EVB-905, "LI-ION BATTERY HEATER RELAY UNIT : Disassembly and Assembly"](#).

NO >> Repair harness or connector.

P33ED BATTERY PARALLEL DIAGNOSIS

< DTC/CIRCUIT DIAGNOSIS >

[TYPE 4]

P33ED BATTERY PARALLEL DIAGNOSIS

DTC Logic

INFOID:000000011104460

DTC DETECTION LOGIC

DTC	Trouble diagnosis name	DTC detecting condition	Possible causes
P33ED	BATTERY PARALLEL DIAGNOSIS	When a sudden voltage fluctuation is detected in module.	Module

A

B

EVB

DTC CONFIRMATION PROCEDURE

1. CHECK LI-ION BATTERY AVAILABLE CHARGE GAUGE

Check the indication of the Li-ion battery available charge gauge.

NOTE:

Check 12 segments for lighting status.

Is the lighting status 1 Segment or none?

YES >> GO TO 3.

NO >> GO TO 2.

2. DISCHARGE OF LI-ION BATTERY

1. Set the vehicle to READY.
2. Set the vehicle, according to the following conditions.

A/C set temperature	: Full hot
A/C fan speed	: Maximum speed
A/C air outlet	:  Defroster
Headlamp	: High beam ON
Door glass	: Full open

3. Let the Li-ion battery discharge until the Li-ion battery available charge gauge shows segment 1 or below.

>> GO TO 3.

3. CHARGE OF LI-ION BATTERY

1. Charge the Li-ion battery by normal charge until the level reaches full charge.
2. After the completion of normal charge, check that the indication of the Li-ion battery available charge gauge shows 12 segments.

>> GO TO 4.

4. PERFORM DTC CONFIRMATION PROCEDURE

 With CONSULT

1. Power switch ON and wait for 10 seconds or more.
2. Select "Self Diagnostic Result" of "HV BAT".
3. Check DTC.

Is P33ED detected?

YES >> Refer to [EV8-843, "Diagnosis Procedure"](#).

NO >> INSPECTION END

Diagnosis Procedure

INFOID:000000011104461

1. CHECK DATA MONITOR OR FREEZE FRAME DATA (FFD)

 With CONSULT

1. Select "DATA MONITOR" or "FFD".
2. Check to see if there is a cell voltage which largely differ from the others.

Is there any abnormal cell?

P33ED BATTERY PARALLEL DIAGNOSIS

[TYPE 4]

< DTC/CIRCUIT DIAGNOSIS >

YES >> Replace corresponding Module. Refer to [EVB-915, "FRONT MODULE STACK : Disassembly and Assembly"](#) (Front module) or [EVB-930, "REAR MODULE STACK : Disassembly and Assembly"](#) (Rear module).

NO >> GO TO 2.

2. DTC CONFIRMATION PROCEDURE OPERATION

1. If abnormal cell is not identified, perform DTC confirmation procedure. Refer to [EVB-843, "DTC Logic"](#).
2. Check cell voltage again using "DATA MONITOR" or "FFD" to identify malfunctioning cell.

>> Replace corresponding Module. Refer to [EVB-915, "FRONT MODULE STACK : Disassembly and Assembly"](#) (Front module) or [EVB-930, "REAR MODULE STACK : Disassembly and Assembly"](#) (Rear module).

P33EE BATTERY HEATER CONTROL SYSTEM

< DTC/CIRCUIT DIAGNOSIS >

[TYPE 4]

P33EE BATTERY HEATER CONTROL SYSTEM

DTC Logic

INFOID:0000000011104462

DTC DETECTION LOGIC

DTC	Trouble diagnosis name	DTC detecting condition	Possible causes
P33EE	BATTERY HEATER CONTROL SYSTEM	Under extremely low temperatures that Li-ion battery heater activates, Li-ion battery controller judges that the temperature of Li-ion battery is still low after a lapse of specified time.	<ul style="list-style-type: none">• Li-ion battery controller• Heater relay unit• Li-ion battery heater• Harness or connector

Diagnosis Procedure

INFOID:0000000011104463

WARNING:

- Because hybrid vehicles and electric vehicles contain a high voltage battery, there is the risk of electric shock, electric leakage, or similar accidents if the high voltage component and vehicle are handled incorrectly. Be sure to follow the correct work procedures when performing inspection and maintenance.
- Be sure to remove the service plug in order to disconnect the high voltage circuits before performing inspection or maintenance of high voltage system harnesses and parts.
- To prevent the removed service plug from being connected by mistake during the procedure, always carry it in your pocket or put it in the tool box.
- Be sure to wear insulating protective equipment before beginning work on the high voltage system.
- Clearly identify the persons responsible for high voltage work and ensure that other persons do not touch the vehicle. When not working, cover high voltage parts with an insulating cover sheet or similar item to prevent other persons from contacting them.
- Refer to [EVB-695, "High Voltage Precautions"](#).

CAUTION:

There is the possibility of a malfunction occurring if the vehicle is changed to READY status while the service plug is removed. Therefore do not change the vehicle to READY status unless instructed to do so in the Service Manual.

1. PRECONDITIONING

WARNING:

Disconnect the high voltage. Refer to [GI-31, "How to Disconnect High Voltage"](#).

1. Remove Li-ion battery. Refer to [EVB-866, "Removal and Installation"](#).
2. Remove battery pack upper case. Refer to [EVB-875, "BATTERY PACK UPPER CASE : Removal and Installation"](#).

>> GO TO 2.

2. CHECK INSTALLATION CONDITION OF LI-ION BATTERY HEATER

Check the main body of Li-ion battery heater for installation condition.

Is the inspection result normal?

YES >> GO TO 3.

NO >> Tighten the mounting nut of the Li-ion battery heater to the specified torque. Refer to [EVB-898, "LI-ION BATTERY HEATER : Exploded view"](#).

3. CHECK CONNECTION STATUS OF LI-ION BATTERY HEATER CONNECTOR

Check the connection status of the Li-ion battery heater connector.

Is the inspection result normal?

YES >> GO TO 4.

NO >> Restore the connection status of the Li-ion battery heater connector.

4. CHECK RESISTANCE OF LI-ION BATTERY HEATER

Check resistance of Li-ion battery heater.

P33EE BATTERY HEATER CONTROL SYSTEM

< DTC/CIRCUIT DIAGNOSIS >

[TYPE 4]

Li-ion battery heater			Resistance
Item	Terminal		
LH 1	1	2	Less than 5,269 Ω
LH 2			
RH 1			
RH 2			
RR 1	1	2	Less than 1,265 Ω
RR 2			

Is the inspection result normal?

YES >> GO TO 5.

NO >> Replace applicable Li-ion battery heater. Refer to [EVB-899. "LI-ION BATTERY HEATER : Disassembly and Assembly"](#).

5. CHECK CONTINUITY OF LI-ION BATTERY HEATER AND BATTERY JUNCTION BOX

1. Disconnect Li-ion battery heater and battery junction box harness connector.
2. Check continuity Li-ion battery heater and battery junction box harness connector.

Li-ion battery heater			Battery junction box		Continuity
Item	Connector	Terminal	Connector	Terminal	
LH 1	LB19	2	LB25	15	Existed
LH 2	LB20	2			
RH 1	LB23	2			
RH 2	LB24	2			
RR 1	LB21	2			
RR 2	LB22	2			

Is the inspection result normal?

YES >> GO TO 6

NO >> Repair harness or connector.

6. CHECK CONTINUITY OF LI-ION BATTERY HEATER AND HEATER RELAY UNIT

1. Disconnect Li-ion battery heater and heater relay unit harness connector harness connector.
2. Check continuity Li-ion battery heater and heater relay unit harness connector harness connector.

Li-ion battery heater			Heater relay unit		Continuity
Item	Connector	Terminal	Connector	Terminal	
LH 1	LB19	1	LB18	11	Existed
LH 2	LB20	1			
RH 1	LB23	1			
RH 2	LB24	1			
RR 1	LB21	1			
RR 2	LB22	1			

Is the inspection result normal?

YES >> Replace heater relay unit. Refer to [EVB-905. "LI-ION BATTERY HEATER RELAY UNIT : Disassembly and Assembly"](#).

NO >> Repair harness or connector.

U1000 CAN COMM CIRCUIT

< DTC/CIRCUIT DIAGNOSIS >

[TYPE 4]

U1000 CAN COMM CIRCUIT

Description

INFOID:0000000011104464

CAN (Controller Area Network) is a serial communication line for real time applications. It is an on-vehicle multiplex communication line with high data communication speed and excellent error detection ability. Modern vehicle is equipped with many electronic control units, and each control unit shares information and links with other control units during operation (not independent). In CAN communication, control units are connected with 2 communication lines (CAN-H, CAN-L) allowing a high rate of information transmission with less wiring. Each control unit transmits/receives data but selectively reads the required data only.

CAN communication signal chart. Refer to [LAN-33. "CAN COMMUNICATION SYSTEM : CAN Communication Signal Chart"](#).

DTC Logic

INFOID:0000000011104465

DTC DETECTION LOGIC

DTC	Trouble diagnosis name	DTC detecting condition	Possible causes
U1000	CAN COMM CIRCUIT	When no CAN communication signal is received continuously for 2 seconds or more.	CAN communication system

Diagnosis Procedure

INFOID:0000000011104466

For the diagnosis procedure, refer to [LAN-15. "Trouble Diagnosis Flow Chart"](#).

A
B
EVB
D
E
F
G
H
I
J
K
L
M
N
O
P

LI-ION BATTERY INSULATION RESISTANCE LOSS CHECK

< DTC/CIRCUIT DIAGNOSIS >

[TYPE 4]

LI-ION BATTERY INSULATION RESISTANCE LOSS CHECK

Component Inspection

INFOID:000000011104467

WARNING:

- Because hybrid vehicles and electric vehicles contain a high voltage battery, there is the risk of electric shock, electric leakage, or similar accidents if the high voltage component and vehicle are handled incorrectly. Be sure to follow the correct work procedures when performing inspection and maintenance.
- Be sure to remove the service plug in order to disconnect the high voltage circuits before performing inspection or maintenance of high voltage system harnesses and parts.
- To prevent the removed service plug from being connected by mistake during the procedure, always carry it in your pocket or put it in the tool box.
- Be sure to wear insulating protective equipment consisting of glove, shoes, face shield and glasses before beginning work on the high voltage system.
- Clearly identify the persons responsible for high voltage work and ensure that other persons do not touch the vehicle. When not working, cover high voltage parts with an insulating cover sheet or similar item to prevent other persons from contacting them.
- Refer to [EVB-695, "High Voltage Precautions"](#).

CAUTION:

There is the possibility of a malfunction occurring if the vehicle is changed to READY status while the service plug is removed. Therefore do not change the vehicle to READY status unless instructed to do so in the Service Manual.

The following diagnosis procedure must be performed when "P0AA6 or P33E1" are detected and Li-ion battery is judged that its insulation resistance is dropping.

1. CHECK MAXIMUM CELL VOLTAGE

Ⓟ With CONSULT

1. Power switch ON.
2. Select "DATA MONITOR" of "HV BAT".
3. Record "MAXIMUM CELL VOLTAGE".

NOTE:

It is used, when replace a malfunction module.

>> GO TO 2

2. CHECK INSULATION OF FRONT MODULE STACK LH-1

CAUTION:

Check that high voltage harness and harness shield have no scratches and cracks. If any damage is found, replace damaged parts.

1. Remove Li-ion battery. Refer to [EVB-866, "Removal and Installation"](#).
2. Remove Li-ion battery controller. Refer to [EVB-885, "LI-ION BATTERY CONTROLLER : Removal and Installation"](#).
3. Remove bus bar that connects front module stack LH and front module stack RH.
4. Measure voltages between positive terminal (A) of front module stack LH and battery pack ground, and between positive terminal (B) of front module stack LH and battery pack ground.

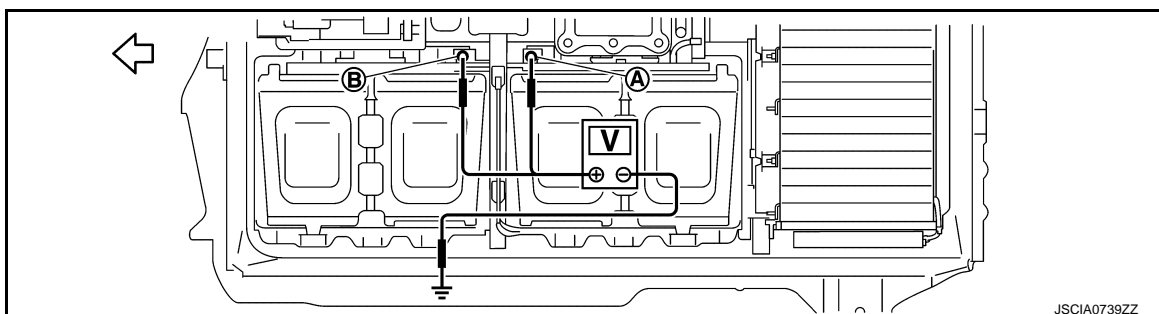

↩ : Battery pack front

LI-ION BATTERY INSULATION RESISTANCE LOSS CHECK

< DTC/CIRCUIT DIAGNOSIS >

[TYPE 4]

+	-	Voltage
Front module stack LH		
Terminal		
Ⓐ, Ⓑ	Battery pack ground	Approx. 0 V

Is the inspection result normal?

- YES >> GO TO 8.
- NO >> GO TO 3.

3. CHECK INSULATION OF FRONT MODULE STACK LH-2

1. Disconnect vehicle communication harness connector of front module stack LH.
2. Measure voltages between positive terminal Ⓐ of front module stack LH and battery pack ground, and between positive terminal Ⓑ of front module stack LH and battery pack ground.

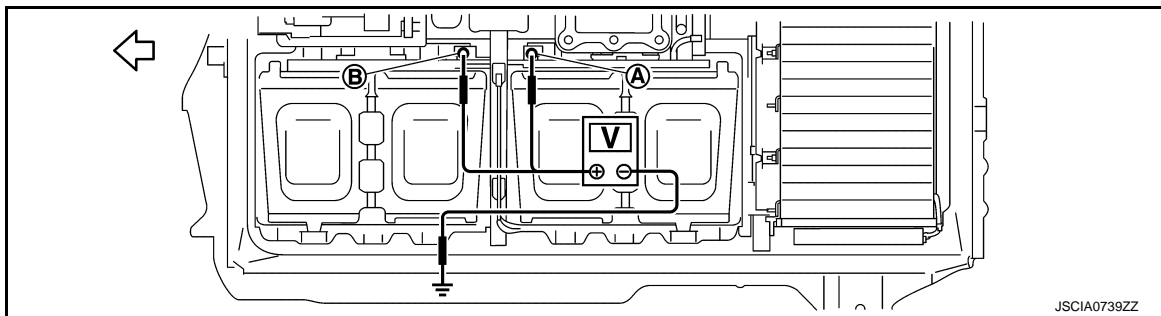

⇐ : Battery pack front

+	-	Voltage
Front module stack LH		
Terminal		
Ⓐ, Ⓑ	Battery pack ground	Approx. 0 V

Is the inspection result normal?

- YES >> Replace vehicle communication harness of front module stack LH and GO TO 8.
- NO >> GO TO 4.

4. CHECK INSULATION OF FRONT MODULE STACK LH-3

1. Remove bus bar that connects service plug and front module stack LH.
2. Measure voltages between positive terminal Ⓐ of front module stack LH and battery pack ground, and between positive terminal Ⓑ of front module stack LH and battery pack ground.

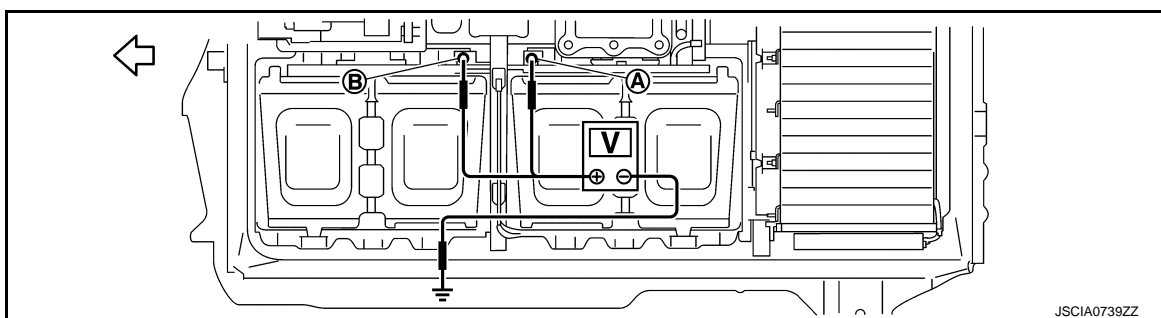

⇐ : Battery pack front

LI-ION BATTERY INSULATION RESISTANCE LOSS CHECK

< DTC/CIRCUIT DIAGNOSIS >

[TYPE 4]

+	-	Voltage
Front module stack LH		
Terminal		
(A), (B)	Battery pack ground	Approx. 0 V

Is the inspection result normal?

- YES >> GO TO 5.
NO >> GO TO 6.

5. CHECK SERVICE PLUG SWITCH INSULATION RESISTANCE

- Remove bus bar that connects service plug and front module stack LH from service plug switch bracket.
- Using insulation resistance tester, measure insulation resistance between service plug switch terminal and service plug switch bracket.

WARNING:

Unlike the ordinary tester, the insulation resistance tester applies 500 V when measuring. If used incorrectly, there is the danger of electric shock. If used in the vehicle 12V system, there is the danger of damage to electronic devices. Read the insulation resistance tester instruction manual carefully and be sure to work safely.

CAUTION:

Be sure to set the insulation resistance tester to 500 V when performing this test. Using a setting higher than 500 V can result in damage to the component being inspected.

NOTE:

Check resistance without disassembling service plug switch and service plug switch bracket.

+	-	Resistance
Service plug switch terminal	Service plug switch bracket	1000 MΩ or more

Is the inspection result normal?

- YES >> Replace bus bar that connects service plug and front module stack LH and GO TO 8.
NO >> Replace service plug switch (Refer to [EVB-888, "BATTERY JUNCTION BOX AND BATTERY HARNESS : Exploded View"](#).) and GO TO 8.

6. CHECK MODULE-1

- Remove front module stack LH. Refer to [EVB-915, "FRONT MODULE STACK : Disassembly and Assembly"](#).

NOTE:

Do not disassemble module stack.

- Measure voltages between terminal (A)/(B) of all modules in front module stack LH and module body.

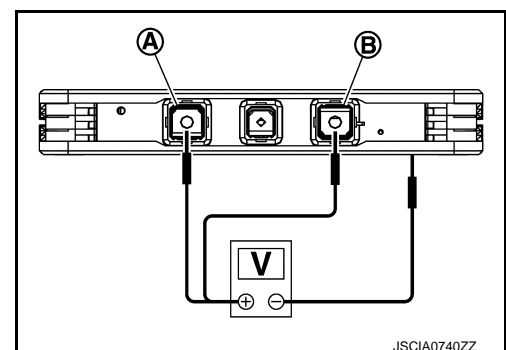

+	-	Voltage
Module		
Terminal		
(A)	Module body	Approx. 0 V
(B)		

LI-ION BATTERY INSULATION RESISTANCE LOSS CHECK

[TYPE 4]

< DTC/CIRCUIT DIAGNOSIS >

Is the inspection result normal?

YES >> GO TO 7.

NO >> Replace malfunctioning module (Refer to [EVB-915. "FRONT MODULE STACK : Disassembly and Assembly"](#).) and GO TO 8.

7. CHECK MODULE-2

Measure insulation resistance between terminal (A)/(B) of all modules in front module stack LH and module body.

WARNING:

Unlike the ordinary tester, the insulation resistance tester applies 500 V when measuring. If used incorrectly, there is the danger of electric shock. If used in the vehicle 12V system, there is the danger of damage to electronic devices. Read the insulation resistance tester instruction manual carefully and be sure to work safely.

CAUTION:

Be sure to set the insulation resistance tester to 500 V when performing this test. Using a setting higher than 500 V can result in damage to the component being inspected.

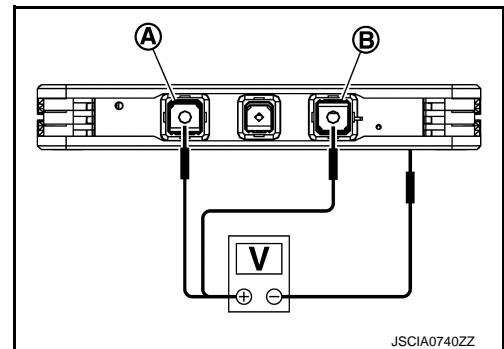

+	-	resistance
Module		
Terminal	Module body	100 MΩ or more
(A)		
(B)		

Is the inspection result normal?

YES >> Check insulation resistance of front module stack RH, because front module stack LH is normal. GO TO 8.

NO >> Replace malfunctioning module (Refer to [EVB-915. "FRONT MODULE STACK : Disassembly and Assembly"](#).) and GO TO 8.

8. CHECK INSULATION OF FRONT MODULE STACK RH-1

1. Measure voltages between positive terminal (A) of front module stack RH and battery pack ground, and between positive terminal (B) of front module stack LH and battery pack ground.

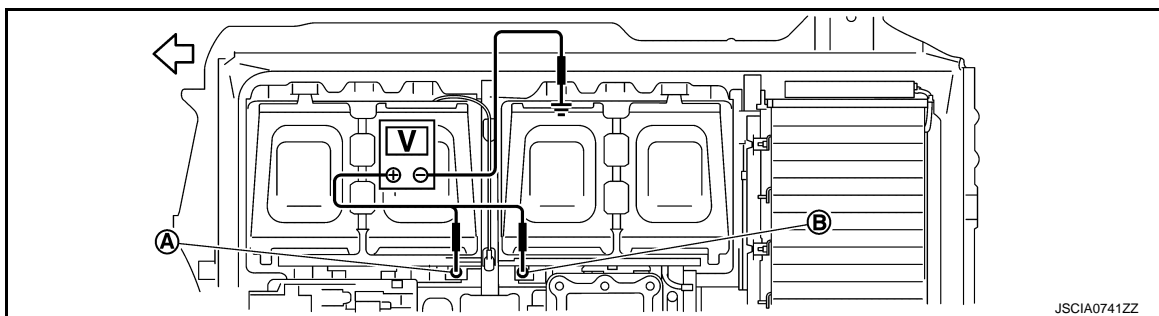

↩ : Battery pack front

+	-	Voltage
Front module stack RH		
Terminal	Battery pack ground	Approx. 0 V
(A), (B)		

Is the inspection result normal?

YES >> GO TO 14.

LI-ION BATTERY INSULATION RESISTANCE LOSS CHECK

[TYPE 4]

< DTC/CIRCUIT DIAGNOSIS >

NO >> GO TO 9.

9. CHECK INSULATION OF FRONT MODULE STACK RH-2

1. Disconnect vehicle communication harness connector of front module stack RH.
2. Measure voltages between positive terminal (A) of front module stack RH and battery pack ground, and between positive terminal (B) of front module stack RH and battery pack ground.

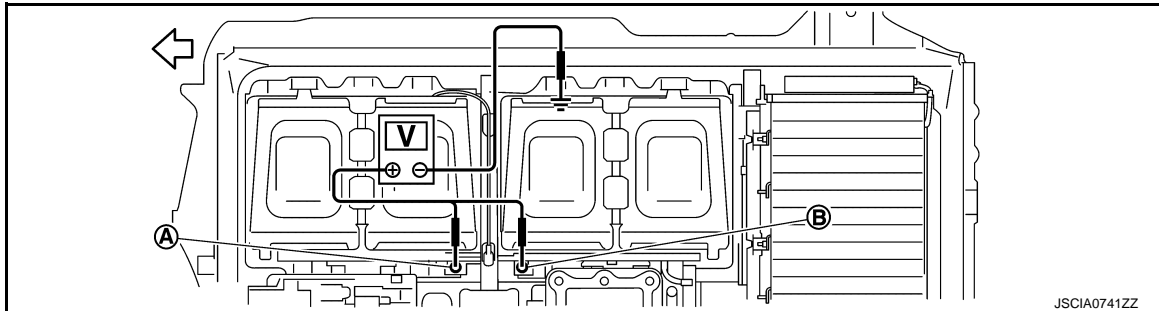

↙ : Battery pack front

+		
Front module stack RH	-	Voltage
Terminal		
(A), (B)	Battery pack ground	Approx. 0 V

Is the inspection result normal?

- YES >> Replace vehicle communication harness of front module stack RH and GO TO 14.
 NO >> GO TO 10.

10. CHECK INSULATION OF FRONT MODULE STACK RH-3

1. Remove bus bar that connects front module stack RH and battery junction box.
2. Measure voltages between positive terminal (A) of front module stack RH and battery pack ground, and between positive terminal (B) of front module stack RH and battery pack ground.

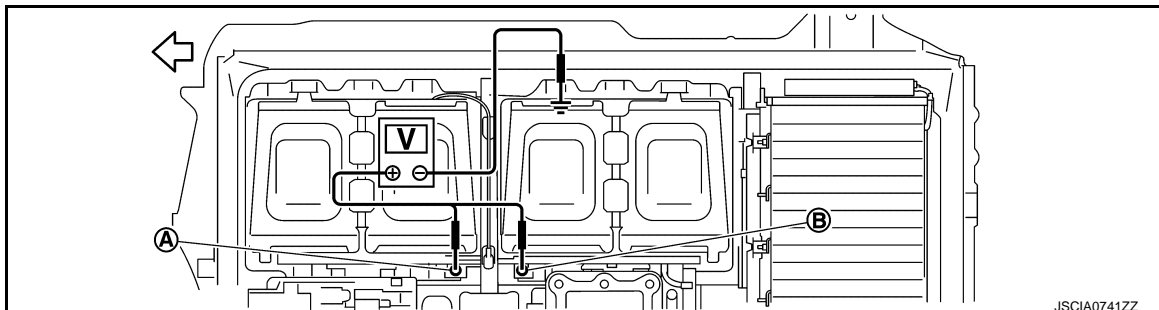

↙ : Battery pack front

+		
Front module stack RH	-	Voltage
Terminal		
(A), (B)	Battery pack ground	Approx. 0 V

Is the inspection result normal?

- YES >> GO TO 11.
 NO >> GO TO 12.

LI-ION BATTERY INSULATION RESISTANCE LOSS CHECK

< DTC/CIRCUIT DIAGNOSIS >

[TYPE 4]

11. CHECK BATTERY JUNCTION BOX INSULATION RESISTANCE

- Using insulation resistance tester, measure insulation resistance between high voltage terminal (A)/(B) of battery junction box and battery pack ground.

← : Battery pack front

WARNING:

Unlike the ordinary tester, the insulation resistance tester applies 500 V when measuring. If used incorrectly, there is the danger of electric shock. If used in the vehicle 12V system, there is the danger of damage to electronic devices. Read the insulation resistance tester instruction manual carefully and be sure to work safely.

CAUTION:

Be sure to set the insulation resistance tester to 500 V when performing this test. Using a setting higher than 500 V can result in damage to the component being inspected.

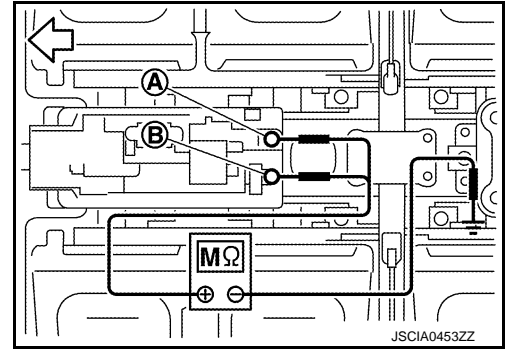

Battery junction box Terminal	—	Resistance
(A)	Battery pack ground	1000 MΩ or more
(B)		

Is the inspection result normal?

- YES >> Replace bus bar that connects front module stack RH and battery junction box and GO TO 14.
 NO >> Replace battery junction box (Refer to [EVB-890, "BATTERY JUNCTION BOX AND BATTERY HARNESS : Disassembly and Assembly"](#)) and GO TO 14.

12. CHECK MODULE-3

- Remove front module stack RH. Refer to [EVB-915, "FRONT MODULE STACK : Disassembly and Assembly"](#).

NOTE:

Do not disassemble module stack.

- Measure voltages between terminal (A)/(B) of all modules in front module stack RH and module body.

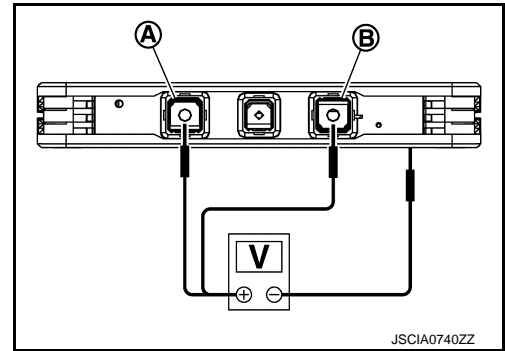

+ Module Terminal	—	Voltage
(A)	Module body	Approx. 0 V
(B)		

Is the inspection result normal?

- YES >> GO TO 13.
 NO >> Replace malfunctioning module (Refer to [EVB-915, "FRONT MODULE STACK : Disassembly and Assembly"](#).) and GO TO 14.

LI-ION BATTERY INSULATION RESISTANCE LOSS CHECK

< DTC/CIRCUIT DIAGNOSIS >

[TYPE 4]

13.CHECK MODULE-4

Measure insulation resistance between terminal (A)/(B) of all modules in front module stack RH and module body.

WARNING:

Unlike the ordinary tester, the insulation resistance tester applies 500 V when measuring. If used incorrectly, there is the danger of electric shock. If used in the vehicle 12V system, there is the danger of damage to electronic devices. Read the insulation resistance tester instruction manual carefully and be sure to work safely.

CAUTION:

Be sure to set the insulation resistance tester to 500 V when performing this test. Using a setting higher than 500 V can result in damage to the component being inspected.

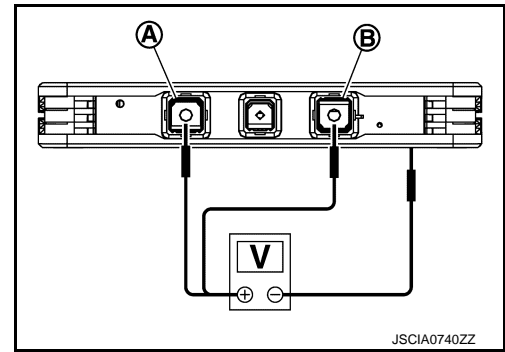

+		
Module	-	resistance
Terminal		
(A)	Module body	100 MΩ or more
(B)		

Is the inspection result normal?

YES >> Check insulation resistance of front module stack RH, because front module stack LH is normal.
GO TO 14.

NO >> Replace malfunctioning module (Refer to [EVB-915, "FRONT MODULE STACK : Disassembly and Assembly"](#).) and GO TO 14.

14.CHECK INSULATION OF REAR MODULE STACK-1

1. Measure voltages between positive terminal (A) of rear module stack and battery pack ground, and between positive terminal (B) of rear module stack and battery pack ground.

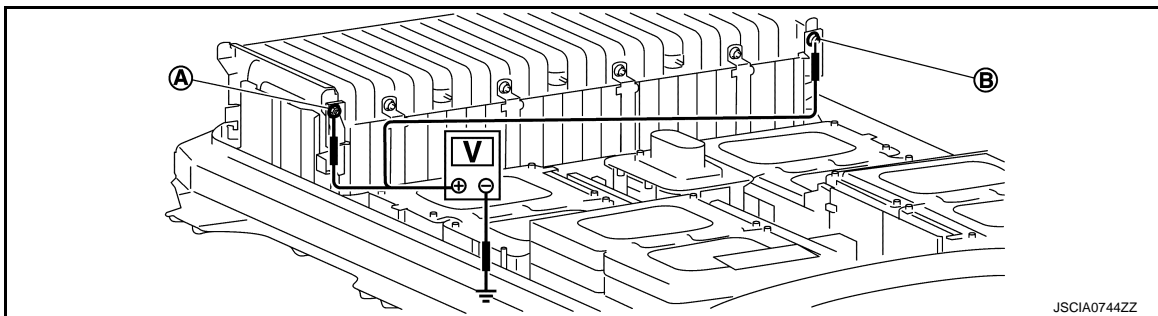

+		
Rear module stack	-	Voltage
Terminal		
(A), (B)	Battery pack ground	Approx. 0 V

Is the inspection result normal?

YES-1 >> Replace or repair of malfunctioning part is not-yet performed: Replace Li-ion battery controller.
Refer to [EVB-885, "LI-ION BATTERY CONTROLLER : Removal and Installation"](#).

YES-2 >> Replace or repair of malfunctioning part is complete: INSPECTION END.

NO >> GO TO 15.

15.CHECK INSULATION OF REAR MODULE STACK-2

LI-ION BATTERY INSULATION RESISTANCE LOSS CHECK

< DTC/CIRCUIT DIAGNOSIS >

[TYPE 4]

1. Disconnect vehicle communication harness connector (A) of rear module stack.

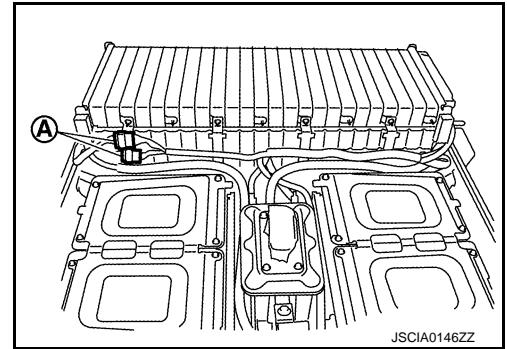

2. Measure voltages between positive terminal (A) of rear module stack and battery pack ground, and between positive terminal (B) of rear module stack and battery pack ground.

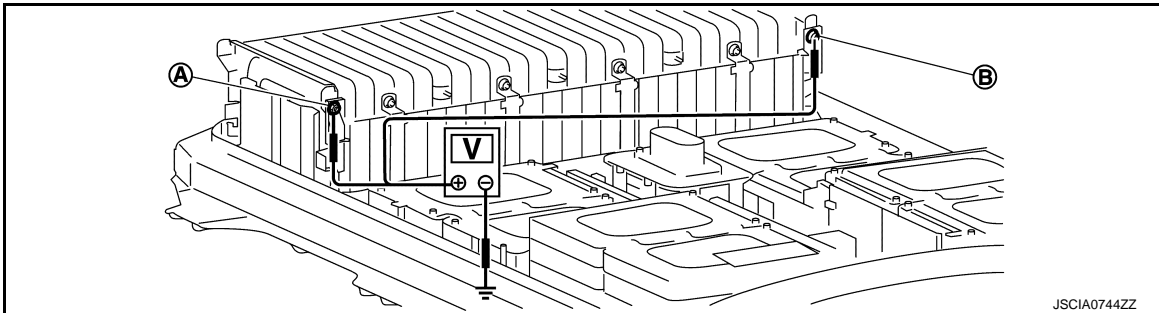

+		
Front module stack RH	-	Voltage
Terminal		
(A), (B)	Battery pack ground	Approx. 0 V

Is the inspection result normal?

YES >> Replace vehicle communication harness of rear module stack.

NO >> GO TO 16.

16. CHECK INSULATION OF FRONT MODULE STACK RH-3

1. Remove mounting nuts (A/B) and remove high voltage harness from rear module stack.

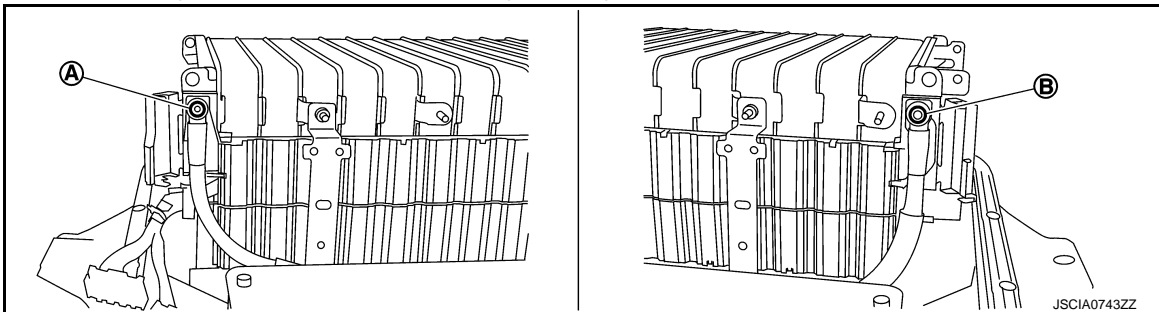

2. Measure voltages between positive terminal (A) of rear module stack and battery pack ground, and between positive terminal (B) of rear module stack and battery pack ground.

LI-ION BATTERY INSULATION RESISTANCE LOSS CHECK

< DTC/CIRCUIT DIAGNOSIS >

[TYPE 4]

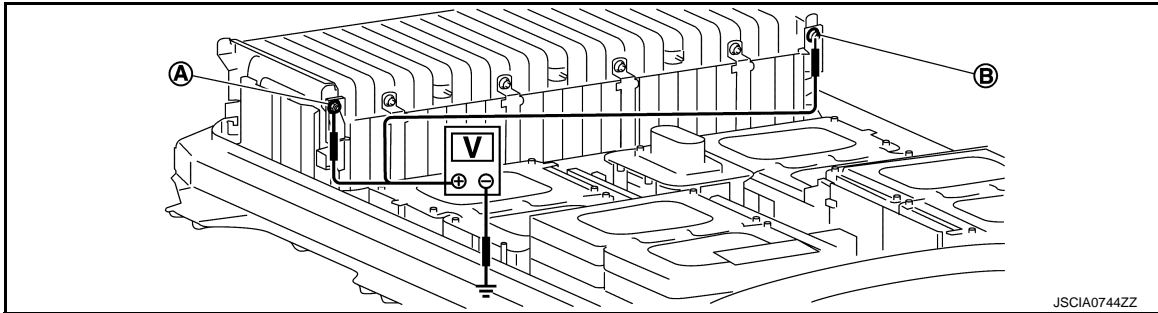

+	-	Voltage
Rear module stack		
Terminal		
(A), (B)	Battery pack ground	Approx. 0 V

Is the inspection result normal?

YES >> .Replace high voltage harness.

NO >> GO TO 17.

17.CHECK MODULE-5

1. Remove rear module stack. Refer to [EVB-930, "REAR MODULE STACK : Disassembly and Assembly"](#).

NOTE:

Do not disassemble module stack.

2. Measure voltages between terminal (A)/(B) of all modules in rear module stack and module body.

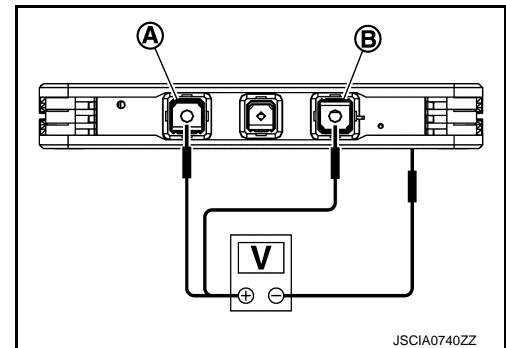

+	-	Voltage
Module		
Terminal		
(A)	Module body	Approx. 0 V
(B)		

Is the inspection result normal?

YES >> GO TO 18.

NO >> Replace malfunctioning module. Refer to [EVB-930, "REAR MODULE STACK : Disassembly and Assembly"](#).

18.CHECK MODULE-6

LI-ION BATTERY INSULATION RESISTANCE LOSS CHECK

[TYPE 4]

< DTC/CIRCUIT DIAGNOSIS >

Measure insulation resistance between terminal (A)/(B) of all modules in rear module stack and module body.

WARNING:

Unlike the ordinary tester, the insulation resistance tester applies 500 V when measuring. If used incorrectly, there is the danger of electric shock. If used in the vehicle 12V system, there is the danger of damage to electronic devices. Read the insulation resistance tester instruction manual carefully and be sure to work safely.

CAUTION:

Be sure to set the insulation resistance tester to 500 V when performing this test. Using a setting higher than 500 V can result in damage to the component being inspected.

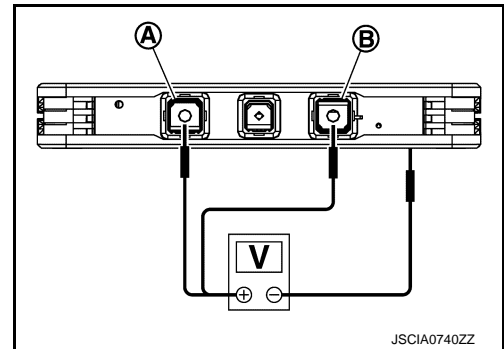

+	-	resistance
Module Terminal		
(A)	Module body	100 MΩ or more
(B)		

Is the inspection result normal?

YES-1 >> Replace or repair of malfunctioning part is not-yet performed: Replace Li-ion battery controller. Refer to [EV8-885, "LI-ION BATTERY CONTROLLER : Removal and Installation"](#).

YES-2 >> Replace or repair of malfunctioning part is complete: INSPECTION END.

NO >> Replace malfunctioning module. Refer to [EV8-930, "REAR MODULE STACK : Disassembly and Assembly"](#).

A
B
EVB
D
E
F
G
H
I
J
K
L
M
N
O
P

LI-ION BATTERY HEATER SYSTEM INSULATION RESISTANCE CHECK

< DTC/CIRCUIT DIAGNOSIS >

[TYPE 4]

LI-ION BATTERY HEATER SYSTEM INSULATION RESISTANCE CHECK

Diagnosis Procedure

INFOID:000000011104468

WARNING:

- Because hybrid vehicles and electric vehicles contain a high voltage battery, there is the risk of electric shock, electric leakage, or similar accidents if the high voltage component and vehicle are handled incorrectly. Be sure to follow the correct work procedures when performing inspection and maintenance.
- Be sure to remove the service plug in order to disconnect the high voltage circuits before performing inspection or maintenance of high voltage system harnesses and parts.
- To prevent the removed service plug from being connected by mistake during the procedure, always carry it in your pocket or put it in the tool box.
- Be sure to wear insulating protective equipment before beginning work on the high voltage system.
- Clearly identify the persons responsible for high voltage work and ensure that other persons do not touch the vehicle. When not working, cover high voltage parts with an insulating cover sheet or similar item to prevent other persons from contacting them.
- Refer to [EVB-695, "High Voltage Precautions"](#).

CAUTION:

There is the possibility of a malfunction occurring if the vehicle is changed to READY status while the service plug is removed. Therefore do not change the vehicle to READY status unless instructed to do so in the Service Manual.

1. PRECONDITIONING

WARNING:

Disconnect the high voltage. Refer to [GI-31, "How to Disconnect High Voltage"](#).

1. Remove Li-ion battery. Refer to [EVB-866, "Removal and Installation"](#).
2. Remove battery pack upper case. Refer to [EVB-875, "BATTERY PACK UPPER CASE : Removal and Installation"](#).

>> GO TO 2.

2. CHECK HIGH VOLTAGE HARNESS

Check the harness shield between the heater relay unit and the Li-ion battery heater for scratches and cracks.

Is the inspection result normal?

YES >> GO TO 3.

NO >> Repair or replace error-detected parts and Li-ion battery controller.

3. CHECK HEATER RELAY UNIT INSULATION RESISTANCE

WARNING:

Unlike the ordinary tester, the insulation resistance tester applies 500 V when measuring. If used incorrectly, there is the danger of electric shock. If used in the vehicle 12 V system, there is the danger of damage to electronic devices. Read the insulation resistance tester instruction manual carefully and be sure to work safely.

1. Disconnect high voltage harness connector from heater relay unit.

NOTE:

Check the heater relay with it installed on the battery pack.

2. Use 500 V range of insulation resistance tester to measure insulation resistance. Wait for 30 seconds until the value becomes stable.

CAUTION:

Be sure to set the insulation resistance tester to 500 V when performing this test. Using a setting higher than 500 V can result in damage to the component being inspected.

Heater relay unit	Ground	Resistance
Terminal		
10	Battery pack lower case	1000 MΩ or more
11		

LI-ION BATTERY HEATER SYSTEM INSULATION RESISTANCE CHECK

< DTC/CIRCUIT DIAGNOSIS >

[TYPE 4]

Is the inspection result normal?

- YES >> GO TO 4.
- NO >> Replace heater relay unit and Li-ion battery controller.

4. CHECK LI-ION BATTERY HEATER

WARNING:

Unlike the ordinary tester, the insulation resistance tester applies 500 V when measuring. If used incorrectly, there is the danger of electric shock. If used in the vehicle 12 V system, there is the danger of damage to electronic devices. Read the insulation resistance tester instruction manual carefully and be sure to work safely.

1. Disconnect high voltage harness connector from Li-ion battery heater.

NOTE:

Check the heater relay with it installed on the battery pack.

2. Use 500 V range of insulation resistance tester to measure insulation resistance. Wait for 30 seconds until the value becomes stable.

CAUTION:

Be sure to set the insulation resistance tester to 500 V when performing this test. Using a setting higher than 500 V can result in damage to the component being inspected.

Li-ion battery heater			Ground	Resistance
Item	Connector	Terminal		
LH1	LB19	1	Battery pack lower case	1000 MΩ or more
		2		
LH2	LB20	1		1000 MΩ or more
		2		
RH1	LB23	1		1000 MΩ or more
		2		
RH2	LB24	1		1000 MΩ or more
		2		
RR1	LB21	1		1000 MΩ or more
		2		
RR2	LB22	1		1000 MΩ or more
		2		

Is the inspection result normal?

- YES >> GO TO 5.
- NO >> Replace corresponding Li-ion battery heater and Li-ion battery controller.

5. CHECK HIGH VOLTAGE HARNESS INSULATION RESISTANCE

WARNING:

Unlike the ordinary tester, the insulation resistance tester applies 500 V when measuring. If used incorrectly, there is the danger of electric shock. If used in the vehicle 12 V system, there is the danger of damage to electronic devices. Read the insulation resistance tester instruction manual carefully and be sure to work safely.

1. Use 500 V range of insulation resistance tester to measure insulation resistance. Wait for 30 seconds until the value becomes stable.

CAUTION:

Be sure to set the insulation resistance tester to 500V when performing this test. Using a setting higher than 500 V can result in damage to the component being inspected.

High voltage harness		Ground	Resistance
Connector	Terminal		
LB18	11	Battery pack lower case	1000 MΩ or more

Is the inspection result normal?

LI-ION BATTERY HEATER SYSTEM INSULATION RESISTANCE CHECK

< DTC/CIRCUIT DIAGNOSIS >

[TYPE 4]

- YES >> INSPECTION END.
- NO >> Replace high voltage harness.

POWER SUPPLY AND GROUND CIRCUIT

< DTC/CIRCUIT DIAGNOSIS >

[TYPE 4]

POWER SUPPLY AND GROUND CIRCUIT

Diagnosis Procedure

INFOID:000000011104469

WARNING:

- Because hybrid vehicles and electric vehicles contain a high voltage battery, there is the risk of electric shock, electric leakage, or similar accidents if the high voltage component and vehicle are handled incorrectly. Be sure to follow the correct work procedures when performing inspection and maintenance.
- Be sure to remove the service plug in order to shut off the high voltage circuits before performing inspection or maintenance of high voltage system harnesses and parts.
- Be sure to put the removed service plug in your pocket and carry it with you so that another person does not accidentally connect it while work is in progress.
- Be sure to wear insulating protective gear consisting of glove, shoes and face shield before beginning work on the high voltage system.
- Clearly identify the persons responsible for high voltage work and ensure that other persons do not touch the vehicle. When not working, cover high voltage parts with an insulating cover sheet or similar item to prevent other persons from contacting them.
- Refer to [EVB-695, "High Voltage Precautions"](#).

CAUTION:

There is the possibility of a malfunction occurring if the vehicle is changed to READY status while the service plug is removed. Therefore do not change the vehicle to READY status unless instructed to do so in the Service Manual.

1. CHECK FUSE

Check that the following fuse is not fusing.

Power supply	Fuse No.
Battery	43
Power switch ON	55
	74

Is the fuse fusing?

YES >> Replace the fuse after repairing the applicable circuit.

NO >> GO TO 2.

2. CHECK LI-ION BATTERY CONTROLLER GROUND CIRCUIT

1. Turn power switch OFF.
2. Disconnect Li-ion battery vehicle communication harness connector.
3. Check the continuity between Li-ion battery vehicle communication harness connector and ground.

+		-	Continuity
Li-ion battery			
Connector	Terminal	Ground	Existed
B24	6		
	7		
	8		

Is the inspection result normal?

YES >> GO TO 3.

NO >> Repair or replace error-detected parts.

3. CHECK BATTERY POWER SUPPLY

Check the voltage between Li-ion battery vehicle communication harness connector and ground.

POWER SUPPLY AND GROUND CIRCUIT

[TYPE 4]

< DTC/CIRCUIT DIAGNOSIS >

+		-	Voltage
Li-ion battery			
Connector	Terminal		
B24	5	Ground	12V battery power supply

Is the inspection result normal?

YES >> GO TO 5.

NO >> GO TO 4.

4.CHECK BATTERY POWER SUPPLY CIRCUIT

1. Check the continuity between Li-ion battery vehicle communication harness connector and fuse terminal.

+		-	Continuity
Li-ion battery			
Connector	Terminal		
B24	5	No.43 fuse terminal	Existed

2. Also check harness for short to ground.

Is the inspection result normal?

YES >> Check power supply circuit for battery power supply.

NO >> Repair or replace error-detected parts.

5.CHECK IGNITION POWER SUPPLY

1. Turn power switch ON.
2. Check the voltage between Li-ion battery vehicle communication harness and ground.

+		-	Voltage (Approx.)
Li-ion battery			
Connector	Terminal		
B24	4	Ground	11 – 14 V
	21		

Is the inspection result normal?

YES >> GO TO 8.

NO >> GO TO 6.

6.CHECK IGNITION POWER SUPPLY CIRCUIT-1

1. Turn power switch OFF.
2. Disconnect IPDM E/R harness connector.
3. Check the continuity between Li-ion battery vehicle communication harness and IPDM E/R harness connector.

Li-ion battery		IPDM E/R		Continuity
Connector	Terminal	Connector	Terminal	
B24	4	E15	57	Existed

4. Also check harness for short to ground.

Is the inspection result normal?

YES >> GO TO 7.

NO >> Repair or replace error-detected parts.

7.CHECK IGNITION POWER SUPPLY CIRCUIT-2

1. Check the continuity between Li-ion battery vehicle communication harness and fuse terminal.

POWER SUPPLY AND GROUND CIRCUIT

< DTC/CIRCUIT DIAGNOSIS >

[TYPE 4]

Li-ion battery		—	Continuity
Connector	Terminal		
B24	21	No.74 fuse terminal	Existed

2. Also check harness for short to ground.

Is the inspection result normal?

YES >> Check power supply circuit for battery power supply.

NO >> Repair or replace error-detected parts.

8. PRECONDITIONING

WARNING:

Shut off high voltage circuit. Refer to [GI-31, "How to Disconnect High Voltage"](#).

1. Remove Li-ion battery. Refer to [EV-866, "Removal and Installation"](#).

2. Remove battery pack upper case. Refer to [EV-875, "BATTERY PACK UPPER CASE : Removal and Installation"](#).

>> GO TO 9.

9. CHECK HARNESS BETWEEN LI-ION BATTERY AND LI-ION BATTERY CONTROLLER

1. Check the continuity between Li-ion battery vehicle communication harness connector and Li-ion battery controller harness connector.

LBC		Li-ion battery		Continuity
Connector	Terminal	Connector	Terminal	
LB11	5	LB1	21	Existed
	6		4	
	21		5	
	3		8	
	15		7	
	16		6	

2. Also check harness for short to ground.

Is the inspection result normal?

YES >> INSPECTION END

NO >> Repair or replace error-detected parts.

REDUCTION IN THE DRIVING RANGE

[TYPE 4]

< SYMPTOM DIAGNOSIS >

SYMPTOM DIAGNOSIS

REDUCTION IN THE DRIVING RANGE

Description

INFOID:000000011104470

- The driving range is shorter than before.
- Sudden change (decrease/increase) in possible travel distance indicated on the combination meter.

Diagnosis Procedure

INFOID:000000011104471

1. CHECK LI-ION BATTERY AVAILABLE CHARGE GAUGE

Check the indication of the Li-ion battery available charge gauge.

NOTE:

Check 12 segments for lighting status.

Is the lighting status 1 Segment or none?

YES >> GO TO 3.

NO >> GO TO 2.

2. DISCHARGE OF LI-ION BATTERY

1. Set the vehicle to READY.
2. Set the vehicle, according to the following conditions.

A/C set temperature	: Full hot
A/C fan speed	: Maximum speed
A/C air outlet	:  Defroster
Headlamp	: High beam ON
Door glass	: Full open

3. Let the Li-ion battery discharge until the Li-ion battery available charge gauge shows Segment 1 or below.

>> GO TO 3.

3. CHARGE OF LI-ION BATTERY

1. Charge the Li-ion battery by normal charge until the level reaches full charge.
2. After the completion of normal charge, check that the indication of the Li-ion battery available charge gauge shows 12 segments.

>> GO TO 4.

4. PERFORM DTC CONFIRMATION PROCEDURE

 With CONSULT

1. Power switch ON and wait for 10 seconds or more.
2. Select "Self Diagnostic Result" of "HV BAT".
3. Check DTC.

Is any DTC detected?

YES >> Perform diagnosis on the detected DTC. Refer to [EVB-734, "DTC Index"](#).

NO >> INSPECTION END

EV BATTERY USAGE REPORT

< PERIODIC MAINTENANCE >

[TYPE 4]

PERIODIC MAINTENANCE

EV BATTERY USAGE REPORT

Inspection

INFOID:000000011104472

Generation of the EV battery usage report is one of the maintenance items.

This maintenance item generates a report that will help the customer understand the vehicle operating conditions needed to keep the Li-ion battery in the best possible condition.

For details about how to generate this report, please refer to EV battery usage report in the CONSULT III plus operation manual.

A

B

EVB

D

E

F

G

H

I

J

K

L

M

N

O

P

LI-ION BATTERY

< UNIT REMOVAL AND INSTALLATION >

[TYPE 4]

UNIT REMOVAL AND INSTALLATION

LI-ION BATTERY

Exploded View

INFOID:000000011191506

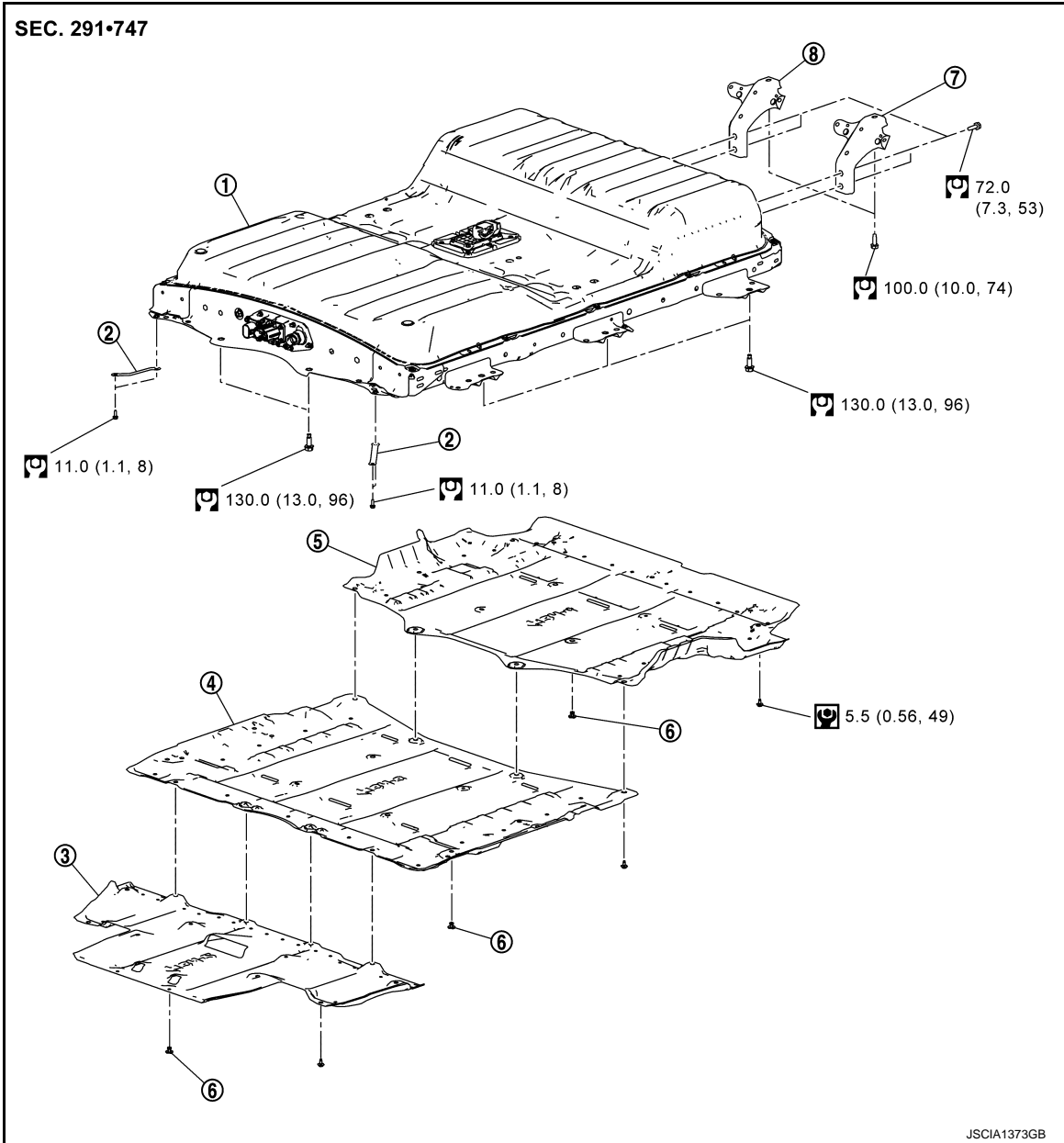

- ① Li-ion battery
- ② Bonding plate (stamped No. 4.)
- ③ Li-ion battery undercover (front)
- ④ Li-ion battery undercover (center)
- ⑤ Li-ion battery undercover (rear)
- ⑥ Clip
- ⑦ Battery mounting bracket (left)
- ⑧ Battery mounting bracket (right)

 : N·m (kg·m ft·lb)

 : N·m (kg·m, in·lb)

Removal and Installation

INFOID:000000011191507

DANGER:

LI-ION BATTERY

< UNIT REMOVAL AND INSTALLATION >

[TYPE 4]

 Because hybrid vehicles and electric vehicles contain a high voltage battery, there is a risk of electric shock, electric leakage, or similar accidents if the vehicle is handled incorrectly. Be sure to follow the correct work procedures when performing inspection and maintenance.

WARNING:

- Be sure to remove the service plug in order to shut off the high voltage circuits before performing inspection or maintenance of high voltage system harnesses and parts.
- Be sure to put the removed service plug in pocket and carry it or store it in a tool box or other container so that another person does not accidentally connect it while work is in progress.
- Be sure to put on insulating protective gear before beginning work on the high voltage system.
- Clearly identify the persons responsible for high voltage work and ensure that other persons do not touch the vehicle. When not working, cover high voltage components with an anti-static cover sheet or similar item to prevent contact with other persons.
- Refer to [EVB-469, "High Voltage Precautions"](#).

CAUTION:

There is the possibility of a malfunction occurring if the vehicle is changed to READY status while the service plug is removed. Therefore do not change the vehicle to READY status unless instructed to do so in the Service Manual.

REMOVAL

WARNING:

Prepare for work on the high-voltage system. Refer to [GI-31, "How to Disconnect High Voltage"](#).

1. Lift up the vehicle and remove the Li-ion battery undercover. Refer to [EVB-866, "Exploded View"](#).
2. Remove the harness clamp (A) and disconnect the Li-ion battery high-voltage harness connector (B).

DANGER:

-  There is the danger of electric shock caused by contact with the terminals. Be sure to wear insulated protective gear.



-  Because there is the danger of electric shock, immediately insulate disconnected high voltage connectors and terminals with insulating tape.

- Follow the procedure below to disconnect the high-voltage harness connector.

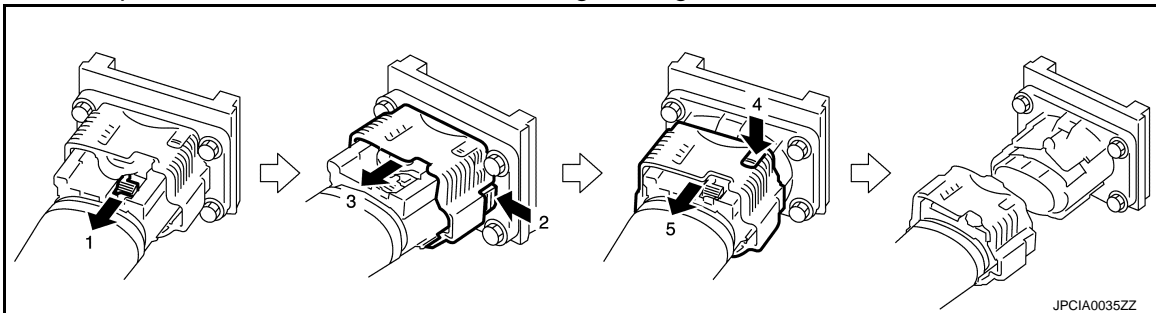

3. Disconnect the Li-ion battery vehicle communications connector (A) while rotating it in the counterclockwise direction.

WARNING:

-  To prevent electric shock, wear insulated protective gear.

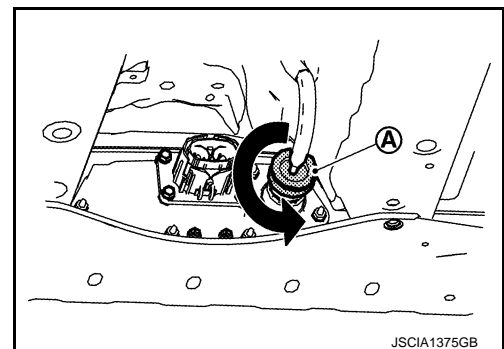
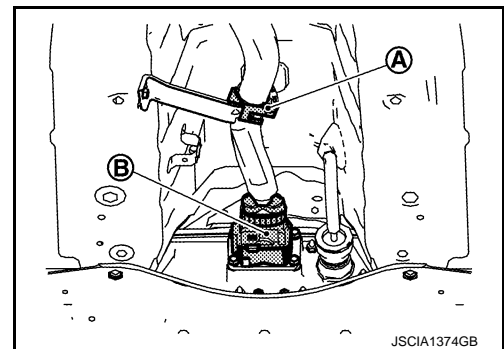

LI-ION BATTERY

< UNIT REMOVAL AND INSTALLATION >

[TYPE 4]

4. Remove bonding plate ①.

WARNING:



To prevent electric shock, wear insulated protective gear.

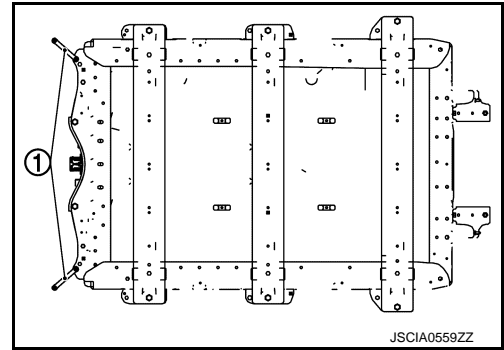

5. Remove Li-ion battery mounting bolts ①.

WARNING:



To prevent electric shock, wear insulated protective gear.



CAUTION:

Do not remove the 4 bolts shown by ② in the figure.

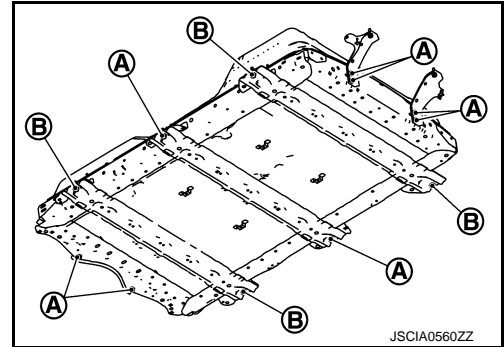

6. Set the pallet [SST: — (J-50583)] onto the lift table.
- Align the pallet ① center mark ① and the lift table ② center mark ②.

- ③ Front
- ④ Side

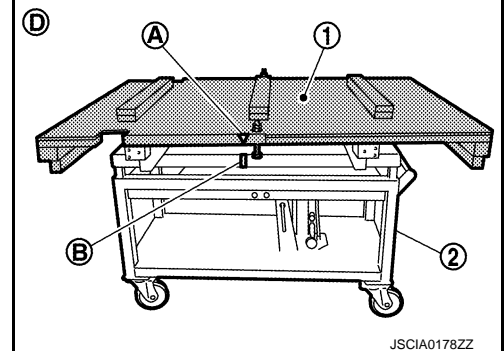
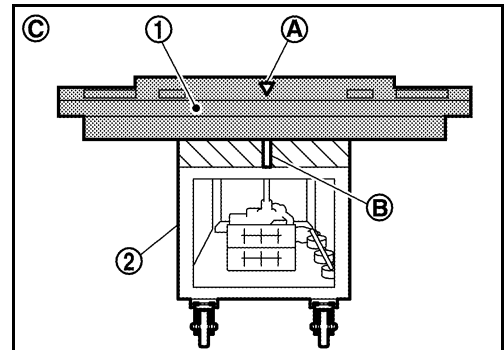

7. Set the pallet ① onto the Li-ion battery.
- CAUTION:**
For preventing the battery from falling, fasten the pallet and battery with transport fastening bolts.

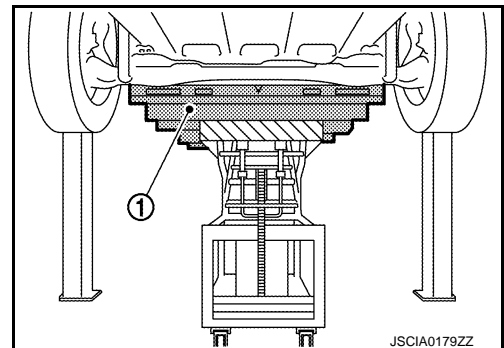

LI-ION BATTERY

< UNIT REMOVAL AND INSTALLATION >

[TYPE 4]

8. Remove the Li-ion battery mounting bolts (4 bolts) (A).

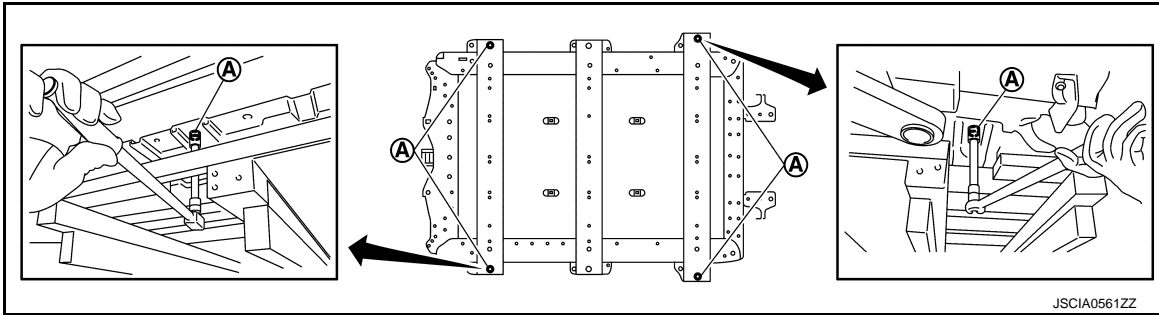

WARNING:

 To prevent electric shock, wear insulated protective gear.



9. Lower the pallet, and remove the Li-ion battery (1) from the vehicle.

WARNING:

 To prevent electric shock, wear insulated protective gear.

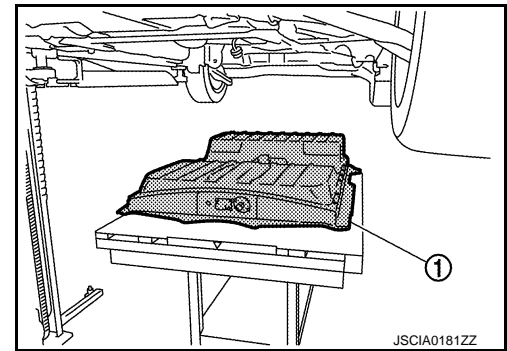

10. Lower the Li-ion battery from the lift table together with the pallet.

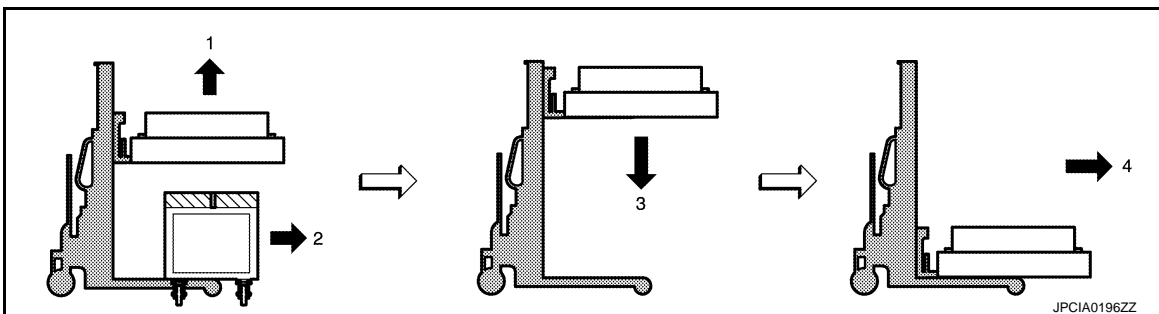

1. Lift up the Li-ion battery.
2. Move the lift table.
3. Lower the Li-ion battery.
4. Operate the stacker and move the Li-ion battery.

CAUTION:

Because there is the danger of tipping over, do not move the stacker while the Li-ion battery is lifted up.

INSTALLATION

1. When replacing the Li-ion battery with a new battery, perform the work listed below.
 - a. Enter the date of the (replacement) work on the EV battery tracking identification seal that is packaged together with the new part.
 - b. Cut the EV battery tracking identification seal into 2 pieces and apply them to the body of the replaced (old) Li-ion battery and to the "Li-ion battery replacement history record".
 - c. Enter the necessary information in the "Li-ion battery replacement history record".

A
B
EVB
D
E
F
G
H
I
J
K
L
M
N
O
P

LI-ION BATTERY

< UNIT REMOVAL AND INSTALLATION >

[TYPE 4]

2. Install the locating pin ① [SST: KV99111300 (J-50306)] in the position on the body as shown in the figure.

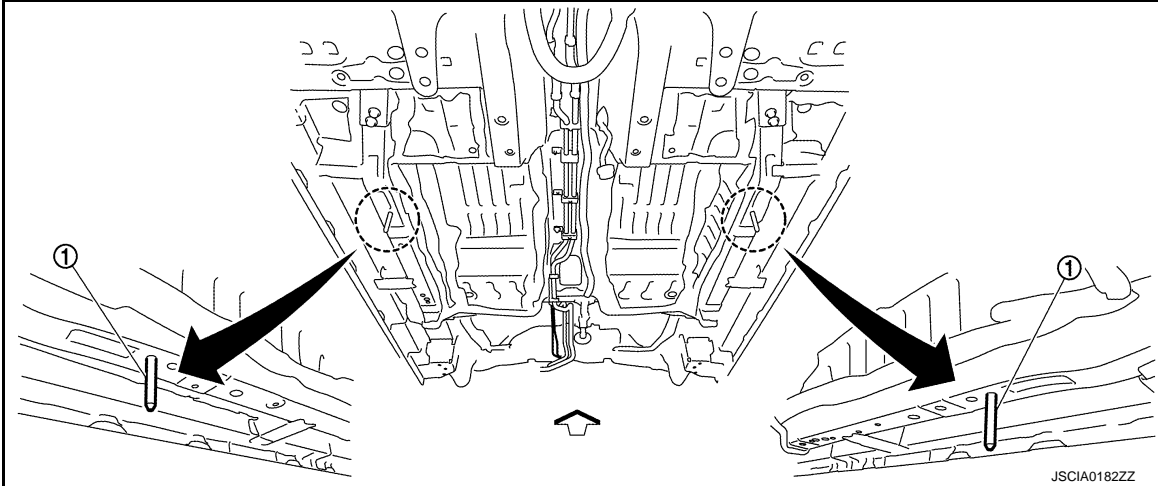

← : Vehicle front

3. Install the Li-ion battery onto the vehicle body.
 - Align the Li-ion battery ① and the locating pin ②.

WARNING:



To prevent electric shock, wear insulated protective gear.

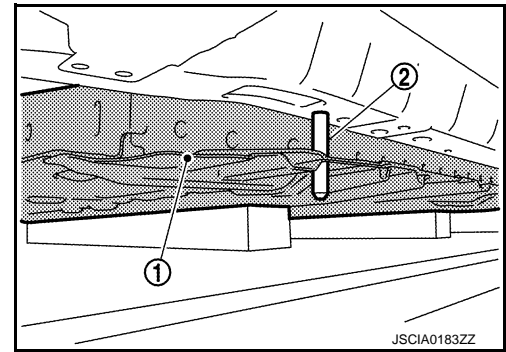

4. Tighten the Li-ion battery mounting bolts (4 bolts) ①, then remove the pallet.

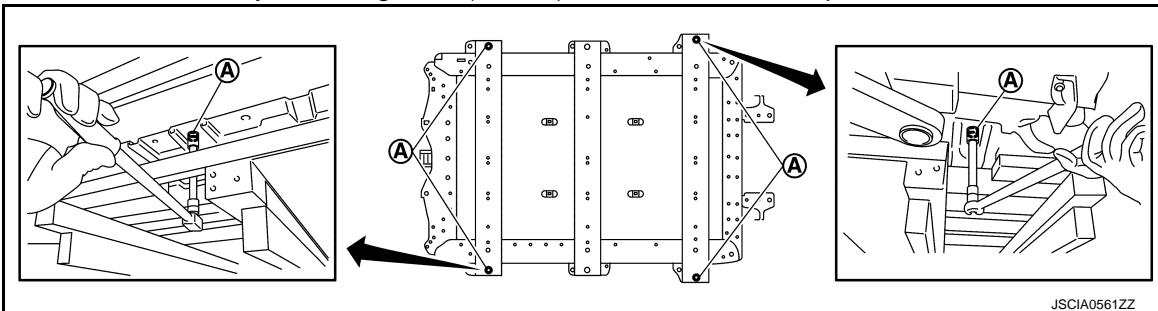

WARNING:



To prevent electric shock, wear insulated protective gear.



5. Remove the locating pin from the body.

LI-ION BATTERY

< UNIT REMOVAL AND INSTALLATION >

[TYPE 4]

- If the locating pin ① is stuck and cannot be removed, remove it using a wrench.

WARNING:



To prevent electric shock, wear insulated protective gear.

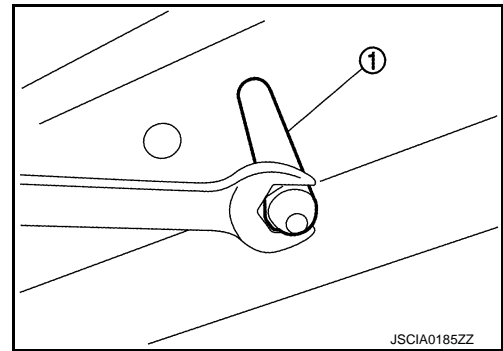

6. Install the Li-ion battery mounting bolts ①.

WARNING:



To prevent electric shock, wear insulated protective gear.

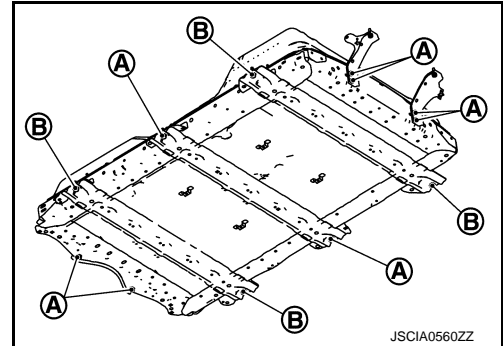

7. Install the bonding plate ①.

WARNING:



To prevent electric shock, wear insulated protective gear.

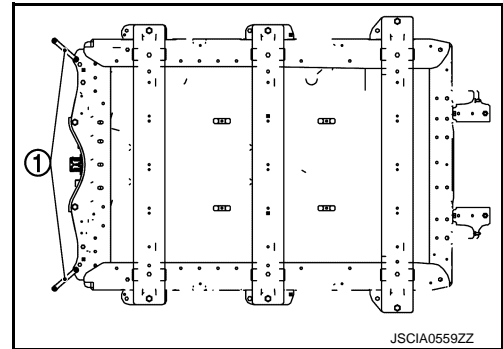

8. After installing the bonding plate, perform an electric equipotential test. [EV8-872. "Inspection"](#).

9. Rotate the vehicle communications connector ① clockwise to connect it.

WARNING:



To prevent electric shock, wear insulated protective gear.

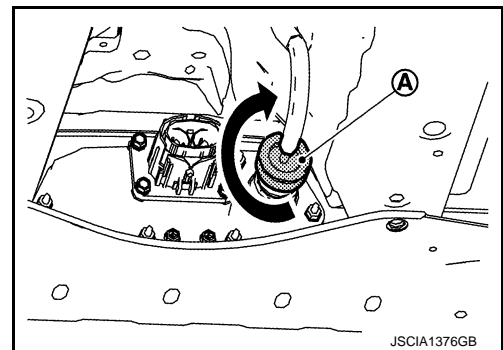

A
B
EVB
D
E
F
G
H
I
J
K
L
M
N
O
P

LI-ION BATTERY

< UNIT REMOVAL AND INSTALLATION >

[TYPE 4]

10. Install the high-voltage harness connector (B) and install the harness clamp (A).

WARNING:



To prevent electric shock, wear insulated protective gear.

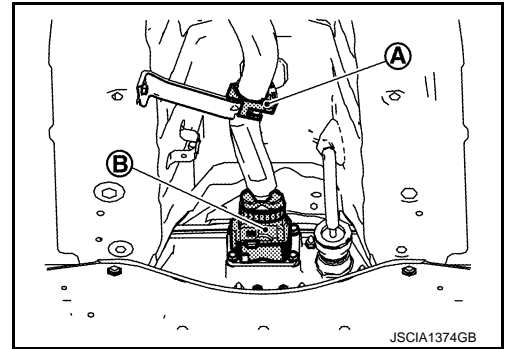

- Connect the high-voltage harness connector by the following procedure.

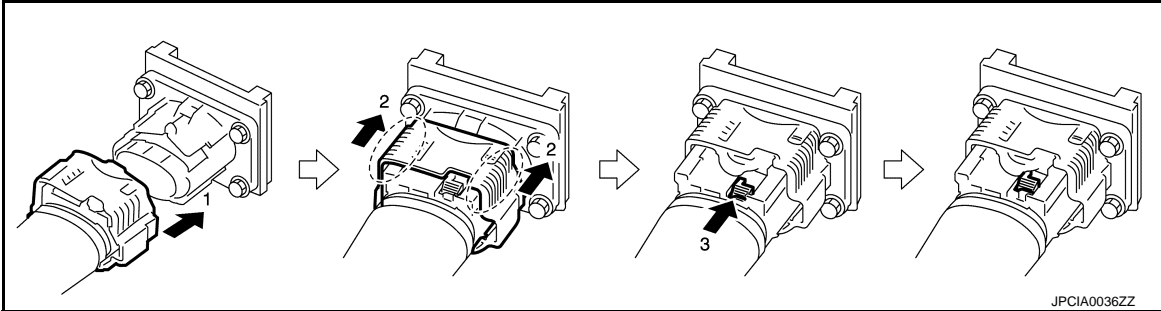

11. Install the Li-ion battery undercover.
12. Install the service plug Refer to [GI-31, "How to Disconnect High Voltage"](#).

Inspection

INFOID:000000011191508

ELECTRIC EQUIPOTENTIAL TEST

After installing the Li-ion battery, measure the resistance between the battery pack ground bolt (A) and the body ground.

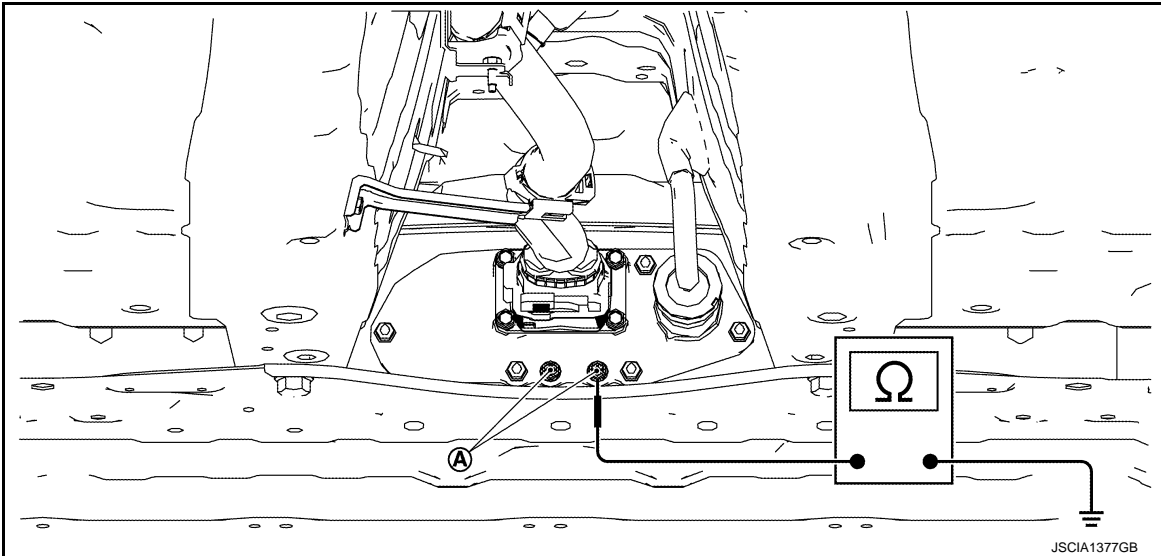

WARNING:



To prevent electric shock, wear insulated protective gear.



Standard : Less than 0.1Ω

If the result deviates from the standard value, check the following and correct the malfunction location.

LI-ION BATTERY

< UNIT REMOVAL AND INSTALLATION >

[TYPE 4]

- Conditions of bonding plate connection
- Corrosion on bonding plate mounting surface
- Presence of paint, oil, dirt, or other substance on the bonding plate mounting surface

A

B

EVB

D

E

F

G

H

I

J

K

L

M

N

O

P

LI-ION BATTERY

< UNIT DISASSEMBLY AND ASSEMBLY >

[TYPE 4]

UNIT DISASSEMBLY AND ASSEMBLY

LI-ION BATTERY

BATTERY PACK UPPER CASE

BATTERY PACK UPPER CASE : Exploded View

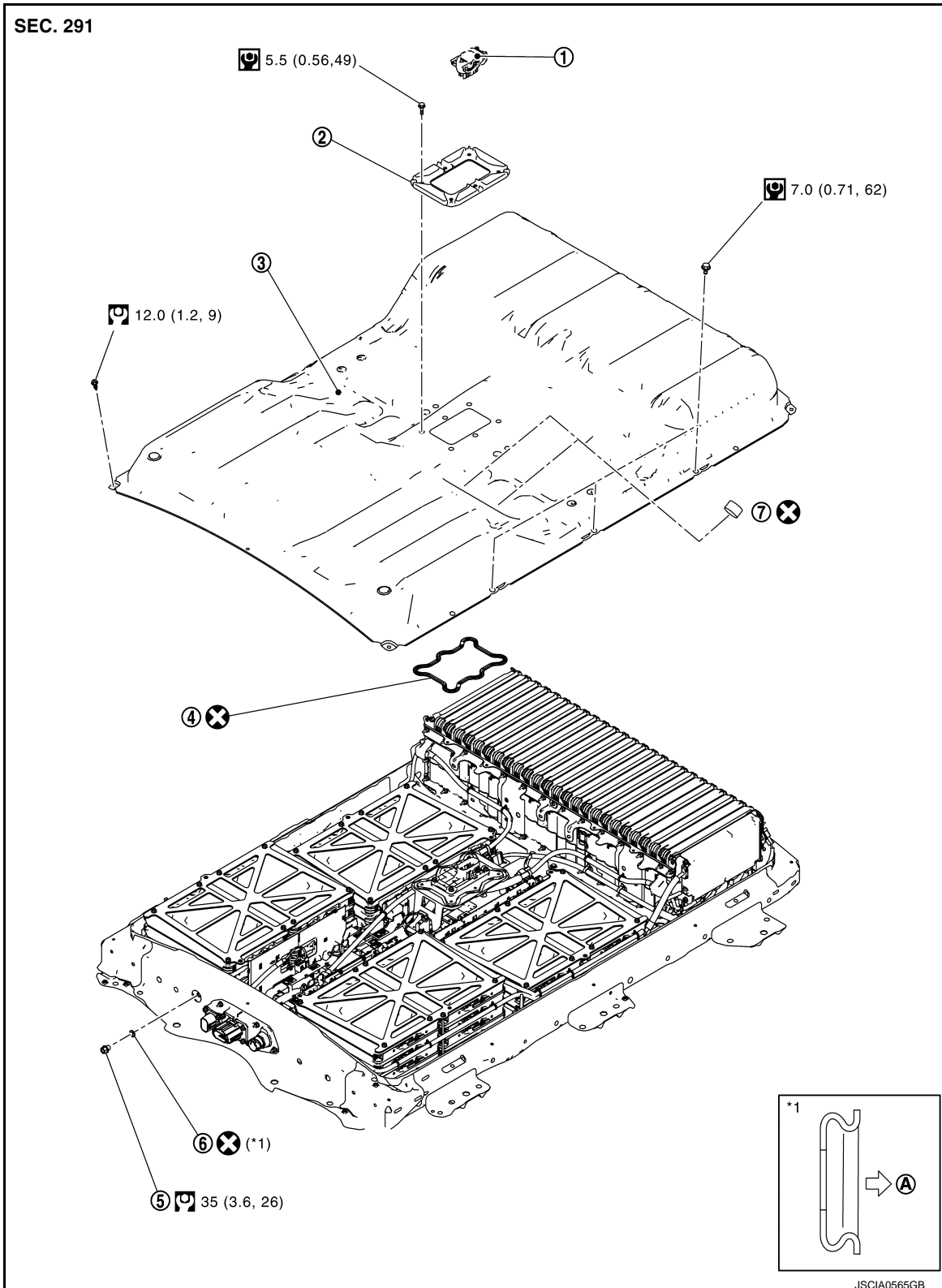

INFOID:000000011191509



LI-ION BATTERY

< UNIT DISASSEMBLY AND ASSEMBLY >

[TYPE 4]

- | | | |
|--------------------------|-------------------------|---------------------------|
| ① Service plug | ② Service plug retainer | ③ Battery pack upper case |
| ④ Seal | ⑤ Plug | ⑥ Plug washer |
| ⑦ Breather | | |
| Ⓐ Battery pack case side | | |
-  : Always replace after every disassembly.
-  : N-m (kg-m, in-lb)
-  : N-m (kg-m, ft-lb)

A
B
D

EVB

BATTERY PACK UPPER CASE : Removal and Installation

INFOID:0000000011191510

DANGER:

 Since hybrid vehicles and electric vehicles contain a high voltage battery, there is the risk of electric shock, electric leakage, or similar accidents if the high voltage component and vehicle are handled incorrectly. Be sure to follow the correct work procedures when performing inspection and maintenance.

WARNING:

- Be sure to remove the service plug in order to shut off the high voltage circuits before performing inspection or maintenance of high voltage system harnesses and parts.
- Be sure to put the removed service plug in pocket and carry it or store it in a tool box or other container so that another person does not accidentally connect it while work is in progress.
- Be sure to put on insulating protective gear before beginning work on the high voltage system.
- Clearly identify the persons responsible for high voltage work and ensure that other persons do not touch the vehicle. When not working, cover high voltage components with an anti-static cover sheet or similar item to prevent contact with other persons.
- Refer to [EVB-695, "High Voltage Precautions"](#).
- If the battery pack is to be disassembled, be sure to remove the Li-ion battery controller for preventing electric shock, fire, and damage to parts.

CAUTION:

There is the possibility of a malfunction occurring if the vehicle is changed to READY status while the service plug is removed. Therefore do not change the vehicle to READY status unless instructed to do so in the Service Manual.

ENVIRONMENT FOR LI-ION BATTERY DISASSEMBLY WORK

1. Must be an indoor environment.
 - The environment must utilize a shutter or other means to shut out the outside environment and prevent rain, snow, dust, or other substances from entering.
 - The environment must not cause the intrusion of sweat during work, or cause condensation to occur due to high temperature or humidity.
2. Metal powder, grease, and other foreign substances must not enter.
 - The indoor environment must also prevent metal powder, grease, and other foreign substances from entering due to maintenance performed on other vehicles and other sources during disassembly work.
 - If there is a risk of the above substances entering, take appropriate countermeasures, such as use of a vinyl curtain or an equivalent to shut out the outside environment.
3. The floor must be dry.
 - The floor must not be wet as a result of factors such as vehicle entry during rain or snow.
4. Work space
 - The work space must be approximately the size of one entire vehicle.
 - Take appropriate countermeasures so that persons other than the operator do not enter the work space, such as by placing signs indicating that disassembly work is in progress.
5. Standard fire fighting equipment
 - Always place a standard fire fighting equipment in the disassembly work area.
 - Depending on type of fire (vehicle or battery) use standard fire fighting equipment (water or extinguisher).

REMOVAL

LI-ION BATTERY

< UNIT DISASSEMBLY AND ASSEMBLY >

[TYPE 4]

1. Clean any dust or dirt adhered to the battery pack.
2. Remove the service plug retainer ①.

WARNING:

 To prevent electric shock, wear insulated protective gear and use insulated tools.

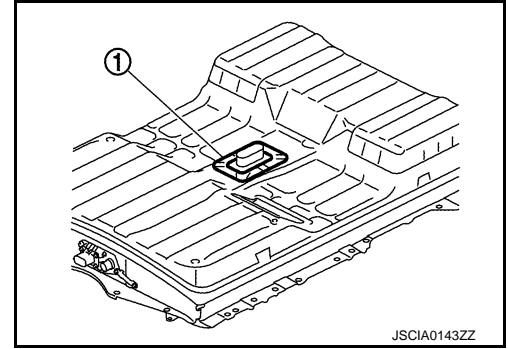

JSCIA0143ZZ

3. Remove the battery pack upper case mounting bolts ① and ground bolts ②.

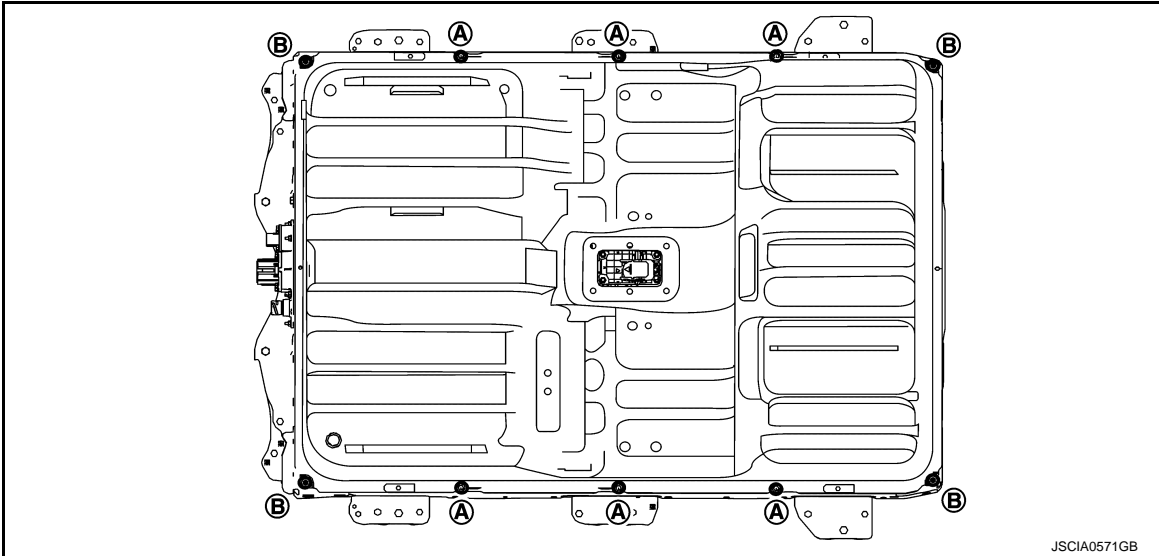

JSCIA0571GB

WARNING:

 To prevent electric shock, wear insulated protective gear and use insulated tools.



4. Cut the battery pack upper case adhesive according to the following procedure.

WARNING:

 To prevent electric shock, wear insulated protective gear.



- a. Prepare a windshield cutter.

NOTE:

- Sharpen the blade of the windshield cutter ①.
- Apply a tape ② for preventing damage to the battery pack.

③ : 38 mm (1.50 in)

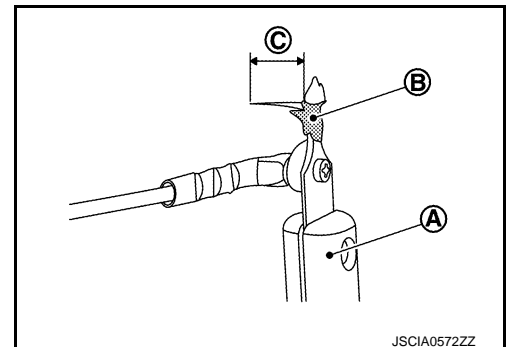

JSCIA0572ZZ

LI-ION BATTERY

< UNIT DISASSEMBLY AND ASSEMBLY >

[TYPE 4]

b. Use the windshield cutter and cut the adhesive in the order from 1 to 4 as shown in the figure.

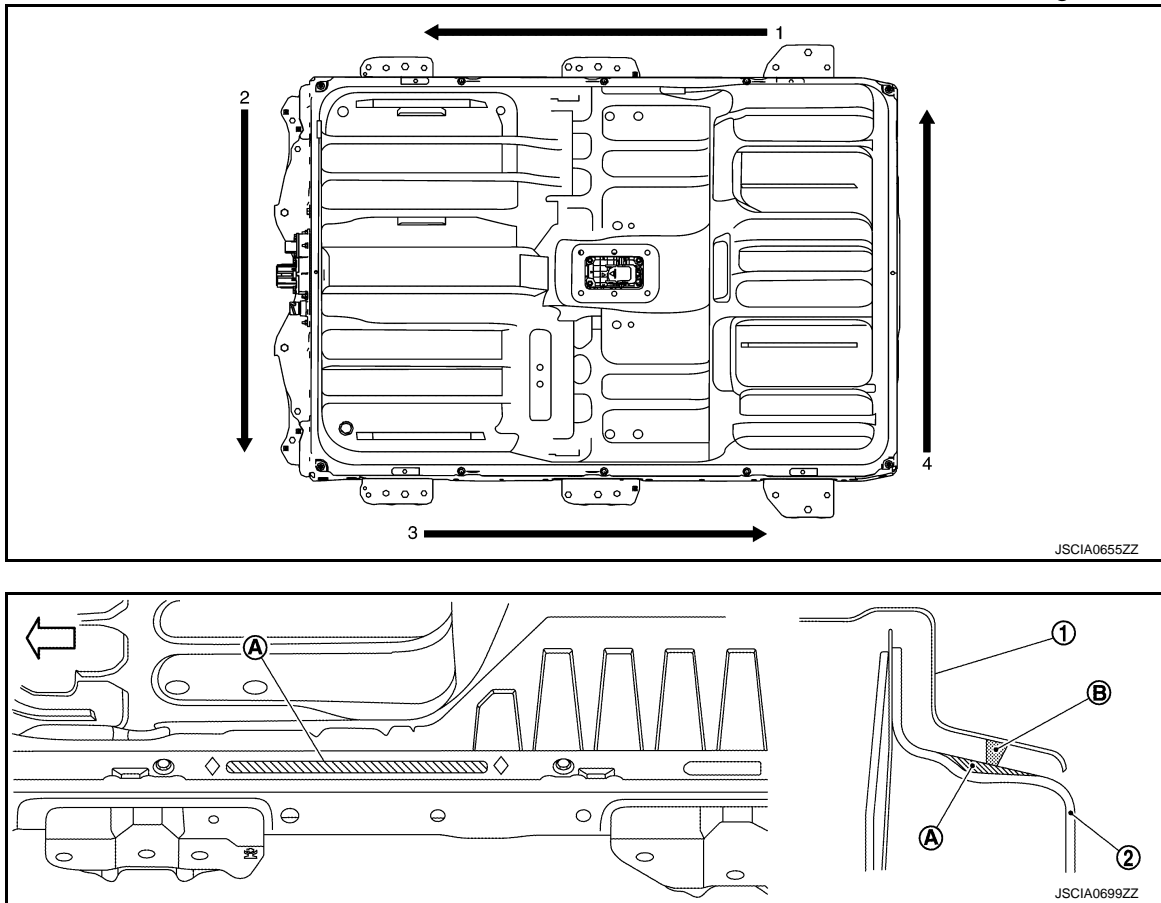

- ① Battery pack upper case
- ② Battery pack lower case
- Ⓐ Paint sealant
- Ⓑ Adhesive
- ◇ : Paint sealant mark
- ↶ : Battery front

CAUTION:

- When cutting the adhesive, be careful to avoid scratching the battery pack coating to the maximum extent possible.
- The paint sealant is set between the paint sealant marks stamped on the battery pack upper case (between ◇ to ◇). Therefore be careful not to damage the paint sealant when cutting the adhesive.
- Because the paint sealant functions to release pressure from inside the battery pack, if the paint sealant is damaged beyond the limit, the battery pack lower case must be replaced. If the paint sealant damage is less than the limit, repair by applying primer (adhesive primer: 999MP-43533PP).

Paint sealant damage limit:

Continuous length of undamaged section: : 210 mm (8.27 in) or more

NOTE:

- Because there is no clearance at the embossed part, cut the adhesive there last.

LI-ION BATTERY

< UNIT DISASSEMBLY AND ASSEMBLY >

[TYPE 4]

- Set the windshield cutter (A) at an angle of 90° to the surface of the battery case.

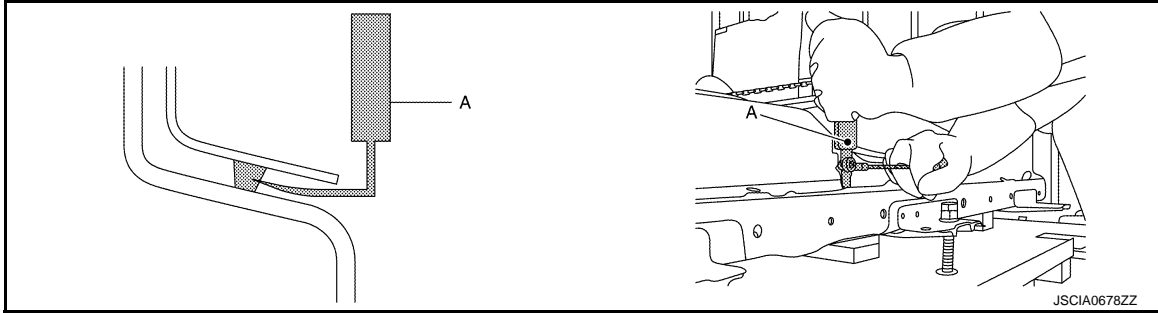

- Hold the windshield cutter facing toward the grip, and cut the adhesive while holding the blade level.

- c. Use piano wire (A) to cut the adhesive at the battery pack corners.

CAUTION:

When cutting the adhesive, be careful to avoid scratching the battery pack coating and paint sealant to the maximum extent possible.

NOTE:

Press the piano wire against the adhesive at the battery pack corner, and pull it in alternate directions for cutting of adhesive.

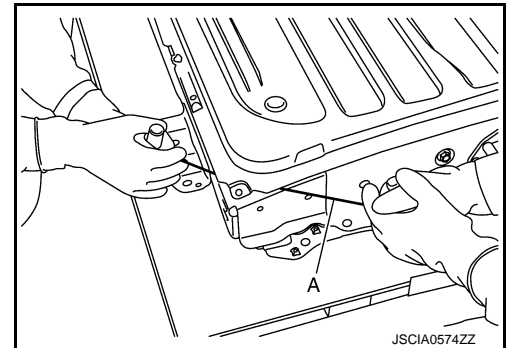

- d. Use the windshield cutter (A) for cutting adhesive at the embossed locations.



- i. Insert a plastic remover tool (B) into the embossed locations to open a clearance.

CAUTION:

Do not press the remover tool farther in than necessary. Doing so may deform the battery pack upper case.

- ii. Tilt the windshield cutter blade at an angle and cut the adhesive at the embossed locations.

CAUTION:

When cutting the adhesive, be careful to avoid scratching the battery pack coating to the maximum extent possible.

5. Remove the battery pack upper case.

WARNING:



To prevent electric shock, wear insulated protective gear.



CAUTION:

- Check that the adhesive is fully cut before removing. Use of excessive force during removal may deform the battery pack upper case.
- When removing the battery pack upper case, be careful that cutting particles do not enter the battery pack.

LI-ION BATTERY

< UNIT DISASSEMBLY AND ASSEMBLY >

[TYPE 4]

- If adhesive cutting particles enter the battery pack, clean (use of air blow is prohibited) when assembling so that no particles remain on the battery module, bus bar, and high-voltage harness.
- Operation must be performed by 2 persons. Be careful that the battery pack upper case does not contact the battery module.

INSTALLATION

1. To remove remaining adhesive on the battery pack upper case and battery pack lower case (A), use a scraper (B), and cut so that the surface is smooth, leaving approximately 1 – 2 mm (0.04 – 0.08 in) (C) of adhesive behind.

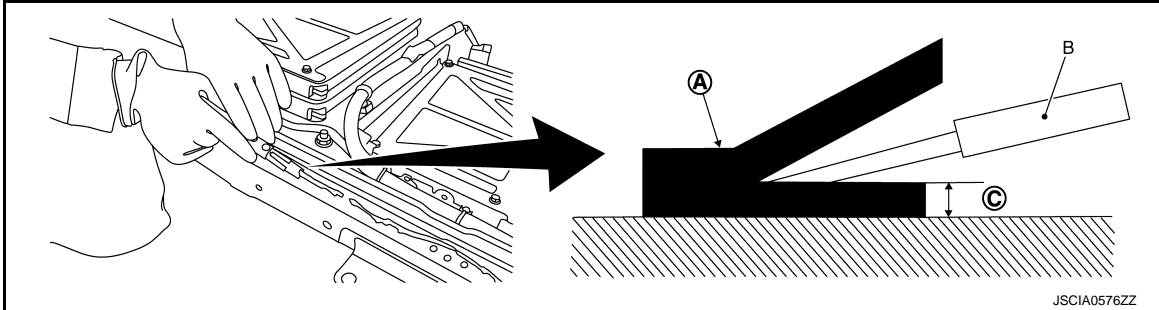

CAUTION:

- Because airtightness leakage is likely to occur, cut the seal in such a way that burrs are not produced.
- Be careful not to damage the paint sealant.
- If the paint sealant on a straight section is damaged in excess of the limit, the battery pack lower case must be replaced. If the paint sealant damage is less than the limit, repair by applying primer (adhesive primer: 999MP-43533PP).

Paint sealant damage limit:

Continuous length of undamaged section: : 210 mm (8.27 in) or more

- If the paint sealant damage on a corner is damaged, repair by applying primer (adhesive primer: 999MP-43533PP).

NOTE:

- Leave 1 – 2 mm (0.04 – 0.08 in) of adhesive so that the battery pack coating surface and paint sealant are not damaged.
- Sharpen the blade of the scraper.

2. Repair scratches to the battery pack upper case by the following procedure.

- a. Protect the seal with masking tape (A).

NOTE:

If primer surfacer (anti-corrosion primer) contacts the seal, the adhesive strength is reduced.

- b. Spray primer surfacer (anti-corrosion primer) (B) into the cracks in the battery pack upper case.

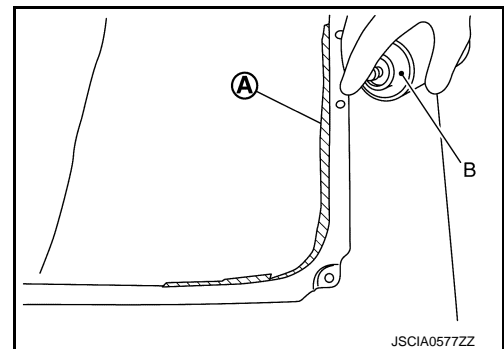

LI-ION BATTERY

< UNIT DISASSEMBLY AND ASSEMBLY >

[TYPE 4]

3. Install a carabiner (A) onto the bracket of the battery pack upper case.

NOTE:

This is to provide a handle for use after the adhesive is applied and prevent adhesive from adhering to the operator's hands.

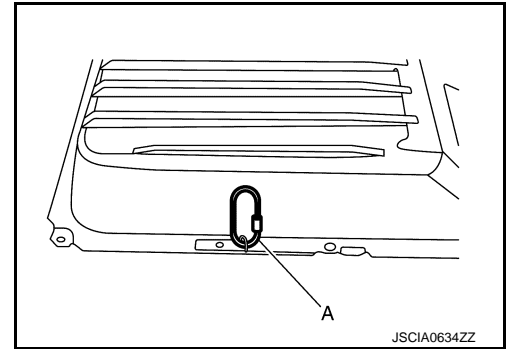

4. Apply dam rubber (KA390-0059U) (B) on the inside of the old adhesive (A) on the battery pack lower case.

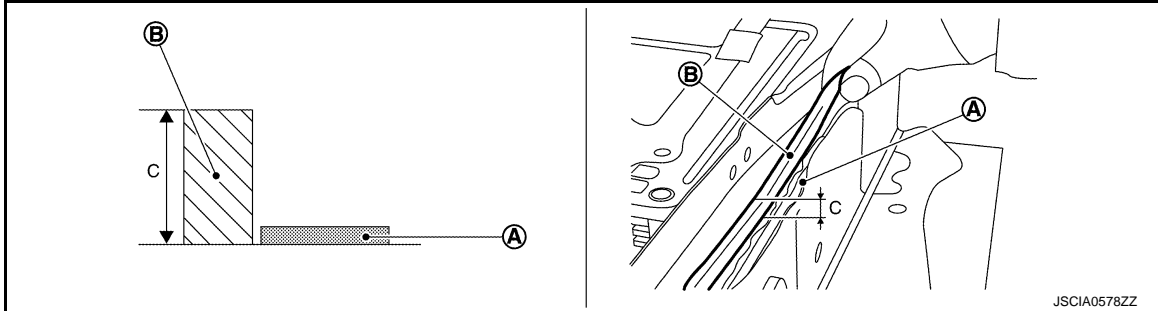

C : 10 mm (0.39 in)

WARNING:



To prevent electric shock, wear insulated protective gear.



CAUTION:

If dam rubber is already applied there, replace it with new dam rubber.

NOTE:

Apply the dam rubber so that adhesive does not enter the inner side. If the adhesive enters the inner side, then the next time the battery pack is disassembled, the windshield cutter may not be able to reach the adhesive and removing the battery pack upper case may be difficult.

5. Apply adhesive (999MP-57302NP) to the battery pack lower case as shown in the figure.

WARNING:



To prevent electric shock, wear insulated protective gear.



LI-ION BATTERY

< UNIT DISASSEMBLY AND ASSEMBLY >

[TYPE 4]

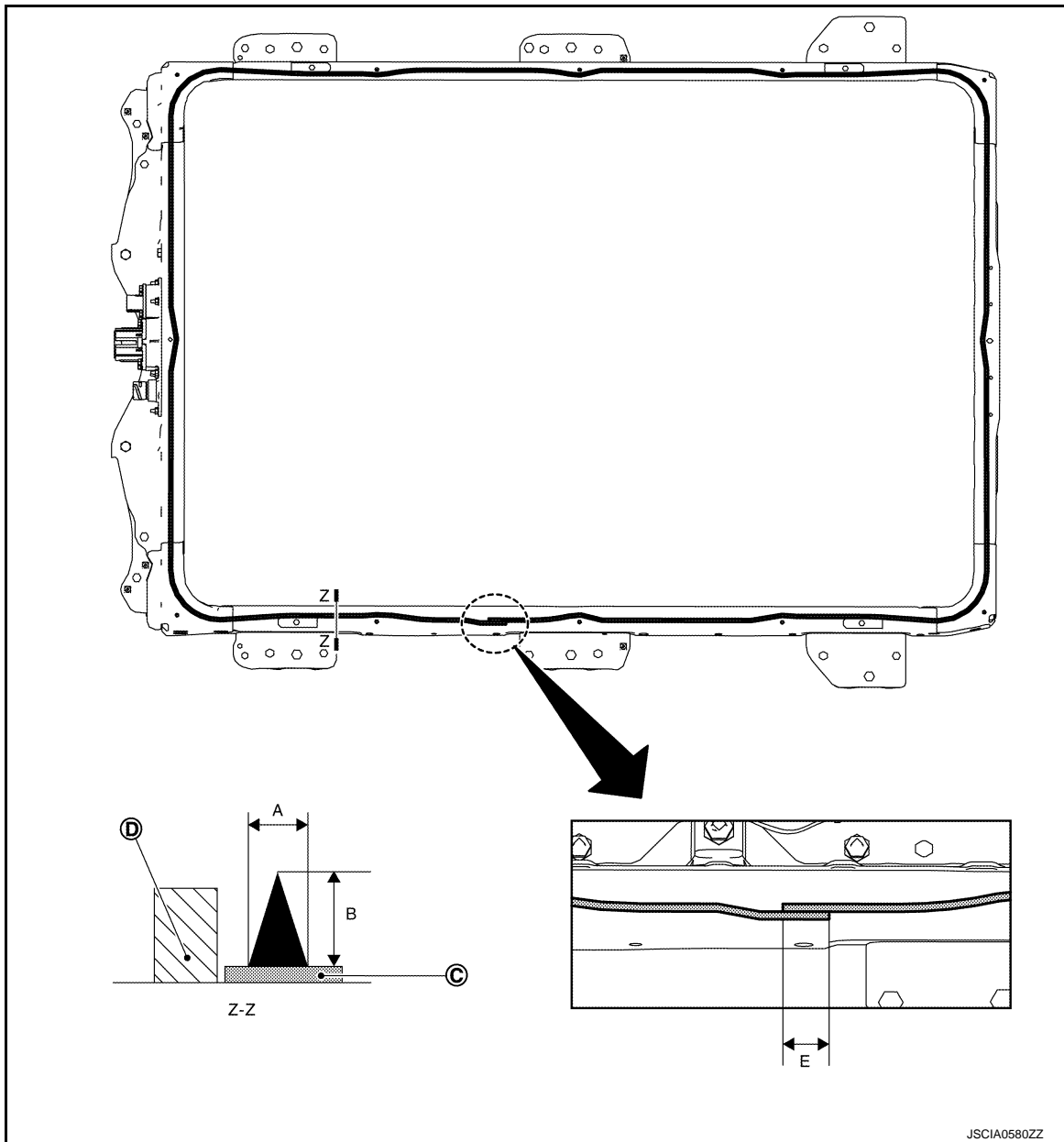

A : 5 mm (0.20 in)

B : 10 mm (0.39 in)

© : Old adhesive

Ⓓ : Dam rubber

E : 50 mm (1.97 in) or more

CAUTION:

- Because there is a risk of airtightness leakage, apply the adhesive so that there are no seams or overlaps.
- Complete installation of the battery pack upper case before the adhesive surface hardens. The adhesive begins to harden in as little as 12 minutes. [Humidity: 80%, Temperature: 35°C (95°F)]
- Before installing the battery pack upper case, check that there are no locations of insufficient adhesive. If there is insufficient adhesive, correct the location. (If the adhesive height is lower than the height of the dam rubber, then the amount of adhesive is insufficient.)
- Do not apply too much adhesive as doing so may make work difficult the next time the battery pack upper case is removed.

NOTE:

LI-ION BATTERY

< UNIT DISASSEMBLY AND ASSEMBLY >

[TYPE 4]

- For applying the adhesive in a triangle, cut the end of the nozzle as shown in the figure.

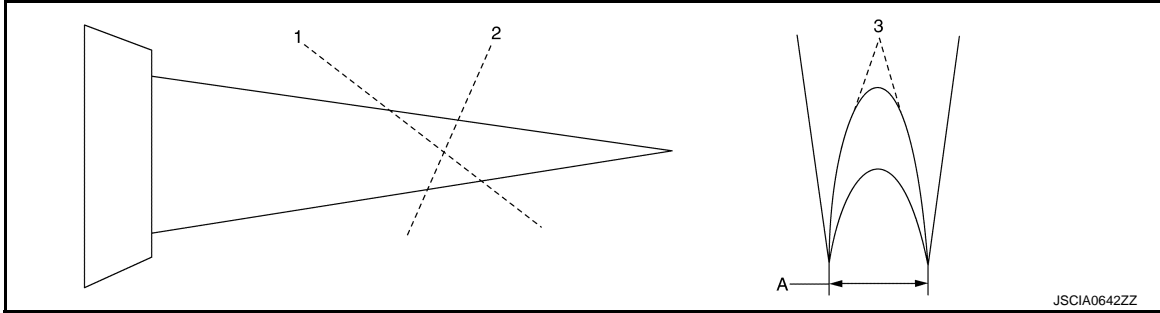

Nozzle inner diameter (A) : Approx. 5 mm (0.20 in)

6. Grasp the carabiner installed in Step 3, and install the battery pack upper case while visually aligning the alignment holes on the battery pack upper case and battery pack lower case (A).

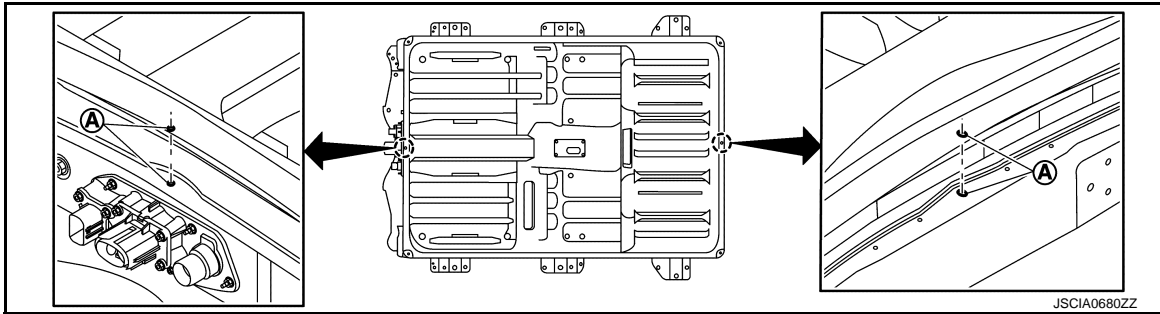

WARNING:



To prevent electric shock, wear insulated protective gear.



CAUTION:

- Operation must be performed by 2 persons. Be careful that the battery pack upper case does not contact the battery module.
- Moving the upper case after it is installed makes airtightness leakage more likely. Therefore, position the upper case carefully.

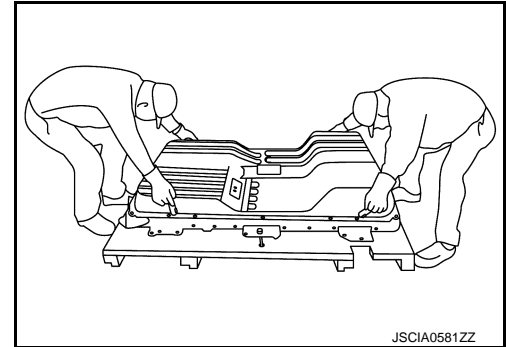

LI-ION BATTERY

< UNIT DISASSEMBLY AND ASSEMBLY >

[TYPE 4]

7. Tighten the mounting bolts in the order from 1 to 6 as shown in the figure.

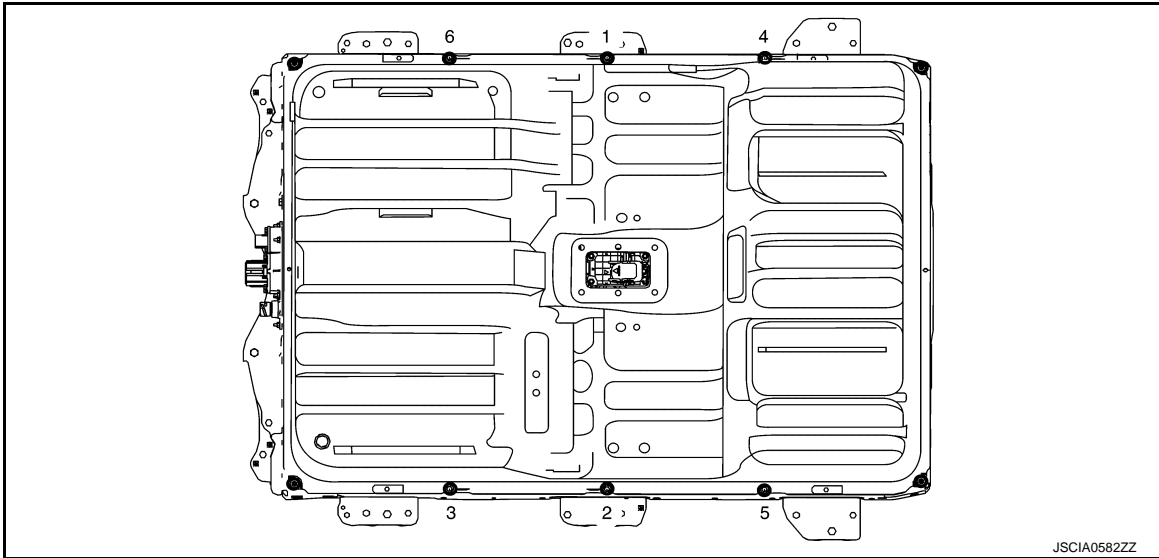

WARNING:

 To prevent electric shock, wear insulated protective gear and use insulated tools.



8. Install the ground bolt (A).

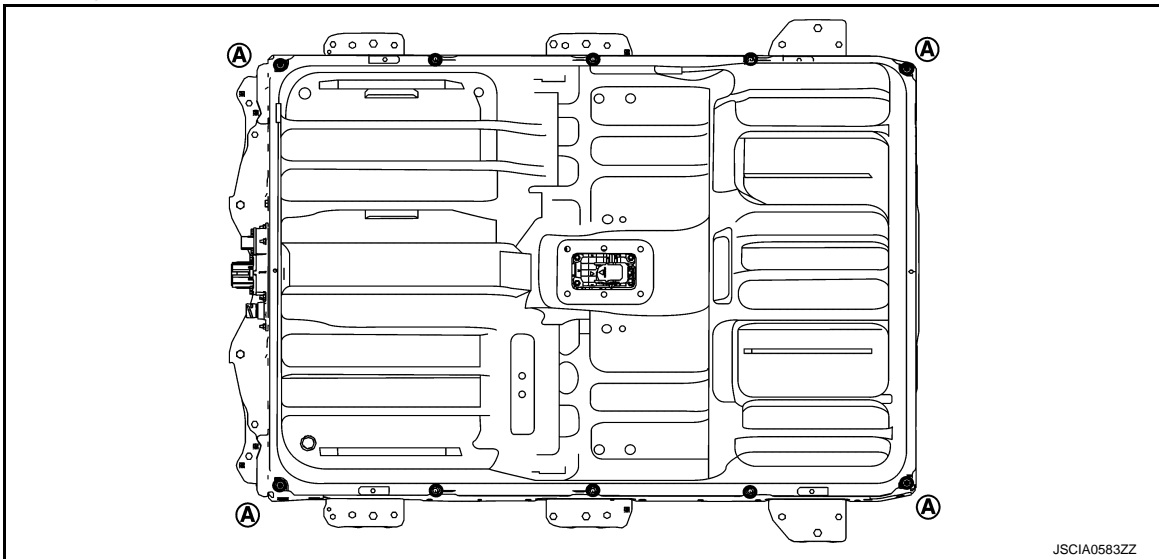

WARNING:

 To prevent electric shock, wear insulated protective gear and use insulated tools.



A
B
EVB
D
E
F
G
H
I
J
K
L
M
N
O
P

LI-ION BATTERY

< UNIT DISASSEMBLY AND ASSEMBLY >

[TYPE 4]

9. Install the service plug retainer ①.

WARNING:



To prevent electric shock, wear insulated protective gear and use insulated tools.

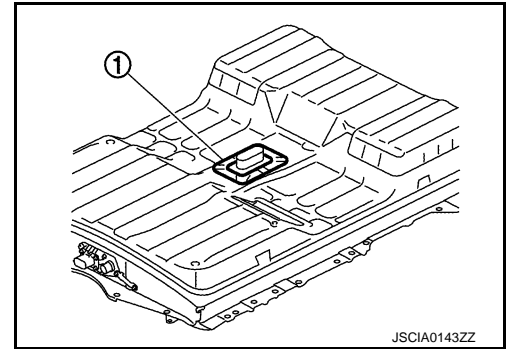

10. Perform a battery pack air leak inspection. Refer to [EVB-938, "Inspection"](#).

CAUTION:

If air leakage occurs, remove the battery pack upper case and wipe off the adhesive, then apply new dam rubber and apply adhesive again. (Proceed to Step 4.)

11. Spray primer surfacer (anti-corrosion primer) (A) into cracks in the periphery of the battery pack adhesive.

WARNING:



To prevent electric shock, wear insulated protective gear.

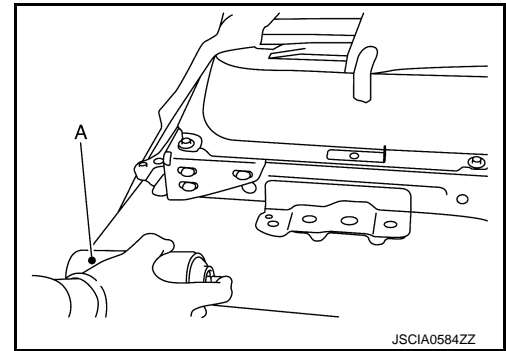

CAUTION:

- After the battery pack is assembled, it can be installed into the vehicle. However the battery pack must not be subjected to any external force (such as high-pressure washing or parking in a location which strains the vehicle body) for approximately 3 hours after installation.
- Be sure to reinstall the high voltage harness clips in their original positions. If a clip is damaged, replace it with a new clip before installing.
- After assembling the battery pack, perform an electric equipotential test.
- Check the following items after installing battery pack: Refer to [EVB-938, "Inspection"](#).

■AIR LEAK INSPECTION

■ELECTRIC EQUIPOTENTIAL TEST

LI-ION BATTERY CONTROLLER

LI-ION BATTERY

< UNIT DISASSEMBLY AND ASSEMBLY >

[TYPE 4]

LI-ION BATTERY CONTROLLER : Exploded View

INFOID:000000011191511

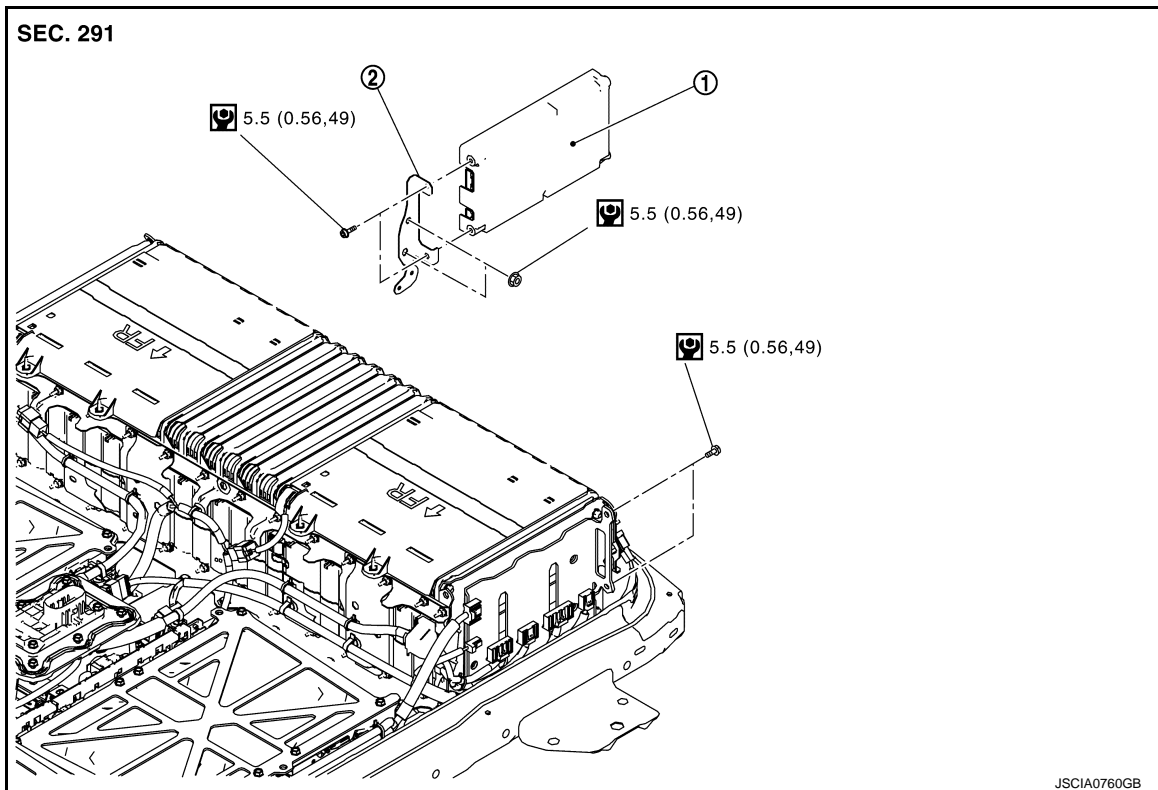

① Li-ion battery controller

② Controller bracket

 : N·m (kg-m, in-lb)

LI-ION BATTERY CONTROLLER : Removal and Installation

INFOID:000000011191512

DANGER:



Since hybrid vehicles and electric vehicles contain a high voltage battery, there is the risk of electric shock, electric leakage, or similar accidents if the high voltage component and vehicle are handled incorrectly. Be sure to follow the correct work procedures when performing inspection and maintenance.

WARNING:

- Be sure to remove the service plug in order to shut off the high voltage circuits before performing inspection or maintenance of high voltage system harnesses and parts.
- Be sure to put the removed service plug in pocket and carry it or store it in a tool box or other container so that another person does not accidentally connect it while work is in progress.
- Be sure to put on insulating protective gear before beginning work on the high voltage system.
- Clearly identify the persons responsible for high voltage work and ensure that other persons do not touch the vehicle. When not working, cover high voltage components with an anti-static cover sheet or similar item to prevent contact with other persons.
- Refer to [EV-B-469, "High Voltage Precautions"](#).
- If the battery pack is to be disassembled, be sure to remove the Li-ion battery controller for preventing electric shock, fire, and damage to parts.

CAUTION:

There is the possibility of a malfunction occurring if the vehicle is changed to READY status while the service plug is removed. Therefore do not change the vehicle to READY status unless instructed to do so in the Service Manual.

ENVIRONMENT FOR LI-ION BATTERY DISASSEMBLY WORK

1. Must be an indoor environment.

LI-ION BATTERY

< UNIT DISASSEMBLY AND ASSEMBLY >

[TYPE 4]

- The environment must utilize a shutter or other means to shut out the outside environment and prevent rain, snow, dust, or other substances from entering.
 - The environment must not cause the intrusion of sweat during work, or cause condensation to occur due to high temperature or humidity.
2. Metal powder, grease, and other foreign substances must not enter.
 - The indoor environment must also prevent metal powder, grease, and other foreign substances from entering due to maintenance performed on other vehicles and other sources during disassembly work.
 - If there is a risk of the above substances entering, take appropriate countermeasures, such as use of a vinyl curtain or an equivalent to shut out the outside environment.
 3. The floor must be dry.
 - The floor must not be wet as a result of factors such as vehicle entry during rain or snow.
 4. Work space
 - The work space must be approximately the size of one entire vehicle.
 - Take appropriate countermeasures so that persons other than the operator do not enter the work space, such as by placing signs indicating that disassembly work is in progress.
 5. Standard fire fighting equipment
 - Always place a standard fire fighting equipment in the disassembly work area.
 - Depending on type of fire (vehicle or battery) use standard fire fighting equipment (water or extinguisher).

REMOVAL

1. Remove the battery pack upper case. Refer to [EVB-875. "BATTERY PACK UPPER CASE : Removal and Installation"](#).

2. Disconnect the low-voltage harness connector (A) of the Li-ion battery controller.

WARNING:

 To prevent electric shock, wear insulated protective gear.

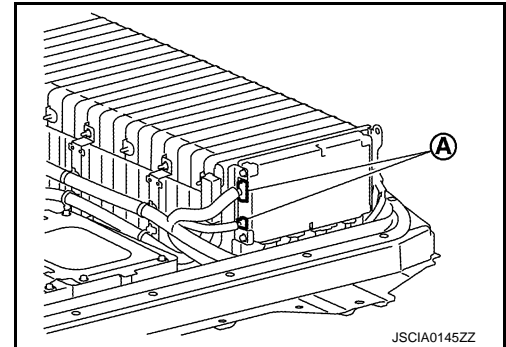

3. Remove the Li-ion battery controller mounting nuts (A), then remove the mounting bolts (B).

WARNING:

 To prevent electric shock, wear insulated protective gear and use insulated tools.

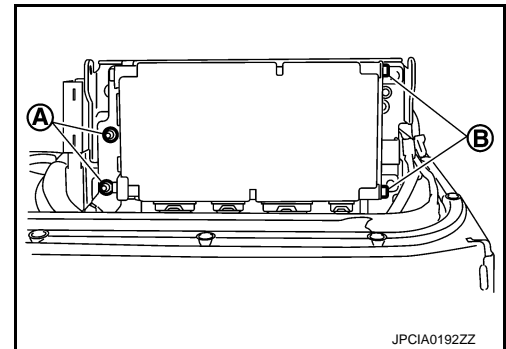

4. Disconnect the high-voltage harness connector (A), then remove the Li-ion battery controller.

(B) : Low-voltage harness connector

← : Battery front

WARNING:

 To prevent electric shock, wear insulated protective gear.

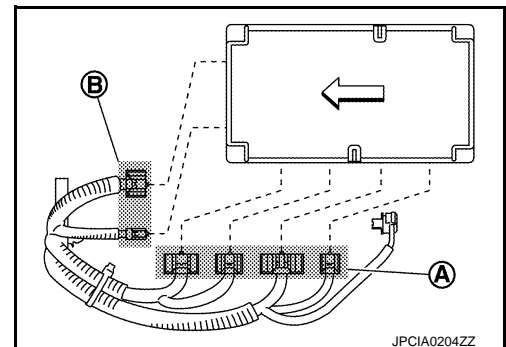

LI-ION BATTERY

< UNIT DISASSEMBLY AND ASSEMBLY >

[TYPE 4]



- ⚠ Because there is a risk of electric shock, immediately protect the terminals of the disconnected high-voltage harness connector with insulating tape so that they are not exposed.

INSTALLATION

1. Install the Li-ion battery controller.

WARNING:

- ⚠ To prevent electric shock, wear insulated protective gear and use insulated tools.



- The Li-ion battery controller includes 2 harness connectors: a high-voltage connector (A) and a low-voltage connector (B). If the high-voltage harness connector is inserted at the low-voltage point, smoking and component damage may occur. Be very careful not to insert the connectors at the wrong points.

← : Battery front

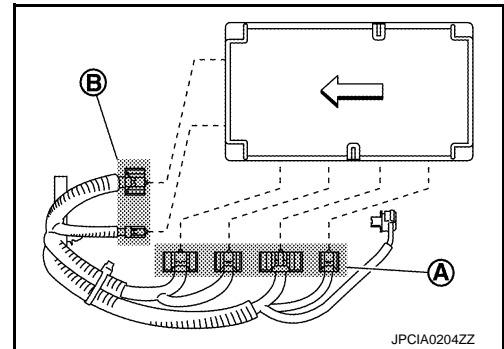

2. Install the battery pack upper case. Refer to [EVB-875, "BATTERY PACK UPPER CASE : Removal and Installation"](#).

CAUTION:

- Be sure to reinstall the high voltage harness clips in their original positions. If a clip is damaged, replace it with a new clip before installing.
- Check the following items after installing battery pack: Refer to [EVB-938, "Inspection"](#).

■AIR LEAK INSPECTION

■ELECTRIC EQUIPOTENTIAL TEST

BATTERY JUNCTION BOX AND BATTERY HARNESS

LI-ION BATTERY

< UNIT DISASSEMBLY AND ASSEMBLY >

[TYPE 4]

BATTERY JUNCTION BOX AND BATTERY HARNESS : Exploded View

INFOID:000000011191513

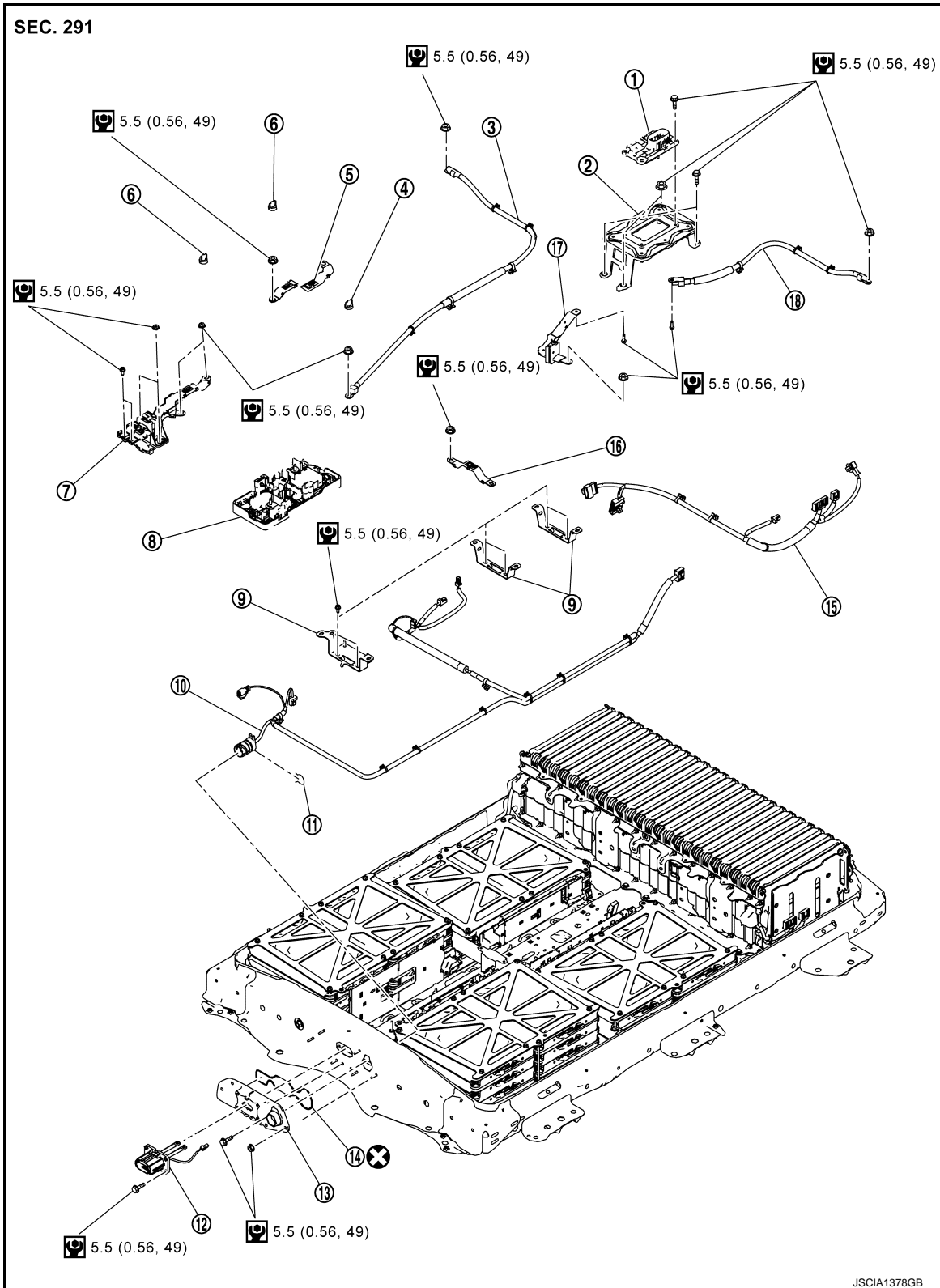

- | | | |
|--|-------------------------------|----------------------------------|
| ① Service plug switch | ② Service plug switch bracket | ③ High-voltage battery harness |
| ④ Bus bar nut cap | ⑤ Bus bar | ⑥ Bus bar nut cap |
| ⑦ Bus bar (integrated with noise filter) | ⑧ Battery junction box | ⑨ Harness bracket |
| ⑩ Vehicle communications harness | ⑪ Snap ring | ⑫ High-voltage harness connector |

LI-ION BATTERY

< UNIT DISASSEMBLY AND ASSEMBLY >

[TYPE 4]

⑬ Connector flange

⑭ Seal

⑮ Voltage detection harness

⑯ Bus bar

⑰ Battery current sensor (integrated with bus bar)

⑱ High-voltage battery harness

 : Always replace after every disassembly.

 : N·m (kg·m, in·lb)

A

B

Bus bar Layout

EVB

DANGER:

D

E

F

G

H

I

J

K

L

M

N

O

P

LI-ION BATTERY

< UNIT DISASSEMBLY AND ASSEMBLY >

[TYPE 4]



Because there is a danger of electric shock and fire, never contact bus bar in a wrong terminal.

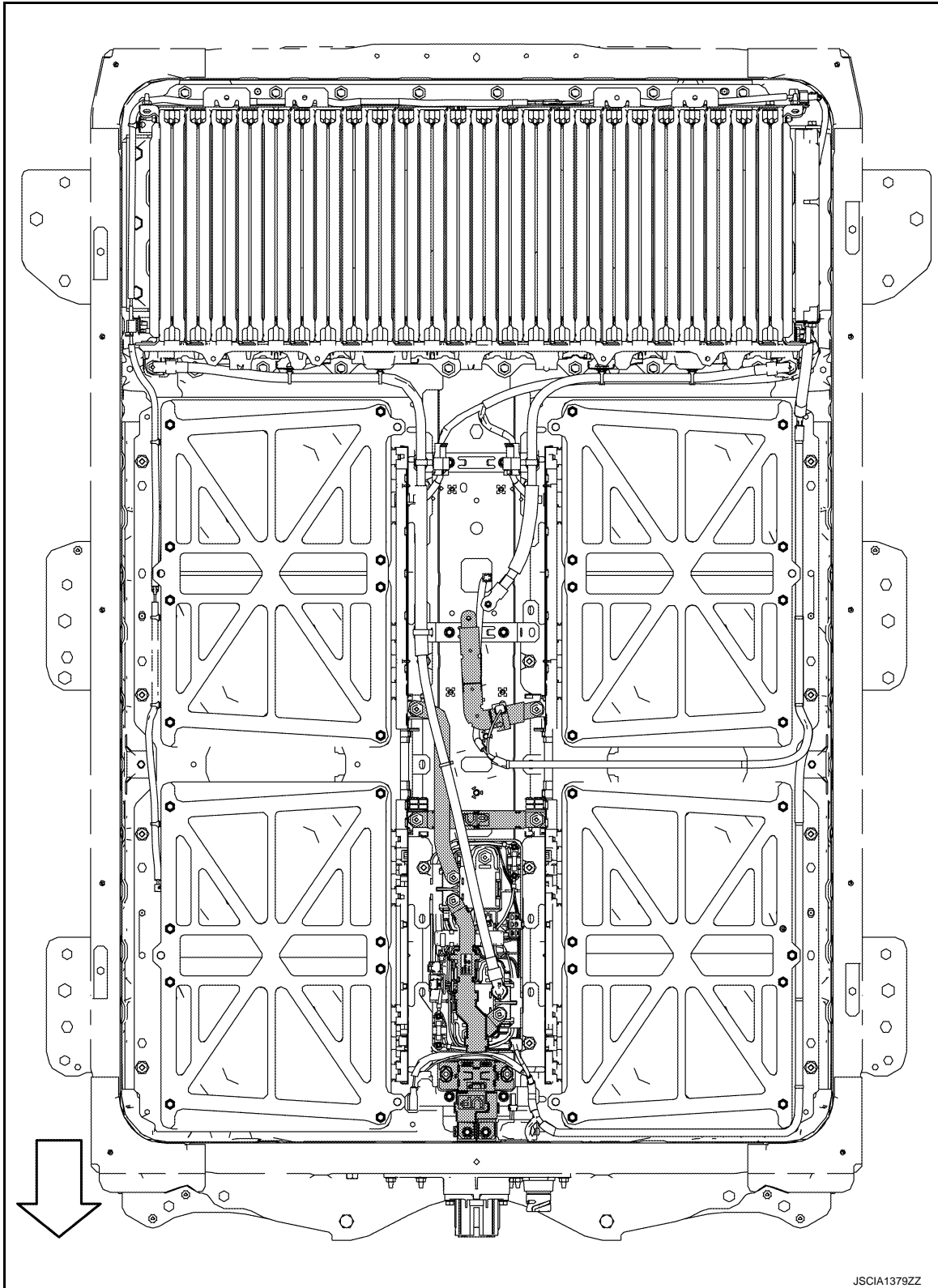

JSCIA1379ZZ

⇐ : Battery front

BATTERY JUNCTION BOX AND BATTERY HARNESS : Disassembly and Assembly

INFOID:000000011191514

DANGER:

LI-ION BATTERY

< UNIT DISASSEMBLY AND ASSEMBLY >

[TYPE 4]



Since hybrid vehicles and electric vehicles contain a high voltage battery, there is the risk of electric shock, electric leakage, or similar accidents if the high voltage component and vehicle are handled incorrectly. Be sure to follow the correct work procedures when performing inspection and maintenance.

WARNING:

- Be sure to remove the service plug in order to shut off the high voltage circuits before performing inspection or maintenance of high voltage system harnesses and parts.
- Be sure to put the removed service plug in pocket and carry it or store it in a tool box or other container so that another person does not accidentally connect it while work is in progress.
- Be sure to put on insulating protective gear before beginning work on the high voltage system.
- Clearly identify the persons responsible for high voltage work and ensure that other persons do not touch the vehicle. When not working, cover high voltage components with an anti-static cover sheet or similar item to prevent contact with other persons.
- Refer to [EVB-469, "High Voltage Precautions"](#).
- If the battery pack is to be disassembled, be sure to remove the Li-ion battery controller for preventing electric shock, fire, and damage to parts.

CAUTION:

There is the possibility of a malfunction occurring if the vehicle is changed to READY status while the service plug is removed. Therefore do not change the vehicle to READY status unless instructed to do so in the Service Manual.

ENVIRONMENT FOR LI-ION BATTERY DISASSEMBLY WORK

1. Must be an indoor environment.
 - The environment must utilize a shutter or other means to shut out the outside environment and prevent rain, snow, dust, or other substances from entering.
 - The environment must not cause the intrusion of sweat during work, or cause condensation to occur due to high temperature or humidity.
2. Metal powder, grease, and other foreign substances must not enter.
 - The indoor environment must also prevent metal powder, grease, and other foreign substances from entering due to maintenance performed on other vehicles and other sources during disassembly work.
 - If there is a risk of the above substances entering, take appropriate countermeasures, such as use of a vinyl curtain or an equivalent to shut out the outside environment.
3. The floor must be dry.
 - The floor must not be wet as a result of factors such as vehicle entry during rain or snow.
4. Work space
 - The work space must be approximately the size of one entire vehicle.
 - Take appropriate countermeasures so that persons other than the operator do not enter the work space, such as by placing signs indicating that disassembly work is in progress.
5. Standard fire fighting equipment
 - Always place a standard fire fighting equipment in the disassembly work area.
 - Depending on type of fire (vehicle or battery) use standard fire fighting equipment (water or extinguisher).

DISASSEMBLY

1. Remove the battery pack upper case. Refer to [EVB-875, "BATTERY PACK UPPER CASE : Removal and Installation"](#).
2. Remove Li-ion battery controller. Refer to [EVB-885, "LI-ION BATTERY CONTROLLER : Removal and Installation"](#).

LI-ION BATTERY

[TYPE 4]

< UNIT DISASSEMBLY AND ASSEMBLY >

3. Disconnect the high-voltage harness engagement detection switch harness connector (A).

WARNING:



To prevent electric shock, wear insulated protective gear.

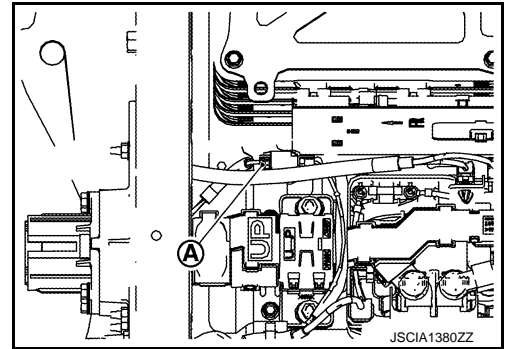

JSCIA1380ZZ

4. Open the bus bar cover and remove the high-voltage harness connector terminal mounting bolt (A).

DANGER:



There is the danger of electric shock caused by contact with the terminals. Be sure to wear insulated protective gear and use insulated tools.



Because of the danger of electric shock, be sure to close the bus bar cover after removing the bus bar.

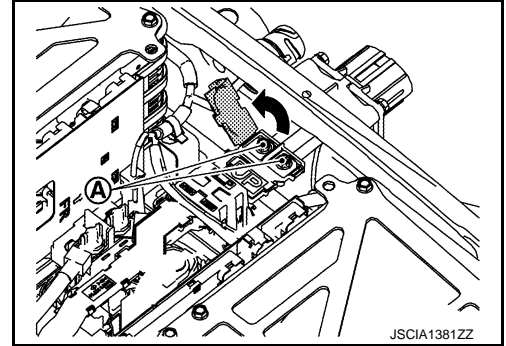

JSCIA1381ZZ

5. Remove the mounting bolt (A) and disconnect the high-voltage harness connector from the connector flange.

WARNING:



To prevent electric shock, wear insulated protective gear and use insulated tools.

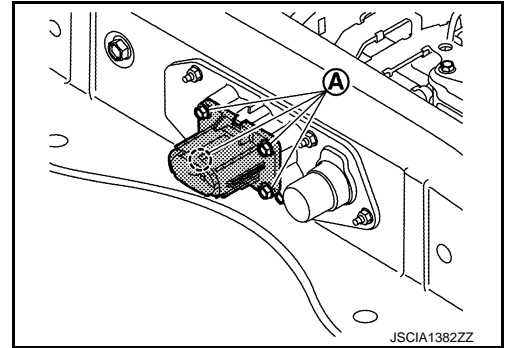

JSCIA1382ZZ

6. Disconnect the vehicle communications harness connector (A), connector clips (B), and Li-ion battery heater harness connector (C).

WARNING:



To prevent electric shock, wear insulated protective gear and use insulated tools.

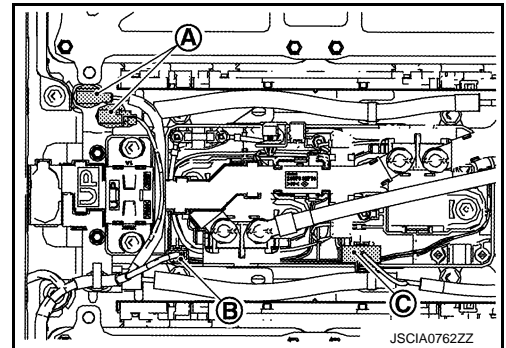

JSCIA0762ZZ

LI-ION BATTERY

< UNIT DISASSEMBLY AND ASSEMBLY >

[TYPE 4]

7. Remove the bus bar nut caps (A).

WARNING:

 To prevent electric shock, wear insulated protective gear and use insulated tools.

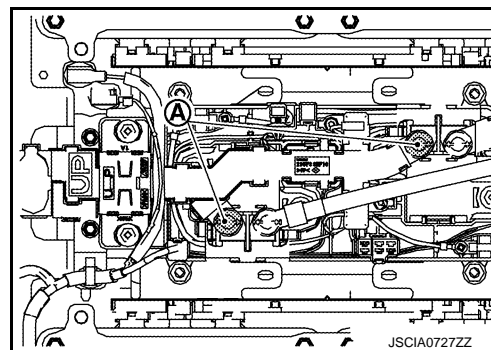

8. Remove the bus bar mounting nuts (A) and (B), and remove the bus bar (integrated with noise filter) (1).

WARNING:

 To prevent electric shock, wear insulated protective gear and use insulated tools.

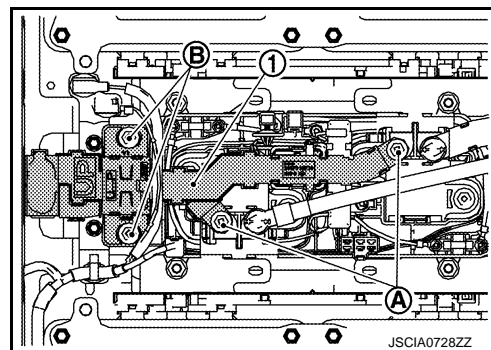

9. Remove the harness clips, then remove the battery member pipe (1).

WARNING:

 To prevent electric shock, wear insulated protective gear and use insulated tools.



NOTE:

The right-side mounting hole is larger for facilitating removal of the battery member pipe. Lifting up the left side first makes removal easier.

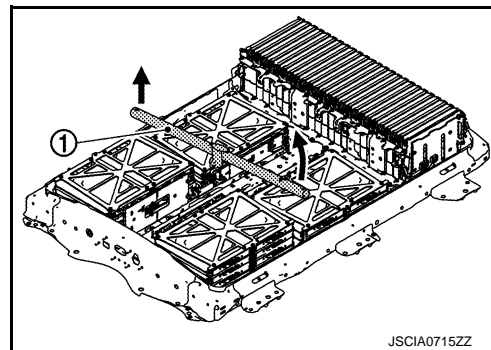

10. Remove the bus bar nut cap (1) and remove the high-voltage harness nut cap (2), then open the bus bar cover (3).

WARNING:

 To prevent electric shock, wear insulated protective gear.

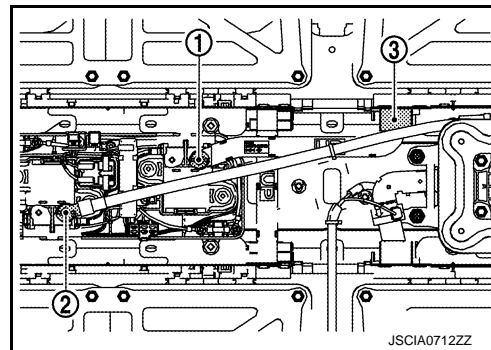

A
B
EVB
D
E
F
G
H
I
J
K
L
M
N
O
P

LI-ION BATTERY

< UNIT DISASSEMBLY AND ASSEMBLY >

[TYPE 4]

11. Remove the mounting nuts (A), and remove the bus bar (1) and high-voltage harness (2).

DANGER:

- ⚡ There is the danger of electric shock caused by contact with the terminals. Be sure to wear insulated protective gear and use insulated tools.



- ⚡ Because there is a risk of electric shock, immediately protect the terminals of the disconnected high-voltage harness connector (high-voltage terminals) with insulating tape so that they are not exposed.
- ⚡ Because of the danger of electric shock, be sure to close the bus bar cover after removing the bus bar.

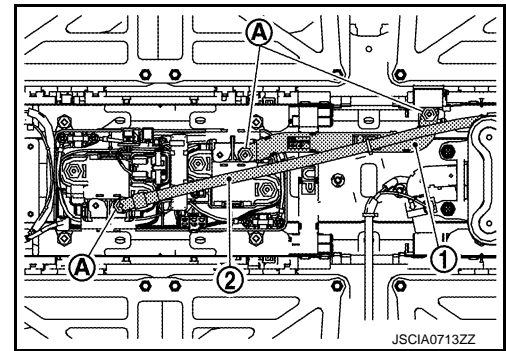

12. Remove the mounting nuts (A) and remove the junction box (1).

WARNING:

- ⚡ To prevent electric shock, wear insulated protective gear and use insulated tools.

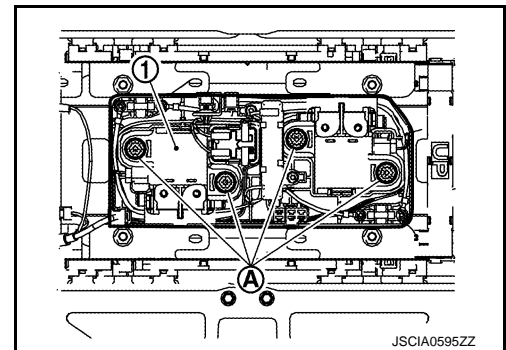

13. Disconnect the current sensor harness connector (1).

WARNING:

- ⚡ To prevent electric shock, wear insulated protective gear and use insulated tools.

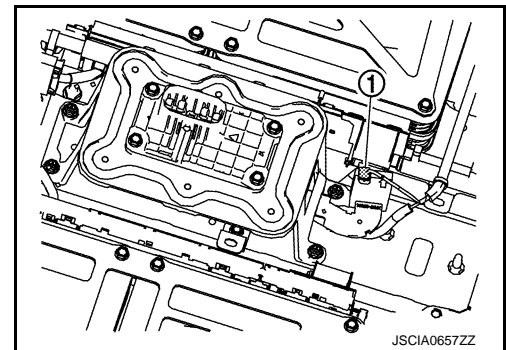

14. Remove the bus bar mounting nut which connects the current sensor and left front module stack (A).

DANGER:

- ⚡ There is the danger of electric shock caused by contact with the terminals. Be sure to wear insulated protective gear and use insulated tools.



- ⚡ Because of the danger of electric shock, be sure to close the bus bar cover after removing the bus bar.

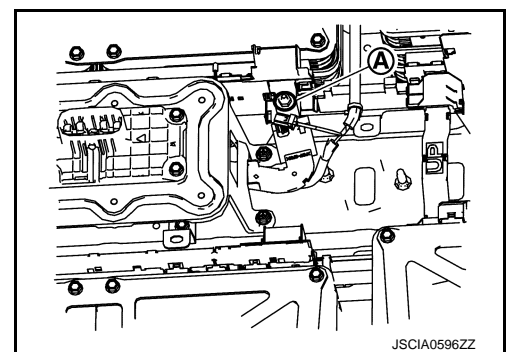

LI-ION BATTERY

< UNIT DISASSEMBLY AND ASSEMBLY >

[TYPE 4]

15. Remove the service plug switch bracket ① mounting bolts ① and mounting nuts ②.

WARNING:

 To prevent electric shock, wear insulated protective gear and use insulated tools.

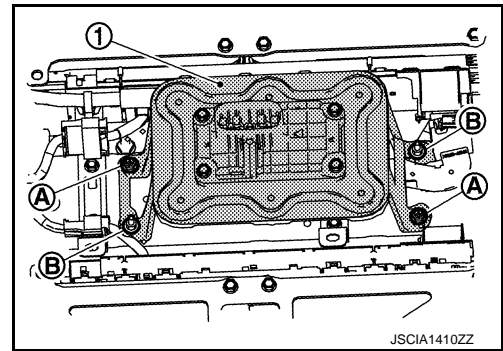

16. Invert the service plug switch bracket and remove the high-voltage harness mounting bolt ①, current sensor mounting bolt ②, and the connector ③, then remove the service plug switch bracket ④.

DANGER:

-  There is the danger of electric shock caused by contact with the terminals. Be sure to wear insulated protective gear and use insulated tools.

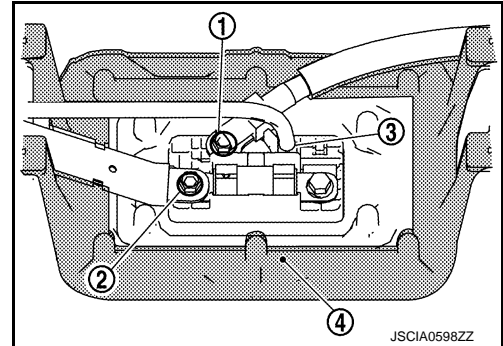

-  Because there is a risk of electric shock, immediately protect the terminals of the disconnected high-voltage harness connector (high-voltage terminals) with insulating tape so that they are not exposed.

17. Remove the mounting nuts ①, then remove high-voltage harness ① and ②.

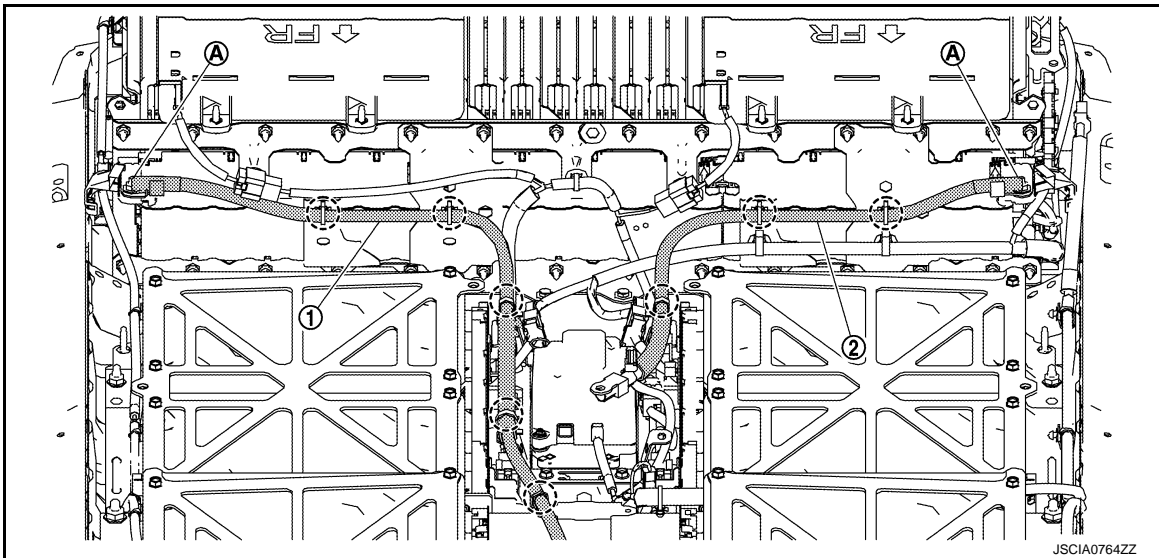

 : Harness clip

DANGER:

-  There is the danger of electric shock caused by contact with the terminals. Be sure to wear insulated protective gear and use insulated tools.



A
B
EVB
D
E
F
G
H
I
J
K
L
M
N
O
P

LI-ION BATTERY

< UNIT DISASSEMBLY AND ASSEMBLY >

[TYPE 4]

- ⚡ Because of the danger of electric shock, be sure to close the bus bar cover after removing the bus bar.

18. Remove the vehicle communications harness and voltage detection harness.

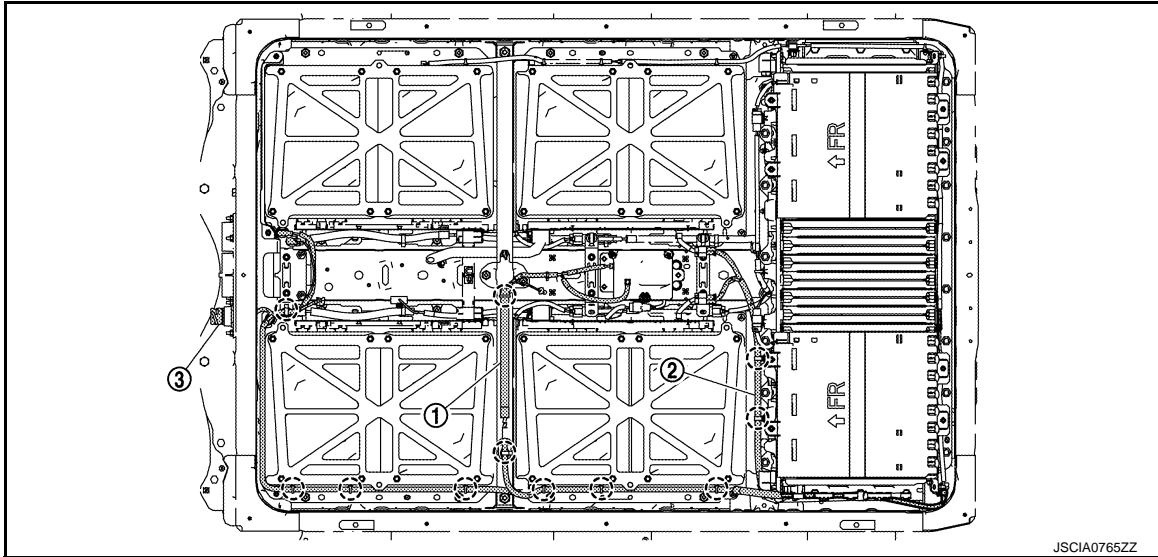

- ① Vehicle communications harness ② Voltage detection harness ③ Snap ring
○ : Harness clip

WARNING:

⚡ To prevent electric shock, wear insulated protective gear and use insulated tools.



ASSEMBLY

Note the following items, and disassembly in the reverse order of disassembly.

DANGER:

- ⚡ There is the danger of electric shock caused by contact with the terminals. Be sure to wear insulated protective gear and use insulated tools.



- ⚡ Because there is a danger of electric shock and fire, never allow bus bar to contact a wrong terminal.
 - If bus bar contacts a wrong terminal, the circuit becomes energized and a short may occur.
 - Always keep the bus bar cover closed until immediately before the installation of bus bar.
 - Since the correct installation position for the bus bar connected to both front module stacks is commonly-confused with the wrong position ②, install the bus bar to the correct position ① with extreme caution.

LI-ION BATTERY

< UNIT DISASSEMBLY AND ASSEMBLY >

[TYPE 4]

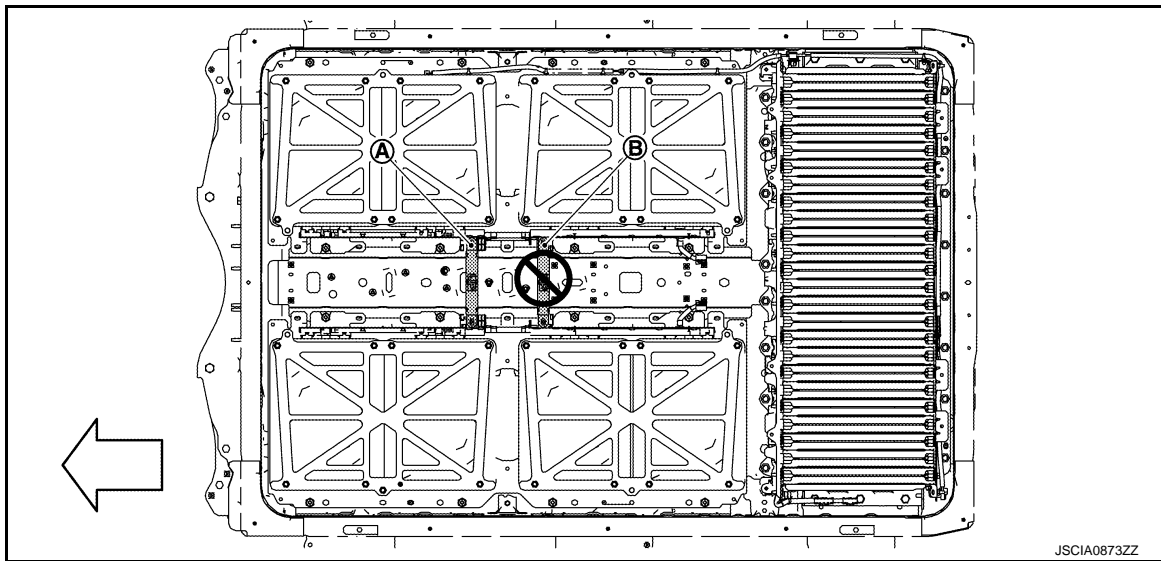

(A) Correct position

(B) Wrong position

← : Battery front

WARNING:

Install the Li-ion battery controller immediately before installing the battery pack upper case. Refer to [EVB-885, "LI-ION BATTERY CONTROLLER : Removal and Installation"](#).

CAUTION:

- Perform the "LI-ION BATTERY JUNCTION BOX DATA CLEAR" when battery junction box is replaced. Refer to [EVC-110, "Work Procedure"](#).
- Be sure to reinstall the high voltage harness clips in their original positions. If a clip is damaged, replace it with a new clip before installing.
- Check the following items after installing battery pack: Refer to [EVB-938, "Inspection"](#).

■ AIR LEAK INSPECTION

■ ELECTRIC EQUIPOTENTIAL TEST

LI-ION BATTERY HEATER

A
B
EVB
D
E
F
G
H
I
J
K
L
M
N
O
P

LI-ION BATTERY

< UNIT DISASSEMBLY AND ASSEMBLY >

[TYPE 4]

LI-ION BATTERY HEATER : Exploded view

INFOID:000000011191515

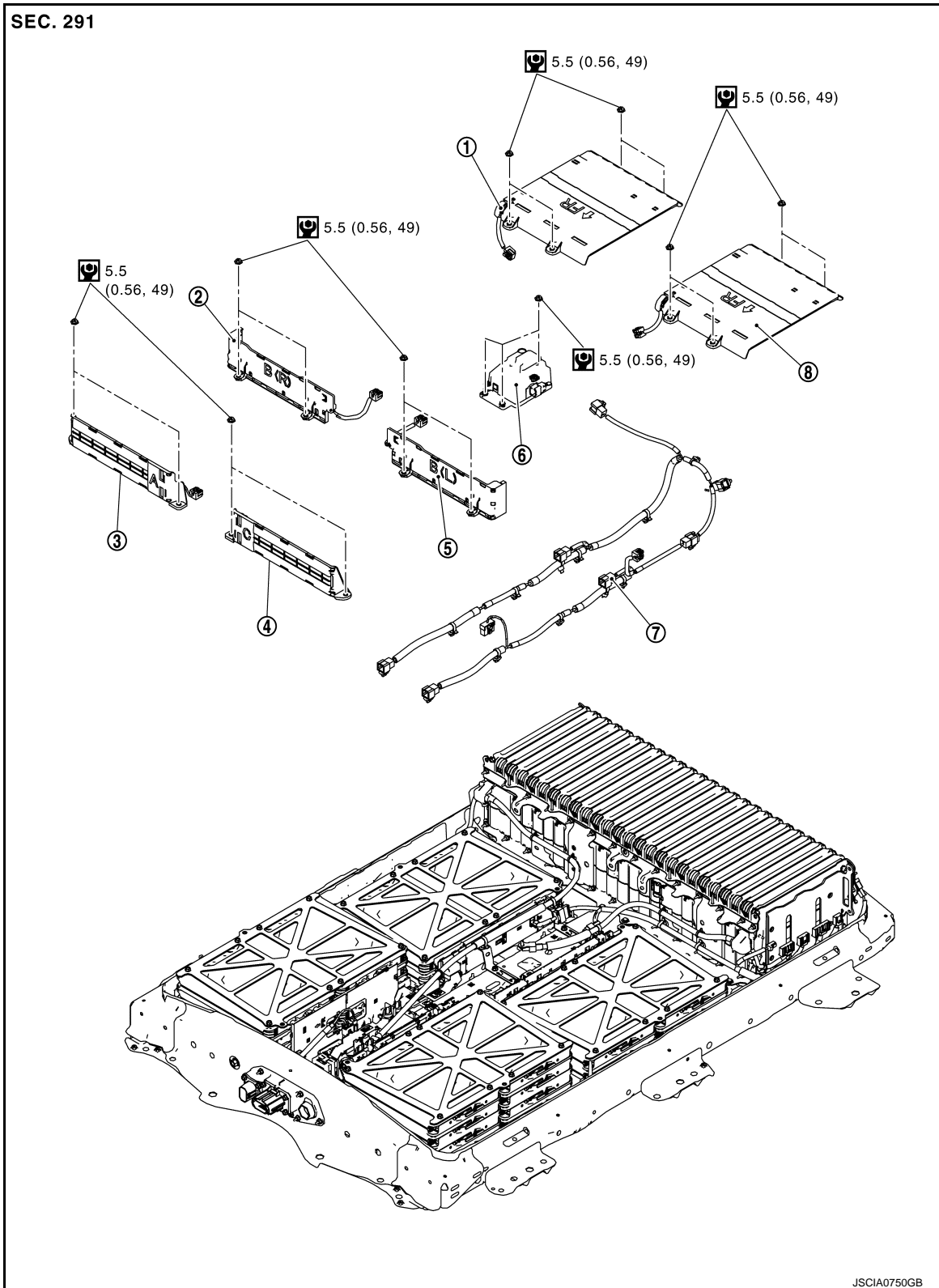

① Li-ion battery heater RR2

② Li-ion battery heater RH2

③ Li-ion battery heater RH1

④ Li-ion battery heater LH1

⑤ Li-ion battery heater LH2

⑥ Li-ion battery heater relay unit

LI-ION BATTERY

< UNIT DISASSEMBLY AND ASSEMBLY >

[TYPE 4]

- ⑦ Li-ion battery heater harness ⑧ Li-ion battery heater RR1

 : N·m (kg·m, in·lb)

LI-ION BATTERY HEATER : Disassembly and Assembly

INFOID:000000011191516

DANGER:



Since hybrid vehicles and electric vehicles contain a high voltage battery, there is the risk of electric shock, electric leakage, or similar accidents if the high voltage component and vehicle are handled incorrectly. Be sure to follow the correct work procedures when performing inspection and maintenance.

WARNING:

- Be sure to remove the service plug in order to disconnect the high voltage circuits before performing inspection or maintenance of high voltage system harnesses and parts.
- To prevent the removed service plug from being connected by mistake during the procedure, always carry it in your pocket or put it in the tool box.
- Be sure to wear insulating protective equipment consisting of glove, shoes, face shield and glasses before beginning work on the high voltage system.
- Refer to [EVB-469, "High Voltage Precautions"](#).
- To prevent electric shock hazards, ignition, and damage to parts, always remove Li-ion battery controller before disassembling battery pack.

CAUTION:

There is the possibility of a malfunction occurring if the vehicle is changed to READY status while the service plug is removed. Therefore do not change the vehicle to READY status unless instructed to do so in the Service Manual.

WORK ENVIRONMENT FOR DISASSEMBLY OF LI-ION BATTERY

1. Must be an indoor environment.
 - The work environment must be able to be isolated from the outside by shutters or other means to prevent the intrusion of rain, snow, sand, and other substances.
 - The environment must prevent the entry of sweat during work, and also prevent condensation from occurring as a result of high temperature and humidity.
2. No entry of foreign materials.
 - In addition to being indoors, the environment must not permit the entry during disassembly work of metal powders, oil, or foreign substances resulting from causes such as servicing of other vehicles.
 - If there is any risk of the above, use a plastic curtain or other means to block off the work area, or take other necessary steps.
3. The floor must be dry.
 - The floor must not become wet as a result of causes such as vehicles entering when it is raining or snowing.
4. Work space
 - Space approximately the size of one vehicle must be secured as the disassembly space.
 - A sign indicating that disassembly is in progress or other measures must be taken so that persons other than the workers do not enter the work space.
5. Standard fire fighting equipment
 - Always place a standard fire fighting equipment in the disassembly work area.
 - Depending on type of fire (vehicle or battery) use standard fire fighting equipment (water or extinguisher).

REMOVAL

Li-Ion Battery Heater RR1 & RR2

1. Remove battery pack upper case. Refer to [EVB-875, "BATTERY PACK UPPER CASE : Removal and Installation"](#).
2. Remove Li-ion battery controller. Refer to [EVB-885, "LI-ION BATTERY CONTROLLER : Removal and Installation"](#).

LI-ION BATTERY

< UNIT DISASSEMBLY AND ASSEMBLY >

[TYPE 4]

3. Disconnect the harness connectors (A).

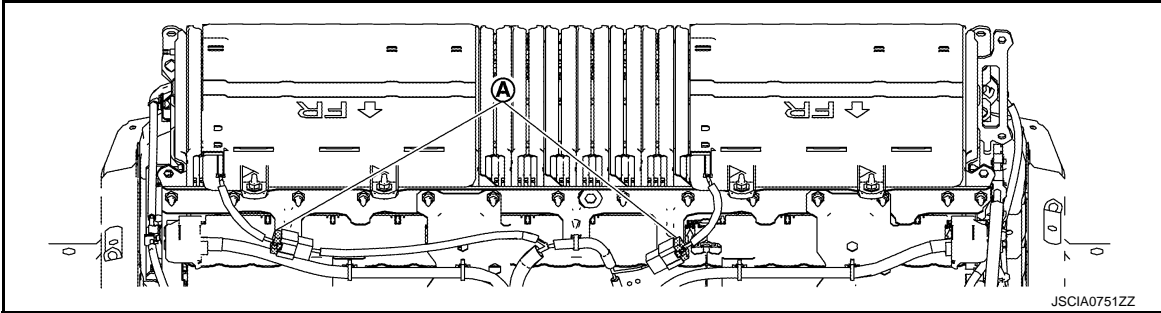

WARNING:



To prevent electric shock hazards, be sure to put on insulated protective gear and use insulated tools.



4. Remove mounting nuts (A) and then remove Li-ion battery heaters.

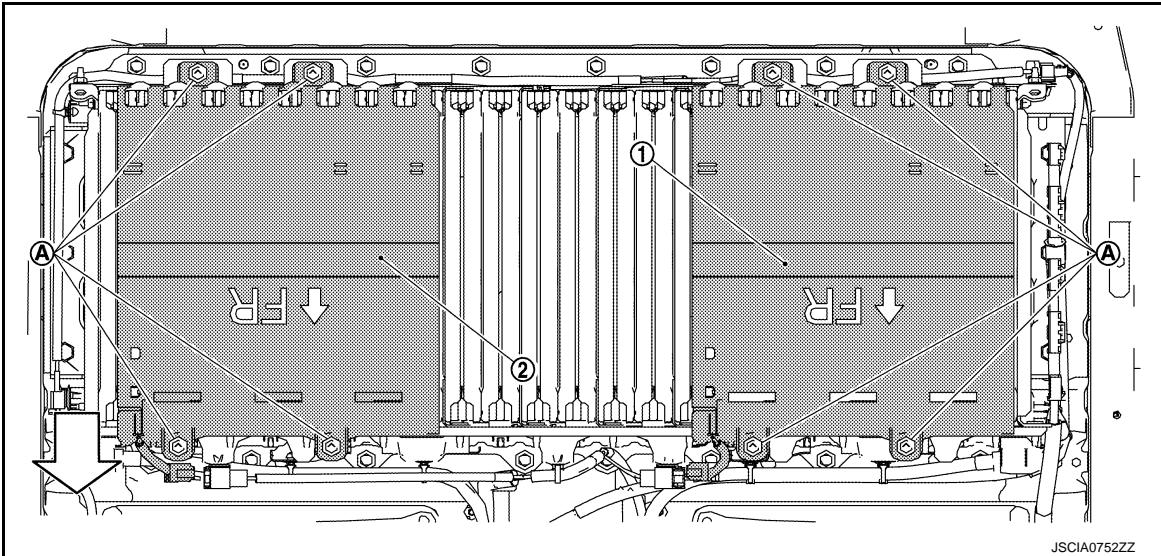

① Li-ion battery heater RR1

② Li-ion battery heater RR2

⇐ : Battery front

WARNING:



To prevent electric shock hazards, be sure to put on insulated protective gear and use insulated tools.



Li-Ion Battery Heater LH1

1. Remove battery pack upper case. Refer to [EVB-875. "BATTERY PACK UPPER CASE : Removal and Installation"](#).
2. Remove Li-ion battery controller. Refer to [EVB-885. "LI-ION BATTERY CONTROLLER : Removal and Installation"](#).
3. Remove vehicle communication harness. Refer to [EVB-890. "BATTERY JUNCTION BOX AND BATTERY HARNESS : Disassembly and Assembly"](#).

LI-ION BATTERY

< UNIT DISASSEMBLY AND ASSEMBLY >

[TYPE 4]

4. Disconnect Li-ion battery heater LH1 harness connector (A).

← : Battery front

WARNING:

 To prevent electric shock hazards, be sure to put on insulated protective gear and use insulated tools.



5. Remove mounting nuts (B) and then remove Li-ion battery heater LH1 (1).

WARNING:

 To prevent electric shock hazards, be sure to put on insulated protective gear and use insulated tools.

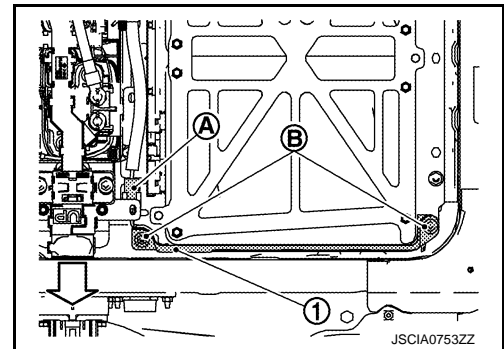

Li-Ion Battery Heater RH1

1. Remove battery pack upper case. Refer to [EV8-875, "BATTERY PACK UPPER CASE : Removal and Installation"](#).
2. Remove Li-ion battery controller. Refer to [EV8-885, "LI-ION BATTERY CONTROLLER : Removal and Installation"](#).
3. Disconnect Li-ion battery heater RH1 harness connector (A).

← : Battery front

WARNING:

 To prevent electric shock hazards, be sure to put on insulated protective gear and use insulated tools.



4. Remove mounting nuts (B) and then remove Li-ion battery heater RH1 (1).

WARNING:

 To prevent electric shock hazards, be sure to put on insulated protective gear and use insulated tools.

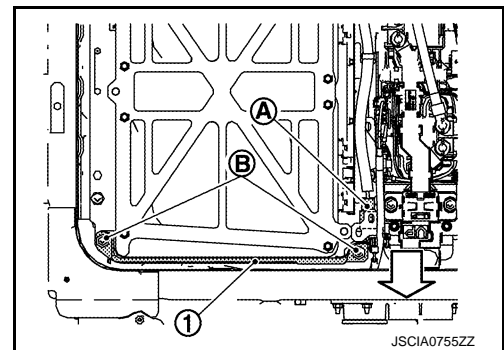

Li-Ion Battery Heater LH2

1. Remove battery pack upper case. Refer to [EV8-875, "BATTERY PACK UPPER CASE : Removal and Installation"](#).
2. Remove Li-ion battery controller. Refer to [EV8-885, "LI-ION BATTERY CONTROLLER : Removal and Installation"](#).
3. Remove the following parts; Refer to [EV8-890, "BATTERY JUNCTION BOX AND BATTERY HARNESS : Disassembly and Assembly"](#).
 - Vehicle communication harness
 - Battery current sensor (integrated with bus bar)

LI-ION BATTERY

< UNIT DISASSEMBLY AND ASSEMBLY >

[TYPE 4]

4. Remove the battery member pipe ①.

WARNING:



To prevent electric shock, wear insulated protective gear and use insulated tools.



NOTE:

The right-side mounting hole is larger for facilitating removal of the battery member pipe. Lifting up the left side first makes removal easier.

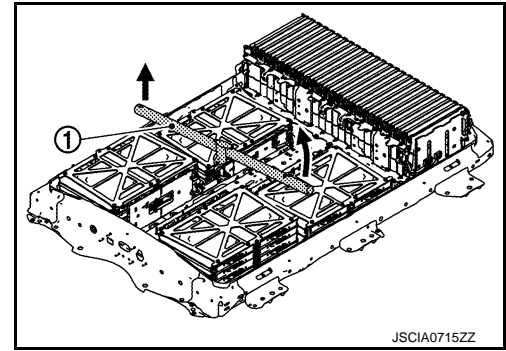

5. Disconnect Li-ion battery heater LH2 harness connector ①.



: Battery front

WARNING:



To prevent electric shock hazards, be sure to put on insulated protective gear and use insulated tools.



6. Remove mounting nuts ② and then remove Li-ion battery heater LH2 ①.

WARNING:



To prevent electric shock hazards, be sure to put on insulated protective gear and use insulated tools.

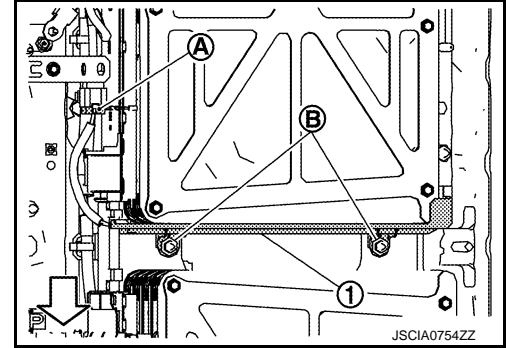

Li-Ion Battery Heater RH2

1. Remove battery pack upper case. Refer to [EVB-874, "BATTERY PACK UPPER CASE : Exploded View"](#).
2. Remove Li-ion battery controller. Refer to [EVB-885, "LI-ION BATTERY CONTROLLER : Removal and Installation"](#).
3. Remove the following parts; Refer to [EVB-890, "BATTERY JUNCTION BOX AND BATTERY HARNESS : Disassembly and Assembly"](#).
 - Vehicle communication harness
 - Bus bar [Battery junction box – Front module stack (RH)]

4. Remove the battery member pipe ①.

WARNING:



To prevent electric shock, wear insulated protective gear and use insulated tools.



NOTE:

The right-side mounting hole is larger for facilitating removal of the battery member pipe. Lifting up the left side first makes removal easier.

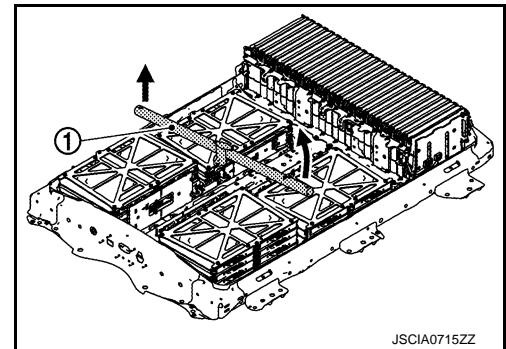

LI-ION BATTERY

[TYPE 4]

< UNIT DISASSEMBLY AND ASSEMBLY >

5. Disconnect Li-ion battery heater RH2 harness connector (A).

← : Battery front

WARNING:

 To prevent electric shock hazards, be sure to put on insulated protective gear and use insulated tools.

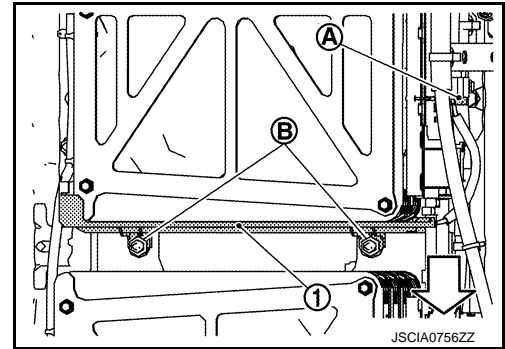

6. Remove mounting nuts (B) and then remove Li-ion battery heater RH2 (1).

WARNING:

 To prevent electric shock hazards, be sure to put on insulated protective gear and use insulated tools.



Li-ion battery heater harness

Remove Li-ion battery heater harness after front module stack is removed. Refer to [EVB-909, "FRONT MODULE STACK : Removal and Installation"](#).

INSTALLATION

Note the following, and install in the reverse order of removal.

WARNING:

 To prevent electric shock hazards, be sure to put on insulated protective gear and use insulated tools.



CAUTION:

- Install Li-ion battery controller immediately before installing battery pack upper case. Refer to [EVB-885, "LI-ION BATTERY CONTROLLER : Removal and Installation"](#).
- Be sure to reinstall the high voltage harness clips in their original positions. If a clip is damaged, replace it with a new clip before installing.
- Check the following items after installing battery pack: Refer to [EVB-938, "Inspection"](#).

■AIR LEAK INSPECTION

■ELECTRIC EQUIPOTENTIAL TEST

LI-ION BATTERY HEATER RELAY UNIT

LI-ION BATTERY

< UNIT DISASSEMBLY AND ASSEMBLY >

[TYPE 4]

LI-ION BATTERY HEATER RELAY UNIT : Exploded view

INFOID:000000011191517

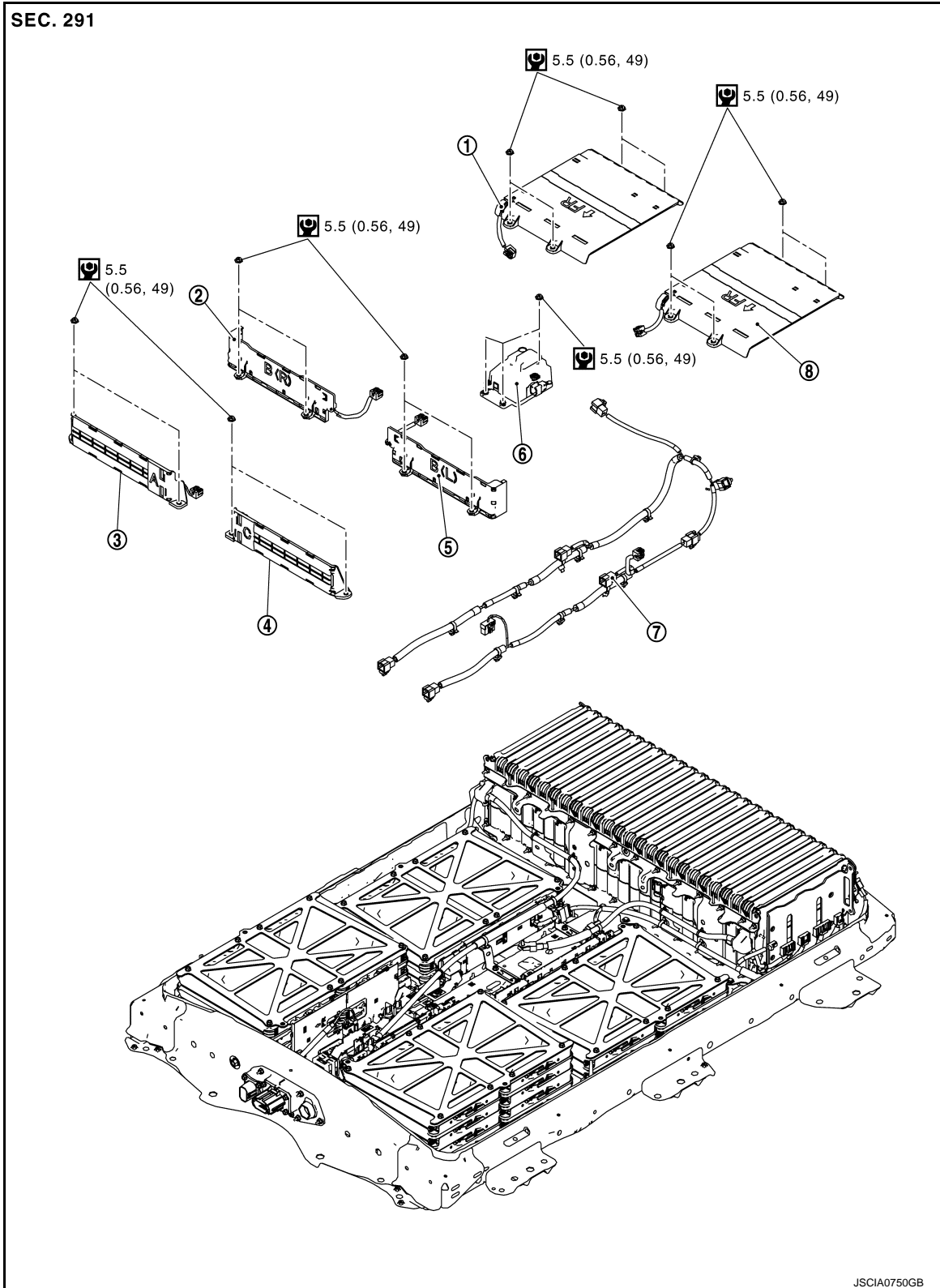

① Li-ion battery heater RR2

② Li-ion battery heater RH2

③ Li-ion battery heater RH1

④ Li-ion battery heater LH1

⑤ Li-ion battery heater LH2

⑥ Li-ion battery heater relay unit

LI-ION BATTERY

< UNIT DISASSEMBLY AND ASSEMBLY >

[TYPE 4]

- ⑦ Li-ion battery heater harness ⑧ Li-ion battery heater RR1

 : N·m (kg·m, in·lb)

LI-ION BATTERY HEATER RELAY UNIT : Disassembly and Assembly

INFOID:000000011191518

DANGER:



Since hybrid vehicles and electric vehicles contain a high voltage battery, there is the risk of electric shock, electric leakage, or similar accidents if the high voltage component and vehicle are handled incorrectly. Be sure to follow the correct work procedures when performing inspection and maintenance.

WARNING:

- Be sure to remove the service plug in order to disconnect the high voltage circuits before performing inspection or maintenance of high voltage system harnesses and parts.
- To prevent the removed service plug from being connected by mistake during the procedure, always carry it in your pocket or put it in the tool box.
- Be sure to wear insulating protective equipment consisting of glove, shoes, face shield and glasses before beginning work on the high voltage system.
- Refer to [EVB-469, "High Voltage Precautions"](#).
- To prevent electric shock hazards, ignition, and damage to parts, always remove Li-ion battery controller before disassembling battery pack.

CAUTION:

There is the possibility of a malfunction occurring if the vehicle is changed to READY status while the service plug is removed. Therefore do not change the vehicle to READY status unless instructed to do so in the Service Manual.

WORK ENVIRONMENT FOR DISASSEMBLY OF LI-ION BATTERY

1. Must be an indoor environment.
 - The work environment must be able to be isolated from the outside by shutters or other means to prevent the intrusion of rain, snow, sand, and other substances.
 - The environment must prevent the entry of sweat during work, and also prevent condensation from occurring as a result of high temperature and humidity.
2. No entry of foreign materials.
 - In addition to being indoors, the environment must not permit the entry during disassembly work of metal powders, oil, or foreign substances resulting from causes such as servicing of other vehicles.
 - If there is any risk of the above, use a plastic curtain or other means to block off the work area, or take other necessary steps.
3. The floor must be dry.
 - The floor must not become wet as a result of causes such as vehicles entering when it is raining or snowing.
4. Work space
 - Space approximately the size of one vehicle must be secured as the disassembly space.
 - A sign indicating that disassembly is in progress or other measures must be taken so that persons other than the workers do not enter the work space.
5. Standard fire fighting equipment
 - Always place a standard fire fighting equipment in the disassembly work area.
 - Depending on type of fire (vehicle or battery) use standard fire fighting equipment (water or extinguisher).

DISASSEMBLY

1. Remove battery pack upper case. Refer to [EVB-875, "BATTERY PACK UPPER CASE : Removal and Installation"](#).
2. Remove Li-ion battery controller. Refer to [EVB-885, "LI-ION BATTERY CONTROLLER : Removal and Installation"](#).
3. Remove the following; Refer to [EVB-890, "BATTERY JUNCTION BOX AND BATTERY HARNESS : Disassembly and Assembly"](#).
 - Battery current sensor (integrated with bus bar)
 - Service plug switch bracket

LI-ION BATTERY

< UNIT DISASSEMBLY AND ASSEMBLY >

[TYPE 4]

4. Disconnect harness connector (A) and heater harness connector (B).

WARNING:

 To prevent electric shock hazards, be sure to put on insulated protective gear and use insulated tools.



5. Remove mounting nuts (C) and then remove the Li-ion battery heater relay unit (1).

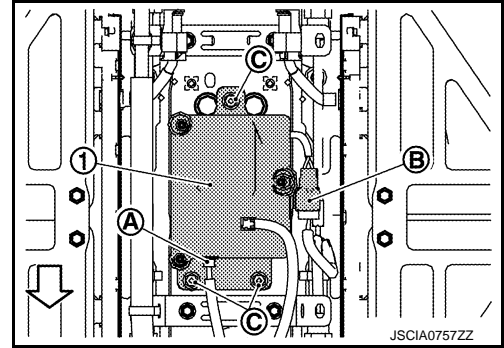

ASSEMBLY

Assemble in the reverse order of disassembly.

WARNING:

 To prevent electric shock hazards, be sure to put on insulated protective gear and use insulated tools.



CAUTION:

- Check the following items after installing battery pack: Refer to [EVB-938, "Inspection"](#).
 - AIR LEAK INSPECTION
 - ELECTRIC EQUIPOTENTIAL TEST
- Install Li-ion battery controller immediately before installing battery pack upper case.

FRONT MODULE STACK

FRONT MODULE STACK : Exploded View

INFOID:000000011191519

REMOVAL AND INSTALLATION

LI-ION BATTERY

< UNIT DISASSEMBLY AND ASSEMBLY >

[TYPE 4]

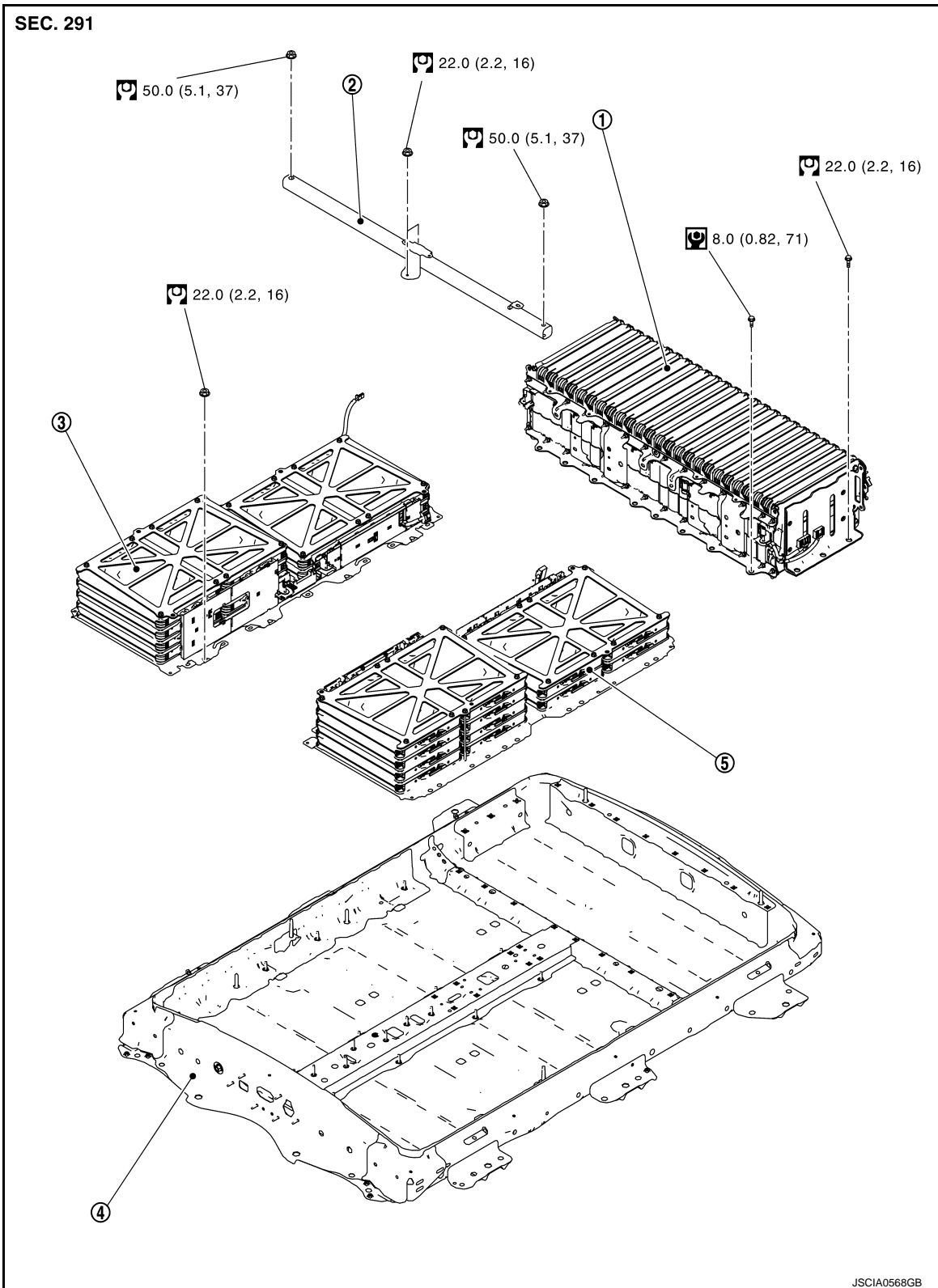

- ① Rear module stack
- ② Battery member pipe
- ③ Front module stack RH
- ④ Battery pack lower case
- ⑤ Front module stack LH

: N·m (kg·m, in·lb)

: N·m (kg·m, ft·lb)

A
B
EVB
D
E
F
G
H
I
J
K
L
M
N
O
P

LI-ION BATTERY

< UNIT DISASSEMBLY AND ASSEMBLY >
DISASSEMBLY AND ASSEMBLY

[TYPE 4]

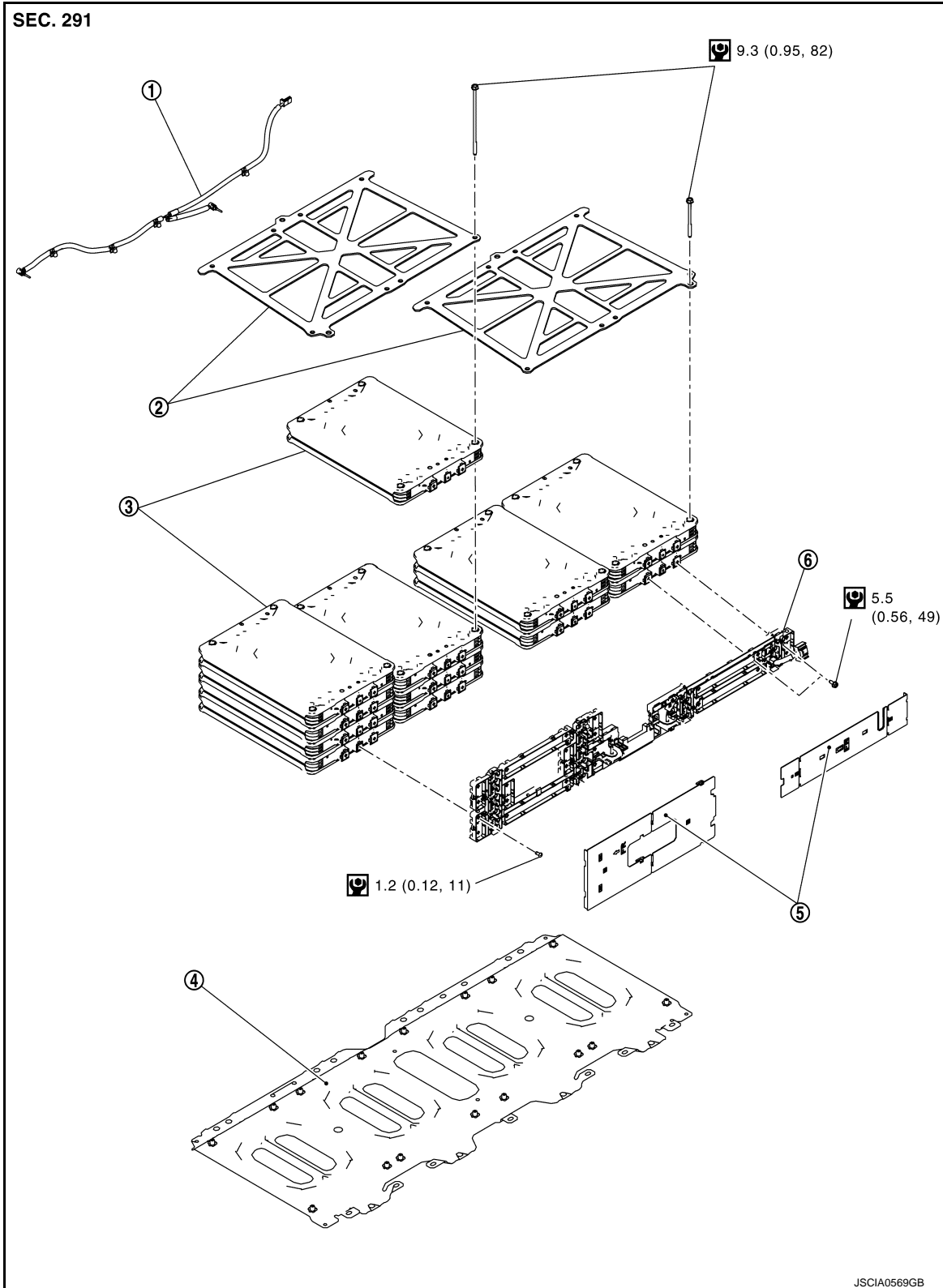

① Battery temperature sensor harness (front)

② End plate

③ Module

④ Sub frame

⑤ Bus bar cover

⑥ Bus bar module

☒ : N·m (kg·m, in·lb)

LI-ION BATTERY

< UNIT DISASSEMBLY AND ASSEMBLY >

[TYPE 4]

NOTE:

The figure shows the right front.

Module layout

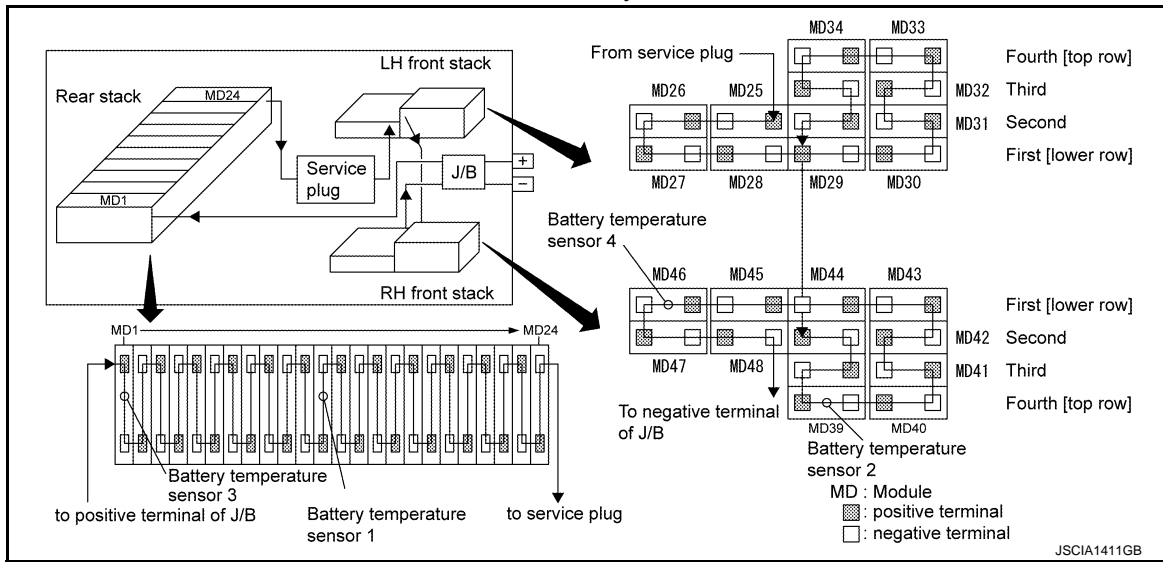

Left front module stack			Right front module stack		
Module No.	Module name	Cell No.	Module No.	Module name	Cell No.
MD25	Module A	49 & 50	MD37	Module A	73 & 74
MD26	Module A	51 & 52	MD38	Module A	75 & 76
MD27	Module A	53 & 54	MD39	Module A	77 & 78
MD28	Module A	55 & 56	MD40	Module A	79 & 80
MD29	Module A	57 & 58	MD41	Module A	81 & 82
MD30	Module A	59 & 60	MD42	Module A	83 & 84
MD31	Module A	61 & 62	MD43	Module A	85 & 86
MD32	Module A	63 & 64	MD44	Module A	87 & 88
MD33	Module A	65 & 66	MD45	Module A	89 & 90
MD34	Module A	67 & 68	MD46	Module A	91 & 92
MD35	Module A	69 & 70	MD47	Module A	93 & 94
MD36	Module A	71 & 72	MD48	Module A	95 & 96

FRONT MODULE STACK : Removal and Installation

INFOID:000000011191520

DANGER:



Since hybrid vehicles and electric vehicles contain a high voltage battery, there is the risk of electric shock, electric leakage, or similar accidents if the high voltage component and vehicle are handled incorrectly. Be sure to follow the correct work procedures when performing inspection and maintenance.

WARNING:

- Be sure to remove the service plug in order to shut off the high voltage circuits before performing inspection or maintenance of high voltage system harnesses and parts.
- Be sure to put the removed service plug in pocket and carry it or store it in a tool box or other container so that another person does not accidentally connect it while work is in progress.
- Be sure to put on insulating protective gear before beginning work on the high voltage system.
- Clearly identify the persons responsible for high voltage work and ensure that other persons do not touch the vehicle. When not working, cover high voltage components with an anti-static cover sheet or similar item to prevent contact with other persons.
- Refer to [EVB-469, "High Voltage Precautions"](#).

LI-ION BATTERY

< UNIT DISASSEMBLY AND ASSEMBLY >

[TYPE 4]

- If the battery pack is to be disassembled, be sure to remove the Li-ion battery controller for preventing electric shock, fire, and damage to parts.

CAUTION:

There is the possibility of a malfunction occurring if the vehicle is changed to READY status while the service plug is removed. Therefore do not change the vehicle to READY status unless instructed to do so in the Service Manual.

ENVIRONMENT FOR LI-ION BATTERY DISASSEMBLY WORK

1. Must be an indoor environment.
 - The environment must utilize a shutter or other means to shut out the outside environment and prevent rain, snow, dust, or other substances from entering.
 - The environment must not cause the intrusion of sweat during work, or cause condensation to occur due to high temperature or humidity.
2. Metal powder, grease, and other foreign substances must not enter.
 - The indoor environment must also prevent metal powder, grease, and other foreign substances from entering due to maintenance performed on other vehicles and other sources during disassembly work.
 - If there is a risk of the above substances entering, take appropriate countermeasures, such as use of a vinyl curtain or an equivalent to shut out the outside environment.
3. The floor must be dry.
 - The floor must not be wet as a result of factors such as vehicle entry during rain or snow.
4. Work space
 - The work space must be approximately the size of one entire vehicle.
 - Take appropriate countermeasures so that persons other than the operator do not enter the work space, such as by placing signs indicating that disassembly work is in progress.
5. Standard fire fighting equipment
 - Always place a standard fire fighting equipment in the disassembly work area.
 - Depending on type of fire (vehicle or battery) use standard fire fighting equipment (water or extinguisher).

REMOVAL

1. Remove the battery pack upper case. [EVB-875. "BATTERY PACK UPPER CASE : Removal and Installation"](#).
2. Remove Li-ion battery controller. Refer to [EVB-885. "LI-ION BATTERY CONTROLLER : Removal and Installation"](#).
3. Remove the following parts. Refer to [EVB-890. "BATTERY JUNCTION BOX AND BATTERY HARNESS : Disassembly and Assembly"](#).
 - Battery junction box
 - Service plug switch bracket
 - High-voltage battery harnesses
 - Vehicle communications harness
 - Voltage detection harness
 - Harness brackets
4. Disconnect the harness connector ① between the battery temperature sensor harness (front) and the battery temperature sensor harness (rear).

WARNING:



To prevent electric shock, wear insulated protective gear.

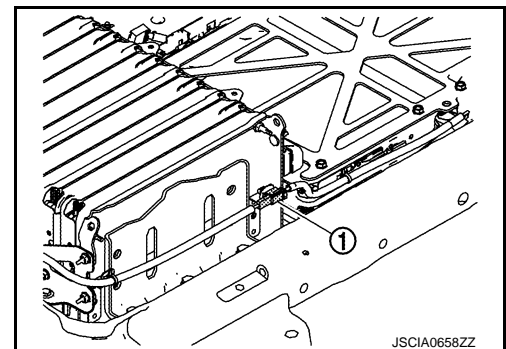

5. Remove the battery temperature sensor harness (front) ① from the front module stack RH.

LI-ION BATTERY

< UNIT DISASSEMBLY AND ASSEMBLY >

[TYPE 4]

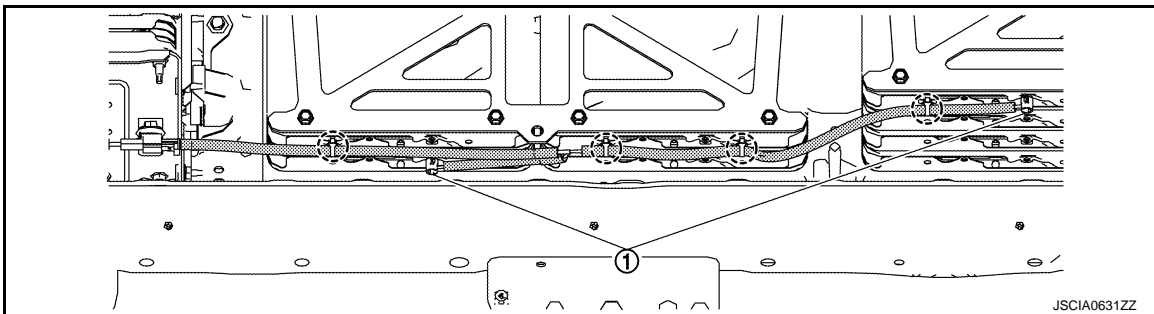

○ : Harness clip

WARNING:

To prevent electric shock, wear insulated protective gear and use insulated tools.



6. Remove the battery member pipe ①.

WARNING:

To prevent electric shock, wear insulated protective gear and use insulated tools.



NOTE:

The right-side mounting hole is larger for facilitating removal of the battery member pipe. Lifting up the left side first makes removal easier.

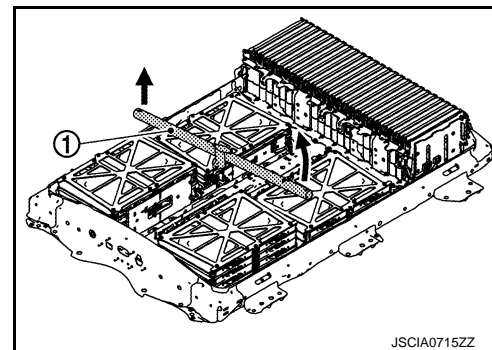

7. Remove the mounting nuts (A), then remove the bus bar ① which connects the left and right front module stacks.

← : Battery front

DANGER:

There is the danger of electric shock caused by contact with the terminals. Be sure to wear insulated protective gear and use insulated tools.



Because there is a danger of electric shock, be sure to close the bus bar cover after removing the bus bar.

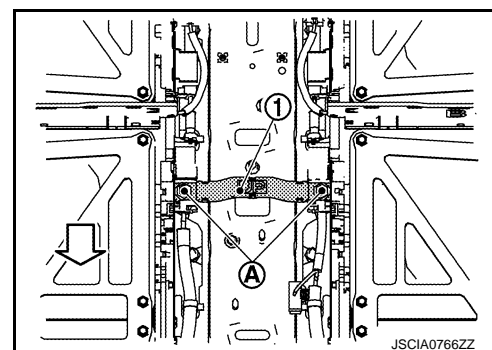

8. Remove the following parts. Refer to [EVB-899. "LI-ION BATTERY HEATER : Disassembly and Assembly"](#).

- Li-ion battery heater RH1
- Li-ion battery heater RH2
- Li-ion battery heater LH1
- Li-ion battery heater LH2

9. Remove the Li-ion battery heater relay unit. Refer to [EVB-905. "LI-ION BATTERY HEATER RELAY UNIT : Disassembly and Assembly"](#).

A
B
EVB
D
E
F
G
H
I
J
K
L
M
N
O
P

LI-ION BATTERY

< UNIT DISASSEMBLY AND ASSEMBLY >

[TYPE 4]

10. Disconnect the Li-ion battery heater harness connector ①. And then remove the harness clips and move them to a location where they do not inhibit with work.

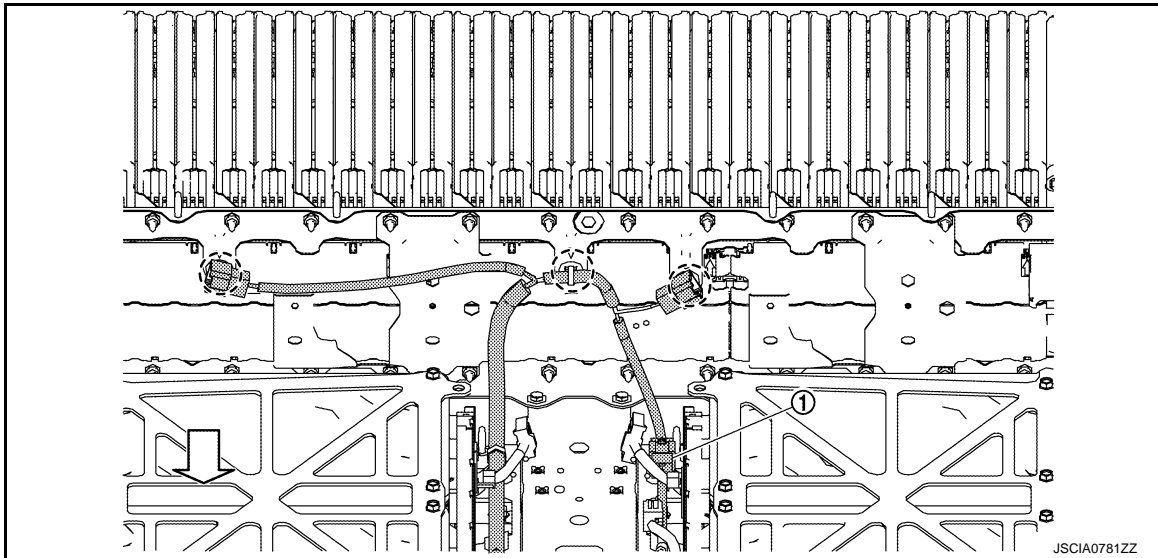

○ : Harness clip

WARNING:

 To prevent electric shock, wear insulated protective gear and use insulated tools.



12. Remove the front module stack mounting nuts ①.

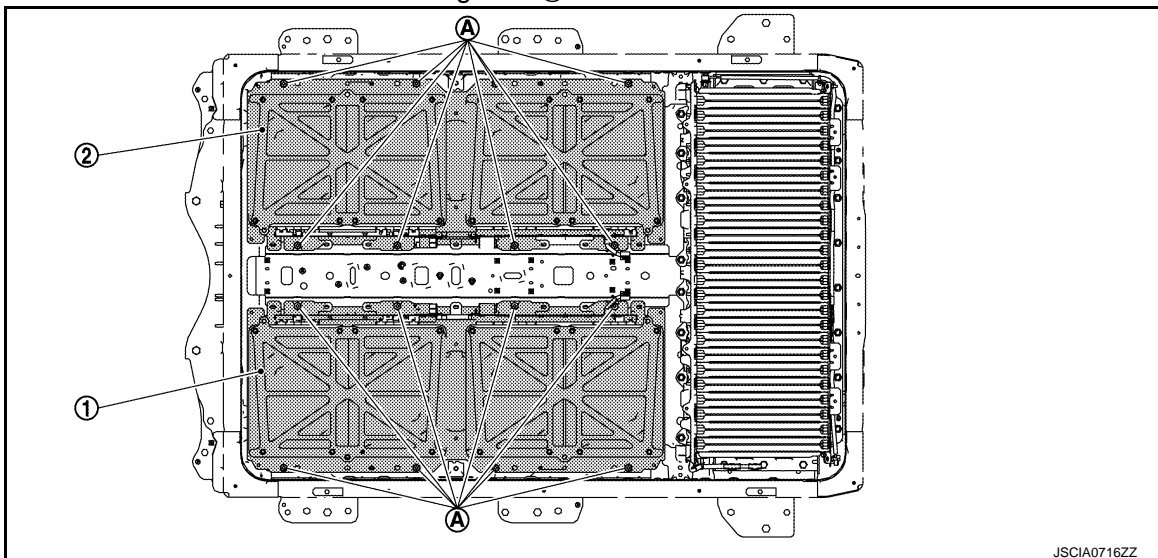

① Front module stack LH

② Front module stack RH

WARNING:

 To prevent electric shock, wear insulated protective gear and use insulated tools.



13. Follow the procedure below and remove the front module stack from the battery pack.

LI-ION BATTERY

< UNIT DISASSEMBLY AND ASSEMBLY >

[TYPE 4]

- a. Attach a carabiner at position (A) as shown in the figure, and attach a sling belt to it.

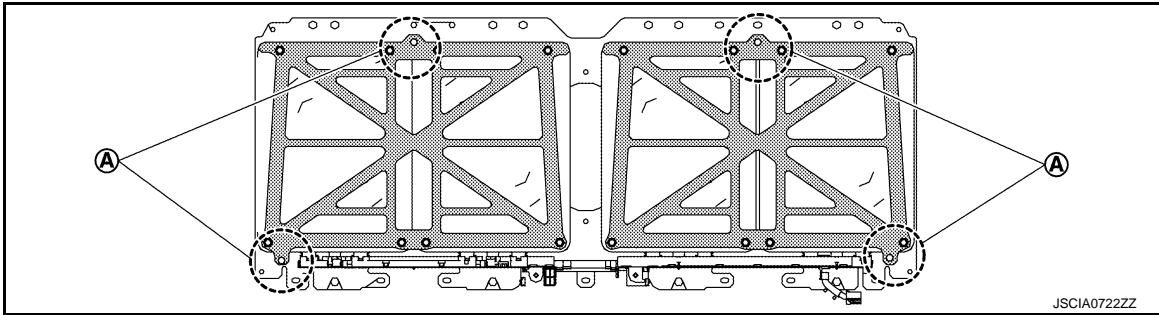

WARNING:

 To prevent electric shock, wear insulated protective gear.



- b. Use the engine frame (A) and lift up the front module stack.

WARNING:

 To prevent electric shock, wear insulated protective gear.



CAUTION:

Do not move the engine crane when the front module stack is lifted up.

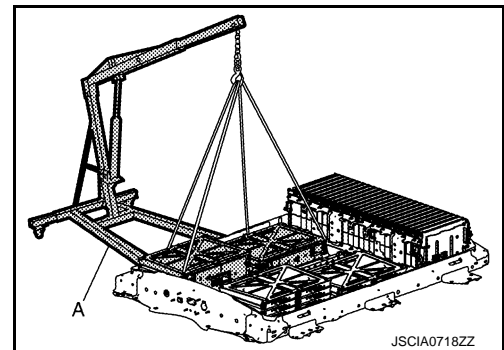

- c. Move the battery pack and place the workbench below the front module stack.

WARNING:

 To prevent electric shock, wear insulated protective gear.



CAUTION:

Place the removed battery pack upper case onto the battery pack for storage.

- d. Place the front module stack onto the workbench.

WARNING:

•  To prevent electric shock, wear insulated protective gear.



•  Because there is a risk of electric shock, lay an anti-static rubber sheet on the workbench.

NOTE:

The figure shows the front module stack RH.

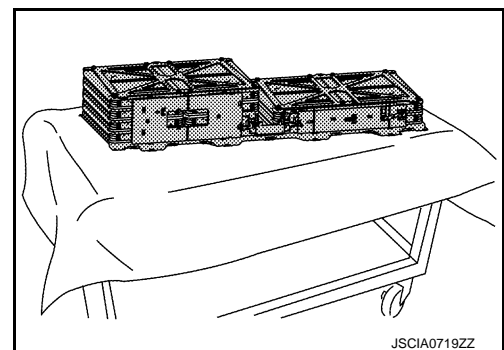

14. Remove the Li-ion battery heater harness ①.

A

B

EVB

D

E

F

G

H

I

J

K

L

M

N

O

P

LI-ION BATTERY

< UNIT DISASSEMBLY AND ASSEMBLY >

[TYPE 4]

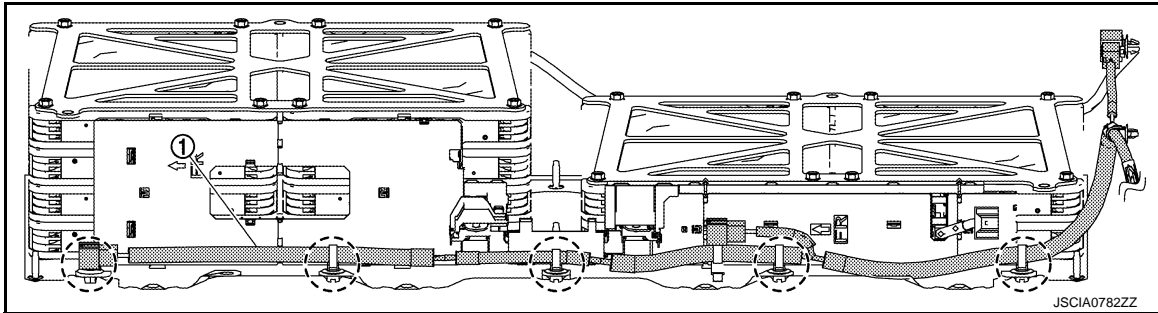

○ : Harness clip

WARNING:

 To prevent electric shock, wear insulated protective gear and use insulated tools.



INSTALLATION

Note the following items, and disassembly in the reverse order of disassembly.

DANGER:

-  There is the danger of electric shock caused by contact with the terminals. Be sure to wear insulated protective gear and use insulated tools.



-  Because there is a danger of electric shock and fire, never allow bus bar to contact a wrong terminal.
 - If bus bar contacts a wrong terminal, the circuit becomes energized and a short may occur.
 - Always keep the bus bar cover closed until immediately before the installation of bus bar.
 - Since the correct installation position for the bus bar connected to both front module stacks is commonly-confused with the wrong position (B), install the bus bar to the correct position (A) with extreme caution.

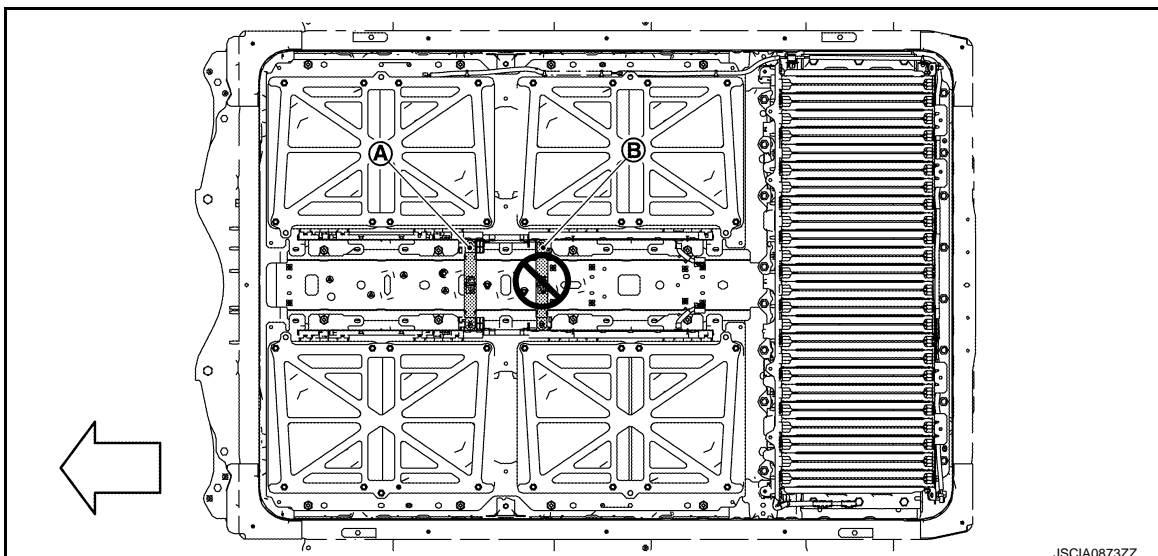

(A) Correct position

(B) Wrong position

⇐ : Battery front

LI-ION BATTERY

< UNIT DISASSEMBLY AND ASSEMBLY >

[TYPE 4]

WARNING:

Install the Li-ion battery controller immediately before installing the battery pack upper case. Refer to [EVB-885, "LI-ION BATTERY CONTROLLER : Removal and Installation"](#).

EV Battery Tracking Identification Seal

When replacing the Li-ion battery with a new battery, perform the following operation.

1. Enter the date of the (replacement) work on the EV battery tracking identification seal that is packaged together with the new part.
2. Cut the EV battery tracking identification tool into 2 pieces and apply them to the body of the replaced (old) Li-ion battery and to the "Li-ion battery replacement history record".
3. Enter the necessary information in the "Li-ion battery replacement history record".

Battery Temperature Sensor Harness (Front)

Install the battery temperature sensor harness (front) onto the front module stack RH.

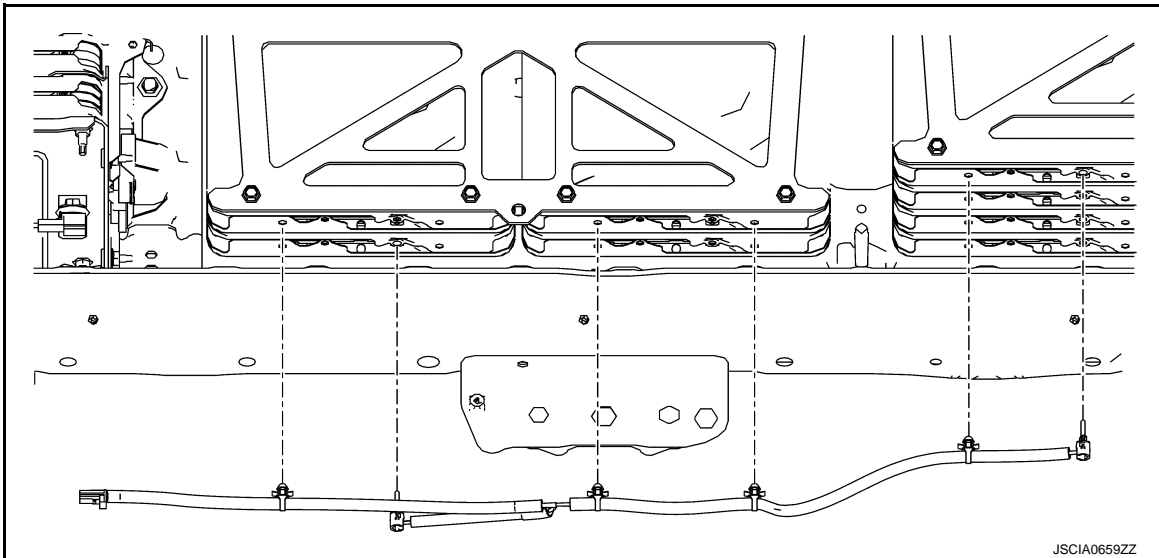

CAUTION:

- Be sure to reinstall the high voltage harness clips in their original positions. If a clip is damaged, replace it with a new clip before installing.
- Check the following items after installing battery pack: Refer to [EVB-938, "Inspection"](#).

■AIR LEAK INSPECTION

■ELECTRIC EQUIPOTENTIAL TEST

NOTE:

Install the battery temperature sensor onto module No. MD39 and MD46.

FRONT MODULE STACK : Disassembly and Assembly

INFOID:000000011191521

DANGER:

 Since hybrid vehicles and electric vehicles contain a high voltage battery, there is the risk of electric shock, electric leakage, or similar accidents if the high voltage component and vehicle are handled incorrectly. Be sure to follow the correct work procedures when performing inspection and maintenance.

WARNING:

- Be sure to remove the service plug in order to shut off the high voltage circuits before performing inspection or maintenance of high voltage system harnesses and parts.
- Be sure to put the removed service plug in pocket and carry it or store it in a tool box or other container so that another person does not accidentally connect it while work is in progress.
- Be sure to put on insulating protective gear before beginning work on the high voltage system.
- Clearly identify the persons responsible for high voltage work and ensure that other persons do not touch the vehicle. When not working, cover high voltage components with an anti-static cover sheet or similar item to prevent contact with other persons.
- Refer to [EVB-469, "High Voltage Precautions"](#).
- If the battery pack is to be disassembled, be sure to remove the Li-ion battery controller for preventing electric shock, fire, and damage to parts.

LI-ION BATTERY

< UNIT DISASSEMBLY AND ASSEMBLY >

[TYPE 4]

CAUTION:

There is the possibility of a malfunction occurring if the vehicle is changed to READY status while the service plug is removed. Therefore do not change the vehicle to READY status unless instructed to do so in the Service Manual.

ENVIRONMENT FOR LI-ION BATTERY DISASSEMBLY WORK

1. Must be an indoor environment.
 - The environment must utilize a shutter or other means to shut out the outside environment and prevent rain, snow, dust, or other substances from entering.
 - The environment must not cause the intrusion of sweat during work, or cause condensation to occur due to high temperature or humidity.
2. Metal powder, grease, and other foreign substances must not enter.
 - The indoor environment must also prevent metal powder, grease, and other foreign substances from entering due to maintenance performed on other vehicles and other sources during disassembly work.
 - If there is a risk of the above substances entering, take appropriate countermeasures, such as use of a vinyl curtain or an equivalent to shut out the outside environment.
3. The floor must be dry.
 - The floor must not be wet as a result of factors such as vehicle entry during rain or snow.
4. Work space
 - The work space must be approximately the size of one entire vehicle.
 - Take appropriate countermeasures so that persons other than the operator do not enter the work space, such as by placing signs indicating that disassembly work is in progress.
5. Standard fire fighting equipment
 - Always place a standard fire fighting equipment in the disassembly work area.
 - Depending on type of fire (vehicle or battery) use standard fire fighting equipment (water or extinguisher).

DISASSEMBLY

1. Follow the procedure below and remove the bus bar module from the front module stack.
 - a. Remove the bus bar cover, then remove the module terminal mounting bolts (A).

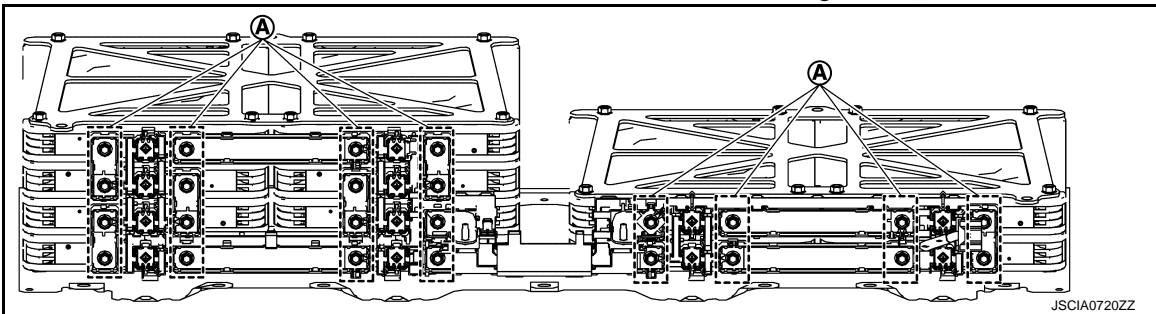

DANGER:

-  There is the danger of electric shock caused by contact with the terminals. Be sure to wear insulated protective gear and use insulated tools.



-  This work must not be performed by multiple operators because there is a risk of electric shock if the operators contact one another.

LI-ION BATTERY

< UNIT DISASSEMBLY AND ASSEMBLY >

[TYPE 4]

- b. Remove the voltage detection terminal mounting screws (A), then remove the bus bar module (1) from the front module stack.

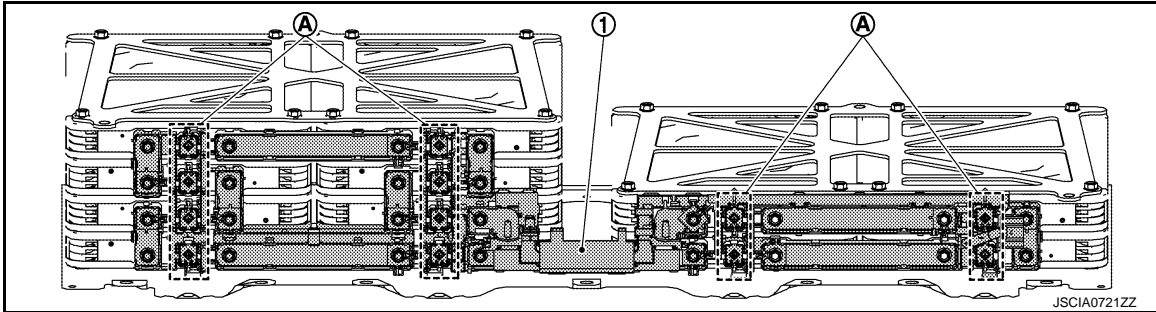

DANGER:

- ⚡ There is the danger of electric shock caused by contact with the terminals. Be sure to wear insulated protective gear and use insulated tools.



- ⚡ This work must not be performed by multiple operators because there is a risk of electric shock if the operators contact one another.

- c. Install a module terminal cover [SST: KV99111500 (—)] (A) onto all module terminals.

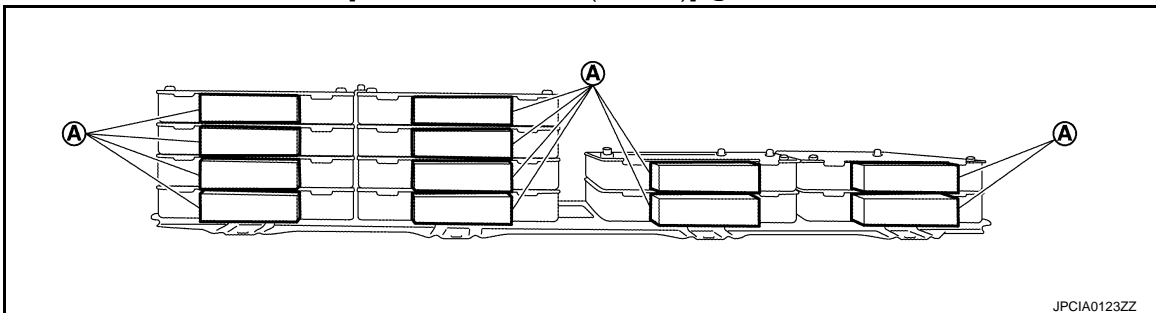

WARNING:

- ⚡ To prevent electric shock, wear insulated protective gear.



2. Remove the end plate and disassemble the front module stack.

WARNING:

- ⚡ To prevent electric shock, wear insulated protective gear and use insulated tools.



ASSEMBLY

- When replacing the Li-ion battery with a new battery, perform the following operation.
 - Enter the date of the (replacement) work on the EV battery tracking identification seal that is packaged together with the new part.
 - Cut the EV battery tracking identification tool into 2 pieces and apply them to the body of the replaced (old) Li-ion battery and to the "Li-ion battery replacement history record".
 - Enter the necessary information in the "Li-ion battery replacement history record".
- Follow the procedure below to assemble the front module stack.

DANGER:

A
B
EVB

D
E
F
G
H
I
J
K
L
M
N
O
P

LI-ION BATTERY

< UNIT DISASSEMBLY AND ASSEMBLY >

[TYPE 4]



There is the danger of electric shock caused by contact with the terminals. Be sure to wear insulated protective gear and use insulated tools.



a. Assemble the module so that the module terminals are arranged as shown in the figure.

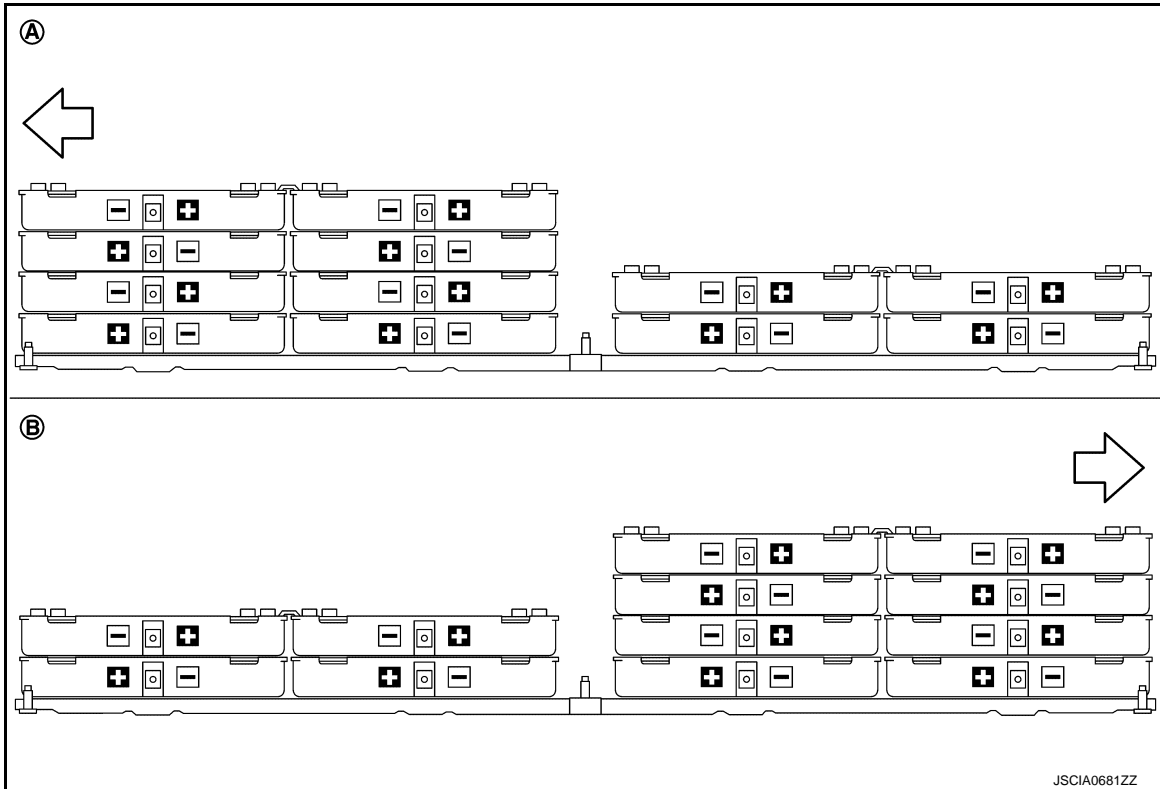

(A) Right module stack

(B) Left module stack

← : Battery front

WARNING:



Be careful of the directions of the + terminal and – terminal when assembling the module. If the polarity is incorrect, there is a risk of electric shock, fire, and component damage.

NOTE:

- To identify the module + terminal and – terminal, refer to the figure.

+ terminal identification color (A) : Red

– terminal identification color (B) : Black

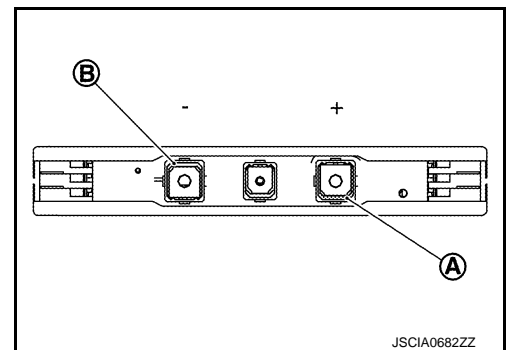

LI-ION BATTERY

< UNIT DISASSEMBLY AND ASSEMBLY >

[TYPE 4]

- Install the module while aligning the position of the module collar ①.

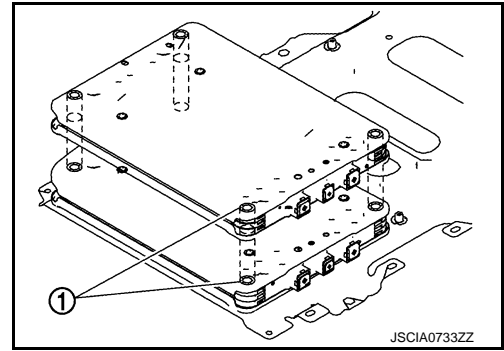

- b. Install so that the end plate carabiner installation holes (A) are in the positions shown in the figure.

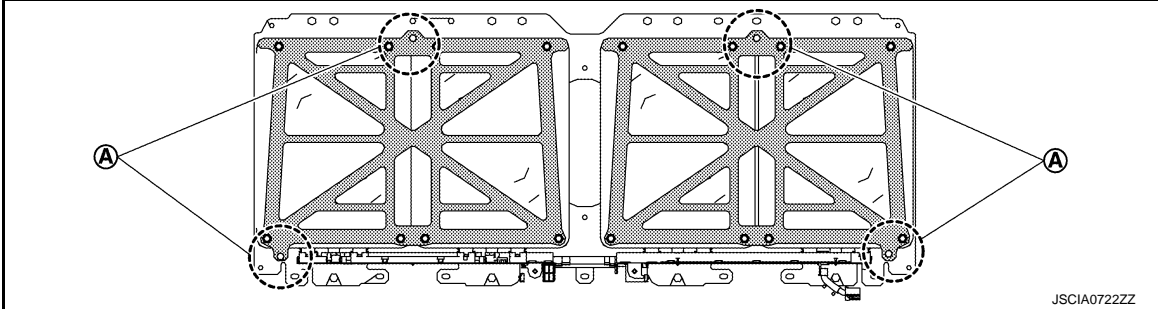

NOTE:

There are 2 end plates, each with different carabiner installation hole positions. If they are installed reversed, the carabiner installation hole is positioned on the inside and lifting up is not possible.

- c. Install the mounting bolts (A) at opposite corners for each module, then insert $\phi 7$ mm (0.28 in) metal bars (B) into the empty bolt holes and perform centering of the module collar position.

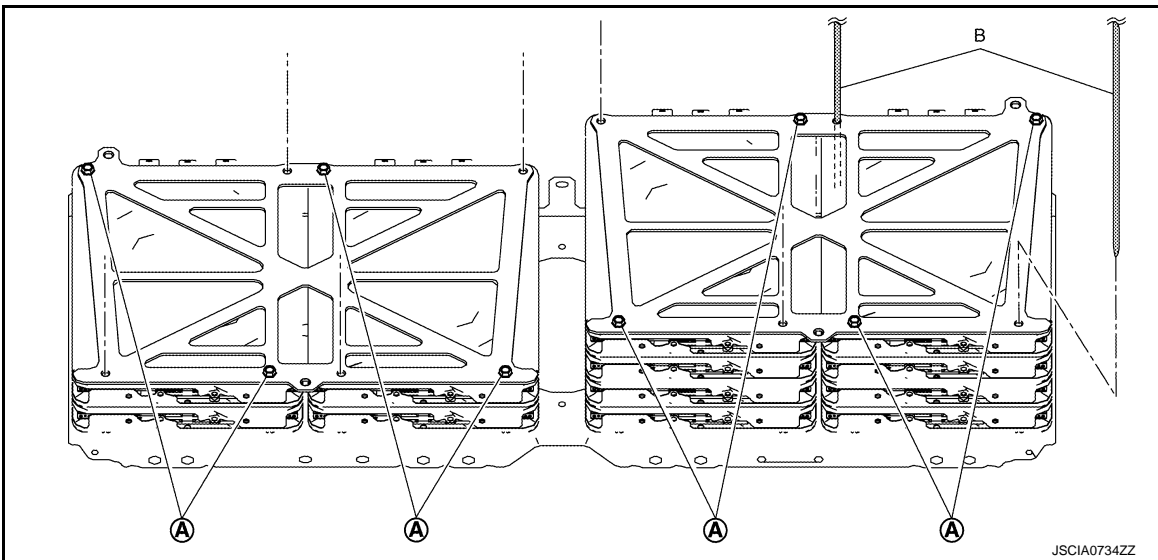

CAUTION:

If the collar position is incorrect, there is a risk of the bolts loosening because they are not supported by the collar between the modules.

- d. Tighten the mounting bolt to the specified torque.
3. Follow the following procedure and install the bus bar module onto the front module stack.

A
B
EVB
D
E
F
G
H
I
J
K
L
M
N
O
P

LI-ION BATTERY

< UNIT DISASSEMBLY AND ASSEMBLY >

[TYPE 4]

- a. Install the bus bar module ①, then use an insulated torque driver to tighten the voltage detection terminal mounting screws ②.

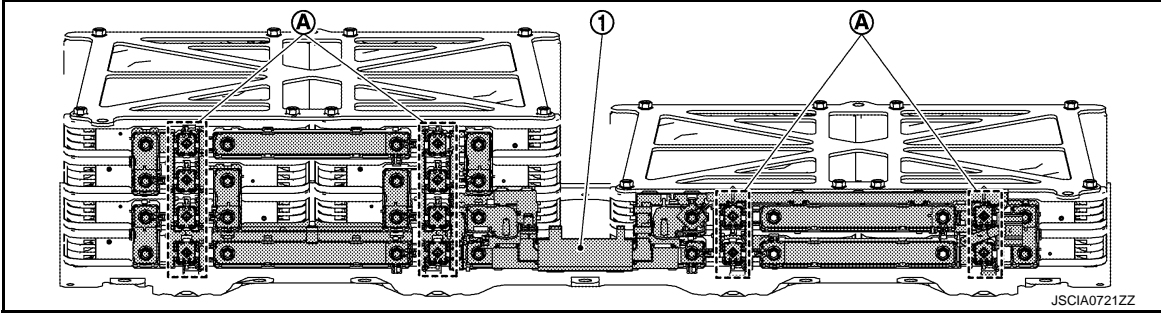

DANGER:

- ⚡ There is the danger of electric shock caused by contact with the terminals. Be sure to wear insulated protective gear and use insulated tools.



- ⚡ This work must not be performed by multiple operators because there is a risk of electric shock if the operators contact one another.

- b. Tighten the module terminal mounting bolts in numerical order as shown in the figure.

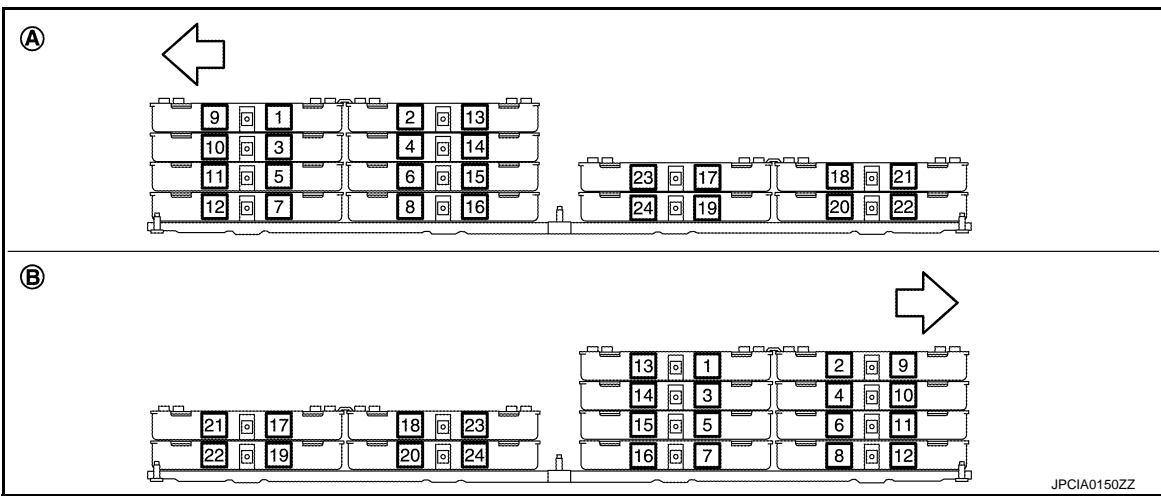

Ⓐ Right module stack

Ⓑ Left module stack

← : Battery front

DANGER:

- ⚡ There is the danger of electric shock caused by contact with the terminals. Be sure to wear insulated protective gear and use insulated tools.



- ⚡ This work must not be performed by multiple operators because there is a risk of electric shock if the operators contact one another.

- c. Install the bus bar cover.

REAR MODULE STACK

LI-ION BATTERY

< UNIT DISASSEMBLY AND ASSEMBLY >

[TYPE 4]

REAR MODULE STACK : Exploded View

INFOID:000000011191522

REMOVAL AND INSTALLATION

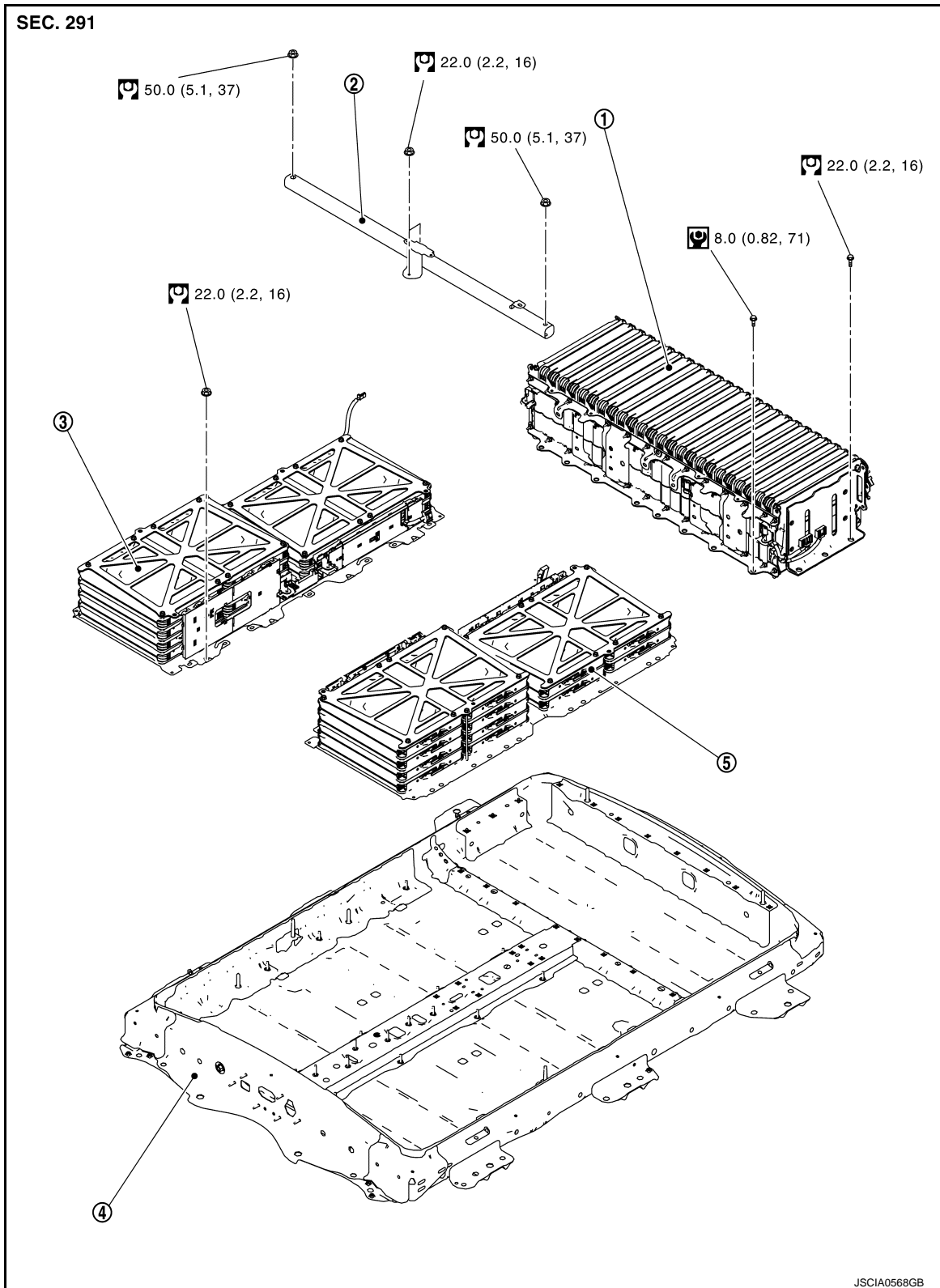



- ① Rear module stack
- ② Battery member pipe
- ③ Front module stack RH
- ④ Battery pack lower case
- ⑤ Front module stack LH

LI-ION BATTERY

< UNIT DISASSEMBLY AND ASSEMBLY >

[TYPE 4]

 : N·m (kg-m, in-lb)

 : N·m (kg-m, ft-lb)

DISASSEMBLY AND ASSEMBLY

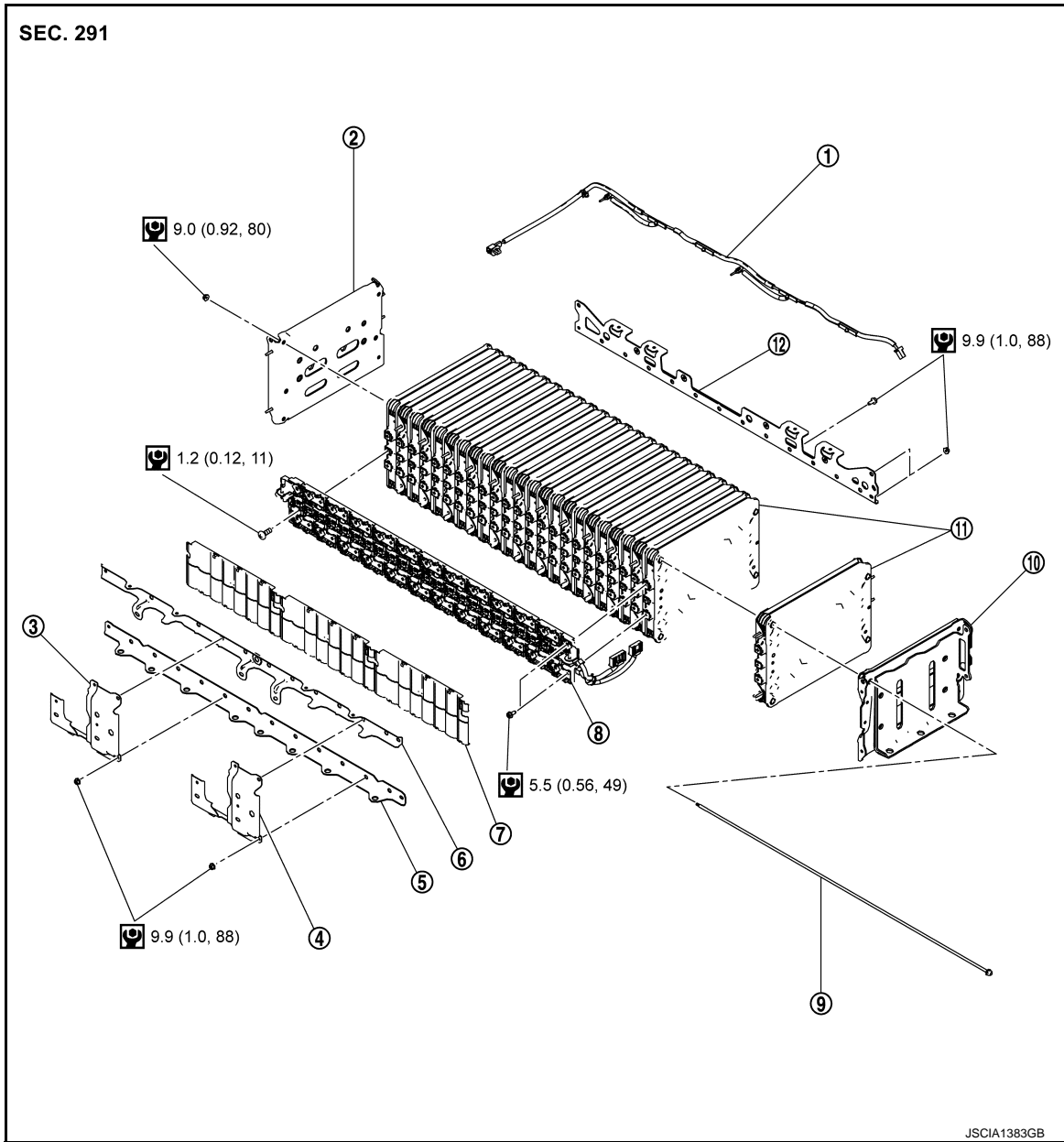

- | | | |
|---|----------------------|---------------------|
| ① Battery temperature sensor harness (rear) | ② Right end plate | ③ Harness bracket |
| ④ Harness bracket | ⑤ Front stack member | ⑥ Harness bracket |
| ⑦ Bus bar cover | ⑧ Bus bar module | ⑨ Through-bolt |
| ⑩ Left end plate | ⑪ Module | ⑫ Rear stack member |

 : N·m (kg-m, in-lb)

LI-ION BATTERY

< UNIT DISASSEMBLY AND ASSEMBLY >

[TYPE 4]

Module layout

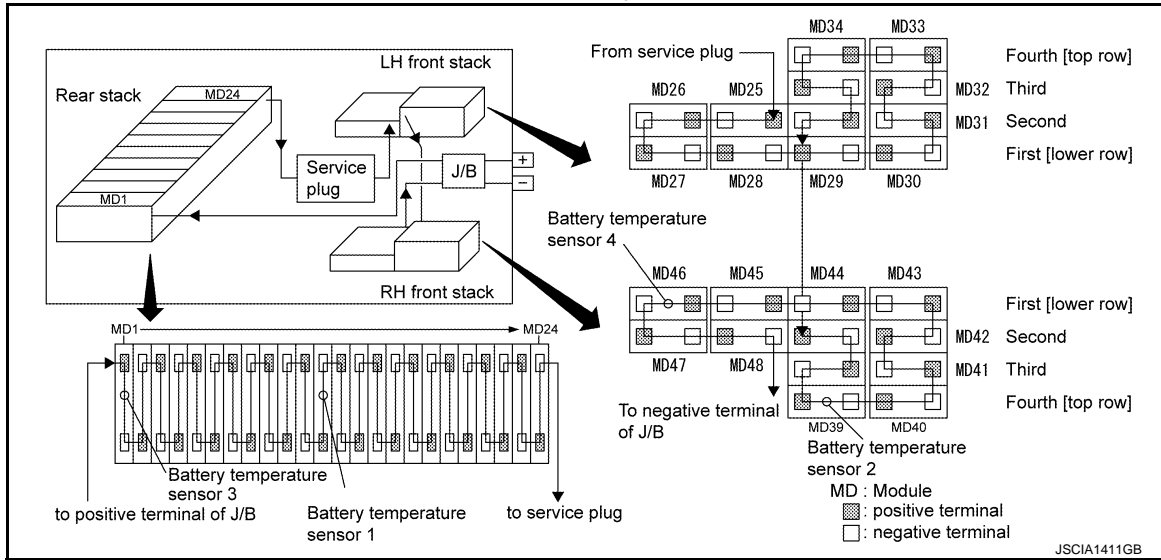

Rear module stack

Module No.	Module name	Cell No.	Module No.	Module name	Cell No.
MD1	Module A	1 & 2	MD13	Module A	25 & 26
MD2	Module B	3 & 4	MD14	Module B	27 & 28
MD3	Module A	5 & 6	MD15	Module A	29 & 30
MD4	Module B	7 & 8	MD16	Module B	31 & 32
MD5	Module A	9 & 10	MD17	Module A	33 & 34
MD6	Module B	11 & 12	MD18	Module B	35 & 36
MD7	Module A	13 & 14	MD19	Module A	37 & 38
MD8	Module B	15 & 16	MD20	Module B	39 & 40
MD9	Module A	17 & 18	MD21	Module A	41 & 42
MD10	Module B	19 & 20	MD22	Module B	43 & 44
MD11	Module A	21 & 22	MD23	Module A	45 & 46
MD12	Module B	23 & 24	MD24	Module B	47 & 48

NOTE:

- Module A: No bracket
- Module B: With bracket

REAR MODULE STACK : Removal and Installation

INFOID:000000011191523

DANGER:



Since hybrid vehicles and electric vehicles contain a high voltage battery, there is the risk of electric shock, electric leakage, or similar accidents if the high voltage component and vehicle are handled incorrectly. Be sure to follow the correct work procedures when performing inspection and maintenance.

WARNING:

- Be sure to remove the service plug in order to shut off the high voltage circuits before performing inspection or maintenance of high voltage system harnesses and parts.
- Be sure to put the removed service plug in pocket and carry it or store it in a tool box or other container so that another person does not accidentally connect it while work is in progress.
- Be sure to put on insulating protective gear before beginning work on the high voltage system.
- Clearly identify the persons responsible for high voltage work and ensure that other persons do not touch the vehicle. When not working, cover high voltage components with an anti-static cover sheet or similar item to prevent contact with other persons.
- Refer to [EVB-469, "High Voltage Precautions"](#).

LI-ION BATTERY

< UNIT DISASSEMBLY AND ASSEMBLY >

[TYPE 4]

- If the battery pack is to be disassembled, be sure to remove the Li-ion battery controller for preventing electric shock, fire, and damage to parts.

CAUTION:

There is the possibility of a malfunction occurring if the vehicle is changed to READY status while the service plug is removed. Therefore do not change the vehicle to READY status unless instructed to do so in the Service Manual.

ENVIRONMENT FOR LI-ION BATTERY DISASSEMBLY WORK

1. Must be an indoor environment.
 - The environment must utilize a shutter or other means to shut out the outside environment and prevent rain, snow, dust, or other substances from entering.
 - The environment must not cause the intrusion of sweat during work, or cause condensation to occur due to high temperature or humidity.
2. Metal powder, grease, and other foreign substances must not enter.
 - The indoor environment must also prevent metal powder, grease, and other foreign substances from entering due to maintenance performed on other vehicles and other sources during disassembly work.
 - If there is a risk of the above substances entering, take appropriate countermeasures, such as use of a vinyl curtain or an equivalent to shut out the outside environment.
3. The floor must be dry.
 - The floor must not be wet as a result of factors such as vehicle entry during rain or snow.
4. Work space
 - The work space must be approximately the size of one entire vehicle.
 - Take appropriate countermeasures so that persons other than the operator do not enter the work space, such as by placing signs indicating that disassembly work is in progress.
5. Standard fire fighting equipment
 - Always place a standard fire fighting equipment in the disassembly work area.
 - Depending on type of fire (vehicle or battery) use standard fire fighting equipment (water or extinguisher).

REMOVAL

1. Remove the battery pack upper case. Refer to [EVB-875. "BATTERY PACK UPPER CASE : Removal and Installation"](#).
2. Remove Li-ion battery controller. Refer to [EVB-885. "LI-ION BATTERY CONTROLLER : Removal and Installation"](#).
3. Remove Li-ion battery heater RR1 and RR2. Refer to [EVB-899. "LI-ION BATTERY HEATER : Disassembly and Assembly"](#).
4. Disconnect the harness connector ① between the battery temperature sensor harness (front) and the battery temperature sensor harness (rear).

WARNING:



To prevent electric shock, wear insulated protective gear.

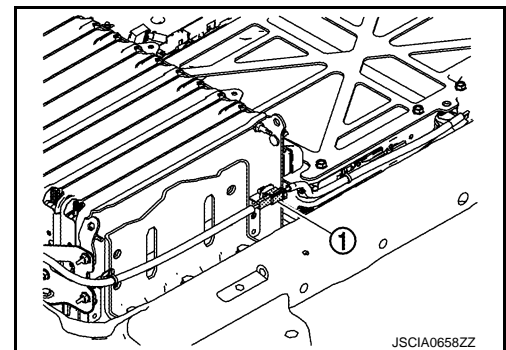

LI-ION BATTERY

< UNIT DISASSEMBLY AND ASSEMBLY >

[TYPE 4]

5. Disconnect the connector, and then remove the battery temperature sensor harness (rear).

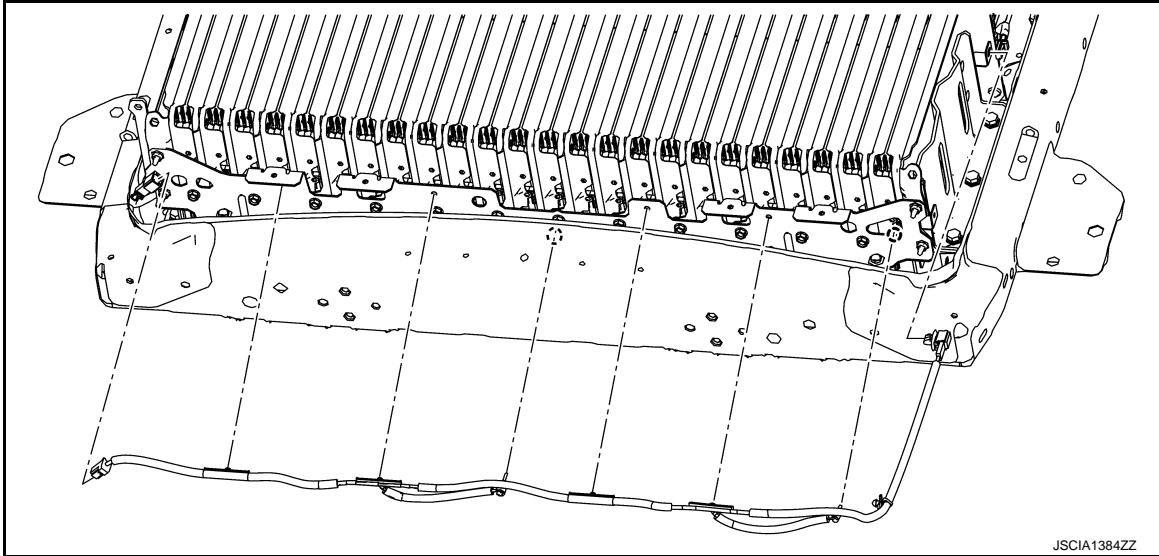



WARNING:

 To prevent electric shock, wear insulated protective gear and use insulated tools.

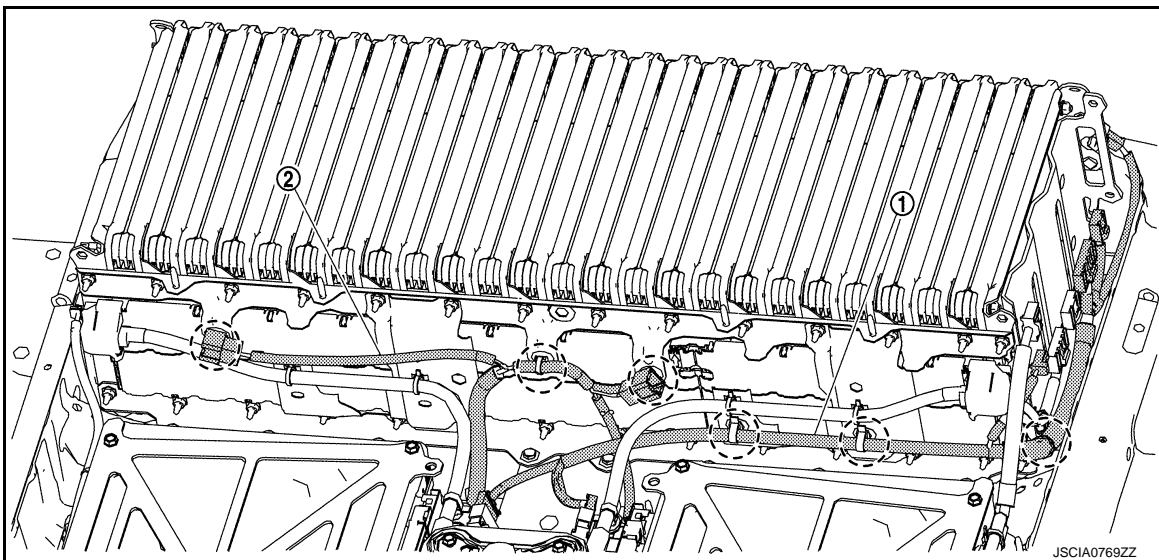

6. Remove the harness clips of the voltage detection harness ① and the Li-ion battery heater harness ② from the harness bracket, and move them to a location where they do not inhibit with work.



 : Harness clip

WARNING:

 To prevent electric shock, wear insulated protective gear and use insulated tools.



7. Remove the mounting nuts ① and remove the high-voltage harness ①, ② from the rear module stack.

A
B
EVB
D
E
F
G
H
I
J
K
L
M
N
O
P

LI-ION BATTERY

< UNIT DISASSEMBLY AND ASSEMBLY >

[TYPE 4]

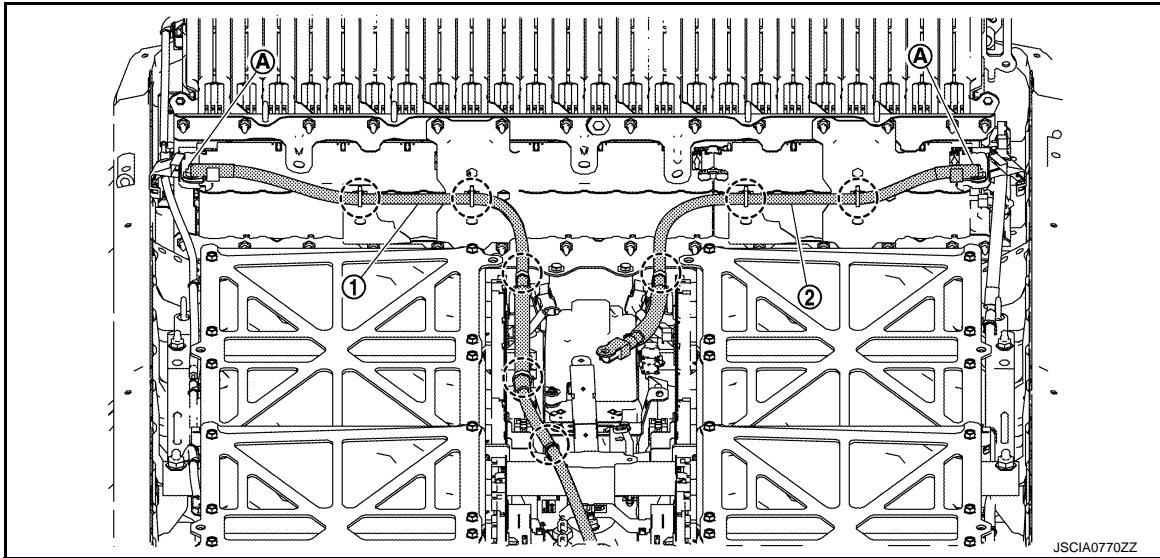

○ : Harness clip

DANGER:

- ⚡ There is the danger of electric shock caused by contact with the terminals. Be sure to wear insulated protective gear and use insulated tools.



- ⚡ Because there is a risk of electric shock, immediately protect the disconnected high-voltage terminals with insulating tape so that they are not exposed.

8. Remove the rear module stack ① mounting bolts (A).

WARNING:

- ⚡ To prevent electric shock, wear insulated protective gear and use insulated tools.

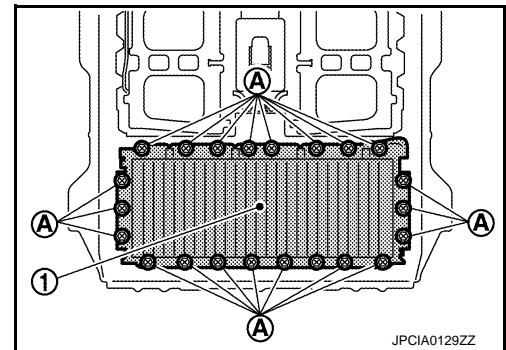

9. Follow the procedure below and remove the rear module stack from the battery pack.

- Attach a carabiner to position (A) as shown in the figure and connect a lashing belt to it.

WARNING:

- ⚡ To prevent electric shock, wear insulated protective gear.

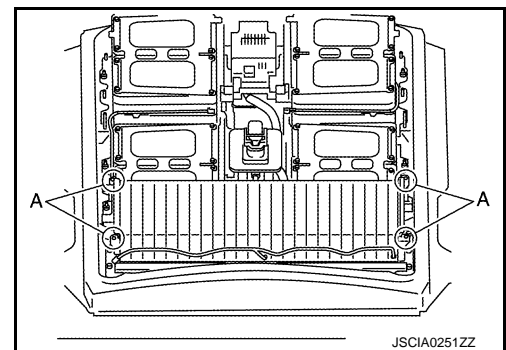

LI-ION BATTERY

< UNIT DISASSEMBLY AND ASSEMBLY >

[TYPE 4]

- b. Use the engine frame (A) and lift up the rear module stack ①.

WARNING:



To prevent electric shock, wear insulated protective gear.



CAUTION:

Do not move the engine crane when the rear module stack is lifted up.

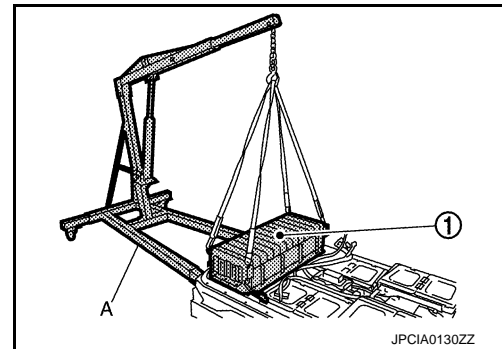

- c. Move the battery pack and place the workbench below the rear module stack.

WARNING:



To prevent electric shock, wear insulated protective gear.



CAUTION:

Place the removed battery pack upper case onto the battery pack for storage.

- d. Place the rear module stack onto the workbench.

WARNING:



To prevent electric shock, wear insulated protective gear.



Because there is a risk of electric shock, lay an anti-static rubber sheet on the workbench.

INSTALLATION

1. When replacing the Li-ion battery with a new battery, perform the following operation.

- Enter the date of the (replacement) work on the EV battery tracking identification seal that is packaged together with the new part.
 - Cut the EV battery tracking identification tool into 2 pieces and apply them to the body of the replaced (old) Li-ion battery and to the "Li-ion battery replacement history record".
 - Enter the necessary information in the "Li-ion battery replacement history record".
2. Follow the following procedure and install the rear module stack onto the battery pack.

- a. Use the engine frame (A) and lift up the rear module stack ①.

WARNING:



To prevent electric shock, wear insulated protective gear.



CAUTION:

Do not move the engine crane when the rear module stack is lifted up.

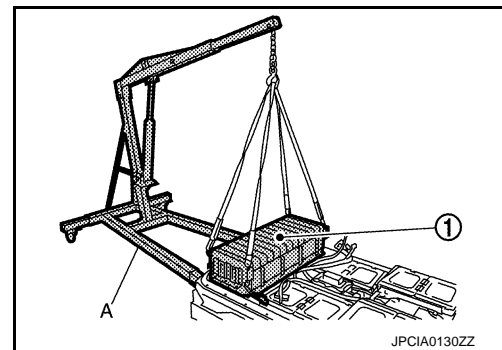

- Move the workbench and place the battery pack below the rear module stack.
- Mount the rear module stack onto the battery pack.

WARNING:



To prevent electric shock, wear insulated protective gear.

LI-ION BATTERY

< UNIT DISASSEMBLY AND ASSEMBLY >

[TYPE 4]



CAUTION:

Be sure to align the locating pin position.

3. Tighten the rear module stack ① mounting bolts (A).

WARNING:



To prevent electric shock, wear insulated protective gear and use insulated tools.

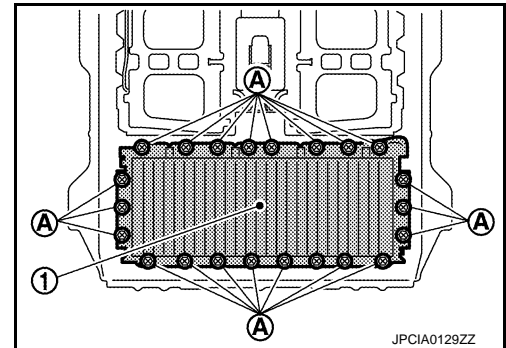

4. Tighten the mounting nuts (A), and then install the high-voltage harness (1), (2) onto the rear module stack.

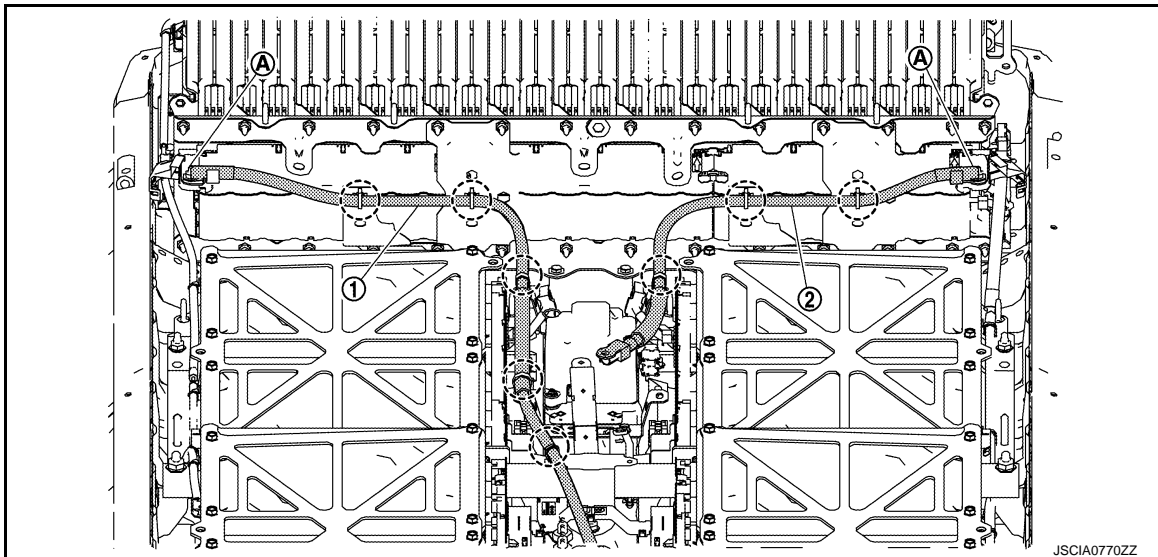

 : Harness clip

DANGER:

-  There is the danger of electric shock caused by contact with the terminals. Be sure to wear insulated protective gear and use insulated tools.



-  Because there is a risk of electric shock, immediately protect the disconnected high-voltage terminals with insulating tape so that they are not exposed.

5. Install the voltage detection harness (1) and the Li-ion battery heater harness (2).

LI-ION BATTERY

< UNIT DISASSEMBLY AND ASSEMBLY >

[TYPE 4]

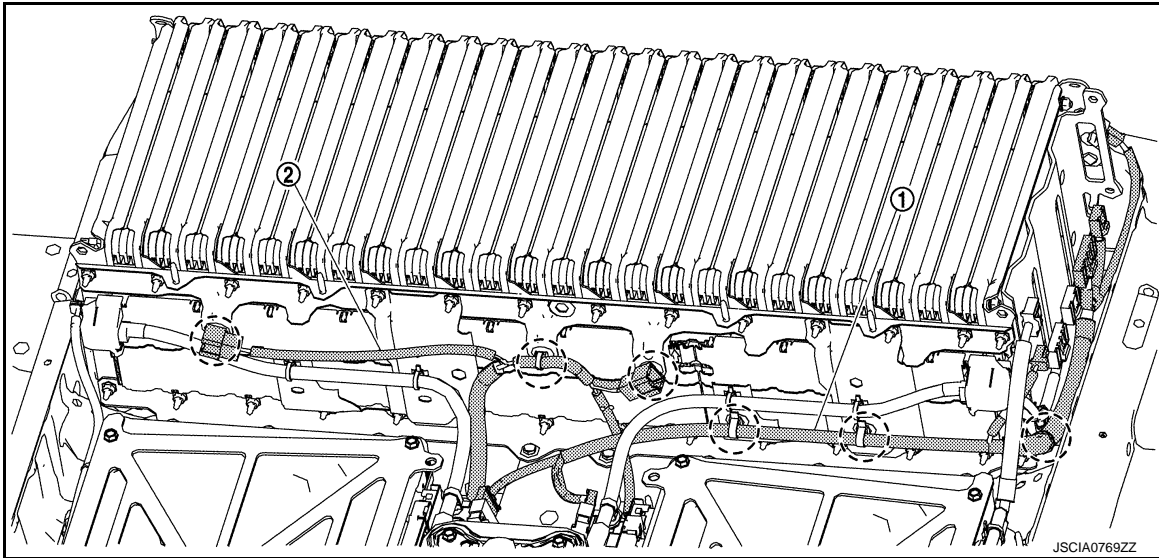

 : Harness clip

WARNING:

 To prevent electric shock, wear insulated protective gear.



6. Install the battery temperature sensor harness (rear).

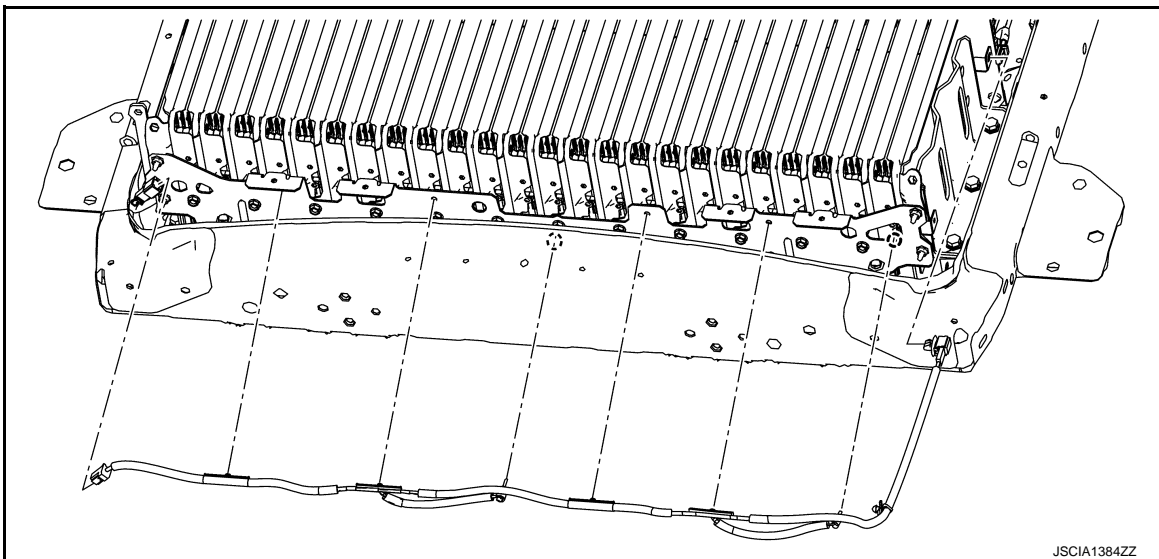

WARNING:

 To prevent electric shock, wear insulated protective gear and use insulated tools.



NOTE:

Install the battery temperature sensor onto module No. MD1 and MD12.

A
B
EVB
D
E
F
G
H
I
J
K
L
M
N
O
P

LI-ION BATTERY

< UNIT DISASSEMBLY AND ASSEMBLY >

[TYPE 4]

7. Connect the harness connector ① between the battery temperature sensor harness (front) and battery temperature sensor harness (rear).

WARNING:



To prevent electric shock, wear insulated protective gear.

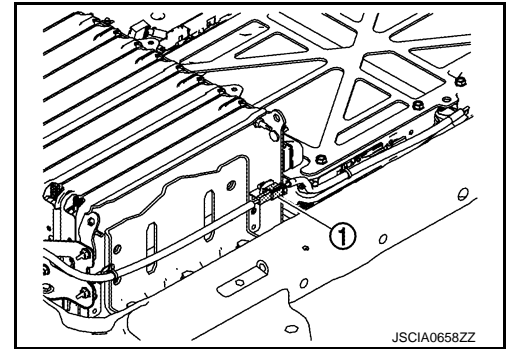

8. Install the Li-ion battery heater RR1 and RR2. Refer to [EVB-899, "LI-ION BATTERY HEATER : Disassembly and Assembly"](#).
9. Install the Li-ion battery controller. Refer to [EVB-885, "LI-ION BATTERY CONTROLLER : Removal and Installation"](#).
10. Install the battery pack upper case. Refer to [EVB-875, "BATTERY PACK UPPER CASE : Removal and Installation"](#).

CAUTION:

- Be sure to reinstall the high voltage harness clips in their original positions. If a clip is damaged, replace it with a new clip before installing.
- Check the following items after installing battery pack: Refer to [EVB-938, "Inspection"](#).

■AIR LEAK INSPECTION

■ELECTRIC EQUIPOTENTIAL TEST

REAR MODULE STACK : Disassembly and Assembly

INFOID:000000011191524

DANGER:



Since hybrid vehicles and electric vehicles contain a high voltage battery, there is the risk of electric shock, electric leakage, or similar accidents if the high voltage component and vehicle are handled incorrectly. Be sure to follow the correct work procedures when performing inspection and maintenance.

WARNING:

- Be sure to remove the service plug for shutting off high voltage circuits before performing inspection or maintenance of high voltage system harnesses and parts.
- Be sure to put the removed service plug in pocket and carry it or store it in a tool box or other container so that another person does not accidentally connect it while work is in progress.
- Be sure to put on insulating protective gear before beginning work on the high voltage system.
- Clearly identify the persons responsible for high voltage work and ensure that other persons do not touch the vehicle. When not working, cover high voltage components with an anti-static cover sheet or similar item to prevent contact with other persons.
- Refer to [EVB-469, "High Voltage Precautions"](#).
- If the battery pack is to be disassembled, be sure to remove the Li-ion battery controller for preventing electric shock, fire, and damage to parts.

CAUTION:

There is the possibility of a malfunction occurring if the vehicle is changed to READY status while the service plug is removed. Therefore do not change the vehicle to READY status unless instructed to do so in the Service Manual.

ENVIRONMENT FOR LI-ION BATTERY DISASSEMBLY WORK

1. Must be an indoor environment.
 - The environment must utilize a shutter or other means to shut out the outside environment and prevent rain, snow, dust, or other substances from entering.
 - The environment must not cause the intrusion of sweat during work, or cause condensation to occur due to high temperature or humidity.
2. Metal powder, grease, and other foreign substances must not enter.
 - The indoor environment must also prevent metal powder, grease, and other foreign substances from entering due to maintenance performed on other vehicles and other sources during disassembly work.

LI-ION BATTERY

[TYPE 4]

< UNIT DISASSEMBLY AND ASSEMBLY >

- If there is a risk of the above substances entering, take appropriate countermeasures, such as use of a vinyl curtain or an equivalent to shut out the outside environment.
3. The floor must be dry.
 - The floor must not be wet as a result of factors such as vehicle entry during rain or snow.
 4. Work space
 - The work space must be approximately the size of one entire vehicle.
 - Take appropriate countermeasures so that persons other than the operator do not enter the work space, such as by placing signs indicating that disassembly work is in progress.
 5. Standard fire fighting equipment
 - Always place a standard fire fighting equipment in the disassembly work area.
 - Depending on type of fire (vehicle or battery) use standard fire fighting equipment (water or extinguisher).

DISASSEMBLY

1. Remove harness bracket ①, ② and ③ from the rear module stack.

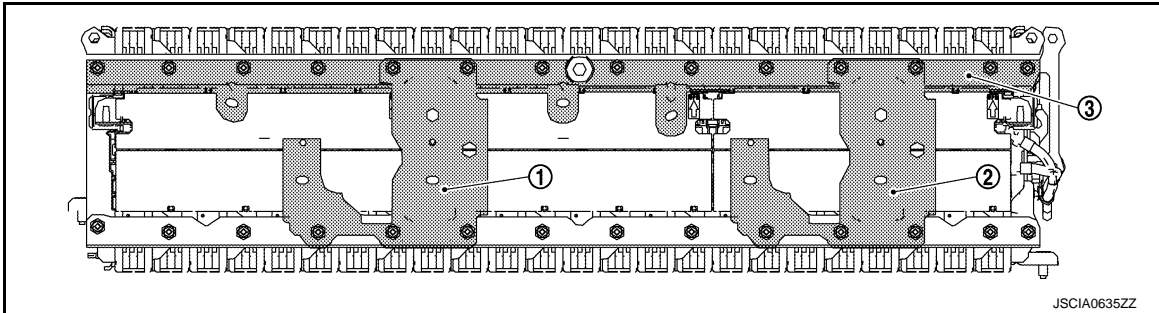

WARNING:



To prevent electric shock, wear insulated protective gear and use insulated tools.



2. Follow the following procedure and remove the bus bar from the rear module stack.

- a. Remove the center bus bar cover, then remove the module terminal mounting bolts (A).

DANGER:

-  There is the danger of electric shock caused by contact with the terminals. Be sure to wear insulated protective gear and use insulated tools.



-  This work must not be performed by multiple operators because there is a risk of electric shock if the operators contact one another.

CAUTION:

Do not remove all bus bar covers and all module terminal mounting bolts at the same time.

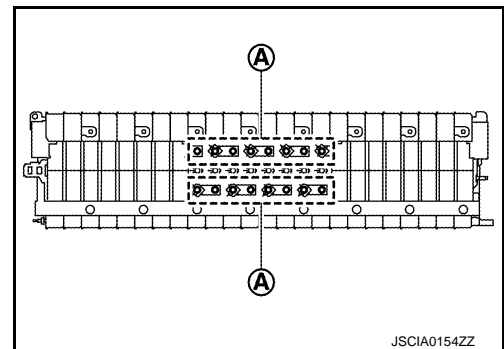

LI-ION BATTERY

< UNIT DISASSEMBLY AND ASSEMBLY >

[TYPE 4]

- b. Remove the left-side bus bar cover, then remove the module terminal mounting bolts (A).

DANGER:

- ⚡ There is the danger of electric shock caused by contact with the terminals. Be sure to wear insulated protective gear and use insulated tools.



- ⚡ This work must not be performed by multiple operators because there is a risk of electric shock if the operators contact one another.

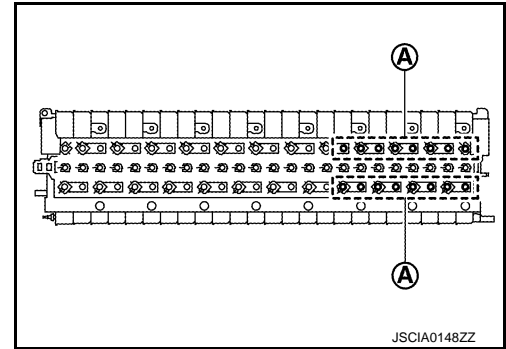

- c. Remove the right-side bus bar cover, then remove the module terminal mounting bolts (A).

DANGER:

- ⚡ There is the danger of electric shock caused by contact with the terminals. Be sure to wear insulated protective gear and use insulated tools.



- ⚡ This work must not be performed by multiple operators because there is a risk of electric shock if the operators contact one another.

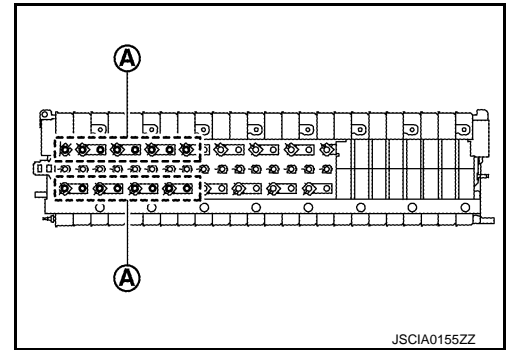

- d. Remove the voltage detection terminal mounting screws (A), then remove the bus bar from the rear module stack.

DANGER:

- ⚡ There is the danger of electric shock caused by contact with the terminals. Be sure to wear insulated protective gear and use insulated tools.



- ⚡ This work must not be performed by multiple operators because there is a risk of electric shock if the operators contact one another.

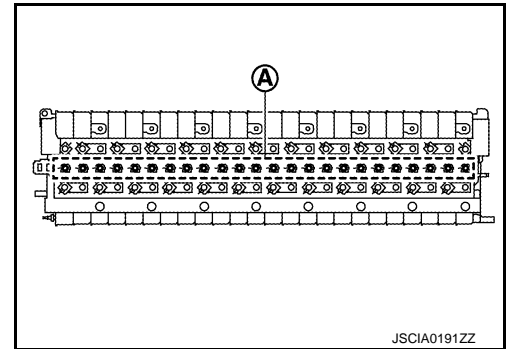

- e. Install a module terminal cover [SST: KV99111500 (—)] (A) onto all module terminals.

WARNING:

- ⚡ To prevent electric shock, wear insulated protective gear.



NOTE:

- Because "module B" interferes with the bracket and cover, cut the module terminal cover at the position shown in the figure.

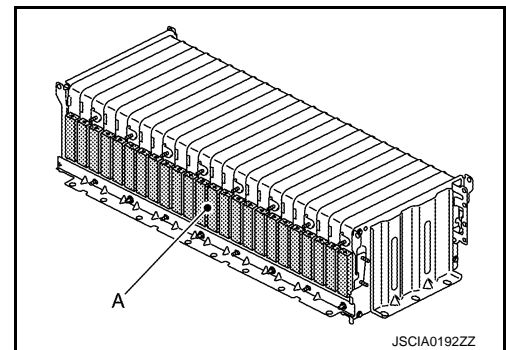

LI-ION BATTERY

< UNIT DISASSEMBLY AND ASSEMBLY >

[TYPE 4]

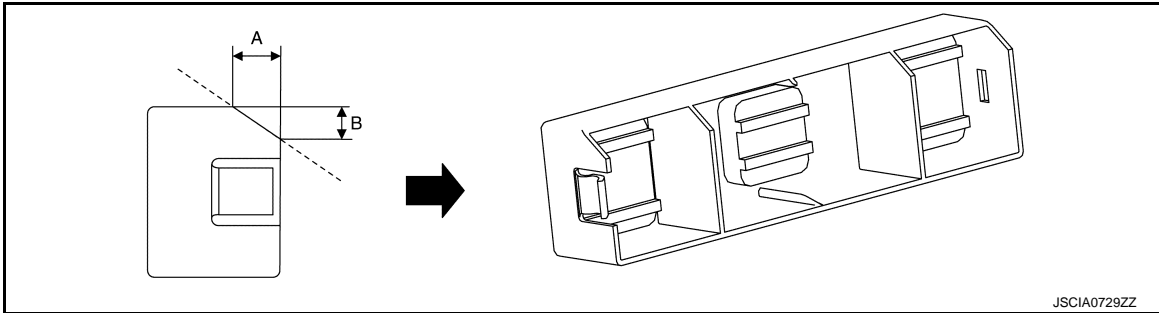

A : 7 mm (0.28 in)

B : 5 mm (0.20 in)

3. Remove the front stack member ①.

WARNING:

 To prevent electric shock, wear insulated protective gear and use insulated tools.

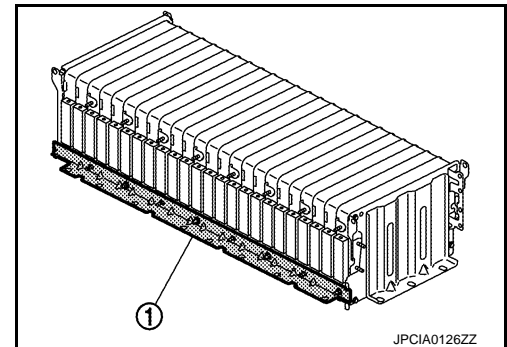

4. Remove the rear stack member ①.

WARNING:

 To prevent electric shock, wear insulated protective gear and use insulated tools.

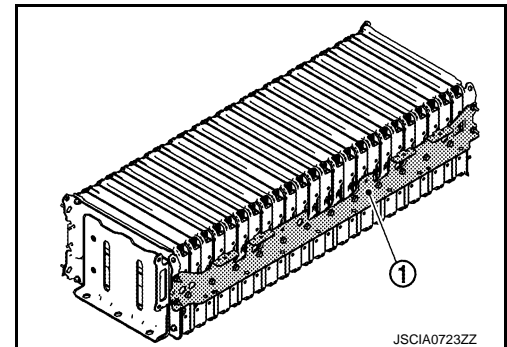

5. Fasten the rear module stack ① with a lashing belt ②.

WARNING:

 To prevent electric shock, wear insulated protective gear.

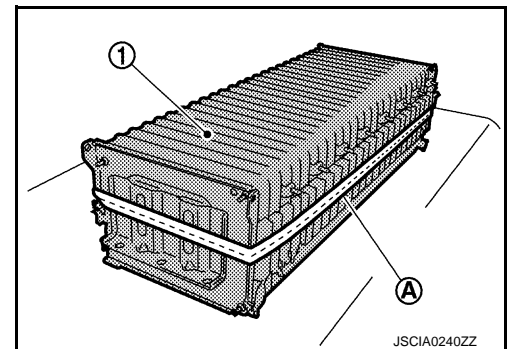

A
B
EVB
D
E
F
G
H
I
J
K
L
M
N
O
P

LI-ION BATTERY

< UNIT DISASSEMBLY AND ASSEMBLY >

[TYPE 4]

6. Remove the through bolt (A) mounting nut, then disassemble the rear module stack (1).

WARNING:



To prevent electric shock, wear insulated protective gear and use insulated tools.

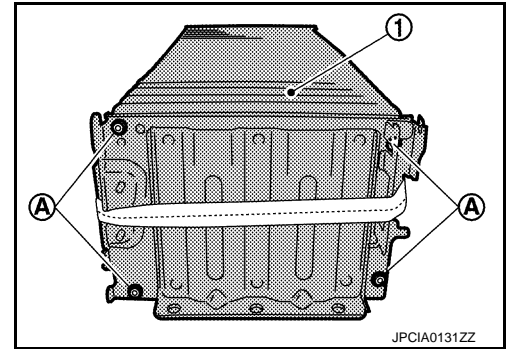

ASSEMBLY

1. When replacing the Li-ion battery with a new battery, perform the following operation.
 - a. Enter the date of the (replacement) work on the EV battery tracking identification seal that is packaged together with the new part.
 - b. Cut the EV battery tracking identification tool into 2 pieces and apply them to the body of the replaced (old) Li-ion battery and to the "Li-ion battery replacement history record".
 - c. Enter the necessary information in the "Li-ion battery replacement history record".
2. Follow the procedure below to assemble the rear module.

WARNING:



To prevent electric shock, wear insulated protective gear and use insulated tools.



- a. Assemble the rear module so that the module terminals are arranged as shown in the figure.

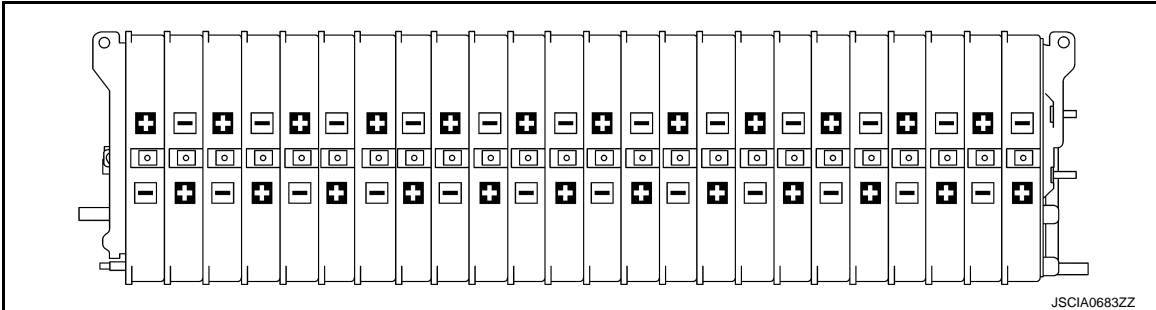

WARNING:



Be careful of the directions of the + terminal and - terminal when assembling the module. If the polarity is incorrect, there is a risk of electric shock, fire, and component damage.

NOTE:

- To identify the module + terminal and - terminal, refer to the figure.

- + terminal identification color (A) : Red
- terminal identification color (B) : Black

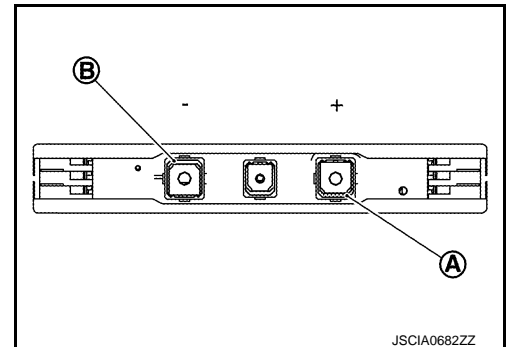

LI-ION BATTERY

< UNIT DISASSEMBLY AND ASSEMBLY >

[TYPE 4]

- b. Use a lashing belt (A) and apply pressure to the rear module stack (1).

WARNING:



To prevent electric shock, wear insulated protective gear.

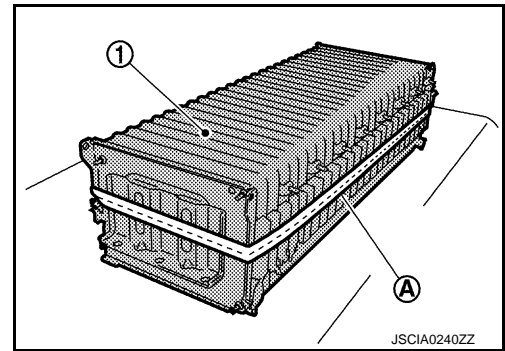

- c. Inspect the module installation condition, and correct it if it is skewed or a large distortion is found.

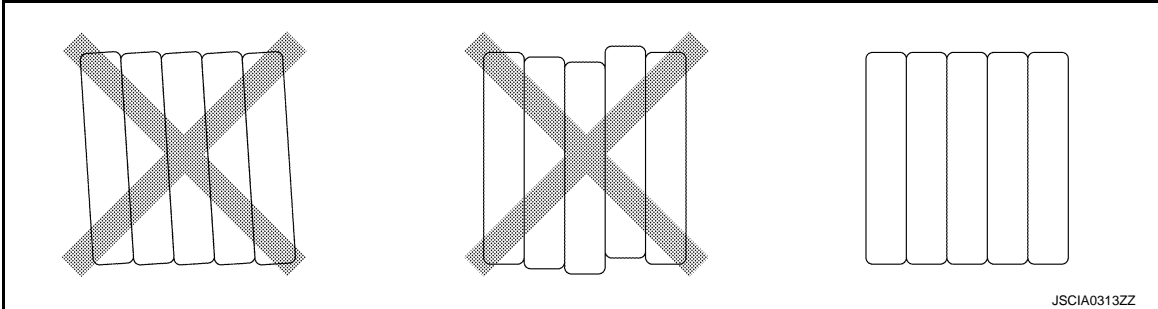

WARNING:



To prevent electric shock, wear insulated protective gear and use insulated tools.



- d. Install the 2 through-bolts (B) at opposite corners of the module, then insert $\phi 7$ mm (0.28 in) metal bars (A) into the bolt holes and tighten the mounting nuts to the prescribed torque.

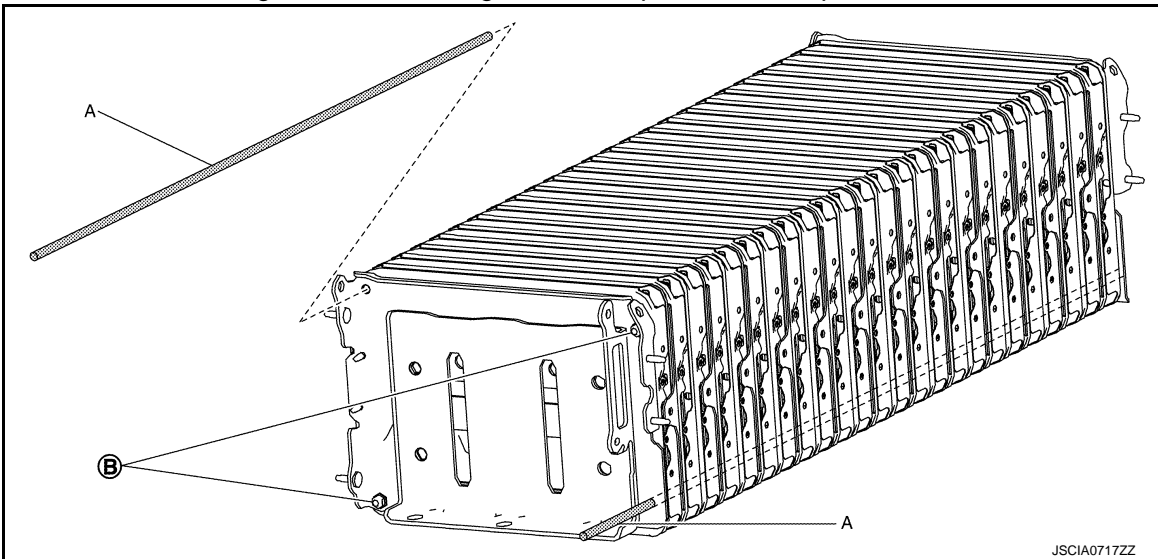

CAUTION:

If the collar position is incorrect, there is a risk of the bolts loosening because they are not supported by the collar between the modules.

- e. Install the remaining 2 through-bolts, and tighten the mounting nuts to the prescribed torque.

A
B
EVB
D
E
F
G
H
I
J
K
L
M
N
O
P

LI-ION BATTERY

< UNIT DISASSEMBLY AND ASSEMBLY >

[TYPE 4]

- When installing, hold the end of the through bolt stationary and tighten the installation nut.

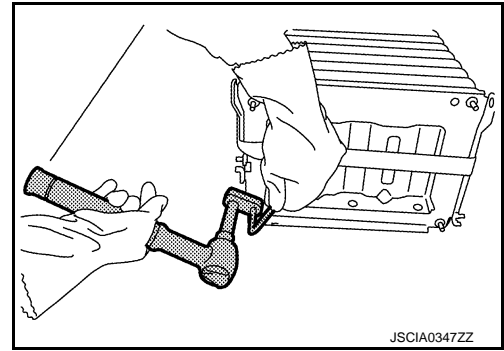

3. Install the rear stack member ①.

WARNING:

 To prevent electric shock, wear insulated protective gear and use insulated tools.

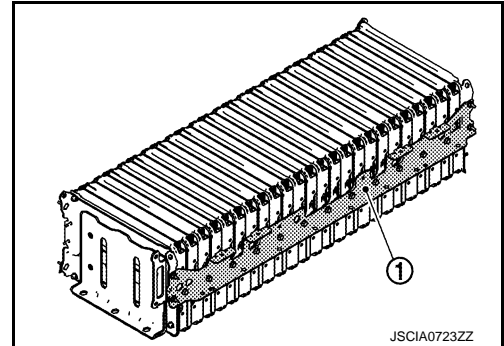

4. Install the front stack member ①.

WARNING:

 To prevent electric shock, wear insulated protective gear and use insulated tools.

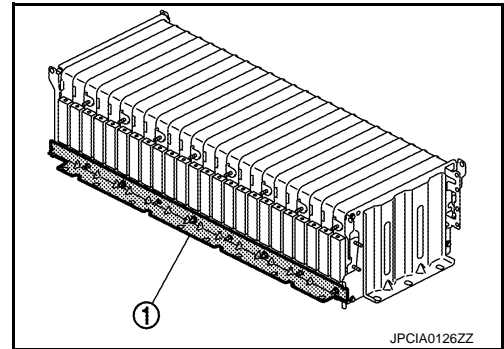

5. Remove the module terminal cover [SST: KV99111500 (—)] (A).

WARNING:

 To prevent electric shock, wear insulated protective gear.

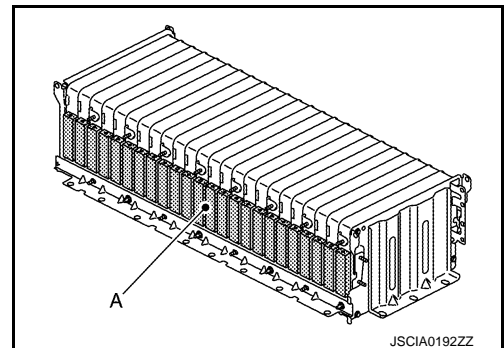

6. Follow the procedure below and install the bus bar module onto the rear module stack.

- a. Install the bus bar module onto the rear module stack.

WARNING:

 To prevent electric shock, wear insulated protective gear.



LI-ION BATTERY

[TYPE 4]

< UNIT DISASSEMBLY AND ASSEMBLY >

- b. Use an insulated torque driver (A) and tighten the voltage detection terminal mounting screws to the prescribed torque.

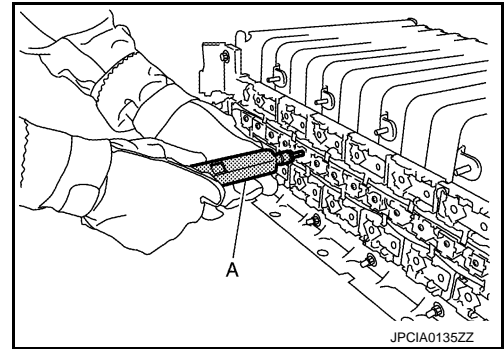

DANGER:

- ⚡ There is the danger of electric shock caused by contact with the terminals. Be sure to wear insulated protective gear and use insulated tools.



- ⚡ This work must not be performed by multiple operators because there is a risk of electric shock if the operators contact one another.

- c. Tighten the module terminal mounting bolts in numerical order as shown in the figure.
- When tightening of 1 – 16 is completed, install the left-side bus bar cover.
 - When tightening of 17 – 32 is completed, install the right-side bus bar cover.
 - When tightening of 33 – 48 is completed, install the center bus bar cover.

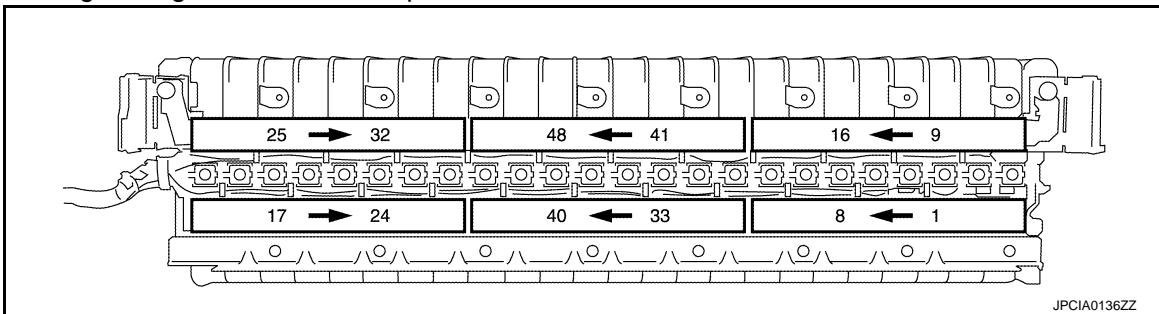

DANGER:

- ⚡ There is the danger of electric shock caused by contact with the terminals. Be sure to wear insulated protective gear and use insulated tools.



- ⚡ This work must not be performed by multiple operators because there is a risk of electric shock if the operators contact one another.

- d. Install the bus bar cover ①.

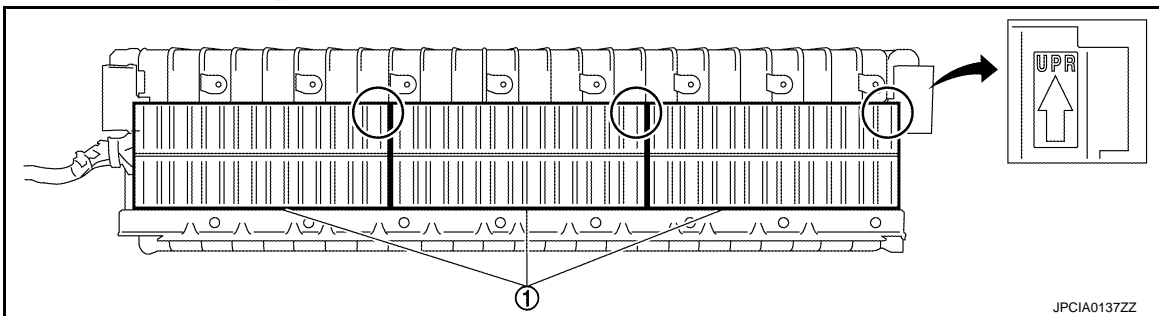

WARNING:

- ⚡ To prevent electric shock, wear insulated protective gear.



CAUTION:

- Be careful not to install with the top and bottom facing in the wrong directions.
- After installation, check that the mating is not skewed.

A
B
EVB
D
E
F
G
H
I
J
K
L
M
N
O
P

LI-ION BATTERY

< UNIT DISASSEMBLY AND ASSEMBLY >

[TYPE 4]

7. Install the harness bracket ①, ② and ③ to the rear module stack.

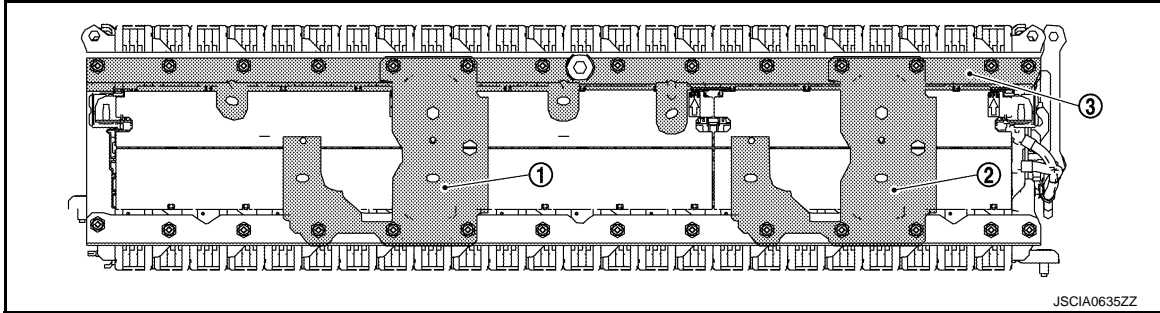

WARNING:



To prevent electric shock, wear insulated protective gear and use insulated tools.



CAUTION:

- Be sure to reinstall the high voltage harness clips in their original positions. If a clip is damaged, replace it with a new clip before installing.
- Check the following items after installing battery pack: Refer to [EVB-938, "Inspection"](#).

■AIR LEAK INSPECTION

■ELECTRIC EQUIPOTENTIAL TEST

Inspection

INFOID:0000000011191525

AIR LEAK INSPECTION

1. Use vinyl tape or similar means (A) for preventing air leakage from the harness connectors.
 - Use wide vinyl tape that is capable of covering all of the harness connector with one strip.
 - Apply carefully so that no wrinkles in the tape occur.

WARNING:



To prevent electric shock, wear insulated protective gear.

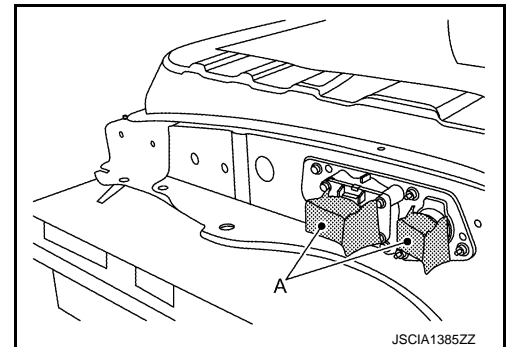

2. Use vinyl tape or similar means (A) to prevent air leakage from the breather.
 - Use wide vinyl tape that is capable of covering all of the breather with one strip.
 - Apply carefully so that no wrinkles in the tape occur.

WARNING:



To prevent electric shock, wear insulated protective gear.

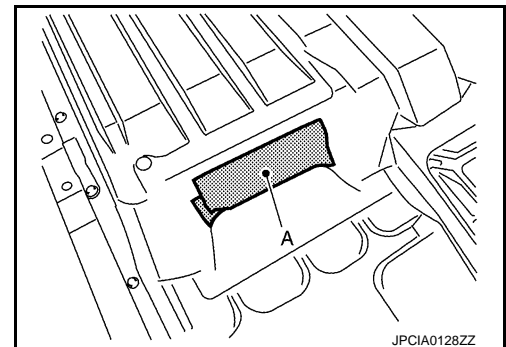

LI-ION BATTERY

< UNIT DISASSEMBLY AND ASSEMBLY >

[TYPE 4]

3. Remove the plug and install the adapter (A) of the air leak tester [SST: KV99111400 (—)].

WARNING:



To prevent electric shock, wear insulated protective gear.

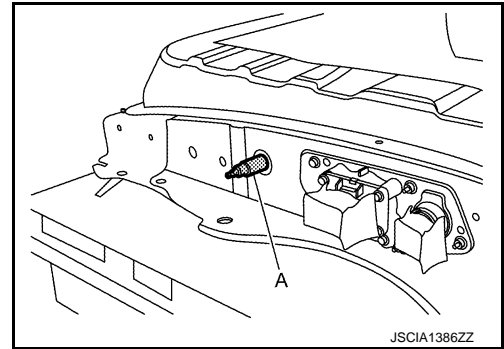

4. Install the gauge (A) of the air leak tester [SST: KV99111400 (—)].

WARNING:



To prevent electric shock, wear insulated protective gear.



CAUTION:

The gauge is a precision instrument. Be careful not to drop it when handling it.

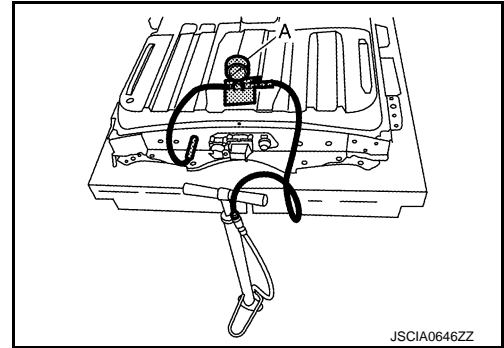

5. Install the service plug.

DANGER:



There is the danger of electric shock caused by contact with the terminals. Be sure to wear insulated protective gear.



NOTE:

Because the service plug location is open, install the service plug for sealing the case.

6. Follow the procedure below to check the battery case pressure.

WARNING:



To prevent electric shock, wear insulated protective gear.



- a. Open the cock (A) on the air leak tester.

CAUTION:

Do not operate the pump before opening the cock on the air leak tester. Doing so may damage the gauge. If the pump is operated before the cock is opened, first disconnect the air pump hose to release the pressure.

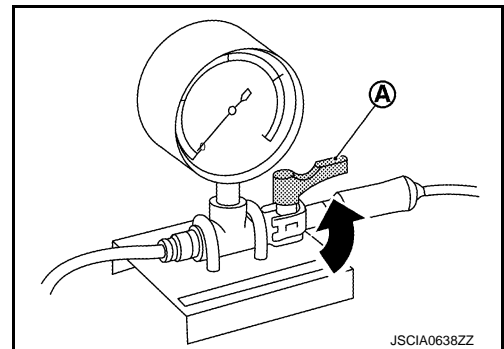

- b. Operate the air pump slowly and apply the specified inspection pressure inside the battery pack. If the gauge pressure does not rise, or if the gauge reading fluctuates, check for the location of air leakage.

Specified inspection pressure : 1.6 kPa (0.016 bar, 0.0163 kg/cm², 0.232 psi)

A
B
EVB
D
E
F
G
H
I
J
K
L
M
N
O
P

LI-ION BATTERY

< UNIT DISASSEMBLY AND ASSEMBLY >

[TYPE 4]

CAUTION:

- Operate the air pump carefully when applying pressure. If pressure is applied suddenly to the gauge, the gauge may be damaged.
 - Do not apply pressure of 2.0 kPa (0.0204 kg/cm²) or more to the battery case or air leak tester.
- c. Close the cock and wait for 1 minute.
- d. Check that the air leak tester reading remains at or above the limit value.

Repair limit : 1.4 kPa (0.014 bar, 0.0142 kg/cm², 0.203 psi)

- e. If the pressure is below the limit value, check for the locations of air leakage.

NOTE:

Check for air leakage from the sound of air escaping when pressure is applied.

ELECTRIC EQUIPOTENTIAL TEST

After assembling the Li-ion battery pack, remove the battery pack upper case ground bolt (A), then measure the resistance between the high-voltage harness connector flange ground bolts (B) and the ground bolt seat (location of coating peeling) (C).

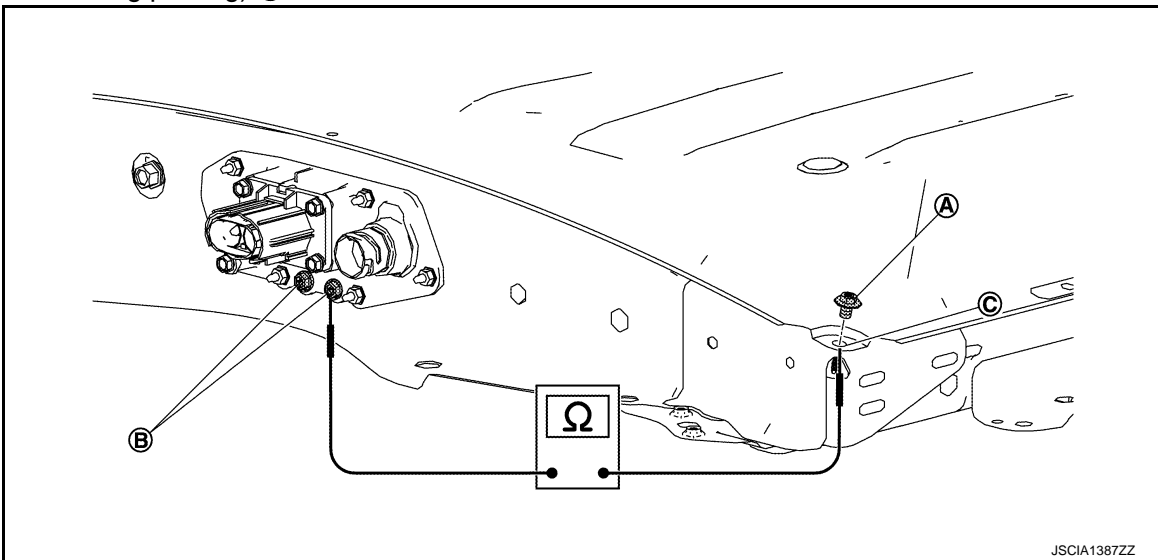

WARNING:



To prevent electric shock, wear insulated protective gear.



Standard : Less than 0.1Ω

If the result deviates from the standard value, check the following and correct the malfunction location.

- Ground bolt connection condition
- Corrosion on ground bolt mounting surface
- Presence of paint, oil, dirt, or other substance on ground bolt mounting surface

SERVICE DATA AND SPECIFICATIONS (SDS)

< SERVICE DATA AND SPECIFICATIONS (SDS)

[TYPE 4]

SERVICE DATA AND SPECIFICATIONS (SDS)

SERVICE DATA AND SPECIFICATIONS (SDS)

Li-ion Battery

INFOID:000000011191526

Items	Specification
Type	Li-ion battery
Structure	48 modules (192 cells)
Rated voltage (V)	Approx. 360
Battery capacity (kWh)	Approx. 24
Weight [kg (lb)]	Approx. 275 (606)

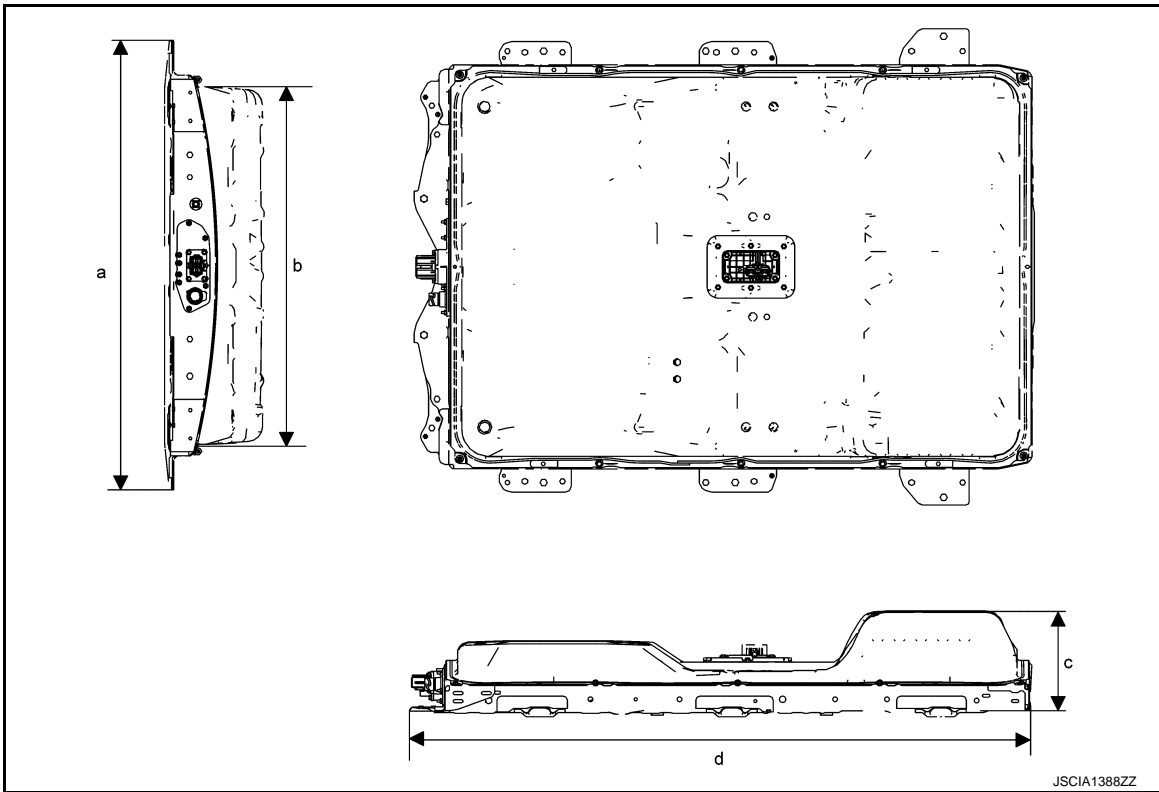

External dimension	"a"	[mm (in)]	1188 (46.77)
	"b"	[mm (in)]	1007 (39.65)
	"c"	[mm (in)]	264 (10.39)
	"d"	[mm (in)]	1547 (60.90)

A
B
EVB
D
E
F
G
H
I
J
K
L
M
N
O
P