

**SECTION** **GI**  
**GENERAL INFORMATION**

B  
C  
D  
E  
F  
G  
H  
I  
J  
K  
L  
M  
N  
O  
P

**CONTENTS**

<b>HOW TO USE THIS MANUAL .....</b>	<b>3</b>	<b>PRECAUTION .....</b>	<b>25</b>
<b>HOW TO USE THIS MANUAL .....</b>	<b>3</b>	<b>PRECAUTIONS .....</b>	<b>25</b>
Description .....	3	Description .....	25
Terms .....	3	Precaution for Technicians Using Medical Electric...	25
Units .....	3	Point to Be Checked Before Starting Maintenance	
Contents .....	4	Work .....	25
Relation between Illustrations and Descriptions .....	4	Precaution for Supplemental Restraint System	
Components .....	4	(SRS) "AIR BAG" and "SEAT BELT PRE-TENSIONER" .....	25
<b>HOW TO FOLLOW TROUBLE DIAGNOSES.....</b>	<b>6</b>	Precautions Necessary for Steering Wheel Rotation	
Description .....	6	After Battery Disconnection .....	26
How to Follow Test Groups in Trouble Diagnosis.....	6	Precaution for Procedure without Cowl Top Cover....	27
Key to Symbols Signifying Measurements or Procedures .....	7	Precautions for Removing Battery Terminal .....	27
<b>HOW TO READ WIRING DIAGRAMS .....</b>	<b>9</b>	Cautions in Removing 12V Battery Terminal and	
Connector Symbols .....	9	AV Control Unit (Models with AV Control Unit) .....	27
Sample/Wiring Diagram -Example- .....	10	General Precautions .....	28
Connector Information .....	12	Hoses .....	29
<b>ABBREVIATIONS .....</b>	<b>14</b>	Air Conditioning .....	30
Abbreviation List .....	14	<b>CAUTIONS AS TO HIGH VOLTAGE .....</b>	<b>31</b>
<b>TIGHTENING TORQUE OF STANDARD</b>		How to Disconnect High Voltage .....	31
<b>BOLTS .....</b>	<b>19</b>	High Voltage Precautions .....	33
Description .....	19	High Voltage Warning Label .....	35
Tightening Torque Table (New Standard Included) .....	19	Insulated Protective Wear and Insulating Tools .....	35
<b>RECOMMENDED CHEMICAL PRODUCTS</b>		Handling of Damaged Vehicles .....	36
<b>AND SEALANTS .....</b>	<b>21</b>	Cautions for Scrapping Vehicles .....	40
Recommended Chemical Products and Sealants....	21	Handling of a Vehicle with a Dead Battery .....	40
<b>VEHICLE INFORMATION .....</b>	<b>22</b>	<b>LIFTING POINT .....</b>	<b>41</b>
<b>IDENTIFICATION INFORMATION .....</b>	<b>22</b>	Commercial Service Tools .....	41
Model Variation .....	22	Garage Jack and Safety Stand and 2-Pole Lift .....	41
Information About Identification or Model Code .....	22	Board-On Lift .....	42
Dimensions .....	24	<b>TOW TRUCK TOWING .....</b>	<b>43</b>
Wheels & Tires .....	24	Tow Truck Towing .....	43
		Vehicle Recovery (Freeing a Stuck Vehicle) .....	43
		<b>PROCEDURE FOR PARK LOCK RELEASE ...</b>	<b>45</b>
		PROCEDURE FOR PARK LOCK RELEASE .....	45
		<b>BASIC INSPECTION .....</b>	<b>47</b>

---

**SERVICE INFORMATION FOR ELECTRICAL**

<b>INCIDENT</b> .....	<b>47</b>
Work Flow .....	47
Control Units and Electrical Parts .....	47
How to Check Terminal .....	48
Intermittent Incident .....	51
Circuit Inspection .....	54
<b>CONSULT/GST CHECKING SYSTEM</b> .....	<b>59</b>
Description .....	59
CONSULT Function and System Application*1 .....	59

CONSULT/GST Data Link Connector (DLC) Circuit .....	60
Wiring Diagram - CONSULT/GST CHECKING SYSTEM - .....	61

**INSPECTION AND ADJUSTMENT** ..... 67

<b>ADDITIONAL SERVICE WHEN REMOVING BATTERY NEGATIVE TERMINAL</b> .....	<b>67</b>
ADDITIONAL SERVICE WHEN REMOVING BATTERY NEGATIVE TERMINAL : Required Procedure After Battery Disconnection .....	67

# HOW TO USE THIS MANUAL

< HOW TO USE THIS MANUAL >

## HOW TO USE THIS MANUAL

### HOW TO USE THIS MANUAL

GI

#### Description







INFOID:000000006825117

This volume explains “Removal, Disassembly, Installation, Inspection and Adjustment” and “Trouble Diagnoses”.

#### Terms

INFOID:000000006893176

Item	Description
DANGER	To be used to inform an operation which will cause a death or serious personal injury if instructions are not following. Example: Touching high voltage components without using the appropriate protective equipment will cause electrocution.
WARNING	To be used to inform an operation which may cause a death or serious personal injury if instructions are not following.
CAUTION	To be used to inform an operation which may cause personal injury or component damage if instructions are not following.
NOTE	To be used to inform you helpful information.
BOLD STATEMENTS except DANGER, WARNING and NOTE	Give you helpful information. <ul style="list-style-type: none"> <li>• Standard value: Tolerance at inspection and adjustment.</li> <li>• Limit value: The maximum or minimum limit value that should not be exceeded at inspection and adjustment.</li> </ul>

Symbol	Description
 Electric shock symbol	It may cause an electric shock if instructions are not following to be used in caution for an operation. To be used to describe the removal of component, connector, etc. where high voltage is/might be present.
 Insulated gloves	Always wear when inspecting or performing service operation of high voltage components.
 Insulated safety shoes/Insulated rubber sheet	Always wear when inspecting or performing service operation of high voltage components on lift-up vehicle.
 Safety glasses	Always wear during under the circumstances <ul style="list-style-type: none"> <li>• During removal/installation or check operation of high voltage terminals and harnessed where spark might terminal appear by short circuit.</li> <li>• Operation inside battery pack.</li> </ul>
 Face shield	
 Insulated hand tools	Always use when performing high voltage presents operation such as operation inside high voltage battery pack.

#### Units

INFOID:000000006825119

- The **UNITS** given in this manual are primarily expressed as the SI UNIT (International System of Unit), and alternatively expressed in the metric system and in the yard/pound system.  
Also with regard to tightening torque of bolts and nuts, there are descriptions both about range and about the standard tightening torque.

**“Example”**  
Range

# HOW TO USE THIS MANUAL

## < HOW TO USE THIS MANUAL >

**Outer Socket Lock Nut : 59 - 78 N-m (6.0 - 8.0 kg-m, 43 - 58 ft-lb)**

### Standard

**Drive Shaft Installation Bolt : 44.3 N-m (4.5 kg-m, 33 ft-lb)**

## Contents

INFOID:000000006825120

- **A QUICK REFERENCE INDEX**, a black tab (e.g. **BR**) is provided on the first page. You can quickly find the first page of each section by matching it to the section's black tab.
- **THE CONTENTS** are listed on the first page of each section.
- **THE TITLE** is indicated on the upper portion of each page and shows the part or system.
- **THE PAGE NUMBER** of each section consists of two or three letters which designate the particular section and a number (e.g. "BR-5").
- **THE SMALL ILLUSTRATIONS** show the important steps such as inspection, use of special tools, knacks of work and hidden or tricky steps which are not shown in the previous large illustrations. Assembly, inspection and adjustment procedures for the complicated units such as the automatic transaxle or transmission, etc. are presented in a step-by-step format where necessary.

## Relation between Illustrations and Descriptions

INFOID:000000006825121

The following sample explains the relationship between the part description in an illustration, the part name in the text and the service procedures.

< Example 1 >

1. Remove return spring (1) from parking pawl (2).

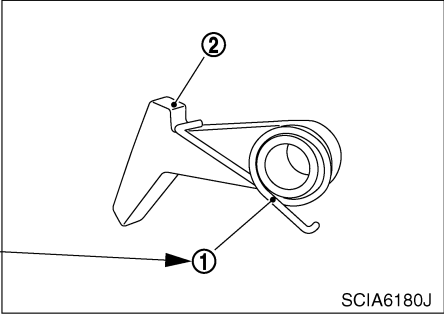

The identifier number of the part name in the text is consistent with the identifier part number in the illustration.

SCIA6180J

Direction mark

< Example 2 >

-  : Vehicle front
- Tighten rear member mounting bolts following the numerical order shown in the illustration.
- Note : View upward

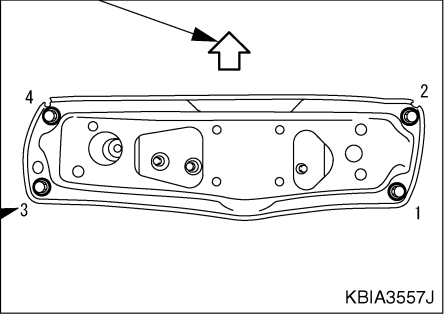

The numbers in the illustration are consistent with the service operation instructions.

KBIA3557J

SAIA0519E

## Components

INFOID:000000006825122

- **THE LARGE ILLUSTRATIONS** are exploded views (see the following) and contain tightening torques, lubrication points, section number of the **PARTS CATALOG** (e.g. SEC. 440) and other information necessary to perform repairs.

# HOW TO USE THIS MANUAL

## < HOW TO USE THIS MANUAL >

The illustrations should be used in reference to service matters only. When ordering parts, refer to the appropriate **PARTS CATALOG**.

Components shown in an illustration may be identified by a circled number. When this style of illustration is used, the text description of the components will follow the illustration.

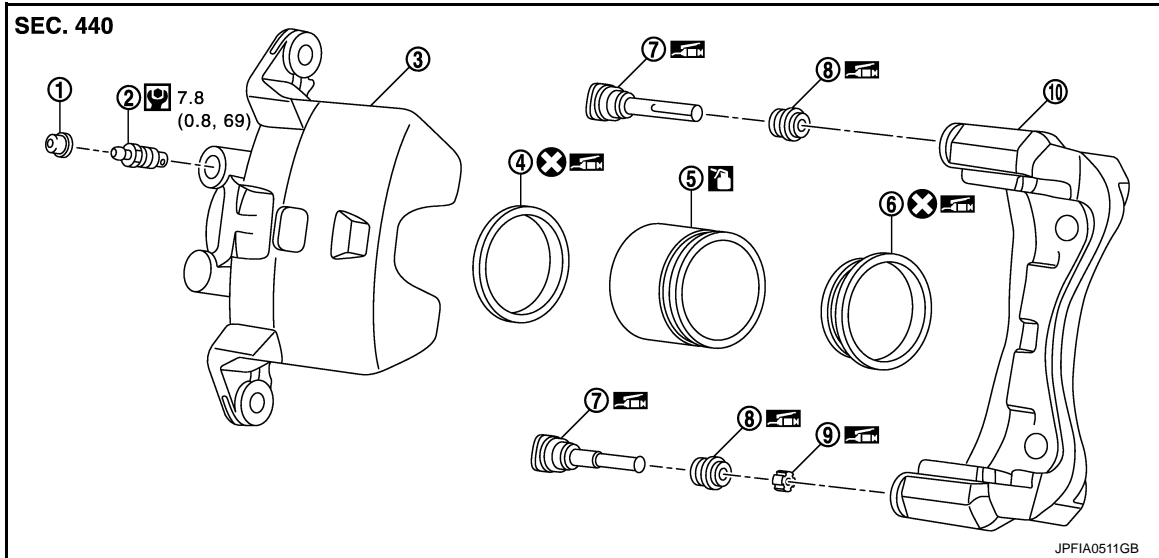

- |                   |                     |                  |
|-------------------|---------------------|------------------|
| 1. Cap            | 2. Bleeder valve    | 3. Cylinder body |
| 4. Piston seal    | 5. Piston           | 6. Piston boot   |
| 7. Sliding pin    | 8. Sliding pin boot | 9. Bushing       |
| 10. Torque member |                     |                  |

: Apply rubber grease.

: Apply brake fluid.

: N·m (kg·m, in·lb)

: Always replace after every disassembly

## SYMBOLS

SYMBOL	DESCRIPTION	SYMBOL	DESCRIPTION
	Tightening torque The tightening torque specifications of bolts and nuts may be presented as either a range or a standard tightening torque.	: N·m (kg·m, ft·lb)	Always replace after every disassembly.
		: N·m (kg·m, in·lb)	Apply petroleum jelly.
	Should be lubricated with grease. Unless otherwise indicated, use recommended multi-purpose grease.	Apply molybdenum added petroleum jelly.	
	Should be lubricated with oil.	Apply ATF.	
	Sealing point	★ Select with proper thickness.	
	Sealing point with locking sealant.	☆ Adjustment is required.	
	Checking point		

SAIA0749E

# HOW TO FOLLOW TROUBLE DIAGNOSES

< HOW TO USE THIS MANUAL >

## HOW TO FOLLOW TROUBLE DIAGNOSES

### Description

INFOID:000000006825123

#### NOTICE:

Trouble diagnoses indicate work procedures required to diagnose problems effectively. Observe the following instructions before diagnosing.

- Before performing trouble diagnoses, read the “Work Flow” in each section.
- After repairs, re-check that the problem has been completely eliminated.
- Refer to Component Parts and Harness Connector Location for the Systems described in each section for identification/location of components and harness connectors.
- When checking circuit continuity, ignition switch should be OFF.
- Refer to the Circuit Diagram for quick pinpoint check.

If you need to check circuit continuity between harness connectors in more detail, such as when a sub-harness is used, refer to Wiring Diagram in each individual section and Harness Layout in PG section for identification of harness connectors.

- Before checking voltage at connectors, check battery voltage.
- After accomplishing the Diagnosis Procedures and Electrical Components Inspection, check that all harness connectors are reconnected as they were.

### How to Follow Test Groups in Trouble Diagnosis

INFOID:000000006825124

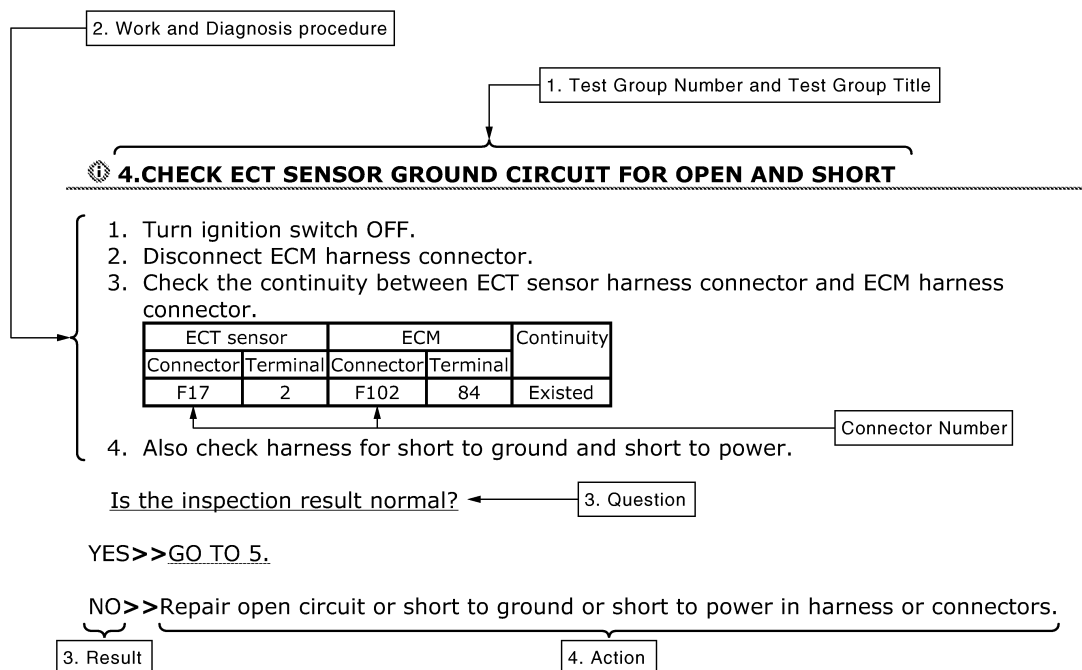

JPAIA0021GB

1. Test group number and test group title
  - Test group number and test group title are shown in the upper portion of each test group.
2. Work and diagnosis procedure
  - Start to diagnose a problem using procedures indicated in enclosed test groups.
3. Questions and results
  - Questions and required results are indicated in test group.
4. Action
  - Next action for each test group is indicated based on result of each question.

# HOW TO FOLLOW TROUBLE DIAGNOSES

< HOW TO USE THIS MANUAL >

## Key to Symbols Signifying Measurements or Procedures

INFOID:000000006950543

SYMBOL	DESCRIPTION	SYMBOL	DESCRIPTION
	Check after disconnecting the connector to be measured.		Procedure with Generic Scan Tool. (GST, OBD-II scan tool)
	Check after connecting the connector to be measured.		Procedure without CONSULT or GST
	Insert key into ignition switch.		A/C switch is "OFF".
	Remove key from ignition switch.		A/C switch is "ON".
	Insert and remove key repeatedly.		REC switch is "ON".
	Turn ignition switch to "OFF" position.		REC switch is "OFF".
	Turn ignition switch to "ACC" position.		Fan switch is "ON". (At any position except for "OFF" position)
	Turn ignition switch to "ON" position.		Fan switch is "OFF".
	Turn ignition switch to "START" position.		Apply fuse.
	Turn ignition switch from "OFF" to "ACC" position.		Apply positive voltage from battery with fuse directly to components.
	Turn ignition switch from "ACC" to "ON" position.		
	Turn ignition switch from "ACC" to "OFF" position.		

JPAIA0982GB

GI

B

C

D

E

F

G

H

I

J

K

L

M

N

O

P

# HOW TO FOLLOW TROUBLE DIAGNOSES

## < HOW TO USE THIS MANUAL >

SYMBOL	DESCRIPTION	SYMBOL	DESCRIPTION
	Turn ignition switch from "OFF" to "ON" position.		Drive vehicle.
	Turn ignition switch from "ON" to "OFF" position.		
	Do not start engine, or check with engine stopped.		Disconnect battery negative cable.
	Start engine, or check with engine running.		Depress brake pedal.
	Apply parking brake.		Release brake pedal.
	Release parking brake.		Depress accelerator pedal.
	Release parking brake.		Release accelerator pedal.
	Check after engine is warmed up sufficiently.	  	Pin terminal check for SMJ type ECM or TCM connectors. <b>For details regarding the terminal arrangement, refer to the "ELECTRICAL UNITS" electrical reference page at the end of the manual.</b>
	Voltage should be measured with a voltmeter.		
	Circuit resistance should be measured with an ohmmeter.		
			
	Current should be measured with an ammeter.		
	Pulse signal should be checked with an oscilloscope.		
	Procedure with CONSULT		
	Procedure without CONSULT		
	Place selector lever in "P" position.		
	Place selector lever in "N" position.		
	Jack up front portion.		
	Jack up rear portion.		
	Inspect under engine room.		
	Inspect under floor.		
	Inspect rear under floor.		

JSAIA1461GB



# HOW TO READ WIRING DIAGRAMS

< HOW TO USE THIS MANUAL >

## HOW TO READ WIRING DIAGRAMS

### Connector Symbols

INFOID:000000007492015

Most of connector symbols in wiring diagrams are shown from the terminal side.

- Connector symbols shown from the terminal side are enclosed by a single line and followed by the direction mark.
- Connector symbols shown from the harness side are enclosed by a double line and followed by the direction mark.
- Certain systems and components, especially those related to OBD, may use a new style slide-locking type harness connector. For description and how to disconnect, refer to PG section, "Description", "HARNESS CONNECTOR".

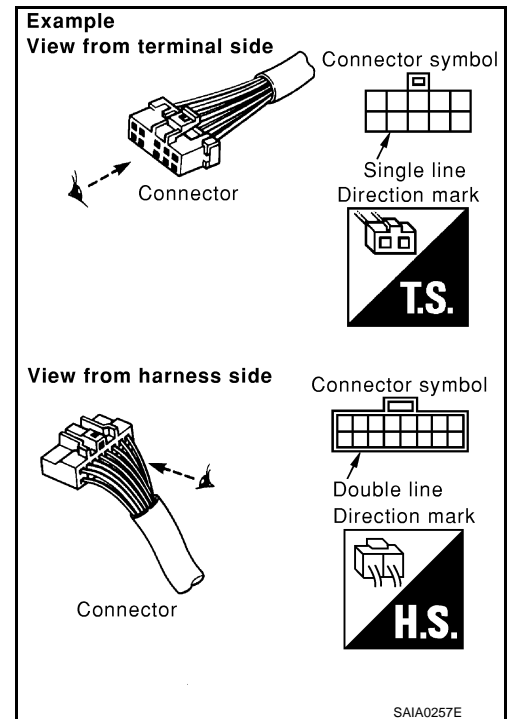

- Male and female terminals  
Connector guides for male terminals are shown in black and female terminals in white in wiring diagrams.

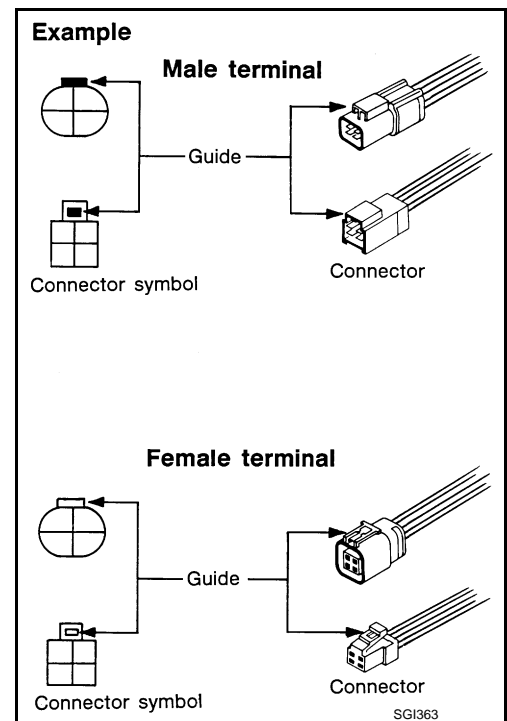

GI  
B  
C  
D  
E  
F  
G  
H  
I  
J  
K  
L  
M  
N  
O  
P

# HOW TO READ WIRING DIAGRAMS

< HOW TO USE THIS MANUAL >

## Sample/Wiring Diagram -Example-

INFOID:000000007492016

Each section includes wiring diagrams.

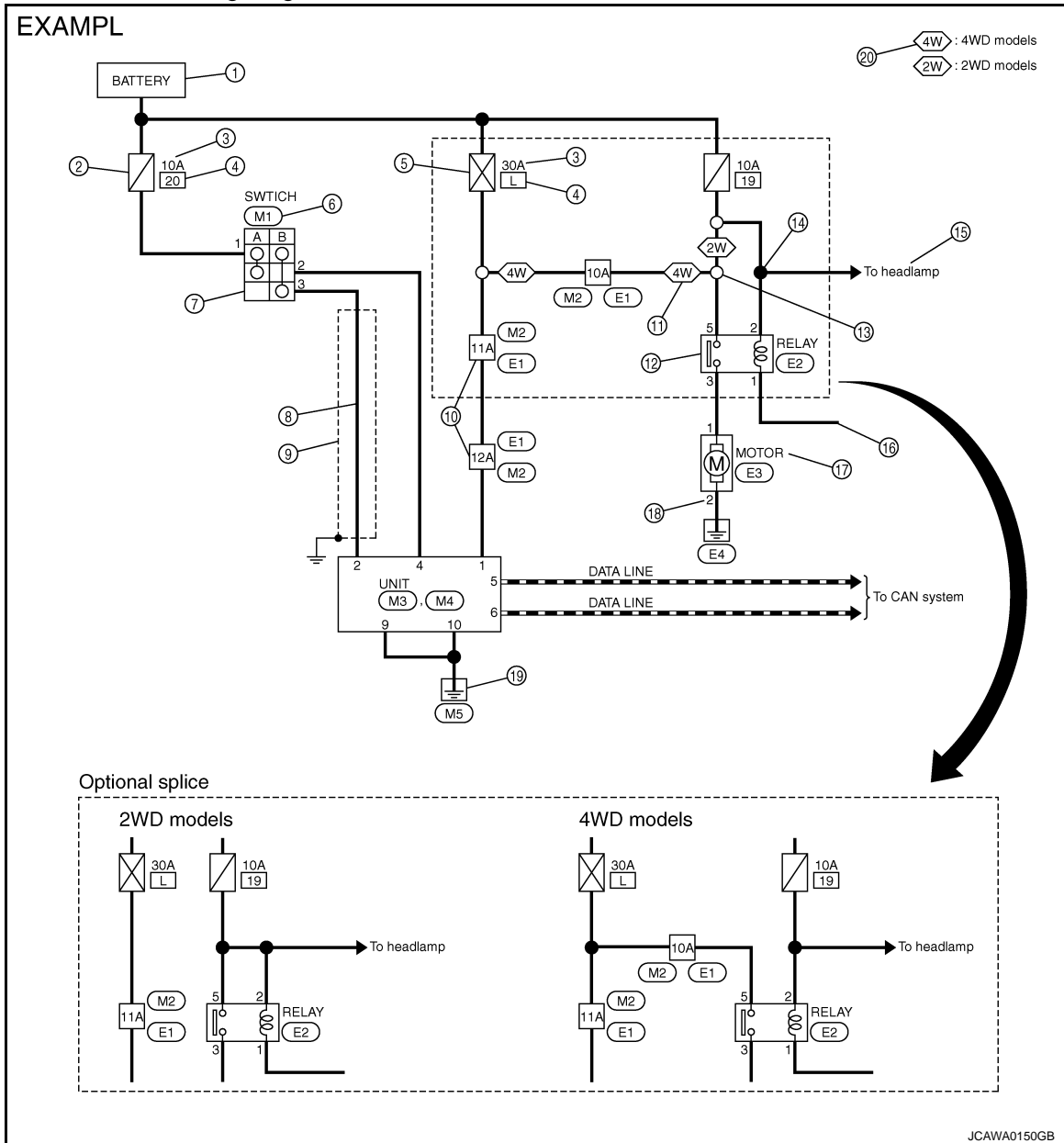

### Description

Number	Item	Description
1	Power supply	• This means the power supply of fusible link or fuse.
2	Fuse	• “/” means the fuse.
3	Current rating of fusible link/fuse	• This means the current rating of the fusible link or fuse.
4	Number of fusible link/fuse	• This means the number of fusible link or fuse location.
5	Fusible link	• “X” means the fusible link.
6	Connector number	• Alphabetic characters show to which harness the connector is placed. • Numeric characters show the identification number of connectors.
7	Switch	• This shows that continuity exists between terminals 1 and 2 when the switch is in the A position. Continuity exists between terminals 1 and 3 when the switch is in the B position.
8	Circuit (Wiring)	• This means the wiring.

# HOW TO READ WIRING DIAGRAMS

## < HOW TO USE THIS MANUAL >

Number	Item	Description
9	Shielded line	• The line enclosed by broken line circle shows shield wire.
10	Connectors	• This means that a transmission line bypasses two connectors or more.
11	Option abbreviation	• This means the vehicle specifications which layouts the circuit between “O”.
12	Relay	• This shows an internal representation of the relay.
13	Optional splice	• The open circle shows that the splice is optional depending on vehicle application.
14	Splice	• The shaded circle “●” means the splice.
15	System branch	• This shows that the circuit is branched to other systems.
16	Page crossing	• This circuit continues to an adjacent page.
17	Component name	• This shows the name of a component.
18	Terminal number	• This means the terminal number of a connector.
19	Ground (GND)	• This shows the ground connection.
20	Explanation of option description	• This shows a explanation of the option abbreviation used on the same page.

### SWITCH POSITIONS

Switches are shown in wiring diagrams as if the vehicle is in the “normal” condition.

A vehicle is in the “normal” condition when:

- ignition switch is “OFF”
- doors, hood and trunk lid/back door are closed
- pedals are not depressed
- parking brake is released

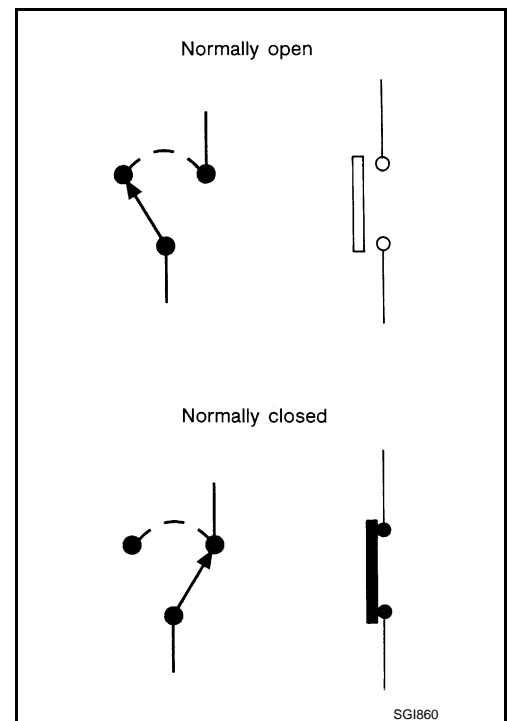

### MULTIPLE SWITCH

The continuity of multiple switch is described in two ways as shown below.

- The switch chart is used in schematic diagrams.

# HOW TO READ WIRING DIAGRAMS

## < HOW TO USE THIS MANUAL >

- The switch diagram is used in wiring diagrams.

**Example**

(SWITCH CHART)

WIPER SWITCH		OFF	INT	LO	HI	WASH
1						○
2				○		
3	○	○	○			
4	○	○				
5		○				
6		○	○	○	○	

(SWITCH DIAGRAM)

Both switches are turned in combination.

Continuity circuit of wiper switch

SWITCH POSITION	CONTINUITY CIRCUIT
OFF	3-4
INT	3-4, 5-6
LO	3-6
HI	2-6
WASH	1-6

JSAIA0017GB

## Connector Information

INFOID:000000007492017

① Connector No. M3

Connector Name UNIT

② Connector Type NS06FW-M2

Terminal No.	Color of Wire	Signal Name [Specification]
1	W	BAT
2	G	SWITCH B
4	V	SWITCH A
5	L	CAN-H
6	P	CAN-L

Connector No. M4

Connector Name UNIT

Connector Type NS10FW-CS

Terminal No.	Color of Wire	Signal Name [Specification]
9	B	GND
10	B	GND

JCAWA0152GB

### Description

Number	Item	Description
1	Connector number	<ul style="list-style-type: none"> <li>Alphabetic characters show to which harness the connector is placed.</li> <li>Numeric characters show the identification number of connectors.</li> </ul>
2	Connector type	<ul style="list-style-type: none"> <li>This means the connector number.</li> </ul>
3	Terminal number	<ul style="list-style-type: none"> <li>This means the terminal number of a connector.</li> </ul>

# HOW TO READ WIRING DIAGRAMS

## < HOW TO USE THIS MANUAL >

Number	Item	Description																
4	Wire color	<ul style="list-style-type: none"> <li>This shows a code for the color of the wire.</li> </ul>																
		<table border="0"> <tr> <td>B = Black</td> <td>BR = Brown</td> </tr> <tr> <td>W = White</td> <td>OR or O = Orange</td> </tr> <tr> <td>R = Red</td> <td>P = Pink</td> </tr> <tr> <td>G = Green</td> <td>PU or V (Violet) = Purple</td> </tr> <tr> <td>L = Blue</td> <td>GY or GR = Gray</td> </tr> <tr> <td>Y = Yellow</td> <td>SB = Sky Blue</td> </tr> <tr> <td>LG = Light Green</td> <td>CH = Dark Brown</td> </tr> <tr> <td>BG = Beige</td> <td>DG = Dark Green</td> </tr> </table>	B = Black	BR = Brown	W = White	OR or O = Orange	R = Red	P = Pink	G = Green	PU or V (Violet) = Purple	L = Blue	GY or GR = Gray	Y = Yellow	SB = Sky Blue	LG = Light Green	CH = Dark Brown	BG = Beige	DG = Dark Green
		B = Black	BR = Brown															
W = White	OR or O = Orange																	
R = Red	P = Pink																	
G = Green	PU or V (Violet) = Purple																	
L = Blue	GY or GR = Gray																	
Y = Yellow	SB = Sky Blue																	
LG = Light Green	CH = Dark Brown																	
BG = Beige	DG = Dark Green																	
<ul style="list-style-type: none"> <li>When the wire color is striped, the base color is given first, followed by the stripe color as shown below: Example: L/W = Blue with White Stripe</li> </ul>																		
5	Connector	<ul style="list-style-type: none"> <li>This means the connector information.</li> <li>This unit-side is described by the connector symbols.</li> </ul>																

GI

B

C

D

E

F

G

H

I

J

K

L

M

N

O

P

# ABBREVIATIONS

< HOW TO USE THIS MANUAL >

## ABBREVIATIONS

### Abbreviation List

INFOID:00000006856139

The following **ABBREVIATIONS** are used:

A

ABBREVIATION	DESCRIPTION
A/C	Air conditioner
A/C	Air conditioning
A/F sensor	Air fuel ratio sensor
A/T	Automatic transaxle/transmission
ABS	Anti-lock braking system
ACCS	Advance climate control system
ACL	Air cleaner
AP	Accelerator pedal
APP	Accelerator pedal position
ATF	Automatic transmission fluid
AV	Audio visual
AWD	All wheel drive

B

ABBREVIATION	DESCRIPTION
BARO	Barometric pressure
BCI	Back-up collision intervention
BCM	Body control module
BLSD	Brake limited slip differential
BPP	Brake pedal position
BSW	Blind spot warning

C

ABBREVIATION	DESCRIPTION
CKP	Crankshaft position
CL	Closed loop
CMP	Camshaft position
CPP	Clutch pedal position
CTP	Closed throttle position
CVT	Continuously variable transaxle/transmission

D

ABBREVIATION	DESCRIPTION
D1	Drive range first gear
D2	Drive range second gear
D3	Drive range third gear
D4	Drive range fourth gear
DCA	Distance control assist
DDS	Downhill drive support
DFI	Direct fuel injection system
DLC	Data link connector
DTC	Diagnostic trouble code

## ABBREVIATIONS

### < HOW TO USE THIS MANUAL >

E		
ABBREVIATION	DESCRIPTION	
E/T	Exhaust temperature	GI
EBD	Electric brake force distribution	
EC	Engine control	B
ECL	Engine coolant level	
ECM	Engine control module	C
ECT	Engine coolant temperature	
ECV	Electrical control valve	
EEPROM	Electrically erasable programmable read only memory	D
EFT	Engine fuel temperature	
EGR	Exhaust gas recirculation	E
EGRT	Exhaust gas recirculation temperature	
EGT	Exhaust gas temperature	
EOP	Engine oil pressure	F
EP	Exhaust pressure	
EPR	Exhaust pressure regulator	G
EPS	Electronically controlled power steering	
ESP	Electronic stability program system	H
EVAP canister	Evaporative emission canister	
EVSE	Electric vehicle supply equipment	I
EXC	Exhaust control	
F		
ABBREVIATION	DESCRIPTION	
FC	Fan control	J
FCW	Forward collision warning	
FEB	Forward emergency braking	K
FIC	Fuel injector control	
FP	Fuel pump	L
FR	Front	
FRP	Fuel rail pressure	M
FRT	Fuel rail temperature	
FTP	Fuel tank pressure	
FTT	Fuel tank temperature	N
G		
ABBREVIATION	DESCRIPTION	
GND	Ground	O
GPS	Global positioning system	
GST	Generic scan tool	
H		
ABBREVIATION	DESCRIPTION	
HBMC	Hydraulic body-motion control system	P
HDD	Hard disk drive	
HO2S	Heated oxygen sensor	
HOC	Heated oxidation catalyst	
HPCM	Hybrid power train control module	

# ABBREVIATIONS

## < HOW TO USE THIS MANUAL >

I	
ABBREVIATION	DESCRIPTION
I/M	Inspection and maintenance
IA	Intake air
IAC	Idle air control
IAT	Intake air temperature
IBA	Intelligent brake assist
IC	Ignition control
ICC	Intelligent cruise control
ICM	Ignition control module
IPDM E/R	Intelligent power distribution module engine room
ISC	Idle speed control
ISS	Input shaft speed

K	
ABBREVIATION	DESCRIPTION
KS	Knock sensor

L	
ABBREVIATION	DESCRIPTION
LBC	Li-ion battery controller
LCD	Liquid crystal display
LCU	Local control unit
LDP	Lane departure prevention
LDW	Lane departure warning
LED	Light emitting diode
LH	Left-hand
LIN	Local interconnect network

M	
ABBREVIATION	DESCRIPTION
M/T	Manual transaxle/transmission
MAF	Mass airflow
MAP	Manifold absolute pressure
MDU	Multi display unit
MI	Malfunction indicator
MIL	Malfunction indicator lamp

N	
ABBREVIATION	DESCRIPTION
NOX	Nitrogen oxides

O	
ABBREVIATION	DESCRIPTION
O2	Oxygen
O2S	Oxygen sensor
OBD	On board diagnostic
OC	Oxidation catalytic converter
OD	Overdrive
OL	Open loop
OSS	Output shaft speed



# ABBREVIATIONS

## < HOW TO USE THIS MANUAL >

P		
ABBREVIATION	DESCRIPTION	
P/S	Power steering	GI
PBR	Potential balance resistor	
PCV	Positive crankcase ventilation	B
PFCW	Predictive forward collision warning	
PNP	Park/Neutral position	C
PSP	Power steering pressure	
PTC	Positive temperature coefficient	
PTO	Power takeoff	D
PWM	Pulse width modulation	
R		
ABBREVIATION	DESCRIPTION	
RAM	Random access memory	E
RAS	Rear active steer	F
RH	Right-hand	
ROM	Read only memory	G
RPM	Engine speed	
RR	Rear	
S		
ABBREVIATION	DESCRIPTION	
SAE	Society of Automotive Engineers, Inc.	H
SCK	Serial clock	I
SDS	Service Data and Specifications	
SRT	System readiness test	J
SST	Special Service Tools	
T		
ABBREVIATION	DESCRIPTION	
TC	Turbocharger	K
TCM	Transmission control module	
TCS	Traction control system	L
TCU	Telematics communication unit	
TP	Throttle position	M
TPMS	Tire pressure monitoring system	
TSS	Turbine shaft speed	
TWC	Three way catalytic converter	N
U		
ABBREVIATION	DESCRIPTION	
USS	Uphill start support	O
V		
ABBREVIATION	DESCRIPTION	
VCM	Vehicle control module	P
VDC	Vehicle dynamics control system	
VIN	Vehicle identification number	
VSS	Vehicle speed sensor	

# ABBREVIATIONS

## < HOW TO USE THIS MANUAL >

W

ABBREVIATION	DESCRIPTION
WOT	Wide open throttle

1

ABBREVIATION	DESCRIPTION
11	1st range first gear
12	1st range second gear
1GR	First gear

2

ABBREVIATION	DESCRIPTION
21	2nd range first gear
22	2nd range second gear
2GR	Second gear
2WD	2-wheel drive

3

ABBREVIATION	DESCRIPTION
3GR	Third gear

4

ABBREVIATION	DESCRIPTION
4GR	Fourth gear
4WAS	Four wheel active steer
4WD	Four wheel drive

5

ABBREVIATION	DESCRIPTION
5GR	Fifth gear

6

ABBREVIATION	DESCRIPTION
6GR	Sixth gear

7

ABBREVIATION	DESCRIPTION
7GR	Seventh gear

# TIGHTENING TORQUE OF STANDARD BOLTS

< HOW TO USE THIS MANUAL >

## TIGHTENING TORQUE OF STANDARD BOLTS

GI

### Description

INFOID:000000006825130

This vehicle has both new standard based on ISO\* and previous standard bolts/nuts. There are some differences between these two types of bolts/ nuts; shape of the head, grade of strength, hexagonal width across flats and the standard tightening torque.

- For guidance in discriminating, refer to [GI-19, "Tightening Torque Table \(New Standard Included\)"](#).
- The new standard machine screws and tapping screws have a head of ISO standard torx recess.
- If the tightening torque is not described in the description or figure, refer to [GI-19, "Tightening Torque Table \(New Standard Included\)"](#).

\*ISO: International Organization for Standardization

### Tightening Torque Table (New Standard Included)

INFOID:000000006825131

#### CAUTION:

- The special parts are excluded.
- The bolts/nuts in these tables have a strength (discrimination) number/symbol assigned to the head or the like. As to the relation between the strength grade in these tables and the strength (discrimination) number/symbol, refer to "DISCRIMINATION OF BOLTS AND NUTS".

### PREVIOUS STANDARD

Grade (Strength grade)	Bolt size	Bolt di- ameter mm	Hexagonal width across flats mm	Pitch mm	Tightening torque (Without lubricant)							
					Hexagon head bolt				Hexagon flange bolt			
					N-m	kg-m	ft-lb	in-lb	N-m	kg-m	ft-lb	in-lb
4T	M6	6.0	10	1.0	5.5	0.56	4	49	7	0.71	5	62
	M8	8.0	12	1.25	13.5	1.4	10	—	17	1.7	13	—
				1.0	13.5	1.4	10	—	17	1.7	13	—
	M10	10.0	14	1.5	28	2.9	21	—	35	3.6	26	—
				1.25	28	2.9	21	—	35	3.6	26	—
	M12	12.0	17	1.75	45	4.6	33	—	55	5.6	41	—
1.25				45	4.6	33	—	65	6.6	48	—	
M14	14.0	19	1.5	80	8.2	59	—	100	10	74	—	
7T	M6	6.0	10	1.0	9	0.92	7	80	11	1.1	8	97
	M8	8.0	12	1.25	22	2.2	16	—	28	2.9	21	—
				1.0	22	2.2	16	—	28	2.9	21	—
	M10	10.0	14	1.5	45	4.6	33	—	55	5.6	41	—
				1.25	45	4.6	33	—	55	5.6	41	—
	M12	12.0	17	1.75	80	8.2	59	—	100	10	74	—
1.25				80	8.2	59	—	100	10	74	—	
M14	14.0	19	1.5	130	13	96	—	170	17	125	—	
9T	M6	6.0	10	1.0	11	1.1	8	—	13.5	1.4	10	—
	M8	8.0	12	1.25	28	2.9	21	—	35	3.6	26	—
				1.0	28	2.9	21	—	35	3.6	26	—
	M10	10.0	14	1.5	55	5.6	41	—	80	8.2	59	—
				1.25	55	5.6	41	—	80	8.2	59	—
	M12	12.0	17	1.75	100	10	74	—	130	13	96	—
1.25				100	10	74	—	130	13	96	—	
M14	14.0	19	1.5	170	17	125	—	210	21	155	—	

#### CAUTION:

# TIGHTENING TORQUE OF STANDARD BOLTS

< HOW TO USE THIS MANUAL >

**The parts with aluminum or the cast iron washer surface/thread surface are excluded.**

NEW STANDARD BASED ON ISO

Grade (Strength grade)	Bolt size	Bolt di- ameter mm	Hexagonal width across flats mm	Pitch mm	Tightening torque							
					Hexagon head bolt				Hexagon flange bolt			
					N-m	kg-m	ft-lb	in-lb	N-m	kg-m	ft-lb	in-lb
4.8 (Without lubricant)	M6	6.0	10	1.0	5.5	0.56	4	49	7	0.71	5	62
	M8	8.0	13	1.25	13.5	1.4	10	—	17	1.7	13	—
				1.0	13.5	1.4	10	—	17	1.7	13	—
	M10	10.0	16	1.5	28	2.9	21	—	35	3.6	26	—
				1.25	28	2.9	21	—	35	3.6	26	—
	M12	12.0	18	1.75	45	4.6	33	—	55	5.6	41	—
1.25				45	4.6	33	—	65	6.6	48	—	
M14	14.0	21	1.5	80	8.2	59	—	100	10	74	—	
4.8 (With lu- bricant)	M6	6.0	10	1.0	4	0.41	3	35	5.5	0.56	4	49
	M8	8.0	13	1.25	11	1.1	8	—	13.5	1.4	10	—
				1.0	11	1.1	8	—	13.5	1.4	10	—
	M10	10.0	16	1.5	22	2.2	16	—	28	2.9	21	—
				1.25	22	2.2	16	—	28	2.9	21	—
	M12	12.0	18	1.75	35	3.6	26	—	45	4.6	33	—
1.25				35	3.6	26	—	45	4.6	33	—	
M14	14.0	21	1.5	65	6.6	48	—	80	8.2	59	—	
8.8 (With lu- bricant)	M6	6.0	10	1.0	8	0.82	6	71	10	1.0	7	89
	M8	8.0	13	1.25	21	2.1	15	—	25	2.6	18	—
				1.0	21	2.1	15	—	25	2.6	18	—
	M10	10.0	16	1.5	40	4.1	30	—	50	5.1	37	—
				1.25	40	4.1	30	—	50	5.1	37	—
	M12	12.0	18	1.75	70	7.1	52	—	85	8.7	63	—
1.25				70	7.1	52	—	85	8.7	63	—	
M14	14.0	21	1.5	120	12	89	—	140	14	103	—	
10.9 (With lu- bricant)	M6	6.0	10	1.0	10	1.0	7	89	12	1.2	9	106
	M8	8.0	13	1.25	27	2.8	20	—	32	3.3	24	—
				1.0	27	2.8	20	—	32	3.3	24	—
	M10	10.0	16	1.5	55	5.6	41	—	65	6.6	48	—
				1.25	55	5.6	41	—	65	6.6	48	—
	M12	12.0	18	1.75	95	9.7	70	—	110	11	81	—
1.25				95	9.7	70	—	110	11	81	—	
M14	14.0	21	1.5	160	16	118	—	180	18	133	—	

**CAUTION:**

1. Use tightening torque with lubricant for the new standard bolts/nuts in principle. Friction coefficient stabilizer is applied to the new standard bolts/nuts.
2. However, use tightening torque without lubricant for the following cases. Friction coefficient stabilizer is not applied to the following bolts/nuts.
  - Grade 4.8, M6 size bolt, Conical spring washer installed
  - Paint removing nut (Size M6 and M8) for fixing with weld bolt

# RECOMMENDED CHEMICAL PRODUCTS AND SEALANTS

< HOW TO USE THIS MANUAL >

## RECOMMENDED CHEMICAL PRODUCTS AND SEALANTS

### Recommended Chemical Products and Sealants

INFOID:000000006826362

Refer to the following chart for help in selecting the appropriate chemical product or sealant.

	Product Description	Purpose	Nissan North America Part No. (USA)	Nissan Canada Part No. (Canada)	Aftermarket Cross-reference Part Nos.
1	Rear View Mirror Adhesive	Used to permanently re-mount rear view mirrors to windows.	999MP-AM000P	99998-50505	Permatex 81844
2	Anaerobic Liquid Gasket	For metal-to-metal flange sealing. Can fill a 0.38 mm (0.015 inch) gap and provide instant sealing for most powertrain applications.	999MP-AM001P	99998-50503	Permatex 51813 and 51817
3	High Performance Thread Sealant	Provides instant sealing on any threaded straight or parallel threaded fitting. (Thread sealant only, no locking ability.) • Do not use on plastic.	999MP-AM002P	999MP-AM002P	Permatex 56521
4	Silicone RTV	Gasket Maker	999MP-AM003P (Ultra Grey)	99998-50506 (Ultra Grey)	Permatex Ultra Grey 82194; Three Bond 1207, 1215, 1216, 1217F, 1217G and 1217H Nissan RTV Part No. 999MP-A7007
		Gasket Maker for Maxima/Quest 5-speed automatic transmission (RE5F22A)	—	—	Three Bond 1281B or exact equivalent in its quality
5	High Temperature, High Strength Thread Locking Sealant (Red)	Threadlocker	999MP-AM004P	999MP-AM004P	Permatex 27200; Three Bond 1360, 1360N, 1305 N&P, 1307N, 1335, 1335B, 1363B, 1377C, 1386B, D&E and 1388 Loctite 648
6	Medium Strength Thread Locking Sealant (Blue)	Threadlocker (service tool removable)	999MP-AM005P	999MP-AM005P	Permatex 24200, 24206, 24240, 24283 and 09178; Three Bond 1322, 1322N, 1324 D&N, 1333D, 1361C, 1364D, 1370C and 1374

GI

B

C

D

E

F

G

H

I

J

K

L

M

N

O

P

# IDENTIFICATION INFORMATION

< VEHICLE INFORMATION >

## VEHICLE INFORMATION

### IDENTIFICATION INFORMATION

#### Model Variation

INFOID:000000006825132

Destination	Body	Transmission	Axle	Motor	Grade	Model
USA	4-door Hatchback	Reduction gear	2WD	EM61	L2	FSDALD9-BUA
CANADA						FSDALD9-BNA

Model variation code (Prefix and suffix designations)

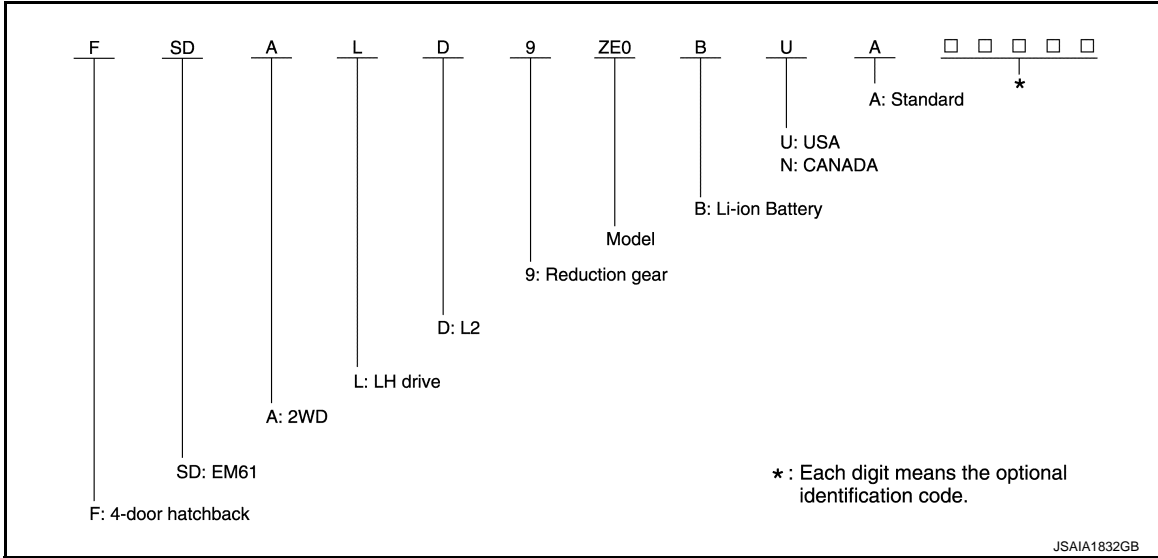

#### Information About Identification or Model Code

INFOID:000000006825133

#### IDENTIFICATION NUMBER

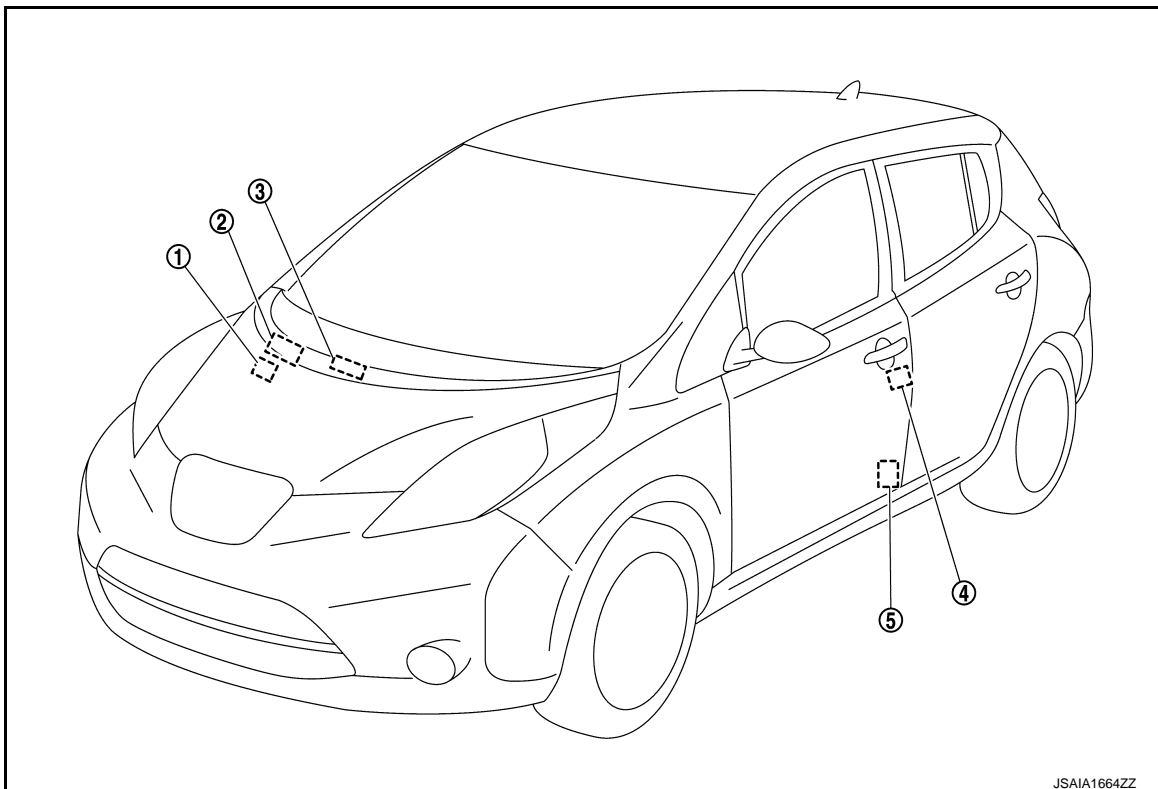

# IDENTIFICATION INFORMATION

## < VEHICLE INFORMATION >

1. Vehicle identification plate
2. Vehicle identification number (Chassis number)
3. Air conditioner specification label
4. Tire placard
5. FMVSS certification label

## VEHICLE IDENTIFICATION NUMBER ARRANGEMENT

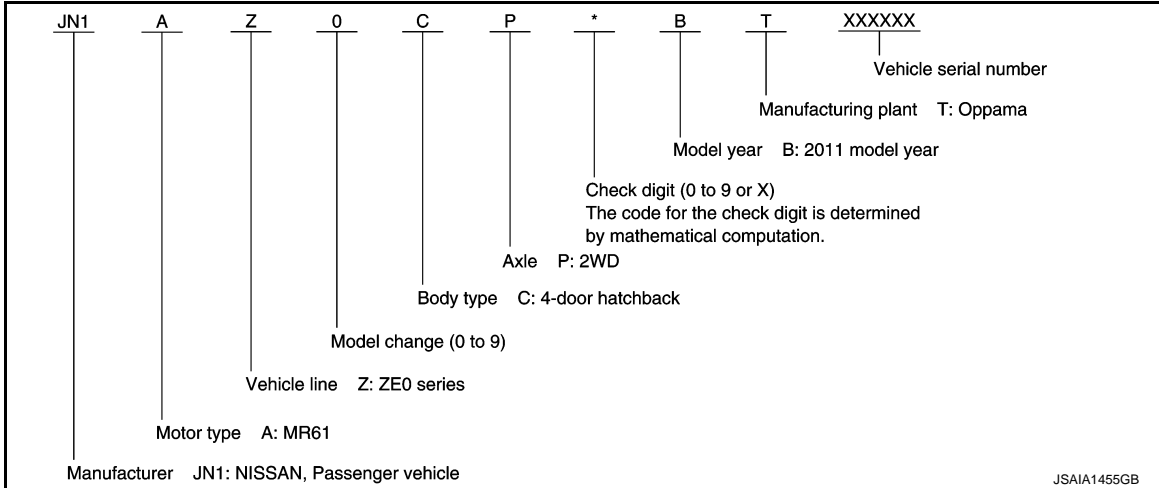

## IDENTIFICATION PLATE

For USA

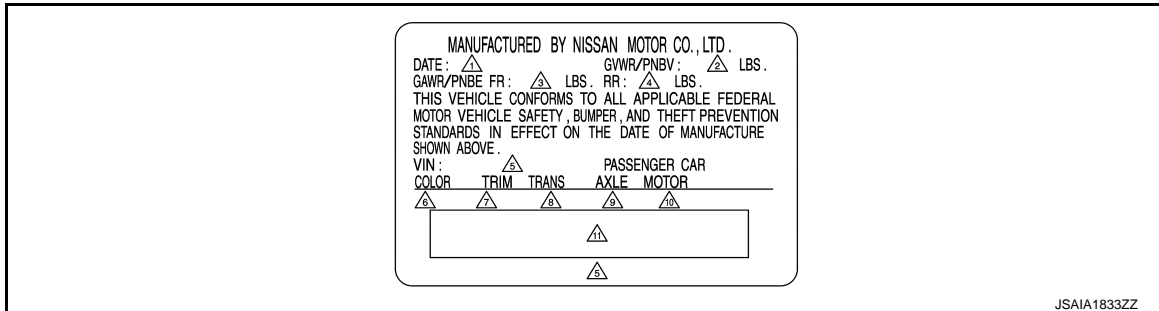

1. MFR Month/Year
2. Gross vehicle weight rating
3. Gross axle weight rating (Front)
4. Gross axle weight rating (Rear)
5. Vehicle identification number
6. Body color code
7. Trim color code
8. Transmission model
9. Axle model
10. Motor model
11. Vin bar code

For CANADA

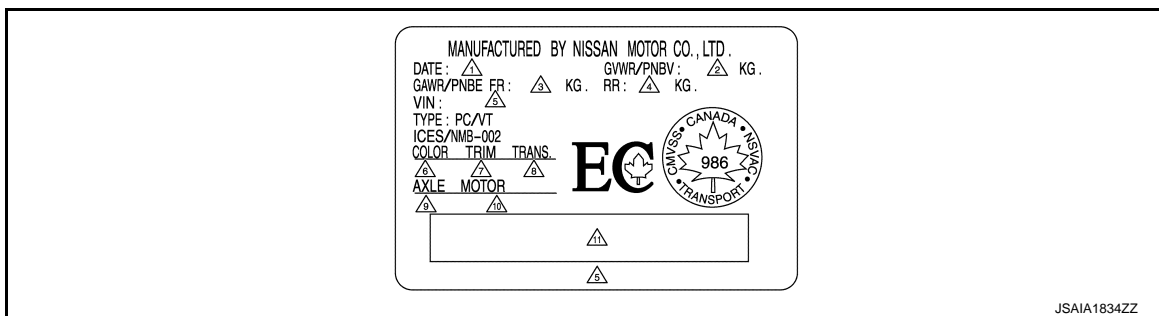

1. MFR Month/Year
2. Gross vehicle weight rating
3. Gross axle weight rating (Front)
4. Gross axle weight rating (Rear)
5. Vehicle identification number
6. Body color code

# IDENTIFICATION INFORMATION

## < VEHICLE INFORMATION >

- |                    |                       |               |
|--------------------|-----------------------|---------------|
| 7. Trim color code | 8. Transmission model | 9. Axle model |
| 10. Motor model    | 11. Vin bar code      |               |

## MOTOR SERIAL NUMBER

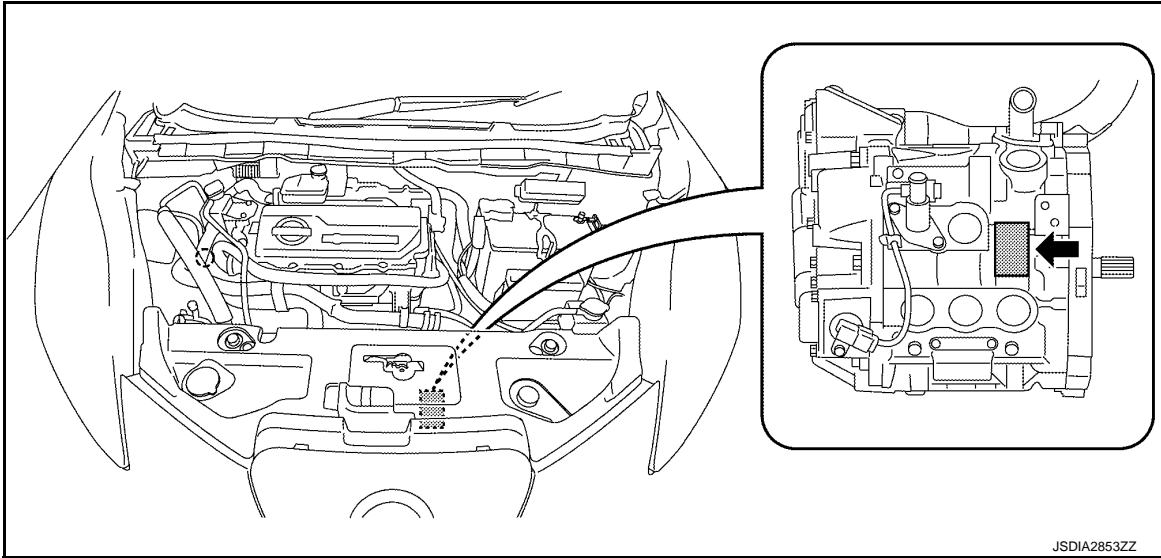

## Dimensions

INFOID:000000006856140

Unit: mm (in)

Overall length (with license plate bracket)	4,446.8 (175.1)
Overall width	1,771.4 (69.7)
Overall height	1,549.5 (61.0)
Front tread	1,540 (60.6)
Rear tread	1,535 (60.4)
Wheelbase	2,700 (106.3)

## Wheels & Tires

INFOID:000000006856141

Conventional	Tire		205/55R16 91V
	Road wheel (Aluminum)	Size	16 × 6-1/2J
		Offset	40 mm (1.57in)
Spare	Tire		Puncture repair kit
	Road wheel	Size	
		Offset	



# PRECAUTIONS

< PRECAUTION >

## PRECAUTION

### PRECAUTIONS

#### Description

INFOID:000000006825136

Observe the following precautions to ensure safe and proper servicing. These precautions are not described in each individual section.

#### Precaution for Technicians Using Medical Electric

INFOID:000000007076757

#### OPERATION PROHIBITION

##### **WARNING:**

- Parts with strong magnet is used in this vehicle.
- Technicians using a medical electric device such as pacemaker must never perform operation on the vehicle, as magnetic field can affect the device function by approaching to such parts.

#### NORMAL CHARGE PRECAUTION

##### **WARNING:**

- If a technician uses a medical electric device such as an implantable cardiac pacemaker or an implantable cardioverter defibrillator, the possible effects on the devices must be checked with the device manufacturer before starting the charge operation.
- As radiated electromagnetic wave generated by on board charger at normal charge operation may effect medical electric devices, a technician using a medical electric device such as implantable cardiac pacemaker or an implantable cardioverter defibrillator must not enter the vehicle compartment (including luggage room) during normal charge operation.

#### PRECAUTION AT TELEMATICS SYSTEM OPERATION

##### **WARNING:**

- If a technician uses implantable cardiac pacemaker or implantable cardioverter defibrillator (ICD), avoid the device implanted part from approaching within approximately 220 mm (8.66 in) from interior/exterior antenna.
- The electromagnetic wave of TCU might affect the function of the implantable cardiac pacemaker or the implantable cardioverter defibrillator (ICD), when using the service, etc.
- If a technician uses other medical electric devices than implantable cardiac pacemaker or implantable cardioverter defibrillator (ICD), the electromagnetic wave of TCU might affect the function of the device. The possible effects on the devices must be checked with the device manufacturer before TCU use.

#### PRECAUTION AT INTELLIGENT KEY SYSTEM OPERATION

##### **WARNING:**

- If a technician uses implantable cardiac pacemaker or implantable cardioverter defibrillator (ICD), avoid the device implanted part from approaching within approximately 220 mm (8.66 in) from interior/exterior antenna.
- The electromagnetic wave of Intelligent Key might affect the function of the implantable cardiac pacemaker or the implantable cardioverter defibrillator (ICD), at door operation, at each request switch operation, or at engine starting.
- If a technician uses other medical electric devices than implantable cardiac pacemaker or implantable cardioverter defibrillator (ICD), the electromagnetic wave of Intelligent Key might affect the function of the device. The possible effects on the devices must be checked with the device manufacturer before Intelligent Key use.

#### Point to Be Checked Before Starting Maintenance Work

INFOID:000000007079500

The high voltage system may starts automatically. It is required to check that the timer air conditioner and timer charge (during EVSE connection) are not set before starting maintenance work.

##### **NOTE:**

If the timer air conditioner or timer charge (during EVSE connection) is set, the high voltage system starts automatically even when the power switch is in OFF state.

#### Precaution for Supplemental Restraint System (SRS) "AIR BAG" and "SEAT BELT

# PRECAUTIONS

< PRECAUTION >

## PRE-TENSIONER"

INFOID:000000007037021

The Supplemental Restraint System such as "AIR BAG" and "SEAT BELT PRE-TENSIONER", used along with a front seat belt, helps to reduce the risk or severity of injury to the driver and front passenger for certain types of collision. This system includes seat belt switch inputs and dual stage front air bag modules. The SRS system uses the seat belt switches to determine the front air bag deployment, and may only deploy one front air bag, depending on the severity of a collision and whether the front occupants are belted or unbelted. Information necessary to service the system safely is included in the "SRS AIR BAG" and "SEAT BELT" of this Service Manual.

### **WARNING:**

Always observe the following items for preventing accidental activation.

- To avoid rendering the SRS inoperative, which could increase the risk of personal injury or death in the event of a collision that would result in air bag inflation, all maintenance must be performed by an authorized NISSAN/INFINITI dealer.
- Improper maintenance, including incorrect removal and installation of the SRS, can lead to personal injury caused by unintentional activation of the system. For removal of Spiral Cable and Air Bag Module, see "SRS AIR BAG".
- Never use electrical test equipment on any circuit related to the SRS unless instructed to in this Service Manual. SRS wiring harnesses can be identified by yellow and/or orange harnesses or harness connectors.

## PRECAUTIONS WHEN USING POWER TOOLS (AIR OR ELECTRIC) AND HAMMERS

### **WARNING:**

Always observe the following items for preventing accidental activation.

- When working near the Air Bag Diagnosis Sensor Unit or other Air Bag System sensors with the power switch ON, never use air or electric power tools or strike near the sensor(s) with a hammer. Heavy vibration could activate the sensor(s) and deploy the air bag(s), possibly causing serious injury.
- When using air or electric power tools or hammers, always switch the power switch OFF, disconnect the 12V battery, and wait at least 3 minutes before performing any service.

## Precautions Necessary for Steering Wheel Rotation After Battery Disconnection

INFOID:000000006825250

### **CAUTION:**

Comply with the following cautions to prevent any error and malfunction.

- Before removing and installing any control units, first turn the ignition switch to the LOCK position, then disconnect both battery cables.
- After finishing work, confirm that all control unit connectors are connected properly, then re-connect both battery cables.
- Always use CONSULT to perform self-diagnosis as a part of each function inspection after finishing work. If a DTC is detected, perform trouble diagnosis according to self-diagnosis results.

For vehicle with steering lock unit, if the battery is disconnected or discharged, the steering wheel will lock and cannot be turned.

If turning the steering wheel is required with the battery disconnected or discharged, follow the operation procedure below before starting the repair operation.

## OPERATION PROCEDURE

1. Connect both battery cables.

### **NOTE:**

Supply power using jumper cables if battery is discharged.

2. Turn the ignition switch to ACC position.  
(At this time, the steering lock will be released.)
3. Disconnect both battery cables. The steering lock will remain released with both battery cables disconnected and the steering wheel can be turned.
4. Perform the necessary repair operation.
5. When the repair work is completed, re-connect both battery cables. With the brake pedal released, turn the ignition switch from ACC position to ON position, then to LOCK position. (The steering wheel will lock when the ignition switch is turned to LOCK position.)
6. Perform self-diagnosis check of all control units using CONSULT.

# PRECAUTIONS

## < PRECAUTION >

### Precaution for Procedure without Cowl Top Cover

INFOID:000000006825251

When performing the procedure after removing cowl top cover, cover the lower end of windshield with urethane, etc to prevent damage to windshield.

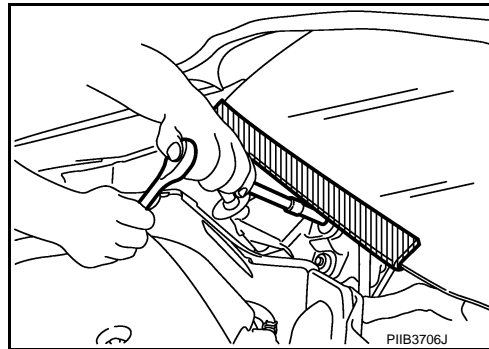

### Precautions for Removing Battery Terminal

INFOID:000000006931587

- When removing the 12V battery terminal, turn OFF the power switch and wait at least 5 minutes.

**NOTE:**

ECU may be active for several minutes after the power switch is turned OFF. If the battery terminal is removed before ECU stops, then a DTC detection error or ECU data corruption may occur.

- Always disconnect the battery terminal within 60 minutes after turning OFF the power switch. Even when the power switch is OFF, the 12V battery automatic charge control may automatically start after a lapse of 60 minutes from power switch OFF.
- Disconnect 12V battery terminal according to the following steps.

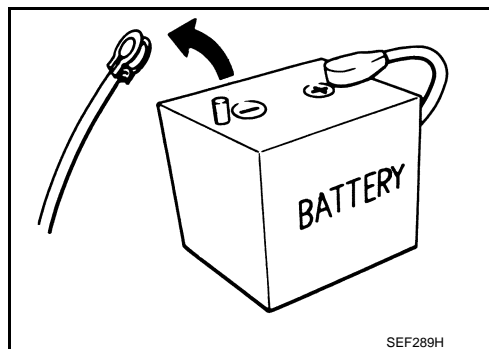

### WORK PROCEDURE

1. Check that EVSE is not connected.

**NOTE:**

If EVSE is connected, the air conditioning system may be automatically activated by the timer A/C function.

2. Turn the power switch OFF → ON → OFF. Get out of the vehicle. Close all doors (including back door).
3. Check that the charge status indicator lamp does not blink and wait for 5 minutes or more.

**NOTE:**

If the battery is removed within 5 minutes after the power switch is turned OFF, plural DTCs may be detected.

4. Remove 12V battery terminal within 60 minutes after turning the power switch OFF → ON → OFF.

**CAUTION:**

- After all doors (including back door) are closed, if a door (including back door) is opened before battery terminals are disconnected, start over from Step 1.
- After turning the power switch OFF, if "Remote A/C" is activated by user operation, stop the air conditioner and start over from Step 1.

**NOTE:**

Once the power switch is turned ON → OFF, the 12V battery automatic charge control does not start for approximately 1 hour.

- For vehicles with the 2-batteries, be sure to connect the main battery and the sub battery before turning ON the power switch.

**NOTE:**

If the power switch is turned ON with any one of the terminals of main battery and sub battery disconnected, then DTC may be detected.

- After installing the 12V battery, always check "Self Diagnosis Result" of all ECUs and erase DTC.

**NOTE:**

The removal of 12V battery may cause a DTC detection error.

### Cautions in Removing 12V Battery Terminal and AV Control Unit (Models with AV Control Unit)

INFOID:000000008234912

**CAUTION:**

# PRECAUTIONS

## < PRECAUTION >

**Remove 12V battery terminal and AV control unit after a lapse of 30 seconds or more after turning the power switch OFF.**

**NOTE:**

After the power switch is turned OFF, the AV control unit continues operating for approximately 30 seconds. Therefore, data corruption may occur if 12V battery voltage is cut off within 30 seconds.

## General Precautions

INFOID:000000006825140

- Before jacking up the vehicle, apply wheel chocks or other tire blocks to the wheels to prevent the vehicle from moving. After jacking up the vehicle, support the vehicle weight with safety stands at the points designated for proper lifting before working on the vehicle.  
These operations should be done on a level surface.
- When removing a heavy component such as the engine or transaxle/transmission, be careful not to lose your balance and drop them. Also, do not allow them to strike adjacent parts, especially the brake tubes and master cylinder.

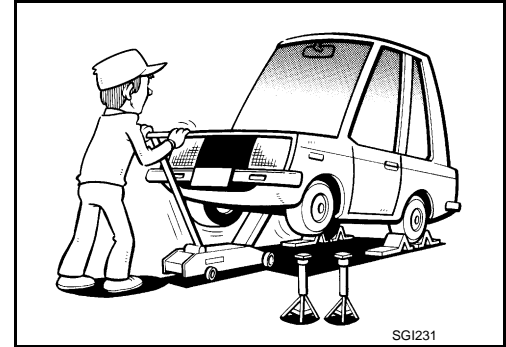

- Before starting repairs which do not require battery power:  
Turn off power switch.  
Disconnect the negative battery terminal.
- If the battery terminals are disconnected, recorded memory of radio and each control unit is erased.

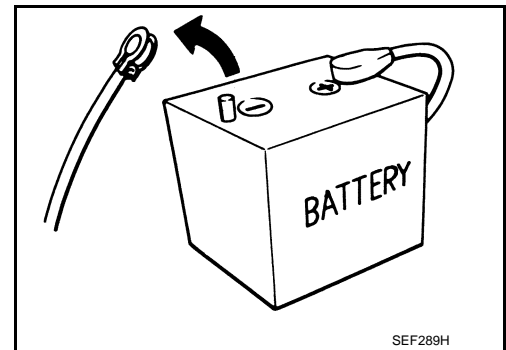

- To prevent serious burns:  
Avoid contact with hot metal parts.  
Do not remove the radiator cap when the engine is hot.
- Dispose of drained oil or the solvent used for cleaning parts in an appropriate manner.
- Do not attempt to top off the fuel tank after the fuel pump nozzle shuts off automatically.  
Continued refueling may cause fuel overflow, resulting in fuel spray and possibly a fire.
- Clean all disassembled parts in the designated liquid or solvent prior to inspection or assembly.
- Replace oil seals, gaskets, packings, O-rings, locking washers, cotter pins, self-locking nuts, etc. with new ones.
- Replace inner and outer races of tapered roller bearings and needle bearings as a set.
- Arrange the disassembled parts in accordance with their assembled locations and sequence.
- Do not touch the terminals of electrical components which use microcomputers (such as ECM).  
Static electricity may damage internal electronic components.
- After disconnecting vacuum or air hoses, attach a tag to indicate the proper connection.
- Use only the fluids and lubricants specified in this manual.
- Use approved bonding agent, sealants or their equivalents when required.



# PRECAUTIONS

## < PRECAUTION >

- Use hand tools, power tools (disassembly only) and recommended special tools where specified for safe and efficient service repairs.
- When repairing the fuel, oil, water, vacuum or exhaust systems, check all affected lines for leakage.

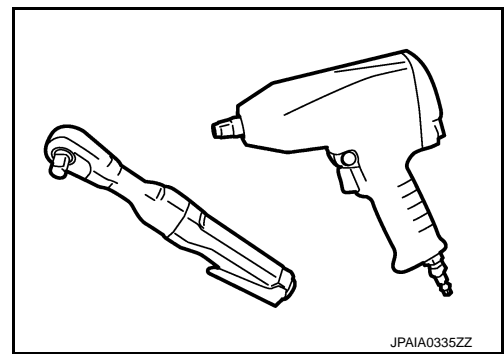

- Before servicing the vehicle:  
Protect fenders, upholstery and carpeting with appropriate covers.  
Take caution that keys, buckles or buttons do not scratch paint.

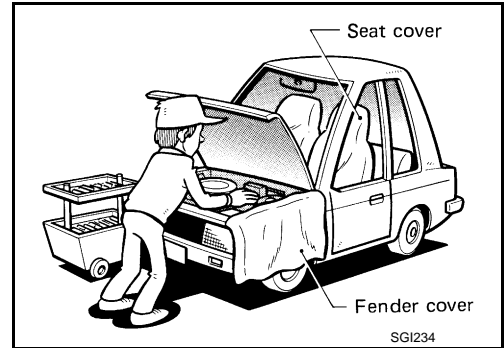

## **WARNING:**

To prevent ECM from storing the diagnostic trouble codes, do not carelessly disconnect the harness connectors which are related to the engine control system and TCM (transmission control module) system. The connectors should be disconnected only when working according to the WORK FLOW of TROUBLE DIAGNOSES in EC and TM sections.

## Hoses

INFOID:000000006825141

### HOSE REMOVAL AND INSTALLATION

- To prevent damage to rubber hose, do not pry off rubber hose with tapered tool or screwdriver.

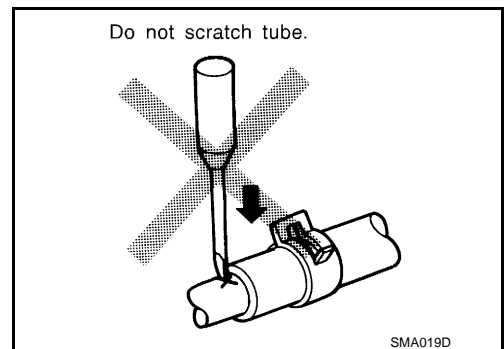

- To reinstall the rubber hose securely, check that hose insertion length and orientation is correct. (If tube is equipped with hose stopper, insert rubber hose into tube until it butts up against hose stopper.)

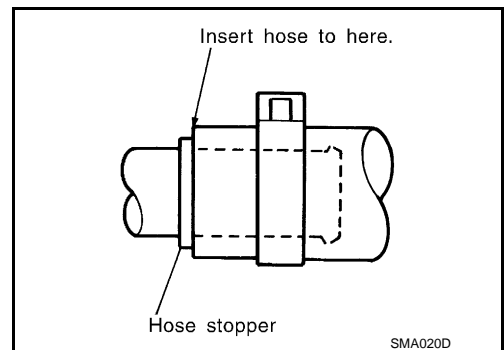

### HOSE CLAMPING

GI  
B  
C  
D  
E  
F  
G  
H  
I  
J  
K  
L  
M  
N  
O  
P

## PRECAUTIONS

### < PRECAUTION >

- If old rubber hose is re-used, install hose clamp in its original position (at the indentation where the old clamp was). If there is a trace of tube bulging left on the old rubber hose, align rubber hose at that position.
- Discard old clamps; replace with new ones.

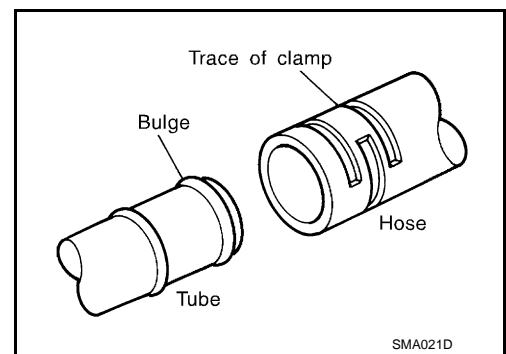

- After installing plate clamps, apply force to them in the direction of the arrow, tightening rubber hose equally all around.

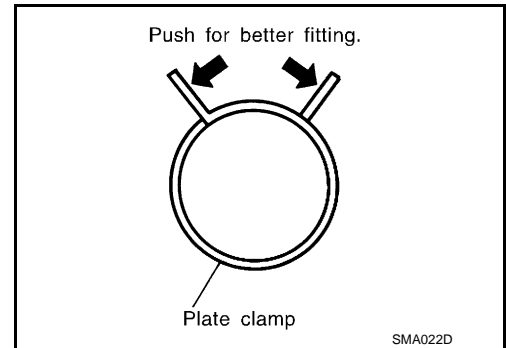

## Air Conditioning

INFOID:000000006825142

Use an approved refrigerant recovery unit any time the air conditioning system must be discharged. Refer to HA section "REFRIGERANT" for specific instructions.

# CAUTIONS AS TO HIGH VOLTAGE

< PRECAUTION >

## CAUTIONS AS TO HIGH VOLTAGE

GI

### How to Disconnect High Voltage

INFOID:000000006918519

#### PROCEDURE FOR DISCONNECTING HIGH VOLTAGE

Be sure to follow the procedure below and disconnect the high voltage before performing inspection or servicing of the high voltage system.

1. Turn power switch OFF.

**CAUTION:**

**The worker must keep the intelligent key on his/her person.**

2. Disconnect 12V battery negative terminal.
3. Remove service plug, following below procedure.
- a. Put finger to the notched part (A), and pull of the floor carpet (1).

⇐ :Vehicle front

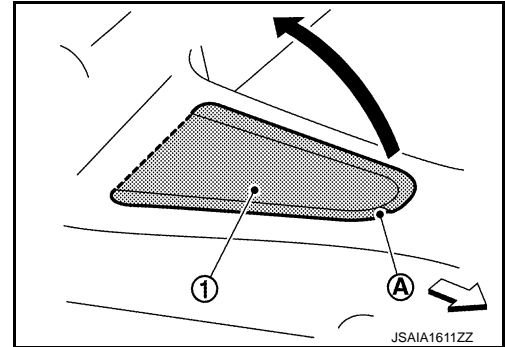

- b. Remove inspection hole cover installation bolt (A) and take the inspection hole cover (1) off.

⇐ :Vehicle front

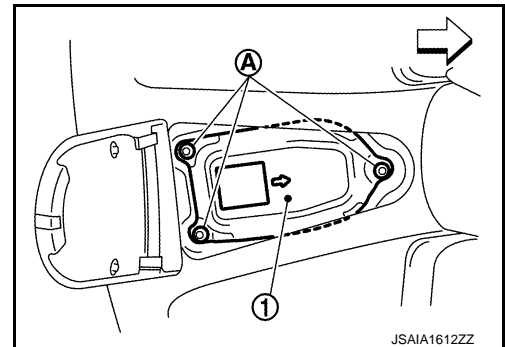

- c. Remove the service plug.

#### TYPE A

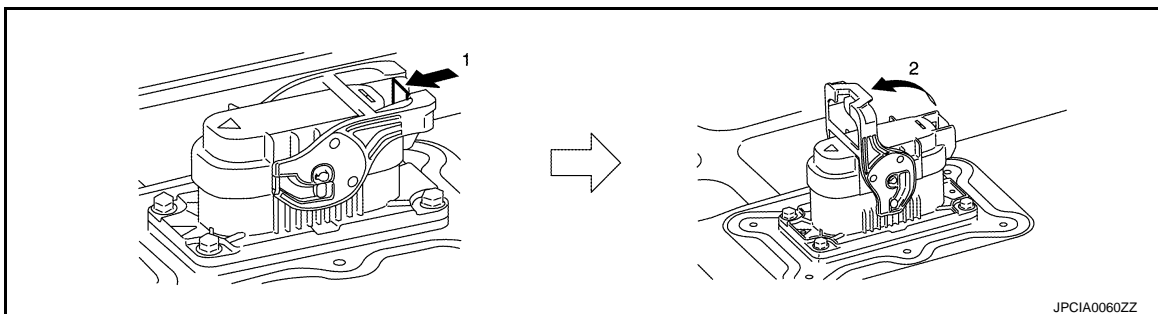

B  
C  
D  
E  
F  
G  
H  
I  
J  
K  
L  
M  
N  
O  
P

# CAUTIONS AS TO HIGH VOLTAGE

< PRECAUTION >

TYPE B

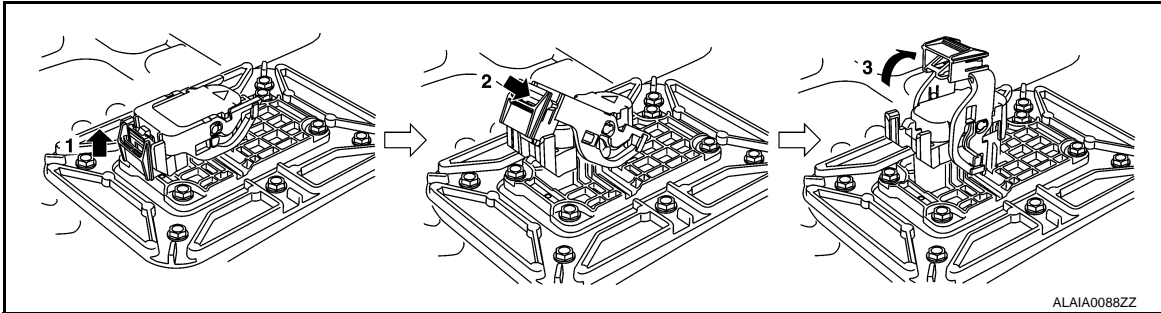

**DANGER:**



Touching high voltage components without using the appropriate protective equipment will cause electrocution.



**WARNING:**

- Immediately insulate removed high voltage connectors and terminals with insulating tape.
- Be sure to put the removed service plug in your pocket and carry it with you so that another person does not accidentally connect it while work is in progress.

4. Wait for a minimum of approximately 10 minutes after the service plug is removed.

## PROCEDURE FOR CONNECTING HIGH VOLTAGE

1. Check that 12V battery negative terminal is disconnected.
2. Install service plug as per the following steps.

TYPE A

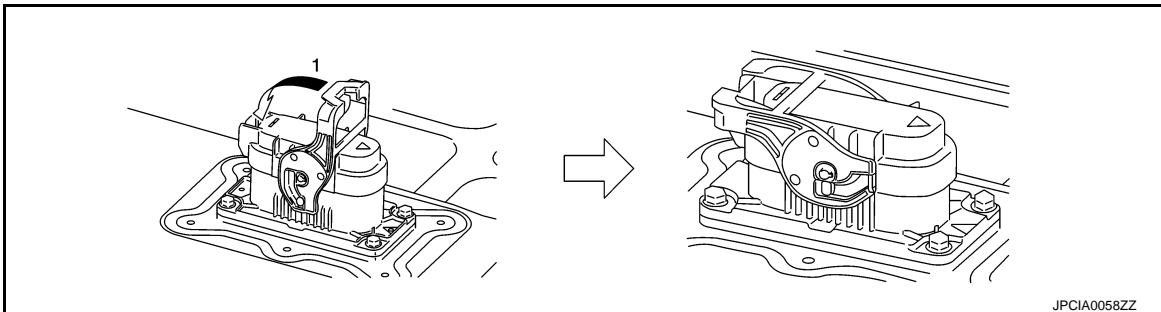

TYPE B

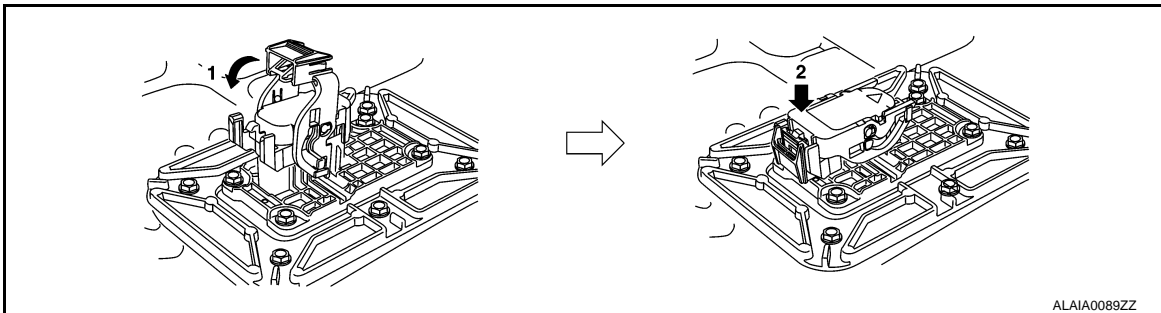

**DANGER:**



Touching high voltage components without using the appropriate protective equipment will cause electrocution.



**WARNING:**

- Immediately insulate removed high voltage connectors and terminals with insulating tape.



# CAUTIONS AS TO HIGH VOLTAGE

## < PRECAUTION >

- Be sure to put the removed service plug in your pocket and carry it with you so that another person does not accidentally connect it while work is in progress.

3. Connect 12V battery negative terminal.

## High Voltage Precautions

INFOID:000000007429636

### DANGER:



Since hybrid vehicles and electric vehicles contain a high voltage battery, there is the risk of electric shock, electric leakage, or similar accidents if the high voltage component and vehicle are handled incorrectly. Be sure to follow the correct work procedures when performing inspection and maintenance.

### WARNING:

- Be sure to remove the service plug in order to disconnect the high voltage circuits before performing inspection or maintenance of high voltage system harnesses and parts.
- The removed service plug must always be carried in a pocket of the responsible worker or placed in the tool box during the procedure to prevent the plug from being connected by mistake.
- Be sure to wear insulated protective equipment before beginning work on the high voltage system.
- Never allow workers other than the responsible person to touch the vehicle containing high voltage parts. To keep others from touching the high voltage parts, these parts must be covered with an insulating sheet except when using them.

### CAUTION:

Never bring the vehicle into the READY status with the service plug removed unless otherwise instructed in the Service Manual. A malfunction may occur if this is not observed.

## HIGH VOLTAGE HARNESS AND EQUIPMENT IDENTIFICATION

All the high voltage harnesses and connectors are orange. The Li-ion battery and other high voltage devices include an orange high voltage label. Never touch these harnesses and high voltage parts.

## HANDLING OF HIGH VOLTAGE HARNESS AND TERMINALS

Immediately insulate disconnected high voltage connectors and terminals with insulating tape.

## REGULATIONS ON WORKERS WITH MEDICAL ELECTRONICS

### WARNING:

The vehicle contains parts that contain powerful magnets. If a person who is wearing a heart pacemaker or other medical device is close to these parts, the medical device may be affected by the magnets. Such persons must not perform work on the vehicle.

## PROHIBITED ITEMS TO CARRY DURING THE WORK

Hybrid vehicles and electric vehicles contain parts with high voltage and intense magnetic force. Never carry metal products and magnetic recording media (e.g. cash card, prepaid card) to repair/inspect high voltage parts. If this is not observed, the metal products may create a risk of short circuit and the magnetic recording media may lose their magnetic recording.

## POSTING A SIGN OF "DANGER! HIGH VOLTAGE AREA. KEEP OUT"

GI

B

C

D

E

F

G

H

I

J

K

L

M

N

O

P

## CAUTIONS AS TO HIGH VOLTAGE

< PRECAUTION >

To call the attention of other workers, indicate "High voltage work in progress. Do not touch!" on vehicles where work is being performed on the high voltage systems.

<b>Person in charge: _____</b>
<b>DO NOT TOUCH!</b> <b>REPAIR IN PROGRESS.</b> <b>HIGH VOLTAGE</b> <b>DANGER:</b>
<b>DANGER:</b> <b>HIGH VOLTAGE</b> <b>REPAIR IN PROGRESS.</b> <b>DO NOT TOUCH!</b> <b>Person in charge: _____</b>
<b>Copy this page and put it after folding on the roof of the vehicle in service.</b>
<small>JSAIA1600GB</small>

# CAUTIONS AS TO HIGH VOLTAGE

< PRECAUTION >

## High Voltage Warning Label

INFOID:000000006918521

GI

### LOCATION TO APPLY HIGH VOLTAGE WARNING LABEL

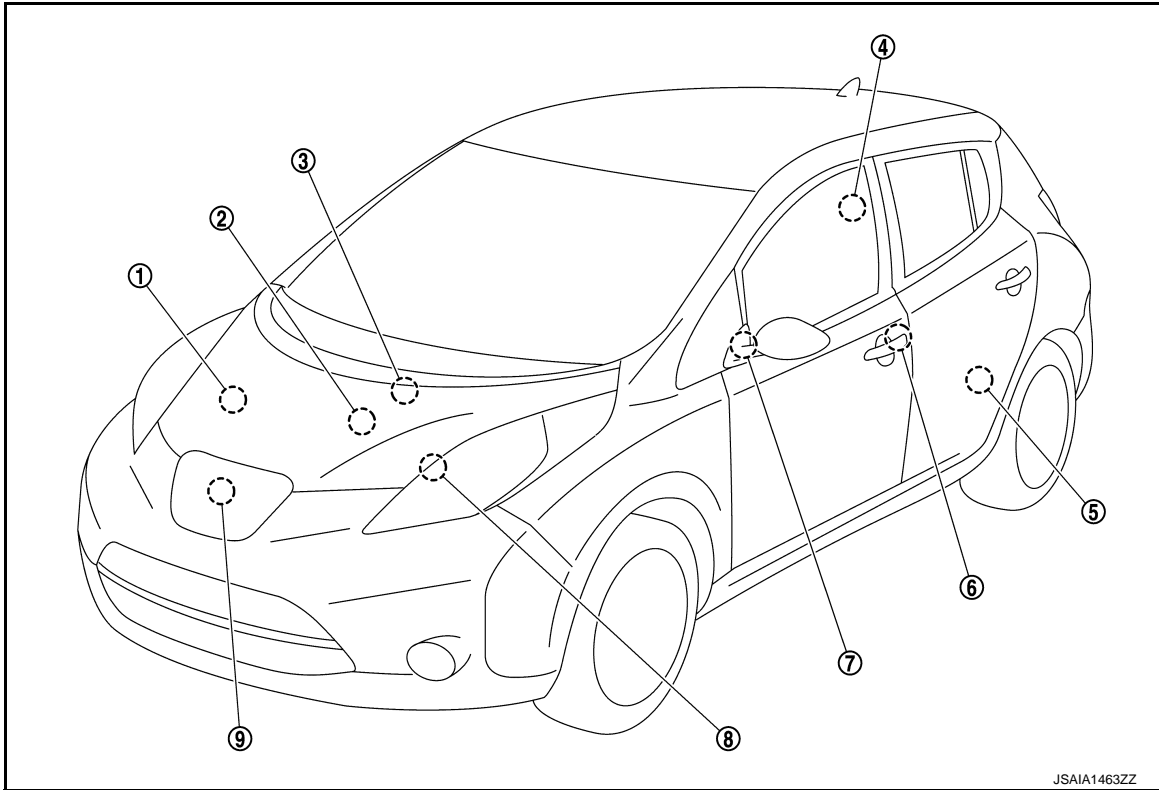

JSA1A1463ZZ

No.	Position to apply	Refer to
1	Traction motor	<a href="#">TMS-14, "High Voltage Warning Label"</a>
2	Traction motor inverter	<a href="#">TMS-14, "High Voltage Warning Label"</a>
3	DC/DC-J/B	<a href="#">EVC-27, "High Voltage Warning Label"</a>
4	On board charger	<a href="#">VC-13, "High Voltage Warning Label"</a>
5	Li-ion battery controller	<a href="#">EVB-29, "High Voltage Warning Label"</a>
6	Li-ion battery	<a href="#">EVB-29, "High Voltage Warning Label"</a>
7	Service plug	<a href="#">EVB-29, "High Voltage Warning Label"</a>
8	PTC elements heater	<a href="#">HA-25, "High Voltage Warning Label"</a>
9	Electric compressor	<a href="#">HA-25, "High Voltage Warning Label"</a>

#### CAUTION:

At times such as when a part was replaced, or when a label had become peeled, be sure to apply the new product label in the same position and facing in the same direction.

### Insulated Protective Wear and Insulating Tools

INFOID:000000006918522

#### PROTECTIVE WEAR CONTROL

- Perform an inspection before beginning work, and do not use any items where abnormalities are found.

#### DAILY INSPECTION

This inspection is performed before and after use, the worker in responsible who will directly use the items inspects them and checks for deterioration and damage.

- Insulated gloves

## CAUTIONS AS TO HIGH VOLTAGE

### < PRECAUTION >

Inspect the insulated gloves for scratches, holes, and tears. (Visual check and air leakage test)

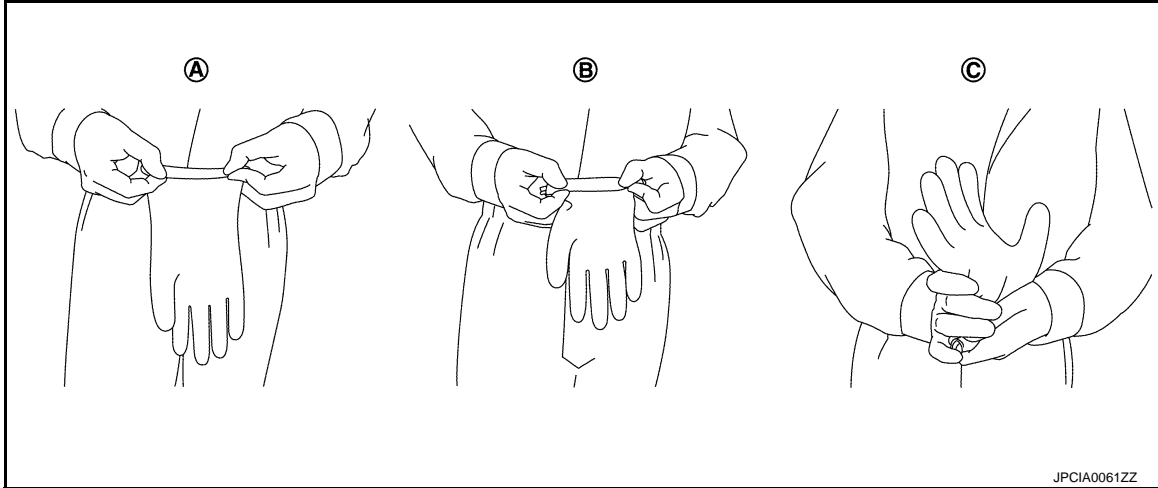

- A : Hold glove and fold as shown in the figure.
- B : Fold three or four more times, preventing air from escaping from the glove.
- C : Squeeze glove to check that the glove has no holes.

- Insulated safety shoes  
Inspect the insulated safety boots for holes, damage, nails, metal pieces, wear or other problems on the soles. (Visual check)
- Insulated rubber sheet  
Inspect the insulated rubber sheet for tears. (Visual inspection)

### INSULATING TOOLS

When performing work at locations where high voltage is applied (such as terminals), use insulated tools.

### HANDLING OF INSULATION RESISTANCE TESTER

#### **CAUTION:**

**Unlike the ordinary tester, the insulation resistance tester applies 500V when measuring. If used incorrectly, there is the danger of electric shock. If used in the vehicle 12V system, there is the danger of damage to electronic devices. Read the insulation resistance tester instruction manual carefully and be sure to work safely.**

### Handling of Damaged Vehicles

INFOID:000000007080557

### PREPARATION ITEMS

Preparation items		Specification	Purpose
PPE (Personal Protective Equipment)	Insulated gloves	Up to 1,000 V	To protect people from high voltage electrical shock.
	Insulated safety shoes	—	
	Safety shield	—	
Wrenches		Size: 10mm	To remove the service plug access cover bolts. To remove the 12V battery terminal bolt.
Heat proof solvent resistant protection gloves Heat proof solvent resistant protection shoes		Heat proof solvent resistant protection tools.	To utilize in the event of a Li-ion battery electrolytic solution leak.
Absorbent pad		The same pad used for internal combustion engine fluids can be used.	To absorb any Li-ion battery electrolytic solution leakage.

## CAUTIONS AS TO HIGH VOLTAGE

### < PRECAUTION >

Preparation items	Specification	Purpose
Extinguisher	Type ABC For electrical fires caused by the electrical harnesses and components, etc. and oil fires.	To extinguish a fire.
Insulated tape	Insulating	To cover the damaged harnesses to protect from and prevent electrical shock. Tape should cover all bare or damaged wire.



### HOW TO HANDLE THE DAMAGED VEHICLES AT AN ACCIDENT SCENE

#### High voltage system shut-down procedure



Shut down the high voltage system according to vehicle damage level. Any of the following procedures can shut down the high voltage system. The first response operation should be done after shutting down the high voltage system.

If the vehicle is heavily damaged, for example the Li-ion battery is deformed, broken or cracked, appropriate PPE must be used and the Li-ion battery and high voltage components must not be touched.

#### **DANGER:**

-  Failure to properly shut down the high voltage system before the Emergency Response Procedures are performed may result in serious injury or death from electrical shock. To prevent from serious injury or death, DO NOT touch high voltage harnesses or components with bare hands.
-  When contact with high voltage components or high voltage harnesses is unavoidable, or when there is risk of such contact, be sure to wear appropriate PPE.

#### **WARNING:**

-  If the charge connector is connected to the vehicle, remove it. Refer to Removing the Charge Connector.
-  The vehicle contains parts that contain powerful magnets. If a person who is wearing a pacemaker or other medical device is close to these parts, the medical device may be affected by the magnets. Such persons must not perform work on the vehicle.
- Be sure to check the READY indicator in the instrument cluster, and verify that the READY indicator is off and the high voltage system is stopped.
- There is a possibility of remaining high voltage in the air conditioning system by the remote air conditioning system. If the READY indicator is turned OFF and the air conditioning remote timer indicator is turned ON the high voltage system is active. Please ensure that the air conditioning remote timer indicator is turned OFF and the air conditioning system is inactive.
- After high voltage system shut-down, please wait for 10 minutes for complete discharge of the high voltage condenser. While waiting, do not operate any vehicle functions.
- The high voltage full discharge takes 10 minute, but after 5 minutes the voltage has dropped below 60 V.
- Remove the 12V battery negative terminal and wait for 3 minutes to discharge the air bag condenser. Even though the 12V battery negative is disconnected, the Supplemental Restraint System (SRS) air

GI  
 B  
 C  
 D  
 E  
 F  
 G  
 H  
 I  
 J  
 K  
 L  
 M  
 N  
 O  
 P

## CAUTIONS AS TO HIGH VOLTAGE

< PRECAUTION >

bag maintains voltage for 3 minutes. There is a possibility of sudden SRS air bag inflation due to harness short circuit or damage and it may cause serious injuries.

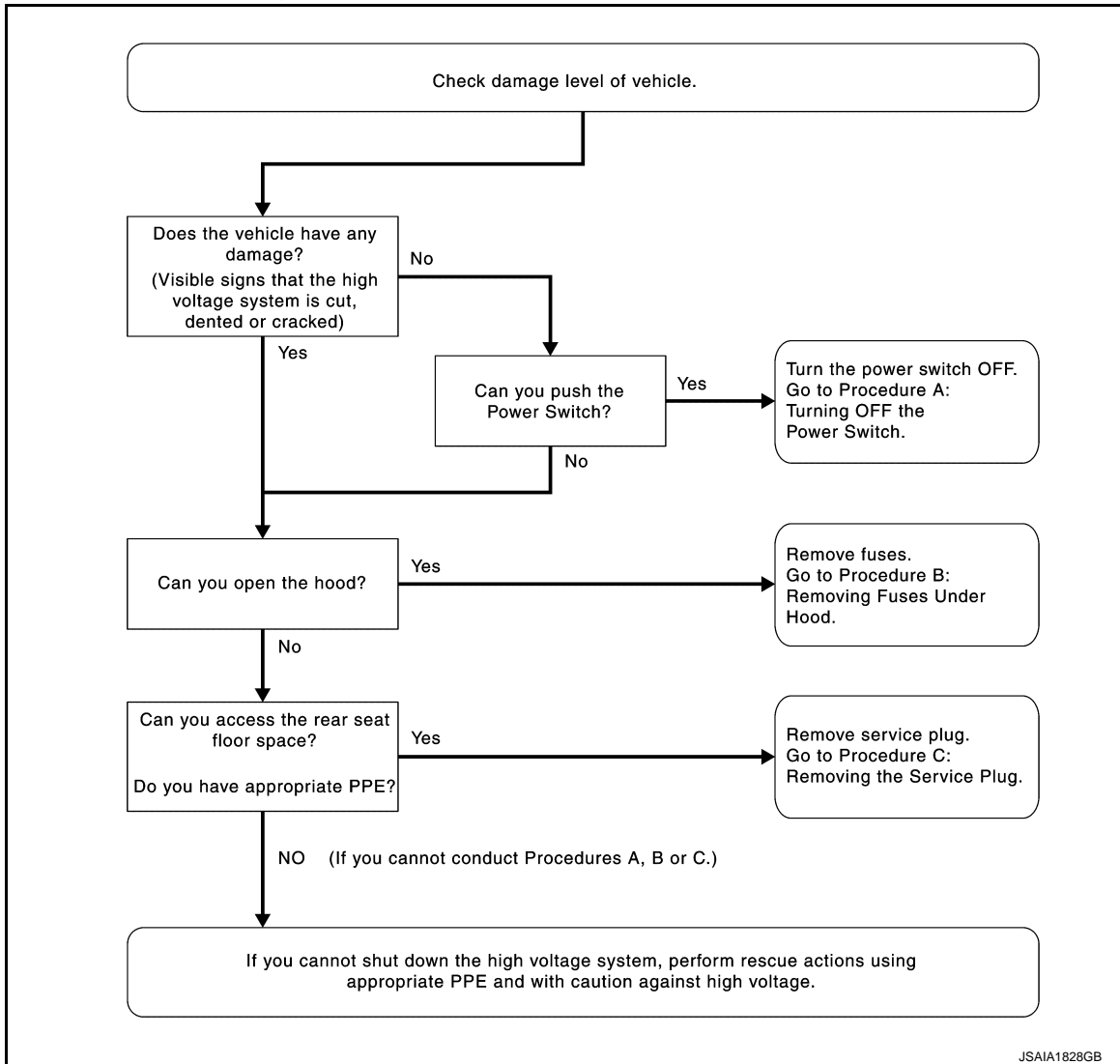

Indications the high voltage system is ON

1. If the READY indicator is ON, the high voltage system is active.
2. If the charge indicator is ON, the high voltage system is active.
3. If the air conditioning remote timer indicator (located on the HVAC controller) is ON, the high voltage system is active.
4. If the remote controlled air conditioning system is active, push the power switch to the ON position. This will turn OFF the remote controlled air conditioning system.

### NOTE:

Remote controlled air conditioning system is a feature that allows the vehicle owner to activate the air conditioning system via telematics communication (cell phone, personal computer, etc.). When this system is active, the air conditioning remote timer indicator (located on the HVAC controller) is illuminated.

Before disconnecting the 12V battery terminal, if necessary, set the parking brake, lower the windows, unlock the doors, and open the rear hatch as required. Once 12V battery is disconnected, power controls will not operate.

Procedure 1: Turning OFF the Power Switch.

1. Check the READY indicator status. If it is ON, the high voltage system is active.
2. Press the power switch once to turn OFF the high voltage system. Then verify whether the READY indicator is OFF.
3. If possible, keep the intelligent key at least 5 meters (16 feet) away from the vehicle.
4. Open the hood.
5. Disconnect the negative 12V battery cable. Insulate the negative 12V battery cable terminal with insulated tape.

## CAUTIONS AS TO HIGH VOLTAGE

### < PRECAUTION >

6. Wait 10 minutes for complete discharge of the high voltage condenser after the power switch has been turned OFF and the battery cable has been disconnected.
7. Perform the first response action.

#### Procedure B: Removing Fuses Under Hood



1. Open the hood.
2. Press and expand the pawls on the sides of the fuse box and remove the fuse box from its housing.
3. Remove the following fuses:
  - VCM ING fuse (F15 VCM IGN 10A)
  - PBW Fuse (F21 PBW IGN 15A)
  - VCM Fuse (F3 VCM 20A)
4. If you cannot identify the above fuses, remove all fuse in the fuse box.
5. Disconnect the negative 12V battery cable. Insulate the negative 12V battery cable terminal with insulated tape.
6. Wait 10 minutes for complete discharge of the high voltage condenser after the fuses and pulled and battery cable has been disconnected.
7. Perform the first response action.

#### WARNING:

-  **To avoid unintended installation and risk of electrical shock, the rescuer should carry the fuses on his/her person and cover the fuse box with insulated tape.**

#### Procedure C: Removing the Service Plug

#### DANGER:

-  **Do not remove the service plug without wearing appropriate PPE to help protect the responder from any serious injury or death by electrical shock.**
-  **Immediately cover the service plug socket with insulated tape. To avoid electric shock, DO NOT touch the terminals inside the socket.**

#### WARNING:

-  **To avoid unintended installation and risk of electrical shock, the rescuer should carry the service plug on his/her person while work is in progress.**

1. Locate the carpet flap (1) behind center console on the floor raised area. At the notched area (A) pull up on the carpet flap (1).

 : Vehicle front

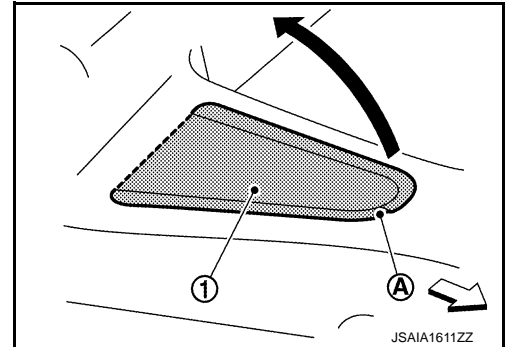

2. Remove the access cover bolts (A) and remove the cover (1).

 : Vehicle front

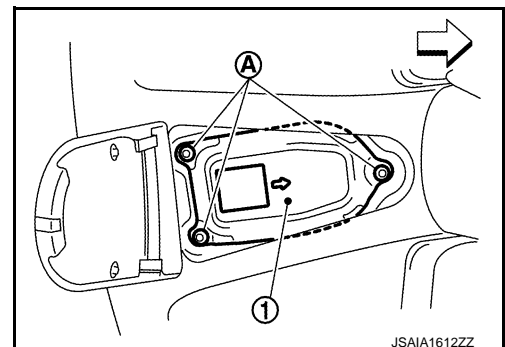

## CAUTIONS AS TO HIGH VOLTAGE

### < PRECAUTION >

3. Remove the service plug by pressing the locking tab (1) and rotating the handle (2) upward. Using the handle, pull the service plug completely out of its socket.

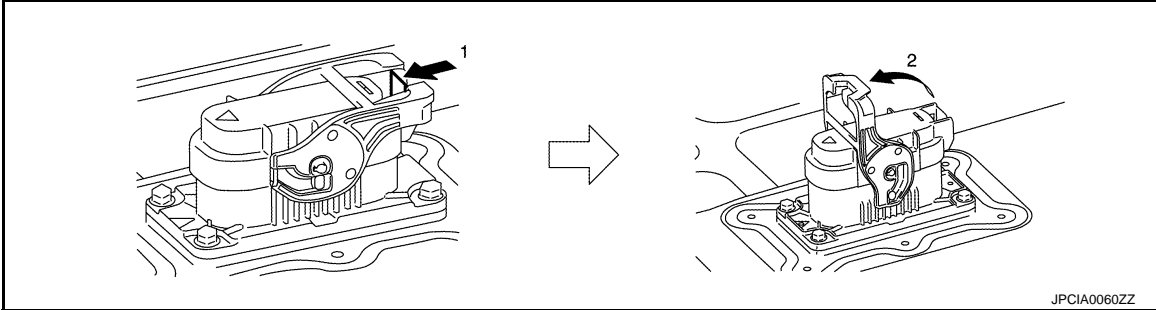

4. Wait 10 minutes for complete discharge of the high voltage condenser after the service plug has been removed.
5. Open the hood.
6. Disconnect the negative 12 V battery cable. Insulate the negative 12V battery cable terminal with insulated tape.
7. Wait 3 minutes for complete discharge of the air bag condenser after the battery cable has been disconnected.
8. Perform the first response action.

### VEHICLE FIRE

#### **WARNING:**

In the case of extinguishing a fire with water, large amounts of water from a fire hydrant (if possible) must be used. DO NOT extinguish fire with a small amount of water. Small amounts of water will make toxic gas produced by a chemical reaction between the Li-ion battery electrolyte and water.

#### **CAUTION:**

In the event of a small fire, a Type ABC fire extinguisher may be used for an electrical fire caused by wiring harnesses, electrical components, etc. or oil fire.

In case of vehicle fire, contact fire department immediately and extinguish the fire if possible. If you must walk away from the vehicle, notify an appropriate responder or a rescue person of the fact that the vehicle is an electric car and contains a high voltage system and warn all others.

### LI-ION BATTERY DAMAGE AND FLUID LEAKS

Li-ion Battery Electrolyte Solution Characteristics:

- Clear in color
- Sweet odor
- Similar viscosity to water
- Skin irritant
- Eye irritant - If contact with plenty of water and see a doctor immediately.
- Highly flammable
- Electrolyte liquid or fumes that have come into contact with water vapors in the air will create an oxidized substance. This substance may irritate skin and eyes. In these cases, rinse with plenty of water and see a doctor immediately.
- Since the Li-ion battery is made up of many small sealed battery modules, electrolyte solution should not leak in large quantity.

#### **NOTE:**

Other fluids in the vehicle (such as washer fluid, brake fluid, coolant, etc.) are the same as those in a conventional internal combustion vehicle.

### Cautions for Scrapping Vehicles

INFOID:000000006918523

The Li-ion battery must be removed from the vehicle before the vehicle is scrapped.

#### **CAUTION:**

Insulate the terminals of the removed Li-ion battery with insulating tape.

### Handling of a Vehicle with a Dead Battery

INFOID:000000006918524

For the handling of a vehicle when the battery is dead, refer to [GI-43. "Tow Truck Towing"](#).



# LIFTING POINT

< PRECAUTION >

## LIFTING POINT

Commercial Service Tools

INFOID:000000006825143

GI

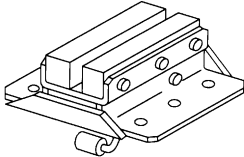
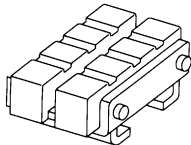
Tool name	Description
Board on attachment	 <p style="text-align: right;">S-NT001</p>
Safety stand attachment	 <p style="text-align: right;">S-NT002</p>

B

C

D

E

F

G

**CAUTION:**

- Every time the vehicle is lifted up, maintain the complete vehicle curb condition.
- Since the vehicle's center of gravity changes when removing main parts on the front side (engine, transmission, suspension etc.), support a jack up point on the rear side garage jack with a mission jack or equivalent.
- Since the vehicle's center of gravity changes when removing main parts on the rear side (rear axle, suspension, etc.), support a jack up point on the front side garage jack with a mission jack or equivalent.
- Be careful not to smash or never do anything that would affect piping parts.

H

I

J

### Garage Jack and Safety Stand and 2-Pole Lift

INFOID:000000006825144

**WARNING:**

- Park the vehicle on a level surface when using the jack. Check to avoid damaging pipes, tubes, etc. under the vehicle.
- Never get under the vehicle while it is supported only by the jack. Always use safety stands when you have to get under the vehicle.
- Place wheel chocks at both front and back of the wheels on the ground.
- When lifting the vehicle, open the lift arms as wide as possible and ensure that the front and rear of the vehicle are well balanced.
- When setting the lift arm, never allow the arm to contact the brake tubes, brake cable, fuel lines and sill spoiler.

K

L

M

N

O

P

# LIFTING POINT

< PRECAUTION >

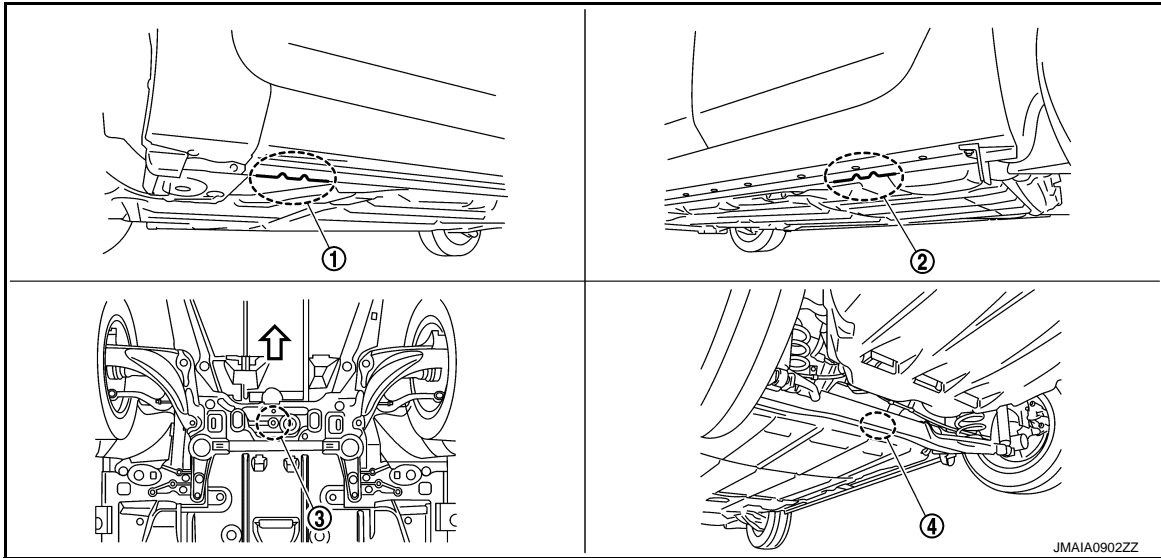

1. Safety stand point and lift up point (front)
2. Safety stand point and lift up point (rear)
3. Garage jack point (front)
4. Garage jack point (rear)

⇐ : Vehicle front

## Board-On Lift

INFOID:000000006825145

### CAUTION:

Check vehicle is empty when lifting.

- The board-on lift attachment (A) set at front end of vehicle should be set on the front of the sill under the front door opening.
- Position attachments at front and rear ends of board-on lift.

⇐ : Vehicle front

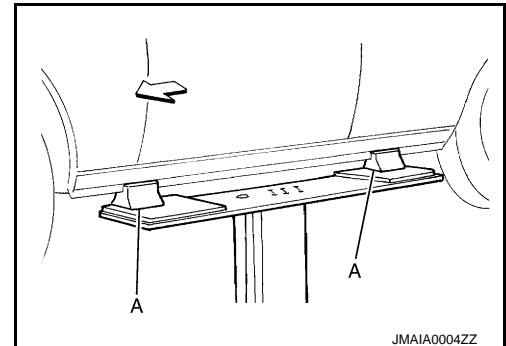

# TOW TRUCK TOWING

< PRECAUTION >

## TOW TRUCK TOWING

GI

### Tow Truck Towing

INFOID:000000006952958

#### CAUTION:

- All applicable State or Provincial (in Canada) laws and local laws regarding the towing operation must be obeyed.
- It is necessary to use proper towing equipment to avoid possible damage to the vehicle during towing operation. Towing instructions are available from a NISSAN certified LEAF dealer.
- Always attach safety chains before towing.
- When towing, make sure that the axles, steering system and powertrain are in working condition. If any unit is damaged, a flatbed must be used.

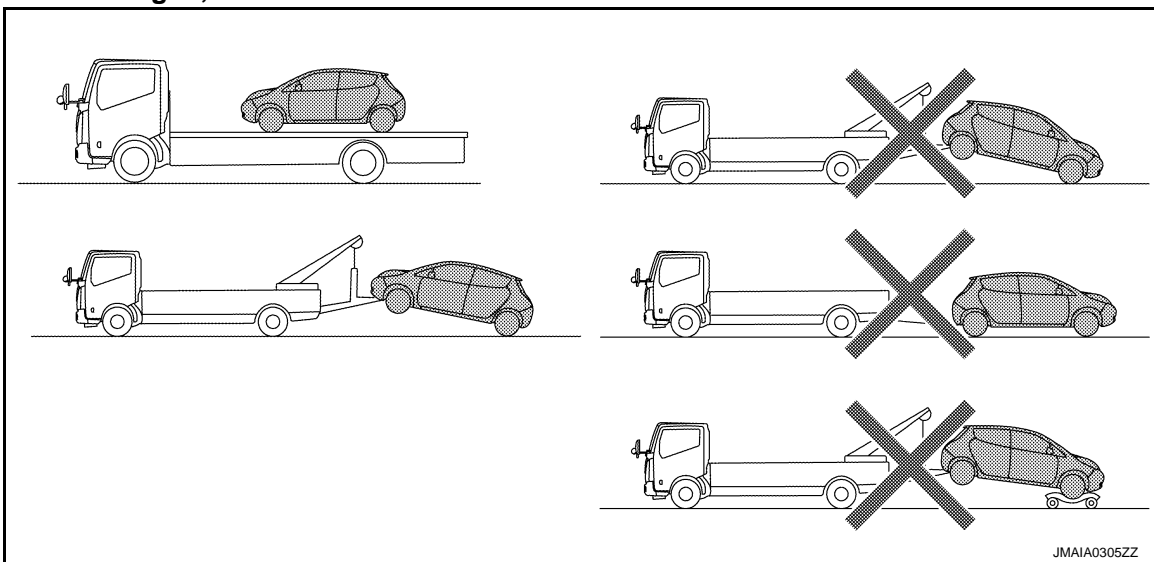

- NISSAN recommends that the vehicle be towed with the driving (front) wheels off the ground or that the vehicle be placed on a flatbed truck as illustrated.

### Vehicle Recovery (Freeing a Stuck Vehicle)

INFOID:000000006825147

#### FRONT

Securely install the vehicle recovery hook stored with jacking tools. Check that the hook is properly secured in the stored place after use.

#### WARNING:

- Stand clear of a stuck vehicle.
- Never spin your tires at high speed. This could cause them to explode and result in serious injury. Parts of your vehicle could also overheat and be damaged.

#### CAUTION:

- Tow chains or cables must be attached only to the vehicle recovery hooks or main structural members of the vehicle. Otherwise, the vehicle body will be damaged.
- Never use the vehicle tie downs to free a vehicle stuck in sand, snow, mud, etc. Never tow the vehicle using the vehicle tie downs or recovery hooks.
- Always pull the cable straight out from the front of the vehicle. Never pull on the hook at an angle.
- Pulling devices should be routed so they never touch any part of the suspension, steering, brake or cooling systems.
- Pulling devices such as ropes or canvas straps are not recommended for use in vehicle towing or recovery.

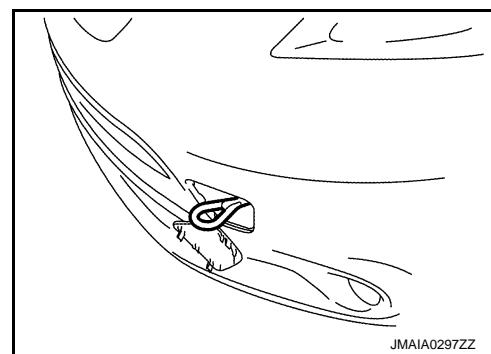

#### REAR

## TOW TRUCK TOWING

### < PRECAUTION >

Rear hook is designed as the recovery hook.

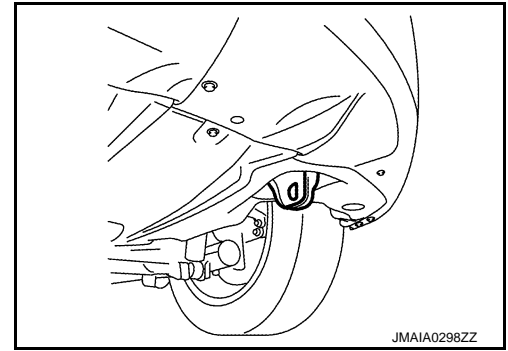



## PROCEDURE FOR PARK LOCK RELEASE

< PRECAUTION >

• METER 1

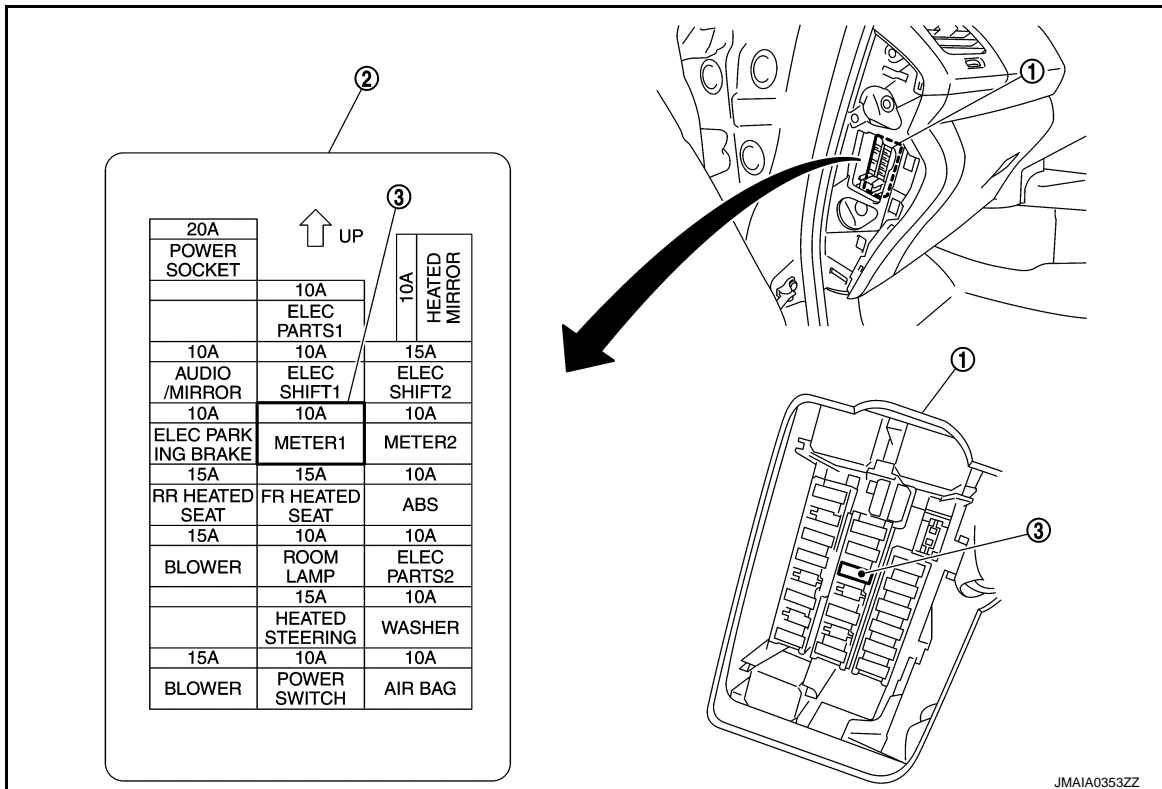

1. Fuse block
3. METER 1 fuse

2. Installment mask LH

4. Release electric parking brake.
5. Turn power switch OFF. (Release brake pedal)
6. Move the vehicle while power switch is OFF.
7. Fix the vehicle after moving. (Using electric parking brake or tire stopper)
8. Install fuse that is removed.
9. Turn power switch ON (Press switch twice without depressing brake pedal) and wait for 5 seconds at this moment, maintain the shift position to the N position. (Charge 12V battery if its voltage is low)
10. Turn power switch OFF. (Wait for 5 seconds)

JMAIA0353ZZ

# SERVICE INFORMATION FOR ELECTRICAL INCIDENT

< BASIC INSPECTION >

## BASIC INSPECTION

### SERVICE INFORMATION FOR ELECTRICAL INCIDENT

Work Flow

INFOID:000000006825148

#### WORK FLOW

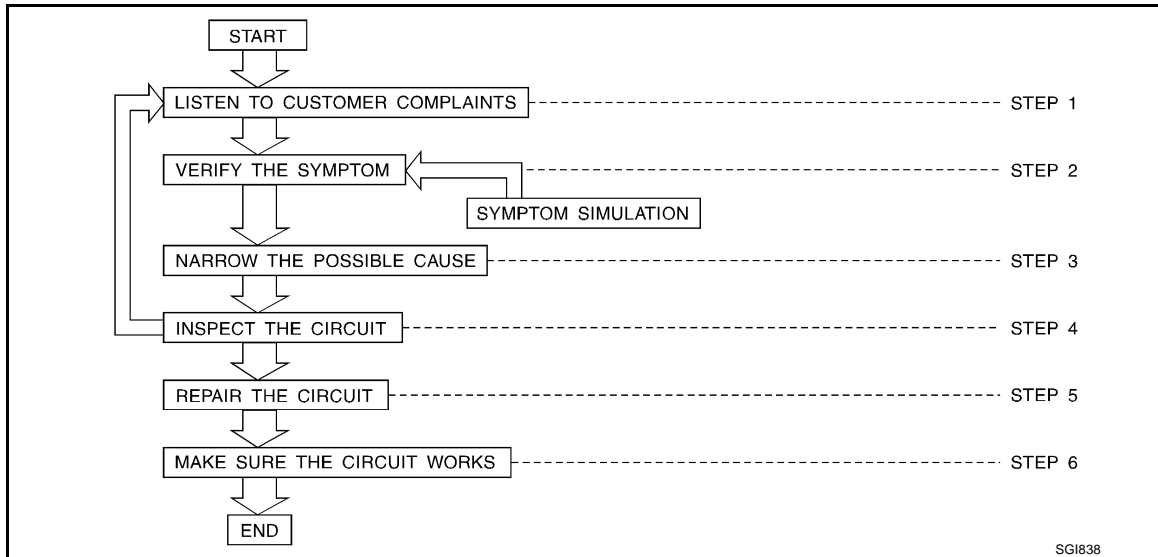

STEP	DESCRIPTION	
STEP 1	Get detailed information about the conditions and the environment when the incident occurred. The following are key pieces of information required to make a good analysis:	
	<b>WHAT</b>	Vehicle Model, Engine, Transmission/Transaxle and the System (i.e. Radio).
	<b>WHEN</b>	Date, Time of Day, Weather Conditions, Frequency.
	<b>WHERE</b>	Road Conditions, Altitude and Traffic Situation.
STEP 2	<b>HOW</b>	System Symptoms, Operating Conditions (Other Components Interaction). Service History and if any After Market Accessories have been installed.
	Operate the system, road test if necessary. Verify the parameter of the incident. If the problem cannot be duplicated, refer to "Incident Simulation Tests".	
STEP 3	Get the proper diagnosis materials together including: <ul style="list-style-type: none"> <li>• Power Supply Routing</li> <li>• System Operation Descriptions</li> <li>• Applicable Service Manual Sections</li> <li>• Check for any Service Bulletins</li> </ul> Identify where to begin diagnosis based upon your knowledge of the system operation and the customer comments.	
STEP 4	Inspect the system for mechanical binding, loose connectors or wiring damage. Determine which circuits and components are involved and diagnose using the Power Supply Routing and Harness Layouts.	
STEP 5	Repair or replace the incident circuit or component.	
STEP 6	Operate the system in all modes. Verify the system works properly under all conditions. Check you have not inadvertently created a new incident during your diagnosis or repair steps.	

#### Control Units and Electrical Parts

INFOID:000000006825149

#### PRECAUTIONS

- Never reverse polarity of battery terminals.
- Install only parts specified for a vehicle.
- Before replacing the control unit, check the input and output and functions of the component parts.
- Do not apply excessive force when disconnecting a connector.

# SERVICE INFORMATION FOR ELECTRICAL INCIDENT

## < BASIC INSPECTION >

- Do not apply excessive shock to the control unit by dropping or hitting it.
- Be careful to prevent condensation in the control unit due to rapid temperature changes and do not let water or rain get on it. If water is found in the control unit, dry it fully and then install it in the vehicle.
- Be careful not to let oil get on the control unit connector.
- Avoid cleaning the control unit with volatile oil.
- Do not disassemble the control unit, and do not remove the upper and lower covers.

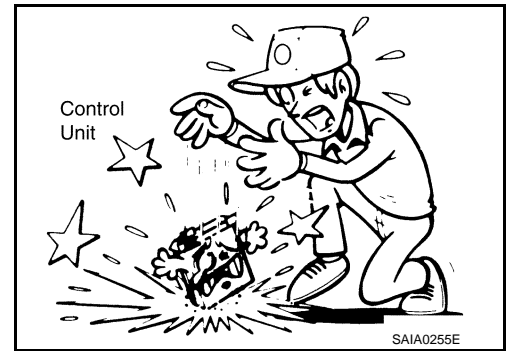

- When using a DMM, be careful not to let test probes get close to each other to prevent the power transistor in the control unit from damaging battery voltage because of short circuiting.
- When checking input and output signals of the control unit, use the specified check adapter.

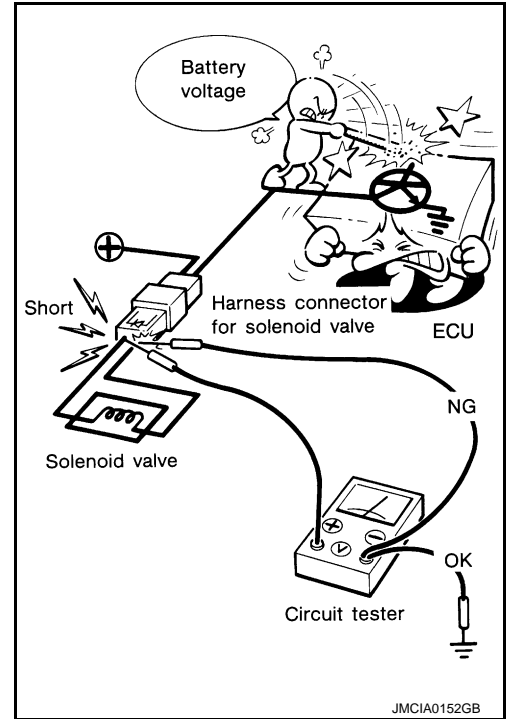

## How to Check Terminal

INFOID:000000006825614

## CONNECTOR AND TERMINAL PIN KIT

- Use the connector and terminal pin kits listed below when replacing connectors or terminals.
- The connector and terminal pin kits contain some of the most commonly used NISSAN/INFINITI connectors and terminals. For detailed connector and terminal pin replacement procedures, refer to the latest NISSAN/INFINITI CONNECTOR AND TERMINAL PIN SERVICE MANUAL.



# SERVICE INFORMATION FOR ELECTRICAL INCIDENT

## < BASIC INSPECTION >

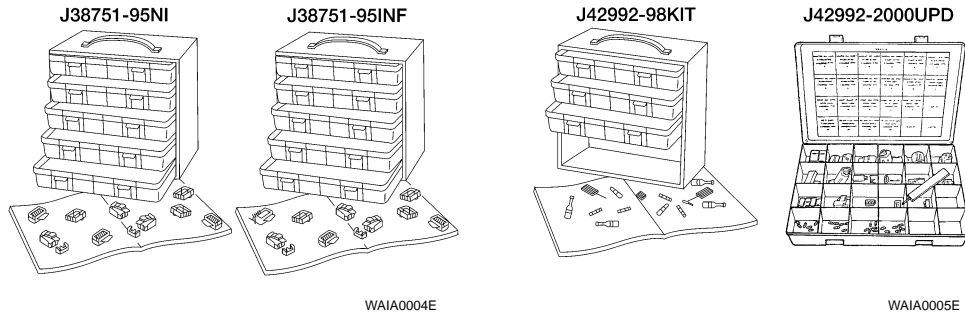
Tool number (Kent-Moore No.) Tool name	Description
- (J38751-95NI) Connector and terminal pin kit (NISSAN) - (J38751-95INF) Connector and terminal pin kit (INFINITI) - (J42992-98KIT) OBD and terminal repair kit - (J42992-2000UPD) OBD-II Connector Kit Up- date	

GI  
B  
C  
D  
E  
F  
G  
H  
I  
J  
K  
L  
M  
N  
O  
P

### HOW TO PROBE CONNECTORS

- Connector damage and an intermittent connection can result from improperly probing of the connector during circuit checks.
- The probe of a digital multimeter (DMM) may not correctly fit the connector cavity. To correctly probe the connector, follow the procedures below using a "T" pin. For the best contact grasp the "T" pin using an alligator clip.

#### Probing from Harness Side

Standard type (not waterproof type) connector should be probed from harness side with "T" pin.

- If the connector has a rear cover such as a ECM connector, remove the rear cover before probing the terminal.
- Do not probe waterproof connector from harness side. Damage to the seal between wire and connector may result.

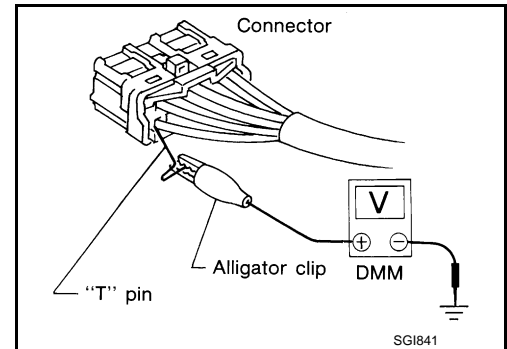

#### Probing from Terminal Side

##### FEMALE TERMINAL

- There is a small notch above each female terminal. Probe each terminal with the "T" pin through the notch. Do not insert any object other than the same type male terminal into female terminal.

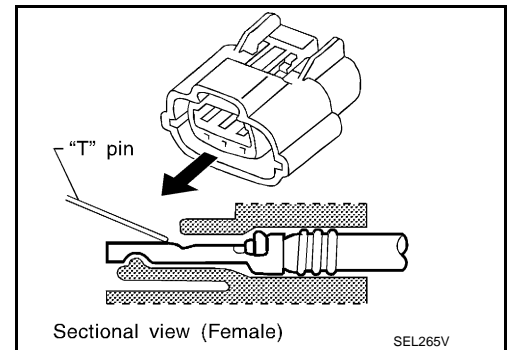

# SERVICE INFORMATION FOR ELECTRICAL INCIDENT

## < BASIC INSPECTION >

- Some connectors do not have a notch above each terminal. To probe each terminal, remove the connector retainer to make contact space for probing.

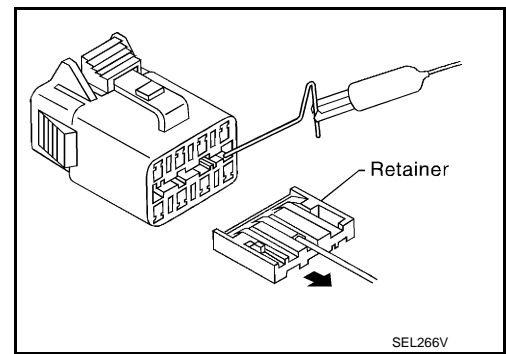

### MALE TERMINAL

- Carefully probe the contact surface of each terminal using a "T" pin.

**CAUTION:**

**Never bend terminal.**

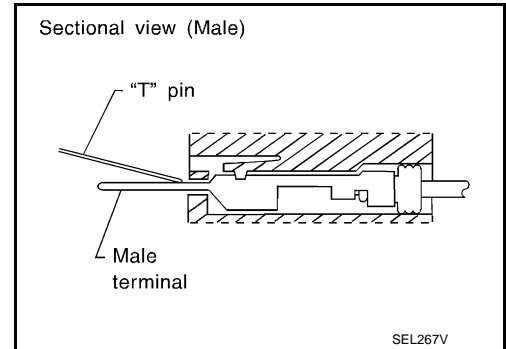

### How to Check Enlarged Contact Spring of Terminal

- An enlarged contact spring of a terminal may create intermittent signals in the circuit.
- If the intermittent open circuit occurs, follow the procedure below to inspect for open wires and enlarged contact spring of female terminal.

- Assemble a male terminal and approx. 10 cm (3.9 in) of wire.

**NOTE:**

**Use a male terminal which matches the female terminal.**

- Disconnect the suspected faulty connector and hold it terminal side up.

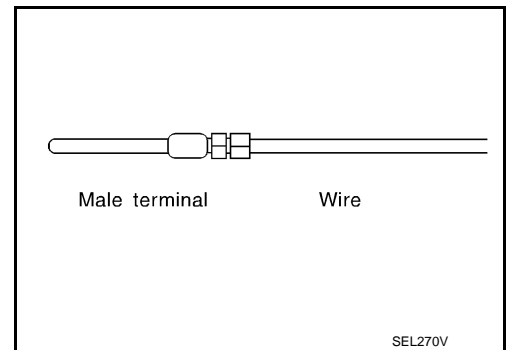

- While holding the wire of the male terminal, try to insert the male terminal into the female terminal.

**CAUTION:**

**Never force the male terminal into the female terminal with your hands.**

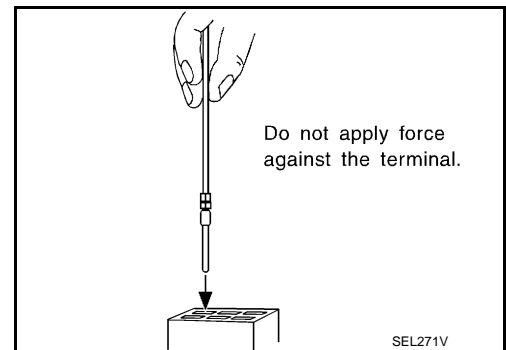

# SERVICE INFORMATION FOR ELECTRICAL INCIDENT

## < BASIC INSPECTION >

4. While moving the connector, check whether the male terminal can be easily inserted or not.

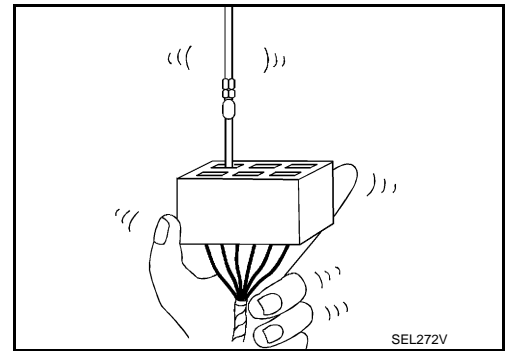

- If the male terminal can be easily inserted into the female terminal, replace the female terminal.

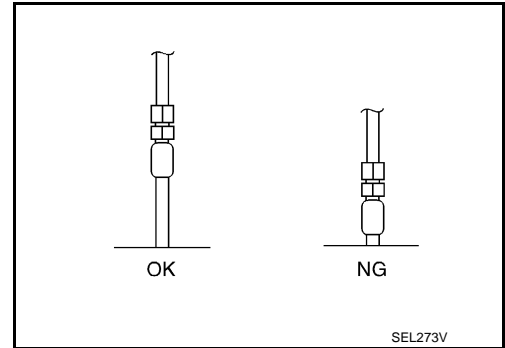

### Waterproof Connector Inspection

If water enters the connector, it can short interior circuits. This may lead to intermittent problems. Check the following items to maintain the original waterproof characteristics.

#### RUBBER SEAL INSPECTION

- Most waterproof connectors are provided with a rubber seal between the male and female connectors. If the seal is missing, the waterproof performance may not meet specifications.
- The rubber seal may come off when connectors are disconnected. Whenever connectors are reconnected, make sure the rubber seal is properly installed on either side of male or female connector.

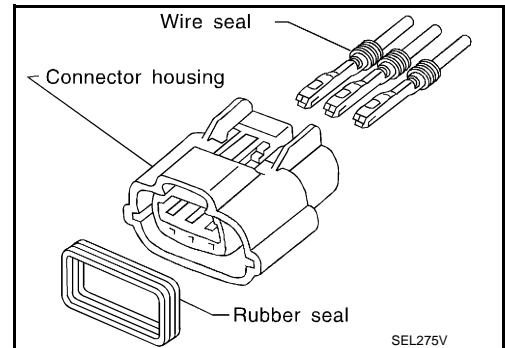

#### WIRE SEAL INSPECTION

- The wire seal must be installed on the wire insertion area of a waterproof connector. Be sure that the seal is installed properly.

### Terminal Lock Inspection

Check for unlocked terminals by pulling wire at the end of connector. An unlocked terminal may create intermittent signals in the circuit.

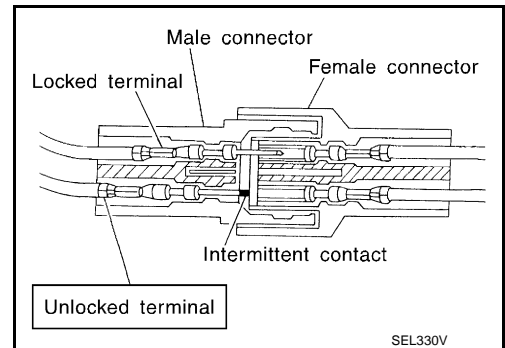

## Intermittent Incident

INFOID:0000000006825150

### DESCRIPTION

Sometimes the symptom is not present when the vehicle is brought in for service. If possible, re-create the conditions present at the time of the incident. Doing so may help avoid a No Trouble Found Diagnosis. The fol-

GI  
B  
C  
D  
E  
F  
G  
H  
I  
J  
K  
L  
M  
N  
O  
P

# SERVICE INFORMATION FOR ELECTRICAL INCIDENT

## < BASIC INSPECTION >

Following section illustrates ways to simulate the conditions/environment under which the owner experiences an electrical incident.

The section is broken into the six following topics:

- Vehicle vibration
- Heat sensitive
- Freezing
- Water intrusion
- Electrical load
- Cold or hot start up

Get a thorough description of the incident from the customer. It is important for simulating the conditions of the problem.

### VEHICLE VIBRATION

The problem may occur or become worse while driving on a rough road or when engine is vibrating (idle with A/C on). In such a case, you will want to check for a vibration related condition. Refer to the following illustration.

#### Connector & Harness

Determine which connectors and wiring harness would affect the electrical system you are inspecting. Gently shake each connector and harness while monitoring the system for the incident you are trying to duplicate. This test may indicate a loose or poor electrical connection.

#### Hint

Connectors can be exposed to moisture. It is possible to get a thin film of corrosion on the connector terminals. A visual inspection may not reveal this without disconnecting the connector. If the problem occurs intermittently, perhaps the problem is caused by corrosion. It is a good idea to disconnect, inspect and clean the terminals on related connectors in the system.

#### Sensor & Relay

Gently apply a slight vibration to sensors and relays in the system you are inspecting. This test may indicate a loose or poorly mounted sensor or relay.

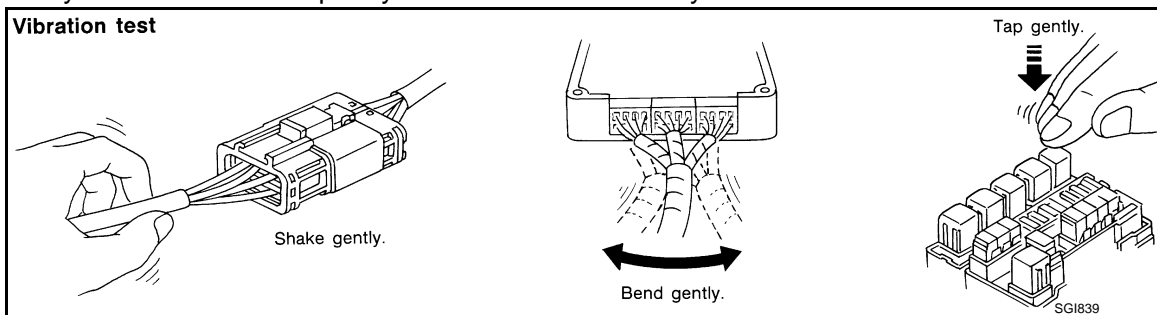

#### Engine Compartment

There are several reasons a vehicle or engine vibration could cause an electrical complaint. Some of the things to check for are:

- Connectors not fully seated.
- Wiring harness not long enough and is being stressed due to engine vibrations or rocking.
- Wires laying across brackets or moving components.
- Loose, dirty or corroded ground wires.
- Wires routed too close to hot components.

To inspect components under the hood, start by verifying the integrity of ground connections. (Refer to Ground Inspection described later.) First check that the system is properly grounded. Then check for loose connection by gently shaking the wiring or components as previously explained. Using the wiring diagrams inspect the wiring for continuity.

#### Behind the Instrument Panel

An improperly routed or improperly clamped harness can become pinched during accessory installation. Vehicle vibration can aggravate a harness which is routed along a bracket or near a screw.

#### Under Seating Areas

# SERVICE INFORMATION FOR ELECTRICAL INCIDENT

## < BASIC INSPECTION >

An unclamped or loose harness can cause wiring to be pinched by seat components (such as slide guides) during vehicle vibration. If the wiring runs under seating areas, inspect wire routing for possible damage or pinching.

### HEAT SENSITIVE

- The customer's concern may occur during hot weather or after car has sat for a short time. In such cases you will want to check for a heat sensitive condition.
- To determine if an electrical component is heat sensitive, heat the component with a heat gun or equivalent.

**CAUTION:**

**Never heat components above 60°C (140°F).**

- If incident occurs while heating the unit, either replace or properly insulate the component.

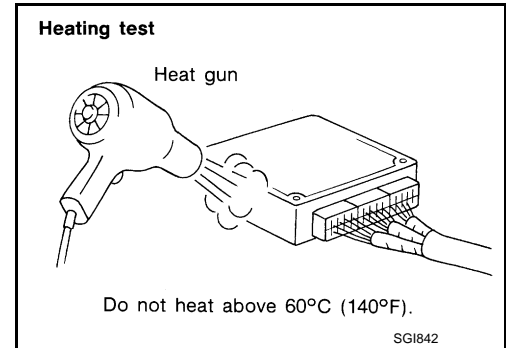

### FREEZING

- The customer may indicate the incident goes away after the car warms up (winter time). The cause could be related to water freezing somewhere in the wiring/electrical system.
- There are two methods to check for this. The first is to arrange for the owner to leave his car overnight. Check it will get cold enough to demonstrate his complaint. Leave the car parked outside overnight. In the morning, do a quick and thorough diagnosis of those electrical components which could be affected.
- The second method is to put the suspect component into a freezer long enough for any water to freeze. Reinstall the part into the car and check for the reoccurrence of the incident. If it occurs, repair or replace the component.

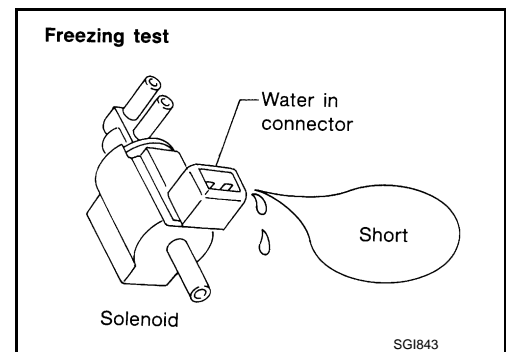

### WATER INTRUSION

The incident may occur only during high humidity or in rainy/snowy weather. In such cases the incident could be caused by water intrusion on an electrical part. This can be simulated by soaking the car or running it through a car wash.

**CAUTION:**

**Never spray water directly on any electrical components.**

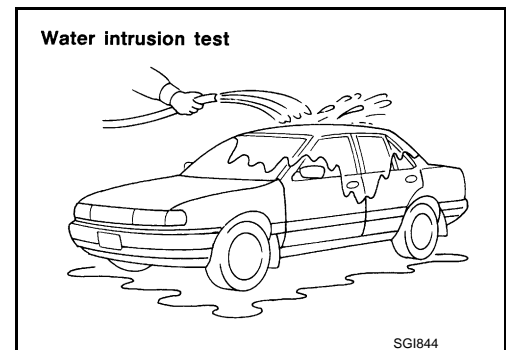

### ELECTRICAL LOAD

The incident may be electrical load sensitive. Perform diagnosis with all accessories (including A/C, rear window defogger, radio, fog lamps) turned on.

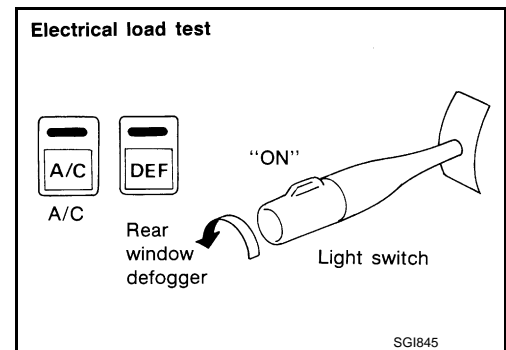

### COLD OR HOT START UP

On some occasions an electrical incident may occur only when the car is started cold, or it may occur when the car is restarted hot shortly after being turned off. In these cases you may have to keep the car overnight to make a proper diagnosis.

GI

B

C

D

E

F

G

H

I

J

K

L

M

N

O

P

# SERVICE INFORMATION FOR ELECTRICAL INCIDENT

## < BASIC INSPECTION >

### Circuit Inspection

INFOID:00000006825151

#### DESCRIPTION

- In general, testing electrical circuits is an easy task if it is approached in a logical and organized method. Before beginning it is important to have all available information on the system to be tested. Also, get a thorough understanding of system operation. Then you will be able to use the appropriate equipment and follow the correct test procedure.
- You may have to simulate vehicle vibrations while testing electrical components. Gently shake the wiring harness or electrical component to do this.

OPEN	A circuit is open when there is no continuity through a section of the circuit.	
SHORT	There are two types of shorts.	
	• SHORT CIRCUIT	When a circuit contacts another circuit and causes the normal resistance to change.
	• SHORT TO GROUND	When a circuit contacts a ground source and grounds the circuit.

#### TESTING FOR "OPENS" IN THE CIRCUIT

Before you begin to diagnose and test the system, you should rough sketch a schematic of the system. This will help you to logically walk through the diagnosis process. Drawing the sketch will also reinforce your working knowledge of the system.

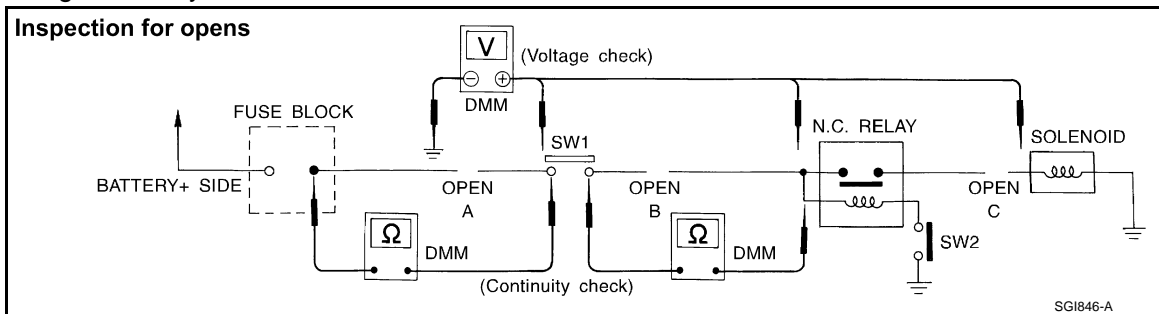

#### Continuity Check Method

The continuity check is used to find an open in the circuit. The digital multimeter (DMM) set on the resistance function will indicate an open circuit as over limit (no beep tone or no ohms symbol). Check to always start with the DMM at the highest resistance level.

To help in understanding the diagnosis of open circuits, please refer to the previous schematic.

- Disconnect the battery negative cable.
- Start at one end of the circuit and work your way to the other end. (At the fuse block in this example)
- Connect one probe of the DMM to the fuse block terminal on the load side.
- Connect the other probe to the fuse block (power) side of SW1. Little or no resistance will indicate that portion of the circuit has good continuity. If there were an open in the circuit, the DMM would indicate an over limit or infinite resistance condition. (point A)
- Connect the probes between SW1 and the relay. Little or no resistance will indicate that portion of the circuit has good continuity. If there were an open in the circuit, the DMM would indicate an over limit or infinite resistance condition. (point B)
- Connect the probes between the relay and the solenoid. Little or no resistance will indicate that portion of the circuit has good continuity. If there were an open in the circuit, the DMM would indicate an over limit or infinite resistance condition. (point C)

Any circuit can be diagnosed using the approach in the previous example.

#### Voltage Check Method

To help in understanding the diagnosis of open circuits please refer to the previous schematic.

In any powered circuit, an open can be found by methodically checking the system for the presence of voltage. This is done by switching the DMM to the voltage function.

- Connect one probe of the DMM to a known good ground.
- Begin probing at one end of the circuit and work your way to the other end.
- With SW1 open, probe at SW1 to check for voltage.
  - voltage: open is further down the circuit than SW1.
  - no voltage: open is between fuse block and SW1 (point A).
- Close SW1 and probe at relay.

# SERVICE INFORMATION FOR ELECTRICAL INCIDENT

## < BASIC INSPECTION >

- voltage: open is further down the circuit than the relay.
  - no voltage: open is between SW1 and relay (point B).
  - Close the relay and probe at the solenoid.
  - voltage: open is further down the circuit than the solenoid.
  - no voltage: open is between relay and solenoid (point C).
- Any powered circuit can be diagnosed using the approach in the previous example.

## TESTING FOR "SHORTS" IN THE CIRCUIT

To simplify the discussion of shorts in the system, please refer to the following schematic.

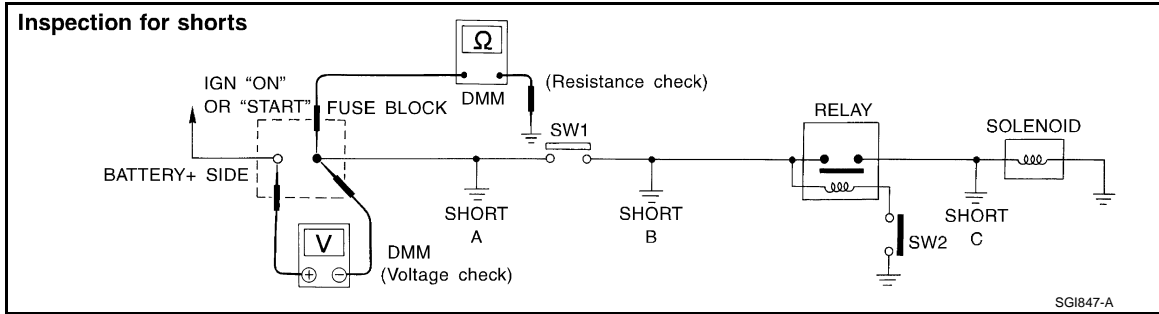

### Resistance Check Method

- Disconnect the battery negative cable and remove the blown fuse.
- Disconnect all loads (SW1 open, relay disconnected and solenoid disconnected) powered through the fuse.
- Connect one probe of the DMM to the load side of the fuse terminal. Connect the other probe to a known good ground.
- With SW1 open, check for continuity.
- continuity: short is between fuse terminal and SW1 (point A).
- no continuity: short is further down the circuit than SW1.
- Close SW1 and disconnect the relay. Put probes at the load side of fuse terminal and a known good ground. Then, check for continuity.
- continuity: short is between SW1 and the relay (point B).
- no continuity: short is further down the circuit than the relay.
- Close SW1 and jump the relay contacts with jumper wire. Put probes at the load side of fuse terminal and a known good ground. Then, check for continuity.
- continuity: short is between relay and solenoid (point C).
- no continuity: check solenoid, retrace steps.

### Voltage Check Method

- Remove the blown fuse and disconnect all loads (i.e. SW1 open, relay disconnected and solenoid disconnected) powered through the fuse.
- Turn the power switch to the ON or START position. Verify battery voltage at the battery + side of the fuse terminal (one lead on the battery + terminal side of the fuse block and one lead on a known good ground).
- With SW1 open and the DMM leads across both fuse terminals, check for voltage.
- voltage: short is between fuse block and SW1 (point A).
- no voltage: short is further down the circuit than SW1.
- With SW1 closed, relay and solenoid disconnected and the DMM leads across both fuse terminals, check for voltage.
- voltage: short is between SW1 and the relay (point B).
- no voltage: short is further down the circuit than the relay.
- With SW1 closed, relay contacts jumped with fused jumper wire check for voltage.
- voltage: short is down the circuit of the relay or between the relay and the disconnected solenoid (point C).
- no voltage: retrace steps and check power to fuse block.

## GROUND INSPECTION

- Ground connections are very important to the proper operation of electrical and electronic circuits. Ground connections are often exposed to moisture, dirt and other corrosive elements. The corrosion (rust) can become an unwanted resistance. This unwanted resistance can change the way a circuit works.
- Electronically controlled circuits are very sensitive to proper grounding. A loose or corroded ground can drastically affect an electronically controlled circuit. A poor or corroded ground can easily affect the circuit. Even when the ground connection looks clean, there can be a thin film of rust on the surface.
- When inspecting a ground connection follow these rules:
  - Remove the ground bolt or screw.

# SERVICE INFORMATION FOR ELECTRICAL INCIDENT

## < BASIC INSPECTION >

- Inspect all mating surfaces for tarnish, dirt, rust, etc.
- Clean as required to assure good contact.
- Reinstall bolt or screw securely.
- Inspect for “add-on” accessories which may be interfering with the ground circuit.
- If several wires are crimped into one ground eyelet terminal, check for proper crimps. Check all of the wires are clean, securely fastened and providing a good ground path. If multiple wires are cased in one eyelet check no ground wires have excess wire insulation.
- For detailed ground distribution information, refer to “Ground Distribution” in PG section.

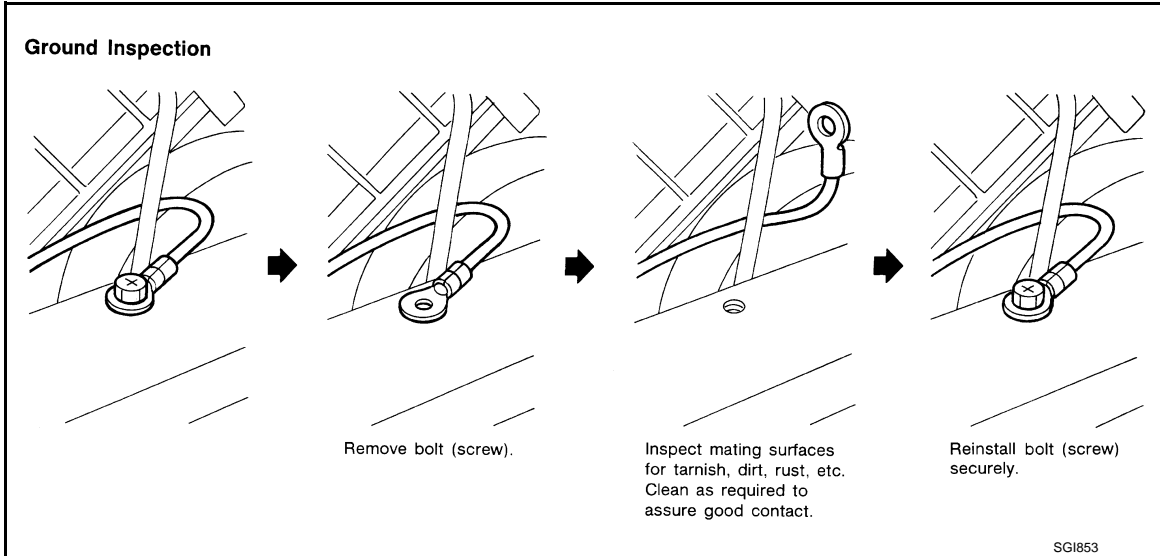

## VOLTAGE DROP TESTS

- Voltage drop tests are often used to find components or circuits which have excessive resistance. A voltage drop in a circuit is caused by a resistance when the circuit is in operation.
- Check the wire in the illustration. When measuring resistance with DMM, contact by a single strand of wire will give reading of 0 ohms. This would indicate a good circuit. When the circuit operates, this single strand of wire is not able to carry the current. The single strand will have a high resistance to the current. This will be picked up as a slight voltage drop.
- Unwanted resistance can be caused by many situations as follows:
  - Undersized wiring (single strand example)
  - Corrosion on switch contacts
  - Loose wire connections or splices.
- If repairs are needed always use wire that is of the same or larger gauge.

### Measuring Voltage Drop — Accumulated Method

- Connect the DMM across the connector or part of the circuit you want to check. The positive lead of the DMM should be closer to power and the negative lead closer to ground.
- Operate the circuit.
- The DMM will indicate how many volts are being used to “push” current through that part of the circuit.



# SERVICE INFORMATION FOR ELECTRICAL INCIDENT

## < BASIC INSPECTION >

Note in the illustration that there is an excessive 4.1 volt drop between the battery and the bulb.

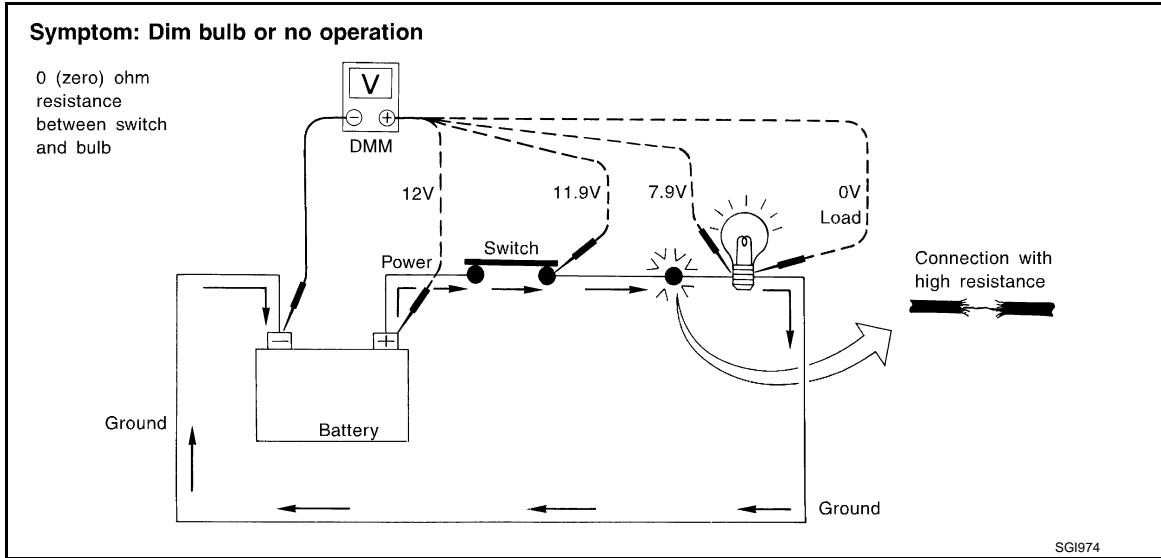

### Measuring Voltage Drop — Step-by-Step

- The step-by-step method is most useful for isolating excessive drops in low voltage systems (such as those in “Computer Controlled Systems”).
- Circuits in the “Computer Controlled System” operate on very low amperage.
- The (Computer Controlled) system operations can be adversely affected by any variation in resistance in the system. Such resistance variation may be caused by poor connection, improper installation, improper wire gauge or corrosion.
- The step by step voltage drop test can identify a component or wire with too much resistance.

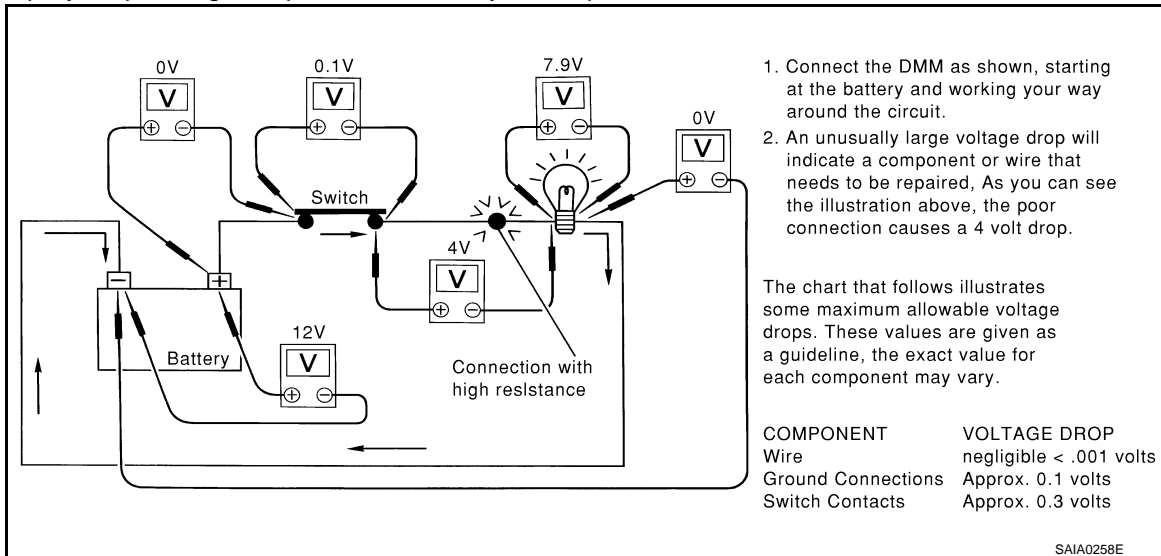

### CONTROL UNIT CIRCUIT TEST

#### System Description

- When the switch is ON, the control unit lights up the lamp.

#### CASE 1

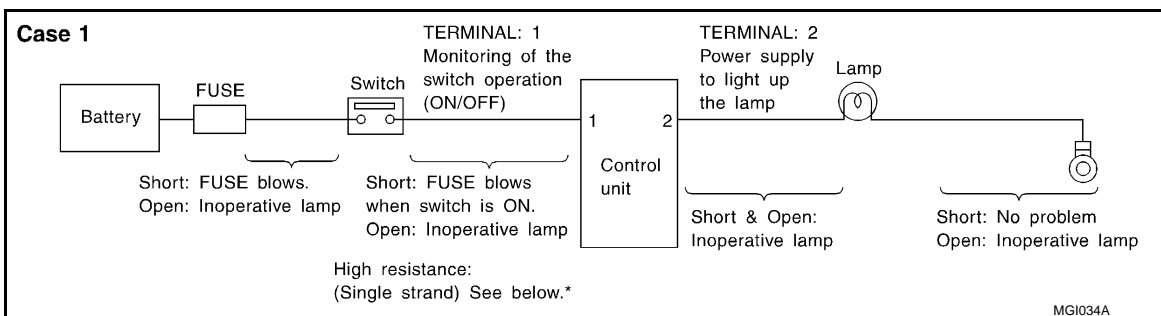

# SERVICE INFORMATION FOR ELECTRICAL INCIDENT

## < BASIC INSPECTION >

### INPUT-OUTPUT VOLTAGE CHART

Terminal No.		Description		Condition	Value (Approx.)	In case of high resistance such as single strand (V) *
+	-	Signal name	Input/Output			
1	Body ground	Switch	Input	Switch ON	Battery voltage	Lower than battery voltage Approx. 8 (Example)
				Switch OFF	0 V	Approx. 0
2	Body ground	Lamp	Output	Switch ON	Battery voltage	Approx. 0 (Inoperative lamp)
				Switch OFF	0 V	Approx. 0

- The voltage value is based on the body ground.
- \*: If high resistance exists in the switch side circuit (caused by a single strand), terminal 1 does not detect battery voltage. Control unit does not detect the switch is ON even if the switch does not turn ON. Therefore, the control unit does not supply power to light up the lamp.

### CASE 2

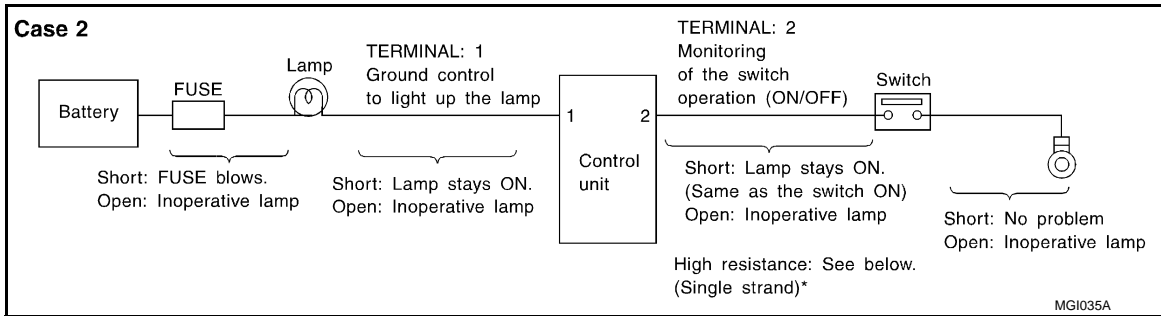

### INPUT-OUTPUT VOLTAGE CHART

Terminal No.		Description		Condition	Value (Approx.)	In case of high resistance such as single strand (V) *
+	-	Signal name	Input/Output			
1	Body ground	Lamp	Output	Switch ON	0 V	Battery voltage (Inoperative lamp)
				Switch OFF	Battery voltage	Battery voltage
2	Body ground	Switch	Input	Switch ON	0 V	Higher than 0 Approx. 4 (Example)
				Switch OFF	5 V	Approx. 5

- The voltage value is based on the body ground.
- \*: If high resistance exists in the switch side circuit (caused by a single strand), terminal 2 does not detect approx. 0 V. Control unit does not detect the switch is ON even if the switch does not turn ON. Therefore, the control unit does not control ground to light up the lamp.

# CONSULT/GST CHECKING SYSTEM

< BASIC INSPECTION >

## CONSULT/GST CHECKING SYSTEM

GI

### Description

INFOID:000000006856142

- When CONSULT/GST is connected with a data link connector (A) equipped on the vehicle side, it will communicate with the control unit equipped in the vehicle and then enable various kinds of diagnostic tests.

1 : Instrument lower panel LH

- Refer to CONSULT Software Operation Manual for more information.

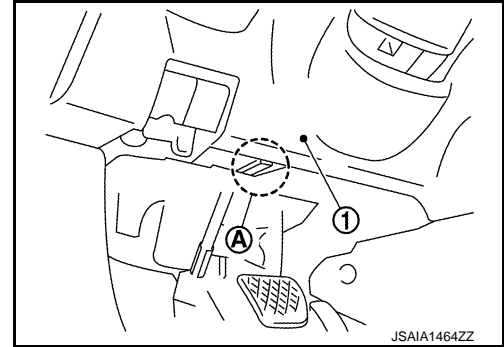

B

C

D

E

### CONSULT Function and System Application\*1

INFOID:000000006918515

#### FUNCTION

Mode	Function
All DTC Reading	Display all DTCs or diagnostic items that all ECUs are recording and judging.
Work Support	This mode enables a technician to adjust some devices faster and more accurately.
Self Diagnostic Results	Retrieve DTC from ECU and display diagnostic items.
Data Monitor	Monitor the input/output signal of the control unit in real time.
CAN Diagnosis	This mode displays a network diagnosis result about CAN by diagram.
CAN Diagnosis Support Monitor	It monitors the status of CAN communication.
Active Test	Send the drive signal from CONSULT to the actuator. The operation check can be performed.
DTC & SRT confirmation	The status of system monitoring tests and the self-diagnosis status/result can be confirmed.
ECU Identification	Display the ECU identification number (part number etc.) of the selected system.
Configuration	Function to READ/WRITE vehicle configuration.
Other	Other results or histories, etc. that are recorded in ECU are displayed.

F

G

H

I

J

K

#### SYSTEM APPLICATION\*1

System	All DTC Reading	Work Support	Self Diagnostic Results	Data Monitor	CAN Diagnosis	CAN Diagnosis Support Monitor	Active Test	DTC & SRT confirmation	ECU Identification	Configuration	Other
AIR BAG	x	-	x	-	x	-	-	-	x	-	<ul style="list-style-type: none"> <li>SELF-DIAG (PAST)</li> <li>SELF-DIAG (CAN)</li> <li>CAUSE OF WARNING</li> </ul>
METER / M&A	x	-	x	x	x	x	-	-	-	-	<ul style="list-style-type: none"> <li>W/L ON HISTORY</li> </ul>
BCM	x	x	x	x	x	x	x	-	x	x	—
IPDM E/R	x	-	x	x	x	x	x	-	x	-	—
EPS	x	-	x	x	x	x	-	-	x	-	—
MULTI AV	-	-	x	x	x	x	x	-	-	-	—

L

M

N

O

P

# CONSULT/GST CHECKING SYSTEM

< BASIC INSPECTION >

System	All DTC Reading	Work Support	Self Diagnostic Results	Data Monitor	CAN Diagnosis	CAN Diagnosis Support Monitor	Active Test	DTC & SRT confirmation	ECU Identification	Configuration	Other
HVAC	-	x	x	x	x	x	x	-	x	-	—
ABS	x	x	x	x	x	x	x	-	x	-	—
TCU	x	x	x	x	x	x	-	-	x	-	—
HV BAT	x	x	x	x	x	x	x	-	x	-	—
EV/HEV	x	x	x	x	x	x	x	-	x	-	• LOAD BATTERY ID
CHARGER	x	-	x	x	x	x	x	-	x	-	—
MOTOR CONTROL	x	x	x	x	x	x	-	-	x	-	—
SHIFT	x	x	x	x	x	x	-	-	x	-	—
HEADLAMP LEVELIZER	-	x	x	x	-	-	x	-	x	-	—
BRAKE	x	x	x	x	x	x	-	-	x	-	—
EHS/PKB	x	x	x	x	x	x	-	-	x	-	—
VSP	x	-	x	x	-	-	x	-	x	-	—

x: Applicable

\*1 : If GST application is equipped, functions in accordance with SAE J1979 and ISO 15031-5 can be used.

## CONSULT/GST Data Link Connector (DLC) Circuit

INFOID:000000006856144

### INSPECTION PROCEDURE

If the CONSULT/GST cannot diagnose the system properly, check the following items.

Symptom	Check item
CONSULT/GST cannot access any system.	<ul style="list-style-type: none"> <li>CONSULT/GST DLC power supply circuit (Terminal 8 and 16) and ground circuit (Terminal 4 and 5)</li> </ul>
CONSULT cannot access individual system. (Other systems can be accessed.)	<ul style="list-style-type: none"> <li>Power supply and ground circuit for the control unit of the system (For detailed circuit, refer to wiring diagram for each system.)</li> <li>Open or short circuit between the system and CONSULT DLC (For detailed circuit, refer to wiring diagram for each system.)</li> <li>Open or short circuit CAN communication line. Refer to <a href="#">LAN-15, "Trouble Diagnosis Flow Chart"</a>.</li> </ul>

#### NOTE:

The DDL1 and DDL2 circuits from DLC pins 12, 13, 14 and 15 may be connected to more than one system. A short in a DDL circuit connected to a control unit in one system may affect CONSULT access to other systems. If the GST cannot operate properly, check the circuit based on the information of SAE J1962 and ISO 15031-3.

# CONSULT/GST CHECKING SYSTEM

< BASIC INSPECTION >

## Wiring Diagram - CONSULT/GST CHECKING SYSTEM -

INFOID:000000006856145

GI

### CONSULT CHECKING SYSTEM

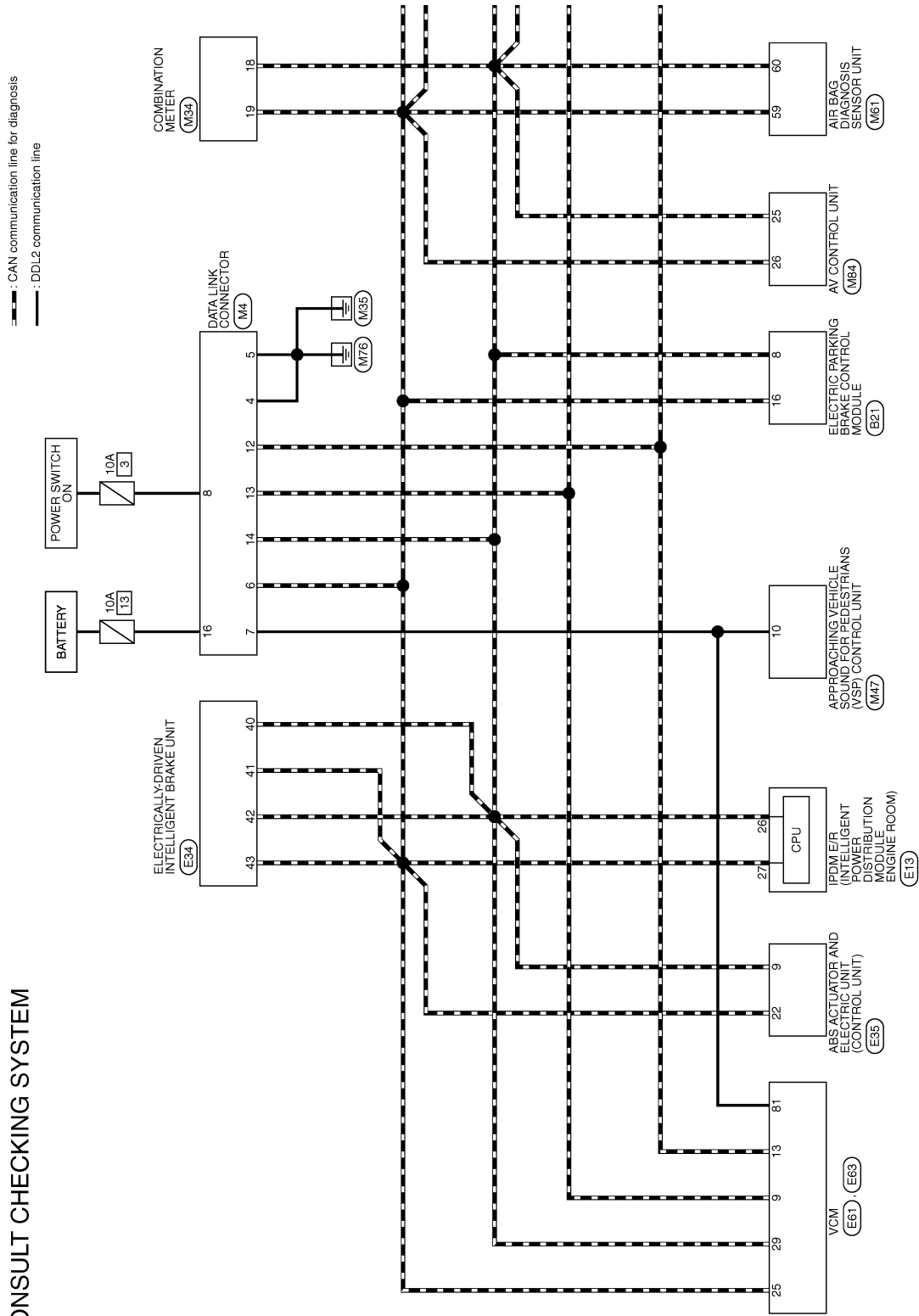

2010/10/29

JCAWA0254GB

B  
C  
D  
E  
F  
G  
H  
I  
J  
K  
L  
M  
N  
O  
P

# CONSULT/GST CHECKING SYSTEM

< BASIC INSPECTION >

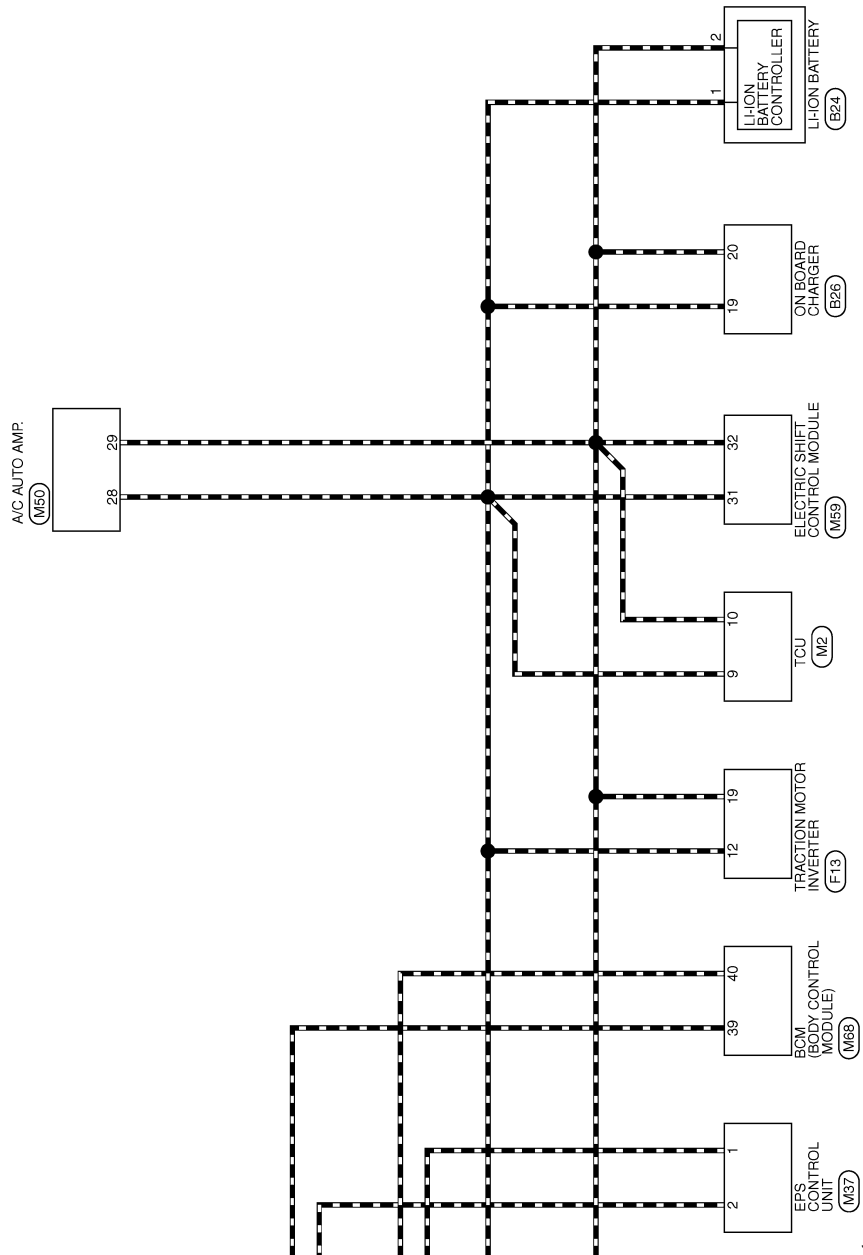

JCAWA0255GB

# CONSULT/GST CHECKING SYSTEM

< BASIC INSPECTION >

## CONSULT CHECKING SYSTEM

Connector No.	B21
Connector Name	ELECTRIC PARKING BRAKE CONTROL MODULE
Connector Type	TH16PW-NH

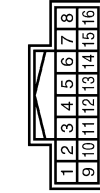

Terminal No.	Color of Wire	Signal Name [Specification]
1	W	TENSION SENSOR1 SIGNAL
2	LG	TENSION SENSOR POWER SUPPLY
3	R	TENSION SENSOR2 SIGNAL
5	GR	POWER SWITCH ON
7	W	CONTROL MODULE BATTERY
8	P	CAN-L
9	L	RELEASE SW SIGNAL
10	W	ANALOG SW POWER SUPPLY
11	B	TENSION SENSOR GND
12	B	ANALOG SW GND
13	SB	BRAKE SW SIGNAL
15	G	SHIELD GND
16	L	CAN-H

Connector No.	B24
Connector Name	L-ION BATTERY
Connector Type	Yaasak: 7263-8750-30



Terminal No.	Color of Wire	Signal Name [Specification]
1	L	EV CAN-H
2	G	EV CAN-L
4	R	IGN
5	R	BAT
6	B	GND3
7	B	GND2
8	B	GND1
10	B	PRE CHG GND
11	G	PRE CHG V

13	B	RLY2 GND
14	L	RLY2 V
16	B	RLY1 GND
17	Y	RLY1 V
21	R	CHG IGN

Connector No.	B26
Connector Name	ON BOARD CHARGER
Connector Type	RH12FB

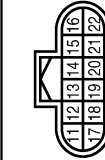

Terminal No.	Color of Wire	Signal Name [Specification]
11	Y	BATTERY POWER SUPPLY
12	W	BATTERY POWER SUPPLY
13	V	POWER ON POWER SUPPLY
14	P	NORMAL CHARGE RELAY +
15	LG	NORMAL CHARGE RELAY -
16	L	QUICK CHARGE RELAY +
17	SB	QUICK CHARGE RELAY -
18	GR	EV ACTIVATION REQUEST SIGNAL
19	L	EV SYSTEM CAN-H
20	G	EV SYSTEM CAN-L
21	BR	PLUG IN SIGNAL
22	B	GROUND

Connector No.	E13
Connector Name	INTELLIGENT POWER DISTRIBUTION MODULE FRAME BOARD
Connector Type	TH12FW-MH

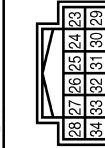

Terminal No.	Color of Wire	Signal Name [Specification]
25	R	
26	P	
27	L	

28	G	
32	SB	
34	W	

Connector No.	E34
Connector Name	ELECTRICALLY-DRIVEN INTELLIGENT BRAKE UNIT
Connector Type	SA242FB-SJZ4-S

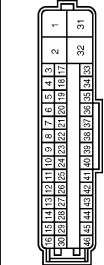

Terminal No.	Color of Wire	Signal Name [Specification]
1	R	MOTOR BATTERY
2	R	MOTOR BATTERY
5	L/O	STROKE SENSOR GND
7	W	PRESS SENSOR SIGNAL
8	O	BRAKE POWER SUPPLY BACKUP UNIT MAKEUP SIGNAL
10	W	BRAKE POWER SUPPLY BACKUP COMM
11	Y	CONTROL MODULE BATTERY
13	SB	STOP LAMP SW SIGNAL
19	W/L	STROKE SENSOR POWER SUPPLY
21	B	PRESS SENSOR POWER SUPPLY
22	W	BUZZER SIGNAL
24	B	BRAKE COMM
25	R	BRAKE POWER SUPPLY
26	V	POWER SWITCH ON
31	W	BRAKE POWER SUPPLY BACKUP UNIT BACKUP SIGNAL
32	W	GND
35	L/V	STROKE SENSOR1 SIGNAL
37	G	STROKE SENSOR2 SIGNAL
38	R	PRESS SENSOR GND
40	P	CANZ-L
41	L	CANZ-H
42	P	CANI-L
43	L	CANI-H

Connector No.	E35
Connector Name	ABS ACTUATOR AND ELECTRIC UNIT CONTROL UNIT
Connector Type	RH28FB-NJ4-DH

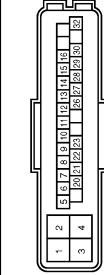

Terminal No.	Color of Wire	Signal Name [Specification]
1	G	MOTOR BATTERY
2	R	VALVE BATTERY
3	B	GND
4	B	GND
5	P	ESP OFF SW SIGNAL
6	O	BRAKE SW SIGNAL
7	L/Y	PRESS SENSOR SIGNAL
8	SB	STOP LAMP SW SIGNAL
9	P	CAN-L
10	W/L	PRESS SENSOR POWER SUPPLY
11	BR	FR RH WHEEL SENSOR POWER SUPPLY
12	W	FR RH WHEEL SENSOR SIGNAL
13	G	G SENSOR POWER SUPPLY
14	B	G SENSOR SIGNAL (+)
15	LG	RR RH WHEEL SENSOR SIGNAL
16	V	POWER SWITCH ON
20	B	BRAKE COMM
21	B	FR RH WHEEL SENSOR POWER SUPPLY
22	L	CAN-H
23	R	FR LH WHEEL SENSOR POWER SUPPLY
26	B	RR LH WHEEL SENSOR POWER SUPPLY
27	Y	FR LH WHEEL SENSOR SIGNAL
28	R	G SENSOR GND
29	Y	G SENSOR SIGNAL (-)
30	G	RR LH WHEEL SENSOR SIGNAL
32	L/O	PRESS SENSOR GND

GI B C D E F G H I J K L M N O P

# CONSULT/GST CHECKING SYSTEM

< BASIC INSPECTION >

## CONSULT CHECKING SYSTEM

Connector No.	E61
Connector Name	VCM
Connector Type	RH24FY-R28-R-RH

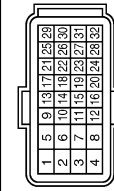

Terminal No.	Color of Wire	Signal Name [Specification]
1	G	POWER ON POWER SUPPLY
4	B/R	GROUND
5	SB	A/C RELAY
6	R	BATTERY POWER SUPPLY
7	W	SSOFF RELAY
8	B/R	GROUND
9	L	EV SYSTEM CAN-H
13	G	EV SYSTEM CAN-L
15	O	ASCD BRAKE SWITCH SIGNAL
18	SB	STOP LAMP SW SIGNAL
21	R	POWER ON POWER SUPPLY
23	P	HIGH VOLTAGE CABLE INTERLOCK
25	L	CAN-H
26	Y	WATER PUMP 2 SIGNAL
28	W	WATER PUMP 1 SIGNAL
29	P	CAN-L

Connector No.	E63
Connector Name	VCM
Connector Type	RH24FB-R28-L-RH

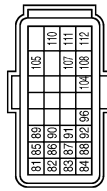

Terminal No.	Color of Wire	Signal Name [Specification]
81	GR	K-LINE
84	LG	EV SYSTEM ACTIVATION REQUEST SIGNAL
85	P	CHARGING STATUS INDICATOR 2
86	V	CHARGING STATUS INDICATOR 1
87	L	PLUG IN INDICATOR LAMP
88	Y	A/SP CONTROL SIGNAL

89	V	IMMEDIATE CHARGING SWITCH
90	W	STARTER RELAY CONT
91	O	ELECTRIC SHIFTS WARNING SIGNAL
92	C	CHARGING STATUS INDICATOR 2
96	GR	EV SYSTEM ACTIVATION REQUEST SIGNAL
104	SB	ASCD STEERING SWITCH
105	L/O	PRE-CHARGE RELAY
107	W/L	SYSTEM MAIN RELAY 1
108	BR	ASCD STEERING SWITCH GROUND
110	L/Y	SYSTEM MAIN RELAY 2
111	B/R	GROUND
112	B/R	GROUND

Connector No.	F13
Connector Name	TRACTION MOTOR INVERTER
Connector Type	RH38FG-GY

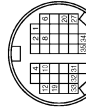

Terminal No.	Color of Wire	Signal Name [Specification]
1	B	TRACTION MOTOR RESOLVER SIGNAL (S1)
2	B	GROUND
4	G	POWER SUPPLY (BATTERY)
6	W	TRACTION MOTOR RESOLVER SIGNAL (S3)
8	B	GROUND
10	G	POWER SUPPLY (BATTERY)
12	L	EV SYSTEM CAN-H
19	G	EV SYSTEM CAN-L
20	L	TRACTION MOTOR RESOLVER SIGNAL (S2)
27	P	TRACTION MOTOR RESOLVER SIGNAL (S4)
31	O	TRACTION MOTOR TEMPERATURE SENSOR GROUND
32	B/P	TRACTION MOTOR TEMPERATURE SENSOR
33	LG	POWER SUPPLY (IGN)
34	R	TRACTION MOTOR RESOLVER SIGNAL (R1)
35	G	TRACTION MOTOR RESOLVER SIGNAL (R2)

Connector No.	M2
Connector Name	TCU
Connector Type	TH40FW-NH

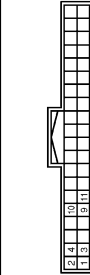

Terminal No.	Color of Wire	Signal Name [Specification]
1	BR	BATTERY POWER SUPPLY
2	B	GROUND
3	G	AGS POWER SUPPLY
4	V	POWER SWITCH ON SIGNAL
9	L	EV SYSTEM CAN-H
10	G	EV SYSTEM CAN-L
11	LG	EV SYSTEM ACTIVATION REQUEST SIGNAL

Connector No.	M4
Connector Name	DATA LINK CONNECTOR
Connector Type	BD16FW

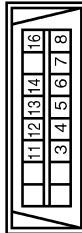

Terminal No.	Color of Wire	Signal Name [Specification]
3	LG	--
4	B	--
5	B	--
6	L	--
7	GR	--
8	G	--
11	SB	--
12	G	--
13	L	--
14	P	--
16	Y	--

Connector No.	M34
Connector Name	COMBINATION METER
Connector Type	TH40FW-NH

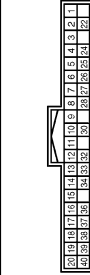

Terminal No.	Color of Wire	Signal Name [Specification]
1	LG	BATTERY POWER SUPPLY
2	R	BATTERY POWER SUPPLY (FOR UPPER METER)
3	GR	POWER SWITCH SUPPLY
4	BR	POWER SWITCH SUPPLY (FOR UPPER METER)
5	B	GROUND
6	B	GROUND
7	V	ELECTRIC SHIFTS WARNING SIGNAL
8	Y	WASHER LEVEL SWITCH SIGNAL
9	G	PLUG IN SIGNAL
10	L	COMMUNICATION SIGNAL (METER → VSP)
11	P	COMMUNICATION SIGNAL (VSP → METER)
12	V	METER CONTROL SWITCH GROUND
13	LG	ENTER SWITCH SIGNAL
14	W	SELECT SWITCH SIGNAL
15	BR	TRIP RESET SWITCH SIGNAL
16	BR	ILLUMINATION CONTROL SWITCH SIGNAL
17	V	ILLUMINATION CONTROL (FOR UPPER METER)
18	P	CAN-L
19	L	CAN-H
20	V	SEAT BELT BUCKLE SWITCH SIGNAL (PASSENGER SIDE)
22	GR	GROUND (FOR UPPER METER)
24	BR	ELECTRIC PARKING BRAKE CONTROL (FOR UPPER METER) SIGNAL
25	SB	BRAKE FLUID LEVEL SWITCH SIGNAL
26	B	ILLUMINATION CONTROL SIGNAL
27	R	AIR BAG SIGNAL
28	R	SECURITY SIGNAL
30	GR	VEHICLE SPEED SIGNAL (8-PULSE)
32	W	COMMUNICATION SIGNAL (METER → UPPER)
33	LG	CLOCK SIGNAL
34	L	PLUG IN INDICATOR LAMP SIGNAL
38	V	LED HEADLAMP (RH) WARNING SIGNAL
39	LG	LED HEADLAMP (LH) WARNING SIGNAL
40	Y	SEAT BELT BUCKLE SWITCH SIGNAL (DRIVER SIDE)



# CONSULT/GST CHECKING SYSTEM

< BASIC INSPECTION >

## CONSULT CHECKING SYSTEM

Connector No.	M37
Connector Name	EPS CONTROL UNIT
Connector Type	TH08PV-NH

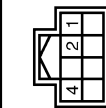

Terminal No.	Color of Wire	Signal Name [Specification]
1	P	CAN-L
2	L	CAN-H
4	V	POWER SUPPLY (POWER SWITCH)

Connector No.	M47
Connector Name	DRIVING VEHICLE SOUND FOR PEDESTRIANS (VSP) CONTROL UNIT
Connector Type	TH16PV-NH

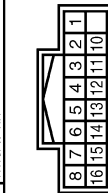

Terminal No.	Color of Wire	Signal Name [Specification]
1	B	GROUND
2	L	COMMUNICATION SIGNAL (METER → VSP)
3	SB	POWER SWITCH SIGNAL
4	P	COMMUNICATION SIGNAL (VSP → METER)
5	G	VSP OFF SWITCH SIGNAL
6	Y	CHARGE PULSE SIGNAL
7	L	VSP SPEAKER SIGNAL (-)
8	Y	VSP SPEAKER SIGNAL (+)
10	GR	K-LINE (CONSULT)
11	GR	POWER SWITCH SUPPLY
12	SB	STOP LAMP SWITCH SIGNAL
13	L	BATTERY POWER SUPPLY
14	LG	VSP OFF INDICATOR SIGNAL
15	R	STRAT UP SOUND SPEAKER SIGNAL (-)
16	W	STRAT UP SOUND SPEAKER SIGNAL (+)

Connector No.	M50
Connector Name	A/C AUTO AMP
Connector Type	TH40PV-NH

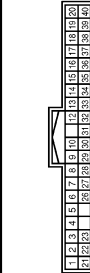

Terminal No.	Color of Wire	Signal Name [Specification]
1	V	REC
2	R	MODE4
3	P	MODE3
4	Y	MODE2
5	V	MODE1
6	BR	MX4
7	SB	MX3
8	LG	MX2
9	L	MX1
10	B	GROUND
12	GR	BLOWER PWM
13	V	W/PUMP PWM
14	L	COMP TX
15	W	RR DEF SW O/P
16	LG	HEATED STEERING WHEEL SWITCH SIGNAL
17	R	W/PUMP F/B
18	W	COMP RX
19	W	LIGHT+
20	B	LIGHT-
21	G	FRESH
22	LG	HEATED STEERING WHEEL RELAY CONTROL SIGNAL
23	SB	SEAT HEAT RELAY
27	W	SV OUT
28	L	EV CAN-H
29	G	EV CAN-L
30	R	SENS GND
31	W	BATT
32	Y	IGN1
33	LG	INCAR SENS
34	G	INTAKE SENS
35	P	SUN SENS
36	GR	AMB SENS
37	BR	WATER SENS
38	SB	INT F/B
40	SB	PTC LIN

Connector No.	M59
Connector Name	ELECTRIC SHIFT CONTROL MODULE
Connector Type	TH20PV-TB6-TV

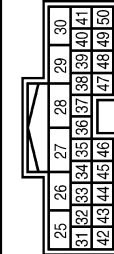

Terminal No.	Color of Wire	Signal Name [Specification]
25	B	GND (MOTOR)
26	R	D POSITION OUTPUT
27	BR	MOTOR COIL B L-PHASE
28	G	MOTOR COIL B W-PHASE
29	R	MOTOR COIL B W-PHASE
30	Y	R POSITION OUTPUT
31	L	EV SYSTEM CAN-H
32	G	EV SYSTEM CAN-L
33	GR	PARKING ACTUATOR RELAY B
34	LG	ELECTRIC SHIFT SENSOR NO. 1
35	L	ELECTRIC SHIFT SENSOR NO. 2
36	P	ELECTRIC SHIFT SENSOR NO. 3
37	Y	ELECTRIC SHIFT SENSOR NO. 4
38	B	P POSITION OUTPUT
39	LG	ANGLE SENSOR 2 POWER SUPPLY
40	P	ANGLE SENSOR 2 SIGNAL
41	BR	ELECTRIC SHIFT SENSOR GND 1
42	G	POWER SW 2
43	W	MAIN POWER SUPPLY 2
44	SB	ELECTRIC SHIFT SENSOR NO. 5
45	BR	ELECTRIC SHIFT SENSOR NO. 6
46	R	P POSITION SWITCH NO. 7
47	B	P POSITION SWITCH NO. 8
48	SB	ELECTRIC SHIFT SENSOR POWER SUPPLY 2
49	G	ANGLE SENSOR 2 GND
50	LG	ELECTRIC SHIFT SENSOR GND 2

Connector No.	M61
Connector Name	AIR BAG DIAGNOSIS SENSOR UNIT
Connector Type	NH20FY-EX

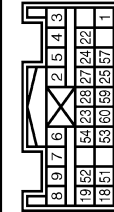

Terminal No.	Color of Wire	Signal Name [Specification]
1	BR	IGN
2	B	GND
3	Y	DR 1 (+)
4	GR	DR1 (-) DR2 (-)
5	V/V	DR 2 (+)
6	Y/G	AS1 (+)
7	Y/B	AS1 (-)
8	Y/L	AS2 (+)
9	Y/V	AS2 (-)
18	R	EGZS (+)
19	W	EGZS (-)
22	SHIELD	SHIELD
23	R	AIR BAG W/L
24	LG	SEAT BELT W/L
25	R	CUTOFF TELLTALE
51	Y	FMVSS SENS RH+
52	BR	FMVSS SENS RH-
53	G	FMVSS SENS LH+
54	R	FMVSS SENS LH-
59	L	CAN-H
60	P	CAN-L

JCAWA00343GB

GI  
B  
C  
D  
E  
F  
G  
H  
I  
J  
K  
L  
M  
N  
O  
P

# CONSULT/GST CHECKING SYSTEM

< BASIC INSPECTION >

## CONSULT CHECKING SYSTEM

Connector No.	M68
Connector Name	BCM BODY CONTROL MODULE
Connector Type	TH4CFB-NH



1	2	3	4	5	6	7	8	9	10	11	12	13	14	15	16	17	18	19	20
---	---	---	---	---	---	---	---	---	----	----	----	----	----	----	----	----	----	----	----

Terminal No.	Color of Wire	Signal Name [Specification]
2	L	COMBI SW INPUT 5
3	GR	COMBI SW INPUT 4
4	BR	COMBI SW INPUT 3
5	G	COMBI SW INPUT 2
6	V	COMBI SW INPUT 1
7	GR	KEY CYL UNLK SW
8	R	KEY CYL LOCK SW
9	BR	STOP LAMP SW 1
12	Y	DOOR LK & UNLK SW LOCK
13	BR	DOOR LK & UNLK SW UNLOCK
14	G	OPTICAL SENS
15	W	REAR WINDOW DEF SW
16	R	DIMMER
17	Y	OPTICAL SENS FWR SPLY
18	V	SENS/RECEIV GND
21	P	NATS ANTENNA AMP
23	R	SECURITY IND LAMP CONT
24	SB	DONGLE UNLK
25	LG	NATS ANTENNA AMP
29	P	HAZARD SW
30	L	BK DOOR OPENER SW
31	W	DR DOOR UNLK SENS
32	LG	COMBI SW OUTPUT 5
33	Y	COMBI SW OUTPUT 4
34	W	COMBI SW OUTPUT 3
35	R	COMBI SW OUTPUT 2
36	P	COMBI SW OUTPUT 1
37	W	P POSITION
38	SB	RECEIVER COMM
39	L	CAN-H
40	P	CAN-L

Connector No.	M64
Connector Name	AV CONTROL UNIT
Connector Type	TH4CFW-NH



1	2	3	4	5	6	7	8	9	10	11	12	13	14	15	16	17	18	19	20
---	---	---	---	---	---	---	---	---	----	----	----	----	----	----	----	----	----	----	----

Terminal No.	Color of Wire	Signal Name [Specification]
21	LG	AV COMM (L)
22	SB	AV COMM (H)
23	LG	AV COMM (L)
24	SB	AV COMM (H)
25	P	CAN-L
26	L	CAN-H
28	GR	VEHICLE SPEED SIGNAL (8-PULSE)
29	BR	PARKING BRAKE SIGNAL
30	G	REVERSE SIGNAL
31	V	POWER SWITCH ON SIGNAL
32	R	DIMMER SIGNAL
46	L	MICROPHONE SIGNAL
47	Y	MICROPHONE VCC
48	SHIELD	MICROPHONE SHIELD
49	R	AUX SOUND SIGNAL LH (+)
50	W	AUX SOUND SIGNAL RH (+)
51	B	AUX SOUND SIGNAL (-)
52	SHIELD	SHIELD
56	B	CAMERA CONNECTION RECOGNITION SIGNAL
57	R	CAMERA POWER SUPPLY
58	W	CAMERA GROUND
59	R	CAMERA IMAGE SIGNAL
60	SHIELD	SHIELD

JCAWA0344GB

# INSPECTION AND ADJUSTMENT

< BASIC INSPECTION >

## INSPECTION AND ADJUSTMENT

### ADDITIONAL SERVICE WHEN REMOVING BATTERY NEGATIVE TERMINAL

### ADDITIONAL SERVICE WHEN REMOVING BATTERY NEGATIVE TERMINAL : Required Procedure After Battery Disconnection

INFOID:000000006918518

SYSTEM	ITEM	REFERENCE
Automatic temperature control	Temperature setting trimmer	<a href="#">HAC-57, "Temperature Setting Trimmer"</a>
	Foot position setting trimmer	<a href="#">HAC-58, "Foot Position Setting Trimmer"</a>
	Inlet port memory function	—
	Inlet port Memory function (FRE)	<a href="#">HAC-58, "Inlet Port Memory Function (FRE)"</a>
	Inlet port Memory Function (REC)	<a href="#">HAC-57, "Inlet Port Memory Function (REC)"</a>
	Gas Sensor Sensitivity Adjustment Function	—
	Auto Intake Switch Interlocking Movement Change	—
	Clean Switch Interlocking Movement Change	—
Automatic drive positioner	Automatic drive positioner system	—
Power window control	Power window control system	<a href="#">PWC-25, "Description"</a>
Sunroof system	Sunroof system	—
Sunshade system	Sunshade system	—
Rear view monitor	Rear view monitor predictive course line center position adjustment	—
Around view monitor*	Predictive course line center position adjustment	—
Automatic back door system	Automatic back door system	—
Engine oil level read	Engine oil level read	—
VCM timer set	VCM timer set	<a href="#">EVC-105, "Description"</a>

\*: Not equipped.