

SECTION **IP**
INSTRUMENT PANEL

A
B
C
D
E
F
G
H
I
IP
K
L
M
N
O
P

CONTENTS

PRECAUTION	2	SYMPTOM DIAGNOSIS	7
PRECAUTIONS	2	SQUEAK AND RATTLE TROUBLE DIAG- NOSES	7
Precaution for Technicians Using Medical Electric.....	2	Work Flow	7
Point to Be Checked Before Starting Maintenance		Inspection Procedure	9
Work	2	Diagnostic Worksheet	11
Precautions for Removing Battery Terminal	3	REMOVAL AND INSTALLATION	13
Precaution for Supplemental Restraint System (SRS) "AIR BAG" and "SEAT BELT PRE-TEN- SIONER"	3	INSTRUMENT PANEL ASSEMBLY	13
Precaution for Work	4	Exploded View	13
PREPARATION	5	Removal and Installation	14
PREPARATION	5	CENTER CONSOLE ASSEMBLY	27
Special Service Tools	5	Exploded View	27
Commercial Service Tools	5	Removal and Installation	27
CLIP LIST	6	Disassembly and Assembly	30
Clip List	6		

PRECAUTIONS

< PRECAUTION >

PRECAUTION

PRECAUTIONS

Precaution for Technicians Using Medical Electric

INFOID:000000007075393

OPERATION PROHIBITION

WARNING:

- Parts with strong magnet is used in this vehicle.
- Technicians using a medical electric device such as pacemaker must never perform operation on the vehicle, as magnetic field can affect the device function by approaching to such parts.

NORMAL CHARGE PRECAUTION

WARNING:

- If a technician uses a medical electric device such as an implantable cardiac pacemaker or an implantable cardioverter defibrillator, the possible effects on the devices must be checked with the device manufacturer before starting the charge operation.
- As radiated electromagnetic wave generated by on board charger at normal charge operation may effect medical electric devices, a technician using a medical electric device such as implantable cardiac pacemaker or an implantable cardioverter defibrillator must not enter the vehicle compartment (including luggage room) during normal charge operation.

PRECAUTION AT TELEMATICS SYSTEM OPERATION

WARNING:

- If a technician uses implantable cardiac pacemaker or implantable cardioverter defibrillator (ICD), avoid the device implanted part from approaching within approximately 220 mm (8.66 in) from interior/exterior antenna.
- The electromagnetic wave of TCU might affect the function of the implantable cardiac pacemaker or the implantable cardioverter defibrillator (ICD), when using the service, etc.
- If a technician uses other medical electric devices than implantable cardiac pacemaker or implantable cardioverter defibrillator (ICD), the electromagnetic wave of TCU might affect the function of the device. The possible effects on the devices must be checked with the device manufacturer before TCU use.

PRECAUTION AT INTELLIGENT KEY SYSTEM OPERATION

WARNING:

- If a technician uses implantable cardiac pacemaker or implantable cardioverter defibrillator (ICD), avoid the device implanted part from approaching within approximately 220 mm (8.66 in) from interior/exterior antenna.
- The electromagnetic wave of Intelligent Key might affect the function of the implantable cardiac pacemaker or the implantable cardioverter defibrillator (ICD), at door operation, at each request switch operation, or at engine starting.
- If a technician uses other medical electric devices than implantable cardiac pacemaker or implantable cardioverter defibrillator (ICD), the electromagnetic wave of Intelligent Key might affect the function of the device. The possible effects on the devices must be checked with the device manufacturer before Intelligent Key use.

Point to Be Checked Before Starting Maintenance Work

INFOID:000000007079495

The high voltage system may starts automatically. It is required to check that the timer air conditioner and timer charge (during EVSE connection) are not set before starting maintenance work.

NOTE:

If the timer air conditioner or timer charge (during EVSE connection) is set, the high voltage system starts automatically even when the power switch is in OFF state.

PRECAUTIONS

< PRECAUTION >

Precautions for Removing Battery Terminal

INFOID:000000006952039

- When removing the 12V battery terminal, turn OFF the power switch and wait at least 5 minutes.

NOTE:

ECU may be active for several minutes after the power switch is turned OFF. If the battery terminal is removed before ECU stops, then a DTC detection error or ECU data corruption may occur.

- Always disconnect the battery terminal within 60 minutes after turning OFF the power switch. Even when the power switch is OFF, the 12V battery automatic charge control may automatically start after a lapse of 60 minutes from power switch OFF.
- Disconnect 12V battery terminal according to the following steps.

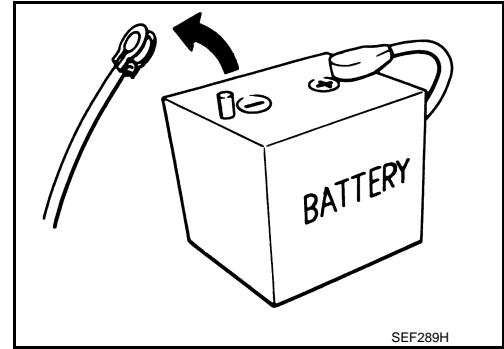

WORK PROCEDURE

1. Check that EVSE is not connected.

NOTE:

If EVSE is connected, the air conditioning system may be automatically activated by the timer A/C function.

2. Turn the power switch OFF → ON → OFF. Get out of the vehicle. Close all doors (including back door).
3. Check that the charge status indicator lamp does not blink and wait for 5 minutes or more.

NOTE:

If the battery is removed within 5 minutes after the power switch is turned OFF, plural DTCs may be detected.

4. Remove 12V battery terminal within 60 minutes after turning the power switch OFF → ON → OFF.

CAUTION:

- After all doors (including back door) are closed, if a door (including back door) is opened before battery terminals are disconnected, start over from Step 1.
- After turning the power switch OFF, if "Remote A/C" is activated by user operation, stop the air conditioner and start over from Step 1.

NOTE:

Once the power switch is turned ON → OFF, the 12V battery automatic charge control does not start for approximately 1 hour.

- For vehicles with the 2-batteries, be sure to connect the main battery and the sub battery before turning ON the power switch.

NOTE:

If the power switch is turned ON with any one of the terminals of main battery and sub battery disconnected, then DTC may be detected.

- After installing the 12V battery, always check "Self Diagnosis Result" of all ECUs and erase DTC.

NOTE:

The removal of 12V battery may cause a DTC detection error.

Precaution for Supplemental Restraint System (SRS) "AIR BAG" and "SEAT BELT PRE-TENSIONER"

INFOID:000000006892172

The Supplemental Restraint System such as "AIR BAG" and "SEAT BELT PRE-TENSIONER", used along with a front seat belt, helps to reduce the risk or severity of injury to the driver and front passenger for certain types of collision. This system includes seat belt switch inputs and dual stage front air bag modules. The SRS system uses the seat belt switches to determine the front air bag deployment, and may only deploy one front air bag, depending on the severity of a collision and whether the front occupants are belted or unbelted. Information necessary to service the system safely is included in the "SRS AIR BAG" and "SEAT BELT" of this Service Manual.

WARNING:

Always observe the following items for preventing accidental activation.

- To avoid rendering the SRS inoperative, which could increase the risk of personal injury or death in the event of a collision that would result in air bag inflation, all maintenance must be performed by an authorized NISSAN/INFINITI dealer.

PRECAUTIONS

< PRECAUTION >

- **Improper maintenance, including incorrect removal and installation of the SRS, can lead to personal injury caused by unintentional activation of the system. For removal of Spiral Cable and Air Bag Module, see “SRS AIR BAG”.**
- **Never use electrical test equipment on any circuit related to the SRS unless instructed to in this Service Manual. SRS wiring harnesses can be identified by yellow and/or orange harnesses or harness connectors.**

PRECAUTIONS WHEN USING POWER TOOLS (AIR OR ELECTRIC) AND HAMMERS

WARNING:

Always observe the following items for preventing accidental activation.

- **When working near the Air Bag Diagnosis Sensor Unit or other Air Bag System sensors with the power switch ON, never use air or electric power tools or strike near the sensor(s) with a hammer. Heavy vibration could activate the sensor(s) and deploy the air bag(s), possibly causing serious injury.**
- **When using air or electric power tools or hammers, always switch the power switch OFF, disconnect the 12V battery, and wait at least 3 minutes before performing any service.**

Precaution for Work

INFOID:000000006952041

- Disconnect both 12V battery cables in advance.
- Disconnect air bag system line in advance.
- Never tamper with or force air bag lid open, as this may adversely affect air bag performance.
- Be careful not to scratch pad and other parts.
- When removing or disassembling any part, be careful not to damage or deform it. Protect parts, which may get in the way with a shop cloth.
- When removing parts with a screwdriver or other tool, cover the tool surface by vinyl tape to protect parts.
- Keep removed parts protected with a shop cloth.
- If a clip is deformed or damaged, replace it.
- If an un reusable part is removed, replace it with a new one.
- Tighten bolts and nuts firmly to the specified torque.
- After reassembly has been completed, make sure each part functions correctly.
- Remove stains in the following way.

Water-soluble stains:

Dip a soft cloth in warm water, and then squeeze it tightly. After wiping the stain, wipe with a soft dry cloth.

Oil stain:

Dissolve a synthetic detergent in warm water (density of 2 to 3%), dip the cloth, then clean off the stain with the cloth. Next, dip the cloth in fresh water and squeeze it tightly. Then clean off the detergent completely. Then wipe the area with a soft dry cloth.

- Never use any organic solvent, such as thinner or benzine.

PREPARATION

< PREPARATION >

PREPARATION

PREPARATION

Special Service Tools

INFOID:000000007034927

The actual shapes of Kent-Moore tools may differ from those of special service tools illustrated here.

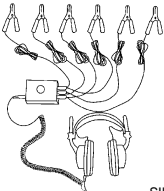
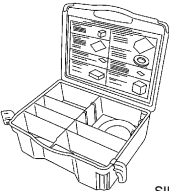
Tool number (Kent-Moore No.) Tool name	Description
(J-39570) Chassis ear  SIIA0993E	Locates the noise
(J-43980) NISSAN Squeak and Rattle Kit  SIIA0994E	Repairs the cause of noise

Commercial Service Tools

INFOID:0000000006892157

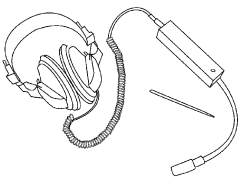
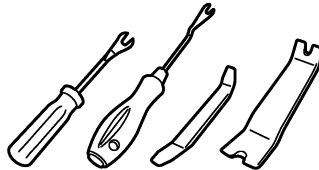
Tool name	Description
Engine ear  SIIA0995E	Locates the noise
Remover tool  JMKIA3050ZZ	Removes clips, pawls and metal clips

CLIP LIST

< PREPARATION >

CLIP LIST

Clip List

INFOID:000000006892158

Shapes	Removal & Installation	Shapes	Removal & Installation
	<p>Removal: Remove by bending up with flat-bladed screwdrivers or clip remover.</p>		<p>Removal:</p>
	<p>Removal: Remove with a clip remover.</p>		<p>Removal:</p>
	<p>Removal: Push center pin to catching position. (Do not remove center pin by hitting it.)</p> <p>Installation:</p>		<p>Removal: Holder portion of clip must be spread out to remove rod.</p>
	<p>Removal: Remove by bending up with flat-bladed screwdrivers or clip remover.</p>		<p>Removal:</p> <ol style="list-style-type: none"> Screw out with a Phillips screwdriver. Remove female portion with flat-bladed screwdriver.
	<p>Removal:</p>		<p>Removal:</p> <p>Rotate 45° to remove.</p> <p>Installation:</p>
	<p>Removal:</p>		<p>Removal:</p>

JMJIA3734GB

SQUEAK AND RATTLE TROUBLE DIAGNOSES

< SYMPTOM DIAGNOSIS >

SYMPTOM DIAGNOSIS

SQUEAK AND RATTLE TROUBLE DIAGNOSES

Work Flow

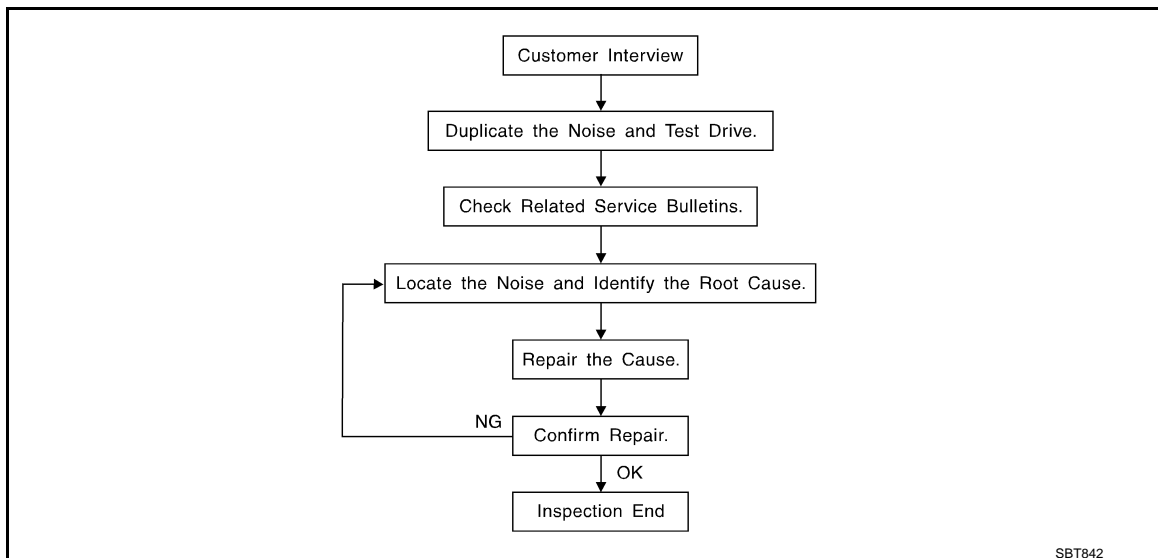

CUSTOMER INTERVIEW

Interview the customer if possible, to determine the conditions that exist when the noise occurs. Use the Diagnostic Worksheet during the interview to document the facts and conditions when the noise occurs and any customer comments. Refer to [EXT-10. "Diagnostic Worksheet"](#). This information is necessary to duplicate the conditions that exist when the noise occurs.

- The customer may not be able to provide a detailed description or the location of the noise. Attempt to obtain all the facts and conditions that exist when the noise occurs (or does not occur).
- If there is more than one noise in the vehicle, perform a diagnosis and repair the noise that the customer is concerned about. This can be accomplished by performing a test drive with the customer.
- After identifying the type of noise, isolate the noise in terms of its characteristics. The noise characteristics are provided so that the customer, service adviser, and technician use the same language when describing the noise.
- Squeak – (Like tennis shoes on a clean floor)
Squeak characteristics include the light contact / fast movement / brought on by road conditions / hard surfaces = high-pitched noise / softer surfaces = low-pitched noises / edge to surface = chirping
- Creak – (Like walking on an old wooden floor)
Creak characteristics include firm contact / slow movement/twisting with a rotational movement / pitch dependent on materials / often brought on by activity.
- Rattle – (Like shaking a baby rattle)
Rattle characteristics include fast repeated contact / vibration or similar movement / loose parts/missing clip or fastener / incorrect clearance.
- Knock – (Like a knock on a door)
Knock characteristics include hollow sounds / sometimes repeating / often brought on by driver action.
- Tick – (Like a clock second hand)
Tick characteristics include gentle contacting of light materials / loose components / can be caused by driver action or road conditions.
- Thump – (Heavy, muffled knock noise)
Thump characteristics include softer knock / dull sounds often brought on by activity.
- Buzz – (Like a bumblebee)
Buzz characteristics include high frequency rattle / firm contact.
- Often the degree of acceptable noise level varies depending upon the person. A noise that a technician may judge as acceptable may be very irritating to a customer.
- Weather conditions, especially humidity and temperature, may have a great effect on noise level.

DUPLICATE THE NOISE AND TEST DRIVE

SQUEAK AND RATTLE TROUBLE DIAGNOSES

< SYMPTOM DIAGNOSIS >

If possible, drive the vehicle with the customer until the noise is duplicated. Note any additional information on the Diagnostic Worksheet regarding the conditions or location of the noise. This information can be used to duplicate the same conditions when the repair is reconfirmed.

If the noise can be duplicated easily during the test drive, to help identify the source of the noise, try to duplicate the noise with the vehicle stopped by doing one or all of the following items:

- 1) Close a door.
 - 2) Tap or push/pull around the area where the noise appears to be coming from.
 - 3) Rev the motor.
 - 4) Use a floor jack to recreate vehicle "twist".
 - 5) At idle, apply motor load (electrical load, half-clutch on M/T models, drive position on A/T models).
 - 6) Raise the vehicle on a hoist and hit a tire with a rubber hammer.
- Drive the vehicle and attempt to duplicate the conditions the customer states exist when the noise occurs.
 - If it is difficult to duplicate the noise, drive the vehicle slowly on an undulating or rough road to stress the vehicle body.

CHECK RELATED SERVICE BULLETINS

After verifying the customer concern or symptom, check ASIST for Technical Service Bulletins (TSBs) related to the concern or symptom.

If a TSB relates to the symptom, follow the procedure to repair the noise.

LOCATE THE NOISE AND IDENTIFY THE ROOT CAUSE

1. Narrow down the noise to a general area. To help pinpoint the source of the noise, use a listening tool (Chassis ear: J-39570, engine ear, and mechanics stethoscope).
2. Narrow down the noise to a more specific area and identify the cause of the noise by:
 - Removing the component(s) in the area that is / are suspected to be the cause of the noise.
Do not use too much force when removing clips and fasteners, otherwise clips and fasteners can be broken or lost during the repair, resulting in the creation of new noise.
 - Tapping or pushing/pulling the component(s) that is / are suspected to be the cause of the noise.
Do not tap or push/pull the component(s) with excessive force, otherwise the noise is eliminated only temporarily.
 - Feeling for a vibration by hand by touching the component(s) that is / are suspected to be the cause of the noise.
 - Placing a piece of paper between components that are suspected to be the cause of the noise.
 - Looking for loose components and contact marks.
Refer to [IP-9, "Inspection Procedure"](#).

REPAIR THE CAUSE

- If the cause is a loose component, tighten the component securely.
- If the cause is insufficient clearance between components:
 - Separate components by repositioning or loosening and retightening the components, if possible.
 - Insulate components with a suitable insulator such as urethane pads, foam blocks, felt cloth tape, or urethane tape. A NISSAN Squeak and Rattle Kit (J-43980) is available through the authorized NISSAN Parts Department.

CAUTION:

Never use excessive force as many components are constructed of plastic and may be damaged.

NOTE:

Always check with the Parts Department for the latest parts information.

The following materials are contained in the NISSAN Squeak and Rattle Kit (J-43980). Each item can be ordered separately as needed.

URETHANE PADS [1.5 mm (0.059 in) thick]

Insulates connectors, harness, etc.

- 76268-9E005: 100 × 135 mm (3.937 × 5.315 in)
- 76884-71L01: 60 × 85 mm (2.362 × 3.346 in)
- 76884-71L02: 15 × 25 mm (0.591 × 0.984 in)

INSULATOR (Foam blocks)

Insulates components from contact. Can be used to fill space behind a panel.

- 73982-9E000: 45 mm (1.772 in) thick, 50 × 50 mm (1.969 × 1.969 in)
- 73982-50Y00: 10 mm (0.394 in) thick, 50 × 50 mm (1.969 × 1.969 in)

INSULATOR (Light foam block)

80845-71L00: 30 mm (1.181 in) thick, 30 × 50 mm (1.181 × 1.969 in)

FELT CLOTHTAPE

SQUEAK AND RATTLE TROUBLE DIAGNOSES

< SYMPTOM DIAGNOSIS >

Used to insulate where movement does not occur. Ideal for instrument panel applications.

- 68370-4B000: 15 × 25 mm (0.591 × 0.984 in) pad
- 68239-13E00: 5 mm (0.197 in) wide tape roll

The following materials, not found in the kit, can also be used to repair squeaks and rattles.

UHMW (TEFLON) TAPE

Insulates where slight movement is present. Ideal for instrument panel applications.

SILICONE GREASE

Used in place of UHMW tape that is visible or does not fit. Only lasts a few months.

SILICONE SPRAY

Used when grease cannot be applied.

DUCT TAPE

Used to eliminate movement.

CONFIRM THE REPAIR

After repair is complete, test drive the vehicle to confirm that the cause of noise is repaired by test driving the vehicle. Operate the vehicle under the same conditions as when the noise originally occurred. Refer to the notes on the Diagnostic Worksheet.

Inspection Procedure

INFOID:000000007049709

Refer to Table of Contents for specific component removal and installation information.

INSTRUMENT PANEL

Most incidents are caused by contact and movement between:

1. The cluster lid A and instrument panel
2. Acrylic lens and combination meter housing
3. Instrument panel to front pillar garnish
4. Instrument panel to windshield
5. Instrument panel mounting pins
6. Wiring harnesses behind the combination meter
7. A/C defroster duct and duct joint

These incidents can usually be located by tapping or moving the components to duplicate the noise or by pressing on the components while driving to stop the noise. Most of these incidents can be repaired by applying felt cloth tape or silicon spray (in hard to reach areas). Urethane pads can be used to insulate wiring harness.

CAUTION:

Never use silicone spray to isolate a squeak or rattle. If the area is saturated with silicone, the recheck of repair becomes impossible.

CENTER CONSOLE

Components to check include:

1. Shifter assembly cover to finisher
2. A/C control unit and cluster lid C
3. Wiring harnesses behind audio and A/C control unit

The instrument panel repair and isolation procedures also apply to the center console.

DOORS

Check the following items:

1. Finisher and inner panel making a slapping noise
2. Inside handle escutcheon connection to door finisher
3. Wiring harnesses tapping
4. Door striker out of alignment causing a popping noise on starts and stops

Tapping, moving the components, or pressing on them while driving to duplicate the conditions can isolate many of these incidents. The areas can usually be insulated with felt cloth tape or insulator foam blocks from the NISSAN Squeak and Rattle Kit (J-43980) to repair the noise.

TRUNK

Trunk noises are often caused by a loose jack or loose items put into the trunk by the customer.

In addition check for the following items:

SQUEAK AND RATTLE TROUBLE DIAGNOSES

< SYMPTOM DIAGNOSIS >

1. Trunk lid dumpers out of adjustment
2. Trunk lid striker out of adjustment
3. Trunk lid torsion bars knocking together
4. A loose license plate or bracket

Most of these incidents can be repaired by adjusting, securing, or insulating the item(s) or component(s) causing the noise.

SUNROOF/HEADLINING

Noises in the sunroof / headlining area can often be traced to one of the following items:

1. Sunroof lid, rail, linkage, or seals making a rattle or light knocking noise
2. Sunvisor shaft shaking in the holder
3. Front or rear windshield touching headlining and squeaking

Again, pressing on the components to stop the noise while duplicating the conditions can isolate most of these incidents. Repairs usually consist of insulating with felt cloth tape.

SEATS

When isolating seat noise it is important to note the position the seat is in and the load placed on the seat when the noise occurs. These conditions should be duplicated when verifying and isolating the cause of the noise.

Causes of seat noise include:

1. Headrest rods and holder
2. A squeak between the seat pad cushion and frame
3. The rear seatback lock and bracket

These noises can be isolated by moving or pressing on the suspected components while duplicating the conditions under which the noise occurs. Most of these incidents can be repaired by repositioning the component or applying urethane tape to the contact area.

UNDERHOOD

Some interior noise may be caused by components under the hood or on the motor wall. The noise is then transmitted into the passenger compartment.

Causes of transmitted underhood noise include:

1. Any component mounted to the motor wall
2. Components that pass through the motor wall
3. Motor wall mounts and connectors
4. Loose radiator mounting pins
5. Hood bumpers out of adjustment
6. Hood striker out of adjustment

These noises can be difficult to isolate since they cannot be reached from the interior of the vehicle. The best method is to secure, move, or insulate one component at a time and test drive the vehicle. Also, motor RPM or load can be changed to isolate the noise. Repairs can usually be made by moving, adjusting, securing, or insulating the component causing the noise.

SQUEAK AND RATTLE TROUBLE DIAGNOSES

< SYMPTOM DIAGNOSIS >

Diagnostic Worksheet

INFOID:000000006892171



SQUEAK & RATTLE DIAGNOSTIC WORKSHEET

Dear Nissan Customer:

We are concerned about your satisfaction with your Nissan vehicle. Repairing a squeak or rattle sometimes can be very difficult. To help us fix your Nissan right the first time, please take a moment to note the area of the vehicle where the squeak or rattle occurs and under what conditions. You may be asked to take a test drive with a service advisor or technician to ensure we confirm the noise you are hearing.

I. WHERE DOES THE NOISE COME FROM? (circle the area of the vehicle)

The illustrations are for reference only, and may not reflect the actual configuration of your vehicle.

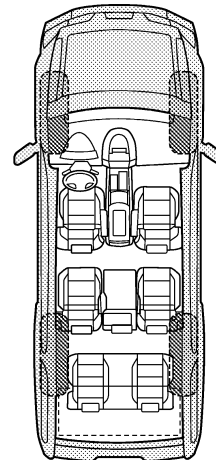
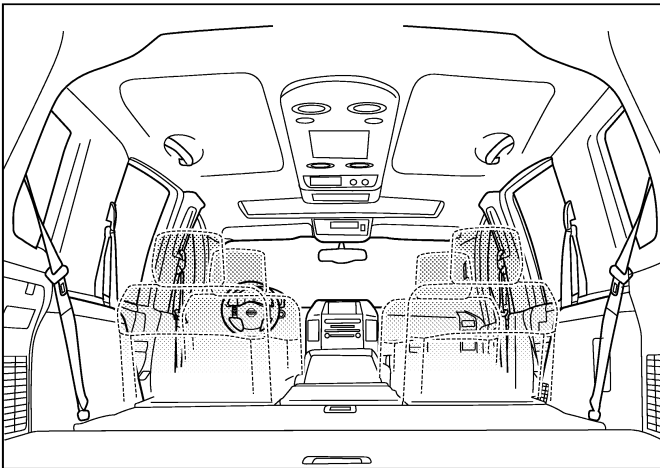
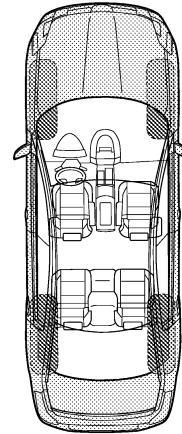
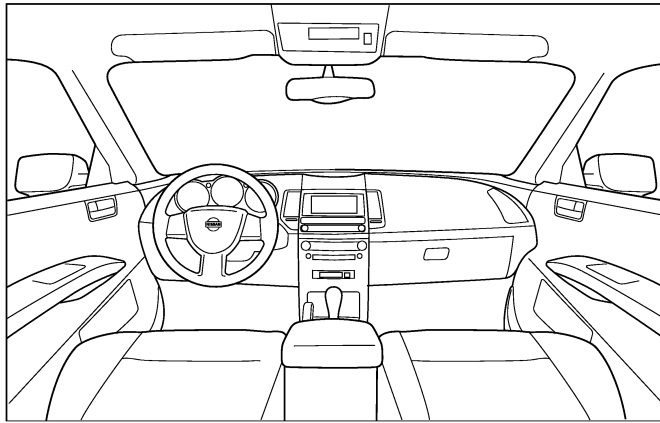

Continue to page 2 of the worksheet and briefly describe the location of the noise or rattle. In addition, please indicate the conditions which are present when the noise occurs.

PIIB8740E

A
B
C
D
E
F
G
H
I
IP
K
L
M
N
O
P

SQUEAK AND RATTLE TROUBLE DIAGNOSES

< SYMPTOM DIAGNOSIS >

SQUEAK & RATTLE DIAGNOSTIC WORKSHEET - page 2

Briefly describe the location where the noise occurs:

II. WHEN DOES IT OCCUR? (please check the boxes that apply)

- | | |
|---|--|
| <input type="checkbox"/> anytime | <input type="checkbox"/> after sitting out in the rain |
| <input type="checkbox"/> 1st time in the morning | <input type="checkbox"/> when it is raining or wet |
| <input type="checkbox"/> only when it is cold outside | <input type="checkbox"/> dry or dusty conditions |
| <input type="checkbox"/> only when it is hot outside | <input type="checkbox"/> other: |

III. WHEN DRIVING:

- through driveways
- over rough roads
- over speed bumps
- only about ____ mph
- on acceleration
- coming to a stop
- on turns: left, right or either (circle)
- with passengers or cargo
- other: _____
- after driving ____ miles or ____ minutes

IV. WHAT TYPE OF NOISE

- squeak (like tennis shoes on a clean floor)
- creak (like walking on an old wooden floor)
- rattle (like shaking a baby rattle)
- knock (like a knock at the door)
- tick (like a clock second hand)
- thump (heavy, muffled knock noise)
- buzz (like a bumble bee)

TO BE COMPLETED BY DEALERSHIP PERSONNEL

Test Drive Notes:

	YES	NO	Initials of person performing
Vehicle test driven with customer	<input type="checkbox"/>	<input type="checkbox"/>	_____
- Noise verified on test drive	<input type="checkbox"/>	<input type="checkbox"/>	_____
- Noise source located and repaired	<input type="checkbox"/>	<input type="checkbox"/>	_____
- Follow up test drive performed to confirm repair	<input type="checkbox"/>	<input type="checkbox"/>	_____

VIN: _____ Customer Name: _____
 W.O.# _____ Date: _____

This form must be attached to Work Order

PIIB8742E

INSTRUMENT PANEL ASSEMBLY

< REMOVAL AND INSTALLATION >

REMOVAL AND INSTALLATION

INSTRUMENT PANEL ASSEMBLY

Exploded View

INFOID:000000006892162

SEC. 680

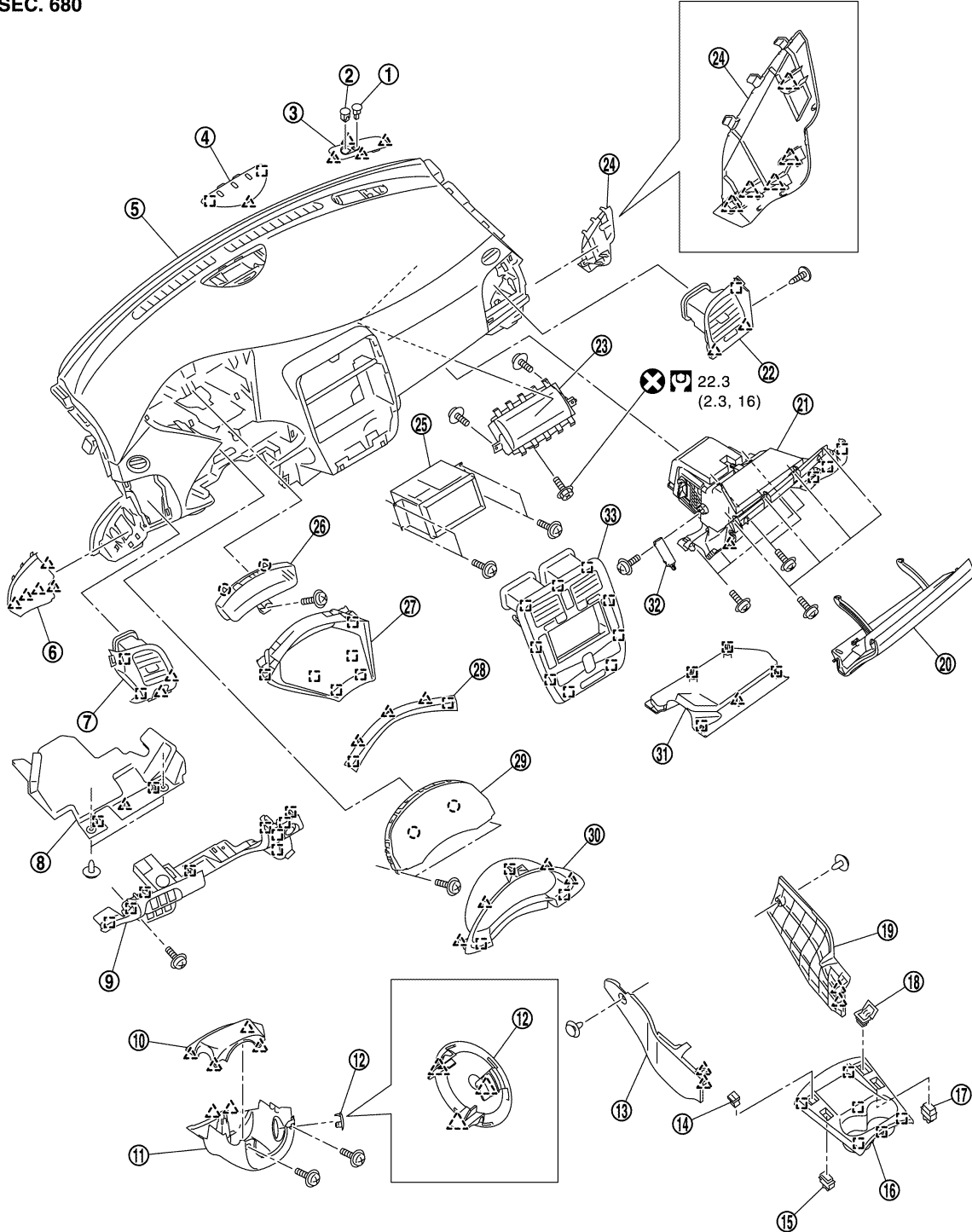

A
B
C
D
E
F
G
H
I
IP
K
L
M
N
O
P

JMJIA5861GB

INSTRUMENT PANEL ASSEMBLY

< REMOVAL AND INSTALLATION >

- | | | |
|-----------------------------------|---------------------------------|------------------------------|
| 1. Sunload sensor | 2. Optical sensor | 3. Switch panel |
| 4. Charging status indicator | 5. Instrument panel assembly | 6. Instrument mask LH |
| 7. Side ventilator grille LH | 8. Instrument under cover LH | 9. Instrument lower panel LH |
| 10. Steering column upper cover | 11. Steering column lower cover | 12. Steering column mask |
| 13. Instrument lower cover LH | 14. USB connector | 15. Switch hole mask |
| 16. Instrument lower center cover | 17. Switch hole mask | 18. Auxiliary input jacks |
| 19. Instrument lower cover RH | 20. Glove box lid | 21. Glove box cover assembly |
| 22. Side ventilator grille RH | 23. Passenger air bag module | 24. Instrument mask RH |
| 25. AV control unit | 26. Upper meter | 27. Cluster lid finisher |
| 28. Meter cover | 29. Combination meter | 30. Cluster lid A |
| 31. Instrument under cover RH | 32. Glove box dumper | 33. Cluster lid C |

 : Clip

 : Pawl

 : Metal clip

 : Always replace after every disassembly.

 : N·m (kg·m, ft·lb)

Removal and Installation

INFOID:000000006892163

WORK STEP

When removing instrument panel assembly, combination meter, upper meter, or AV control unit take steps as per the order shown in the following chart.

PARTS	INSTRUMENT PANEL ASSEMBLY	COMBINATION METER	UPPER METER	AV CONTROL UNIT
Instrument lower center cover	[1]			
Instrument lower cover LH	[2]			
Instrument lower cover RH	[3]			
Front body side welt LH	[4]			
Instrument side panel LH	[5]			
Front pillar garnish LH	[6]			
Instrument mask LH	[7]			
Meter cover	[8]			
Cluster lid finisher	[9]	[1]	[1]	
Upper meter	[10]	[2]	[2]	
Cluster lid A	[11]	[3]		
Combination meter	[12]	[4]		
Instrument under cover LH	[13]			
Instrument lower panel LH	[14]			
Side ventilator assembly LH	[15]			
Driver air bag module	[16]			
Steering wheel	[17]			
Steering column covers	[18]			
Combination switch	[19]			
Spiral cable	[20]			
Cluster lid C	[21]			[1]
AV control unit	[22]			[2]

INSTRUMENT PANEL ASSEMBLY

< REMOVAL AND INSTALLATION >

Charging status indicator	[23]			
Switch panel	[24]			
Front body side welt RH	[25]			
Instrument side panel RH	[26]			
Front pillar garnish RH	[27]			
Instrument mask RH	[28]			
Instrument under cover RH	[29]			
Glove box lid	[30]			
Glove box cover assembly	[31]			
Passenger air bag module harness connector	[32]			
Passenger air bag module mounting bolt	[33]			
Instrument panel assembly	[34]			

[]: Number indicates step in removal procedures.

WARNING:

To prevent accidental explosion, before servicing, turn ignition switch OFF, disconnect 12V battery negative terminal and wait 5 minutes or more.

CAUTION:

To prevent damage to the parts, when removing, always use a remover tool that is made of plastic.

REMOVAL

1. Remove instrument lower center cover.
 1. Apply protective tape (A) for a console finisher assembly meeting to protect it from the damage.

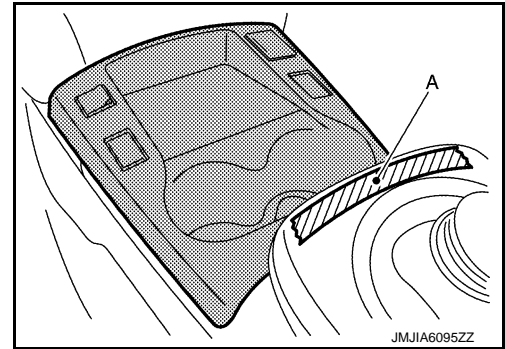

2. Apply protective tape (A) on the part to protect it from damage.

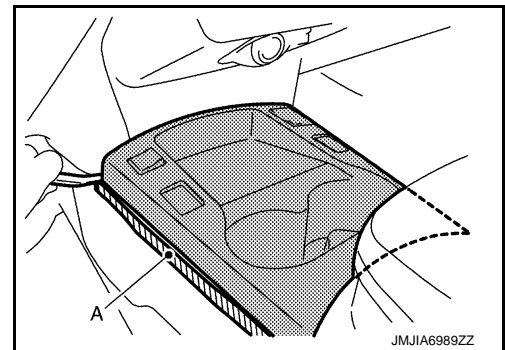

A
B
C
D
E
F
G
H
I
IP
K
L
M
N
O
P

INSTRUMENT PANEL ASSEMBLY

< REMOVAL AND INSTALLATION >

3. Insert remover tool (A) between instrument lower center cover and center console assembly to disengage the metal clips as shown in the figure.

 : Metal clip

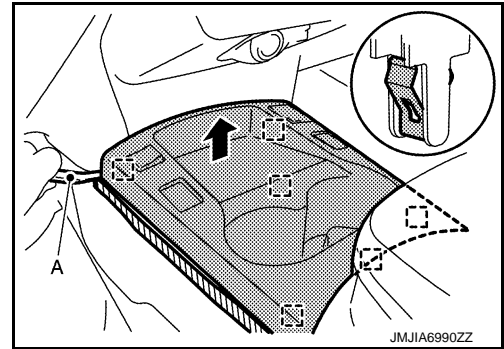

4. Lift up instrument lower center cover, and then disconnect harness connectors.

CAUTION:

Be careful not to scratch console finisher assembly with pawl or metal clip of instrument lower center cover.

2. Remove instrument lower cover LH.

1. Remove fixing clip (A).
2. Pull the instrument lower cover LH crosswise, and disengage the pawls.

CAUTION:

Remove pawls slowly so that they are not damaged.

 : Pawl

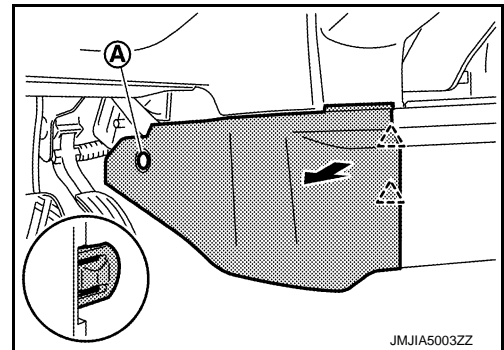

3. Remove instrument lower cover RH.

1. Remove fixing clip (A).
2. Pull the instrument lower cover RH crosswise, and disengage the pawls.

CAUTION:

Remove pawls slowly so that they are not damaged.

 : Pawl

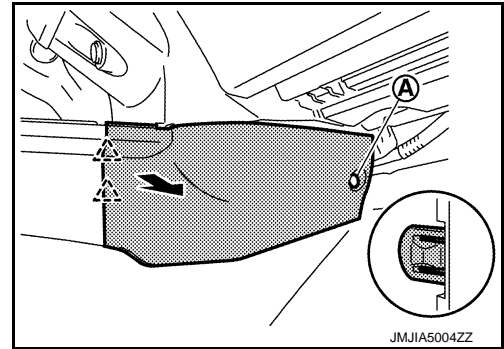

4. Release front pillar portion of front body side welt LH. Refer to [INT-24, "BODY SIDE WELT : Removal and Installation"](#).
5. Remove instrument side panel LH. Refer to [INT-20, "INSTRUMENT SIDE PANEL : Removal and Installation"](#).
6. Remove front pillar garnish LH. Refer to [INT-21, "FRONT PILLAR GARNISH : Removal and Installation"](#).
7. Remove instrument mask LH.
 1. Apply protective tape (A) on the part to protect it from damage.

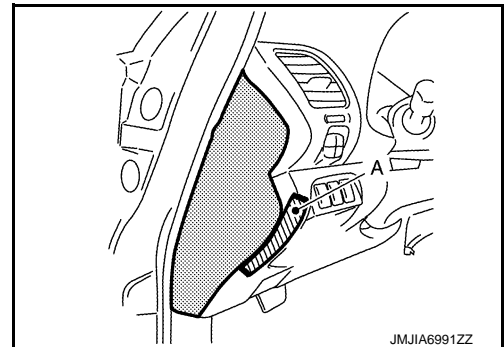

INSTRUMENT PANEL ASSEMBLY

< REMOVAL AND INSTALLATION >

2. Insert remover tool (A) between instrument mask LH and instrument panel assembly to disengage the pawls as shown in the figure.
3. Pull back instrument mask LH.

 : Pawl

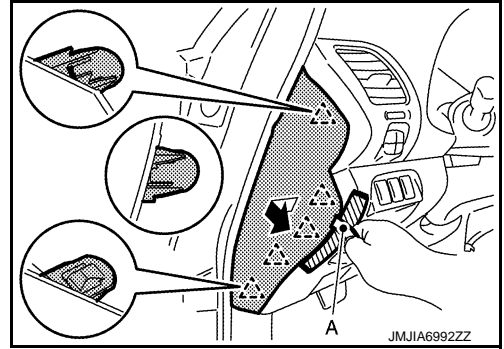

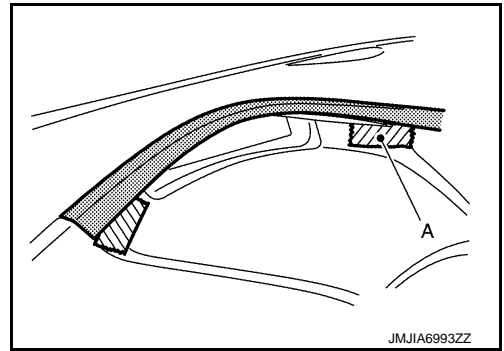

8. Remove meter cover.
 1. Apply protective tape (A) on the part to protect it from damage.

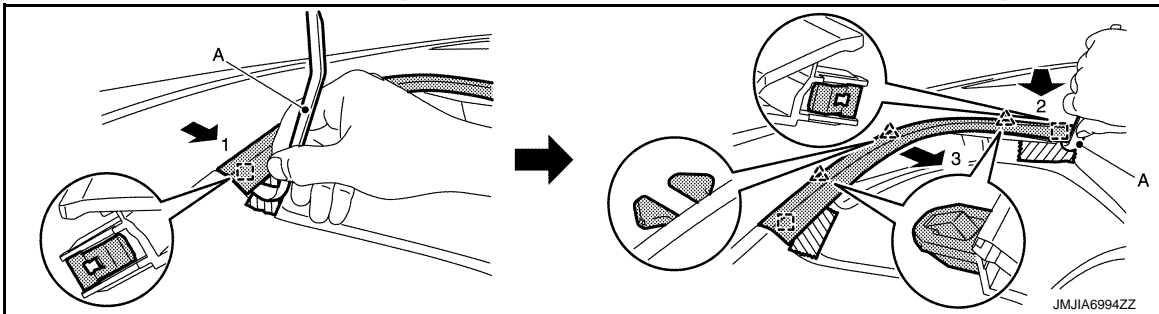

2. Insert remover tool (A) between meter cover and cluster lid finisher to disengage the metal clips of meter cover both side according to the numerical order 1 → 2 as shown in the figure.



3. Pull back meter cover to disengage the pawls according to the numerical order 3 as shown in the figure.

 : Pawl
 : Metal clip

9. Remove cluster lid finisher.

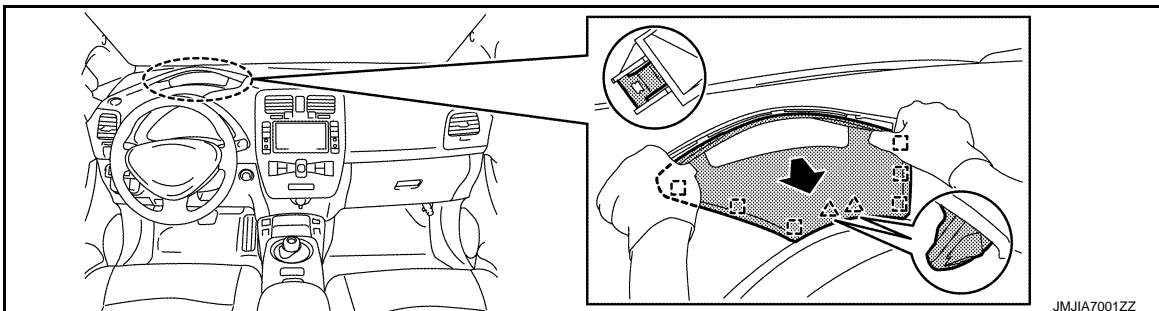

Pull back cluster lid finisher, and disengage the pawls and metal clips.

CAUTION:
 Wear a gloves to prevent an injury.

A
B
C
D
E
F
G
H
I
IP
K
L
M
N
O
P

INSTRUMENT PANEL ASSEMBLY

< REMOVAL AND INSTALLATION >

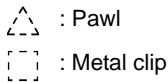

10. Remove upper meter. Refer to [MWI-102, "Removal and Installation"](#).
11. Remove cluster lid A.
 1. Place the tilt to the lowest level.
 2. Apply protective tape (A) on the instrument panel assembly meeting to protect it from the damage.

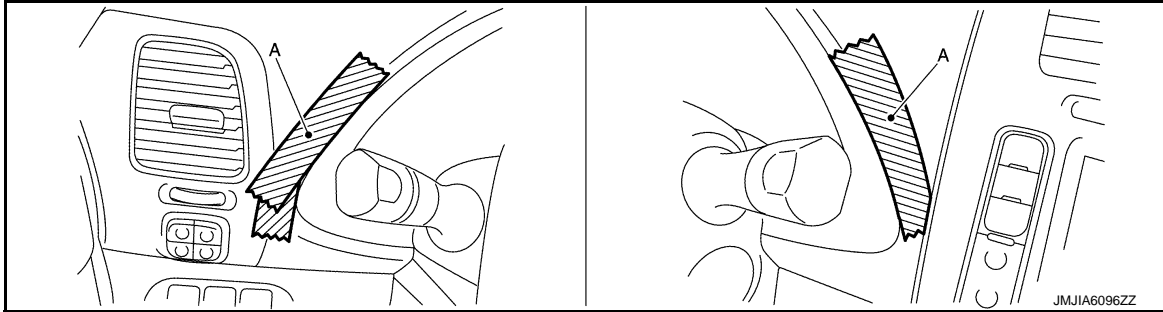

3. Pull back cluster lid A while holding the upper side (center) and disengage the metal clips topside.
CAUTION:
Wear a gloves to prevent an injury.

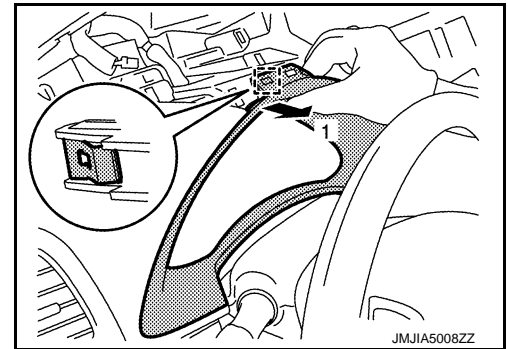
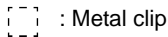

4. Hold sides of cluster lid A and pull it out towards vehicle rear, and disengage pawls and metal clips underside according to the numerical order 2 → 3 as shown in the figure.

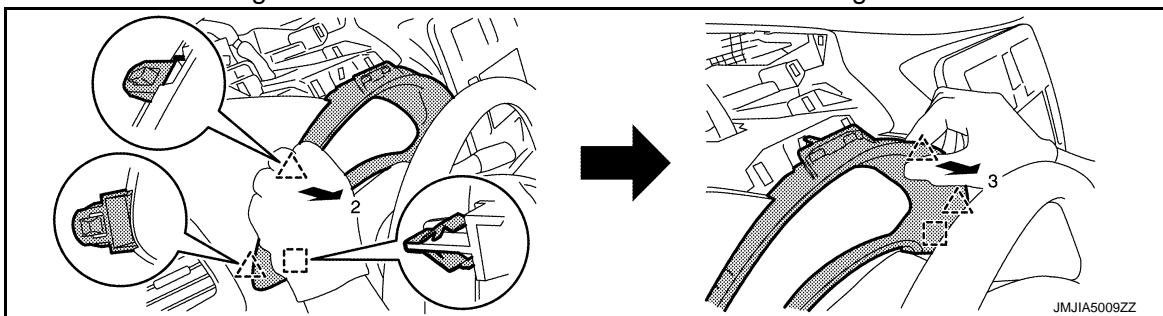

- CAUTION:**
- Wear a gloves to prevent an injury.
 - Be careful not to scratch instrument panel assembly with pawls of cluster lid A.

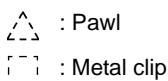

12. Remove combination meter. Refer to [MWI-101, "Removal and Installation"](#).
13. Remove instrument under cover LH.

INSTRUMENT PANEL ASSEMBLY

< REMOVAL AND INSTALLATION >

1. Remove fixing clips (A) and (B).
2. Pull downward and disengage pawl and metal clips.
3. Pull back instrument under cover LH.

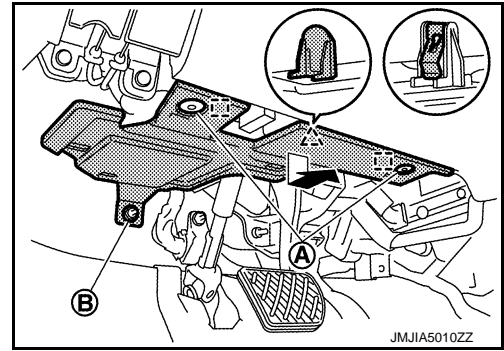
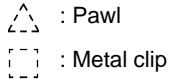

14. Remove instrument lower panel LH.

1. Remove hood opener and charge port lid opener lever fixing bolts. Refer to [DLK-178, "HOOD LOCK CONTROL CABLE : Removal and Installation"](#).
2. Remove instrument lower panel LH fixing screw (A).
3. Disengage metal clips according to the numerical order 1 → 4 as shown in the figure.
4. Pull instrument lower panel LH, backward to disengage from instrument panel assembly.

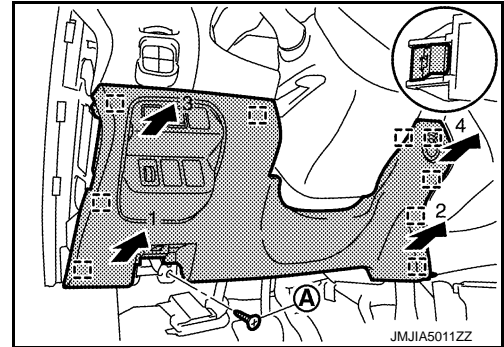

5. Release data link connector (pawl) then remove it from instrument lower panel LH.
6. Disconnect harness connectors and aspirator duct.

15. Remove side ventilator grille assembly LH. Refer to [VTL-15, "SIDE VENTILATOR GRILLE : Removal and Installation"](#).

16. Remove driver air bag module. Refer to [SR-19, "Removal and Installation"](#).

17. Remove steering wheel assembly. Refer to [ST-30, "Removal and Installation"](#).

18. Remove steering column covers.

1. Remove steering column cover fixing screws (A).
2. Pull up steering column upper cover (1), and then remove steering column upper cover.
3. Pull down steering column lower cover (2), and then remove steering column lower cover.

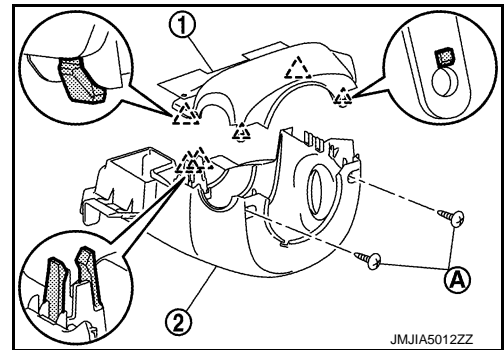
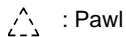

19. Remove combination switch. Refer to [BCS-78, "Removal and Installation"](#).

20. Remove spiral cable. Refer to [SR-22, "Removal and Installation"](#).

21. Remove cluster lid C.

A
B
C
D
E
F
G
H
I
IP
K
L
M
N
O
P

INSTRUMENT PANEL ASSEMBLY

< REMOVAL AND INSTALLATION >

1. Hold both upper sides of cluster lid C and pull it out towards vehicle rear, and disengage metal clips topside.

CAUTION:

Hooks of cluster lid C are engaged at upper. Never pull cluster lid C forcefully.

 : Metal clip

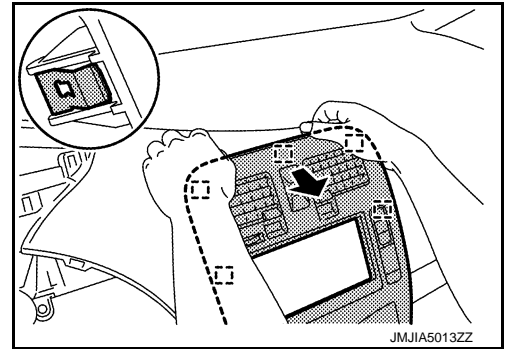

2. Hold both lower sides of cluster lid C and pull it out towards vehicle rear, and disengage metal clips underside.

CAUTION:

Hooks of cluster lid C are engaged at upper. Never pull cluster lid C forcefully.

 : Metal clip

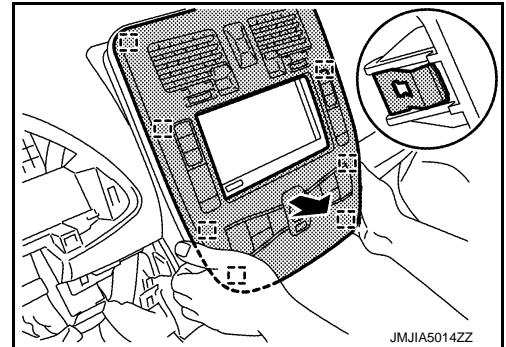

3. Bypassing hooks (B) of both upper side.

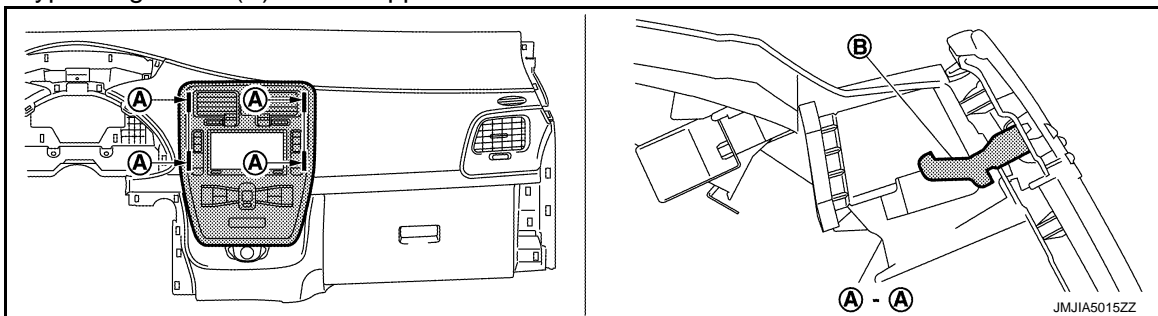

CAUTION:

- Remove hooks slowly so that they are not damaged.
- Be careful not to scratch instrument panel assembly with center ventilator grille.

4. Disconnect harness connectors.
22. Remove AV control unit. Refer to [AV-119, "Removal and Installation"](#).
23. Remove charging status indicator.

1. Apply protective tape (A) on the part to protect it from damage.

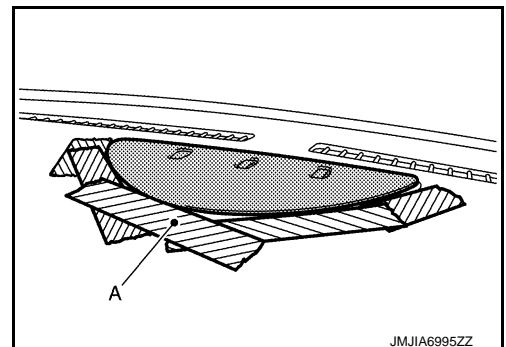

INSTRUMENT PANEL ASSEMBLY

< REMOVAL AND INSTALLATION >

2. Insert remover tool (A) between charging status indicator and instrument panel assembly to disengage the pawl and metal clips as shown in the figure.
3. Pull toward the arrow direction.
4. Disconnect harness connector.

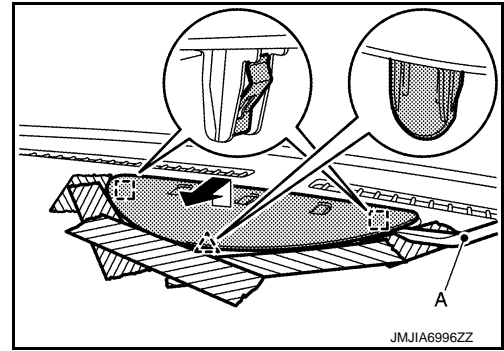
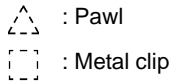

24. Remove switch panel.

1. Apply protective tape (A) on the part to protect it from damage.

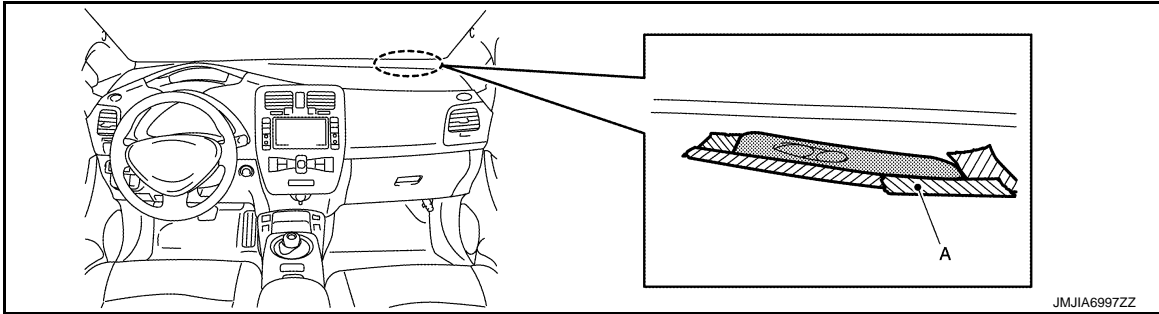

2. Insert remover tool (A) between switch panel and instrument panel assembly to disengage the pawls as shown in the figure.
3. Pull up switch panel, and then disconnect harness connectors.

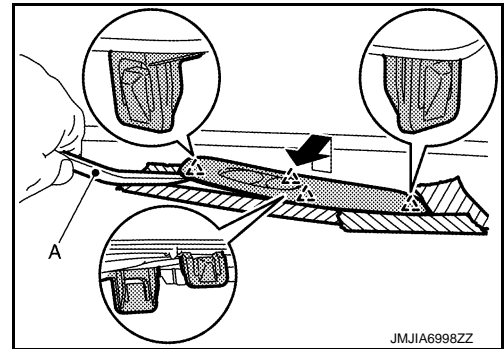
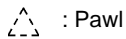

25. Release front pillar portion of front body side welt RH. Refer to [INT-24, "BODY SIDE WELT : Removal and Installation"](#).

26. Remove instrument side panel RH. Refer to [INT-20, "INSTRUMENT SIDE PANEL : Removal and Installation"](#).

27. Remove front pillar garnish RH. Refer to [INT-21, "FRONT PILLAR GARNISH : Removal and Installation"](#).

28. Remove instrument mask RH.

1. Apply protective tape (A) on the part to protect it from damage.

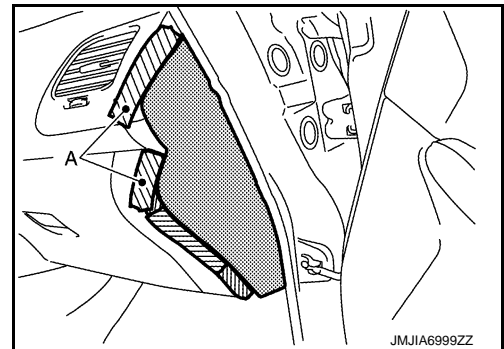



A
B
C
D
E
F
G
H
I
IP
K
L
M
N
O
P

INSTRUMENT PANEL ASSEMBLY

< REMOVAL AND INSTALLATION >

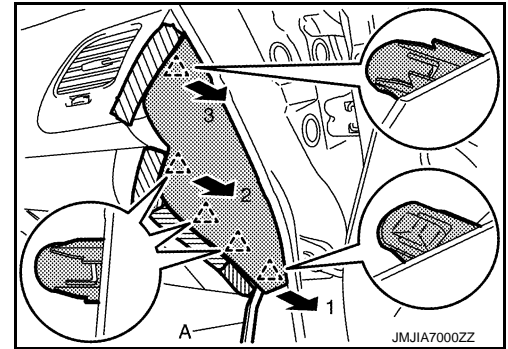
2. Insert remover tool (A) between instrument mask RH and instrument panel assembly to disengage the pawls according to the numerical order 1 → 3 as shown in the figure.
3. Pull back instrument mask RH.



 : Pawl

29. Remove instrument under cover RH.

1. Insert remover tool (A) between instrument under cover RH and glove box cover assembly to disengage the pawls and metal clips as shown in the figure.

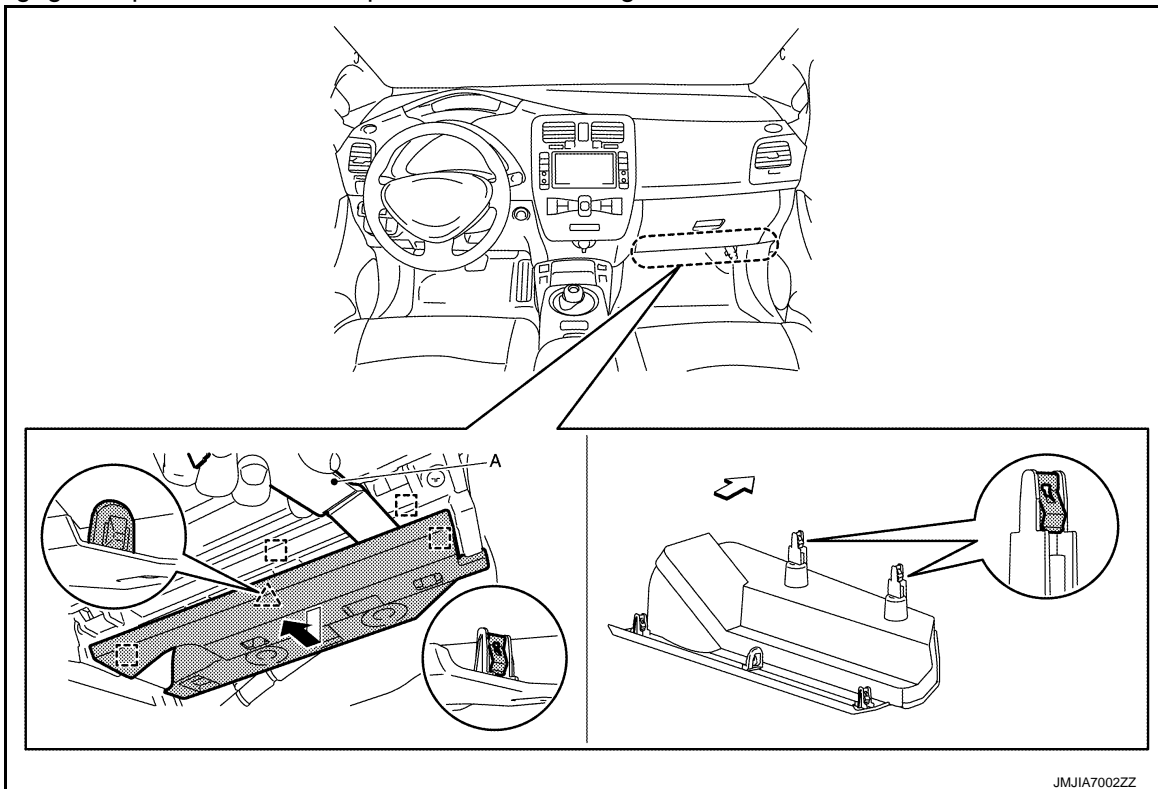

2. Pull downward and disengage metal clips of the back side.
3. Pull back instrument under cover RH.

 : Pawl

 : Metal clip

 : Vehicle front

30. Remove glove box lid.

1. Open glove box lid.

INSTRUMENT PANEL ASSEMBLY

< REMOVAL AND INSTALLATION >

- Disengage the pawl, and then remove damper pin on left side.

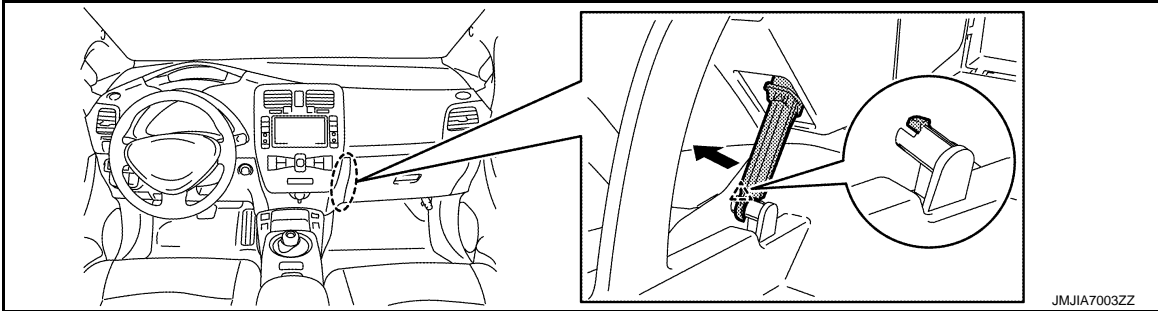

CAUTION:
Never excessively pull string of glove box damper.

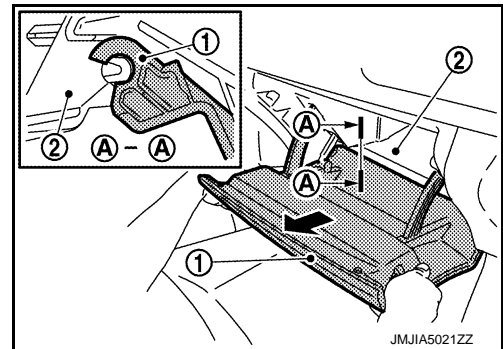

 : Pawl

- Pull glove box lid (1) toward vehicle rear, and then disengage the joint from glove box cover assembly (2).



- Remove glove box cover assembly.

- Remove fixing screws (A).
- Pull back the glove box cover assembly while holding the lower side and disengage the pawl and metal clips according to the numerical order 1 → 3 as shown in the figure.

 : Pawl
 : Metal clip

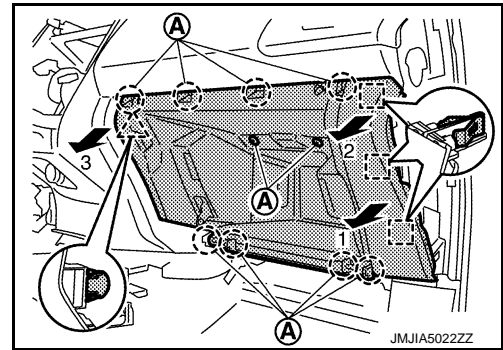

- Disconnect harness connector.
- Disconnect passenger air bag module harness connector. Refer to [SR-25. "Exploded View"](#).
- Remove passenger air bag module fixing bolt. Refer to [SR-25. "Exploded View"](#).
- Remove instrument panel assembly.

A
B
C
D
E
F
G
H
I
IP
K
L
M
N
O
P

INSTRUMENT PANEL ASSEMBLY

< REMOVAL AND INSTALLATION >

1. Remove instrument panel assembly mounting bolt (A), screws (B).

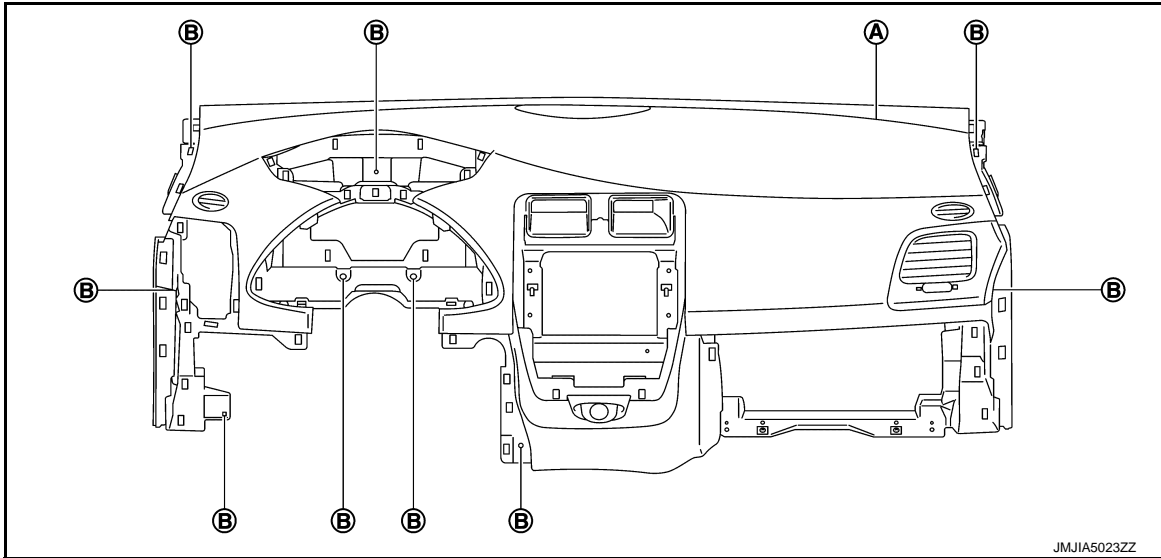

CAUTION:

Cover tool with a shop cloth to prevent windshield glass from being damaged.

2. Disconnect TCU harness connector (A) and remove harness clip (B).

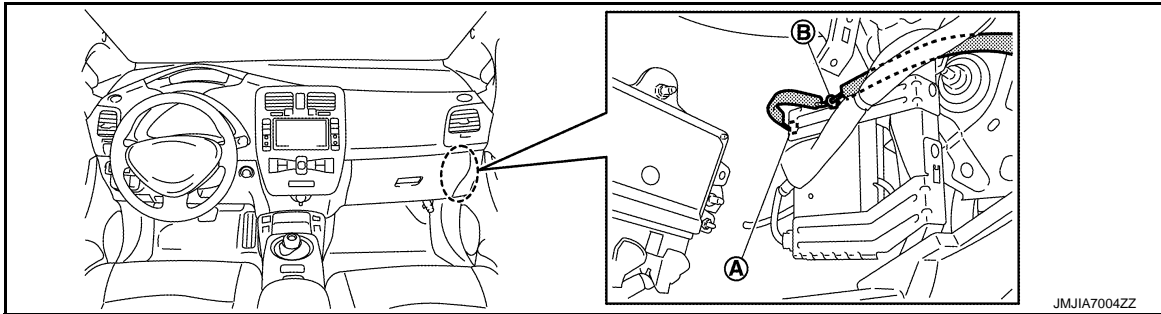

3. Disconnect power socket harness connector. Refer to [PWO-7, "Removal and Installation"](#).

INSTRUMENT PANEL ASSEMBLY

< REMOVAL AND INSTALLATION >

4. Disengage harness (A) and harness (B) of front pillar LH and RH portions from instrument panel assembly.

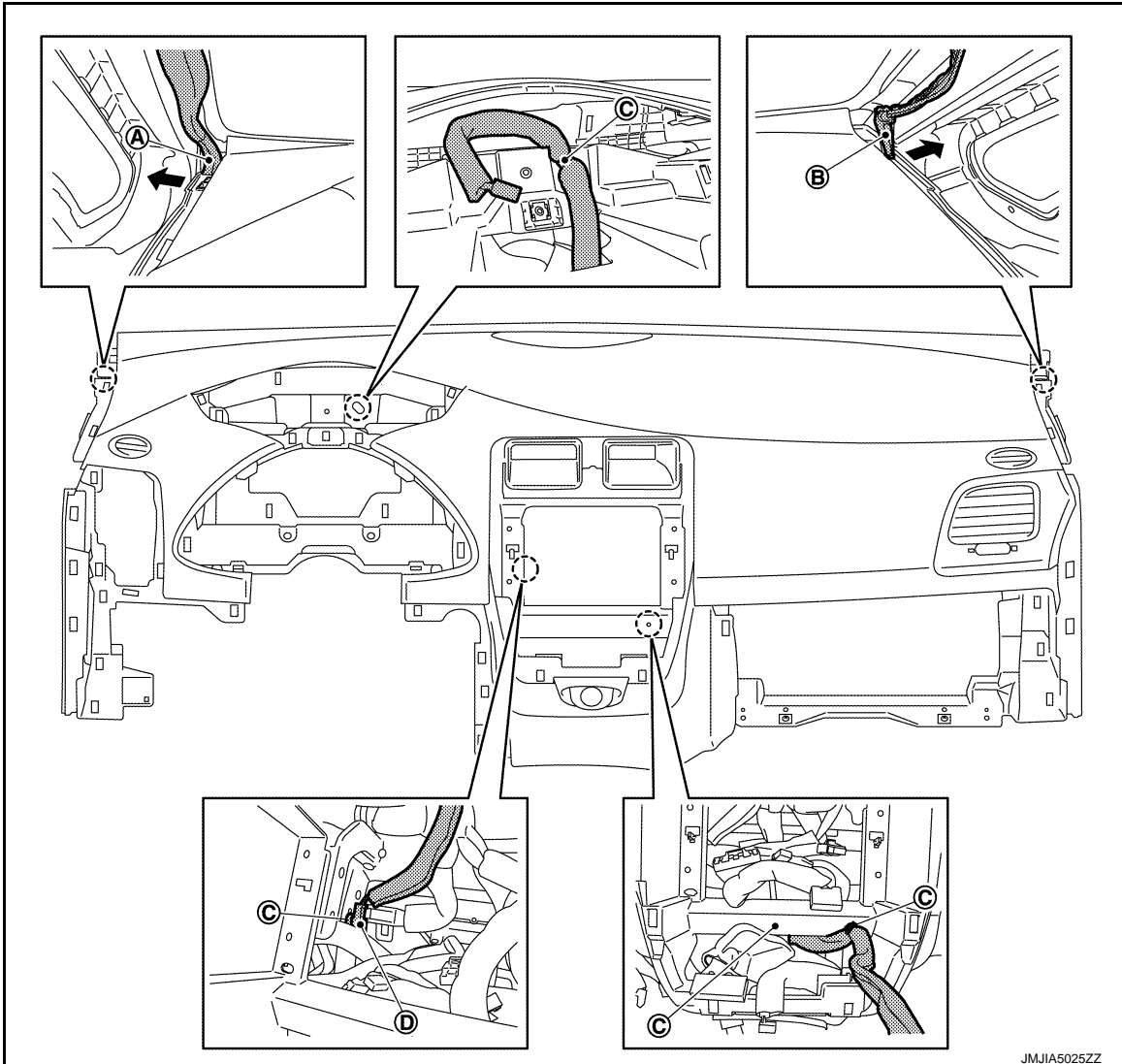

5. Remove harness clips (C) from instrument panel assembly.
6. Disconnect harness connector (D).
7. Remove instrument panel from passenger door opening portion.

CAUTION:

- Cover center console upper surface with a shop cloth to prevent it from being damaged.
- When removing instrument panel assembly, 2 workers are required so as to prevent it from dropping.

35. Remove the following parts after removing instrument panel assembly.
 - Passenger air bag module: Refer to [SR-25, "Removal and Installation"](#).
 - Side ventilator grille RH: Refer to [VTL-15, "SIDE VENTILATOR GRILLE : Removal and Installation"](#).
 - Side defroster nozzle LH/RH: Refer to [VTL-16, "SIDE DEFROSTER GRILLE : Removal and Installation"](#).
 - Side defroster grille LH/RH: Refer to [VTL-19, "SIDE DEFROSTER NOZZLE 2 : Removal and Installation"](#).
 - Center ventilator duct: Refer to [VTL-17, "CENTER VENTILATOR DUCT : Removal and Installation"](#).
 - Side ventilator duct: Refer to [VTL-17, "SIDE VENTILATOR DUCT : Removal and Installation"](#).
 - Front defroster nozzle. Refer to [VTL-18, "FRONT DEFROSTER NOZZLE : Removal and Installation"](#).
 - GPS antenna: Refer to [AV-125, "Removal and Installation"](#).
 - TEL antenna: Refer to [AV-214, "Removal and Installation"](#).

INSTALLATION

Note the following items, and then install in the reverse order of removal.

CAUTION:

INSTRUMENT PANEL ASSEMBLY

< REMOVAL AND INSTALLATION >

- **Never use the steering wheel mounting nut after removal, replace with the new nut.**
- **Never use the driver air bag module mounting bolts after removal, replace with the new bolts.**
- **Never use the passenger air bag module mounting bolt after removal, replace with the new bolt.**

CENTER CONSOLE ASSEMBLY

< REMOVAL AND INSTALLATION >

CENTER CONSOLE ASSEMBLY

Exploded View

INFOID:000000006892164

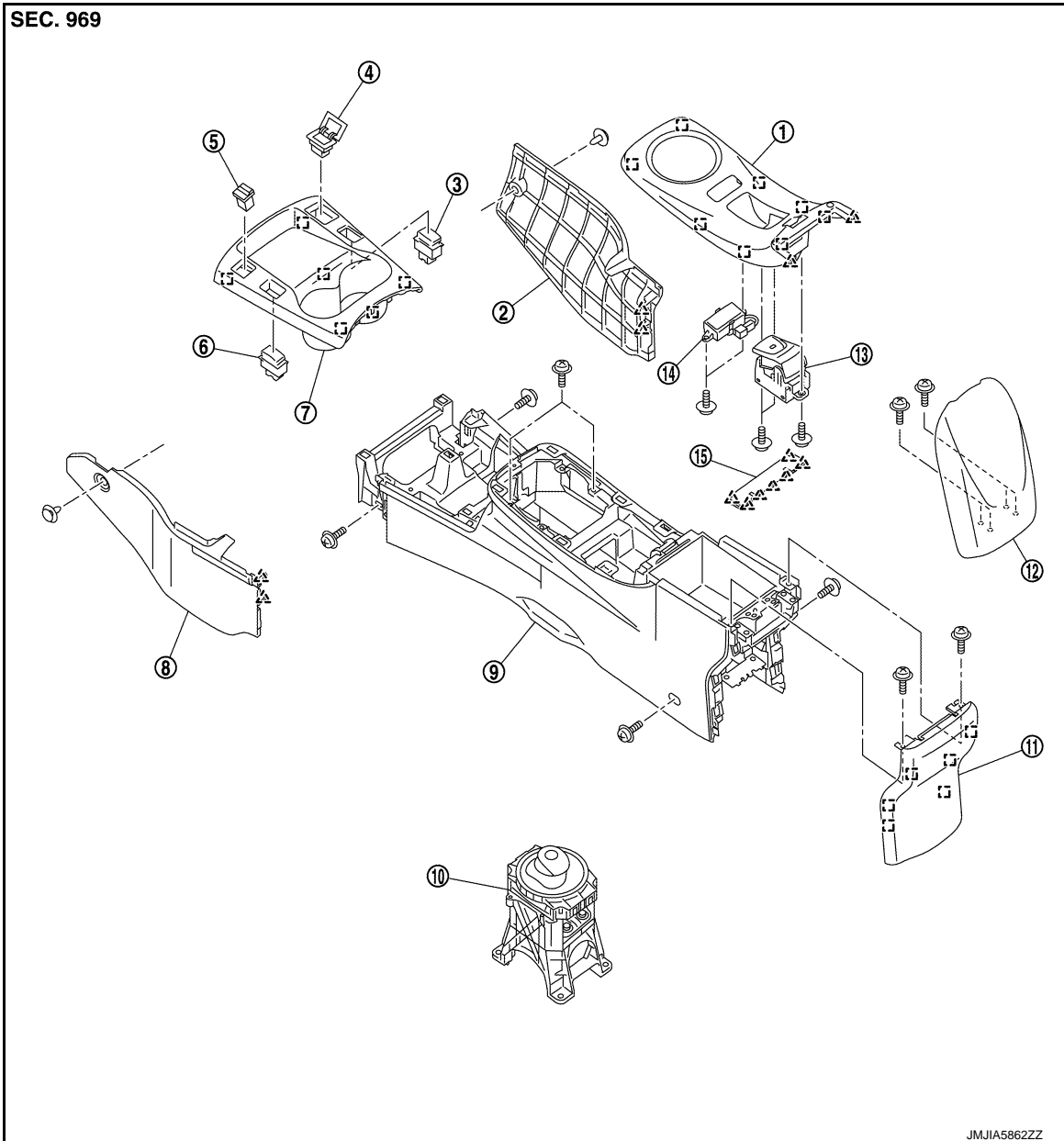

- | | | |
|----------------------------------|------------------------------|----------------------------|
| 1. Console finisher assembly | 2. Instrument lower cover RH | 3. Switch hole mask |
| 4. Auxiliary input jacks | 5. USB connector | 6. Switch hole mask |
| 7. Instrument lower center cover | 8. Instrument lower cover LH | 9. Center console assembly |
| 10. Electric shift selector | 11. Console rear finisher | 12. Console lid assembly |
| 13. Parking brake switch | 14. Selector indicator | 15. Console mask |

- △ : Pawl
 □ : Metal clip

Removal and Installation

INFOID:000000006892165

CAUTION:

To prevent damage to the parts, when removing, always use a remover tool that is made of plastic.

A
B
C
D
E
F
G
H
I
IP
K
L
M
N
O
P

CENTER CONSOLE ASSEMBLY

< REMOVAL AND INSTALLATION >

REMOVAL

1. Remove instrument lower center cover.
 1. Apply protective tape (A) for a console finisher assembly meeting to protect it from damage.

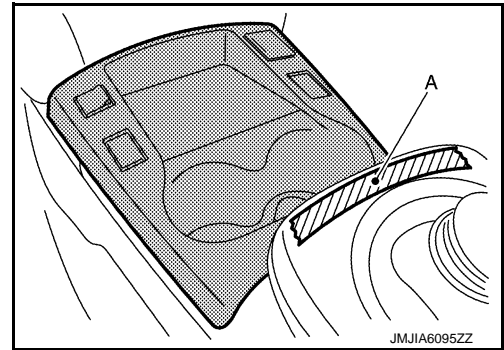

2. Apply protective tape (A) on the part to protect it from damage.

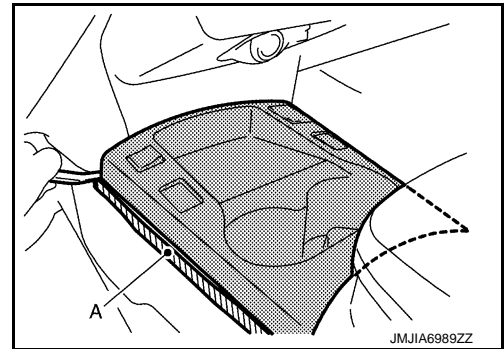

3. Insert remover tool (A) between instrument lower center cover and center console assembly to disengage the metal clips as shown in the figure.

 : Metal clip

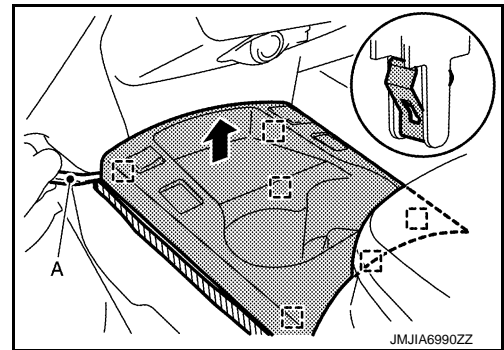

4. Lift up instrument lower center cover, and then disconnect harness connectors.

CAUTION:

Be careful not to scratch console finisher assembly with pawl or metal clip of instrument lower center cover.

2. Remove instrument lower cover LH.
 1. Remove fixing clip (A).
 2. Pull the instrument lower cover LH crosswise, and disengage the pawls.

CAUTION:

Remove pawls slowly so that they are not damaged.

 : Pawl

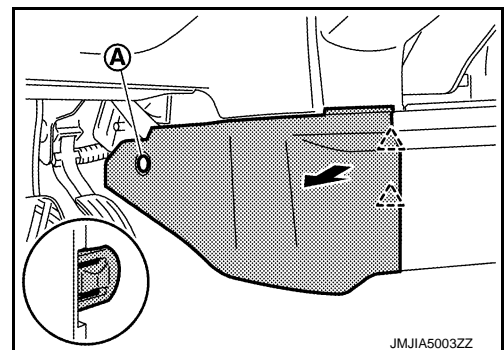

CENTER CONSOLE ASSEMBLY

< REMOVAL AND INSTALLATION >

3. Remove center console assembly fixing screw (A).

↶ : Vehicle front

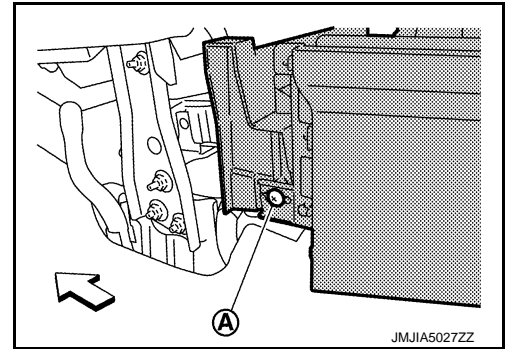

4. Remove instrument lower cover RH.
1. Remove fixing clip (A).
 2. Pull the instrument lower cover RH crosswise, and disengage the pawls.
- CAUTION:**
Remove pawls slowly so that they are not damaged.

△ : Pawl

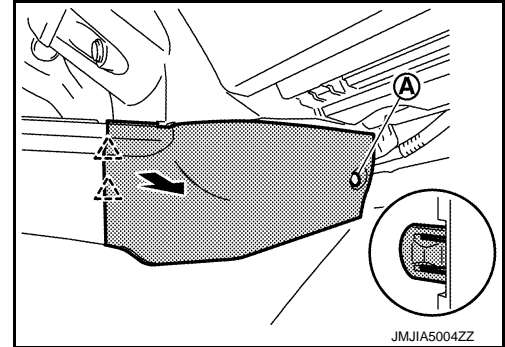

5. Remove center console assembly fixing screw (A).

↶ : Vehicle front

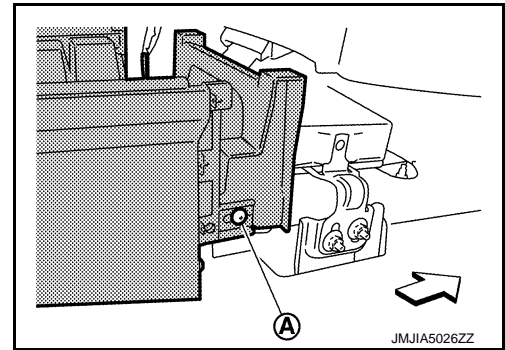

6. Remove console finisher assembly.
1. Lift up console finisher assembly back side, and then disengage the pawls and metal clips according to the numerical order 1 → 6 as shown in the figure.
 2. Disconnect harness connectors.
- CAUTION:**
Disengage slowly so that pawls in rear end of console finisher assembly are not damaged.

△ : Pawl

□ : Metal clip

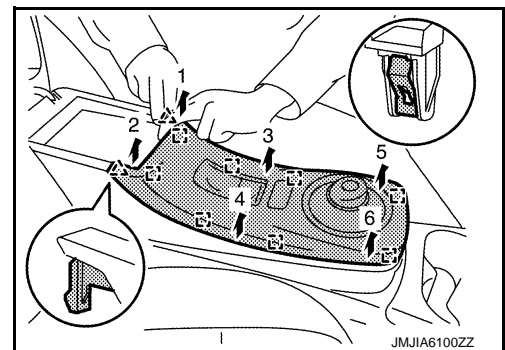

A
B
C
D
E
F
G
H
I
IP
K
L
M
N
O
P

CENTER CONSOLE ASSEMBLY

< REMOVAL AND INSTALLATION >

7. Remove center console assembly fixing screws (A).

↔ : Vehicle front

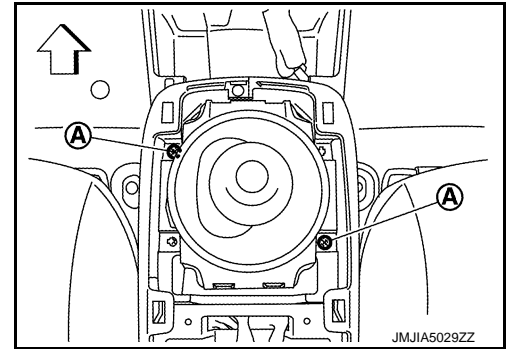

8. Put front seat to frontmost position.
9. Remove center console assembly fixing screws (A).

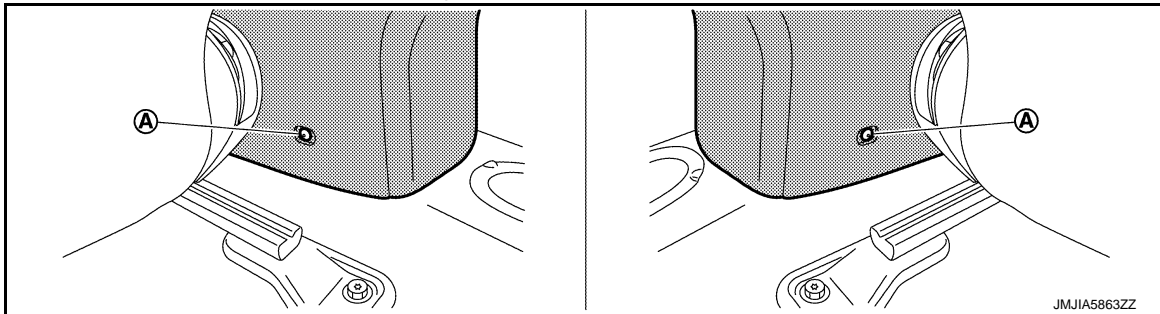

10. Put front seat to rearmost position.
11. Remove console harness clips (A) and (B).

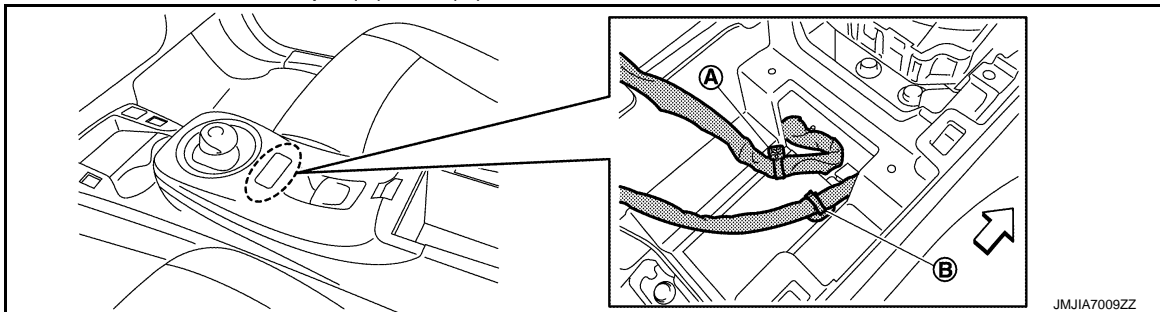

↔ : Vehicle front

12. Lift up center console assembly back side, and then remove center console assembly.

INSTALLATION

Install in the reverse order of removal.

Disassembly and Assembly

INFOID:000000006892166

CAUTION:

To prevent damage to the parts, when disassembling, always use a remover tool that is made of plastic.

DISASSEMBLY

1. Remove center console assembly. Refer to [IP-27, "Removal and Installation"](#).
2. Remove console mask.
 1. Open the console lid assembly.

CENTER CONSOLE ASSEMBLY

< REMOVAL AND INSTALLATION >

2. Apply protective tape (A) on the part to protect it from damage.

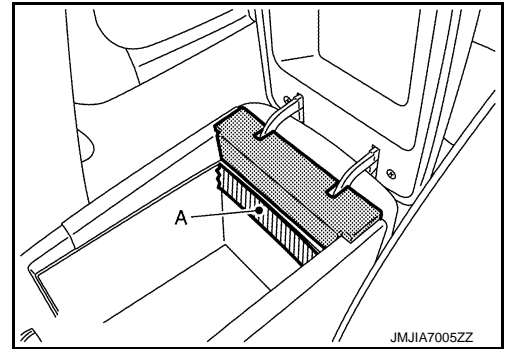

3. Insert remover tool (A) between console mask and console body assembly to disengage the pawls as shown in the figure.
4. Pull up console mask.
CAUTION:
Disengage slowly so that pawls in front end of console mask are not damaged.

 : Pawl

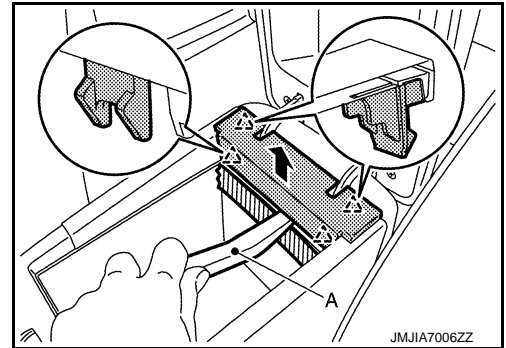

3. Remove console rear finisher.
 1. Remove screws (A).

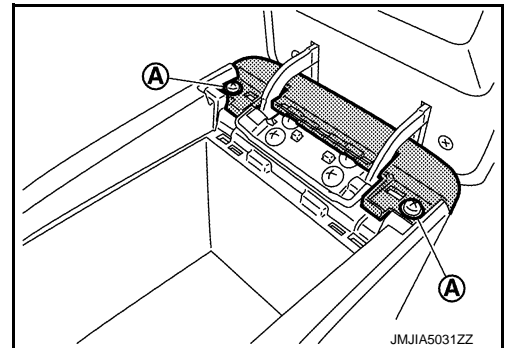

2. Close the console lid assembly.
3. Apply protective tape (A) on the part to protect it from damage.

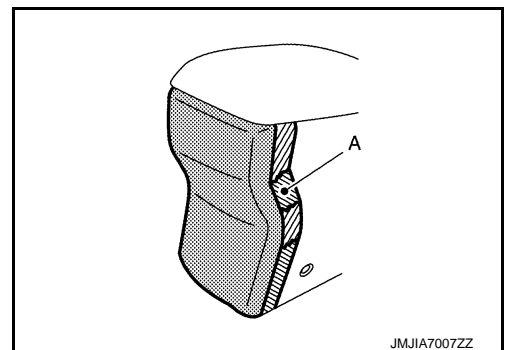

A
B
C
D
E
F
G
H
I
IP
K
L
M
N
O
P

CENTER CONSOLE ASSEMBLY

< REMOVAL AND INSTALLATION >

4. Insert remover tool (A) between console rear finisher and console body assembly to disengage the metal clips according to the numerical order 1 → 6 as shown in the figure.
5. Pull back console rear finisher.

 : Metal clip

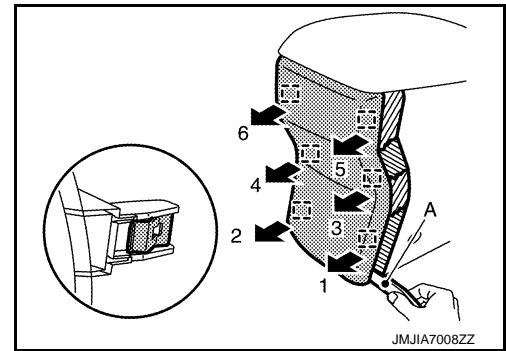

4. Remove console lid assembly.
 1. Open the console lid.
 2. Remove console lid assembly fixing screws (A) and then remove console lid assembly.

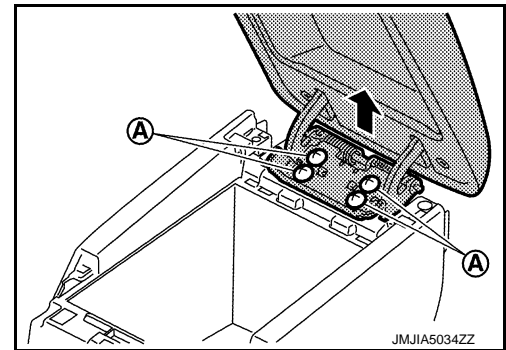

ASSEMBLY

Assemble in the reverse order of disassembly.