

SECTION **SR**

SRS AIRBAG

A
B
C
D
E
F
G
SR
I
J
K
L
M
N
O
P

CONTENTS

PRECAUTION	3	MAIN COMPONENT PARTS AND FUNCTIONS :	
PRECAUTIONS	3	Air bag diagnosis sensor unit	12
Precaution for Technicians Using Medical Electric.....	3	MAIN COMPONENT PARTS AND FUNCTIONS :	
Point to Be Checked Before Starting Maintenance		Air bag warning lamp	12
Work	3	BASIC INSPECTION	13
Precautions for Removing Battery Terminal	4	COLLISION DIAGNOSIS	13
Precaution for Supplemental Restraint System		FOR FRONTAL COLLISION	13
(SRS) "AIR BAG" and "SEAT BELT PRE-TENSIONER"	4	FOR FRONTAL COLLISION : When SRS is activated in a collision	13
Occupant Classification System	5	FOR FRONTAL COLLISION : When SRS is not activated in a collision	14
Precaution for Work	5	FOR SIDE AND ROLLOVER COLLISION	15
PREPARATION	6	FOR SIDE AND ROLLOVER COLLISION : When SRS is activated in a collision	15
PREPARATION	6	FOR SIDE AND ROLLOVER COLLISION : When SRS is not activated in a collision	16
Commercial Service Tools	6	REMOVAL AND INSTALLATION	19
SYSTEM DESCRIPTION	7	DRIVER AIR BAG MODULE	19
COMPONENT PARTS	7	Exploded View	19
AIR BAG MODULE	7	Removal and Installation	19
AIR BAG MODULE : Driver air bag module	7	SPIRAL CABLE	22
AIR BAG MODULE : Passenger air bag module	7	Exploded View	22
AIR BAG MODULE : Side air bag module	8	Removal and Installation	22
AIR BAG MODULE : Curtain air bag module	8	PASSENGER AIR BAG MODULE	25
INFLATOR	8	Exploded View	25
INFLATOR : Driver air bag inflator	9	Removal and Installation	25
INFLATOR : Passenger air bag inflator	9	CURTAIN AIR BAG MODULE	28
INFLATOR : Side air bag inflator	10	Exploded View	28
INFLATOR : Curtain air bag inflator	10	Removal and Installation	28
MAIN COMPONENT PARTS AND FUNCTIONS	11	CRASH ZONE SENSOR	30
MAIN COMPONENT PARTS AND FUNCTIONS :		Exploded View	30
Spiral cable	11	Removal and Installation	30
MAIN COMPONENT PARTS AND FUNCTIONS :			
Crash zone sensor	11		
MAIN COMPONENT PARTS AND FUNCTIONS :			
Satellite sensor	11		

SATELLITE SENSOR	32	Removal and Installation	37
Exploded View	32		
Removal and Installation	32		
DIAGNOSIS SENSOR UNIT	35		
Exploded View	35		
Removal and Installation	35		
SEAT BELT PRE-TENSIONER	37		
Exploded View	37		
		LAP PRE-TENSIONER	38
		Exploded View	38
		Removal and Installation	38
		OCCUPANT CLASSIFICATION SYSTEM	
		CONTROL UNIT	39
		Exploded View	39
		Removal and Installation	39

PRECAUTIONS

< PRECAUTION >

PRECAUTION

PRECAUTIONS

Precaution for Technicians Using Medical Electric

INFOID:000000007075274

OPERATION PROHIBITION

WARNING:

- Parts with strong magnet is used in this vehicle.
- Technicians using a medical electric device such as pacemaker must never perform operation on the vehicle, as magnetic field can affect the device function by approaching to such parts.

NORMAL CHARGE PRECAUTION

WARNING:

- If a technician uses a medical electric device such as an implantable cardiac pacemaker or an implantable cardioverter defibrillator, the possible effects on the devices must be checked with the device manufacturer before starting the charge operation.
- As radiated electromagnetic wave generated by on board charger at normal charge operation may effect medical electric devices, a technician using a medical electric device such as implantable cardiac pacemaker or an implantable cardioverter defibrillator must not enter the vehicle compartment (including luggage room) during normal charge operation.

PRECAUTION AT TELEMATICS SYSTEM OPERATION

WARNING:

- If a technician uses implantable cardiac pacemaker or implantable cardioverter defibrillator (ICD), avoid the device implanted part from approaching within approximately 220 mm (8.66 in) from interior/exterior antenna.
- The electromagnetic wave of TCU might affect the function of the implantable cardiac pacemaker or the implantable cardioverter defibrillator (ICD), when using the service, etc.
- If a technician uses other medical electric devices than implantable cardiac pacemaker or implantable cardioverter defibrillator (ICD), the electromagnetic wave of TCU might affect the function of the device. The possible effects on the devices must be checked with the device manufacturer before TCU use.

PRECAUTION AT INTELLIGENT KEY SYSTEM OPERATION

WARNING:

- If a technician uses implantable cardiac pacemaker or implantable cardioverter defibrillator (ICD), avoid the device implanted part from approaching within approximately 220 mm (8.66 in) from interior/exterior antenna.
- The electromagnetic wave of Intelligent Key might affect the function of the implantable cardiac pacemaker or the implantable cardioverter defibrillator (ICD), at door operation, at each request switch operation, or at engine starting.
- If a technician uses other medical electric devices than implantable cardiac pacemaker or implantable cardioverter defibrillator (ICD), the electromagnetic wave of Intelligent Key might affect the function of the device. The possible effects on the devices must be checked with the device manufacturer before Intelligent Key use.

Point to Be Checked Before Starting Maintenance Work

INFOID:000000007079484

The high voltage system may starts automatically. It is required to check that the timer air conditioner and timer charge (during EVSE connection) are not set before starting maintenance work.

NOTE:

If the timer air conditioner or timer charge (during EVSE connection) is set, the high voltage system starts automatically even when the power switch is in OFF state.

PRECAUTIONS

< PRECAUTION >

Precautions for Removing Battery Terminal

INFOID:000000006952037

- When removing the 12V battery terminal, turn OFF the power switch and wait at least 5 minutes.

NOTE:

ECU may be active for several minutes after the power switch is turned OFF. If the battery terminal is removed before ECU stops, then a DTC detection error or ECU data corruption may occur.

- Always disconnect the battery terminal within 60 minutes after turning OFF the power switch. Even when the power switch is OFF, the 12V battery automatic charge control may automatically start after a lapse of 60 minutes from power switch OFF.
- Disconnect 12V battery terminal according to the following steps.

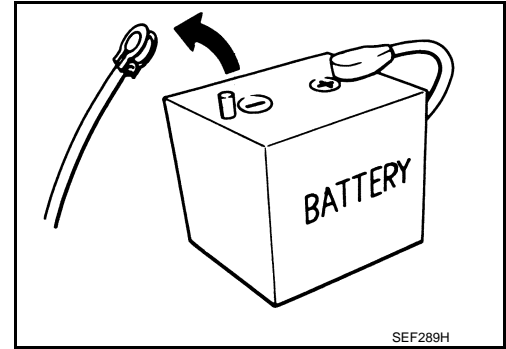

WORK PROCEDURE

1. Check that EVSE is not connected.

NOTE:

If EVSE is connected, the air conditioning system may be automatically activated by the timer A/C function.

2. Turn the power switch OFF → ON → OFF. Get out of the vehicle. Close all doors (including back door).
3. Check that the charge status indicator lamp does not blink and wait for 5 minutes or more.

NOTE:

If the battery is removed within 5 minutes after the power switch is turned OFF, plural DTCs may be detected.

4. Remove 12V battery terminal within 60 minutes after turning the power switch OFF → ON → OFF.

CAUTION:

- After all doors (including back door) are closed, if a door (including back door) is opened before battery terminals are disconnected, start over from Step 1.
- After turning the power switch OFF, if "Remote A/C" is activated by user operation, stop the air conditioner and start over from Step 1.

NOTE:

Once the power switch is turned ON → OFF, the 12V battery automatic charge control does not start for approximately 1 hour.

- For vehicles with the 2-batteries, be sure to connect the main battery and the sub battery before turning ON the power switch.

NOTE:

If the power switch is turned ON with any one of the terminals of main battery and sub battery disconnected, then DTC may be detected.

- After installing the 12V battery, always check "Self Diagnosis Result" of all ECUs and erase DTC.

NOTE:

The removal of 12V battery may cause a DTC detection error.

Precaution for Supplemental Restraint System (SRS) "AIR BAG" and "SEAT BELT PRE-TENSIONER"

INFOID:000000006892173

The Supplemental Restraint System such as "AIR BAG" and "SEAT BELT PRE-TENSIONER", used along with a front seat belt, helps to reduce the risk or severity of injury to the driver and front passenger for certain types of collision. This system includes seat belt switch inputs and dual stage front air bag modules. The SRS system uses the seat belt switches to determine the front air bag deployment, and may only deploy one front air bag, depending on the severity of a collision and whether the front occupants are belted or unbelted. Information necessary to service the system safely is included in the "SRS AIR BAG" and "SEAT BELT" of this Service Manual.

WARNING:

Always observe the following items for preventing accidental activation.

- To avoid rendering the SRS inoperative, which could increase the risk of personal injury or death in the event of a collision that would result in air bag inflation, all maintenance must be performed by an authorized NISSAN/INFINITI dealer.

PRECAUTIONS

< PRECAUTION >

- **Improper maintenance, including incorrect removal and installation of the SRS, can lead to personal injury caused by unintentional activation of the system. For removal of Spiral Cable and Air Bag Module, see “SRS AIR BAG”.**
- **Never use electrical test equipment on any circuit related to the SRS unless instructed to in this Service Manual. SRS wiring harnesses can be identified by yellow and/or orange harnesses or harness connectors.**

PRECAUTIONS WHEN USING POWER TOOLS (AIR OR ELECTRIC) AND HAMMERS

WARNING:

Always observe the following items for preventing accidental activation.

- **When working near the Air Bag Diagnosis Sensor Unit or other Air Bag System sensors with the power switch ON, never use air or electric power tools or strike near the sensor(s) with a hammer. Heavy vibration could activate the sensor(s) and deploy the air bag(s), possibly causing serious injury.**
- **When using air or electric power tools or hammers, always switch the power switch OFF, disconnect the 12V battery, and wait at least 3 minutes before performing any service.**

Occupant Classification System

INFOID:000000006892149

Replace occupant classification system control unit and passenger front seat cushion as an assembly. Refer to [SE-20, "Exploded View"](#).

Precaution for Work

INFOID:000000006892150

- Never use electrical test equipment to check SRS circuits unless instructed to in this Service Manual.
- Before servicing the SRS, turn ignition switch OFF, disconnect 12V battery negative terminal and wait 3 minutes or more.
For approximately 3 minutes after the cables are removed, it is still possible for the air bag and seat belt pretensioner to deploy. Therefore, never work on any SRS connectors or wires until at least 3 minutes have elapsed.
- Diagnosis sensor unit must always be installed with their arrow marks “←” pointing towards the front of the vehicle for proper operation. Also check diagnosis sensor unit for cracks, deformities or rust before installation and replace as required.
- The spiral cable must be aligned in the neutral position since its rotations are limited. Never turn steering wheel and column after removal of steering gear.
- Handle air bag module carefully. Always place driver and front passenger air bag modules with the pad side facing upward and seat mounted front side air bag module standing with the stud bolt side facing down.
- Conduct self-diagnosis to check entire SRS for proper functioning after replacing any components.
- After air bag inflates, the instrument panel assembly should be replaced if damaged.

A
B
C
D
E
F
G
I
J
K
L
M
N
O
P

SR

PREPARATION

< PREPARATION >

PREPARATION

PREPARATION

Commercial Service Tools

INFOID:000000006892151

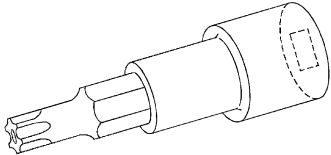
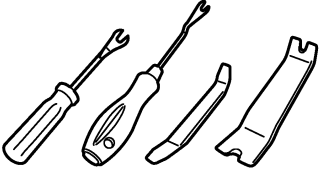
Tool name	Description
<p data-bbox="181 514 451 546">Tamper resistant TORX bit</p>  <p data-bbox="820 630 876 646">S-NT757</p>	<p data-bbox="987 504 1437 562">Removes tool of driver air bag module and/or Diagnosis sensor unit</p>
<p data-bbox="181 766 321 798">Remover tool</p>  <p data-bbox="820 882 909 898">JMKIA3050ZZ</p>	<p data-bbox="987 766 1360 798">Removes clips, pawls and metal clips</p>

COMPONENT PARTS

< SYSTEM DESCRIPTION >

SYSTEM DESCRIPTION

COMPONENT PARTS

AIR BAG MODULE

AIR BAG MODULE : Driver air bag module

INFOID:000000008197558

- Driver air bag module is built into steering wheel.
- Driver air bag module mainly consists of air bag (1) and inflator (2) which inflates air bag.

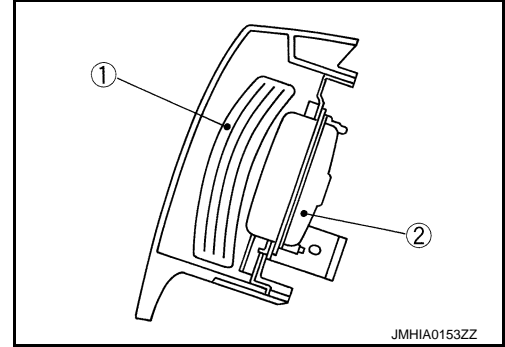

- Driver air bag inflates by breaking steering wheel center pad surface (A).

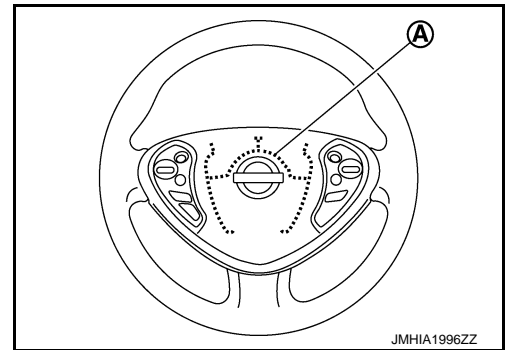

AIR BAG MODULE : Passenger air bag module

INFOID:000000008197559

- Passenger air bag module is built into instrument panel.
- Passenger air bag module mainly consists of air bag (1) and inflator (2) which inflates air bag.

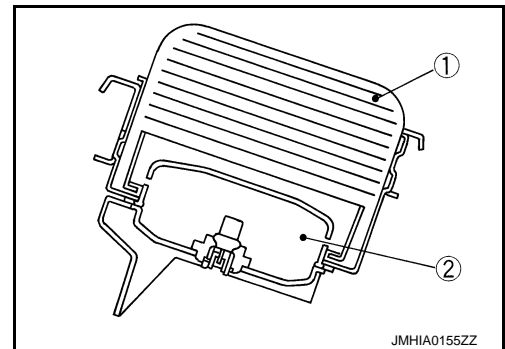

- Passenger air bag inflates by breaking instrument panel surface (A).

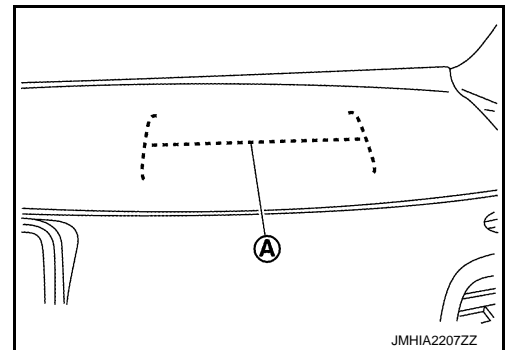

A

B

C

D

E

F

G

SR

I

J

K

L

M

N

O

P

COMPONENT PARTS

< SYSTEM DESCRIPTION >

AIR BAG MODULE : Side air bag module

INFOID:000000008197561

- Side air bag module is built into seatback side.
- Side air bag module mainly consists of air bag (1) and inflator (2) which inflates air bag.

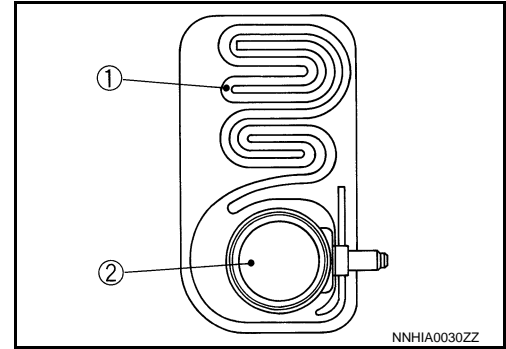

- Side air bag inflates through seatback side stitch (2).
- Identification mark (1) is installed to seatback side stitch indicating that side air bag is equipped.

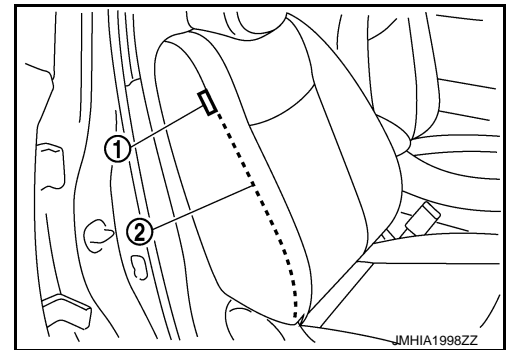

AIR BAG MODULE : Curtain air bag module

INFOID:000000008197561

- Curtain air bag module is built into roof side portion LH and RH.
- Identification mark (A) is installed to center pillar upper garnish upper indicating that SRS curtain air bag is equipped.
- Curtain air bag inflates through a space (B) between headliner and roof side portion.

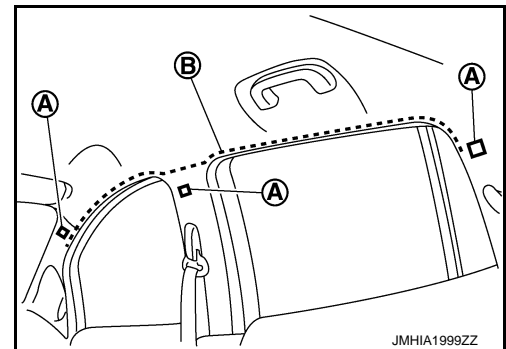

- Curtain air bag module mainly consists of air bag (2) and inflator (1) which inflates air bag.

↔ : Vehicle front

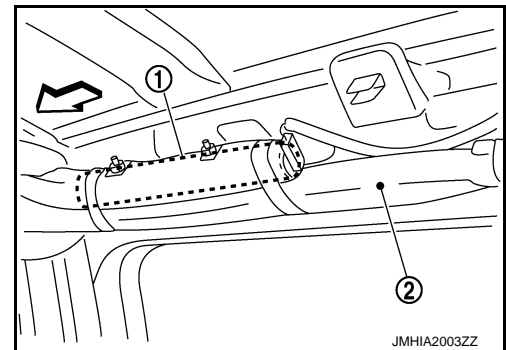

INFLATOR

COMPONENT PARTS

< SYSTEM DESCRIPTION >

INFLATOR : Driver air bag inflator

INFOID:000000008197562

- Driver air bag inflator (1) mainly consists of electric ignition device (squib), igniting agent, gas generating agent, and filter. These items are stored in a container.
- In a frontal collision which exceeds the specified limit of the vehicle, electric ignition device (squib) ignites igniting agent. Gas generating agent burns due to heat from igniting agent. Generated gas (high temperature) inflates air bag through filter.

NOTE:

Filter removes and cools residues of gas generating agent.

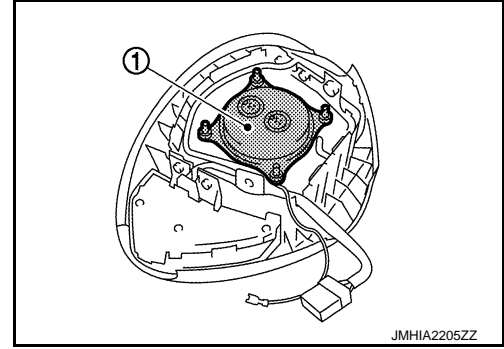

CROSS-SECTION OF DRIVER AIR BAG INFLATOR

- 1 : Filter
- 2 : Gas generating agent
- 3 : Igniting agent
- 4 : Electric ignition device (squib)
- 5 : Cushion
- 6 : Flame
- 7 : Generated gas

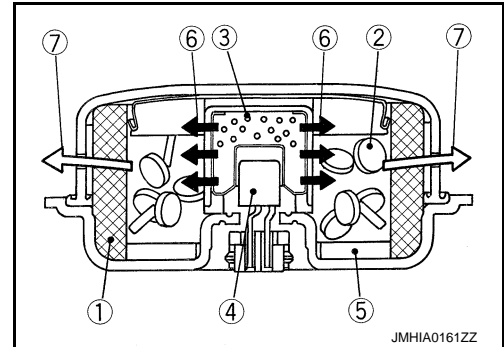

INFLATOR : Passenger air bag inflator

INFOID:000000008197563

- Passenger air bag inflator (1) mainly consists of electric ignition device (squib), igniting agent, gas generating agent, and filter. These items are stored in a container.
- In a frontal collision which exceeds the specified limit of the vehicle, electric ignition device (squib) ignites igniting agent. Gas generating agent burns due to heat from igniting agent. Generated gas (high temperature) inflates air bag through filter.

NOTE:

Filter removes and cools residues of gas generating agent.

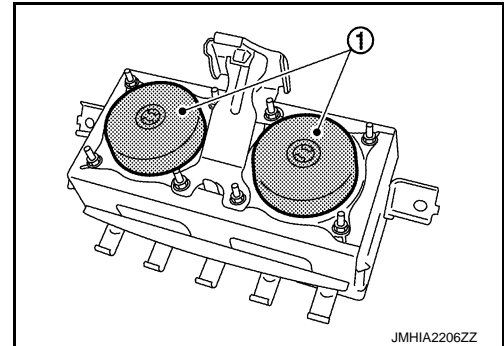

CROSS-SECTION OF PASSENGER AIR BAG INFLATOR

- 1 : Filter
- 2 : Gas generating agent
- 3 : Igniting agent
- 4 : Electric ignition device (squib)
- 5 : Cushion
- 6 : Flame
- 7 : Generated gas

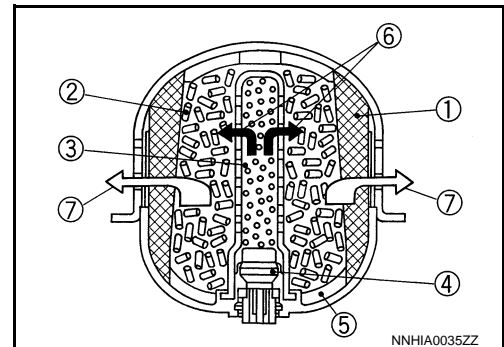

COMPONENT PARTS

< SYSTEM DESCRIPTION >

INFLATOR : Side air bag inflator

INFOID:000000008197564

Side air bag inflator (1) mainly consists of electric ignition device (squib), heating agent, compressed gas, filter, and diffuser. These items are stored in a cylinder-type container.

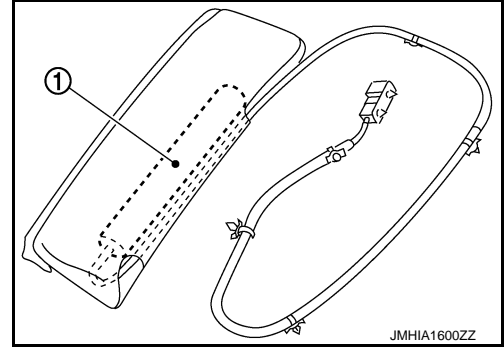

CROSS-SECTION OF SIDE AIR BAG INFLATOR

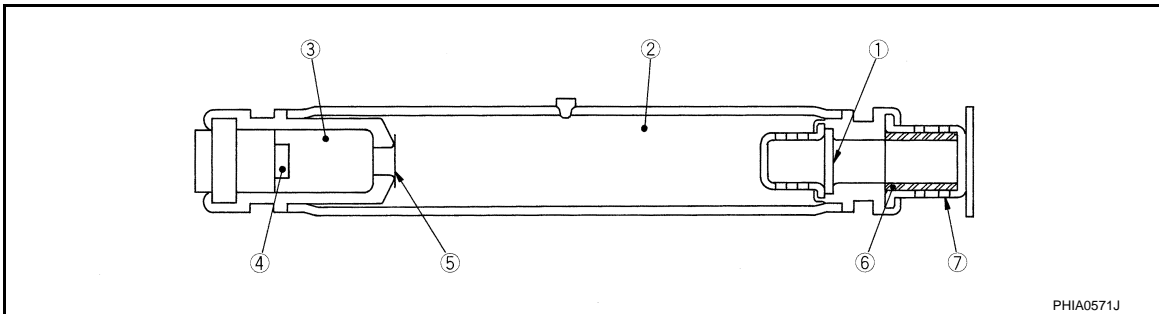

- | | | |
|-------------------------------------|-------------------|-------------------------------|
| 1. Burst disc B | 2. Compressed gas | 3. Heating agent (propellant) |
| 4. Electric ignition device (squib) | 5. Burst disc A | 6. Filter |
| 7. Diffuser | | |

In a frontal collision which exceeds the specified limit of the vehicle, electric ignition device (squib) ignites and burns heating agent. Compressed gas breaks burst disc A, inflates gas in compressed gas chamber, breaks burst disc B, and then inflates air bag through filter and diffuser.

INFLATOR : Curtain air bag inflator

INFOID:000000008197565

Curtain air bag inflator mainly consists of electric ignition device (squib), heating agent, compressed gas, and diffuser. These items are stored in a cylinder-type container.

- 1 : Curtain air bag inflator
- 2 : Curtain air bag
- ⇐ : Vehicle front

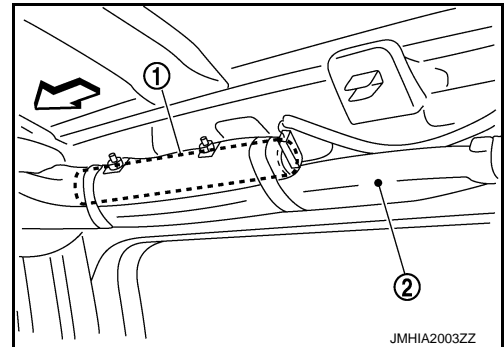

CROSS-SECTION OF CURTAIN AIR BAG INFLATOR

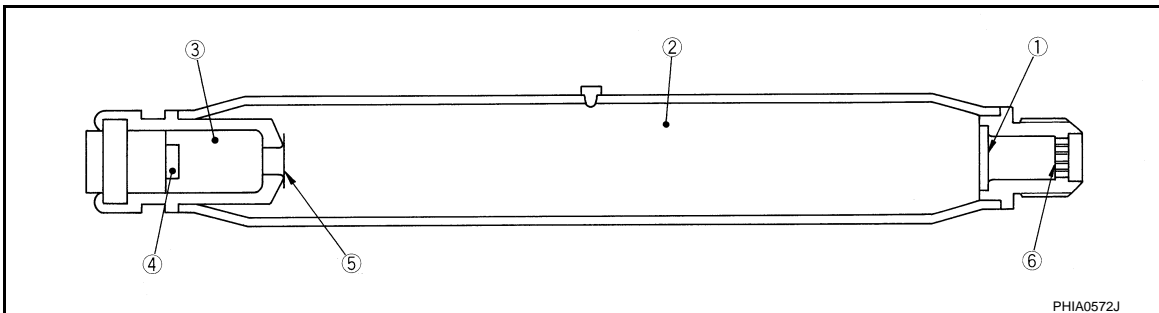

COMPONENT PARTS

< SYSTEM DESCRIPTION >

- | | | |
|-------------------------------------|-------------------|-------------------------------|
| 1. Burst disk | 2. Compressed gas | 3. Heating agent (propellant) |
| 4. Electric ignition device (squib) | 5. Burst disk A | 6. Diffuser |

In a frontal collision which exceeds the specified limit of the vehicle, electric ignition device (squib) ignites and burns heating agent. Burned gas breaks burst disc A, inflates gas in compressed gas chamber, breaks burst disc B, and then inflates air bag through filter and diffuser.

MAIN COMPONENT PARTS AND FUNCTIONS

MAIN COMPONENT PARTS AND FUNCTIONS : Spiral cable

INFOID:000000008197566

- Spiral cable electrically connects air bag diagnosis sensor unit and driver air bag module. Spiral cable mainly consists of the rotating portion (A) which performs the same movement as steering wheel, the fixed case (B) which is installed on steering wheel, and the cable which connects the rotating portion.
- Spiral cable is built into steering angle sensor which is installed to a space between combination switch and steering wheel.

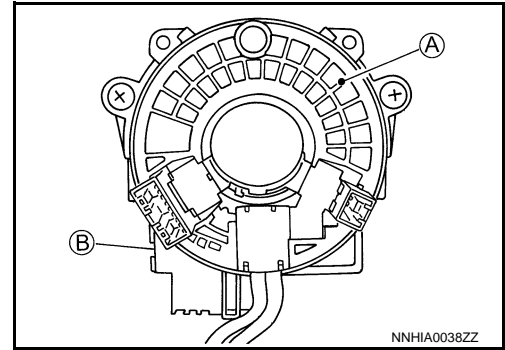

MAIN COMPONENT PARTS AND FUNCTIONS : Crash zone sensor

INFOID:000000008197567

- Crush zone sensor (1) is installed to charge port lid hinge assembly. Crash zone sensor integrates frontal collision "G" sensor which detects frontal collision impact that exceeds the specified limit of the vehicle.

← : Vehicle front

- In a frontal collision that exceeds the specified limit of the vehicle, crush zone sensor detects impact. If frontal collision safing sensor in air bag diagnosis sensor unit judges that impact is due to a collision, driver air bag, passenger air bag and front pre-tensioner seat belt operate.

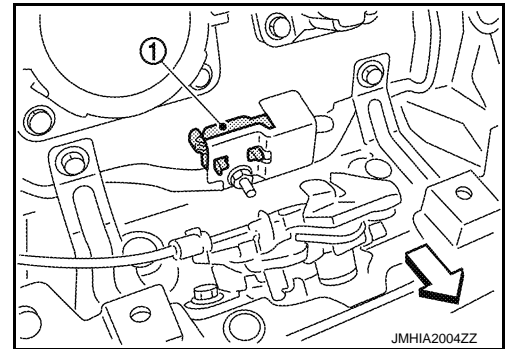

MAIN COMPONENT PARTS AND FUNCTIONS : Satellite sensor

INFOID:000000008197568

FRONT SATELLITE SENSOR

- Front door satellite sensor (1) is installed to front door panel front side.

← : Vehicle front

- Front door satellite sensor integrates lateral collision "G" sensor which detects lateral collision impact that exceeds the specified limit of the vehicle. (Lateral collision "G" sensor adopts electronic sensor of which operating principles are the same as those of frontal collision "G" sensor in air bag diagnosis sensor unit.)
- In a lateral collision that exceeds the specified limit of the vehicle, front door satellite sensor detects impact. If lateral collision safing sensor in air bag diagnosis sensor unit judges that impact is due to a collision, side air bag and curtain air bag operate.

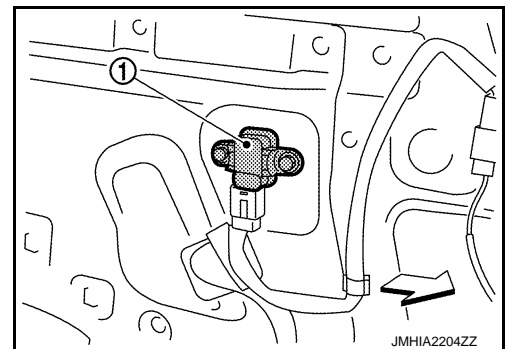

REAR SATELLITE SENSOR

COMPONENT PARTS

< SYSTEM DESCRIPTION >

- Rear satellite sensor (1) is installed to center pillar lower portion of front seat belt retractor rear side.

↔ : Vehicle front

- Rear satellite sensor integrates lateral collision “G” sensor which detects lateral collision impact that exceeds the specified limit of the vehicle. (Lateral collision “G” sensor adopts electronic sensor of which operating principles are the same as those of frontal collision “G” sensor in air bag diagnosis sensor unit.)
- In a lateral collision that exceeds the specified limit of the vehicle, rear satellite sensor detects impact. If lateral collision safing sensor in air bag diagnosis sensor unit judges that impact is due to a collision, side air bag and curtain air bag operate.

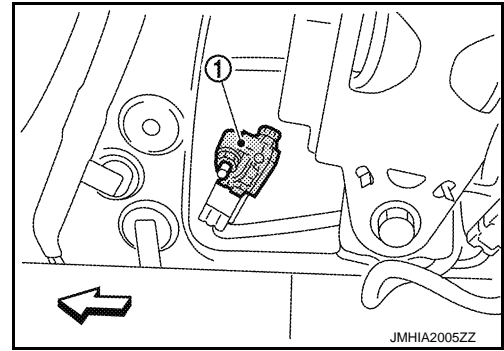

MAIN COMPONENT PARTS AND FUNCTIONS : Air bag diagnosis sensor unit

INFOID:000000008197569

- Air bag diagnosis sensor unit (1) is installed to front seat center portion (under center console). Air bag diagnosis sensor unit integrates control functions of driver air bag, passenger air bag, side air bag, curtain air bag, and pre-tensioner seat belt.

↔ : Vehicle front

- Air bag diagnosis sensor unit integrates frontal collision “G” sensor, frontal collision safing sensor, and lateral collision safing sensor (only for models with curtain air bag).
- Air bag diagnosis sensor unit has a function that judges impact due to frontal and lateral collisions exceeding the specified limit of the vehicle. Air bag diagnosis sensor unit also has an auxiliary power supply function that supplements 12 V battery power supply in the event battery is damaged in a collision.
- Air bag diagnosis sensor unit diagnoses electric system of entire system. Self-diagnosis function is adopted, which indicates system malfunction by blinking or turning ON air bag warning lamp on combination meter when a malfunction is detected. Diagnosis using CONSULT is possible.

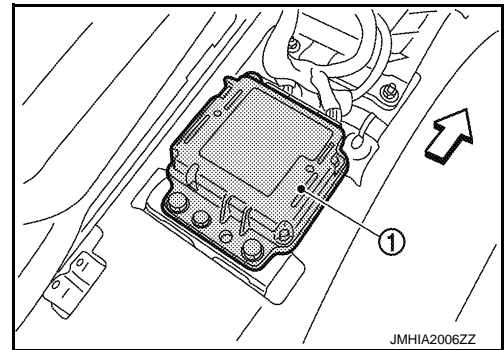

MAIN COMPONENT PARTS AND FUNCTIONS : Air bag warning lamp

INFOID:000000008197570

- Air bag warning lamp blinks or turns ON indicating a system malfunction when a malfunction is detected for electric system of SRS air bag system and pre-tensioner seat belt system.
- For operation check purposes, air bag warning lamp turns ON for 7 seconds after power switch is turned ON. During this period of time, air bag diagnosis sensor unit performs system diagnosis.
- Air bag warning lamp indicates self-diagnosis result according to the number of times it blinks. (in diagnosis mode)

NOTE:

SRS air bag and pre-tensioner seat belt do not operate for approximately 7 seconds (air bag warning lamp is blinking or turning ON) after power switch is turned ON.

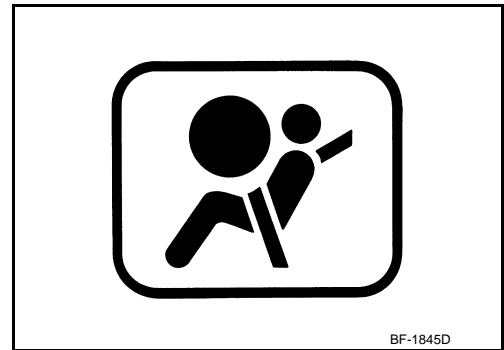

COLLISION DIAGNOSIS

< BASIC INSPECTION >

BASIC INSPECTION

COLLISION DIAGNOSIS FOR FRONTAL COLLISION

FOR FRONTAL COLLISION : When SRS is activated in a collision

INFOID:000000006892110

CAUTION:

Due to varying models and option levels, not all parts listed in the chart below apply to all vehicles.

WORK PROCEDURE

1. Before performing any of the following steps, ensure that all vehicle body and structural repairs have been completed.
2. Replace the diagnosis sensor unit.
3. Remove the front air bag modules, crash zone sensor, bracket and seat belt pre-tensioner assemblies.
4. Check the SRS components using the table below:
Replace any SRS components showing visible signs of damage. (dents, cracks and deformation, etc.)
5. Install new front air bag modules, crash zone sensor assembly, bracket and seat belt pre-tensioner assemblies.
6. Perform self-diagnosis using CONSULT or "AIR BAG" warning lamp. Refer to [SRC-17, "CONSULT Function"](#) or [SRC-13, "On Board Diagnosis Function"](#) for details. Ensure entire SRS operates properly.
7. After the work is completed, perform self-diagnosis to check that no malfunction is detected. Refer to [SRC-13, "Description"](#).

SRS INSPECTION (FOR FRONTAL COLLISION)

Part	Inspection
Driver air bag module	If the driver air bag has deployed: REPLACE Install with new fasteners.
Passenger air bag module (if equipped)	If the passenger air bag has deployed: REPLACE Install with new fasteners.
Crash zone sensor	If any of the front air bags or seat belt pre-tensioners* have been activated: REPLACE the crash zone sensor and bracket with new fasteners. *: Confirm seat belt pre-tensioner activation using CONSULT only.
Seat belt pre-tensioner assemblies (All applicable locations: buckle, retractor, lap outer)	If either the driver or passenger seat belt pre-tensioner* has been activated: REPLACE all seat belt pre-tensioner assemblies with new fasteners. *: Confirm seat belt pre-tensioner activation using CONSULT only.
Diagnosis sensor unit	If any of the SRS components have been activated: REPLACE the diagnosis sensor unit. Install with new fasteners.
Steering wheel	<ol style="list-style-type: none"> 1. Visually check steering wheel for deformities. 2. Check harness (built into steering wheel) and connectors for damage, and terminals for deformities. 3. Install driver air bag module into the steering wheel to check fit and alignment with the wheel. 4. Check steering wheel for excessive free play. 5. If no damage is found, reinstall. 6. If damaged – REPLACE.
Spiral cable	If the driver front air bag has deployed: REPLACE the spiral cable.
Occupant classification system (Passenger seat)	<ol style="list-style-type: none"> 1. Remove passenger seat assembly. 2. Check control unit case for dents, cracks or deformities. 3. Check connectors and pressure sensor tube for damage, and terminals for deformities. 4. Check seat frame and cushion pan for dents or deformities. 5. If no damage is found, reinstall seat with new fasteners. 6. If damaged – REPLACE seat cushion assembly with new fasteners.

COLLISION DIAGNOSIS

< BASIC INSPECTION >

Part	Inspection
Harness and connectors	<ol style="list-style-type: none"> 1. Check connectors for poor connection, damage, and terminals for deformities. 2. Check harness for binding, chafing, cuts, or deformities. 3. If no damage is found, reinstall the harness and connectors. 4. If damaged – REPLACE the damaged harness. Do not attempt to repair, splice or modify any SRS harness.
Instrument panel assembly	If the passenger air bag has deployed: REPLACE the instrument panel assembly. (integrated type)

FOR FRONTAL COLLISION : When SRS is not activated in a collision

INFOID:000000006892111

CAUTION:

Due to varying models and option levels, not all parts listed in the chart below apply to all vehicles.

WORK PROCEDURE

1. Before performing any of the following steps, ensure that all vehicle body and structural repairs have been completed.
2. Check the SRS components using the table below:
Replace any SRS components showing visible signs of damage. (dents, cracks and deformation, etc.)
3. Perform self-diagnosis using CONSULT or "" warning lamp. Refer to [SRC-17, "CONSULT Function"](#) or [SRC-13, "On Board Diagnosis Function"](#) for details. Ensure entire SRS operates properly.
4. After the work is completed, perform self-diagnosis to check that no malfunction is detected. Refer to [SRC-13, "Description"](#).

SRS INSPECTION (FOR FRONTAL COLLISION)

Part	Inspection
Driver air bag module	<p>If the driver air bag has NOT been deployed:</p> <ol style="list-style-type: none"> 1. Remove driver air bag module. Check harness cover and connectors for damage, terminals for deformities, and harness for binding. 2. Install driver air bag module into the steering wheel to check fit and alignment with the wheel. 3. If no damage is found, reinstall with new fasteners. 4. If damaged – REPLACE. Install driver air bag module with new fasteners.
Passenger air bag module (if equipped)	<p>If the passenger air bag has NOT been deployed:</p> <ol style="list-style-type: none"> 1. Remove passenger air bag module. Check harness cover and connectors for damage, terminals for deformities, and harness for binding. 2. Install passenger air bag module into the instrument panel to check fit with the instrument panel. 3. If no damage is found, reinstall with new fasteners. 4. If damaged – REPLACE. Install passenger air bag modules with new fasteners.
Crash zone sensor	<p>If the front air bags or seat belt pre-tensioners have NOT been activated:</p> <ol style="list-style-type: none"> 1. Remove the crash zone sensor. Check harness connectors for damage, terminals for deformities, and harness for binding. 2. Check for visible signs of damage (dents, cracks, deformation, etc.) of the crash zone sensor and bracket. 3. Install the crash zone sensor to check fit. 4. If no damage is found, reinstall with new fasteners. 5. If damaged – REPLACE the crash zone sensor and bracket with new fasteners.
Seat belt pre-tensioner assemblies (All applicable locations: buckle, retractor, lap outer)	<p>If the pre-tensioners have NOT been activated:</p> <ol style="list-style-type: none"> 1. Remove seat belt pre-tensioners. Check harness cover and connectors for damage, terminals for deformities, and harness for binding. 2. Check belts for damage and anchors for loose mounting. 3. Check retractor for smooth operation. 4. Check seat belt adjuster for damage. 5. Check for deformities of the center pillar inner. 6. If the center pillar inner has no damage, REPLACE the seat belt pre-tensioner assembly. 7. If no damage is found, reinstall seat belt pre-tensioner assembly. 8. If damaged – REPLACE. Install the seat belt pre-tensioners with new fasteners.

COLLISION DIAGNOSIS

< BASIC INSPECTION >

Part	Inspection
Diagnosis sensor unit	If none of the SRS components have been activated: 1. Check case for dents, cracks or deformities. 2. Check connectors for damage, and terminals for deformities. 3. If no damage is found, reinstall with new fasteners. 4. If damaged – REPLACE. Install diagnosis sensor unit with new fasteners.
Steering wheel	1. Visually check steering wheel for deformities. 2. Check harness (built into steering wheel) and connectors for damage, and terminals for deformities. 3. Install driver air bag module into the steering wheel to check fit and alignment with the wheel. 4. Check steering wheel for excessive free play. 5. If no damage is found, reinstall. 6. If damaged – REPLACE.
Spiral cable	If the driver front air bag has not deployed: 1. Visually check spiral cable and combination switch for damage. 2. Check connectors and protective tape for damage. 3. Check steering wheel for noise, binding or heavy operation. 4. If no damage is found, reinstall. 5. If damaged – REPLACE.
Occupant classification system (Passenger seat)	1. Remove passenger seat assembly. 2. Check control unit case for dents, cracks or deformities. 3. Check connectors and pressure sensor tube for damage, and terminals for deformities. 4. Check seat frame and cushion pan for dents or deformities. 5. If no damage is found, reinstall seat with new fasteners. 6. If damaged – REPLACE seat cushion assembly with new fasteners.
Harness and connectors	1. Check connectors for poor connection, damage, and terminals for deformities. 2. Check harness for binding, chafing, cuts, or deformities. 3. If no damage is found, reinstall the harness and connectors. 4. If damaged – REPLACE the damaged harness. Do not attempt to repair, splice or modify any SRS harness.
Instrument panel assembly	If the passenger air bag has NOT deployed: 1. Visually check instrument panel assembly for damage. 2. If no damage is found, reinstall the instrument panel assembly. 3. If damaged – REPLACE the instrument panel assembly.

A
B
C
D
E
F
G
SR
I
J

FOR SIDE AND ROLLOVER COLLISION

FOR SIDE AND ROLLOVER COLLISION : When SRS is activated in a collision

INFOID:000000006892112

CAUTION:

Due to varying models and option levels, not all parts listed in the chart below apply to all vehicles.

WORK PROCEDURE

1. Before performing any of the following steps, ensure that all vehicle body and structural repairs have been completed.
2. Replace the following components:
 - Front seat back assembly (on the side on which side air bag is activated)
 - Door finisher (on the side on which door-mounted curtain air bag is activated)
 - Pop-up roll bar assemblies and pop-up roll bar covers
 - Satellite sensor LH/RH (on the side on which side air bag is activated)
 - Diagnosis sensor unit
 - Seat belt pre-tensioner assemblies
3. Check the SRS components and the related parts using the following table. Replace any SRS components and the related parts showing visible signs of damage. (dents, cracks, deformation, etc.)
4. Perform self-diagnosis using CONSULT and "AIR BAG" warning lamp. Refer to [SRC-17. "CONSULT Function"](#) or [SRC-13. "On Board Diagnosis Function"](#) for details. Make sure entire SRS operates properly.
5. After the work is completed, perform self-diagnosis to check that no malfunction is detected. Refer to [SRC-13. "Description"](#).

K
L
M
N
O
P

COLLISION DIAGNOSIS

< BASIC INSPECTION >

SRS INSPECTION (FOR SIDE AND ROLLOVER COLLISION)

Part	Inspection
Curtain air bag module LH	If the curtain air bag LH has deployed: REPLACE the curtain air bag module LH. Install with new fasteners.
Curtain air bag module RH	If the curtain air bag RH has deployed: REPLACE the curtain air bag module RH. Install with new fasteners.
Side air bag module LH	If the side air bag LH has deployed: REPLACE front seatback assembly LH.
Side air bag module RH	If the side air bag RH has deployed: REPLACE front seatback assembly RH.
Satellite sensor (LH or RH)	If any of the SRS components have deployed: REPLACE the satellite sensor on the collision side with new fasteners.
Diagnosis sensor unit	If any of the SRS components have deployed: REPLACE the diagnosis sensor unit with new fasteners.
Seat belt pre-tensioner assemblies (All applicable locations: buckle, retractor, lap outer)	If either the driver or passenger seat belt pre-tensioner* has been activated: REPLACE all seat belt pre-tensioner assemblies with new fasteners. *: Confirm seat belt pre-tensioner activation using CONSULT only.
Center inner pillar	1. Check the center inner pillar on the collision side for damage (dents, cracks, deformation, etc.). 2. If damaged – REPAIR the center inner pillar.
Trim/headlining	1. Check for visible signs of damage (dents, cracks, deformation, etc.) of the interior trim on the collision side. 2. If damaged – REPLACE the damaged trim parts.
Door-mounted curtain air bag module LH	If the door-mounted curtain air bag module LH has deployed: REPLACE the door finisher LH and door-mounted curtain air bag module. Install with new fasteners.
Door-mounted curtain air bag module RH	If the door-mounted curtain air bag module RH has deployed: REPLACE the door finisher RH and door-mounted curtain air bag module. Install with new fasteners.
Pop-up roll bar assemblies	If the pop-up roll bar has deployed: REPLACE pop-up roll bar assemblies and pop-up roll bar covers. Install with new fasteners.

FOR SIDE AND ROLLOVER COLLISION : When SRS is not activated in a collision

INFOID:000000006892113

CAUTION:

Due to varying models and option levels, not all parts listed in the chart below apply to all vehicles.

WORK PROCEDURE

1. Before performing any of the following steps, ensure that all vehicle body and structural repairs have been completed.
2. Check the SRS components and the related parts using the following table.
 - If the front seat back assembly is damaged, the front seat back assembly must be replaced.
 - If the door finisher assembly is damaged, the door finisher assembly and door-mounted curtain air bag module must be replaced.
3. Perform self-diagnosis using CONSULT and “AIR BAG” warning lamp. Refer to [SRC-17, "CONSULT Function"](#) or [SRC-13, "On Board Diagnosis Function"](#) for details. Make sure entire SRS operates properly.
4. After the work is completed, perform self-diagnosis to check that no malfunction is detected. Refer to [SRC-13, "Description"](#).

SRS INSPECTION (FOR SIDE AND ROLLOVER COLLISION)

COLLISION DIAGNOSIS

< BASIC INSPECTION >

Part	Inspection	
Curtain air bag module LH	If the curtain air bag LH has NOT deployed: 1. Check for visible signs of damage (dents, tears, deformation, etc.) of the center pillar on the collision side. 2. If damaged – Remove the curtain air bag module LH. 3. Check for visible signs of damage (tears etc.) of the curtain air bag module LH. 4. Check harness and connectors for damage, and terminals for deformities. 5. If no damage is found, reinstall the curtain air bag module LH with new fasteners. 6. If damaged – REPLACE the curtain air bag module LH with new fasteners.	A B C
Curtain air bag module RH	If the curtain air bag RH has NOT deployed: 1. Check for visible signs of damage (dents, tears, deformation, etc.) of the center pillar on the collision side. 2. If damaged – Remove the curtain air bag module RH. 3. Check for visible signs of damage (tears etc.) of the curtain air bag module RH. 4. Check harness and connectors for damage, and terminals for deformities. 5. If no damage is found, reinstall the curtain air bag module RH with new fasteners. 6. If damaged – REPLACE the curtain air bag module RH with new fasteners.	D E
Side air bag module LH	If the side air bag LH has NOT deployed: 1. Check for visible signs of damage (dents, tears, deformation, etc.) of the seat back on the collision side. 2. Check harness and connectors for damage, and terminals for deformities. 3. If damaged – REPLACE the front seatback assembly LH.	F
Side air bag module RH	If the side air bag RH has NOT deployed: 1. Check for visible signs of damage (dents, tears, deformation, etc.) of the seat back on the collision side. 2. Check harness and connectors for damage, and terminals for deformities. 3. If damaged – REPLACE the front seatback assembly RH.	G SR
Satellite sensor (LH or RH)	If none of the SRS components have been activated: 1. Remove the satellite sensor (LH or RH) on the collision side. Check harness connectors for damage, terminals for deformities, and harness for binding. 2. Check for visible signs of damage (dents, cracks, deformation, etc.) of the satellite sensor (LH or RH). 3. Install the satellite sensor (LH or RH) to check fit. 4. If no damage is found, reinstall the satellite sensor (LH or RH) with new fasteners. 5. If damaged – REPLACE the satellite sensor (LH or RH) with new fasteners.	I J
Diagnosis sensor unit	If none of the SRS components have been activated: 1. Check case and bracket for dents, cracks or deformities. 2. Check connectors for damage, and terminals for deformities. 3. If no damage is found, reinstall the diagnosis sensor unit with new fasteners. 4. If damaged – REPLACE the diagnosis sensor unit with new fasteners.	K L
Seat belt pre-tensioner assemblies (All applicable locations: buckle, retractor, lap outer)	If the pre-tensioners have NOT been activated: 1. Remove seat belt pre-tensioners. Check harness cover and connectors for damage, terminals for deformities, and harness for binding. 2. Check belts for damage and anchors for loose mounting. 3. Check retractor for smooth operation. 4. Check seat belt adjuster for damage. 5. Check for deformities of the center pillar inner. 6. If the center pillar inner has no damage, REPLACE the seat belt pre-tensioner assembly. 7. If no damage is found, reinstall seat belt pre-tensioner assembly. 8. If damaged – REPLACE. Install the seat belt pre-tensioners with new fasteners.	M N O
Seat (with side air bag)	If the front LH or front RH side air bag modules have NOT deployed: 1. Visually check the seat on the collision side. 2. Remove the seat on the collision side and check the following for damage and deformities. - Harness, connectors and terminals - Frame and recliner (for front and rear seat), and also adjuster and slides (for front seat) 3. If no damage is found, reinstall the seat. 4. If damaged – REPLACE the damaged seat parts using new fasteners. If the front seat back is damaged, the front seat back assembly must be replaced.	P
Center inner pillar	1. Check the center inner pillar on the collision side for damage (dents, cracks, deformation, etc.). 2. If damaged – REPAIR the center inner pillar.	

COLLISION DIAGNOSIS

< BASIC INSPECTION >

Part	Inspection
Trim/headlining	<ol style="list-style-type: none"> 1. Check for visible signs of damage (dents, cracks, deformation, etc.) of the interior trim on the collision side. 2. If damaged – REPLACE the damaged trim parts.
Door-mounted curtain air bag module LH	<p>If the door-mounted curtain air bag LH has NOT deployed:</p> <ol style="list-style-type: none"> 1. Check for visible signs of damage (dents, tears, deformation, etc.) of the door finisher on the collision side. 2. If damaged – REPLACE the door finisher LH with new fasteners. 3. Check for visible signs of damaged (tears etc.) of the door-mounted curtain air bag module LH. 4. Check harness and connectors for damage, and terminals for deformities. 5. If no damage is found, reinstall door finisher. CAUTION: When removing door-mounted curtain air bag module from door finisher, never reuse door finisher. 6. If damaged – REPLACE the door finisher LH and door-mounted curtain air bag module LH with new fasteners.
Door-mounted curtain air bag module RH	<p>If the door-mounted curtain air bag RH has NOT deployed:</p> <ol style="list-style-type: none"> 1. Check for visible signs of damage (dents, tears, deformation, etc.) of the door finisher on the collision side. 2. If damaged – REPLACE the door finisher RH with new fasteners. 3. Check for visible signs of damage (tears etc.) of the door-mounted curtain air bag module RH. 4. Check harness and connectors for damage, and terminals for deformities. 5. If no damage is found, reinstall door finisher. CAUTION: When removing door-mounted curtain air bag module from door finisher, never reuse door finisher. 6. If damaged – REPLACE the door finisher RH and door-mounted curtain air bag module RH with new fasteners.
Pop-up roll bar	<p>If the pop-up roll bar has NOT deployed:</p> <ol style="list-style-type: none"> 1. Check for visible signs of damage (dents, tears, deformation, etc.) of the pop-up roll bar. 2. If damaged – REPLACE the pop-up roll bar with new fasteners. 3. Check harness and connectors for damage, and terminals for deformities. 4. If no damage is found, reinstall the pop-up roll bar with new fasteners. 5. Check for visible signs of damage (dents, cracks, deformation, etc.) of the seatback support brace assembly. 6. If damaged – REPAIR the seatback support brace assembly.

DRIVER AIR BAG MODULE

< REMOVAL AND INSTALLATION >

REMOVAL AND INSTALLATION

DRIVER AIR BAG MODULE

Exploded View

INFOID:000000006892114

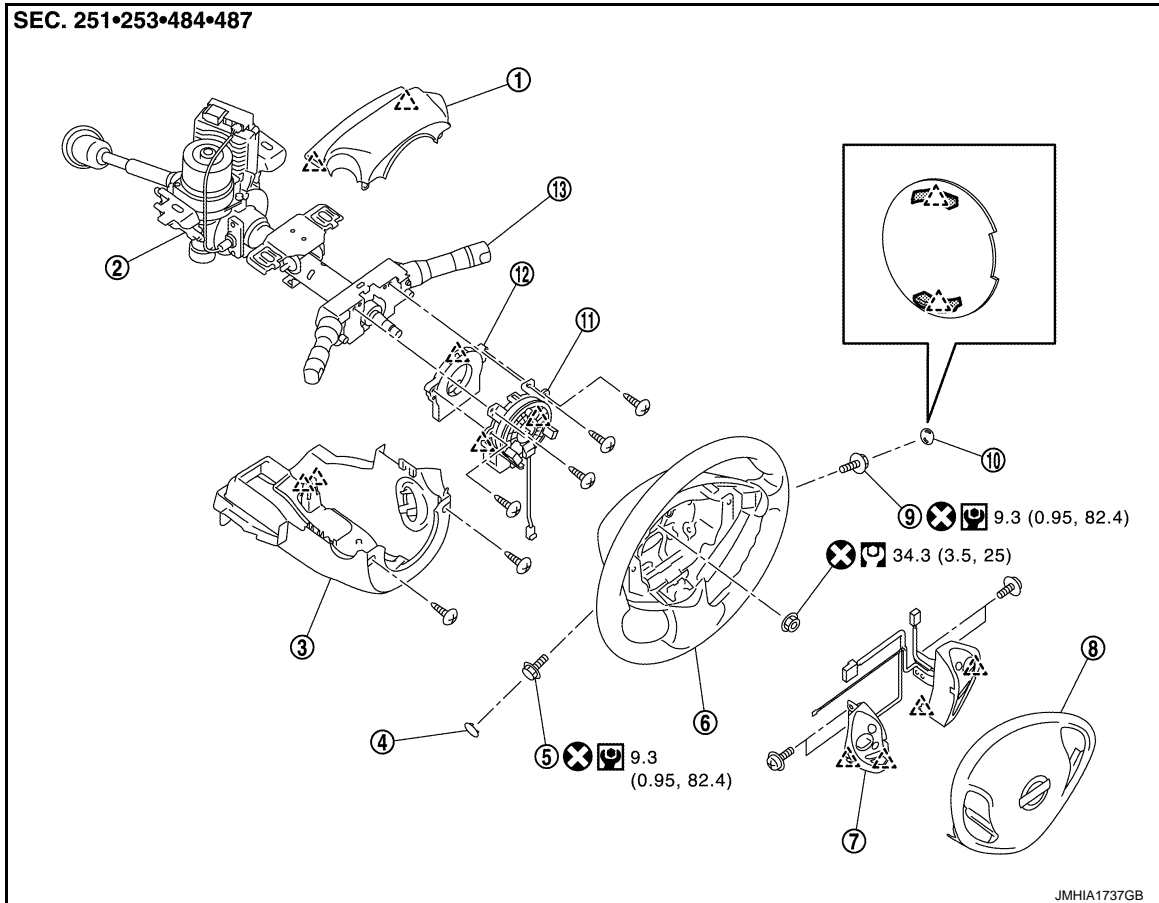

- | | | |
|--------------------------------|-----------------------------|--------------------------------|
| 1. Steering column upper cover | 2. Steering column assembly | 3. Steering column lower cover |
| 4. Side lid LH | 5. TORX bolt | 6. Steering wheel |
| 7. Steering switch | 8. Driver air bag module | 9. TORX bolt |
| 10. Side lid RH | 11. Spiral cable | 12. Steering angle sensor |
| 13. Combination switch | | |

 : Pawl

 : Always replace after every disassembly.

 : N-m (kg-m, in-lb)

 : N-m (kg-m, ft-lb)

Removal and Installation

INFOID:000000006892115

WARNING:

Always observe the following items for preventing accidental activation.

- Before servicing, push power switch OFF, disconnect 12V battery negative terminal and wait for 5 minutes or more. Refer to [SR-4, "Precautions for Removing Battery Terminal"](#).
- Always work from the side of air bag module. Never work in front of it.
- Never use air tools or electric tools for servicing.

REMOVAL

DRIVER AIR BAG MODULE

< REMOVAL AND INSTALLATION >

1. Remove side lid (LH and RH).
Insert flat-bladed screwdriver between side lid and steering wheel to disengage pawls as shown in the figure.

 : Pawl

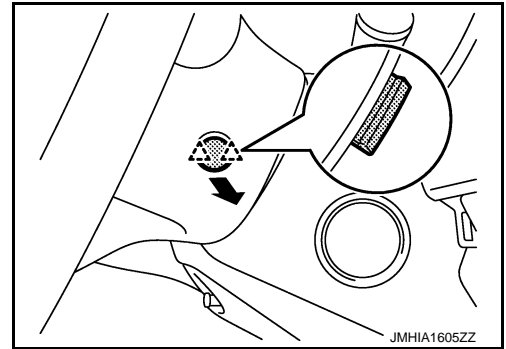

2. Remove TORX bolts (LH and RH) from the steering wheel lower side.
3. Pull out driver air bag module.
4. Disconnect steering switch harness connector (A).
5. Disconnect driver air bag harness connectors (B).

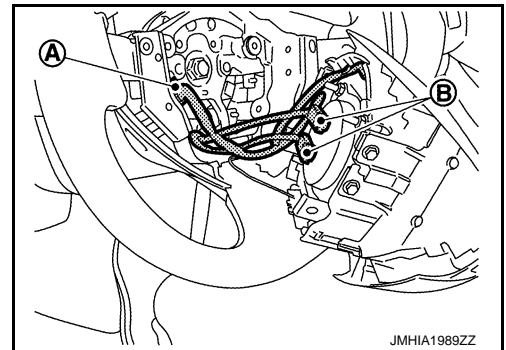

CAUTION:

- For installing/removing the driver air bag module harness connector, insert a thin screwdriver wrapped in tape into notch, lift lock and remove the connector.
- Install the connector with lock raised, and push lock into the connector.
- After installing the connector, check that the lock is pushed securely into it.

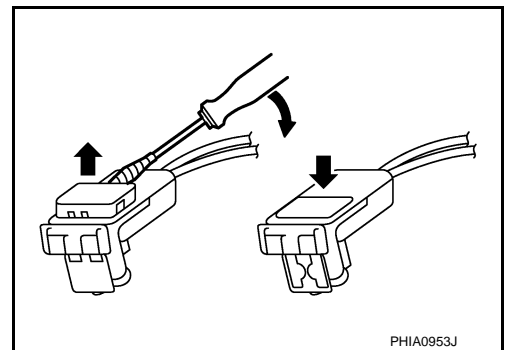

6. Remove driver air bag module.

CAUTION:

- To prevent accidental explosion, always place the driver air bag module with pad side facing upward.

 : Upward

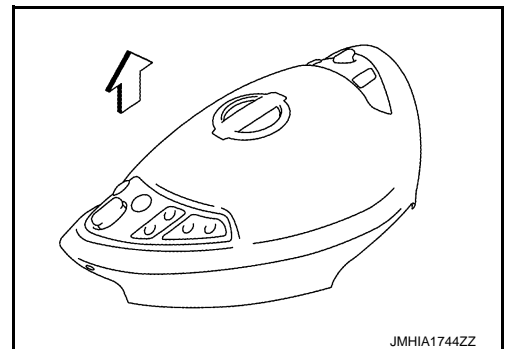

DRIVER AIR BAG MODULE

< REMOVAL AND INSTALLATION >

- To prevent damage to the parts, never impact the driver air bag module.
- Replace the driver air bag module if it is dropped or sustains an impact.



- To prevent accidental explosion, never insert any foreign objects (screwdriver, etc.) into the driver air bag module.
- To prevent accidental explosion, never disassemble the driver air bag module.
- To prevent accidental explosion, never expose the driver air bag module to temperature of more than 90°C (194°F).
- To prevent accidental explosion, never allow oil, grease, detergent, or water to come in contact with the driver air bag module.

INSTALLATION

Note the following items, and then install in the reverse order of removal.

CAUTION:

- Never reuse TORX bolts after removal, replace with new TORX bolts.
- Fix the driver air bag module harnesses to the harness fixing hook (A).

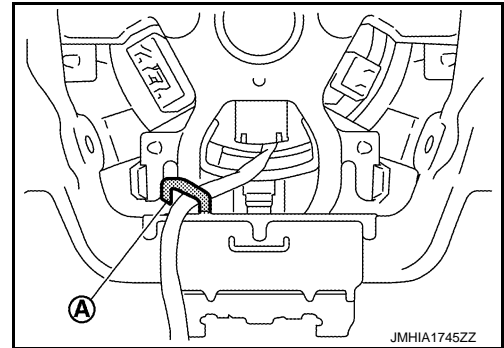

- Never damage the harness while installing.
- Tighten the TORX bolts after completely adjusting the centers of fixing holes on the driver air bag module side and the steering wheel side. If the holes are misaligned, the bolt threads are damaged and the module is not installed securely.
- If malfunction is detected by the air bag warning lamp, after repair or replacement of the malfunctioning parts, reset the memory using self-diagnosis or CONSULT. Refer to [SRC-13, "On Board Diagnosis Function"](#) or [SRC-17, "CONSULT Function"](#).
- After the work is complete, check that no system malfunction is detected by air bag warning lamp.

SPIRAL CABLE

< REMOVAL AND INSTALLATION >

SPIRAL CABLE

Exploded View

INFOID:000000007521398

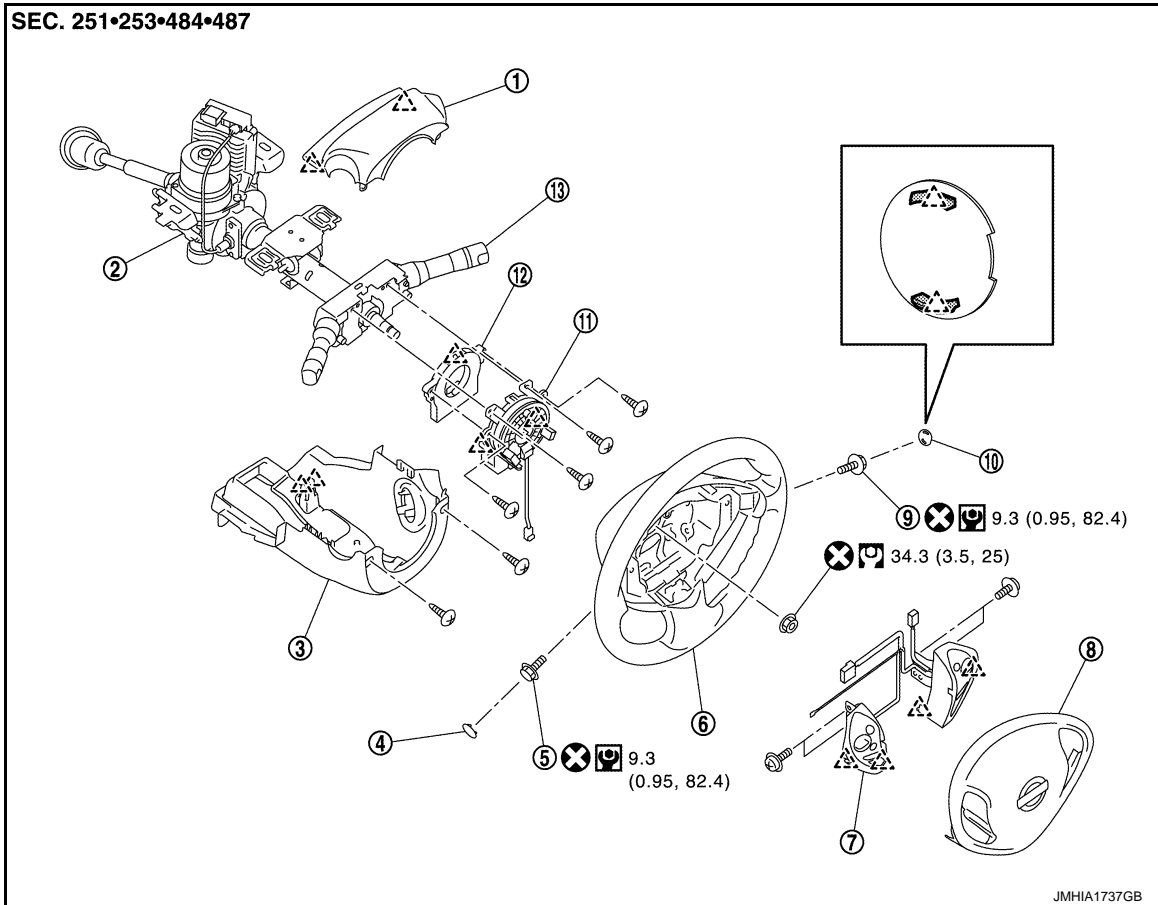

- | | | |
|--------------------------------|-----------------------------|--------------------------------|
| 1. Steering column upper cover | 2. Steering column assembly | 3. Steering column lower cover |
| 4. Side lid LH | 5. TORX bolt | 6. Steering wheel |
| 7. Steering switch | 8. Driver air bag module | 9. TORX bolt |
| 10. Side lid RH | 11. Spiral cable | 12. Steering angle sensor |
| 13. Combination switch | | |

: Pawl

: Always replace after every disassembly.

: N-m (kg-m, in-lb)

: N-m (kg-m, ft-lb)

Removal and Installation

INFOID:000000006892117

WARNING:

Always observe the following items for preventing accidental activation.

- Before servicing, push power switch OFF, disconnect 12V battery negative terminal and wait for 5 minutes or more. Refer to [SR-4, "Precautions for Removing Battery Terminal"](#).
- Never use air tools or electric tools for servicing.

REMOVAL

1. Remove driver air bag module. Refer to [SR-19, "Removal and Installation"](#).
2. Remove steering wheel. Refer to [ST-30, "Removal and Installation"](#).

SPIRAL CABLE

< REMOVAL AND INSTALLATION >

3. Remove steering column upper cover and steering column lower cover. Refer to [JP-14, "Removal and Installation"](#).
4. Disconnect the spiral cable body side harness connectors (A), (B) and steering angle sensor harness connectors (C).

NOTE:

Disconnect the spiral cable body side harness connector (B) after removing the spiral cable (A).

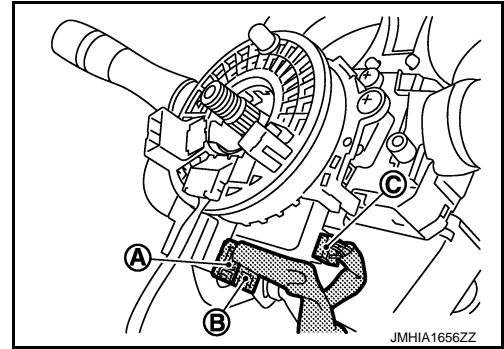

5. Remove the spiral cable fixing screws.
6. Remove the spiral cable fixing pawls with remover tool (A).

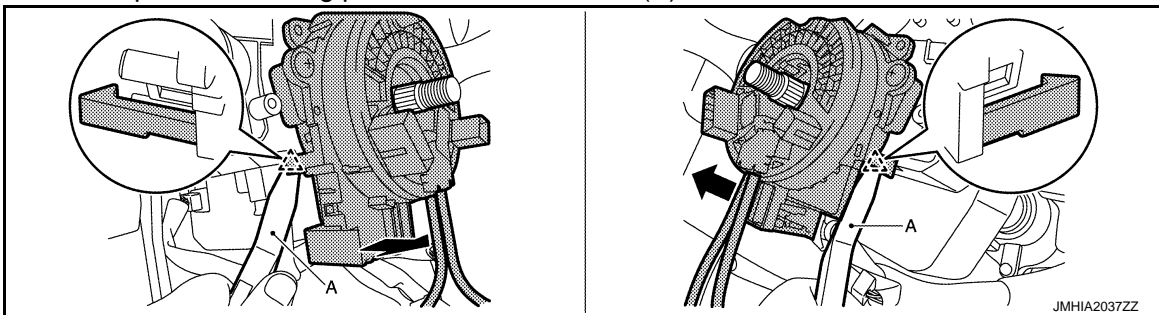

 : Pawl

CAUTION:

Remove pawls slowly so that they are not damaged.

7. Remove the steering angle sensor. Refer to [BRC-157, "Removal and Installation"](#).

CAUTION:

- To prevent damage to the parts, never impact the spiral cable.
- Replace the spiral cable if it is dropped or sustains an impact.



- To prevent damage to the parts, never disassemble the spiral cable.
- To prevent damage to the parts, never apply lubricant to the spiral cable.
- To prevent damage to the parts, never allow oil, grease, detergent, or water to come in contact with the spiral cable.

INSTALLATION

Note the following items, and then install in the reverse order of removal.

CAUTION:

SPIRAL CABLE

< REMOVAL AND INSTALLATION >

- The spiral cable may snap during steering operation if the cable is installed in an improper position.
The neutral position is set as per the following.
- Carefully turn the spiral cable clockwise to the end position. Then turn it counterclockwise (about 2 and a half turns) and stop turning at the mark (B) when the stopper insertion holes are in the same position.
- The service part is installed in the neutral position by the stopper and can be set without adjusting after the stopper is removed.
- Never over turn the spiral cable or go beyond the number of turns required. (This causes the cable to snap)
- Adjust the spiral cable locating pin (A) to the steering wheel locating pin hole (C).

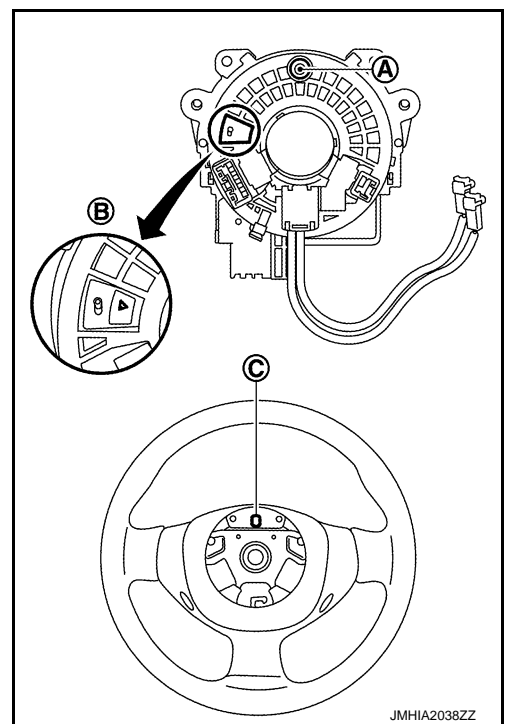

- Fix the driver air bag module harnesses to the harness fixing hook (A).

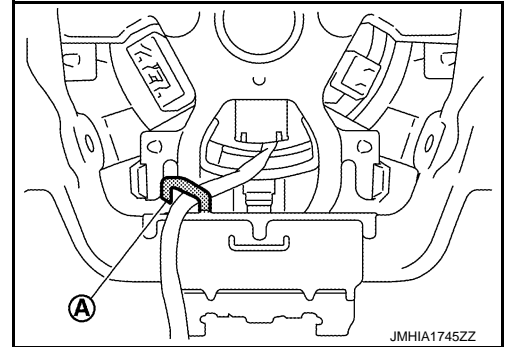

- If malfunction is detected by the air bag warning lamp, after repair or replacement of the malfunctioning parts, reset the memory using self-diagnosis or CONSULT. Refer to [SRC-13. "On Board Diagnosis Function"](#) or [SRC-17. "CONSULT Function"](#).
- After the work is completed, check that no system malfunction is detected by air bag warning lamp.

PASSENGER AIR BAG MODULE

< REMOVAL AND INSTALLATION >

PASSENGER AIR BAG MODULE

Exploded View

INFOID:000000006892118

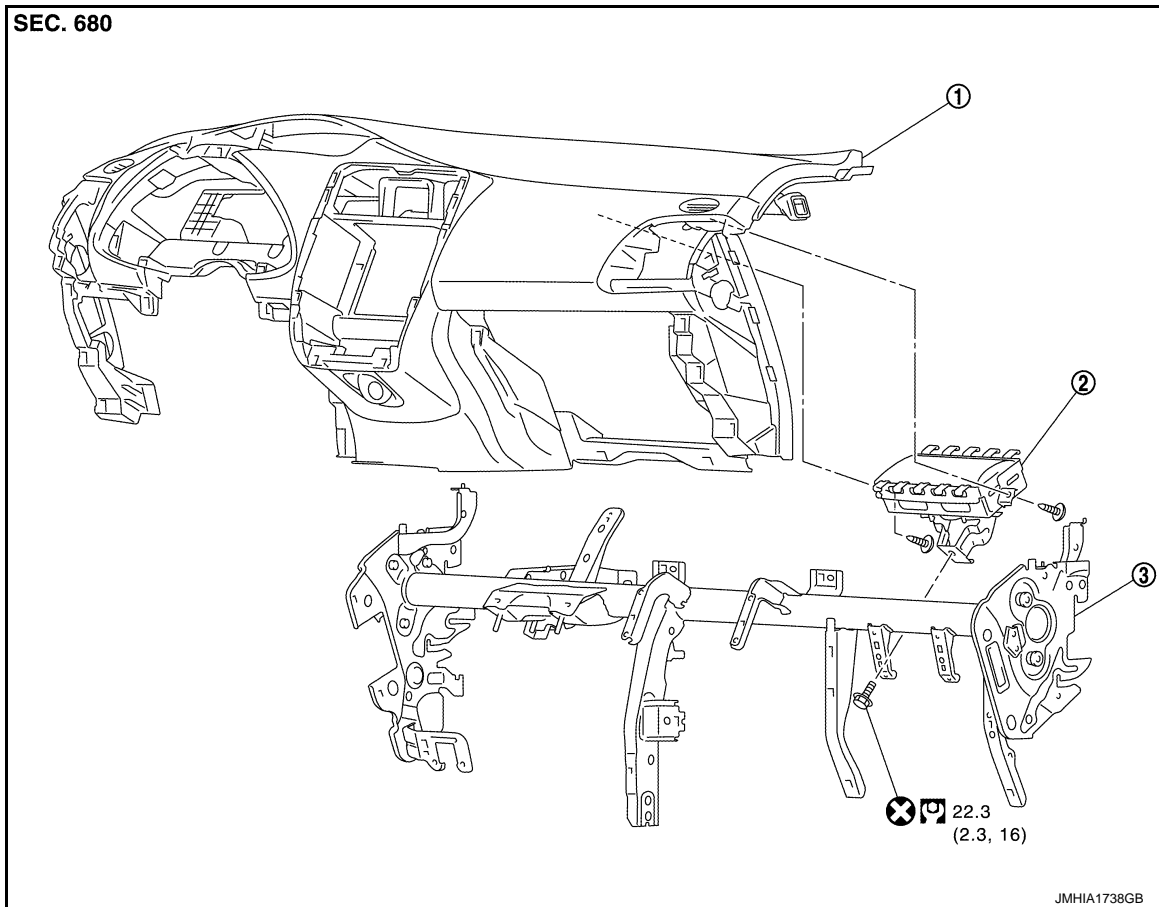

1. Instrument panel assembly 2. Passenger air bag module 3. Steering member assembly

△ : Pawl

⊗ : Always replace after every disassembly.

Ⓜ : N·m (kg·m, ft·lb)

Removal and Installation

INFOID:000000006892119

WARNING:

Always observe the following items for preventing accidental activation.

- Before servicing, push power switch OFF, disconnect 12V battery negative terminal and wait for 5 minutes or more. Refer to [SR-4, "Precautions for Removing Battery Terminal"](#).
- Always work from the side of air bag module. Never work in front of it.
- Never use air tools or electric tools for servicing.

REMOVAL

1. Remove the instrument panel assembly. Refer to [IP-14, "Removal and Installation"](#).

PASSENGER AIR BAG MODULE

< REMOVAL AND INSTALLATION >

2. Remove the passenger air bag module fixing screws (A).

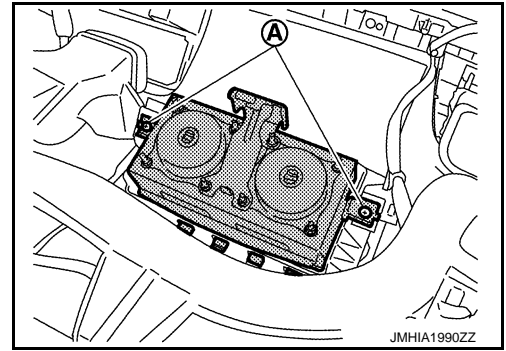

3. Pull up air bag grid portion of instrument panel, and then disengage the passenger air bag module.
4. Remove passenger air bag module from instrument panel.

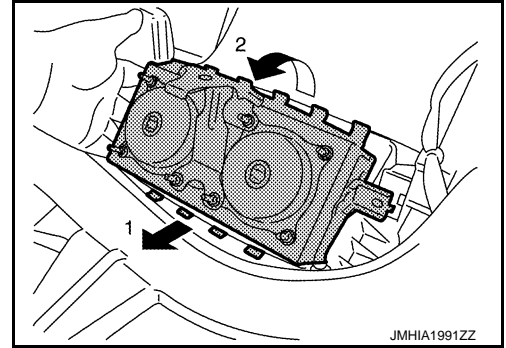

CAUTION:

- To prevent accidental explosion, always place the passenger air bag module with pad side facing upward.

↕ : Upward

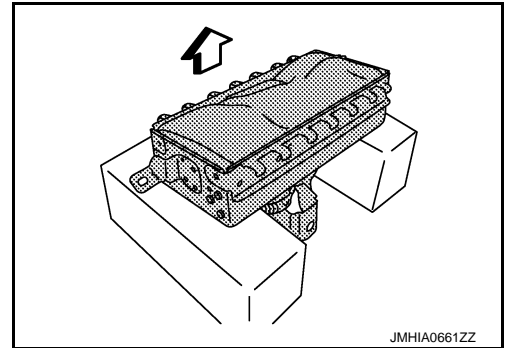

- To prevent damage to the parts, never impact the passenger air bag module.
- Replace the passenger air bag module if it is dropped or sustains an impact.



- To prevent accidental explosion, never insert any foreign objects (screwdriver, etc.) into the passenger air bag module.
- To prevent accidental explosion, never disassemble the passenger air bag module.
- To prevent accidental explosion, never expose the passenger air bag module to temperature of more than 90°C (194°F).
- To prevent damage to the parts, never allow oil, grease, detergent, or water to come in contact with the passenger air bag module.

INSTALLATION

Note the following items, and then install in the reverse order of removal.

PASSENGER AIR BAG MODULE

< REMOVAL AND INSTALLATION >

CAUTION:

- Never reuse mounting bolts after removal, replace with new bolts.
- Never damage the harness while installing.
- If malfunction is detected by the air bag warning lamp, after repair or replacement of the malfunctioning parts, reset the memory using self-diagnosis or CONSULT. Refer to [SRC-13, "On Board Diagnosis Function"](#) or [SRC-17, "CONSULT Function"](#).
- After the work is completed, check that no system malfunction is detected by air bag warning lamp.

A
B
C
D
E
F
G
SR
I
J
K
L
M
N
O
P

SR

CURTAIN AIR BAG MODULE

< REMOVAL AND INSTALLATION >

CURTAIN AIR BAG MODULE

Exploded View

INFOID:000000006892122

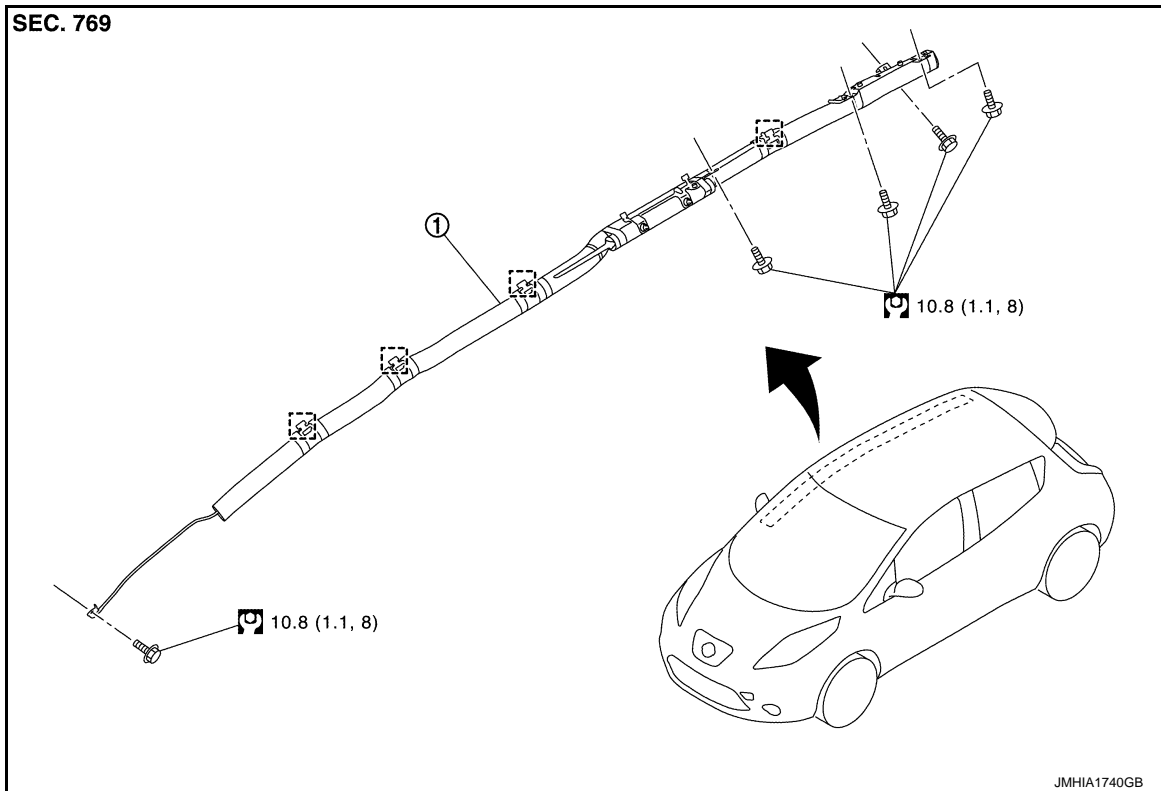

1. Curtain air bag module

 : Metal clip

 : N·m (kg·m, ft·lb)

Removal and Installation

INFOID:000000006892123

WARNING:

Always observe the following items for preventing accidental activation.

- Before servicing, push power switch OFF, disconnect 12V battery negative terminal and wait for 5 minutes or more. Refer to [SR-4, "Precautions for Removing Battery Terminal"](#).
- Always work from the side of curtain air bag module. Never work in front of it.
- Never use air tools or electric tools for servicing.

REMOVAL

1. Remove headlining assembly. Refer to [INT-32, "Removal and Installation"](#).
2. Remove the curtain air bag module mounting bolt that is located on the front pillar.
3. Disengage metal clips on the front roof.

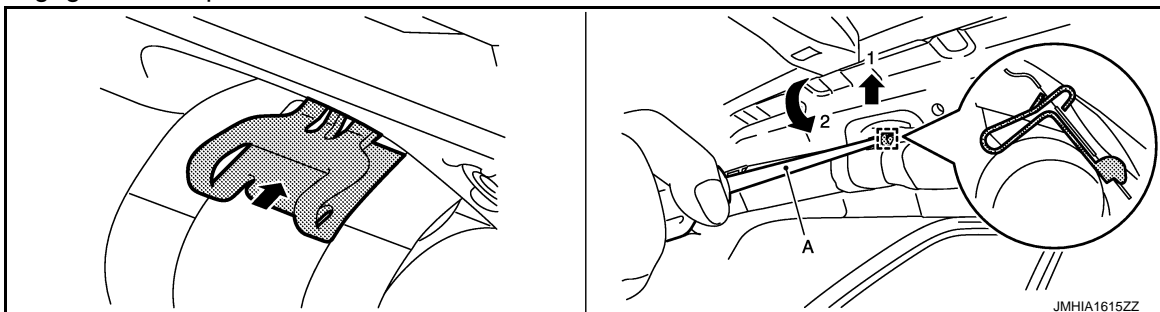

CURTAIN AIR BAG MODULE

< REMOVAL AND INSTALLATION >

 : Metal clip

- a. Fully insert a flat-bladed screwdriver (A) into center of metal clip.
- b. Lift the flat-bladed screwdriver upward according to the numerical order 1 → 2 as shown in the figure and disengage upper side of metal clip.
- c. Rotate the flat-bladed screwdriver as shown in the figure and disengage lower side of metal clip.

CAUTION:

Never deform metal clip.

4. Disconnect curtain air bag module harness connector.

CAUTION:

- For installing/removing the curtain air bag harness connector, insert a thin screwdriver wrapped in tape into notch, lift lock and remove the connector.
- Install the connector with lock raised, and push lock into the connector.
- After installing the connector, check that the lock is pushed securely into it.

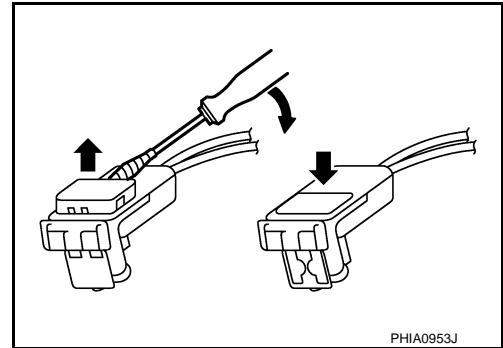

5. Remove the curtain air bag module mounting bolts that are located on the rear pillar.
6. Remove the curtain air bag module mounting bolts that are located on the inflator, and then remove curtain air bag module.

CAUTION:

- To prevent damage to the parts, never impact the curtain air bag module.
- Replace the curtain air bag module if it is dropped or sustains an impact.



- To prevent accidental explosion, never insert any foreign objects (screwdriver, etc.) into the curtain air bag module.
- To prevent accidental explosion, never disassemble the curtain air bag module.
- To prevent accidental explosion, never expose the curtain air bag module to temperature of more than 90°C (194°F).
- To prevent damage to the parts, never allow oil, grease, detergent, or water to come in contact with the curtain air bag module.

INSTALLATION

Note the following items, and then install in the reverse order of removal.

CAUTION:

- Insert metal clips of front roof until a locking sound is heard. Pull metal clips and check that it is fully locked to the vehicle body.
- Check perforation of curtain air bag module to check that curtain air bag module is not twisted.
- Never damage the harness while installing.
- If malfunction is detected by the air bag warning lamp, after repair or replacement of the malfunctioning parts, reset the memory using self-diagnosis or CONSULT. Refer to [SRC-13, "On Board Diagnosis Function"](#) or [SRC-17, "CONSULT Function"](#).
- After the work is completed, check that no system malfunction is detected by air bag warning lamp.

CRASH ZONE SENSOR

< REMOVAL AND INSTALLATION >

CRASH ZONE SENSOR

Exploded View

INFOID:000000006892124

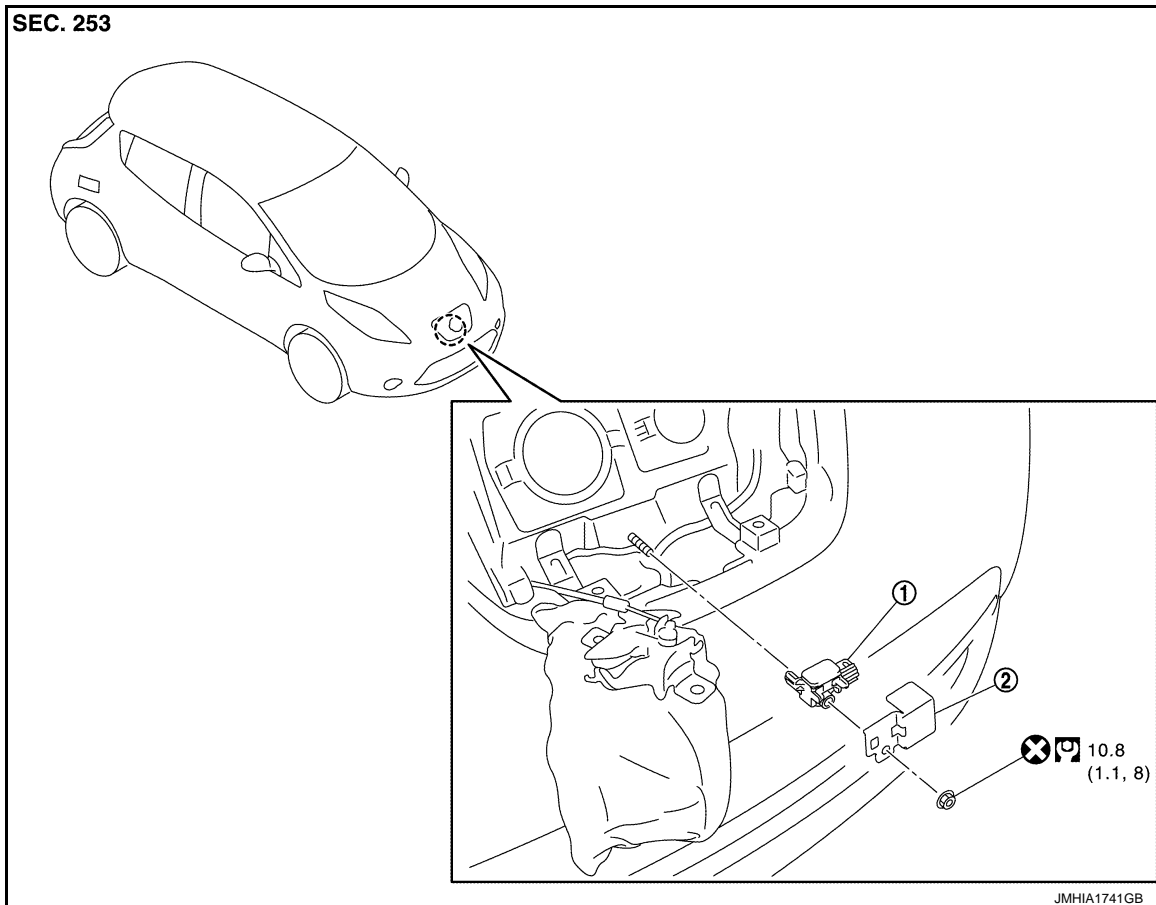

1. Crash zone sensor 2. Bracket

⊗ : Always replace after every disassembly.

⊙ : N·m (kg-m, ft-lb)

Removal and Installation

INFOID:000000006892125

WARNING:

Always observe the following items for preventing accidental activation.

- Before servicing, push power switch OFF, disconnect 12V battery negative terminal and wait for 5 minutes or more. Refer to [SR-4, "Precautions for Removing Battery Terminal"](#).
- Never use air tools or electric tools for servicing.

REMOVAL

1. Remove charge port cover. Refer to [DLK-149, "CHARGE PORT COVER : Removal and Installation"](#).
2. Remove charge port lid lock. Refer to [DLK-180, "Removal and Installation"](#).

CRASH ZONE SENSOR

< REMOVAL AND INSTALLATION >

3. Remove the crash zone sensor mounting nut (A), and then pull the bracket (1) and crash zone sensor (2) for vehicle front.

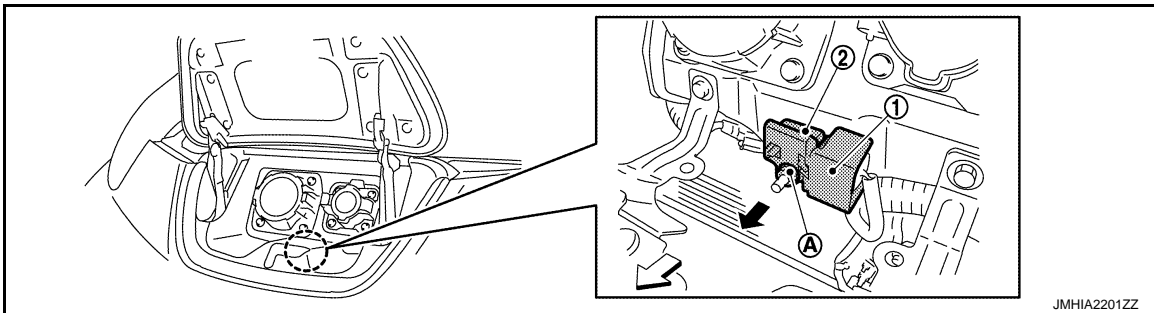

↶ : Vehicle front

4. Disconnect the crash zone sensor harness connector, and then remove crash zone sensor.

CAUTION:

- To prevent damage to the parts, never impact the crash zone sensor.
- Replace the crash zone sensor if it is dropped or sustains an impact.



- Replace the crash zone sensor of deployed driver air bag, deployed passenger air bag, seat belt pre-tensioner and deployed lap pre-tensioner.

INSTALLATION

Note the following items, and then install in the reverse order of removal.

CAUTION:

- Never reuse mounting nut after removal, replace with new nut.
- Never damage the harness while installing.
- Always install normally aligning to the cutout hole, because performance of the crash zone sensor excessively fluctuates according to the installation position.
- If malfunction is detected by the air bag warning lamp, after repair or replacement of the malfunctioning parts, reset the memory using self-diagnosis or CONSULT. Refer to [SRC-13, "On Board Diagnosis Function"](#) or [SRC-17, "CONSULT Function"](#).
- After the work is completed, check that no system malfunction is detected by air bag warning lamp.

SATELLITE SENSOR

< REMOVAL AND INSTALLATION >

SATELLITE SENSOR

Exploded View

INFOID:000000006892126

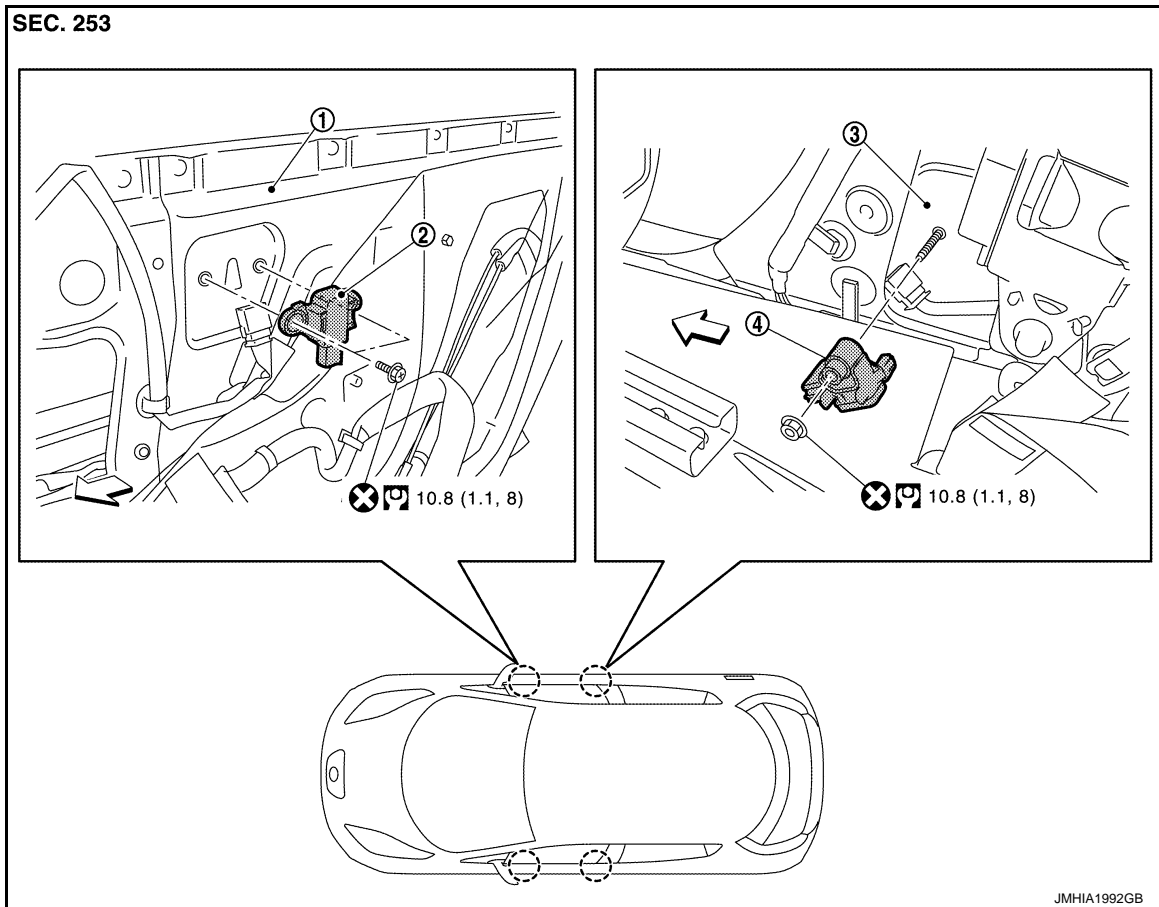

1. Front door panel 2. Front satellite sensor 3. Center pillar outer panel

4. Rear satellite sensor

↶ : Vehicle front

⊗ : Always replace after every disassembly.

N : N-m (kg-m, ft-lb)

Removal and Installation

INFOID:000000006892127

WARNING:

Always observe the following items for preventing accidental activation.

- Before servicing, push power switch OFF, disconnect 12V battery negative terminal and wait for 5 minutes or more. Refer to [SR-4, "Precautions for Removing Battery Terminal"](#).
- Never use air tools or electric tools for servicing.

FRONT SATELLITE SENSOR

Removal

1. Remove the front door finisher. Refer to [INT-14, "Removal and Installation"](#).
2. Remove sealing screen partially.

NOTE:

Cut the butyl-tape with utility knives so that some parts of the butyl-tape do not remain on the sealing screen, if the sealing screen is reused.

SATELLITE SENSOR

< REMOVAL AND INSTALLATION >

3. Remove the front satellite sensor mounting bolts (A), and then pull the front satellite sensor (1).

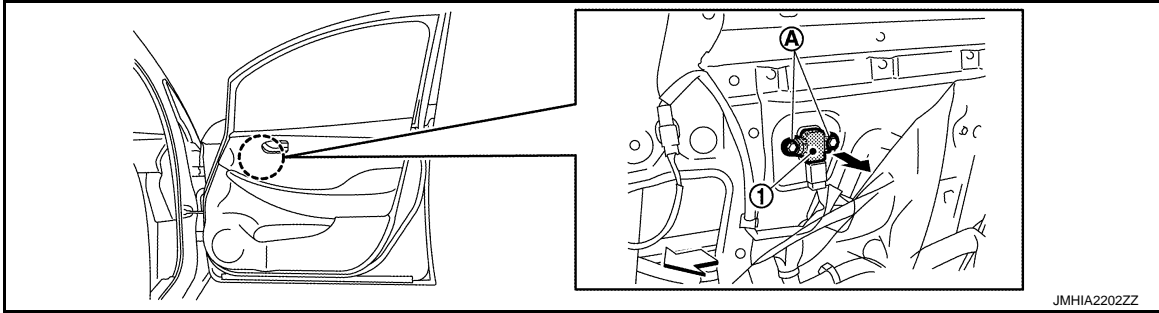

↶ : Vehicle front

4. Disconnect the harness connector and then remove the front satellite sensor.

CAUTION:

- To prevent damage to the parts, never impact the front satellite sensor.
- Replace the front satellite sensor if it is dropped or sustains an impact.



- Replace the front satellite sensor of deployed SRS side air bag module and deployed SRS curtain air bag module.

Installation

Note the following items, and then install in the reverse order of removal.

CAUTION:

- Never reuse mounting bolts after removal, replace with new bolts.
- Never damage the harness while installing.
- Always install normally aligning to the cutout hole, because performance of the front satellite sensor excessively fluctuates according to the installation position.
- If malfunction is detected by the air bag warning lamp, after repair or replacement of the malfunctioning parts, reset the memory using self-diagnosis or CONSULT. Refer to [SRC-13, "On Board Diagnosis Function"](#) or [SRC-17, "CONSULT Function"](#).
- After the work is completed, check that no system malfunction is detected by air bag warning lamp.

REAR SATELLITE SENSOR

Removal

1. Remove the center pillar lower garnish. Refer to [INT-26, "CENTER PILLAR UPPER GARNISH : Removal and Installation"](#).
2. Remove the rear satellite sensor mounting nut (A), and then pull the rear satellite sensor (1).

↶ : Vehicle front

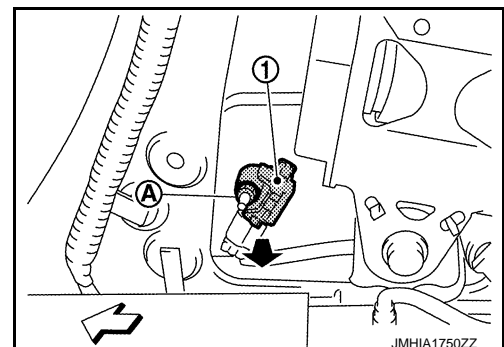

SATELLITE SENSOR

< REMOVAL AND INSTALLATION >

3. Disconnect the harness connector and then remove the rear satellite sensor.

CAUTION:

- To prevent damage to the parts, never impact the rear satellite sensor.
- Replace the rear satellite sensor if it is dropped or sustains an impact.



- Replace the rear satellite sensor of deployed SRS side air bag module and deployed SRS curtain air bag module.

Installation

Note the following items, and then install in the reverse order of removal.

CAUTION:

- Never reuse mounting nut after removal, replace with new nut.
- Never damage the harness while installing.
- Always install normally aligning to the cutout hole, because performance of the rear satellite sensor excessively fluctuates according to the installation position.
- If malfunction is detected by the air bag warning lamp, after repair or replacement of the malfunctioning parts, reset the memory using self-diagnosis or CONSULT. Refer to [SRC-13, "On Board Diagnosis Function"](#) or [SRC-17, "CONSULT Function"](#).
- After the work is completed, check that no system malfunction is detected by air bag warning lamp.

DIAGNOSIS SENSOR UNIT

< REMOVAL AND INSTALLATION >

DIAGNOSIS SENSOR UNIT

Exploded View

INFOID:000000006892128

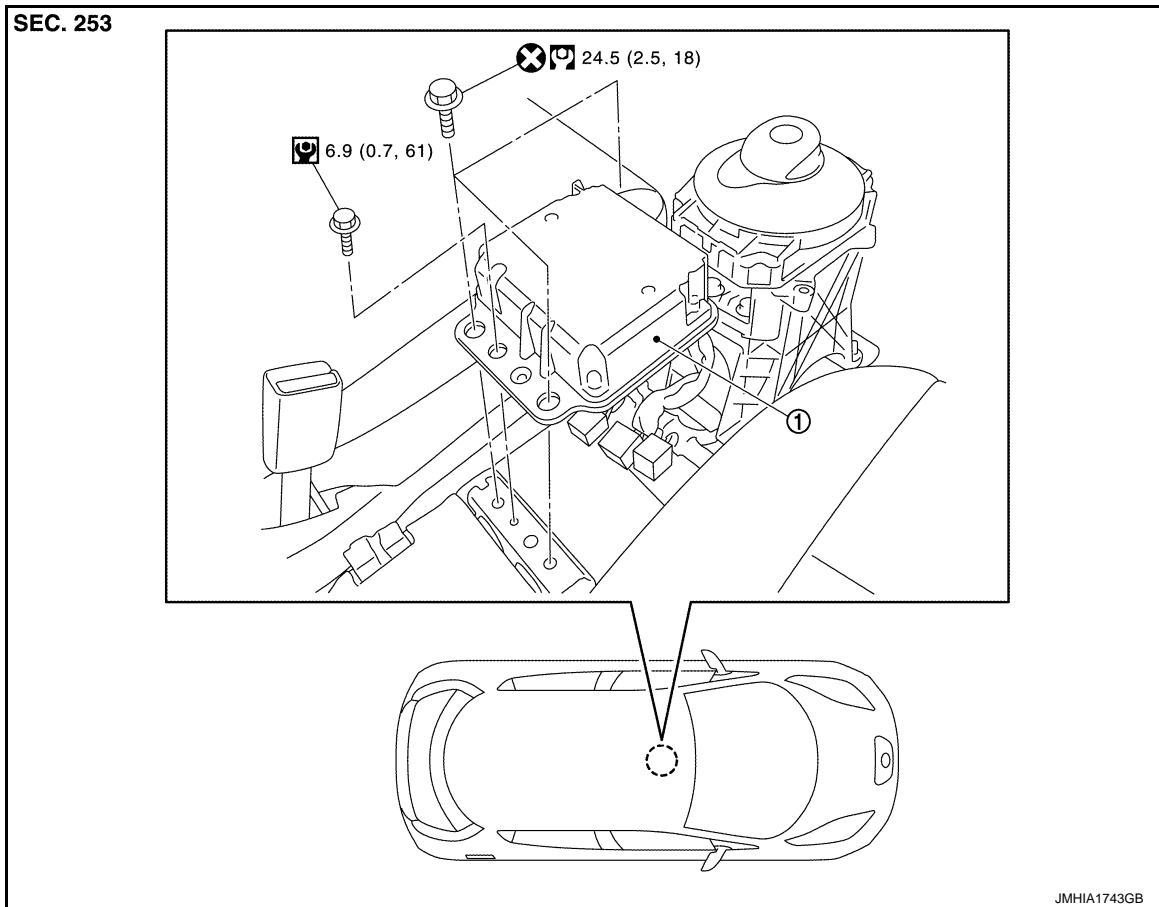

1. Diagnosis sensor unit

⊗ : Always replace after every disassembly.

⊙ : N·m (kg-m, in-lb)

⊕ : N·m (kg-m, ft-lb)

Removal and Installation

INFOID:000000006892129

WARNING:

Always observe the following items for preventing accidental activation.

- Before servicing, push power switch OFF, disconnect 12V battery negative terminal and wait for 5 minutes or more. Refer to [SR-4, "Precautions for Removing Battery Terminal"](#).
- Before disconnecting the air bag sensor unit harness connector, be sure to disconnect the each harness connector of the air bag module and pre-tensioner seat belt to prevent air bag deployment by static electricity and pre-tensioner seat belt operation.
- Never use air tools or electric tools for servicing.
- When replacing the air bag diagnosis sensor unit, always check with the parts department for the latest parts information. Installing an incorrect air bag diagnosis sensor unit may or may not cause the air bag warning lamp to illuminate and may cause incorrect deployment of the supplemental air bags and seat belt pre-tensioners in a collision resulting in serious personal injury or death.

REMOVAL

1. Always check the air bag diagnosis sensor unit ECU discriminated number (identification number) using CONSULT.

DIAGNOSIS SENSOR UNIT

< REMOVAL AND INSTALLATION >

2. Disconnect the each connector of all air bag modules and pre-tensioner seat belts.
3. Remove the center console assembly. Refer to [IP-27, "Removal and Installation"](#).
4. Disconnect the diagnosis sensor unit harness connectors (A).

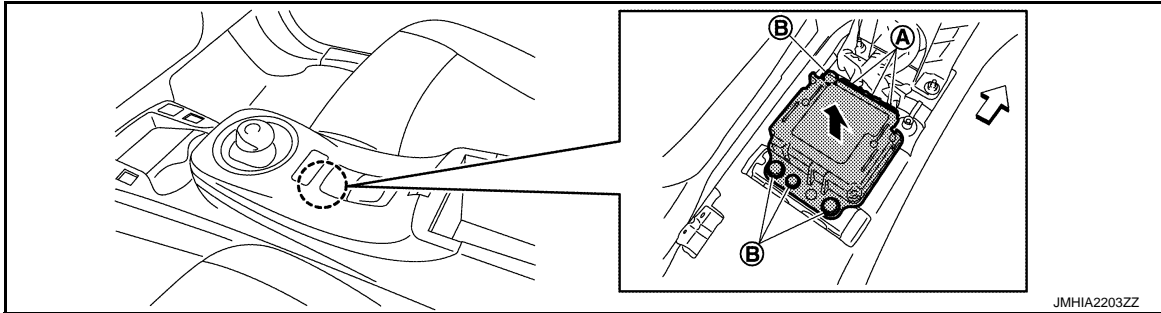

5. Remove the diagnosis sensor unit mounting bolts (B), and then remove the diagnosis sensor unit.

← : Vehicle front

CAUTION:

- To prevent damage to the parts, never impact the diagnosis sensor unit.
- Replace the diagnosis sensor unit if it is dropped or sustains an impact.



- Replace the diagnosis sensor unit of deployed SRS air bag and deployed SRS front seat belt pre-tensioner.

INSTALLATION

Note the following items, and then install in the reverse order of removal.

CAUTION:

- Never reuse bolts after removal, replace with new bolts.
- Never damage the harness while installing.
- If malfunction is detected by the air bag warning lamp, after repair or replacement of the malfunctioning parts, reset the memory using self-diagnosis or CONSULT. Refer to [SRC-13, "On Board Diagnosis Function"](#) or [SRC-17, "CONSULT Function"](#).
- After the work is completed, check that no system malfunction is detected by air bag warning lamp.
- After replacing the air bag diagnosis sensor unit, confirm using CONSULT that the ECU discriminated number (identification number) of the new replacement air bag sensor unit matches the ECU discriminated number (identification number) of the replaced (old) air bag diagnosis sensor unit.

NOTE:

If the ECU discriminated number of the new replacement air bag diagnosis sensor unit differs from the ECU discriminated number of the replaced air bag diagnosis sensor unit, reconfirm the parts information and verify that the correct air bag diagnosis sensor unit is installed.

SEAT BELT PRE-TENSIONER

< REMOVAL AND INSTALLATION >

SEAT BELT PRE-TENSIONER

Exploded View

INFOID:000000006892130

Refer to [SB-7, "Exploded View"](#).

Removal and Installation

INFOID:000000006892131

For removal and installation procedures, refer to [SB-8, "SEAT BELT RETRACTOR : Removal and Installation"](#).

A

B

C

D

E

F

G

SR

I

J

K

L

M

N

O

P

LAP PRE-TENSIONER

< REMOVAL AND INSTALLATION >

LAP PRE-TENSIONER

Exploded View

INFOID:000000006892132

Refer to [SB-7. "Exploded View"](#).

Removal and Installation

INFOID:000000006892133

For removal and installation procedures, refer to [SB-8. "SEAT BELT RETRACTOR : Removal and Installation"](#).

OCCUPANT CLASSIFICATION SYSTEM CONTROL UNIT

< REMOVAL AND INSTALLATION >

OCCUPANT CLASSIFICATION SYSTEM CONTROL UNIT

Exploded View

INFOID:000000006892155

Refer to [SE-20, "Exploded View"](#).

Removal and Installation

INFOID:000000006892156

For removal and installation

The occupant classification system control unit and seat sensor mat are an integral part of the front passenger seat cushion and are replaced as an assembly. Refer to [SE-23, "Removal and Installation"](#).

A

B

C

D

E

F

G

SR

I

J

K

L

M

N

O

P