

SECTION **SEC**

SECURITY CONTROL SYSTEM

A
B
C
D
E
F
G
H
I
J
L
M
N
O
P

CONTENTS

WITH INTELLIGENT KEY SYSTEM		
PRECAUTION	4	
PRECAUTIONS	4	
Precaution for Technicians Using Medical Electric.....	4	
Precaution for Supplemental Restraint System (SRS) "AIR BAG" and "SEAT BELT PRE-TENSIONER"	4	
Precautions for Removing Battery Terminal	5	
Precaution for Procedure without Cowl Top Cover.....	6	
Point to Be Checked Before Starting Maintenance Work	6	
PREPARATION	7	
PREPARATION	7	
Special Service Tools	7	
Commercial Service Tools	7	
SYSTEM DESCRIPTION	9	
COMPONENT PARTS	9	
Component Parts Location	9	
NATS Antenna Amp.	11	
SYSTEM	12	
INTELLIGENT KEY SYSTEM/READY SET FUNCTION	12	
INTELLIGENT KEY SYSTEM/READY SET FUNCTION : System Description	12	
INTELLIGENT KEY SYSTEM/READY SET FUNCTION : Circuit Diagram	15	
NISSAN VEHICLE IMMOBILIZER SYSTEM-NATS...	16	
NISSAN VEHICLE IMMOBILIZER SYSTEM-NATS : System Description	17	
NISSAN VEHICLE IMMOBILIZER SYSTEM-NATS : Circuit Diagram	20	
VEHICLE SECURITY SYSTEM	21	
		VEHICLE SECURITY SYSTEM : System Description (Except for Canada)
		22
		VEHICLE SECURITY SYSTEM : System Description (For Canada)
		25
		VEHICLE SECURITY SYSTEM : Circuit Diagram.....
		29
		DIAGNOSIS SYSTEM (BCM)
		31
		COMMON ITEM
		31
		COMMON ITEM : CONSULT Function (BCM - COMMON ITEM)
		31
		INTELLIGENT KEY
		32
		INTELLIGENT KEY : CONSULT Function (BCM - INTELLIGENT KEY)
		33
		THEFT ALM
		35
		THEFT ALM : CONSULT Function (BCM - THEFT)
		35
		IMMU
		36
		IMMU : CONSULT Function (BCM - IMMU)
		36
		DIAGNOSIS SYSTEM (IPDM E/R)
		38
		CONSULT Function (IPDM E/R)
		38
		ECU DIAGNOSIS INFORMATION
		40
		VCM, IPDM E/R, BCM
		40
		List of ECU Reference
		40
		WIRING DIAGRAM
		41
		SECURITY CONTROL SYSTEM
		41
		Wiring Diagram
		41
		BASIC INSPECTION
		44
		DIAGNOSIS AND REPAIR WORK FLOW
		44
		Work Flow
		44
		ADDITIONAL SERVICE WHEN REPLACING CONTROL UNIT
		47

SEC

VCM	47	B2602 SHIFT POSITION	68
VCM : Description	47	DTC Logic	68
VCM : Work Procedure	47	Diagnosis Procedure	68
BCM	47	B2603 SHIFT POSITION	70
BCM : Description	47	DTC Logic	70
BCM : Work Procedure	47	Diagnosis Procedure	70
DTC/CIRCUIT DIAGNOSIS	49	B2604 SHIFT POSITION	72
P1610 LOCK MODE	49	DTC Logic	72
Description	49	Diagnosis Procedure	72
DTC Logic	49	B2617 READY SIGNAL CIRCUIT	74
Diagnosis Procedure	49	DTC Logic	74
P1611 ID DISCORD, IMM-U-VCM	50	Diagnosis Procedure	74
DTC Logic	50	B2619 BCM	76
Diagnosis Procedure	50	DTC Logic	76
P1612 CHAIN OF VCM-IMMU	51	Diagnosis Procedure	76
DTC Logic	51	B261A POWER SWITCH	77
Diagnosis Procedure	51	DTC Logic	77
B2192 ID DISCORD, IMM-U-ECM	52	Diagnosis Procedure	77
DTC Logic	52	B261E VEHICLE TYPE	79
Diagnosis Procedure	52	Description	79
B2193 CHAIN OF ECM-IMMU	53	DTC Logic	79
DTC Logic	53	Diagnosis Procedure	79
Diagnosis Procedure	53	B26F7 BCM	80
B2195 ANTI-SCANNING	54	DTC Logic	80
DTC Logic	54	Diagnosis Procedure	80
Diagnosis Procedure	54	B26FC KEY REGISTRATION	81
B2196 DONGLE UNIT	55	DTC Logic	81
Description	55	Diagnosis Procedure	81
DTC Logic	55	HEADLAMP FUNCTION	82
Diagnosis Procedure	55	Component Function Check	82
B2198 NATS ANTENNA AMP.	57	Diagnosis Procedure	82
DTC Logic	57	HOOD SWITCH	83
Diagnosis Procedure	57	Component Function Check	83
B2555 STOP LAMP	60	Diagnosis Procedure	83
DTC Logic	60	Component Inspection	84
Diagnosis Procedure	60	HORN FUNCTION	85
Component Inspection	61	Component Function Check	85
B2556 POWER SWITCH	63	Diagnosis Procedure	85
DTC Logic	63	SECURITY INDICATOR LAMP	87
Diagnosis Procedure	63	Component Function Check	87
Component Inspection	64	Diagnosis Procedure	87
B2557 VEHICLE SPEED	65	SYMPTOM DIAGNOSIS	89
DTC Logic	65	VEHICLE CANNOT BE SET TO READY	
Diagnosis Procedure	65	WHEN INTELLIGENT KEY IS INSIDE OF VE-	
B2601 SHIFT POSITION	66	HICLE	89
DTC Logic	66	Description	89
Diagnosis Procedure	66	Diagnosis Procedure	89

SECURITY INDICATOR LAMP DOES NOT TURN ON OR BLINK	90		
Description	90		
Diagnosis Procedure	90		
VEHICLE SECURITY SYSTEM CANNOT BE SET	91		
INTELLIGENT KEY	91		
INTELLIGENT KEY : Description	91		
INTELLIGENT KEY : Diagnosis Procedure (Ex- cept for Canada)	91		
INTELLIGENT KEY : Diagnosis Procedure (For Canada)	91		
DOOR REQUEST SWITCH	91		
DOOR REQUEST SWITCH : Description	92		
DOOR REQUEST SWITCH : Diagnosis Proce- dure (Except for Canada)	92		
DOOR REQUEST SWITCH : Diagnosis Proce- dure (For Canada)	92		
DOOR KEY CYLINDER	92		
DOOR KEY CYLINDER : Description	92		
		DOOR KEY CYLINDER : Diagnosis Procedure (Except for Canada)	93
		DOOR KEY CYLINDER : Diagnosis Procedure (For Canada)	93
		DOOR LOCK AND UNLOCK SWITCH	93
		DOOR LOCK AND UNLOCK SWITCH : Descrip- tion	93
		DOOR LOCK AND UNLOCK SWITCH : Diagnosis Procedure (Except for Canada)	94
		DOOR LOCK AND UNLOCK SWITCH : Diagnosis Procedure (For Canada)	94
		VEHICLE SECURITY ALARM DOES NOT ACTIVATE	95
		Description	95
		Diagnosis Procedure (Except for Canada)	95
		Diagnosis Procedure (For Canada)	95
		REMOVAL AND INSTALLATION	97
		NATS ANTENNA AMP.	97
		Removal and Installation	97
		POWER SWITCH	98
		Removal and Installation	

A
B
C
D
E
F
G
H
I
J
L
M
N
O
P

SEC

PRECAUTION

PRECAUTIONS

Precaution for Technicians Using Medical Electric

INFOID:000000007634153

OPERATION PROHIBITION

WARNING:

- Parts with strong magnet is used in this vehicle.
- Technicians using a medical electric device such as pacemaker must never perform operation on the vehicle, as magnetic field can affect the device function by approaching to such parts.

NORMAL CHARGE PRECAUTION

WARNING:

- If a technician uses a medical electric device such as an implantable cardiac pacemaker or an implantable cardioverter defibrillator, the possible effects on the devices must be checked with the device manufacturer before starting the charge operation.
- As radiated electromagnetic wave generated by on board charger at normal charge operation may effect medical electric devices, a technician using a medical electric device such as implantable cardiac pacemaker or an implantable cardioverter defibrillator must not enter the vehicle compartment (including luggage room) during normal charge operation.

PRECAUTION AT TELEMATICS SYSTEM OPERATION

WARNING:

- If a technician uses implantable cardiac pacemaker or implantable cardioverter defibrillator (ICD), avoid the device implanted part from approaching within approximately 220 mm (8.66 in) from interior/exterior antenna.
- The electromagnetic wave of TCU might affect the function of the implantable cardiac pacemaker or the implantable cardioverter defibrillator (ICD), when using the service, etc.
- If a technician uses other medical electric devices than implantable cardiac pacemaker or implantable cardioverter defibrillator (ICD), the electromagnetic wave of TCU might affect the function of the device. The possible effects on the devices must be checked with the device manufacturer before TCU use.

PRECAUTION AT INTELLIGENT KEY SYSTEM OPERATION

WARNING:

- If a technician uses implantable cardiac pacemaker or implantable cardioverter defibrillator (ICD), avoid the device implanted part from approaching within approximately 220 mm (8.66 in) from interior/exterior antenna.
- The electromagnetic wave of Intelligent Key might affect the function of the implantable cardiac pacemaker or the implantable cardioverter defibrillator (ICD), at door operation, at each request switch operation, or at engine starting.
- If a technician uses other medical electric devices than implantable cardiac pacemaker or implantable cardioverter defibrillator (ICD), the electromagnetic wave of Intelligent Key might affect the function of the device. The possible effects on the devices must be checked with the device manufacturer before Intelligent Key use.

Precaution for Supplemental Restraint System (SRS) "AIR BAG" and "SEAT BELT PRE-TENSIONER"

INFOID:000000007634154

The Supplemental Restraint System such as "AIR BAG" and "SEAT BELT PRE-TENSIONER", used along with a front seat belt, helps to reduce the risk or severity of injury to the driver and front passenger for certain types of collision. This system includes seat belt switch inputs and dual stage front air bag modules. The SRS system uses the seat belt switches to determine the front air bag deployment, and may only deploy one front air bag, depending on the severity of a collision and whether the front occupants are belted or unbelted. Information necessary to service the system safely is included in the "SRS AIR BAG" and "SEAT BELT" of this Service Manual.

WARNING:

Always observe the following items for preventing accidental activation.

PRECAUTIONS

[WITH INTELLIGENT KEY SYSTEM]

< PRECAUTION >

- To avoid rendering the SRS inoperative, which could increase the risk of personal injury or death in the event of a collision that would result in air bag inflation, all maintenance must be performed by an authorized NISSAN/INFINITI dealer.
- Improper maintenance, including incorrect removal and installation of the SRS, can lead to personal injury caused by unintentional activation of the system. For removal of Spiral Cable and Air Bag Module, see "SRS AIR BAG".
- Never use electrical test equipment on any circuit related to the SRS unless instructed to in this Service Manual. SRS wiring harnesses can be identified by yellow and/or orange harnesses or harness connectors.

PRECAUTIONS WHEN USING POWER TOOLS (AIR OR ELECTRIC) AND HAMMERS

WARNING:

Always observe the following items for preventing accidental activation.

- When working near the Air Bag Diagnosis Sensor Unit or other Air Bag System sensors with the power switch ON, never use air or electric power tools or strike near the sensor(s) with a hammer. Heavy vibration could activate the sensor(s) and deploy the air bag(s), possibly causing serious injury.
- When using air or electric power tools or hammers, always switch the power switch OFF, disconnect the 12V battery, and wait at least 3 minutes before performing any service.

Precautions for Removing Battery Terminal

INFOID:000000007634155

- When removing the 12V battery terminal, turn OFF the power switch and wait at least 5 minutes.

NOTE:

ECU may be active for several minutes after the power switch is turned OFF. If the battery terminal is removed before ECU stops, then a DTC detection error or ECU data corruption may occur.

- Always disconnect the battery terminal within 60 minutes after turning OFF the power switch. Even when the power switch is OFF, the 12V battery automatic charge control may automatically start after a lapse of 60 minutes from power switch OFF.
- Disconnect 12V battery terminal according to the following steps.

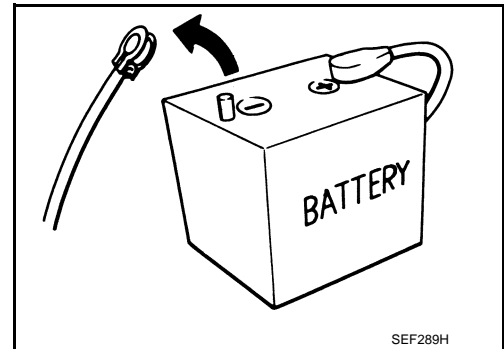

WORK PROCEDURE

1. Check that EVSE is not connected.

NOTE:

If EVSE is connected, the air conditioning system may be automatically activated by the timer A/C function.

2. Turn the power switch OFF → ON → OFF. Get out of the vehicle. Close all doors (including back door).
3. Check that the charge status indicator lamp does not blink and wait for 5 minutes or more.

NOTE:

If the battery is removed within 5 minutes after the power switch is turned OFF, plural DTCs may be detected.

4. Remove 12V battery terminal within 60 minutes after turning the power switch OFF → ON → OFF.

CAUTION:

- After all doors (including back door) are closed, if a door (including back door) is opened before battery terminals are disconnected, start over from Step 1.
- After turning the power switch OFF, if "Remote A/C" is activated by user operation, stop the air conditioner and start over from Step 1.

NOTE:

Once the power switch is turned ON → OFF, the 12V battery automatic charge control does not start for approximately 1 hour.

- For vehicles with the 2-batteries, be sure to connect the main battery and the sub battery before turning ON the power switch.

NOTE:

If the power switch is turned ON with any one of the terminals of main battery and sub battery disconnected, then DTC may be detected.

- After installing the 12V battery, always check "Self Diagnosis Result" of all ECUs and erase DTC.

NOTE:

SEC

PRECAUTIONS

[WITH INTELLIGENT KEY SYSTEM]

< PRECAUTION >

The removal of 12V battery may cause a DTC detection error.

Precaution for Procedure without Cowl Top Cover

INFOID:000000007634156

When performing the procedure after removing cowl top cover, cover the lower end of windshield with urethane, etc to prevent damage to windshield.

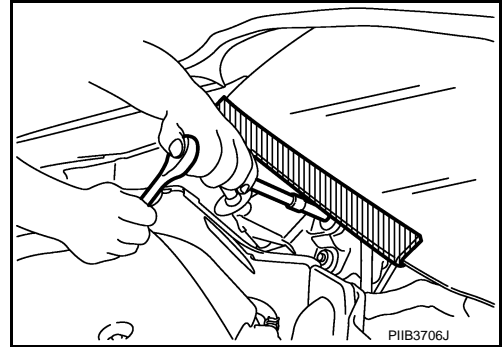

Point to Be Checked Before Starting Maintenance Work

INFOID:000000007634157

The high voltage system may start automatically. It is required to check that the timer air conditioner and timer charge (during EVSE connection) are not set before starting maintenance work.

NOTE:

If the timer air conditioner or timer charge (during EVSE connection) is set, the high voltage system starts automatically even when the power switch is in OFF state.

PREPARATION

< PREPARATION >

[WITH INTELLIGENT KEY SYSTEM]

PREPARATION

PREPARATION

Special Service Tools

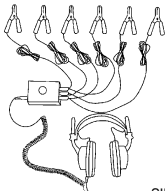
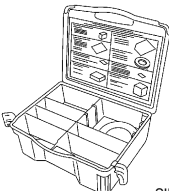

INFOID:000000007634158

The actual shapes of Kent-Moore tools may differ from those of special service tools illustrated here.

Tool number (Kent-Moore No.) Tool name	Description
<p>(J-39570) Chassis ear</p>  <p>SIIA0993E</p>	<p>Locates the noise</p>
<p>(J-43980) NISSAN Squeak and Rattle Kit</p>  <p>SIIA0994E</p>	<p>Repairs the cause of noise</p>

Commercial Service Tools

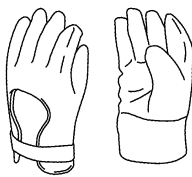
INFOID:000000007634159

Tool name	Description
<p>Insulated gloves [Guaranteed insulation performance for 1000V/300A]</p>  <p>JMCI A0149ZZ</p>	<p>Removing and installing high voltage components</p>
<p>Leather gloves [Use leather gloves that can fasten the wrist tight]</p>  <p>JPCIA0066ZZ</p>	<ul style="list-style-type: none"> • Removing and installing high voltage components • Protect insulated gloves
<p>Insulated safety shoes</p>  <p>JPCIA0011ZZ</p>	<p>Removing and installing high voltage components</p>

A

B

C

D

E

F

G

H

I

J

SEC

L

M

N



O

P

PREPARATION

< PREPARATION >

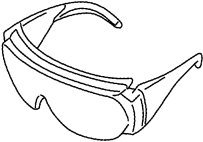
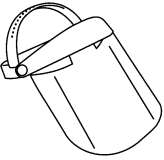
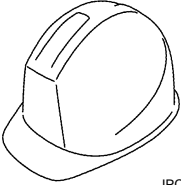
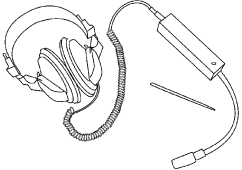
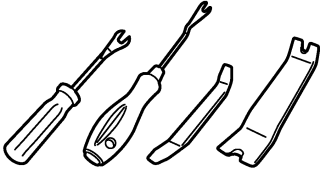
[WITH INTELLIGENT KEY SYSTEM]

Tool name	Description
<p>Safety glasses [ANSI Z87.1]</p>	<div style="text-align: center;">  <p>JPCIA0012ZZ</p> </div> <ul style="list-style-type: none"> • Removing and installing high voltage components • To protect eye from the spatter on the work to electric line
<p>Face shield</p>	<div style="text-align: center;">  <p>JPCIA0167ZZ</p> </div> <ul style="list-style-type: none"> • Removing and installing high voltage components • To protect eye from the spatter on the work to electric line
<p>Insulated helmet</p>	<div style="text-align: center;">  <p>JPCIA0013ZZ</p> </div> <p>Removing and installing high voltage components</p>
<p>Engine ear</p>	<div style="text-align: center;">  <p>SIIA0995E</p> </div> <p>Locates the noise</p>
<p>Remover tool</p>	<div style="text-align: center;">  <p>JMKIA3050ZZ</p> </div> <p>Removes the clips, pawls, and metal clips</p>
<p>Power tool</p>	<div style="text-align: center;">  <p>PIIB1407E</p> </div>

COMPONENT PARTS

< SYSTEM DESCRIPTION >

[WITH INTELLIGENT KEY SYSTEM]

SYSTEM DESCRIPTION

COMPONENT PARTS

Component Parts Location

INFOID:000000007634160

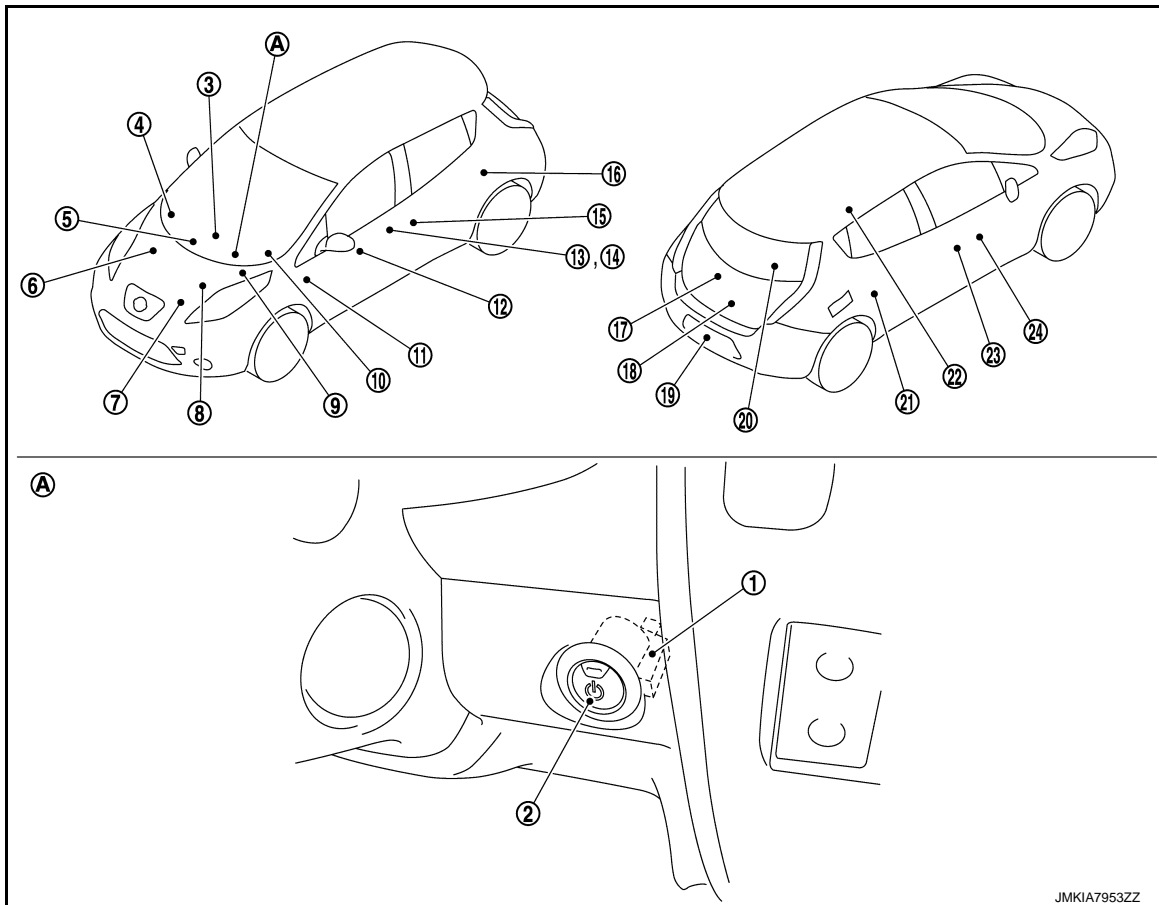

A. Behind power switch

No.	Component	Function
1	NATS antenna amp.	SEC-11. "NATS Antenna Amp."
2	Power switch	Power switch has push switch inside which detects that power switch is pressed, and then transmits the signal to BCM. BCM changes the power supply position with the operation of power switch. BCM maintains the power supply position status while power switch is not operated. Refer to PCS-34. "Power Switch" for detailed installation location.
3	Electric shift control module	Electric shift control module detects the shift position, and then transmits the P position signal to BCM and IPDM E/R. And electric shift control module transmits the P/N position signal to BCM. BCM confirms the shift position with the following 4 signals. <ul style="list-style-type: none"> • P position signal from electric shift control module • P/N position signal from electric shift control module • P position signal from IPDM E/R (CAN) • Shift position signal from VCM (CAN) Refer to TM-28. "Component Parts Location" for detailed installation location.
4	Remote keyless entry receiver	Remote keyless entry receiver receives each button operation signal and electronic key ID signal from Intelligent Key, and then transmits the signal to BCM. Refer to DLK-16. "Remote Keyless Entry Receiver" for detailed installation location.

A

B

C

D

E

F

G

H

I

J

SEC

L

M

N

O

P

COMPONENT PARTS

< SYSTEM DESCRIPTION >

[WITH INTELLIGENT KEY SYSTEM]

No.	Component	Function
5	Inside key antenna (Instrument center)	Inside key antenna (Instrument center) detects whether Intelligent Key is inside the vehicle or not, and transmits the signal to BCM. Refer to DLK-15, "Inside Key Antenna (Instrument Center)" for detailed installation location.
6	VCM	VCM controls the vehicle. When power switch is turned to the ON position, BCM starts communication with VCM and performs the ID verification between BCM and VCM. If the verification result is OK, the vehicle can be set to READY. If the verification result is NG, the vehicle can not be set to READY. Refer to EVC-17, "Component Parts Location" for detailed installation location.
7	Stop lamp switch	Stop lamp switch detects that brake pedal is depressed, and then transmits the signal to BCM. Refer to BRC-10, "Component Parts Location" for detailed installation location.
8	ABS actuator and electric unit (control unit)	ABS actuator and electric unit (control unit) transmits the vehicle speed signal to BCM via CAN communication. BCM also receives the vehicle speed signal from combination meter via CAN communication. BCM compares both signals to detect the vehicle speed. Refer to BRC-10, "Component Parts Location" for detailed installation location.
9	IPDM E/R	IPDM E/R has headlamp relays inside. Headlamp relays are used for the vehicle security function. IPDM E/R controls these relays while communicating with BCM. When IPDM E/R receives the alarm request signal from BCM, IPDM E/R activates vehicle security horn and headlamps intermittently. Refer to PCS-7, "Component Parts Location" for detailed installation location.
10	Combination meter	Combination meter transmits the vehicle speed signal to BCM via CAN communication. BCM also receives the vehicle speed signal from ABS actuator and electric unit (control unit) via CAN communication. BCM compares both signals to detect the vehicle speed. Security indicator lamp is located on combination meter. Security indicator lamp blinks when power switch is in any position other than ON to warn that NISSAN VEHICLE IMMOBILIZER SYSTEM-NATS [NVIS (NATS)] is on board. Refer to MWI-7, "METER SYSTEM : Component Parts Location" for detailed installation location.
11	BCM	BCM controls INTELLIGENT KEY SYSTEM (READY SET FUNCTION), NISSAN VEHICLE IMMOBILIZER SYSTEM-NATS [NVIS (NATS)] and VEHICLE SECURITY SYSTEM. BCM performs the ID verification between BCM and Intelligent Key when the Intelligent Key is carried into the detection area of inside key antenna, and power switch is pressed. If the ID verification result is OK, power switch operation is available. Then, when the power switch is turned to the ON position, BCM performs ID verification between BCM and VCM. If the ID verification result is OK, vehicle can be set to READY. Refer to BCS-6, "BODY CONTROL SYSTEM : Component Parts Location" for detailed installation location.
12	Door lock and unlock switch	Door lock and unlock switch is integrated into the power window main switch and front power window switch (passenger side). Door lock and unlock switch transmits door lock/unlock operation signal to BCM. Refer to DLK-17, "Door Lock and Unlock Switch" for detailed installation location.
13	Outside door handle (Driver side)	Outside key antenna and door request switch are integrated into outside door handle. <ul style="list-style-type: none"> • Outside key antenna detects whether Intelligent Key is within the detection area or not, and then transmits signal to BCM. • Front door request switch transmits door lock/unlock request signal to BCM. • Refer to DLK-17, "Front Door Request Switch (Driver Side)" and DLK-16, "Outside Key Antenna (Driver Side)" for detailed installation location.
14	Door key cylinder switch	Door key cylinder switch is integrated into front door lock assembly (driver side). Door key cylinder switch detects door LOCK/UNLOCK operation using mechanical key, and then transmits door lock/unlock operation signal to BCM. Refer to DLK-13, "Component Parts Location" for detailed installation location.
15	Front door switch (Driver side)	Door switch detects door open/close condition, and then transmits ON/OFF signal to BCM. Refer to DLK-18, "Door Switch" for detailed installation location.
16	Rear door switch LH	Door switch detects door open/close condition, and then transmits ON/OFF signal to BCM. Refer to DLK-18, "Door Switch" for detailed installation location.

COMPONENT PARTS

< SYSTEM DESCRIPTION >

[WITH INTELLIGENT KEY SYSTEM]

No.	Component	Function
17	Back door opener switch assembly	Back door opener switch and back door request switch are integrated into back door switch assembly. <ul style="list-style-type: none"> • Back door opener switch transmits back door opening operation signal to BCM. • Back door request switch transmits door lock/unlock request signal to BCM. • Refer to DLK-18, "Back Door Opener Switch" and DLK-18, "Back Door Request Switch" for detailed installation location.
18	Back door lock assembly	Back door switch is integrated into back door lock assembly. Back door switch detects back door open/close condition, and then transmits ON/OFF signal to BCM. Refer to DLK-17, "Back Door Lock Assembly" for detailed installation location.
19	Outside key antenna (Rear bumper)	Outside key antenna (Rear bumper) detects whether Intelligent Key is within the detection area or not, and then transmits signal to BCM. Refer to DLK-15, "Outside Key Antenna (Rear Bumper)" for detailed installation location.
20	Inside key antenna (Luggage room)	Inside key antenna (Luggage room) detects whether Intelligent Key is inside the vehicle or not, and transmits the signal to BCM. Refer to DLK-15, "Inside Key Antenna (Luggage Room)" for detailed installation location.
21	Rear door switch RH	Door switch detects door open/close condition, and then transmits ON/OFF signal to BCM.
22	Inside key antenna (Rear seat)	Inside key antenna (Rear seat) detects whether Intelligent Key is inside the vehicle or not, and then transmits the signal to BCM. Refer to DLK-15, "Inside Key Antenna (Rear Seat)" for detailed installation location.
23	Front door switch (Passenger side)	Door switch detects door open/close condition, and then transmits ON/OFF signal to BCM. Refer to DLK-18, "Door Switch" for detailed installation location.
24	Outside door handle (Passenger side)	Outside key antenna and door request switch are integrated into outside door handle. <ul style="list-style-type: none"> • Outside key antenna detects whether Intelligent Key is within the detection area or not, and then transmits signal to BCM. • Front door request switch transmits door lock/unlock request signal to BCM. • Refer to DLK-18, "Front Door Request Switch (Passenger Side)" and DLK-16, "Outside Key Antenna (Passenger Side)" for detailed installation location.

NATS Antenna Amp.

INFOID:000000007799500

The ID verification is performed between BCM and transponder integrated into Intelligent Key via NATS antenna amp. when Intelligent Key backside is contacted to power switch in case that Intelligent Key battery is discharged. If the ID verification result is OK, the operation of power switch is available.

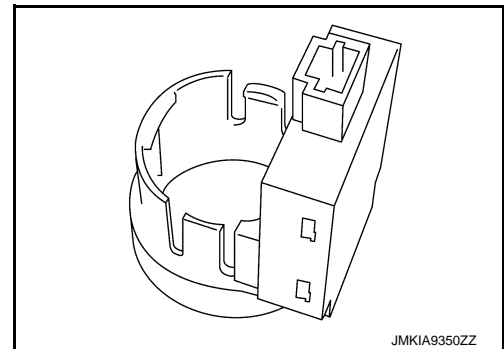

A
B
C
D
E
F
G
H
I
J
L
M
N
O
P

SEC

SYSTEM

< SYSTEM DESCRIPTION >

[WITH INTELLIGENT KEY SYSTEM]

SYSTEM

INTELLIGENT KEY SYSTEM/READY SET FUNCTION

INTELLIGENT KEY SYSTEM/READY SET FUNCTION : System Description

INFOID:000000007634161

SYSTEM DIAGRAM

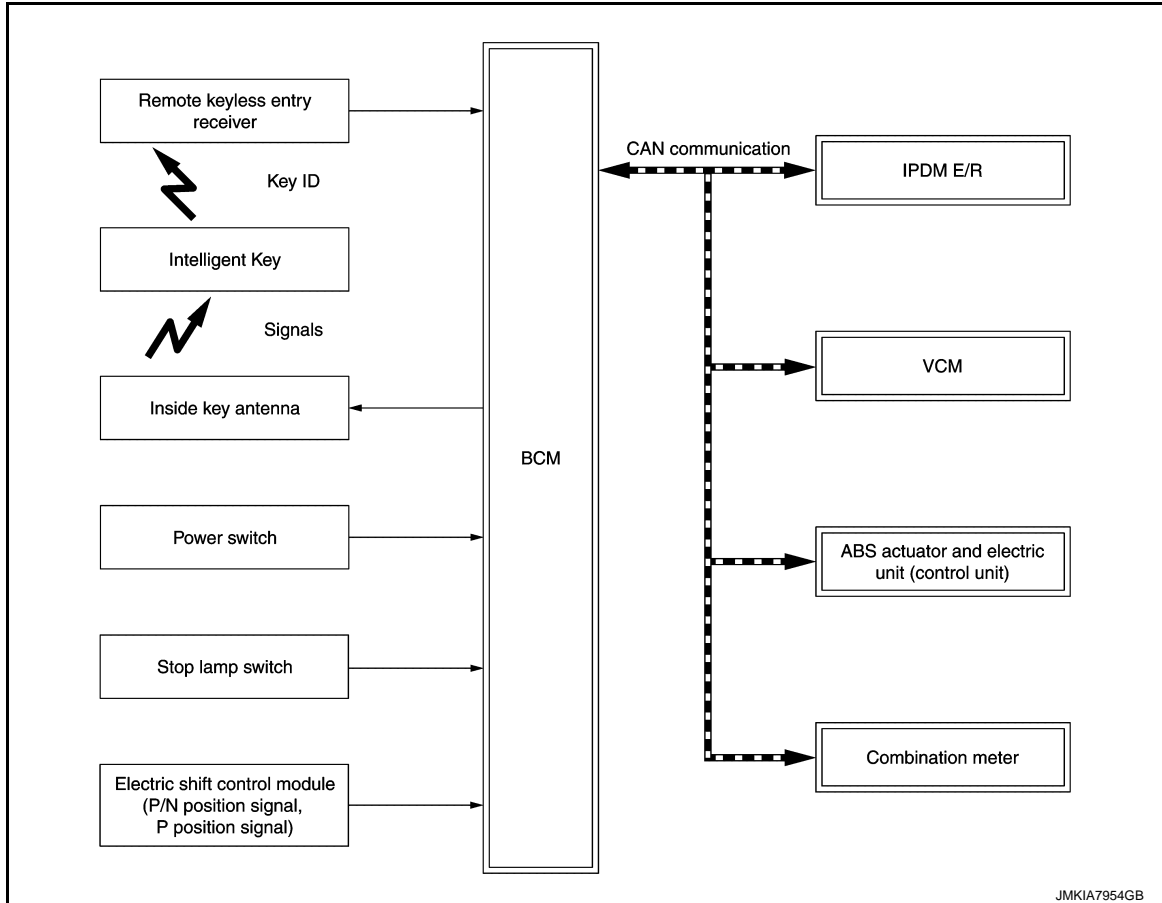

JMKIA7954GB

INPUT/OUTPUT SIGNAL CHART

Input Signal Item

Transmit unit	Signal name	
VCM	CAN communication	ID verification signal VCM status signal READY set signal Shift position signal
IPDM E/R		Power switch status signal P position signal
Combination meter		Vehicle speed signal
ABS actuator and electric unit (control unit)		Vehicle speed signal
Remote keyless entry receiver	Key ID signal	
Power switch	Power switch operation signal	
Stop lamp switch	Brake pedal operation signal	
Electric shift control module	P position signal P/N position signal	

Output Signal Item

SYSTEM

< SYSTEM DESCRIPTION >

[WITH INTELLIGENT KEY SYSTEM]

Reception unit	Signal name	
Combination meter	CAN communication	Key warning lamp signal
VCM		ID verification signal
Inside key antenna	READY signal	
	Key ID request signal	

SYSTEM DESCRIPTION

- The READY set function of Intelligent Key system makes it possible to set the vehicle to READY without using the key, based on the electronic ID verification. The electronic ID verification is performed between BCM and Intelligent Key when the power switch is pressed while the Intelligent Key is within the detection area of inside key antenna.

NOTE:

The driver should carry the Intelligent Key at all times.

- Intelligent Key has 2 IDs [Intelligent Key ID and NVIS (NATS) ID]. It can perform the door lock/unlock operation and the power switch operation when the registered Intelligent Key is carried.
- If the ID is successfully verified, power switch operation can be available and the vehicle can be set to READY.
- Up to 4 Intelligent Keys can be registered upon request from the customer.

NOTE:

Refer to [DLK-22. "INTELLIGENT KEY SYSTEM : System Description"](#) for any functions other than the READY set function of Intelligent Key system.

PRECAUTIONS FOR INTELLIGENT KEY SYSTEM

The transponder [the chip for NVIS (NATS) ID verification] is integrated into the Intelligent Key. Therefore, ID verification cannot be performed using mechanical key only.

When Intelligent Key battery is discharged, the NVIS (NATS) ID verification can be performed by operating power switch after contacting Intelligent Key backside to power switch. If verification result is OK, the vehicle can be set to READY.

OPERATION WHEN INTELLIGENT KEY IS CARRIED

1. When the power switch is pressed, BCM activates the inside key antenna and transmits the request signal to the Intelligent Key.
2. The Intelligent Key receives the request signal and transmits the Intelligent Key ID signal to BCM.
3. BCM receives the Intelligent Key ID signal via remote keyless entry receiver, and verifies it with the registered ID.
4. BCM turns ACC relay ON and transmits ON power supply signal to IPDM E/R if the verification results are OK.
5. IPDM E/R turns the ignition relay ON to start ON power supply.
6. BCM detects that the shift position and brake pedal operating condition.
7. BCM transmits READY signal to VCM if BCM judges that the READY set condition* is satisfied.
*: For READY set condition, refer to "READY SET CONDITION TABLE BY POWER SWITCH OPERATION" below.

NOTE:

- If a malfunction is detected in the Intelligent Key system, "I-KEY system fault" on information display appears. In this case, BCM does not transmits READY signal.
 - When the Intelligent Key is carried outside of the vehicle (inside key antenna detection area) while the power switch position is ACC or ON, BCM does not transmits READY signal even if READY set condition* is satisfied.
8. When BCM receives feedback signal from VCM indicating that the vehicle is set to READY, BCM stops transmitting READY signal.

OPERATION RANGE

Vehicle can be set to READY when Intelligent Key is inside the vehicle. However, sometimes vehicle may not be set to READY when Intelligent Key is on instrument panel or in glove box.

READY SET OPERATION WHEN INTELLIGENT KEY IS CONTACTED TO POWER SWITCH

SYSTEM

< SYSTEM DESCRIPTION >

[WITH INTELLIGENT KEY SYSTEM]

When Intelligent Key battery is discharged, the NVIS (NATS) ID verification between transponder integrated into Intelligent Key and BCM is performed when Intelligent Key backside is contacted to power switch. If the verification result is OK, vehicle can be set to READY.

READY SET CONDITION TABLE BY POWER SWITCH OPERATION

The vehicle can be set to READY by the following operations.

For details for the power supply position, refer to [PCS-35, "POWER DISTRIBUTION SYSTEM : System Description"](#).

NOTE:

- When an Intelligent Key is within the detection area of inside key antenna and when Intelligent Key backside is contacted to power switch, it is equivalent to the operations below.
- When setting the vehicle to READY, the BCM monitors READY set conditions,
 - Brake pedal operating condition
 - Shift position
 - Vehicle speed

Vehicle speed: less than 4 km/h (2.5 MPH)

	Vehicle condition		Power switch operation frequency
	Shift position	Brake pedal operation condition	
OFF → ACC	—	Not depressed	1
OFF → ACC → ON	—	Not depressed	2
OFF → ACC → ON → OFF	—	Not depressed	3
OFF → READY ACC → READY ON → READY	P or N	Depressed	1
READY → OFF	—	—	1

Vehicle speed: 4 km/h (2.5 MPH) or more

	Vehicle condition		Power switch operation frequency
	Shift position	Brake pedal operation condition	
READY → ACC	—	—	Emergency stop operation
ACC → READY (Return operation after emergency stop operation while driving)	N position	—	1

Emergency stop operation

- Press and hold the power switch for 2 seconds or more.
- Press the power switch 3 times or more within 1.5 seconds.

SYSTEM

< SYSTEM DESCRIPTION >

[WITH INTELLIGENT KEY SYSTEM]

INTELLIGENT KEY SYSTEM/READY SET FUNCTION : Circuit Diagram

INFOID:000000007634162

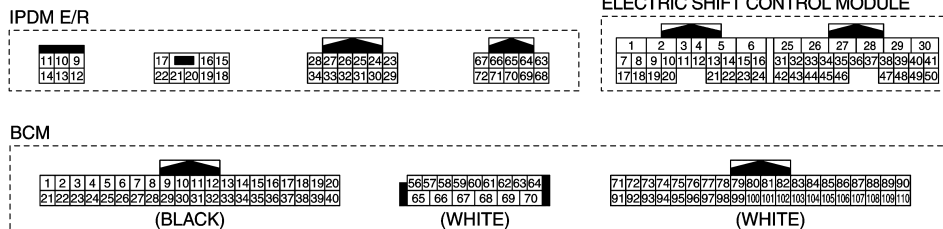
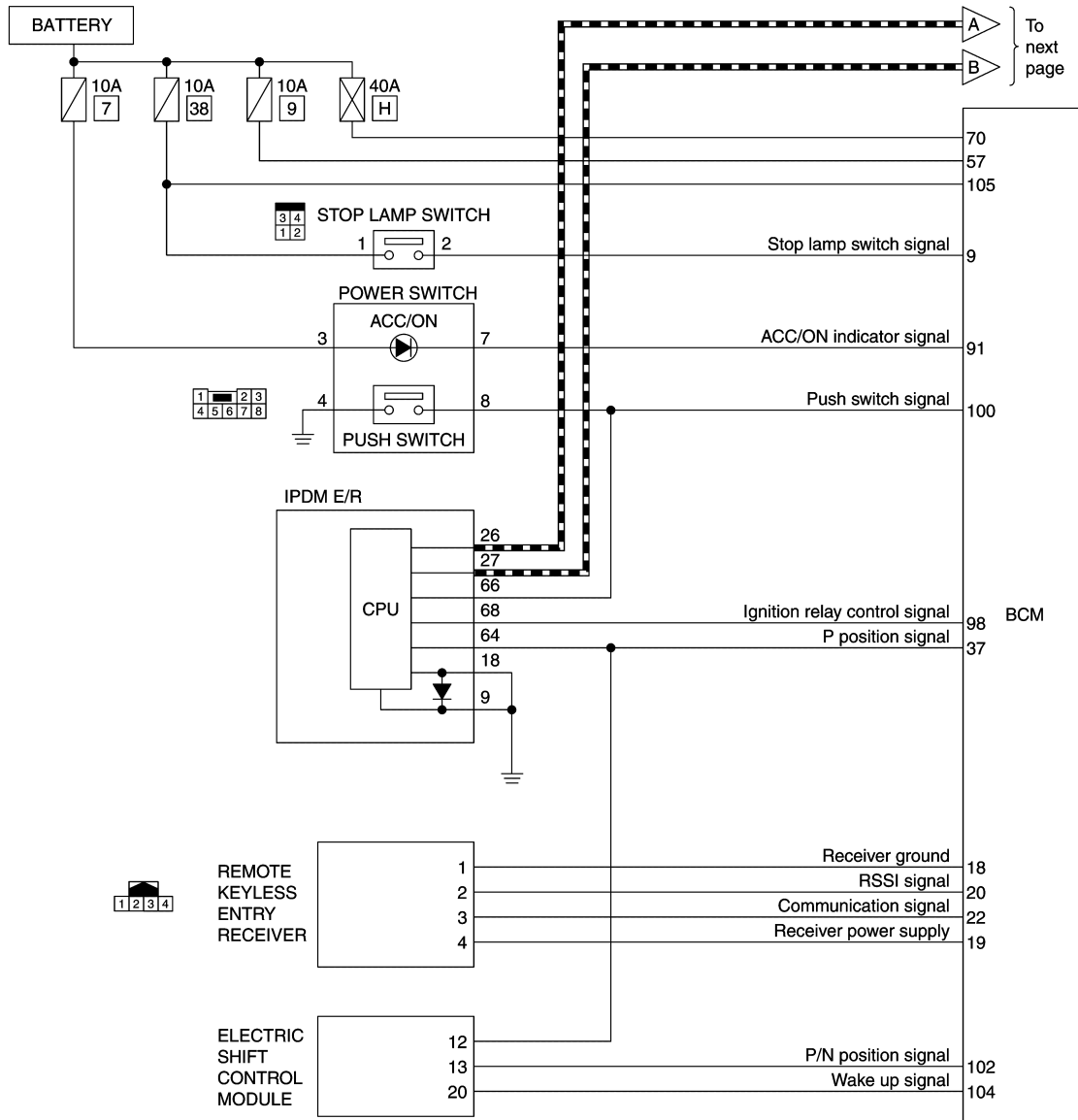

JMKIA7957GB

A
B
C
D
E
F
G
H
I
J
K
L
M
N
O
P

SEC

SYSTEM

< SYSTEM DESCRIPTION >

[WITH INTELLIGENT KEY SYSTEM]

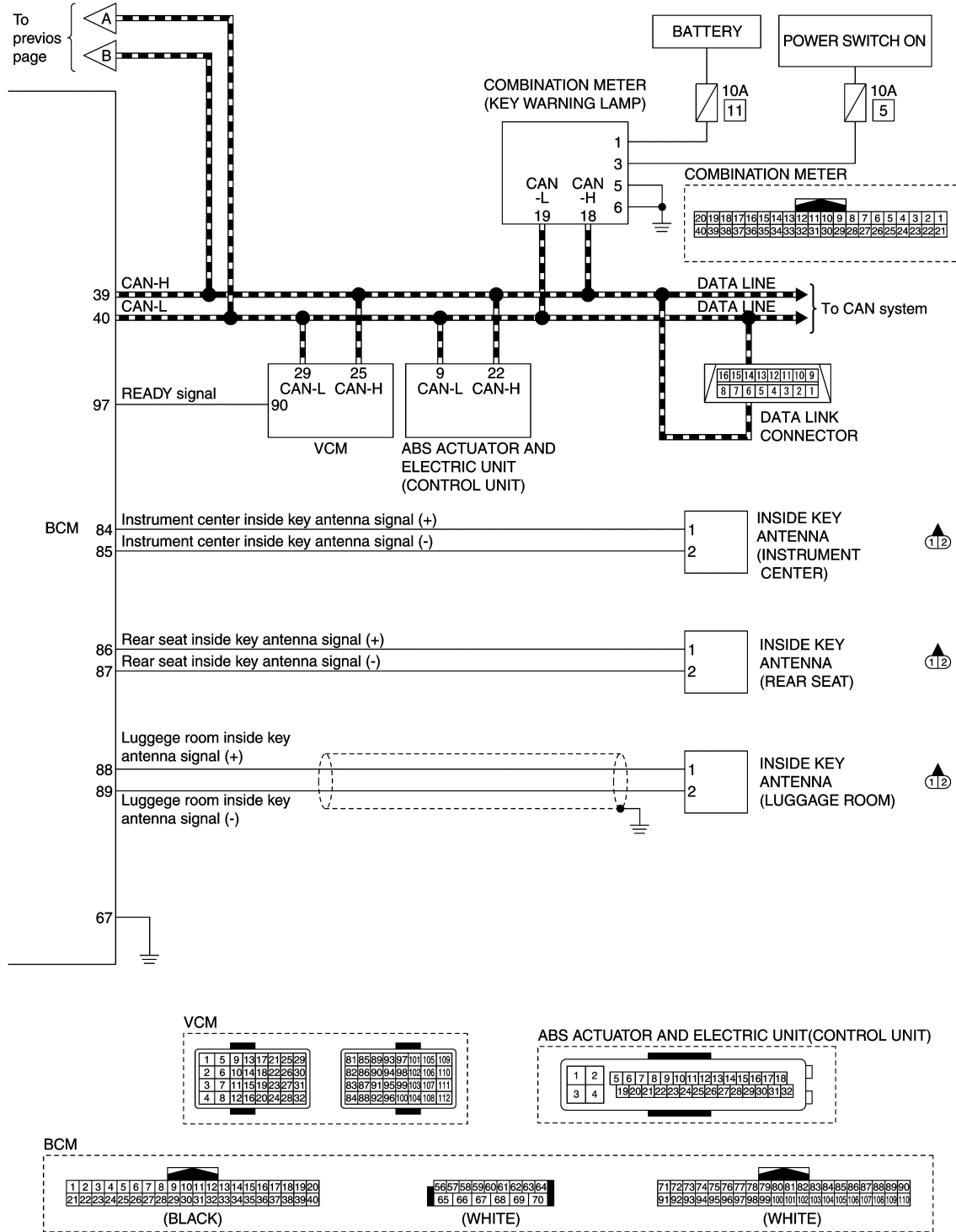

JMKIA7958GB

NISSAN VEHICLE IMMOBILIZER SYSTEM-NATS

SYSTEM

< SYSTEM DESCRIPTION >

[WITH INTELLIGENT KEY SYSTEM]

NISSAN VEHICLE IMMOBILIZER SYSTEM-NATS : System Description

INFOID:000000007634163

SYSTEM DIAGRAM

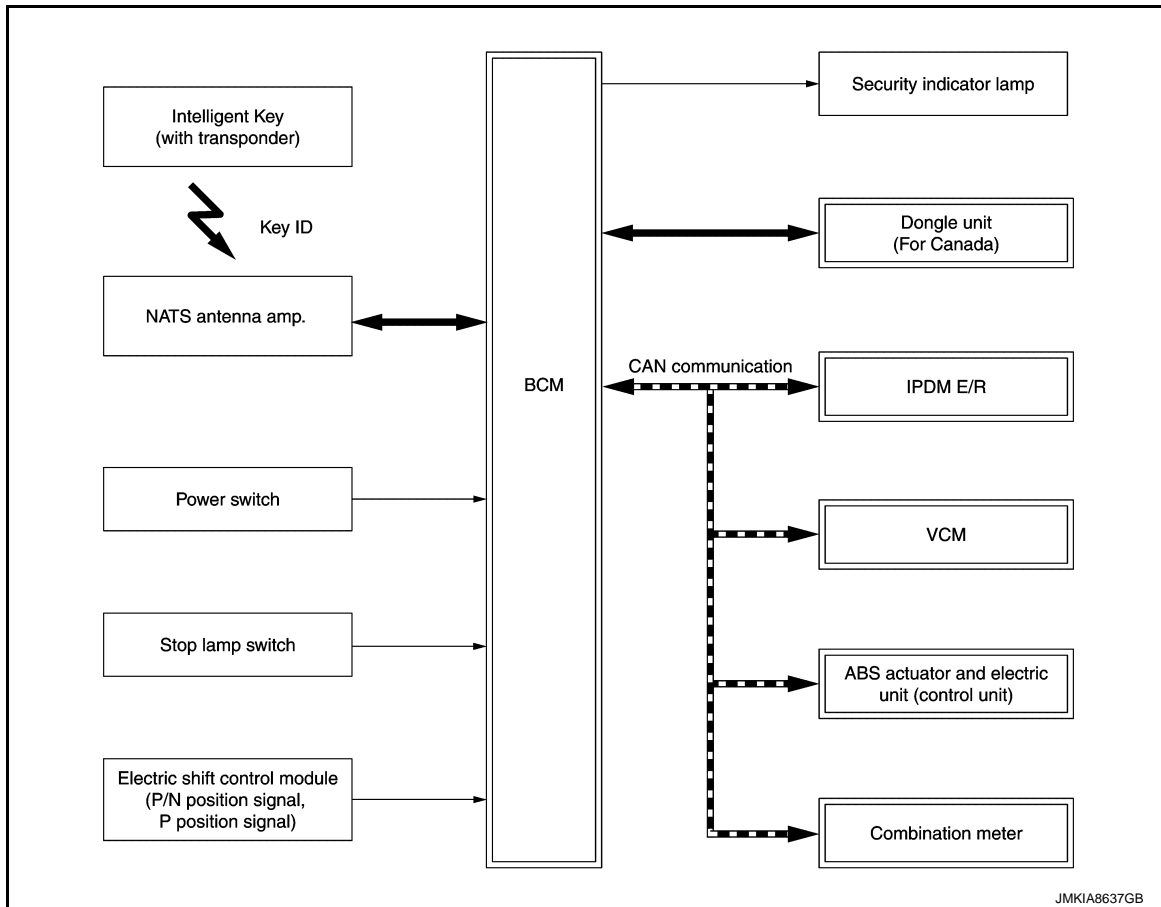

INPUT/OUTPUT SIGNAL CHART

Input Signal Item

Transmit unit	Signal name	
VCM	CAN communication	ID verification signal VCM status signal READY set signal Shift position signal
IPDM E/R		Power switch status signal P position signal
Combination meter		Vehicle speed signal
ABS actuator and electric unit (control unit)		Vehicle speed signal
NATS antenna amp.	Key ID signal	
Power switch	Power switch operation signal	
Stop lamp switch	Brake pedal operation signal	
Electric shift control module	P position signal P/N position signal	

Output Signal Item

A
B
C
D
E
F
G
H
I
J

SEC

L
M
N
O
P

SYSTEM

< SYSTEM DESCRIPTION >

[WITH INTELLIGENT KEY SYSTEM]

Reception unit	Signal name	
VCM	CAN communication	ID verification signal
	READY signal	
Combination meter	Security indicator lamp signal	

SYSTEM DESCRIPTION

- The NISSAN VEHICLE IMMOBILIZER SYSTEM-NATS [NVIS (NATS)] prevents the vehicle from being set to READY by Intelligent Key whose ID is not registered to the vehicle (BCM). It has higher protection against auto theft involving the duplication of mechanical keys.
- The mechanical key integrated into the Intelligent Key cannot set the vehicle to READY. When the Intelligent Key battery is discharged, the NVIS (NATS) ID verification is performed between the transponder integrated into Intelligent Key and BCM via NATS antenna amp. when the Intelligent Key backside is contacted to power switch. If the verification results are OK, the vehicle can be set to READY by the power switch operation.
- Security indicator lamp is located on combination meter, and always blinks when the power switch is in any position other than ON to warn that the vehicle is equipped with NVIS (NATS).
- Up to 4 Intelligent Keys can be registered upon request from the owner.
- When replacing VCM, BCM or Intelligent Key, the specified procedure (Initialization and registration) using CONSULT is required.
- Possible symptom of NVIS (NATS) malfunction is "Vehicle cannot be set to READY". This symptom also occurs because of other than NVIS (NATS) malfunction, so start the trouble diagnosis according to [SEC-44. "Work Flow"](#).
- If VCM other than genuine part is installed, the vehicle cannot be set to READY. For VCM replacement procedure, refer to [EVC-369. "Removal and Installation"](#).

PRECAUTIONS FOR KEY REGISTRATION

- When registering the Intelligent Key, perform the procedure following the instruction of CONSULT display.
- The ID registration procedure erases the current NVIS (NATS) ID once, and then reregisters a new ID. Therefore before starting the registration procedure, collect all registered Intelligent Keys from the customer.

SECURITY INDICATOR LAMP

Security indicator lamp always blinks when the power switch is in any position other than ON, to warn that the vehicle is equipped with NVIS (NATS).

NOTE:

Because security indicator lamp is highly efficient, the 12V battery is barely affected.

OPERATION WHEN INTELLIGENT KEY IS CONTACTED TO POWER SWITCH

1. When brake pedal is depressed while shift position is P, BCM activates NATS antenna amp. which is located behind power switch.
2. When Intelligent Key (transponder built-in) backside is contacted to power switch, BCM starts NVIS (NATS) ID verification between BCM and Intelligent Key (transponder built-in) via NATS antenna amp.
3. When the NVIS (NATS) ID verification result is OK, buzzer in combination meter sounds.
4. BCM turns ACC relay ON and transmits ON power supply signal to IPDM E/R.
5. IPDM E/R turns the ignition relay ON to start ON power supply.
6. BCM detects that the shift position and brake pedal operating position.
7. BCM transmits READY signal to VCM if BCM judges that the READY set condition* is satisfied.
*: For READY set condition, refer to "READY SET CONDITION TABLE BY POWER SWITCH OPERATION" below.
8. When BCM receives feedback signal from VCM indicating that the vehicle is set to READY, BCM stops transmitting READY signal.

READY SET CONDITION TABLE BY POWER SWITCH OPERATION

The vehicle can be set to READY by the following operations.

For details for the power supply position, refer to [PCS-35. "POWER DISTRIBUTION SYSTEM : System Description"](#).

NOTE:

- When an Intelligent Key is within the detection area of inside key antenna and when Intelligent Key backside is contacted to power switch, it is equivalent to the operations below.

SYSTEM

[WITH INTELLIGENT KEY SYSTEM]

< SYSTEM DESCRIPTION >

- When setting the vehicle to READY, the BCM monitors READY set conditions,
 - Brake pedal operating condition
 - Shift position
 - Vehicle speed

Vehicle speed: less than 4 km/h (2.5 MPH)

	Vehicle condition		Power switch operation frequency
	Shift position	Brake pedal operation condition	
OFF → ACC	—	Not depressed	1
OFF → ACC → ON	—	Not depressed	2
OFF → ACC → ON → OFF	—	Not depressed	3
OFF → READY ACC → READY ON → READY	P or N	Depressed	1
READY → OFF	—	—	1

Vehicle speed: 4 km/h (2.5 MPH) or more

	Vehicle condition		Power switch operation frequency
	Shift position	Brake pedal operation condition	
READY → ACC	—	—	Emergency stop operation
ACC → READY (Return operation after emergency stop operation while driving)	N position	—	1

Emergency stop operation

- Press and hold the power switch for 2 seconds or more.
- Press the power switch 3 times or more within 1.5 seconds.

A
B
C
D
E
F
G
H
I
J
L
M
N
O
P

SEC

SYSTEM

< SYSTEM DESCRIPTION >

[WITH INTELLIGENT KEY SYSTEM]

NISSAN VEHICLE IMMOBILIZER SYSTEM-NATS : Circuit Diagram

INFOID:000000007634164

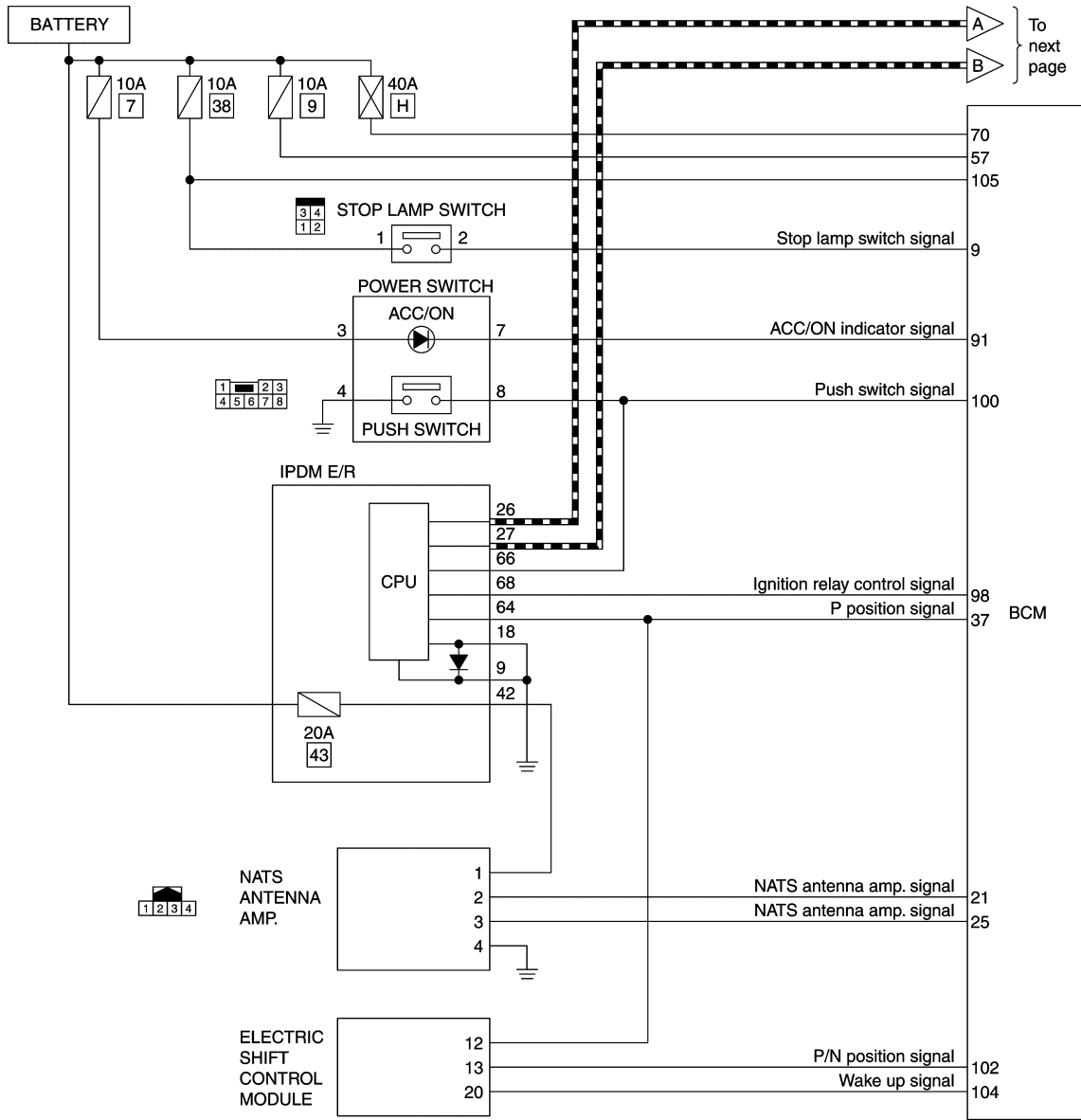

IPDM E/R

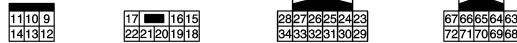

BCM

ELECTRIC SHIFT CONTROL MODULE

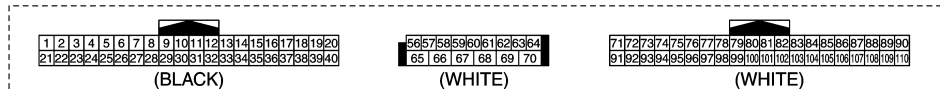
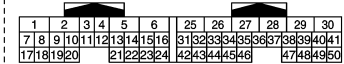

JMKIA7959GB

SYSTEM

< SYSTEM DESCRIPTION >

[WITH INTELLIGENT KEY SYSTEM]

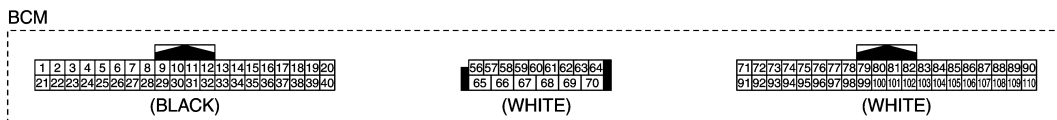
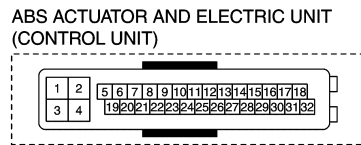
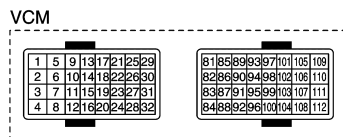
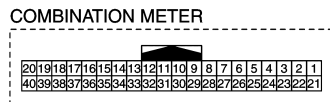
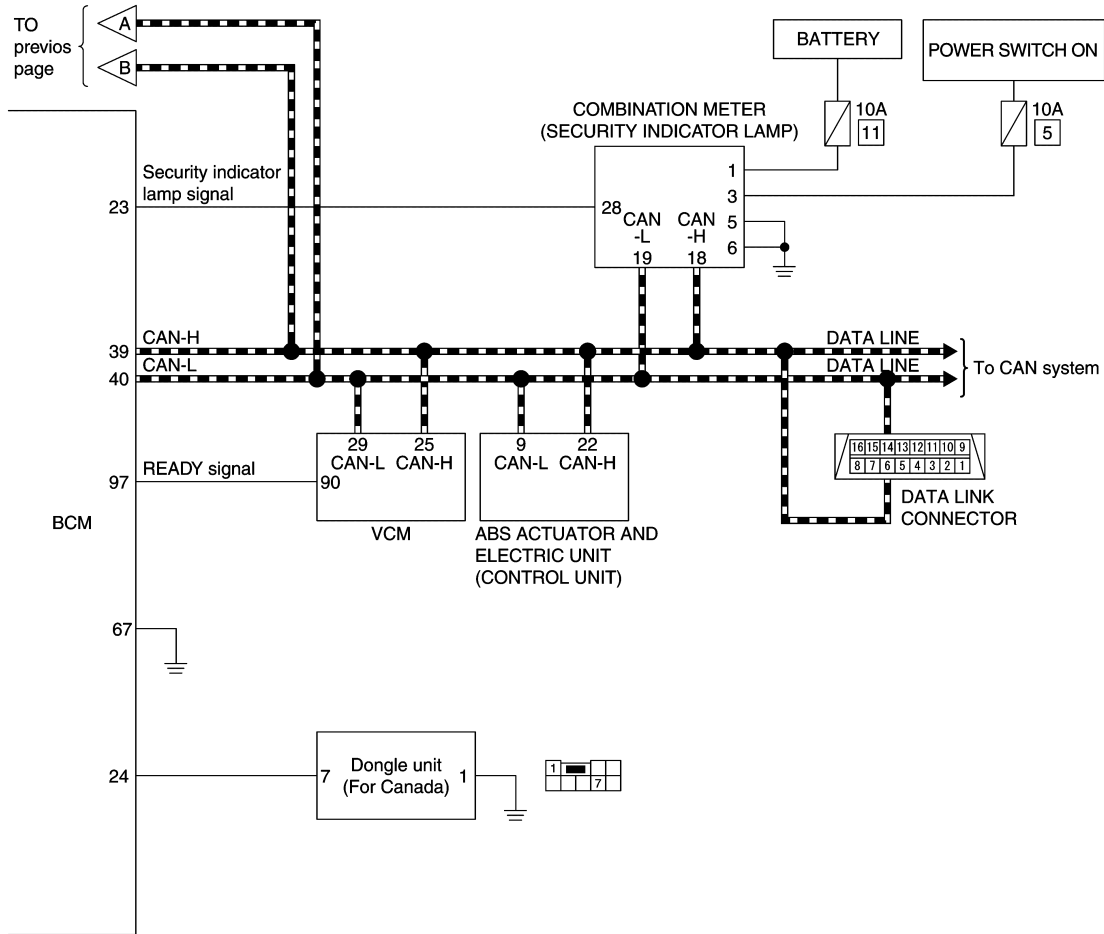

JMKIA8636GB

VEHICLE SECURITY SYSTEM

A
B
C
D
E
F
G
H
I
J
K
L
M
N
O
P

SEC

SYSTEM

< SYSTEM DESCRIPTION >

[WITH INTELLIGENT KEY SYSTEM]

VEHICLE SECURITY SYSTEM : System Description (Except for Canada) INFOID:000000007634165

SYSTEM DIAGRAM

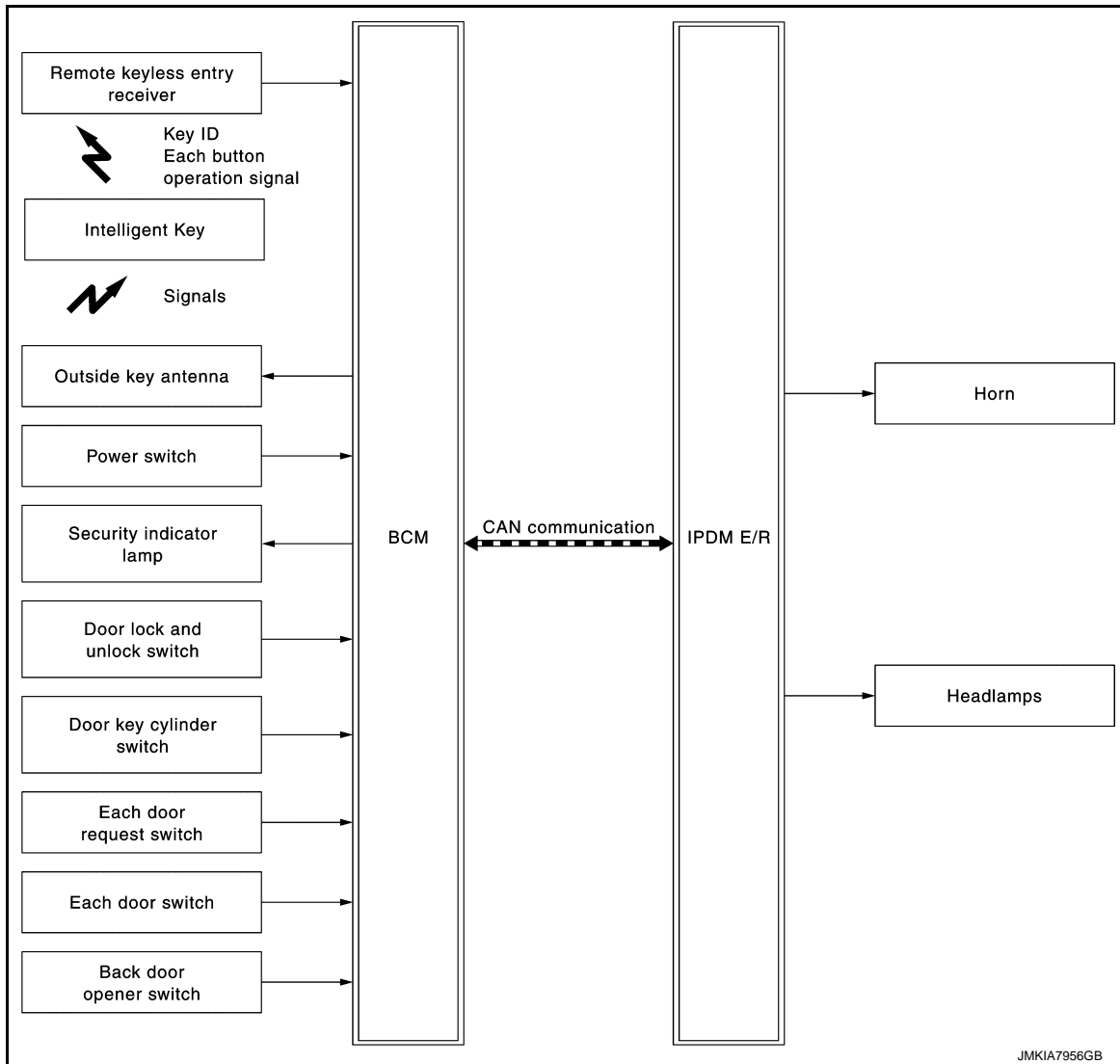

INPUT/OUTPUT SIGNAL CHART

Input Signal Item

Transmit unit	Signal name	
IPDM E/R	CAN communication	Power switch status signal
Remote keyless entry receiver	Key ID signal Intelligent Key button operation signal	
Power switch	Power switch operation signal	
Each door switch	Door open/close condition signal	
Each door request switch	Door lock/unlock request signal	
Back door opener switch	Back door opener operation signal	
Door key cylinder switch	Door key cylinder lock/unlock switch signal	
Door lock and unlock switch	Door lock/unlock switch operation signal	

Output Signal Item

SYSTEM

< SYSTEM DESCRIPTION >

[WITH INTELLIGENT KEY SYSTEM]

Reception unit	Signal name	
Combination meter	CAN communication	
IPDM E/R		Security indicator lamp signal
		Vehicle security horn request signal
Outside key antenna	High beam request signal	
	Key ID request signal	

SYSTEM DESCRIPTION

- The vehicle security system has two alarm functions (theft warning alarm and panic alarm), and reduces the possibility of a theft or mischief by activating horns and headlamps intermittently.
 - The panic alarm does not start when the theft warning alarm is activating, and the panic alarm stops when the theft warning alarm is activated.
- The priority of the functions are as per the following.

Priority	Function
1	Theft warning alarm
2	Panic alarm

THEFT WARNING ALARM

- The theft warning alarm function activates horns and headlamps intermittently when BCM detects that any door is opened by unauthorized means, while the system is in the ARMED state.
- Security indicator lamp on combination meter always blinks when power supply position is any position other than ON. Security indicator lamp blinking warns that the vehicle is equipped with a vehicle security system.

Operation Flow

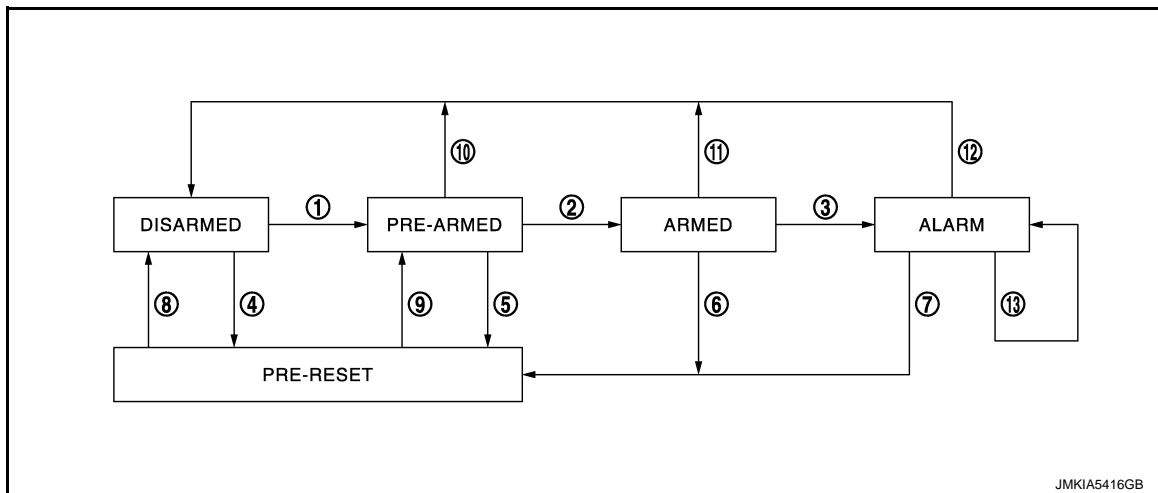

SEC

No.	System state	Switching condition					
		A	B				
1	DISARMED to PRE-ARMED	When all conditions of A and one condition of B is satisfied.	<table border="1" style="width: 100%; border-collapse: collapse;"> <tr> <td style="width: 50%; text-align: center;">A</td> <td style="width: 50%; text-align: center;">B</td> </tr> <tr> <td> <ul style="list-style-type: none"> Power switch: OFF All doors: Closed </td> <td> All doors are locked by: <ul style="list-style-type: none"> Door key cylinder LOCK switch LOCK button of Intelligent Key Door request switch Door lock and unlock switch </td> </tr> </table>	A	B	<ul style="list-style-type: none"> Power switch: OFF All doors: Closed 	All doors are locked by: <ul style="list-style-type: none"> Door key cylinder LOCK switch LOCK button of Intelligent Key Door request switch Door lock and unlock switch
A	B						
<ul style="list-style-type: none"> Power switch: OFF All doors: Closed 	All doors are locked by: <ul style="list-style-type: none"> Door key cylinder LOCK switch LOCK button of Intelligent Key Door request switch Door lock and unlock switch 						
2	PRE-ARMED to ARMED	When all of the following conditions are satisfied for 30 seconds.	<ul style="list-style-type: none"> Power switch: OFF All doors: Locked 				
3	ARMED to ALARM	When all conditions of A and B are satisfied.	<table border="1" style="width: 100%; border-collapse: collapse;"> <tr> <td style="width: 50%; text-align: center;">A</td> <td style="width: 50%; text-align: center;">B</td> </tr> <tr> <td>Intelligent Key: Not used</td> <td> <ul style="list-style-type: none"> Any door: Open </td> </tr> </table>	A	B	Intelligent Key: Not used	<ul style="list-style-type: none"> Any door: Open
			A	B			
Intelligent Key: Not used	<ul style="list-style-type: none"> Any door: Open 						

SYSTEM

< SYSTEM DESCRIPTION >

[WITH INTELLIGENT KEY SYSTEM]

No.	System state	Switching condition	
4	DISARMED to PRE-RESET	No conditions.	
5	PRE-ARMED to PRE-RESET		
6	ARMED to PRE-RESET		
7	ALARM to PRE-RESET		
8	PRE-RESET to DISARMED		
9	PRE-RESET to PRE-ARMED		
10	PRE-ARMED to DISARMED	When one of the following condition is satisfied.	<ul style="list-style-type: none"> • Power switch: ACC/ON • Door key cylinder UNLOCK switch: ON • UNLOCK button of Intelligent Key: ON • Door request switch: ON • Back door opener switch: ON • Any door: Open
11	ARMED to DISARMED	When one of the following condition is satisfied.	<ul style="list-style-type: none"> • Power switch: ACC/ON • Door key cylinder UNLOCK switch: ON • UNLOCK button of Intelligent Key: ON • Door request switch: ON • Back door opener switch: ON
12	ALARM to DISARMED		
13	RE-ALARM	When the following condition is satisfied after the ALARM operation is finished.	<ul style="list-style-type: none"> • Any door: Open

NOTE:

- BCM ignores the door key cylinder UNLOCK switch signal input for 1 second after the door key cylinder LOCK switch signal input.
- To lock/unlock all doors by operating remote controller button of Intelligent Key or door request switch, Intelligent Key must be within the detection area of outside key antenna. For details, refer to [DLK-26, "DOOR LOCK FUNCTION : System Description"](#).
- To open back door by operating back door opener switch, Intelligent Key must be within the detection area of outside key antenna. For details, refer to [DLK-26, "DOOR LOCK FUNCTION : System Description"](#).

DISARMED Phase

The vehicle security system is not set in the DISARMED phase. The vehicle security system stays in this phase while any door is open, because it is assumed that the owner is inside or nearby the vehicle. Security indicator lamp blinks every 2.4 seconds.

When the vehicle security system is reset, each phase switches to the DISARMED phase directly.

PRE-ARMED Phase

The PRE-ARMED phase is the transient state between the DISARMED phase and the ARMED phase. This phase is maintained for 30 seconds, so that the owner can reset the setting due to a mis-operation. This phase switches to the ARMED phase when vehicle conditions are not changed for 30 seconds. Security indicator lamp illuminates while being in this phase.

To reset the PRE-ARMED phase, refer to the switching condition of No. 10 in the table above.

ARMED Phase

The vehicle security system is set, and BCM monitors all necessary inputs. If any door is opened without using Intelligent Key, vehicle security system switches to the ALARM phase. Security indicator lamp blinks every 2.4 seconds.

To reset the ARMED phase, refer to the switching condition of No. 11 in the table above.

ALARM Phase

BCM transmits "Theft Warning Horn Request" signal and "High Beam Request" signal intermittently to IPDM E/R via CAN communication. In this phase, horns and headlamps are activated intermittently for approximately 50 seconds to warn that the vehicle is accessed by unauthorized means. ON/OFF timing of horns and headlamps are synchronized. After 50 seconds, the vehicle security system returns to the ARMED phase. At this time, if BCM still detects unauthorized access to the vehicle, the system is switched to the ALARM phase again. This RE-ALARM operation is carried out a maximum of 2 times.

SYSTEM

< SYSTEM DESCRIPTION >

[WITH INTELLIGENT KEY SYSTEM]

To cancel the ALARM operation, refer to the switching condition of No. 12 in the table above.

NOTE:

If a battery terminal is disconnected during the ALARM phase, theft warning alarm stops. But when the battery terminal is reconnected, theft warning alarm is activated again.

PRE-RESET Phase

The PRE-RESET phase is the transient state between each phase and DISARMED phase.

The PRE-RESET phase is not available for this models.

PANIC ALARM

- The panic alarm function activates horns and headlamps intermittently when the owner presses the PANIC ALARM button of Intelligent Key outside the vehicle while the power supply position is OFF.
- When BCM receives panic alarm signal from Intelligent Key, BCM transmits "Theft Warning Horn Request" signal and "High Beam Request" signal intermittently to IPDM E/R via CAN communication. To prevent the activation due to mis-operation of Intelligent Key by owner, the panic alarm function is activated when BCM receives the signal for 0.4 - 0.6 seconds.
- Panic alarm operation is maintained for 25 seconds.
- Panic alarm operation is cancelled when BCM receives one of the following signals.
 - LOCK button of Intelligent Key: ON
 - UNLOCK button of Intelligent Key: ON
 - PANIC ALARM button of Intelligent Key: Long pressed
 - Any door request switch: ON

VEHICLE SECURITY SYSTEM : System Description (For Canada)

INFOID:000000007634166

SYSTEM DIAGRAM

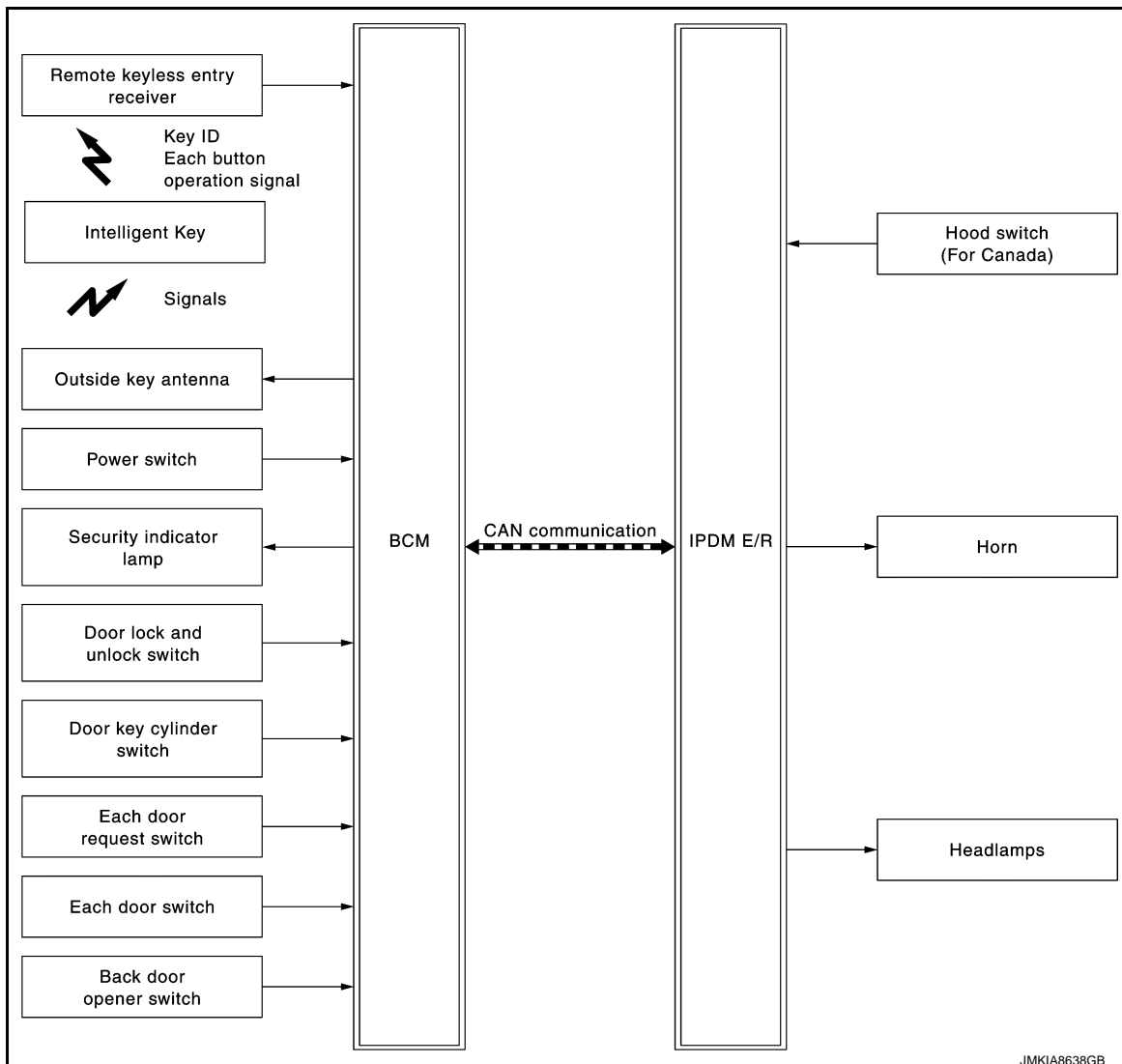

A
B
C
D
E
F
G
H
I
J
L
M
N
O
P

SEC

SYSTEM

< SYSTEM DESCRIPTION >

[WITH INTELLIGENT KEY SYSTEM]

INPUT/OUTPUT SIGNAL CHART

Input Signal Item

Transmit unit	Signal name	
IPDM E/R	CAN communication	Power switch status signal
Remote keyless entry receiver	Key ID signal Intelligent Key button operation signal	
Hood switch	CAN communication	Hood switch signal
Power switch	Power switch operation signal	
Each door switch	Door open/close condition signal	
Each door request switch	Door lock/unlock request signal	
Back door opener switch	Back door opener operation signal	
Door key cylinder switch	Door key cylinder lock/unlock switch signal	
Door lock and unlock switch	Door lock/unlock switch operation signal	

Output Signal Item

Reception unit	Signal name	
Combination meter	CAN communication	Security indicator lamp signal
IPDM E/R		Vehicle security horn request signal
		High beam request signal
Outside key antenna	Key ID request signal	

SYSTEM DESCRIPTION

- The vehicle security system has two alarm functions (theft warning alarm and panic alarm), and reduces the possibility of a theft or mischief by activating horns and headlamps intermittently.
- The panic alarm does not start when the theft warning alarm is activating, and the panic alarm stops when the theft warning alarm is activated.

The priority of the functions are as per the following.

Priority	Function
1	Theft warning alarm
2	Panic alarm

THEFT WARNING ALARM

- The theft warning alarm function activates horns and headlamps intermittently when BCM detects that any door or hood is opened by unauthorized means, while the system is in the ARMED state.
- Security indicator lamp on combination meter always blinks when power supply position is any position other than ON. Security indicator lamp blinking warns that the vehicle is equipped with a vehicle security system.

SYSTEM

< SYSTEM DESCRIPTION >

[WITH INTELLIGENT KEY SYSTEM]

Operation Flow

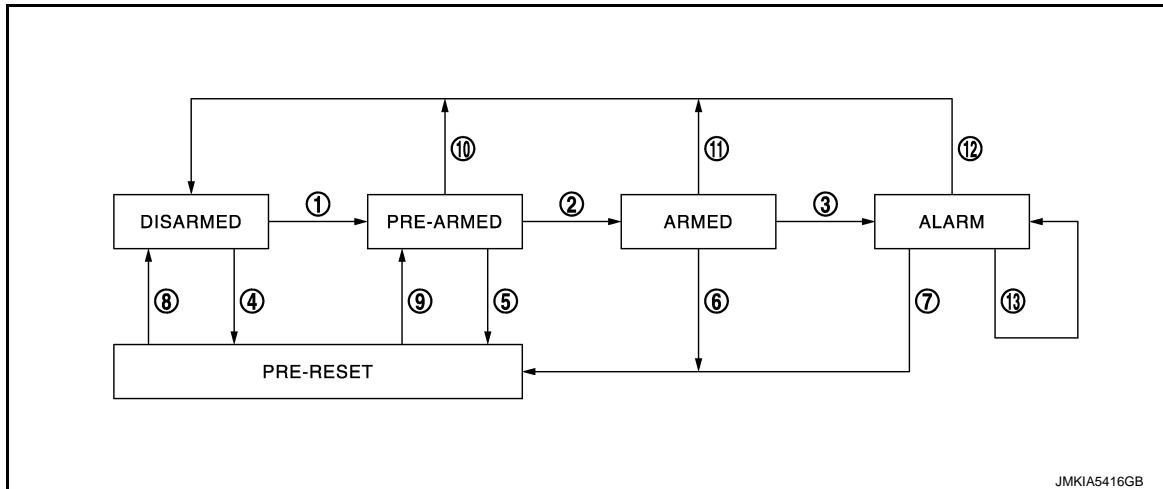

A
B
C
D
E
F
G
H
I
J
L
M
N
O
P

SEC

No.	System state	Switching condition					
1	DISARMED to PRE-ARMED	When all conditions of A and one condition of B is satisfied.	<table border="1" style="width: 100%;"> <tr> <th>A</th> <th>B</th> </tr> <tr> <td> <ul style="list-style-type: none"> Power switch: OFF All doors: Closed Hood: Closed </td> <td> All doors are locked by: <ul style="list-style-type: none"> Door key cylinder LOCK switch LOCK button of Intelligent Key Door request switch Door lock and unlock switch </td> </tr> </table>	A	B	<ul style="list-style-type: none"> Power switch: OFF All doors: Closed Hood: Closed 	All doors are locked by: <ul style="list-style-type: none"> Door key cylinder LOCK switch LOCK button of Intelligent Key Door request switch Door lock and unlock switch
A	B						
<ul style="list-style-type: none"> Power switch: OFF All doors: Closed Hood: Closed 	All doors are locked by: <ul style="list-style-type: none"> Door key cylinder LOCK switch LOCK button of Intelligent Key Door request switch Door lock and unlock switch 						
2	PRE-ARMED to ARMED	When all of the following conditions are satisfied for 30 seconds.	<ul style="list-style-type: none"> Power switch: OFF All doors: Locked Hood: Closed 				
3	ARMED to ALARM	When condition A and one condition of B are satisfied.	<table border="1" style="width: 100%;"> <tr> <th>A</th> <th>B</th> </tr> <tr> <td>Intelligent Key: Not used</td> <td> <ul style="list-style-type: none"> Any door: Open Hood: Open </td> </tr> </table>	A	B	Intelligent Key: Not used	<ul style="list-style-type: none"> Any door: Open Hood: Open
A	B						
Intelligent Key: Not used	<ul style="list-style-type: none"> Any door: Open Hood: Open 						
4	DISARMED to PRE-RESET	When all conditions of A and one condition of B are satisfied.	<table border="1" style="width: 100%;"> <tr> <th>A</th> <th>B</th> </tr> <tr> <td> <ul style="list-style-type: none"> Power switch: OFF All doors: Closed Hood: Open </td> <td> All doors are locked by: <ul style="list-style-type: none"> Door key cylinder LOCK switch LOCK button of Intelligent Key Door request switch </td> </tr> </table>	A	B	<ul style="list-style-type: none"> Power switch: OFF All doors: Closed Hood: Open 	All doors are locked by: <ul style="list-style-type: none"> Door key cylinder LOCK switch LOCK button of Intelligent Key Door request switch
A	B						
<ul style="list-style-type: none"> Power switch: OFF All doors: Closed Hood: Open 	All doors are locked by: <ul style="list-style-type: none"> Door key cylinder LOCK switch LOCK button of Intelligent Key Door request switch 						
5	PRE-ARMED to PRE-RESET	When the following condition is satisfied.	Hood: Open				
6	ARMED to PRE-RESET	No conditions.					
7	ALARM to PRE-RESET						
8	PRE-RESET to DISARMED	When one of the following condition is satisfied.	<ul style="list-style-type: none"> Power switch: ACC/ON Door key cylinder UNLOCK switch: ON UNLOCK button of Intelligent Key: ON Door request switch: ON Back door opener switch: ON UNLOCK switch of door lock and unlock switch: ON Any door: Open 				
9	PRE-RESET to PRE-ARMED	When one of the following condition is satisfied.	<ul style="list-style-type: none"> Power switch: OFF All doors: Locked Hood: Closed 				
10	PRE-ARMED to DISARMED	When one of the following condition is satisfied.	<ul style="list-style-type: none"> Power switch: ACC/ON Door key cylinder UNLOCK switch: ON UNLOCK button of Intelligent Key: ON Door request switch: ON Back door opener switch: ON Any door: Open 				

SYSTEM

< SYSTEM DESCRIPTION >

[WITH INTELLIGENT KEY SYSTEM]

No.	System state	Switching condition	
11	ARMED to DISARMED	When one of the following condition is satisfied.	<ul style="list-style-type: none">• Power switch: ACC/ON• Door key cylinder UNLOCK switch: ON• UNLOCK button of Intelligent Key: ON• Door request switch: ON• Back door opener switch: ON
12	ALARM to DISARMED		
13	RE-ALARM	When the following condition is satisfied after the ALARM operation is finished.	<ul style="list-style-type: none">• Any door: Open• Hood: Open

NOTE:

- BCM ignores the door key cylinder UNLOCK switch signal input for 1 second after the door key cylinder LOCK switch signal input.
- To lock/unlock all doors by operating remote controller button of Intelligent Key or door request switch, Intelligent Key must be within the detection area of outside key antenna. For details, refer to [DLK-26, "DOOR LOCK FUNCTION : System Description"](#).
- To open back door by operating back door opener switch, Intelligent Key must be within the detection area of outside key antenna. For details, refer to [DLK-26, "DOOR LOCK FUNCTION : System Description"](#).

DISARMED Phase

The vehicle security system is not set in the DISARMED phase. The vehicle security system stays in this phase while any door is open, because it is assumed that the owner is inside or nearby the vehicle. Security indicator lamp blinks every 2.4 seconds.

When the vehicle security system is reset, each phase switches to the DISARMED phase directly.

PRE-ARMED Phase

The PRE-ARMED phase is the transient state between the DISARMED phase and the ARMED phase. This phase is maintained for 30 seconds, so that the owner can reset the setting due to a mis-operation. This phase switches to the ARMED phase when vehicle conditions are not changed for 30 seconds. Security indicator lamp illuminates while being in this phase.

To reset the PRE-ARMED phase, refer to the switching condition of No. 10 in the table above.

ARMED Phase

The vehicle security system is set, and BCM monitors all necessary inputs. If any door or hood is opened without using Intelligent Key, vehicle security system switches to the ALARM phase. Security indicator lamp blinks every 2.4 seconds.

To reset the ARMED phase, refer to the switching condition of No. 11 in the table above.

ALARM Phase

BCM transmits "Theft Warning Horn Request" signal and "High Beam Request" signal intermittently to IPDM E/R via CAN communication. In this phase, horns and headlamps are activated intermittently for approximately 50 seconds to warn that the vehicle is accessed by unauthorized means. ON/OFF timing of horns and headlamps are synchronized. After 50 seconds, the vehicle security system returns to the ARMED phase. At this time, if BCM still detects unauthorized access to the vehicle, the system is switched to the ALARM phase again. This RE-ALARM operation is carried out a maximum of 2 times.

To cancel the ALARM operation, refer to the switching condition of No. 12 in the table above.

NOTE:

If a battery terminal is disconnected during the ALARM phase, theft warning alarm stops. But when the battery terminal is reconnected, theft warning alarm is activated again.

PRE-RESET Phase

The PRE-RESET phase is the transient state between each phase and DISARMED phase. If only the condition of hood is not satisfied, the system switches to the PRE-RESET phase. Then, when any condition is changed, the system switches to the DISARMED phase or PRE-ARMED phase.

PANIC ALARM

- The panic alarm function activates horns and headlamps intermittently when the owner presses the PANIC ALARM button of Intelligent Key outside the vehicle while the power supply position is OFF.
- When BCM receives panic alarm signal from Intelligent Key, BCM transmits "Theft Warning Horn Request" signal and "High Beam Request" signal intermittently to IPDM E/R via CAN communication. To prevent the activation due to mis-operation of Intelligent Key by owner, the panic alarm function is activated when BCM receives the signal for 0.4 - 0.6 seconds.
- Panic alarm operation is maintained for 25 seconds.
- Panic alarm operation is cancelled when BCM receives one of the following signals.
 - LOCK button of Intelligent Key: ON
 - UNLOCK button of Intelligent Key: ON

SYSTEM

[WITH INTELLIGENT KEY SYSTEM]

< SYSTEM DESCRIPTION >

- PANIC ALARM button of Intelligent Key: Long pressed
- Any door request switch: ON

VEHICLE SECURITY SYSTEM : Circuit Diagram

INFOID:000000007634167

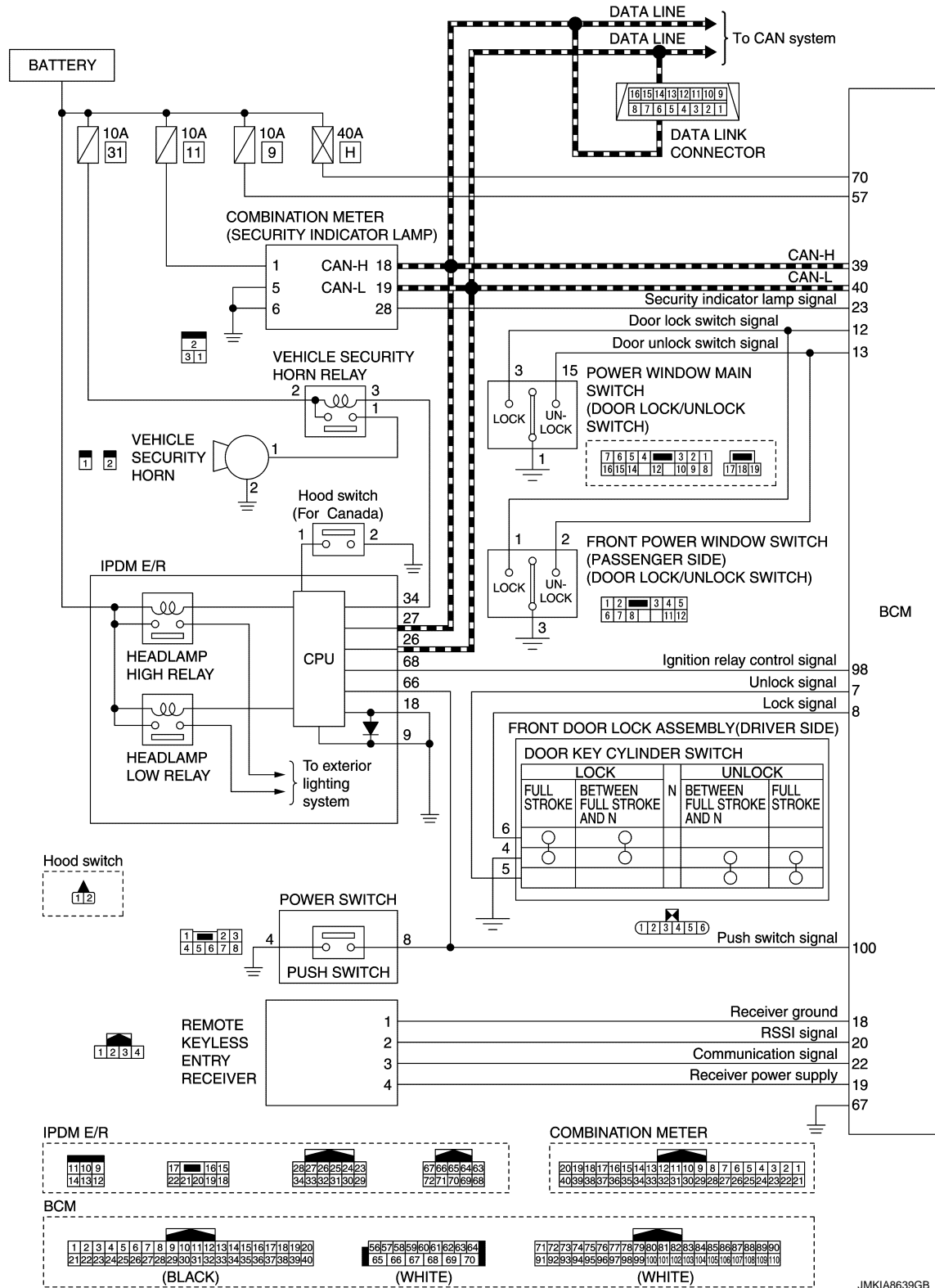

A
B
C
D
E
F
G
H
I
J
K
L
M
N
O
P

SEC

SYSTEM

< SYSTEM DESCRIPTION >

[WITH INTELLIGENT KEY SYSTEM]

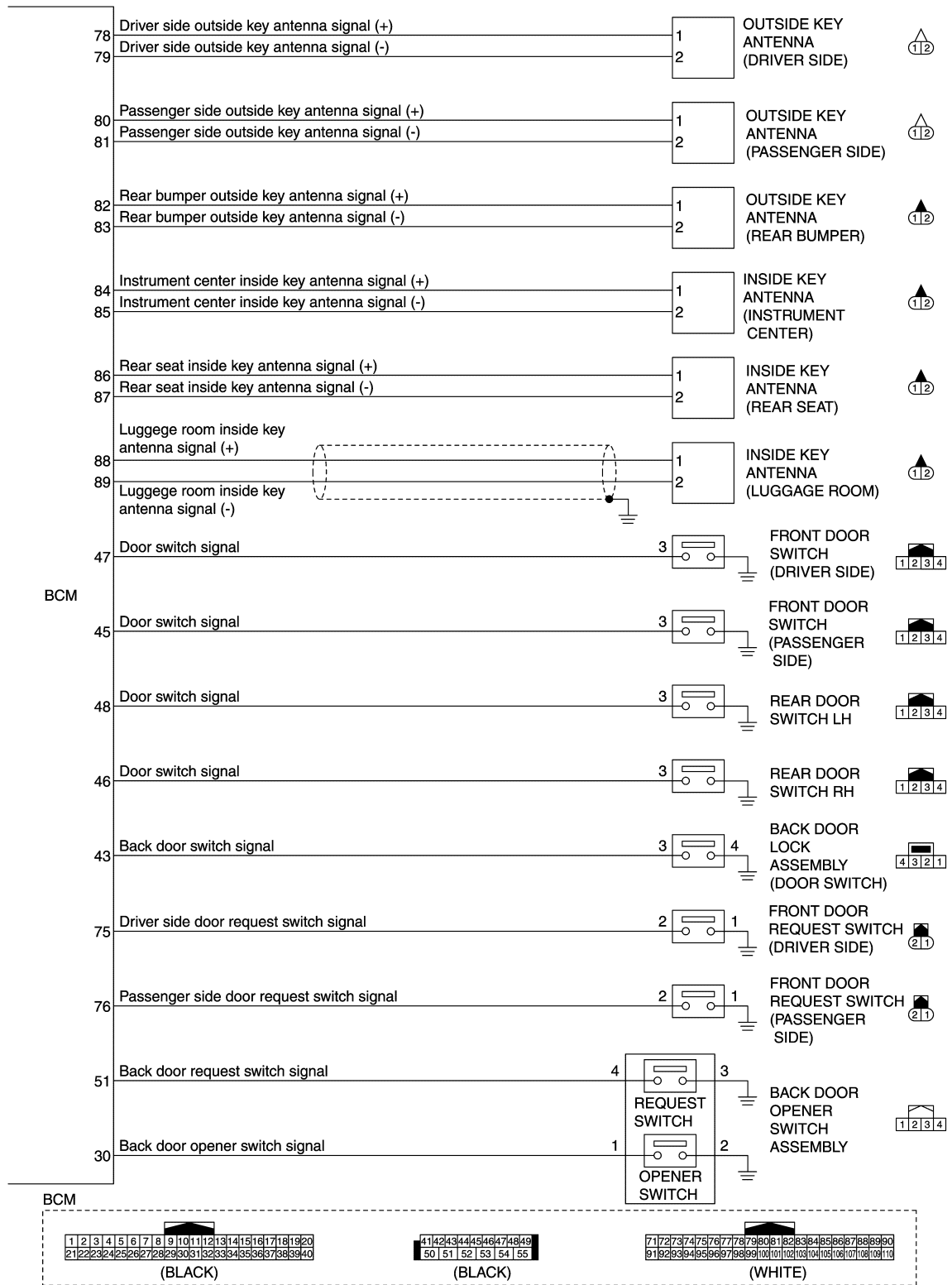

DIAGNOSIS SYSTEM (BCM)

[WITH INTELLIGENT KEY SYSTEM]

< SYSTEM DESCRIPTION >

DIAGNOSIS SYSTEM (BCM)

COMMON ITEM

COMMON ITEM : CONSULT Function (BCM - COMMON ITEM)

INFOID:000000007634168

APPLICATION ITEM

CONSULT performs the following functions via CAN communication with BCM.

Diagnosis mode	Function Description
Work Support	Changes the setting for each system function.
Self Diagnostic Result	Displays the diagnosis results judged by BCM.
CAN Diag Support Monitor	Monitors the reception status of CAN communication viewed from BCM.
Data Monitor	The BCM input/output signals are displayed.
Active Test	The signals used to activate each device are forcibly supplied from BCM.
Ecu Identification	The BCM part number is displayed.
Configuration	<ul style="list-style-type: none"> Read and save the vehicle specification. Write the vehicle specification when replacing BCM.

SYSTEM APPLICATION

BCM can perform the following functions for each system.

NOTE:

It can perform the diagnosis modes except the following for all sub system selection items.

×: Applicable item

System	Sub system selection item	Diagnosis mode		
		Work Support	Data Monitor	Active Test
Door lock	DOOR LOCK	×	×	×
Rear window defogger	REAR DEFOGGER		×	×
Warning chime	BUZZER		×	×
Interior room lamp timer	INT LAMP	×	×	×
Exterior lamp	HEAD LAMP	×	×	×
Wiper and washer	WIPER	×	×	×
Turn signal and hazard warning lamps	FLASHER	×	×	×
—	AIR CONDITONER*		×	×
Intelligent Key system	INTELLIGENT KEY	×	×	×
Combination switch	COMB SW		×	
Body control system	BCM	×		
NVIS - NATS	IMMU	×	×	×
Interior room lamp battery saver	BATTERY SAVER	×	×	×
Back door open	TRUNK		×	
Theft warning alarm	THEFT ALM	×	×	×
RAP system	RETAINED PWR		×	
Signal buffer system	SIGNAL BUFFER		×	×
TPMS	AIR PRESSURE MONITOR	×	×	×

*: This item is displayed, but not used.

FREEZE FRAME DATA (FFD)

The BCM records the following vehicle condition at the time a particular DTC is detected, and displays on CONSULT.

DIAGNOSIS SYSTEM (BCM)

[WITH INTELLIGENT KEY SYSTEM]

< SYSTEM DESCRIPTION >

CONSULT screen item	Indication/Unit	Description	
Vehicle Speed	km/h	Vehicle speed of the moment a particular DTC is detected	
Odo/Trip Meter	km	Total mileage (Odometer value) of the moment a particular DTC is detected	
Vehicle Condition	SLEEP>LOCK	Power supply position status of the moment a particular DTC is detected*	While turning BCM status from low power consumption mode to normal mode [Power supply position is OFF (LOCK)]
	SLEEP>OFF		While turning BCM status from low power consumption mode to normal mode [Power supply position is OFF (OFF)]
	LOCK>ACC		While turning power supply position from OFF (LOCK) to ACC
	ACC>ON		While turning power supply position from ACC to ON
	RUN>ACC		While turning power supply position from READY (RUN) to ACC (Except emergency stop operation)
	CRANK>RUN		While turning power supply position from READY (CRANK) to READY (RUN)
	RUN>URGENT		While turning power supply position from READY (RUN) to ACC (Emergency stop operation)
	ACC>OFF		While turning power supply position from ACC to OFF (OFF)
	OFF>LOCK		While turning power supply position from OFF (OFF) to OFF (LOCK)
	OFF>ACC		While turning power supply position from OFF (OFF) to ACC
	ON>CRANK		While turning power supply position from ON to READY (CRANK)
	OFF>SLEEP		While turning BCM status from normal mode [Power supply position is OFF (OFF)] to low power consumption mode
	LOCK>SLEEP		While turning BCM status from normal mode [Power supply position is OFF (LOCK)] to low power consumption mode
	LOCK		Power supply position is OFF (LOCK)
	OFF		Power supply position is OFF (OFF)
	ACC		Power supply position is ACC
	ON		Power supply position is ON
	ENGINE RUN		Power supply position is READY (RUN)
CRANKING	Power supply position is READY (CRANK)		
IGN Counter	0 - 39	The number of times that power switch is turned ON after DTC is detected <ul style="list-style-type: none"> • The number is 0 when a malfunction is detected now. • The number increases like 1 → 2 → 3...38 → 39 after returning to the normal condition whenever power switch OFF → ON. • The number is fixed to 39 until the self-diagnosis results are erased if it is over 39. 	

NOTE:

*: Refer to the following for details of the power supply position.

- OFF (OFF, LOCK): Power switch OFF
- ACC: Power switch ACC
- ON: Power switch ON
- READY (CRANK): Shifting to vehicle condition READY (Transmitting the READY signal from BCM to VCM)
- READY (RUN): Vehicle condition READY

Power supply position shifts to "OFF (LOCK)" from "OFF (OFF)", when power switch is in the OFF position, shift position is in the P position, and any of the following conditions are met.

- Closing door
- Opening door
- Door is locked using door request switch
- Door is locked using Intelligent Key

The power supply position shifts to "ACC" when the power switch (push switch) is pushed at "OFF (LOCK)".

INTELLIGENT KEY

DIAGNOSIS SYSTEM (BCM)

[WITH INTELLIGENT KEY SYSTEM]

< SYSTEM DESCRIPTION >

INTELLIGENT KEY : CONSULT Function (BCM - INTELLIGENT KEY)

INFOID:000000007634169

WORK SUPPORT

Monitor item	Description
INSIDE ANT DIAGNOSIS	This function allows inside key antenna self-diagnosis
LOCK/UNLOCK BY I-KEY	Door lock/unlock function by door request switch mode can be changed to operation in this mode <ul style="list-style-type: none"> • On: Operate • Off: Non-operation
ENGINE START BY I-KEY	READY set function mode can be changed to operation with this mode <ul style="list-style-type: none"> • On: Operate • Off: Non-operation
TRUNK/GLASS HATCH OPEN	NOTE: This item is displayed, but cannot be used
HORN WITH KEYLESS LOCK	Horn reminder function mode by Intelligent Key button can be changed to operate (ON) or not operate (OFF) with this mode <ul style="list-style-type: none"> • On: Operate • Off: Non-operation
PANIC ALARM SET	Panic alarm button pressing time on Intelligent Key remote control button can be selected from the following with this mode <ul style="list-style-type: none"> • MODE 1: 0.5 sec. • MODE 2: Non-operation • MODE 3: 1.5 sec.
TRUNK OPEN DELAY	NOTE: This item is displayed, but cannot be used
LO- BATT OF KEY FOB WARN	Intelligent Key low battery warning mode can be changed to operation with this mode <ul style="list-style-type: none"> • On: Operate • Off: Non-operation
ANTI KEY LOCK IN FUNCTI	Key reminder function mode can be changed to operation with this mode <ul style="list-style-type: none"> • On: Operate • Off: Non-operation
HAZARD ANSWER BACK	Hazard reminder function mode by door request switch and Intelligent Key button can be selected from the following with this mode <ul style="list-style-type: none"> • Lock Only: Door lock operation only • Unlock Only: Door unlock operation only • Lock/Unlock: Lock and unlock operation • Off: Non-operation
ANS BACK I-KEY LOCK	Buzzer reminder function (lock operation) mode by door request switch can be selected from the following with this mode <ul style="list-style-type: none"> • Horn Chirp: Sound horn • Buzzer: Sound Intelligent Key warning buzzer • Off: Non-operation
ANS BACK I-KEY UNLOCK	Buzzer reminder function (unlock operation) mode by door request switch can be changed to operation with this mode <ul style="list-style-type: none"> • On: Operate • Off: Non-operation
SHORT CRANKING OUTPUT	NOTE: This item is displayed, but cannot be used
CONFIRM KEY FOB ID	It can be checked whether Intelligent Key ID code is registered or not in this mode
AUTO LOCK SET	Auto door lock operation time can be changed in this mode <ul style="list-style-type: none"> • MODE 1: OFF • MODE 2: 30 sec. • MODE 3: 1 minute • MODE 4: 2 minutes • MODE 5: 3 minutes • MODE 6: 4 minutes • MODE 7: 5 minutes

A
B
C
D
E
F
G
H
I
J

SEC

L
M
N
O
P

DIAGNOSIS SYSTEM (BCM)

[WITH INTELLIGENT KEY SYSTEM]

< SYSTEM DESCRIPTION >

SELF-DIAG RESULT

Refer to [BCS-56. "DTC Index"](#).

DATA MONITOR

Monitor Item	Condition
REQ SW -DR	Indicates [On/Off] condition of door request switch (driver side)
REQ SW -AS	Indicates [On/Off] condition of door request switch (passenger side)
REQ SW -BD/TR	Indicates [On/Off] condition of back door request switch
PUSH SW	Indicates [On/Off] condition of power switch
CLUTCH SW	NOTE: This item is displayed, but cannot be monitored
BRAKE SW 1	Indicates [On/Off]* condition of stop lamp switch power supply
BRAKE SW 2	Indicates [On/Off] condition of stop lamp switch
DETE/CANCL SW	Indicates [On/Off] condition of P position
SFT PN/N SW	Indicates [On/Off] condition of P or N position
UNLK SEN -DR	Indicates [On/Off] condition of driver door UNLOCK status
PUSH SW -IPDM	Indicates [On/Off] condition of power switch
IGN RLY1 -F/B	Indicates [On/Off] condition of ignition relay 1
DETE SW -IPDM	Indicates [On/Off] condition of P position
SFT PN -IPDM	NOTE: This item is displayed, but cannot be monitored
SFT P -MET	Indicates [On/Off] condition of P position
SFT N -MET	Indicates [On/Off] condition of N position
ENGINE STATE	NOTE: This item is displayed, but cannot be monitored
S/L LOCK-IPDM	NOTE: This item is displayed, but cannot be monitored
S/L UNLK-IPDM	NOTE: This item is displayed, but cannot be monitored
S/L RELAY-REQ	NOTE: This item is displayed, but cannot be monitored
VEH SPEED 1	Display the vehicle speed signal received from combination meter by numerical value [km/h]
VEH SPEED 2	Display the vehicle speed signal received from ABS actuator and electric unit (control unit) by numerical value [km/h]
DOOR STAT-DR	Indicates [LOCK/READY/UNLK] condition of driver side door status
DOOR STAT-AS	Indicates [LOCK/READY/UNLK] condition of passenger side door status
ID OK FLAG	Indicates [Set/Reset] condition of key ID
PRMT ENG STRT	Indicates [Set/Reset] condition of ENGINE START BY I-KEY setting in WORK SUPPORT mode
PRMT RKE STRT	NOTE: This item is displayed, but cannot be monitored
TRNK/HAT MNTR	NOTE: This item is displayed, but cannot be monitored
RKE-LOCK	Indicates [On/Off] condition of LOCK signal from Intelligent Key
RKE-UNLOCK	Indicates [On/Off] condition of UNLOCK signal from Intelligent Key
RKE-TR/BD	NOTE: This item is displayed, but cannot be monitored
RKE-PANIC	Indicates [On/Off] condition of PANIC button of Intelligent Key
RKE-MODE CHG	Indicates [On/Off] condition of MODE CHANGE signal from Intelligent Key

DIAGNOSIS SYSTEM (BCM)

[WITH INTELLIGENT KEY SYSTEM]

< SYSTEM DESCRIPTION >

Monitor Item	Condition
RKE OPE COUN1	When remote keyless entry receiver receives the signal transmitted while operating on Intelligent Key, the numerical value start changing
RKE OPE COUN2	NOTE: This item is displayed, but cannot be monitored

*: OFF is displayed when brake pedal is depressed while brake switch power supply is OFF.

ACTIVE TEST

Test item	Description
OUTSIDE BUZZER	This test is able to check Intelligent Key warning buzzer operation <ul style="list-style-type: none"> • On: Operate • Off: Non-operation
INSIDE BUZZER	This test is able to check warning chime in combination meter operation <ul style="list-style-type: none"> • Take Out: Take away warning chime sounds when CONSULT screen is touched • Key: Key warning chime sounds when CONSULT screen is touched • Knob: OFF position warning chime sounds when CONSULT screen is touched • Off: Non-operation
INDICATOR	This test is able to check warning lamp operation <ul style="list-style-type: none"> • KEY ON: "KEY" Warning lamp illuminates when CONSULT screen is touched • KEY IND: "KEY" Warning lamp blinks when CONSULT screen is touched • Off: Non-operation
INT LAMP	This test is able to check interior room lamp operation <ul style="list-style-type: none"> • On: Operate • Off: Non-operation
LCD	This test is able to check meter display information <ul style="list-style-type: none"> • Traction motor start information displays when "BP N" on CONSULT screen is touched • Traction motor start information displays when "BP I" on CONSULT screen is touched • Key ID warning displays when "ID NG" on CONSULT screen is touched • ROTAT: This item is displayed, but cannot be used • INSRT: This item is displayed, but cannot be used • Intelligent Key low battery warning displays when "BATT" on CONSULT screen is touched • Take away warning displays when "OUTKEY" on CONSULT screen is touched • OFF position warning displays when "LK WN" on CONSULT screen is touched
FLASHER	This test is able to check security hazard lamp operation The hazard lamps are activated after "LH/RH/Off" on CONSULT screen is touched
HORN	This test is able to check horn operation <ul style="list-style-type: none"> • On: Operate • Off: Non-operation
P RANGE	This test is able to check P position signal from electric shift control unit <ul style="list-style-type: none"> • On: Operate • Off: Non-operation
ENGINE SW ILLUMI	This test is able to check power switch illumination operation Power switch illumination illuminates when "ON" on CONSULT screen is touched
PUSH SWITCH INDICATOR	This test is able to check LOCK indicator in power switch operation LOCK indicator in power switch illuminates when "ON" on CONSULT screen is touched
BATTERY SAVER	This test is able to check interior room lamp operation. The interior room lamp will be activated after "ON" on CONSULT screen is touched.
TRUNK/BACK DOOR	This test is able to check back door opener actuator open operation. This actuator opens when "Open" on CONSULT screen is touched.

THEFT ALM

THEFT ALM : CONSULT Function (BCM - THEFT)

INFOID:000000007634170

WORK SUPPORT

DIAGNOSIS SYSTEM (BCM)

[WITH INTELLIGENT KEY SYSTEM]

< SYSTEM DESCRIPTION >

Service Item	Description
SECURITY ALARM SET	This mode is able to confirm and change security alarm ON-OFF setting.
THEFT ALM TRG	The switch which triggered vehicle security alarm is recorded. This mode is able to confirm and erase the record of vehicle security alarm. The trigger data can be erased by touching "CLEAR" on CONSULT screen.

DATA MONITOR

Monitored Item	Description
REQ SW -DR	Indicates [On/Off] condition of door request switch (driver side).
REQ SW -AS	Indicates [On/Off] condition of door request switch (passenger side).
REQ SW -RR	NOTE: This is displayed even when it is not equipped.
REQ SW -RL	NOTE: This is displayed even when it is not equipped.
REQ SW -BD/TR	Indicates [On/Off] condition of back door request switch.
PUSH SW	Indicates [On/Off] condition of power switch
UNLK SEN -DR	Indicates [On/Off] condition of driver door UNLOCK status.
DOOR SW-DR	Indicates [On/Off] condition of front door switch (driver side).
DOOR SW-AS	Indicates [On/Off] condition of front door switch (passenger side).
DOOR SW-RR	Indicates [On/Off] condition of rear door switch RH.
DOOR SW-RL	Indicates [On/Off] condition of rear door switch LH.
DOOR SW-BK	Indicates [On/Off] condition of back door switch.
CDL LOCK SW	Indicates [On/Off] condition of lock signal from door lock/unlock switch.
CDL UNLOCK SW	Indicates [On/Off] condition of unlock signal from door lock/unlock switch.
KEY CYL LK-SW	Indicates [On/Off] condition of lock signal from door key cylinder.
KEY CYL UN-SW	Indicates [On/Off] condition of unlock signal from door key cylinder.
TR/BD OPEN SW	Indicates [On/Off] condition of back door opener switch.
TRNK/HAT MNTR	NOTE: This is displayed even when it is not equipped.
RKE-LOCK	Indicates [On/Off] condition of LOCK signal from Intelligent Key.
RKE-UNLOCK	Indicates [On/Off] condition of UNLOCK signal from Intelligent Key.
RKE-TR/BD	NOTE: This is displayed even when it is not equipped.

ACTIVE TEST

Test Item	Description
THEFT IND	This test is able to check security indicator lamp operation. Security indicator lamp is turned on when "ON" on CONSULT screen is touched.
VEHICLE SECURITY HORN	This test is able to check horns operation. Horns are activated for 0.5 seconds after "ON" on CONSULT screen is touched.
HEADLAMP(HI)	This test is able to check headlamp operation. Headlamps are activated for 0.5 seconds after "ON" on CONSULT screen is touched.
FLASHER	This test is able to check hazard warning lamp operation. Hazard warning lamps are activated after "ON" on CONSULT screen is touched.

IMMU

IMMU : CONSULT Function (BCM - IMMU)

INFOID:000000007634171

DATA MONITOR

DIAGNOSIS SYSTEM (BCM)

[WITH INTELLIGENT KEY SYSTEM]

< SYSTEM DESCRIPTION >

Monitor item	Content	
CONFIRM ID ALL	Indicates [YET] at all time. Switches to [DONE] when a registered Intelligent Key backside is contacted to power switch.	A
CONFIRM ID4		B
CONFIRM ID3		
CONFIRM ID2		C
CONFIRM ID1		
NOT REGISTERED	Indicates [ID OK] when key ID that is registered is received or is not yet received. Indicates [ID NG] when key ID that is not registered is received.	
TP 4	Indicates the number of IDs that are registered.	D
TP 3		E
TP 2		
TP 1		
PUSH SW	Indicates [ON/OFF] condition of power switch.	

ACTIVE TEST

Test item	Description	
THEFT IND	This test is able to check security indicator lamp operation. Security indicator lamp is turned on when "ON" on CONSULT screen touched.	G

WORK SUPPORT

Service item	Description	
CONFIRM DONGLE ID	It is possible to check that dongle unit is applied to the vehicle.	I

SEC

DIAGNOSIS SYSTEM (IPDM E/R)

< SYSTEM DESCRIPTION >

[WITH INTELLIGENT KEY SYSTEM]

DIAGNOSIS SYSTEM (IPDM E/R)

CONSULT Function (IPDM E/R)

INFOID:000000007634172

APPLICATION ITEM

CONSULT performs the following functions via CAN communication with IPDM E/R.

Diagnosis mode	Description
Ecu Identification	Allows confirmation of IPDM E/R part number.
Self Diagnostic Result	Displays the diagnosis results judged by IPDM E/R.
Data Monitor	Displays the real-time input/output data from IPDM E/R input/output data.
Active Test	IPDM E/R can provide a drive signal to electronic components to check their operations.
CAN Diag Support Monitor	The results of transmit/receive diagnosis of CAN communication can be read.

SELF DIAGNOSTIC RESULT

Refer to [PCS-21, "DTC Index"](#).

DATA MONITOR

Monitor item

Monitor Item [Unit]	MAIN SIGNALS	Description
AC COMP REQ [Off/On]	×	NOTE: The item is indicated, but not monitored.
TAIL&CLR REQ [Off/On]	×	Displays the status of the position light request signal received from BCM via CAN communication.
HL LO REQ [Off/On]	×	Displays the status of the low beam request signal received from BCM via CAN communication.
HL HI REQ [Off/On]	×	Displays the status of the high beam request signal received from BCM via CAN communication.
FR FOG REQ [Off/On]	×	Displays the status of the front fog light request signal received from BCM via CAN communication.
FR WIP REQ [Stop/1LOW/Low/Hi]	×	Displays the status of the front wiper request signal received from BCM via CAN communication.
WIP AUTO STOP [STOP P/ACT P]	×	Displays the status of the front wiper auto stop signal judged by IPDM E/R.
WIP PROT [Off/BLOCK]	×	Displays the status of the front wiper fail-safe operation judged by IPDM E/R.
IGN RLY1 -REQ [Off/On]		Displays the status of the power switch ON signal received from BCM via CAN communication.
IGN RLY [Off/On]	×	Displays the status of the ignition relay judged by IPDM E/R.
PUSH SW [Off/On]		Displays the status of the power switch judged by IPDM E/R.
INTER/NP SW [Off/On]		NOTE: The item is indicated, but not monitored.
ST RLY CONT [Off/On]		NOTE: The item is indicated, but not monitored.
IHBT RLY -REQ [Off/On]		NOTE: The item is indicated, but not monitored.
ST/INHI RLY [Off/ ST ON/INHI ON/UNKWN]		NOTE: The item is indicated, but not monitored.
DETENT SW [Off/On]		Displays the status of the P position signal judged by IPDM E/R.

DIAGNOSIS SYSTEM (IPDM E/R)

< SYSTEM DESCRIPTION >

[WITH INTELLIGENT KEY SYSTEM]

Monitor Item [Unit]	MAIN SIGNALS	Description
S/L RLY -REQ [Off/On]		NOTE: The item is indicated, but not monitored.
S/L STATE [LOCK/UNLK/UNKWN]		NOTE: The item is indicated, but not monitored.
DTRL REQ [Off/On]		Displays the status of the daytime running light request signal received from BCM via CAN communication. NOTE: This item is monitored only for vehicle with the daytime running light system.
OIL P SW [Open/Close]		NOTE: The item is indicated, but not monitored.
HOOD SW [Off/On]		Displays the status of the hood switch judged by IPDM E/R. NOTE: This item is monitored only for vehicle with the vehicle security system.
HL WASHER REQ [Off/On]		NOTE: The item is indicated, but not monitored.
THFT HRN REQ [Off/On]		Displays the status of the theft warning horn request signal received from BCM via CAN communication.
HORN CHIRP [Off/On]		Displays the status of the horn reminder signal received from BCM via CAN communication.

ACTIVE TEST

Test item

Test item	Operation	Description
HORN	On	Operates horn relay for 20 ms.
REAR DEFOGGER	Off	OFF
	On	Operates the rear window defogger relay.
FRONT WIPER	Off	OFF
	Lo	Operates the front wiper relay.
	Hi	Operates the front wiper relay and front wiper high relay.
MOTOR FAN	1	NOTE: This item is indicated, but cannot be tested.
	2	
	3	
	4	
HEAD LAMP WASHER	On	NOTE: This item is indicated, but cannot be tested.
EXTERNAL LAMPS	Off	OFF
	TAIL	Operates the tail lamp relay.
	Lo	Operates the headlamp low relay.
	Hi	Operates the headlamp low relay and ON/OFF the headlamp high relay at 1 second intervals.
	Fog	Operates the front fog lamp relay.

A
B
C
D
E
F
G
H
I
J
L
M
N
O
P

SEC

ECU DIAGNOSIS INFORMATION

VCM, IPDM E/R, BCM

List of ECU Reference

INFOID:000000007634173

ECU		Reference
VCM	Reference Value	EVC-66, "Reference Value"
	Fail-safe	EVC-79, "Fail-Safe"
	DTC Inspection Priority Chart	EVC-82, "DTC Inspection Priority Chart"
	DTC Index	EVC-84, "DTC Index"
IPDM E/R	Reference Value	PCS-16, "Reference Value"
	Fail-safe	PCS-20, "Fail-Safe"
	DTC Index	PCS-21, "DTC Index"
BCM	Reference Value	BCS-34, "Reference Value"
	Fail-safe	BCS-54, "Fail-safe"
	DTC Inspection Priority Chart	BCS-55, "DTC Inspection Priority Chart"
	DTC Index	BCS-56, "DTC Index"

SECURITY CONTROL SYSTEM

[WITH INTELLIGENT KEY SYSTEM]

< WIRING DIAGRAM >

WIRING DIAGRAM

SECURITY CONTROL SYSTEM

Wiring Diagram

INFOID:000000007634174

For connector terminal arrangements, harness layouts, and alphabets in a  (option abbreviation; if not described in wiring diagram), refer to [GI-12, "Connector Information"](#).

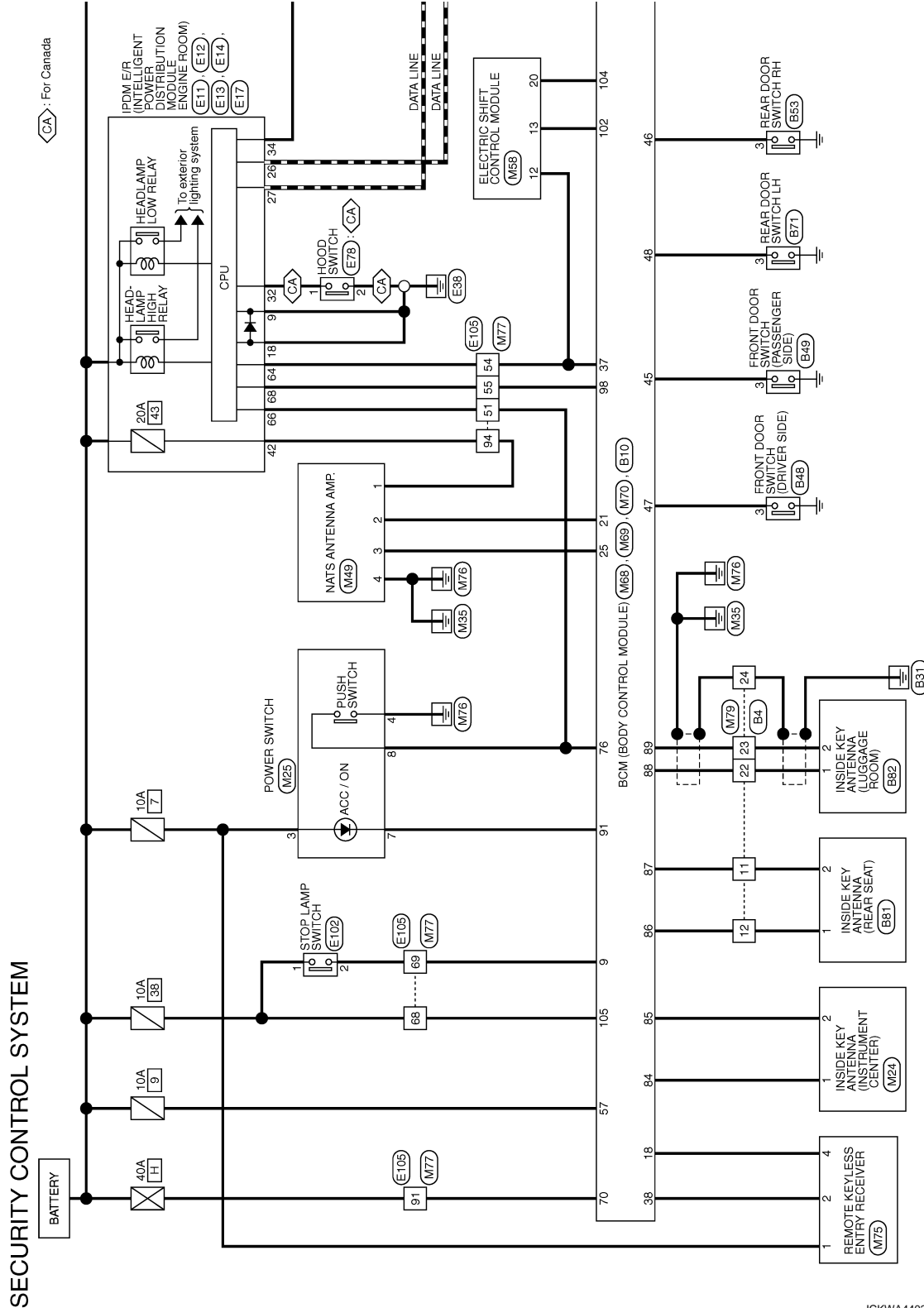

2011/03/25

JCKWA4402GB

A
B
C
D
E
F
G
H
I
J
L
M
N
O
P

SEC

SECURITY CONTROL SYSTEM

< WIRING DIAGRAM >

[WITH INTELLIGENT KEY SYSTEM]

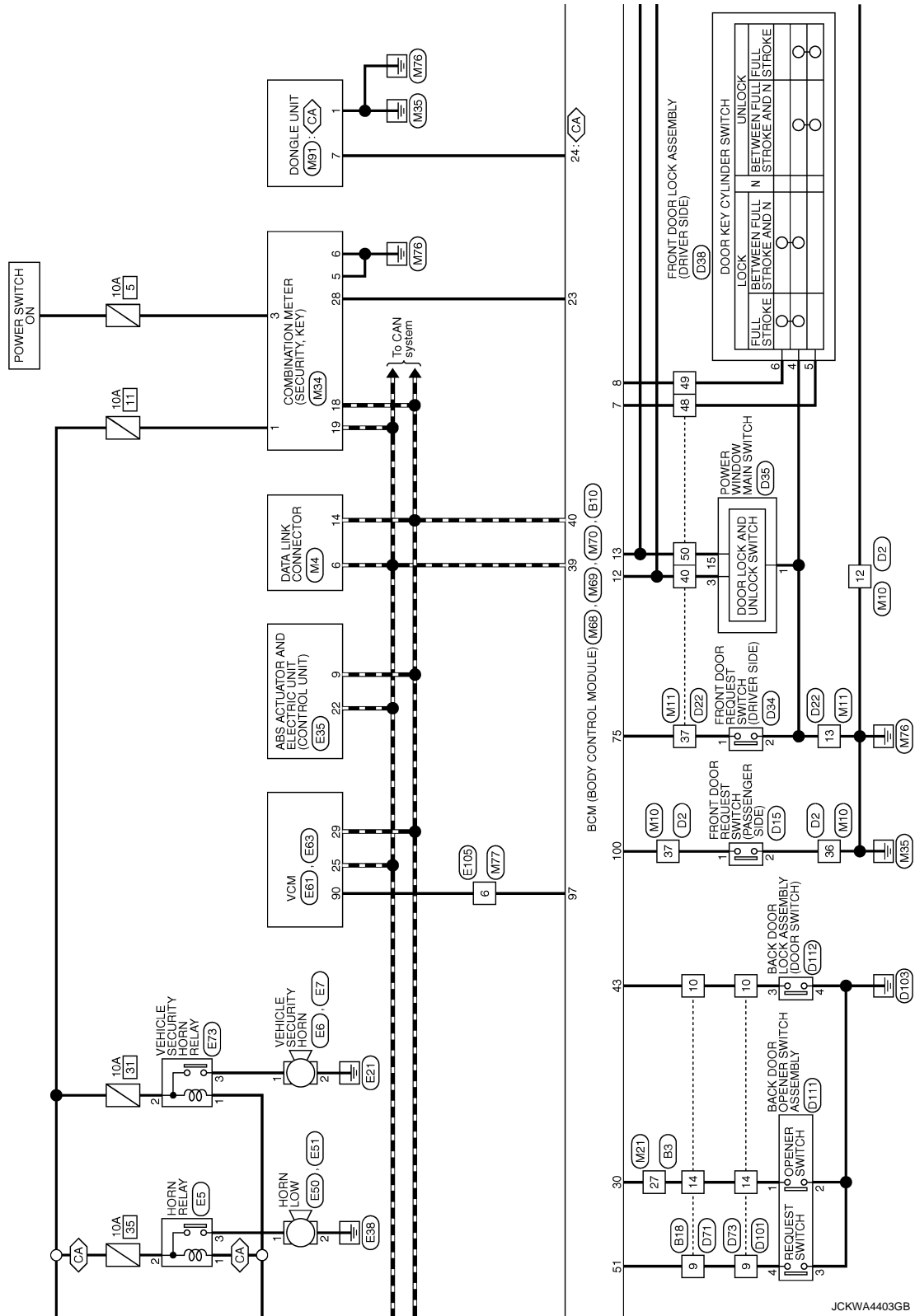

JCKWA4403GB

SECURITY CONTROL SYSTEM

< WIRING DIAGRAM >

[WITH INTELLIGENT KEY SYSTEM]

A
B
C
D
E
F
G
H
I
J
L
M
N
O
P

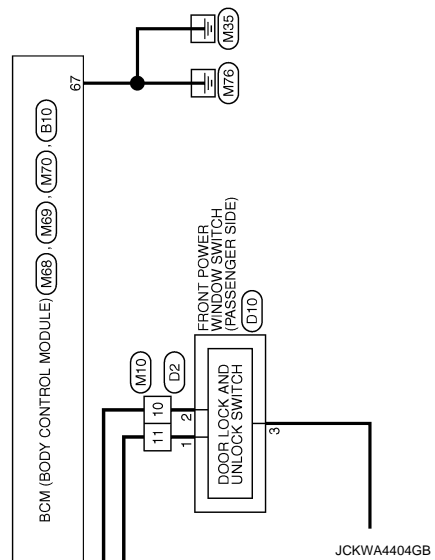

SEC

DIAGNOSIS AND REPAIR WORK FLOW

< BASIC INSPECTION >

[WITH INTELLIGENT KEY SYSTEM]

BASIC INSPECTION

DIAGNOSIS AND REPAIR WORK FLOW

Work Flow

INFOID:000000007634175

OVERALL SEQUENCE

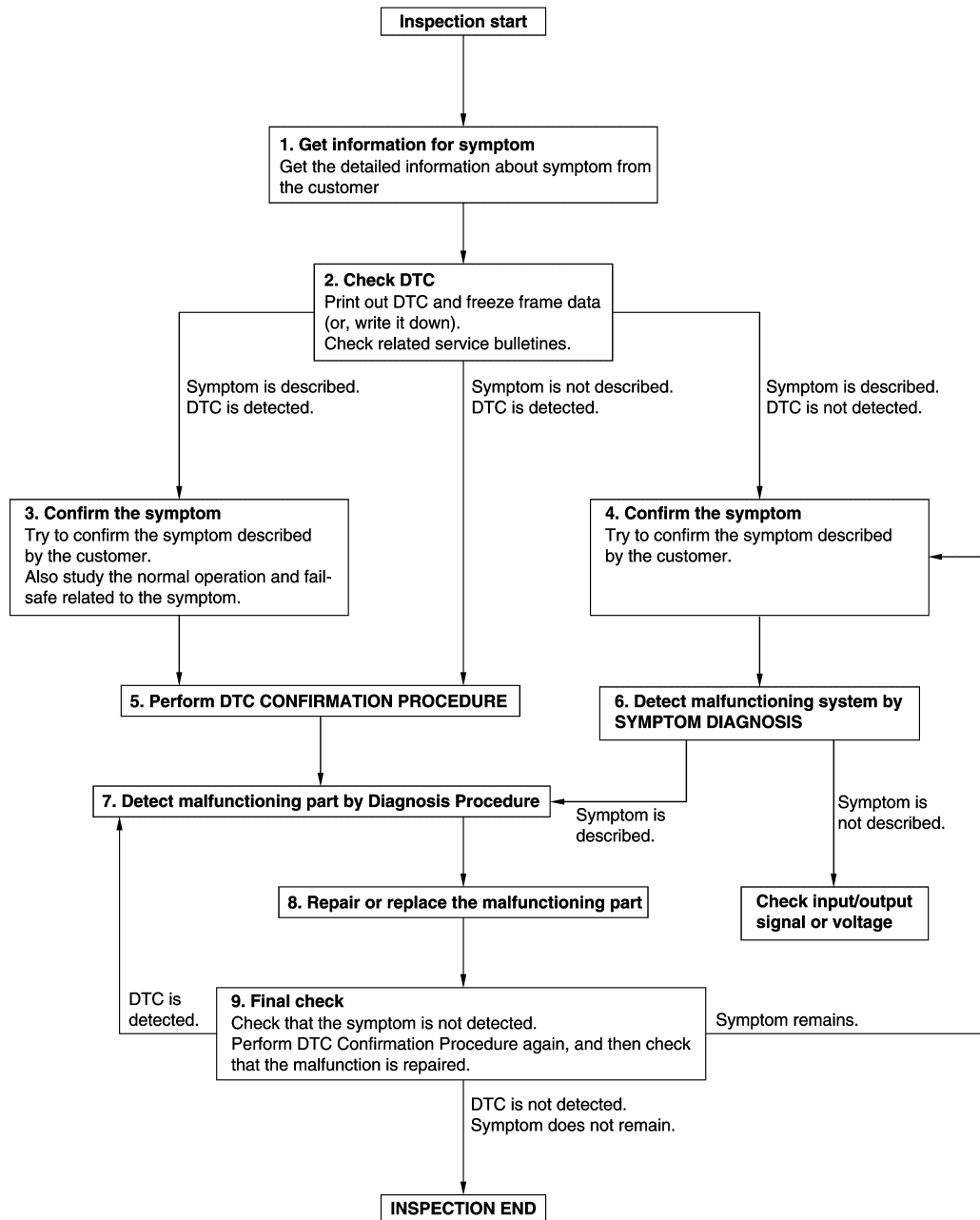

JMKIA8652GB

DETAILED FLOW

Revision: 2014 June

SEC-44

2012 LEAF

DIAGNOSIS AND REPAIR WORK FLOW

[WITH INTELLIGENT KEY SYSTEM]

< BASIC INSPECTION >

1.GET INFORMATION FOR SYMPTOM

1. Get detailed information from the customer about the symptom (the condition and the environment when the incident/malfunction occurs).
2. Check operation condition of the function that is malfunctioning.

>> GO TO 2.

2.CHECK DTC

1. Check DTC.
2. Perform the following procedure if DTC is detected.
 - Record DTC and freeze frame data (Print them out using CONSULT.)
 - Erase DTC.
 - Study the relationship between the cause detected by DTC and the symptom described by the customer.
3. Check related service bulletins for information.

Are any symptoms described and any DTC detected?

Symptom is described, DTC is detected>>GO TO 3.

Symptom is described, DTC is not detected>>GO TO 4.

Symptom is not described, DTC is detected>>GO TO 5.

3.CONFIRM THE SYMPTOM

Try to confirm the symptom described by the customer.

Also study the normal operation and fail-safe related to the symptom.

Verify relation between the symptom and the condition when the symptom is detected.

>> GO TO 5.

4.CONFIRM THE SYMPTOM

Try to confirm the symptom described by the customer.

Verify relation between the symptom and the condition when the symptom is detected.

>> GO TO 6.

5.PERFORM DTC CONFIRMATION PROCEDURE

Perform DTC CONFIRMATION PROCEDURE for the detected DTC, and then check that DTC is detected again. At this time, always connect CONSULT to the vehicle, and check self diagnostic results in real time.

If two or more DTCs are detected, refer to [BCS-55. "DTC Inspection Priority Chart"](#) and determine trouble diagnosis order.

NOTE:

- Freeze frame data is useful if the DTC is not detected.
- Perform Component Function Check if DTC CONFIRMATION PROCEDURE is not included on Service Manual. This simplified check procedure is an effective alternative though DTC cannot be detected during this check.

If the result of Component Function Check is NG, it is the same as the detection of DTC by DTC CONFIRMATION PROCEDURE.

Is DTC detected?

YES >> GO TO 7.

NO >> Check according to [GI-51. "Intermittent Incident"](#).

6.DETECT MALFUNCTIONING SYSTEM BY SYMPTOM DIAGNOSIS

Detect malfunctioning system according to SYMPTOM DIAGNOSIS based on the confirmed symptom in step 4, and determine the trouble diagnosis order based on possible causes and symptom.

Is the symptom described?

YES >> GO TO 7.

NO >> Monitor input data from related sensors or check voltage of related module terminals using CONSULT.

7.DETECT MALFUNCTIONING PART BY DIAGNOSTIC PROCEDURE

A
B
C
D
E
F
G
H
I
J
L
M
N
O
P

SEC

DIAGNOSIS AND REPAIR WORK FLOW

[WITH INTELLIGENT KEY SYSTEM]

< BASIC INSPECTION >

Inspect according to Diagnostic Procedure of the system.

Is malfunctioning part detected?

YES >> GO TO 8.

NO >> Check according to [GI-51. "Intermittent Incident"](#).

8. REPAIR OR REPLACE THE MALFUNCTIONING PART

1. Repair or replace the malfunctioning part.
2. Reconnect parts or connectors disconnected during Diagnostic Procedure again after repair and replacement.
3. Check DTC. If DTC is detected, erase it.

>> GO TO 9.

9. FINAL CHECK

When DTC is detected in step 2, perform DTC CONFIRMATION PROCEDURE again, and then check that the malfunction is repaired securely.

When symptom is described by the customer, refer to confirmed symptom in step 3 or 4, and check that the symptom is not detected.

Is DTC detected and does symptom remain?

YES-1 >> DTC is detected: GO TO 7.

YES-2 >> Symptom remains: GO TO 4.

NO >> Before returning the vehicle to the customer, always erase DTC.

ADDITIONAL SERVICE WHEN REPLACING CONTROL UNIT

< BASIC INSPECTION >

[WITH INTELLIGENT KEY SYSTEM]

ADDITIONAL SERVICE WHEN REPLACING CONTROL UNIT

VCM

VCM : Description

INFOID:000000007634176

Performing the following procedure can automatically activate recommunication of VCM and BCM, but only when the VCM is replaced with a new one*.

*: New one means a virgin VCM that has never been energized on-board.

(In this step, initialization procedure using CONSULT is not necessary)

NOTE:

- When the replaced VCM is not a brand new, the initialization of BCM using CONSULT is necessary.
- If multiple keys are attached to the key holder, separate them before beginning work.
- Distinguish keys with unregistered key IDs from those with registered IDs.

VCM : Work Procedure

INFOID:000000007634177

1.PERFORM VCM RECOMMUNICATING FUNCTION

1. Install VCM.
2. Contact backside of registered Intelligent key* to power switch while brake pedal is depressed, then turn power switch to the ON position.
*: To perform this step, use the key that is used before performing VCM replacement.
3. Maintain power switch in the ON position for at least 5 seconds.
4. Turn power switch to the OFF position.
5. Check that the vehicle can be set to READY.

>> GO TO 2.

2.PERFORM ADDITIONAL SERVICE WHEN REPLACING VCM

Perform the following procedure [EVC-369, "Removal and Installation"](#).

>> END

BCM

BCM : Description

INFOID:000000007634178

BEFORE REPLACEMENT

When replacing BCM, save or print current vehicle specification with CONSULT configuration before replacement.

NOTE:

If "READ CONFIGURATION" can not be used, use the "WRITE CONFIGURATION - Manual selection" after replacing BCM.

AFTER REPLACEMENT

CAUTION:

When replacing BCM, always perform "WRITE CONFIGURATION" with CONSULT. Or not doing so, BCM control function does not operate normally.

- Complete the procedure of "WRITE CONFIGURATION" in order.
- Configuration is different for each vehicle model. Confirm configuration of each vehicle model.
- If you set incorrect "WRITE CONFIGURATION", incidents might occur.

NOTE:

When replacing BCM, perform the system initialization (NATS) (if equipped).

BCM : Work Procedure

INFOID:000000007634179

1.SAVING VEHICLE SPECIFICATION

CONSULT Configuration

Perform "READ CONFIGURATION" to save or print current vehicle specification. Refer to [BCS-64, "CONFIGURATION \(BCM\) : Description"](#).

A
B
C
D
E
F
G
H
I
J
L
M
N
O
P

SEC

ADDITIONAL SERVICE WHEN REPLACING CONTROL UNIT

< BASIC INSPECTION >

[WITH INTELLIGENT KEY SYSTEM]

NOTE:

If "READ CONFIGURATION" can not be used, use the "WRITE CONFIGURATION - Manual selection" after replacing BCM.

>> GO TO 2.

2. REPLACE BCM

Replace BCM. Refer to [BCS-77, "Removal and Installation"](#).

>> GO TO 3.

3. WRITING VEHICLE SPECIFICATION

ⓈCONSULT Configuration

Perform "WRITE CONFIGURATION - Config file" or "WRITE CONFIGURATION - Manual selection" to write vehicle specification. Refer to [BCS-64, "CONFIGURATION \(BCM\) : Work Procedure"](#).

>> GO TO 4.

4. INITIALIZE BCM (NATS) (IF EQUIPPED)

Perform BCM initialization. (NATS)

>> WORK END

P1610 LOCK MODE

< DTC/CIRCUIT DIAGNOSIS >

[WITH INTELLIGENT KEY SYSTEM]

DTC/CIRCUIT DIAGNOSIS

P1610 LOCK MODE

Description

INFOID:000000007634180

VCM forcibly switches to the mode that inhibits vehicle to be READY, when READY set operation is performed 5 times or more while communication between VCM and BCM is not normal.

DTC Logic

INFOID:000000007634181

DTC DETECTION LOGIC

NOTE:

If DTC P1610 is displayed with other DTC (for BCM or EV/HEV), first perform the trouble diagnosis for other DTC.

DTC No.	Trouble diagnosis name	DTC detecting condition	Possible cause
P1610	LOCK MODE	When VCM detects a communication malfunction between VCM and BCM 5 times or more.	—

DTC CONFIRMATION PROCEDURE

1. PERFORM DTC CONFIRMATION PROCEDURE

1. Turn power switch ON.
2. Check DTC in "Self Diagnostic Result" mode of "EV/HEV" using CONSULT.

Is DTC detected?

- YES >> Go to [SEC-49. "Diagnosis Procedure"](#).
NO >> INSPECTION END

Diagnosis Procedure

INFOID:000000007634182

1. CHECK VEHICLE READY SET FUNCTION

1. Check that DTC except DTC P1610 is not detected.
If detected, erase the DTC after fixing.
2. Turn power switch OFF.
3. Contact the registered Intelligent Key backside to power switch and wait 5 seconds.
4. Turn power switch ON.
5. Turn power switch OFF and wait 5 seconds.
6. Repeat steps 3 and 5 twice (a total of 3 times).
7. Check that vehicle can be set to READY.

>> INSPECTION END

A
B
C
D
E
F
G
H
I
J
L
M
N
O
P

SEC

P1611 ID DISCORD, IMMU-VCM

< DTC/CIRCUIT DIAGNOSIS >

[WITH INTELLIGENT KEY SYSTEM]

P1611 ID DISCORD, IMMU-VCM

DTC Logic

INFOID:000000007634183

DTC DETECTION LOGIC

DTC No.	Trouble diagnosis name	DTC detecting condition	Possible cause
P1611	ID DISCORD, IMMU-VCM	The ID verification results between BCM and VCM are NG.	<ul style="list-style-type: none">• BCM• VCM

DTC CONFIRMATION PROCEDURE

1.PERFORM DTC CONFIRMATION PROCEDURE

1. Turn power switch ON.
2. Check DTC in "Self Diagnostic Result" mode of "EV/HEV" using CONSULT.

Is DTC detected?

- YES >> Go to [SEC-50, "Diagnosis Procedure"](#).
NO >> INSPECTION END

Diagnosis Procedure

INFOID:000000007634184

1.PERFORM INITIALIZATION

1. Perform initialization of BCM and registration of all Intelligent Keys using CONSULT.
2. Check that the vehicle can be set to READY using registered Intelligent Key.

Is the inspection result normal?

- YES >> INSPECTION END
NO >> GO TO 2.

2.CHECK SELF DIAGNOSTIC RESULT

1. Select "Self Diagnostic Result" mode of "EV/HEV" using CONSULT.
2. Erase DTC.
3. Perform DTC CONFIRMATION PROCEDURE for DTC P1611. Refer to [SEC-50, "DTC Logic"](#).

Is DTC detected?

- YES >> GO TO 3.
NO >> INSPECTION END

3.REPLACE BCM

1. Replace BCM. Refer to [BCS-77, "Removal and Installation"](#).
2. Perform initialization of BCM and registration of all Intelligent Keys using CONSULT.
3. Check that the vehicle can be set to READY using registered Intelligent Key.

Is the inspection result normal?

- YES >> INSPECTION END
NO >> GO TO 4.

4.REPLACE VCM

Replace VCM. Refer to [EVC-369, "Removal and Installation"](#).

>> INSPECTION END

P1612 CHAIN OF VCM-IMMU

< DTC/CIRCUIT DIAGNOSIS >

[WITH INTELLIGENT KEY SYSTEM]

P1612 CHAIN OF VCM-IMMU

DTC Logic

INFOID:000000007634185

DTC DETECTION LOGIC

NOTE:

- If DTC P1612 is displayed with DTC U1000 (for BCM), first perform the trouble diagnosis for DTC U1000. Refer to [BCS-66, "DTC Logic"](#).
- If DTC P1612 is displayed with DTC U1010 (for BCM), first perform the trouble diagnosis for DTC U1010. Refer to [BCS-67, "DTC Logic"](#).

DTC No.	Trouble diagnosis name	DTC detecting condition	Possible cause
P1612	CHAIN OF VCM-IMMU	Inactive communication between VCM and BCM	<ul style="list-style-type: none">• Harness or connectors (The CAN communication line is open or shorted.)• BCM• VCM

DTC CONFIRMATION PROCEDURE

1.PERFORM DTC CONFIRMATION PROCEDURE

1. Turn power switch ON.
2. Check DTC in "Self Diagnostic Result" mode of "EV/HEV" using CONSULT.

Is DTC detected?

- YES >> Go to [SEC-51, "Diagnosis Procedure"](#).
NO >> INSPECTION END

Diagnosis Procedure

INFOID:000000007634186

1.REPLACE BCM

1. Replace BCM. Refer to [BCS-77, "Removal and Installation"](#).
2. Perform initialization of BCM and registration of all Intelligent Keys using CONSULT.
3. Check that the vehicle can be set to READY using registered Intelligent Key.

Is the inspection result normal?

- YES >> INSPECTION END
NO >> GO TO 2.

2.REPLACE VCM

Replace VCM. Refer to [EVC-369, "Removal and Installation"](#).

>> INSPECTION END

A
B
C
D
E
F
G
H
I
J
L
M
N
O
P

SEC

B2192 ID DISCORD, IMMUECM

< DTC/CIRCUIT DIAGNOSIS >

[WITH INTELLIGENT KEY SYSTEM]

B2192 ID DISCORD, IMMUECM

DTC Logic

INFOID:000000007634187

DTC DETECTION LOGIC

DTC No.	Trouble diagnosis name	DTC detecting condition	Possible cause
B2192	ID DISCORD BCM-ECM*	The ID verification results between BCM and VCM are NG.	<ul style="list-style-type: none">• BCM• VCM

*: "ECM" is indicated on CONSULT display, however this means VCM on this vehicle.

DTC CONFIRMATION PROCEDURE

1. PERFORM DTC CONFIRMATION PROCEDURE

1. Turn power switch ON.
2. Check DTC in "Self Diagnostic Result" mode of "BCM" using CONSULT.

Is DTC detected?

- YES >> Go to [SEC-52, "Diagnosis Procedure"](#).
NO >> INSPECTION END

Diagnosis Procedure

INFOID:000000007634188

1. PERFORM INITIALIZATION

1. Perform initialization of BCM and registration of all Intelligent Keys using CONSULT.
2. Check that the vehicle can be set to READY using registered Intelligent Key.

Is the inspection result normal?

- YES >> INSPECTION END
NO >> GO TO 2.

2. CHECK SELF-DIAGNOSIS RESULT

1. Select "Self Diagnostic Result" mode of "BCM" using CONSULT.
2. Erase DTC.
3. Perform DTC CONFIRMATION PROCEDURE for DTC B2192. Refer to [SEC-52, "DTC Logic"](#).

Is DTC detected?

- YES >> GO TO 3.
NO >> INSPECTION END

3. REPLACE BCM

1. Replace BCM. Refer to [BCS-77, "Removal and Installation"](#).
2. Perform initialization of BCM and registration of all Intelligent Keys using CONSULT.
3. Check that the vehicle can be set to READY using registered Intelligent Key.

Is the inspection result normal?

- YES >> INSPECTION END
NO >> GO TO 4.

4. REPLACE VCM

Replace VCM. Refer to [EVC-369, "Removal and Installation"](#).

>> INSPECTION END

B2193 CHAIN OF ECM-IMMU

[WITH INTELLIGENT KEY SYSTEM]

< DTC/CIRCUIT DIAGNOSIS >

B2193 CHAIN OF ECM-IMMU

DTC Logic

INFOID:000000007634189

DTC DETECTION LOGIC

NOTE:

- If DTC B2193 is displayed with DTC U1000, first perform the trouble diagnosis for DTC U1000. Refer to [BCS-66, "DTC Logic"](#).
- If DTC B2193 is displayed with DTC U1010, first perform the trouble diagnosis for DTC U1010. Refer to [BCS-67, "DTC Logic"](#).

DTC No.	Trouble diagnosis name	DTC detecting condition	Possible cause
B2193	CHAIN OF BCM-ECM*	Inactive communication between BCM and VCM	<ul style="list-style-type: none">• Harness or connectors (The CAN communication line is open or shorted.)• BCM• VCM

*: "ECM" is indicated on CONSULT display, however this means VCM on this vehicle.

DTC CONFIRMATION PROCEDURE

1. PERFORM DTC CONFIRMATION PROCEDURE

1. Turn power switch ON.
2. Check DTC in "Self Diagnostic Result" mode of "BCM" using CONSULT.

Is DTC detected?

- YES >> Go to [SEC-53, "Diagnosis Procedure"](#).
NO >> INSPECTION END

Diagnosis Procedure

INFOID:000000007634190

1. REPLACE BCM

1. Replace BCM. Refer to [BCS-77, "Removal and Installation"](#).
2. Perform initialization of BCM and registration of all Intelligent Keys using CONSULT.
3. Check that the vehicle can be set to READY using registered Intelligent Key.

Is the inspection result normal?

- YES >> INSPECTION END
NO >> GO TO 2.

2. REPLACE VCM

Replace VCM. Refer to [EVC-369, "Removal and Installation"](#).

>> INSPECTION END

A
B
C
D
E
F
G
H
I
J
L
M
N
O
P

SEC

B2195 ANTI-SCANNING

[WITH INTELLIGENT KEY SYSTEM]

< DTC/CIRCUIT DIAGNOSIS >

B2195 ANTI-SCANNING

DTC Logic

INFOID:000000007634191

DTC DETECTION LOGIC

DTC No.	Trouble diagnosis name	DTC detecting condition	Possible cause
B2195	ANTI-SCANNING	ID verification between BCM and VCM that is out of the specified specification is detected.	ID verification request out of the specified specification

DTC CONFIRMATION PROCEDURE

1. PERFORM DTC CONFIRMATION PROCEDURE

1. Turn power switch ON.
2. Check DTC in "Self Diagnostic Result" mode of "BCM" using CONSULT.

Is DTC detected?

- YES >> Refer to [SEC-54, "Diagnosis Procedure"](#).
NO >> INSPECTION END

Diagnosis Procedure

INFOID:000000007634192

1. CHECK SELF DIAGNOSTIC RESULT 1

1. Select "Self Diagnostic Result" mode of "BCM" using CONSULT.
2. Erase DTC.
3. Perform DTC CONFIRMATION PROCEDURE for DTC B2195. Refer to [SEC-54, "DTC Logic"](#).

Is DTC detected?

- YES >> GO TO 2.
NO >> INSPECTION END

2. CHECK EQUIPMENT OF THE VEHICLE

Check that unspecified accessory part related to set vehicle to READY is not installed.

Is unspecified accessory part installed?

- YES >> GO TO 3.
NO >> GO TO 4.

3. CHECK SELF DIAGNOSTIC RESULT 2

1. Obtain the customers approval to remove unspecified accessory part related to set vehicle to READY, and then remove it.
2. Select "Self Diagnostic Result" of "BCM" using CONSULT.
3. Erase DTC.
4. Perform DTC CONFIRMATION PROCEDURE for DTC B2195. Refer to [SEC-54, "DTC Logic"](#).

Is DTC detected?

- YES >> GO TO 4.
NO >> INSPECTION END

4. REPLACE BCM

1. Replace BCM. Refer to [BCS-77, "Removal and Installation"](#).
2. Perform initialization of BCM and registration of all Intelligent Keys using CONSULT.

>> INSPECTION END

B2196 DONGLE UNIT

< DTC/CIRCUIT DIAGNOSIS >

[WITH INTELLIGENT KEY SYSTEM]

B2196 DONGLE UNIT

Description

INFOID:000000007634193

BCM performs ID verification between BCM and dongle unit.
When verification result is OK, BCM permits cranking.

DTC Logic

INFOID:000000007634194

DTC DETECTION LOGIC

DTC No.	Trouble diagnosis name	DTC detecting condition	Possible cause
B2196	DONGLE NG	The ID verification results between BCM and dongle unit is NG.	<ul style="list-style-type: none">• Harness or connectors (Dongle unit circuit is open or shorted.)• Dongle unit

DTC CONFIRMATION PROCEDURE

1.PERFORM DTC CONFIRMATION PROCEDURE

1. Turn ignition switch ON.
2. Turn ignition switch OFF.
3. Turn ignition switch ON.
4. Check DTC in "Self Diagnostic Result" mode of "BCM" using CONSULT.

Is the DTC detected?

- YES >> Refer to [SEC-55, "Diagnosis Procedure"](#).
NO >> INSPECTION END

Diagnosis Procedure

INFOID:000000007634195

1.PERFORM INITIALIZATION

1. Perform initialization of BCM and registration of all Intelligent Keys using CONSULT.
2. Start the engine.

Dose the engine start?

- YES >> INSPECTION END
NO >> GO TO 2.

2.CHECK DONGLE UNIT CIRCUIT

1. Turn ignition switch OFF.
2. Disconnect BCM connector and dongle unit connector.
3. Check continuity between BCM harness connector and dongle unit harness connector.

BCM		Dongle unit		Continuity
Connector	Terminal	Connector	Terminal	
M68	24	M91	7	Existed

4. Check continuity between BCM harness connector and ground.

BCM		Ground	Continuity
Connector	Terminal		
M68	24		Not existed

Is the inspection result normal?

- YES >> GO TO 3.
NO >> Repair or replace harness.

3.CHECK DONGLE UNIT GROUND CIRCUIT

Check continuity between dongle unit harness connector and ground.

B2196 DONGLE UNIT

< DTC/CIRCUIT DIAGNOSIS >

[WITH INTELLIGENT KEY SYSTEM]

Dongle unit		Ground	Continuity
Connector	Terminal		Existed
M91	1		

Is the inspection result normal?

- YES >> Replace dongle unit.
- NO >> Repair or replace harness.

B2198 NATS ANTENNA AMP.

< DTC/CIRCUIT DIAGNOSIS >

[WITH INTELLIGENT KEY SYSTEM]

B2198 NATS ANTENNA AMP.

DTC Logic

INFOID:000000007634196

DTC DETECTION LOGIC

DTC No.	Trouble diagnosis name	DTC detecting condition	Possible cause
B2198	NATS ANTENNA AMP.	Inactive communication between NATS antenna amp. and BCM is detected when BCM enters in the low power consumption mode (BCM sleep condition)	<ul style="list-style-type: none"> • Harness or connectors (NATS antenna amp. circuit is open or shorted.) • NATS antenna amp. • BCM

DTC CONFIRMATION PROCEDURE

1.PERFORM DTC CONFIRMATION PROCEDURE

1. Make the conditions that BCM enters in the low power consumption mode (BCM sleep condition), and wait 15 to 60 minutes. Refer to [BCS-13, "POWER CONSUMPTION CONTROL SYSTEM : System Description"](#).
2. Turn power switch ON.
3. Check DTC in "Self Diagnostic Result" mode of "BCM" using CONSULT.

Is DTC detected?

- YES >> Go to [SEC-57, "Diagnosis Procedure"](#).
 NO >> INSPECTION END

Diagnosis Procedure

INFOID:000000007634197

1.CHECK FUSE

1. Turn power switch OFF.
2. Check that the following fuse in IPDM E/R is not blown.

Signal name	Fuse No.
Battery power supply	43

Is the inspection result normal?

- YES >> GO TO 2.
 NO >> Replace the blown fuse after repairing the cause of blowing.

2.CHECK NATS ANTENNA AMP. POWER SUPPLY

1. Disconnect NATS antenna amp. connector.
2. Check voltage between NATS antenna amp. harness connector and ground.

(+)		(-)	Voltage (V) (Approx.)
NATS antenna amp.			
Connector	Terminal		
M49	1	Ground	6 – 16

Is the inspection result normal?

- YES >> GO TO 4.
 NO >> GO TO 3.

3.CHECK NATS ANTENNA AMP. POWER SUPPLY CIRCUIT

1. Disconnect IPDM E/R connector.
2. Check continuity between IPDM E/R harness connector and NATS antenna amp. connector.

IPDM E/R		NATS antenna amp.		Continuity
Connector	Terminal	Connector	Terminal	
E14	42	M49	1	Existed

B2198 NATS ANTENNA AMP.

[WITH INTELLIGENT KEY SYSTEM]

< DTC/CIRCUIT DIAGNOSIS >

Is the inspection result normal?

YES >> Replace IPDM E/R. Refer to [PCS-29, "Removal and Installation"](#).

NO >> Repair or replace harness.

4. CHECK NATS ANTENNA AMP. GROUND CIRCUIT

Check continuity between NATS antenna amp. harness connector and ground.

NATS antenna amp.		Ground	Continuity
Connector	Terminal		
M49	4		Existed

Is the inspection result normal?

YES >> GO TO 5.

NO >> Repair or replace harness.

5. CHECK NATS ANTENNA AMP. COMMUNICATION SIGNAL 1

Check voltage signal between NATS antenna amp. harness connector and ground using an oscilloscope.

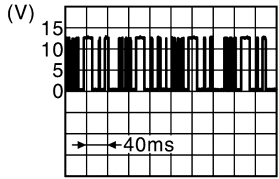
(+)		(-)	Condition	Voltage (V) (Approx.)
NATS antenna amp.				
Connector	Terminal			
M49	2	Ground	Intelligent Key: Intelligent Key battery is removed Brake pedal: Depressed NOTE: Waveform varies each time when brake pedal is depressed	
			Brake pedal: Released	9 - 16

Is the inspection result normal?

YES >> GO TO 7.

NO >> GO TO 6.

6. CHECK NATS ANTENNA AMP. OUTPUT SIGNAL CIRCUIT 1

1. Disconnect BCM connector.
2. Check continuity between NATS antenna amp. harness connector and BCM connector.

NATS antenna amp.		BCM		Continuity
Connector	Terminal	Connector	Terminal	
M49	2	M68	21	Existed

3. Check continuity between NATS antenna amp. harness connector and ground.

NATS antenna amp.		Ground	Continuity
Connector	Terminal		
M49	2		Not existed

Is the inspection result normal?

YES >> GO TO 9.

NO >> Repair or replace harness.

7. CHECK NATS ANTENNA AMP. COMMUNICATION SIGNAL 2

Check voltage signal between NATS antenna amp. harness connector and ground using an oscilloscope.

B2198 NATS ANTENNA AMP.

[WITH INTELLIGENT KEY SYSTEM]

< DTC/CIRCUIT DIAGNOSIS >

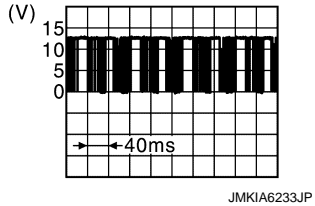
(+)		(-)	Condition		Voltage (V) (Approx.)
NATS antenna amp.					
Connector	Terminal				
M49	3	Ground	Intelligent Key: Intelligent Key battery is removed	Brake pedal: Depressed	
				Brake pedal: Released	

Is the inspection result normal?

YES >> Replace NATS antenna amp. Refer to [SEC-97, "Removal and Installation"](#).

NO >> GO TO 8.

8. CHECK NATS ANTENNA AMP. OUTPUT SIGNAL CIRCUIT 2

1. Disconnect BCM connector.
2. Check continuity between NATS antenna amp. harness connector and BCM connector.

NATS antenna amp.		BCM		Continuity
Connector	Terminal	Connector	Terminal	
M49	3	M68	25	Existed

3. Check continuity between NATS antenna amp. harness connector and ground.

NATS antenna amp.		Ground	Continuity
Connector	Terminal		
M49	3		Not existed

Is the inspection result normal?

YES >> GO TO 9.

NO >> Repair or replace harness.

9. REPLACE BCM

1. Replace BCM. Refer to [BCS-77, "Removal and Installation"](#).
2. Perform initialization of BCM and registration of all Intelligent Keys using CONSULT.

>> INSPECTION END

A
B
C
D
E
F
G
H
I
J
L
M
N
O
P

SEC

B2555 STOP LAMP

< DTC/CIRCUIT DIAGNOSIS >

[WITH INTELLIGENT KEY SYSTEM]

B2555 STOP LAMP

DTC Logic

INFOID:000000007634198

DTC DETECTION LOGIC

DTC No.	Trouble diagnosis name	DTC detecting condition	Possible cause
B2555	STOP LAMP	BCM makes a comparison between the upper voltage and the lower voltage of stop lamp switch. It judges from their values to detect the malfunctioning circuit.	<ul style="list-style-type: none"> • Harness or connectors (Stop lamp switch circuit is open or shorted.) • Stop lamp switch • Fuse • BCM

DTC CONFIRMATION PROCEDURE

1. PERFORM DTC CONFIRMATION PROCEDURE

1. Depress brake pedal and wait 1 second or more.
2. Check DTC in "Self Diagnostic Result" mode of "BCM" using CONSULT.

Is DTC detected?

- YES >> Go to [SEC-60. "Diagnosis Procedure"](#).
 NO >> INSPECTION END

Diagnosis Procedure

INFOID:000000007634199

1. CHECK STOP LAMP SWITCH INPUT SIGNAL 1

1. Turn power switch OFF.
2. Disconnect BCM connector.
3. Check voltage between BCM harness connector and ground.

(+)		(-)	Voltage (V) (Approx.)
BCM			
Connector	Terminal		
M70	105	Ground	9 – 16

Is the inspection normal?

- YES >> GO TO 2.
 NO-1 >> Check 10 A fuse [No. 38, located in the fuse block (J/B)].
 NO-2 >> Check harness for open or short between BCM and fuse.

2. CHECK STOP LAMP SWITCH POWER SUPPLY CIRCUIT

1. Disconnect stop lamp switch connector.
2. Check voltage between stop lamp switch harness connector and ground.

(+)		(-)	Voltage (V) (Approx.)
Stop lamp switch			
Connector	Terminal		
E102	1	Ground	9 – 16

Is the inspection result normal?

- YES >> GO TO 3.
 NO >> Check harness for open or short between stop lamp switch and fuse.

3. CHECK STOP LAMP SWITCH INPUT SIGNAL 2

1. Connect stop lamp switch connector.
2. Check voltage between BCM harness connector and ground.

B2555 STOP LAMP

< DTC/CIRCUIT DIAGNOSIS >

[WITH INTELLIGENT KEY SYSTEM]

(+)		(-)	Condition		Voltage (V) (Approx.)
BCM					
Connector	Terminal				
M68	9	Ground	Brake pedal	Depressed	9 – 16
				Not depressed	0

Is the inspecting result normal?

YES >> GO TO 4.

NO >> GO TO 5.

4. REPLACE BCM

1. Replace BCM. Refer to [BCS-77, "Removal and Installation"](#).
2. Perform initialization of BCM and registration of all Intelligent Keys using CONSULT.

>> INSPECTION END

5. CHECK STOP LAMP SWITCH CIRCUIT

1. Disconnect stop lamp switch connector.
2. Check continuity between stop lamp switch harness connector and BCM harness connector.

Stop lamp switch		BCM		Continuity
Connector	Terminal	Connector	Terminal	
E102	2	M68	9	Existed

3. Check continuity between stop lamp switch harness connector and ground.

Stop lamp switch		Ground	Continuity
Connector	Terminal		
E102	2		Not existed

Is the inspection result normal?

YES >> GO TO 6.

NO >> Repair or replace harness.

6. CHECK STOP LAMP SWITCH

Refer to [SEC-61, "Component Inspection"](#).

Is the inspection result normal?

YES >> GO TO 7.

NO >> Replace stop lamp switch. Refer to [BR-248, "Removal and Installation"](#).

7. CHECK INTERMITTENT INCIDENT

Refer to [GI-51, "Intermittent Incident"](#).

>> INSPECTION END

Component Inspection

INFOID:000000007634200

1. CHECK STOP LAMP SWITCH

1. Turn power switch OFF.
2. Disconnect stop lamp switch connector.
3. Check continuity between stop lamp switch terminals.

A
B
C
D
E
F
G
H
I
J
L
M
N
O
P

SEC

B2555 STOP LAMP

< DTC/CIRCUIT DIAGNOSIS >

[WITH INTELLIGENT KEY SYSTEM]

Stop lamp switch		Condition		Continuity
Terminal				
1	2	Brake pedal	Not depressed	Not existed
			Depressed	Existed

Is the inspection result normal?

YES >> INSPECTION END

NO >> Replace stop lamp switch. Refer to [BR-248, "Removal and Installation"](#).

B2556 POWER SWITCH

< DTC/CIRCUIT DIAGNOSIS >

[WITH INTELLIGENT KEY SYSTEM]

B2556 POWER SWITCH

DTC Logic

INFOID:000000007634201

DTC DETECTION LOGIC

DTC No.	Trouble diagnosis name	DTC detecting condition	Possible cause
B2556	PUSH-BTN IGN SW*	BCM detects the power switch stuck at ON for 100 seconds or more.	<ul style="list-style-type: none"> • Harness or connectors (Power switch circuit is shorted.) • Power switch • BCM

*: "PUSH-BTN IGN SW" is indicated on CONSULT screen, however this means power switch on this vehicle.

DTC CONFIRMATION PROCEDURE

1. PERFORM DTC CONFIRMATION PROCEDURE

1. Press power switch under the following condition.
 - Brake pedal: Not depressed
2. Release power switch and wait 100 seconds or more.
3. Check DTC in "Self Diagnostic Result" mode of "BCM" using CONSULT.

Is DTC detected?

- YES >> Go to [SEC-63. "Diagnosis Procedure"](#).
 NO >> INSPECTION END

Diagnosis Procedure

INFOID:000000007634202

1. CHECK POWER SWITCH INPUT SIGNAL

1. Turn power switch OFF.
2. Disconnect power switch connector.
3. Check voltage between power switch harness connector and ground.

(+)		(-)	Voltage (V) (Approx.)
Power switch			
Connector	Terminal	Ground	9 – 16
M25	8		

Is the inspection result normal?

- YES >> GO TO 4.
 NO >> GO TO 2.

2. CHECK POWER SWITCH CIRCUIT

1. Disconnect BCM connector and IPDM E/R connector.
2. Check continuity between power switch harness connector and BCM harness connector.

Power switch		BCM		Continuity
Connector	Terminal	Connector	Terminal	
M25	8	M70	76	Existed

3. Check continuity between power switch harness connector and ground.

Power switch		Ground	Continuity
Connector	Terminal		
M25	8		Not existed

Is the inspection result normal?

- YES >> GO TO 3.
 NO >> Repair or replace harness.

B2556 POWER SWITCH

[WITH INTELLIGENT KEY SYSTEM]

< DTC/CIRCUIT DIAGNOSIS >

3. REPLACE BCM

1. Replace BCM. Refer to [BCS-77, "Removal and Installation"](#).
2. Perform initialization of BCM and registration of all Intelligent Keys using CONSULT.

>> INSPECTION END

4. CHECK POWER SWITCH GROUND CIRCUIT

Check continuity between power switch harness connector and ground.

Power switch		Ground	Continuity
Connector	Terminal		
M25	4		Existed

Is the inspection result normal?

- YES >> GO TO 5.
NO >> Repair or replace harness.

5. CHECK POWER SWITCH

Refer to [SEC-64, "Component Inspection"](#).

Is the inspection result normal?

- YES >> GO TO 6.
NO >> Replace power switch. Refer to [SEC-98, "Removal and Installation"](#).

6. CHECK INTERMITTENT INCIDENT

Refer to [GI-51, "Intermittent Incident"](#).

>> INSPECTION END

Component Inspection

INFOID:000000007634203

1. CHECK POWER SWITCH

1. Turn power switch OFF.
2. Disconnect power switch connector.
3. Check continuity between power switch terminals.

Power switch		Condition	Continuity
Terminal			
8	4	Power switch	Pressed Existed
			Not pressed Not existed

Is the inspection result normal?

- YES >> INSPECTION END
NO >> Replace power switch. Refer to [SEC-98, "Removal and Installation"](#).

B2557 VEHICLE SPEED

< DTC/CIRCUIT DIAGNOSIS >

[WITH INTELLIGENT KEY SYSTEM]

B2557 VEHICLE SPEED

DTC Logic

INFOID:000000007634204

DTC DETECTION LOGIC

NOTE:

- If DTC B2557 is displayed with DTC U1000, first perform the trouble diagnosis for DTC U1000. Refer to [BCS-66, "DTC Logic"](#).
- If DTC B2557 is displayed with DTC U1010, first perform the trouble diagnosis for DTC U1010. Refer to [BCS-67, "DTC Logic"](#).

DTC No.	Trouble diagnosis name	DTC detecting condition	Possible causes
B2557	VEHICLE SPEED	BCM detects one of the following conditions for 10 seconds continuously. <ul style="list-style-type: none">• Vehicle speed signal from combination meter is 10 km/h (6.2 MPH) or more, and vehicle speed signal from ABS actuator and electric unit (control unit) is 4 km/h (2.5 MPH) or less.• Vehicle speed signal from combination meter is 4 km/h (2.5 MPH) or less, and vehicle speed signal from ABS actuator and electric unit (control unit) is 10 km/h (6.2 MPH) or more.	<ul style="list-style-type: none">• Harness or connectors (The CAN communication line is open or shorted.)• Combination meter• ABS actuator and electric unit (control unit)

DTC CONFIRMATION PROCEDURE

1. PERFORM DTC CONFIRMATION PROCEDURE

1. Set vehicle to READY and wait 10 seconds or more.
2. Drive vehicle at a vehicle speed of 10 km/h (6.2 MPH) or more for 10 seconds or more.
3. Check DTC in "Self Diagnostic Result" mode of "BCM" using CONSULT.

Is DTC detected?

- YES >> Go to [SEC-65, "Diagnosis Procedure"](#).
NO >> INSPECTION END

Diagnosis Procedure

INFOID:000000007634205

1. CHECK DTC OF ABS ACTUATOR AND ELECTRIC UNIT (CONTROL UNIT)

Check DTC in "Self Diagnostic Result" mode of "ABS" using CONSULT.

Is DTC detected?

- YES >> Perform the trouble diagnosis related to the detected DTC. Refer to [BRC-50, "DTC Index"](#).
NO >> GO TO 2.

2. CHECK DTC OF COMBINATION METER

Check DTC in "Self Diagnostic Result" mode of "METER/M&A" using CONSULT.

Is DTC detected?

- YES >> Perform the trouble diagnosis related to the detected DTC. Refer to [MWI-68, "DTC Index"](#).
NO >> GO TO 3.

3. CHECK INTERMITTENT INCIDENT

Refer to [GI-51, "Intermittent Incident"](#).

>> INSPECTION END

B2601 SHIFT POSITION

< DTC/CIRCUIT DIAGNOSIS >

[WITH INTELLIGENT KEY SYSTEM]

B2601 SHIFT POSITION

DTC Logic

INFOID:000000007634206

DTC DETECTION LOGIC

NOTE:

- If DTC B2601 is displayed with DTC U1000, first perform the trouble diagnosis for DTC U1000. Refer to [BCS-66, "DTC Logic"](#).
- If DTC B2601 is displayed with DTC U1010, first perform the trouble diagnosis for DTC U1010. Refer to [BCS-66, "DTC Logic"](#).

DTC No.	Trouble diagnosis name	DTC detecting condition	Possible cause
B2601	SHIFT POSITION	When there is a difference between P position signal from electric shift control module and P position signal from IPDM E/R (CAN).	<ul style="list-style-type: none">• Harness or connectors (CAN communication line is open or shorted.)• Harness or connectors (Electric shift control module circuit is open or shorted.)• IPDM E/R• BCM

DTC CONFIRMATION PROCEDURE

1. PERFORM DTC CONFIRMATION PROCEDURE

1. Turn power switch ON.
2. Operate electric shift selector to change shift position to P, and wait 2 seconds or more.
3. Operate electric shift selector to change shift position to any position other than P, and wait 2 seconds or more.
4. Check DTC in "Self Diagnostic Result" mode of "BCM" using CONSULT.

Is DTC detected?

- YES >> Go to [SEC-66, "Diagnosis Procedure"](#).
NO >> INSPECTION END

Diagnosis Procedure

INFOID:000000007634207

1. CHECK P POSITION SIGNAL CIRCUIT 1

1. Turn power switch OFF.
2. Disconnect BCM connector.
3. Disconnect electric shift control module connector.
4. Check continuity between BCM harness connector and electric shift control module harness connector.

BCM		Electric shift control module		Continuity
Connector	Terminal	Connector	Terminal	
M68	37	M58	12	Existed

Is the inspection result normal?

- YES >> GO TO 2.
NO >> Repair or replace harness.

2. CHECK P POSITION SIGNAL CIRCUIT 2

1. Disconnect IPDM E/R connector.
2. Check continuity between IPDM E/R harness connector and electric shift control module harness connector.

IPDM E/R		Electric shift control module		Continuity
Connector	Terminal	Connector	Terminal	
E17	64	M58	12	Existed

Is the inspection result normal?

B2601 SHIFT POSITION

[WITH INTELLIGENT KEY SYSTEM]

< DTC/CIRCUIT DIAGNOSIS >

- YES >> GO TO 3.
- NO >> Repair or replace harness.

3.REPLACE BCM

1. Replace BCM. Refer to [BCS-77. "Removal and Installation"](#).
2. Perform initialization of BCM and registration of all Intelligent Keys using CONSULT.
3. Perform DTC CONFIRMATION PROCEDURE for B2601. Refer to [SEC-66. "DTC Logic"](#).

Is DTC detected?

- YES >> Replace IPDM E/R. Refer to [PCS-29. "Removal and Installation"](#).
- NO >> INSPECTION END

A
B
C
D
E
F
G
H
I
J
L
M
N
O
P

SEC

B2602 SHIFT POSITION

< DTC/CIRCUIT DIAGNOSIS >

[WITH INTELLIGENT KEY SYSTEM]

B2602 SHIFT POSITION

DTC Logic

INFOID:000000007634208

DTC DETECTION LOGIC

NOTE:

- If DTC B2602 is displayed with DTC U1000, first perform the trouble diagnosis for DTC U1000. Refer to [BCS-66, "DTC Logic"](#).
- If DTC B2602 is displayed with DTC U1010, first perform the trouble diagnosis for DTC U1010. Refer to [BCS-67, "DTC Logic"](#).

DTC No.	Trouble diagnosis name	DTC detecting condition	Possible cause
B2602	SHIFT POSITION	BCM detects the following status for 10 seconds. <ul style="list-style-type: none">• Electric shift selector is in the P position• Vehicle speed is 4 km/h (2.5 MPH) or more• Power switch is in the ON position	<ul style="list-style-type: none">• Harness or connectors (CAN communication line is open or shorted.)• Harness or connectors (Electric shift control module circuit is open or shorted.)• Electric shift control module• ABS actuator and electric unit (control unit)• Combination meter• BCM

DTC CONFIRMATION PROCEDURE

1. PERFORM DTC CONFIRMATION PROCEDURE

1. Set vehicle to READY.
2. Drive vehicle at a speed of 4 km/h (2.5 MPH) or more for 10 seconds or more.
3. Check DTC in "Self Diagnostic Result" mode of "BCM" using CONSULT.

Is DTC detected?

- YES >> Go to [SEC-68, "Diagnosis Procedure"](#).
NO >> INSPECTION END

Diagnosis Procedure

INFOID:000000007634209

1. CHECK DTC OF ABS ACTUATOR AND ELECTRIC UNIT (CONTROL UNIT)

Check DTC in "Self Diagnostic Result" mode of "ABS" using CONSULT.

Is DTC detected?

- YES >> Perform the trouble diagnosis related to the detected DTC. Refer to [BRC-50, "DTC Index"](#).
NO >> GO TO 2.

2. CHECK DTC OF COMBINATION METER

Check DTC in "Self Diagnostic Result" mode of "METER/M&A" using CONSULT.

Is DTC detected?

- YES >> Perform the trouble diagnosis related to the detected DTC. Refer to [MWI-68, "DTC Index"](#).
NO >> GO TO 3.

3. CHECK DTC OF ELECTRIC SHIFT CONTROL MODULE

Check DTC in "Self Diagnostic Result" mode of "SHIFT" using CONSULT.

Is DTC detected?

- YES >> Perform the trouble diagnosis related to the detected DTC. Refer to [TM-47, "DTC Index"](#).
NO >> GO TO 4.

4. CHECK P POSITION SIGNAL CIRCUIT

1. Turn power switch OFF.
2. Disconnect BCM connector.
3. Disconnect electric shift control module connector.
4. Check continuity between BCM harness connector and electric shift control module harness connector.

B2602 SHIFT POSITION

< DTC/CIRCUIT DIAGNOSIS >

[WITH INTELLIGENT KEY SYSTEM]

BCM		Electric shift control module		Continuity
Connector	Terminal	Connector	Terminal	
M68	37	M58	12	Existed

5. Check continuity between BCM harness connector and ground.

BCM		Ground	Continuity
Connector	Terminal		
M68	37		Not existed

Is the inspection result normal?

YES >> GO TO 5.

NO >> Repair or replace harness.

5.REPLACE BCM

1. Replace BCM. Refer to [BCS-77, "Removal and Installation"](#).
2. Perform initialization of BCM and registration of all Intelligent Keys using CONSULT.

>> INSPECTION END

A
B
C
D
E
F
G
H
I
J
L
M
N
O
P

SEC

B2603 SHIFT POSITION

< DTC/CIRCUIT DIAGNOSIS >

[WITH INTELLIGENT KEY SYSTEM]

B2603 SHIFT POSITION

DTC Logic

INFOID:000000007634210

DTC DETECTION LOGIC

NOTE:

- If DTC B2603 is displayed with DTC B2601, first perform the trouble diagnosis for DTC B2601. Refer to [SEC-66, "DTC Logic"](#).

DTC No.	Trouble diagnosis name	DTC detecting condition	Possible causes
B2603	SHIFT POSI STATUS	BCM detects the following status. <ul style="list-style-type: none"> • P position signal from electric shift control module: approx. 0 V (P position) • P/N position signal from electric shift control module: approx. 0 V (Other than P/N position) 	<ul style="list-style-type: none"> • Harness or connector (Electric shift control module circuit is open or shorted.) • Electric shift control module • BCM

DTC CONFIRMATION PROCEDURE

1. PERFORM DTC CONFIRMATION PROCEDURE 1

1. Turn power switch ON.
2. Operate electric shift selector to change shift position to P, and wait 1 second or more.
3. Check DTC in "Self Diagnostic Result" mode of "BCM" using CONSULT.

Is DTC detected?

- YES >> Go to [SEC-70, "Diagnosis Procedure"](#).
 NO >> GO TO 2.

2. PERFORM DTC CONFIRMATION PROCEDURE 2

1. Operate electric shift selector to change shift position to any position other than P, and wait 1 second or more.
2. Check DTC in "Self Diagnostic Result" mode of "BCM" using CONSULT.

Is DTC detected?

- YES >> Go to [SEC-70, "Diagnosis Procedure"](#).
 NO >> INSPECTION END

Diagnosis Procedure

INFOID:000000007634211

1. INSPECTION START

Perform inspection in accordance with the procedure that confirms DTC.

Which procedure confirms DTC?

- DTC confirmation procedure 1 >> GO TO 2.
 DTC confirmation procedure 2 >> GO TO 5.

2. CHECK DTC OF ELECTRIC SHIFT CONTROL MODULE

Check DTC in "Self Diagnostic Result" mode of "SHIFT" using CONSULT.

Is DTC detected?

- YES >> Perform the trouble diagnosis related to the detected DTC. Refer to [TM-47, "DTC Index"](#).
 NO >> GO TO 3.

3. CHECK P/N POSITION SIGNAL CIRCUIT

1. Turn power switch OFF.
2. Disconnect BCM connector.
3. Disconnect electric shift control module connector.
4. Check continuity between BCM harness connector and electric shift control module harness connector.

BCM		Electric shift control module		Continuity
Connector	Terminal	Connector	Terminal	
M70	102	M58	13	Existed

B2603 SHIFT POSITION

< DTC/CIRCUIT DIAGNOSIS >

[WITH INTELLIGENT KEY SYSTEM]

5. Check continuity between BCM harness connector and ground.

BCM		Ground	Continuity
Connector	Terminal		
M70	102		Not existed

Is the inspection result normal?

YES >> GO TO 4.

NO >> Repair or replace harness.

4.REPLACE BCM

1. Replace BCM. Refer to [BCS-77, "Removal and Installation"](#).
2. Perform initialization of BCM and registration of all Intelligent Keys using CONSULT.

>> INSPECTION END

5.CHECK DTC OF ELECTRIC SHIFT CONTROL MODULE

Check DTC in "Self Diagnostic Result" mode of "SHIFT" using CONSULT.

Is DTC detected?

YES >> Perform the trouble diagnosis related to the detected DTC. Refer to [TM-47, "DTC Index"](#).

NO >> GO TO 6.

6.CHECK P POSITION SIGNAL CIRCUIT

1. Turn power switch OFF.
2. Disconnect BCM connector.
3. Disconnect electric shift control module connector.
4. Check continuity between BCM harness connector and electric shift control module harness connector.

BCM		Electric shift control module		Continuity
Connector	Terminal	Connector	Terminal	
M68	37	M58	12	Existed

5. Check continuity between BCM harness connector and ground.

BCM		Ground	Continuity
Connector	Terminal		
M68	37		Not existed

Is the inspection result normal?

YES >> GO TO 7.

NO >> Repair or replace harness.

7.REPLACE BCM

1. Replace BCM. Refer to [BCS-77, "Removal and Installation"](#).
2. Perform initialization of BCM and registration of all Intelligent Keys using CONSULT.

>> INSPECTION END

B2604 SHIFT POSITION

< DTC/CIRCUIT DIAGNOSIS >

[WITH INTELLIGENT KEY SYSTEM]

B2604 SHIFT POSITION

DTC Logic

INFOID:000000007634212

DTC DETECTION LOGIC

NOTE:

- If DTC B2604 is displayed with DTC U1000, first perform the trouble diagnosis for DTC U1000. Refer to [BCS-66, "DTC Logic"](#).
- If DTC B2604 is displayed with DTC U1010, first perform the trouble diagnosis for DTC U1010. Refer to [BCS-67, "DTC Logic"](#).

DTC No.	Trouble diagnosis name	DTC detecting condition	Possible cause
B2604	PNP/CLUTCH SW	<p>The following states are detected for 5 seconds while power switch is ON.</p> <ul style="list-style-type: none"> • P/N position signal is sent from electric shift control module but shift position signal input (CAN) from VCM is other than P and N • P/N position signal is not sent from electric shift control module but shift position signal input (CAN) from VCM is P or N 	<ul style="list-style-type: none"> • Harness or connectors (CAN communication line is open or shorted.) • Harness or connectors (Electric shift control module circuit is open or shorted.) • Electric shift control module • VCM • BCM

DTC CONFIRMATION PROCEDURE

1.PERFORM DTC CONFIRMATION PROCEDURE

1. Turn power switch ON.
2. Operate electric shift selector to change shift position to P, and wait 5 seconds or more.
3. Operate electric shift selector to change shift position to N, and wait 5 seconds or more.
4. Operate electric shift selector to change shift position to any position other than P and N, and wait 5 seconds or more.
5. Check DTC in "Self Diagnostic Result" mode of "BCM" using CONSULT.

Is DTC detected?

- YES >> Go to [SEC-72, "Diagnosis Procedure"](#).
 NO >> INSPECTION END

Diagnosis Procedure

INFOID:000000007634213

1.CHECK DTC OF VCM

Check DTC in "Self Diagnostic Result" mode of "EV/HEV" using CONSULT.

Is DTC detected?

- YES >> Perform the trouble diagnosis related to the detected DTC. Refer to [EVC-84, "DTC Index"](#).
 NO >> GO TO 2.

2.CHECK DTC OF ELECTRIC SHIFT CONTROL MODULE

Check DTC in "Self Diagnostic Result" mode of "SHIFT" using CONSULT.

Is DTC detected?

- YES >> Perform the trouble diagnosis related to the detected DTC. Refer to [TM-47, "DTC Index"](#).
 NO >> GO TO 3.

3.CHECK BCM INPUT SIGNAL

1. Turn power switch ON.
2. Check voltage between BCM harness connector and ground.

B2604 SHIFT POSITION

< DTC/CIRCUIT DIAGNOSIS >

[WITH INTELLIGENT KEY SYSTEM]

(+)		(-)	Condition		Voltage (V) (Approx.)
BCM					
Connector	Terminal				
M70	102	Ground	Shift position	P or N	9 – 16
				Other than above	0 – 1.5

Is the inspection result normal?

YES >> GO TO 4.

NO >> GO TO 5.

4. REPLACE BCM

1. Replace BCM. Refer to [BCS-77, "Removal and Installation"](#).
2. Perform initialization of BCM and registration of all Intelligent Keys using CONSULT.

>> INSPECTION END

5. CHECK BCM INPUT SIGNAL CIRCUIT

1. Turn power switch OFF.
2. Disconnect BCM connector.
3. Disconnect electric shift control module connector.
4. Check continuity between BCM harness connector and electric shift control module harness connector.

BCM		Electric shift control module		Continuity
Connector	Terminal	Connector	Terminal	
M70	102	M58	13	Existed

5. Check continuity between BCM harness connector and ground.

BCM		Ground	Continuity
Connector	Terminal		
M70	102		Not existed

Is the inspection result normal?

YES >> GO TO 6.

NO >> Repair or replace harness.

6. CHECK INTERMITTENT INCIDENT

Refer to [GI-51, "Intermittent Incident"](#).

>> INSPECTION END

A
B
C
D
E
F
G
H
I
J
L
M
N
O
P

SEC

B2617 READY SIGNAL CIRCUIT

< DTC/CIRCUIT DIAGNOSIS >

[WITH INTELLIGENT KEY SYSTEM]

B2617 READY SIGNAL CIRCUIT

DTC Logic

INFOID:000000007634214

DTC DETECTION LOGIC

NOTE:

- If DTC B2617 is displayed with DTC U1000, first perform the trouble diagnosis for DTC U1000. Refer to [BCS-66, "DTC Logic"](#).
- If DTC B2617 is displayed with DTC U1010, first perform the trouble diagnosis for DTC U1010. Refer to [BCS-67, "DTC Logic"](#).

DTC No.	Trouble diagnosis name	DTC detecting condition	Possible cause
B2617	BCM	An immediate operation of setting vehicle to READY is requested by BCM, but there is no response for more than 1 second from VCM	<ul style="list-style-type: none">• Harness or connectors (READY signal circuit is open or shorted.)• BCM• VCM

DTC CONFIRMATION PROCEDURE

1. PERFORM DTC CONFIRMATION PROCEDURE

1. Press power switch under the following conditions, and wait at least 1 second.
 - Shift position: P or N
 - Brake pedal: Depressed
2. Check DTC in "Self Diagnostic Result" mode of "BCM" using CONSULT.

Is DTC detected?

- YES >> Go to [SEC-74, "Diagnosis Procedure"](#).
NO >> INSPECTION END

Diagnosis Procedure

INFOID:000000007634215

1. CHECK DTC OF VCM

Check DTC in "Self Diagnostic Result" mode of "EV/HEV" using CONSULT.

Is DTC detected?

- YES >> Perform the trouble diagnosis related to the detected DTC. Refer to [EVC-84, "DTC Index"](#).
NO >> GO TO 2.

2. CHECK READY SIGNAL

1. Turn power switch ON.
2. Check voltage between VCM harness connector and ground.

(+)		(-)	Condition	Voltage (V) (Approx.)
VCM				
Connector	Terminal			
E63	90	Ground	Power switch ON	9 – 16
			Power switch ON → Vehicle READY	0 – 0.5

Is the inspection result normal?

- YES >> GO TO 5.
NO >> GO TO 3.

3. CHECK READY SIGNAL CIRCUIT

1. Turn power switch OFF.
2. Disconnect BCM connector and VCM connector.
3. Check continuity between BCM harness connector and VCM harness connector.

B2617 READY SIGNAL CIRCUIT

< DTC/CIRCUIT DIAGNOSIS >

[WITH INTELLIGENT KEY SYSTEM]

BCM		VCM		Continuity
Connector	Terminal	Connector	Terminal	
M70	97	E63	90	Existed

4. Check continuity between BCM harness connector and ground.

BCM		Ground	Continuity
Connector	Terminal		
M70	97		Not existed

Is the inspection result normal?

YES >> GO TO 4.

NO >> Repair or replace harness or connector.

4.CHECK INTERMITTENT INCIDENT

Refer to [GI-51, "Intermittent Incident"](#).

>> INSPECTION END

5.REPLACE BCM

1. Replace BCM. Refer to [BCS-77, "Removal and Installation"](#).
2. Perform initialization of BCM and registration of all Intelligent Keys using CONSULT.

>> INSPECTION END

A
B
C
D
E
F
G
H
I
J
L
M
N
O
P

SEC

< DTC/CIRCUIT DIAGNOSIS >

B2619 BCM**DTC Logic**

INFOID:000000007634216

DTC DETECTION LOGIC

DTC No.	Trouble diagnosis name	DTC detecting condition	Possible cause
B2619	BCM	There is a difference between power supply output to steering lock unit and steering lock unit F/B result.	BCM

DTC CONFIRMATION PROCEDURE**1.PERFORM DTC CONFIRMATION PROCEDURE**

1. Press power switch under the following conditions and wait 1 second or more.
 - Shift position: P
 - Brake pedal: Not depressed
2. Check DTC in "Self Diagnostic Result" of "BCM" using CONSULT.

Is DTC detected?

- YES >> Go to [SEC-76, "Diagnosis Procedure"](#).
 NO >> INSPECTION END

Diagnosis Procedure

INFOID:000000007634217

1.INSPECTION START

1. Turn power switch ON.
2. Select "Self Diagnostic Result" mode of "BCM" using CONSULT.
3. Touch "ERASE".
4. Perform DTC CONFIRMATION PROCEDURE for DTC B2619. Refer to [SEC-76, "DTC Logic"](#).

Is DTC detected?

- YES >> GO TO 2.
 NO >> INSPECTION END

2.REPLACE BCM

1. Replace BCM. Refer to [BCS-77, "Removal and Installation"](#).
2. Perform initialization of BCM and registration of all Intelligent Keys using CONSULT.

>> INSPECTION END

B261A POWER SWITCH

< DTC/CIRCUIT DIAGNOSIS >

[WITH INTELLIGENT KEY SYSTEM]

B261A POWER SWITCH

DTC Logic

INFOID:000000007634218

DTC DETECTION LOGIC

NOTE:

- If DTC B261A is displayed with DTC U1000, first perform the trouble diagnosis for DTC U1000. Refer to [BCS-66, "DTC Logic"](#).
- If DTC B261A is displayed with DTC U1010, first perform the trouble diagnosis for DTC U1010. Refer to [BCS-67, "DTC Logic"](#).

DTC No.	Trouble diagnosis name	DTC detecting condition	Possible cause
B261A	PUSH-BTN IGN SW*	BCM detects the mismatch between the following for 1 second or more <ul style="list-style-type: none"> • Power switch status judged by push switch signal • Power switch status signal from IPDM E/R (CAN) 	<ul style="list-style-type: none"> • Harness or connectors (Power switch circuit is open or shorted) <ul style="list-style-type: none"> - Between BCM and power switch - Between IPDM E/R and power switch • IPDM E/R • BCM

*: "PUSH-BTN IGN SW" is indicated on CONSULT screen, however this means power switch on this vehicle.

DTC CONFIRMATION PROCEDURE

1. PERFORM DTC CONFIRMATION PROCEDURE

1. Press power switch for 1 second under the following conditions.
 - Shift position: P
 - Brake pedal: Not depressed
2. Release power switch and wait 1 second.
3. Check DTC in "Self Diagnostic Result" mode of "BCM" using CONSULT.

Is DTC detected?

- YES >> Go to [SEC-77, "Diagnosis Procedure"](#)
 NO >> INSPECTION END

Diagnosis Procedure

INFOID:000000007634219

1. CHECK POWER SWITCH POWER SUPPLY CIRCUIT

1. Turn power switch OFF.
2. Disconnect power switch connector.
3. Disconnect IPDM E/R connector.
4. Check voltage between power switch harness connector and ground.

(+)		(-)	Voltage (V) (Approx.)
Power switch			
Connector	Terminal	Ground	9 – 16
M25	8		

Is the inspection result normal?

- YES >> GO TO 2.
 NO >> GO TO 3.

2. CHECK POWER SWITCH CIRCUIT 1

1. Check continuity between power switch harness connector and IPDM E/R harness connector.

Power switch		IPDM E/R		Continuity
Connector	Terminal	Connector	Terminal	
M25	8	E17	66	Existed

2. Check continuity between power switch harness connector and ground.

B261A POWER SWITCH

< DTC/CIRCUIT DIAGNOSIS >

[WITH INTELLIGENT KEY SYSTEM]

Power switch		Ground	Continuity
Connector	Terminal		
M25	8		Not existed

Is the inspection result normal?

YES >> Replace IPDM E/R. Refer to [PCS-29, "Removal and Installation"](#).

NO >> Repair harness or connector.

3. CHECK POWER SWITCH CIRCUIT 2

1. Disconnect BCM connector.
2. Check continuity between power switch harness connector and BCM harness connector.

Power switch		BCM		Continuity
Connector	Terminal	Connector	Terminal	
M25	8	M70	76	Existed

3. Check continuity between power switch harness connector and ground.

Power switch		Ground	Continuity
Connector	Terminal		
M25	8		Not existed

Is the inspection result normal?

YES >> GO TO 4.

NO >> Repair harness or connector.

4. REPLACE BCM

1. Replace BCM. Refer to [BCS-77, "Removal and Installation"](#).
2. Perform initialization of BCM and registration of all Intelligent Keys using CONSULT.

>> INSPECTION END

B261E VEHICLE TYPE

[WITH INTELLIGENT KEY SYSTEM]

< DTC/CIRCUIT DIAGNOSIS >

B261E VEHICLE TYPE

Description

INFOID:000000007634220

There are two types of vehicle.

- EV/HEV
- Conventional

DTC Logic

INFOID:000000007634221

DTC DETECTION LOGIC

NOTE:

- If DTC B261E is displayed with DTC U1000, first perform the trouble diagnosis for DTC U1000. Refer to [BCS-66, "DTC Logic"](#).
- If DTC B261E is displayed with DTC U1010, first perform the trouble diagnosis for DTC U1010. Refer to [BCS-67, "DTC Logic"](#).

DTC No.	Trouble diagnosis name	DTC detecting condition	Possible cause
B261E	VEHICLE TYPE	Difference of BCM configuration	BCM

DTC CONFIRMATION PROCEDURE

1. PERFORM DTC CONFIRMATION PROCEDURE

1. Turn power switch ON.
2. Check DTC in "Self Diagnostic Result" mode of "BCM" using CONSULT.

Is DTC detected?

- YES >> Go to [SEC-79, "Diagnosis Procedure"](#).
NO >> INSPECTION END

Diagnosis Procedure

INFOID:000000007634222

1. INSPECTION START

1. Turn power switch ON.
2. Select "Self Diagnostic Result" mode of "BCM" using CONSULT.
3. Touch "ERASE".
4. Perform DTC CONFIRMATION PROCEDURE for DTC B261E. Refer to [SEC-79, "DTC Logic"](#).

Is the DTC B261E detected again?

- YES >> GO TO 2.
NO >> INSPECTION END

2. REPLACE BCM

1. Replace BCM. Refer to [BCS-77, "Removal and Installation"](#).
2. Perform initialization of BCM and registration of all Intelligent Keys using CONSULT.

>> INSPECTION END

< DTC/CIRCUIT DIAGNOSIS >

B26F7 BCM**DTC Logic**

INFOID:000000007634223

DTC DETECTION LOGIC

DTC No.	Trouble diagnosis name	DTC detecting condition	Possible cause
B26F7	BCM	Inside key antenna output circuit in BCM is malfunctioning.	BCM

DTC CONFIRMATION PROCEDURE**1.PERFORM DTC CONFIRMATION PROCEDURE**

1. Press door request switch.
2. Turn power switch ON.
3. Check DTC in "Self Diagnostic Result" mode of "BCM" using CONSULT.

Is DTC detected?

- YES >> Go to [SEC-80, "Diagnosis Procedure"](#).
 NO >> INSPECTION END

Diagnosis Procedure

INFOID:000000007634224

1.INSPECTION START

1. Turn power switch ON.
2. Select "Self Diagnostic Result" mode of "BCM" using CONSULT.
3. Touch "ERASE".
4. Perform DTC CONFIRMATION PROCEDURE for DTC B26F7. Refer to [SEC-80, "DTC Logic"](#).

Is DTC detected?

- YES >> GO TO 2.
 NO >> INSPECTION END

2.REPLACE BCM

1. Replace BCM. Refer to [BCS-77, "Removal and Installation"](#).
2. Perform initialization of BCM and registration of all Intelligent Keys using CONSULT.

>> INSPECTION END

B26FC KEY REGISTRATION

< DTC/CIRCUIT DIAGNOSIS >

[WITH INTELLIGENT KEY SYSTEM]

B26FC KEY REGISTRATION

DTC Logic

INFOID:000000007634225

DTC DETECTION LOGIC

DTC No.	Trouble diagnosis name	DTC detecting condition	Possible cause
B26FC	KEY REGISTRATION	Intelligent Key that does not match the vehicle is registered.	<ul style="list-style-type: none">Improper registration operationIntelligent KeyBCM

DTC CONFIRMATION PROCEDURE

1.PERFORM DTC CONFIRMATION PROCEDURE

1. Perform initialization of BCM and registration of all Intelligent Keys using CONSULT.
2. Check DTC in "Self Diagnostic Result" mode of "BCM" using CONSULT.

Is DTC detected?

- YES >> Go to [SEC-81. "Diagnosis Procedure"](#)
NO >> INSPECTION END

Diagnosis Procedure

INFOID:000000007634226

1.REPLACE INTELLIGENT KEY

1. Prepare Intelligent Key that matches the vehicle.
2. Perform initialization of BCM and registration of Intelligent Key using CONSULT.
3. Check DTC in "Self Diagnostic Result" mode of "BCM" using CONSULT.

Is DTC detected?

- YES >> GO TO 2.
NO >> INSPECTION END

2.REPLACE BCM

1. Replace BCM. Refer to [BCS-77. "Removal and Installation"](#).
2. Perform initialization of BCM and registration of all Intelligent Keys using CONSULT.

>> INSPECTION END

A
B
C
D
E
F
G
H
I
J
L
M
N
O
P

SEC

HEADLAMP FUNCTION

< DTC/CIRCUIT DIAGNOSIS >

[WITH INTELLIGENT KEY SYSTEM]

HEADLAMP FUNCTION

Component Function Check

INFOID:000000007634227

1.CHECK FUNCTION

1. Perform "HEAD LAMP(HI)" in "ACTIVE TEST" mode of "THEFT ALM" of "BCM" using CONSULT.
2. Check headlamps operation.

Test item		Description	
HEAD LAMP (HI)	ON	Headlamps (Hi)	Light
	OFF		Do not light

Is the inspection result normal?

- YES >> INSPECTION END
- NO >> Refer to [SEC-82, "Diagnosis Procedure"](#).

Diagnosis Procedure

INFOID:000000007634228

1.CHECK HEADLAMP FUNCTION

Refer to [EXL-51, "WITHOUT DAYTIME RUNNING LIGHT SYSTEM : Component Function Check"](#).

Is the inspection result normal?

- YES >> GO TO 2.
- NO >> Repair or replace the malfunctioning parts.

2.CHECK INTERMITTENT INCIDENT

Refer to [GI-51, "Intermittent Incident"](#).

>> INSPECTION END

HOOD SWITCH

< DTC/CIRCUIT DIAGNOSIS >

[WITH INTELLIGENT KEY SYSTEM]

HOOD SWITCH

Component Function Check

INFOID:000000007634229

1.CHECK FUNCTION

1. Select "HOOD SW" in "Data Monitor" mode of "IPDM E/R" using CONSULT.
2. Check "HOOD SW" indication under the following condition.

Monitor item	Condition		Indication
HOOD SW	Hood	Open	ON
		Close	OFF

Is the indication normal?

- YES >> Hood switch is OK.
 NO >> Go to [SEC-83, "Diagnosis Procedure"](#).

Diagnosis Procedure

INFOID:000000007634230

1.CHECK HOOD SWITCH SIGNAL CIRCUIT 1

1. Turn ignition switch OFF.
2. Disconnect hood switch connector.
3. Check voltage between hood switch harness connector and ground.

(+)		(-)	Voltage (Approx.)
Hood switch			
Connector	Terminal	Ground	9 – 16
E78	1		

Is the inspection result normal?

- YES >> GO TO 3.
 NO >> GO TO 2.

2.CHECK HOOD SWITCH SIGNAL CIRCUIT 2

1. Disconnect IPDM E/R connector.
2. Check continuity between IPDM E/R harness connector and hood switch harness connector.

IPDM E/R		Hood switch		Continuity
Connector	Terminal	Connector	Terminal	
E13	32	E78	1	Existed

3. Check continuity between IPDM E/R harness connector and ground.

IPDM E/R		Ground	Continuity
Connector	Terminal		
E13	32		Not existed

Is the inspection result normal?

- YES >> Replace IPDM E/R. Refer to [PCS-29, "Removal and Installation"](#).
 NO >> Repair or replace harness.

3.CHECK HOOD SWITCH GROUND CIRCUIT

Check continuity between hood switch harness connector and ground.

Hood switch		Ground	Continuity
Connector	Terminal		
E78	2		Existed

HOOD SWITCH

[WITH INTELLIGENT KEY SYSTEM]

< DTC/CIRCUIT DIAGNOSIS >

Is the inspection result normal?

- YES >> GO TO 4.
- NO >> Repair or replace harness.

4.CHECK HOOD SWITCH

Refer to [SEC-84, "Component Inspection"](#).

Is the inspection result normal?

- YES >> GO TO 5.
- NO >> Replace hood switch.

5.CHECK INTERMITTENT INCIDENT

Refer to [GI-51, "Intermittent Incident"](#).

>> INSPECTION END

Component Inspection

INFOID:000000007634231

1.CHECK HOOD SWITCH

1. Turn ignition switch OFF.
2. Disconnect hood switch connector.
3. Check continuity between hood switch terminals.

Hood switch		Condition		Continuity
Terminal				
1	2	Hood switch	Press	Not existed
			Release	Existed

Is the inspection result normal?

- YES >> INSPECTION END
- NO >> Replace hood switch.

HORN FUNCTION

< DTC/CIRCUIT DIAGNOSIS >

[WITH INTELLIGENT KEY SYSTEM]

HORN FUNCTION

Component Function Check

INFOID:000000007634232

1.CHECK FUNCTION 1

1. Disconnect vehicle security horn relay.
2. Perform "VEHICLE SECURITY HORN" in "ACTIVE TEST" mode of "THEFT ALM" of "BCM" using CONSULT.
3. Check the horn operation.

Test item		Description	
VEHICLE SECURITY HORN	ON	Horn	Sounds (for 0.5 sec)

Is the operation normal?

YES >> GO TO 2.

NO >> Go to [SEC-85, "Diagnosis Procedure"](#).

2.CHECK FUNCTION 2

1. Reconnect vehicle security horn relay.
2. Disconnect horn relay.
3. Perform "VEHICLE SECURITY HORN" in "ACTIVE TEST" mode of "THEFT ALM" of "BCM" using CONSULT.
4. Check the horn operation.

Test item		Description	
VEHICLE SECURITY HORN	ON	Vehicle security horn	Sounds (for 0.5 sec)

Is the operation normal?

YES >> INSPECTION END

NO >> Go to [SEC-85, "Diagnosis Procedure"](#).

Diagnosis Procedure

INFOID:000000007634233

1.INSPECTION START

Perform inspection in accordance with procedure that confirms malfunction.

Which procedure confirms malfunction?

Component Function Check 1>>GO TO 2.

Component Function Check 2>>GO TO 4.

2.CHECK HORN FUNCTION

Check horn function using horn switch.

Do the horn sound?

YES >> GO TO 3.

NO >> Check horn circuit. Refer to [HRN-5, "Wiring Diagram"](#).

3.CHECK HORN CONTROL CIRCUIT 1

1. Disconnect horn relay.
2. Disconnect IPDM E/R connector.
3. Check continuity between IPDM E/R harness connector and horn relay harness connector.

IPDM E/R		Horn relay		Continuity
Connector	Terminal	Connector	Terminal	
E13	34	E5	1	Existed

4. Check continuity between IPDM E/R harness connector and ground.

A
B
C
D
E
F
G
H
I
J
L
M
N
O
P

SEC

HORN FUNCTION

< DTC/CIRCUIT DIAGNOSIS >

[WITH INTELLIGENT KEY SYSTEM]

IPDM E/R		Ground	Continuity
Connector	Terminal		
E13	34		Not existed

Is the inspection result normal?

YES >> Replace IPDM E/R. Refer to [PCS-29, "Removal and Installation"](#).

NO >> Repair or replace harness.

4. CHECK VEHICLE SECURITY HORN RELAY POWER SUPPLY

1. Disconnect vehicle security horn relay.
2. Check voltage between vehicle security horn relay harness connector and ground.

(+)		(-)	Voltage (Approx.)
Vehicle security horn relay			
Connector	Terminal		
E73	2	Ground	Battery voltage

Is the inspection result normal?

YES >> GO TO 5.

NO >> Repair or replace harness.

5. CHECK HORN CONTROL CIRCUIT 2

1. Disconnect IPDM E/R connector.
2. Check continuity between IPDM E/R harness connector and vehicle security horn relay harness connector.

IPDM E/R		Vehicle security horn relay		Continuity
Connector	Terminal	Connector	Terminal	
E13	34	E73	1	Existed

3. Check continuity between IPDM E/R harness connector and ground.

IPDM E/R		Ground	Continuity
Connector	Terminal		
E13	34		Not existed

Is the inspection result normal?

YES >> Replace IPDM E/R. Refer to [PCS-29, "Removal and Installation"](#).

NO >> Repair or replace harness.

SECURITY INDICATOR LAMP

[WITH INTELLIGENT KEY SYSTEM]

< DTC/CIRCUIT DIAGNOSIS >

SECURITY INDICATOR LAMP

Component Function Check

INFOID:000000007634234

1.CHECK FUNCTION

1. Perform "THEFT IND" in "ACTIVE TEST" mode of "IMMU" of "BCM" using CONSULT.
2. Check security indicator lamp operation.

Test item		Description	
THEFT IND	ON	Security indicator lamp	Illuminates
	OFF		Does not illuminate

Is the inspection result normal?

- YES >> INSPECTION END
NO >> Go to [SEC-87, "Diagnosis Procedure"](#).

Diagnosis Procedure

INFOID:000000007634235

1.CHECK SECURITY INDICATOR LAMP POWER SUPPLY CIRCUIT

1. Turn power switch OFF.
2. Disconnect combination meter connector.
3. Check voltage between combination meter harness connector and ground.

(+)		(-)	Voltage (V) (Approx.)
Combination meter			
Connector	Terminal	Ground	Battery voltage
M34	1		

Is the inspection result normal?

- YES >> GO TO 2.
NO-1 >> Check 10 A fuse [No. 11, located in the fuse block (J/B)].
NO-2 >> Check harness for open or short between combination meter and fuse.

2.CHECK SECURITY INDICATOR LAMP SIGNAL

1. Connect combination meter connector.
2. Disconnect BCM connector.
3. Check voltage between BCM harness connector and ground.

(+)		(-)	Voltage (V) (Approx.)
BCM			
Connector	Terminal	Ground	9 – 16
M68	23		

Is the inspection result normal?

- YES >> GO TO 3.
NO >> GO TO 4.

3.REPLACE BCM

1. Replace BCM. Refer to [BCS-77, "Removal and Installation"](#).
2. Perform initialization of BCM and registration of all Intelligent Keys using CONSULT.

>> INSPECTION END

4.CHECK SECURITY INDICATOR LAMP CIRCUIT

1. Disconnect combination meter connector.
2. Check continuity between combination meter harness connector and BCM harness connector.

SECURITY INDICATOR LAMP

< DTC/CIRCUIT DIAGNOSIS >

[WITH INTELLIGENT KEY SYSTEM]

Combination meter		BCM		Continuity
Connector	Terminal	Connector	Terminal	
M34	28	M68	23	Existed

3. Check continuity between combination meter harness connector and ground.

Combination meter		Ground	Continuity
Connector	Terminal		
M34	28		Not existed

Is the inspection result normal?

- YES >> Replace combination meter. Refer to [MWI-96, "Removal and Installation"](#).
- NO >> Repair or replace harness.

VEHICLE CANNOT BE SET TO READY WHEN INTELLIGENT KEY IS INSIDE OF VEHICLE

< SYMPTOM DIAGNOSIS >

[WITH INTELLIGENT KEY SYSTEM]

SYMPTOM DIAGNOSIS

VEHICLE CANNOT BE SET TO READY WHEN INTELLIGENT KEY IS INSIDE OF VEHICLE

Description

INFOID:000000007634236

Vehicle cannot be set to READY when brake pedal is depressed and power switch is pressed while carrying Intelligent Key.

NOTE:

- Check that vehicle is under the condition shown in “Conditions of vehicle” before starting diagnosis, and check each symptom.
- The vehicle READY set function, door lock function, power distribution system, and NATS-IVIS/NVIS in the Intelligent Key system are closely related to each other regarding control. The vehicle security function can operate only when the door lock and power distribution system are operating normally.

Conditions of Vehicle (Operating Conditions)

- “ENGINE START BY I-KEY”: ON
Check the setting of “ENGINE START BY I-KEY” in “Work Support” mode of “INTELLIGENT KEY” of “BCM” using CONSULT.
- One or more of Intelligent Keys with registered Intelligent Key ID is in the vehicle.

Diagnosis Procedure

INFOID:000000007634237

1.PERFORM WORK SUPPORT

Perform “INSIDE ANT DIAGNOSIS” in “Work Support” mode of “INTELLIGENT KEY” of “BCM” using CONSULT.

Refer to [SEC-33, "INTELLIGENT KEY : CONSULT Function \(BCM - INTELLIGENT KEY\)"](#).

>> GO TO 2.

2.CHECK SELF DIAGNOSTIC RESULT

Select “Self Diagnostic Result” mode of “BCM” using CONSULT, and check whether or not DTC of inside key antenna is detected.

Is DTC detected?

- YES >> Perform the trouble diagnosis for detected DTC. Refer to [BCS-56, "DTC Index"](#).
- NO >> GO TO 3.

3.CHECK POWER SWITCH

Check power switch.

Refer to [PCS-60, "Component Function Check"](#).

Is the inspection result normal?

- YES >> GO TO 4.
- NO >> Repair or replace malfunctioning parts.

4.CHECK STOP LAMP SWITCH

Check stop lamp switch.

Refer to [SEC-61, "Component Inspection"](#).

Is the inspection result normal?

- YES >> GO TO 5.
- NO >> Repair or replace malfunctioning parts.

5.CONFIRM THE OPERATION

Confirm the operation again.

Is the inspection result normal?

- YES >> Check intermittent incident. Refer to [GI-51, "Intermittent Incident"](#).
- NO >> GO TO 1.

SECURITY INDICATOR LAMP DOES NOT TURN ON OR BLINK

< SYMPTOM DIAGNOSIS >

[WITH INTELLIGENT KEY SYSTEM]

SECURITY INDICATOR LAMP DOES NOT TURN ON OR BLINK

Description

INFOID:000000007634238

Security indicator lamp does not blink when power switch is in a position other than ON

NOTE:

- Before performing the diagnosis, check "Work Flow". Refer to [SEC-44, "Work Flow"](#).
- Check that vehicle is under the condition shown in "Conditions of vehicle" before starting diagnosis, and check each symptom.

Conditions of Vehicle (Operating Conditions)

Power switch is not in the ON position.

Diagnosis Procedure

INFOID:000000007634239

1. CHECK SECURITY INDICATOR LAMP

Check security indicator lamp.

Refer to [SEC-87, "Component Function Check"](#).

Is the inspection result normal?

YES >> GO TO 2.

NO >> Repair or replace the malfunctioning parts.

2. CONFIRM THE OPERATION

Confirm the operation again.

Is the result normal?

YES >> Check intermittent incident. Refer to [GI-51, "Intermittent Incident"](#).

NO >> GO TO 1.

VEHICLE SECURITY SYSTEM CANNOT BE SET

< SYMPTOM DIAGNOSIS >

[WITH INTELLIGENT KEY SYSTEM]

VEHICLE SECURITY SYSTEM CANNOT BE SET INTELLIGENT KEY

INTELLIGENT KEY : Description

INFOID:000000007634240

Armed phase is not activated when all doors are locked using Intelligent Key.

NOTE:

Check that vehicle is under the condition shown in "CONDITIONS OF VEHICLE (OPERATING CONDITIONS)" before starting diagnosis, and check each symptom.

CONDITION OF VEHICLE (OPERATING CONDITIONS)

"SECURITY ALARM SET": ON

Check the setting of "SECURITY ALARM SET" in "Work Support" mode of "THEFT ALM" of "BCM" using CONSULT.

INTELLIGENT KEY : Diagnosis Procedure (Except for Canada)

INFOID:000000007634241

1.CHECK INTELLIGENT KEY SYSTEM (REMOTE KEYLESS ENTRY FUNCTION)

Lock/unlock door with Intelligent Key.

Refer to [DLK-26, "DOOR LOCK FUNCTION : System Description"](#).

Is the inspection result normal?

YES >> GO TO 2.

NO >> Check Intelligent Key system (remote keyless entry function). Refer to [DLK-108, "Diagnosis Procedure"](#).

2.CONFIRM THE OPERATION

Confirm the operation again.

Is the result normal?

YES >> Check intermittent incident. Refer to [GI-51, "Intermittent Incident"](#).

NO >> GO TO 1.

INTELLIGENT KEY : Diagnosis Procedure (For Canada)

INFOID:000000007634242

1.CHECK INTELLIGENT KEY SYSTEM (REMOTE KEYLESS ENTRY FUNCTION)

Lock/unlock door with Intelligent Key.

Refer to [DLK-26, "DOOR LOCK FUNCTION : System Description"](#).

Is the inspection result normal?

YES >> GO TO 2.

NO >> Check Intelligent Key system (remote keyless entry function). Refer to [DLK-108, "Diagnosis Procedure"](#).

2.CHECK HOOD SWITCH

Check hood switch.

Refer to [SEC-83, "Component Function Check"](#).

Is the inspection result normal?

YES >> GO TO 3.

NO >> Repair or replace hood switch.

3.CONFIRM THE OPERATION

Confirm the operation again.

Is the result normal?

YES >> Check intermittent incident. Refer to [GI-51, "Intermittent Incident"](#).

NO >> GO TO 1.

DOOR REQUEST SWITCH

A
B
C
D
E
F
G
H
I
J
L
M
N
O
P

SEC

VEHICLE SECURITY SYSTEM CANNOT BE SET

< SYMPTOM DIAGNOSIS >

[WITH INTELLIGENT KEY SYSTEM]

DOOR REQUEST SWITCH : Description

INFOID:000000007634243

Armed phase is not activated when all doors are locked using door request switch.

NOTE:

Check that vehicle is under the condition shown in "CONDITIONS OF VEHICLE (OPERATING CONDITIONS)" before starting diagnosis, and check each symptom.

CONDITION OF VEHICLE (OPERATING CONDITIONS)

"SECURITY ALARM SET": ON

Check the setting of "SECURITY ALARM SET" in "Work Support" mode of "THEFT ALM" of "BCM" using CONSULT.

DOOR REQUEST SWITCH : Diagnosis Procedure (Except for Canada)

INFOID:000000007634244

1. CHECK INTELLIGENT KEY SYSTEM (DOOR LOCK FUNCTION)

Lock/unlock door with door request switch.

Refer to [DLK-26, "DOOR LOCK FUNCTION : System Description"](#).

Is the inspection result normal?

YES >> GO TO 2.

NO >> Check Intelligent Key system (door lock function). Refer to [DLK-104, "ALL DOOR REQUEST SWITCHES : Diagnosis Procedure"](#).

2. CONFIRM THE OPERATION

Confirm the operation again.

Is the result normal?

YES >> Check intermittent incident. Refer to [GI-51, "Intermittent Incident"](#).

NO >> GO TO 1.

DOOR REQUEST SWITCH : Diagnosis Procedure (For Canada)

INFOID:000000007634245

1. CHECK INTELLIGENT KEY SYSTEM (DOOR LOCK FUNCTION)

Lock/unlock door with door request switch.

Refer to [DLK-26, "DOOR LOCK FUNCTION : System Description"](#).

Is the inspection result normal?

YES >> GO TO 2.

NO >> Check Intelligent Key system (door lock function). Refer to [DLK-104, "ALL DOOR REQUEST SWITCHES : Diagnosis Procedure"](#).

2. CHECK HOOD SWITCH

Check hood switch.

Refer to [SEC-83, "Component Function Check"](#).

Is the inspection result normal?

YES >> GO TO 3.

NO >> Repair or replace hood switch.

3. CONFIRM THE OPERATION

Confirm the operation again.

Is the result normal?

YES >> Check intermittent incident. Refer to [GI-51, "Intermittent Incident"](#).

NO >> GO TO 1.

DOOR KEY CYLINDER

DOOR KEY CYLINDER : Description

INFOID:000000007634246

ARMED phase is not activated when all doors are locked using mechanical key.

NOTE:

Check that vehicle is under the condition shown in "Conditions of vehicle" before starting diagnosis, and check each symptom.

VEHICLE SECURITY SYSTEM CANNOT BE SET

[WITH INTELLIGENT KEY SYSTEM]

< SYMPTOM DIAGNOSIS >

CONDITION OF VEHICLE (OPERATING CONDITION)

- SECURITY ALARM SET: ON
Check the setting of "SECURITY ALARM SET" in "Work Support" mode of "THEFT ALM" of "BCM" using CONSULT.

DOOR KEY CYLINDER : Diagnosis Procedure (Except for Canada)

INFOID:000000007634247

1. CHECK POWER DOOR LOCK SYSTEM

Lock or unlock doors using mechanical key.

Refer to [DLK-26. "DOOR LOCK FUNCTION : System Description"](#).

Is the inspection result normal?

YES >> GO TO 2.

NO >> Check power door lock system. Refer to [DLK-107. "Diagnosis Procedure"](#).

2. CONFIRM THE OPERATION

Confirm the operation again.

Is the result normal?

YES >> Check intermittent incident. Refer to [GI-51. "Intermittent Incident"](#).

NO >> GO TO 1.

DOOR KEY CYLINDER : Diagnosis Procedure (For Canada)

INFOID:000000007634248

1. CHECK POWER DOOR LOCK SYSTEM

Lock or unlock doors using mechanical key.

Refer to [DLK-26. "DOOR LOCK FUNCTION : System Description"](#).

Is the inspection result normal?

YES >> GO TO 2.

NO >> Check power door lock system. Refer to [DLK-107. "Diagnosis Procedure"](#).

2. CHECK HOOD SWITCH

Check hood switch.

Refer to [SEC-83. "Component Function Check"](#).

Is the inspection result normal?

YES >> GO TO 3.

NO >> Repair or replace hood switch.

3. CONFIRM THE OPERATION

Confirm the operation again.

Is the result normal?

YES >> Check intermittent incident. Refer to [GI-51. "Intermittent Incident"](#).

NO >> GO TO 1.

DOOR LOCK AND UNLOCK SWITCH

DOOR LOCK AND UNLOCK SWITCH : Description

INFOID:000000007634249

Armed phase is not activated when all doors are locked by door lock and unlock switch.

NOTE:

Check that vehicle is under the condition shown in "CONDITIONS OF VEHICLE (OPERATING CONDITIONS)" before starting diagnosis, and check each symptom.

CONDITION OF VEHICLE (OPERATING CONDITIONS)

"SECURITY ALARM SET": ON

Check the setting of "SECURITY ALARM SET" in "Work Support" mode of "THEFT ALM" of "BCM" using CONSULT.

VEHICLE SECURITY SYSTEM CANNOT BE SET

< SYMPTOM DIAGNOSIS >

[WITH INTELLIGENT KEY SYSTEM]

DOOR LOCK AND UNLOCK SWITCH : Diagnosis Procedure (Except for Canada)

INFOID:000000007634250

1.CHECK DOOR LOCK FUNCTION

Lock/unlock door using mechanical key inserted into door key cylinder.

Refer to [DLK-26, "DOOR LOCK FUNCTION : System Description"](#).

Is the inspection result normal?

YES >> GO TO 2.

NO >> Check Intelligent Key system (remote keyless entry function). Refer to [DLK-22, "INTELLIGENT KEY SYSTEM : System Description"](#).

2.CONFIRM THE OPERATION

Confirm the operation again.

Is the result normal?

YES >> Check intermittent incident. Refer to [GI-51, "Intermittent Incident"](#).

NO >> GO TO 1.

DOOR LOCK AND UNLOCK SWITCH : Diagnosis Procedure (For Canada)

INFOID:000000007634251

1.CHECK DOOR LOCK FUNCTION

Lock/unlock door using mechanical key inserted into door key cylinder.

Refer to [DLK-26, "DOOR LOCK FUNCTION : System Description"](#).

Is the inspection result normal?

YES >> GO TO 2.

NO >> Check Intelligent Key system (remote keyless entry function). Refer to [DLK-22, "INTELLIGENT KEY SYSTEM : System Description"](#).

2.CHECK HOOD SWITCH

Check hood switch.

Refer to [SEC-83, "Component Function Check"](#).

Is the inspection result normal?

YES >> GO TO 3.

NO >> Repair or replace hood switch.

3.CONFIRM THE OPERATION

Confirm the operation again.

Is the result normal?

YES >> Check intermittent incident. Refer to [GI-51, "Intermittent Incident"](#).

NO >> GO TO 1.

VEHICLE SECURITY ALARM DOES NOT ACTIVATE

< SYMPTOM DIAGNOSIS >

[WITH INTELLIGENT KEY SYSTEM]

VEHICLE SECURITY ALARM DOES NOT ACTIVATE

Description

INFOID:000000007634252

Alarm does not operate when alarm operating condition is satisfied.

NOTE:

Check that vehicle is under the condition shown in "CONDITIONS OF VEHICLE (OPERATING CONDITIONS)" before starting diagnosis, and check each symptom.

CONDITION OF VEHICLE (OPERATING CONDITIONS)

"SECURITY ALARM SET": ON

Check the setting of "SECURITY ALARM SET" in "Work Support" mode of "THEFT ALM" of "BCM" using CONSULT.

Diagnosis Procedure (Except for Canada)

INFOID:000000007634253

1.CHECK DOOR SWITCH

Check door switch.

Refer to [DLK-87, "Component Function Check"](#).

Is the inspection result normal?

YES >> GO TO 2.

NO >> Replace the malfunctioning door switch

2.CHECK HEADLAMPS FUNCTION

Check head lamps function.

Refer to [SEC-82, "Component Function Check"](#).

Is the inspection result normal?

YES >> GO TO 3.

NO >> Repair or replace the malfunctioning parts.

3.CHECK HORN FUNCTION

Check horn function.

Refer to [SEC-85, "Component Function Check"](#).

Is the inspection result normal?

YES >> GO TO 4.

NO >> Repair or replace the malfunctioning parts.

4.CONFIRM THE OPERATION

Confirm the operation again.

Is the result normal?

YES >> Check intermittent incident. Refer to [GI-51, "Intermittent Incident"](#).

NO >> GO TO 1.

Diagnosis Procedure (For Canada)

INFOID:000000007634254

1.CHECK DOOR SWITCH

Check door switch.

Refer to [DLK-87, "Component Function Check"](#).

Is the inspection result normal?

YES >> GO TO 2.

NO >> Replace the malfunctioning door switch.

2.CHECK HOOD SWITCH

Check hood switch.

Refer to [SEC-83, "Component Function Check"](#).

Is the inspection result normal?

YES >> GO TO 3.

A

B

C

D

E

F

G

H

I

J

SEC

L

M

N

O

P

VEHICLE SECURITY ALARM DOES NOT ACTIVATE

[WITH INTELLIGENT KEY SYSTEM]

< SYMPTOM DIAGNOSIS >

NO >> Replace the hood switch.

3.CHECK HEADLAMPS FUNCTION

Check head lamps function.

Refer to [SEC-82. "Component Function Check"](#).

Is the inspection result normal?

YES >> GO TO 4.

NO >> Repair or replace the malfunctioning parts.

4.CHECK HORN FUNCTION

Check horn function.

Refer to [SEC-85. "Component Function Check"](#).

Is the inspection result normal?

YES >> GO TO 5.

NO >> Repair or replace the malfunctioning parts.

5.CONFIRM THE OPERATION

Confirm the operation again.

Is the result normal?

YES >> Check intermittent incident. Refer to [GI-51. "Intermittent Incident"](#).

NO >> GO TO 1.

NATS ANTENNA AMP.

< REMOVAL AND INSTALLATION >

[WITH INTELLIGENT KEY SYSTEM]

REMOVAL AND INSTALLATION

NATS ANTENNA AMP.

Removal and Installation

INFOID:000000007634255

REMOVAL

1. Remove the cluster lid A. Refer to [JP-14. "Removal and Installation"](#).
2. Remove the NATS antenna amp.
 1. Disengage the NATS antenna amp. (1) fixing pawls using remover tool etc.
 2. Pull NATS antenna amp. to remove it from power switch (2).

 : Pawl

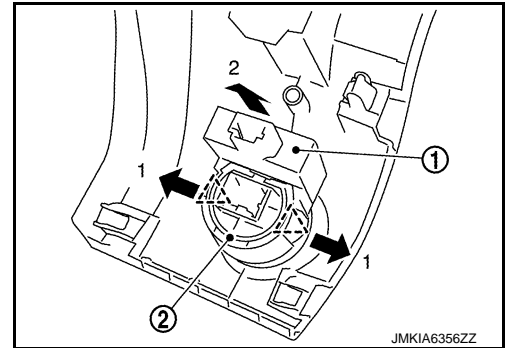

INSTALLATION

Install in the reverse order of removal.

A
B
C
D
E
F
G
H
I
J
L
M
N
O
P

SEC

POWER SWITCH

< REMOVAL AND INSTALLATION >

[WITH INTELLIGENT KEY SYSTEM]

POWER SWITCH

Removal and Installation

INFOID:000000007634256

REMOVAL

1. Remove the NATS antenna amp. Refer to [SEC-97. "Removal and Installation"](#).
2. Remove the power switch (1).
 1. Disengage the power switch fixing pawls.
 2. Press the power switch to remove it from cluster lid A (2).

 : Pawl

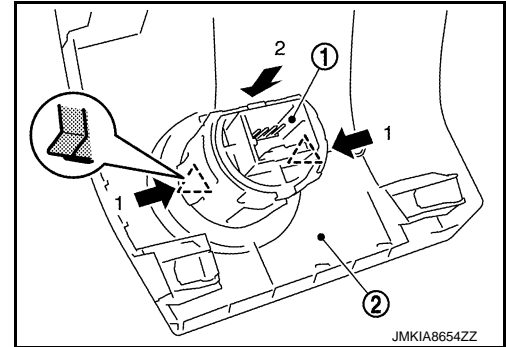

INSTALLATION

Install in the reverse order of removal.