

A
B
C
D

WT

SECTION

ROAD WHEELS & TIRES

WT

CONTENTS

<p>PRECAUTION 3</p> <p>PRECAUTIONS 3</p> <p style="padding-left: 20px;">Precaution for Technicians Using Medical Electric.....3</p> <p style="padding-left: 20px;">Point to Be Checked Before Starting Maintenance Work3</p> <p style="padding-left: 20px;">Precaution for Supplemental Restraint System (SRS) "AIR BAG" and "SEAT BELT PRE-TENSIONER"3</p> <p style="padding-left: 20px;">Precautions for Removing Battery Terminal4</p> <p style="padding-left: 20px;">Service Notice and Precautions for TPMS5</p> <p style="padding-left: 20px;">Service Notice and Precautions for Road Wheel5</p> <p>PREPARATION 6</p> <p>PREPARATION 6</p> <p style="padding-left: 20px;">Special Service Tool6</p> <p style="padding-left: 20px;">Commercial Service Tool6</p> <p>SYSTEM DESCRIPTION 7</p> <p>COMPONENT PARTS 7</p> <p style="padding-left: 20px;">Component Parts Location7</p> <p style="padding-left: 20px;">BCM8</p> <p style="padding-left: 20px;">Tire Pressure Sensor8</p> <p style="padding-left: 20px;">Tire Pressure Receiver8</p> <p style="padding-left: 20px;">Information Display8</p> <p>SYSTEM10</p> <p style="padding-left: 20px;">System Description10</p> <p style="padding-left: 20px;">Circuit Diagram11</p> <p style="padding-left: 20px;">Easy Fill Tire Alert Function11</p> <p>DIAGNOSIS SYSTEM (BCM)13</p> <p>COMMON ITEM13</p> <p style="padding-left: 20px;">COMMON ITEM : CONSULT Function (BCM - COMMON ITEM)13</p> <p>AIR PRESSURE MONITOR14</p> <p style="padding-left: 20px;">AIR PRESSURE MONITOR : CONSULT Function (BCM - AIR PRESSURE MONITOR)15</p>	<p>ECU DIAGNOSIS INFORMATION17</p> <p>BCM17</p> <p style="padding-left: 20px;">List of ECU Reference17</p> <p>WIRING DIAGRAM18</p> <p>TIRE PRESSURE MONITORING SYSTEM18</p> <p style="padding-left: 20px;">Wiring Diagram18</p> <p>BASIC INSPECTION19</p> <p>DIAGNOSIS AND REPAIR WORK FLOW19</p> <p style="padding-left: 20px;">Work Flow19</p> <p>ADDITIONAL SERVICE WHEN REPLACING BCM21</p> <p style="padding-left: 20px;">Description21</p> <p style="padding-left: 20px;">Work Procedure21</p> <p>TIRE PRESSURE SENSOR ID REGISTRATION22</p> <p style="padding-left: 20px;">Description22</p> <p style="padding-left: 20px;">Work Procedure22</p> <p>DTC/CIRCUIT DIAGNOSIS24</p> <p>C1704, C1705, C1706, C1707 LOW TIRE PRESSURE24</p> <p style="padding-left: 20px;">DTC Logic24</p> <p style="padding-left: 20px;">Diagnosis Procedure24</p> <p>C1708, C1709, C1710, C1711 TIRE PRESSURE SENSOR26</p> <p style="padding-left: 20px;">DTC Logic26</p> <p style="padding-left: 20px;">Diagnosis Procedure26</p> <p>C1716, C1717, C1718, C1719 TIRE PRESSURE SENSOR28</p> <p style="padding-left: 20px;">DTC Logic28</p> <p style="padding-left: 20px;">Diagnosis Procedure28</p> <p>C1729 VEHICLE SPEED SIGNAL30</p>	<p>F</p> <p>G</p> <p>H</p> <p>I</p> <p>J</p> <p>K</p> <p>L</p> <p>M</p> <p>N</p> <p>O</p> <p>P</p>
---	---	--

DTC Logic	30	NOISE, VIBRATION AND HARSHNESS	
Diagnosis Procedure	30	(NVH) TROUBLESHOOTING	41
		NVH Troubleshooting Chart	41
POWER SUPPLY AND GROUND CIRCUIT	31	PERIODIC MAINTENANCE	42
Diagnosis Procedure	31	ROAD WHEEL	42
SYMPTOM DIAGNOSIS	32	Inspection	42
TPMS	32	Wheel Balance Adjustment	42
Symptom Table	32	Tire Rotation	44
LOW TIRE PRESSURE WARNING LAMP		REMOVAL AND INSTALLATION	45
DOES NOT TURN ON	35	ROAD WHEEL TIRE ASSEMBLY	45
Description	35	Exploded View	45
Diagnosis Procedure	35	Removal and Installation	45
LOW TIRE PRESSURE WARNING LAMP		Inspection	45
DOES NOT TURN OFF	36	How to Handle Puncture Repair Agent	45
Description	36	TIRE PRESSURE SENSOR	47
Diagnosis Procedure	36	Exploded View	47
LOW TIRE PRESSURE WARNING LAMP		Removal and Installation	47
BLINKS	37	TIRE PRESSURE RECEIVER	49
Description	37	Removal and Installation	49
Diagnosis Procedure	37	SERVICE DATA AND SPECIFICATIONS	
EASY FILL TIRE ALERT DOES NOT ACTI-		(SDS)	50
VATE	38	SERVICE DATA AND SPECIFICATIONS	
Description	38	(SDS)	50
Diagnosis Procedure	38	Road Wheel	50
TIRE PRESSURE SENSOR ID REGISTRA-		Tire Air Pressure	50
TION CANNOT BE COMPLETED	40		
Description	40		
Diagnosis Procedure	40		

PRECAUTIONS

< PRECAUTION >

PRECAUTION

PRECAUTIONS

Precaution for Technicians Using Medical Electric

INFOID:000000007635408

OPERATION PROHIBITION

WARNING:

- Parts with strong magnet is used in this vehicle.
- Technicians using a medical electric device such as pacemaker must never perform operation on the vehicle, as magnetic field can affect the device function by approaching to such parts.

NORMAL CHARGE PRECAUTION

WARNING:

- If a technician uses a medical electric device such as an implantable cardiac pacemaker or an implantable cardioverter defibrillator, the possible effects on the devices must be checked with the device manufacturer before starting the charge operation.
- As radiated electromagnetic wave generated by on board charger at normal charge operation may effect medical electric devices, a technician using a medical electric device such as implantable cardiac pacemaker or an implantable cardioverter defibrillator must not enter the vehicle compartment (including luggage room) during normal charge operation.

PRECAUTION AT TELEMATICS SYSTEM OPERATION

WARNING:

- If a technician uses implantable cardiac pacemaker or implantable cardioverter defibrillator (ICD), avoid the device implanted part from approaching within approximately 220 mm (8.66 in) from interior/exterior antenna.
- The electromagnetic wave of TCU might affect the function of the implantable cardiac pacemaker or the implantable cardioverter defibrillator (ICD), when using the service, etc.
- If a technician uses other medical electric devices than implantable cardiac pacemaker or implantable cardioverter defibrillator (ICD), the electromagnetic wave of TCU might affect the function of the device. The possible effects on the devices must be checked with the device manufacturer before TCU use.

PRECAUTION AT INTELLIGENT KEY SYSTEM OPERATION

WARNING:

- If a technician uses implantable cardiac pacemaker or implantable cardioverter defibrillator (ICD), avoid the device implanted part from approaching within approximately 220 mm (8.66 in) from interior/exterior antenna.
- The electromagnetic wave of Intelligent Key might affect the function of the implantable cardiac pacemaker or the implantable cardioverter defibrillator (ICD), at door operation, at each request switch operation, or at engine starting.
- If a technician uses other medical electric devices than implantable cardiac pacemaker or implantable cardioverter defibrillator (ICD), the electromagnetic wave of Intelligent Key might affect the function of the device. The possible effects on the devices must be checked with the device manufacturer before Intelligent Key use.

Point to Be Checked Before Starting Maintenance Work

INFOID:000000007635409

The high voltage system may starts automatically. It is required to check that the timer air conditioner and timer charge (during EVSE connection) are not set before starting maintenance work.

NOTE:

If the timer air conditioner or timer charge (during EVSE connection) is set, the high voltage system starts automatically even when the power switch is in OFF state.

Precaution for Supplemental Restraint System (SRS) "AIR BAG" and "SEAT BELT PRE-TENSIONER"

INFOID:000000007635410

The Supplemental Restraint System such as "AIR BAG" and "SEAT BELT PRE-TENSIONER", used along with a front seat belt, helps to reduce the risk or severity of injury to the driver and front passenger for certain types of collision. This system includes seat belt switch inputs and dual stage front air bag modules. The SRS

A
B
C
D
WT
F
G
H
I
J
K
L
M
N
O
P

PRECAUTIONS

< PRECAUTION >

system uses the seat belt switches to determine the front air bag deployment, and may only deploy one front air bag, depending on the severity of a collision and whether the front occupants are belted or unbelted. Information necessary to service the system safely is included in the “SRS AIR BAG” and “SEAT BELT” of this Service Manual.

WARNING:

Always observe the following items for preventing accidental activation.

- To avoid rendering the SRS inoperative, which could increase the risk of personal injury or death in the event of a collision that would result in air bag inflation, all maintenance must be performed by an authorized NISSAN/INFINITI dealer.
- Improper maintenance, including incorrect removal and installation of the SRS, can lead to personal injury caused by unintentional activation of the system. For removal of Spiral Cable and Air Bag Module, see “SRS AIR BAG”.
- Never use electrical test equipment on any circuit related to the SRS unless instructed to in this Service Manual. SRS wiring harnesses can be identified by yellow and/or orange harnesses or harness connectors.

PRECAUTIONS WHEN USING POWER TOOLS (AIR OR ELECTRIC) AND HAMMERS

WARNING:

Always observe the following items for preventing accidental activation.

- When working near the Air Bag Diagnosis Sensor Unit or other Air Bag System sensors with the power switch ON, never use air or electric power tools or strike near the sensor(s) with a hammer. Heavy vibration could activate the sensor(s) and deploy the air bag(s), possibly causing serious injury.
- When using air or electric power tools or hammers, always switch the power switch OFF, disconnect the 12V battery, and wait at least 3 minutes before performing any service.

Precautions for Removing Battery Terminal

INFOID:000000007635411

- When removing the 12V battery terminal, turn OFF the power switch and wait at least 5 minutes.

NOTE:

ECU may be active for several minutes after the power switch is turned OFF. If the battery terminal is removed before ECU stops, then a DTC detection error or ECU data corruption may occur.

- Always disconnect the battery terminal within 60 minutes after turning OFF the power switch. Even when the power switch is OFF, the 12V battery automatic charge control may automatically start after a lapse of 60 minutes from power switch OFF.
- Disconnect 12V battery terminal according to the following steps.

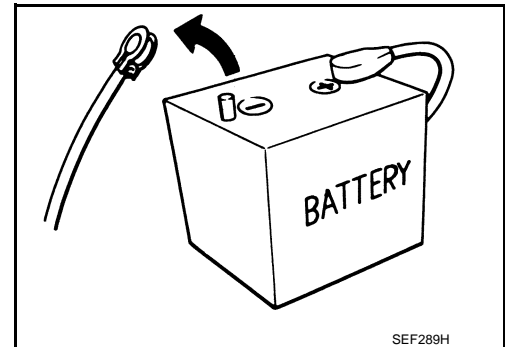

WORK PROCEDURE

1. Check that EVSE is not connected.

NOTE:

If EVSE is connected, the air conditioning system may be automatically activated by the timer A/C function.

2. Turn the power switch OFF → ON → OFF. Get out of the vehicle. Close all doors (including back door).
3. Check that the charge status indicator lamp does not blink and wait for 5 minutes or more.

NOTE:

If the battery is removed within 5 minutes after the power switch is turned OFF, plural DTCs may be detected.

4. Remove 12V battery terminal within 60 minutes after turning the power switch OFF → ON → OFF.

CAUTION:

- After all doors (including back door) are closed, if a door (including back door) is opened before battery terminals are disconnected, start over from Step 1.
- After turning the power switch OFF, if “Remote A/C” is activated by user operation, stop the air conditioner and start over from Step 1.

NOTE:

Once the power switch is turned ON → OFF, the 12V battery automatic charge control does not start for approximately 1 hour.

PRECAUTIONS

< PRECAUTION >

- For vehicles with the 2-batteries, be sure to connect the main battery and the sub battery before turning ON the power switch. A
NOTE:
If the power switch is turned ON with any one of the terminals of main battery and sub battery disconnected, then DTC may be detected.
- After installing the 12V battery, always check "Self Diagnosis Result" of all ECUs and erase DTC. B
NOTE:
The removal of 12V battery may cause a DTC detection error. C

Service Notice and Precautions for TPMS

INFOID:000000007635412

- Low tire pressure warning lamp blinks for 1min, then turns ON when occurring any malfunction except low tire pressure. Erase the self-diagnosis memories for Tire Pressure Monitoring System (TPMS), or register the ID to turn low tire pressure warning lamp OFF. For ID registration, refer to [WT-22, "Work Procedure"](#). D
- ID registration is required when replacing or rotating wheels, replacing tire pressure sensor or BCM. Refer to [WT-22, "Work Procedure"](#). WT
- Replace grommet seal, valve core and valve cap of tire pressure sensor in TPMS, when replacing each tire by reaching the wear limit. Refer to [WT-47, "Exploded View"](#).
- For easy fill tire alert function, refer to the following. F
 - When inflating the tires, park the vehicle in the safe area and ensure the safety of the working area.
 - Read and understand the easy fill tire alert function prior to use.
 - Inflate the tires one at a time.
 - If there is no response for approximately 15 seconds or more after inflating the tires, cancel the use of the easy fill tire alert function or move the vehicle approximately 1 m (3.2 ft) backward or forward to try again. The air filler pressure may be weak or out of service area. G
 - Despite the high-precision TPMS pressure sensor, an indicated value may differ from that of the pressure gauge. H
 - Air pressure is measured rather high due to the rise in tire air temperature after driving.
 - If TPMS is malfunctioning, the easy fill tire alert is unusable.
- Because the tire pressure sensor conforms to North America radio law, the following items must be observed. I
 - The sensor may be used only in North America.
 - It may not be used in any method other than the specified method. J
 - It must not be disassembled or modified.

Service Notice and Precautions for Road Wheel

INFOID:000000007635413

- Genuine NISSAN aluminum wheel is designed for each type of vehicle. Use it on the specified vehicle only. K
- Use Genuine NISSAN parts for the road wheels, valve caps and wheel nuts. L
- Always use them after adjusting the wheel balance. For the balance weights, use Genuine NISSAN aluminum wheel weights. M
- Use caution when handling the aluminum wheels, because they can be easily scratched. When removing dirt, do not use any abrasives, a wire brush, or other items that may scratch the coating. Use a neutral detergent if a detergent is needed.
- After driving on roads scattered with anti-icing salts, wash off the wheels completely.
- When installing road wheels onto the vehicle, always wipe off any dirt or foreign substances to prevent them from being trapped between the contact surfaces of wheel. N
- Never apply oil to nut and bolt threads. O
- When tightening the valve cap there is a risk of damaging the valve cap if a tool is used. Tighten by hand. P

PREPARATION

< PREPARATION >

PREPARATION

PREPARATION

Special Service Tool

INFOID:000000007635414

The actual shapes of Kent-Moore tools may differ from those of special service tools illustrated here.

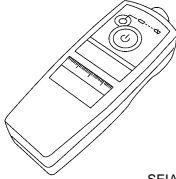
Tool number (Kent-Moore No.) Tool name	Description
— (J-45295) Tire pressure sensor activation tool  SEIA0462E	ID registration

Commercial Service Tool

INFOID:000000007635415

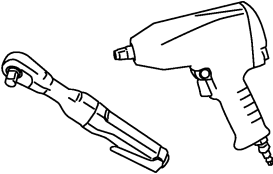
Tool name	Description
Power tool  PBIC0190E	Loosening bolts and nuts

COMPONENT PARTS

< SYSTEM DESCRIPTION >

SYSTEM DESCRIPTION

COMPONENT PARTS

Component Parts Location

INFOID:000000007635416

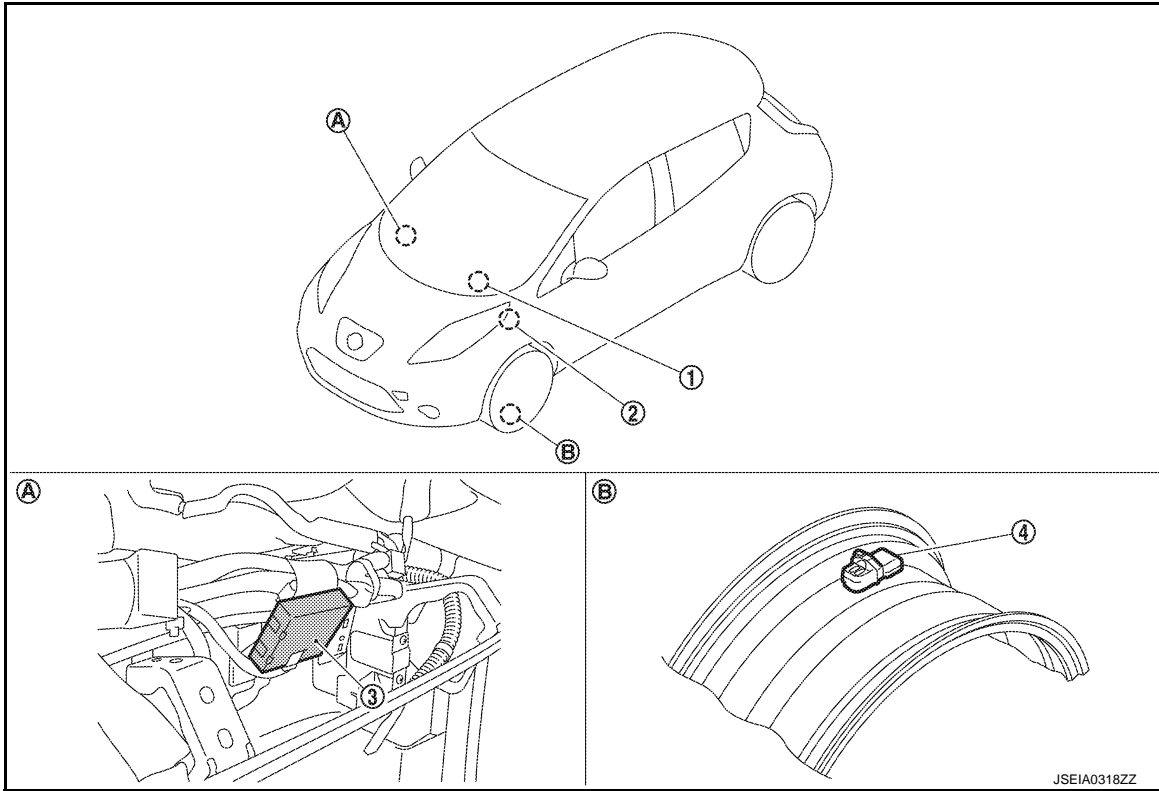

A. View with the glove box assembly re- B. Wheel moved

No.	Component parts	Function
1.	Low tire pressure warning lamp (In combination meter)	Refer to WT-10, "System Description" .
	Information display (In combination meter)	Refer to WT-8, "Information Display" .
2.	BCM	<ul style="list-style-type: none"> Refer to WT-8, "BCM". Refer to BCS-6, "BODY CONTROL SYSTEM : Component Parts Location" for detailed installation location.
3.	Remote keyless entry receiver (Tire pressure receiver)	Refer to WT-8, "Tire Pressure Receiver" .
4.	Tire pressure sensor	Refer to WT-8, "Tire Pressure Sensor" .

COMPONENT PARTS

< SYSTEM DESCRIPTION >

BCM

INFOID:000000007635417

- The BCM (1) reads the air pressure signal received by the tire pressure receiver, controls the low tire pressure warning lamp, hazard warning lamp, and horn operation. It also has a judgment function to detect a system malfunction.
- Controls easy fill tire alert function. Refer to [WT-11, "Easy Fill Tire Alert Function"](#).

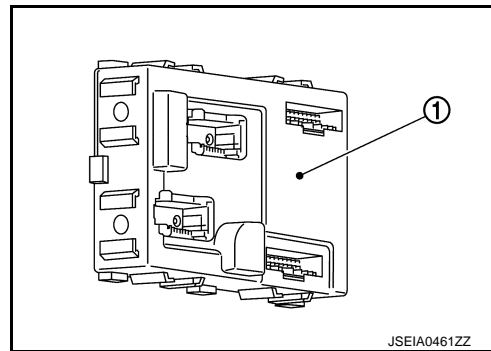

Tire Pressure Sensor

INFOID:000000007635418

The tire pressure sensor (1) integrated with a valve is installed on a wheel (2), and transmits a detected air pressure signal by radio wave.

⇐ : Outside

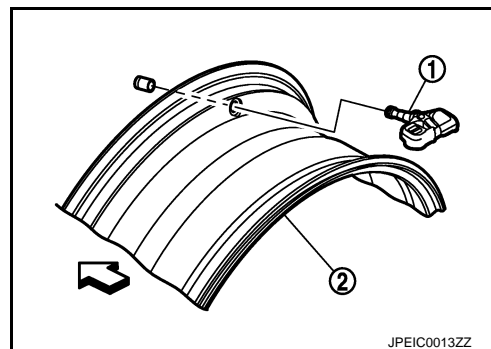

Tire Pressure Receiver

INFOID:000000007635419

- Tire pressure receiver is incorporated into remote keyless entry receiver.
- The tire pressure receiver receives the air pressure signal transmitted by the tire pressure sensor in each wheel.

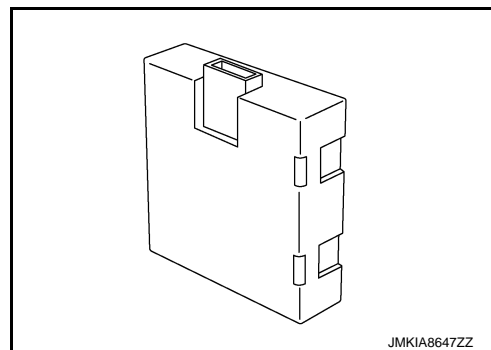

Information Display

INFOID:000000007635420

The vehicle information display (1) is shown when a low tire pressure warning lamp signal is transmitted from BCM to combination meter via CAN communication.

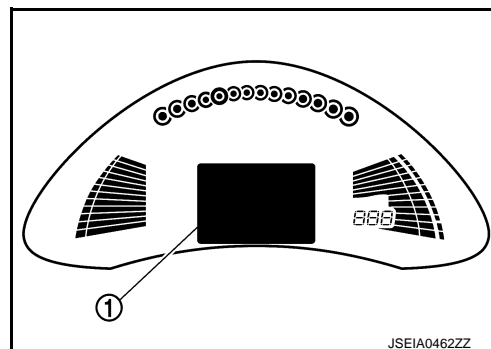

COMPONENT PARTS

< SYSTEM DESCRIPTION >

Condition		Vehicle information display
Power switch OFF		Not indicated
Power switch ON	Low tire pressure warning lamp remains ON after blinking for one minute. [Tire Pressure Monitoring System (TPMS) malfunction.]	Not indicated
Power switch ON	Low tire pressure warning lamp remains ON. (low tire pressure)	Indicated

A

B

C

D

WT

F

G

H

I

J

K

L

M

N

O

P

SYSTEM

< SYSTEM DESCRIPTION >

SYSTEM

System Description

INFOID:000000007635421

- During driving, the TPMS (Tire Pressure Monitoring System) receives the signal transmitted from tire pressure sensor installed in each wheel. The BCM (Body Control Module) of this system has pressure judgment and trouble diagnosis functions. When the tire pressure monitoring system detects low inflation pressure or another unusual symptom, the low tire pressure warning lamps in the combination meter comes on.
- If the tire pressure is less than the specified value, the low tire pressure warning lamp illuminates that the tire pressure is less than the specified value.
- Activates the TPMS (Tire Pressure Monitoring System) when the vehicle speed is 40 km/h (25 MPH) or more.
- Added easy fill tire alert function to TPMS (Tire Pressure Monitoring System). Refer to [WT-11, "Easy Fill Tire Alert Function"](#).

SYSTEM DIAGRAM

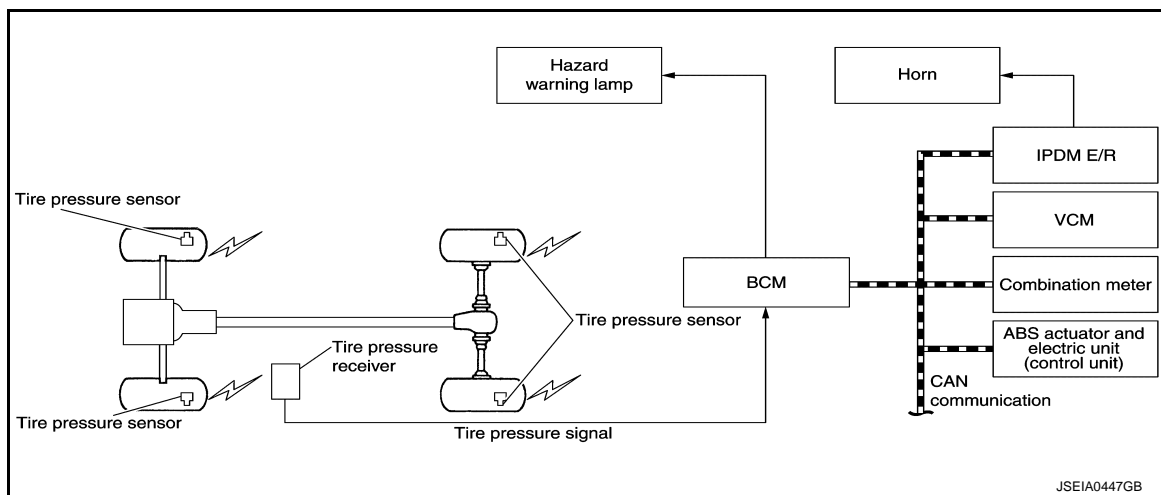

INPUT/OUTPUT SIGNAL

Major signal transmission between each unit via communication lines is shown in the following table.

Component parts	Signal item
Combination meter	Mainly receives the following signals from BCM via CAN communication. <ul style="list-style-type: none"> • Low tire pressure warning lamp signal • TPMS malfunction warning lamp signal
ABS actuator and electric unit (control unit)	Mainly transmits the following signals to BCM via CAN communication. <ul style="list-style-type: none"> • Vehicle speed signal (ABS)
VCM (Vehicle Control Module)	Mainly transmits the following signals to BCM via CAN communication. <ul style="list-style-type: none"> • Shift position signal (P range signal)
IPDM E/R	Mainly transmits the following signals to BCM via CAN communication. <ul style="list-style-type: none"> • Horn reminder signal

LOW TIRE PRESSURE WARNING LAMP INDICATION CONDITION

Uses CAN communication from the BCM to illuminate the low tire pressure warning lamp on the combination meter.

Condition	Low tire pressure warning lamp
Power switch OFF	OFF
Power switch ON (System normal)	Warning lamp turns on for 1second, then turns off.

SYSTEM

< SYSTEM DESCRIPTION >

Condition	Low tire pressure warning lamp
Low tire pressure	ON
Tire pressure sensor ID not registered in BCM	
Tire pressure monitoring system malfunction (Other diagnostic item)	Warning lamp blinks 1 min, then turns on.

HAZARD WARNING LAMP INDICATION CONDITION

The hazard warning lamp blinks under the following conditions.

- When ID registration is completed. Refer to [WT-22. "Work Procedure"](#).
- During the use of the easy fill tire alert function.

HORN CONTROL CONDITION

During the use of easy fill tire alert function.

Circuit Diagram

INFOID:000000007635422

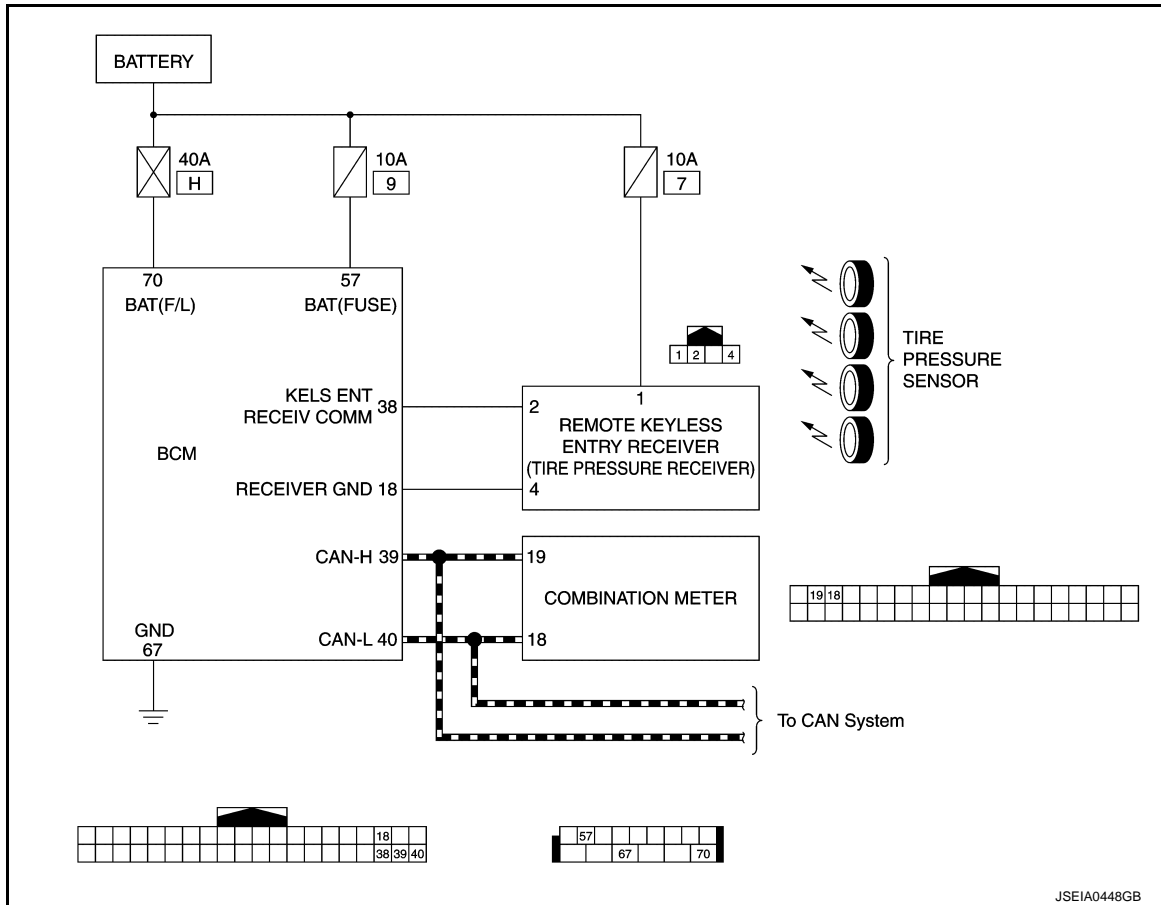

Easy Fill Tire Alert Function

INFOID:000000007635423

- This function operates only when the select lever position is in P-range with the power switch ON or with the set the vehicle to READY.

NOTE:

The easy fill tire alert function is recommended to use with the power switch ON.

SYSTEM

< SYSTEM DESCRIPTION >

- This function informs the driver of the satisfaction of the recommended COLD tire pressure.
The hazard warning lamp blinks when reaching the recommended COLD tire pressure during radio wave reception. After reaching the recommended COLD tire pressure, the horn sounds once and the hazard warning lamp stops blinking.
- When tire pressure becomes a value equal to or more than 30 kPa (0.31 kg/cm², 4 psi) more than the recommended COLD tire pressure, the hazard warning lamp and the horn operates three times. After deflating the tire and reaching the recommended COLD tire pressure, the horn sounds only once and the hazard warning lamp stops blinking.

NOTE:

- After starting to inflate the tire, it takes a few seconds for the easy fill tire alert to function.
- If there is no response for approximately 15 seconds or more after inflating the tires, cancel the use of the easy fill tire alert function or move the vehicle approximately 1 m (3.2 ft) backward or forward to try again. The air filler pressure may be weak or out of service area.

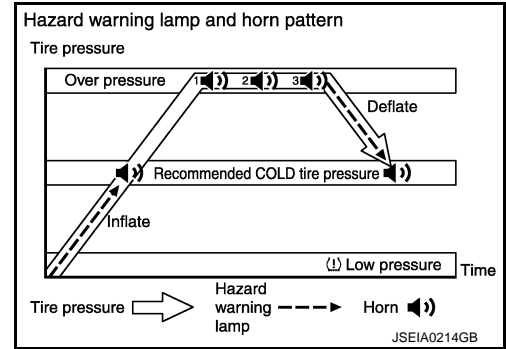

DIAGNOSIS SYSTEM (BCM)

< SYSTEM DESCRIPTION >

DIAGNOSIS SYSTEM (BCM)

COMMON ITEM

COMMON ITEM : CONSULT Function (BCM - COMMON ITEM)

INFOID:000000007835406

APPLICATION ITEM

CONSULT performs the following functions via CAN communication with BCM.

Diagnosis mode	Function Description
Work Support	Changes the setting for each system function.
Self Diagnostic Result	Displays the diagnosis results judged by BCM.
CAN Diag Support Monitor	Monitors the reception status of CAN communication viewed from BCM.
Data Monitor	The BCM input/output signals are displayed.
Active Test	The signals used to activate each device are forcibly supplied from BCM.
Ecu Identification	The BCM part number is displayed.
Configuration	<ul style="list-style-type: none"> Read and save the vehicle specification. Write the vehicle specification when replacing BCM.

SYSTEM APPLICATION

BCM can perform the following functions for each system.

NOTE:

It can perform the diagnosis modes except the following for all sub system selection items.

×: Applicable item

System	Sub system selection item	Diagnosis mode		
		Work Support	Data Monitor	Active Test
Door lock	DOOR LOCK	×	×	×
Rear window defogger	REAR DEFOGGER		×	×
Warning chime	BUZZER		×	×
Interior room lamp timer	INT LAMP	×	×	×
Exterior lamp	HEAD LAMP	×	×	×
Wiper and washer	WIPER	×	×	×
Turn signal and hazard warning lamps	FLASHER	×	×	×
—	AIR CONDITONER*		×	×
Intelligent Key system	INTELLIGENT KEY	×	×	×
Combination switch	COMB SW		×	
Body control system	BCM	×		
NVIS - NATS	IMMU	×	×	×
Interior room lamp battery saver	BATTERY SAVER	×	×	×
Back door open	TRUNK		×	
Theft warning alarm	THEFT ALM	×	×	×
RAP system	RETAINED PWR		×	
Signal buffer system	SIGNAL BUFFER		×	×
TPMS	AIR PRESSURE MONITOR	×	×	×

*: This item is displayed, but not used.

FREEZE FRAME DATA (FFD)

The BCM records the following vehicle condition at the time a particular DTC is detected, and displays on CONSULT.

DIAGNOSIS SYSTEM (BCM)

< SYSTEM DESCRIPTION >

CONSULT screen item	Indication/Unit	Description	
Vehicle Speed	km/h	Vehicle speed of the moment a particular DTC is detected	
Odo/Trip Meter	km	Total mileage (Odometer value) of the moment a particular DTC is detected	
Vehicle Condition	SLEEP>LOCK	Power supply position status of the moment a particular DTC is detected*	While turning BCM status from low power consumption mode to normal mode [Power supply position is OFF (LOCK)]
	SLEEP>OFF		While turning BCM status from low power consumption mode to normal mode [Power supply position is OFF (OFF)]
	LOCK>ACC		While turning power supply position from OFF (LOCK) to ACC
	ACC>ON		While turning power supply position from ACC to ON
	RUN>ACC		While turning power supply position from READY (RUN) to ACC (Except emergency stop operation)
	CRANK>RUN		While turning power supply position from READY (CRANK) to READY (RUN)
	RUN>URGENT		While turning power supply position from READY (RUN) to ACC (Emergency stop operation)
	ACC>OFF		While turning power supply position from ACC to OFF (OFF)
	OFF>LOCK		While turning power supply position from OFF (OFF) to OFF (LOCK)
	OFF>ACC		While turning power supply position from OFF (OFF) to ACC
	ON>CRANK		While turning power supply position from ON to READY (CRANK)
	OFF>SLEEP		While turning BCM status from normal mode [Power supply position is OFF (OFF)] to low power consumption mode
	LOCK>SLEEP		While turning BCM status from normal mode [Power supply position is OFF (LOCK)] to low power consumption mode
	LOCK		Power supply position is OFF (LOCK)
	OFF		Power supply position is OFF (OFF)
	ACC		Power supply position is ACC
	ON		Power supply position is ON
	ENGINE RUN		Power supply position is READY (RUN)
	CRANKING		Power supply position is READY (CRANK)
IGN Counter	0 - 39	The number of times that power switch is turned ON after DTC is detected <ul style="list-style-type: none"> • The number is 0 when a malfunction is detected now. • The number increases like 1 → 2 → 3...38 → 39 after returning to the normal condition whenever power switch OFF → ON. • The number is fixed to 39 until the self-diagnosis results are erased if it is over 39. 	

NOTE:

*: Refer to the following for details of the power supply position.

- OFF (OFF, LOCK): Power switch OFF
- ACC: Power switch ACC
- ON: Power switch ON
- READY (CRANK): Shifting to vehicle condition READY (Transmitting the READY signal from BCM to VCM)
- READY (RUN): Vehicle condition READY

Power supply position shifts to "OFF (LOCK)" from "OFF (OFF)", when power switch is in the OFF position, shift position is in the P position, and any of the following conditions are met.

- Closing door
- Opening door
- Door is locked using door request switch
- Door is locked using Intelligent Key

The power supply position shifts to "ACC" when the power switch (push switch) is pushed at "OFF (LOCK)".

AIR PRESSURE MONITOR

DIAGNOSIS SYSTEM (BCM)

< SYSTEM DESCRIPTION >

AIR PRESSURE MONITOR : CONSULT Function (BCM - AIR PRESSURE MONITOR)

INFOID:000000007635425

APPLICATION ITEM

CONSULT performs the following functions via CAN communication with BCM.

Diagnosis mode	Function Description
Self Diagnostic Result	Retrieve DTC from ECU and display diagnostic items.
Data Monitor	Monitor the input/output signal of the control unit in real time.
Active Test	Send the drive signal from CONSULT to the actuator. The operation check can be performed.
Work Support	This mode enables a technician to adjust some devices faster and more accurately.

SELF DIAGNOSTIC RESULT

Refer to [BCS-56. "DTC Index"](#).

DATA MONITOR MODE

Monitor item (Unit)	Remarks
AIR PRESS FL (kPa, kg/cm ² or Psi)	Tire pressure
AIR PRESS FR (kPa, kg/cm ² or Psi)	
AIR PRESS RR (kPa, kg/cm ² or Psi)	
AIR PRESS RL (kPa, kg/cm ² or Psi)	
ID REGST FL1 (Yet, Done)	Registration ID
ID REGST FR1 (Yet, Done)	
ID REGST RR1 (Yet, Done)	
ID REGST RL1 (Yet, Done)	
WARNING LAMP (On/Off)	Low tire pressure warning lamp
BUZZER (On/Off)	NOTE: This item is displayed, but cannot be use this item.

ACTIVE TEST MODE

NOTE:

After completing the work below, perform an active test.

1. Check ID registration state and perform self-diagnosis.
2. Erase the self-diagnosis result history.

Item	Description
WARNING LAMP	Low tire pressure warning lamp can be turned ON arbitrarily.
ID REGIST WARNING	NOTE: Displayed but not used in TPMS.
RUN FLAT TIRE W/L	NOTE: Displayed but not used in TPMS.
RUN FLAT/T WARN BUZZER	NOTE: Displayed but not used in TPMS.

DIAGNOSIS SYSTEM (BCM)

< SYSTEM DESCRIPTION >

Item	Description
FLASHER	Turn signal lamps can be turned ON arbitrarily.
HORN	This test is able to check to check that the horn sounds.

WORK SUPPORT

Item	Description
ID READ	Registered tire pressure sensor ID can be displayed.
ID REGIST	Tire pressure sensor ID can be registered.

BCM

< ECU DIAGNOSIS INFORMATION >

ECU DIAGNOSIS INFORMATION

BCM

List of ECU Reference

INFOID:000000007635426

ECU	Reference
BCM	BCS-34, "Reference Value"
	BCS-54, "Fail-safe"
	BCS-55, "DTC Inspection Priority Chart"
	BCS-56, "DTC Index"

A

B

C

D

WT

F

G

H

I

J

K

L

M

N

O

P

TIRE PRESSURE MONITORING SYSTEM

< WIRING DIAGRAM >

WIRING DIAGRAM

TIRE PRESSURE MONITORING SYSTEM

Wiring Diagram

INFOID:000000007635427

For connector terminal arrangements, harness layouts, and alphabets in a  (option abbreviation; if not described in wiring diagram), refer to [GI-12, "Connector Information"](#).

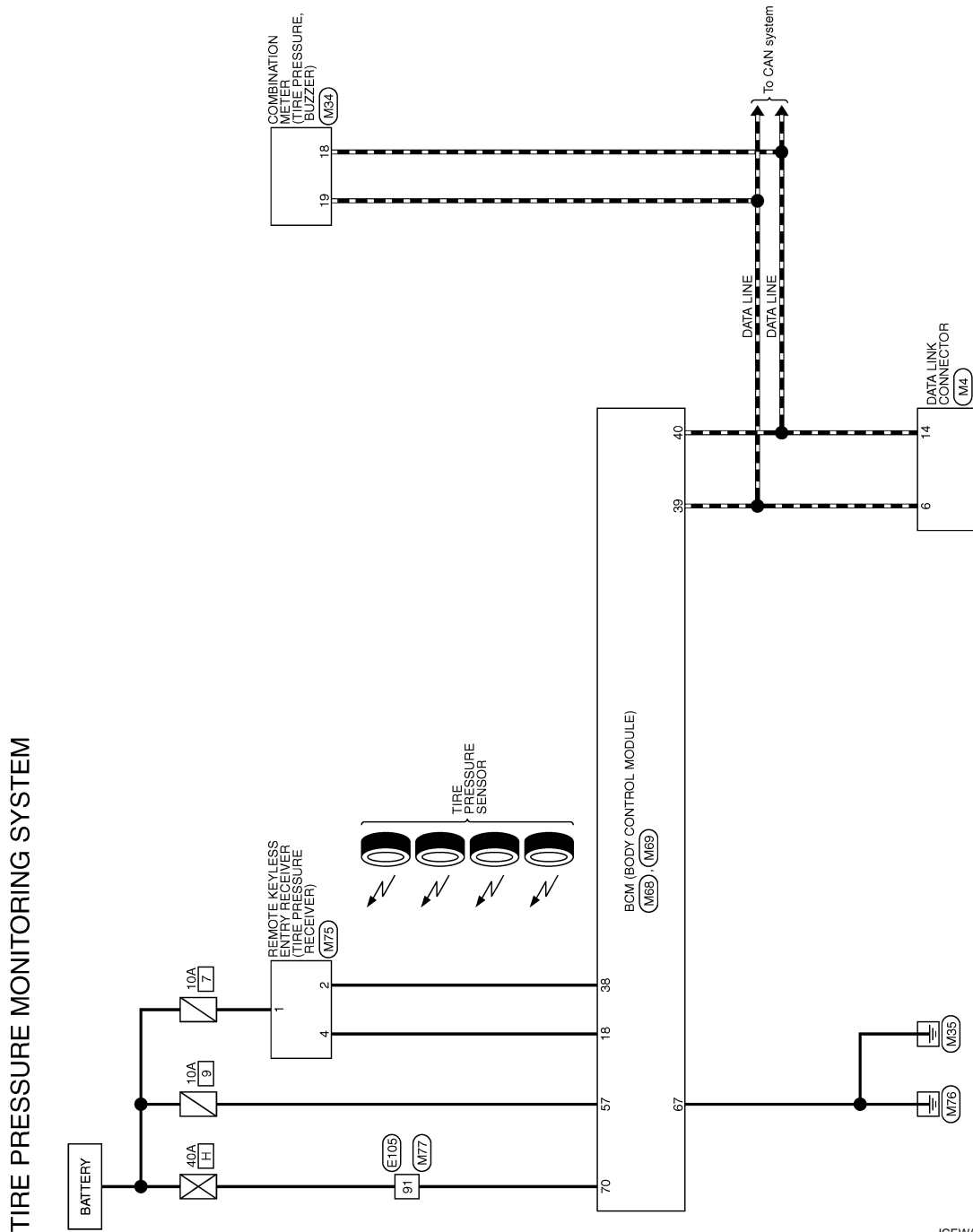

2010/10/29

JCEWA0217GB

DIAGNOSIS AND REPAIR WORK FLOW

< BASIC INSPECTION >

BASIC INSPECTION

DIAGNOSIS AND REPAIR WORK FLOW

Work Flow

INFOID:000000007635428

DETAILED FLOW

1. COLLECT THE INFORMATION FROM THE CUSTOMER

It is also important to clarify customer concerns before starting the inspection. Reproduce the symptom, and understand it fully. Interview the customer about the concerns carefully. In some cases, it is necessary to check the symptoms by driving the vehicle with the customer.

CAUTION:

Customers are not professionals. Never assume “maybe the customer means...” or “maybe the customer mentioned this symptom.”

>> GO TO 2.

2. BASIC INSPECTION

1. Turn the power switch ON.

CAUTION:

Never set the vehicle to READY.

2. Check the tire pressure for all wheels and adjust to the specified value. Refer to [WT-50. "Tire Air Pressure"](#).

Is the inspection result normal?

YES >> GO TO 3.

NO >> Inspect or repair the tires or wheels.

3. CHECK LOW TIRE PRESSURE WARNING LAMP

Check low tire pressure warning lamp display.

Does not low tire pressure warning lamp turn OFF?

YES >> GO TO 4.

NO >> GO TO 8.

4. PERFORM SELF-DIAGNOSIS

 **With CONSULT**

Perform “SELF-DIAG RESULTS”.

Is any DTC detected?

YES >> Record or print DTC and freeze frame data (FFD). GO TO 5.

NO >> GO TO 7.

5. RECHECK THE SYMPTOM

 **With CONSULT**

Perform “DTC CONFIRMATION PROCEDURE” with recorded DTC.

If two or more DTCs are detected, refer to [BCS-56. "DTC Index"](#) and determine trouble diagnosis order.

Is any DTC detected?

YES >> GO TO 6.

NO >> GO TO 7.

6. REPAIR OR REPLACE ERROR-DETECTED PART

- Repair or replace error-detected parts.
- Reconnect part or connector after repairing or replacing.
- When DTC is detected, erase self-diagnostic result in “AIR PRESSURE MONITOR” of “BCM”.

>> GO TO 9.

7. CRUISE FOR SYMPTOM CHECK

A

B

C

D

WT

F

G

H

I

J

K

L

M

N

O

P

DIAGNOSIS AND REPAIR WORK FLOW

< BASIC INSPECTION >

1. Set the vehicle to READY.
2. Drive for 10 minutes at a speed of 40 km/h (25 MPH) or more, then stop the vehicle.

CAUTION:

Total time driving at a speed of 40 km/h (25 MPH) or more must be 10 minutes.

>> GO TO 8.

8. IDENTIFY ERROR-DETECTED SYSTEM BY SYMPTOM DIAGNOSIS

Estimate error-detected system based on symptom diagnosis.

>> GO TO 10.

9. FINAL CHECK (WHEN DTC WAS DETECTED)

 **With CONSULT**

Perform "DTC CONFIRMATION PROCEDURE" with displayed DTC.

Is any DTC detected?

YES >> GO TO 6.

NO >> INSPECTION END

10. FINAL CHECK (WHEN SYMPTOM OCCURRED)

Make sure that the symptom is not detected.

Does symptom remain?

YES >> GO TO 8.

NO >> INSPECTION END

ADDITIONAL SERVICE WHEN REPLACING BCM

< BASIC INSPECTION >

ADDITIONAL SERVICE WHEN REPLACING BCM

Description

INFOID:000000007635429

When replacing BCM, tire pressure sensor ID registration is required.

Work Procedure

INFOID:000000007635430

1. PERFORM TIRE PRESSURE SENSOR ID REGISTRATION

Perform tire pressure sensor ID registration.

>> Refer to [WT-22. "Work Procedure"](#).

A

B

C

D

WT

F

G

H

I

J

K

L

M

N

O

P

TIRE PRESSURE SENSOR ID REGISTRATION

< BASIC INSPECTION >

TIRE PRESSURE SENSOR ID REGISTRATION

Description

INFOID:000000007635431

This procedure must be done after replacing or rotating wheels, replacing tire pressure sensor or BCM.

Work Procedure

INFOID:000000007635432

1. TIRE PRESSURE SENSOR ID REGISTRATION PROCEDURE

CAUTION:

To perform ID registration, observe the following points:

- Never register ID in a place where radio waves are interfered (e.g. radio tower).
- Never register ID in a place close to vehicles including TPMS.

Ⓟ With CONSULT

1. Display the "WORK SUPPORT" screen and select "ID REGIST".

Is the tire pressure sensor activation tool (J-45295) used for the tire pressure sensor ID registration procedure?

- YES >> GO TO 2.
NO >> GO TO 3.

2. TIRE PRESSURE SENSOR ID REGISTRATION PROCEDURE (WITH TIRE PRESSURE SENSOR ACTIVATION TOOL)

1. Turn the power switch ON.
2. Select the start button on the "ID REGIST" screen.
3. Contact the tire pressure sensor activation tool (J-45295) (1) to the side of the tire at the location to the tire pressure sensor.
4. Press and hold the tire pressure sensor activation tool button while pushing the tool to the tire surface. (approximately for 5 seconds)

CAUTION:

Perform the ID registration procedure starting from the vehicle front left wheel, then repeat the procedure in the order of the front right wheel, rear right wheel, and rear left wheel.

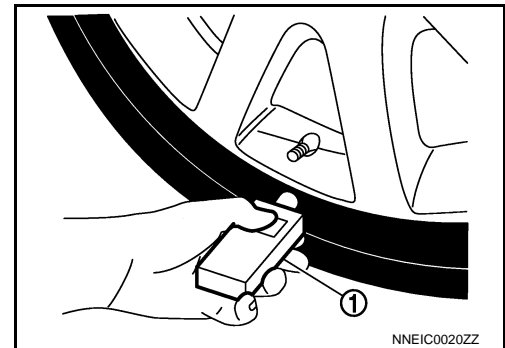

NNEIC0020ZZ

5. When ID registration is completed, check the following pattern at each wheel.

Sequence	ID registration position	Hazard warning lamp	CONSULT
1	Front left wheel	2 blinks	"Red" ↓ "Green"
2	Front right wheel		
3	Rear right wheel		
4	Rear left wheel		

6. After the ID registration procedure for all wheels is completed, press "END" to end ID registration, and check that ID registration for all wheels is completed.

Is the check result normal?

- YES >> ID registration END.
NO >> Refer to [WT-40. "Diagnosis Procedure"](#).

3. TIRE PRESSURE SENSOR ID REGISTRATION PROCEDURE (WITHOUT TIRE PRESSURE SENSOR ACTIVATION TOOL)

1. Adjust the tire pressure for all wheels to match the list below.

TIRE PRESSURE SENSOR ID REGISTRATION

< BASIC INSPECTION >

Tire position	Tire pressure kPa (kg/cm ² , psi)
Front LH	240 (2.4, 35)
Front RH	220 (2.2, 31)
Rear RH	200 (2.0, 29)
Rear LH	180 (1.8, 26)

2. Drive the vehicle at a speed at more than 40 km/h (25 MPH) for 3 minutes or more, then perform the tire pressure sensor ID registration procedure.
3. After ID registration for all wheels is completed, press "END" to end ID registration.

ID registration position	CONSULT
Front LH	"Red" ↓ "Green"
Front RH	
Rear RH	
Rear LH	

4. Adjust the tire pressures for all wheels to the specified value. Refer to [WT-50. "Tire Air Pressure"](#).

Is ID registrations for all wheels completed?

YES >> ID registration END.

NO >> Performs trouble-diagnosis of the Tire Pressure Monitoring System (TPMS). Refer to [BCS-56. "DTC Index"](#).

A
B
C
D
E
F
G
H
I
J
K
L
M
N
O
P

WT

C1704, C1705, C1706, C1707 LOW TIRE PRESSURE

< DTC/CIRCUIT DIAGNOSIS >

DTC/CIRCUIT DIAGNOSIS

C1704, C1705, C1706, C1707 LOW TIRE PRESSURE

DTC Logic

INFOID:000000007635433

DTC DETECTION LOGIC

DTC	Display Item	Malfunction detected condition	Possible causes
C1704	LOW PRESSURE FL	Front LH tire pressure drops to * kPa (* kg/cm ² , * psi) or less.	Low tire pressure
C1705	LOW PRESSURE FR	Front RH tire pressure drops to * kPa (* kg/cm ² , * psi) or less.	
C1706	LOW PRESSURE RR	Rear RH tire pressure drops to * kPa (* kg/cm ² , * psi) or less.	
C1707	LOW PRESSURE RL	Rear LH tire pressure drops to * kPa (* kg/cm ² , * psi) or less.	

*:196.5 kPa (2.0 kg/cm², 28 psi) [Standard air pressure is for 250 kPa (2.5 kg/cm², 36 psi) vehicles.]

DTC CONFIRMATION PROCEDURE

1. PERFORM DTC CONFIRMATION

With CONSULT

1. Turn the power switch ON.

CAUTION:

Never set the vehicle to READY.

2. Check the tire pressure for all wheels and adjust to the specified value. Refer to [WT-50, "Tire Air Pressure"](#).
3. Perform self-diagnosis for "AIR PRESSURE MONITOR" of "BCM".

Is DTC "C1704", "C1705", "C1706", or "C1707" detected?

- YES >> Proceed to [WT-24, "Diagnosis Procedure"](#).
 NO >> INSPECTION END

Diagnosis Procedure

INFOID:000000007635434

1. TIRE PRESSURE SENSOR ID REGISTRATION

Perform tire pressure sensor ID registration. Refer to [WT-22, "Work Procedure"](#).

Is tire pressure sensor ID registration completed?

- YES >> GO TO 2.
 NO >> Replace applicable tire pressure sensor. Refer to [WT-47, "Removal and Installation"](#).

2. CHECK TIRE PRESSURE

Check the air pressure of all wheels. Refer to [WT-50, "Tire Air Pressure"](#).

CAUTION:

If the checked value is close to the standard, reduce the tire pressure, and then with the power switch ON, adjust the tire pressure again so that it is within the standard.

Is the inspection result normal?

- YES >> Perform "DTC CONFIRMATION PROCEDURE" (self-diagnosis) again. Refer to [BCS-56, "DTC Index"](#).
 NO >> After adjusting the air pressure, GO TO 3

3. CHECK TIRE PRESSURE SIGNAL

With CONSULT

1. Select "DATA MONITOR" in "AIR PRESSURE MONITOR" of "BCM".
2. Check that the tire pressures match the standard value.

Monitor item	Displayed value
AIR PRESS FL	Approximately equal to the indication on tire gauge value for front LH tire
AIR PRESS FR	Approximately equal to the indication on tire gauge value for front RH tire

C1704, C1705, C1706, C1707 LOW TIRE PRESSURE

< DTC/CIRCUIT DIAGNOSIS >

Monitor item	Displayed value
AIR PRESS RR	Approximately equal to the indication on tire gauge value for rear RH tire
AIR PRESS RL	Approximately equal to the indication on tire gauge value for rear LH tire

Is the inspection result normal?

- YES >> After erasing DTC record, INSPECTION END.
- NO >> Repair or replace error-detected parts.

A
B
C
D
WT
F
G
H
I
J
K
L
M
N
O
P

C1708, C1709, C1710, C1711 TIRE PRESSURE SENSOR

< DTC/CIRCUIT DIAGNOSIS >

C1708, C1709, C1710, C1711 TIRE PRESSURE SENSOR

DTC Logic

INFOID:000000007635435

DTC DETECTION LOGIC

DTC	Display Item	Malfunction detected condition	Possible causes
C1708	[NO DATA] FL	Tire pressure data signal from the front LH wheel tire pressure sensor cannot be detected.	<ul style="list-style-type: none">• Harness or connector (Tire pressure receiver, BCM)• Tire pressure sensor ID registration incomplete• Tire pressure sensor• Tire pressure sensor battery voltage• Driving in area where radio wave cannot be transmitted/received.
C1709	[NO DATA] FR	Tire pressure data signal from the front RH wheel tire pressure sensor cannot be detected.	
C1710	[NO DATA] RR	Tire pressure data signal from the rear RH wheel tire pressure sensor cannot be detected.	
C1711	[NO DATA] RL	Tire pressure data signal from the rear LH wheel tire pressure sensor cannot be detected.	

DTC CONFIRMATION PROCEDURE

1. TIRE PRESSURE SENSOR ID REGISTRATION

Perform tire pressure sensor ID registration. Refer to [WT-22, "Work Procedure"](#).

>> GO TO 2.

2. PERFORM DTC CONFIRMATION

With CONSULT

1. Drive the vehicle at 40 km/h (25 MPH) or more for 10 minutes.

CAUTION:

Total time driving at a speed of 40 km/h (25 MPH) or more must be 10 minutes.

NOTE:

Avoid driving in area where radio wave cannot be transmitted/received.

2. Stop the vehicle.
3. Perform self-diagnosis for "AIR PRESSURE MONITOR" of "BCM".

Is DTC "C1708", "C1709", "C1710" or "C1711" detected?

- YES >> Proceed to [WT-26, "Diagnosis Procedure"](#).
NO >> INSPECTION END

Diagnosis Procedure

INFOID:000000007635436

1. CHECK TIRE PRESSURE SIGNAL

With CONSULT

1. Select "DATA MONITOR" in "AIR PRESSURE MONITOR" of "BCM".
2. Check the values that are displayed for "AIR PRESS FL", "AIR PRESS FR", "AIR PRESS RR", and "AIR PRESS RL".

Are all tire pressures displayed 0 kPa (kg/cm², psi)?

- YES >> GO TO 2.
NO >> Replace applicable tire pressure sensor. Refer to [WT-47, "Removal and Installation"](#).

2. CHECK RECEIVER CIRCUIT

1. Turn the power switch OFF.
2. Check 10A fuse (#7).
CAUTION:
Check that the fuse is not blown, that there are no other abnormalities, and that the fuse is of the specified capacity.
3. Disconnect BCM harness connector and tire pressure receiver harness connector.
4. Check the continuity between BCM harness connector and tire pressure receiver harness connector.

C1708, C1709, C1710, C1711 TIRE PRESSURE SENSOR

< DTC/CIRCUIT DIAGNOSIS >

BCM		Tire pressure receiver		Continuity
Connector	Terminal	Connector	Terminal	
M68	18	M75	4	Existed
	38		2	

5. Check the continuity between BCM harness connector and ground.

BCM		—	Continuity
Connector	Terminal		
M68	18	Ground	Not existed
	38		

Is the inspection result normal?

YES >> GO TO 3.

NO >> Repair or replace error-detected parts.

3. CHECK TIRE PRESSURE RECEIVER POWER SUPPLY CIRCUIT

1. Connect tire pressure receiver harness connector.
2. Check the voltage between tire pressure receiver harness connector and the ground when the power switch is turned ON and OFF.

CAUTION:

Never set the vehicle to READY.

Tire pressure receiver		—	Voltage
Connector	Terminal		
M75	1	Ground	9 – 16 V

Is the inspection result normal?

YES >> GO TO 4.

NO >> Repair or replace error-detected parts.

4. CHECK TIRE PRESSURE SIGNAL

Check the function tire pressure receiver. Refer to [DLK-94, "Component Function Check"](#).

Is the inspection result normal?

YES >> Replace the BCM.

NO >> Repair or replace error-detected parts.

C1716, C1717, C1718, C1719 TIRE PRESSURE SENSOR

< DTC/CIRCUIT DIAGNOSIS >

C1716, C1717, C1718, C1719 TIRE PRESSURE SENSOR

DTC Logic

INFOID:000000007635437

DTC DETECTION LOGIC

DTC	Display Item	Malfunction detected condition	Possible causes
C1716	[PRESSDATA ERR] FL	Malfunction in the tire pressure data from the front LH wheel tire pressure sensor.	<ul style="list-style-type: none">Excessive tire pressureTire pressure sensor ID registration incompleteTire pressure sensor
C1717	[PRESSDATA ERR] FR	Malfunction in the tire pressure data from the front RH wheel tire pressure sensor.	
C1718	[PRESSDATA ERR] RR	Malfunction in the tire pressure data from the rear RH wheel tire pressure sensor.	
C1719	[PRESSDATA ERR] RL	Malfunction in the tire pressure data from the rear LH wheel tire pressure sensor.	

DTC CONFIRMATION PROCEDURE

1. PERFORM DTC CONFIRMATION

With CONSULT

- Turn the power switch ON.

CAUTION:

Never set the vehicle to READY.

- Check the tire pressure for all wheels and adjust to the specified value. Refer to [WT-50, "Tire Air Pressure"](#).

CAUTION:

If the tire pressure before adjustment is close to the standard, reduce the tire pressure, and then with the power switch ON, adjust the tire pressure again so that it is within the standard.

- Perform self-diagnosis in "AIR PRESSURE MONITOR" of "BCM".

Is DTC "C1716", "C1717", "C1718", or "C1719" detected?

- YES >> GO TO 2.
NO >> INSPECTION END

2. CHECK LOW TIRE PRESSURE WARNING LAMP

Check that after the power switch is turned ON, the low tire pressure warning lamp illuminates for approximately 1 second and then turns OFF.

Is the inspection result normal?

- YES >> After erase DTC, INSPECTION END.
NO >> Leave the power switch ON and proceed to [WT-28, "Diagnosis Procedure"](#).

Diagnosis Procedure

INFOID:000000007635438

1. PERFORM TIRE PRESSURE SENSOR ID REGISTRATION

Perform tire pressure sensor ID registration for all wheels. Refer to [WT-22, "Work Procedure"](#).

Is tire pressure sensor ID registration completed?

- YES >> GO TO 2.
NO >> Replace tire pressure sensor. Refer to [WT-47, "Removal and Installation"](#).

2. CHECK TIRE PRESSURE SIGNAL

With CONSULT

- Check the tire pressure for all wheels and adjust to the specified value. Refer to [WT-50, "Tire Air Pressure"](#).
- Stop the vehicle.
- Select "DATA MONITOR" in "AIR PRESSURE MONITOR" of "BCM".
- Within 15 minutes after vehicle stopped, read the values that are displayed for "AIR PRESS FL", "AIR PRESS FR", "AIR PRESS RR", and "AIR PRESS RL".

Which tire pressures is displayed as 438.60 kPa (4.47 kg/cm², 63.60 psi)?

C1716, C1717, C1718, C1719 TIRE PRESSURE SENSOR

< DTC/CIRCUIT DIAGNOSIS >

- YES >> Replace tire pressure sensor the tire pressure as 438.60 kPa (4.47 kg/cm², 63.60 psi) displayed. Refer to [WT-47, "Removal and Installation"](#).
- NO >> Perform "DTC CONFIRMATION PROCEDURE" (self-diagnosis) again. Refer to [BCS-56, "DTC Index"](#).

A

B

C

D

WT

F

G

H

I

J

K

L

M

N

O

P

C1729 VEHICLE SPEED SIGNAL

< DTC/CIRCUIT DIAGNOSIS >

C1729 VEHICLE SPEED SIGNAL

DTC Logic

INFOID:000000007635439

DTC DETECTION LOGIC

DTC	Display Item	Malfunction detected condition	Possible causes
C1729	VHCL SPEED SIG ERR	Vehicle speed signal not detected.	<ul style="list-style-type: none">• CAN communication• BCM• ABS actuator and electric unit (control unit) malfunction

DTC CONFIRMATION PROCEDURE

1. DTC CONFIRMATION PROCEDURE

Ⓟ With CONSULT

1. Drive the vehicle.
2. Stop the vehicle.
3. Perform self-diagnosis in "AIR PRESSURE MONITOR" of "BCM".

Is DTC "C1729" detected?

- YES >> Proceed to [WT-30, "Diagnosis Procedure"](#).
NO >> INSPECTION END

Diagnosis Procedure

INFOID:000000007635440

1. PERFORM ABS ACTUATOR AND ELECTRIC UNIT (CONTROL UNIT) SELF-DIAGNOSIS

Ⓟ With CONSULT

Perform self-diagnosis for "ABS".

Is any DTCs detected?

- YES >> Check the DTCs.
NO >> GO TO 2.

2. CHECK BCM INPUT/OUTPUT SIGNAL

Check BCM input/output signal values. Refer to [BCS-34, "Reference Value"](#).

Is the inspection result normal?

- YES >> Check pin terminal and connection of each harness connector for malfunctioning conditions.
NO >> Replace the BCM. Refer to [BCS-77, "Removal and Installation"](#).

POWER SUPPLY AND GROUND CIRCUIT

< DTC/CIRCUIT DIAGNOSIS >

POWER SUPPLY AND GROUND CIRCUIT

Diagnosis Procedure

INFOID:000000007635441

1. CHECK BCM POWER SUPPLY AND GROUND CIRCUIT

Check BCM power supply and ground. Refer to [BCS-71, "Diagnosis Procedure"](#).

Is the inspection result normal?

YES >> INSPECTION END

NO >> Repair open circuit or short to ground or short to power in harness or connectors.

A
B
C
D
E
F
G
H
I
J
K
L
M
N
O
P

WT

< SYMPTOM DIAGNOSIS >

SYMPTOM DIAGNOSIS

TPMS















Symptom Table

INFOID:000000007635442

LOW TIRE PRESSURE WARNING LAMP SYMPTOM CHART

TPMS

< SYMPTOM DIAGNOSIS >

Diagnosis items	Symptom (Power switch ON)	Low tire pressure warning lamp	Cause	Action
Low tire pressure warning lamp	The low tire pressure warning lamp illuminates for 1 second, then turns OFF.	  ON 1 sec > stays OFF <small>SEIA0592E</small>	Wake-up operation for all tire pressure sensors at wheels is completed.	No system malfunctions
	The low tire pressure warning lamp repeats blinking ON for 2 seconds and OFF for 0.2 seconds.	 Blinks:  ON 2 sec > OFF 0.2 sec <small>SEIA0593E</small>	Wake-up operation for all tire pressure sensors at wheels is not completed.	Perform the ID registration for all tire pressure sensors at wheels. Refer to WT-22, "Work Procedure" .
	The low tire pressure warning lamp blinks once.	 Blinks 1 time ON 0.3 sec > OFF 1.0 sec <small>JPEIC0090GB</small>	The front left tire pressure sensor is not activated.	Perform the ID registration for the tire pressure sensor at front left wheel. Refer to WT-22, "Work Procedure" .
	The low tire pressure warning lamp repeats blinking twice.	  Blinks 2 times ON 0.3 sec > OFF 0.3 sec <small>SEIA0595E</small>	The front right tire pressure sensor is not activated.	Perform the ID registration for the tire pressure sensor at front right wheel. Refer to WT-22, "Work Procedure" .
	The low tire pressure warning lamp repeats blinking for 3 times.	   Blinks 3 times ON 0.3 sec > OFF 0.3 sec <small>SEIA0596E</small>	The rear right tire pressure sensor is not activated.	Perform the ID registration for the tire pressure sensor at rear right wheel. Refer to WT-22, "Work Procedure" .
	The low tire pressure warning lamp repeats blinking for 4 times.	    Blinks 4 times ON 0.3 sec > OFF 0.3 sec <small>SEIA0597E</small>	The rear left tire pressure sensor is not activated.	Perform the ID registration for the tire pressure sensor at rear left wheel. Refer to WT-22, "Work Procedure" .
	The low tire pressure warning lamp turns ON and stays illuminated.	 Comes ON and stays ON <small>SEIA0598E</small>	Low tire pressure	Check the tire pressure for all wheels and adjust to the specified value. Refer to WT-50, "Tire Air Pressure" .

A
B
C
D
E
F
G
H
I
J
K
L
M
N
O
P

WT

TPMS

< SYMPTOM DIAGNOSIS >

Diagnosis items	Symptom (Power switch ON)	Low tire pressure warning lamp	Cause	Action
Low tire pressure warning lamp	The low tire pressure warning lamp repeats blinking at 0.5-second intervals for 1 minute, and then stays illuminated.	 <p style="text-align: center;">Blinks 1 min</p> <p style="text-align: center;">ON 0.5 sec > OFF 0.5 sec and stays ON</p> <p style="text-align: center;"><small>SEIA0788E</small></p>	The combination meter fuse is open or removed (or pulled out).	Check and install the combination meter fuse. If necessary, replace the fuse.
			The BCM harness connector is removed.	Check the connection conditions of the BCM harness connector, and repair if necessary.
			Tire Pressure Monitoring System (TPMS) malfunction.	<ul style="list-style-type: none"> Perform CONSULT self-diagnosis. Refer to WT-15, "AIR PRESSURE MONITOR : CONSULT Function (BCM - AIR PRESSURE MONITOR)". If necessary, perform tire pressure sensor ID registration. Refer to WT-22, "Work Procedure".

NOTE:

If tire pressure sensor wake-up operation is not completed for two or more tire pressure sensors, the applicable low tire pressure warning lamp blinking patterns are displayed continuously.
 (Example: Blinks once/OFF/blinks 3 times = Wake-up operation is not completed at the front left wheel and rear right wheel tire pressure sensors.)

LOW TIRE PRESSURE WARNING LAMP DOES NOT TURN ON

< SYMPTOM DIAGNOSIS >

LOW TIRE PRESSURE WARNING LAMP DOES NOT TURN ON

Description

INFOID:000000007635443

The low tire pressure warning lamp does not illuminate when the power switch is turned ON.

NOTE:

The low tire pressure warning lamp illuminates for approximately 1 second and then turns OFF when the power switch is turned ON. This is to check that no abnormal condition is present in the tire pressure monitoring system.

The lamp bulb may be burnt out or the tire pressure monitoring system may be malfunctioning if the low tire pressure warning lamp does not illuminate when the power switch is turned ON.

Diagnosis Procedure

INFOID:000000007635444

1. CHECK LOW TIRE PRESSURE WARNING LAMP SIGNAL

With CONSULT

1. Turn the power switch ON.

CAUTION:

Never set the vehicle to READY.

2. Select "ACTIVE TEST" in "AIR PRESSURE MONITOR" of "BCM".
3. Touch "WARNING LAMP" to turn ON the low tire pressure warning lamp.

When "ACTIVE TEST" is performed, does the low tire pressure warning lamp in the combination meter turn ON?

YES >> GO TO 2.

NO >> GO TO 3.

2. CHECK LOW TIRE PRESSURE WARNING LAMP OPERATION

Check that the low tire pressure warning lamp is turned OFF after turns ON for approximately 1 second, when the power switch is turned ON.

Is the inspection result normal?

YES >> Check intermittent incident. Refer to [GI-51, "Intermittent Incident"](#).

NO >> Replace the BCM. Refer to [BCS-77, "Removal and Installation"](#).

3. CHECK COMBINATION METER POWER SUPPLY CIRCUIT

Perform the trouble diagnosis for combination meter power supply circuit. Refer to [WT-31, "Diagnosis Procedure"](#).

Is the inspection result normal?

YES-1 >> INSPECTION END

NO >> Repair or replace error-detected parts.

A
B
C
D
E
F
G
H
I
J
K
L
M
N
O
P

WT

LOW TIRE PRESSURE WARNING LAMP DOES NOT TURN OFF

< SYMPTOM DIAGNOSIS >

LOW TIRE PRESSURE WARNING LAMP DOES NOT TURN OFF

Description

INFOID:000000007635445

The low tire pressure warning lamp does not turn OFF after several seconds is passed after set the vehicle to READY.

Diagnosis Procedure

INFOID:000000007635446

1. CHECK TIRE PRESSURE

1. Turn the power switch ON.

CAUTION:

Never set the vehicle to READY.

2. Check the tire pressure for all wheels and adjust to the specified value. Refer to [WT-50, "Tire Air Pressure"](#).

Is the inspection result normal?

YES >> GO TO 2.

NO >> Inspect or repair the tires or wheels.

2. CHECK LOW TIRE PRESSURE WARNING LAMP

Check low tire pressure warning lamp display.

Does not low tire pressure warning lamp turn OFF?

YES >> GO TO 3.

NO >> INSPECTION END

3. CHECK BCM

Ⓟ **With CONSULT**

Perform "SELF-DIAG RESULTS" in "AIR PRESSURE MONITOR" of "BCM".

Is any DTC detected?

YES >> Check the DTC. Refer to [BCS-56, "DTC Index"](#).

NO >> GO TO 4.

4. CHECK BCM POWER SUPPLY AND GROUND CIRCUIT

Perform the trouble diagnosis for power supply and ground circuit. Refer to [WT-31, "Diagnosis Procedure"](#).

Is the inspection result normal?

YES >> Replace the BCM. Refer to [BCS-77, "Removal and Installation"](#).

NO >> Repair or replace error-detected parts.

LOW TIRE PRESSURE WARNING LAMP BLINKS

< SYMPTOM DIAGNOSIS >

LOW TIRE PRESSURE WARNING LAMP BLINKS

Description

INFOID:000000007635447

The low tire pressure warning lamp blinks when the power switch is turned ON.

NOTE:

The position of an inactive tire pressure sensor can be identified by checking the blinking timing of the low tire pressure warning lamp.

Low tire pressure warning lamp blinking timing		Activation tire position
ON OFF		a : 0.3 sec. b : 1.0 sec. Front LH
ON OFF		a : 0.3 sec. b : 1.0 sec. Front RH
ON OFF		a : 0.3 sec. b : 1.0 sec. Rear RH
ON OFF		a : 0.3 sec. b : 1.0 sec. Rear LH
ON OFF		a : 2 sec. b : 0.2 sec. All tires

JPEIC0089GB

Diagnosis Procedure

INFOID:000000007635448

1. TIRE PRESSURE SENSOR ID REGISTRATION

Perform tire pressure sensor ID registration. Refer to [WT-22, "Work Procedure"](#).

Is tire pressure sensor ID registration completed?

YES >> INSPECTION END

NO >> Perform the self-diagnosis for "AIR PRESSURE MONITOR" of "BCM". Refer to [BCS-56, "DTC Index"](#).

EASY FILL TIRE ALERT DOES NOT ACTIVATE

< SYMPTOM DIAGNOSIS >

EASY FILL TIRE ALERT DOES NOT ACTIVATE

Description

INFOID:000000007635449

The easy fill tire alert does not function while inflating a tire when the select lever position is in P-range with the power switch ON or with the set the vehicle to READY.

NOTE:

- After starting to inflate the tire, it takes a few seconds for the easy fill tire alert to function.
- If there is no response for approximately 15 seconds or more after inflating the tires, cancel the use of the easy fill tire alert function or move the vehicle approximately 1 m (3.2 ft) backward or forward to try again. The air filler pressure may be weak or out of service area.
- For easy fill tire alert, Refer to [WT-11, "Easy Fill Tire Alert Function"](#).

Diagnosis Procedure

INFOID:000000007635450

1. LOCATION CHANGE

Move the vehicle to other area and repeat the procedure of the easy fill tire alert function. Refer to [WT-11, "Easy Fill Tire Alert Function"](#).

Is the function normal?

- YES >> Normal (the easy fill tire alert may not operate, depending on reception condition.)
NO >> GO TO 2.

2. PERFORM BCM SELF-DIAGNOSIS

With CONSULT

Perform self-diagnosis for "AIR PRESSURE MONITOR" of "BCM".

Is any DTC detected?

- YES >> Perform trouble diagnosis for detected DTC. Refer to [BCS-56, "DTC Index"](#).
NO >> GO TO 3.

3. CHECK HAZARD WARNING LAMP OPERATION

Check hazard warning lamp operation with hazard switch.

Does the hazard warning lamp blink?

- YES >> GO TO 4.
NO >> Perform trouble diagnosis for the hazard warning lamp. Refer to [EXL-77, "Diagnosis Procedure"](#).

4. PERFORM ELECTRIC SHIFT CONTROL MODULE SELF-DIAGNOSIS

With CONSULT

Perform self-diagnosis for "SHIFT".

Is any DTC detected?

- YES >> Check malfunctioning circuit. Refer to [TM-47, "DTC Index"](#).
NO >> GO TO 5.

5. CHECK HORN OPERATION

Check horn operation. Refer to [SEC-85, "Component Function Check"](#).

Is the operation normal?

- YES >> GO TO 6.
NO >> Repair or replace error-detected parts.

6. PERFORM BCM SELF-DIAGNOSIS

With CONSULT

1. Drive for 10 minutes at a speed of 40 km/h (25 MPH) or more.

CAUTION:

Total time driving at a speed of 40 km/h (25 MPH) or more must be 10 minutes.

2. Stop the vehicle.

3. Perform self-diagnosis for "AIR PRESSURE MONITOR" of "BCM".

Is any DTC detected?

- YES >> Check malfunctioning circuit. Refer to [BCS-56, "DTC Index"](#).

EASY FILL TIRE ALERT DOES NOT ACTIVATE

< SYMPTOM DIAGNOSIS >

NO >> Replace BCM. Refer to [BCS-77. "Removal and Installation"](#).

A

B

C

D

WT

F

G

H

I

J

K

L

M

N

O

P

TIRE PRESSURE SENSOR ID REGISTRATION CANNOT BE COMPLETED

< SYMPTOM DIAGNOSIS >

TIRE PRESSURE SENSOR ID REGISTRATION CANNOT BE COMPLETED

Description

INFOID:000000007635451

The ID of the tire pressure sensor installed in each wheel cannot be registered in the tire pressure monitoring system. Inspect the tire pressure sensor or the tire pressure monitoring system circuit.

Diagnosis Procedure

INFOID:000000007635452

1. CHECK TIRE PRESSURE SENSOR ACTIVATION TOOL

Check tire pressure sensor activation tool.

Is the inspection result normal?

YES >> GO TO 2.

NO >> Replace the battery of tire pressure sensor activation tool or repair/replace the tire pressure sensor activation tool.

2. TIRE PRESSURE SENSOR ID REGISTRATION

Perform tire pressure sensor ID registration. Refer to [WT-22, "Work Procedure"](#).

CAUTION:

To perform ID registration, observe the following points:

- Never register ID in a place where radio waves are interfered (e.g. radio tower).
- Never register ID in a place close to vehicles including TPMS.

Is tire pressure sensor ID registration completed?

YES >> INSPECTION END

NO >> GO TO 3.

3. CHECK TIRE PRESSURE SIGNAL

Change the work location and perform ID registration again.

NOTE:

Depending on the tire pressure sensor position*, a blind spot exists, and the tire pressure receiver gets a poor reception. If an ID registration is performed under this condition, the registration may not be completed. In such case, follow the instructions below to improve the radio wave receiving environment.

- Rotate tire by 90°, 180°, or 270°. (This Step is to change tire pressure sensor position.)
- Open the door close to the tire of which ID registration is ongoing.

*: Radio wave reception condition depends on vehicle architecture (e.g. body harness layout, tire wheel design) or environment.

When ID registration is performed, which wheels do not react?

All wheels react and ID registration is possible.>>INSPECTION END

Only certain wheel(s) do not react.>>Replace applicable tire pressure sensor. Refer to [WT-47, "Removal and Installation"](#).

All wheels do not react.>>Check the tire pressure receiver. Refer to [DLK-94, "Component Function Check"](#).

NOISE, VIBRATION AND HARSHNESS (NVH) TROUBLESHOOTING

< SYMPTOM DIAGNOSIS >

NOISE, VIBRATION AND HARSHNESS (NVH) TROUBLESHOOTING

NVH Troubleshooting Chart

INFOID:000000007635453

Use the chart below to find the cause of the symptom. If necessary, repair or replace these parts.

Symptom		Possible cause and SUSPECTED PARTS										Reference					
		Improper installation, looseness	Out-of-round	Unbalance	Incorrect tire pressure	Uneven tire wear	Deformation or damage	Non-uniformity	Incorrect tire size	FRONT AXLE AND FRONT SUSPENSION	REAR AXLE AND REAR SUSPENSION	TIRE	ROAD WHEELS	DRIVE SHAFT	BRAKE	STEERING	
TIRE	Noise	x	x	x	x	x	x	x		x	x		x	x	x	x	WT-45, "Exploded View" WT-45, "Inspection" WT-42, "Wheel Balance Adjustment" WT-50, "Tire Air Pressure" WT-42, "Inspection" — — WT-50, "Tire Air Pressure"
	Shake	x	x	x	x	x	x		x	x	x		x	x	x	x	
	Vibration				x				x	x	x			x		x	
	Shimmy	x	x	x	x	x	x	x	x	x	x		x		x	x	
	Judder	x	x	x	x	x	x		x	x	x		x		x	x	
	Poor quality ride or handling	x	x	x	x	x	x		x	x		x	x				
	Noise	x	x	x			x			x	x	x		x	x	x	
	Shake	x	x	x			x			x	x	x		x	x	x	
ROAD WHEEL	Shimmy, Judder	x	x	x			x			x	x	x			x	x	
	Poor quality ride or handling	x	x	x			x			x	x	x					

x: Applicable

A
B
C
D
E
F
G
H
I
J
K
L
M
N
O
P

WT

ROAD WHEEL

< PERIODIC MAINTENANCE >

PERIODIC MAINTENANCE

ROAD WHEEL

Inspection

INFOID:000000007635454

APPEARANCE

Check the road wheel for bend, damage, crack or wear.

Wheel Balance Adjustment

INFOID:000000007635455

PREPARATION BEFORE ADJUSTMENT

Using releasing agent, remove double-faced adhesive tape from the road wheel.

CAUTION:

- Be careful not to scratch the road wheel during removal.
- After removing double-faced adhesive tape, wipe clean traces of releasing agent from the road wheel.

ADJUSTMENT

- The details of the adjustment procedure are different for each model of wheel balancer. Therefore, refer to each instruction manual.
- If a tire balance machine has adhesion balance weight mode settings and drive-in weight mode setting, select and adjust a drive-in weight mode suitable for aluminum wheels.

1. Set road wheel on tire balance machine using the center hole as a guide. Start the tire balance machine.
2. When inner and outer unbalance values are shown on the tire balance machine indicator, multiply outer unbalance value by $5/3$ to determine balance weight that should be used. Select the outer balance weight with a value closest to the calculated value above and install to the designated outer position of, or at the designated angle in relation to the road wheel.

CAUTION:

- Never install the inner balance weight before installing the outer balance weight.
- Before installing the balance weight, always to clean the mating surface of the road wheel.

- a. Indicated unbalance value $\times 5/3$ = balance weight to be installed

Calculation example:

$23 \text{ g (0.81 oz)} \times 5/3 = 38.33 \text{ g (1.35 oz)} \Rightarrow 40 \text{ g (1.41 oz)}$ balance weight (closer to calculated balance weight value)

NOTE:

Note that balance weight value must be closer to the calculated balance weight value.

Example:

$37.4 \Rightarrow 35 \text{ g (1.23 oz)}$

$37.5 \Rightarrow 40 \text{ g (1.41 oz)}$

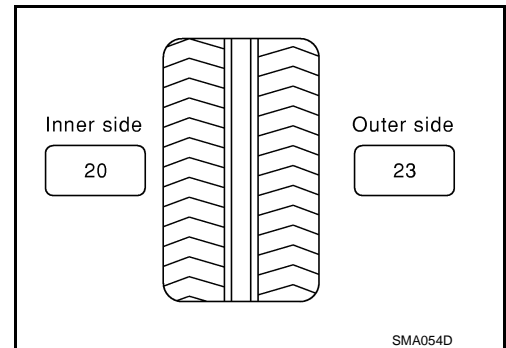

- b. Installed balance weight in the position.

ROAD WHEEL

< PERIODIC MAINTENANCE >

- When installing balance weight (1) to road wheels, set it into the grooved area (A) on the inner wall of the road wheel as shown in the figure so that the balance weight center (B) is aligned with the tire balance machine indication position (angle) (C).

CAUTION:

- Always use genuine NISSAN balance weights.
- Balance weights are non-reusable; always replace with new ones.
- Never install three or more sheets of balance weight.

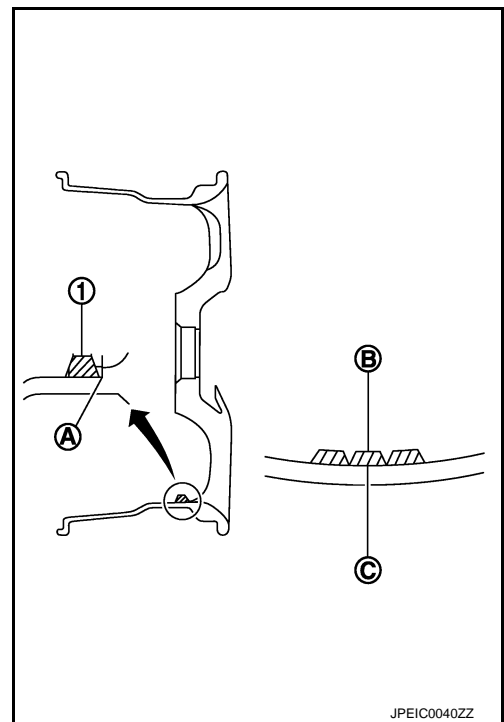

- c. If calculated balance weight value exceeds 50 g (1.76 oz), install two balance weight sheets in line with each other as shown in the figure.

CAUTION:

Never install one balance weight sheet on top of another.

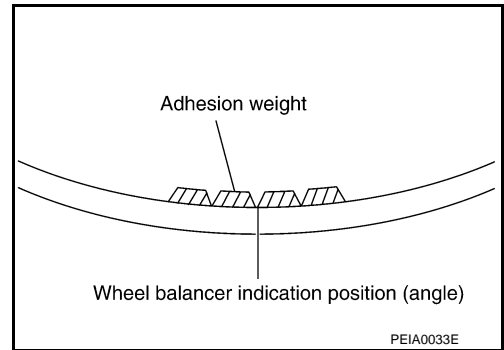

- Start the tire balance machine again.
- Install drive-in balance weight on inner side of road wheel in the tire balance machine indication position (angle).
- Start the tire balance machine. Check that the inner and outer residual unbalance value is within the allowable unbalance value.

CAUTION:

If either residual unbalance value exceeds limit, repeat installation procedures.

Allowable unbalance value

Dynamic (At flange) : Refer to [WT-50, "Road Wheel"](#).

Static (At flange) : Refer to [WT-50, "Road Wheel"](#).

ROAD WHEEL

< PERIODIC MAINTENANCE >

Tire Rotation

INFOID:000000007635456

- Follow the maintenance schedule for tire rotation service intervals. Refer to [MA-4. "FOR NORTH AMERICA : Explanation of General Maintenance"](#).
 - When installing the wheel, tighten wheel nuts to the specified torque. Refer to [WT-45. "Exploded View"](#).
- CAUTION:**
- **When installing wheels, tighten them diagonally by dividing the work two to three times in order to prevent the wheels from developing any distortion.**
 - **Be careful not to tighten wheel nut at torque exceeding the criteria.**
 - **Use NISSAN genuine wheel nut.**
- Perform the ID registration, after tire rotation. Refer to [WT-22. "Work Procedure"](#).

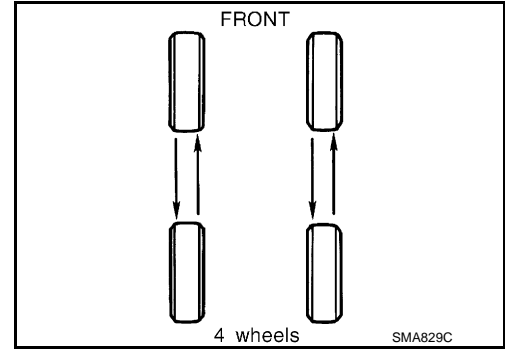

ROAD WHEEL TIRE ASSEMBLY

< REMOVAL AND INSTALLATION >

REMOVAL AND INSTALLATION

ROAD WHEEL TIRE ASSEMBLY

Exploded View

INFOID:000000007635457

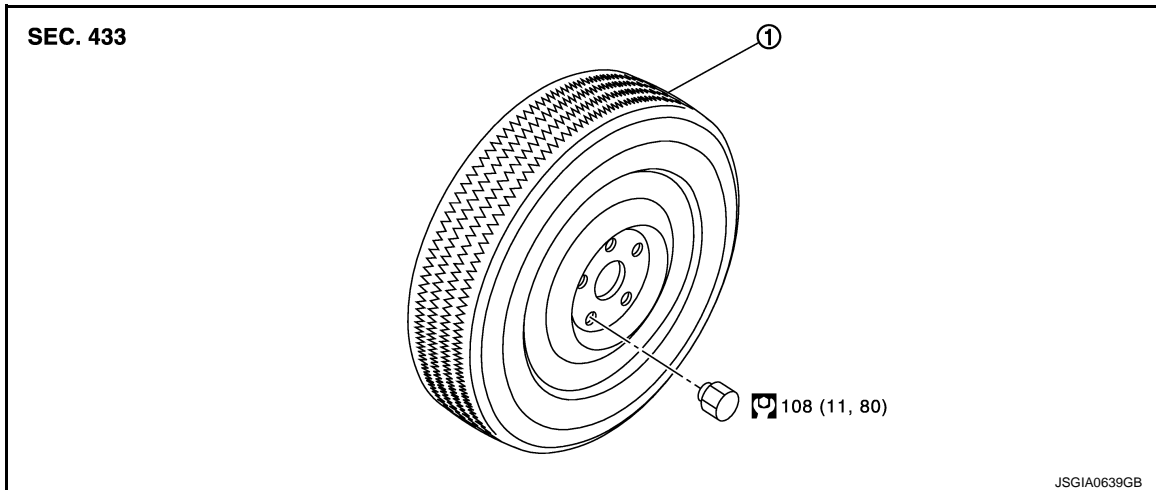

1. Tire assembly

: N·m (kg·m, ft·lb)

Removal and Installation

INFOID:000000007635458

REMOVAL

1. Remove wheel nuts.
2. Remove tire assembly.

INSTALLATION

Note the following, install in the reverse order of removal.

- When replacing or rotating wheels, perform the ID registration. Refer to [WT-22, "Work Procedure"](#).

Inspection

INFOID:000000007635459

1. Check tires for wear and improper inflation.
2. Check wheels for deformation, cracks and other damage. If deformed, remove wheel and check wheel runout.
 - a. Remove tire from aluminum wheel and mount on a tire balance machine.
 - b. Set dial indicator as shown in the figure.
 - c. Check runout, if the axial runout (A) or radial runout (B) exceeds the limit, replace aluminum wheel.

Limit

Axial runout (A) : Refer to [WT-50, "Road Wheel"](#).

Radial runout (B) : Refer to [WT-50, "Road Wheel"](#).

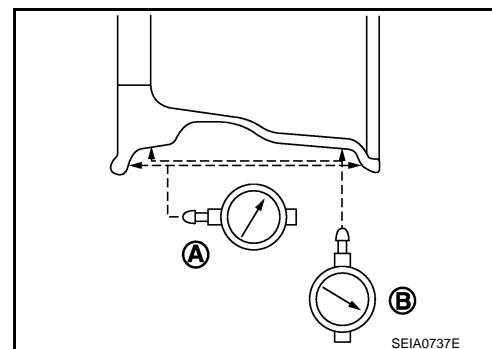

How to Handle Puncture Repair Agent

INFOID:000000007635460

CAUTION:

ROAD WHEEL TIRE ASSEMBLY

< REMOVAL AND INSTALLATION >

- **Never spill the sealant in the tire during repair.**
- **If the sealant spills, wipe it out with a waste cloth.**
- **Never reuse the repair kit hose used for a temporary repair of a flat tire because some of the puncture repair agent remains in the hose.**
- **After using a puncture repair agent, replace tire pressure sensor with a new one.**

1. Remove tires from the vehicle.
2. Remove tire from road wheel, using a tire changer.

CAUTION:

- **When deflating a tire, cover the tire pressure sensor with a waste cloth to prevent the sealant from splattering.**
- **Never spill the sealant in the tire during repair.**

3. Dispose of sealant in the removed tire.

CAUTION:

- **Wipe out sealant spilled on the road wheel, tire, tire changer, and floor with a waste cloth.**
- **Drained sealant or expired sealant returned by the customer must be disposed according to the law and local regulations.**
- Fix a tire blowout, if repairable.

NOTE:

Sealant blocks holes caused by blowouts. These holes may not be found and repaired, depending on the level of blowout. Therefore, it is necessary to check tire air pressure frequently and replace tire with a new one, if the air pressure is decreasing.

- Replace tire with a new one, if not repairable.

CAUTION:

Never dispose of tires with the sealant contained.

TIRE PRESSURE SENSOR

< REMOVAL AND INSTALLATION >

TIRE PRESSURE SENSOR

Exploded View

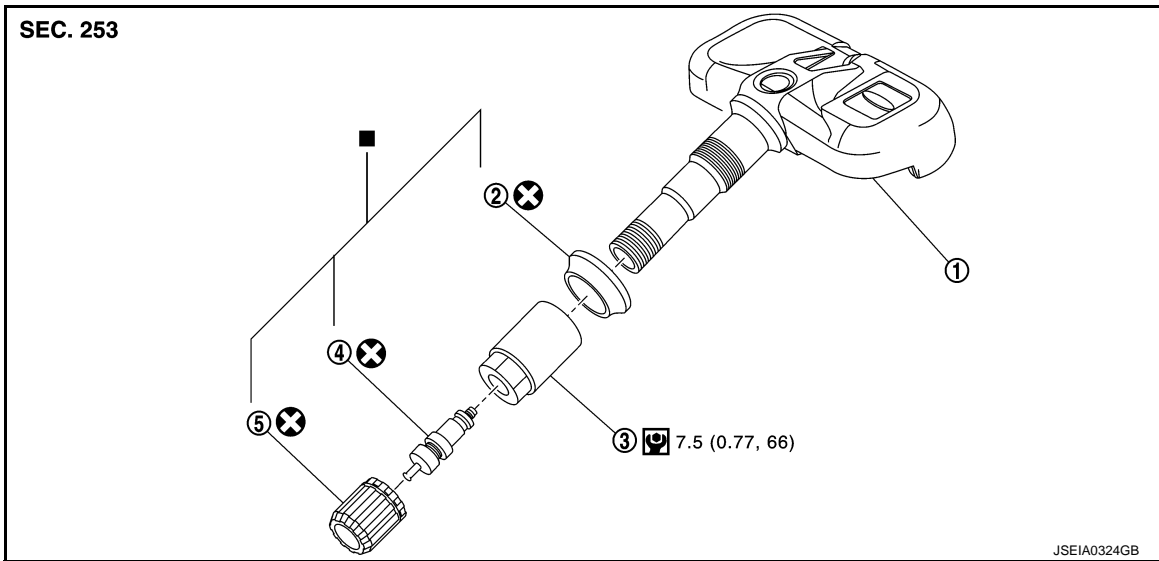

1. Tire pressure sensor
2. Grommet seal
3. Valve nut
4. Valve core
5. Valve cap

: N·m (kg·m, in·lb)

: Always replace after every disassembly.

: Parts that are replaced as a set when the tire is replaced.

Removal and Installation

INFOID:000000007635462

REMOVAL

1. Remove tire assembly. Refer to [WT-45, "Removal and Installation"](#).
2. Remove valve cap, valve core and then deflate tire.

NOTE:

If the tire is reused, apply a matching mark to the position of the tire road wheel valve hole for the purpose of wheel balance adjustment after installation.

3. Remove valve nut retaining tire pressure sensor and allow tire pressure sensor to fall into tire.
4. Use the tire changer and disengage the tire beads.

CAUTION:

- Verify that the tire pressure sensor (1) is at the bottom of the tire while performing the above.
- Be sure not to damage the road wheel or tire pressure sensor.

5. Apply bead cream or an equivalent to the tire beads.
6. Set tire onto the tire changer turntable so that the tire pressure sensor inside the tire is located close to the road wheel valve hole.

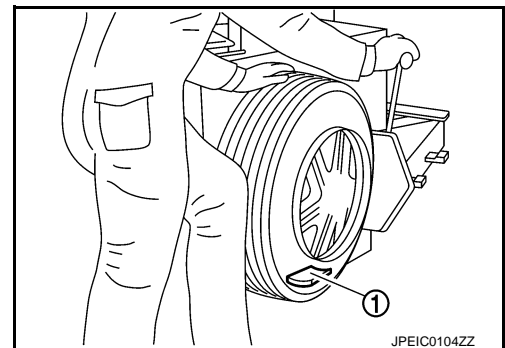

TIRE PRESSURE SENSOR

< REMOVAL AND INSTALLATION >

- Turn tire so that valve hole is at bottom and bounce so that tire pressure sensor (1) is near valve hole. Carefully lift tire onto turntable and position valve hole (and tire pressure sensor) 270 degree from mounting/dismounting head (2).

CAUTION:

Be sure not to damage the road wheel and tire pressure sensor.

- Remove tire pressure sensor from tire.
- Remove the grommet seal.

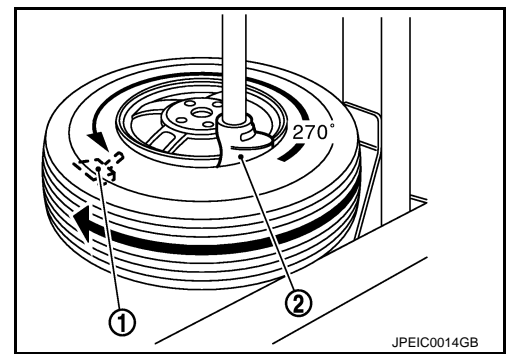

INSTALLATION

- Apply bead cream or an equivalent to the tire beads.
- Install the tire inside beads (1) onto the road wheel (2) in the position shown in the figure.
- Install grommet seal to the tire pressure sensor.

CAUTION:

- Never reuse grommet seal.
- Insert grommet seal all the way to the base.

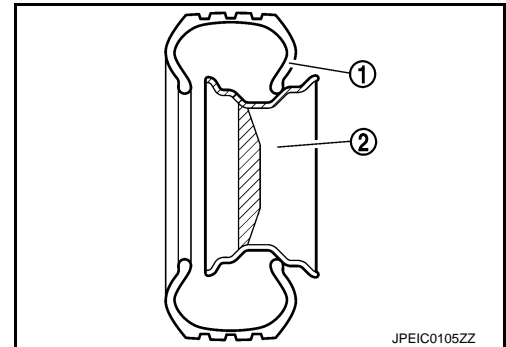

- Hold tire pressure sensor as shown in the figure, and press the sensor in the direction shown by arrow (←) to bring it into absolute contact with valve hole. After this, tighten valve nut to the specified torque.

CAUTION:

- Never reuse valve core and valve cap.
- Check that grommet seal is free of foreign matter.
- Check that grommet seal contacts horizontally with road wheel.
- Manually tighten valve nut all the way to the wheel. (Never use a power tool to avoid impact.)

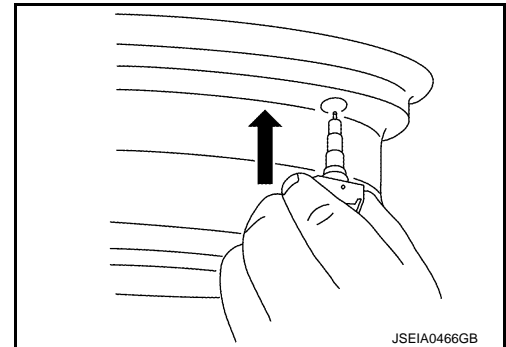

- Set the tire onto the turntable so that the tire changer arm (2) is at a position approximately 270° from the tire pressure sensor (1).

CAUTION:

Be sure that the arm does not contact the tire pressure sensor.

- Install the tire outer side beads onto the road wheel.

CAUTION:

When installing, check that the tire does not turn together with the road wheel.

- Check the tire pressure for all wheels and adjust to the specified value. Refer to [WT-50. "Tire Air Pressure"](#).

NOTE:

Before adding air, align the tire with the position of the matching mark applied at the time of removal.

- Install tire to the vehicle. Refer to [WT-45. "Removal and Installation"](#).
- Perform tire pressure sensor ID registration. Refer to [WT-22. "Work Procedure"](#).

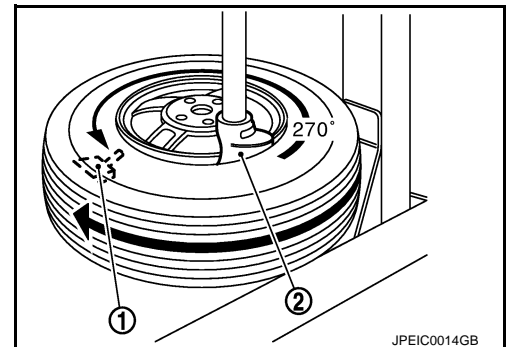

TIRE PRESSURE RECEIVER

< REMOVAL AND INSTALLATION >

TIRE PRESSURE RECEIVER

Removal and Installation

INFOID:000000007635463

REMOVAL

1. Remove the remote keyless entry receiver. (The tire pressure receiver is incorporated into remote keyless entry receiver.) Refer to [DLK-187, "Removal and Installation"](#).

INSTALLATION

Install in the reverse order of removal.

A

B

C

D

WT

F

G

H

I

J

K

L

M

N

O

P

SERVICE DATA AND SPECIFICATIONS (SDS)

< SERVICE DATA AND SPECIFICATIONS (SDS)

SERVICE DATA AND SPECIFICATIONS (SDS)

SERVICE DATA AND SPECIFICATIONS (SDS)

Road Wheel

INFOID:000000007635464

Item		Limit
Runout	Axial runout	Less than 0.3 mm (0.012 in)
	Radial runout	
Allowable unbalance	Dynamic (At flange)	Less than 5 g (0.17 oz) (one side)
	Static (At flange)	Less than 10 g (0.35 oz)

Tire Air Pressure

INFOID:000000007635465

Unit: kPa (kgf/cm², psi)

Item	Standard	
	Front	Rear
P205/55R16 89H	250 (2.5, 36)	