

SECTION **SE**
SEAT

A
B
C
D
E
F
G
H
I
SE
K
L
M
N
O
P

CONTENTS

PRECAUTION	3	HEATED SEAT SYSTEM : System Description	11
PRECAUTIONS	3	WIRING DIAGRAM	12
Precaution for Technicians Using Medical Electric.....	3	HEATED SEAT SYSTEM	12
Point to Be Checked Before Starting Maintenance		Wiring Diagram	12
Work	3	SYMPTOM DIAGNOSIS	19
Precaution for Supplemental Restraint System		SQUEAK AND RATTLE TROUBLE DIAG-	
(SRS) "AIR BAG" and "SEAT BELT PRE-TEN-		NOSES	19
SIONER"	3	Work Flow	19
Precaution for Removing 12V Battery	4	Inspection Procedure	21
Service Notice	4	Diagnostic Worksheet	23
Precaution for Work	5	REMOVAL AND INSTALLATION	25
PREPARATION	6	FRONT SEAT	25
PREPARATION	6	Exploded View	25
Special Service Tool	6	Removal and Installation	28
Commercial Service Tool	6	SEATBACK	29
CLIP LIST	7	SEATBACK : Disassembly and Assembly	29
Clip List	7	SEAT CUSHION	31
SYSTEM DESCRIPTION	8	SEAT CUSHION : Disassembly and Assembly	31
COMPONENT PARTS	8	REAR SEAT	35
HEATED SEAT SYSTEM	8	Exploded View	35
HEATED SEAT SYSTEM : Component Parts Lo-		SEATBACK	35
cation	8	SEATBACK : Removal and Installation	36
HEATED SEAT SYSTEM : Front Heated Seat		SEATBACK : Disassembly and Assembly	36
Switch	9	SEAT CUSHION	39
HEATED SEAT SYSTEM : Heated Seat Relay	9	SEAT CUSHION : Removal and Installation	39
HEATED SEAT SYSTEM : Front Seat Heater	9	SEAT CUSHION : Disassembly and Assembly	40
HEATED SEAT SYSTEM : Rear Heated Seat		SEATBACK HINGE	40
Switch	9	SEATBACK HINGE : Removal and Installation	40
HEATED SEAT SYSTEM : Rear Heated Seat Re-		SEATBACK STRIKER	42
lay	9	SEATBACK STRIKER : Removal and Installation...	42
HEATED SEAT SYSTEM : Rear Seat Heater	10		
SYSTEM	11		
HEATED SEAT SYSTEM	11		

HEATED SEAT SWITCH	43	REAR	43
FRONT	43	REAR : Removal and Installation	43
FRONT : Removal and Installation	43		

PRECAUTIONS

< PRECAUTION >

PRECAUTION

PRECAUTIONS

Precaution for Technicians Using Medical Electric

INFOID:000000009347468

OPERATION PROHIBITION

WARNING:

- Parts with strong magnet is used in this vehicle.
- Technicians using a medical electric device such as pacemaker must never perform operation on the vehicle, as magnetic field can affect the device function by approaching to such parts.

NORMAL CHARGE PRECAUTION

WARNING:

- If a technician uses a medical electric device such as an implantable cardiac pacemaker or an implantable cardioverter defibrillator, the possible effects on the devices must be checked with the device manufacturer before starting the charge operation.
- As radiated electromagnetic wave generated by PDM (Power Delivery Module) at normal charge operation may affect medical electric devices, a technician using a medical electric device such as implantable cardiac pacemaker or an implantable cardioverter defibrillator must not approach motor room [PDM (Power Delivery Module)] at the hood-opened condition during normal charge operation.

PRECAUTION AT TELEMATICS SYSTEM OPERATION

WARNING:

- If a technician uses implantable cardiac pacemaker or implantable cardioverter defibrillator (ICD), avoid the device implanted part from approaching within approximately 220 mm (8.66 in) from interior/exterior antenna.
- The electromagnetic wave of TCU might affect the function of the implantable cardiac pacemaker or the implantable cardioverter defibrillator (ICD), when using the service, etc.
- If a technician uses other medical electric devices than implantable cardiac pacemaker or implantable cardioverter defibrillator (ICD), the electromagnetic wave of TCU might affect the function of the device. The possible effects on the devices must be checked with the device manufacturer before TCU use.

PRECAUTION AT INTELLIGENT KEY SYSTEM OPERATION

WARNING:

- If a technician uses implantable cardiac pacemaker or implantable cardioverter defibrillator (ICD), avoid the device implanted part from approaching within approximately 220 mm (8.66 in) from interior/exterior antenna.
- The electromagnetic wave of Intelligent Key might affect the function of the implantable cardiac pacemaker or the implantable cardioverter defibrillator (ICD), at door operation, at each request switch operation, or at engine starting.
- If a technician uses other medical electric devices than implantable cardiac pacemaker or implantable cardioverter defibrillator (ICD), the electromagnetic wave of Intelligent Key might affect the function of the device. The possible effects on the devices must be checked with the device manufacturer before Intelligent Key use.

Point to Be Checked Before Starting Maintenance Work

INFOID:000000008745556

The high voltage system may starts automatically. It is required to check that the timer air conditioner and timer charge (during EVSE connection) are not set before starting maintenance work.

NOTE:

If the timer air conditioner or timer charge (during EVSE connection) is set, the high voltage system starts automatically even when the power switch is in OFF state.

Precaution for Supplemental Restraint System (SRS) "AIR BAG" and "SEAT BELT PRE-TENSIONER"

INFOID:000000009342277

The Supplemental Restraint System such as "AIR BAG" and "SEAT BELT PRE-TENSIONER", used along with a front seat belt, helps to reduce the risk or severity of injury to the driver and front passenger for certain types of collision. This system includes seat belt switch inputs and dual stage front air bag modules. The SRS

PRECAUTIONS

< PRECAUTION >

system uses the seat belt switches to determine the front air bag deployment, and may only deploy one front air bag, depending on the severity of a collision and whether the front occupants are belted or unbelted. Information necessary to service the system safely is included in the SR and SB section of this Service Manual.

WARNING:

- **To avoid rendering the SRS inoperative, which could increase the risk of personal injury or death in the event of a collision which would result in air bag inflation, all maintenance must be performed by an authorized NISSAN/INFINITI dealer.**
- **Improper maintenance, including incorrect removal and installation of the SRS, can lead to personal injury caused by unintentional activation of the system. For removal of Spiral Cable and Air Bag Module, see the SR section.**
- **Do not use electrical test equipment on any circuit related to the SRS unless instructed to in this Service Manual. SRS wiring harnesses can be identified by yellow and/or orange harnesses or harness connectors.**

PRECAUTIONS WHEN USING POWER TOOLS (AIR OR ELECTRIC) AND HAMMERS

WARNING:

- **When working near the Airbag Diagnosis Sensor Unit or other Airbag System sensors with the Ignition ON or engine running, DO NOT use air or electric power tools or strike near the sensor(s) with a hammer. Heavy vibration could activate the sensor(s) and deploy the air bag(s), possibly causing serious injury.**
- **When using air or electric power tools or hammers, always switch the Ignition OFF, disconnect the battery and wait at least three minutes before performing any service.**

Precaution for Removing 12V Battery

INFOID:000000008745558

1. Check that EVSE is not connected.

NOTE:

If EVSE is connected, the air conditioning system may be automatically activated by the timer A/C function.

2. Turn the power switch OFF → ON → OFF. Get out of the vehicle. Close all doors (including back door).
3. Check that the charge status indicator lamp does not blink and wait for 5 minutes or more.

NOTE:

If the battery is removed within 5 minutes after the power switch is turned OFF, plural DTCs may be detected.

4. Remove 12V battery within 1 hour after turning the power switch OFF → ON → OFF.

NOTE:

- The 12V battery automatic charge control may start automatically even when the power switch is in OFF state.
- Once the power switch is turned ON → OFF, the 12V battery automatic charge control does not start for approximately 1 hour.

CAUTION:

- **After all doors (including back door) are closed, if a door (including back door) is opened before battery terminals are disconnected, start over from Step 1.**
- **After turning the power switch OFF, if “Remote A/C” is activated by user operation, stop the air conditioner and start over from Step 1.**

Service Notice

INFOID:000000008745559

- When removing or installing various parts, place a cloth or padding onto the vehicle body to prevent scratches.
- Handle trim, molding, instruments, grille, etc. carefully during removing or installing. Be careful not to oil or damage them.
- Apply sealing compound where necessary when installing parts.
- When applying sealing compound, be careful that the sealing compound does not protrude from parts.
- When replacing any metal parts (for example body outer panel, members, etc.), be sure to take rust prevention measures.

PRECAUTIONS

< PRECAUTION >

Precaution for Work

INFOID:000000009342278

- When removing or disassembling each component, be careful not to damage or deform it. If a component may be subject to interference, be sure to protect it with a shop cloth.
- When removing (disengaging) components with a screwdriver or similar tool, be sure to wrap the component with a shop cloth or vinyl tape to protect it.
- Protect the removed parts with a shop cloth and prevent them from being dropped.
- Replace a deformed or damaged clip.
- If a part is specified as a non-reusable part, always replace it with a new one.
- Be sure to tighten bolts and nuts securely to the specified torque.
- After installation is complete, be sure to check that each part works properly.
- Follow the steps below to clean components:
 - Water soluble dirt:
 - Dip a soft cloth into lukewarm water, wring the water out of the cloth and wipe the dirty area.
 - Then rub with a soft, dry cloth.
 - Oily dirt:
 - Dip a soft cloth into lukewarm water with mild detergent (concentration: within 2 to 3%) and wipe the dirty area.
 - Then dip a cloth into fresh water, wring the water out of the cloth and wipe the detergent off.
 - Then rub with a soft, dry cloth.
 - Do not use organic solvent such as thinner, benzene, alcohol or gasoline.
 - For genuine leather seats, use a genuine leather seat cleaner.

A
B
C
D
E
F
G
H
I
K
L
M
N
O
P

SE

PREPARATION

< PREPARATION >

PREPARATION

PREPARATION

Special Service Tool

INFOID:000000008745561

The actual shape of the tools may differ from those illustrated here.

Tool number (TechMate No.) Tool name	Description
— (J-39570) Chassis Ear	Locating the noise
— (J-50397) NISSAN Squeak and Rattle Kit	Repairing the cause of noise
— (J-46534) Trim Tool Set	Removing trim components

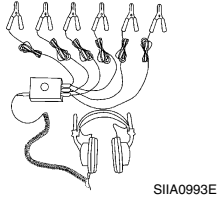

SIIA0993E



ALJIA1232ZZ

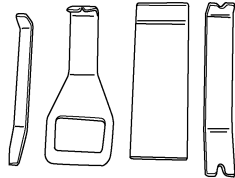

AWJIA0483ZZ

Commercial Service Tool

INFOID:000000008745562

(TechMate No.) Tool name	Description
(J-39565) Engine Ear	Locating the noise
(—) Hook and Pick Tool	Removes snap rings

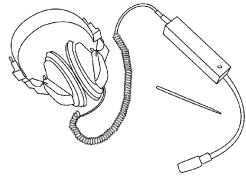

SIIA0995E

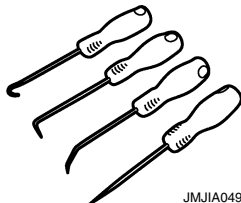

JMJIA0490ZZ

CLIP LIST

< PREPARATION >

CLIP LIST

Clip List

INFOID:000000008745563

Shapes	Removal & Installation	Shapes	Removal & Installation
	<p>Removal: Remove by bending up with flat-bladed screwdrivers or clip remover.</p>		<p>Removal:</p>
	<p>Removal: Remove with a clip remover.</p>		<p>Removal:</p>
	<p>Removal: Push center pin to catching position. (Do not remove center pin by hitting it.)</p> <p>Installation:</p>		<p>Removal: Holder portion of clip must be spread out to remove rod.</p>
	<p>Removal: Remove by bending up with flat-bladed screwdrivers or clip remover.</p>		<p>Removal:</p> <ol style="list-style-type: none"> Screw out with a Phillips screwdriver. Remove female portion with flat-bladed screwdriver.
	<p>Removal:</p>		<p>Removal:</p> <p>Rotate 45° to remove.</p> <p>Installation:</p>
	<p>Removal:</p>		<p>Removal:</p>

JMJIA3734GB

A
B
C
D
E
F
G
H
I
SE
K
L
M
N
O
P

COMPONENT PARTS

< SYSTEM DESCRIPTION >

SYSTEM DESCRIPTION

COMPONENT PARTS HEATED SEAT SYSTEM

HEATED SEAT SYSTEM : Component Parts Location

INFOID:000000008745564

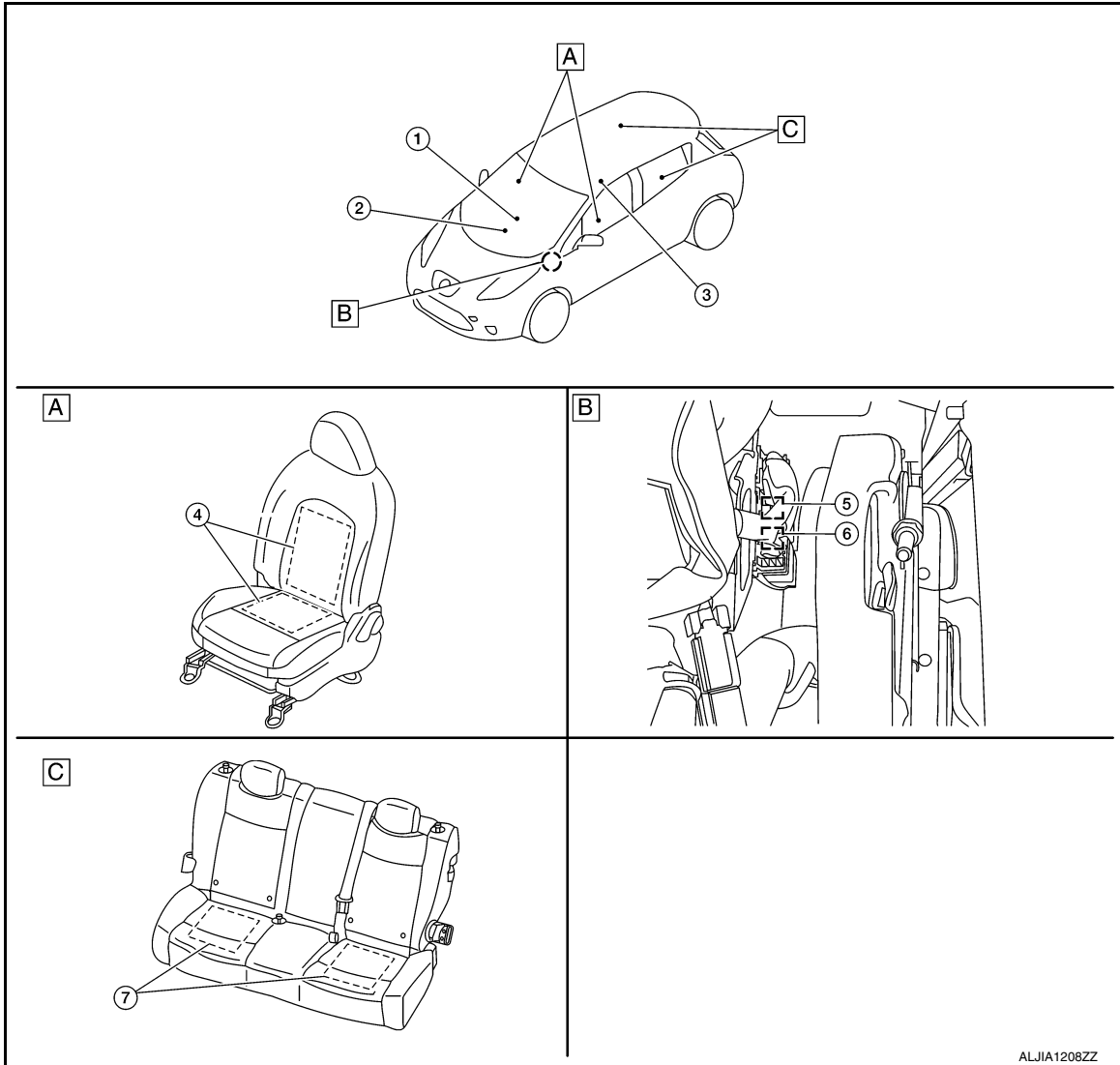

A. Inside of front seat

B. Behind LH side of instrument panel

C. Inside of rear seat

No.	Component	Function
1.	Front heated seat switch (LH/RH)	Refer to SE-9, "HEATED SEAT SYSTEM : Front Heated Seat Switch" .
2.	A/C auto amp.	A/C auto amp. controls heated seat relay and rear heated seat relay. Refer to HAC-19, "AUTOMATIC AIR CONDITIONING SYSTEM : Component Parts Location" for detailed installation location.
3.	Rear heated seat switch	Rear heated seat switch changes ON/OFF operation and HIGH/LOW operation, and supplies power source to rear heated seat. It is integrated into front passenger's seatback. Refer to SE-29, "SEATBACK : Disassembly and Assembly" for detailed installation location.
4.	Front seat heater (Driver side and passenger side)	Refer to SE-9, "HEATED SEAT SYSTEM : Front Seat Heater" .

COMPONENT PARTS

< SYSTEM DESCRIPTION >

No.	Component	Function
5.	Heated seat relay	Refer to SE-9. "HEATED SEAT SYSTEM : Heated Seat Relay" .
6.	Rear heated seat relay	Refer to SE-9. "HEATED SEAT SYSTEM : Rear Heated Seat Relay" .
7.	Rear seat heater (LH/RH)	Refer to SE-10. "HEATED SEAT SYSTEM : Rear Seat Heater" .

HEATED SEAT SYSTEM : Front Heated Seat Switch

INFOID:000000008745565

Front heated seat switch changes ON/OFF operation and HIGH/LOW operation, and supplies power source to front heated seats.

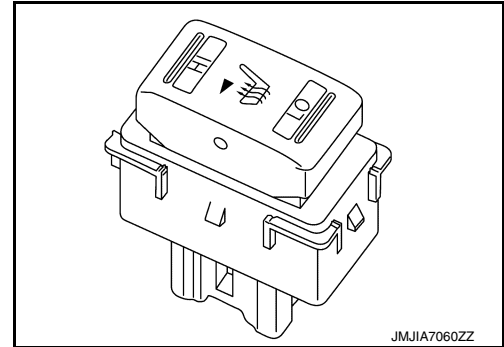

HEATED SEAT SYSTEM : Heated Seat Relay

INFOID:000000008745567

Heated seat relay is controlled by A/C auto amp. and supplies power source to front heated seats and rear heated seat relay.

HEATED SEAT SYSTEM : Front Seat Heater

INFOID:000000008745566

Front seat heater is located inside of front heated seat cushion and seat back, and operates with power source provided via front heated seat switch.

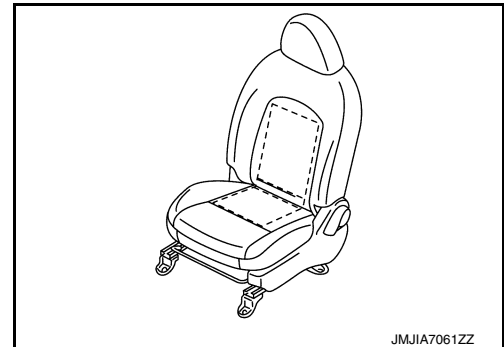

HEATED SEAT SYSTEM : Rear Heated Seat Switch

INFOID:000000009336825

Rear heated seat switch changes ON/OFF operation and HIGH/LOW operation, and supplies power source to rear heated seats.

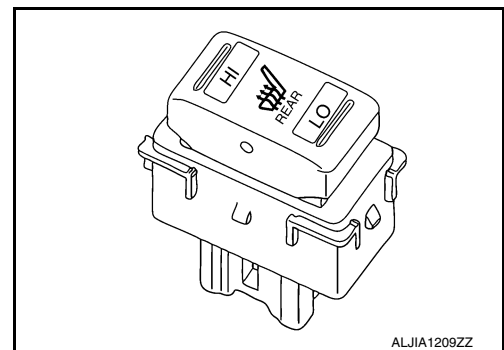

HEATED SEAT SYSTEM : Rear Heated Seat Relay

INFOID:000000008745568

Rear heated seat relay is turned ON when front heated seat relay is turned ON, and supplies power source to rear heated seat.

A
B
C
D
E
F
G
H
I
SE
K
L
M
N
O
P

COMPONENT PARTS

< SYSTEM DESCRIPTION >

HEATED SEAT SYSTEM : Rear Seat Heater

INFOID:000000008745569

Rear seat heater is located inside of rear heated seat cushion, and operates with power source provided via rear heated seat switch.

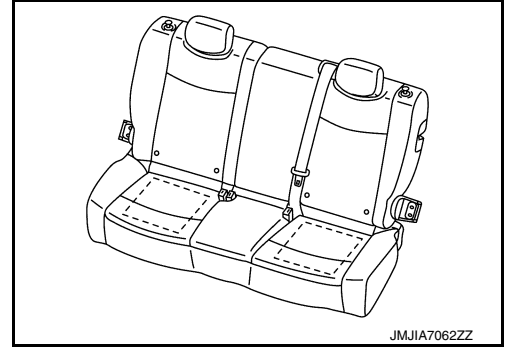

SYSTEM

< SYSTEM DESCRIPTION >

SYSTEM

HEATED SEAT SYSTEM

HEATED SEAT SYSTEM : System Description

INFOID:000000008745570

- Heated seat system (Driver side, passenger side and rear seats) consists of heated seat relay, heated seat switch, seat heater and A/C auto amp.
- Heated seat relay and rear heated seat relay are turned ON by A/C auto amp. to provide power source to the heated seat system when any of the following conditions is met.
 - The vehicle is set to READY.
 - The timer A/C control is operating. Refer to [HAC-38. "AUTOMATIC AIR CONDITIONING SYSTEM : A/C-Heater Timer \(Climate Ctrl. Timer\)".](#)
 - The remote A/C control is operating. Refer to [HAC-39. "AUTOMATIC AIR CONDITIONING SYSTEM : Remote Climate Control".](#)
- Heated seat switch changes ON/OFF operation and HIGH/LOW mode of heated seat system.
- Heated seat switch has HIGH/LOW indicators which indicates the system operation condition.

A
B
C
D
E
F
G
H
I
K
L
M
N
O
P

SE

HEATED SEAT SYSTEM

< WIRING DIAGRAM >

WIRING DIAGRAM

HEATED SEAT SYSTEM

Wiring Diagram

INFOID:000000008745571

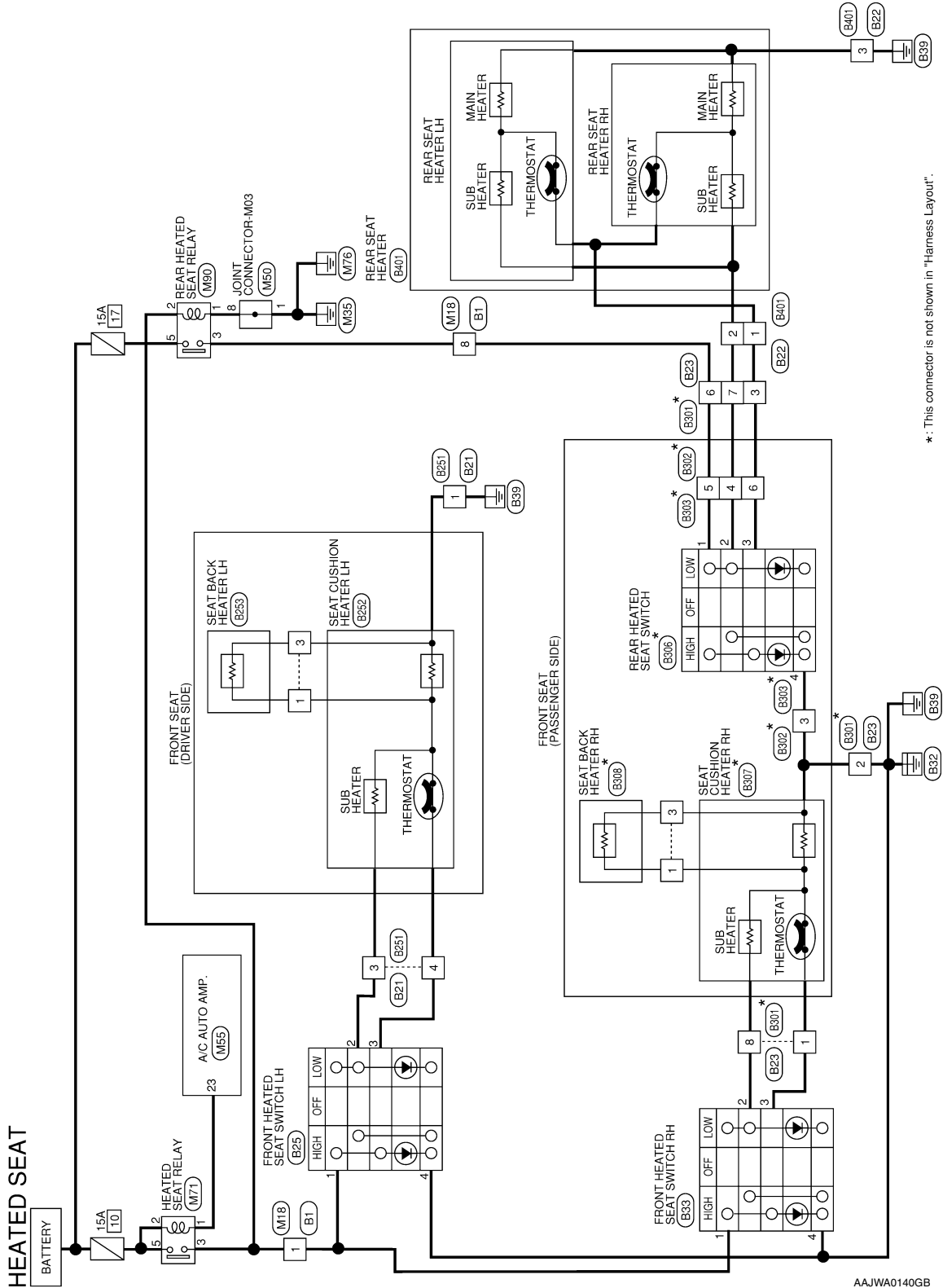

*: This connector is not shown in "Harness Layout".

AAJWA0140GB

HEATED SEAT SYSTEM

< WIRING DIAGRAM >

HEATED SEAT - CONNECTORS

Connector No.	M18
Connector Name	WIRE TO WIRE
Connector Color	

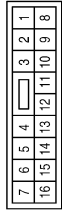

Terminal No.	Color of Wire	Signal Name
1	-	-
2	-	-
3	-	-
4	-	-
5	-	-
6	-	-
7	-	-
8	-	-
9	-	-
10	-	-
11	-	-
12	-	-
13	-	-
14	-	-
15	-	-
16	-	-

Connector No.	M50
Connector Name	JOINT CONNECTOR-M03
Connector Color	PINK

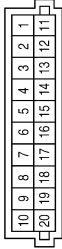

Terminal No.	Color of Wire	Signal Name
1	-	-
2	-	-
3	-	-
4	-	-
5	-	-
6	-	-
7	-	-
8	-	-
9	-	-
10	-	-
11	-	-
12	-	-
13	-	-
14	-	-
15	-	-
16	-	-
17	-	-
18	-	-
19	-	-
20	-	-

A
B
C
D
E
F
G
H
I
SE
K
L
M
N
O
P

AAJIA0338GB

HEATED SEAT SYSTEM

< WIRING DIAGRAM >

Connector No.	M71
Connector Name	HEATED SEAT RELAY
Connector Color	BLUE



Terminal No.	Color of Wire	Signal Name
1	SB	-
2	R	-
3	G	-
5	GR	-

Terminal No.	Color of Wire	Signal Name
14	L	COMP TX
15	W	REAR DEF
16	LG	STGR HEATER SW
17	W	TA1
18	W	COMP RX
19	W	ILL+
20	B	ILL-
21	G	FRESH
22	V	STEER RLY
23	SB	HEATER SEAT RLY
24	-	-
25	-	-
26	-	-
27	W	5V OUT
28	L	CAN-H
29	G	CAN-L
30	R	S GND
31	G	BAT
32	Y	IGN 1
33	LG	INC S
34	G	INT S
35	P	SUN S
36	GR	AMB S
37	Y	TA 2
38	SB	INT F/B
39	-	-
40	SB	LIN

Connector No.	M55
Connector Name	A/C AUTO AMP.
Connector Color	WHITE



1	2	3	4	5	6	7	8	9	10	11	12	13	14	15	16	17	18	19	20	21	22	23	24	25	26	27	28	29	30	31	32	33	34	35	36	37	38	39	40
---	---	---	---	---	---	---	---	---	----	----	----	----	----	----	----	----	----	----	----	----	----	----	----	----	----	----	----	----	----	----	----	----	----	----	----	----	----	----	----

Terminal No.	Color of Wire	Signal Name
1	V	REC
2	R	MODE4
3	P	MODE3
4	BG	MODE2
5	V	MODE1
6	BR	MIX4
7	GR	MIX3
8	LG	MIX2
9	L	MIX1
10	B	GND
11	-	-
12	GR	BLR PWM
13	-	-

AAJIA0339GB

HEATED SEAT SYSTEM

< WIRING DIAGRAM >

Connector No.	B1
Connector Name	WIRE TO WIRE
Connector Color	WHITE

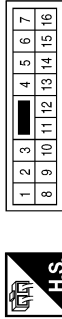

Terminal No.	Color of Wire	Signal Name
1	B	-
2	-	-
3	GR	-
4	L	-
5	G	-
6	R	-
7	BR	-
8	SB	-
9	GR	-
10	W	-
11	LG	-
12	P	-
13	V	-
14	Y	-
15	W	-
16	L	-

Connector No.	M90
Connector Name	REAR HEATED SEAT RELAY
Connector Color	BLUE



Terminal No.	Color of Wire	Signal Name
1	B	-
2	G	-
3	P	-
4	-	-
5	R	-

A
B
C
D
E
F
G
H
I
SE
K
L
M
N
O
P

AAJIA0340GB

HEATED SEAT SYSTEM

< WIRING DIAGRAM >

Connector No.	B23
Connector Name	WIRE TO WIRE
Connector Color	WHITE

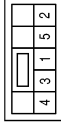

Terminal No.	Color of Wire	Signal Name
1	G	-
2	SB	-
3	-	-
4	-	-
5	-	-
6	-	-
7	-	-
8	-	-

Connector No.	B22
Connector Name	WIRE TO WIRE
Connector Color	WHITE

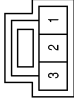

Terminal No.	Color of Wire	Signal Name
1	V	-
2	W	-

Connector No.	B21
Connector Name	WIRE TO WIRE
Connector Color	WHITE

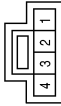

Terminal No.	Color of Wire	Signal Name
1	SB	-
2	BR	-

Connector No.	B25
Connector Name	FRONT HEATED SEAT SWITCH RH
Connector Color	WHITE



Terminal No.	Color of Wire	Signal Name
1	-	-
2	Y	-
3	B	-
4	G	-
5	L	-
6	R	-

AAJIA0341GB

HEATED SEAT SYSTEM

< WIRING DIAGRAM >

Connector No.	B252
Connector Name	SEAT CUSHION HEATER LH
Connector Color	WHITE

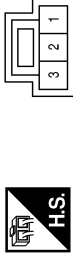

Terminal No.	Color of Wire	Signal Name
1	B	-
2	-	-
3	L	-

Connector No.	B251
Connector Name	WIRE TO WIRE
Connector Color	WHITE

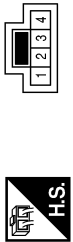

Terminal No.	Color of Wire	Signal Name
1	B	-
2	-	-
3	W	-
4	R	-

Connector No.	B33
Connector Name	FRONT HEATED SEAT SWITCH RH
Connector Color	BROWN

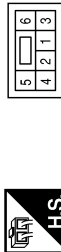

Terminal No.	Color of Wire	Signal Name
1	G	-
2	BR	-
3	LG	-
4	B	-
5	Y	-
6	GR	-

Connector No.	B302
Connector Name	WIRE TO WIRE
Connector Color	BROWN



Terminal No.	Color of Wire	Signal Name
1	P	-
2	V	-
3	B	-
4	O	-
5	BR	-
6	Y	-

Connector No.	B301
Connector Name	WIRE TO WIRE
Connector Color	WHITE

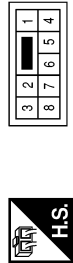

Terminal No.	Color of Wire	Signal Name
1	R	-
2	B	-
3	Y	-
4	V	-
5	P	-
6	BR	-
7	O	-
8	W	-

Connector No.	B253
Connector Name	SEAT BACK HEATER LH
Connector Color	WHITE

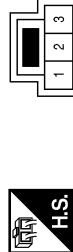

Terminal No.	Color of Wire	Signal Name
1	B	-
2	-	-
3	L	-

AAJIA0342GB

A
B
C
D
E
F
G
H
I
SE
K
L
M
N
O
P

HEATED SEAT SYSTEM

< WIRING DIAGRAM >

Connector No.	B303
Connector Name	WIRE TO WIRE
Connector Color	BROWN

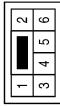

Terminal No.	Color of Wire	Signal Name
1	Y	-
2	W	-
3	B	-
4	G	-
5	R	-
6	L	-

Connector No.	B306
Connector Name	REAR HEATED SEAT SWITCH
Connector Color	BROWN

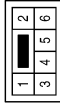

Terminal No.	Color of Wire	Signal Name
1	W	-
2	Y	-
3	B	-
4	G	-
5	R	-
6	L	-

Connector No.	B307
Connector Name	SEAT CUSHION HEATER RH
Connector Color	WHITE

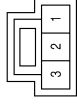

Terminal No.	Color of Wire	Signal Name
1	B	-
2	-	-
3	L	-

Connector No.	B308
Connector Name	SEAT BACK HEATER RH
Connector Color	WHITE

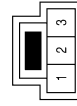

Terminal No.	Color of Wire	Signal Name
1	B	-
2	-	-
3	L	-

Connector No.	B401
Connector Name	REAR SEAT HEATER
Connector Color	WHITE

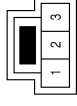

Terminal No.	Color of Wire	Signal Name
1	R	-
2	Y	-
3	B	-

SQUEAK AND RATTLE TROUBLE DIAGNOSES

< SYMPTOM DIAGNOSIS >

SYMPTOM DIAGNOSIS

SQUEAK AND RATTLE TROUBLE DIAGNOSES

Work Flow

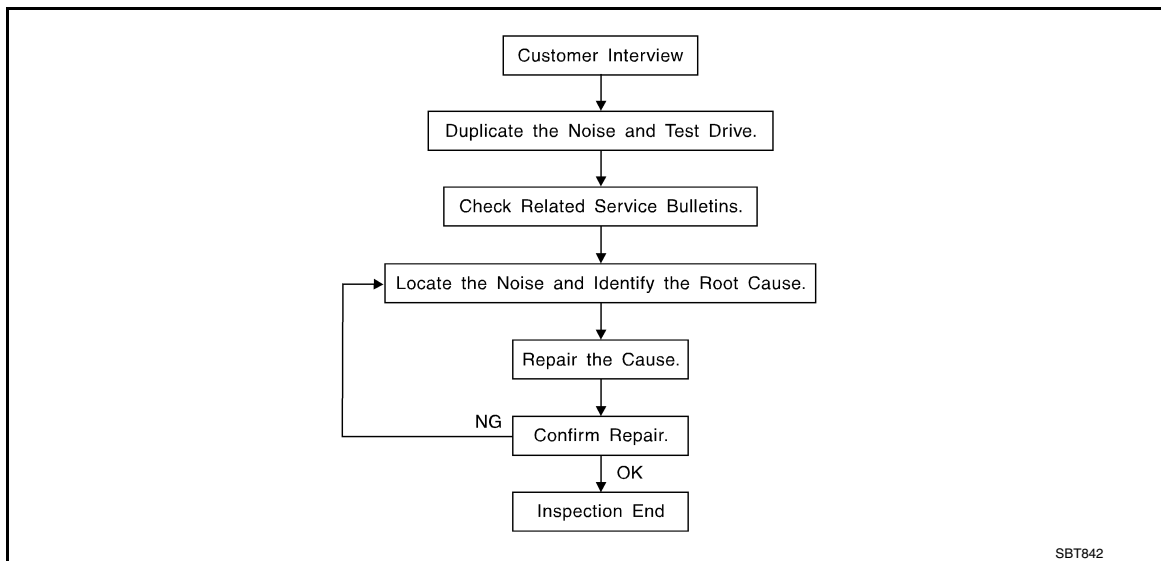

CUSTOMER INTERVIEW

Interview the customer if possible, to determine the conditions that exist when the noise occurs. Use the Diagnostic Worksheet during the interview to document the facts and conditions when the noise occurs and any customer comments. Refer to [SE-23. "Diagnostic Worksheet"](#). This information is necessary to duplicate the conditions that exist when the noise occurs.

- The customer may not be able to provide a detailed description or the location of the noise. Attempt to obtain all the facts and conditions that exist when the noise occurs (or does not occur).
- If there is more than one noise in the vehicle, perform a diagnosis and repair the noise that the customer is concerned about. This can be accomplished by performing a test drive with the customer.
- After identifying the type of noise, isolate the noise in terms of its characteristics. The noise characteristics are provided so that the customer, service adviser, and technician use the same language when describing the noise.
- Squeak – (Like tennis shoes on a clean floor)
Squeak characteristics include the light contact / fast movement / brought on by road conditions / hard surfaces = high-pitched noise / softer surfaces = low-pitched noises / edge to surface = chirping
- Creak – (Like walking on an old wooden floor)
Creak characteristics include firm contact / slow movement/twisting with a rotational movement / pitch dependent on materials / often brought on by activity.
- Rattle – (Like shaking a baby rattle)
Rattle characteristics include fast repeated contact / vibration or similar movement / loose parts/missing clip or fastener / incorrect clearance.
- Knock – (Like a knock on a door)
Knock characteristics include hollow sounds / sometimes repeating / often brought on by driver action.
- Tick – (Like a clock second hand)
Tick characteristics include gentle contacting of light materials / loose components / can be caused by driver action or road conditions.
- Thump – (Heavy, muffled knock noise)
Thump characteristics include softer knock / dull sounds often brought on by activity.
- Buzz – (Like a bumblebee)
Buzz characteristics include high frequency rattle / firm contact.
- Often the degree of acceptable noise level varies depending upon the person. A noise that a technician may judge as acceptable may be very irritating to a customer.
- Weather conditions, especially humidity and temperature, may have a great effect on noise level.

DUPLICATE THE NOISE AND TEST DRIVE

SQUEAK AND RATTLE TROUBLE DIAGNOSES

< SYMPTOM DIAGNOSIS >

If possible, drive the vehicle with the customer until the noise is duplicated. Note any additional information on the Diagnostic Worksheet regarding the conditions or location of the noise. This information can be used to duplicate the same conditions when the repair is reconfirmed.

If the noise can be duplicated easily during the test drive, to help identify the source of the noise, try to duplicate the noise with the vehicle stopped by doing one or all of the following items:

- 1) Close a door.
 - 2) Tap or push/pull around the area where the noise appears to be coming from.
 - 3) Rev the motor.
 - 4) Use a floor jack to recreate vehicle "twist".
 - 5) At idle, apply motor load (electrical load, half-clutch on M/T models, drive position on A/T models).
 - 6) Raise the vehicle on a hoist and hit a tire with a rubber hammer.
- Drive the vehicle and attempt to duplicate the conditions the customer states exist when the noise occurs.
 - If it is difficult to duplicate the noise, drive the vehicle slowly on an undulating or rough road to stress the vehicle body.

CHECK RELATED SERVICE BULLETINS

After verifying the customer concern or symptom, check ASIST for Technical Service Bulletins (TSBs) related to the concern or symptom.

If a TSB relates to the symptom, follow the procedure to repair the noise.

LOCATE THE NOISE AND IDENTIFY THE ROOT CAUSE

1. Narrow down the noise to a general area. To help pinpoint the source of the noise, use a listening tool (Chassis ear: J-39570, engine ear, and mechanics stethoscope).
2. Narrow down the noise to a more specific area and identify the cause of the noise by:
 - Removing the component(s) in the area that is / are suspected to be the cause of the noise.
Do not use too much force when removing clips and fasteners, otherwise clips and fasteners can be broken or lost during the repair, resulting in the creation of new noise.
 - Tapping or pushing/pulling the component(s) that is / are suspected to be the cause of the noise.
Do not tap or push/pull the component(s) with excessive force, otherwise the noise is eliminated only temporarily.
 - Feeling for a vibration by hand by touching the component(s) that is / are suspected to be the cause of the noise.
 - Placing a piece of paper between components that are suspected to be the cause of the noise.
 - Looking for loose components and contact marks.
Refer to [SE-21. "Inspection Procedure"](#).

REPAIR THE CAUSE

- If the cause is a loose component, tighten the component securely.
- If the cause is insufficient clearance between components:
 - separate components by repositioning or loosening and retightening the component, if possible.
 - insulate components with a suitable insulator such as urethane pads, foam blocks, felt cloth tape or urethane tape. A NISSAN Squeak and Rattle Kit (J-50397) is available through your authorized NISSAN Parts Department.

CAUTION:

Do not use excessive force as many components are constructed of plastic and may be damaged.

NOTE:

- Always check with the Parts Department for the latest parts information.
- The materials contained in the NISSAN Squeak and Rattle Kit (J-50397) are listed on the inside cover of the kit; and can each be ordered separately as needed.
- The following materials not found in the kit can also be used to repair squeaks and rattles.
 - SILICONE GREASE: Use instead of UHMW tape that will be visible or does not fit. The silicone grease will only last a few months.
 - SILICONE SPRAY: Use when grease cannot be applied.
 - DUCT TAPE: Use to eliminate movement.

CONFIRM THE REPAIR

After repair is complete, test drive the vehicle to confirm that the cause of noise is repaired by test driving the vehicle. Operate the vehicle under the same conditions as when the noise originally occurred. Refer to the notes on the Diagnostic Worksheet.

SQUEAK AND RATTLE TROUBLE DIAGNOSES

< SYMPTOM DIAGNOSIS >

Inspection Procedure

INFOID:000000008745573

Refer to Table of Contents for specific component removal and installation information.

INSTRUMENT PANEL

Most incidents are caused by contact and movement between:

1. The cluster lid A and instrument panel
2. Acrylic lens and combination meter housing
3. Instrument panel to front pillar garnish
4. Instrument panel to windshield
5. Instrument panel mounting pins
6. Wiring harnesses behind the combination meter
7. A/C defroster duct and duct joint

These incidents can usually be located by tapping or moving the components to duplicate the noise or by pressing on the components while driving to stop the noise. Most of these incidents can be repaired by applying felt cloth tape or silicon spray (in hard to reach areas). Urethane pads can be used to insulate wiring harness.

CAUTION:

Never use silicone spray to isolate a squeak or rattle. If the area is saturated with silicone, the recheck of repair becomes impossible.

CENTER CONSOLE

Components to check include:

1. Shifter assembly cover to finisher
2. A/C control unit and cluster lid C
3. Wiring harnesses behind audio and A/C control unit

The instrument panel repair and isolation procedures also apply to the center console.

DOORS

Pay attention to the:

1. Finisher and inner panel making a slapping noise
2. Inside handle escutcheon to door finisher
3. Wiring harnesses tapping
4. Door striker out of alignment causing a popping noise on starts and stops

Tapping or moving the components or pressing on them while driving to duplicate the conditions can isolate many of these incidents. You can usually insulate the areas with felt cloth tape or insulator foam blocks from the NISSAN Squeak and Rattle Kit (J-50397) to repair the noise.

TRUNK

Trunk noises are often caused by a loose jack or loose items put into the trunk by the customer.

In addition check for the following items:

1. Trunk lid dumpers out of adjustment
2. Trunk lid striker out of adjustment
3. Trunk lid torsion bars knocking together
4. A loose license plate or bracket

Most of these incidents can be repaired by adjusting, securing, or insulating the item(s) or component(s) causing the noise.

SUNROOF/HEADLINING

Noises in the sunroof / headlining area can often be traced to one of the following items:

1. Sunroof lid, rail, linkage, or seals making a rattle or light knocking noise
2. Sunvisor shaft shaking in the holder
3. Front or rear windshield touching headlining and squeaking

Again, pressing on the components to stop the noise while duplicating the conditions can isolate most of these incidents. Repairs usually consist of insulating with felt cloth tape.

A

B

C

D

E

F

G

H

I

SE

K

L

M

N

O

P

SQUEAK AND RATTLE TROUBLE DIAGNOSES

< SYMPTOM DIAGNOSIS >

SEATS

When isolating seat noise it is important to note the position the seat is in and the load placed on the seat when the noise occurs. These conditions should be duplicated when verifying and isolating the cause of the noise.

Causes of seat noise include:

1. Headrest rods and holder
2. A squeak between the seat pad cushion and frame
3. The rear seatback lock and bracket

These noises can be isolated by moving or pressing on the suspected components while duplicating the conditions under which the noise occurs. Most of these incidents can be repaired by repositioning the component or applying urethane tape to the contact area.

UNDERHOOD

Some interior noise may be caused by components under the hood or on the motor wall. The noise is then transmitted into the passenger compartment.

Causes of transmitted underhood noise include:

1. Any component mounted to the motor wall
2. Components that pass through the motor wall
3. Motor wall mounts and connectors
4. Loose radiator mounting pins
5. Hood bumpers out of adjustment
6. Hood striker out of adjustment

These noises can be difficult to isolate since they cannot be reached from the interior of the vehicle. The best method is to secure, move, or insulate one component at a time and test drive the vehicle. Also, motor RPM or load can be changed to isolate the noise. Repairs can usually be made by moving, adjusting, securing, or insulating the component causing the noise.

SQUEAK AND RATTLE TROUBLE DIAGNOSES

< SYMPTOM DIAGNOSIS >

Diagnostic Worksheet

INFOID:000000008745574



SQUEAK & RATTLE DIAGNOSTIC WORKSHEET

Dear Nissan Customer:

We are concerned about your satisfaction with your Nissan vehicle. Repairing a squeak or rattle sometimes can be very difficult. To help us fix your Nissan right the first time, please take a moment to note the area of the vehicle where the squeak or rattle occurs and under what conditions. You may be asked to take a test drive with a service advisor or technician to ensure we confirm the noise you are hearing.

I. WHERE DOES THE NOISE COME FROM? (circle the area of the vehicle)

The illustrations are for reference only, and may not reflect the actual configuration of your vehicle.

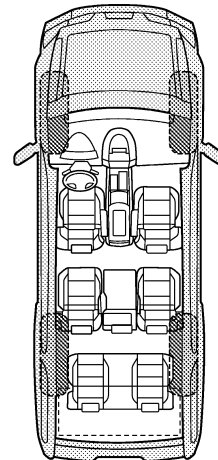
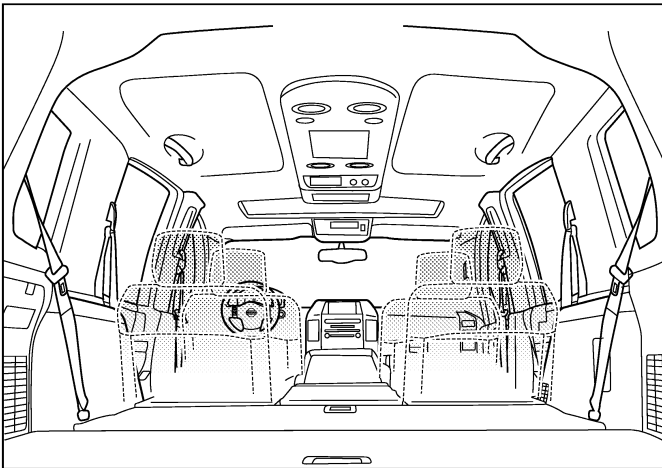
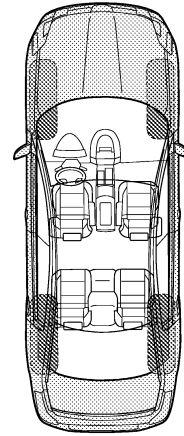
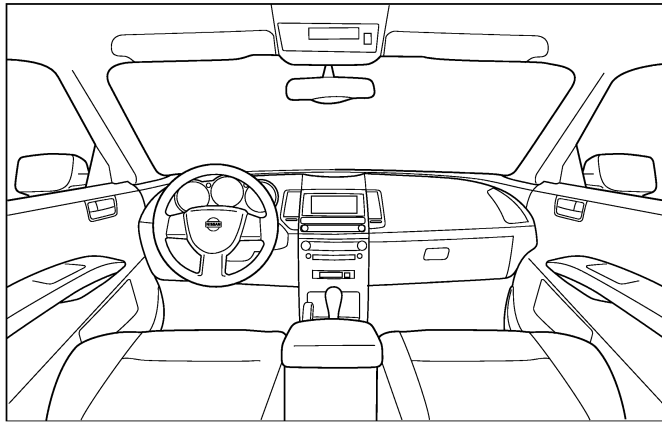

Continue to page 2 of the worksheet and briefly describe the location of the noise or rattle. In addition, please indicate the conditions which are present when the noise occurs.

PIIB8740E

A
B
C
D
E
F
G
H
I
SE
K
L
M
N
O
P

SQUEAK AND RATTLE TROUBLE DIAGNOSES

< SYMPTOM DIAGNOSIS >

SQUEAK & RATTLE DIAGNOSTIC WORKSHEET - page 2

Briefly describe the location where the noise occurs:

II. WHEN DOES IT OCCUR? (please check the boxes that apply)

- | | |
|---|--|
| <input type="checkbox"/> anytime | <input type="checkbox"/> after sitting out in the rain |
| <input type="checkbox"/> 1st time in the morning | <input type="checkbox"/> when it is raining or wet |
| <input type="checkbox"/> only when it is cold outside | <input type="checkbox"/> dry or dusty conditions |
| <input type="checkbox"/> only when it is hot outside | <input type="checkbox"/> other: |

III. WHEN DRIVING:

- through driveways
- over rough roads
- over speed bumps
- only about ____ mph
- on acceleration
- coming to a stop
- on turns: left, right or either (circle)
- with passengers or cargo
- other: _____
- after driving ____ miles or ____ minutes

IV. WHAT TYPE OF NOISE

- squeak (like tennis shoes on a clean floor)
- creak (like walking on an old wooden floor)
- rattle (like shaking a baby rattle)
- knock (like a knock at the door)
- tick (like a clock second hand)
- thump (heavy, muffled knock noise)
- buzz (like a bumble bee)

TO BE COMPLETED BY DEALERSHIP PERSONNEL

Test Drive Notes:

	YES	NO	Initials of person performing
Vehicle test driven with customer	<input type="checkbox"/>	<input type="checkbox"/>	_____
- Noise verified on test drive	<input type="checkbox"/>	<input type="checkbox"/>	_____
- Noise source located and repaired	<input type="checkbox"/>	<input type="checkbox"/>	_____
- Follow up test drive performed to confirm repair	<input type="checkbox"/>	<input type="checkbox"/>	_____

VIN: _____ Customer Name: _____
W.O.# _____ Date: _____

This form must be attached to Work Order

PIIB8742E

FRONT SEAT

< REMOVAL AND INSTALLATION >

REMOVAL AND INSTALLATION

FRONT SEAT

Exploded View

INFOID:000000008745575

DRIVER SEAT

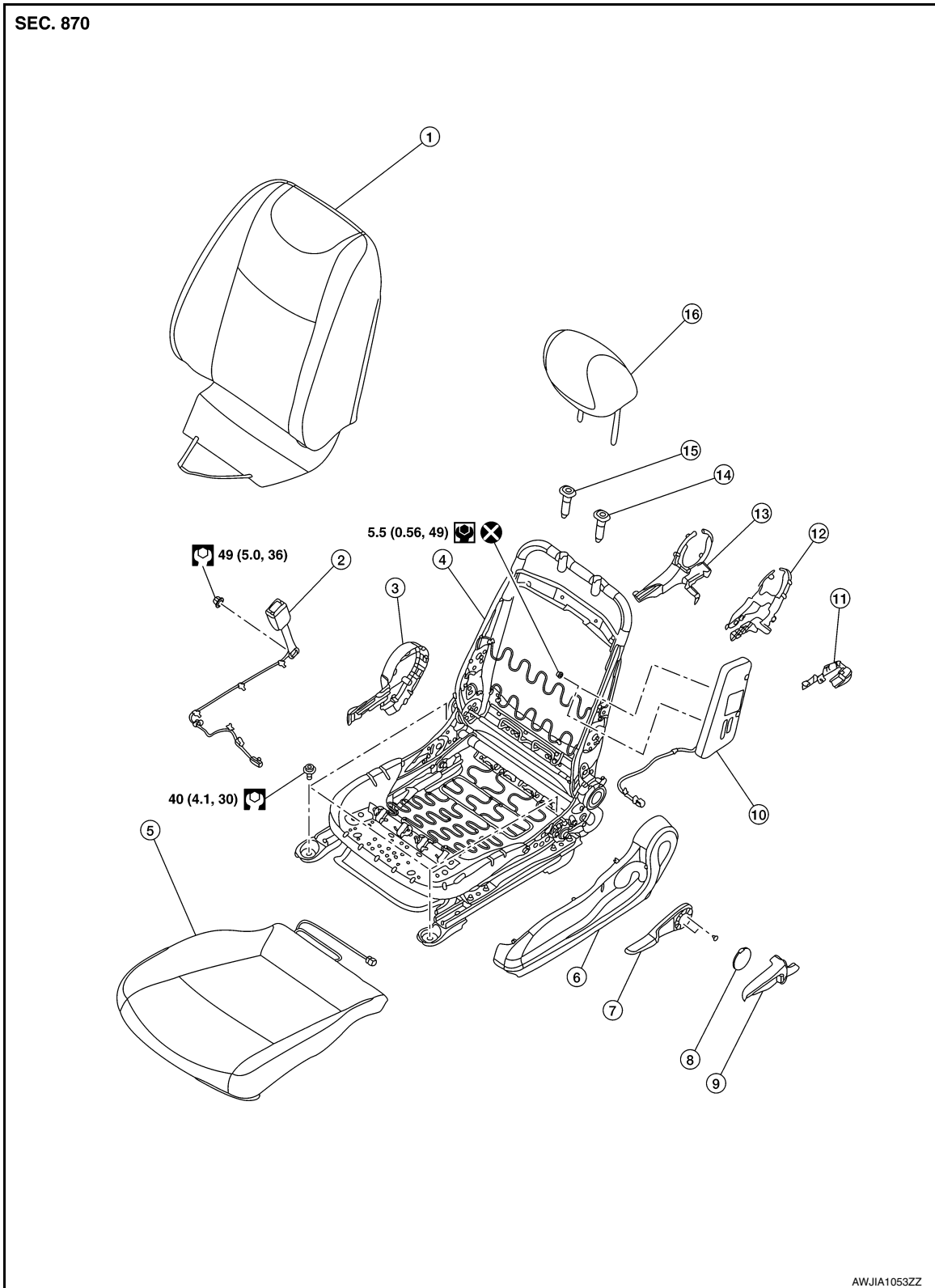

FRONT SEAT

< REMOVAL AND INSTALLATION >

- | | | |
|--|------------------------------|--------------------------------------|
| 1. Seatback | 2. Seat belt buckle | 3. Seat cushion outer finisher (RH) |
| 4. Seat frame assembly | 5. Seat cushion | 6. Seat cushion outer finisher (LH) |
| 7. Lift lever | 8. Lift lever finisher | 9. Recline lever finisher |
| 10. Side air bag module (not service-able) | 11. Slide finisher (rear) | 12. Seat cushion inner finisher (LH) |
| 13. Seat cushion inner finisher (RH) | 14. Headrest holder (locked) | 15. Headrest holder (free) |
| 16. Headrest | | |

FRONT SEAT

< REMOVAL AND INSTALLATION >

PASSENGER SEAT

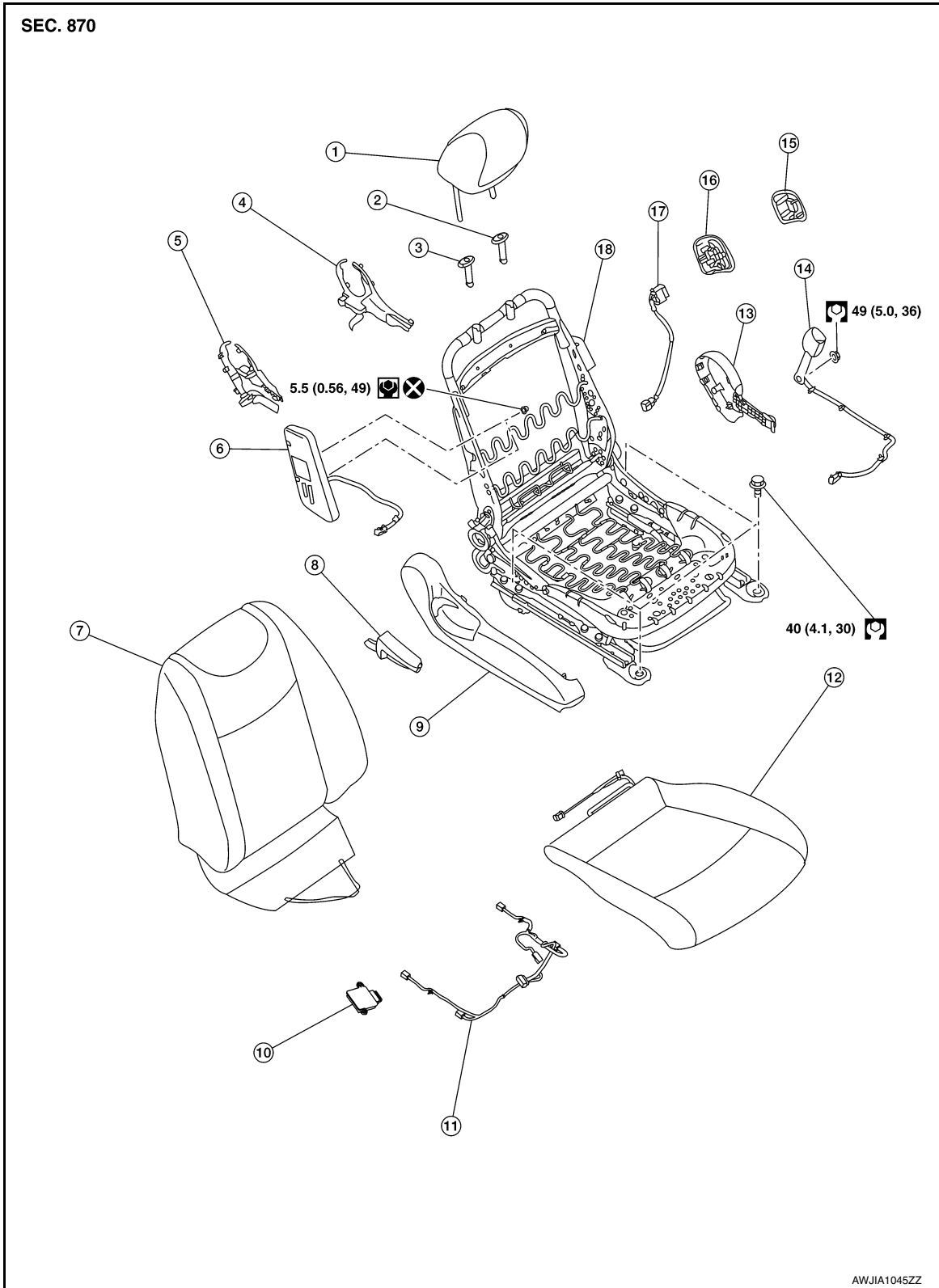

- | | | |
|---|-------------------------------------|--|
| 1. Headrest | 2. Headrest holder (locked) | 3. Headrest holder (free) |
| 4. Seat cushion inner finisher (LH) | 5. Seat cushion inner finisher (RH) | 6. Side air bag module (not serviceable) |
| 7. Seatback | 8. Lift lever finisher | 9. Seat cushion outer finisher (RH) |
| 10. Occupant Classification System control unit | 11. Seat harness | 12. Seat cushion |

A
B
C
D
E
F
G
H
I
SE
K
L
M
N
O
P

FRONT SEAT

< REMOVAL AND INSTALLATION >

- | | | |
|--------------------------------------|-----------------------------|--------------------------------------|
| 13. Seat cushion outer finisher (LH) | 14. Seat belt buckle | 15. Rear heated seat switch finisher |
| 16. Switch bracket | 17. Rear heated seat switch | 18. Seat frame assembly |

Removal and Installation

INFOID:000000008745576

REMOVAL

WARNING:

Do not leave any objects (screwdrivers, tools, etc.) on the seat during seatback repair. It can lead to personal injury if the side air bag module should accidentally deploy.

CAUTION:

- When removing or installing the seat trim, handle it carefully to keep dirt out and to avoid damage.
- Do not drop, tilt, or bump the side air bag module while installing the seat. Always handle it with care.
- After the side air bag module inflates, the seat frame assembly must be replaced.
- When removing and installing the seat, use shop cloths to protect components from damage.
- Before removing the front seat, turn the ignition switch OFF, disconnect both 12V battery cables and wait at least three minutes.

1. Disconnect the negative and positive 12V battery terminals and wait at least three minutes. Refer to [PG-65, "Removal and Installation"](#).
2. Slide the seat to the full forward position.
3. Remove the seat rear bolts.
4. Slide the seat to the full rearward position.
5. Remove the seat front bolts.
6. Tilt the seat rearward to disconnect the harness connectors and unclip from the seat frame assembly.

NOTE:

Take note of harness routing and attachment location for correct installation.

7. Remove seat from the vehicle.

INSTALLATION

Installation is in the reverse order of removal.

WARNING:

- Perform additional services when installing front passenger seat. Refer to [SRC-50, "ZERO POINT RESET : Description"](#).
- Zero point reset must be performed every time the front passenger seat is removed from the vehicle.
- Zero point reset is done after the front passenger seat is installed in vehicle and all bolts are tightened to specification.

CAUTION:

Make sure that the seat harness or the floor carpet is not damaged during installation.

NOTE:

- When installing the front seat (LH), tighten the bolts in the order shown.
- Tighten the seat bolts to specification. Refer to [SE-25, "Exploded View"](#).

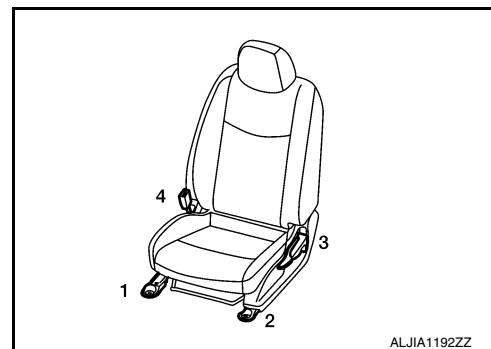

ALJIA1192ZZ

FRONT SEAT

< REMOVAL AND INSTALLATION >

- When installing the front seat (RH), tighten the bolts in the order shown.
- Tighten the seat bolts to specification. Refer to [SE-25, "Exploded View"](#).

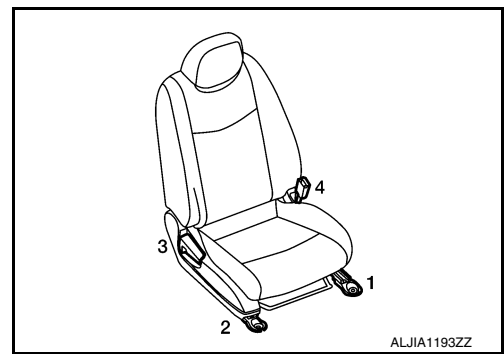

SEATBACK

SEATBACK : Disassembly and Assembly

INFOID:000000008745577

DISASSEMBLY

WARNING:

Do not leave any objects (screwdrivers, tools, etc.) on the seat during seatback repair. It can lead to personal injury if the side air bag module should accidentally deploy.

CAUTION:

- Before servicing, turn the ignition switch OFF, disconnect both 12V battery terminals and wait at least three minutes.
- Handle the side air bag module carefully. During disassembly, always hold the side air bag module, do not let it hang by the wire harness.
- Always work from the side or back of the seatback, do not work in front of seat.
- Do not use air tools or electric tools for servicing the seat assembly.
- Replace the side air bag module if it has been dropped or sustained an impact.
- Do not insert any objects into the side air bag module.
- Do not attempt to disassemble the side air bag module.
- Do not expose the side air bag module to temperatures exceeding 90°C (194°F).
- Do not expose the side air bag module to any oil, grease, detergent or water.
- During disassembly, do not damage the seatback board, chutes, connectors, retainers, clips, module harness or the side air bag module.

NOTE:

If the vehicle has been involved in a collision and the side air bag module has deployed, the seatback assembly must be replaced.

1. Remove the front seat assembly. Refer to [SE-28, "Removal and Installation"](#).
2. Release seatback trim strap and J-hook retainers on underside of seat.
3. Release J-clip retainer (A) and unzip the seatback zippers (B).

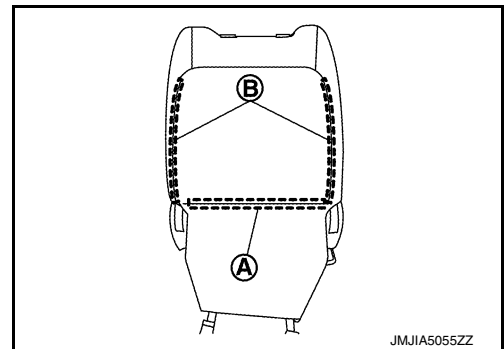

FRONT SEAT

< REMOVAL AND INSTALLATION >

4. Release pawls in order as shown (←) and remove the rear heated seat switch finisher from seatback (passenger seat only).

△: Pawl

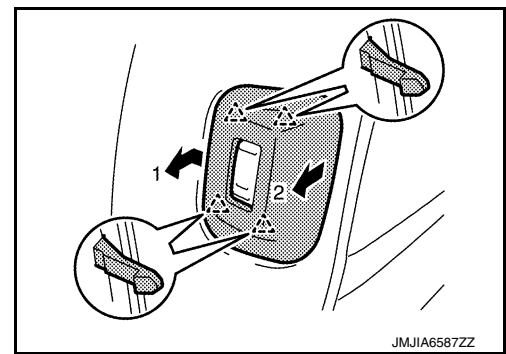

5. Release the headrest holder locks as shown and remove the headrest holders.

CAUTION:

Before removing/installing the headrest holder, check its orientation (front/rear and right/left).

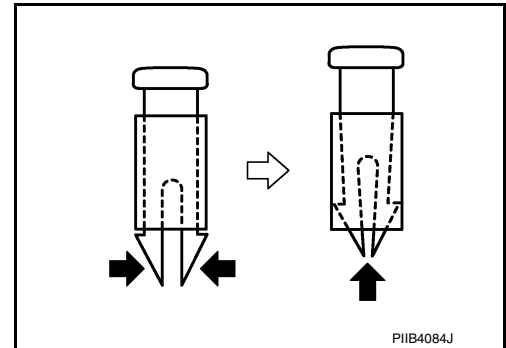

6. Remove the seatback from the seat frame assembly.

- a. Remove and discard the side air bag module nuts (A).

CAUTION:

Do not reuse the side air bag module nuts.

- b. Unclip the side air bag module harness from the seat frame assembly and route the harness through the seat cushion trim.

NOTE:

Take note of harness routing and attachment location for correct installation.

- c. Disconnect the harness connector from the seatback heater and unclip from the seat frame assembly.

NOTE:

Take note of harness routing and attachment location for correct installation.

- d. Release the side air bag module studs from the seat frame assembly and lift the seatback from the seat frame assembly.

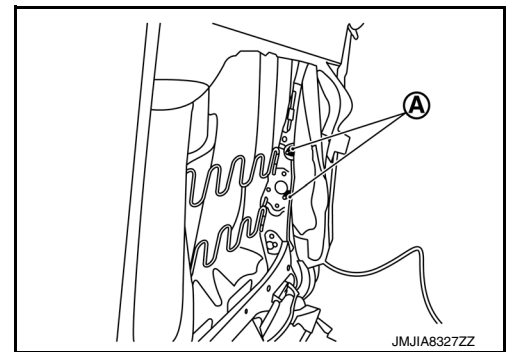

7. Remove the side air bag module from the seatback.

- a. Open the seatback and release the side air bag module studs (A) from the holes in the chute (1).

- b. Pull the side air bag module (2) out of the chute (1) and remove.

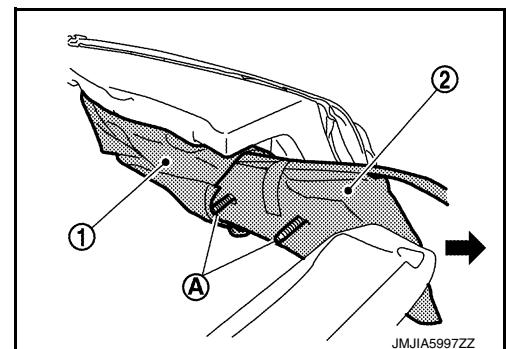

CAUTION:

- Do not damage the seatback trim or chute.

FRONT SEAT

< REMOVAL AND INSTALLATION >

- Place side air bag module as a unit with side air bag deployment surface facing upward (stud bolts facing downward). (This is to prevent accidental deployment.)

⇐: Upward

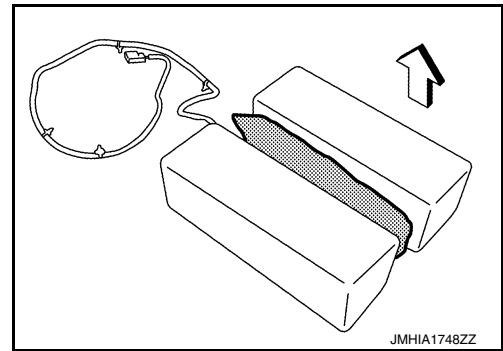

- Replace the side air bag module if it has been dropped or sustains an impact.
- Do not strike the side air bag module.



ASSEMBLY

Assembly is in the reverse order of disassembly.

Tighten the side air bag nuts to specification. Refer to [SE-25, "Exploded View"](#).

CAUTION:

- Check that side air bag module (1) and chute (2) is in the position as shown in the figure.

⇐: Front

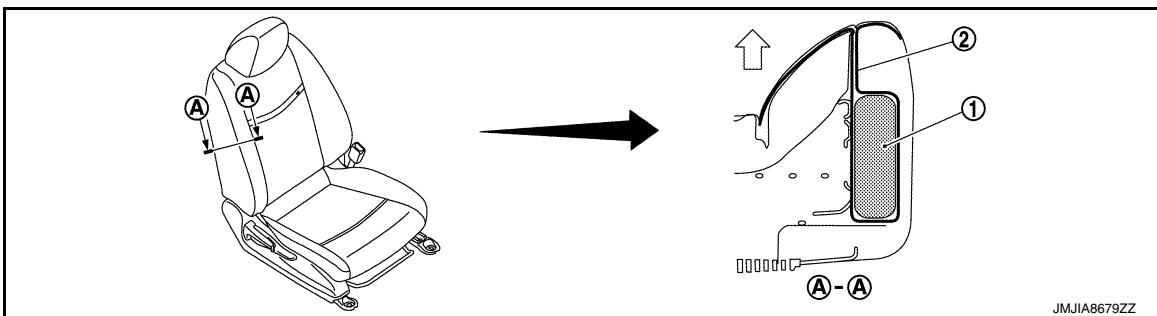

- Do not reuse the side air bag module nuts.
- Inspect seatback pad, seatback trim and chute. Replace if damaged.
- Smooth out all wrinkles during assembly.
- Always route side air bag module harness in original location. Replace any deformed or damaged clips with same type and color. Always install clips in the original location in the harness.
- After work is completed, check that no system malfunction is detected causing the air bag warning lamp to illuminate.
- If a malfunction is detected by the air bag warning lamp after repair or replacement of the malfunction parts, perform the self diagnosis using the air bag warning lamp or CONSULT. Refer to [SRC-11, "On Board Diagnosis Function"](#) or [SRC-15, "CONSULT Function"](#).
- When installing the side air bag module, make sure there are no wrinkles and the chute is not folded, twisted or pinched.

SEAT CUSHION

SEAT CUSHION : Disassembly and Assembly

INFOID:000000008745578

DISASSEMBLY

FRONT SEAT

< REMOVAL AND INSTALLATION >

WARNING:

Do not leave any objects (screwdrivers, tools, etc.) on the seat during seat cushion repair. It can lead to personal injury if the side air bag module should accidentally deploy.

CAUTION:

- Before servicing, turn the ignition switch OFF, disconnect both 12V battery terminals and wait at least three minutes.
- Always work from the side or back of the seatback assembly, do not work in front of seat.
- Do not use air tools or electric tools for servicing the seat assembly.
- During disassembly, do not damage the seatback cover, chutes, connectors, retainers, clips, module harness or the side air bag module.

1. Remove the front seat assembly. Refer to [SE-28, "Removal and Installation"](#).
2. Remove recline lever finisher.
 - a. Apply protective tape (A) on the parts to protect it from damage.

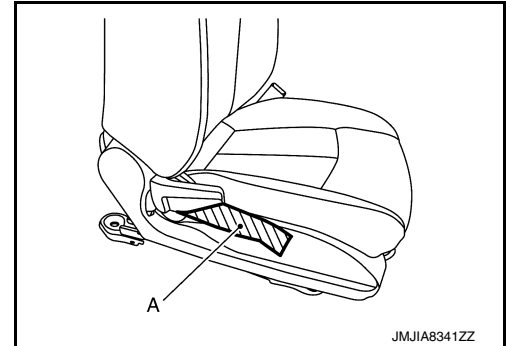

- b. Pull out the recline lever finisher while pushing the tip down.

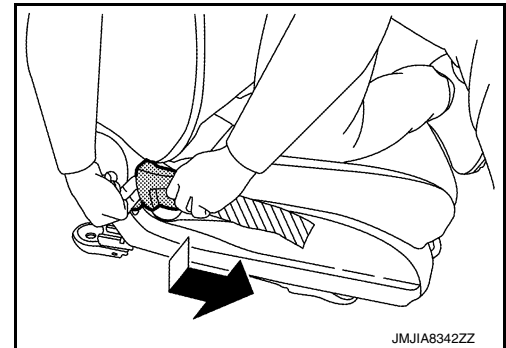

3. Remove lift lever (driver side only).
 - a. Release pawls using a suitable tool (A) and remove the lift lever finisher (1).

△: Pawl

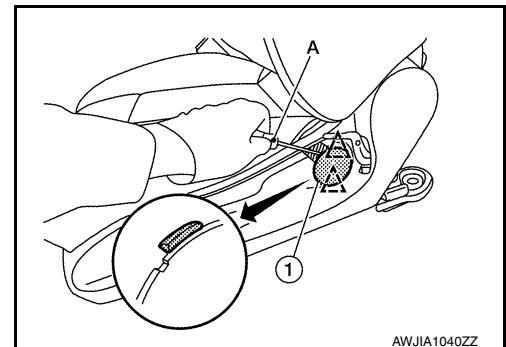

FRONT SEAT

< REMOVAL AND INSTALLATION >

b. Remove screws (A) and the lift lever (1).

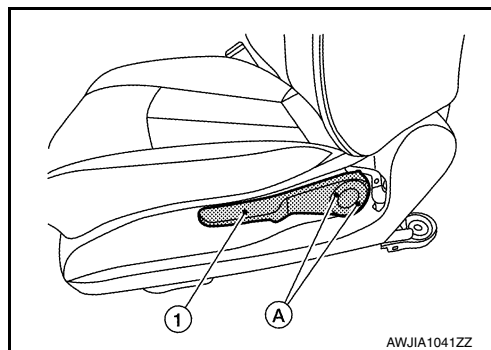

4. Release clips and pawls, then remove the seat cushion outer finisher (1).

- : Clip
- △: Pawl

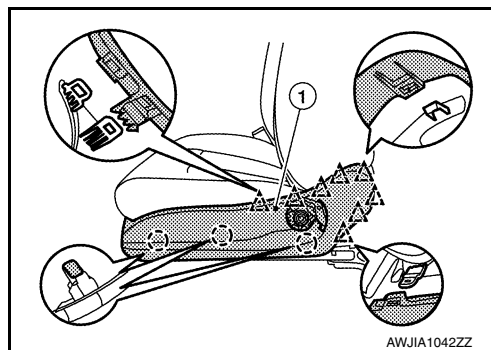

5. Release clips and pawls, then remove the seat cushion outer finisher (1).

- : Clip
- △: Pawl

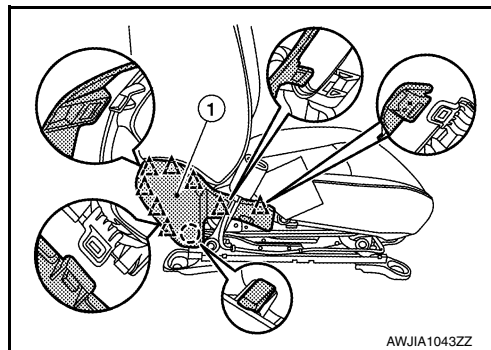

6. Release the seatback trim strap (A) and J-hook retainers (B).

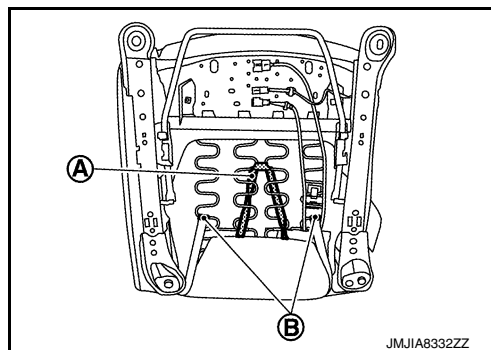

7. Release J-clip retainer (A) unzip the seatback zippers (B).

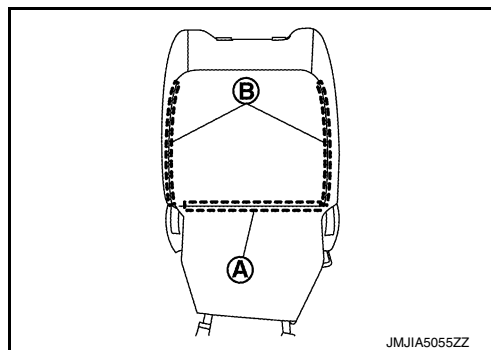

A
B
C
D
E
F
G
H
I
SE
K
L
M
N
O
P

FRONT SEAT

< REMOVAL AND INSTALLATION >

- Unclip the side air bag module harness from the seat frame assembly and route the harness through the seat cushion trim.

NOTE:

Take note of harness routing and attachment location for correct installation.

- Disconnect the seat cushion harness connector and unclip it from the seat frame assembly.

NOTE:

Take note of harness routing and attachment location for correct installation.

- Release J-clip retainers (A) from the seat frame assembly.

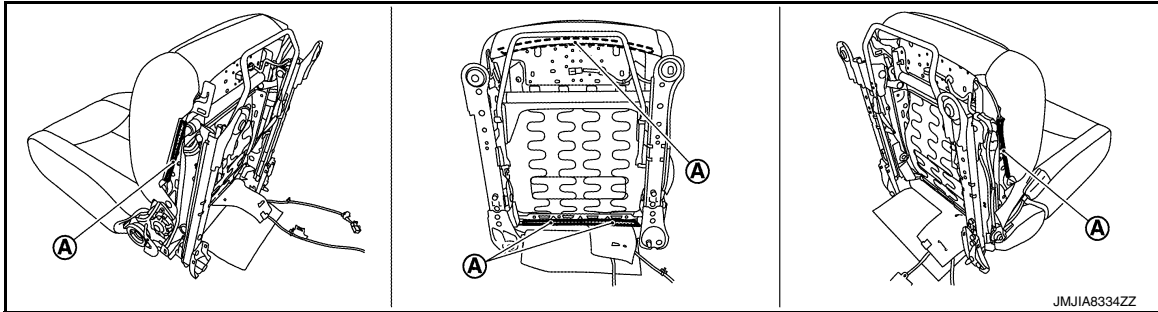

- Remove the seat cushion from the seat frame assembly.

ASSEMBLY

Assembly is in the reverse order of disassembly.

CAUTION:

- Smooth out all wrinkles during assembly.
- Always route side air bag module harness in original location. Replace any deformed or damaged clips with same type and color. Always install clips in the original location in the harness.
- After work is completed, check that no system malfunction is detected causing the air bag warning lamp to illuminate.
- If a malfunction is detected by the air bag warning lamp after repair or replacement of the malfunction parts, perform the self diagnosis using the air bag warning lamp or CONSULT. Refer to [SRC-11, "On Board Diagnosis Function"](#) or [SRC-15, "CONSULT Function"](#).

REAR SEAT

< REMOVAL AND INSTALLATION >

REAR SEAT

Exploded View

INFOID:000000008745579

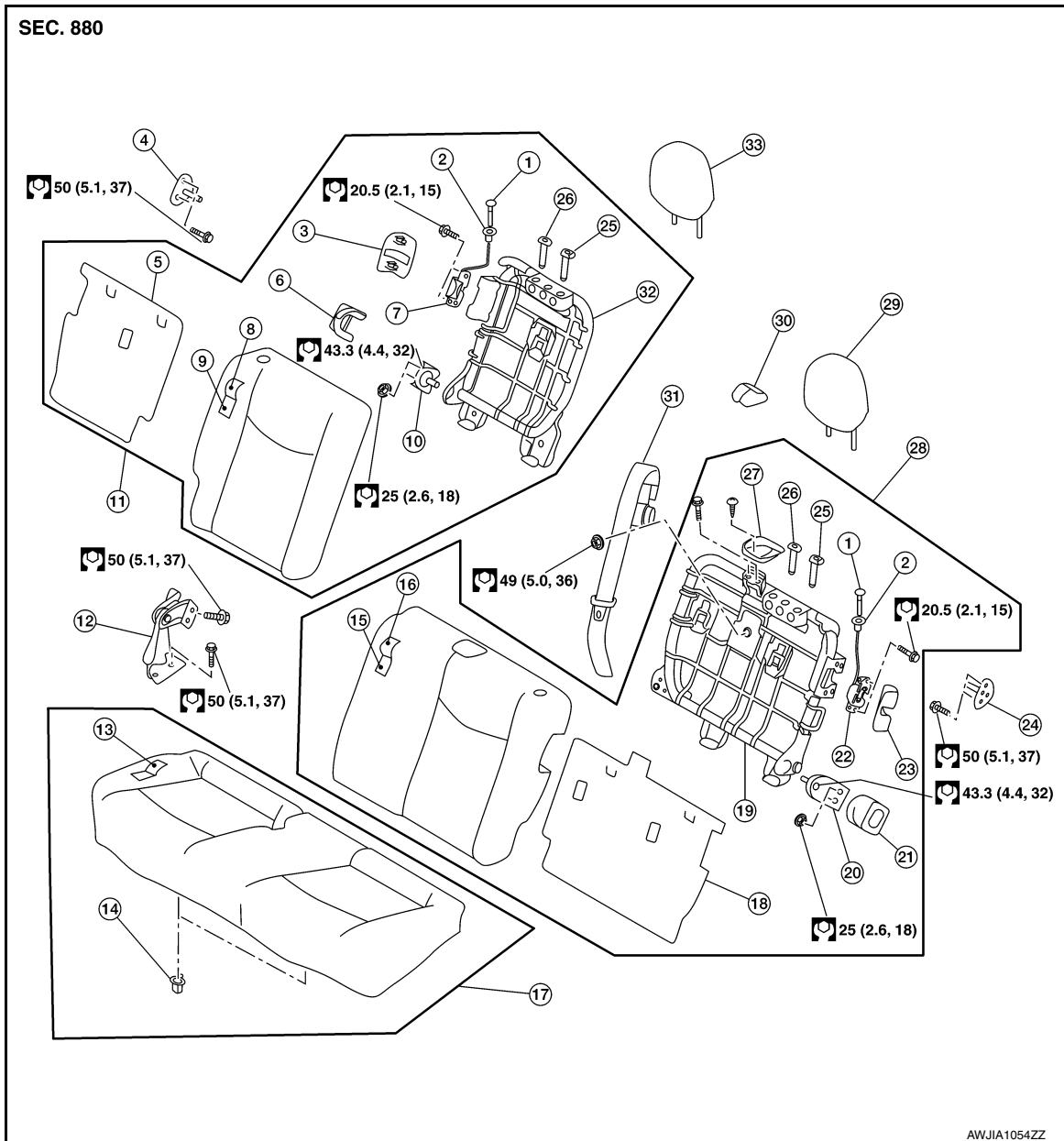

- | | | |
|----------------------------------|-------------------------------------|--|
| 1. Seatback latch release knob | 2. Seat latch release knob finisher | 3. Seatback latch finisher (RH) |
| 4. Seatback striker (RH) | 5. Seatback support (RH) | 6. Seatback hinge bracket finisher (RH) |
| 7. Seatback latch assembly (RH) | 8. Seatback trim (RH) | 9. Seatback pad (RH) |
| 10. Seatback hinge bracket (RH) | 11. Seatback assembly (RH) | 12. Seatback hinge bracket (center) |
| 13. Seat cushion trim | 14. Seat cushion hook | 15. Seatback pad (LH) |
| 16. Seatback trim (LH) | 17. Seat cushion assembly | 18. Seatback support (LH) |
| 19. Seatback frame (LH) | 20. Seatback hinge bracket (LH) | 21. Seatback hinge bracket finisher (LH) |
| 22. Seatback latch assembly (LH) | 23. Seatback latch finisher (LH) | 24. Seatback striker (LH) |
| 25. Headrest holder (locked) | 26. Headrest holder (free) | 27. Center seat belt cover |
| 28. Seatback assembly (LH) | 29. Headrest (LH) | 30. Center seat belt finisher |
| 31. Center seat belt retractor | 32. Seatback frame (RH) | 33. Headrest (RH) |

SEATBACK

REAR SEAT

< REMOVAL AND INSTALLATION >

SEATBACK : Removal and Installation

INFOID:000000008745580

REMOVAL

Seatback Assembly (LH)

1. Remove the seat cushion assembly. Refer to [SE-39, "SEAT CUSHION : Removal and Installation"](#).
2. Remove center anchor bolt of center seat belt retractor. Refer to [SB-14, "Exploded View"](#).
3. Place the rear seatback assembly (LH) in the folded down position.
4. Pull up seatback trim, then remove bolts from the seatback hinge bracket (center).
5. Remove the luggage finisher mask (LH). Refer to [INT-42, "LUGGAGE FINISHER MASK : Removal and Installation"](#).
6. Remove nuts from the seatback hinge bracket (LH).
7. Remove seatback assembly (LH) from the vehicle.

CAUTION:

When removing and installing, use shop cloths to protect parts from damage.

Seatback Assembly (RH)

1. Remove the seat cushion assembly. Refer to [SE-39, "SEAT CUSHION : Removal and Installation"](#).
2. Place the seatback assembly (RH) in the folded down position.
3. Pull up seatback trim, then remove bolts from the seatback hinge bracket (center).
4. Remove the luggage finisher mask (RH). Refer to [INT-42, "LUGGAGE FINISHER MASK : Removal and Installation"](#).
5. Remove nuts from the seatback hinge bracket (RH).
6. Remove seatback assembly (RH) from the vehicle.

CAUTION:

When removing and installing, use shop cloths to protect parts from damage.

INSTALLATION

Installation is in the reverse order of removal.

- Temporary install bolts, position seatback assembly (LH/RH) to the latched position. Check that seatback latch assembly and seatback striker do not interfere, then tighten bolts to specification. Refer to [SE-35, "Exploded View"](#).
- Tighten the center anchor bolt to specification. Refer to [SB-14, "Exploded View"](#).

SEATBACK : Disassembly and Assembly

INFOID:000000008745581

DISASSEMBLY

1. Remove seatback hinge bracket (LH/RH). Refer to [SE-40, "SEATBACK HINGE : Removal and Installation"](#).
2. Release J-clip retainer (A) and then unzip seatback zippers (B).
 - Seatback assembly (LH)

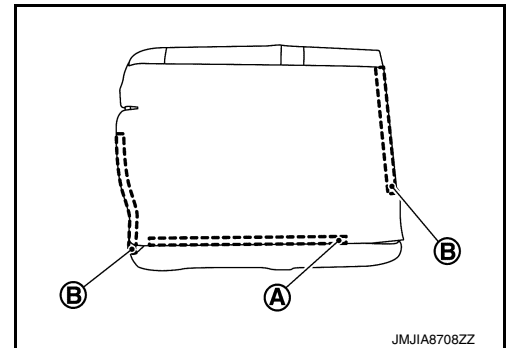

REAR SEAT

< REMOVAL AND INSTALLATION >

- Seatback assembly (RH)

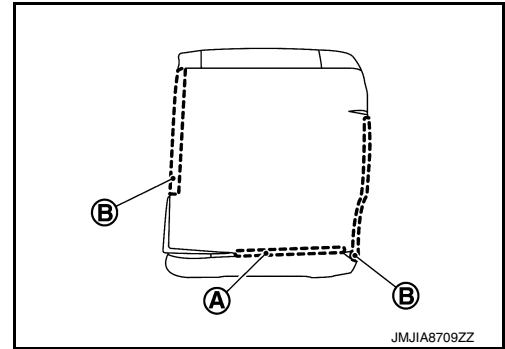

3. Remove seatback support.
Release the seatback support from seatback frame at locations (A) and remove the seatback support.
- Seatback assembly (LH)

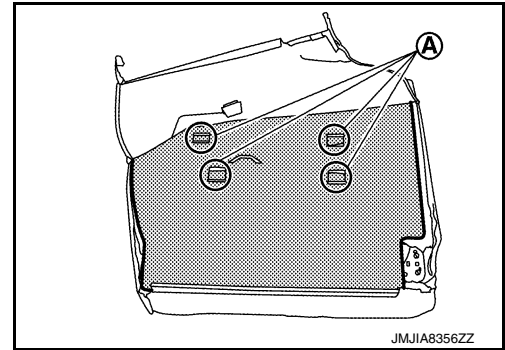

- Seatback assembly (RH)

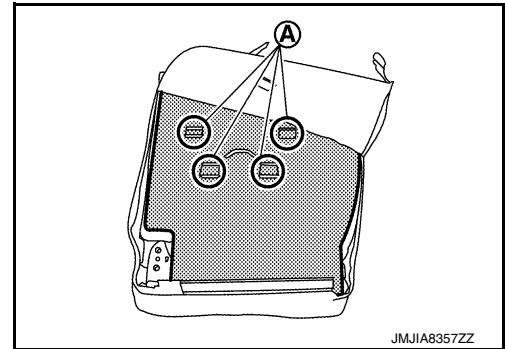

4. Pull out seatback trim from ISO FIX at locations (A).
- Seatback assembly (LH)

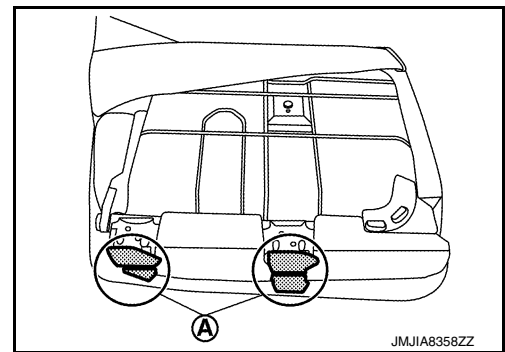

A
B
C
D
E
F
G
H
I
SE
K
L
M
N
O
P

REAR SEAT

< REMOVAL AND INSTALLATION >

- Seatback assembly (RH)

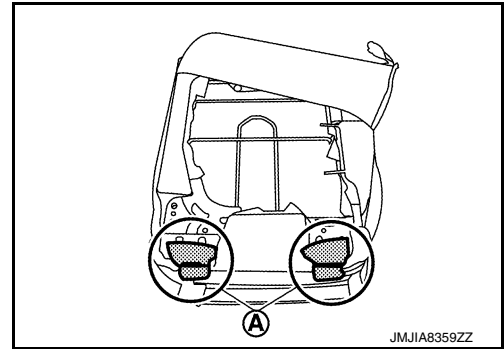

5. Remove center seat belt finisher (seatback assembly (LH) only).
 - a. Pull up on front of center seat belt finisher, then release pawls.
 - b. Pull up on sides of center seat belt finisher, release pawls and remove.

△: Pawl

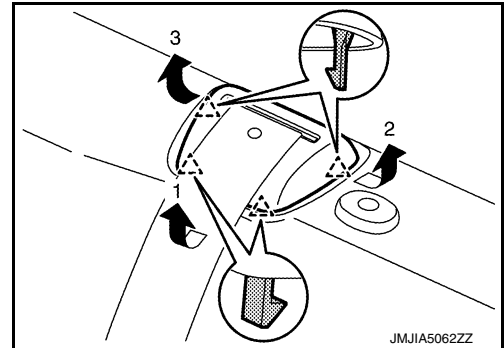

6. Release the headrest holder locks as shown and remove the headrest holders.

CAUTION:

Before removing/installing the headrest holder, check its orientation (front/rear and right/left).

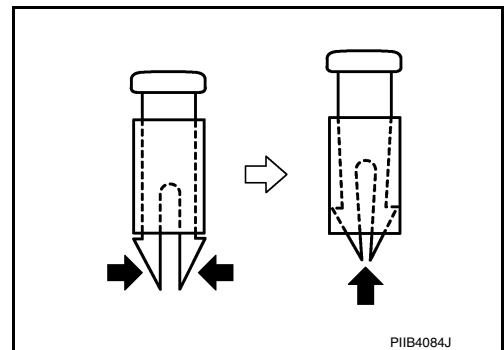

7. Rotate the seatback latch release knob counterclockwise and remove.

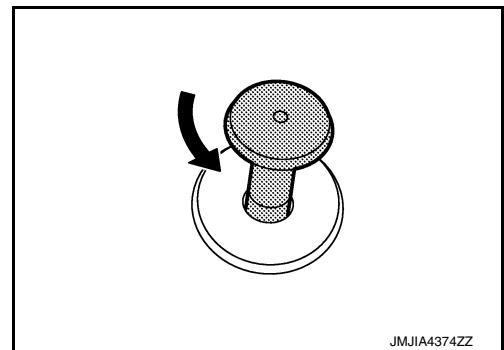

REAR SEAT

< REMOVAL AND INSTALLATION >

- Reach up through seatback pad and remove the seatback latch release knob finisher as shown.

CAUTION:

When installing seatback lock knob finisher, check front and rear orientation and be careful to install it normally.

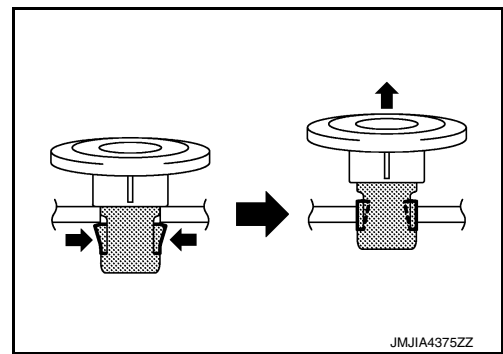

- Remove seatback trim and seatback pad as an assembly.
- Remove hog rings and separate the seatback trim from the seatback pad.
NOTE:
Remove all hog rings and discard them.
- Remove seatback latch assembly bolts and the seatback latch assembly.
- Remove center seat belt retractor. Refer to [SB-15. "SEAT BELT RETRACTOR : Removal and Installation"](#).

ASSEMBLY

Assemble is in the reverse order of disassembly.

- Install new hog rings on the seatback trim in original positions.
- Use only one hog ring in each designated location.
- Make sure hog rings are correctly fastened around both the seatback trim and seatback pad wires.
- Use NISSAN standard hog rings and tools to assemble.

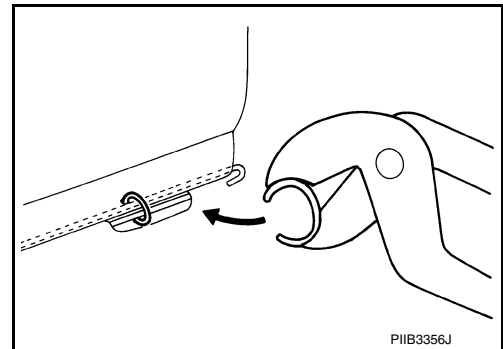

SEAT CUSHION

SEAT CUSHION : Removal and Installation

INFOID:000000008745582

REMOVAL

CAUTION:

When removing the seat cushion, do not damage the rear seat heater harness and harness connector.

- Lift up the seat cushion assembly close to the front edge (B) to release it from the seat cushion hooks (A) (one for each side) and remove the seat cushion assembly.

⇐: Front

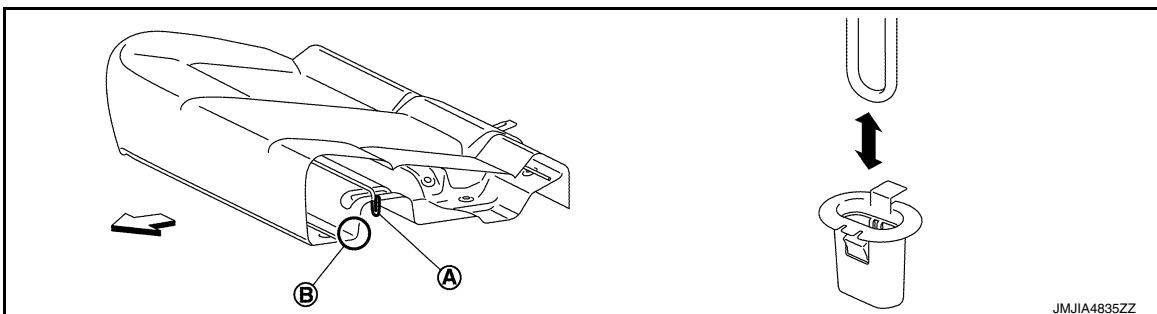

CAUTION:

Do not use excessive force to front of seat cushion assembly when removing. To avoid damage, lift seat cushion assembly closest to seat cushion hooks.

REAR SEAT

< REMOVAL AND INSTALLATION >

2. Pull out seat belt buckle from seat cushion assembly.
3. Lift up seat cushion assembly, and then disconnect the rear seat heater harness connector (A) and unclip the harness from the seat cushion assembly.

: Clip

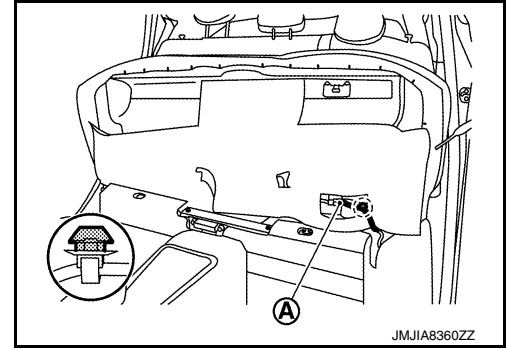

4. Remove seat cushion assembly from vehicle.

INSTALLATION

Installation is in the reverse order of removal.

CAUTION:

- If center seat belt buckle (1) and seat belt buckle RH (2) are not installed in normal position, the seat belt cannot be fastened. After seat cushion assembly installation, check that center seat belt buckle is positioned as shown.

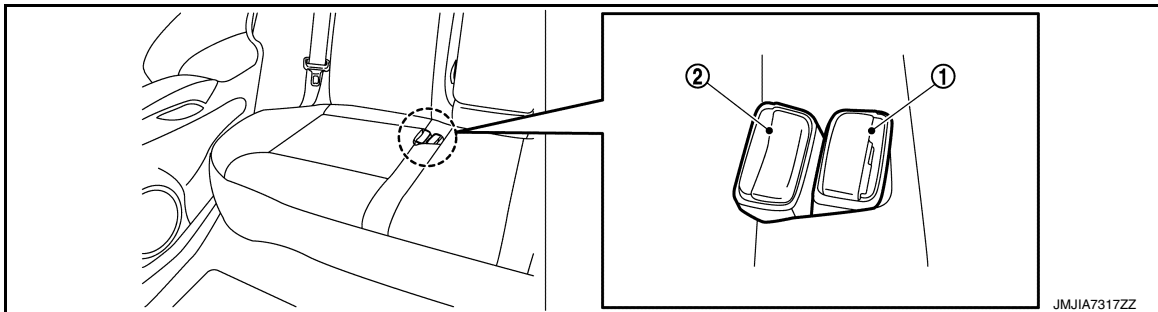

SEAT CUSHION : Disassembly and Assembly

INFOID:000000008745583

DISASSEMBLY

1. Remove the seat cushion assembly. Refer to [SE-39. "SEAT CUSHION : Removal and Installation"](#).
2. Remove the hog rings and separate the seat cushion trim from the seat cushion pad.

NOTE:

Remove all pieces of hog rings and discard them.

ASSEMBLY

Assemble is in the reverse order of disassembly.

- Install new hog rings on the seat cushion trim in original positions.
- Use only one hog ring in each designated location.
- Make sure hog rings are correctly fastened around both the seat cushion trim and seat cushion pad wires.
- Use NISSAN standard hog rings and tools to assemble.

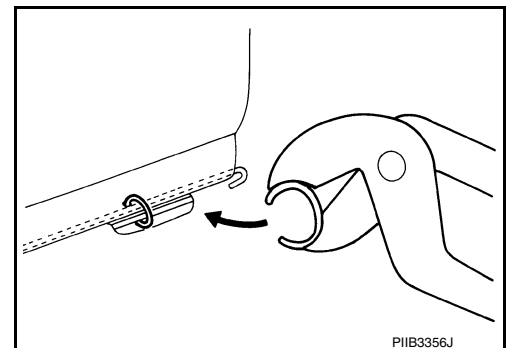

SEATBACK HINGE

SEATBACK HINGE : Removal and Installation

INFOID:000000008745584

Seatback hinge bracket (center)

REAR SEAT

< REMOVAL AND INSTALLATION >

REMOVAL

1. Remove seatback assembly (LH/RH). Refer to [SE-36. "SEATBACK : Removal and Installation"](#).
2. Remove seatback hinge bracket (center) bolts and remove.

INSTALLATION

1. Temporarily tighten all bolts, then tighten bolts to specification in order shown. Refer to [SE-35. "Exploded View"](#).
⇐: Front

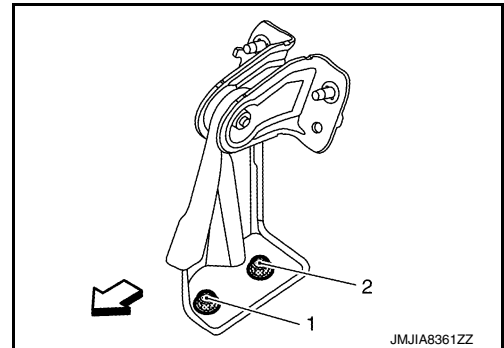

Seatback hinge bracket (LH/RH)

REMOVAL

1. Remove seatback assembly. Refer to [SE-36. "SEATBACK : Removal and Installation"](#).
2. Remove seatback hinge bracket finisher.
 - a. Pull seatback hinge finisher in direction shown (⇐) and release at locations (A).

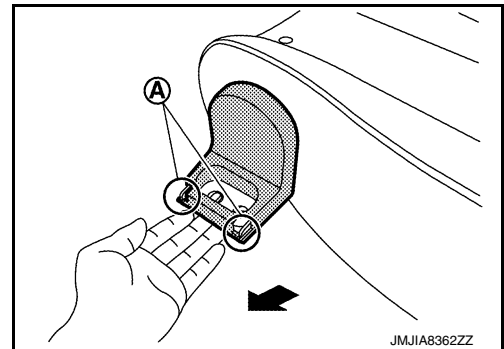

- b. Then lift in direction shown (⇑) and remove.

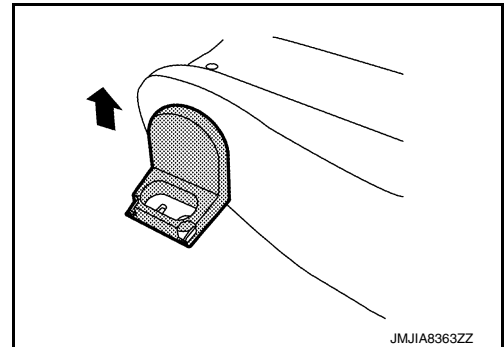

3. Remove bolt (A) and the seatback hinge bracket.

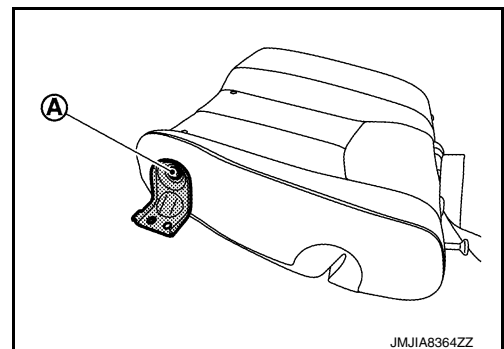

A
B
C
D
E
F
G
H
I
SE
K
L
M
N
O
P

REAR SEAT

< REMOVAL AND INSTALLATION >

INSTALLATION

Installation is in the reverse order of removal.

Tighten the seatback hinge bracket bolt to specification. Refer to [SE-35, "Exploded View"](#).

SEATBACK STRIKER

SEATBACK STRIKER : Removal and Installation

INFOID:000000008745585

REMOVAL

1. Remove the luggage side lower finisher. Refer to [INT-43, "LUGGAGE SIDE LOWER FINISHER : Removal and Installation"](#).
2. Remove bolts and the seatback striker.

INSTALLATION

Installation is in the reverse order of removal.

NOTE:

- Temporarily tighten bolts.
- Then tighten the bolts to specification, in the order shown. Refer to [SE-35, "Exploded View"](#).

↶ Front

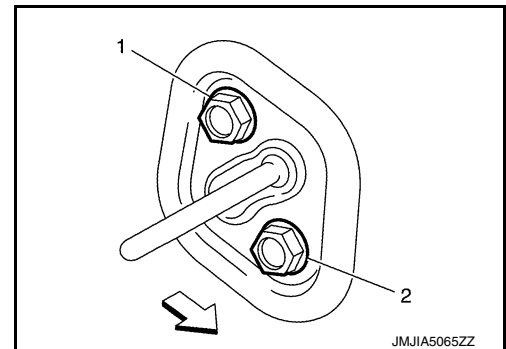

HEATED SEAT SWITCH

< REMOVAL AND INSTALLATION >

HEATED SEAT SWITCH FRONT

FRONT : Removal and Installation

INFOID:000000008745586

REMOVAL

CAUTION:

When removing and installing, use shop cloths to protect parts from damage.

1. Remove console finisher assembly from center console assembly. Refer to [JP-30, "Removal and Installation"](#).
2. Release pawls using a suitable tool (A) and remove front heated seat switch (1) from console finisher assembly.

△: Pawl

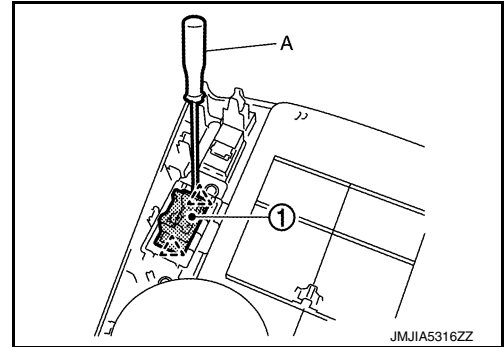

INSTALLATION

Installation is in the reverse order of removal.

REAR

REAR : Removal and Installation

INFOID:000000008745587

REMOVAL

1. Release pawls as shown (←) and remove the rear heated seat switch finisher from seatback.

△: Pawl

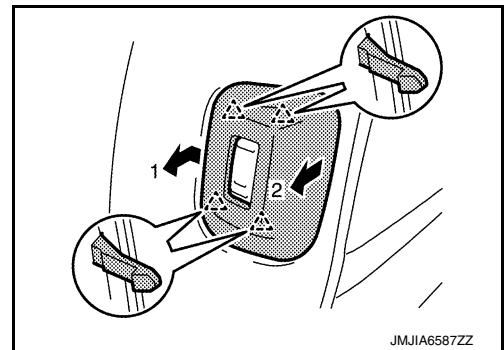

2. Unzip the seatback zipper.
3. Remove screw (1) then slide switch bracket (2) as shown (←) to remove.

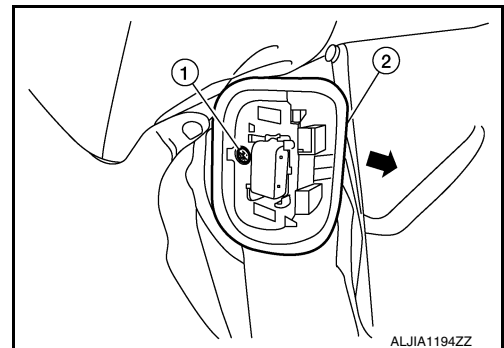

4. Disconnect the harness connector for the rear heated seat switch and unclip from the seat frame assembly.

HEATED SEAT SWITCH

< REMOVAL AND INSTALLATION >

5. Release pawls and remove the rear heated seat switch (1) from the switch bracket (2).

△: Pawl

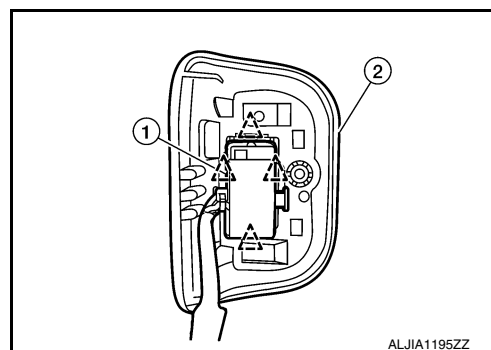

INSTALLATION

Installation is in the reverse order of removal.