

SECTION **EXT**  
EXTERIOR

A  
B  
C  
D  
E  
F  
G  
H  
I  
J  
K  
L  
M  
N  
O  
P

CONTENTS

<b>PRECAUTION</b> .....	2	<b>FENDER PROTECTOR</b> .....	21
<b>PRECAUTIONS</b> .....	2	<b>FENDER PROTECTOR</b> .....	21
Precaution for Technicians Using Medical Electric.....	2	FENDER PROTECTOR : Exploded View .....	21
Point to Be Checked Before Starting Maintenance		FENDER PROTECTOR : Removal and Installa-	
Work .....	2	tion .....	21
Precaution for Supplemental Restraint System		<b>FLOOR SIDE FAIRING</b> .....	23
(SRS) "AIR BAG" and "SEAT BELT PRE-TEN-		<b>FRONT UNDER COVER</b> .....	23
SIONER" .....	2	FRONT UNDER COVER : Exploded View .....	23
Precaution for Removing 12V Battery .....	3	FRONT UNDER COVER : Removal and Installa-	
Precaution for Procedure without Cowl Top Cover.....	3	tion .....	23
Precaution for Work .....	4	<b>REAR DIFFUSER</b> .....	23
<b>PREPARATION</b> .....	5	REAR DIFFUSER : Exploded View .....	23
<b>PREPARATION</b> .....	5	REAR DIFFUSER : Removal and Installation .....	24
Special Service Tools .....	5	<b>ROOF SIDE MOLDING</b> .....	25
Commercial Service Tools .....	5	Exploded View .....	25
<b>SYMPTOM DIAGNOSIS</b> .....	6	Removal and Installation .....	26
<b>SQUEAK AND RATTLE TROUBLE DIAG-</b>		<b>DOOR SASH MOLDING</b> .....	28
<b>NOSES</b> .....	6	Exploded View .....	28
Work Flow .....	6	Removal and Installation .....	29
Inspection Procedure .....	8	<b>DOOR OUTSIDE MOLDING</b> .....	32
Diagnostic Worksheet .....	10	Exploded View .....	32
<b>REMOVAL AND INSTALLATION</b> .....	12	Removal and Installation .....	32
<b>FRONT BUMPER</b> .....	12	<b>DOOR PARTING SEAL</b> .....	34
Exploded View .....	12	Exploded View .....	34
Removal and Installation .....	13	Removal and Installation .....	34
<b>REAR BUMPER</b> .....	16	<b>REAR SPOILER</b> .....	35
Exploded View .....	16	Exploded View .....	35
Removal and Installation .....	17	Removal and Installation .....	36
<b>COWL TOP</b> .....	19	<b>REAR FENDER COVER</b> .....	38
Exploded View .....	19	Exploded View .....	38
Removal and Installation .....	19	Removal and Installation .....	38

EXT

# PRECAUTIONS

< PRECAUTION >

## PRECAUTION

### PRECAUTIONS

#### Precaution for Technicians Using Medical Electric

INFOID:000000010119975

##### OPERATION PROHIBITION

###### **WARNING:**

- Parts with strong magnet is used in this vehicle.
- Technicians using a medical electric device such as pacemaker must never perform operation on the vehicle, as magnetic field can affect the device function by approaching to such parts.

##### NORMAL CHARGE PRECAUTION

###### **WARNING:**

- If a technician uses a medical electric device such as an implantable cardiac pacemaker or an implantable cardioverter defibrillator, the possible effects on the devices must be checked with the device manufacturer before starting the charge operation.
- As radiated electromagnetic wave generated by PDM (Power Delivery Module) at normal charge operation may affect medical electric devices, a technician using a medical electric device such as implantable cardiac pacemaker or an implantable cardioverter defibrillator must not approach motor room [PDM (Power Delivery Module)] at the hood-opened condition during normal charge operation.

##### PRECAUTION AT TELEMATICS SYSTEM OPERATION

###### **WARNING:**

- If a technician uses implantable cardiac pacemaker or implantable cardioverter defibrillator (ICD), avoid the device implanted part from approaching within approximately 220 mm (8.66 in) from interior/exterior antenna.
- The electromagnetic wave of TCU might affect the function of the implantable cardiac pacemaker or the implantable cardioverter defibrillator (ICD), when using the service, etc.
- If a technician uses other medical electric devices than implantable cardiac pacemaker or implantable cardioverter defibrillator (ICD), the electromagnetic wave of TCU might affect the function of the device. The possible effects on the devices must be checked with the device manufacturer before TCU use.

##### PRECAUTION AT INTELLIGENT KEY SYSTEM OPERATION

###### **WARNING:**

- If a technician uses implantable cardiac pacemaker or implantable cardioverter defibrillator (ICD), avoid the device implanted part from approaching within approximately 220 mm (8.66 in) from interior/exterior antenna.
- The electromagnetic wave of Intelligent Key might affect the function of the implantable cardiac pacemaker or the implantable cardioverter defibrillator (ICD), at door operation, at each request switch operation, or at engine starting.
- If a technician uses other medical electric devices than implantable cardiac pacemaker or implantable cardioverter defibrillator (ICD), the electromagnetic wave of Intelligent Key might affect the function of the device. The possible effects on the devices must be checked with the device manufacturer before Intelligent Key use.

#### Point to Be Checked Before Starting Maintenance Work

INFOID:000000010119976

The high voltage system may starts automatically. It is required to check that the timer air conditioner and timer charge (during EVSE connection) are not set before starting maintenance work.

###### **NOTE:**

If the timer air conditioner or timer charge (during EVSE connection) is set, the high voltage system starts automatically even when the power switch is in OFF state.

#### Precaution for Supplemental Restraint System (SRS) "AIR BAG" and "SEAT BELT PRE-TENSIONER"

INFOID:000000010119977

The Supplemental Restraint System such as "AIR BAG" and "SEAT BELT PRE-TENSIONER", used along with a front seat belt, helps to reduce the risk or severity of injury to the driver and front passenger for certain types of collision. This system includes seat belt switch inputs and dual stage front air bag modules. The SRS

# PRECAUTIONS

## < PRECAUTION >

system uses the seat belt switches to determine the front air bag deployment, and may only deploy one front air bag, depending on the severity of a collision and whether the front occupants are belted or unbelted. Information necessary to service the system safely is included in the SR and SB section of this Service Manual.

### **WARNING:**

- To avoid rendering the SRS inoperative, which could increase the risk of personal injury or death in the event of a collision which would result in air bag inflation, all maintenance must be performed by an authorized NISSAN/INFINITI dealer.
- Improper maintenance, including incorrect removal and installation of the SRS, can lead to personal injury caused by unintentional activation of the system. For removal of Spiral Cable and Air Bag Module, see the SR section.
- Do not use electrical test equipment on any circuit related to the SRS unless instructed to in this Service Manual. SRS wiring harnesses can be identified by yellow and/or orange harnesses or harness connectors.

## PRECAUTIONS WHEN USING POWER TOOLS (AIR OR ELECTRIC) AND HAMMERS

### **WARNING:**

- When working near the Airbag Diagnosis Sensor Unit or other Airbag System sensors with the Ignition ON or engine running, DO NOT use air or electric power tools or strike near the sensor(s) with a hammer. Heavy vibration could activate the sensor(s) and deploy the air bag(s), possibly causing serious injury.
- When using air or electric power tools or hammers, always switch the Ignition OFF, disconnect the battery and wait at least three minutes before performing any service.

## Precaution for Removing 12V Battery

INFOID:000000010119978

1. Check that EVSE is not connected.

### **NOTE:**

If EVSE is connected, the air conditioning system may be automatically activated by the timer A/C function.

2. Turn the power switch OFF → ON → OFF. Get out of the vehicle. Close all doors (including back door).
3. Check that the charge status indicator lamp does not blink and wait for 5 minutes or more.

### **NOTE:**

If the battery is removed within 5 minutes after the power switch is turned OFF, plural DTCs may be detected.

4. Remove 12V battery within 1 hour after turning the power switch OFF → ON → OFF.

### **NOTE:**

- The 12V battery automatic charge control may start automatically even when the power switch is in OFF state.
- Once the power switch is turned ON → OFF, the 12V battery automatic charge control does not start for approximately 1 hour.

### **CAUTION:**

- After all doors (including back door) are closed, if a door (including back door) is opened before battery terminals are disconnected, start over from Step 1.
- After turning the power switch OFF, if "Remote A/C" is activated by user operation, stop the air conditioner and start over from Step 1.

## Precaution for Procedure without Cowl Top Cover

INFOID:000000010119979

When performing the procedure after removing cowl top cover, cover the lower end of windshield with urethane, etc to prevent damage to windshield.

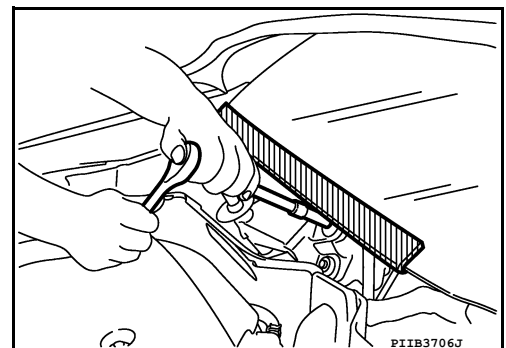

# PRECAUTIONS

< PRECAUTION >

## Precaution for Work

INFOID:000000010119980

- When removing or disassembling each component, be careful not to damage or deform it. If a component may be subject to interference, be sure to protect it with a shop cloth.
- When removing (disengaging) components with a screwdriver or similar tool, be sure to wrap the component with a shop cloth or vinyl tape to protect it.
- Protect the removed parts with a shop cloth and prevent them from being dropped.
- Replace a deformed or damaged clip.
- If a part is specified as a non-reusable part, always replace it with a new one.
- Be sure to tighten bolts and nuts securely to the specified torque.
- After installation is complete, be sure to check that each part works properly.
- Follow the steps below to clean components:
  - Water soluble dirt:
    - Dip a soft cloth into lukewarm water, wring the water out of the cloth and wipe the dirty area.
    - Then rub with a soft, dry cloth.
  - Oily dirt:
    - Dip a soft cloth into lukewarm water with mild detergent (concentration: within 2 to 3%) and wipe the dirty area.
    - Then dip a cloth into fresh water, wring the water out of the cloth and wipe the detergent off.
    - Then rub with a soft, dry cloth.
  - Do not use organic solvent such as thinner, benzene, alcohol or gasoline.
  - For genuine leather seats, use a genuine leather seat cleaner.

# PREPARATION

< PREPARATION >



## PREPARATION

### PREPARATION

#### Special Service Tools

INFOID:000000010119981

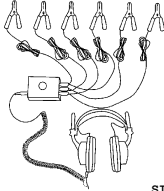
The actual shape of the tools may differ from those illustrated here.

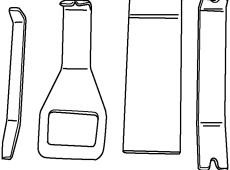
Tool number (TechMate No.) Tool name	Description
(J-39570) Chassis Ear 	Locates the noise
(J-50397) NISSAN Squeak and Rattle Kit 	Repairs the cause of noise
— (J-46534) Trim Tool Set 	Removing trim components

#### Commercial Service Tools

INFOID:000000010119982

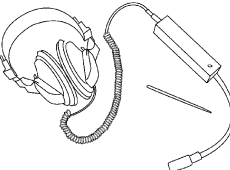
(TechMate No.) Tool name	Description
(J-39565) Engine Ear 	Locates the noise

A  
B  
C  
D  
E  
F  
G  
H  
I  
J  
EXT  
L  
M  
N  
O  
P

# SQUEAK AND RATTLE TROUBLE DIAGNOSES

< SYMPTOM DIAGNOSIS >

## SYMPTOM DIAGNOSIS

### SQUEAK AND RATTLE TROUBLE DIAGNOSES

#### Work Flow

INFOID:000000010119983

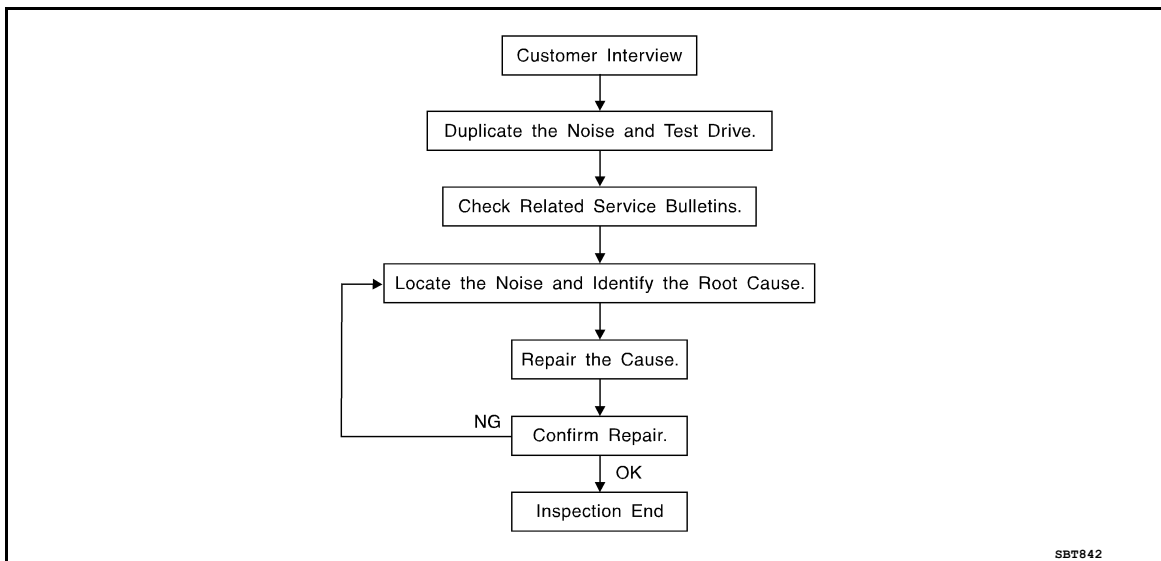

#### CUSTOMER INTERVIEW

Interview the customer if possible, to determine the conditions that exist when the noise occurs. Use the Diagnostic Worksheet during the interview to document the facts and conditions when the noise occurs and any customer comments. Refer to [EXT-10. "Diagnostic Worksheet"](#). This information is necessary to duplicate the conditions that exist when the noise occurs.

- The customer may not be able to provide a detailed description or the location of the noise. Attempt to obtain all the facts and conditions that exist when the noise occurs (or does not occur).
- If there is more than one noise in the vehicle, perform a diagnosis and repair the noise that the customer is concerned about. This can be accomplished by performing a test drive with the customer.
- After identifying the type of noise, isolate the noise in terms of its characteristics. The noise characteristics are provided so that the customer, service adviser, and technician use the same language when describing the noise.
- Squeak – (Like tennis shoes on a clean floor)  
Squeak characteristics include the light contact / fast movement / brought on by road conditions / hard surfaces = high-pitched noise / softer surfaces = low-pitched noises / edge to surface = chirping
- Creak – (Like walking on an old wooden floor)  
Creak characteristics include firm contact / slow movement/twisting with a rotational movement / pitch dependent on materials / often brought on by activity.
- Rattle – (Like shaking a baby rattle)  
Rattle characteristics include fast repeated contact / vibration or similar movement / loose parts/missing clip or fastener / incorrect clearance.
- Knock – (Like a knock on a door)  
Knock characteristics include hollow sounds / sometimes repeating / often brought on by driver action.
- Tick – (Like a clock second hand)  
Tick characteristics include gentle contacting of light materials / loose components / can be caused by driver action or road conditions.
- Thump – (Heavy, muffled knock noise)  
Thump characteristics include softer knock / dull sounds often brought on by activity.
- Buzz – (Like a bumblebee)  
Buzz characteristics include high frequency rattle / firm contact.
- Often the degree of acceptable noise level varies depending upon the person. A noise that a technician may judge as acceptable may be very irritating to a customer.
- Weather conditions, especially humidity and temperature, may have a great effect on noise level.

#### DUPLICATE THE NOISE AND TEST DRIVE

# SQUEAK AND RATTLE TROUBLE DIAGNOSES

## < SYMPTOM DIAGNOSIS >

If possible, drive the vehicle with the customer until the noise is duplicated. Note any additional information on the Diagnostic Worksheet regarding the conditions or location of the noise. This information can be used to duplicate the same conditions when the repair is reconfirmed.

If the noise can be duplicated easily during the test drive, to help identify the source of the noise, try to duplicate the noise with the vehicle stopped by doing one or all of the following items:

- 1) Close a door.
  - 2) Tap or push/pull around the area where the noise appears to be coming from.
  - 3) Rev the motor.
  - 4) Use a floor jack to recreate vehicle "twist".
  - 5) At idle, apply motor load (electrical load, half-clutch on M/T models, drive position on A/T models).
  - 6) Raise the vehicle on a hoist and hit a tire with a rubber hammer.
- Drive the vehicle and attempt to duplicate the conditions the customer states exist when the noise occurs.
  - If it is difficult to duplicate the noise, drive the vehicle slowly on an undulating or rough road to stress the vehicle body.

## CHECK RELATED SERVICE BULLETINS

After verifying the customer concern or symptom, check ASIST for Technical Service Bulletins (TSBs) related to the concern or symptom.

If a TSB relates to the symptom, follow the procedure to repair the noise.

## LOCATE THE NOISE AND IDENTIFY THE ROOT CAUSE

1. Narrow down the noise to a general area. To help pinpoint the source of the noise, use a listening tool (Chassis ear: J-39570, engine ear, and mechanics stethoscope).
2. Narrow down the noise to a more specific area and identify the cause of the noise by:
  - Removing the component(s) in the area that is / are suspected to be the cause of the noise. Do not use too much force when removing clips and fasteners, otherwise clips and fasteners can be broken or lost during the repair, resulting in the creation of new noise.
  - Tapping or pushing/pulling the component(s) that is / are suspected to be the cause of the noise. Do not tap or push/pull the component(s) with excessive force, otherwise the noise is eliminated only temporarily.
  - Feeling for a vibration by hand by touching the component(s) that is / are suspected to be the cause of the noise.
  - Placing a piece of paper between components that are suspected to be the cause of the noise.
  - Looking for loose components and contact marks.  
Refer to [EXT-8. "Inspection Procedure"](#).

## REPAIR THE CAUSE

- If the cause is a loose component, tighten the component securely.
- If the cause is insufficient clearance between components:
  - separate components by repositioning or loosening and retightening the component, if possible.
  - insulate components with a suitable insulator such as urethane pads, foam blocks, felt cloth tape or urethane tape. A NISSAN Squeak and Rattle Kit (J-50397) is available through your authorized NISSAN Parts Department.

### **CAUTION:**

**Do not use excessive force as many components are constructed of plastic and may be damaged.**

### **NOTE:**

- Always check with the Parts Department for the latest parts information.
- The materials contained in the NISSAN Squeak and Rattle Kit (J-50397) are listed on the inside cover of the kit; and can each be ordered separately as needed.
- The following materials not found in the kit can also be used to repair squeaks and rattles.
  - SILICONE GREASE: Use instead of UHMW tape that will be visible or does not fit. The silicone grease will only last a few months.
  - SILICONE SPRAY: Use when grease cannot be applied.
  - DUCT TAPE: Use to eliminate movement.

## CONFIRM THE REPAIR

After repair is complete, test drive the vehicle to confirm that the cause of noise is repaired by test driving the vehicle. Operate the vehicle under the same conditions as when the noise originally occurred. Refer to the notes on the Diagnostic Worksheet.

# SQUEAK AND RATTLE TROUBLE DIAGNOSES

< SYMPTOM DIAGNOSIS >

---

## Inspection Procedure

INFOID:000000010119984

Refer to Table of Contents for specific component removal and installation information.

### INSTRUMENT PANEL

Most incidents are caused by contact and movement between:

1. The cluster lid A and instrument panel
2. Acrylic lens and combination meter housing
3. Instrument panel to front pillar garnish
4. Instrument panel to windshield
5. Instrument panel mounting pins
6. Wiring harnesses behind the combination meter
7. A/C defroster duct and duct joint

These incidents can usually be located by tapping or moving the components to duplicate the noise or by pressing on the components while driving to stop the noise. Most of these incidents can be repaired by applying felt cloth tape or silicon spray (in hard to reach areas). Urethane pads can be used to insulate wiring harness.

#### **CAUTION:**

**Never use silicone spray to isolate a squeak or rattle. If the area is saturated with silicone, the recheck of repair becomes impossible.**

### CENTER CONSOLE

Components to check include:

1. Shifter assembly cover to finisher
2. A/C control unit and cluster lid C
3. Wiring harnesses behind audio and A/C control unit

The instrument panel repair and isolation procedures also apply to the center console.

### DOORS

Pay attention to the:

1. Finisher and inner panel making a slapping noise
2. Inside handle escutcheon to door finisher
3. Wiring harnesses tapping
4. Door striker out of alignment causing a popping noise on starts and stops

Tapping or moving the components or pressing on them while driving to duplicate the conditions can isolate many of these incidents. You can usually insulate the areas with felt cloth tape or insulator foam blocks from the NISSAN Squeak and Rattle Kit (J-50397) to repair the noise.

### TRUNK

Trunk noises are often caused by a loose jack or loose items put into the trunk by the customer.

In addition check for the following items:

1. Trunk lid dumpers out of adjustment
2. Trunk lid striker out of adjustment
3. Trunk lid torsion bars knocking together
4. A loose license plate or bracket

Most of these incidents can be repaired by adjusting, securing, or insulating the item(s) or component(s) causing the noise.

### SUNROOF/HEADLINING

Noises in the sunroof / headlining area can often be traced to one of the following items:

1. Sunroof lid, rail, linkage, or seals making a rattle or light knocking noise
2. Sunvisor shaft shaking in the holder
3. Front or rear windshield touching headlining and squeaking

Again, pressing on the components to stop the noise while duplicating the conditions can isolate most of these incidents. Repairs usually consist of insulating with felt cloth tape.



# SQUEAK AND RATTLE TROUBLE DIAGNOSES

## < SYMPTOM DIAGNOSIS >

---

### SEATS

When isolating seat noise it is important to note the position the seat is in and the load placed on the seat when the noise occurs. These conditions should be duplicated when verifying and isolating the cause of the noise.

Causes of seat noise include:

1. Headrest rods and holder
2. A squeak between the seat pad cushion and frame
3. The rear seatback lock and bracket

These noises can be isolated by moving or pressing on the suspected components while duplicating the conditions under which the noise occurs. Most of these incidents can be repaired by repositioning the component or applying urethane tape to the contact area.

### UNDERHOOD

Some interior noise may be caused by components under the hood or on the motor wall. The noise is then transmitted into the passenger compartment.

Causes of transmitted underhood noise include:

1. Any component mounted to the motor wall
2. Components that pass through the motor wall
3. Motor wall mounts and connectors
4. Loose radiator mounting pins
5. Hood bumpers out of adjustment
6. Hood striker out of adjustment

These noises can be difficult to isolate since they cannot be reached from the interior of the vehicle. The best method is to secure, move, or insulate one component at a time and test drive the vehicle. Also, motor RPM or load can be changed to isolate the noise. Repairs can usually be made by moving, adjusting, securing, or insulating the component causing the noise.

A  
B  
C  
D  
E  
F  
G  
H  
I  
J  
L  
M  
N  
O  
P

EXT

# SQUEAK AND RATTLE TROUBLE DIAGNOSES

< SYMPTOM DIAGNOSIS >

## Diagnostic Worksheet

INFOID:000000010119985



### SQUEAK & RATTLE DIAGNOSTIC WORKSHEET

Dear Nissan Customer:

We are concerned about your satisfaction with your Nissan vehicle. Repairing a squeak or rattle sometimes can be very difficult. To help us fix your Nissan right the first time, please take a moment to note the area of the vehicle where the squeak or rattle occurs and under what conditions. You may be asked to take a test drive with a service advisor or technician to ensure we confirm the noise you are hearing.

#### I. WHERE DOES THE NOISE COME FROM? (circle the area of the vehicle)

The illustrations are for reference only, and may not reflect the actual configuration of your vehicle.

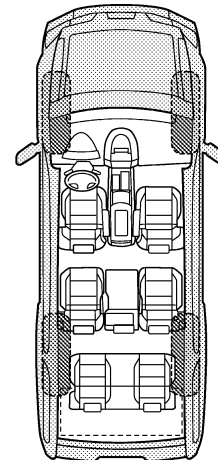
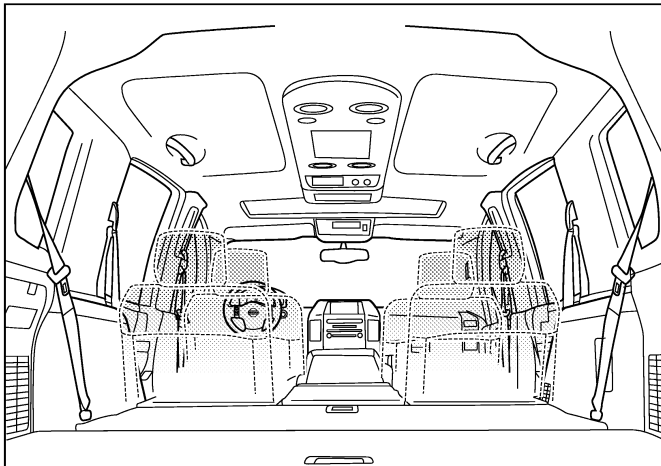
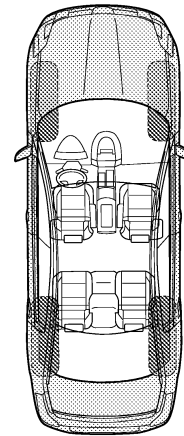
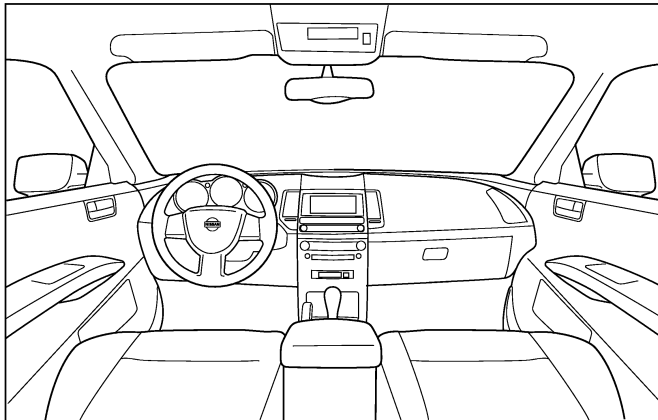

Continue to page 2 of the worksheet and briefly describe the location of the noise or rattle. In addition, please indicate the conditions which are present when the noise occurs.

PIIB8740E

# SQUEAK AND RATTLE TROUBLE DIAGNOSES

< SYMPTOM DIAGNOSIS >

## SQUEAK & RATTLE DIAGNOSTIC WORKSHEET - page 2

Briefly describe the location where the noise occurs:

---

---

### II. WHEN DOES IT OCCUR? (please check the boxes that apply)

- |   |  |
|---|--|
| <input type="checkbox"/> anytime                      | <input type="checkbox"/> after sitting out in the rain |
| <input type="checkbox"/> 1st time in the morning      | <input type="checkbox"/> when it is raining or wet     |
| <input type="checkbox"/> only when it is cold outside | <input type="checkbox"/> dry or dusty conditions       |
| <input type="checkbox"/> only when it is hot outside  | <input type="checkbox"/> other:                        |

### III. WHEN DRIVING:

- through driveways
- over rough roads
- over speed bumps
- only about \_\_\_\_ mph
- on acceleration
- coming to a stop
- on turns: left, right or either (circle)
- with passengers or cargo
- other: \_\_\_\_\_
- after driving \_\_\_\_ miles or \_\_\_\_ minutes

### IV. WHAT TYPE OF NOISE

- squeak (like tennis shoes on a clean floor)
- creak (like walking on an old wooden floor)
- rattle (like shaking a baby rattle)
- knock (like a knock at the door)
- tick (like a clock second hand)
- thump (heavy, muffled knock noise)
- buzz (like a bumble bee)

### TO BE COMPLETED BY DEALERSHIP PERSONNEL

#### Test Drive Notes:

---

---

---

	YES	NO	Initials of person performing
Vehicle test driven with customer	<input type="checkbox"/>	<input type="checkbox"/>	_____
- Noise verified on test drive	<input type="checkbox"/>	<input type="checkbox"/>	_____
- Noise source located and repaired	<input type="checkbox"/>	<input type="checkbox"/>	_____
- Follow up test drive performed to confirm repair	<input type="checkbox"/>	<input type="checkbox"/>	_____

VIN: \_\_\_\_\_ Customer Name: \_\_\_\_\_  
W.O.# \_\_\_\_\_ Date: \_\_\_\_\_

This form must be attached to Work Order

PIIB8742E

A  
B  
C  
D  
E  
F  
G  
H  
I  
J  
L  
M  
N  
O  
P

EXT

# FRONT BUMPER

< REMOVAL AND INSTALLATION >

## REMOVAL AND INSTALLATION

### FRONT BUMPER

Exploded View

INFOID:000000010119986

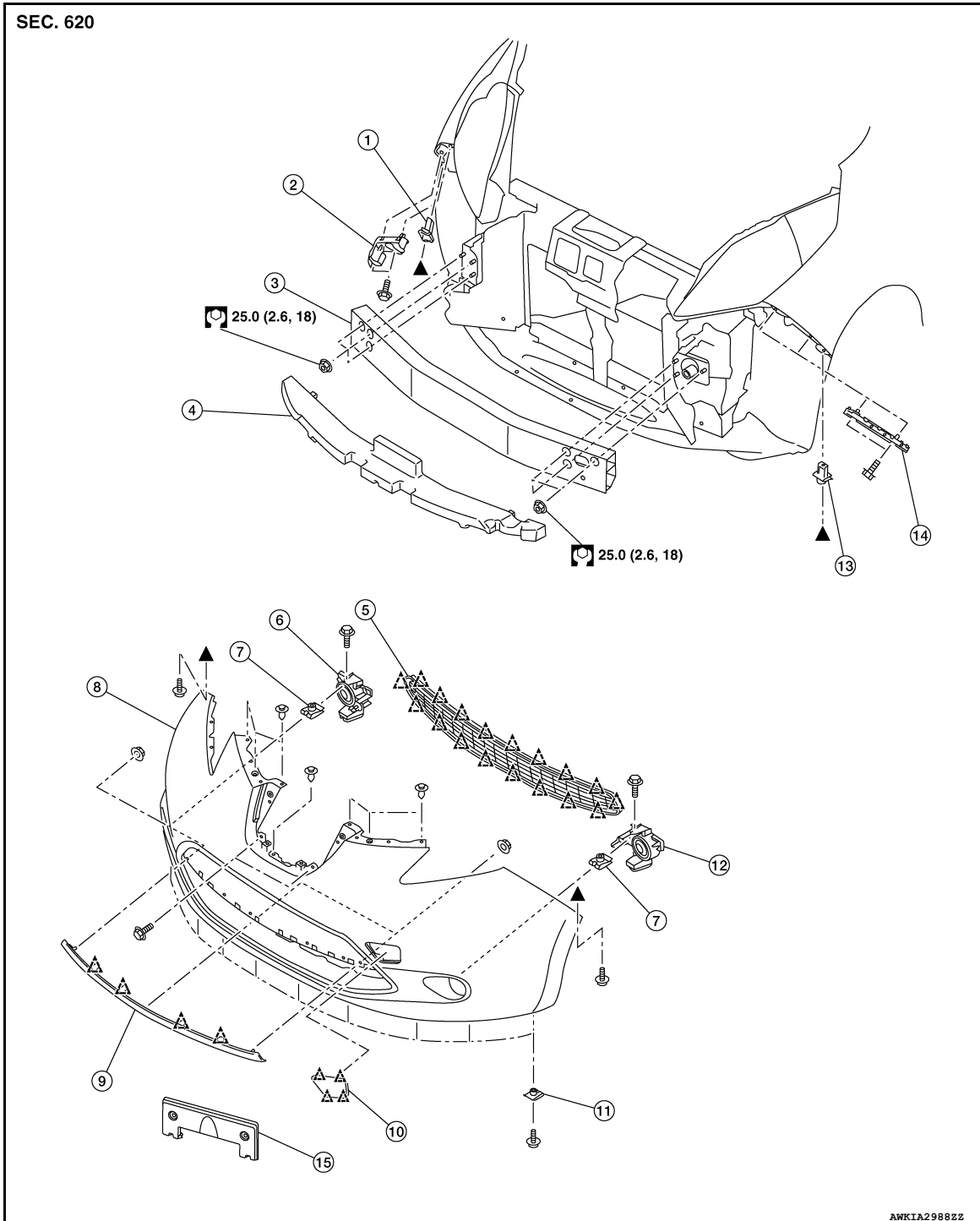

- |                           |                              |   |
|---------------------------|------------------------------|---|
| 1. Screw grommet (RH)     | 2. Bumper side bracket (RH)  | 3. Bumper reinforcement                       |
| 4. Bumper energy absorber | 5. Bumper grille             | 6. Front fog lamp (RH) (if equipped)          |
| 7. Spring nut             | 8. Bumper fascia             | 9. Bumper moulding                            |
| 10. Bumper cover          | 11. J nut                    | 12. Front fog lamp (LH) (if equipped)         |
| 13. Screw grommet (LH)    | 14. Bumper side bracket (LH) | 15. Front license plate bracket (Mexico only) |

# FRONT BUMPER

## < REMOVAL AND INSTALLATION >

 : Pawl

 : N·m (kg-m, ft-lb)

▲: Indicates that the part is connected at points with same symbol in actual vehicle.

## Removal and Installation

INFOID:000000010119987

### REMOVAL

#### CAUTION:

Bumper fascia is made of resin. Never apply strong force to it, and be careful to prevent contact with oil.

1. Remove radiator upper grille. Refer to [DLK-165. "RADIATOR UPPER GRILLE : Removal and Installation"](#).
2. Remove charge port cover. Refer to [DLK-158. "CHARGE PORT LID ASSEMBLY : Removal and Installation"](#).
3. Remove bumper fascia upper side mounting bolts (A).

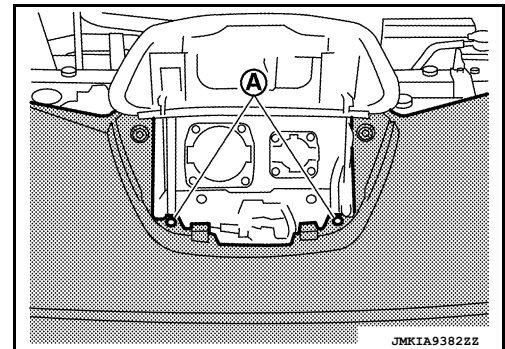

4. Remove bumper fascia upper side fixing clips (A).

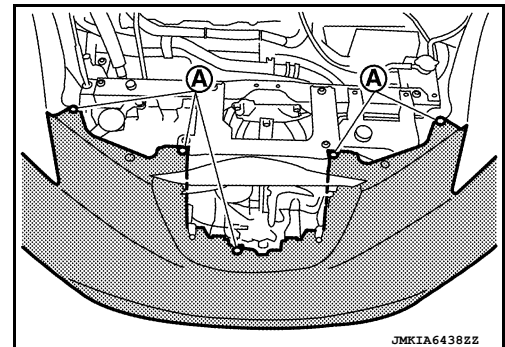

5. Remove fender protector mounting bolts (A) and clip (B) (LH/RH).

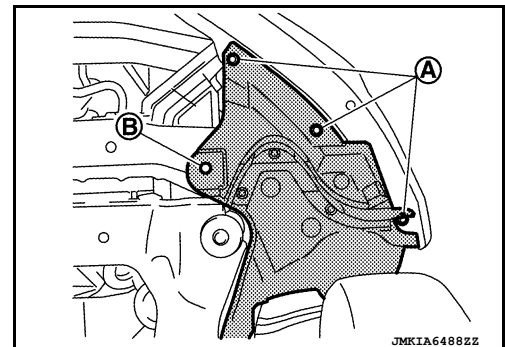

6. Remove bumper fascia lower mounting screws.
7. Remove fender protector fixing clips and screws to access bumper fascia assembly fixing screw, and then remove bumper fascia assembly fixing screws (LH and RH).

A  
B  
C  
D  
E  
F  
G  
H  
I  
J  
EXT  
L  
M  
N  
O  
P

# FRONT BUMPER

## < REMOVAL AND INSTALLATION >

8. Apply protective tape on the part to protect it from damage.

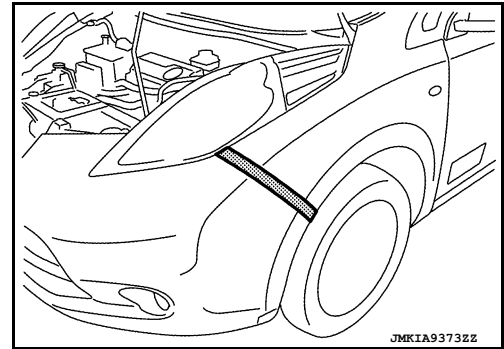

9. Pull bumper fascia assembly side toward the vehicle outside as shown by the arrows in the figure, and then disengage bumper fascia assembly from bumper side brackets (LH and RH).

**CAUTION:**

**When removing bumper fascia, 2 workers are required so as to prevent it from dropping.**

 : Pawl

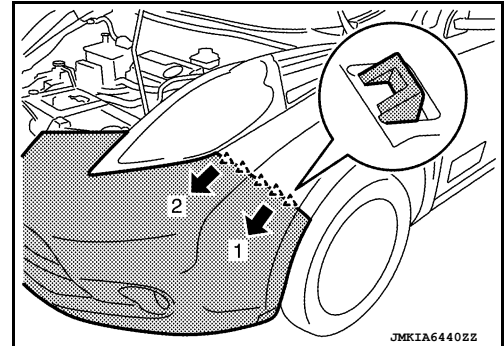

10. Disconnect front fog lamp harness connectors (LH and RH) (if equipped).

11. Remove bumper fascia assembly.

**CAUTION:**

**When removing bumper fascia, 2 workers are required so as to prevent it from dropping.**

12. Remove the following parts after removing bumper fascia.

- License plate bracket
- Front bumper grille
- Front fog lamps (LH and RH). Refer to [EXL-135, "Removal and Installation"](#).

13. Remove bumper energy absorber.

14. Remove bumper reinforcement mounting nuts, and then remove bumper reinforcement.

## INSTALLATION

Note the following items, and then install in the reverse order of removal.

**NOTE:**

- The following table shows the specified values for checking normal installation status.
- Fitting adjustment cannot be performed.

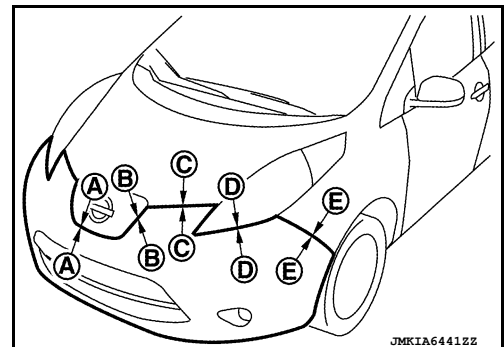

Portion		Clearance	Surface height difference
Bumper fascia assembly – Charge port lid	A – A	2.1 – 4.5 mm (0.083 – 0.177 in)	2.0 – 5.0 mm (0.079 – 0.197 in)
	B – B	1.4 – 3.8 mm (0.091 – 0.303 in)	0.0 – 3.0 mm (0.000 – 0.118 in)

## FRONT BUMPER

< REMOVAL AND INSTALLATION >

Portion		Clearance	Surface height difference
Bumper fascia assembly – Hood	C – C	2.3 – 7.7 mm (0.012 – 0.130 in)	[(-1.0) – (+3.0) mm] [(-0.039) – (+0.118) in]
Bumper fascia assembly – Front combination lamp	D – D	0.2 – 3.8 mm (0.008 – 0.150 in)	—
Front bumper – Front fender	E – E	0.3 – 1.0 mm (0.012 – 0.039 in)	[(-0.3) – (+1.7) mm] [(-0.012) – (+0.067) in]

A  
B  
C  
D  
E  
F  
G  
H  
I  
J  
L  
M  
N  
O  
P

**EXT**

# REAR BUMPER

< REMOVAL AND INSTALLATION >

## REAR BUMPER

Exploded View

INFOID:000000010119988

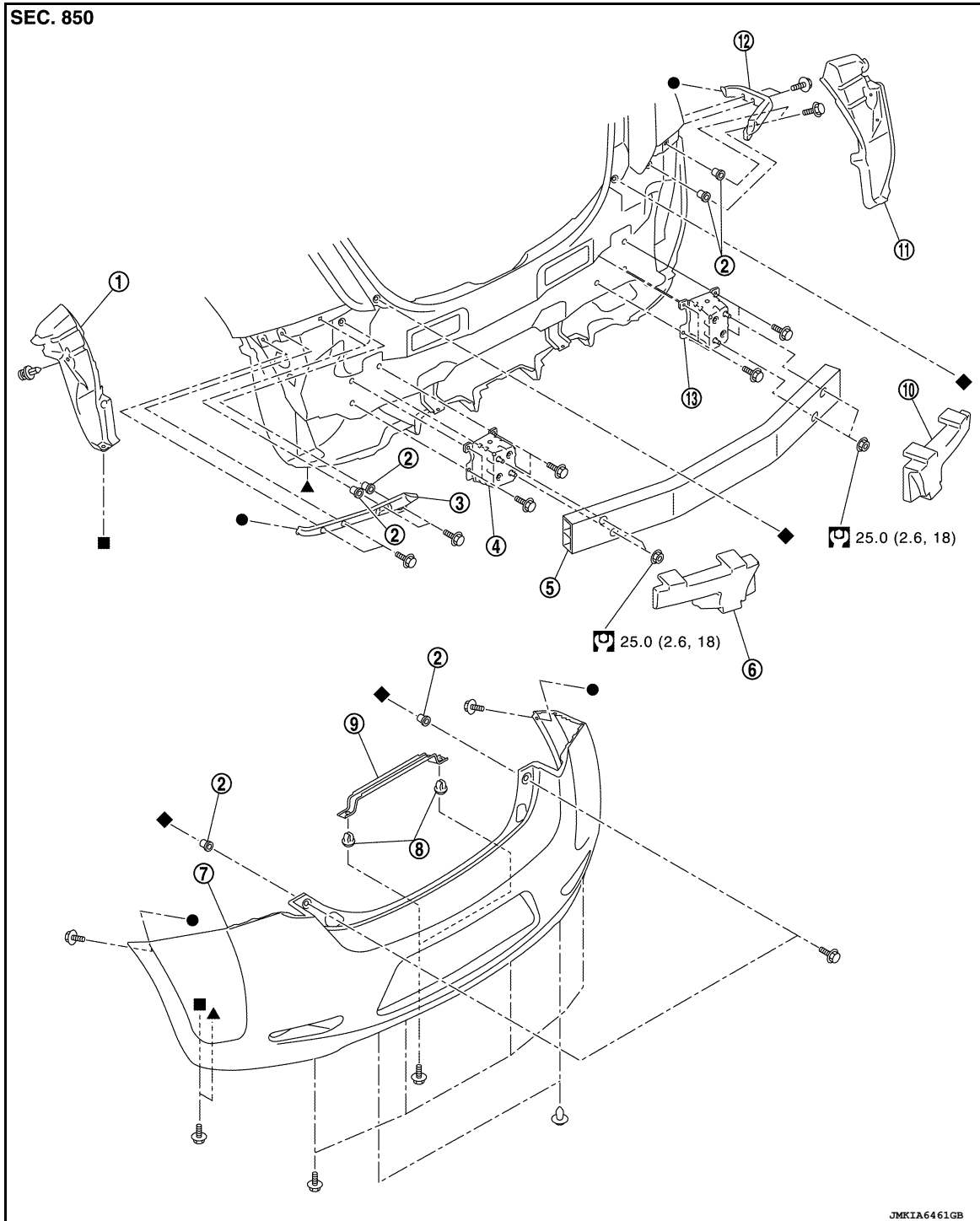

- |                               |                         |                              |
|-------------------------------|-------------------------|------------------------------|
| 1. Bumper closing LH          | 2. Grommet              | 3. Rear side bracket LH      |
| 4. Bumper stay LH             | 5. Bumper reinforcement | 6. Bumper energy absorber LH |
| 7. Bumper fascia              | 8. Grommet              | 9. License lamp bracket      |
| 10. Bumper energy absorber RH | 11. Bumper closing RH   | 12. Rear side bracket RH     |
| 13. Bumper stay RH            |                         |                              |



# REAR BUMPER

## < REMOVAL AND INSTALLATION >

 : N·m (kg-m, ft-lb)

●, ▲, ■, ◆: Indicates that the part is connected at points with same symbol in actual vehicle.

### Removal and Installation

INFOID:000000010119989

#### REMOVAL

##### CAUTION:

Bumper fascia is made of resin. Never apply strong force to it, and be careful to prevent contact with oil.

1. Remove rear combination lamps (RH/LH). Refer to [EXL-140. "Removal and Installation"](#).
2. Remove bumper fascia upper side fixing screws (A) (LH/RH).

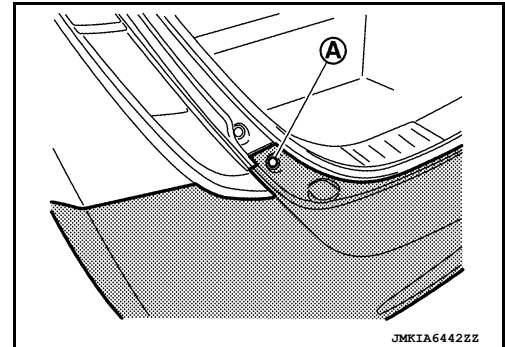

3. Remove bumper fascia lower side fixing bolts and clips.
4. Remove bumper fascia side fixing screws (A) (LH/RH).

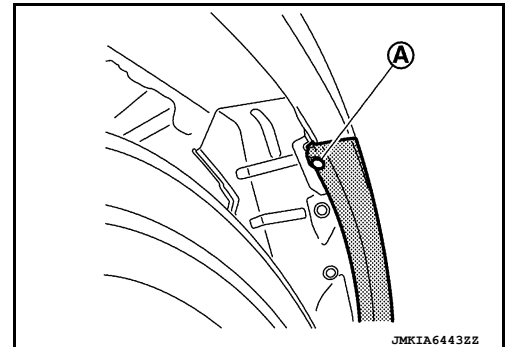

5. Apply protective tape on the part to protect it from damage.

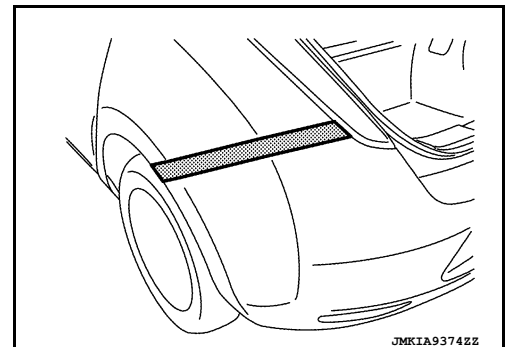

A  
B  
C  
D  
E  
F  
G  
H  
I  
J  
EXT  
L  
M  
N  
O  
P

# REAR BUMPER

## < REMOVAL AND INSTALLATION >

- Pull bumper fascia side toward the vehicle side to disengage the fitting of bumper side bracket and bumper fascia side as shown by the arrow in the figure.

 : Pawl

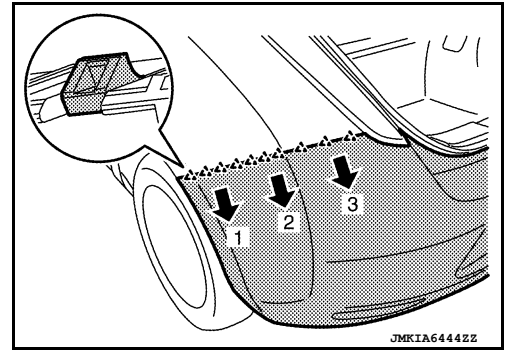

- Disengage license lamp harness connectors.
- Remove bumper fascia assembly.
 

**CAUTION:**  
When removing bumper fascia, 2 workers are required so as to prevent it from dropping.
- Remove the following parts after removing bumper fascia.
  - License lamps (LH and RH). Refer to [EXL-146. "Removal and Installation"](#).
  - Bumper closings (LH and RH)
  - Bumper side brackets (LH and RH)
  - Reflectors (LH and RH) Refer to [EXL-148. "Removal and Installation"](#).
- Remove bumper energy absorbers (LH and RH).
- Remove bumper reinforcement mounting nuts, and then remove bumper reinforcement.

## INSTALLATION

Note the following items, and then install in the reverse order of removal.

### NOTE:

- The following table shows the specified values for checking normal installation status.
- Fitting adjustment cannot be performed.

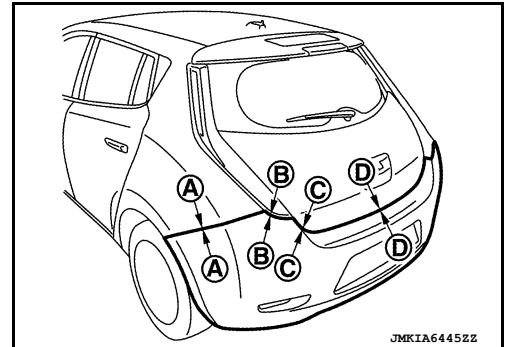

Portion		Clearance	Surface height difference
Bumper fascia assembly – Rear fender	A – A	0.3 – 1.0 mm (0.012 – 0.039 in)	[(-0.3) – (+1.7) mm] [(-0.012 – (+0.067) in]
	B – B	0.4 – 3.6 mm (0.016 – 0.142 in)	—
Bumper fascia assembly – Back door	C – C	3.3 – 7.3 mm (0.130 – 0.287 in)	—
	D – D	6.0 – 10.0 mm (0.236 – 0.394 in)	—

# COWL TOP

< REMOVAL AND INSTALLATION >

## COWL TOP

Exploded View

INFOID:000000010119990

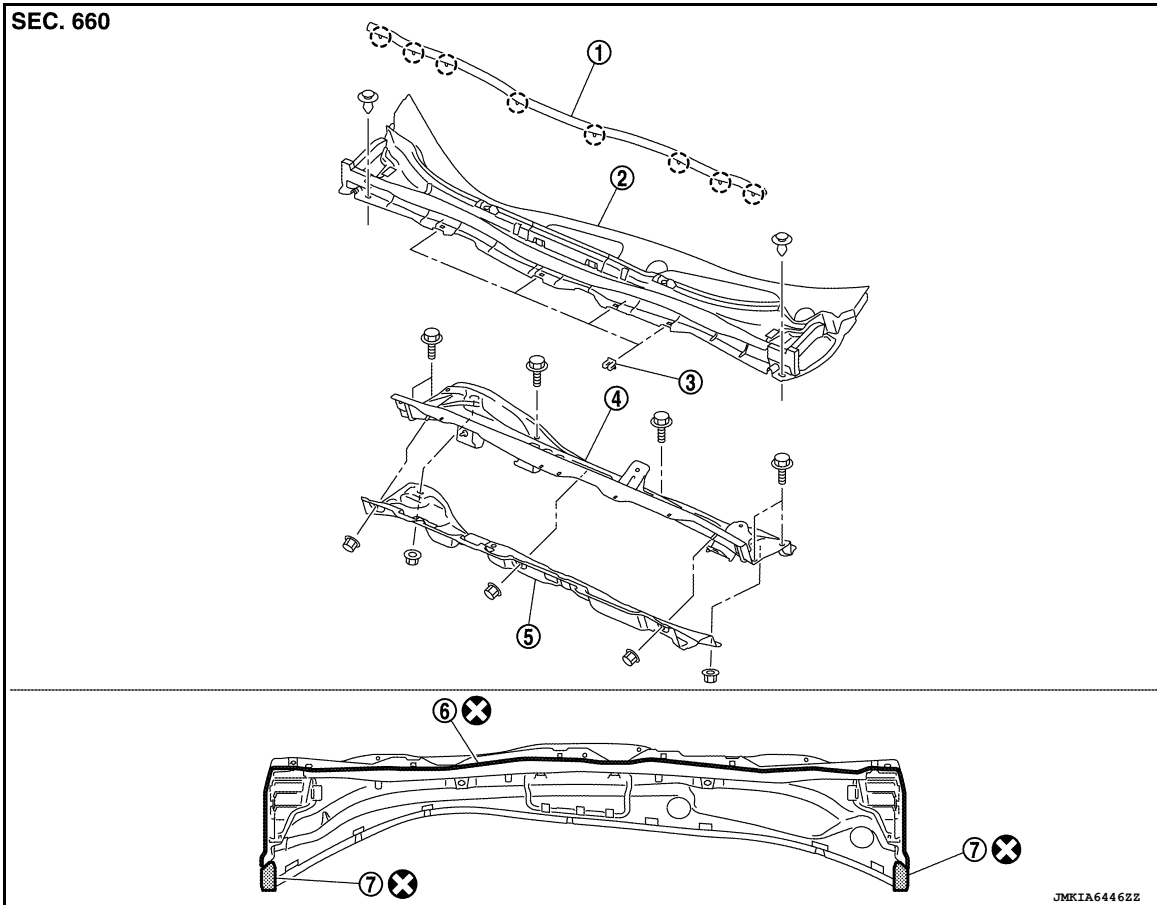

- |                                    |                       |                                   |
|------------------------------------|-----------------------|-----------------------------------|
| 1. Cowl top cover seal             | 2. Cowl top cover     | 3. Cowl top cover clip            |
| 4. Cowl top extension              | 5. Cowl top insulator | 6. EPT sealer [3.0 mm (0.118 in)] |
| 7. EPT sealer [20.0 mm (0.787 in)] |                       |                                   |

○ : Clip

⊗ : Always replace after every disassembly.

## Removal and Installation

INFOID:000000010119991

### COWL TOP COVER

#### Removal

1. Fully open hood assembly.
2. Remove front wiper arms (LH and RH). Refer to [WW-49. "Removal and Installation"](#).
3. Remove front fender cover. Refer to [DLK-168. "Exploded View"](#).
4. Disconnect washer tube joint on cowl top cover right side.

A  
B  
C  
D  
E  
F  
G  
H  
I  
J  
EXT  
L  
M  
N  
O  
P

# COWL TOP

## < REMOVAL AND INSTALLATION >

5. Expand center portion of clip that is fixing clip of cowl top cover and cowl top extension in the upper and lower direction indicated by arrows as shown in the figure, and then pull out clip toward vehicle front.

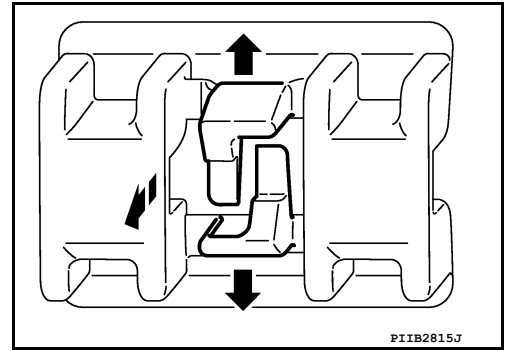

6. Pull forward to release cowl top cover from windshield glass.

**CAUTION:**

When performing the procedure after removing cowl top cover, cover the lower end of windshield glass with urethane etc to prevent damage to windshield.

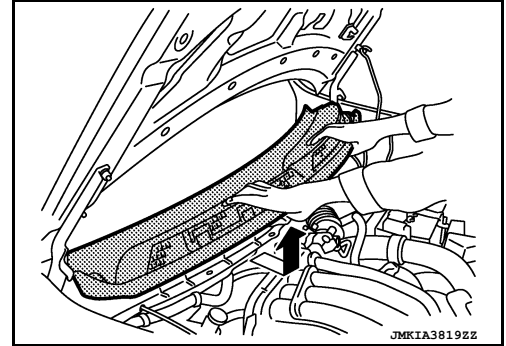

7. Remove cowl top cover.
8. Remove the following parts after removing cowl top cover.
- EPT sealer
  - Cowl top cover seal
  - Washer tube
  - Washer nozzles. Refer to [WW-46, "Removal and Installation"](#).

### Installation

Installation is in the reverse order of removal.

**CAUTION:**

Always replace cowl top cover EPT sealer on rear of vehicle with a new one when installing old cowl top cover.

## COWL TOP EXTENTION

### Removal

1. Remove cowl top cover. Refer to [EXT-19, "Removal and Installation"](#).
2. Remove front wiper drive assembly. Refer to [WW-54, "Removal and Installation"](#).
3. Remove cowl top extension mounting bolts, and then cowl top extension.

### Installation

Installation is in the reverse order of removal.

When installing the cowl top extension, tighten the bolts in the order shown.

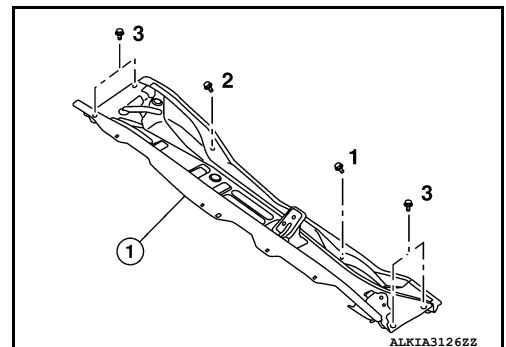

# FENDER PROTECTOR

< REMOVAL AND INSTALLATION >

## FENDER PROTECTOR

## FENDER PROTECTOR

## FENDER PROTECTOR : Exploded View

INFOID:000000010119992

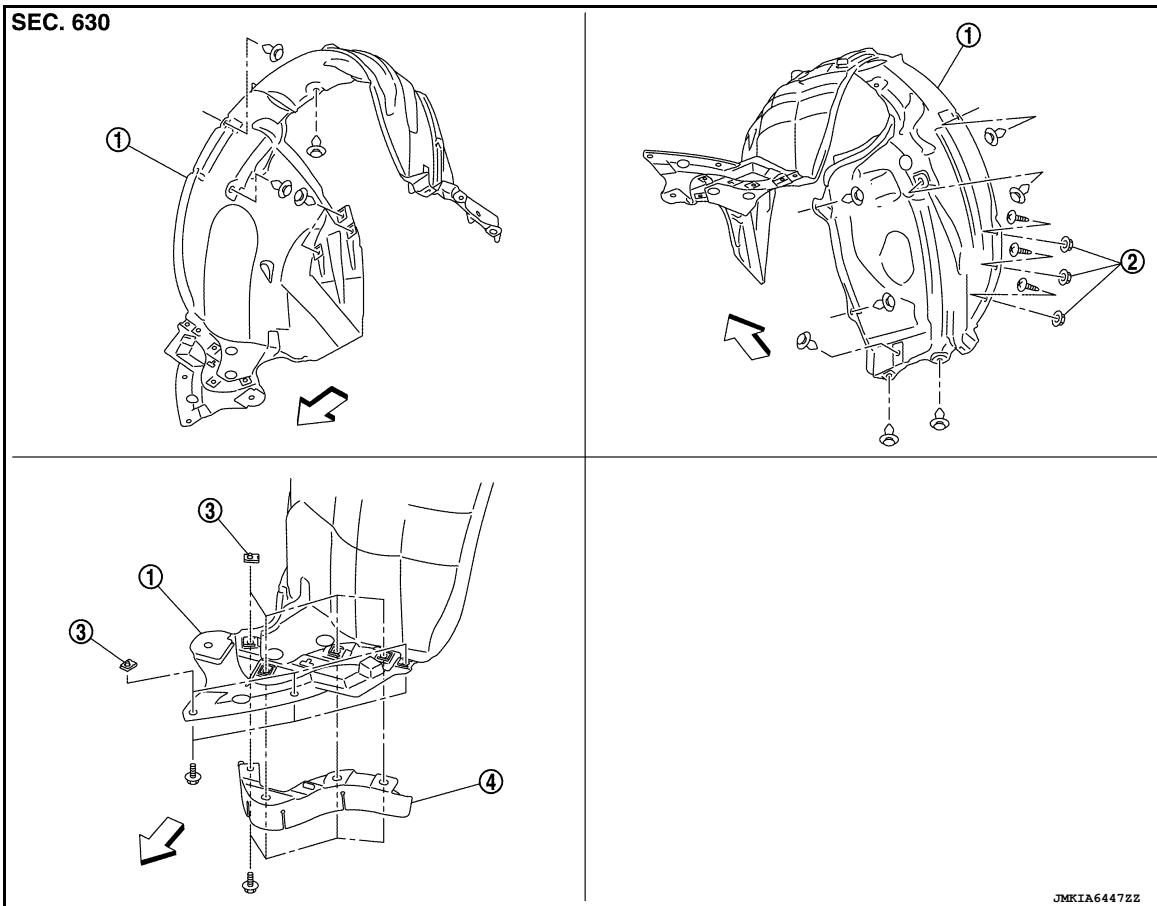

JMKIA6447ZZ

1. Fender protector

2. Grommet

3. J nut

4. Wind deflector

←: Vehicle front

A  
B  
C  
D  
E  
F  
G  
H  
I  
J

EXT

## FENDER PROTECTOR : Removal and Installation

INFOID:000000010119993

### REMOVAL

1. Remove front fender protector front end fixing bolts (A) and clip (B).

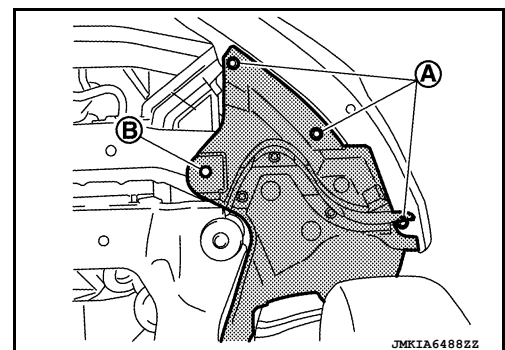

JMKIA6488ZZ

L  
M  
N  
O  
P

## FENDER PROTECTOR

### < REMOVAL AND INSTALLATION >

2. Remove front fender protector fixing screws (A).

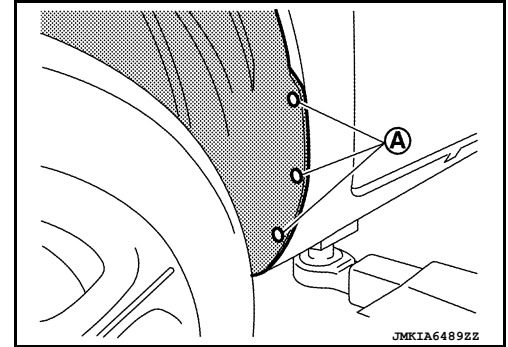

3. Remove front fender protector fixing clips, and then remove front fender protector.

### INSTALLATION

Install in the reverse order of removal.

# FLOOR SIDE FAIRING

< REMOVAL AND INSTALLATION >

## FLOOR SIDE FAIRING

### FRONT UNDER COVER

#### FRONT UNDER COVER : Exploded View

INFOID:000000010119994

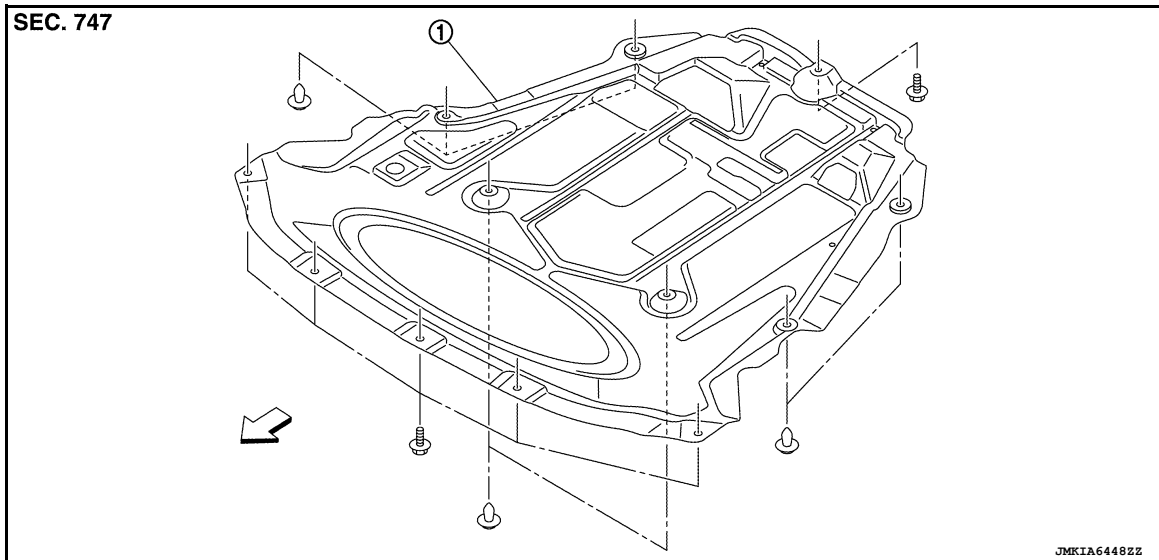

1. Front under cover

↔ : Vehicle front

#### FRONT UNDER COVER : Removal and Installation

INFOID:000000010119995

##### REMOVAL

1. Remove front under cover front mounting bolts.
2. Remove front under cover fixing clips and then remove front under cover.

##### INSTALLATION

Install in the reverse order of removal.

### REAR DIFFUSER

#### REAR DIFFUSER : Exploded View

INFOID:000000010119996

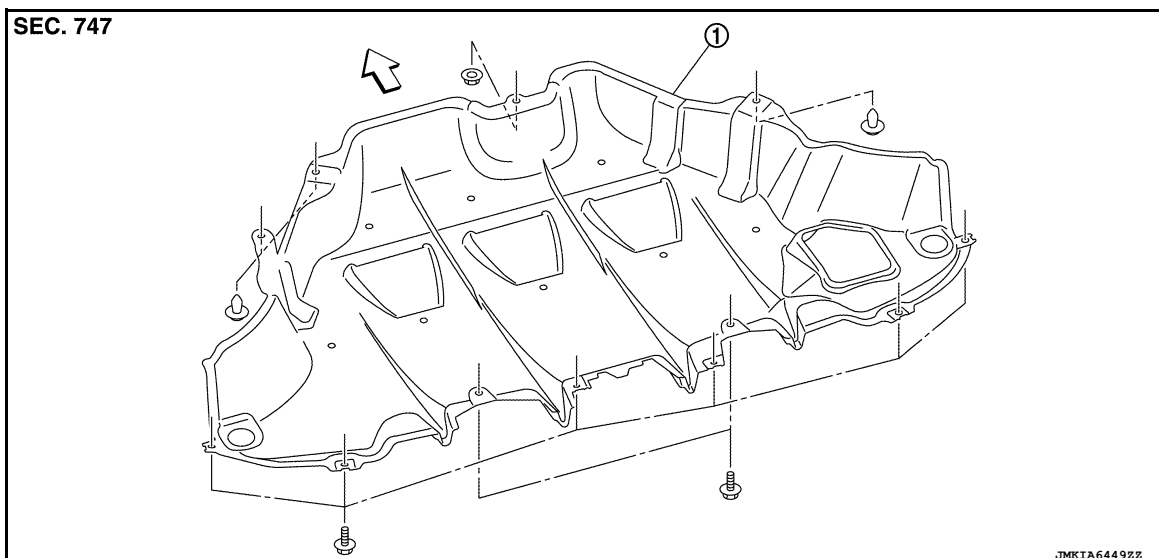

A  
B  
C  
D  
E  
F  
G  
H  
I  
J  
EXT  
L  
M  
N  
O  
P

# FLOOR SIDE FAIRING

## < REMOVAL AND INSTALLATION >

---

1. Rear diffuser

↩ : Vehicle front

### REAR DIFFUSER : Removal and Installation

INFOID:000000010119997

#### REMOVAL

1. Remove rear diffuser mounting bolts, clips and nut.
2. Remove rear diffuser.

#### INSTALLATION

Install in the reverse order of removal.



# ROOF SIDE MOLDING

< REMOVAL AND INSTALLATION >

## ROOF SIDE MOLDING

Exploded View

INFOID:000000010119998

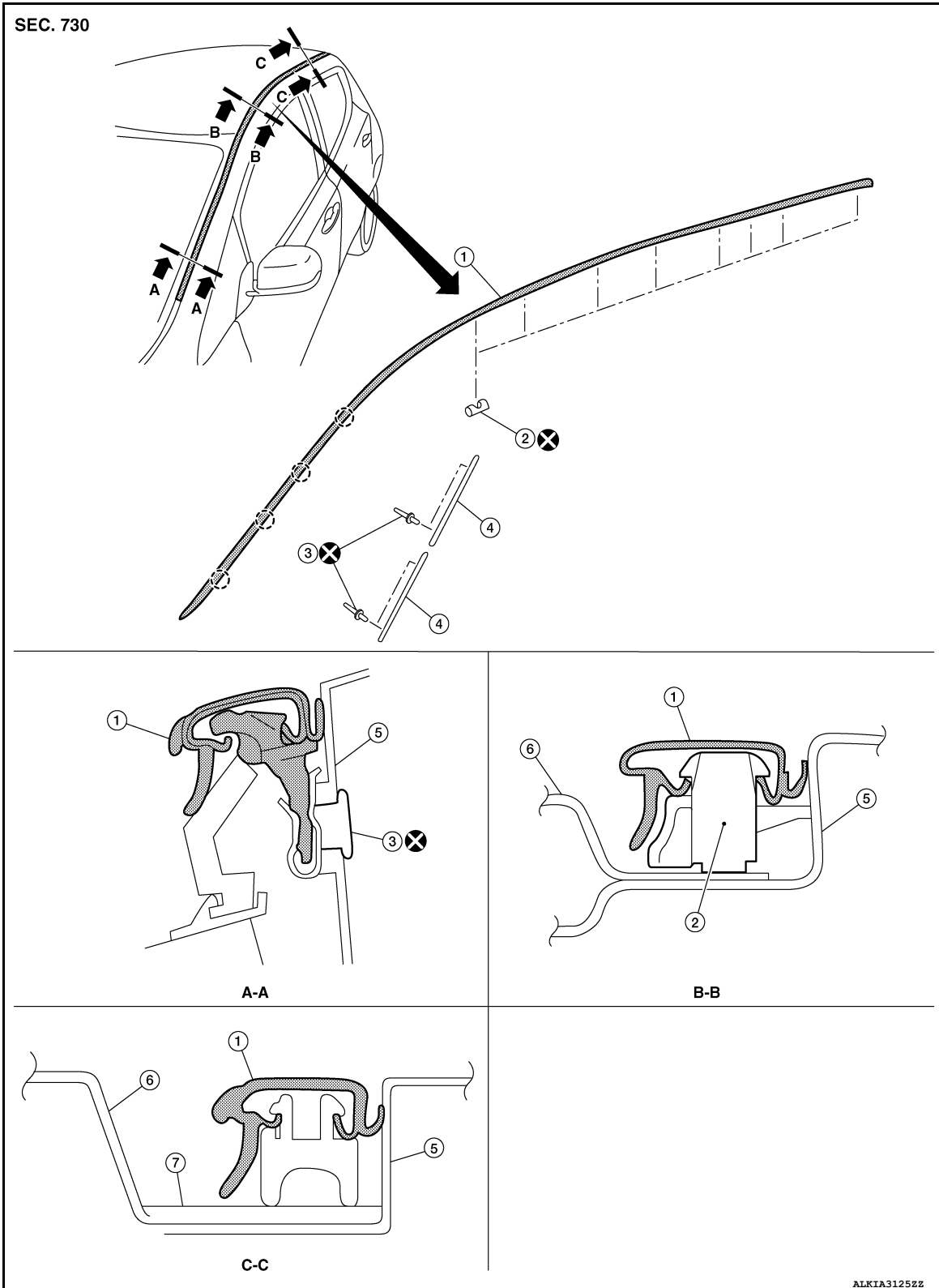

- 1. Roof side molding
- 4. Molding fastener
- 7. Paint seal

- 2. Roof side molding clip
- 5. Body side outer panel

- 3. Rivet
- 6. Roof panel

A  
B  
C  
D  
E  
F  
G  
H  
I  
J  
EXT  
L  
M  
N  
O  
P

# ROOF SIDE MOLDING

## < REMOVAL AND INSTALLATION >

 : Clip

 : Always replace after every disassembly.

## Removal and Installation

INFOID:000000010119999

### REMOVAL

1. Remove front fender cover (LH and RH). Refer to [DLK-168. "Exploded View"](#)
2. Disengage roof side molding fixing clips form front end.

**CAUTION:**

**Never pull the roof side molding strongly to prevent damage to the parts.**

 : Clip

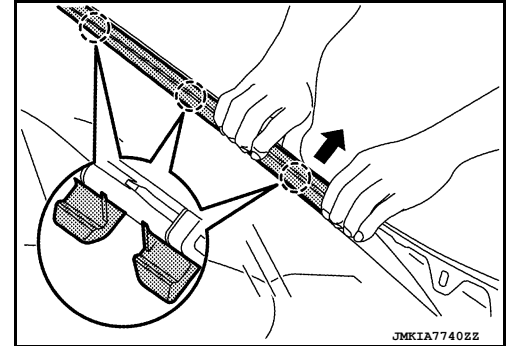

3. Twist roof side molding toward vehicle outside, lift it up and remove it while disengaging clips.

**CAUTION:**

**Never pull the roof side molding strongly to prevent damage to the parts.**

 : Clip

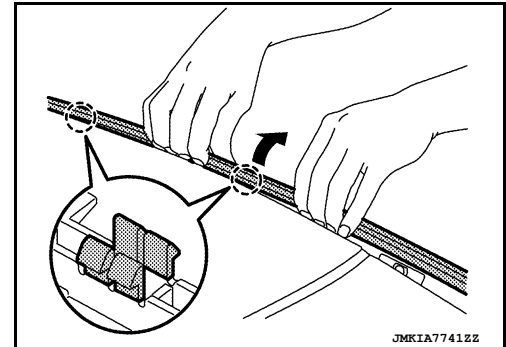

### INSTALLATION

Note the following item, and then install in the reverse order of removal.

**CAUTION:**

**Install spacer roof molding between rear end of roof molding fixing clips.**

### REMOVAL AND INSTALLATION OF ROOF SIDE MOLDING CLIP

#### Removal

1. Remove roof side molding.
2. Heat adhesive tape interface using a dryer, and then peel roof side molding clips (body side) using long-nose pliers.

**CAUTION:**

**Be careful not to damage the body.**

#### Installation

1. Clean tape removed surface with a shop cloth soaked in white gasoline or IPA.
2. Use two-part epoxy adhesive.

**Adhesive** : 3M-weld DP-100 or equivalent

3. Apply adhesive evenly to clip tape surface.

**Thickness** : Approximately 0.5 mm (0.020 in)

4. Position applied parts to the proper location, and then sufficiently press-fit until the adhesive protrudes to tape side.

## ROOF SIDE MOLDING

< REMOVAL AND INSTALLATION >

---

**Press-fit limit : 19.6 N (2.0 Kg - 4.41 lb) × 2 seconds**

5. Tape clips after press fit, and temporarily hold it for specified time based on the following.

**5 to 10 °C (41 to 50 °F) : 1 hour or more**

**11 to 23 °C (52 to 73 °F) : 30 minutes or more**

**24 °C or more (75 °F or more) : 15 minutes or more**

6. Install from roof side molding rear end to front end in this order after temporarily holding.

**CAUTION:**

- Use double-faced adhesive tape after hardening for clips.
- Securely insert molding rear end cap onto roof rear end cutout (installation standard).
- When installing roof side molding of windshield portion, check that molding fastener is securely inserted and then press in.
- Never wash the vehicle with in 24 hours so as to keep adhesive.

A

B

C

D

E

F

G

H

I

J

EXT

L

M

N

O

P

# DOOR SASH MOLDING

< REMOVAL AND INSTALLATION >

## DOOR SASH MOLDING

Exploded View

INFOID:000000010120000

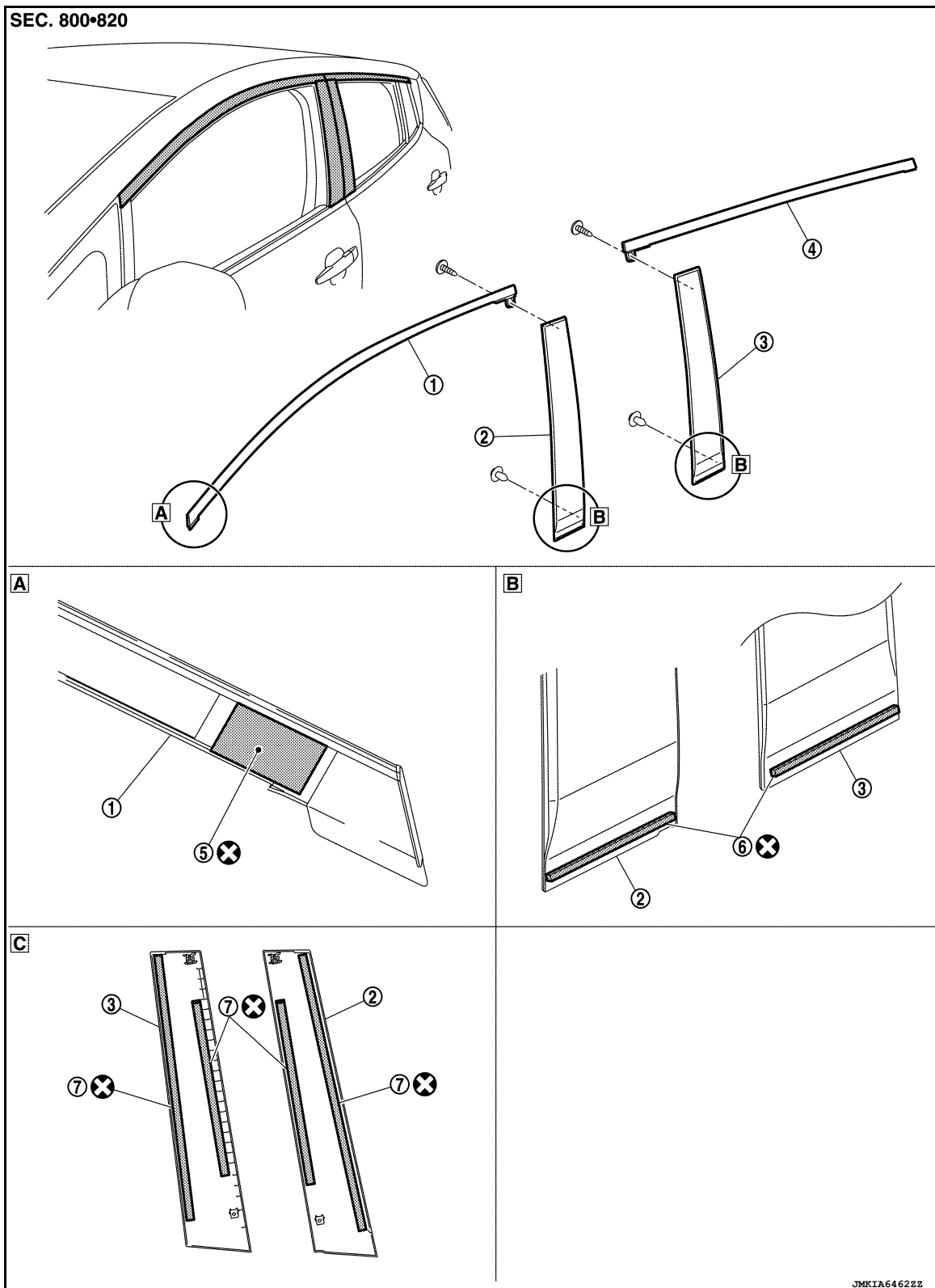

- 1. Front door sash molding
- 4. Rear door sash molding

- 2. Front door sash cover
- 5. Double-sided tape  
[t: 1.2 mm (0.047 in)]

- 3. Rear door sash cover
- 6. EPT sealer [t: 3.0 mm (0.118 in)]

# DOOR SASH MOLDING

## < REMOVAL AND INSTALLATION >

7. Double-sided tape  
[t: 0.8 mm (0.031 in)]

⊗ : Always replace after every disassembly.

## Removal and Installation

INFOID:000000010120001

### FRONT DOOR SASH MOLDING

#### Removal

1. Remove front door sash molding fixing screw (A).

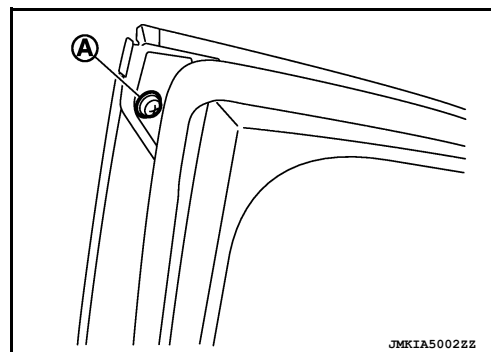

2. Release front door weather-strip and glass run rubber.  
3. Insert a suitable tool (A) between front door panel and front door sash molding (1), and then take off double-sided tape (B) with cutter knife.

#### CAUTION:

- Apply protective tape (C) on door sash panel to protect damage.
- Never lift front door sash molding with excessive force to prevent damage to the parts.

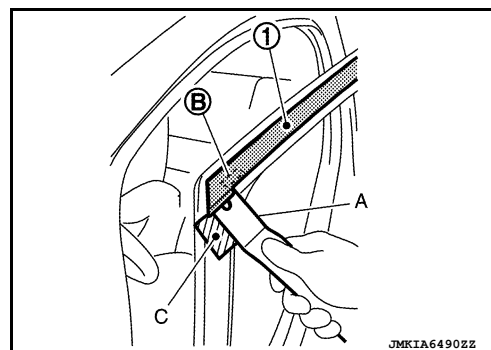

4. Remove front door sash molding connection between door panel and molding from glass run side, using a suitable tool.

#### Installation

Note the following items, and then install in the reverse order of removal.

#### CAUTION:

- Replace double-sided tape on back of molding with a new tape if front door sash molding is reused.
- Remove double-sided tape remaining on body and back of molding using double-sided tape remover when removing front door sash molding.
- Install after cleaning adhesive parts of door side and back of front door sash molding.
- To secure contact, never wash vehicle within 24 hours after installation.

### REAR DOOR SASH MOLDING

#### Removal

1. Remove rear door sash molding fixing screw.  
2. Remove rear door weather-strip.  
3. Release roof portion of rear door glass run.

# DOOR SASH MOLDING

## < REMOVAL AND INSTALLATION >

4. Remove rear door sash molding (1) connection between door panel and molding from glass run side, using a suitable tool (A).

**CAUTION:**

Never use a material for suitable tool which could damage door panel to prevent damage to the parts.

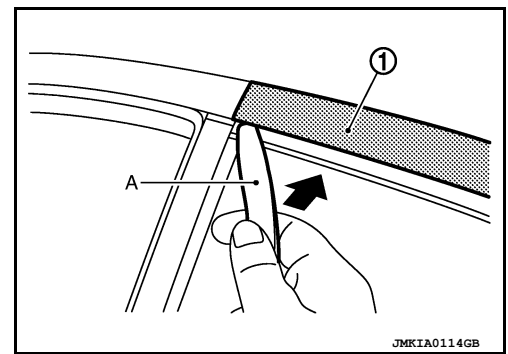

### Installation

Install in the reverse order of removal.

## FRONT DOOR SASH COVER

### Removal

1. Remove front door sash cover mounting screw (A) and clip (B).

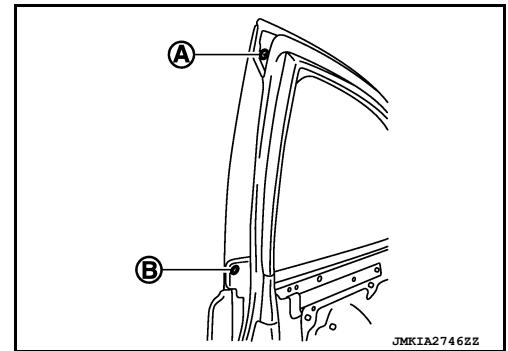

2. Insert a suitable tool (A) between front door sash cover (1) and door panel, cut double-sided tape using a cutter (B) while lifting front door sash cover, and remove front door sash cover.

**CAUTION:**

- Use a suitable tool which is made of a material that does not damage door panel to prevent damage to the parts.
- Never lift front door sash cover with excessive force to prevent damage to the parts.

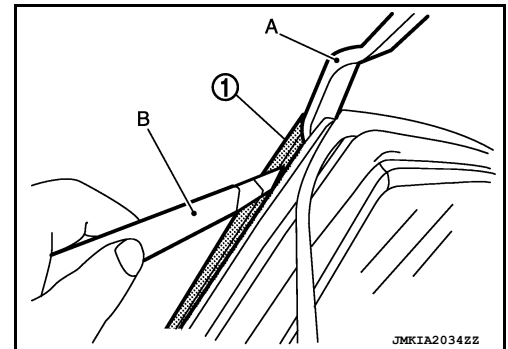

### Installation

Note the following items, and install in the reverse order of removal.

**CAUTION:**

- When installing, slide and install front door sash cover (2) from door rear side, so that front door outside molding (1) is not deformed.

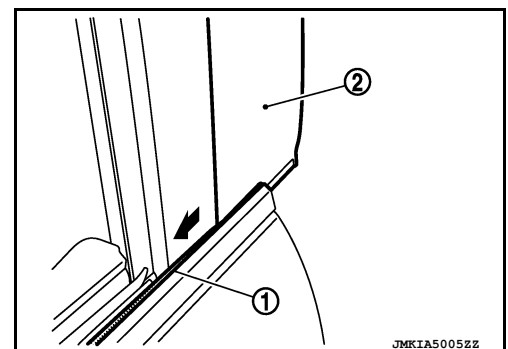

- Replace double-sided tape on back of front door sash cover with a new double-sided tape if front door sash cover is reused.

# DOOR SASH MOLDING

## < REMOVAL AND INSTALLATION >

- Replace EPT sealer of front door sash cover with a new EPT sealer if front door sash cover is reused.
- Remove double-sided tape remaining on body and back of front door sash cover using double-sided tape remover when removing front door sash molding.
- Install after cleaning adhesive parts of door side and back of front door sash cover.
- To secure contact, never wash vehicle within 24 hours after installation.

## REAR DOOR SASH COVER

### Removal

1. Remove rear door sash cover mounting screw (A) and clip (B).

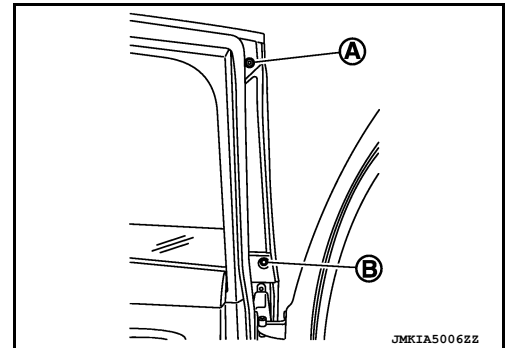

2. Insert a suitable tool (A) between rear door sash cover (1) and door panel, cut double-sided tape using a cutter (B) while lifting rear door sash cover, and remove rear door sash cover.

### CAUTION:

- Never use an item as a suitable tool that could damage door panel to prevent damage to the parts.
- Never lift rear door sash cover with excessive force to prevent damage to the parts.

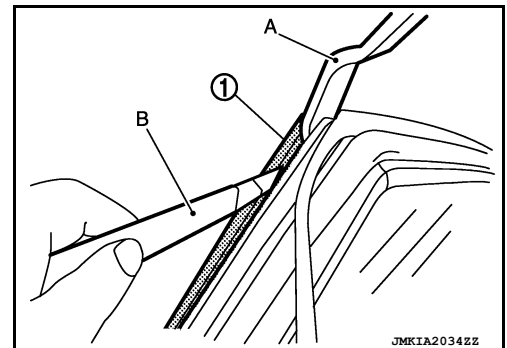

### Installation

Note the following items, and install in the reverse order of removal.

### CAUTION:

- When installing, slide and install rear door sash cover (2) from door front, so that rear door outside molding (1) is not deformed.

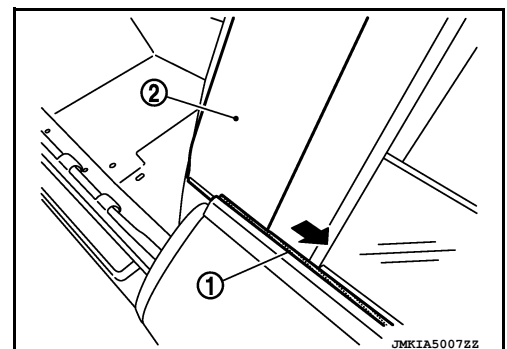

- Replace double-sided tape on back of rear door sash cover with a new double-sided tape if rear door sash cover is reused.
- Replace EPT sealer of rear door sash cover with a new EPT sealer if rear door sash cover is reused.
- Remove double-sided tape remaining on body and back of rear door sash cover using double-sided tape remover when removing rear door sash cover.
- Install after cleaning adhesive parts of door side and back of rear door sash cover.
- To secure contact, never wash vehicle within 24 hours after installation.

A  
B  
C  
D  
E  
F  
G  
H  
I  
J

EXT

L  
M  
N

O  
P

# DOOR OUTSIDE MOLDING

< REMOVAL AND INSTALLATION >

## DOOR OUTSIDE MOLDING

Exploded View

INFOID:000000010120002

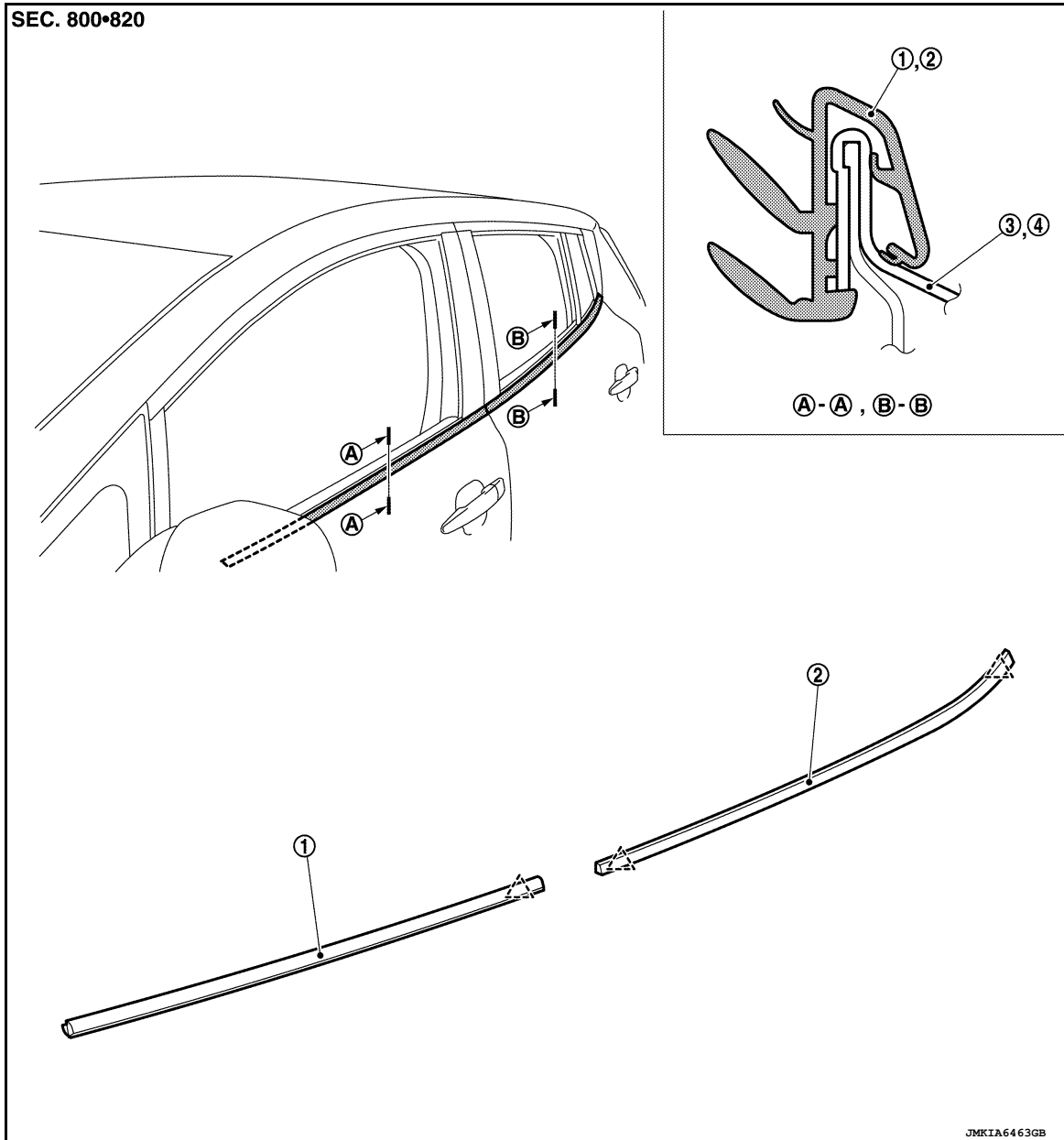

1. Front door outside molding

2. Rear door outside molding

3. Front door panel

4. Rear door panel

 : Pawl

### Removal and Installation

INFOID:000000010120003

#### REMOVAL

##### FRONT DOOR OUTSIDE MOLDING

1. Fully open front door glass.



# DOOR OUTSIDE MOLDING

## < REMOVAL AND INSTALLATION >

- Disengage fixing pawl of front door outside molding rear end, using suitable tool (A) and (B).

**CAUTION:**

- Apply a protective tape (C) on the body to protect the painted surface from damage.
- Never lift front door outside molding with excessive force to prevent damage to the parts.

 : Pawl

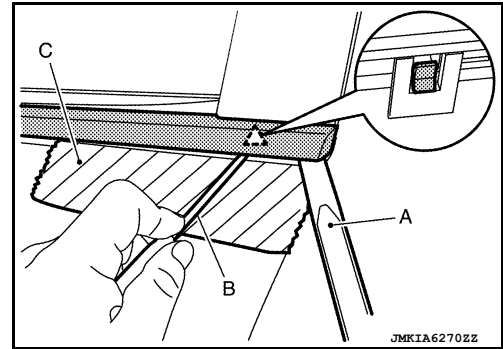

- Twist door outside molding toward the outside of the vehicle, and then lift up and remove it while disengaging the pawls.

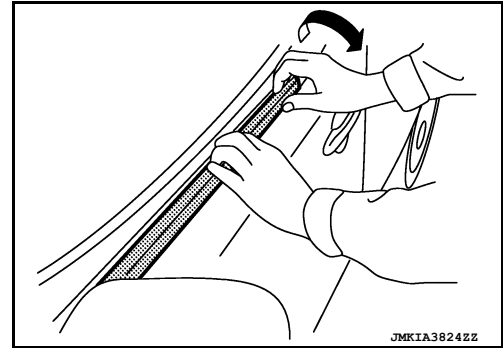

## REAR DOOR OUTSIDE MOLDING

- Fully open door window.
- Disengage fixing pawl of front door outside molding front and rear end, using suitable tool (A) and (B).

**CAUTION:**

- Apply a protective tape (C) on the body to protect the painted surface from damage.
- Never lift rear door outside molding with excessive force to prevent damage to the parts.

 : Pawl

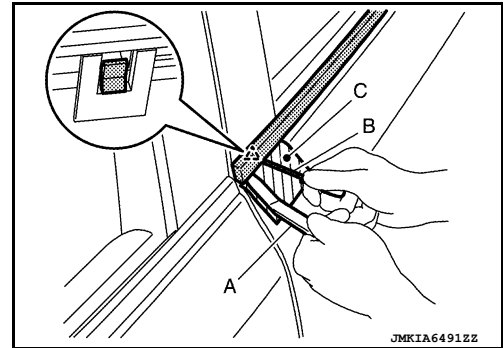

## INSTALLATION

Install in the reverse order of removal.

A  
B  
C  
D  
E  
F  
G  
H  
I  
J  
EXT  
L  
M  
N  
O  
P

# DOOR PARTING SEAL

< REMOVAL AND INSTALLATION >

## DOOR PARTING SEAL

Exploded View

INFOID:000000010120004

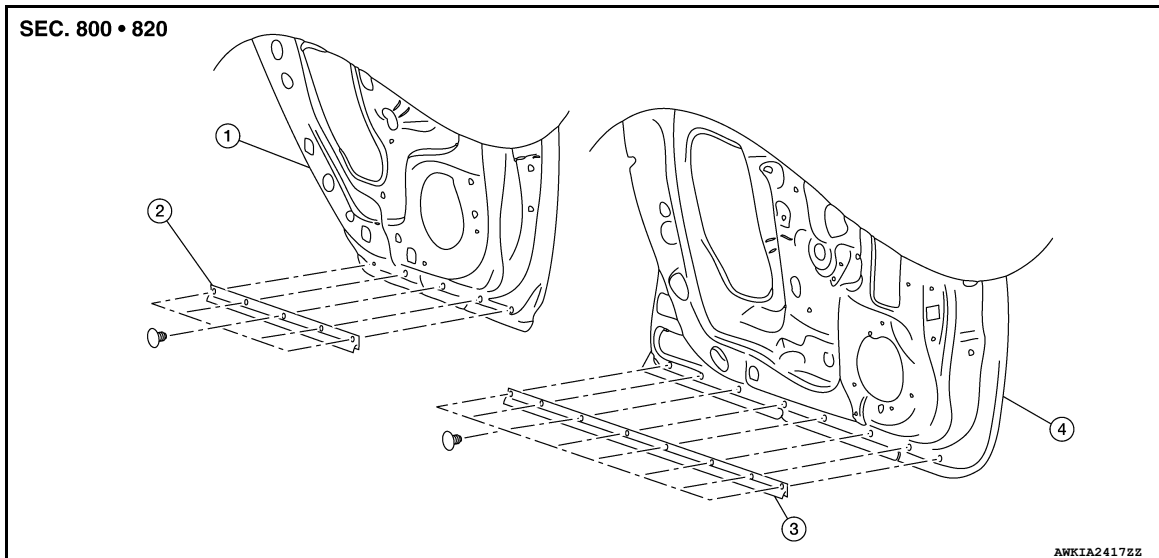

1. Rear door panel
2. Rear door parting seal
3. Front door parting seal
4. Front door panel

## Removal and Installation

INFOID:000000010120005

### REMOVAL

#### FRONT DOOR PARTING SEAL

1. Fully open front door.
2. Disengage front door parting seal fixing clips, using suitable tool.  
**CAUTION:**
  - Disengage the clips slowly and carefully.
  - Never pull the front door parting seal strongly to prevent damage to the parts.
3. Remove front door parting seal.

#### REAR DOOR PARTING SEAL

1. Fully open rear door.
2. Disengage rear door parting seal fixing clips, using suitable tool.  
**CAUTION:**
  - Disengage the clips slowly and carefully.
  - Never pull the rear door parting seal strongly to prevent damage to the parts.
3. Remove rear door parting seal.

### INSTALLATION

Note the following items, and then install in the reverse order of removal.

#### **CAUTION:**

- When installing door parting seal, check that blind clips are securely fitted in door panel holes to prevent damage to the parts.
- When installing, visually check the door parting seal and the clips, then replace them with new parts if they are damaged.

# REAR SPOILER

< REMOVAL AND INSTALLATION >

## REAR SPOILER

Exploded View

INFOID:000000010120006

### REMOVAL

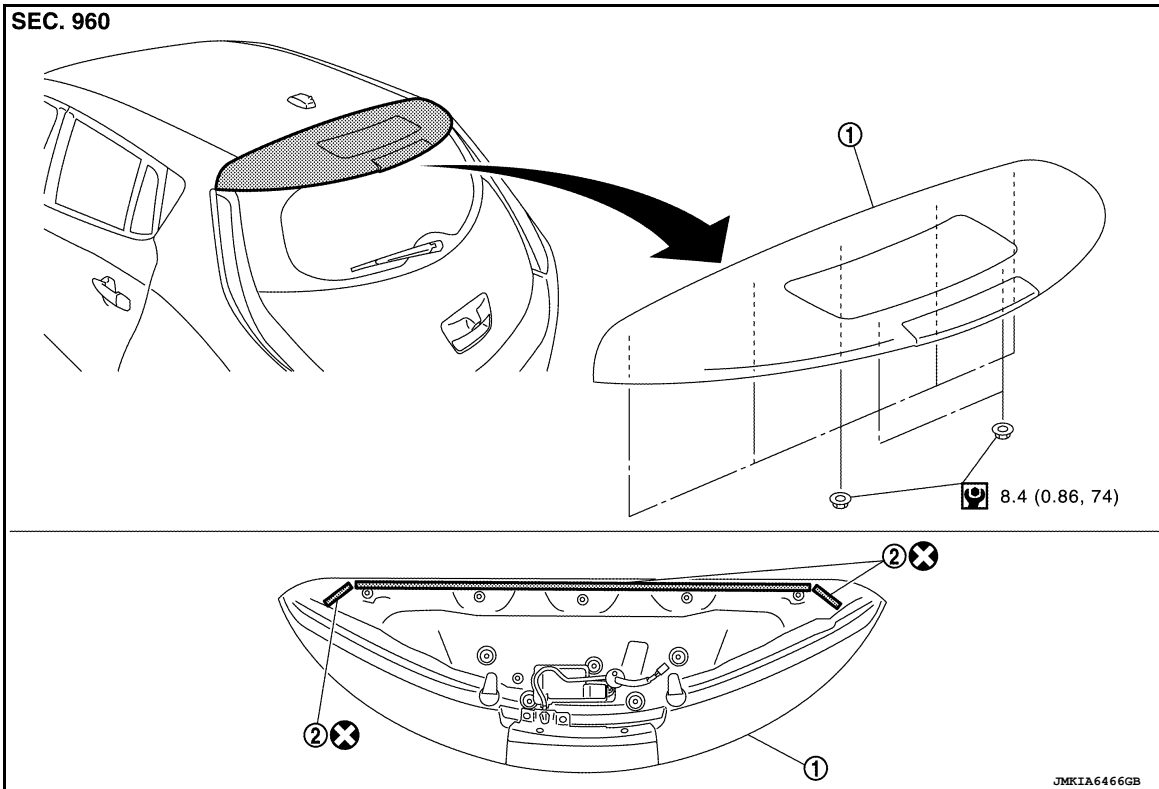

1. Rear spoiler assembly

2. Double-sided tape  
[t: 1.5 mm (0.059 in)]

 : N·m (kg-m, in-lb)

 : Always replace after every disassembly.

### DISASSEMBLY

A  
B  
C  
D  
E  
F  
G  
H  
I  
J

EXT

L  
M  
N  
O  
P

# REAR SPOILER

< REMOVAL AND INSTALLATION >

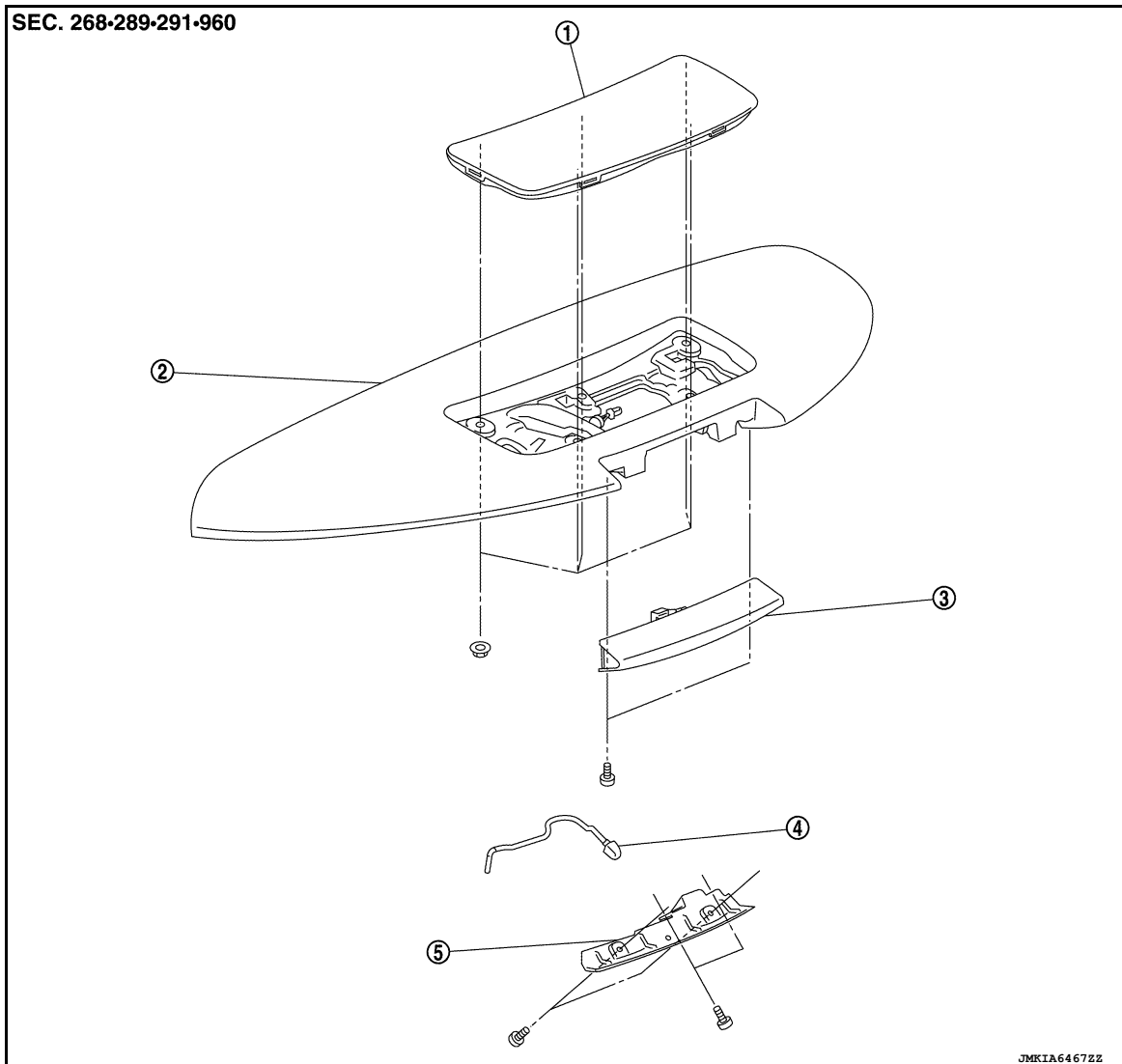

- |                                    |                                 |                           |
|------------------------------------|---------------------------------|---------------------------|
| 1. Solar cell module (if equipped) | 2. Rear spoiler assembly        | 3. High-mounted stop lamp |
| 4. Washer nozzle                   | 5. High-mounted stop lamp cover |                           |

## Removal and Installation

INFOID:000000010120007

### REMOVAL

1. Remove back door upper finisher. Refer to [INT-46. "BACK DOOR UPPER FINISHER : Removal and Installation"](#).
2. Remove rear spoiler mounting nuts.
3. Cut rear spoiler fixing double-sided tape with cutter knife.
4. Lift rear spoiler, and then disconnect harness connector and rear washer tube.  
**CAUTION:**  
**Never lift rear spoiler with excessive force to prevent damage to the parts.**
5. Remove rear spoiler.
6. Remove following parts after removing rear spoiler.
  - High-mounted stop lamp. Refer to [EXL-145. "Removal and Installation"](#).
  - Washer nozzle
  - Solar cell module (if equipped). Refer to [CHG-15. "Removal and Installation"](#).

### INSTALLATION

Note the following items, and then install in the reverse order of removal.

# REAR SPOILER

## < REMOVAL AND INSTALLATION >

---

### **CAUTION:**

- Be careful no to damage the back door.
- Always replace double-sided tape with a new one, if rear spoiler is reused.
- Remove double-sided tape remaining on back door panel and back of rear spoiler with a double-sided tape remover, after removing rear spoiler.
- When installing rear spoiler, check that bolts are securely fitted in back door panel holes to prevent damage to the parts.
- Never wash the vehicle within 24 hours after installing so as to keep adhesive.

A

B

C

D

E

F

G

H

I

J

EXT

L

M

N

O

P

# REAR FENDER COVER

< REMOVAL AND INSTALLATION >

## REAR FENDER COVER

### Exploded View

INFOID:000000010120008

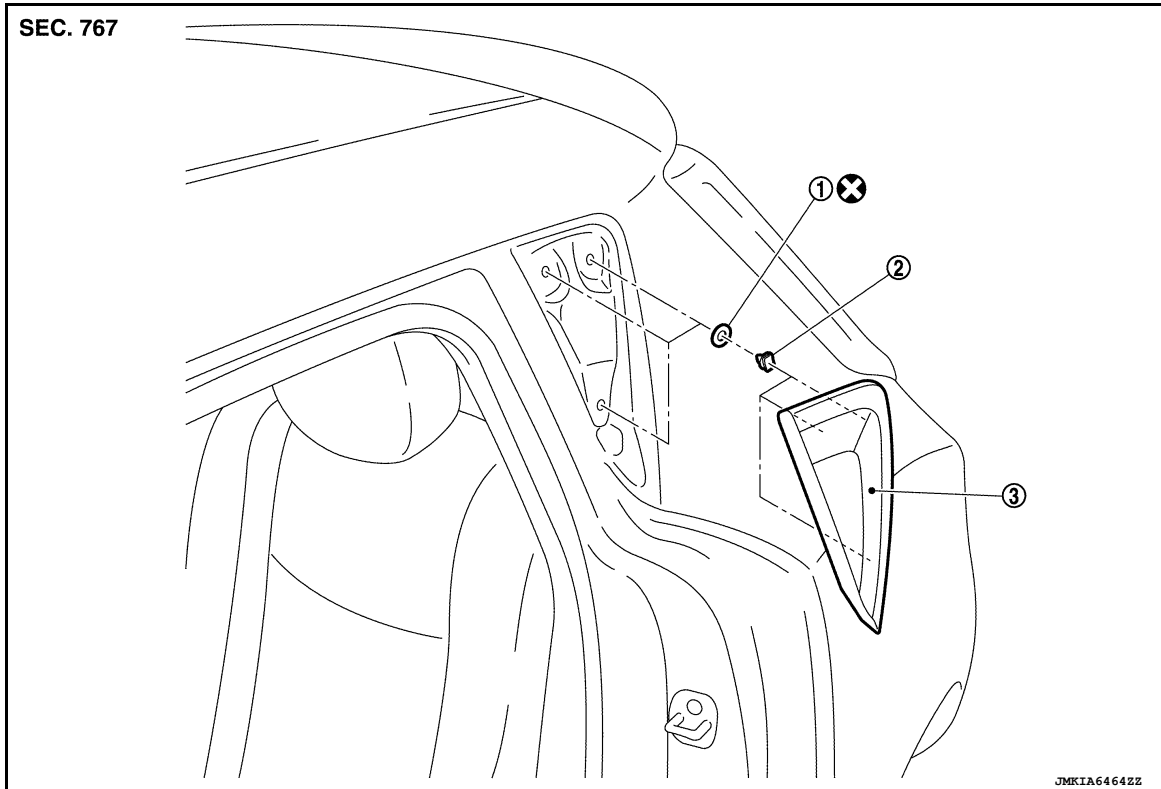

1. Seal packing

2. Clip

3. Rear fender cover

⊗ : Always replace after every disassembly.

### Removal and Installation

INFOID:000000010120009

#### REMOVAL

Disengage rear fender cover fixing clips using suitable tool (A), and then remove rear fender cover.

#### CAUTION:

Apply protective tape (B) to the body side to protect from damage.

○ : Clip

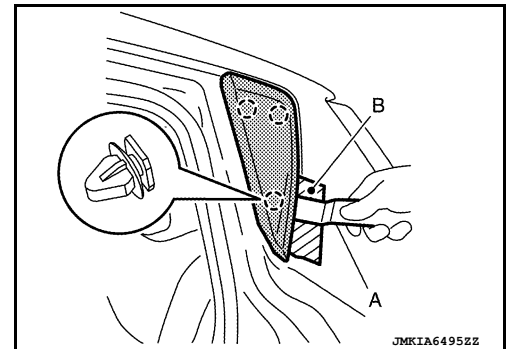

#### INSTALLATION

Note the following item, and install in the reverse order of removal.

#### CAUTION:

When installing rear fender cover, check that clips are securely fitted in body panel holes, and then press them in.