

SECTION **IP**
INSTRUMENT PANEL

A
B
C
D
E
F
G
H
I
IP
K
L
M
N
O
P

CONTENTS

PRECAUTION	2	SYMPTOM DIAGNOSIS	10
PRECAUTIONS	2	SQUEAK AND RATTLE TROUBLE DIAG- NOSES	10
Precaution for Technicians Using Medical Electric.....	2	Work Flow	10
Point to Be Checked Before Starting Maintenance		Generic Squeak and Rattle Troubleshooting	11
Work	2	Diagnostic Worksheet	14
Precaution for Removing 12V Battery	2	REMOVAL AND INSTALLATION	16
Precaution for Supplemental Restraint System (SRS) "AIR BAG" and "SEAT BELT PRE-TEN- SIONER"	3	INSTRUMENT PANEL ASSEMBLY	16
Precaution for Work	3	Exploded View	16
PREPARATION	5	Removal and Installation	17
PREPARATION	5	CENTER CONSOLE ASSEMBLY	28
Special Service Tool	5	Exploded View	28
Commercial Service Tools	5	Removal and Installation	28
CLIP LIST	6	Disassembly and Assembly	31
Descriptions for Clips	6		

PRECAUTIONS

< PRECAUTION >

PRECAUTION

PRECAUTIONS

Precaution for Technicians Using Medical Electric

INFOID:0000000010120149

OPERATION PROHIBITION

WARNING:

- Parts with strong magnet is used in this vehicle.
- Technicians using a medical electric device such as pacemaker must never perform operation on the vehicle, as magnetic field can affect the device function by approaching to such parts.

NORMAL CHARGE PRECAUTION

WARNING:

- If a technician uses a medical electric device such as an implantable cardiac pacemaker or an implantable cardioverter defibrillator, the possible effects on the devices must be checked with the device manufacturer before starting the charge operation.
- As radiated electromagnetic wave generated by PDM (Power Delivery Module) at normal charge operation may affect medical electric devices, a technician using a medical electric device such as implantable cardiac pacemaker or an implantable cardioverter defibrillator must not approach motor room [PDM (Power Delivery Module)] at the hood-opened condition during normal charge operation.

PRECAUTION AT TELEMATICS SYSTEM OPERATION

WARNING:

- If a technician uses implantable cardiac pacemaker or implantable cardioverter defibrillator (ICD), avoid the device implanted part from approaching within approximately 220 mm (8.66 in) from interior/exterior antenna.
- The electromagnetic wave of TCU might affect the function of the implantable cardiac pacemaker or the implantable cardioverter defibrillator (ICD), when using the service, etc.
- If a technician uses other medical electric devices than implantable cardiac pacemaker or implantable cardioverter defibrillator (ICD), the electromagnetic wave of TCU might affect the function of the device. The possible effects on the devices must be checked with the device manufacturer before TCU use.

PRECAUTION AT INTELLIGENT KEY SYSTEM OPERATION

WARNING:

- If a technician uses implantable cardiac pacemaker or implantable cardioverter defibrillator (ICD), avoid the device implanted part from approaching within approximately 220 mm (8.66 in) from interior/exterior antenna.
- The electromagnetic wave of Intelligent Key might affect the function of the implantable cardiac pacemaker or the implantable cardioverter defibrillator (ICD), at door operation, at each request switch operation, or at engine starting.
- If a technician uses other medical electric devices than implantable cardiac pacemaker or implantable cardioverter defibrillator (ICD), the electromagnetic wave of Intelligent Key might affect the function of the device. The possible effects on the devices must be checked with the device manufacturer before Intelligent Key use.

Point to Be Checked Before Starting Maintenance Work

INFOID:0000000010120150

The high voltage system may starts automatically. It is required to check that the timer air conditioner and timer charge (during EVSE connection) are not set before starting maintenance work.

NOTE:

If the timer air conditioner or timer charge (during EVSE connection) is set, the high voltage system starts automatically even when the power switch is in OFF state.

Precaution for Removing 12V Battery

INFOID:0000000010120151

1. Check that EVSE is not connected.

NOTE:

If EVSE is connected, the air conditioning system may be automatically activated by the timer A/C function.

PRECAUTIONS

< PRECAUTION >

2. Turn the power switch OFF → ON → OFF. Get out of the vehicle. Close all doors (including back door).
3. Check that the charge status indicator lamp does not blink and wait for 5 minutes or more.

NOTE:

If the battery is removed within 5 minutes after the power switch is turned OFF, plural DTCs may be detected.

4. Remove 12V battery within 1 hour after turning the power switch OFF → ON → OFF.

NOTE:

- The 12V battery automatic charge control may start automatically even when the power switch is in OFF state.
- Once the power switch is turned ON → OFF, the 12V battery automatic charge control does not start for approximately 1 hour.

CAUTION:

- **After all doors (including back door) are closed, if a door (including back door) is opened before battery terminals are disconnected, start over from Step 1.**
- **After turning the power switch OFF, if "Remote A/C" is activated by user operation, stop the air conditioner and start over from Step 1.**

Precaution for Supplemental Restraint System (SRS) "AIR BAG" and "SEAT BELT PRE-TENSIONER"

INFOID:000000010120152

The Supplemental Restraint System such as "AIR BAG" and "SEAT BELT PRE-TENSIONER", used along with a front seat belt, helps to reduce the risk or severity of injury to the driver and front passenger for certain types of collision. This system includes seat belt switch inputs and dual stage front air bag modules. The SRS system uses the seat belt switches to determine the front air bag deployment, and may only deploy one front air bag, depending on the severity of a collision and whether the front occupants are belted or unbelted. Information necessary to service the system safely is included in the SR and SB section of this Service Manual.

WARNING:

- **To avoid rendering the SRS inoperative, which could increase the risk of personal injury or death in the event of a collision which would result in air bag inflation, all maintenance must be performed by an authorized NISSAN/INFINITI dealer.**
- **Improper maintenance, including incorrect removal and installation of the SRS, can lead to personal injury caused by unintentional activation of the system. For removal of Spiral Cable and Air Bag Module, see the SR section.**
- **Do not use electrical test equipment on any circuit related to the SRS unless instructed to in this Service Manual. SRS wiring harnesses can be identified by yellow and/or orange harnesses or harness connectors.**

PRECAUTIONS WHEN USING POWER TOOLS (AIR OR ELECTRIC) AND HAMMERS

WARNING:

- **When working near the Airbag Diagnosis Sensor Unit or other Airbag System sensors with the Ignition ON or engine running, DO NOT use air or electric power tools or strike near the sensor(s) with a hammer. Heavy vibration could activate the sensor(s) and deploy the air bag(s), possibly causing serious injury.**
- **When using air or electric power tools or hammers, always switch the Ignition OFF, disconnect the battery and wait at least three minutes before performing any service.**

Precaution for Work

INFOID:000000010120153

- Disconnect both 12V battery cables in advance.
- Disconnect air bag system line in advance.
- Do not tamper with or force air bag lid open, as this may adversely affect airbag performance.
- When removing or disassembling each component, be careful not to damage or deform it. If a component may be subject to interference, be sure to protect it with a shop cloth.
- When removing (disengaging) components with a screwdriver or similar tool, be sure to wrap the component with a shop cloth or vinyl tape to protect it.
- Protect the removed parts with a shop cloth and prevent them from being dropped.
- Replace a deformed or damaged clip.
- If a part is specified as a non-reusable part, always replace it with a new one.
- Be sure to tighten bolts and nuts securely to the specified torque.

PRECAUTIONS

< PRECAUTION >

- After installation is complete, be sure to check that each part works properly.
- Follow the steps below to clean components:
 - Water soluble dirt:
 - Dip a soft cloth into lukewarm water, wring the water out of the cloth and wipe the dirty area.
 - Then rub with a soft, dry cloth.
 - Oily dirt:
 - Dip a soft cloth into lukewarm water with mild detergent (concentration: within 2 to 3%) and wipe the dirty area.
 - Then dip a cloth into fresh water, wring the water out of the cloth and wipe the detergent off.
 - Then rub with a soft, dry cloth.
 - Do not use organic solvent such as thinner, benzene, alcohol or gasoline.
 - For genuine leather seats, use a genuine leather seat cleaner.

PREPARATION

< PREPARATION >

PREPARATION

PREPARATION

Special Service Tool

INFOID:000000010120154

The actual shape of the tools may differ from those illustrated here.

Tool number (TechMate No.) Tool name	Description
— (J-39570) Chassis Ear	Locating the noise
— (J-50397) NISSAN Squeak and Rattle Kit	Repairing the cause of noise
— (J-46534) Trim Tool Set	Removing trim components

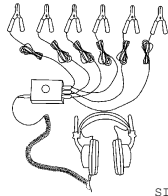

SIIA0993E



ALJIA1232Z

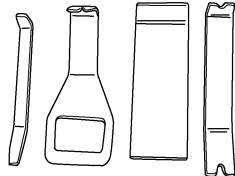

AWJIA0483Z

Commercial Service Tools

INFOID:000000010120155

(TechMate No.) Tool name	Description
(J-39565) Engine Ear	Locating the noise
(—) Power tool	Loosening nuts, screws and bolts

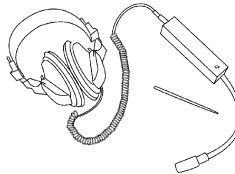

SIIA0995E



PIIB1407E

CLIP LIST







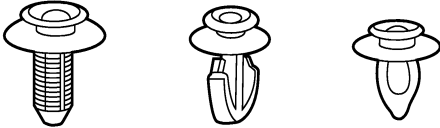

< PREPARATION >

CLIP LIST

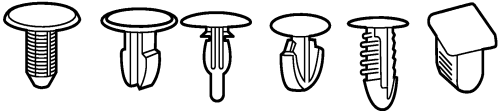
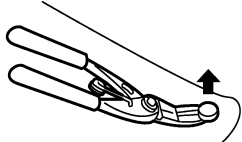
Descriptions for Clips

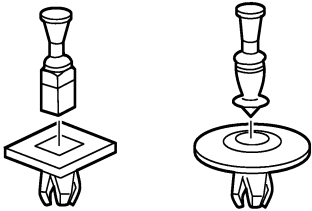
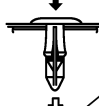
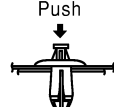
INFOID:000000010120156

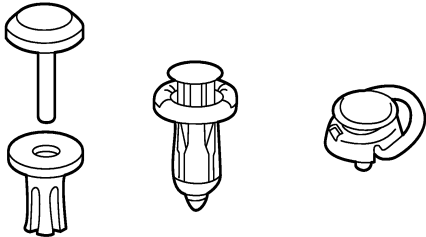
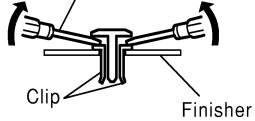

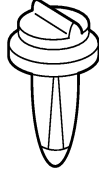
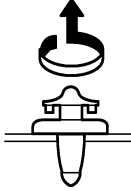





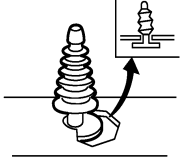
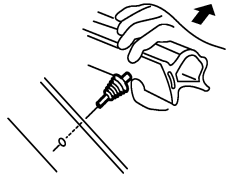

Replace any clips which are damaged during removal or installation.

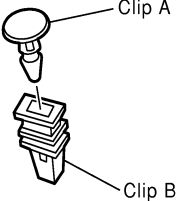
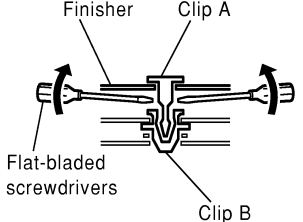
Symbol No.	Shapes	Removal & Installation
<p>C101</p> 		<p>Removal: Remove by bending up with flat-bladed screwdrivers or clip remover.</p> 
<p>C103</p> 		 <p>Removal: Remove with a clip remover.</p>
<p>C203</p> 		<p>Removal: Push center pin to catching position. (Do not remove center pin by hitting it.)</p> <p>Push</p>  <p>Installation:</p> 
<p>C205</p> 		<p>Removal:</p> 
<p>C206</p> 		<p>Removal:</p> 

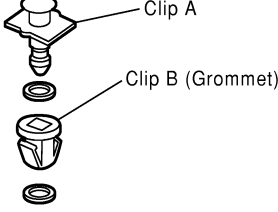
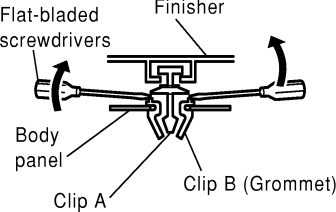
S1IA0315E

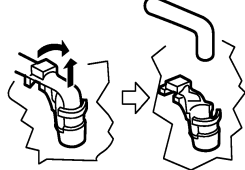
CLIP LIST

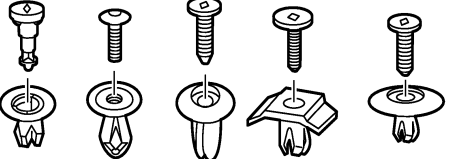
< PREPARATION >







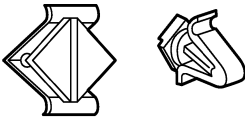
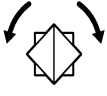
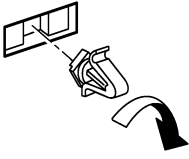

Symbol No.	Shapes	Removal & Installation
<p>CE103</p> 		<p>Removal:</p> 
<p>CF110</p> 		<p>Removal:</p> 
<p>CF118</p> 		<p>Removal:</p> 
<p>CR103</p> 		<p>Removal: Holder portion of clip must be spread out to remove rod.</p> 
<p>CS101</p> 		<p>Removal:</p> <ol style="list-style-type: none"> 1. Screw out with a Phillips screwdriver. 2. Remove female portion with flat-bladed screwdriver. 

SIIA0316E

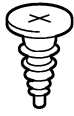
A
B
C
D
E
F
G
H
I
IP
K
L
M
N
O
P

CLIP LIST

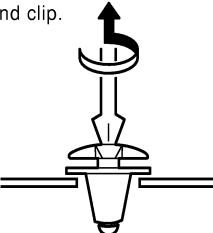

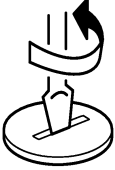
< PREPARATION >

Symbol No.	Shapes	Removal & Installation	
CG101 		Removal:  Rotate 45° to remove	Installation: 
CS102 			
CS113 		Removal: Disconnect upper connection of clip with a flat-bladed screwdriver, then remove clip while inserting a flat-bladed screwdriver between body panel and clip. 	
C111 			

SIIA0317E

CLIP LIST

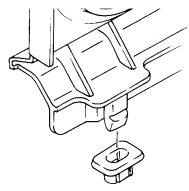
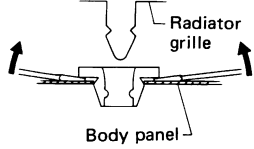
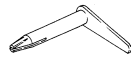
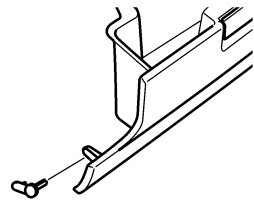
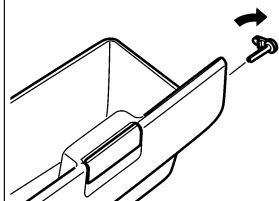
< PREPARATION >

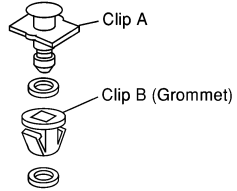
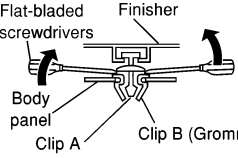
Symbol No.	Shapes	Removal & Installation
<p>CG104</p> 		<p>Removal: Remove by bending up with flat-bladed screwdrivers.</p> 
<p>CE114</p> 		
<p>CF118</p> 		<p>Removal: Flat-bladed screwdrivers</p> 

ALJIA0564GB

A
B
C
D
E
F
G
H
I
IP
K
L
M
N
O
P

SQUEAK AND RATTLE TROUBLE DIAGNOSES

< SYMPTOM DIAGNOSIS >

SYMPTOM DIAGNOSIS

SQUEAK AND RATTLE TROUBLE DIAGNOSES

Work Flow

INFOID:000000010120157

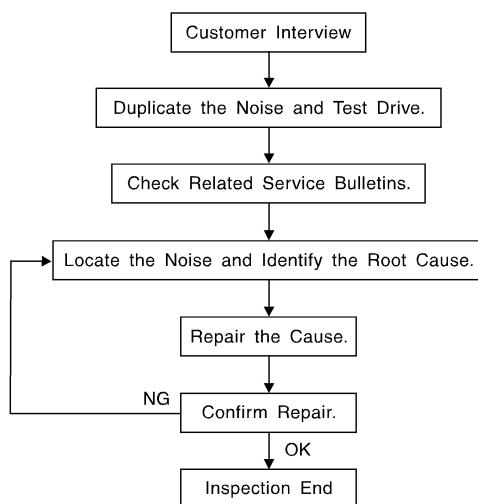

SBT842

CUSTOMER INTERVIEW

Interview the customer if possible, to determine the conditions that exist when the noise occurs. Use the Diagnostic Worksheet during the interview to document the facts and conditions when the noise occurs and any customer's comments; refer to [IP-14. "Diagnostic Worksheet"](#). This information is necessary to duplicate the conditions that exist when the noise occurs.

- The customer may not be able to provide a detailed description or the location of the noise. Attempt to obtain all the facts and conditions that exist when the noise occurs (or does not occur).
- If there is more than one noise in the vehicle, be sure to diagnose and repair the noise that the customer is concerned about. This can be accomplished by test driving the vehicle with the customer.
- After identifying the type of noise, isolate the noise in terms of its characteristics. The noise characteristics are provided so the customer, service adviser and technician are all speaking the same language when defining the noise.
- Squeak —(Like tennis shoes on a clean floor)
Squeak characteristics include the light contact/fast movement/brought on by road conditions/hard surfaces = higher pitch noise/softer surfaces = lower pitch noises/edge to surface = chirping.
- Creak—(Like walking on an old wooden floor)
Creak characteristics include firm contact/slow movement/twisting with a rotational movement/pitch dependent on materials/often brought on by activity.
- Rattle—(Like shaking a baby rattle)
Rattle characteristics include the fast repeated contact/vibration or similar movement/loose parts/missing clip or fastener/incorrect clearance.
- Knock —(Like a knock on a door)
Knock characteristics include hollow sounding/sometimes repeating/often brought on by driver action.
- Tick—(Like a clock second hand)
Tick characteristics include gentle contacting of light materials/loose components/can be caused by driver action or road conditions.
- Thump—(Heavy, muffled knock noise)
Thump characteristics include softer knock/dead sound often brought on by activity.
- Buzz—(Like a bumble bee)
Buzz characteristics include high frequency rattle/firm contact.
- Often the degree of acceptable noise level will vary depending upon the person. A noise that you may judge as acceptable may be very irritating to the customer.
- Weather conditions, especially humidity and temperature, may have a great effect on noise level.

DUPLICATE THE NOISE AND TEST DRIVE

SQUEAK AND RATTLE TROUBLE DIAGNOSES

< SYMPTOM DIAGNOSIS >

If possible, drive the vehicle with the customer until the noise is duplicated. Note any additional information on the Diagnostic Worksheet regarding the conditions or location of the noise. This information can be used to duplicate the same conditions when you confirm the repair.

If the noise can be duplicated easily during the test drive, to help identify the source of the noise, try to duplicate the noise with the vehicle stopped by doing one or all of the following:

- 1) Close a door.
 - 2) Tap or push/pull around the area where the noise appears to be coming from.
 - 3) Rev the engine.
 - 4) Use a floor jack to recreate vehicle "twist".
 - 5) At idle, apply engine load (electrical load, half-clutch on M/T model, drive position on CVT and A/T models).
 - 6) Raise the vehicle on a hoist and hit a tire with a rubber hammer.
- Drive the vehicle and attempt to duplicate the conditions the customer states exist when the noise occurs.
 - If it is difficult to duplicate the noise, drive the vehicle slowly on an undulating or rough road to stress the vehicle body.

CHECK RELATED SERVICE BULLETINS

After verifying the customer concern or symptom, check ASIST for Technical Service Bulletins (TSBs) related to that concern or symptom.

If a TSB relates to the symptom, follow the procedure to repair the noise.

LOCATE THE NOISE AND IDENTIFY THE ROOT CAUSE

1. Narrow down the noise to a general area. To help pinpoint the source of the noise, use a listening tool (Chassis Ear: J-39570, Engine Ear: J-39565 and mechanic's stethoscope).
2. Narrow down the noise to a more specific area and identify the cause of the noise by:
 - removing the components in the area that you suspect the noise is coming from.
Do not use too much force when removing clips and fasteners, otherwise clips and fasteners can be broken or lost during the repair, resulting in the creation of new noise.
 - tapping or pushing/pulling the component that you suspect is causing the noise.
Do not tap or push/pull the component with excessive force, otherwise the noise will be eliminated only temporarily.
 - feeling for a vibration with your hand by touching the component(s) that you suspect is (are) causing the noise.
 - placing a piece of paper between components that you suspect are causing the noise.
 - looking for loose components and contact marks.Refer to [IP-11, "Generic Squeak and Rattle Troubleshooting"](#).

REPAIR THE CAUSE

- If the cause is a loose component, tighten the component securely.
- If the cause is insufficient clearance between components:
 - separate components by repositioning or loosening and retightening the component, if possible.
 - insulate components with a suitable insulator such as urethane pads, foam blocks, felt cloth tape or urethane tape. A NISSAN Squeak and Rattle Kit (J-50397) is available through your authorized NISSAN Parts Department.

CAUTION:

Do not use excessive force as many components are constructed of plastic and may be damaged.

NOTE:

- Always check with the Parts Department for the latest parts information.
- The materials contained in the NISSAN Squeak and Rattle Kit (J-50397) are listed on the inside cover of the kit; and can each be ordered separately as needed.
- The following materials not found in the kit can also be used to repair squeaks and rattles.
 - SILICONE GREASE: Use instead of UHMW tape that will be visible or does not fit. The silicone grease will only last a few months.
 - SILICONE SPRAY: Use when grease cannot be applied.
 - DUCT TAPE: Use to eliminate movement.

CONFIRM THE REPAIR

Confirm that the cause of a noise is repaired by test driving the vehicle. Operate the vehicle under the same conditions as when the noise originally occurred. Refer to the notes on the Diagnostic Worksheet.

Generic Squeak and Rattle Troubleshooting

INFOID:000000010120158

Refer to Table of Contents for specific component removal and installation information.

SQUEAK AND RATTLE TROUBLE DIAGNOSES

< SYMPTOM DIAGNOSIS >

INSTRUMENT PANEL

Most incidents are caused by contact and movement between:

1. Cluster lid A and the instrument panel
2. Acrylic lens and combination meter housing
3. Instrument panel to front pillar finisher
4. Instrument panel to windshield
5. Instrument panel pins
6. Wiring harnesses behind the combination meter
7. A/C defroster duct and duct joint

These incidents can usually be located by tapping or moving the components to duplicate the noise or by pressing on the components while driving to stop the noise. Most of these incidents can be repaired by applying felt cloth tape or silicone spray (in hard to reach areas). Urethane pads can be used to insulate wiring harness.

CAUTION:

Do not use silicone spray to isolate a squeak or rattle. If you saturate the area with silicone, you will not be able to recheck the repair.

CENTER CONSOLE

Components to pay attention to include:

1. Shift selector assembly cover to finisher
2. A/C control unit and cluster lid C
3. Wiring harnesses behind audio and A/C control unit

The instrument panel repair and isolation procedures also apply to the center console.

DOORS

Pay attention to the:

1. Finisher and inner panel making a slapping noise
2. Inside handle escutcheon to door finisher
3. Wiring harnesses tapping
4. Door striker out of alignment causing a popping noise on starts and stops

Tapping or moving the components or pressing on them while driving to duplicate the conditions can isolate many of these incidents. You can usually insulate the areas with felt cloth tape or insulator foam blocks from the NISSAN Squeak and Rattle Kit (J-50397) to repair the noise.

TRUNK

Trunk noises are often caused by a loose jack or loose items put into the trunk by the owner.

In addition look for:

1. Trunk lid bumpers out of adjustment
2. Trunk lid striker out of adjustment
3. The trunk lid torsion bars knocking together
4. A loose license plate or bracket

Most of these incidents can be repaired by adjusting, securing or insulating the item(s) or component(s) causing the noise.

SUNROOF/HEADLINING

Noises in the sunroof/headlining area can often be traced to one of the following:

1. Sunroof lid, rail, linkage or seals making a rattle or light knocking noise
2. Sun visor shaft shaking in the holder
3. Front or rear windshield touching headlining and squeaking

Again, pressing on the components to stop the noise while duplicating the conditions can isolate most of these incidents. Repairs usually consist of insulating with felt cloth tape.

OVERHEAD CONSOLE (FRONT AND REAR)

Overhead console noises are often caused by the console panel clips not being engaged correctly. Most of these incidents are repaired by pushing up on the console at the clip locations until the clips engage.

In addition look for:

SQUEAK AND RATTLE TROUBLE DIAGNOSES

< SYMPTOM DIAGNOSIS >

1. Loose harness or harness connectors.
2. Front console map/reading lamp lens loose.
3. Loose screws at console attachment points.

A

SEATS

When isolating seat noise it's important to note the position the seat is in and the load placed on the seat when the noise is present. These conditions should be duplicated when verifying and isolating the cause of the noise.

B

Cause of seat noise include:

C

1. Headrest rods and holder
2. A squeak between the seat pad cushion and frame
3. The rear seatback lock and bracket

D

These noises can be isolated by moving or pressing on the suspected components while duplicating the conditions under which the noise occurs. Most of these incidents can be repaired by repositioning the component or applying urethane tape to the contact area.

E

UNDERHOOD

Some interior noise may be caused by components under the hood or on the engine wall. The noise is then transmitted into the passenger compartment.

F

Causes of transmitted underhood noise include:

1. Any component installed to the engine wall
2. Components that pass through the engine wall
3. Engine wall mounts and connectors
4. Loose radiator installation pins
5. Hood bumpers out of adjustment
6. Hood striker out of adjustment

G

H

These noises can be difficult to isolate since they cannot be reached from the interior of the vehicle. The best method is to secure, move or insulate one component at a time and test drive the vehicle. Also, engine rpm or load can be changed to isolate the noise. Repairs can usually be made by moving, adjusting, securing, or insulating the component causing the noise.

I

IP

K

L

M

N

O

P

SQUEAK AND RATTLE TROUBLE DIAGNOSES

< SYMPTOM DIAGNOSIS >

Diagnostic Worksheet

INFOID:000000010120159

Dear Customer:

We are concerned about your satisfaction with your vehicle. Repairing a squeak or rattle sometimes can be very difficult. To help us fix your vehicle right the first time, please take a moment to note the area of the vehicle where the squeak or rattle occurs and under what conditions. You may be asked to take a test drive with a service advisor or technician to ensure we confirm the noise you are hearing.

SQUEAK & RATTLE DIAGNOSTIC WORKSHEET

I. WHERE DOES THE NOISE COME FROM? (circle the area of the vehicle)

The illustrations are for reference only, and may not reflect the actual configuration of your vehicle.



Continue to page 2 of the worksheet and briefly describe the location of the noise or rattle. In addition, please indicate the conditions which are present when the noise occurs.

SQUEAK AND RATTLE TROUBLE DIAGNOSES

< SYMPTOM DIAGNOSIS >

SQUEAK & RATTLE DIAGNOSTIC WORKSHEET - page 2

Briefly describe the location where the noise occurs:

II. WHEN DOES IT OCCUR? (please check the boxes that apply)

- | | |
|---|--|
| <input type="checkbox"/> Anytime | <input type="checkbox"/> After sitting out in the rain |
| <input type="checkbox"/> 1st time in the morning | <input type="checkbox"/> When it is raining or wet |
| <input type="checkbox"/> Only when it is cold outside | <input type="checkbox"/> Dry or dusty conditions |
| <input type="checkbox"/> Only when it is hot outside | <input type="checkbox"/> Other: |

III. WHEN DRIVING:

- Through driveways
- Over rough roads
- Over speed bumps
- Only about ____ mph
- On acceleration
- Coming to a stop
- On turns: left, right or either (circle)
- With passengers or cargo
- Other: _____
- After driving ____ miles or ____ minutes

IV. WHAT TYPE OF NOISE

- Squeak (like tennis shoes on a clean floor)
- Creak (like walking on an old wooden floor)
- Rattle (like shaking a baby rattle)
- Knock (like a knock at the door)
- Tick (like a clock second hand)
- Thump (heavy muffled knock noise)
- Buzz (like a bumble bee)

TO BE COMPLETED BY DEALERSHIP PERSONNEL

Test Drive Notes:

	YES	NO	Initials of person performing
Vehicle test driven with customer	<input type="checkbox"/>	<input type="checkbox"/>	_____
- Noise verified on test drive	<input type="checkbox"/>	<input type="checkbox"/>	_____
- Noise source located and repaired	<input type="checkbox"/>	<input type="checkbox"/>	_____
- Follow up test drive performed to confirm repair	<input type="checkbox"/>	<input type="checkbox"/>	_____

VIN: _____ Customer Name _____

W.O.# _____ Date: _____

This form must be attached to Work Order

LATA0071E

INSTRUMENT PANEL ASSEMBLY

< REMOVAL AND INSTALLATION >

REMOVAL AND INSTALLATION

INSTRUMENT PANEL ASSEMBLY

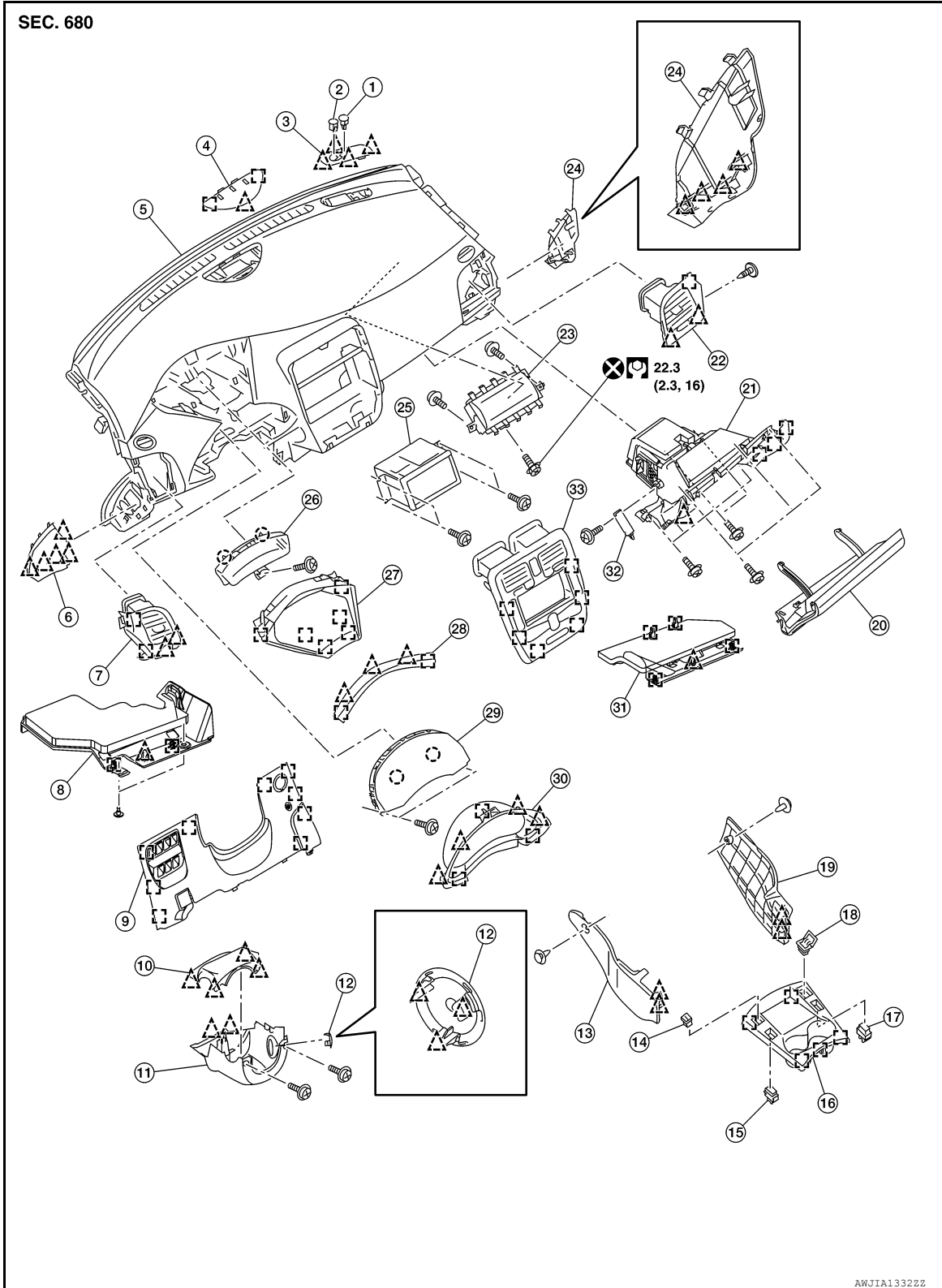

Exploded View

INFOID:000000010120160



INSTRUMENT PANEL ASSEMBLY

< REMOVAL AND INSTALLATION >

- | | | | |
|--|--|--|---|
| 1. Sunload sensor | 2. Optical sensor (if equipped) or switch hole mask | 3. Switch panel | A |
| 4. Charging status indicator | 5. Instrument panel assembly | 6. Instrument mask LH | |
| 7. Side ventilator grille LH | 8. Instrument under cover LH | 9. Instrument lower panel LH | B |
| 10. Steering column upper cover | 11. Steering column lower cover | 12. Steering column mask | |
| 13. Instrument lower cover LH | 14. USB connector | 15. Heated seat switch LH | |
| 16. Instrument lower center cover | 17. Heated seat switch RH | 18. Auxiliary input jacks (if equipped) | C |
| 19. Instrument lower cover RH | 20. Glove box lid | 21. Glove box cover assembly | |
| 22. Side ventilator grille RH | 23. Passenger air bag module | 24. Instrument mask RH | |
| 25. Audio or AV control unit | 26. Upper meter | 27. Cluster lid finisher | D |
| 28. Meter cover | 29. Combination meter | 30. Cluster lid A | |
| 31. Instrument under cover RH | 32. Glove box damper | 33. Cluster lid C | |
|  Clip |  Pawl |  Metal clip | E |

Removal and Installation

INFOID:000000010120161

WORK STEP

When removing instrument panel assembly, combination meter, upper meter, audio or AV control unit take steps as per the order shown in the following chart.

PARTS	INSTRUMENT PANEL ASSEMBLY	COMBINATION METER	UPPER METER	AUDIO OR AV CONTROL UNIT
Instrument lower center cover	[1]			
Instrument lower cover LH	[2]			
Instrument lower cover RH	[3]			
Front body side welt LH	[4]			
Instrument side panel LH	[5]			
Front pillar garnish LH	[6]			
Instrument mask LH	[7]			
Meter cover	[8]			
Cluster lid finisher	[9]	[1]	[1]	
Upper meter	[10]	[2]	[2]	
Cluster lid A	[11]	[3]		
Combination meter	[12]	[4]		
Instrument under cover LH	[13]			
Instrument lower panel LH	[14]			
Side ventilator assembly LH	[15]			
Driver air bag module	[16]			
Steering wheel	[17]			
Steering column covers	[18]			
Combination switch	[19]			
Spiral cable	[20]			
Cluster lid C	[21]			[1]
Audio or AV control unit	[22]			[2]
Charging status indicator	[23]			
Switch panel	[24]			
Front body side welt RH	[25]			
Instrument side panel RH	[26]			

INSTRUMENT PANEL ASSEMBLY

< REMOVAL AND INSTALLATION >

Front pillar garnish RH	[27]			
Instrument mask RH	[28]			
Instrument under cover RH	[29]			
Glove box lid	[30]			
Glove box cover assembly	[31]			
Passenger air bag module harness connector	[32]			
Passenger air bag module bolt	[33]			
Instrument panel assembly	[34]			

[]: Number indicates step in removal procedures.

WARNING:

To prevent accidental explosion, before servicing, turn ignition switch OFF, disconnect 12V battery negative terminal and wait 5 minutes or more.

CAUTION:

To prevent damage to the parts, when removing, always use a suitable tool that is made of plastic.

REMOVAL

1. Remove instrument lower center cover.
 1. Apply protective tape (A) to console finisher assembly to protect from the damage.

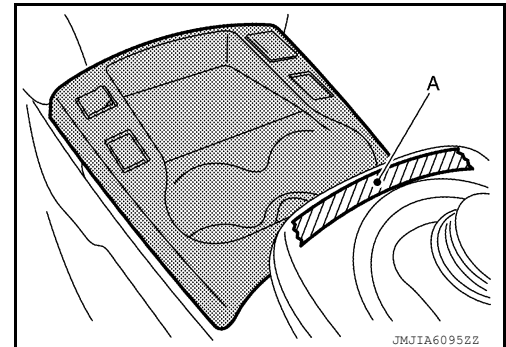

2. Apply protective tape (A) around the part to protect from damage.

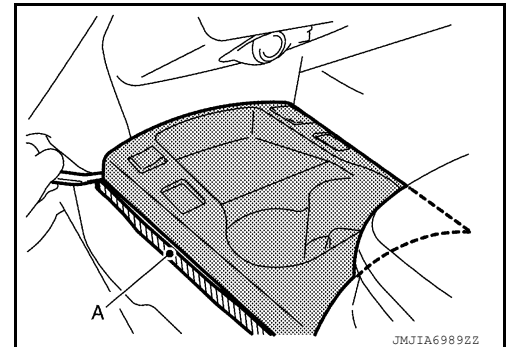

3. Insert suitable tool (A) between instrument lower center cover and center console assembly to disengage the metal clips as shown.

[] : Metal clip

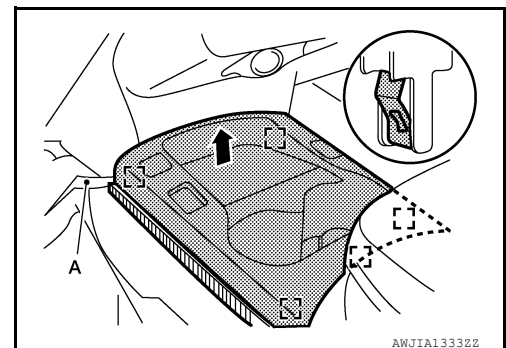

4. Lift up instrument lower center cover, then disconnect harness connectors.

CAUTION:

INSTRUMENT PANEL ASSEMBLY

< REMOVAL AND INSTALLATION >

Be careful not to scratch console finisher assembly with pawl or metal clip of instrument lower center cover.

2. Remove instrument lower cover LH.
 1. Remove clip (A).
 2. Pull the instrument lower cover LH crosswise, and disengage the pawls.

CAUTION:
Release pawls slowly so that they are not damaged.

 : Pawl

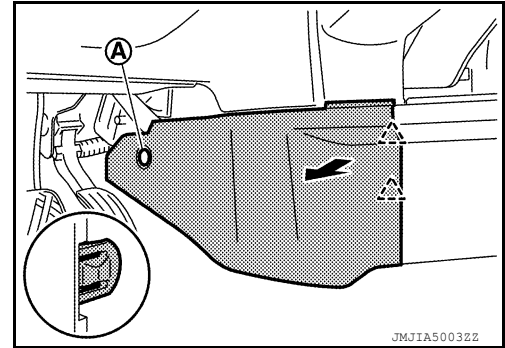

3. Remove instrument lower cover RH.
 1. Remove clip (A).
 2. Pull the instrument lower cover RH crosswise, and disengage the pawls.

CAUTION:
Release pawls slowly so that they are not damaged.

 : Pawl

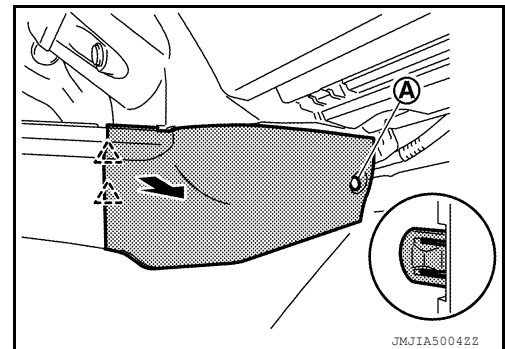

4. Release front pillar portion of front body side welt LH. Refer to [INT-29. "BODY SIDE WELT : Removal and Installation"](#).
5. Remove front pillar garnish LH. Refer to [INT-26. "FRONT PILLAR GARNISH : Removal and Installation"](#).
6. Remove instrument mask LH.
 1. Apply protective tape (A) around the part to protect from damage.

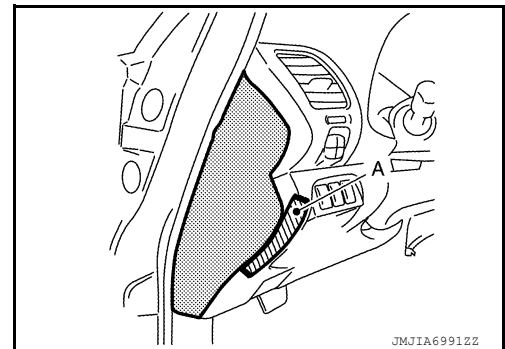

2. Insert suitable tool (A) between instrument mask LH and instrument panel assembly to disengage the pawls as shown.
3. Pull back instrument mask LH.

 : Pawl

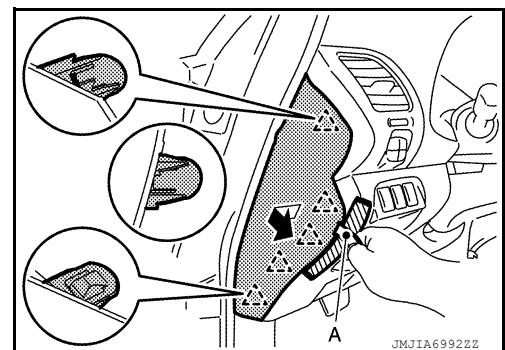

7. Remove meter cover.

INSTRUMENT PANEL ASSEMBLY

< REMOVAL AND INSTALLATION >

1. Apply protective tape (A) around the part to protect from damage.

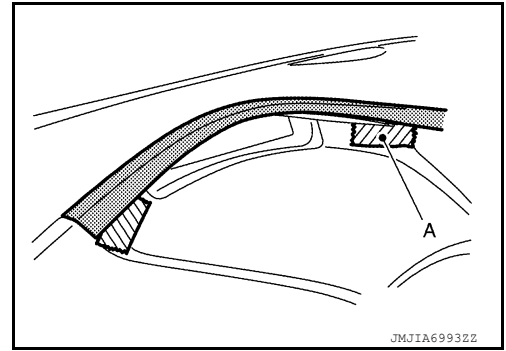

2. Insert suitable tool (A) between meter cover and cluster lid finisher to disengage the metal clips of meter cover both side according to the numerical order 1 → 2 as shown.

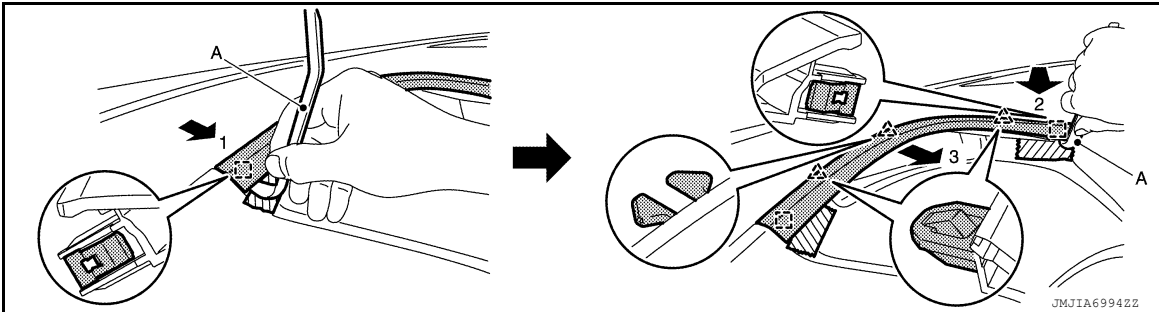

3. Pull back meter cover to disengage the pawls according to the numerical order 3 as shown.

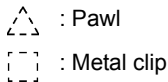

8. Remove cluster lid finisher.

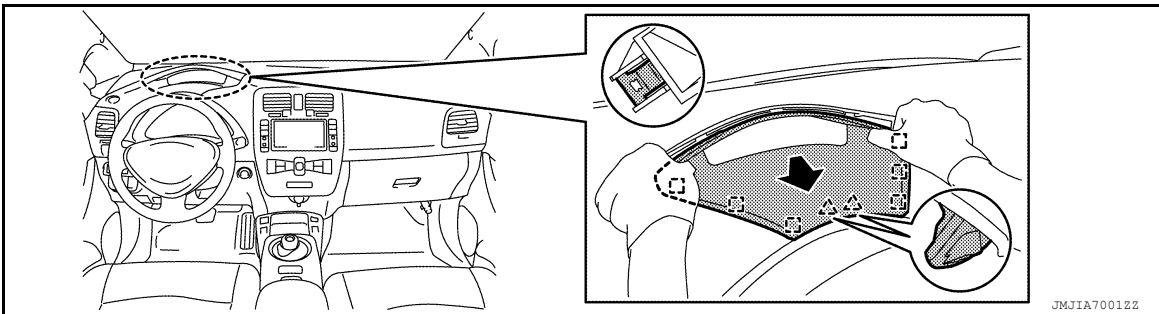

Pull back cluster lid finisher to disengage the pawls and metal clips.

CAUTION:

Wear a gloves to prevent an injury.

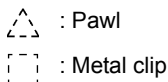

9. Remove cluster lid A.
 1. Place the tilt to the lowest level.

INSTRUMENT PANEL ASSEMBLY

< REMOVAL AND INSTALLATION >

- Apply protective tape (A) to the instrument panel assembly meeting to protect from damage.



- Pull rearward on cluster lid A while holding the upper side (center) to disengage the metal clip at the top according to numerical order 1 the as shown.

CAUTION:

Wear a gloves to prevent an injury.

 : Metal clip

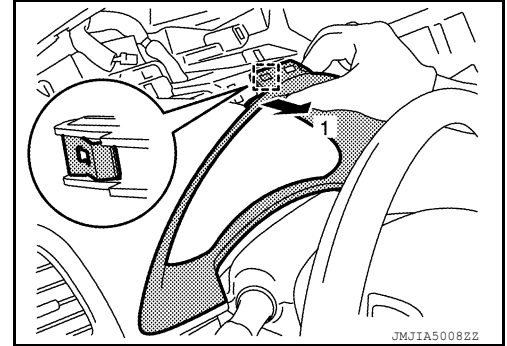

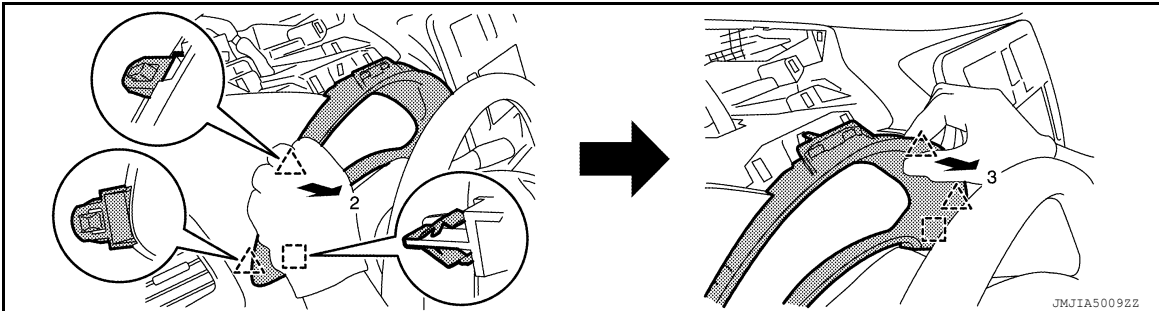

- Hold sides of cluster lid A and pull it out towards vehicle rear to disengage pawls and metal clips underside according to numerical order 2 → 3 the as shown.



CAUTION:

- **Wear a gloves to prevent an injury.**
- **Be careful not to scratch instrument panel assembly with pawls of cluster lid A.**

 : Pawl
 : Metal clip

- Remove combination meter. Refer to [MWI-102. "Removal and Installation"](#).
- Remove instrument under cover LH.
 - Remove clips.
 - Pull downward and disengage pawl and metal clips.
 - Pull back instrument under cover LH.
- Remove instrument lower panel LH.
 - Remove hood opener and charge port lid opener lever bolts. Refer to [DLK-188. "HOOD LOCK CONTROL CABLE : Removal and Installation"](#).

INSTRUMENT PANEL ASSEMBLY

< REMOVAL AND INSTALLATION >

2. Remove instrument lower panel LH screw (A).
3. Disengage metal clips according to the numerical order 1 → 4 as shown.
4. Pull instrument lower panel LH rearward to remove from instrument panel assembly.

 : Metal clip

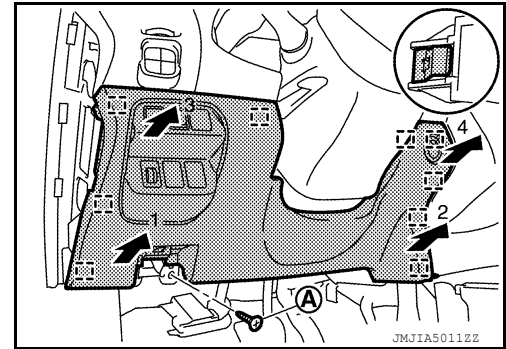

5. Release data link connector (pawl) to remove from instrument lower panel LH.
6. Disconnect harness connectors and aspirator duct.
13. Remove side ventilator grille assembly LH. Refer to [VTL-13, "SIDE VENTILATOR GRILLE : Removal and Installation"](#).
14. Remove steering wheel assembly. Refer to [ST-34, "Removal and Installation"](#).
15. Remove steering column covers.

1. Remove steering column cover screws (A).
2. Pull up steering column upper cover (1), then remove steering column upper cover.
3. Pull down steering column lower cover (2), then remove steering column lower cover.

 : Pawl

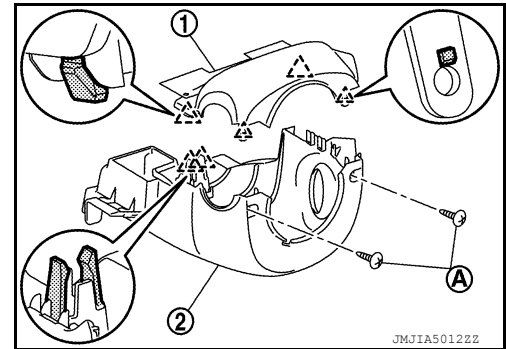

16. Remove combination switch. Refer to [BCS-73, "Removal and Installation"](#).
17. Remove spiral cable. Refer to [SR-23, "Removal and Installation"](#).
18. Remove cluster lid C.

1. Grasp both lower sides of cluster lid C and pull towards vehicle rear to disengage the lower metal clips.
2. Grasp both two sides of cluster lid C and pull towards vehicle rear to disengage the metal clips.

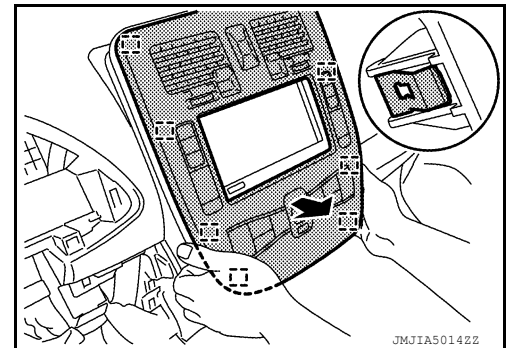

3. Disconnect harness connectors from cluster lid C and remove.
19. Remove audio unit or AV control unit. Refer to [AV-69, "Removal and Installation"](#) (DISPLAY AUDIO), [AV-192, "Removal and Installation"](#) (PREMIUM WITHOUT NAVIGATION), [AV-318, "Removal and Installation"](#) (NAVIGATION WITHOUT BOSE), [AV-488, "Removal and Installation"](#) (NAVIGATION WITHOUT BOSE) or [AV-593, "Removal and Installation"](#) (TELEMATICS SYSTEM).
20. Remove charging status indicator.



INSTRUMENT PANEL ASSEMBLY

< REMOVAL AND INSTALLATION >

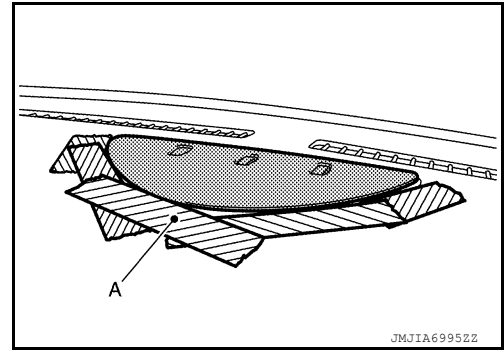
1. Apply protective tape (A) around the part to protect from damage.



2. Insert suitable tool (A) between charging status indicator and instrument panel assembly to disengage the pawl and metal clips as shown.
3. Pull toward the arrow direction.
4. Disconnect harness connector.

 : Pawl
 : Metal clip

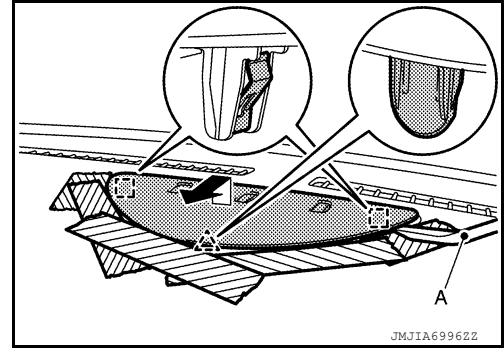

21. Remove switch panel.

1. Apply protective tape (A) around the part to protect from damage.

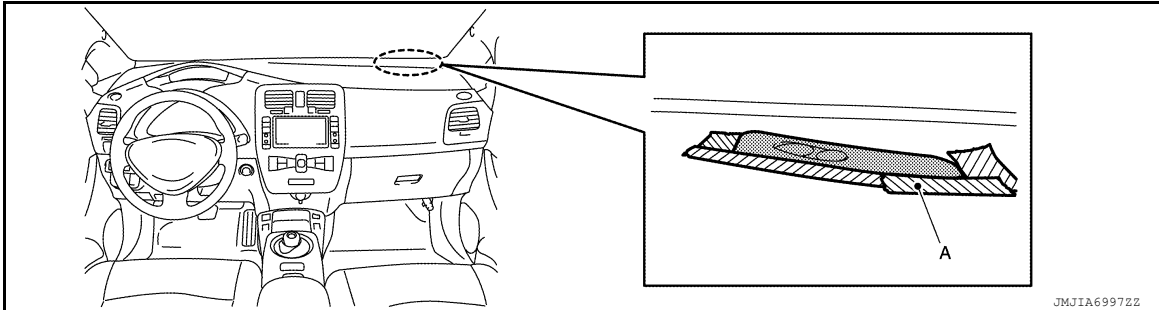

2. Insert suitable tool (A) between switch panel and instrument panel assembly to disengage the pawls as shown.
3. Pull up switch panel, then disconnect harness connectors.

 : Pawl

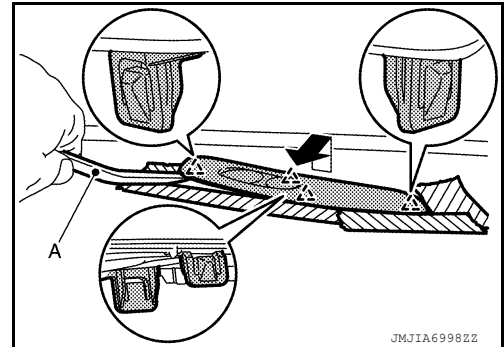

22. Release front pillar portion of front body side welt RH. Refer to [INT-29, "BODY SIDE WELT : Removal and Installation"](#).

23. Remove front pillar garnish RH. Refer to [INT-26, "FRONT PILLAR GARNISH : Removal and Installation"](#).

24. Remove instrument mask RH.

INSTRUMENT PANEL ASSEMBLY

< REMOVAL AND INSTALLATION >

1. Apply protective tape (A) around the part to protect from damage.

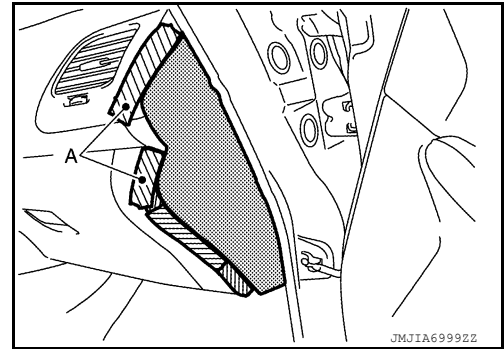

2. Insert suitable tool (A) between instrument mask RH and instrument panel assembly to disengage the pawls according to numerical order 1 → 3 the as shown.
3. Pull back instrument mask RH.

 : Pawl

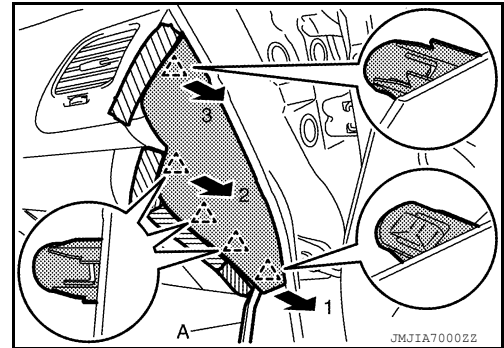

25. Remove instrument under cover RH.

1. Insert suitable tool between instrument under cover RH and glove box cover assembly to disengage the pawls and metal clips as shown.
2. Pull downward and disengage metal clips of the back side.
3. Pull back instrument under cover RH.

26. Remove glove box lid.

1. Open glove box lid.
2. Disengage the pawl, then remove damper pin on left side.

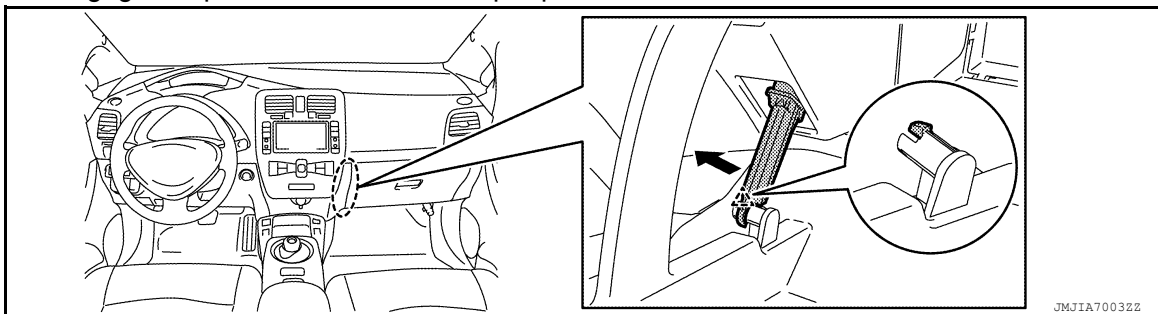

CAUTION:

Do not excessively pull string of glove box damper.

 : Pawl

INSTRUMENT PANEL ASSEMBLY

< REMOVAL AND INSTALLATION >

3. Pull glove box lid (1) toward vehicle rear, then disengage the joint from glove box cover assembly (2).

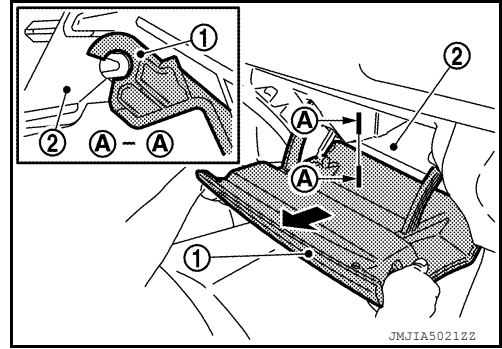

27. Remove glove box cover assembly.

1. Remove screws (A).
2. Pull back the glove box cover assembly while holding the lower side and disengage the pawl and metal clips according to numerical order 1 → 3 the as shown.

: Pawl
 : Metal clip

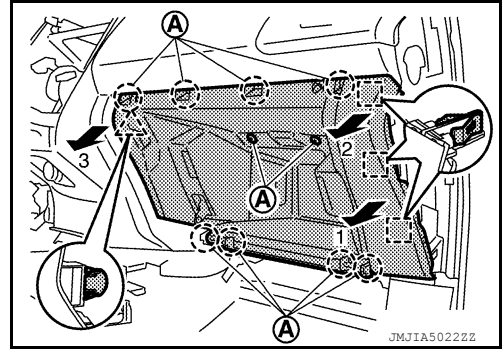

28. Disconnect passenger air bag module harness connector. Refer to [SR-26. "Exploded View"](#).

29. Remove passenger air bag module bolt. Refer to [SR-26. "Exploded View"](#).

30. Remove instrument panel assembly.

1. Remove instrument panel assembly bolt (A) and screws (B).

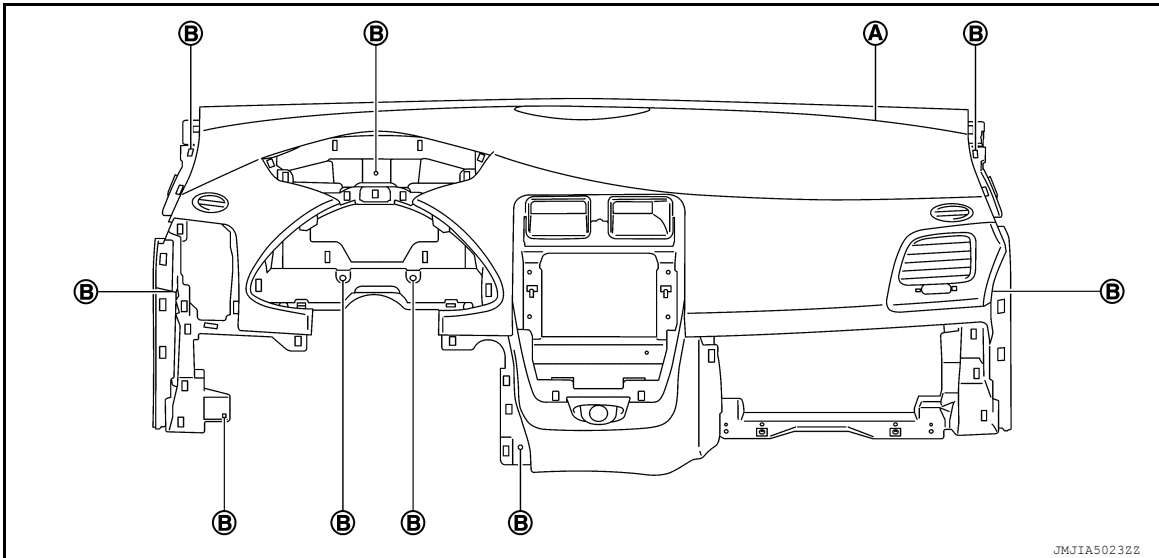

CAUTION:

Cover tool with a shop cloth to prevent windshield glass from being damaged.

2. Disconnect TCU harness connector (A) (if equipped) and remove harness clip (B).

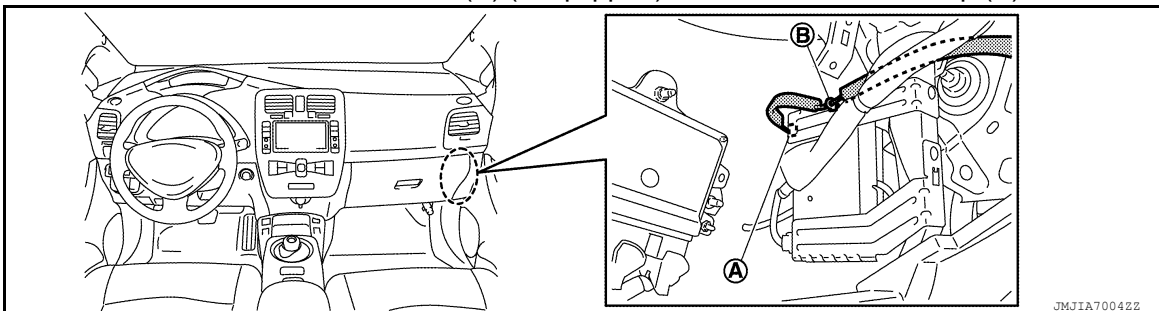

A
B
C
D
E
F
G
H
I
IP
K
L
M
N
O
P

INSTRUMENT PANEL ASSEMBLY

< REMOVAL AND INSTALLATION >

3. Disconnect power socket harness connector. Refer to [PWO-6. "Removal and Installation"](#).
4. Disengage harness (A) and harness (B) of front pillar LH and RH portions from instrument panel assembly.

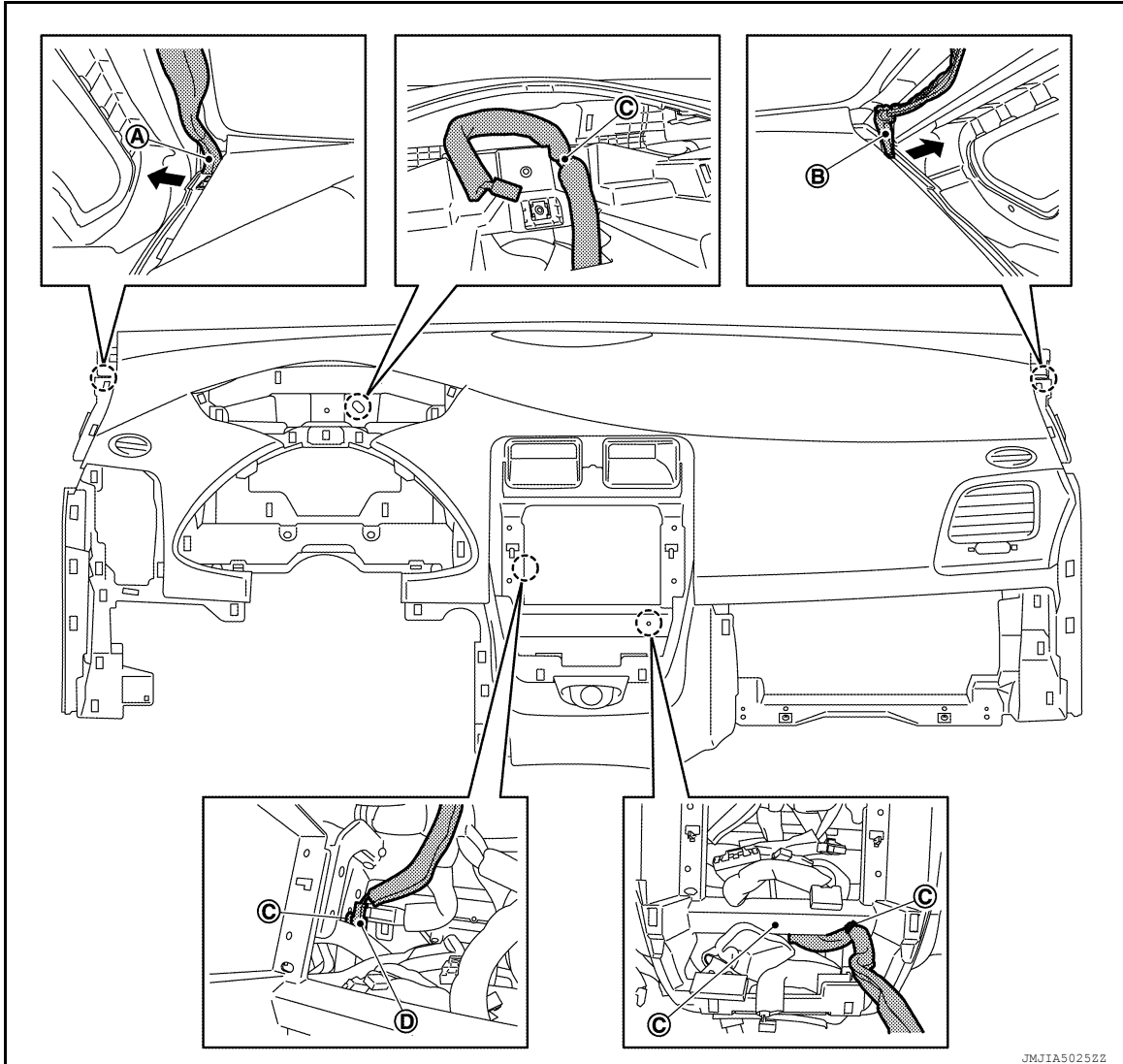

5. Remove harness clips (C) from instrument panel assembly.
 6. Disconnect harness connector (D).
 7. Remove instrument panel from passenger door opening portion.
CAUTION:
 - Cover center console upper surface with a shop cloth to prevent it from being damaged.
 - When removing instrument panel assembly, two workers are required to prevent from dropping.
31. Remove the following parts after removing instrument panel assembly.
- Passenger air bag module: Refer to [SR-26. "Removal and Installation"](#).
 - Side ventilator grille RH: Refer to [VTL-13. "SIDE VENTILATOR GRILLE : Removal and Installation"](#).
 - Side defroster nozzle LH/RH: Refer to [VTL-16. "SIDE DEFROSTER DUCT : Removal and Installation - Side Defroster Duct 1"](#).
 - Side defroster grille LH/RH: Refer to [VTL-14. "SIDE DEFROSTER GRILLE : Removal and Installation"](#).
 - Center ventilator duct: Refer to [VTL-15. "CENTER VENTILATOR DUCT : Removal and Installation"](#).
 - Side ventilator duct: Refer to [VTL-15. "SIDE VENTILATOR DUCT : Removal and Installation"](#).
 - Front defroster nozzle. Refer to [VTL-15. "FRONT DEFROSTER DUCT : Removal and Installation"](#).
 - GPS antenna (if equipped): Refer to [AV-323. "Removal and Installation"](#).
 - TEL antenna (if equipped): Refer to [AV-597. "Removal and Installation"](#).

INSTALLATION

Note the following items, and then install in the reverse order of removal.

CAUTION:

INSTRUMENT PANEL ASSEMBLY

< REMOVAL AND INSTALLATION >

- Do not use the steering wheel nut after removal, replace with a new nut.
- Do not use the driver air bag module bolts after removal, replace with new bolts.
- Do not use the passenger air bag module bolt after removal, replace with a new bolt.

A

B

C

D

E

F

G

H

I

IP

K

L

M

N

O

P

CENTER CONSOLE ASSEMBLY



< REMOVAL AND INSTALLATION >

CENTER CONSOLE ASSEMBLY

Exploded View

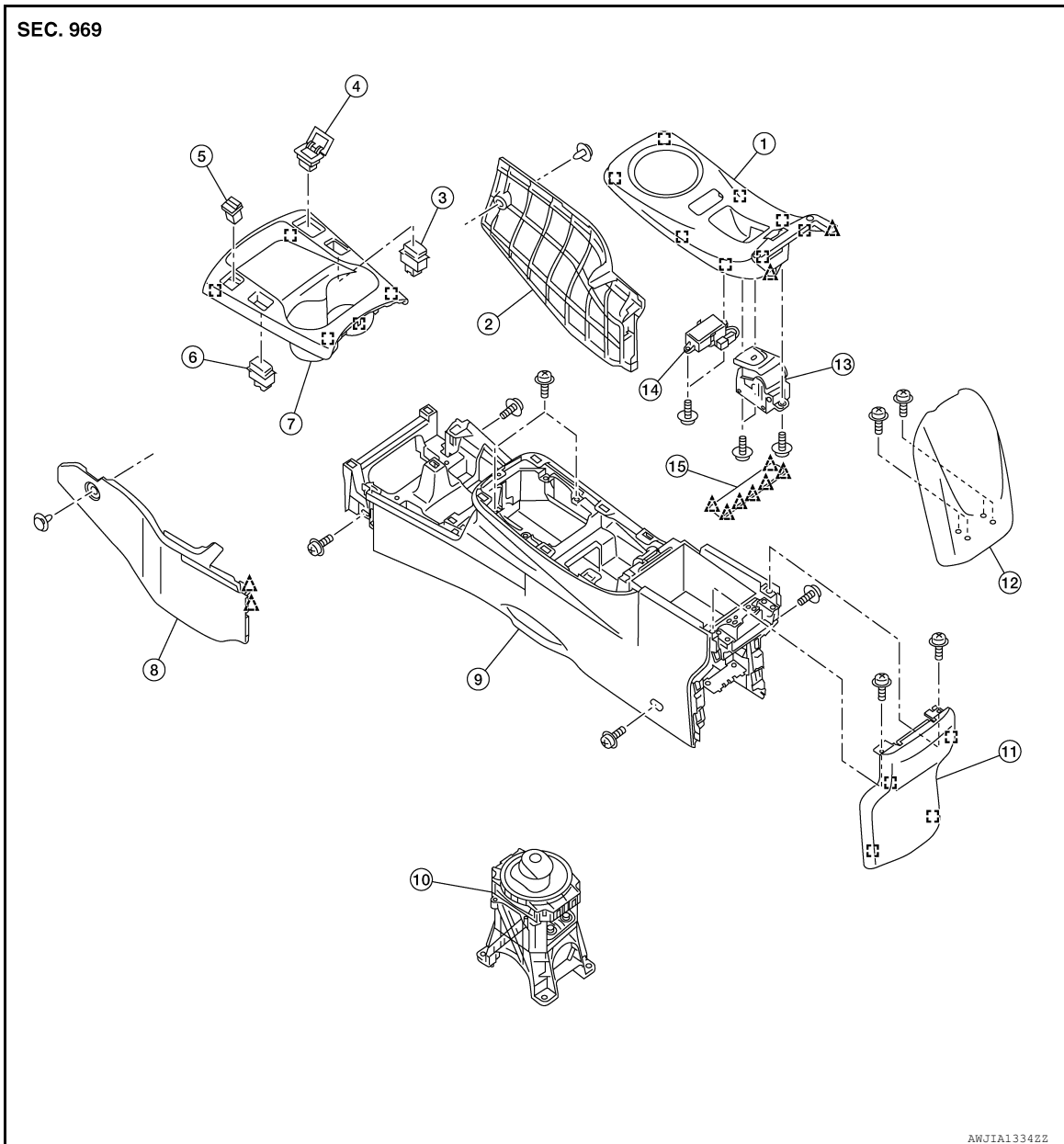
INFOID:000000010120162



- | | | |
|---------------------------------------|------------------------------|----------------------------|
| 1. Console finisher assembly | 2. Instrument lower cover RH | 3. Heated seat switch RH |
| 4. Auxiliary input jack (if equipped) | 5. USB connector | 6. Heated seat switch LH |
| 7. Instrument lower center cover | 8. Instrument lower cover LH | 9. Center console assembly |
| 10. Shift selector | 11. Console rear finisher | 12. Console lid assembly |
| 13. Parking brake switch | 14. Selector indicator | 15. Console mask |
-  Pawl
  Metal clip

Removal and Installation

INFOID:000000010120163

CAUTION:

To prevent damage to the parts, when removing, always use a suitable tool that is made of plastic.

REMOVAL

CENTER CONSOLE ASSEMBLY

< REMOVAL AND INSTALLATION >

1. Remove instrument lower center cover.
 1. Apply protective tape (A) to console finisher assembly to protect from damage.

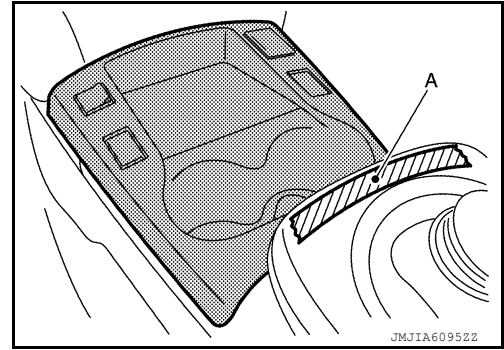

2. Apply protective tape (A) around the part to protect from damage.

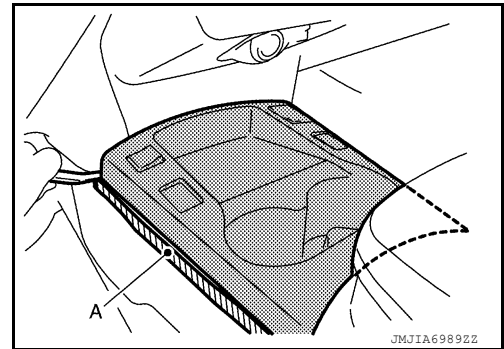

3. Insert suitable tool (A) between instrument lower center cover and center console assembly to disengage the metal clips as shown.

 : Metal clip

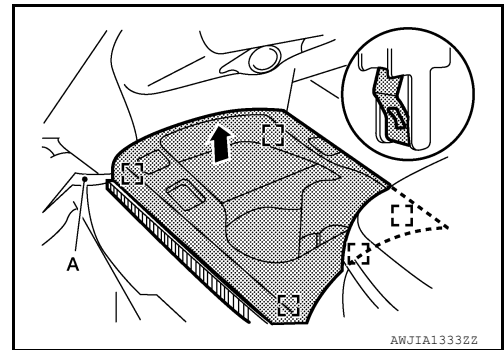

4. Lift up instrument lower center cover, then disconnect harness connectors.

CAUTION:

Be careful not to scratch console finisher assembly with pawl or metal clip of instrument lower center cover.

2. Remove instrument lower cover LH.
 1. Remove clip (A).
 2. Pull the instrument lower cover LH crosswise, and disengage the pawls.

CAUTION:

Release pawls slowly so that they are not damaged.

 : Pawl

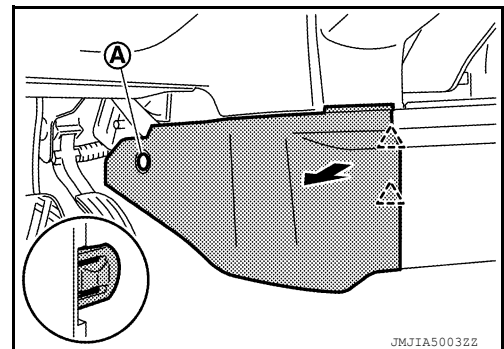

CENTER CONSOLE ASSEMBLY

< REMOVAL AND INSTALLATION >

3. Remove center console assembly screw (A).

↔ : Vehicle front

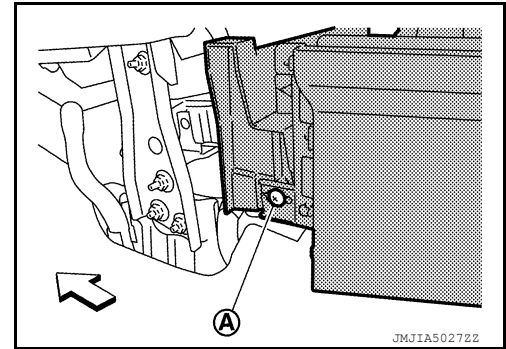

4. Remove instrument lower cover RH.
1. Remove clip (A).
2. Pull the instrument lower cover RH crosswise, and disengage the pawls.

CAUTION:

Release pawls slowly so that they are not damaged.

△ : Pawl

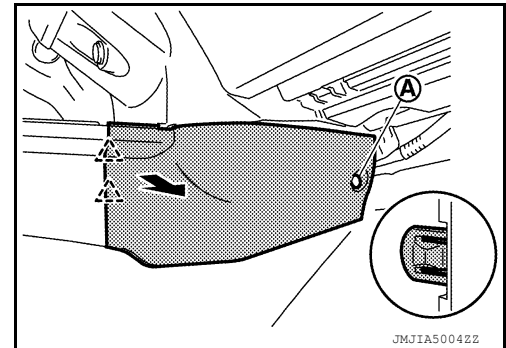

5. Remove center console assembly screw (A).

↔ : Vehicle front

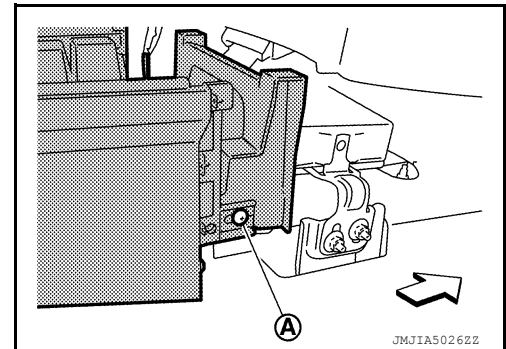

6. Remove console finisher assembly.
1. Lift up console finisher assembly back side, then disengage the pawls and metal clips according to the numerical order 1 → 6 as shown.
2. Disconnect harness connectors.

CAUTION:

- Apply protective tape (B) around the part to protect from damage.
- Disengage slowly so that pawls in rear end of console finisher assembly are not damaged.

△ : Pawl

□ : Metal clip

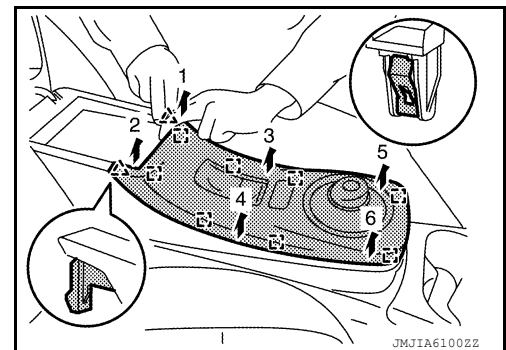

CENTER CONSOLE ASSEMBLY

< REMOVAL AND INSTALLATION >

7. Remove center console assembly screws (A).

↶ : Vehicle front

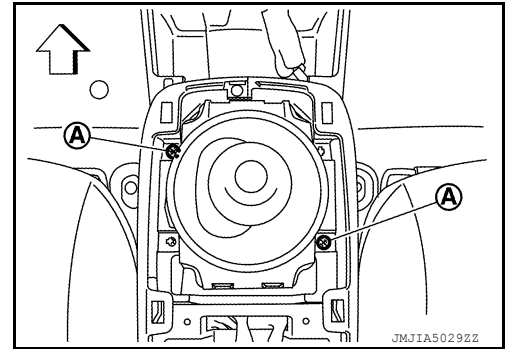

8. Put front seat to frontmost position.
9. Remove center console assembly screws (A).

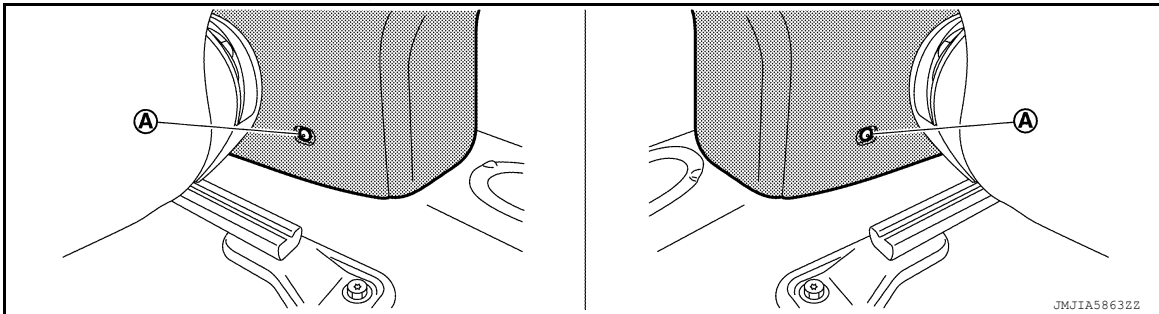

10. Put front seat to rearmost position.
11. Remove console harness clip (A) and (B).

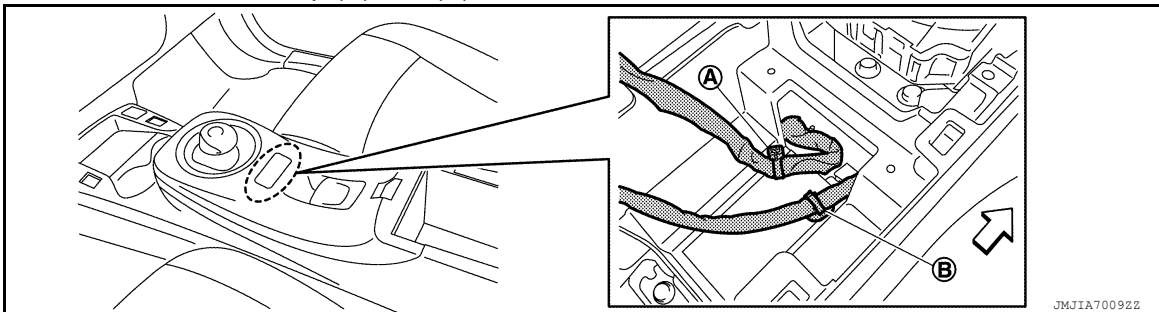

↶ : Vehicle front

12. Lift up center console assembly back side, then remove center console assembly.

INSTALLATION

Install in the reverse order of removal.

Disassembly and Assembly

INFOID:000000010120164

CAUTION:

To prevent damage to the parts, when disassembling, always use a suitable tool that is made of plastic.

DISASSEMBLY

1. Remove center console assembly. Refer to [IP-28. "Removal and Installation"](#).
2. Remove console mask.
 1. Open the console lid assembly.

CENTER CONSOLE ASSEMBLY

< REMOVAL AND INSTALLATION >

2. Apply protective tape (A) around the part to protect from damage.

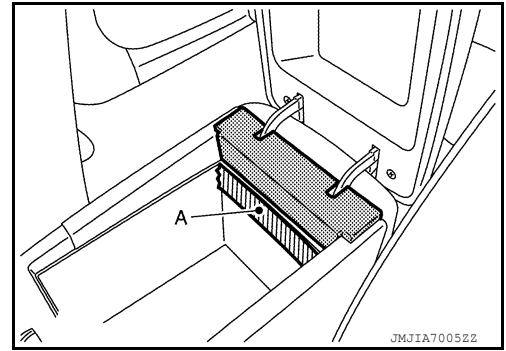

3. Insert suitable tool (A) between console mask and console body assembly to disengage the pawls as shown.
4. Pull up console mask.

CAUTION:

Disengage slowly so that pawls in front end of console mask are not damaged.

 : Pawl

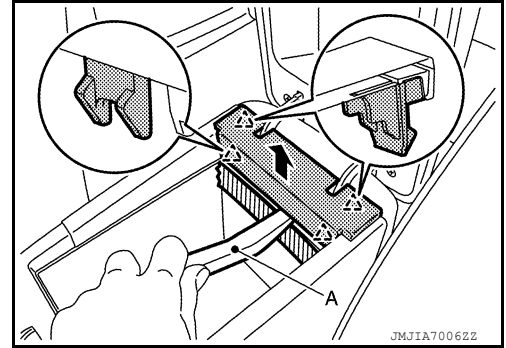

3. Remove console rear finisher.

1. Remove screws (A).

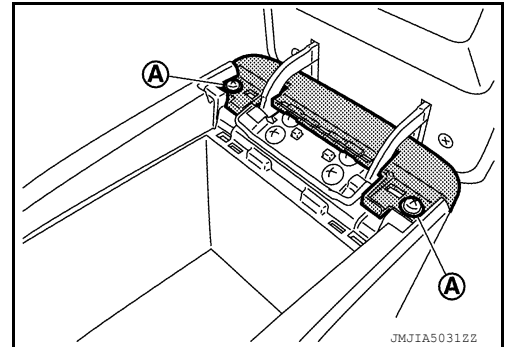

2. Close the console lid assembly.
3. Apply protective tape (A) around the part to protect from damage.

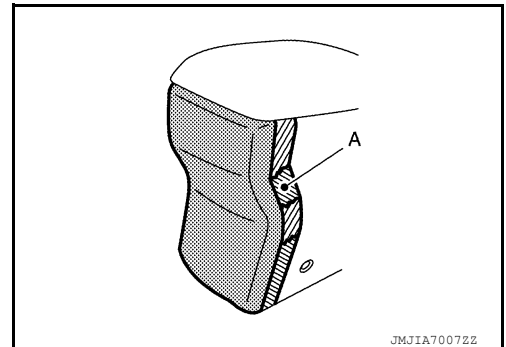

CENTER CONSOLE ASSEMBLY

< REMOVAL AND INSTALLATION >

4. Insert suitable tool (A) between console rear finisher and console body assembly to disengage the metal clips according to the numerical order 1 → 4 as shown.
5. Pull back console rear finisher.

 : Metal clip

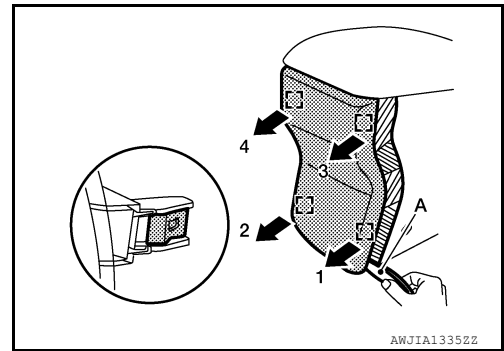

4. Remove console lid assembly.
 1. Open the console lid.
 2. Remove console lid assembly screws (A) and console lid assembly.

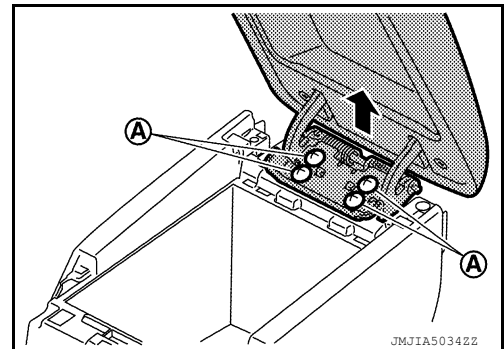

ASSEMBLY

Assemble in the reverse order of disassembly.

A
B
C
D
E
F
G
H
I
IP
K
L
M
N
O
P