

A  
B  
C

# GW

## SECTION

# GLASS & WINDOW SYSTEM

### CONTENTS

|  |   |
|--|---|
| <p><b>PRECAUTION</b> ..... 2</p> <p><b>PRECAUTIONS</b> ..... 2</p> <p style="padding-left: 20px;">Precaution for Technicians Using Medical Electric.....2</p> <p style="padding-left: 20px;">Point to Be Checked Before Starting Maintenance Work .....2</p> <p style="padding-left: 20px;">Precaution for Supplemental Restraint System (SRS) "AIR BAG" and "SEAT BELT PRE-TENSIONER" .....2</p> <p style="padding-left: 20px;">Precaution for Procedure without Cowl Top Cover.....3</p> <p style="padding-left: 20px;">Precaution for Handling Adhesive and Primer .....3</p> <p style="padding-left: 20px;">Precaution for Work .....3</p> <p><b>PREPARATION</b> ..... 5</p> <p><b>PREPARATION</b> ..... 5</p> <p style="padding-left: 20px;">Special Service Tool .....5</p> <p style="padding-left: 20px;">Commercial Service Tool .....5</p> <p><b>SYMPTOM DIAGNOSIS</b> ..... 6</p> <p><b>SQUEAK AND RATTLE TROUBLE DIAGNOSES</b> ..... 6</p> <p style="padding-left: 20px;">Work Flow .....6</p> <p style="padding-left: 20px;">Generic Squeak and Rattle Troubleshooting .....7</p> <p style="padding-left: 20px;">Diagnostic Worksheet ..... 10</p> <p><b>REMOVAL AND INSTALLATION</b> .....12</p> <p><b>WINDSHIELD GLASS</b> .....12</p> <p style="padding-left: 20px;">Exploded View ..... 12</p> <p style="padding-left: 20px;">Removal and Installation ..... 13</p> <p style="padding-left: 20px;">Inspection ..... 14</p> | <p><b>OPERA WINDOW</b> .....15</p> <p style="padding-left: 20px;">Exploded View .....15</p> <p style="padding-left: 20px;">Removal and Installation .....15</p> <p style="padding-left: 20px;">Inspection .....16</p> <p><b>BACK DOOR WINDOW GLASS</b> .....17</p> <p style="padding-left: 20px;">Exploded View .....17</p> <p style="padding-left: 20px;">Removal and Installation .....18</p> <p style="padding-left: 20px;">Inspection .....19</p> <p><b>FRONT DOOR GLASS</b> .....20</p> <p style="padding-left: 20px;">Exploded View .....20</p> <p style="padding-left: 20px;">Removal and Installation .....20</p> <p style="padding-left: 20px;">Inspection and Adjustment .....21</p> <p><b>FRONT REGULATOR</b> .....22</p> <p style="padding-left: 20px;">Exploded View .....22</p> <p style="padding-left: 20px;">Removal and Installation .....22</p> <p style="padding-left: 20px;">Disassembly and Assembly .....23</p> <p style="padding-left: 20px;">Inspection and Adjustment .....23</p> <p><b>REAR DOOR GLASS</b> .....24</p> <p style="padding-left: 20px;">Exploded View .....24</p> <p style="padding-left: 20px;">Removal and Installation .....24</p> <p style="padding-left: 20px;">Inspection and Adjustment .....25</p> <p><b>REAR REGULATOR</b> .....26</p> <p style="padding-left: 20px;">Exploded View .....26</p> <p style="padding-left: 20px;">Removal and Installation .....26</p> <p style="padding-left: 20px;">Disassembly and Assembly .....27</p> <p style="padding-left: 20px;">Inspection and Adjustment .....27</p> |
|--|---|

A  
B  
C  
D  
E  
F  
G  
H  
I  
J  
L  
M  
N  
O  
P



# PRECAUTIONS

< PRECAUTION >

## PRECAUTION

### PRECAUTIONS

#### Precaution for Technicians Using Medical Electric

INFOID:0000000110639254

##### OPERATION PROHIBITION

###### **WARNING:**

- Parts with strong magnet is used in this vehicle.
- Technicians using a medical electric device such as pacemaker must never perform operation on the vehicle, as magnetic field can affect the device function by approaching to such parts.

##### NORMAL CHARGE PRECAUTION

###### **WARNING:**

- If a technician uses a medical electric device such as an implantable cardiac pacemaker or an implantable cardioverter defibrillator, the possible effects on the devices must be checked with the device manufacturer before starting the charge operation.
- As radiated electromagnetic wave generated by PDM (Power Delivery Module) at normal charge operation may affect medical electric devices, a technician using a medical electric device such as implantable cardiac pacemaker or an implantable cardioverter defibrillator must not approach motor room [PDM (Power Delivery Module)] at the hood-opened condition during normal charge operation.

##### PRECAUTION AT TELEMATICS SYSTEM OPERATION

###### **WARNING:**

- If a technician uses implantable cardiac pacemaker or implantable cardioverter defibrillator (ICD), avoid the device implanted part from approaching within approximately 220 mm (8.66 in) from interior/exterior antenna.
- The electromagnetic wave of TCU might affect the function of the implantable cardiac pacemaker or the implantable cardioverter defibrillator (ICD), when using the service, etc.
- If a technician uses other medical electric devices than implantable cardiac pacemaker or implantable cardioverter defibrillator (ICD), the electromagnetic wave of TCU might affect the function of the device. The possible effects on the devices must be checked with the device manufacturer before TCU use.

##### PRECAUTION AT INTELLIGENT KEY SYSTEM OPERATION

###### **WARNING:**

- If a technician uses implantable cardiac pacemaker or implantable cardioverter defibrillator (ICD), avoid the device implanted part from approaching within approximately 220 mm (8.66 in) from interior/exterior antenna.
- The electromagnetic wave of Intelligent Key might affect the function of the implantable cardiac pacemaker or the implantable cardioverter defibrillator (ICD), at door operation, at each request switch operation, or at engine starting.
- If a technician uses other medical electric devices than implantable cardiac pacemaker or implantable cardioverter defibrillator (ICD), the electromagnetic wave of Intelligent Key might affect the function of the device. The possible effects on the devices must be checked with the device manufacturer before Intelligent Key use.

#### Point to Be Checked Before Starting Maintenance Work

INFOID:0000000110639255

The high voltage system may starts automatically. It is required to check that the timer air conditioner and timer charge (during EVSE connection) are not set before starting maintenance work.

###### **NOTE:**

If the timer air conditioner or timer charge (during EVSE connection) is set, the high voltage system starts automatically even when the power switch is in OFF state.

#### Precaution for Supplemental Restraint System (SRS) "AIR BAG" and "SEAT BELT PRE-TENSIONER"

INFOID:0000000110639256

The Supplemental Restraint System such as "AIR BAG" and "SEAT BELT PRE-TENSIONER", used along with a front seat belt, helps to reduce the risk or severity of injury to the driver and front passenger for certain types of collision. This system includes seat belt switch inputs and dual stage front air bag modules. The SRS

# PRECAUTIONS

## < PRECAUTION >

system uses the seat belt switches to determine the front air bag deployment, and may only deploy one front air bag, depending on the severity of a collision and whether the front occupants are belted or unbelted. Information necessary to service the system safely is included in the SR and SB section of this Service Manual.

### **WARNING:**

- To avoid rendering the SRS inoperative, which could increase the risk of personal injury or death in the event of a collision which would result in air bag inflation, all maintenance must be performed by an authorized NISSAN/INFINITI dealer.
- Improper maintenance, including incorrect removal and installation of the SRS, can lead to personal injury caused by unintentional activation of the system. For removal of Spiral Cable and Air Bag Module, see the SR section.
- Do not use electrical test equipment on any circuit related to the SRS unless instructed to in this Service Manual. SRS wiring harnesses can be identified by yellow and/or orange harnesses or harness connectors.

## PRECAUTIONS WHEN USING POWER TOOLS (AIR OR ELECTRIC) AND HAMMERS

### **WARNING:**

- When working near the Airbag Diagnosis Sensor Unit or other Airbag System sensors with the Ignition ON or engine running, DO NOT use air or electric power tools or strike near the sensor(s) with a hammer. Heavy vibration could activate the sensor(s) and deploy the air bag(s), possibly causing serious injury.
- When using air or electric power tools or hammers, always switch the Ignition OFF, disconnect the battery and wait at least three minutes before performing any service.

## Precaution for Procedure without Cowl Top Cover

INFOID:0000000110639257

When performing the procedure after removing cowl top cover, cover the lower end of windshield with urethane, etc to prevent damage to windshield.

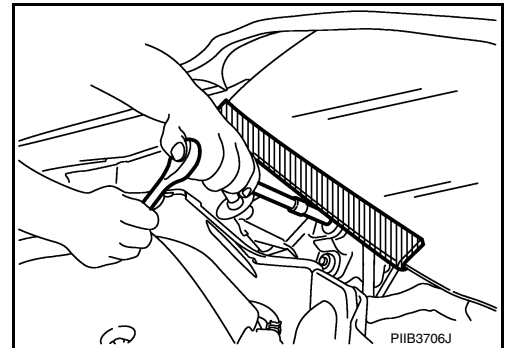

## Precaution for Handling Adhesive and Primer

INFOID:0000000110639258

- Do not use an adhesive which is past its usable date. Shelf life of this product is limited to six months after the date of manufacture. Carefully adhere to the expiration or manufacture date printed on the box.
- Keep primers and adhesive in a cool, dry place. Ideally, they should be stored in a refrigerator.
- Open the seal of the primer and adhesive just before application. Discard the remainder.
- Before application, be sure to shake the primer container to stir the contents. If any floating material is found, do not use it.
- If any primer or adhesive contacts the skin, wipe it off with gasoline or equivalent and wash the skin with soap.
- When using primer and adhesive, always observe the precautions in the instruction manual.

## Precaution for Work

INFOID:000000011107748

- When removing or disassembling each component, be careful not to damage or deform it. If a component may be subject to interference, be sure to protect it with a shop cloth.
- When removing (disengaging) components with a screwdriver or similar tool, be sure to wrap the component with a shop cloth or vinyl tape to protect it.
- Protect the removed parts with a shop cloth and prevent them from being dropped.
- Replace a deformed or damaged clip.
- If a part is specified as a non-reusable part, always replace it with a new one.
- Be sure to tighten bolts and nuts securely to the specified torque.
- After installation is complete, be sure to check that each part works properly.
- Follow the steps below to clean components:

## PRECAUTIONS

### < PRECAUTION >

---

- Water soluble dirt:
  - Dip a soft cloth into lukewarm water, wring the water out of the cloth and wipe the dirty area.
  - Then rub with a soft, dry cloth.
- Oily dirt:
  - Dip a soft cloth into lukewarm water with mild detergent (concentration: within 2 to 3%) and wipe the dirty area.
  - Then dip a cloth into fresh water, wring the water out of the cloth and wipe the detergent off.
  - Then rub with a soft, dry cloth.
- Do not use organic solvent such as thinner, benzene, alcohol or gasoline.
- For genuine leather seats, use a genuine leather seat cleaner.

# PREPARATION

< PREPARATION >

## PREPARATION

### PREPARATION

#### Special Service Tool

INFOID:000000010639259

The actual shape of the tools may differ from those illustrated here.

| Tool number<br>(TechMate No.)<br>Tool name            | Description                  |
|---|------------------------------|
| —<br>(J-39570)<br>Chassis Ear                         | Locating the noise           |
| —<br>(J-50397)<br>NISSAN Squeak and Rattle Repair Kit | Repairing the cause of noise |
| —<br>(J-46534)<br>Trim Tool Set                       | Removing trim components     |

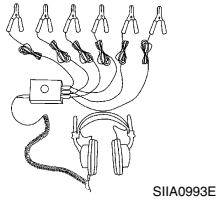

SIAA0993E



ALJIA1232ZZ

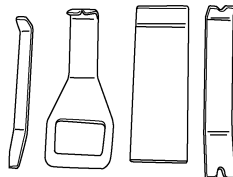

AWJIA0483ZZ

#### Commercial Service Tool

INFOID:000000010639260

GW

| (TechMate No.)<br>Tool name | Description        |
|-----------------------------|--------------------|
| (J-39565)<br>Engine Ear     | Locating the noise |
| ( — )<br>Suction Lifter     | Holding door glass |

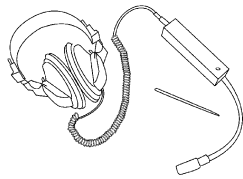

SIAA0995E

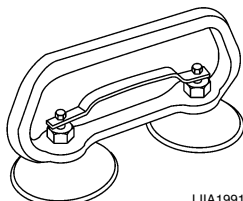

LIIA1991E

# SQUEAK AND RATTLE TROUBLE DIAGNOSES

< SYMPTOM DIAGNOSIS >

## SYMPTOM DIAGNOSIS

### SQUEAK AND RATTLE TROUBLE DIAGNOSES

#### Work Flow

INFOID:000000010639261

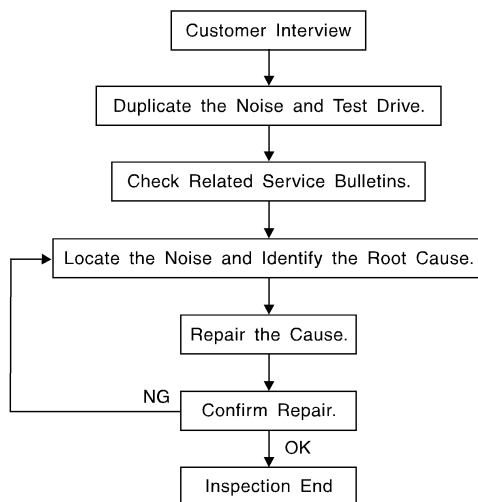

SBT842

#### CUSTOMER INTERVIEW

Interview the customer if possible, to determine the conditions that exist when the noise occurs. Use the Diagnostic Worksheet during the interview to document the facts and conditions when the noise occurs and any customer's comments; refer to [GW-10, "Diagnostic Worksheet"](#). This information is necessary to duplicate the conditions that exist when the noise occurs.

- The customer may not be able to provide a detailed description or the location of the noise. Attempt to obtain all the facts and conditions that exist when the noise occurs (or does not occur).
- If there is more than one noise in the vehicle, be sure to diagnose and repair the noise that the customer is concerned about. This can be accomplished by test driving the vehicle with the customer.
- After identifying the type of noise, isolate the noise in terms of its characteristics. The noise characteristics are provided so the customer, service adviser and technician are all speaking the same language when defining the noise.
- Squeak —(Like tennis shoes on a clean floor)  
Squeak characteristics include the light contact/fast movement/brought on by road conditions/hard surfaces = higher pitch noise/softer surfaces = lower pitch noises/edge to surface = chirping.
- Creak—(Like walking on an old wooden floor)  
Creak characteristics include firm contact/slow movement/twisting with a rotational movement/pitch dependent on materials/often brought on by activity.
- Rattle—(Like shaking a baby rattle)  
Rattle characteristics include the fast repeated contact/vibration or similar movement/loose parts/missing clip or fastener/incorrect clearance.
- Knock —(Like a knock on a door)  
Knock characteristics include hollow sounding/sometimes repeating/often brought on by driver action.
- Tick—(Like a clock second hand)  
Tick characteristics include gentle contacting of light materials/loose components/can be caused by driver action or road conditions.
- Thump—(Heavy, muffled knock noise)  
Thump characteristics include softer knock/dead sound often brought on by activity.
- Buzz—(Like a bumble bee)  
Buzz characteristics include high frequency rattle/firm contact.
- Often the degree of acceptable noise level will vary depending upon the person. A noise that you may judge as acceptable may be very irritating to the customer.
- Weather conditions, especially humidity and temperature, may have a great effect on noise level.

#### DUPLICATE THE NOISE AND TEST DRIVE

# SQUEAK AND RATTLE TROUBLE DIAGNOSES

## < SYMPTOM DIAGNOSIS >

If possible, drive the vehicle with the customer until the noise is duplicated. Note any additional information on the Diagnostic Worksheet regarding the conditions or location of the noise. This information can be used to duplicate the same conditions when you confirm the repair.

If the noise can be duplicated easily during the test drive, to help identify the source of the noise, try to duplicate the noise with the vehicle stopped by doing one or all of the following:

- 1) Close a door.
  - 2) Tap or push/pull around the area where the noise appears to be coming from.
  - 3) Rev the engine.
  - 4) Use a floor jack to recreate vehicle "twist".
  - 5) At idle, apply engine load (electrical load, half-clutch on M/T model, drive position on CVT and A/T models).
  - 6) Raise the vehicle on a hoist and hit a tire with a rubber hammer.
- Drive the vehicle and attempt to duplicate the conditions the customer states exist when the noise occurs.
  - If it is difficult to duplicate the noise, drive the vehicle slowly on an undulating or rough road to stress the vehicle body.

## CHECK RELATED SERVICE BULLETINS

After verifying the customer concern or symptom, check ASIST for Technical Service Bulletins (TSBs) related to that concern or symptom.

If a TSB relates to the symptom, follow the procedure to repair the noise.

## LOCATE THE NOISE AND IDENTIFY THE ROOT CAUSE

1. Narrow down the noise to a general area. To help pinpoint the source of the noise, use a listening tool (Chassis Ear: J-39570, Engine Ear: J-39565 and mechanic's stethoscope).
2. Narrow down the noise to a more specific area and identify the cause of the noise by:
  - removing the components in the area that you suspect the noise is coming from.  
Do not use too much force when removing clips and fasteners, otherwise clips and fasteners can be broken or lost during the repair, resulting in the creation of new noise.
  - tapping or pushing/pulling the component that you suspect is causing the noise.  
Do not tap or push/pull the component with excessive force, otherwise the noise will be eliminated only temporarily.
  - feeling for a vibration with your hand by touching the component(s) that you suspect is (are) causing the noise.
  - placing a piece of paper between components that you suspect are causing the noise.
  - looking for loose components and contact marks.Refer to [GW-7, "Generic Squeak and Rattle Troubleshooting"](#).

## REPAIR THE CAUSE

- If the cause is a loose component, tighten the component securely.
- If the cause is insufficient clearance between components:
  - separate components by repositioning or loosening and retightening the component, if possible.
  - insulate components with a suitable insulator such as urethane pads, foam blocks, felt cloth tape or urethane tape. A NISSAN Squeak and Rattle Kit (J-50397) is available through your authorized NISSAN Parts Department.

### CAUTION:

**Do not use excessive force as many components are constructed of plastic and may be damaged.**

### NOTE:

- Always check with the Parts Department for the latest parts information.
- The materials contained in the NISSAN Squeak and Rattle Kit (J-50397) are listed on the inside cover of the kit; and can each be ordered separately as needed.
- The following materials not found in the kit can also be used to repair squeaks and rattles.
  - SILICONE GREASE: Use instead of UHMW tape that will be visible or does not fit. The silicone grease will only last a few months.
  - SILICONE SPRAY: Use when grease cannot be applied.
  - DUCT TAPE: Use to eliminate movement.

## CONFIRM THE REPAIR

Confirm that the cause of a noise is repaired by test driving the vehicle. Operate the vehicle under the same conditions as when the noise originally occurred. Refer to the notes on the Diagnostic Worksheet.

## Generic Squeak and Rattle Troubleshooting

INFOID:000000010639262

Refer to Table of Contents for specific component removal and installation information.

# SQUEAK AND RATTLE TROUBLE DIAGNOSES

## < SYMPTOM DIAGNOSIS >

---

### INSTRUMENT PANEL

Most incidents are caused by contact and movement between:

1. Cluster lid A and the instrument panel
2. Acrylic lens and combination meter housing
3. Instrument panel to front pillar finisher
4. Instrument panel to windshield
5. Instrument panel pins
6. Wiring harnesses behind the combination meter
7. A/C defroster duct and duct joint

These incidents can usually be located by tapping or moving the components to duplicate the noise or by pressing on the components while driving to stop the noise. Most of these incidents can be repaired by applying felt cloth tape or silicone spray (in hard to reach areas). Urethane pads can be used to insulate wiring harness.

#### **CAUTION:**

**Do not use silicone spray to isolate a squeak or rattle. If you saturate the area with silicone, you will not be able to recheck the repair.**

### CENTER CONSOLE

Components to pay attention to include:

1. Shift selector assembly cover to finisher
2. A/C control unit and cluster lid C
3. Wiring harnesses behind audio and A/C control unit

The instrument panel repair and isolation procedures also apply to the center console.

### DOORS

Pay attention to the:

1. Finisher and inner panel making a slapping noise
2. Inside handle escutcheon to door finisher
3. Wiring harnesses tapping
4. Door striker out of alignment causing a popping noise on starts and stops

Tapping or moving the components or pressing on them while driving to duplicate the conditions can isolate many of these incidents. You can usually insulate the areas with felt cloth tape or insulator foam blocks from the NISSAN Squeak and Rattle Kit (J-50397) to repair the noise.

### TRUNK

Trunk noises are often caused by a loose jack or loose items put into the trunk by the owner.

In addition look for:

1. Trunk lid bumpers out of adjustment
2. Trunk lid striker out of adjustment
3. The trunk lid torsion bars knocking together
4. A loose license plate or bracket

Most of these incidents can be repaired by adjusting, securing or insulating the item(s) or component(s) causing the noise.

### SUNROOF/HEADLINING

Noises in the sunroof/headlining area can often be traced to one of the following:

1. Sunroof lid, rail, linkage or seals making a rattle or light knocking noise
2. Sun visor shaft shaking in the holder
3. Front or rear windshield touching headlining and squeaking

Again, pressing on the components to stop the noise while duplicating the conditions can isolate most of these incidents. Repairs usually consist of insulating with felt cloth tape.

### OVERHEAD CONSOLE (FRONT AND REAR)

Overhead console noises are often caused by the console panel clips not being engaged correctly. Most of these incidents are repaired by pushing up on the console at the clip locations until the clips engage.

In addition look for:



# SQUEAK AND RATTLE TROUBLE DIAGNOSES

## < SYMPTOM DIAGNOSIS >

---

1. Loose harness or harness connectors.
2. Front console map/reading lamp lens loose.
3. Loose screws at console attachment points.

A

## SEATS

When isolating seat noise it's important to note the position the seat is in and the load placed on the seat when the noise is present. These conditions should be duplicated when verifying and isolating the cause of the noise.

B

Cause of seat noise include:

C

1. Headrest rods and holder
2. A squeak between the seat pad cushion and frame
3. The rear seatback lock and bracket

D

These noises can be isolated by moving or pressing on the suspected components while duplicating the conditions under which the noise occurs. Most of these incidents can be repaired by repositioning the component or applying urethane tape to the contact area.

E

## UNDERHOOD

Some interior noise may be caused by components under the hood or on the engine wall. The noise is then transmitted into the passenger compartment.

F

Causes of transmitted underhood noise include:

1. Any component installed to the engine wall
2. Components that pass through the engine wall
3. Engine wall mounts and connectors
4. Loose radiator installation pins
5. Hood bumpers out of adjustment
6. Hood striker out of adjustment

G

H

These noises can be difficult to isolate since they cannot be reached from the interior of the vehicle. The best method is to secure, move or insulate one component at a time and test drive the vehicle. Also, engine rpm or load can be changed to isolate the noise. Repairs can usually be made by moving, adjusting, securing, or insulating the component causing the noise.

I

J

GW

L

M

N

O

P

# SQUEAK AND RATTLE TROUBLE DIAGNOSES

< SYMPTOM DIAGNOSIS >

## Diagnostic Worksheet

INFOID:000000010639263

Dear Customer:

We are concerned about your satisfaction with your vehicle. Repairing a squeak or rattle sometimes can be very difficult. To help us fix your vehicle right the first time, please take a moment to note the area of the vehicle where the squeak or rattle occurs and under what conditions. You may be asked to take a test drive with a service advisor or technician to ensure we confirm the noise you are hearing.

### SQUEAK & RATTLE DIAGNOSTIC WORKSHEET

#### I. WHERE DOES THE NOISE COME FROM? (circle the area of the vehicle)

The illustrations are for reference only, and may not reflect the actual configuration of your vehicle.

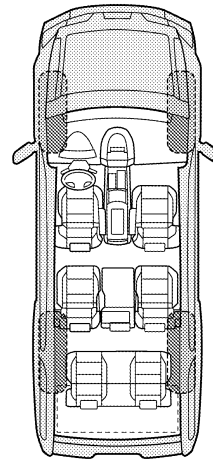
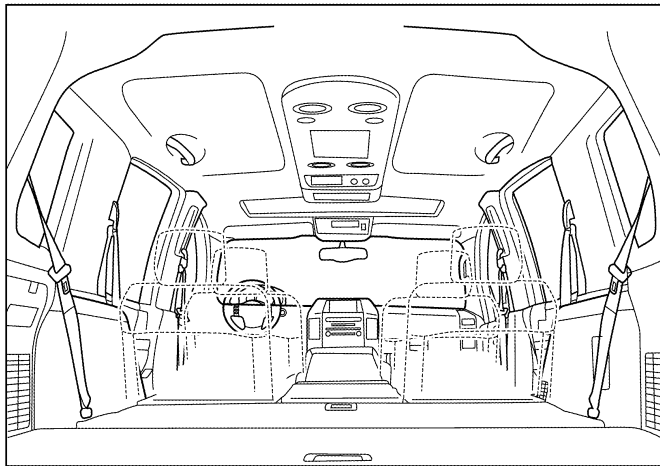
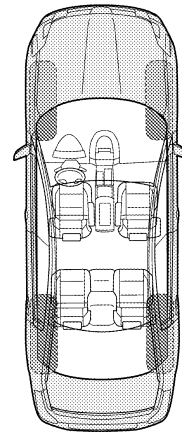
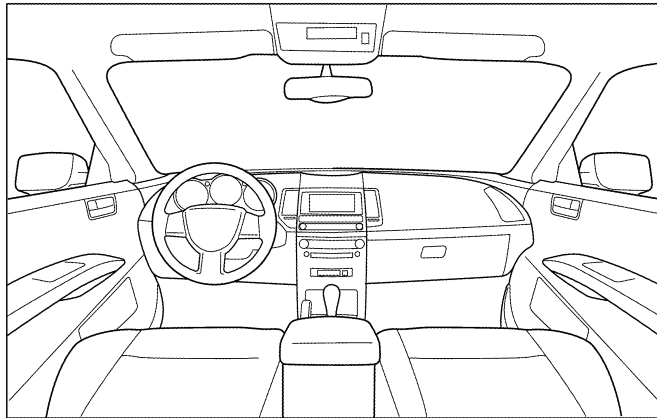

Continue to page 2 of the worksheet and briefly describe the location of the noise or rattle. In addition, please indicate the conditions which are present when the noise occurs.

# SQUEAK AND RATTLE TROUBLE DIAGNOSES

< SYMPTOM DIAGNOSIS >

## SQUEAK & RATTLE DIAGNOSTIC WORKSHEET - page 2

Briefly describe the location where the noise occurs:

---

---

### II. WHEN DOES IT OCCUR? (please check the boxes that apply)

- |   |  |
|---|--|
| <input type="checkbox"/> Anytime                      | <input type="checkbox"/> After sitting out in the rain |
| <input type="checkbox"/> 1st time in the morning      | <input type="checkbox"/> When it is raining or wet     |
| <input type="checkbox"/> Only when it is cold outside | <input type="checkbox"/> Dry or dusty conditions       |
| <input type="checkbox"/> Only when it is hot outside  | <input type="checkbox"/> Other:                        |

### III. WHEN DRIVING:

- Through driveways
- Over rough roads
- Over speed bumps
- Only about \_\_\_\_ mph
- On acceleration
- Coming to a stop
- On turns: left, right or either (circle)
- With passengers or cargo
- Other: \_\_\_\_\_
- After driving \_\_\_\_ miles or \_\_\_\_ minutes

### IV. WHAT TYPE OF NOISE

- Squeak (like tennis shoes on a clean floor)
- Creak (like walking on an old wooden floor)
- Rattle (like shaking a baby rattle)
- Knock (like a knock at the door)
- Tick (like a clock second hand)
- Thump (heavy muffled knock noise)
- Buzz (like a bumble bee)

### TO BE COMPLETED BY DEALERSHIP PERSONNEL

Test Drive Notes:

---

---

---

|  | YES                      | NO                       | Initials of person performing |
|--|--------------------------|--------------------------|-------------------------------|
| Vehicle test driven with customer                  | <input type="checkbox"/> | <input type="checkbox"/> | _____                         |
| - Noise verified on test drive                     | <input type="checkbox"/> | <input type="checkbox"/> | _____                         |
| - Noise source located and repaired                | <input type="checkbox"/> | <input type="checkbox"/> | _____                         |
| - Follow up test drive performed to confirm repair | <input type="checkbox"/> | <input type="checkbox"/> | _____                         |

VIN: \_\_\_\_\_ Customer Name \_\_\_\_\_

W.O.# \_\_\_\_\_ Date: \_\_\_\_\_

This form must be attached to Work Order

LAI/A0071E

A  
B  
C  
D  
E  
F  
G  
H  
I  
J  
L  
M  
N  
O  
P

GW

# WINDSHIELD GLASS

< REMOVAL AND INSTALLATION >

## REMOVAL AND INSTALLATION

### WINDSHIELD GLASS

Exploded View

INFOID:000000010639264

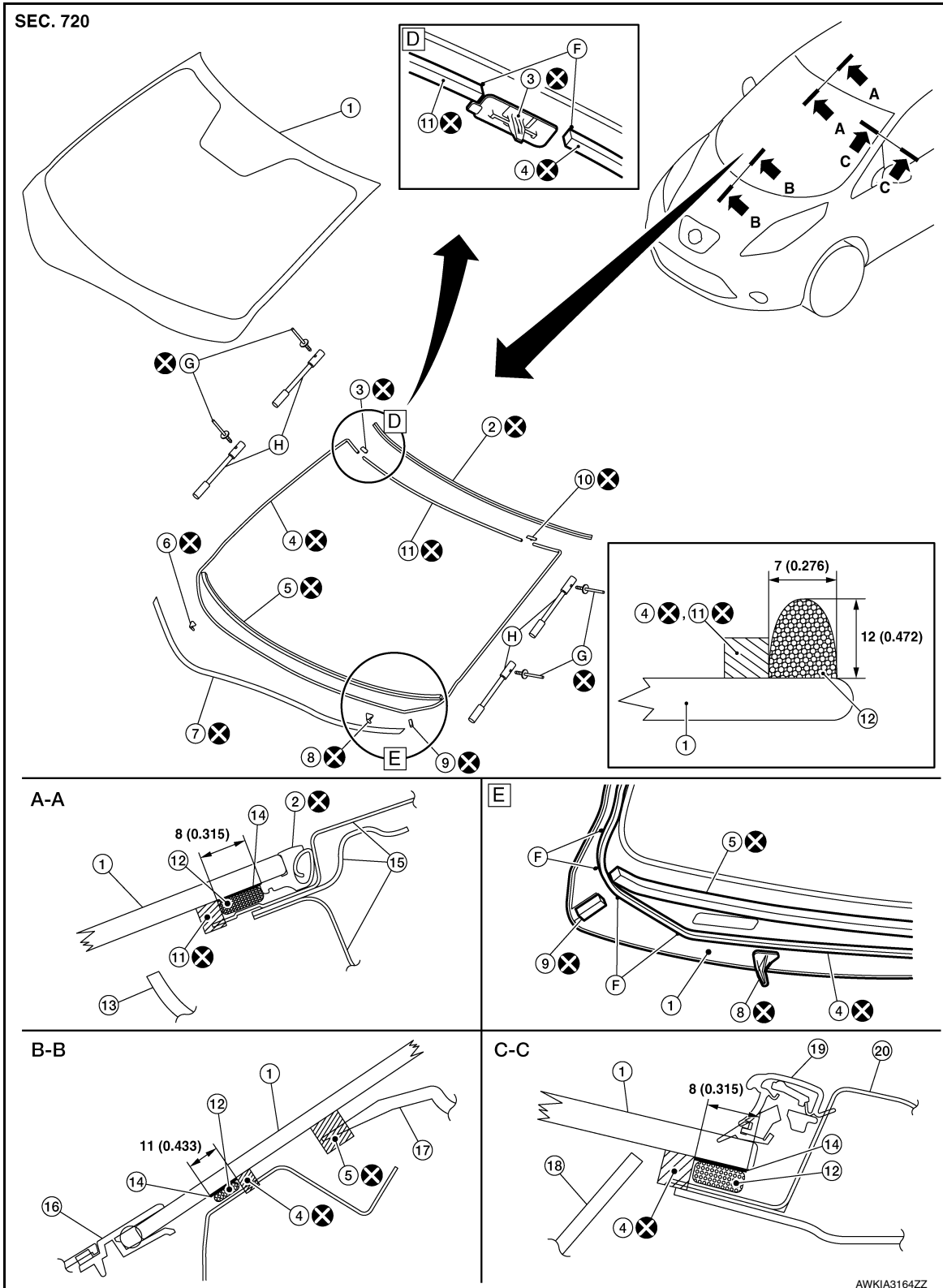

AWKIA3164ZZ

# WINDSHIELD GLASS

## < REMOVAL AND INSTALLATION >

Unit:mm (in)

- |                                |                                |   |   |
|--------------------------------|--------------------------------|---|---|
| 1. Windshield glass            | 2. Windshield glass molding    | 3. Upper clip (RH)                            | A |
| 4. Dam sealant rubber (lower)  | 5. Glass insulator             | 6. Lower clip (RH)                            | B |
| 7. Adhesive tape               | 8. Lower clip (LH)             | 9. Windshield lower spacer (Driver side only) | C |
| 10. Upper clip (LH)            | 11. Dam sealant rubber (upper) | 12. Adhesive                                  | D |
| 13. Headlining assembly        | 14. Glass primer               | 15. Roof assembly                             | E |
| 16. Cowl top cover             | 17. Instrument panel assembly  | 18. Front pillar finisher                     | F |
| 19. Roof side molding assembly | 20. Body side outer panel      | F. Black print mark                           | G |
| G. Rivet                       | H. Fastener molding            |   | H |

## Removal and Installation

INFOID:0000000010639265

### CAUTION:

Remove inside mirror only when windshield glass is not reusable.

### REMOVAL

1. Remove front pillar finishers (LH/RH). Refer to [INT-26. "FRONT PILLAR GARNISH : Removal and Installation"](#).
2. Remove inside mirror assembly. Refer to [MIR-20. "Removal and Installation"](#).  
**CAUTION:**  
Replace inside mirror assembly after removal, when installing new windshield glass.
3. Remove partially the headlining (front edge). Refer to [INT-37. "Removal and Installation"](#).
4. Remove roof side molding assembly (LH/RH). Refer to [EXT-26. "Removal and Installation"](#).
5. Remove cowl top and cowl top extension. Refer to [EXT-19. "Removal and Installation"](#).
6. Remove relay box from cowl top extension.
7. Apply protective tape around the windshield glass to protect the painted surface from damage.
8. Remove glass using piano wire or power cutting tool A and an inflatable pump bag B after removing moldings.

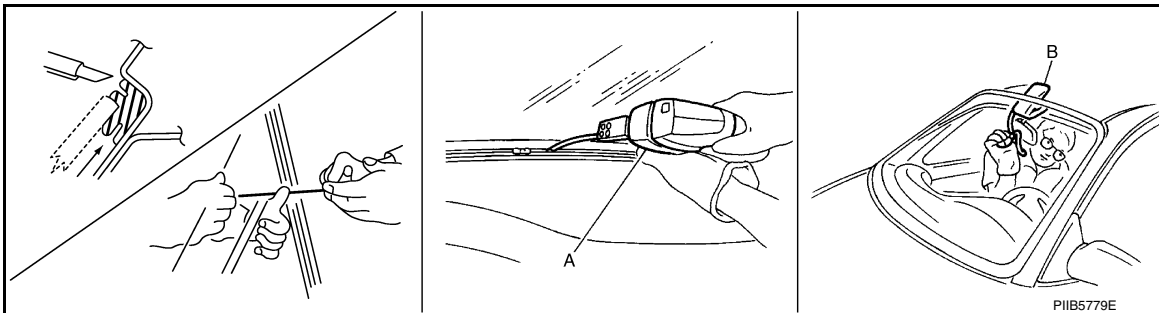

### NOTE:

Mark the body and the glass with matching marks if the windshield glass is reused.

### WARNING:

When cutting the glass from the vehicle, always wear safety glasses and heavy gloves to help prevent glass splinters from entering your eyes or cutting your hands.

### CAUTION:

- Be careful not to scratch the glass when removing.
- Do not set or stand glass on its edge. Small chips may develop into cracks.
- Apply protective tape around the windshield glass to protect the painted surface from damage.

### INSTALLATION

- Use a Genuine NISSAN Urethane Adhesive Kit (if available) or equivalent and follow the instructions furnished with it.
- Adhesive shall be continuously applied to assure watertightness. Glass installation shall be finished within five minutes after applying the adhesive.
- While the urethane adhesive is curing, open a door window. This will prevent the glass from being forced out by passenger compartment air pressure when a door is closed.
- The molding must be installed securely so that it is in position and leaves no gap.
- Inform the customer that the vehicle should remain stationary until the urethane adhesive has completely cured (preferably 24 hours). Curing time varies with temperature and humidity.

# WINDSHIELD GLASS

< REMOVAL AND INSTALLATION >

---

**WARNING:**

- Keep heat and open flames away as primers and adhesive are flammable.
- The materials contained in the kit are harmful if swallowed, and may irritate skin and eyes. Avoid contact with the skin and eyes.
- Use in an open, well ventilated location. Avoid breathing the vapors. They can be harmful if inhaled. If affected by vapor inhalation, immediately move to an area with fresh air.
- Driving the vehicle before the urethane adhesive has completely cured may affect the performance of the windshield in case of an accident.

**CAUTION:**

- Do not use an adhesive which is past its usable term. Shelf life of this product is limited to six months after the date of manufacture. Carefully adhere to the expiration or manufacture date printed on the box.
- Keep primers and adhesive in a cool, dry place. Ideally, they should be stored in a refrigerator.
- Do not leave primers or adhesive cartridge unattended with their caps open or off.
- The vehicle should not be driven for at least 24 hours or until the urethane adhesive has completely cured. Curing time varies depending on temperature and humidity. The curing time will increase under lower temperatures and lower humidity.

## Inspection

INFOID:0000000010639266

## REPAIRING WATER LEAKAGE FOR WINDSHIELD GLASS

Leakage can be repaired without removing the windshield glass.

Determine the extent of leakage if water is leaking between the urethane adhesive material and body or glass.

This can be done by applying water to the windshield area while pushing glass outward.

Apply primer (if necessary) and then urethane adhesive to the leakage point to stop the leakage.

# OPERA WINDOW

< REMOVAL AND INSTALLATION >

## OPERA WINDOW

Exploded View

INFOID:0000000110639267

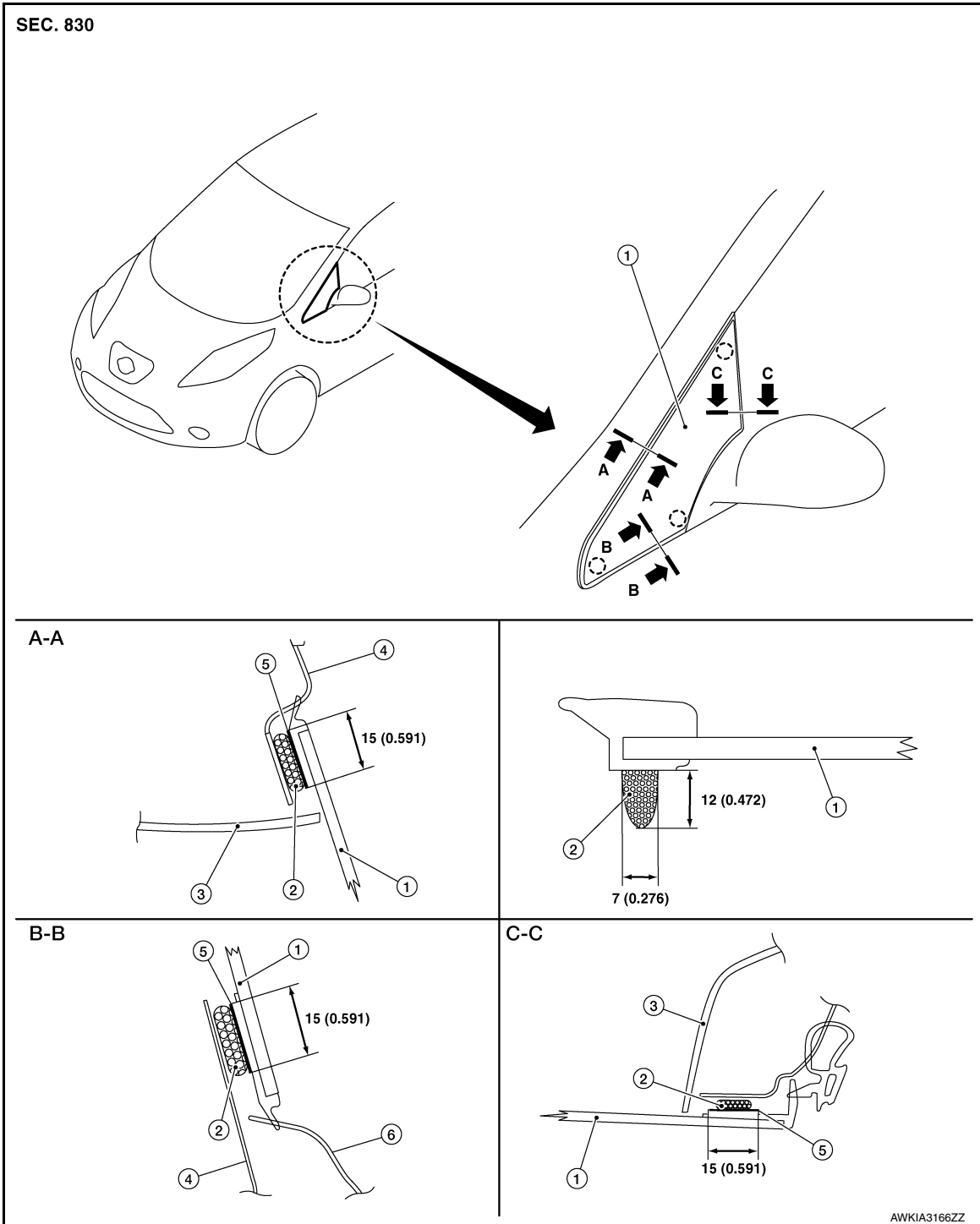

Unit mm (in)

- |                       |                 |                          |
|-----------------------|-----------------|--------------------------|
| 1. Opera window glass | 2. Adhesive     | 3. Front pillar finisher |
| 4. Body side outer    | 5. Glass primer | 6. Front fender panel    |

⊖ Pawl

## Removal and Installation

INFOID:0000000110639268

### REMOVAL

Revision: June 2014

GW-15

2015 Leaf NAM

A  
B  
C  
D  
E  
F  
G  
H  
I  
J  
GW  
L  
M  
N  
O  
P

# OPERA WINDOW

## < REMOVAL AND INSTALLATION >

1. Remove front pillar finisher. Refer to [INT-26. "FRONT PILLAR GARNISH : Removal and Installation"](#).
2. Remove the opera window glass using piano wire or power cutting tool and an inflatable pump bag.

### **WARNING:**

When cutting the glass from the vehicle, always wear safety glasses and heavy gloves to help prevent glass splinters from entering your eyes or cutting your hands.

### **CAUTION:**

- Be careful not to scratch the glass when removing.
- Do not set or stand glass on its edge. Small chips may develop into cracks.
- Apply protective tape around the opera window glass to protect the painted surface from damage.

## INSTALLATION

- Use a Genuine NISSAN Urethane Adhesive Kit (if available) or an equivalent and follow the instructions provided with it.
- Open a door window while the urethane adhesive is curing. This prevents the glass from being forced out by passenger room air pressure when all door windows are closed.
- Inform the customer that the vehicle should remain stationary until the urethane adhesive is completely cured (approximately 24 hours). Curing time varies with temperature and humidity.

### **WARNING:**

- Keep heat and open flames away as primers and adhesive are flammable.
- The materials contained in the kit are harmful if swallowed, and may irritate skin and eyes. Avoid contact with the skin and eyes.
- Use in an open, well ventilated location. Avoid breathing the vapors. They can be harmful if inhaled. If affected by vapor inhalation, immediately move to an area with fresh air.
- Driving the vehicle before the urethane adhesive has completely cured may affect the performance of the opera window glass in case of an accident.

### **CAUTION:**

- Do not use an adhesive which is past its usable term. Shelf life of this product is limited to six months after the date of manufacture. Carefully adhere to the expiration or manufacture date printed on the box.
- Keep primers and adhesive in a cool, dry place. Ideally, they should be stored in a refrigerator.
- Do not leave primers or adhesive cartridge unattended with their caps open or off.
- The vehicle should not be driven for at least 24 hours or until the urethane adhesive has completely cured. Curing time varies depending on temperature and humidity. The curing time will increase under lower temperatures and lower humidity.

## Inspection

INFOID:000000010639269

## REPAIRING WATER LEAKAGE FOR OPERA WINDOW GLASS

Leakage can be repaired without removing the opera window glass.

Determine the extent of leakage if water is leaking between the urethane adhesive material and body or glass.

This can be done by applying water to the opera window glass area while pushing glass outward.

Apply primer (if necessary) and then urethane adhesive to the leakage point to stop the leakage.



# BACK DOOR WINDOW GLASS

< REMOVAL AND INSTALLATION >

## BACK DOOR WINDOW GLASS

Exploded View

INFOID:0000000110639270

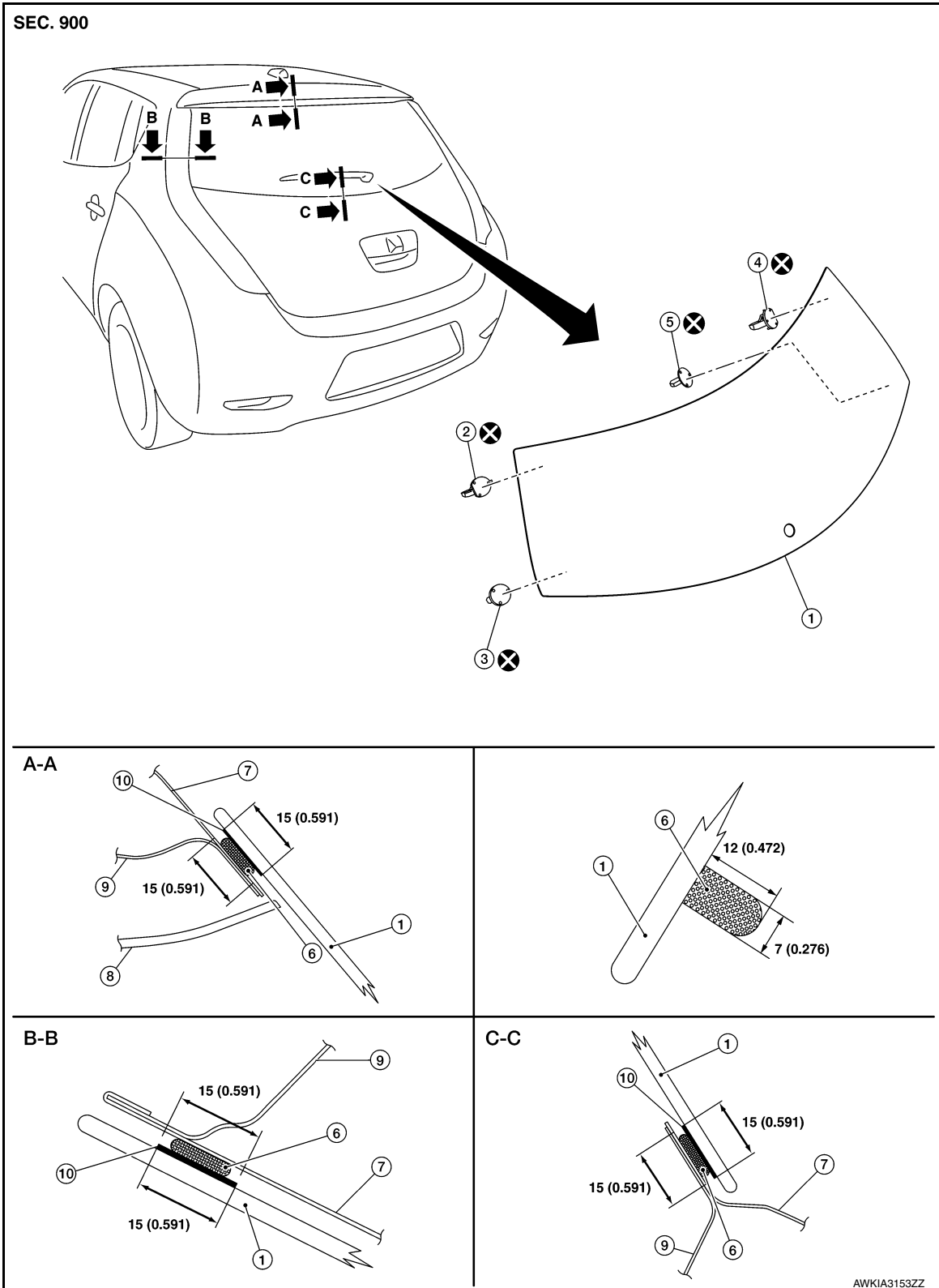

- |                            |                            |                            |
|----------------------------|----------------------------|----------------------------|
| 1. Back door window glass  | 2. Glass holder (upper LH) | 3. Glass holder (lower LH) |
| 4. Glass holder (upper RH) | 5. Glass holder (lower RH) | 6. Adhesive                |

Unit:mm (in)

A  
B  
C  
D  
E  
F  
G  
H  
I  
J  
L  
M  
N  
O  
P

GW

# BACK DOOR WINDOW GLASS

## < REMOVAL AND INSTALLATION >

7. Back door outer
8. Back door finisher
9. Back door inner
10. Glass primer

## Removal and Installation

INFOID:000000010639271

### REMOVAL

1. Remove back door upper finisher. Refer to [INT-44, "BACK DOOR UPPER FINISHER : Removal and Installation"](#).
2. Remove back door side finisher (LH/RH). Refer to [INT-45, "BACK DOOR SIDE FINISHER : Removal and Installation"](#).
3. Remove back door lower finisher. Refer to [INT-46, "BACK DOOR LOWER FINISHER : Removal and Installation"](#).
4. Remove rear wiper arm. Refer to [WW-57, "Removal and Installation"](#).
5. Remove rear spoiler. Refer to [EXT-36, "Removal and Installation"](#).
6. Remove the connectors and grounds for the back door window glass defogger.
7. Remove glass using piano wire or power cutting tool A and an inflatable pump bag B after removing molding using pliers.

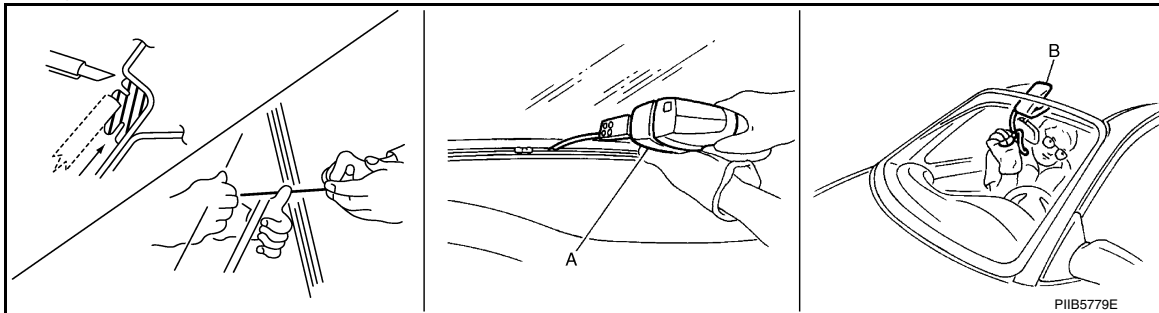

### NOTE:

Mark the body and glass with a matching marks if the back door window glass is reused.

### WARNING:

When cutting the glass from the vehicle, always wear safety glasses and heavy gloves to help prevent glass splinters from entering your eyes or cutting your hands.

### CAUTION:

- Be careful not to scratch the glass when removing.
- Do not set or stand glass on its edge. Small chips may develop into cracks.
- Apply protective tape around the back door window glass to protect the painted surface from damage.

### INSTALLATION

- Use a Genuine NISSAN Urethane Adhesive Kit (if available) or an equivalent and follow the instructions provided with it.
- Open a door window while the urethane adhesive is curing. This prevents the glass from being forced out by passenger compartment air pressure when all door windows are closed.
- Inform the customer that the vehicle should remain stationary until the urethane adhesive is completely cured (approximately 24 hours). Curing time varies with temperature and humidity.

### WARNING:

- Keep heat and open flames away as primers and adhesive are flammable.
- The materials contained in the kit are harmful if swallowed, and may irritate skin and eyes. Never let them come in contact with the skin and eyes.
- Use in an open, well ventilated location. Never breathe the vapors. They may be harmful if inhaled. Move immediately to an area with fresh air if affected by vapor inhalation.
- Driving the vehicle before the urethane adhesive is completely cured may affect the performance of the back door window glass in an accident.

### CAUTION:

- Perform adjustment of rear wiper arm stop location. Refer to [WW-58, "Adjustment"](#).
- Do not use an adhesive that is past its usable term. Shelf life of this product is limited to six months after the date of manufacture. Adhere carefully to the expiration or manufacture date printed on the box.

# BACK DOOR WINDOW GLASS

## < REMOVAL AND INSTALLATION >

---

- **Keep primers and adhesive in a cool, dry place. Ideally, they should be stored in a refrigerator.**
- **Do not leave primers or adhesive cartridge unattended with their caps open or off.**
- **The vehicle should not be driven for 24 hours or more or until the urethane adhesive is completely cured. Curing time varies depending on temperature and humidity. The curing time increases under lower temperature and lower humidity.**

### Inspection

INFOID:000000010639272

### REPAIRING WATER LEAKAGE FOR BACK DOOR WINDOW GLASS

Leakage can be repaired without removing the glass.

Determine the extent of leakage if water is leaking between the urethane adhesive material and body or glass.

This can be done by applying water to the back door window glass area while pushing glass outward.

Apply primer (if necessary) and then urethane adhesive to the leakage point to stop the leakage.

A  
B  
C  
D  
E  
F  
G  
H  
I  
J  
L  
M  
N  
O  
P

GW

# FRONT DOOR GLASS

< REMOVAL AND INSTALLATION >

## FRONT DOOR GLASS

Exploded View

INFOID:000000010639273

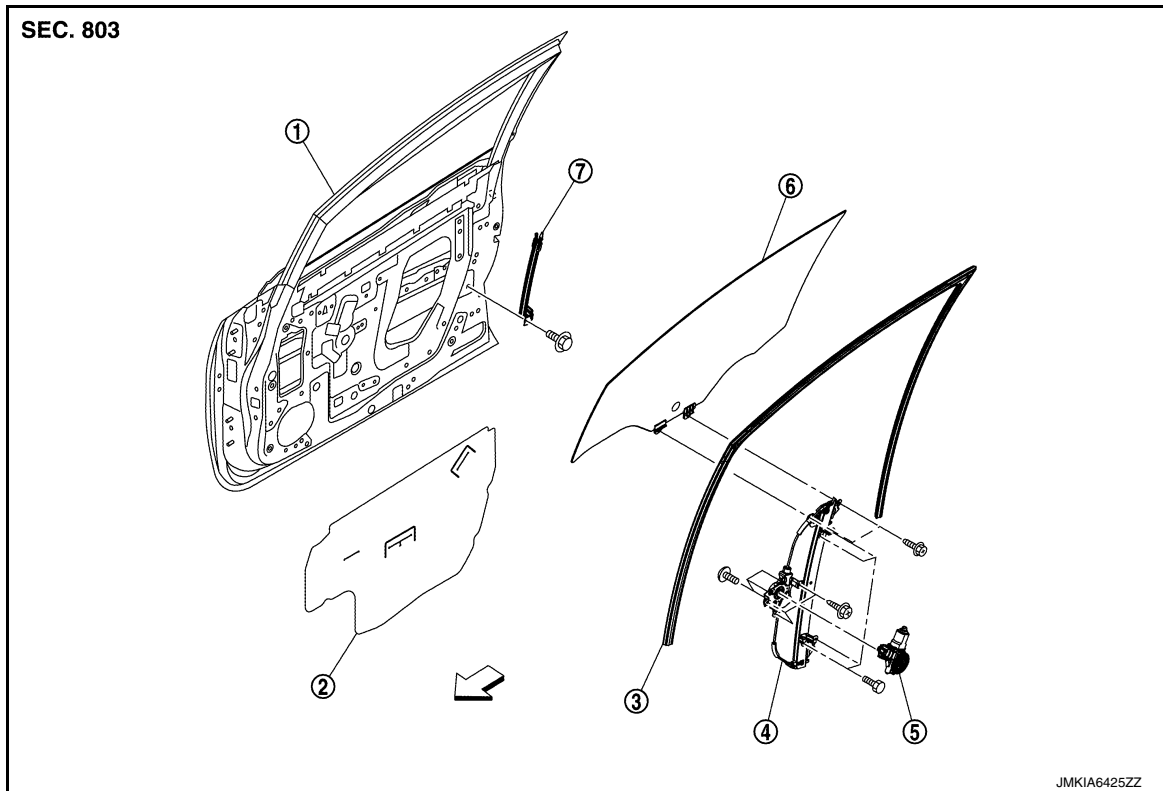

- |                         |                       |                         |
|-------------------------|-----------------------|-------------------------|
| 1. Front door panel     | 2. Sealing screen     | 3. Front door glass run |
| 4. Front door regulator | 5. Power window motor | 6. Front door glass     |
| 7. Lower sash           | ↔ Front               |                         |

## Removal and Installation

INFOID:000000010639274

### REMOVAL

1. Fully open front door glass.
2. Remove front door finisher. Refer to [INT-19, "Removal and Installation"](#).
3. Disconnect front door speaker harness connector and remove sealing screen.  
**NOTE:**  
Cut the butyl-tape so that some parts of the butyl-tape do not remain on the sealing screen, if the sealing screen is reused.
4. Reconnect the power window main switch and operate the power window main switch (LH) or power window switch (RH) to raise or lower the door window until the front door glass bolts can be seen.
5. Remove the front door glass bolts.

## FRONT DOOR GLASS

### < REMOVAL AND INSTALLATION >

- Securely hold the front door glass and pull it out of the sash to remove, as shown in the figure.

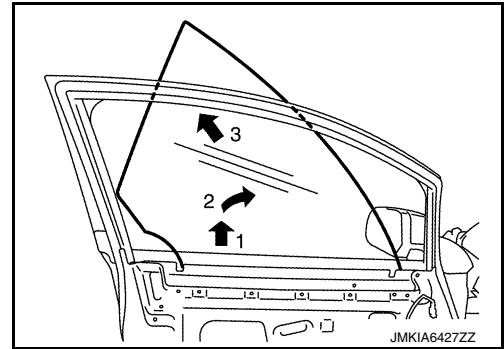

- Remove lower sash.
- Remove front door glass run.

### INSTALLATION

Installation is in the reverse order of removal.

### Inspection and Adjustment

INFOID:000000010639275

### SYSTEM INITIALIZATION

Initialize the system if any of the following work is complete. Refer to [PWC-28, "Work Procedure"](#).

### FITTING INSPECTION

- Check that the glass is fit securely into the sash groove.
- Lower the glass slightly [approximately 10 to 20 mm (0.394 to 0.787 in)], and check that the clearance to the sash is parallel. If the clearance between the glass and sash is not parallel, loosen the regulator bolts, guide rail bolts and glass bolts to correct the glass position.

A  
B  
C  
D  
E  
F  
G  
H  
I  
J  
GW  
L  
M  
N  
O  
P

# FRONT REGULATOR

< REMOVAL AND INSTALLATION >

## FRONT REGULATOR

Exploded View

INFOID:0000000010639276

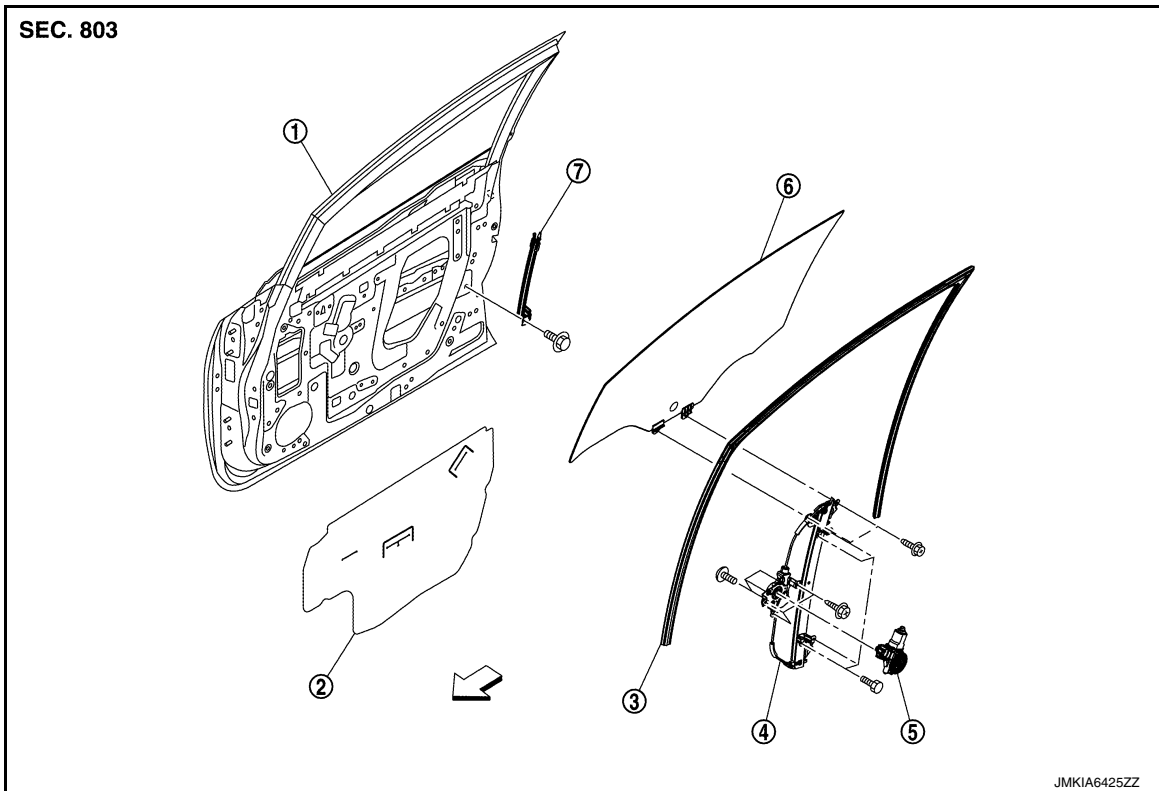

- |                         |                       |                         |
|-------------------------|-----------------------|-------------------------|
| 1. Front door panel     | 2. Sealing screen     | 3. Front door glass run |
| 4. Front door regulator | 5. Power window motor | 6. Front door glass     |
| 7. Lower sash           | ↔ Front               |                         |

## Removal and Installation

INFOID:0000000010639277

### REMOVAL

1. Remove the front door glass. Refer to [GW-20. "Removal and Installation"](#).
2. Disconnect the power window motor harness connector and harness clip.
3. Remove the front door regulator assembly bolts.
4. Remove the front door regulator assembly from the door panel, as shown in the figure.

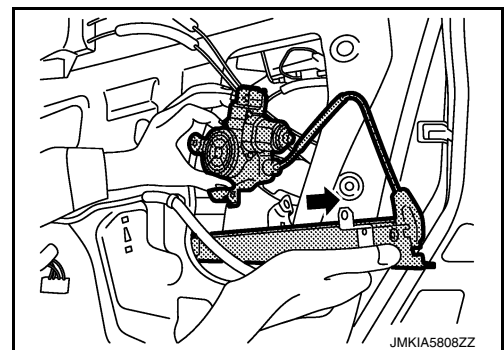

### INSTALLATION

Installation is in the reverse order of removal.

# FRONT REGULATOR

< REMOVAL AND INSTALLATION >

## Disassembly and Assembly

INFOID:000000010639278

### DISASSEMBLY

Remove the power window motor from the front door regulator.

### INSPECTION AFTER REMOVAL

Check the front door regulator assembly for the following items. Replace or grease it if a malfunction is detected.

- Wire wear
- Regulator deformation

### ASSEMBLY

Assembly is in the reverse order of disassembly.

## Inspection and Adjustment

INFOID:000000010639279

### Inspection after removal

Check the front regulator for the following items. Replace or grease it if a malfunction is detected.

- Wire wear
- Front regulator deformation
- Grease condition for each sliding part

### SYSTEM INITIALIZATION

Initialize the system if any of the following work is complete. Refer to [PWC-28. "Work Procedure"](#).

### FITTING INSPECTION

- Check that the glass is fit securely into the sash groove.
- Lower the glass slightly [approximately 10 to 20 mm (0.394 to 0.787 in)], and check that the clearance to the sash is parallel. If the clearance between the glass and sash is not parallel, loosen the regulator bolts, guide rail bolts and glass bolts to correct the glass position.

A  
B  
C  
D  
E  
F  
G  
H  
I  
J  
L  
M  
N  
O  
P

GW

# REAR DOOR GLASS

< REMOVAL AND INSTALLATION >

## REAR DOOR GLASS

Exploded View

INFOID:000000010639280

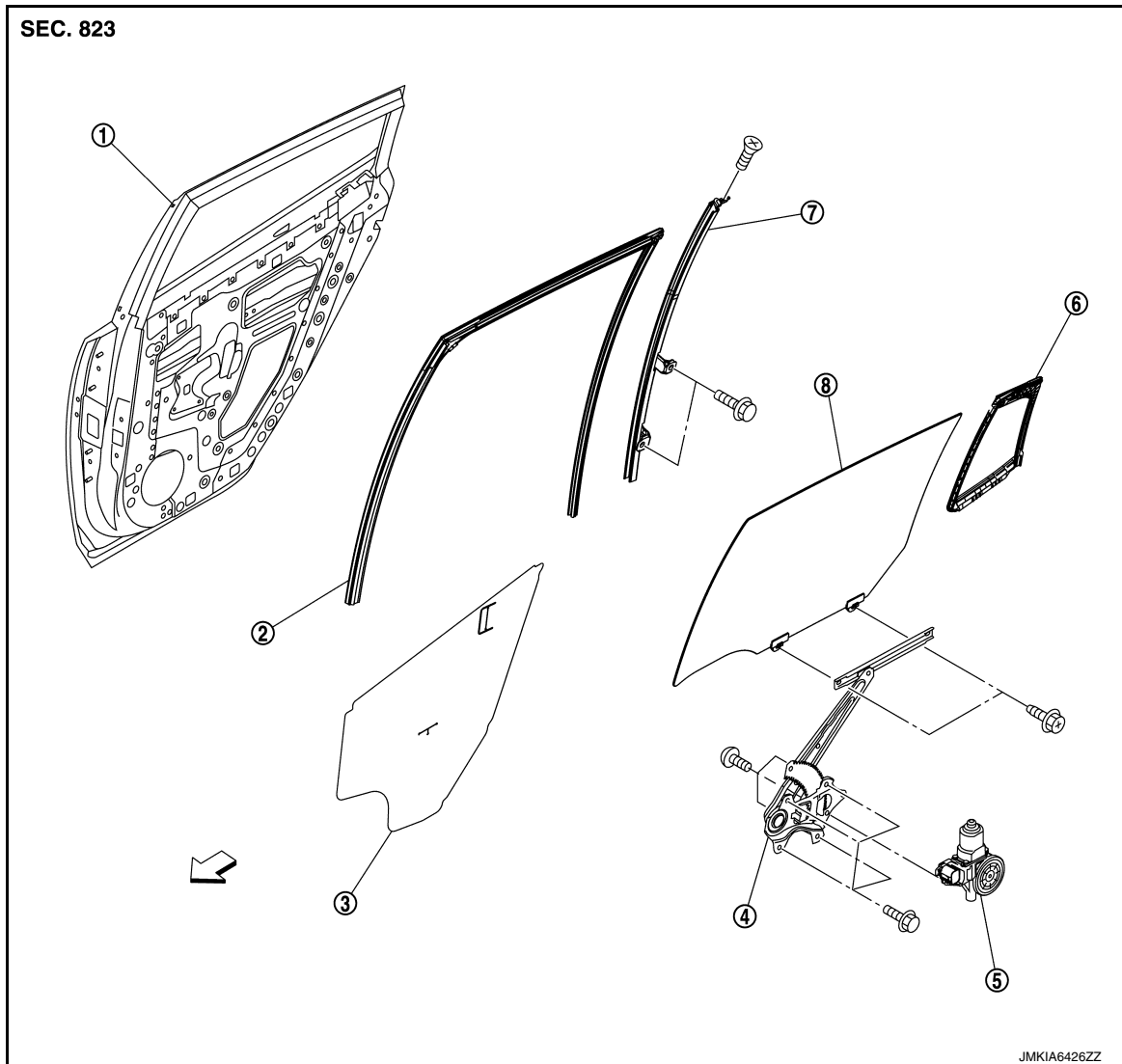

- |                        |                        |                    |
|------------------------|------------------------|--------------------|
| 1. Rear door panel     | 2. Rear door glass run | 3. Sealing screen  |
| 4. Rear door regulator | 5. Power window motor  | 6. Partition glass |
| 7. Partition sash      | 8. Rear door glass     | ⇐ Front            |

## Removal and Installation

INFOID:000000010639281

### REMOVAL

1. Remove rear door finisher. Refer to [INT-22. "Removal and Installation"](#).
2. Disconnect rear door speaker and remove the sealing screen.  
**NOTE:**  
Cut the butyl-tape so that some parts of the butyl-tape do not remain on the sealing screen, if the sealing screen is reused.
3. Fully open rear door glass.
4. Remove partition sash mounting bolts and screw.
5. Reconnect the power window switch and operate the power window switch to raise the door window until the rear door glass bolts can be seen.
6. Loosen the rear door glass bolts.



# REAR DOOR GLASS

## < REMOVAL AND INSTALLATION >

7. Operate the power window switch to lower the rear door glass.
8. Remove rear door glass run from partition sash.
9. Pull partition sash (1) out of the rear door panel to remove, as shown in the figure.

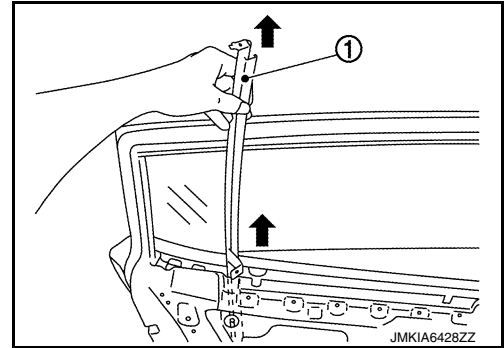

10. Remove rear door glass from the rear door panel, as shown in the figure.

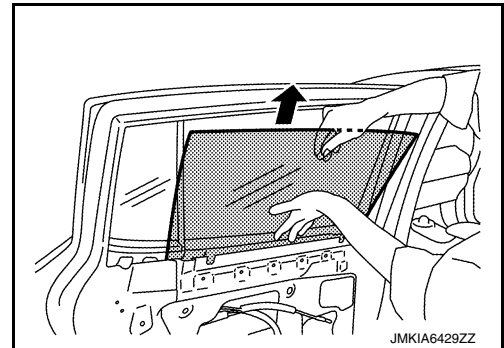

11. Remove partition glass.
  - a. Slide partition glass toward the direction of arrow 1.
  - b. Pull partition glass toward the direction of arrow 2 to remove.

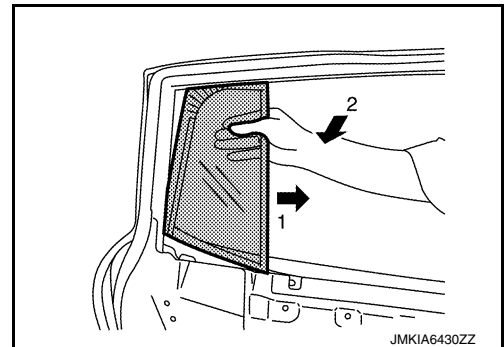

## INSTALLATION

Installation is in the reverse order of removal.

## Inspection and Adjustment

INFOID:000000010639282

## FITTING INSPECTION

- Check that the glass is fit securely into the sash groove.
- Lower the glass slightly [approximately 10 to 20 mm (0.394 to 0.787 in)], and check that the clearance to the sash is parallel. If the clearance between the glass and sash is not parallel, loosen the regulator bolts, guide rail bolts and glass bolts to correct the glass position.

A  
B  
C  
D  
E  
F  
G  
H  
I  
J  
GW  
L  
M  
N  
O  
P

# REAR REGULATOR

< REMOVAL AND INSTALLATION >

## REAR REGULATOR

Exploded View

INFOID:000000010639283

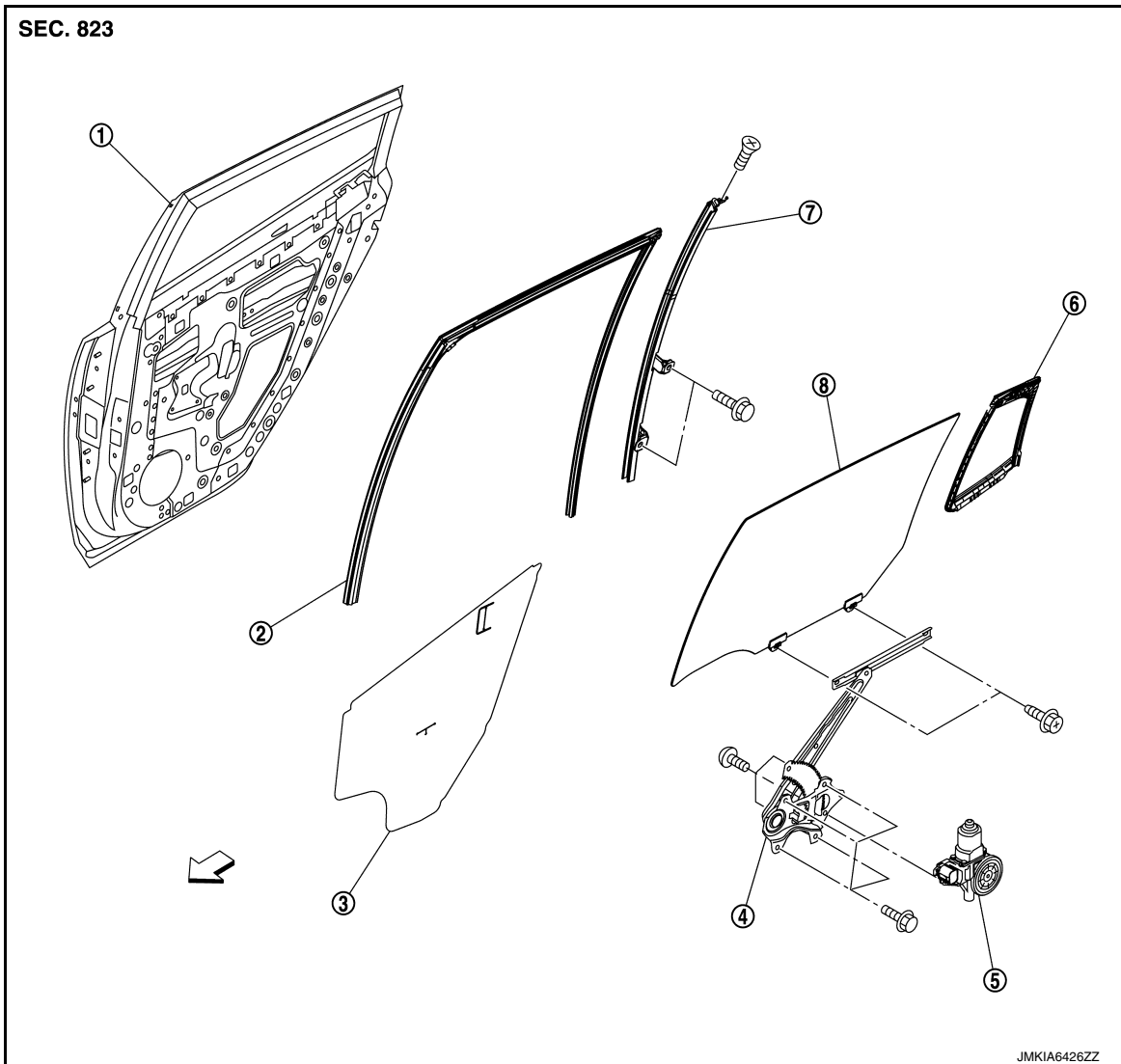

- |                        |                        |                    |
|------------------------|------------------------|--------------------|
| 1. Rear door panel     | 2. Rear door glass run | 3. Sealing screen  |
| 4. Rear door regulator | 5. Power window motor  | 6. Partition glass |
| 7. Partition sash      | 8. Rear door glass     | ⇐ Front            |

### Removal and Installation

INFOID:000000010639284

#### REMOVAL

1. Remove rear door glass. Refer to [GW-24. "Removal and Installation"](#).
2. Disconnect the power window motor harness connector.

# REAR REGULATOR

## < REMOVAL AND INSTALLATION >

3. Remove the rear door regulator assembly bolts and nuts, then remove rear door regulator assembly from door panel, as shown in the figure.

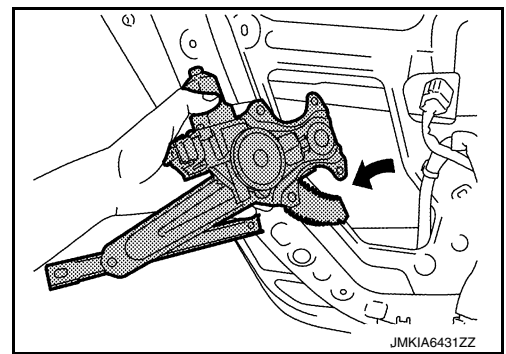

## INSTALLATION

Installation is in the reverse order of removal.

## Disassembly and Assembly

INFOID:0000000110639285

## DISASSEMBLY

Remove the power window motor from the rear door regulator.

## INSPECTION AFTER REMOVAL

Check the rear door regulator assembly for the following items. Replace or grease it if a malfunction is detected.

- Wire wear
- Regulator deformation

## ASSEMBLY

Assembly is in the reverse order of disassembly.

## Inspection and Adjustment

INFOID:0000000110639286

### Inspection after removal

Check the rear regulator assembly for the following items. Replace or grease it if a malfunction is detected.

- Wire wear
- Rear regulator deformation
- Grease condition for each sliding part

## FITTING INSPECTION

- Check that the glass is fit securely into the sash groove.
- Lower the glass slightly [approximately 10 to 20 mm (0.394 to 0.787 in)], and check that the clearance to the sash is parallel. If the clearance between the glass and sash is not parallel, loosen the regulator bolts, guide rail bolts and glass bolts to correct the glass position.

A  
B  
C  
D  
E  
F  
G  
H  
I  
J  
L  
M  
N  
O  
P

GW