

SECTION **HA**

**HEATER & AIR CONDITIONING SYSTEM**

**CONTENTS**

<b>WITH HEAT PUMP SYSTEM</b>		
<b>PRECAUTION</b> .....	4	
<b>PRECAUTIONS</b> .....	4	
Precaution for Technicians Using Medical Electric.....	4	
Point to Be Checked Before Starting Maintenance Work .....	4	
Precaution for Supplemental Restraint System (SRS) "AIR BAG" and "SEAT BELT PRE-TENSIONER" .....	4	
Precaution for Procedure without Cowl Top Cover.....	5	
High Voltage Precautions .....	5	
Precaution for Removing 12V Battery .....	7	
Precautions for Service Work of Cooler System .....	8	
Service Equipment .....	10	
<b>PREPARATION</b> .....	12	
<b>PREPARATION</b> .....	12	
Special Service Tool .....	12	
Commercial Service Tools .....	12	
Oil and Grease .....	14	
<b>SYSTEM DESCRIPTION</b> .....	15	
<b>COMPONENT PARTS</b> .....	15	
<b>REFRIGERATION SYSTEM</b> .....	15	
REFRIGERATION SYSTEM : Component Parts Location .....	15	
<b>HEATING AND COOLING UNIT ASSEMBLY</b> .....	16	
HEATING AND COOLING UNIT ASSEMBLY : Heating and Cooling Unit .....	16	
HEATING AND COOLING UNIT ASSEMBLY : Evaporator .....	16	
HEATING AND COOLING UNIT ASSEMBLY : Inner condenser .....	16	
Condenser .....	16	
Electric Compressor .....	17	
Orifice .....	19	
Accumulator .....	19	
Refrigerant and Compressor Oil .....	20	
High Voltage Warning Label .....	20	
<b>SYSTEM</b> .....	21	
<b>REFRIGERATION SYSTEM</b> .....	21	
REFRIGERATION SYSTEM : System Diagram .....	21	
REFRIGERATION SYSTEM : System Description .....	21	
<b>HEATING SYSTEM</b> .....	22	
HEATING SYSTEM : System Diagram .....	22	
HEATING SYSTEM : System Description .....	22	
<b>BASIC INSPECTION</b> .....	24	
<b>DIAGNOSIS AND REPAIR WORK FLOW</b> .....	24	
Workflow .....	24	
<b>REFRIGERANT</b> .....	26	
Description .....	26	
Check Refrigerant Leakage .....	26	
Recycle Refrigerant .....	27	
Charge Refrigerant .....	28	
<b>LUBRICANT</b> .....	29	
Description .....	29	
Inspection .....	29	
Perform Lubricant Return Operation .....	29	
Lubricant Adjusting Procedure for Components Replacement Except Compressor .....	29	
Lubricant Adjusting Procedure for Compressor Replacement .....	30	
<b>PERFORMANCE TEST</b> .....	31	
Inspection .....	31	
<b>SYMPTOM DIAGNOSIS</b> .....	34	
<b>REFRIGERATION SYSTEM SYMPTOMS</b> .....	34	
Trouble Diagnosis For Unusual Pressure .....	34	
Symptom Table .....	34	

A  
B  
C  
D  
E  
F  
G  
H  
HA  
J  
K  
L  
M  
N  
O  
P

<b>NOISE</b> .....	<b>36</b>	<b>PRECAUTION</b> .....	<b>64</b>
Symptom Table .....	36	<b>PRECAUTIONS</b> .....	<b>64</b>
<b>REMOVAL AND INSTALLATION</b> .....	<b>37</b>	Precaution for Technicians Using Medical Electric... 64	
<b>ELECTRIC COMPRESSOR</b> .....	<b>37</b>	Point to Be Checked Before Starting Maintenance Work .....	64
Exploded View .....	37	Precaution for Supplemental Restraint System (SRS) "AIR BAG" and "SEAT BELT PRE-TENSIONER" .....	64
Removal and Installation .....	37	Precaution for Procedure without Cowl Top Cover... 65	
Inspection .....	42	High Voltage Precautions .....	65
<b>COOLER PIPE AND HOSE</b> .....	<b>43</b>	Precaution for Removing 12V Battery .....	67
Exploded View .....	43	Precautions for Service Work of Cooler System .... 68	
<b>HIGH-PRESSURE FLEXIBLE HOSE</b> .....	<b>43</b>	Service Equipment .....	70
HIGH-PRESSURE FLEXIBLE HOSE : Removal and Installation .....	43	<b>PREPARATION</b> .....	<b>72</b>
<b>LOW-PRESSURE FLEXIBLE HOSE</b> .....	<b>45</b>	<b>PREPARATION</b> .....	<b>72</b>
LOW-PRESSURE FLEXIBLE HOSE : Removal and Installation .....	45	Special Service Tool .....	72
<b>HIGH-PRESSURE PIPE</b> .....	<b>46</b>	Commercial Service Tools .....	72
HIGH-PRESSURE PIPE : Removal and Installation .....	46	Oil and Grease .....	74
<b>2-WAY VALVE AND 3-WAY VALVE ASSEMBLY</b> ... 47		<b>SYSTEM DESCRIPTION</b> .....	<b>75</b>
2-WAY VALVE AND 3-WAY VALVE ASSEMBLY : Removal and Installation .....	47	<b>COMPONENT PARTS</b> .....	<b>75</b>
<b>ACCUMULATOR ASSEMBLY</b> .....	<b>50</b>	<b>REFRIGERATION SYSTEM</b> .....	<b>75</b>
ACCUMULATOR ASSEMBLY : Removal and Installation .....	50	REFRIGERATION SYSTEM : Component Parts Location .....	75
<b>CONDENSER</b> .....	<b>52</b>	<b>HEATING AND COOLING UNIT ASSEMBLY</b> .....	<b>75</b>
Exploded View .....	52	HEATING AND COOLING UNIT ASSEMBLY : Heating and Cooling Unit Assembly .....	76
Removal and Installation .....	52	HEATING AND COOLING UNIT ASSEMBLY : Evaporator .....	76
<b>REFRIGERANT PRESSURE SENSOR</b> .....	<b>55</b>	HEATING AND COOLING UNIT ASSEMBLY : Expansion Valve .....	76
Removal and Installation .....	55	<b>CONDENSER</b> .....	<b>76</b>
<b>HEATING AND COOLING UNIT ASSEMBLY</b> ... 56		CONDENSER : Condenser .....	76
Exploded View .....	56	CONDENSER : Liquid Tank .....	77
<b>HEATING AND COOLING UNIT ASSEMBLY</b> .....	<b>58</b>	Electric Compressor .....	77
HEATING AND COOLING UNIT ASSEMBLY : Removal and Installation .....	58	Refrigerant and Compressor Oil .....	79
<b>EVAPORATOR</b> .....	<b>61</b>	High Voltage Warning Label .....	79
EVAPORATOR : Removal and Installation .....	61	<b>SYSTEM</b> .....	<b>81</b>
<b>INNER CONDENSER</b> .....	<b>62</b>	<b>REFRIGERATION SYSTEM</b> .....	<b>81</b>
INNER CONDENSER : Removal and Installation... 62		REFRIGERATION SYSTEM : System Diagram .... 81	
<b>SERVICE DATA AND SPECIFICATIONS (SDS)</b> .....	<b>63</b>	REFRIGERATION SYSTEM : System Description ... 81	
<b>SERVICE DATA AND SPECIFICATIONS (SDS)</b> .....	<b>63</b>	<b>BASIC INSPECTION</b> .....	<b>83</b>
Compressor .....	63	<b>DIAGNOSIS AND REPAIR WORK FLOW</b> .....	<b>83</b>
Lubricant .....	63	Workflow .....	83
Refrigerant .....	63	<b>REFRIGERANT</b> .....	<b>85</b>
<b>WITHOUT HEAT PUMP SYSTEM</b>		Description .....	85
		Check Refrigerant Leakage .....	85
		Recycle Refrigerant .....	86
		Charge Refrigerant .....	87

<b>LUBRICANT</b> .....	<b>88</b>	HIGH-PRESSURE PIPE : Removal and Installation .....	105	A
Description .....	88			
Inspection .....	88	<b>LOW-PRESSURE PIPE</b> .....	<b>106</b>	B
Perform Lubricant Return Operation .....	88	LOW-PRESSURE PIPE : Removal and Installation .....	106	
Lubricant Adjusting Procedure for Components Replacement Except Compressor .....	88			
Lubricant Adjusting Procedure for Compressor Replacement .....	89	<b>CONDENSER</b> .....	<b>108</b>	C
		Exploded View .....	108	
<b>PERFORMANCE TEST</b> .....	<b>90</b>	<b>CONDENSER</b> .....	<b>108</b>	D
Inspection .....	90	CONDENSER : Removal and Installation .....	108	
<b>SYMPTOM DIAGNOSIS</b> .....	<b>93</b>	<b>LIQUID TANK</b> .....	<b>110</b>	E
<b>REFRIGERATION SYSTEM SYMPTOMS</b> .....	<b>93</b>	LIQUID TANK : Removal and Installation .....	111	
Trouble Diagnosis For Unusual Pressure .....	93	<b>REFRIGERANT PRESSURE SENSOR</b> .....	<b>113</b>	F
Symptom Table .....	93	Removal and Installation .....	113	
<b>NOISE</b> .....	<b>95</b>	<b>HEATING AND COOLING UNIT ASSEMBLY</b> .....	<b>114</b>	G
Symptom Table .....	95	Exploded View .....	114	
<b>REMOVAL AND INSTALLATION</b> .....	<b>96</b>	<b>HEATING AND COOLING UNIT ASSEMBLY</b> .....	<b>116</b>	H
<b>ELECTRIC COMPRESSOR</b> .....	<b>96</b>	HEATING AND COOLING UNIT ASSEMBLY : Removal and Installation .....	116	
Exploded View .....	96	<b>EVAPORATOR</b> .....	<b>119</b>	I
Removal and Installation .....	96	EVAPORATOR : Removal and Installation .....	119	
Inspection .....	101	<b>EXPANSION VALVE</b> .....	<b>119</b>	HA
<b>COOLER PIPE AND HOSE</b> .....	<b>102</b>	EXPANSION VALVE : Removal and Installation .....	119	
Exploded View .....	102	<b>SERVICE DATA AND SPECIFICATIONS (SDS)</b> .....	<b>121</b>	J
<b>HIGH-PRESSURE FLEXIBLE HOSE</b> .....	<b>102</b>	<b>SERVICE DATA AND SPECIFICATIONS (SDS)</b> .....	<b>121</b>	K
HIGH-PRESSURE FLEXIBLE HOSE : Removal and Installation .....	102	Compressor .....	121	
<b>LOW-PRESSURE FLEXIBLE HOSE</b> .....	<b>104</b>	Lubricant .....	121	L
LOW-PRESSURE FLEXIBLE HOSE : Removal and Installation .....	104	Refrigerant .....	121	
<b>HIGH-PRESSURE PIPE</b> .....	<b>105</b>			M
				N
				O
				P

## PRECAUTION

### PRECAUTIONS

#### Precaution for Technicians Using Medical Electric

INFOID:000000010640902

##### OPERATION PROHIBITION

###### **WARNING:**

- Parts with strong magnet is used in this vehicle.
- Technicians using a medical electric device such as pacemaker must never perform operation on the vehicle, as magnetic field can affect the device function by approaching to such parts.

##### NORMAL CHARGE PRECAUTION

###### **WARNING:**

- If a technician uses a medical electric device such as an implantable cardiac pacemaker or an implantable cardioverter defibrillator, the possible effects on the devices must be checked with the device manufacturer before starting the charge operation.
- As radiated electromagnetic wave generated by PDM (Power Delivery Module) at normal charge operation may affect medical electric devices, a technician using a medical electric device such as implantable cardiac pacemaker or an implantable cardioverter defibrillator must not approach motor room [PDM (Power Delivery Module)] at the hood-opened condition during normal charge operation.

##### PRECAUTION AT TELEMATICS SYSTEM OPERATION

###### **WARNING:**

- If a technician uses implantable cardiac pacemaker or implantable cardioverter defibrillator (ICD), avoid the device implanted part from approaching within approximately 220 mm (8.66 in) from interior/exterior antenna.
- The electromagnetic wave of TCU might affect the function of the implantable cardiac pacemaker or the implantable cardioverter defibrillator (ICD), when using the service, etc.
- If a technician uses other medical electric devices than implantable cardiac pacemaker or implantable cardioverter defibrillator (ICD), the electromagnetic wave of TCU might affect the function of the device. The possible effects on the devices must be checked with the device manufacturer before TCU use.

##### PRECAUTION AT INTELLIGENT KEY SYSTEM OPERATION

###### **WARNING:**

- If a technician uses implantable cardiac pacemaker or implantable cardioverter defibrillator (ICD), avoid the device implanted part from approaching within approximately 220 mm (8.66 in) from interior/exterior antenna.
- The electromagnetic wave of Intelligent Key might affect the function of the implantable cardiac pacemaker or the implantable cardioverter defibrillator (ICD), at door operation, at each request switch operation, or at engine starting.
- If a technician uses other medical electric devices than implantable cardiac pacemaker or implantable cardioverter defibrillator (ICD), the electromagnetic wave of Intelligent Key might affect the function of the device. The possible effects on the devices must be checked with the device manufacturer before Intelligent Key use.

#### Point to Be Checked Before Starting Maintenance Work

INFOID:000000010640903

The high voltage system may starts automatically. It is required to check that the timer air conditioner and timer charge (during EVSE connection) are not set before starting maintenance work.

###### **NOTE:**

If the timer air conditioner or timer charge (during EVSE connection) is set, the high voltage system starts automatically even when the power switch is in OFF state.

#### Precaution for Supplemental Restraint System (SRS) "AIR BAG" and "SEAT BELT PRE-TENSIONER"

INFOID:000000010640904

The Supplemental Restraint System such as "AIR BAG" and "SEAT BELT PRE-TENSIONER", used along with a front seat belt, helps to reduce the risk or severity of injury to the driver and front passenger for certain types of collision. This system includes seat belt switch inputs and dual stage front air bag modules. The SRS

# PRECAUTIONS

< PRECAUTION >

[WITH HEAT PUMP SYSTEM]

system uses the seat belt switches to determine the front air bag deployment, and may only deploy one front air bag, depending on the severity of a collision and whether the front occupants are belted or unbelted. Information necessary to service the system safely is included in the SR and SB section of this Service Manual.

## WARNING:

- To avoid rendering the SRS inoperative, which could increase the risk of personal injury or death in the event of a collision which would result in air bag inflation, all maintenance must be performed by an authorized NISSAN/INFINITI dealer.
- Improper maintenance, including incorrect removal and installation of the SRS, can lead to personal injury caused by unintentional activation of the system. For removal of Spiral Cable and Air Bag Module, see the SR section.
- Do not use electrical test equipment on any circuit related to the SRS unless instructed to in this Service Manual. SRS wiring harnesses can be identified by yellow and/or orange harnesses or harness connectors.

## PRECAUTIONS WHEN USING POWER TOOLS (AIR OR ELECTRIC) AND HAMMERS

### WARNING:

- When working near the Airbag Diagnosis Sensor Unit or other Airbag System sensors with the Ignition ON or engine running, DO NOT use air or electric power tools or strike near the sensor(s) with a hammer. Heavy vibration could activate the sensor(s) and deploy the air bag(s), possibly causing serious injury.
- When using air or electric power tools or hammers, always switch the Ignition OFF, disconnect the battery and wait at least three minutes before performing any service.

## Precaution for Procedure without Cowl Top Cover

INFOID:000000010640905

When performing the procedure after removing cowl top cover, cover the lower end of windshield with urethane, etc to prevent damage to windshield.

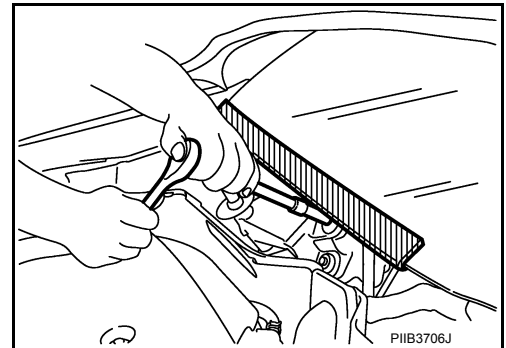

## High Voltage Precautions

INFOID:000000010640906

### DANGER:

 Since hybrid vehicles and electric vehicles contain a high voltage battery, there is the risk of electric shock, electric leakage, or similar accidents if the high voltage component and vehicle are handled incorrectly. Be sure to follow the correct work procedures when performing inspection and maintenance.

### WARNING:

- Be sure to remove the service plug in order to disconnect the high voltage circuits before performing inspection or maintenance of high voltage system harnesses and parts.
- The removed service plug must always be carried in a pocket of the responsible worker or placed in the tool box during the procedure to prevent the plug from being connected by mistake.
- Be sure to wear insulated protective equipment before beginning work on the high voltage system.
- Never allow workers other than the responsible person to touch the vehicle containing high voltage parts. To keep others from touching the high voltage parts, these parts must be covered with an insulating sheet except when using them.

### CAUTION:

Never bring the vehicle into the READY status with the service plug removed unless otherwise instructed in the Service Manual. A malfunction may occur if this is not observed.

## HIGH VOLTAGE HARNESS AND EQUIPMENT IDENTIFICATION

## PRECAUTIONS

[WITH HEAT PUMP SYSTEM]

< PRECAUTION >

All the high voltage harnesses and connectors are orange. The Li-ion battery and other high voltage devices include an orange high voltage label. Never touch these harnesses and high voltage parts.

### HANDLING OF HIGH VOLTAGE HARNESS AND TERMINALS

Immediately insulate disconnected high voltage connectors and terminals with insulating tape.

### REGULATIONS ON WORKERS WITH MEDICAL ELECTRONICS

#### **WARNING:**

**The vehicle contains parts that contain powerful magnets. If a person who is wearing a heart pacemaker or other medical device is close to these parts, the medical device may be affected by the magnets. Such persons must not perform work on the vehicle.**

### PROHIBITED ITEMS TO CARRY DURING THE WORK

Hybrid vehicles and electric vehicles contain parts with high voltage and intense magnetic force. Never carry metal products and magnetic recording media (e.g. cash card, prepaid card) to repair/inspect high voltage parts. If this is not observed, the metal products may create a risk of short circuit and the magnetic recording media may lose their magnetic recording.

POSTING A SIGN OF “DANGER! HIGH VOLTAGE AREA. KEEP OUT”

# PRECAUTIONS

[WITH HEAT PUMP SYSTEM]

< PRECAUTION >

Indicate "HIGH VOLTAGE. DO NOT TOUCH" on the vehicle under repair/inspection to call attention to other workers.

**Person in charge: \_\_\_\_\_**

**DO NOT TOUCH!**

**REPAIR IN PROGRESS.**

**HIGH VOLTAGE**

**DANGER:**

---

**DANGER:**

**HIGH VOLTAGE**

**REPAIR IN PROGRESS.**

**DO NOT TOUCH!**

**Person in charge: \_\_\_\_\_**

**Copy this page and put it after folding on the roof of the vehicle in service.**

JSAIA1600GB

A  
B  
C  
D  
E  
F  
G  
H  
HA  
J  
K  
L  
M  
N  
O  
P

## Precaution for Removing 12V Battery

INFOID:000000010640907

1. Check that EVSE is not connected.

**NOTE:**

If EVSE is connected, the air conditioning system may be automatically activated by the timer A/C function.

2. Turn the power switch OFF → ON → OFF. Get out of the vehicle. Close all doors (including back door).

# PRECAUTIONS

[WITH HEAT PUMP SYSTEM]

< PRECAUTION >

3. Check that the charge status indicator lamp does not blink and wait for 5 minutes or more.  
**NOTE:**  
If the battery is removed within 5 minutes after the power switch is turned OFF, plural DTCs may be detected.
4. Remove 12V battery within 1 hour after turning the power switch OFF → ON → OFF.  
**NOTE:**
  - The 12V battery automatic charge control may start automatically even when the power switch is in OFF state.
  - Once the power switch is turned ON → OFF, the 12V battery automatic charge control does not start for approximately 1 hour.**CAUTION:**
  - After all doors (including back door) are closed, if a door (including back door) is opened before battery terminals are disconnected, start over from Step 1.
  - After turning the power switch OFF, if “Remote A/C” is activated by user operation, stop the air conditioner and start over from Step 1.

## Precautions for Service Work of Cooler System

INFOID:000000010640908

### GENERAL REFRIGERANT PRECAUTION

#### **WARNING:**

- Never breathe A/C refrigerant and lubricant vapor or mist. Exposure may irritate eyes, nose and throat. Remove HFC-134a (R-134a) from the A/C system, using certified service equipment meeting requirements of SAE J-2210 [HFC-134a (R-134a) recycling equipment], or J-2209 [HFC-134a (R-134a) recovery equipment]. Ventilate work area before resuming service if accidental system discharge occurs. Additional health and safety information may be obtained from refrigerant and lubricant manufacturers.
- Never release refrigerant into the air. Use approved recovery/recycling recharging equipment to capture the refrigerant each time an air conditioning system is discharged.
- Wear always eye and hand protection (goggles and gloves) when working with any refrigerant or air conditioning system.
- Never store or heat refrigerant containers above 52°C (126°F).
- Never heat a refrigerant container with an open flame; Place the bottom of the container in a warm pail of water if container warming is required.
- Never intentionally drop, puncture, or incinerate refrigerant containers.
- Keep refrigerant away from open flames: poisonous gas is produced if refrigerant burns.
- Refrigerant displaces oxygen, therefore be certain to work in well ventilated areas to prevent suffocation.
- Never pressure test or leakage test HFC-134a (R-134a) service equipment and/or vehicle air conditioning systems with compressed air during repair. Some mixtures of air and HFC-134a (R-134a) have been shown to be combustible at elevated pressures. These mixtures, if ignited, may cause injury or property damage. Additional health and safety information may be obtained from refrigerant manufacturers.

### WORKING WITH HFC-134a (R-134a)

#### **CAUTION:**

- CFC-12 (R-12) refrigerant and HFC-134a (R-134a) refrigerant are not compatible. Compressor malfunction is likely to occur if the refrigerants are mixed, refer to “CONTAMINATED REFRIGERANT” below. To determine the purity of HFC-134a (R-134a) in the vehicle and recovery tank, use Refrigerant recovery/recycling recharging equipment and Refrigerant Identifier.
- Use only specified lubricant for the HFC-134a (R-134a) A/C system and HFC-134a (R-134a) components. Compressor malfunction is likely to occur if lubricant other than that specified is used.
- If rotary compressor oil (DH-PR), swash plate compressor oil (DH-PS), or CFC-12 compressor oil (mineral oil) is used, the insulation resistance may be reduced. Never use these oils.
- The specified HFC-134a (R-134a) lubricant rapidly absorbs moisture from the atmosphere. The following handling precautions must be observed:
  - Cap (seal) immediately the component to minimize the entry of moisture from the atmosphere when removing refrigerant components from a vehicle.
  - Never remove the caps (unseal) until just before connecting the components when installing refrigerant components to a vehicle. Connect all refrigerant loop components as quickly as possible to minimize the entry of moisture into system.



# PRECAUTIONS

[WITH HEAT PUMP SYSTEM]

< PRECAUTION >

- Use only the specified lubricant from a sealed container. Reseal immediately containers of lubricant. Lubricant becomes moisture saturated and should not be used without proper sealing.
- Never allow lubricant to come in contact with styrene foam parts. Damage may result.

## REFRIGERANT CONNECTION

A new type refrigerant connection has been introduced to most refrigerant lines.

### WARNING:

Check that all refrigerant is discharged into the recycling equipment and the pressure in the system is less than atmospheric pressure. Then gradually loosen the discharge side hose fitting and remove it.

### CAUTION:

Observe the following when replacing or cleaning refrigerant cycle components.

- To prevent fluorescent indicator from entering, prepare and use exclusive hose for EV (electric vehicle) and HEV (hybrid vehicle) when connecting recovery/recycling/recharging equipment.
- Store it in the same way at it is when mounted on the car when the compressor is removed. Failure to do so will cause lubricant to enter the low-pressure chamber.
- Use the torque wrench or the backup wrench when installing the piping.
- Plug immediately all openings to prevent entry of dust and moisture after disconnecting tubes.
- Connect the pipes at the final stage of the operation when installing an air conditioner in the vehicle. Never remove the seal caps of pipes and other components until just before required for connection.
- Allow components stored in cool areas to warm to working area temperature before removing seal caps. This prevents condensation from forming inside A/C components.
- Remove thoroughly moisture from the refrigeration system before charging the refrigerant.
- Replace always used O-rings.
- Apply lubricant to the O-rings shown in illustrations when connecting tube. Be careful not to apply lubricant to threaded portion.
- O-ring must be closely attached to the groove portion of tubes.
- Be careful not to damage O-ring and tube when replacing the O-ring.
- Connect tube until a click can be heard. Then tighten the nut or bolt by hand. Check that the O-ring is installed to tube correctly.
- Perform leakage test and make sure that there is no leakage from connections after connecting line. Disconnect that line and replace the O-ring when the refrigerant leaking point is found. Then tighten connections of seal seat to the specified torque.

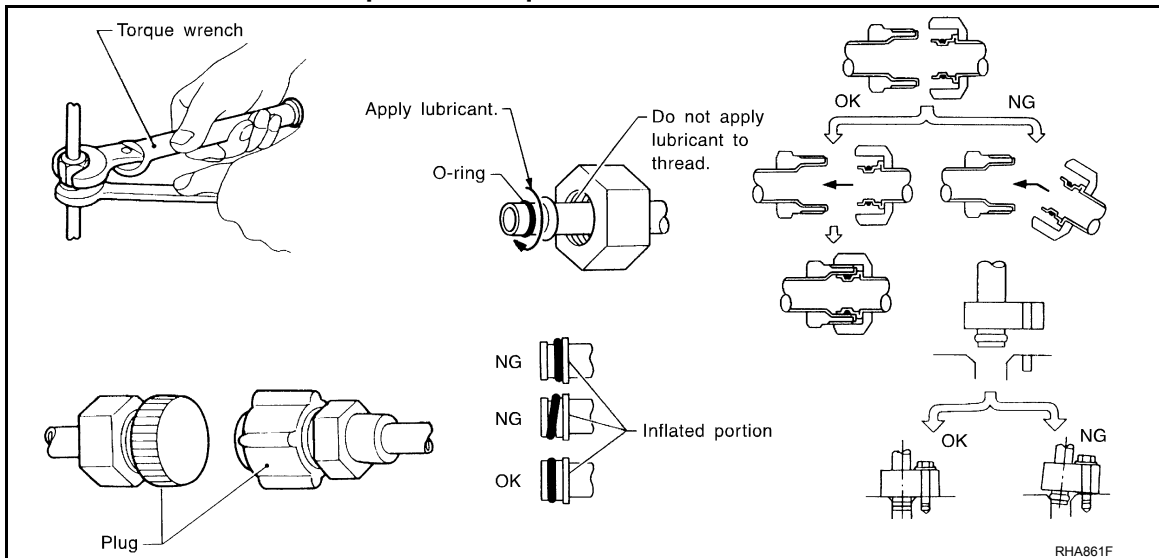

## COMPRESSOR

### CAUTION:

- Plug all openings to prevent moisture and foreign matter from entering.
- Store it in the same way at it is when mounted on the car when the compressor is removed.
- Follow "Maintenance of Lubricant Quantity in Compressor" exactly when replacing or repairing compressor. Refer to [HA-17, "Electric Compressor"](#).

## REFRIGERANT LEAKAGE DETECTING FLOURESCENT INDICATOR

### CAUTION:

- Never use fluorescent indicators as these may reduce the insulation resistance.

# PRECAUTIONS

[WITH HEAT PUMP SYSTEM]

## < PRECAUTION >

- If a fluorescent indicator enters the refrigerant cycle, either wash the refrigerant cycle parts or replace the parts.

## Service Equipment

INFOID:000000010640909

### RECOVERY/RECYCLING RECHARGING EQUIPMENT

Be certain to follow the manufacturer's instructions for machine operation and machine maintenance. Never introduce any refrigerant other than that specified into the machine.

### VACUUM PUMP

The lubricant contained inside the vacuum pump is not compatible with the specified lubricant for HFC-134a (R-134a) A/C systems. The vent side of the vacuum pump is exposed to atmospheric pressure. So the vacuum pump lubricant may migrate out of the pump into the service hose. This is possible when the pump is switched OFF after evacuation (vacuuming) and hose is connected to it. To prevent this migration, use a manual valve placed near the hose-to-pump connection, as per the following.

- Vacuum pumps usually have a manual isolator valve as part of the pump. Close this valve to isolate the service hose from the pump.
- Use a hose equipped with a manual shut-off valve near the pump end for pumps without an isolator. Close the valve to isolate the hose from the pump.
- Disconnect the hose from the pump if the hose has an automatic shut-off valve. As long as the hose is connected, the valve is open and lubricating oil may migrate.

Some one-way valves open when vacuum is applied and close under no vacuum condition. Such valves may restrict the pump's ability to pull a deep vacuum and are not recommended.

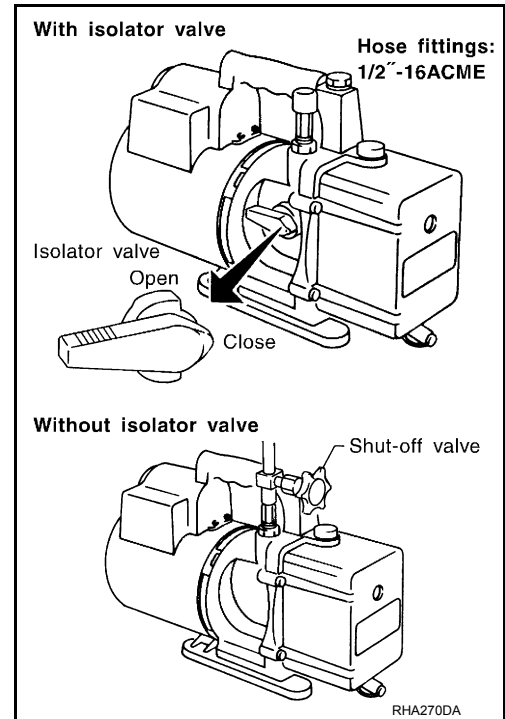

### MANIFOLD GAUGE SET

Be certain that the gauge face indicates HFC-134a or R-134a. Be sure the gauge set has 1/2"-16 ACME threaded connections for service hoses. Confirm the set has been used only with refrigerant HFC-134a (R-134a) and specified lubricants.

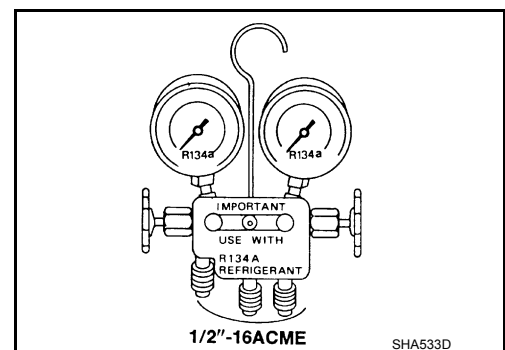

### SERVICE HOSES

Be certain that the service hoses display the markings described (colored hose with black stripe). All hoses must equip positive shut-off devices (either manual or automatic) near the end of the hoses opposite to the manifold gauge.

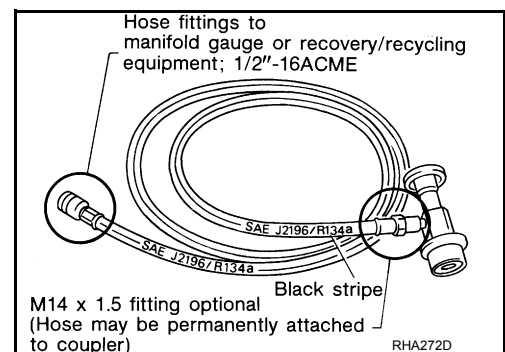

### SERVICE COUPLERS

# PRECAUTIONS

## < PRECAUTION >

Never attempt to connect HFC-134a (R-134a) service couplers to the CFC-12 (R-12) A/C system. The HFC-134a (R-134a) couplers do not properly connect to the CFC-12 (R-12) system. However, if an improper connection is attempted, discharging and contamination may occur.

Shut-off valve rotation	A/C service valve
Clockwise	Open
Counterclockwise	Close

## [WITH HEAT PUMP SYSTEM]

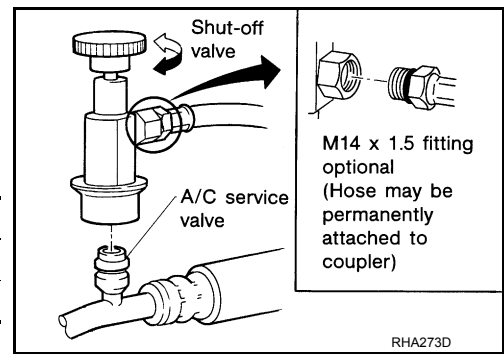

## REFRIGERANT WEIGHT SCALE

Verify that no refrigerant other than HFC-134a (R-134a) and specified lubricants have been used with the scale. The hose fitting must be 1/2"-16 ACME if the scale controls refrigerant flow electronically.

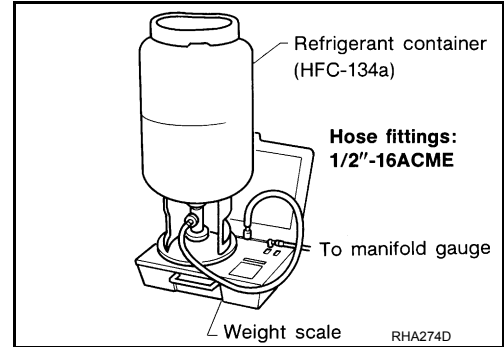

## CALIBRATING ACR4 WEIGHT SCALE

Calibrate the scale each three month.

To calibrate the weight scale on the ACR4:

1. Press "**Shift/Reset**" and "**Enter**" at the same time.
2. Press "**8787**". "**A1**" is displayed.
3. Remove all weight from the scale.
4. Press "**0**", then press "**Enter**". "**0.00**" is displayed and change to "**A2**".
5. Place a known weight (dumbbell or similar weight), between 4.5 and 8.6 kg (10 and 19 lb.) on the center of the weight scale.
6. Enter the known weight using four digits. (Example 10 lb. = 10.00, 10.5 lb. = 10.50)
7. Press "**Enter**" — the display returns to the vacuum mode.
8. Press "**Shift/Reset**" and "**Enter**" at the same time.
9. Press "**6**" — the known weight on the scale is displayed.
10. Remove the known weight from the scale. "**0.00**" is displayed.
11. Press "**Shift/Reset**" to return the ACR4 to the program mode.

## CHARGING CYLINDER

Using a charging cylinder is not recommended. Refrigerant may be vented into air from cylinder's top valve when filling the cylinder with refrigerant. Also, the accuracy of the cylinder is generally less than that of an electronic scale or of quality recycle/recharge equipment.

# PREPARATION

< PREPARATION >

[WITH HEAT PUMP SYSTEM]

## PREPARATION

### PREPARATION

#### Special Service Tool

INFOID:000000011007810

The actual shape of the tools may differ from those illustrated here.

Tool number (TechMate No.) Tool name	Description
(J-48710) NISSAN ACR2009 RRR Unit	Function: Refrigerant recovery, recycling and recharging
(J-41995) Electrical leak detector	Power supply: DC12V(Battery terminal)

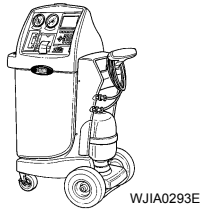

#### Commercial Service Tools

INFOID:000000010640910

Tool name	Description
Service hoses <ul style="list-style-type: none"> <li>• High-pressure side hose</li> <li>• Low-pressure side hose</li> <li>• Utility hose</li> </ul>	Hose color: <ul style="list-style-type: none"> <li>• Low-pressure side hose: Blue with black stripe</li> <li>• High-pressure side hose: Red with black stripe</li> <li>• Utility hose: Yellow with black stripe or green with black stripe</li> </ul> Hose fitting to gauge: <ul style="list-style-type: none"> <li>• 1/2"-16 ACME</li> </ul>
Insulated gloves Comply with EN60903: <ul style="list-style-type: none"> <li>• Use protective gloves made of insulating material.</li> <li>• The protective gloves must be capable of resisting the voltage of 600 or more.</li> </ul>	Removing and installing high voltage components
Leather gloves [Use leather gloves that can fasten the wrist tight]	<ul style="list-style-type: none"> <li>• Removing and installing high voltage components</li> <li>• Protect insulated gloves</li> </ul>

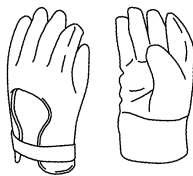
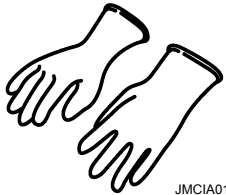
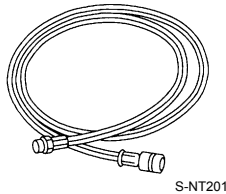

# PREPARATION

## < PREPARATION >

## [WITH HEAT PUMP SYSTEM]

Tool name	Description
<p>Insulated safety shoes Comply with EN60903:</p> <ul style="list-style-type: none"> <li>• Use protective shoes made of insulating material.</li> <li>• The protective shoes must be capable of resisting the voltage of 600 or more.</li> </ul>	<p>Removing and installing high voltage components</p>
<p>Face shield [Comply with EN166.]</p>	<ul style="list-style-type: none"> <li>• Removing and installing high voltage components</li> <li>• To protect face from the spatter on the work to electric line</li> </ul>
<p>Insulated helmet</p>	<p>Removing and installing high voltage components</p>
<p>Insulation resistance tester (Multi tester)</p>	<p>Measuring insulation resistance, voltage and resistance</p>
<p>(J-41995) Electrical leak detector</p>	<p>Power supply: DC12V(Battery terminal)</p>
<p>Manifold gauge set (with hoses and couplers)</p>	<p>Identification:</p> <ul style="list-style-type: none"> <li>• The gauge face indicates HFC-134a (R-134a).</li> </ul> <p>Fitting size: Thread size</p> <ul style="list-style-type: none"> <li>• 1/2" -16 ACME</li> </ul>

A  
B  
C  
D  
E  
F  
G  
H  
HA  
J  
K  
L  
M  
N  
O  
P

# PREPARATION

## < PREPARATION >

## [WITH HEAT PUMP SYSTEM]

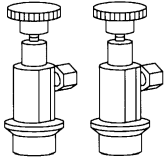
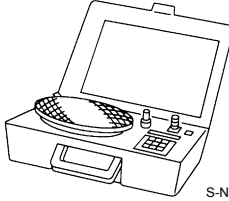
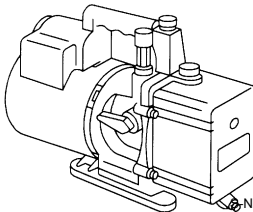
Tool name	Description
Service couplers <ul style="list-style-type: none"> <li>• High-pressure side coupler</li> <li>• Low-pressure side coupler</li> </ul> <div style="text-align: center;">  <p style="font-size: small; margin-top: 5px;">S-NT202</p> </div>	Hose fitting to service hose: M14 x 1.5 fitting is optional or permanently attached.
Refrigerant weight scale <div style="text-align: center;">  <p style="font-size: small; margin-top: 5px;">S-NT200</p> </div>	For measuring of refrigerant Fitting size: Thread size 1/2"-16 ACME
Vacuum pump (Including the isolator valve) <div style="text-align: center;">  <p style="font-size: small; margin-top: 5px;">S-NT203</p> </div>	Capacity: <ul style="list-style-type: none"> <li>• Air displacement: 4 CFM</li> <li>• Micron rating: 20 microns</li> <li>• Oil capacity: 482 m ℓ (17 Imp fl oz.)</li> </ul> Fitting size: Thread size <ul style="list-style-type: none"> <li>• 1/2"-16 ACME</li> </ul>

## Oil and Grease

INFOID:000000010640911

Name	Application	Note
Refrigerant can (HFC-134a)	Charging refrigerant	—
Compressor oil (ND-OIL11)	Refilling compressor oil	—

# COMPONENT PARTS

< SYSTEM DESCRIPTION >

[WITH HEAT PUMP SYSTEM]

## SYSTEM DESCRIPTION

### COMPONENT PARTS REFRIGERATION SYSTEM

#### REFRIGERATION SYSTEM : Component Parts Location

INFOID:000000010640912

#### COMPONENT PARTS LOCATION

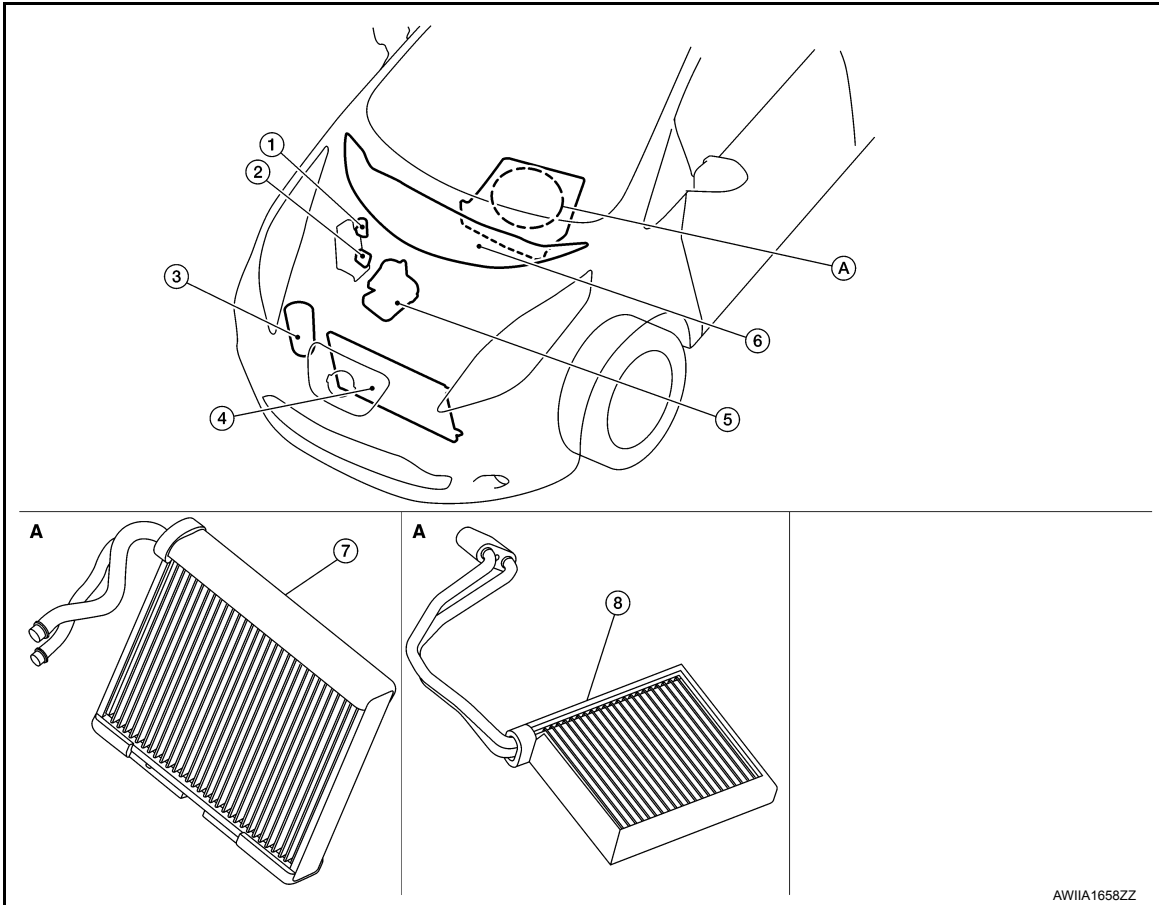

A. Built-in heating and cooling unit assembly

#### COMPONENT PARTS DESCRIPTION

No.	Location	DESCRIPTION
1.	3-way valve	Controls refrigerant flow for cooling or heating applications.
2.	2-way valve	Controls refrigerant flow for cooling or heating applications.
3.	Accumulator	Refer to <a href="#">HA-19, "Accumulator"</a> .
4.	Condenser	Cools the high-temperature high-pressure refrigerant discharged from the compressor to change it into a liquid. Refer to <a href="#">HA-16, "Condenser"</a> .
5.	Electric compressor	Performs the intake, compression, and discharge of refrigerant, and circulates the refrigerant in the cooler cycle. Refer to <a href="#">HA-17, "Electric Compressor"</a> .
6.	PTC heater	Provides heated air.

# COMPONENT PARTS

< SYSTEM DESCRIPTION >

[WITH HEAT PUMP SYSTEM]

No.	Location	DESCRIPTION
7.	Evaporator	The misty liquid refrigerant causes evaporation and turns into gas by the air blown from blower motor. Cools the air by vaporization heat at this time. Refer to <a href="#">HA-16, "HEATING AND COOLING UNIT ASSEMBLY : Evaporator"</a> .
8.	Inner Condenser	The refrigerant gas condenses into liquid by the air blown from blower motor. Released heat warms the air by condensation at this time. Refer to <a href="#">HA-16, "HEATING AND COOLING UNIT ASSEMBLY : Inner condenser"</a> .

## HEATING AND COOLING UNIT ASSEMBLY

### HEATING AND COOLING UNIT ASSEMBLY : Heating and Cooling Unit

INFOID:000000010640913

This unit combines the blower unit, heating unit, and cooling unit into an assembly.

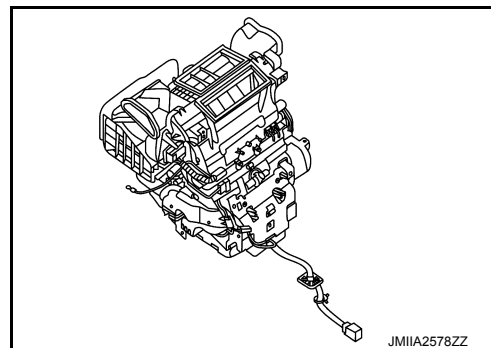

### HEATING AND COOLING UNIT ASSEMBLY : Evaporator

INFOID:000000010640914

A thin laminate pipeless evaporator is used.

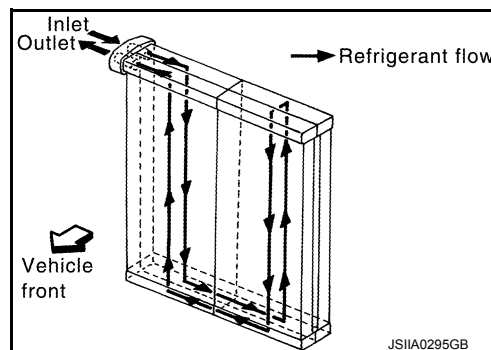

### HEATING AND COOLING UNIT ASSEMBLY : Inner condenser

INFOID:000000010640915

An aluminum corrugated fin inner condenser is used.

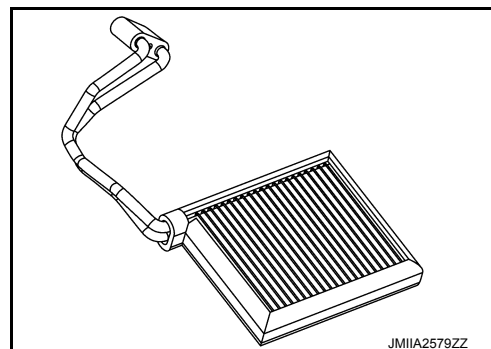

## Condenser

INFOID:000000010640916

### DESCRIPTION

A parallel-flow condenser with a sub-cool cycle is used.

### STRUCTURE AND OPERATION



# COMPONENT PARTS

< SYSTEM DESCRIPTION >

[WITH HEAT PUMP SYSTEM]

The sub-cool section further cools the liquid refrigerant, increasing the amount of heat that the liquid refrigerant can absorb and improving cooling performance.

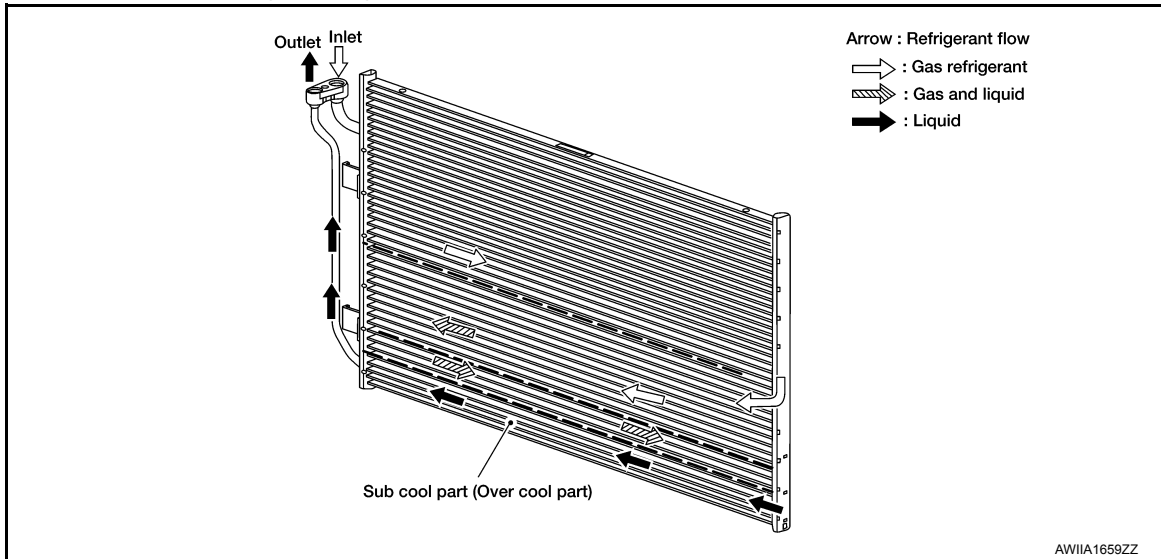

## Electric Compressor

INFOID:0000000010640917

- An electric scroll compressor is used.
- A 3-phase output inverter with IPM<sup>Note</sup> is used.
- The inverter is adopted to IPM<sup>Note</sup> for smaller size and improved reliability.

### NOTE:

IPM (Intelligent Power Module) is the element which delivered power device equivalent to IGBT and the protection feature of the circuit to one package.

### NOTE:

IGBT (Insulated Gate Bipolar Transistor) is a transistor which is suitable for high voltages and large currents and which can control large electrical power using a small gate voltage.

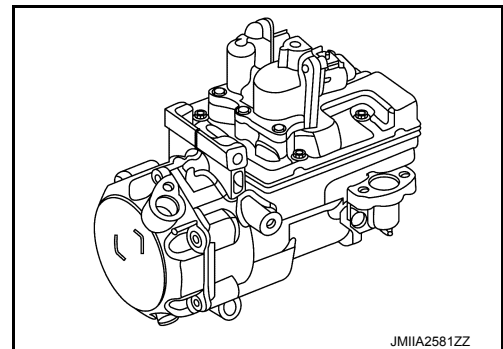

- The structure integrates the inverter, compressor, and motor, allowing compressor to operate at any speed.

A  
B  
C  
D  
E  
F  
G  
H  
HA  
J  
K  
L  
M  
N  
O  
P

# COMPONENT PARTS

< SYSTEM DESCRIPTION >

[WITH HEAT PUMP SYSTEM]

- The inverter communicates with A/C auto amp., and uses PWM control<sup>Note</sup> to control the motor speed via the drive circuit.

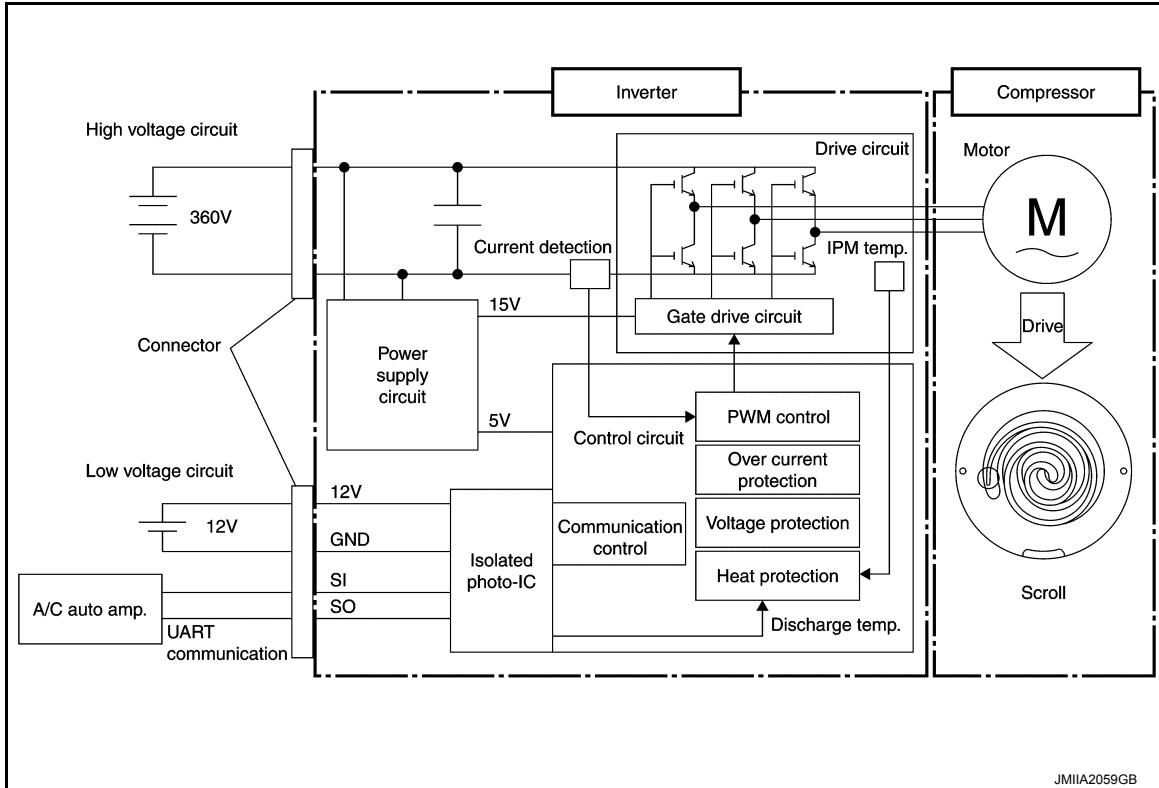

**NOTE:**

- PWM (Pulse Width Modulation) is a system that controls current and voltage by changing the duty ratio of a constant frequency pulse wave.
- PWM is used as the adjustment method of output voltage when inverter is used as a power supply for controlling motor speed.
- PWM changes voltage application time (pulse width) using a semiconductor element and controls motor speed.
- The IPM contains an internal protection circuit, and uses the inverter control circuit to monitor for an increase in motor drive circuit temperature in order to prevent circuit overheating.
- The motor uses a DC brushless motor, with speed control performed by the inverter drive circuit.

# COMPONENT PARTS

## < SYSTEM DESCRIPTION >

[WITH HEAT PUMP SYSTEM]

- A scroll-type compressor is used. The motor drive force is used to rotate the moveable scroll and perform refrigerant intake, compression, and discharge.

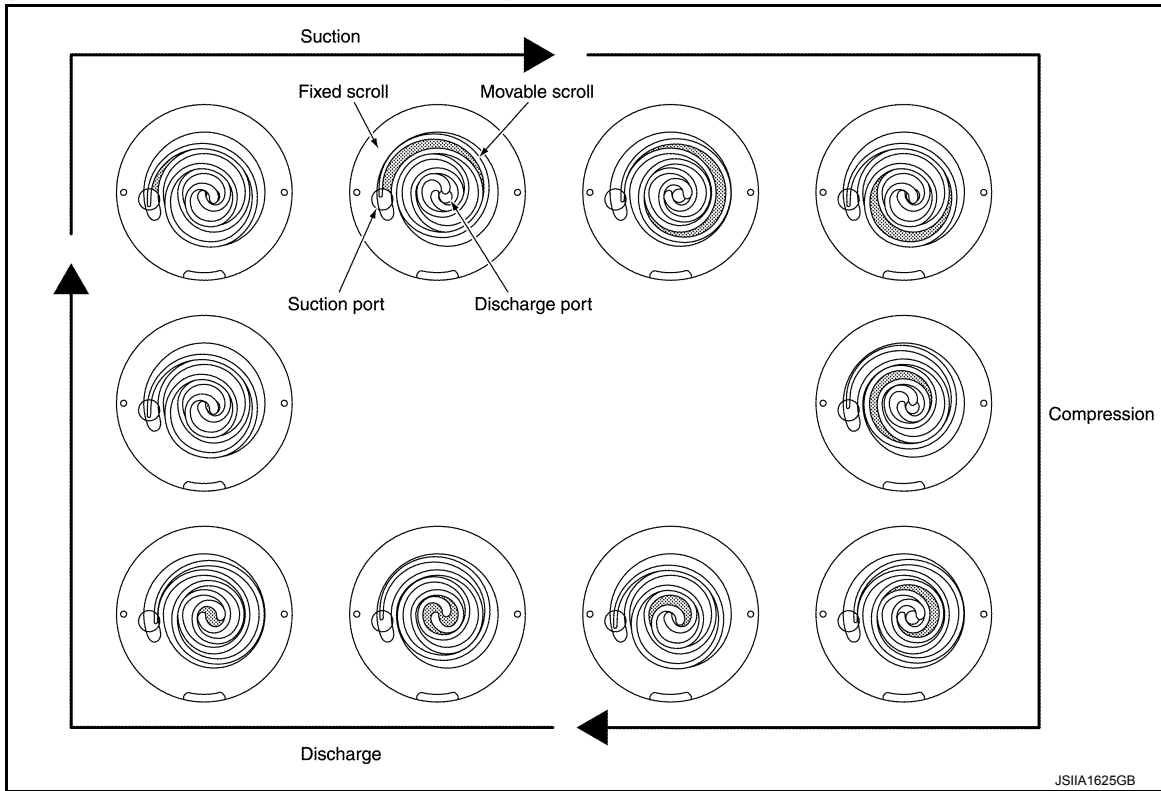

A  
B  
C  
D  
E  
F  
G  
H

## Orifice

INFOID:000000010640918

HA

- An orifice is used to control the pressure and temperature of the refrigerant.
- Both the heating and cooling systems use an orifice tube.

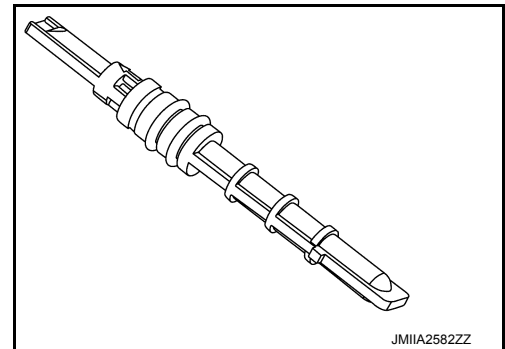

J  
K  
L  
M

## PTC

- PTC stands for "Positive Temperature Coefficient", and is a ceramic material with barium titanate as the primary component.
- When current is applied, it heats up. Upon reaching a certain temperature (Curie temperature) the resistance suddenly increases, limiting the current, and maintaining a constant amount of heating.

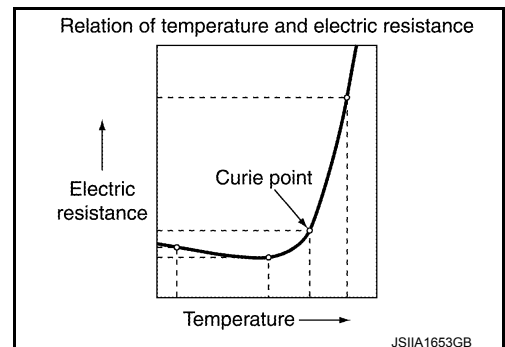

N  
O  
P

## Accumulator

INFOID:000000010640919

- An accumulator is used to store and clean the refrigerant.

# COMPONENT PARTS

## < SYSTEM DESCRIPTION >

[WITH HEAT PUMP SYSTEM]

- The accumulator is used during heating and cooling operations.

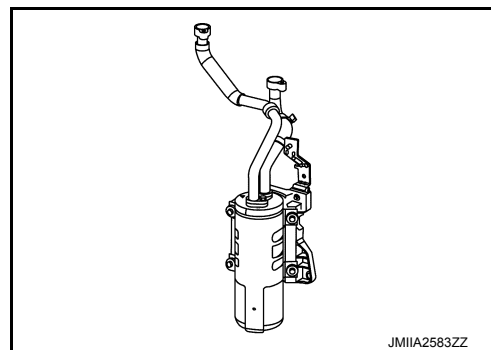

## Refrigerant and Compressor Oil

INFOID:000000010640920

- The refrigerant is HFC-134a, which contains no chlorine (Cl), a substance which damages the ozone layer.
- The compressor oil is ND-OIL 11, an ester oil with high insulation performance, designed especially for electric compressors.

### CAUTION:

- The special electric compressor oil has different properties from the conventional HFC-134a compressor oil (PAG oil) and CFC-12 compressor oil (mineral oil). Be sure not to mix these oil types with the compressor oil, as doing so may cause electric leakage.

### NOTE:

- HFC: HydroFluoroCarbon
- CFC: ChloroFluoroCarbon

## High Voltage Warning Label

INFOID:000000010640921

- High voltage warning label is stuck on each component parts below.
- When replacing component parts make sure to stick it on original position.

## Electric Compressor

The label (1) is stuck on the compressor stay.

⇐ : Application direction of the label

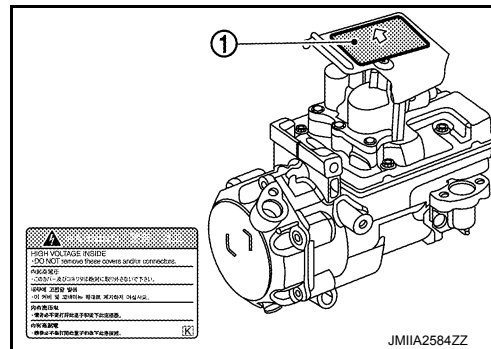

## PTC Heater

The label (1) is stuck on the housing of the PTC heater.

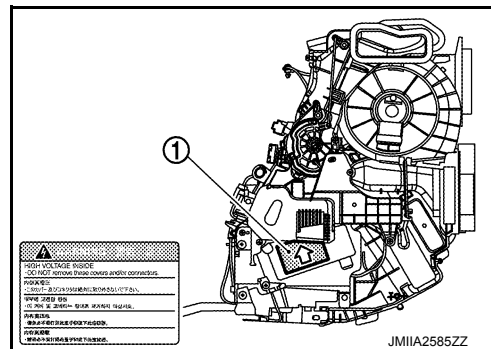

# SYSTEM

< SYSTEM DESCRIPTION >

[WITH HEAT PUMP SYSTEM]

## SYSTEM REFRIGERATION SYSTEM

### REFRIGERATION SYSTEM : System Diagram

INFOID:000000010640922

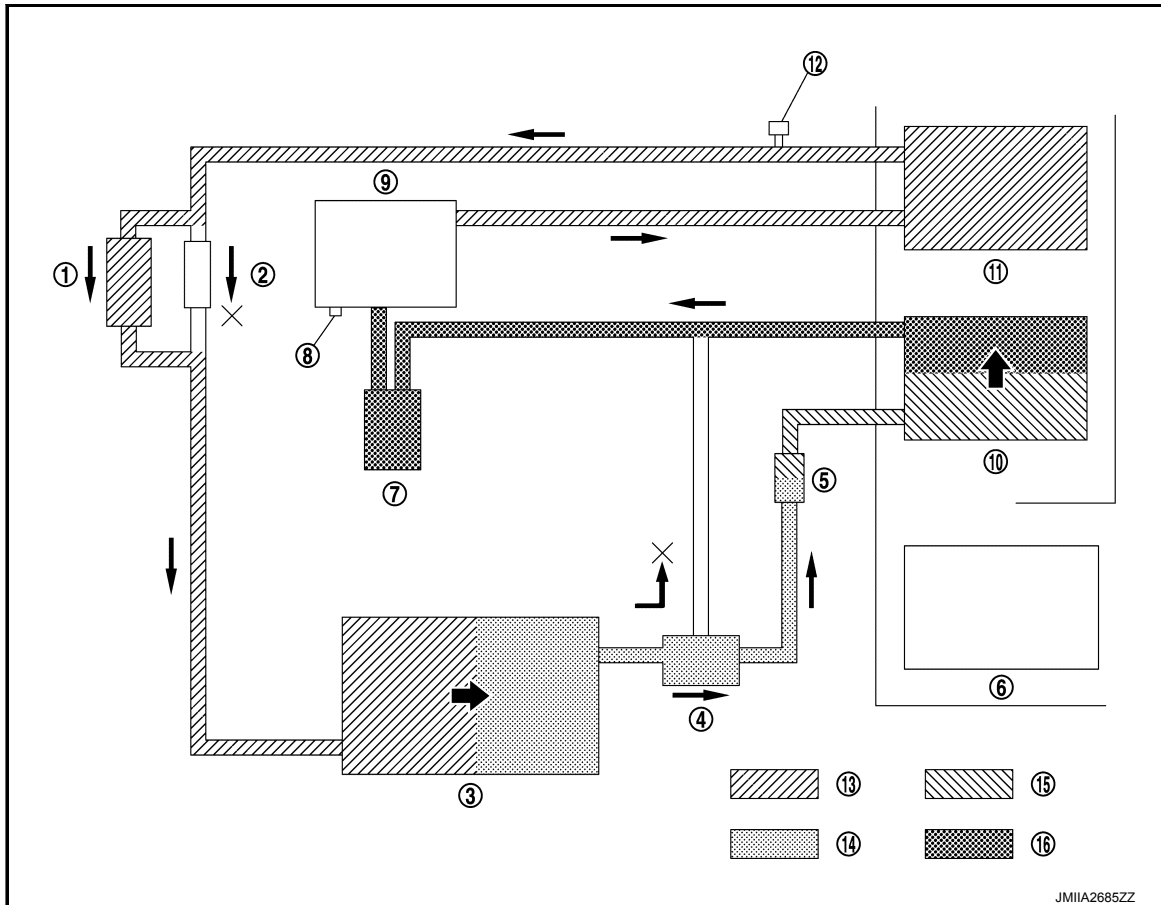

- |                       |                                   |                         |
|-----------------------|-----------------------------------|-------------------------|
| 1. 2-way valve        | 2. Orifice tube (Inner condenser) | 3. Condenser            |
| 4. 3-way valve        | 5. Orifice tube (Evaporator)      | 6. PTC heater           |
| 7. Accumulator        | 8. Pressure relief valve          | 9. Electric compressor  |
| 10. Evaporator        | 11. Inner condenser               | 12. Pressure sensor     |
| 13. High-pressure gas | 14. High-pressure liquid          | 15. Low-pressure liquid |
| 16. Low-pressure gas  |                                   |                         |

### REFRIGERATION SYSTEM : System Description

INFOID:000000010640923

#### REFRIGERANT CYCLE

##### Refrigerant Flow

The basic path of refrigerant flow is through the electric compressor, inner condenser, condenser, evaporator, and accumulator, and then it returns to the electric compressor. The vaporization of evaporator refrigerant is controlled by the expansion valve.

##### Evaporator Cryoprotective Protection Control

- If the air temperature after passing through the evaporator (detected by the intake sensor) is 1°C (34°F) or less, the A/C auto amp., sends a request for speed 0 rpm to the electric compressor.
- Based on this signal from A/C auto amp., the electric compressor stops.

#### REFRIGERANT SYSTEM PROTECTION

##### Refrigerant Pressure Sensor

- The refrigerant system is protected from significant high pressure and low pressure by the refrigerant pressure sensor that is installed at the inner condenser outlet.

# SYSTEM

[WITH HEAT PUMP SYSTEM]

## < SYSTEM DESCRIPTION >

- The refrigerant pressure sensor outputs a signal to the VCM.
- If the A/C auto amp., judges that there is a malfunction (the conditions shown below) in the cooler cycle based on the refrigerant pressure sensor detection value sent from VCM via EV CAN communications, it stops operation of the electric compressor.
  - Approximately 2,650 kPa (26.5 bar, 27.0 kg/cm<sup>2</sup>, 384.3 psi) or more
  - Approximately 140 kPa (1.4 bar, 1.4 kg/cm<sup>2</sup>, 20.3 psi) or less

### NOTE:

The values indicate gauge pressure.

### Pressure Relief Valve

- The refrigerant system is protected from significant high pressure by the pressure relief valve that is installed in the electric compressor.
- If the pressure in the cooler cycle is excessively increased [3,430 kPa (35 bar, 35 kg/cm<sup>2</sup>, 497.4 psi) - 4,140 kPa (41.4 bar, 42.2 kg/cm<sup>2</sup>, 600.3 psi) or more], the pressure relief valve opens, releasing refrigerant into the atmosphere.

## HEATING SYSTEM

### HEATING SYSTEM : System Diagram

INFOID:000000010640924

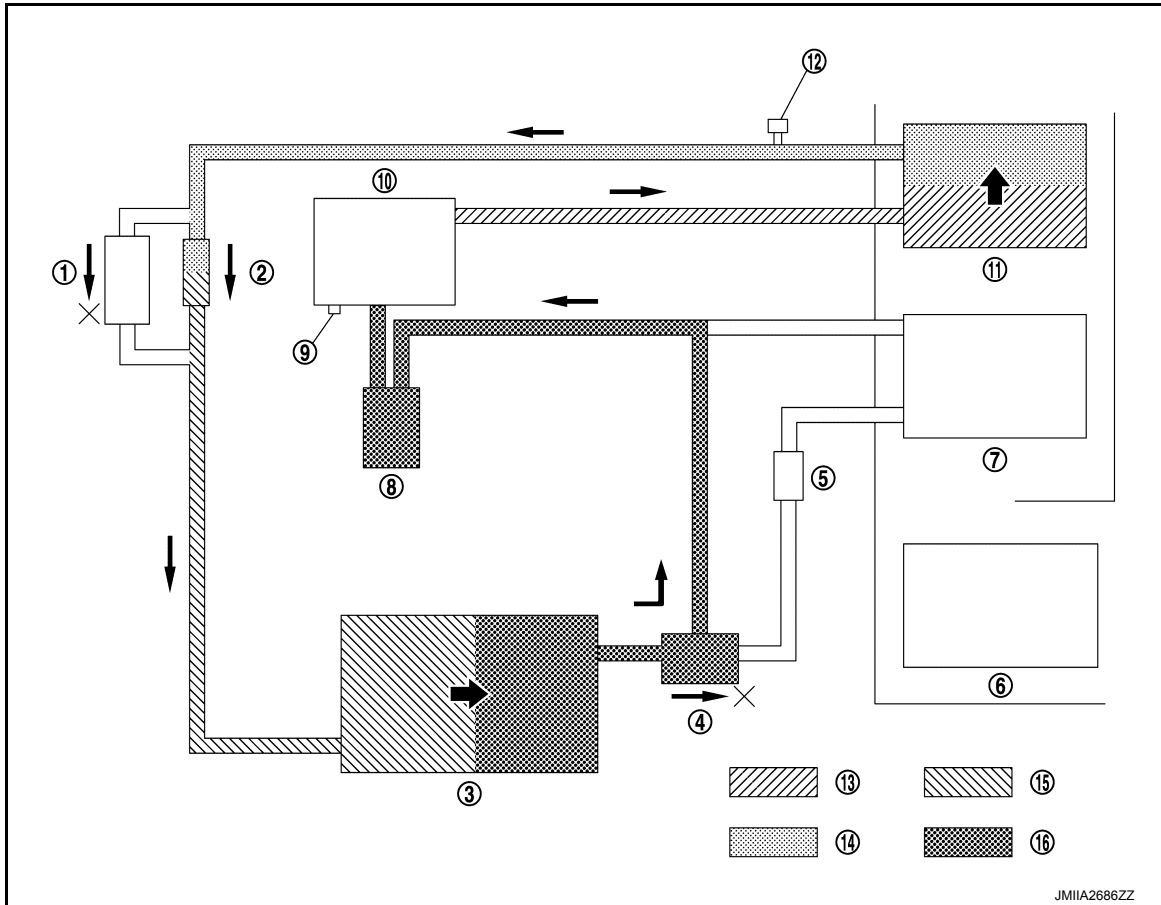

JMIA2686ZZ

- |                         |                                   |                          |
|-------------------------|-----------------------------------|--------------------------|
| 1. 2-way valve          | 2. Orifice tube (Inner condenser) | 3. Condenser             |
| 4. 3-way valve          | 5. Orifice tube (Evaporator)      | 6. PTC heater            |
| 7. Evaporator           | 8. Accumulator                    | 9. Pressure relief valve |
| 10. Electric compressor | 11. Inner condenser               | 12. Pressure sensor      |
| 13. High-pressure gas   | 14. High-pressure liquid          | 15. Low-pressure liquid  |
| 16. Low-pressure gas    |                                   |                          |

### HEATING SYSTEM : System Description

INFOID:000000010640925

### HEATING CYCLE

# SYSTEM

[WITH HEAT PUMP SYSTEM]

## < SYSTEM DESCRIPTION >

### Refrigerant Flow

- The basic path of refrigerant flow is through the electric compressor, inner condenser, condenser then it returns to the electric compressor.
- The refrigerant is heated as it is compressed by the electric compressor. The condensing of refrigerant inside the inner condenser provides interior heat.
- The electric PTC heater provides supplemental interior heat.

A

B

C

D

E

F

G

H

HA

J

K

L

M

N

O

P

# DIAGNOSIS AND REPAIR WORK FLOW

< BASIC INSPECTION >

[WITH HEAT PUMP SYSTEM]

## BASIC INSPECTION

### DIAGNOSIS AND REPAIR WORK FLOW

Workflow

INFOID:000000010640926

#### OVERALL SEQUENCE

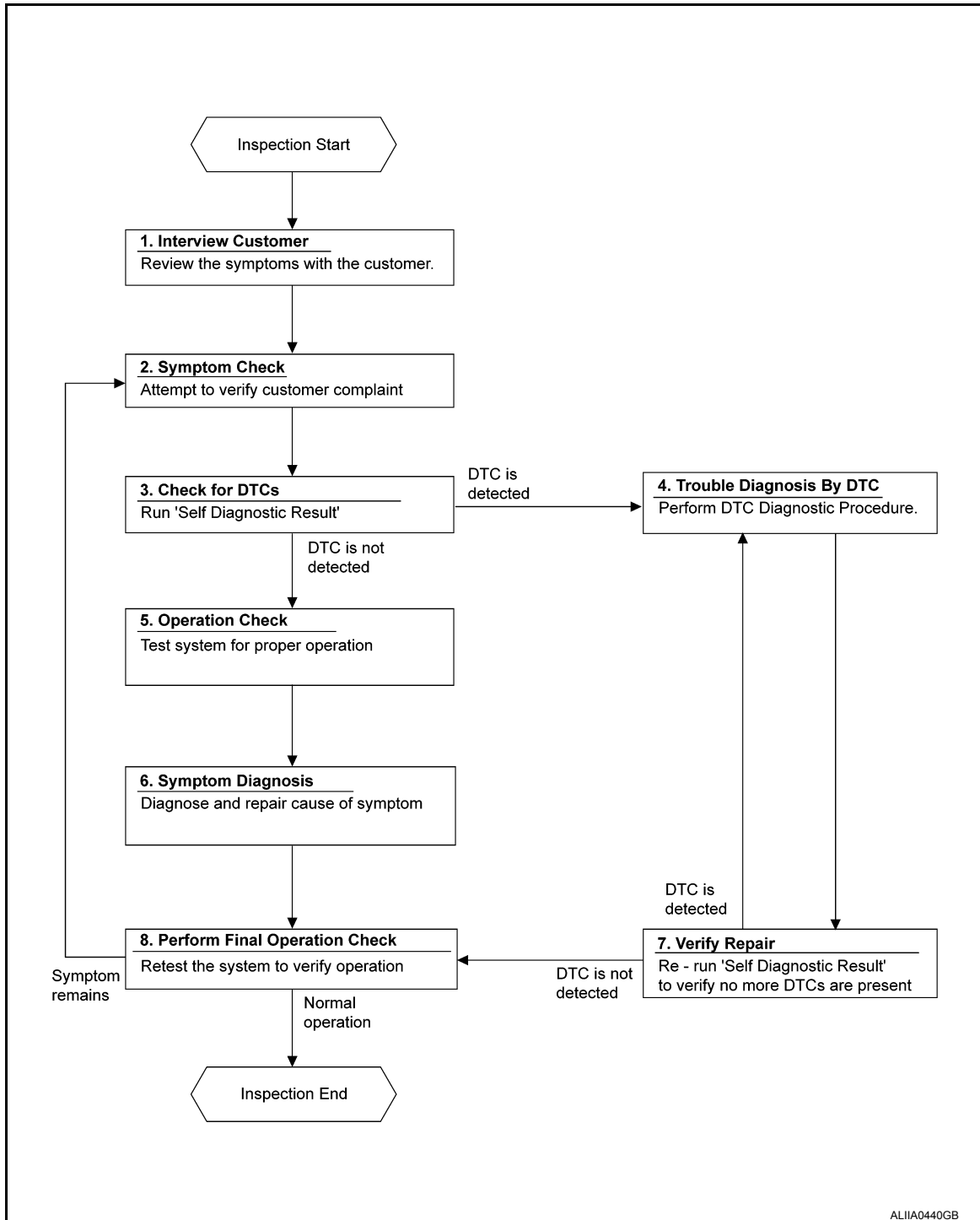

#### DETAILED FLOW

##### 1. INTERVIEW CUSTOMER

Interview the customer to obtain as much information as possible about the conditions and environment under which the malfunction occurred.



# DIAGNOSIS AND REPAIR WORK FLOW

< BASIC INSPECTION >

[WITH HEAT PUMP SYSTEM]

>> GO TO 2.

## 2. SYMPTOM CHECK

Verify symptoms.

>> GO TO 3.

## 3. CHECK FOR DTCS

④ With CONSULT

1. Turn ignition switch ON.
2. Select "Self Diagnostic Result" mode of "HVAC" using CONSULT.
3. Check DTC.

Is any DTC detected?

YES >> GO TO 4.

NO >> GO TO 5.

## 4. PERFORM DTC DIAGNOSTIC PROCEDURE

Perform the diagnostic procedure for the detected DTC. Refer to [HAC-56. "DTC Index"](#).

>> GO TO 7.

## 5. OPERATION CHECK

Perform the operation check. Refer to [HAC-78. "Work Procedure"](#).

>> GO TO 6.

## 6. SYMPTOM DIAGNOSIS

Check the symptom diagnosis table. Refer to [HAC-183. "Symptom Table"](#).

>> GO TO 8.

## 7. VERIFY REPAIR.

④ With CONSULT

1. Turn ignition switch ON.
2. Select "Self Diagnostic Result" mode of "HVAC" using CONSULT.
3. Check DTC.

Is any DTC detected?

YES >> GO TO 4.

NO >> GO TO 8.

## 8. PERFORM FINAL OPERATION CHECK

Perform the operation check. Refer to [HAC-78. "Work Procedure"](#).

Does it operate normally?

YES >> Inspection End.

NO >> GO TO 2.

A  
B  
C  
D  
E  
F  
G  
H  
HA  
J  
K  
L  
M  
N  
O  
P

## REFRIGERANT

## Description

INFOID:0000000010640927

## CONNECTION OF SERVICE TOOLS AND EQUIPMENT

**CAUTION:**

To prevent fluorescent indicator from entering, prepare and use exclusive hose for EV (electric vehicle) and HEV (hybrid vehicle) when connecting recovery/recycling/recharging equipment.

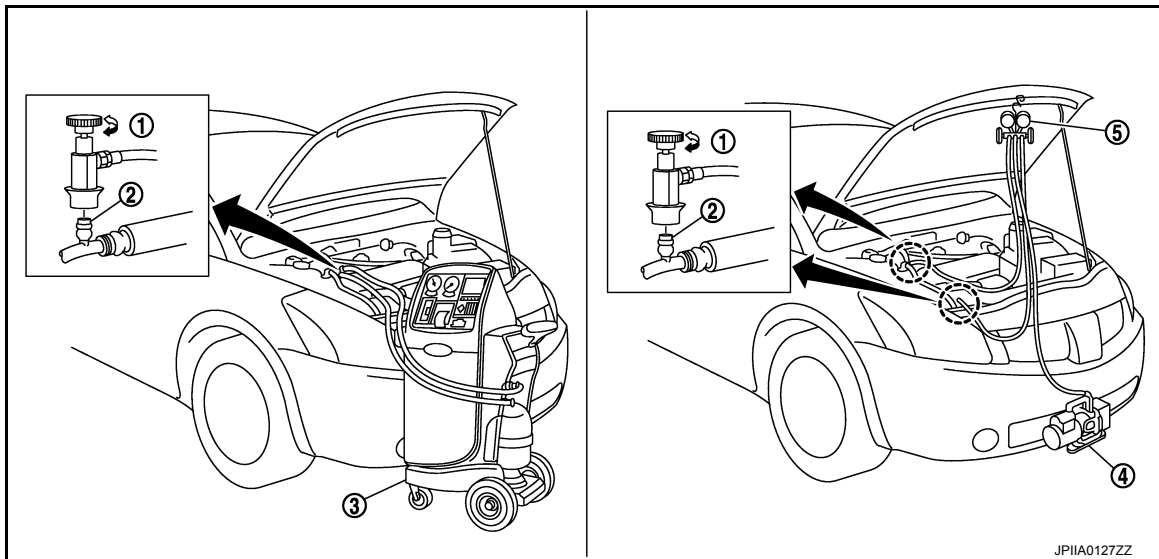

- |                   |                       |   |
|-------------------|-----------------------|---|
| 1. Shut-off valve | 2. A/C service valve  | 3. Recovery/recycling/recharging equipment (for HFC-134a) |
| 4. Vacuum pump    | 5. Manifold gauge set |   |

## Check Refrigerant Leakage

INFOID:0000000010640928

## DETECTING LEAKAGES WITH FLUORESCENT INDICATOR

**CAUTION:**

Do not use fluorescent indicators as these may reduce the insulation resistance.

## CHECK REFRIGERANT LEAKAGE USING ELECTRICAL LEAK DETECTOR

**CAUTION:**

Be careful of the following items so that inaccurate checks or misidentifications are avoided.

- Do not allow refrigerant vapor, shop chemical vapors, cigarette smoke, or others around the vehicle.
- Always check refrigerant leakage in a low air flow environment so that refrigerant may not disperse when leakage occurs.

1. Connect recovery/recycling/recharging equipment (for HFC-134a) or manifold gauge set to A/C service valve.
2. Check that refrigerant gas pressure is 345 kPa (3.5 kg/cm<sup>2</sup>, 50 psi) or more when temperature is 16°C (61°F) or more. When pressure is lower than the specified value, fully recover all refrigerant and then charge with refrigerant from the service can to the specified level.

**NOTE:**

Leakages may not be detected if refrigerant gas pressure is 345 kPa (3.5 kg/cm<sup>2</sup>, 50 psi) less when temperature is 16°C (61°F) or less.

3. Clean area where refrigerant leakage check is performed, and check refrigerant leakage along all surfaces of pipe connections and A/C system components using electrical leak detector probe.

**CAUTION:**

- Even when a leakage point has been found, always continue and complete checking along all pipe connections and A/C system components for additional leakage.
- When a leakage is detected, clean leakage area using compressed air and check again.

# REFRIGERANT

< BASIC INSPECTION >

[WITH HEAT PUMP SYSTEM]

- When checking leakage of cooling unit inside, always clean inside of drain hose so that the probe surface may not be exposed to water or dirt.

**NOTE:**

- Always check leakage starting from high-pressure side and continue to low-pressure side.
  - When checking for leakage inside cooling unit, operate blower motor for 15 minutes or more at the maximum fan speed, and then insert electrical leak detector probe into drain hose and leave it inserted for 10 minutes or more.
  - When disconnecting shut-off valve that is connected to A/C service valve, always evacuate remaining refrigerant so that misidentification can be avoided.
4. Repair or replace parts where refrigerant leakage is detected. (Leakage is detected but leakage location is unknown. GO TO 5.)
  5. Start the vehicle and set A/C control in the following conditions.
    - A/C switch: ON
    - Mode switch: Ventilation set
    - Intake switch: Recirculation set
    - Temperature setting: Full cold
    - Blower motor speed: Maximum speed set
  6. Operate A/C for 2 minutes or longer.
  7. Stop the A/C. Check again for refrigerant leakage. GO TO 3.

**NOTE:**

- Start refrigerant leakage check immediately after the A/C is stopped.
- When refrigerant circulation is stopped, pressure on the low-pressure side rises gradually, and after this, pressure on the high-pressure side falls gradually.
- The higher the pressure is, the easier it is to find the refrigerant leakage.

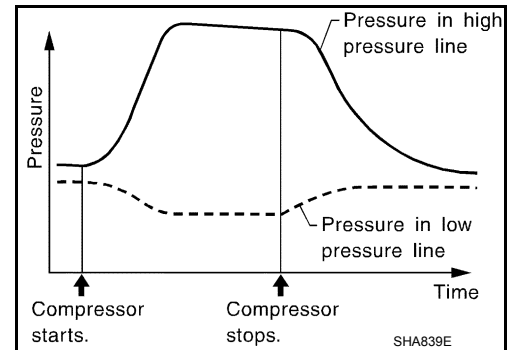

## Recycle Refrigerant

INFOID:000000010640929

**WARNING:**

- Always use HFC-134a for refrigerant gas. If CFC-12 is accidentally charged, compressor is damaged due to insufficient lubrication.
  - Always observe and follow precautions described on refrigerant container. Incorrect handling may result in an explosion of refrigerant container, frostbite, or the loss of eyesight.
  - Do not breathe refrigerant gas and lubricant vapor or mist. Exposure may irritate eyes, nose, or throat.
  - Do not allow HFC-134a to be exposed to an open flame or others because it generates poisonous gas when in contact with high temperature objects. Keep workshop well ventilated.
  - To prevent fluorescent indicator from entering, prepare and use exclusive hose for EV (electric vehicle) and HEV (hybrid vehicle) when connecting recovery/recycling/recharging equipment.
1. Perform oil return operation. Refer to [HA-29, "Perform Lubricant Return Operation"](#). (If refrigerant or lubricant leakage is detected in a large amount, omit this step, and then GO TO 2.)

**CAUTION:**

Do not perform lubricant return operation if a large amount of refrigerant or lubricant leakage is detected.

2. Check gauge pressure readings of recovery/recycling/recharging equipment (for HFC-134a). When remaining pressure exists, recycle refrigerant from high-pressure hose and low-pressure hose.

**NOTE:**

Follow manufacturer instructions for the handling or maintenance of the equipment. Never fill the equipment with non-specified refrigerant.

3. Remove A/C service valve cap from the vehicle.
4. Connect recovery/recycling/recharging equipment (for HFC-134a) to the A/C service valve.
5. Operate recovery/recycling/recharging equipment (for HFC-134a), and recycle refrigerant from the vehicle.

# REFRIGERANT

[WITH HEAT PUMP SYSTEM]

< BASIC INSPECTION >

6. Evacuate air for 10 minutes or more to remove any remaining refrigerant integrated to compressor lubricant, etc.
7. Refrigerant recycle operation is complete.

## Charge Refrigerant

INFOID:000000010640930

### **WARNING:**

- Always use HFC-134a for refrigerant. If CFC-12 is accidentally charged, compressor is damaged due to insufficient lubrication.
- Always observe and follow precautions described on refrigerant container. Incorrect handling may result in an explosion of refrigerant container, frostbite, or the loss of eyesight.
- When charging with refrigerant gas, charge with the prescribed amount from a new service can.
- Do not breathe refrigerant gas and lubricant vapor or mist. Exposure may irritate eyes, nose, or throat.
- Do not allow HFC-134a to be exposed to an open flame or others because it generates poisonous gas when in contact with high temperature objects. Keep workshop well ventilated.
- To prevent fluorescent indicator from entering, prepare and use exclusive hose for EV (electric vehicle) and HEV (hybrid vehicle) when connecting recovery/recycling/recharging equipment.

1. Connect manifold gauge (for HFC-134a) to the service valve.
2. Connect vacuum pump to manifold gauge and operate the pump. Apply vacuum to the cooler cycle for approximately 25 minutes or longer.

### **CAUTION:**

**Evacuate air for 15 minutes or more if the parts are replaced.**

3. Check the airtightness of A/C system for 25 minutes or more. If pressure raises more than the specified level, charge A/C system with approximately 200 g (0.4 lb) refrigerant and check that there is no refrigerant leakage. Refer to [HA-26. "Check Refrigerant Leakage"](#).

### **CAUTION:**

**Check the airtightness for 15 minutes or more if the parts are replaced.**

4. If parts other than compressor were replaced, add compressor oil according to parts that were replaced. Refer to [HA-29. "Lubricant Adjusting Procedure for Components Replacement Except Compressor"](#).
5. Charge the A/C system from a service can with the specified amount of refrigerant.
6. Check that A/C system operates normally.
7. Disconnect manifold gauge.
8. Install A/C service valve cap.
9. Refrigerant charge is complete.

## LUBRICANT

### Description

INFOID:000000010640931

### MAINTENANCE OF LUBRICANT LEVEL

The compressor lubricant is circulating in the system together with the refrigerant. It is necessary to fill compressor with lubricant when replacing A/C system parts or when a large amount of refrigerant leakage is detected. It is important to always maintain lubricant level within the specified level. Or otherwise, the following conditions may occur.

- Insufficient lubricant amount: Stuck compressor
- Excessive lubricant amount: Insufficient cooling (caused by insufficient heat exchange)

**Specified lubricant ND-OIL 11 (special oil for electric compressors)**

### Inspection

INFOID:000000010640932

If there is a malfunction (abnormal noise from inside, cooling failure) in the compressor unit, check the compressor oil.

#### 1. CHECK COMPRESSOR OIL

1. Remove electric compressor. [HA-37. "Exploded View"](#).
2. Refer to the diagram and judge the drained compressor oil.

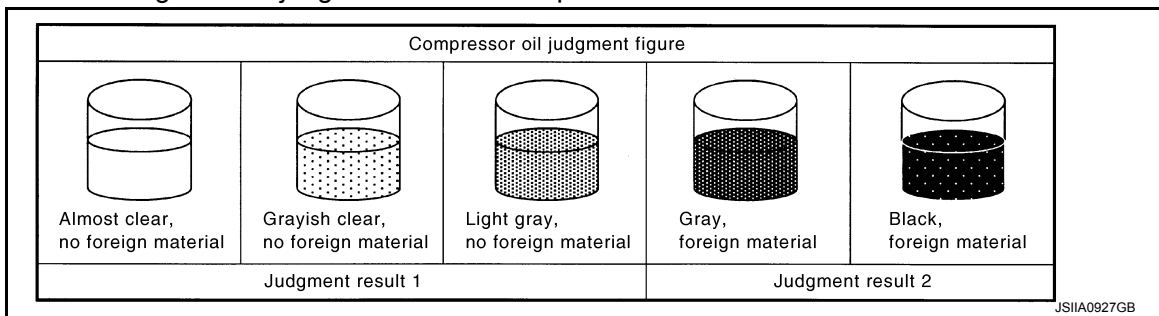

Judgment result 1:>>Replace only compressor.

Judgment result 2:>>Replace compressor and liquid tank.

### Perform Lubricant Return Operation

INFOID:000000010640933

#### CAUTION:

**If a large amount of refrigerant or lubricant leakage is detected, never perform lubricant return operation.**

1. Start the vehicle and set to the following conditions.
  - A/C switch: ON
  - Blower motor speed: Maximum speed set
  - Intake switch: Recirculation set
  - Temperature setting: Full cold
2. Perform lubricant return operation for approximately 10 minutes.
3. Stop A/C operation.
4. Oil return operation is complete.

### Lubricant Adjusting Procedure for Components Replacement Except Compressor

INFOID:000000010640934

Fill with lubricant for the amount that is calculated according to the following conditions.

Example: Lubricant amount to be added when replacing evaporator [mℓ (Imp fl oz)] = 35 (1.2) + α

# LUBRICANT

< BASIC INSPECTION >

[WITH HEAT PUMP SYSTEM]

Item		Lubricant amount to be added to A/C system m ℓ (Imp fl oz)
Replace evaporator		35 (1.2)
Replace condenser		15 (0.5)
Refrigerant leakage is detected	Large amount leakage	30 (1.1)
	Small amount leakage	—
Lubricant amount that is recycled together with refrigerant during recycle operation		α

## Lubricant Adjusting Procedure for Compressor Replacement

INFOID:000000010640935

### 1. Drain lubricant from removed compressor and measure lubricant amount.

1. Turn the compressor so that it faces downward, and drain the compressor oil from high-pressure port (A) and low-pressure port (B).
2. Measure total amount of lubricant that is drained from removed compressor.

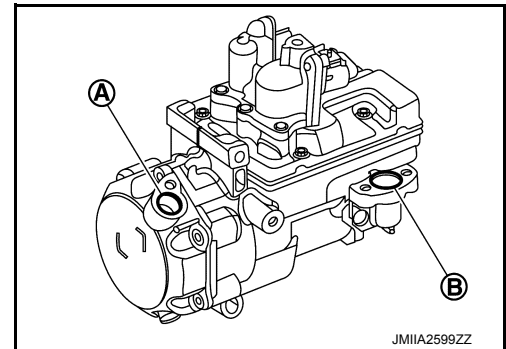

### 2. Drain lubricant from a new compressor that is calculated according to the following conditions.

#### Amount to be drained (A)

$$[m \ell \text{ (Imp fl oz)}] = F - (D + S + R + \alpha)$$

**F** : Lubricant amount that a new compressor contains [150 (5.3)]

**D** : Lubricant amount that is drained from removed compressor

**S** : Lubricant amount that remains inside of removed compressor [20 (0.7)]

**R** : Lubricant amount to be added according to components that are removed except compressor

**α** : Lubricant amount that is recycled together with refrigerant during recycle operation

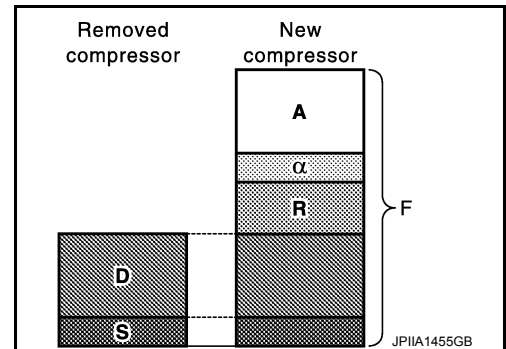

#### CAUTION:

If lubricant amount that is drained from removed compressor is less than 60 m ℓ (2.1 Imp fl oz), perform calculation by setting “D” as 40 m ℓ (1.4 Imp fl oz).

Item	Lubricant amount to be added to A/C system m ℓ (Imp fl oz)
Replace evaporator	35 (1.2)
Replace condenser	15 (0.5)

Example: Lubricant amount to be drained from a new compressor when replacing compressor [m ℓ (Imp fl oz)] [D = 60 (2.1), α = 5 (0.2)]

$$150 (5.3) - [60 (2.1) + 20 (0.7) + 5 (0.2)] = 65 (2.3)$$

### 3. Install compressor and check the operation.

# PERFORMANCE TEST

< BASIC INSPECTION >

[WITH HEAT PUMP SYSTEM]

## PERFORMANCE TEST



### Inspection

INFOID:000000010640936

### INSPECTION PROCEDURE

1. Connect the manifold gauge set.
2. Set the vehicle, and set to the following condition.

#### Test condition

Surrounding condition		Indoors or in the shade (in a well-ventilated place)
Vehicle condition	Door	Closed
	Door glass	Full open
	Hood	Open
A/C condition	Temperature control switch or dial	Full cold
	A/C switch	ON
	Mode switch	 (Ventilation) set
	Intake switch	 (Recirculation) set
	 Blower motor speed	Maximum speed set

3. Maintain test condition until A/C system becomes stable. (Approximately 10 minutes)
4. Check that the characteristics for “intake temperature vs. discharge temperature” and “ambient temperature vs. pressure” are within the standard values.
5. When test results are within the specified value, inspection is complete.  
If any of test result is out of the specified value, perform diagnosis by gauge pressure. Refer to [HA-34, "Trouble Diagnosis For Unusual Pressure"](#).

# PERFORMANCE TEST

< BASIC INSPECTION >

[WITH HEAT PUMP SYSTEM]

INTAKE -DISCHARGE

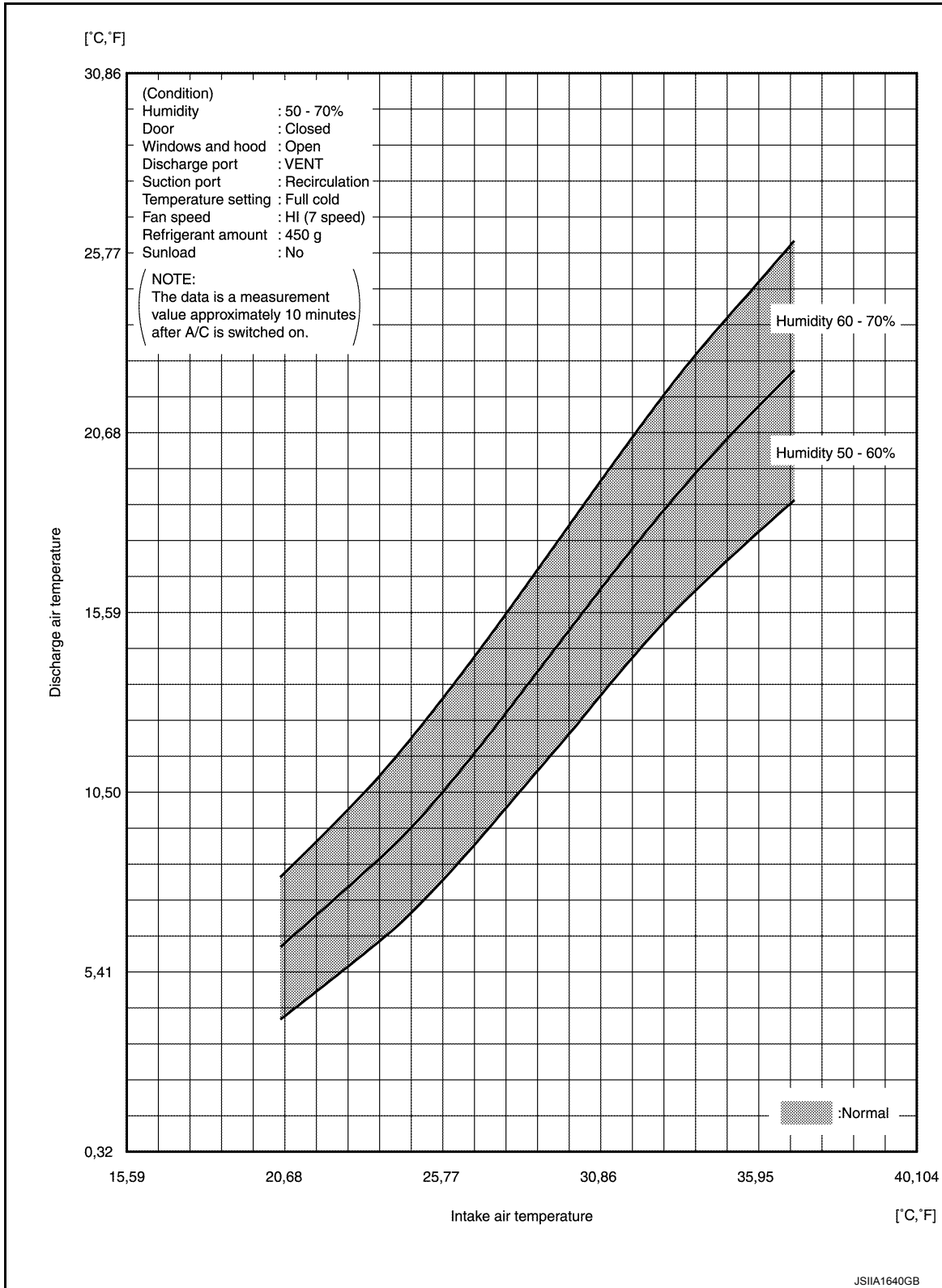



# PERFORMANCE TEST

< BASIC INSPECTION >

[WITH HEAT PUMP SYSTEM]

## AMBIENT TEMPERATURE-PRESSURE CHARACTERISTICS

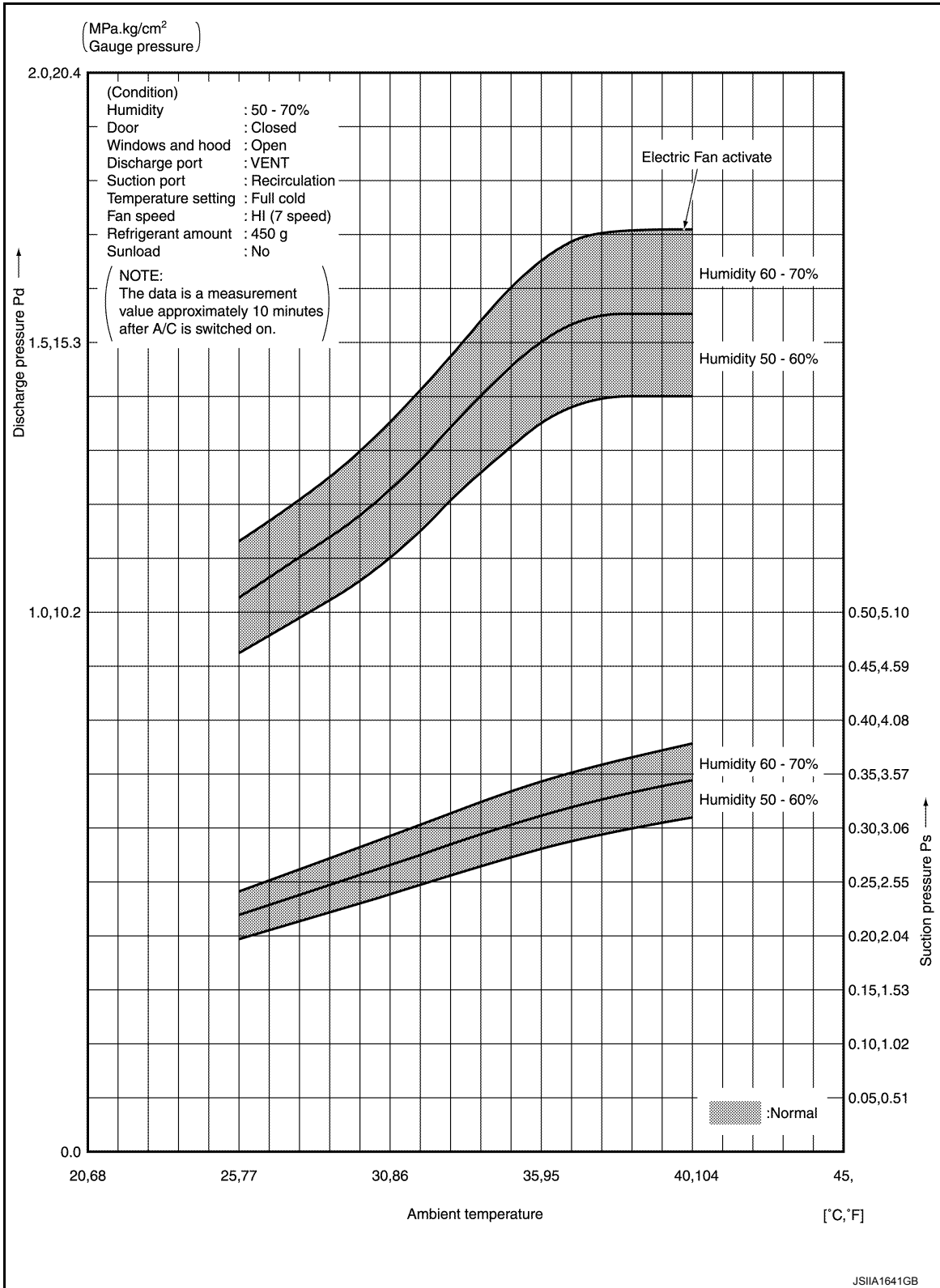

A  
B  
C  
D  
E  
F  
G  
H  
HA  
J  
K  
L  
M  
N  
O  
P

# REFRIGERATION SYSTEM SYMPTOMS

< SYMPTOM DIAGNOSIS >

[WITH HEAT PUMP SYSTEM]

## SYMPTOM DIAGNOSIS

### REFRIGERATION SYSTEM SYMPTOMS

#### Trouble Diagnosis For Unusual Pressure

INFOID:000000010640937

Diagnose using a manifold gauge whenever system's high and/or low side pressure(s) is/are unusual. The marker above the gauge scale in the following tables indicates the standard (usual) pressure range. Refer to above table (Ambient air temperature-to-operating pressure table) since the standard (usual) pressure, however, differs from vehicle to vehicle.

#### Symptom Table

INFOID:000000010640938

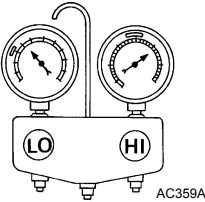
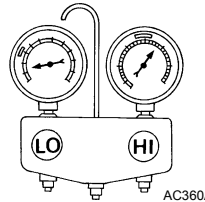
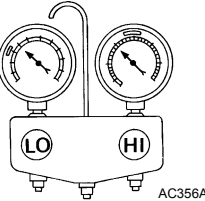
Gauge indication	Refrigerant cycle	Probable cause	Corrective action
<p>Both high and low-pressure sides are too high.</p>  <p>AC359A</p>	<p>The pressure returns to normal soon after sprinkling water on condenser.</p>	<p>Overfilled refrigerant.</p>	<p>Collect all refrigerant, evacuate refrigerant cycle again, and then refill it with the specified amount of refrigerant.</p>
	<p>Air flow to condenser is insufficient.</p>	<p>Insufficient condenser cooling performance.</p> <ul style="list-style-type: none"> <li>• Poor fan rotation of radiator and condenser.</li> <li>• Improper installation of air guide.</li> <li>• Clogged or dirty condenser fins.</li> </ul>	<ul style="list-style-type: none"> <li>• Repair or replace malfunctioning parts.</li> <li>• Clean and repair condenser fins.</li> </ul>
	<p>When compressor is stopped, a high-pressure reading quickly drops by approximately 196 kPa (2 kg/cm<sup>2</sup>, 28.4 psi). It then gradually decreases.</p>	<p>Air mixed in refrigerant cycle.</p>	<p>Collect all refrigerant, evacuate refrigerant cycle again, and then refill it with the specified amount of refrigerant.</p>
<p>High-pressure side is excessively high and low-pressure side is too low.</p>  <p>AC360A</p>	<p>High-pressure pipe and upper side of condenser become hot.</p>	<p>Clogged or crushed high-pressure pipe located between compressor and condenser.</p>	<p>Repair or replace the malfunctioning parts.</p>
<p>High-pressure side is too low and low-pressure side is too high.</p>  <p>AC356A</p>	<ul style="list-style-type: none"> <li>• The readings of both sides become equal soon after compressor operation stops.</li> <li>• There is no temperature difference between high- and low-pressure sides.</li> </ul>	<p>Malfunction in compressor system (insufficient compressor pressure operation).</p> <ul style="list-style-type: none"> <li>• Damage or breakage of valve.</li> <li>• Malfunctioning gaskets.</li> </ul>	<p>Replace compressor.</p>

# REFRIGERATION SYSTEM SYMPTOMS

< SYMPTOM DIAGNOSIS >

[WITH HEAT PUMP SYSTEM]

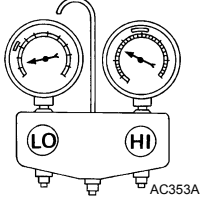
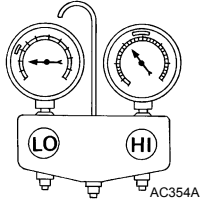
Gauge indication	Refrigerant cycle	Probable cause	Corrective action
<p>Both high and low-pressure sides are too low.</p> 	Evaporator becomes frosted.	<ul style="list-style-type: none"> <li>Clogged or crushed low-pressure pipe.</li> </ul>	<ul style="list-style-type: none"> <li>Repair or replace malfunctioning parts.</li> </ul>
	There is a small temperature difference between the high and low pressure pipes for refrigerant cycle.	<ul style="list-style-type: none"> <li>Malfunction in intake sensor.</li> </ul>	<ul style="list-style-type: none"> <li>Check intake sensor system. Refer to <a href="#">HAC-95, "Diagnosis Procedure"</a>.</li> </ul>
<p>Low-pressure side sometimes becomes negative.</p> 	<ul style="list-style-type: none"> <li>Sometimes the area around evaporator outlet does not become cold.</li> <li>Sometimes the area around evaporator inlet is frosted.</li> </ul>	<ul style="list-style-type: none"> <li>Shortage of refrigerant.</li> <li>Leakage of refrigerant.</li> </ul>	<ul style="list-style-type: none"> <li>Check for leakage.</li> <li>Collect all refrigerant, evacuate refrigerant cycle again, and then refill it with the specified amount of refrigerant.</li> </ul>
	<ul style="list-style-type: none"> <li>Sometimes the area around evaporator outlet does not become cold.</li> <li>Sometimes the area around evaporator inlet is frosted.</li> </ul>	<ul style="list-style-type: none"> <li>Icing caused by the mixing of water in cooler cycle.</li> <li>Deteriorated dryer in accumulator.</li> </ul>	<ul style="list-style-type: none"> <li>Collect all refrigerant.</li> <li>Evacuate refrigerant cycle completely, and then refill it with the specified amount of refrigerant. At this time, always replace accumulator.</li> </ul>

A  
B  
C  
D  
E  
F  
G  
H  
HA  
J  
K  
L  
M  
N  
O  
P

# NOISE

< SYMPTOM DIAGNOSIS >

[WITH HEAT PUMP SYSTEM]

## NOISE

### Symptom Table

INFOID:000000010640939

Symptom	Noise source	Probable cause	Corrective action
Unusual noise from compressor when A/C is ON.	Inside of compressor	Wear, breakage, or clogging of foreign material inside compressor parts.	Check compressor oil. Refer to <a href="#">HA-29, "Inspection"</a> .
	Compressor body	Loosened compressor mounting bolts.	Check bolts for tightness. Refer to <a href="#">HA-37, "Exploded View"</a> .
Unusual noise from cooler piping.	Cooler piping (pipe and flexible hose)	Improper installation of clip and bracket.	Check the installation condition of the cooler piping. Refer to <a href="#">HA-43, "Exploded View"</a> .

# ELECTRIC COMPRESSOR

< REMOVAL AND INSTALLATION >

[WITH HEAT PUMP SYSTEM]

## REMOVAL AND INSTALLATION

### ELECTRIC COMPRESSOR

Exploded View

INFOID:000000010640940

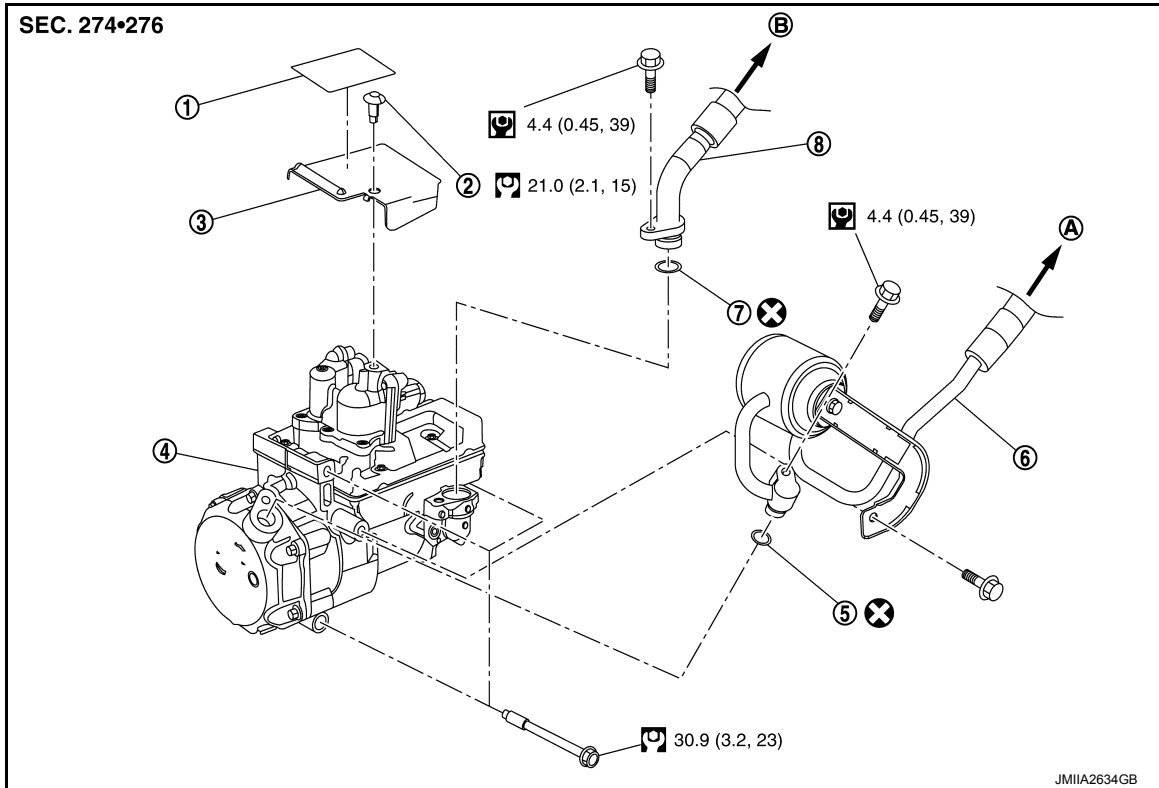

- |                               |                               |                                |
|-------------------------------|-------------------------------|--------------------------------|
| 1. High voltage warning label | 2. Fastener                   | 3. Compressor stay             |
| 4. Electric compressor        | 5. O-ring                     | 6. High-pressure flexible hose |
| 7. O-ring                     | 8. Low-pressure flexible hose |                                |
| A. To condenser               | B. To evaporator              |                                |

⊗: Always replace after every disassembly.

⊙: N·m (kg-m, in-lb)

⊙: N·m (kg-m, ft-lb)

### Removal and Installation

INFOID:000000010640941

#### **DANGER:**

 Since hybrid vehicles and electric vehicles contain a high voltage battery, there is the risk of electric shock, electric leakage, or similar accidents if the high voltage component and vehicle are handled incorrectly. Be sure to follow the correct work procedures when performing inspection and maintenance.

#### **WARNING:**

- Be sure to remove the service plug in order to disconnect the high voltage circuits before performing inspection or maintenance of high voltage system harnesses and parts.
- The removed service plug must always be carried in a pocket of the responsible worker or placed in the tool box during the procedure to prevent the plug from being connected by mistake.
- Be sure to wear insulating protective equipment consisting of glove, shoes, face shield and glasses before beginning work on the high voltage system.

# ELECTRIC COMPRESSOR

< REMOVAL AND INSTALLATION >

[WITH HEAT PUMP SYSTEM]

- Never allow workers other than the responsible person to touch the vehicle containing high voltage parts. To keep others from touching the high voltage parts, these parts must be covered with an insulating sheet except when using them. Refer to [GI-34, "High Voltage Precautions"](#).

## CAUTION:

Never bring the vehicle into the READY status with the service plug removed unless otherwise instructed in the Service Manual. A malfunction may occur if this is not observed.

## REMOVAL

### WARNING:

Disconnect high voltage circuit. Refer to [GI-33, "How to Disconnect High Voltage"](#).

1. Check voltage in high voltage circuit. (Check that condenser are discharged.)
  - a. Lift up the vehicle, and then remove Li-ion battery under covers. Refer to [EVB-181, "Exploded View"](#).
  - b. Disconnect high voltage connector from front side of Li-ion battery. Refer to [EVB-181, "Removal and Installation"](#).
  - c. Measure voltage between high voltage harness terminals.

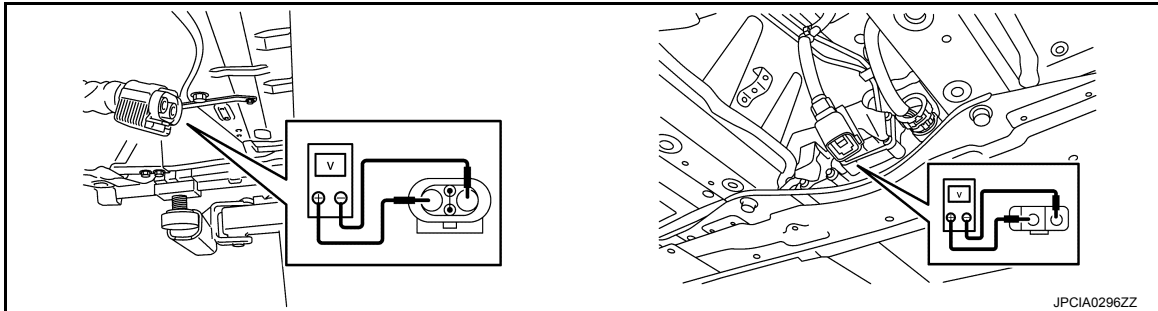

### DANGER:

 Touching high voltage components without using the appropriate protective equipment will cause electrocution.



Standard

: 5 V or less

### CAUTION:

For voltage measurements, use a tester which can measure to 500 V or higher.

2. Use the refrigerant recovery equipment (for HFC134a) and recover the refrigerant. [HA-27, "Recycle Refrigerant"](#).
3. Remove radiator upper grille. Refer to [DLK-166, "RADIATOR UPPER GRILLE : Removal and Installation"](#).
4. Remove bolt (A) and disconnect low-pressure flexible hose from electric compressor.

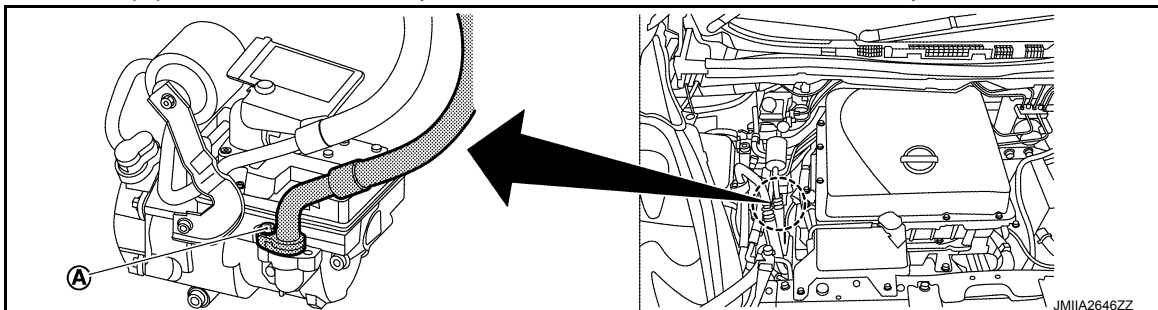

### WARNING:

 To prevent electric shock hazards, be sure to wear protective gear.



# ELECTRIC COMPRESSOR

< REMOVAL AND INSTALLATION >

[WITH HEAT PUMP SYSTEM]

**CAUTION:**

- Cover the low pressure port of the electric compressor with a cap to prevent oil from spilling.
- To prevent the inclusion of foreign matter, use a cap or vinyl tape to seal off the pipe connection port from the atmosphere.

5. Remove bolts (A) and disconnect high-pressure flexible hose from electric compressor.

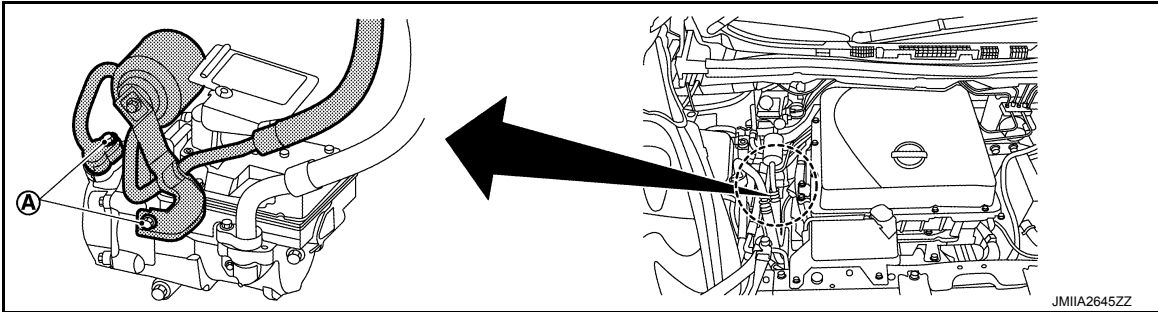

**WARNING:**



To prevent electric shock hazards, be sure to wear protective gear.



**CAUTION:**

- Cover the high pressure port of the electric compressor with a cap to prevent oil from spilling.
- To prevent the inclusion of foreign matter, use a cap or vinyl tape to seal off the pipe connection port from the atmosphere.

6. Disconnect quick charge port connectors (1) inside motor room.

← : Vehicle front

**WARNING:**



To prevent electric shock hazards, be sure to wear protective gear.



- To prevent electric shock hazards, immediately wrap insulating tape around disconnected high voltage connector terminals.

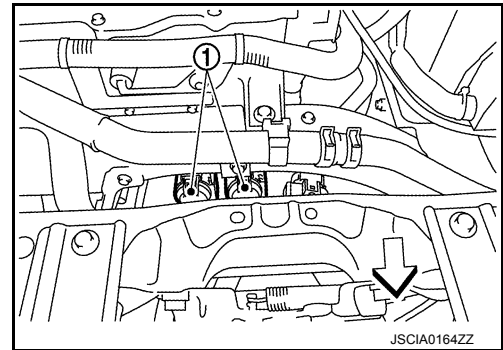

7. Disconnect normal charge port connector (1) inside motor room.

← : Vehicle front

**WARNING:**



To prevent electric shock hazards, be sure to wear protective gear.



- To prevent electric shock hazards, immediately wrap insulating tape around disconnected high voltage connector terminals.

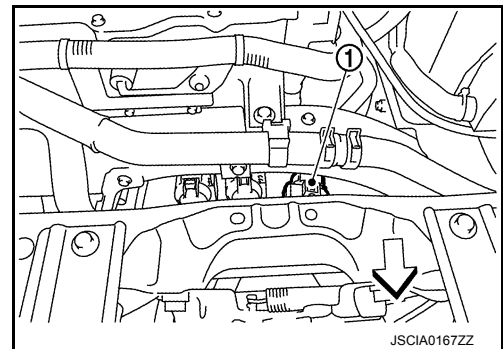

8. Move the water hose to a position where it will not interfere with work.

9. Remove front under cover. Refer to [EXT-23. "FRONT UNDER COVER : Removal and Installation"](#).

10. Remove front wheel and tire (RH). Refer to [WT-45. "Removal and Installation"](#).

11. Remove fender protector. Refer to [EXT-21. "FENDER PROTECTOR : Removal and Installation"](#).

A  
B  
C  
D  
E  
F  
G  
H  
HA  
J  
K  
L  
M  
N  
O  
P

# ELECTRIC COMPRESSOR

< REMOVAL AND INSTALLATION >

[WITH HEAT PUMP SYSTEM]

12. Remove bolt (A), and then remove compressor stay.

**WARNING:**

 To prevent electric shock hazards, be sure to wear protective gear.

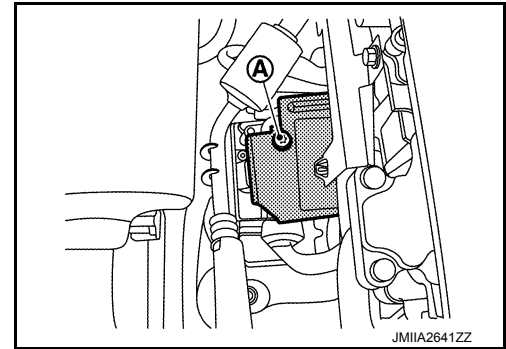

13. Disconnect high voltage harness connector.

**WARNING:**

•  To prevent electric shock hazards, be sure to wear protective gear.



• To prevent electric shock hazards, immediately wrap insulating tape around disconnected high voltage connector terminals.

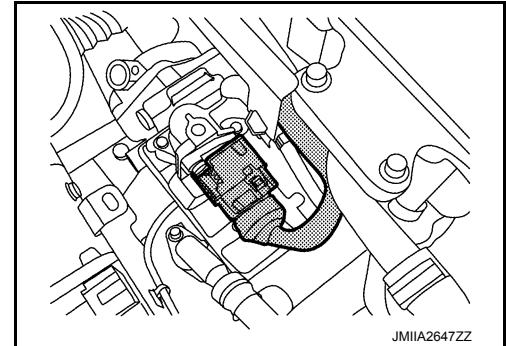

• Follow the procedure below and disconnect high voltage harness connector.

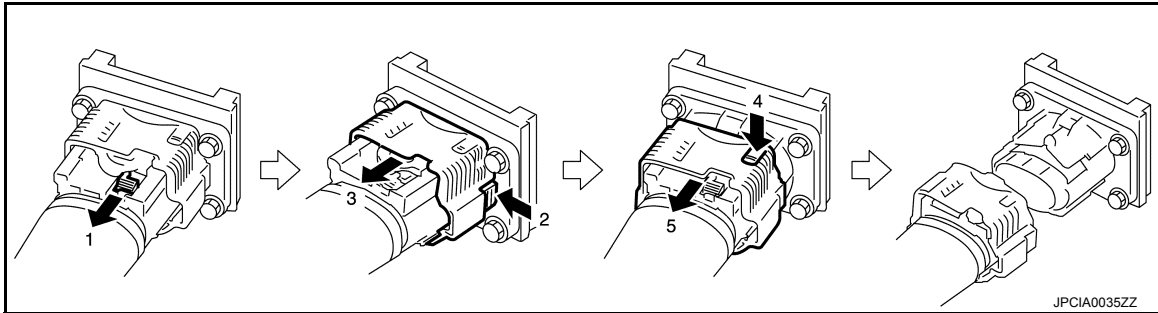

14. Disconnect low voltage harness connector.

**WARNING:**

 To prevent electric shock hazards, be sure to wear protective gear.

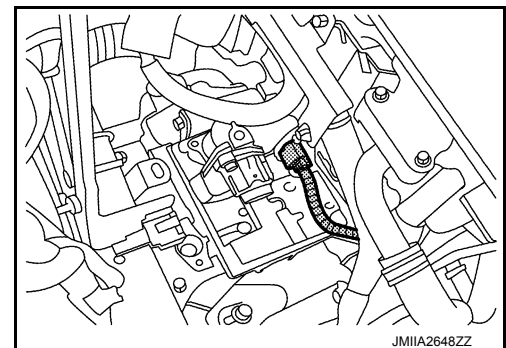

15. Remove bolts (A) from electric compressor (1).

**WARNING:**

 To prevent electric shock hazards, be sure to wear protective gear.

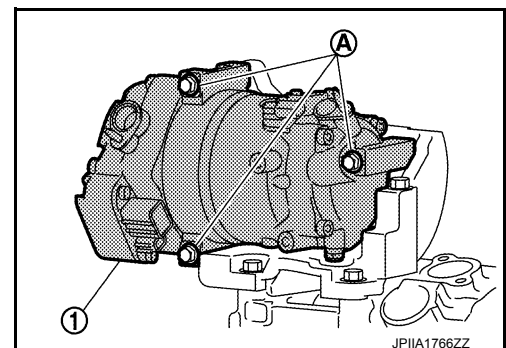



# ELECTRIC COMPRESSOR

< REMOVAL AND INSTALLATION >

[WITH HEAT PUMP SYSTEM]

16. Remove electric compressor (1) from the vehicle.

**WARNING:**

 To prevent electric shock hazards, be sure to wear protective gear.

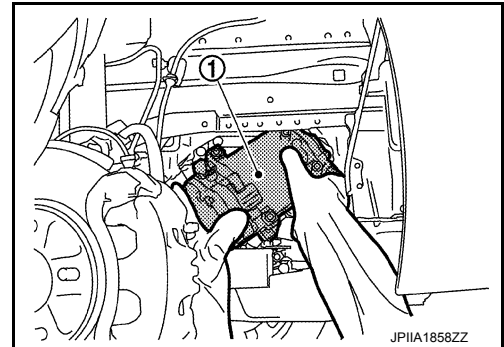

## INSTALLATION

Note the following items, and then install in the reverse order of removal.

**WARNING:**

 To prevent electric shock hazards, be sure to wear protective gear.



**CAUTION:**

- Be sure to reinstall high voltage harness clips in their original positions. If a clip is damaged, replace it with a new clip before installing.
- Before installing the new compressor, adjust the compressor oil level. Refer to [HA-30, "Lubricant Adjusting Procedure for Compressor Replacement"](#).
- To prevent degradation in insulation performance, use special electric compressor oil as the compressor oil.
- In order to prevent conventional PAG oil from becoming mixed in, never reuse recovered compressor oil and instead always use new oil. The use of oil including the conventional PAG oil may degrade the performance of insulation.
- To prevent performance degradation, never use a fluorescent agent in order to detect refrigerant leakage. Also be careful that a fluorescent agent never enter the oil.
- To prevent leakage of refrigerant, replace the O-ring with a new one. Apply a coat of compressor oil to the O-ring prior to installation.
- Perform a check for refrigerant leakage when charging with refrigerant. Refer to [HA-26, "Check Refrigerant Leakage"](#).
- Set the vehicle to **READY** and operate the air-conditioner for at least 1 minute with the vehicle parked to perform a break-in.

- If the compressor stay was replaced, first check that there is no dust or dirt on the surface of the compressor stay, then apply the new high voltage warning label at position (A), with the direction indicated by the arrow facing up.

 : Application direction of the label

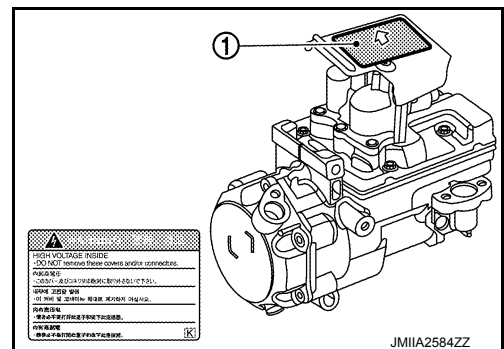

# ELECTRIC COMPRESSOR

< REMOVAL AND INSTALLATION >

[WITH HEAT PUMP SYSTEM]

- Follow the procedure below and connect the high voltage harness connector.

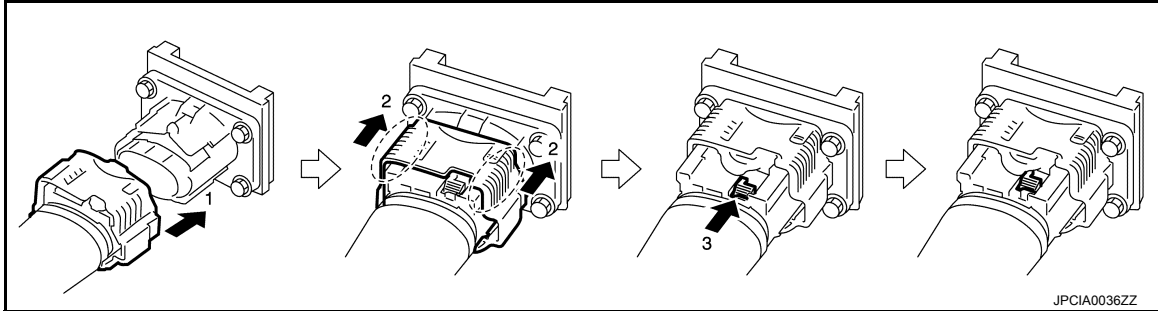

- After all parts are installed, be sure to check the equipotential. Refer to [HA-42. "Inspection"](#).

## Inspection

INFOID:000000010640942

### EQUIPOTENTIAL TEST

After installing the electric compressor, measure the resistance below.

- Between electric compressor (aluminum part) and body (ground bolt).
- Between electric compressor (aluminum part) and DC/DC-J/B (aluminum part).

#### **WARNING:**



To prevent electric shock hazards, be sure to wear protective gear.



**Standard** : **Less than 0.1  $\Omega$**

If the result deviates from the standard value, check for paint, oil, dirt, or other substance adhering to the bolts or conductive mounting parts. If such substances are found, clean the surrounding area and remove foreign substances.

# COOLER PIPE AND HOSE

< REMOVAL AND INSTALLATION >

[WITH HEAT PUMP SYSTEM]

## COOLER PIPE AND HOSE

Exploded View

INFOID:000000010640943

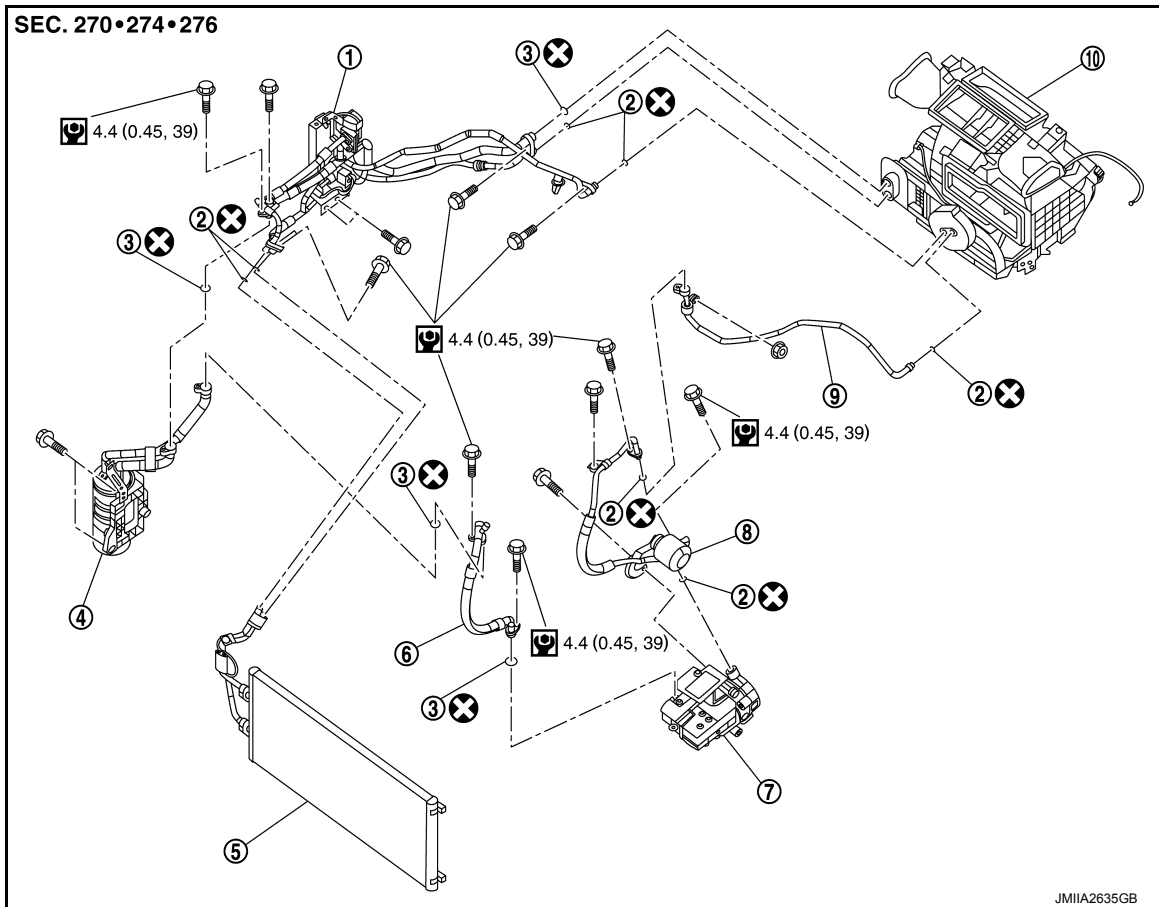

- |                                       |                                |                               |
|---------------------------------------|--------------------------------|-------------------------------|
| 1. 2-way and 3-way valve assembly     | 2. O-ring                      | 3. O-ring                     |
| 4. Accumulator assembly               | 5. Condenser                   | 6. Low-pressure flexible hose |
| 7. Electric compressor                | 8. High-pressure flexible hose | 9. High-pressure pipe         |
| 10. Heating and cooling unit assembly |                                |                               |

⊗: Always replace after every disassembly.

Ⓜ: N·m (kg-m, in-lb)

## HIGH-PRESSURE FLEXIBLE HOSE

### HIGH-PRESSURE FLEXIBLE HOSE : Removal and Installation

INFOID:000000010640944

#### DANGER:

 Since hybrid vehicles and electric vehicles contain a high voltage battery, there is the risk of electric shock, electric leakage, or similar accidents if the high voltage component and vehicle are handled incorrectly. Be sure to follow the correct work procedures when performing inspection and maintenance.

#### WARNING:

- Be sure to remove the service plug in order to disconnect the high voltage circuits before performing inspection or maintenance of high voltage system harnesses and parts.
- The removed service plug must always be carried in a pocket of the responsible worker or placed in the tool box during the procedure to prevent the plug from being connected by mistake.
- Be sure to wear insulating protective equipment consisting of glove, shoes, face shield and glasses before beginning work on the high voltage system.

A  
B  
C  
D  
E  
F  
G  
H  
HA  
J  
K  
L  
M  
N  
O  
P

# COOLER PIPE AND HOSE

< REMOVAL AND INSTALLATION >

[WITH HEAT PUMP SYSTEM]

- Never allow workers other than the responsible person to touch the vehicle containing high voltage parts. To keep others from touching the high voltage parts, these parts must be covered with an insulating sheet except when using them. Refer to [GI-34. "High Voltage Precautions"](#).

## CAUTION:

Never bring the vehicle into the READY status with the service plug removed unless otherwise instructed in the Service Manual. A malfunction may occur if this is not observed.

## REMOVAL

1. Use the refrigerant recovery equipment (for HFC134a) and recover the refrigerant. Refer to [HA-27. "Recycle Refrigerant"](#).
2. Remove radiator upper grille. Refer to [DLK-166. "RADIATOR UPPER GRILLE : Removal and Installation"](#).
3. Remove washer tank inlet. Refer to [WW-45. "Exploded View"](#).
4. Remove bolts (A), and then disconnect high-pressure flexible hose (1) from high pressure pipe (2).

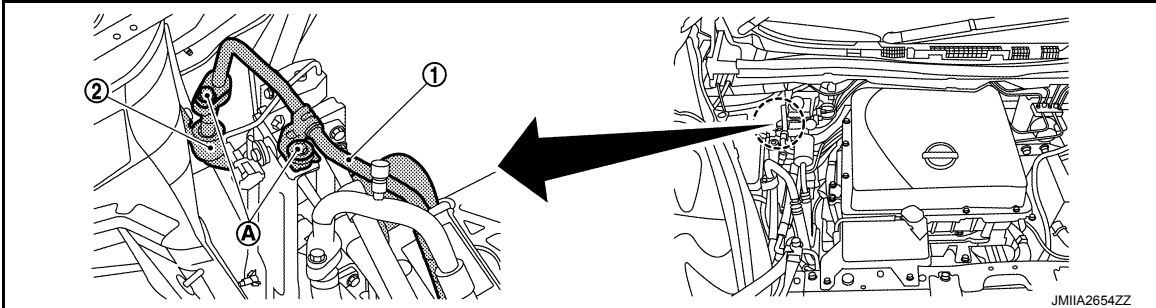

## CAUTION:

To prevent the inclusion of foreign matter, use a cap or vinyl tape to seal off the connection ports of the pipe and condenser from the atmosphere.

5. Remove bolts (A), and then disconnect high-pressure flexible hose from electric compressor.

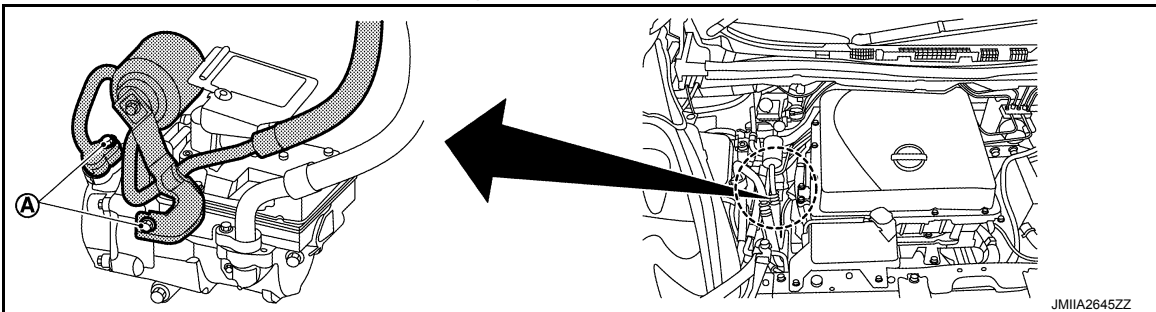

## WARNING:



To prevent electric shock hazards, be sure to wear protective gear.



## CAUTION:

To prevent the inclusion of foreign matter, use a cap or vinyl tape to seal off the connection ports of the pipe and electric compressor from the atmosphere.

6. Disconnect high-pressure flexible hose from the vehicle.

## INSTALLATION

Note the following items, and then install in the reverse order of removal.

## CAUTION:

- To prevent degradation in insulation performance, use special electric compressor oil as the compressor oil.
- In order to prevent conventional PAG oil from becoming mixed in, never reuse recovered compressor oil and instead always use new oil. The use of oil including the conventional PAG oil may degrade the performance of insulation.
- To prevent performance degradation, never use a fluorescent agent in order to detect refrigerant leakage. Also be careful that a fluorescent agent never enter the oil.

# COOLER PIPE AND HOSE

< REMOVAL AND INSTALLATION >

[WITH HEAT PUMP SYSTEM]

- To prevent leakage of refrigerant, replace the O-ring with a new one. Apply a coat of compressor oil to the O-ring prior to installation.
- Perform a check for refrigerant leakage when charging with refrigerant. Refer to [HA-26, "Check Refrigerant Leakage"](#).

## LOW-PRESSURE FLEXIBLE HOSE

### LOW-PRESSURE FLEXIBLE HOSE : Removal and Installation

INFOID:000000010640945

#### DANGER:

 Since hybrid vehicles and electric vehicles contain a high voltage battery, there is the risk of electric shock, electric leakage, or similar accidents if the high voltage component and vehicle are handled incorrectly. Be sure to follow the correct work procedures when performing inspection and maintenance.

#### WARNING:

- Be sure to remove the service plug in order to disconnect the high voltage circuits before performing inspection or maintenance of high voltage system harnesses and parts.
- The removed service plug must always be carried in a pocket of the responsible worker or placed in the tool box during the procedure to prevent the plug from being connected by mistake.
- Be sure to wear insulating protective equipment consisting of glove, shoes, face shield and glasses before beginning work on the high voltage system.
- Never allow workers other than the responsible person to touch the vehicle containing high voltage parts. To keep others from touching the high voltage parts, these parts must be covered with an insulating sheet except when using them. Refer to [GI-34, "High Voltage Precautions"](#).

#### CAUTION:

Never bring the vehicle into the READY status with the service plug removed unless otherwise instructed in the Service Manual. A malfunction may occur if this is not observed.

#### REMOVAL

1. Use the refrigerant recovery equipment (for HFC134a) and recover the refrigerant. Refer to [HA-27, "Recycle Refrigerant"](#).
2. Remove cowl top extension. Refer to [EXT-19, "Removal and Installation"](#).
3. Remove radiator upper grille. Refer to [DLK-166, "RADIATOR UPPER GRILLE : Removal and Installation"](#).
4. Remove bolt (A), and then disconnect low-pressure flexible hose (1) from accumulator assembly (2).

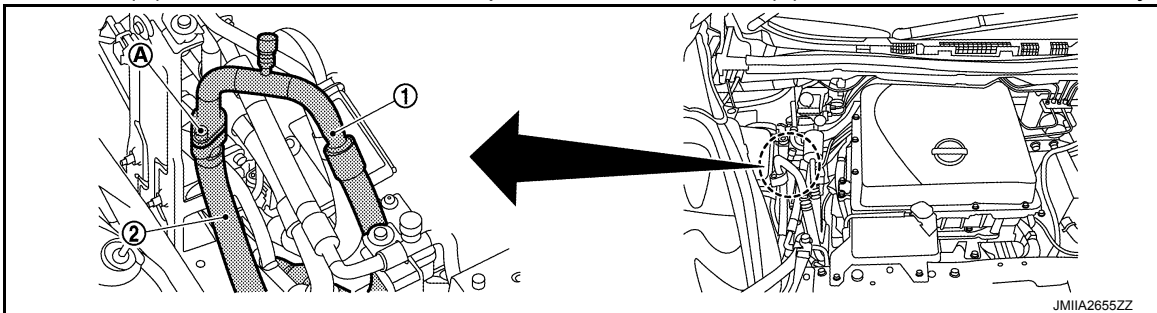

#### CAUTION:

To prevent the inclusion of foreign matter, use a cap or vinyl tape to seal off the connection ports of the pipe and expansion valve from the atmosphere.

5. Remove bolt (A), and then disconnect low-pressure flexible hose from electric compressor.

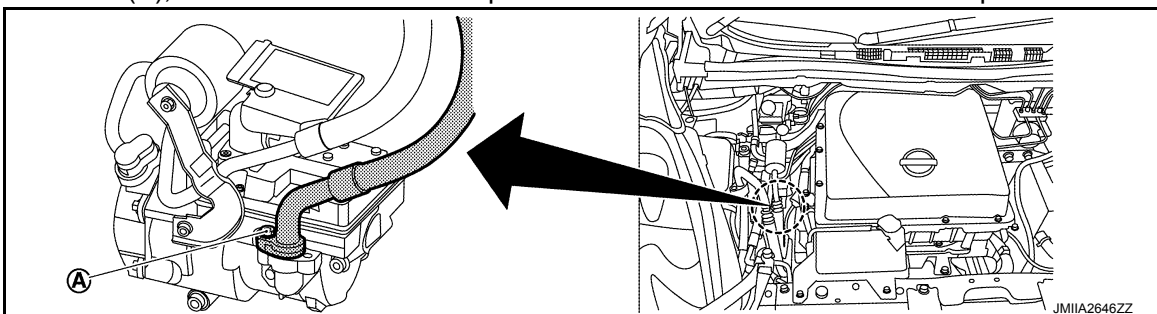

# COOLER PIPE AND HOSE

< REMOVAL AND INSTALLATION >

[WITH HEAT PUMP SYSTEM]

## WARNING:



To prevent electric shock hazards, be sure to wear protective gear.



## CAUTION:

To prevent the inclusion of foreign matter, use a cap or vinyl tape to seal off the connection ports of the pipe and electric compressor from the atmosphere.

6. Disconnect low-pressure flexible hose from the vehicle.

## INSTALLATION

Note the following items, and then install in the reverse order of removal.

### CAUTION:

- To prevent degradation in insulation performance, use special electric compressor oil as the compressor oil.
- In order to prevent conventional PAG oil from becoming mixed in, never reuse recovered compressor oil and instead always use new oil. The use of oil including the conventional PAG oil may degrade the performance of insulation.
- To prevent performance degradation, never use a fluorescent agent in order to detect refrigerant leakage. Also be careful that a fluorescent agent never enter the oil.
- To prevent leakage of refrigerant, replace the O-ring with a new one. Apply a coat of compressor oil to the O-ring prior to installation.
- Perform a check for refrigerant leakage when charging with refrigerant. Refer to [HA-26, "Check Refrigerant Leakage"](#).

## HIGH-PRESSURE PIPE

### HIGH-PRESSURE PIPE : Removal and Installation

INFOID:000000010640946

### DANGER:



Since hybrid vehicles and electric vehicles contain a high voltage battery, there is the risk of electric shock, electric leakage, or similar accidents if the high voltage component and vehicle are handled incorrectly. Be sure to follow the correct work procedures when performing inspection and maintenance.

### WARNING:

- Be sure to remove the service plug in order to disconnect the high voltage circuits before performing inspection or maintenance of high voltage system harnesses and parts.
- The removed service plug must always be carried in a pocket of the responsible worker or placed in the tool box during the procedure to prevent the plug from being connected by mistake.
- Be sure to wear insulating protective equipment consisting of glove, shoes, face shield and glasses before beginning work on the high voltage system.
- Never allow workers other than the responsible person to touch the vehicle containing high voltage parts. To keep others from touching the high voltage parts, these parts must be covered with an insulating sheet except when using them. Refer to [GI-34, "High Voltage Precautions"](#).

### CAUTION:

Never bring the vehicle into the READY status with the service plug removed unless otherwise instructed in the Service Manual. A malfunction may occur if this is not observed.

## REMOVAL

1. Remove low-pressure flexible hose. Refer to [HA-45, "LOW-PRESSURE FLEXIBLE HOSE : Removal and Installation"](#).
2. Remove washer tank inlet. Refer to [WW-45, "Exploded View"](#).
3. Remove cowl top extension. Refer to [EXT-19, "Removal and Installation"](#).



## COOLER PIPE AND HOSE

< REMOVAL AND INSTALLATION >

[WITH HEAT PUMP SYSTEM]

4. Remove bolts (A), and then disconnect high-pressure flexible hose (1) from the high-pressure pipe (2).

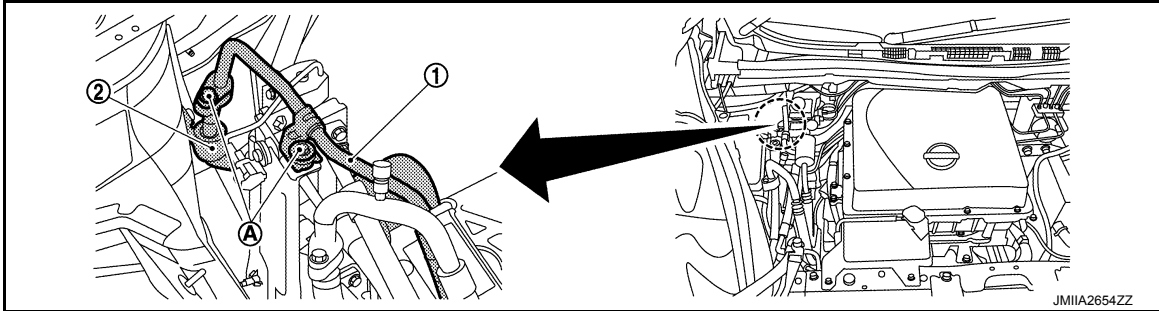

**CAUTION:**

To prevent the inclusion of foreign matter, use a cap or vinyl tape to seal off the connection ports of the pipe and condenser from the atmosphere.

5. Remove bolt (A), and then disconnect high-pressure pipe (2) from the inner condenser.

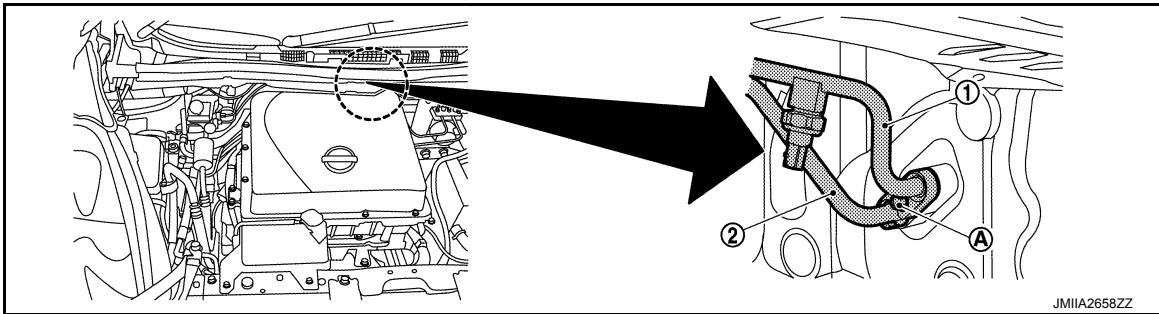

**CAUTION:**

To prevent the inclusion of foreign matter, use a cap or vinyl tape to seal off the connection ports of the pipe and expansion valve from the atmosphere.

6. Remove nut (A) and disconnect high-pressure pipe from the vehicle.

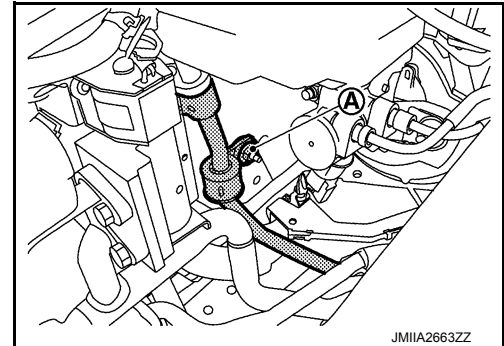

### INSTALLATION

Note the following items, and then install in the reverse order of removal.

**CAUTION:**

- To prevent degradation in insulation performance, use special electric compressor oil as the compressor oil.
- In order to prevent conventional PAG oil from becoming mixed in, never reuse recovered compressor oil and instead always use new oil. The use of oil including the conventional PAG oil may degrade the performance of insulation.
- To prevent performance degradation, never use a fluorescent agent in order to detect refrigerant leakage. Also be careful that a fluorescent agent never enter the oil.
- To prevent leakage of refrigerant, replace the O-ring with a new one. Apply a coat of compressor oil to the O-ring prior to installation.
- Perform a check for refrigerant leakage when charging with refrigerant. Refer to [HA-26. "Check Refrigerant Leakage"](#).

### 2-WAY VALVE AND 3-WAY VALVE ASSEMBLY

2-WAY VALVE AND 3-WAY VALVE ASSEMBLY : Removal and Installation INFOID:0000000110640947

**DANGER:**

# COOLER PIPE AND HOSE

< REMOVAL AND INSTALLATION >

[WITH HEAT PUMP SYSTEM]

**⚠** Since hybrid vehicles and electric vehicles contain a high voltage battery, there is the risk of electric shock, electric leakage, or similar accidents if the high voltage component and vehicle are handled incorrectly. Be sure to follow the correct work procedures when performing inspection and maintenance.

## WARNING:

- Be sure to remove the service plug in order to disconnect the high voltage circuits before performing inspection or maintenance of high voltage system harnesses and parts.
- The removed service plug must always be carried in a pocket of the responsible worker or placed in the tool box during the procedure to prevent the plug from being connected by mistake.
- Be sure to wear insulating protective equipment consisting of glove, shoes, face shield and glasses before beginning work on the high voltage system.
- Never allow workers other than the responsible person to touch the vehicle containing high voltage parts. To keep others from touching the high voltage parts, these parts must be covered with an insulating sheet except when using them. Refer to [GI-34, "High Voltage Precautions"](#).

## CAUTION:

Never bring the vehicle into the READY status with the service plug removed unless otherwise instructed in the Service Manual. A malfunction may occur if this is not observed.

## REMOVAL

1. Use the refrigerant recovery equipment (for HFC134a) and recover the refrigerant. Refer to [HA-27, "Recycle Refrigerant"](#).
2. Remove radiator upper grille. Refer to [DLK-166, "RADIATOR UPPER GRILLE : Removal and Installation"](#).
3. Remove washer tank inlet. Refer to [WW-45, "Exploded View"](#).
4. Remove bolts (A), and then disconnect high-pressure flexible hose (1) from the high-pressure pipe (2).

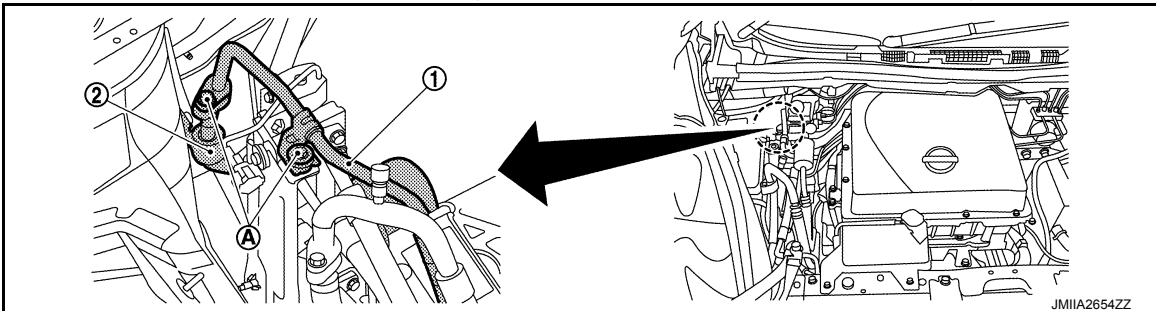

## CAUTION:

To prevent the inclusion of foreign matter, use a cap or vinyl tape to seal off the connection ports of the hose and pipe from the atmosphere.

5. Remove bolts (A), and then disconnect high-pressure hoses and pipes (1) from condenser (2).

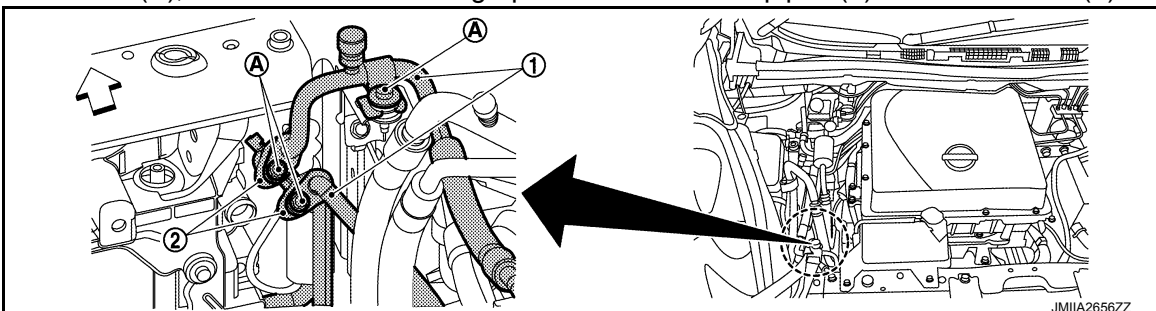

## CAUTION:

To prevent the inclusion of foreign matter, use a cap or vinyl tape to seal off the connection ports of the hose and pipe from the atmosphere.



# COOLER PIPE AND HOSE

< REMOVAL AND INSTALLATION >

[WITH HEAT PUMP SYSTEM]

6. Remove bolt (A) and then disconnect high-pressure pipes (1) and (2) from inner condenser.

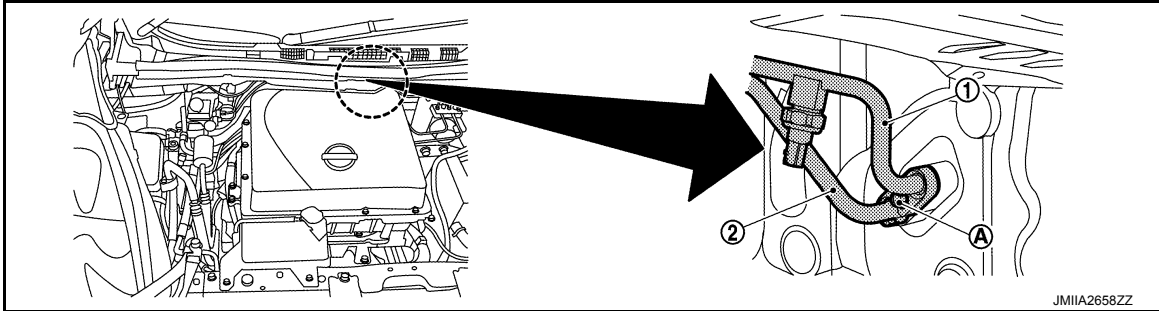

**CAUTION:**

To prevent the inclusion of foreign matter, use a cap or vinyl tape to seal off the connection ports and the hose and pipe from the atmosphere.

7. Remove bolt (A) and then disconnect low pressure pipes (1) from evaporator.

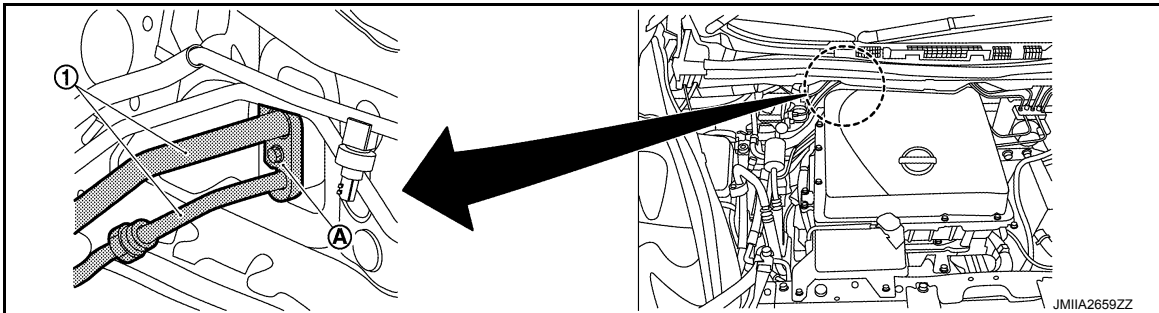

**CAUTION:**

To prevent the inclusion of foreign matter, use a cap or vinyl tape to seal off the connection ports and the pipes from the atmosphere.

8. Remove bolt (A), and then disconnect low-pressure hose (1) from accumulator assembly.

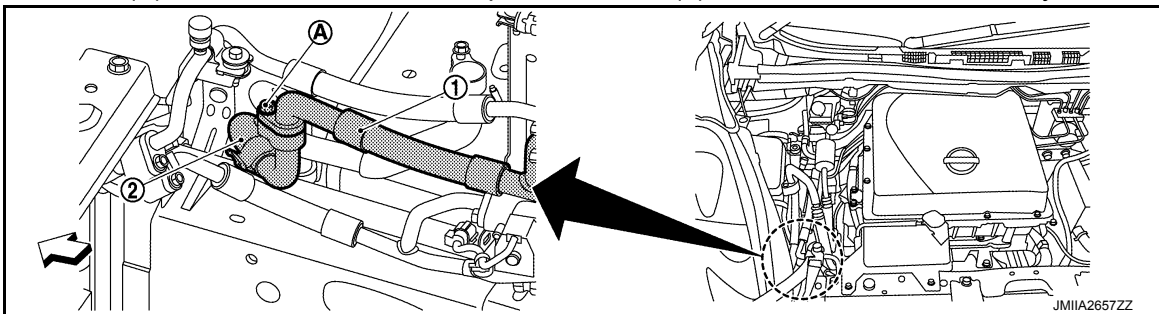

← : Vehicle front

**CAUTION:**

To prevent the inclusion of foreign matter, use a cap or vinyl tape to seal off the connection ports and the hose from the atmosphere.

9. Disconnect harness connectors, remove bolts (A), and then remove the 2-way valve and 3-way valve assembly.

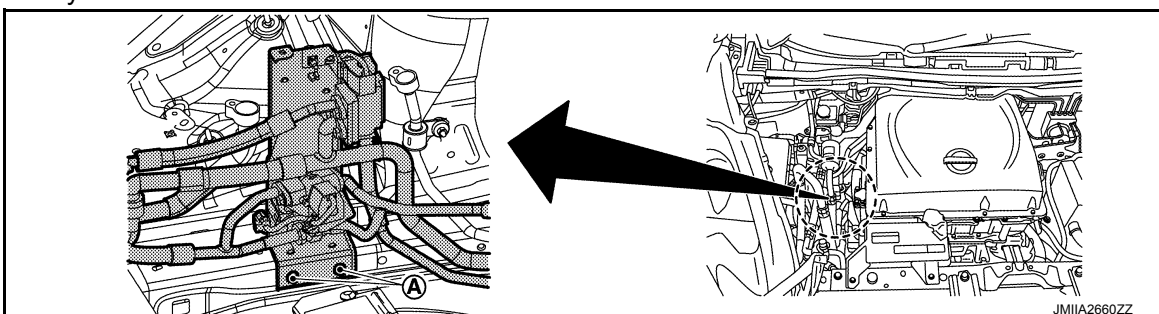

A  
B  
C  
D  
E  
F  
G  
H  
HA  
J  
K  
L  
M  
N  
O  
P

# COOLER PIPE AND HOSE

< REMOVAL AND INSTALLATION >

[WITH HEAT PUMP SYSTEM]

## CAUTION:

To prevent the inclusion of foreign matter, use a cap or vinyl tape to seal off the hoses and pipes from the atmosphere.

## INSTALLATION

Note the following items, and then install in the reverse order of removal.

## CAUTION:

- To prevent degradation in insulation performance, use special electric compressor oil as the compressor oil.
- In order to prevent conventional PAG oil from becoming mixed in, never reuse recovered compressor oil and instead always use new oil. The use of oil including the conventional PAG oil may degrade the performance of insulation.
- To prevent performance degradation, never use a fluorescent agent in order to detect refrigerant leakage. Also be careful that a fluorescent agent never enter the oil.
- To prevent leakage of refrigerant, replace the O-ring with a new one. Apply a coat of compressor oil to the O-ring prior to installation.
- Perform a check for refrigerant leakage when charging with refrigerant. Refer to [HA-26, "Check Refrigerant Leakage"](#).

## ACCUMULATOR ASSEMBLY

### ACCUMULATOR ASSEMBLY : Removal and Installation

INFOID:0000000010640948

## DANGER:

 Since hybrid vehicles and electric vehicles contain a high voltage battery, there is the risk of electric shock, electric leakage, or similar accidents if the high voltage component and vehicle are handled incorrectly. Be sure to follow the correct work procedures when performing inspection and maintenance.

## WARNING:

- Be sure to remove the service plug in order to disconnect the high voltage circuits before performing inspection or maintenance of high voltage system harnesses and parts.
- The removed service plug must always be carried in a pocket of the responsible worker or placed in the tool box during the procedure to prevent the plug from being connected by mistake.
- Be sure to wear insulating protective equipment consisting of glove, shoes, face shield and glasses before beginning work on the high voltage system.
- Never allow workers other than the responsible person to touch the vehicle containing high voltage parts. To keep others from touching the high voltage parts, these parts must be covered with an insulating sheet except when using them. Refer to [GI-34, "High Voltage Precautions"](#).

## CAUTION:

Never bring the vehicle into the READY status with the service plug removed unless otherwise instructed in the Service Manual. A malfunction may occur if this is not observed.

## REMOVAL

1. Use the refrigerant recovery equipment (for HFC134a) and recover the refrigerant. Refer to [HA-27, "Recycle Refrigerant"](#).
2. Remove radiator upper grille. Refer to [DLK-166, "RADIATOR UPPER GRILLE : Removal and Installation"](#).
3. Remove bolt (A) from low-pressure flexible hose (1).

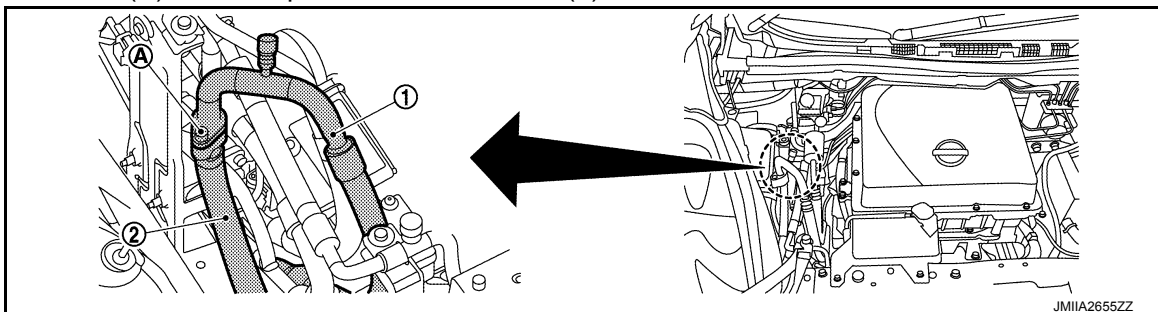

## COOLER PIPE AND HOSE

< REMOVAL AND INSTALLATION >

[WITH HEAT PUMP SYSTEM]

4. Remove mounting bolt (A), and then disconnect low-pressure hose (1) from accumulator assembly (2).

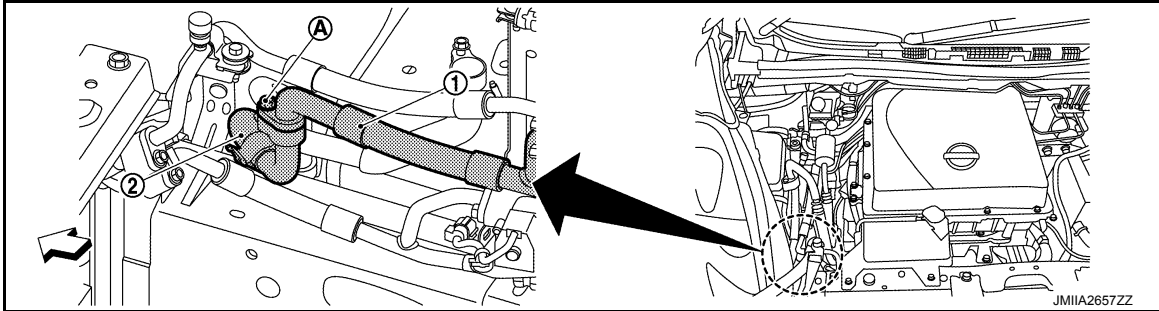

**CAUTION:**

To prevent the inclusion of foreign matter, use a cap or vinyl tape to seal off the connection ports of the pipe and expansion valve from the atmosphere.

5. Remove front wheel and tire (RH). Refer to [WT-45, "Removal and Installation"](#).
6. Remove front fender protector (RH). Refer to [EXT-21, "FENDER PROTECTOR : Removal and Installation"](#).
7. Remove nuts (A), and then lift and twist accumulator to remove from the vehicle.

**WARNING:**

 To prevent electric shock hazards, be sure to wear protective gear.



**CAUTION:**

To prevent the inclusion of foreign matter, use a cap or vinyl tape to seal off the connection ports of the pipes and accumulator from the atmosphere.

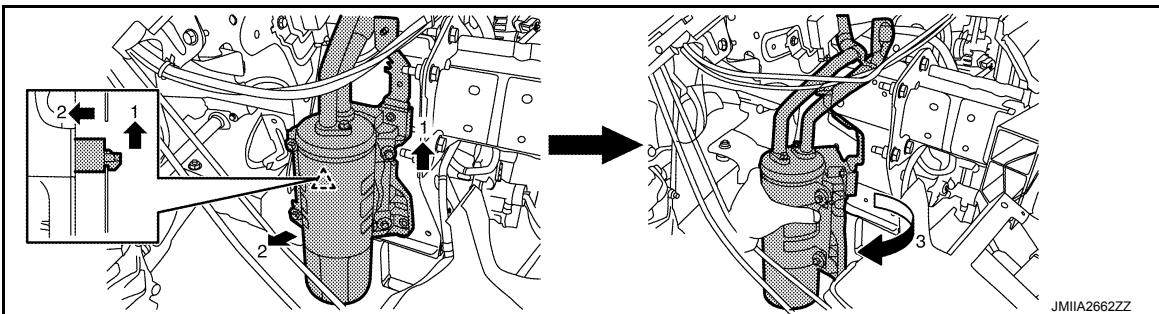
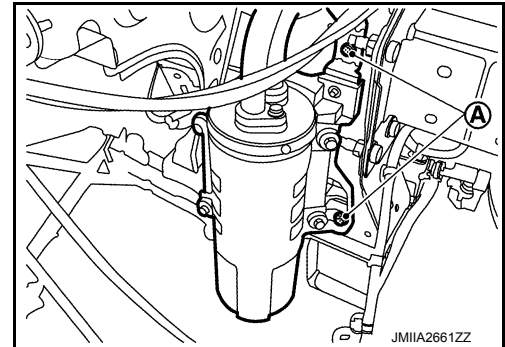

### INSTALLATION

Note the following items, and then install in the reverse order of removal.

**CAUTION:**

- To prevent degradation in insulation performance, use special electric compressor oil as the compressor oil.
- In order to prevent conventional PAG oil from becoming mixed in, never reuse recovered compressor oil and instead always use new oil. The use of oil including the conventional PAG oil may degrade the performance of insulation.
- To prevent performance degradation, never use a fluorescent agent in order to detect refrigerant leakage. Also be careful that a fluorescent agent never enter the oil.
- To prevent leakage of refrigerant, replace the O-ring with a new one. Apply a coat of compressor oil to the O-ring prior to installation.
- Perform a check for refrigerant leakage when charging with refrigerant. Refer to [HA-26, "Check Refrigerant Leakage"](#).

# CONDENSER

< REMOVAL AND INSTALLATION >

[WITH HEAT PUMP SYSTEM]

## CONDENSER

Exploded View

INFOID:000000010640949

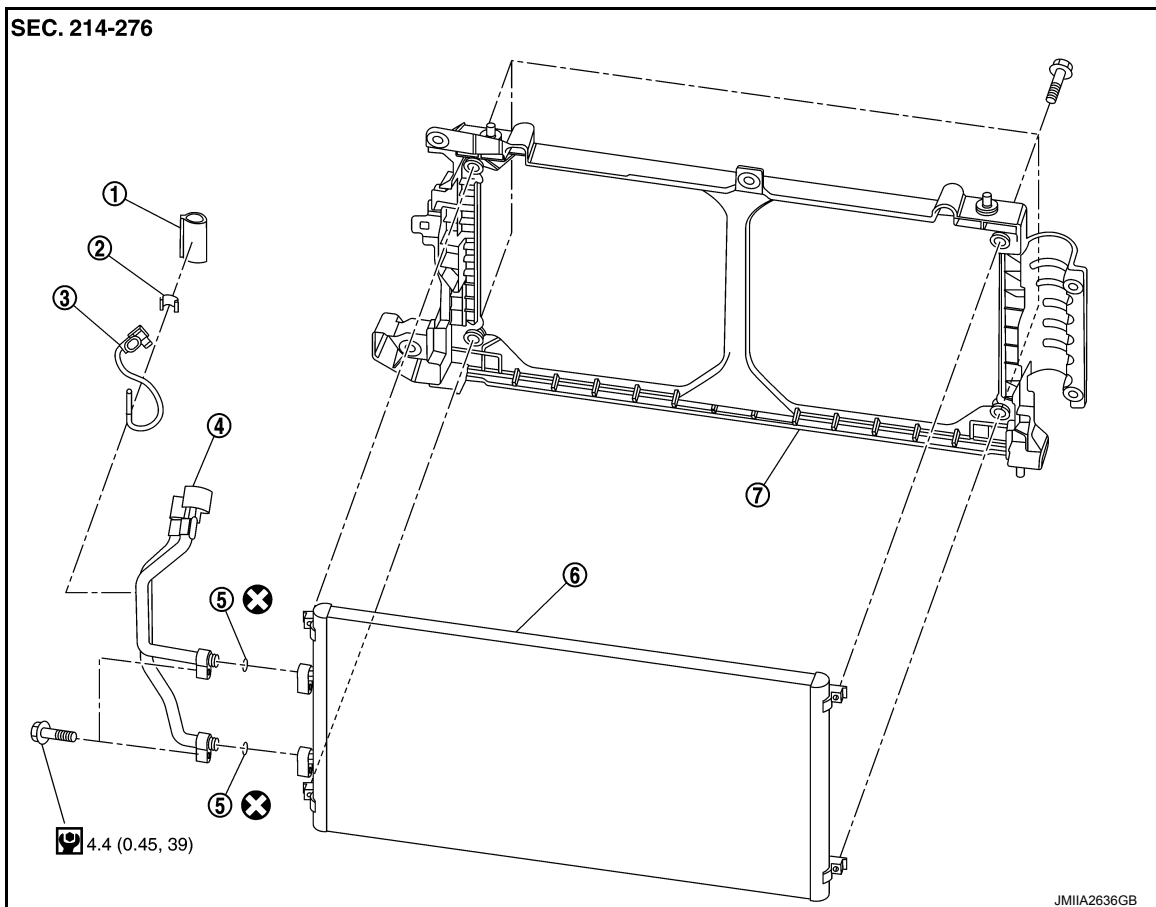

- |                               |           |  |
|-------------------------------|-----------|--|
| 1. Sleeve                     | 2. Clip   | 3. Compressor suction refrigerant temperature sensor |
| 4. Condenser pipe assembly    | 5. O-ring | 6. Condenser   |
| 7. Condenser support assembly |           |  |

⊗: Always replace after every disassembly.

⊙: N·m (kg-m, in-lb)

⊙: N·m (kg-m, ft-lb)

## Removal and Installation

INFOID:000000010640950

### DANGER:



Since hybrid vehicles and electric vehicles contain a high voltage battery, there is the risk of electric shock, electric leakage, or similar accidents if the high voltage component and vehicle are handled incorrectly. Be sure to follow the correct work procedures when performing inspection and maintenance.

### WARNING:

- Be sure to remove the service plug in order to disconnect the high voltage circuits before performing inspection or maintenance of high voltage system harnesses and parts.
- The removed service plug must always be carried in a pocket of the responsible worker or placed in the tool box during the procedure to prevent the plug from being connected by mistake.
- Be sure to wear insulating protective equipment consisting of glove, shoes, face shield and glasses before beginning work on the high voltage system.



# CONDENSER

< REMOVAL AND INSTALLATION >

[WITH HEAT PUMP SYSTEM]

- Never allow workers other than the responsible person to touch the vehicle containing high voltage parts. To keep others from touching the high voltage parts, these parts must be covered with an insulating sheet except when using them. Refer to [GI-34, "High Voltage Precautions"](#).

**CAUTION:**

Never bring the vehicle into the READY status with the service plug removed unless otherwise instructed in the Service Manual. A malfunction may occur if this is not observed.

## REMOVAL

1. Use the refrigerant recovery equipment (for HFC134a) and recover the refrigerant. Refer to [HA-27, "Recycle Refrigerant"](#).
2. Remove radiator upper grille. Refer to [DLK-166, "RADIATOR UPPER GRILLE : Removal and Installation"](#).
3. Remove washer tank inlet. Refer to [WW-45, "Exploded View"](#).
4. Remove bolts (A), and then disconnect high-pressure flexible hose (1) and high-pressure pipe (2) from condenser.

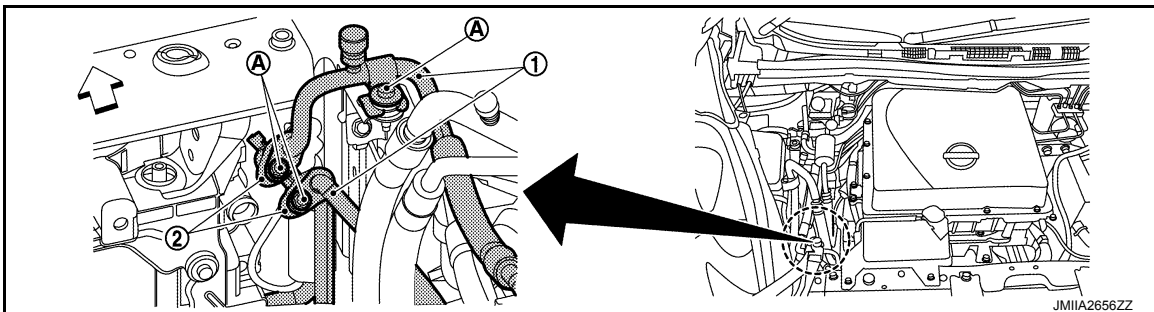

**CAUTION:**

To prevent the inclusion of foreign matter, use a cap or vinyl tape to seal off the connection ports of the pipe and condenser from the atmosphere.

5. Remove charge port bracket. Refer to [DLK-159, "Exploded View"](#).
6. Remove radiator core support lower stay. Refer to [DLK-162, "Exploded View"](#).
7. Remove radiator core support upper. Refer to [DLK-162, "RADIATOR CORE SUPPORT UPPER : Removal and Installation"](#).
8. Remove cooling fan assembly. Refer to [HCO-22, "Removal and Installation"](#).
9. Remove bolts (A) then tilt condenser upwards to remove.

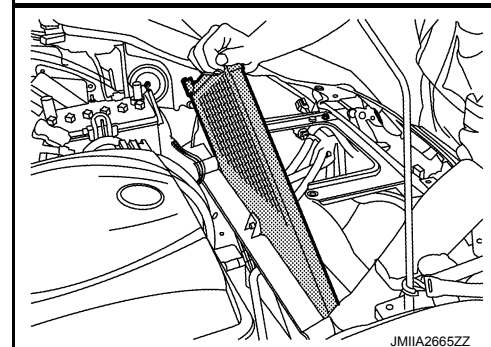
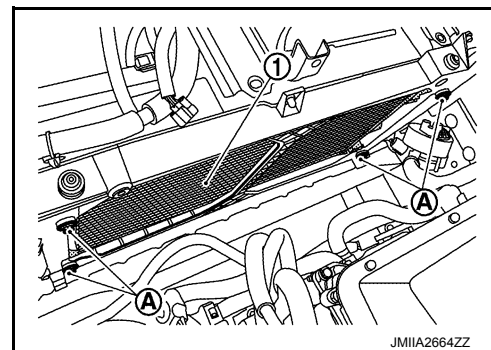

## INSTALLATION

# CONDENSER

< REMOVAL AND INSTALLATION >

[WITH HEAT PUMP SYSTEM]

Note the following items, and then install in the reverse order of removal.

**CAUTION:**

- When installing the condenser, securely insert the mating part indicated by the arrow in the diagram.
- To prevent degradation in insulation performance, use special electric compressor oil as the compressor oil.
- In order to prevent conventional PAG oil from becoming mixed in, never reuse recovered compressor oil and instead always use new oil. The use of oil including the conventional PAG oil may degrade the performance of insulation.
- To prevent performance degradation, never use a fluorescent agent in order to detect refrigerant leakage. Also be careful that a fluorescent agent never enter the oil.
- After installing a new condenser, adjust the compressor oil level. Refer to [HA-29, "Lubricant Adjusting Procedure for Components Replacement Except Compressor"](#).
- To prevent leakage of refrigerant, replace the O-ring with a new one. Apply a coat of compressor oil to the O-ring prior to installation.
- Perform a check for refrigerant leakage when charging with refrigerant. Refer to [HA-26, "Check Refrigerant Leakage"](#).

# REFRIGERANT PRESSURE SENSOR

< REMOVAL AND INSTALLATION >

[WITH HEAT PUMP SYSTEM]

## REFRIGERANT PRESSURE SENSOR

### Removal and Installation

INFOID:0000000011059265

#### DANGER:



Since hybrid vehicles and electric vehicles contain a high voltage battery, there is the risk of electric shock, electric leakage, or similar accidents if the high voltage component and vehicle are handled incorrectly. Be sure to follow the correct work procedures when performing inspection and maintenance.

#### WARNING:

- Be sure to remove the service plug in order to disconnect the high voltage circuits before performing inspection or maintenance of high voltage system harnesses and parts.
- The removed service plug must always be carried in a pocket of the responsible worker or placed in the tool box during the procedure to prevent the plug from being connected by mistake.
- Be sure to wear insulating protective equipment consisting of glove, shoes, face shield and glasses before beginning work on the high voltage system.
- Never allow workers other than the responsible person to touch the vehicle containing high voltage parts. To keep others from touching the high voltage parts, these parts must be covered with an insulating sheet except when using them. Refer to [GI-34, "High Voltage Precautions"](#).

#### CAUTION:

Never bring the vehicle into the READY status with the service plug removed unless otherwise instructed in the Service Manual. A malfunction may occur if this is not observed.

### REMOVAL

1. Remove cowl top. Refer to [EXT-19, "Removal and Installation"](#).
2. Disconnect harness (A) to remove pressure sensor (1).

#### CAUTION:

- Wrap the liquid tank with shop cloth to prevent scratches.
- To prevent the inclusion of foreign matter, use a cap or vinyl tape to seal off the refrigerant pressure sensor mounting point on the liquid tank from the atmosphere.

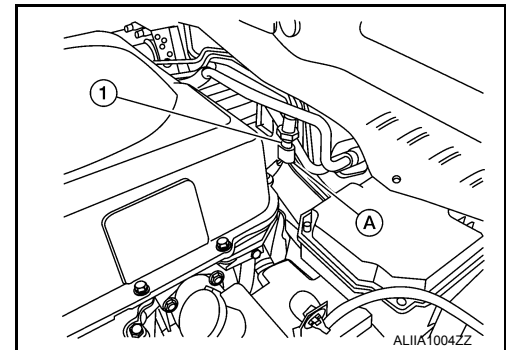

### INSTALLATION

Note the following items, and then install in the reverse order of removal.

#### CAUTION:

- To prevent leakage of refrigerant, replace the O-ring with a new one. Apply a coat of compressor oil to the O-ring prior to installation.
- Perform a check for refrigerant leakage when charging with refrigerant. Refer to [HA-85, "Check Refrigerant Leakage"](#).

# HEATING AND COOLING UNIT ASSEMBLY

< REMOVAL AND INSTALLATION >

[WITH HEAT PUMP SYSTEM]

## HEATING AND COOLING UNIT ASSEMBLY

Exploded View

INFOID:000000010640951

### REMOVAL

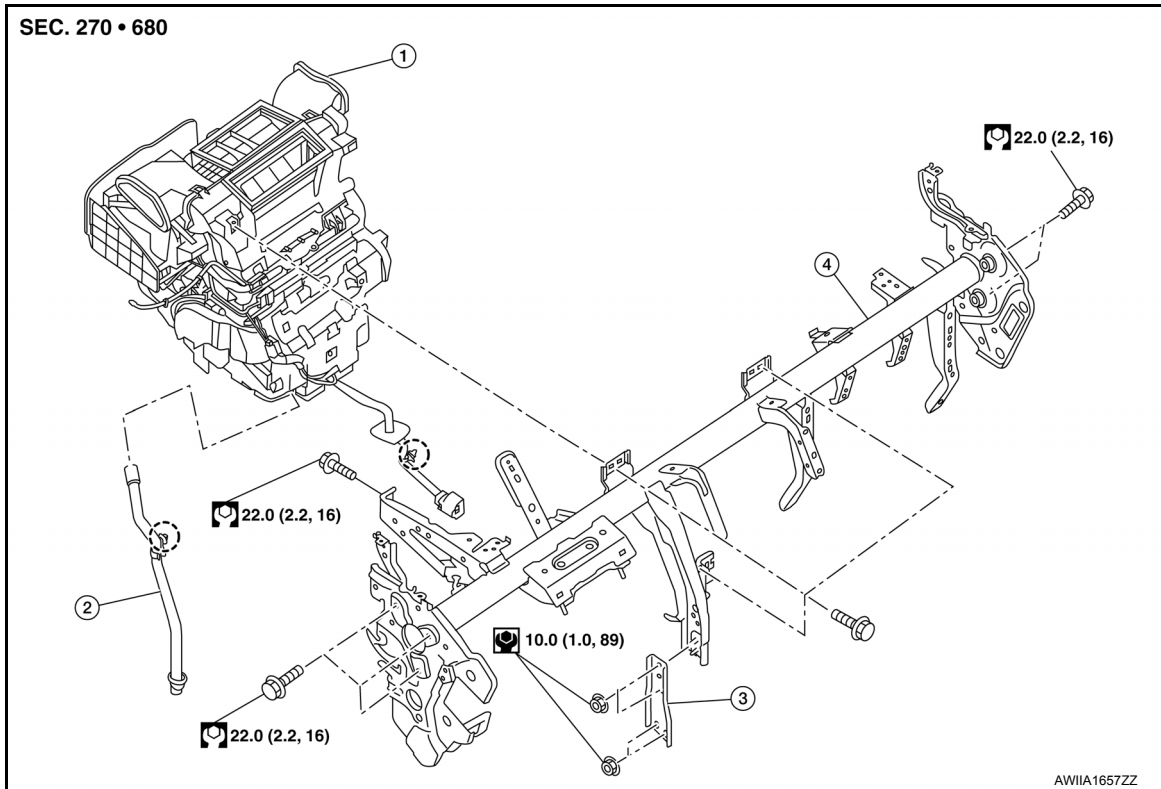

1. Heating and cooling unit assembly
2. Drain hose
3. Instrument stay
4. Steering member

○ : Clip

⊙ : N·m (kg-m, in-lb)

⊙ : N·m (kg-m, ft-lb)

### DISASSEMBLY



# HEATING AND COOLING UNIT ASSEMBLY

< REMOVAL AND INSTALLATION >

[WITH HEAT PUMP SYSTEM]

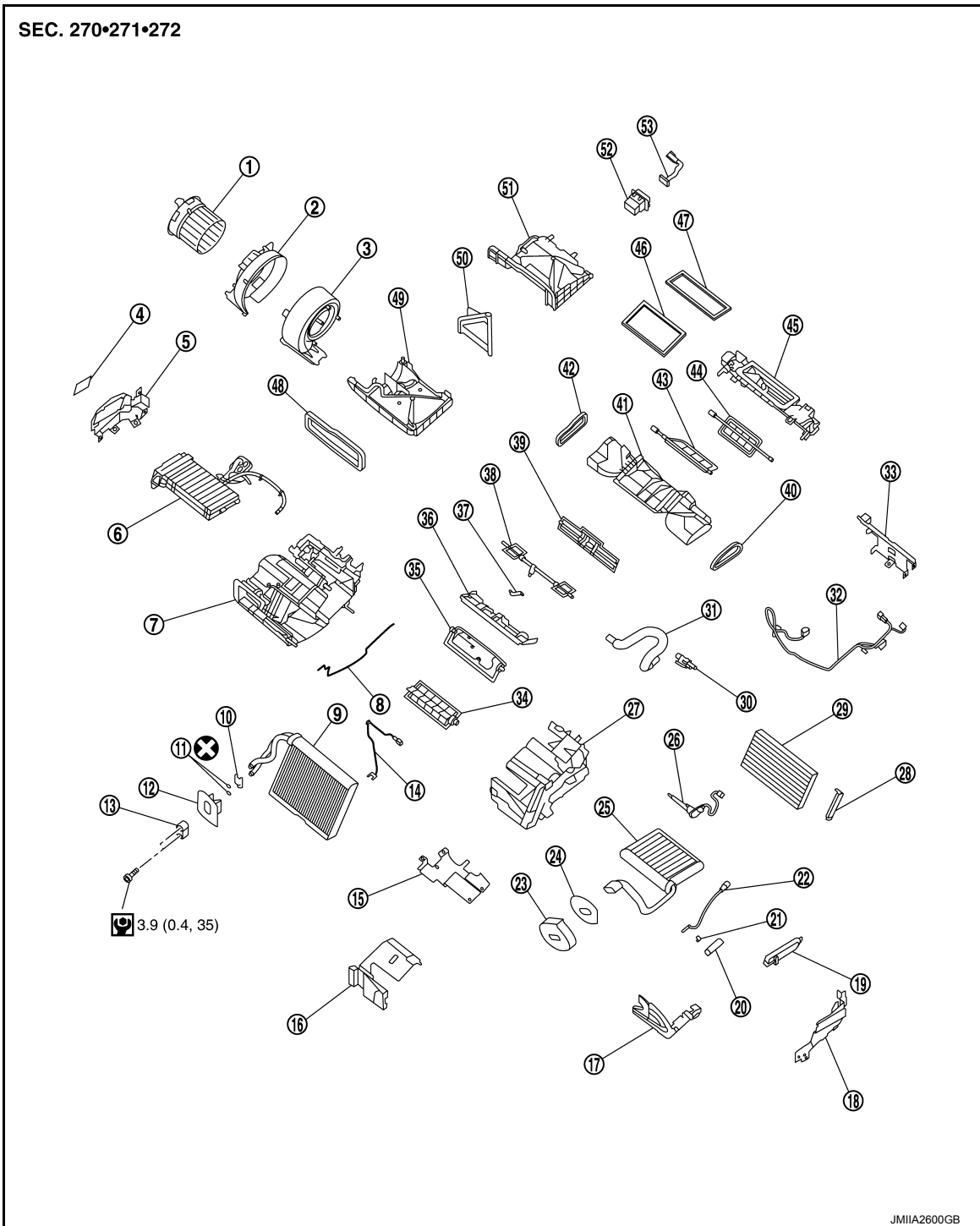

- |   |                                |                             |
|---|--------------------------------|-----------------------------|
| 1. Blower motor   | 2. Blower case RH              | 3. Blower case LH           |
| 4. High voltage warning label                           | 5. PTC heater shield RH        | 6. PTC heater               |
| 7. Heating and cooling unit assembly case RH            | 8. Case packing                | 9. Evaporator               |
| 10. Plate   | 11. O-rings                    | 12. Grommet                 |
| 13. Low pressure pipe flange                            | 14. Intake sensor              | 15. PTC heater shield lower |
| 16. Evaporator cover                                    | 17. Inner condenser pipe cover | 18. PTC heater shield LH    |
| 19. Inner condenser cover                               | 20. Sleeve                     | 21. Clip                    |
| 22. Compressor discharge refrigerant temperature sensor | 23. Grommet                    | 24. Gasket                  |

A  
B  
C  
D  
E  
F  
G  
H  
HA  
J  
K  
L  
M  
N  
O  
P

# HEATING AND COOLING UNIT ASSEMBLY

< REMOVAL AND INSTALLATION >

[WITH HEAT PUMP SYSTEM]

- |  |   |   |
|--|---|---|
| 25. Inner condenser                      | 26. PTC heater outlet and A/C unit case air temperature sensor assembly | 27. Heating and cooling unit assembly case LH |
| 28. Filter cover                         | 29. Filter  | 30. Aspirator                                 |
| 31. Aspirator hose                       | 32. Harness   | 33. PTC heater shield                         |
| 34. Lower air mix door                   | 35. Upper air mix door  | 36. Air mix door guide                        |
| 37. Front door rod                       | 38. Side ventilator door  | 39. Foot door                                 |
| 40. Side ventilator seal LH              | 41. Lower attachment case   | 42. Side ventilator seal RH                   |
| 43. Center ventilator and defroster door | 44. Sub defroster door  | 45. Upper attachment case                     |
| 46. Defroster seal                       | 47. Ventilator seal   | 48. Intake seal                               |
| 49. Lower intake case                    | 50. Intake door   | 51. Upper intake seal                         |
| 52. Power transistor                     | 53. Sub harness   |   |

⊗ : Always replace after every disassembly.

⊙ : N·m (kg·m, in·lb)

## HEATING AND COOLING UNIT ASSEMBLY

### HEATING AND COOLING UNIT ASSEMBLY : Removal and Installation

INFOID:000000010640952

#### **DANGER:**

 Since hybrid vehicles and electric vehicles contain a high voltage battery, there is the risk of electric shock, electric leakage, or similar accidents if the high voltage component and vehicle are handled incorrectly. Be sure to follow the correct work procedures when performing inspection and maintenance.

#### **WARNING:**

- Be sure to remove the service plug in order to disconnect the high voltage circuits before performing inspection or maintenance of high voltage system harnesses and parts.
- The removed service plug must always be carried in a pocket of the responsible worker or placed in the tool box during the procedure to prevent the plug from being connected by mistake.
- Be sure to wear insulating protective equipment consisting of glove, shoes, face shield and glasses before beginning work on the high voltage system.
- Never allow workers other than the responsible person to touch the vehicle containing high voltage parts. To keep others from touching the high voltage parts, these parts must be covered with an insulating sheet except when using them. Refer to [GI-34, "High Voltage Precautions"](#).

#### **CAUTION:**

Never bring the vehicle into the READY status with the service plug removed unless otherwise instructed in the Service Manual. A malfunction may occur if this is not observed.

#### REMOVAL

#### **WARNING:**

Disconnect high voltage circuit. Refer to [GI-33, "How to Disconnect High Voltage"](#).

1. Check voltage in high voltage circuit. (Check that condenser are discharged.)
  - a. Lift up the vehicle, and then remove Li-ion battery under covers. Refer to [EVB-181, "Exploded View"](#).
  - b. Disconnect high voltage connector from front side of Li-ion battery. Refer to [EVB-181, "Removal and Installation"](#).
  - c. Measure voltage between high voltage harness terminals.

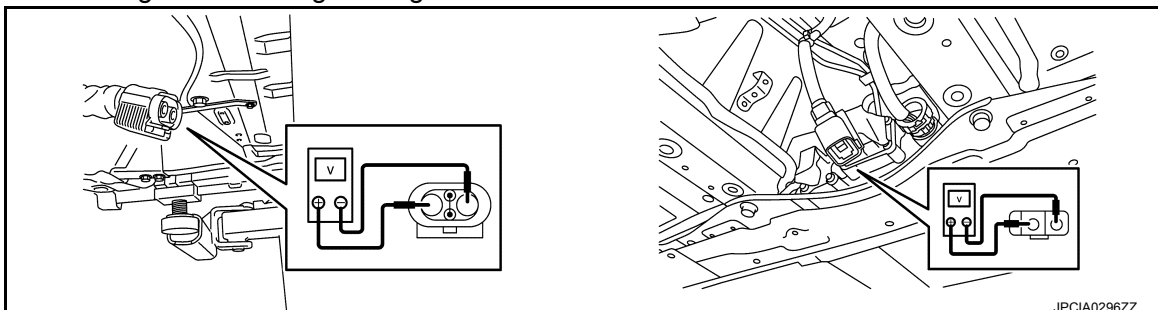

# HEATING AND COOLING UNIT ASSEMBLY

< REMOVAL AND INSTALLATION >

[WITH HEAT PUMP SYSTEM]

**DANGER:**

 Touching high voltage components without using the appropriate protective equipment will cause electrocution.



**Standard : 5 V or less**

**CAUTION:**

For voltage measurements, use a tester which can measure to 500 V or higher.

2. Use the refrigerant recovery equipment (for HFC134a) and recover the refrigerant. Refer to [HA-27, "Recycle Refrigerant"](#).
3. Remove cowl top extension. Refer to [EXT-19, "Removal and Installation"](#).
4. Remove bolt (A), and then disconnect low-pressure pipe (1) and high-pressure pipe (2) from evaporator.

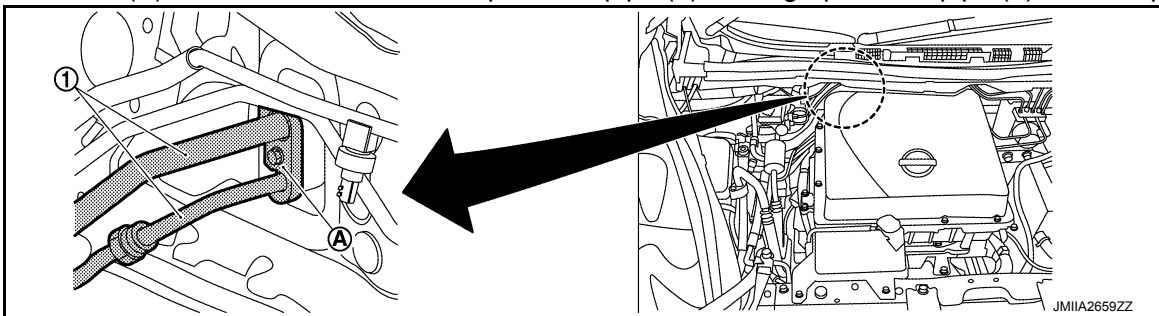

**CAUTION:**

To prevent the inclusion of foreign matter, use a cap or vinyl tape to seal off the connection ports of the pipes and evaporator from the atmosphere.

5. Remove bolt (A) then disconnect high pressure pipes (1) and (2) from inner condenser.

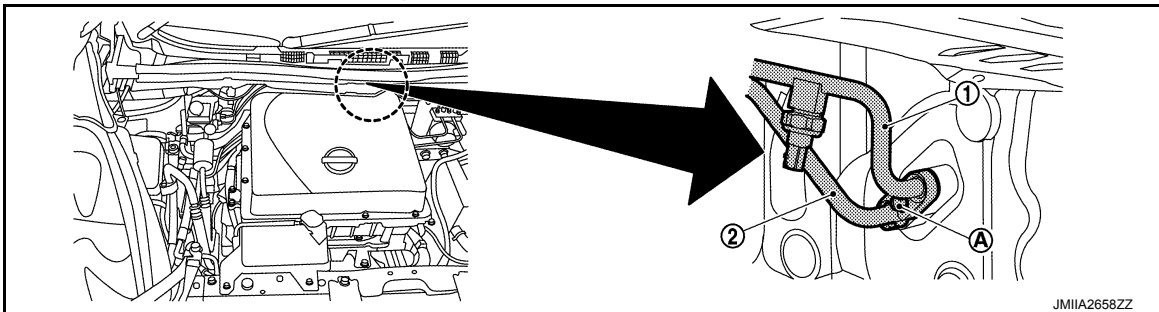

**CAUTION:**

To prevent the inclusion of foreign matter, use a cap or vinyl tape to seal off the connection ports of the pipes and evaporator from the atmosphere.

6. Remove instrument panel assembly. Refer to [IP-17, "Removal and Installation"](#).
7. Remove side ventilator duct. Refer to [IP-16, "Exploded View"](#).
8. Disconnect drain hose (1).

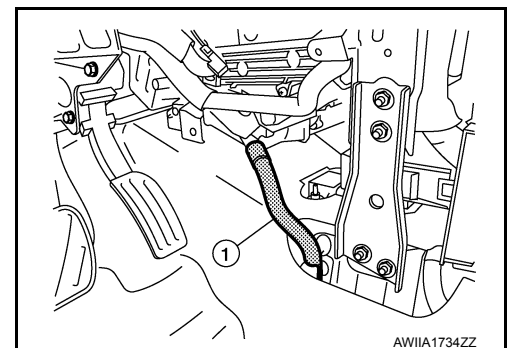

## HEATING AND COOLING UNIT ASSEMBLY

< REMOVAL AND INSTALLATION >

[WITH HEAT PUMP SYSTEM]

9. Remove nuts (A), and then remove instrument stay (1).

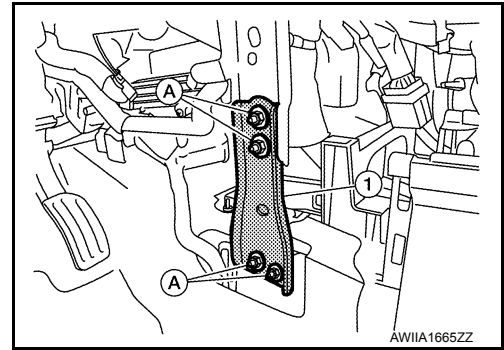

10. Remove screws (A), and then remove fuse block (J/B) (1).

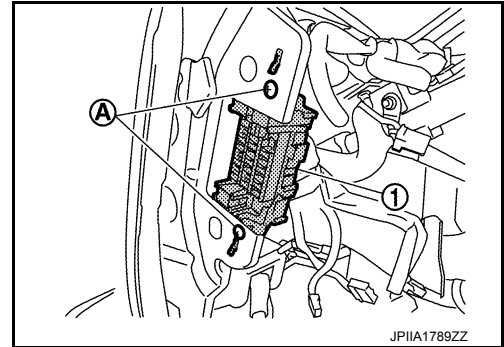

11. Remove bolts (A) of ground wires from steering member.



12. Remove all harness connectors and mounting nuts necessary to allow steering column assembly to be moved. Refer to [ST-35, "Removal and Installation"](#).
13. Move steering column assembly to secure work space.
14. Remove all harness connectors and clips necessary to allow steering member to be removed. Move main harness aside and secure work space so that steering member can be easily removed.

# HEATING AND COOLING UNIT ASSEMBLY

< REMOVAL AND INSTALLATION >

[WITH HEAT PUMP SYSTEM]

15. Remove bolts (A) and (B), and then remove steering member (1) from the vehicle.

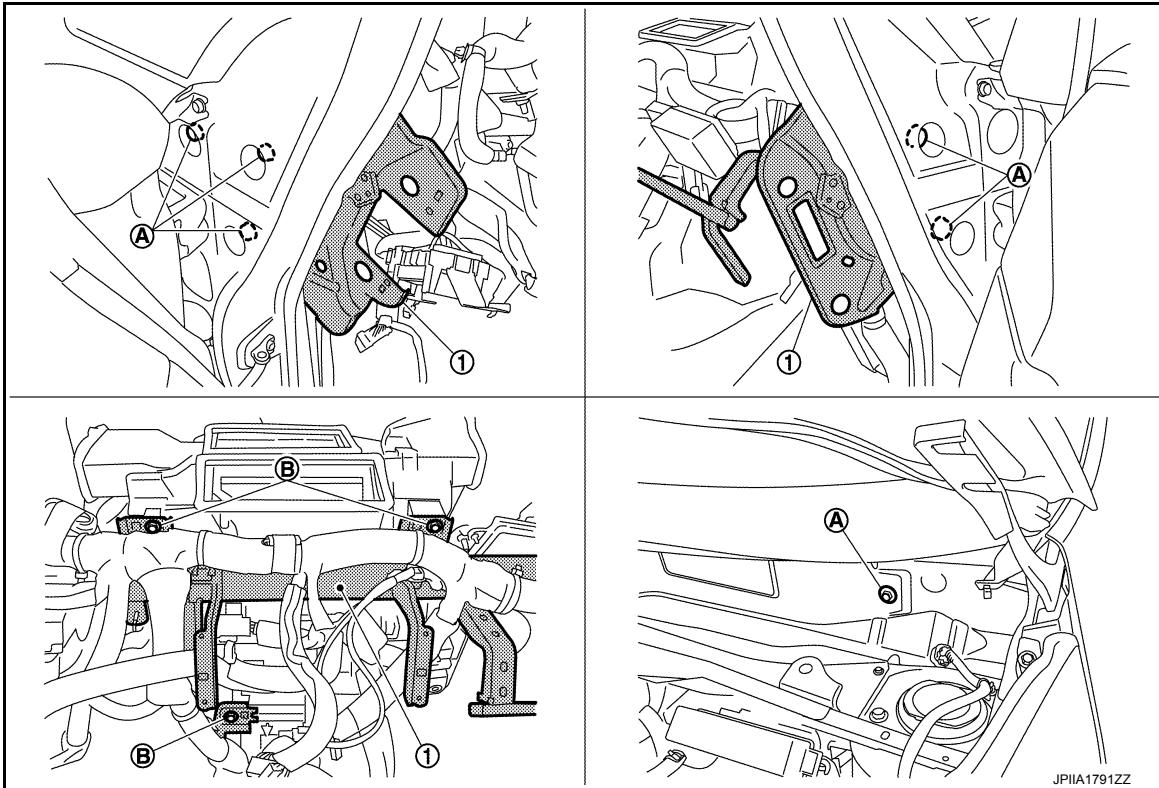

## CAUTION:

When removing steering member, 2 workers are required to prevent it from dropping.

16. Remove heating and cooling unit assembly from the vehicle.

## INSTALLATION

Note the following items, and then install in the reverse order of removal.

### CAUTION:

- To prevent degradation in insulation performance, use special electric compressor oil as the compressor oil.
- In order to prevent conventional PAG oil from becoming mixed in, never reuse recovered compressor oil and instead always use new oil. The use of oil including the conventional PAG oil may degrade the performance of insulation.
- To prevent performance degradation, never use a fluorescent agent in order to detect refrigerant leakage. Also be careful that a fluorescent agent never enter the oil.
- To prevent leakage of refrigerant, replace the O-ring with a new one. Apply a coat of compressor oil to the O-ring prior to installation.
- Perform a check for refrigerant leakage when charging with refrigerant. Refer to [HA-26, "Check Refrigerant Leakage"](#).

## EVAPORATOR

### EVAPORATOR : Removal and Installation

INFOID:000000010640953

## REMOVAL

1. Remove heating and cooling unit assembly. Refer to [HA-58, "HEATING AND COOLING UNIT ASSEMBLY : Removal and Installation"](#).
2. Disassemble the heating and cooling unit assembly, and then remove evaporator assembly.
3. Remove intake sensor from evaporator assembly.

## INSTALLATION

Note the following items, and then install in the reverse order of removal.

### CAUTION:

- To prevent leakage of refrigerant, replace the O-ring with a new one. Apply a coat of compressor oil to the O-ring prior to installation.

# HEATING AND COOLING UNIT ASSEMBLY

[WITH HEAT PUMP SYSTEM]

< REMOVAL AND INSTALLATION >

- When installing the new evaporator, be sure to install the intake sensor in the same position as before it was removed.
- When removing or installing the intake sensor, be sure not to rotate the bracket insertion part. Failure to do this may cause damage to the evaporator.
- After installing a new evaporator, adjust the compressor oil level. Refer to [HA-29, "Lubricant Adjusting Procedure for Components Replacement Except Compressor"](#).

## INNER CONDENSER

### INNER CONDENSER : Removal and Installation

INFOID:000000010640954

#### REMOVAL

1. Remove heating and cooling unit assembly. Refer to [HA-58, "HEATING AND COOLING UNIT ASSEMBLY : Removal and Installation"](#).
2. Remove screws (A) and (B), then remove PTC heater shield LH.

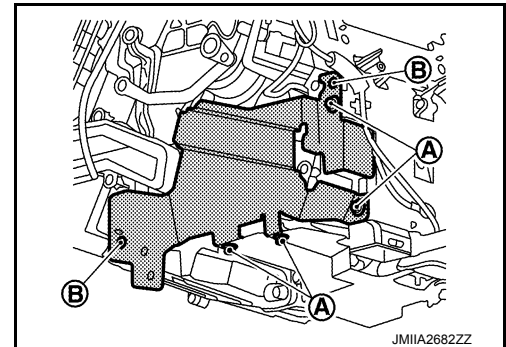

3. Remove screws (A), then remove inner condenser pipe cover.

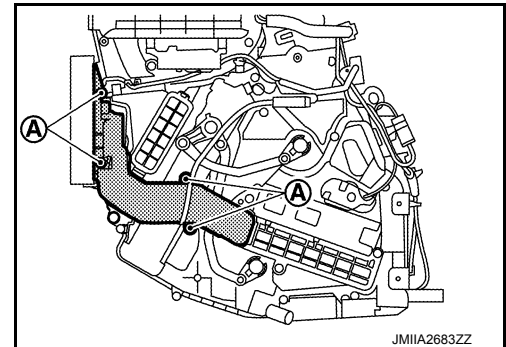

4. Remove inner condenser cover screws (A), then remove inner condenser from heating and cooling unit assembly.

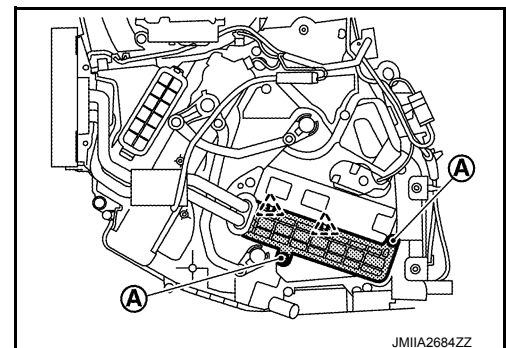

#### INSTALLATION

Install in the reverse order of removal.

# SERVICE DATA AND SPECIFICATIONS (SDS)

< SERVICE DATA AND SPECIFICATIONS (SDS)

[WITH HEAT PUMP SYSTEM]

## SERVICE DATA AND SPECIFICATIONS (SDS)

### SERVICE DATA AND SPECIFICATIONS (SDS)

#### Compressor

INFOID:0000000010640955

Type	Electric drive scroll type (Includes inverter)
------	--

#### Lubricant

INFOID:0000000010640956

Name	ND-OIL11 (Exclusive use for electric compressor)
Capacity	mℓ (US fl oz, Imp fl oz) 140 (4.7, 4.9)

#### Refrigerant

INFOID:0000000010640957

Name	HFC-134a (R-134a)
Capacity	kg (lb) 0.850 (1.874)

A

B

C

D

E

F

G

H

HA

J

K

L

M

N

O

P



# PRECAUTIONS

< PRECAUTION >

[WITHOUT HEAT PUMP SYSTEM]

## PRECAUTION

### PRECAUTIONS

#### Precaution for Technicians Using Medical Electric

INFOID:000000010640958

##### OPERATION PROHIBITION

###### **WARNING:**

- Parts with strong magnet is used in this vehicle.
- Technicians using a medical electric device such as pacemaker must never perform operation on the vehicle, as magnetic field can affect the device function by approaching to such parts.

##### NORMAL CHARGE PRECAUTION

###### **WARNING:**

- If a technician uses a medical electric device such as an implantable cardiac pacemaker or an implantable cardioverter defibrillator, the possible effects on the devices must be checked with the device manufacturer before starting the charge operation.
- As radiated electromagnetic wave generated by PDM (Power Delivery Module) at normal charge operation may affect medical electric devices, a technician using a medical electric device such as implantable cardiac pacemaker or an implantable cardioverter defibrillator must not approach motor room [PDM (Power Delivery Module)] at the hood-opened condition during normal charge operation.

##### PRECAUTION AT TELEMATICS SYSTEM OPERATION

###### **WARNING:**

- If a technician uses implantable cardiac pacemaker or implantable cardioverter defibrillator (ICD), avoid the device implanted part from approaching within approximately 220 mm (8.66 in) from interior/exterior antenna.
- The electromagnetic wave of TCU might affect the function of the implantable cardiac pacemaker or the implantable cardioverter defibrillator (ICD), when using the service, etc.
- If a technician uses other medical electric devices than implantable cardiac pacemaker or implantable cardioverter defibrillator (ICD), the electromagnetic wave of TCU might affect the function of the device. The possible effects on the devices must be checked with the device manufacturer before TCU use.

##### PRECAUTION AT INTELLIGENT KEY SYSTEM OPERATION

###### **WARNING:**

- If a technician uses implantable cardiac pacemaker or implantable cardioverter defibrillator (ICD), avoid the device implanted part from approaching within approximately 220 mm (8.66 in) from interior/exterior antenna.
- The electromagnetic wave of Intelligent Key might affect the function of the implantable cardiac pacemaker or the implantable cardioverter defibrillator (ICD), at door operation, at each request switch operation, or at engine starting.
- If a technician uses other medical electric devices than implantable cardiac pacemaker or implantable cardioverter defibrillator (ICD), the electromagnetic wave of Intelligent Key might affect the function of the device. The possible effects on the devices must be checked with the device manufacturer before Intelligent Key use.

#### Point to Be Checked Before Starting Maintenance Work

INFOID:000000010640959

The high voltage system may starts automatically. It is required to check that the timer air conditioner and timer charge (during EVSE connection) are not set before starting maintenance work.

###### **NOTE:**

If the timer air conditioner or timer charge (during EVSE connection) is set, the high voltage system starts automatically even when the power switch is in OFF state.

#### Precaution for Supplemental Restraint System (SRS) "AIR BAG" and "SEAT BELT PRE-TENSIONER"

INFOID:000000010640960

The Supplemental Restraint System such as "AIR BAG" and "SEAT BELT PRE-TENSIONER", used along with a front seat belt, helps to reduce the risk or severity of injury to the driver and front passenger for certain types of collision. This system includes seat belt switch inputs and dual stage front air bag modules. The SRS



# PRECAUTIONS

< PRECAUTION >

[WITHOUT HEAT PUMP SYSTEM]

system uses the seat belt switches to determine the front air bag deployment, and may only deploy one front air bag, depending on the severity of a collision and whether the front occupants are belted or unbelted. Information necessary to service the system safely is included in the SR and SB section of this Service Manual.

## WARNING:

- To avoid rendering the SRS inoperative, which could increase the risk of personal injury or death in the event of a collision which would result in air bag inflation, all maintenance must be performed by an authorized NISSAN/INFINITI dealer.
- Improper maintenance, including incorrect removal and installation of the SRS, can lead to personal injury caused by unintentional activation of the system. For removal of Spiral Cable and Air Bag Module, see the SR section.
- Do not use electrical test equipment on any circuit related to the SRS unless instructed to in this Service Manual. SRS wiring harnesses can be identified by yellow and/or orange harnesses or harness connectors.

## PRECAUTIONS WHEN USING POWER TOOLS (AIR OR ELECTRIC) AND HAMMERS

### WARNING:

- When working near the Airbag Diagnosis Sensor Unit or other Airbag System sensors with the Ignition ON or engine running, DO NOT use air or electric power tools or strike near the sensor(s) with a hammer. Heavy vibration could activate the sensor(s) and deploy the air bag(s), possibly causing serious injury.
- When using air or electric power tools or hammers, always switch the Ignition OFF, disconnect the battery and wait at least three minutes before performing any service.

## Precaution for Procedure without Cowl Top Cover

INFOID:000000010640961

When performing the procedure after removing cowl top cover, cover the lower end of windshield with urethane, etc to prevent damage to windshield.

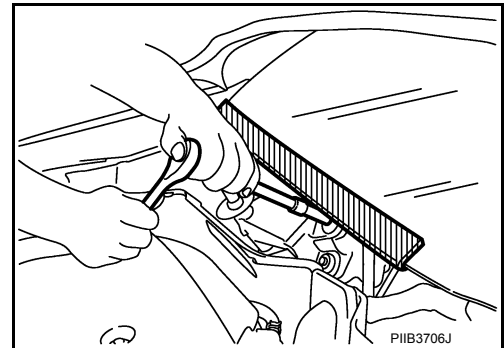

## High Voltage Precautions

INFOID:000000010640962

### DANGER:

 Since hybrid vehicles and electric vehicles contain a high voltage battery, there is the risk of electric shock, electric leakage, or similar accidents if the high voltage component and vehicle are handled incorrectly. Be sure to follow the correct work procedures when performing inspection and maintenance.

### WARNING:

- Be sure to remove the service plug in order to disconnect the high voltage circuits before performing inspection or maintenance of high voltage system harnesses and parts.
- The removed service plug must always be carried in a pocket of the responsible worker or placed in the tool box during the procedure to prevent the plug from being connected by mistake.
- Be sure to wear insulated protective equipment before beginning work on the high voltage system.
- Never allow workers other than the responsible person to touch the vehicle containing high voltage parts. To keep others from touching the high voltage parts, these parts must be covered with an insulating sheet except when using them.

### CAUTION:

Never bring the vehicle into the READY status with the service plug removed unless otherwise instructed in the Service Manual. A malfunction may occur if this is not observed.

## HIGH VOLTAGE HARNESS AND EQUIPMENT IDENTIFICATION

## PRECAUTIONS

< PRECAUTION >

[WITHOUT HEAT PUMP SYSTEM]

All the high voltage harnesses and connectors are orange. The Li-ion battery and other high voltage devices include an orange high voltage label. Never touch these harnesses and high voltage parts.

### HANDLING OF HIGH VOLTAGE HARNESS AND TERMINALS

Immediately insulate disconnected high voltage connectors and terminals with insulating tape.

### REGULATIONS ON WORKERS WITH MEDICAL ELECTRONICS

**WARNING:**

**The vehicle contains parts that contain powerful magnets. If a person who is wearing a heart pacemaker or other medical device is close to these parts, the medical device may be affected by the magnets. Such persons must not perform work on the vehicle.**

### PROHIBITED ITEMS TO CARRY DURING THE WORK

Hybrid vehicles and electric vehicles contain parts with high voltage and intense magnetic force. Never carry metal products and magnetic recording media (e.g. cash card, prepaid card) to repair/inspect high voltage parts. If this is not observed, the metal products may create a risk of short circuit and the magnetic recording media may lose their magnetic recording.

POSTING A SIGN OF “DANGER! HIGH VOLTAGE AREA. KEEP OUT”

# PRECAUTIONS

[WITHOUT HEAT PUMP SYSTEM]

< PRECAUTION >

Indicate "HIGH VOLTAGE. DO NOT TOUCH" on the vehicle under repair/inspection to call attention to other workers.

**DANGER:  
HIGH VOLTAGE  
REPAIR IN PROGRESS.  
DO NOT TOUCH!**

Person in charge: \_\_\_\_\_

---

**DANGER:  
HIGH VOLTAGE  
REPAIR IN PROGRESS.  
DO NOT TOUCH!**

Person in charge: \_\_\_\_\_

---

**Copy this page and put it after folding on the roof of the vehicle in service.**

JSAIA1600GB

A  
B  
C  
D  
E  
F  
G  
H  
HA  
J  
K  
L  
M  
N  
O  
P

## Precaution for Removing 12V Battery

INFOID:000000010640963

1. Check that EVSE is not connected.

**NOTE:**

If EVSE is connected, the air conditioning system may be automatically activated by the timer A/C function.

2. Turn the power switch OFF → ON → OFF. Get out of the vehicle. Close all doors (including back door).

# PRECAUTIONS

[WITHOUT HEAT PUMP SYSTEM]

< PRECAUTION >

3. Check that the charge status indicator lamp does not blink and wait for 5 minutes or more.  
**NOTE:**  
If the battery is removed within 5 minutes after the power switch is turned OFF, plural DTCs may be detected.
4. Remove 12V battery within 1 hour after turning the power switch OFF → ON → OFF.  
**NOTE:**
  - The 12V battery automatic charge control may start automatically even when the power switch is in OFF state.
  - Once the power switch is turned ON → OFF, the 12V battery automatic charge control does not start for approximately 1 hour.**CAUTION:**
  - After all doors (including back door) are closed, if a door (including back door) is opened before battery terminals are disconnected, start over from Step 1.
  - After turning the power switch OFF, if “Remote A/C” is activated by user operation, stop the air conditioner and start over from Step 1.

## Precautions for Service Work of Cooler System

INFOID:000000010640964

### GENERAL REFRIGERANT PRECAUTION

#### **WARNING:**

- Never breathe A/C refrigerant and lubricant vapor or mist. Exposure may irritate eyes, nose and throat. Remove HFC-134a (R-134a) from the A/C system, using certified service equipment meeting requirements of SAE J-2210 [HFC-134a (R-134a) recycling equipment], or J-2209 [HFC-134a (R-134a) recovery equipment]. Ventilate work area before resuming service if accidental system discharge occurs. Additional health and safety information may be obtained from refrigerant and lubricant manufacturers.
- Never release refrigerant into the air. Use approved recovery/recycling recharging equipment to capture the refrigerant each time an air conditioning system is discharged.
- Wear always eye and hand protection (goggles and gloves) when working with any refrigerant or air conditioning system.
- Never store or heat refrigerant containers above 52°C (126°F).
- Never heat a refrigerant container with an open flame; Place the bottom of the container in a warm pail of water if container warming is required.
- Never intentionally drop, puncture, or incinerate refrigerant containers.
- Keep refrigerant away from open flames: poisonous gas is produced if refrigerant burns.
- Refrigerant displaces oxygen, therefore be certain to work in well ventilated areas to prevent suffocation.
- Never pressure test or leakage test HFC-134a (R-134a) service equipment and/or vehicle air conditioning systems with compressed air during repair. Some mixtures of air and HFC-134a (R-134a) have been shown to be combustible at elevated pressures. These mixtures, if ignited, may cause injury or property damage. Additional health and safety information may be obtained from refrigerant manufacturers.

### WORKING WITH HFC-134a (R-134a)

#### **CAUTION:**

- CFC-12 (R-12) refrigerant and HFC-134a (R-134a) refrigerant are not compatible. Compressor malfunction is likely to occur if the refrigerants are mixed, refer to “CONTAMINATED REFRIGERANT” below. To determine the purity of HFC-134a (R-134a) in the vehicle and recovery tank, use Refrigerant recovery/recycling recharging equipment and Refrigerant Identifier.
- Use only specified lubricant for the HFC-134a (R-134a) A/C system and HFC-134a (R-134a) components. Compressor malfunction is likely to occur if lubricant other than that specified is used.
- If rotary compressor oil (DH-PR), swash plate compressor oil (DH-PS), or CFC-12 compressor oil (mineral oil) is used, the insulation resistance may be reduced. Never use these oils.
- The specified HFC-134a (R-134a) lubricant rapidly absorbs moisture from the atmosphere. The following handling precautions must be observed:
  - Cap (seal) immediately the component to minimize the entry of moisture from the atmosphere when removing refrigerant components from a vehicle.
  - Never remove the caps (unseal) until just before connecting the components when installing refrigerant components to a vehicle. Connect all refrigerant loop components as quickly as possible to minimize the entry of moisture into system.

# PRECAUTIONS

[WITHOUT HEAT PUMP SYSTEM]

< PRECAUTION >

- Use only the specified lubricant from a sealed container. Reseal immediately containers of lubricant. Lubricant becomes moisture saturated and should not be used without proper sealing.
- Never allow lubricant to come in contact with styrene foam parts. Damage may result.

## REFRIGERANT CONNECTION

A new type refrigerant connection has been introduced to all refrigerant lines except the following location.

- Expansion valve to evaporator
- Refrigerant pressure sensor to liquid tank

### WARNING:

Check that all refrigerant is discharged into the recycling equipment and the pressure in the system is less than atmospheric pressure. Then gradually loosen the discharge side hose fitting and remove it.

### CAUTION:

Observe the following when replacing or cleaning refrigerant cycle components.

- To prevent fluorescent indicator from entering, prepare and use exclusive hose for EV (electric vehicle) and HEV (hybrid vehicle) when connecting recovery/recycling/recharging equipment.
- Store it in the same way at it is when mounted on the car when the compressor is removed. Failure to do so will cause lubricant to enter the low-pressure chamber.
- Use the torque wrench or the backup wrench when installing the piping.
- Plug immediately all openings to prevent entry of dust and moisture after disconnecting tubes.
- Connect the pipes at the final stage of the operation when installing an air conditioner in the vehicle. Never remove the seal caps of pipes and other components until just before required for connection.
- Allow components stored in cool areas to warm to working area temperature before removing seal caps. This prevents condensation from forming inside A/C components.
- Remove thoroughly moisture from the refrigeration system before charging the refrigerant.
- Replace always used O-rings.
- Apply lubricant to the O-rings shown in illustrations when connecting tubes. Be careful not to apply lubricant to threaded portion.
- O-ring must be closely attached to the groove portion of tube.
- Be careful not to damage O-ring and tube when replacing the O-ring.
- Connect tube until a click can be heard. Then tighten the nut or bolt by hand. Check that the O-ring is installed to tube correctly.
- Perform leakage test and make sure that there is no leakage from connections after connecting line. Disconnect that line and replace the O-ring when the refrigerant leaking point is found. Then tighten connections of seal seat to the specified torque.

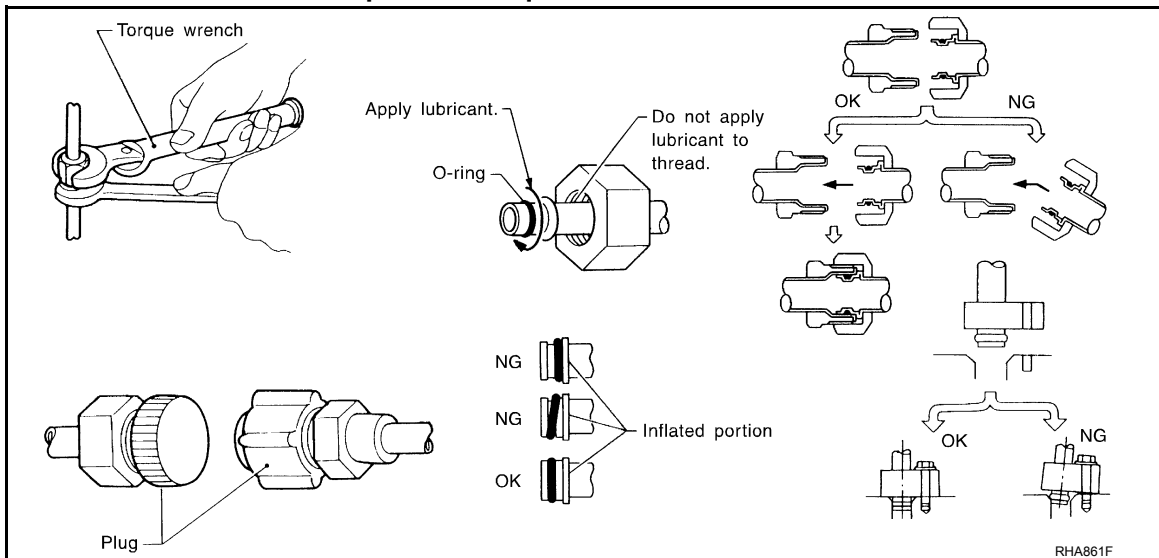

## COMPRESSOR

### CAUTION:

- Plug all openings to prevent moisture and foreign matter from entering.
- Store it in the same way at it is when mounted on the car when the compressor is removed.
- Follow "Maintenance of Lubricant Quantity in Compressor" exactly when replacing or repairing compressor. Refer to [HA-88, "Description"](#).

## REFRIGERANT LEAKAGE DETECTING FLOURESCENT INDICATOR

### CAUTION:

# PRECAUTIONS

[WITHOUT HEAT PUMP SYSTEM]

< PRECAUTION >

- **Never use fluorescent indicators as these may reduce the insulation resistance.**
- **If a fluorescent indicator enters the refrigerant cycle, either wash the refrigerant cycle parts or replace the parts.**

## Service Equipment

INFOID:000000010640965

### RECOVERY/RECYCLING RECHARGING EQUIPMENT

Be certain to follow the manufacturer's instructions for machine operation and machine maintenance. Never introduce any refrigerant other than that specified into the machine.

### VACUUM PUMP

The lubricant contained inside the vacuum pump is not compatible with the specified lubricant for HFC-134a (R-134a) A/C systems. The vent side of the vacuum pump is exposed to atmospheric pressure. So the vacuum pump lubricant may migrate out of the pump into the service hose. This is possible when the pump is switched OFF after evacuation (vacuuming) and hose is connected to it. To prevent this migration, use a manual valve placed near the hose-to-pump connection, as per the following.

- Vacuum pumps usually have a manual isolator valve as part of the pump. Close this valve to isolate the service hose from the pump.
- Use a hose equipped with a manual shut-off valve near the pump end for pumps without an isolator. Close the valve to isolate the hose from the pump.
- Disconnect the hose from the pump if the hose has an automatic shut-off valve. As long as the hose is connected, the valve is open and lubricating oil may migrate.

Some one-way valves open when vacuum is applied and close under no vacuum condition. Such valves may restrict the pump's ability to pull a deep vacuum and are not recommended.

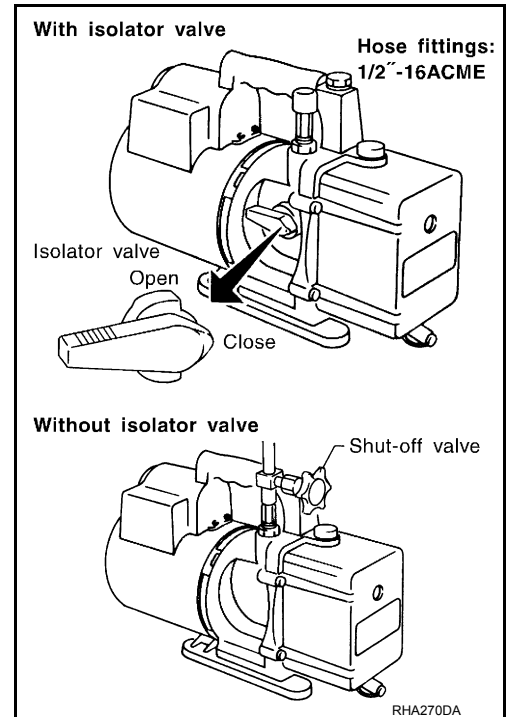

### MANIFOLD GAUGE SET

Be certain that the gauge face indicates HFC-134a or R-134a. Be sure the gauge set has 1/2"-16 ACME threaded connections for service hoses. Confirm the set has been used only with refrigerant HFC-134a (R-134a) and specified lubricants.

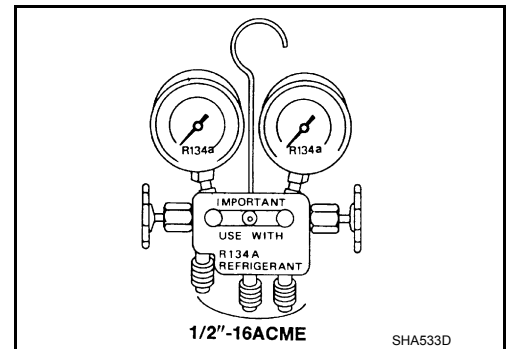

### SERVICE HOSES

Be certain that the service hoses display the markings described (colored hose with black stripe). All hoses must equip positive shut-off devices (either manual or automatic) near the end of the hoses opposite to the manifold gauge.

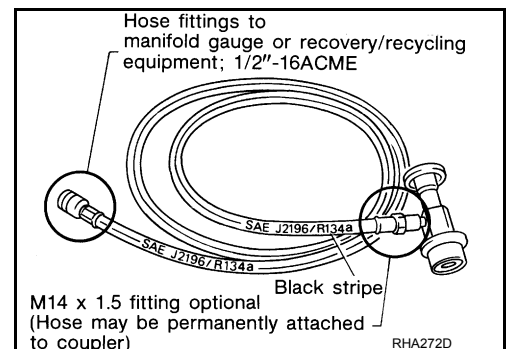

# PRECAUTIONS

< PRECAUTION >

[WITHOUT HEAT PUMP SYSTEM]

## SERVICE COUPLERS

Never attempt to connect HFC-134a (R-134a) service couplers to the CFC-12 (R-12) A/C system. The HFC-134a (R-134a) couplers do not properly connect to the CFC-12 (R-12) system. However, if an improper connection is attempted, discharging and contamination may occur.

Shut-off valve rotation	A/C service valve
Clockwise	Open
Counterclockwise	Close

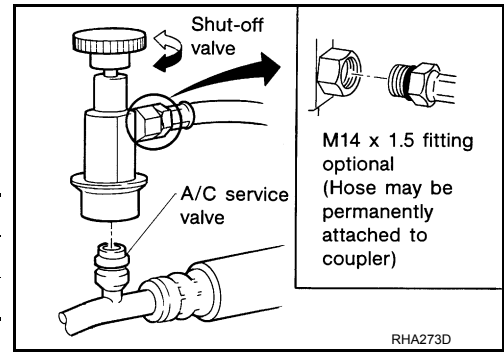

## REFRIGERANT WEIGHT SCALE

Verify that no refrigerant other than HFC-134a (R-134a) and specified lubricants have been used with the scale. The hose fitting must be 1/2"-16 ACME if the scale controls refrigerant flow electronically.

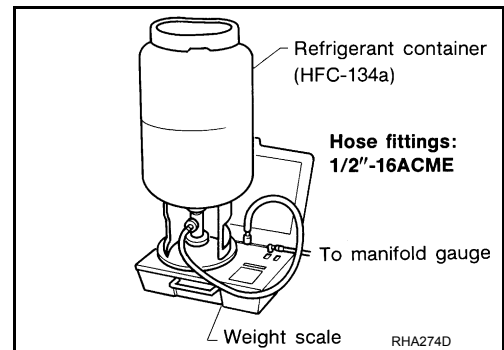

## CALIBRATING ACR4 WEIGHT SCALE

Calibrate the scale each three month.

To calibrate the weight scale on the ACR4:

1. Press "**Shift/Reset**" and "**Enter**" at the same time.
2. Press "**8787**". "**A1**" is displayed.
3. Remove all weight from the scale.
4. Press "**0**", then press "**Enter**". "**0.00**" is displayed and change to "**A2**".
5. Place a known weight (dumbbell or similar weight), between 4.5 and 8.6 kg (10 and 19 lb.) on the center of the weight scale.
6. Enter the known weight using four digits. (Example 10 lb. = 10.00, 10.5 lb. = 10.50)
7. Press "**Enter**" — the display returns to the vacuum mode.
8. Press "**Shift/Reset**" and "**Enter**" at the same time.
9. Press "**6**" — the known weight on the scale is displayed.
10. Remove the known weight from the scale. "**0.00**" is displayed.
11. Press "**Shift/Reset**" to return the ACR4 to the program mode.

## CHARGING CYLINDER

Using a charging cylinder is not recommended. Refrigerant may be vented into air from cylinder's top valve when filling the cylinder with refrigerant. Also, the accuracy of the cylinder is generally less than that of an electronic scale or of quality recycle/recharge equipment.

# PREPARATION

< PREPARATION >

[WITHOUT HEAT PUMP SYSTEM]

## PREPARATION

### PREPARATION

#### Special Service Tool

INFOID:000000011006872

The actual shape of the tools may differ from those illustrated here.

Tool number (TechMate No.) Tool name	Description
(J-48710) NISSAN ACR2009 RRR Unit	Function: Refrigerant recovery, recycling and recharging
(J-41995) Electrical leak detector	Power supply: DC12V(Battery terminal)

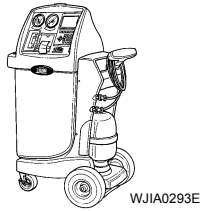

#### Commercial Service Tools

INFOID:000000010640966

Tool name	Description
Service hoses <ul style="list-style-type: none"> <li>• High-pressure side hose</li> <li>• Low-pressure side hose</li> <li>• Utility hose</li> </ul>	Hose color: <ul style="list-style-type: none"> <li>• Low-pressure side hose: Blue with black stripe</li> <li>• High-pressure side hose: Red with black stripe</li> <li>• Utility hose: Yellow with black stripe or green with black stripe</li> </ul> Hose fitting to gauge: <ul style="list-style-type: none"> <li>• 1/2"-16 ACME</li> </ul>
Insulated gloves Comply with EN60903: <ul style="list-style-type: none"> <li>• Use protective gloves made of insulating material.</li> <li>• The protective gloves must be capable of resisting the voltage of 600 or more.</li> </ul>	Removing and installing high voltage components
Leather gloves [Use leather gloves that can fasten the wrist tight]	<ul style="list-style-type: none"> <li>• Removing and installing high voltage components</li> <li>• Protect insulated gloves</li> </ul>

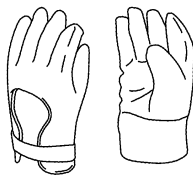
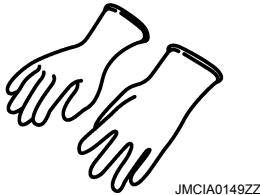
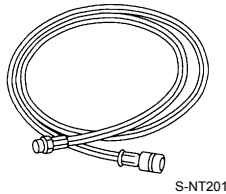



# PREPARATION

< PREPARATION >

[WITHOUT HEAT PUMP SYSTEM]

Tool name	Description
<p>Insulated safety shoes Comply with EN60903:</p> <ul style="list-style-type: none"> <li>• Use protective shoes made of insulating material.</li> <li>• The protective shoes must be capable of resisting the voltage of 600 or more.</li> </ul>	<p>Removing and installing high voltage components</p>
<p>Face shield [Comply with EN166.]</p>	<ul style="list-style-type: none"> <li>• Removing and installing high voltage components</li> <li>• To protect face from the spatter on the work to electric line</li> </ul>
<p>Insulated helmet</p>	<p>Removing and installing high voltage components</p>
<p>(J-41995) Electrical leak detector</p>	<p>Power supply: DC12V(Battery terminal)</p>
<p>Manifold gauge set (with hoses and couplers)</p>	<p>Identification:</p> <ul style="list-style-type: none"> <li>• The gauge face indicates HFC-134a (R-134a).</li> </ul> <p>Fitting size: Thread size</p> <ul style="list-style-type: none"> <li>• 1/2"-16 ACME</li> </ul>
<p>Service couplers</p> <ul style="list-style-type: none"> <li>• High-pressure side coupler</li> <li>• Low-pressure side coupler</li> </ul>	<p>Hose fitting to service hose: M14 x 1.5 fitting is optional or permanently attached.</p>

A  
B  
C  
D  
E  
F  
G  
H  
HA  
J  
K  
L  
M  
N  
O  
P



JPCIA0011ZZ

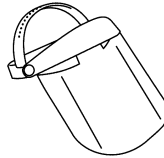

JPCIA0167ZZ

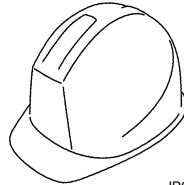

JPCIA0013ZZ

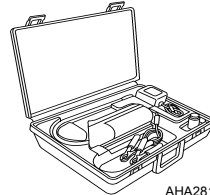

AHA281A

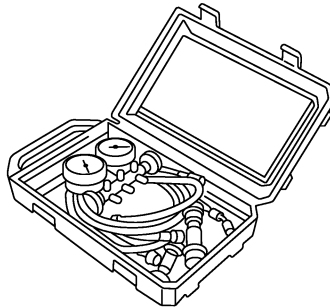

RJIA0196E

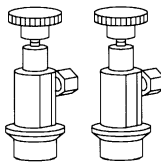

S-NT202

# PREPARATION

< PREPARATION >

[WITHOUT HEAT PUMP SYSTEM]

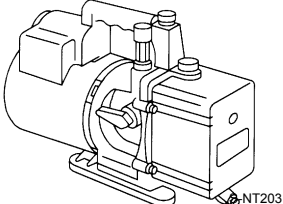
Tool name	Description
Refrigerant weight scale   S-NT200	For measuring of refrigerant Fitting size: Thread size 1/2" -16 ACME
Vacuum pump (Including the isolator valve)   NT203	Capacity: • Air displacement: 4 CFM • Micron rating: 20 microns • Oil capacity: 482 mℓ (17 Imp fl oz.) Fitting size: Thread size • 1/2" -16 ACME

## Oil and Grease

INFOID:0000000010640967

Name	Application	Note
Refrigerant can (HFC-134a)	Charging refrigerant	—
Compressor oil (ND-OIL11)	Refilling compressor oil	—

# COMPONENT PARTS

< SYSTEM DESCRIPTION >

[WITHOUT HEAT PUMP SYSTEM]

## SYSTEM DESCRIPTION

### COMPONENT PARTS REFRIGERATION SYSTEM

#### REFRIGERATION SYSTEM : Component Parts Location

INFOID:000000010640968

#### COMPONENT PARTS LOCATION

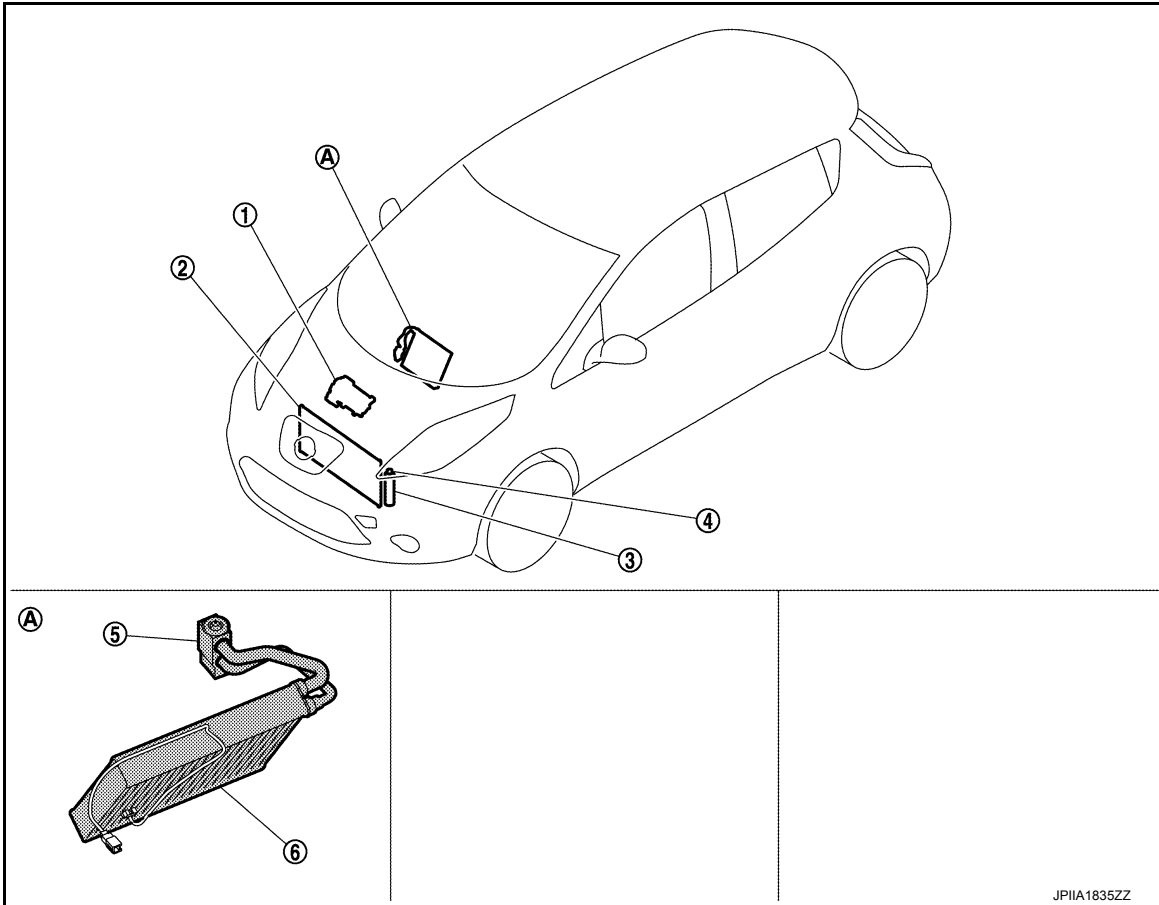

A. Built-in A/C unit assembly

#### COMPONENT PARTS DESCRIPTION

No.	Location	DESCRIPTION
1.	Electric compressor	Performs the intake, compression, and discharge of refrigerant, and circulates the refrigerant in the cooler cycle. Refer to <a href="#">HA-77. "Electric Compressor"</a> .
2.	Condenser	Cools the high-temperature high-pressure refrigerant discharged from compressor to change it to the liquid refrigerant. Refer to <a href="#">HA-76. "CONDENSER : Condenser"</a> .
3.	Liquid tank	Remove foreign materials from refrigerant that is discharged from condenser, and then temporarily collect the liquid refrigerant. Refer to <a href="#">HA-77. "CONDENSER : Liquid Tank"</a> .
4.	Refrigerant pressure sensor	Refer to <a href="#">EVC-363. "DTC Logic"</a> .
5.	Expansion valve	Turn the high-pressure liquid refrigerant to the misty low-pressure liquid refrigerant by squeezing action. Refer to <a href="#">HA-76. "HEATING AND COOLING UNIT ASSEMBLY : Expansion Valve"</a> .
6.	Evaporator	The misty liquid refrigerant causes evaporation and turns into gas by the air blown from blower motor. Cool the air by vaporization heat at this time. Refer to <a href="#">HA-76. "HEATING AND COOLING UNIT ASSEMBLY : Evaporator"</a> .

#### HEATING AND COOLING UNIT ASSEMBLY

# COMPONENT PARTS

< SYSTEM DESCRIPTION >

[WITHOUT HEAT PUMP SYSTEM]

## HEATING AND COOLING UNIT ASSEMBLY : Heating and Cooling Unit Assembly

INFOID:000000010640969

This unit combines the blower unit, heating unit, and cooling unit in an assembly.

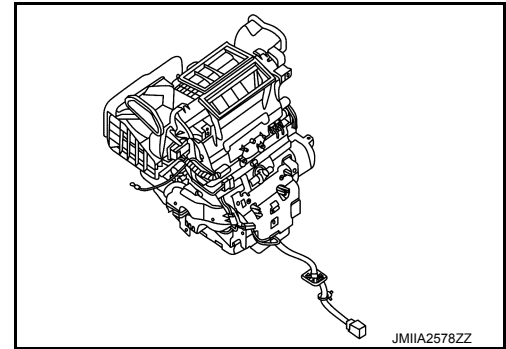

## HEATING AND COOLING UNIT ASSEMBLY : Evaporator

INFOID:000000010640970

A thin laminate pipeless evaporator is used.

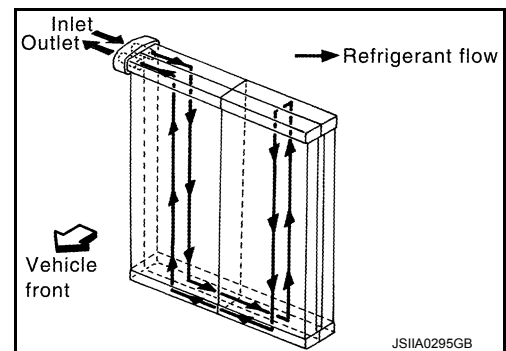

## HEATING AND COOLING UNIT ASSEMBLY : Expansion Valve

INFOID:000000010640971

The refrigerant temperature is detected by the temperature sensing part located in low-pressure refrigerant path inside expansion valve. The lift amount of high-pressure side ball valve is changed to regulate the refrigerant flow.

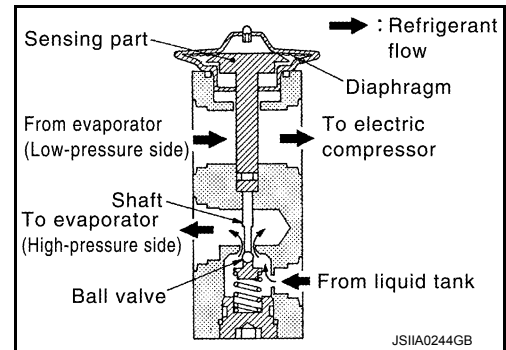

## CONDENSER

### CONDENSER : Condenser

INFOID:000000010640972

#### DESCRIPTION

A sub-cool condenser that combines a parallel-flow condenser and liquid tank in the sub-cool cycle is used.

#### STRUCTURE AND OPERATION

# COMPONENT PARTS

< SYSTEM DESCRIPTION >

[WITHOUT HEAT PUMP SYSTEM]

The sub-cool section is installed on the condenser, and the liquid refrigerant that exits the liquid tank is further cooled by the condenser sub-cool section, increasing the amount of heat that the liquid refrigerant can absorb and improving cooling performance.

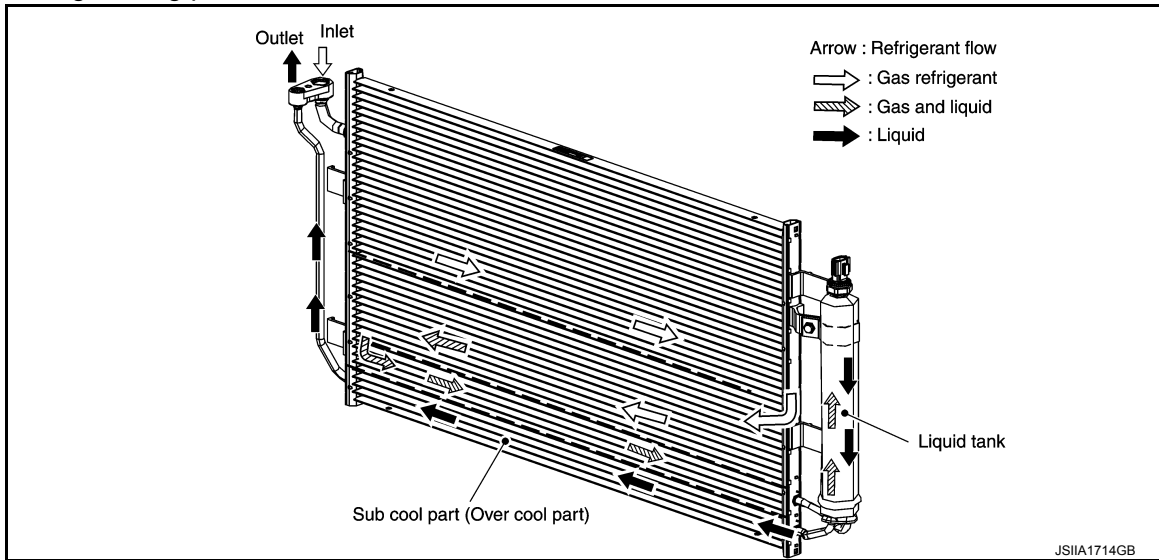

## CONDENSER : Liquid Tank

INFOID:000000010640973

- A liquid tank compatible with HFC-134a refrigerant is used.
- A refrigerant pressure sensor for cooler cycle protection control and compressor speed control is installed on the liquid tank.

## Electric Compressor

INFOID:000000010640974

- An electric scroll compressor is used.
- A 3-phase output inverter with IPM<sup>Note</sup> is used.
- The inverter is adopted to IPM<sup>Note</sup> for smaller size and improved reliability.

### NOTE:

IPM (Intelligent Power Module) is the element which delivered power device equivalent to IGBT and the protection feature of the circuit to one package.

### NOTE:

IGBT (Insulated Gate Bipolar Transistor) is a transistor which is suitable for high voltages and large currents and which can control large electrical power using a small gate voltage.

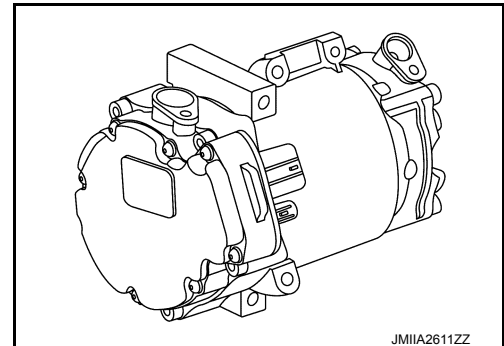

- The structure integrates the inverter, compressor, and motor, allowing compressor to operate at any speed.

# COMPONENT PARTS

< SYSTEM DESCRIPTION >

[WITHOUT HEAT PUMP SYSTEM]

- The inverter communicates with A/C auto amp., and uses PWM control<sup>Note</sup> to control the motor speed via the drive circuit.

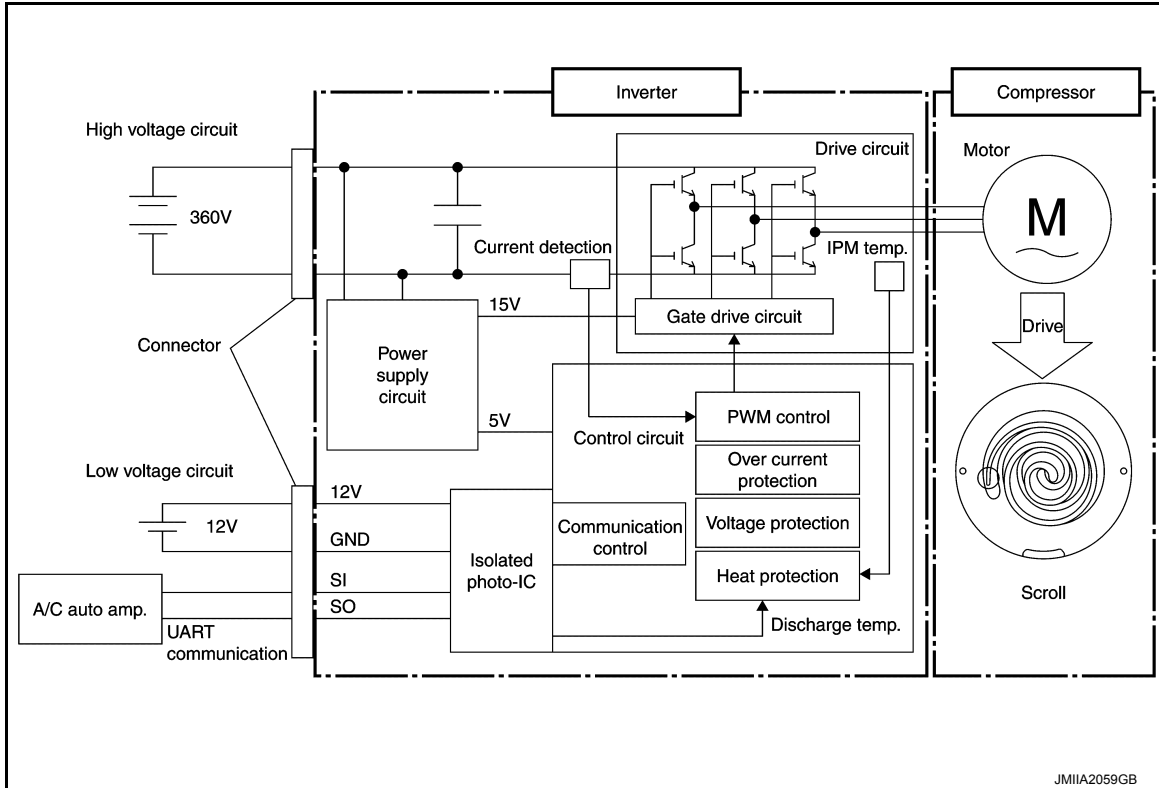

**NOTE:**

- PWM (Pulse Width Modulation) is a system that controls current and voltage by changing the duty ratio of a constant frequency pulse wave.
- PWM is used as the adjustment method of output voltage when inverter is used as a power supply for controlling motor speed.
- PWM changes voltage application time (pulse width) using a semiconductor element and controls motor speed.
- The IPM contains an internal protection circuit, and uses the inverter control circuit to monitor for an increase in motor drive circuit temperature in order to prevent circuit overheating.
- The motor uses a DC brushless motor, with speed control performed by the inverter drive circuit.

# COMPONENT PARTS

< SYSTEM DESCRIPTION >

[WITHOUT HEAT PUMP SYSTEM]

- A scroll-type compressor is used. The motor drive force is used to rotate the moveable scroll and perform refrigerant intake, compression, and discharge.

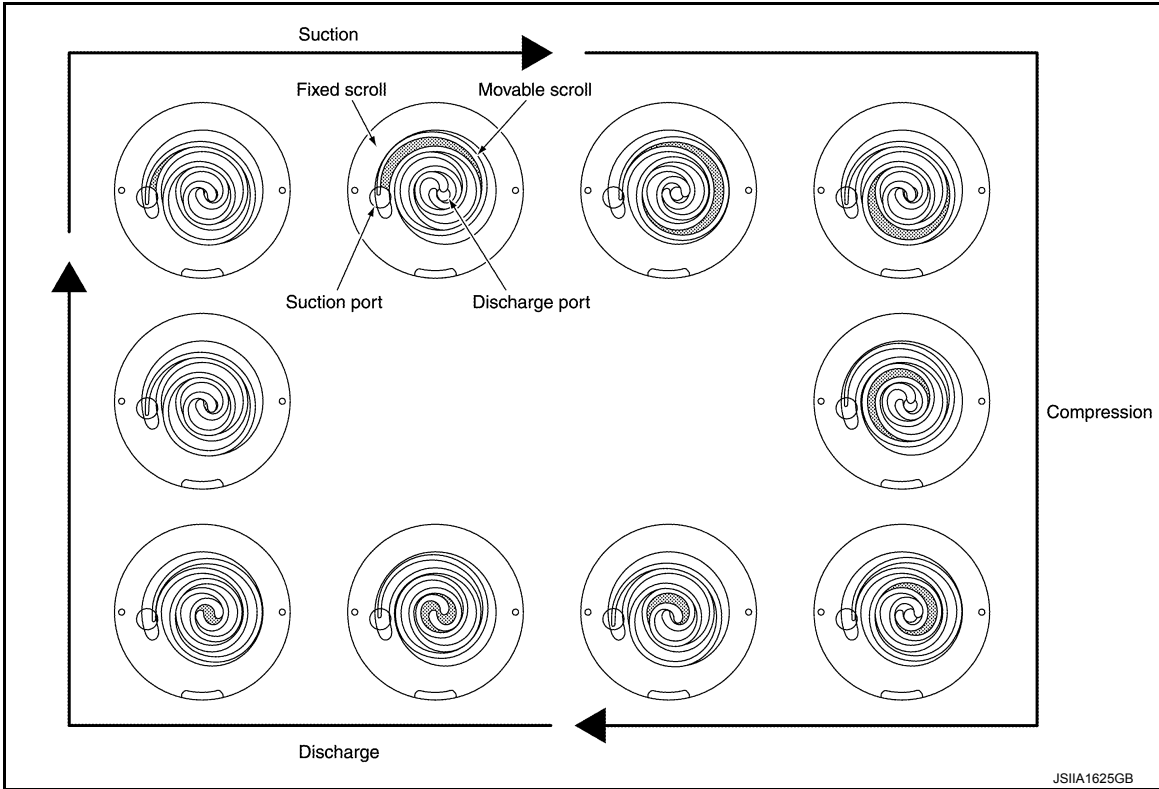

## Refrigerant and Compressor Oil

INFOID:000000010640975

- The refrigerant is HFC-134a, which contains no chlorine (Cl), a substance which damages the ozone layer.
- The compressor oil is ND-OIL 11, an ester oil with high insulation performance, designed especially for electric compressors.

### CAUTION:

- **The special electric compressor oil has different properties from the conventional HFC-134a compressor oil (PAG oil) and CFC-12 compressor oil (mineral oil). Be sure not to mix these oil types with the compressor oil, as doing so may cause electric leakage.**

### NOTE:

- HFC: HydroFluoroCarbon
- CFC: ChloroFluoroCarbon

## High Voltage Warning Label

INFOID:000000010640976

- High voltage warning label is stuck on each component parts below.
- When replacing component parts make sure to stick it on original position.

### Electric Compressor

The label (1) is stuck on the compressor stay.

← : Application direction of the label

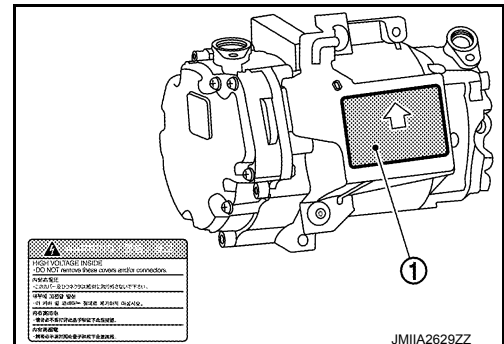

### PTC Heater

# COMPONENT PARTS

< SYSTEM DESCRIPTION >

[WITHOUT HEAT PUMP SYSTEM]

The label (1) is stuck on the housing of PTC heater.

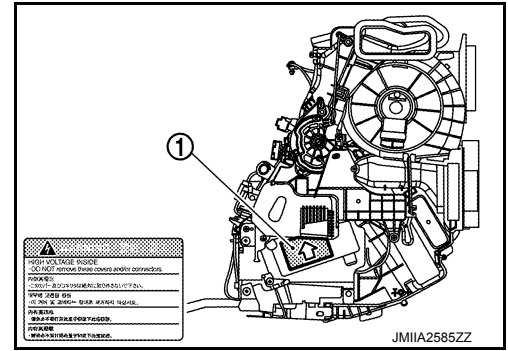



# SYSTEM

< SYSTEM DESCRIPTION >

[WITHOUT HEAT PUMP SYSTEM]

## SYSTEM REFRIGERATION SYSTEM

### REFRIGERATION SYSTEM : System Diagram

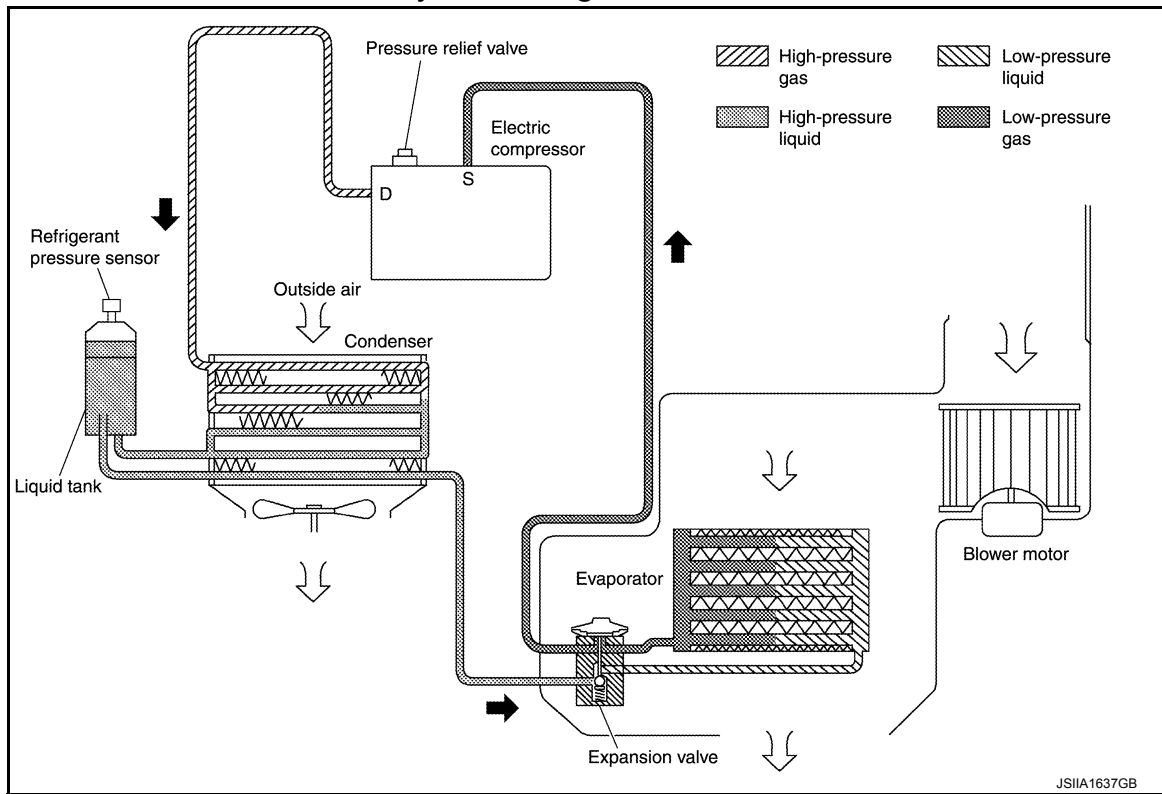

### REFRIGERATION SYSTEM : System Description

INFOID:000000010640978

#### REFRIGERANT CYCLE

##### Refrigerant Flow

The basic path of refrigerant flow is through the electric compressor, condenser, liquid tank, and evaporator, and then it returns to the electric compressor. The vaporization of evaporator refrigerant is controlled by the expansion valve.

##### Evaporator Cryoprotective Protection Control

- If the air temperature after passing through the evaporator (detected by the intake sensor) is 1°C (34°F) or less, the A/C auto amp., sends a request for speed 0 rpm to the electric compressor.
- Based on this signal from A/C auto amp., the electric compressor stops.

#### REFRIGERANT SYSTEM PROTECTION

##### Refrigerant Pressure Sensor

- The refrigerant system is protected from significant high pressure and low pressure by the refrigerant pressure sensor that is installed on the liquid tank.
- The refrigerant pressure sensor outputs a signal to the VCM.
- If the A/C auto amp., judges that there is a malfunction (the conditions shown below) in the cooler cycle based on the refrigerant pressure sensor detection value sent from VCM via EV CAN communications, it stops operation of the electric compressor.

- Approximately 2,650 kPa (26.5 bar, 27.0 kg/cm<sup>2</sup>, 384.3 psi) or more
- Approximately 140 kPa (1.4 bar, 1.4 kg/cm<sup>2</sup>, 20.3 psi) or less

##### NOTE:

The values indicate gauge pressure.

##### Pressure Relief Valve

## SYSTEM

< SYSTEM DESCRIPTION >

**[WITHOUT HEAT PUMP SYSTEM]**

- The refrigerant system is protected from significant high pressure by the pressure relief valve that is installed in the electric compressor.
- If the pressure in the cooler cycle is excessively increased [3,500 kPa (35 bar, 35.7 kg/cm<sup>2</sup>, 507.5 psi) - 4,140 kPa (41.4 bar, 42.2 kg/cm<sup>2</sup>, 600.3 psi) or more], the pressure relief valve opens, releasing refrigerant into the atmosphere.

# DIAGNOSIS AND REPAIR WORK FLOW

< BASIC INSPECTION >

[WITHOUT HEAT PUMP SYSTEM]

## BASIC INSPECTION

### DIAGNOSIS AND REPAIR WORK FLOW

Workflow

INFOID:0000000010640979

#### OVERALL SEQUENCE

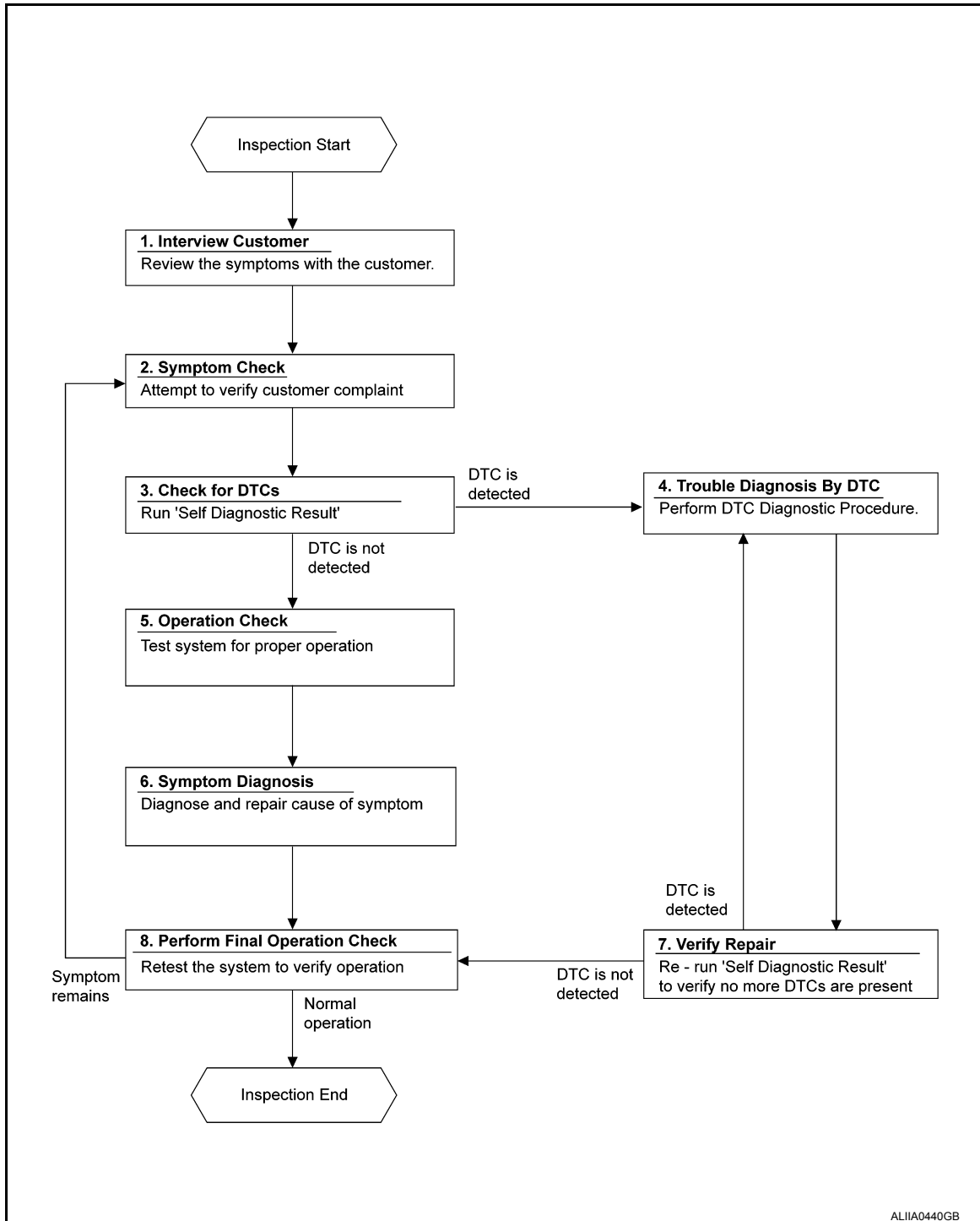

#### DETAILED FLOW

##### 1. INTERVIEW CUSTOMER

Interview the customer to obtain as much information as possible about the conditions and environment under which the malfunction occurred.

# DIAGNOSIS AND REPAIR WORK FLOW

[WITHOUT HEAT PUMP SYSTEM]

< BASIC INSPECTION >

---

>> GO TO 2.

## 2. SYMPTOM CHECK

---

Verify symptoms.

>> GO TO 3.

## 3. CHECK FOR DTCS

---

Ⓜ With CONSULT

1. Turn ignition switch ON.
2. Select "Self Diagnostic Result" mode of "HVAC" using CONSULT.
3. Check DTC.

Is any DTC detected?

YES >> GO TO 4.

NO >> GO TO 5.

## 4. PERFORM DTC DIAGNOSTIC PROCEDURE

---

Perform the diagnostic procedure for the detected DTC. Refer to [HAC-252, "DTC Index"](#).

>> GO TO 7.

## 5. OPERATION CHECK

---

Perform the operation check. Refer to [HAC-270, "Work Procedure"](#).

>> GO TO 6.

## 6. SYMPTOM DIAGNOSIS

---

Check the symptom diagnosis table. Refer to [HAC-344, "Symptom Table"](#).

>> GO TO 8.

## 7. VERIFY REPAIR.

---

Ⓜ With CONSULT

1. Turn ignition switch ON.
2. Select "Self Diagnostic Result" mode of "HVAC" using CONSULT.
3. Check DTC.

Is any DTC detected?

YES >> GO TO 4.

NO >> GO TO 8.

## 8. PERFORM FINAL OPERATION CHECK

---

Perform the operation check. Refer to [HAC-270, "Work Procedure"](#).

Does it operate normally?

YES >> Inspection End.

NO >> GO TO 2.

# REFRIGERANT

< BASIC INSPECTION >

[WITHOUT HEAT PUMP SYSTEM]

## REFRIGERANT

### Description

INFOID:000000010640980

### CONNECTION OF SERVICE TOOLS AND EQUIPMENT

#### CAUTION:

To prevent fluorescent indicator from entering, prepare and use exclusive hose for EV (electric vehicle) and HEV (hybrid vehicle) when connecting recovery/recycling/recharging equipment.

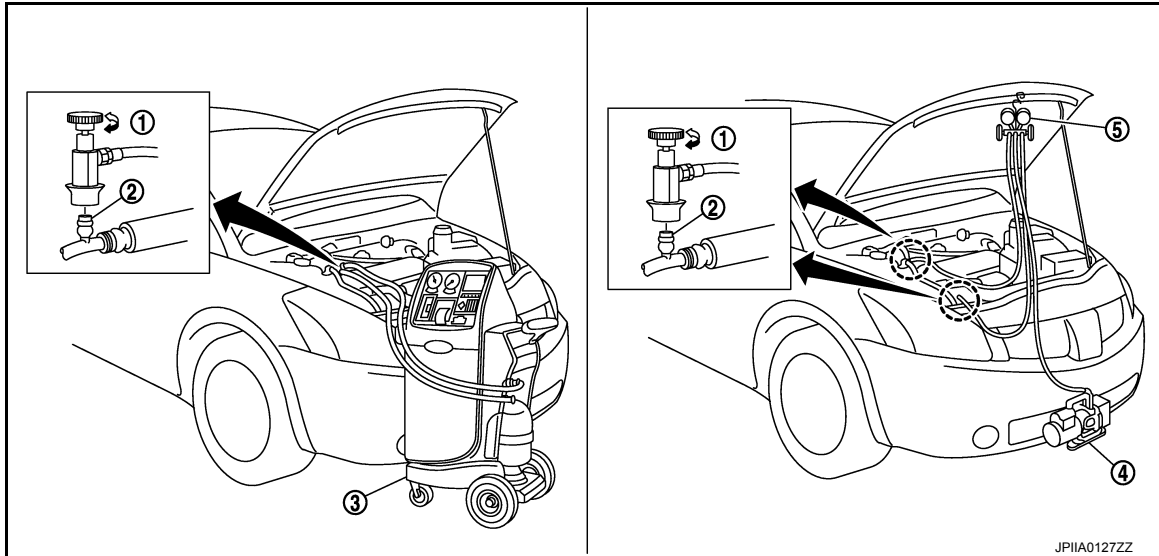

1. Shut-off valve
2. A/C service valve
3. Recovery/recycling/recharging equipment (for HFC-134a)
4. Vacuum pump
5. Manifold gauge set

### Check Refrigerant Leakage

INFOID:000000010640981

#### DETECTING LEAKAGES WITH FLUORESCENT INDICATOR

#### CAUTION:

Do not use fluorescent indicators as these may reduce the insulation resistance.

#### CHECK REFRIGERANT LEAKAGE USING ELECTRICAL LEAK DETECTOR

#### CAUTION:

Be careful of the following items so that inaccurate checks or misidentifications are avoided.

- Do not allow refrigerant vapor, shop chemical vapors, cigarette smoke, or others around the vehicle.
- Always check refrigerant leakage in a low air flow environment so that refrigerant may not disperse when leakage occurs.

1. Connect recovery/recycling/recharging equipment (for HFC-134a) or manifold gauge to A/C service valve.
2. Check that refrigerant gas pressure is 345 kPa (3.5 kg/cm<sup>2</sup>, 50 psi) or more when temperature is 16°C (61°F) or more. When pressure is lower than the specified value, fully recover all refrigerant and then charge with refrigerant from the service can to the specified level.

#### NOTE:

Leakages may not be detected if refrigerant gas pressure is 345 kPa (3.5 kg/cm<sup>2</sup>, 50 psi) less when temperature is 16°C (61°F) or less.

3. Clean area where refrigerant leakage check is performed, and check refrigerant leakage along all surfaces of pipe connections and A/C system components using electrical leak detector probe.

#### CAUTION:

- Even when a leakage point has been found, always continue and complete checking along all pipe connections and A/C system components for additional leakage.
- When a leakage is detected, clean leakage area using compressed air and check again.
- When checking leakage of cooling unit inside, always clean inside of drain hose so that the probe surface may not be exposed to water or dirt.

A  
B  
C  
D  
E  
F  
G  
H

HA

J  
K  
L  
M  
N  
O  
P

# REFRIGERANT

< BASIC INSPECTION >

[WITHOUT HEAT PUMP SYSTEM]

## NOTE:

- Always check leakage starting from high-pressure side and continue to low-pressure side.
  - When checking for leakage inside cooling unit, operate blower motor for 15 minutes or more at the maximum fan speed, and then insert electrical leak detector probe into drain hose and leave it inserted for 10 minutes or more.
  - When disconnecting shut-off valve that is connected to A/C service valve, always evacuate remaining refrigerant so that misidentification can be avoided.
4. Repair or replace parts where refrigerant leakage is detected. (Leakage is detected but leakage location is unknown. GO TO 5.)
  5. Start the vehicle and set A/C control in the following conditions.
    - A/C switch: ON
    - Mode switch: Ventilation set
    - Intake switch: Recirculation set
    - Temperature setting: Full cold
    - Blower motor speed: Maximum speed set
  6. Operate A/C for 2 minutes or longer.
  7. Stop the A/C. Check again for refrigerant leakage. GO TO 3.

## NOTE:

- Start refrigerant leakage check immediately after the A/C is stopped.
- When refrigerant circulation is stopped, pressure on the low-pressure side rises gradually, and after this, pressure on the high-pressure side falls gradually.
- The higher the pressure is, the easier it is to find the refrigerant leakage.

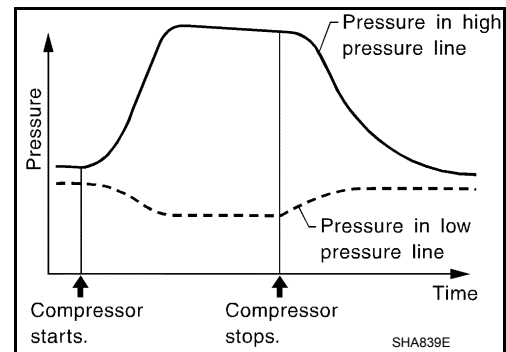

## Recycle Refrigerant

INFOID:000000010640982

## WARNING:

- Always use HFC-134a for refrigerant gas. If CFC-12 is accidentally charged, compressor is damaged due to insufficient lubrication.
  - Always observe and follow precautions described on refrigerant container. Incorrect handling may result in an explosion of refrigerant container, frostbite, or the loss of eyesight.
  - Do not breathe refrigerant gas and lubricant vapor or mist. Exposure may irritate eyes, nose, or throat.
  - Do not allow HFC-134a to be exposed to an open flame or others because it generates poisonous gas when in contact with high temperature objects. Keep workshop well ventilated.
  - To prevent fluorescent indicator from entering, prepare and use exclusive hose for EV (electric vehicle) and HEV (hybrid vehicle) when connecting recovery/recycling/recharging equipment.
1. Perform oil return operation. Refer to [HA-88. "Perform Lubricant Return Operation"](#). (If refrigerant or lubricant leakage is detected in a large amount, omit this step, and then GO TO 2.)

## CAUTION:

**Do not perform lubricant return operation if a large amount of refrigerant or lubricant leakage is detected.**

2. Check gauge pressure readings of recovery/recycling/recharging equipment (for HFC-134a). When remaining pressure exists, recycle refrigerant from high-pressure hose and low-pressure hose.

## NOTE:

Follow manufacturer instructions for the handling or maintenance of the equipment. Never fill the equipment with non-specified refrigerant.

3. Remove A/C service valve cap from the vehicle.
4. Connect recovery/recycling/recharging equipment (for HFC-134a) to the A/C service valve.
5. Operate recovery/recycling/recharging equipment (for HFC-134a), and recycle refrigerant from the vehicle.

# REFRIGERANT

< BASIC INSPECTION >

[WITHOUT HEAT PUMP SYSTEM]

6. Evacuate air for 10 minutes or more to remove any remaining refrigerant integrated to compressor lubricant, etc.
7. Refrigerant recycle operation is complete.

## Charge Refrigerant

INFOID:000000010640983

### WARNING:

- Always use HFC-134a for refrigerant. If CFC-12 is accidentally charged, compressor is damaged due to insufficient lubrication.
- Always observe and follow precautions described on refrigerant container. Incorrect handling may result in an explosion of refrigerant container, frostbite, or the loss of eyesight.
- When charging with refrigerant gas, charge with the prescribed amount from a new service can.
- Do not breathe refrigerant gas and lubricant vapor or mist. Exposure may irritate eyes, nose, or throat.
- Do not allow HFC-134a to be exposed to an open flame or others because it generates poisonous gas when in contact with high temperature objects. Keep workshop well ventilated.
- To prevent fluorescent indicator from entering, prepare and use exclusive hose for EV (electric vehicle) and HEV (hybrid vehicle) when connecting recovery/recycling/recharging equipment.

1. Connect manifold gauge (for HFC-134a) to the service valve.
2. Connect vacuum pump to manifold gauge and operate the pump. Apply vacuum to the cooler cycle for approximately 25 minutes or longer.

### CAUTION:

**Evacuate air for 15 minutes or more if the parts are replaced.**

3. Check the airtightness of A/C system for 25 minutes or more. If pressure raises more than the specified level, charge A/C system with approximately 200 g (0.4 lb) refrigerant and check that there is no refrigerant leakage. Refer to [HA-85. "Check Refrigerant Leakage"](#).

### CAUTION:

**Check the airtightness for 15 minutes or more if the parts are replaced.**

4. If parts other than compressor were replaced, add compressor oil according to parts that were replaced. Refer to [HA-88. "Lubricant Adjusting Procedure for Components Replacement Except Compressor"](#).
5. Charge the A/C system from a service can with the specified amount of refrigerant.
6. Check that A/C system operates normally.
7. Disconnect manifold gauge.
8. Install A/C service valve cap.
9. Refrigerant charge is complete.

## LUBRICANT

### Description

INFOID:000000010640984

#### MAINTENANCE OF LUBRICANT LEVEL

The compressor lubricant is circulating in the system together with the refrigerant. It is necessary to fill compressor with lubricant when replacing A/C system parts or when a large amount of refrigerant leakage is detected. It is important to always maintain lubricant level within the specified level. Or otherwise, the following conditions may occur.

- Insufficient lubricant amount: Stuck compressor
- Excessive lubricant amount: Insufficient cooling (caused by insufficient heat exchange)

**Specified lubricant    ND-OIL11 (special oil for electric compressors)**

### Inspection

INFOID:000000010640985

If there is a malfunction (abnormal noise from inside, cooling failure) in the compressor unit, check the compressor oil.

#### 1. CHECK COMPRESSOR OIL

1. Remove electric compressor. Refer to [HA-96. "Removal and Installation"](#).
2. Refer to the diagram and judge the drained compressor oil.

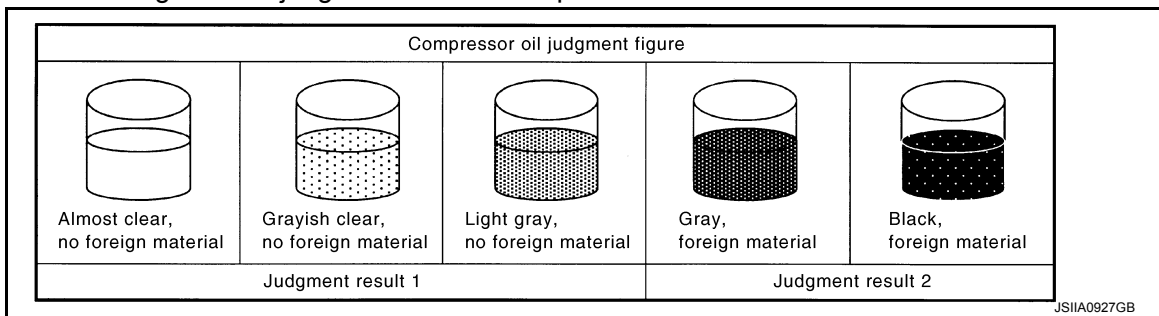

- Judgment result 1:>>Replace only compressor.  
 Judgment result 2:>>Replace compressor and liquid tank.

### Perform Lubricant Return Operation

INFOID:000000010640986

#### **CAUTION:**

**If a large amount of refrigerant or lubricant leakage is detected, never perform lubricant return operation.**

1. Start the vehicle and set to the following conditions.
  - A/C switch: ON
  - Blower motor speed: Maximum speed set
  - Intake switch: Recirculation set
  - Temperature setting: Full cold
2. Perform lubricant return operation for approximately 10 minutes.
3. Stop A/C operation.
4. Oil return operation is complete.

### Lubricant Adjusting Procedure for Components Replacement Except Compressor

INFOID:000000010640987

Fill with lubricant for the amount that is calculated according to the following conditions.

Example: Lubricant amount to be added when replacing evaporator and liquid tank [mℓ (Imp fl oz)] = 35 (1.2) + 10 (0.4) + α



# LUBRICANT

< BASIC INSPECTION >

[WITHOUT HEAT PUMP SYSTEM]

Item		Lubricant amount to be added to A/C system m ℓ (Imp fl oz)
Replace evaporator		35 (1.2)
Replace condenser		15 (0.5)
Replace liquid tank		5 (0.2)
Refrigerant leakage is detected	Large amount leakage	30 (1.1)
	Small amount leakage	—
Lubricant amount that is recycled together with refrigerant during recycle operation		$\alpha$

## Lubricant Adjusting Procedure for Compressor Replacement

INFOID:0000000010640988

1. Drain lubricant from removed compressor and measure lubricant amount.

1. Turn the compressor so that it faces downward, and drain the compressor oil from high-pressure port (A) and low-pressure port (B).
2. Measure total amount of lubricant that is drained from removed compressor.

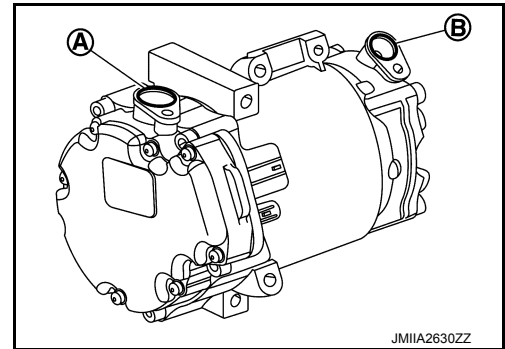

2. Drain lubricant from a new compressor that is calculated according to the following conditions.

### Amount to be drained (A)

$$[m \ell \text{ (Imp fl oz)}] = F - (D + S + R + \alpha)$$

**F** : Lubricant amount that a new compressor contains [150 (5.3)]

**D** : Lubricant amount that is drained from removed compressor

**S** : Lubricant amount that remains inside of removed compressor [20 (0.7)]

**R** : Lubricant amount to be added according to components that are removed except compressor

$\alpha$  : Lubricant amount that is recycled together with refrigerant during recycle operation

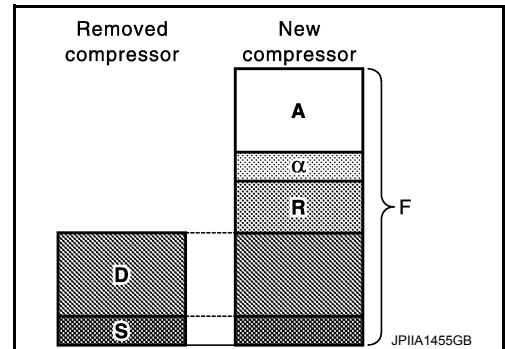

### CAUTION:

If lubricant amount that is drained from removed compressor is less than 60 m ℓ (2.1 Imp fl oz), perform calculation by setting "D" as 40 m ℓ (1.4 Imp fl oz).

Item	Lubricant amount to be added to A/C system m ℓ (Imp fl oz)
Replace evaporator	35 (1.2)
Replace condenser	15 (0.5)
Replace liquid tank	5 (0.2)

Example: Lubricant amount to be drained from a new compressor when replacing compressor and liquid tank [m ℓ (Imp fl oz)] [D = 60 (2.1),  $\alpha$  = 5 (0.2)]  
 $150 (5.3) - [60 (2.1) + 20 (0.7) + 5 (0.2) + 5 (0.2)] = 60 (2.1)$

3. Install compressor and check the operation.

# PERFORMANCE TEST

< BASIC INSPECTION >

[WITHOUT HEAT PUMP SYSTEM]



## PERFORMANCE TEST

### Inspection

INFOID:000000010640989

#### INSPECTION PROCEDURE

1. Connect the manifold gauge set.
2. Set the vehicle, and set to the following condition.

Test condition		
Surrounding condition		Indoors or in the shade (in a well-ventilated place)
Vehicle condition	Door	Closed
	Door glass	Full open
	Hood	Open
A/C condition	Temperature control switch or dial	Full cold
	A/C switch	ON
	Mode switch	 (Ventilation) set
	Intake switch	 (Recirculation) set
	 Blower motor speed	Maximum speed set

3. Maintain test condition until A/C system becomes stable. (Approximately 10 minutes)
4. Check that the characteristics for “intake temperature vs. discharge temperature” and “ambient temperature vs. pressure” are within the standard values.
5. When test results are within the specified value, inspection is complete.  
If any of test result is out of the specified value, perform diagnosis by gauge pressure. Refer to [HA-93, "Trouble Diagnosis For Unusual Pressure"](#).

# PERFORMANCE TEST

< BASIC INSPECTION >

[WITHOUT HEAT PUMP SYSTEM]

INTAKE -DISCHARGE

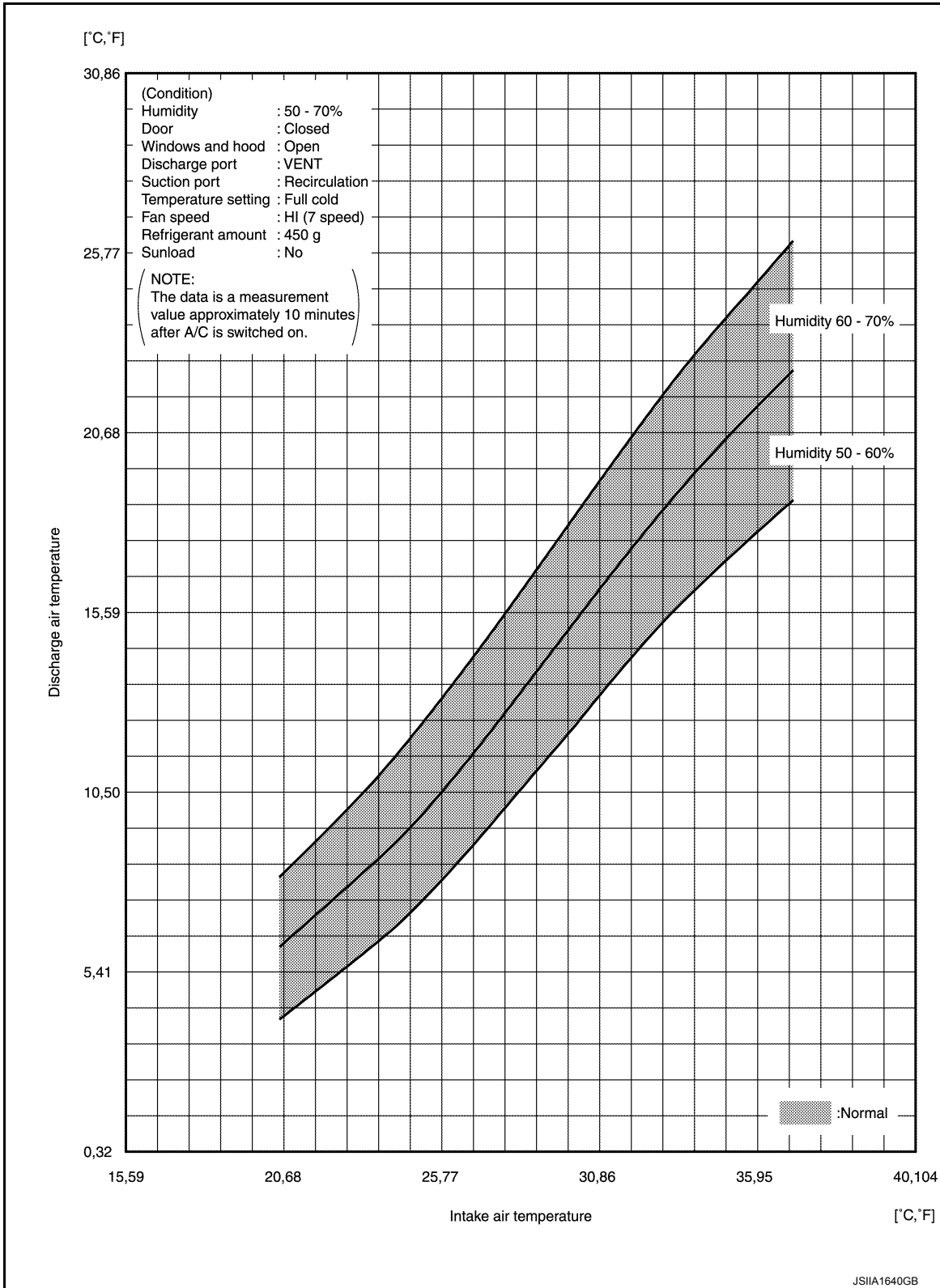

A  
B  
C  
D  
E  
F  
G  
H  
HA  
J  
K  
L  
M  
N  
O  
P

# PERFORMANCE TEST

< BASIC INSPECTION >

[WITHOUT HEAT PUMP SYSTEM]

## AMBIENT TEMPERATURE-PRESSURE CHARACTERISTICS

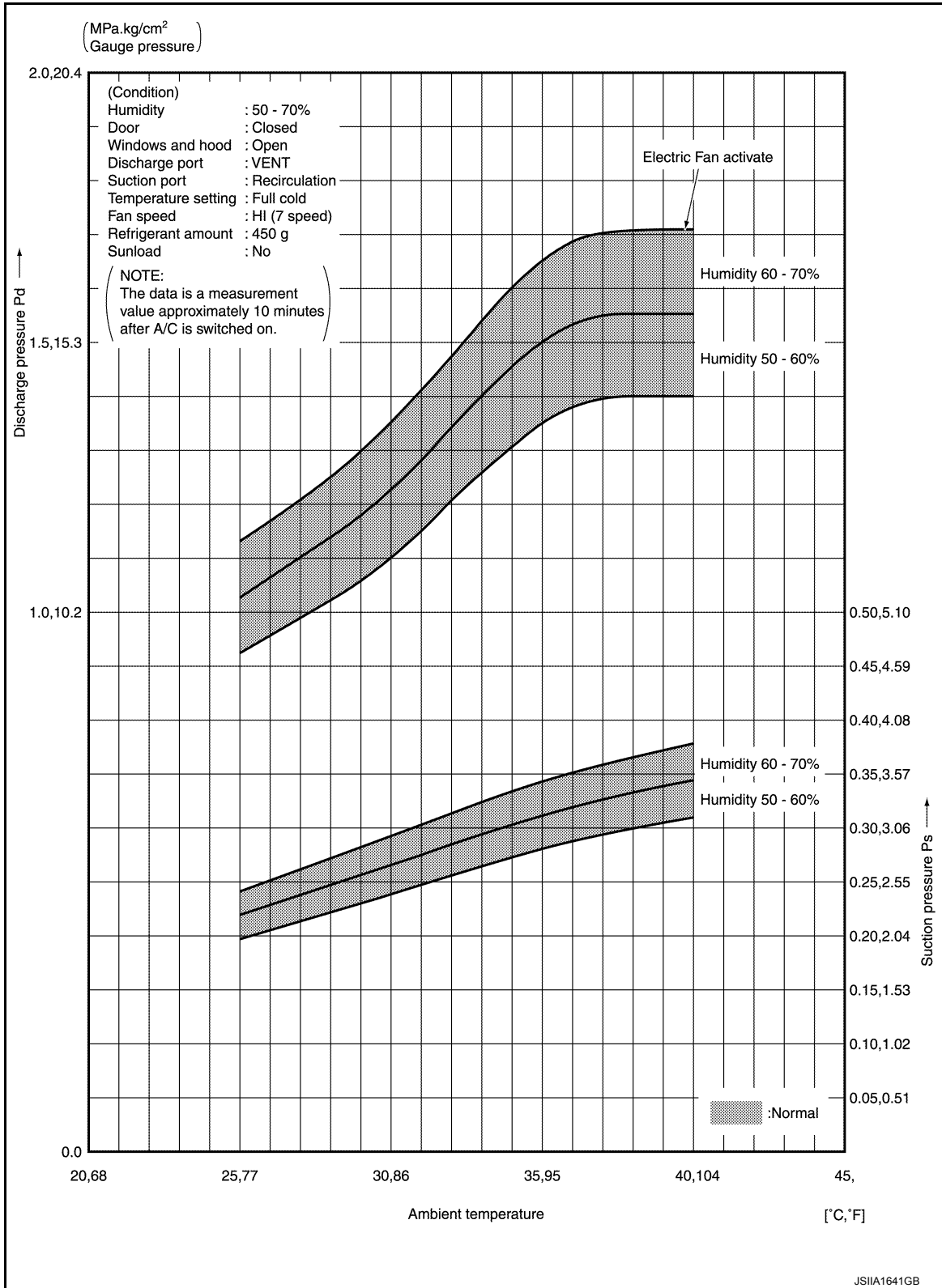

# REFRIGERATION SYSTEM SYMPTOMS

< SYMPTOM DIAGNOSIS >

[WITHOUT HEAT PUMP SYSTEM]

## SYMPTOM DIAGNOSIS

### REFRIGERATION SYSTEM SYMPTOMS

#### Trouble Diagnosis For Unusual Pressure

INFOID:0000000010640990

Diagnose using a manifold gauge whenever system's high and/or low side pressure(s) is/are unusual. The marker above the gauge scale in the following tables indicates the standard (usual) pressure range. Refer to above table (Ambient air temperature-to-operating pressure table) since the standard (usual) pressure, however, differs from vehicle to vehicle.

#### Symptom Table

INFOID:0000000010640991

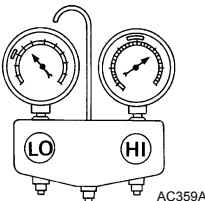
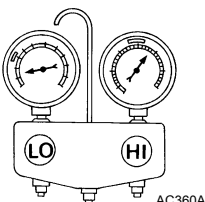
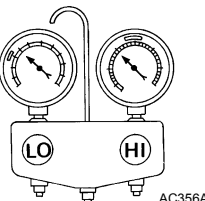
Gauge indication	Refrigerant cycle	Probable cause	Corrective action
<p>Both high- and low-pressure sides are too high.</p> 	<p>The pressure returns to normal soon after sprinkling water on condenser.</p>	<p>Overfilled refrigerant.</p>	<p>Collect all refrigerant, evacuate refrigerant cycle again, and then refill it with the specified amount of refrigerant.</p>
	<p>Air flow to condenser is insufficient.</p>	<p>Insufficient condenser cooling performance.</p> <ul style="list-style-type: none"> <li>Poor fan rotation of radiator and condenser.</li> <li>Improper installation of air guide.</li> <li>Clogged or dirty condenser fins.</li> </ul>	<ul style="list-style-type: none"> <li>Repair or replace malfunctioning parts.</li> <li>Clean and repair condenser fins.</li> </ul>
	<p>When compressor is stopped, a high-pressure reading quickly drops by approximately 196 kPa (2 kg/cm<sup>2</sup>, 28.4 psi). It then gradually decreases.</p>	<p>Air mixed in refrigerant cycle.</p>	<p>Collect all refrigerant, evacuate refrigerant cycle again, and then refill it with the specified amount of refrigerant.</p>
	<ul style="list-style-type: none"> <li>Low-pressure pipe is cooler than the outlet of evaporator.</li> <li>Low-pressure pipe is frosted.</li> </ul>	<p>Expansion valve opened too much (excessive flow of refrigerant).</p>	<p>Replace expansion valve.</p>
<p>High-pressure side is excessively high and low-pressure side is too low.</p> 	<p>High-pressure pipe and upper side of condenser become hot, however, liquid tank does not become so hot.</p>	<p>Clogged or crushed high-pressure pipe located between compressor and condenser.</p>	<p>Repair or replace the malfunctioning parts.</p>
<p>High-pressure side is too low and low-pressure side is too high.</p> 	<ul style="list-style-type: none"> <li>The readings of both sides become equal soon after compressor operation stops.</li> <li>There is no temperature difference between high- and low-pressure sides.</li> </ul>	<p>Malfunction in compressor system (insufficient compressor pressure operation).</p> <ul style="list-style-type: none"> <li>Damage or breakage of valve.</li> <li>Malfunctioning gaskets.</li> </ul>	<p>Replace compressor.</p>

# REFRIGERATION SYSTEM SYMPTOMS

[WITHOUT HEAT PUMP SYSTEM]

< SYMPTOM DIAGNOSIS >

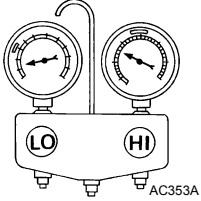
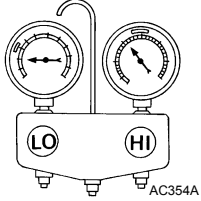
Gauge indication	Refrigerant cycle	Probable cause	Corrective action
<p>Both high- and low-pressure sides are too low.</p> 	<ul style="list-style-type: none"> <li>The area around evaporator outlet does not become cold.</li> <li>The area around evaporator inlet becomes frosted.</li> </ul>	<p>Clogged expansion valve.</p> <ul style="list-style-type: none"> <li>Breakage of temperature sensor.</li> <li>Clogging by foreign material.</li> </ul>	<p>Eliminate foreign material from expansion valve, or replace it.</p>
	<ul style="list-style-type: none"> <li>There is a temperature difference between the areas around outlet and inlet pipes of liquid tank.</li> <li>Liquid tank becomes frosted.</li> </ul>	<p>Malfunction inside liquid tank (clogged strainer).</p>	<p>Replace liquid tank.</p>
	<p>Evaporator becomes frosted.</p>	<p>Clogged or crushed low-pressure pipe.</p>	<p>Repair or replace malfunctioning parts.</p>
	<p>There is a small temperature difference between the high and low pressure pipes for refrigerant cycle.</p>	<ul style="list-style-type: none"> <li>Shortage of refrigerant.</li> <li>Leakage of refrigerant.</li> </ul>	<p>Check intake sensor system. Refer to <a href="#">HAC-287, "Diagnosis Procedure"</a>.</p>
<p>Low-pressure side sometimes becomes negative.</p> 	<ul style="list-style-type: none"> <li>Sometimes the area around evaporator outlet does not become cold.</li> <li>Sometimes the area around evaporator inlet is frosted.</li> </ul>	<ul style="list-style-type: none"> <li>Icing caused by the mixing of water in cooler cycle.</li> <li>Deteriorated dryer in liquid tank.</li> </ul>	<ul style="list-style-type: none"> <li>Check for leakage.</li> <li>Collect all refrigerant, evacuate refrigerant cycle again, and then refill it with the specified amount of refrigerant.</li> </ul>
	<ul style="list-style-type: none"> <li>Sometimes the area around evaporator outlet does not become cold.</li> <li>Sometimes the area around evaporator inlet is frosted.</li> </ul>	<ul style="list-style-type: none"> <li>Collect all refrigerant.</li> <li>Evacuate refrigerant cycle completely, and then refill it with the specified amount of refrigerant. At this time, always replace liquid tank.</li> </ul>	

# NOISE

< SYMPTOM DIAGNOSIS >

[WITHOUT HEAT PUMP SYSTEM]

## NOISE

### Symptom Table

INFOID:0000000110640992

Symptom	Noise source	Probable cause	Corrective action
Unusual noise from compressor when A/C is ON.	Inside of compressor	Wear, breakage, or clogging of foreign material in inner parts.	Check compressor oil. Refer to <a href="#">HA-88, "Inspection"</a> .
	Compressor body	Loosened compressor mounting bolts.	Check bolts for tightness. Refer to <a href="#">HA-96, "Exploded View"</a> .
Unusual noise from cooler piping.	Cooler piping (pipe and flexible hose)	Improper installation of clip and bracket.	Check the installation condition of the cooler piping. Refer to <a href="#">HA-102, "Exploded View"</a> .
Unusual noise from expansion valve when A/C is ON.	Expansion valve	Shortage of refrigerant.	<ul style="list-style-type: none"> <li>• Check for leakage.</li> <li>• Collect all refrigerant, evacuate refrigerant cycle again, and then refill it with the specified amount of refrigerant.</li> </ul>
		Wear, breakage, or clogging of foreign material in inner parts.	Eliminate foreign material from expansion valve, or replace it.

A  
B  
C  
D  
E  
F  
G  
H  
J  
K  
L  
M  
N  
O  
P

HA

# ELECTRIC COMPRESSOR

< REMOVAL AND INSTALLATION >

[WITHOUT HEAT PUMP SYSTEM]

## REMOVAL AND INSTALLATION

### ELECTRIC COMPRESSOR

Exploded View

INFOID:000000010640993

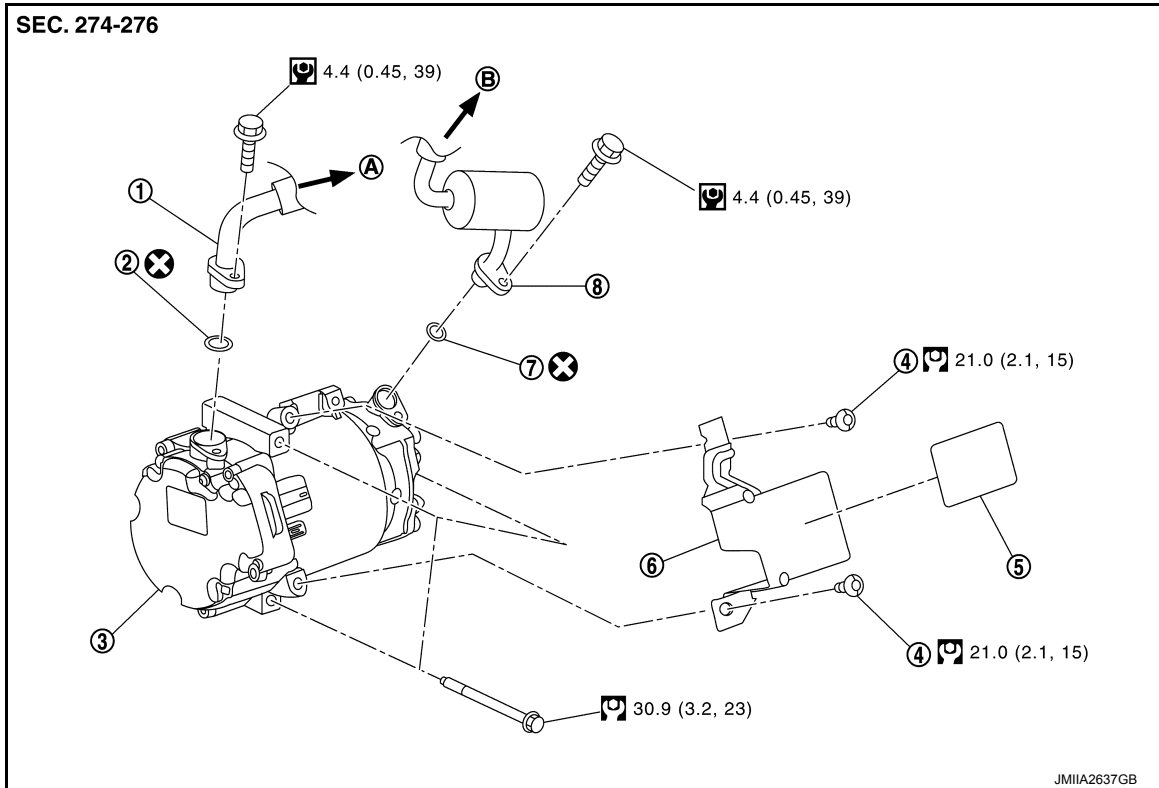

- |                               |                                |                        |
|-------------------------------|--------------------------------|------------------------|
| 1. Low-pressure flexible hose | 2. O-ring                      | 3. Electric compressor |
| 4. Bolts                      | 5. High voltage warning label  | 6. Compressor stay     |
| 7. O-ring                     | 8. High-pressure flexible hose |                        |
| A. To evaporator              | B. To condenser                |                        |

### Removal and Installation

INFOID:000000010640994

#### **DANGER:**

 Since hybrid vehicles and electric vehicles contain a high voltage battery, there is the risk of electric shock, electric leakage, or similar accidents if the high voltage component and vehicle are handled incorrectly. Be sure to follow the correct work procedures when performing inspection and maintenance.

#### **WARNING:**

- Be sure to remove the service plug in order to disconnect the high voltage circuits before performing inspection or maintenance of high voltage system harnesses and parts.
- The removed service plug must always be carried in a pocket of the responsible worker or placed in the tool box during the procedure to prevent the plug from being connected by mistake.
- Be sure to wear insulating protective equipment consisting of glove, shoes, face shield and glasses before beginning work on the high voltage system.
- Never allow workers other than the responsible person to touch the vehicle containing high voltage parts. To keep others from touching the high voltage parts, these parts must be covered with an insulating sheet except when using them. Refer to [GI-34, "High Voltage Precautions"](#).

#### **CAUTION:**

Never bring the vehicle into the READY status with the service plug removed unless otherwise instructed in the Service Manual. A malfunction may occur if this is not observed.



# ELECTRIC COMPRESSOR

< REMOVAL AND INSTALLATION >

[WITHOUT HEAT PUMP SYSTEM]

## REMOVAL

### WARNING:

Disconnect high voltage circuit. Refer to [GI-33, "How to Disconnect High Voltage"](#).

1. Check voltage in high voltage circuit. (Check that condenser are discharged.)
  - a. Lift up the vehicle, and then remove Li-ion battery under covers. Refer to [EVB-181, "Exploded View"](#).
  - b. Disconnect high voltage connector from front side of Li-ion battery. Refer to [EVB-181, "Removal and Installation"](#).
  - c. Measure voltage between high voltage harness terminals.

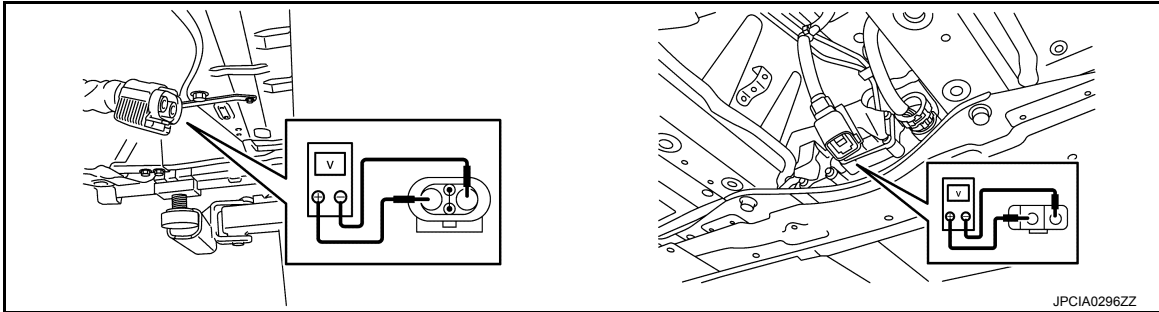

### DANGER:

 Touching high voltage components without using the appropriate protective equipment will cause electrocution.



Standard

: 5 V or less

### CAUTION:

For voltage measurements, use a tester which can measure to 500 V or higher.

2. Use the refrigerant recovery equipment (for HFC134a) and recover the refrigerant. [HA-86, "Recycle Refrigerant"](#).
3. Remove radiator upper grille. Refer to [DLK-166, "RADIATOR UPPER GRILLE : Removal and Installation"](#).
4. Remove nut (A) and disconnect low-pressure flexible hose from electric compressor.

### WARNING:

 To prevent electric shock hazards, be sure to wear protective gear.



### CAUTION:

- Cover the low pressure port of the electric compressor with a cap to prevent oil from spilling.
- To prevent the inclusion of foreign matter, use a cap or vinyl tape to seal off the pipe connection port from the atmosphere.

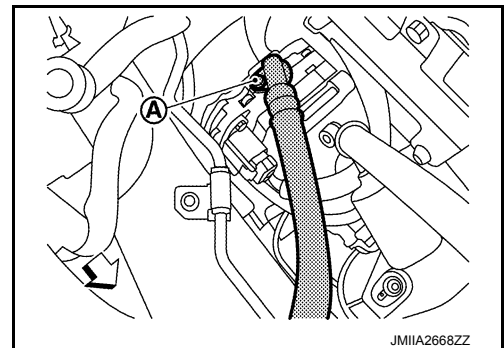

# ELECTRIC COMPRESSOR

## < REMOVAL AND INSTALLATION >

[WITHOUT HEAT PUMP SYSTEM]

5. Remove nut (A) and disconnect high-pressure flexible hose from electric compressor.

**WARNING:**

 To prevent electric shock hazards, be sure to wear protective gear.



**CAUTION:**

- Cover the high pressure port of the electric compressor with a cap to prevent oil from spilling.
- To prevent the inclusion of foreign matter, use a cap or vinyl tape to seal off the pipe connection port from the atmosphere.

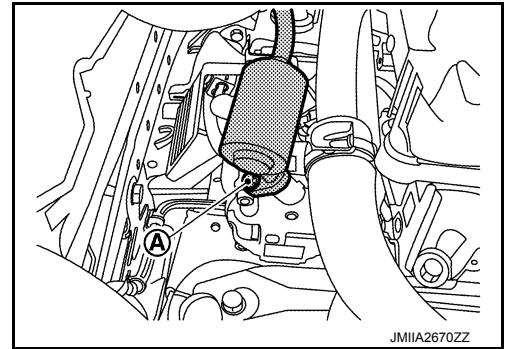

6. Disconnect quick charge port connectors (1) inside motor room.

 : Vehicle front

**WARNING:**

 To prevent electric shock hazards, be sure to wear protective gear.



- To prevent electric shock hazards, immediately wrap insulating tape around disconnected high voltage connector terminals.

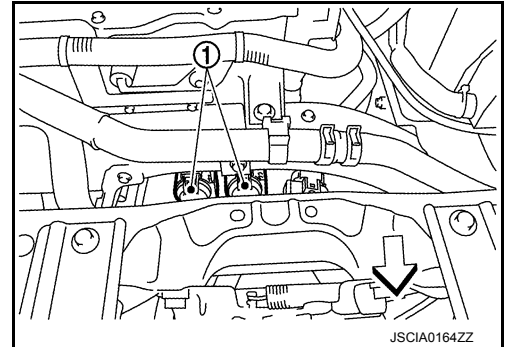

7. Disconnect normal charge port connector (1) inside motor room.

 : Vehicle front

**WARNING:**

 To prevent electric shock hazards, be sure to wear protective gear.



- To prevent electric shock hazards, immediately wrap insulating tape around disconnected high voltage connector terminals.

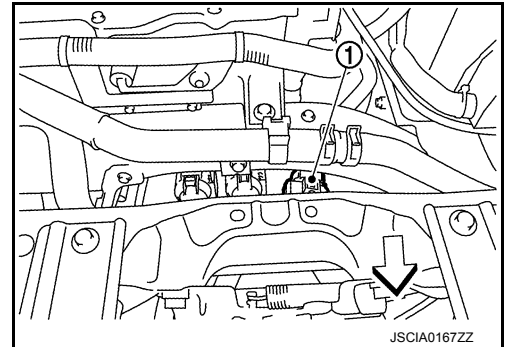

8. Move the water hose to a position where it will not interfere with work.
9. Remove front under cover. Refer to [EXT-23. "FRONT UNDER COVER : Removal and Installation"](#).
10. Remove front wheel and tire (RH). Refer to [WT-45. "Removal and Installation"](#).
11. Remove fender protector. Refer to [EXT-21. "FENDER PROTECTOR : Removal and Installation"](#).
12. Remove bolts (A), and then remove compressor stay (1).

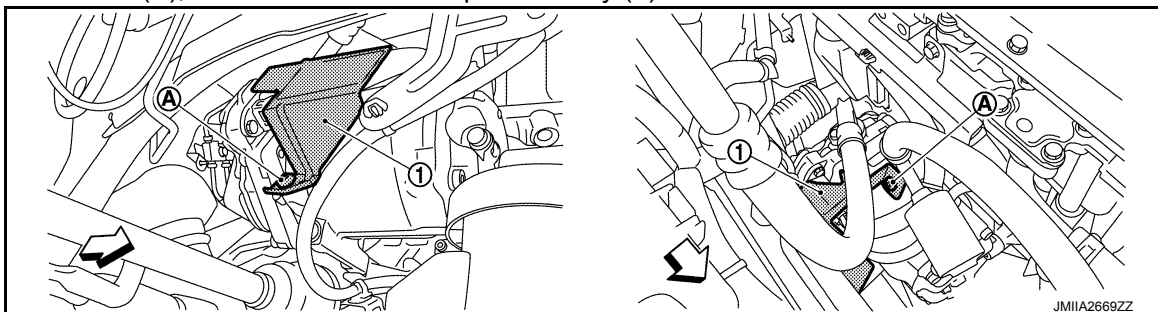

# ELECTRIC COMPRESSOR

< REMOVAL AND INSTALLATION >

[WITHOUT HEAT PUMP SYSTEM]

← : Vehicle front

## WARNING:



To prevent electric shock hazards, be sure to wear protective gear.



13. Disconnect high voltage harness connector.

← : Vehicle front

## WARNING:



To prevent electric shock hazards, be sure to wear protective gear.



To prevent electric shock hazards, immediately wrap insulating tape around disconnected high voltage connector terminals.

Follow the procedure below and disconnect high voltage harness connector.

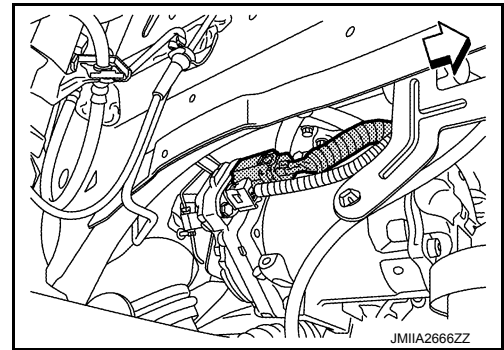
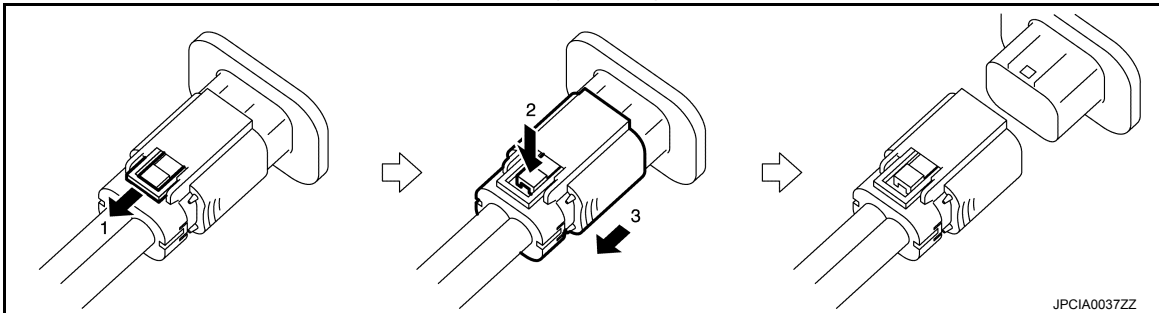

14. Disconnect low voltage harness connector.

← : Vehicle front

## WARNING:



To prevent electric shock hazards, be sure to wear protective gear.

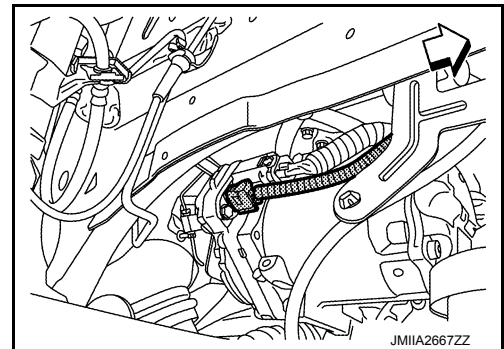

15. Remove bolts (A) from electric compressor (1).

## WARNING:



To prevent electric shock hazards, be sure to wear protective gear.

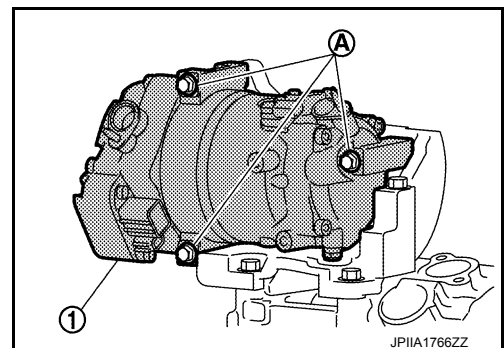

A  
B  
C  
D  
E  
F  
G  
H  
HA  
J  
K  
L  
M  
N  
O  
P

# ELECTRIC COMPRESSOR

< REMOVAL AND INSTALLATION >

[WITHOUT HEAT PUMP SYSTEM]

16. Remove electric compressor (1) from the vehicle.

**WARNING:**

 To prevent electric shock hazards, be sure to wear protective gear.

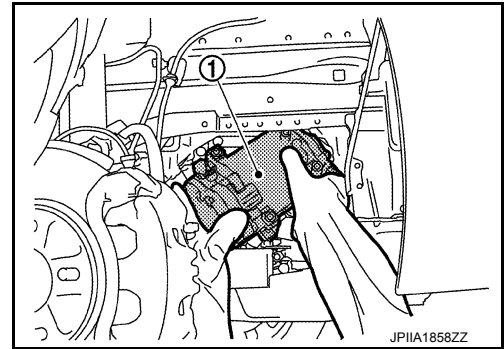

17. Remove bolts (A), and then remove compressor bracket (1).

**WARNING:**

 To prevent electric shock hazards, be sure to wear protective gear.

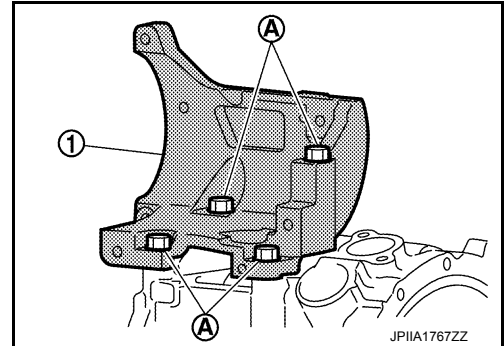

## INSTALLATION

Note the following items, and then install in the reverse order of removal.

**WARNING:**

 To prevent electric shock hazards, be sure to wear protective gear.



**CAUTION:**

- Be sure to reinstall high voltage harness clips in their original positions. If a clip is damaged, replace it with a new clip before installing.
- Before installing the new compressor, adjust the compressor oil level. Refer to [HA-89. "Lubricant Adjusting Procedure for Compressor Replacement"](#).
- To prevent degradation in insulation performance, use special electric compressor oil as the compressor oil.
- In order to prevent conventional PAG oil from becoming mixed in, never reuse recovered compressor oil and instead always use new oil. The use of oil including the conventional PAG oil may degrade the performance of insulation.
- To prevent performance degradation, never use a fluorescent agent in order to detect refrigerant leakage. Also be careful that a fluorescent agent never enter the oil.
- To prevent leakage of refrigerant, replace the O-ring with a new one. Apply a coat of compressor oil to the O-ring prior to installation.
- Perform a check for refrigerant leakage when charging with refrigerant. Refer to [HA-85. "Check Refrigerant Leakage"](#).
- Set the vehicle to READY and operate the air-conditioner for at least 1 minute with the vehicle parked to perform a break-in.

# ELECTRIC COMPRESSOR

## < REMOVAL AND INSTALLATION >

## [WITHOUT HEAT PUMP SYSTEM]

- If the compressor stay was replaced, first check that there is no dust or dirt on the surface of the compressor stay, then apply the new high voltage warning label at position (1), with the direction indicated by the arrow facing up.

← : Application direction of the label

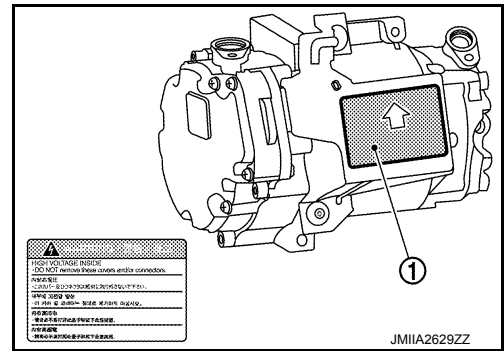

- Follow the procedure below and connect the high voltage harness connector.

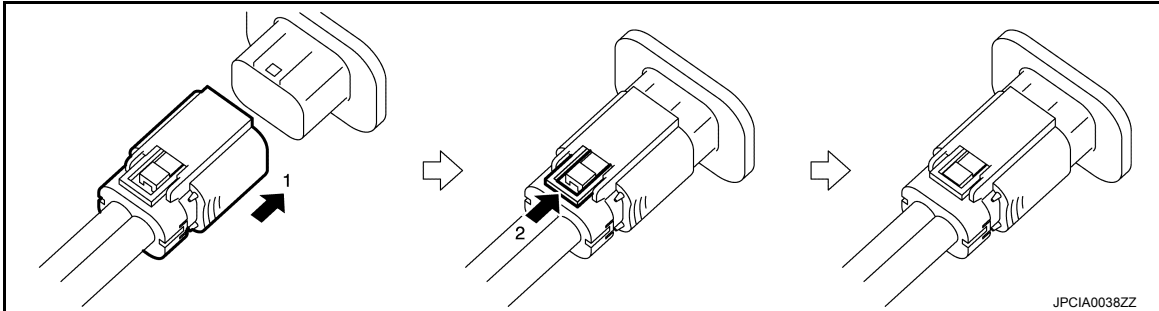

- After all parts are installed, be sure to check the equipotential. Refer to [HA-101, "Inspection"](#).

## Inspection

INFOID:000000010640995

### EQUIPOTENTIAL TEST

After installing the electric compressor, measure the resistance below.

- Between electric compressor (aluminum part) and body (ground bolt).
- Between electric compressor (aluminum part) and DC/DC-J/B (aluminum part).

#### WARNING:



To prevent electric shock hazards, be sure to wear protective gear.



**Standard : Less than 0.1  $\Omega$**

If the result deviates from the standard value, check for paint, oil, dirt, or other substance adhering to the bolts or conductive mounting parts. If such substances are found, clean the surrounding area and remove foreign substances.

A  
B  
C  
D  
E  
F  
G  
H  
HA  
J  
K  
L  
M  
N  
O  
P

# COOLER PIPE AND HOSE

< REMOVAL AND INSTALLATION >

[WITHOUT HEAT PUMP SYSTEM]

## COOLER PIPE AND HOSE

Exploded View

INFOID:000000010640996

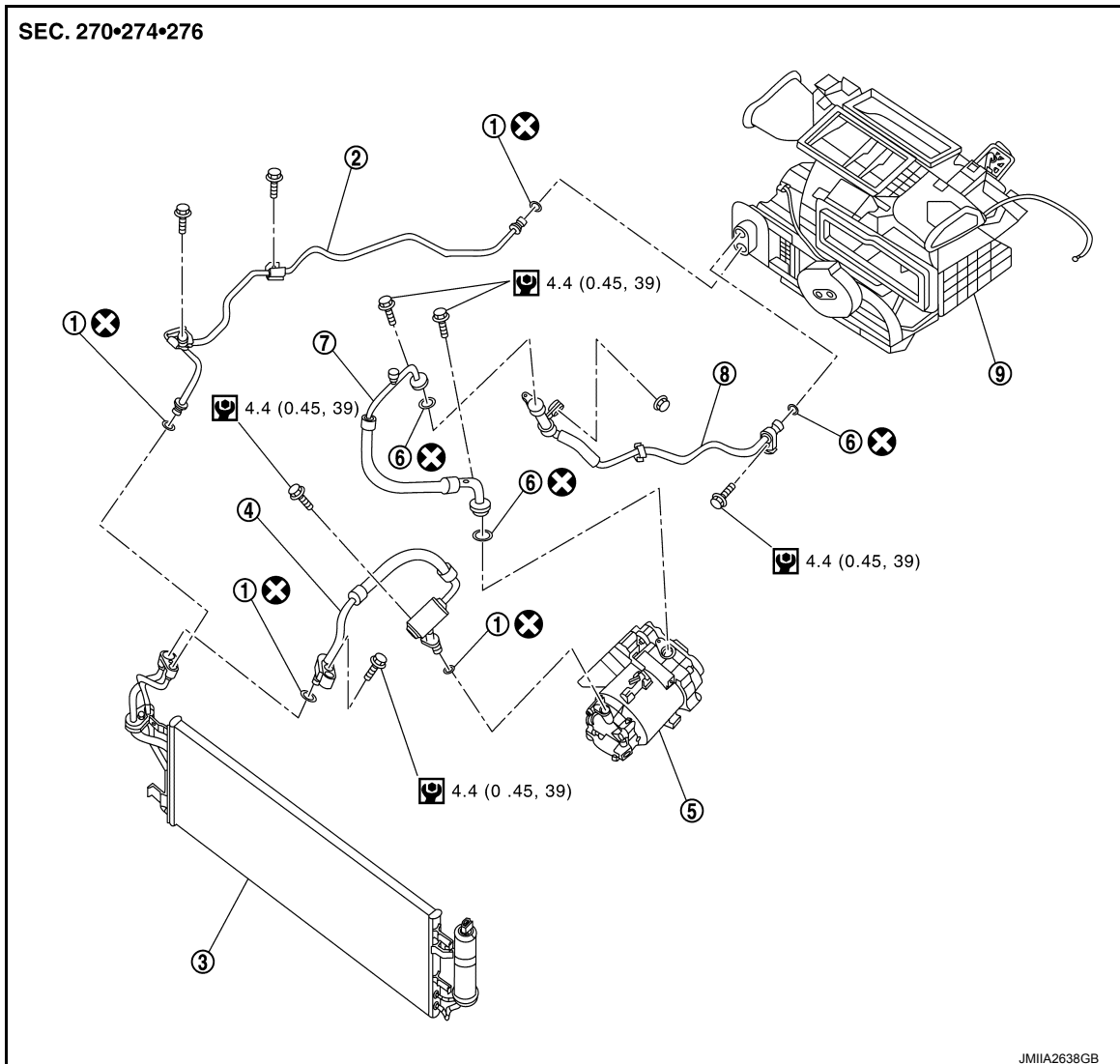

- |                                |                        |                                      |
|--------------------------------|------------------------|--------------------------------------|
| 1. O-ring                      | 2. High-pressure pipe  | 3. Condenser                         |
| 4. High-pressure flexible hose | 5. Electric compressor | 6. O-ring                            |
| 7. Low-pressure flexible hose  | 8. Low-pressure pipe   | 9. Heating and cooling unit assembly |

⊗ : Always replace after every disassembly.

Ⓜ : N·m (kg-m, in-lb)

## HIGH-PRESSURE FLEXIBLE HOSE

### HIGH-PRESSURE FLEXIBLE HOSE : Removal and Installation

INFOID:000000010640997

**DANGER:**

 Since hybrid vehicles and electric vehicles contain a high voltage battery, there is the risk of electric shock, electric leakage, or similar accidents if the high voltage component and vehicle are handled incorrectly. Be sure to follow the correct work procedures when performing inspection and maintenance.

**WARNING:**



# COOLER PIPE AND HOSE

< REMOVAL AND INSTALLATION >

[WITHOUT HEAT PUMP SYSTEM]

- Be sure to remove the service plug in order to disconnect the high voltage circuits before performing inspection or maintenance of high voltage system harnesses and parts.
- The removed service plug must always be carried in a pocket of the responsible worker or placed in the tool box during the procedure to prevent the plug from being connected by mistake.
- Be sure to wear insulating protective equipment consisting of glove, shoes, face shield and glasses before beginning work on the high voltage system.
- Never allow workers other than the responsible person to touch the vehicle containing high voltage parts. To keep others from touching the high voltage parts, these parts must be covered with an insulating sheet except when using them. Refer to [GI-34, "High Voltage Precautions"](#).

## CAUTION:

Never bring the vehicle into the READY status with the service plug removed unless otherwise instructed in the Service Manual. A malfunction may occur if this is not observed.

## REMOVAL

1. Use the refrigerant recovery equipment (for HFC134a) and recover the refrigerant. Refer to [HA-86, "Recycle Refrigerant"](#).
2. Remove radiator upper grille. Refer to [DLK-166, "RADIATOR UPPER GRILLE : Removal and Installation"](#).
3. Remove washer tank inlet. Refer to [WW-45, "Exploded View"](#).
4. Remove bolt (A), and then disconnect high-pressure flexible hose (1) from condenser.

← : Vehicle front

## CAUTION:

To prevent the inclusion of foreign matter, use a cap or vinyl tape to seal off the connection ports of the pipe and condenser from the atmosphere.

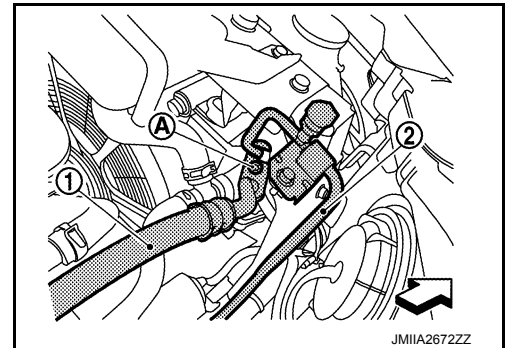

5. Remove nut (A), and then disconnect high-pressure flexible hose from electric compressor.

## WARNING:

 To prevent electric shock hazards, be sure to wear protective gear.



## CAUTION:

To prevent the inclusion of foreign matter, use a cap or vinyl tape to seal off the connection ports of the pipe and electric compressor from the atmosphere.

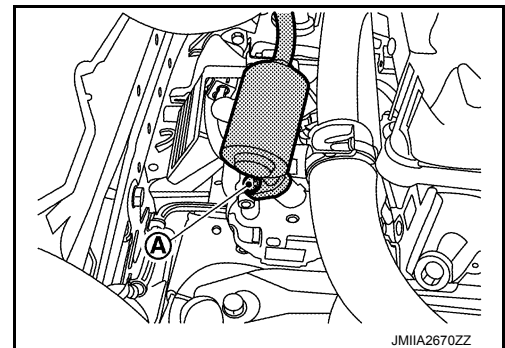

6. Disconnect high-pressure flexible hose from the vehicle.

## INSTALLATION

Note the following items, and then install in the reverse order of removal.

## CAUTION:

- To prevent degradation in insulation performance, use special electric compressor oil as the compressor oil.
- In order to prevent conventional PAG oil from becoming mixed in, never reuse recovered compressor oil and instead always use new oil. The use of oil including the conventional PAG oil may degrade the performance of insulation.
- To prevent performance degradation, never use a fluorescent agent in order to detect refrigerant leakage. Also be careful that a fluorescent agent never enter the oil.
- To prevent leakage of refrigerant, replace the O-ring with a new one. Apply a coat of compressor oil to the O-ring prior to installation.

# COOLER PIPE AND HOSE

< REMOVAL AND INSTALLATION >

[WITHOUT HEAT PUMP SYSTEM]

- Perform a check for refrigerant leakage when charging with refrigerant. Refer to [HA-85, "Check Refrigerant Leakage"](#).

## LOW-PRESSURE FLEXIBLE HOSE

### LOW-PRESSURE FLEXIBLE HOSE : Removal and Installation

INFOID:000000010640998

#### DANGER:

 Since hybrid vehicles and electric vehicles contain a high voltage battery, there is the risk of electric shock, electric leakage, or similar accidents if the high voltage component and vehicle are handled incorrectly. Be sure to follow the correct work procedures when performing inspection and maintenance.

#### WARNING:

- Be sure to remove the service plug in order to disconnect the high voltage circuits before performing inspection or maintenance of high voltage system harnesses and parts.
- The removed service plug must always be carried in a pocket of the responsible worker or placed in the tool box during the procedure to prevent the plug from being connected by mistake.
- Be sure to wear insulating protective equipment consisting of glove, shoes, face shield and glasses before beginning work on the high voltage system.
- Never allow workers other than the responsible person to touch the vehicle containing high voltage parts. To keep others from touching the high voltage parts, these parts must be covered with an insulating sheet except when using them. Refer to [GI-34, "High Voltage Precautions"](#).

#### CAUTION:

Never bring the vehicle into the READY status with the service plug removed unless otherwise instructed in the Service Manual. A malfunction may occur if this is not observed.

#### REMOVAL

1. Use the refrigerant recovery equipment (for HFC134a) and recover the refrigerant. Refer to [HA-86, "Recycle Refrigerant"](#).
2. Remove cowl top extension. Refer to [EXT-19, "Removal and Installation"](#).
3. Remove radiator upper grille. Refer to [DLK-166, "RADIATOR UPPER GRILLE : Removal and Installation"](#).
4. Remove nut (A), and then disconnect low-pressure flexible hose (1) from low-pressure pipe (2).

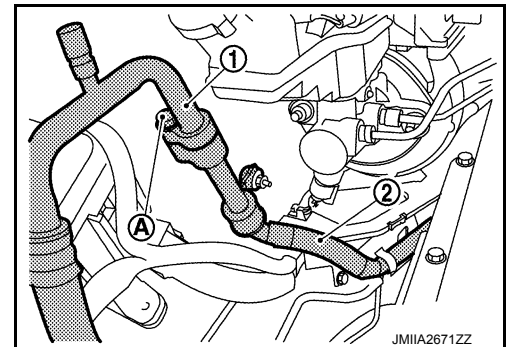

5. Remove nut (A), and then disconnect low-pressure flexible hose from electric compressor.

#### WARNING:

 To prevent electric shock hazards, be sure to wear protective gear.



#### CAUTION:

To prevent the inclusion of foreign matter, use a cap or vinyl tape to seal off the connection ports of the pipe and electric compressor from the atmosphere.

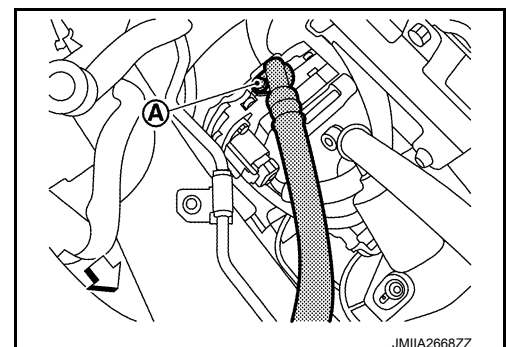

6. Disconnect low-pressure flexible hose from the vehicle.



# COOLER PIPE AND HOSE

< REMOVAL AND INSTALLATION >

[WITHOUT HEAT PUMP SYSTEM]

## INSTALLATION

Note the following items, and then install in the reverse order of removal.

### CAUTION:

- To prevent degradation in insulation performance, use special electric compressor oil as the compressor oil.
- In order to prevent conventional PAG oil from becoming mixed in, never reuse recovered compressor oil and instead always use new oil. The use of oil including the conventional PAG oil may degrade the performance of insulation.
- To prevent performance degradation, never use a fluorescent agent in order to detect refrigerant leakage. Also be careful that a fluorescent agent never enter the oil.
- To prevent leakage of refrigerant, replace the O-ring with a new one. Apply a coat of compressor oil to the O-ring prior to installation.
- Perform a check for refrigerant leakage when charging with refrigerant. Refer to [HA-85. "Check Refrigerant Leakage"](#).

## HIGH-PRESSURE PIPE

### HIGH-PRESSURE PIPE : Removal and Installation

INFOID:0000000110640999

### DANGER:



Since hybrid vehicles and electric vehicles contain a high voltage battery, there is the risk of electric shock, electric leakage, or similar accidents if the high voltage component and vehicle are handled incorrectly. Be sure to follow the correct work procedures when performing inspection and maintenance.

### WARNING:

- Be sure to remove the service plug in order to disconnect the high voltage circuits before performing inspection or maintenance of high voltage system harnesses and parts.
- The removed service plug must always be carried in a pocket of the responsible worker or placed in the tool box during the procedure to prevent the plug from being connected by mistake.
- Be sure to wear insulating protective equipment consisting of glove, shoes, face shield and glasses before beginning work on the high voltage system.
- Never allow workers other than the responsible person to touch the vehicle containing high voltage parts. To keep others from touching the high voltage parts, these parts must be covered with an insulating sheet except when using them. Refer to [GI-34. "High Voltage Precautions"](#).

### CAUTION:

Never bring the vehicle into the READY status with the service plug removed unless otherwise instructed in the Service Manual. A malfunction may occur if this is not observed.

## REMOVAL

1. Remove low-pressure flexible hose. Refer to [HA-104. "LOW-PRESSURE FLEXIBLE HOSE : Removal and Installation"](#).
2. Remove washer tank inlet. Refer to [WW-45. "Exploded View"](#).
3. Remove cowl top extension. Refer to [EXT-19. "Removal and Installation"](#).
4. Remove bolt (A), and then disconnect high-pressure flexible hose (1) and high-pressure pipe (2) from condenser.

### CAUTION:

To prevent the inclusion of foreign matter, use a cap or vinyl tape to seal off the connection ports of the pipe and condenser from the atmosphere.

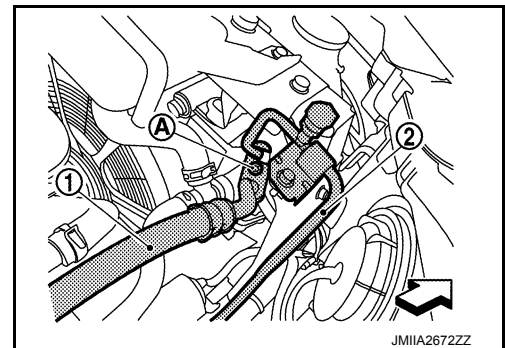

## COOLER PIPE AND HOSE

< REMOVAL AND INSTALLATION >

[WITHOUT HEAT PUMP SYSTEM]

5. Remove bolt (A), then disconnect high-pressure pipe (2) from the expansion valve.

**CAUTION:**

To prevent the inclusion of foreign matter, use a cap or vinyl tape to seal off the connection ports of the pipe and expansion valve from the atmosphere.

6. Move electric water pump 1 to secure work space. Refer to [HCO-24, "Exploded View"](#).
7. Disconnect high-pressure pipe from the vehicle.

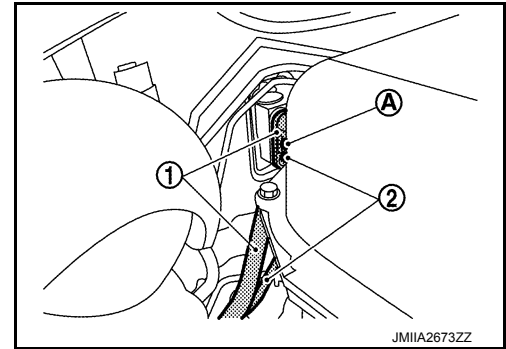

### INSTALLATION

Note the following items, and then install in the reverse order of removal.

**CAUTION:**

- To prevent degradation in insulation performance, use special electric compressor oil as the compressor oil.
- In order to prevent conventional PAG oil from becoming mixed in, never reuse recovered compressor oil and instead always use new oil. The use of oil including the conventional PAG oil may degrade the performance of insulation.
- To prevent performance degradation, never use a fluorescent agent in order to detect refrigerant leakage. Also be careful that a fluorescent agent never enter the oil.
- To prevent leakage of refrigerant, replace the O-ring with a new one. Apply a coat of compressor oil to the O-ring prior to installation.
- Perform a check for refrigerant leakage when charging with refrigerant. Refer to [HA-85, "Check Refrigerant Leakage"](#).

### LOW-PRESSURE PIPE

#### LOW-PRESSURE PIPE : Removal and Installation

INFOID:0000000110641000

**DANGER:**



Since hybrid vehicles and electric vehicles contain a high voltage battery, there is the risk of electric shock, electric leakage, or similar accidents if the high voltage component and vehicle are handled incorrectly. Be sure to follow the correct work procedures when performing inspection and maintenance.

**WARNING:**

- Be sure to remove the service plug in order to disconnect the high voltage circuits before performing inspection or maintenance of high voltage system harnesses and parts.
- The removed service plug must always be carried in a pocket of the responsible worker or placed in the tool box during the procedure to prevent the plug from being connected by mistake.
- Be sure to wear insulating protective equipment consisting of glove, shoes, face shield and glasses before beginning work on the high voltage system.
- Never allow workers other than the responsible person to touch the vehicle containing high voltage parts. To keep others from touching the high voltage parts, these parts must be covered with an insulating sheet except when using them. Refer to [GI-34, "High Voltage Precautions"](#).

**CAUTION:**

Never bring the vehicle into the READY status with the service plug removed unless otherwise instructed in the Service Manual. A malfunction may occur if this is not observed.

### REMOVAL

1. Use the refrigerant recovery equipment (for HFC134a) and recover the refrigerant. Refer to [HA-86, "Recycle Refrigerant"](#).

## COOLER PIPE AND HOSE

### < REMOVAL AND INSTALLATION >

[WITHOUT HEAT PUMP SYSTEM]

- Remove bolt (A), and then disconnect low-pressure flexible hose (1) from low-pressure pipe (2).

**CAUTION:**

To prevent the inclusion of foreign matter, use a cap or vinyl tape to seal off the connection ports of the hose and pipe from the atmosphere.

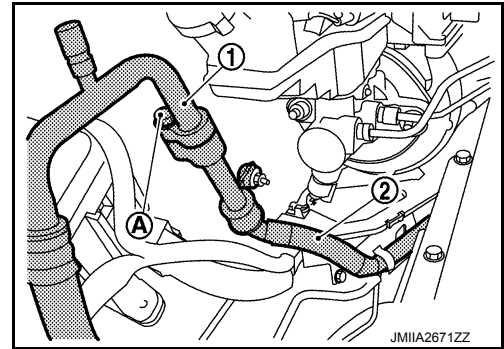

- Remove bolt (A) and then disconnect low-pressure pipe (1) from expansion valve.

**CAUTION:**

To prevent the inclusion of foreign matter, use a cap or vinyl tape to seal off the connection ports of the pipe and expansion valve from the atmosphere.

- Remove cowl top extension. Refer to [EXT-19. "Removal and Installation"](#).
- Move electric water pump 1 to secure work space. Refer to [HCO-24. "Exploded View"](#).
- Disconnect low-pressure pipe from the vehicle.

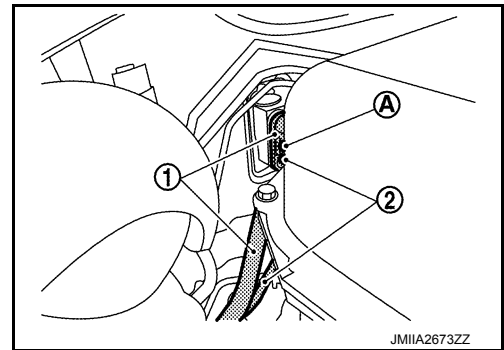

### INSTALLATION

Note the following items, and then install in the reverse order of removal.

**CAUTION:**

- To prevent degradation in insulation performance, use special electric compressor oil as the compressor oil.
- In order to prevent conventional PAG oil from becoming mixed in, never reuse recovered compressor oil and instead always use new oil. The use of oil including the conventional PAG oil may degrade the performance of insulation.
- To prevent performance degradation, never use a fluorescent agent in order to detect refrigerant leakage. Also be careful that a fluorescent agent never enter the oil.
- To prevent leakage of refrigerant, replace the O-ring with a new one. Apply a coat of compressor oil to the O-ring prior to installation.
- Perform a check for refrigerant leakage when charging with refrigerant. Refer to [HA-85. "Check Refrigerant Leakage"](#).

# CONDENSER

< REMOVAL AND INSTALLATION >

[WITHOUT HEAT PUMP SYSTEM]

## CONDENSER

Exploded View

INFOID:000000010641001

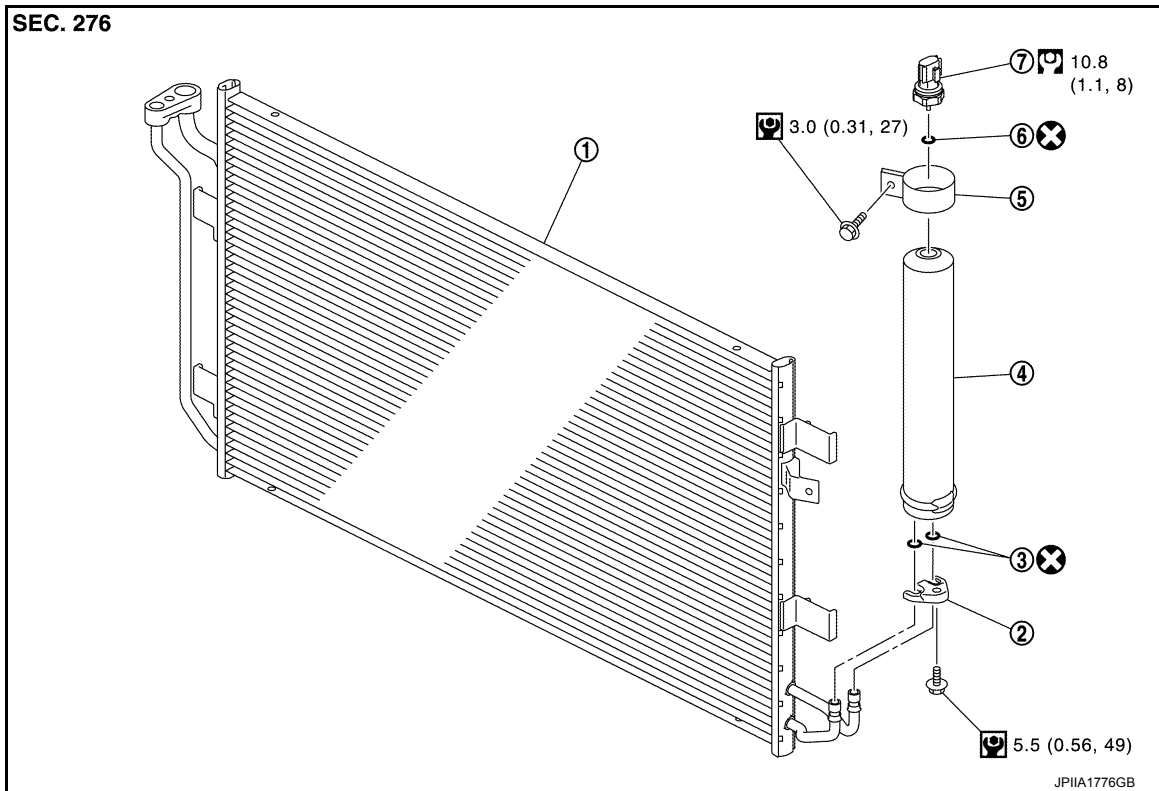

- |                                |                        |           |
|--------------------------------|------------------------|-----------|
| 1. Condenser                   | 2. Bracket             | 3. O-ring |
| 4. Liquid tank                 | 5. Liquid tank bracket | 6. O-ring |
| 7. Refrigerant pressure sensor |                        |           |

⊗: Always replace after every disassembly.

🔧: N·m (kg-m, in-lb)

🔧: N·m (kg-m, ft-lb)

## CONDENSER

### CONDENSER : Removal and Installation

INFOID:000000010641002

#### DANGER:

 Since hybrid vehicles and electric vehicles contain a high voltage battery, there is the risk of electric shock, electric leakage, or similar accidents if the high voltage component and vehicle are handled incorrectly. Be sure to follow the correct work procedures when performing inspection and maintenance.

#### WARNING:

- Be sure to remove the service plug in order to disconnect the high voltage circuits before performing inspection or maintenance of high voltage system harnesses and parts.
- The removed service plug must always be carried in a pocket of the responsible worker or placed in the tool box during the procedure to prevent the plug from being connected by mistake.
- Be sure to wear insulating protective equipment consisting of glove, shoes, face shield and glasses before beginning work on the high voltage system.
- Never allow workers other than the responsible person to touch the vehicle containing high voltage parts. To keep others from touching the high voltage parts, these parts must be covered with an insulating sheet except when using them. Refer to [GI-34, "High Voltage Precautions"](#).

# CONDENSER

< REMOVAL AND INSTALLATION >

[WITHOUT HEAT PUMP SYSTEM]

## CAUTION:

Never bring the vehicle into the READY status with the service plug removed unless otherwise instructed in the Service Manual. A malfunction may occur if this is not observed.

## REMOVAL

1. Use the refrigerant recovery equipment (for HFC134a) and recover the refrigerant. Refer to [HA-86, "Recycle Refrigerant"](#).
2. Remove radiator upper grille. Refer to [DLK-166, "RADIATOR UPPER GRILLE : Removal and Installation"](#).
3. Remove washer tank inlet. Refer to [WW-45, "Exploded View"](#).
4. Remove bolt (A), and then disconnect high-pressure flexible hose (1) and high-pressure pipe (2) from condenser.

← : Vehicle front

## CAUTION:

To prevent the inclusion of foreign matter, use a cap or vinyl tape to seal off the connection ports of the pipe and condenser from the atmosphere.

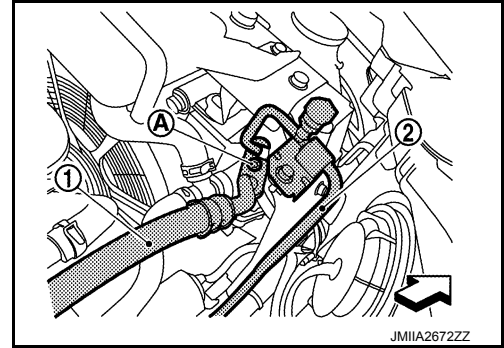

5. Remove charge port bracket. Refer to [DLK-159, "Exploded View"](#).
6. Remove radiator core support lower stay. Refer to [DLK-164, "RADIATOR CORE SUPPORT LOWER : Removal and Installation"](#).
7. Remove radiator core support upper. Refer to [DLK-162, "RADIATOR CORE SUPPORT UPPER : Removal and Installation"](#).
8. Disconnect refrigerant pressure sensor connector (A).

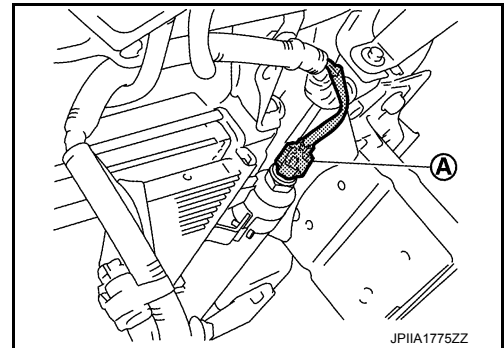

## CONDENSER

< REMOVAL AND INSTALLATION >

[WITHOUT HEAT PUMP SYSTEM]

9. Lift the condenser upwards while pressing the tabs (1) on the right and left of the radiator to remove condenser.

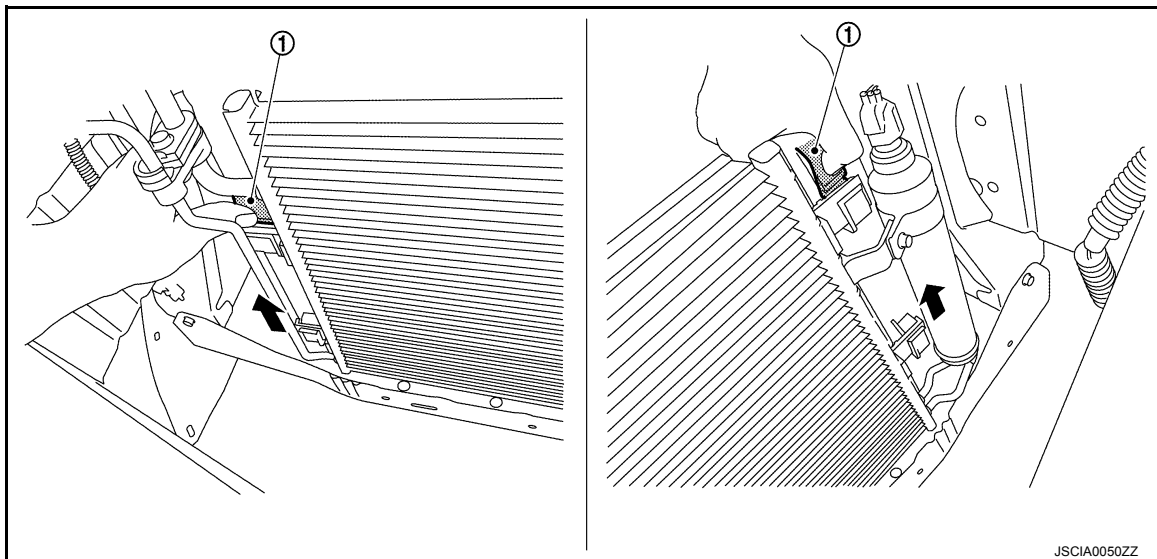

### INSTALLATION

Note the following items, and then install in the reverse order of removal.

#### CAUTION:

- When installing the condenser, securely insert the mating part indicated by the arrow in the diagram.

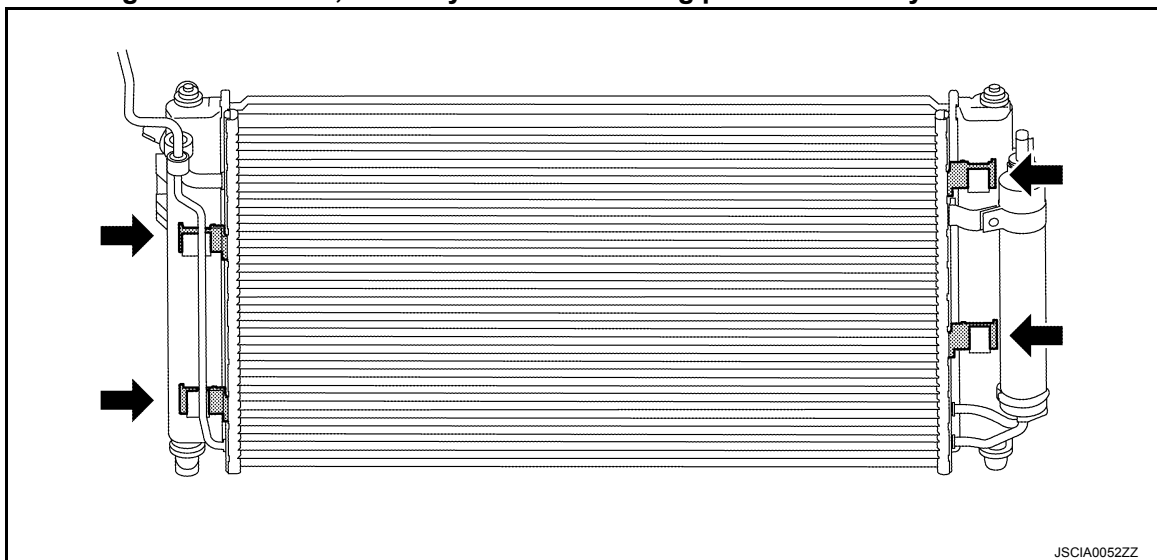

- To prevent degradation in insulation performance, use special electric compressor oil as the compressor oil.
- In order to prevent conventional PAG oil from becoming mixed in, never reuse recovered compressor oil and instead always use new oil. The use of oil including the conventional PAG oil may degrade the performance of insulation.
- To prevent performance degradation, never use a fluorescent agent in order to detect refrigerant leakage. Also be careful that a fluorescent agent never enter the oil.
- After installing a new condenser, adjust the compressor oil level. Refer to [HA-88, "Lubricant Adjusting Procedure for Components Replacement Except Compressor"](#).
- To prevent leakage of refrigerant, replace the O-ring with a new one. Apply a coat of compressor oil to the O-ring prior to installation.
- Perform a check for refrigerant leakage when charging with refrigerant. Refer to [HA-85, "Check Refrigerant Leakage"](#).

### LIQUID TANK



# CONDENSER

< REMOVAL AND INSTALLATION >

[WITHOUT HEAT PUMP SYSTEM]

## LIQUID TANK : Removal and Installation

INFOID:000000010641003

### DANGER:



Since hybrid vehicles and electric vehicles contain a high voltage battery, there is the risk of electric shock, electric leakage, or similar accidents if the high voltage component and vehicle are handled incorrectly. Be sure to follow the correct work procedures when performing inspection and maintenance.

### WARNING:

- Be sure to remove the service plug in order to disconnect the high voltage circuits before performing inspection or maintenance of high voltage system harnesses and parts.
- The removed service plug must always be carried in a pocket of the responsible worker or placed in the tool box during the procedure to prevent the plug from being connected by mistake.
- Be sure to wear insulating protective equipment consisting of glove, shoes, face shield and glasses before beginning work on the high voltage system.
- Never allow workers other than the responsible person to touch the vehicle containing high voltage parts. To keep others from touching the high voltage parts, these parts must be covered with an insulating sheet except when using them. Refer to [GI-34, "High Voltage Precautions"](#).

### CAUTION:

Never bring the vehicle into the READY status with the service plug removed unless otherwise instructed in the Service Manual. A malfunction may occur if this is not observed.

### REMOVAL

1. Use the refrigerant recovery equipment (for HFC134a) and recover the refrigerant. Refer to [HA-86, "Recycle Refrigerant"](#).
2. Disconnect refrigerant pressure sensor connector (A).

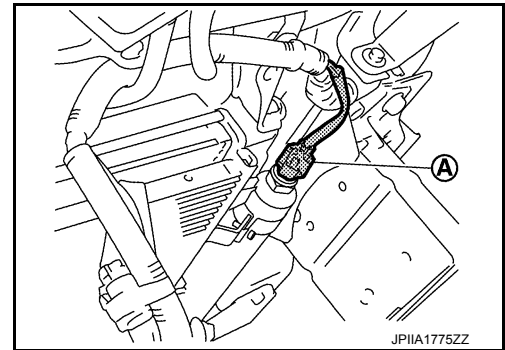

3. Clean around the liquid tank to remove any dirt or corrosion.
4. Remove bolts (A), and then remove liquid tank (1) from condenser.

### CAUTION:

To prevent the inclusion of foreign matter, use a cap or vinyl tape to seal off the connection ports of the liquid tank and condenser from the atmosphere.

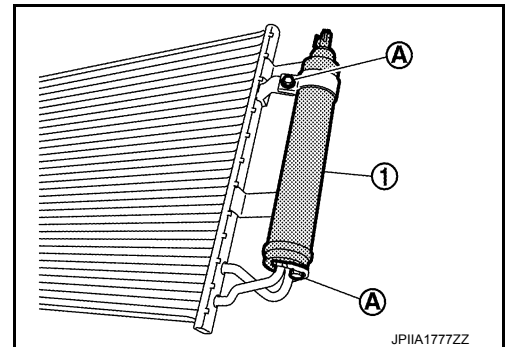

### INSTALLATION

Note the following items, and then install in the reverse order of removal.

### CAUTION:

- To prevent degradation in insulation performance, use special electric compressor oil as the compressor oil.
- In order to prevent conventional PAG oil from becoming mixed in, never reuse recovered compressor oil and instead always use new oil. The use of oil including the conventional PAG oil may degrade the performance of insulation.

A  
B  
C  
D  
E  
F  
G  
H  
HA  
J  
K  
L  
M  
N  
O  
P

## CONDENSER

< REMOVAL AND INSTALLATION >

[WITHOUT HEAT PUMP SYSTEM]

- To prevent performance degradation, never use a fluorescent agent in order to detect refrigerant leakage. Also be careful that a fluorescent agent never enter the oil.
- After installing a new liquid tank, adjust the compressor oil level. Refer to [HA-88. "Lubricant Adjusting Procedure for Components Replacement Except Compressor"](#).
- To prevent leakage of refrigerant, replace the O-ring with a new one. Apply a coat of compressor oil to the O-ring prior to installation.
- Perform a check for refrigerant leakage when charging with refrigerant. Refer to [HA-85. "Check Refrigerant Leakage"](#).



# REFRIGERANT PRESSURE SENSOR

< REMOVAL AND INSTALLATION >

[WITHOUT HEAT PUMP SYSTEM]

## REFRIGERANT PRESSURE SENSOR

### Removal and Installation

INFOID:0000000011059272

#### **DANGER:**



Since hybrid vehicles and electric vehicles contain a high voltage battery, there is the risk of electric shock, electric leakage, or similar accidents if the high voltage component and vehicle are handled incorrectly. Be sure to follow the correct work procedures when performing inspection and maintenance.

#### **WARNING:**

- Be sure to remove the service plug in order to disconnect the high voltage circuits before performing inspection or maintenance of high voltage system harnesses and parts.
- The removed service plug must always be carried in a pocket of the responsible worker or placed in the tool box during the procedure to prevent the plug from being connected by mistake.
- Be sure to wear insulating protective equipment consisting of glove, shoes, face shield and glasses before beginning work on the high voltage system.
- Never allow workers other than the responsible person to touch the vehicle containing high voltage parts. To keep others from touching the high voltage parts, these parts must be covered with an insulating sheet except when using them. Refer to [GI-34, "High Voltage Precautions"](#).

#### **CAUTION:**

Never bring the vehicle into the READY status with the service plug removed unless otherwise instructed in the Service Manual. A malfunction may occur if this is not observed.

### REMOVAL

1. Remove cowl top. Refer to [EXT-19, "Removal and Installation"](#).
2. Disconnect harness (A) to remove pressure sensor (1).

#### **CAUTION:**

- Wrap the liquid tank with shop cloth to prevent scratches.
- To prevent the inclusion of foreign matter, use a cap or vinyl tape to seal off the refrigerant pressure sensor mounting point on the liquid tank from the atmosphere.

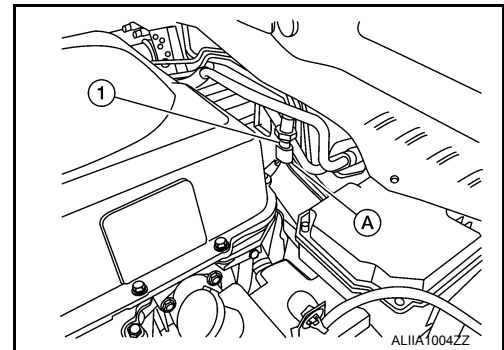

### INSTALLATION

Note the following items, and then install in the reverse order of removal.

#### **CAUTION:**

- To prevent leakage of refrigerant, replace the O-ring with a new one. Apply a coat of compressor oil to the O-ring prior to installation.
- Perform a check for refrigerant leakage when charging with refrigerant. Refer to [HA-85, "Check Refrigerant Leakage"](#).

# HEATING AND COOLING UNIT ASSEMBLY

< REMOVAL AND INSTALLATION >

[WITHOUT HEAT PUMP SYSTEM]

## HEATING AND COOLING UNIT ASSEMBLY

Exploded View

INFOID:000000010641005

### REMOVAL

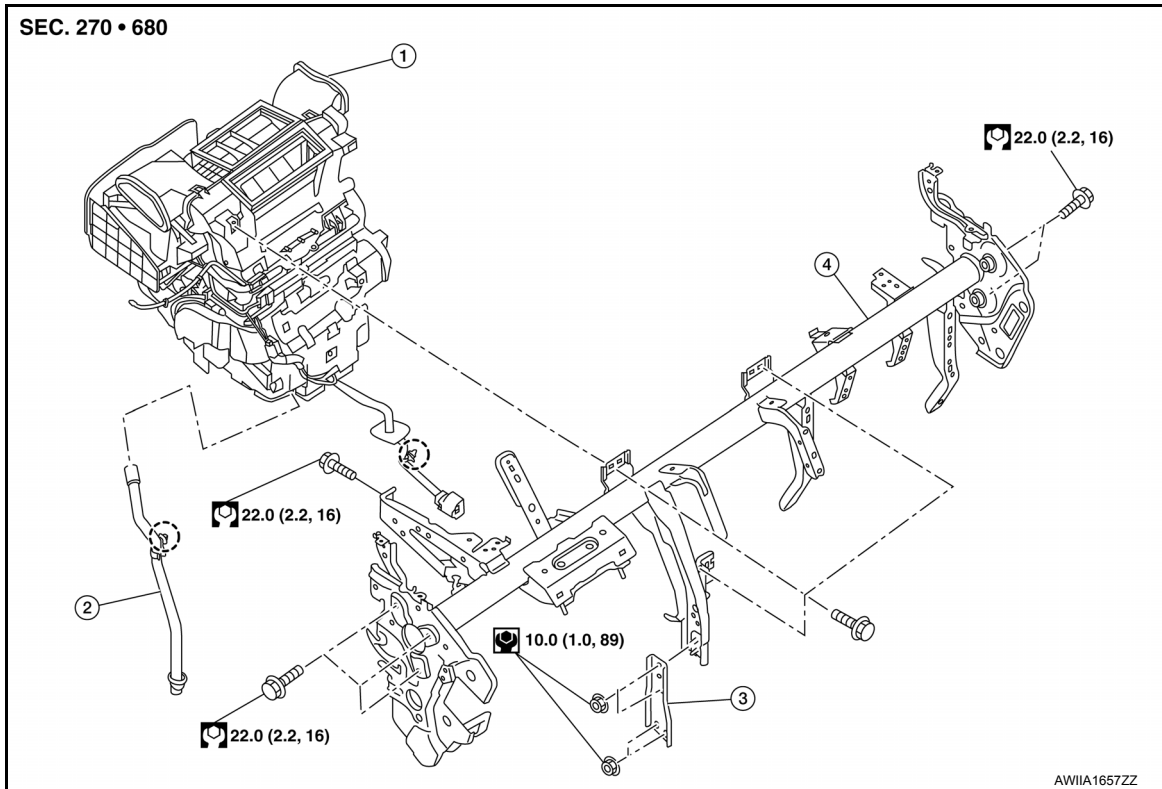

1. Heating and cooling unit assembly
2. Drain hose
3. Instrument stay
4. Steering member

○ : Clip

⊙ : N·m (kg-m, in-lb)

⊙ : N·m (kg-m, ft-lb)

### DISASSEMBLY

# HEATING AND COOLING UNIT ASSEMBLY

< REMOVAL AND INSTALLATION >

[WITHOUT HEAT PUMP SYSTEM]

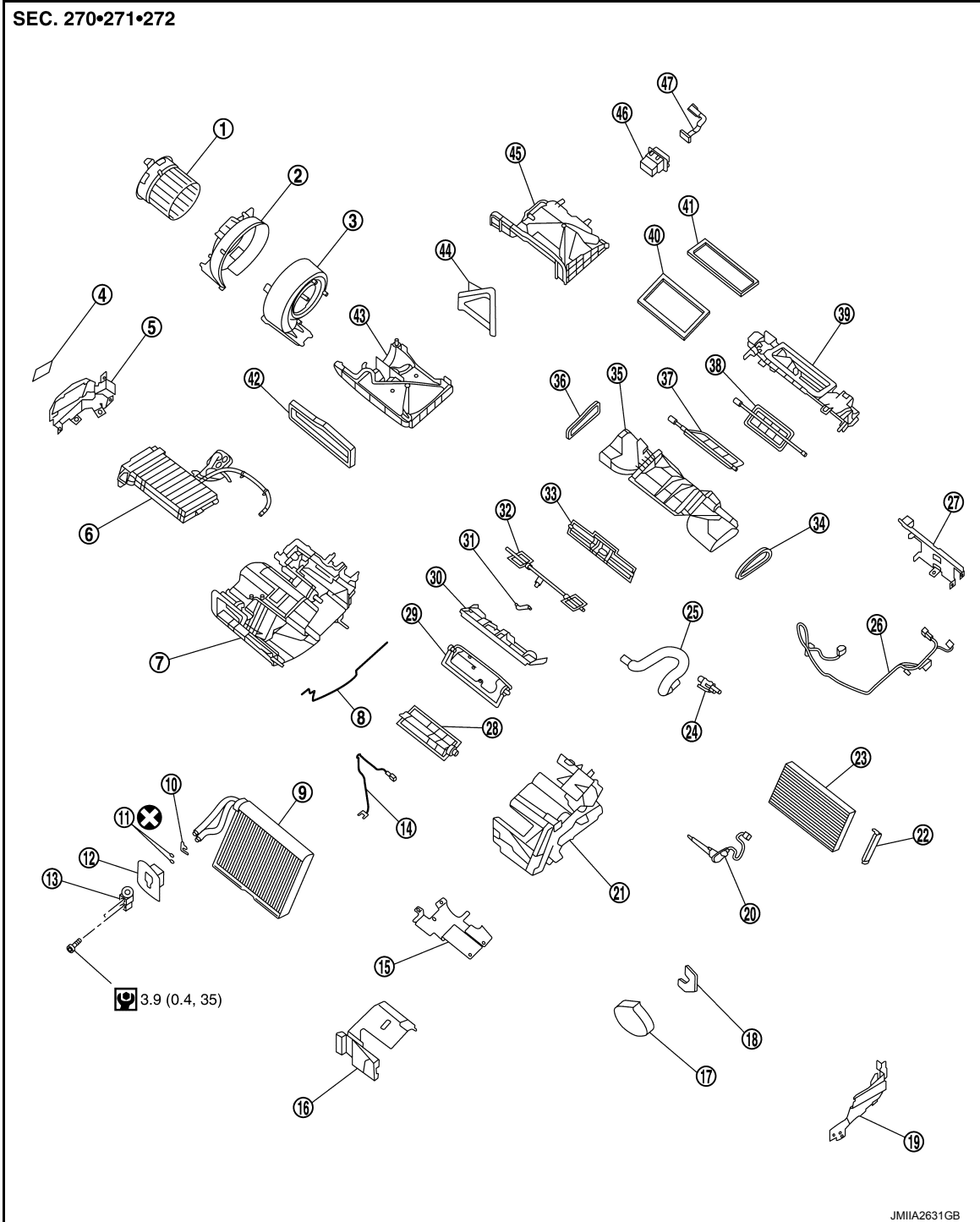

A  
B  
C  
D  
E  
F  
G  
H  
HA  
J  
K  
L  
M  
N

- |  |   |   |
|--|---|---|
| 1. Blower motor                              | 2. Blower case RH   | 3. Blower case LH                             |
| 4. High voltage warning label                | 5. PTC heater shield RH   | 6. PTC heater                                 |
| 7. Heating and cooling unit assembly case RH | 8. Case packing   | 9. Evaporator                                 |
| 10. Plate                                    | 11. O-rings   | 12. Grommet                                   |
| 13. Expansion valve                          | 14. Intake sensor   | 15. PTC heater shield lower                   |
| 16. Evaporator cover                         | 17. Gasket  | 18. Seal                                      |
| 19. PTC elements heater shield LH            | 20. PTC heater outlet and A/C unit case air temperature sensor assembly | 21. Heating and cooling unit assembly case LH |
| 22. Filter cover                             | 23. Filter  | 24. Aspirator                                 |
| 25. Aspirator tube                           | 26. Harness   | 27. PTC heater shield                         |

# HEATING AND COOLING UNIT ASSEMBLY

< REMOVAL AND INSTALLATION >

[WITHOUT HEAT PUMP SYSTEM]

- |  |                           |                             |
|--|---------------------------|-----------------------------|
| 28. Lower air mix door                   | 29. Upper air mix door    | 30. Air mix door guide      |
| 31. Foot door rod                        | 32. Side ventilator door  | 33. Foot door               |
| 34. Side ventilator door seal LH         | 35. Lower attachment case | 36. Side ventilator seal RH |
| 37. Center ventilator and defroster door | 38. Sub defroster door    | 39. Upper attachment case   |
| 40. Defroster seal                       | 41. Ventilator seal       | 42. Intake seal             |
| 43. Lower intake case                    | 44. Intake door           | 45. Upper intake case       |
| 46. Power transistor                     | 47. Sub harness           |                             |

⊗ : Always replace after every disassembly.

🔧 : N·m (kg·m, in·lb)

## HEATING AND COOLING UNIT ASSEMBLY

### HEATING AND COOLING UNIT ASSEMBLY : Removal and Installation

INFOID:0000000010641006

#### DANGER:

 Since hybrid vehicles and electric vehicles contain a high voltage battery, there is the risk of electric shock, electric leakage, or similar accidents if the high voltage component and vehicle are handled incorrectly. Be sure to follow the correct work procedures when performing inspection and maintenance.

#### WARNING:

- Be sure to remove the service plug in order to disconnect the high voltage circuits before performing inspection or maintenance of high voltage system harnesses and parts.
- The removed service plug must always be carried in a pocket of the responsible worker or placed in the tool box during the procedure to prevent the plug from being connected by mistake.
- Be sure to wear insulating protective equipment consisting of glove, shoes, face shield and glasses before beginning work on the high voltage system.
- Never allow workers other than the responsible person to touch the vehicle containing high voltage parts. To keep others from touching the high voltage parts, these parts must be covered with an insulating sheet except when using them. Refer to [GI-34, "High Voltage Precautions"](#).

#### CAUTION:

Never bring the vehicle into the READY status with the service plug removed unless otherwise instructed in the Service Manual. A malfunction may occur if this is not observed.

#### REMOVAL

#### WARNING:

Disconnect high voltage circuit. Refer to [GI-33, "How to Disconnect High Voltage"](#).

1. Check voltage in high voltage circuit. (Check that condenser are discharged.)
  - a. Lift up the vehicle, and then remove Li-ion battery under covers. Refer to [EVB-181, "Exploded View"](#).
  - b. Disconnect high voltage connector from front side of Li-ion battery. Refer to [EVB-181, "Removal and Installation"](#).
  - c. Measure voltage between high voltage harness terminals.

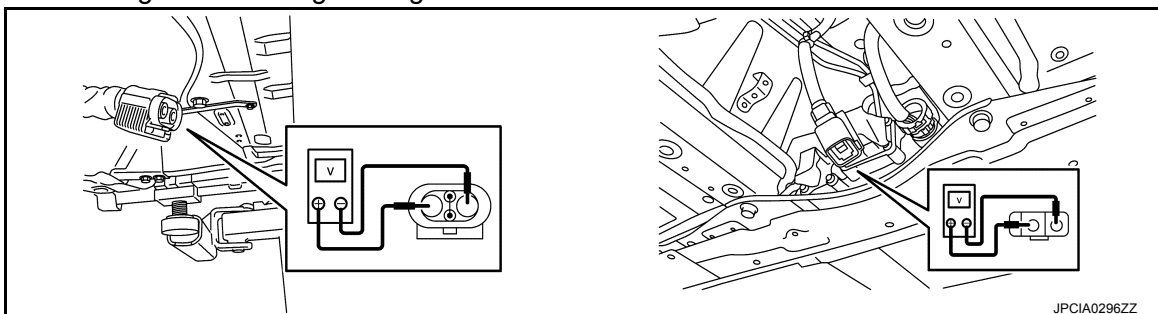

#### DANGER:

 Touching high voltage components without using the appropriate protective equipment will cause electrocution.

# HEATING AND COOLING UNIT ASSEMBLY

< REMOVAL AND INSTALLATION >

[WITHOUT HEAT PUMP SYSTEM]



Standard

: 5 V or less

**CAUTION:**

For voltage measurements, use a tester which can measure to 500 V or higher.

2. Use the refrigerant recovery equipment (for HFC134a) and recover the refrigerant. Refer to [HA-86, "Recycle Refrigerant"](#).
3. Remove cowl top extension. Refer to [EXT-19, "Removal and Installation"](#).
4. Remove bolt (A), and then disconnect low-pressure pipe (1) and high-pressure pipe (2) from expansion valve.

**CAUTION:**

To prevent the inclusion of foreign matter, use a cap or vinyl tape to seal off the connection ports of the pipe and expansion valve from the atmosphere.

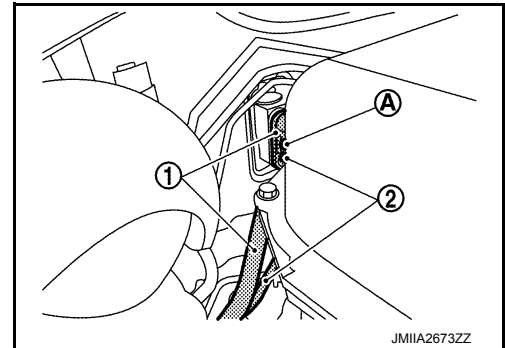

5. Remove instrument panel assembly. Refer to [HA-116, "HEATING AND COOLING UNIT ASSEMBLY : Removal and Installation"](#).
6. Remove side ventilator duct. Refer to [VTL-12, "Exploded View"](#).
7. Disconnect drain hose (1).

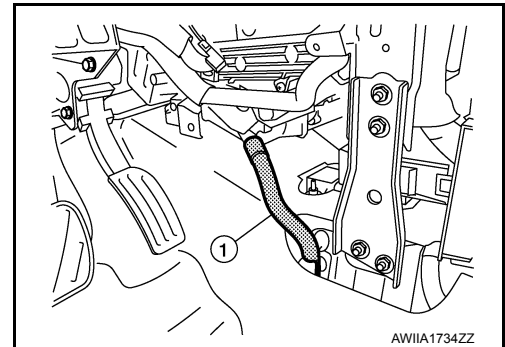

8. Remove nuts (A), and then remove instrument stay (1).

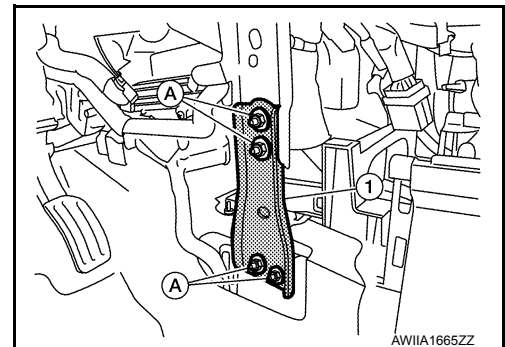

A  
B  
C  
D  
E  
F  
G  
H  
HA  
J  
K  
L  
M  
N  
O  
P

# HEATING AND COOLING UNIT ASSEMBLY

< REMOVAL AND INSTALLATION >

[WITHOUT HEAT PUMP SYSTEM]

9. Remove screws (A), and then remove fuse block (J/B) (1).

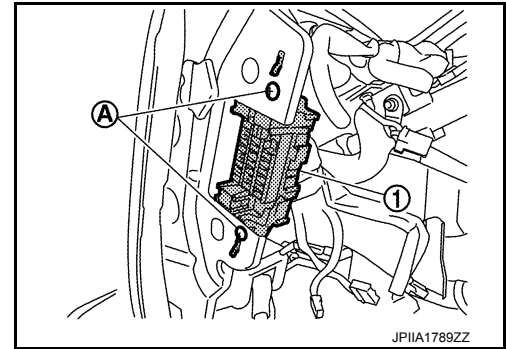

10. Remove bolts (A) of ground wire from steering member.



11. Remove all harness connectors and mounting nuts necessary to allow steering column assembly to be moved. Refer to [ST-35, "Removal and Installation"](#).
12. Move steering column assembly to secure work space.
13. Remove all harness connectors and clips necessary to allow steering member to be removed. Move main harness aside and secure work space so that steering member can be easily removed.
14. Remove bolts (A) and (B), and then remove steering member (1) from the vehicle.

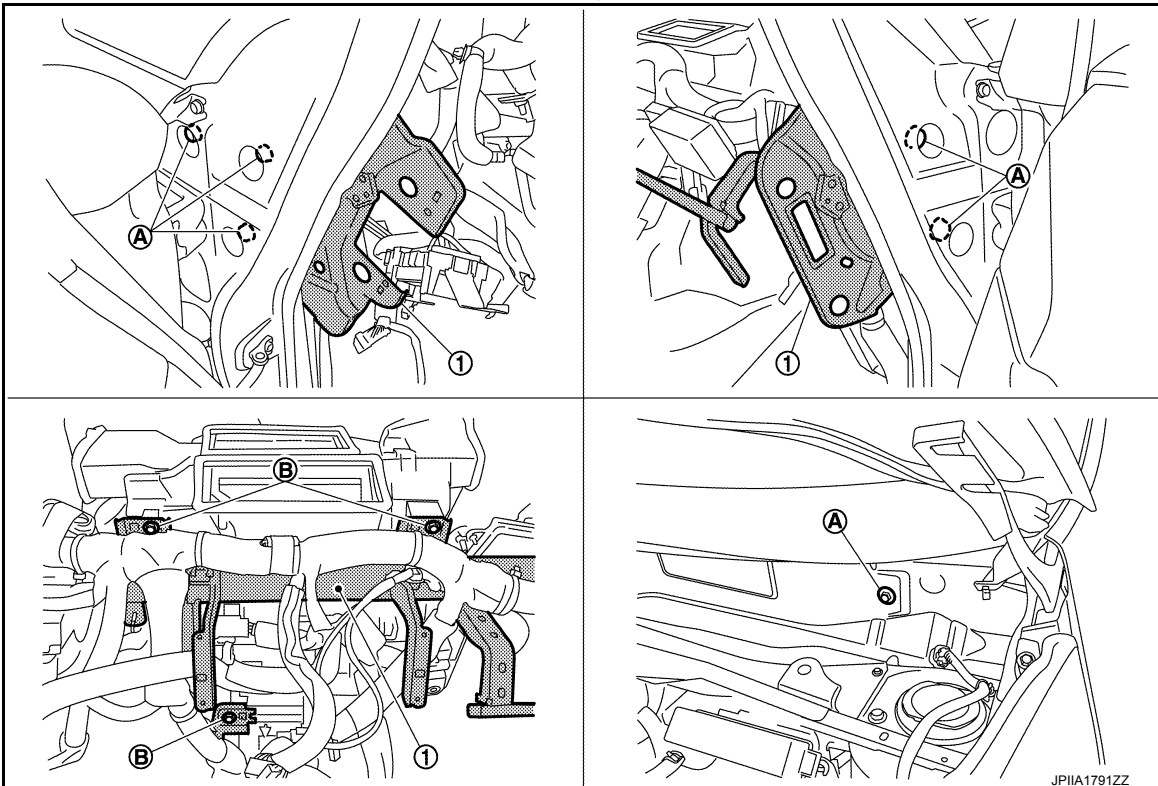

## CAUTION:

When removing steering member, 2 workers are required to prevent it from dropping.

15. Remove heating and cooling unit assembly from the vehicle.

INSTALLATION

# HEATING AND COOLING UNIT ASSEMBLY

[WITHOUT HEAT PUMP SYSTEM]

< REMOVAL AND INSTALLATION >

Note the following items, and then install in the reverse order of removal.

**CAUTION:**

- To prevent degradation in insulation performance, use special electric compressor oil as the compressor oil.
- In order to prevent conventional PAG oil from becoming mixed in, never reuse recovered compressor oil and instead always use new oil. The use of oil including the conventional PAG oil may degrade the performance of insulation.
- To prevent performance degradation, never use a fluorescent agent in order to detect refrigerant leakage. Also be careful that a fluorescent agent never enter the oil.
- To prevent leakage of refrigerant, replace the O-ring with a new one. Apply a coat of compressor oil to the O-ring prior to installation.
- Perform a check for refrigerant leakage when charging with refrigerant. Refer to [HA-85, "Check Refrigerant Leakage"](#).

## EVAPORATOR

### EVAPORATOR : Removal and Installation

INFOID:000000010641007

#### REMOVAL

1. Remove heating and cooling unit assembly. Refer to [HA-116, "HEATING AND COOLING UNIT ASSEMBLY : Removal and Installation"](#).
2. Disassemble heating and cooling unit assembly, and then remove evaporator assembly.
3. Remove expansion valve and intake sensor from evaporator assembly.

#### INSTALLATION

Note the following items, and then install in the reverse order of removal.

**CAUTION:**

- To prevent leakage of refrigerant, replace the O-ring with a new one. Apply a coat of compressor oil to the O-ring prior to installation.
- When installing the new evaporator, be sure to install the intake sensor in the same position as before it was removed.
- When removing or installing the intake sensor, be sure not to rotate the bracket insertion part. Failure to do this may cause damage to the evaporator.
- After installing a new evaporator, adjust the compressor oil level. Refer to [HA-88, "Lubricant Adjusting Procedure for Components Replacement Except Compressor"](#).

## EXPANSION VALVE

### EXPANSION VALVE : Removal and Installation

INFOID:000000010641008

**DANGER:**

 Since hybrid vehicles and electric vehicles contain a high voltage battery, there is the risk of electric shock, electric leakage, or similar accidents if the high voltage component and vehicle are handled incorrectly. Be sure to follow the correct work procedures when performing inspection and maintenance.

**WARNING:**

- Be sure to remove the service plug in order to disconnect the high voltage circuits before performing inspection or maintenance of high voltage system harnesses and parts.
- The removed service plug must always be carried in a pocket of the responsible worker or placed in the tool box during the procedure to prevent the plug from being connected by mistake.
- Be sure to wear insulating protective equipment consisting of glove, shoes, face shield and glasses before beginning work on the high voltage system.
- Never allow workers other than the responsible person to touch the vehicle containing high voltage parts. To keep others from touching the high voltage parts, these parts must be covered with an insulating sheet except when using them. Refer to [GI-34, "High Voltage Precautions"](#).

**CAUTION:**

Never bring the vehicle into the READY status with the service plug removed unless otherwise instructed in the Service Manual. A malfunction may occur if this is not observed.

#### REMOVAL



# HEATING AND COOLING UNIT ASSEMBLY

< REMOVAL AND INSTALLATION >

[WITHOUT HEAT PUMP SYSTEM]

1. Use the refrigerant recovery equipment (for HFC134a) and recover the refrigerant. Refer to [HA-86. "Recycle Refrigerant"](#).
2. Remove bolt (A), and then disconnect low-pressure pipe (1) and high-pressure pipe (2) from expansion valve.

**CAUTION:**

To prevent the inclusion of foreign matter, use a cap or vinyl tape to seal off the connection ports of the pipes and expansion valve from the atmosphere.

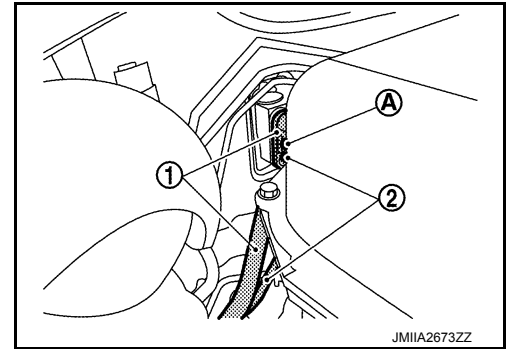

3. Remove bolts (A), and then remove expansion valve (1).

**CAUTION:**

To prevent the inclusion of foreign matter, use a cap or vinyl tape to seal off the connection ports of the expansion valve and evaporator from the atmosphere.

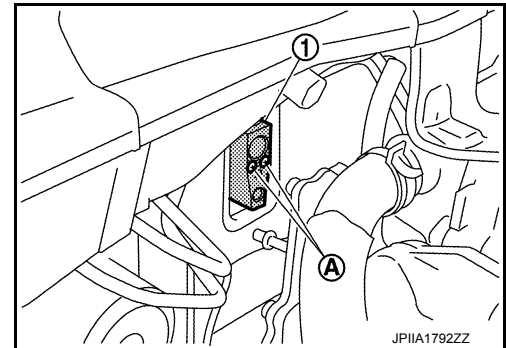

## INSTALLATION

Note the following items, and then install in the reverse order of removal.

**CAUTION:**

- To prevent degradation in insulation performance, use special electric compressor oil as the compressor oil.
- In order to prevent conventional PAG oil from becoming mixed in, never reuse recovered compressor oil and instead always use new oil. The use of oil including the conventional PAG oil may degrade the performance of insulation.
- To prevent performance degradation, never use a fluorescent agent in order to detect refrigerant leakage. Also be careful that a fluorescent agent never enter the oil.
- To prevent leakage of refrigerant, replace the O-ring with a new one. Apply a coat of compressor oil to the O-ring prior to installation.
- Perform a check for refrigerant leakage when charging with refrigerant. Refer to [HA-85. "Check Refrigerant Leakage"](#).



# SERVICE DATA AND SPECIFICATIONS (SDS)

< SERVICE DATA AND SPECIFICATIONS (SDS)

[WITHOUT HEAT PUMP SYSTEM]

## SERVICE DATA AND SPECIFICATIONS (SDS)

### SERVICE DATA AND SPECIFICATIONS (SDS)

#### Compressor

INFOID:0000000010641009

Type	Electric drive scroll type (Includes inverter)
------	--

#### Lubricant

INFOID:0000000010641010

Name	ND-OIL11 (Exclusive use for electric compressor)
Capacity	mℓ (US fl oz, Imp fl oz) 150 (5.1, 5.3)

#### Refrigerant

INFOID:0000000010641011

Name	HFC-134a (R-134a)
Capacity	kg (lb) 0.425 (0.937)

A  
B  
C  
D  
E  
F  
G  
H  
J  
K  
L  
M  
N  
O  
P

HA