

SECTION **HCO**

HIGH VOLTAGE COOLING SYSTEM

A

B

HCO

D

E

CONTENTS

PRECAUTION	2		
PRECAUTIONS	2		
Precaution for Technicians Using Medical Electric.....	2		
Point to Be Checked Before Starting Maintenance Work	2		
Precaution for Supplemental Restraint System (SRS) "AIR BAG" and "SEAT BELT PRE-TENSIONER"	2		
Precautions for Removing Battery Terminal	3		
PREPARATION	5		
PREPARATION	5		
Commercial Service Tools	5		
SYSTEM DESCRIPTION	6		
COMPONENT PARTS	6		
Radiator	6		
Cooling fan (electric fan)	6		
Electric water pump	6		
SYSTEM	7		
High Voltage Cooling System	7		
BASIC INSPECTION	9		
RADIATOR	9		
Inspection	9		
SYMPTOM DIAGNOSIS	10		
OVERHEATING CAUSE ANALYSIS	10		
Troubleshooting Chart	10		
PERIODIC MAINTENANCE	11		
			F
			G
			H
			I
			J
			K
			L
			M
			N
			O
			P

PRECAUTIONS

< PRECAUTION >

PRECAUTION

PRECAUTIONS

Precaution for Technicians Using Medical Electric

INFOID:0000000110635277

OPERATION PROHIBITION

WARNING:

- Parts with strong magnet is used in this vehicle.
- Technicians using a medical electric device such as pacemaker must never perform operation on the vehicle, as magnetic field can affect the device function by approaching to such parts.

NORMAL CHARGE PRECAUTION

WARNING:

- If a technician uses a medical electric device such as an implantable cardiac pacemaker or an implantable cardioverter defibrillator, the possible effects on the devices must be checked with the device manufacturer before starting the charge operation.
- As radiated electromagnetic wave generated by PDM (Power Delivery Module) at normal charge operation may affect medical electric devices, a technician using a medical electric device such as implantable cardiac pacemaker or an implantable cardioverter defibrillator must not approach motor room [PDM (Power Delivery Module)] at the hood-opened condition during normal charge operation.

PRECAUTION AT TELEMATICS SYSTEM OPERATION

WARNING:

- If a technician uses implantable cardiac pacemaker or implantable cardioverter defibrillator (ICD), avoid the device implanted part from approaching within approximately 220 mm (8.66 in) from interior/exterior antenna.
- The electromagnetic wave of TCU might affect the function of the implantable cardiac pacemaker or the implantable cardioverter defibrillator (ICD), when using the service, etc.
- If a technician uses other medical electric devices than implantable cardiac pacemaker or implantable cardioverter defibrillator (ICD), the electromagnetic wave of TCU might affect the function of the device. The possible effects on the devices must be checked with the device manufacturer before TCU use.

PRECAUTION AT INTELLIGENT KEY SYSTEM OPERATION

WARNING:

- If a technician uses implantable cardiac pacemaker or implantable cardioverter defibrillator (ICD), avoid the device implanted part from approaching within approximately 220 mm (8.66 in) from interior/exterior antenna.
- The electromagnetic wave of Intelligent Key might affect the function of the implantable cardiac pacemaker or the implantable cardioverter defibrillator (ICD), at door operation, at each request switch operation, or at engine starting.
- If a technician uses other medical electric devices than implantable cardiac pacemaker or implantable cardioverter defibrillator (ICD), the electromagnetic wave of Intelligent Key might affect the function of the device. The possible effects on the devices must be checked with the device manufacturer before Intelligent Key use.

Point to Be Checked Before Starting Maintenance Work

INFOID:0000000110635278

The high voltage system may starts automatically. It is required to check that the timer air conditioner and timer charge (during EVSE connection) are not set before starting maintenance work.

NOTE:

If the timer air conditioner or timer charge (during EVSE connection) is set, the high voltage system starts automatically even when the power switch is in OFF state.

Precaution for Supplemental Restraint System (SRS) "AIR BAG" and "SEAT BELT PRE-TENSIONER"

INFOID:000000011005809

The Supplemental Restraint System such as "AIR BAG" and "SEAT BELT PRE-TENSIONER", used along with a front seat belt, helps to reduce the risk or severity of injury to the driver and front passenger for certain types of collision. This system includes seat belt switch inputs and dual stage front air bag modules. The SRS

PRECAUTIONS

< PRECAUTION >

system uses the seat belt switches to determine the front air bag deployment, and may only deploy one front air bag, depending on the severity of a collision and whether the front occupants are belted or unbelted. Information necessary to service the system safely is included in the SR and SB section of this Service Manual.

WARNING:

- To avoid rendering the SRS inoperative, which could increase the risk of personal injury or death in the event of a collision which would result in air bag inflation, all maintenance must be performed by an authorized NISSAN/INFINITI dealer.
- Improper maintenance, including incorrect removal and installation of the SRS, can lead to personal injury caused by unintentional activation of the system. For removal of Spiral Cable and Air Bag Module, see the SR section.
- Do not use electrical test equipment on any circuit related to the SRS unless instructed to in this Service Manual. SRS wiring harnesses can be identified by yellow and/or orange harnesses or harness connectors.

PRECAUTIONS WHEN USING POWER TOOLS (AIR OR ELECTRIC) AND HAMMERS

WARNING:

- When working near the Airbag Diagnosis Sensor Unit or other Airbag System sensors with the Ignition ON or engine running, DO NOT use air or electric power tools or strike near the sensor(s) with a hammer. Heavy vibration could activate the sensor(s) and deploy the air bag(s), possibly causing serious injury.
- When using air or electric power tools or hammers, always switch the Ignition OFF, disconnect the battery and wait at least three minutes before performing any service.

Precautions for Removing Battery Terminal

INFOID:000000010635280

- When removing the 12V battery terminal, turn OFF the power switch and wait at least 5 minutes.

NOTE:

ECU may be active for several minutes after the power switch is turned OFF. If the battery terminal is removed before ECU stops, then a DTC detection error or ECU data corruption may occur.

- Always disconnect the battery terminal within 60 minutes after turning OFF the power switch. Even when the power switch is OFF, the 12V battery automatic charge control may automatically start after a lapse of 60 minutes from power switch OFF.
- Disconnect 12V battery terminal according to the following steps.

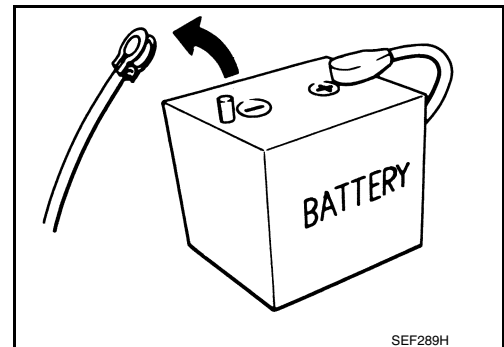

WORK PROCEDURE

1. Check that EVSE is not connected.

NOTE:

If EVSE is connected, the air conditioning system may be automatically activated by the timer A/C function.

2. Turn the power switch OFF → ON → OFF. Get out of the vehicle. Close all doors (including back door).
3. Check that the charge status indicator lamp does not blink and wait for 5 minutes or more.

NOTE:

If the battery is removed within 5 minutes after the power switch is turned OFF, plural DTCs may be detected.

4. Remove 12V battery terminal within 60 minutes after turning the power switch OFF → ON → OFF.

CAUTION:

- After all doors (including back door) are closed, if a door (including back door) is opened before battery terminals are disconnected, start over from Step 1.
- After turning the power switch OFF, if "Remote A/C" is activated by user operation, stop the air conditioner and start over from Step 1.

NOTE:

Once the power switch is turned ON → OFF, the 12V battery automatic charge control does not start for approximately 1 hour.

- For vehicles with the 2-batteries, be sure to connect the main battery and the sub battery before turning ON the power switch.

NOTE:

PRECAUTIONS

< PRECAUTION >

If the power switch is turned ON with any one of the terminals of main battery and sub battery disconnected, then DTC may be detected.

- After installing the 12V battery, always check "Self Diagnosis Result" of all ECUs and erase DTC.

NOTE:

The removal of 12V battery may cause a DTC detection error.

PREPARATION

< PREPARATION >

PREPARATION

PREPARATION

Commercial Service Tools

INFOID:0000000010635281

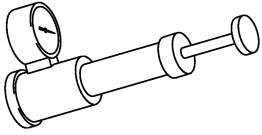
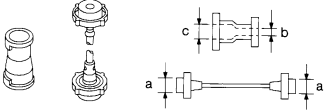
Tool name	Description
<p>Radiator cap tester</p>  <p>PBIC1982E</p>	<p>Cooling system leakage test</p>
<p>Radiator cap tester adapter</p>  <p>S-NT564</p>	<p>Adapting radiator cap tester to reservoir tank a: 28 (1.10) dia. b: 31.4 (1.236) dia. c: 41.3 (1.626) dia. Unit: mm (in)</p>

A

B

HCO

D

E

F

G

H

I

J

K

L

M

N

O

P

COMPONENT PARTS

< SYSTEM DESCRIPTION >

SYSTEM DESCRIPTION

COMPONENT PARTS

Radiator

INFOID:0000000110635282

- This radiator is a side-flow type and made of aluminum.
- The radiator side tank has a water temperature sensor.

- ① : Radiator assembly
- ② : Water temperature sensor

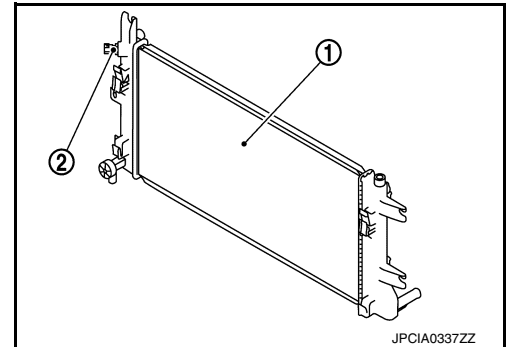

Cooling fan (electric fan)

INFOID:0000000110635283

- This cooling fan has a resin shroud.

- ① : Cooling fan control module
- ② : Cooling fan motor
- ③ : Cooling fan

- The installation of shroud to the cooling fan control module allows the controlling of cooling fan motor revolutions.
- The cooling fan control module is controlled by a control signal transmitted from VCM (Vehicle Control Module), according to a coolant temperature, vehicle speed, and request from air conditioner.

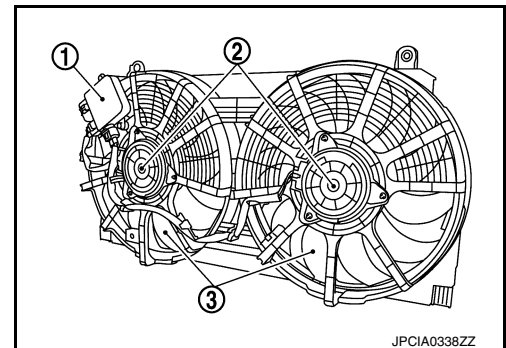

Electric water pump

INFOID:0000000110635284

- An electric water pump ① is used.
- It is installed at the bottom of the reservoir tank on the right side of the motor room.
- An electric water pump is installed in the coolant circuit, and the VCM (Vehicle Control Module) controls the coolant flow according to the coolant temperature and vehicle speed.

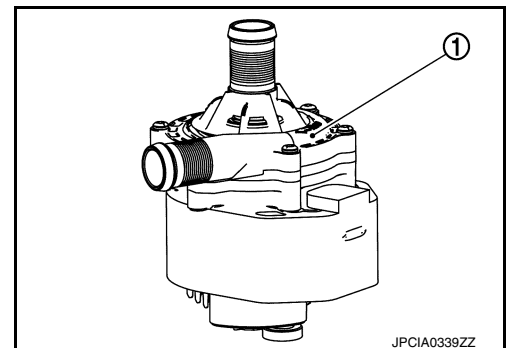

SYSTEM

< SYSTEM DESCRIPTION >

SYSTEM

High Voltage Cooling System

INFOID:0000000110635285

- The HV cooling system is the system which cools the following high-voltage components.
 - Traction motor
 - Traction motor inverter
 - PDM (Power Delivery Module)
- Coolant is circulated by means of the electric water pump, and the electric water pump is controlled by the VCM (Vehicle Control Module).

COOLING SYSTEM DIAGRAM

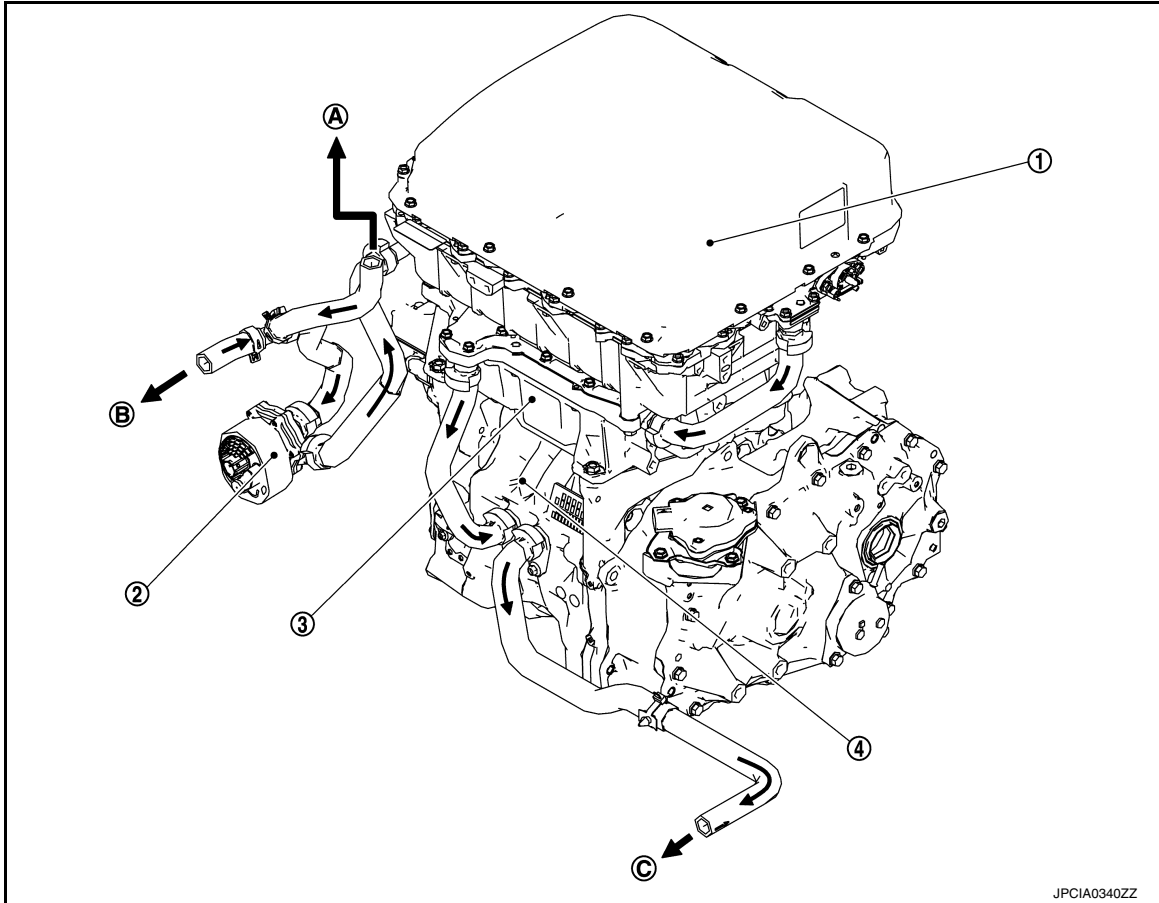

- | | | |
|-------------------------------|-----------------------|---------------------------|
| ① PDM (Power Delivery Module) | ② Electric water pump | ③ Traction motor inverter |
| ④ Traction motor | | |
| Ⓐ To reservoir tank | Ⓑ To radiator | Ⓒ To radiator |

SYSTEM

< SYSTEM DESCRIPTION >

HIGH VOLTAGE COOLING SYSTEM SCHEMATIC

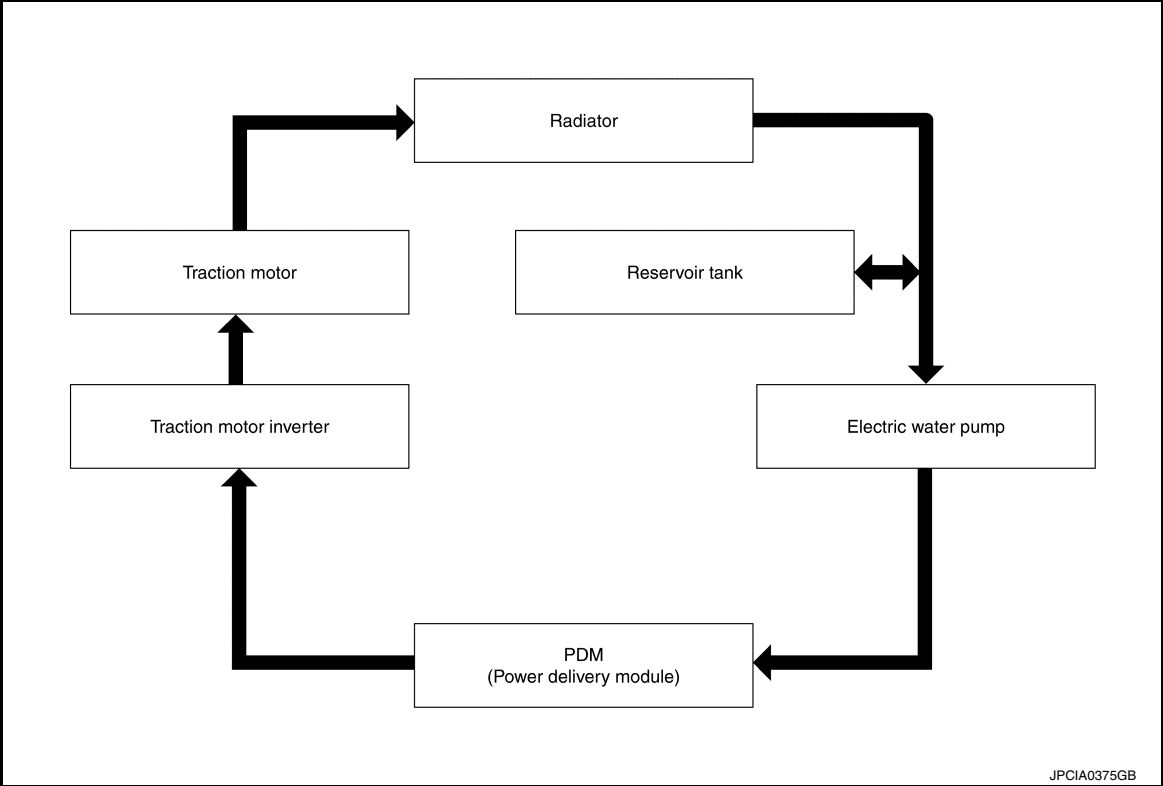

RADIATOR

< BASIC INSPECTION >

BASIC INSPECTION

RADIATOR

Inspection

INFOID:0000000010635286

Check radiator for mud or clogging. If necessary, clean radiator as follows.

CAUTION:

- **Be careful not to bend or damage radiator fins.**
- **When radiator is cleaned without removal, remove all surrounding parts such as radiator cooling fan assembly and horns. Then tape harness and harness connectors to prevent water from entering.**

1. Apply water by hose to the back side of the radiator core vertically downward.
2. Apply water again to all radiator core surfaces once per minute.
3. Stop washing if any stains no longer flow out from radiator.
4. Blow air into the back side of radiator core vertically downward.
 - Use compressed air lower than 490 kPa (5 kg/cm², 71 psi) and keep distance more than 30 cm (11.81 in).
5. Blow air again into all the radiator core surfaces once per minute until no water sprays out.

A

B

HCO

D

E

F

G

H

I

J

K

L

M

N

O

P

OVERHEATING CAUSE ANALYSIS

< SYMPTOM DIAGNOSIS >

SYMPTOM DIAGNOSIS

OVERHEATING CAUSE ANALYSIS

Troubleshooting Chart

INFOID:0000000010635287

Symptom		Check items		
Cooling system parts malfunction	Poor heat transfer	Water pump malfunction	—	
		Damaged fins	Dust contamination or paper clogging	
			Physical damage	
	Clogged radiator cooling tube	Excess foreign material (rust, dirt, sand, etc.)		
	Reduced air flow	Cooling fan does not operate	Fan assembly	
		High resistance to fan rotation		
		Damaged fan blades		
	Damaged radiator shroud		—	
	Improper coolant mixture ratio		—	
	Poor coolant quality		Coolant viscosity	
	Insufficient coolant	Coolant leakage	Cooling hose	Loose clamp Cracked hose
			Water pump	Poor sealing
Radiator			O-ring for damage, deterioration or improper fitting	
			Cracked radiator tank	
			Cracked radiator core	
Reservoir tank			Cracked reservoir tank	
Except cooling system parts malfunction	Blocked or restricted air flow	Blocked bumper	—	
		Blocked radiator grille	Installed car brassiere	
			Mud contamination or paper clogging	
		Blocked radiator	—	
		Blocked condenser	Blocked air flow	
	Installed large fog lamp			

COOLANT

< PERIODIC MAINTENANCE >

PERIODIC MAINTENANCE

COOLANT

Inspection

INFOID:0000000010635288

COOLANT AMOUNT INSPECTION

- When coolant temperature is low (about 50°C or less), confirm that the coolant level of the reservoir tank is in the range from MIN to MAX.

Ⓐ : MAX

Ⓑ : MIN

- Adjust level if it is outside the range.

CAUTION:

- Refill Genuine NISSAN Long Life Antifreeze/Coolant (blue) or equivalent in its quality mixed with water (distilled or demineralized). Refer to [MA-17, "FOR USA AND CANADA : Fluids and Lubricants"](#) (United States and Canada) or [MA-18, "FOR MEXICO : Fluids and Lubricants"](#) (Mexico).
- Confirm that the reservoir tank cap is tightened.

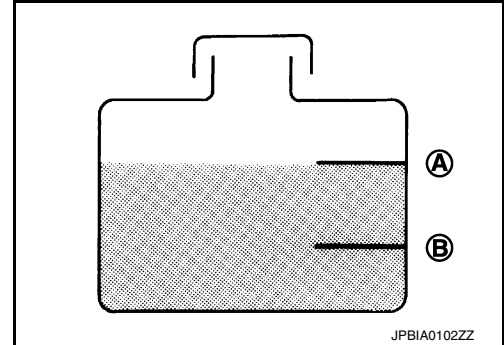

LEAK CHECK

- Apply pressure to the cooling system using suitable tool (A). Check system for coolant leaks.

Maximum pressure : Refer to [HCO-28, "Periodical Maintenance Specification"](#).

CAUTION:

- Remove the reservoir tank cap when coolant temperature is low.
- Perform the inspection with the radiator filled with water.
- Use suitable tool (B) between suitable tool (A) and the filler neck so that the reservoir tank filler neck is not deformed.
- Be sure to observe the maximum pressure standards. Otherwise, radiator may be damaged.
- If there is a malfunction, repair and replace applicable part.

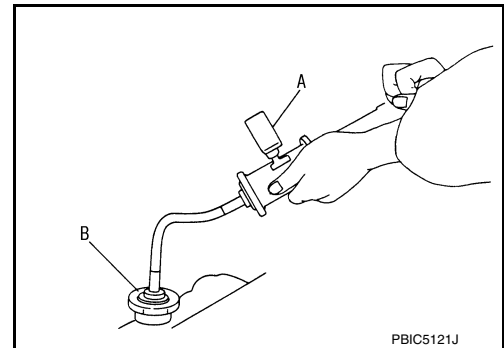

Draining

INFOID:0000000010635289

CAUTION:

- Be sure to drain when coolant temperature is cold.
 - This should be performed so that coolant does not come in contact with surrounding parts.
- Remove Li-ion battery undercover.
 - Remove radiator drain plug ①, and drain coolant.

↔ : Vehicle front

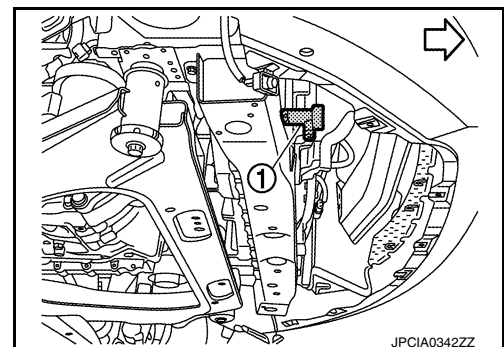

- Remove reservoir tank and drain the coolant as per the following procedure.
 - Remove radiator upper grille cover.
 - Remove water hose (reservoir tank side) and reservoir tank bolts.

COOLANT

< PERIODIC MAINTENANCE >

Refilling

INFOID:000000010635290

REFILLING

CAUTION:

- Do not reuse O-rings.
- Do not put additive such as waterleak preventive, since it may cause cooling waterway clogging.
- When refilling use Genuine NISSAN Long Life Antifreeze/Coolant (blue) or equivalent in its quality mixed with water (distilled or demineralized). Refer to [MA-17, "FOR USA AND CANADA : Fluids and Lubricants"](#) (United States and Canada) or [MA-18, "FOR MEXICO : Fluids and Lubricants"](#) (Mexico).

1. Install reservoir tank if removed and radiator drain plug.

CAUTION:

Be sure to clean drain plug and install with new O-ring.

Radiator drain plug : Refer to [HCO-14, "Exploded View"](#).

2. Check that each hose clamp has been firmly tightened.
3. Refill reservoir tank to "MAX" level line with engine coolant.

Ⓐ : MAX

Ⓑ : MIN

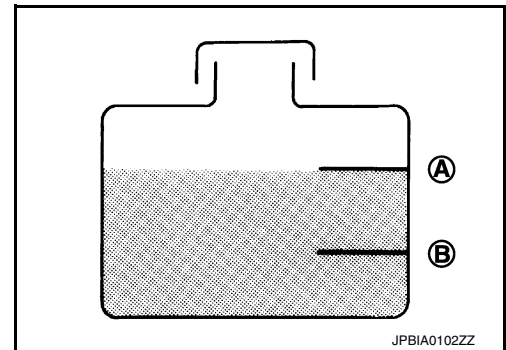

4. Install reservoir tank cap.
5. Set the vehicle to READY and operate the electric water pump.
6. If reservoir tank fluid level drops, set the vehicle in READY OFF state and fill with coolant to the "MAX" line of the reservoir tank.
7. Repeat from Step 4 to 7 until the reservoir tank fluid level stops dropping.
8. Operate the electrically-controlled water pump for approximately 10 minutes with the vehicle set in READY state, and check that the reservoir tank fluid level does not drop.
9. If reservoir tank fluid level drops, repeat from Step 4 to 7.

CHECK WATER FLOW SOUND

CAUTION:

Prior to check, be sure to close windows, doors, and hood, and turn off audio system and other electrical loads.

1. Set the vehicle to READY and operate the electric water pump.
2. Operate the electric water pump for 1 minute.
3. Check if water flow sound can be heard from the back of the compartment (near the on board charger).
4. If water flow sound is heard, operate the electric water pump until it cannot be heard.
5. When water flow sound cannot be heard, fill the reservoir tank up to "MAX" line.

CAUTION:

- Insufficient coolant may cause low power or stop of vehicle due to insufficient cooling of the traction motor inverter. Be sure to bleed air thoroughly.
- Do not operate the electric water pump without coolant.

RESERVOIR TANK CAP

< PERIODIC MAINTENANCE >

RESERVOIR TANK CAP

Inspection

INFOID:000000010635291

- Check valve seat (A) of reservoir tank cap.

(B) : Metal plunger

- Check that valve seat is swollen to the extent that the edge of the plunger cannot be seen when watching it vertically from the top.
- Check that valve seat has no soil and damage.

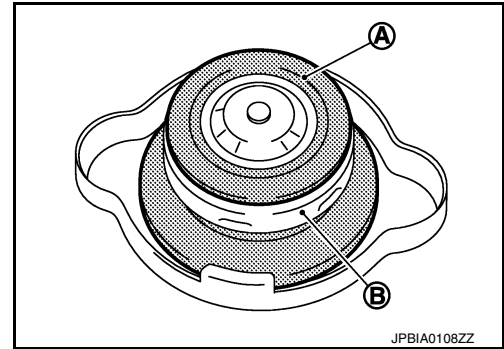

- Pull negative-pressure valve to open it, and that it close completely when released.
- Check that there is no dirt or damage on the valve seat of reservoir tank cap negative-pressure valve.
- Check that there are no unusualness in the opening and closing conditions of negative-pressure valve.

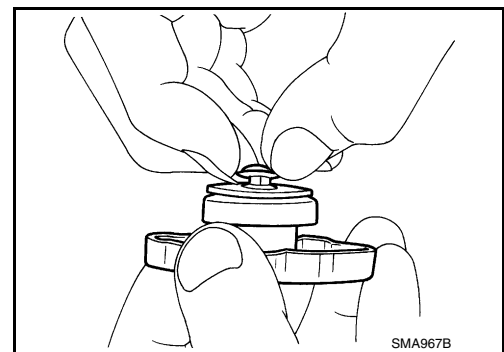

- Check reservoir tank cap relief pressure.

Standard

: Refer to [HCO-28, "Periodical Maintenance Specification"](#).

- When connecting reservoir tank cap to suitable tool (A) and suitable tool (B), apply engine coolant to the cap seal surface.

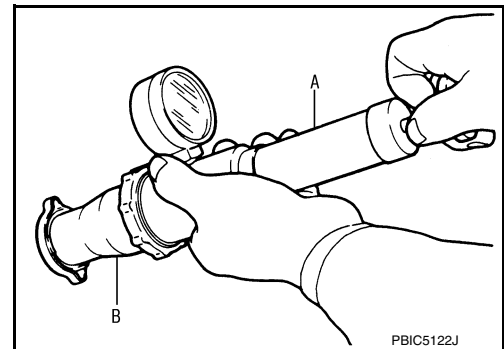

- Replace reservoir tank cap if there is an unusualness related to the above three.

A
B
HCO
D
E
F
G
H
I
J
K
L
M
N
O
P

RADIATOR

< REMOVAL AND INSTALLATION >

REMOVAL AND INSTALLATION

RADIATOR

Exploded View

INFOID:000000010635292

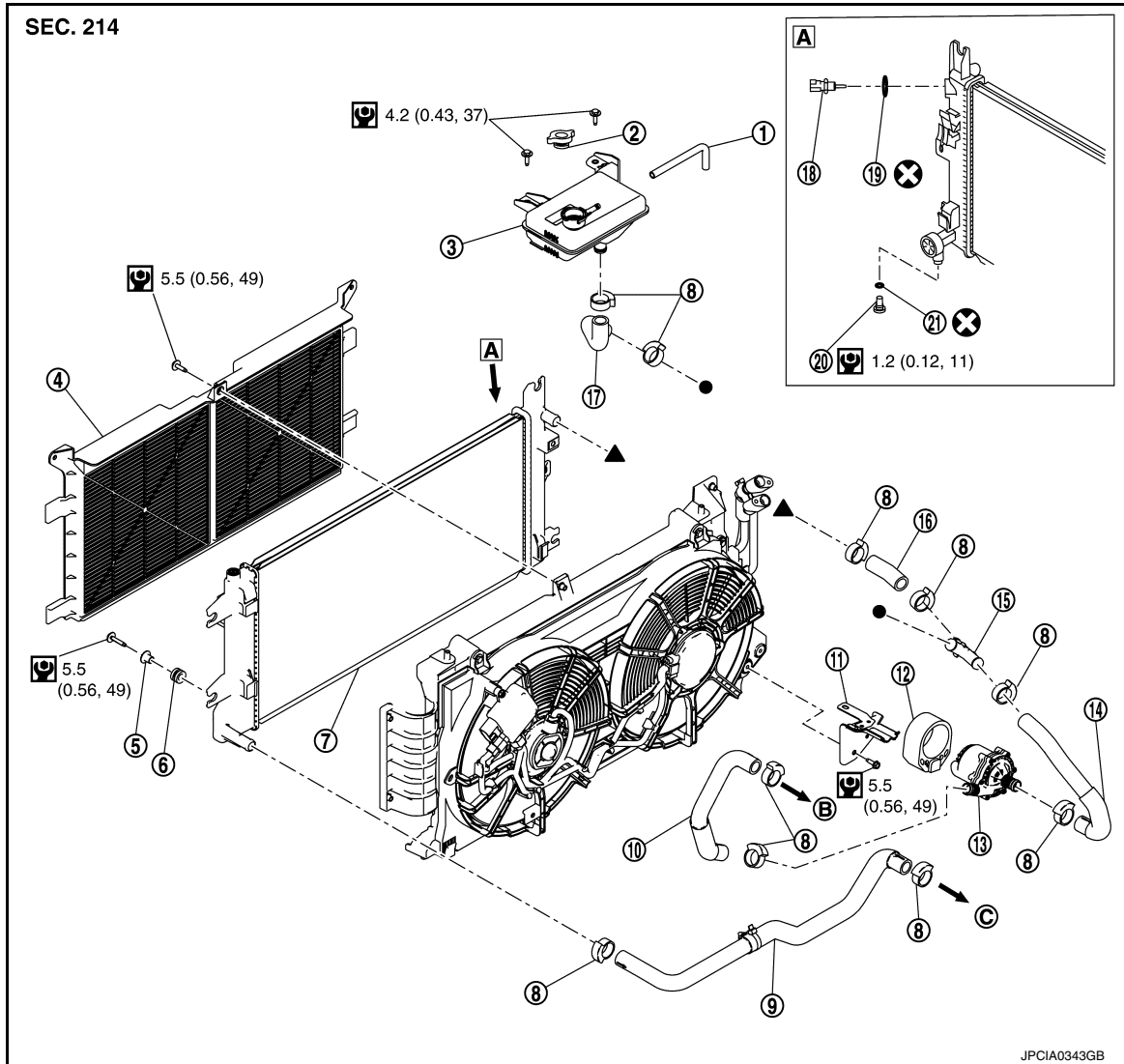

- | | | |
|-------------------------------|----------------------------------|-------------------------------------|
| ① Reservoir tank hose | ② Reservoir tank cap | ③ Reservoir tank |
| ④ Chipping guard | ⑤ Collar | ⑥ Bushing |
| ⑦ Radiator | ⑧ Clamp | ⑨ Radiator hose (lower) |
| ⑩ Water hose | ⑪ Pump bracket | ⑫ Mount rubber |
| ⑬ Electric water pump | ⑭ Radiator hose (upper rear) | ⑮ Water hose adapter |
| ⑯ Radiator hose (upper front) | ⑰ Water hose | ⑱ Engine coolant temperature sensor |
| ⑲ Gasket | ⑳ Drain plug | ㉑ O-ring |
| Ⓐ Arrow view | Ⓑ To PDM (Power Delivery Module) | Ⓒ To traction motor |

Ⓜ : N·m (kg-m, in-lb)

⊗ : Always replace after every disassembly

RADIATOR

< REMOVAL AND INSTALLATION >

Removal and Installation

INFOID:0000000110635293

REMOVAL

WARNING:

Do not remove the reservoir tank cap if the drive motor or other high voltage part is hot. Hot liquid may spray out from the radiator, causing serious injury.

NOTE:

When removing components such as hoses, tubes/lines, etc., cap or plug openings to prevent fluid from spilling.

1. Remove front under cover. Refer to [EXT-23. "FRONT UNDER COVER : Removal and Installation"](#).
2. Remove the fender protector. Refer to [EXT-21. "FENDER PROTECTOR : Removal and Installation"](#).
3. Drain coolant from radiator drain plug. Refer to [HCO-11. "Draining"](#).
4. Remove the radiator upper grille. Refer to [DLK-166. "RADIATOR UPPER GRILLE : Removal and Installation"](#).
5. Disconnect the cooling fan control module harness connector.
6. Remove the cooling fan control module harness clip ①.

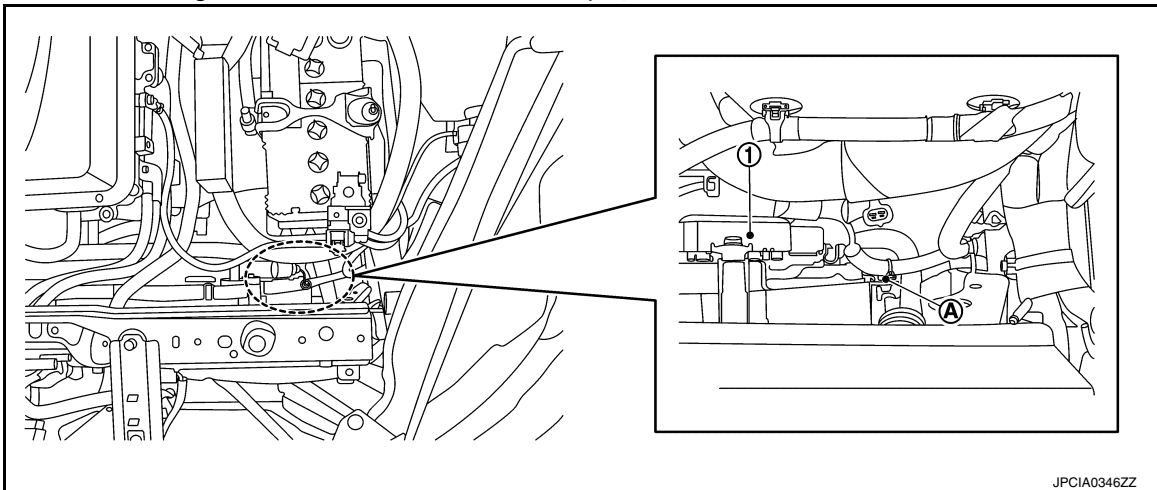

7. Remove the washer tank inlet. Refer to [WW-45. "Exploded View"](#).
8. Disconnect the water temperature sensor connector. ①.

← : Front

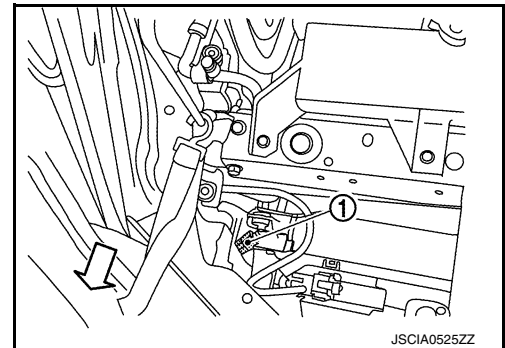

9. Remove the reservoir tank.
10. Disconnect the radiator hose (upper front) ①.

← : Front

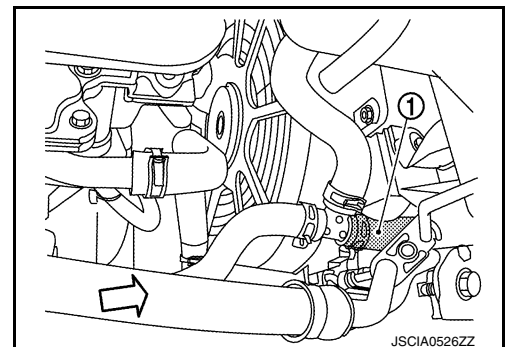

A
B
HCO
D
E
F
G
H
I
J
K
L
M
N
O
P

RADIATOR

< REMOVAL AND INSTALLATION >

11. Remove the condenser bolt (A). (without heat pump systems)

① : Radiator hose (upper rear)

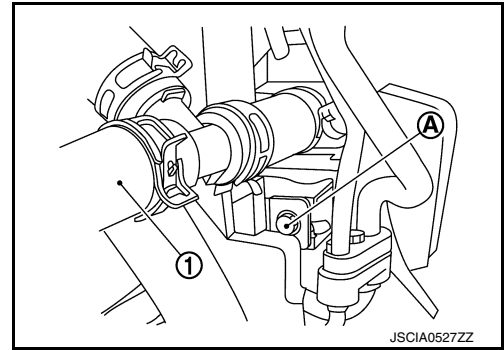

12. Remove the radiator bolt (top left) (A).

← : Front

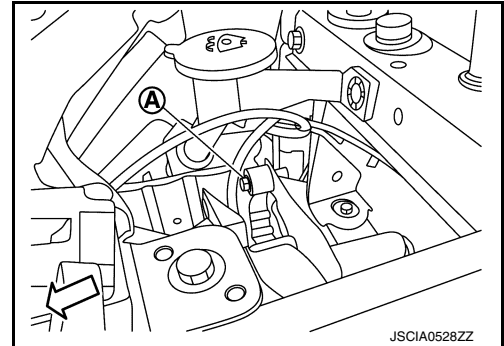

13. Remove the radiator core support lower. Refer to [DLK-164. "RADIATOR CORE SUPPORT LOWER : Removal and Installation"](#).

CAUTION:

Be careful not to damage the radiator core.

14. Remove the condenser bolts (With Heat Pump). Refer to [HA-52. "Exploded View"](#).

15. Lift up the chipping guard (1) and disconnect the parts (2) which mate with the radiator.

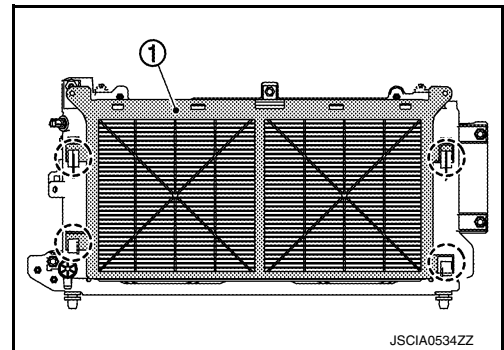

16. Remove the radiator bolts (A).

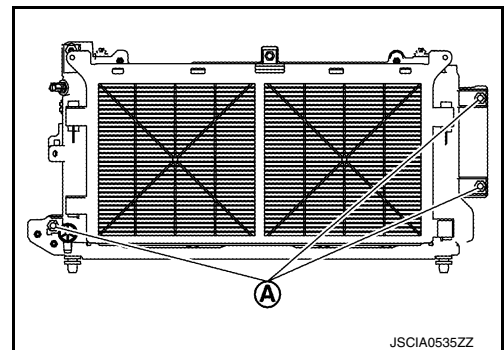

RADIATOR

< REMOVAL AND INSTALLATION >

17. Press the radiator top left tab (A) while lowering the radiator (1) downwards to disengage it from the condenser (2). (Models without heat pump systems)

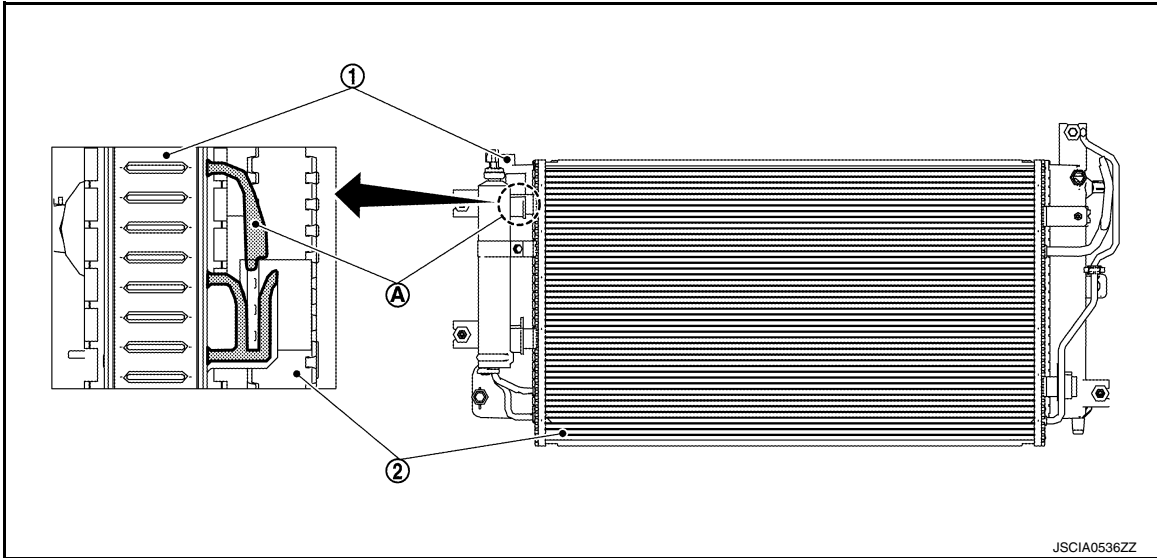

CAUTION:

Because there is a risk of bending the air conditioner pipe, do not lift up the capacitor more than is necessary to disengage it.

18. Disconnect the radiator side of the radiator hose (lower).
19. Remove the radiator by pulling it out downwards from between the clipping guard and condenser.

CAUTION:

Be careful not to damage the condenser core.

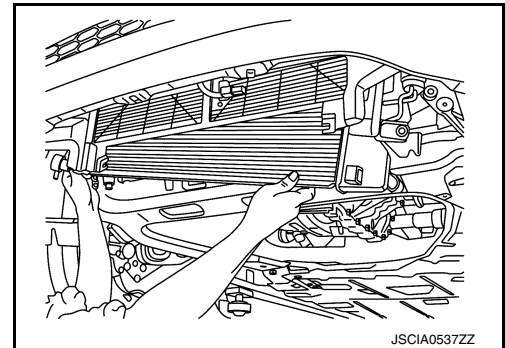

20. Remove cooling fan from radiator (if necessary).

INSTALLATION

Installation is in the reverse order of removal.

CAUTION:

Be sure to perform correct air bleeding after adding coolant. Refer to [HCO-12. "Refilling"](#).

Radiator

A
B
HCO
D
E
F
G
H
I
J
K
L
M
N
O
P

RADIATOR

< REMOVAL AND INSTALLATION >

- When installing the radiator, securely insert the engaging points shown by the arrows (←) shown. (Models without heat pump systems)

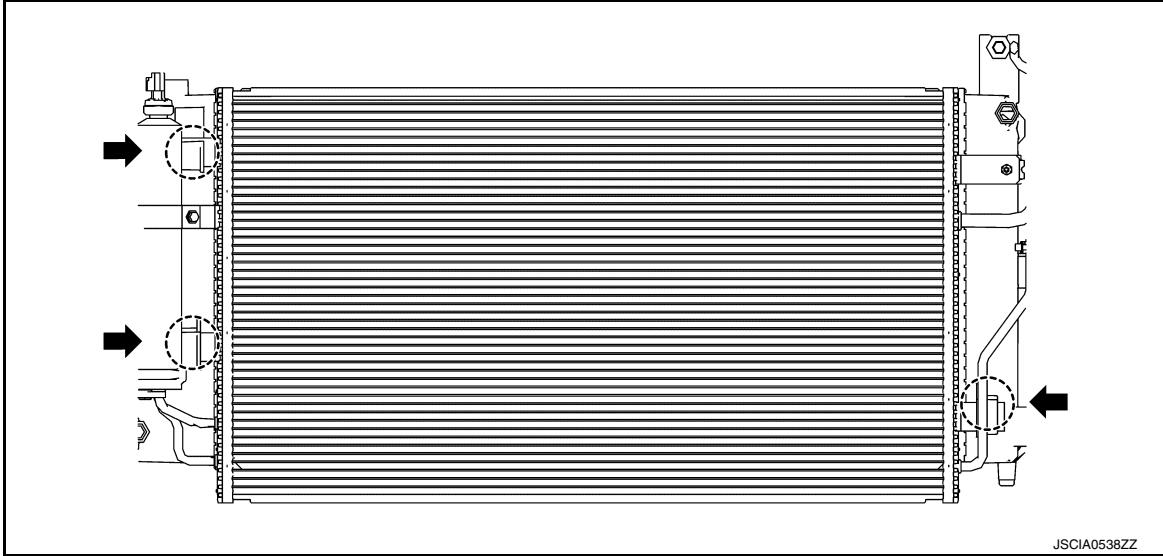

Chipping Guard

- When installing the chipping guard, securely insert the engaging points shown by the arrows (←) shown.

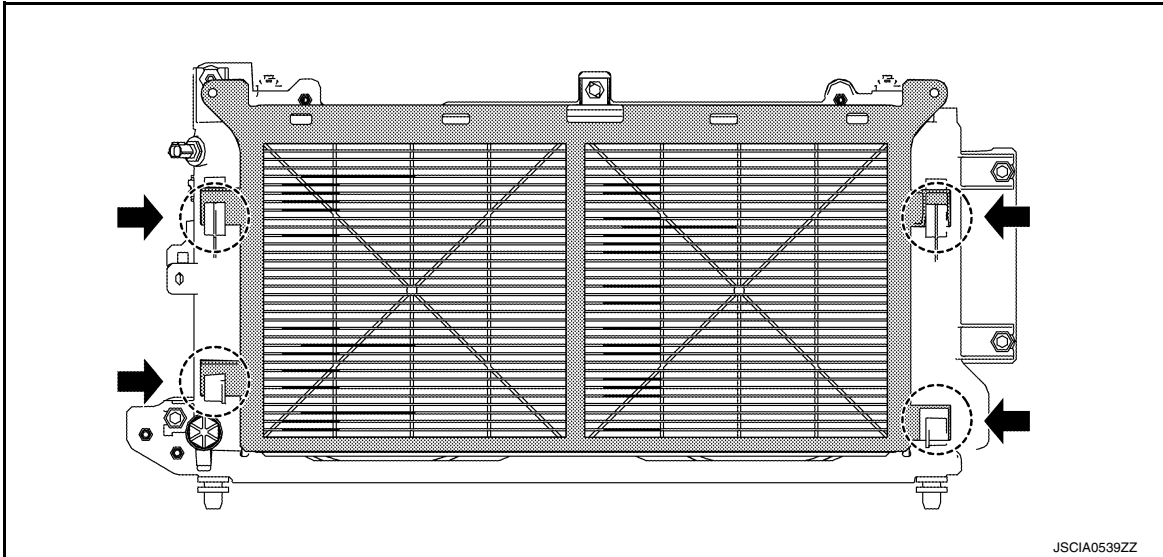

Radiator Hose / Water Hose

- When inserting the radiator hose and water hose, insert all the way until it contacts the end, regardless of whether or not there is a stopper ①.

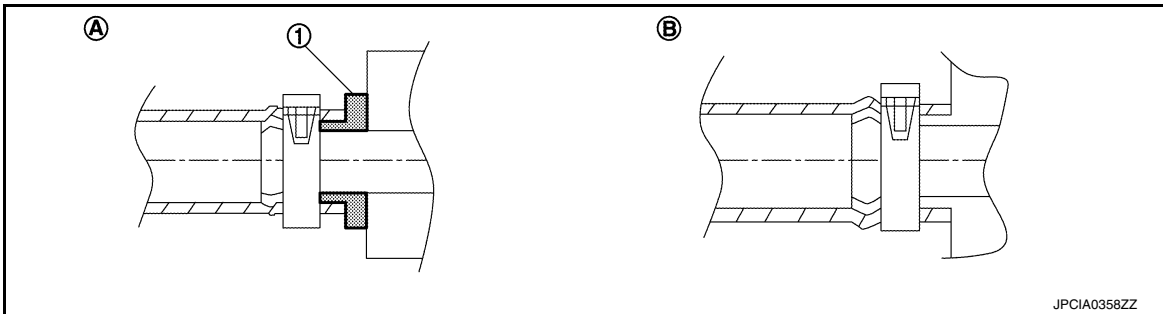

Ⓐ With stopper

Ⓑ No stopper

RADIATOR

< REMOVAL AND INSTALLATION >

- Refer to the following table when installing the hose clamps.

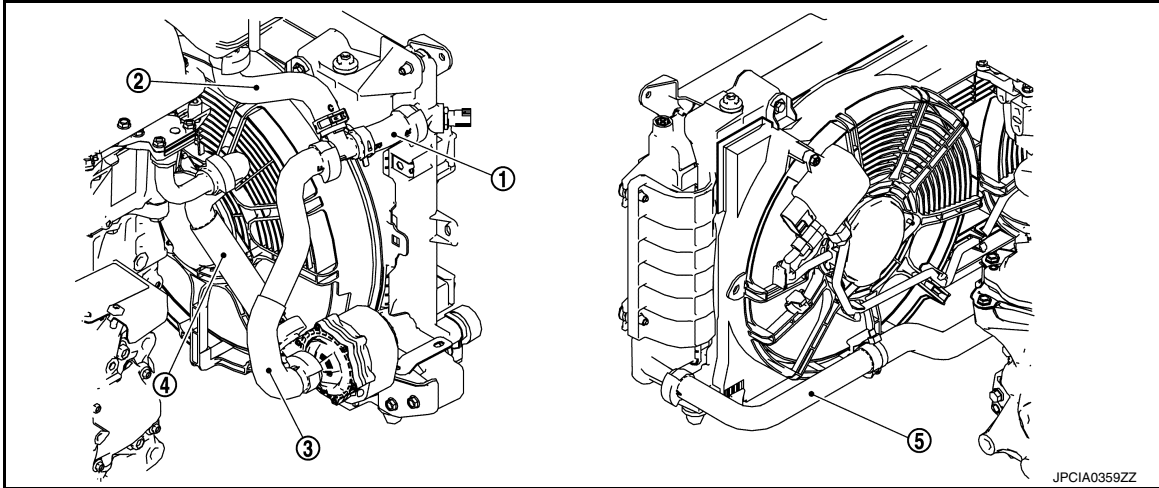

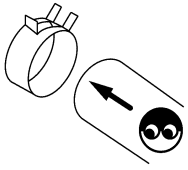
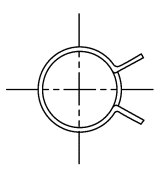
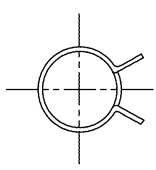
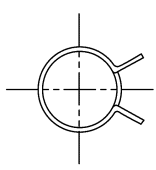
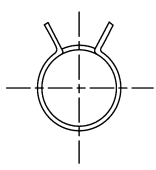
Hose location	Hose end	Direction of paint mark	Direction of hose clamp tabs  JPCIA0366ZZ ←: Vehicle upper ←: Vehicle front
① Radiator hose (upper front)	Radiator side	Vehicle right	 JPCIA0360ZZ
② Water hose	Reservoir tank side	Vehicle front	 JPCIA0361ZZ
③ Radiator hose (upper rear)	Radiator side	Vehicle right	 JPCIA0360ZZ
	Electric water pump side	Toward vehicle upper	 JPCIA0362ZZ

A

B

HCO

D

E

F

G

H

I

J

K

L

M



N

O

P

RADIATOR

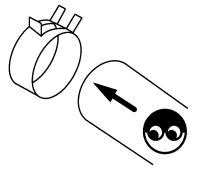
< REMOVAL AND INSTALLATION >

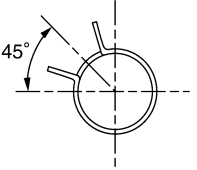
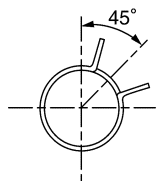
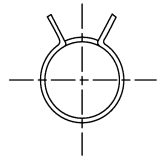
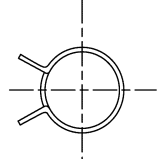
Hose location	Hose end	Direction of paint mark	<p>Direction of hose clamp tabs</p>  <p>JPCIA0366ZZ</p> <p>←: Vehicle upper : Vehicle front</p>
④ Water hose	PDM (Power Delivery Module) side	Vehicle upper left	 <p>JPCIA0365ZZ</p>
	Electric water pump side	Vehicle upper right	 <p>JPCIA0363ZZ</p>
⑤ Radiator hose (lower)	Motor side	Toward vehicle upper	 <p>JPCIA0362ZZ</p>
	Radiator side	Vehicle left	 <p>JPCIA0364ZZ</p>

- The direction of the hose clamp tabs must be within $\pm 30^\circ$ (b) of the indicated position (A).

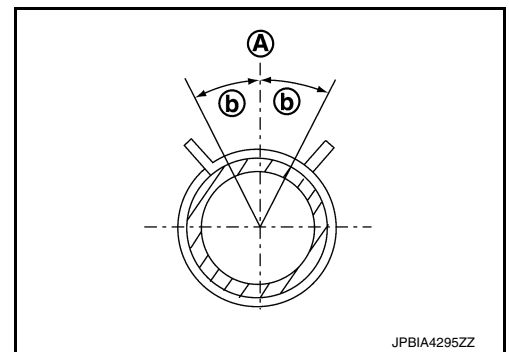

RADIATOR

< REMOVAL AND INSTALLATION >

- When installing hose clamp ①, check that the distance “A” between the end of the radiator hose paint mark ② and the hose clamp is within the standard range.

Dimension “A” : 0 - 1mm (0 - 0.04 in)

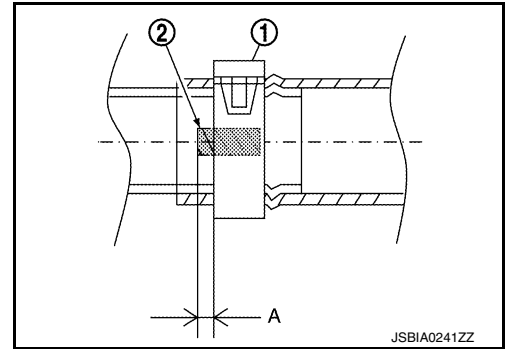

Inspection

INFOID:000000010635294

INSPECTION AFTER INSTALLATION

- Confirm that the reservoir tank cap is tightened.
- With a suitable tool, check that there is no leaks of coolant. Refer to [HCO-11, "Inspection"](#).
- Start the electric pump, and check the joints for coolant leaks.

COOLING FAN

< REMOVAL AND INSTALLATION >

COOLING FAN

Exploded View

INFOID:000000010635295

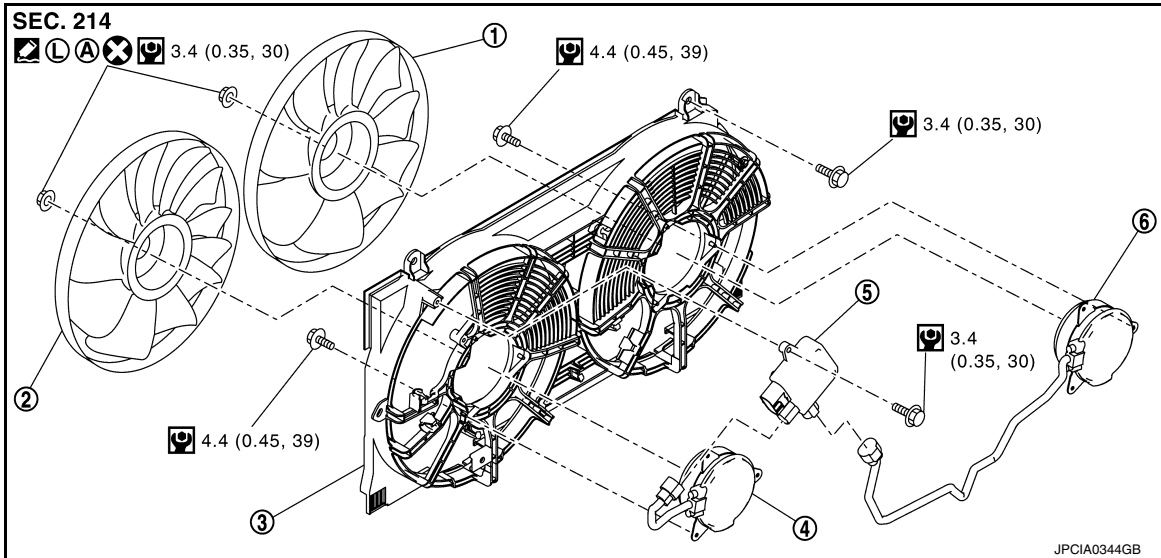

- | | | | | | |
|---|---------------------|---|--------------------------|---|-------------------|
| ① | Cooling fan (right) | ② | Cooling fan (left) | ③ | Fan shroud |
| ④ | Fan motor (left) | ⑤ | Cooling fan control unit | ⑥ | Fan motor (right) |

Ⓐ Apply thread locking adhesive to the shaft of fan motor.

Ⓛ : Thread locking adhesive

Ⓜ : N·m (kg·m, in·lb)

⊗ : Always replace after every disassembly

NOTE:

The figure shows a model with heat pump system.

With models that do not have heat pump systems, the shape of the fan motor (left) and harness installation are somewhat different.

Removal and Installation

INFOID:000000010635296

WARNING:

Do not remove the reservoir tank cap if the drive motor or other high voltage part is hot. Hot liquid may spray out from the radiator, causing serious injury.

NOTE:

When removing components such as hoses, tubes/lines, etc., cap or plug openings to prevent fluid from spilling.

REMOVAL

1. Remove radiator. Refer to [DLK-166. "RADIATOR UPPER GRILLE : Removal and Installation"](#).

COOLING FAN

< REMOVAL AND INSTALLATION >

2. Remove bolts (A) and remove the cooling fan (1) from radiator (2).

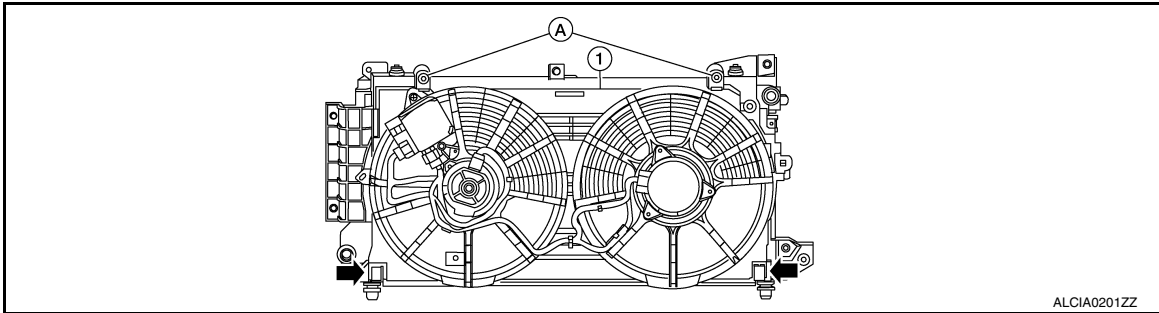

INSTALLATION

Installation in the reverse order of removal.

A

B

HCO

D

E

F

G

H

I

J

K

L

M

N

O

P

ELECTRIC WATER PUMP

< REMOVAL AND INSTALLATION >

ELECTRIC WATER PUMP

Exploded View

INFOID:000000010635298

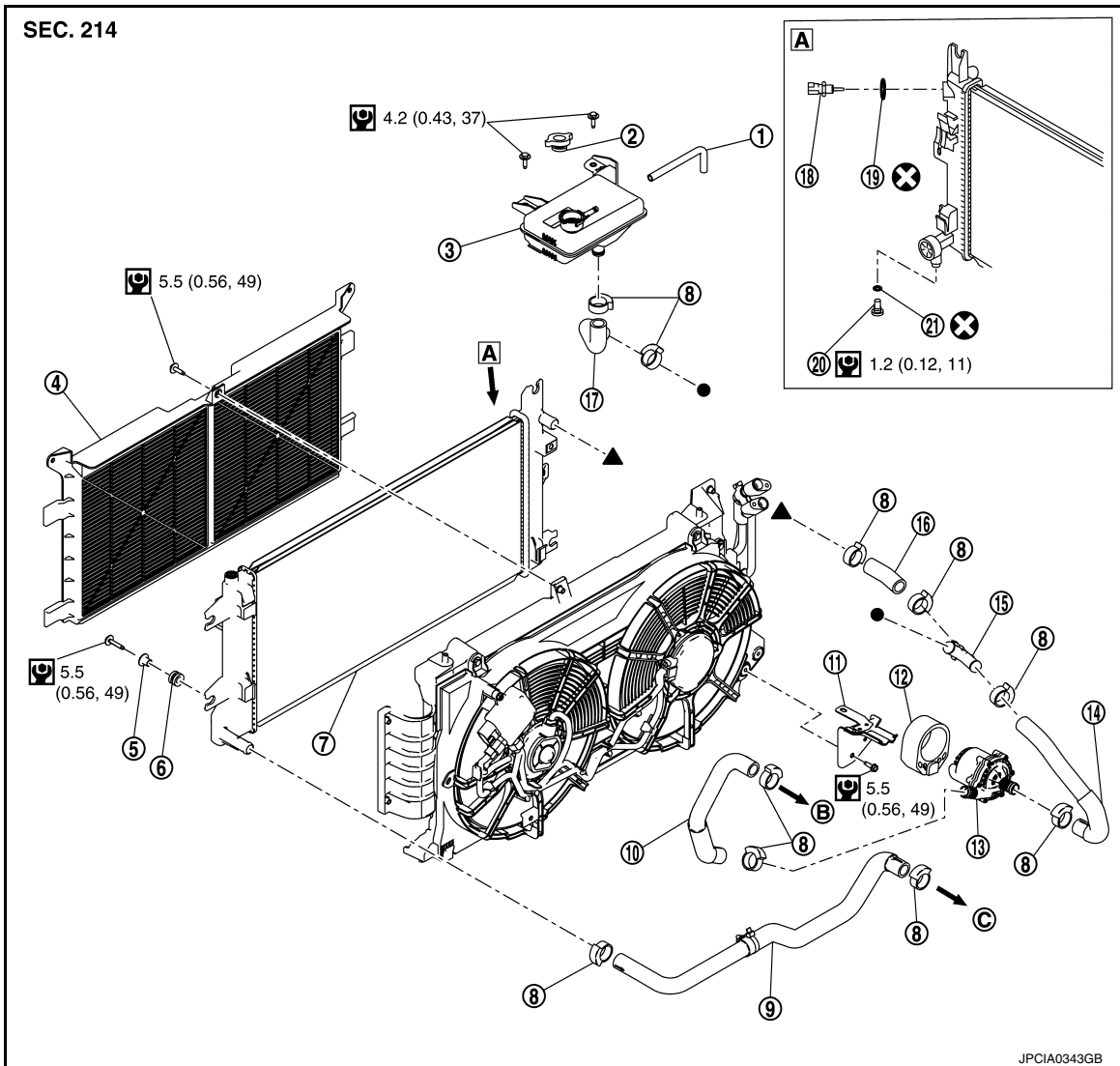

- | | | |
|-----------------------|----------------------------------|-------------------------------------|
| ① Reservoir tank hose | ② Reservoir tank cap | ③ Reservoir tank |
| ④ Chipping guard | ⑤ Collar | ⑥ Bushing |
| ⑦ Radiator | ⑧ Clamp | ⑨ Radiator hose (lower) |
| ⑩ Water hose | ⑪ Pump bracket | ⑫ Mount rubber |
| ⑬ Electric water pump | ⑭ Water hose | ⑮ Water hose adapter |
| ⑯ Water hose | ⑰ Water hose | ⑱ Engine coolant temperature sensor |
| ⑲ Gasket | ⑳ Drain plug | ㉑ O-ring |
| Ⓐ Arrow view | Ⓑ To PDM (Power Delivery Module) | Ⓒ To traction motor |

Ⓜ : N·m (kg-m, in-lb)

⊗ : Always replace after every disassembly

Removal and Installation

INFOID:000000010635299

CAUTION:

ELECTRIC WATER PUMP

< REMOVAL AND INSTALLATION >

Do not use an electric water pump that is dropped, or subjected to excessive impact due to contact with other parts.

NOTE:

When removing components such as hoses, tubes/lines, etc., cap or plug openings to prevent fluid from spilling.

REMOVAL

1. Drain coolant from radiator. Refer to [HCO-11, "Draining"](#).

CAUTION:

Drain the coolant when it is cool.

2. Remove the front side of the right fender protector to create space for work. Refer to [EXT-21, "FENDER PROTECTOR : Exploded View"](#).
3. Disconnect the electric water pump ① harness connector ②.

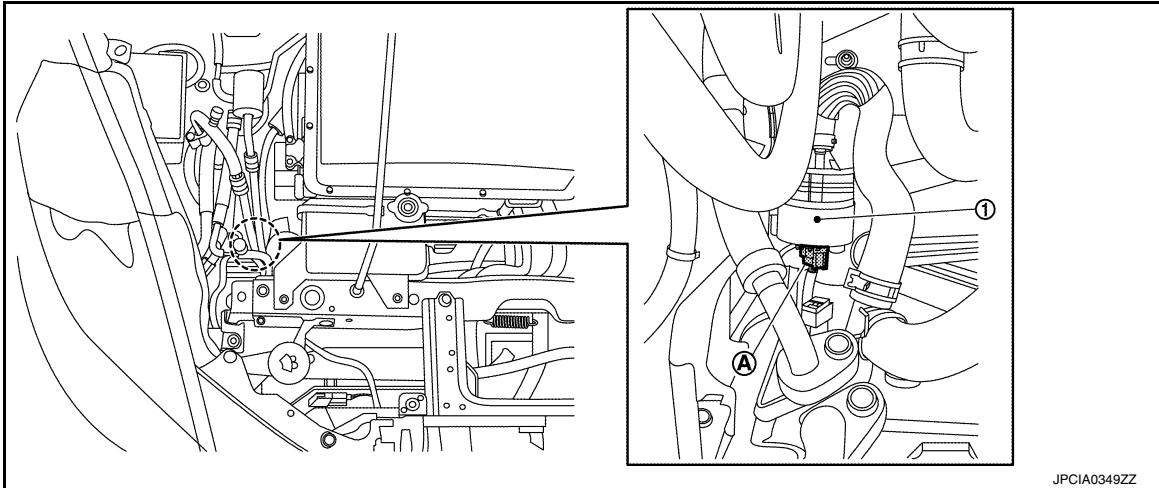

4. Disconnect the water hoses ①.

⇐ : Front

CAUTION:

- Take care that coolant does not contact the high voltage connectors.
- If coolant contacts a high voltage connector, immediately use an air blow and fully remove the moisture.

5. Remove the two bolts ② and remove the electric water pump together with the bracket.

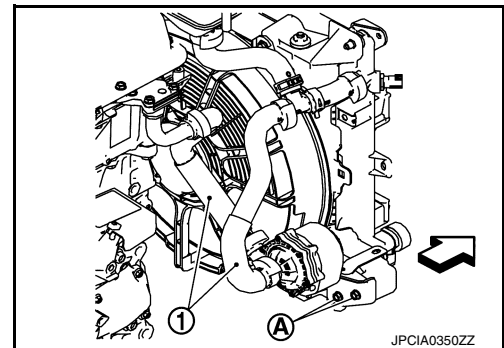

6. Remove the electric water pump harness connector clamp from the bracket.

INSTALLATION

Note the following, and install in the reverse order of removal.

CAUTION:

- Hold the electric water pump with one hand while inserting the water hose into the electric water pump.
- Be sure to perform correct air bleeding after adding coolant. Refer to [HCO-12, "Refilling"](#).

COOLING FAN

< UNIT DISASSEMBLY AND ASSEMBLY >

UNIT DISASSEMBLY AND ASSEMBLY

COOLING FAN

Exploded View

INFOID:000000011006869

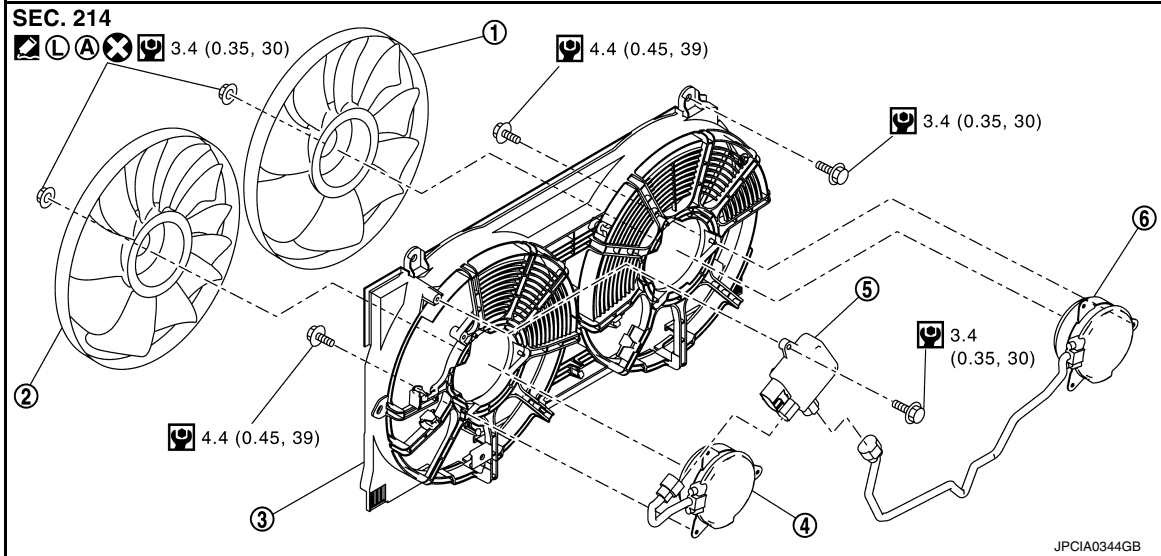

- ① Cooling fan (right)
- ② Cooling fan (left)
- ③ Fan shroud
- ④ Fan motor (left)
- ⑤ Cooling fan control unit
- ⑥ Fan motor (right)

(A) Apply thread locking adhesive to the shaft of fan motor.

(L) : Thread locking adhesive

(N) : N·m (kg-m, in-lb)

(X) : Always replace after every disassembly

NOTE:

The figure shows a model with heat pump system.

With models that do not have heat pump systems, the shape of the fan motor (left) and harness installation are somewhat different.

Disassembly and Assembly

INFOID:000000011006870

DISASSEMBLY

1. Disconnect sub-harness (A) from fan motor (LH/RH) (1) and cooling fan control module (2).

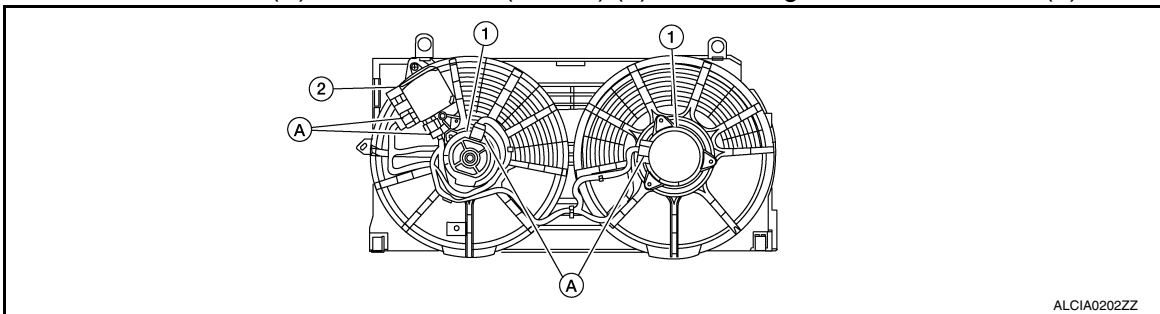

2. Remove cooling fan control module from fan shroud.
CAUTION:
Handle it carefully and avoid subjecting it to impact.
3. Remove fan mounting nuts, and then remove the fan.

COOLING FAN

< UNIT DISASSEMBLY AND ASSEMBLY >

- 4. Remove fan motor.
 - Identify installation position of each valve. Arrange removed valves so that they cannot be mixed up.

ASSEMBLY

Note the following, and assemble in the reverse order of disassembly.

- If fan motor is reused, install in its original position.
- Install each fan in the following position.

	Vehicle left	Vehicle right
Models with heat pump systems	9 fans	11 fans
Models without heat pump systems	6 fans	9 fans

- Apply thread locking adhesive (Three Bond Thread Lock Super 1303 or an equivalent) to the threads of the fan motor shaft, and tighten the fan mounting nuts.
- Secure the sub-harness tightly to the fan shroud to prevent it from interfering with the fan rotation area.

A
B
HCO
D
E
F
G
H
I
J
K
L
M
N
O
P

SERVICE DATA AND SPECIFICATIONS (SDS)

< SERVICE DATA AND SPECIFICATIONS (SDS)

SERVICE DATA AND SPECIFICATIONS (SDS)

SERVICE DATA AND SPECIFICATIONS (SDS)

Periodical Maintenance Specification

INFOID:0000000010635300

COOLANT CAPACITY (APPROXIMATE)

Unit: ℓ (US qt, Imp qt)

Coolant capacity (With reservoir tank at "MAX" level)	5.3 (5-5/8, 4-5/8)
Reservoir tank coolant capacity (At "MAX" level)	0.5 (4/8, 4/8)

RESERVOIR TANK CAP

Unit: kPa (kg/cm², psi)

Cap relief pressure	24 - 36 (0.2 - 0.3, 3.5 - 5.2)
---------------------	--------------------------------

RADIATOR

Unit: kPa (kg/cm², psi)

Leakage testing pressure	32 (0.3, 5)
--------------------------	--------------