

**SECTION MA**  
**MAINTENANCE**

A  
B  
C  
D  
E  
F  
G  
H  
I  
J  
K  
L  
M  
N  
O  
MA

**CONTENTS**

|   |    |   |    |
|---|----|---|----|
| <b>PRECAUTION</b> .....   | 3  | <b>FOR MEXICO</b> .....                                 | 18 |
| <b>PRECAUTIONS</b> .....  | 3  | FOR MEXICO : Fluids and Lubricants .....                | 18 |
| Precaution for Technicians Using Medical Electric.....  | 3  | FOR MEXICO : Coolant Mixture Ratio .....                | 18 |
| High Voltage Precautions .....  | 3  | <b>EV SYSTEM MAINTENANCE</b> .....                      | 20 |
| Precaution for Supplemental Restraint System<br>(SRS) "AIR BAG" and "SEAT BELT PRE-TENSIONER" ..... | 5  | <b>COOLANT</b> .....                                    | 20 |
| <b>PREPARATION</b> .....  | 7  | COOLANT : Inspection .....                              | 20 |
| <b>PREPARATION</b> .....  | 7  | COOLANT : Draining .....                                | 20 |
| Commercial Service Tool .....   | 7  | COOLANT : Refilling .....                               | 21 |
| <b>PERIODIC MAINTENANCE</b> .....   | 8  | <b>RESERVOIR TANK CAP</b> .....                         | 21 |
| <b>GENERAL MAINTENANCE</b> .....  | 8  | RESERVOIR TANK CAP : Inspection .....                   | 22 |
| <b>FOR USA AND CANADA</b> .....   | 8  | <b>CHARGE PORT</b> .....                                | 22 |
| FOR USA AND CANADA : Explanation of General<br>Maintenance .....                                    | 8  | CHARGE PORT : Inspection .....                          | 22 |
| <b>FOR MEXICO</b> .....   | 9  | <b>CHASSIS MAINTENANCE</b> .....                        | 25 |
| FOR MEXICO : General Maintenance .....  | 9  | <b>REDUCTION GEAR OIL</b> .....                         | 25 |
| <b>PERIODIC MAINTENANCE</b> .....   | 12 | REDUCTION GEAR OIL : Inspection .....                   | 25 |
| <b>FOR USA AND CANADA</b> .....   | 12 | REDUCTION GEAR OIL : Draining and Refilling ....        | 25 |
| FOR USA AND CANADA : Introduction of Periodic<br>Maintenance .....                                  | 12 | <b>WHEELS</b> .....                                     | 25 |
| FOR USA AND CANADA : Schedule 1 .....   | 12 | WHEELS : Inspection .....                               | 26 |
| FOR USA AND CANADA : Schedule 2 .....   | 13 | WHEELS : Wheel Balance Adjustment .....                 | 26 |
| <b>FOR MEXICO</b> .....   | 14 | WHEELS : Tire Rotation .....                            | 27 |
| FOR MEXICO : Periodic Maintenance .....   | 14 | <b>BRAKE FLUID LEVEL AND LEAKS</b> .....                | 27 |
| <b>RECOMMENDED FLUIDS AND LUBRICANTS</b> .....  | 17 | BRAKE FLUID LEVEL AND LEAKS : Inspection ....           | 28 |
| <b>FOR USA AND CANADA</b> .....   | 17 | <b>BRAKE LINES AND CABLES</b> .....                     | 28 |
| FOR USA AND CANADA : Fluids and Lubricants... ..  | 17 | BRAKE LINES AND CABLES : Inspection .....               | 28 |
| FOR USA AND CANADA : Anti-Freeze Coolant<br>Mixture Ratio .....                                     | 17 | <b>BRAKE FLUID</b> .....                                | 28 |
|   |    | BRAKE FLUID : Draining .....                            | 28 |
|   |    | BRAKE FLUID : Refilling .....                           | 28 |
|   |    | <b>FRONT DISC BRAKE</b> .....                           | 29 |
|   |    | FRONT DISC BRAKE : Inspection and Adjust-<br>ment ..... | 29 |
|   |    | FRONT DISC BRAKE : Inspection and Adjust-<br>ment ..... | 29 |

---

|   |           |  |           |
|---|-----------|--|-----------|
| <b>REAR DISC BRAKE</b> .....                  | <b>30</b> | <b>SEAT BELT, BUCKLES, RETRACTORS, AN-</b>     |           |
| REAR DISC BRAKE : Inspection and Adjustment.. | 30        | <b>CHORS AND ADJUSTERS</b> .....               | <b>34</b> |
| REAR DISC BRAKE : Inspection and Adjustment.. | 31        | SEAT BELT, BUCKLES, RETRACTORS, AN-            |           |
| <b>STEERING GEAR AND LINKAGE</b> .....        | <b>32</b> | CHORS AND ADJUSTERS : Inspection .....         | 34        |
| STEERING GEAR AND LINKAGE : Inspection .....  | 32        | <b>BODY CORROSION</b> .....                    | <b>34</b> |
| <b>AXLE AND SUSPENSION PARTS</b> .....        | <b>32</b> | BODY CORROSION : Checking Body Corrosion...    | 34        |
| AXLE AND SUSPENSION PARTS : Inspection .....  | 32        | <b>SERVICE DATA AND SPECIFICATIONS</b>         |           |
| <b>DRIVE SHAFT</b> .....                      | <b>32</b> | <b>(SDS)</b> .....                             | <b>36</b> |
| DRIVE SHAFT : Inspection .....                | 33        | <b>SERVICE DATA AND SPECIFICATIONS</b>         |           |
| <b>BODY MAINTENANCE</b> .....                 | <b>34</b> | <b>(SDS)</b> .....                             | <b>36</b> |
| <b>LOCKS, HINGES AND HOOD LATCH</b> .....     | <b>34</b> | <b>COOLANT</b> .....                           | <b>36</b> |
| LOCKS, HINGES AND HOOD LATCH : Lubricat-      |           | COOLANT : Periodical Maintenance Specification |           |
| ing .....                                     | 34        | ... 36   |           |
|   |           | <b>ROAD WHEEL</b> .....                        | <b>36</b> |
|   |           | ROAD WHEEL : Road Wheel .....                  | 36        |

# PRECAUTIONS

< PRECAUTION >

## PRECAUTION

### PRECAUTIONS

#### Precaution for Technicians Using Medical Electric

INFOID:0000000010640788

##### OPERATION PROHIBITION

###### **WARNING:**

- Parts with strong magnet is used in this vehicle.
- Technicians using a medical electric device such as pacemaker must never perform operation on the vehicle, as magnetic field can affect the device function by approaching to such parts.

##### NORMAL CHARGE PRECAUTION

###### **WARNING:**

- If a technician uses a medical electric device such as an implantable cardiac pacemaker or an implantable cardioverter defibrillator, the possible effects on the devices must be checked with the device manufacturer before starting the charge operation.
- As radiated electromagnetic wave generated by PDM (Power Delivery Module) at normal charge operation may affect medical electric devices, a technician using a medical electric device such as implantable cardiac pacemaker or an implantable cardioverter defibrillator must not approach motor room [PDM (Power Delivery Module)] at the hood-opened condition during normal charge operation.

##### PRECAUTION AT TELEMATICS SYSTEM OPERATION

###### **WARNING:**

- If a technician uses implantable cardiac pacemaker or implantable cardioverter defibrillator (ICD), avoid the device implanted part from approaching within approximately 220 mm (8.66 in) from interior/exterior antenna.
- The electromagnetic wave of TCU might affect the function of the implantable cardiac pacemaker or the implantable cardioverter defibrillator (ICD), when using the service, etc.
- If a technician uses other medical electric devices than implantable cardiac pacemaker or implantable cardioverter defibrillator (ICD), the electromagnetic wave of TCU might affect the function of the device. The possible effects on the devices must be checked with the device manufacturer before TCU use.

##### PRECAUTION AT INTELLIGENT KEY SYSTEM OPERATION

###### **WARNING:**

- If a technician uses implantable cardiac pacemaker or implantable cardioverter defibrillator (ICD), avoid the device implanted part from approaching within approximately 220 mm (8.66 in) from interior/exterior antenna.
- The electromagnetic wave of Intelligent Key might affect the function of the implantable cardiac pacemaker or the implantable cardioverter defibrillator (ICD), at door operation, at each request switch operation, or at engine starting.
- If a technician uses other medical electric devices than implantable cardiac pacemaker or implantable cardioverter defibrillator (ICD), the electromagnetic wave of Intelligent Key might affect the function of the device. The possible effects on the devices must be checked with the device manufacturer before Intelligent Key use.

#### High Voltage Precautions

INFOID:0000000010640790

###### **DANGER:**



Since hybrid vehicles and electric vehicles contain a high voltage battery, there is the risk of electric shock, electric leakage, or similar accidents if the high voltage component and vehicle are handled incorrectly. Be sure to follow the correct work procedures when performing inspection and maintenance.

###### **WARNING:**

- Be sure to remove the service plug in order to disconnect the high voltage circuits before performing inspection or maintenance of high voltage system harnesses and parts.
- The removed service plug must always be carried in a pocket of the responsible worker or placed in the tool box during the procedure to prevent the plug from being connected by mistake.

A  
B  
C  
D  
E  
F  
G  
H  
I  
J  
K  
L  
M  
N  
O

MA

# PRECAUTIONS

## < PRECAUTION >

---

- Be sure to wear insulated protective equipment before beginning work on the high voltage system.
- Never allow workers other than the responsible person to touch the vehicle containing high voltage parts. To keep others from touching the high voltage parts, these parts must be covered with an insulating sheet except when using them.

### **CAUTION:**

Never bring the vehicle into the READY status with the service plug removed unless otherwise instructed in the Service Manual. A malfunction may occur if this is not observed.

### HIGH VOLTAGE HARNESS AND EQUIPMENT IDENTIFICATION

All the high voltage harnesses and connectors are orange. The Li-ion battery and other high voltage devices include an orange high voltage label. Never touch these harnesses and high voltage parts.

### HANDLING OF HIGH VOLTAGE HARNESS AND TERMINALS

Immediately insulate disconnected high voltage connectors and terminals with insulating tape.

### REGULATIONS ON WORKERS WITH MEDICAL ELECTRONICS

### **WARNING:**

The vehicle contains parts that contain powerful magnets. If a person who is wearing a heart pacemaker or other medical device is close to these parts, the medical device may be affected by the magnets. Such persons must not perform work on the vehicle.

### PROHIBITED ITEMS TO CARRY DURING THE WORK

Hybrid vehicles and electric vehicles contain parts with high voltage and intense magnetic force. Never carry metal products and magnetic recording media (e.g. cash card, prepaid card) to repair/inspect high voltage parts. If this is not observed, the metal products may create a risk of short circuit and the magnetic recording media may lose their magnetic recording.

POSTING A SIGN OF "DANGER! HIGH VOLTAGE AREA. KEEP OUT"

# PRECAUTIONS

## < PRECAUTION >

Indicate "HIGH VOLTAGE. DO NOT TOUCH" on the vehicle under repair/inspection to call attention to other workers.

**DANGER:  
HIGH VOLTAGE  
REPAIR IN PROGRESS.  
DO NOT TOUCH!**

Person in charge: \_\_\_\_\_

---

**DANGER:  
HIGH VOLTAGE  
REPAIR IN PROGRESS.  
DO NOT TOUCH!**

Person in charge: \_\_\_\_\_

---

**Copy this page and put it after folding on the roof of the vehicle in service.**

JSAIA1600GB

A  
B  
C  
D  
E  
F  
G  
H  
I  
J  
K  
L  
M  
N  
O

MA

### Precaution for Supplemental Restraint System (SRS) "AIR BAG" and "SEAT BELT PRE-TENSIONER"

INFOID:000000011045327

The Supplemental Restraint System such as "AIR BAG" and "SEAT BELT PRE-TENSIONER", used along with a front seat belt, helps to reduce the risk or severity of injury to the driver and front passenger for certain types of collision. This system includes seat belt switch inputs and dual stage front air bag modules. The SRS

## PRECAUTIONS

### < PRECAUTION >

system uses the seat belt switches to determine the front air bag deployment, and may only deploy one front air bag, depending on the severity of a collision and whether the front occupants are belted or unbelted. Information necessary to service the system safely is included in the SR and SB section of this Service Manual.

#### **WARNING:**

- To avoid rendering the SRS inoperative, which could increase the risk of personal injury or death in the event of a collision which would result in air bag inflation, all maintenance must be performed by an authorized NISSAN/INFINITI dealer.
- Improper maintenance, including incorrect removal and installation of the SRS, can lead to personal injury caused by unintentional activation of the system. For removal of Spiral Cable and Air Bag Module, see the SR section.
- Do not use electrical test equipment on any circuit related to the SRS unless instructed to in this Service Manual. SRS wiring harnesses can be identified by yellow and/or orange harnesses or harness connectors.

### PRECAUTIONS WHEN USING POWER TOOLS (AIR OR ELECTRIC) AND HAMMERS

#### **WARNING:**

- When working near the Airbag Diagnosis Sensor Unit or other Airbag System sensors with the Ignition ON or engine running, DO NOT use air or electric power tools or strike near the sensor(s) with a hammer. Heavy vibration could activate the sensor(s) and deploy the air bag(s), possibly causing serious injury.
- When using air or electric power tools or hammers, always switch the Ignition OFF, disconnect the battery and wait at least three minutes before performing any service.

# PREPARATION

< PREPARATION >

## PREPARATION

### PREPARATION

#### Commercial Service Tool

INFOID:0000000010640791

| Tool name  | Description   |
|--|---|
| <p data-bbox="164 415 272 443">Power tool</p>  <p data-bbox="829 632 894 653">PIIB1407E</p> | <p data-bbox="1013 415 1349 443">Loosening nuts, screws and bolts</p> |

A  
B  
C  
D  
E  
F  
G  
H  
I  
J  
K  
L  
M  
N  
O

MA

# GENERAL MAINTENANCE

< PERIODIC MAINTENANCE >

## PERIODIC MAINTENANCE

### GENERAL MAINTENANCE FOR USA AND CANADA

#### FOR USA AND CANADA : Explanation of General Maintenance

INFOID:0000000010640792

General maintenance includes those items which should be checked during the normal day-to-day operation of the vehicle. They are essential if the vehicle is to continue operating properly. The owners can perform checks and inspections themselves or have their **NISSAN** certified LEAF dealer do them.

#### OUTSIDE THE VEHICLE

The maintenance items listed here should be performed from time to time, unless otherwise specified.

|  | Item  | Reference page   |
|--|---|--|
| <b>Doors and motor hood</b>  | Check that all doors and the hood operate smoothly as well as the back door. Also make sure that all latches lock securely. Lubricate if necessary. Make sure that the secondary latch keeps the hood from opening when the primary latch is released. When driving in areas using road salt or other corrosive materials, check for lubrication frequently.  | <a href="#">MA-34</a>  |
| <b>Lamps</b>   | Make sure that the headlamps, stop lamps, tail lamps, turn signal lamps, and other lamps are all operating properly and installed securely. Also check headlamp aim. Check for cracks and clean the headlamps on a regular basis. The Low-headlamps are LED lamps. If any repairs are necessary, have these performed at a NISSAN certified LEAF dealer. Be sure to check that all indicator lamps display operate normally.                                  | —  |
| <b>Wheel nuts</b>  | When checking the tires, make sure no nuts are missing, and check for any loose nuts. Tighten if necessary.   | —  |
| <b>Tire rotation</b>   | Tires should be rotated every 7,500 miles (12,000 km).  | <a href="#">WT-44</a>  |
| <b>Tires</b>   | Check the pressure with a gauge often and always prior to long distance trips. Adjust the pressure in all tires, including the spare, to the pressure specified. Check carefully for damage, cuts or excessive wear.  | <a href="#">WT-51</a>  |
| <b>Tire Pressure Monitoring System (TPMS) transmitter components</b> | Replace the TPMS transmitter grommet seal, valve core and cap when the tires are replaced due to wear or age.   | <a href="#">WT-47</a>  |
| <b>Wheel alignment and balance</b>                                   | If the vehicle should pull to either side while driving on a straight and level road, or if you detect uneven or abnormal tire wear, there may be a need for wheel alignment. If the steering wheel or seat vibrates at normal highway speeds, wheel balancing may be needed. For additional information regarding tires, refer to "Important Tire Safety Information" (US) or "Tire Safety Information" (Canada) in the NISSAN Warranty Information Booklet. | <a href="#">FSU-11</a><br><a href="#">RSU-7</a><br><a href="#">WT-43</a> |
| <b>Windshield</b>  | Clean the windshield on a regular basis. Check the windshield at least every six months for cracks or other damage. Repair as necessary.  | —  |
| <b>Windshield wiper blades</b>                                       | Check for cracks or wear if they do not wipe properly.  | —  |

#### INSIDE THE VEHICLE

The maintenance items listed here should be checked on a regular basis, such as when performing periodic maintenance, cleaning the vehicle, etc.

|   | Item   | Reference page         |
|---|--|------------------------|
| <b>Accelerator pedal</b>                          | Check the pedal for smooth operation and make sure the pedal does not catch or require uneven effort. Keep the floor mats away from the pedal.   | —                      |
| <b>Brake pedal</b>                                | Check the pedal for smooth operation and make sure it has the proper distance under it when depressed fully. Be sure to keep the floor mats away from the pedal.   | <a href="#">BR-490</a> |
| <b>Brakes</b>                                     | Check that the brake does not pull the vehicle to one side when applied.   | —                      |
| <b>Electric shift P (Park) position mechanism</b> | Check that the park button on the selector lever operates properly and smoothly. On a fairly steep hill check that the vehicle is held securely with the park switch in the P (Park) position without applying any brakes. | —                      |



# GENERAL MAINTENANCE

## < PERIODIC MAINTENANCE >

| Item                               |   | Reference page        |   |
|------------------------------------|---|-----------------------|---|
| <b>Parking brake</b>               | Check that the pedal has the proper travel and make sure that the vehicle is held securely on a fairly steep hill when only the parking brake is applied.   | —                     | A |
| <b>Seats</b>                       | Check seat position controls such as seat adjusters, seatback recliner, etc. to make sure they operate smoothly and that all latches lock securely in every position. Check that the head restraints move up and down smoothly and that the locks (if equipped) hold securely in all latched positions. Check that the latches lock securely for folding-down rear seatbacks. | —                     | B |
| <b>Seat belts</b>                  | Check that all parts of the seat belt system (e.g. buckles, anchors, adjusters and retractors) operate properly and smoothly, and are installed securely. Check the belt webbing for cuts, fraying, wear or damage.   | <a href="#">MA-34</a> | C |
| <b>Steering wheel</b>              | Check that it has the specified play. Check for changes in the steering condition, such as excessive play, hard steering or strange noises.<br><b>Free play: Less than 35 mm (1.38 in)</b>  | —                     | D |
| <b>Warning lamps and chimes</b>    | Make sure that all warning lamps and chimes are operating properly.   | —                     | E |
| <b>Windshield defroster</b>        | Check that the air comes out of the defroster outlets properly and in sufficient quantity when operating the heater or air conditioner.   | —                     | F |
| <b>Windshield wiper and washer</b> | Check that the wipers and washer operate properly and that the wipers do not streak.  | —                     | G |

## UNDER THE HOOD AND VEHICLE

The maintenance items listed here should be checked periodically.

| Item                           |   | Reference page         |   |
|--------------------------------|---|------------------------|---|
| <b>12-volt Battery</b>         | Check the fluid level in each cell. It should be between the "MAX" and "MIN" lines. Vehicles operated in high temperatures or under severe conditions require frequent checks of the 12V battery fluid level.   | <a href="#">PG-76</a>  | H |
| <b>Brake fluid level</b>       | Make sure that the brake fluid level is between the "MAX" and "MIN" lines on the reservoir.   | <a href="#">MA-28</a>  | I |
| <b>Coolant level</b>           | Make sure that the coolant level is between the "MAX" and "MIN" lines on the reservoirs. Check the coolant level when the coolant is cold.  | <a href="#">HCO-11</a> | J |
| <b>Fluid leaks</b>             | Check under the vehicle for oil, water or other fluid leaks after the vehicle has been parked for a while. Water dripping from the air conditioner after use is normal. If you should notice any leaks, check for the cause and correct it immediately.   | —                      | K |
| <b>Radiator and hoses</b>      | Check the front of the radiator and clean off any dirt, insects, leaves, etc., that may have accumulated. Make sure the hoses have no cracks, deformation, deterioration or loose connections.  | —                      | L |
| <b>Underbody</b>               | The underbody is frequently exposed to corrosive substances such as those used on icy roads or to control dust. It is very important to remove these substances, otherwise rust will form on the floor pan and frame. At the end of winter, the underbody should be thoroughly flushed with plain water, being careful to clean those areas where mud and dirt can easily accumulate. | —                      | M |
| <b>Windshield washer fluid</b> | Check that there is adequate fluid in the tank.   | —                      | N |

## FOR MEXICO

### FOR MEXICO : General Maintenance

INFOID:000000010640793

General maintenance includes those items which should be checked during the normal day-to-day operation of the vehicle. They are essential if the vehicle is to continue operating properly. The owners can perform the checks and inspections themselves or they can have their **NISSAN** dealers do them.

## OUTSIDE THE VEHICLE

# GENERAL MAINTENANCE

## < PERIODIC MAINTENANCE >

The maintenance items listed here should be performed from time to time, unless otherwise specified.

|  | Item  | Reference page                                 |
|--|---|--|
| <b>Doors and hood</b>  | Check that all doors and the hood operate smoothly as well as the back door, trunk lid and hatch. Also make sure that all latches lock securely. Lubricate if necessary. Make sure that the secondary latch keeps the hood from opening when the primary latch is released. When driving in areas using road salt or other corrosive materials, check for lubrication frequently.   | <a href="#">MA-34</a>                          |
| <b>Lamps</b>   | Clean the headlamps on a regular basis. Make sure that the headlamps, stop lamps, tail lamps, turn signal lamps, and other lamps are all operating properly and installed securely. Also check the aim of the headlamps.  | —  |
| <b>Tires</b>   | Check the pressure with a gauge often and always prior to long distance trips. Adjust the pressure in all tires, including the spare, to the pressure specified. Check carefully for damage, cuts or excessive wear.  | <a href="#">WT-51</a>                          |
| <b>Tire rotation</b>   | <p>In the case that Two-Wheel Drive (2WD) and front &amp; rear tires are same size; Tires should be rotated every 10,000 km (6,000 miles). Tires marked with directional indicators can only be rotated between front and rear. Make sure that the directional indicators point in the direction of wheel rotation after the tire rotation is completed.</p> <p>In the case that Four-Wheel Drive (4WD) and front &amp; rear tires are same size; Tires should be rotated every 5,000 km (3,000 miles). Tires marked with directional indicators can only be rotated between front and rear. Make sure that the directional indicators point in the direction of wheel rotation after the tire rotation is completed.</p> <p>In the case that front tires are different size from rear tires; Tires cannot be rotated. However, the timing for tire rotation may vary according to your driving habits and the road surface conditions.</p> | <a href="#">WT-44</a>                          |
| <b>Tire Pressure Monitoring System (TPMS) transmitter components (if equipped)</b> | Replace the TPMS transmitter grommet seal, valve core and cap when the tires are replaced due to wear or age.   | —  |
| <b>Wheel alignment and balance</b>   | If the vehicle should pull to either side while driving on a straight and level road, or if you detect uneven or abnormal tire wear, there may be a need for wheel alignment. If the steering wheel or seat vibrates at normal highway speeds, wheel balancing may be needed.   | <a href="#">WT-43</a><br><a href="#">WT-43</a> |
| <b>Windshield</b>  | Clean the windshield on a regular basis. Check the windshield at least every six months for cracks or other damage. Repair as necessary.  | —  |
| <b>Windshield wiper blades</b>   | Check for cracks or wear if not functioning correctly.  | —  |

## INSIDE THE VEHICLE

The maintenance items listed here should be checked on a regular basis, such as when performing periodic maintenance, cleaning the vehicle, etc.

|                          | Item  | Reference page         |
|--------------------------|---|------------------------|
| <b>Accelerator pedal</b> | Check the pedal for smooth operation and make sure that the pedal does not catch or require uneven effort. Keep the floor mats away from the pedal.   | —                      |
| <b>Brake pedal</b>       | Check the pedal for smooth operation and make sure that it is the proper distance from the floor mat when depressed fully. Be sure to keep the floor mats away from the pedal.  | <a href="#">BR-490</a> |
| <b>Parking brake</b>     | Check the parking brake operation regularly. Check that the lever (if equipped) or the pedal (if equipped) has the proper travel. Also make sure that the vehicle is held securely on a fairly steep hill when only the parking brake is applied. | <a href="#">PB-6</a>   |
| <b>Seat belts</b>        | Check that all parts of the seat belt system (e.g. buckles, anchors, adjusters and retractors) operate properly and smoothly, and are installed securely. Check the belt webbing for cuts, fraying, wear or damage.                               | <a href="#">SB-6</a>   |
| <b>Steering wheel</b>    | <p>Check for changes in the steering conditions, such as excessive play, hard steering or strange noises.</p> <p>Check that it has the specified play.</p> <p><b>Free play: Less than 35 mm (1.38 in)</b></p>                                     | —                      |

# GENERAL MAINTENANCE

## < PERIODIC MAINTENANCE >

| Item                               |  | Reference page |
|------------------------------------|--|----------------|
| <b>Warning lamps and chimes</b>    | Make sure that all warning lamps and chimes are operating properly.  | —              |
| <b>Windshield defogger</b>         | Check that the air comes out of the defogger outlets properly and in good quantity when operating the heater or air conditioner. | —              |
| <b>Windshield wiper and washer</b> | Check that the wipers and washer operate properly and that the wipers do not streak.   | —              |

## UNDER THE HOOD AND VEHICLE

The maintenance items listed here should be checked periodically.

| Item                           |  | Reference page         |
|--------------------------------|--|------------------------|
| <b>12-volt Battery</b>         | Except for maintenance free battery: Check the fluid level in each cell. It should be between the "UPPER" and "LOWER" lines. Vehicles operated in high temperatures or under severe conditions require frequent checks of the battery fluid level.         | <a href="#">PG-76</a>  |
| <b>Brake fluid level</b>       | Make sure that the brake fluid level is between the "MAX" and "MIN" lines on the reservoir.  | <a href="#">MA-28</a>  |
| <b>Coolant level</b>           | Check the coolant level when the coolant is cold. Make sure that the coolant level is between the "MAX" and "MIN" lines on the reservoir.  | <a href="#">HCO-11</a> |
| <b>Fluid leaks</b>             | Check under the vehicle for oil, water or other fluid leaks after the vehicle has been parked for a while. Water dripping from the air conditioner after use is normal. If you should notice any leaks, check for cause and have it corrected immediately. | —                      |
| <b>Windshield washer fluid</b> | Check that there is adequate fluid in the reservoir.   | —                      |

A  
B  
C  
D  
E  
F  
G  
H  
I  
J  
K  
L  
M  
N  
O

MA

# PERIODIC MAINTENANCE

< PERIODIC MAINTENANCE >

## PERIODIC MAINTENANCE FOR USA AND CANADA

### FOR USA AND CANADA : Introduction of Periodic Maintenance

INFOID:0000000010640794

Two different maintenance schedules are provided, and should be used, depending upon the conditions in which the vehicle is mainly operated. **After 60,000 miles (96,000 km) or 48 months, continue the periodic maintenance at the same mileage/time intervals.**

|            |  |                              |                       |
|------------|--|------------------------------|-----------------------|
| Schedule 1 | Follow Periodic Maintenance Schedule 1 if the driving habits frequently include one or more of the following driving conditions: <ul style="list-style-type: none"> <li>Repeated short trips of less than 5 miles (8 km).</li> <li>Repeated short trips of less than 10 miles (16 km) with outside temperatures remaining below freezing.</li> <li>Operating in hot weather in stop-and-go "rush hour" traffic.</li> <li>Low speed driving for long distances, such as police, taxi or door-to-door delivery use.</li> <li>Driving in dusty conditions.</li> <li>Driving on rough, muddy, or salt spread roads.</li> <li>Using a car-top carrier.</li> </ul> | EV System Maintenance        | <a href="#">MA-12</a> |
|            |  | Chassis and Body Maintenance |                       |
| Schedule 2 | Follow Periodic Maintenance Schedule 2 if none of driving conditions shown in Schedule 1 apply to the driving habits.  | EV System Maintenance        | <a href="#">MA-13</a> |
|            |  | Chassis and Body Maintenance |                       |

### FOR USA AND CANADA : Schedule 1

INFOID:0000000010640795

#### EV System Maintenance

Abbreviations: R = Replace. I = Inspect. Correct or replace if necessary.

| MAINTENANCE OPERATION  |                                      | MAINTENANCE INTERVAL |           |            |         |            |           |            |         | Reference Section - Page or - Content Title |
|--|--------------------------------------|----------------------|-----------|------------|---------|------------|-----------|------------|---------|---|
| Perform at number of miles, kilometers or months, whichever comes first. | Miles x 1,000 (km x 1,000)<br>Months | 3.75 (6)             | 7.50 (12) | 11.25 (18) | 15 (24) | 18.75 (30) | 22.5 (36) | 26.25 (42) | 30 (48) |   |
| Charging port  |                                      |                      |           |            | I       |            |           |            | I       | <a href="#">VC-52</a>                       |
| Charging port sealing cap  |                                      |                      |           |            |         |            |           |            | I       | <a href="#">VC-52</a>                       |
| Cooling system coolant   | NOTE (1)                             |                      |           |            |         |            |           |            |         | <a href="#">HCO-11</a>                      |
| EV battery usage report  |                                      |                      |           |            | I       |            |           |            | I       | <a href="#">EVB-180</a>                     |

| MAINTENANCE OPERATION  |                                      | MAINTENANCE INTERVAL |           |            |         |            |           |            |         | Reference Section - Page or - Content Title |
|--|--------------------------------------|----------------------|-----------|------------|---------|------------|-----------|------------|---------|---|
| Perform at number of miles, kilometers or months, whichever comes first. | Miles x 1,000 (km x 1,000)<br>Months | 33.75 (54)           | 37.5 (60) | 41.25 (66) | 45 (72) | 48.75 (78) | 52.5 (84) | 56.25 (90) | 60 (96) |   |
| Charging port  |                                      |                      |           |            | I       |            |           |            | I       | <a href="#">VC-52</a>                       |
| Charging port sealing cap  |                                      |                      |           |            |         |            |           |            | I       | <a href="#">VC-52</a>                       |
| Cooling system coolant   | NOTE (1)                             |                      |           |            |         |            |           |            |         | <a href="#">HCO-11</a>                      |
| EV battery usage report  |                                      |                      |           |            | I       |            |           |            | I       | <a href="#">EVB-180</a>                     |

#### NOTE:

(1) First replacement interval is 125,000 miles (200,000 km) or 15 years. After first replacement, replace every 75,000 miles (120,000 km) or 60 months. Use only Genuine NISSAN Long Life Antifreeze/Coolant (blue) or equivalent with proper mixture ratio of 50% anti-freeze and 50% demineralized or distilled water. Mixing any other type of coolant or the use of non-distilled water will reduce the life expectancy of the factory-fill coolant.

#### Chassis and Body Maintenance

# PERIODIC MAINTENANCE

< PERIODIC MAINTENANCE >

Abbreviations: R = Replace. I = Inspect. Correct or replace if necessary.

| MAINTENANCE OPERATION  |                                   | MAINTENANCE INTERVAL |           |            |         |            |           |            |         | Reference Section - Page or - Content Title  |
|--|-----------------------------------|----------------------|-----------|------------|---------|------------|-----------|------------|---------|--|
| Perform at number of miles, kilometers or months, whichever comes first. | Miles x 1,000 (km x 1,000) Months | 3.75 (6)             | 7.50 (12) | 11.25 (18) | 15 (24) | 18.75 (30) | 22.5 (36) | 26.25 (42) | 30 (48) |  |
| Brake lines & cables   |                                   |                      |           |            | I       |            |           |            | I       | <a href="#">MA-28</a>  |
| Brake pads & rotors  |                                   |                      | I         |            | I       |            | I         |            | I       | <a href="#">BR-496</a><br><a href="#">BR-496</a><br><a href="#">BR-498</a><br><a href="#">BR-498</a> |
| Brake fluid  |                                   |                      |           |            | R       |            |           |            | R       | <a href="#">BR-493</a>   |
| Reduction gear oil   |                                   |                      |           |            | I       |            |           |            | I       | <a href="#">TM-13</a>  |
| Steering gear & linkage, axle & suspension parts                         |                                   |                      | I         |            | I       |            | I         |            | I       | <a href="#">MA-32</a><br><a href="#">MA-32</a>   |
| Tire rotation  | NOTE (1)                          |                      |           |            |         |            |           |            |         | <a href="#">MA-8</a><br><a href="#">WT-43</a>  |
| Drive shaft boots  |                                   |                      | I         |            | I       |            | I         |            | I       | <a href="#">MA-33</a>  |
| In-cabin microfilter   |                                   |                      |           |            | R       |            |           |            | R       | <a href="#">VTL-9</a>  |

| MAINTENANCE OPERATION  |                                   | MAINTENANCE INTERVAL |           |            |         |            |           |            |         | Reference Section - Page or - Content Title  |
|--|-----------------------------------|----------------------|-----------|------------|---------|------------|-----------|------------|---------|--|
| Perform at number of miles, kilometers or months, whichever comes first. | Miles x 1,000 (km x 1,000) Months | 33.75 (54)           | 37.5 (60) | 41.25 (66) | 45 (72) | 48.75 (78) | 52.5 (84) | 56.25 (90) | 60 (96) |  |
| Brake lines & cables   |                                   | 27                   | 30        | 33         | I       |            |           |            | I       | <a href="#">MA-28</a>  |
| Brake pads & rotors  |                                   |                      | I         |            | I       |            | I         |            | I       | <a href="#">BR-496</a><br><a href="#">BR-496</a><br><a href="#">BR-498</a><br><a href="#">BR-498</a> |
| Brake fluid  |                                   |                      |           |            | R       |            |           |            | R       | <a href="#">BR-493</a>   |
| Reduction gear oil   |                                   |                      |           |            | I       |            |           |            | I       | <a href="#">TM-13</a>  |
| Steering gear & linkage, axle & suspension parts                         |                                   |                      | I         |            | I       |            | I         |            | I       | <a href="#">MA-32</a><br><a href="#">MA-32</a>   |
| Tire rotation  | NOTE (1)                          |                      |           |            |         |            |           |            |         | <a href="#">MA-8</a><br><a href="#">WT-43</a>  |
| Drive shaft boots  |                                   |                      | I         |            | I       |            | I         |            | I       | <a href="#">MA-33</a>  |
| In-cabin microfilter   |                                   |                      |           |            | R       |            |           |            | R       | <a href="#">VTL-9</a>  |

**NOTE:**

(1) Refer to "Tire rotation" under the "General maintenance" heading earlier in this section.

## FOR USA AND CANADA : Schedule 2

INFOID:000000010640796

### EV System Maintenance

Abbreviations: R = Replace. I = Inspect. Correct or replace if necessary.

| MAINTENANCE OPERATION  |                                   | MAINTENANCE INTERVAL |         |           |         |           |         |           |         | Reference Section - Page or - Content Title |
|--|-----------------------------------|----------------------|---------|-----------|---------|-----------|---------|-----------|---------|---|
| Perform at number of miles, kilometers or months, whichever comes first. | Miles x 1,000 (km x 1,000) Months | 7.5 (12)             | 15 (24) | 22.5 (36) | 30 (48) | 37.5 (60) | 45 (72) | 52.5 (84) | 60 (96) |   |
| Charging port  |                                   | 6                    | 12      | 18        | 24      | 30        | 36      | 42        | 48      | <a href="#">VC-52</a>                       |
| Charging port sealing cap  |                                   |                      |         |           | I       |           |         |           | I       | <a href="#">VC-52</a>                       |
| Cooling system coolant   | NOTE (1)                          |                      |         |           |         |           |         |           |         | <a href="#">HCO-11</a>                      |
| EV battery usage report  |                                   |                      | I       |           | I       |           | I       |           | I       | <a href="#">EVB-180</a>                     |

**NOTE:**

# PERIODIC MAINTENANCE

## < PERIODIC MAINTENANCE >

(1) First replacement interval is 125,000 miles (200,000 km) or 15 years. After first replacement, replace every 75,000 miles (120,000 km) or 60 months. Use only Genuine NISSAN Long Life Antifreeze/Coolant (blue) or equivalent with proper mixture ratio of 50% anti-freeze and 50% demineralized or distilled water. Mixing any other type of coolant or the use of non-distilled water will reduce the life expectancy of the factory-fill coolant.

### Chassis and Body Maintenance

Abbreviations: R = Replace. I = Inspect. Correct or replace if necessary.

| MAINTENANCE OPERATION  |   | MAINTENANCE INTERVAL |                  |                    |                  |                    |                  |                    |                  | Reference Section - Page or - Content Title  |
|--|---|----------------------|------------------|--------------------|------------------|--------------------|------------------|--------------------|------------------|--|
| Perform at number of miles, kilometers or months, whichever comes first. | Miles x 1,000<br>(km x 1,000)<br>Months | 7.5<br>(12)<br>6     | 15<br>(24)<br>12 | 22.5<br>(36)<br>18 | 30<br>(48)<br>24 | 37.5<br>(60)<br>30 | 45<br>(72)<br>36 | 52.5<br>(84)<br>42 | 60<br>(96)<br>48 |  |
| Brake lines & cables   |   |                      | I                |                    | I                |                    | I                |                    | I                | <a href="#">MA-28</a>  |
| Brake pads & rotors  |   |                      | I                |                    | I                |                    | I                |                    | I                | <a href="#">BR-496</a><br><a href="#">BR-496</a><br><a href="#">BR-498</a><br><a href="#">BR-498</a> |
| Brake fluid  |   |                      |                  |                    | R                |                    |                  |                    | R                | <a href="#">BR-493</a>   |
| Reduction gear oil   |   |                      | I                |                    | I                |                    | I                |                    | I                | <a href="#">TM-13</a>  |
| Steering gear & linkage, axle & suspension parts                         |   |                      |                  |                    | I                |                    |                  |                    | I                | <a href="#">MA-32</a><br><a href="#">MA-32</a>   |
| Tire rotation  | NOTE (1)                                |                      |                  |                    |                  |                    |                  |                    |                  | <a href="#">MA-8</a><br><a href="#">WT-44, "Tire Rotation"</a>                                       |
| Drive shaft boots  |   |                      | I                |                    | I                |                    | I                |                    | I                | <a href="#">MA-33</a>  |
| In-cabin microfilter   |   |                      | R                |                    | R                |                    | R                |                    | R                | <a href="#">VTL-9</a>  |

#### NOTE:

(1) Refer to "Tire rotation" under the "General maintenance" heading earlier in this section.

## FOR MEXICO

### FOR MEXICO : Periodic Maintenance

INFOID:000000010640797

The following tables show the normal maintenance schedule. Depending upon weather and atmospheric conditions, varying road surfaces, individual driving habits and vehicle usage, additional or more frequent maintenance may be required.

**Periodic maintenance beyond the last period shown on the tables requires similar maintenance.**

### EV SYSTEM MAINTENANCE

Abbreviations: I = Inspect and correct or replace as necessary, R = Replace, E = Check and correct the coolant mixture ratio.

| MAINTENANCE OPERATION   |   | MAINTENANCE INTERVAL |                  |                  |                  |                  |                  |                  |                  |  | Reference page |
|---|---|----------------------|------------------|------------------|------------------|------------------|------------------|------------------|------------------|--|----------------|
| Perform at number of kilometers (miles) or months, whichever comes first. | km x 1,000<br>(Miles x 1,000)<br>Months | 10<br>(6)<br>6       | 20<br>(12)<br>12 | 30<br>(18)<br>18 | 40<br>(24)<br>24 | 50<br>(30)<br>30 | 60<br>(36)<br>36 | 70<br>(42)<br>42 | 80<br>(48)<br>48 |  |                |
| Charging port   |   |                      | I                |                  | I                |                  | I                |                  | I                | <a href="#">VC-52</a>                            |                |
| Charging port rubber cap  |   |                      |                  |                  | I                |                  |                  |                  | I                | <a href="#">VC-52</a>                            |                |
| Cooling system  |   |                      | I                |                  | I                |                  | I                |                  | I                | <a href="#">HCO-11</a><br><a href="#">HCO-13</a> |                |
| Cooling system coolant  | See<br>NOTE (1)                         |                      |                  |                  |                  | E                |                  |                  | E                | <a href="#">HCO-11</a>                           |                |
| EV battery usage report   |   |                      | I                |                  | I                |                  | I                |                  | I                | <a href="#">EVB-180</a>                          |                |
| Computer diagnosis  |   |                      | I                |                  | I                |                  | I                |                  | I                | —  |                |

#### NOTE:

- (1) When adding or replacing coolant, be sure to use only Genuine NISSAN Coolant (blue) or equivalent with the proper mixture, in order to avoid possible aluminum corrosion within the cooling system caused by the use of non-genuine coolant. The recommended service interval of the factory-fill coolant is 200,000 km (125,000 miles) or 15 years, whichever comes first. Subsequent

# PERIODIC MAINTENANCE

## < PERIODIC MAINTENANCE >

replacement of Genuine NISSAN Coolant (blue) should occur every 80,000 km (48,000 miles) or 4 years, whichever comes first. Mixing any other type of coolant or the use of non-distilled water will reduce the recommended service interval of the coolant. Perform "E" (Checking the mixture ratio and correcting the mixture ratio if necessary) every 40,000 km (24,000 miles) or 24 months.

## CHASSIS AND BODY MAINTENANCE

Abbreviations: I = Inspect and correct or replace as necessary, R = Replace, L = Lubricate.

| MAINTENANCE OPERATION  | km × 1,000<br>(Miles × 1,000)<br>Months | MAINTENANCE INTERVAL |            |            |            |            |            |            |            | Reference page   |
|--|---|----------------------|------------|------------|------------|------------|------------|------------|------------|--|
|  |   | 10<br>(6)            | 20<br>(12) | 30<br>(18) | 40<br>(24) | 50<br>(30) | 60<br>(36) | 70<br>(42) | 80<br>(48) |  |
| <b>Underhood and under vehicle</b>   |   |                      |            |            |            |            |            |            |            |  |
| Brake system and fluid (For level & leaks)                                 |   | I                    | I          | I          | I          | I          | I          | I          | I          | <a href="#">MA-28</a>  |
| Brake fluid★   |   |                      |            |            | R          |            |            |            | R          | <a href="#">BR-493</a><br><a href="#">BR-493</a>   |
| Reduction gear oil   |   |                      | I          |            | I          |            | I          |            | I          | <a href="#">TM-13</a>  |
| Steering gear & linkage, axle & suspension parts, front drive shaft boots★ |   |                      | I          |            | I          |            | I          |            | I          | <a href="#">MA-32</a><br><a href="#">MA-32</a><br><a href="#">MA-33</a>                              |
| Wheel alignment (If necessary, rotate & balance wheels)                    |   |                      | I          |            | I          |            | I          |            | I          | <a href="#">WT-43</a><br><a href="#">WT-43</a><br><a href="#">WT-44</a>                              |
| Brake pads, rotors & other brake components★                               |   | I                    | I          | I          | I          | I          | I          | I          | I          | <a href="#">BR-496</a><br><a href="#">BR-496</a><br><a href="#">BR-498</a><br><a href="#">BR-498</a> |
| Locks, hinges & hood latch★  |   | L                    | L          | L          | L          | L          | L          | L          | L          | <a href="#">MA-34</a>  |
| Seat belts, buckles, retractors, anchors & adjusters                       |   |                      | I          |            | I          |            | I          |            | I          | <a href="#">MA-34</a>  |
| Foot brake & parking brake (For free play, stroke & operation)             |   | I                    | I          | I          | I          | I          | I          | I          | I          | <a href="#">PB-6</a><br><a href="#">PB-6</a>   |
| Air conditioner filter★  |   |                      | R          |            | R          |            | R          |            | R          | <a href="#">VTL-9</a>  |

### NOTE:

- Maintenance items with "★" should be performed more frequently according to "Maintenance Under Severe Driving Conditions".

## MAINTENANCE UNDER SEVERE DRIVING CONDITIONS

The maintenance intervals shown on the preceding pages are for normal operating conditions. If the vehicle is mainly operated under severe driving conditions as shown below, more frequent maintenance must be performed on the following items as shown in the table.

### Severe driving conditions

- A — Driving under dusty conditions
- B — Driving repeatedly short distances
- C — Towing a trailer or caravan
- D — Extensive idling
- E — Driving in extremely adverse weather conditions or in areas where ambient temperatures are either extremely low or extremely high
- F — Driving in high humidity or mountainous areas
- G — Driving in areas using salt or other corrosive materials
- H — Driving on rough and/or muddy roads or in the desert
- I — Driving with frequent use of braking or in mountainous areas

Maintenance operation: Inspection = Check and correct or replace as necessary.

## PERIODIC MAINTENANCE

< PERIODIC MAINTENANCE >

| Driving condition |   |   |   |   |   |   |   |   |   |   | Maintenance item  | Maintenance operation | Maintenance interval                        | Reference page   |
|-------------------|---|---|---|---|---|---|---|---|---|---|---|-----------------------|---|--|
| .                 | . | . | . | . | F | . | . | . | . | . | Brake fluid   | Replace               | Every 20,000 km (12,000 miles) or 12 months | <a href="#">BR-493</a><br><a href="#">BR-493</a>   |
| .                 | . | . | . | . | . | G | H | . | . | . | Steering gear & linkage, axle & suspension parts, front drive shaft boots | Inspect               | Every 10,000 km (6,000 miles) or 6 months   | <a href="#">MA-32</a><br><a href="#">MA-32</a><br><a href="#">MA-33</a>                              |
| A                 | . | . | . | . | . | G | H | I | . | . | Brake pads, rotors & other brake components                               | Inspect               | Every 5,000 km (3,000 miles) or 3 months    | <a href="#">BR-496</a><br><a href="#">BR-496</a><br><a href="#">BR-498</a><br><a href="#">BR-498</a> |
| .                 | . | . | . | . | . | G | . | . | . | . | Locks, hinges & hood latch  | Lubricate             | Every 5,000 km (3,000 miles) or 3 months    | <a href="#">MA-34</a>  |
| A                 | . | . | . | . | . | . | . | . | . | . | Air conditioner filter  | Replace               | Every 10,000 km (6,000 miles) or 6 months   | <a href="#">VTL-9</a>  |



# RECOMMENDED FLUIDS AND LUBRICANTS

< PERIODIC MAINTENANCE >

## RECOMMENDED FLUIDS AND LUBRICANTS FOR USA AND CANADA

FOR USA AND CANADA : Fluids and Lubricants

INFOID:0000000010640798

|                                     |                          | Capacity (Approximate) |             |          | Recommended Fluids/Lubricants  |
|-------------------------------------|--------------------------|------------------------|-------------|----------|--|
|                                     |                          | US measure             | Imp measure | Liter    |  |
| Cooling system                      | With reservoir tank      | 5-5/8 qt               | 4-5/8 qt    | 5.3      | Pre-diluted Genuine NISSAN Long Life Antifreeze/Coolant (blue) or equivalent   |
|                                     | Reservoir tank           | 4/8 qt                 | 4/8 qt      | 0.5      |  |
| Reduction gear fluid                |                          | 3 pt                   | 2-1/2 pt    | 1.41     | Genuine NISSAN Matic S ATF<br>• Using reduction gear fluid other than Genuine NISSAN Matic S ATF will cause deterioration in driveability and reduction gear durability, and may damage the reduction gear, which is not covered by the NISSAN new vehicle limited warranty. |
| Brake fluid                         |                          | —                      | —           | —        | Genuine NISSAN Super Heavy Duty Brake Fluid, or equivalent DOT3 (US FMVSS No. 116)<br>• Available in mainland U.S.A through a NISSAN certified LEAF dealer.  |
| Windshield washer fluid             | Canada                   | 4-3/4 qt               | 4 qt        | 4.5 ℓ    | Genuine NISSAN Windshield Washer Concentrate Cleaner & Antifreeze fluid or equivalent  |
|                                     | USA                      | 2-3/5 qt               | 2-1/5 qt    | 2.5 ℓ    |  |
| Air conditioning system refrigerant | With heat pump system    | 1.874 lb               | 1.874 lb    | 0.850 kg | HFC-134a (R-134a)  |
|                                     | Without heat pump system | 0.937 lb               | 0.937 lb    | 0.425 kg |  |
| Air conditioning system lubricants  | With heat pump system    | 4.7 fl oz              | 4.9 fl oz   | 140 m ℓ  | Compressor Oil ND-OIL11 or equivalent  |
|                                     | Without heat pump system | 5.1 fl oz              | 5.3 fl oz   | 150 m ℓ  | Compressor Oil ND-OIL11 or equivalent  |
| Multi-purpose grease                |                          | —                      | —           | —        | NLGI No. 2 (Lithium soap base)   |

## FOR USA AND CANADA : Anti-Freeze Coolant Mixture Ratio

INFOID:0000000010640799

The cooling system is filled at the factory with a pre-diluted mixture of 50% Genuine NISSAN Long Life Antifreeze/Coolant (blue) and 50% water to provide year-round anti-freeze and coolant protection. The anti-freeze solution contains rust and corrosion inhibitors. Additional cooling/heating system additives are not necessary.

### WARNING:

- Do not remove the coolant reservoir cap when the motor is hot. Wait until the motor and radiator cool down. Serious burns could be caused by high pressure fluid escaping from the radiator. See precautions in "If your vehicle overheats" found in the "In case of emergency" section of this manual.
- The coolant reservoir is equipped with a pressure type radiator cap. To prevent motor damage, use only a Genuine NISSAN coolant reservoir cap.

### CAUTION:

- When adding or replacing coolant, be sure to use only Genuine NISSAN Long Life Antifreeze/Coolant (blue) or equivalent. Genuine NISSAN Long Life Antifreeze/Coolant (blue) is pre-diluted to provide antifreeze protection to -34°F (-37°C). If additional freeze protection is needed due to weather condition where you operate your vehicle, add Genuine NISSAN Long Life Antifreeze/Coolant (blue) concentrate following the directions on the container. If an equivalent coolant other than Genuine NISSAN Long Life Antifreeze/Coolant (blue) is used, follow the coolant manufacture's instructions to maintain minimum antifreeze protection to -34°F (-37°C). The use of other types of coolant solutions other than Genuine NISSAN Long Life Antifreeze/Coolant (blue) or equivalent may damage the cooling system.

# RECOMMENDED FLUIDS AND LUBRICANTS

## < PERIODIC MAINTENANCE >

- The life expectancy of the factory-fill coolant is 125,000 miles (200,000 km) or 15 years. Mixing any other type of coolant other than Genuine NISSAN Long Life Antifreeze/Coolant (blue), including Genuine NISSAN Long Life Antifreeze/Coolant (green), or the use of non-distilled water will reduce the life expectancy of the factory-fill coolant. Refer to the Nissan Service and Maintenance Guide for more details.

## FOR MEXICO

### FOR MEXICO : Fluids and Lubricants

INFOID:000000010640800

|                                     |                       | Capacity (Approximate) |             |          | Recommended Fluids/Lubricants  |
|-------------------------------------|-----------------------|------------------------|-------------|----------|--|
|                                     |                       | US measure             | Imp measure | Liter    |  |
| Cooling system                      | With reservoir tank   | 5-5/8 qt               | 4-5/8 qt    | 5.3      | Genuine NISSAN Coolant (blue) or equivalent<br>• Use Genuine NISSAN Coolant (blue) or equivalent in its quality, in order to avoid possible aluminium corrosion within the cooling system caused by the use of non-genuine coolant.<br><b>Note that any repairs for the incidents within the cooling system while using non-genuine coolant may not be covered by the warranty even if such incidents occurred during the warranty period.</b> |
|                                     | Reservoir tank        | 4/8 qt                 | 4/8 qt      | 0.5      |  |
| Reduction gear fluid                |                       | 3 pt                   | 2-1/2 pt    | 1.41     | Genuine NISSAN Matic S ATF<br>• Using reduction gear other than Genuine NISSAN Matic S ATF will cause deterioration in driveability and reduction gear durability, and may damage the reduction gear, which is not covered by the warranty.  |
| Brake fluid                         |                       | —                      | —           | —        | Genuine NISSAN Brake Fluid or equivalent DOT3 (US FMVSS No. 116)   |
| Windshield washer fluid             |                       | 2-3/5 qt               | 2-1/5 qt    | 2.5 ℓ    | Genuine NISSAN Windshield Washer Concentrate Cleaner & Antifreeze fluid or equivalent  |
| Air conditioning system refrigerant | With heat pump system | 1.874 lb               | 1.874 lb    | 0.850 kg | HFC-134a (R-134a)  |
| Air conditioning system lubricants  | With heat pump system | 4.7 fl oz              | 4.9 fl oz   | 140 m ℓ  | Compressor Oil ND-OIL11 or equivalent  |
| Multi-purpose grease                |                       | —                      | —           | —        | NLGI No. 2 (Lithium soap base)   |

### FOR MEXICO : Coolant Mixture Ratio

INFOID:000000010640801

The cooling system is filled at the factory with a high-quality, year-round and extended life coolant. The high quality coolant contains the specific solutions effective for the anti-corrosion and the anti-freeze function. Therefore, additional cooling system additives are not necessary.

#### CAUTION:

- When adding or replacing coolant, be sure to use only a Genuine NISSAN Coolant or equivalent in its quality with the proper mixture ratio (50%). See the examples shown in the figure.

The use of other types of coolant may damage the cooling system.

- When checking the coolant mixture ratio by the coolant hydrometer, use the chart below to correct your hydrometer reading (specific gravity) according to coolant temperature.

| Outside temperature down to |     | Composition            |                                       |
|-----------------------------|-----|------------------------|---------------------------------------|
| °C                          | °F  | Coolant (Concentrated) | Deminerlized water or distilled water |
| -15                         | 5   | 30%                    | 70%                                   |
| -35                         | -30 | 50%                    | 50%                                   |

JSPIA0005GB

# RECOMMENDED FLUIDS AND LUBRICANTS

## < PERIODIC MAINTENANCE >

Mixed coolant specific gravity

Unit: specific gravity

| Coolant mixture ratio | Coolant temperature °C (°F) |               |               |               |
|-----------------------|-----------------------------|---------------|---------------|---------------|
|                       | 15 (59)                     | 25 (77)       | 35 (95)       | 45 (113)      |
| 30%                   | 1.046 - 1.050               | 1.042 - 1.046 | 1.038 - 1.042 | 1.033 - 1.038 |
| 50%                   | 1.076 - 1.080               | 1.070 - 1.076 | 1.065 - 1.071 | 1.059 - 1.065 |

**WARNING:**

**Do not remove the coolant tank cap and reservoir tank cap when the motor is hot. Serious burns could be caused by high pressure fluid escaping from the reservoir tank. Wait until the motor cool down.**

A  
B  
C  
D  
E  
F  
G  
H  
I  
J  
K  
L  
M  
N  
O

MA

# EV SYSTEM MAINTENANCE

< PERIODIC MAINTENANCE >

## EV SYSTEM MAINTENANCE

### COOLANT

#### COOLANT : Inspection

INFOID:000000011045343

#### COOLANT AMOUNT INSPECTION

- When coolant temperature is low (about 50°C or less), confirm that the coolant level of the reservoir tank is in the range from MIN to MAX.

Ⓐ : MAX

Ⓑ : MIN

- Adjust level if it is outside the range.

#### CAUTION:

- Refill Genuine NISSAN Long Life Antifreeze/Coolant (blue) or equivalent in its quality mixed with water (distilled or demineralized). Refer to [MA-17, "FOR USA AND CANADA : Fluids and Lubricants"](#) (United States and Canada) or [MA-18, "FOR MEXICO : Fluids and Lubricants"](#) (Mexico).
- Confirm that the reservoir tank cap is tightened.

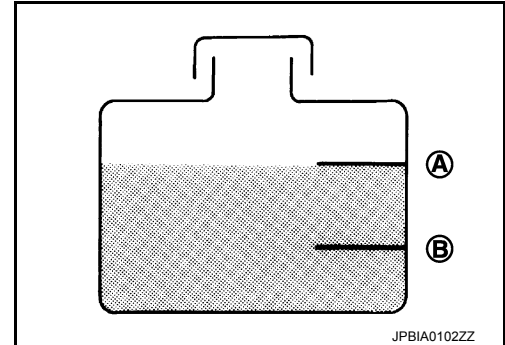

#### LEAK CHECK

- Apply pressure to the cooling system using suitable tool (A). Check system for coolant leaks.

Maximum pressure : Refer to [HCO-28, "Periodical Maintenance Specification"](#).

#### CAUTION:

- Remove the degas tank cap when coolant temperature is low.
- Perform the inspection with the radiator filled with water.
- Use suitable tool (B) between suitable tool (A) and the filler neck so that the degas tank filler neck is not deformed.
- Be sure to observe the maximum pressure standards. Otherwise, radiator may be damaged.
- If there is a malfunction, repair and replace applicable part.

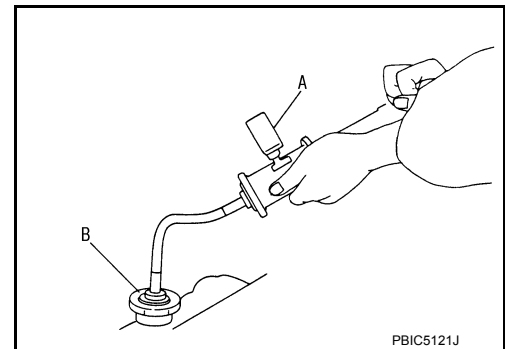

#### COOLANT : Draining

INFOID:000000011045344

#### CAUTION:

- Be sure to drain when coolant temperature is cold.
- This should be performed so that coolant does not come in contact with surrounding parts.

- Remove Li-ion battery undercover.
- Remove radiator drain plug ①, and drain coolant.

↔ : Vehicle front

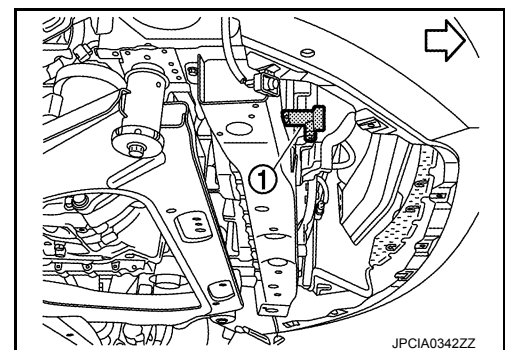

- Remove reservoir tank and drain the coolant as per the following procedure.
  - Remove radiator upper grille cover.
  - Remove water hose (reservoir tank side) and reservoir tank bolts.

# EV SYSTEM MAINTENANCE

< PERIODIC MAINTENANCE >

## COOLANT : Refilling

INFOID:000000011045345

### REFILLING

#### CAUTION:

- Do not reuse O-rings.
- Do not put additive such as waterleak preventive, since it may cause cooling waterway clogging.
- When refilling use Genuine NISSAN Long Life Antifreeze/Coolant (blue) or equivalent in its quality mixed with water (distilled or demineralized). Refer to [MA-17, "FOR USA AND CANADA : Fluids and Lubricants"](#) (United States and Canada) or [MA-18, "FOR MEXICO : Fluids and Lubricants"](#) (Mexico).

1. Install reservoir tank if removed and radiator drain plug.

#### CAUTION:

Be sure to clean drain plug and install with new O-ring.

**Radiator drain plug** : Refer to [HCO-14, "Exploded View"](#).

2. Check that each hose clamp has been firmly tightened.
3. Refill reservoir tank to "MAX" level line with engine coolant.

Ⓐ : MAX

Ⓑ : MIN

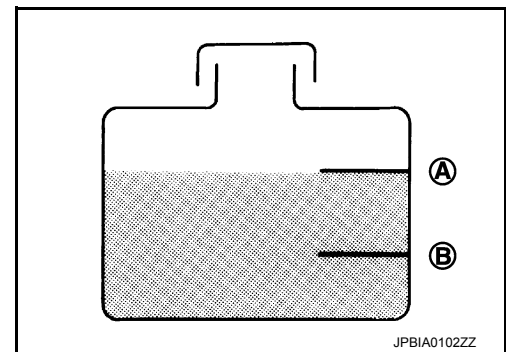

4. Install reservoir tank cap.
5. Set the vehicle to READY and operate the electric water pump.
6. If reservoir tank fluid level drops, set the vehicle in READY OFF state and fill with coolant to the "MAX" line of the reservoir tank.
7. Repeat from Step 4 to 7 until the reservoir tank fluid level stops dropping.
8. Operate the electrically-controlled water pump for approximately 10 minutes with the vehicle set in READY state, and check that the reservoir tank fluid level does not drop.
9. If reservoir tank fluid level drops, repeat from Step 4 to 7.

### CHECK WATER FLOW SOUND

#### CAUTION:

Prior to check, be sure to close windows, doors, and hood, and turn off audio system and other electrical loads.

1. Set the vehicle to READY and operate the electric water pump.
2. Operate the electric water pump for 1 minute.
3. Check if water flow sound can be heard from the back of the compartment (near the on board charger).
4. If water flow sound is heard, operate the electric water pump until it cannot be heard.
5. When water flow sound cannot be heard, fill the reservoir tank up to "MAX" line.

#### CAUTION:

- Insufficient coolant may cause low power or stop of vehicle due to insufficient cooling of the traction motor inverter. Be sure to bleed air thoroughly.
- Do not operate the electric water pump without coolant.

### RESERVOIR TANK CAP

# EV SYSTEM MAINTENANCE

< PERIODIC MAINTENANCE >

## RESERVOIR TANK CAP : Inspection

INFOID:000000011045346

- Check valve seat ① of reservoir tank cap.

② : Metal plunger

- Check that valve seat is swollen to the extent that the edge of the plunger cannot be seen when watching it vertically from the top.
- Check that valve seat has no soil and damage.

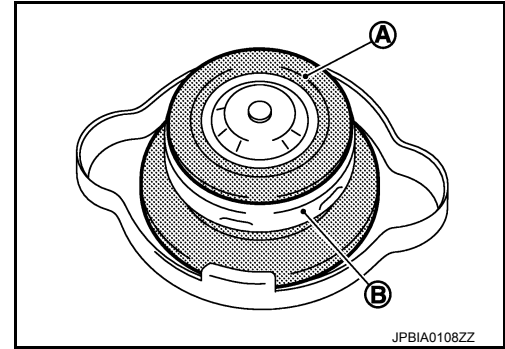

- Pull negative-pressure valve to open it, and that it close completely when released.
- Check that there is no dirt or damage on the valve seat of reservoir tank cap negative-pressure valve.
- Check that there are no unusualness in the opening and closing conditions of negative-pressure valve.

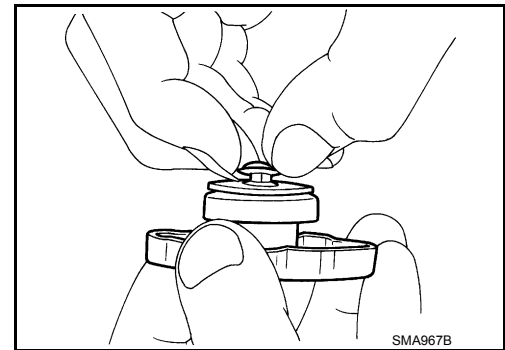

- Check reservoir tank cap relief pressure.

**Standard**

**: Refer to HCO-28. "Periodical Maintenance Specification".**

- When connecting reservoir tank cap to suitable tool (A) and suitable tool (B), apply engine coolant to the cap seal surface.

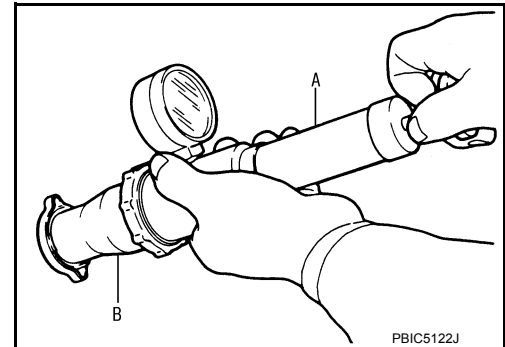

- Replace reservoir tank cap if there is an unusualness related to the above three.

## CHARGE PORT

### CHARGE PORT : Inspection

INFOID:000000011045347

#### INSPECTION PROCEDURES

##### Quick Charge Port

1. Perform the following visual inspections.
  - Dust and foreign matter in the quick charge port and normal charge port
  - Damage in the quick charge port and normal charge port
  - Malfunction in opening/closing the charge port caps and looseness when closed and locked.

# EV SYSTEM MAINTENANCE

## < PERIODIC MAINTENANCE >

- Cracks in the packing ① of quick charge port

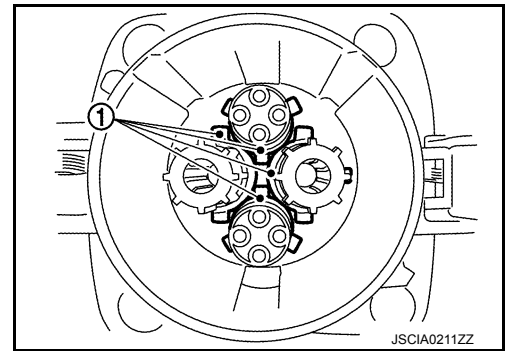

- Check that the quick charge port terminals ① are not welded.

**CAUTION:**

If they are welded, inspect the quick charge gun used for the last charge, and replace the quick charge port. For replacement of the quick charge port, refer to [VC-128](#), "[Removal and Installation](#)".

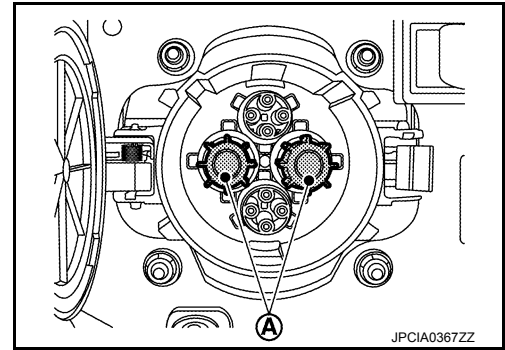

- Check that there is no irregular wear of the quick charge port lock ①.

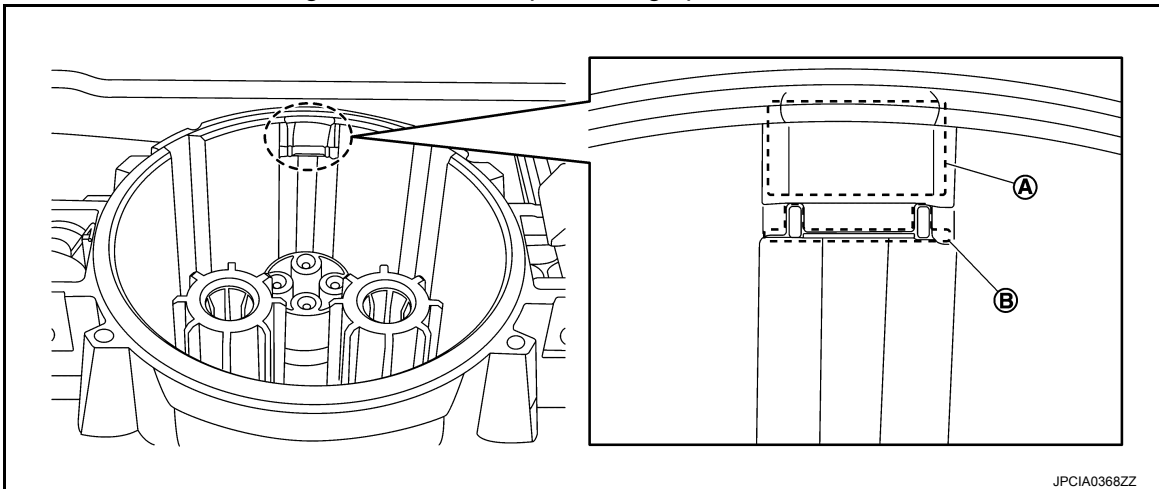

- If the port is damaged, for example if the metal plate ② on the inside is lost, replace the quick charge port. For replacement of the quick charge port, refer to [VC-128](#), "[Removal and Installation](#)".
- If irregular wear is found at the visual inspection, check the charge port inner diameter ① and replace the quick charge port if the limit value is exceeded.

**Repair limit : 71 mm (2.80 in)**

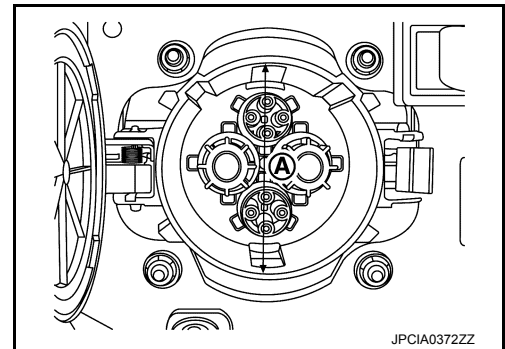

### Normal Charge Port

1. Perform the following visual inspections.
  - Dust and foreign matter in the quick charge port and normal charge port
  - Damage in the quick charge port and normal charge port

A  
B  
C  
D  
E  
F  
G  
H  
I  
J  
K  
L  
M  
N  
O  
MA

# EV SYSTEM MAINTENANCE

## < PERIODIC MAINTENANCE >

- Malfunction in opening/closing the charge port caps and looseness when closed and locked.
- Check that the normal charge port terminals (A) are not bent.
- Check that the contact prevention cap (B) is not missing.

**NOTE:**

If it is missing, it is extremely difficult to engage the charge connector.

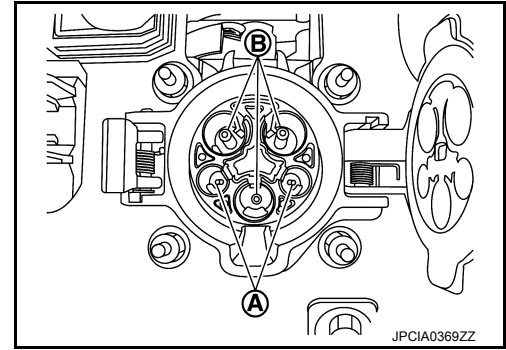

- Check that there is no snow or ice on the normal charge port top side (A).

**NOTE:**

If snow or ice reaches the charge connector lock, charging does not start.

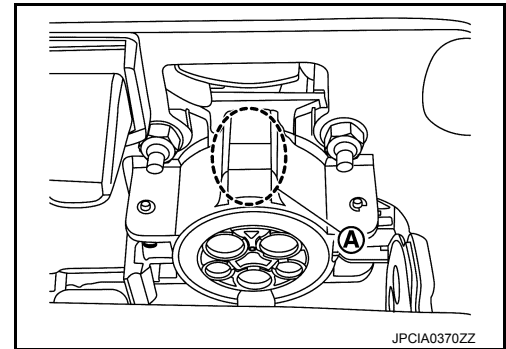

### Handling of charge port

#### Cleaning of charge port

If the charge port becomes dirty, clean the port with an air blow gun.

#### Handling of damaged cap

Perform the following procedure if the cap becomes damaged:

- Replace charge port cap if the charge port cap becomes damaged
- Replace charge port if the packing of quick charge port becomes cracked.
- Replace charge port if the terminal of quick charge port or normal charge port becomes damaged.

#### Cleaning of the inside of rubber cap

If air does not exit through the rubber cap hole, remove the rubber cap from the port and clean the inside so that air exits through the rubber cap hole.



# CHASSIS MAINTENANCE

< PERIODIC MAINTENANCE >

## CHASSIS MAINTENANCE

### REDUCTION GEAR OIL

#### REDUCTION GEAR OIL : Inspection

INFOID:000000011045348

#### OIL LEAKAGE

Check reduction gear surrounding area (oil seal, drain plug, and filler plug etc.) for oil leakage.

#### OIL LEVEL

- Remove filler plug ① and gasket. Then check that oil is filled up from mounting hole for the filler plug.

**CAUTION:**

**Turn the power switch OFF while checking oil level.**

- Set a gasket on filler plug and install it on reduction gear and tighten to the specified torque. Refer to [TM-21, "Exploded View"](#).

**CAUTION:**

- Never reuse gasket.**
- If foreign matter, such as gear abrasion powder, is on the magnet of the filler plug, wipe it free of adherents before installation.**

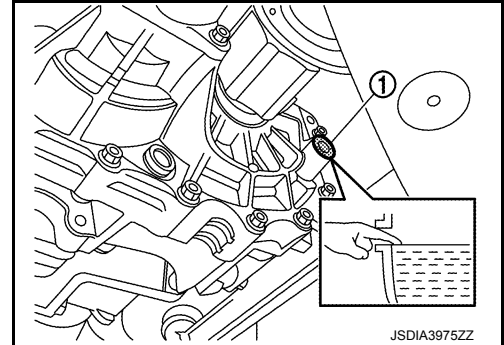

#### REDUCTION GEAR OIL : Draining and Refilling

INFOID:000000011045349

#### DRAINING

- Turn the power switch OFF.
- Remove filler plug.
- Remove drain plug ① and drain gear oil.
- Set a gasket on drain plug and install it to reduction gear and tighten to the specified torque. Refer to [TM-21, "Exploded View"](#).

**CAUTION:**

- Do not reuse gasket.**
- If foreign matter, such as gear abrasion powder, is on the magnet of the drain plug, wipe it free of adherents before installation.**

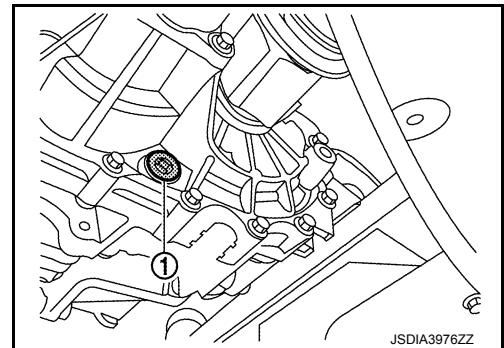

#### REFILLING

- Remove filler plug ①. Fill with new gear oil until oil level reaches the specified level near filler plug mounting hole.

**Oil grade** : Refer to [MA-17, "FOR USA AND CANADA : Fluids and Lubricants"](#) (USA and Canada) and [MA-18, "FOR MEXICO : Fluids and Lubricants"](#) (Mexico).

**Oil capacity** : Refer to [TM-27, "General Specifications"](#).

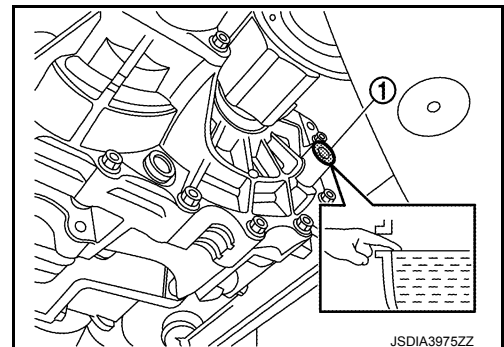

- After refilling oil, check oil level. Set a gasket on filler plug, then install it to reduction gear. Refer to [TM-21, "Exploded View"](#).

**CAUTION:**

- Do not reuse gasket.**
- If foreign matter, such as gear abrasion powder, is on the magnet of the filler plug, wipe it free of adherents before installation.**

#### WHEELS

A  
B  
C  
D  
E  
F  
G  
H  
I  
J  
K  
L  
M  
N  
O

MA

# CHASSIS MAINTENANCE

< PERIODIC MAINTENANCE >

## WHEELS : Inspection

INFOID:000000011045350

### APPEARANCE

Check the road wheel for bend, damage, crack or wear.

## WHEELS : Wheel Balance Adjustment

INFOID:000000011045351

### BALANCING WHEELS (ADHESIVE WEIGHT TYPE)

#### Preparation Before Adjustment

Remove inner and outer balance weights from the road wheel. Using releasing agent, remove double-faced adhesive tape from the road wheel.

#### CAUTION:

- **Be careful not to scratch the road wheel during removal.**
- **After removing double-faced adhesive tape, wipe clean all traces of releasing agent from the road wheel.**

#### Wheel Balance Adjustment

#### CAUTION:

- **DO NOT use center hole cone-type clamping machines to hold the wheel assembly during tire removal/installation or balancing or damage to the wheel paint, cladding or chrome may result. Use only rim-type or universal lug-type clamping machines to hold the wheel assembly during servicing.**
- If a balancer machine has an adhesive weight mode setting, select the adhesive weight mode setting and skip Step 2 below. If a balancer machine only has the clip-on (rim flange) weight mode setting, follow Step 2 to calculate the correct size adhesive weight.

1. Set road wheel on balancer machine using the center hole as a guide. Start the balancer machine.
  2. For balancer machines that only have a clip-on (rim flange) weight mode setting, follow this step to calculate the correct size adhesive weight to use. When inner and outer imbalance values are shown on the balancer machine indicator, multiply outer imbalance value by  $5/3$  (1.67) to determine balance weight that should be used. Select the outer balance weight with a value closest to the calculated value above and install in to the designated outer position of or at the designated angle in relation to the road wheel.
- a. Indicated imbalance value  $\times 5/3$  (1.67) = balance weight to be installed

#### Calculation example:

$23 \text{ g (0.81 oz)} \times 5/3 (1.67) = 38.33 \text{ g (1.35 oz)} \Rightarrow 40 \text{ g (1.41 oz)}$   
balance weight (closer to calculated balance weight value)

#### NOTE:

Note that balance weight value must be closer to the calculated balance weight value.

#### Example:

$37.4 \Rightarrow 35 \text{ g (1.23 oz)}$

$37.5 \Rightarrow 40 \text{ g (1.41 oz)}$

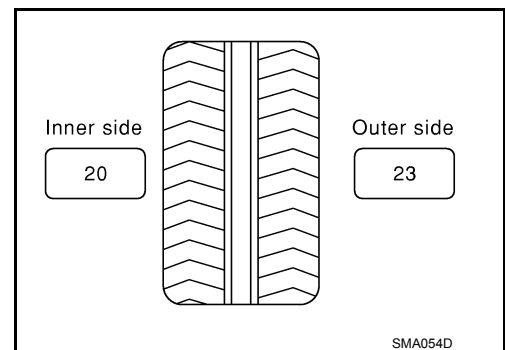

# CHASSIS MAINTENANCE

## < PERIODIC MAINTENANCE >

3. Install balance weight in the position shown.

**CAUTION:**

- Do not install the inner balance weight before installing the outer balance weight.
- Before installing the balance weight, be sure to clean the mating surface of the road wheel.
- When installing balance weight (1) to road wheel, set it into the grooved area (A) on the inner wall of the road wheel as shown so that the balance weight center (B) is aligned with the balancer machine indication position (angle) (C).

**CAUTION:**

- Always use Genuine NISSAN adhesive balance weights.
- Balance weights are non-reusable; always replace with new ones.
- Do not install more than three sheets of balance weights.

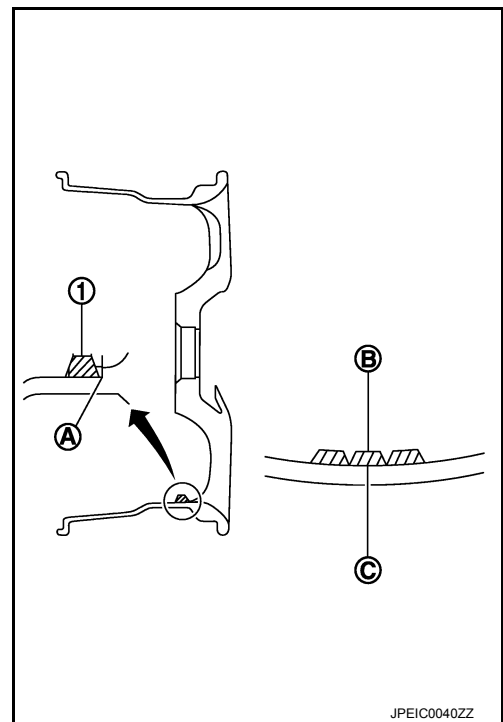

4. If calculated balance weight value exceeds 50 g (1.76 oz), install two balance weight sheets in line with each other as shown.

**CAUTION:**

**Do not install one balance weight sheet on top of another.**

5. Start balancer machine again.

6. Install balance weight on inner side of road wheel in the balancer machine indication position (angle).

**CAUTION:**

**Do not install more than two balance weights.**

7. Start balancer machine. Make sure that inner and outer residual imbalance values are 5 g (0.17 oz) each or below.

8. If either residual imbalance value exceeds 5 g (0.17 oz), repeat installation procedures.

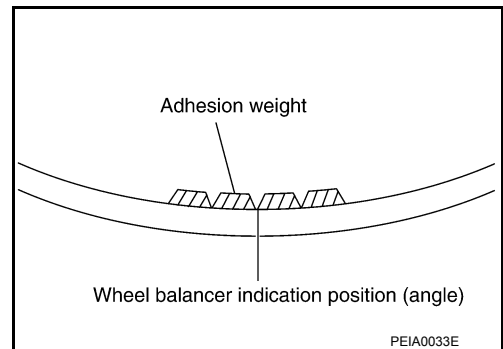

| Wheel balance               | Dynamic (At flange)                            | Static (At flange) |
|-----------------------------|--|--------------------|
| Maximum allowable imbalance | Refer to <a href="#">WT-51, "Road Wheel"</a> . |                    |

## WHEELS : Tire Rotation

INFOID:000000011045352

- Follow the maintenance schedule for tire rotation service intervals. Refer to [MA-8, "FOR USA AND CANADA : Explanation of General Maintenance"](#) (United States and Canada) or [MA-9, "FOR MEXICO : General Maintenance"](#) (Mexico).
- When installing the wheel, tighten wheel nuts to the specified torque. Refer to [WT-45, "Exploded View"](#).

**CAUTION:**

- When installing wheels, tighten them diagonally by dividing the work two to three times in order to prevent the wheels from developing any distortion.
- Be careful not to tighten wheel nut at torque exceeding the criteria.
- Use NISSAN genuine wheel nut.
- Perform the ID registration, after tire rotation. Refer to [WT-21, "Work Procedure"](#).

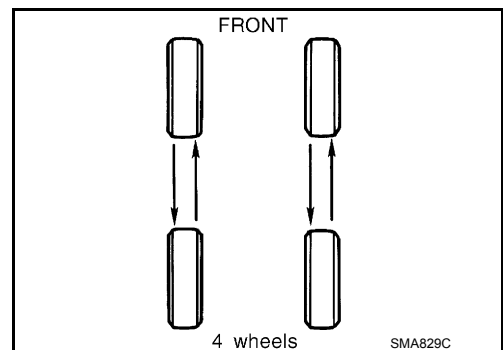

## BRAKE FLUID LEVEL AND LEAKS

A  
B  
C  
D  
E  
F  
G  
H  
I  
J  
K  
L  
M  
N  
O

MA

# CHASSIS MAINTENANCE

< PERIODIC MAINTENANCE >

## BRAKE FLUID LEVEL AND LEAKS : Inspection

INFOID:000000010640812

- If fluid level is extremely low, check brake system for leaks.

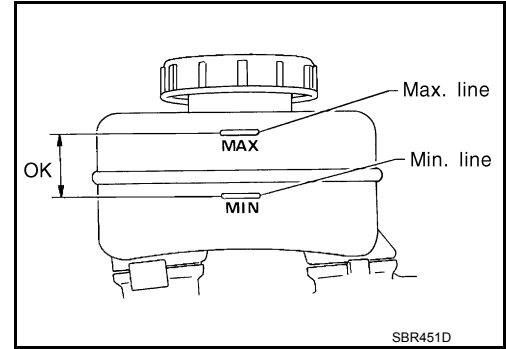

## BRAKE LINES AND CABLES

### BRAKE LINES AND CABLES : Inspection

INFOID:000000010640813

- Check brake fluid lines and parking brake cables for improper attachment, leaks, chafing, abrasions, deterioration, etc.

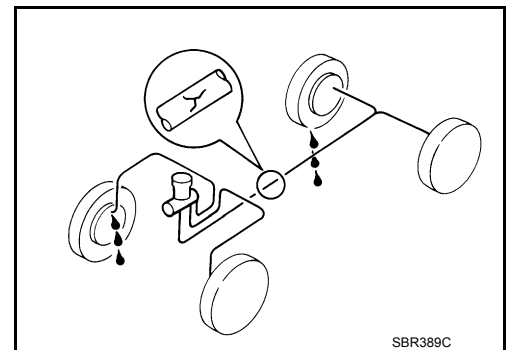

## BRAKE FLUID

### BRAKE FLUID : Draining

INFOID:000000011045353

#### CAUTION:

- Never allow brake fluid to contact the body or other painted surfaces. Brake fluid may damage paint. If it contacts a painted surface, wipe it off immediately and wash with water. However avoid washing brake components with water.
  - Before performing work, turn the power switch OFF to exit CONSULT. Close all doors (including back door), check that the room lamp is OFF, get out of the vehicle, and wait for 3 minutes or more with all doors closed. Disconnect the electrically-driven intelligent brake unit, the ABS actuator control unit harness connector or disconnect the 12V battery cable from the negative terminal. Refer to [BR-6, "Precaution for Removing 12V Battery"](#).
  - Never operate the vehicle and CONSULT while waiting.
  - If brake fluid contacts the disc rotor or brake caliper assembly, wipe it off immediately.
1. Connect a vinyl tube to air bleeder.
  2. Depress the brake pedal and loosen the air bleeder to gradually discharge brake fluid.

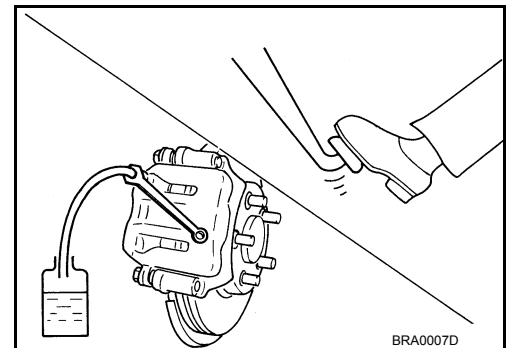

### BRAKE FLUID : Refilling

INFOID:000000011045354

#### CAUTION:

If brake fluid contacts the disc rotor or brake caliper assembly, wipe it off immediately.

# CHASSIS MAINTENANCE

## < PERIODIC MAINTENANCE >

1. Make sure that there is no foreign material in the reservoir tank, and refill with new brake fluid.  
**CAUTION:**
  - **Never reuse drained brake fluid.**
  - **Never allow any oils other than the designated brake fluid to enter the system.**
2. Loosen the air bleeder, slowly depress the brake pedal to the full stroke, and then release the pedal. Repeat this operation at intervals of 2 or 3 seconds until all of the brake fluid is discharged. Then close the air bleeder with the brake pedal depressed. Repeat the same work on each wheel.
3. Perform air bleeding. [BR-494, "Bleeding Brake System"](#).

## FRONT DISC BRAKE

### FRONT DISC BRAKE : Inspection and Adjustment

INFOID:000000011045355

#### Brake pad wear inspection

Check the brake pad thickness from the inspection hole in the cylinder body. Use a scale to check if necessary.

**Wear limit thickness** : Refer to [BR-531, "Front Disc Brake"](#).

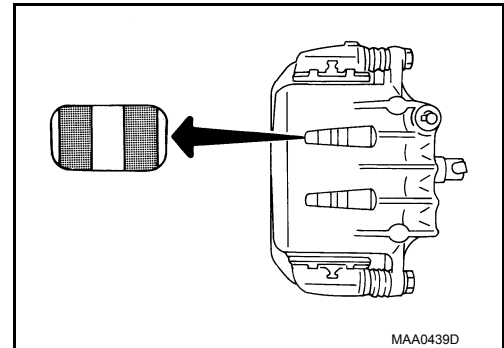

#### ADJUSTMENT

If the brake pad is ground or replaced, or if there is an abnormal feel to the braking force, follow the procedure below and perform break-in work.

#### **CAUTION:**

- **Because the brake effectiveness is reduced, pay sufficient attention to the vehicle speed.**
  - **Perform checks on a safe road and be careful of the traffic conditions.**
1. Drive on straight and flat roads.
  2. Stop the vehicle by depressing the brake pedal to generate braking force that stops the vehicle in 3 to 5 seconds.
  3. Cool the brakes.
  4. Repeat steps 1 to 3 until the abnormal feel in braking force disappears.

### FRONT DISC BRAKE : Inspection and Adjustment

INFOID:000000011045356

#### Visual inspection

Check surface of the disc rotor for uneven wear, cracks, and serious damage. Replace if necessary. Refer to [FAX-9, "Removal and Installation"](#).

#### RUNOUT INSPECTION

1. Use the wheel nuts and fasten the disc rotor to the wheel hub assembly (minimum 2 positions).
2. Check axial end play of wheel hub assembly. [FAX-7, "Inspection"](#).
3. Check runout using a dial indicator [at 10 mm (0.39 in) from outer edge of disc rotor].

**Maximum runout (vehicle stopped)** : Refer to [BR-531, "Front Disc Brake"](#).

4. If runout is outside the specified value, find the minimum runout point by shifting mounting positions of the disc rotor and wheel hub by one hole.
5. If runout is outside the specified value after performing the above operation, refinish disc rotor using Tool.

#### **CAUTION:**

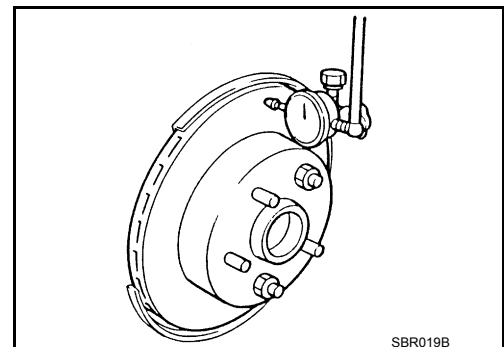

# CHASSIS MAINTENANCE

## < PERIODIC MAINTENANCE >

- Perform grinding of disc rotor if disc rotor thickness is 0.3 mm (0.012 in) or more above the wear limit thickness.
- Replace disc rotor if disc rotor thickness is less than 0.3 mm (0.012 in) above the wear limit thickness. Refer to [FAX-9, "Removal and Installation"](#).

**Wear limit thickness** : Refer to [BR-531, "Front Disc Brake"](#).

**Tool number** : 38-PFM92 ( — )

### THICKNESS INSPECTION

Check thickness of the disc rotor using a micrometer. Replace disc rotor if thickness is under the wear limit. [FAX-9, "Removal and Installation"](#).

**Wear limit thickness** : Refer to [BR-531, "Front Disc Brake"](#).

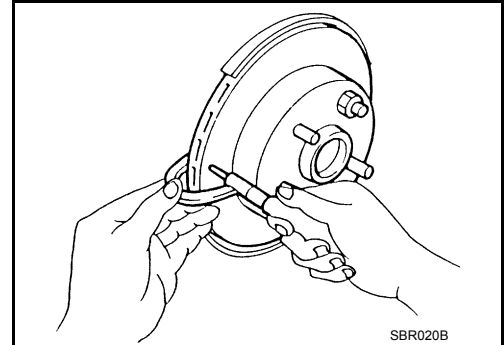

### ADJUSTMENT

If the brake pad is ground or replaced, or if there is an abnormal feel to the braking force, follow the procedure below and perform break-in work.

#### **CAUTION:**

- Because the brake effectiveness is reduced, pay sufficient attention to the vehicle speed.
  - Perform checks on a safe road and be careful of the traffic conditions.
1. Drive on straight and flat roads.
  2. Stop the vehicle by depressing the brake pedal to generate braking force that stops the vehicle in 3 to 5 seconds.
  3. Cool the brakes.
  4. Repeat steps 1 to 3 until the abnormal feel in braking force disappears.

## REAR DISC BRAKE

### REAR DISC BRAKE : Inspection and Adjustment

INFOID:000000011045357

#### Brake pad wear inspection

Check the brake pad thickness from the inspection hole in the cylinder body. Use a scale to check it if necessary.

**Wear limit thickness** : Refer to [BR-531, "Rear Disc Brake"](#).

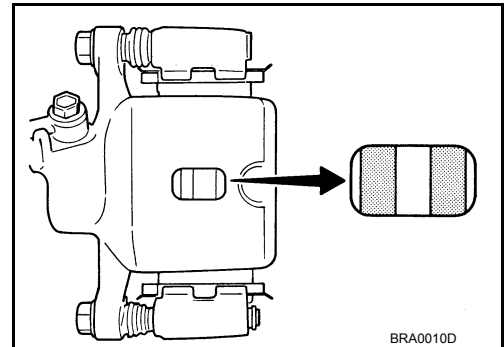

### ADJUSTMENT

If the brake pad is ground or replaced, or if there is an abnormal feel to the braking force, follow the procedure below and perform break-in work.

#### **CAUTION:**

- Because the brake effectiveness is reduced, pay sufficient attention to the vehicle speed.
  - Perform checks on a safe road and be careful of the traffic conditions.
1. Drive on straight and flat roads.

# CHASSIS MAINTENANCE

## < PERIODIC MAINTENANCE >

2. Stop the vehicle by depressing the brake pedal to generate braking force that stops the vehicle in 3 to 5 seconds.
3. Cool the brakes.
4. Repeat steps 1 to 3 until the abnormal feel in braking force disappears.

## REAR DISC BRAKE : Inspection and Adjustment

INFOID:000000011045358

### Visual inspection

Check surface of the disc rotor for uneven wear, cracks, and serious damage. Replace if necessary. Refer to [RAX-7, "Removal and Installation"](#).

### RUNOUT INSPECTION

1. Use the wheel nuts and fasten the disc rotor to the wheel hub assembly (minimum 2 positions).
2. Check axial end play of wheel hub assembly. [RAX-6, "Inspection"](#).
3. Check runout using a dial indicator [at 10 mm (0.39 in) from outer edge of disc rotor].

**Maximum runout (vehicle stopped)** : Refer to [BR-531, "Rear Disc Brake"](#).

4. If runout is outside the specified value, find the minimum runout point by shifting mounting positions of the disc rotor and wheel hub by one hole.
5. If runout is outside the specified value after performing the above operation, refinish disc rotor using Tool.

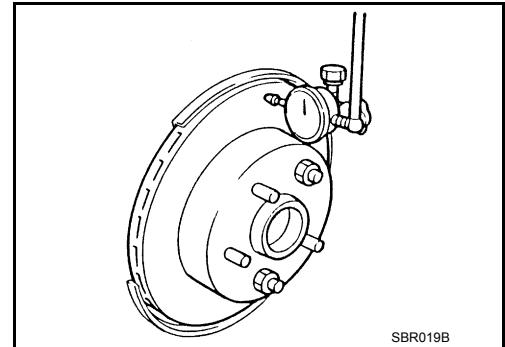

### CAUTION:

- Perform grinding of disc rotor if disc rotor thickness is 0.3 mm (0.012 in) or more above the wear limit thickness.
- Replace disc rotor if disc rotor thickness is less than 0.3 mm (0.012 in) above the wear limit thickness. Refer to [RAX-7, "Removal and Installation"](#).

**Wear limit thickness** : Refer to [BR-531, "Rear Disc Brake"](#).

**Tool number** : 38-PFM92 ( — )

### THICKNESS INSPECTION

Check thickness of the disc rotor using a micrometer. Replace disc rotor if thickness is under the wear limit. Refer to [RAX-7, "Removal and Installation"](#).

**Wear limit thickness** : Refer to [BR-531, "Rear Disc Brake"](#).

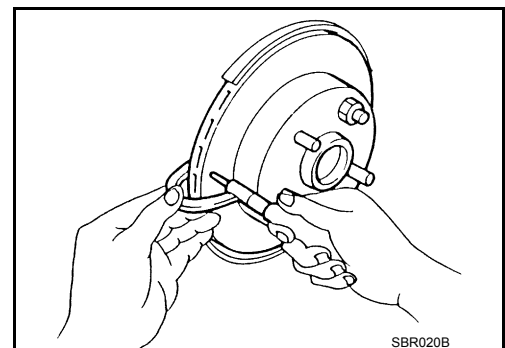

### ADJUSTMENT

If the brake pad is ground or replaced, or if there is an abnormal feel to the braking force, follow the procedure below and perform break-in work.

### CAUTION:

- Because the brake effectiveness is reduced, pay sufficient attention to the vehicle speed.
- Perform checks on a safe road and be careful of the traffic conditions.

1. Drive on straight and flat roads.
2. Stop the vehicle by depressing the brake pedal to generate braking force that stops the vehicle in 3 to 5 seconds.

A  
B  
C  
D  
E  
F  
G  
H  
I  
J  
K  
L  
M  
N  
O

MA

# CHASSIS MAINTENANCE

## < PERIODIC MAINTENANCE >

- Cool the brakes.
- Repeat steps 1 to 3 until the abnormal feel in braking force disappears.

## STEERING GEAR AND LINKAGE

### STEERING GEAR AND LINKAGE : Inspection

INFOID:0000000010640818

#### STEERING GEAR

- Check gear housing and boots for looseness, damage and grease leakage.
- Check connection with steering column for looseness.

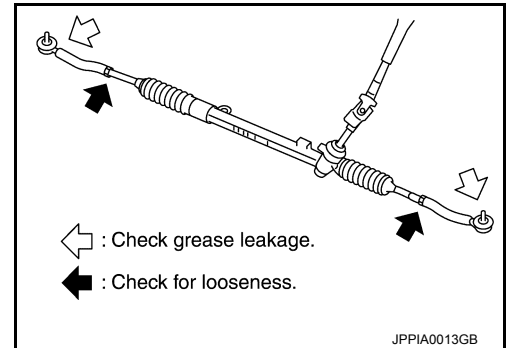

#### STEERING LINKAGE

Check ball joint, dust cover and other component parts for looseness, wear, damage and grease leakage.

## AXLE AND SUSPENSION PARTS

### AXLE AND SUSPENSION PARTS : Inspection

INFOID:0000000010640819

Check front and rear axle and suspension parts for excessive play, cracks, wear or other damage.

- Shake each wheel to check for excessive play.
- Check wheel bearings for smooth operation.
- Check axle and suspension nuts and bolts for looseness.
- Check strut (shock absorber) for oil leakage or other damage.
- Check suspension ball joint for grease leakage and ball joint dust cover for cracks or other damage.

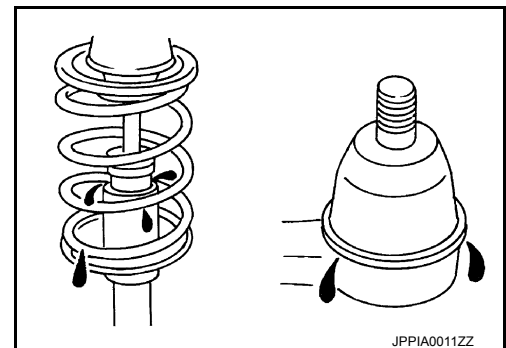
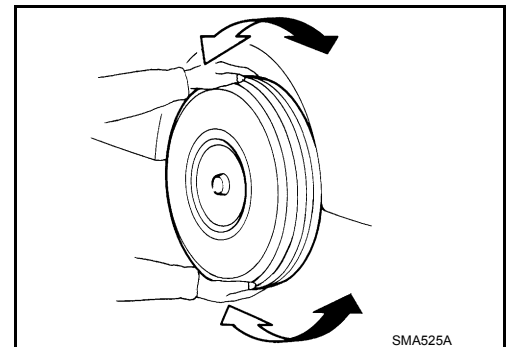

## DRIVE SHAFT



# CHASSIS MAINTENANCE

< PERIODIC MAINTENANCE >

## DRIVE SHAFT : Inspection

INFOID:000000010640820

Check boot and drive shaft for cracks, wear, damage and grease leakage.

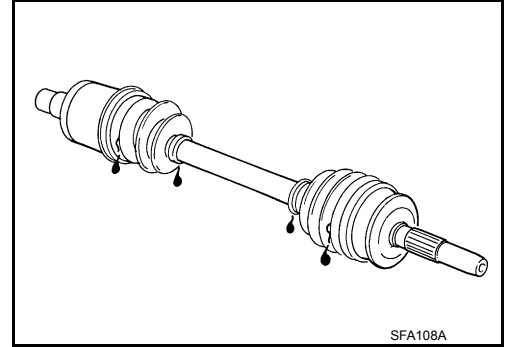

A  
B  
C  
D  
E  
F  
G  
H  
I  
J  
K  
L  
M  
N  
O

MA

# BODY MAINTENANCE

< PERIODIC MAINTENANCE >

## BODY MAINTENANCE

### LOCKS, HINGES AND HOOD LATCH

#### LOCKS, HINGES AND HOOD LATCH : Lubricating

INFOID:000000010640821

For hood and hood lock illustration.

- Hood: Refer to [DLK-155, "Exploded View"](#).
- Hood lock: Refer to [DLK-188, "Exploded View"](#).

For front door and front door lock illustration.

- Front door: Refer to [DLK-171, "Exploded View"](#).
- Front door lock: Refer to [DLK-193, "Exploded View"](#).

For rear door and rear door lock illustration.

- Rear door: Refer to [DLK-176, "Exploded View"](#).
- Rear door lock: Refer to [DLK-197, "Exploded View"](#).

For back door and back door lock illustration.

- Back door: Refer to [DLK-181, "Exploded View"](#).
- Back door lock: Refer to [DLK-201, "Exploded View"](#).

### SEAT BELT, BUCKLES, RETRACTORS, ANCHORS AND ADJUSTERS

#### SEAT BELT, BUCKLES, RETRACTORS, ANCHORS AND ADJUSTERS : Inspection

INFOID:000000010640822

For front seat belt illustration. Refer to [SB-11, "Exploded View"](#).

For rear seat belt illustration. Refer to [SB-16, "Exploded View"](#).

#### **CAUTION:**

- **After any collision, inspect all seat belt assemblies, including retractors and other attached hardware (i.e. anchor bolt, guide rail set). Nissan recommends to replace all seat belt assemblies in use during a collision, unless not damaged and properly operating after minor collision.**

**Also inspect seat belt assemblies not in use during a collision, and replace if damaged or improperly operating.**

**Seat belt pre-tensioner should be replaced even if the seat belts are not in use during a frontal collision where the driver and passenger air bags are deployed.**

- **If any component of seat belt assembly is questionable, do not repair.**

**Replace as seat belt assembly.**

- **If webbing is cut, frayed, or damaged, replace belt assembly.**
- **Never oil tongue and buckle.**
- **Use a genuine NISSAN seat belt assembly.**

For details, refer to [SB-6, "Inspection"](#) in SB section.

- Check anchors for loose mounting
- Check belts for damage
- Check retractor for smooth operation
- Check function of buckles and tongues when buckled and released

### BODY CORROSION

#### BODY CORROSION : Checking Body Corrosion

INFOID:000000010640823

Visually check body panels for collision damage (scratches, chipping, rubbing, etc.) or damage to the anti-corrosion materials. In particular, check the following locations.

#### HEMMED PANELS

Hood front end, door lower end, trunk lid rear end, etc.

#### PANEL JOINT

Side sill of rear fender and center pillar, rear wheel housing of rear fender, around strut tower in engine compartment, etc.

#### PANEL EDGE

Trunk lid opening, sunroof opening, fender wheel-arch flange, charge port lid flange, around holes in panel, etc.

#### PARTS CONTACT

Waist moulding, windshield moulding, bumper, etc.

# BODY MAINTENANCE

## < PERIODIC MAINTENANCE >

---

### PROTECTORS

Damage or condition of mudguard, fender protector, chipping protector, etc.

A

### ANTI-CORROSION MATERIALS

Damage or separation of anti-corrosion materials under the body.

B

### DRAIN HOLES

Condition of drain holes at door and side sill. When repairing corroded areas, refer to the Corrosion Repair Manual.

C

D

E

F

G

H

I

J

K

L

M

N

O

MA

## SERVICE DATA AND SPECIFICATIONS (SDS)

< SERVICE DATA AND SPECIFICATIONS (SDS)

## SERVICE DATA AND SPECIFICATIONS (SDS)

SERVICE DATA AND SPECIFICATIONS (SDS)

COOLANT

COOLANT : Periodical Maintenance Specification

INFOID:0000000010640824

COOLANT CAPACITY (APPROXIMATE)

Unit: ℓ (US qt, Imp qt)

|   |                    |
|---|--------------------|
| Coolant capacity (With reservoir tank at "MAX" level) | 5.3 (5-5/8, 4-5/8) |
| Reservoir tank coolant capacity (At "MAX" level)      | 0.5 (4/8, 4/8)     |

RESERVOIR TANK CAP

Unit: kPa (kg/cm<sup>2</sup>, psi)

|                     |                                |
|---------------------|--------------------------------|
| Cap relief pressure | 24 - 36 (0.2 - 0.3, 3.5 - 5.2) |
|---------------------|--------------------------------|

RADIATOR

Unit: kPa (kg/cm<sup>2</sup>, psi)

|                          |              |
|--------------------------|--------------|
| Leakage testing pressure | 32 ( 0.3, 5) |
|--------------------------|--------------|

ROAD WHEEL

ROAD WHEEL : Road Wheel

INFOID:0000000010640825

| Item                |                     | Limit                              |
|---------------------|---------------------|------------------------------------|
| Runout              | Axial runout        | Less than 0.3 mm (0.012 in)        |
|                     | Radial runout       |                                    |
| Allowable unbalance | Dynamic (At flange) | Less than 5 g (0.17 oz) (one side) |
|                     | Static (At flange)  | Less than 10 g (0.35 oz)           |