

A  
B  
C  
D  
E

# SECTION **PB**

## PARKING BRAKE SYSTEM

### CONTENTS

|   |  |           |
|---|--|-----------|
| <b>PRECAUTION</b> ..... 2   | <b>REMOVAL AND INSTALLATION</b> ..... 8              | <b>PB</b> |
| <b>PRECAUTIONS</b> ..... 2  | <b>PARKING BRAKE CONTROL</b> ..... 8                 |           |
| Precaution for Technicians Using Medical Electric.....2   | Exploded View ..... 8                                | G         |
| Precaution for Supplemental Restraint System (SRS) "AIR BAG" and "SEAT BELT PRE-TENSIONER" .....2 | Removal and Installation ..... 8                     |           |
| Point to Be Checked Before Starting Maintenance Work .....3                                       | Adjustment ..... 8                                   |           |
| Precaution for Removing 12V Battery .....3  | <b>PARKING BRAKE CABLE</b> ..... 9                   | H         |
| Precaution for Parking Brake System .....3  | Removal and Installation ..... 9                     |           |
| Precaution for Harness Repair .....4  | <b>PARKING BRAKE REAR CABLE</b> .....10              | I         |
| <b>PREPARATION</b> ..... 5  | Removal and Installation .....10                     |           |
| <b>PREPARATION</b> ..... 5  | <b>PARKING BRAKE SHOE</b> .....12                    | J         |
| Commercial Service Tools .....5   | Exploded View .....12                                |           |
| <b>PERIODIC MAINTENANCE</b> ..... 6   | Removal and Installation .....12                     |           |
| <b>PARKING BRAKE SYSTEM</b> ..... 6   | Inspection and Adjustment .....14                    | K         |
| Inspection .....6   | <b>PARKING BRAKE SWITCH</b> .....15                  |           |
| Adjustment .....6   | Removal and Installation .....15                     |           |
| <b>PARKING BRAKE SHOE</b> ..... 7   | <b>SERVICE DATA AND SPECIFICATIONS (SDS)</b> .....16 | L         |
| Inspection .....7   | <b>SERVICE DATA AND SPECIFICATIONS (SDS)</b> .....16 | M         |
| Break-in Procedure .....7   | Parking Drum Brake .....16                           |           |
|   | Parking Brake Control .....16                        | N         |
|   |  | O         |
|   |  | P         |

# PRECAUTIONS

< PRECAUTION >

## PRECAUTION

### PRECAUTIONS

#### Precaution for Technicians Using Medical Electric

INFOID:000000010641121

##### OPERATION PROHIBITION

###### **WARNING:**

- Parts with strong magnet is used in this vehicle.
- Technicians using a medical electric device such as pacemaker must never perform operation on the vehicle, as magnetic field can affect the device function by approaching to such parts.

##### NORMAL CHARGE PRECAUTION

###### **WARNING:**

- If a technician uses a medical electric device such as an implantable cardiac pacemaker or an implantable cardioverter defibrillator, the possible effects on the devices must be checked with the device manufacturer before starting the charge operation.
- As radiated electromagnetic wave generated by PDM (Power Delivery Module) at normal charge operation may affect medical electric devices, a technician using a medical electric device such as implantable cardiac pacemaker or an implantable cardioverter defibrillator must not approach motor room [PDM (Power Delivery Module)] at the hood-opened condition during normal charge operation.

##### PRECAUTION AT TELEMATICS SYSTEM OPERATION

###### **WARNING:**

- If a technician uses implantable cardiac pacemaker or implantable cardioverter defibrillator (ICD), avoid the device implanted part from approaching within approximately 220 mm (8.66 in) from interior/exterior antenna.
- The electromagnetic wave of TCU might affect the function of the implantable cardiac pacemaker or the implantable cardioverter defibrillator (ICD), when using the service, etc.
- If a technician uses other medical electric devices than implantable cardiac pacemaker or implantable cardioverter defibrillator (ICD), the electromagnetic wave of TCU might affect the function of the device. The possible effects on the devices must be checked with the device manufacturer before TCU use.

##### PRECAUTION AT INTELLIGENT KEY SYSTEM OPERATION

###### **WARNING:**

- If a technician uses implantable cardiac pacemaker or implantable cardioverter defibrillator (ICD), avoid the device implanted part from approaching within approximately 220 mm (8.66 in) from interior/exterior antenna.
- The electromagnetic wave of Intelligent Key might affect the function of the implantable cardiac pacemaker or the implantable cardioverter defibrillator (ICD), at door operation, at each request switch operation, or at engine starting.
- If a technician uses other medical electric devices than implantable cardiac pacemaker or implantable cardioverter defibrillator (ICD), the electromagnetic wave of Intelligent Key might affect the function of the device. The possible effects on the devices must be checked with the device manufacturer before Intelligent Key use.

#### Precaution for Supplemental Restraint System (SRS) "AIR BAG" and "SEAT BELT PRE-TENSIONER"

INFOID:000000010641122

The Supplemental Restraint System such as "AIR BAG" and "SEAT BELT PRE-TENSIONER", used along with a front seat belt, helps to reduce the risk or severity of injury to the driver and front passenger for certain types of collision. This system includes seat belt switch inputs and dual stage front air bag modules. The SRS system uses the seat belt switches to determine the front air bag deployment, and may only deploy one front air bag, depending on the severity of a collision and whether the front occupants are belted or unbelted. Information necessary to service the system safely is included in the SR and SB section of this Service Manual.

###### **WARNING:**

# PRECAUTIONS

## < PRECAUTION >

- To avoid rendering the SRS inoperative, which could increase the risk of personal injury or death in the event of a collision which would result in air bag inflation, all maintenance must be performed by an authorized NISSAN/INFINITI dealer.
- Improper maintenance, including incorrect removal and installation of the SRS, can lead to personal injury caused by unintentional activation of the system. For removal of Spiral Cable and Air Bag Module, see the SR section.
- Do not use electrical test equipment on any circuit related to the SRS unless instructed to in this Service Manual. SRS wiring harnesses can be identified by yellow and/or orange harnesses or harness connectors.

## PRECAUTIONS WHEN USING POWER TOOLS (AIR OR ELECTRIC) AND HAMMERS

### WARNING:

- When working near the Airbag Diagnosis Sensor Unit or other Airbag System sensors with the Ignition ON or engine running, DO NOT use air or electric power tools or strike near the sensor(s) with a hammer. Heavy vibration could activate the sensor(s) and deploy the air bag(s), possibly causing serious injury.
- When using air or electric power tools or hammers, always switch the Ignition OFF, disconnect the battery and wait at least three minutes before performing any service.

## Point to Be Checked Before Starting Maintenance Work

INFOID:000000010641123

The high voltage system may start automatically. It is required to check that the timer air conditioner and timer charge (during EVSE connection) are not set before starting maintenance work.

### NOTE:

If the timer air conditioner or timer charge (during EVSE connection) is set, the high voltage system starts automatically even when the power switch is in OFF state.

## Precaution for Removing 12V Battery

INFOID:000000010641124

1. Check that EVSE is not connected.

### NOTE:

If EVSE is connected, the air conditioning system may be automatically activated by the timer A/C function.

2. Turn the power switch OFF → ON → OFF. Get out of the vehicle. Close all doors (including back door).
3. Check that the charge status indicator lamp does not blink and wait for 5 minutes or more.

### NOTE:

If the battery is removed within 5 minutes after the power switch is turned OFF, plural DTCs may be detected.

4. Remove 12V battery within 1 hour after turning the power switch OFF → ON → OFF.

### NOTE:

- The 12V battery automatic charge control may start automatically even when the power switch is in OFF state.
- Once the power switch is turned ON → OFF, the 12V battery automatic charge control does not start for approximately 1 hour.

### CAUTION:

- After all doors (including back door) are closed, if a door (including back door) is opened before battery terminals are disconnected, start over from Step 1.
- After turning the power switch OFF, if "Remote A/C" is activated by user operation, stop the air conditioner and start over from Step 1.

## Precaution for Parking Brake System

INFOID:000000010641125

### WARNING:

Since dust covering the parking brake shoes and back plates has an effect on human body, the dust must be removed with a dust collector. Never splatter the dust with an air blow gun.

### CAUTION:

When vehicle is parked, press the select lever P range position switch into the P range.

- When parking brake shoe is ground or replaced, perform break-in operation. Refer to [PB-14. "Inspection and Adjustment"](#).

# PRECAUTIONS

## < PRECAUTION >

### Precaution for Harness Repair

INFOID:000000010641126

- Solder the repair part, and wrap it with tape. [Twisted wire fray must be 110 mm (4.33 in) or less.]

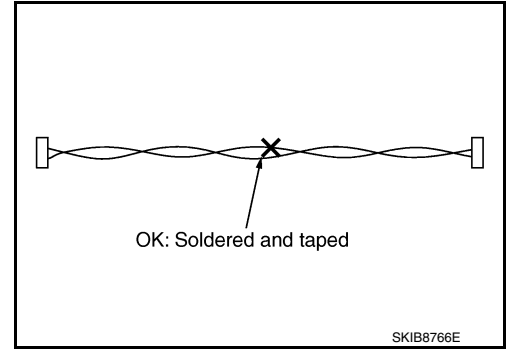

- Never bypass the repair point with wire. (If it is bypassed, the turnout point cannot be separated and the twisted wire characteristics are lost.)

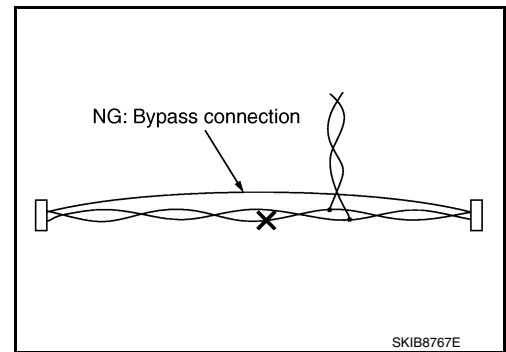

# PREPARATION



< PREPARATION >

## PREPARATION

### PREPARATION

#### Commercial Service Tools

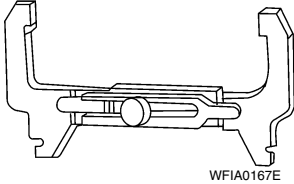
INFOID:0000000010641127

| Tool name  | Description                              |
|--|--|
| Brake drum clearance gauge<br><br>WFIA0167E | Measuring rear rotor drum inner diameter |
| Power tool<br><br>PIIB1407E                 | Loosening nuts, screws and bolts         |

A

B

C

D

E

PB

G

H

I

J

K

L

M

N

O

P

# PARKING BRAKE SYSTEM

< PERIODIC MAINTENANCE >

## PERIODIC MAINTENANCE

### PARKING BRAKE SYSTEM

#### Inspection

INFOID:000000010641128

#### INSPECT COMPONENTS

- Make sure that the mounting conditions (looseness, backlash, etc.) of each component are normal.
- Check the following:
  - Device assembly for bend, damage and cracks. Replace if necessary.
  - Cables and equalizer for wear and damage. Replace if necessary.
  - Parking brake switch. Replace if necessary.

#### PEDAL STROKE

1. Operate parking brake pedal with a force of 196 N (20.0 kg-f, 44.1 lb-f), make sure pedal stroke is within the specified number of notches. (Check it by listening and counting ratchet clicks.)

**Pedal stroke number of notches** : Refer to [PB-16, "Parking Brake Control"](#).

2. When brake warning lamp turns ON, check that the pedal stroke is within the specified number of notches. (Check it by listening to the clicks of the ratchet.)

#### Standard

**Number of notches** : Refer to [PB-16, "Parking Brake Control"](#).

#### Adjustment

INFOID:000000010641129

#### ADJUSTMENT

1. Remove rear wheels and tires using power tool. Refer to [WT-45, "Removal and Installation"](#).
2. Insert a deep socket wrench onto adjusting nut. Rotate adjusting nut to fully loosen cable, and then release parking brake pedal.
3. Secure both disc rotors to hubs using wheel nuts so as not to tilt the disc rotors.
4. Remove both adjuster hole plugs installed on the disc rotors. Turn the adjuster (1) in direction (A) using a suitable tool as shown, until disc rotors are locked. Turn the adjusters in the opposite direction by 7 notches after locking.
5. Rotate the disc rotors to make sure that there is no drag. Install the adjuster hole plugs.
6. Adjust parking brake cable with the following procedure.
  - a. Rotate the adjusting nut to adjust parking brake pedal operating force to 500 N (51.0 kg-f, 112.4 lb-f) just before a full pedal stroke of 217.13 mm (8.55 in).

#### CAUTION:

**Do not reuse adjusting nut after removing it.**

- b. When replacing parking brake cable, operate parking brake pedal 10 or more times with a full stroke of 217.13 mm (8.55 in).
- c. Release the parking brake pedal and rotate the disc rotors to make sure there is no drag.
- d. Rotate the adjusting nut to adjust the parking brake pedal force to 196 N (20.0 kg-f, 44.1 lb-f) when the parking brake pedal stroke is within the specified number of notches. (check it by listening and counting the ratchet clicks).

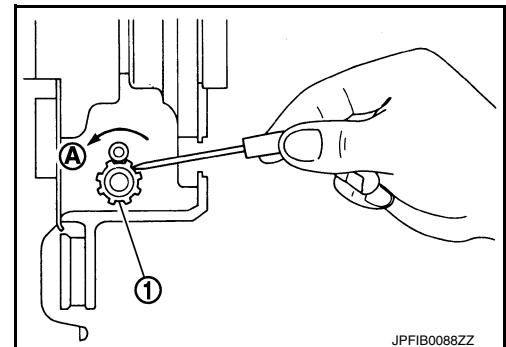

JPFIB008BZZ

**Pedal stroke number of notches** : Refer to [PB-16, "Parking Brake Control"](#)

7. Install rear wheels and tires. Refer to [WT-45, "Exploded View"](#).

# PARKING BRAKE SHOE

< PERIODIC MAINTENANCE >

## PARKING BRAKE SHOE

### Inspection

INFOID:0000000010641130

#### LINING THICKNESS INSPECTION

- Check thickness of lining.

**Wear limit thickness (A)** : Refer to [PB-16, "Parking Drum Brake"](#).

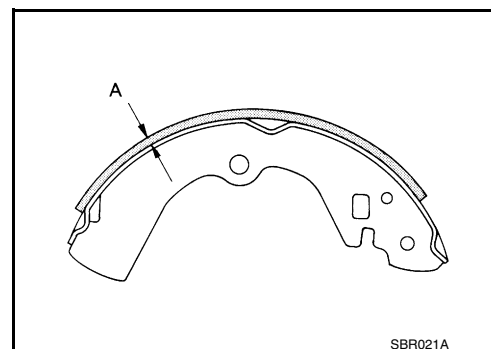

#### DRUM INNER DIAMETER INSPECTION

- Check inner diameter of drum in rear disc rotor using a suitable tool.

**Wear limit of inner diameter** : Refer to [PB-16, "Parking Drum Brake"](#).

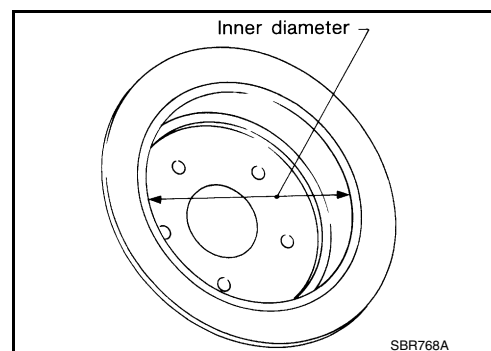

#### OTHER INSPECTIONS

- Check the following:
  - Lining for excessive wear, damage, and peeling.
  - Shoe sliding surface for excessive wear and damage.
  - Anti-rattle pin for excessive wear and corrosion.
  - Return spring for sagging.
- Make sure that adjuster moves smoothly.
- Visually check the inside of drum for excessive wear, cracks, and damage.
- Replace with new parts as necessary.

#### Break-in Procedure

INFOID:0000000010641131

1. Perform parking brake break-in (drag run) operation by driving vehicle under the following conditions:
  - Drive the vehicle forward.
  - Maintain vehicle speed at approximately 40 km/h (25 MPH) keeping it constant in forward direction.
  - Apply the parking brake at the constant operating force specified. Approximately 200+49.0 Nm (20.4+5 kg-f, 45+11 lb-f).
  - Release the parking brake after approximately 5+5/-0 seconds.

**CAUTION:**

To prevent lining from getting too hot, allow a cool off period of approximately 5 minutes after every break-in operation.

2. Check parking brake control device assembly stroke.

**CAUTION:**

Readjust as necessary if it is outside the standard specifications. Refer to [PB-6, "Adjustment"](#).

# PARKING BRAKE CONTROL

< REMOVAL AND INSTALLATION >

## REMOVAL AND INSTALLATION

### PARKING BRAKE CONTROL

Exploded View

INFOID:000000010641132

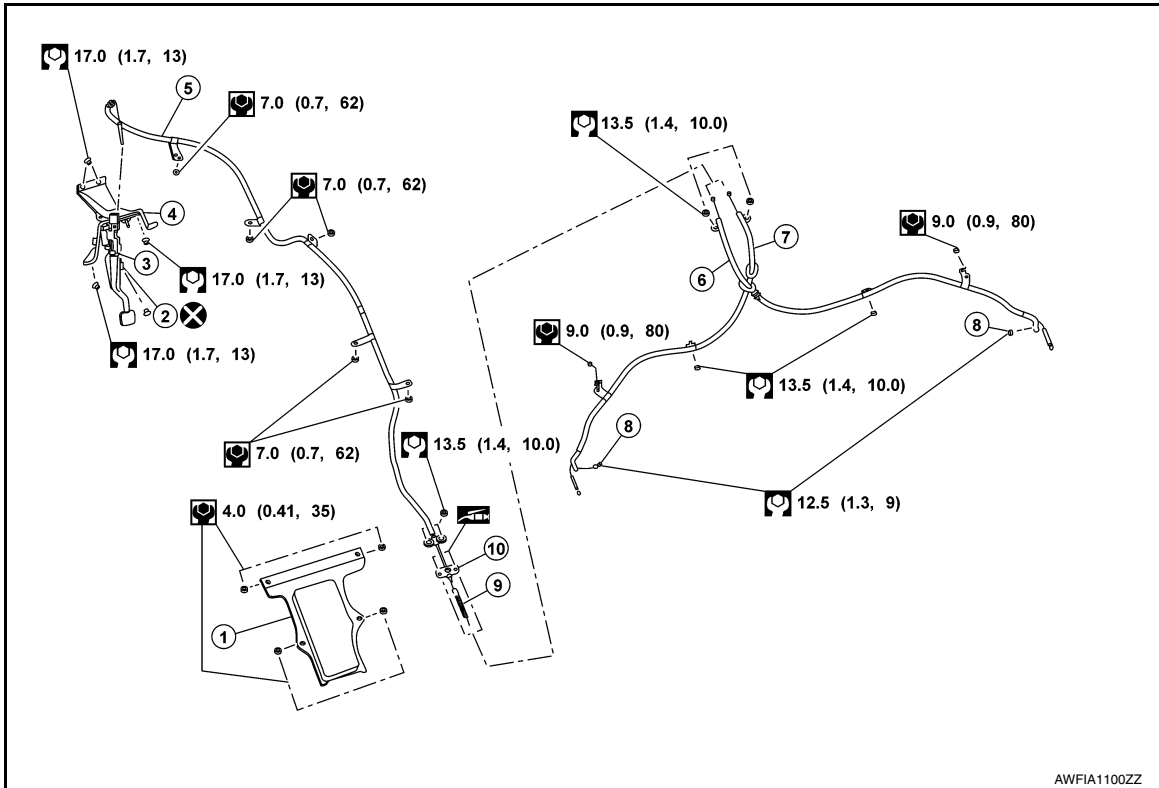

- |                                  |                                   |  |
|----------------------------------|-----------------------------------|--|
| 1. Equalizer cover               | 2. Adjusting nut                  | 3. Parking brake switch  |
| 4. Parking brake control         | 5. Front parking brake cable      | 6. Rear parking brake cable (RH)   |
| 7. Rear parking brake cable (LH) | 8. Rear parking brake cable bolts | 9. Return spring   |
| 10. Equalizer                    |                                   |  Apply multi-purpose grease |

## Removal and Installation

INFOID:000000010641133

### REMOVAL

1. Remove instrument lower panel LH. Refer to [IP-16, "Exploded View"](#).
2. Disconnect the harness connector from the parking brake switch.
3. Remove adjusting nut from the front parking brake cable.
4. Remove parking brake control nuts and lower parking brake control.
5. Remove front cable from parking brake control and remove parking brake control.

### INSTALLATION

Installation is in the reverse order of the removal.

- Adjust the parking brake. Refer to [PB-6, "Adjustment"](#).

### CAUTION:

**Do not reuse the adjusting nut.**

## Adjustment

INFOID:000000010641134

### ADJUSTMENT AFTER INSTALLATION

Adjust the parking brake pedal stroke. Refer to [PB-6, "Adjustment"](#).



# PARKING BRAKE CABLE

< REMOVAL AND INSTALLATION >

## PARKING BRAKE CABLE

### Removal and Installation

INFOID:000000010641135

#### REMOVAL

1. Remove instrument lower panel LH. Refer to [IP-16, "Exploded View"](#).
2. Remove adjusting nut and front cable from parking brake control. Refer to [PB-8, "Exploded View"](#).
3. Remove dash side finisher (LH). Refer to [INT-29, "DASH SIDE FINISHER : Removal and Installation"](#).
4. Remove center pillar lower garnish (LH). Refer to [INT-30, "CENTER PILLAR LOWER GARNISH : Removal and Installation"](#).
5. Remove center console. Refer to [IP-28, "Removal and Installation"](#).
6. Remove the shift selector. Refer to [TM-121, "Exploded View"](#).
7. Remove the diagnosis control unit. Refer to [SR-38, "Removal and Installation"](#).
8. Remove front seat (LH). Refer to [SE-29, "Removal and Installation"](#).
9. Remove rear seat cushion. Refer to [SE-40, "SEAT CUSHION : Removal and Installation"](#).
10. Remove equalizer cover. Refer to [PB-8, "Exploded View"](#).
11. Remove service plug access cover.
12. Position (LH) carpet aside.
13. Remove the rear foot duct (2) (LH). Refer to [VTL-19, "REAR FOOT DUCT 1 : Removal and Installation - LH"](#).
14. Remove the front floor spacer (LH). Refer to [INT-33, "Exploded View"](#).
15. Remove service plug access cover bracket bolts (A) and cover bracket (1).

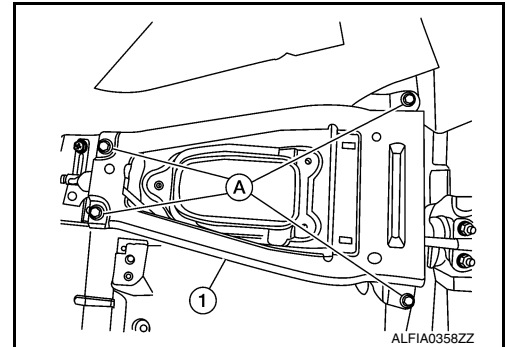

16. Remove rear parking brake cables from equalizer. Refer to [PB-8, "Exploded View"](#).
17. Remove front parking brake cable nuts and remove the front parking brake cable. Refer to [PB-8, "Exploded View"](#).

#### INSTALLATION

Installation is in the reverse order of removal.

- Adjust the parking brake. Refer to [PB-8, "Adjustment"](#).

#### **CAUTION:**

**Do not reuse the adjusting nut.**

# PARKING BRAKE REAR CABLE

< REMOVAL AND INSTALLATION >

## PARKING BRAKE REAR CABLE

### Removal and Installation

INFOID:000000010641136

#### REMOVAL

1. Loosen the adjusting nut. Refer to [PB-8, "Exploded View"](#).
2. Remove rear seat cushion. Refer to [SE-40, "SEAT CUSHION : Removal and Installation"](#).
3. Remove the equalizer cover. Refer to [PB-8, "Exploded View"](#).
4. Remove return spring (A) from equalizer (B).

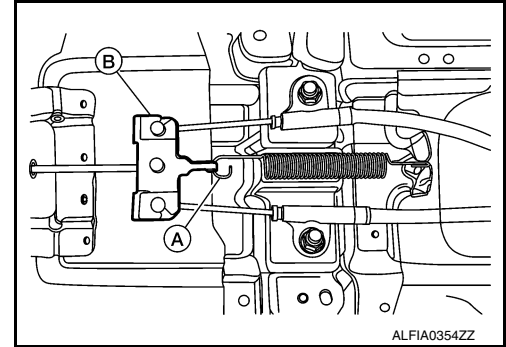

5. Remove rear parking brake cable nuts. Refer to [PB-8, "Exploded View"](#).

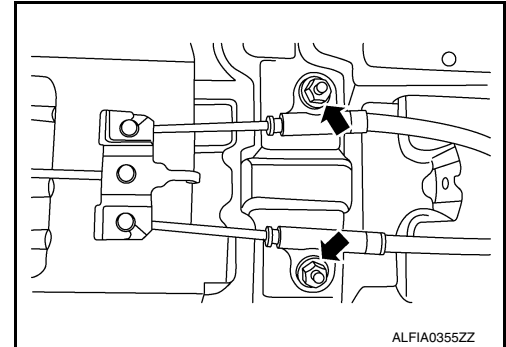

6. Remove rear parking brake cables from the equalizer. Refer to [PB-8, "Exploded View"](#).
7. Remove rear wheels and tires using power tool. Refer to [WT-45, "Exploded View"](#).
8. Remove the rear calipers and torque members, hang with suitable wire. Refer to [BR-525, "BRAKE CALIPER ASSEMBLY : Exploded View"](#).
9. Remove disc rotor. If disc rotor cannot be removed, remove as follows.

#### **CAUTION:**

- Parking brake completely in the released position.
  - Put matching marks (A) on the wheel hub assembly and the disc rotor before removing the disc rotor.
  - Never drop disc rotor.
- a. Fix the disc rotor with wheel nuts and remove the adjusting hole plug.

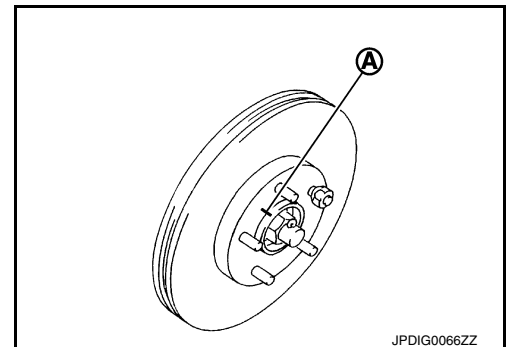

## PARKING BRAKE REAR CABLE

### < REMOVAL AND INSTALLATION >

- b. Using suitable tool, rotate adjuster (1) in the direction (A) to retract and loosen brake shoe.
- c. Remove disc rotor.

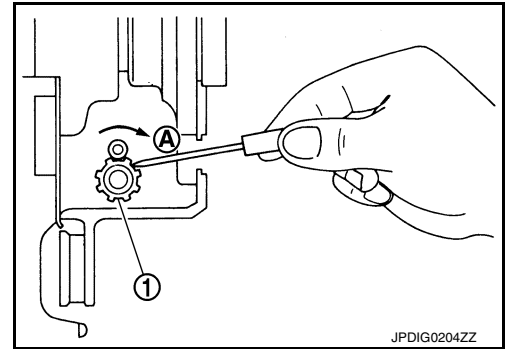

10. Remove parking brake shoe, and remove rear cable from toggle lever. Refer to [PB-12, "Exploded View"](#).
11. Remove rear cable bolts, nuts, and rear cable from vehicle. Refer to [PB-8, "Exploded View"](#).

### INSTALLATION

Installation is in the reverse order of removal.

- Adjust the parking brake. Refer to [PB-6, "Adjustment"](#).

#### **CAUTION:**

**Do not reuse the adjusting nut.**

#### **NOTE:**

Be sure to install rear parking brake cables through the vehicle correctly. Refer to [PB-8, "Exploded View"](#).

A  
B  
C  
D  
E  
PB  
G  
H  
I  
J  
K  
L  
M  
N  
O  
P

# PARKING BRAKE SHOE

< REMOVAL AND INSTALLATION >

## PARKING BRAKE SHOE

Exploded View

INFOID:000000010641137

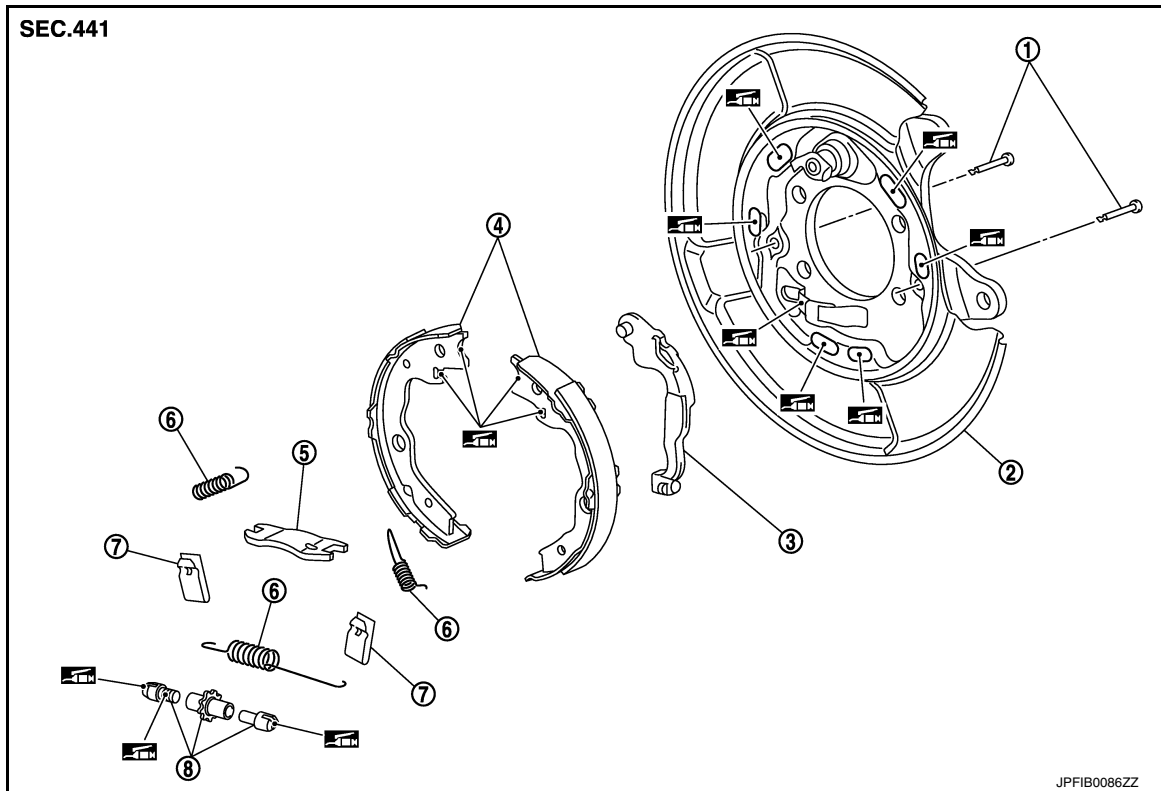

- |                       |                |                  |
|-----------------------|----------------|------------------|
| 1. Anti-rattle pin    | 2. Back plate  | 3. Toggle lever  |
| 4. Parking brake shoe | 5. Brake strut | 6. Return spring |
| 7. Spring             | 8. Adjuster    |                  |

 Apply PBC (Poly Butyl Cuprysil) grease or silicone-based grease.

## Removal and Installation

INFOID:000000010641138

### REMOVAL

#### **WARNING:**

Since dust covering the parking brake shoes and back plates has an affect on human body, the dust must be removed with a dust collector. Do not splatter the dust with an air blow gun.

1. Remove rear wheels and tires using power tool. Refer to [WT-45, "Removal and Installation"](#).
2. Remove the rear brake calipers and torque members, hang with suitable wire. Refer to [BR-525, "BRAKE CALIPER ASSEMBLY : Exploded View"](#).

#### **CAUTION:**

**Do not depress brake pedal while brake caliper is removed.**

3. Remove disc rotor. If disc rotor cannot be removed, remove as follows.

#### **CAUTION:**

- Parking brake completely in the released position.

# PARKING BRAKE SHOE

## < REMOVAL AND INSTALLATION >

- Put matching marks (A) on the wheel hub assembly and the disc rotor before removing the disc rotor.
- Do not drop disc rotor.

a. Fix the disc rotor with wheel nuts and remove the adjusting hole plug.

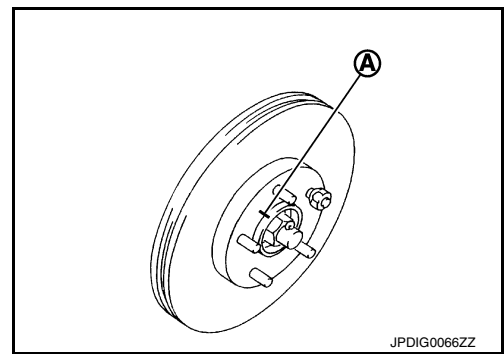

b. Using suitable tool, rotate adjuster (1) in the direction (A) to retract and loosen brake shoe.

c. Remove disc rotor.

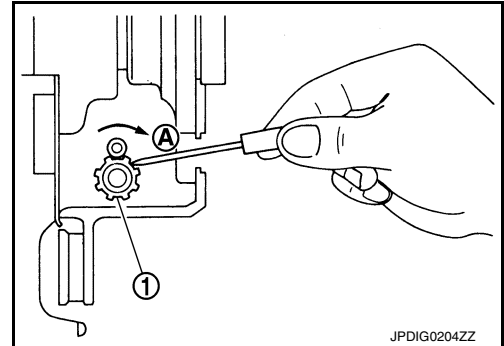

4. Remove return spring (1) of the upper side.

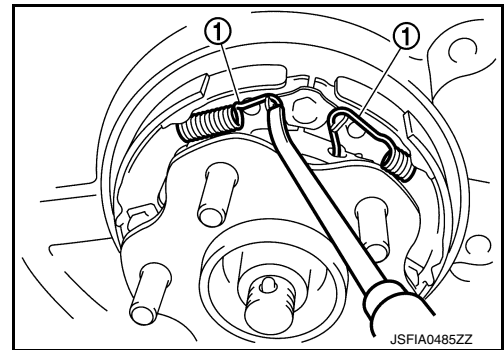

5. Remove return spring (1) of the lower side.

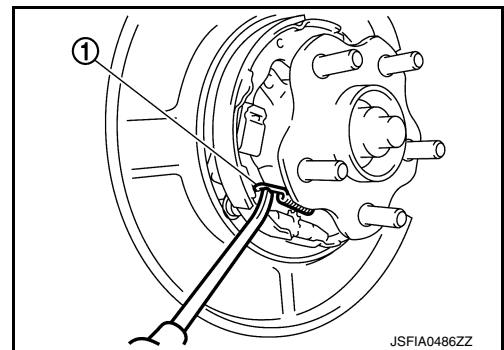

6. Remove spring (1) and anti-rattle pin.

**CAUTION:**  
To prevent damage to the parts, do not drop the removed parts.

7. Remove parking brake shoes, adjuster, brake strut and toggle lever.

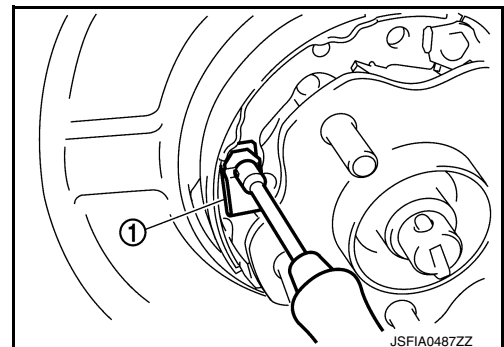

# PARKING BRAKE SHOE

## < REMOVAL AND INSTALLATION >

8. Press the rear cable spring (1) against spring tension to remove rear cable (3) from the clamp (A) of toggle lever (2).

**CAUTION:**

**To prevent damage to the parts, do not bend rear cable.**

9. For the removal of back plate. Refer to [RAX-7, "Removal and Installation"](#).

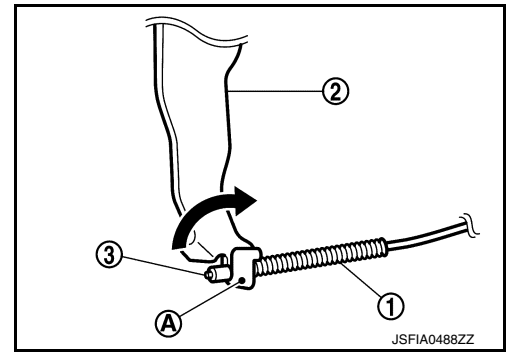

## INSTALLATION

Installation is in the reverse order of removal.

- Apply PBC (Poly Butyl Cuprysil) grease or silicone-based grease to the back plate and brake shoe.
- Assemble adjusters so that threaded part is expanded when rotating it in the direction shown by arrow.

A : For right side brake

B : For left side brake

⇐: Front

◀: Adjuster expands

- Shorten adjuster by rotating it.
- When disassembling apply PBC (Poly Butyl Cuprysil) grease or silicone-based grease to threads.

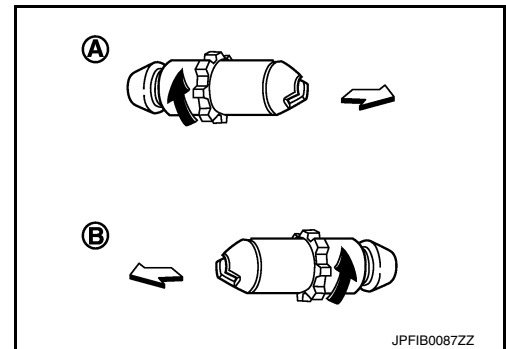

- Check that the component parts of the parking brake shoe are properly installed.
- Check brake shoe sliding surface and drum inner surface for grease. Wipe it off if it adhere on the surfaces.

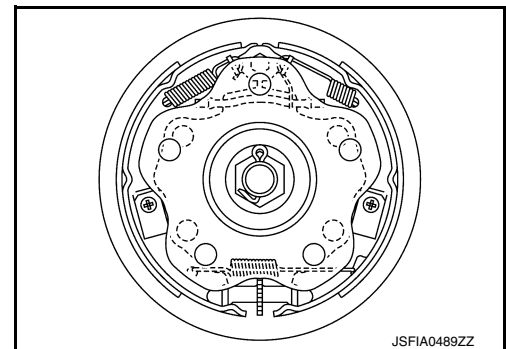

## Inspection and Adjustment

INFOID:000000010641139

### INSPECTION AFTER REMOVAL

Check the following items, and replace the parts if necessary.

- Lining for excessive wear, damage, and peeling.
- Brake shoe sliding surface for excessive wear and damage.
- Anti-rattle pin for excessive wear, damage and rust.
- Return spring and spring for settling, excessive wear, damage, and rust.
- Adjuster for smoothness.
- Toggle lever and brake strut for excessive wear, damage and rust.
- Visually check inside of the drum for excessive wear, cracks, and damage with a pair of vernier calipers.

### ADJUSTMENT AFTER INSTALLATION

1. Rotate the disc rotor to check that there is no drag. Install the plug. If any drag is found, follow the procedure described below.
  - a. Adjust parking brake. Refer to [PB-6, "Adjustment"](#).
  - b. Check rear disc brake. Refer to [BR-529, "BRAKE CALIPER ASSEMBLY : Inspection"](#).
2. Perform break-in procedure for parking brake shoes. Refer to [PB-7, "Break-in Procedure"](#).

# PARKING BRAKE SWITCH

< REMOVAL AND INSTALLATION >

## PARKING BRAKE SWITCH

### Removal and Installation

INFOID:000000010641140

#### REMOVAL

1. Remove instrument lower panel LH. Refer to [IP-16, "Exploded View"](#).
2. Remove the parking brake control nuts and position parking brake control down. Refer to [PB-8, "Exploded View"](#).
3. Remove the parking brake switch screw.
4. Disconnect the parking brake harness connector and remove the parking brake switch. Refer to [PB-8, "Exploded View"](#).

#### INSTALLATION

Installation is in the reverse order of removal.

A  
B  
C  
D  
E  
G  
H  
I  
J  
K  
L  
M  
N  
O  
P

PB

## SERVICE DATA AND SPECIFICATIONS (SDS)

< SERVICE DATA AND SPECIFICATIONS (SDS)

## SERVICE DATA AND SPECIFICATIONS (SDS)

### SERVICE DATA AND SPECIFICATIONS (SDS)

#### Parking Drum Brake

INFOID:000000010641141

Unit: mm (in)

|              | Item                         | Limit       |
|--------------|------------------------------|-------------|
| Brake lining | Thickness                    | 3.2 (0.126) |
|              | Wear thickness               | 1.5 (0.059) |
| Drum         | Inner diameter               | 172 (6.77)  |
|              | Wear limit of inner diameter | 173 (6.81)  |

#### Parking Brake Control

INFOID:000000010641142

|   |            |
|---|------------|
| Control type  | Foot pedal |
| Number of notches [under force of 196 N (20.0 kg-f, 44.1 lb-f)] | 6 - 7      |
| Number of notches when parking brake warning lamp turns on      | 1          |