

SECTION **PG**

POWER SUPPLY, GROUND & CIRCUIT ELEMENTS

CONTENTS

PRECAUTION	3	FUSE BLOCK - JUNCTION BOX (J/B)	71	A
PRECAUTIONS	3	Terminal Arrangement	71	B
Precaution for Technicians Using Medical Electric.....	3	FUSE, FUSIBLE LINK AND RELAY BOX	72	C
Point to Be Checked Before Starting Maintenance		Terminal Arrangement	72	D
Work	3	IPDM E/R (INTELLIGENT POWER DISTRI-		E
High Voltage Precautions	3	BUTION MODULE ENGINE ROOM)	75	F
Precaution for Supplemental Restraint System		IPDM E/R Terminal Arrangement	75	G
(SRS) "AIR BAG" and "SEAT BELT PRE-TEN-		BASIC INSPECTION	76	H
SIONER"	5	12V BATTERY INSPECTION	76	I
Precaution for Removing 12V Battery	6	How to Handle 12V Battery	76	J
Precaution for Power Generation Voltage Variable		Work Flow	76	K
Control System	6	ADDITIONAL SERVICE WHEN REMOVING		L
PREPARATION	7	12V BATTERY NEGATIVE TERMINAL	79	PG
PREPARATION	7	Special Repair Requirement	79	N
Special Service Tools	7	FUSE INSPECTION	80	O
SYSTEM DESCRIPTION	8	Fuse	80	P
ELECTRICAL UNITS LOCATION	8	FUSIBLE LINK INSPECTION	81	
Electrical Units Location	8	Fusible Link	81	
COMPONENT PARTS	12	REMOVAL AND INSTALLATION	82	
Circuit Breaker (Built Into BCM)	12	12V BATTERY	82	
Harness Connector	12	Exploded View	82	
Standardized Relay	15	Removal and Installation	82	
WIRING DIAGRAM	18	BATTERY TRAY	84	
POWER SUPPLY ROUTING CIRCUIT	18	Exploded View	84	
Wiring Diagram — Battery Power Supply —	18	Removal and Installation	84	
Wiring Diagram — Accessory Power Supply —	26	BATTERY TERMINAL WITH FUSIBLE LINK ...	85	
Wiring Diagram—On Power Supply—	29	Exploded View	85	
GROUND	37	Removal and Installation	85	
Ground Distribution	37	BATTERY CURRENT SENSOR	86	
HARNESS	51	Exploded View	86	
Harness Layout	51	Removal and Installation	86	

SERVICE DATA AND SPECIFICATIONS
(SDS) 87

SERVICE DATA AND SPECIFICATIONS
(SDS) 87
 12V Battery 87

PRECAUTIONS

< PRECAUTION >

PRECAUTION

PRECAUTIONS

Precaution for Technicians Using Medical Electric

INFOID:000000010641279

OPERATION PROHIBITION

WARNING:

- Parts with strong magnet is used in this vehicle.
- Technicians using a medical electric device such as pacemaker must never perform operation on the vehicle, as magnetic field can affect the device function by approaching to such parts.

NORMAL CHARGE PRECAUTION

WARNING:

- If a technician uses a medical electric device such as an implantable cardiac pacemaker or an implantable cardioverter defibrillator, the possible effects on the devices must be checked with the device manufacturer before starting the charge operation.
- As radiated electromagnetic wave generated by PDM (Power Delivery Module) at normal charge operation may affect medical electric devices, a technician using a medical electric device such as implantable cardiac pacemaker or an implantable cardioverter defibrillator must not approach motor room [PDM (Power Delivery Module)] at the hood-opened condition during normal charge operation.

PRECAUTION AT TELEMATICS SYSTEM OPERATION

WARNING:

- If a technician uses implantable cardiac pacemaker or implantable cardioverter defibrillator (ICD), avoid the device implanted part from approaching within approximately 220 mm (8.66 in) from interior/exterior antenna.
- The electromagnetic wave of TCU might affect the function of the implantable cardiac pacemaker or the implantable cardioverter defibrillator (ICD), when using the service, etc.
- If a technician uses other medical electric devices than implantable cardiac pacemaker or implantable cardioverter defibrillator (ICD), the electromagnetic wave of TCU might affect the function of the device. The possible effects on the devices must be checked with the device manufacturer before TCU use.

PRECAUTION AT INTELLIGENT KEY SYSTEM OPERATION

WARNING:

- If a technician uses implantable cardiac pacemaker or implantable cardioverter defibrillator (ICD), avoid the device implanted part from approaching within approximately 220 mm (8.66 in) from interior/exterior antenna.
- The electromagnetic wave of Intelligent Key might affect the function of the implantable cardiac pacemaker or the implantable cardioverter defibrillator (ICD), at door operation, at each request switch operation, or at engine starting.
- If a technician uses other medical electric devices than implantable cardiac pacemaker or implantable cardioverter defibrillator (ICD), the electromagnetic wave of Intelligent Key might affect the function of the device. The possible effects on the devices must be checked with the device manufacturer before Intelligent Key use.

Point to Be Checked Before Starting Maintenance Work

INFOID:000000010641280

The high voltage system may starts automatically. It is required to check that the timer air conditioner and timer charge (during EVSE connection) are not set before starting maintenance work.

NOTE:

If the timer air conditioner or timer charge (during EVSE connection) is set, the high voltage system starts automatically even when the power switch is in OFF state.

High Voltage Precautions

INFOID:000000010641281

WARNING:

- Because hybrid vehicles and electric vehicles contain a high voltage battery, there is the risk of electric shock, electric leakage, or similar accidents if the high voltage component and vehicle are han-

A
B
C
D
E
F
G
H
I
J
K
L
PG
N
O
P

PRECAUTIONS

< PRECAUTION >

dled incorrectly. Be sure to follow the correct work procedures when performing inspection and maintenance.

- Be sure to remove the service plug in order to disconnect the high voltage circuits before performing inspection or maintenance of high voltage system harnesses and parts.
- To prevent the removed service plug from being connected by mistake during the procedure, always carry it in your pocket or put it in the tool box.
- Be sure to wear insulating protective equipment before beginning work on the high voltage system.
- Clearly identify the persons responsible for high voltage work and ensure that other persons do not touch the vehicle. When not working, cover high voltage parts with an insulating cover sheet or similar item to prevent other persons from contacting them.

CAUTION:

There is the possibility of a malfunction occurring if the vehicle is changed to READY status while the service plug is removed. Therefore do not change the vehicle to READY status unless instructed to do so in the Service Manual.

HIGH VOLTAGE HARNESS AND EQUIPMENT IDENTIFICATION

The colors of the high voltage harnesses and connectors are all orange. Orange "High Voltage" labels are applied to the Li-ion battery and other high voltage devices. Do not carelessly touch these harnesses and parts.

HANDLING OF HIGH VOLTAGE HARNESS AND TERMINALS

Immediately insulate disconnected high voltage connectors and terminals with insulating tape.

REGULATIONS ON WORKERS WITH MEDICAL ELECTRONICS

WARNING:

The vehicle contains parts that contain powerful magnets. If a person who is wearing a heart pacemaker or other medical device is close to these parts, the medical device may be affected by the magnets. Such persons must not perform work on the vehicle.

PROHIBITED ITEMS TO CARRY DURING THE WORK

Because this vehicle uses components that contain high voltage and powerful magnetism, do not carry any metal products which may cause short circuits, or any magnetic media (cash cards, prepaid cards, etc.) which may be damaged on your person when working.

POSTING A SIGN OF "DANGER! HIGH VOLTAGE AREA. KEEP OUT"

PRECAUTIONS

< PRECAUTION >

To call the attention of other workers, indicate "High voltage work in progress. Do not touch!" on vehicles where work is being performed on the high voltage systems.

Person in charge: _____

DO NOT TOUCH!

REPAIR IN PROGRESS.

HIGH VOLTAGE

DANGER:

DANGER:

HIGH VOLTAGE

REPAIR IN PROGRESS.

DO NOT TOUCH!

Person in charge: _____

Copy this page and put it after folding on the roof of the vehicle in service.

JSAIA1600GB

A
B
C
D
E
F
G
H
I
J
K
L
PG
N
O
P

Precaution for Supplemental Restraint System (SRS) "AIR BAG" and "SEAT BELT PRE-TENSIONER"

INFOID:000000011007779

The Supplemental Restraint System such as "AIR BAG" and "SEAT BELT PRE-TENSIONER", used along with a front seat belt, helps to reduce the risk or severity of injury to the driver and front passenger for certain types of collision. This system includes seat belt switch inputs and dual stage front air bag modules. The SRS

PRECAUTIONS

< PRECAUTION >

system uses the seat belt switches to determine the front air bag deployment, and may only deploy one front air bag, depending on the severity of a collision and whether the front occupants are belted or unbelted. Information necessary to service the system safely is included in the SR and SB section of this Service Manual.

WARNING:

- To avoid rendering the SRS inoperative, which could increase the risk of personal injury or death in the event of a collision which would result in air bag inflation, all maintenance must be performed by an authorized NISSAN/INFINITI dealer.
- Improper maintenance, including incorrect removal and installation of the SRS, can lead to personal injury caused by unintentional activation of the system. For removal of Spiral Cable and Air Bag Module, see the SR section.
- Do not use electrical test equipment on any circuit related to the SRS unless instructed to in this Service Manual. SRS wiring harnesses can be identified by yellow and/or orange harnesses or harness connectors.

PRECAUTIONS WHEN USING POWER TOOLS (AIR OR ELECTRIC) AND HAMMERS

WARNING:

- When working near the Airbag Diagnosis Sensor Unit or other Airbag System sensors with the Ignition ON or engine running, DO NOT use air or electric power tools or strike near the sensor(s) with a hammer. Heavy vibration could activate the sensor(s) and deploy the air bag(s), possibly causing serious injury.
- When using air or electric power tools or hammers, always switch the Ignition OFF, disconnect the battery and wait at least three minutes before performing any service.

Precaution for Removing 12V Battery

INFOID:0000000110641283

1. Check that EVSE is not connected.

NOTE:

If EVSE is connected, the air conditioning system may be automatically activated by the timer A/C function.

2. Turn the power switch OFF → ON → OFF. Get out of the vehicle. Close all doors (including back door).
3. Check that the charge status indicator lamp does not blink and wait for 5 minutes or more.

NOTE:

If the battery is removed within 5 minutes after the power switch is turned OFF, plural DTCs may be detected.

4. Remove 12V battery within 1 hour after turning the power switch OFF → ON → OFF.

NOTE:

- The 12V battery automatic charge control may start automatically even when the power switch is in OFF state.
- Once the power switch is turned ON → OFF, the 12V battery automatic charge control does not start for approximately 1 hour.

CAUTION:

- After all doors (including back door) are closed, if a door (including back door) is opened before battery terminals are disconnected, start over from Step 1.
- After turning the power switch OFF, if “Remote A/C” is activated by user operation, stop the air conditioner and start over from Step 1.

Precaution for Power Generation Voltage Variable Control System

INFOID:000000011007780

CAUTION:

For this model, the battery current sensor that is installed to the battery cable at the negative terminal measures the charging/discharging current of the battery, and performs various controls. If the electrical component or the ground wire is connected directly to the battery terminal, the current other than that being measured with the battery current sensor is charging to or discharging from the battery. This condition causes the malfunction of the control, and then the battery discharge may occur. Do not connect the electrical component or the ground wire directly to the battery terminal.

PREPARATION

< PREPARATION >

PREPARATION

PREPARATION

Special Service Tools

INFOID:0000000010641284

The actual shape of the tools may differ from those illustrated here.

Tool number (TechMate No.) Tool name	Description
— (165-GR8-1200KIT-NI) Nissan battery and electronics tester	Tests batteries, starting and charging systems and charges batteries. For operating instructions, refer to diagnostic station instruction manual.
— (165-EXP-800-NI) Midtronic hand-held battery tester	Tests batteries and charging systems. For operating instructions, refer to diagnostic analyzer instruction manual.

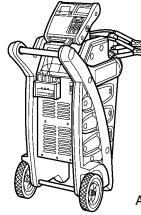

AWIIA1239ZZ

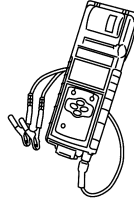

JSMIA0806ZZ

A
B
C
D
E
F
G
H
I
J
K
L
PG
N
O
P

ELECTRICAL UNITS LOCATION

< SYSTEM DESCRIPTION >

SYSTEM DESCRIPTION

ELECTRICAL UNITS LOCATION

Electrical Units Location

INFOID:000000010641296

ENGINE COMPARTMENT

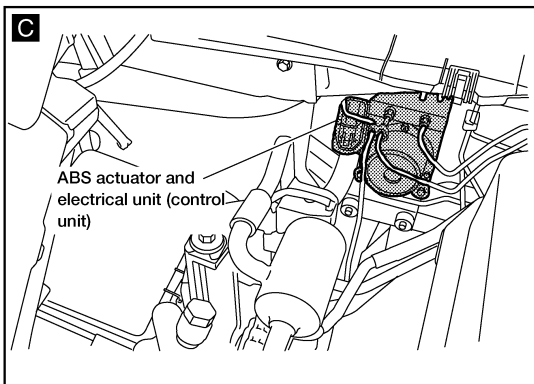
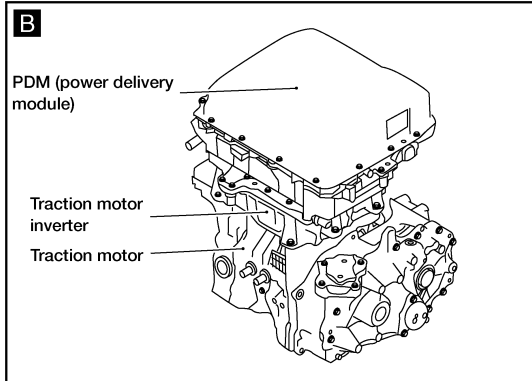
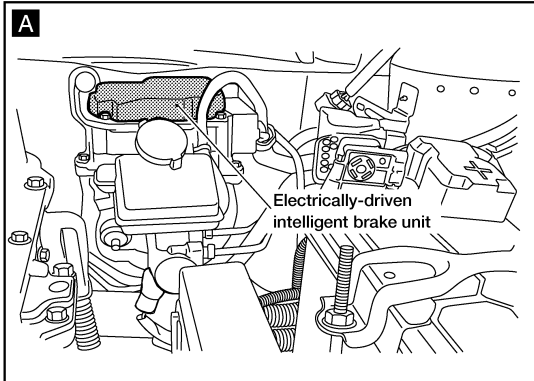
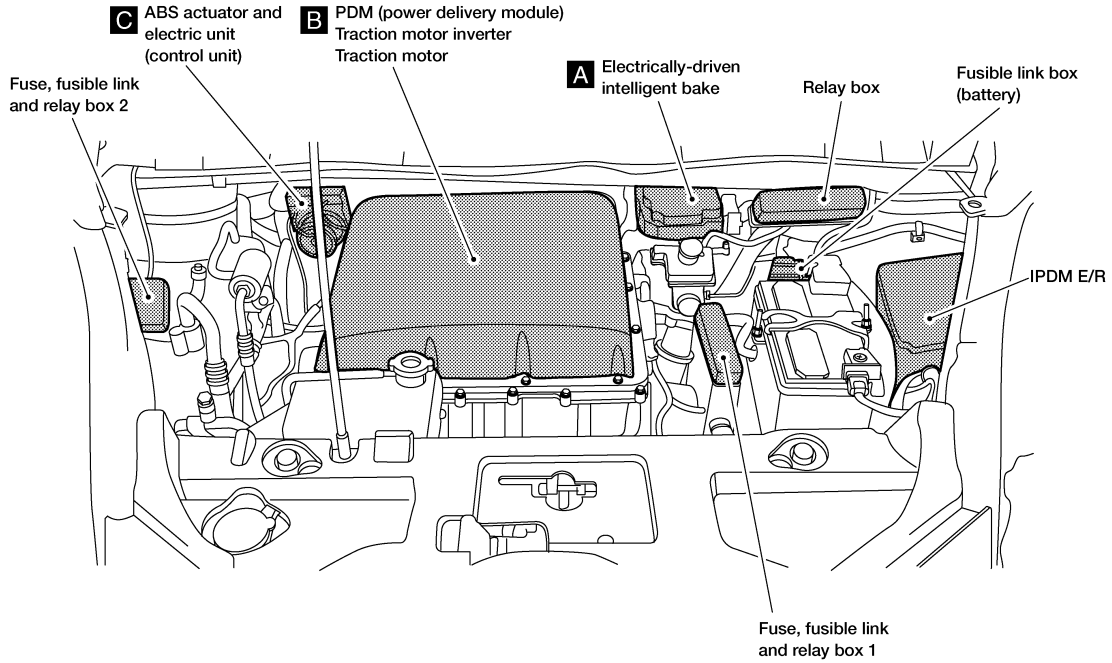

AAMIA2453GB

ELECTRICAL UNITS LOCATION

< SYSTEM DESCRIPTION >

PASSENGER COMPARTMENT

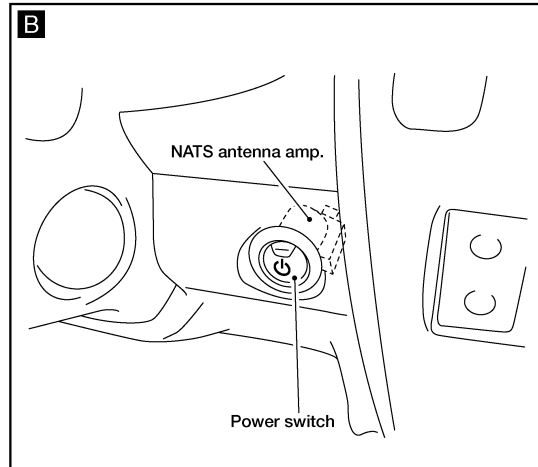
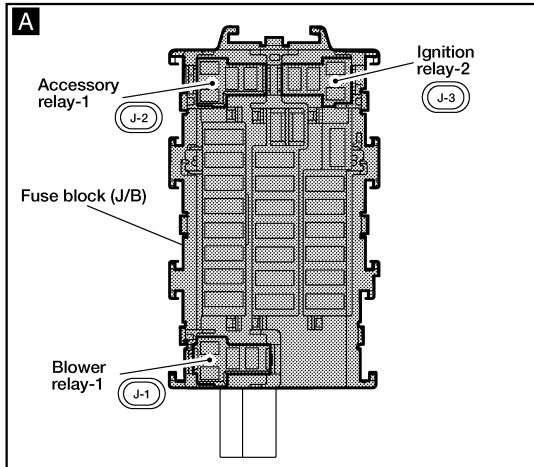
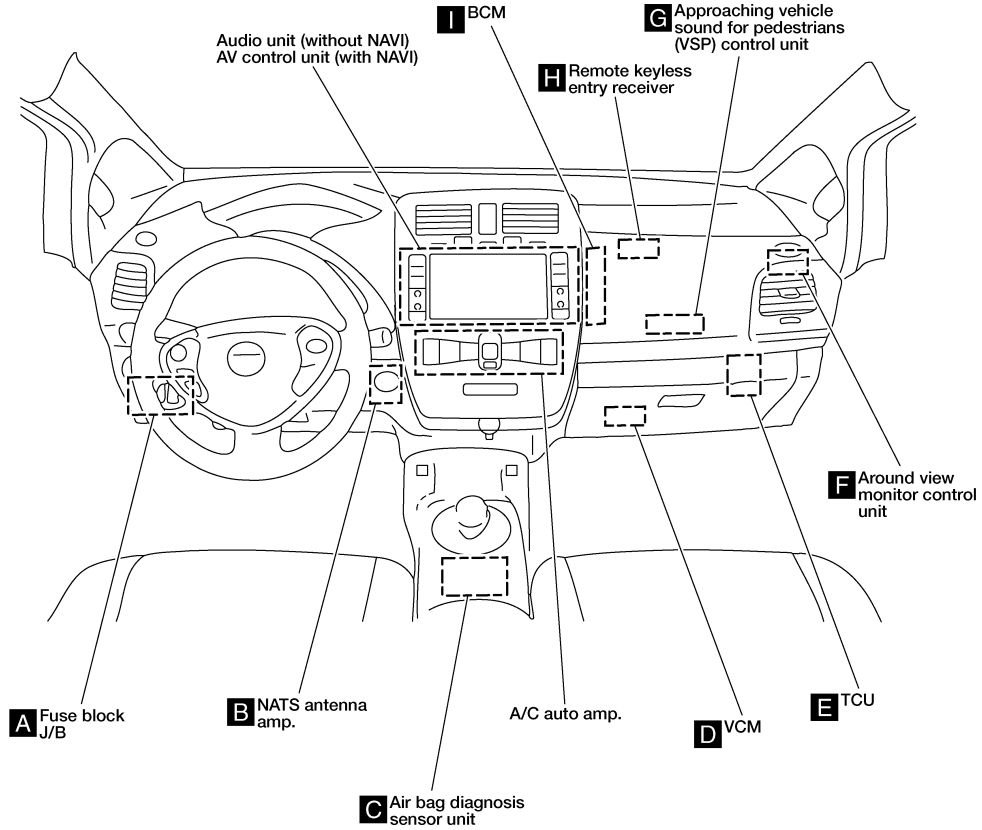

A
B
C
D
E
F
G
H
I
J
K
L
PG
N
O
P

AAMIA2454GB

ELECTRICAL UNITS LOCATION

< SYSTEM DESCRIPTION >

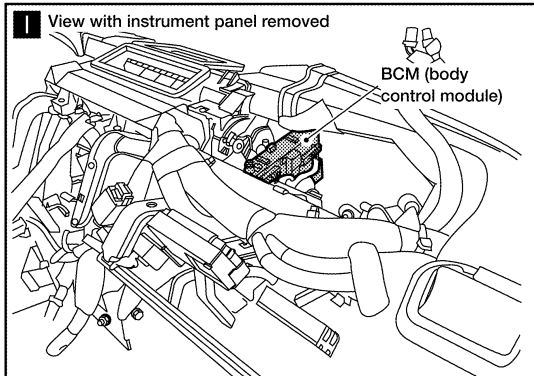
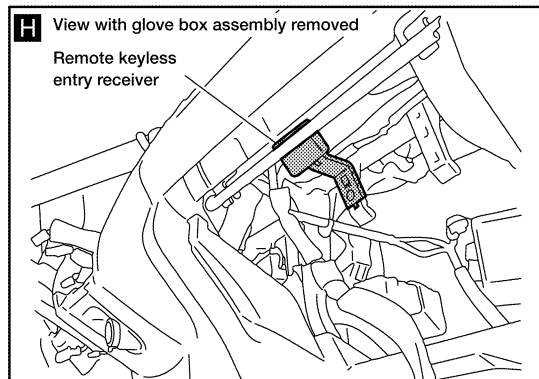
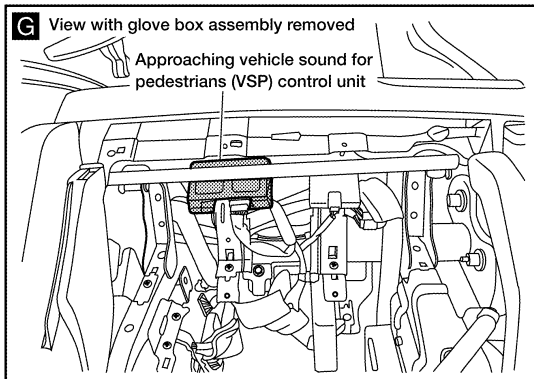
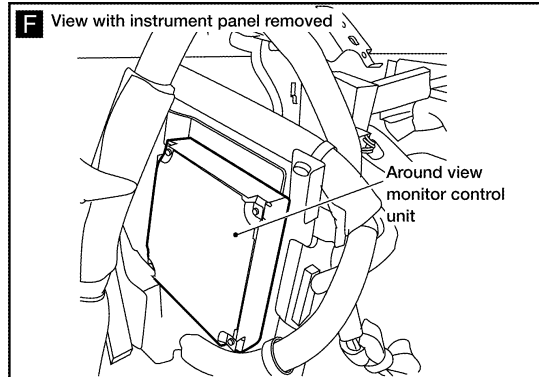
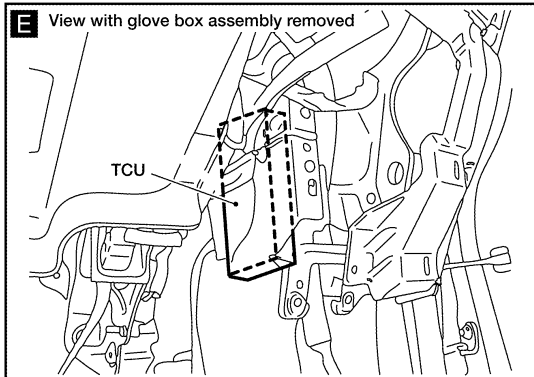
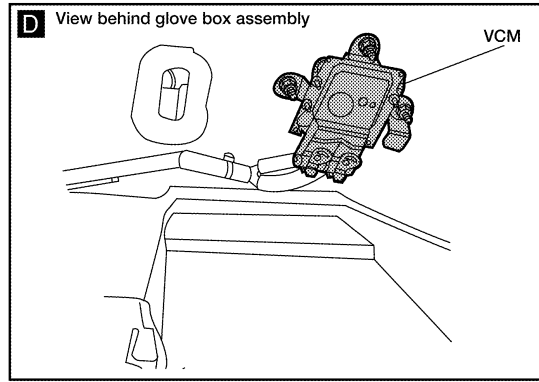
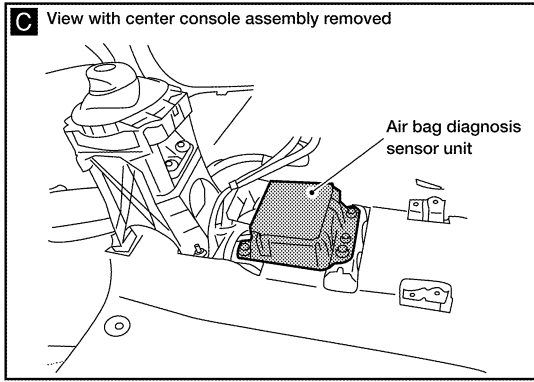

AAMIA2455GB

ELECTRICAL UNITS LOCATION

< SYSTEM DESCRIPTION > LUGGAGE COMPARTMENT

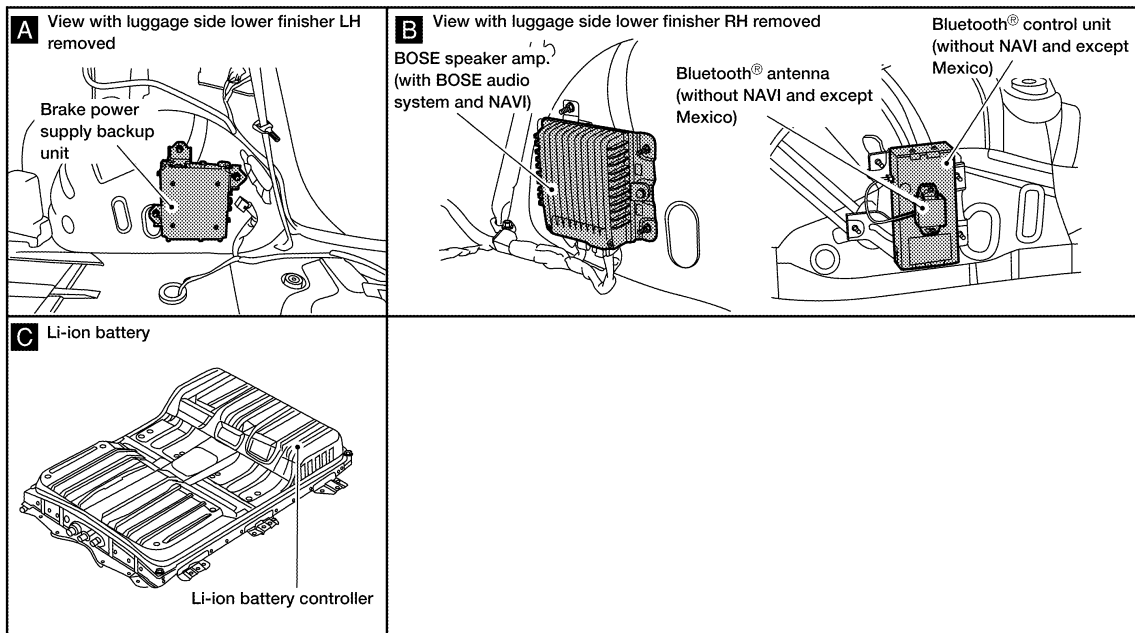
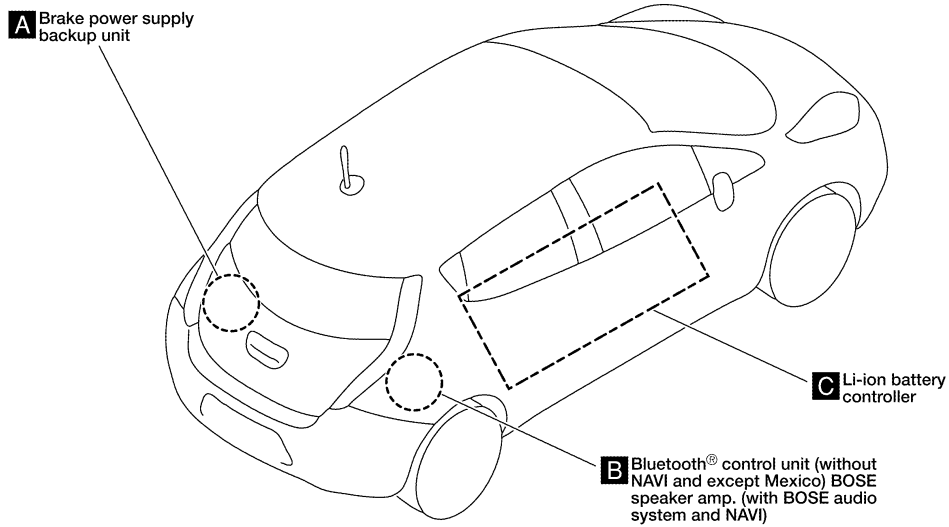

A
B
C
D
E
F
G
H
I
J
K
L
PG
N
O
P

AAMIA2456GB

COMPONENT PARTS

< SYSTEM DESCRIPTION >

COMPONENT PARTS

Circuit Breaker (Built Into BCM)

INFOID:000000011103092

For example, when current is 30A, the circuit is broken within 8 to 20 seconds.

This circuit breaker is used for the following systems:

- Power windows

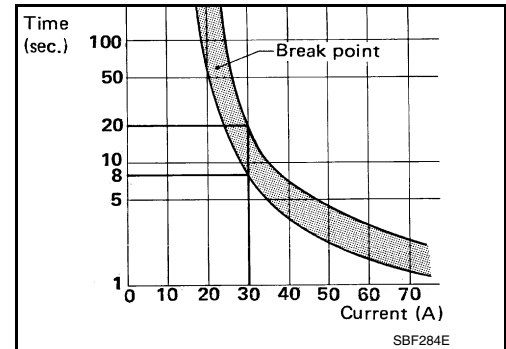

Harness Connector

INFOID:000000011107795

HARNESS CONNECTOR (TAB-LOCKING TYPE)

- The tab-locking type connectors help prevent accidental looseness or disconnection.
- The tab-locking type connectors are disconnected by pushing or lifting the locking tab(s). Refer to the figure below.

Refer to the next page for description of the slide-locking type connector.

CAUTION:

Do not pull the harness or wires when disconnecting the connector.

COMPONENT PARTS

< SYSTEM DESCRIPTION >

[Example]

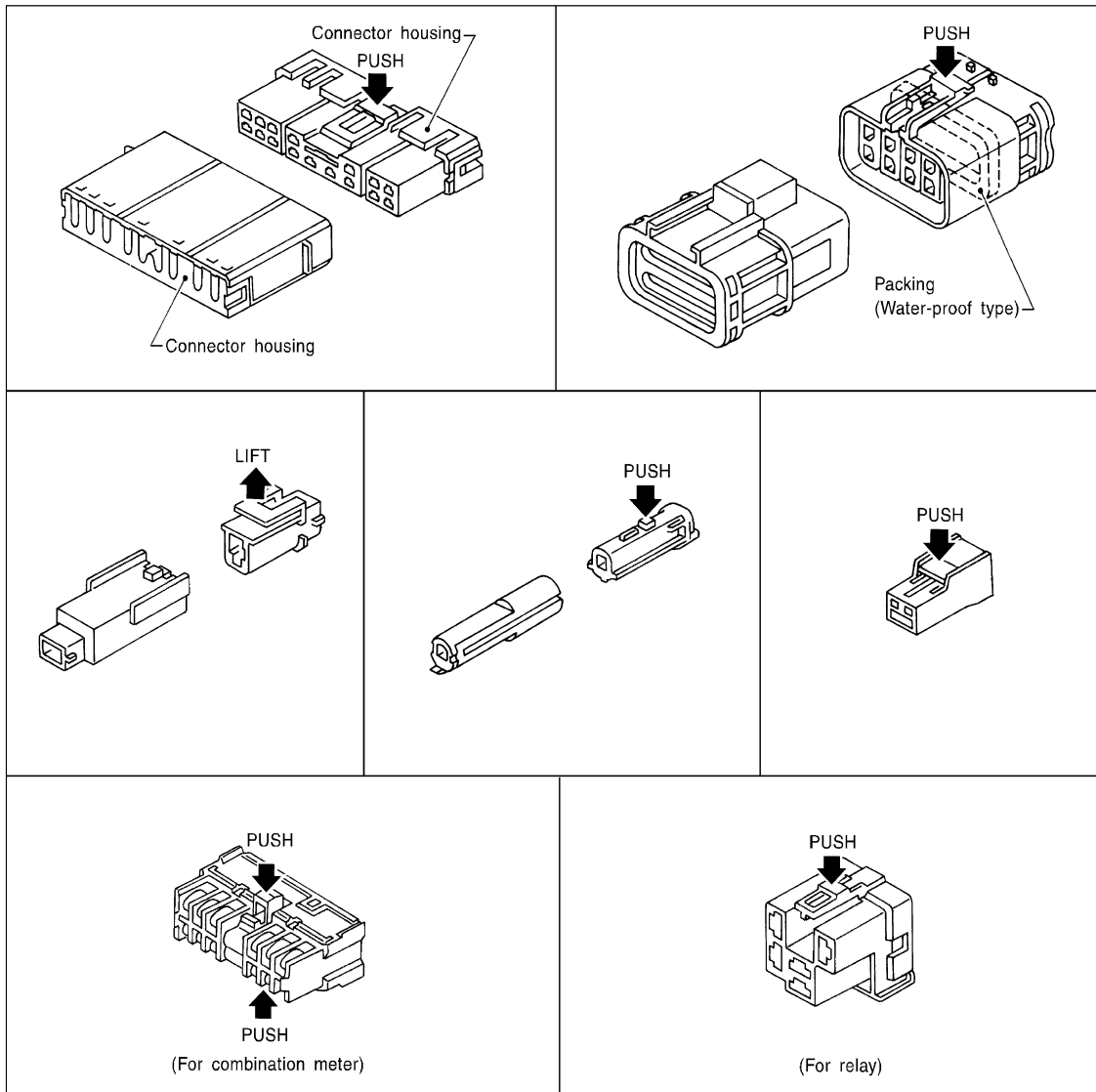

A
B
C
D
E
F
G
H
I
J
K
L

SEL769DA

HARNESS CONNECTOR (SLIDE-LOCKING TYPE)

- A new style slide-locking type connector is used on certain systems and components, especially those related to OBD.
- The slide-locking type connectors help prevent incomplete locking and accidental looseness or disconnection.
- The slide-locking type connectors are disconnected by pushing or pulling the slider. Refer to the figure below.

CAUTION:

- **Do not pull the harness or wires when disconnecting the connector.**
- **Be careful not to damage the connector support bracket when disconnecting the connector.**

PG

N
O
P

COMPONENT PARTS

< SYSTEM DESCRIPTION >

[Example]

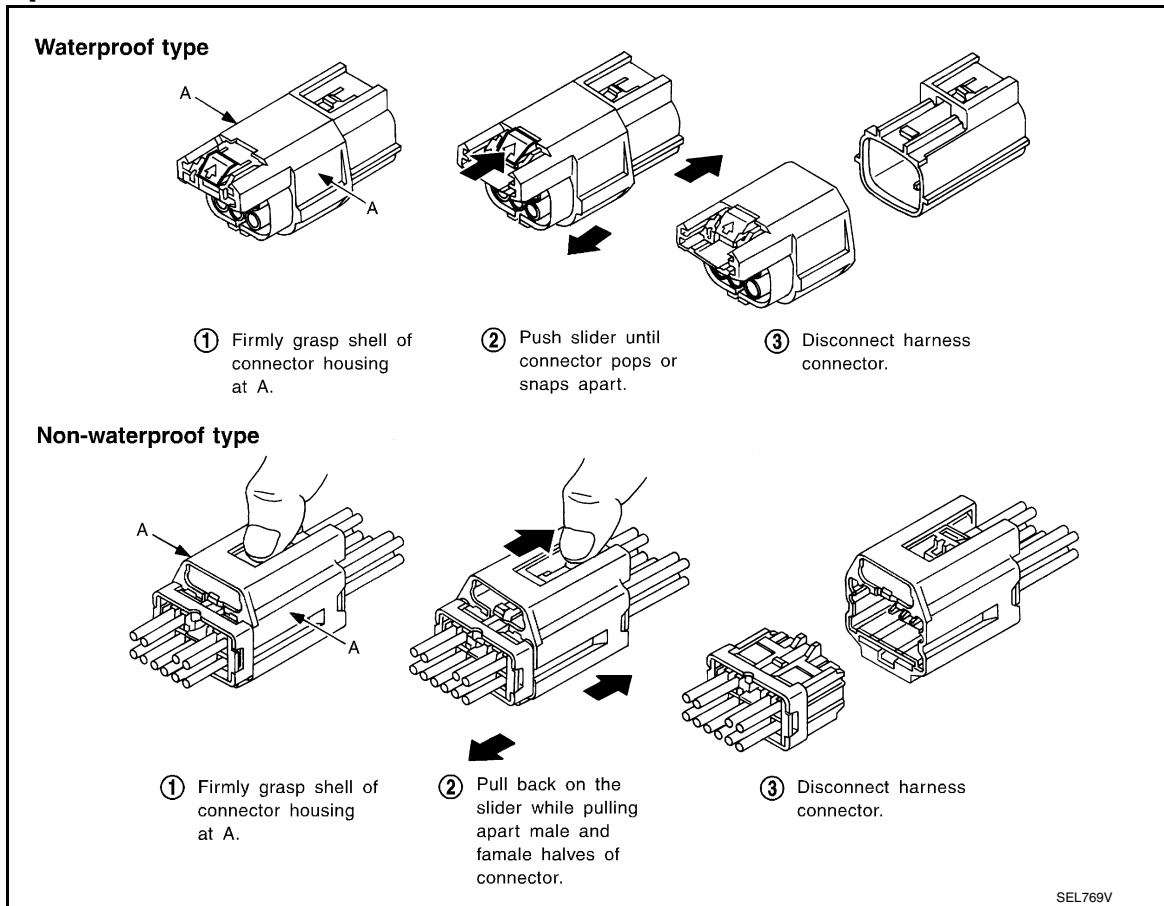

HARNESS CONNECTOR (LEVER LOCKING TYPE)

- Lever locking type harness connectors are used on certain control units and control modules such as ECM, ABS actuator and electric unit (control unit), etc.
- Lever locking type harness connectors are also used on super multiple junction (SMJ) connectors.
- Always confirm the lever is fully locked in place by moving the lever as far as it will go to ensure full connection.

CAUTION:

COMPONENT PARTS

< SYSTEM DESCRIPTION >

- Always confirm the lever is fully released (loosened) before attempting to disconnect or connect these connectors to avoid damage to the connector housing or terminals.

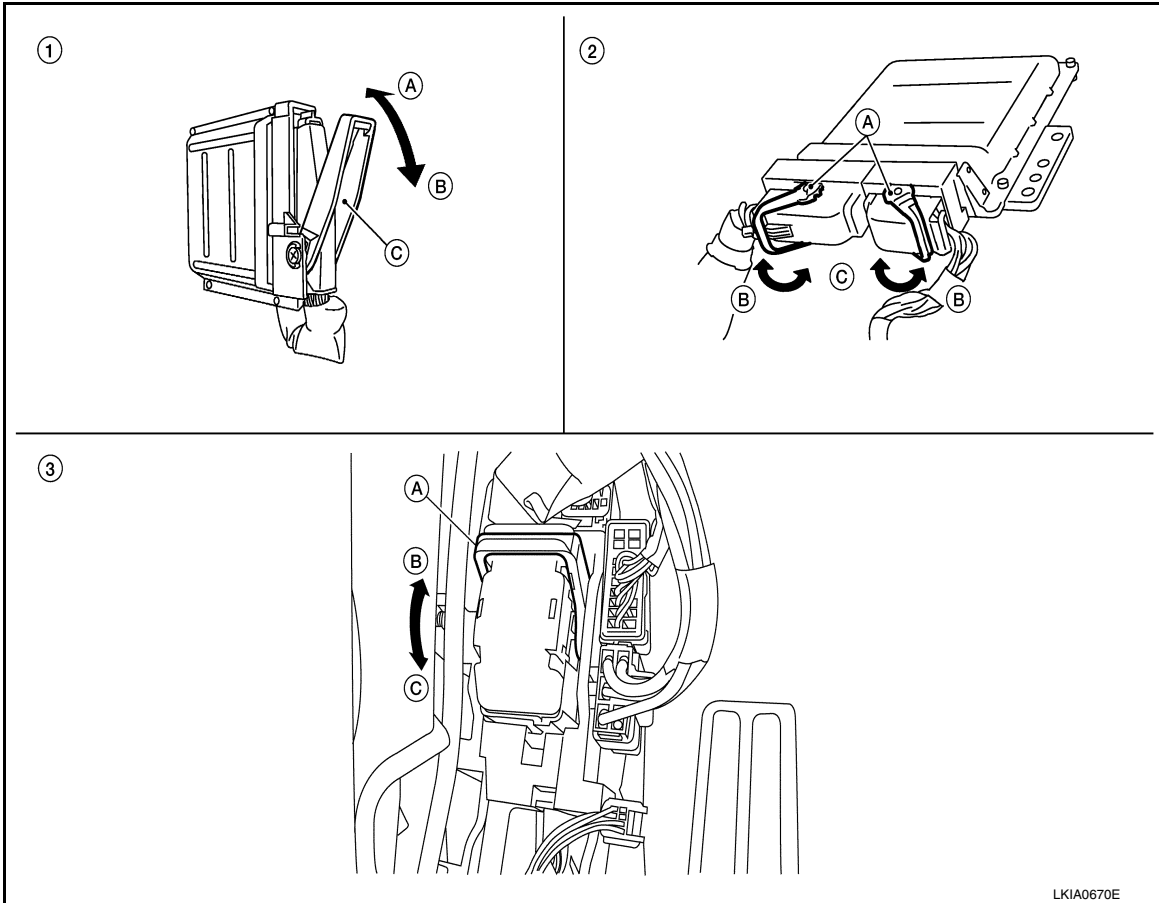

- | | | |
|-----------------------------------|---------------------------------|------------------|
| 1. Control unit with single lever | 2. Control unit with dual lever | 3. SMJ connector |
| A. Fasten | A. Lever | A. Lever |
| B. Loosen | B. Fasten | B. Fasten |
| C. Lever | C. Loosen | C. Loosen |

HARNESS CONNECTOR (DIRECT-CONNECT SRS COMPONENT TYPE)

- SRS direct-connect type harness connectors are used on certain SRS components such as air bag modules and seat belt pre-tensioners.
- Always pull up to release black locking tab prior to removing connector from SRS components.
- Always push down to lock black locking tab after installing connector to SRS components. When locked, the black locking tab is level with the connector housing.

CAUTION:

- Do not pull the harness or wires when removing connectors from SRS components.

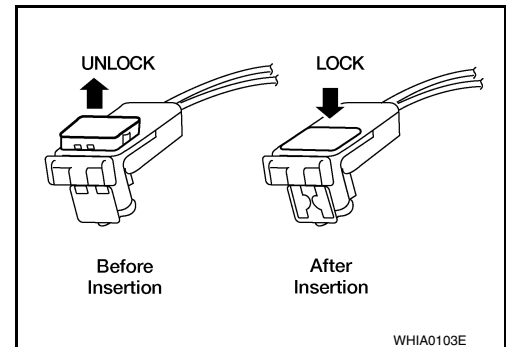

Standardized Relay

NORMAL OPEN, NORMAL CLOSED AND MIXED TYPE RELAYS

A
B
C
D
E
F
G
H
I
J
K
L
PG
N
O
P

COMPONENT PARTS

< SYSTEM DESCRIPTION >

Relays can mainly be divided into three types: normal open, normal closed and mixed type relays.

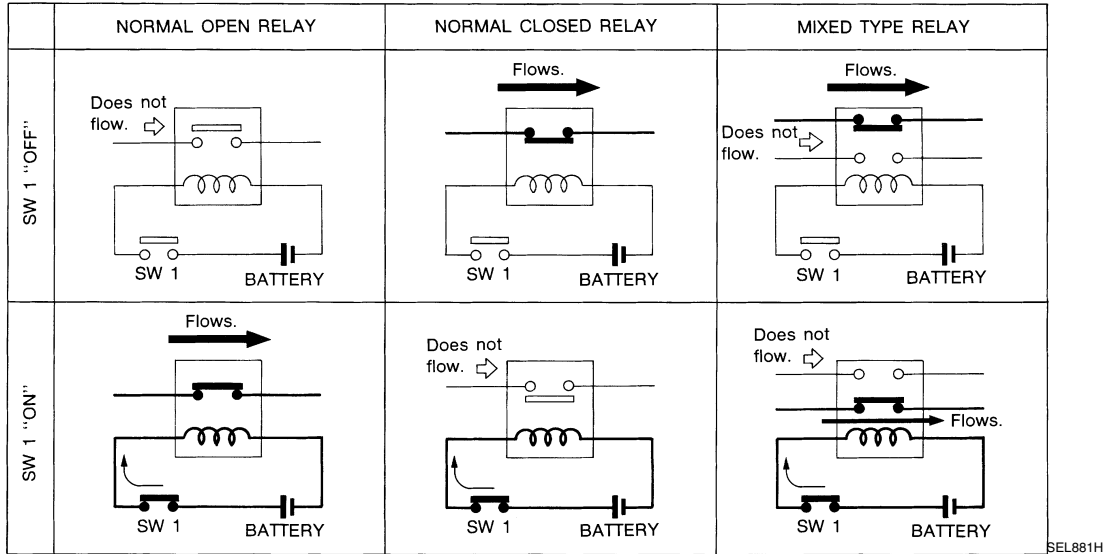

SEL881H

TYPE OF STANDARDIZED RELAYS

- 1M 1 Make
- 1T 1 Transfer
- 2M 2 Make
- 1M·1B 1 Make 1 Break

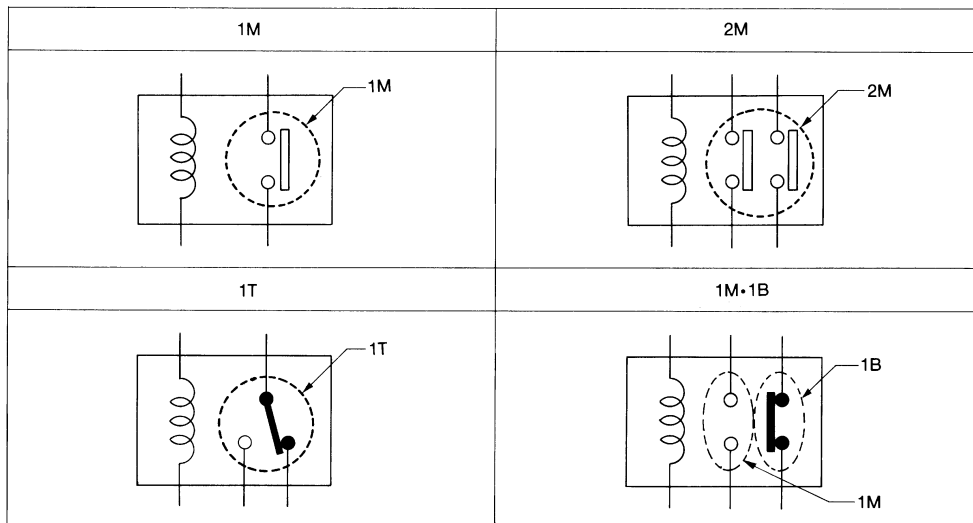

SEL882H

COMPONENT PARTS

< SYSTEM DESCRIPTION >

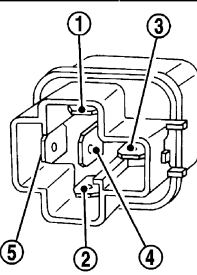
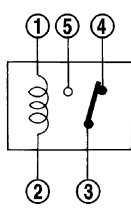
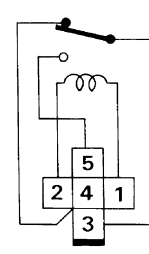
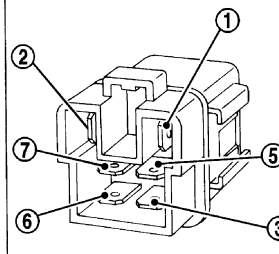
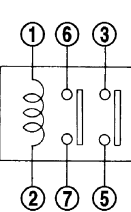
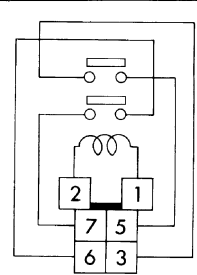
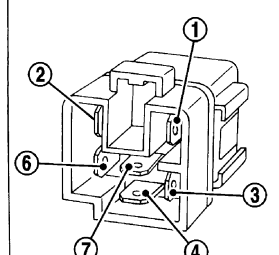
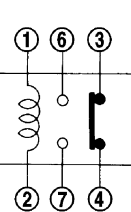
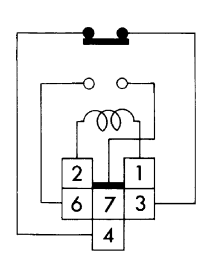
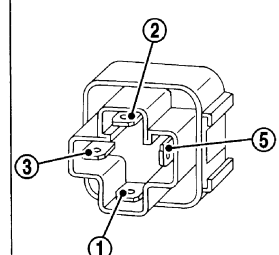
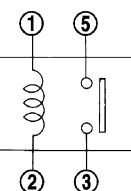
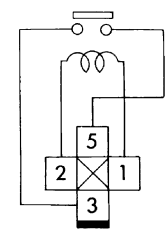
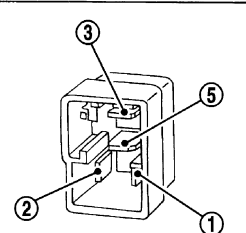
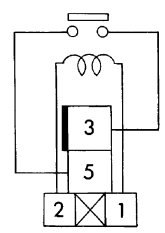
Type	Outer view	Circuit	Connector symbol and connection	Case color
1T				BLACK
2M				BROWN
1M•1B				GRAY
1M				BLUE
				

The arrangement of terminal numbers on the actual relays may differ from those shown above.

SEL188W

A
B
C
D
E
F
G
H
I
J
K
L
PG
N
O
P

POWER SUPPLY ROUTING CIRCUIT

< WIRING DIAGRAM >

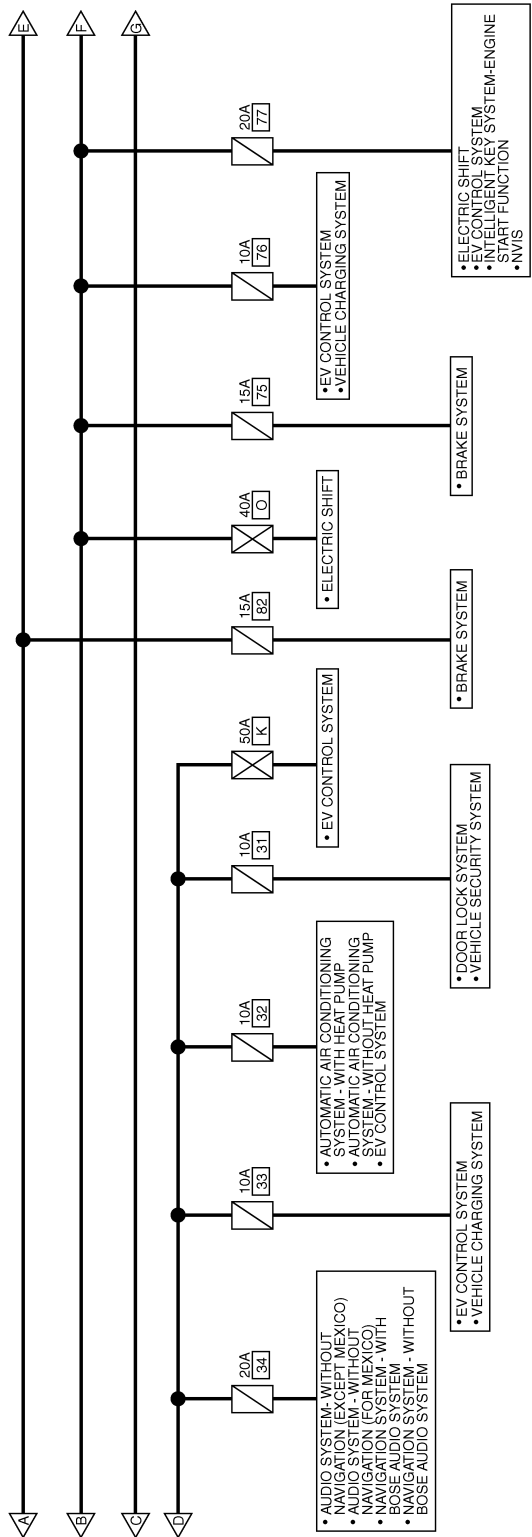

A
B
C
D
E
F
G
H
I
J
K
L
PG
N
O
P

AAMWA1185GB

POWER SUPPLY ROUTING CIRCUIT

< WIRING DIAGRAM >

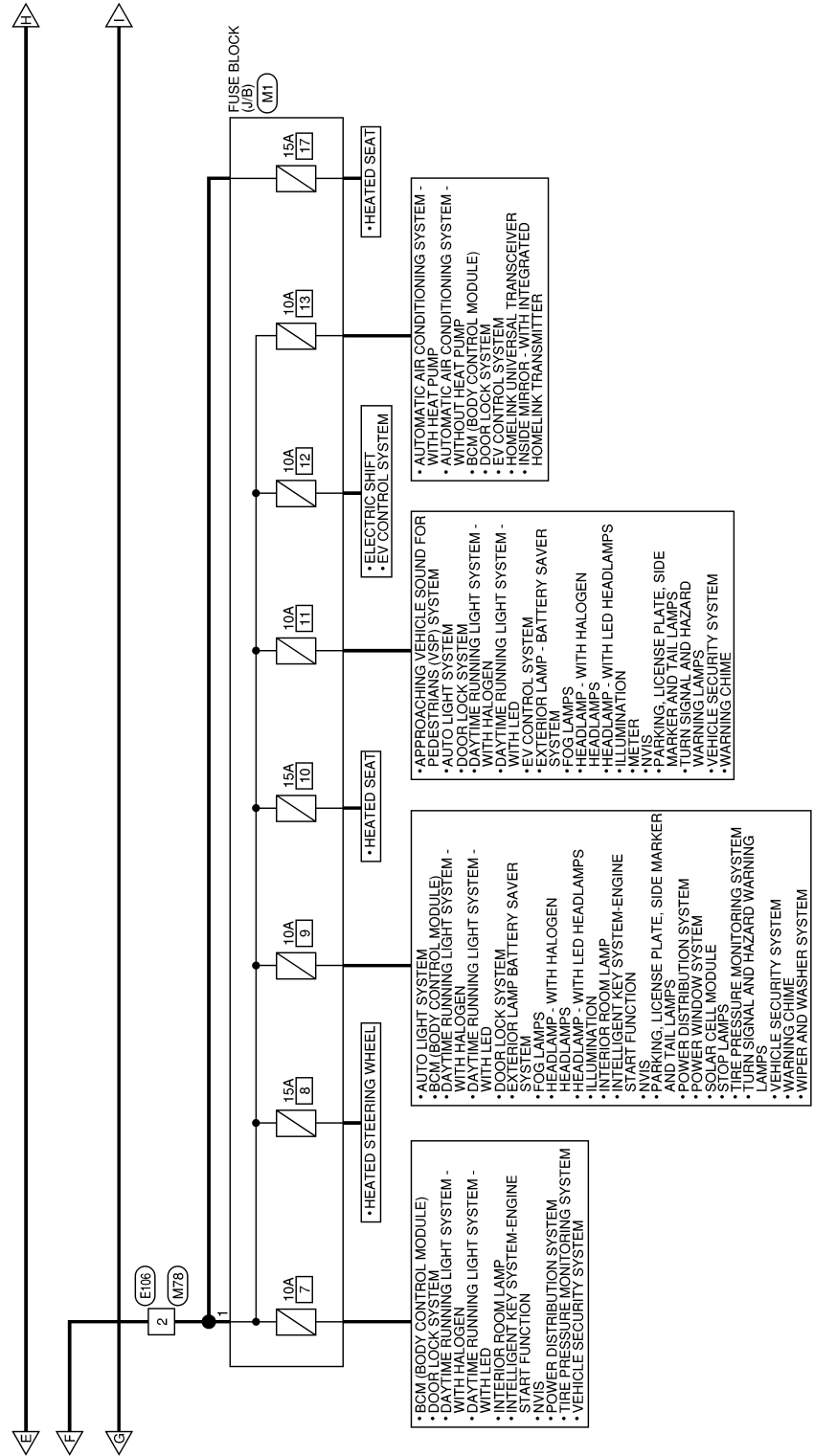

AAMWA1186GB

POWER SUPPLY ROUTING CIRCUIT

< WIRING DIAGRAM >

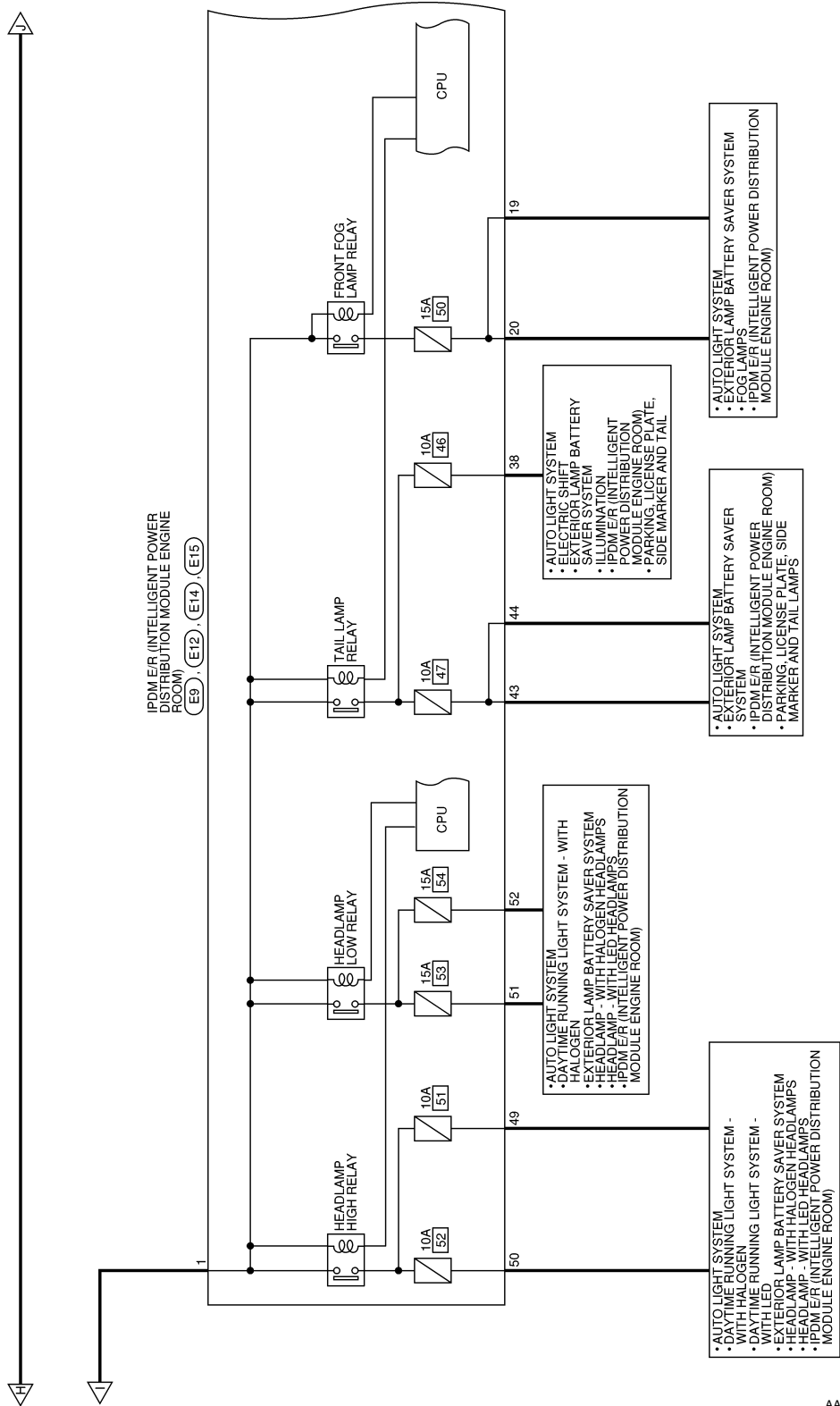

AAMWA1187GB

A
B
C
D
E
F
G
H
I
J
K
L
PG
N
O
P

POWER SUPPLY ROUTING CIRCUIT

< WIRING DIAGRAM >

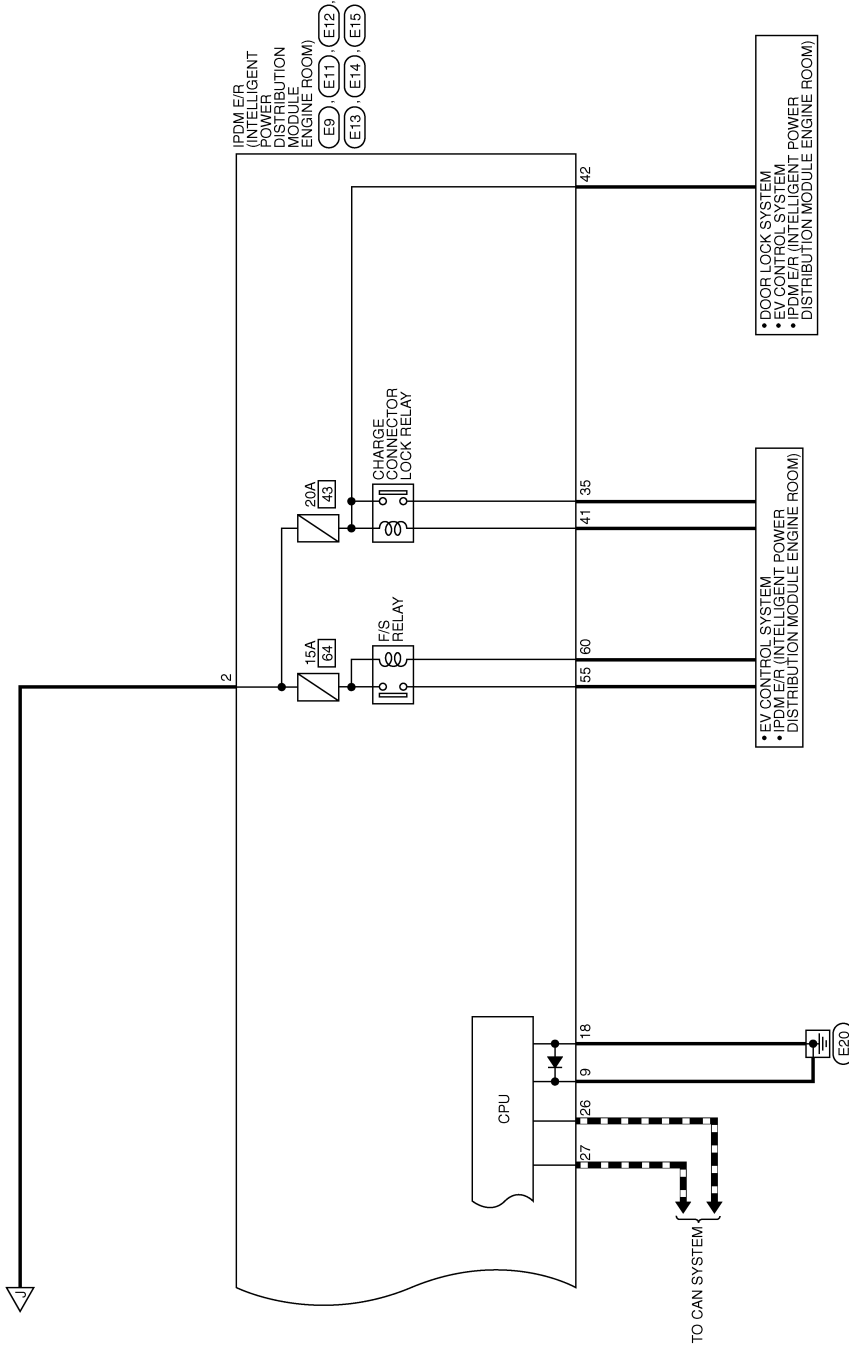

AAMWA1188GB

POWER SUPPLY ROUTING CIRCUIT

< WIRING DIAGRAM >

BATTERY POWER SUPPLY CONNECTORS

Connector No.	M1
Connector Name	FUSE BLOCK (J/B)
Connector Color	WHITE



Terminal No.	Color of Wire	Signal Name
1	W	-

Connector No.	M78
Connector Name	WIRE TO WIRE
Connector Color	BLACK



Terminal No.	Color of Wire	Signal Name
2	W	-

Connector No.	E1
Connector Name	FUSIBLE LINK BOX (BATTERY)
Connector Color	GRAY



Terminal No.	Color of Wire	Signal Name
3	G	-
4	W	-

Connector No.	E2
Connector Name	FUSIBLE LINK BOX (BATTERY)
Connector Color	BROWN



Terminal No.	Color of Wire	Signal Name
1	R	-
2	W	-

Connector No.	E3
Connector Name	FUSIBLE LINK BOX (BATTERY)
Connector Color	BLACK



Terminal No.	Color of Wire	Signal Name
5	R	-

Connector No.	E9
Connector Name	IPDM E/R (INTELLIGENT POWER DISTRIBUTION MODULE ENGINE ROOM)
Connector Color	BLACK



Terminal No.	Color of Wire	Signal Name
1	R	F/L USM
2	G	F/L MAIN

AAMIA2320GB

A
B
C
D
E
F
G
H
I
J
K
L
N
O
P

PG

POWER SUPPLY ROUTING CIRCUIT

< WIRING DIAGRAM >

Connector No.	E13
Connector Name	IPDM E/R (INTELLIGENT POWER DISTRIBUTION MODULE ENGINE ROOM)
Connector Color	WHITE

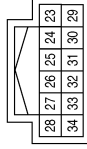

Terminal No.	Color of Wire	Signal Name
26	P	CAN-L
27	L	CAN-H

Connector No.	E12
Connector Name	IPDM E/R (INTELLIGENT POWER DISTRIBUTION MODULE ENGINE ROOM)
Connector Color	BROWN

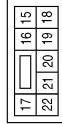

Terminal No.	Color of Wire	Signal Name
18	B/W	SGND
19	W	FR FOG/L RH
20	V	FR FOG/L LH

Connector No.	E11
Connector Name	IPDM E/R (INTELLIGENT POWER DISTRIBUTION MODULE ENGINE ROOM)
Connector Color	BLACK



Terminal No.	Color of Wire	Signal Name
9	B	POWER GROUND

Connector No.	E34
Connector Name	ELECTRICALLY-DRIVEN INTELLIGENT BRAKE UNIT
Connector Color	BLACK

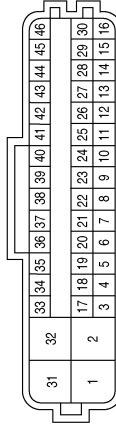

Terminal No.	Color of Wire	Signal Name
1	Y	MOTOR POWER
2	Y	MOTOR POWER

Connector No.	E15
Connector Name	IPDM E/R (INTELLIGENT POWER DISTRIBUTION MODULE ENGINE ROOM)
Connector Color	WHITE

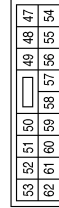

Terminal No.	Color of Wire	Signal Name
49	Y	H/LAMP HI RH
50	G	H/LAMP HI LH
51	L	H/LAMP LO LH
52	P	H/LAMP LO RH
55	LG	FAST CHARGE
60	GR	F/S RLY CONT

Connector No.	E14
Connector Name	IPDM E/R (INTELLIGENT POWER DISTRIBUTION MODULE ENGINE ROOM)
Connector Color	BROWN



Terminal No.	Color of Wire	Signal Name
35	R	VCM VB
38	LG	TAIL 1 (WITHOUT SOLAR CELL)
38	R	TAIL 1 (WITH SOLAR CELL)
41	SB	VCM RLY CONT
42	BR	VCM BAT
43	O	CLEARANCE/LH
44	B	TAIL 2

AAMIA2321GB

POWER SUPPLY ROUTING CIRCUIT

< WIRING DIAGRAM >

Connector No.	E106
Connector Name	WIRE TO WIRE
Connector Color	BLACK



Terminal No.	Color of Wire	Signal Name
2	W	-

Connector No.	E65
Connector Name	M/C RELAY
Connector Color	BLUE



Terminal No.	Color of Wire	Signal Name
1	SB	-
2	R	-
3	R	-
5	W	-

Connector No.	E40
Connector Name	FUSIBLE LINK BOX (BATTERY)
Connector Color	-



Terminal No.	Color of Wire	Signal Name
7	-	-

Connector No.	E201
Connector Name	PDM (POWER DELIVERY MODULE) ON BOARD CHARGER
Connector Color	-



Terminal No.	Color of Wire	Signal Name
37	B/R	-

AAMIA2322GB

A
B
C
D
E
F
G
H
I
J
K
L
PG
N
O
P

POWER SUPPLY ROUTING CIRCUIT

< WIRING DIAGRAM >

Wiring Diagram —Accessory Power Supply —

INFOID:000000010641290

ACCESSORY POWER SUPPLY

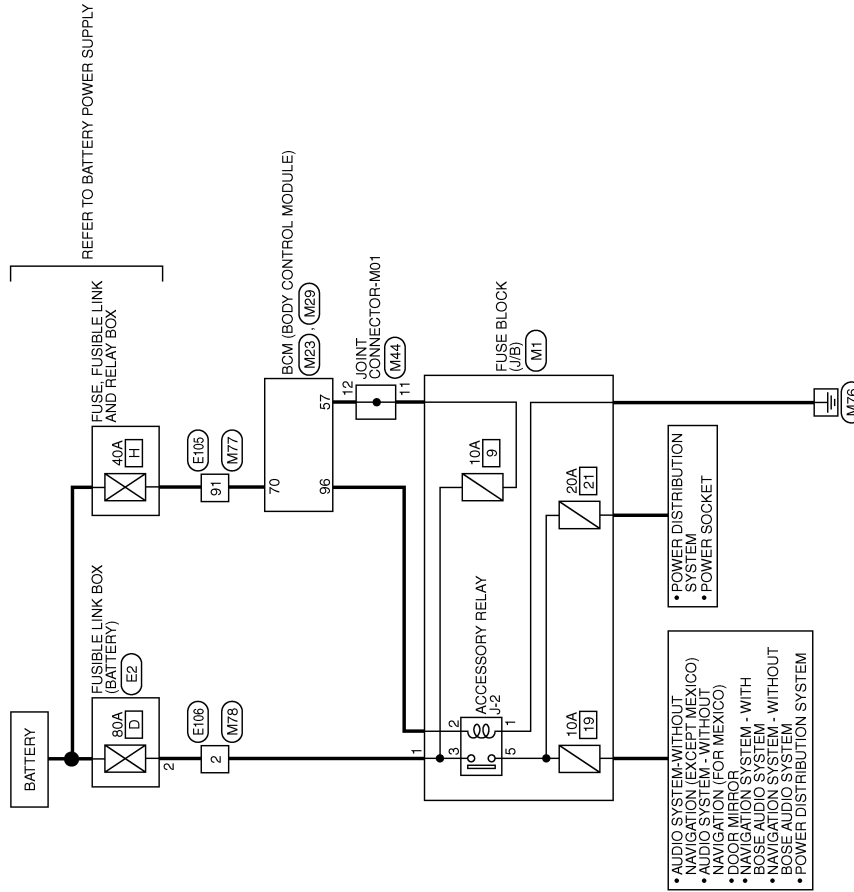

AAMWA1189GB

POWER SUPPLY ROUTING CIRCUIT

< WIRING DIAGRAM >

ACCESSORY POWER SUPPLY CONNECTORS

Connector No.	M1
Connector Name	FUSE BLOCK (J/B)
Connector Color	WHITE



Terminal No.	Color of Wire	Signal Name
1	W	-

Connector No.	M23
Connector Name	BCM (BODY CONTROL MODULE)
Connector Color	WHITE



Terminal No.	Color of Wire	Signal Name
96	BR	ACC RELAY OUTPUT

Connector No.	M25
Connector Name	BCM (BODY CONTROL MODULE)
Connector Color	WHITE



Terminal No.	Color of Wire	Signal Name
57	P	BATTERY (FUSE)
70	Y	BATTERY (F/L)

Connector No.	M44
Connector Name	JOINT CONNECTOR-M01
Connector Color	GRAY



Terminal No.	Color of Wire	Signal Name
11	P	-
12	P	-

Connector No.	M77
Connector Name	WIRE TO WIRE
Connector Color	WHITE

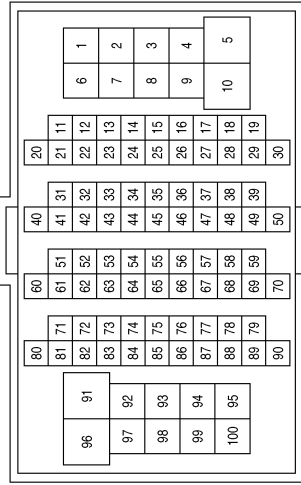

Terminal No.	Color of Wire	Signal Name
91	Y	-

Connector No.	M78
Connector Name	WIRE TO WIRE
Connector Color	BLACK



Terminal No.	Color of Wire	Signal Name
2	W	-

AAMIA2323GB

A
B
C
D
E
F
G
H
I
J
K
L
N
O
P

PG

POWER SUPPLY ROUTING CIRCUIT

< WIRING DIAGRAM >

Connector No.	E106
Connector Name	WIRE TO WIRE
Connector Color	BLACK



Terminal No.	Color of Wire	Signal Name
2	W	-

Connector No.	E105
Connector Name	WIRE TO WIRE
Connector Color	WHITE

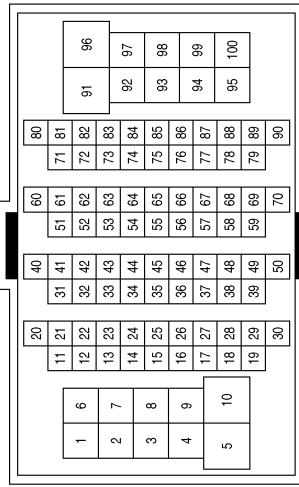

Terminal No.	Color of Wire	Signal Name
91	Y	-

Connector No.	E2
Connector Name	FUSIBLE LINK BOX (BATTERY)
Connector Color	BROWN



Terminal No.	Color of Wire	Signal Name
2	W	-

AAMIA2324GB

POWER SUPPLY ROUTING CIRCUIT

< WIRING DIAGRAM >

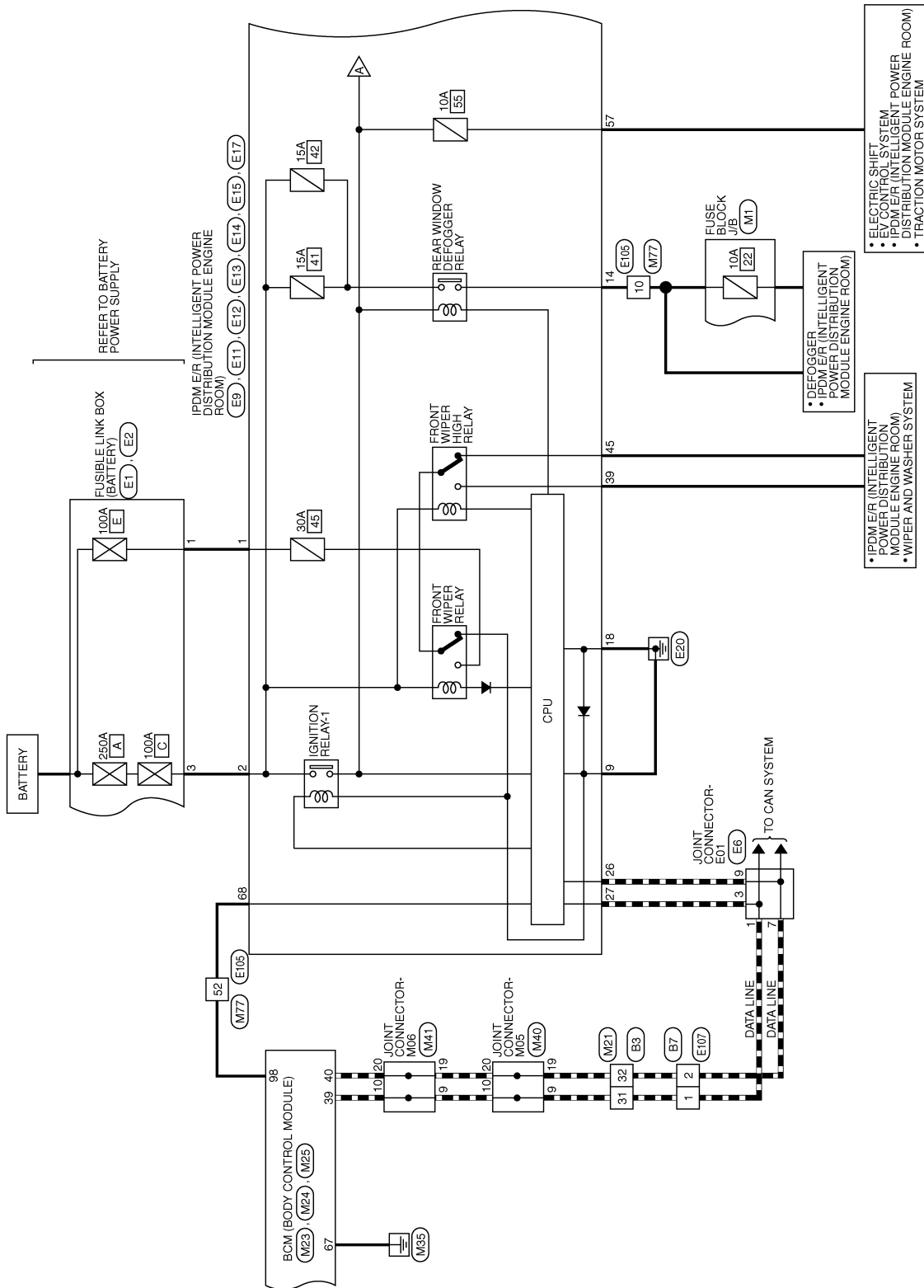

AAMWA1191GB

POWER SUPPLY ROUTING CIRCUIT

< WIRING DIAGRAM >

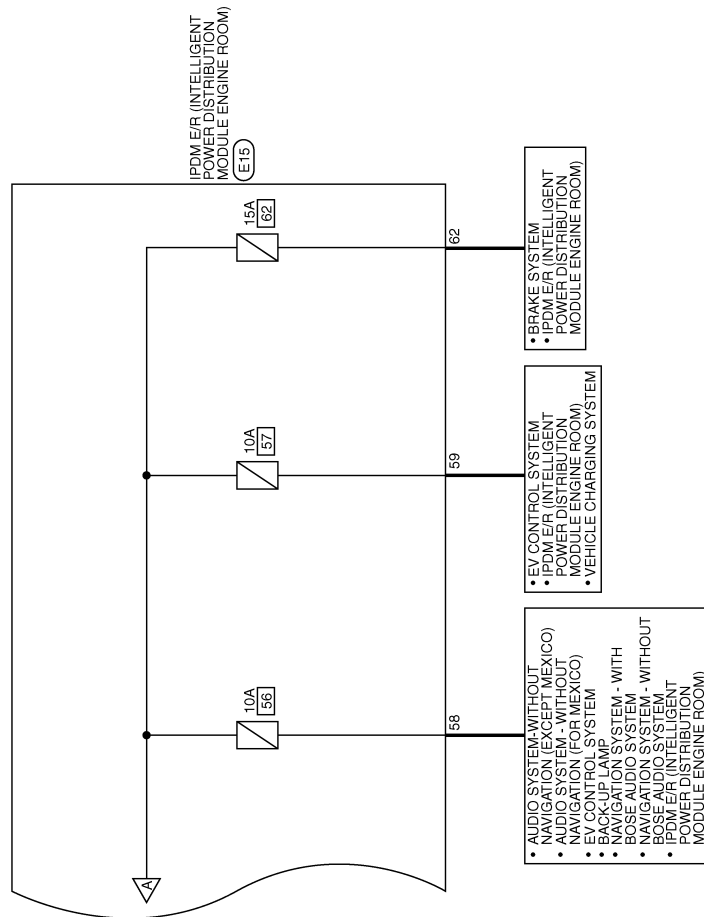

A
B
C
D
E
F
G
H
I
J
K
L
N
O
P

PG

AAMWA1192GB

POWER SUPPLY ROUTING CIRCUIT

< WIRING DIAGRAM >

ON POWER SUPPLY CONNECTORS

Connector No.	M1
Connector Name	FUSE BLOCK (J/B)
Connector Color	WHITE



Terminal No.	Color of Wire	Signal Name
1	W	-

Connector No.	M21
Connector Name	WIRE TO WIRE
Connector Color	WHITE

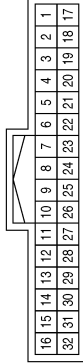

Terminal No.	Color of Wire	Signal Name
31	L	-
32	P	-

Connector No.	M23
Connector Name	BCM (BODY CONTROL MODULE)
Connector Color	WHITE

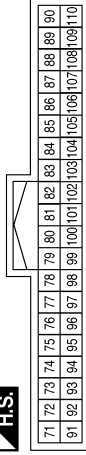

Terminal No.	Color of Wire	Signal Name
98	L	IGN RELAY OUTPUT1 (USM)
99	GR	IGN RELAY OUTPUT2 (ELEC)

Connector No.	M24
Connector Name	BCM (BODY CONTROL MODULE)
Connector Color	BLACK

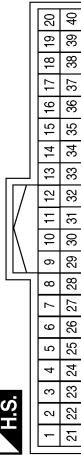

Terminal No.	Color of Wire	Signal Name
39	L	CAN-H
40	P	CAN-L

Connector No.	M25
Connector Name	BCM (BODY CONTROL MODULE)
Connector Color	WHITE



Terminal No.	Color of Wire	Signal Name
57	P	BATTERY (FUSE)
67	B	GND
70	Y	BATTERY (F/L)

Connector No.	M40
Connector Name	JOINT CONNECTOR-M05
Connector Color	BLUE

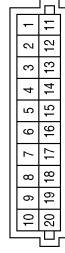

Terminal No.	Color of Wire	Signal Name
9	L	-
10	L	-
19	P	-
20	P	-

POWER SUPPLY ROUTING CIRCUIT

< WIRING DIAGRAM >

Connector No.	M78
Connector Name	WIRE TO WIRE
Connector Color	BLACK



Terminal No.	Color of Wire	Signal Name
2	W	-

Connector No.	M77
Connector Name	WIRE TO WIRE
Connector Color	WHITE

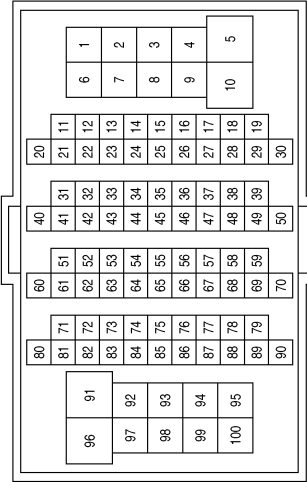

Terminal No.	Color of Wire	Signal Name
10	L	-
52	L	-
91	Y	-
93	W	-
96	P	-

Connector No.	M41
Connector Name	JOINT CONNECTOR-M06
Connector Color	BLUE

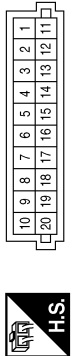

Terminal No.	Color of Wire	Signal Name
9	L	-
10	L	-
19	P	-
20	P	-

Connector No.	E6
Connector Name	JOINT CONNECTOR-E01
Connector Color	BLUE

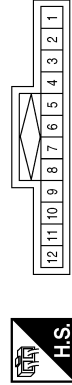

Terminal No.	Color of Wire	Signal Name
1	L	-
3	L	-
7	P	-
9	P	-

Connector No.	E2
Connector Name	FUSIBLE LINK BOX (BATTERY)
Connector Color	BROWN

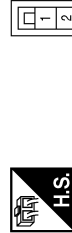

Terminal No.	Color of Wire	Signal Name
1	R	-
2	W	-

Connector No.	E1
Connector Name	FUSIBLE LINK BOX (BATTERY)
Connector Color	GRAY



Terminal No.	Color of Wire	Signal Name
3	G	-

AAMIA2326GB

A B C D E F G H I J K L PG N O P

POWER SUPPLY ROUTING CIRCUIT

< WIRING DIAGRAM >

Connector No.	E12
Connector Name	IPDM E/R (INTELLIGENT POWER DISTRIBUTION MODULE ENGINE ROOM)
Connector Color	BROWN



17	16	15
22	21	20
19	18	

Terminal No.	Color of Wire	Signal Name
18	B/W	SGND

Connector No.	E11
Connector Name	IPDM E/R (INTELLIGENT POWER DISTRIBUTION MODULE ENGINE ROOM)
Connector Color	BLACK



11	10	9
14	13	12

Terminal No.	Color of Wire	Signal Name
9	B	POWER GROUND
14	R	RR DEF

Connector No.	E9
Connector Name	IPDM E/R (INTELLIGENT POWER DISTRIBUTION MODULE ENGINE ROOM)
Connector Color	BLACK



1	2
---	---

Terminal No.	Color of Wire	Signal Name
1	R	F/L USM
2	G	F/L MAIN

Connector No.	E15
Connector Name	IPDM E/R (INTELLIGENT POWER DISTRIBUTION MODULE ENGINE ROOM)
Connector Color	WHITE



53	52	51	50	49	48	47
62	61	60	59	58	57	56
55	54					

Terminal No.	Color of Wire	Signal Name
57	R	VCM IGN
58	O	REVERSE LAMP IGN
59	BR	ABS ECU IGN
62	V	E-ACT/HAS IGN

Connector No.	E14
Connector Name	IPDM E/R (INTELLIGENT POWER DISTRIBUTION MODULE ENGINE ROOM)
Connector Color	BROWN



39	38	37	36	35
46	45	44	43	42
41	40			

Terminal No.	Color of Wire	Signal Name
39	R	FR WIPER HI
45	Y	FR WIPER LO

Connector No.	E13
Connector Name	IPDM E/R (INTELLIGENT POWER DISTRIBUTION MODULE ENGINE ROOM)
Connector Color	WHITE



28	27	26	25	24	23
34	33	32	31	30	29

Terminal No.	Color of Wire	Signal Name
26	P	CAN-L
27	L	CAN-H

AAMIA2327GB

POWER SUPPLY ROUTING CIRCUIT

< WIRING DIAGRAM >

Terminal No.	Color of Wire	Signal Name
1	W	-
2	BR	-
3	R	-
5	W	-
6	R	-
7	O	-

Connector No.	E52
Connector Name	A/C RELAY
Connector Color	BROWN



Connector No.	E17
Connector Name	IPDM E/R (INTELLIGENT POWER DISTRIBUTION MODULE ENGINE ROOM)
Connector Color	BLACK

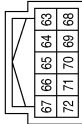

Terminal No.	Color of Wire	Signal Name
68	O	IGN SIGNAL

Connector No.	E106
Connector Name	WIRE TO WIRE
Connector Color	BLACK



Terminal No.	Color of Wire	Signal Name
10	R	-
52	O	-
91	Y	-
93	O	-
96	P	-

Connector No.	E105
Connector Name	WIRE TO WIRE
Connector Color	WHITE

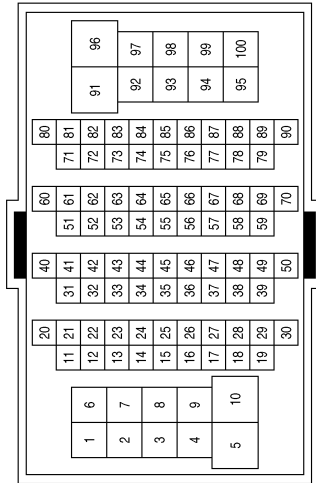

AAMIA2328GB

A
B
C
D
E
F
G
H
I
J
K
L
N
O
P

PG

POWER SUPPLY ROUTING CIRCUIT

< WIRING DIAGRAM >

Connector No.	B7
Connector Name	WIRE TO WIRE
Connector Color	WHITE

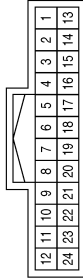

Terminal No.	Color of Wire	Signal Name
1	L	-
2	P	-

Connector No.	B3
Connector Name	WIRE TO WIRE
Connector Color	WHITE

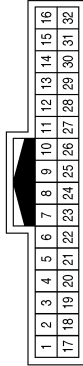

Terminal No.	Color of Wire	Signal Name
31	L	-
32	P	-

Connector No.	E107
Connector Name	WIRE TO WIRE
Connector Color	WHITE

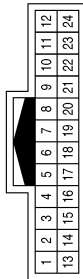

Terminal No.	Color of Wire	Signal Name
1	L	-
2	P	-

AAMIA2329GB

GROUND

< WIRING DIAGRAM >

GROUND

Ground Distribution

INFOID:000000010641294

MAIN HARNESS

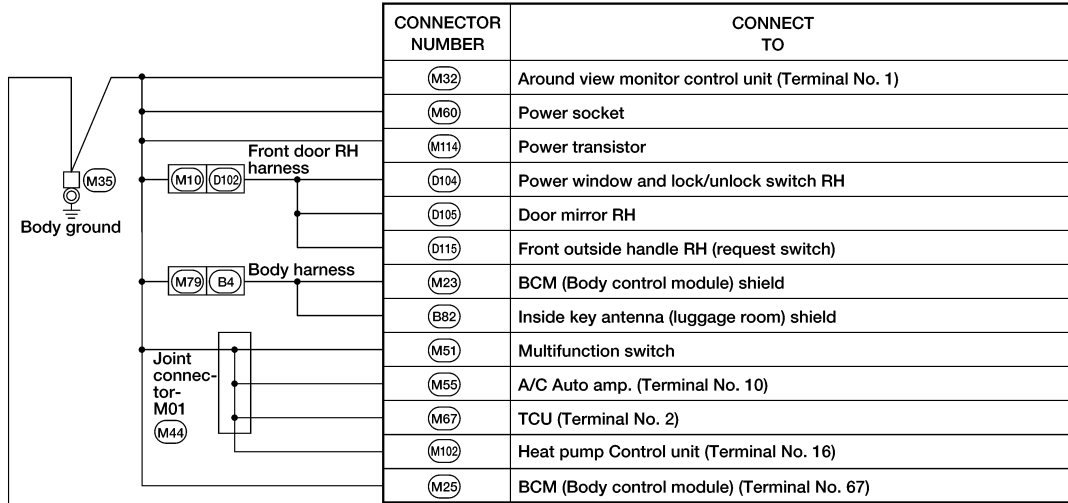
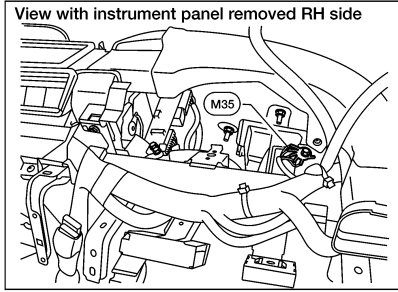

Next page

AAMIA2461GB

GROUND

< WIRING DIAGRAM >

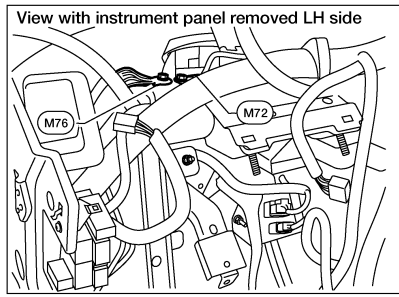

Previous page

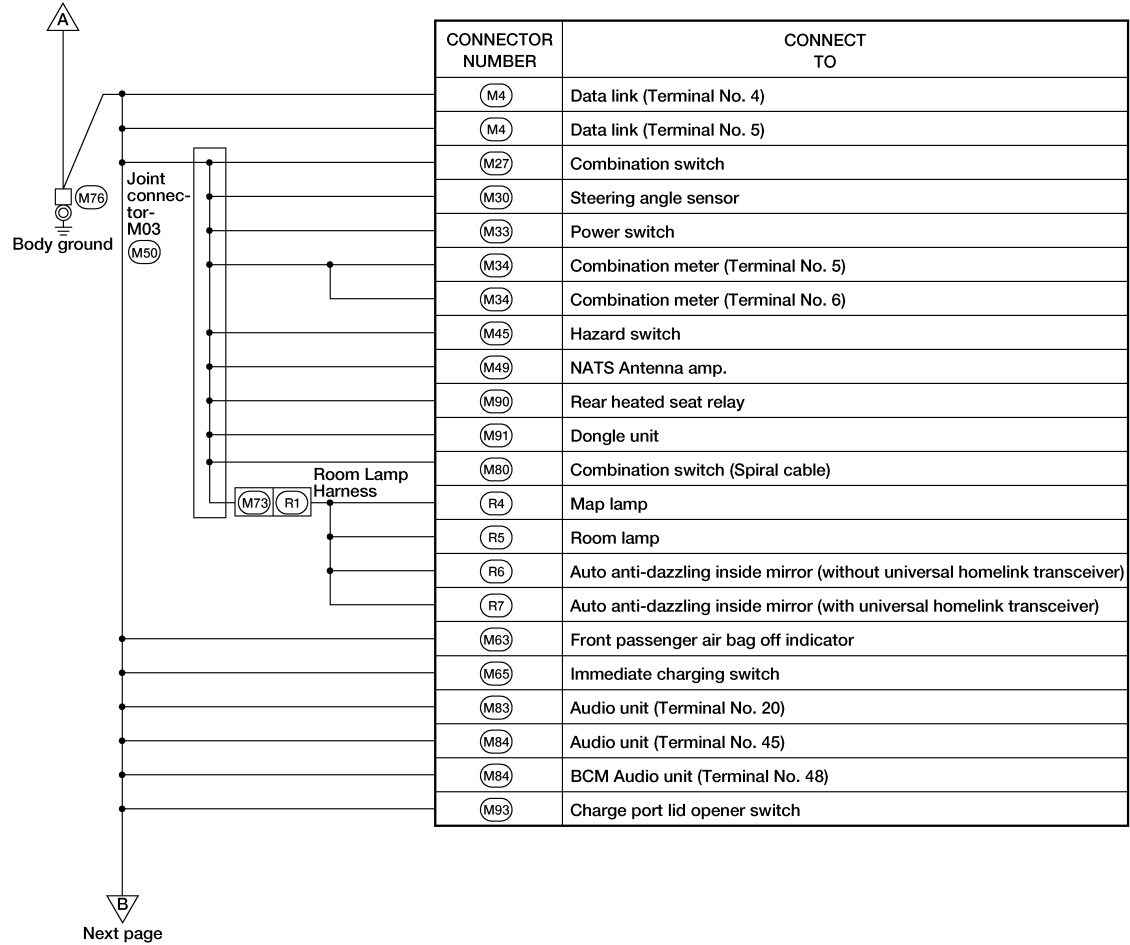

AAMIA2462GB

GROUND

< WIRING DIAGRAM >

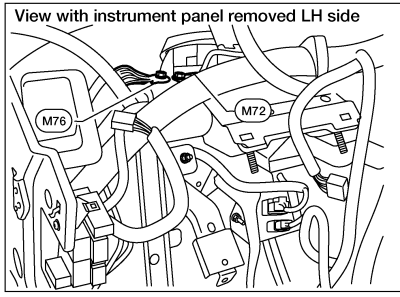

Previous page

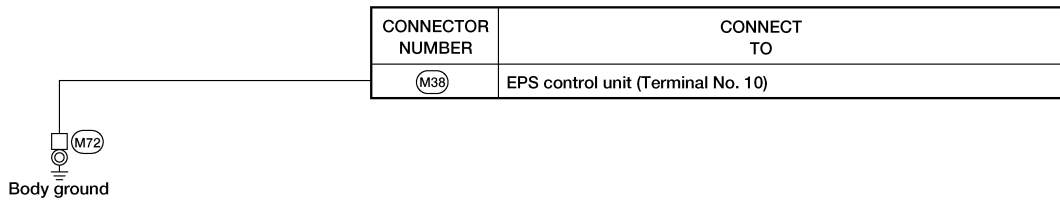
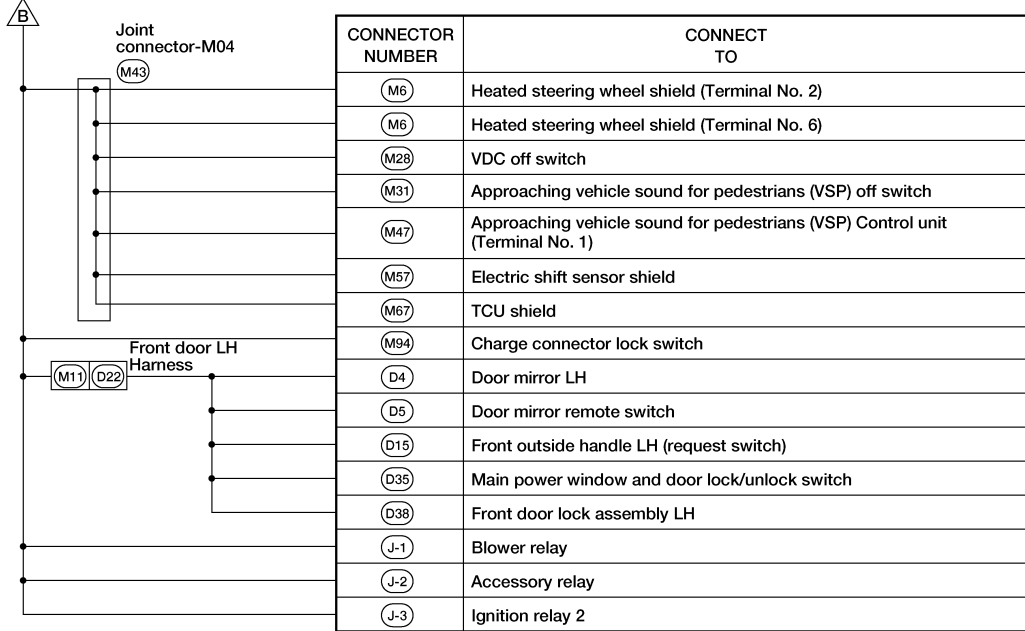

AAMIA2463GB

A
B
C
D
E
F
G
H
I
J
K
L
PG
N
O
P

GROUND

< WIRING DIAGRAM >

MOTOR ROOM HARNESS

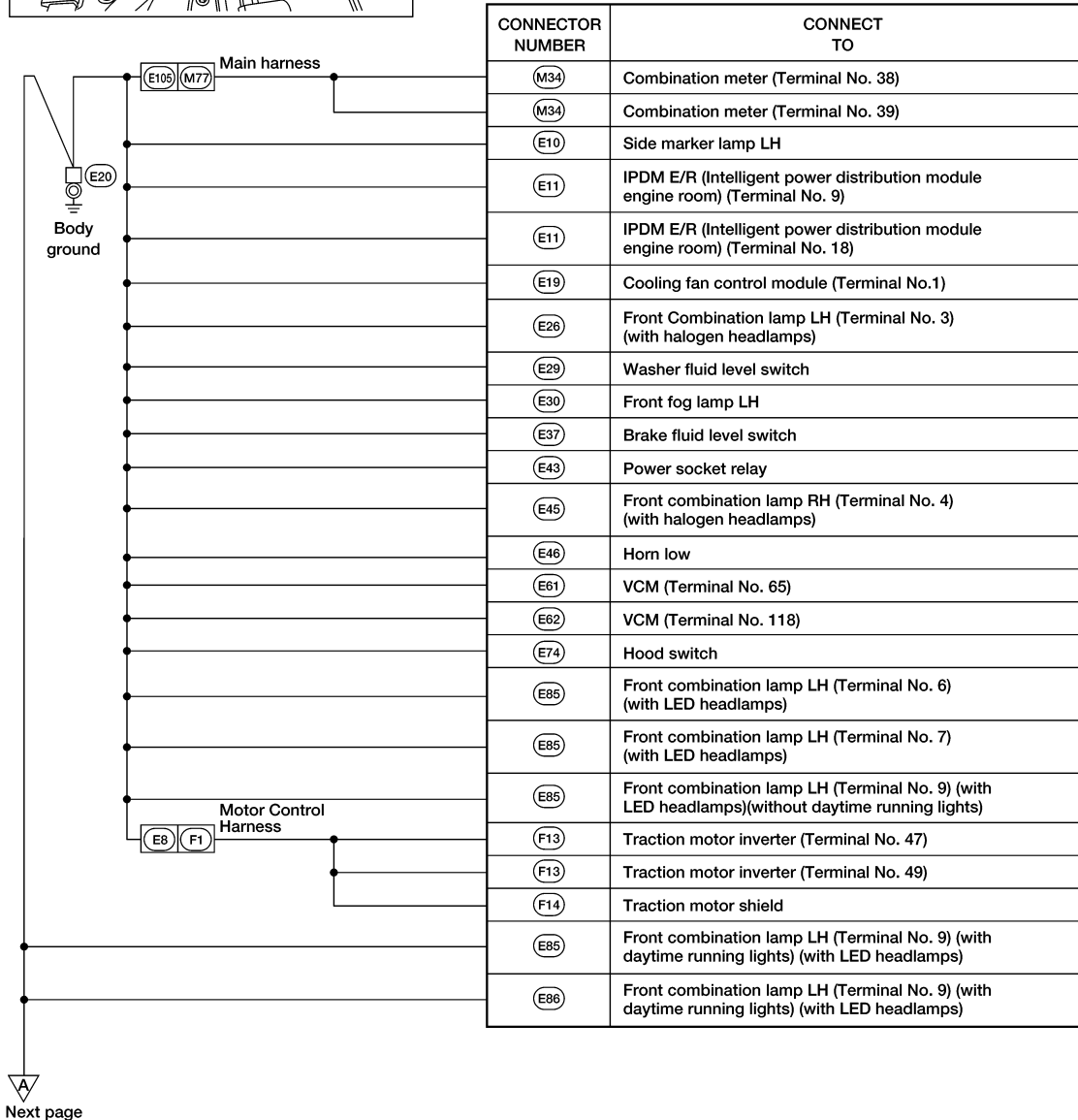
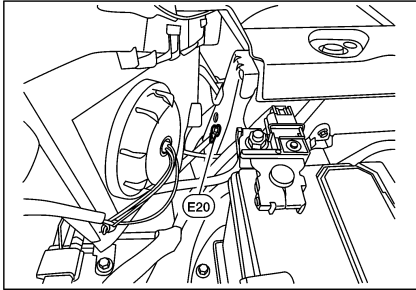

AAMIA2464GB

GROUND

< WIRING DIAGRAM >

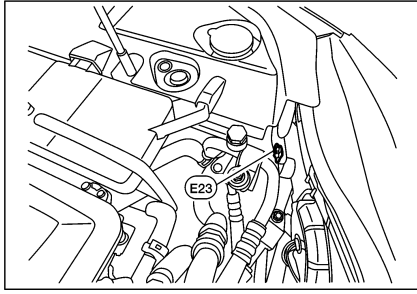

Previous page

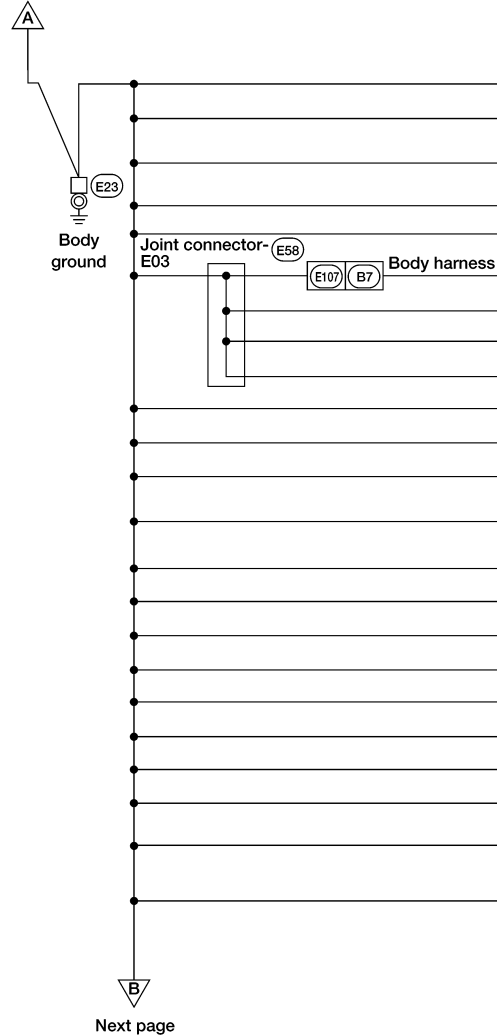

CONNECTOR NUMBER	CONNECT TO
(E16)	Front side marker lamp RH
(E18)	Cooling fan relay
(E26)	Front combination lamp LH (Terminal No. 4) (with halogen headlamps)
(E29)	Washer fluid level switch
(E32)	Front wiper motor
(B15)	Brake power supply back up unit shield
(E31)	Master cylinder pressure sensor shield
(E36)	Stroke sensor shield
(E82)	VCM shield
(E34)	Electronically driven intelligent brake unit shield
(E35)	ABS Actuator and electronic unit (Control unit) shield
(E38)	Charge port lid opener actuator
(E45)	Front combination lamp RH (Terminal No. 3) (with halogen headlamps)
(E48)	Fog lamp RH
(E59)	Vehicle security horn
(E61)	VCM (Terminal No. 58)
(E62)	VCM (Terminal No. 126)
(E67)	Electric water pump
(E76)	Daytime relay 2
(E77)	Daytime relay 1
(E84)	Daytime running light relay
(E86)	Front combination lamp RH (Terminal No. 6) (with LED headlamps)(without daytime running lights)
(E86)	Front combination lamp RH (Terminal No. 9) (with LED headlamps)

Next page

A
B
C
D
E
F
G
H
I
J
K
L
N
O
P

PG

AAMIA2465GB

GROUND

< WIRING DIAGRAM >

Previous page

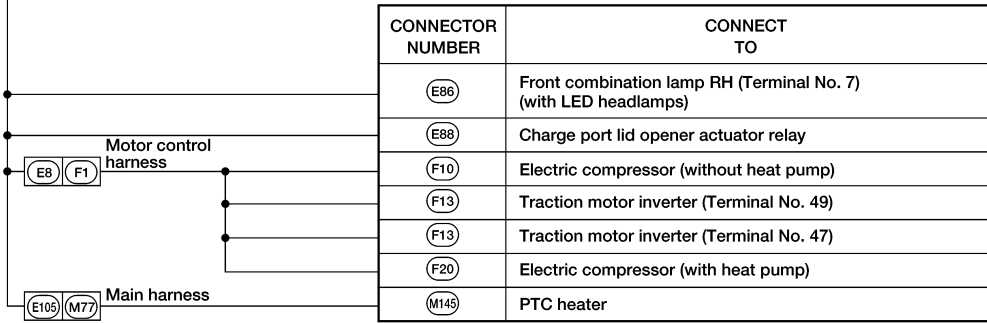

AAMIA2466GB

GROUND

< WIRING DIAGRAM >

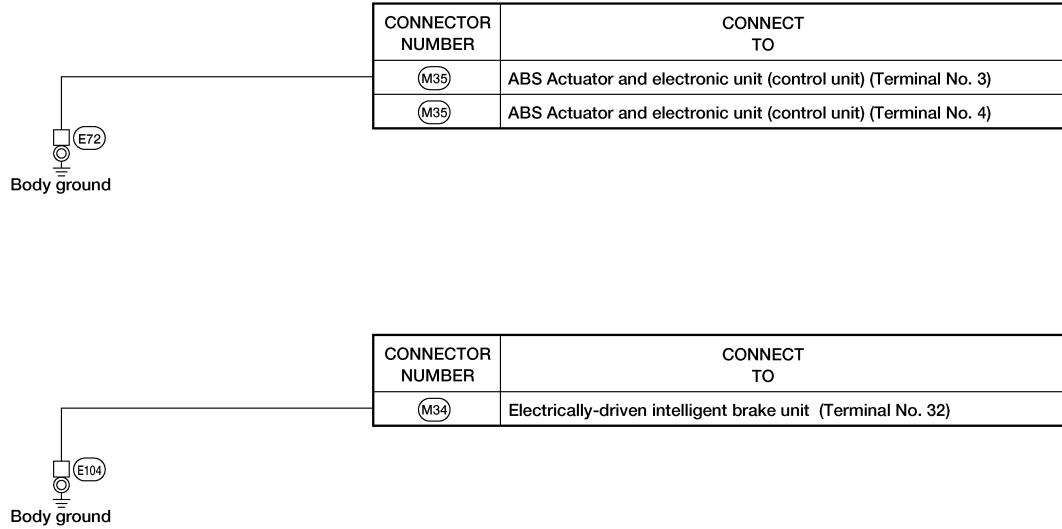
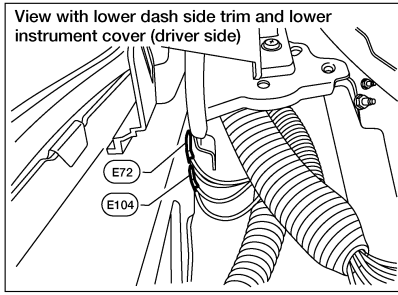

CONNECTOR NUMBER	CONNECT TO
M35	ABS Actuator and electronic unit (control unit) (Terminal No. 3)
M35	ABS Actuator and electronic unit (control unit) (Terminal No. 4)

CONNECTOR NUMBER	CONNECT TO
M34	Electrically-driven intelligent brake unit (Terminal No. 32)

A
B
C
D
E
F
G
H
I
J
K
L
PG
N
O
P

AAMIA2467GB

GROUND

< WIRING DIAGRAM >

MOTOR CONTROL HARNESS

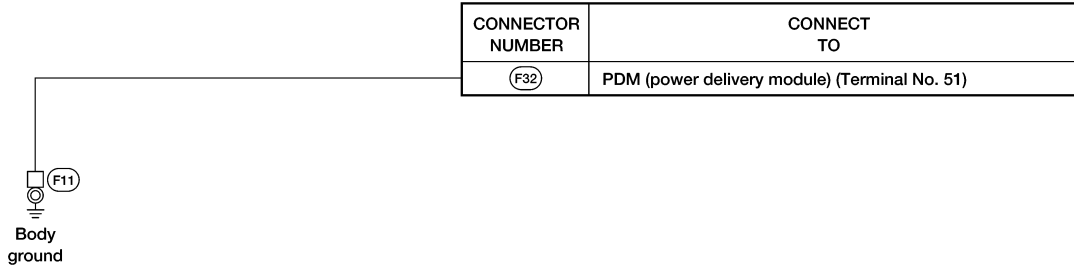
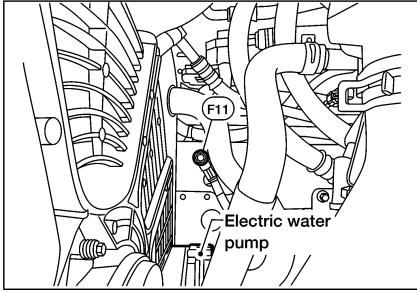

AAMIA2468GB

GROUND

< WIRING DIAGRAM >

BODY HARNESS

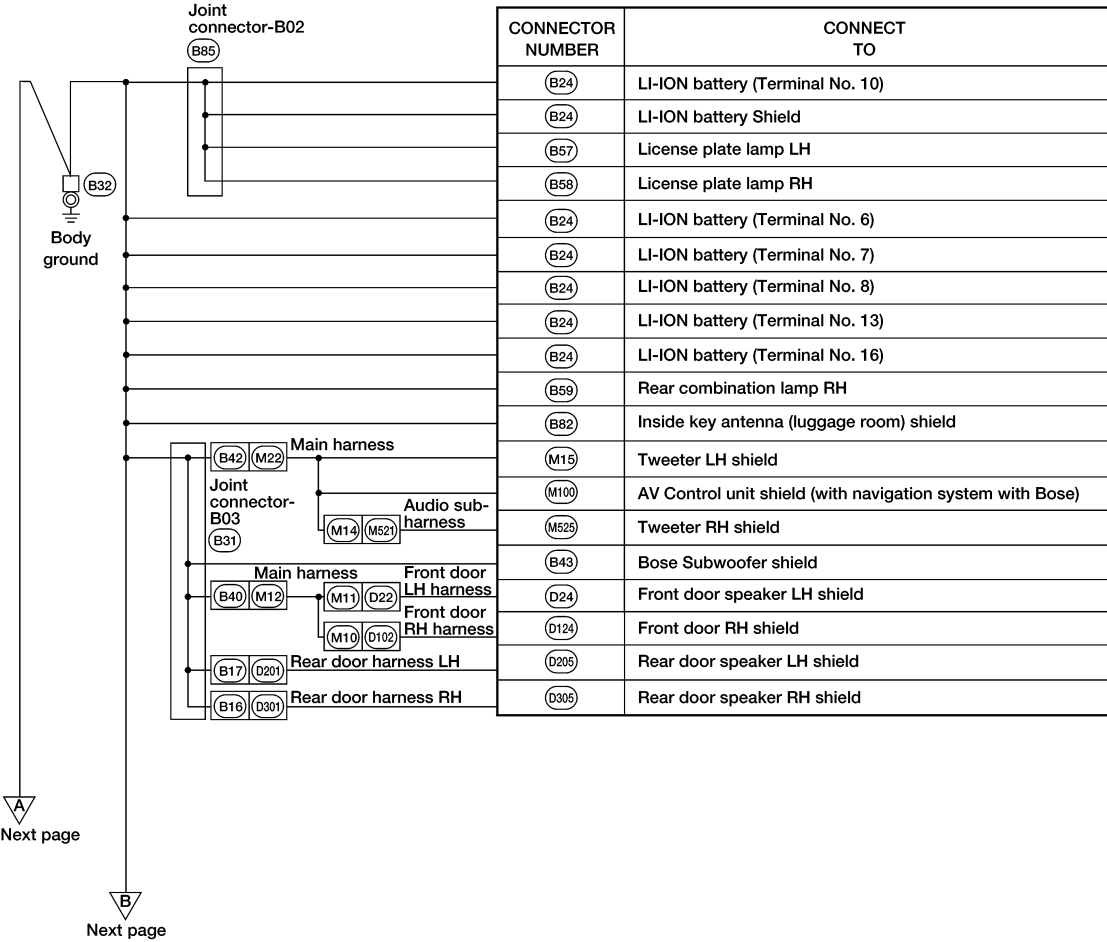
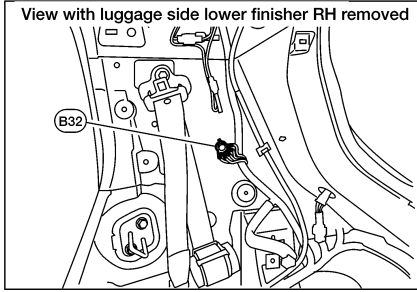

AAMIA2469GB

GROUND

< WIRING DIAGRAM >

Previous page



Previous page

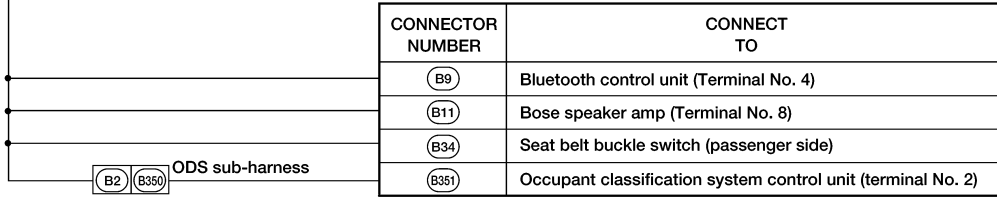

Next page

AAMIA2470GB

GROUND

< WIRING DIAGRAM >

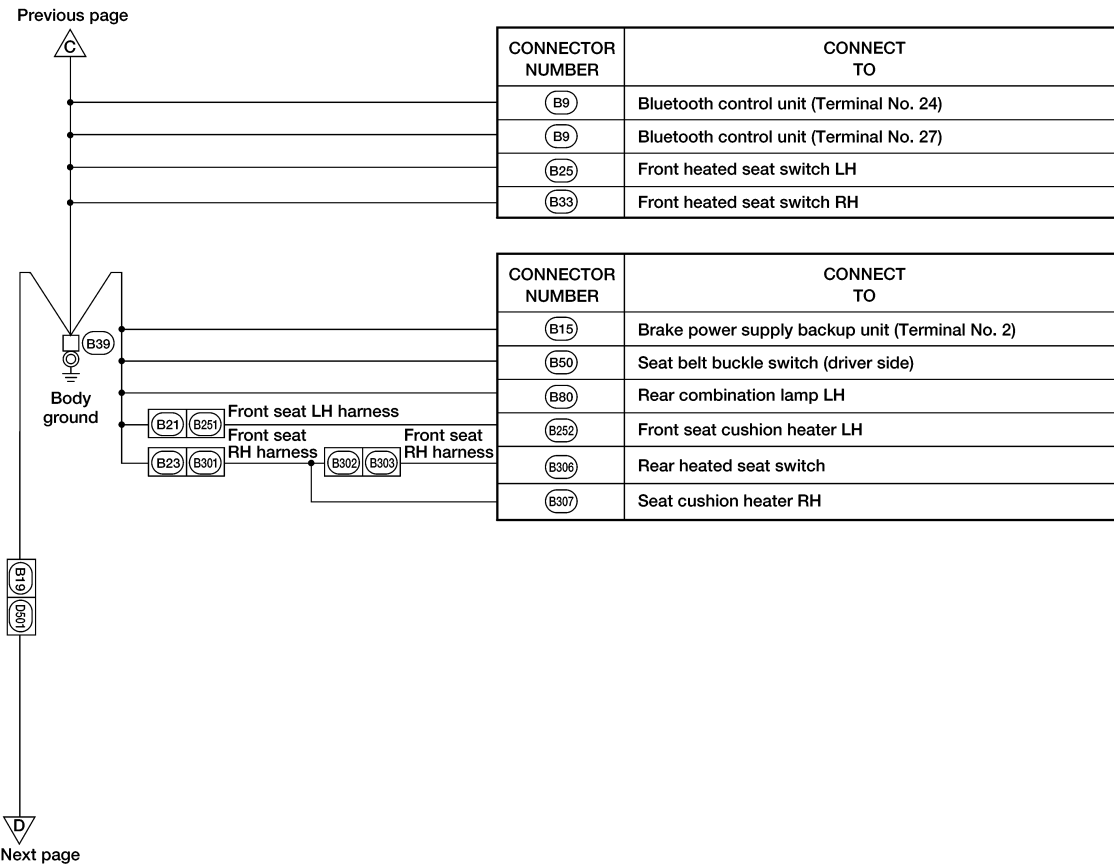
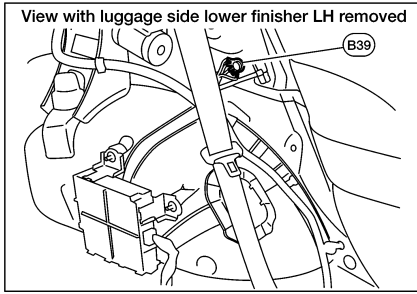

A
B
C
D
E
F
G
H
I
J
K
L

PG

N
O
P

AAMIA2471GB

GROUND

< WIRING DIAGRAM >

BACK DOOR HARNESS

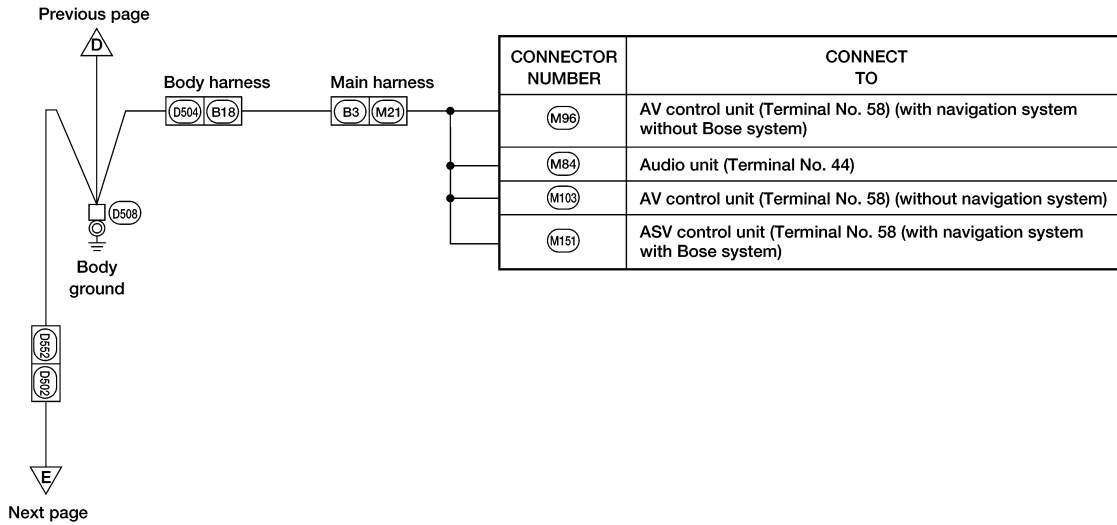
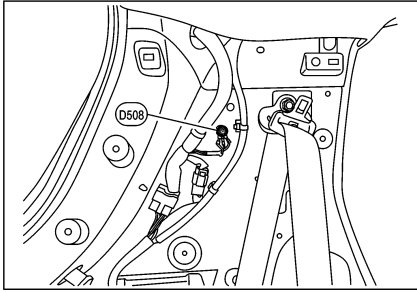

AAMIA2472GB

GROUND

< WIRING DIAGRAM >

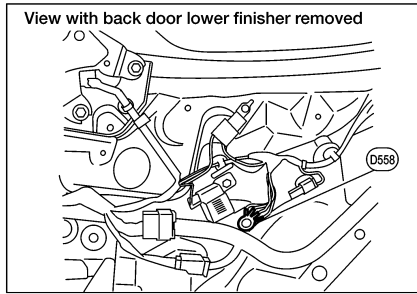

Previous page

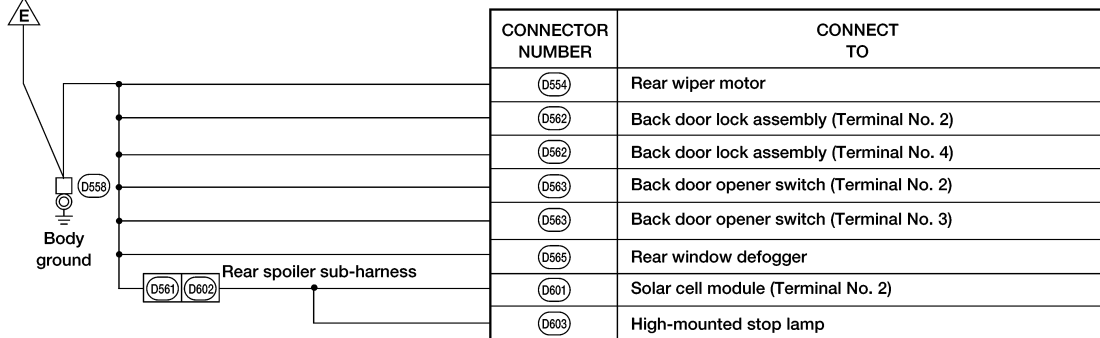

A
B
C
D
E
F
G
H
I
J
K
L
N
O
P

PG

AAMIA2473GB

GROUND

< WIRING DIAGRAM >

HIGH VOLTAGE HARNESS

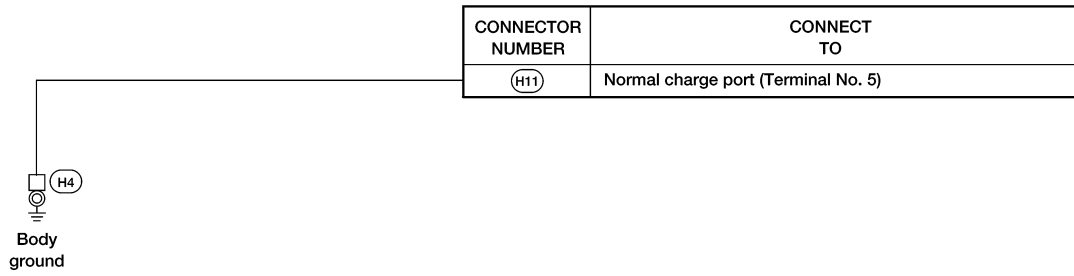

AAMIA2474GB

HARNESS

< WIRING DIAGRAM >

HARNESS

Harness Layout

INFOID:000000010641295

HOW TO READ HARNESS LAYOUT

The following Harness Layouts use a map style grid to help locate connectors on the drawings:

- Main Harness and Main Sub Harness
- Motor Room Harness and Motor Room Sub Harness
- Motor Room Harness (Passenger Compartment)
- Motor Control Harness
- Body Harness and Rear Wheel Speed Sensor Sub Harness
- Room Lamp Harness
- High Voltage Harness

To use the grid reference

1. Find the desired connector number on the connector list.
2. Find the grid reference.
3. On the drawing, find the crossing of the grid reference letter column and number row.
4. Find the connector number in the crossing zone.
5. Follow the line (if used) to the connector.

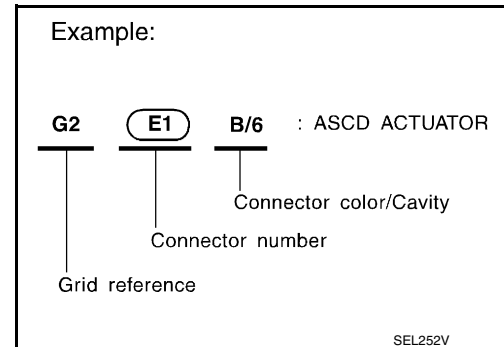

OUTLINE

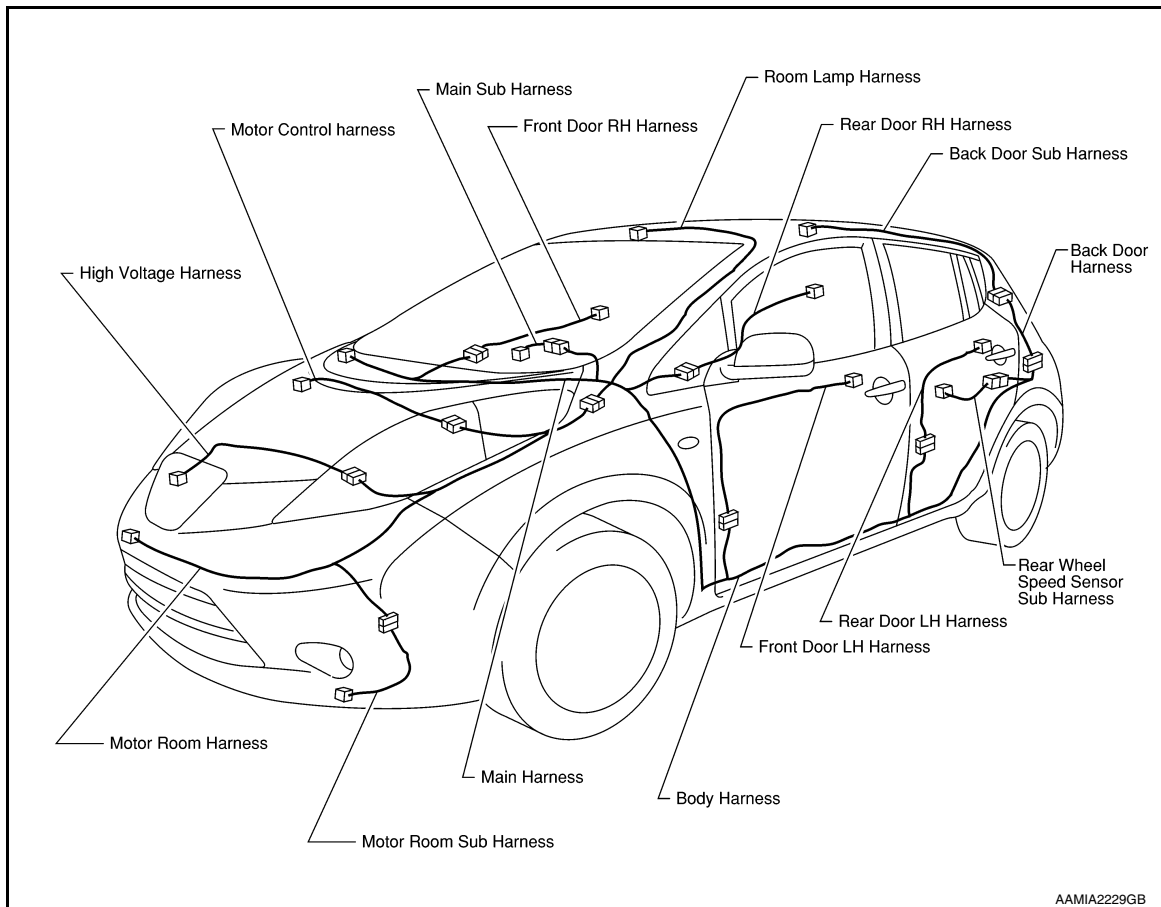

AAMIA2229GB

A
B
C
D
E
F
G
H
I
J
K
L
PG
N
O
P

HARNESS

< WIRING DIAGRAM >

MAIN HARNESS

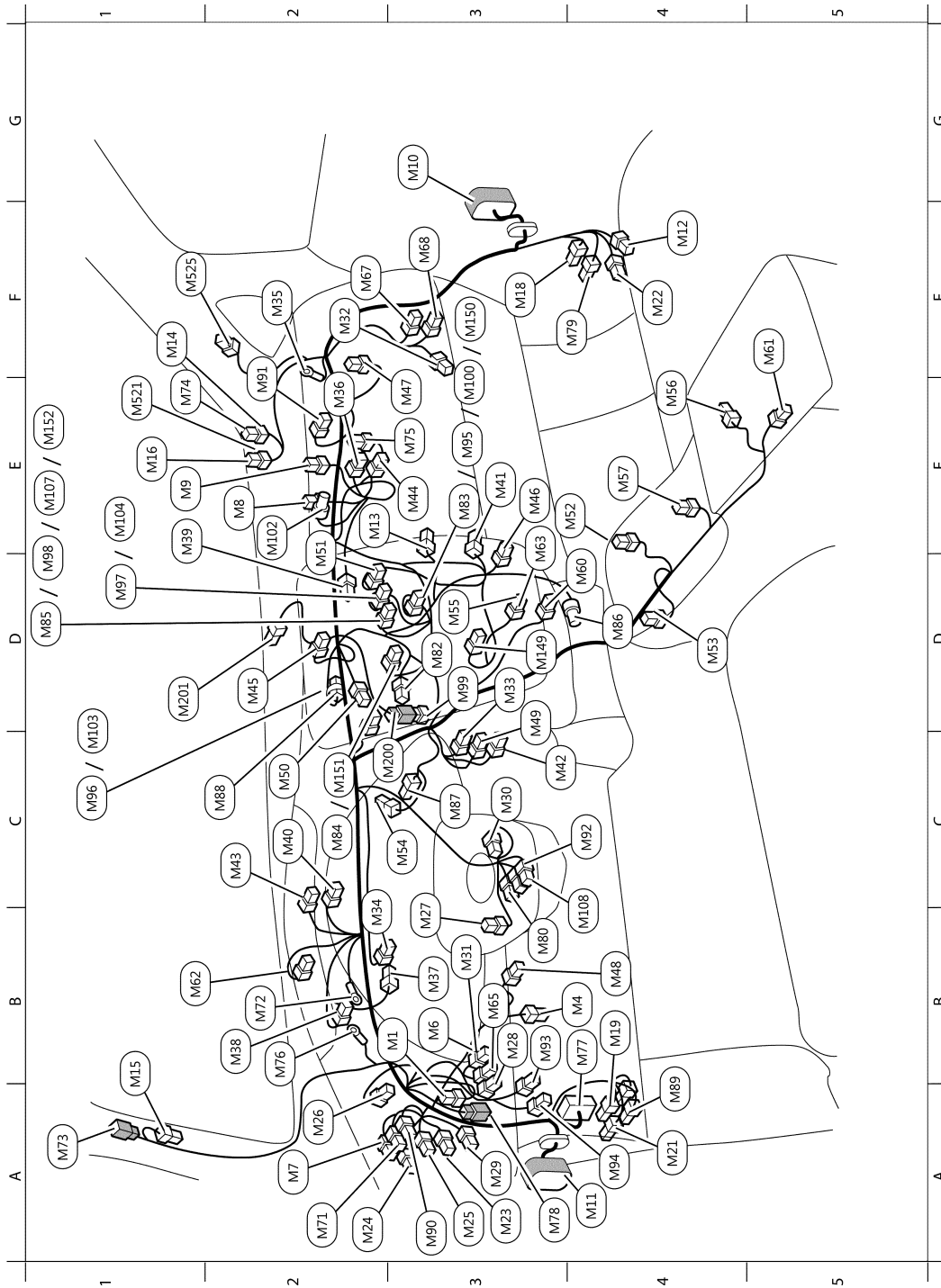

AAMIA0290ZZ

B3	M1	W/1	: Fuse block (J/B)	E4	M57	W/12	: Electric shift sensor
B4	M4	W/16	: Data link connector	D4	M60	B/3	: Power socket
B3	M6	L/8	: Heated steering wheel switch	F5	M61	Y/28	: Air bag diagnosis sensor unit
A2	M7	L/4	: Heated steering wheel relay	B2	M62	W/8	: Upper meter

HARNESS

< WIRING DIAGRAM >

E2	M8	B/2	: Front passenger air bag module	E3	M63	B/5	: Front passenger air bag off indicator	A
E1	M9	O/2	: Front passenger air bag module	B3	M65	GR/8	: Immediate charging switch	
A4	M11	W/55	: To D22	F2	M67	W/40	: TCU	B
F4	M12	W/8	: To B40	F3	M68	GR/17	: TCU	
E2	M13	BR/2	: Warning buzzer	A2	M71	L/4	: Heated seat relay	C
F2	M14	BR/2	: To M505	B2	M72	—	: Body ground	
A1	M15	BR/2	: Tweeter LH	A1	M73	W/16	: To R1	D
E1	M16	W/3	: Optical sensor	F1	M74	W/2	: Sunload sensor	
F3	M18	W/16	: To B1	E3	M75	W/4	: Remote keyless entry receiver	E
B4	M19	W/16	: To B2	B2	M76	—	: Body ground	
A4	M21	W/32	: To B3	B4	M77	SMJ	: To E105	F
F4	M22	W/24	: To B42	A3	M78	B/2	: To E106	
A3	M23	W/40	: BCM (Body control module)	F4	M79	W/32	: To B4	G
A2	M24	B/40	: BCM (Body control module)	B3	M80	W/2	: Combination switch	
A3	M25	W/15	: BCM (Body control module)	D3	M82	W/4	: To M143	H
A2	M26	W/12	: Meter control switch	E3	M83	W/20	: Audio unit	
B3	M27	W/16	: Combination switch	C1	M84	W/32	: Audio unit	I
B3	M28	B/8	: VDC off switch	D1	M85	L/5	: Audio unit	
A3	M29	B/15	: BCM (Body control module)	D4	M86	L/2	: Inside key antenna (Instrument center)	J
C3	M30	W/8	: Steering angle sensor	C3	M87	W/24	: To M140	
B3	M31	W/8	: Approaching vehicle sound for pedestrians (VSP) off switch	C2	M88	W/2	: Diode-3	K
E3	M32	W/40	: Around view monitor control unit	A4	M89	W/2	: To B6	
D3	M33	W/8	: Power switch	A3	M90	L/4	: Rear heated seat relay	L
B2	M34	W/40	: Combination meter	E2	M91	W/4	: Dongle unit	
F2	M35	—	: Body ground	C4	M92	GR/8	: Combination switch (Spiral cable)	PG
E2	M36	GR/20	: Joint connector-M02	B3	M93	G/8	: Charge port lid opener switch	
B3	M37	W/8	: EPS control unit	A4	M94	GR/10	: Charge connector lock switch	N
B2	M38	B/2	: EPS control unit	E3	M95	W/20	: AV control unit (With navigation system without BOSE)	
E1	M39	GR/2	: Blower motor	D1	M96	W/40	: AV control unit (With navigation system without BOSE)	O
C2	M40	L/20	: Joint connector-M05	D1	M97	GR/17	: AV control unit (With navigation system without BOSE)	
E3	M41	L/20	: Joint connector-M06	D1	M98	L/5	: AV control unit (With navigation system without BOSE)	P
C3	M42	W/2	: In-vehicle sensor	D3	M99	W/4	: To M200	
C2	M43	GR/20	: Joint connector-M04	E3	M100	W/20	: AV control unit (With navigation system with BOSE)	
E3	M44	GR/20	: Joint connector-M01	E2	M102	W/16	: Heater pump control unit	
D2	M45	W/4	: Hazard switch	D1	M103	W/40	: AV control unit (With navigation system with BOSE)	
E3	M46	O/20	: Joint connector-M07	E1	M104	GR/17	: AV control unit (With navigation system with BOSE)	
E3	M47	W/16	: Approaching vehicle sound for pedestrians (VSP) control unit	E1	M107	B/5	: AV control unit (With navigation system with BOSE)	
B4	M48	B/2	: Start up sound speaker	F3	M150	W/20	: AV control unit (Without navigation system)	

HARNESS

< WIRING DIAGRAM >

D3	M49	W/4	: NATS antenna amp.	C2	M151	W/40	: AV control unit (Without navigation system)
C2	M50	P/20	: Joint connector-M03	E1	M152	L/5	: AV control unit (Without navigation system)
E2	M51	W/8	: Multifunction switch	B4	M108	Y/6	: Combination switch (Spiral cable)
E4	M52	W/4	: Auxiliary input jack	Main sub harness			
D4	M53	G/5	: USB connector	C2	M200	W/4	: To M99
C2	M54	B/16	: Intake door motor	D1	M201	W/4	: Charging status indicator
D3	M55	W/40	: A/C auto amp.	E1	M521	BR/1	: To M14
E4	M56	W/8	: Selector indicator	F1	M525	BR/2	: Tweeter RH

HARNESS

< WIRING DIAGRAM >

MOTOR ROOM HARNESS

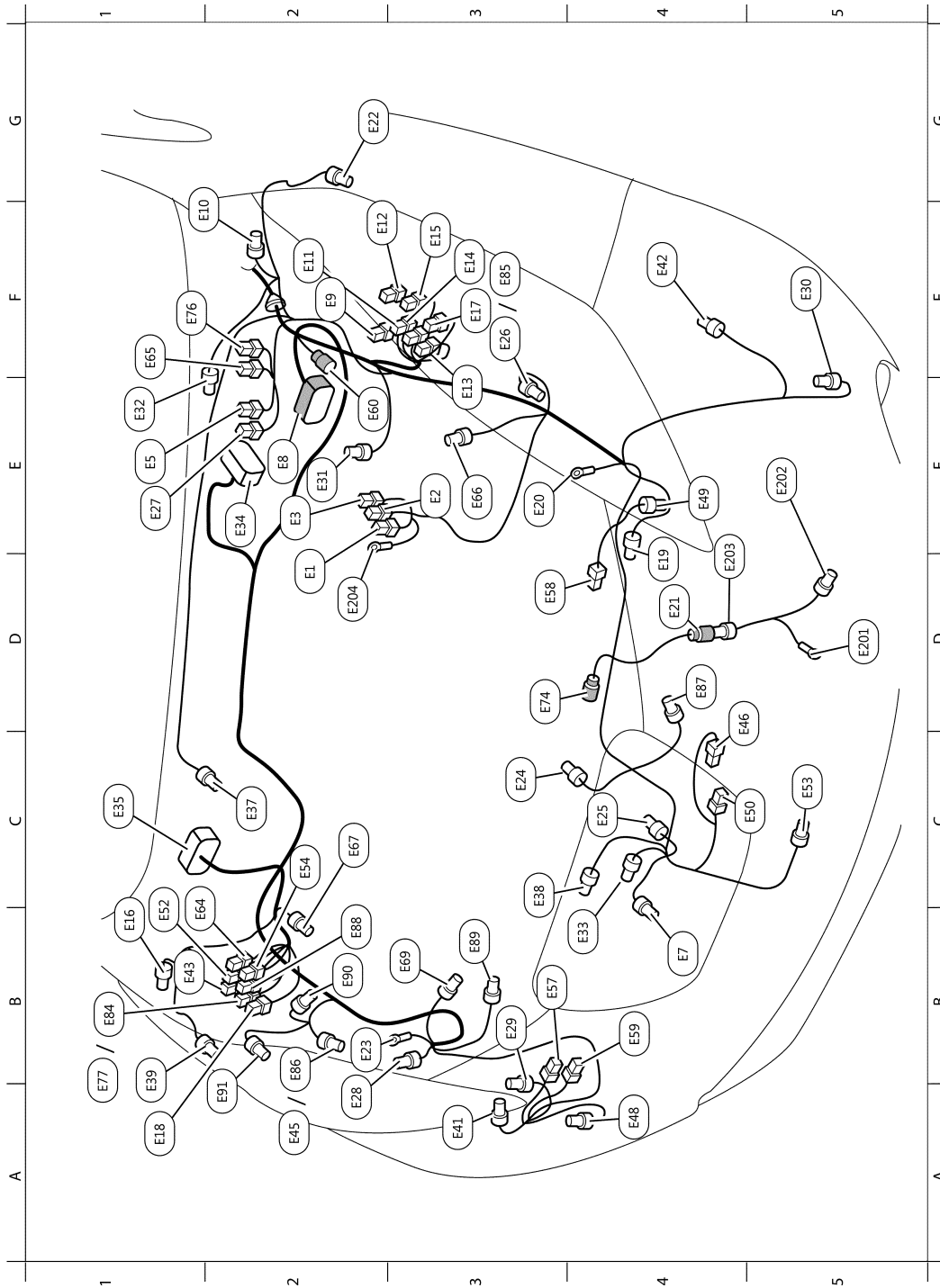

AAMIA0291ZZ

D2	E1	GR/2	: Fusible link box (Battery)	A3	E41	GR/2	: Washer pump
E3	E2	BR/2	: Fusible link box (Battery)	F4	E42	B/2	: Approaching vehicle sound for pedestrians (VSP) speaker
E2	E3	B/1	: Battery terminal with fusible link	B1	E43	L/4	: Power socket relay
E1	E5	W/3	: Anti theft horn relay	A2	E45	GR/6	: Front combination lamp RH (With halogen headlamps)

HARNESS

< WIRING DIAGRAM >

B4	E7	B/10	: Quick charge port	D4	E46	B/1	: Horn (Low)
E2	E8	B/52	: To F1	A4	E48	B/2	: Front fog lamp RH
F2	E9	B/2	: IPDM E/R (Intelligent power distribution module engine room)	E4	E49	B/3	: Refrigerant pressure sensor (With heat pump)
F1	E10	GR/2	: Front side marker lamp LH	C5	E50	B/1	: Horn (Low)
F2	E11	B/6	: IPDM E/R (Intelligent power distribution module engine room)	C1	E52	BR/6	: A/C relay
F2	E12	BR/8	: IPDM E/R (Intelligent power distribution module engine room)	C5	E53	B/2	: Ambient sensor
E3	E13	W/12	: IPDM E/R (Intelligent power distribution module engine room)	C2	E54	L/4	: Parking actuator relay
F3	E14	BR/12	: IPDM E/R (Intelligent power distribution module engine room)	B3	E57	BR/1	: Vehicle security horn
F3	E15	W/16	: IPDM E/R (Intelligent power distribution module engine room)	D3	E58	B/24	: Joint connector-E03
B1	E16	GR/2	: Front side marker lamp RH	B4	E59	B/1	: Vehicle security horn
F3	E17	B/10	: IPDM E/R (Intelligent power distribution module engine room)	E2	E60	B/12	: To F2
A1	E18	B/4	: Cooling fan relay	C1	E64	L/4	: F/S chg relay
D4	E19	GR/3	: Cooling fan control module	F1	E65	L/4	: M/C relay
E3	E20	—	: Body ground	E3	E66	B/4	: Battery current sensor
D4	E21	B/4	: To E203	C2	E67	G/4	: Electric water pump
G2	E22	B/2	: Front wheel sensor LH	B3	E69	GR/2	: Coolant temperature sensor
B2	E23	—	: Body ground	D3	E74	GR/2	: Hood switch
C3	E24	GR/2	: Charge port light	F1	E76	B/5	: Daytime light relay 2
C4	E25	B/2	: Normal charge port	B1	E77	L/4	: Daytime light relay 1
F3	E26	GR/6	: Front combination lamp LH (With halogen headlamps)	B1	E84	B/5	: Daytime running light relay
E1	E27	L/4	: Reverse lamp relay	F3	E85	B/10	: Front combination lamp LH (With LED headlamps)
A2	E28	BR/3	: Intelligent Key warning buzzer	B2	E86	B/10	: Front combination lamp RH (With LED headlamps)
B3	E29	BR/2	: Washer level switch	D4	E87	GR/4	: Charging connector lock actuator
F5	E30	B/2	: Front fog lamp LH	B2	E88	L/4	: Charging port opener actuator relay
E2	E31	B/3	: Master cylinder pressure sensor	B3	E89	BR/2	: Compressor suction refrigerant temperature sensor
E1	E32	GR/5	: Front wiper motor	B2	E90	GR/2	: Refrigerant channel switching 2 way type valve
B4	E33	Y/2	: Crash zone sensor	A2	E91	B/2	: Refrigerant channel switching 3 way type valve
E2	E34	B/46	: Electrically-driven intelligent brake unit	Motor room sub harness			
C1	E35	B/32	: ABS actuator and electric unit (Control unit)	D5	E201	—	: PDM (Power delivery module)
C2	E37	GR/2	: Brake fluid level switch	E5	E202	B/4	: Front camera
C3	E38	B/4	: Charge port lid opener actuator	D4	E203	B/4	: To E21
B1	E39	B/2	: Front wheel sensor RH	D3	E204	—	: Fusible link box (Battery)

HARNESS

< WIRING DIAGRAM >

MOTOR ROOM HARNESS (PASSENGER COMPARTMENT)

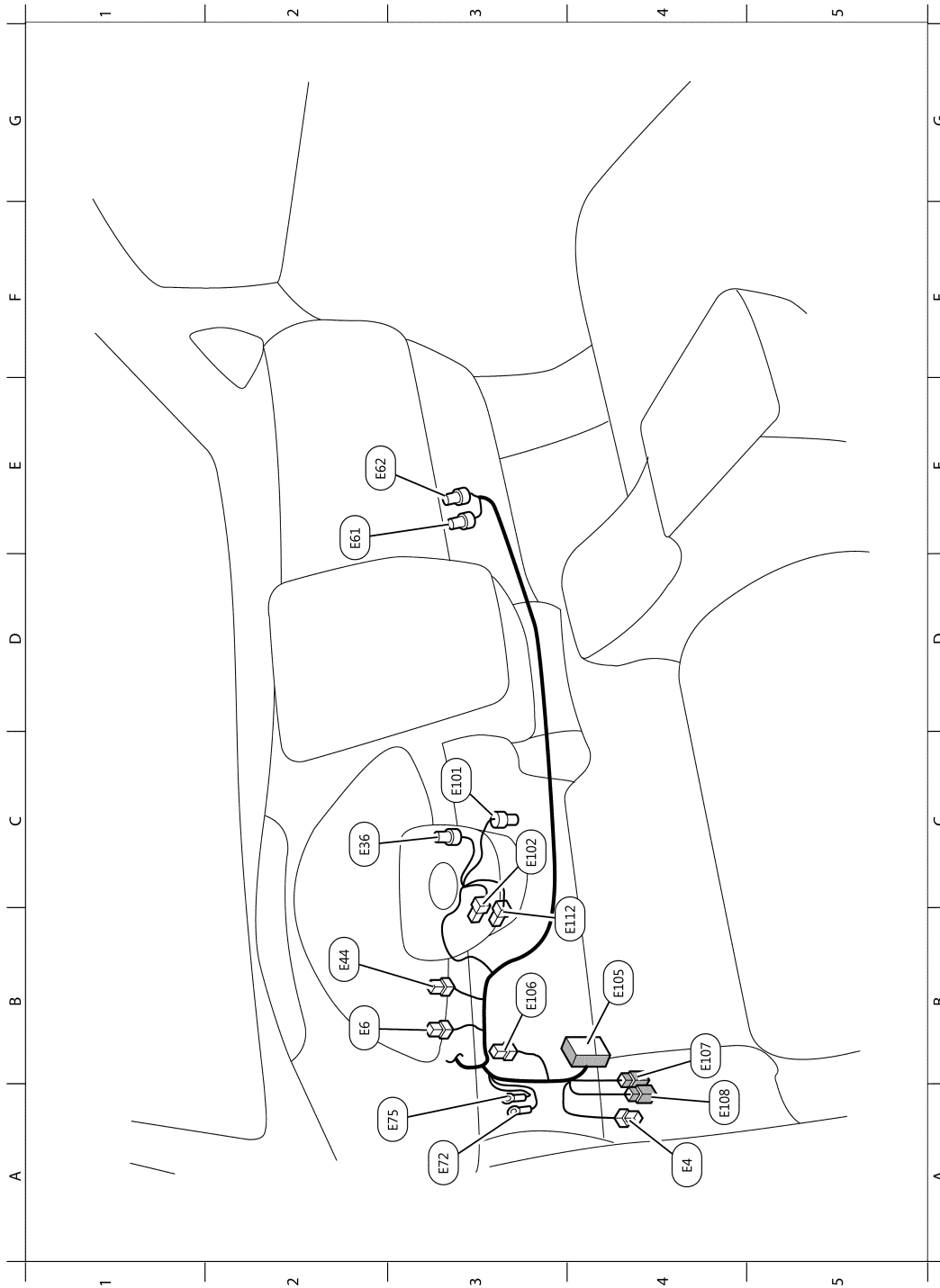

AAMIA0292ZZ

A4	E4	B/1	: Parking brake switch	C3	E101	B/6	: Accelerator pedal position sensor
B2	E6	L/12	: Joint connector-E01	C3	E102	W/4	: Stop lamp switch
C2	E36	B/4	: Stroke sensor	B4	E105	SMJ	: To M77
B2	E44	L/12	: Joint connector-E02	B3	E106	B/2	: To M78
E2	E61	B/65	: VCM	B4	E107	W/24	: To B7

HARNESS

< WIRING DIAGRAM >

E2	E62	BR/65	: VCM	A4	E108	W/4	: To B8
A3	E72	—	: Body ground	B4	E112	BR/2	: Brake pedal position switch
A3	E75	—	: Body ground				

MOTOR CONTROL HARNESS

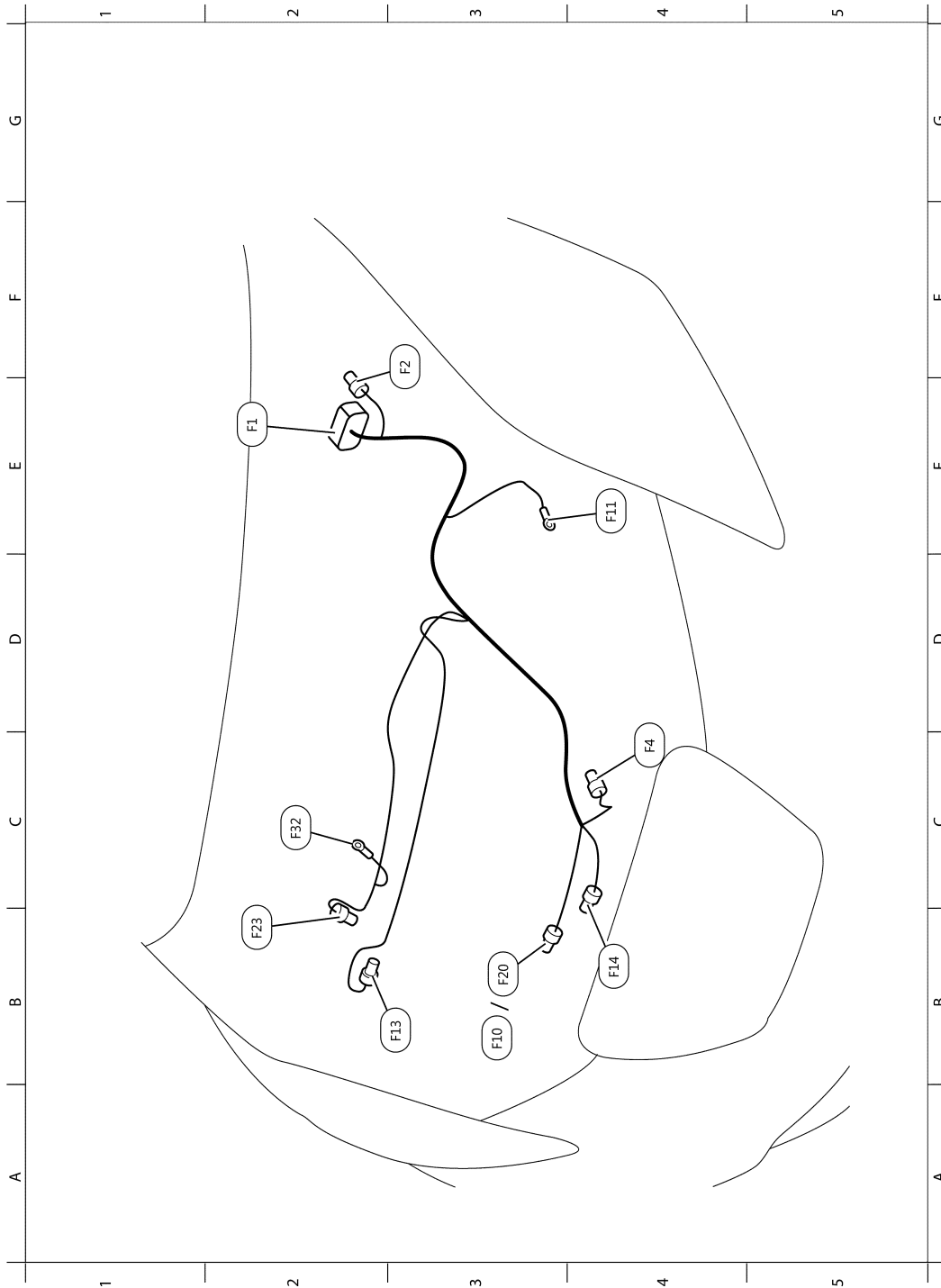

AAMIA0293ZZ

E2	F1	B/52	: To E8	B3	F13	B/49	: Traction motor inverter
F3	F2	B/12	: To E60	B4	F14	B/8	: Traction motor

HARNES

< WIRING DIAGRAM >

C4	F4	B/10	: Parking actuator	B3	F20	B/6	: Electric compressor (With heat pump)
B3	F10	W/6	: Electric compressor (Without heat pump)	B2	F23	G/36	: PDM (Power delivery module)
E4	F11	—	: Body ground	C2	F32	—	: PDM (Power delivery module)

BODY HARNESS (LH SIDE)

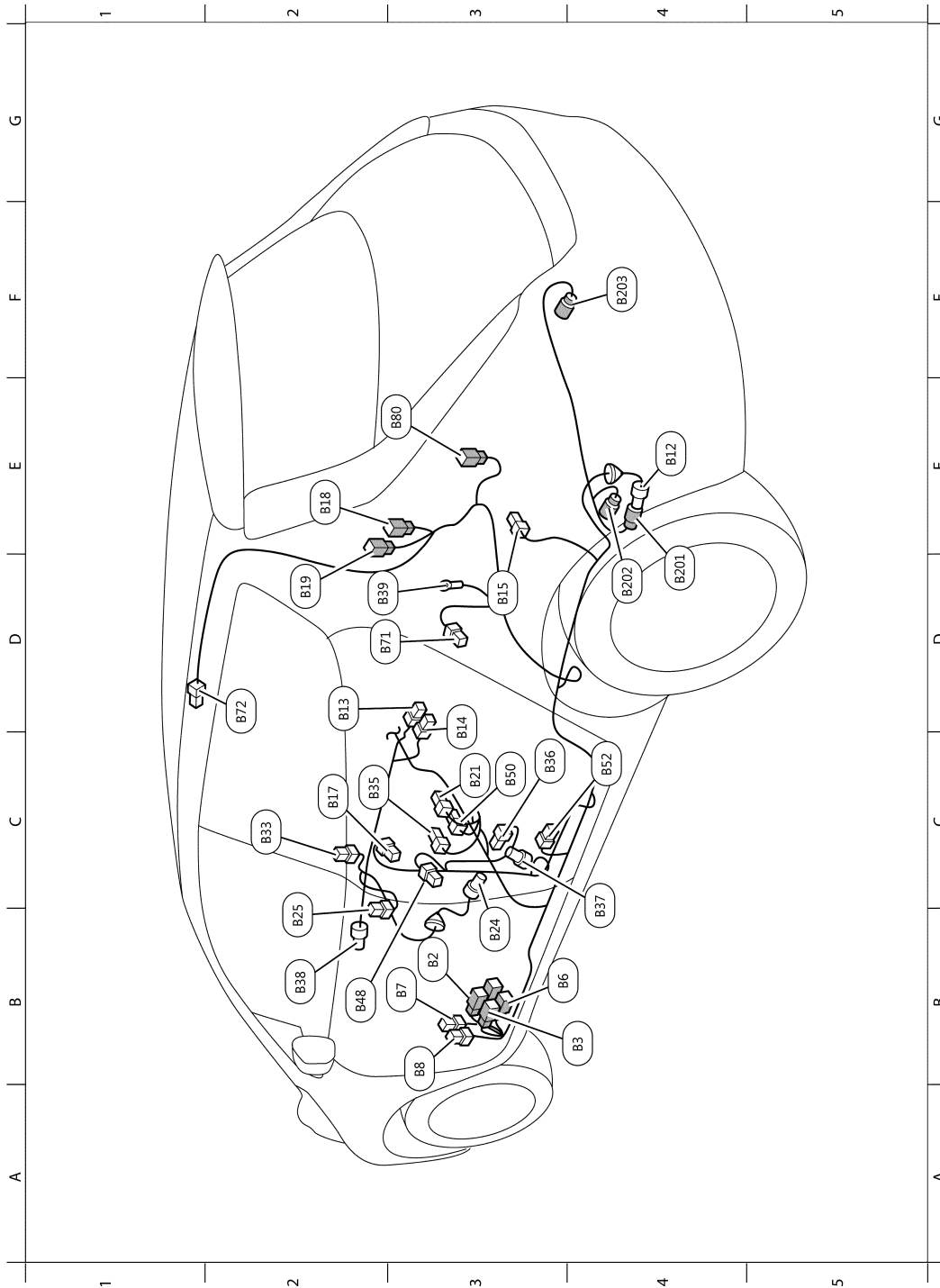

AAMIA0294ZZ

B3	B2	W/16	: To M19	C2	B35	Y/2	: Front LH side air bag module
B4	B3	W/32	: To M21	C3	B36	Y/2	: Front LH seat belt pre-tensioner

A
B
C
D
E
F
G
H
I
J
K
L
PG
N
O
P

HARNES

< WIRING DIAGRAM >

B3	B6	W/2	: To M89	C4	B37	Y/2	: LH side air bag (Satellite) sensor
B3	B7	W/24	: To E107	B2	B38	B/6	: Yaw rate/side/decel G sensor
B3	B8	W/4	: To E108	D2	B39	—	: Body ground
E4	B12	B/10	: To B201	B2	B48	W/4	: Front door switch (Driver side)
D2	B13	Y/22	: Air bag diagnosis sensor unit	C3	B50	W/3	: Seat belt buckle switch (Driver side)
D3	B14	Y/22	: Air bag diagnosis sensor unit	C4	B52	O/2	: Lap seat belt pre-tensioner (Driver side)
D3	B15	W/6	: Brake power supply backup unit	D2	B71	W/4	: Rear door switch LH
C2	B17	W/12	: To D201	D2	B72	Y/2	: LH side front curtain air bag module
E2	B18	W/20	: To D504	E3	B80	W/6	: Rear combination lamp LH
D2	B19	W/4	: To D501	Rear wheel sensor sub harness			
C3	B21	W/4	: To B251	D4	B201	B/10	: To B12
B3	B24	G/36	: Li-ion battery	D4	B202	GR/2	: Rear wheel sensor LH
B2	B25	W/6	: Front heated seat switch LH	F4	B203	GR/2	: Rear wheel sensor RH
C2	B33	BR/6	: Front heated seat switch RH				

HARNESS

< WIRING DIAGRAM >

BODY HARNESS (RH SIDE)

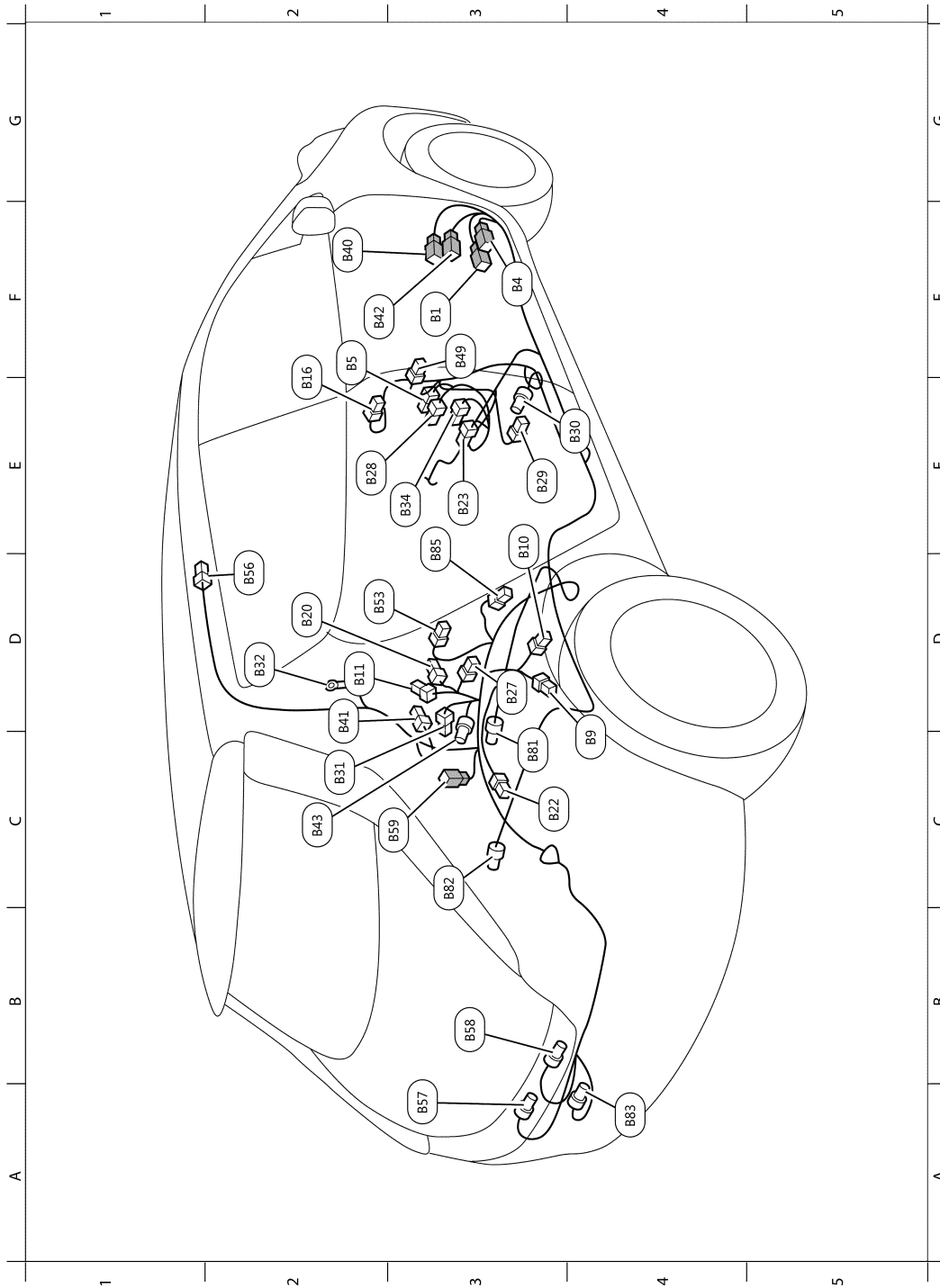

AAMIA0295ZZ

F3	B1	W/16	: To M18	E3	B34	W/2	: Seat belt buckle switch (Passenger side)
F3	B4	W/32	: To M79	F2	B40	W/8	: To M12
F2	B5	W/4	: To B350	D2	B41	W/2	: Luggage room lamp
C4	B9	W/32	: Bluetooth® control unit	F2	B42	W/24	: To M22
E3	B10	W/8	: Bluetooth® control unit	C2	B43	GR/2	: BOSE subwoofer

A
B
C
D
E
F
G
H
I
J
K
L
M
N
O
P

PG

HARNESS

< WIRING DIAGRAM >

D2	B11	B/8	: BOSE speaker amp.	F3	B49	W/4	: Front door switch (Passenger side)
F2	B16	W/12	: To D301	D2	B53	W/4	: Rear door switch RH
D2	B20	B/16	: BOSE speaker amp.	D2	B56	Y/2	: RH side front curtain air bag module
C3	B22	W/3	: To B401	A3	B57	BR/2	: License plate lamp LH
E3	B23	W/8	: To B301	B3	B58	BR/2	: License plate lamp RH
D3	B27	B/16	: BOSE speaker amp.	C3	B59	W/6	: Rear combination lamp RH
E2	B28	Y/2	: Front RH side air bag module	C3	B81	L/2	: Inside key antenna (Rear seat)
E3	B29	Y/2	: Front RH seat belt pre-tensioner	C3	B82	L/2	: Inside key antenna (Luggage room)
E4	B30	Y/2	: RH side air bag (Satellite) sensor	A4	B83	L/2	: Outside key antenna (Rear bumper)
C2	B31	B/20	: Joint connector-B03	E3	B85	B/20	: Joint connector-B02
D2	B32	—	: Body ground				

HARNESS

< WIRING DIAGRAM >

ROOM LAMP HARNESS

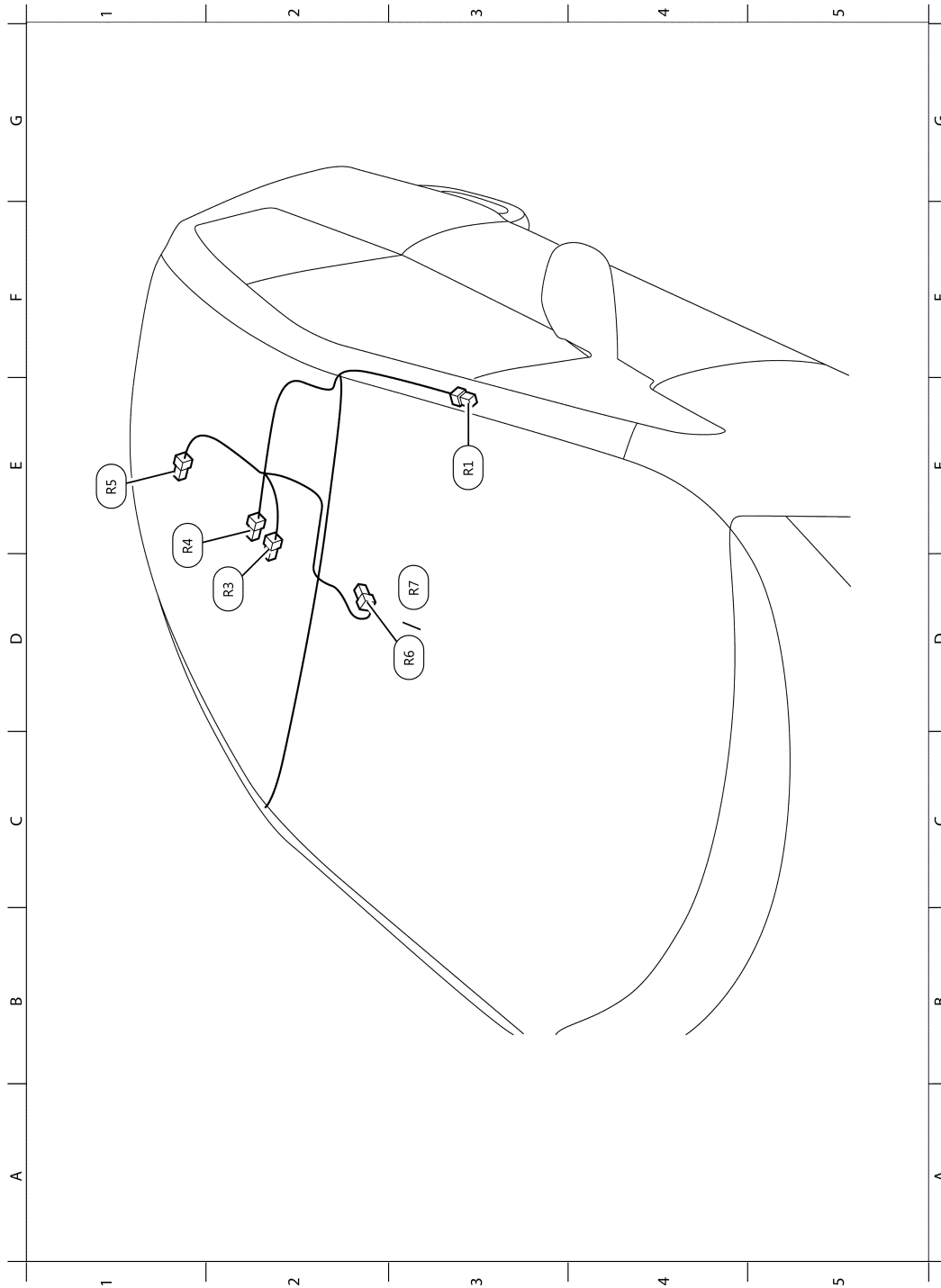

AAMIA0296ZZ

E3	R1	W/16	: To M73	E1	R5	W/3	: Room lamp
D2	R3	W/6	: Microphone	D3	R6	B/7	: Auto anti-dazzling inside mirror (Without universal homelink transceiver)
E1	R4	W/8	: Map lamp	D3	R7	B/10	: Auto anti-dazzling inside mirror (With universal homelink transceiver)

A
B
C
D
E
F
G
H
I
J
K
L
PG
N
O
P

HARNESS

< WIRING DIAGRAM >

FRONT DOOR LH HARNESS

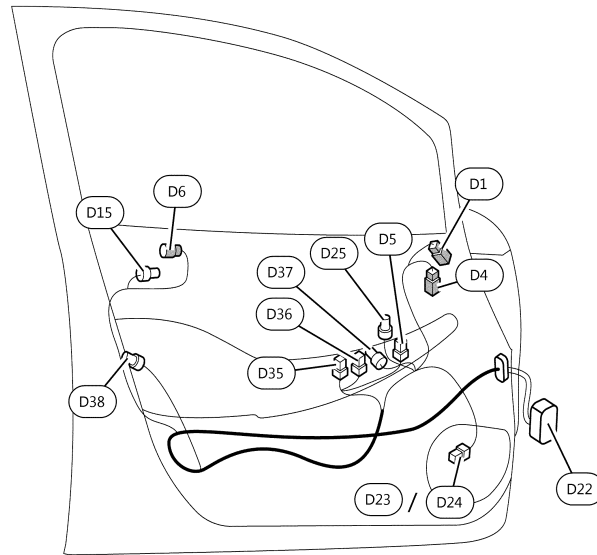

AAMIA0297ZZ

D1	W/4	: Side camera LH	D24	BR/2	: Front door speaker LH (With BOSE audio system)
D4	W/8	: Door mirror LH	D25	Y/2	: Front door satellite sensor LH
D5	W/16	: Door mirror remote control switch	D35	W/16	: Power window main switch
D6	L/2	: Outside key antenna (Driver side)	D36	W/3	: Power window main switch
D15	B/2	: Front door request switch (Driver side)	D37	G/6	: Front power window motor LH (Driver side)
D22	W/55	: To M11	D38	GR/6	: Front door lock assembly (Driver side)
D23	W/2	: Front door speaker LH (Without BOSE audio system)			

HARNESS

< WIRING DIAGRAM >

FRONT DOOR RH HARNESS

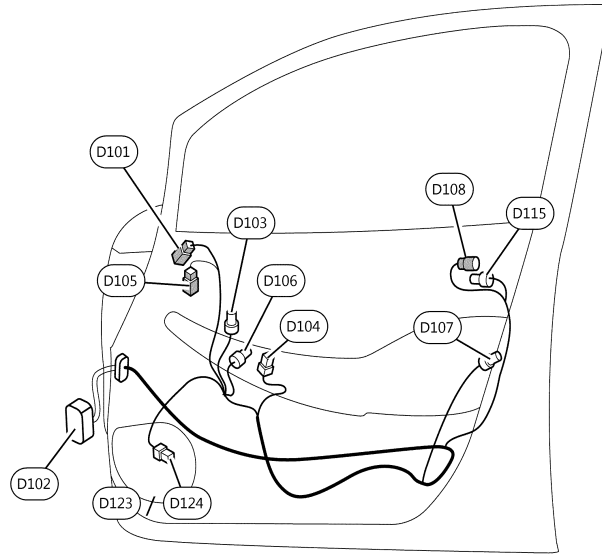

AAMIA0298ZZ

D101	W/4	: Side camera RH	D107	GR/6	: Front door lock assembly (Passenger side)
D102	W/55	: To M10	D108	L/2	: Outside key antenna (Passenger side)
D103	Y/2	: Front door satellite sensor RH	D115	B/2	: Front door request switch (Passenger side)
D104	W/12	: Front power window switch (Passenger side)	D123	W/2	: Front door speaker RH (Without BOSE audio system)
D105	W/8	: Door mirror RH	D124	BR/2	: Front door speaker RH (With BOSE audio system)
D106	G/6	: Front power window motor (Passenger side)			

A
B
C
D
E
F
G
H
I
J
K
L
PG
N
O
P

HARNESS

< WIRING DIAGRAM >

REAR DOOR LH HARNESS

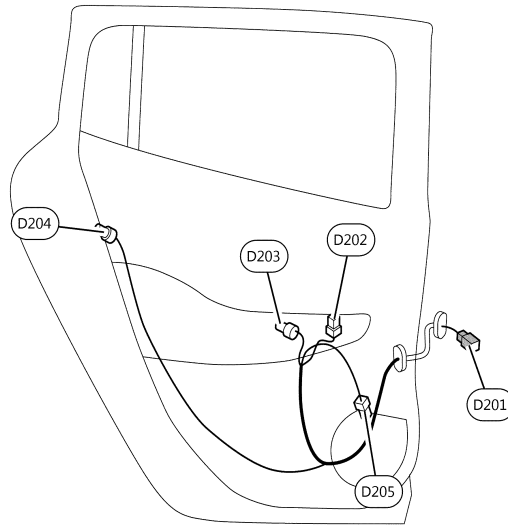

AAMIA0299ZZ

D201	W/12	: To B17	D204	GR/6	: Rear door lock assembly LH
D202	W/8	: Rear power window switch LH	D205	W/2	: Rear door speaker LH
D203	G/6	: Rear power window motor LH			

HARNESS

< WIRING DIAGRAM >

REAR DOOR RH HARNESS

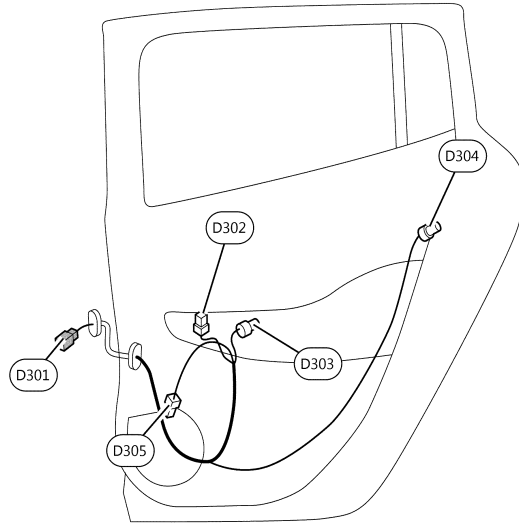

AAMIA0300ZZ

D301	W/12	: To B16	D304	GR/6	: Rear door lock assembly RH
D302	W/8	: Rear power window switch RH	D305	W/2	: Rear door speaker RH
D303	G/6	: Rear power window motor RH			

A
B
C
D
E
F
G
H
I
J
K
L
PG
N
O
P

HARNESS

< WIRING DIAGRAM >

BACK DOOR HARNESS

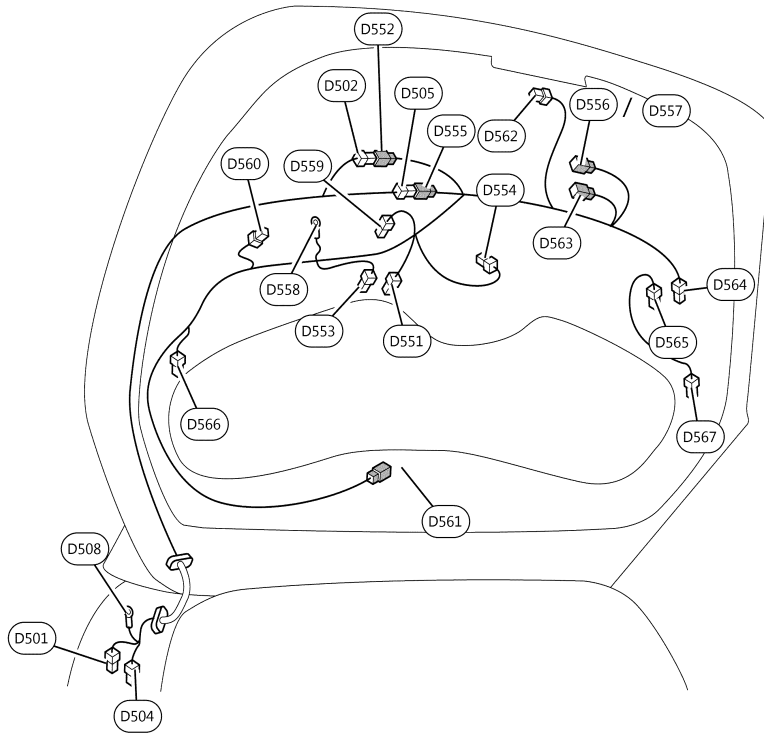

AAMIA0301ZZ

D501	W/4	: To B19	D557	W/8	: Rear view camera (With around view monitor)
D502	W/2	: To D552	D558	—	: Body ground
D504	W/20	: To B18	D559	W/1	: Coil
D505	W/12	: To D555	D560	W/4	: Coil
D508	—	: Body ground	D561	W/4	: To D602
Back door sub harness			D562	W/4	: Back door lock assembly
D551	B/1	: Condenser	D563	GR/4	: Back door opener switch assembly
D552	W/2	: To D502	D564	B/1	: Condenser-1
D553	B/1	: Condenser	D565	B/1	: Rear window defogger
D554	W/4	: Rear wiper motor	D566	B/1	: Condenser-1
D555	W/12	: To D505	D567	B/1	: Rear window defogger
D556	W/4	: Rear view camera (Without around view monitor)			

HARNESS

< WIRING DIAGRAM >

HIGH VOLTAGE HARNESS

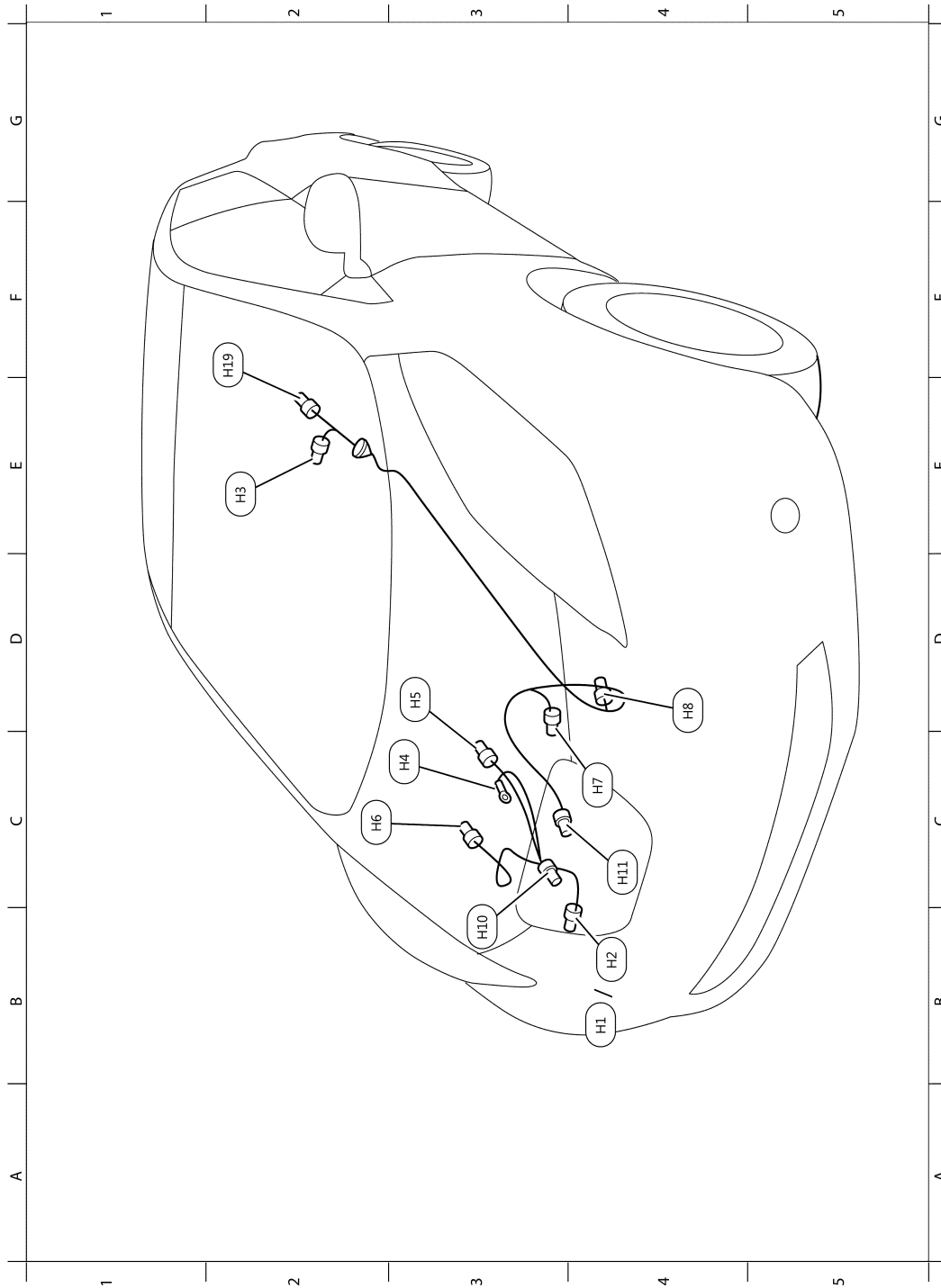

AAMIA0302ZZ

B4	H1	O/4	: Electric compressor (Without heat pump)	C4	H7	O/4	: PDM (Power delivery module)
B4	H2	O/3	: Electric compressor (With heat pump)	D4	H8	O/2	: PDM (Power delivery module)
E2	H3	O/3	: Li-ion battery	B3	H10	O/2	: Quick charge port
C3	H4	—	: Body ground	C4	H11	O/3	: Normal charge port

HARNESS

< WIRING DIAGRAM >

D3	H5	O/3	: PDM (Power delivery module)	F2	H19	O/6	: Li-ion battery
C2	H6	O/3	: PDM (Power delivery module)				

FUSE BLOCK - JUNCTION BOX (J/B)

< WIRING DIAGRAM >

FUSE BLOCK - JUNCTION BOX (J/B)

Terminal Arrangement

INFOID:000000010641299

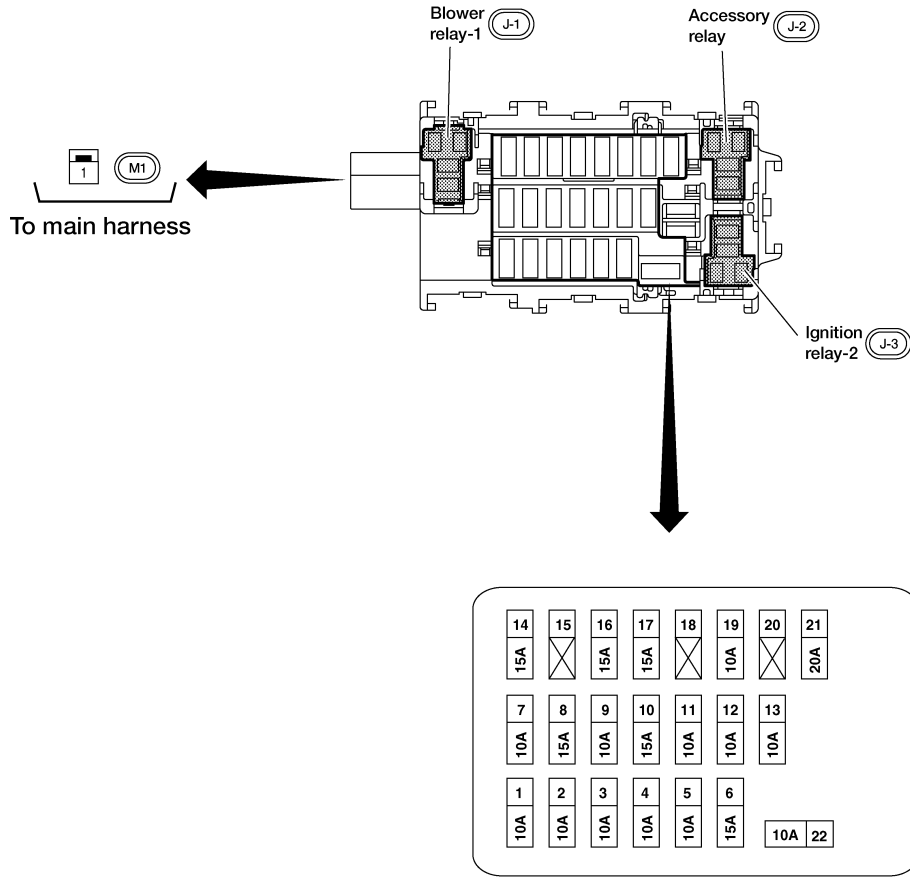

A
B
C
D
E
F
G
H
I
J
K
L
PG
N
O
P

AAMIA2457GB

FUSE, FUSIBLE LINK AND RELAY BOX

< WIRING DIAGRAM >

FUSE, FUSIBLE LINK AND RELAY BOX

Terminal Arrangement

INFOID:000000010641300

FUSE, FUSIBLE LINK AND RELAY BOX 1 AND FUSIBLE LINK BOX (BATTERY)

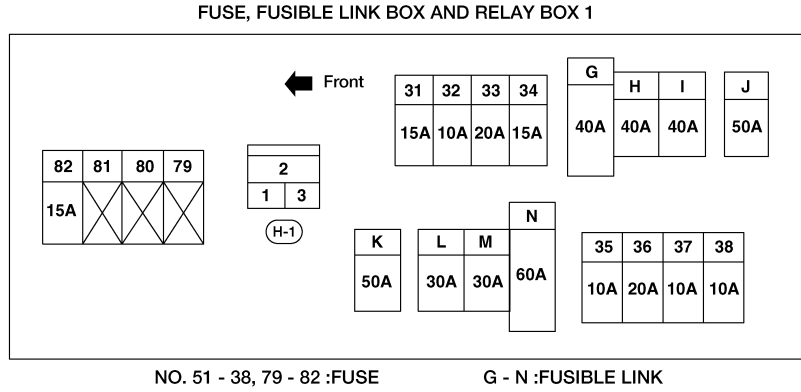

FUSIBLE LINK BOX (BATTERY)

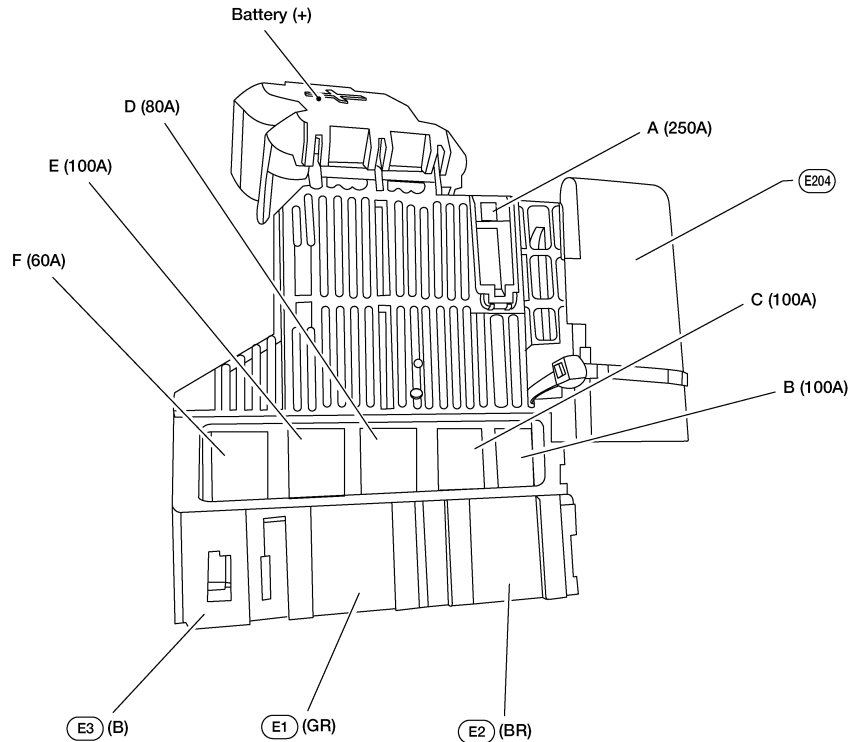

AAMIA2458GB

FUSE, FUSIBLE LINK AND RELAY BOX

< WIRING DIAGRAM >

FUSE AND RELAY BOX

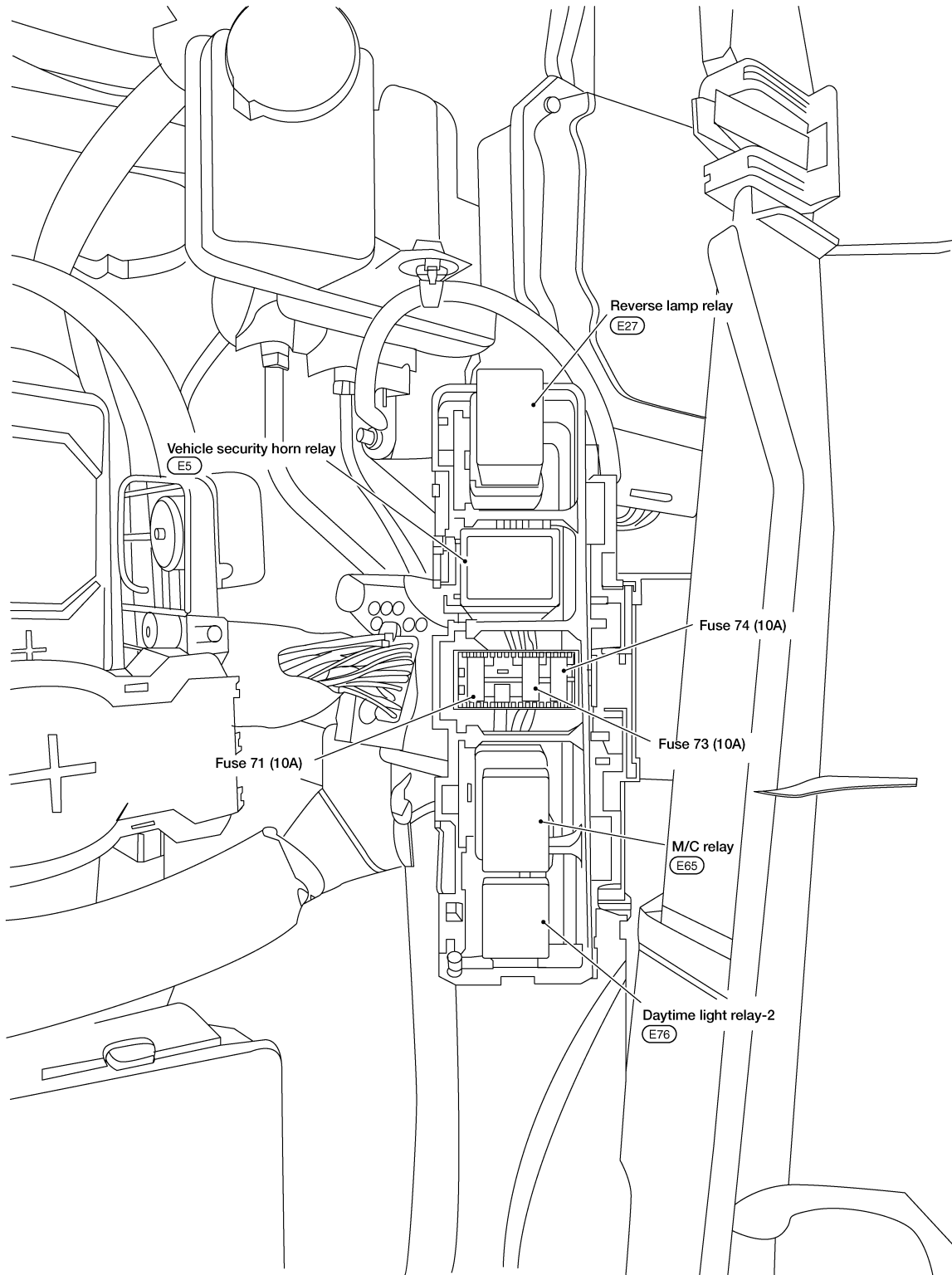

AAMIA2459GB

FUSE, FUSIBLE LINK AND RELAY BOX

< WIRING DIAGRAM >

FUSE, FUSIBLE LINK AND RELAY BOX 2

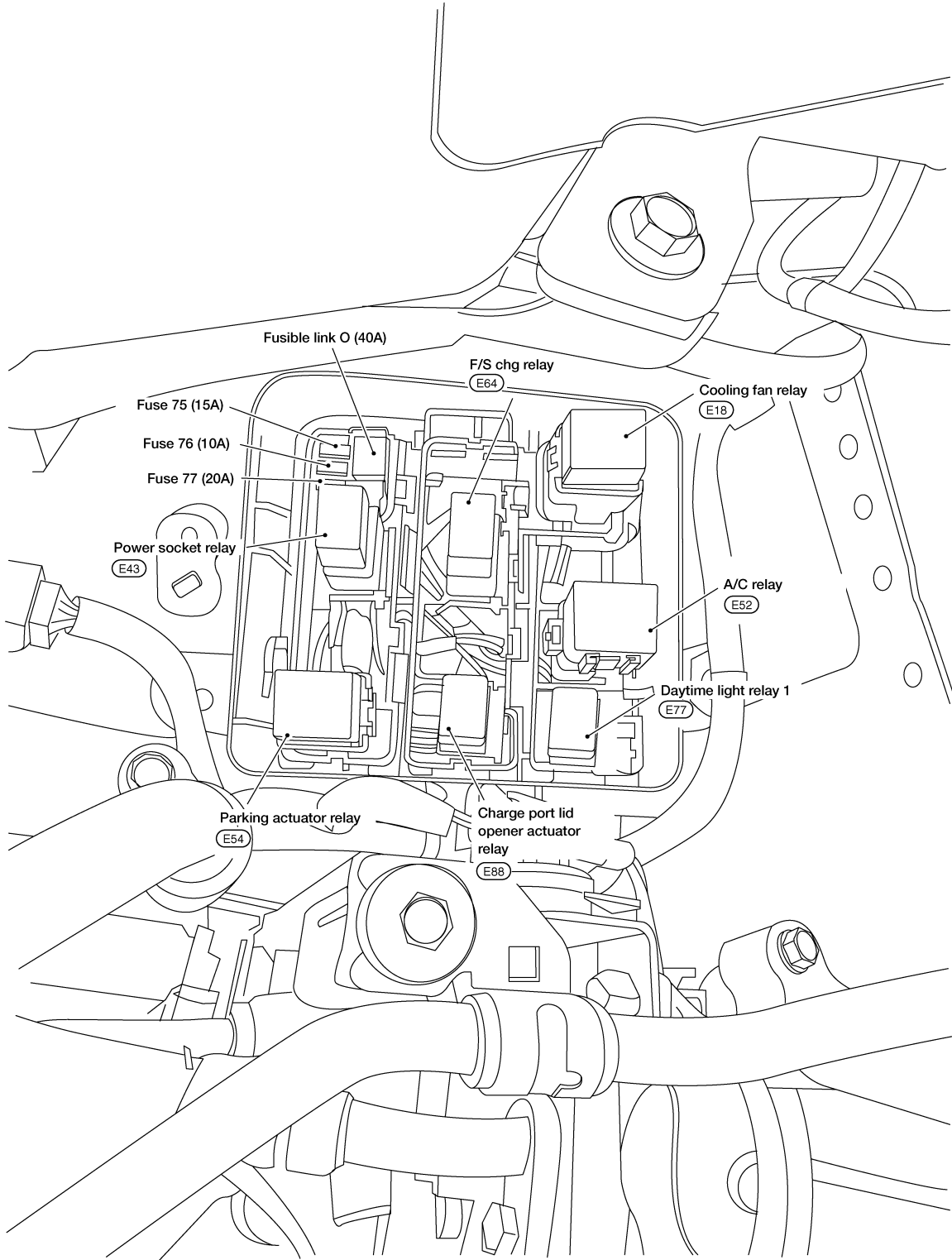

AAMIA2460GB

IPDM E/R (INTELLIGENT POWER DISTRIBUTION MODULE ENGINE ROOM)

< WIRING DIAGRAM >

IPDM E/R (INTELLIGENT POWER DISTRIBUTION MODULE ENGINE ROOM)

IPDM E/R Terminal Arrangement

INFOID:000000010641301

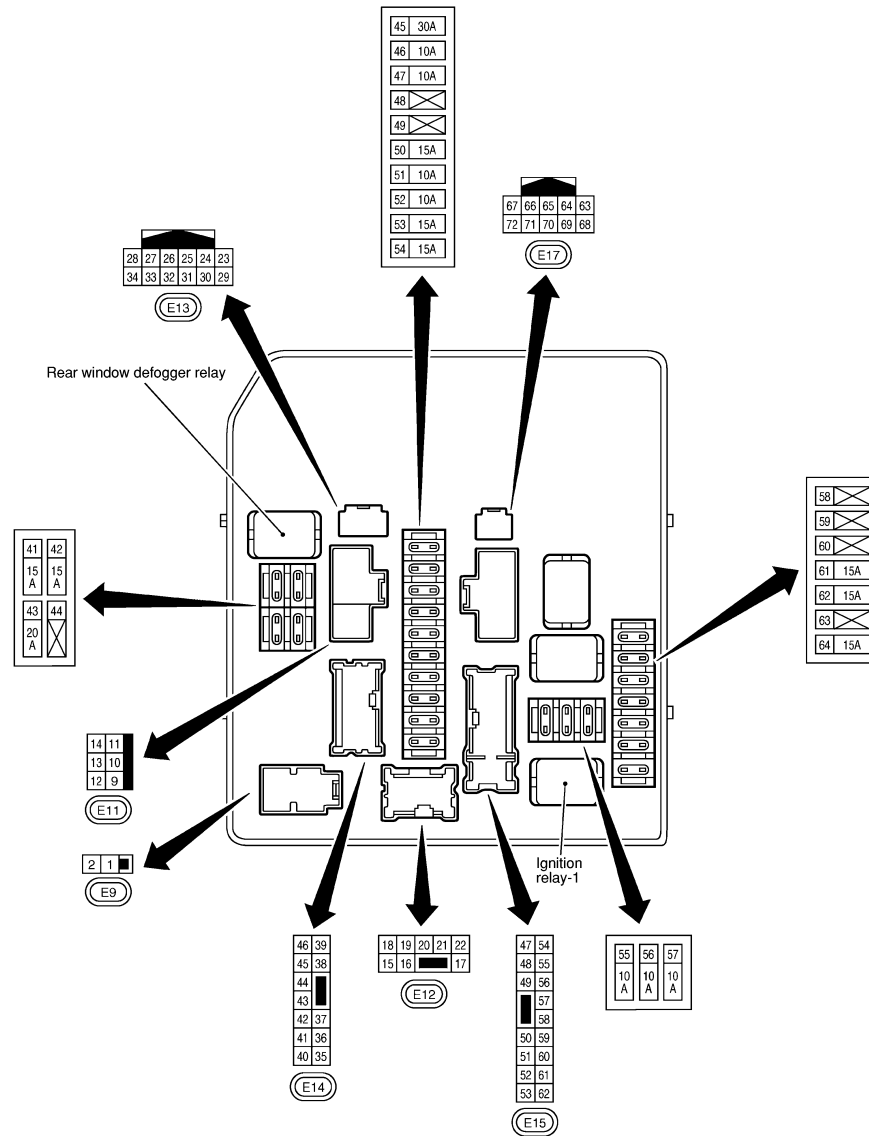

A
B
C
D
E
F
G
H
I
J
K
L
PG
N
O
P

AAMIA2475GB

12V BATTERY INSPECTION

< BASIC INSPECTION >

BASIC INSPECTION

12V BATTERY INSPECTION

How to Handle 12V Battery

INFOID:000000010641302

CAUTION:

- If it becomes necessary to start the EV system with a booster battery and jumper cables, use a 12-volt booster battery.
- After connecting 12V battery cables, ensure that they are tightly clamped to 12V battery terminals for good contact.
- Never add distilled water through the hole used to check specific gravity.

METHODS OF PREVENTING OVER-DISCHARGE

The following precautions must be taken to prevent over-discharging a battery.

- The 12V battery surface (particularly its top) should always be kept clean and dry.
- The terminal connections should be clean and tight.
- At every routine maintenance, check the electrolyte level.
This also applies to batteries designated as "low maintenance" and "maintenance-free".

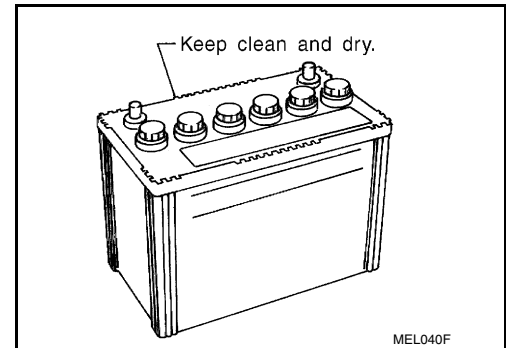

- When the vehicle is not going to be used over a long period of time, disconnect the 12V battery cable from the negative terminal. (If the vehicle has an extended storage switch, turn it off.) Refer to [PG-6, "Precaution for Removing 12V Battery"](#).

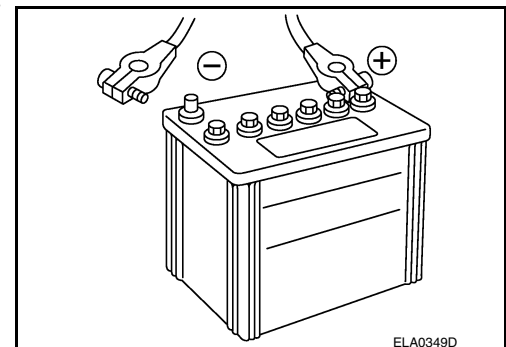

Work Flow

INFOID:000000010641303

12V BATTERY DIAGNOSIS WITH EXP-800 NI OR GR8-1200 NI

To diagnose and confirm the condition of the 12V battery, use the following special service tools:

- EXP-800 NI Battery and electrical diagnostic analyzer
- GR8-1200 NI Multitasking battery and electrical diagnostic station

NOTE:

Refer to the applicable instruction manual for proper battery diagnosis procedures.

12V BATTERY DIAGNOSIS WITHOUT EXP-800 NI OR GR8-1200 NI

Check Electrolyte Level

WARNING:

Never allow battery fluid to come in contact with skin, eyes, fabrics, or painted surfaces. After touching a 12V battery, never touch or rub your eyes until you have thoroughly washed your hands. If acid contacts eyes, skin or clothing, immediately flush with water for 15 minutes and seek medical attention.

Failure to do this may cause personal injury or damage to clothing or the painted surfaces.

12V BATTERY INSPECTION

< BASIC INSPECTION >

- Remove the cell plug using a suitable tool.
- Add distilled water up to the MAX level.

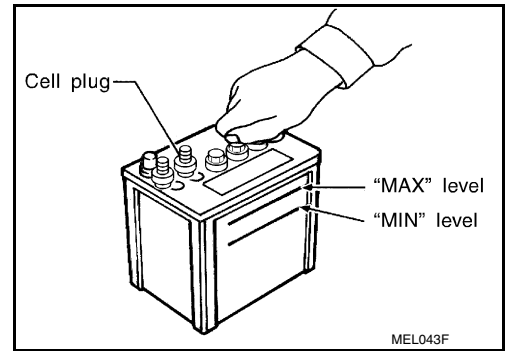

SULFATION

- A 12V battery will be completely discharged if it is left unattended for a long time and the specific gravity will become less than 1.100. This may result in sulfation on the cell plates.
- To determine if a 12V battery has been “sulfated”, note its voltage and current when charging it. As shown in the figure, less current and higher voltage are observed in the initial stage of charging sulfated batteries.
- A sulfated 12V battery may sometimes be brought back into service by means of a long, slow charge, 12 hours or more, followed by a battery capacity test.

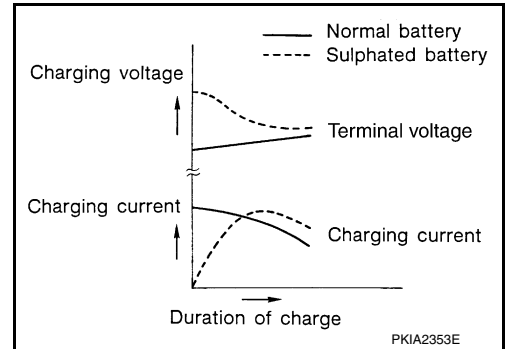

Specific Gravity Check

NOTE:

Check the charge condition of the battery.

Periodically check the specific gravity of the electrolyte. Keep a close check on charge condition to prevent over-discharge.

1. Read hydrometer and thermometer indications at eye level.
2. Use the chart below to correct your hydrometer reading according to electrolyte temperature.

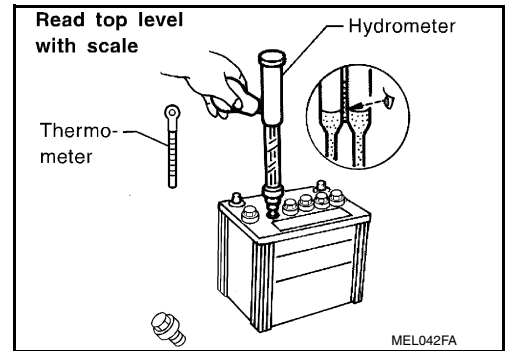

Hydrometer Temperature Correction

12V Battery electrolyte temperature [°C (°F)]	Add to specific gravity reading
71 (160)	0.032
66 (150)	0.028
60 (140)	0.024
54 (130)	0.020
49 (120)	0.016
43 (110)	0.012
38 (100)	0.008
32 (90)	0.004
27 (80)	0
21 (70)	-0.004
16 (60)	-0.008
10 (50)	-0.012

12V BATTERY INSPECTION

< BASIC INSPECTION >

12V Battery electrolyte temperature [°C (°F)]	Add to specific gravity reading
4 (40)	-0.016
-1 (30)	-0.020
-7 (20)	-0.024
-12 (10)	-0.028
-18 (0)	-0.032

Corrected specific gravity	Approximate charge condition
1.260 - 1.280	Fully charged
1.230 - 1.250	3/4 charged
1.200 - 1.220	1/2 charged
1.170 - 1.190	1/4 charged
1.140 - 1.160	Almost discharged
1.110 - 1.130	Completely discharged

Charging The 12V Battery

CAUTION:

- **Never “quick charge” a fully discharged 12V battery.**
- **Keep the 12V battery away from open flame while it is being charged.**
- **When connecting the charger, connect the leads first, then turn on the charger. Never turn on the charger first, as this may cause a spark.**
- **If 12V battery electrolyte temperature rises above 55 °C (131 °F), stop charging. Always charge battery at a temperature below 55 °C (131 °F).**

Charging Rates (Standard Charge)

Approximate charge condition	Charge current (A)	Charge time (h)
Fully charged	7	2
3/4 charged		2.5
1/2 charged		5
1/4 charged		7.5
Almost discharged		9
Completely discharged		10

Charging Rates (Quick Charge)

Approximate charge condition	Charge current (A)	Charge time (h)
Fully charged	—	—
3/4 charged	16	0.5
1/2 charged	33	
1/4 charged		
Almost discharged	—	—
Completely discharged		

NOTE:

The ammeter reading on your 12V battery charger will automatically decrease as the 12V battery charges. This indicates that the voltage of the 12V battery is increasing normally as the state of charge improves. The charging amps indicated above refer to initial charge rate.

- If, after charging, the specific gravity of any two cells varies more than 0.050, the 12V battery should be replaced.

ADDITIONAL SERVICE WHEN REMOVING 12V BATTERY NEGATIVE TERMINAL

< BASIC INSPECTION >

ADDITIONAL SERVICE WHEN REMOVING 12V BATTERY NEGATIVE TERMINAL

Special Repair Requirement

INFOID:000000010641304

System	Item	Reference
EV Control System	VCM Timer Adjustment	EVC-132. "Description"
Power Window Control System	Power Window System Initialization	PWC-30. "Description"
Heater & Air Conditioning Control System	Temperature Setting Trimmer	HAC-83. "Temperature Setting Trimmer" (with heat pump)
	Inlet Port Memory Function (REC)	HAC-83. "Inlet Port Memory Function (REC)" (with heat pump)
	Inlet Port Memory Function (FRE)	HAC-84. "Inlet Port Memory Function (FRE)" (with heat pump)
	Foot Position Setting Trimmer	HAC-84. "Foot Position Setting Trimmer" (with heat pump)
	Compressor Operation Setting at Defroster Mode (Timer/Remote Climate Control)	HAC-84. "Compressor Operation Setting at Defroster Mode (Timer/Remote Climate Control)" (with heat pump)
	Setting of Compressor Maximum Rotation Speed During Pre Air Conditioning	HAC-85. "Setting of Compressor Maximum Rotation Speed During Pre Air Conditioning" (with heat pump)
	Setting of Compressor Maximum Rotation Speed During Idling	HAC-85. "Setting of Compressor Maximum Rotation Speed During Idling" (with heat pump)
	Temperature Setting Trimmer	HAC-275. "Temperature Setting Trimmer" (without heat pump)
	Inlet Port Memory Function (REC)	HAC-275. "Inlet Port Memory Function (REC)" (without heat pump)
	Inlet Port Memory Function (FRE)	HAC-276. "Inlet Port Memory Function (FRE)" (without heat pump)
	Foot Position Setting Trimmer	HAC-276. "Foot Position Setting Trimmer" (without heat pump)
	Compressor Operation Setting at Defroster Mode (Timer/Remote Climate Control)	HAC-276. "Compressor Operation Setting at Defroster Mode (Timer/Remote Climate Control)" (without heat pump)
	Setting of Compressor Maximum Rotation Speed During Pre Air Conditioning	HAC-277. "Setting of Compressor Maximum Rotation Speed During Pre Air Conditioning" (without heat pump)
	Setting of Compressor Maximum Rotation Speed During Idling	HAC-277. "Setting of Compressor Maximum Rotation Speed During Idling" (without heat pump)
Audio, Visual & Navigation System	Audio (Radio Preset)	Refer to Owner's Manual
	Navigation System	Refer to Owner's Manual

FUSE INSPECTION

< BASIC INSPECTION >

FUSE INSPECTION

Fuse

INFOID:000000010641292

- If fuse is blown, be sure to eliminate cause of malfunction before installing new fuse.
- Use fuse of specified rating. Never use fuse of more than specified rating.
- Do not partially install fuse; always insert it into fuse holder properly.
- Remove fuse for "ELECTRICAL PARTS (BAT)" if vehicle is not used for a long period of time.

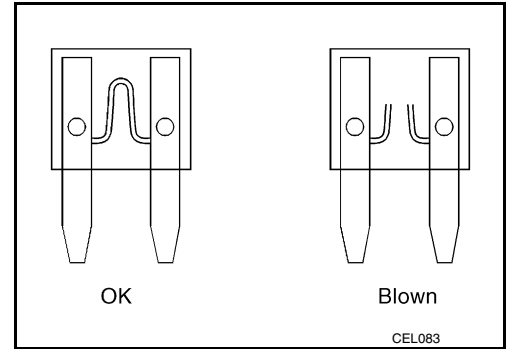

FUSIBLE LINK INSPECTION

< BASIC INSPECTION >

FUSIBLE LINK INSPECTION

Fusible Link

INFOID:0000000110641293

A melted fusible link can be detected either by visual inspection or by feeling with finger tip. If its condition is questionable, use circuit tester or test lamp.

1 : Fusible link

↔: Vehicle front

CAUTION:

- If fusible link should melt, it is possible that critical circuit (power supply or large current carrying circuit) is shorted. In such a case, carefully check and eliminate cause of malfunction.
- Never wrap outside of fusible link with vinyl tape. Important: Never let fusible link touch any other wiring harness, vinyl or rubber parts.

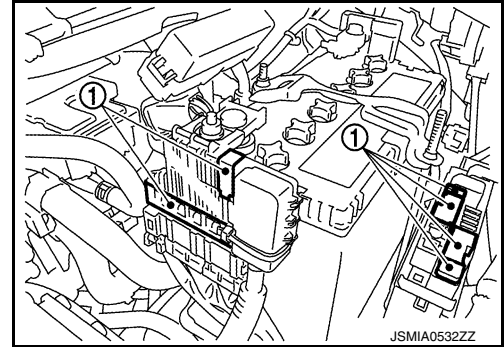

A
B
C
D
E
F
G
H
I
J
K
L
PG
N
O
P

12V BATTERY

< REMOVAL AND INSTALLATION >

REMOVAL AND INSTALLATION

12V BATTERY

Exploded View

INFOID:000000010641307

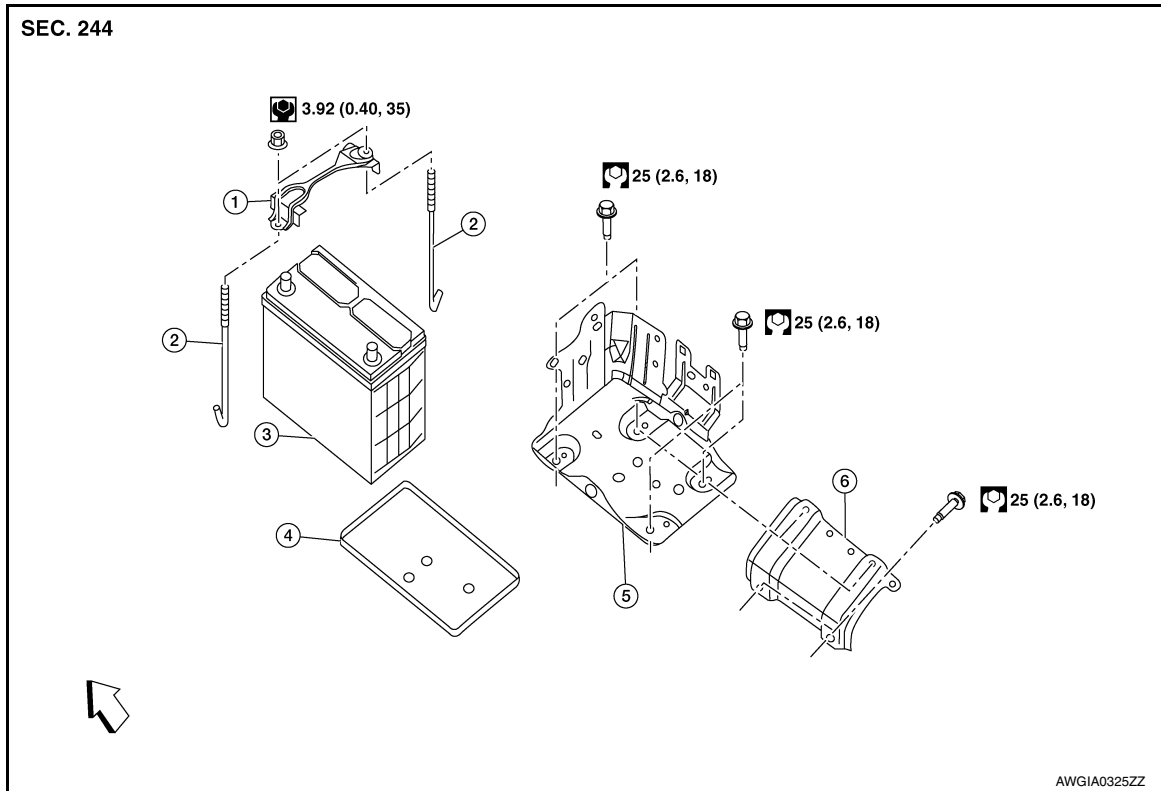

- | | | |
|-----------------------|-----------------|-------------------------|
| 1. Battery frame | 2. Battery rods | 3. 12V battery |
| 4. Battery tray liner | 5. Battery tray | 6. Battery tray bracket |

⇐ Front

Removal and Installation

INFOID:000000010641308

REMOVAL

1. Disconnect the 12V battery cable from the negative terminal. Refer to [PG-6, "Precaution for Removing 12V Battery"](#).

CAUTION:

To prevent damage to the parts, disconnect the 12V battery cable from the negative terminal first.

2. Remove cover of 12V battery positive terminal.
3. Disconnect the 12V battery cable from the positive terminal.
4. Remove battery frame nuts, battery frame and battery rods.
5. Remove 12V battery.

INSTALLATION

Install in the reverse order of removal.

CAUTION:

- To prevent damage to the parts, connect the positive terminal to the 12V battery positive post first.
- After connecting the positive and negative terminals, to securely supply battery voltage, ensure that the positive and negative terminals are tightly clamped to 12V battery positive and negative posts for good contact.
- To securely supply battery voltage, check the positive and negative terminals for poor connection caused by corrosion.

12V BATTERY

< REMOVAL AND INSTALLATION >

Reset electronic systems as necessary. Refer to [PG-79, "Special Repair Requirement"](#).

A

B

C

D

E

F

G

H

I

J

K

L

PG

N

O

P

BATTERY TRAY

< REMOVAL AND INSTALLATION >

BATTERY TRAY

Exploded View

INFOID:000000010641309

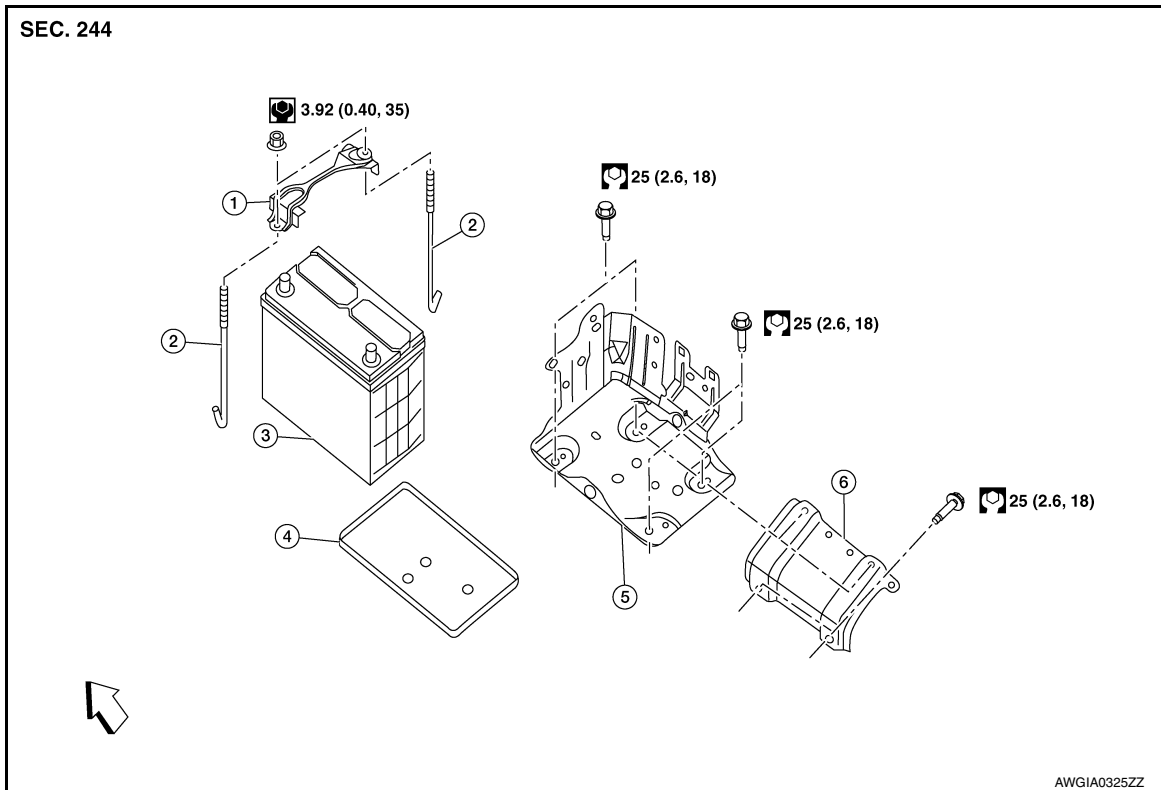

- | | | |
|-----------------------|-----------------|-------------------------|
| 1. Battery frame | 2. Battery rods | 3. 12V battery |
| 4. Battery tray liner | 5. Battery tray | 6. Battery tray bracket |
- ↩ Front

Removal and Installation

INFOID:000000010641310

REMOVAL

1. Remove the 12V battery. Refer to [PG-82. "Removal and Installation"](#).
2. Remove the battery tray liner.
3. Remove the ground strap retainers from the battery tray and set the ground strap aside.
4. Remove battery tray bolts and battery tray.
5. Remove battery tray bracket bolts and battery tray bracket (if necessary).

INSTALLATION

Installation is in the reverse order of removal.

BATTERY TERMINAL WITH FUSIBLE LINK

< REMOVAL AND INSTALLATION >

BATTERY TERMINAL WITH FUSIBLE LINK

Exploded View

INFOID:000000010641311

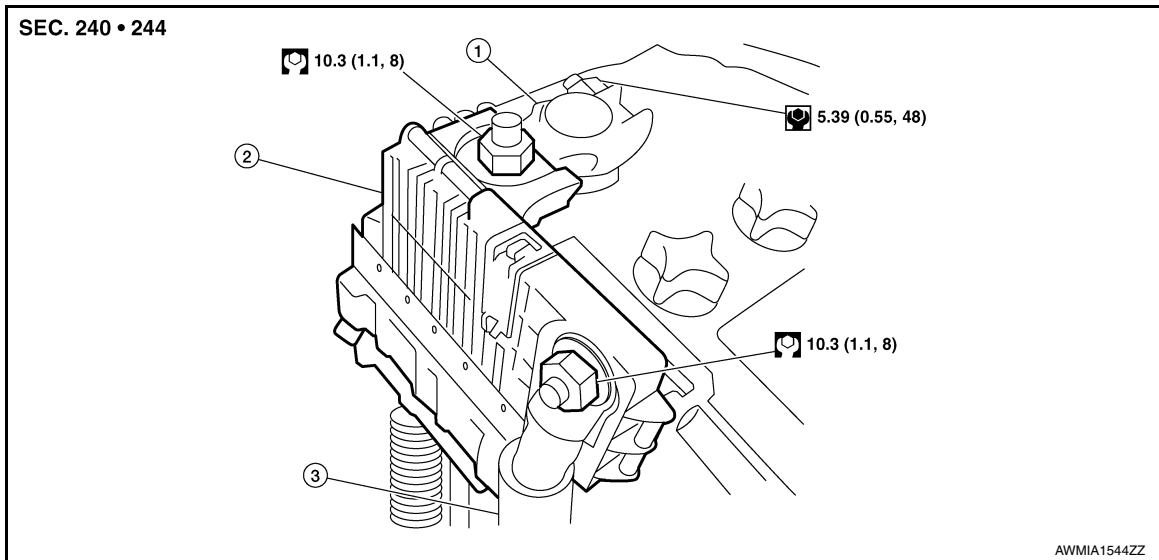

1. Positive terminal 2. Fusible link box (12V battery) 3. Positive cable

Removal and Installation

INFOID:000000010641312

REMOVAL

1. Disconnect the negative terminal from the 12V battery and reposition. Refer to [PG-6, "Precaution for Removing 12V Battery"](#).
CAUTION:
To prevent damage to the parts, disconnect the negative terminal from the 12V battery negative post first.
2. Remove cover from the positive terminal.
3. Disconnect the terminal from the 12V battery.
4. Disconnect positive cable from fusible link box (12V battery).
5. Disconnect harness connectors and separate positive terminal from fusible link box (12V battery).

INSTALLATION

Install in the reverse order of removal.

CAUTION:

- To prevent damage to the parts, connect positive terminal to the 12V battery positive post first.
- After connecting the positive and negative terminals, to securely supply battery voltage, ensure that the positive and negative terminals are tightly clamped to 12V battery positive and negative posts for good contact.
- To securely supply battery voltage, check the positive and negative terminals for poor connection caused by corrosion.

Reset electronic systems as necessary. Refer to [PG-79, "Special Repair Requirement"](#).

BATTERY CURRENT SENSOR

< REMOVAL AND INSTALLATION >

BATTERY CURRENT SENSOR

Exploded View

INFOID:000000010641313

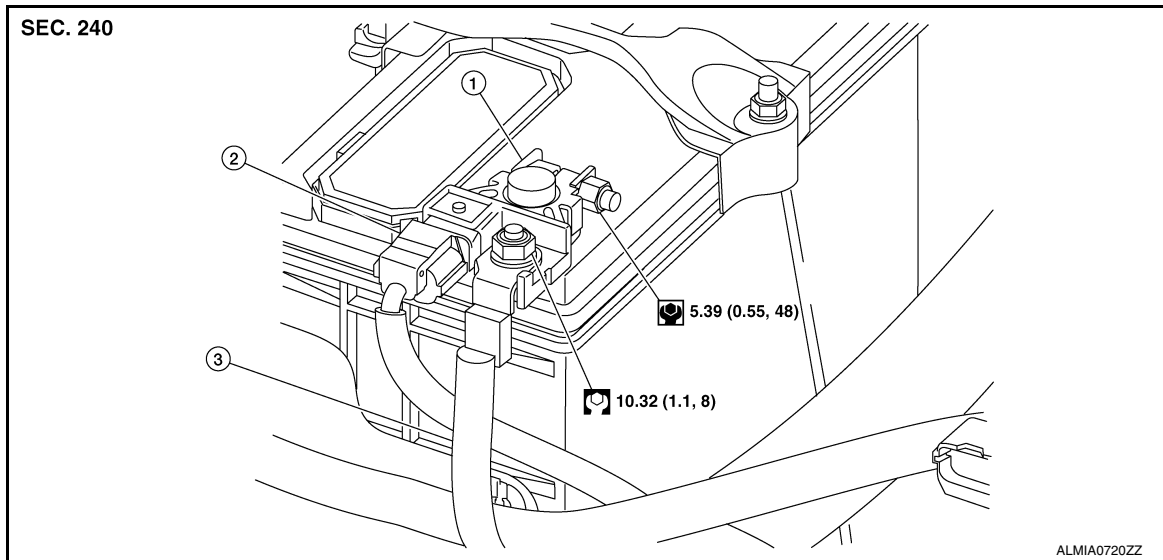

1. Negative terminal

2. Battery current sensor

3. Negative cable

Removal and Installation

INFOID:000000010641314

REMOVAL

1. Disconnect the negative terminal from the 12V battery. Refer to [PG-6, "Precaution for Removing 12V Battery"](#).
2. Disconnect the harness connector from the current sensor.
3. Remove the battery current sensor mounting nut.
4. Remove the battery current sensor from 12V battery negative cable.

INSTALLATION

Install in the reverse order of removal.

CAUTION:

- To prevent damage to the parts, connect positive terminal to the 12V battery positive post first.
- After connecting the positive and negative terminals, to securely supply battery voltage, ensure that the positive and negative terminals are tightly clamped to 12V battery positive and negative posts for good contact.
- To securely supply voltage, check the positive and negative terminals for poor connection caused by corrosion.

Reset electronic systems as necessary. Refer to [PG-79, "Special Repair Requirement"](#).

SERVICE DATA AND SPECIFICATIONS (SDS)

< SERVICE DATA AND SPECIFICATIONS (SDS)

SERVICE DATA AND SPECIFICATIONS (SDS)

SERVICE DATA AND SPECIFICATIONS (SDS)

12V Battery

INFOID:0000000010641315

Type*		51R
20 hour rate capacity	[V – Ah]	12 – 43
Cold cranking current (For reference value)	[A]	410

*: Always check with the Parts Department for the latest parts information.

A
B
C
D
E
F
G
H
I
J
K
L
PG
N
O
P