

1991 M30 CONVERTIBLE  
SERVICE MANUAL SUPPLEMENT

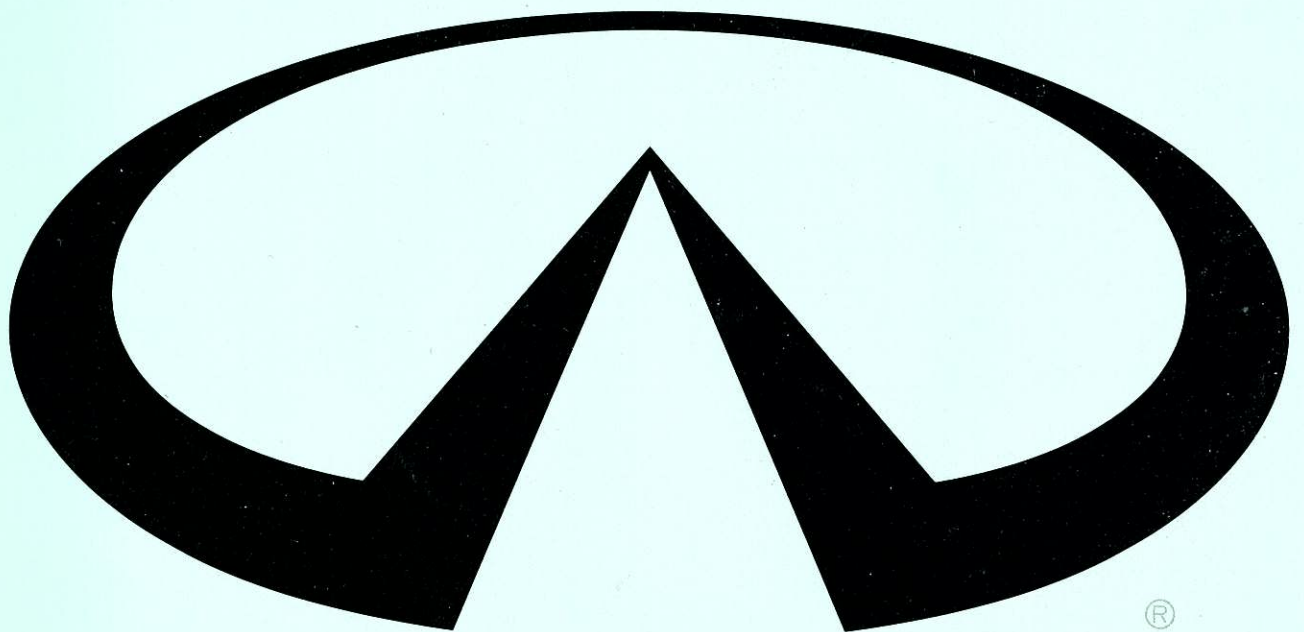



---

# FOREWORD

---

This Service Manual Supplement contains repair procedures for the 1991 INFINITI M30 Convertible. The Supplement covers Convertible matters only. If there are systems in common between the M30 Coupe and the M30 Convertible models, then the regular INFINITI M30 Service Manual is the best source of information. In order to assure your safety and the efficient functioning of the vehicle, refer to the applicable manual before and during the performance of any repair task.

This Service Manual Supplement is based on the latest product information available at the time of publication. INFINITI reserves the right to make changes in specifications, design or methods at any time without prior notice.

---

## IMPORTANT SAFETY NOTICE

The proper performance of service is essential to the safety of the technician and the efficient functioning of the vehicle. The service methods in this Service Manual Supplement are described in such a manner that the service may be performed safely and accurately. If you choose to use service procedures, tools or parts not specifically recommended by INFINITI, you must first completely satisfy yourself that neither your safety nor the vehicle's safety will be jeopardized by the service method selected.



# INFINITI M30 CONVERTIBLE SERVICE MANUAL SUPPLEMENT

## TABLE OF CONTENTS

	<b>Page</b>
General Information	C-2
"Normal" Top-Down, Top-Up Operation	C-2
Convertible Top Stack Timing Sequence	C-5
Safety Information on Convertible Top Operation	C-6
Top and Rear Window Appearance Care	C-7
<b><u>Convertible Component Repair Information</u></b>	<b>Section</b>
Windshield Header Trim	1
Power Pull Down Actuators	2
Windshield Outer Moldings	3
Quarter Belt, Back Belt and Deck Lid Moldings	4
Rear Seat	5
Quarter Trim Panel	6
Seat Belts	7
Quarter Glass, Guide and Regulator	8
Side Guard Molding	9
Door, Guide Pin and Glass	10
Weatherstrips and Retainers	11
Headliner	12
Top Cover Assembly	13
Backlite Assembly	14
Stay Pads, Side and Rear	15
No. 1 Bow	16
No. 2 Bow	17
No. 3 Bow	18
No. 4 Bow	19
Deck Lid Spoiler and High Mount Stop Light	20
Deck Lid, Hinges	21
Hydraulic System, Pump/Motor and Cylinders	22
Electrical, Controls	23
Electrical, Troubleshooting	24
Electrical Wiring Diagrams	25
Body, Structural	26
Index	27

The M30 Convertible is equipped with a vehicle speed sensor that prevents operation of the convertible top while the vehicle is in motion. Safety features such as sensors and timers have been designed into this convertible to prevent the top from possible damage should an electrical or mechanical component fail or malfunction. Before lowering or raising the top using the "Top Down" or "Top Up" switch, the following conditions must be met. If one or more of the conditions is not met, the top lowering system will not operate.

- The vehicle must be at a complete stop.
- The transmission gear selector must be in the "P" position.
- The ignition switch must be in the "ON" position.
- The trunk lid must be closed.
- The manual release valve (see page 22-3) must be closed.

### **"Normal" Top-Down, Top-Up Operation**

The following functions occur when lowering the top automatically using the "Top Down" switch:

#### **Lowering the Top**

To lower the top, press and hold the "TOP DOWN" switch on the instrument panel.

When the "TOP DOWN" switch is first pressed:

- The power pull down actuators turn to release the top from the windshield header.
- The side and quarter windows lower.
- Timer # 1 cycles for 4.3 seconds to activate the hydraulic system.

As Timer #1 begins its counting cycle, the top releases and trips the proximity switches, which:

- De-activate the power pull down actuator motors.
- Detect when the top has fully released from the windshield header.

As Timer # 1 completes its counting cycle of 4.3 seconds:

- The hydraulic pump is activated.
- The top starts to lower.
- Timer # 2 is activated and starts a cycle of 3.3 seconds. Timer # 2 is a secondary control for deactivating the hydraulic pump in the event that the proximity switches are not tripped when the top is released.

Once the top has contacted the down stops, it will not lower any further. To make sure the top has lowered completely, look for no noticeable further movement of the top stack. You should hear the sound of the hydraulic pump slowing down.

**CAUTION:** Do not press the “TOP DOWN” switch for more than 5 seconds after the top has lowered. Otherwise, damage to the pump may result.

### Raising the Top

To raise the top, press and hold the “Top Up” switch on the instrument panel.

When the “Top Up” switch is pressed:

- The side and quarter windows lower.
- The hydraulic pump is activated.

Once the hydraulic pump is activated, the top will raise. When the top has completed the majority of its upward travel, the rear rails will trip the proximity switches, which will cause Timer # 3 to de-activate the hydraulic pump. The top will now drop forward and down toward the windshield header. Release the “Top Up” switch after the top drops forward and down.

Once the rear rails have tripped the proximity switches and Timer #3 has de-activated the hydraulic pump, the power pull down actuators and Timer #4 are ready for the final action.

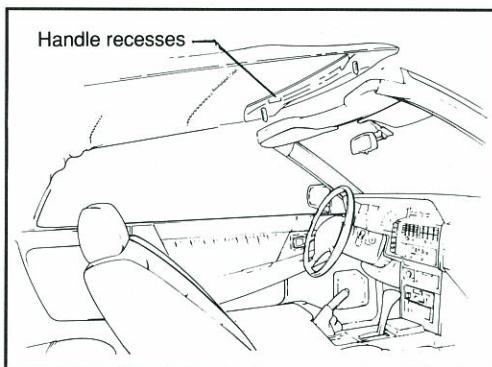

First, in order for the top to secure to the windshield header, the front header bow must be manually pulled down. Use the handles recessed into the header bow and pull downward to engage both top pins into the power pull down actuators.

Now, secure the top to the windshield header by pressing again and holding the “Top Up” switch.

When the “Top Up” switch is pressed:

- The power pull down actuators are activated.
- Timer # 3 cycles for 1 second.
- Timer # 4 starts to cycle for 6.8 seconds.

(At the end of its cycle, Timer # 3 deactivates the hydraulic pump. Timer #4, at the end of its cycle, activates the electrical system for raising the side and quarter windows, but only after the top is completely raised.)

### NOTE:

**The “Top Up” switch must be held in order to continue the sequence for the power pull down actuators and the timers. If the switch is not held in, the sequence will be interrupted and will not continue until the switch is pressed again. The power pull down actuators will turn off automatically after the top is completely secured. Each power pull down actuator has an internal thermo-switch which turns off the actuator when it senses increased load.**

Once the top is completely secured, the side and quarter windows may be raised to the desired height by either of two ways:

1. Hold the "Top Up" switch in for at least 6.0 seconds after the power pull down actuators have turned off. When the windows are raised to the desired height, release the switch.
2. Use the side and quarter window switches to raise the windows.





## CONVERTIBLE REAR SEAT AND BELTS

The M30 Convertible is designed as a 4 passenger vehicle, with seating for two persons only in the rear seat.

### WARNING:

1. Do not allow more than two persons to occupy the rear seat while the vehicle is in motion.
2. While driving, each occupant of the vehicle should be secured by the appropriate seat belt.
3. Do not allow more than one person to use the same seat belt. Failure to observe the above warnings could result in serious personal injury in the event of an accident.

## TOP APPEARANCE CARE

**CAUTION: Do not use harsh or abrasive cleaners or bleaching agents on the top material or damage may result.**

### Cloth Top:

1. Rinse top with fresh water. Wash using mild soap suds, lukewarm water (never hot) and a sponge. Finally, rinse the top with enough clean water to remove all traces of soap. Be careful to rinse any cleaner off the body as it may cause streaking if allowed to dry on the painted surfaces.
2. After cleaning, always be sure the top is completely dry before it is lowered. Lowering the top while it is wet or damp may cause interior water damage, water stains or mildew of the top and rear window material.

## REAR WINDOW APPEARANCE CARE

This convertible has a flexible plastic rear window. Due to its material composition, the window is extremely susceptible to scratches and abrasions. To avoid damage to the rear window, clean it as follows:

1. Generously rinse the window with water to loosen all dust and dirt. Start at the top of the window, using a back and forth motion. Do not spray the top.
2. Gently wash the window with warm or cold (never hot) water and a mild neutral soap. Dip your cloth into the wash bucket frequently. Change the wash water frequently to reduce the possibility of water-borne dirt scratching the window. Do not rub hard. Let the soap and water remove the dirt.
3. Rinse the window thoroughly with fresh water. If any soap dries on the window, it may cause streaking.
4. Dry the window with a clean, soft cotton cloth. The main purpose of drying is to remove excess water so that the window will air dry without water spots. Do not rub or press hard, as this might scratch the window.
5. Before lowering the top, make sure to remove any water that may have accumulated during cleaning in the top stowage well behind the rear seat.

### CAUTION:

- If the coating on the rear window is scratched or removed, the window will become hazed and may allow mildew to form. These conditions will rapidly degrade the rear window and possibly damage the top material also.
- Mildew may occur more rapidly if the top remains lowered for extended lengths of time under damp conditions. Mildew appears brownish in color and may give off an undesirable odor. No amount of cleaning can reverse this condition. If it occurs, the window must be replaced.

## REAR WINDOW APPEARANCE CARE AND TOP OPERATION

- Do not use a dry cloth to remove even the slightest amount of dust. Use a soft cotton cloth saturated with water and gently wipe crosswise on the window.
- Do not use a scraper, de-icing chemicals or sprays to remove frost, snow or ice from the window. In an emergency, warm water (never hot) may be used. Hot water may cause permanent warping or shrinking of the window material.
- Do not use solvents, such as: alcohol, nail polish remover or paint thinners on the window.
- Do not use bleach, ammonia, window cleaner or all-purpose household cleaners on the window.
- Do not use surface protectants, beautifiers or silicone-based dressings on the window. These chemical solutions may remove the protective coating from the window.
- Do not use plastic cleaners, polishes or waxes on the window.
- Do not apply advertising stickers, gummed labels or adhesive tape to the window. Such items will damage the rear window.

### CONVERTIBLE TOP OPERATION

#### WARNING:

1. When raising or lowering the top, keep hands clear from the hinges of the side roof rails and any part of the top linkage.
2. Keep hands and any part of the body away from moving parts such as power windows and the top of the windshield where the convertible top secures.
3. Before and during "up or down" operation of the top, make sure that your passengers are made aware of your intentions. Otherwise, personal injury may result from the side and quarter window unexpectedly raising or lowering.
4. The trunk lid must remain closed before and during lowering or raising, otherwise, the operation of the top will be interrupted. Closing the lid will resume operation.
5. The vehicle should never be driven with the top partially lowered. Make sure the top has been either fully secured to the windshield header or fully lowered and the boot installed before driving.
6. Before lowering the top, make sure to wipe dry the top stowage well behind the rear seat of any water that may have accumulated during cleaning or inclement weather.
7. Make sure the manual release valve on the pump assembly is closed before operating the top electrically.

#### CAUTION:

- Make sure there are no packages in the top stowage well when raising or lowering the convertible top. Even small items may interfere with top operation and can cause damage.
- Do not sit or place excessive weight on the top when the top is up or down. Damage to the top may result.
- Do not use an automatic car wash to clean your convertible. Damage to the convertible top may result.
- Do not raise or lower the top when the temperature is below 41°F (5°C). Damage to the top material and/or rear window may result.
- Do not lower the top when the rear window is dirty. Grit and accumulated foreign matter may scratch the window.
- Do not lower the top if the top is damp or wet. Interior water damage, water stains or mildew may result.

## LOWERING THE CONVERTIBLE TOP

### NOTE:

The trunk lid must remain closed before and during lowering or raising. Otherwise, the operation of the top will be interrupted. Closing the lid will resume operation.

1. Set the parking brake and put the transmission gear selector in the "P" position (automatic transmission).
2. Remove all items or packages from between the rear seat back and the top stowage well.
3. Turn the ignition switch "ON".
4. Detach the headliner retainers from inside the top rails.

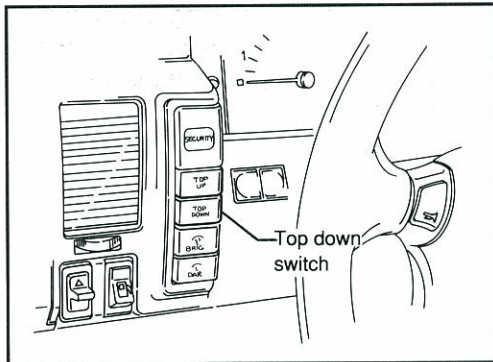

5. Press the "TOP DOWN" switch to release top from the windshield header.

### NOTE:

Before the top starts to lower, the side and quarter windows will lower automatically.

6. Continue pressing the "TOP DOWN" switch until the top is completely down, then release the switch.
7. If desired, raise the side and quarter windows.

### CAUTION:

To avoid damaging the top, do not sit or place excessive weight on the top when the top is in its lowered position.

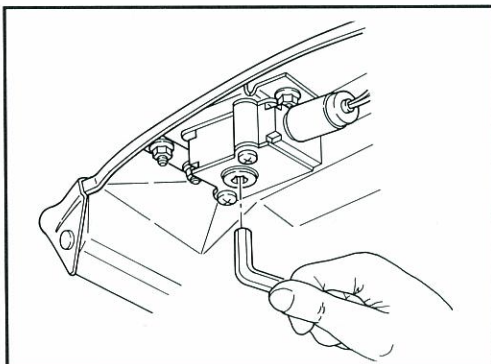

### NOTE:

If the vehicle's battery is discharged and the top is raised and secured, the top cannot be released and lowered automatically (electrically). The battery must be fully charged or the car must be started to release and lower the top automatically. If the battery cannot be charged or the car started, the header garnish must be removed and the power pull down actuators manually released.

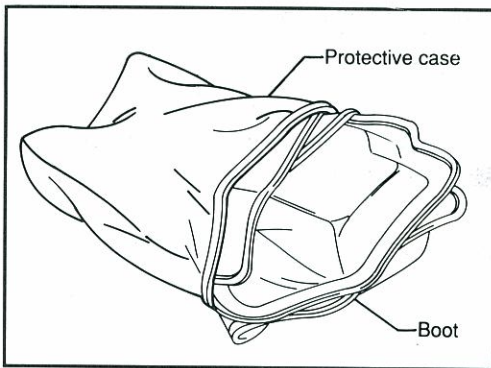

## TOP BOOT

### Installation

The top boot may be used to cover the convertible top when it is completely lowered.

1. Remove the boot from the protective case stored in the luggage compartment and close the trunk lid.
2. Place the boot in position over the lowered top.
3. Secure the boot snaps to the quarter trim panels.
4. Secure the boot rubber retainer to the trim molding. Starting at the center and working towards the outboard ends, secure the channel of the rubber retainer to the trim molding edge by squeezing the retainer onto the molding.

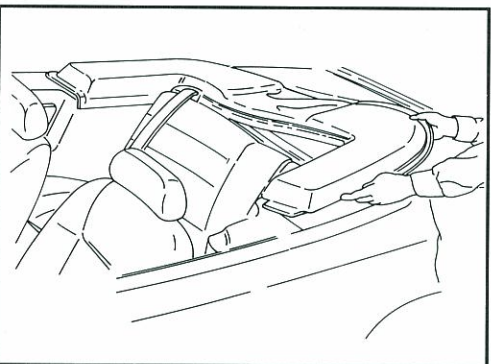
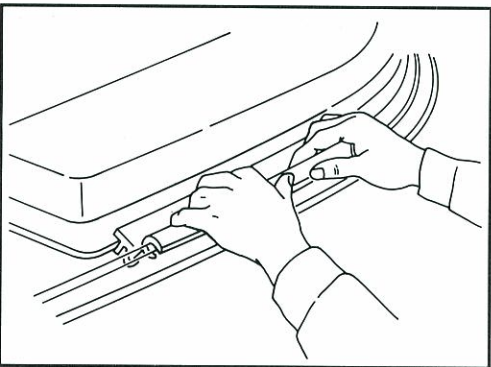
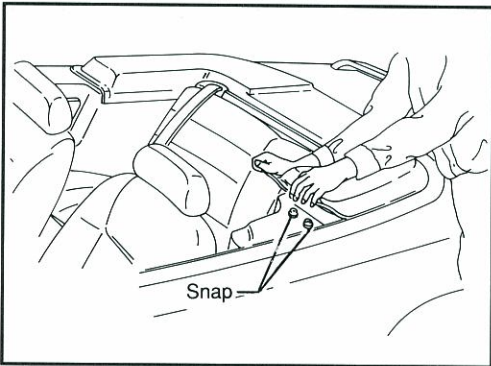

### Removal

1. Un-snap the boot cover from the quarter trim panel, then, disengage the boot from the trim molding and place it in its protective case. Store the boot in the luggage compartment.

## RAISING THE CONVERTIBLE TOP

### WARNING:

When raising the top, always make sure your head and the passenger's head are clear of the side rails of the top, as the side rails travel downward toward the windshield header.

### NOTE:

The trunk lid must remain closed before and during lowering or raising. Otherwise, the operation of the top will be interrupted. Closing the lid will resume operation.

1. Set the parking brake and put the transmission gear selector in "P" (automatic transmission).
2. Remove the boot if it is installed over the lowered top. Store the boot in its protective case in the luggage compartment.

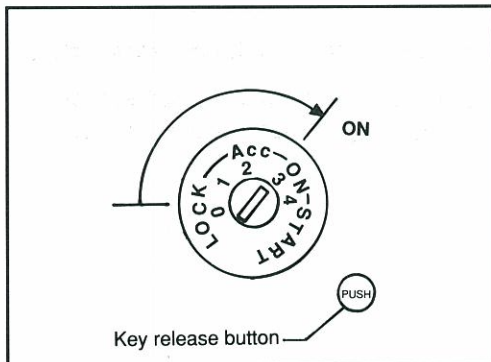

3. Turn the ignition switch "ON".

### NOTE:

If windows are up before the top starts to raise, the side and quarter windows will lower automatically.

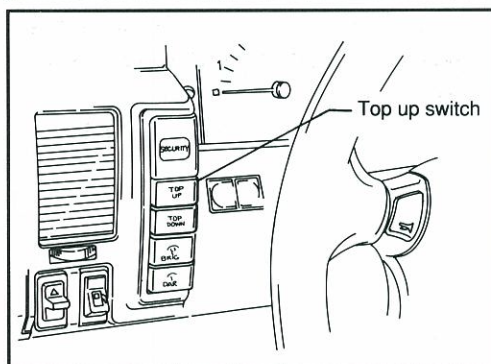

4. Press the "TOP UP" switch to raise the top until the top drops forward and down toward the windshield header; release the switch.

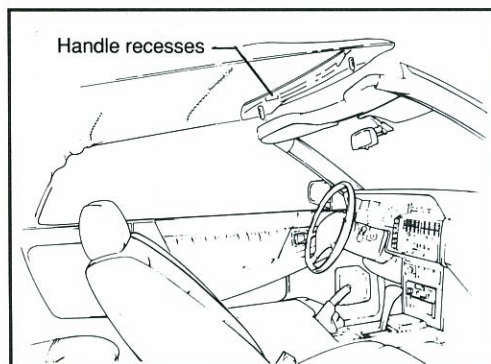

5. Reach up, and using the handle recessed in the header bow, pull the header bow downward to engage both of the top's pull down pins into the power pull down actuators.

**RAISING THE CONVERTIBLE TOP (cont.)**

6. Press the "TOP UP" switch to secure the top into the power pull down actuators located in the windshield header.

**NOTE:**

**If the switch continues to be pressed after the top is completely secured, the side windows will raise automatically until the switch is released.**

7. Re-attach the headliner retainers.
8. If desired, raise the side and quarter windows (if they were not raised in Step #4).

**CAUTION:**

**To avoid damaging the top, do not sit or place excessive weight on the top when it is in the raised position.**

**RAISING THE TOP MANUALLY**

In the event of a hydraulic system and/or electrical system failure, you may raise the top manually by using the following procedure:

1. Make sure the parking brake is firmly set and the transmission is in "P" (automatic transmission).
2. Turn the ignition switch "ON".
3. Using the quarter and side window switches, lower the windows.

**NOTE: If the battery is discharged and the windows cannot be lowered, open both doors before raising the top.**

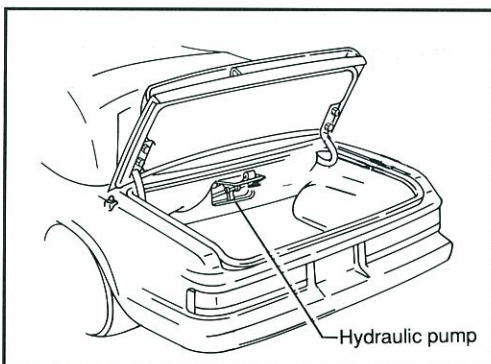

4. With the trunk lid raised, reach under the top stowage well fabric and pull the access door strap on the trunk trim panel to reveal the hydraulic pump assembly.

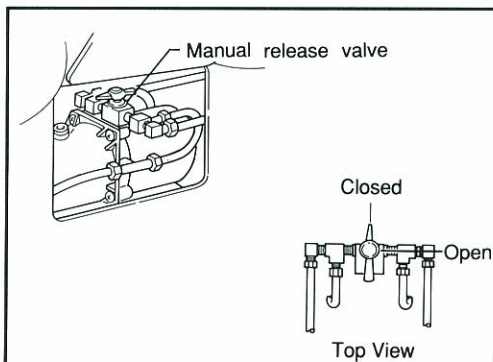

5. Open the manual release valve by turning the handle clockwise 90°.

**RAISING THE TOP MANUALLY (cont.)**

6. Kneel in the center of the rear seat and grasp the center of the top header bow.

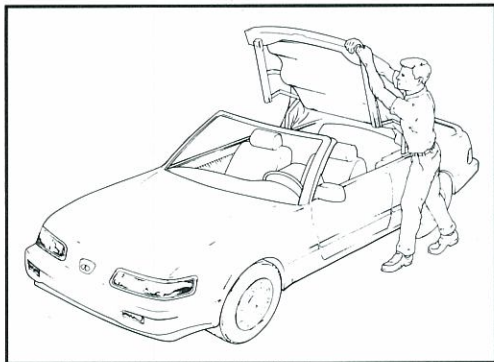

7. Lift and slowly raise the top until it is partially raised in a vertical position.
8. Stand on either side of the vehicle and, with the palm of the hand, continue to push forward and down on the top until it contacts and engages into the power pull down actuators located in the windshield header.

**NOTE:**

**You may find it necessary to pull the top down from inside the car, using the handle recesses in the top header bow, so that both pull down pins on the top engage into the power pull down actuators.**

9. Close the manual release valve by turning the handle counter-clockwise 90°.
10. Close the access door and close the trunk lid.
11. If desired, raise the side and quarter windows.

**LOWERING THE TOP MANUALLY****NOTE:**

**In the event of hydraulic system and/or electrical system failure, do not attempt to lower the top. The header garnish must be removed and the power pull down actuators must be released manually. To release the power pull down actuators, insert a 8mm allen wrench into the opening in the bottom of the power pull down actuator and turn clockwise one-eighth turn.**



---

# WINDSHIELD HEADER TRIM

	Page
WINDSHIELD HEADER TRIM - COMPONENTS .....	1-2
REMOVAL OF WINDSHIELD HEADER TRIM .....	1-3
INSTALLATION OF WINDSHIELD HEADER TRIM .....	1-3
REMOVAL OF REAR VIEW MIRROR .....	1-4
INSTALLATION OF REAR VIEW MIRROR .....	1-5
INSTALLATION OF REAR VIEW MIRROR BUTTON ....	1-6

WINDSHIELD HEADER TRIM - COMPONENTS

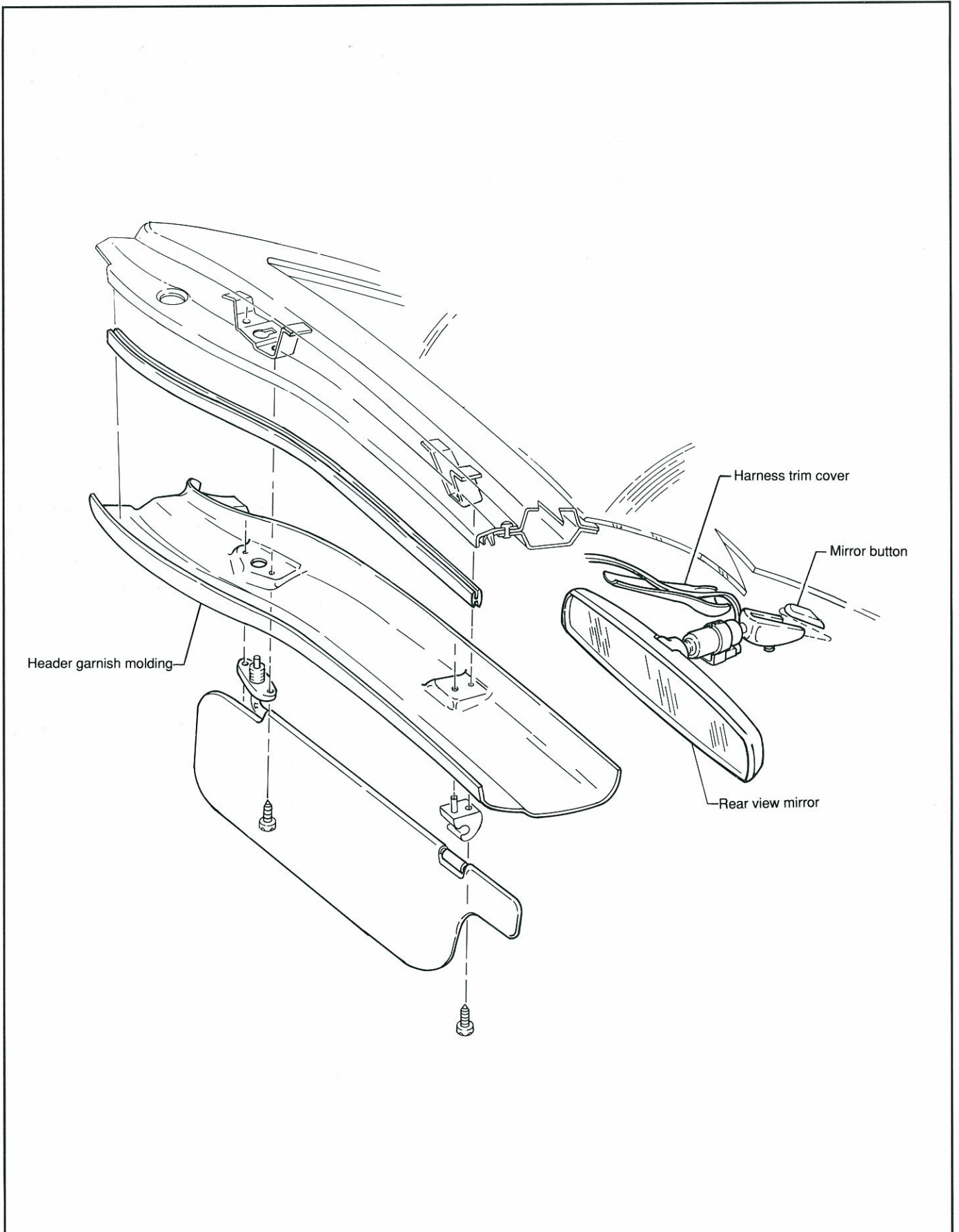

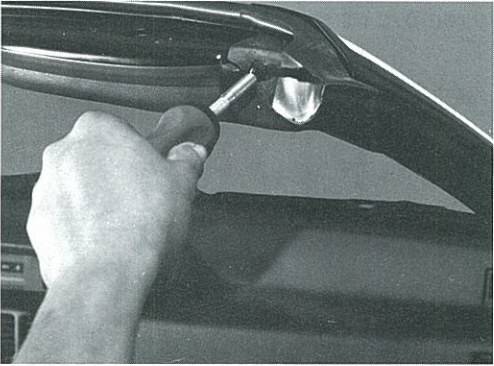
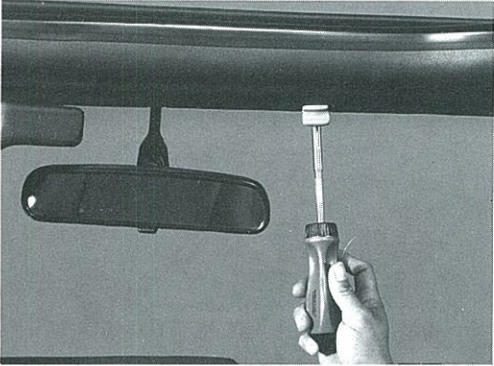
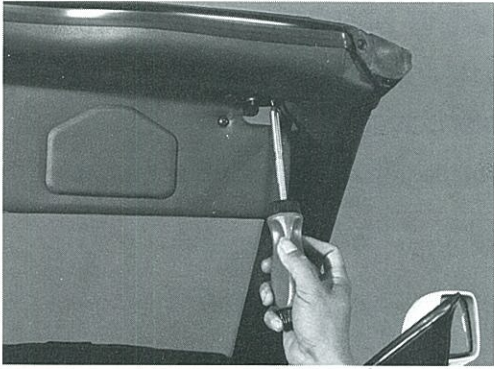

**REMOVAL OF WINDSHIELD HEADER TRIM**

1. LOWER CONVERTIBLE TOP.  
Remove the four (4) screws and the sun visors.
2. REMOVE SUN VISORS.
3. REMOVE SUN VISOR HOLDERS.  
Remove the two (2) screws and the sun visor holders.
4. REMOVE WINDSHIELD HEADER GARNISH MOLDING.  
Remove the two (2) screws attaching the windshield header seal at the "A" pillar and remove the windshield header garnish molding.

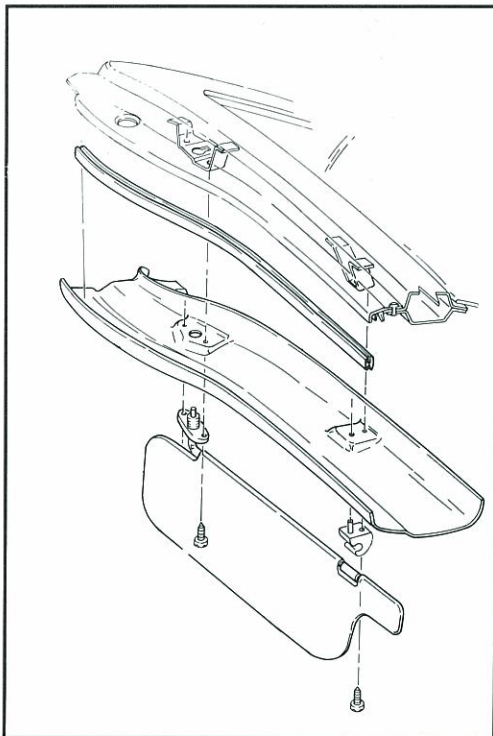

**INSTALLATION OF WINDSHIELD HEADER TRIM IN THE FOLLOWING ORDER:**

- (a) Windshield header garnish molding.
- (b) Sun visor holders.
- (c) Sun visors.

**REMOVAL OF REAR VIEW MIRROR**

1. REMOVE WINDSHIELD HEADER TRIM (See 1-3).
2. REMOVE HARNESS TRIM COVER.

Grasp the upper portion of the trim cover and pull upward to remove.

3. REMOVE REAR VIEW MIRROR.

(a) Disconnect harness connector.

(b) Loosen set screw to remove mirror.

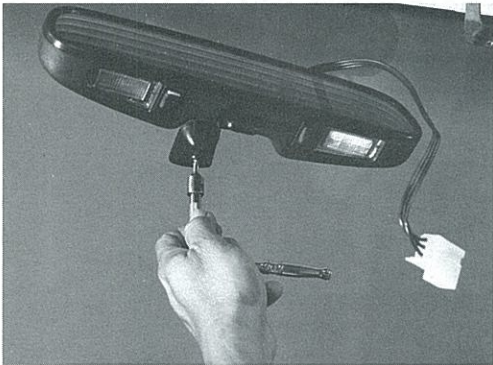
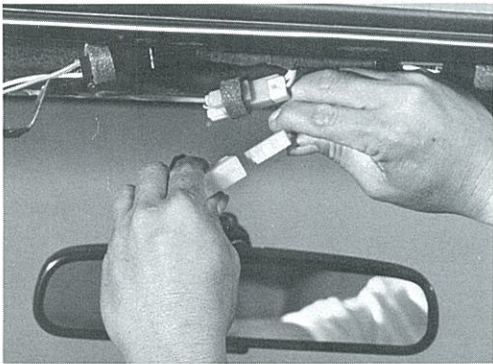
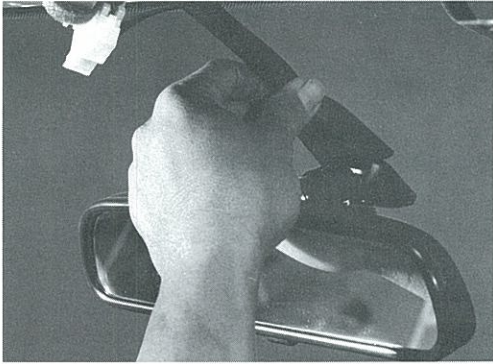

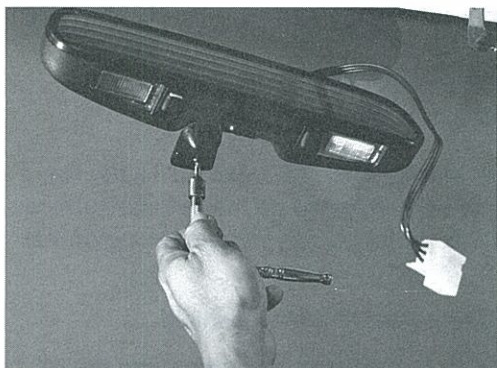

## INSTALLATION OF REAR VIEW MIRROR

1. INSTALL REAR VIEW MIRROR.
  - (a) Install rear view mirror and tighten set screw.  
**Torque: 1.5 N-m (13.25 in-lb).**



- (b) Re-connect harness connector.



2. INSTALL HARNESS TRIM COVER.

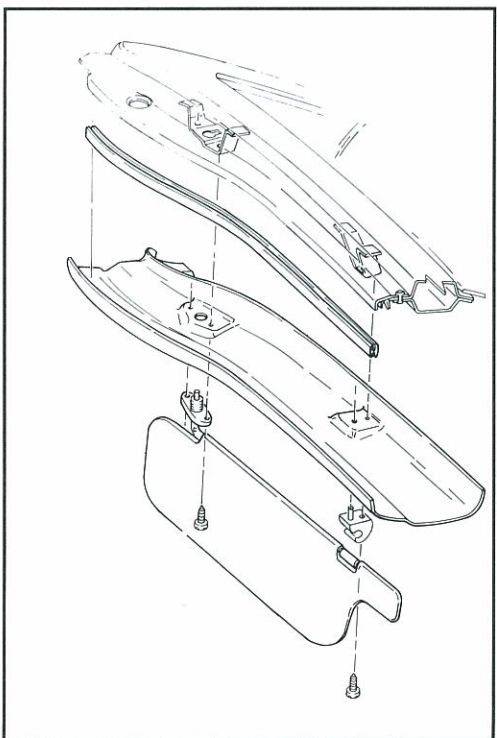

3. INSTALL WINDSHIELD HEADER TRIM (See 1-3).

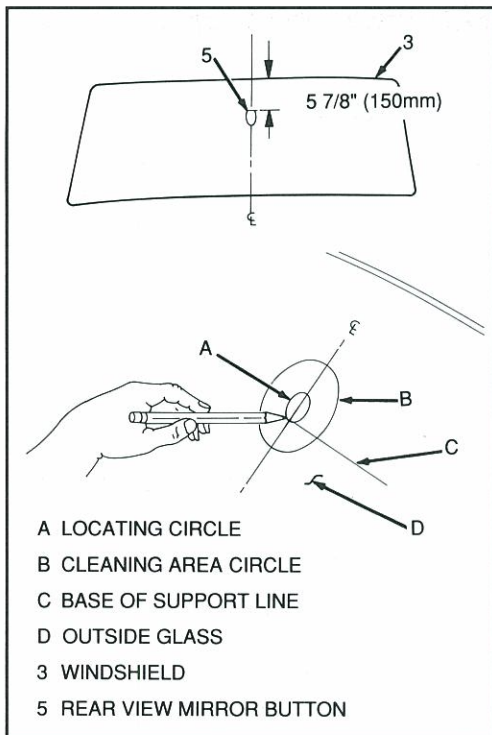

## INSTALLATION OF REAR VIEW MIRROR BUTTON

1. REMOVE WINDSHIELD HEADER TRIM (See 1-3).
2. REMOVE REAR VIEW MIRROR (See 1-4).
3. DETERMINE REARVIEW MIRROR BUTTON LOCATION. The following procedures are to be performed on the outside surface of the windshield. Use a wax pencil or crayon for marking on the glass.
  - (a) Measure and mark the center of the windshield.
  - (b) Measure and mark 5-7/8" (150mm) down from the top of the windshield.
  - (c) Mark the button location with a small circle.
  - (d) Mark a larger diameter circle around the small circle.
4. CLEAN REAR VIEW MIRROR BUTTON LOCATION. The following procedures are to be performed on the inside surface of the windshield.
  - (a) Clean the area of the large circle with paper towels and glass cleaning solution or glass polishing compound.
  - (b) Let the cleaned area dry.
  - (c) Clean the area with an alcohol-saturated paper towel to remove any traces of cleaning solution.
5. PREPARE REAR VIEW MIRROR BUTTON FOR INSTALLATION.
  - (a) Using a piece of fine grit (340X or 360X) emery cloth or sandpaper, sand the bonding surface of the new rear view mirror button. If the original rear view mirror is to be reused, all traces of the factory installed adhesive must be removed prior to installation.
  - (b) Clean the sanded rear view button with an alcohol-saturated paper towel.
  - (c) Let dry.

**INSTALLATION OF REAR VIEW MIRROR BUTTON  
(cont.)**

6. INSTALL REAR VIEW MIRROR BUTTON.
  - (a) Follow the directions on adhesive manufacturer's kit to prepare rear view mirror button prior to installation to the windshield.
  - (b) Lightly apply adhesive accelerator to the bonding surfaces of the rear view mirror button and the windshield.
  - (c) Allow adhesive accelerator to dry completely.
  - (d) Apply two (2) drops of adhesive to the rear view mirror button.
  - (e) Using a toothpick, evenly distribute the adhesive over the entire bonding surface of the rear view mirror button.
  - (f) Position the rear view mirror button to the pre-marked location on the windshield, with the rounded end pointed upward.
  - (g) Press the rear view mirror button against the windshield for 30 to 60 seconds, while exerting steady pressure.
  - (h) After five minutes, remove excess adhesive with an alcohol-moistened paper towel and a single-edge razor blade.
7. INSTALL REAR VIEW MIRROR (See 1-5).
8. INSTALL THE WINDSHIELD HEADER TRIM (See 1-3).





# POWER PULL DOWN ACTUATORS

	Page
POWER PULL DOWN ACTUATORS - COMPONENTS .....	2-2
REMOVAL OF POWER PULL DOWN ACTUATORS ....	2-3
INSTALLATION OF POWER PULL DOWN ACTUATORS .....	2-3
REMOVAL OF TOP PULL DOWN PINS .....	2-4
INSTALLATION OF TOP PULL DOWN PINS .....	2-4

POWER PULL DOWN ACTUATORS -  
COMPONENTS

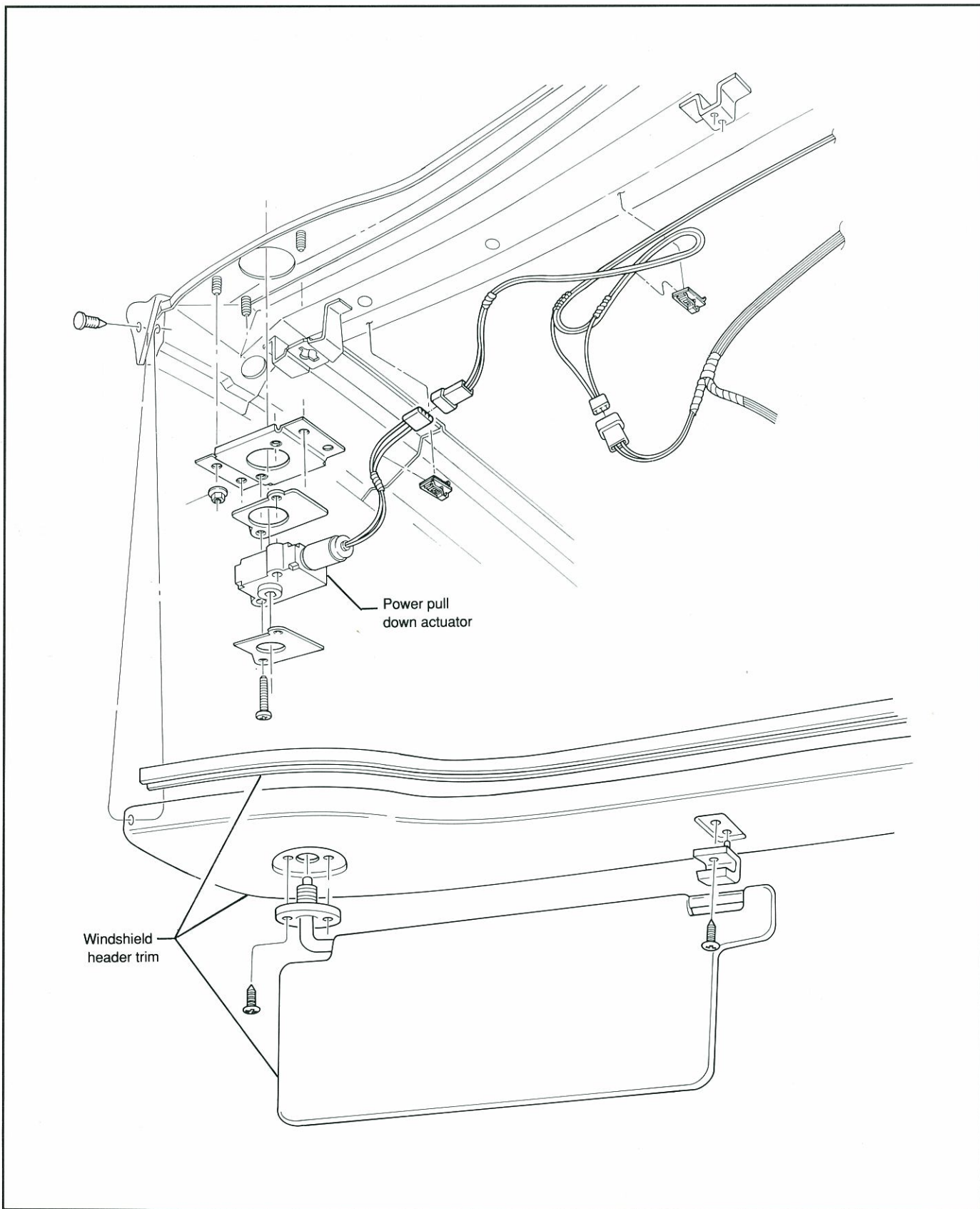

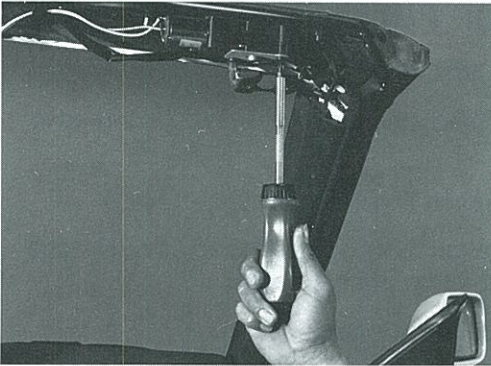
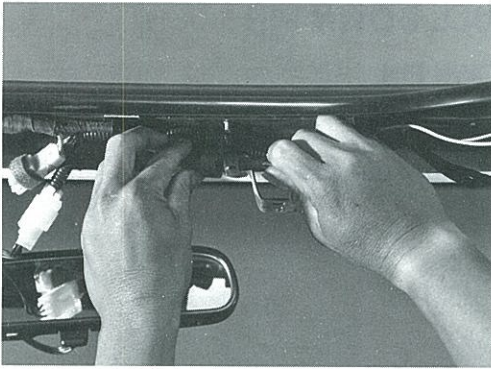

## REMOVAL OF POWER PULL DOWN ACTUATOR

1. LOWER CONVERTIBLE TOP.
2. REMOVE WINDSHIELD HEADER TRIM (See 1-3).
3. REMOVE POWER PULL DOWN ACTUATOR.
  - (a) Disconnect the harness connector.
  - (b) Remove the two (2) bolts to remove the power pull down actuator.

## INSTALLATION OF POWER PULL DOWN ACTUATOR.

1. INSTALL POWER PULL DOWN ACTUATOR.
  - (a) Position the power pull down actuator and install the two (2) bolts.

**Torque: 1.7 N-m (15 in-lb).**
  - (b) Connect the harness connector.
2. INSTALL WINDSHIELD HEADER TRIM (See 1-3).

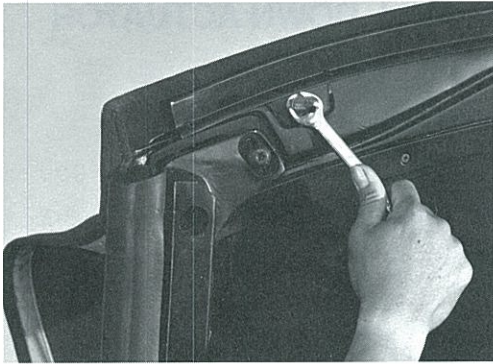

### REMOVAL OF TOP PULL DOWN PIN

1. REMOVE TOP PULL DOWN PIN.
  - (a) Lower top halfway.
  - (b) Loosen lock nut to remove pull down pin.

### INSTALLATION OF TOP PULL DOWN PIN

1. INSTALL TOP PULL DOWN PIN.
  - (a) Using fingers, turn the lock nut all the way up on threaded portion.
  - (b) Install pull down pin and finger tighten.

**CAUTION: Do not use wrench or pliers. Otherwise, damage to auger portion of pull down pin will result.**

- (c) Using a wrench, tighten lock nut.

**Torque: 15.6 N-m (11.5 ft-lb).**

---

# WINDSHIELD OUTER MOLDINGS

	Page
WINDSHIELD OUTER MOLDINGS - COMPONENTS ....	3-2
REMOVAL OF WINDSHIELD OUTER MOLDINGS, WEATHERSTRIP ASSEMBLY AND RETAINERS .....	3-3
INSTALLATION OF WINDSHIELD OUTER MOLDINGS, WEATHERSTRIP ASSEMBLY AND RETAINERS .....	3-6

WINDSHIELD OUTER MOLDINGS - COMPONENTS

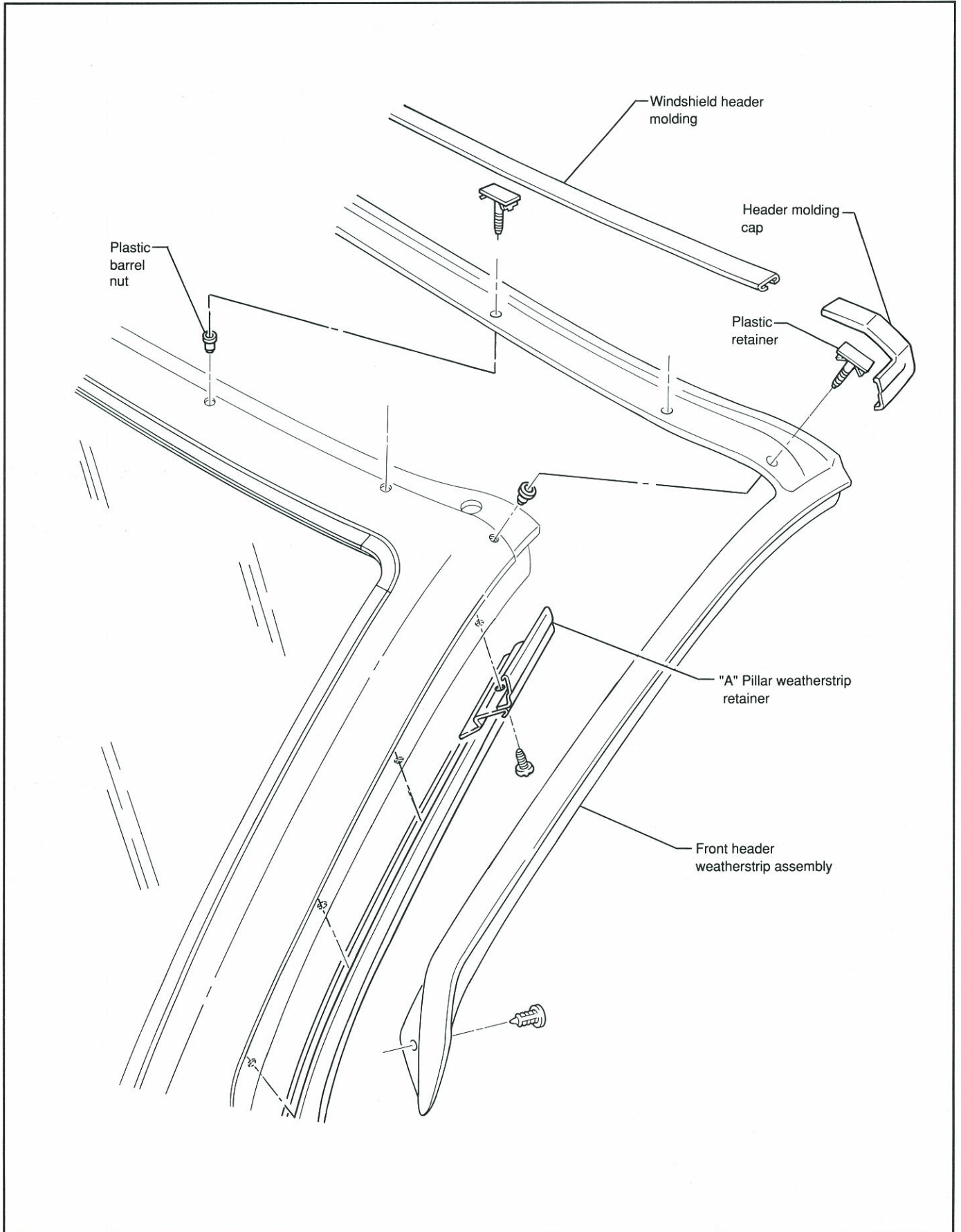

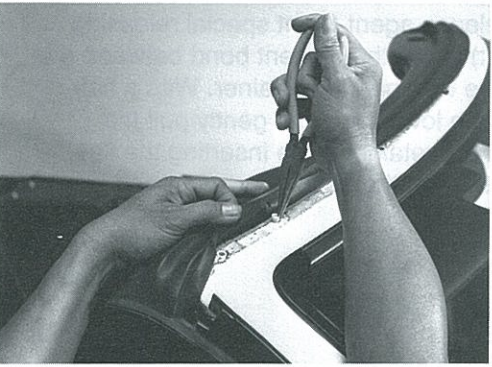
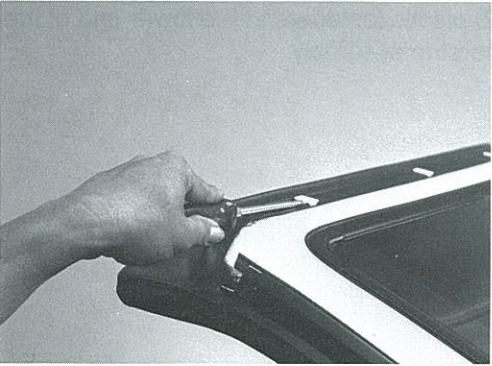
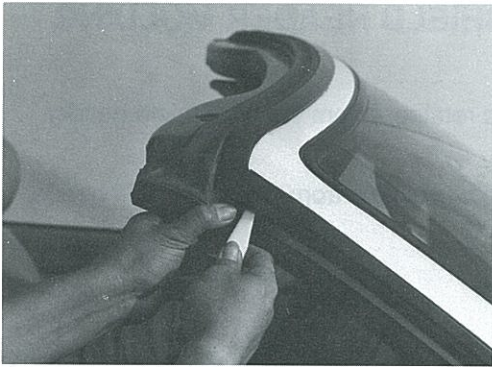

## REMOVAL OF WINDSHIELD OUTER MOLDINGS, WEATHERSTRIP ASSEMBLY AND RETAINERS

1. LOWER CONVERTIBLE TOP.
2. REMOVE WINDSHIELD HEADER MOLDING CAP.
  - (a) Using a suitable non-marring (ie: plastic) flat-bladed pry tool, pry up the molding cap.
  - (b) Stand to one side of the car and grasp the molding cap and pull outward to remove.

**CAUTION: Do not bend the header molding cap.**

- (c) Remove the plastic retainer from the windshield header and discard.

**NOTE: Do not remove the retainer if only the molding cap is being replaced.**

- (d) Remove the plastic barrel nut from the windshield header and discard.

**NOTE: If only the molding cap is being replaced, do not remove the barrel nut.**

3. REMOVE WINDSHIELD HEADER MOLDING.

- (a) Stand to one side of the car and grasp the windshield header molding and pull outward to remove the windshield header molding.

**CAUTION: Do not bend the windshield header molding.**

### REMOVAL OF WINDSHIELD HEADER MOLDING (cont.)

- (b) Remove the plastic retainers from the windshield header and discard.
- (c) Remove the plastic barrel nuts from the windshield header and discard.

### REMOVAL OF FRONT HEADER WEATHERSTRIP ASSEMBLY

1. REMOVE WINDSHIELD HEADER MOLDING AND WINDSHIELD HEADER MOLDING CAPS.
2. REMOVE FRONT HEADER WEATHERSTRIP ASSEMBLY.
  - (a) Remove the two (2) screws at each upper end of the "A" pillar.
  - (b) Remove the two (2) plastic fasteners at the lower end of the front header weatherstrip assembly.
  - (c) Using a suitable release agent (Kent special releasing agent or equivalent) break the cement bond between the weatherstrip and the weatherstrip retainer. With a flat-bladed tool, grasp the lower end and gently pull the weatherstrip out of the retainer while inserting the flat-bladed tool under the weatherstrip.
  - (d) Continue removing the weatherstrip from the front header retainer, using the above technique.

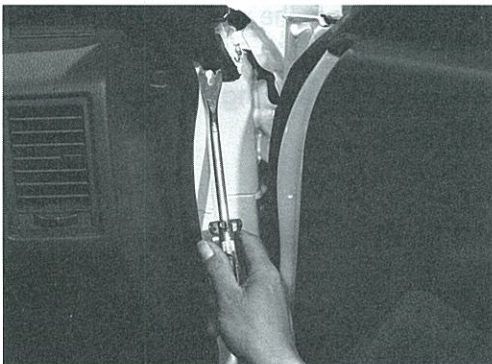
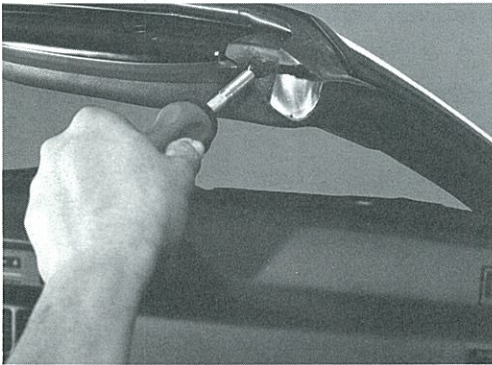



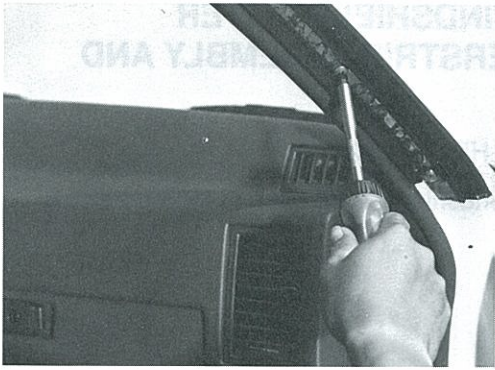

### REMOVAL OF WEATHERSTRIP ASSEMBLY AND RETAINERS (cont.)

3. REMOVE "A" PILLAR WEATHERSTRIP RETAINER.

Remove the four (4) screws and remove the "A" pillar weatherstrip to remove the retainer.

**CAUTION: Do not attempt to remove an "A" pillar weatherstrip retainer alone, without replacing the entire weatherstrip assembly. Damage to the weatherstrip will result.**

4. REMOVE WINDSHIELD HEADER TRIM (See 1-3).

5. REMOVE FRONT HEADER WEATHERSTRIP RETAINER.

- (a) During rivet removal, move wire harness far enough from windshield header to clear drill bit.

**CAUTION: Make sure drill bit does not sever wire harness.**



- (b) Using a drill motor and a 1/8" drill bit, remove the nine (9) rivets and remove the front header weatherstrip retainer.

**CAUTION: Protect the vehicle from flying metal chips by using protective coverings.**

- (c) Vacuum windshield header and all other areas where metal chips may have fallen.

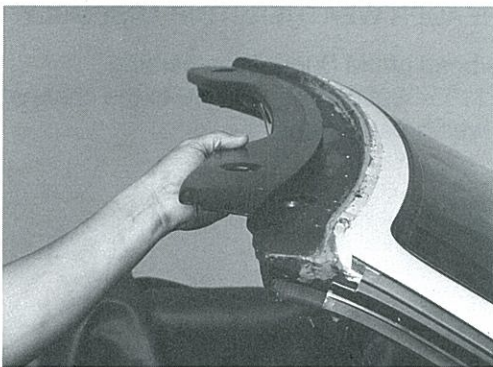

6. REMOVE WINDSHIELD HEADER CAP.



## INSTALLATION OF WINDSHIELD OUTER MOLDINGS, WEATHERSTRIP ASSEMBLY AND RETAINERS

### 1. INSTALL WINDSHIELD HEADER CAP.

Position and align the windshield header cap to the windshield header.

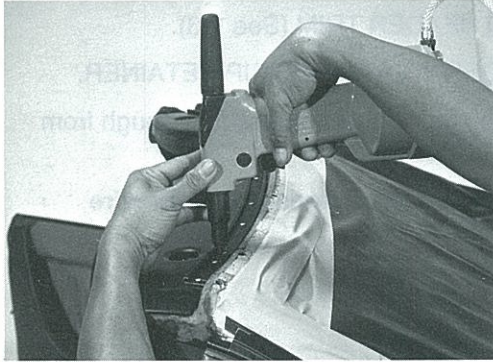

### 2. REMOVE ALL EXCESS ADHESIVE FROM THE FRONT HEADER WEATHERSTRIP RETAINER.

### 3. INSTALL FRONT HEADER WEATHERSTRIP RETAINER.

(a) Position the weatherstrip retainer to the front header and install the nine (9) 1/8" x .312 stainless steel rivets.

(b) Install the harness to the windshield header.



### 4. INSTALL WINDSHIELD HEADER TRIM (See 1-3).

### 5. REMOVE ALL EXCESS ADHESIVE FROM THE "A" PILLAR WEATHERSTRIP RETAINER.

### 6. INSTALL "A" PILLAR WEATHERSTRIP RETAINER.

Position the "A" pillar weatherstrip retainer to the "A" pillar and install the four (4) screws.

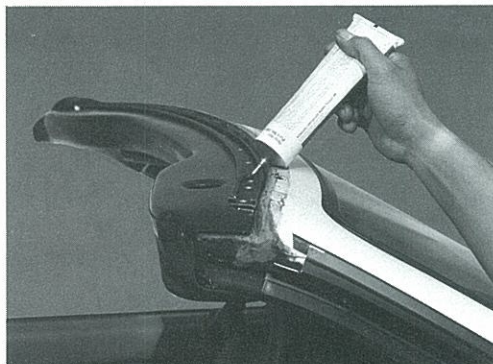

### 7. INSTALL THE FRONT HEADER WEATHERSTRIP ASSEMBLY.

(a) Apply a continuous bead of 3M Super Weatherstrip Adhesive ( 3M #051135-08008 or equivalent) to the channel in the front header weatherstrip retainer.

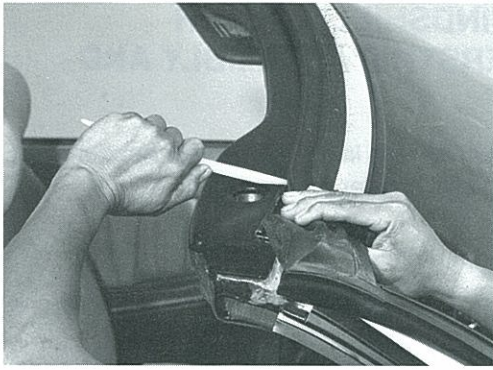

### INSTALLATION OF WINDSHIELD OUTER MOLDINGS, WEATHERSTRIP ASSEMBLY AND RETAINERS (Cont.)

- (b) Position and align the front weatherstrip assembly to the front header weatherstrip retainer.
- (c) Using a flat-bladed tool, install the weatherstrip into the front header weatherstrip retainer.



- (d) Apply a continuous bead of 3M Super Weatherstrip Adhesive (3M # 051135-08008 or equivalent) to the channel of the "A" pillar weatherstrip retainer.



- (e) Position and align the weatherstrip to the retainer.
- (f) Using a flat-bladed tool, install the weatherstrip into the retainer.

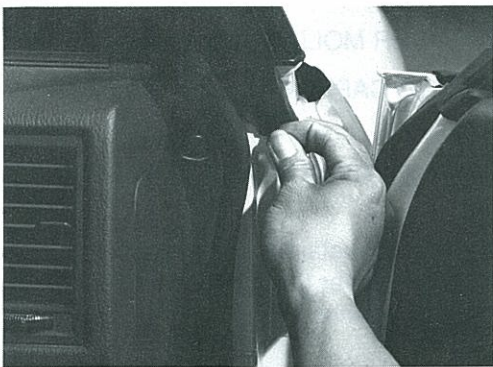

- (g) Install the two (2) plastic fasteners to the lower end of the weatherstrip.



### 8. INSTALL WINDSHIELD HEADER MOLDING

- (a) Install new plastic retainers in the windshield header molding.

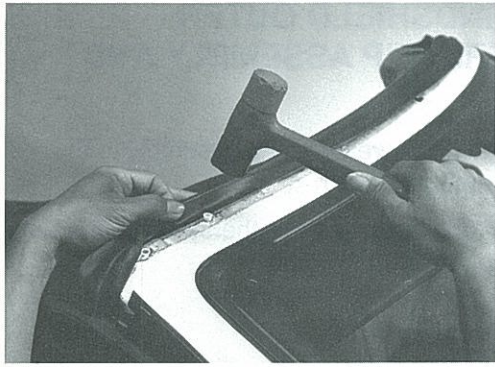

### INSTALLATION OF WINDSHIELD OUTER MOLDINGS, WEATHERSTRIP ASSEMBLY AND RETAINERS (cont.)

- (b) Install new plastic barrel nuts in the windshield header for the header molding and header molding cap.
- (c) Position and align the retainers in the windshield header molding to the barrel nuts in the windshield header.
- (d) Starting at one end, carefully install the header molding into the barrel nuts by pushing down firmly.

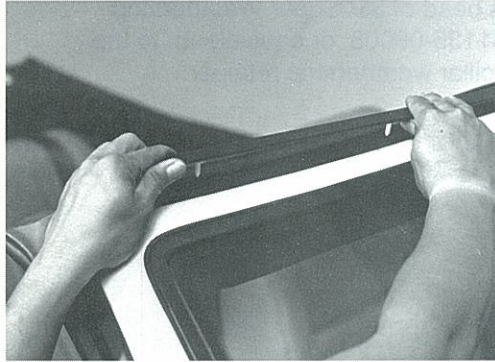

**CAUTION: Do not bend the molding.**



#### 9. INSTALL WINDSHIELD HEADER MOLDING CAP

IF REPLACING THE MOLDING CAP ALONE; PERFORM THE FOLLOWING:

- (a) Position and align the molding cap to the retainer in the windshield header.
- (b) Slide the molding cap into the retainer and snap the molding cap edges securely over the header molding and the "A" pillar weatherstrip retainer.

IF REPLACING THE MOLDING CAP ALONG WITH OTHER PARTS OF THE WINDSHIELD HEADER, PERFORM THE FOLLOWING:

- (a) Install a new plastic retainer in the windshield header molding cap.

---

**INSTALLATION OF WINDSHIELD OUTER  
MOLDINGS, WEATHERSTRIP ASSEMBLY AND  
RETAINERS (cont.)**

- (b) Position and align the molding cap retainer to the barrel nut in the windshield header and push down firmly to secure.



---

# QUARTER BELT, BACK BELT, QUARTER WINDOW AND DECK LID MOLDINGS

	Page
MOLDINGS - COMPONENTS .....	4-2
REMOVAL OF QUARTER BELT AND BACK BELT MOLDINGS .....	4-3
INSTALLATION OF QUARTER BELT AND BACK BELT MOLDINGS .....	4-4
REMOVAL OF QUARTER WINDOW MOLDING .....	4-5
INSTALLATION OF QUARTER WINDOW MOLDING ....	4-6
REMOVAL OF DECK LID MOLDING .....	4-7
INSTALLATION OF DECK LID MOLDING .....	4-7

QUARTER BELT, BACK BELT, QUARTER WINDOW AND DECK LID MOLDINGS - COMPONENTS

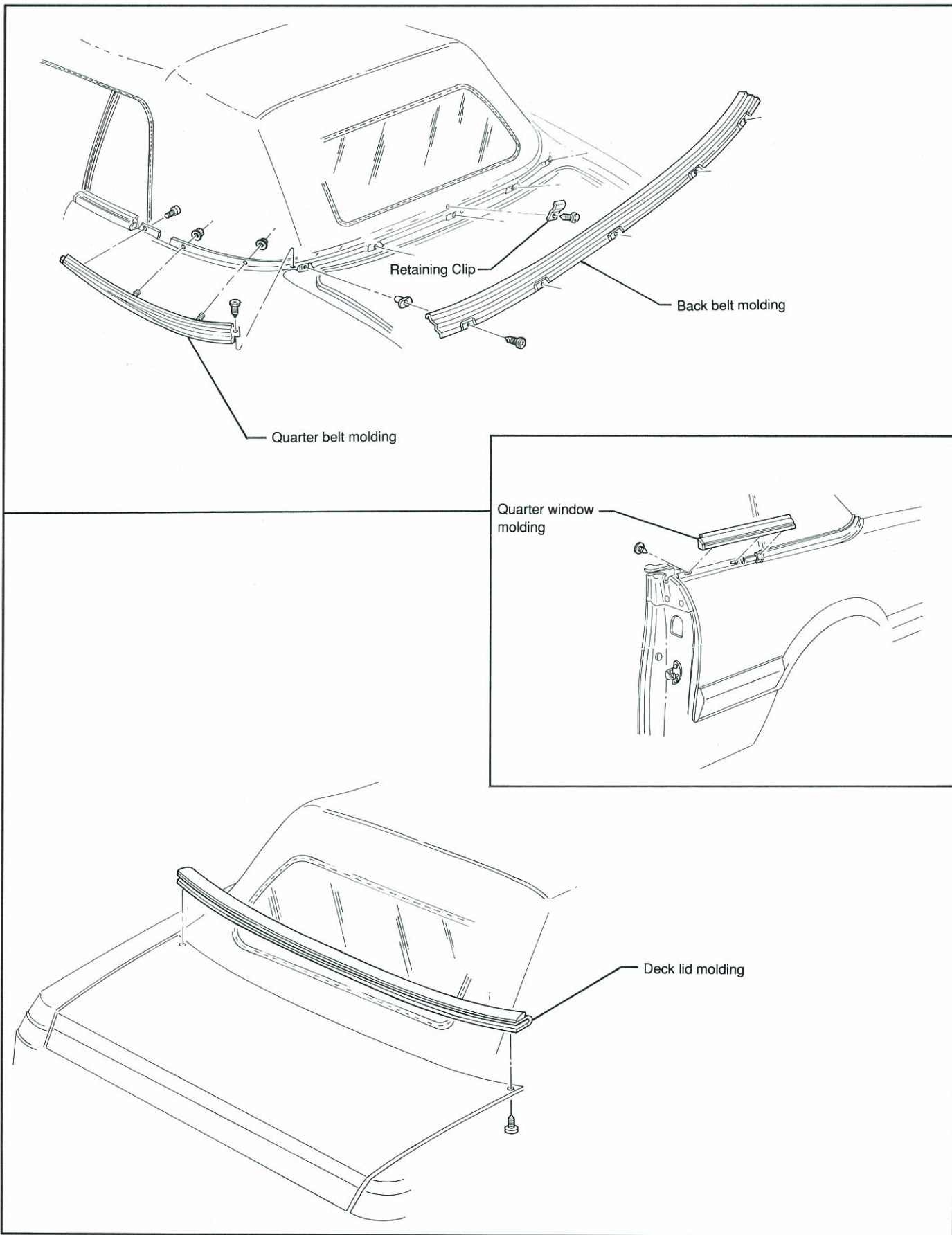



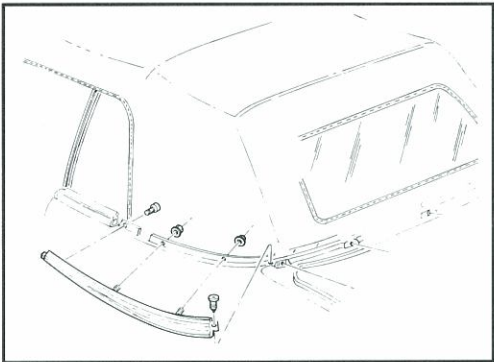
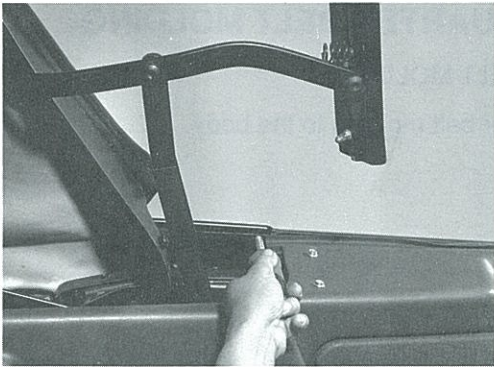
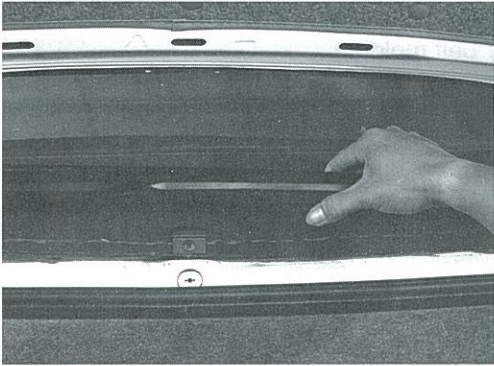
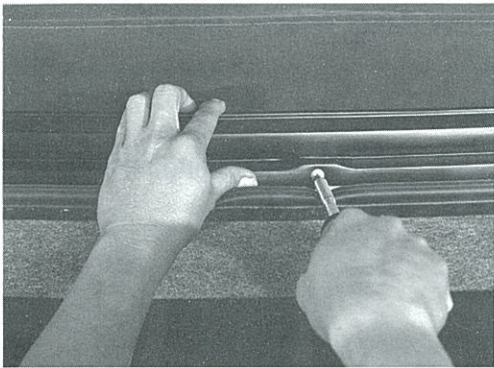

## REMOVAL OF QUARTER BELT AND BACK BELT MOLDINGS

1. RAISE CONVERTIBLE TOP.
2. OPEN DECK LID.
3. REMOVE BACK BELT MOLDING.
  - (a) Remove the five (5) screws.
  - (b) Disengage the back belt molding from the retaining clip to remove the back belt molding.

**CAUTION: Do not bend the molding.**

4. REMOVE QUARTER BELT MOLDING.
  - (a) Close the deck lid.
  - (b) Lower convertible top halfway.
  - (c) Remove the forward screw attaching the quarter belt molding.
  - (d) Remove the two (2) nuts attaching the quarter belt molding.



### REMOVAL OF QUARTER AND BACK BELT MOLDINGS (cont.)

- (e) Remove the rearward screw.

**CAUTION:** Make sure you hold the molding securely while removing the screw.

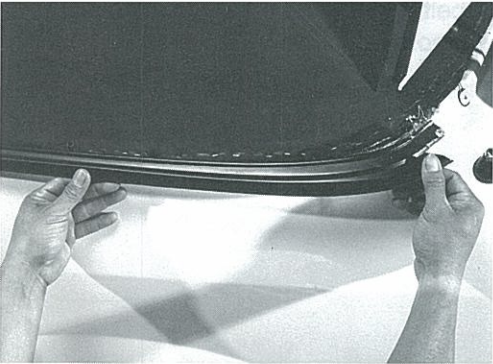

- (f) Disengage the quarter belt molding from the body and remove the quarter belt molding.

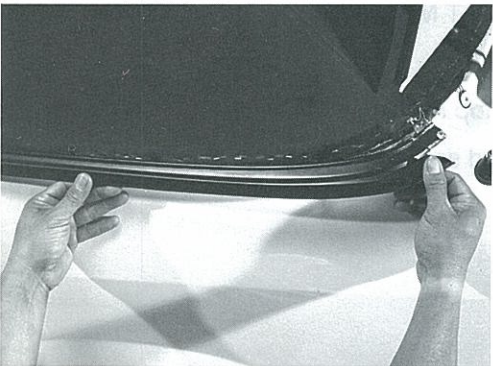

### INSTALLATION OF QUARTER BELT MOLDING

1. INSTALL QUARTER BELT MOLDING.

- (a) Engage the quarter belt molding to the body.



- (b) Install the rearward screw.

- (c) Install the two (2) nuts.

**Torque: 7 N-m (60 in-lb)**

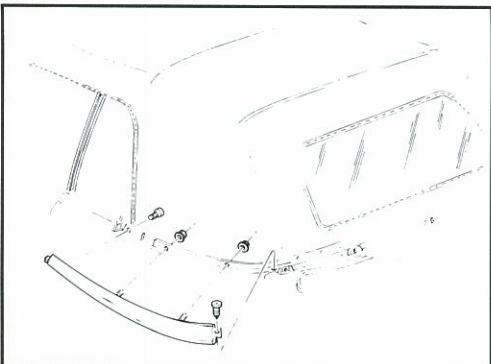

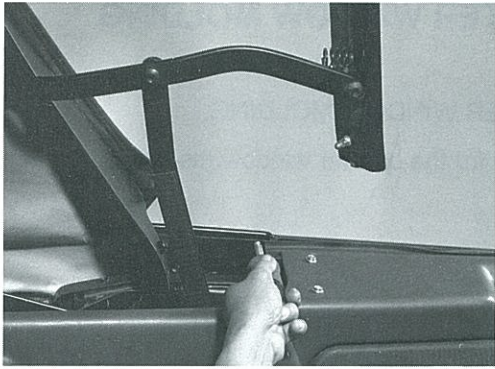

### INSTALLATION OF QUARTER AND BACK BELT MOLDINGS (cont.)

- (d) Install the forward screw.  
**Torque: 1.7 N-m (15 in-lb)**

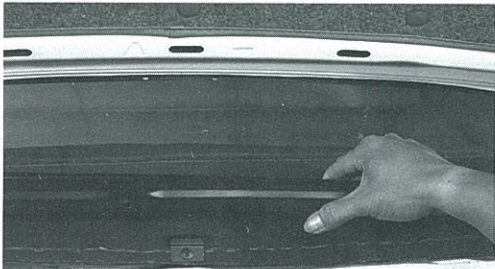

### INSTALLATION OF BACK BELT MOLDING

#### 2. INSTALL BACK BELT MOLDING.

- (a) Engage the back belt molding to the retaining clip and align the the back belt molding to quarter belt moldings.

**CAUTION: Do not bend the molding.**

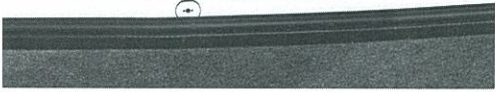

- (b) Install the five (5) screws.



### REMOVAL OF QUARTER WINDOW MOLDING

1. LOWER THE CONVERTIBLE TOP.
2. LOWER THE QUARTER WINDOW HALFWAY.
3. REMOVE THE QUARTER TRIM PANEL (See 6-3).
4. REMOVE THE QUARTER WINDOW INNER WEATHERSTRIP ASSEMBLY.

Remove the three (3) screws for the inner weatherstrip assembly.



### REMOVAL OF QUARTER WINDOW MOLDING (cont.)

5. REMOVE THE QUARTER WINDOW MOLDING.
  - (a) Remove the screw for the quarter window molding.
  - (b) Remove the quarter window molding.

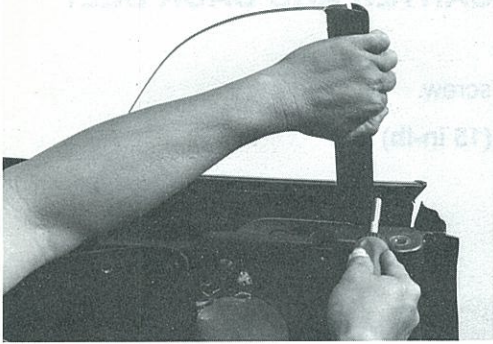

### INSTALLATION OF QUARTER WINDOW MOLDING

1. INSTALL THE QUARTER WINDOW MOLDING.  
Position the quarter window molding and install the screw.

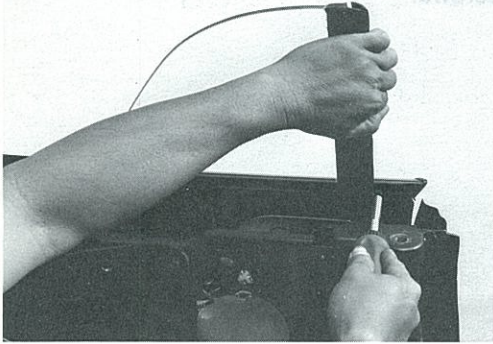

2. INSTALL THE QUARTER WINDOW INNER WEATHERSTRIP ASSEMBLY.

Position the quarter belt lower bracket and install the three (3) screws.

**Torque: 9 N-m (80 in-lb).**



3. INSTALL THE QUARTER TRIM PANEL (See 6-6).



## REMOVAL OF DECK LID MOLDING

1. REMOVE DECK LID MOLDING.
  - (a) Open the deck lid.
  - (b) Remove the six (6) screws attaching the molding to the deck lid.
  - (c) Detach the rubber isolator from the underside of the deck lid and remove the deck lid molding.

**CAUTION: Do not bend the molding.**



## INSTALLATION OF DECK LID MOLDING

1. INSTALL DECK LID MOLDING.
  - (a) Position and align the molding to the deck lid.
  - (b) Attach the rubber isolator to the underside of the deck lid.
  - (c) Install the six (6) screws.

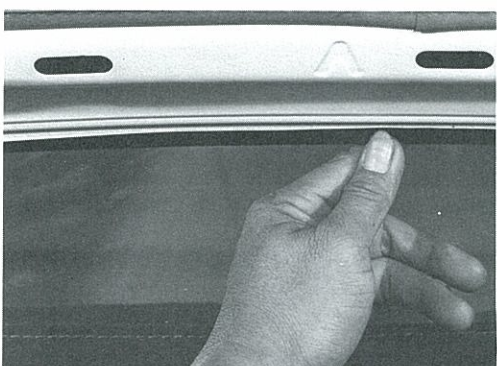
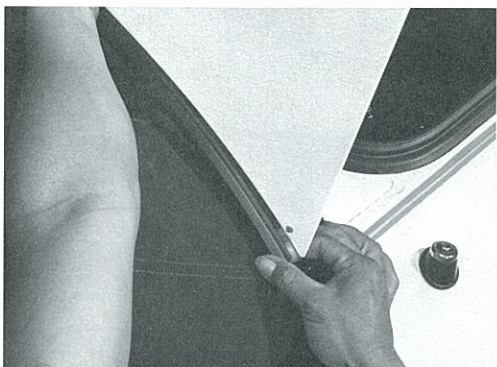



---

# REAR SEAT

	Page
REAR SEAT - COMPONENTS .....	5-2
REMOVAL OF REAR SEAT CUSHION .....	5-3
INSTALLATION OF REAR SEAT CUSHION .....	5-4
REMOVAL OF REAR SEAT BACK .....	5-5
INSTALLATION OF REAR SEAT BACK .....	5-5

REAR SEAT - COMPONENTS

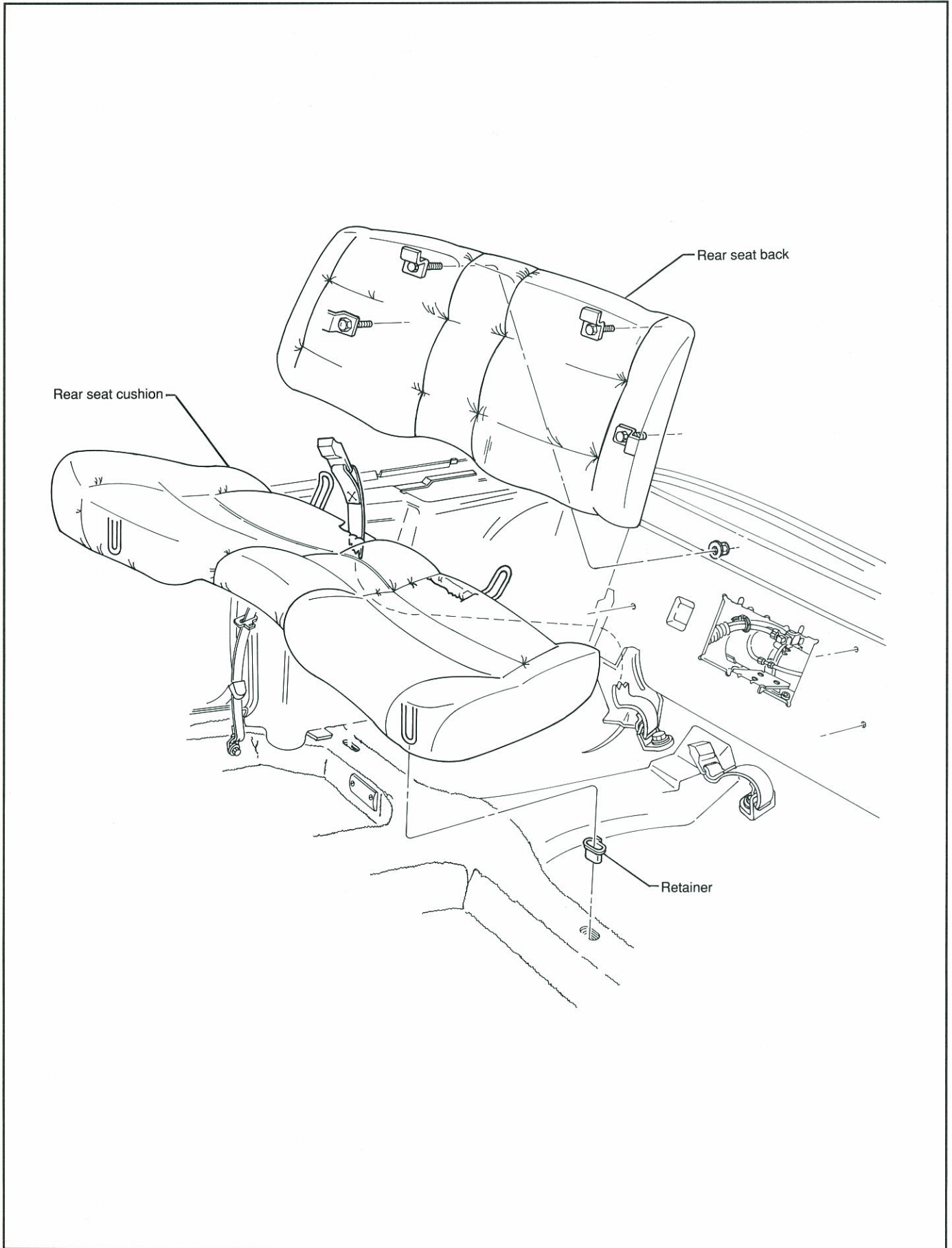





## REMOVAL OF REAR SEAT CUSHION

### 1. REMOVE REAR SEAT CUSHION.

- (a) Lift up forward edge of rear seat cushion to release seat from retainers.

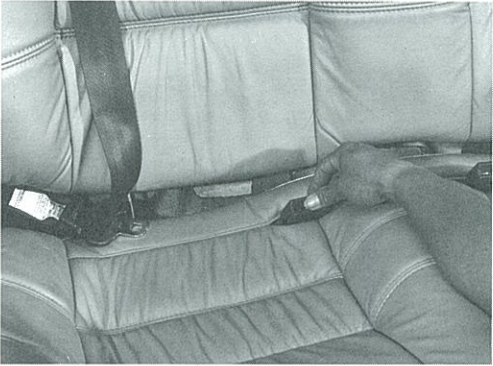

- (b) Feed seat belt buckles through openings in rear seat cushion.



- (c) Remove and discard seat cushion retainers.

**INSTALLATION OF REAR SEAT CUSHION**

## 1. INSTALL REAR SEAT CUSHION.

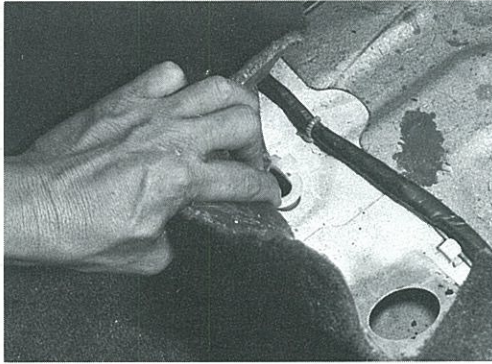

(a) Install new seat cushion retainers.

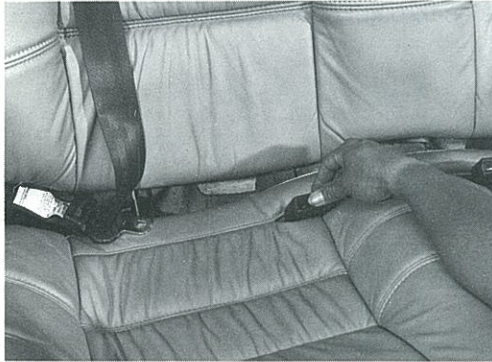

(b) Feed seat belt buckles through openings in rear seat cushion.

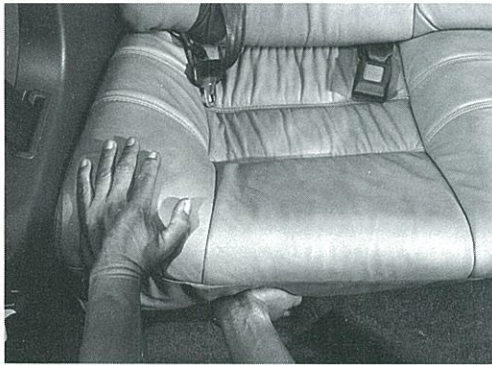

(c) Position rear seat cushion into retainers and push rear seat down firmly.

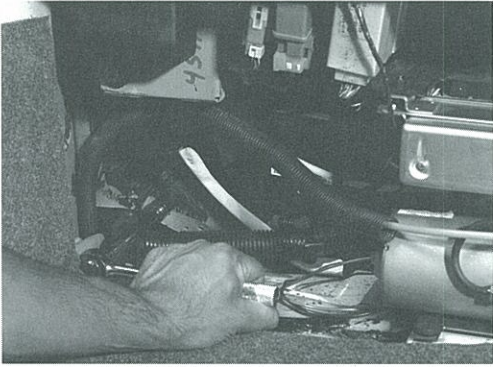

## REMOVAL OF REAR SEAT BACK

1. REMOVE REAR SEAT BACK.
  - (a) Raise the convertible top.
  - (b) Open the deck lid.
  - (c) Lift up the shock tower brace cover to reveal the seat back attaching nuts.
  - (d) Remove the four (4) nuts attaching rear seat back.
  - (e) Remove the seat back from the vehicle.

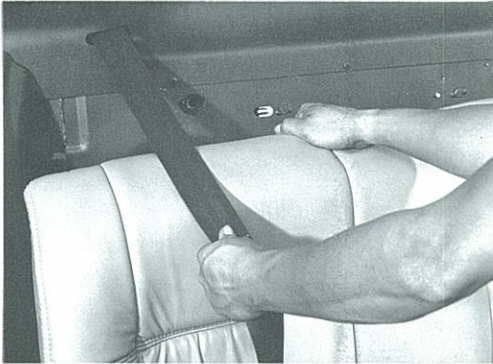

## INSTALLATION OF REAR SEAT BACK

1. INSTALL REAR SEAT BACK.
  - (a) Install rear seat back.
  - (b) Install the four (4) nuts to attach the rear seat back.  
**Torque: 28 N-m (21 ft-lb).**

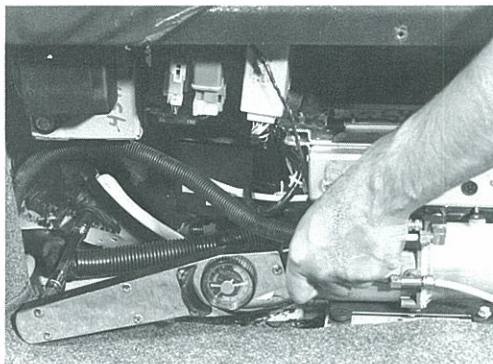



# QUARTER TRIM PANEL

	Page
QUARTER TRIM PANEL - COMPONENTS .....	6-2
REMOVAL OF QUARTER TRIM PANEL .....	6-3
INSTALLATION OF QUARTER TRIM PANEL .....	6-6

QUARTER TRIM PANEL - COMPONENTS

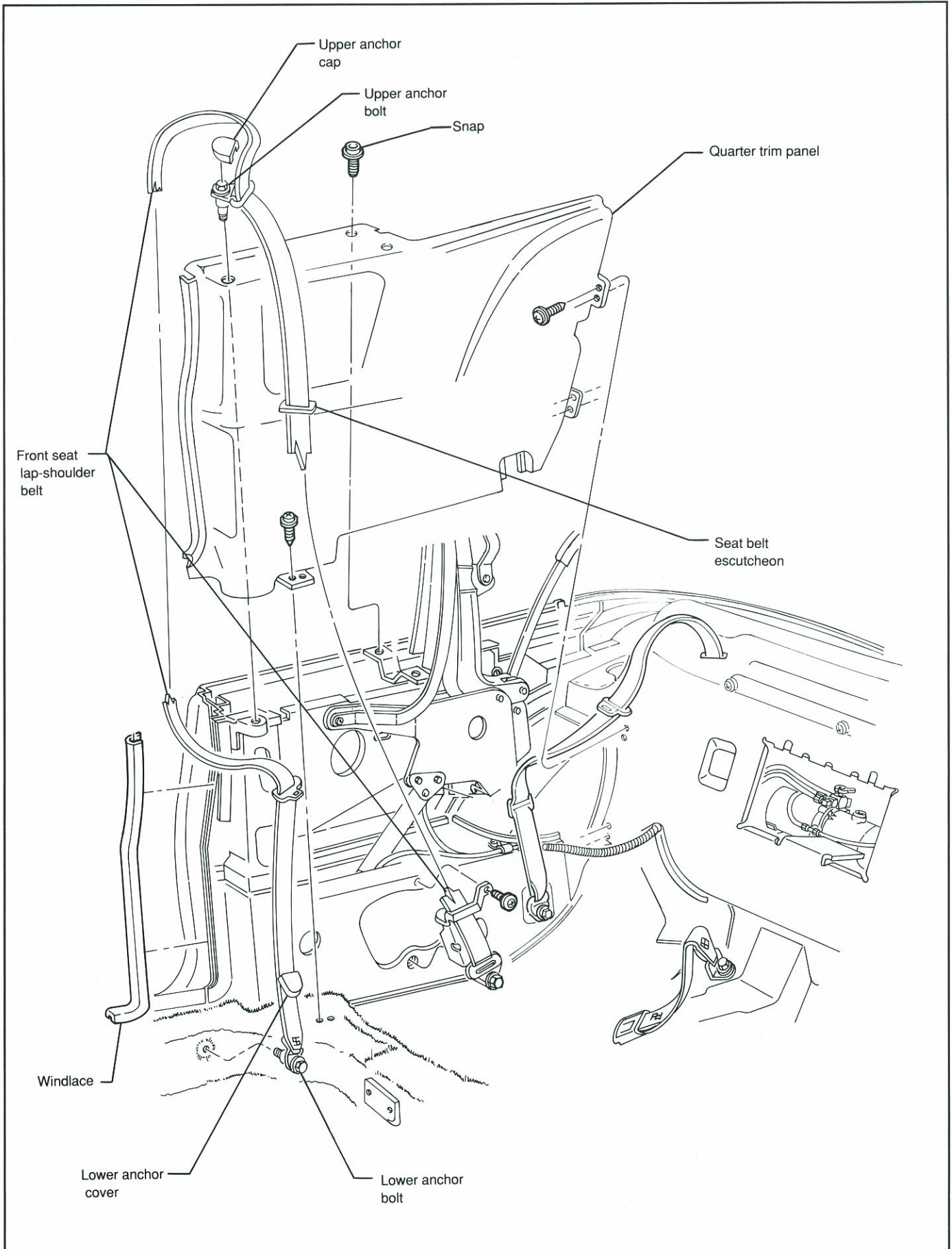



**REMOVAL OF QUARTER TRIM PANEL**

1. REMOVE REAR SEAT CUSHION (See 5-3).
2. REMOVE REAR SEAT BACK (See 5-5).
3. REMOVE QUARTER TRIM PANEL.
  - (a) Lift up door sill finisher to expose windlace.

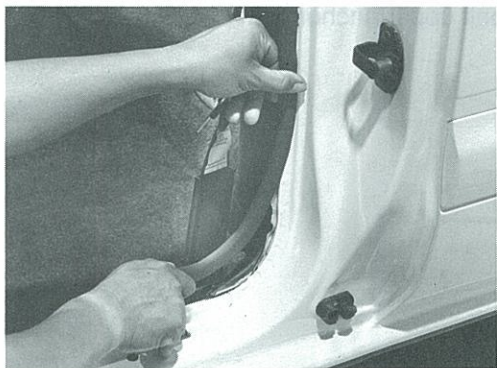

- (b) Remove windlace from lock pillar pinch weld flange.
 

**CAUTION: Do not bend or kink windlace.**



- (c) Remove quarter trim panel material flap from lock pillar pinch weld flange.



4. REMOVE FRONT SEAT LAP-SHOULDER BELT LOWER ANCHOR.
  - (a) Remove the seat belt lower anchor bolt cover and the bolt.



- (b) Remove the seat belt lower anchor bolt, washers and the anchor cover from the end of the seat belt.

**REMOVAL OF QUARTER TRIM PANEL (cont.)**

5. REMOVE FRONT SEAT LAP-SHOULDER BELT UPPER ANCHOR.

- (a) Remove the seat belt upper anchor cap.



- (b) Remove the seat belt upper anchor bolt.



6. REMOVE QUARTER TRIM PANEL.

- (a) Remove the two (2) screws and the snaps.



- (b) Remove the six (6) screws attaching quarter trim panel.

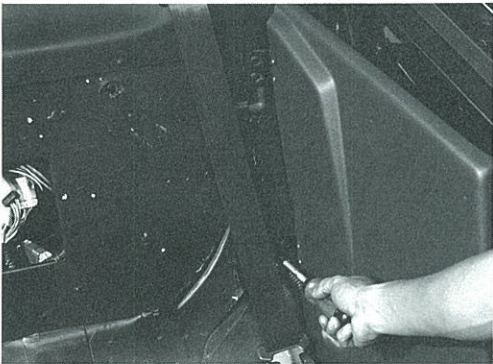

- (c) Lift trim panel up and off quarter window inner weatherstrip.





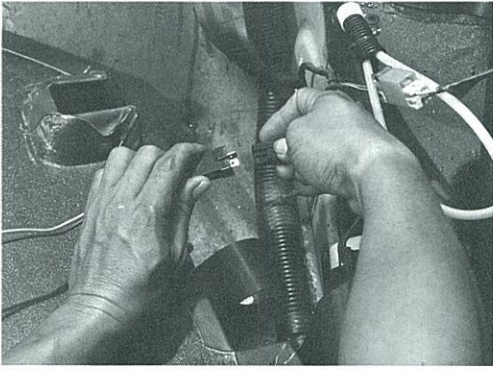

**REMOVAL OF QUARTER TRIM PANEL (cont.)**

(d) Disconnect speaker harness connector.

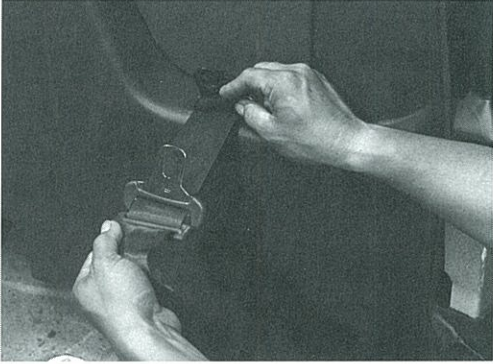

(e) Remove seat belt escutcheon and feed the seat belt through quarter trim panel.

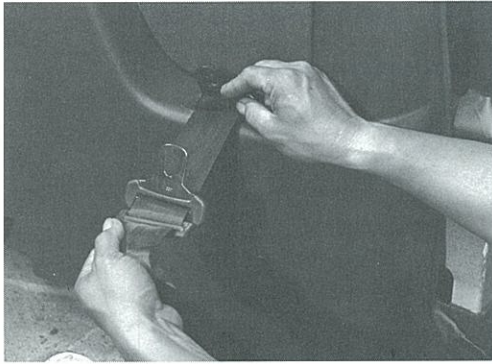
**INSTALLATION OF QUARTER TRIM PANEL****1. INSTALL QUARTER TRIM PANEL.**

- (a) Feed belt through trim panel and install the seat belt escutcheon.



- (b) Connect speaker harness connector.

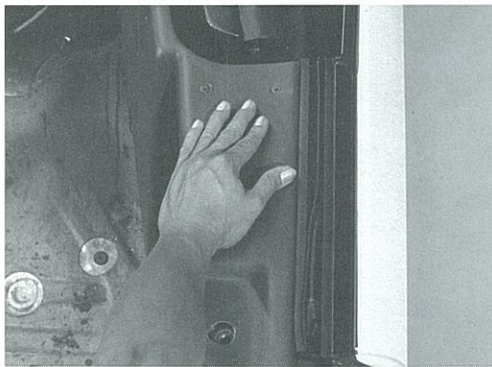

- (c) Position trim panel over quarter window weatherstrip and push down firmly.



- (d) Install the six (6) screws to attach quarter trim panel.

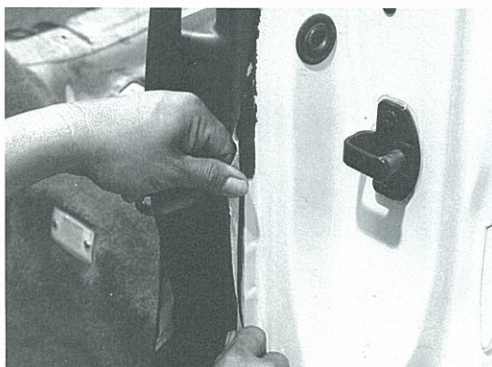

- (e) Re-attach quarter trim panel material around lock pillar pinch weld flange.

**INSTALLATION OF QUARTER TRIM PANEL (cont.)**

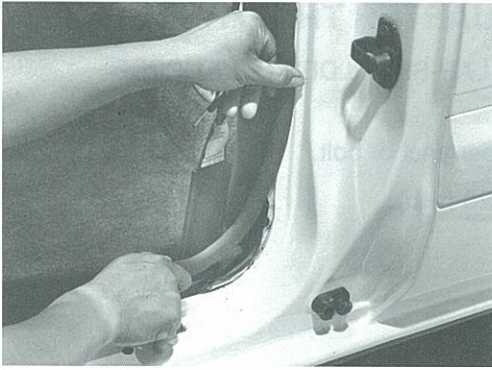

- (f) Install windlace to lock pillar pinch weld flange.

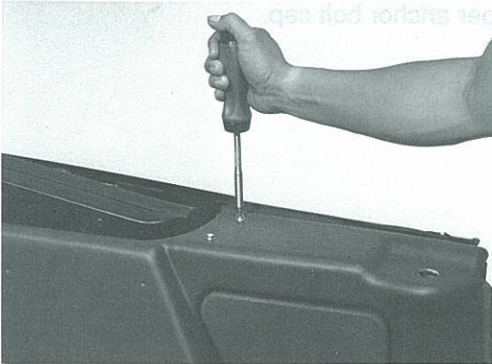

- (g) Install the two (2) snaps and the screws.

**2. INSTALL FRONT SEAT LAP-SHOULDER BELT LOWER ANCHOR.**



- (a) Feed seat belt through seat belt lower anchor cover.

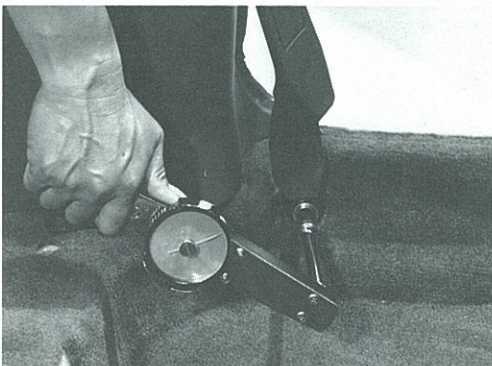

- (b) Install seat belt lower anchor bolt.  
**Torque: 42 N-m (29 ft-lb).**



- (c) Install seat belt lower anchor bolt cover.

**INSTALLATION OF QUARTER TRIM PANEL (cont.)****3. INSTALL FRONT SEAT LAP-SHOULDER BELT UPPER ANCHOR.**

- (a) Install seat belt upper anchor bolt.

**Torque: 42 N-m (29 ft-lb).**

- (b) Install seat belt upper anchor bolt cap.

**4. INSTALL REAR SEAT BACK (See 5-5).****5. INSTALL REAR SEAT CUSHION (See 5-4).**

---

# SEAT BELTS

	Page
SEAT BELTS, FRONT AND REAR SEAT LAP-SHOULDER - COMPONENTS .....	7-2
REMOVAL OF FRONT SEAT LAP-SHOULDER BELT ASSEMBLY .....	7-3
INSTALLATION OF FRONT SEAT LAP-SHOULDER BELT ASSEMBLY .....	7-3
REMOVAL OF REAR SEAT LAP-SHOULDER ASSEMBLY .....	7-4
INSTALLATION OF REAR SEAT LAP-SHOULDER ASSEMBLY .....	7-5
REMOVAL OF REAR SEAT LAP BUCKLE .....	7-6
INSTALLATION OF REAR SEAT LAP BUCKLE.....	7-7

SEAT BELTS, FRONT AND REAR SEAT LAP-SHOULDER - COMPONENTS

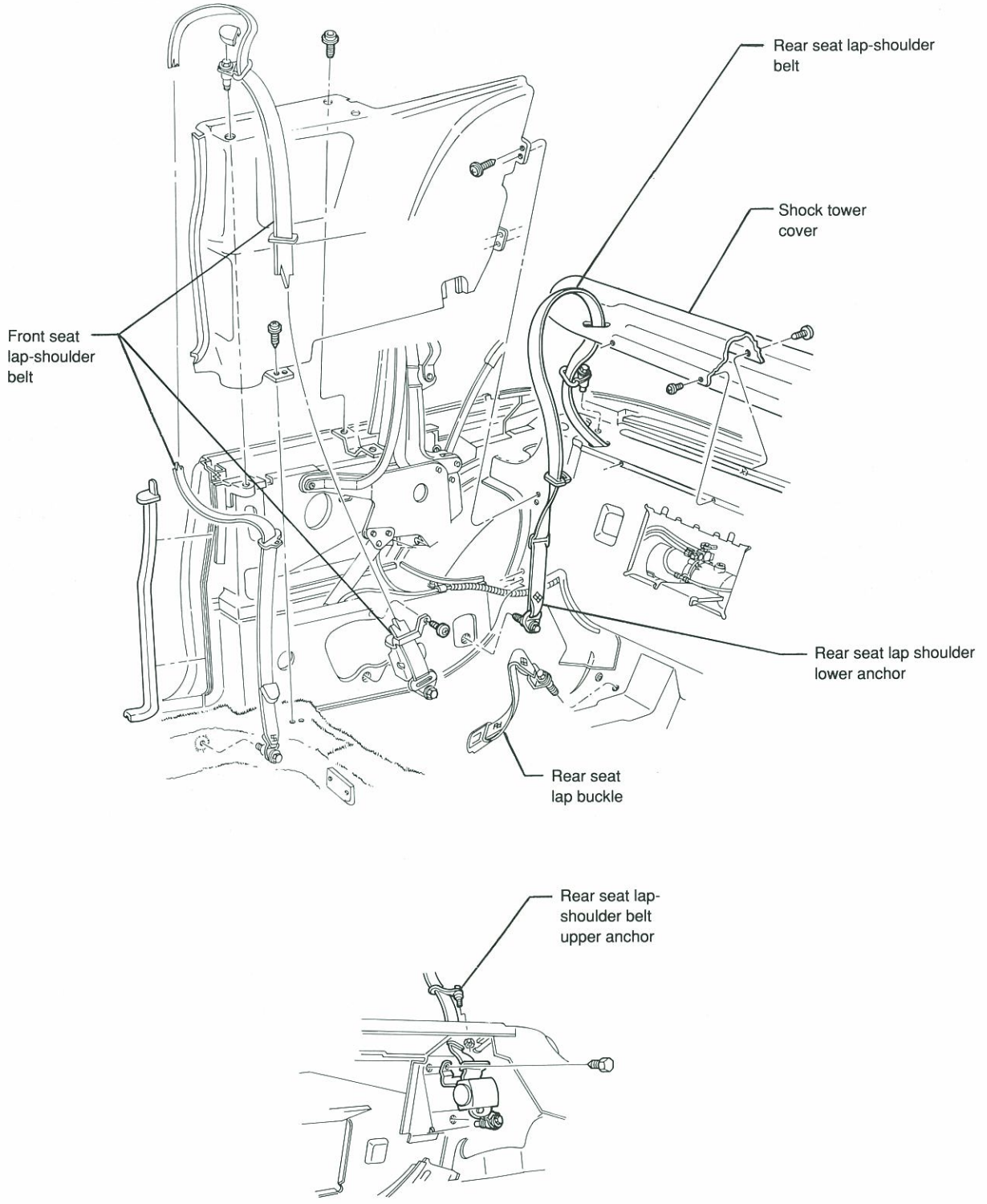

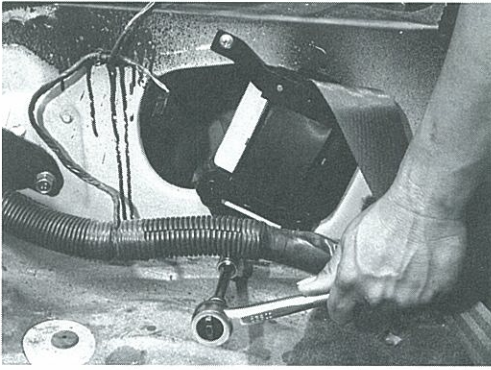

### REMOVAL OF FRONT SEAT LAP-SHOULDER BELT ASSEMBLY

1. REMOVE REAR SEAT CUSHION (See 5-3).
2. REMOVE REAR SEAT BACK (See 5-5).
3. REMOVE QUARTER TRIM PANEL (See 6-3).
4. REMOVE THE FRONT SEAT LAP-SHOULDER BELT ASSEMBLY.

Remove the bolt and the screw for the front seat lap-shoulder assembly.

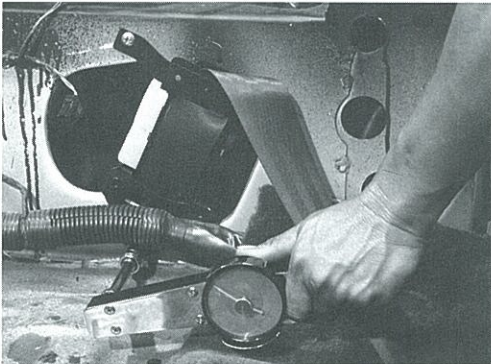

### INSTALLATION OF FRONT SEAT LAP-SHOULDER BELT ASSEMBLY

1. INSTALL THE FRONT SEAT LAP-SHOULDER BELT ASSEMBLY.

Install the front seat lap-shoulder assembly and install the bolt and the screw.

**Torque: 42 N-m (29 ft-lb).**

2. INSTALL QUARTER TRIM PANEL (See 6-6).
3. INSTALL REAR SEAT BACK (See 5-5).
4. INSTALL REAR SEAT CUSHION (See 5-4).

## REMOVAL OF REAR SEAT LAP-SHOULDER ASSEMBLY

1. REMOVE REAR SEAT CUSHION (See 5-3).
2. REMOVE REAR SEAT BACK (See 5-5).
3. RAISE CONVERTIBLE TOP.
4. REMOVE THE REAR SEAT LAP-SHOULDER ASSEMBLY.
  - (a) Remove the lower anchor bolt.
  - (b) Remove the anchor bolt from the end of the seat belt.
  - (c) Remove the nine (9) screws attaching the shock tower cover.

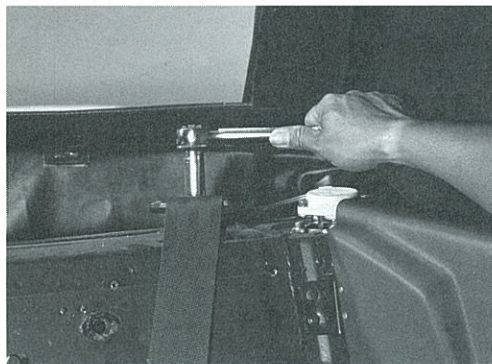
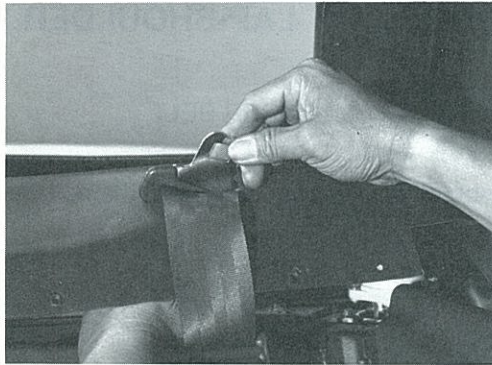
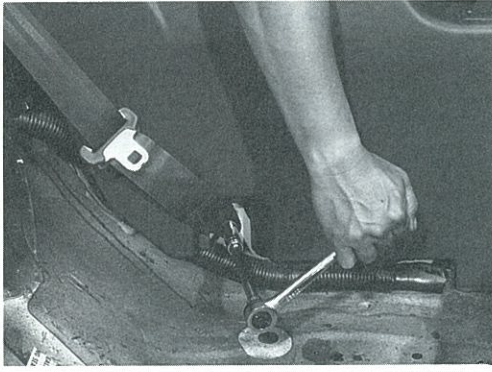

(d) Remove the shock tower cover.

(e) Remove the upper anchor bolt.



## REMOVAL OF REAR SEAT LAP-SHOULDER ASSEMBLY (cont.)



- (f) Open the deck lid.
- (g) Lift up shock tower cover to reveal the two (2) bolts attaching the seat belt retractor.
- (h) Remove the two (2) bolts and remove the retractor.

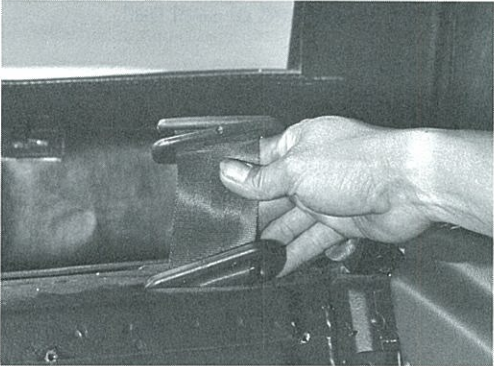

- (i) Feed the seat belt through the shock tower brace and remove the rear seat lap-shoulder assembly.

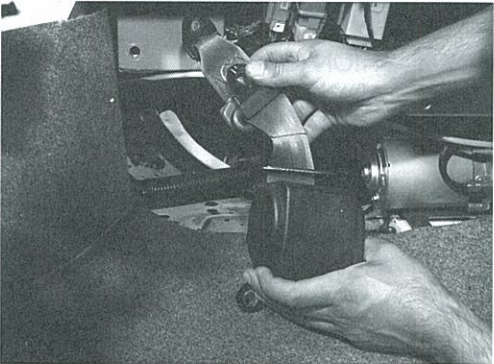

### 1. INSTALL THE REAR SEAT LAP-SHOULDER ASSEMBLY.

- (a) Position the retractor and feed the seat belt up through the shock tower brace.

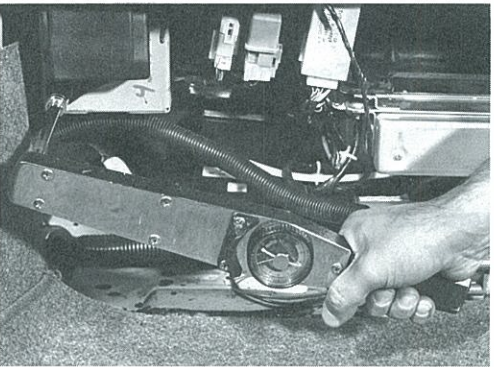

- (b) Position and align the retractor and install the two (2) bolts.  
**Torque: Retractor Anchor - 42 N-m (29 ft-lb).**  
**Torque: Retractor Locator - 10.7 N-m (105 in-lb).**

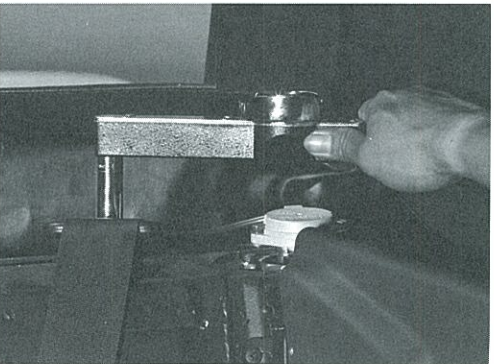

- (c) Close the deck lid.
- (d) Install the upper anchor bolt.  
**Torque: 42 N-m (29 ft-lb).**

### INSTALLATION OF REAR SEAT LAP-SHOULDER ASSEMBLY (cont.)



- (e) Install the shock tower cover and install the nine (9) screws.



- (f) Install the lower anchor bolt to the end of seat belt.

- (g) Install the lower anchor bolt.

**Torque: 42 N-m (29 ft-lb).**

2. INSTALL THE REAR SEAT BACK (See 5-5).
3. INSTALL THE REAR SEAT CUSHION (See 5-4).

### REMOVAL OF REAR SEAT LAP BUCKLE

1. REMOVE REAR SEAT CUSHION (See 5-3).
2. REMOVE THE LAP BUCKLE.

Remove the anchor bolt.

**CAUTION: Be careful not to soil or damage rear seat back cover.**





## INSTALLATION OF REAR SEAT LAP BUCKLE INSTALL THE LAP BUCKLE.

1. Install the anchor bolt.

**CAUTION:** Be careful not to soil or damage rear seat back cover.

**Torque:** 42 N-m (29 ft-lb).

2. INSTALL REAR CUSHION (See 5-4).



---

# QUARTER GLASS, GUIDE AND REGULATOR ASSEMBLIES

	Page
QUARTER GLASS, GUIDE AND REGULATOR ASSEMBLIES - COMPONENTS .....	8-2
REMOVAL OF QUARTER GLASS, GUIDE AND REGULATOR ASSEMBLIES .....	8-3
INSTALLATION OF QUARTER GLASS, GUIDE AND REGULATOR ASSEMBLIES .....	8-6

QUARTER GLASS, GUIDE AND REGULATOR ASSEMBLIES - COMPONENTS

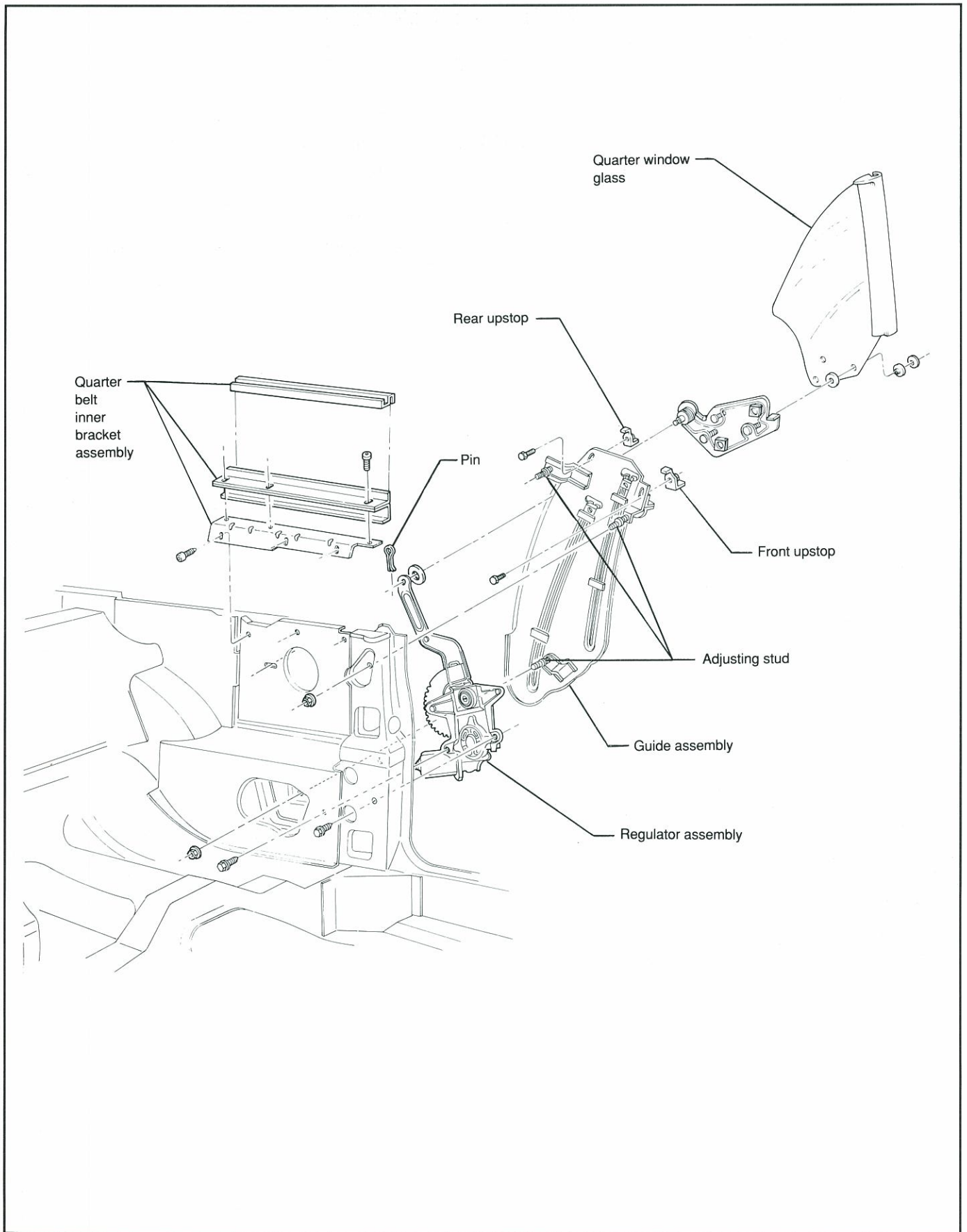

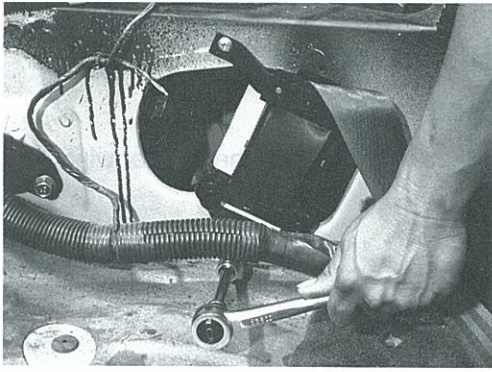

**REMOVAL OF QUARTER GLASS, GUIDE AND REGULATOR ASSEMBLIES**

1. LOWER CONVERTIBLE TOP.
2. LOWER QUARTER GLASS.
3. REMOVE QUARTER TRIM PANEL (See 6-3).
4. REMOVE FRONT SEAT BELT SHOULDER RETRACTOR ASSEMBLY.

Remove the mounting bolt and the locating screw.



5. REMOVE LOCK PILLAR MUCKET SEAL.

Remove the two (2) screws and remove the lock pillar mocket seal.



6. REMOVE QUARTER BELT INNER BRACKET ASSEMBLY.

Remove the three (3) screws and remove the quarter belt inner bracket assembly.

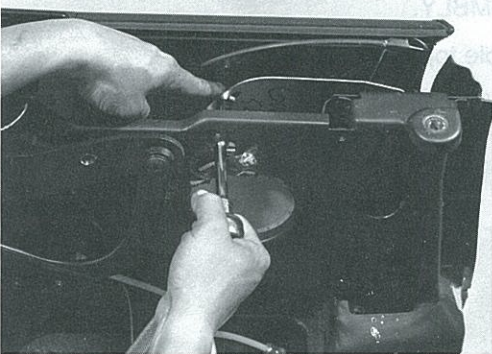

7. REMOVE FRONT UPSTOP.

Remove the bolt for the front upstop.

8. REMOVE REAR UPSTOP.

Remove the bolt for the rear upstop.

**NOTE: Make sure you securely hold the upstops while removing.**

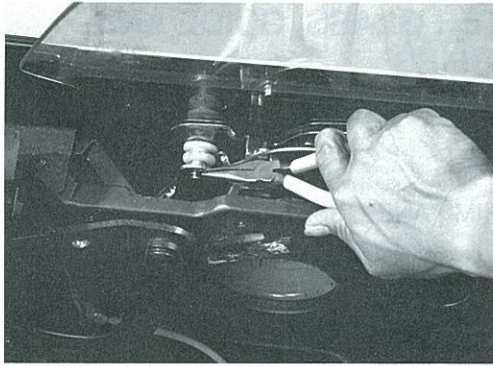

## REMOVAL OF QUARTER GLASS, GUIDE AND REGULATOR ASSEMBLIES (cont.)

### 9. REMOVE QUARTER GLASS ASSEMBLY.

- (a) Carefully raise the window by pressing the quarter window switch.
- (b) Remove the pin.
- (c) Disconnect the regulator arm from the glass bracket assembly.

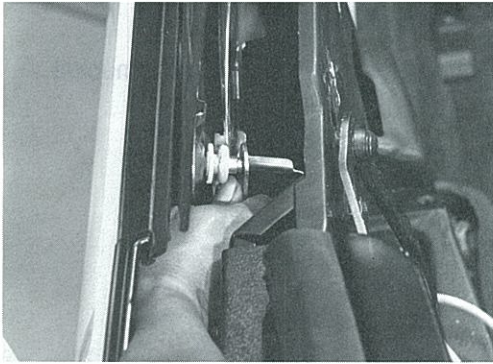

- (d) Remove the quarter glass assembly.

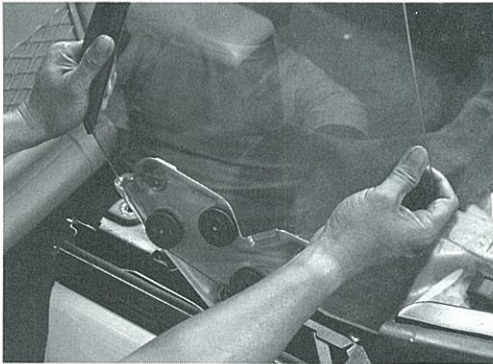

### 10. REMOVE GUIDE ASSEMBLY.

- (a) Raise the convertible top halfway.
- (b) Remove the three (3) nuts.

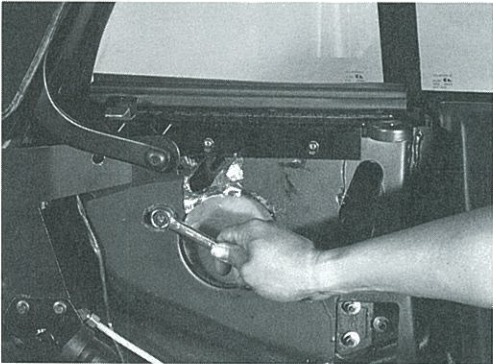

- (c) Rotate the three (3) adjusting studs clockwise until they stop.

**NOTE: Keep one hand on the guide assembly while rotating the adjustment studs.**

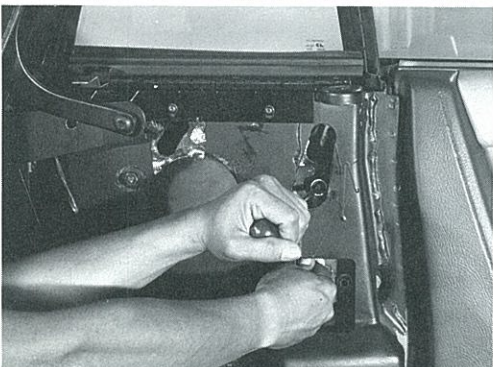



**REMOVAL OF QUARTER GLASS, GUIDE AND REGULATOR ASSEMBLIES (cont.)**

- (d) Remove the guide assembly.

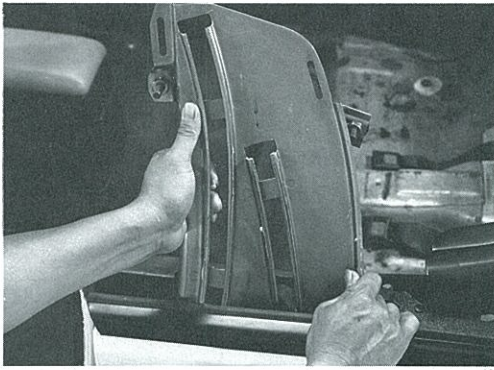

**11.REMOVE REGULATOR ASSEMBLY.**

- (a) Disconnect the harness connector and push the wire back through the hole.

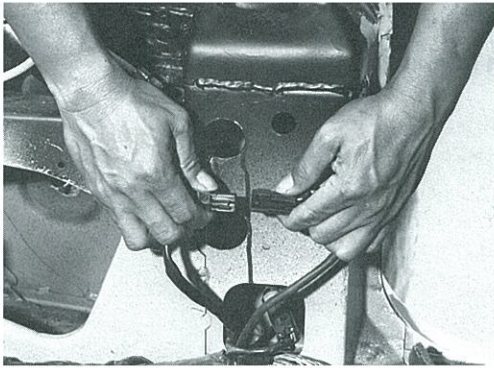

- (b) Remove the four (4) bolts for the regulator assembly.

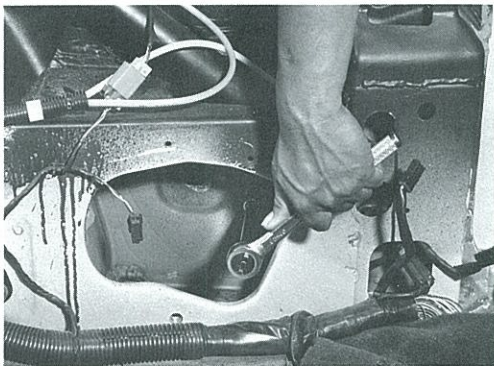

- (c) Remove the regulator assembly.





## INSTALLATION OF QUARTER GLASS, GUIDE AND REGULATOR ASSEMBLIES

### 1. INSTALL REGULATOR ASSEMBLY.

(a) Position and align the regulator assembly.

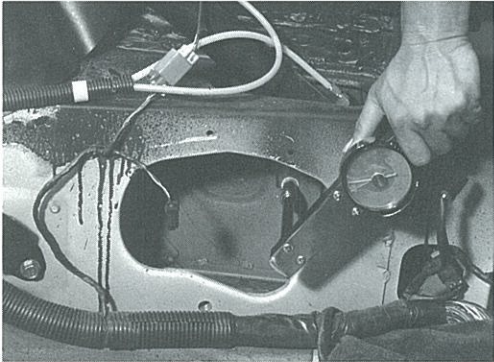

(b) Install the four (4) bolts.

**Torque: 11.5 N-m (105 in-lb).**

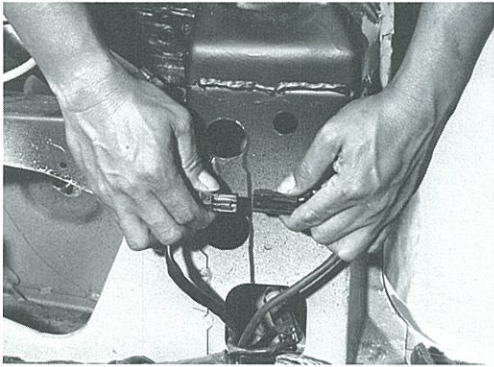

(c) Push the wire through the hole and connect the harness connector.

### 2. INSTALL GUIDE ASSEMBLY.

(a) Position the guide assembly.



(b) Rotate the three (3) adjusting studs counterclockwise to allow the quarter glass to be installed.



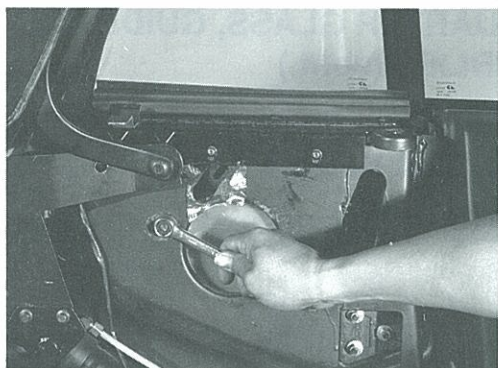

**INSTALLATION OF QUARTER GLASS, GUIDE AND REGULATOR ASSEMBLIES (cont.)**

- (c) Install the three (3) nuts.  
**Torque: 28 N-m (21 ft-lb).**

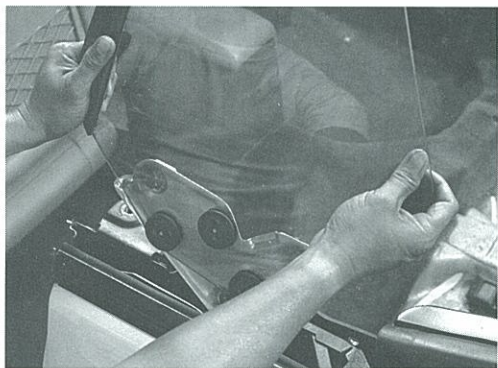

**3. INSTALL QUARTER GLASS ASSEMBLY.**

- (a) Lower the convertible top.
- (b) Install the quarter glass assembly.

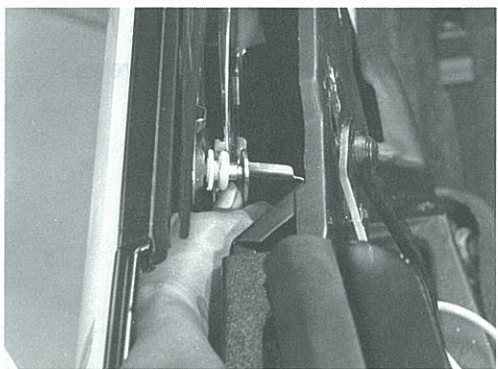

- (c) Connect the regulator arm to the glass bracket assembly.

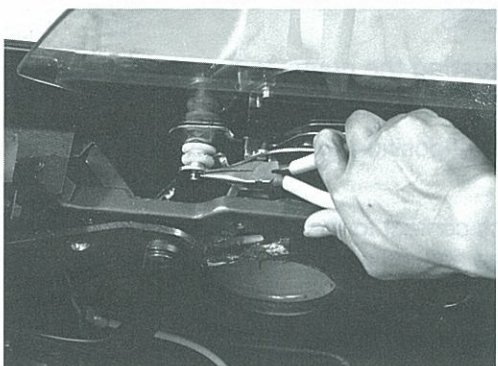

- (d) Install the pin.

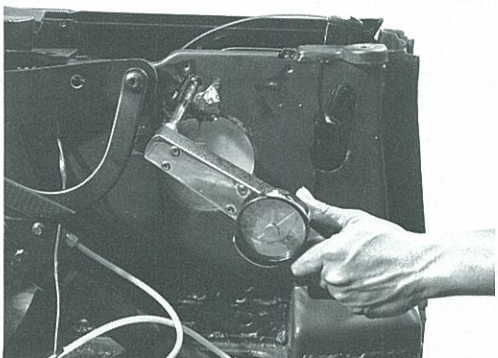

**4. INSTALL REAR UPSTOP.**

- (a) Lower the quarter window by pressing the quarter window switch.
- (b) Install the rear upstop and install the bolt.  
**Torque: 11.5 N-m (105 in-lb).**

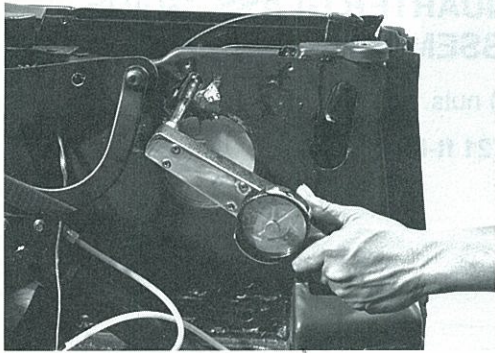

## INSTALLATION OF QUARTER GLASS, GUIDE AND REGULATOR ASSEMBLIES (cont.)

### 5. INSTALL FRONT UPSTOP.

Install the front upstop and install the bolt.

**Torque: 11.5 N-m (105 in-lb).**

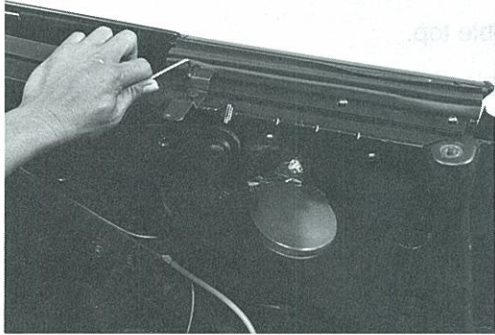

### 6. INSTALL QUARTER BELT INNER BRACKET ASSEMBLY.

Install the quarter belt inner bracket assembly and install the three (3) screws.

**Torque: 9 N-m (80 in-lb).**



### 7. INSTALL LOCK PILLAR MUCKET SEAL.

Position the lock pillar mocket and install the two (2) screws.

### 8. ADJUST QUARTER GLASS.

**Note: Before adjusting the glass, lower the top and raise the door glass fully.**

- (a) Adjust the fore and aft position by sliding the glass back and forth.
- (b) Adjust quarter glass contact to the belt molding and door glass by rotating the adjusting studs.
- (c) Adjust the height of the quarter glass so that it is parallel to the door glass (with the upstops installed).

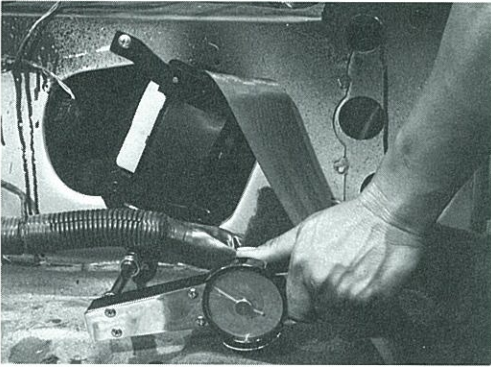

### INSTALLATION OF QUARTER GLASS, GUIDE AND REGULATOR ASSEMBLIES (cont.)

9. INSTALL FRONT SEAT BELT SHOULDER RETRACTOR ASSEMBLY.

Position and align the front seat shoulder belt retractor assembly. Then, install the retractor mounting bolt and locating screw.

**Torque: 42 N-m (29 ft-lb).**

10. INSTALL QUARTER TRIM PANEL (See 6-6).



---

# SIDE GUARD MOLDING

	Page
SIDE GUARD MOLDING - COMPONENTS .....	9-2
REMOVAL OF SIDE GUARD MOLDING .....	9-3
INSTALLATION OF SIDE GUARD MOLDING .....	9-4

SIDE GUARD MOLDING - COMPONENTS

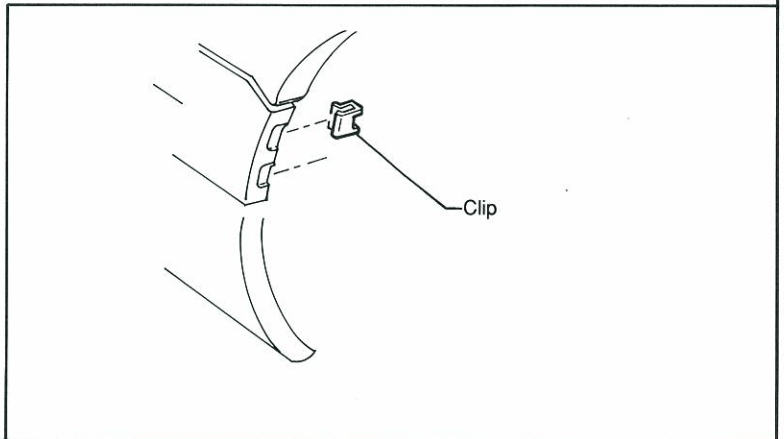
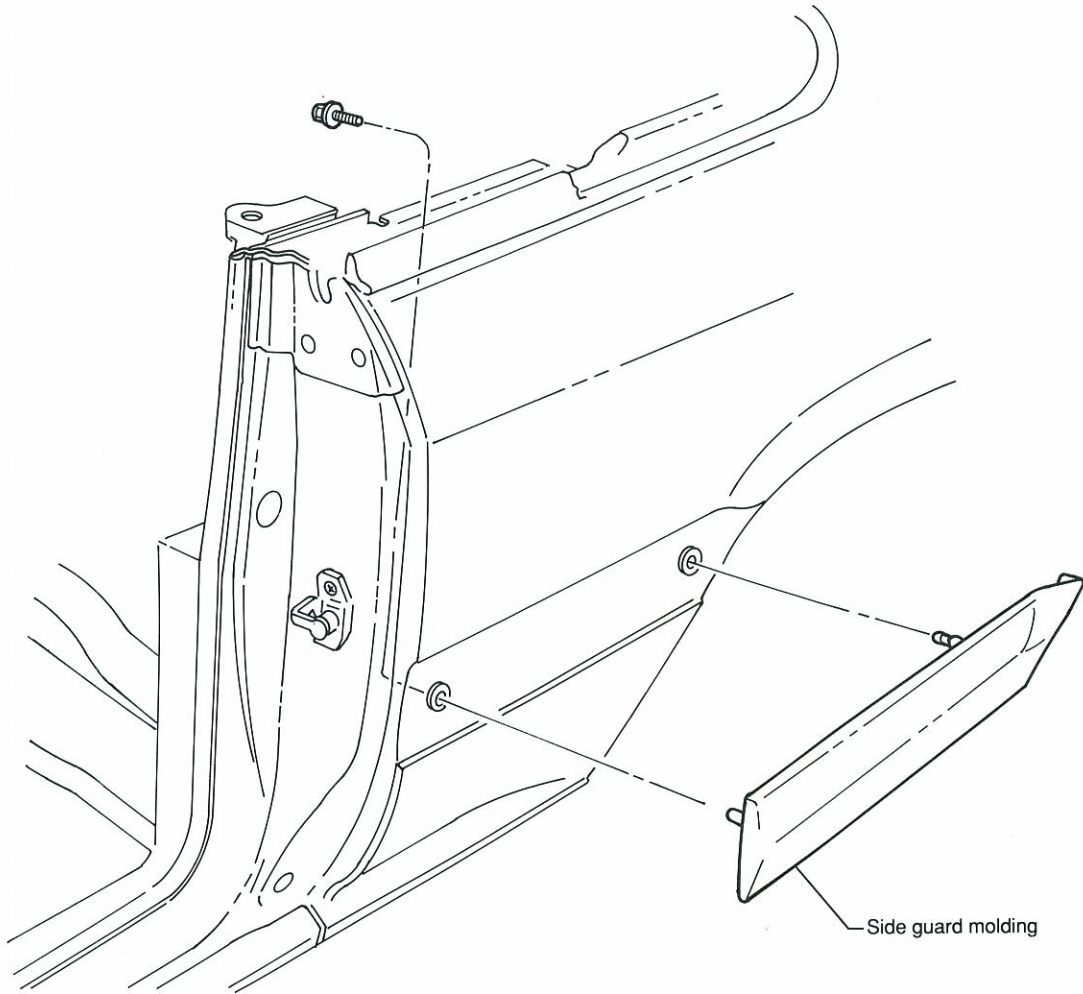



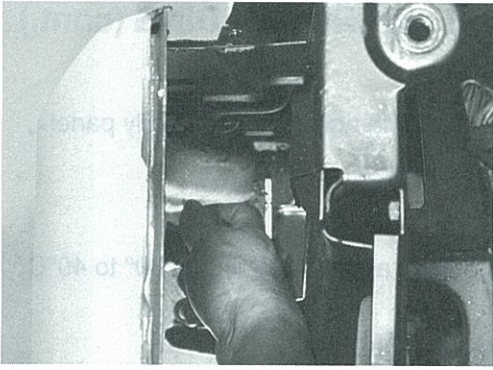

## REMOVAL OF SIDE GUARD MOLDING

**CAUTION:** Remove side guard molding only if it is necessary to do so. This part has been modified to provide clearance for the quarter window.

1. REMOVE THE QUARTER GLASS AND THE QUARTER GLASS GUIDE (See 8-3).
2. REMOVE THE SCREW.

3. HEAT THE MOLDING.

Using a heat gun, heat the molding portion to 30° to 40°C (86° to 104°F).

4. REMOVE THE SIDE GUARD MOLDING.

Raise the end of the side guard molding and, while cutting off the bonding agent, detach the molding.

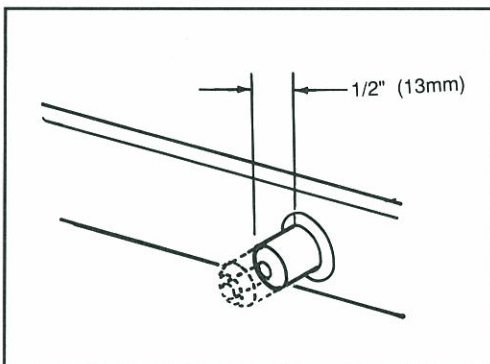

## INSTALLATION OF SIDE GUARD MOLDING

1. MODIFY THE SIDE GUARD MOLDING.

Using side cutters, trim 1/2" (13 mm) from the forward mounting stanchion.

**Note:** If the length of the stanchion exceeds 1/2" (13 mm), damage may result to the quarter window mechanism and/or side guard molding. If the stanchion is too short, the molding may not hold securely.

**INSTALLATION OF SIDE GUARD MOLDING (cont.)**

## 2. CLEAN THE BODY.

- (a) Remove all traces of bonding agent from the body panel.
- (b) Clean contact face of the body.

## 3. HEAT THE BODY.

Using a heat gun, heat the body and the molding to 30° to 40°C (86° to 104°F).

## 4. INSTALL THE SIDE GUARD MOLDING.

- (a) Apply 3M Channel Bonding Adhesive (P/N 051135-08641 or equivalent) to the trimmed stanchion.
- (b) Position and align the side guard molding to the body.
- (c) Press firmly and evenly to secure.

## 5. INSTALL THE MOLDING RETAINING SCREW.

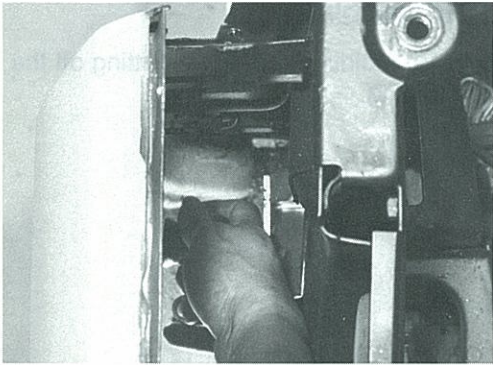

## 6. INSTALL QUARTER GLASS GUIDE AND QUARTER GLASS (See 8-6).

---

# DOOR, GUIDE PIN AND GLASS

	Page
DOOR, GUIDE PIN AND GLASS - COMPONENTS .....	10-2
REMOVAL OF FRONT DOOR GUIDE PIN .....	10-3
INSTALLATION OF FRONT DOOR GUIDE PIN .....	10-4
REMOVAL OF DOOR GLASS .....	10-6
INSTALLATION OF DOOR GLASS .....	10-6
REMOVAL OF FRONT DOOR GUIDE LOCATOR.....	10-6
INSTALLATION OF FRONT DOOR GUIDE LOCATOR	10-6

DOOR, GUIDE PIN AND GLASS - COMPONENTS

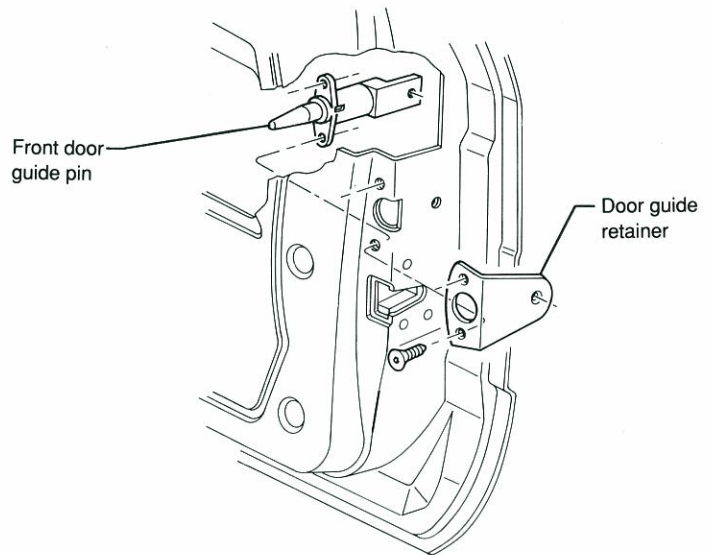
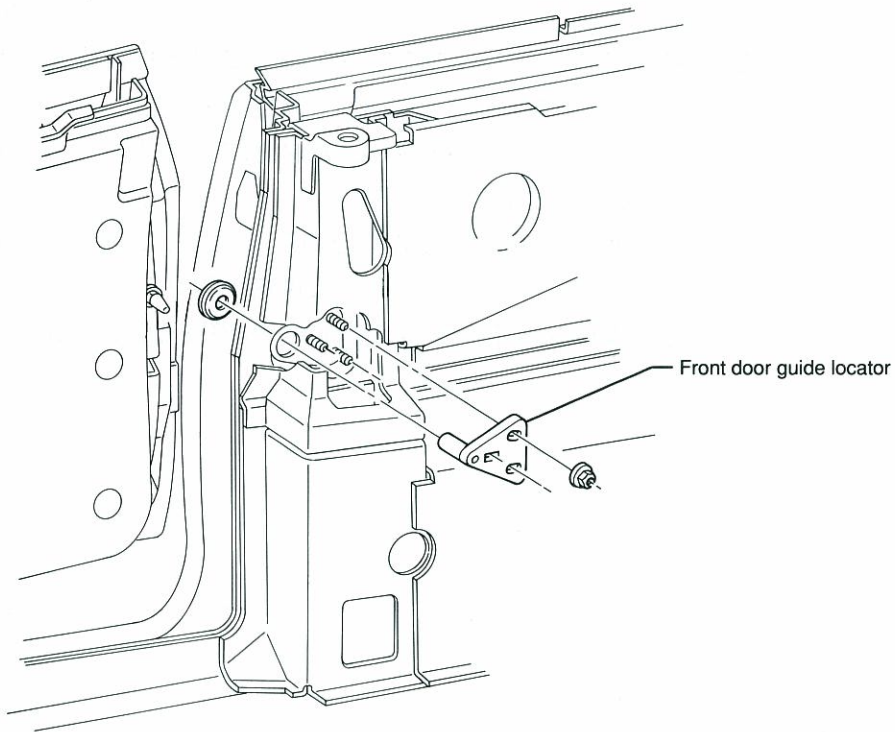

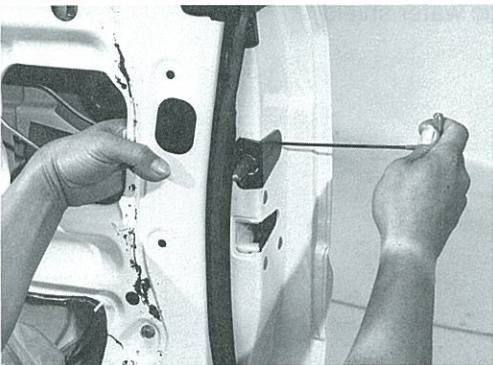
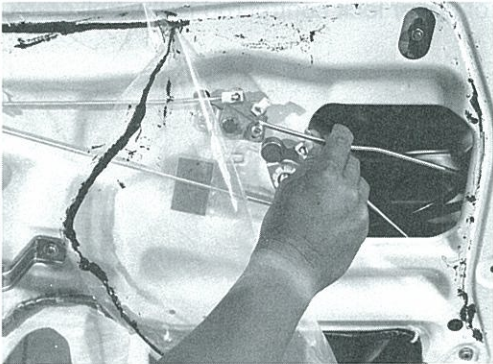
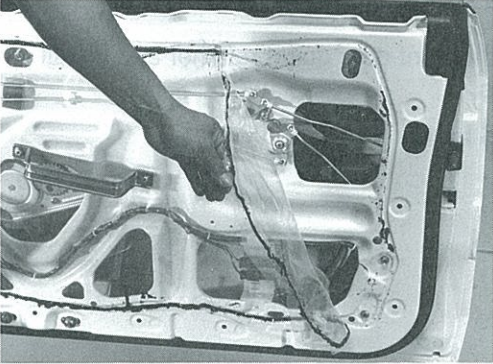
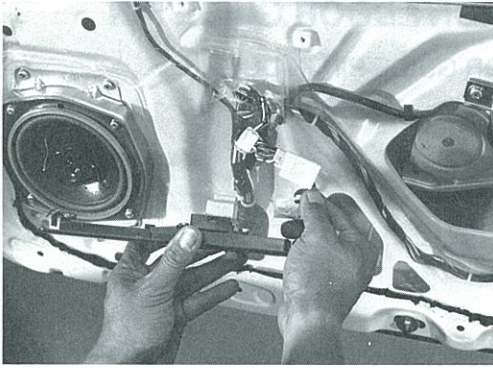

## REMOVAL OF FRONT DOOR GUIDE PIN

1. REMOVE DOOR TRIM PANEL (Refer to vehicle Service Manual).
2. REMOVE FRONT DOOR GUIDE RETAINER.
  - (a) Re-connect the power window switch and raise the door glass.
  - (b) Carefully release the trailing edge of the water shield.
  - (c) Remove the forward end of the upper lock control rod from the bell crank adjustment.
  - (d) Remove the three (3) screws from the door guide retainer.
3. REMOVE FRONT DOOR GUIDE PIN FROM DOOR.

## INSTALLATION OF FRONT DOOR GUIDE PIN

1. POSITION FRONT DOOR GUIDE PIN IN DOOR.

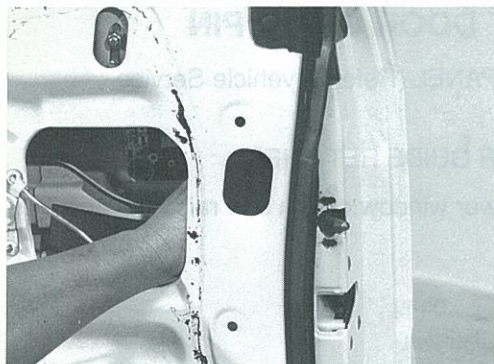

2. INSTALL FRONT DOOR GUIDE RETAINER.

- (a) Position and align the front door guide retainer and install the three (3) screws.

**Torque: 4 N-m (35 in-lb).**

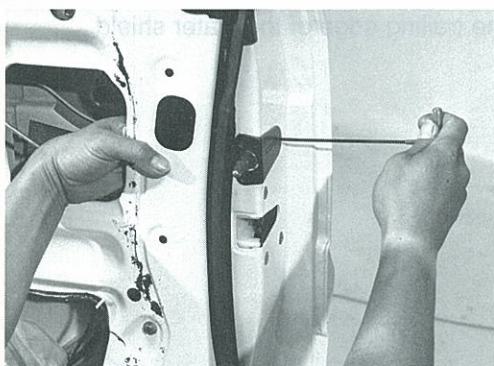

- (b) Install forward end of upper lock control rod to the bell crank adjustment.

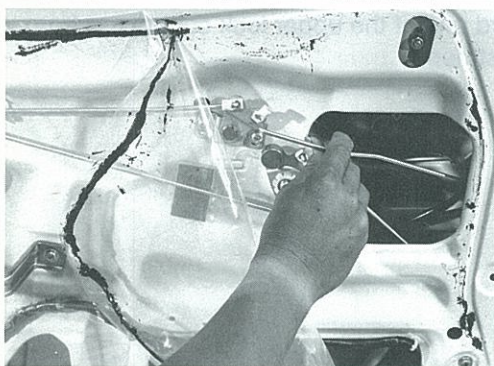

- (c) Re-attach the plastic water shield.

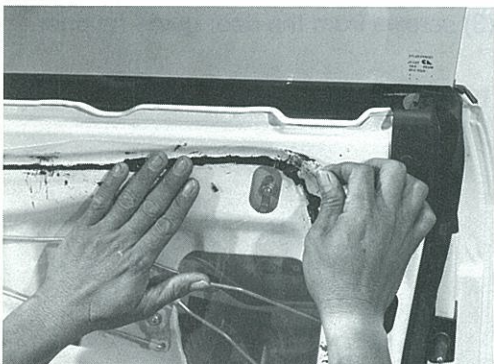

- (d) Lower door glass and disconnect power window switch harness connectors.

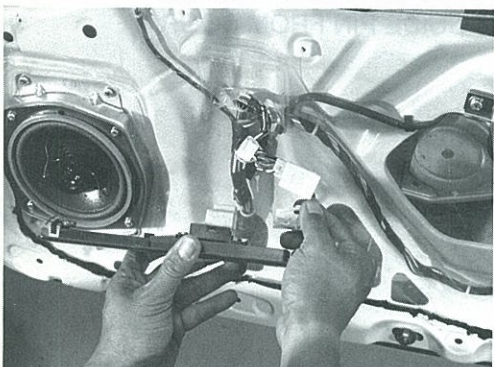

**INSTALLATION OF FRONT DOOR GUIDE PIN  
(cont.)**

3. INSTALL DOOR TRIM PANEL (Refer to vehicle Service Manual).

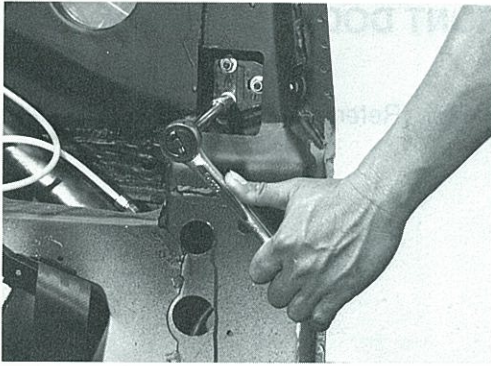

## REMOVAL OF DOOR GLASS

### REMOVAL, INSTALLATION AND ADJUSTMENT OF DOOR GLASS (Refer to vehicle Service Manual).

## REMOVAL OF FRONT DOOR GUIDE LOCATOR

1. REMOVE QUARTER TRIM PANEL (See 6-3).
2. REMOVE FRONT DOOR GUIDE LOCATOR.

Remove the three (3) nuts to remove the front door guide locator.

## INSTALLATION OF FRONT DOOR GUIDE LOCATOR

1. INSTALL FRONT DOOR GUIDE LOCATOR.

Install the front door guide locator and temporarily finger tighten the three (3) nuts.

**NOTE: Front door guide must be able to slide freely for the front door guide locator to align with front door guide pin in the door.**

2. ADJUST FRONT DOOR GUIDE LOCATOR.

(a) Open and close the side door several times to align the locator to guide pin.

(b) Tighten the three (3) nuts.

**Torque: 11.5 N-m (105 in-lb).**

3. INSTALL QUARTER TRIM PANEL (See 6-6).

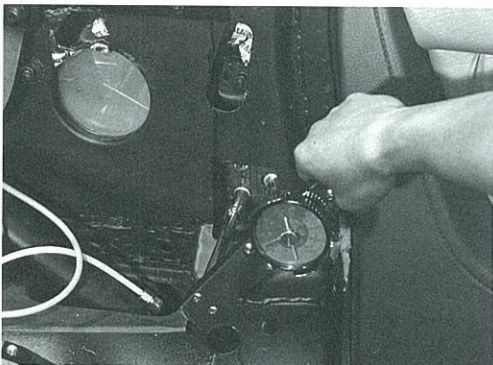



---

# WEATHERSTRIPS AND RETAINERS

	Page
WEATHERSTRIPS AND RETAINERS - COMPONENTS .....	11-2
REMOVAL OF CENTER RAIL WEATHERSTRIP ASSEMBLY AND CENTER RAIL RETAINER.....	11-3
INSTALLATION OF CENTER RAIL WEATHERSTRIP ASSEMBLY AND CENTER RAIL RETAINER .....	11-3
REMOVAL OF REAR RAIL WEATHERSTRIP ASSEMBLY .....	11-4
INSTALLATION OF REAR RAIL WEATHERSTRIP ASSEMBLY .....	11-5

WEATHERSTRIPS AND RETAINERS -  
COMPONENTS

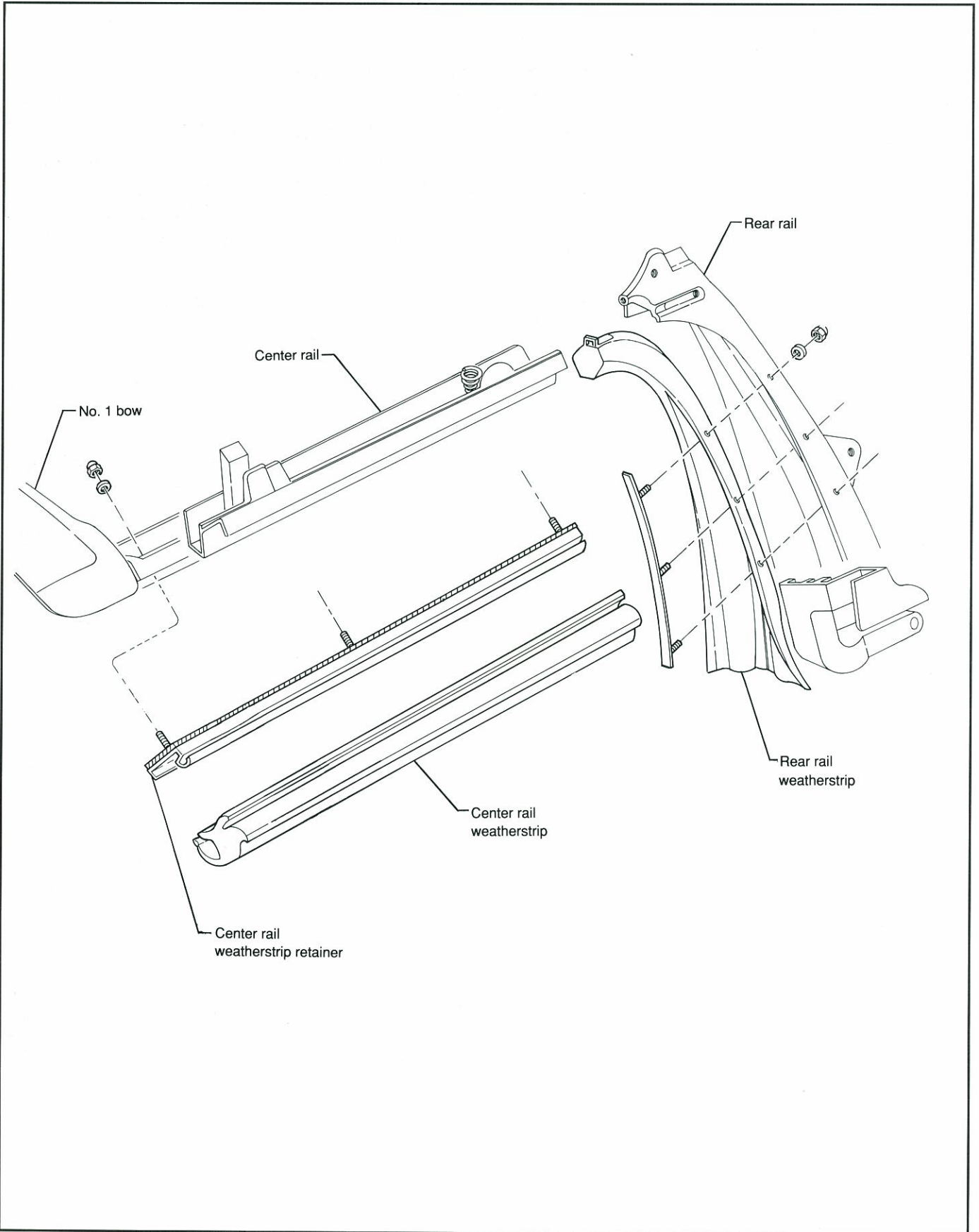



### REMOVAL OF CENTER RAIL WEATHERSTRIP ASSEMBLY AND CENTER RAIL RETAINER

1. REMOVE CENTER RAIL WEATHERSTRIP ASSEMBLY.
  - (a) Lower convertible top halfway.
  - (b) Using a suitable release agent (Kent special releasing agent or equivalent) break the cement bond between the weatherstrip and the weatherstrip retainer. With a flat-bladed tool, grasp the weatherstrip and gently pull upward while inserting the flat-bladed tool under the weatherstrip.
2. REMOVE CENTER RAIL WEATHERSTRIP RETAINER.  
Remove the three (3) nuts and washers and remove the center rail weatherstrip retainer.



### INSTALLATION OF CENTER RAIL WEATHERSTRIP ASSEMBLY AND CENTER RAIL RETAINER

1. REMOVE ALL EXCESS ADHESIVE FROM THE CENTER RAIL WEATHERSTRIP RETAINER.
2. INSTALL CENTER RAIL WEATHERSTRIP RETAINER.
  - (a) Position and align the center rail weatherstrip retainer.
  - (b) Install the three (3) washers and nuts.

**Torque: 5.1 N-m (45 in-lb).**

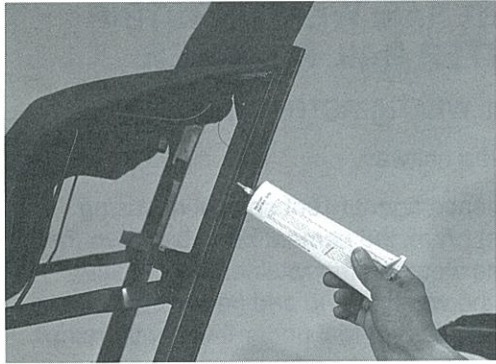

### INSTALLATION OF CENTER RAIL WEATHERSTRIP ASSEMBLY AND CENTER RAIL RETAINER (cont.)

#### 3. INSTALL CENTER RAIL WEATHERSTRIP ASSEMBLY.

- (a) Apply a continuous bead of Super Weatherstrip Adhesive (3M P/N 051135-08008) to retainer.
- (b) Position and align the weatherstrip assembly to the center rail weatherstrip retainer.
- (c) Using a flat-bladed tool, install the weatherstrip onto the center rail weatherstrip retainer.

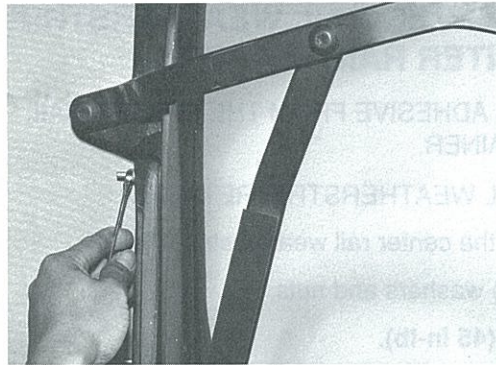
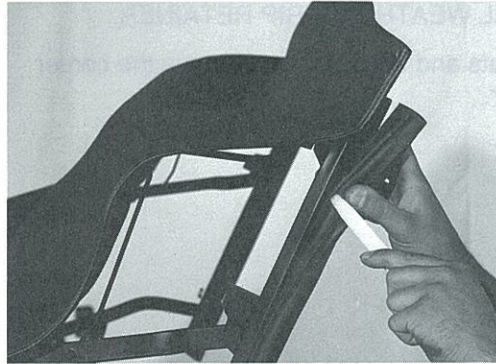

### REMOVAL OF REAR RAIL WEATHERSTRIP ASSEMBLY

#### 1. REMOVE REAR RAIL WEATHERSTRIP ASSEMBLY.

- (a) Lower convertible top halfway.
- (b) Detach headliner from rear rail.
- (c) Remove the three (3) nuts and washers to remove the rear rail weatherstrip retainer.
- (d) Remove the rear rail weatherstrip retainer.



- (e) Using a suitable release agent (Kent special releasing agent or equivalent) break the cement bond between the rear rail weatherstrip and the rear rail. With a flat-bladed tool, grasp the weatherstrip and gently pull upward while inserting the flat-bladed tool under the weatherstrip.

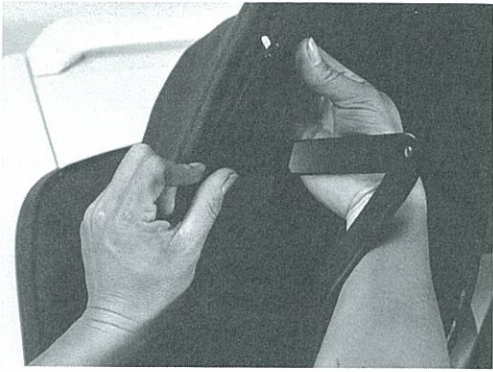

## INSTALLATION OF REAR RAIL WEATHERSTRIP ASSEMBLY

1. REMOVE ALL EXCESS ADHESIVE FROM THE REAR RAIL.
2. INSTALL REAR RAIL WEATHERSTRIP ASSEMBLY.

(a) Insert the rear rail weatherstrip retainer into the rear rail weatherstrip.

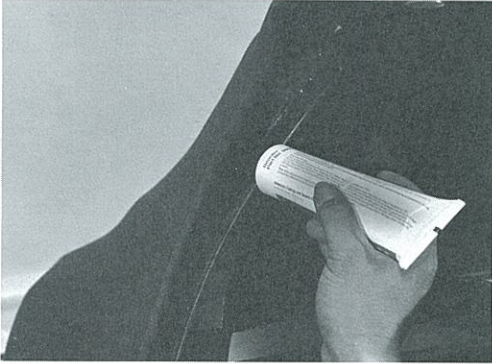

(b) Generously apply Super Weatherstrip Adhesive (3M P/N 051135-08008) to the channel of the rear rail.

**CAUTION: Insufficient adhesive application, especially at the lower portion of the rear rail, will allow quarter glass to damage rear rail seal.**



(c) Position and align the rear rail weatherstrip assembly to the rear rail.

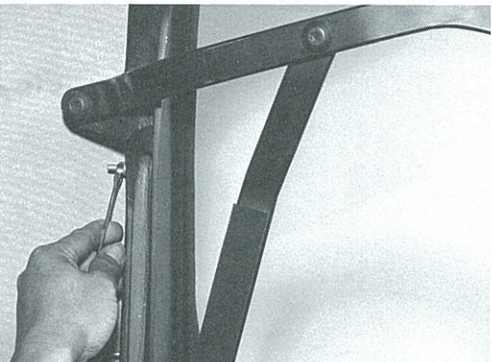

(d) Install the three (3) washers and nuts.

**Torque: 5.1 N-m (45 in-lb).**



---

# HEADLINER ASSEMBLY

	Page
HEADLINER ASSEMBLY - COMPONENTS .....	12-2
REMOVAL OF HEADLINER ASSEMBLY .....	12-3
INSTALLATION OF HEADLINER ASSEMBLY .....	12-4

HEADLINER ASSEMBLY - COMPONENTS

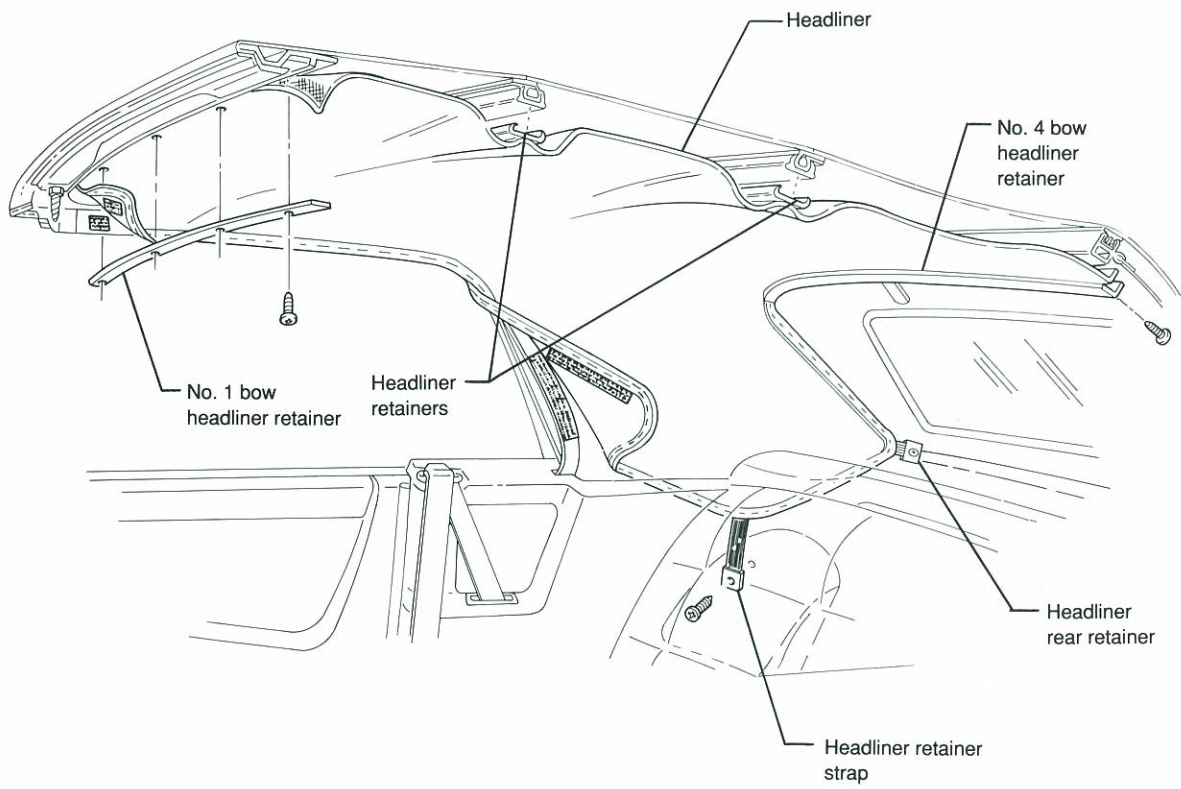



**REMOVAL OF HEADLINER ASSEMBLY**

**NOTE:** Carefully tape a protective cover to both sides of the backlite to protect it from damage.

1. REMOVE THE SCREWS ATTACHING HEADLINER REAR RETAINERS TO THE REAR DRAIN TROUGH.
2. REMOVE THE SCREWS ATTACHING HEADLINER RETAINER STRAPS TO THE WHEELHOUSE.

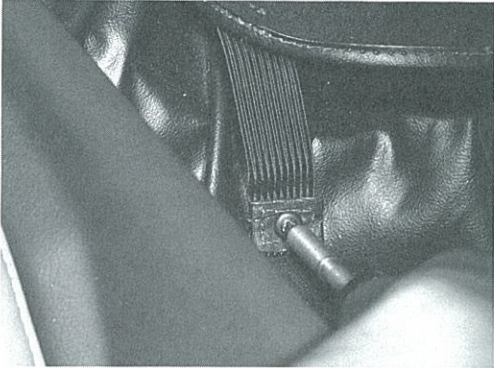
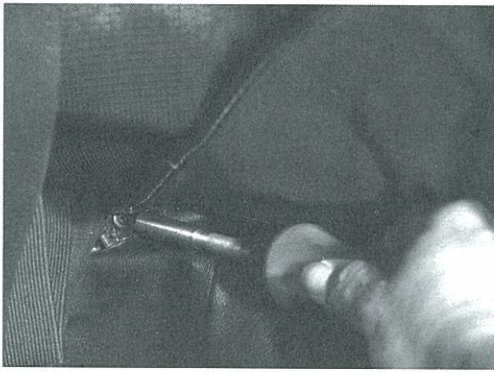

3. REMOVE HEADLINER FROM NO.4 BOW.
  - (a) Remove the seven (7) screws to remove the No. 4 bow headliner retainer.



- (b) Detach the headliner from the No. 4 bow. Carefully pull to break cement bond.

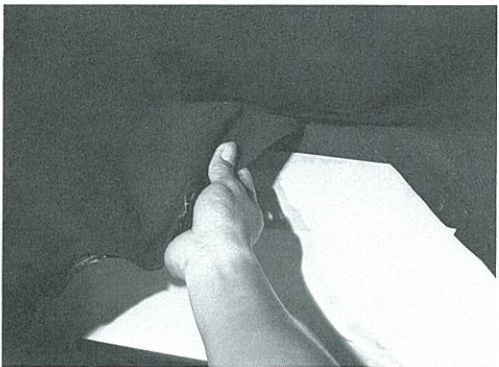

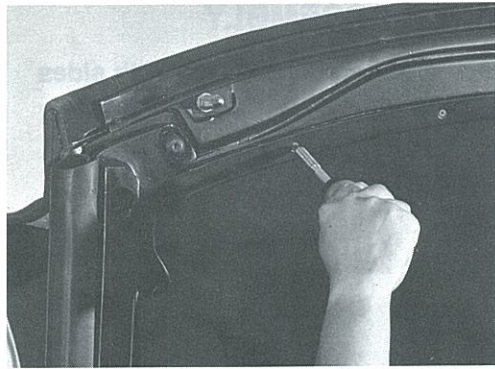
**REMOVAL OF HEADLINER ASSEMBLY (cont.)**

4. LOWER THE CONVERTIBLE TOP HALFWAY.
5. REMOVE HEADLINER FROM NO. 1 BOW.
  - (a) Remove the seven (7) screws and remove the No. 1 bow headliner retainer.



- (b) Detach the headliner from the No. 1 bow. Pull to break cement bond.



6. DETACH HEADLINER FROM NO. 2 AND NO. 3 BOWS.  
Using a suitable flat-bladed tool, detach the headliner No. 2 and No. 3 bow retainers from the No. 2 and No. 3 bows and remove the headliner.

**INSTALLATION OF HEADLINER ASSEMBLY**

1. INSTALL HEADLINER TO NO. 2 AND NO. 3 BOWS.

Align the center marks on the headliner retainers with the center screw holes on the underside of the bows and attach the headliner retainers to the bows.

2. INSTALL HEADLINER TO NO. 4 BOW.

- (a) Brush an even amount of adhesive 3M Super Weatherstrip Adhesive (3M #051135-08008 or equivalent) along the rear surface of the No. 4 bow.

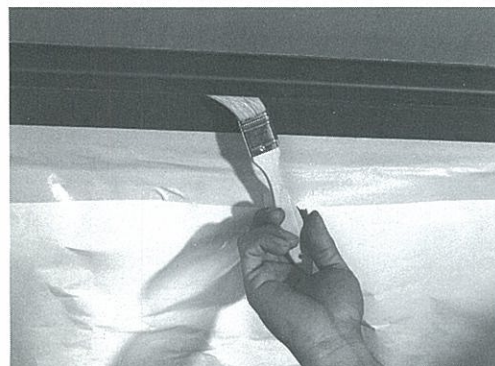

**INSTALLATION OF HEADLINER ASSEMBLY (cont.)**

- (b) Align center notch in headliner with the center hole in No. 4 bow and attach the headliner to bow No. 4. Starting at the center and working toward each end, pull headliner rearward while attaching (to pull out wrinkles).

- (c) Install the No. 4 bow headliner retainer to the No. 4 bow.

- (d) Install the seven (7) screws.

**Torque: 3.5 N-m (30 in-lb).**

3. **INSTALL THE HEADLINER RETAINER STRAPS TO THE WHEELHOUSE.**

Position the headliner retainer straps to the wheelhouse and install the screws.

4. **INSTALL THE HEADLINER REAR RETAINERS TO THE REAR DRAIN TROUGH.**

Position the headliner rear retainers to the rear drain trough and install the screws.

5. **INSTALL HEADLINER TO NO. 1 BOW.**

- (a) Brush an even amount of adhesive 3M Super Weatherstrip Adhesive (3M #051135-08008) along the bottom surface of the No. 1 bow.

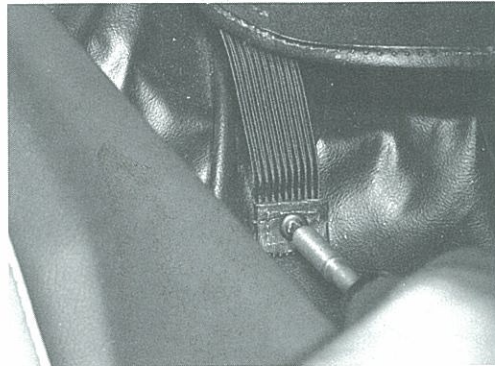
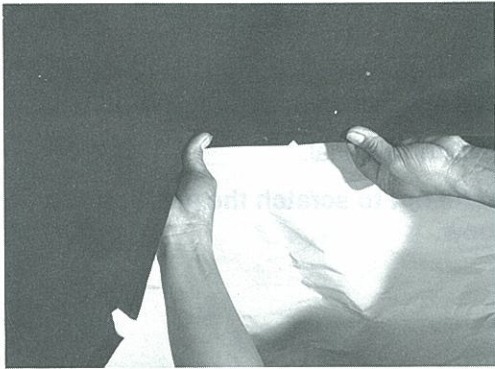

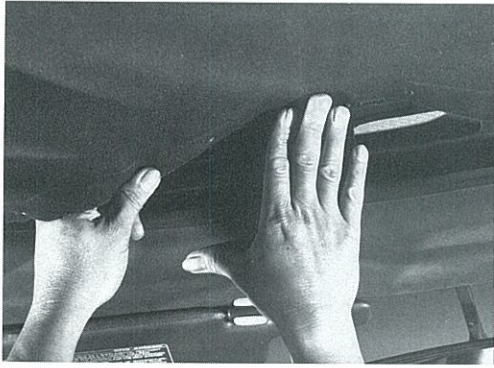

### INSTALLATION OF HEADLINER ASSEMBLY (cont.)

- (b) Align the center notch in the headliner with the center hole on the No. 1 bow and attach the headliner to the No. 1 bow.
- (c) Trim off excess headliner material.

**CAUTION: Be careful not to scratch the paint on the No. 1 bow.**

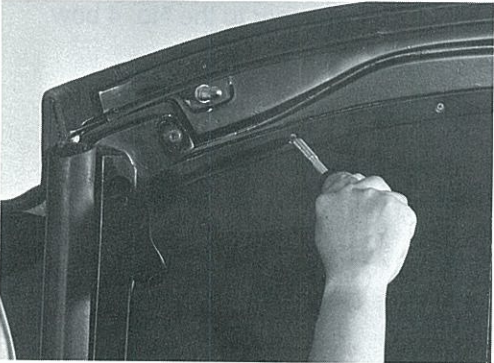

- (d) Position the No. 1 bow headliner retainer to the No. 1 bow and install the seven (7) screws.

**Torque: 3.5 N-m (30 in-lb).**

---

# TOP COVER ASSEMBLY

	<b>Page</b>
TOP COVER ASSEMBLY - COMPONENTS .....	13-2
REMOVAL OF TOP COVER ASSEMBLY .....	13-3
INSTALLATION OF TOP COVER ASSEMBLY .....	13-6

TOP COVER ASSEMBLY - COMPONENTS

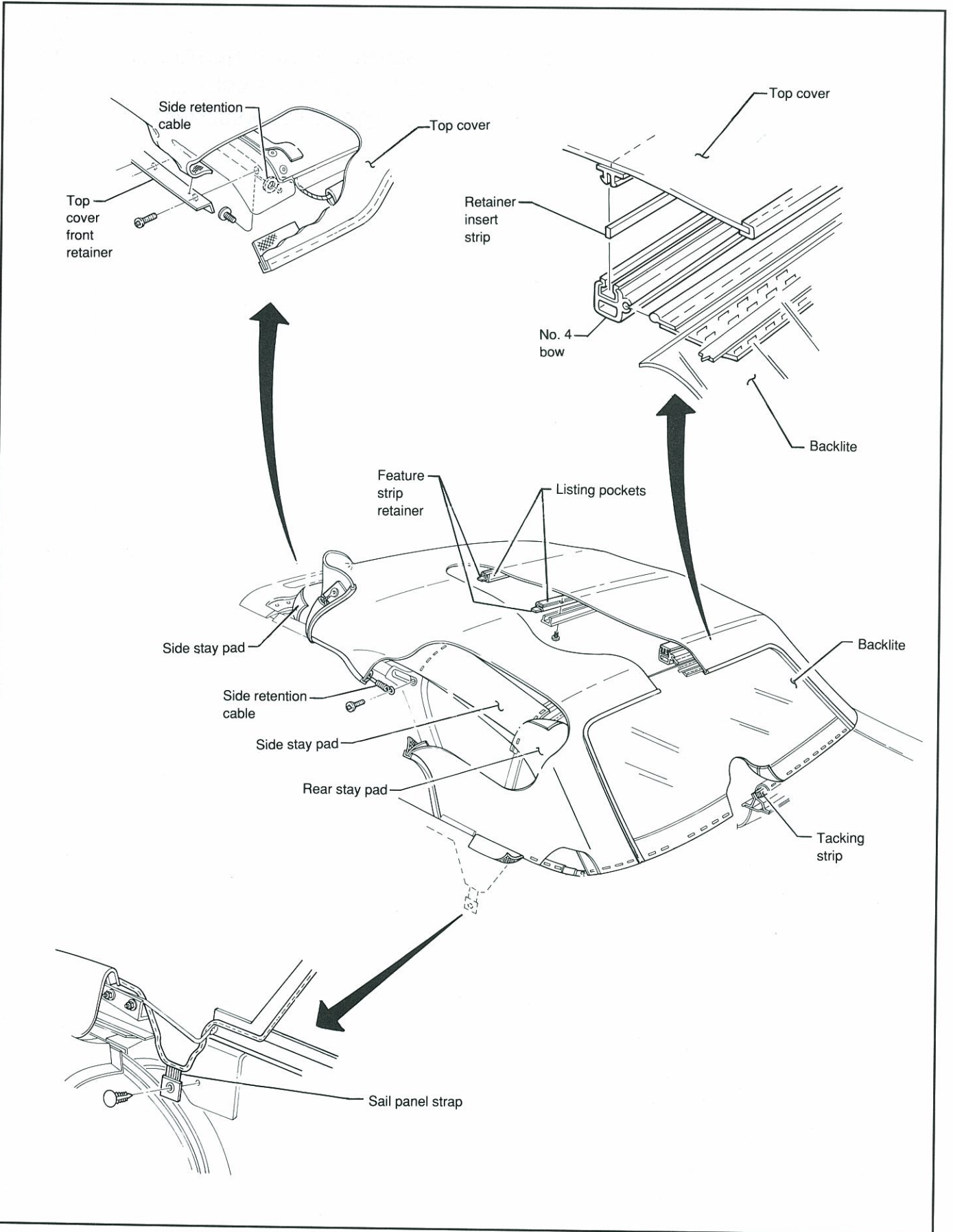



## REMOVAL OF TOP COVER ASSEMBLY

**NOTE:** Carefully tape a protective cover to quarter panel and deck lid to protect the deck lid and body from damage. Tape protective cover to both sides of backlite.

1. REMOVE QUARTER AND BACK BELT MOLDINGS (See 4-3).
2. REMOVE HEADLINER (See 12-3).
3. REMOVE CENTER AND REAR RAIL WEATHERSTRIP ASSEMBLIES (See 11-3 and 11-4).
4. REMOVE BACK BELT MOLDING RETAINER.



5. REMOVE TOP COVER FRONT RETAINER.
  - (a) Lower convertible top halfway.
  - (b) Remove the eight (8) screws and remove the top cover retainer.

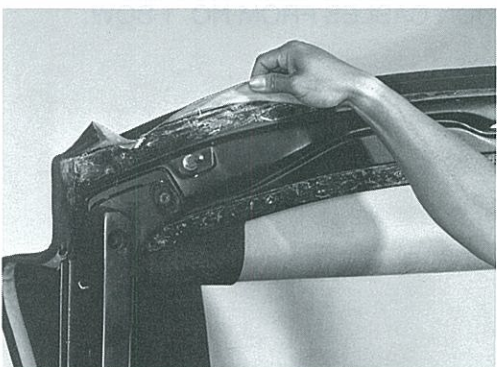

6. DETACH TOP COVER FROM NO. 1 BOW.  
Pull top cover away from the No.1 bow to break the cement bond.



7. DETACH TOP COVER FLAPS FROM NO. 1 BOW.  
Pull top cover away from the No.1 bow to break the cement bond.

**REMOVAL OF TOP COVER ASSEMBLY (cont.)**

8. REMOVE TOP COVER RETAINERS FROM NO. 2 AND NO. 3 BOW LISTING POCKETS.

(a) Remove the three (3) screws from each bow.

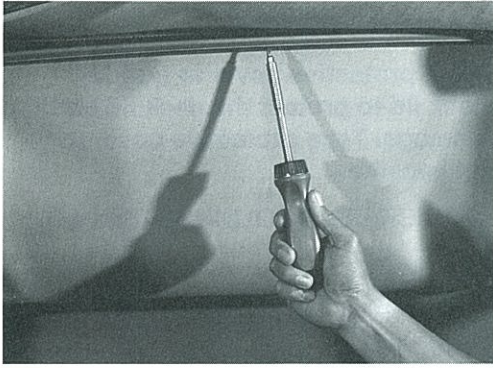

(b) Push top cover rearward, away from No.2 and No.3 bows.

(c) Slide top cover retainers out of listing pockets to remove them.

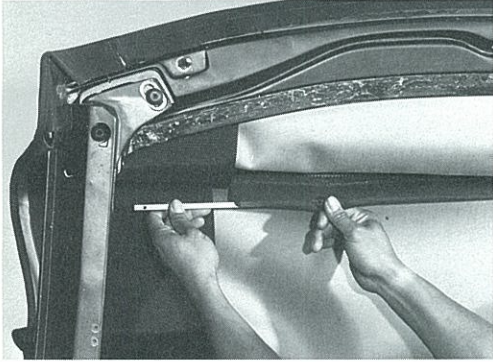

9. DETACH TOP COVER REAR RAIL FLAPS FROM THE REAR RAILS.

Pull the top cover rear rail flaps away from the rear rail to break the cement bond.



10. DETACH SIDE RETENTION CABLES FROM NO. 1 BOW.

Remove the two (2) screws.

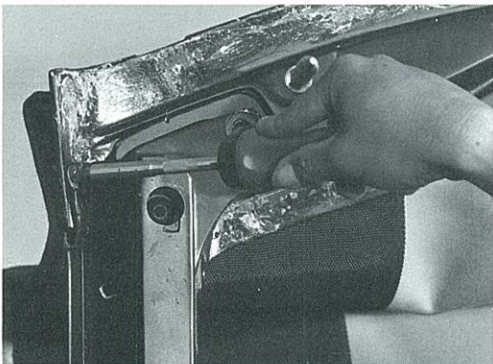

11. REMOVE SIDE RETENTION CABLE FROM TOP COVER.

Pull the cable back through the top cover side listing pocket to remove the cable.

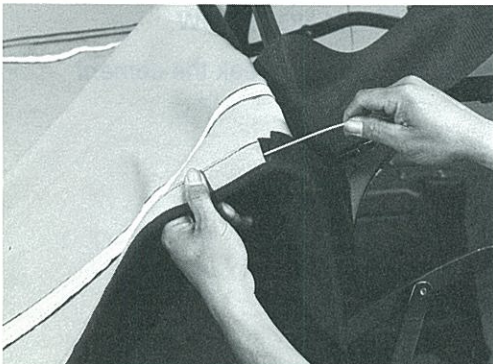



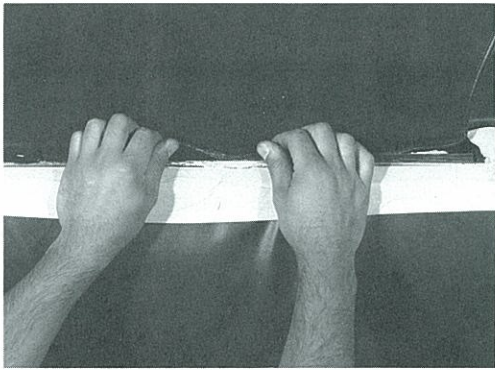

## REMOVAL OF TOP COVER ASSEMBLY (cont.)

12. REMOVE TOP COVER QUARTER OUTER FLAPS FROM THE QUARTER PANEL.

Pull the top cover quarter outer flaps away from the quarter outer to break the cement bond.

**NOTE: Observe location of top cover quarter outer flaps to quarter outer before removing top cover quarter outer flaps.**

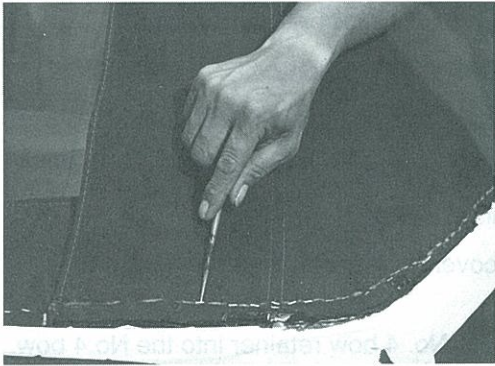

13. DETACH TOP COVER FROM TACKING STRIP.

Using an awl, remove staples retaining top cover to the belt tacking strip.

**NOTE: Before removal, note location and spacing of staples.**

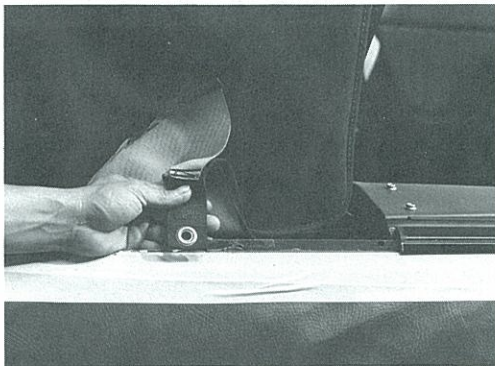

14. REMOVE THE TOP COVER SAIL PANEL STRAP RETAINER FROM THE QUARTER REINFORCEMENT.

- (a) Using a suitable flat-bladed tool, remove the top cover sail panel strap retainer.
- (b) Pull top cover sail panel strap back through rod on quarter inner reinforcement.

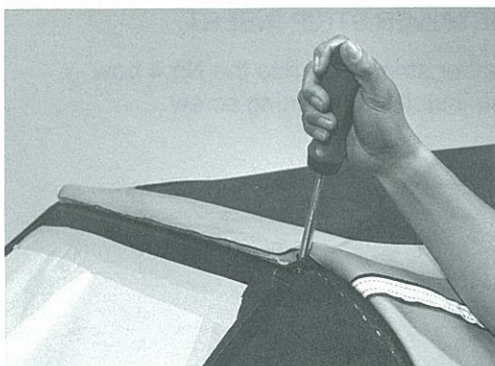

15. REMOVE TOP COVER FROM NO. 4 BOW.

- (a) Fold top cover (rear sail material) toward the center of the car to expose the top cover No. 4 bow retainer.
- (b) Remove one (1) of the two (2) screws that retain the top cover No. 4 retainer insert strip.

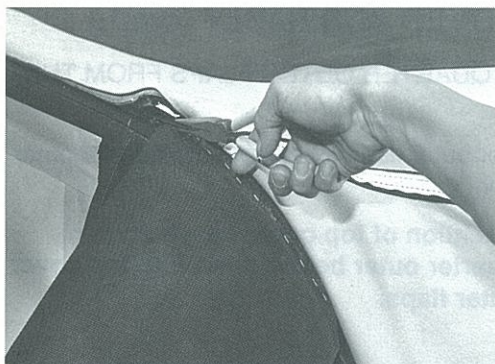

### REMOVAL OF TOP COVER ASSEMBLY (cont.)

- (c) Remove the top cover No. 4 bow retainer insert strip by pulling it out of the top cover No. 4 bow retainer pocket.
- (d) Remove top cover.

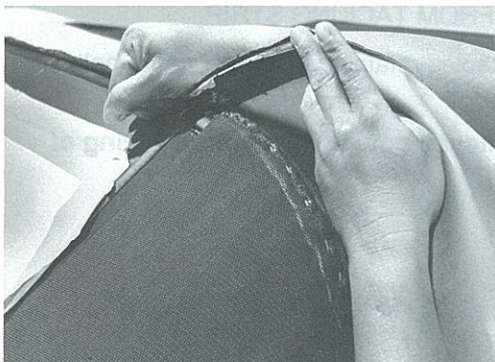

### INSTALLATION OF TOP COVER ASSEMBLY

1. INSTALL TOP COVER ONTO NO. 4 BOW.
  - (a) Position new top cover over top stack framework.
  - (b) Align the top cover No. 4 bow retainer to the No. 4 bow.
  - (c) Center top cover side to side.
  - (d) Fold back the top cover quarter sail material toward the center of the car.
  - (e) Engage the top cover No. 4 bow retainer into the No.4 bow, starting at one end and working toward the other end.

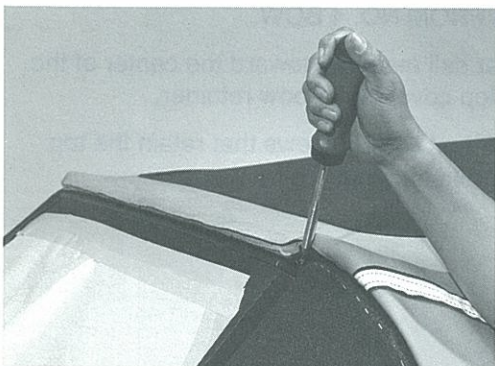

### 2. INSTALL NO. 4 BOW RETAINER STRIP INSERT.

Insert the No. 4 bow retainer strip insert into the No.4 bow retainer strip retainer and install the retaining screw.

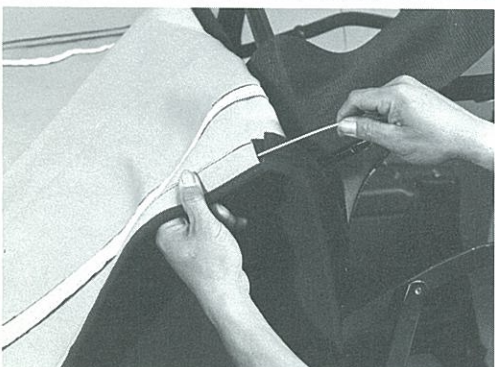

### 3. INSTALL SIDE RETENTION CABLES TO TOP COVER AND TO FRONT SIDE RAILS.

- (a) Bend a hook on one end of a 36" length of stiff wire.
- (b) Insert the hooked end of the wire into the front end of the top cover listing pocket until the hook end of the wire is exposed.

**INSTALLATION OF TOP COVER ASSEMBLY (cont.)**

- (c) Attach the eyelet end of the retention cable to the hook end of the wire.
- (d) Pull the wire back through the top cover listing pocket until the eyelet end of the retention cable is exposed.
- (e) Remove the hooked wire from the retention cable.

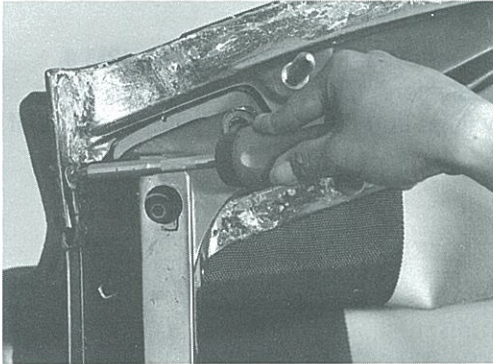

- (f) Lower the top, halfway, and position the front end of the cables into the underside of the No. 1 bow with the screws and install the screws.

**4. ATTACH TOP COVER REAR RAIL FLAPS TO REAR RAILS.**

- (a) Carefully apply 3M Super Weatherstrip Adhesive (3M # 051135-08008 or equivalent) to the cementing area of the rear rail and the corresponding surfaces of the top cover rear rail flaps.

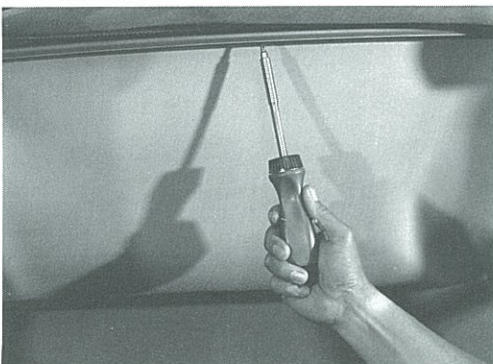

- (b) Attach top cover rear rail flaps to rear rails.

**5. ATTACH TOP COVER TO NO. 2 AND NO. 3 BOW LISTING POCKETS.**

- (a) Insert top cover retainers into listing pockets in top cover.
- (b) Insert listing pockets into No. 2 and No. 3 bows and install the three (3) screws.

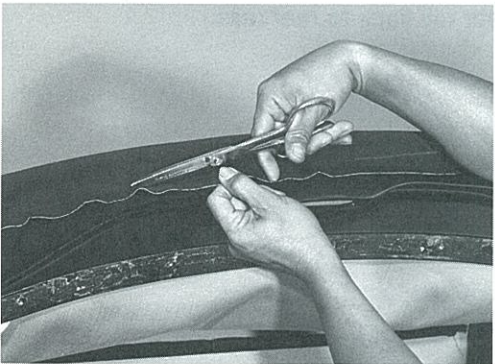
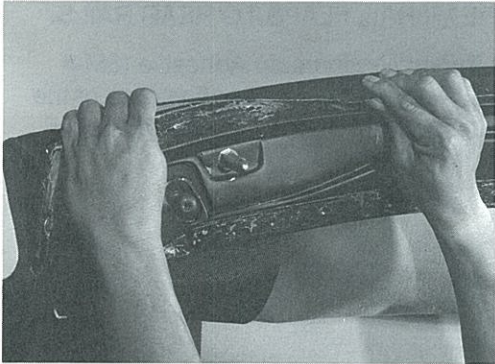
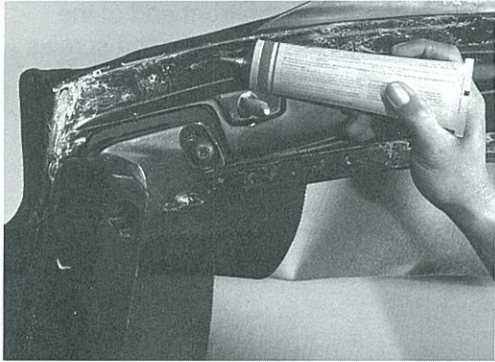
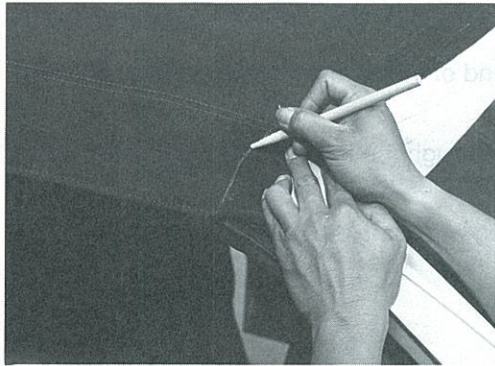
**INSTALLATION OF TOP COVER ASSEMBLY (cont.)**

6. RAISE CONVERTIBLE TOP AND SECURE.
7. ATTACH TOP COVER TO NO. 1 BOW.
  - (a) Pull top cover forward over No. 1 bow. Pull top cover taut so that no wrinkles appear.
  - (b) Using a suitable sharp pencil, mark the edge of the No. 1 bow on the top cover.
  - (c) Lower the convertible top halfway.
  - (d) Carefully apply 3M Super Weatherstrip Adhesive (3M # 051135-08008 or equivalent) to the cementing area of the top cover No.1 bow flaps and the corresponding surfaces of the No.1 bow.
  - (e) Attach top cover No.1 bow flaps to No.1 bow.
 

**NOTE: Pull top cover slightly past the pencil mark on the top cover.**
  - (f) Raise and secure the top to the windshield header.
  - (g) Check for proper fit and appearance to the No. 1 bow.
  - (h) Lower the convertible top halfway.
  - (i) Trim off all excess material.

**INSTALLATION OF TOP COVER ASSEMBLY (cont.)****8. INSTALL TOP COVER FRONT RETAINER.**

Position the top cover front retainer and install the eight (8) screws.

**9. INSTALL TOP COVER SAIL PANEL STRAP TO QUARTER REINFORCEMENT.**

(a) Push top cover sail panel strap through rod on quarter inner reinforcement and install the top cover sail panel retainer.

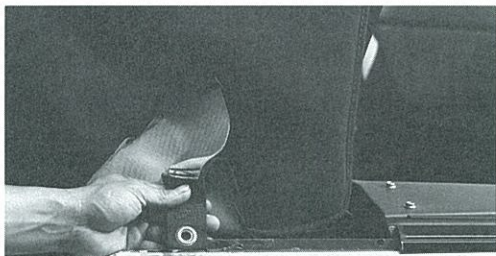
**10. INSTALL THE TOP COVER TO THE TACKING STRIP.**

- (a) Raise the convertible top and secure.
- (b) Check for equal position and appearance of the top cover seams at the ends of the No.4 bow. Adjust as necessary.
- (c) Align the top cover seams with the joint at the quarter panel and the deck lid.
- (d) Tack top cover to tacking strip starting from the seam of the top cover. Work inward then outward of the seam, around to the quarter panel.

**NOTE: Avoid excessive stretching, but keep material taut during tacking operation.**

**11. INSTALL TOP COVER QUARTER OUTER FLAPS TO THE QUARTER PANEL.**

Carefully apply 3M Super Weatherstrip Adhesive (3M # 051135-08008 or equivalent) to the cementing area of the top cover quarter outer flaps and the corresponding surfaces of the quarter outer.

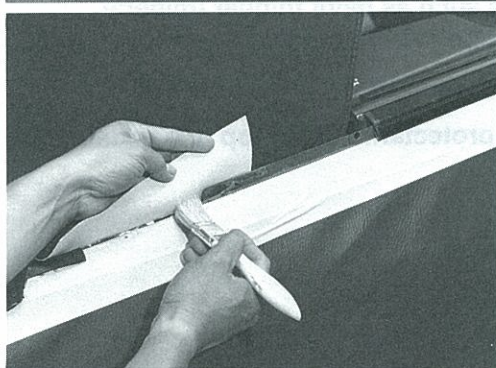
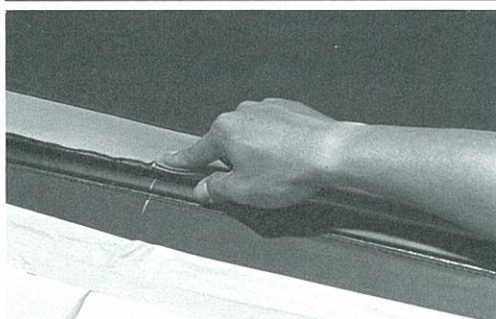

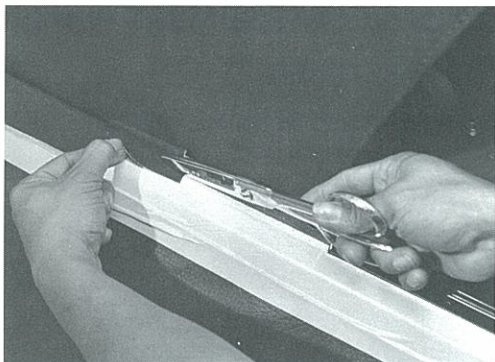

### INSTALLATION OF TOP COVER ASSEMBLY (cont.)

12. TRIM EXCESS MATERIAL WITH SCISSORS ALONG TACKING STRIP AND QUARTER PANEL.

13. CHECK APPEARANCE AND OPERATION OF CONVERTIBLE TOP.

- (a) Lower the convertible top, then raise the top and secure.
- (b) Check the convertible top for proper appearance and operation.

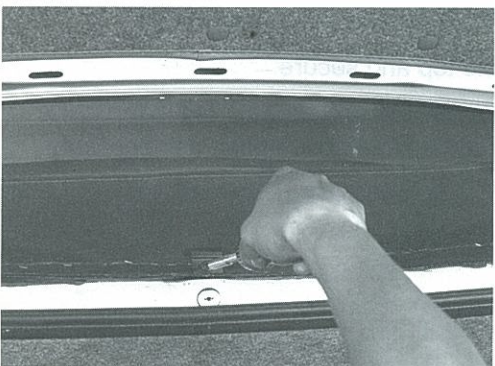

14. INSTALL BACK BELT MOLDING RETAINER.

Position the back belt retainer and install the screw.

15. INSTALL CENTER AND REAR RAIL WEATHERSTRIP ASSEMBLIES (See 11-3 and 11-5).

16. INSTALL HEADLINER (See 12-4).

17. INSTALL QUARTER AND BACK BELT MOLDINGS (See 4-4).

18. CAREFULLY REMOVE PROTECTIVE COVER FROM QUARTER PANEL AND DECK LID.

19. CLEAN UP TOP MATERIAL AND CAR AS REQUIRED.

#### CAUTION:

- λ **Only use solvents such as paint thinner (mineral spirits), sparingly, on the top cover material.**
- λ **Use only soap and water to clean the backlite.**
- λ **Do not apply any protectants to the top or backlite.**

# BACKLITE ASSEMBLY

	Page
BACKLITE ASSEMBLY - COMPONENTS .....	14-2
REMOVAL OF BACKLITE ASSEMBLY .....	14-3
INSTALLATION OF BACKLITE ASSEMBLY .....	14-5

BACKLITE ASSEMBLY - COMPONENTS

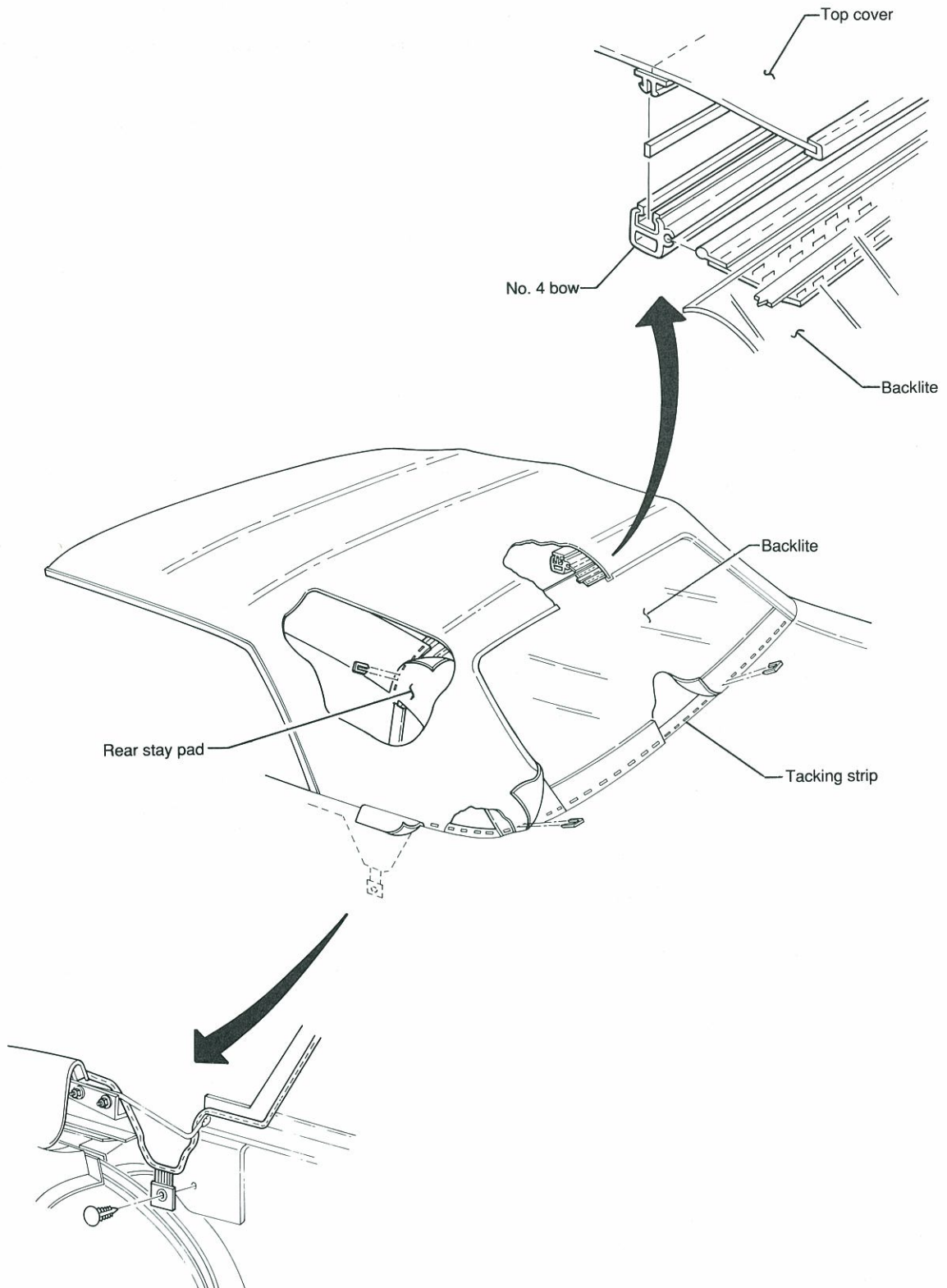



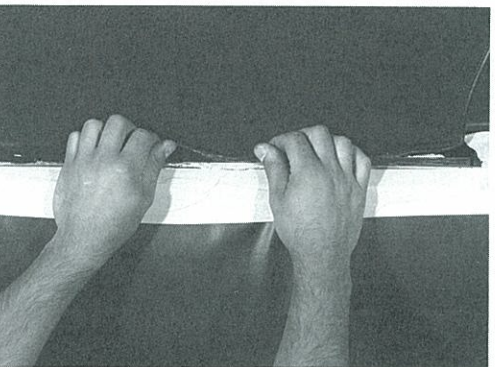
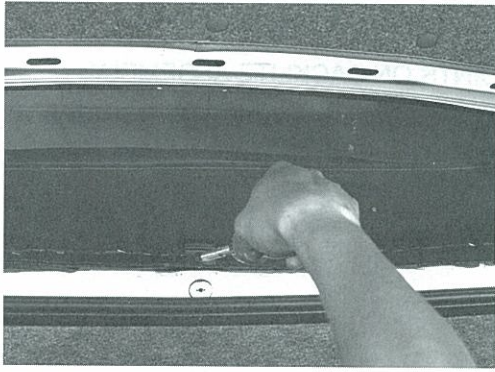

## REMOVAL OF BACKLITE ASSEMBLY

**NOTE:** Carefully tape a protective cover to quarter panel and deck lid to protect the deck lid and body from damage.

1. REMOVE QUARTER AND BACK BELT MOLDINGS (See 4-3).
2. REMOVE HEADLINER (See 12-3).
3. REMOVE BACK BELT MOLDING RETAINER.  
Remove the screw to remove the back belt molding retainer.
4. MARK REFERENCE POINTS ON BACKLITE ASSEMBLY.  
Using a suitable sharp pencil, mark the location of the top cover on the valance portion of the backlite.
5. DETACH ONE SIDE OF TOP COVER TO EXPOSE STAY PAD AND BACKLITE FOR REMOVAL.
  - (a) Using an awl, remove the staples attaching the top cover to the tacking strip.  
**Note:** Before removal, note the location and spacing of staples.
  - (b) Detach the top cover quarter outer flaps from the quarter panel. Pull to break the cement bond.
6. DETACH OTHER SIDE OF TOP COVER FROM TACKING STRIP TO EXPOSE STAY PAD AND BACKLITE.  
Use the method described above (14-3, # 5).

**REMOVAL OF BACKLITE ASSEMBLY (cont.)****7. MARK REFERENCE POINTS ON BACKLITE ASSEMBLY.**

- (a) Using a suitable sharp pencil, accurately mark the center and side welt location of the backlite and stay pads on the rearward edge of the No.4 bow.

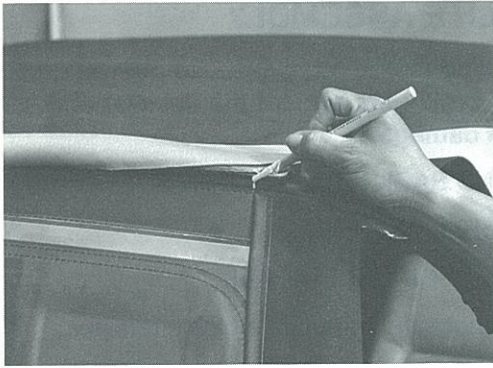

- (b) Mark the centerline of the staples.

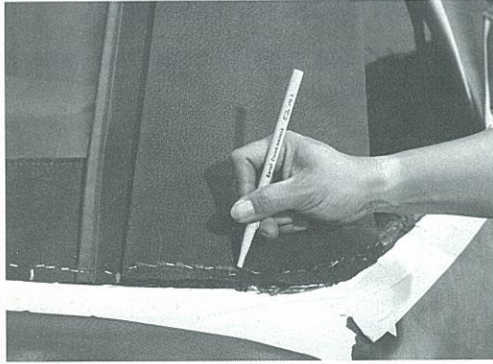
**8. DETACH LOWER END OF EXPOSED REAR STAY PAD.**

- (a) Using an awl, remove the staples retaining backlite to the back belt portion of the tacking strip up to the quarter panel.

**Note: Before removal, note the location and spacing of staples.**

- (b) Move the lower end of the stay pad back over the top stack to expose the backlite and the No. 4 bow.

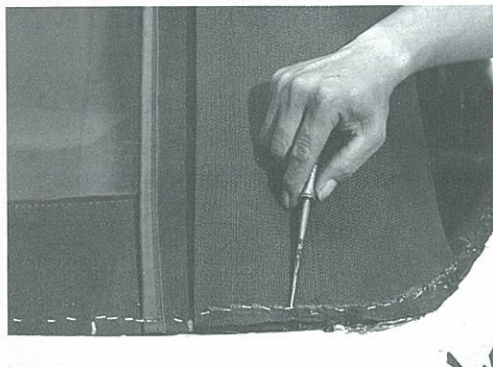
**9. DETACH BACKLITE FROM TACKING STRIP.**

Using an awl, remove the staples retaining top cover to the back belt portion of the tacking strip up to the quarter panel.

**Note: Before removal, note the location and spacing of staples.**

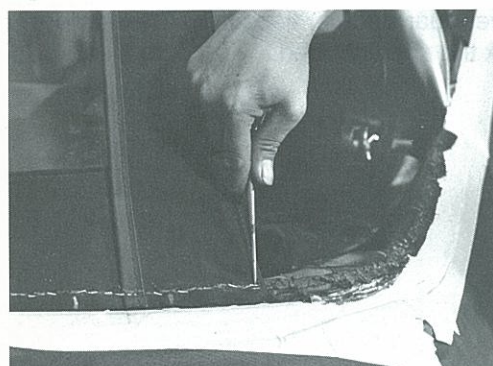

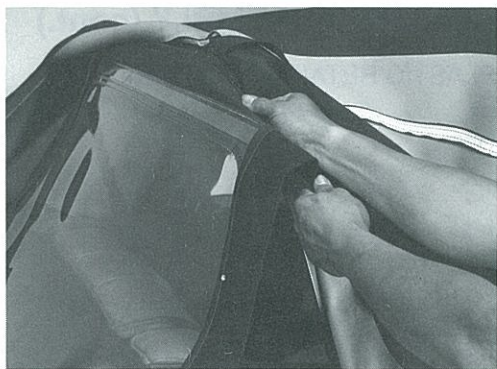

## REMOVAL OF BACKLITE ASSEMBLY (cont.)

### 10. REMOVE BACKLITE FROM NO. 4 BOW.

- (a) Standing at the side of the car that has the rear stay pad detached, grasp the backlite retainer strip and pull the backlite out from the No. 4 bow.

## INSTALLATION OF BACKLITE

### 1. INSPECT NEW BACKLITE.

- (a) Detach protective paper covering from new backlite and inspect for scratches or damage on both sides of the backlite window.
- (b) Reattach protective paper covering to new backlite window.

**CAUTION: Do not rub surfaces of backlite while inspecting. Otherwise, permanent scratches will result. Use only a clean soft cotton towel dampened with clean water if handling is necessary. Do not install new backlite if it is scratched or damaged.**

### 2. TRANSFER REFERENCE MARKS FROM REMOVED BACKLITE TO NEW BACKLITE.

- (a) Place new backlite on a clean, covered work surface with inner surface of the backlite facing down.
- (b) Position removed backlite over new backlite.
- (c) Using a suitable sharpened pencil, transfer reference marks for rear stay pads and top cover from the removed backlite to the new backlite.

- (d) Transfer the centerline marks for the staples.

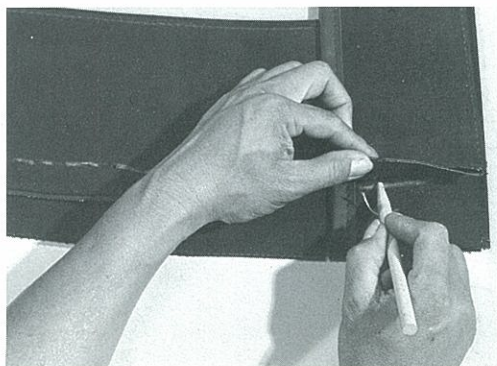
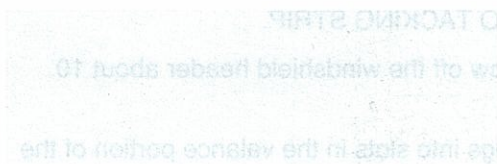

## INSTALLATION OF BACKLITE ASSEMBLY (cont.)

3. MARK AND TRIM THE PLASTIC RETAINER STRIP AT THE TOP OF THE BACKLITE.



4. INSTALL BACKLITE TO NO. 4 BOW.

- (a) Standing at the side of the car that has the rear stay pad detached, insert the backlite retainer strip on the backlite into the No. 4 bow.
- (b) Push the backlite into the No. 4 bow.
- (c) Align reference marks on the backlite with the reference marks on the rear edge of the No. 4 bow.

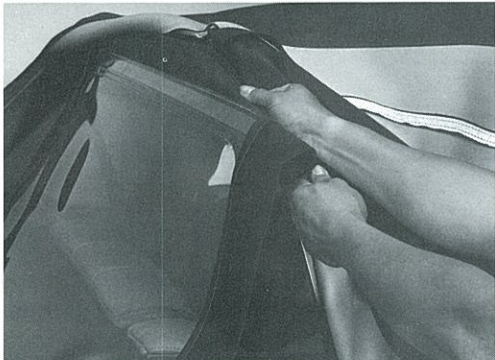

5. ATTACH BACKLITE TO TACKING STRIP.

- (a) Raise the No. 1 bow off the windshield header about 10 inches (255 mm).
- (b) Insert helper-springs into slots in the valance portion of the backlite.
- (c) Using two (2) staples, tack the backlite 6 inches (152 mm) to right and to the left of center.

**Note:** Use heavy-duty stainless steel staples (.31x.31) in an air or electric powered stapler. Do not use a hand-powered stapler.

**CAUTION:** Make sure reference marks are aligned properly before tacking.

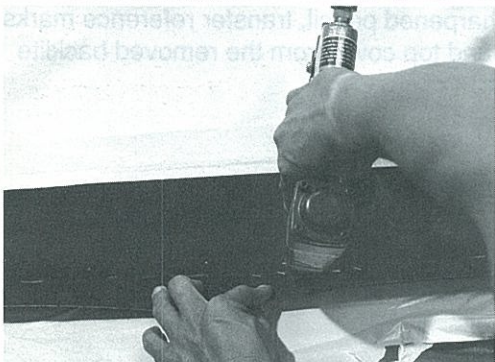
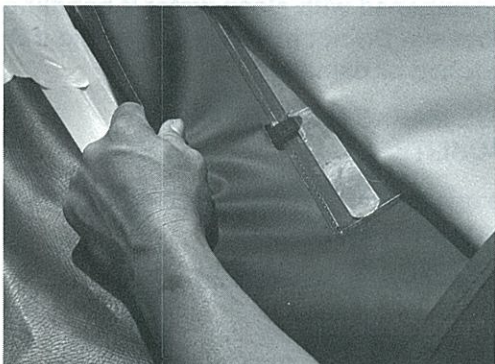

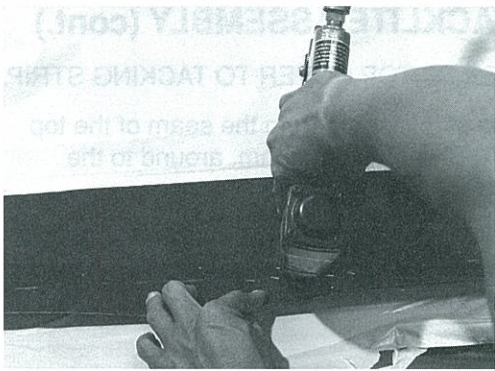

### INSTALLATION OF BACKLITE ASSEMBLY (cont.)

- (d) Carefully lower the top to the windshield header, but do not secure.
- (e) Tack the backlite to the tacking strip starting from the center and working toward the outboard ends. Pull to remove all fullness from the backlite during installation. Avoid excessive stretching of backlite, but keep material taut during tacking operation.

**Note:** Use heavy-duty stainless steel staples (.31x.31) in an air or electric powered stapler. Do not use a hand-powered stapler.

#### 6. INSPECT BACKLITE ASSEMBLY FOR WRINKLES.

- (a) Secure top to the windshield header.
- (b) Remove protective covering from both sides of the backlite.

**NOTE:** If slight wrinkles or waves are present perform the following: Apply heat to the backlite surface using a hot-air gun. The hot air gun should be held about 50mm (2 inches) from the backlite and moved in a circular motion for about 5 minutes. Let the backlite cool down for at least 20 minutes before reinspection.

**CAUTION:** Excess heat applied to the backlite surface may cause permanent damage. Extreme care should be exercised when performing this procedure.

#### 7. TRIM EXCESS BACKLITE MATERIAL FROM VALANCE PORTION OF THE BACKLITE.

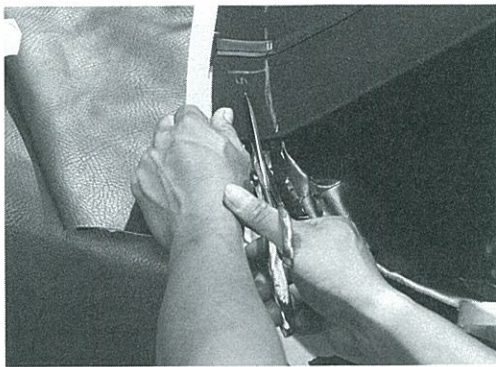

#### 8. REATTACH LOWER END OF THE REAR STAY PAD.

Tack the lower end of the rear stay pad to the tacking strip.

**Note:** Avoid excessive stretching of rear stay pad, but keep material flat during tacking operation. Use heavy-duty stainless steel staples (.51x.31) in an air or electric powered stapler. Do not use a hand-powered stapler.





### INSTALLATION OF BACKLITE ASSEMBLY (cont.)

9. REATTACH BOTH SIDES OF TOP COVER TO TACKING STRIP.

Tack top cover to tacking strip starting from the seam of the top cover. Work inward then outward of the seam, around to the quarter panel.

**Note:** Use heavy-duty stainless steel staples (.31x.31) in an air or electric-powered stapler. Do not use a hand-powered stapler.

10. INSTALL BACK BELT MOLDING RETAINER.

Position the back belt molding retainer and install the screw.

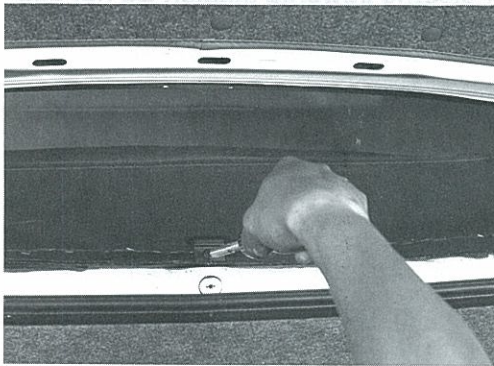

11. INSTALL QUARTER AND BACK BELT MOLDINGS (See 4-4).
12. CAREFULLY REMOVE PROTECTIVE COVER FROM QUARTER PANEL AND DECK LID.
13. INSTALL HEADLINER (See 12-4).

---

# STAY PADS, SIDE AND REAR

	Page
STAY PADS, SIDE AND REAR - COMPONENTS .....	15-2
REMOVAL OF SIDE AND REAR STAY PADS .....	15-3
INSTALLATION OF SIDE AND REAR STAY PADS ....	15-4

STAY PADS, SIDE AND REAR - COMPONENTS

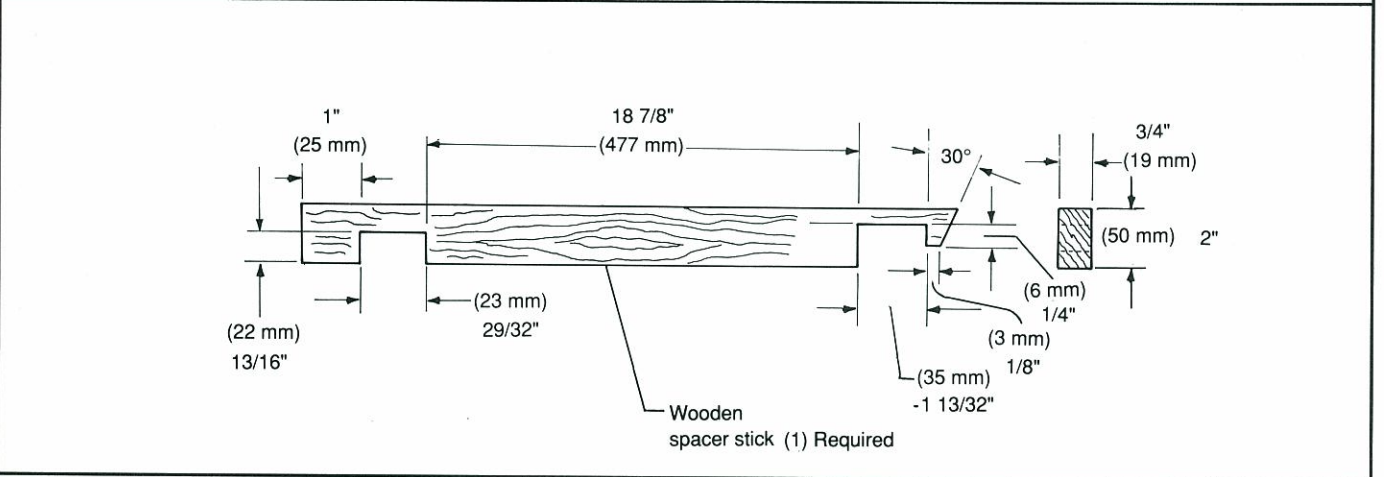
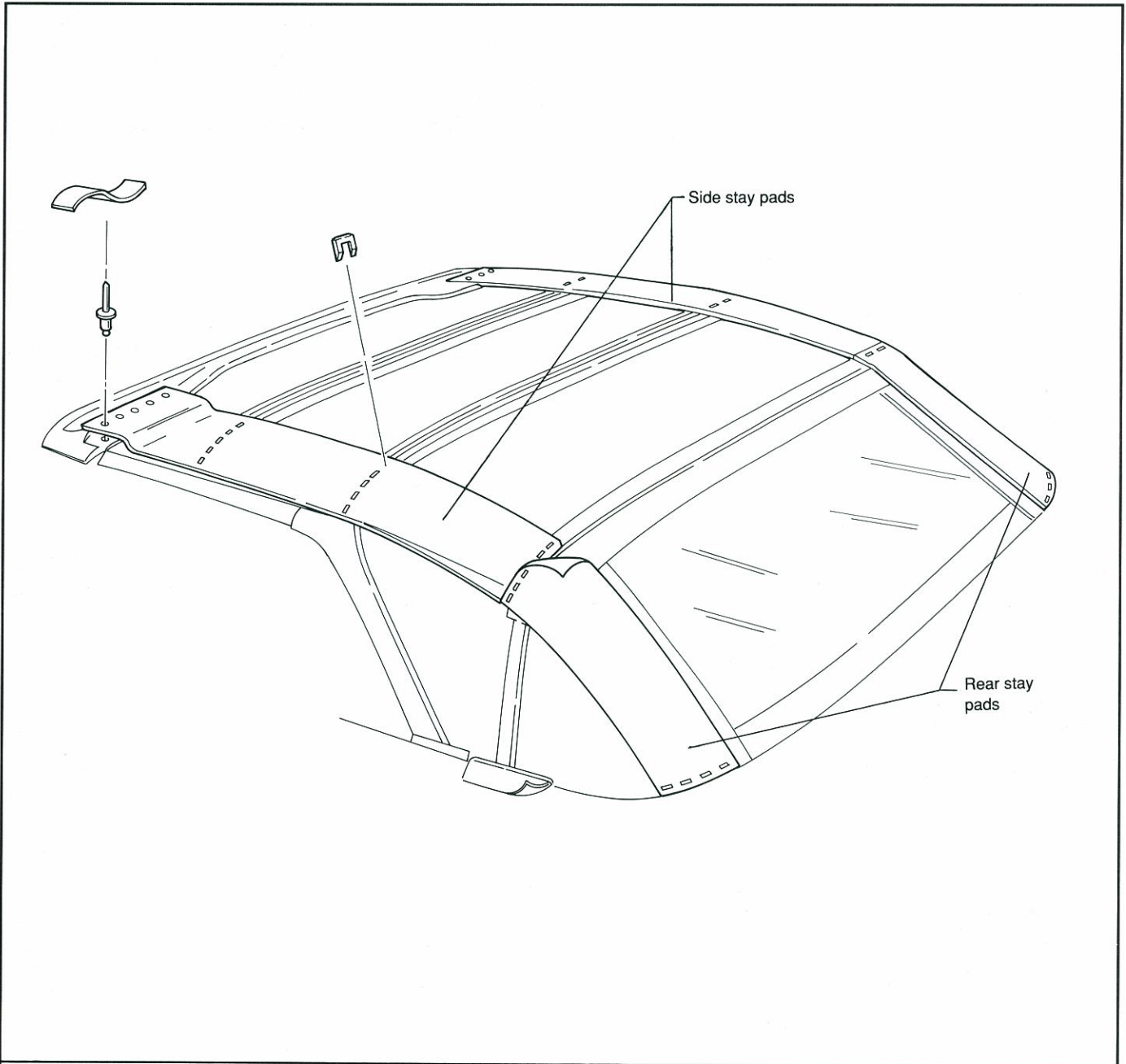



## REMOVAL OF SIDE AND REAR STAY PADS

**NOTE:** Carefully tape a protective cover to the deck lid, quarter panel and outside of backlite to protect from damage.

1. REMOVE HEADLINER (See 12-3).
2. REMOVE QUARTER BELT AND BACK BELT MOLDINGS (See 4-3).
3. REMOVE TOP COVER (See 13-3).
4. MARK REFERENCE POINTS ON STAY PADS.

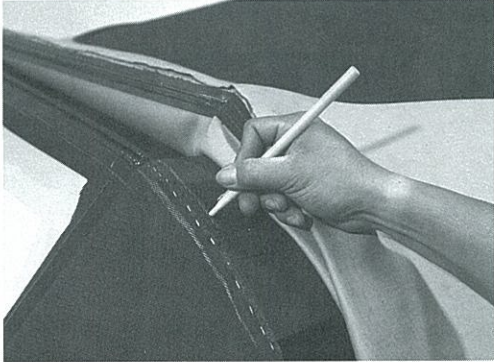

- (a) Raise and secure convertible top.
- (b) Using a suitable sharpened pencil, accurately mark the location of the of the No. 4 bow on the top side of the rear and side stay pad.

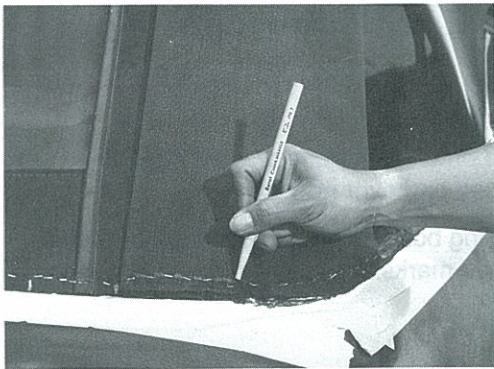

- (c) Mark the centerline of the staples on the rear stay pads.
- (d) Mark the location of the inner vertical edge of the stay pads on the backlite.

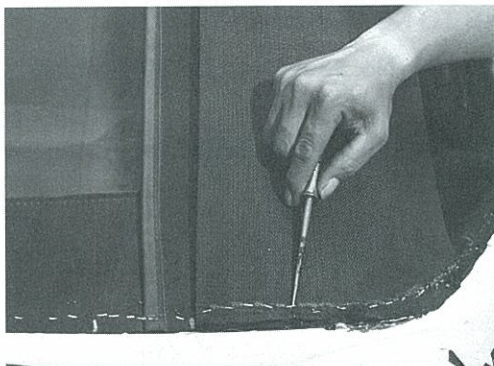

5. DETACH REAR STAY PADS FROM BELT TACKING STRIP AND NO.4 BOW.

Using an awl, remove staples retaining the rear stay pads to the belt tacking strip and the No.4 bow.

**NOTE:** Before removal, note location and spacing of staples.

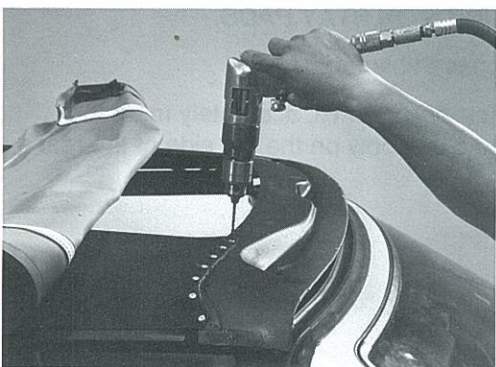
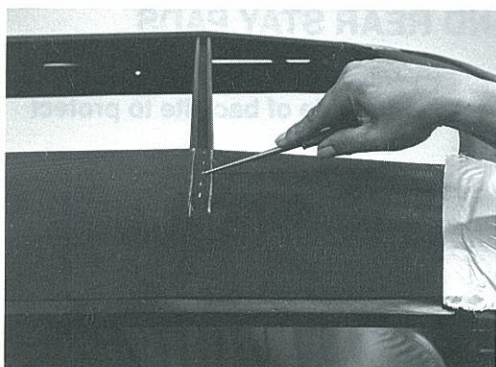

### REMOVAL OF SIDE AND REAR STAY PADS (cont.)

6. DETACH SIDE STAY PADS FROM NO. 2, 3 AND 4 BOWS.

Using an awl, remove staples retaining the side stay pads to the No. 2, 3 and 4 bows.

**NOTE: Before removal, note location and spacing of staples.**

7. REMOVE SIDE STAY PADS FROM NO. 1 BOW.

Using a drill with a 1/8 inch (3.2mm) drill bit, remove the seven (7) rivets from each stay pad and remove the stay pads.

### INSTALLATION OF SIDE AND REAR STAY PADS

1. TRANSFER REFERENCE MARKS FROM REMOVED STAY PADS TO NEW STAY PADS.

- (a) Place new stay pad on a flat surface or work bench and position removed stay pad over new one.
- (b) While securely holding both stay pads together, carefully transfer the reference marks from removed pad to new one.

2. INSTALL SIDE STAY PAD TO NO. 1 BOW.

Position the side stay pad to the No. 1 bow and install seven (7) 1/8" x 3/8" aluminum rivets.

**NOTE: Avoid stretching, but keep material flat during rivet installation.**

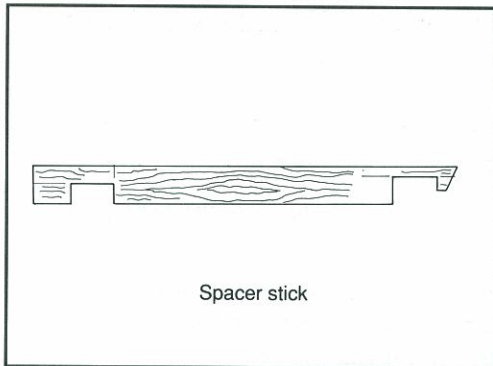

## INSTALLATION OF SIDE AND REAR STAY PADS (cont.)

### 3. INSTALL SIDE PAD TO NO. 4 BOW.

- (a) Install spacer stick along the centerline, between the No. 3 and 4 bows.

**NOTE:** The purpose of the spacer sticks is to hold the bows in position during installation of the stay pads. The spacer stick can be fabricated out of any suitable material such as wood.

- (b) Tack the side stay pad to the No. 4 bow.

**NOTE:** Avoid excessive stretching of stay pad, but keep material taut during tacking operation. Use heavy-duty stainless steel staples (.51x.31) in an air or electric powered stapler. Do not use a hand-powered stapler.

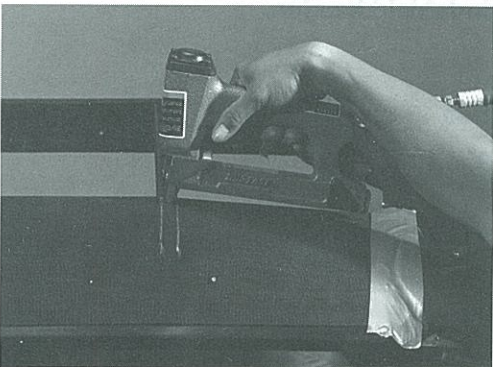
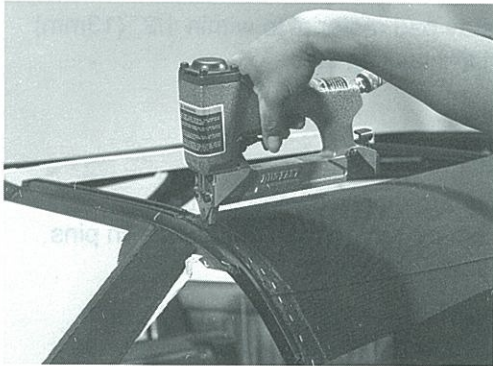

- (c) Tack the side stay pad to the No. 2 and 3 bows using the method described above.
- (d) Remove spacer stick.
- (e) Trim off excess stay pad material from the rear edge of the No. 4 bow.



### 4. INSTALL REAR STAY PAD TO NO. 4 BOW.

- (a) Position the rear stay pad to the No. 4 bow according to the reference marks.
- (b) Tack the rear stay pad to the No. 4 bow starting from inner edge toward the outer edge.

**NOTE:** Avoid stretching, but keep material flat during tacking operation.



### 5. INSTALL REAR STAY PAD TO REAR BELT TACKING STRIP.

- (a) Position the rear stay pad to the rear belt tacking strip according to the reference marks.
- (b) Tack the rear stay pad to the rear belt tacking strip starting from inner edge toward the outer edge.

**NOTE:** Avoid stretching, but keep material flat during tacking operation.

## INSTALLATION OF SIDE AND REAR STAY PADS (cont.)

6. CHECK APPEARANCE AND OPERATION OF TOP STACK.
  - (a) Lower the convertible top. Then, raise the top and secure.
  - (b) Check the convertible top for appearance and proper operation.

**NOTE: The properly installed stay pads should not bind or distort the top stack bows or the backlite while operating the top stack.**

- (c) Trim off all excess stay pad material to within 1/2" (13mm) of the lower edge of the tacking strip.
7. CHECK FOR PULL DOWN EFFORT.
  - (a) Lower the convertible top then raise the top to the windshield header, but do not engage the pull down pins into the power pull down actuators.

**NOTE: A properly-tensioned convertible top stack should stop about 8-10 (200-250mm) inches from the windshield header.**

8. INSTALL TOP COVER (See 13-6).
9. INSTALL HEADLINER (See 12-4).

---

# NO. 1 BOW

	<b>Page</b>
<b>NO. 1 BOW - COMPONENTS .....</b>	<b>16-2</b>
<b>REMOVAL OF NO. 1 BOW .....</b>	<b>16-3</b>
<b>INSTALLATION OF NO. 1 BOW .....</b>	<b>16-5</b>

NO. 1 BOW - COMPONENTS

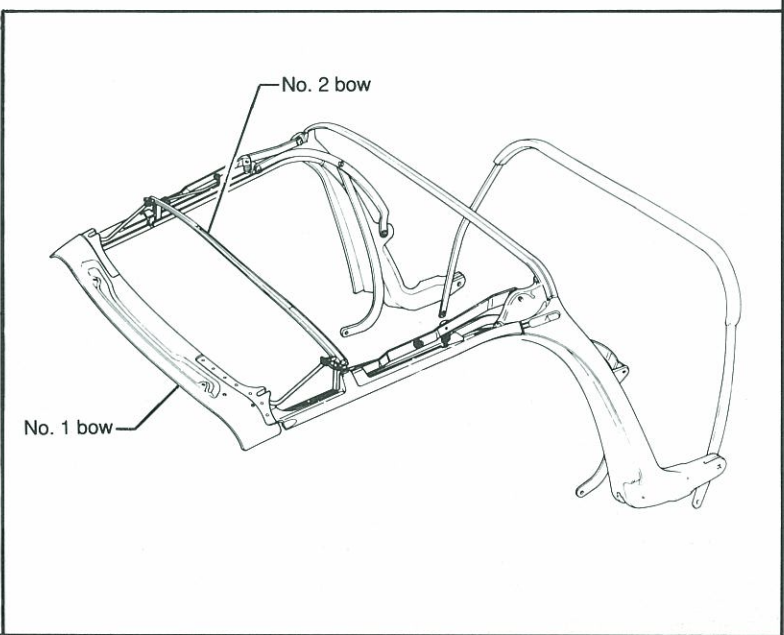
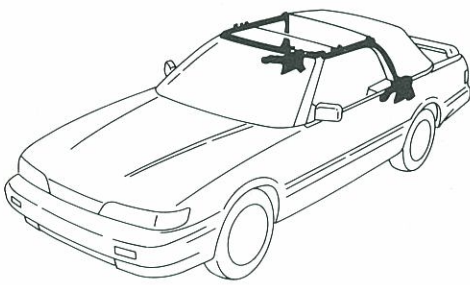
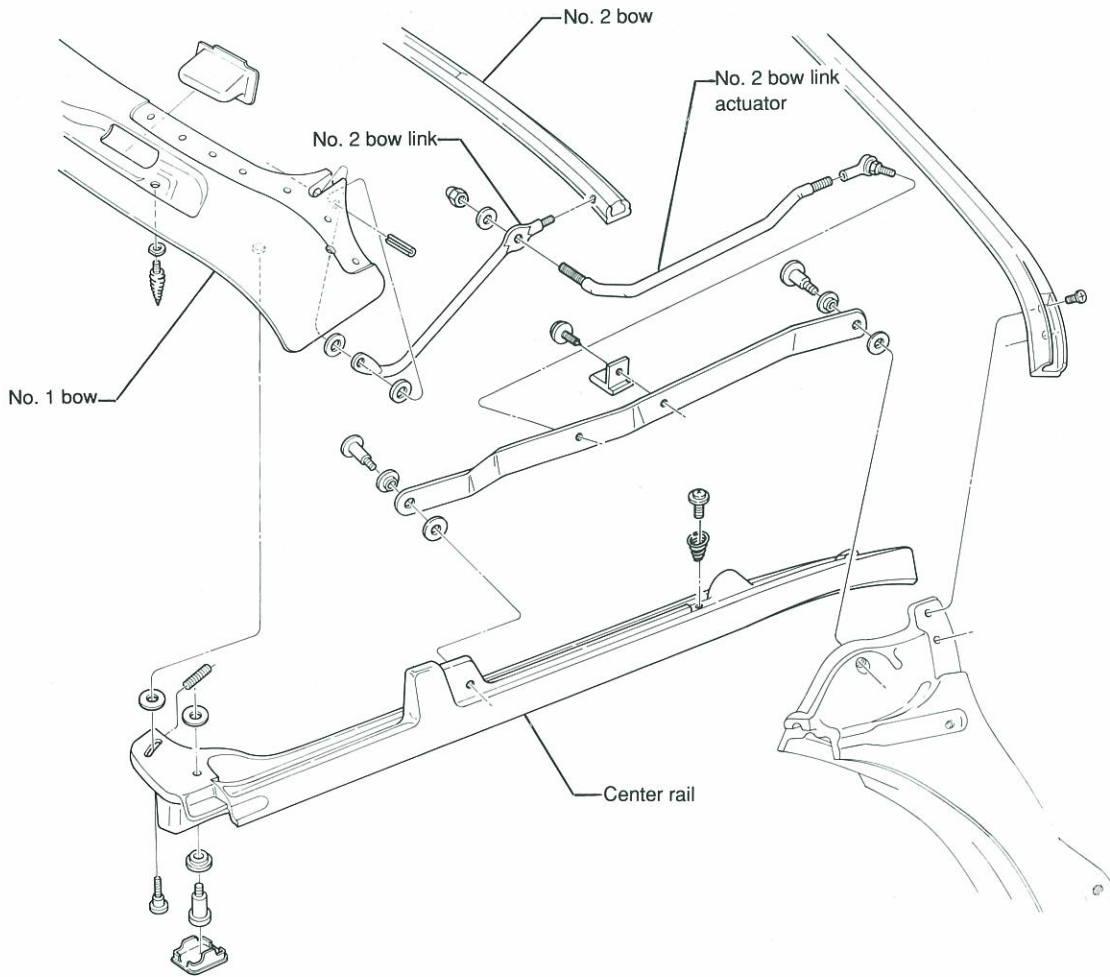

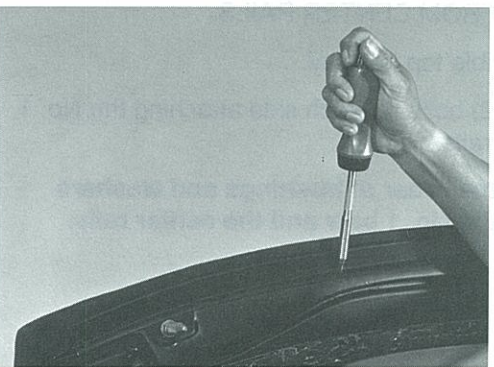
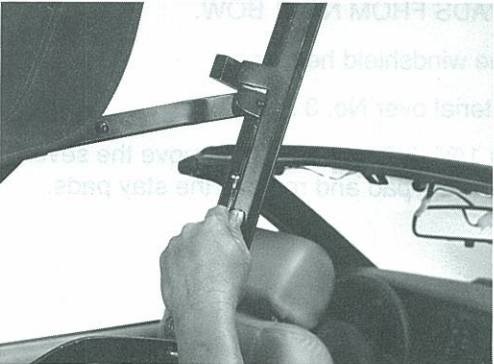
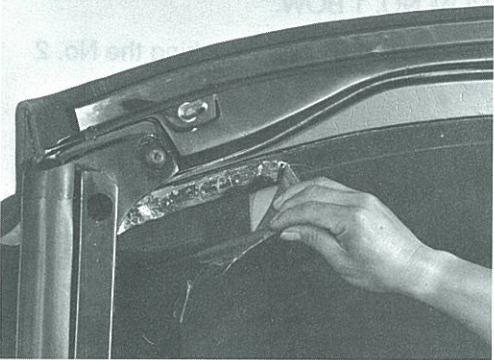
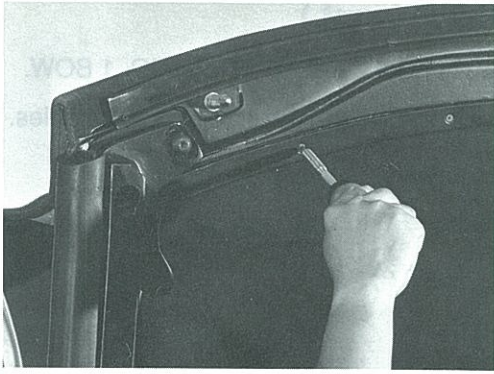

## REMOVAL OF NO. 1 BOW

1. RAISE THE CONVERTIBLE TOP HALFWAY.
2. DETACH HEADLINER FROM NO. 1 BOW.
  - (a) Remove the seven (7) screws from No. 1 bow headliner retainer to remove the retainer.
  - (b) Detach the headliner from the No. 1 bow. Pull to break the cement bond.
3. REMOVE CENTER RAIL WEATHERSTRIP RETAINER ASSEMBLY.
 

Remove the three (3) nuts and washers to remove the center rail weatherstrip retainer assembly.
4. REMOVE TOP COVER FRONT RETAINER.
 

Remove the eight (8) screws for the top cover retainer.
5. DETACH TOP COVER FROM NO. 1 BOW.
  - (a) Using a sharpened pencil, mark the position of the top cover along the forward edge of the No. 1 bow.
  - (b) Pull top cover away from the No.1 bow to break the cement bond.

**REMOVAL OF NO. 1 BOW (cont.)**

6. DETACH THE SIDE RETENTION CABLES FROM NO. 1 BOW.  
Remove the two (2) screws and detach the side retention cables.

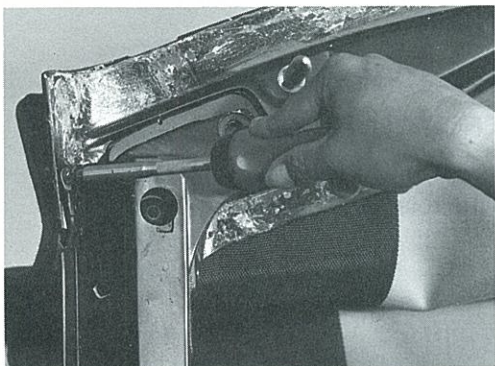

7. DETACH NO. 2 BOW FROM NO. 1 BOW.

Using a punch, remove the two (2) roll pins attaching the No. 2 bow links to the No. 1 bow.



8. DETACH SIDE STAY PADS FROM NO. 1 BOW.

- (a) Raise the top to the windshield header.
- (b) Fold top cover material over No. 3 bow.
- (c) Using a drill with a 1/8" (3.2mm) drill bit, remove the seven (7) rivets from each stay pad and remove the stay pads.

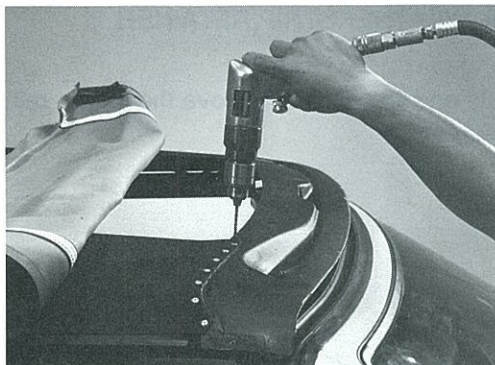

9. REMOVE NO. 1 BOW FROM CENTER RAILS.

- (a) Lower the convertible top halfway.
- (b) Remove the two (2) bolts on each side attaching the No. 1 bow to the center rails.

**NOTE: Observe the order of bushings and washers between the No. 1 bow and the center rails.**





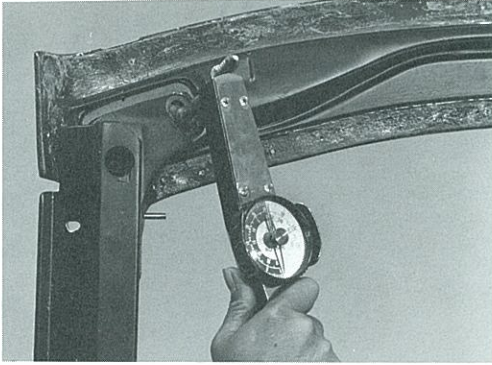

## INSTALLATION OF NO. 1 BOW

### 1. INSTALL NO. 1 BOW TO CENTER RAILS.

Position and align the No. 1 bow to the center rails and install the two (2) bolts on each side.

**NOTE: Observe the order of bushings and washers between the No. 1 bow and the center rails.**

**Torque: M8 28 N-m (21 ft-lb).**

**Torque: M6 11.5 N-m (105 in-lb).**

### 2. ATTACH SIDE STAY PADS TO NO. 1 BOW.

- (a) Raise the top to the windshield header, but do not secure.
- (b) Position and align the side stay pads to the No. 1 bow and install the seven (7) 1/8" x 3/8" aluminum rivets in each side stay pad.

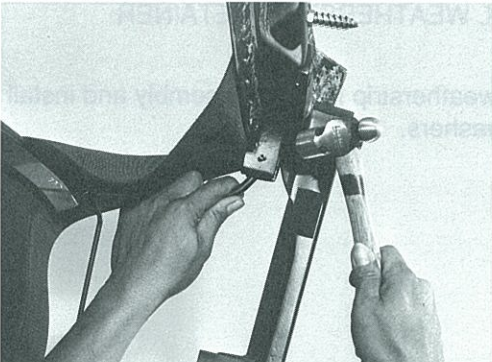

### 3. ATTACH NO. 2 BOW TO NO. 1 BOW.

- (a) Lower the convertible top halfway.
- (b) Position and align the ends of the No. 2 bow links into the No. 1 bow.
- (c) Install the two (2) roll pins.

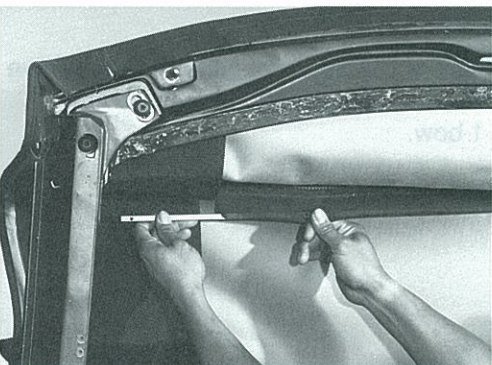

### 4. ATTACH THE SIDE RETENTION CABLES TO NO. 1 BOW.

- (a) Fold the top cover over the No. 1 bow.
- (b) Position the side retention cables into the underside of the No. 1 bow with the screws and install the screws.

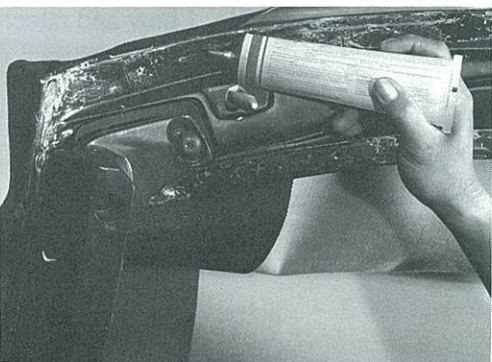

### 5. ATTACH TOP COVER TO NO. 1 BOW.

- (a) Carefully apply 3M Super Weatherstrip Adhesive (3M P/N 051135-08008 or equivalent) to the cementing area of the top cover No. 1 bow flaps and the corresponding surfaces of the No. 1 bow.
- (b) Attach the top cover No. 1 bow flaps to the No. 1 bow according to reference marks.

**INSTALLATION OF NO. 1 BOW (cont.)**

- (c) Raise and secure the convertible top.
- (d) Check for proper fit to the No. 1 bow.

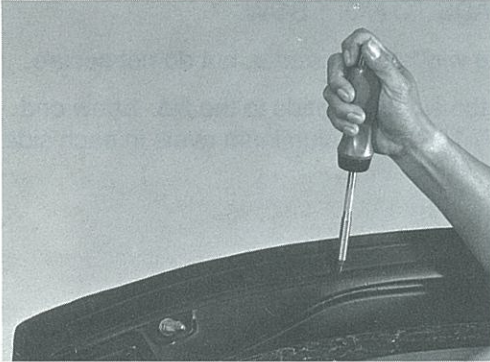

6. **INSTALL THE TOP COVER FRONT RETAINER.**  
Position the top cover retainer and install the eight (8) screws.



7. **INSTALL CENTER RAIL WEATHERSTRIP RETAINER ASSEMBLY.**  
Position the center rail weatherstrip retainer assembly and install the three (3) nuts and washers.

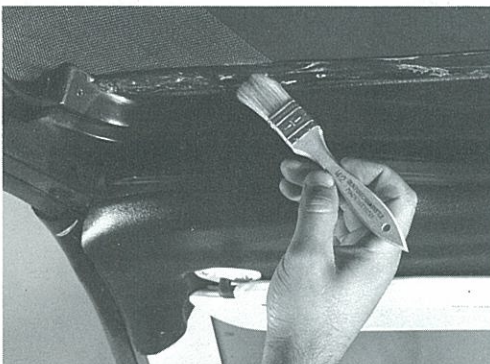

8. **ATTACH HEADLINER TO NO. 1 BOW.**  
(a) Brush an even amount of 3M Super Weatherstrip Adhesive (3M P/N 051135-08008 or equivalent) along the bottom surface of the No. 1 bow.



- (b) Position and align the headliner to the No. 1 bow and attach the headliner.

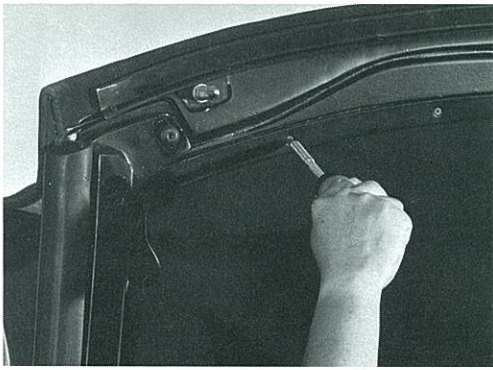

### INSTALLATION OF NO. 1 BOW (cont.)

- (c) Position the headliner retainer and install the seven (7) screws.

**Torque: 3.5 N-m (30 in-lb).**



# NO. 2 BOW

	Page
NO. 2 BOW - COMPONENTS .....	17-2
REMOVAL OF NO. 2 BOW .....	17-3
INSTALLATION OF NO. 2 BOW .....	17-5

NO. 2 BOW - COMPONENTS

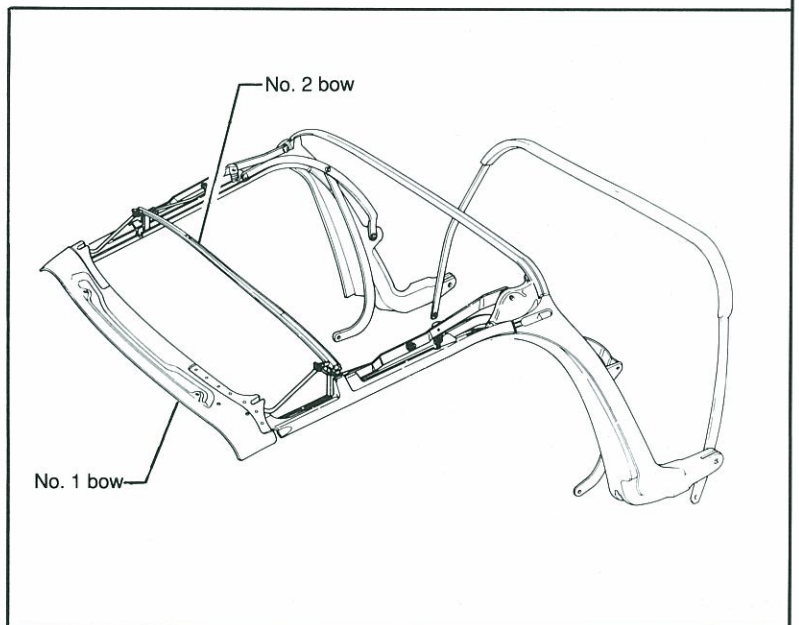
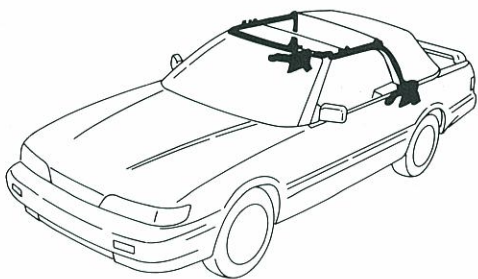
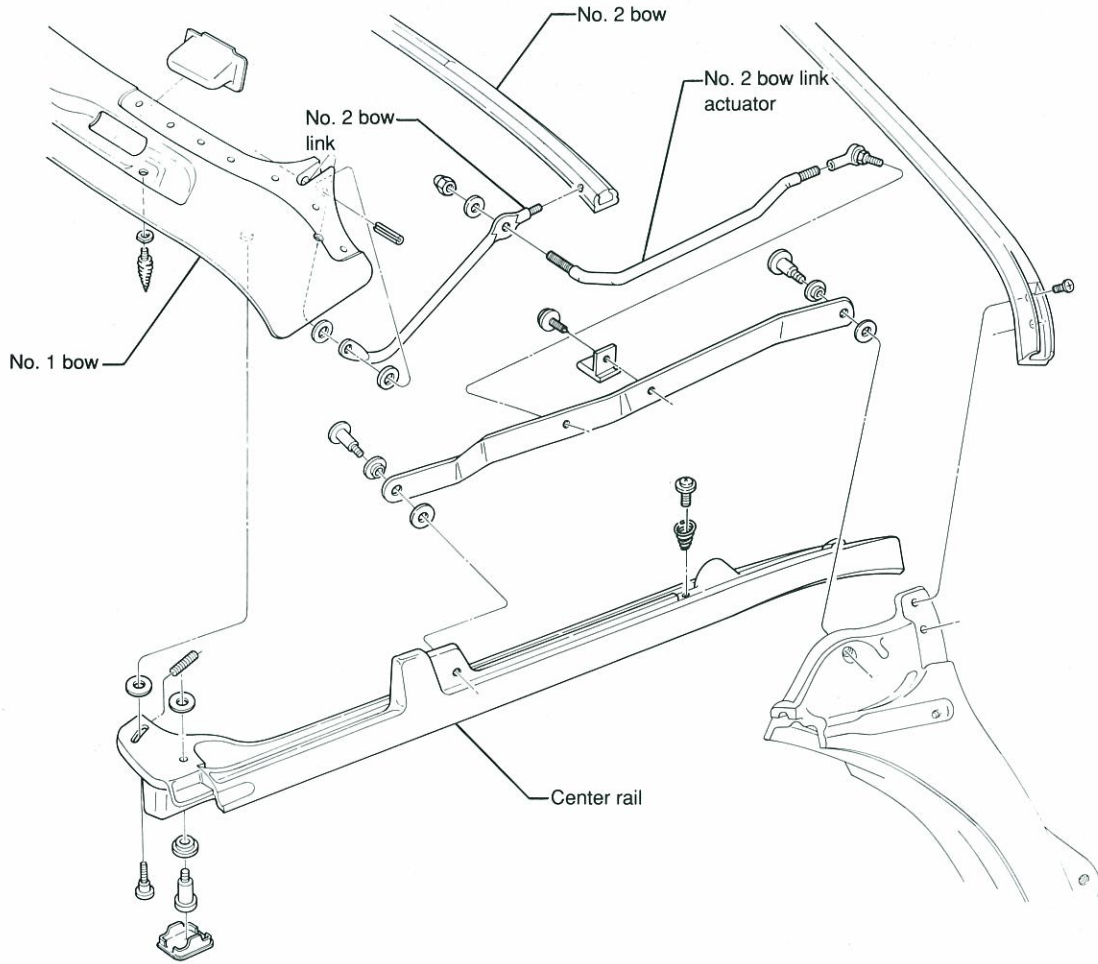

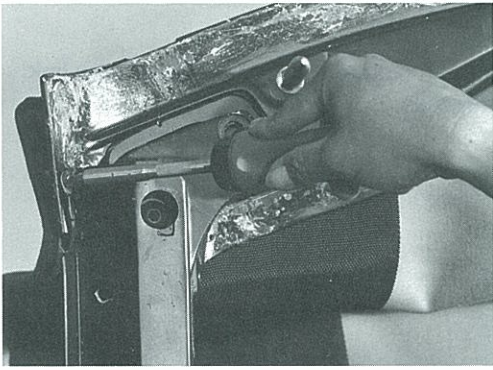

## REMOVAL OF NO. 2 BOW

1. LOWER THE CONVERTIBLE TOP HALFWAY.
2. REMOVE CENTER RAIL WEATHERSTRIP RETAINERS. (See 11-3, step 2)
3. REMOVE HEADLINER FROM NO. 1 AND 2 BOWS. (See 12-4, steps 5 and 6)
4. REMOVE TOP COVER FROM NO. 1 AND 2 BOWS. (See 13-3, steps 5 through 8)
5. DETACH SIDE RETENTION CABLES FROM NO. 1 BOW.

Remove the two (2) screws and detach the side retention cables.

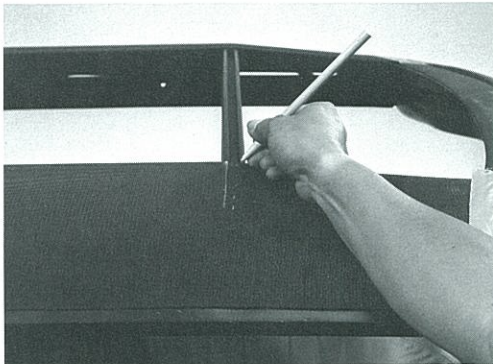

6. MARK REFERENCE POINTS ON SIDE STAY PADS.
  - (a) Raise and secure convertible top.
  - (b) Using a sharpened pencil, accurately mark the location of the No. 2 bow forward and rearward edges on the top side of the stay pads.

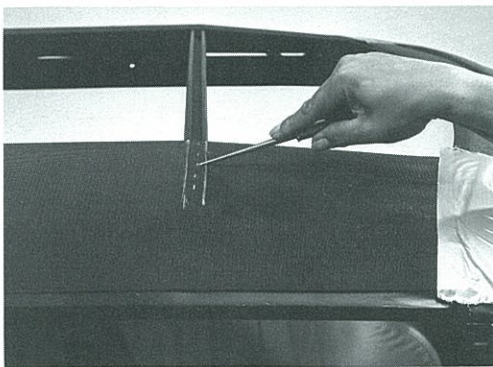

7. DETACH SIDE STAY PADS FROM THE NO. 2 BOW.
 

Using an awl, remove the staples attaching the stay pad to the No.2 bow.

**NOTE: Before removal, note the location and spacing of staples.**

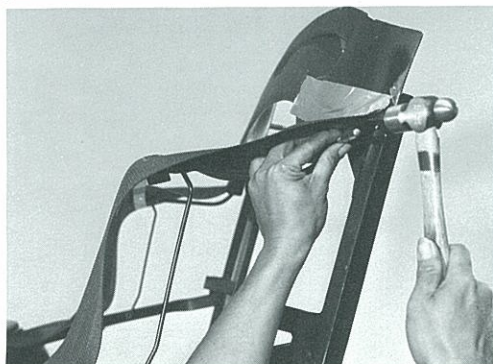

8. REMOVE NO. 2 BOW.
  - (a) Lower the convertible top halfway.
  - (b) Using a punch, remove the two (2) roll pins attaching the No. 2 bow links to the No. 1 bow.

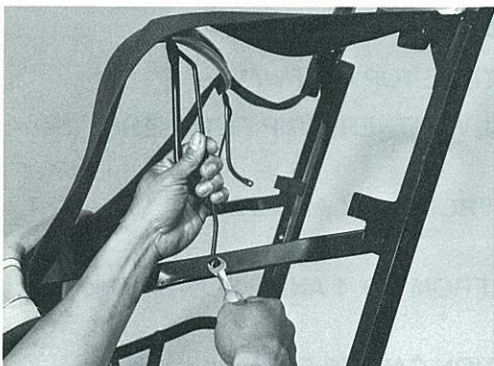

### REMOVAL OF NO. 2 BOW (cont.)

- (c) Remove the nut on each side attaching the No. 2 bow link actuator to the center rails.

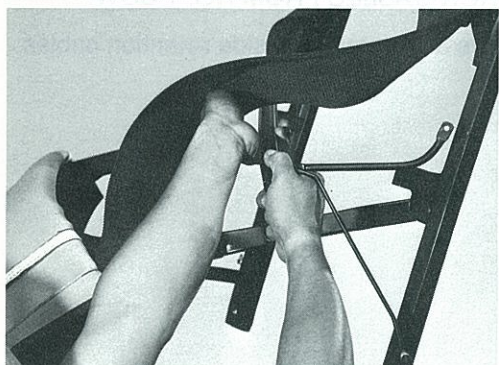

- (d) Remove the No. 2 bow.



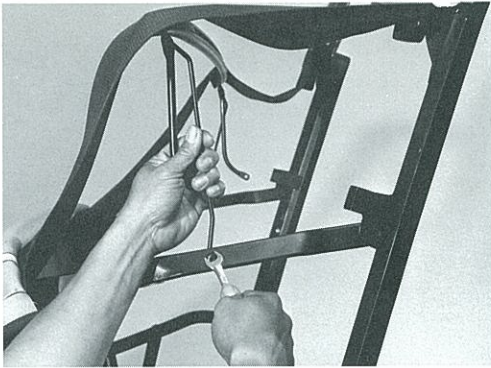

## INSTALLATION OF NO. 2 BOW

### 1. INSTALL NO. 2 BOW.

- (a) Position the No. 2 bow link actuators to the center rails and install the nut on each side.

**Torque: 2.3 N-m (20 in-lb)**

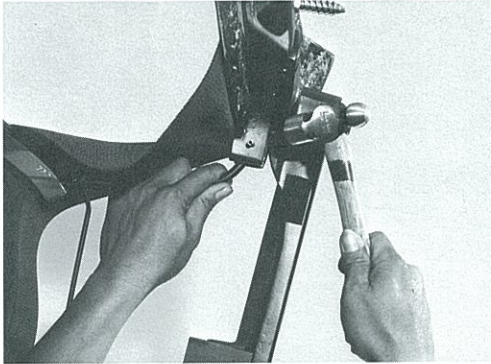

- (b) Position and align the ends of the No. 2 bow links into the No. 1 bow.

- (c) Install the two (2) roll pins.

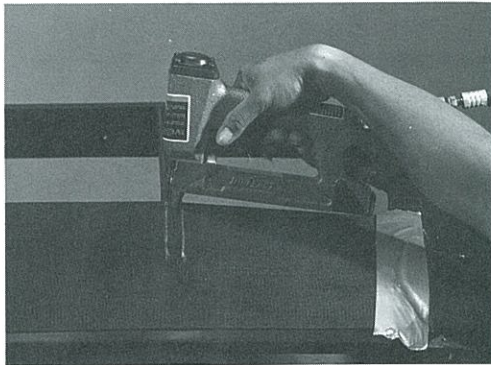

### 2. INSTALL SIDE STAY PADS TO NO. 2 BOW

- (a) Raise and secure the convertible top.
- (b) Position stay pad to No. 2 bow according to reference marks.
- (c) Tack the stay pad to the No. 2 bow.

**NOTE: Use heavy-duty stainless steel staples (.31 x .31) in an air or electric-powered stapler. Do not use a hand-powered stapler. Space between staples must not exceed 1/2" (13 mm).**

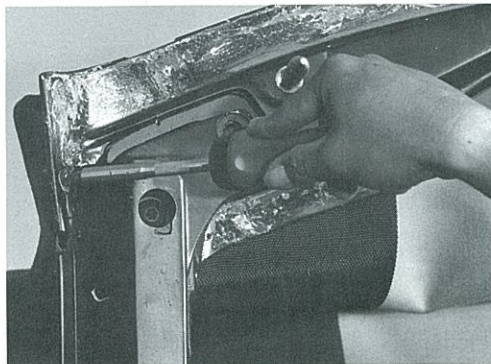

### 3. INSTALL SIDE RETENTION CABLES TO NO. 1 BOW.

- (a) Lower the convertible top halfway.
- (b) Position the end of each retention cable to the No. 1 bow and install the screw to each cable.

**Torque: 5.5 N-m (49 in-lb).**

4. INSTALL TOP COVER TO NO. 1 AND 2 BOWS. (See 13-7, steps 5 through 8)

5. INSTALL HEADLINER TO NO. 1 and 2 BOWS. (See 12-4, steps 1 and 5)

6. INSTALL CENTER RAIL WEATHERSTRIP RETAINERS. (See 11-3, step 2)



---

## NO. 3 BOW

Page

NO.3 BOW - COMPONENTS .....	18-2
REMOVAL OF NO.3 BOW .....	18-3
INSTALLATION OF NO.3 BOW .....	18-4

NO. 3 BOW - COMPONENTS

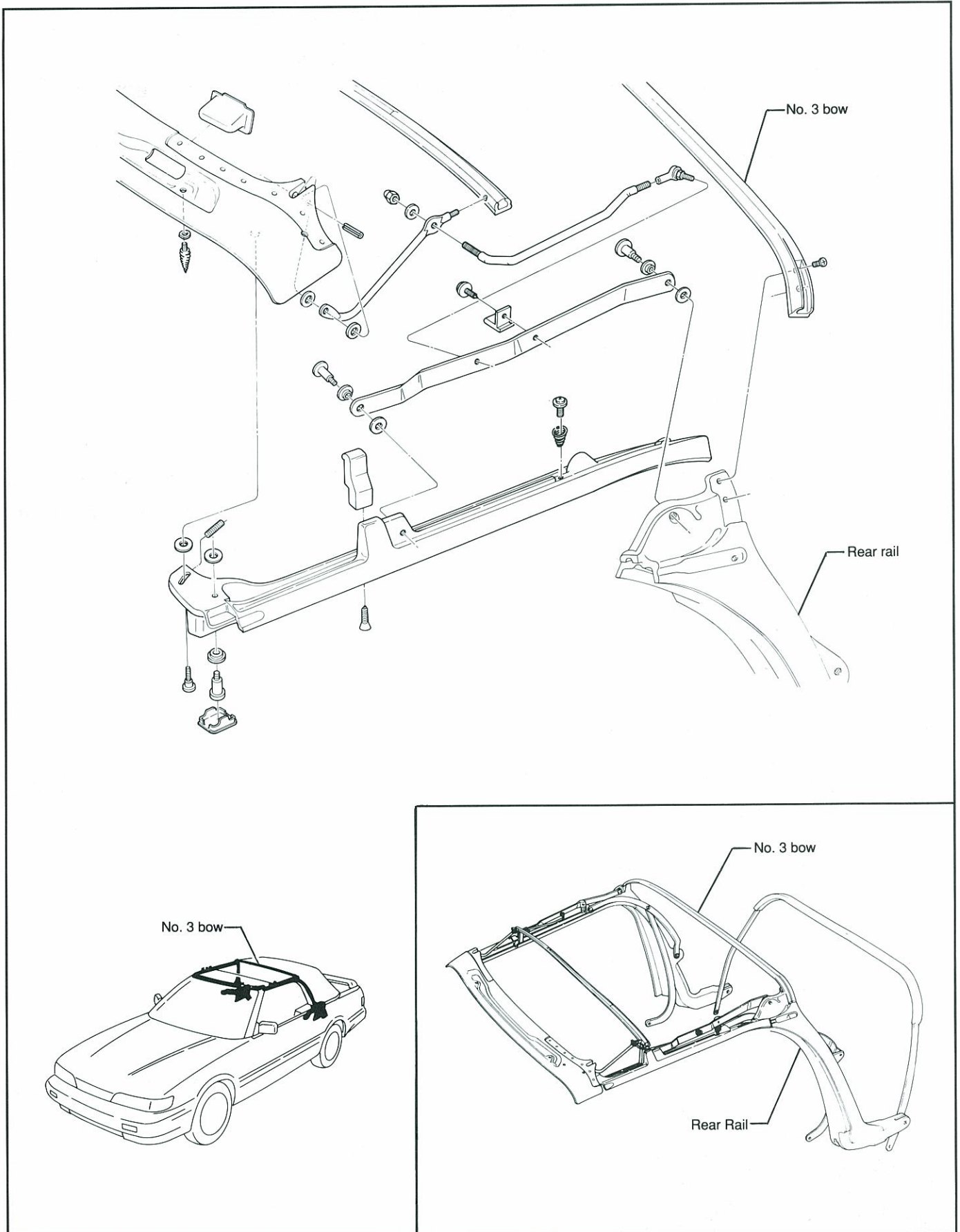

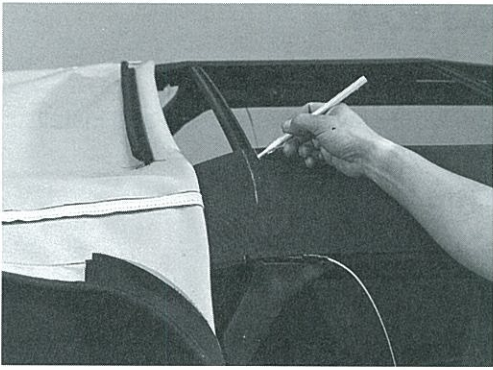

## REMOVAL OF NO.3 BOW

1. LOWER THE CONVERTIBLE TOP HALFWAY.
2. REMOVE CENTER AND REAR RAIL WEATHERSTRIP ASSEMBLIES. (See 11-3 and 11-4)
3. REMOVE HEADLINER FROM NO. 1, 2 AND 3 BOWS. (See 12-4, steps 5 and 6)
4. REMOVE TOP COVER FROM NO. 1, 2 AND 3 BOWS. (See 13-3, steps 5 through 10)
5. MARK REFERENCE POINTS ON SIDE STAY PADS.

Using a sharp pencil, accurately mark the location of the No. 3 bow forward and rearward edges on the top side of each stay pad.

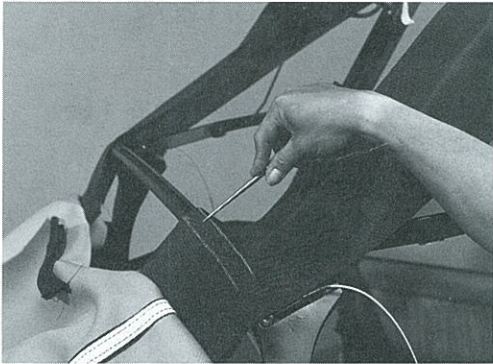

6. DETACH SIDE STAY PADS FROM THE NO. 3 BOW.

Using an awl, remove the staples attaching the stay pads to the No. 3 bow.

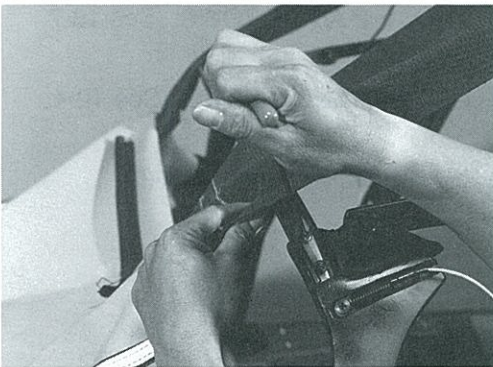

7. REMOVE NO.3 BOW.

- (a) Push the tacking strip upward to expose the No. 3 bow attaching screws and remove the two (2) screws on each side.

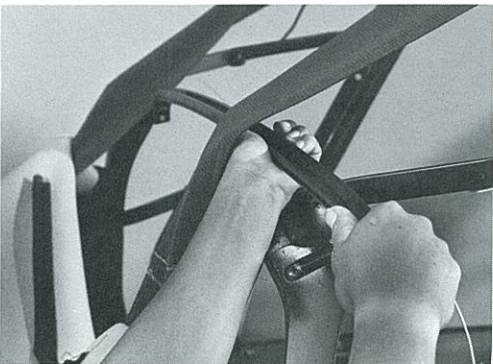

- (b) Remove the No. 3 bow.

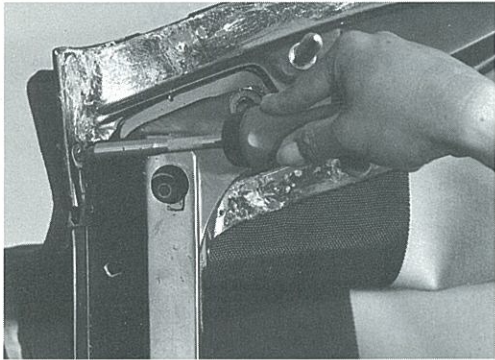
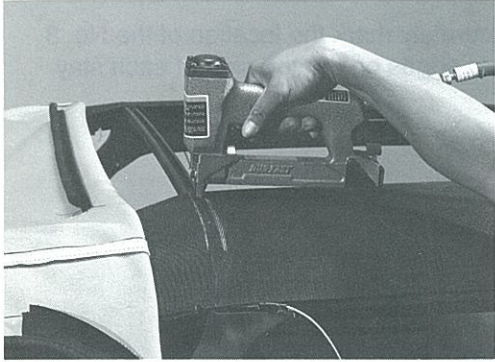

## INSTALLATION OF NO.3 BOW

1. INSTALL NO.3 BOW.
  - (a) Position and align the No.3 bow to the rear rail and install the two (2) screws on each side.
 

**Torque: 11.5 N-m (105 in-lb).**
  - (b) Push the tacking strips into position.
  
2. INSTALL SIDE STAY PADS TO NO. 3 BOW.
  - (a) Raise and secure the convertible top.
  - (b) Position the stay pads to the No. 3 bow according to reference marks.
  - (c) Tack the stay pads to the No. 3 bow.
 

**Note: Use heavy-duty stainless steel staples (.31 x .31) in an air or electric-powered stapler. Do not use a hand-powered stapler. Space between staples must not exceed 1/2" (13mm).**
  
3. INSTALL SIDE RETENTION CABLES TO NO. 1 BOW.
  - (a) Lower the convertible top halfway.
  - (b) Position the end of each retention cable to the No. 1 bow and install the screw to each cable.
 

**Torque: 5.5 N-m (49 in-lb).**
  
4. INSTALL TOP COVER TO NO. 1, 2 AND 3 BOWS. (See 13-7, steps 4 through 8)
5. INSTALL HEADLINER TO NO. 1, 2 AND 3 BOWS. (See 12-4, steps 1 and 5)
6. INSTALL CENTER AND REAR RAIL WEATHERSTRIP ASSEMBLIES. (See 11-1)

---

## NO. 4 BOW

	<b>Page</b>
NO. 4 BOW - COMPONENTS .....	19-2
REMOVAL OF NO. 4 BOW .....	19-3
INSTALLATION OF NO. 4 BOW .....	19-6

NO. 4 BOW - COMPONENTS

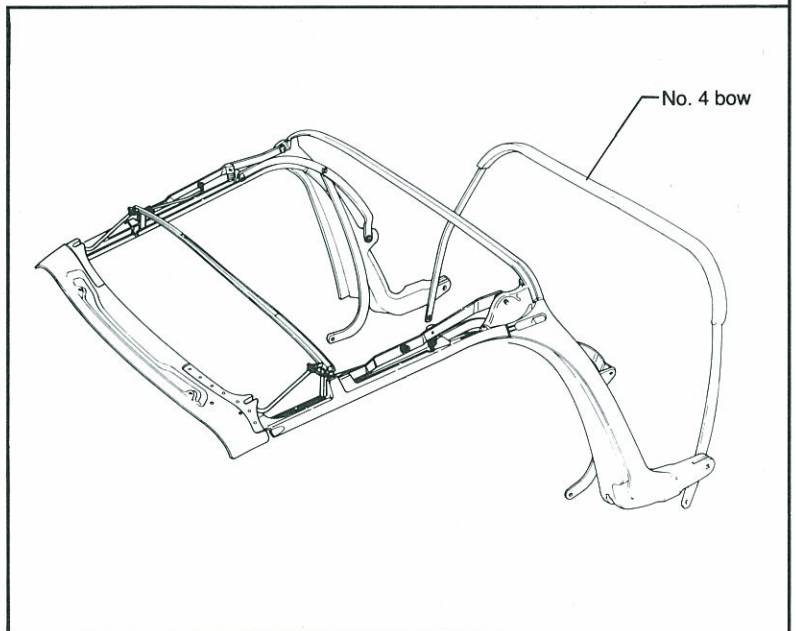
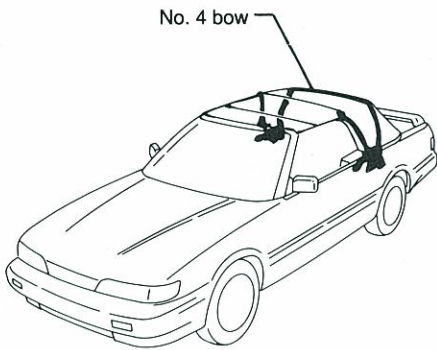
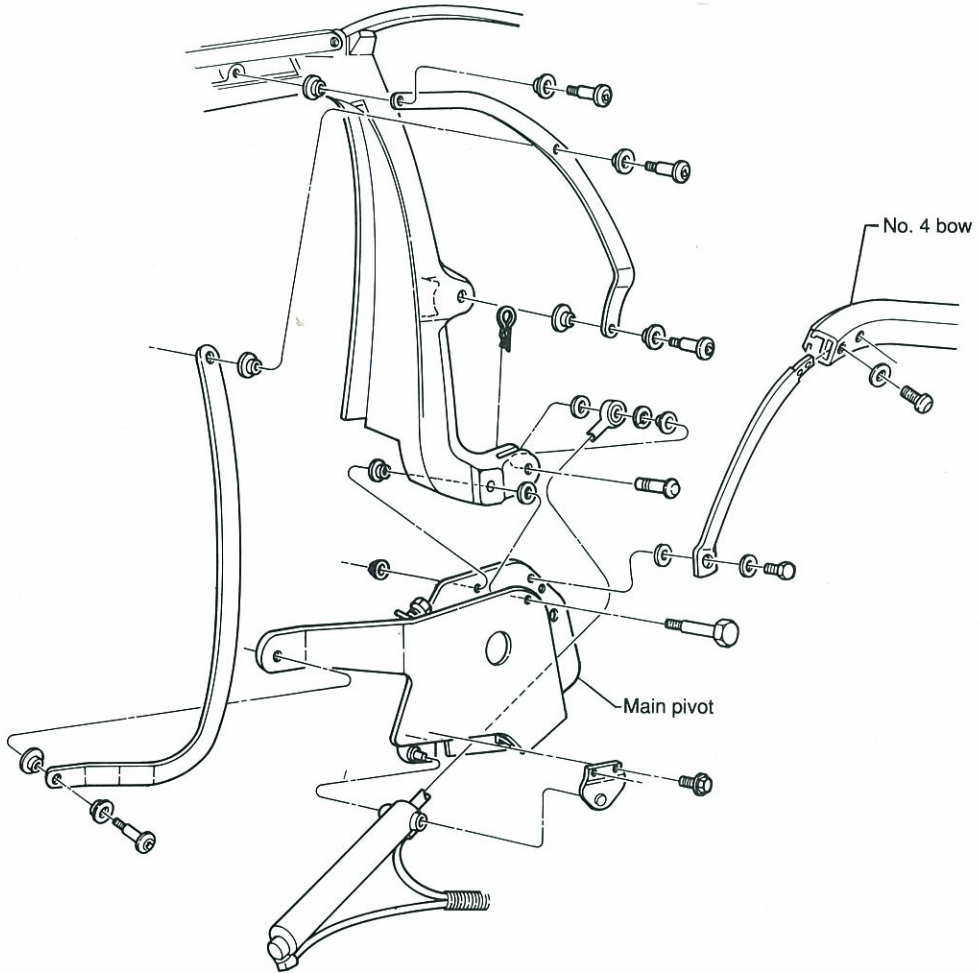



## REMOVAL OF NO. 4 BOW

**NOTE: Carefully tape protective covers to the quarter panel and deck lid to protect the deck lid and the body.**

1. REMOVE QUARTER BELT AND BACK BELT MOLDINGS.  
(See 4-3, steps 1 through 4)
2. REMOVE HEADLINER FROM NO. 4 BOW.  
(See 12-3, steps 1 through 4)
3. MARK REFERENCE POINTS ON TOP COVER AND BACKLITE ASSEMBLIES.

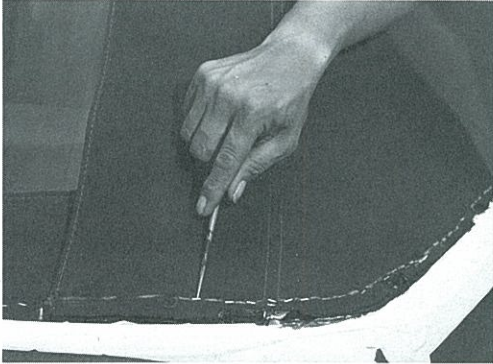

- (a) Using a sharpened pencil, mark the location of the inner vertical edge of the top cover backlite opening on the backlite valance.

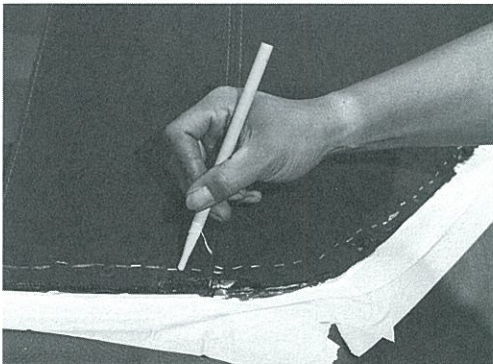

- (b) Mark the location of the tacking strip staples on the top cover. Mark a line along the center of the staples to aid in re-assembly.



4. DETACH TOP COVER FROM TACKING STRIP.

Using an awl, remove staples retaining the top cover to the tacking strip.

**NOTE: Before removal, note location and spacing of staples.**



5. REMOVE TOP COVER FROM NO. 4 BOW.

- (a) Fold top cover (sail panel material) back over the No. 4 bow.
- (b) Remove the No. 4 bow feature strip insert retaining screw.

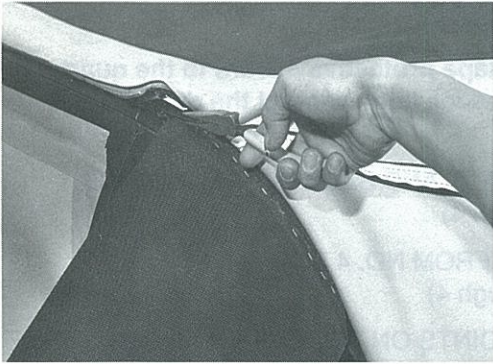
**REMOVAL OF NO. 4 BOW (cont.)**

- (c) Remove the No. 4 bow feature strip insert by pulling the insert out of the No. 4 bow feature strip retainer.

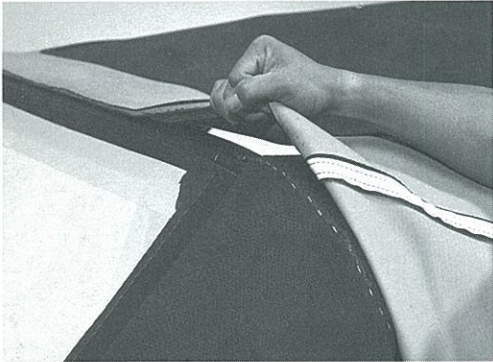

- (d) Detach the top cover feature strip from the No. 4 bow pulling the top cover back over the No. 4 bow to detach it from the No. 4 bow retainer.



6. **MARK REFERENCE POINTS ON REAR AND SIDE STAY PADS.**

- (a) Using a sharpened pencil, mark the location of the rear edge of the No. 4 bow on the top side of the rear stay pads.

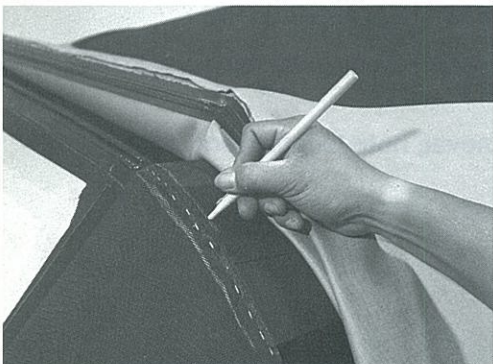

- (b) Using a sharpened pencil, mark the location of the front edge of the No. 4 bow on the top side of the side stay pads.

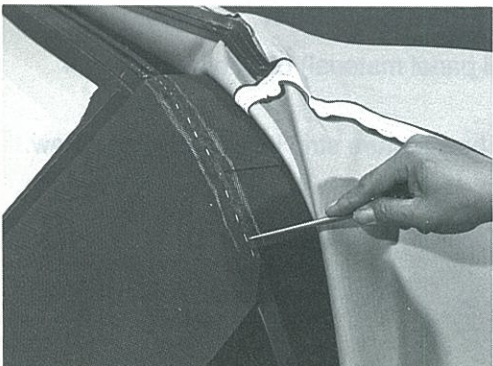

7. **REMOVE REAR AND SIDE STAY PADS FROM NO. 4 BOW.**

- (a) Using an awl, remove staples retaining the rear stay pads to the No. 4 bow.

**NOTE: Before removal, note location and spacing of staples.**

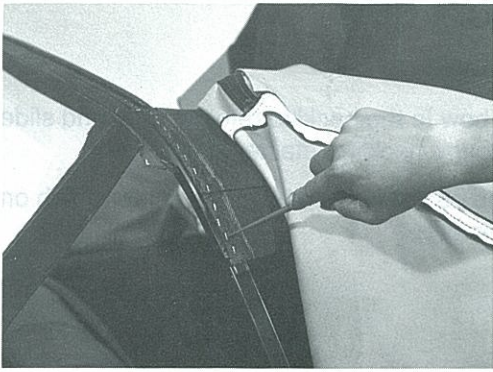

### REMOVAL OF NO. 4 BOW (cont.)

- (b) Using an awl, remove staples retaining the side stay pads to the No. 4 bow.

**NOTE: Before removal, note location and spacing of staples.**

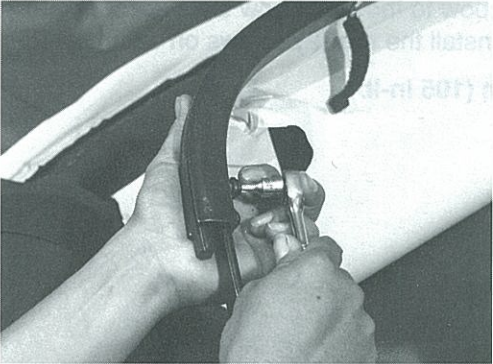

### 8. REMOVE NO.4 BOW.

- (a) Using a sharpened pencil, mark the location of the lower edge of the No. 4 bow on the No. 4 bow slats. This will aid in reassembly.

- (b) Remove the two (2) bolts on each side.

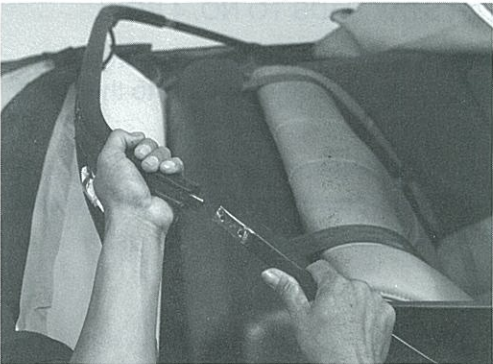

- (c) Disengage the No. 4 bow from the No. 4 slats.



- (d) Remove the No. 4 bow, by sliding the No. 4 bow out of the backlite retainer strip.

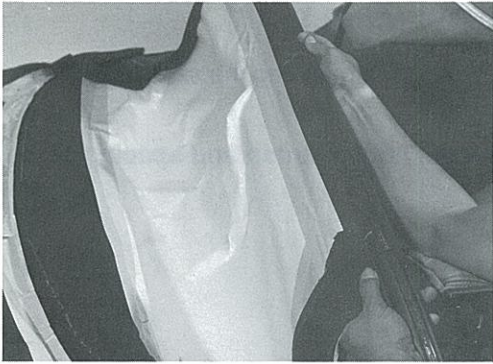

## INSTALLATION OF NO. 4 BOW

### 1. INSTALL THE NO. 4 BOW.

- (a) Position the No. 4 bow to the backlite retainer strip and slide the No. 4 bow on to the backlite retainer strip.
- (b) Align the center line on the No. 4 bow to the center notch on the backlite retainer strip.

- (c) Position the No. 4 bow to the No. 4 bow slats according to reference marks. Install the two (2) screws on each side.

**Torque: 11.5 N-m (105 in-lb).**

### 2. INSTALL SIDE AND REAR STAY PADS TO NO. 4 BOW.

- (a) Position the side stay pads to the No. 4 bow according to reference marks and staple the side stay pads to the No. 4 bow.

**NOTE: Use heavy-duty stainless steel staples (.31 x .31) in an air or electric-powered stapler. Do not use a hand-powered stapler.**

- (b) Position the rear stay pads to the No. 4 bow according to reference marks and staple the rear stay pads to the No. 4 bow.

### 3. INSTALL TOP COVER TO NO. 4 BOW.

- (a) Fold top cover (rear sail material) back over the No. 4 bow.
- (b) Position and align the center notch on the top cover feature strip to the center line on the No. 4 bow.
- (c) Engage the top cover feature strip to the No. 4 bow feature strip retainer.

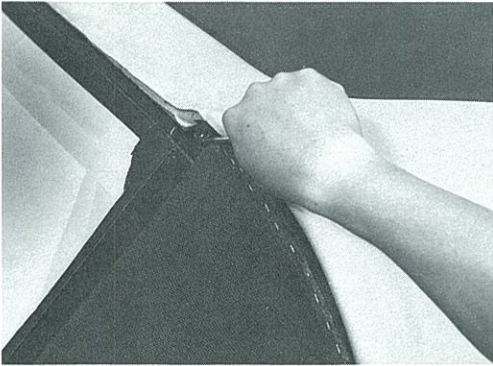

### INSTALLATION OF NO. 4 BOW (cont.)

- (d) Install the No. 4 bow feature strip insert into the No. 4 bow feature strip retainer.

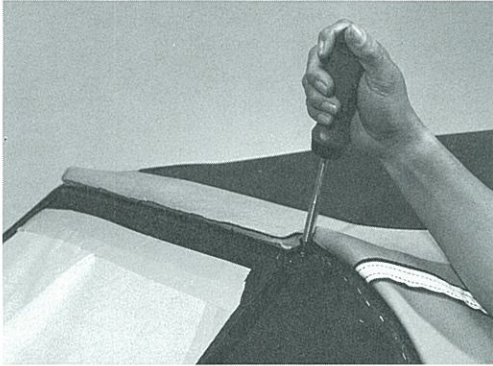

- (e) Install the No. 4 bow feature strip insert retaining screw.

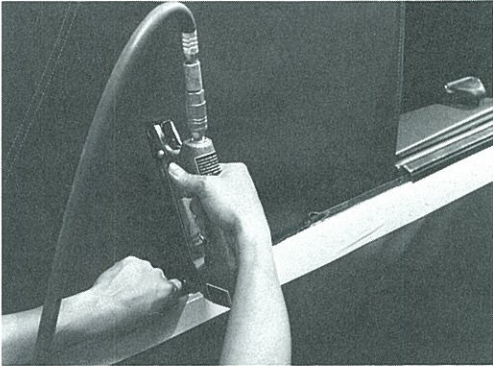

#### 4. INSTALL TOP COVER TO TACKING STRIP.

- (a) Position and locate top cover to tacking strip according to reference marks.
- (b) Tack the top cover to the tacking strip, starting at the top cover seam working forward to the end of the tacking strip.



- (c) Then, tack from the rearward seam to the top cover backlite opening.

#### 5. INSTALL QUARTER BELT AND BACK BELT MOLDINGS. (See 4-4, steps 1 and 2)

#### 6. INSTALL HEADLINER TO NO. 4 BOW. (See 12-4, steps 2 through 4)



# DECK LID SPOILER AND HIGH MOUNT STOP LIGHT

	Page
DECK LID SPOILER AND HIGH MOUNT STOP LIGHT - COMPONENTS .....	20-2
REMOVAL OF HIGH MOUNT STOP LIGHT .....	20-3
INSTALLATION OF HIGH MOUNT STOP LIGHT .....	20-3
REMOVAL OF DECK LID SPOILER .....	20-4
INSTALLATION OF DECK LID SPOILER .....	20-5

DECK LID SPOILER AND HIGH MOUNT STOP LIGHT - COMPONENTS

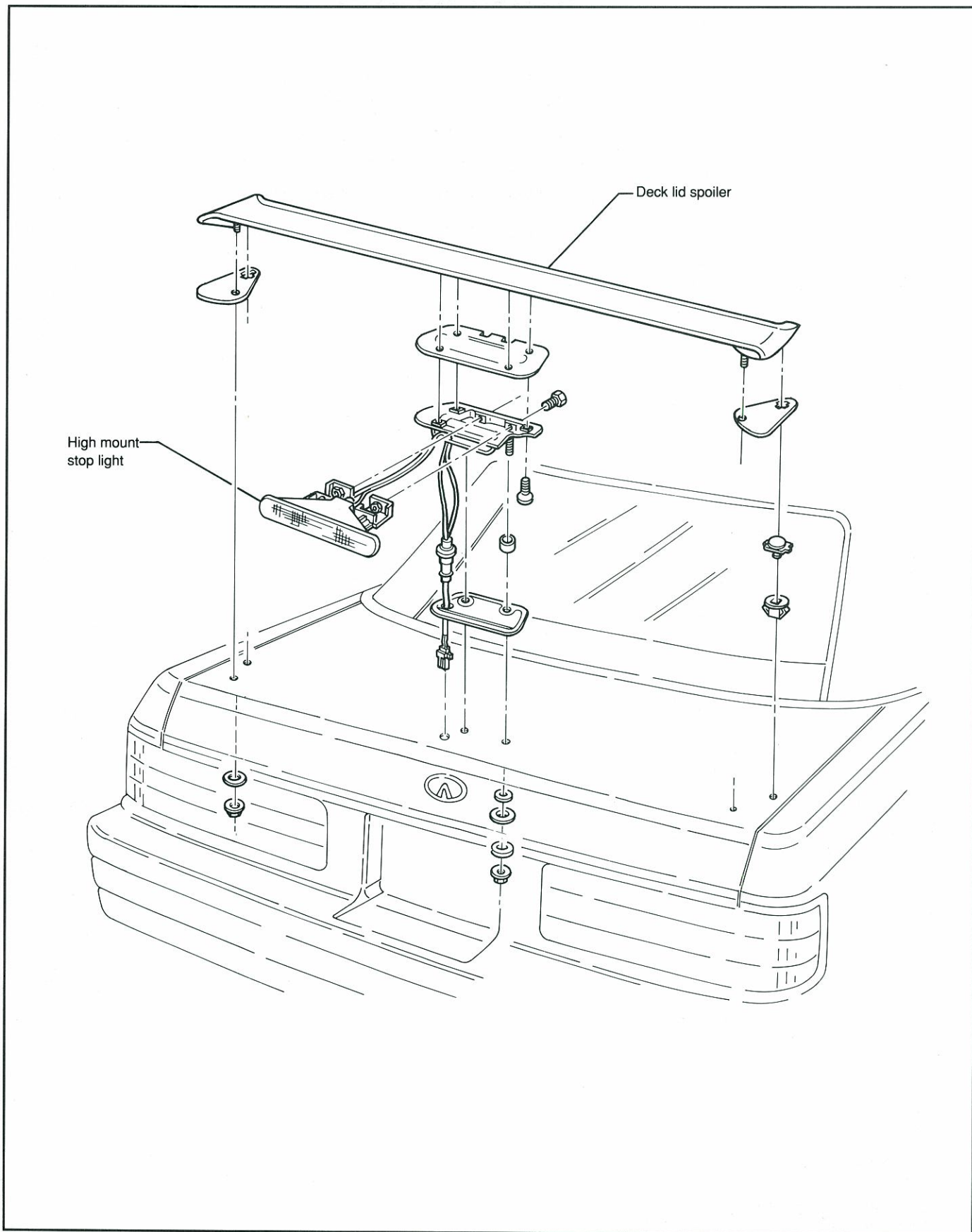



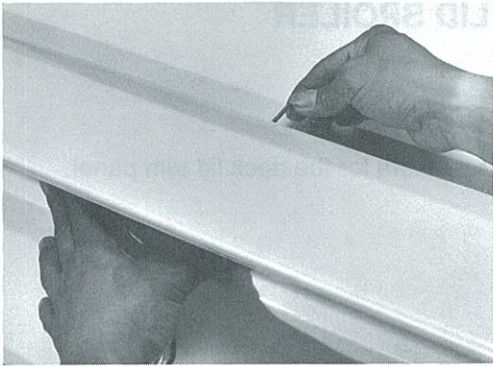

## REMOVAL OF HIGH MOUNT STOP LIGHT

### 1. REMOVE HIGH MOUNT STOP LIGHT

- (a) Remove the two (2) screws.

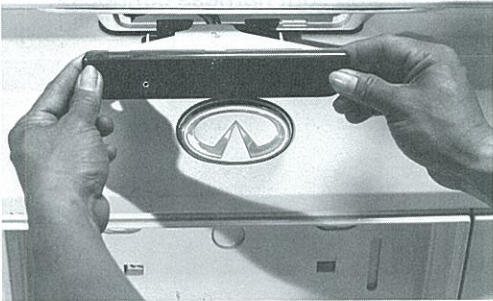

- (b) Remove the high mount stop light.



- (c) Disconnect the harness connector.



## INSTALLATION OF HIGH MOUNT STOP LIGHT

### 1. INSTALL HIGH MOUNT STOP LIGHT

- (a) Re-connect the harness connector.



- (b) Position the high mount stop light and install the two (2) screws.

**Torque: 4.5 N-m (40 in-lb).**

**REMOVAL OF DECK LID SPOILER**

1. OPEN DECK LID

2. REMOVE THE DECK LID TRIM PANEL

Remove the fifteen (15) fasteners for the deck lid trim panel.

3. REMOVE DECK LID SPOILER

- (a) Disconnect the high mount stop light harness connector.

- (b) Remove the four (4) nuts.

- (c) Close the deck lid.

- (d) Detach the deck lid spoiler from the deck lid by pulling up.

- (e) Pull the high mount stop light harness through the hole in the deck lid and remove the deck lid spoiler.

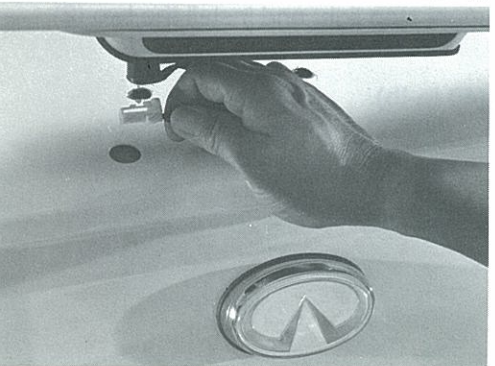
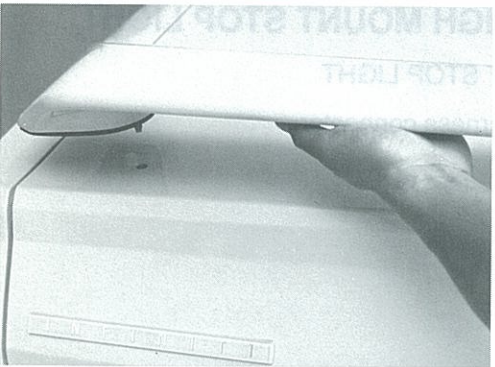
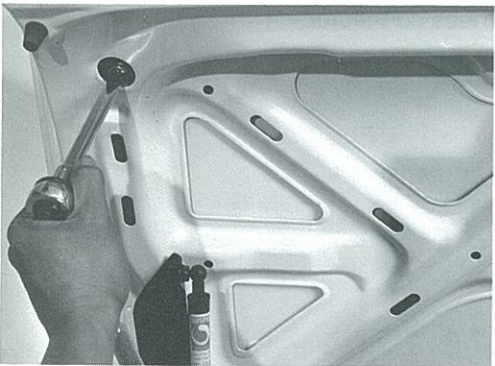
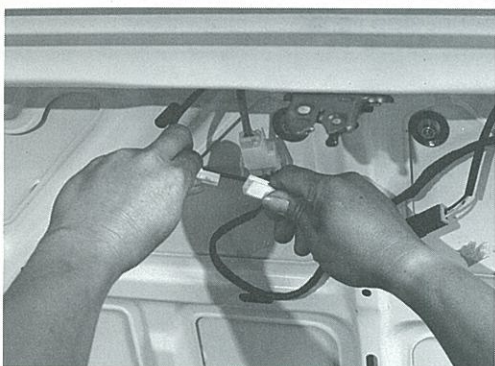
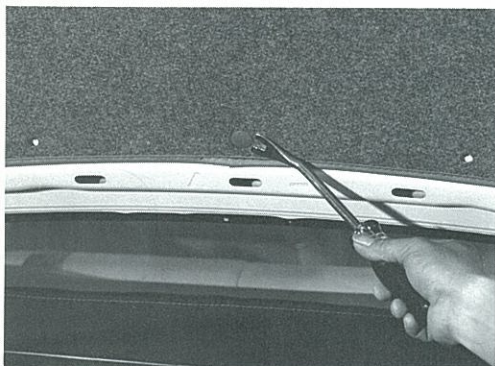

## INSTALLATION OF DECK LID SPOILER

### 1. INSTALL THE DECK LID SPOILER

- (a) Push the high mount stop light harness through the hole in the deck lid.
- (b) Position the deck lid spoiler over the retainers in the deck lid and push down firmly.
- (c) Open the deck lid.
- (d) Install the four (4) nuts.  
**Torque: 11.5 N-m (105 in-lb).**

- (e) Re-connect the high mount stop light harness connector.

### 2. INSTALL THE DECK LID TRIM PANEL

Position the trim panel and install the fifteen (15) fasteners.

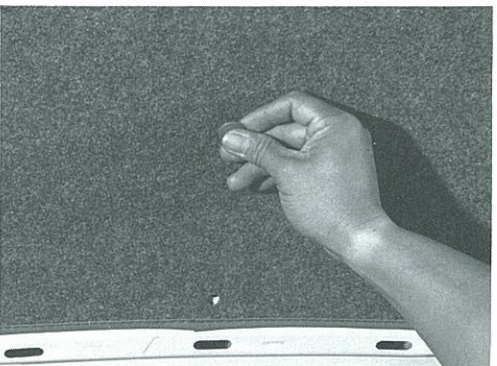
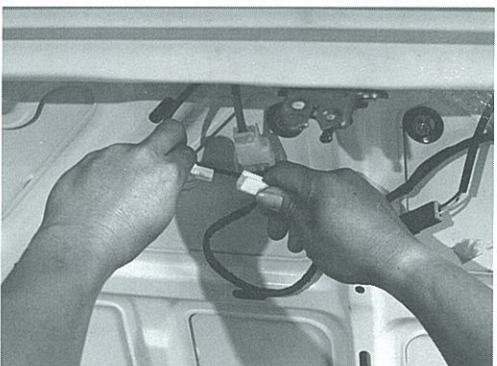
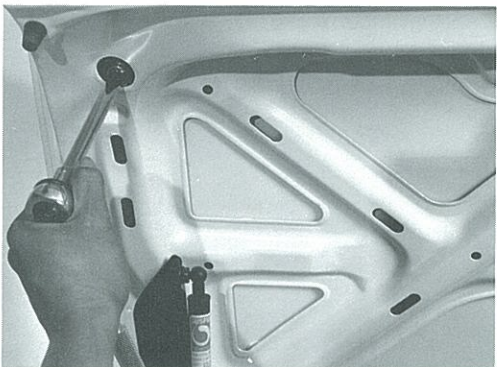
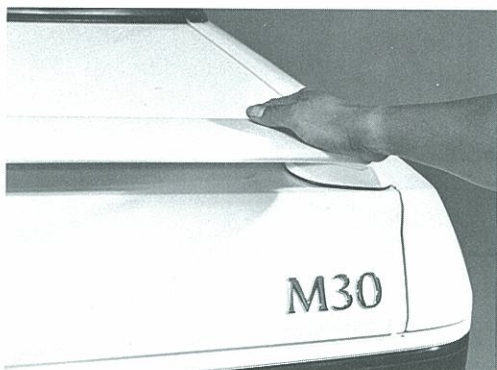
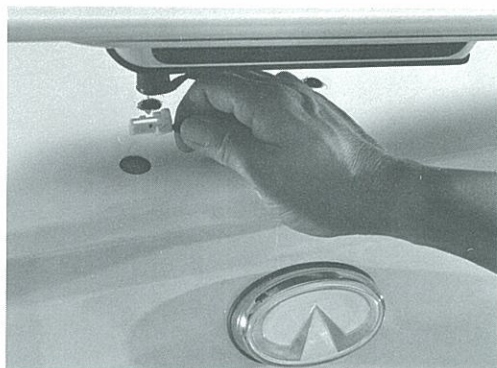



# DECK LID, HINGES

	Page
DECK LID, HINGES - COMPONENTS .....	21-2

DECK LID, HINGES - COMPONENTS

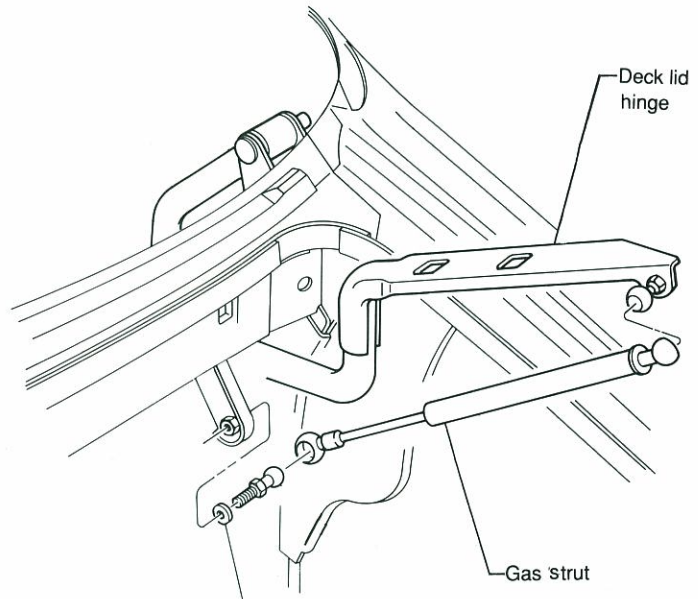
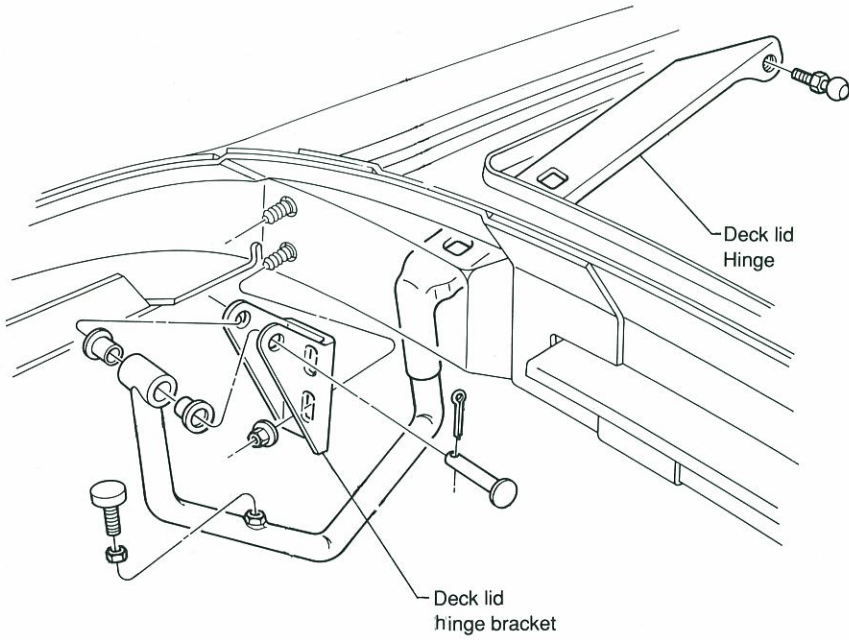

---

# HYDRAULIC SYSTEM, PUMP/ MOTOR CYLINDERS

	Page
HYDRAULIC SYSTEM, PUMP/MOTOR CYLINDERS - COMPONENTS .....	22-2
HYDRAULIC SYSTEM THEORY OF OPERATION .....	22-3
REMOVAL OF HYDRAULIC PUMP/MOTOR ASSEMBLY .....	22-5
INSTALLATION OF HYDRAULIC PUMP/MOTOR ASSEMBLY .....	22-6
HYDRAULIC SYSTEM CHECKING PROCEDURE .....	22-8
HYDRAULIC CYLINDER BLEEDING PROCEDURE .....	22-10
REMOVAL OF TOP STACK HYDRAULIC CYLINDER .....	22-13
INSTALLATION OF TOP STACK HYDRAULIC CYLINDER .....	22-16
HYDRAULIC SYSTEM DIAGNOSTIC FLOW CHART .....	22-17

HYDRAULIC SYSTEM, PUMP/MOTOR AND CYLINDERS - COMPONENTS

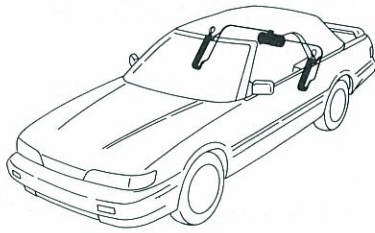

Hydraulic pump motor

Manual release valve

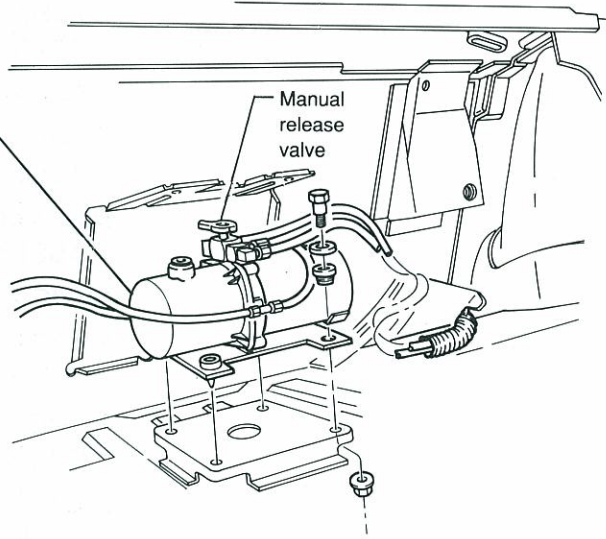

Hydraulic cylinder

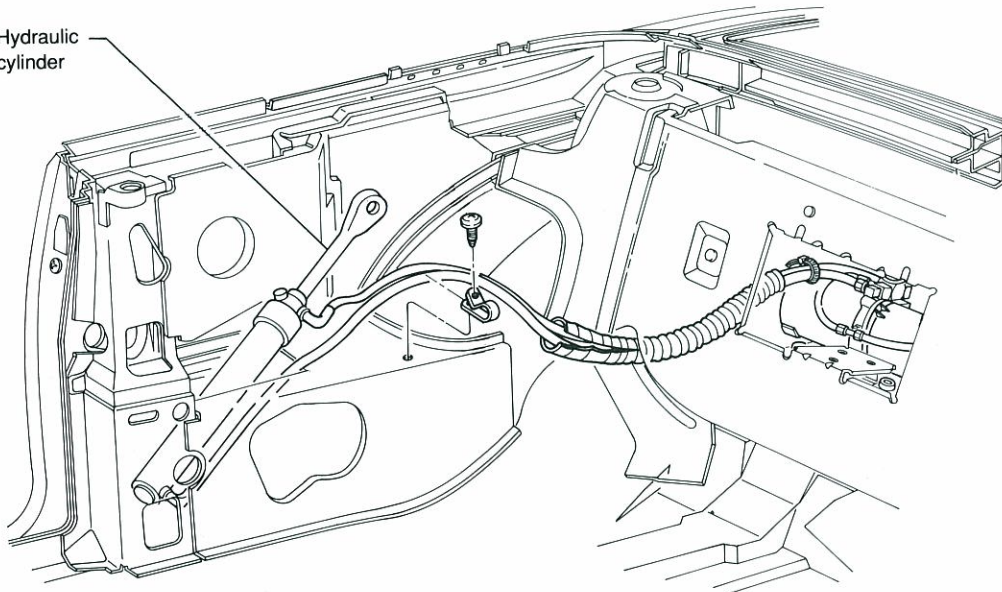



**THEORY OF OPERATION**

The convertible top installed in this vehicle is hydraulically-operated. This system consists of an electric motor/pump/reservoir assembly, two double-acting hydraulic cylinders and connecting lines. Integrated into the hydraulic's electrical system are electronic timers, switches, sensors and control devices.

**MANUAL RELEASE VALVE**

The hydraulic pump/motor assembly is equipped with a manual release valve. During normal operation of the top the valve must remain fully closed in order for hydraulic pressure to be applied to the top stack hydraulic cylinders which operate the convertible top (See Fig. 22-1).

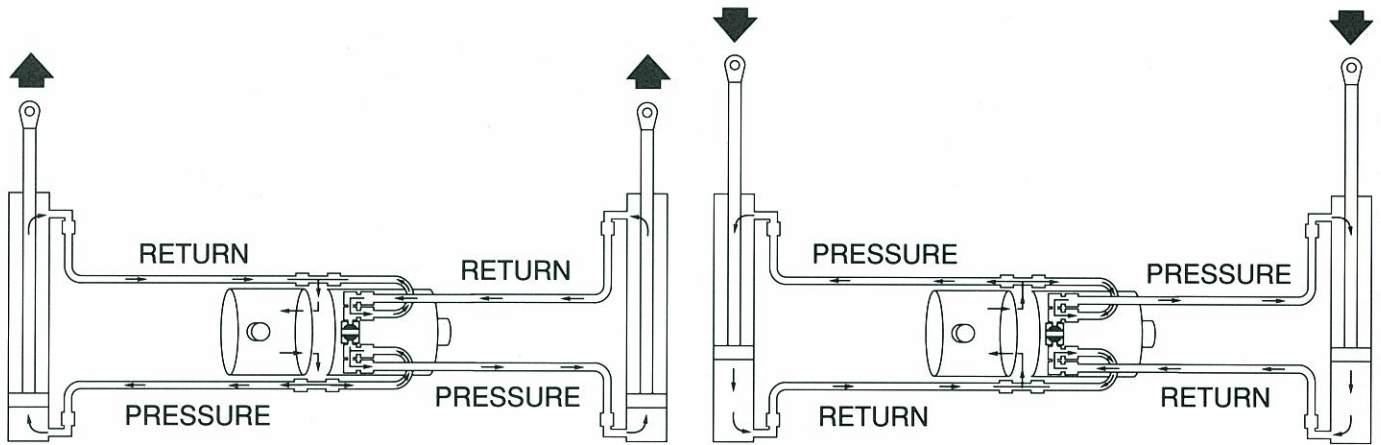

Fig. 22-1

The function of the manual release valve is to allow hydraulic fluid to bypass the pump. In the event of a mechanical or electrical malfunction or failure, the valve can be placed in the "open" position. This will reduce back pressure, allowing the hydraulic fluid in the cylinders and in the system to return to the reservoir when the top is raised or lowered manually (See Fig.22-2).

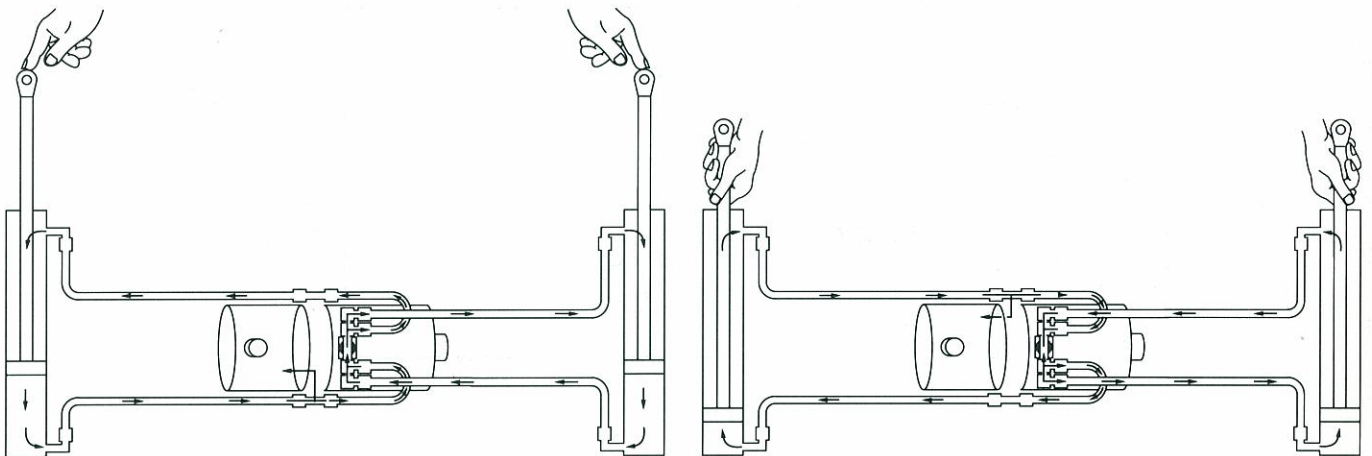

Fig. 22-2

**THEORY OF OPERATION (cont.)**

When the manual release valve is placed in the "open" position and the pump is activated, the valve diverts hydraulic fluid from the pressure side to the return side of the pump. As a result, the fluid is recirculated and no pressure is generated to operate the convertible top (See Fig. 22-3).

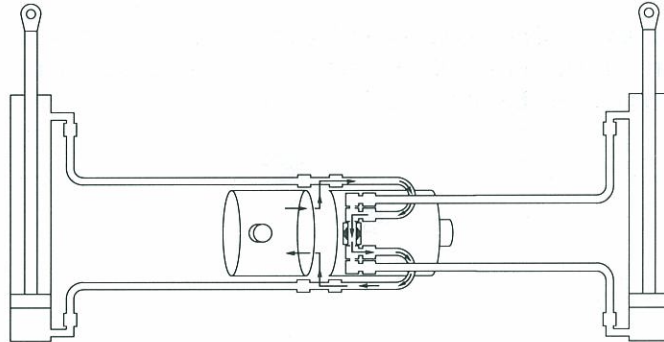

Fig. 22-3

**CAUTION:** If the vehicle battery is discharged and the top is raised and secured, the top cannot be released and lowered automatically (electrically). The battery must be fully-charged or the car must be started (with a functioning charging system) to release and lower the convertible top automatically. If the battery can neither be charged nor the car started or another malfunction has occurred, the top can be released manually. The windshield header garnish must be removed to gain access to the power pull down actuators (See 1-3).

To release the power pull down actuators, insert a 8mm allen wrench and turn clockwise one-eighth turn (See Fig. 22-4).

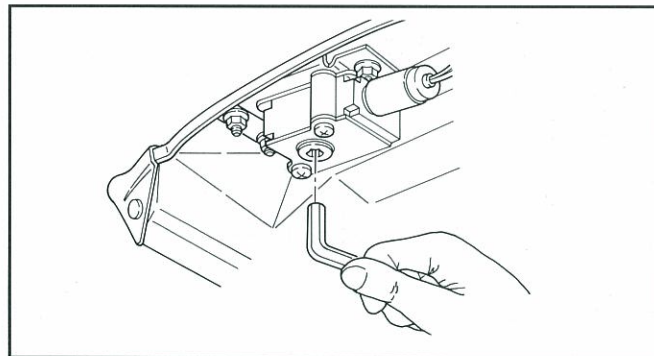
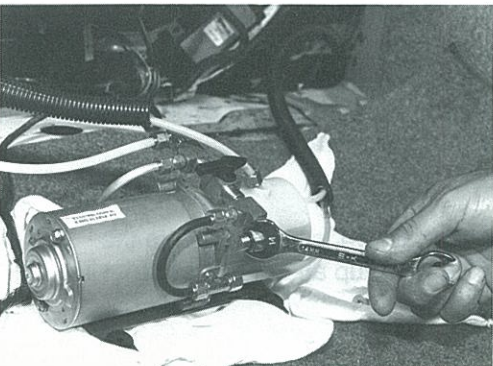
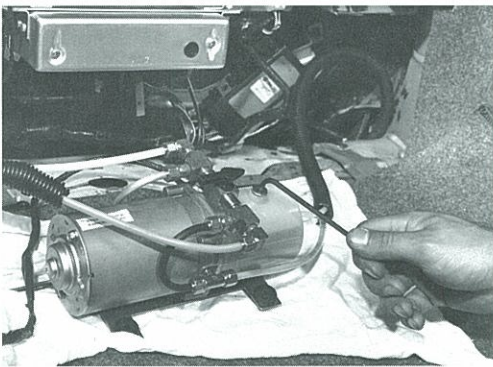
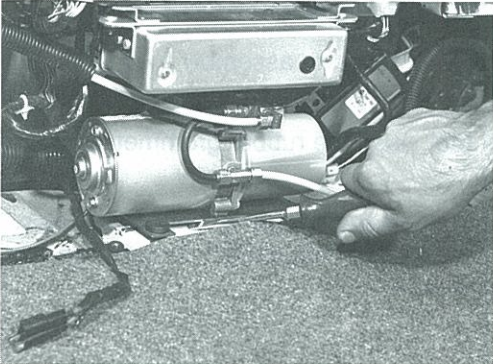
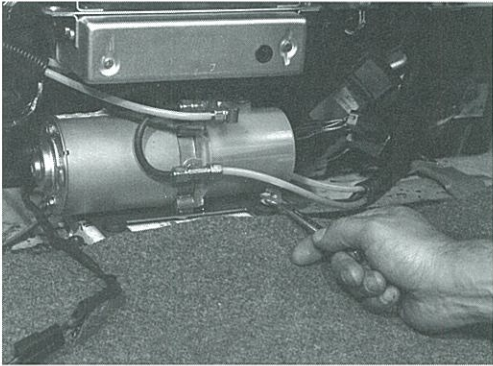
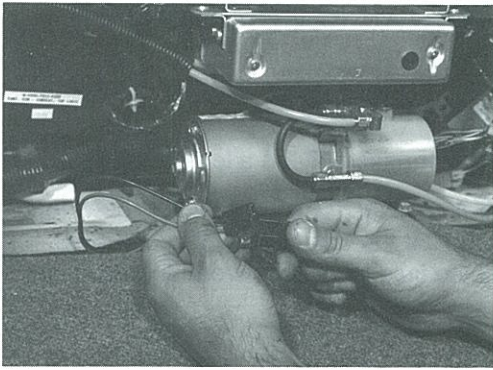

Fig. 22-4



## REMOVAL OF HYDRAULIC PUMP/MOTOR ASSEMBLY

1. RAISE THE CONVERTIBLE TOP.
2. OPEN THE DECK LID.
3. LIFT UP THE SHOCK TOWER BRACE COVER TO REVEAL THE HYDRAULIC PUMP/MOTOR ASSEMBLY.
4. REMOVE THE HYDRAULIC PUMP/MOTOR ASSEMBLY.

- (a) Disconnect the harness connector.
- (b) Remove the retaining bolt from the pump/motor.

- (c) Using a screwdriver, pry up the hydraulic pump/motor assembly from the mounting bracket to remove. Then move the hydraulic pump/motor assembly rearward.

**CAUTION:** Take care not to kink the hydraulic lines.

- (d) Vent the reservoir by removing and then re-installing the filler plug.

**NOTE:** Venting the reservoir relieves any air pressure, reducing the possibility of hydraulic fluid being forced out when disconnecting the lines.

- (e) Disconnect the hydraulic lines from the pump/motor assembly and cap the open fittings to prevent leakage of fluid. Then remove the pump/motor assembly.

**NOTE:** Before removal, label the position of each hydraulic line.

**CAUTION:** Place a cloth under pump/motor assembly when disconnecting hydraulic lines to absorb any leaking fluid. Observe proper safety precautions when handling this oil as with other motor oils.

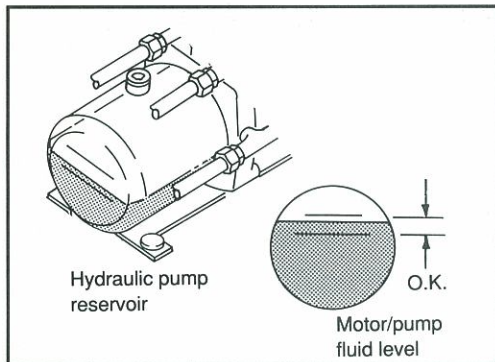

## INSTALLATION OF HYDRAULIC PUMP/MOTOR ASSEMBLY

1. CHECK THE RESERVOIR FLUID LEVEL.
  - (a) Position the pump/motor assembly on a level surface.
  - (b) Check the reservoir fluid level. If the fluid level is between the two marks, it is O.K. If the fluid level is low add SAE 10W motor oil until the fluid level is between the two fluid level marks.
2. CONNECT THE HYDRAULIC LINES TO THE PUMP/MOTOR ASSEMBLY.
 

Observing the labels, install the hydraulic lines to the pump/motor assembly.

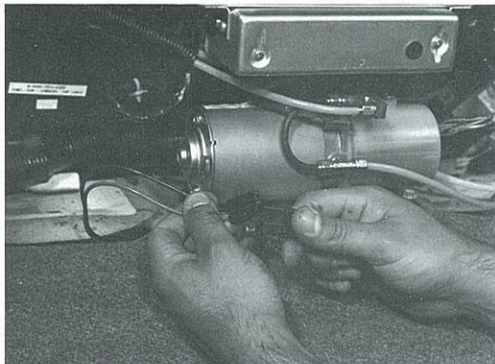
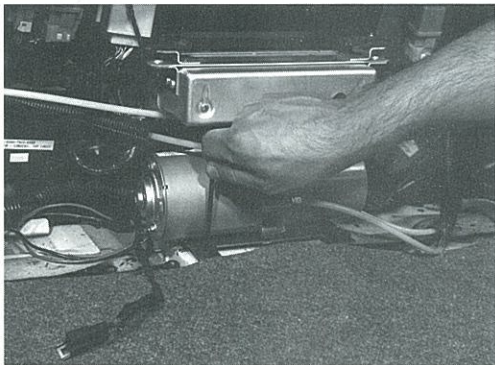
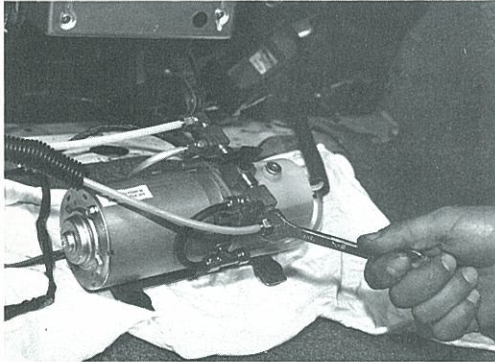

3. INSTALL THE HYDRAULIC PUMP/MOTOR ASSEMBLY.
  - (a) Position and align the pump/motor assembly over the mounting bracket.
  - (b) Using a small blunt tool, push the rubber grommets into the mounting bracket.
 

**NOTE: To make installing the rubber grommets easier, wet the pointed ends with water. Do not use any type of lubricants.**
  - (c) Re-install the retaining bolt.  
**Torque: 15N-m (11 ft-lb)**
  - (d) Connect the harness connector.

4. CHECK THE HYDRAULIC SYSTEM.
  - (a) Close the deck lid.
 

**NOTE: The deck lid must be closed in order for the convertible top to operate.**
  - (b) Using the "Top Up" "Top Down" switch, operate the convertible top through one "up and down" cycle.

### INSTALLATION OF HYDRAULIC PUMP/MOTOR ASSEMBLY (cont.)

- (c) Open the deck lid.
- (d) Check the hydraulic system for leaks.
- (e) Check the reservoir fluid level.
- (f) Close the deck lid.
- (g) Operate the top through two more "up and down" cycles.
- (h) Open the deck lid.
- (i) Check the hydraulic system for leaks.
- (j) Close the deck lid.
- (k) Operate the convertible top "up and down" at least five (5) more times to bleed the hydraulic system of air bubbles.

**NOTE:** The presence of air bubbles still in the system can be identified. Observe the pump reservoir for aerated (foamed) oil and/or erratic surging of the hydraulic pump motor combined with sluggish or uncoordinated action of the convertible top. Aerated oil must be allowed to settle. After the oil has settled, vent the pump reservoir, then repeat steps (f) through (k). If air still remains in the system, see HYDRAULIC CYLINDER.

**CAUTION:** Any air trapped in the system may cause severe major operational problems and possible damage to the top stack mechanism or pump.

## HYDRAULIC SYSTEM CHECKING PROCEDURE

Hydraulic system failure may be caused by the lack of hydraulic fluid (motor oil) leaks in the hydraulic system, obstructions or kinks in the hydraulic lines or faulty operation of a cylinder or the pump/motor.

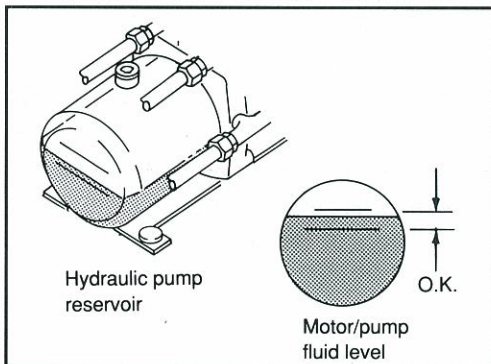
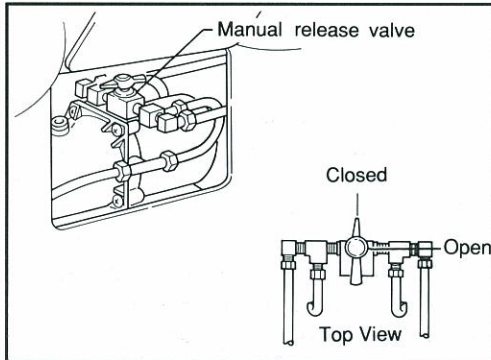

### CHECKING OF THE HYDRAULIC FLUID LEVEL IN THE RESERVOIR

1. MAKE SURE THE VEHICLE IS PARKED ON A LEVEL SURFACE.
2. CHECK THE HYDRAULIC FLUID LEVEL.
  - (a) Open the deck lid.
  - (b) Lift up the access door in the shock tower brace cover.
  - (c) Make sure the manual release valve is in the "closed" position.
  - (d) Check the reservoir fluid level. If the fluid level is between the two marks, it is O.K. If the fluid level is low add SAE 10W motor oil until the fluid level is between the two fluid level marks.

**CAUTION:** Observe proper safety precautions when handling this oil as with other motor oils.

### CHECKING THE OPERATION OF THE HYDRAULIC CYLINDERS

**NOTE:** To insure proper operation of the hydraulic cylinders the hydraulic cylinder rods should be cleaned and lubricated on a regular basis. To perform this operation, raise the top to its "up" position and detach the headliner retainers. Wipe the exposed portion of each rod with a cloth dampened with a high grade, light industrial white mineral oil to remove any oxidation (rust) and/or accumulation of grime. Rusted or dirty cylinder rods will damage the cylinder seals.

**CAUTION:** Exercise care so that cleaning fluid does not come in contact with any trim or painted parts of car. Observe proper safety precautions when using this fluid as with other chemicals.

## HYDRAULIC SYSTEM CHECKING PROCEDURE (cont.)

1. Operate the top "up and down" several times and observe the top for uncoordinated or sluggish operation.
2. If the top does not operate properly, check the hydraulic lines from the pump/motor to the cylinders for kinks or leaks in the hydraulic lines.

**NOTE: To check the hydraulic lines; the rear seat and quarter trim panels must be removed (see Sections 5 and 6).**

3. If the top still does not operate properly, both cylinders must be detached from the top stack mechanism (see 22-13, Steps 1-6c). Using the "TOP UP" "TOP DOWN" switch, retract and extend the hydraulic cylinders several times.
4. If one cylinder moves slower than the other and the hydraulic lines are free of kinks and leaks, then the cylinder having the slower moving rod may be defective or air may be trapped in the system. If air is in the system, see "Hydraulic Cylinder Bleeding Procedure," Section 22-10.
5. Once the trapped air has been bled and the system still does not operate properly; the defective cylinder must be replaced, see "Removal of Top Stack Hydraulic Cylinder," Section 22-13.

## HYDRAULIC CYLINDER BLEEDING PROCEDURE

**CAUTION:** While performing the following steps, do not allow the fluid level in the reservoir to drop lower than the bottom line on the end of the reservoir, as an excessive amount of air will be drawn into the system. Fill the reservoir, as needed, to insure that the proper fluid level is maintained.

1. REMOVE THE QUARTER TRIM PANELS (See 6-3).
2. DETACH BOTH HYDRAULIC CYLINDERS FROM THE TOP MECHANISM.

(a) Remove the cotter pins.

(b) Remove the cylinder connecting pins.

(c) Remove the two (2) bolts attaching the main pivot bracket extension plates to remove the cylinders.

**CAUTION:** Make sure that the cylinders are placed clear of any components that could be damaged when the cylinder rods extend and retract.

3. DETACH HYDRAULIC LINES FROM BODY STRUCTURE.

Remove the screw attaching the plastic hose clip and detach the hydraulic lines.

4. PLACE ABSORBENT RAGS UNDER THE PUMP ASSEMBLY.
5. DISCONNECT THE PINK-COLORED UPPER HYDRAULIC LINE AT THE PUMP.

(a) Remove the filler plug from the reservoir.

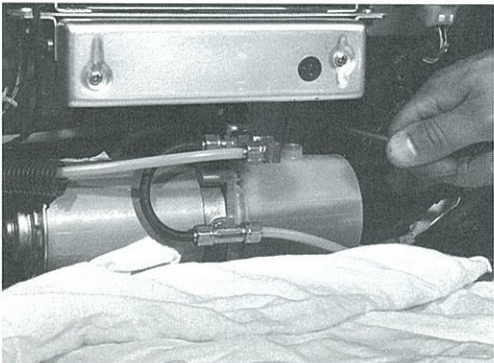
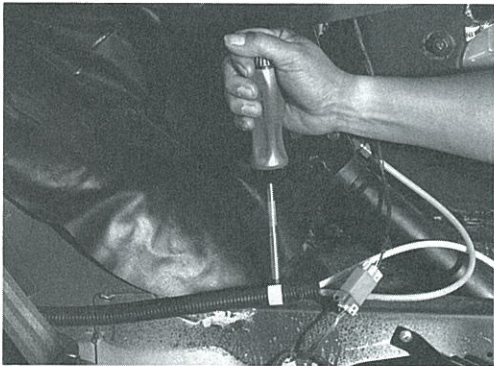
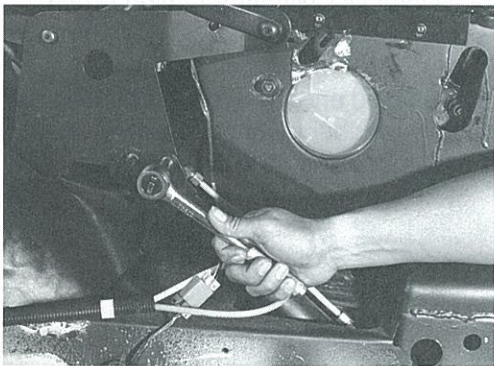
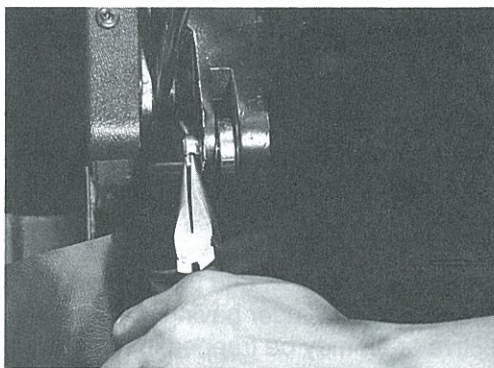



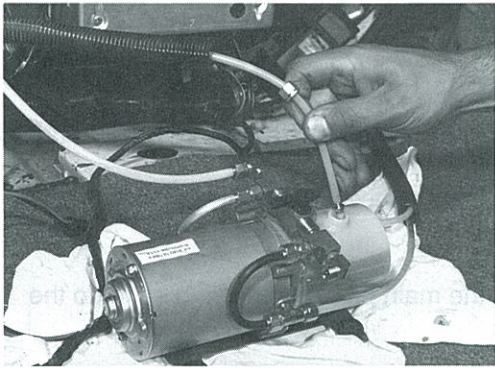

## HYDRAULIC CYLINDER BLEEDING PROCEDURE (cont.)

- (b) Disconnect the pink upper hydraulic line from the pump/motor that leads to the cylinder to be bled and insert that line into the reservoir filler hole.
- (c) Cap off the pink upper hydraulic line connection at the pump/motor.

### 6. BLEED THE HYDRAULIC SYSTEM - ONE SIDE AT A TIME.

- (a) Disconnect both rear rail proximity switch harnesses.
- (b) Using the shaft of a screwdriver, trip the deck lid latch mechanism. This will allow the pump/motor to operate while the deck lid is open.
- (c) Press the "TOP UP" switch to fully extend the cylinder rods.

**CAUTION: Release the switch after the cylinder rods have fully extended or fully retracted.**

- (d) Press the "TOP DOWN" switch to retract the cylinder rods halfway.
- (e) Press the "TOP UP" switch to fully extend the cylinder rods.

### 7. CONNECT PINK UPPER HYDRAULIC LINE AT PUMP.

- (a) Remove the cap from the pink upper hydraulic line connection at the pump.
- (b) Remove the hydraulic line from the reservoir filler hole and connect the pink upper hydraulic line to the pump.
- (c) Install the filler plug to the reservoir.

### 8. REPEAT STEPS 5b - 7b TO BLEED OFF THE OTHER SIDE.

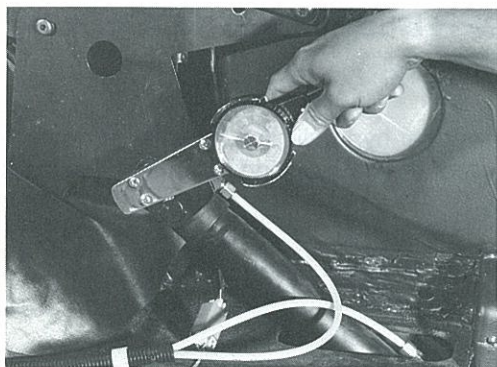

## HYDRAULIC CYLINDER BLEEDING PROCEDURE (cont.)

9. ATTACH BOTH HYDRAULIC CYLINDERS TO TOP MECHANISM.

- (a) Position and align the hydraulic cylinder with the main pivot bracket.
- (b) Position and align the main pivot extension bracket to the hydraulic cylinder.
- (c) Install the two (2) bolts.

**Torque: 28 N-m (21 ft-lb).**

- (d) Install the two (2) connecting pins and the two (2) cotter pins.

10. ATTACH THE HYDRAULIC LINES TO THE BODY STRUCTURE.

11. CHECK THE HYDRAULIC SYSTEM FOR LEAKS (see 22-8).

12. INSTALL THE QUARTER TRIM PANELS (see 6-6).

13. RELEASE THE DECK LID MECHANISM.

Insert the appropriate key in the latch and turn it.

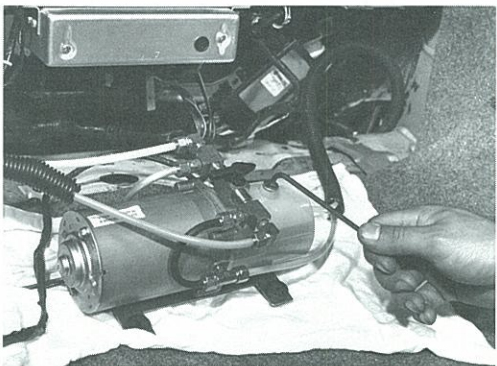
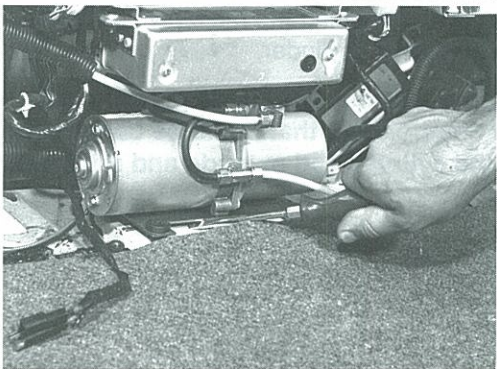
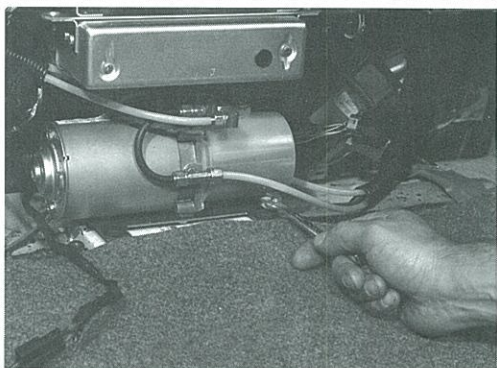

## REMOVAL OF TOP STACK HYDRAULIC CYLINDER

1. LOWER THE CONVERTIBLE TOP.
2. OPEN THE DECK LID.
3. LIFT UP THE SHOCK TOWER BRACE COVER TO REVEAL THE HYDRAULIC PUMP/MOTOR ASSEMBLY.
4. REMOVE THE HYDRAULIC PUMP/MOTOR ASSEMBLY.
  - (a) Disconnect the harness connector.
  - (b) Remove the retaining bolt from the pump/motor.
  - (c) Using a screwdriver, pry up the hydraulic pump/motor assembly from the mounting bracket to remove. Then move the hydraulic pump/motor assembly rearward.

**CAUTION: Take care not to kink the hydraulic lines.**

- (d) Vent the reservoir by removing and then re-installing the filler plug.

**NOTE: Venting the reservoir relieves any air pressure, reducing the possibility of hydraulic fluid being forced out when disconnecting the lines.**

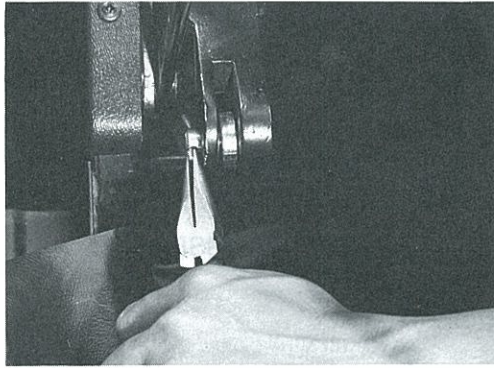

## REMOVAL OF TOP STACK HYDRAULIC CYLINDER (cont.)

5. REMOVE THE QUARTER TRIM PANEL (See 6-3).
6. REMOVE THE DEFECTIVE HYDRAULIC CYLINDER FROM THE TOP MECHANISM.

(a) Remove the cotter pin.

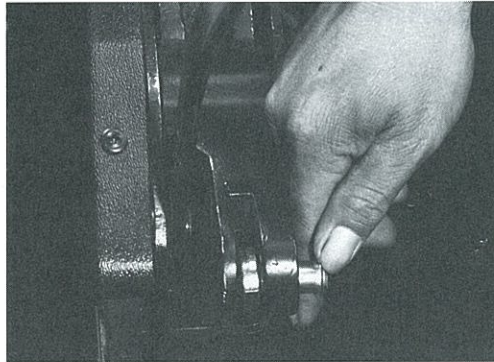

(b) Remove the cylinder connecting pin.

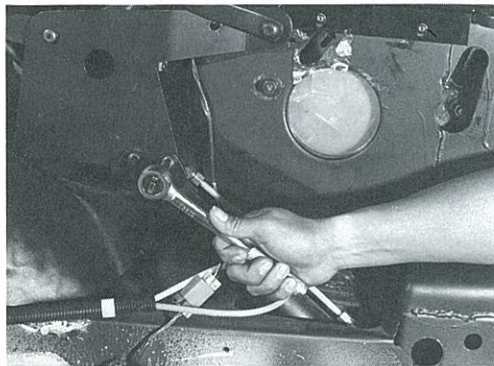

(c) Remove the two (2) bolts attaching the main pivot bracket extension plate to remove the cylinder.

**CAUTION:** Make sure that the cylinder is placed clear of any components that could be damaged when the cylinder rod extends and retracts.



7. DETACH HYDRAULIC LINES FROM BODY STRUCTURE.

Remove the screw attaching the plastic hose clip and detach the hydraulic lines.

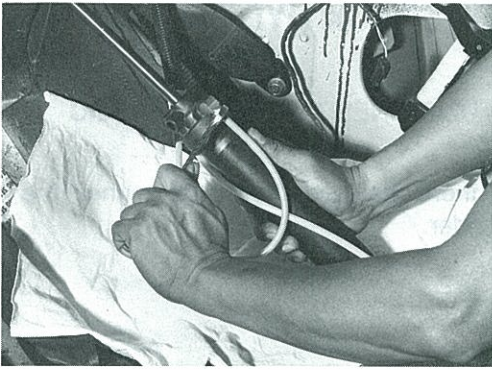

## REMOVAL OF TOP STACK HYDRAULIC CYLINDER (cont.)

8. PLACE ABSORBENT RAGS UNDER THE HYDRAULIC CYLINDER.
9. DISCONNECT THE HYDRAULIC LINES FROM THE HYDRAULIC CYLINDER.

Disconnect the lines from the hydraulic cylinder and cap the open fittings to prevent leakage of fluid. Then, remove the hydraulic cylinder.

**NOTE:** Before removal, label the position of each hydraulic line.

**CAUTION:** Place a cloth under the hydraulic cylinder when disconnecting hydraulic lines to absorb any leaking fluid. Observe proper safety precautions when handling this oil as with other motor oils.

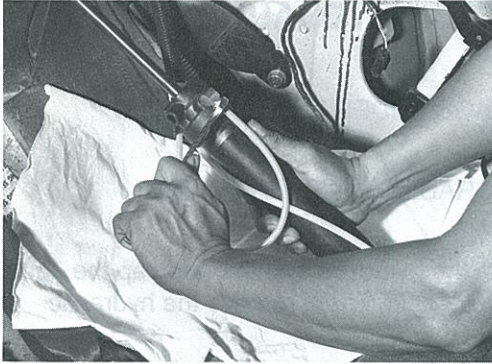

### **INSTALLATION OF TOP STACK HYDRAULIC CYLINDER**

1. **CONNECT THE HYDRAULIC LINES TO THE HYDRAULIC CYLINDER.**

Remove the fitting caps, then, observing the labels, connect the lines to the hydraulic cylinder.

2. **BLEED THE HYDRAULIC SYSTEM** (See 22-10, steps 3 through 11).
3. **CHECK THE HYDRAULIC SYSTEM FOR LEAKS** (See 22-8).
4. **INSTALL THE QUARTER TRIM PANEL** (See 6-6).

HYDRAULIC SYSTEM DIAGNOSTIC FLOW CHART

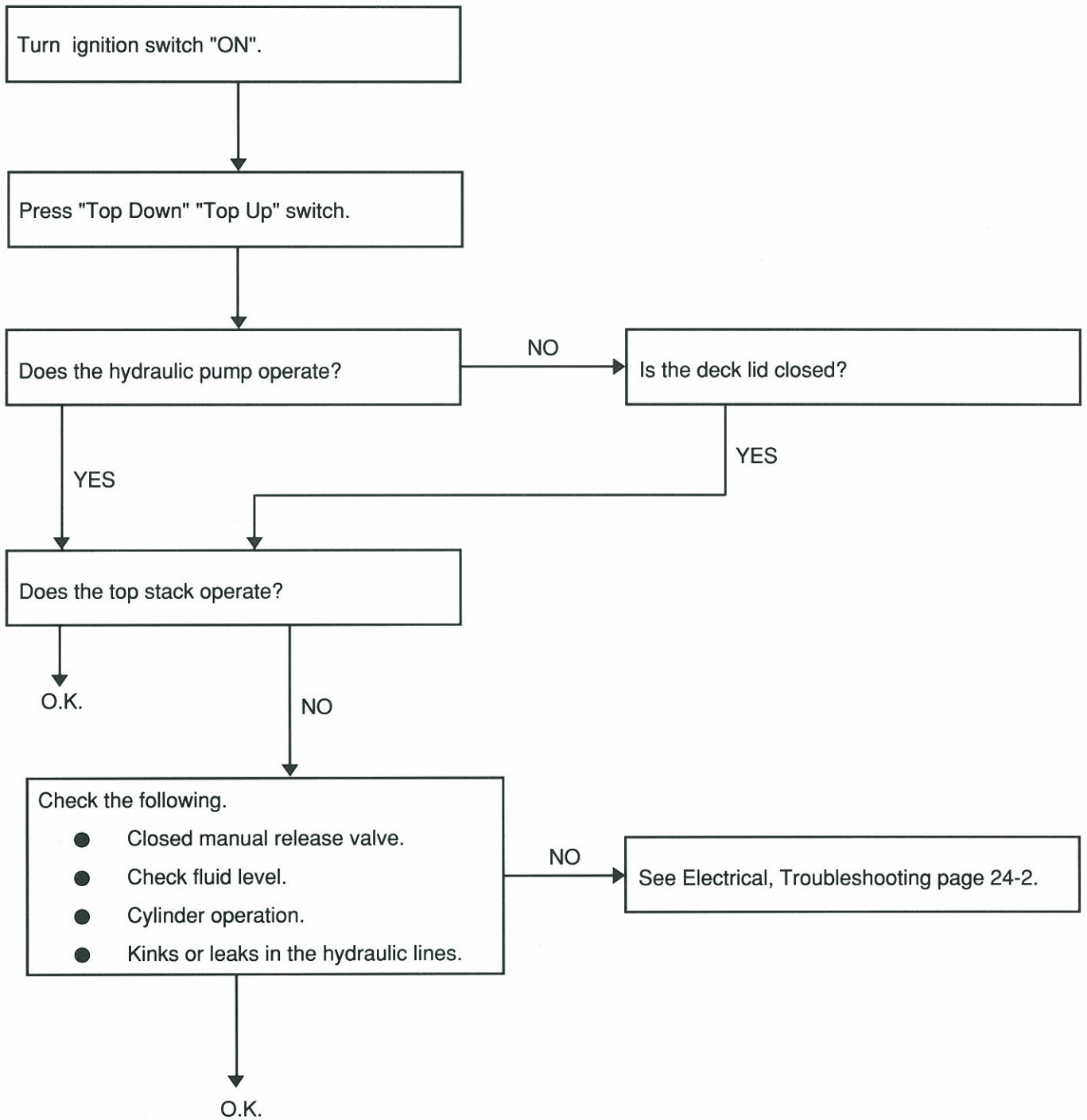





# ELECTRICAL CONTROLS

Page

ELECTRICAL CONTROLS - COMPONENTS ..... 23-2

## ELECTRICAL CONTROLS - COMPONENTS

**NOTE:** Some electronic components such as the Anti-Lock Braking Module; ASCD (automatic speed control device) with ASCD Relay and Ride Control Module have been relocated behind the rear seat in the luggage compartment. The components were relocated to accommodate the convertible top modification. The relocated components do not have any relation to the operation of the convertible top itself. Components that have been relocated are denoted by an asterisk (\*). For servicing of the relocated components refer to the vehicle Service Manual.

**CAUTION:** Do not touch the terminals of electrical components which use microcomputers (such as electronic control units). Static electricity may damage internal electronic components.

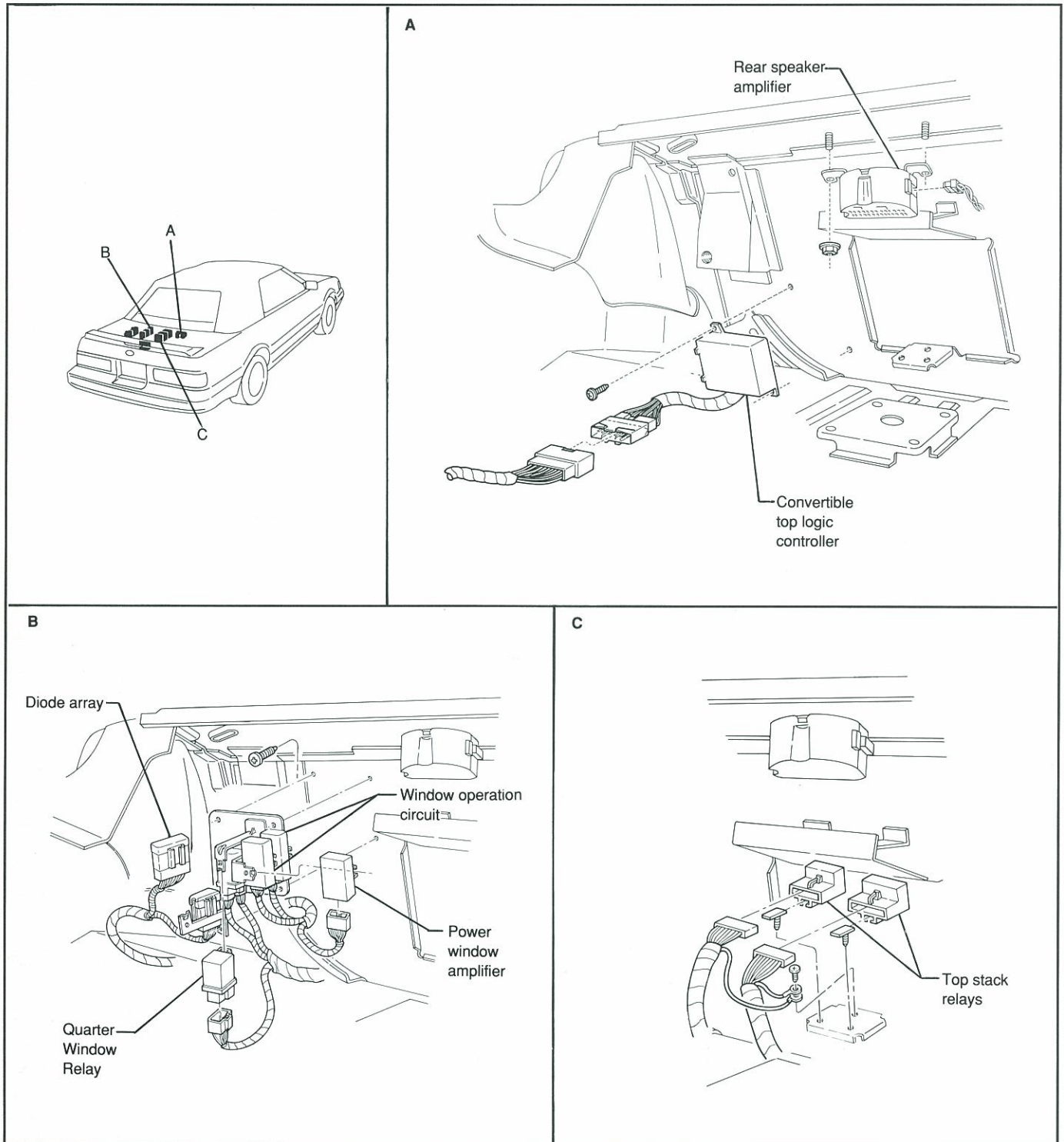

ELECTRICAL CONTROLS - COMPONENTS (cont.)

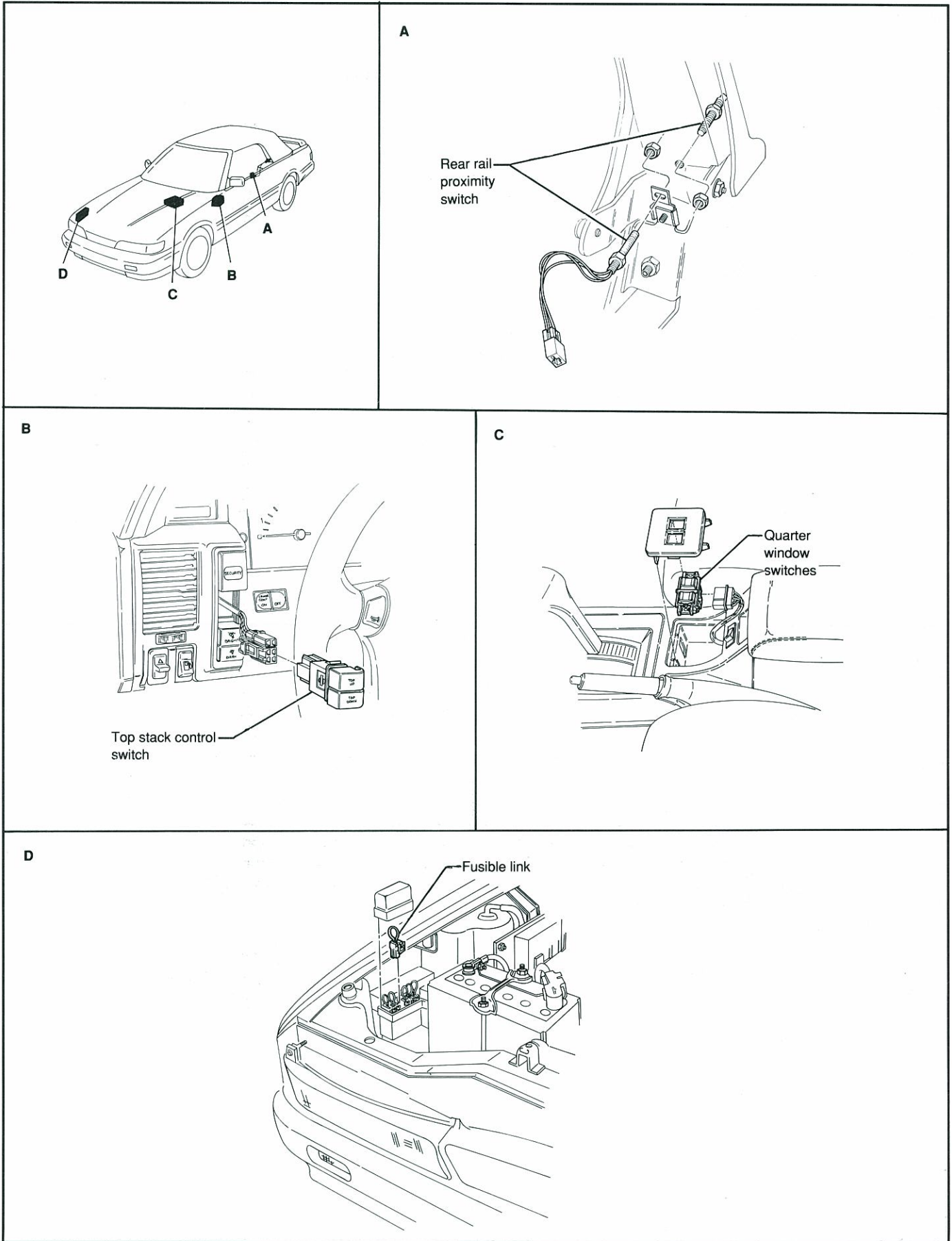

ELECTRICAL CONTROLS - COMPONENTS (cont.)

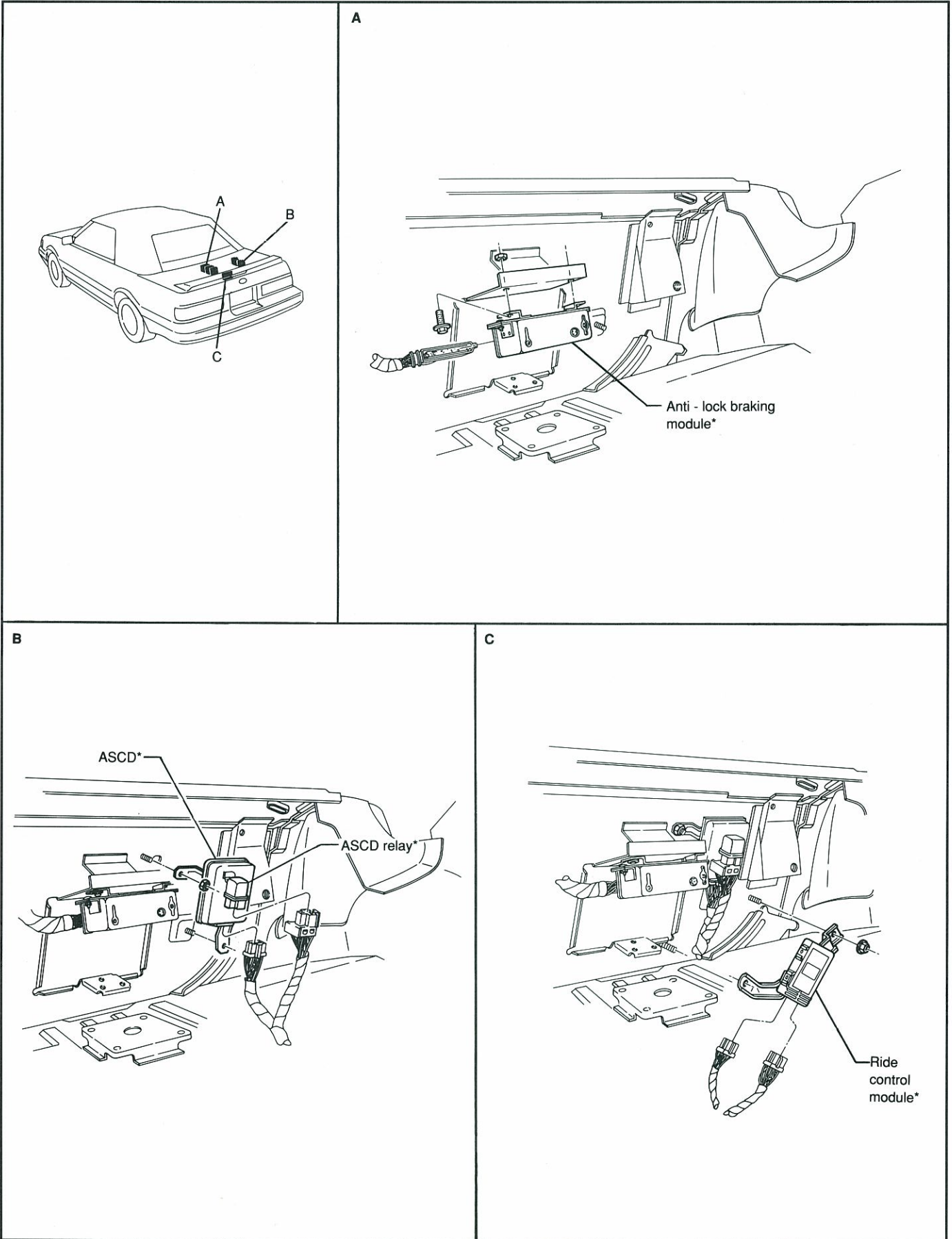

# **ELECTRICAL, TROUBLESHOOTING**

Before lowering or raising the top using the "Top Down" or "Top Down" switch, the following conditions must be met. If one or more of the conditions are not met, the top lowering system will not operate.

- The vehicle must be at a complete stop.
- The transmission gear selector must be in the "P" position.
- The ignition switch must be in the "ON" position.
- The deck lid must be closed.
- The manual release valve must be closed.

#### PRELIMINARY CHECK #1 - CHECK OPERATION OF THE CONVERTIBLE TOP

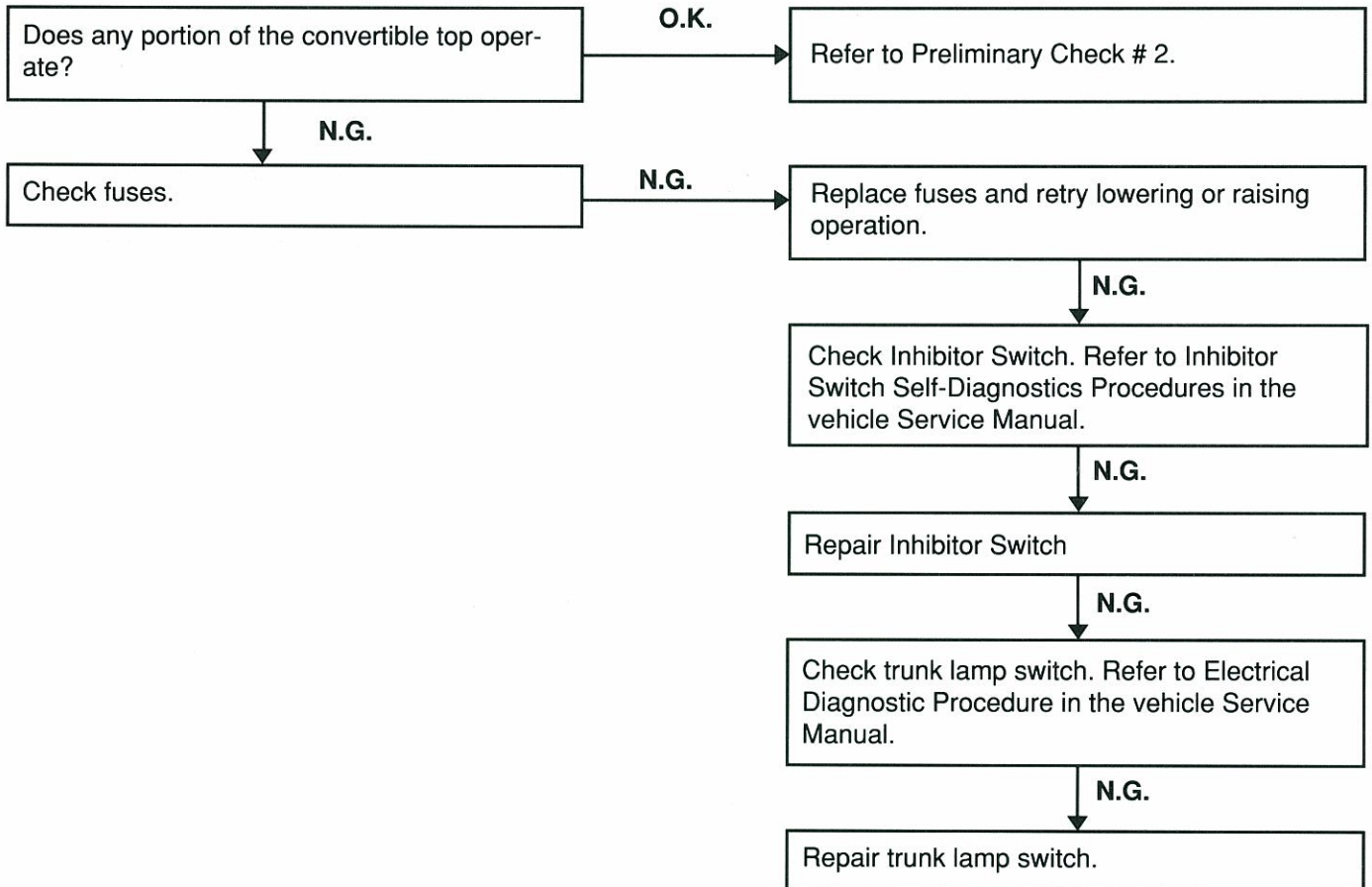

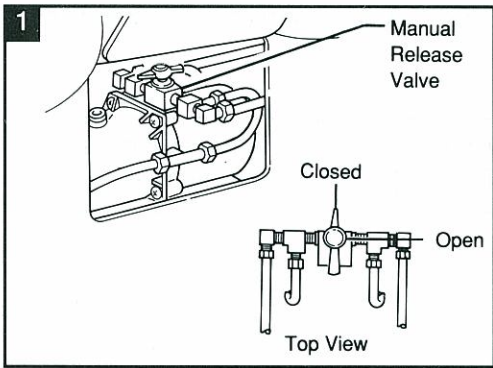

**PRELIMINARY CHECK #2 -  
AUDIBLE CHECKING OF HYDRAULIC PUMP/MOTOR**

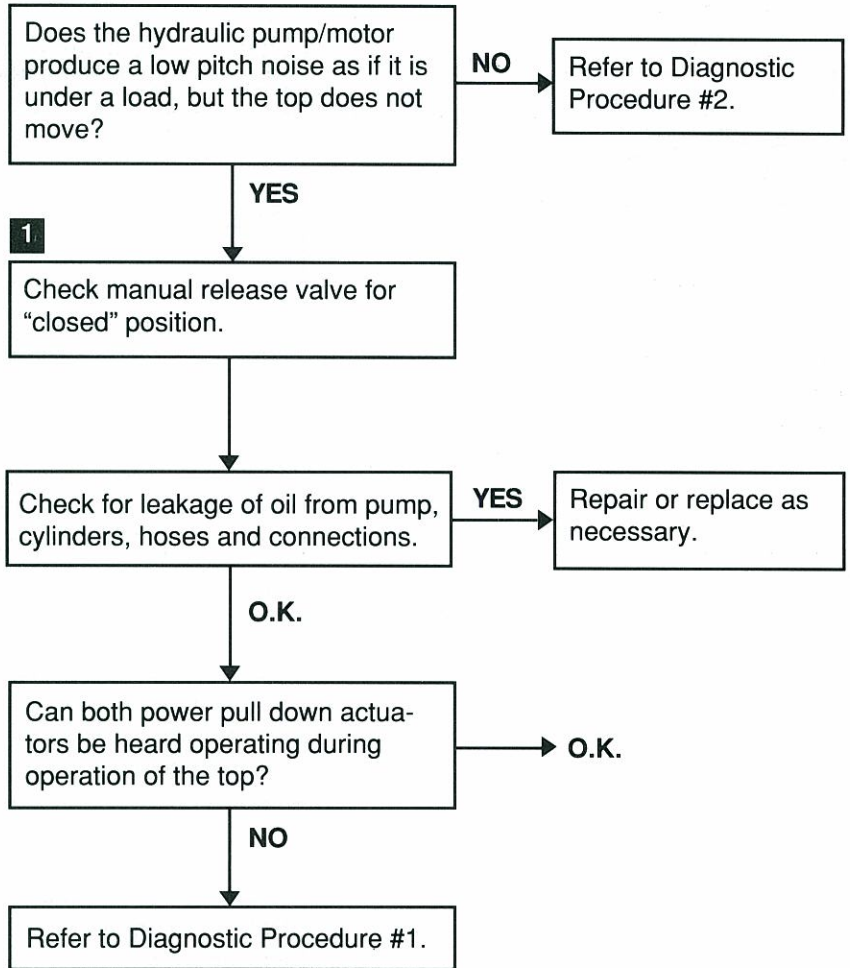

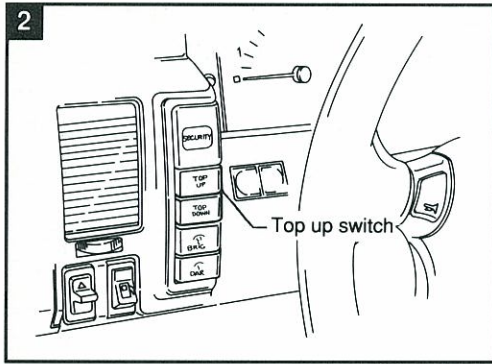

**PRELIMINARY CHECK #3 - DOOR AND QUARTER GLASS OPERATING PROCEDURE**

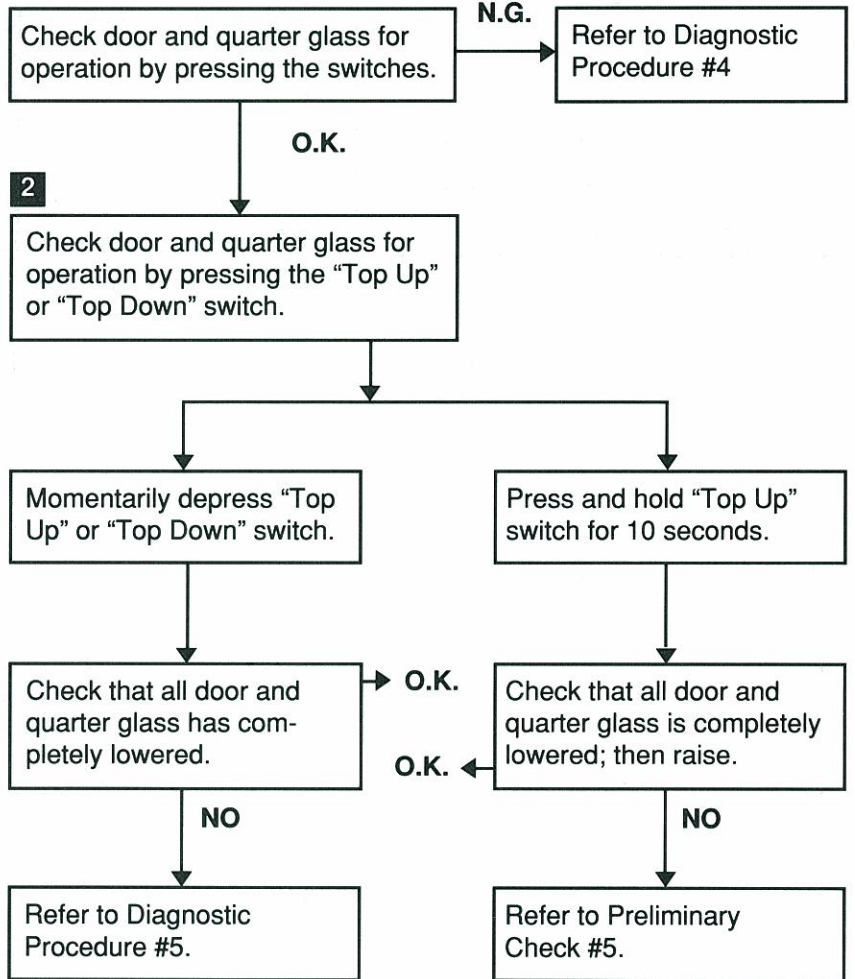

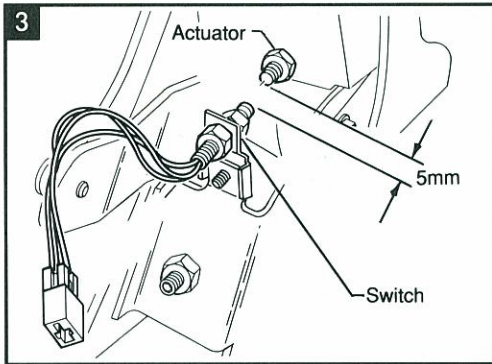

**PRELIMINARY CHECK #4 - REAR RAIL PROXIMITY SWITCH****3**

With the top raised and secured, check for the rear rail clearance of 3/16" (5mm).

**CAUTION: Switch and actuator are made of plastic. Do not overtighten.**

**Torque: Finger tighten, then 1/4 turn.**

**DIAGNOSTIC PROCEDURE #1**

Symptom: Power pull down system does not work in the "up" and "down" mode.

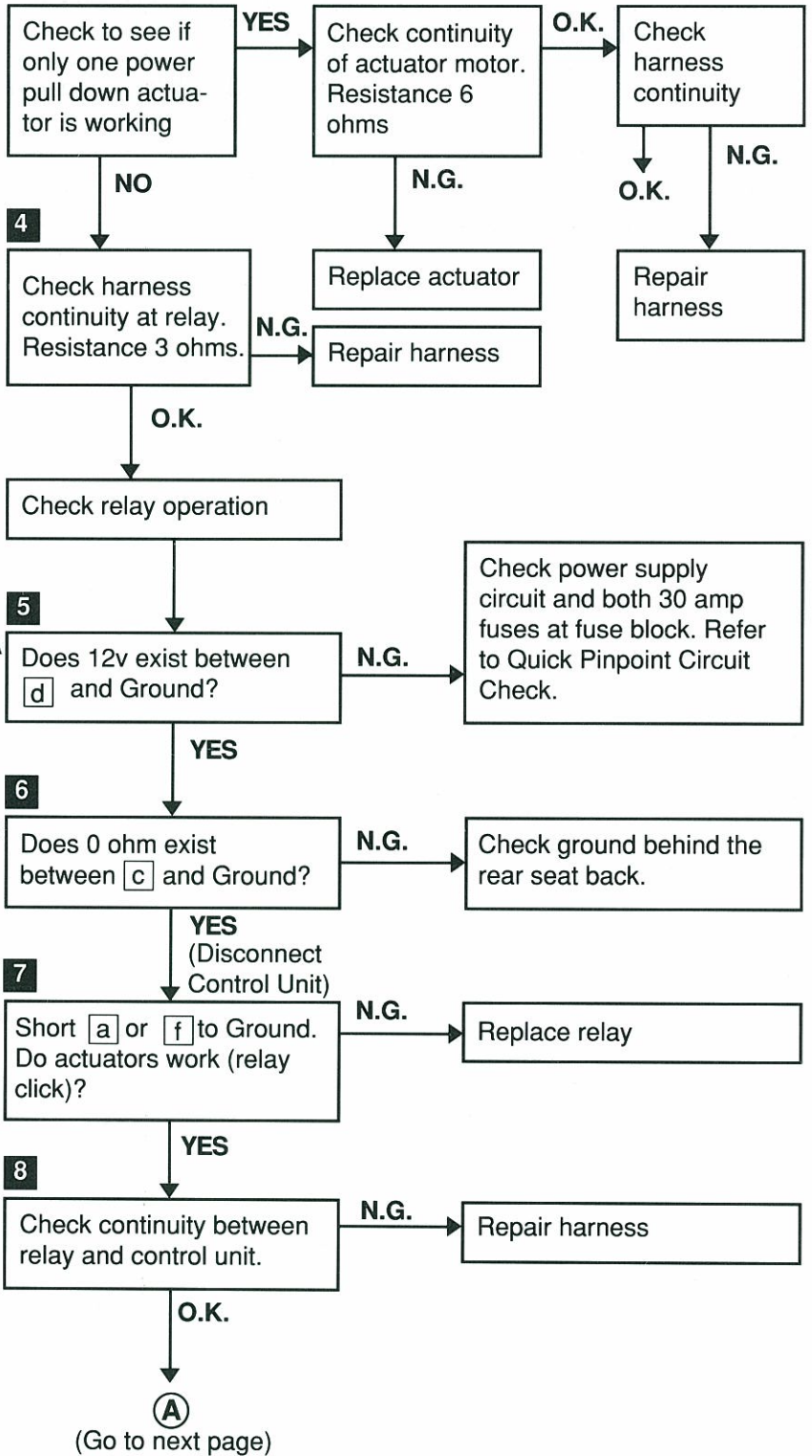
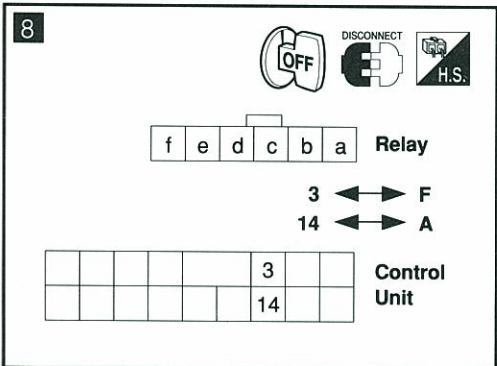
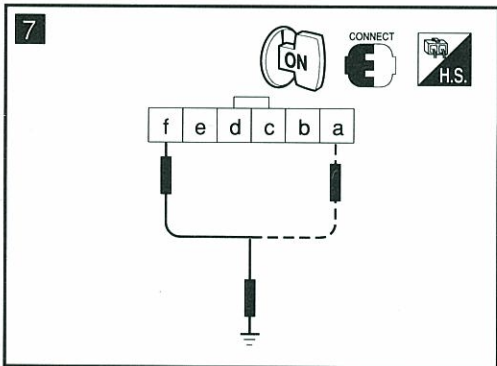
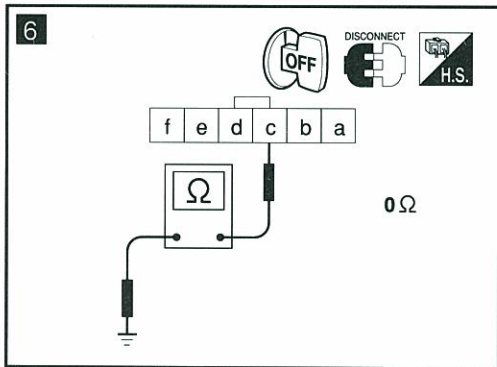
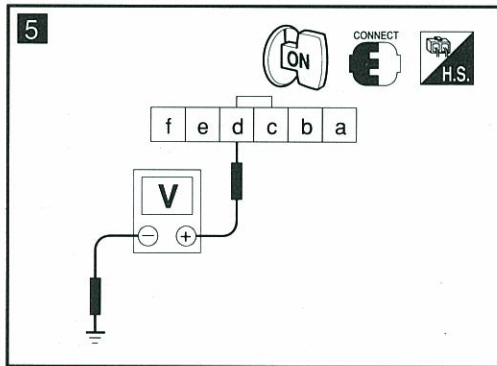
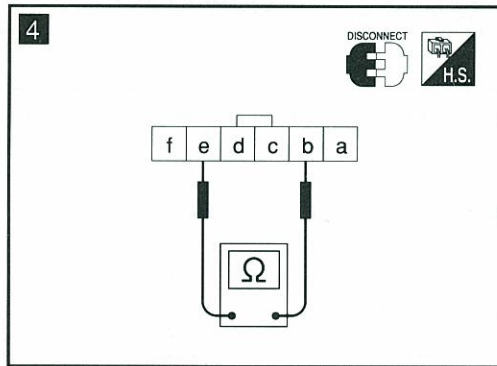

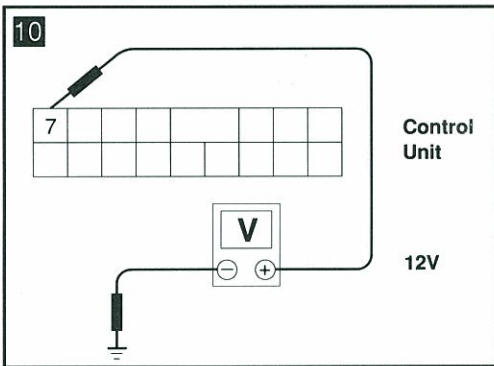
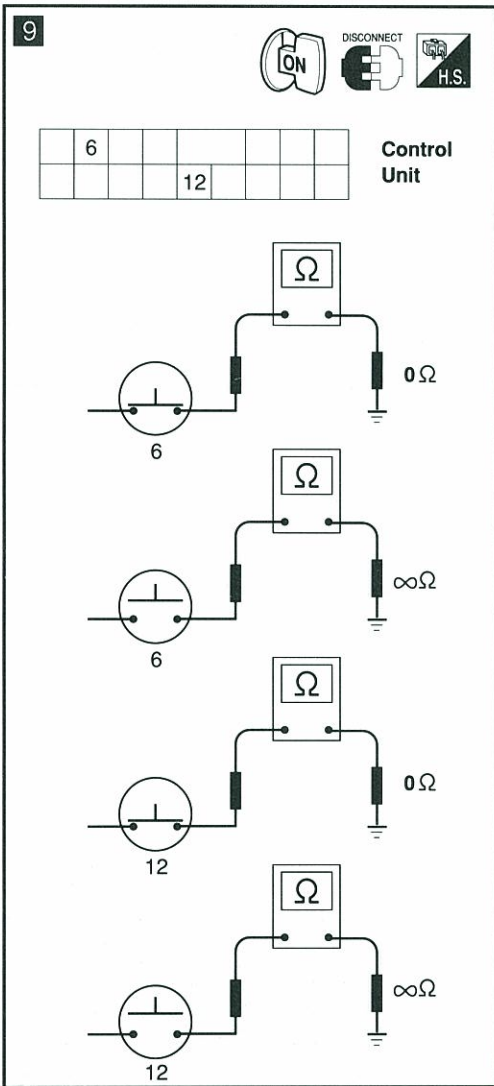

**DIAGNOSTIC PROCEDURE #1**

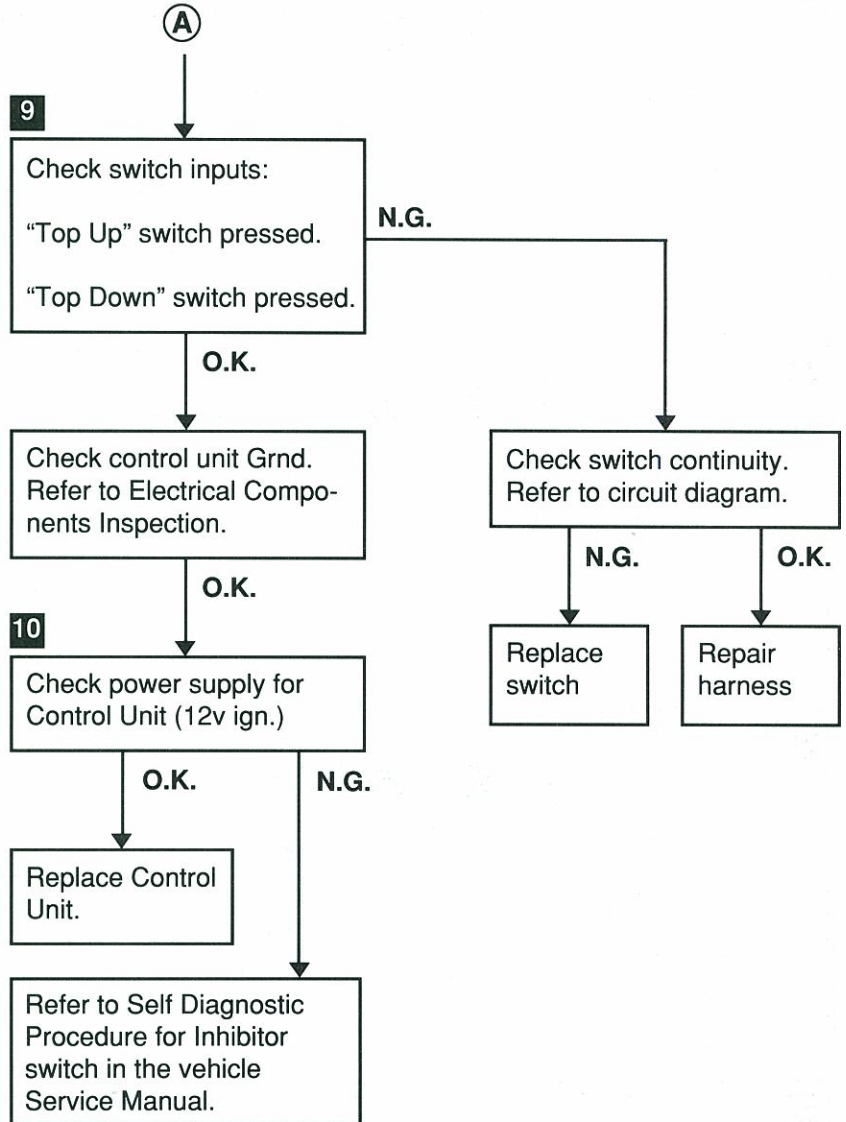

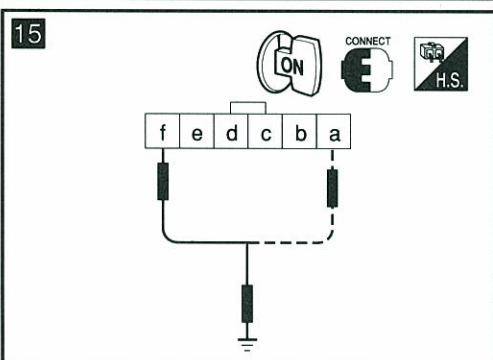
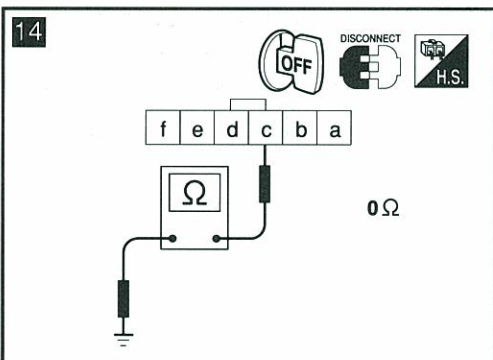
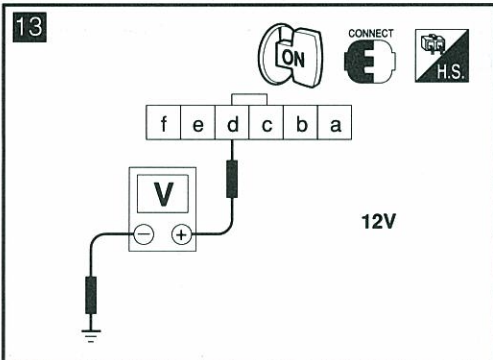
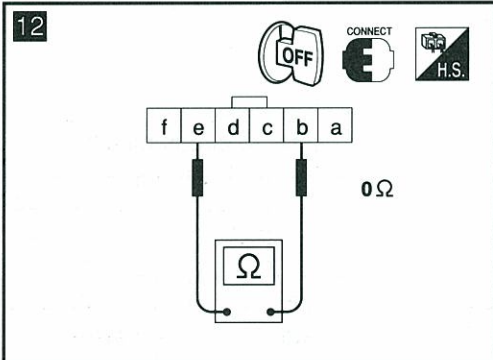
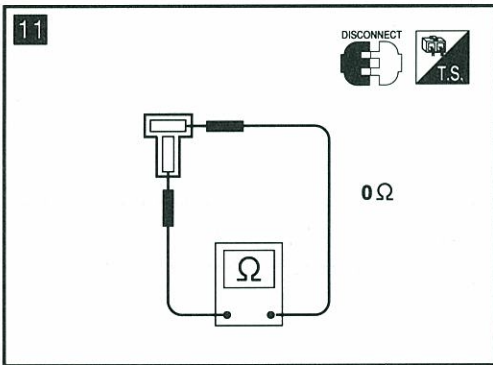

**DIAGNOSTIC PROCEDURE #2**

Symptom: Hydraulic pump/motor does not work in the “up” and “down” mode.

```

    graph TD
      Start[Check if manual release valve is closed.] -- O.K. --> Step11[11 Check pump/motor continuity. Resistance 0 ohm.]
      Step11 -- N.G. --> Action1[Replace pump/motor]
      Step11 -- O.K. --> Step12[12 Check harness continuity at relay. e & b]
      Step12 -- N.G. --> Action2[Repair harness]
      Step12 -- O.K. --> Step13[Check relay operation]
      Step13 --> Step13A[A Does 12v exist between d and Ground?]
      Step13A -- N.G. --> Action3[Check power supply circuit and both 30 amp fuses at fuse block. Refer to Quick Pinpoint Circuit Check.]
      Step13A -- YES --> Step14[B Does 0 ohm exist between c and Ground?]
      Step14 -- N.G. --> Action4[Check ground behind the rear seat back.]
      Step14 -- YES --> Step15[C Short a or f to Ground. Does the pump & motor activate?]
      Step15 -- N.G. --> Action5[Replace relay]
      Step15 --> End((A))
      End --> NextPage[Go to next page.]
  
```

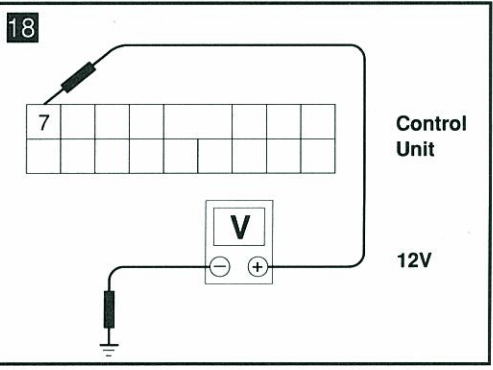
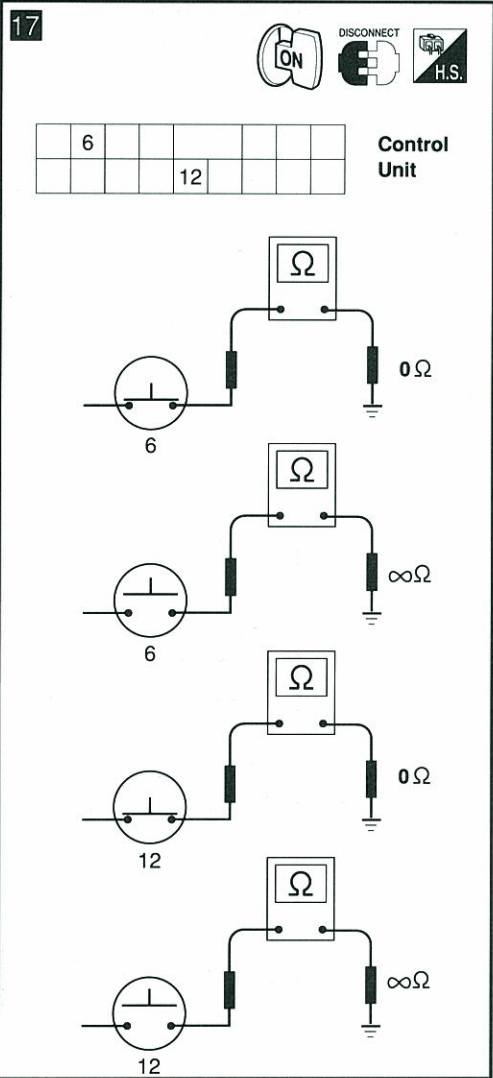
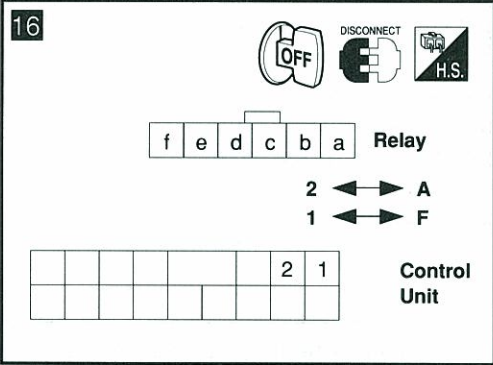

**DIAGNOSTIC PROCEDURE #2**

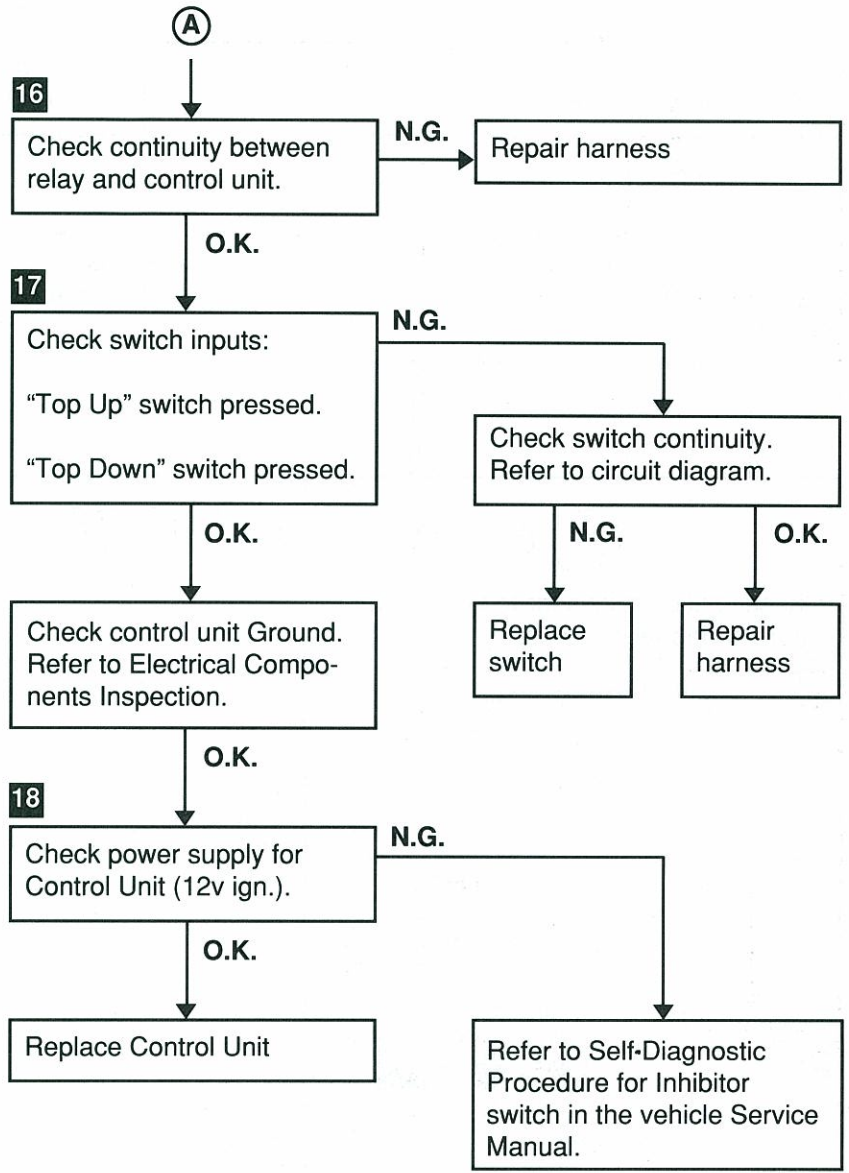

**DIAGNOSTIC PROCEDURE #3**

Symptom: Door and quarter glass do not operate "down" in the "up" and "down" mode.

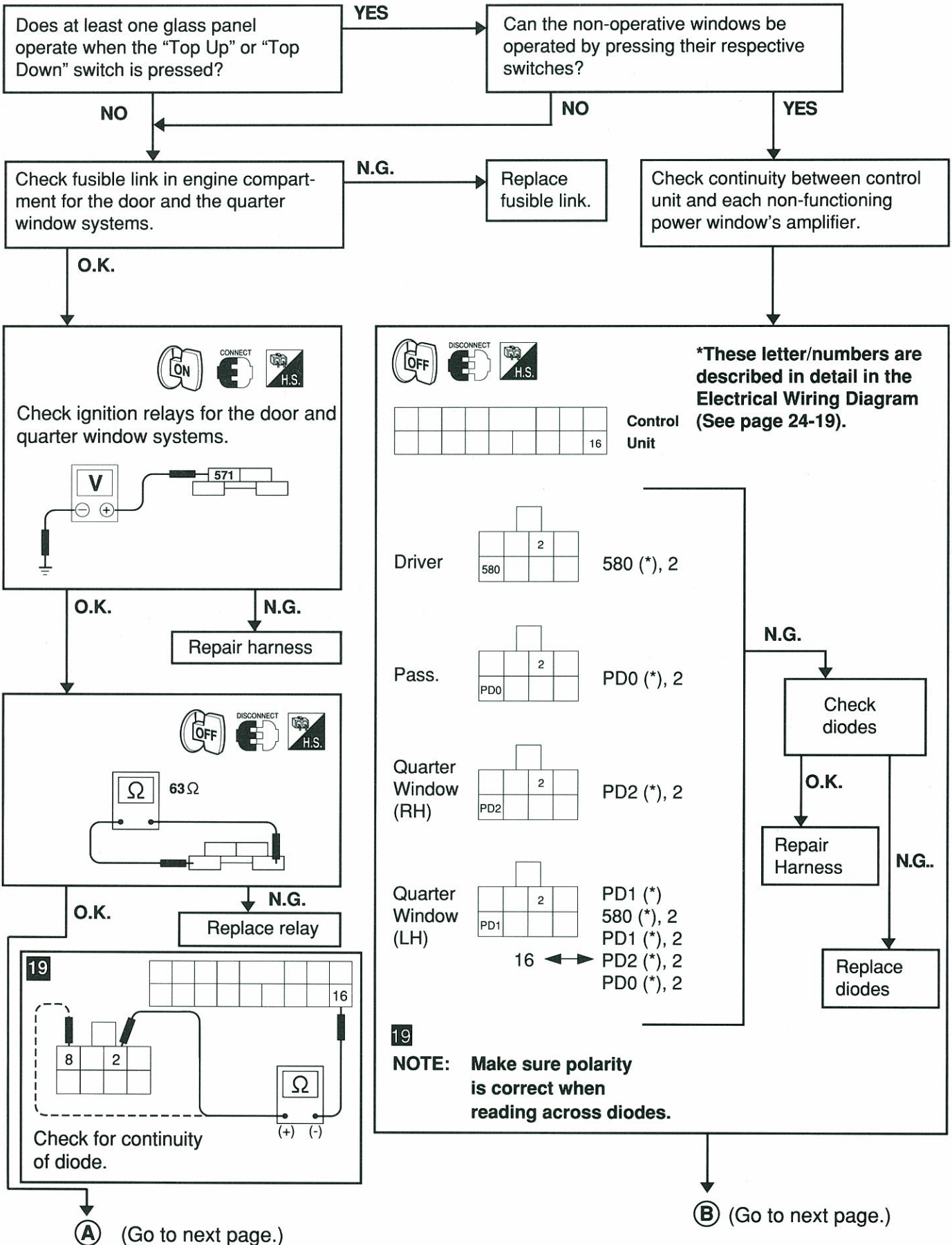

DIAGNOSTIC PROCEDURE #3

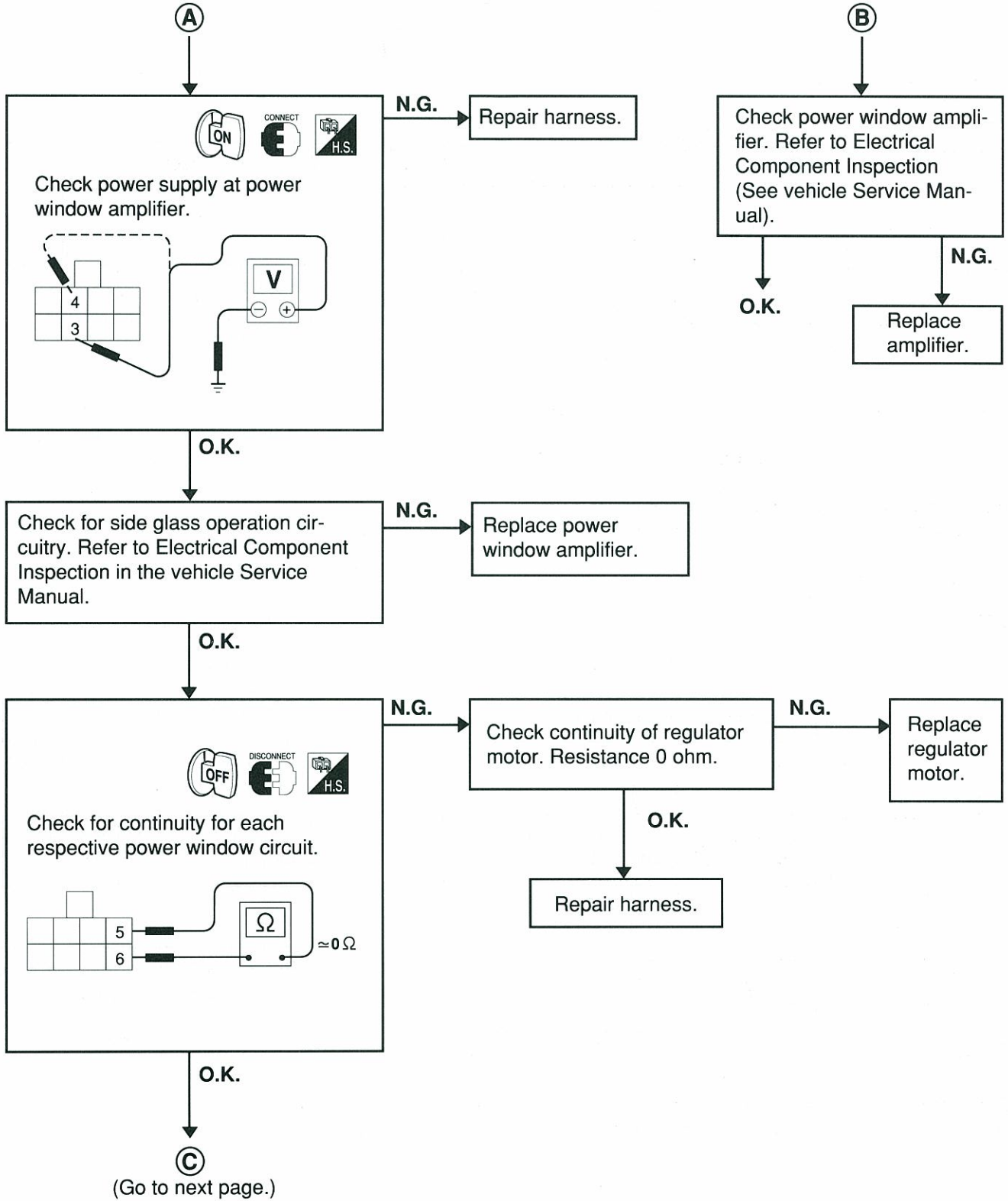

DIAGNOSTIC PROCEDURE #3

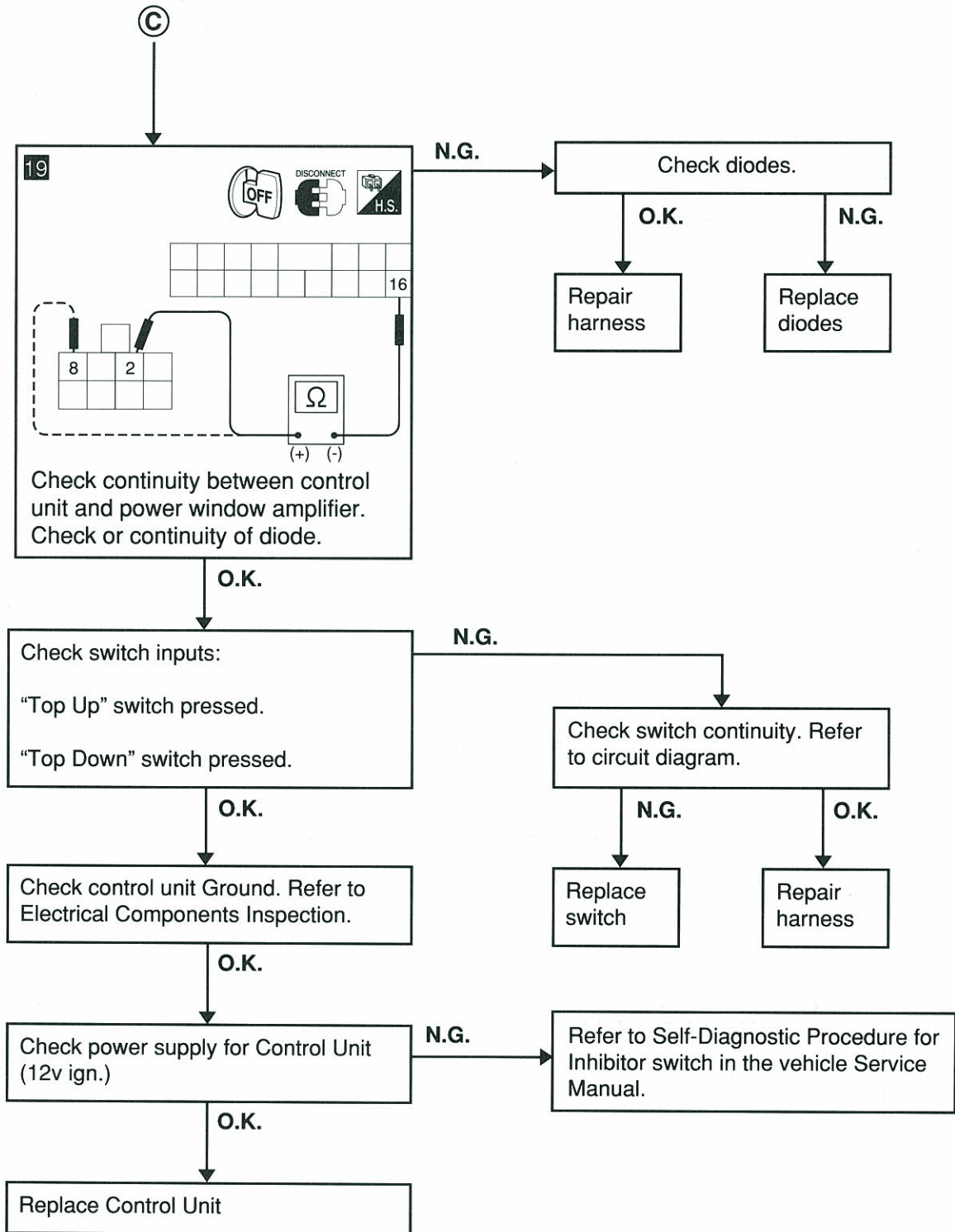



**DIAGNOSTIC PROCEDURE #4**

Symptom: Door and quarter glass do not raise in the "up" mode, but does lower in the "down" mode.

**NOTE: Make sure the window Lock-out switch is not activated.**

Check the continuity of the rear rail proximity switch input at the controller. Make sure the convertible top is raised and secured.

Check the continuity of the rear rail proximity switch at the rear rail proximity switch harness connector.

N.G.

O.K.

Repair harness.

Check proximity switch mounting (See Preliminary Check #4).

O.K.

N.G.

Replace switch.

Adjust mounting position.

Check continuity between switch and amplifier. Refer to window circuit diagram for each specific window application.

**A**

(Go to next page.)

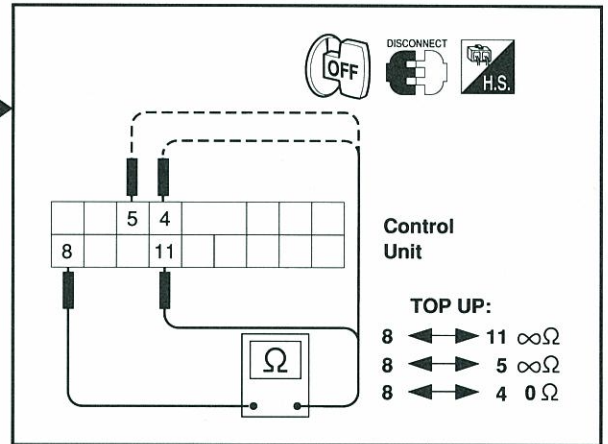

O.K.

Can side and quarter windows be operated by pressing their respective switch?

NO

YES

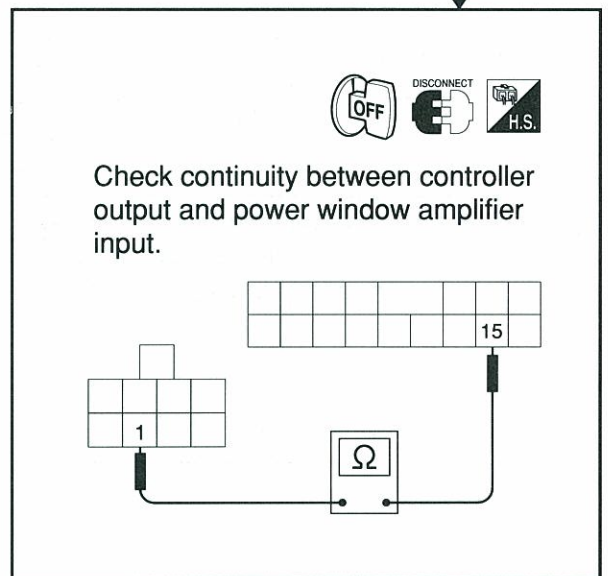

N.G.

O.K.

Repair harness

Replace controller

DIAGNOSTIC PROCEDURE #4

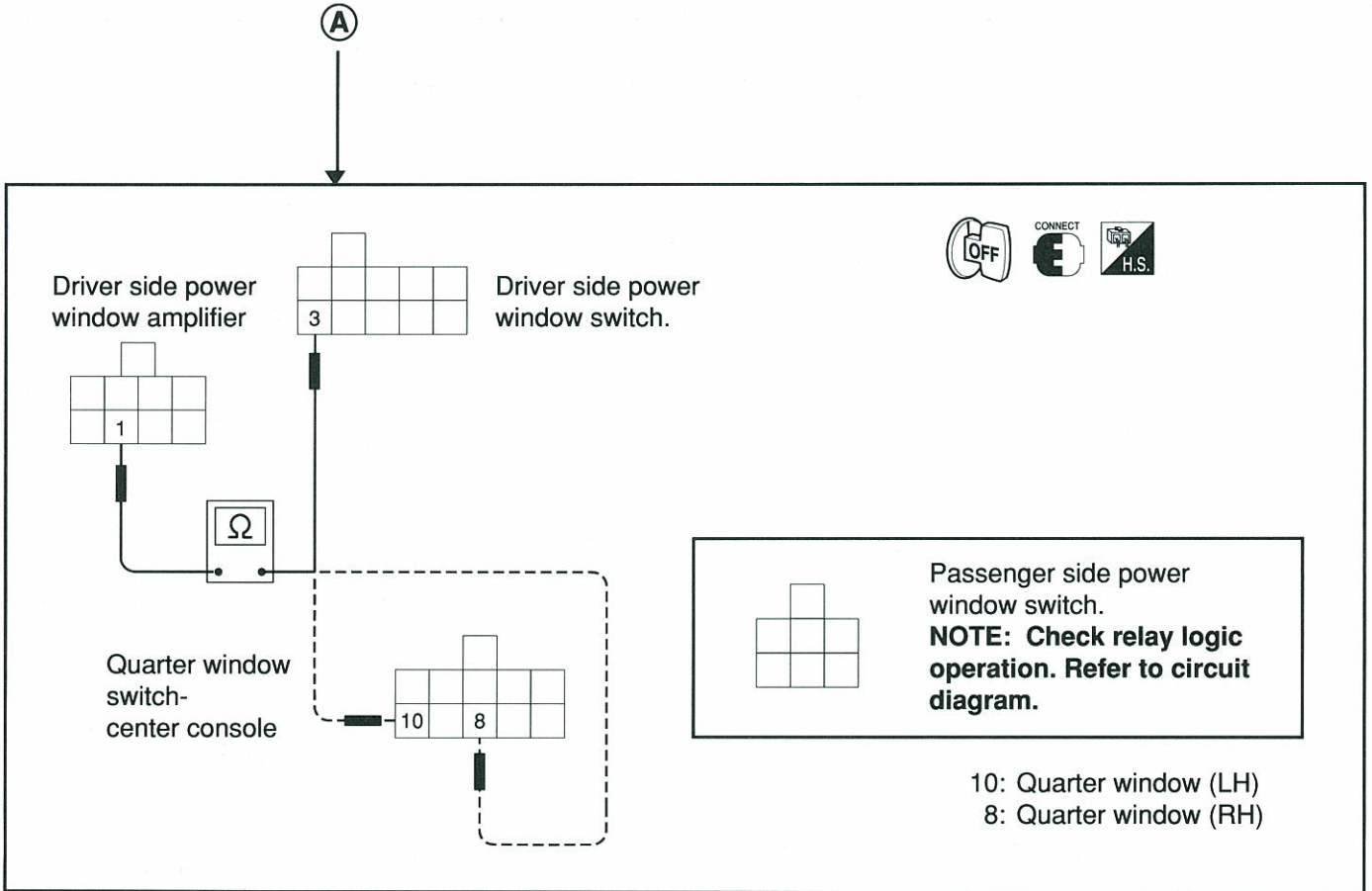

O.K.

N.G.

Check operation of each power window switch. Refer to window circuit diagram.

N.G.

Replace switch.

O.K.

Check power window amplifier operation. Refer to the vehicle Service Manual.

N.G.

Replace amplifier.



Repair harness.

**DIAGNOSTIC PROCEDURE #5**

Symptom: Top operates intermittently.

Check continuity of the rear rail proximity switch inputs with the top raised and secured.

**A** The top stops after  $\approx 1$  second of operation in the "up" mode.

Check continuity of the rear rail proximity switch inputs with the top raised and secured.

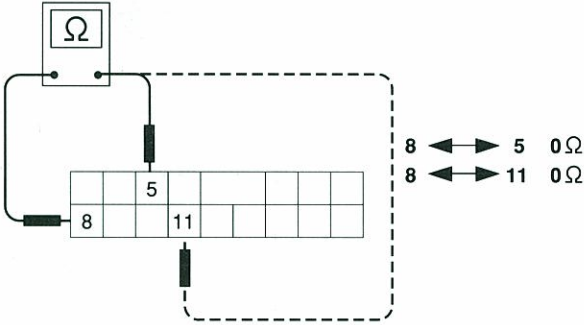

8  $\longleftrightarrow$  5 0  $\Omega$   
 8  $\longleftrightarrow$  11 0  $\Omega$

N.G.

Check continuity at rear rail proximity switch.

N.G.

Replace switch.

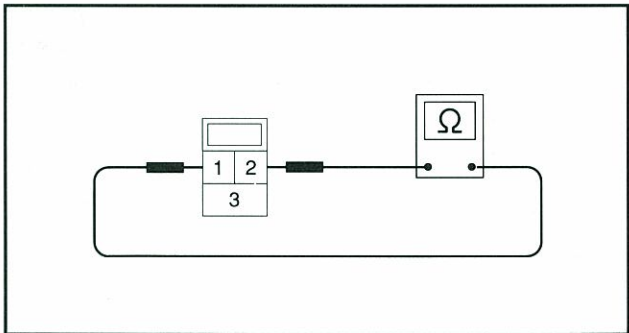

O.K.

Repair harness.

**A**

(Go to next page.)

## DIAGNOSTIC PROCEDURE #5

Symptom: Top operates intermittently.

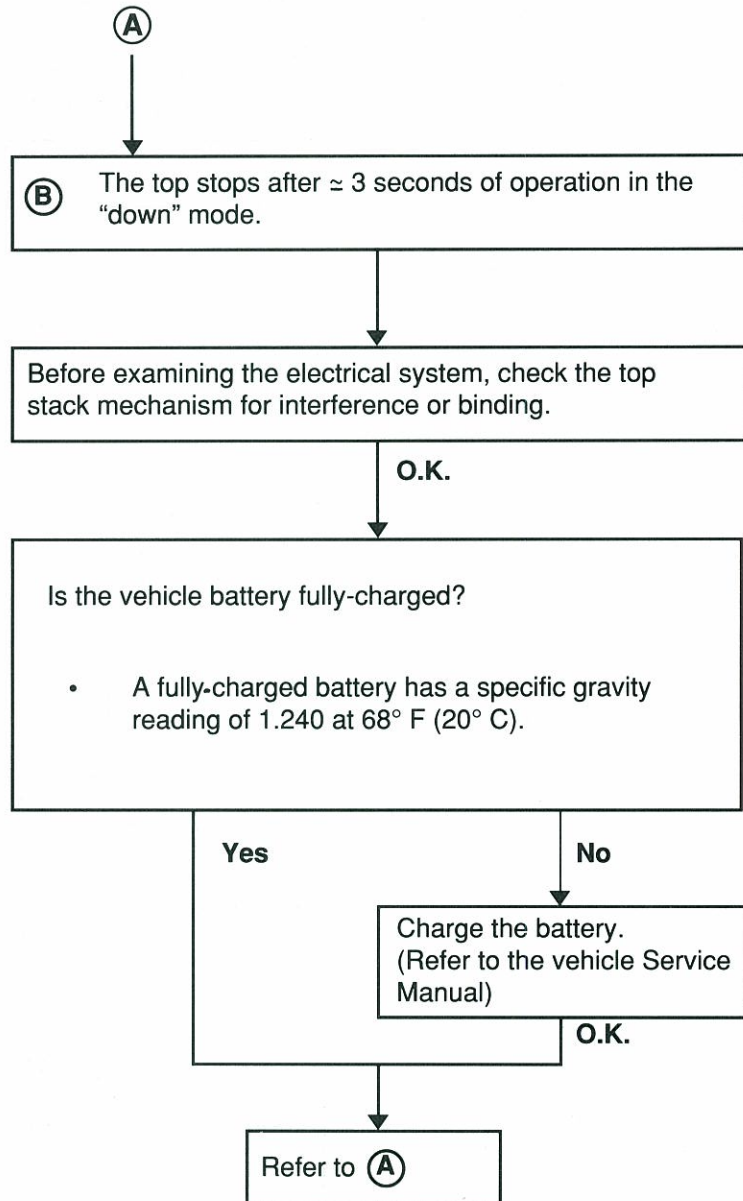

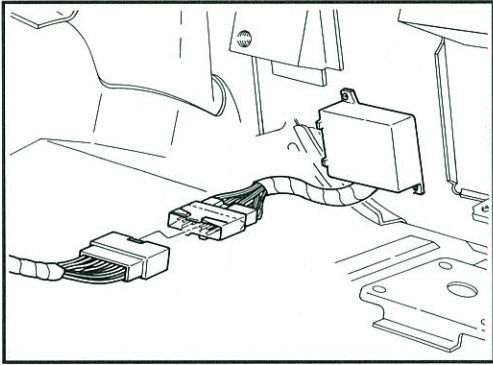

CONTROL UNIT

CONTROL UNIT GROUND LOCATION

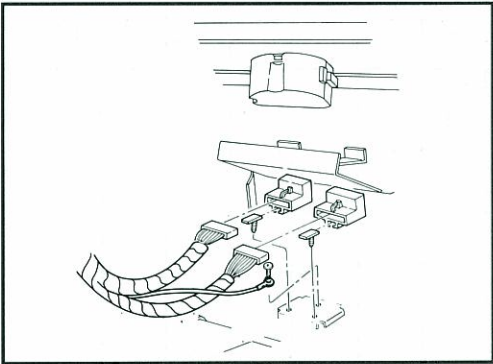
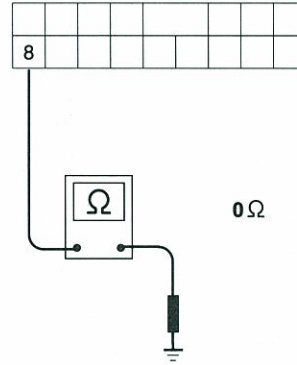

GROUND FOR CONTROL UNIT

DOOR AND QUARTER GLASS SYSTEM GROUND

NOTE: Verify for each power window amplifier .

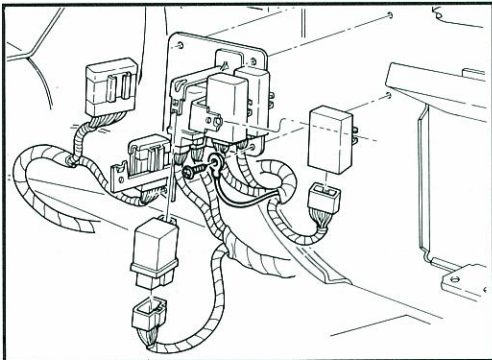

GROUND FOR POWER WINDOW CIRCUIT

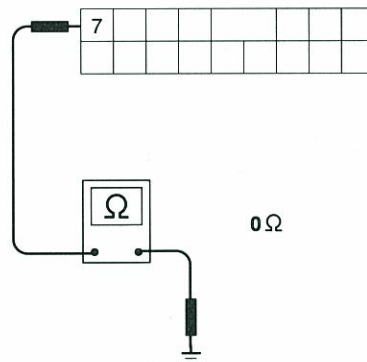



QUICK PIN POINT CIRCUIT CHECK

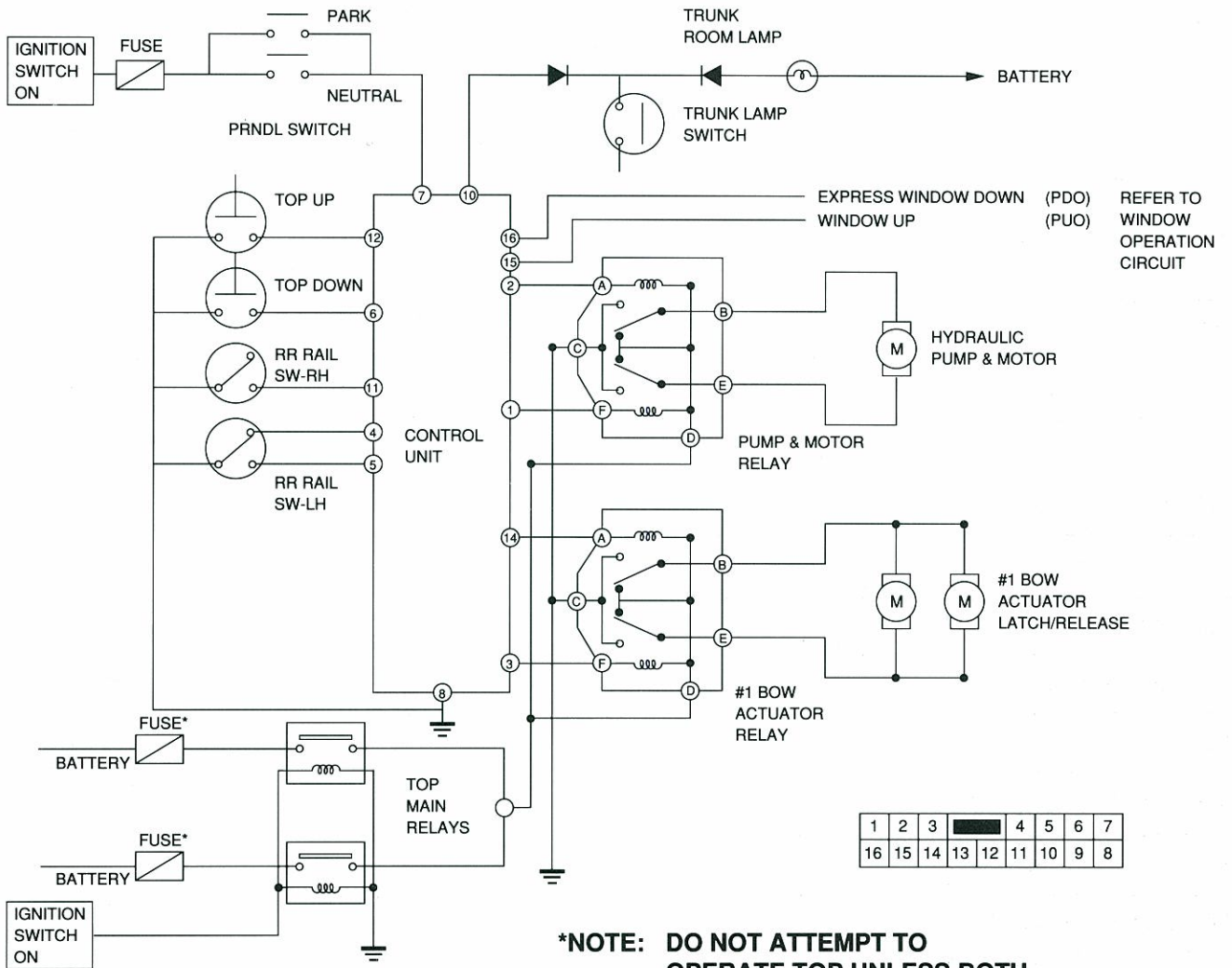

**\*NOTE: DO NOT ATTEMPT TO OPERATE TOP UNLESS BOTH FUSES ARE FUNCTIONAL**





# ELECTRICAL DIAGRAMS

## TABLE OF CONTENTS

PREFACE TO ELECTRICAL DIAGRAM SECTION .....	25-3
POWER SUPPLY ROUTING .....	25-4
RADIATOR FAN MOTOR	
CIRCUIT DIAGRAM .....	25-6
WIRING DIAGRAM .....	25-7
ECCS CIRCUIT DIAGRAM .....	25-8
ECCS DIAGNOSTIC DIAGRAMS	
MAIN POWER SUPPLY .....	25-9
CRANK ANGLE SENSOR .....	25-10
AIR FLOW METER .....	25-11
VEHICLE SPEED SENSOR .....	25-12
IGNITION SIGNAL .....	25-13
FUEL PUMP CONTROL .....	25-14
EGR CONTROL .....	25-15
EXHAUST GAS SENSOR .....	25-16
DETONATION SENSOR.....	25-17
INJECTOR CIRCUIT .....	25-18
START SIGNAL .....	25-19
AIR REGULATOR .....	25-20
AAC VALVE .....	25-21
A/T SHIFT LOCK SYSTEM WIRING DIAGRAM .....	25-22
SONAR SUSPENSION	
CIRCUIT DIAGRAM .....	25-23
WIRING DIAGRAM .....	25-24
ANTI-LOCK BRAKING SYSTEM WIRING DIAGRAM .....	25-25
CONVERTIBLE TOP	
WIRING DIAGRAM 1 .....	25-26
WIRING DIAGRAM 2 .....	25-27
TRUNK LID OPENER AND FUEL FILLER LID OPENER	
WIRING DIAGRAM .....	25-28
POWER DOOR LOCK WIRING DIAGRAM .....	25-29

---

POWER WINDOW WIRING DIAGRAM .....	25-30
DOOR MIRROR WIRING DIAGRAM .....	25-32
MANUAL AIR CONDITIONER	
CIRCUIT DIAGRAM.....	25-33
WIRING DIAGRAM .....	25-34
CLEARANCE, LICENSE, TAIL AND STOP LAMPS	
WIRING DIAGRAM .....	25-36
INTERIOR LAMPS	
ILLUMINATION WIRING DIAGRAM .....	25-37
SPOT, STEP AND TRUNK	
ROOM LAMPS WIRING DIAGRAM .....	25-38
TACHOMETER, TEMPERATURE AND FUEL GAUGES	
WIRING DIAGRAM .....	25-39
AUDIO WIRING DIAGRAM .....	25-40
A.S.C.D.	
CIRCUIT DIAGRAM.....	25-41
WIRING DIAGRAM .....	25-42
TIME CONTROL SYSTEM WIRING DIAGRAM .....	25-43
NOTES .....	25-44
THEFT WARNING SYSTEM	
CIRCUIT DIAGRAM.....	25-45
WIRING DIAGRAM .....	25-46
MAIN HARNESS LAYOUT DIAGRAMS	
ENGINE COMPARTMENT .....	25-48
PASSENGER COMPARTMENT .....	25-50
BODY HARNESS .....	25-52
INSTRUMENT HARNESS .....	25-54
DOOR HARNESS .....	25-55
ECCS WIRING DIAGRAM (FOLDOUT) .....	25-56
VEHICLE WIRING DIAGRAM (FOLDOUT) .....	25-57

---

## PREFACE TO ELECTRICAL DIAGRAM SECTION

This section contains diagrams for all electrical circuits and systems that are unique to the INFINITI M30 Convertible. As you will see, a number of these circuits are common to the M30 Coupe, but have been modified in some way, for example by the addition of a fusible link or by a change in connections or wire colors. Other circuits, such as those that operate the Convertible top, will not be found in the M30 Coupe in any form.

The rule of thumb for this M30 Convertible Service Manual Supplement, and particularly this Electrical Diagram section, is that it should be used in conjunction with the regular INFINITI M30 Service Manual. The Supplement covers Convertible matters only. If there are systems in common between the M30 Coupe and the M30 Convertible models, then the regular INFINITI Service Manual is the best source of information.

Wiring Diagram

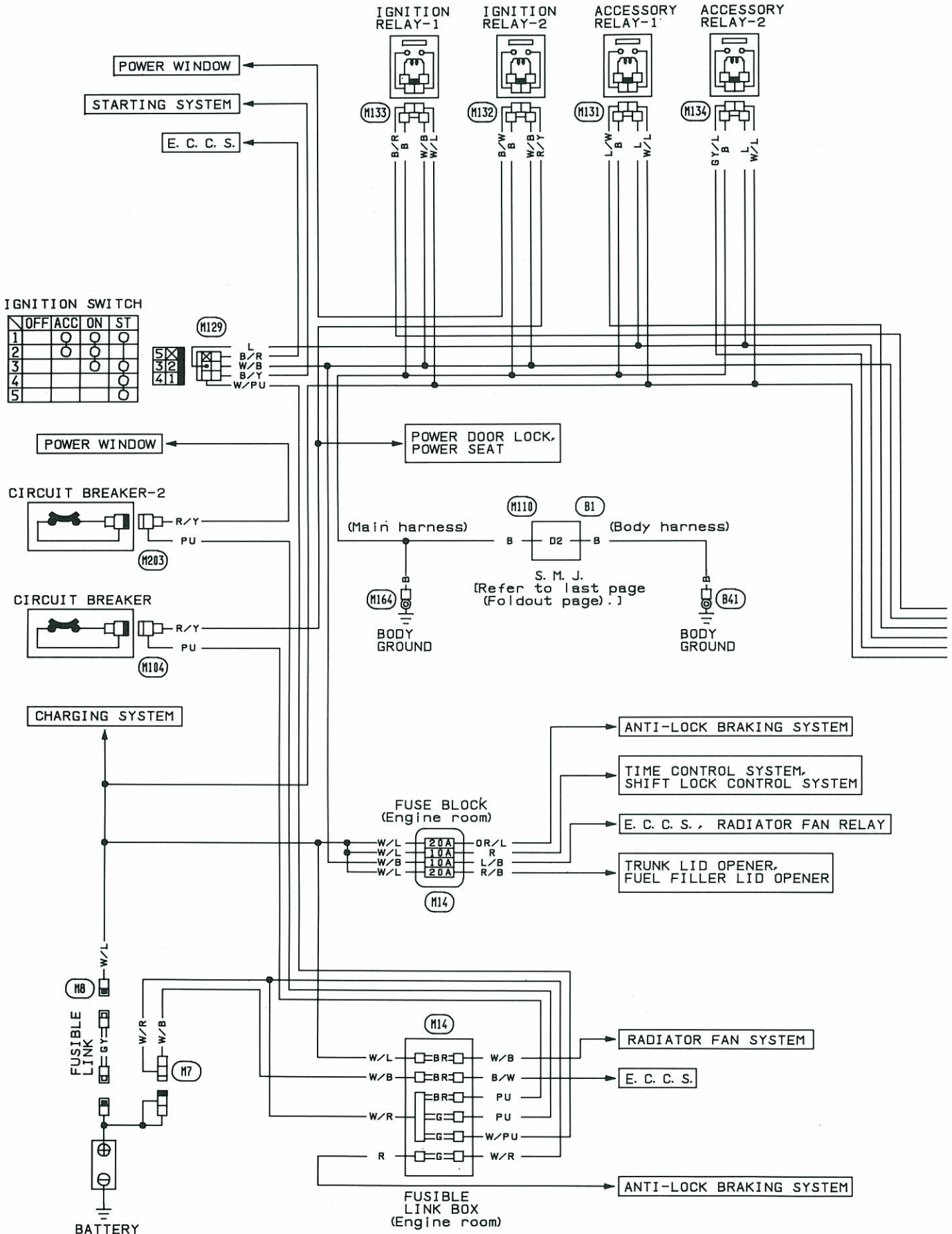

Wiring Diagram

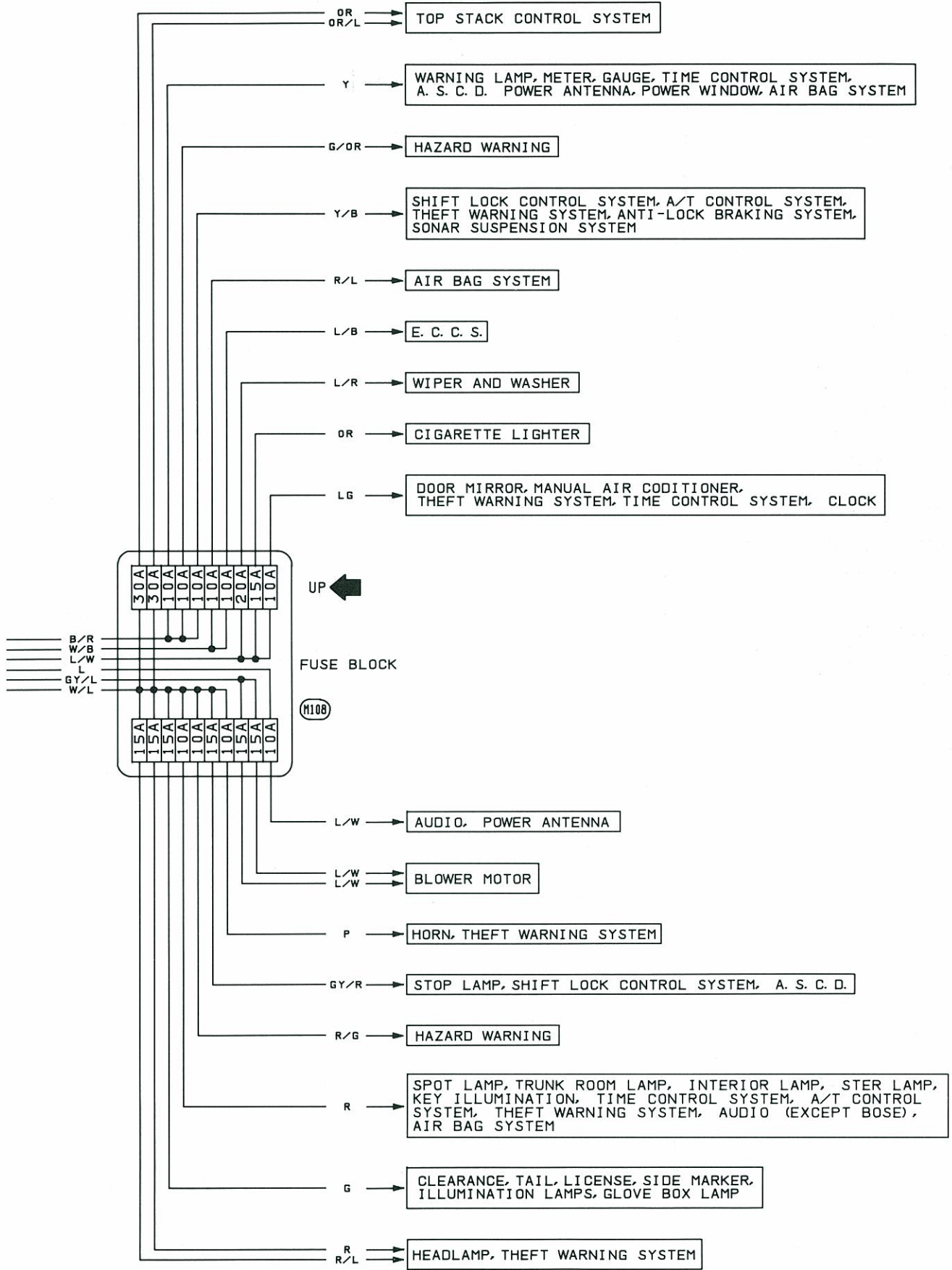

Circuit Diagram

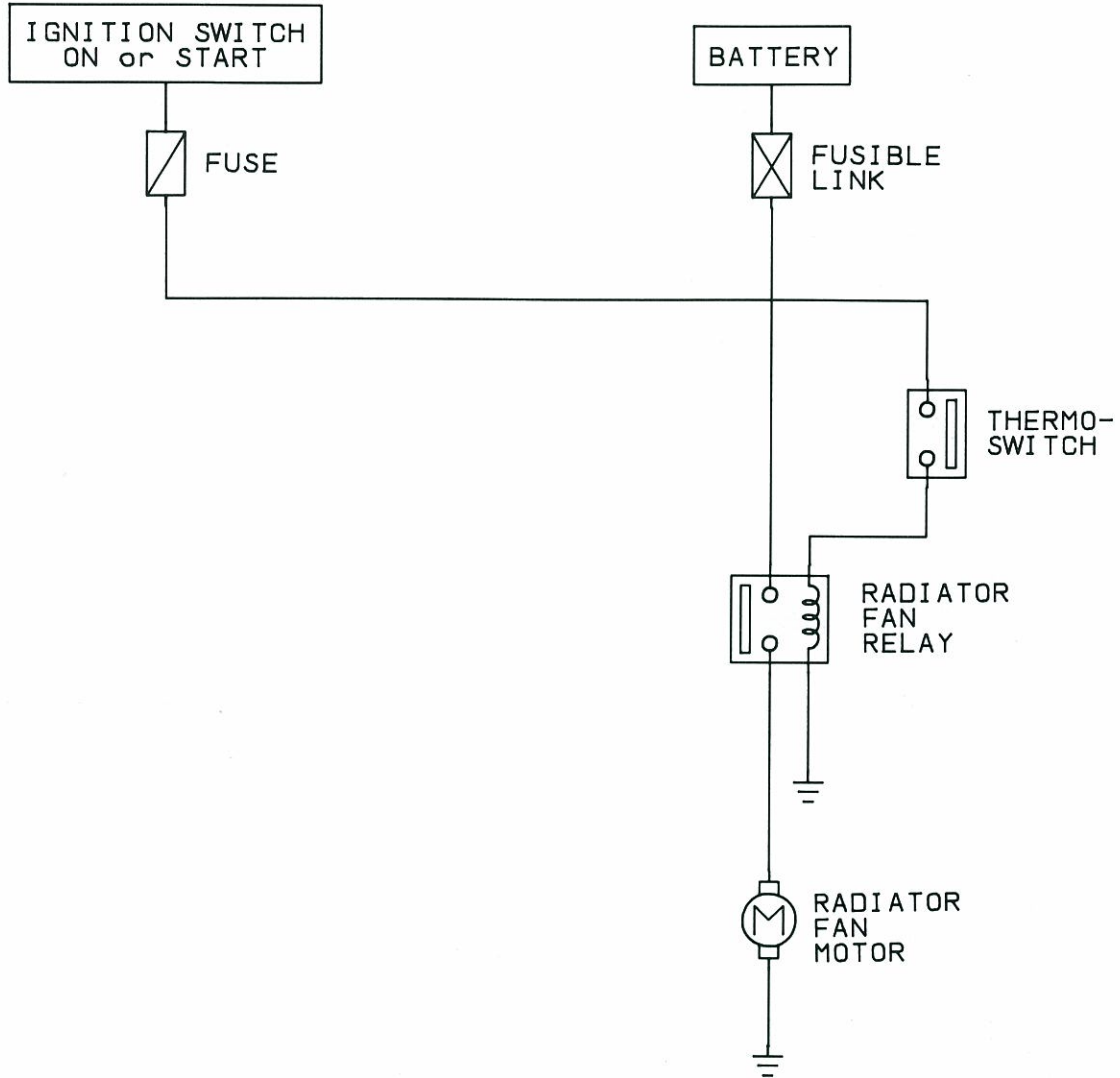

Wiring Diagram

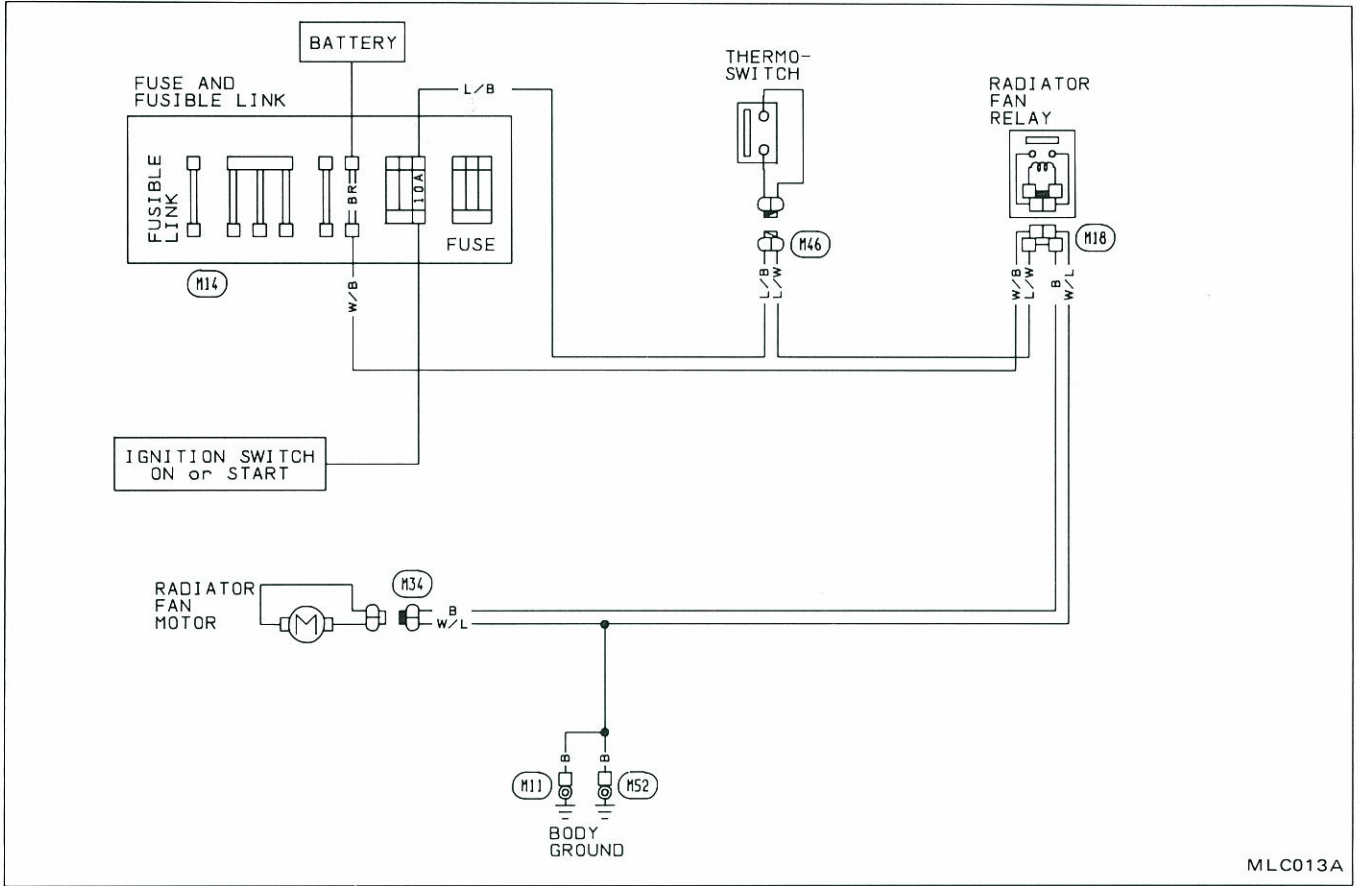

MLC013A

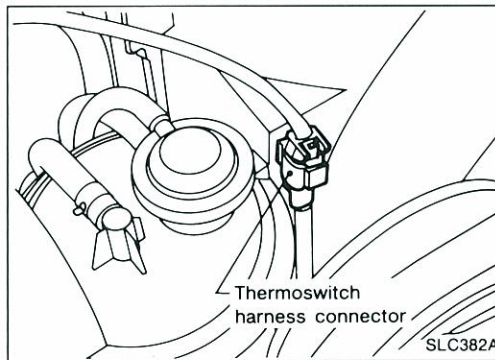
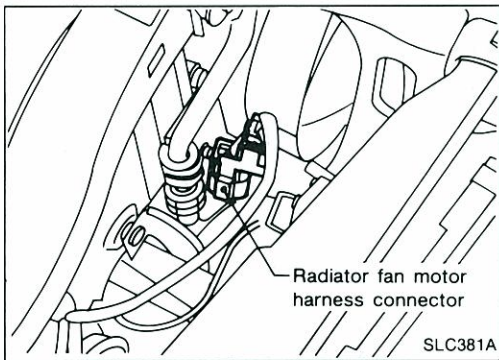

Circuit Diagram

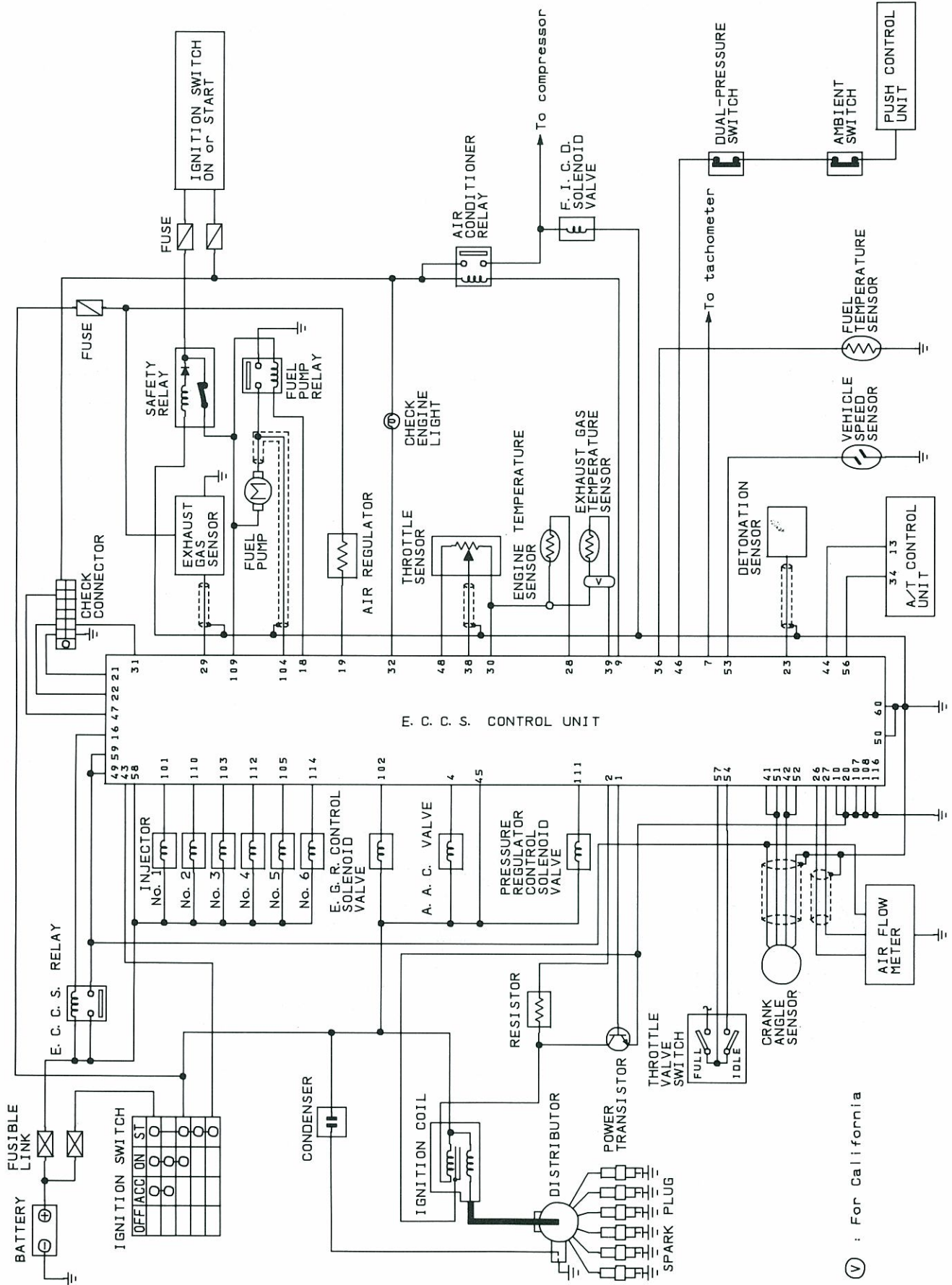

(V) : For California



Diagnostic Procedure 22

MAIN POWER SUPPLY AND GROUND CIRCUIT (Not self-diagnostic item)

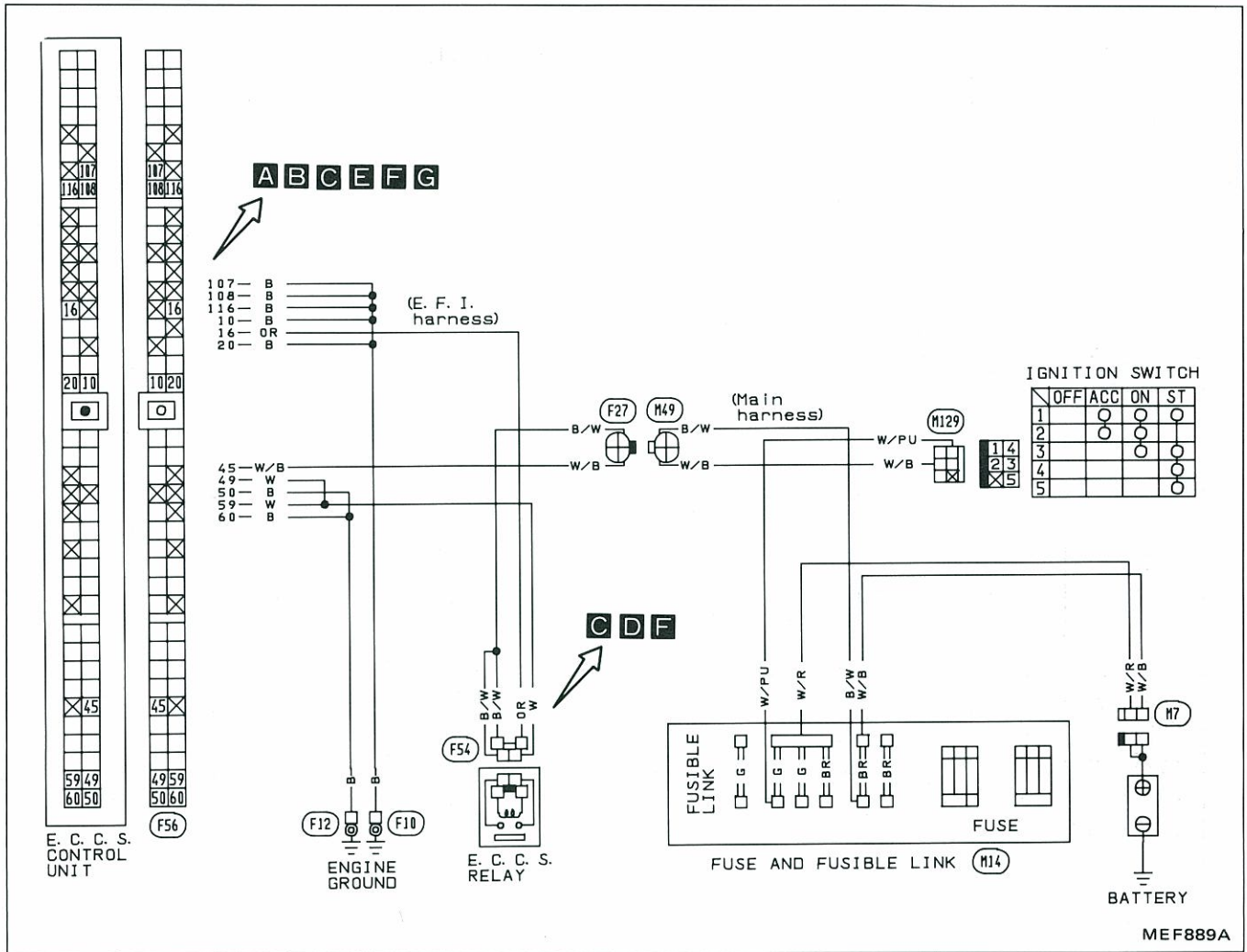

Harness layout

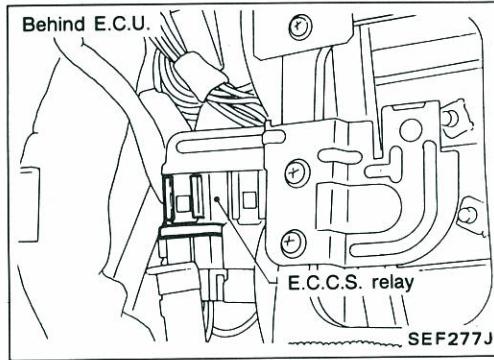
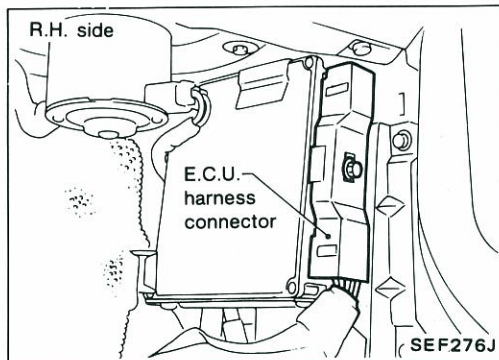

Diagnostic Procedure 23

CRANK ANGLE SENSOR (Code No. 11)

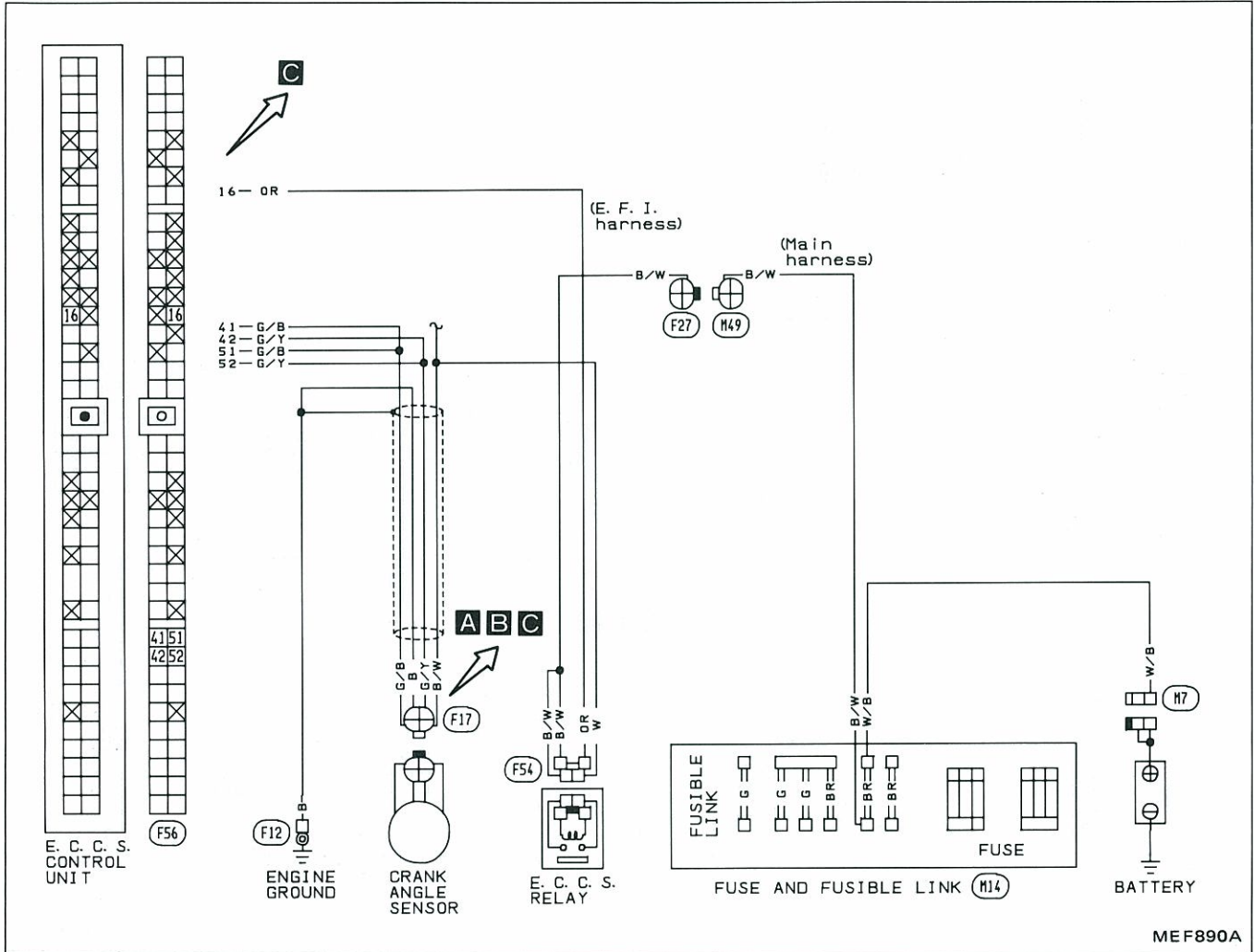

MEF890A

Harness layout

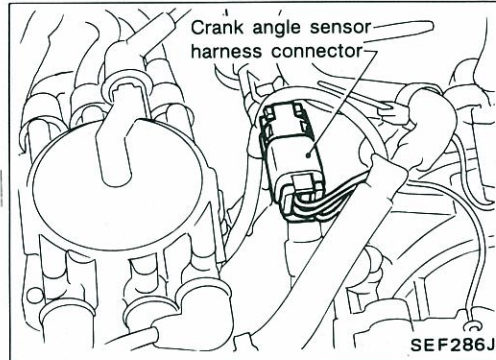
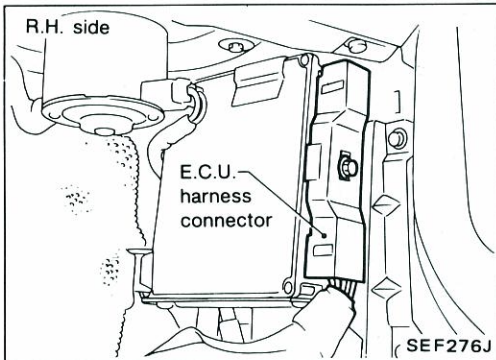

Diagnostic Procedure 24

AIR FLOW METER (Code No. 12)  (CHECK ENGINE LIGHT ITEM)

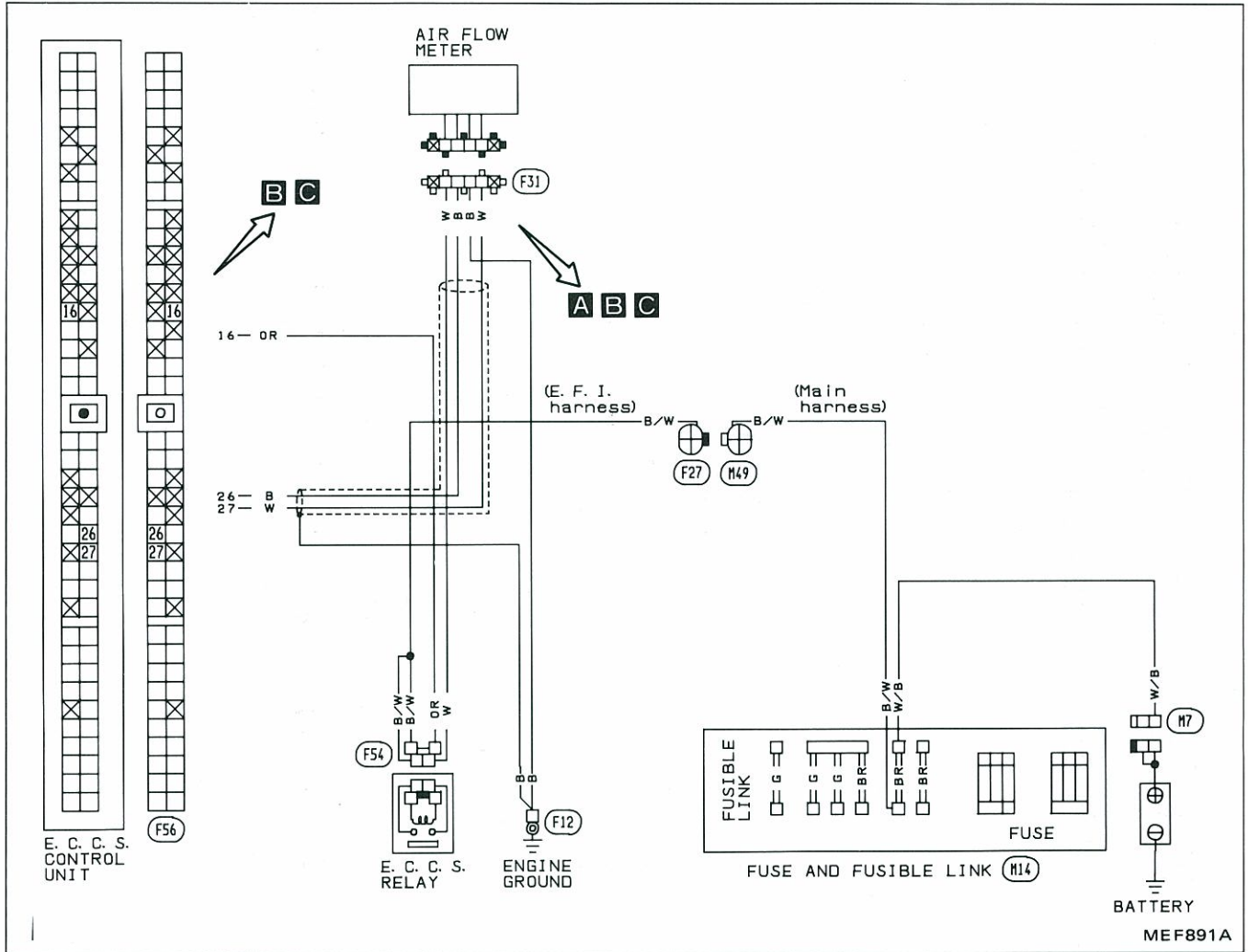

Harness layout

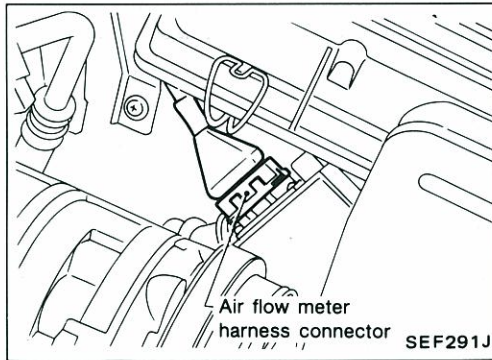
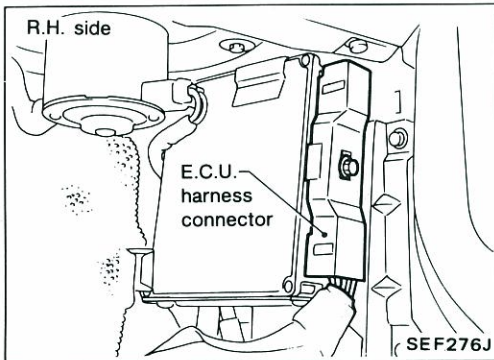

Diagnostic Procedure 26

VEHICLE SPEED SENSOR (Code No. 14)  (CHECK ENGINE LIGHT ITEM)

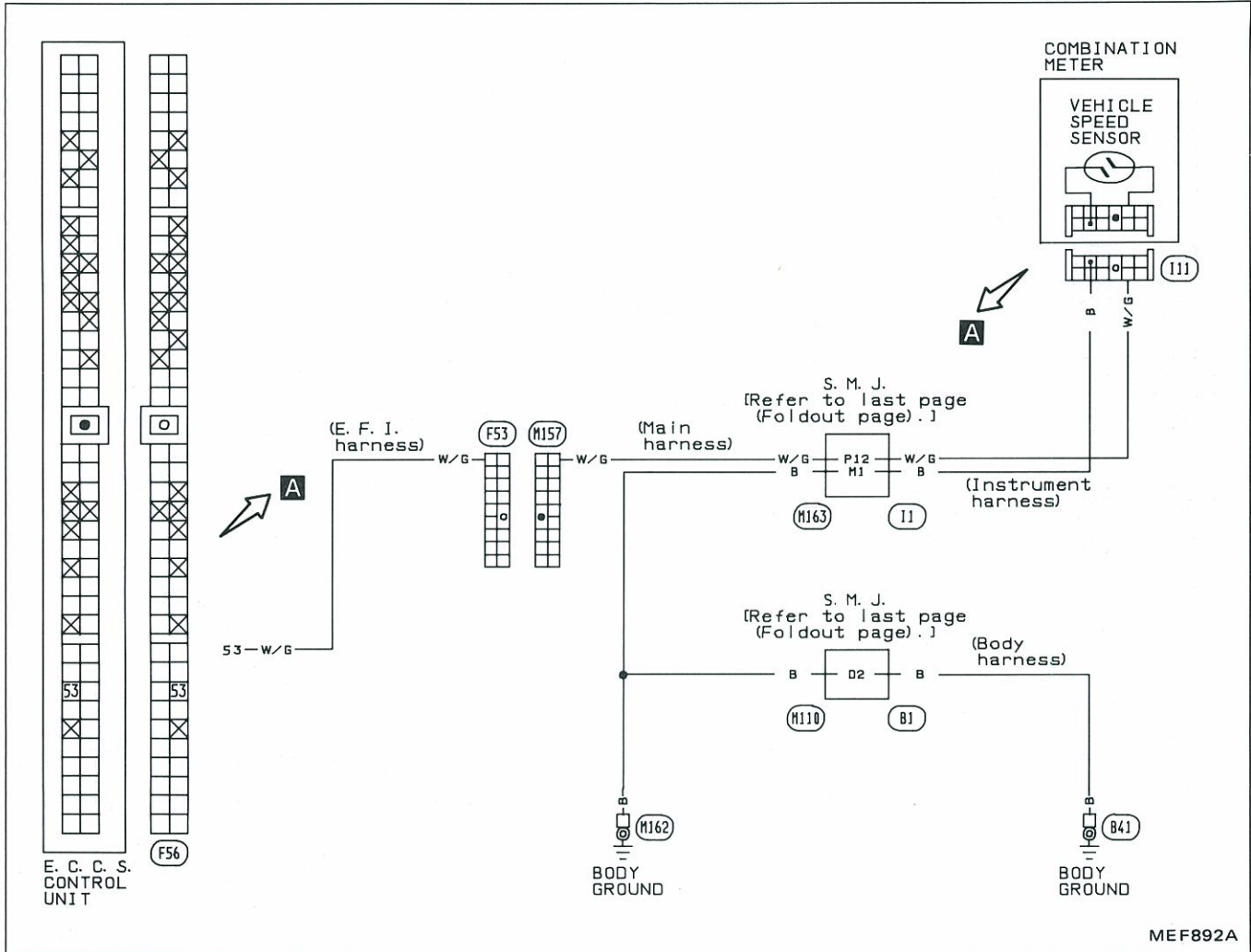

Harness layout

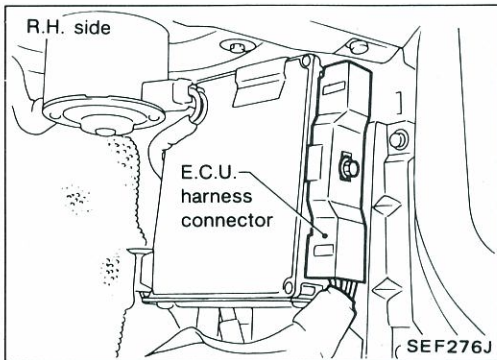

Diagnostic Procedure 27

IGNITION SIGNAL (Code No. 21)

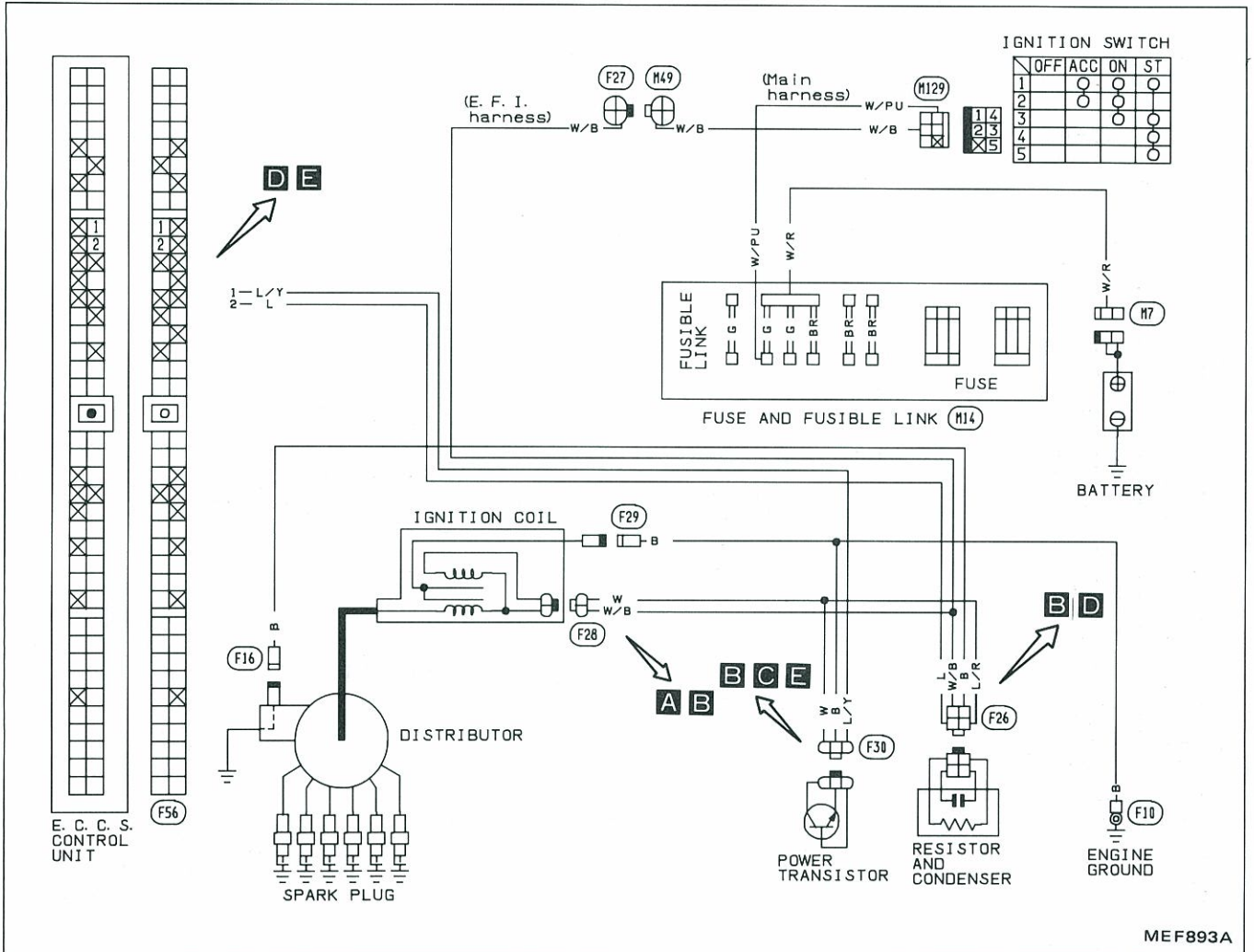

MEF893A

Harness layout

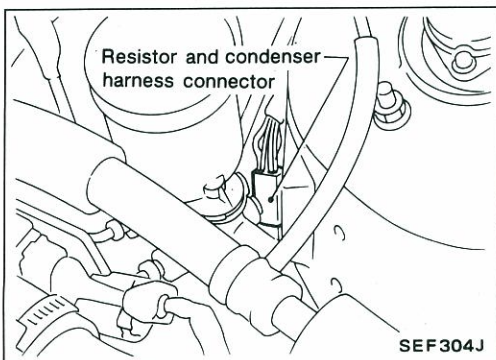
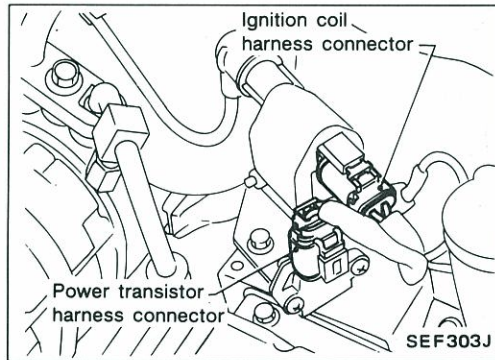
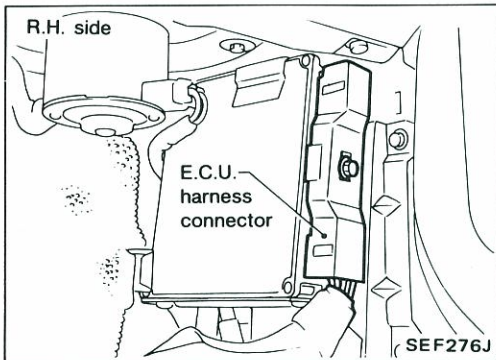

Diagnostic Procedure 28

FUEL PUMP CONTROL (Code No. 22)

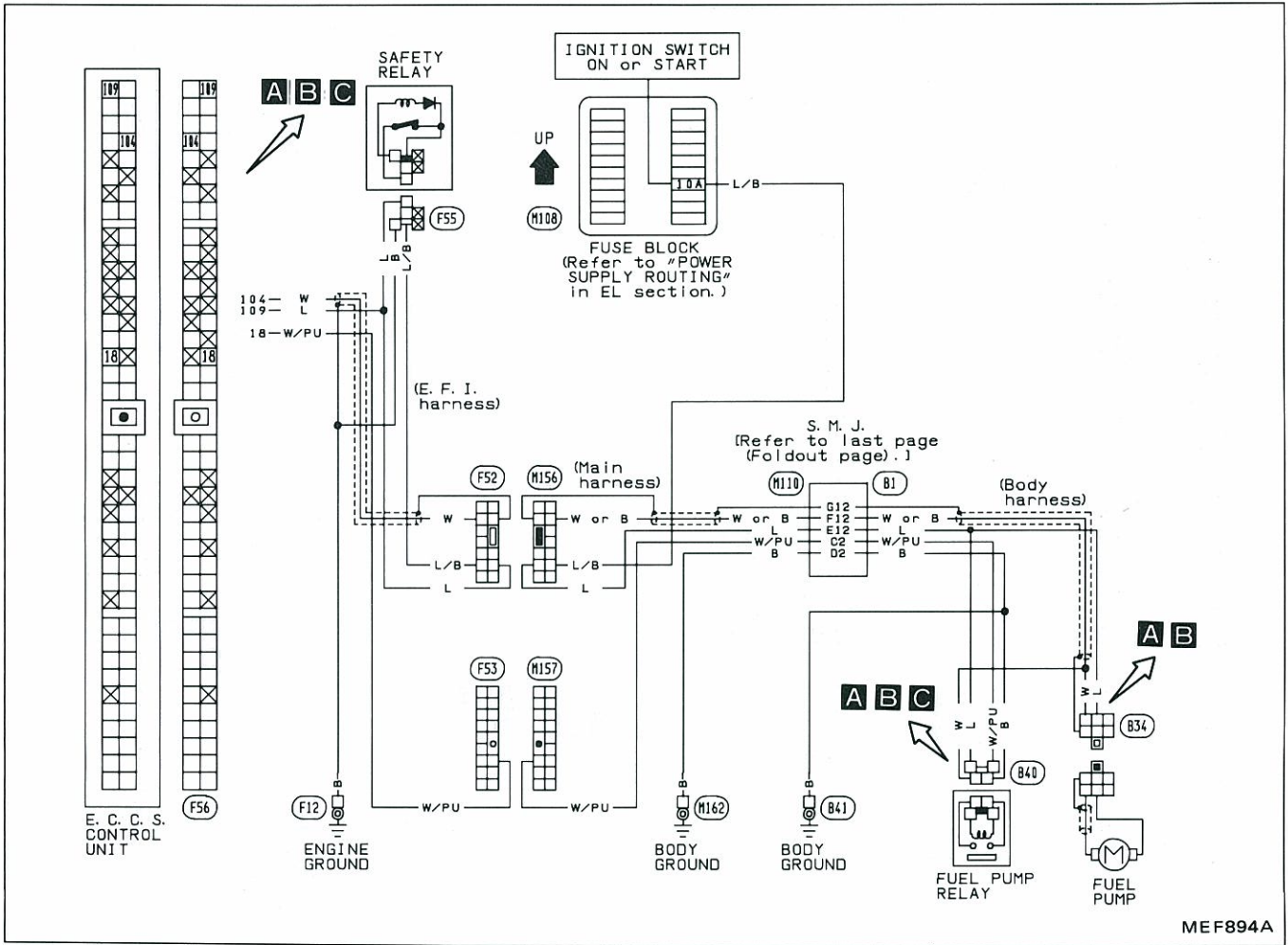

MEF894A

Harness layout

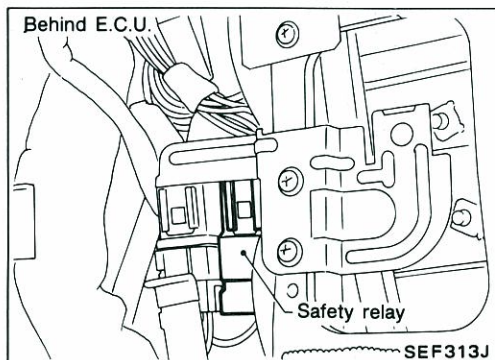
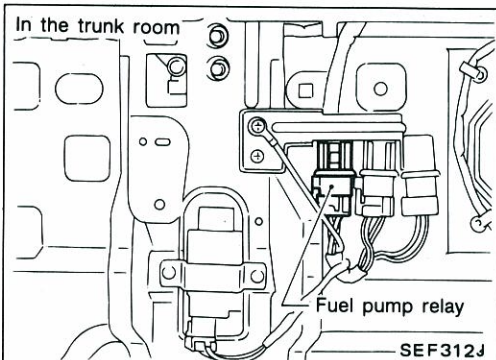
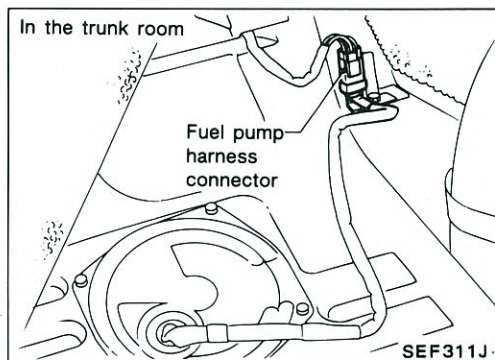
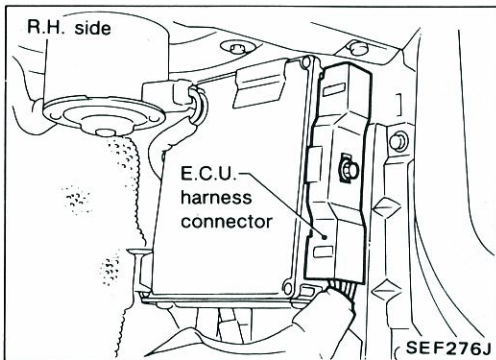

Diagnostic Procedure 30

E.G.R. FUNCTION (Code No. 32)  (CHECK ENGINE LIGHT ITEM): CALIFORNIA MODEL  
 E.G.R. CONTROL (Not self-diagnostic item): NON-CALIFORNIA MODEL

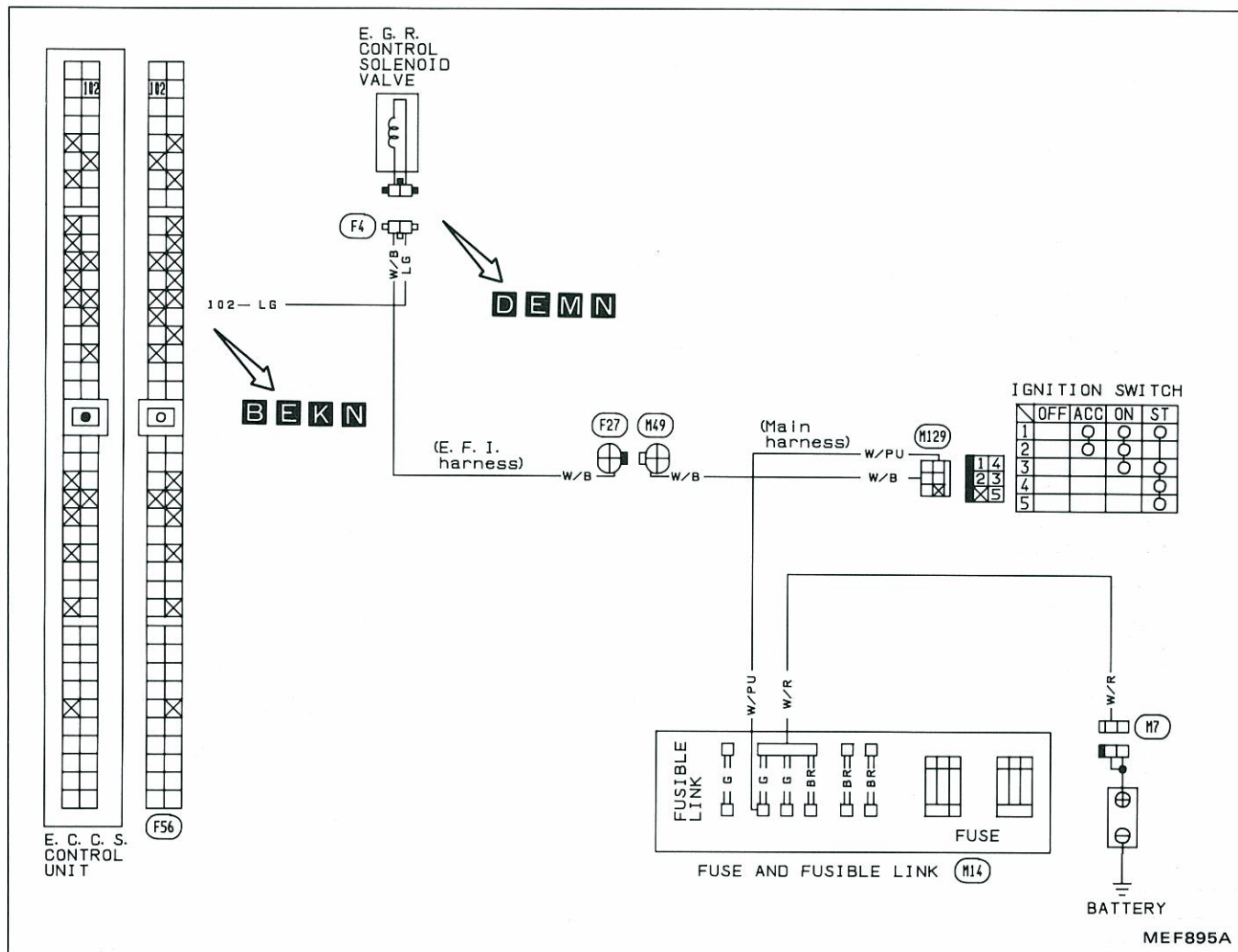

Harness layout

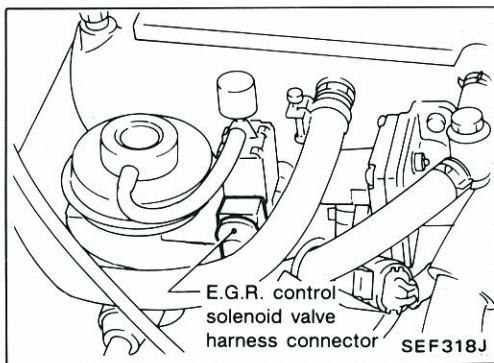
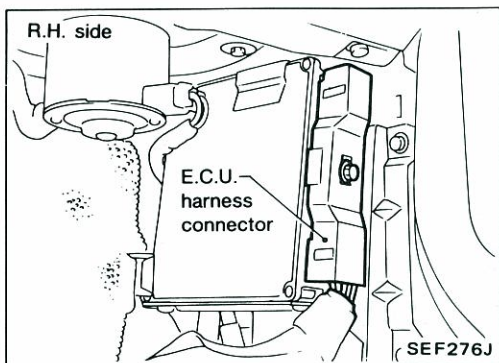

Diagnostic Procedure 31

EXHAUST GAS SENSOR (Code No. 33)

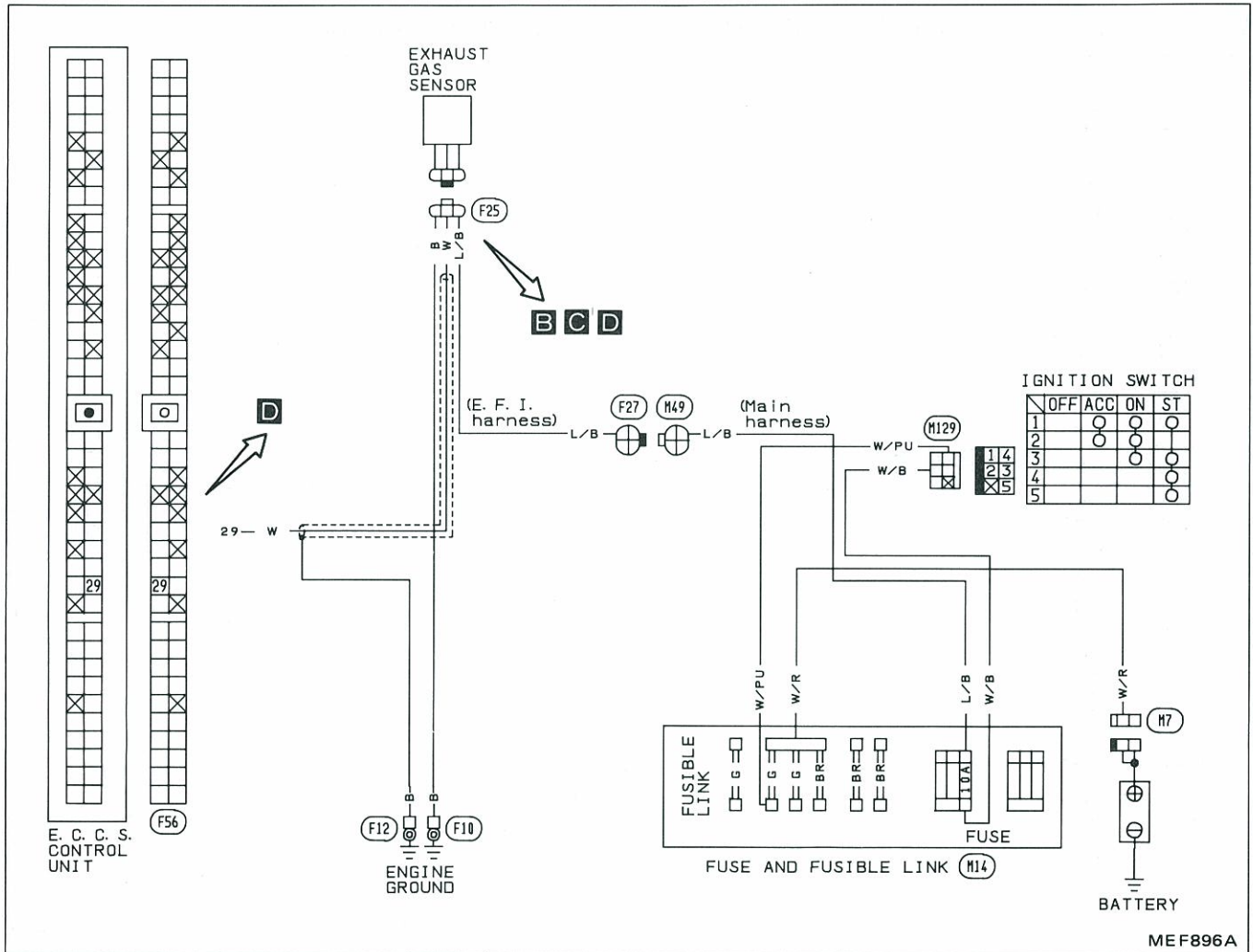

Harness layout

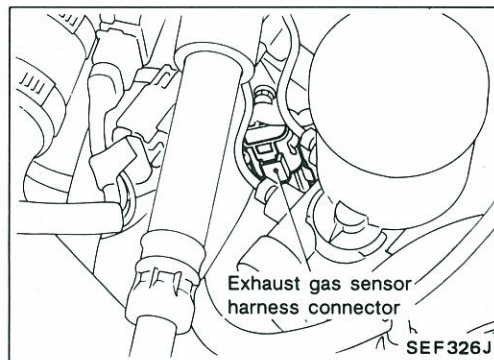
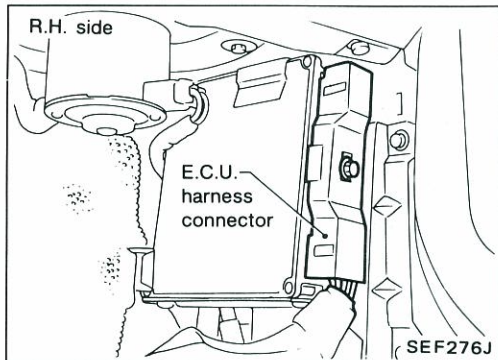



Diagnostic Procedure 32

DETONATION SENSOR (Code No. 34)

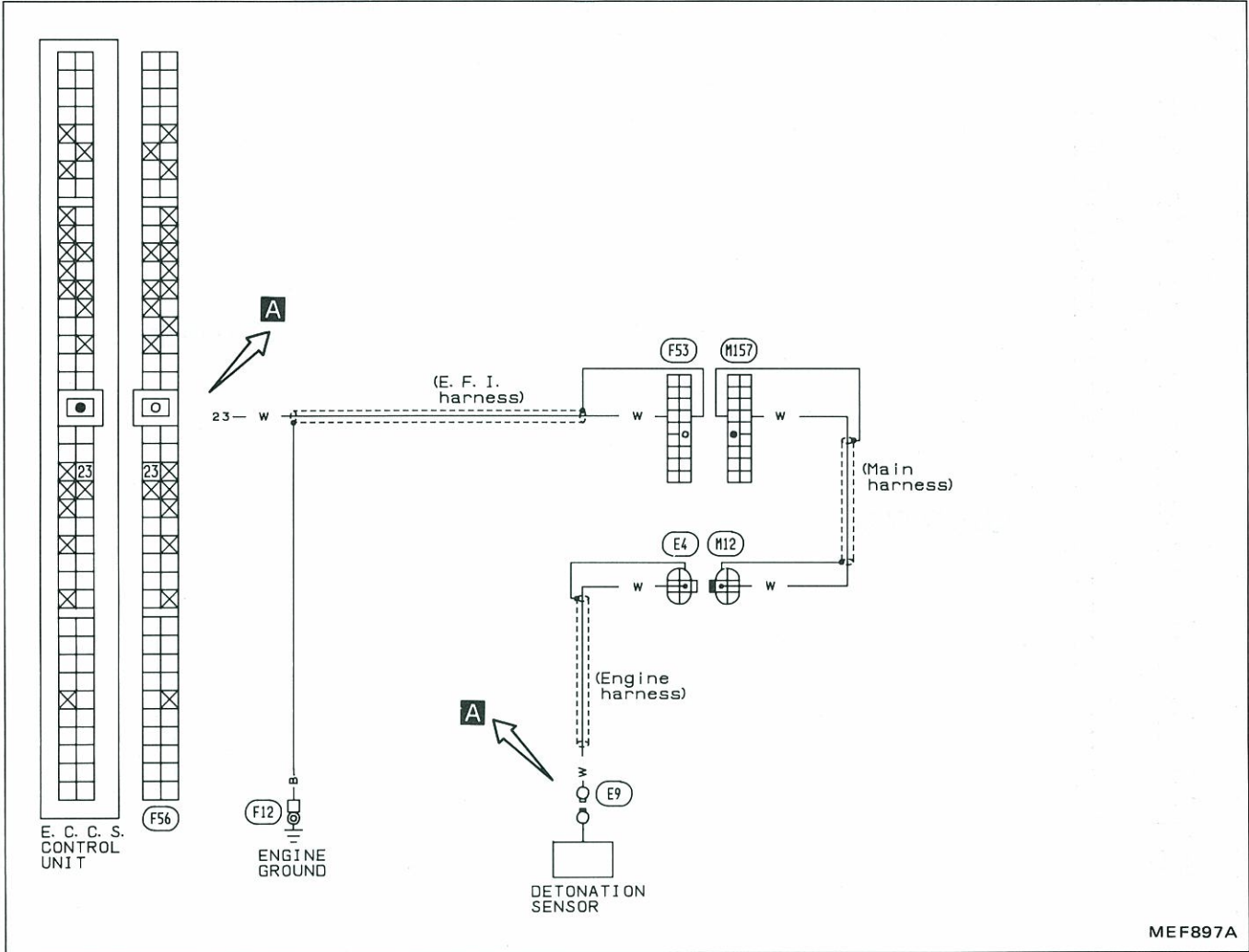

Harness layout

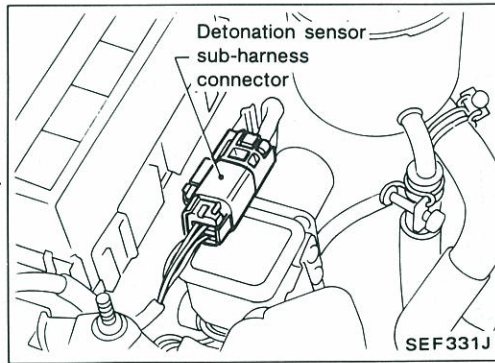
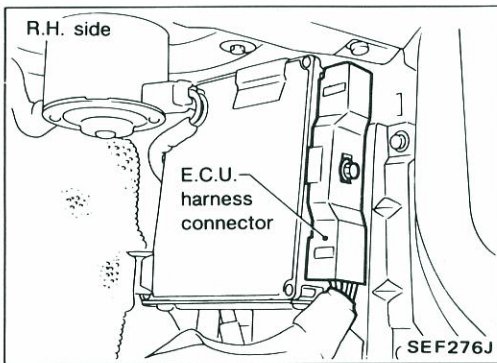

Diagnostic Procedure 37

INJECTOR CIRCUIT (Code No. 51) <sup>H</sup>CHECK (CHECK ENGINE LIGHT ITEM): CALIFORNIA MODEL  
 INJECTOR CIRCUIT (Not self-diagnostic item): NON-CALIFORNIA MODEL

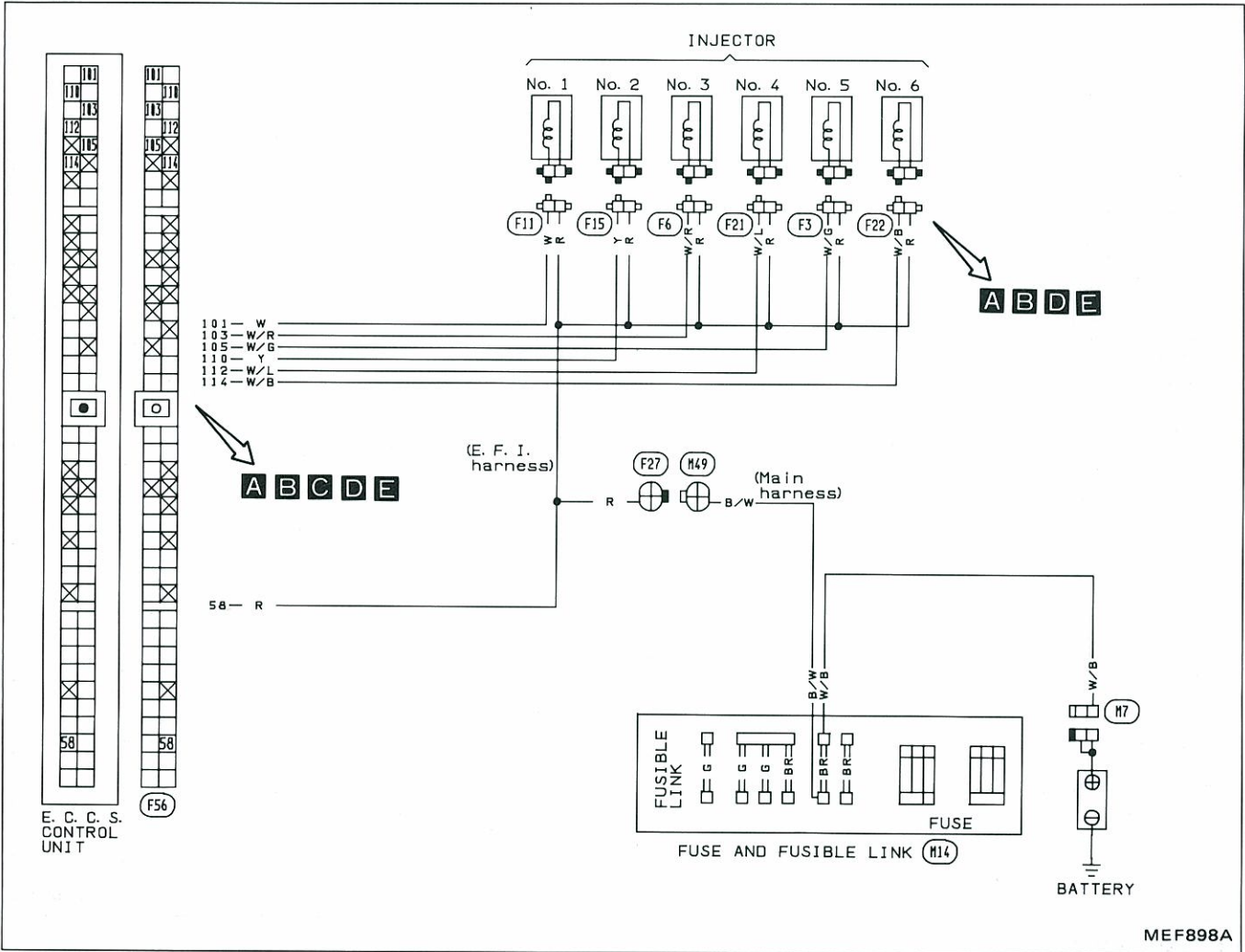

Harness layout

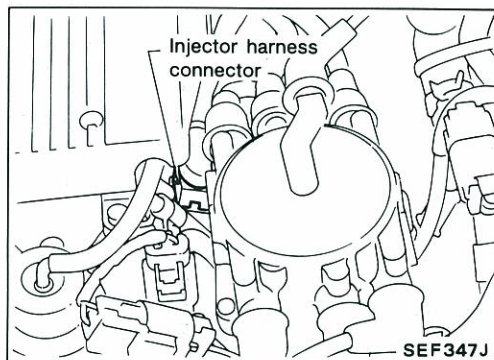
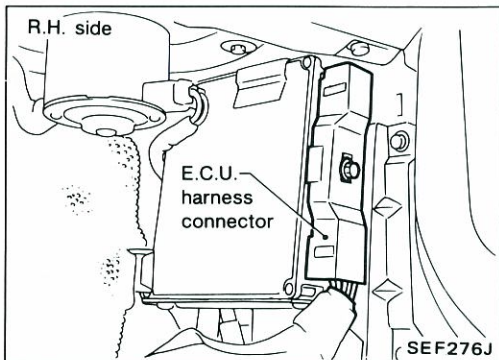

Diagnostic Procedure 39

START SIGNAL (Not self-diagnostic item)

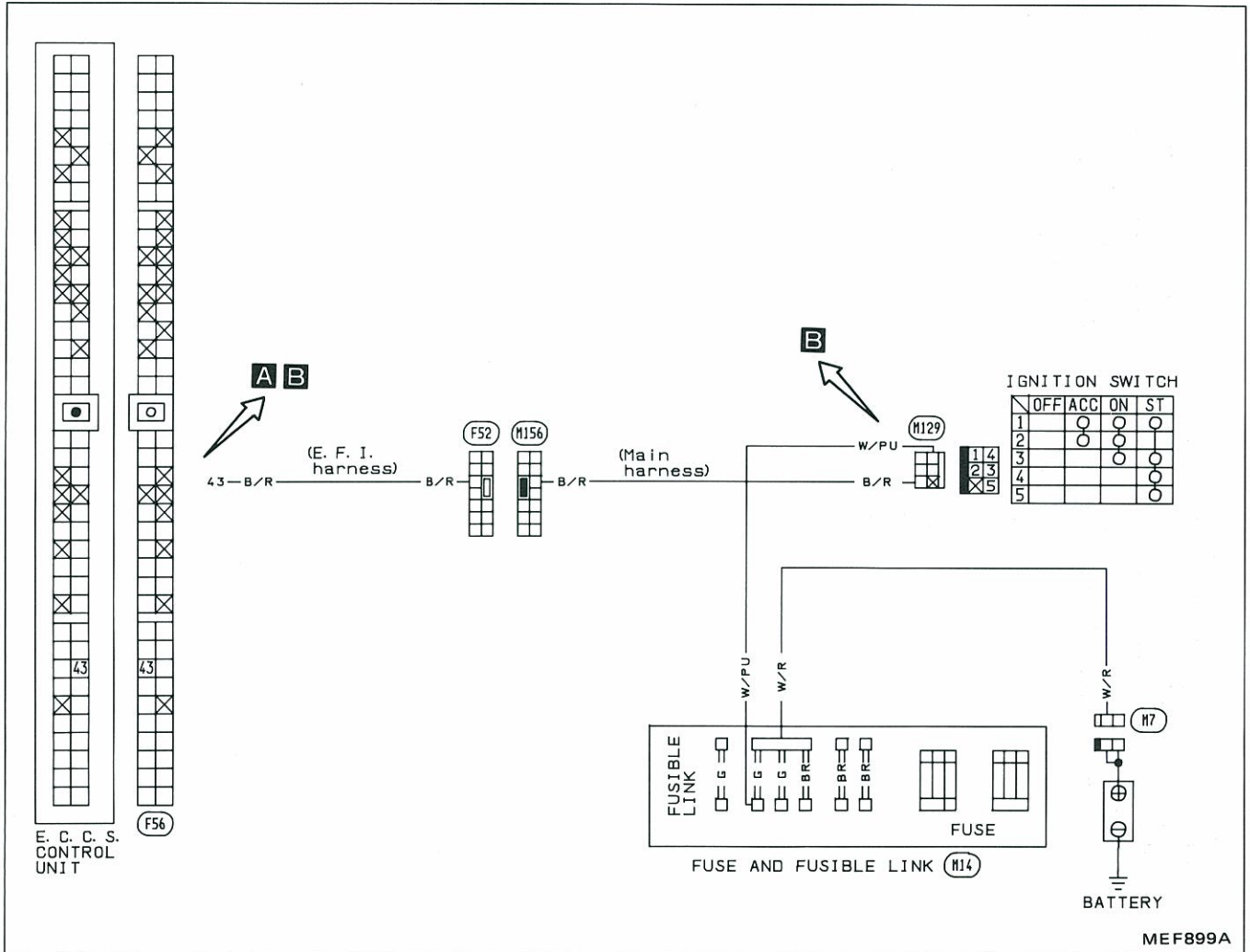

Harness layout

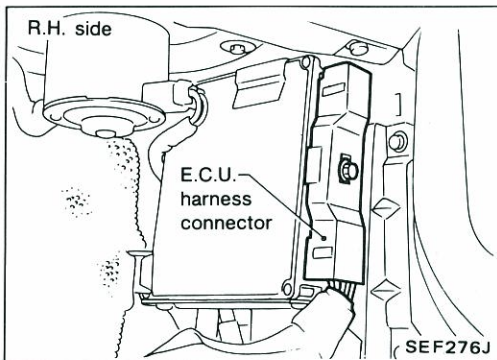

Diagnostic Procedure 41

AIR REGULATOR (Not self-diagnostic item)

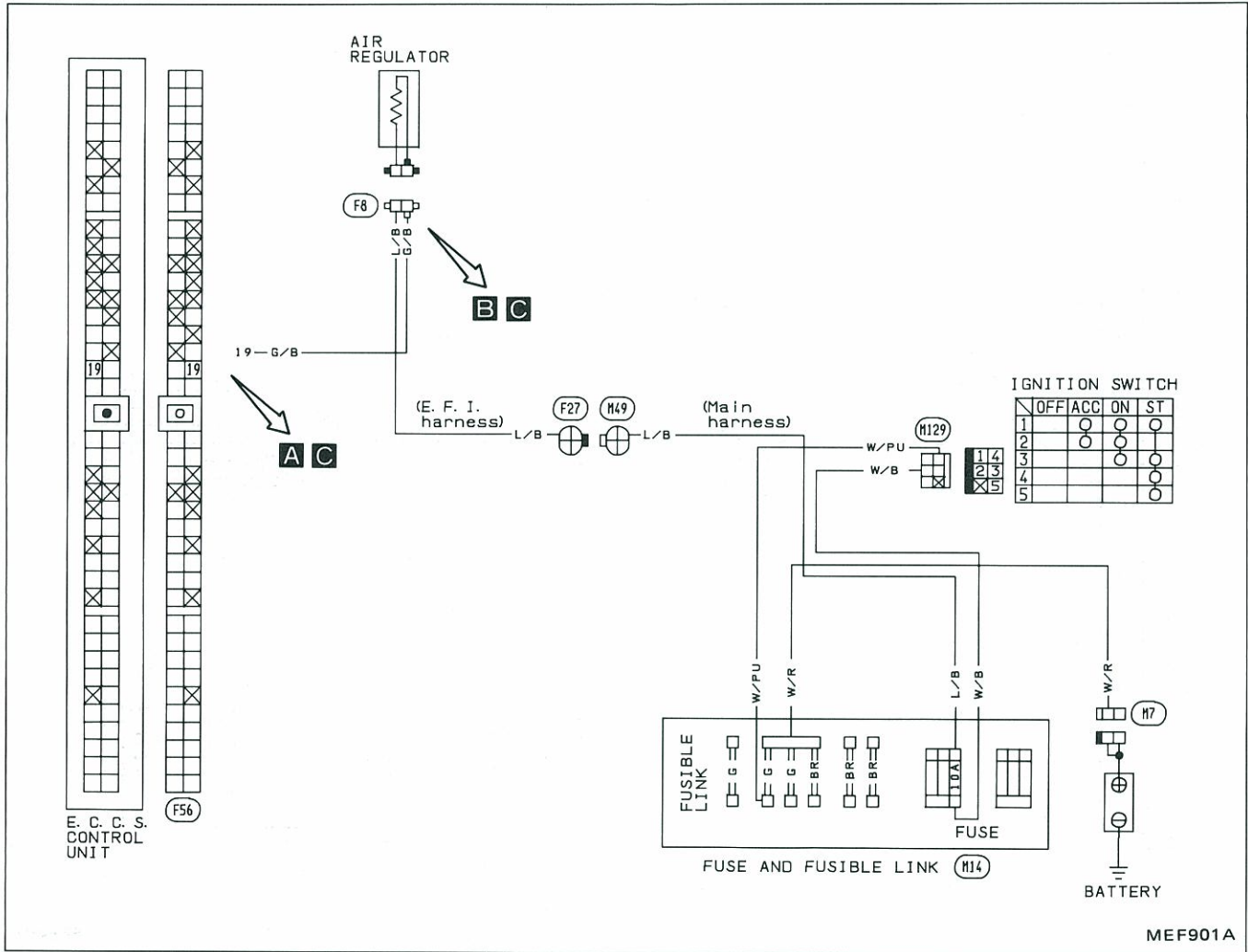

MEF901A

Harness layout

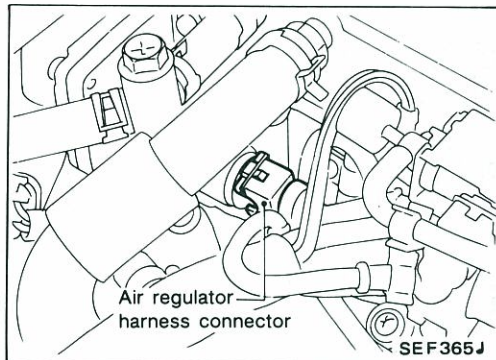
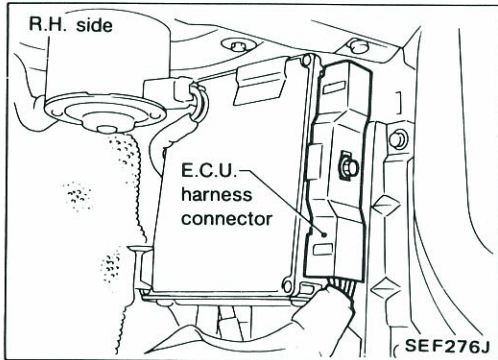

Diagnostic Procedure 42

A.A.C. VALVE (Not self-diagnostic item)

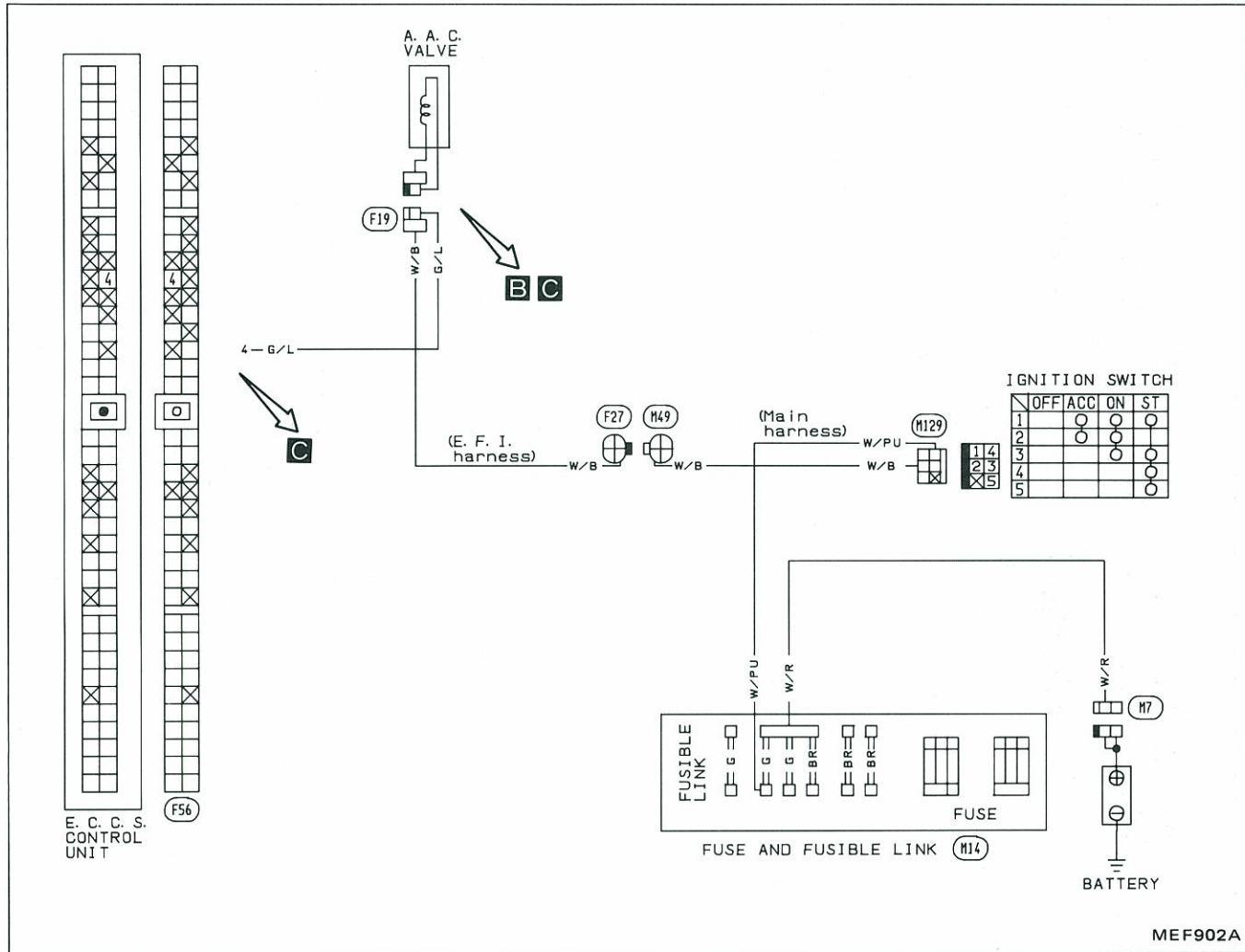

MEF902A

Harness layout

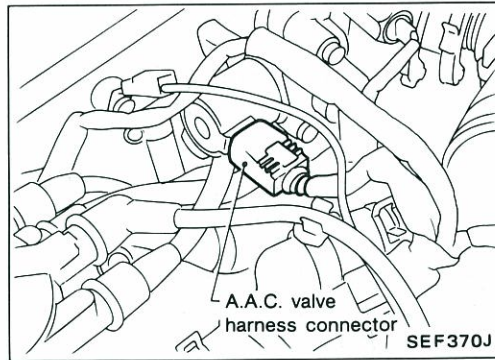
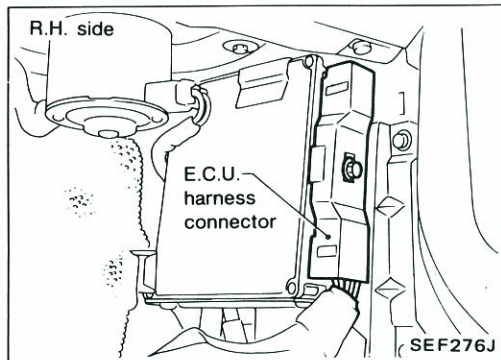

A/T Shift Lock System (Cont'd)

WIRING DIAGRAM

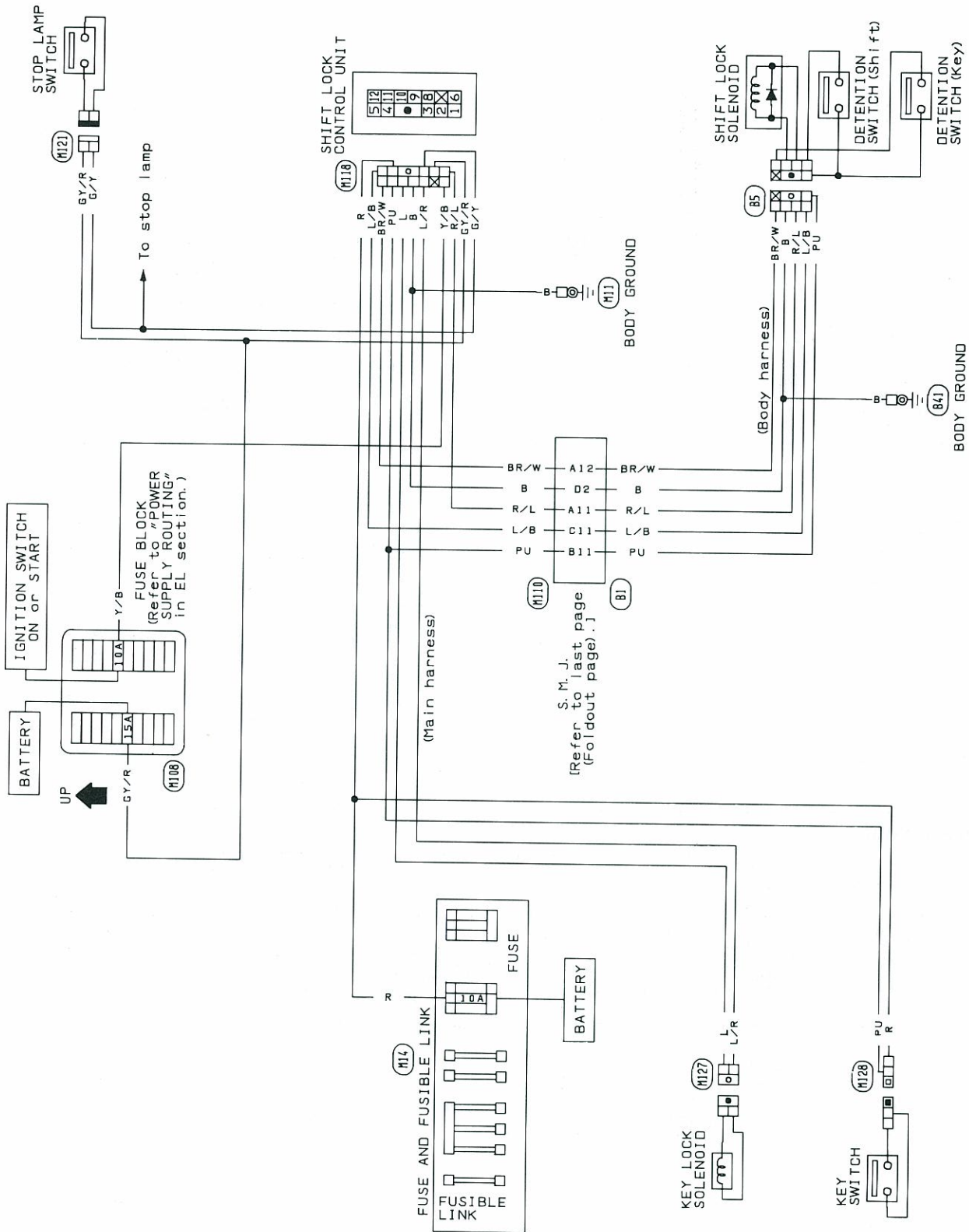

Circuit Diagram for Quick Pinpoint Check

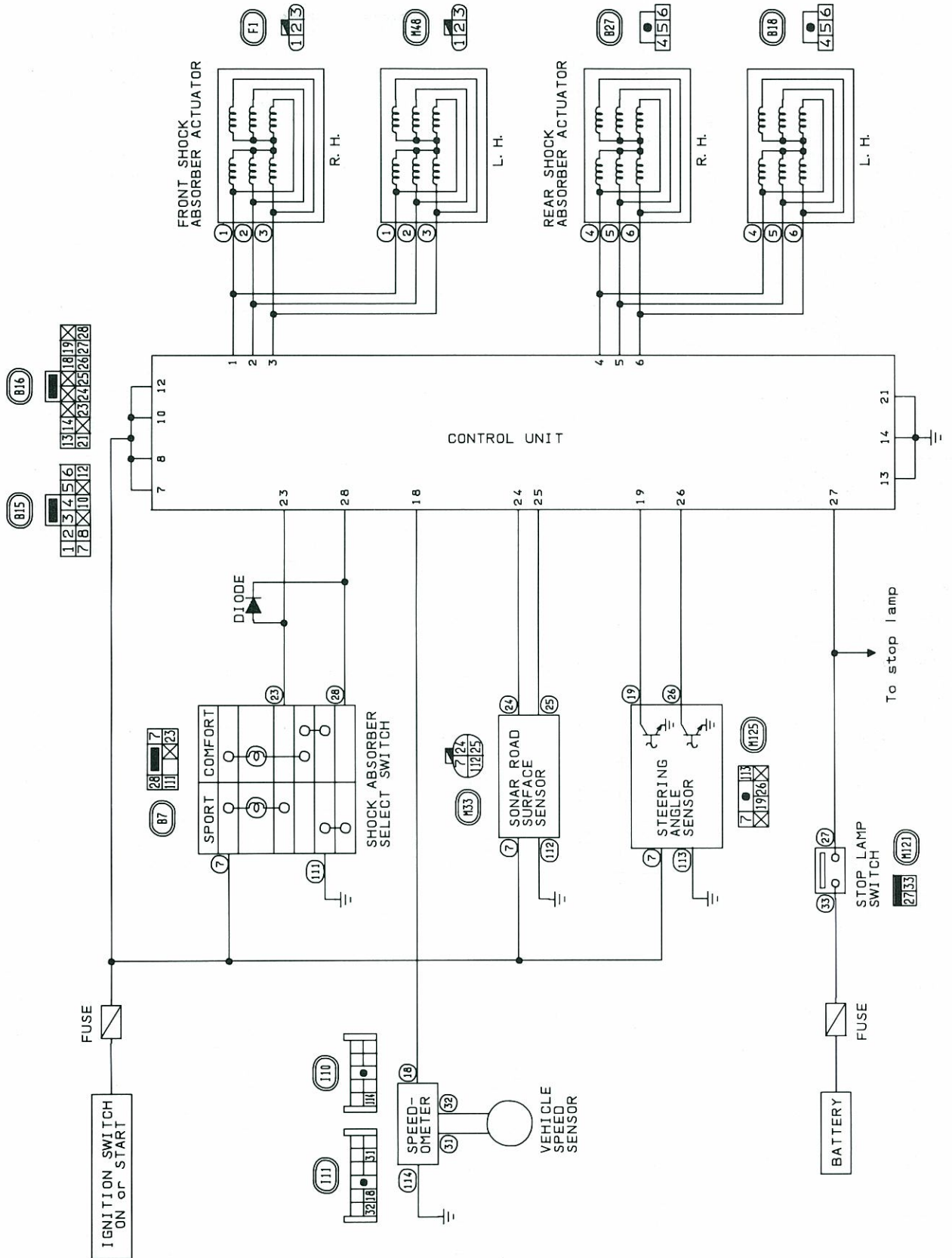

Wiring Diagram

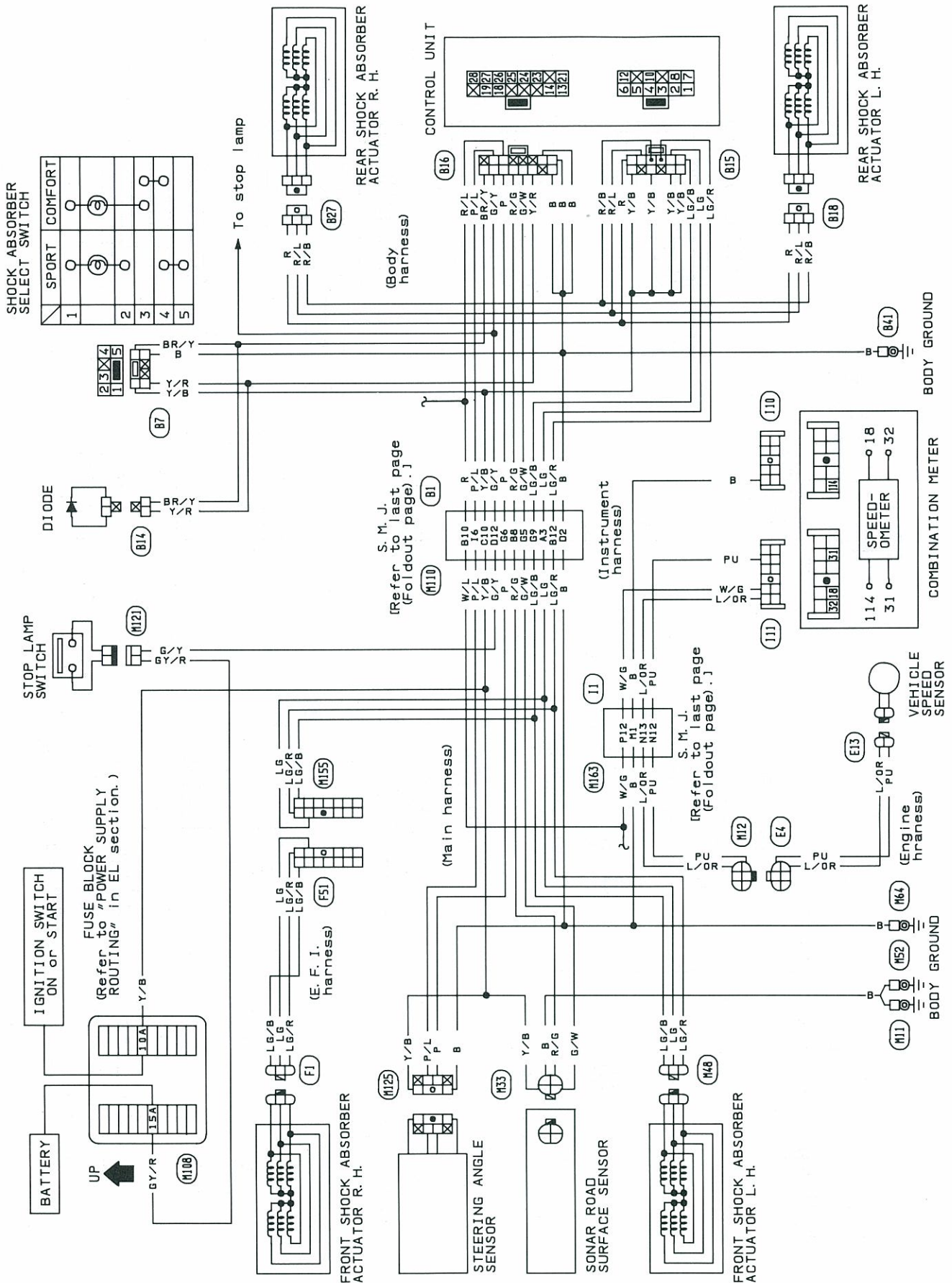



Wiring Diagram

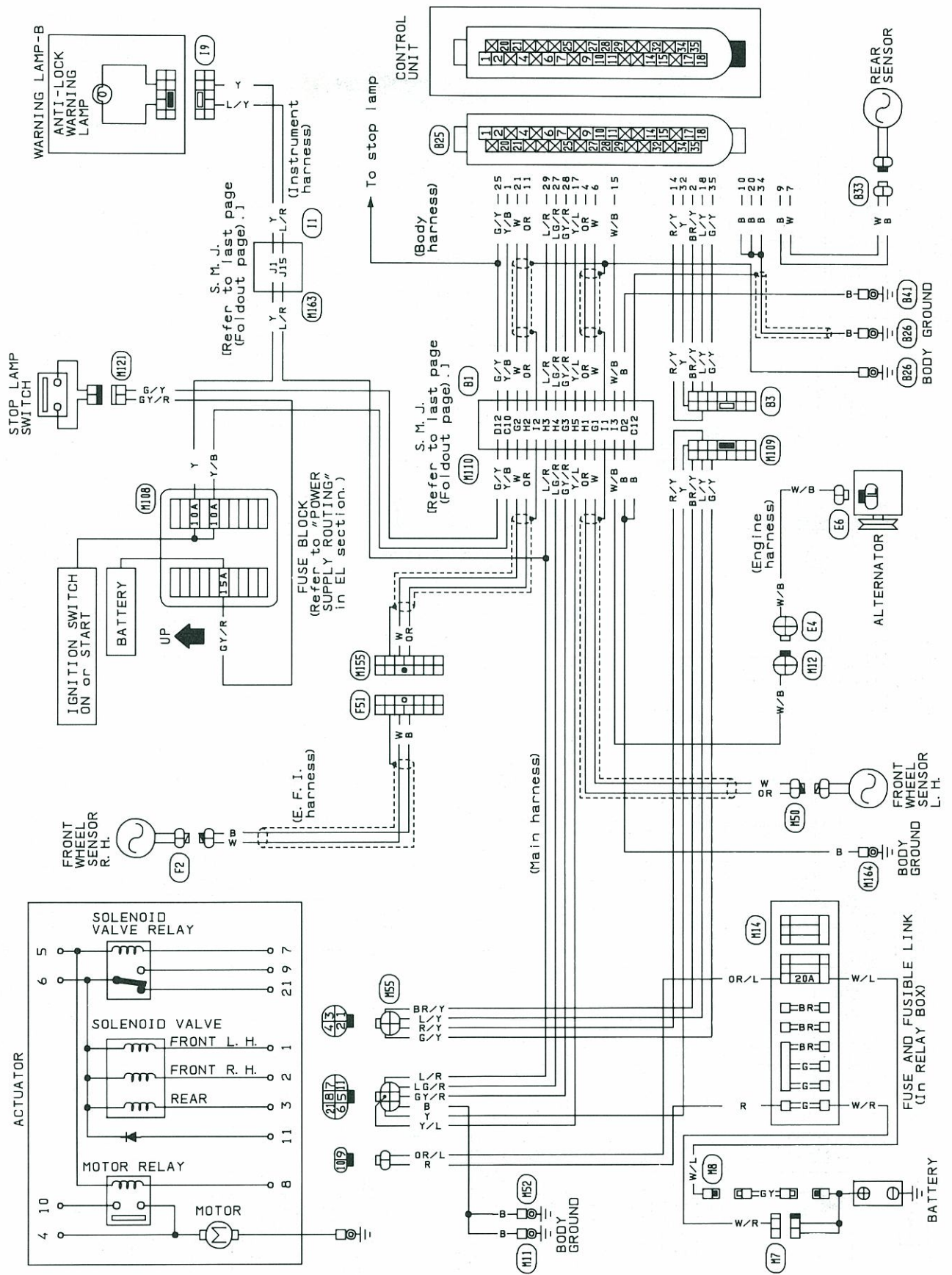

Wiring Diagram

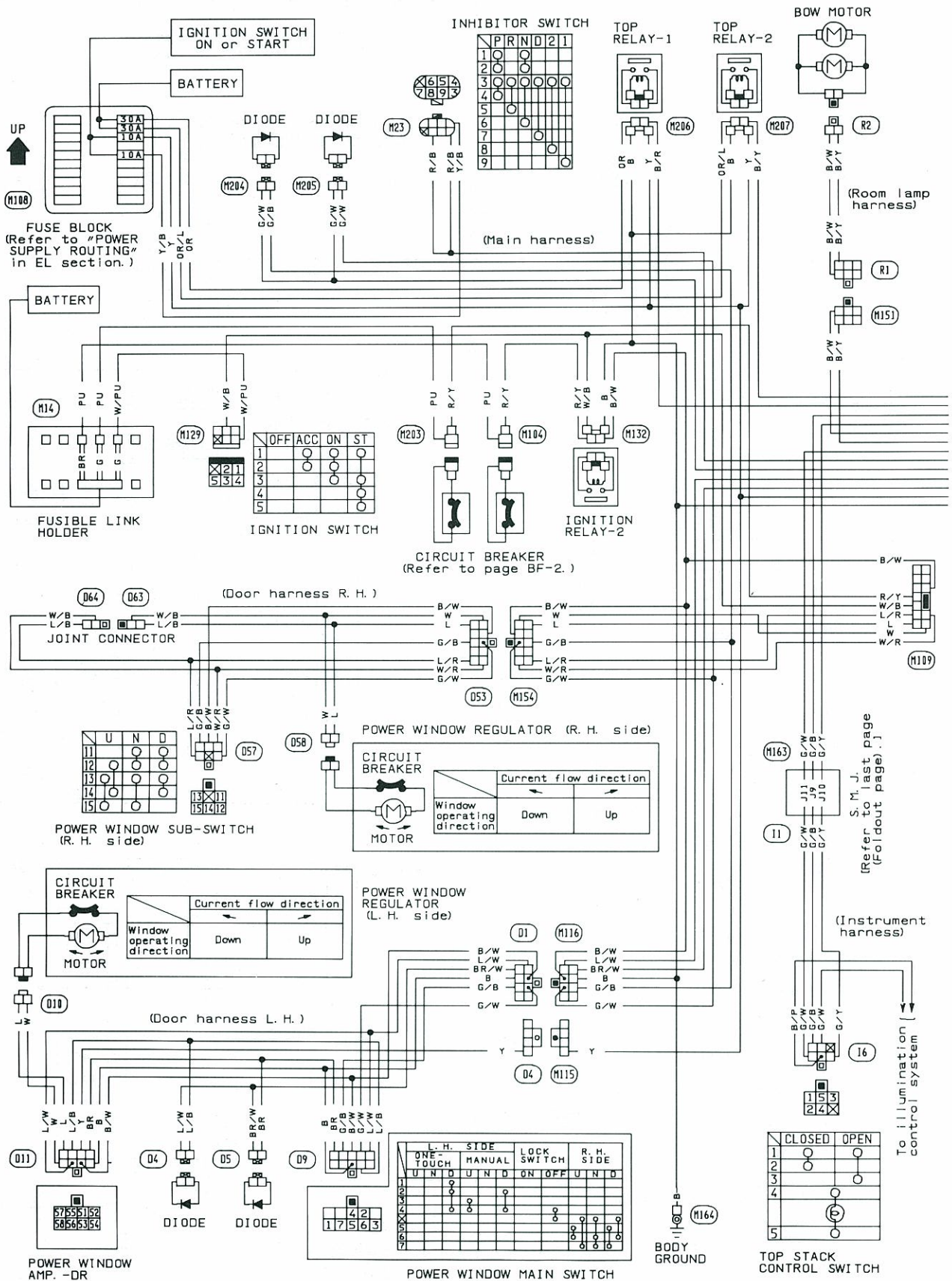

Wiring Diagram (Cont'd)

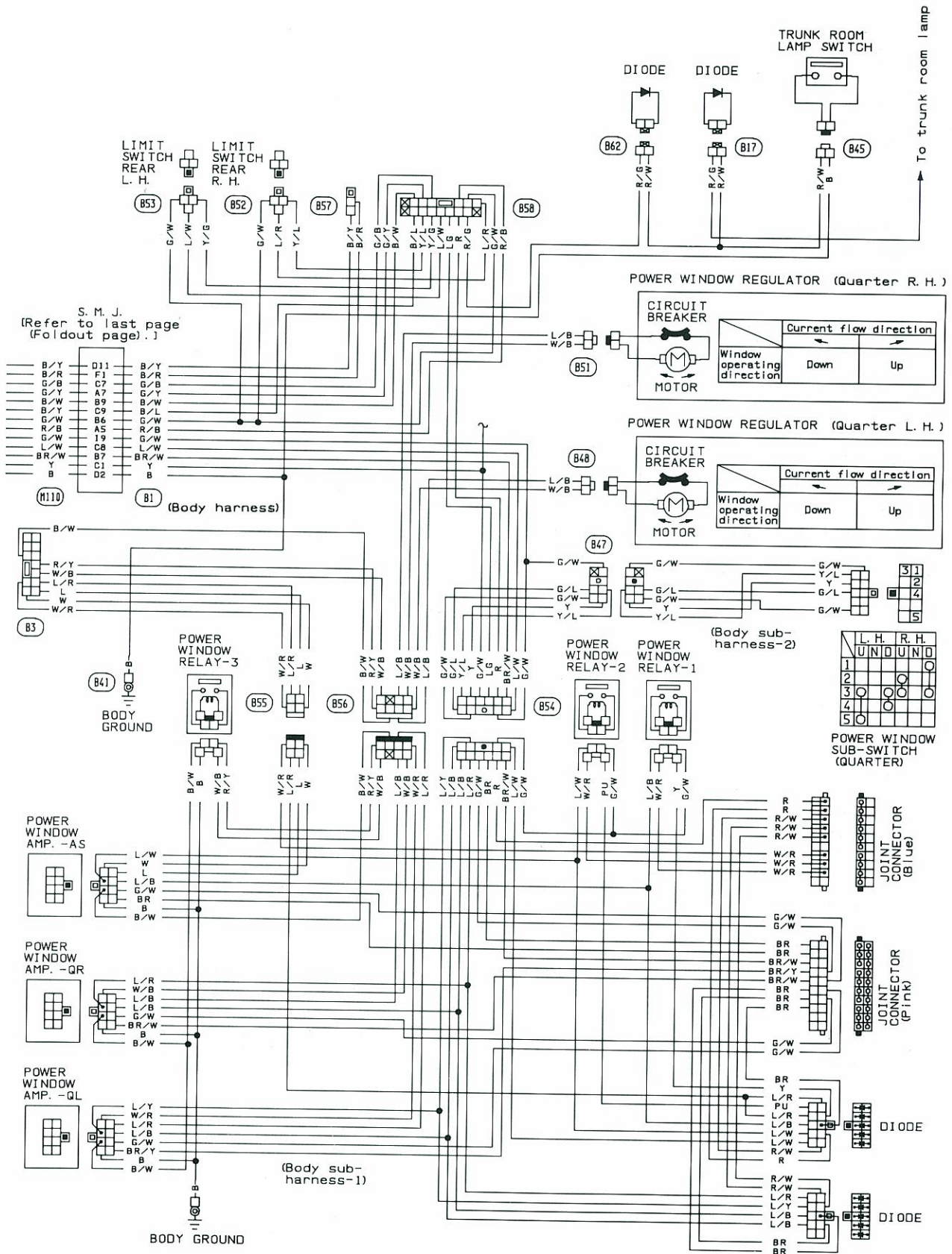

S. M. J.  
(Refer to last page  
(Foldout page).)

B/Y	D11	B/Y
B/R	F1	B/R
G/B	C7	G/B
G/Y	A7	G/Y
B/W	B9	B/W
B/Y	C9	B/Y
G/W	B6	G/W
R/B	A5	R/B
G/W	19	G/W
L/W	C8	L/W
BR/W	B7	BR/W
Y	C1	Y
B	D2	B

	L.H.	R.H.
	U	N
	U	N
	U	N
	U	N
	U	N
	U	N
	U	N
	U	N
	U	N

POWER WINDOW SUB-SWITCH (QUARTER)

Body Rear End and Opener

TRUNK LID OPENER AND FUEL FILLER LID OPENER/WIRING DIAGRAM

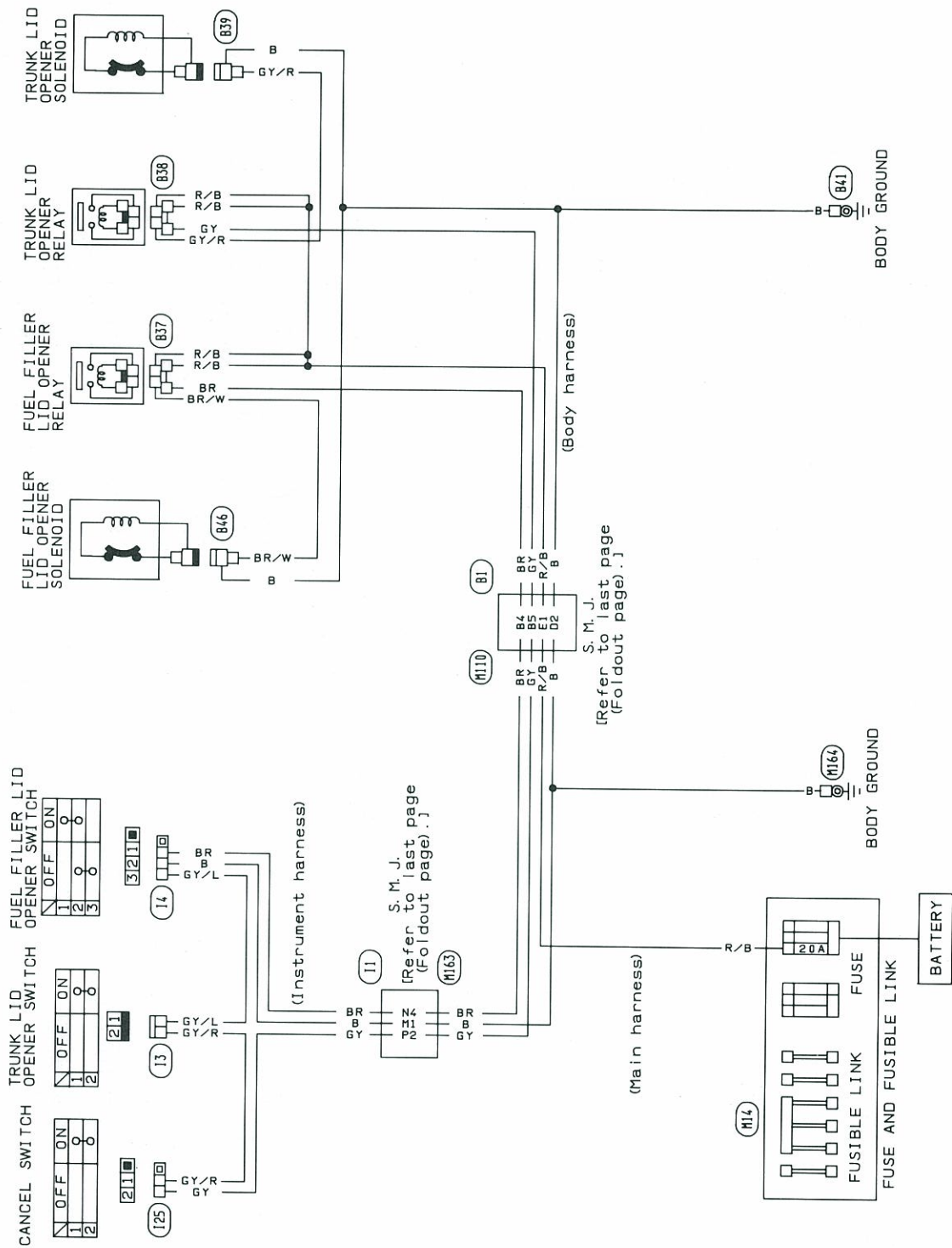

Power Door Lock

WIRING DIAGRAM

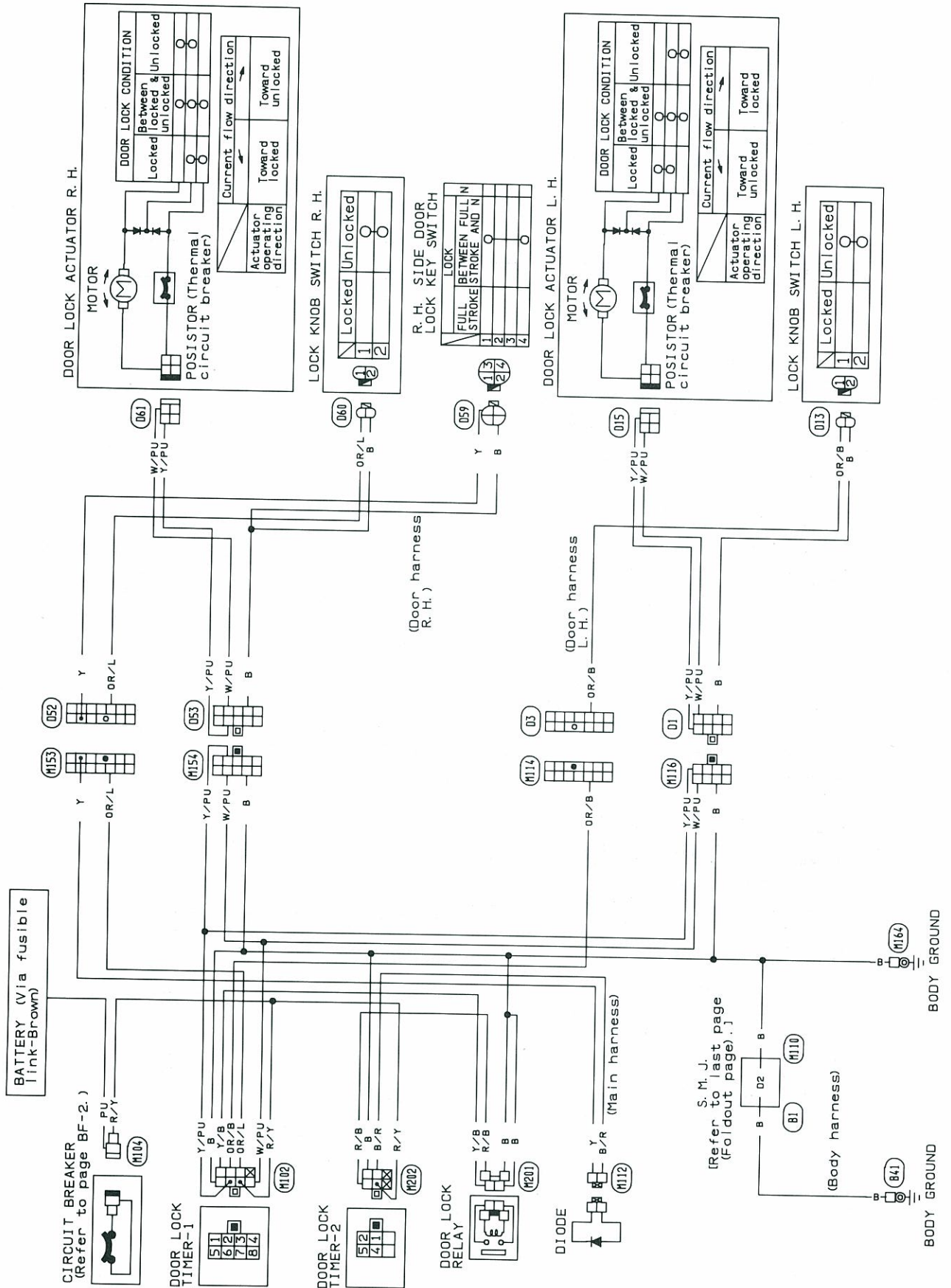





Door Mirror

WIRING DIAGRAM

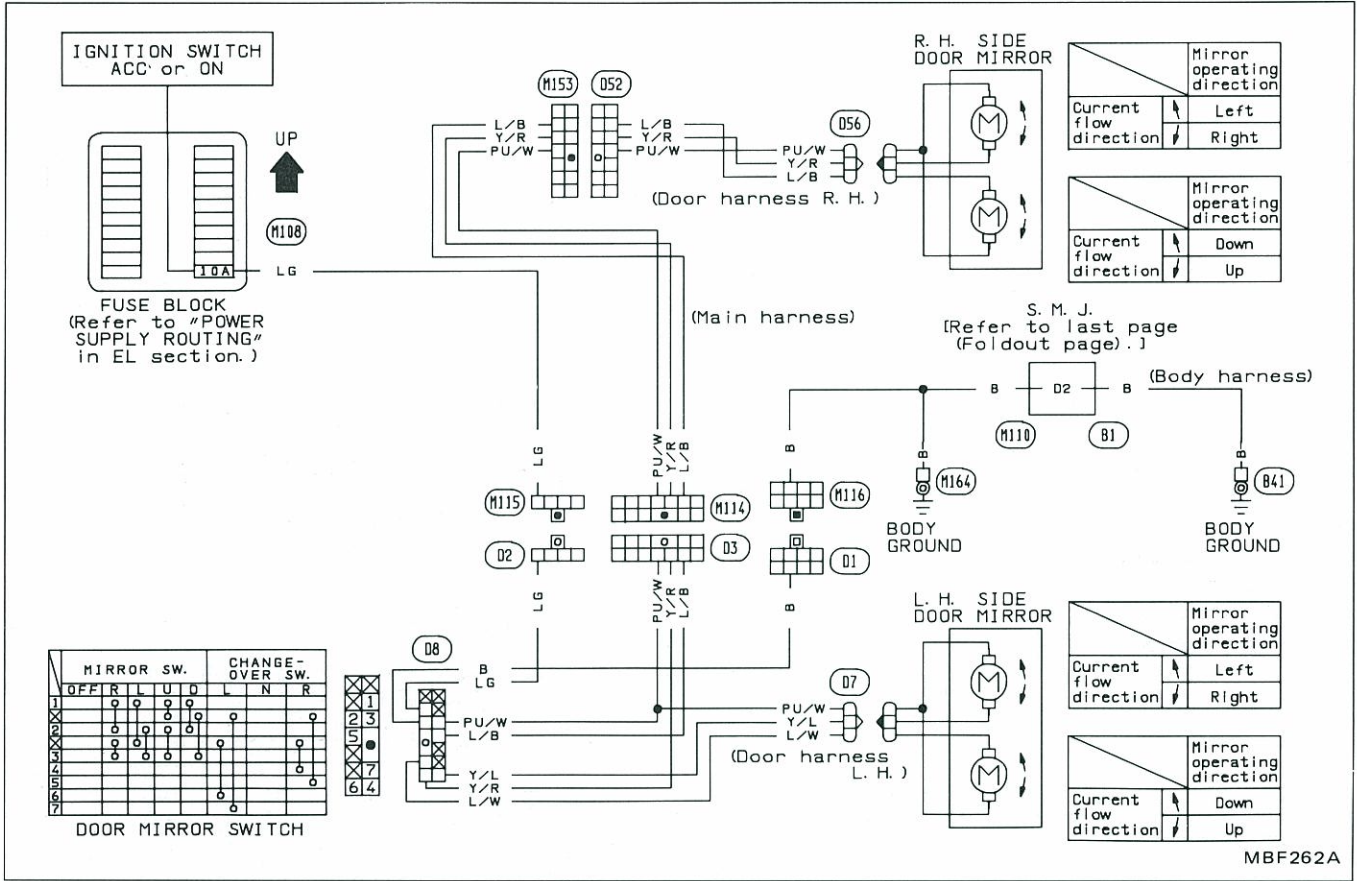



Circuit Diagram for Quick Pinpoint Check

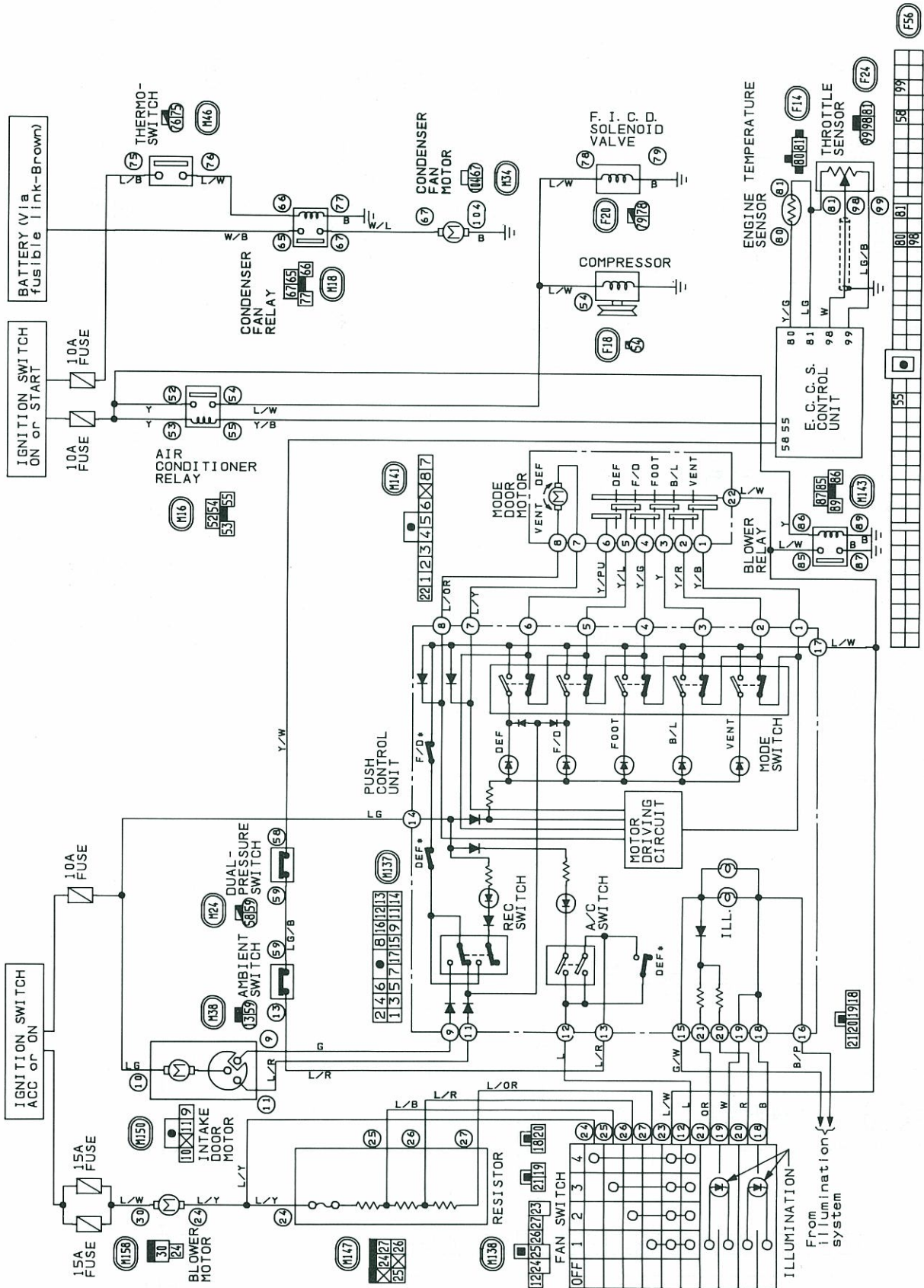

- All connectors shown in this illustration are unit side connectors.
- The unit side connectors with a double circle "⊖" are connected to the harness side connectors shown in the "Harness Layout for A/C System". (See pages HA-64 - HA-65.)
- The terminal numbers in the connector coincide with the circuit numbers surrounded by a single circle "○".
- These switches are built into push control unit and mechanically linked to control unit.

Wiring Diagram

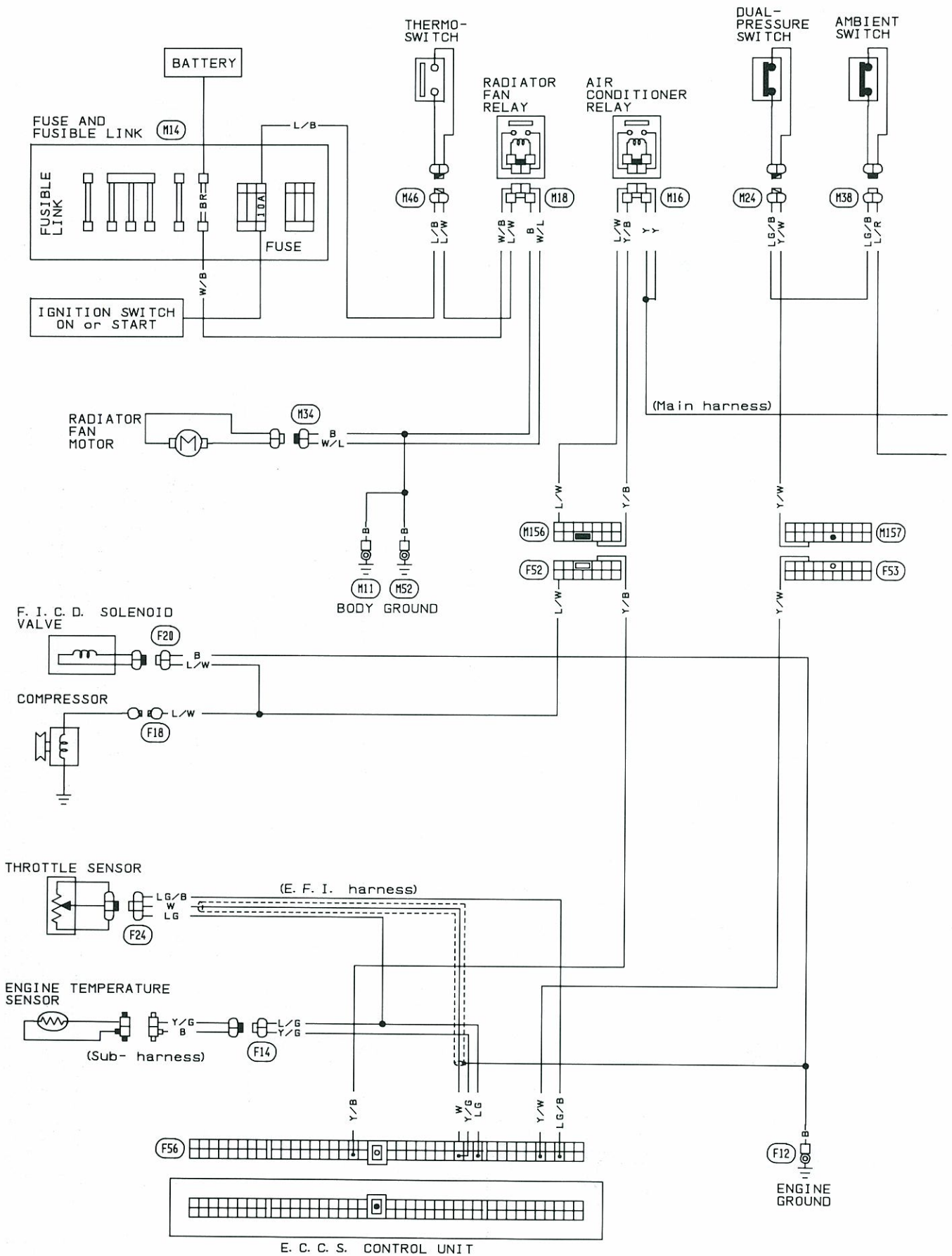

Wiring Diagram (Cont'd)

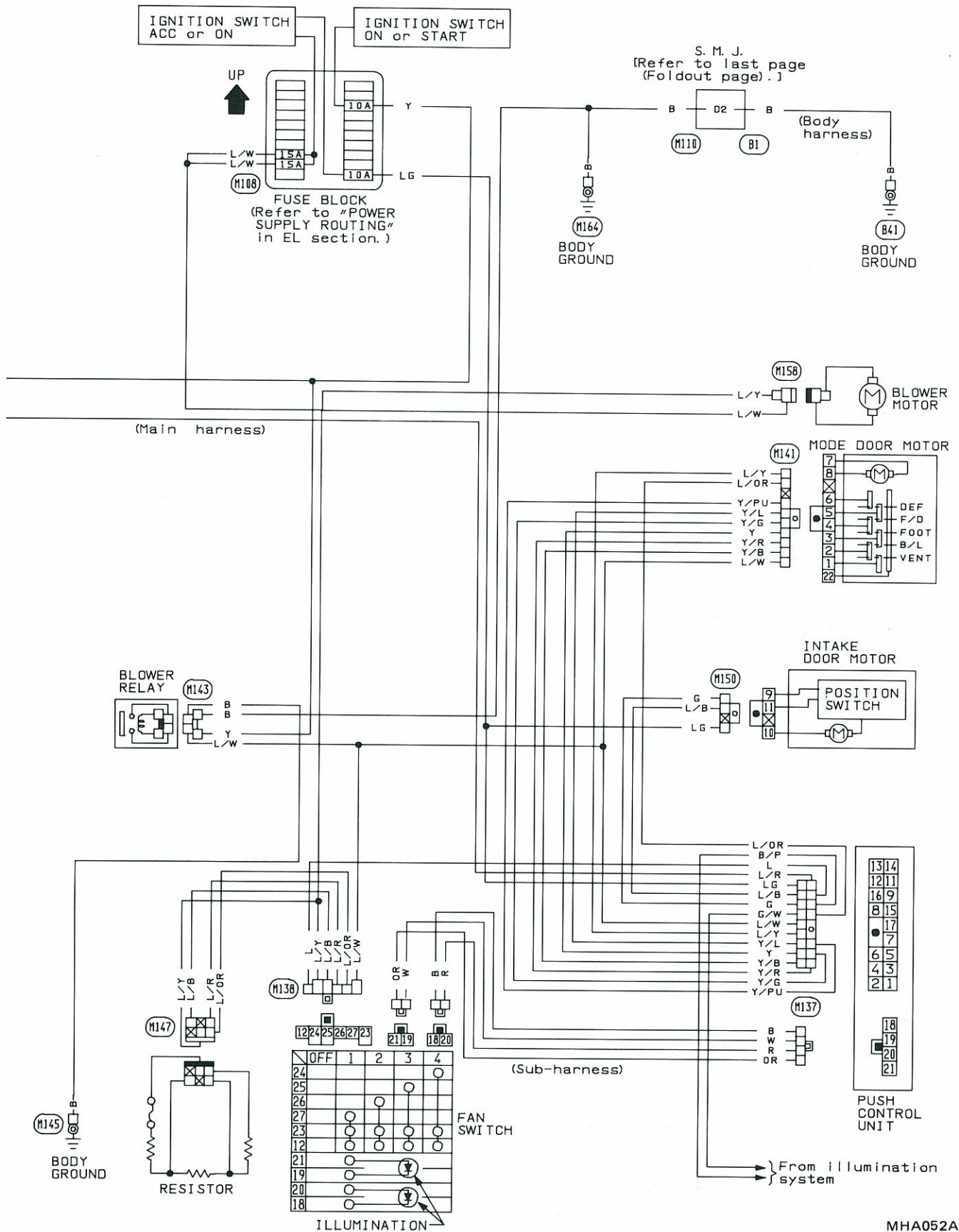

S. M. J.  
[Refer to last page  
(Foldout page).]

Clearance, License, Tail and Stop Lamps/Wiring Diagram

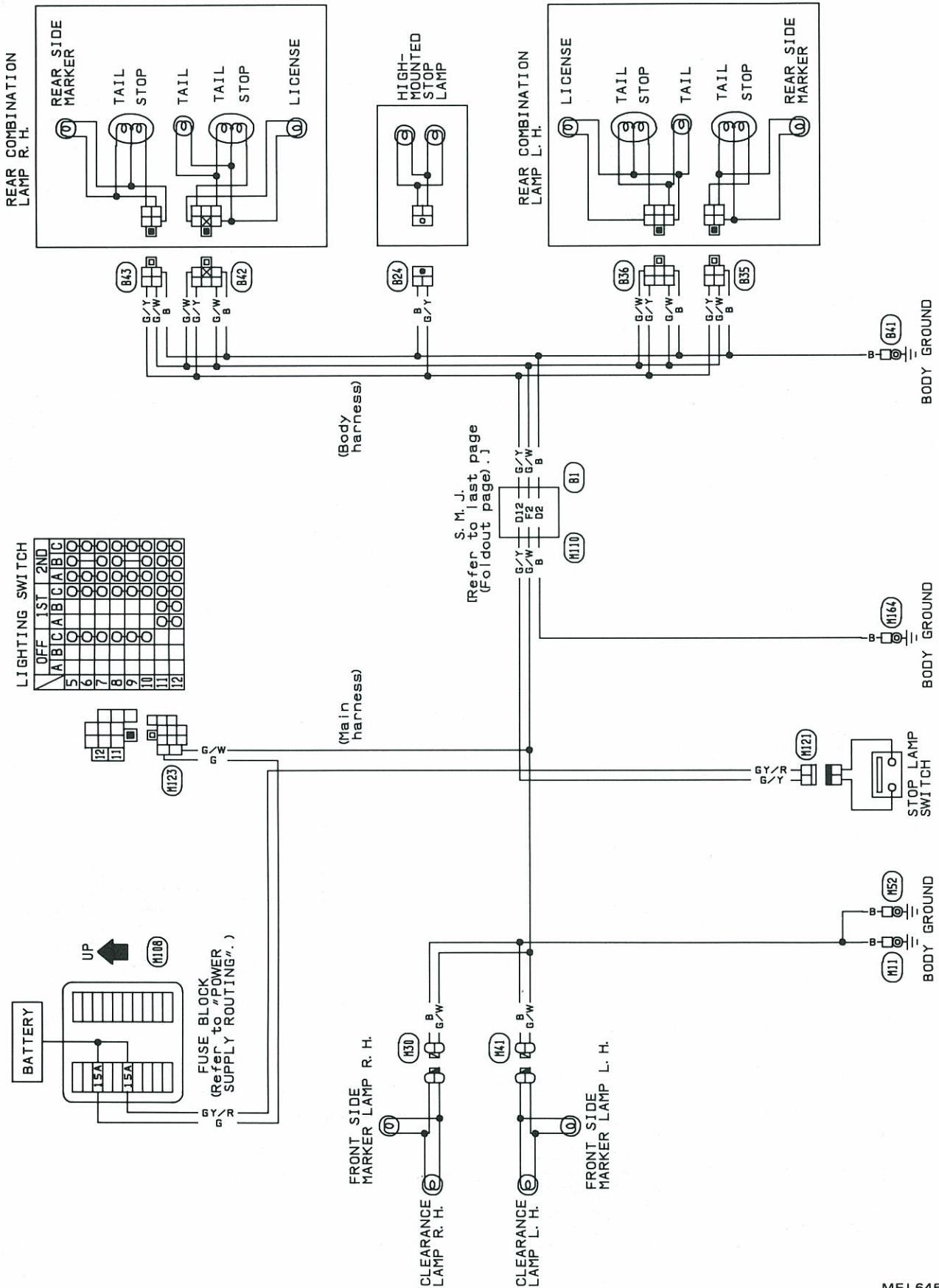

Illumination/Wiring Diagram

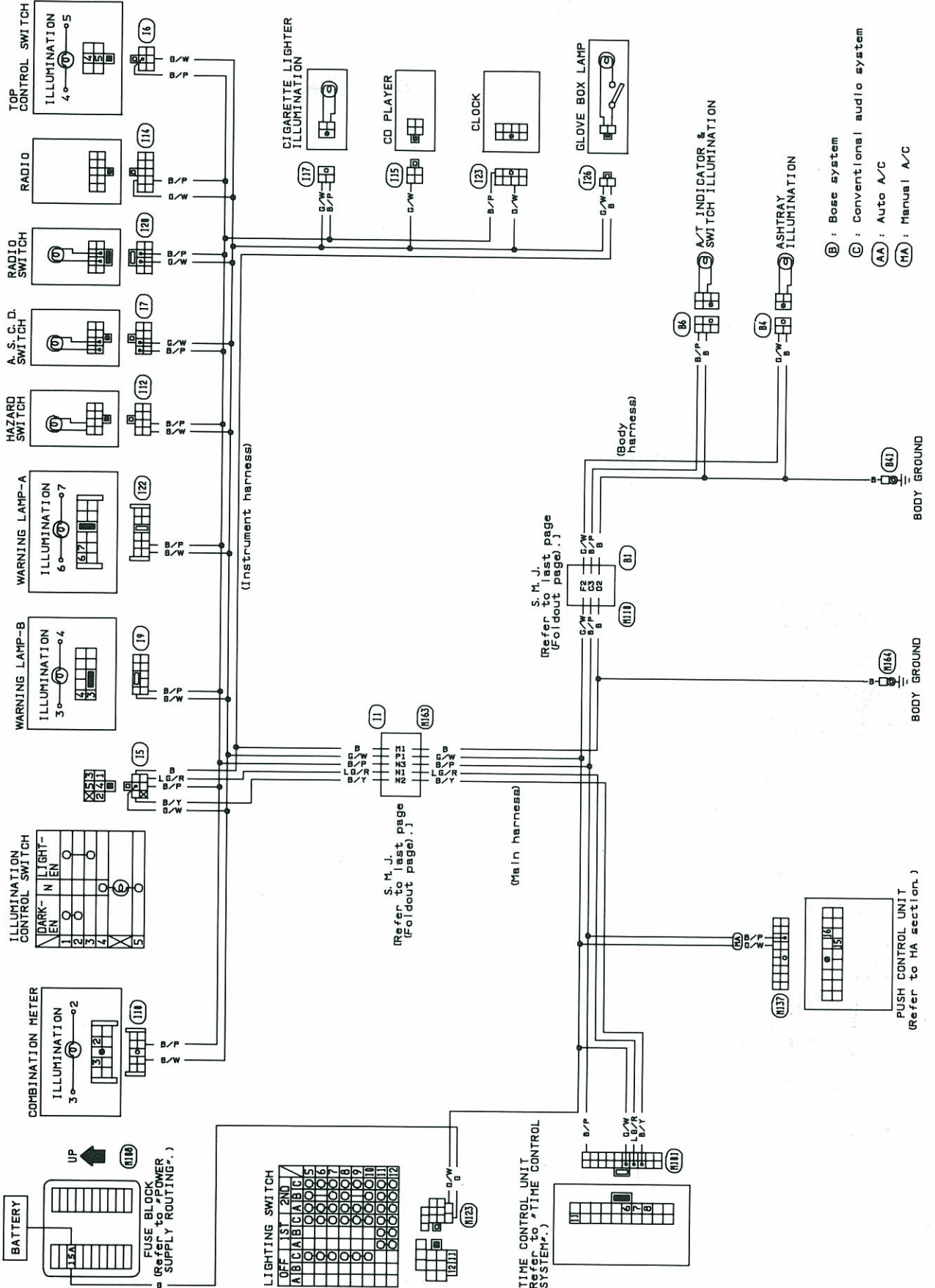









Wiring Diagram

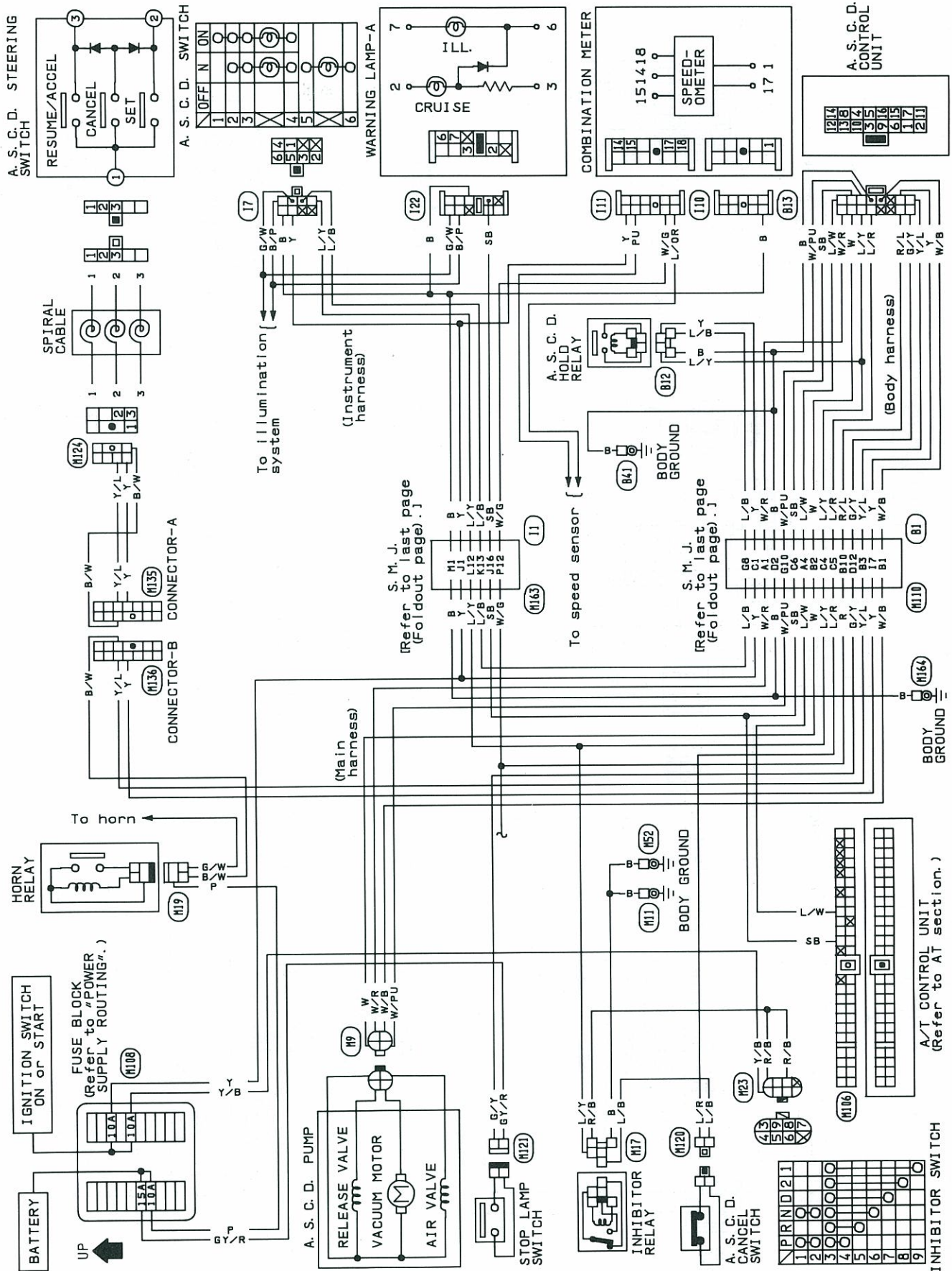

Trouble Diagnoses

CIRCUIT DIAGRAM FOR QUICK PINPOINT CHECK

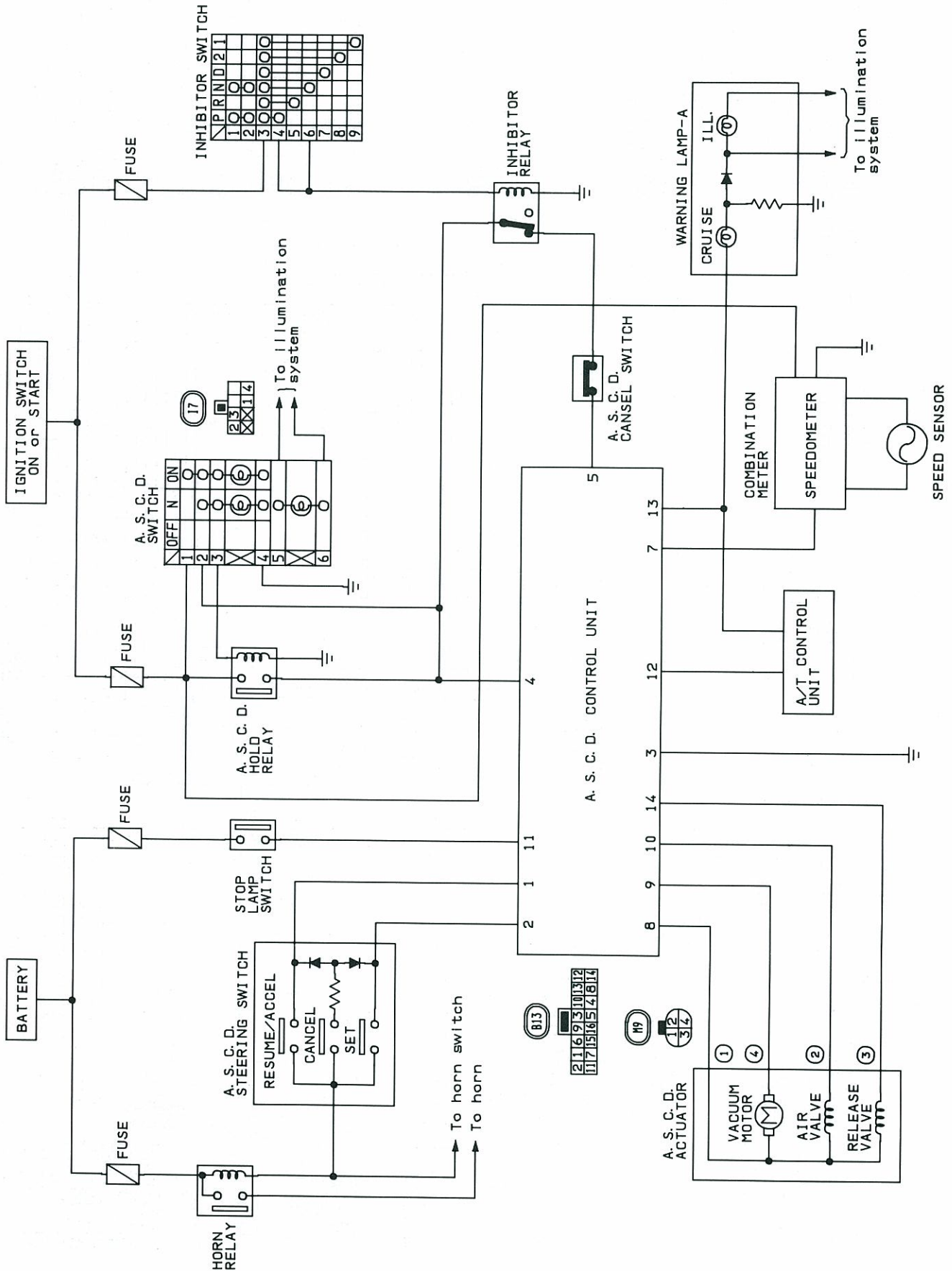





Trouble Diagnoses (Cont'd)

CIRCUIT DIAGRAM FOR QUICK PINPOINT CHECK

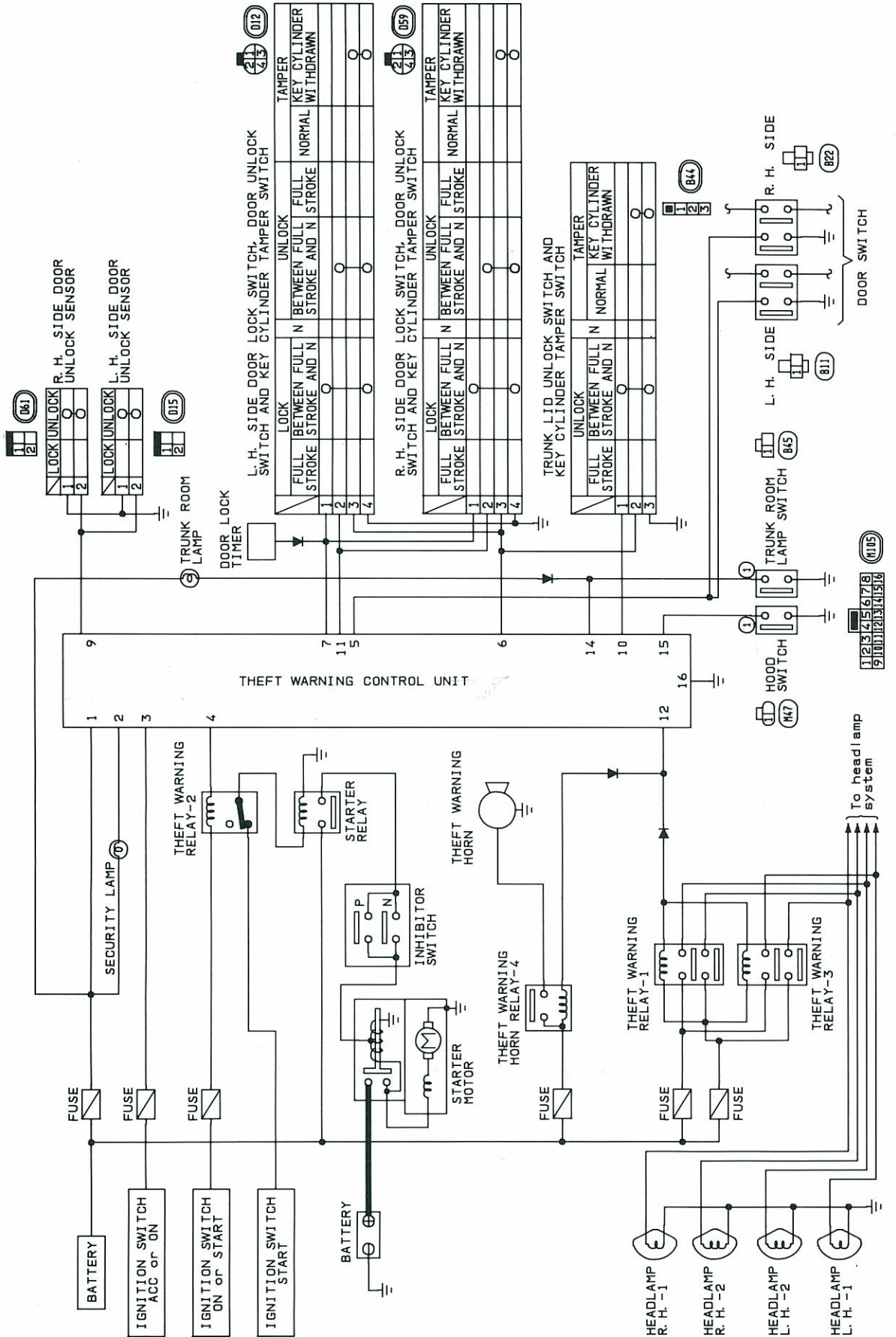

Wiring Diagram

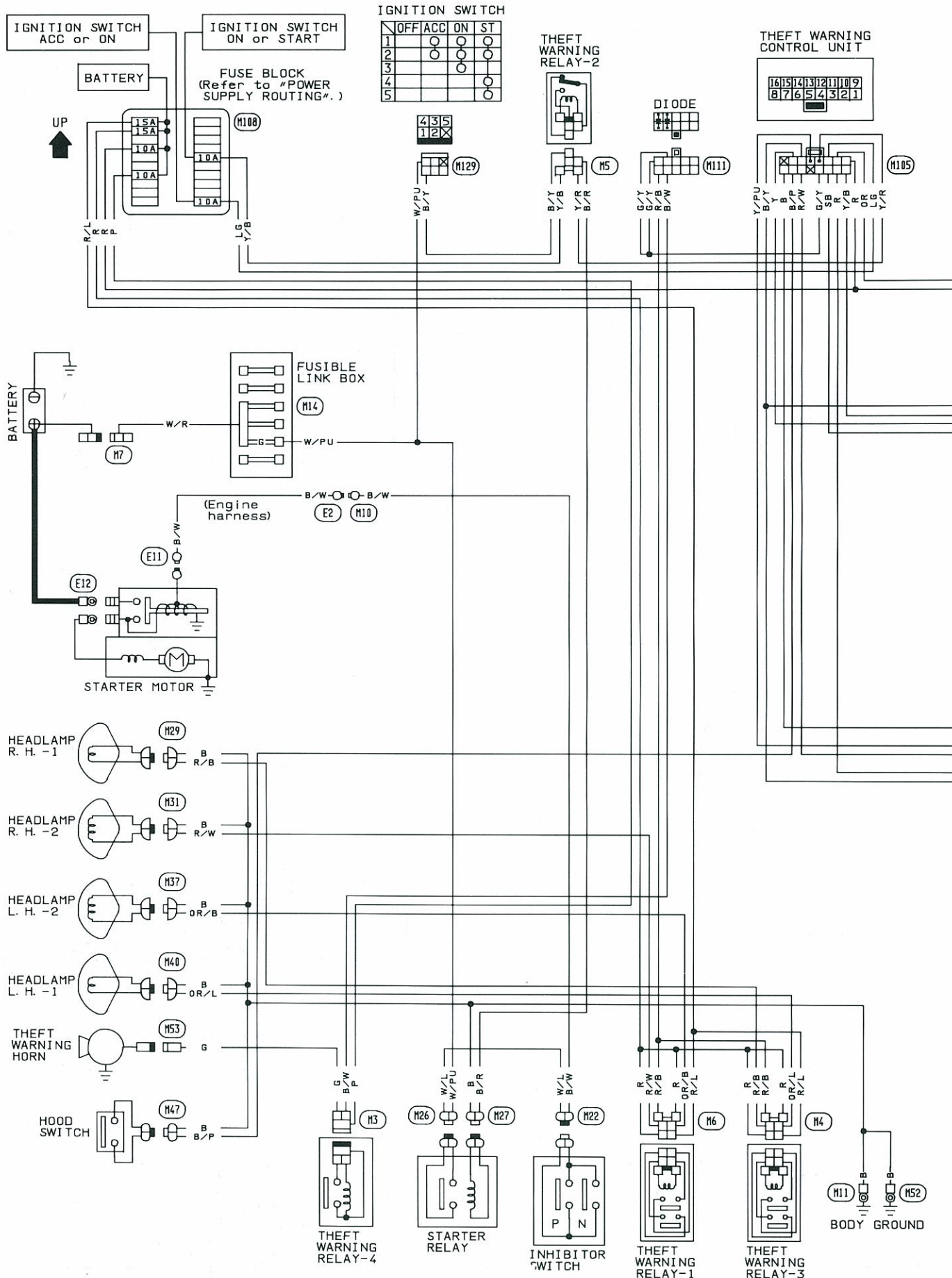

Wiring Diagram (Cont'd)

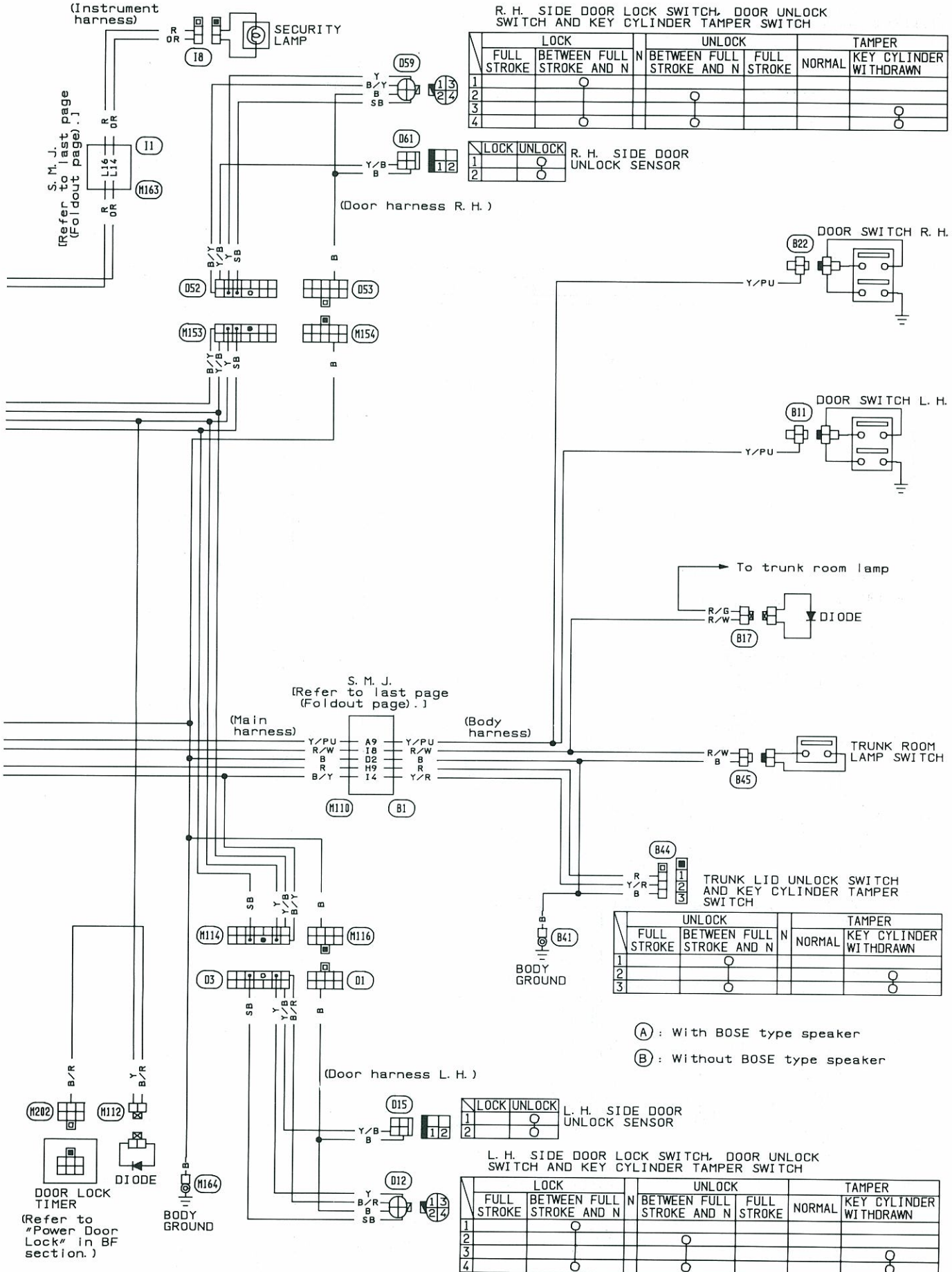

Main Harness

ENGINE COMPARTMENT

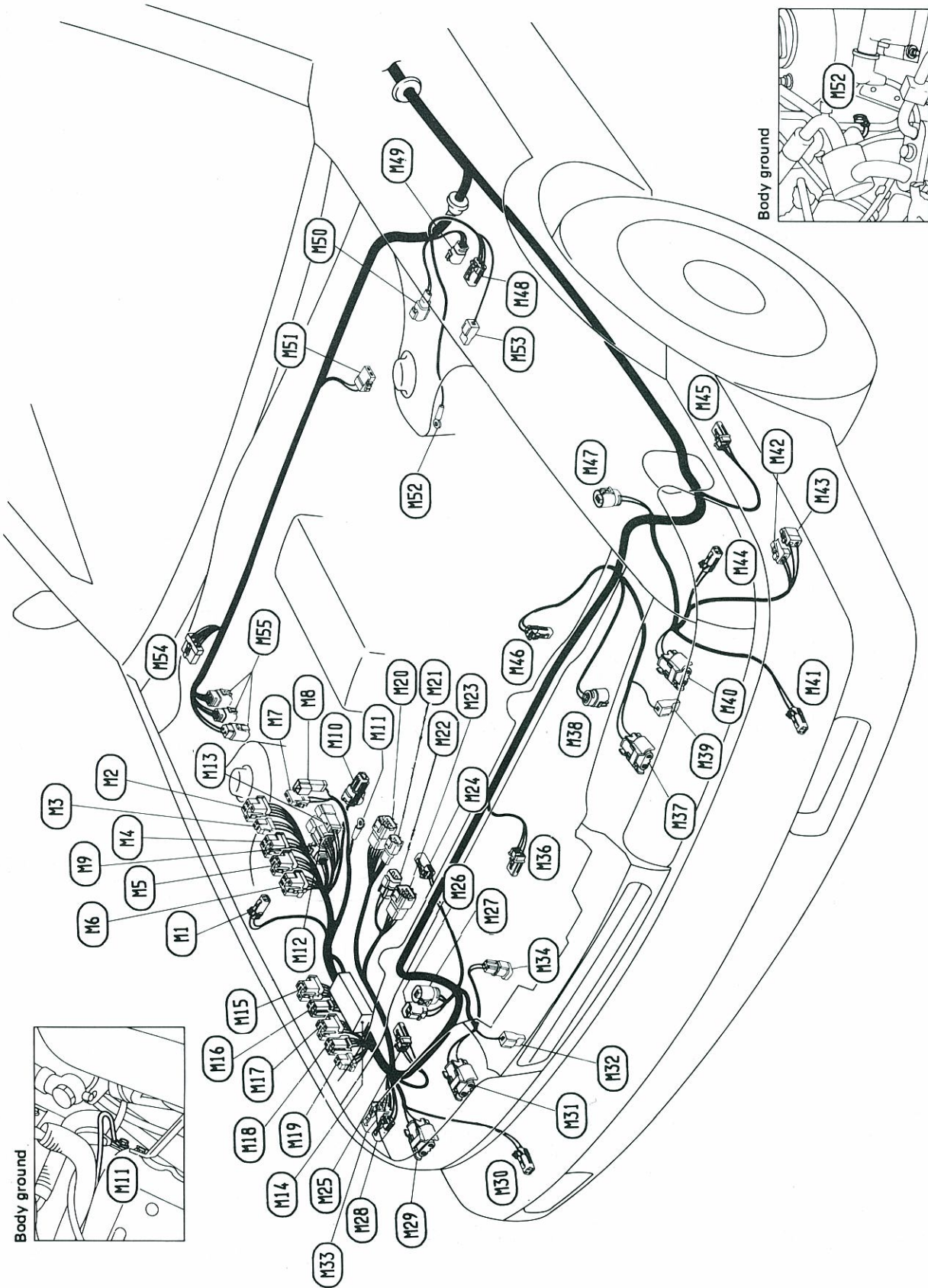



Main Harness

- ④30 : Front clearance lamp R.H.
- ④31 : Headlamp R.H.-2
- ④32 : Horn R.H.
- ④33 : Sonar road surface sensor
- ④34 : Radiator fan motor
- ④35 : Center crach zone sensor (Air bag)
- ④36 : Headlamp L.H.-2
- ④37 : Ambient switch (Manual A/C)
- ④38 : Ambient sensor (Auto A/C)
- ④39 : Horn L.H.
- ④40 : Headlamp L.H.-1
- ④41 : Front clearance lamp L.H.
- ④42 : Washer sensor
- ④43 : Washer motor
- ④44 : Front turn signal lamp L.H.
- ④45 : Left crash zone sensor (Air bag)
- ④46 : Thermoswitch
- ④47 : Hood switch
- ④48 : Front shock absorber actuator-L.H.  
(For sonar suspension system)
- ④49 : To ②27
- ④50 : Front sensor L.H.  
(For anti-lock braking system)
- ④51 : Brake fluid level switch
- ④52 : Body ground
- ④53 : Theft warning horn
- ④54 : Wiper motor
- ④55 : Actuator (For anti-lock braking system)

- ④11 : Dropping resistor
- ④12 : Switching relay
- ④13 : Theft warning horn relay
- ④14 : Theft warning relay-3
- ④15 : Theft warning relay-2
- ④16 : Theft warning relay-1
- ④17 : Battery
- ④18 : Fusible link
- ④19 : A.S.C.D. pump
- ④20 : To ②2
- ④21 : Body ground
- ④22 : To ②4
- ④23 : To ②3
- ④24 : Fusible link box & Fuse block
- ④25 : Wiper relay
- ④26 : Air conditioner relay
- ④27 : Inhibitor relay
- ④28 : Radiator fan relay
- ④29 : Horn relay
- ④30 : To terminal cord assembly
- ④31 : Revolution sensor
- ④32 : Inhibitor switch
- ④33 : Inhibitor switch
- ④34 : Dual-pressure switch
- ④35 : Right crash zone sensor (Air bag)
- ④36 : Starter relay
- ④37 : Starter relay
- ④38 : Front turn signal lamp R.H.
- ④39 : Headlamp R.H.-1

Main Harness (Cont'd)

PASSENGER COMPARTMENT

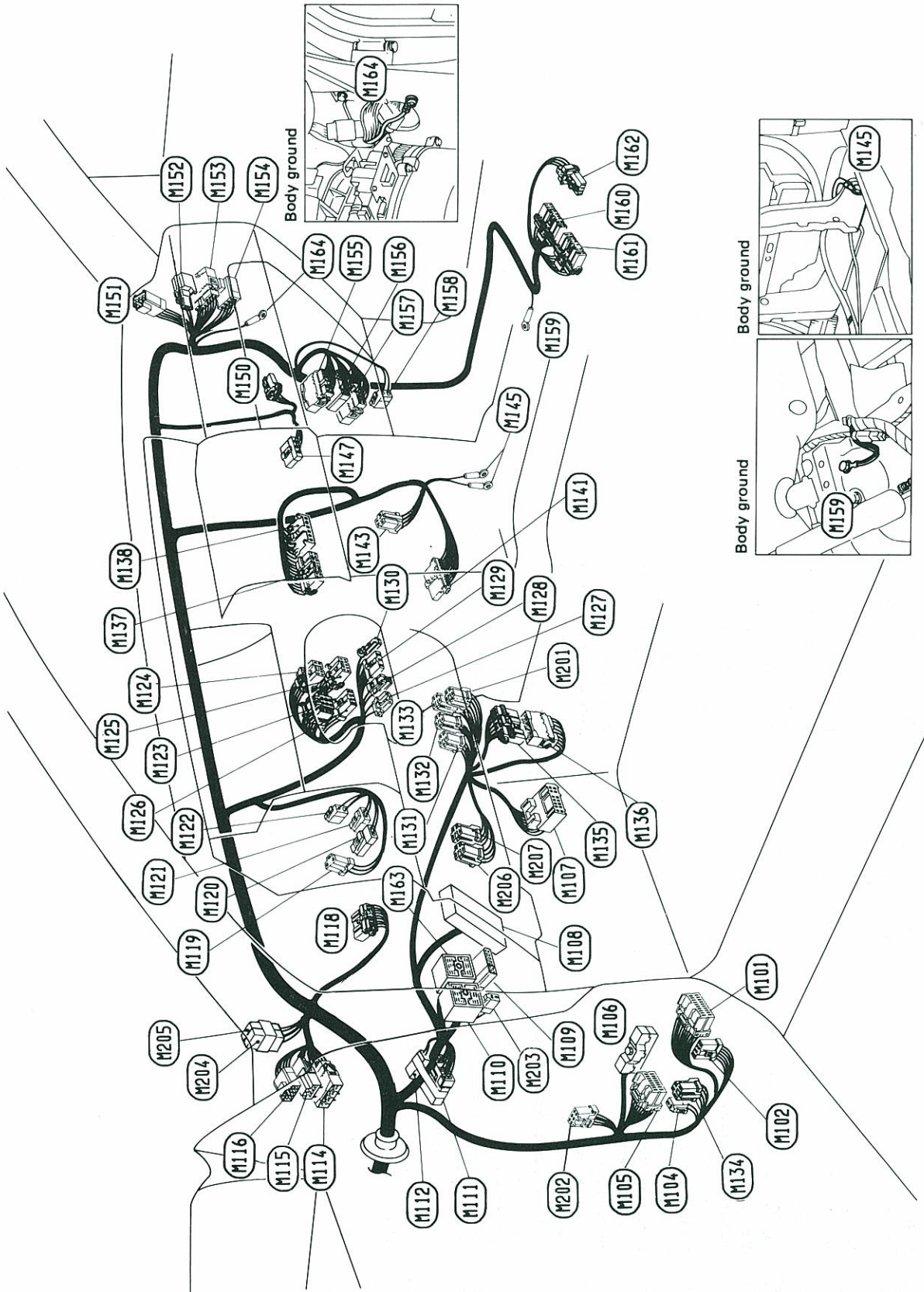

Main Harness

- (M159) : Body ground
- (M160) : Air bag control unit
- (M161) : Air bag control unit
- (M162) : Tunnel sensor and safing sensor (Air bag)
- (M163) : (11)
- (M164) : Body ground
- (M281) : Door lock relay
- (M202) : Door lock timer-2
- (M203) : Circuit breaker-2
- (M284) : Diode C1
- (M205) : Diode C2
- (M286) : Top main relay-1
- (M287) : Top main relay-2

- (M141) : Mode door motor (A/C)
- (M143) : Blower relay (Manual A/C)
- (M145) : Body ground
- (M147) : Resistor (Manual A/C)
- (M150) : Intake door motor
- (M151) : To (R1)
- (M152) : To (D51)
- (M153) : To (D52)
- (M154) : To (D53)
- (M155) : To (F51)
- (M156) : To (F52)
- (M157) : To (F53)
- (M158) : Blower motor

- (M101) : Time control unit
- (M102) : Door lock timer-1
- (M104) : Circuit breaker
- (M105) : Theft warning control unit
- (M106) : A/T control unit
- (M107) : Diagnostic connector
- (M108) : Fuse block
- (M109) : To (B3)
- (M110) : To (B1) (S.M.J.)
- (M111) : Diode
- (M112) : Diode
- (M114) : To (D1)
- (M115) : To (D2)
- (M116) : To (D1)
- (M118) : Shift lock control unit
- (M119) : Combination flasher unit
- (M120) : A.S.C.D. cancel switch
- (M121) : Stop lamp switch
- (M122) : Kickdown switch
- (M123) : Lighting switch
- (M124) : A.S.C.D. steering switch, horn switch and air bag module
- (M125) : Steering angle sensor
- (M126) : Wiper switch
- (M127) : Key lock solenoid
- (M128) : Key-in switch
- (M129) : Ignition switch
- (M130) : Key illumination
- (M131) : Accessory relay-1
- (M132) : Ignition relay-2
- (M133) : Ignition relay-1
- (M134) : Accessory relay-2
- (M135) : Connector-A
- (M136) : Connector-B
- (M137) : Push control unit (Manual A/C)
- (M138) : Fan switch (Manual A/C)

Diode (M111)

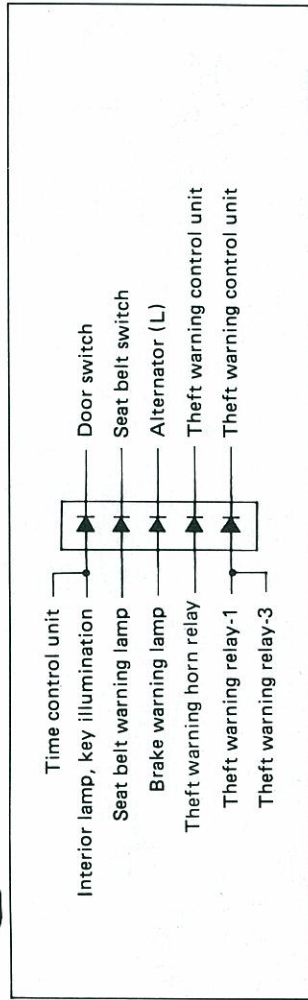

Diode (M112)

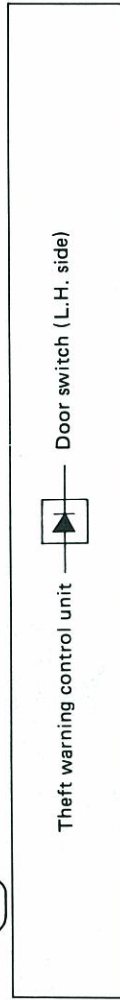

Body Harness

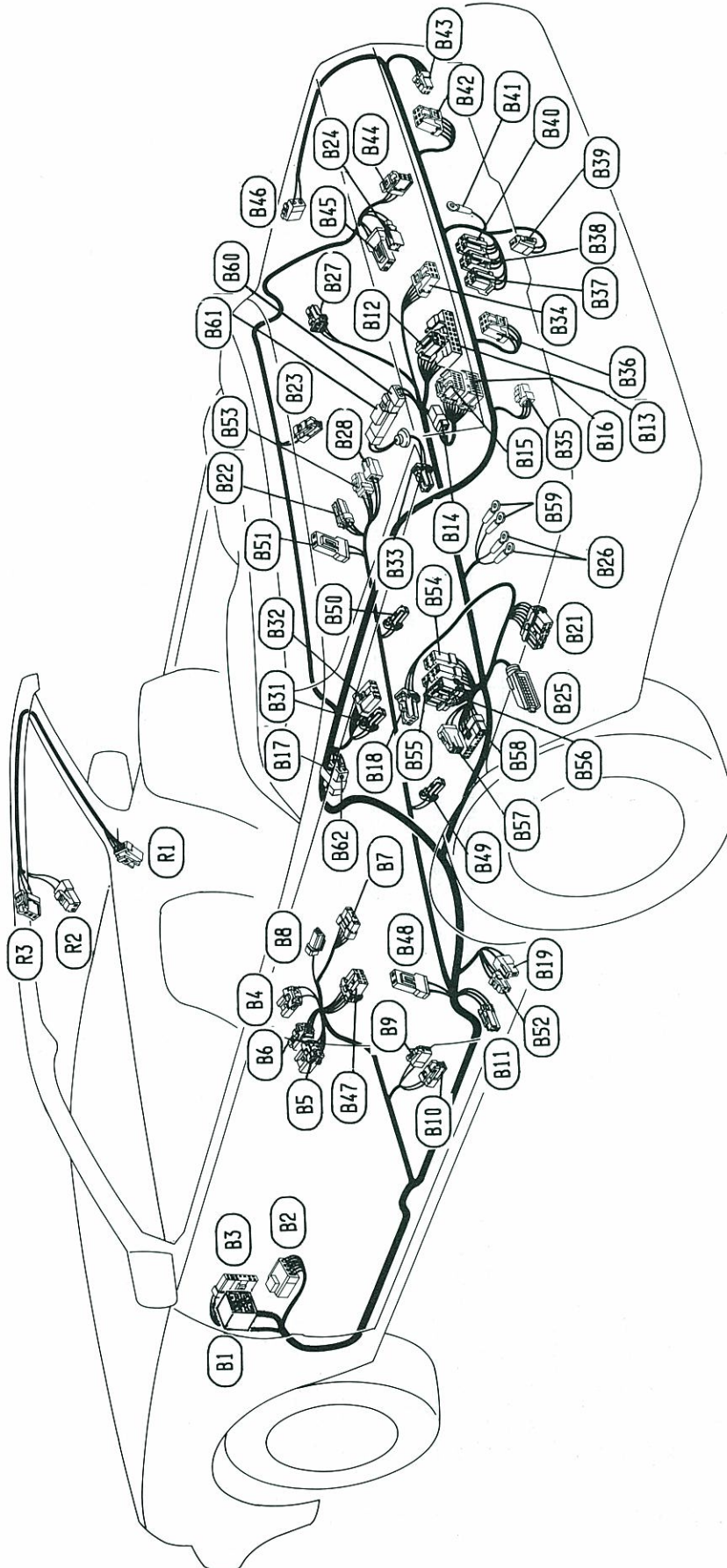

Body Harness (Cont'd)

- 81 : To (1110) (S.M.J.)
- 82 : To (12)
- 83 : To (1109)
- 84 : Ash tray illumination
- 85 : Shift lock solenoid and detention switch
- 86 : Overdrive switch and A/T indicator illumination
- 87 : Shock absorber select switch (For sonar suspension system)
- 88 : Parking brake switch
- 89 : To power seat harness L.H.
- 90 : Seat belt switch
- 91 : Door switch L.H.
- 92 : A.S.C.D. hold relay
- 93 : A.S.C.D. control unit
- 94 : Diode
- 95 : Sonar suspension control unit
- 96 : Sonar suspension control unit
- 97 : Diode
- 98 : Rear shock absorber actuator L.H.
- 99 : Rear speaker L.H. (Active speaker type)
- 100 : Rear amplifier (Active speaker type)
- 101 : Door switch R.H.
- 102 : Trunk room lamp
- 103 : High-mounted stop lamp
- 104 : A.B.S. control unit
- 105 : Body ground
- 106 : Rear shock absorber actuator R.H. (For sonar suspension system)

- 847 : Sub-harness 2
- 848 : Quarter window motor LH
- 849 : Courtesy lamp LH
- 850 : Courtesy lamp RH
- 851 : Quarter window motor RH
- 852 : Rear rail switch LH
- 853 : Rear rail switch RH
- 854 : Sub-harness
- 855 : Sub-harness
- 856 : Sub-harness
- 857 : Top stack pwr
- 858 : Top stack control unit
- 859 : Body ground
- 860 : Add-F
- 861 : Add-M
- 862 : Diode

- 837 : Fuel filler lid opener relay
- 838 : Trunk lid opener relay
- 839 : Trunk lid opener solenoid
- 840 : Fuel pump relay
- 841 : Body ground
- 842 : Rear combination lamp R.H.
- 843 : Rear combination lamp R.H.
- 844 : Trunk room unlock switch
- 845 : Trunk room lamp switch
- 846 : Fuel filler lid opener solenoid

- 828 : Rear speaker R.H. (Active speaker type)
- 831 : Power antenna motor
- 832 : Power antenna timer
- 833 : Rear sensor braking (For anti-lock braking system)
- 834 : Fuel tank gauge unit
- 835 : Rear combination lamp L.H.
- 836 : Rear combination lamp L.H.

Diode (B14)

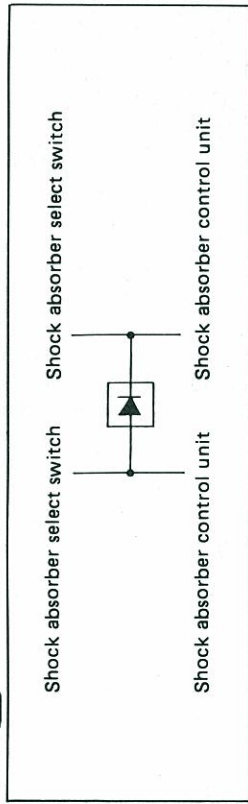

Diode (B17)



Room lamp harness

- R1 : To (115)
- R2 : Blow motor
- R3 : Interior lamp

## Instrument Harness

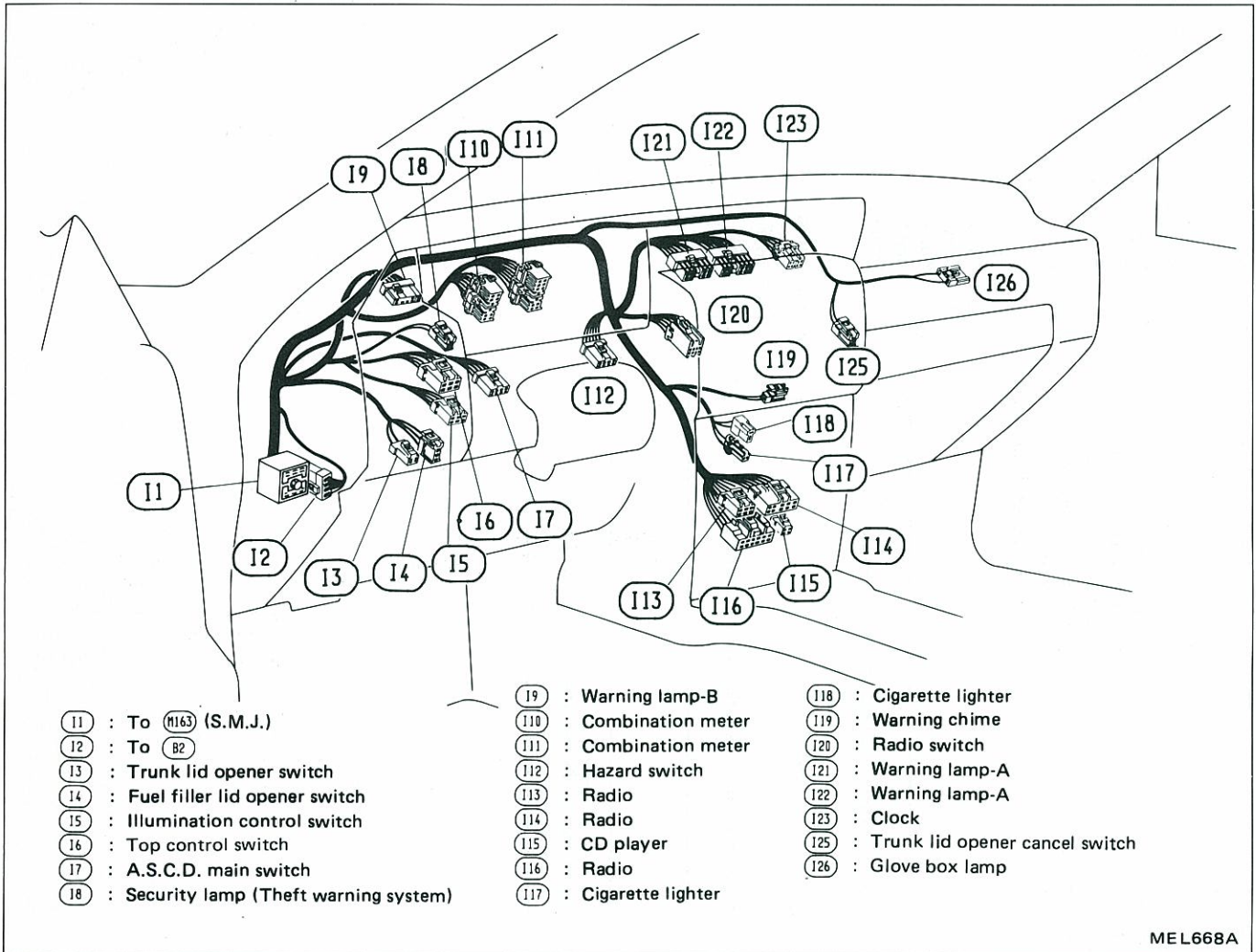

MEL668A

Door Harness

L.H. SIDE

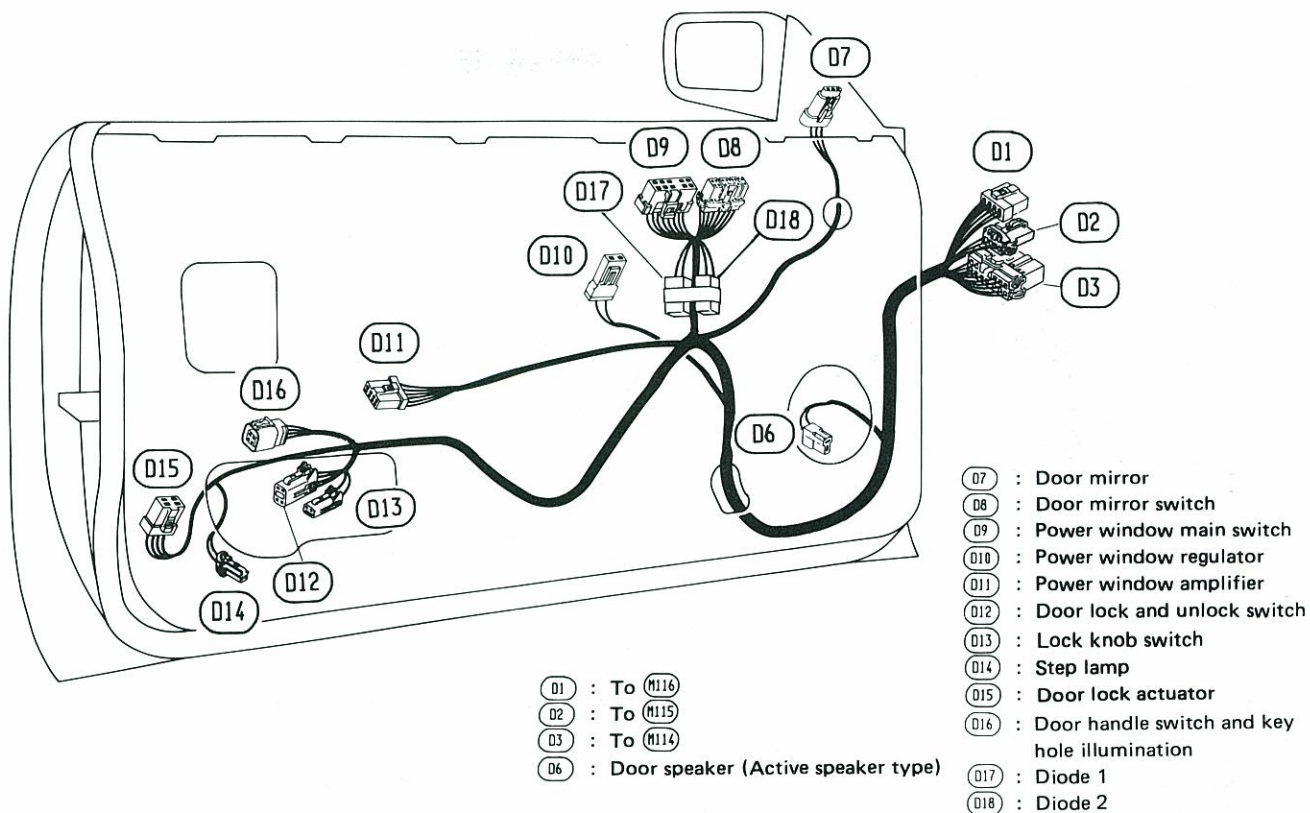

MEL669A

R.H. SIDE

- D51 : To M152
- D52 : To M153
- D53 : To M154
- D54 : Door handle switch and key hole illumination
- D55 : Door speaker (Active speaker type)

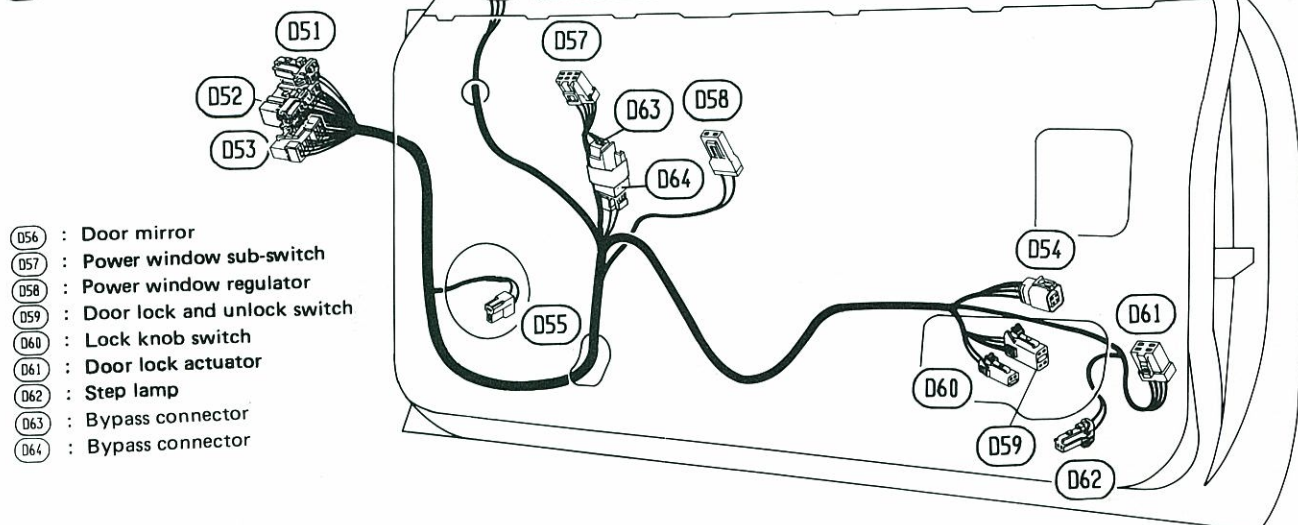

MEL670A





# BODY, STRUCTURAL

	Page
BODY, STRUCTURAL - COMPONENTS .....	26-2

BODY, STRUCTURAL - COMPONENTS

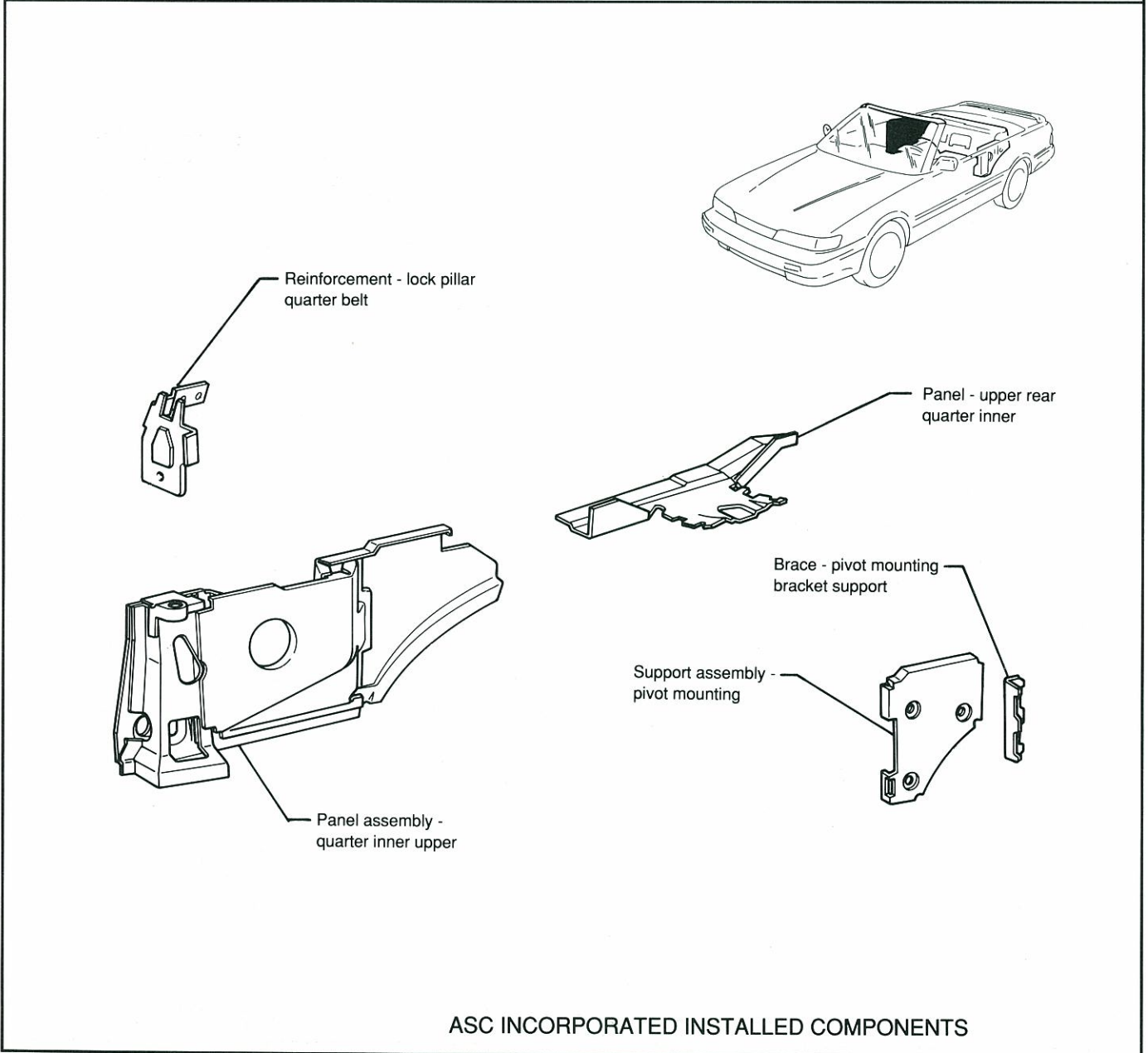
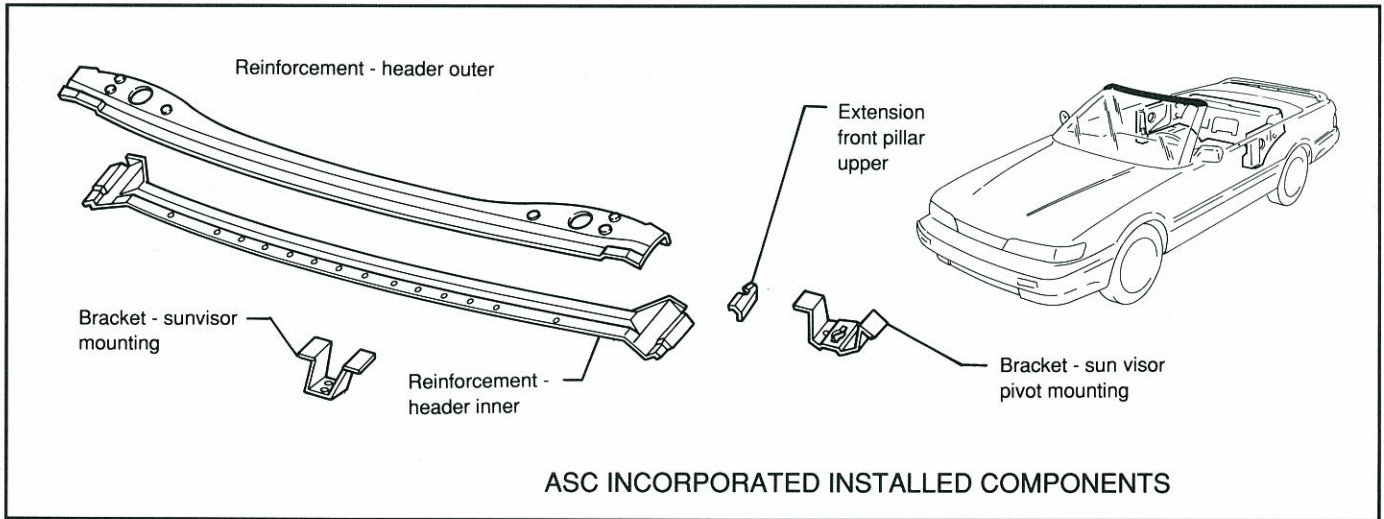

BODY, STRUCTURAL - COMPONENTS (Cont.)

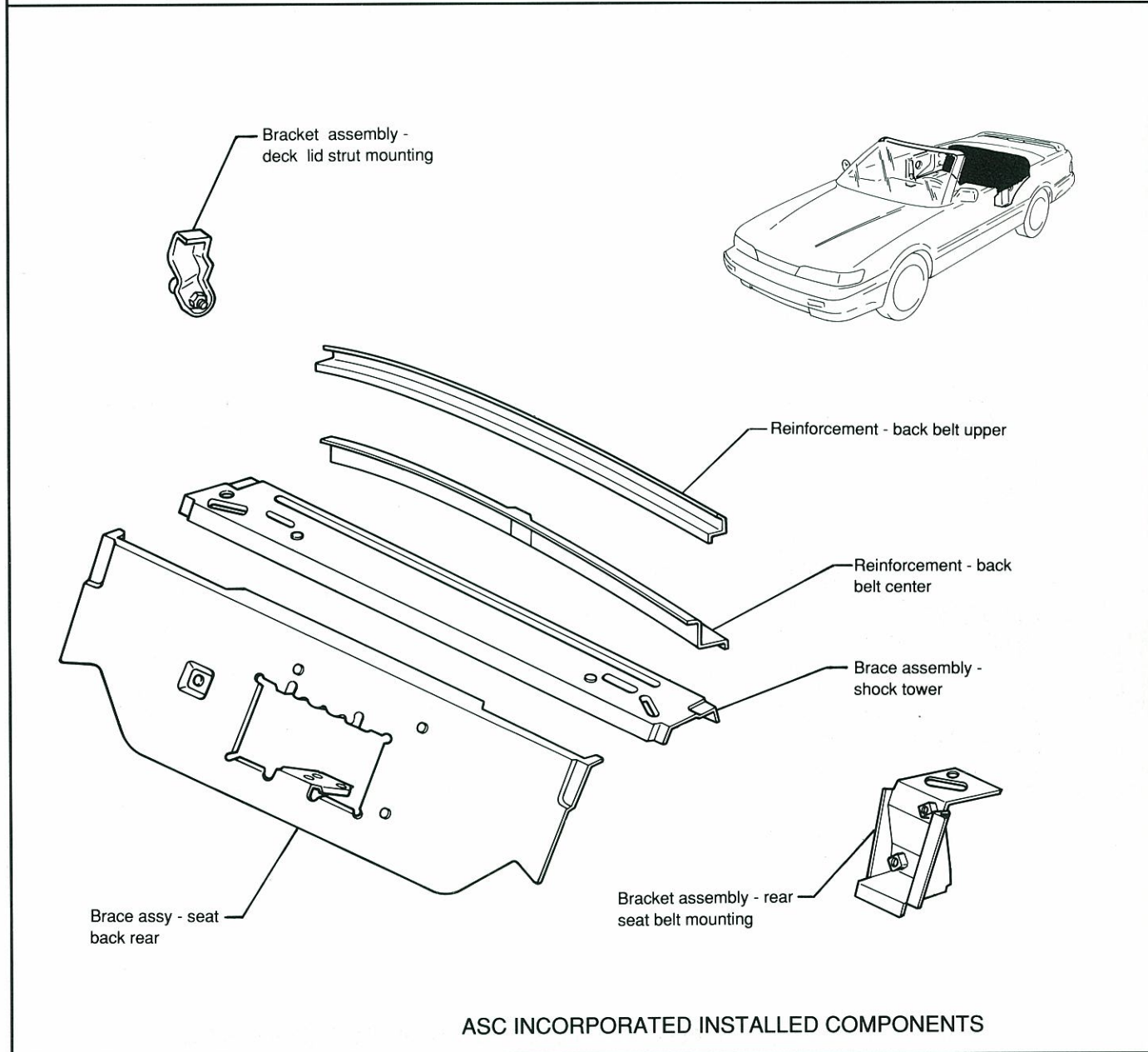
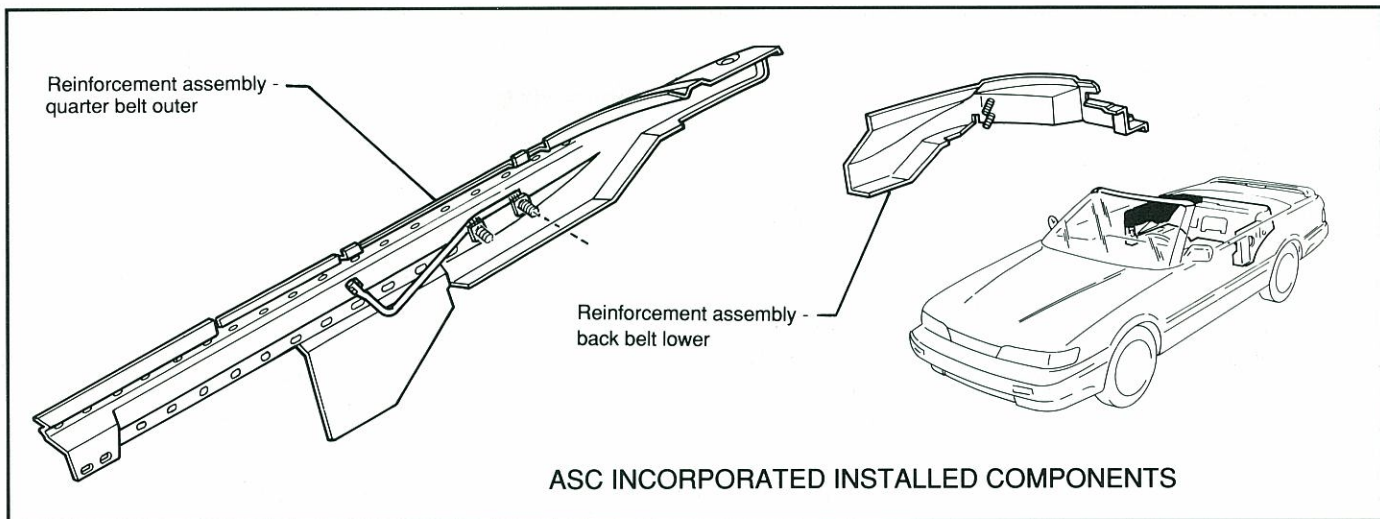

BODY, STRUCTURAL - COMPONENTS (Cont.)

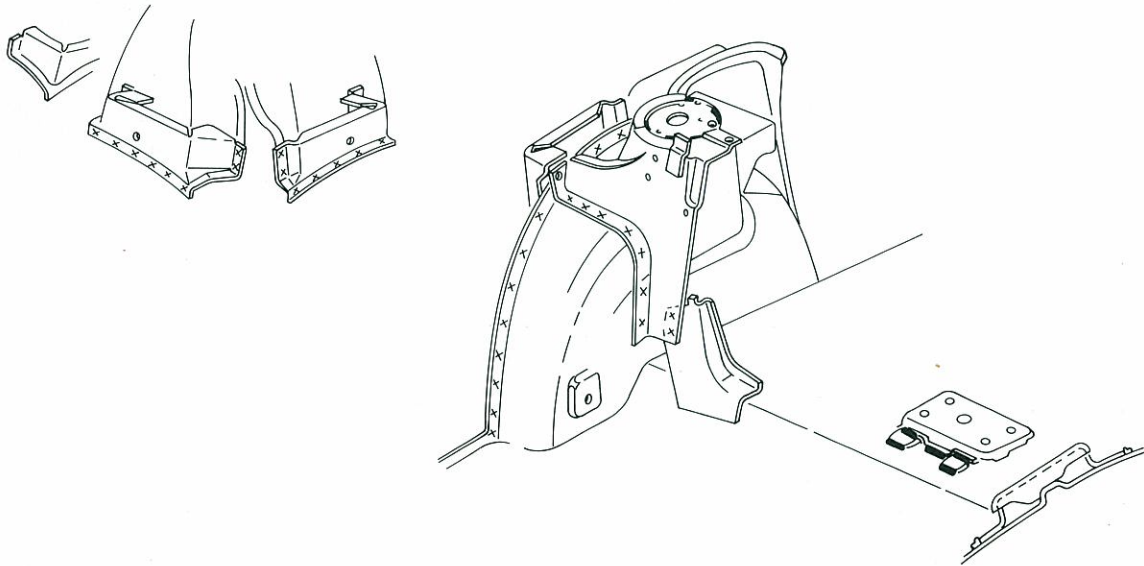

NISSAN JAPAN INSTALLED COMPONENTS

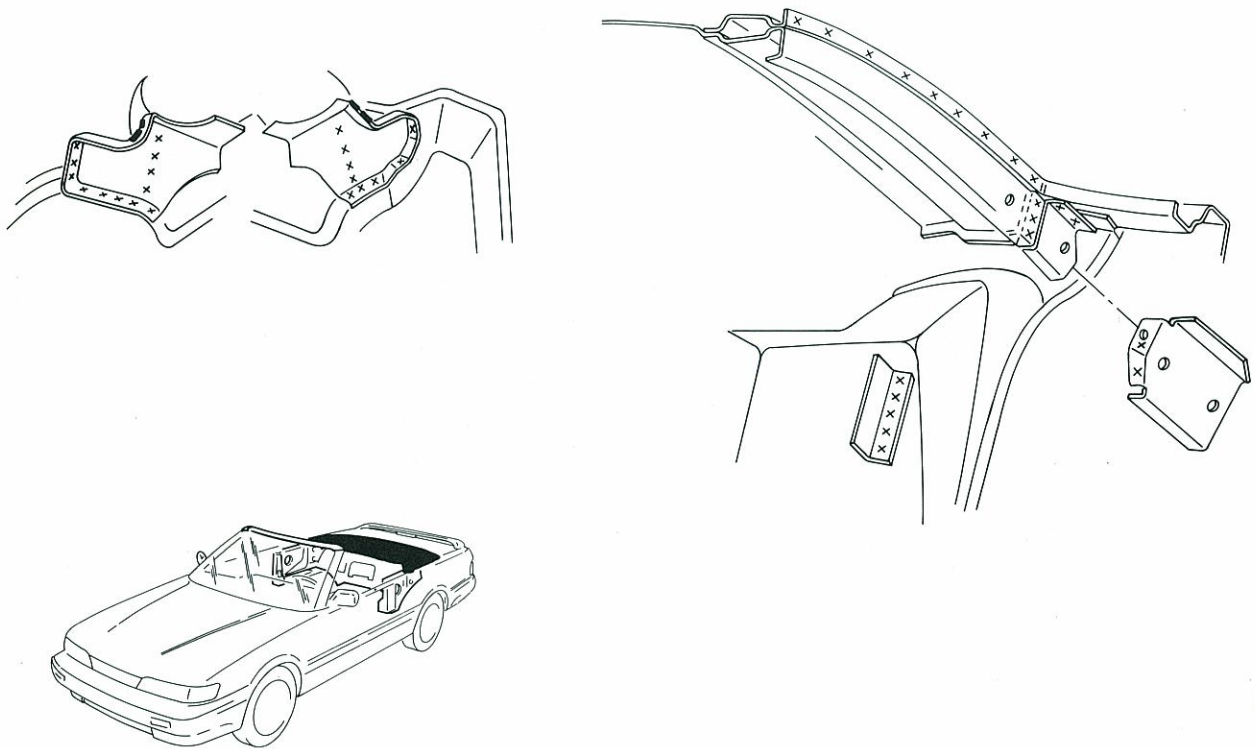

NISSAN JAPAN INSTALLED COMPONENTS

BODY, STRUCTURAL - COMPONENTS (Cont.)

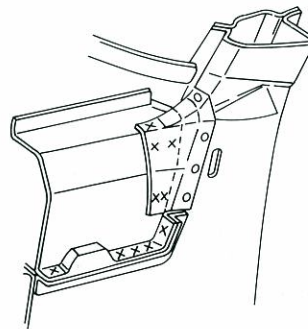
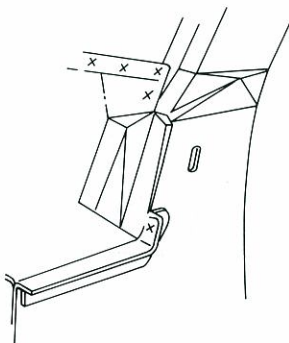
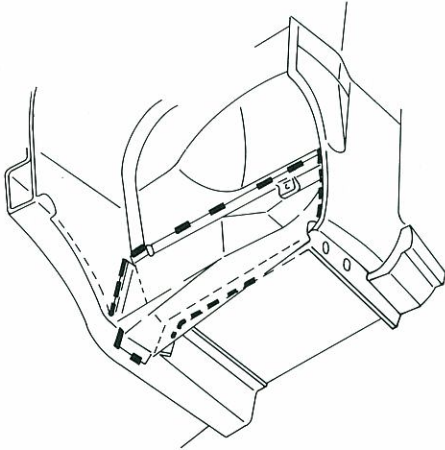
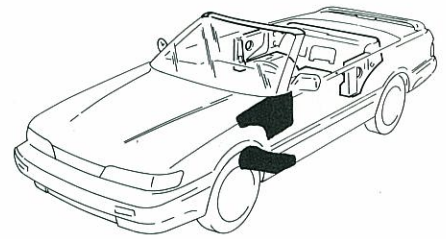

NISSAN JAPAN INSTALLED COMPONENTS

BODY, STRUCTURAL - COMPONENTS (Cont.)

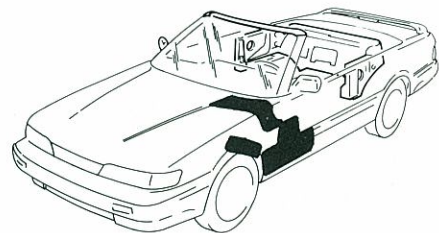
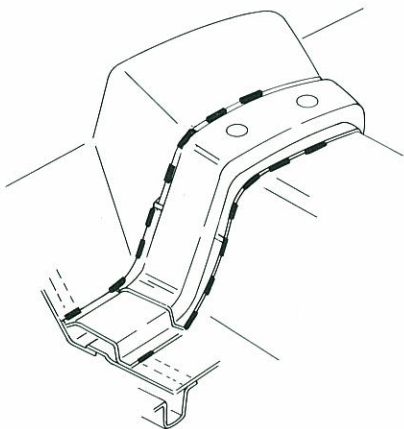
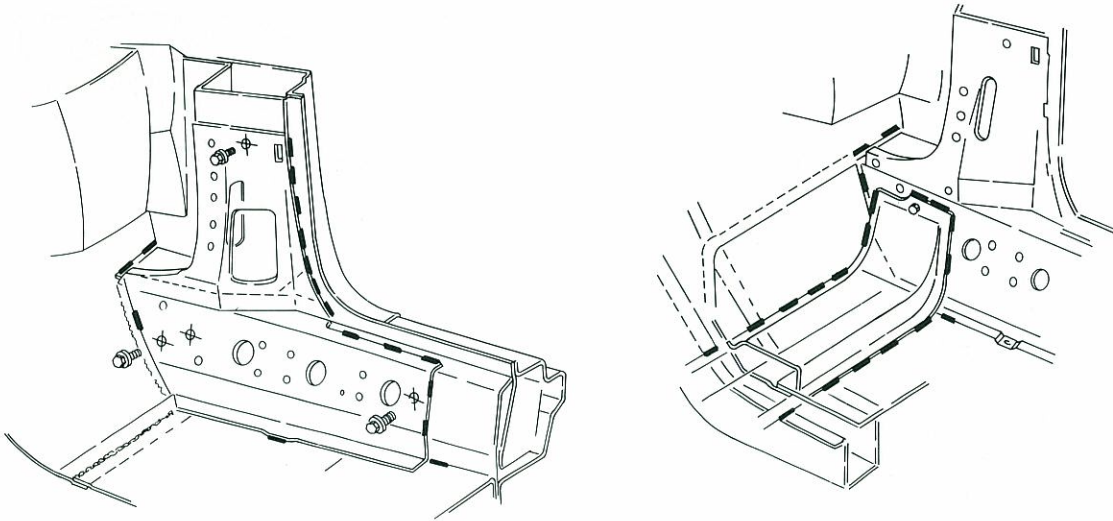

NISSAN JAPAN INSTALLED COMPONENTS

BODY, STRUCTURAL - COMPONENTS (Cont.)

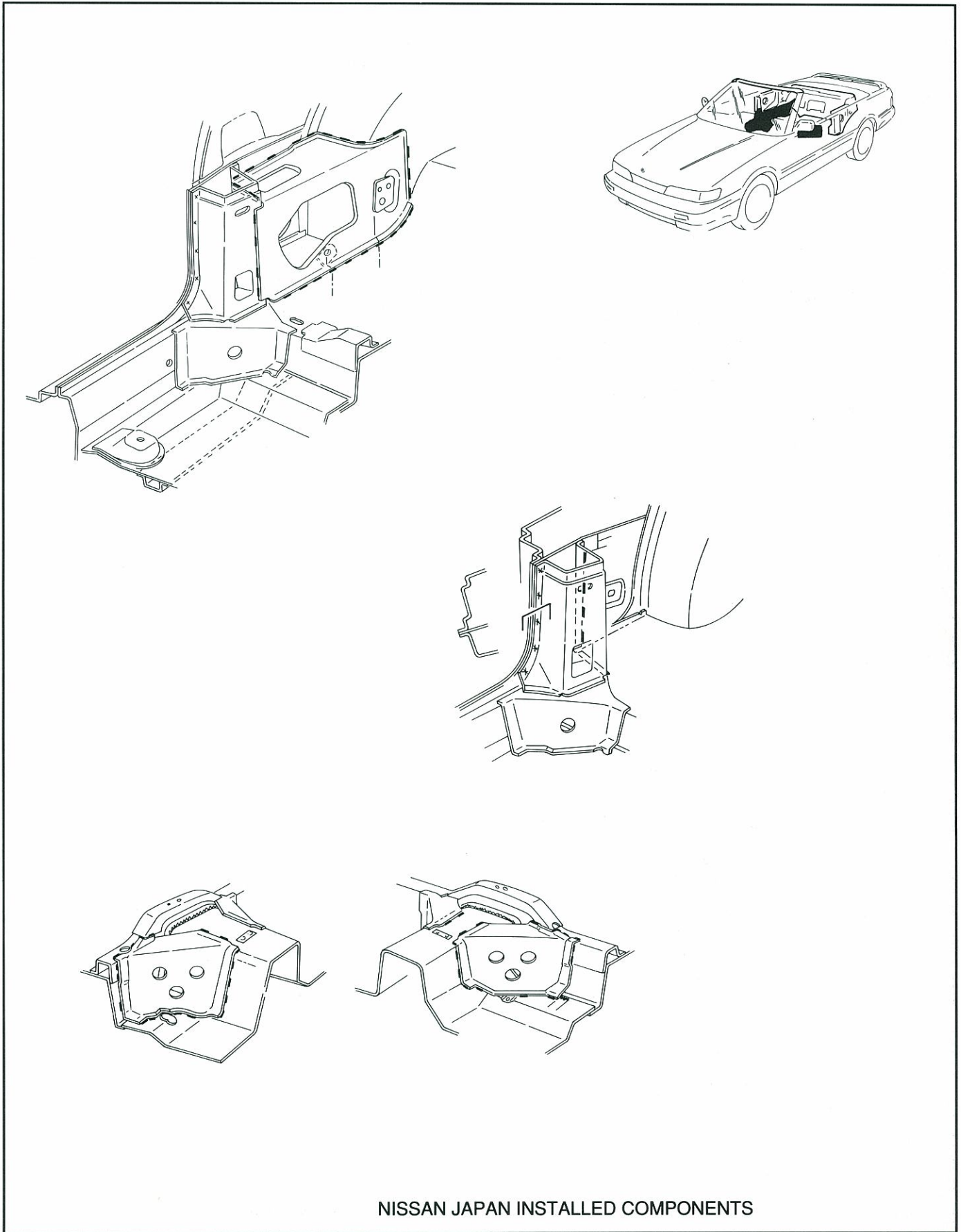

NISSAN JAPAN INSTALLED COMPONENTS

BODY, STRUCTURAL - COMPONENTS (Cont.)

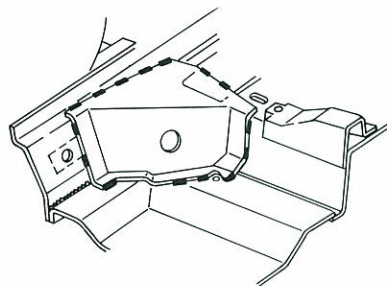
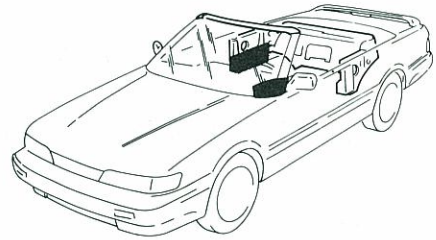
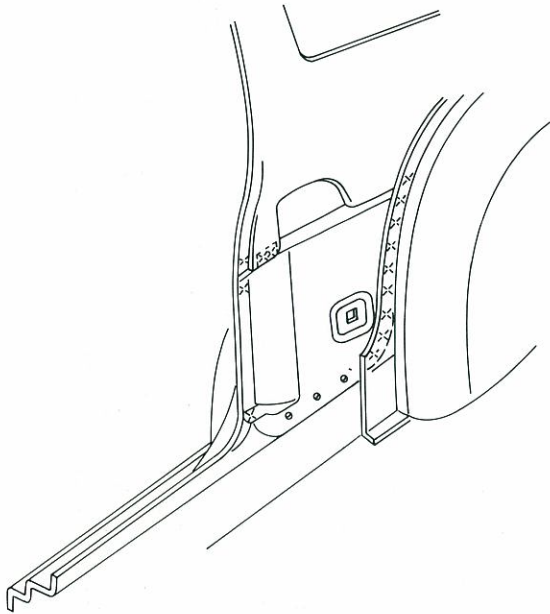

NISSAN JAPAN INSTALLED COMPONENTS



**A**

Actuators, Power Pull Down .....	SECTION 2
Anti-Lock Brake System Wiring Diagram .....	25.25
A.S.C.D. Circuit, Wiring Diagrams .....	25.41-25.42
Audio Wiring Diagram .....	25.40
A/T Shift Lock System Wiring Diagram .....	25.22

**B**

Backlite (Rear Window):	
maintenance .....	C.6
special cautions .....	C.6, C.7
replacement	
removal .....	14.3-14.5
installation .....	14.5-14.8
Battery, Vehicle - Importance of Full-Charge .....	24.16
Body, Structural (Additional Body Panels) .....	SECTION 25
Bow, (Convertible Top) #1 .....	SECTION 16
Bow, (Convertible Top) #2 .....	SECTION 17
Bow, (Convertible Top) #3 .....	SECTION 18
Bow, (Convertible Top) #4 .....	SECTION 19

**C**

Clearance, License, Tail & Stop Lamp	
Wiring Diagram .....	25.36
Convertible Top Wiring Diagrams .....	25.26-25.27
Convertible Top:	
maintenance .....	C.6
special cautions .....	C.7

Convertible Top Replacement	
removal .....	13.3-13.6
installation .....	13.7-13.10
operating instructions	
lowering .....	C.8
lowering manually .....	C.12; 22.4
raising .....	C.10, C.11

**D**

Door Guide Pin .....	10.3-10.5
front guide locator .....	10.6
Door Mirror Wiring Diagram .....	25.32

**E**

ECCS Circuit Diagram .....	25.8
ECCS Diagnostic Diagrams .....	25.9-25-21
ECCS Wiring Diagram (fold-out) .....	25.56
Electrical Components/Controls	
location diagram .....	SECTION 23
Electrical Diagrams .....	SECTION 25
Electrical Sub-Harness Layout Diagram .....	24.20
Electrical Sub-Harness Wiring Diagram .....	24.21
Electrical Troubleshooting:	
symptoms flow chart .....	24.18
quick pin point circuit check .....	24.19

**G**

Glass, Door .....	10.6
Quarter .....	8.4; 8.7
Adjustment .....	8.8
Guide .....	8.4-8.6
Regulator .....	8.5; 8.6

Grounds, Location of Control Unit..... 24.17

## H

Headliner..... SECTION 12

Hinges, Deck Lid ..... SECTION 21

Hydraulic Fluid ..... 22.6; 22.8

### Hydraulic System

theory of operation ..... 22.3-22.4

removal of hydraulic pump/  
motor assembly ..... 22.5

installation of hydraulic  
pump/motor assembly ..... 22.6-22.7

checking fluid level ..... 22.8

checking hydraulic system ..... 22.8-22.9; 22.17

bleeding procedure ..... 22.10-22.12

removal of top stack hydraulic cylinder ..... 22.13-22.15

installation of top stack hydraulic cylinder ..... 22.16

## I

Interior Lamps/Illumination Wiring Diagram ..... 25.37

Interior Spot, Step & Trunk Room Lamps  
Wiring Diagram ..... 25.38

## M

### Main Harness Layout Diagrams

Engine Compartment ..... 25.48-25.49

Passenger Compartment ..... 25.50-25.51

Body Harness ..... 25.52-25.53

Instrument Harness ..... 25.54

Door Harness ..... 25.55

Manual Air Conditioner Circuit & Wiring Diagrams ..... 25.33-25.35

Manual Release Valve (for hydraulic system) ..... 22.3-22.4

Mirror, Rear View ..... 1.4-1.7

Moldings,	
back belt .....	4.3-4.5
deck lid .....	4.7
quarter belt .....	4.3-4.5
quarter window belt.....	4.3-4.6
side guard .....	SECTION 9
windshield outer .....	SECTION 3
Motor, Electric (for Hydraulic Top Stack) .....	22.3; 24.3; 24.8;24.18
<b>O</b>	
Operational Theory, Convertible Top .....	C.2-C.5
Warnings/Cautions .....	C.7
<b>P</b>	
Power Door Lock Wiring Diagram .....	25.29
Power Supply Routing Diagram (Electrical) .....	25.4-25.5
Power Window Wiring Diagram .....	25.30-25.31
Pump, Hydraulic .....	22.3-22.7; 22.9; 22.13; 22.17
<b>Q</b>	
Quick Pin Point Circuit Check .....	24.19
<b>R</b>	
Radiator Fan Motor Circuit & Wiring Diagrams .....	25.6-25.7
Rear Rail Proximity Switch .....	24.5; 24.15
<b>S</b>	
Safety Features, Convertible Top Operation .....	C.2
Seal, Lock Pillar Mocket .....	8.3; 8.8
Seat Belts .....	SECTION 7

Seat, Rear	
back .....	5.5
cushion .....	5.3-5.4
Sonar Suspension Circuit & Wiring Diagrams .....	25.23-25.24
Spoiler, Deck Lid .....	20.4-20.5
Stay Pads, Side and Rear	
removal .....	15.3-15.4
installation .....	15.4-15.6
Stop Light, High-Mount .....	20.3
<b>T</b>	
Tachometer, Temperature & Fuel Gauges	
Wiring Diagram .....	25.39
Theft Warning System Circuit & Wiring Diagrams .....	25.45-25.47
Time Control System Wiring Diagram .....	25.43
Top Boot .....	C.9
Trim Panel, Quarter .....	SECTION 6
Trunk Lid & Fuel Filler Opener Wiring Diagram .....	25.28
<b>U</b>	
Upstop, Rear .....	8.3; 8.7-8.8
<b>V</b>	
Vehicle Wiring Diagram (fold-out) .....	25.57
<b>W</b>	
Weatherstrip Retainers .....	SECTION 11
Window, Rear (See "Backlite")	
Windshield Header Trim .....	SECTION 1



# 1991 INFINITI M30 CONVERTIBLE E. C. C. S. WIRING DIAGRAM

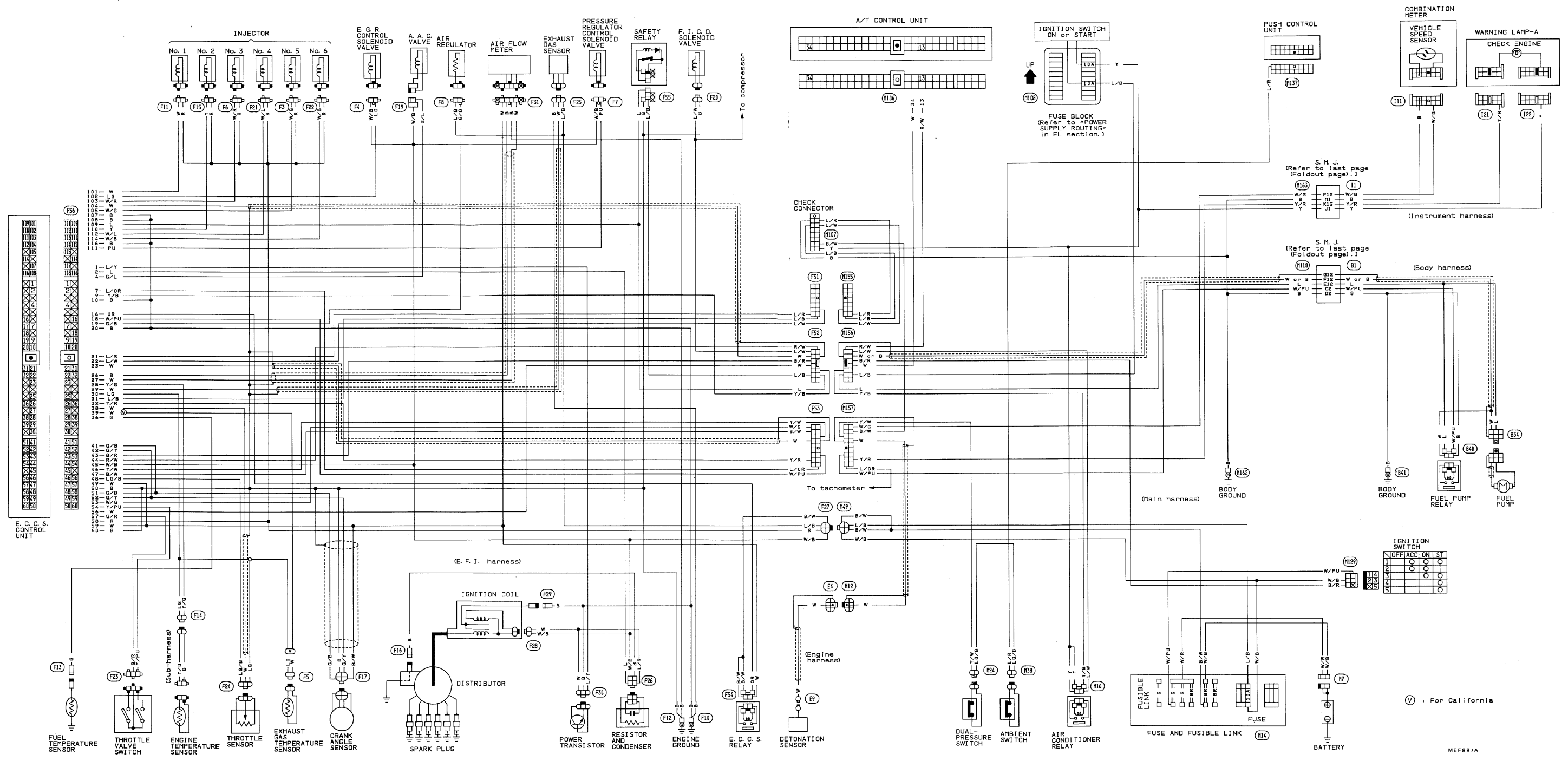









I N F I N I T I .<sup>®</sup>

NISSAN MOTOR CORPORATION IN U.S.A.  
TECHNICAL PUBLICATIONS DEPARTMENT  
GARDENA, CA

EDITION: OCTOBER 1990  
PRINTING: OCTOBER 1990  
PUBLICATION NO. SM1E-0F32U0