

SECTION **EX**
EXHAUST SYSTEM

CONTENTS

PREPARATION	2	INSTALLATION	6	F
Special Service Tools	2	Trouble Diagnoses	7	
Commercial Service Tools	2	WIRING DIAGRAM	7	
EXHAUST SYSTEM	3	PARTS LOCATION	8	G
Checking Exhaust System	3	INSPECTION OF VALVE OPERATION	8	
Removal and Installation	3	INSPECTION OF DUAL MODE MUFFLER		
REMOVAL	4	ACTUATOR INPUT SIGNAL	8	H
INSTALLATION	4	INSPECTION OF DUAL MODE MUFFLER CON-		
INSPECTION AFTER INSTALLATION	4	CONTROL UNIT OUTPUT SIGNAL	9	I
DUAL MODE MUFFLER	5	INSPECTION OF DUAL MODE MUFFLER CON-		
Removal and Installation	5	CONTROL UNIT INPUT SIGNAL	9	
REMOVAL (CABLE)	5	INSPECTION OF ECM OUTPUT SIGNAL	9	J
INSTALLATION	5	INSPECTION OF HARNESS CONTINUITY	9	
REMOVAL (ACTUATOR)	6	SERVICE DATA AND SPECIFICATIONS (SDS)	10	
INSTALLATION	6	Tightening torque	10	
REMOVAL (MUFFLER CONTROL UNIT)	6			

PREPARATION

PREPARATION

PFP:00002

Special Service Tools

ABS004QP

The actual shapes of Kent-Moore tools may differ from those of special service tools illustrated here.

Tool number (Kent-Moore No.) Tool name	Description
KV10114400 (J-38365) Heated oxygen sensor wrench	Loosening or tightening heated oxygen sensors a: 22 mm (0.87 in)

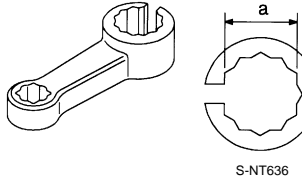

Commercial Service Tools

ABS004QQ

(Kent-Moore No.) Tool name	Description
(J-43897-18) (J-43897-12) Heated oxygen sensor thread cleaner	Reconditioning the exhaust system threads before installing a new heated oxygen sensor (Use with anti-seize lubricant shown below.) a: J-43897-18 (18 mm dia.) for zirconia heated oxygen sensor b: J-43897-12 (12 mm dia.) for titania heated oxygen sensor
Anti-seize lubricant (Permatex 133AR or equivalent meeting MIL specification MIL-A-907)	Lubricating heated oxygen sensor thread cleaning tool when reconditioning exhaust system threads
Power tool	Loosening bolts and nuts

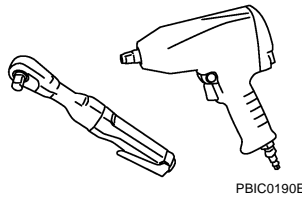
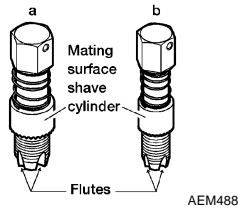

EXHAUST SYSTEM

EXHAUST SYSTEM

PFP:20100

Checking Exhaust System

ABS004QR

Check exhaust pipes, muffler and mounting for improper attachment, leaks, cracks, damage or deterioration.

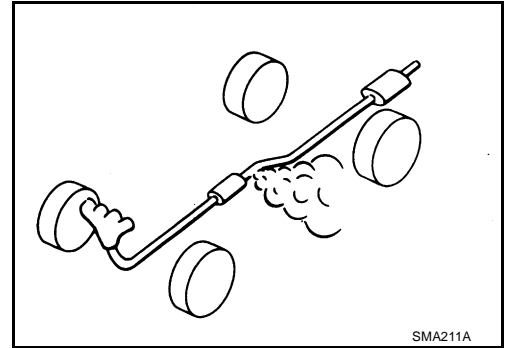

SMA211A

Removal and Installation

ABS004QS

CAUTION:

- Be sure to use genuine exhaust system parts or equivalents which are specially designed for heat resistance, corrosion resistance, and shape.
- Perform the operation with the exhaust system fully cooled down because the system will be hot just after the engine stops.
- Be careful not to cut your hand on the insulator edge.

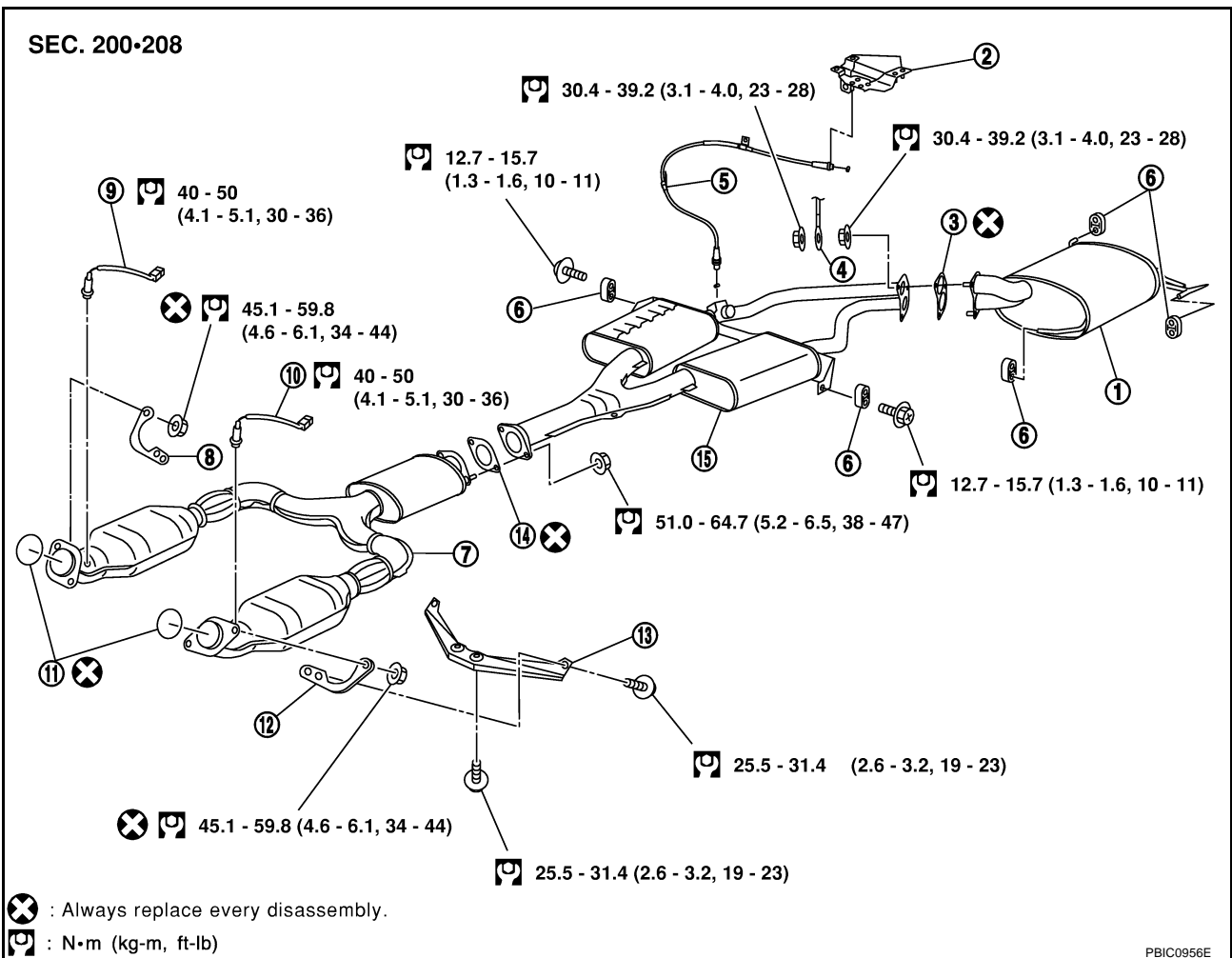

- | | | |
|-----------------------|-------------|------------------------------------|
| 1. Main muffler | 2. Actuator | 3. Gasket |
| 4. Ground cable | 5. Cable | 6. Mounting rubber |
| 7. Exhaust front tube | 8. Bracket | 9. Heated oxygen sensor 2 (bank 2) |

EXHAUST SYSTEM

- | | | |
|-------------------------------------|-----------------|--------------------|
| 10. Heated oxygen sensor 2 (bank 1) | 11. Ring gasket | 12. Bracket |
| 13. Bracket | 14. Gasket | 15. Center muffler |

REMOVAL

1. Remove cable from exhaust control valve.
Refer to Dual mode muffler, [EX-5, "Removal and Installation"](#).
2. Disconnect each joint and mounting.

INSTALLATION

Install in the reverse order of removal.

CAUTION:

- Always replace exhaust gaskets with new ones when reassembling.
- Discard any heated oxygen sensor which has been dropped from a height of more than 0.5 m (19.7 in) onto a hard surface such as a concrete floor; use a new one.
- Before installing a new heated oxygen sensor, clean exhaust system threads using heated oxygen sensor thread cleaner tool, J-43897-18 or J-43897-12, and apply anti-seize lubricant.
- Do not over torque the heated oxygen sensor. Doing so may cause damage to the heated oxygen sensor, resulting in the MIL coming on.
- If the insulator is badly deformed, repair or replace it. If deposits such as mud pile up on the insulator, remove them.
- When installing the insulator avoid large gaps or interference between the insulator and each exhaust pipe.
- Remove deposits and left over gasket material from the sealing surface of each connection. Connect them securely to avoid gas leakage.
- Temporarily tighten mounting nuts on the exhaust manifold side and mounting bolts on the vehicle side. Check each part for abnormal interference, and then tighten them to the specified torque.
- When installing each clamp, align the protrusion on the insulator with the clamp hole.
- When installing each mounting rubber, avoid twisting or abnormal extension in up/down and right/left directions.
- Install mounting rubbers on rear main muffler as shown.

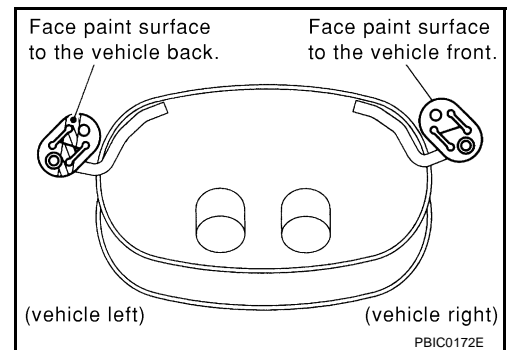

INSPECTION AFTER INSTALLATION

- With the engine running, check exhaust tube joints for gas leakage and unusual noises.
- Check to ensure that mounting brackets and mounting insulators are installed properly and free from undue stress. Improper installation could result in excessive noise and vibration.

DUAL MODE MUFFLER

DUAL MODE MUFFLER Removal and Installation

PF20130

ABS004QU

A
EX
C
D
E
F
G
H
I
J
K
L
M

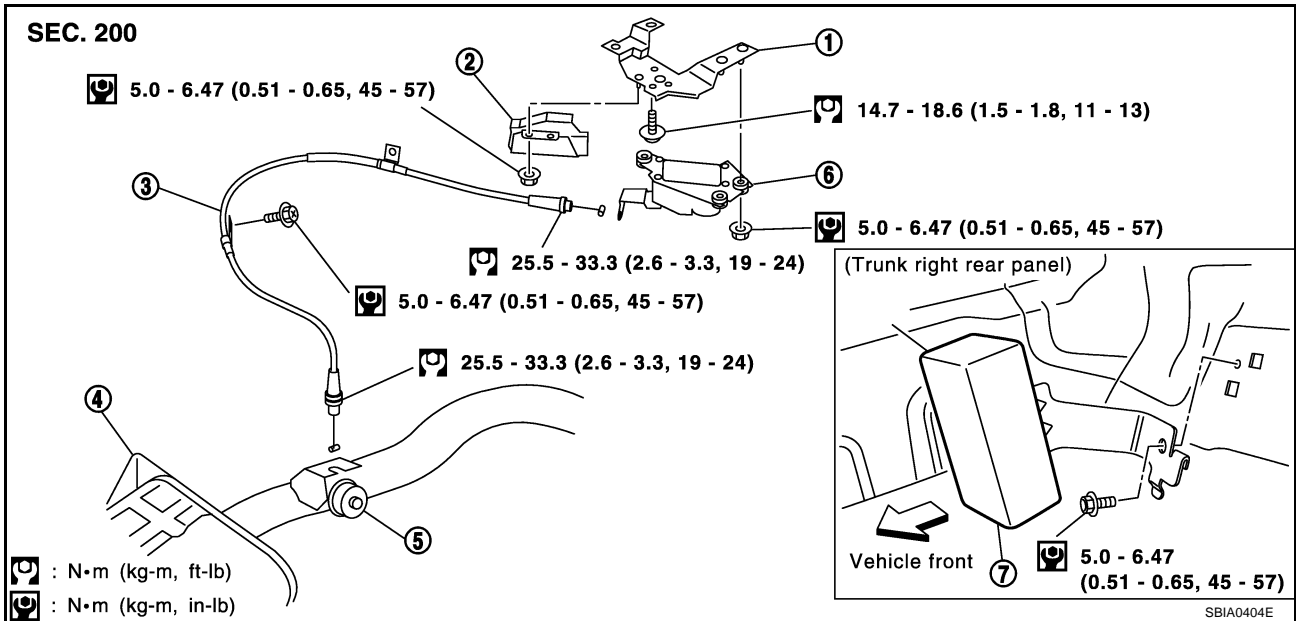

- | | | |
|-------------------------|---|-------------|
| 1. Bracket | 2. Cover | 3. Cable |
| 4. Center muffler | 5. Exhaust control valve
(Do not disassemble.) | 6. Actuator |
| 7. Muffler control unit | | |

NOTE:

Exhaust control valve is provided in center muffler and not permitted to disassemble.

REMOVAL (CABLE)

NOTE:

Removal and installation procedure is the same on both side of actuator and exhaust control valve.

- Remove cable from actuator and exhaust control valve.
 - Loosen lock nut A.
 - Do not loosen positioning nuts B and C.
- Remove middle clamp bolt and cable.

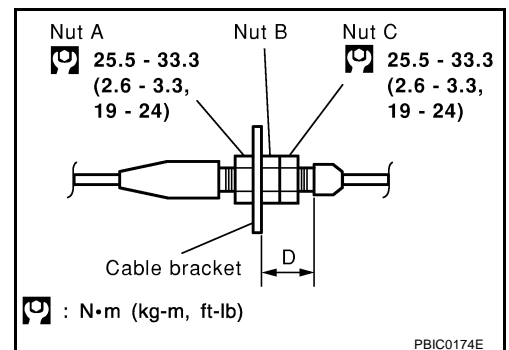

INSTALLATION

- Install in the reverse order of removal.
- Install cable on cable bracket and then tighten lock nut A to specified torque.
- To avoid twisting the cable when tightening the lock nut A, hold the positioning nut B or C with a wrench.
- If the positioning nuts B and C are loosened, place the nut B so that span D becomes 17.5 mm (0.689 in) to 18.5 mm (0.728 in). Hold the nut B with a wrench and tighten the nut C to specified torque.

NOTE:

Additional adjustment is unnecessary.

DUAL MODE MUFFLER

REMOVAL (ACTUATOR)

1. Remove insulator on lower side of actuator.
2. Disconnect harness connector and cable from actuator.
Refer to [EX-5, "REMOVAL \(CABLE\)"](#) .
3. Remove actuator.

INSTALLATION

Install in the reverse order of removal.

REMOVAL (MUFFLER CONTROL UNIT)

1. Open trunk lid, and remove trunk side finisher (right).
2. Remove muffler control unit fixing bolt.
3. Disconnect harness connector and remove muffler control unit along with bracket.

CAUTION:

Do not drop or damage muffler control unit when removing.

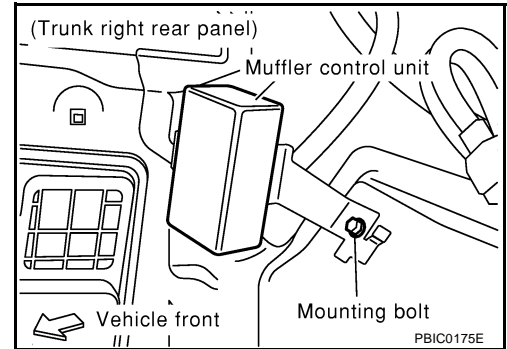

INSTALLATION

Install in the reverse order of removal.

DUAL MODE MUFFLER

Trouble Diagnoses WIRING DIAGRAM

ABS004QW

EX-VEXH-01

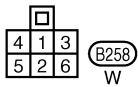
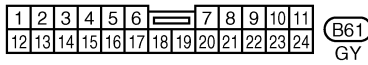
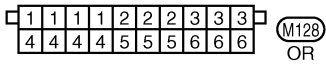
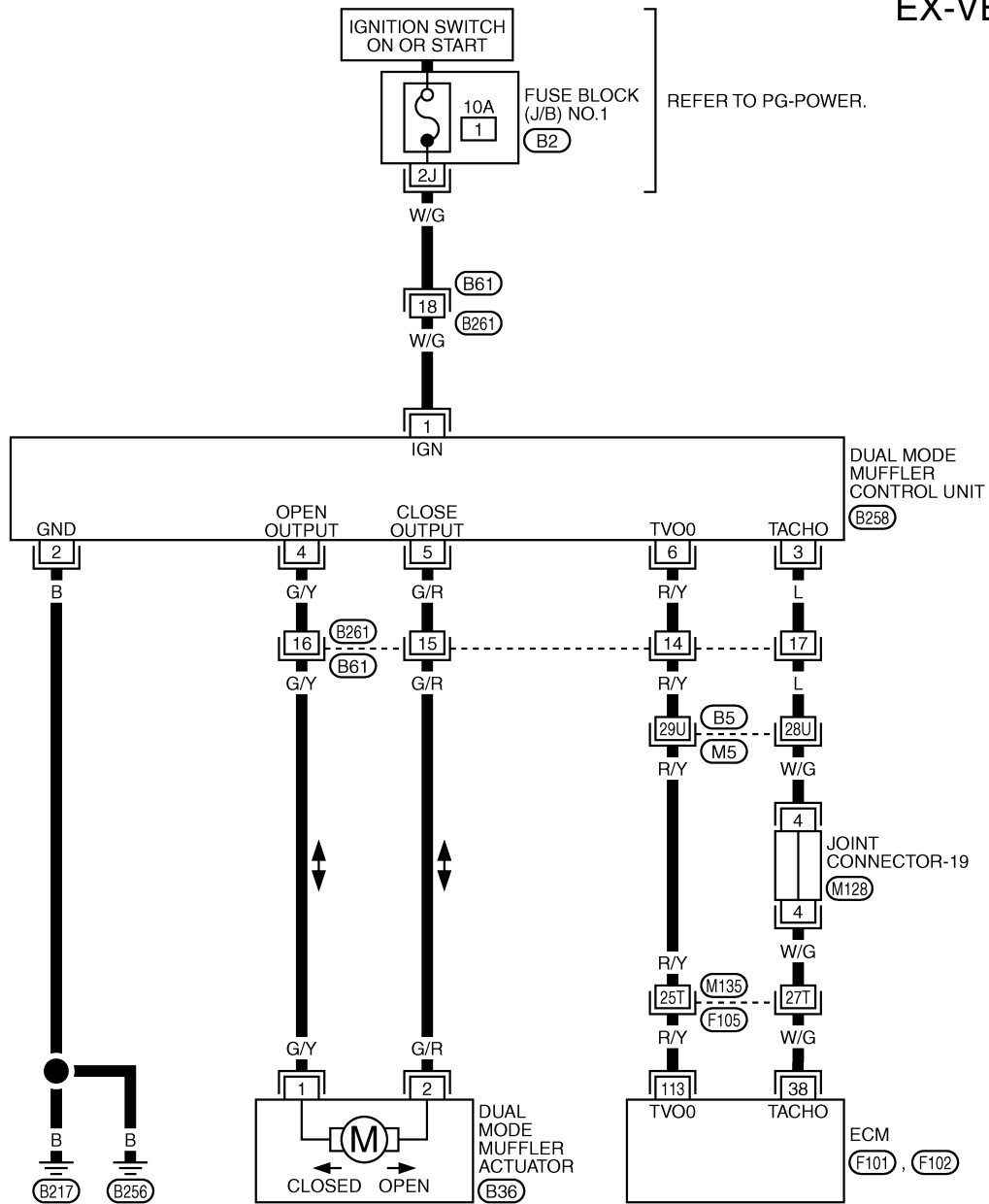

REFER TO THE FOLLOWING.

(M5), (F105) -SUPER MULTIPLE JUNCTION (SMJ)

(B2) -FUSE BLOCK-JUNCTION BOX (J/B) NO.1

(F101), (F102) -ELECTRICAL UNITS

TBWA0317E

DUAL MODE MUFFLER

PARTS LOCATION

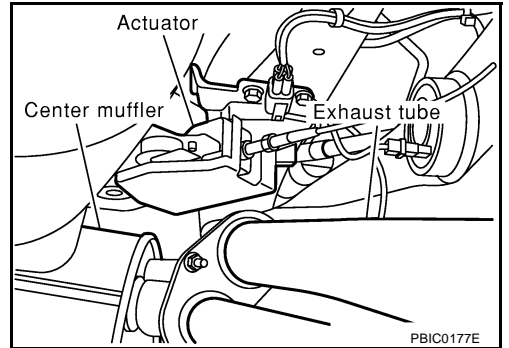
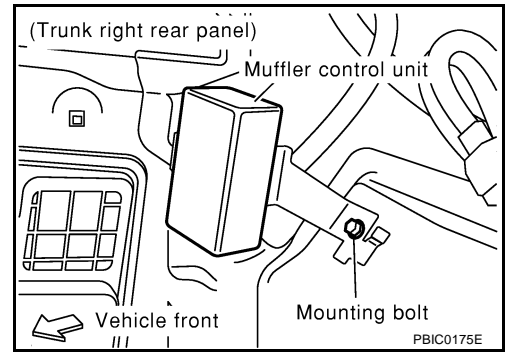

INSPECTION OF VALVE OPERATION

- Check operation of valve and actuator by revving engine.

When accelerator pedal position sensor opening is below half in no-load condition:

Valve should open at engine revolution above approximate 4,830 rpm.

Valve should close at engine revolution below approximate 4,730 rpm.

When accelerator pedal position sensor opening is over half in loaded condition:

Valve should open at engine revolution above approximate 475 rpm.

Valve should close at engine revolution below approximate 375 rpm.

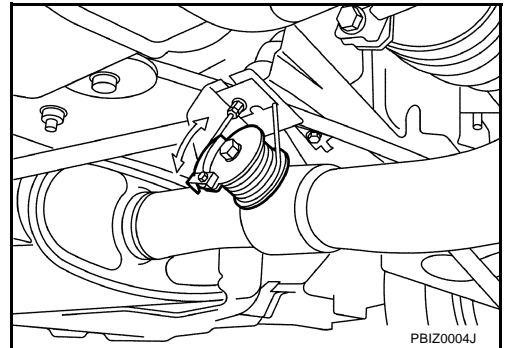

INSPECTION OF DUAL MODE MUFFLER ACTUATOR INPUT SIGNAL

- Check voltage between terminals 1 and 2 of dual mode muffler actuator harness connector and ground.

Terminals		Input signal (Exhaust control valve)	Condition	Voltage V	
(+)	(-)				
Terminal (Wire color)					
1 (G/Y)	GND	Open	ING ON	Battery voltage (11 - 14)	0 - 1
2 (G/R)		Close		0 - 1	Battery voltage (11 - 14)

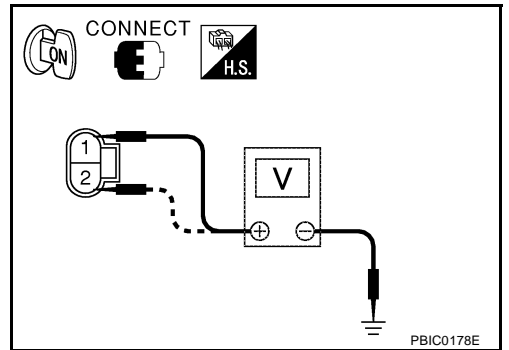

DUAL MODE MUFFLER

INSPECTION OF DUAL MODE MUFFLER CONTROL UNIT OUTPUT SIGNAL

- Check voltage between terminals 4 and 5 of dual mode muffler control unit harness connector and ground.

Terminals		Input signal (Exhaust control valve)	Condition	Voltage V	
(+)	(-)				
Terminal (Wire color)					
4 (G/Y)	GND	Open	ING ON	Battery voltage (11 - 14)	0 - 1
5 (G/R)		Close		0 - 1	Battery voltage (11 - 14)

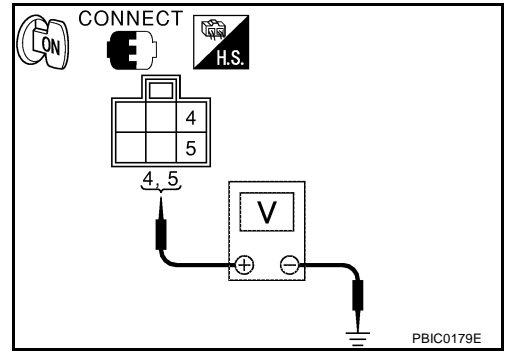

INSPECTION OF DUAL MODE MUFFLER CONTROL UNIT INPUT SIGNAL

- Check voltage between terminals 1, 2, 3 and 6 of dual mode muffler control unit harness connector and ground.

Terminals		Input signal	Condition	Voltage V	
(+)	(-)				
Terminal (Wire color)					
1 (W/G)	GND	Battery	ING ON	Battery voltage (11 - 14)	
3 (L)		Revolution	Idling	Approx. 4 - 6	
2 (B)		Earth	IGN OFF	0	
6 (R/Y)	GND	Accelerator pedal position sensor opening	Over half	ING ON	More than approx. 2.4
			Below half		Approx. 0 - 2.4

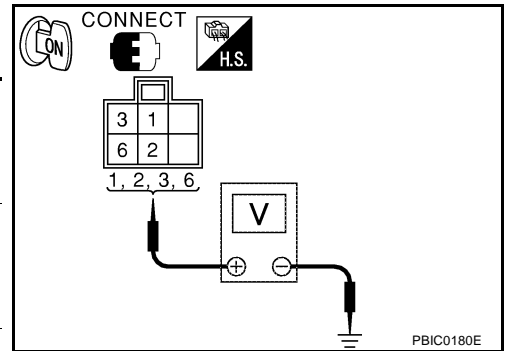

INSPECTION OF ECM OUTPUT SIGNAL

- Check that tachometer operates normally.
- Check voltage between ECM terminals 38, 113 and ground at idling engine.

Terminals		Output signal	Condition	Voltage V	
(+)	(-)				
Terminal (Wire color)					
38 (W/G)	GND	Revolution	Idling	Approx. 4 - 6	
113 (R/Y)		Accelerator pedal position sensor opening	Over half	ING ON	More than approx. 2.4
	Below half	Approx. 0 - 2.4			

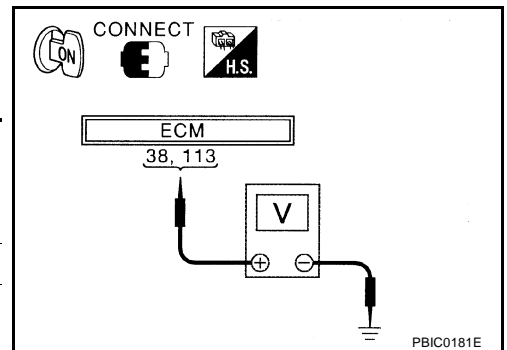

INSPECTION OF HARNESS CONTINUITY

- Disconnect connectors of ECM, dual mode muffler control unit and actuator. Check resistance between terminals.

Terminals (Wire color)	Resistance Ω
Actuator terminal 1 (G/Y) and muffler control unit terminal 4 (G/Y)	0
Actuator terminal 2 (G/R) and muffler control unit terminal 5 (G/R)	
ECM terminal 38 (W/G) and muffler control unit terminal 3 (L)	
ECM terminal 113 (R/Y) and muffler control unit terminal 6 (R/Y)	

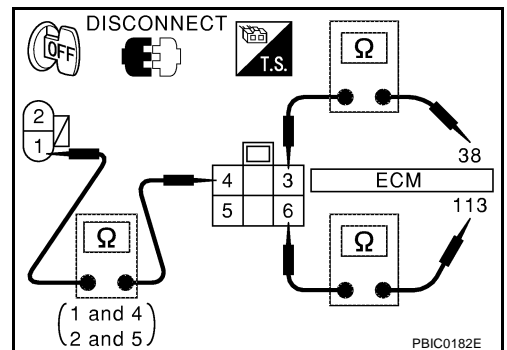

SERVICE DATA AND SPECIFICATIONS (SDS)

SERVICE DATA AND SPECIFICATIONS (SDS)

PFP:00030

Tightening torque

ABS004QT

Unit: N·m (kg-m, ft-lb)
Unit: N·m (kg-m, in-lb)*

Exhaust system connections	
Between exhaust manifold and exhaust front tube	45.1 - 59.8 (4.6 - 6.1, 34 - 44)
Between exhaust front tube and center muffler	51.0 - 64.7 (5.2 - 6.5, 38 - 47)
Between center muffler and main muffler	30.4 - 39.2 (3.1 - 3.9, 23 - 28)
Exhaust mounting fixing bolts	
For exhaust front tube	25.5 - 31.4 (2.6 - 3.2, 19 - 23)
For center muffler	12.7 - 15.7 (1.3 - 1.6, 10 - 11)
Heated oxygen sensor 2 (bank 1) (bank 2)	40 - 50 (4.1 - 5.1, 30 - 36)
Dual mode muffler	
Muffler control unit	5.0 - 6.47 (0.51 - 0.65, 45 - 57)*
Actuator	5.0 - 6.47 (0.51 - 0.65, 45 - 57)*
Actuator mounting bracket	14.7 - 18.6 (1.5 - 1.8, 11 - 13)
Actuator cover	5.0 - 6.47 (0.51 - 0.65, 45 - 57)*
Cable lock nut (Both actuator and valve side)	25.5 - 33.3 (2.6 - 3.3, 19 - 24)
Cable middle clamp tightening bolt	5.0 - 6.47 (0.51 - 0.65, 45 - 57)*