

**SECTION IP**  
**INSTRUMENT PANEL**

A  
 B  
 C  
 D  
 E  
 F  
 G  
 H  
 IP  
 J  
 K  
 L  
 M

**CONTENTS**

<b>PRECAUTIONS</b> .....	<b>2</b>	Generic Squeak and Rattle Troubleshooting .....	<b>6</b>
Precautions for Supplemental Restraint System (SRS) "AIR BAG" and "SEAT BELT PRE-TENSIONER" .....	2	INSTRUMENT PANEL .....	6
Precautions .....	2	CENTER CONSOLE .....	6
<b>PREPARATION</b> .....	<b>3</b>	DOORS .....	6
Special Service Tools .....	3	TRUNK .....	7
Commercial Service Tools .....	3	SUNROOF/HEADLINING .....	7
<b>SQUEAK AND RATTLE TROUBLE DIAGNOSES</b> .....	<b>4</b>	SEATS .....	7
Work Flow .....	4	UNDERHOOD .....	7
CUSTOMER INTERVIEW .....	4	Diagnostic Worksheet .....	8
DUPLICATE THE NOISE AND TEST DRIVE .....	5	<b>INSTRUMENT PANEL ASSEMBLY</b> .....	<b>10</b>
CHECK RELATED SERVICE BULLETINS .....	5	Component Parts Drawing .....	10
LOCATE THE NOISE AND IDENTIFY THE ROOT CAUSE .....	5	Removal and Installation .....	11
REPAIR THE CAUSE .....	5	WORK STEPS .....	11
CONFIRM THE REPAIR .....	6	REMOVAL .....	12
		INSTALLATION .....	15
		Disassembly and Assembly .....	16
		CONSOLE BOX ASSEMBLY .....	16

# PRECAUTIONS

## PRECAUTIONS

PF0:00001

### Precautions for Supplemental Restraint System (SRS) “AIR BAG” and “SEAT BELT PRE-TENSIONER”

AIS00106

The Supplemental Restraint System such as “AIR BAG” and “SEAT BELT PRE-TENSIONER”, used along with a front seat belt, helps to reduce the risk or severity of injury to the driver and front passenger for certain types of collision. This system includes seat belt switch inputs and dual stage front air bag modules. The SRS system uses the seat belt switches to determine the front air bag deployment, and may only deploy one front air bag, depending on the severity of a collision and whether the front occupants are belted or unbelted. Information necessary to service the system safely is included in the SRS and SB section of this Service Manual.

#### **WARNING:**

- **To avoid rendering the SRS inoperative, which could increase the risk of personal injury or death in the event of a collision which would result in air bag inflation, all maintenance must be performed by an authorized NISSAN/INFINITI dealer.**
- **Improper maintenance, including incorrect removal and installation of the SRS, can lead to personal injury caused by unintentional activation of the system. For removal of Spiral Cable and Air Bag Module, see the SRS section.**
- **Do not use electrical test equipment on any circuit related to the SRS unless instructed to in this Service Manual. SRS wiring harnesses can be identified by yellow and/or orange harnesses or harness connectors.**

## Precautions

AIS001J4

- Disconnect both battery cables in advance.
- Disconnect air bag system line in advance.
- Never tamper with or force air bag lid open, as this may adversely affect air bag performance.
- Be careful not to scratch pad and other parts.
- When removing or disassembling any part, be careful not to damage or deform it. Protect parts, which may get in the way with cloth.
- When removing parts with a screwdriver or other tool, protect parts by wrapping them with vinyl or tape.
- Keep removed parts protected with cloth.
- If a clip is deformed or damaged, replace it.
- If an un reusable part is removed, replace it with a new one.
- Tighten bolts and nuts firmly to the specified torque.
- After re-assembly has been completed, make sure each part functions correctly.
- Remove stains in the following way.

Water-soluble stains:

Dip a soft cloth in warm water, and then squeeze it tightly. After wiping the stain, wipe with a soft dry cloth.

Oil stain:

Dissolve a synthetic detergent in warm water (density of 2 to 3% or less), dip the cloth, then clean off the stain with the cloth. Next, dip the cloth in fresh water and squeeze it tightly. Then clean off the detergent completely. Then wipe the area with a soft dry cloth.

- Do not use any organic solvent, such as thinner or benzene.

# PREPARATION



## PREPARATION

PPF:00002

### Special Service Tools

AIS001J5

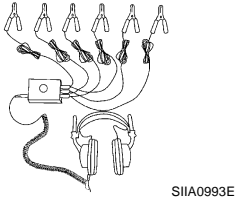
The actual shapes of Kent-Moore tools may differ from those of special service tools illustrated here.

Tool number (Kent-Moore No.) Tool name	Description
<p>(J39570) Chassis ear</p>  <p>SIIA0993E</p>	<p>Location the noise</p>
<p>(J43980) NISSAN Squeak and Rattle Kit</p>  <p>SIIA0994E</p>	<p>Repairing the cause of noise</p>

## Commercial Service Tools

AIS001J6

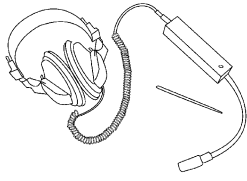
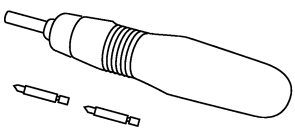
Tool name	Description
<p>Engine ear</p>  <p>SIIA0995E</p>	<p>Location the noise</p>
<p>Power tool</p>  <p>PBIC0191E</p>	

# SQUEAK AND RATTLE TROUBLE DIAGNOSES

## SQUEAK AND RATTLE TROUBLE DIAGNOSES

PFP:00000

### Work Flow

AIS001J7

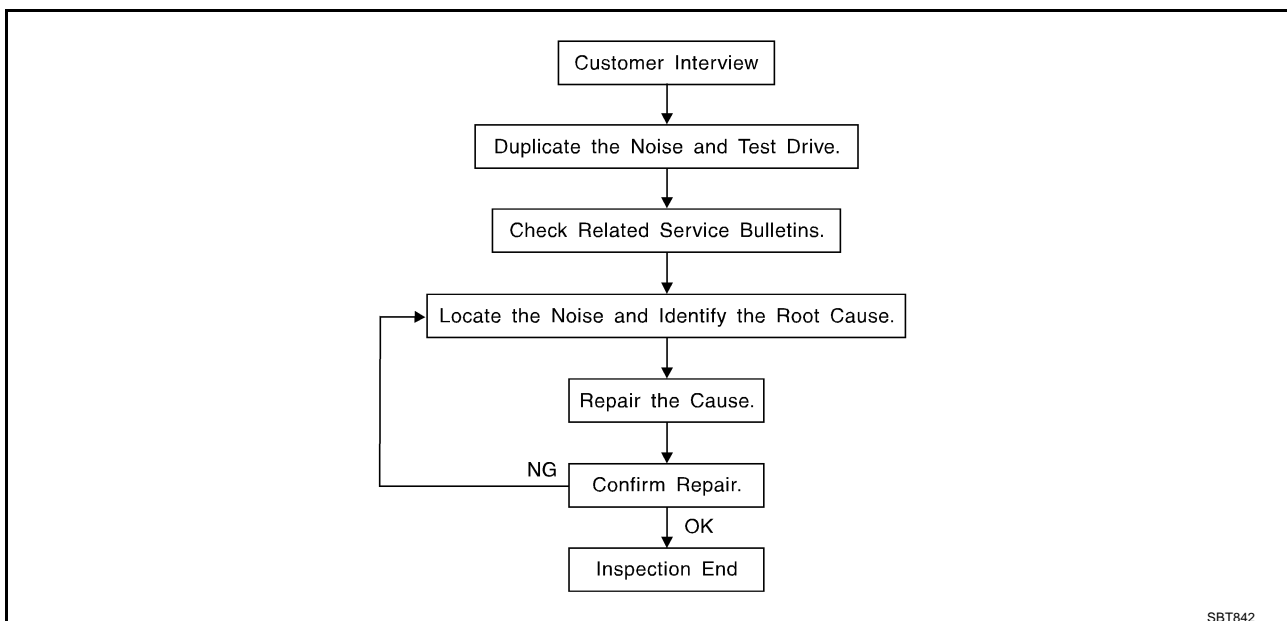

### CUSTOMER INTERVIEW

Interview the customer if possible, to determine the conditions that exist when the noise occurs. Use the Diagnostic Worksheet during the interview to document the facts and conditions when the noise occurs and any customer's comments; refer to [IP-8, "Diagnostic Worksheet"](#). This information is necessary to duplicate the conditions that exist when the noise occurs.

- The customer may not be able to provide a detailed description or the location of the noise. Attempt to obtain all the facts and conditions that exist when the noise occurs (or does not occur).
- If there is more than one noise in the vehicle, be sure to diagnose and repair the noise that the customer is concerned about. This can be accomplished by test driving the vehicle with the customer.
- After identifying the type of noise, isolate the noise in terms of its characteristics. The noise characteristics are provided so the customer, service adviser and technician are all speaking the same language when defining the noise.
- Squeak —(Like tennis shoes on a clean floor)  
Squeak characteristics include the light contact/fast movement/brought on by road conditions/hard surfaces=higher pitch noise/softer surfaces=lower pitch noises/edge to surface=chirping
- Creak—(Like walking on an old wooden floor)  
Creak characteristics include firm contact/slow movement/twisting with a rotational movement/pitch dependent on materials/often brought on by activity.
- Rattle—(Like shaking a baby rattle)  
Rattle characteristics include the fast repeated contact/vibration or similar movement/loose parts/missing clip or fastener/incorrect clearance.
- Knock —(Like a knock on a door)  
Knock characteristics include hollow sounding/sometimes repeating/often brought on by driver action.
- Tick—(Like a clock second hand)  
Tick characteristics include gentle contacting of light materials/loose components/can be caused by driver action or road conditions.
- Thump—(Heavy, muffled knock noise)  
Thump characteristics include softer knock/dead sound often brought on by activity.
- Buzz—(Like a bumble bee)  
Buzz characteristics include high frequency rattle/firm contact.
- Often the degree of acceptable noise level will vary depending upon the person. A noise that you may judge as acceptable may be very irritating to the customer.
- Weather conditions, especially humidity and temperature, may have a great effect on noise level.

# SQUEAK AND RATTLE TROUBLE DIAGNOSES

## DUPLICATE THE NOISE AND TEST DRIVE

If possible, drive the vehicle with the customer until the noise is duplicated. Note any additional information on the Diagnostic Worksheet regarding the conditions or location of the noise. This information can be used to duplicate the same conditions when you confirm the repair.

If the noise can be duplicated easily during the test drive, to help identify the source of the noise, try to duplicate the noise with the vehicle stopped by doing one or all of the following:

- 1) Close a door.
  - 2) Tap or push/pull around the area where the noise appears to be coming from.
  - 3) Rev the engine.
  - 4) Use a floor jack to recreate vehicle "twist".
  - 5) At idle, apply engine load (electrical load, half-clutch on M/T model, drive position on A/T model).
  - 6) Raise the vehicle on a hoist and hit a tire with a rubber hammer.
- Drive the vehicle and attempt to duplicate the conditions the customer states exist when the noise occurs.
  - If it is difficult to duplicate the noise, drive the vehicle slowly on an undulating or rough road to stress the vehicle body.

## CHECK RELATED SERVICE BULLETINS

After verifying the customer concern or symptom, check ASIST for Technical Service Bulletins (TSBs) related to that concern or symptom.

If a TSB relates to the symptom, follow the procedure to repair the noise.

## LOCATE THE NOISE AND IDENTIFY THE ROOT CAUSE

1. Narrow down the noise to a general area. To help pinpoint the source of the noise, use a listening tool (Chassis Ear: J39570, Engine Ear and mechanics stethoscope).
2. Narrow down the noise to a more specific area and identify the cause of the noise by:
  - removing the components in the area that you suspect the noise is coming from.  
Do not use too much force when removing clips and fasteners, otherwise clips and fastener can be broken or lost during the repair, resulting in the creation of new noise.
  - tapping or pushing/pulling the component that you suspect is causing the noise.  
Do not tap or push/pull the component with excessive force, otherwise the noise will be eliminated only temporarily.
  - feeling for a vibration with your hand by touching the component(s) that you suspect is (are) causing the noise.
  - placing a piece of paper between components that you suspect are causing the noise.
  - looking for loose components and contact marks.  
Refer to [IP-6, "Generic Squeak and Rattle Troubleshooting"](#)

## REPAIR THE CAUSE

- If the cause is a loose component, tighten the component securely.
- If the cause is insufficient clearance between components:
  - separate components by repositioning or loosening and retightening the component, if possible.
  - insulate components with a suitable insulator such as urethane pads, foam blocks, felt cloth tape or urethane tape. A NISSAN Squeak and Rattle Kit (J43980) is available through your authorized NISSAN Parts Department.

### CAUTION:

**Do not use excessive force as many components are constructed of plastic and may be damaged.**

**Always check with the Parts Department for the latest parts information.**

**The following materials are contained in the NISSAN Squeak and Rattle Kit (J43980). Each item can be ordered separately as needed.**

**URETHANE PADS [1.5mm(0.059 in) thick]**

**Insulates connectors, harness, etc.**

**76268-9E005: 100×135mm(3.94×5.31 in)/76884-71L01: 60×85mm(2.36×3.35 in)/76884-71L02: 15×25mm(0.59×0.98 in)**

**INSULATOR (Foam blocks)**

**Insulates components from contact. Can be used to fill space behind a panel.**

**73982-9E000: 45mm(1.77 in) thick, 50×50mm(1.97×1.97 in)/73982-50Y00: 10mm(0.39 in) thick, 50×50mm(1.97×1.97 in)**

# SQUEAK AND RATTLE TROUBLE DIAGNOSES

---

## **INSULATOR (Light foam block)**

80845-71L00: 30mm(1.18 in) thick, 30×50mm(1.18×1.97 in)

## **FELT CLOTHTAPE**

Used to insulate where movement does not occur. Ideal for instrument panel applications.

68370-4B000: 15×25mm(0.59×0.98 in) pad/68239-13E00: 5mm(0.20 in) wide tape roll The following materials, not found in the kit, can also be used to repair squeaks and rattles.

## **UHMW(TEFLON) TAPE**

Insulates where slight movement is present. Ideal for instrument panel applications.

## **SILICONE GREASE**

Used in of UHMW tape that will be visible or not fit.

Note: Will only last a few months.

## **SILICONE SPRAY**

Use when grease cannot be applied.

## **DUCT TAPE**

Use to eliminate movement.

## **CONFIRM THE REPAIR**

Confirm that the cause of a noise is repaired by test driving the vehicle. Operate the vehicle under the same conditions as when the noise originally occurred. Refer to the notes on the Diagnostic Worksheet.

## **Generic Squeak and Rattle Troubleshooting**

AIS001J8

Refer to Table of Contents for specific component removal and installation information.

## **INSTRUMENT PANEL**

Most incidents are caused by contact and movement between:

1. The cluster lid A and instrument panel
2. Acrylic lens and combination meter housing
3. Instrument panel to front pillar garnish
4. Instrument panel to windshield
5. Instrument panel mounting pins
6. Wiring harnesses behind the combination meter
7. A/C defroster duct and duct joint

These incidents can usually be located by tapping or moving the components to duplicate the noise or by pressing on the components while driving to stop the noise. Most of these incidents can be repaired by applying felt cloth tape or silicon spray (in hard to reach areas). Urethane pads can be used to insulate wiring harness.

### **CAUTION:**

**Do not use silicone spray to isolate a squeak or rattle. If you saturate the area with silicone, you will not be able to recheck the repair.**

## **CENTER CONSOLE**

Components to pay attention to include:

1. Shifter assembly cover to finisher
2. A/C control unit and cluster lid C
3. Wiring harnesses behind audio and A/C control unit

The instrument panel repair and isolation procedures also apply to the center console.

## **DOORS**

Pay attention to the:

1. Finisher and inner panel making a slapping noise
2. Inside handle escutcheon to door finisher
3. Wiring harnesses tapping
4. Door striker out of alignment causing a popping noise on starts and stops

Tapping or moving the components or pressing on them while driving to duplicate the conditions can isolate many of these incidents. You can usually insulate the areas with felt cloth tape or insulator foam blocks from the NISSAN Squeak and Rattle Kit (J-43980) to repair the noise.

# SQUEAK AND RATTLE TROUBLE DIAGNOSES

## TRUNK

Trunk noises are often caused by a loose jack or loose items put into the trunk by the owner. In addition look for:

1. Trunk lid dumpers out of adjustment
2. Trunk lid striker out of adjustment
3. The trunk lid torsion bars knocking together
4. A loose license plate or bracket

Most of these incidents can be repaired by adjusting, securing or insulating the item(s) or component(s) causing the noise.

## SUNROOF/HEADLINING

Noises in the sunroof/headlining area can often be traced to one of the following:

1. Sunroof lid, rail, linkage or seals making a rattle or light knocking noise
2. Sunvisor shaft shaking in the holder
3. Front or rear windshield touching headlining and squeaking

Again, pressing on the components to stop the noise while duplicating the conditions can isolate most of these incidents. Repairs usually consist of insulating with felt cloth tape.

## SEATS

When isolating seat noise it's important to note the position the seat is in and the load placed on the seat when the noise is present. These conditions should be duplicated when verifying and isolating the cause of the noise.

Cause of seat noise include:

1. Headrest rods and holder
2. A squeak between the seat pad cushion and frame
3. The rear seat back lock and bracket

These noises can be isolated by moving or pressing on the suspected components while duplicating the conditions under which the noise occurs. Most of these incidents can be repaired by repositioning the component or applying urethane tape to the contact area.

## UNDERHOOD

Some interior noise may be caused by components under the hood or on the engine wall. The noise is then transmitted into the passenger compartment.

Causes of transmitted underhood noise include:

1. Any component mounted to the engine wall
2. Components that pass through the engine wall
3. Engine wall mounts and connectors
4. Loose radiator mounting pins
5. Hood bumpers out of adjustment
6. Hood striker out of adjustment

These noise can be difficult to isolate since they cannot be reached from the interior of the vehicle. The best method is to secure, move or insulate one component at a time and test drive the vehicle. Also, engine RPM or load can be changed to isolate the noise. Repairs can usually be made by moving, adjusting securing, or insulating the component causing the noise.

A

B

C

D

E

F

G

H

IP

J

K

L

M

# SQUEAK AND RATTLE TROUBLE DIAGNOSES

## Diagnostic Worksheet

AIS001J9



### SQUEAK & RATTLE DIAGNOSTIC WORKSHEET

Dear Infiniti Customer:

We are concerned about your satisfaction with your Infiniti vehicle. Repairing a squeak or rattle sometimes can be very difficult. To help us fix your Infiniti right the first time, please take a moment to note the area of the vehicle where the squeak or rattle occurs and under what conditions. You may be asked to take a test drive with a service advisor or technician to ensure we confirm the noise you are hearing.

#### I. WHERE DOES THE NOISE COME FROM? (circle the area of the vehicle)

The illustrations are for reference only, and may not reflect the actual configuration of your vehicle.

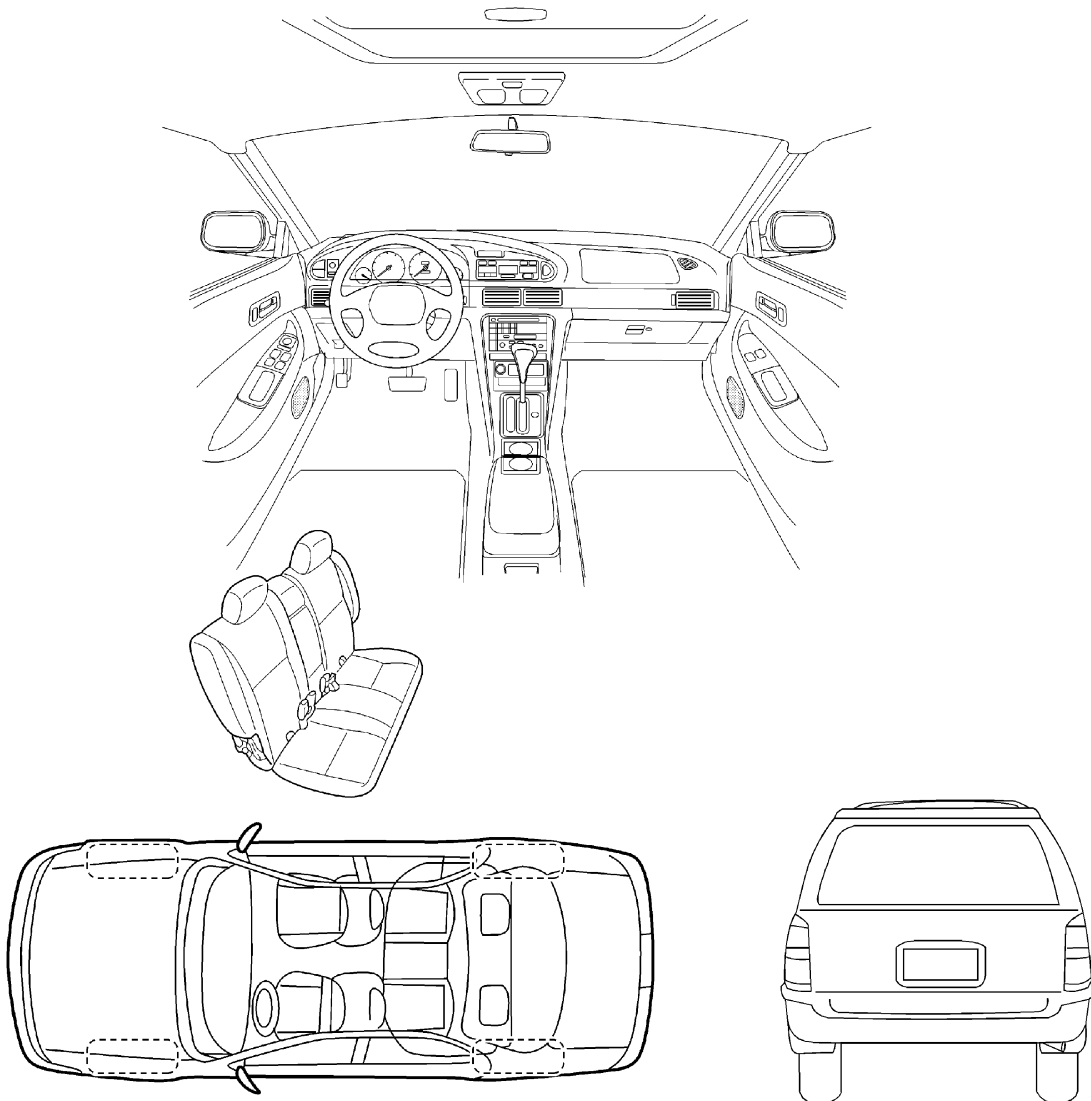

Continue to the back of the worksheet and briefly describe the location of the noise or rattle. In addition, please indicate the conditions which are present when the noise occurs.

SBT860



# SQUEAK AND RATTLE TROUBLE DIAGNOSES

## SQUEAK & RATTLE DIAGNOSTIC WORKSHEET- page 2

Briefly describe the location where the noise occurs:

---

---

---

### II. WHEN DOES IT OCCUR? (check the boxes that apply)

- |  |   |
|--|---|
| <input type="checkbox"/> anytime                             | <input type="checkbox"/> after sitting out in the sun |
| <input type="checkbox"/> 1 <sup>st</sup> time in the morning | <input type="checkbox"/> when it is raining or wet    |
| <input type="checkbox"/> only when it is cold outside        | <input type="checkbox"/> dry or dusty conditions      |
| <input type="checkbox"/> only when it is hot outside         | <input type="checkbox"/> other: _____                 |

### III. WHEN DRIVING:

- through driveways
- over rough roads
- over speed bumps
- only at about \_\_\_\_ mph
- on acceleration
- coming to a stop
- on turns : left, right or either (circle)
- with passengers or cargo
- other: \_\_\_\_\_
- after driving \_\_\_\_ miles or \_\_\_\_ minutes

### IV. WHAT TYPE OF NOISE?

- squeak (like tennis shoes on a clean floor)
- creak (like walking on an old wooden floor)
- rattle (like shaking a baby rattle)
- knock (like a knock on a door)
- tick (like a clock second hand)
- thump (heavy, muffled knock noise)
- buzz (like a bumble bee)

### TO BE COMPLETED BY DEALERSHIP PERSONNEL

#### Test Drive Notes:

---

---

	YES	NO	Initials of person performing
Vehicle test driven with customer	<input type="checkbox"/>	<input type="checkbox"/>	_____
- Noise verified on test drive	<input type="checkbox"/>	<input type="checkbox"/>	_____
- Noise source located and repaired	<input type="checkbox"/>	<input type="checkbox"/>	_____
- Follow up test drive performed to confirm repair	<input type="checkbox"/>	<input type="checkbox"/>	_____

VIN: \_\_\_\_\_ Customer Name: \_\_\_\_\_

W.O. #: \_\_\_\_\_ Date: \_\_\_\_\_

**This form must be attached to Work Order**

SBT844

# INSTRUMENT PANEL ASSEMBLY

## INSTRUMENT PANEL ASSEMBLY

PFP:68200

### Component Parts Drawing

AIS004UV

SEC. 251•280•487•680•969

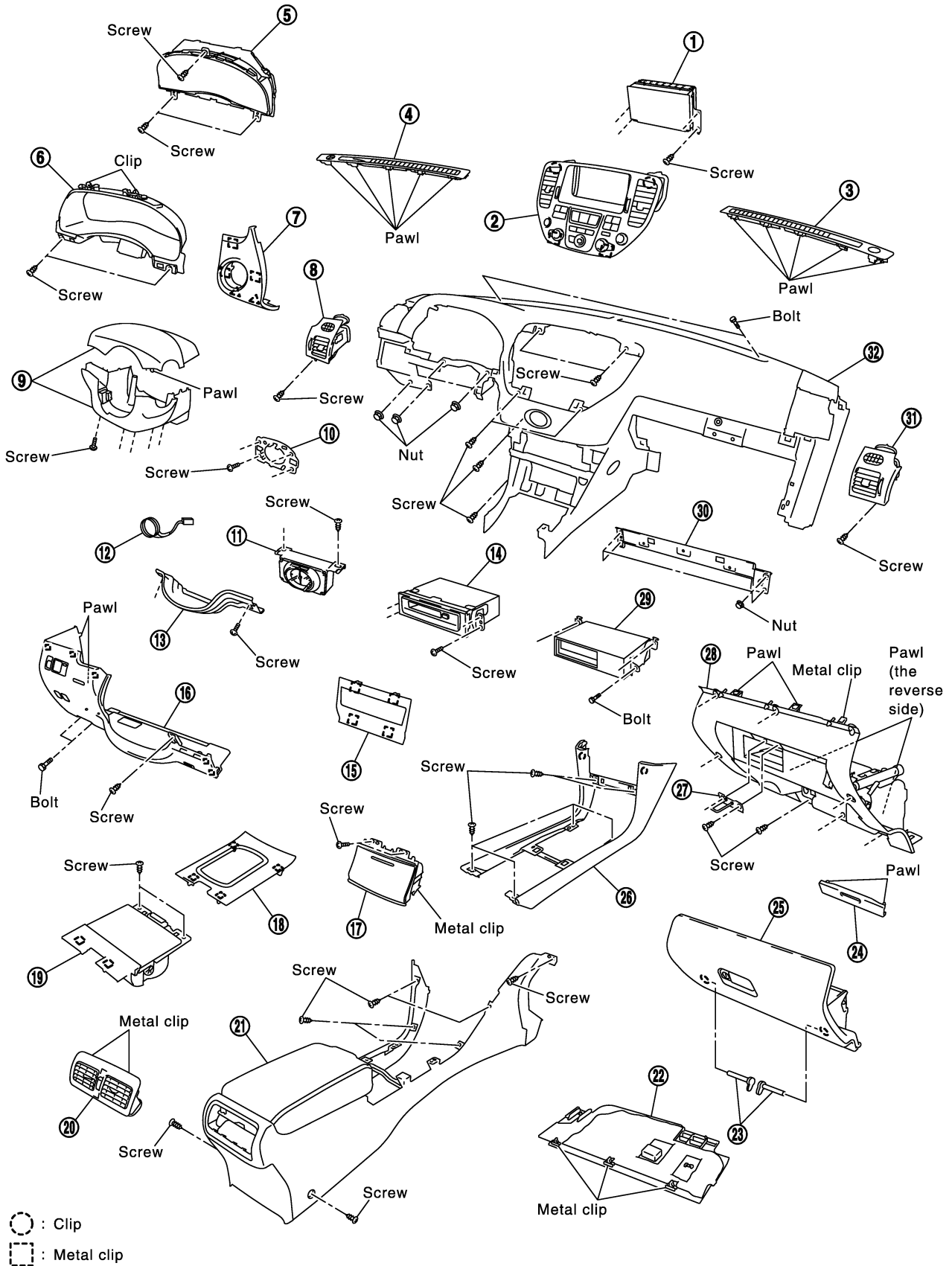

PIIA2602E

# INSTRUMENT PANEL ASSEMBLY

- |                                   |                              |  |
|-----------------------------------|------------------------------|--|
| 1. Display unit                   | 2. Cluster lid C             | 3. Front defroster grille (RH)             |
| 4. Front defroster grille (LH)    | 5. Combination meter         | 6. Cluster lid A                           |
| 7. Steering lock escutcheon       | 8. Side ventilation (LH)     | 9. Steering column cover                   |
| 10. Instrument panel bracket      | 11. Clock                    | 12. Ignition key lamp assembly             |
| 13. Knee protector lower          | 14. Audio unit               | 15. Cluster lid center lower               |
| 16. Instrument lower driver panel | 17. Ashtray                  | 18. A/T console finisher                   |
| 19. Cup holder                    | 20. Center ventilator grille | 21. Console box assembly                   |
| 22. Instrument lower cover        | 23. Glove box pin            | 24. Escutcheon glove box                   |
| 25. Glove box assembly            | 26. Console upper finisher   | 27. Glove box striker                      |
| 28. Glove box cover               | 29. CD auto changer          | 30. Instrument panel reinforcement bracket |
| 31. Side ventilation (RH)         | 32. Instrument panel and pad |  |

A  
B  
C  
D

## Removal and Installation WORK STEPS

AIS004UW

E  
F

When removing instrument panel and pad, combination meter, display unit or console box assembly, take steps in the order shown by ( ) numbers below.

	Parts	Reference page	Instrument panel and pad	Combination meter	Display unit	Console box assembly
(A)	Steering lock escutcheon	<a href="#">IP-12</a>	(1)	(1)		
(B)	Steering column cover	<a href="#">IP-12</a>	(2)	(2)		
(C)	Instrument lower driver panel	<a href="#">IP-12</a>	(3)	(3)		
(D)	Cluster lid A	<a href="#">IP-12</a>	(4)	(4)		
(E)	Combination meter	<a href="#">IP-13</a>	(5)	(5)		
(F)	Cluster lid C	<a href="#">IP-13</a>	(6)		(1)	
(G)	Display unit	<a href="#">DI-96</a>	(7)		(2)	
(H)	Clock	<a href="#">DI-155</a>	(8)			
(I)	A/T console finisher	<a href="#">IP-13</a>	(9)			(1)
(J)	Cup holder	<a href="#">IP-13</a>	(10)			(2)
(K)	Cluster lid center lower	<a href="#">IP-14</a>	(11)			(3)
(L)	Console upper finisher	<a href="#">IP-14</a>	(12)			(4)
(M)	Audio unit	<a href="#">AV-29</a>	(13)			
(N)	Ashtray	<a href="#">IP-14</a>	(14)			
(O)	Instrument lower cover	<a href="#">IP-14</a>	(15)			(5)
(P)	Glove box assembly	<a href="#">IP-14</a>	(16)			(6)
(Q)	Glove box cover	<a href="#">IP-15</a>	(17)			(7)
(R)	CD auto changer	<a href="#">AV-29</a>	(18)			
(S)	Center ventilator grille	<a href="#">ATC-127</a>	(19)			(8)
(T)	Console box assembly	<a href="#">IP-15</a>	(20)			(9)
(U)	Front defroster grille (LH/RH)	<a href="#">IP-15</a>	(21)			
(V)	Front pillar garnish (LH/RH)	<a href="#">EI-34</a>	(23)			
(W)	Instrument panel bracket	<a href="#">IP-15</a>	(24)			
(X)	Instrument panel reinforcement bracket	<a href="#">IP-15</a>	(25)			
(Y)	Instrument panel and pad	<a href="#">IP-15</a>	(26)			

G  
H

IP

J  
K  
L  
M

( ):number indicates step in removal procedures.

# INSTRUMENT PANEL ASSEMBLY

## REMOVAL

### (A) Steering Lock Escutcheon

Pull back to your side, and disconnect metal clips.

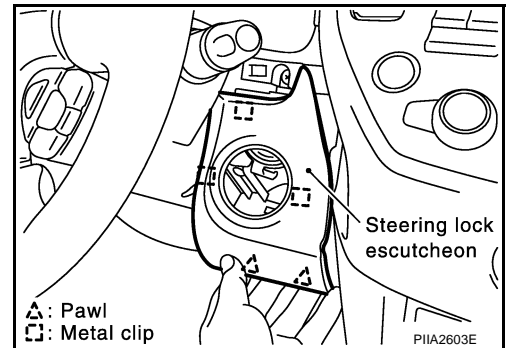

### (B) Steering Column Cover

1. Remove screws with power tool.
2. Disengage steering position switch connector, then remove steering column cover.

#### NOTE:

- Move the steering column telescopic to the rear most position.
- Move the steering column tilt to the lower bottom position.

### (C) Instrument Lower Driver Panel

1. Remove bolts and nuts with power tool, then remove hood lock opener lever.
2. Pull straight to your side, disconnect connectors, and remove instrument lower driver panel.

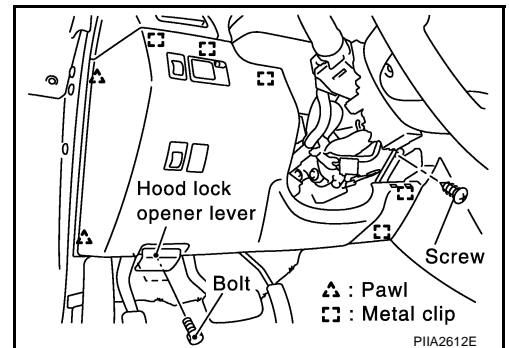

### (D) Cluster Lid A

1. Remove screws with power tool.
2. Pull upper side downward, and disconnect clips.

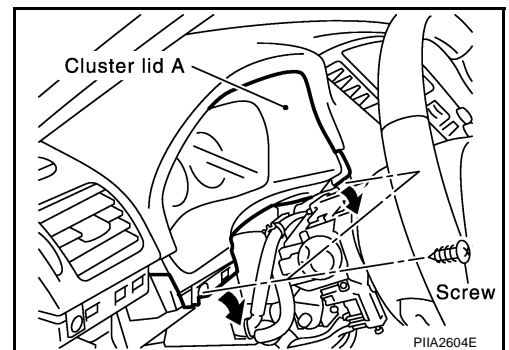

3. Make upper and lower side narrower, and pull it back to your side.
4. Remove as covering steering wheel.

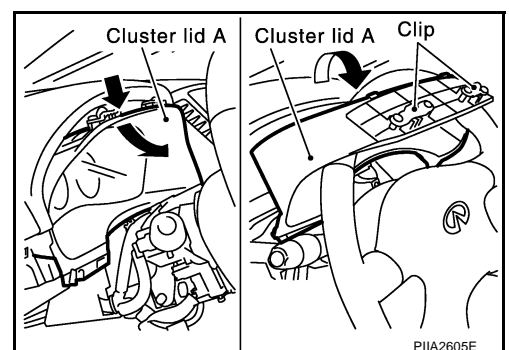

# INSTRUMENT PANEL ASSEMBLY

## (E) Combination Meter

1. Remove screws with power tool and then disconnect harness connector.
2. Pull lower part straight forward and remove location pin.
3. Push right side of meter rearward and then pull straight forward on left side.

### CAUTION:

To prevent it from being damaged by interference with the meter bracket, protect the meter with cloths.

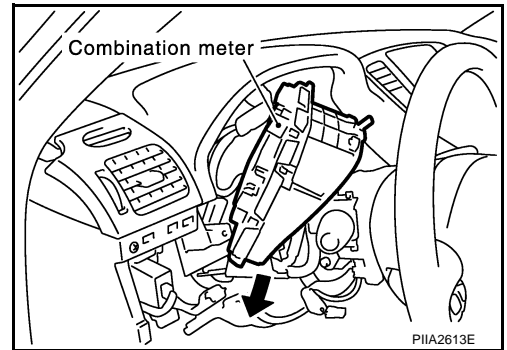

## (F) Cluster Lid C

1. Insert a remover, or thin spatula into dip between instrument panel, pull back to your side, and disconnect metal clips below.
2. Disconnect harness connectors, and remove.

### CAUTION:

Cover surroundings with cloth to avoid scratches or damages.

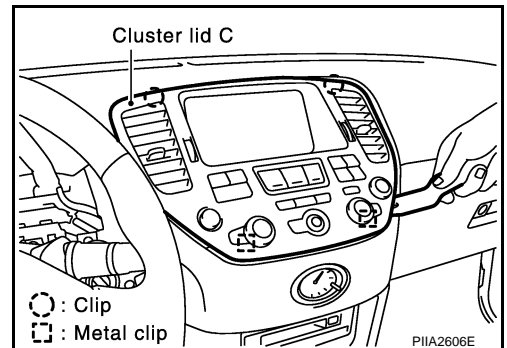

## (G) DISPLAY UNIT

1. Remove screws with power tool.
2. Disconnect harness connector. Refer to [DI-96, "Removal and Installation of Display"](#) in DI section.

## (H) Clock

1. Remove screws, push to frontward and remove.
2. Disconnect harness connector. Refer to [DI-155, "Removal and Installation"](#) in DI section.

## (I) A/T Console Finisher

Open cup holder lid. Hold rear part of A/T console finisher, lift it up, and disconnect metal clips at its rear end.

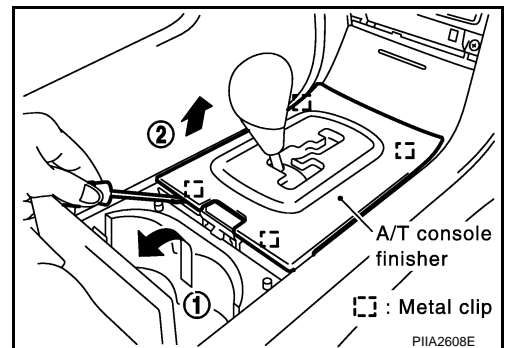

## (J) CUP HOLDER

Remove screws with power tool, lift it up, disconnect metal clips at its rear end, and remove.

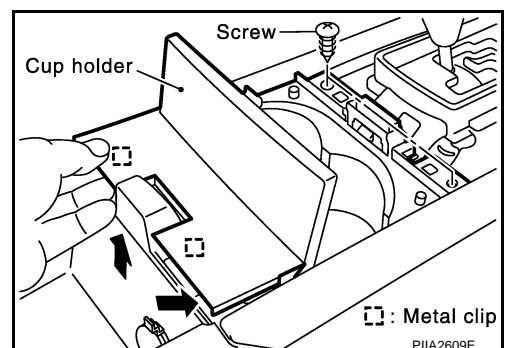

A  
B  
C  
D  
E  
F  
G  
H

IP

J  
K  
L  
M

# INSTRUMENT PANEL ASSEMBLY

## (K) Cluster Lid Center Lower

Open lid of ashtray. Hold lower part of cluster lid center lower, and pull back to your side. Disconnect both metal clips, and remove.

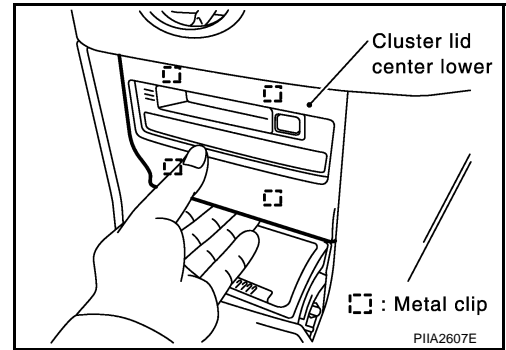

## (L) Console Upper Finisher

Remove screws with power tool, hold front part of console upper finisher, pull back to your side, and disconnect clips.

## (M) Audio Unit

Remove screws with power tool, disconnect connectors, and remove audio unit. Refer to [AV-29, "Removal and Installation of Audio Unit"](#) in AV section.

## (N) Ashtray

1. Remove screws with power tool, pull back to your side, and disconnect metal clips.
2. Disconnect harness connectors, and remove.

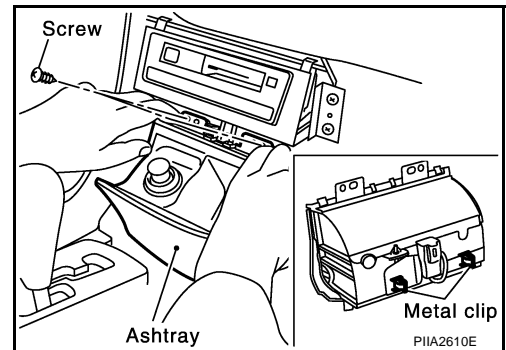

## (O) Instrument Lower Cover

1. Pull down front of instrument lower cover, and disconnect metal clips.
2. Pull it horizontally, and remove from lower cover clips.

### **CAUTION:**

**Remove connectors of air bag from instrument lower cover.**

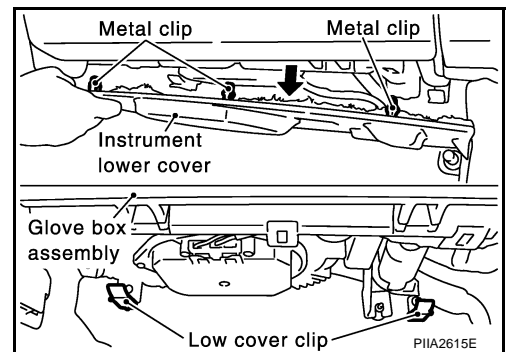

## (P) Glove Box Assembly

1. Remove clip to outside.

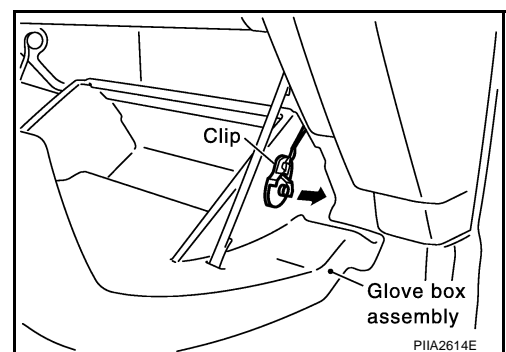

# INSTRUMENT PANEL ASSEMBLY

2. Remove both of the right and left two place clips of the strap.
3. Remove glove box pins, and remove glove box.

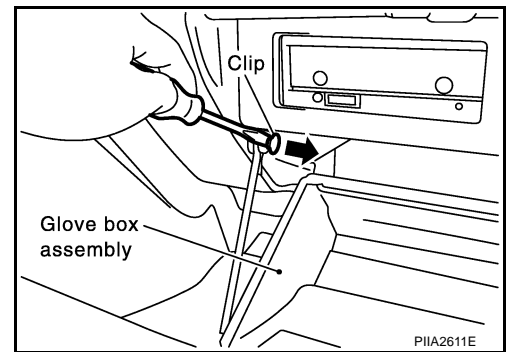

A  
B  
C  
D

## (Q) Glove Box Cover

Remove screws with power tool and glove box striker, disconnect harness connectors, and remove glove box cover.

## (R) CD Auto Changer

Remove bolts with power tool, disconnect harness connectors, and remove CD auto changer. Refer to [AV-29, "Removal and Installation of CD Auto Changer"](#) in AV section.

## (S) Center Ventilator Grille

Pull back to your side and remove center ventilator grille. Refer to [ATC-127, "Center Ventilator Grille"](#) in ATC section.

## (T) Console Box Assembly

1. Remove screws with power tool.
2. Pull center console rearward of vehicle, and remove from instrument panel and rear cooler duct.
3. Disconnect harness connectors, and remove console box assembly.

E  
F  
G  
H

## (U) Front Defroster Grille (LH/RH)

Insert a remover into gaps between front defroster grille and instrument panel, lift front defroster grille up, and remove front defroster grille.

## (V) Front Pillar Garnish (LH/RH)

Pull front pillar garnish straight inside of vehicle, disconnect metal clips, and remove front pillar garnish. Refer to [EI-34, "FRONT PILLAR GARNISH"](#) in EI section.

## (W) Instrument Panel Bracket

Remove ignition key lamp, remove screws, and remove instrument panel bracket.

## (X) Instrument Panel Reinforcement Bracket

Remove nuts, and remove instrument panel reinforcement bracket.

## (Y) Instrument Panel And Pad

Remove bolts, nuts and screws securing instrument panel and pad, and remove instrument panel.

IP  
J  
K  
L  
M

## INSTALLATION

Install in the reverse order of removal.

### CAUTION:

- To install, confirm locating pins on back of instrument panel are completely inserted into holes on vehicle.
- Do not leave harness stuck when installing.

# INSTRUMENT PANEL ASSEMBLY

AIS004UX

## Disassembly and Assembly CONSOLE BOX ASSEMBLY

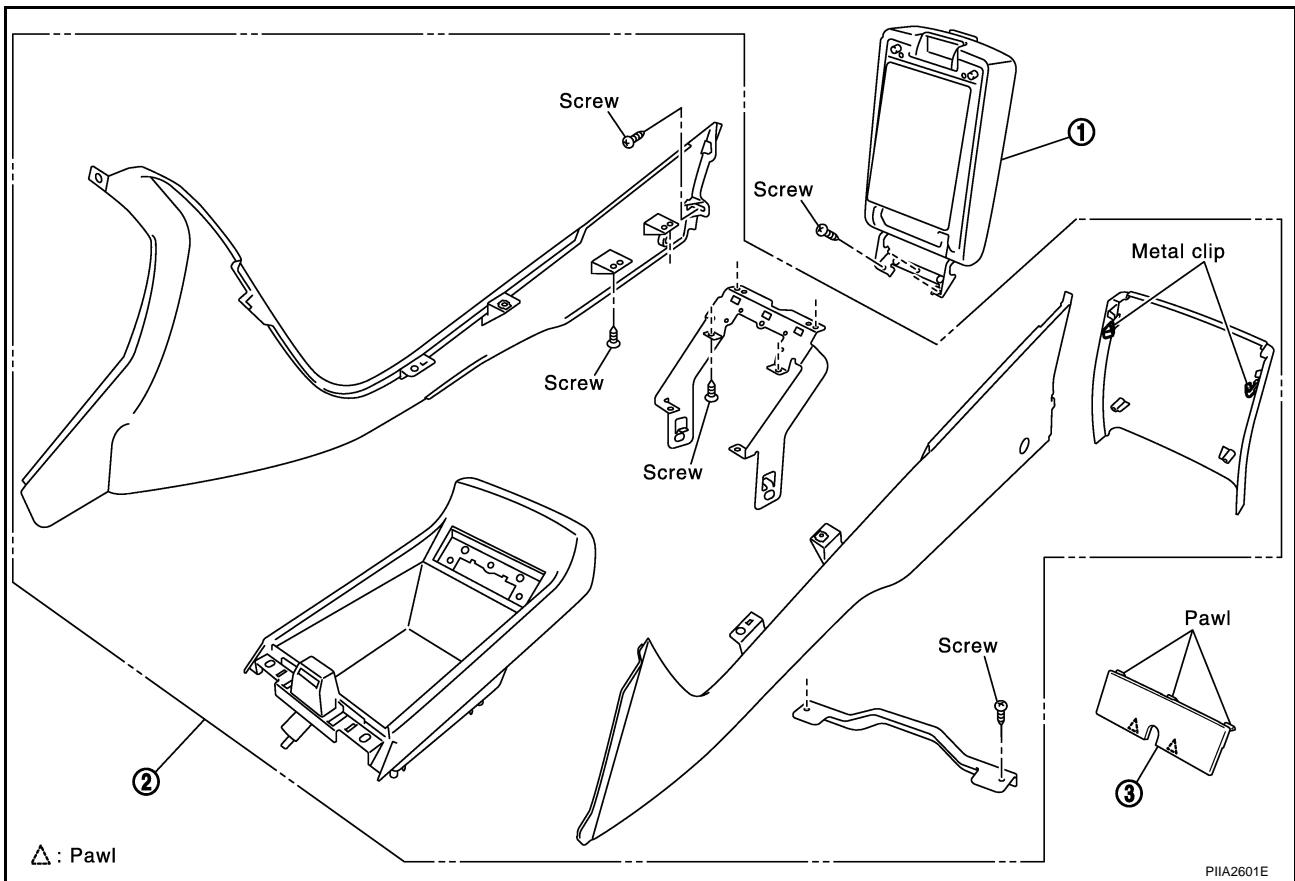

1. Console lid

2. Console body assembly

3. Console mask

### Disassembly

1. Remove console mask.
2. Remove screws, and then remove console lid.

### Assembly

Assemble in the reverse order of disassembly.