

SECTION **FSU**  
FRONT SUSPENSION

A  
B  
C  
D

**FSU**

CONTENTS

<b>PRECAUTIONS</b> .....	<b>2</b>	<b>INSTALLATION</b> .....	<b>9</b>	<b>F</b>
Caution .....	2	Disassembly and Assembly .....	10	
<b>PREPARATION</b> .....	<b>3</b>	DISASSEMBLY .....	10	<b>G</b>
Special Service Tools .....	3	INSPECTION AFTER DISASSEMBLY .....	10	
Commercial Service Tools .....	4	ASSEMBLY .....	11	<b>H</b>
<b>NOISE, VIBRATION AND HARSHNESS (NVH)</b>		<b>SUSPENSION ARM</b> .....	<b>12</b>	
<b>TROUBLESHOOTING</b> .....	<b>5</b>	Removal and Installation .....	12	<b>I</b>
NVH Troubleshooting Chart .....	5	REMOVAL .....	12	<b>J</b>
<b>FRONT SUSPENSION ASSEMBLY</b> .....	<b>6</b>	INSPECTION AFTER REMOVAL .....	12	
On-Vehicle Inspection and Service .....	6	INSTALLATION .....	13	<b>K</b>
INSPECTION OF SUSPENSION ARM BALL		<b>STABILIZER BAR</b> .....	<b>14</b>	
JOINT END PLAY .....	6	Removal and Installation .....	14	<b>L</b>
STRUT INSPECTION .....	6	REMOVAL .....	14	<b>M</b>
Wheel Alignment Inspection .....	6	INSPECTION AFTER REMOVAL .....	14	
DESCRIPTION .....	6	INSTALLATION .....	14	
PRELIMINARY INSPECTION .....	6	<b>FRONT SUSPENSION MEMBER</b> .....	<b>15</b>	
INSPECTION OF CAMBER, CASTER AND		Removal and Installation .....	15	
KINGPIN INCLINATION ANGLES. ....	6	REMOVAL .....	15	
Components .....	8	INSPECTION AFTER REMOVAL .....	15	
<b>COIL SPRING AND STRUT</b> .....	<b>9</b>	INSTALLATION .....	15	
Removal and Installation .....	9	<b>SERVICE DATA</b> .....	<b>16</b>	
REMOVAL .....	9	Wheel Alignment (Unladen) .....	16	
		Ball Joint .....	16	
		Wheelarch Height (Unladen*) .....	16	

# PRECAUTIONS

---

## PRECAUTIONS

PFP:00001

### Caution

AES0008C

- When installing rubber bushings, final tightening must be carried out under unladen condition with tires on level ground. Oil will shorten the life of rubber bushings. Be sure to wipe off any spilled oil.
- Unladen condition means that fuel, coolant and lubricant are full. Spare tire, jack, hand tools and mats in designated positions.
- After servicing suspension parts, be sure to check wheel alignment.
- Caulking nuts are not reusable. Always use new ones when installing. Since new caulking nuts are pre-oiled, tighten as they are.

# PREPARATION

## PREPARATION

PPF:00002

### Special Service Tools

AES0008D

The actual shapes of Kent-Moore tools may differ from those of special service tools illustrated here.

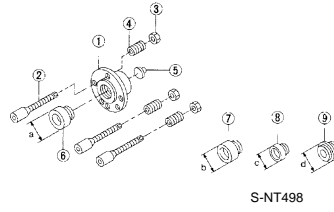
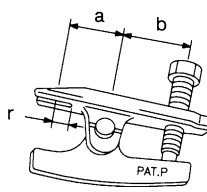
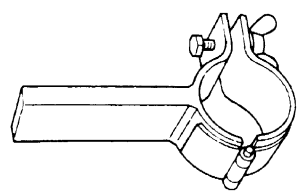
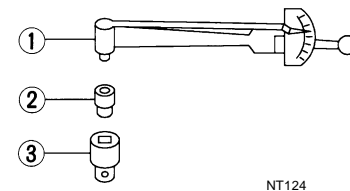
Tool number (Kent-Moore No.) Tool name	Description
KV991040S0 ( — ) CCK gauge attachment 1. Plate 2. Guide bolt 3. Nuts 4. Springs 5. Center plate 6. KV99104020 Adapter A a: 72 mm (2.83 in) dia. 7. KV99104030 Adapter B b: 65 mm (2.56 in) dia. 8. KV99104040 Adapter C c: 57 mm (2.24 in) dia. 9. KV99104050 Adapter D d: 53.4 mm (2.102 in) dia.	 <p>S-NT498</p> <p>Measuring wheel alignment</p>
HT72520000 (J 25730-A) Ball joint remover a: 33 mm (1.30 in) b: 50 mm (1.97 in) r: 11.5 mm (0.453 in)	 <p>PAT.P</p> <p>NT546</p> <p>Removing steering outer socket</p>
ST35652000 ( — ) Strut attachment	 <p>ZZA0807D</p> <p>Disassembling and assembling strut assembly</p>
ST3127 S000 (See J25742-1) Preload gauge 1. GC91030000 Torque wrench (J25765-A) 2. HT62940000 ( — ) Socket adapter (1/2") 3. HT62900000 ( — ) Socket adapter (3/8")	 <p>NT124</p> <p>Measuring sliding torque of ball joint</p>

A  
B  
C  
D  
FSU  
F  
G  
H  
I  
J  
K  
L  
M

# PREPARATION

## Commercial Service Tools

AES0008E

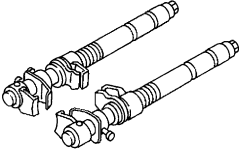
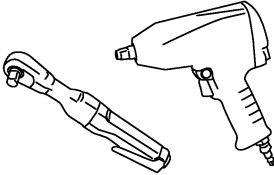
Tool name	Description
<p data-bbox="135 346 327 374">Spring compressor</p>  <p data-bbox="898 453 954 470">S-NT717</p>	<p data-bbox="1050 346 1262 374">Removing coil spring</p>
<p data-bbox="135 591 242 619">Power tool</p>  <p data-bbox="898 704 970 721">PBIC0190E</p>	<ul data-bbox="1050 519 1417 693" style="list-style-type: none"><li>● Removing wheel nuts</li><li>● Removing brake caliper assembly</li><li>● Removing stabilizer assembly</li><li>● Removing tower bar</li><li>● Removing undercover</li></ul>

# NOISE, VIBRATION AND HARSHNESS (NVH) TROUBLESHOOTING

## NOISE, VIBRATION AND HARSHNESS (NVH) TROUBLESHOOTING

PFP:00003

### NVH Troubleshooting Chart

AES0008F

Use chart below to help you find the cause of the symptom. If necessary, repair or replace these parts.

Reference page			<a href="#">FSU-8</a>	<a href="#">FSU-10</a>	—	—	—	<a href="#">FSU-8</a>	<a href="#">FSU-6</a>	<a href="#">FSU-14</a>	NVH in PR section	NVH in RFD section.	NVH in RAX and RSU section.	NVH in WT section.	NVH in WT section.	NVH in RAX section.	NVH in BR section.	NVH in PS section.
Possible cause and SUSPECTED PARTS			Improper installation, looseness	Strut deformation, damage or deflection	Bushing or mounting deterioration	Parts interference	Spring fatigue	Suspension looseness	Incorrect wheel alignment	Stabilizer bar fatigue	PROPELLER SHAFT	DIFFERENTIAL	REAR AXLE AND REAR SUSPENSION	TIRES	ROAD WHEEL	DRIVE SHAFT	BRAKES	STEERING
Symptom	FRONT SUSPENSION	Noise	x	x	x	x	x	x			x	x	x	x	x	x	x	x
		Shake	x	x	x	x		x			x		x	x	x	x	x	x
		Vibration	x	x	x	x	x				x		x	x		x		x
		Shimmy	x	x	x	x			x				x	x	x		x	x
		Judder	x	x	x								x	x	x		x	x
		Poor quality ride or handling	x	x	x	x	x		x	x			x	x	x			

x: Applicable

A  
B  
C  
D  
E  
FSU  
F  
G  
H  
I  
J  
K  
L  
M

# FRONT SUSPENSION ASSEMBLY

## FRONT SUSPENSION ASSEMBLY

PFP:54010

### On-Vehicle Inspection and Service

AES0008H

Check that the mounting conditions (looseness, back lash) of each component and component statuses (wear, damage) are normal.

#### INSPECTION OF SUSPENSION ARM BALL JOINT END PLAY

1. Set front wheels in a straight-ahead position. Do not depress brake pedal.
2. Measure axial end play by installing and moving up/down with an iron pry bar or something similar between suspension arm and steering knuckle.

##### Standard value

**Axial end play : 0 mm (0 in)**

##### CAUTION:

**Be careful not to damage ball joint boot.**

#### STRUT INSPECTION

- Check strut for oil leakage, damage and replace if necessary.

#### Wheel Alignment Inspection

AES0008I

##### DESCRIPTION

- Measure wheel alignment under unladen conditions. "Unladen conditions" means that fuel, coolant, and lubricant are full. Spare tire, jack, hand tools and mats in designated positions.

#### PRELIMINARY INSPECTION

1. Check tires for improper air pressure and wear.
2. Check road wheels for runout.
3. Check wheel bearing axial end play.
4. Check suspension arm ball joint axial end play.
5. Check strut operation.
6. Check each mounting point of axle and suspension for looseness and deformation.
7. Check each link, rod and member for cracks, deformation and other damage.
8. Check vehicle posture.

#### INSPECTION OF CAMBER, CASTER AND KINGPIN INCLINATION ANGLES.

- Camber, caster, kingpin inclination angles cannot be adjusted.
- Before inspection, mount front wheels onto turning radius gauge. Mount rear wheels onto a stand that has same height so vehicle will remain horizontal.

#### Using a CCK Gauge

1. Remove wheel nuts (3), and install a guide bolt (special service tool) to hub bolt.
2. Screw adapter (special service tool) into plate body (special service tool) until it contacts body tightly.
3. Screw center plate (special service tool) into plate body (special service tool).
4. Insert plate (special service tool) on guide bolt (special service tool). Put spring in, and then evenly screw in guide bolt nut (special service tool). When fastening guide bolt nut, do not completely compress spring.

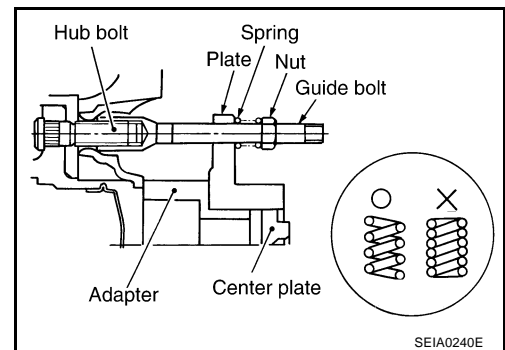

# FRONT SUSPENSION ASSEMBLY

- Place the dent of alignment gauge onto the projection of center plate (special service tool) and tightly contact them to measure.

**Standard value**

**Camber, caster, kingpin inclination angles:**

Refer to [FSU-16, "SERVICE DATA"](#) .

**CAUTION:**

- If camber, caster, or kingpin inclination angle is outside the standard, check front suspension parts for wear and damage, and replace suspect parts if necessary.
- King pin inclination angle is reference value, no inspection is required.

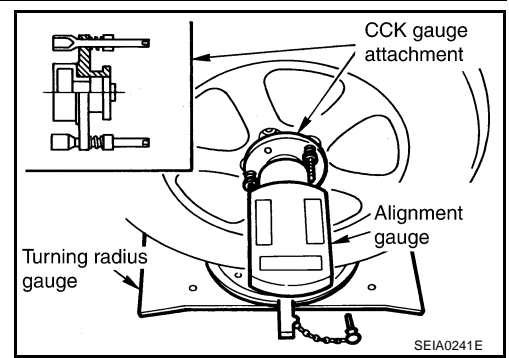

A  
B  
C  
D

## Toe-In Inspection

Measure toe-in using the following procedure.

**WARNING:**

- Always perform the following procedure on a flat surface.
  - Make sure that no person is in front of vehicle before pushing it.
- Bounce front of vehicle up and down to stabilize the posture.
  - Push vehicle straight ahead about 5 m (16 ft).
  - Put a mark on base line of the tread (rear side) of both tires at the same height of hub center. These are measuring points.

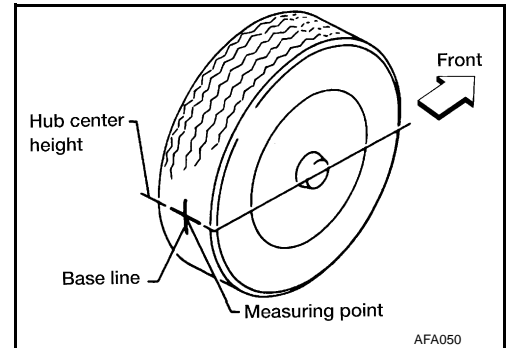

FSU

F  
G  
H

- Measure distance "A" (rear side).
- Push vehicle slowly ahead to rotate wheels 180 degrees (1/2 turn).

If wheels have rotated more than 180 degrees (1/2 turn), try the above procedure again from the beginning. Never push vehicle backward.

- Measure distance "B" (front side).

**Standard value**

**Total toe-in** : Refer to [FSU-16, "SERVICE DATA"](#) .

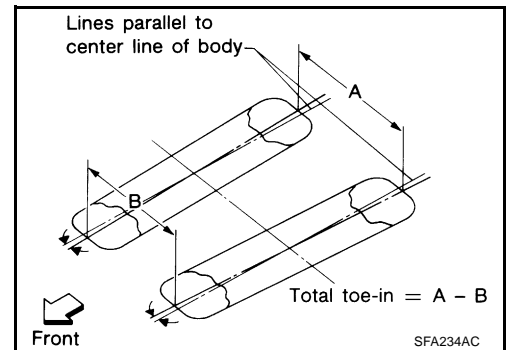

I  
J  
K  
L  
M

# FRONT SUSPENSION ASSEMBLY

## Components

AES0008G

SEC.401

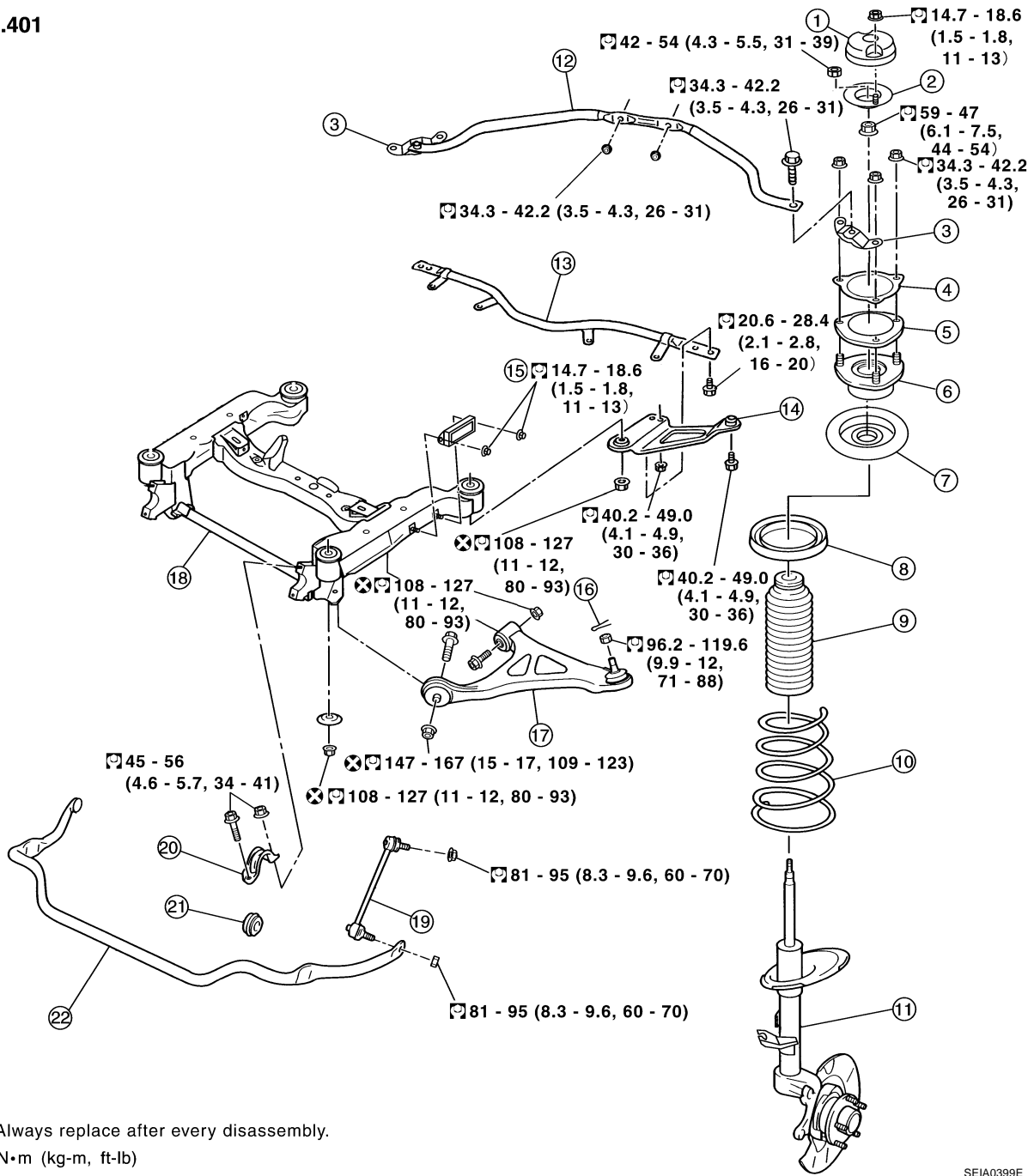

SEIA0399E

- |                               |                                     |                             |
|-------------------------------|-------------------------------------|-----------------------------|
| 1. Mass damper                | 2. Mass damper bracket              | 3. Tower bar bracket        |
| 4. Gasket                     | 5. Strut mounting insulator bracket | 6. Strut mounting insulator |
| 7. Spring upper seat          | 8. Rubber seat                      | 9. Bound bumper             |
| 10. Coil spring               | 11. Strut assembly                  | 12. Tower bar               |
| 13. Front cross bar           | 14. Member stay                     | 15. Dynamic dumper          |
| 16. Cotter pin                | 17. Suspension arm                  | 18. Front suspension member |
| 19. Stabilizer connecting rod | 20. Stabilizer clamp                | 21. Stabilizer bushing      |
| 22. Stabilizer bar            |                                     |                             |



# COIL SPRING AND STRUT

## COIL SPRING AND STRUT

PPF:55302

### Removal and Installation

AES00090

#### REMOVAL

1. Remove tire with power tool.
2. Remove brake caliper with power tool. Hang it in a place where it will not interfere with work. Refer to [BR-23, "FRONT DISC BRAKE"](#).

**CAUTION:**

**Avoid depressing brake pedal while brake caliper is removed.**

3. Remove harness of wheel sensor from strut assembly. Refer to [BRC-63, "WHEEL SENSORS"](#).

**CAUTION:**

**Do not pull on wheel sensor harness.**

4. Remove mounting nuts of brake hose from strut assembly.
5. Remove stabilizer connecting rod upper nut, separate strut assembly and stabilizer connecting rod with power tool.
6. Remove cotter pin and lock nut of steering outer socket.
7. Use a ball joint remover (special service tool) to remove steering outer socket from strut assembly. Be careful not to damage ball joint.

**CAUTION:**

**To prevent damage to threads and to prevent ball joint remover (special service tool) from coming off, and temporarily tighten mounting nuts.**

8. Remove cotter pin of suspension arm ball joint, then loosen mounting nut.
9. Use a ball joint remover (suitable tool) to remove strut assembly from suspension arm. Be careful not to damage ball joint boot.

**CAUTION:**

**To prevent damage to threads and to prevent ball joint remover (special service tool) from coming off, and temporarily tighten mounting nuts.**

10. Remove mass damper and mass damper bracket.
11. Remove tower bar and tower bar bracket with power tool.
12. Remove mounting nuts on strut mounting insulator, then remove gasket, strut mounting insulator bracket and strut assembly from vehicle.

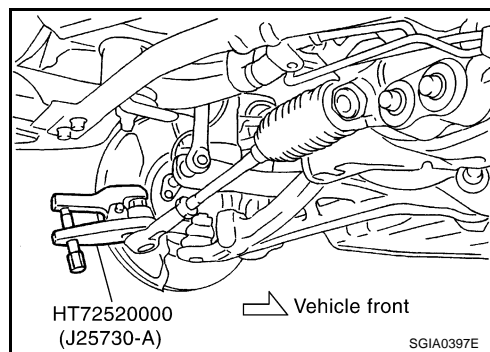

#### INSTALLATION

- Refer to [FSU-8, "Components"](#) for tightening torque. Tighten in the reverse order of removal.

**CAUTION:**

**Refer to component parts location and do not reuse non-reusable parts.**

- Attach strut mounting insulator bracket as shown in the figure.

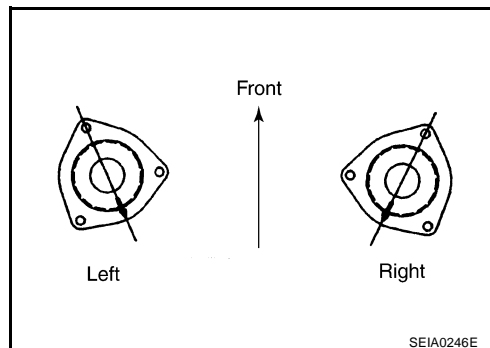

# COIL SPRING AND STRUT

AES0009P

## Disassembly and Assembly

### DISASSEMBLY

#### CAUTION:

Make sure piston rod on strut assembly is not damaged when removing components from strut assembly.

1. Install strut attachment (special service tool) to strut assembly and fix it in a vice.

#### CAUTION:

When installing strut attachment (special service tool) to strut assembly, wrap a shop cloth around strut assembly to protect it from damage.

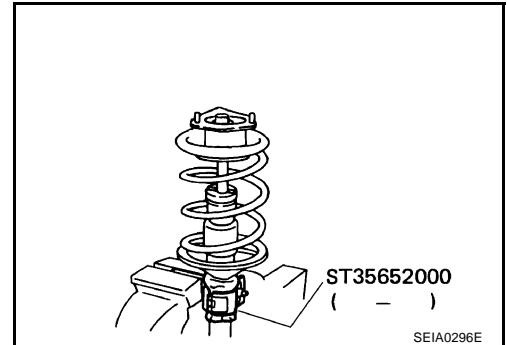

2. Using a spring compressor (commercial service tool), compress coil spring between spring upper seat and spring lower seat (on strut) until coil spring is free.

#### CAUTION:

Be sure spring compressor (commercial service tool) is securely attached to coil spring. Compress coil spring.

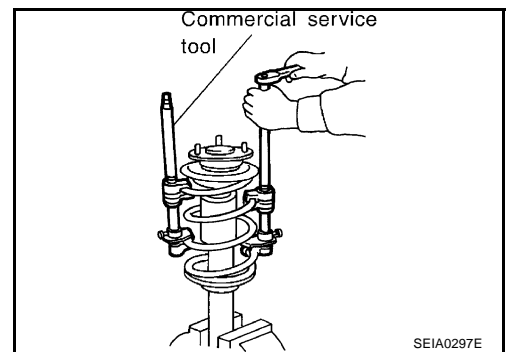

3. After making sure coil spring is free between spring upper seat and spring lower seat of strut assembly, then remove piston rod lock nut.
4. Remove strut mounting insulator, spring upper seat, rubber seat, coil spring and bound bumper from strut assembly.
5. Gradually release spring compressor (commercial service tool), and remove coil spring.

#### CAUTION:

Loosen while making sure coil spring attachment position does not move.

6. Remove strut attachment (special service tool) from strut assembly.

## INSPECTION AFTER DISASSEMBLY

### Strut Inspection

- Check strut assembly for deformation, cracks, damage, and replace if necessary.
- Check piston rod for damage, uneven wear, distortion, and replace if necessary.
- Check welded and sealed areas for oil leakage, and replace if necessary.

### Strut Mounting Insulator and Rubber Parts Inspection

Check strut mounting insulator, strut mounting insulator bracket for cracks and rubber parts for wear. Replace them if necessary.

### Coil Spring Inspection

Check coil spring for cracks, wear, damage and replace if necessary.

# COIL SPRING AND STRUT

## ASSEMBLY

### CAUTION:

Make sure piston rod on strut assembly is not damaged when attaching components to strut assembly.

1. Install strut attachment (special service tool) to strut assembly and fix it in a vice.

### CAUTION:

When installing strut attachment (special service tool) to strut assembly, wrap a shop cloth around strut assembly to protect it from damage.

2. Compress coil spring using a spring compressor (commercial service tool), and install it onto strut assembly.

### CAUTION:

- Face tube side of coil spring downward. Align lower end to spring seat as shown in the figure.

- Be sure spring compressor (commercial service tool) is securely attached to coil spring. Compress coil spring.

3. Apply soapy water to bound bumper and insert into strut mounting insulator.

### CAUTION:

Do not use machine oil.

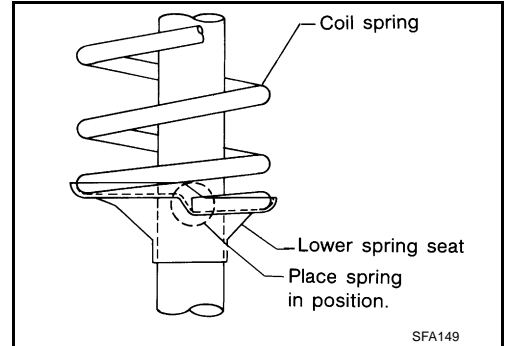

4. Install rubber seat, spring upper seat, strut mounting insulator.

- Installation position of spring upper seat is as shown in the figure.

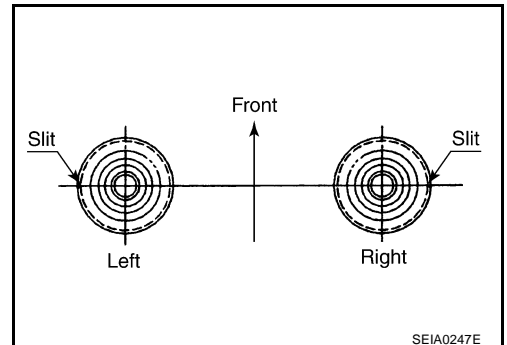

5. Fix strut mounting insulator, then tighten piston rod lock nut with the specified torque.

### CAUTION:

Be careful not to deform strut mounting insulator.

6. Gradually release spring compressor (commercial service tool), and remove coil spring.

### CAUTION:

Loosen while making sure coil spring attachment position does not move.

7. Remove strut attachment (special service tool) from strut assembly.

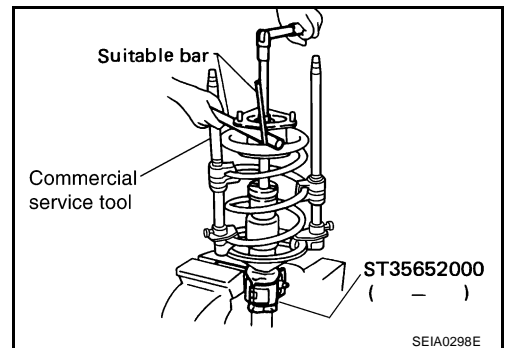

A

B

C

D

FSU

F

G

H

I

J

K

L

M

# SUSPENSION ARM

PFP:55501

AES0008L

## SUSPENSION ARM

### Removal and Installation

#### REMOVAL

1. Remove tire with power tool.
2. Remove undercover with power tool.
3. Remove cotter pin of suspension arm ball joint, then loosen mounting nut.
4. Use a ball joint remover (suitable tool) to remove suspension arm from strut assembly. Be careful not to damage ball joint boot.

#### CAUTION:

To prevent damage to threads and to prevent ball joint remover (suitable tool) from coming off, and temporarily tighten mounting nuts.

5. Remove fixing bolts and nuts then remove suspension arm from vehicle.

#### INSPECTION AFTER REMOVAL

##### Visual Inspection

- Check suspension arm and bushing for deformation, cracks, or damage. If any non-standard condition is found, replace it.
- Check boot of ball joint for cracks, or damage, and also for grease leakage. If any non-standard condition is found, replace it.

##### Ball Joint Inspection

- Manually move ball stud to confirm it moves smoothly with no binding.

##### Swing Torque Inspection

#### CAUTION:

Before measurement, move ball joint at least ten times by hand to check for smooth movement.

- Hook spring scale at cotter pin mounting hole. Confirm spring scale measurement value is within specifications when ball stud begins moving.

**Standard value**

**Swing torque:**

**0.5 - 3.4 N·m (0.06 - 0.34 kg·m, 5 - 30 in·lb)**

**Measured value of spring scale:**

**8.8 - 59.6 N (0.90 - 6.08 kg, 1.98 - 13.41 lb)**

- If it is outside the specified range, replace suspension arm assembly.

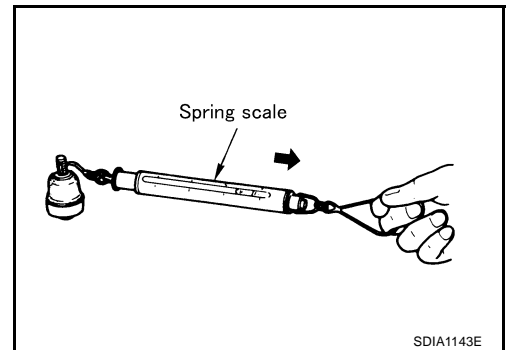

##### Rotating Torque Inspection

- Attach mounting nut to ball stud. Check that rotating torque is within specifications with a preload gauge (special service tool).

**Standard value**

**Rotating torque:**

**0.5 - 3.4 N·m (0.06 - 0.34 kg·m, 5 - 30 in·lb)**

- If it is outside the specified range, replace suspension arm assembly.

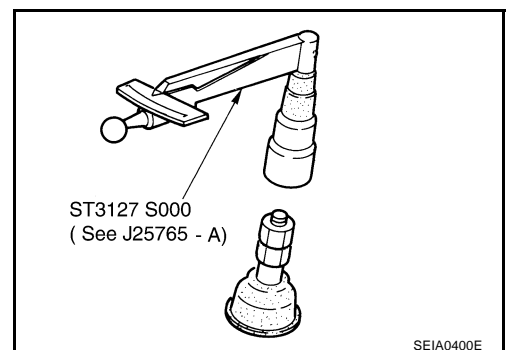

##### Axial End Play Inspection

- Move tip of ball joint in axial direction to check for looseness.

**Standard value**

**Axial end play : 0 mm (0 in)**

# SUSPENSION ARM

---

- If it is outside the specified range, replace suspension arm assembly.

## INSTALLATION

- Refer to [FSU-8, "Components"](#) for tightening torque. Tighten in the reverse order of removal.

**CAUTION:**

**Refer to component parts location and do not reuse non-reusable parts.**

- After installing suspension arm, check wheel alignment and adjust if necessary. Refer to [FSU-6, "Wheel Alignment Inspection"](#).

A

B

C

D

FSU

F

G

H

I

J

K

L

M

# STABILIZER BAR

## STABILIZER BAR

PFP:56230

### Removal and Installation

AES0008M

#### REMOVAL

1. Remove tire with power tool.
2. Remove undercover with power tool.
3. Remove stabilizer connecting rod upper nut, separate strut assembly and stabilizer connecting rod with power tool.
4. Remove stabilizer clamp mounting bolts and nuts with power tool.
5. Remove stabilizer bar from vehicle.

#### INSPECTION AFTER REMOVAL

Check stabilizer bar, stabilizer connecting rod, stabilizer bushing and stabilizer clamp for deformation, cracks and damage, and replace if necessary.

#### INSTALLATION

- Refer to [FSU-8, "Components"](#) for tightening torque. Tighten in the reverse order of removal.

#### **CAUTION:**

**Refer to component parts location and do not reuse non-reusable parts.**

- Tighten bolts and nuts for tightening stabilizer clamp. Tightening order is Front LH, Rear RH, Front RH, Rear LH.
- Stabilizer bar uses pillow ball type connecting rod. Position ball joint with case on pillow ball head parallel to stabilizer bar.

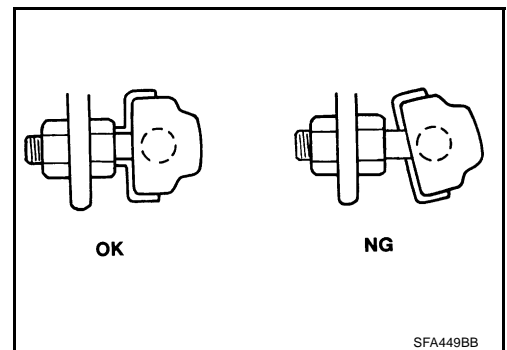

# FRONT SUSPENSION MEMBER

## FRONT SUSPENSION MEMBER

PPF:54401

AES0008N

### Removal and Installation

#### REMOVAL

1. Set engine slinger to engine, then suspend an engine.
2. Remove tire with power tool.
3. Remove undercover with power tool.
4. Remove steering hydraulic piping bracket from front suspension member. Refer to [PS-31, "HYDRAULIC LINE"](#) .
5. Remove steering gear from front suspension member and hang steering gear on vehicle. Refer to [PS-13, "POWER STEERING GEAR AND LINKAGE"](#) .
6. Remove suspension arm from front suspension member. Refer to [FSU-12, "SUSPENSION ARM"](#) .
7. Remove stabilizer bar mounting bolts and nuts from front suspension member and hang stabilizer on vehicle with power tool. Refer to [FSU-14, "STABILIZER BAR"](#) .
8. Set jack under front suspension member.
9. Remove mounting bolts and nuts of member stay, then remove member stay from vehicle.
10. Remove fixing nuts between engine mounting insulator and front suspension member. Refer to [EM-76, "ENGINE ASSEMBLY"](#) .
11. Remove front suspension member fixing nuts from body.
12. Slowly down jack to remove front suspension member from vehicle.

#### INSPECTION AFTER REMOVAL

Check front suspension member for deformed parts, cracks, or any other damage. Replace if necessary.

#### INSTALLATION

- Refer to [FSU-8, "Components"](#) for tightening torque. Tighten in the reverse order of removal.  
**CAUTION:**  
**Refer to component parts location and do not reuse non-reusable parts.**
- Perform final tightening of each part under unladen conditions with tires on ground. Check wheel alignment. Refer to [FSU-6, "Wheel Alignment Inspection"](#) .

# SERVICE DATA

## SERVICE DATA

PFP:00030

### Wheel Alignment (Unladen)

AES00080

Camber Degree minute (Decimal degree)	Minimum	-1°25' (-1.42°)	
	Nominal	- 0°40' (- 0.67°)	
	Maximum	0°05' (0.08°)	
	Left and right difference	45' (0.75°) or less	
Caster Degree minute (Decimal degree)	Minimum	5°50' (5.83°)	
	Nominal	6°35' (6.58°)	
	Maximum	7°20' (7.33°)	
	Left and right difference	45' (0.75°) or less	
Kingpin inclination Degree minute (Decimal degree)	Minimum	12°40' (12.67°)	
	Nominal	13°25' (13.42°)	
	Maximum	14°10' (14.17°)	
Total toe-in	Distance (A - B)	Minimum	1 mm (0.04 in)
		Nominal	2 mm (0.08 in)
		Maximum	3 mm (0.12 in)
	Angle (left plus right) Degree minute (Degree)	Minimum	2' (0.03°)
		Nominal	5' (0.08°)
		Maximum	8' (0.13°)

### Ball Joint

AES0008P

Axial end play	0 mm (0 in)
Swing torque	0.5 - 3.4 N·m (0.06 - 0.34 kg·m, 5 - 30 in·lb)
Measurement on spring balance (cotter pinhole position)	8.8 - 59.6 N (0.90 - 6.08 kg, 1.98 - 13.41 lb)
Rotating torque	0.5 - 3.4 N·m (0.06 - 0.34 kg·m, 5 - 30 in·lb)

### Wheelarch Height (Unladen\*)

AES0008Q

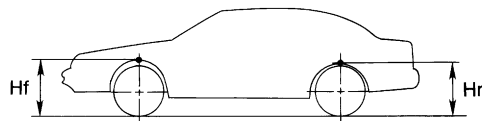

SFA818A

Applied model	235/45R18 P235/45R18
Front (Hf)	711 mm (27.99 in) [USA model] 712 mm (28.03 in) [Canada model]
Rear (Hr)	706 mm (27.79 in) [USA model] 707 mm (27.83 in) [Canada model]

\*: Fuel, radiator coolant and engine oil full. Spare tire, jack, hand tools and mats in designated positions.