

LT
SECTION
LIGHTING SYSTEM

A
B
C
D
E
F
G
H
I
J
LT
L
M
N
O
P

CONTENTS

| | |
|---|--|
| <p>SERVICE INFORMATION 4</p> <p>DTC INDEX 4</p> <p style="padding-left: 20px;">U1000-U10104</p> <p style="padding-left: 20px;">B2503-B25234</p> <p>PRECAUTIONS 5</p> <p style="padding-left: 20px;">Precaution for Supplemental Restraint System (SRS) "AIR BAG" and "SEAT BELT PRE-TENSIONER"5</p> <p style="padding-left: 20px;">General Precaution for Service Operation5</p> <p>HEADLAMP (FOR USA) - CONVENTIONAL TYPE - 6</p> <p style="padding-left: 20px;">Component Parts and Harness Connector Location6</p> <p style="padding-left: 20px;">System Description6</p> <p style="padding-left: 20px;">CAN Communication System Description8</p> <p style="padding-left: 20px;">CAN Communication Unit8</p> <p style="padding-left: 20px;">Schematic9</p> <p style="padding-left: 20px;">Wiring Diagram - H/LAMP - 10</p> <p style="padding-left: 20px;">Terminal and Reference Value for BCM 15</p> <p style="padding-left: 20px;">Terminal and Reference Value for IPDM E/R 17</p> <p style="padding-left: 20px;">How to Perform Trouble Diagnosis 18</p> <p style="padding-left: 20px;">Preliminary Check 18</p> <p style="padding-left: 20px;">CONSULT-III Functions (BCM - HEAD LAMP) 19</p> <p style="padding-left: 20px;">CONSULT-III Functions (IPDM E/R) 20</p> <p style="padding-left: 20px;">Headlamp High Beam Does Not Illuminate (Both Sides) 21</p> <p style="padding-left: 20px;">Headlamp High Beam Does Not Illuminate (One Side) 23</p> <p style="padding-left: 20px;">High Beam Indicator Lamp Does Not Illuminate 25</p> <p style="padding-left: 20px;">Headlamp Low Beam Does Not Illuminate (Both Sides) 25</p> <p style="padding-left: 20px;">Headlamp Low Beam Does Not Illuminate (One Side) 27</p> <p style="padding-left: 20px;">Headlamps Do Not Turn OFF 29</p> <p style="padding-left: 20px;">Aiming Adjustment 30</p> <p style="padding-left: 20px;">Bulb Replacement 31</p> <p style="padding-left: 20px;">Removal and Installation 32</p> <p style="padding-left: 20px;">Disassembly and Assembly 33</p> | <p>HEADLAMP (FOR USA) - XENON TYPE -34</p> <p style="padding-left: 20px;">Component Parts and Harness Connector Location34</p> <p style="padding-left: 20px;">System Description34</p> <p style="padding-left: 20px;">CAN Communication System Description36</p> <p style="padding-left: 20px;">CAN Communication Unit36</p> <p style="padding-left: 20px;">Schematic37</p> <p style="padding-left: 20px;">Wiring Diagram - H/LAMP -38</p> <p style="padding-left: 20px;">Terminal and Reference Value for BCM43</p> <p style="padding-left: 20px;">Terminal and Reference Value for IPDM E/R45</p> <p style="padding-left: 20px;">How to Perform Trouble Diagnosis46</p> <p style="padding-left: 20px;">Preliminary Check46</p> <p style="padding-left: 20px;">CONSULT-III Functions (BCM - HEAD LAMP)47</p> <p style="padding-left: 20px;">CONSULT-III Functions (IPDM E/R)48</p> <p style="padding-left: 20px;">Headlamp High Beam Does Not Illuminate (Both Sides)49</p> <p style="padding-left: 20px;">Headlamp High Beam Does Not Illuminate (One Side)51</p> <p style="padding-left: 20px;">High Beam Indicator Lamp Does Not Illuminate53</p> <p style="padding-left: 20px;">Headlamp Low Beam Does Not Illuminate (Both Sides)53</p> <p style="padding-left: 20px;">Headlamp Low Beam Does Not Illuminate (One Side)55</p> <p style="padding-left: 20px;">Headlamps Do Not Turn OFF57</p> <p style="padding-left: 20px;">General Information for Xenon Headlamp Trouble Diagnosis57</p> <p style="padding-left: 20px;">Caution:57</p> <p style="padding-left: 20px;">Xenon Headlamp Trouble Diagnosis58</p> <p style="padding-left: 20px;">Aiming Adjustment58</p> <p style="padding-left: 20px;">Bulb Replacement59</p> <p style="padding-left: 20px;">Removal and Installation61</p> <p style="padding-left: 20px;">Disassembly and Assembly61</p> <p>HEADLAMP (FOR CANADA) - DAYTIME LIGHT SYSTEM - 63</p> <p style="padding-left: 20px;">Component Parts and Harness Connector Location63</p> <p style="padding-left: 20px;">System Description63</p> <p style="padding-left: 20px;">CAN Communication System Description65</p> <p style="padding-left: 20px;">CAN Communication Unit65</p> |
|---|--|

| | | | |
|--|------------|---|------------|
| Schematic | 66 | Preliminary Check | 125 |
| Wiring Diagram - DTRL - | 67 | CONSULT-III Function (ADAPTIVE LIGHT) | 126 |
| Terminal and Reference Value for BCM | 72 | Symptom Chart | 132 |
| Terminal and Reference Value for IPDM E/R | 74 | DTC U1000 CAN COMM CIRCUIT | 133 |
| How to Perform Trouble Diagnosis | 75 | DTC U1010 CONTROL UNIT (CAN) | 134 |
| Preliminary Check | 75 | DTC B2503 SWIVEL ACTUATOR RH | 134 |
| CONSULT-III Functions (BCM - HEAD LAMP) | 77 | DTC B2504 SWIVEL ACTUATOR LH | 139 |
| CONSULT-III Functions (IPDM E/R) | 78 | DTC B2514 HI SEN UNUSUAL RR | 144 |
| Daytime Light Control Does Not Operate Properly (Normal Headlamps Operate Properly) | 79 | DTC B2515 ST ANG SEN SIG | 147 |
| Headlamp High Beam Does Not Illuminate (Both Sides) | 81 | DTC B2516 SIFT SIG [P,R] | 147 |
| RH High Beam Does Not Illuminate But LH High Beam Illuminates | 84 | DTC B2517 VEHICLE SPEED SIG | 148 |
| LH High Beam Does Not Illuminate But RH High Beam Illuminates | 85 | DTC B2518 HEADLAMP SIG | 148 |
| Headlamp Low Beam Does Not Illuminate (Both Sides) | 87 | DTC B2519 LEVELIZER CALIB | 148 |
| Headlamp Low Beam Does Not Illuminate (One Side) | 89 | DTC B2520 ST ANGLE SEN CALIB | 149 |
| Headlamps Do Not Turn OFF | 90 | DTC B2521 ECU CIRC | 149 |
| General Information for Xenon Headlamp Trouble Diagnosis | 91 | DTC B2522 ECM SIG | 152 |
| Caution | 91 | DTC B2523 AFS SIG | 152 |
| Xenon Headlamp Trouble Diagnosis | 91 | AFS Operation Check (Function Test) | 152 |
| Aiming Adjustment | 92 | Auto Aiming Operation Check (Function Test) | 153 |
| Bulb Replacement | 92 | AFS Switch Does Not Operate | 155 |
| Removal and Installation | 92 | Auto Aiming Does Not Operate (Check Aiming Motor System Circuit) | 157 |
| Disassembly and Assembly | 92 | AFS OFF Indicator Does Not Operate | 159 |
| AUTO LIGHT SYSTEM | 93 | Removal and Installation of Steering Angle Sen- sor | 160 |
| Component Parts and Harness Connector Loca- tion | 93 | Removal and Installation of Front Combination Lamp | 160 |
| System Description | 93 | Removal and Installation of AFS Control Unit | 160 |
| CAN Communication System Description | 94 | Removal and Installation of AFS Switch | 160 |
| CAN Communication Unit | 94 | Removal and Installation of Height Sensor | 161 |
| Major Component and Functions | 94 | FRONT FOG LAMP | 162 |
| Schematic | 95 | Component Parts and Harness Connector Loca- tion | 162 |
| Wiring Diagram - AUTO/L - | 96 | System Description | 162 |
| Terminal and Reference Value for BCM | 100 | CAN Communication System Description | 163 |
| Terminal and Reference Value for IPDM E/R | 103 | CAN Communication Unit | 164 |
| How to Perform Trouble Diagnosis | 103 | Schematic | 164 |
| Preliminary Check | 103 | Wiring Diagram - F/FOG - | 165 |
| CONSULT-III Functions (BCM - HEAD LAMP) | 104 | Terminal and Reference Value for BCM | 168 |
| Symptom Chart | 106 | Terminal and Reference Value for IPDM E/R | 170 |
| Lighting Switch Inspection | 106 | How to Perform Trouble Diagnosis | 170 |
| Optical Sensor System Inspection | 107 | Preliminary Check | 170 |
| Removal and Installation for Optical Sensor | 108 | CONSULT-III Functions (BCM - HEAD LAMP) | 171 |
| ACTIVE AFS | 110 | CONSULT-III Functions (IPDM E/R) | 171 |
| Component Parts and Harness Connector Loca- tion | 110 | Front Fog Lamps Do Not Illuminate (Both Sides) . | 171 |
| System Description | 110 | Front Fog Lamp Does Not Illuminate (One Side) . | 173 |
| Component Parts Description | 115 | Front Fog Lamps Do Not Turn OFF | 175 |
| Schematic | 117 | Aiming Adjustment | 175 |
| Wiring Diagram - AFS - | 118 | Bulb Replacement | 176 |
| Terminal and Reference Value for AFS Control Unit | 124 | STANDARD TYPE | 176 |
| How to Proceed with Trouble Diagnosis | 125 | STANDARD TYPE : Removal and Installation | 177 |
| | | SPORTS TYPE | 177 |
| | | SPORTS TYPE : Removal and Installation | 177 |
| | | TURN SIGNAL AND HAZARD WARNING LAMPS | 179 |

| | | | | |
|--|------------|--|------------|----|
| Component Parts and Harness Connector Location | 179 | Wiring Diagram - TAIL/L - | 213 | |
| System Description | 179 | Terminal and Reference Value for BCM | 218 | A |
| CAN Communication System Description | 181 | Terminal and Reference Value for IPDM E/R | 219 | |
| CAN Communication Unit | 181 | How to Perform Trouble Diagnosis | 220 | |
| Schematic | 182 | Preliminary Check | 220 | B |
| Wiring Diagram - TURN - | 183 | CONSULT-III Functions (BCM - HEAD LAMP) | 221 | |
| Terminal and Reference Value for BCM | 186 | CONSULT-III Functions (IPDM E/R) | 221 | |
| How to Perform Trouble Diagnosis | 188 | Parking, License Plate and Tail Lamps Do Not Illuminate | 221 | C |
| Preliminary Check | 188 | Parking, License Plate and Tail Lamps Do Not Turn OFF (After Approx. 10 Minutes) | 225 | |
| CONSULT-III Functions (BCM - FLASHER) | 189 | License Plate Lamp | 225 | D |
| Turn Signal Lamp Does Not Operate | 190 | Removal and Installation | 225 | |
| Hazard Warning Lamp Does Not Operate But Turn Signal Lamp Operates | 191 | Parking Lamp | 226 | |
| Turn Signal Indicator Lamp Does Not Operate | 192 | REAR COMBINATION LAMP | 227 | E |
| Bulb Replacement (Front Turn Signal Lamp) | 193 | Bulb Replacement | 227 | |
| Bulb Replacement (Side Turn Signal Lamp) | 193 | Removal and Installation | 227 | F |
| Bulb Replacement (Rear Turn Signal Lamp) | 193 | INTERIOR ROOM LAMP | 229 | |
| Removal and Installation of Front Turn Signal Lamp | 193 | Component Parts and Harness Connector Location | 229 | G |
| Removal and Installation of Side Turn Signal Lamp | 193 | System Description | 229 | |
| Removal and Installation of Rear Turn Signal Lamp | 194 | Schematic | 234 | |
| LIGHTING AND TURN SIGNAL SWITCH | 195 | Wiring Diagram - ROOM/L - | 236 | H |
| Removal and Installation | 195 | Terminal and Reference Value for BCM | 243 | |
| Switch Circuit Inspection | 195 | How to Perform Trouble Diagnosis | 244 | |
| HAZARD SWITCH | 196 | Preliminary Check | 244 | |
| Removal and Installation | 196 | CONSULT-III Functions (BCM - INT LAMP) | 245 | I |
| COMBINATION SWITCH | 197 | CONSULT-III Functions (BCM - BATTERY SAVER) | 247 | |
| Wiring Diagram - COMB SW - | 197 | Interior Room Lamp Control Does Not Operate | 248 | J |
| Combination Switch Reading Function | 197 | Map Lamp | 249 | |
| Terminal and Reference Value for BCM | 198 | Personal Lamp | 249 | |
| CONSULT-III Functions (BCM - COMB SW) | 201 | Foot Lamp (Driver Side) | 250 | |
| Combination Switch Inspection | 202 | Foot Lamp (Passenger Side) | 250 | LT |
| Removal and Installation | 204 | Vanity Mirror Lamp | 251 | |
| STOP LAMP | 205 | Step Lamp | 251 | |
| Wiring Diagram - STOP LAMP - | 205 | Kicking Plate Illumination | 252 | L |
| High-Mounted Stop Lamp | 206 | Trunk Room Lamp (Upper/Lower) | 252 | |
| Stop Lamp | 207 | ILLUMINATION | 253 | M |
| BACK-UP LAMP | 208 | System Description | 253 | |
| Wiring Diagram - B/LAMP - | 208 | CAN Communication System Description | 255 | |
| Bulb Replacement | 208 | CAN Communication Unit | 255 | |
| Removal and Installation | 209 | Schematic | 256 | N |
| PARKING, LICENSE PLATE AND TAIL LAMPS | 210 | Wiring Diagram - ILL - | 258 | |
| Component Parts and Harness Connector Location | 210 | Glove Box Lamp | 270 | |
| System Description | 210 | Cigarette Lighter Illumination | 271 | O |
| CAN Communication System Description | 211 | Front Ashtray Illumination | 271 | |
| CAN Communication Unit | 211 | Rear Ashtray Illumination | 271 | |
| Schematic | 212 | BULB SPECIFICATIONS | 273 | P |
| | | Headlamp | 273 | |
| | | Exterior Lamp | 273 | |
| | | Interior Lamp/Illumination | 273 | |

DTC INDEX

< SERVICE INFORMATION >

SERVICE INFORMATION

DTC INDEX

U1000-U1010

INFOID:000000002989241

| DTC | Items (CONSULT screen terms) | Reference |
|-------|------------------------------|--|
| U1000 | CAN COMM CIRCUIT | LT-133, "DTC U1000 CAN COMM CIRCUIT" |
| U1010 | CONTROL UNIT (CAN) | LT-134, "DTC U1010 CONTROL UNIT (CAN)" |

B2503-B2523

INFOID:000000002989236

| DTC | Items (CONSULT screen terms) | Reference |
|-------|------------------------------|--|
| B2503 | SWIVEL ACTUATOR [RH] | LT-134, "DTC B2503 SWIVEL ACTUATOR RH" |
| B2504 | SWIVEL ACTUATOR [LH] | LT-139, "DTC B2504 SWIVEL ACTUATOR LH" |
| B2514 | HI SEN UNUSUAL [RR] | LT-144, "DTC B2514 HI SEN UNUSUAL RR" |
| B2515 | ST ANG SEN SIG | LT-147, "DTC B2515 ST ANG SEN SIG" |
| B2516 | SIFT SIG [P,R] | LT-147, "DTC B2516 SIFT SIG [P,R]" |
| B2517 | VEHICLE SPEED SIG | LT-148, "DTC B2517 VEHICLE SPEED SIG" |
| B2518 | HEAD LAMP SIG | LT-148, "DTC B2518 HEADLAMP SIG" |
| B2519 | LEVELIZER CALIB | LT-148, "DTC B2519 LEVELIZER CALIB" |
| B2520 | ST ANGLE SEN CALIB | LT-149, "DTC B2520 ST ANGLE SEN CALIB" |
| B2521 | ECU CIRC | LT-149, "DTC B2521 ECU CIRC" |
| B2522 | ECM SIG | LT-152, "DTC B2522 ECM SIG" |
| B2523 | AFS SIG | LT-152, "DTC B2523 AFS SIG" |

PRECAUTIONS

< SERVICE INFORMATION >

PRECAUTIONS

Precaution for Supplemental Restraint System (SRS) "AIR BAG" and "SEAT BELT PRE-TENSIONER"

INFOID:000000005156694

The Supplemental Restraint System such as "AIR BAG" and "SEAT BELT PRE-TENSIONER", used along with a front seat belt, helps to reduce the risk or severity of injury to the driver and front passenger for certain types of collision. This system includes seat belt switch inputs and dual stage front air bag modules. The SRS system uses the seat belt switches to determine the front air bag deployment, and may only deploy one front air bag, depending on the severity of a collision and whether the front occupants are belted or unbelted. Information necessary to service the system safely is included in the "SUPPLEMENTAL RESTRAINT SYSTEM" and "SEAT BELTS" of this Service Manual.

WARNING:

- To avoid rendering the SRS inoperative, which could increase the risk of personal injury or death in the event of a collision which would result in air bag inflation, all maintenance must be performed by an authorized NISSAN/INFINITI dealer.
- Improper maintenance, including incorrect removal and installation of the SRS, can lead to personal injury caused by unintentional activation of the system. For removal of Spiral Cable and Air Bag Module, see the "SUPPLEMENTAL RESTRAINT SYSTEM".
- Do not use electrical test equipment on any circuit related to the SRS unless instructed to in this Service Manual. SRS wiring harnesses can be identified by yellow and/or orange harnesses or harness connectors.

PRECAUTIONS WHEN USING POWER TOOLS (AIR OR ELECTRIC) AND HAMMERS

WARNING:

- When working near the Air Bag Diagnosis Sensor Unit or other Air Bag System sensors with the ignition ON or engine running, DO NOT use air or electric power tools or strike near the sensor(s) with a hammer. Heavy vibration could activate the sensor(s) and deploy the air bag(s), possibly causing serious injury.
- When using air or electric power tools or hammers, always switch the ignition OFF, disconnect the battery, and wait at least 3 minutes before performing any service.

General Precaution for Service Operation

INFOID:000000002956660

- Never work with wet hands.
- Xenon headlamp includes high voltage generating part. Be sure to disconnect battery negative cable (negative terminal) or power fuse before removing, installing, or touching the xenon headlamp (including lamp bulb).
- Turn the lighting switch OFF before disconnecting and connecting the connector.
- When turning the xenon headlamp on and while it is illuminated, never touch the harness, bulb, and socket of the headlamp.
- When checking the headlamp on/off operation, check it on vehicle and with the power connected to the vehicle-side connector.
- Do not touch the headlamp bulb glass surface with bare hands or allow oil or grease to get on it. Do not touch the headlamp bulb just after the headlamp is turned off, because it is very hot.
- Install the xenon headlamp bulb socket correctly. If it is installed improperly, high-voltage leak or corona discharge may occur that can melt the bulb, connector, and housing. Do not illuminate the xenon headlamp bulb out of the headlamp housing. Doing so can cause fire and harm your eyes.
- When the bulb has burned out, wrap it in a thick vinyl bag and discard. Do not break the bulb.
- Leaving the bulb removed from the headlamp housing for a long period of time can deteriorate the performance of the lens and reflector (dirt, clouding). Always prepare a new bulb and have it on hand when replacing the bulb.
- When adjusting the headlamp aiming, turn the aiming adjustment screw only in the tightening direction. (If it is necessary to loosen the screw, first fully loosen the screw, and then turn it in the tightening direction.)
- Do not use organic solvent (paint thinner or gasoline) to clean lamps and to remove old sealant.

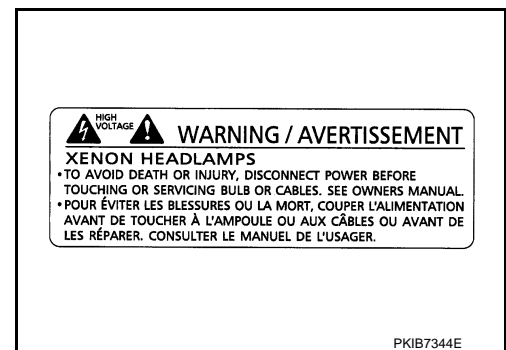

HEADLAMP (FOR USA) - CONVENTIONAL TYPE -

< SERVICE INFORMATION >

HEADLAMP (FOR USA) - CONVENTIONAL TYPE -

Component Parts and Harness Connector Location

INFOID:0000000295661

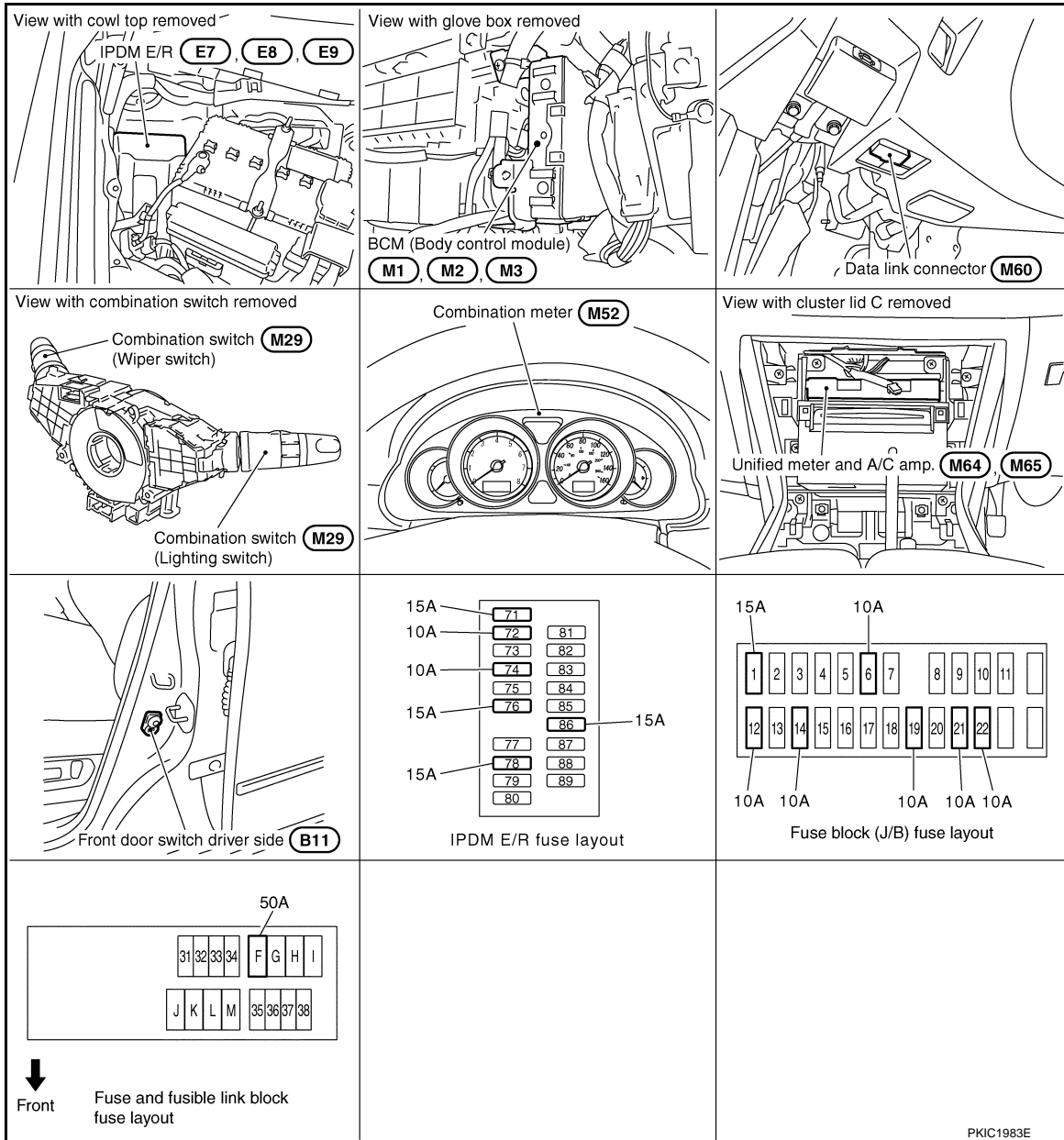

System Description

INFOID:0000000295662

The control of the headlamp system operation is dependent upon the position of the combination switch (lighting switch). When the lighting switch is placed in the 2ND position, the BCM (body control module) receives input signal requesting the headlamps (and tail lamps) illuminate. This input signal is communicated to the IPDM E/R (intelligent power distribution module engine room) across the CAN communication lines. The CPU (central processing unit) located in the IPDM E/R controls the headlamp high and headlamp low relay coils. These relays, when energized, direct power to the respective headlamps, which then illuminate.

OUTLINE

Power is supplied at all times

- to headlamp high relay, located in IPDM E/R and
- to headlamp low relay, located in IPDM E/R, from battery direct,
- through 15A fuse (No. 71, located in IPDM E/R)
- to CPU, located in IPDM E/R,
- through 15A fuse (No. 78, located in IPDM E/R)

HEADLAMP (FOR USA) - CONVENTIONAL TYPE -

< SERVICE INFORMATION >

- to CPU, located in IPDM E/R,
- through 50A fusible link (letter F, located in fuse and fusible link block)
- to BCM terminal 55,
- through 10A fuse [No. 21, located in fuse block (J/B)]
- to BCM terminal 42 and

A

- to combination meter terminal 23,
- through 10A fuse [No. 19, located in fuse block (J/B)]
- to unified meter and A/C amp. terminal 54,
- through 10A fuse [No. 22, located in fuse block (J/B)]
- to key slot terminal 1.

B

When the ignition switch is in the ON or START position, power is supplied

- to CPU, located in IPDM E/R,
- through 15A fuse [No. 1, located in fuse block (J/B)]
- to BCM terminal 38,
- through 10A fuse [No. 14, located in fuse block (J/B)]
- to combination meter terminal 12,
- through 10A fuse [No. 12, located in fuse block (J/B)]
- to unified meter and A/C amp. terminal 53.

D

E

When the ignition switch is in the ACC or ON position, power is supplied

- through 10A fuse [No. 6, located in fuse block (J/B)]
- to BCM terminal 11.

F

Ground is supplied

- to BCM terminal 52
- to combination meter terminals 9, 10, and 11
- to unified meter and A/C amp. terminals 55 and 71
- to push-button ignition switch (push switch) terminal 1
- to key slot terminal 8
- through grounds M16 and M70,
- to IPDM E/R terminals 38 and 51
- through grounds E22 and E43.

G

H

I

HEADLAMP OPERATION

Low Beam Operation

With the lighting switch in 2ND position, the BCM receives input signal requesting the headlamps to illuminate. This input signal is communicated to the IPDM E/R across the CAN communication lines. The CPU located in the IPDM E/R controls the headlamp low relay coil, which when energized, directs power

- through 15A fuse (No. 76, located in IPDM E/R)
- through IPDM E/R terminal 20
- to front combination lamp RH terminal 8,
- through 15A fuse (No. 86, located in IPDM E/R)
- through IPDM E/R terminal 30
- to front combination lamp LH terminal 8.

J

LT

L

Ground is supplied

- to front combination lamp RH terminal 4
- to front combination lamp LH terminal 4
- through grounds E22 and E43.

M

With power and ground supplied, low beam headlamps illuminate.

N

High Beam Operation/Flash-to-Pass Operation

With the lighting switch in 2ND position and placed in HIGH or PASS position, the BCM receives input signal requesting the headlamp high beams and low beams to illuminate. This input signal is communicated to the IPDM E/R across the CAN communication lines. The CPU located in the IPDM E/R controls the headlamp high relay coil and low relay coil, which when energized, directs power

- through 15A fuse (No. 76, located in IPDM E/R)
- through IPDM E/R terminal 20
- to front combination lamp RH terminal 8,
- through 15A fuse (No. 86, located in IPDM E/R)
- through IPDM E/R terminal 30
- to front combination lamp LH terminal 8,
- through 10A fuse (No. 72, located in IPDM E/R)
- through IPDM E/R terminal 27

O

P

HEADLAMP (FOR USA) - CONVENTIONAL TYPE -

< SERVICE INFORMATION >

- to front combination lamp RH terminal 6,
- through 10A fuse (No. 74, located in IPDM E/R)
- through IPDM E/R terminal 28
- to front combination lamp LH terminal 6.

Ground is supplied

- to front combination lamp RH terminal 4
- to front combination lamp LH terminal 4
- to front combination lamp RH terminal 2
- to front combination lamp LH terminal 2
- through grounds E22 and E43.

With power and ground supplied, the high beam and low beam headlamps illuminate.

The unified meter and A/C amp. that received the high beam request signal by BCM across the CAN communication makes a high beam indicator lamp turn on in the combination meter.

COMBINATION SWITCH READING FUNCTION

Refer to [BCS-4. "System Description"](#).

EXTERIOR LAMP BATTERY SAVER CONTROL

When the combination switch (lighting switch) is in the 2ND position (ON), and the ignition switch is turned from ON or ACC to OFF, the battery saver control function is activated.

Under this condition, the headlamps remain illuminated for 5 minutes, then the headlamps are turned off.

Exterior lamp battery saver control mode can be changed by the function setting of CONSULT-III.

AUTO LIGHT OPERATION

Refer to [LT-93. "System Description"](#).

CAN Communication System Description

INFOID:000000002956663

CAN (Controller Area Network) is a serial communication line for real time application. It is an on-vehicle multiplex communication line with high data communication speed and excellent error detection ability. Many electronic control units are equipped onto a vehicle, and each control unit shares information and links with other control units during operation (not independent). In CAN communication, control units are connected with 2 communication lines (CAN H line, CAN L line) allowing a high rate of information transmission with less wiring. Each control unit transmits/receives data but selectively reads required data only.

CAN Communication Unit

INFOID:000000002956664

Refer to [LAN-11. "System Description"](#).

HEADLAMP (FOR USA) - CONVENTIONAL TYPE -

< SERVICE INFORMATION >

Schematic

INFOID:00000002956665

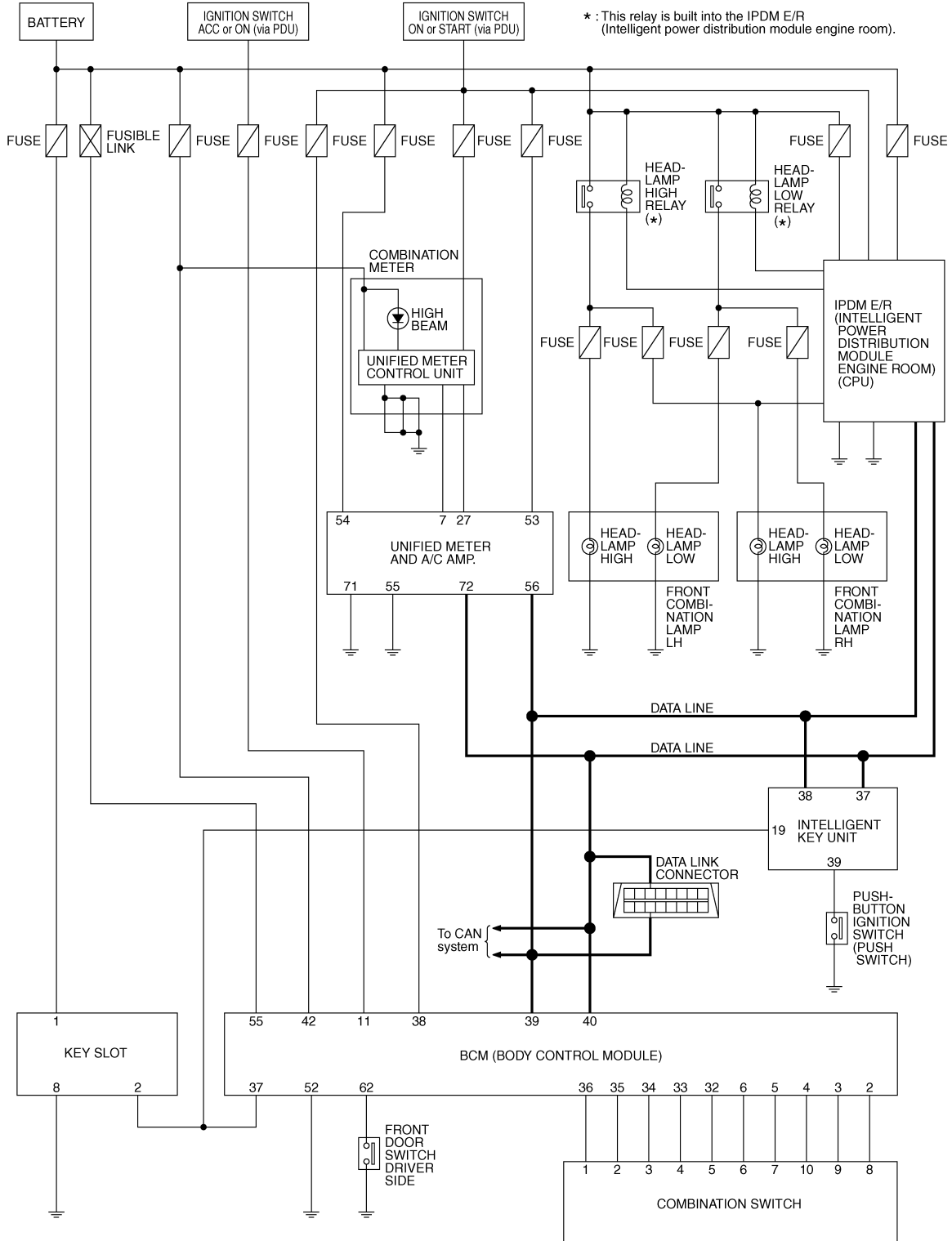

A
B
C
D
E
F
G
H
I
J
LT
L
M
N
O
P

TKWT3350E

HEADLAMP (FOR USA) - CONVENTIONAL TYPE -

< SERVICE INFORMATION >

Wiring Diagram - H/LAMP -

INFOID:00000002956666

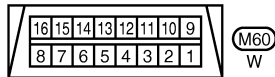
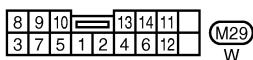
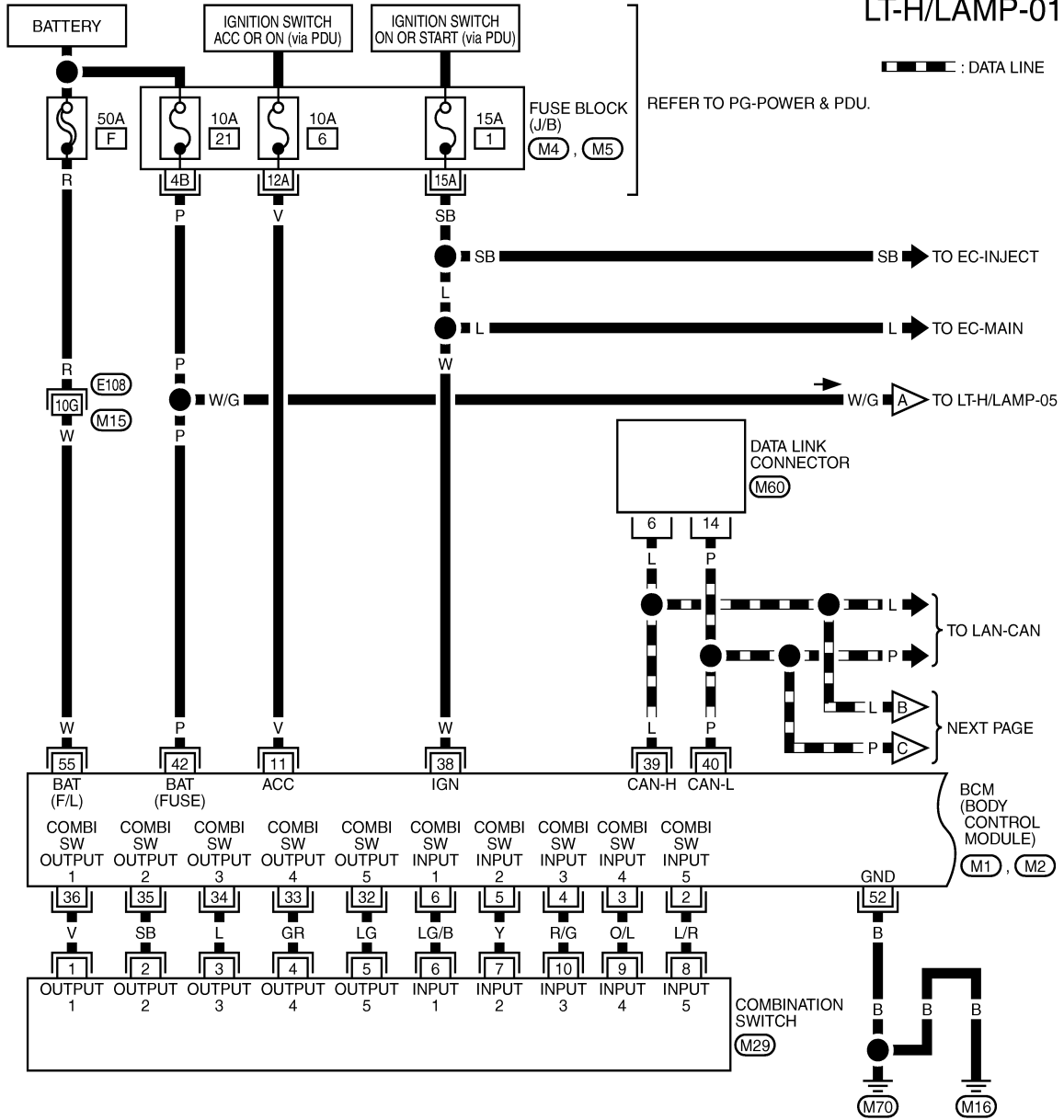

REFER TO THE FOLLOWING.

- (E108) - SUPER MULTIPLE JUNCTION (SMJ)
- (M4), (M5) - FUSE BLOCK - JUNCTION BOX (J/B)
- (M1), (M2) - ELECTRICAL UNITS

TKWT6798E

HEADLAMP (FOR USA) - CONVENTIONAL TYPE -

< SERVICE INFORMATION >

LT-H/LAMP-02

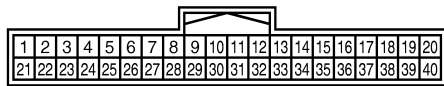
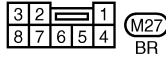
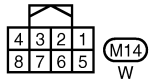
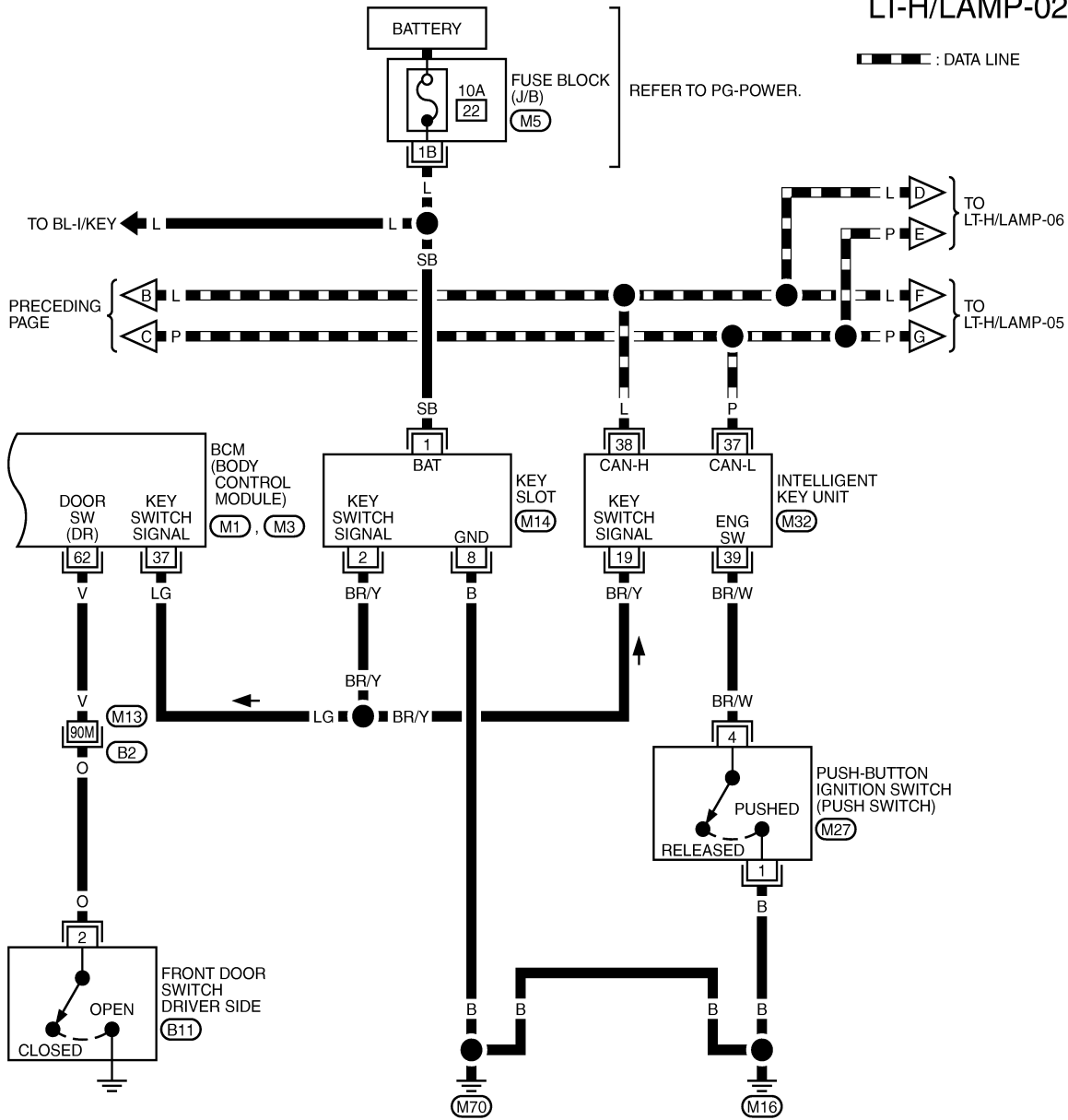

REFER TO THE FOLLOWING.

- (B2) - SUPER MULTIPLE JUNCTION (SMJ)
- (M5) - FUSE BLOCK-JUNCTION BOX (J/B)
- (M1), (M3) - ELECTRICAL UNITS

TKWT6799E

A
B
C
D
E
F
G
H
I
J
K
L
M
N
O
P

LT

HEADLAMP (FOR USA) - CONVENTIONAL TYPE -

< SERVICE INFORMATION >

LT-H/LAMP-03

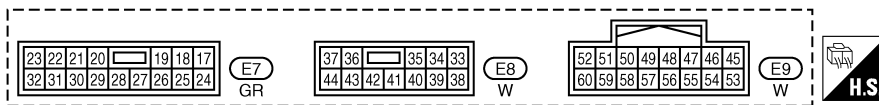
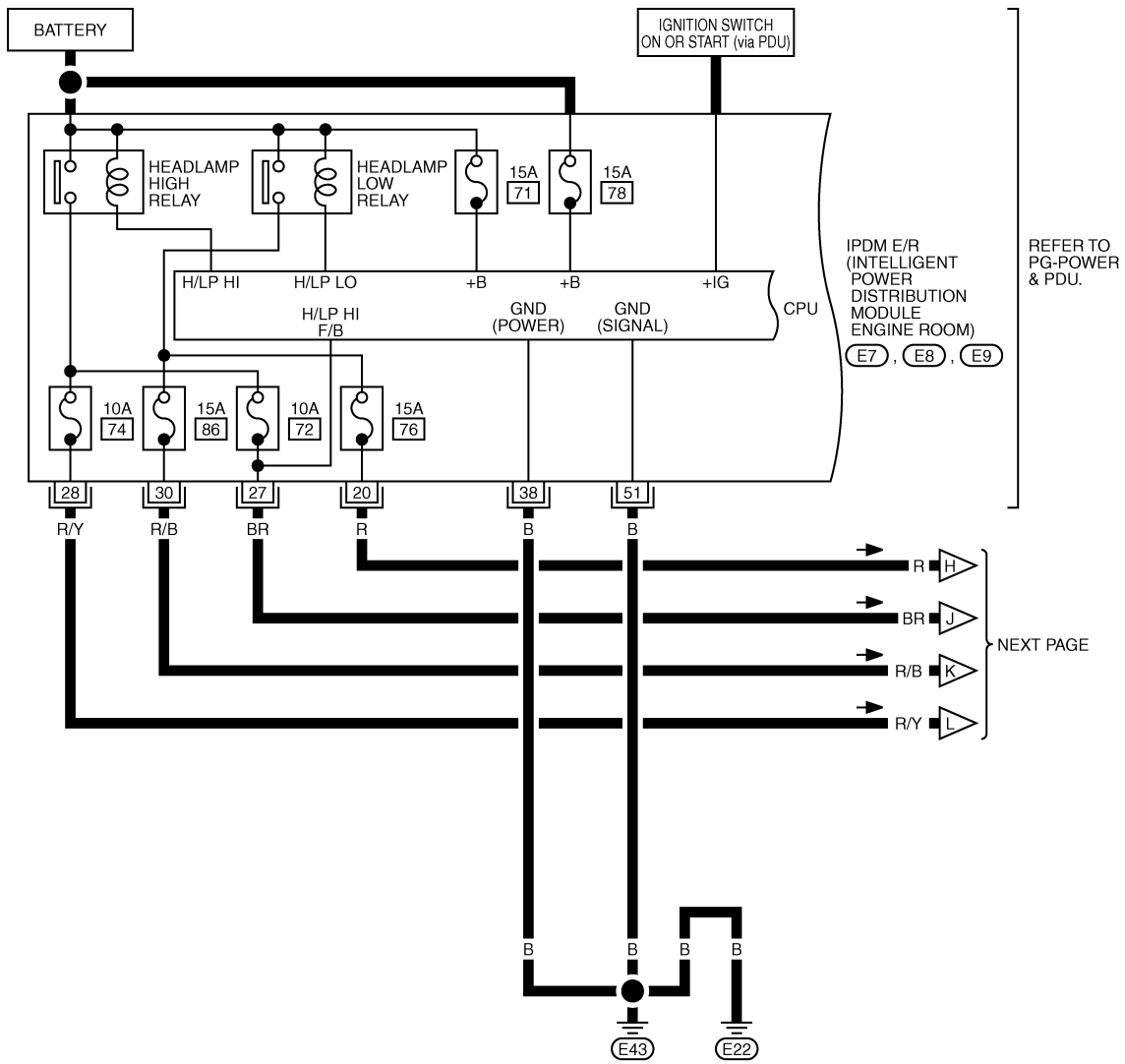

TKWT5253E

HEADLAMP (FOR USA) - CONVENTIONAL TYPE -

< SERVICE INFORMATION >

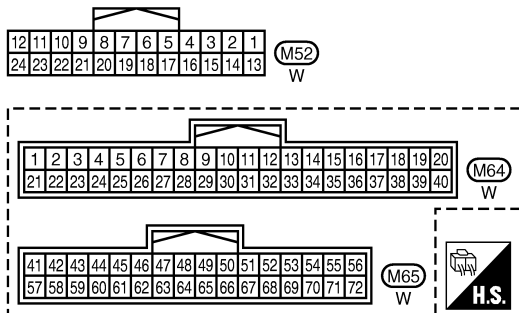
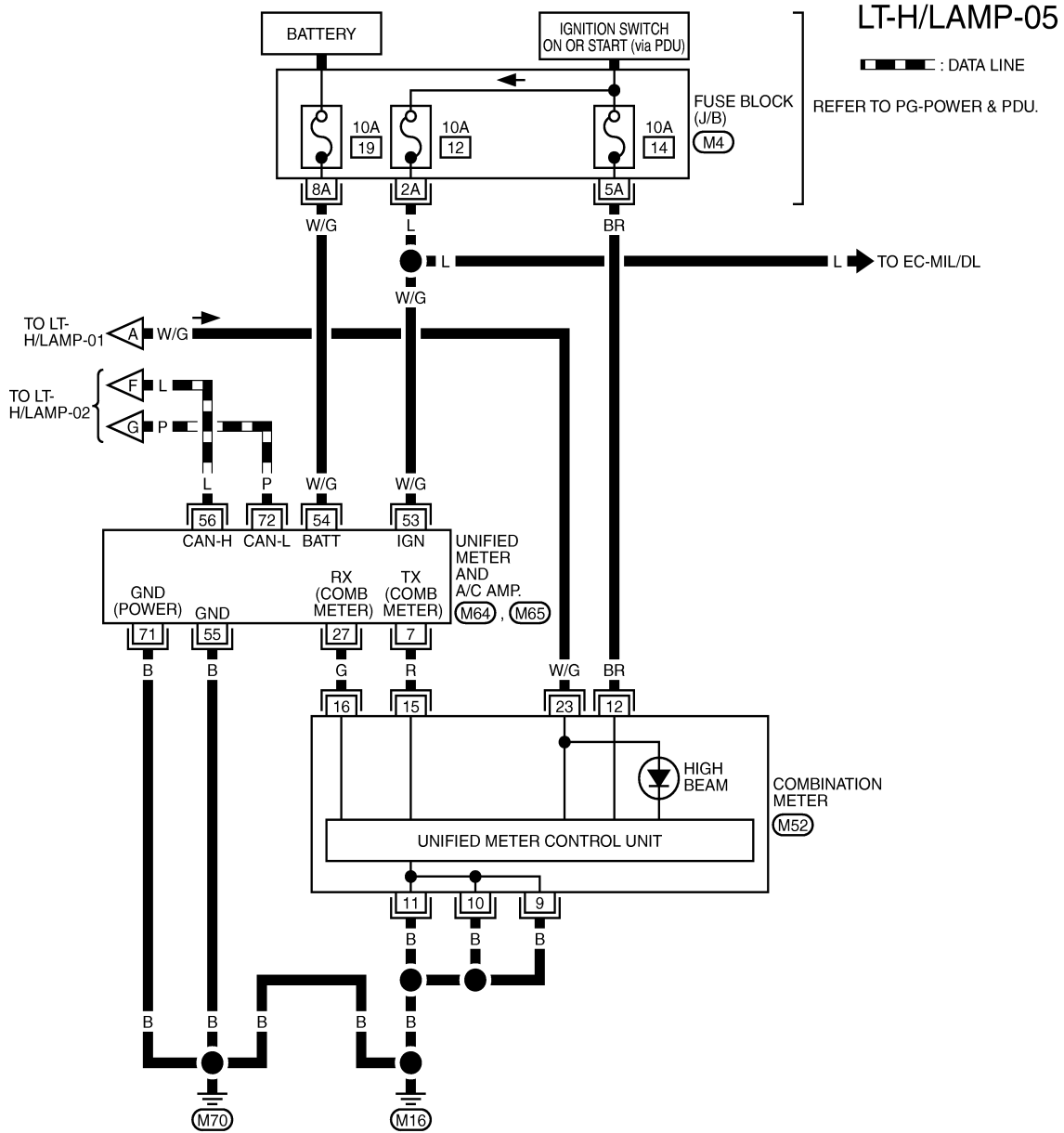

REFER TO THE FOLLOWING.

(M4) - FUSE BLOCK-JUNCTION BOX (J/B)

TKWT6800E

HEADLAMP (FOR USA) - CONVENTIONAL TYPE -

< SERVICE INFORMATION >

LT-H/LAMP-06

▬▬▬ : DATA LINE

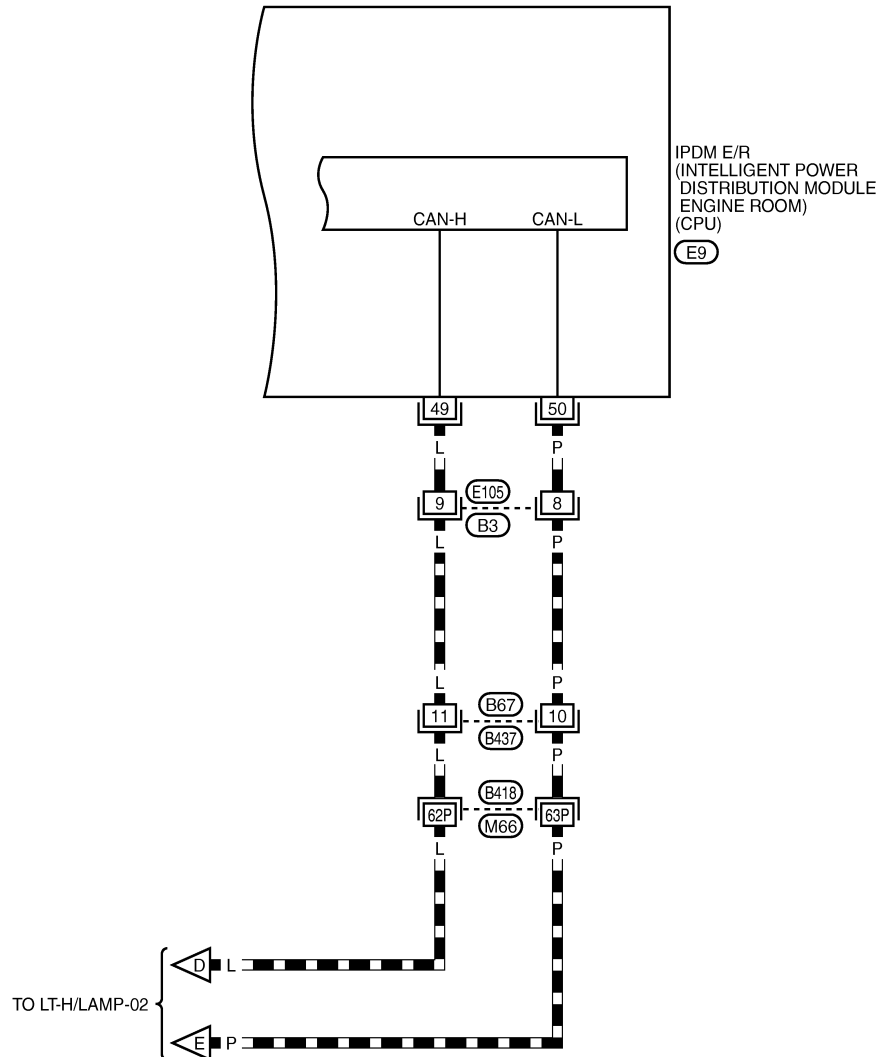

IPDM E/R
(INTELLIGENT POWER
DISTRIBUTION MODULE
ENGINE ROOM)
(CPU)
(E9)

TO LT-H/LAMP-02

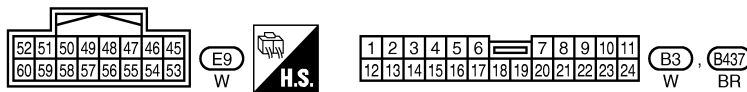

REFER TO THE FOLLOWING.

(B418) - SUPER MULTIPLE JUNCTION (SMJ)

TKWT6801E

INFOID:000000002956667

Terminal and Reference Value for BCM

CAUTION:

- Check combination switch system terminal waveform under the loaded condition with lighting switch, turn signal switch and wiper switch OFF not to be fluctuated by overloaded.
- Turn wiper dial position to 4 except when checking waveform or voltage of wiper dial position. Wiper dial position can be confirmed on CONSULT-III. Refer to [LT-201, "CONSULT-III Functions \(BCM - COMB SW\)"](#).

HEADLAMP (FOR USA) - CONVENTIONAL TYPE -

< SERVICE INFORMATION >

| Terminal No. | Wire color | Signal name | Measuring condition | | Reference value | |
|--------------|------------|-----------------------------|---------------------|---|---|---|
| | | | Ignition switch | Operation or condition | | |
| 2 | L/R | Combination switch input 5 | ON | Lighting, turn, wiper switch (Wiper dial position 4) | Lighting switch HI beam (Operates only HI beam switch) | <p style="text-align: right; font-size: small;">PKIB4957J Approx. 1.0 V</p> |
| | | | | | Lighting switch 2ND | <p style="text-align: right; font-size: small;">PKIB4953J Approx. 2.0 V</p> |
| | | | | OFF | Approx. 0 V | |
| 3 | O/L | Combination switch input 4 | ON | Lighting, turn, wiper switch (Wiper dial position 4) | Any of several conditions below <ul style="list-style-type: none"> • Lighting switch 2ND • Lighting switch PASSING (Operates only PASSING switch) | <p style="text-align: right; font-size: small;">PKIB4957J Approx. 1.0 V</p> |
| | | | | | OFF | Approx. 0 V |
| 11 | V | Ignition switch (ACC) | ACC | — | Battery voltage | |
| 34 | L | Combination switch output 3 | ON | Lighting, turn, wiper switch (Wiper dial position 4) | Any of several conditions below <ul style="list-style-type: none"> • Lighting switch 2ND • Lighting switch HI beam (Operates only HI beam switch) | <p style="text-align: right; font-size: small;">PKIB4958J Approx. 1.2 V</p> |
| | | | | | OFF | <p style="text-align: right; font-size: small;">PKIB4960J Approx. 7.0 - 7.5 V</p> |

HEADLAMP (FOR USA) - CONVENTIONAL TYPE -

< SERVICE INFORMATION >

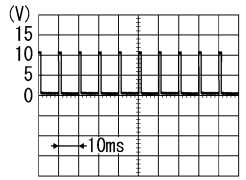
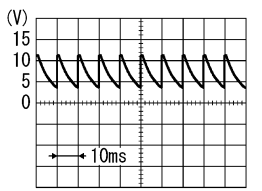
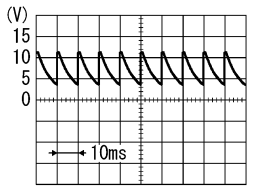
| Terminal No. | Wire color | Signal name | Measuring condition | | Reference value | |
|--------------|------------|--------------------------------------|---------------------|--|---|-------------|
| | | | Ignition switch | Operation or condition | | |
| 35 | SB | Combination switch output 2 | ON | Lighting, turn, wiper switch (Wiper dial position 4) | <p>Any of several conditions below</p> <ul style="list-style-type: none"> • Lighting switch 2ND • Lighting switch PASSING (Operates only PASSING switch)  <p style="text-align: center;">Approx. 1.2 V</p> | |
| | | | | OFF |  <p style="text-align: center;">Approx. 7.0 - 7.5 V</p> | |
| 37 | LG | Key switch signal | OFF | Intelligent Key is inserted into key slot. | Battery voltage | |
| | | | | Intelligent Key is removed from key slot. | Approx. 0 V | |
| 38 | W | Ignition switch (ON) | ON | — | Battery voltage | |
| 39 | L | CAN - H | — | — | — | |
| 40 | P | CAN - L | — | — | — | |
| 42 | P | Battery power supply | OFF | — | Battery voltage | |
| 52 | B | Ground | ON | — | Approx. 0 V | |
| 55 | W | Battery power supply | OFF | — | Battery voltage | |
| 62 | V | Front door switch driver side signal | OFF | Front door switch driver side | ON (open) | Approx. 0 V |
| | | | | OFF (closed) |  <p style="text-align: center;">Approx. 7.5 - 8.0 V</p> | |

Terminal and Reference Value for IPDM E/R

INFOID:000000002956668

| Terminal No. | Wire color | Signal name | Measuring condition | | Reference value | |
|--------------|------------|--------------------|---------------------|--|-----------------|-----------------|
| | | | Ignition switch | Operation or condition | | |
| 20 | R | Headlamp low (RH) | ON | Lighting switch 2ND position | OFF | Approx. 0 V |
| | | | | | ON | Battery voltage |
| 27 | BR | Headlamp high (RH) | ON | Lighting switch HIGH or PASSING position | OFF | Approx. 0 V |
| | | | | | ON | Battery voltage |
| 28 | R/Y | Headlamp high (LH) | ON | Lighting switch HIGH or PASSING position | OFF | Approx. 0 V |
| | | | | | ON | Battery voltage |

HEADLAMP (FOR USA) - CONVENTIONAL TYPE -

< SERVICE INFORMATION >

| Terminal No. | Wire color | Signal name | Measuring condition | | Reference value |
|--------------|------------|-------------------|---------------------|------------------------------|-----------------|
| | | | Ignition switch | Operation or condition | |
| 30 | R/B | Headlamp low (LH) | ON | Lighting switch 2ND position | OFF |
| | | | | | ON |
| 38 | B | Ground | ON | — | Approx. 0 V |
| 49 | L | CAN – H | — | — | — |
| 50 | P | CAN – L | — | — | — |
| 51 | B | Ground | ON | — | Approx. 0 V |

How to Perform Trouble Diagnosis

INFOID:000000002956669

1. Confirm the symptom or customer complaint.
2. Understand operation description and function description. Refer to [LT-6. "System Description"](#).
3. Perform the Preliminary Check. Refer to [LT-18. "Preliminary Check"](#).
4. Check symptom and repair or replace the cause of malfunction.
5. Does the headlamp operate normally? If YES, GO TO 6. If NO, GO TO 4.
6. INSPECTION END

Preliminary Check

INFOID:000000002956670

CHECK POWER SUPPLY AND GROUND CIRCUIT

1. CHECK FUSES AND FUSIBLE LINK

Check for blown fuses and fusible link.

| Unit | Power source | Fuse and fusible link No. |
|----------|--------------------------------------|---------------------------|
| BCM | Battery | F |
| | | 21 |
| | Ignition switch ON or START position | 1 |
| | Ignition switch ACC or ON position | 6 |
| IPDM E/R | Battery | 71 |
| | | 72 |
| | | 74 |
| | | 76 |
| | | 78 |
| | | 86 |

Refer to [LT-10. "Wiring Diagram - H/LAMP -"](#).

OK or NG

OK >> GO TO 2.

NG >> If fuse or fusible link is blown, be sure to eliminate cause of malfunction before installing new fuse or fusible link. Refer to [PG-4](#).

2. CHECK POWER SUPPLY CIRCUIT

1. Turn ignition switch OFF.
2. Disconnect BCM connector.

HEADLAMP (FOR USA) - CONVENTIONAL TYPE -

< SERVICE INFORMATION >

3. Check voltage between BCM harness connector and ground.

| Terminal | | Ignition switch position | | | |
|---------------|----------|--------------------------|-----------------|-----------------|-----------------|
| (+) | | (-) | OFF | ACC | ON |
| BCM connector | Terminal | | | | |
| M1 | 11 | Ground | Approx. 0 V | Battery voltage | Battery voltage |
| | 38 | | Approx. 0 V | Approx. 0 V | Battery voltage |
| M2 | 42 | | Battery voltage | Battery voltage | Battery voltage |
| | 55 | | Battery voltage | Battery voltage | Battery voltage |

OK or NG

OK >> GO TO 3.

NG >> Repair harness or connector.

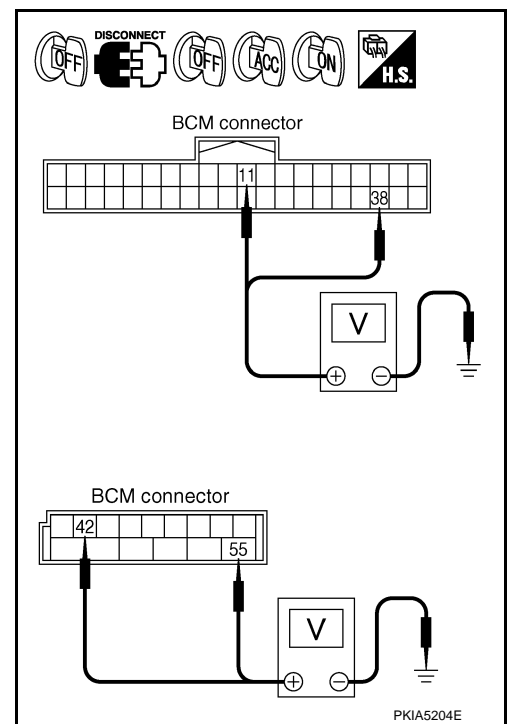

3.CHECK GROUND CIRCUIT

Check continuity between BCM harness connector and ground.

| BCM connector | Terminal | Ground | Continuity |
|---------------|----------|--------|------------|
| M2 | 52 | | Yes |

OK or NG

OK >> INSPECTION END

NG >> Repair harness or connector.

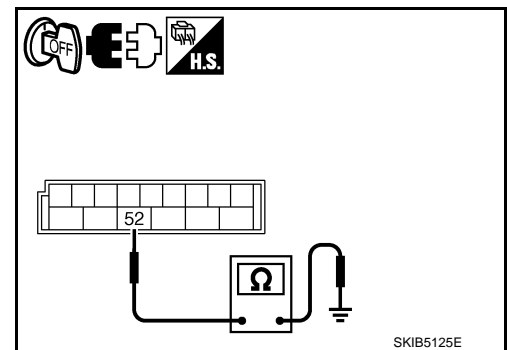

CONSULT-III Functions (BCM - HEAD LAMP)

INFOID:000000002956671

CONSULT-III can display each diagnostic item using the diagnostic test mode shown following.

| Diagnosis mode | Description |
|-----------------------|---|
| WORK SUPPORT | Changes the setting for each function. ^{NOTE} |
| DATA MONITOR | Displays BCM input data in real time. |
| ACTIVE TEST | Operation of electrical loads can be checked by sending drive signal to them. |
| SELF-DIAG RESULTS | BCM performs self-diagnosis of CAN communication. |
| CAN DIAG SUPPORT MNTR | The result of transmit/receive diagnosis of CAN communication can be read. |

NOTE:

Cannot change the setting for headlamp.

DATA MONITOR

Display Item List

| Monitor item | Contents |
|--------------|---|
| IGN ON SW | "On/Off" Displays "IGN position (ON)/OFF, ACC position (OFF)" judged from the ignition switch signal. |
| ACC ON SW | "On/Off" Displays "ACC (ON)/OFF, Ignition OFF (OFF)" status judged from ignition switch signal. |

HEADLAMP (FOR USA) - CONVENTIONAL TYPE -

< SERVICE INFORMATION >

| Monitor item | Contents |
|------------------------------------|--|
| KEY ON SW "On/Off" | Displays "Intelligent Key inserted into key slot (ON)/Intelligent Key removed from key slot (OFF)" status judged from the key switch signal. |
| TURN SIGNAL R "On/Off" | Displays status (turn right: ON/others: OFF) as judged from lighting switch signal. |
| TURN SIGNAL L "On/Off" | Displays status (turn left: ON/others: OFF) as judged from lighting switch signal. |
| HI BEAM SW "On/Off" | Displays status (high beam switch: ON/others: OFF) of high beam switch judged from lighting switch signal. |
| HEAD LAMP SW 1 "On/Off" | Displays status (headlamp switch 1: ON/others: OFF) of headlamp switch 1 judged from lighting switch signal. |
| HEAD LAMP SW 2 "On/Off" | Displays status (headlamp switch 2: ON/others: OFF) of headlamp switch 2 judged from lighting switch signal. |
| TAIL LAMP SW "On/Off" | Displays status (lighting switch 1ST or 2ND position: ON/others: OFF) of lighting switch judged from lighting switch signal. |
| AUTO LIGHT SW "On/Off" | Displays status of the lighting switch as judged from the lighting switch signal. (AUTO position: ON/other than AUTO position: OFF) |
| PASSING SW "On/Off" | Displays status (flash-to-passing switch: ON/others: OFF) of flash-to-passing switch judged from lighting switch signal. |
| FR FOG SW "On/Off" | Displays status (front fog lamp switch: ON/others: OFF) of front fog lamp switch judged from lighting switch signal. |
| DOOR SW - DR "On/Off" | Displays status of the driver door as judged from the driver door switch signal. (door is open: ON/door is closed: OFF) |
| DOOR SW - AS "On/Off" | Displays status of the passenger door as judged from the passenger door switch signal. (door is open: ON/door is closed: OFF) |
| DOOR SW - RR "On/Off" | Displays status of the rear door as judged from the rear door switch (RH) signal. (door is open: ON/door is closed: OFF) |
| DOOR SW - RL "On/Off" | Displays status of the rear door as judged from the rear door switch (LH) signal. (door is open: ON/door is closed: OFF) |
| BACK DOOR SW ^{NOTE} "Off" | — |
| I - KEY LOCK "On/Off" | Displays "locked (ON)/other (OFF)" status, determined from lock signal. |
| OPTICAL SENSOR "0 - 5V" | Displays "outside brightness (close to 5 V when light/close to 0 V when dark)" judged from optical sensor signal. |
| VEHICLE SPEED "km/h" | Displays vehicle speed as judged from vehicle speed signal. |

NOTE:

This item is displayed, but cannot be monitored.

ACTIVE TEST

Display Item List

| Test item | Description |
|---------------------------------------|---|
| TAIL LAMP | Allows tail lamp relay to operate by switching ON-OFF. |
| FR FOG LAMP | Allows front fog lamp relay to operate by switching ON-OFF. |
| DAYTIME RUNNING LIGHT ^{NOTE} | — |
| HEAD LAMP (HI, LO) | Allows headlamp relay to operate by switching ON-OFF. |

NOTE:

This item is displayed, but cannot be tested.

CONSULT-III Functions (IPDM E/R)

INFOID:000000002956672

CONSULT-III can display each diagnostic item using the diagnostic test mode shown following.

HEADLAMP (FOR USA) - CONVENTIONAL TYPE -

< SERVICE INFORMATION >

| Diagnosis Mode | Description |
|-------------------------|--|
| SELF-DIAGNOSTIC RESULTS | Refer to PG-20. "CONSULT-III Function (IPDM E/R)" . |
| DATA MONITOR | The input/output data of IPDM E/R is displayed in real time. |
| CAN DIAG SUPPORT MNTR | The result of transmit/receive diagnosis of CAN communication can be read. |
| ACTIVE TEST | IPDM E/R sends a drive signal to electronic components to check their operation. |

DATA MONITOR

All Signals, Main Signals, Selection From Menu

| Item name | CONSULT-III screen display | Display or unit | Monitor item selection | | | Description |
|----------------------------|----------------------------|-----------------|------------------------|--------------|---------------------|------------------------------|
| | | | ALL SIGNALS | MAIN SIGNALS | SELECTION FROM MENU | |
| Position lights request | TAIL&CLR REQ | On/Off | × | × | × | Signal status input from BCM |
| Headlamp low beam request | HL LO REQ | On/Off | × | × | × | Signal status input from BCM |
| Headlamp high beam request | HL HI REQ | On/Off | × | × | × | Signal status input from BCM |
| Front fog lights request | FR FOG REQ | On/Off | × | × | × | Signal status input from BCM |

NOTE:

Perform monitoring of IPDM E/R data with the ignition switch ON. When the ignition switch is at ACC, the display may not be correct.

ACTIVE TEST

| Test item | CONSULT-III screen display | Description |
|--------------------------------|----------------------------|---|
| Tail lamp relay output | TAIL LAMP | Allows tail lamp relay to operate by switching operation ON-OFF at your option. |
| Headlamp relay (HI, LO) output | LAMPS | Allows headlamp relay (HI, LO) to operate by switching operation (OFF, HI ON, LO ON) at your option (Headlamp high beam repeats ON-OFF every 1 second). |
| Front fog lamp relay output | | Allows fog lamp relay to operate by switching operation ON-OFF at your option. |

Headlamp High Beam Does Not Illuminate (Both Sides)

INFOID:000000002956673

1. CHECK COMBINATION SWITCH INPUT SIGNAL

CONSULT-III DATA MONITOR

- Select "HI BEAM SW" of BCM (HEAD LAMP) data monitor item.
- With operating the lighting switch, check the monitor status.

When lighting switch is HIGH position : HI BEAM SW ON

CHECK THE COMBINATION SWITCH

Refer to [LT-202. "Combination Switch Inspection"](#).

OK or NG

OK >> GO TO 2.

NG >> Check combination switch (lighting switch). Refer to [LT-202. "Combination Switch Inspection"](#).

2. HEADLAMP ACTIVE TEST

CONSULT-III ACTIVE TEST

- Select "LAMPS" of IPDM E/R active test item.
- With operating the test item, check the headlamp high beam operation.

HI : Headlamp high beam ON

Off : Headlamp high beam OFF

NOTE:

Headlamp high beam repeats ON-OFF every 1 second.

HEADLAMP (FOR USA) - CONVENTIONAL TYPE -

< SERVICE INFORMATION >

⊗ IPDM E/R AUTO ACTIVE TEST

1. Activate auto active test. Refer to [PG-22. "Auto Active Test"](#).
2. Make sure headlamp high beam operation.

Headlamp high beam should operate.

OK or NG

- OK >> GO TO 3.
NG >> GO TO 4.

3. CHECK IPDM E/R

Ⓟ CONSULT-III DATA MONITOR

1. Select "HL LO REQ" and "HL HI REQ" of IPDM E/R data monitor item.
2. With operating the lighting switch is in HI position, check the monitor status.

**When lighting switch is HIGH position : HL LO REQ ON
: HL HI REQ ON**

OK or NG

- OK >> Replace IPDM E/R. Refer to [PG-27. "Removal and Installation of IPDM E/R"](#).
NG >> Replace BCM. Refer to [BCS-14. "Removal and Installation of BCM"](#).

4. CHECK HEADLAMP INPUT SIGNAL

Ⓟ CONSULT-III ACTIVE TEST

1. Turn ignition switch OFF.
2. Disconnect front combination lamp RH and LH connector.
3. Select "LAMPS" of IPDM E/R active test item.
4. Touch "HI" screen.
5. With operating the test item, check voltage between front combination lamp (RH and LH) harness connector and ground. (Headlamp high beam repeats ON-OFF every 1 second.)

| Terminal | | | (-) | Voltage (Approx.) |
|----------------------------------|-----|----------|--------|-------------------|
| (+) | | Terminal | | |
| Front combination lamp connector | | | | |
| RH | E47 | 6 | Ground | Battery voltage |
| LH | E54 | 6 | | |

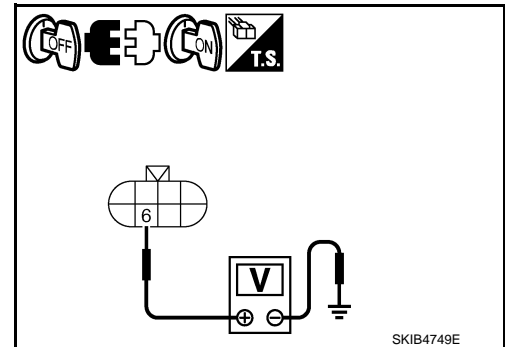

⊗ IPDM E/R AUTO ACTIVE TEST

1. Turn ignition switch OFF.
2. Disconnect front combination lamp connector.
3. Activate auto active test. Refer to [PG-22. "Auto Active Test"](#).
4. When headlamp high beam is operating, check voltage between front combination lamp (RH and LH) harness connector and ground.

| Terminal | | | (-) | Voltage (Approx.) |
|----------------------------------|-----|----------|--------|-------------------|
| (+) | | Terminal | | |
| Front combination lamp connector | | | | |
| RH | E47 | 6 | Ground | Battery voltage |
| LH | E54 | 6 | | |

OK or NG

- OK >> GO TO 5.
NG >> GO TO 7.

5. CHECK HEADLAMP GROUND

HEADLAMP (FOR USA) - CONVENTIONAL TYPE -

< SERVICE INFORMATION >

1. Turn ignition switch OFF.
2. Check continuity between front combination lamp (RH and LH) harness connector and ground.

| Front combination lamp connector | | Terminal | Ground | Continuity |
|----------------------------------|-----|----------|--------|------------|
| RH | E47 | 2 | | Yes |
| LH | E54 | 2 | | |

OK or NG

- OK >> GO TO 6.
 NG >> Repair harness or connector.

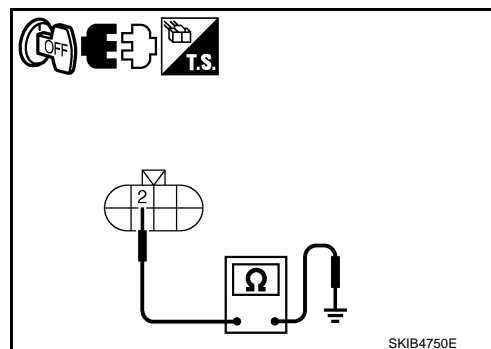

6.CHECK BULB

Check bulbs of lamp (both side).

OK or NG

- OK >> Check connecting condition headlamp harness connector.
 NG >> Replace headlamp bulb.

7.CHECK CIRCUIT BETWEEN IPDM E/R AND FRONT COMBINATION LAMP

1. Turn ignition switch OFF.
2. Disconnect IPDM E/R connector.
3. Check continuity between IPDM E/R harness connector (A) and front combination lamp (RH and LH) harness connector (B).

| Circuit | A | | B | | Continuity |
|---------|-----------|----------|-----------|----------|------------|
| | Connector | Terminal | Connector | Terminal | |
| RH | E7 | 27 | E47 | 6 | Yes |
| LH | | 28 | E54 | 6 | |

4. Check continuity between IPDM E/R harness connector (A) and ground.

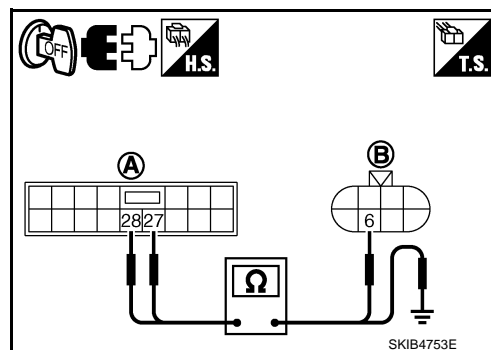

| A | | | Ground | Continuity |
|-----------|----|----------|--------|------------|
| Connector | | Terminal | | No |
| RH | E7 | 27 | | |
| LH | | 28 | | |

OK or NG

- OK >> Replace IPDM E/R. Refer to [PG-27. "Removal and Installation of IPDM E/R"](#).
 NG >> Repair harness or connector.

Headlamp High Beam Does Not Illuminate (One Side)

INFOID:000000002956674

1.CHECK BULB

Check bulb of lamp which does not illuminate.

OK or NG

- OK >> GO TO 2.
 NG >> Replace headlamp bulb.

2.CHECK HEADLAMP INPUT SIGNAL

CONSULT-III ACTIVE TEST

1. Turn ignition switch OFF.
2. Disconnect front combination lamp RH or LH connector.
3. Select "LAMPS" of IPDM E/R active test item.
4. Touch "HI" screen.

HEADLAMP (FOR USA) - CONVENTIONAL TYPE -

< SERVICE INFORMATION >

- With operating the test item, check voltage between front combination lamp RH or LH harness connector and ground. (Headlamp high beam repeats ON-OFF every 1 second.)

| Terminal (+) | | | Terminal (-) | Voltage (Approx.) |
|----------------------------------|----------|---|--------------|-------------------|
| Front combination lamp connector | Terminal | | | |
| RH | E47 | 6 | Ground | Battery voltage |
| LH | E54 | 6 | | |

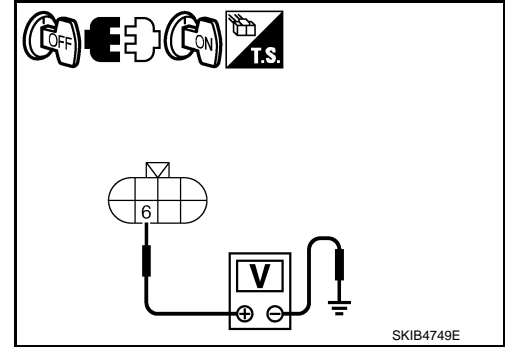

⊗ IPDM E/R AUTO ACTIVE TEST

- Turn ignition switch OFF.
- Disconnect front combination lamp RH or LH connector.
- Activate auto active test. Refer to [PG-22, "Auto Active Test"](#).
- When headlamp high beam is operating, check voltage between front combination lamp RH or LH harness connector and ground.

| Terminal (+) | | | Terminal (-) | Voltage (Approx.) |
|----------------------------------|----------|---|--------------|-------------------|
| Front combination lamp connector | Terminal | | | |
| RH | E47 | 6 | Ground | Battery voltage |
| LH | E54 | 6 | | |

OK or NG

- OK >> GO TO 3.
 NG >> GO TO 4.

3. CHECK HEADLAMP GROUND

- Turn ignition switch OFF.
- Check continuity between front combination lamp RH or LH harness connector and ground.

| Front combination lamp connector | Terminal | Ground | Continuity |
|----------------------------------|----------|--------|------------|
| RH | E47 | | 2 |
| LH | E54 | 2 | |

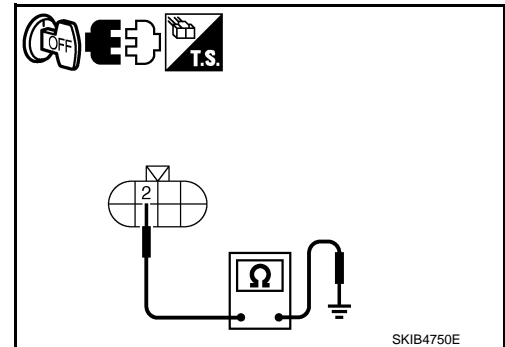

OK or NG

- OK >> Check connecting condition headlamp harness and connector.
 NG >> Repair harness or connector.

4. CHECK CIRCUIT BETWEEN IPDM E/R AND FRONT COMBINATION LAMP

- Turn ignition switch OFF.
- Disconnect IPDM E/R connector and front combination lamp RH or LH connector.

HEADLAMP (FOR USA) - CONVENTIONAL TYPE -

< SERVICE INFORMATION >

3. Check continuity between IPDM E/R harness connector (A) and front combination lamp RH or LH harness connector (B).

| Circuit | A | | B | | Continuity |
|---------|-----------|----------|-----------|----------|------------|
| | Connector | Terminal | Connector | Terminal | |
| RH | E7 | 27 | E47 | 6 | Yes |
| LH | | 28 | E54 | 6 | |

4. Check continuity between IPDM E/R harness connector (A) and ground.

| A | | Ground | Continuity |
|-----------|----------|--------|------------|
| Connector | Terminal | | |
| RH | E7 | 27 | No |
| LH | | 28 | |

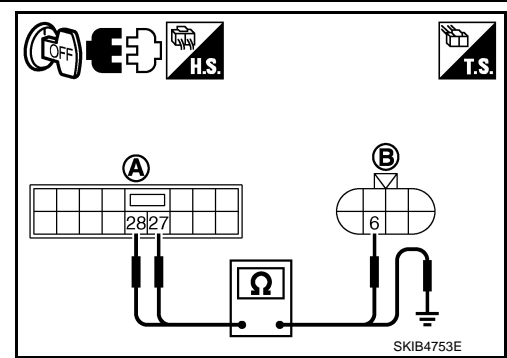

OK or NG

- OK >> Replace IPDM E/R. Refer to [PG-27, "Removal and Installation of IPDM E/R"](#).
 NG >> Repair harness or connector.

High Beam Indicator Lamp Does Not Illuminate

INFOID:000000002956675

1. CHECK UNIFIED METER AND A/C AMP.

CONSULT-III SELF-DIAGNOSIS

- Perform self-diagnosis for "METER A/C AMP" with CONSULT-III.
- Check if malfunction is indicated.

Is malfunction indicated?

- YES >> Repair or replace malfunctioning parts.
 NO >> GO TO 2.

2. CHECK COMBINATION METER INPUT SIGNAL

CONSULT-III DATA MONITOR

- Select "HI-BEAM IND" of METER A/C AMP data monitor item.
- With operating the lighting switch, check the monitor status.

When lighting switch is in the HIGH BEAM position : HI-BEAM IND ON

OK or NG

- OK >> Replace combination meter. Refer to [DI-25, "Removal and Installation of Combination Meter"](#).
 NG >> Replace unified meter and A/C amp. Refer to [DI-33, "Removal and Installation of Unified Meter and A/C Amp"](#).

Headlamp Low Beam Does Not Illuminate (Both Sides)

INFOID:000000002956676

1. CHECK COMBINATION SWITCH INPUT SIGNAL

CONSULT-III DATA MONITOR

- Select "HEAD LAMP SW 1" and "HEAD LAMP SW 2" of BCM (HEAD LAMP) data monitor item.
- With operating the lighting switch, check the monitor status.

**When lighting switch is 2ND position : HEAD LAMP SW 1 ON
 : HEAD LAMP SW 2 ON**

CHECK THE COMBINATION SWITCH

Refer to [LT-202, "Combination Switch Inspection"](#).

OK or NG

- OK >> GO TO 2.

HEADLAMP (FOR USA) - CONVENTIONAL TYPE -

< SERVICE INFORMATION >

NG >> Check combination switch (lighting switch). Refer to [LT-202, "Combination Switch Inspection"](#).

2. HEADLAMP ACTIVE TEST

CONSULT-III ACTIVE TEST

1. Select "LAMPS" of IPDM E/R active test item.
2. With operating the test item, check the headlamp low beam operation.

LO : Headlamp low beam ON

Off : Headlamp low beam OFF

IPDM E/R AUTO ACTIVE TEST

1. Activate auto active test. Refer to [PG-22, "Auto Active Test"](#).
2. Make sure headlamp low beam operation.

Headlamp low beam should operate.

OK or NG

OK >> GO TO 3.

NG >> GO TO 4.

3. CHECK IPDM E/R

CONSULT-III DATA MONITOR

1. Select "HL LO REQ" of IPDM E/R data monitor item.
2. With operating the lighting switch is in 2ND position, check the monitor status.

When lighting switch is 2ND position : HL LO REQ ON

OK or NG

OK >> Replace IPDM E/R. Refer to [PG-27, "Removal and Installation of IPDM E/R"](#).

NG >> Replace BCM. Refer to [BCS-14, "Removal and Installation of BCM"](#).

4. CHECK HEADLAMP INPUT SIGNAL

CONSULT-III ACTIVE TEST

1. Turn ignition switch OFF.
2. Disconnect front combination lamp RH and LH connector.
3. Select "LAMPS" of IPDM E/R active test item.
4. Touch "LO" screen.
5. With operating the test item, check voltage between front combination lamp (RH and LH) harness connector and ground.

| Terminal | | | Voltage (Approx.) |
|----------------------------------|----------|-----|---------------------------|
| (+) | | (-) | |
| Front combination lamp connector | terminal | | |
| RH | E47 | 8 | Ground Battery voltage |
| LH | E54 | 8 | |

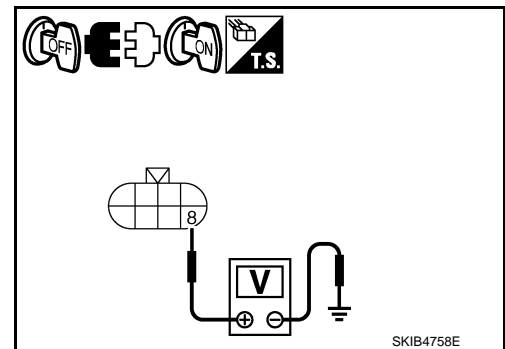

IPDM E/R AUTO ACTIVE TEST

1. Turn ignition switch OFF.
2. Disconnect front combination lamp RH and LH connector.
3. Activate auto active test. Refer to [PG-22, "Auto Active Test"](#).
4. When headlamp low beam is operating, check voltage between front combination lamp (RH and LH) harness connector and ground.

HEADLAMP (FOR USA) - CONVENTIONAL TYPE -

< SERVICE INFORMATION >

| Terminal | | | (-) | Voltage (Approx.) |
|----------------------------------|-----|----------|-----|-------------------|
| (+) | | terminal | | |
| Front combination lamp connector | | | | Ground |
| RH | E47 | 8 | | |
| LH | E54 | 8 | | |

OK or NG

- OK >> GO TO 5.
- NG >> GO TO 6.

5. CHECK HEADLAMP GROUND

1. Turn ignition switch OFF.
2. Check continuity between front combination lamp (RH and LH) harness connector and ground.

| Front combination lamp connector | | Terminal | Ground | Continuity |
|----------------------------------|-----|----------|--------|------------|
| RH | E47 | 4 | | Yes |
| LH | E54 | 4 | | |

OK or NG

- OK >> Check headlamp harness and connectors.
- NG >> Repair harness or connector.

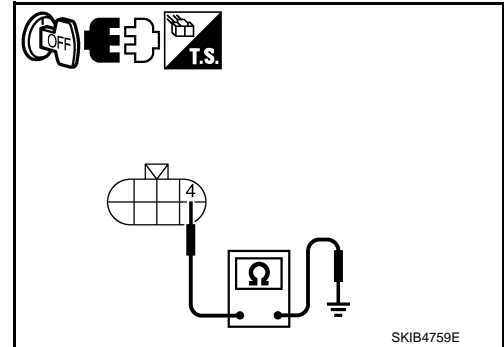

6. CHECK CIRCUIT BETWEEN IPDM E/R AND FRONT COMBINATION LAMP

1. Turn ignition switch OFF.
2. Disconnect IPDM E/R connector.
3. Check continuity between IPDM E/R harness connector (A) and front combination lamp (RH and LH) harness connector (B).

| Circuit | A | | B | | Continuity |
|---------|-----------|----------|-----------|----------|------------|
| | Connector | Terminal | Connector | Terminal | |
| RH | E7 | 20 | E47 | 8 | Yes |
| LH | | 30 | E54 | 8 | |

4. Check continuity between IPDM E/R harness connector (A) and ground.

| A | | Ground | Continuity |
|-----------|----------|--------|------------|
| Connector | Terminal | | |
| RH | E7 | 20 | No |
| LH | | 30 | |

OK or NG

- OK >> Replace IPDM E/R. Refer to [PG-27, "Removal and Installation of IPDM E/R"](#).
- NG >> Repair harness or connector.

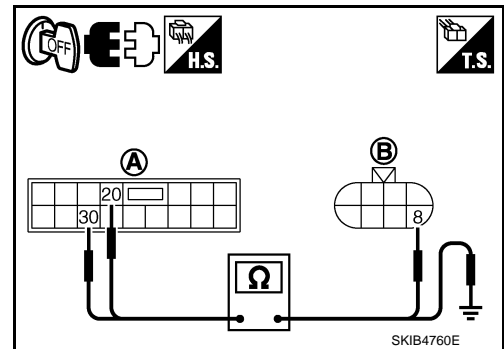

Headlamp Low Beam Does Not Illuminate (One Side)

INFOID:000000002956677

1. CHECK BULB

Check bulb of lamp which does not illuminate.

OK or NG

- OK >> GO TO 2.
- NG >> Replace headlamp bulb.

HEADLAMP (FOR USA) - CONVENTIONAL TYPE -

< SERVICE INFORMATION >

2. CHECK HEADLAMP INPUT SIGNAL

CONSULT-III ACTIVE TEST

1. Turn ignition switch OFF.
2. Disconnect front combination lamp RH or LH connector.
3. Select "LAMPS" of IPDM E/R active test item.
4. Touch "LO" screen.
5. With operating the test item, check voltage between front combination lamp RH or LH harness connector and ground.

| Terminal | | | (-) | Voltage (Approx.) |
|----------------------------------|-----|----------|-----|-------------------|
| (+) | | terminal | | |
| Front combination lamp connector | | | | Ground |
| RH | E47 | 8 | | |
| LH | E54 | 8 | | |

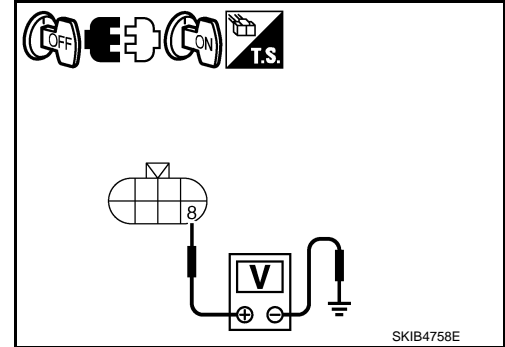

IPDM E/R AUTO ACTIVE TEST

1. Turn ignition switch OFF.
2. Disconnect front combination lamp RH or LH connector.
3. Activate auto active test. Refer to [PG-22, "Auto Active Test"](#).
4. When headlamp low beam is operating, check voltage between front combination lamp RH or LH harness connector and ground.

| Terminal | | | (-) | Voltage (Approx.) |
|----------------------------------|-----|----------|-----|-------------------|
| (+) | | terminal | | |
| Front combination lamp connector | | | | Ground |
| RH | E47 | 8 | | |
| LH | E54 | 8 | | |

OK or NG

- OK >> GO TO 3.
 NG >> GO TO 4.

3. CHECK HEADLAMP GROUND

1. Turn ignition switch OFF.
2. Check continuity between front combination lamp RH or LH harness connector and ground.

| Front combination lamp connector | | Terminal | Ground | Continuity |
|----------------------------------|-----|----------|--------|------------|
| RH | E47 | 4 | | Ground |
| LH | E54 | 4 | | |

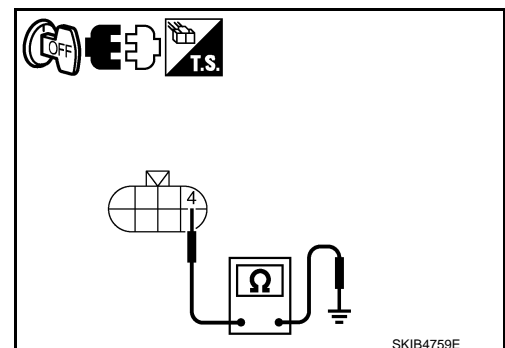

OK or NG

- OK >> Check headlamp harness and connectors.
 NG >> Repair harness or connector.

4. CHECK CIRCUIT BETWEEN IPDM E/R AND FRONT COMBINATION LAMP

1. Turn ignition switch OFF.
2. Disconnect IPDM E/R connector.

HEADLAMP (FOR USA) - CONVENTIONAL TYPE -

< SERVICE INFORMATION >

3. Check continuity between IPDM E/R harness connector (A) and front combination lamp RH or LH harness connector (B).

| Circuit | A | | B | | Continuity |
|---------|-----------|----------|-----------|----------|------------|
| | Connector | Terminal | Connector | Terminal | |
| RH | E7 | 20 | E47 | 8 | Yes |
| LH | | 30 | E54 | 8 | |

4. Check continuity between IPDM E/R harness connector (A) and ground.

| A | | | Ground | Continuity |
|-----------|----------|----|--------|------------|
| Connector | Terminal | | | |
| RH | E7 | 20 | | No |
| LH | | 30 | | |

OK or NG

- OK >> Replace IPDM E/R. Refer to [PG-27, "Removal and Installation of IPDM E/R"](#).
 NG >> Repair harness or connector.

Headlamps Do Not Turn OFF

INFOID:000000002956678

1. CHECK HEADLAMP TURN OFF

Make sure that lighting switch is OFF. And make sure headlamp turns off when ignition switch is turned OFF.

OK or NG

- OK >> GO TO 3.
 NG >> GO TO 2.

2. CHECK COMBINATION SWITCH INPUT SIGNAL

CONSULT-III DATA MONITOR

- Select "HEAD LAMP SW 1" and "HEAD LAMP SW 2" of BCM (HEAD LAMP) data monitor item.
- With operating the lighting switch, check the monitor status.

When lighting switch is OFF : HEAD LAMP SW 1 OFF
position : HEAD LAMP SW 2 OFF

OK or NG

- OK >> Replace IPDM E/R. Refer to [PG-27, "Removal and Installation of IPDM E/R"](#).
 NG >> Check combination switch (lighting switch). Refer to [LT-202, "Combination Switch Inspection"](#).

3. CHECK CAN COMMUNICATIONS BETWEEN BCM AND IPDM E/R

CONSULT-III SELF-DIAGNOSIS

Perform self-diagnosis for "BCM" on CONSULT-III.

Display of self-diagnosis results

- NO DTC>> Replace IPDM E/R. Refer to [PG-27, "Removal and Installation of IPDM E/R"](#).
 CAN COMM CIRCUIT>> Refer to [LAN-17, "CAN Diagnosis with CONSULT-III"](#).

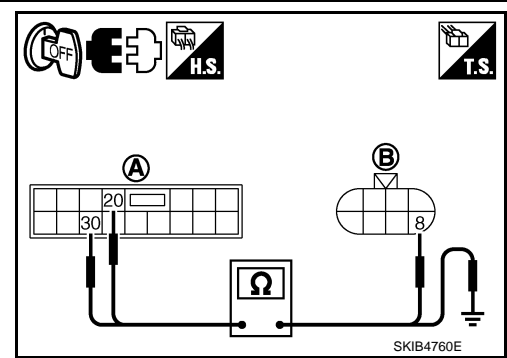

HEADLAMP (FOR USA) - CONVENTIONAL TYPE -

< SERVICE INFORMATION >

Aiming Adjustment

INFOID:00000002956679

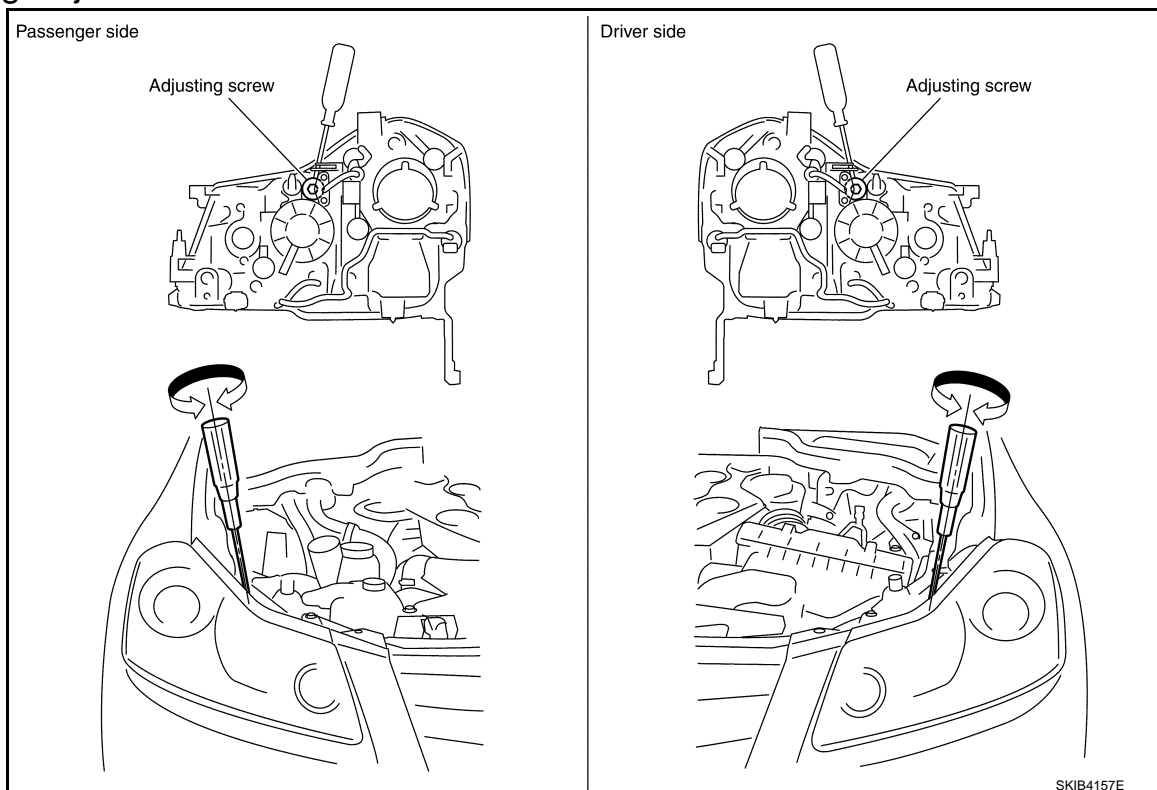

PREPARATION BEFORE ADJUSTING

For details, refer to the regulations in your own country.

Before performing aiming adjustment, check the following.

1. Keep all tires inflated to correct pressures.
2. Place vehicle on flat surface.
3. Set that there is no-load in vehicle other than the driver (or equivalent weight placed in driver's position).
Coolant, engine oil filled up to correct level and full fuel tank.

LOW BEAM AND HIGH BEAM

1. Turn headlamp low beam ON.
2. Use adjusting screws to perform aiming adjustment.

HEADLAMP (FOR USA) - CONVENTIONAL TYPE -

< SERVICE INFORMATION >

ADJUSTMENT USING AN ADJUSTMENT SCREEN (LIGHT/DARK BORDERLINE)

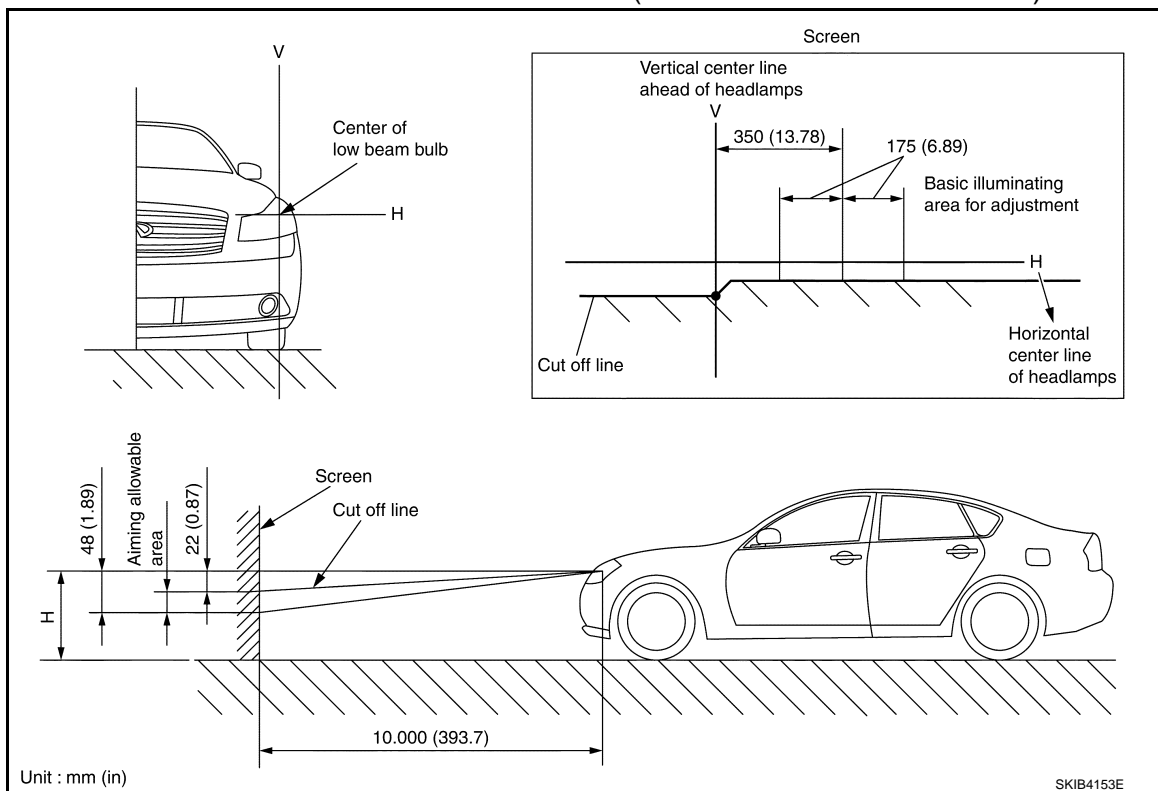

If the vehicle front body has been repaired and/or the headlamp assembly has been replaced, check aiming. Use the aiming chart shown in the figure.

- Basic illumination area for adjustment should be within the range shown on the aiming chart. Adjust headlamp accordingly.

Bulb Replacement

INFOID:000000002956680

CAUTION:

- **Disconnect the battery negative terminal or remove the fuse.**
- **Never touch the glass of bulb directly by hand. Keep grease and other oily matters away from it. Never touch bulb by hand while it is lit or right after being turned off.**
- **Never leave bulb out of lamp reflector for a long time because dust, moisture smoke, etc. may affect the performance of lamp. When replacing bulb, be sure to replace it with new one.**

HEADLAMP (INNER) HIGH BEAM

1. Remove air cleaner case when replacing bulb LH. Refer to [EM-18, "Removal and Installation"](#) (VQ35DE) or [EM-175, "Removal and Installation"](#) (VK45DE).
2. Remove washer tank inlet when replacing bulb RH. Refer to [WW-35, "Removal and Installation of Washer Tank"](#).
3. Turn plastic cap counterclockwise and unlock it.
4. Turn bulb socket counterclockwise and unlock it.
5. Disconnect connector, and remove bulb.

Headlamp (inner) high beam : 12V - 60W (HB3)

HEADLAMP (OUTER) LOW BEAM

1. Remove fender protector (front). Refer to [EI-31, "FENDER PROTECTOR : Component Parts Location"](#).
2. Turn plastic cap counterclockwise and unlock it.
3. Unlock retaining spring and remove bulb from headlamp.
4. Remove the socket connected the bulb.

HEADLAMP (FOR USA) - CONVENTIONAL TYPE -

< SERVICE INFORMATION >

Headlamp (outer) low beam : 12V - 55W (H1)

PARKING LAMP

1. Turn bulb socket counterclockwise and unlock it.
2. Remove bulb from its socket.

Parking lamp : 12V - 5W

FRONT TURN SIGNAL LAMP

1. Remove washer tank inlet when replaced bulb RH. Refer to [WW-35, "Removal and Installation of Washer Tank"](#).
Remove air cleaner case when replacing bulb LH. Refer to [EM-18, "Removal and Installation"](#) (VQ35DE) or [EM-175, "Removal and Installation"](#) (VK45DE).
2. Turn bulb socket counterclockwise and unlock it.
3. Remove bulb from its socket.

Front turn signal lamp : 12V - 21W (amber)

FRONT SIDE MARKER LAMP

1. Remove fender protector (front) to obtain work space between the fender protector and fender.
2. Turn bulb socket counterclockwise and unlock it.
3. Remove bulb from its socket.

Front side marker lamp : 12V - 5W

CAUTION:

After installing bulb, be sure to install plastic cap and socket securely to insure watertightness.

Removal and Installation

INFOID:000000002956681

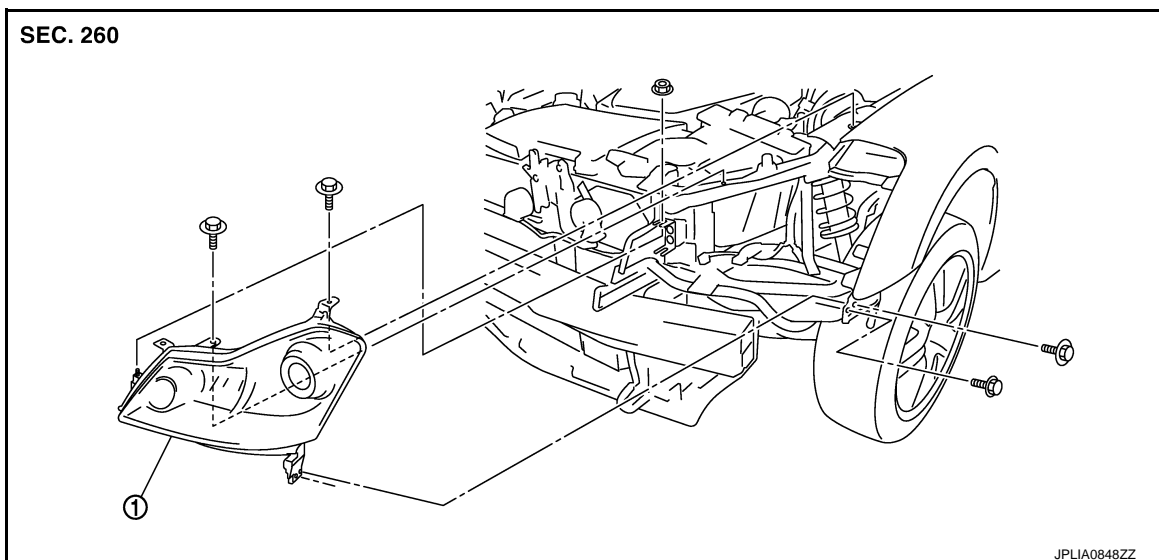

1. Headlamp assembly

REMOVAL

CAUTION:

Disconnect the battery negative terminal or remove the fuse.

1. Remove front bumper. Refer to [EI-12, "STANDARD TYPE : Component Parts Location"](#).
2. Remove front bumper retainer (upper). Refer to [EI-12, "STANDARD TYPE : Component Parts Location"](#).

HEADLAMP (FOR USA) - CONVENTIONAL TYPE -

< SERVICE INFORMATION >

3. Remove front bumper clips. Refer to [EI-12. "STANDARD TYPE : Component Parts Location"](#).
4. Remove headlamp mounting bolts and nuts.
5. Remove plastic bumper bracket, then pull headlamp toward vehicle front, disconnect connector, and remove headlamp.

INSTALLATION

Note the following, and installation is the reverse order of removal.

NOTE:

After installation, perform aiming adjustment. Refer to [LT-30. "Aiming Adjustment"](#).

Disassembly and Assembly

INFOID:000000002956682

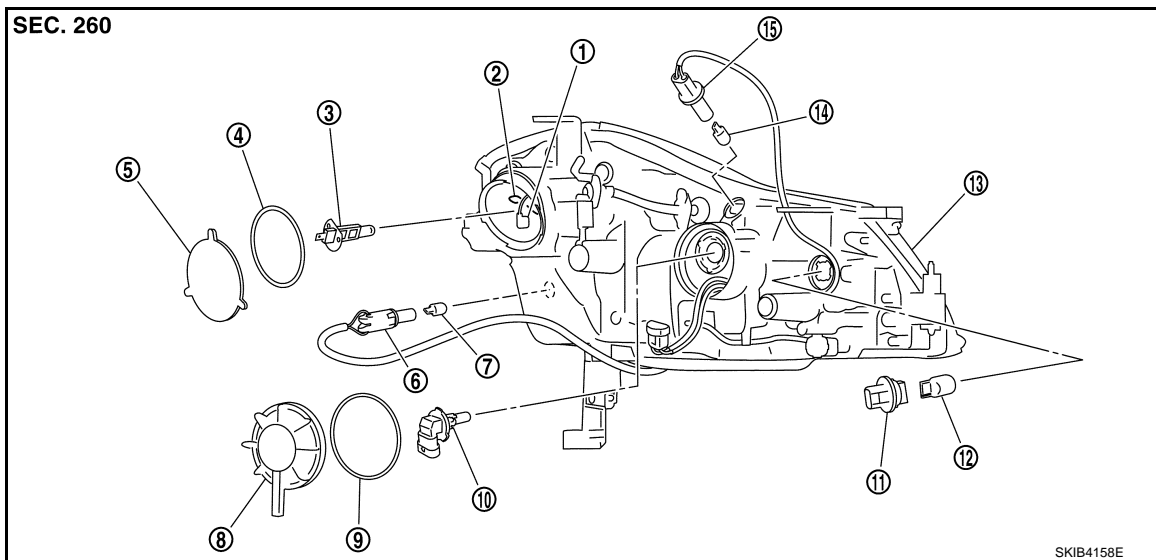

- | | | |
|-------------------------------|--|---------------------------------|
| 1. Bulb socket (low) | 2. Retaining spring | 3. Bulb (low) |
| 4. Seal packing | 5. Plastic cap | 6. Side marker lamp bulb socket |
| 7. Side marker lamp bulb | 8. Plastic cap | 9. Seal packing |
| 10. Bulb (high) | 11. Front turn signal lamp bulb socket | 12. Front turn signal lamp bulb |
| 13. Headlamp housing assembly | 14. Parking lamp bulb | 15. Parking lamp bulb socket |

DISASSEMBLY

1. Turn plastic cap counterclockwise and unlock it.
2. Unlock retaining spring and remove halogen bulb (low).
3. Disconnect the socket connected to the bulb (low).
4. Turn bulb (high) counterclockwise and unlock it.
5. Remove bulb (high) and disconnect connector it.
6. Turn front turn signal lamp bulb socket counterclockwise and unlock it.
7. Remove front turn signal lamp bulb from its socket.
8. Turn parking lamp bulb socket counterclockwise and unlock it.
9. Remove parking lamp bulb from its socket.
10. Turn front side marker lamp bulb socket counterclockwise and unlock it.
11. Remove front side marker lamp bulb from its socket.

ASSEMBLY

Note the following, and installation is the reverse order of removal.

CAUTION:

After installing bulb, be sure to install plastic cap and bulb socket securely to insure watertightness.

HEADLAMP (FOR USA) - XENON TYPE -

< SERVICE INFORMATION >

HEADLAMP (FOR USA) - XENON TYPE -

Component Parts and Harness Connector Location

INFOID:00000002956683

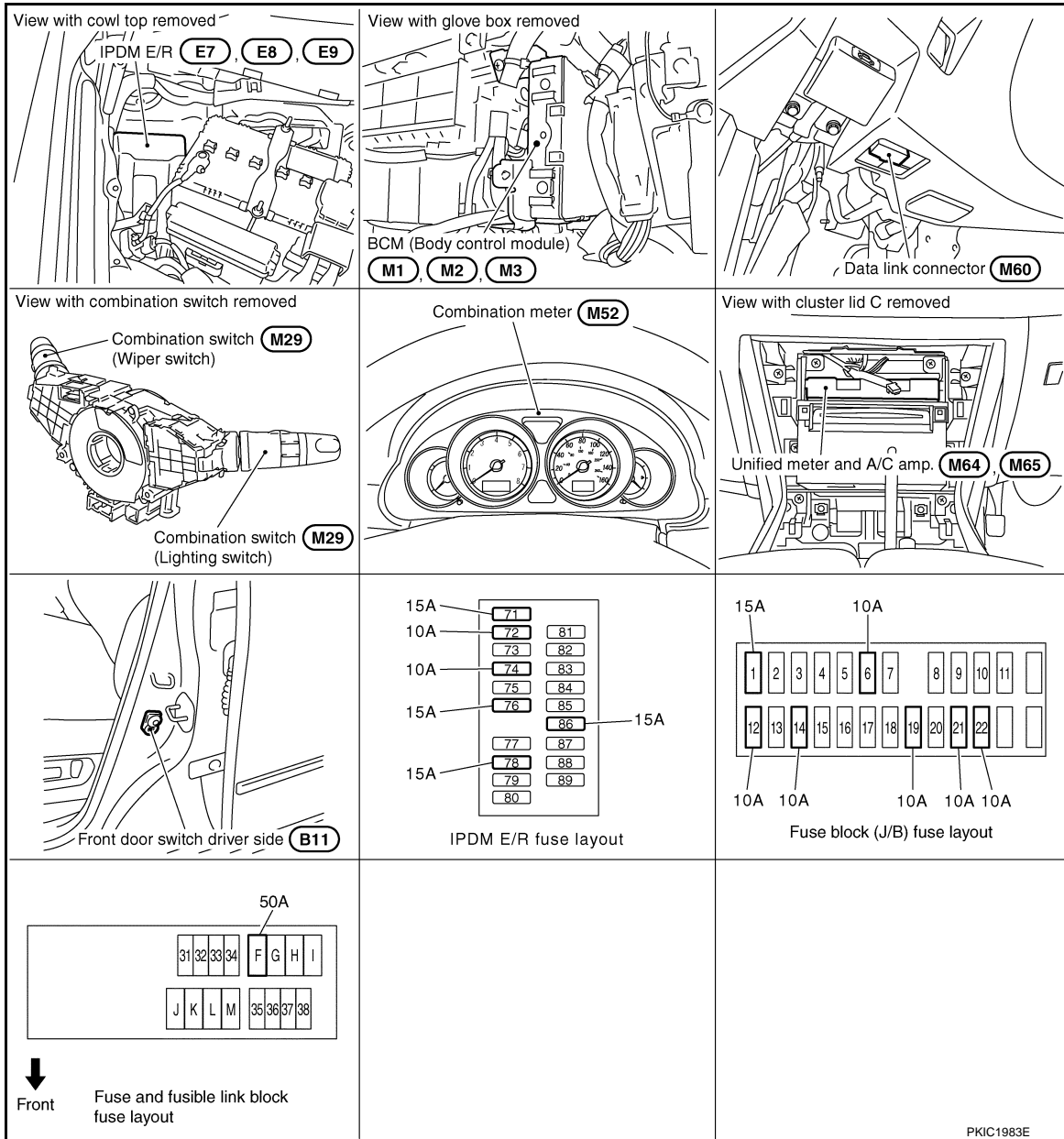

System Description

INFOID:00000002956684

The control of the headlamp system operation is dependent upon the position of the combination switch (lighting switch). When the lighting switch is placed in the 2ND position, the BCM (body control module) receives input signal requesting the headlamps (and tail lamps) illuminate. This input signal is communicated to the IPDM E/R (intelligent power distribution module engine room) across the CAN communication lines. The CPU (central processing unit) located in the IPDM E/R controls the headlamp high and headlamp low relay coils. These relays, when energized, direct power to the respective headlamps, which then illuminate.

OUTLINE

Power is supplied at all times

- to headlamp high relay, located in IPDM E/R and
- to headlamp low relay, located in IPDM E/R, from battery direct,
- through 15A fuse (No. 71, located in IPDM E/R)
- to CPU, located in IPDM E/R,
- through 15A fuse (No. 78, located in IPDM E/R)

HEADLAMP (FOR USA) - XENON TYPE -

< SERVICE INFORMATION >

- to CPU, located in IPDM E/R,
- through 50A fusible link (letter F, located in fuse and fusible link block)
- to BCM terminal 55,
- through 10A fuse [No. 21, located in fuse block (J/B)]
- to BCM terminal 42 and

- to combination meter terminal 23,
- through 10A fuse [No. 19, located in fuse block (J/B)]
- to unified meter and A/C amp. terminal 54,
- through 10A fuse [No. 22, located in fuse block (J/B)]
- to key slot terminal 1.

When the ignition switch is in the ON or START position, power is supplied

- to CPU, located in IPDM E/R,
- through 15A fuse [No. 1, located in fuse block (J/B)]
- to BCM terminal 38,
- through 10A fuse [No. 14, located in fuse block (J/B)]
- to combination meter terminal 12,
- through 10A fuse [No. 12, located in fuse block (J/B)]
- to unified meter and A/C amp. terminal 53.

When the ignition switch is in the ACC or ON position, power is supplied

- through 10A fuse [No. 6, located in fuse block (J/B)]
- to BCM terminal 11.

Ground is supplied

- to BCM terminal 52
- to combination meter terminals 9, 10, and 11
- to unified meter and A/C amp. terminals 55 and 71
- to push-button ignition switch (push switch) terminal 1
- to key slot terminal 8
- through grounds M16 and M70,
- to IPDM E/R terminals 38 and 51
- through grounds E22 and E43.

HEADLAMP OPERATION

Low Beam Operation

With the lighting switch in 2ND position, the BCM receives input signal requesting the headlamps to illuminate. This input signal is communicated to the IPDM E/R across the CAN communication lines. The CPU located in the IPDM E/R controls the headlamp low relay coil, which when energized, directs power

- through 15A fuse (No. 76, located in IPDM E/R)
- through IPDM E/R terminal 20
- to front combination lamp RH terminal 8,
- through 15A fuse (No. 86, located in IPDM E/R)
- through IPDM E/R terminal 30
- to front combination lamp LH terminal 8.

Ground is supplied

- to front combination lamp RH terminal 4
- to front combination lamp LH terminal 4
- through grounds E22 and E43.

With power and ground supplied, low beam headlamps illuminate.

High Beam Operation/Flash-to-Pass Operation

With the lighting switch in 2ND position and placed in HIGH or PASS position, the BCM receives input signal requesting the headlamp high beams and low beams to illuminate. This input signal is communicated to the IPDM E/R across the CAN communication lines. The CPU located in the IPDM E/R controls the headlamp high relay coil and low relay coil, which when energized, directs power

- through 15A fuse (No. 76, located in IPDM E/R)
- through IPDM E/R terminal 20
- to front combination lamp RH terminal 8,
- through 15A fuse (No. 86, located in IPDM E/R)
- through IPDM E/R terminal 30
- to front combination lamp LH terminal 8,
- through 10A fuse (No. 72, located in IPDM E/R)
- through IPDM E/R terminal 27

A

B

C

D

E

F

G

H

I

J

LT

L

M

N

O

P

HEADLAMP (FOR USA) - XENON TYPE -

< SERVICE INFORMATION >

- to front combination lamp RH terminal 6,
- through 10A fuse (No. 74, located in IPDM E/R)
- through IPDM E/R terminal 28
- to front combination lamp LH terminal 6.

Ground is supplied

- to front combination lamp RH terminal 4
- to front combination lamp LH terminal 4
- to front combination lamp RH terminal 2
- to front combination lamp LH terminal 2
- through grounds E22 and E43.

With power and ground supplied, the high beam and low beam headlamps illuminate.

The unified meter and A/C amp. that received the high beam request signal by BCM across the CAN communication makes a high beam indicator lamp turn on in the combination meter.

COMBINATION SWITCH READING FUNCTION

Refer to [BCS-4, "System Description"](#).

EXTERIOR LAMP BATTERY SAVER CONTROL

When the combination switch (lighting switch) is in the 2ND position (ON), and the ignition switch is turned from ON or ACC to OFF, the battery saver control function is activated.

Under this condition, the headlamps remain illuminated for 5 minutes, then the headlamps are turned off.

Exterior lamp battery saver control mode can be changed by the function setting of CONSULT-III.

AUTO LIGHT OPERATION

Refer to [LT-93, "System Description"](#).

XENON HEADLAMP

Xenon type lamps are used for the low beam headlamps. Xenon bulbs do not use a filament. Instead, they produce light when a high voltage current is passed between two tungsten electrodes through a mixture of xenon (an inert gas) and certain other metal halides. In addition to strong lighting power, electronic control of the power supply gives the headlamps stable quality and tone color.

Followings are some advantages of the xenon type headlamp.

- The light produced by the headlamps is white color similar to sunlight that is easy to the eyes.
- Light output is nearly double that of halogen headlamps, affording increased area of illumination.
- Counter-reflected luminance increases and the contrast enhances on the wet road in the rain. That makes visibility go up more than the increase of the light volume.
- Power consumption is approximately 25 percent less than halogen headlamps, reducing battery load.

CAN Communication System Description

INFOID:000000002956685

CAN (Controller Area Network) is a serial communication line for real time application. It is an on-vehicle multiplex communication line with high data communication speed and excellent error detection ability. Many electronic control units are equipped onto a vehicle, and each control unit shares information and links with other control units during operation (not independent). In CAN communication, control units are connected with 2 communication lines (CAN H line, CAN L line) allowing a high rate of information transmission with less wiring. Each control unit transmits/receives data but selectively reads required data only.

CAN Communication Unit

INFOID:000000002956686

Refer to [LAN-11, "System Description"](#).

HEADLAMP (FOR USA) - XENON TYPE -

< SERVICE INFORMATION >

Schematic

INFOID:00000000295687

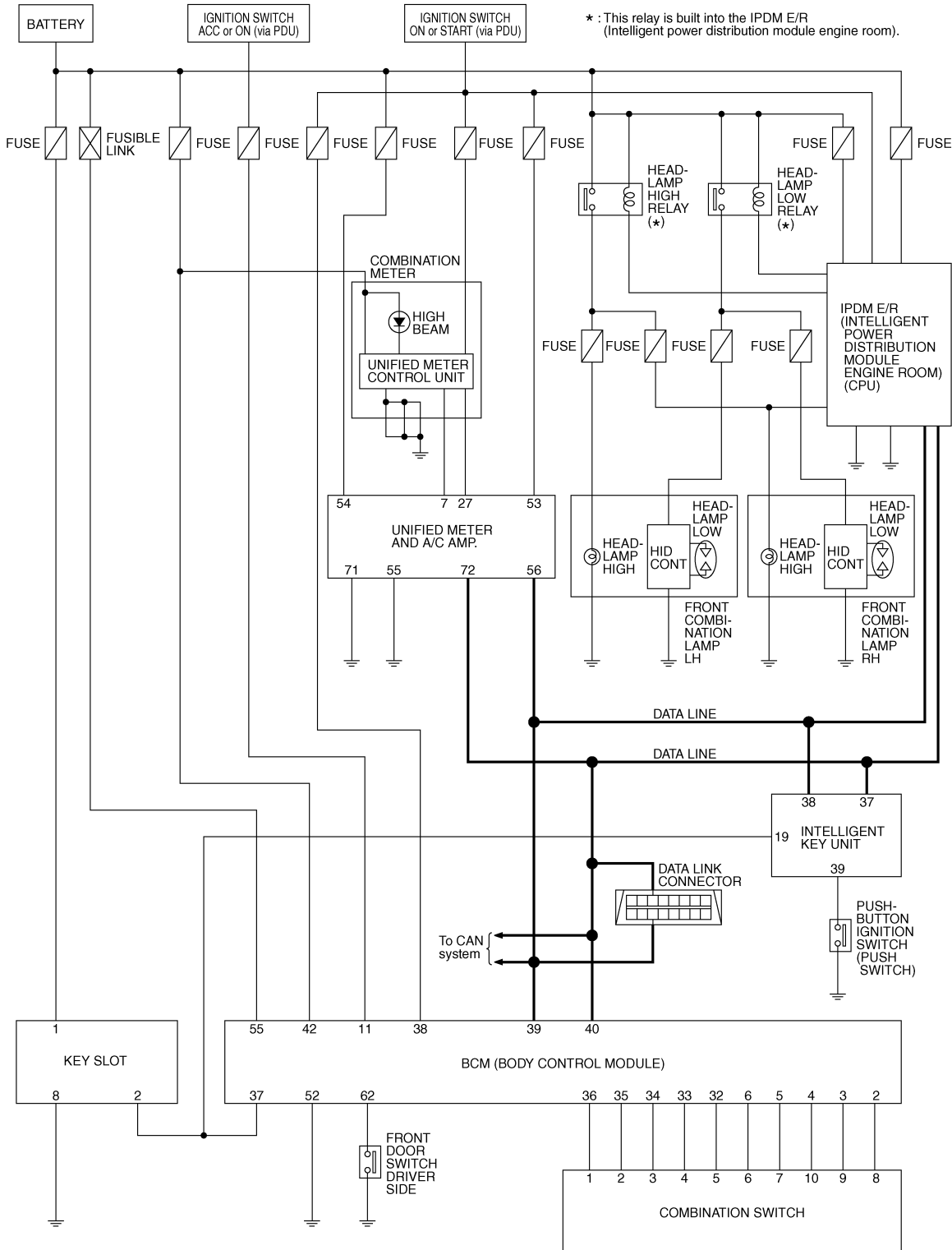

TKWT3356E

A
B
C
D
E
F
G
H
I
J
K
L
M
N
O
P

LT

HEADLAMP (FOR USA) - XENON TYPE -

< SERVICE INFORMATION >

Wiring Diagram - H/LAMP -

INFOID:00000002956688

LT-H/LAMP-07

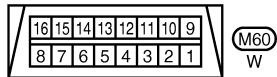
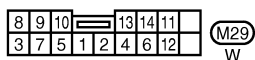
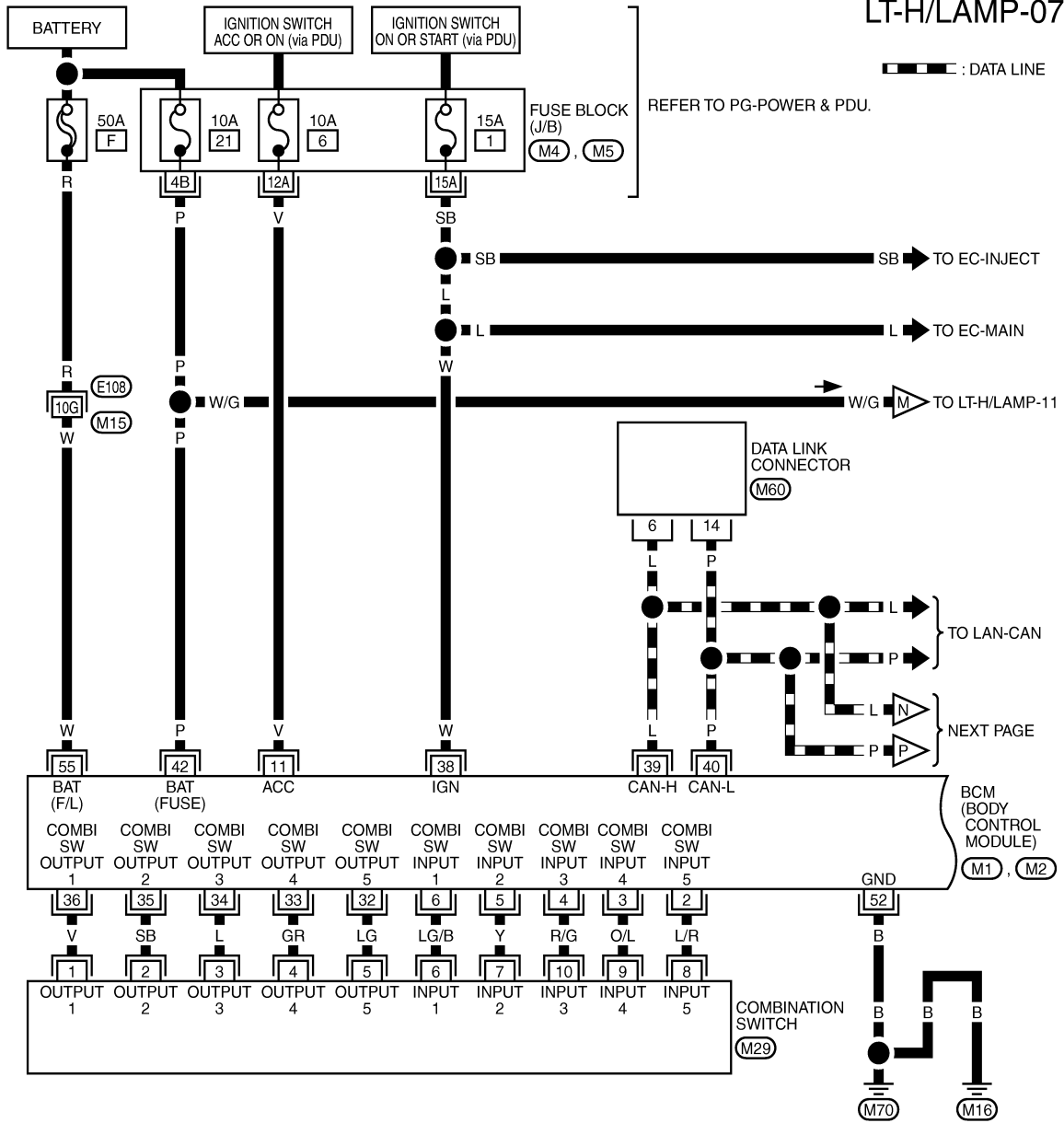

REFER TO THE FOLLOWING.

- (E108) - SUPER MULTIPLE JUNCTION (SMJ)
- (M4), (M5) - FUSE BLOCK - JUNCTION BOX (J/B)
- (M1), (M2) - ELECTRICAL UNITS

TKWT6802E

HEADLAMP (FOR USA) - XENON TYPE -

< SERVICE INFORMATION >

LT-H/LAMP-08

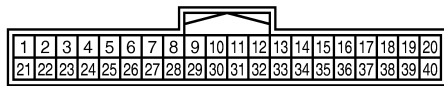
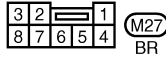
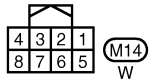
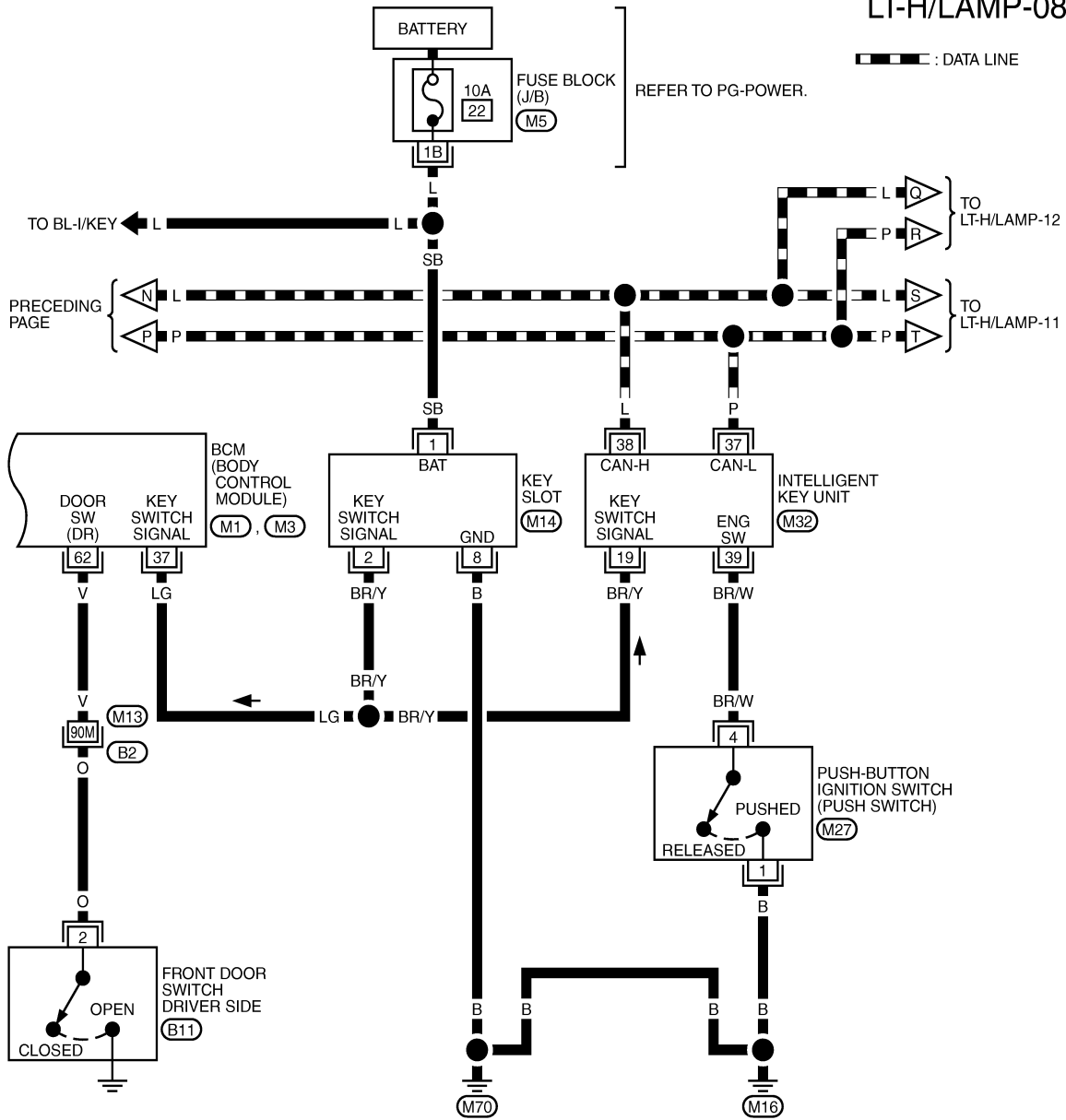

REFER TO THE FOLLOWING.

- (B2) - SUPER MULTIPLE JUNCTION (SMJ)
- (M5) - FUSE BLOCK-JUNCTION BOX (J/B)
- (M1), (M3) - ELECTRICAL UNITS

TKWT6803E

A
B
C
D
E
F
G
H
I
J
LT
L
M
N
O
P

HEADLAMP (FOR USA) - XENON TYPE -

< SERVICE INFORMATION >

LT-H/LAMP-09

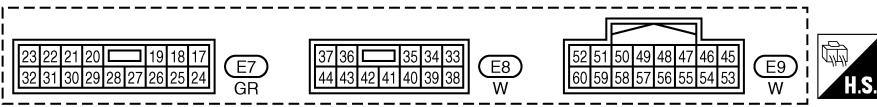
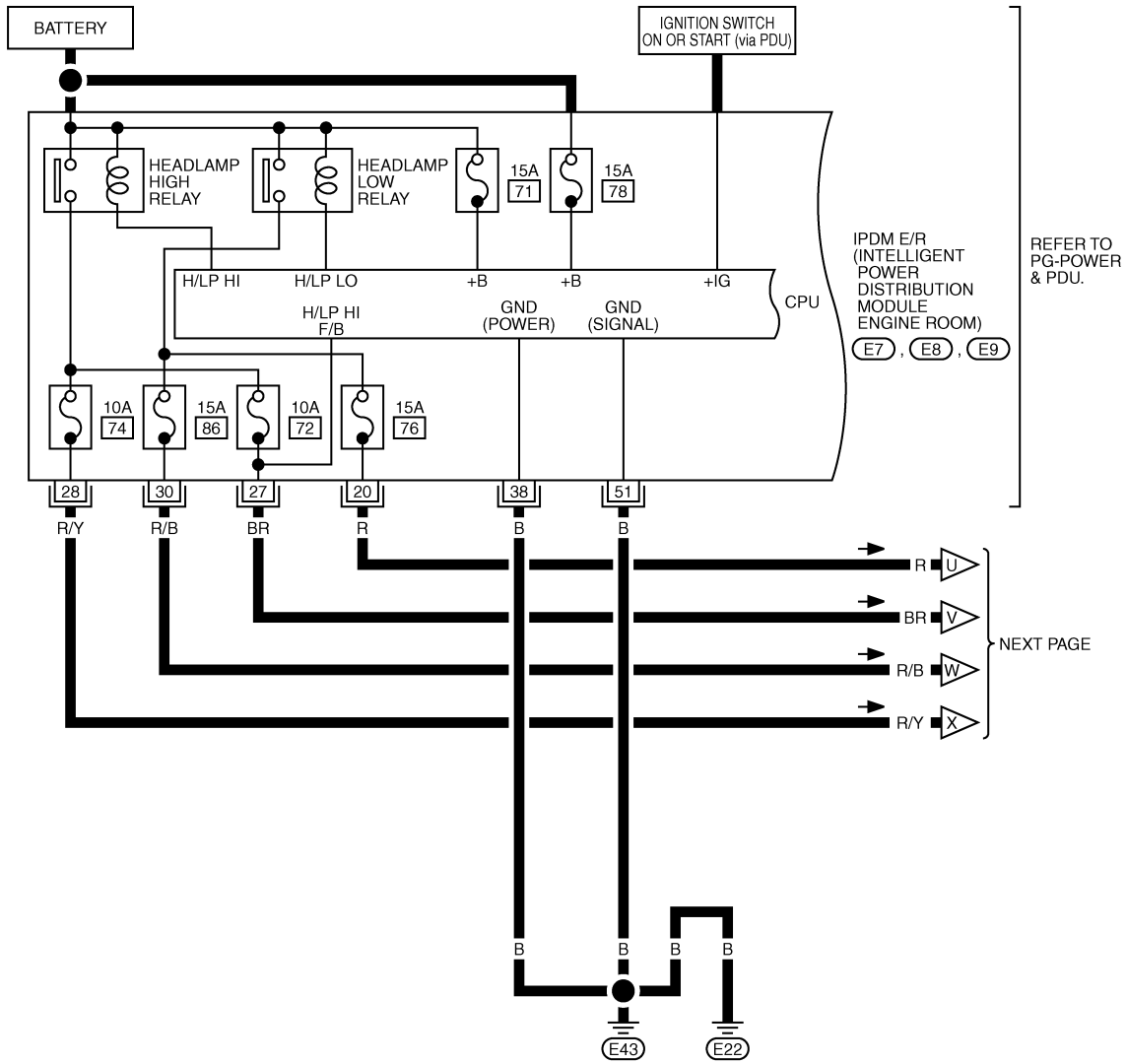

TKWT5256E

HEADLAMP (FOR USA) - XENON TYPE -

< SERVICE INFORMATION >

LT-H/LAMP-10

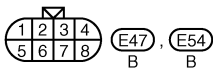
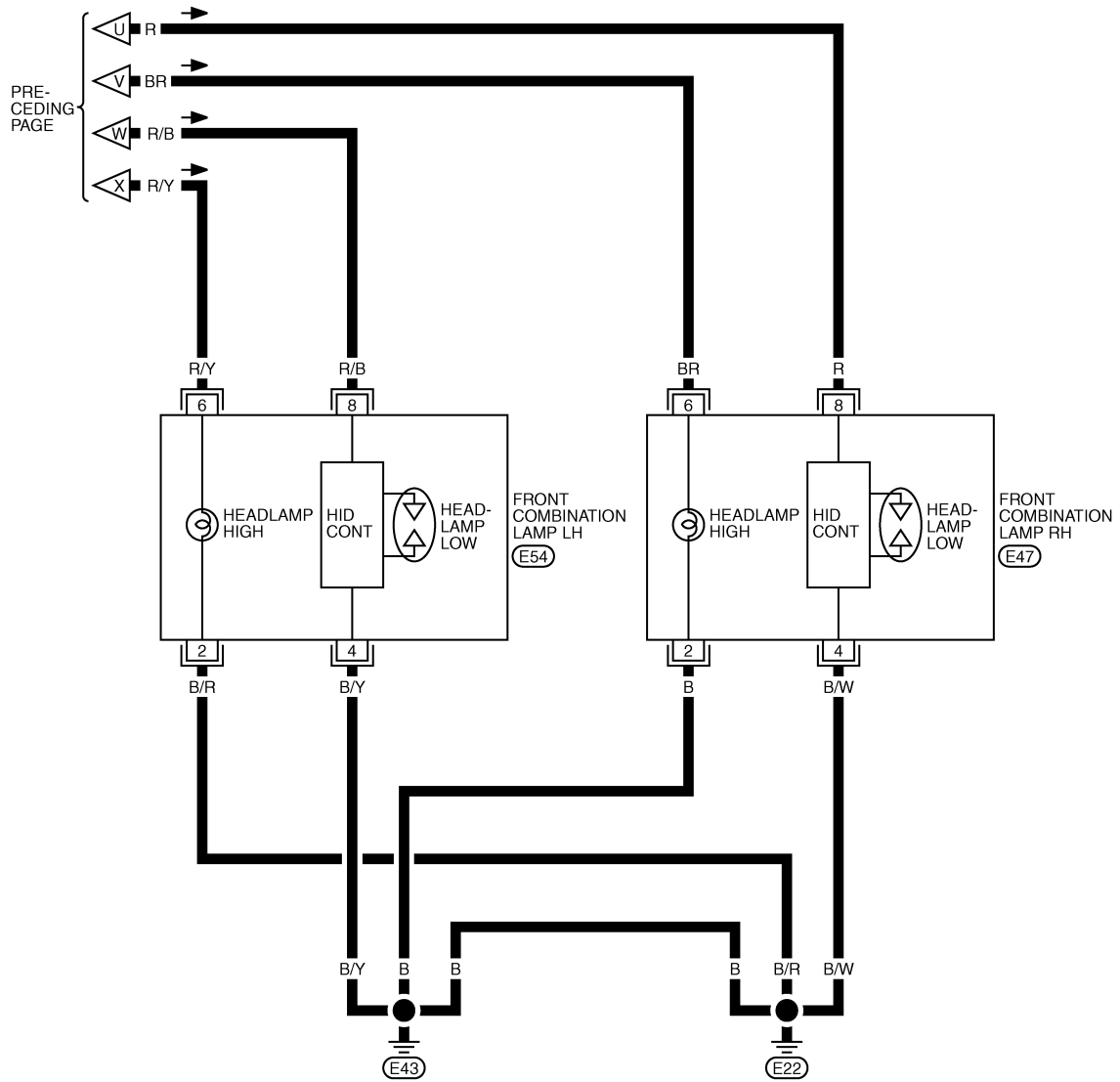

TKWT5257E

A
B
C
D
E
F
G
H
I
J
K
L
M
N
O
P

LT

HEADLAMP (FOR USA) - XENON TYPE -

< SERVICE INFORMATION >

LT-H/LAMP-11

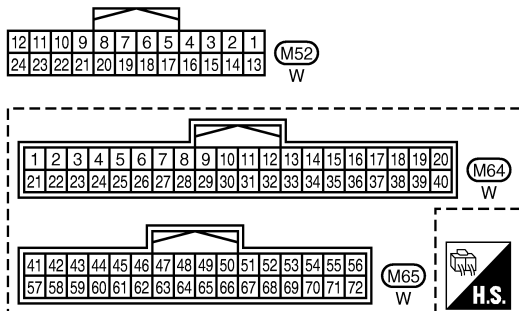
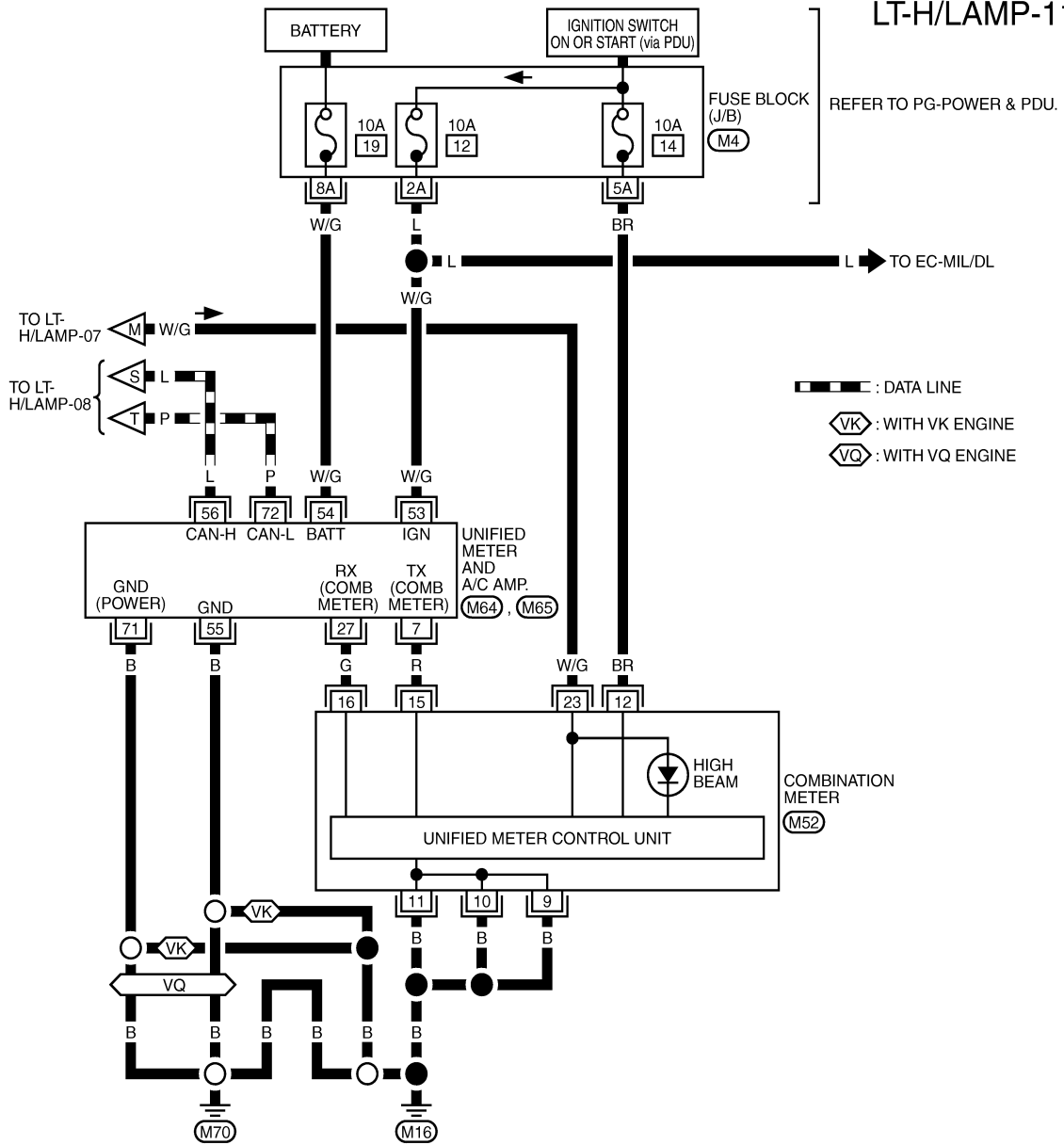

REFER TO THE FOLLOWING.
 (M4) - FUSE BLOCK - JUNCTION BOX (J/B)

TKWT6804E

HEADLAMP (FOR USA) - XENON TYPE -

< SERVICE INFORMATION >

LT-H/LAMP-12

▬ : DATA LINE

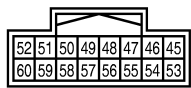
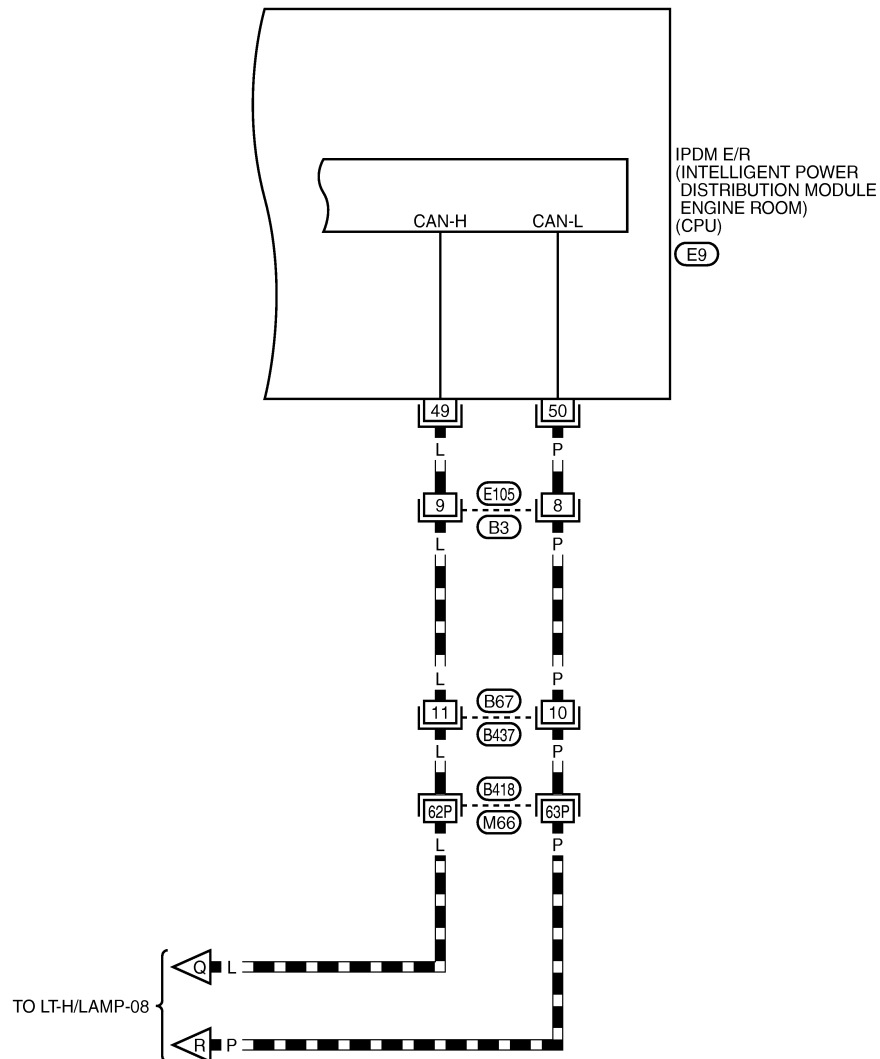

E9
W

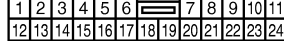

B3
W

B437
BR

REFER TO THE FOLLOWING.

B418 - SUPER MULTIPLE
JUNCTION (SMJ)

TKWT6805E

INFOID:000000002956689

Terminal and Reference Value for BCM

CAUTION:

- Check combination switch system terminal waveform under the loaded condition with lighting switch, turn signal switch and wiper switch OFF not to be fluctuated by overloaded.
- Turn wiper dial position to 4 except when checking waveform or voltage of wiper dial position. Wiper dial position can be confirmed on CONSULT-III. Refer to [LT-201, "CONSULT-III Functions \(BCM - COMB SW\)"](#).

HEADLAMP (FOR USA) - XENON TYPE -

< SERVICE INFORMATION >

| Terminal No. | Wire color | Signal name | Measuring condition | | Reference value | |
|--------------|------------|-----------------------------|---------------------|---|---|---|
| | | | Ignition switch | Operation or condition | | |
| 2 | L/R | Combination switch input 5 | ON | Lighting, turn, wiper switch (Wiper dial position 4) | Lighting switch HI beam (Operates only HI beam switch) | <p style="text-align: right;">PKIB4957J Approx. 1.0 V</p> |
| | | | | | Lighting switch 2ND | <p style="text-align: right;">PKIB4953J Approx. 2.0 V</p> |
| | | | | | OFF | Approx. 0 V |
| 3 | O/L | Combination switch input 4 | ON | Lighting, turn, wiper switch (Wiper dial position 4) | Any of several conditions below <ul style="list-style-type: none"> • Lighting switch 2ND • Lighting switch PASSING (Operates only PASSING switch) | <p style="text-align: right;">PKIB4957J Approx. 1.0 V</p> |
| | | | | | OFF | Approx. 0 V |
| 11 | V | Ignition switch (ACC) | ACC | — | Battery voltage | |
| 34 | L | Combination switch output 3 | ON | Lighting, turn, wiper switch (Wiper dial position 4) | Any of several conditions below <ul style="list-style-type: none"> • Lighting switch 2ND • Lighting switch HI beam (Operates only HI beam switch) | <p style="text-align: right;">PKIB4958J Approx. 1.2 V</p> |
| | | | | | OFF | <p style="text-align: right;">PKIB4960J Approx. 7.0 - 7.5 V</p> |

HEADLAMP (FOR USA) - XENON TYPE -

< SERVICE INFORMATION >

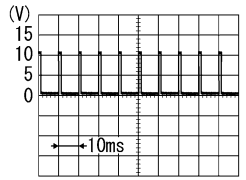
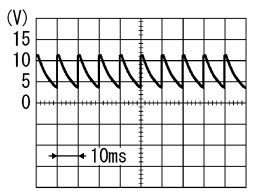
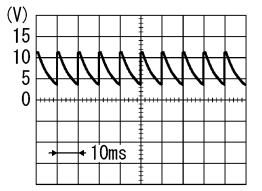
| Terminal No. | Wire color | Signal name | Measuring condition | | Reference value | |
|--------------|------------|--------------------------------------|---------------------|--|---|--|
| | | | Ignition switch | Operation or condition | | |
| 35 | SB | Combination switch output 2 | ON | Lighting, turn, wiper switch (Wiper dial position 4) | Any of several conditions below <ul style="list-style-type: none"> • Lighting switch 2ND • Lighting switch PASSING (Operates only PASSING switch) |  <p style="text-align: center;">Approx. 1.2 V</p> |
| | | | | | OFF |  <p style="text-align: center;">Approx. 7.0 - 7.5 V</p> |
| 38 | W | Ignition switch (ON) | ON | — | Battery voltage | |
| 37 | LG | Key switch signal | OFF | Intelligent Key is inserted into key slot. | Battery voltage | |
| | | | | Intelligent Key is removed from key slot. | Approx. 0 V | |
| 39 | L | CAN - H | — | — | — | |
| 40 | P | CAN - L | — | — | — | |
| 42 | P | Battery power supply | OFF | — | Battery voltage | |
| 52 | B | Ground | ON | — | Approx. 0 V | |
| 55 | W | Battery power supply | OFF | — | Battery voltage | |
| 62 | V | Front door switch driver side signal | OFF | Front door switch driver side | ON (open) | Approx. 0 V |
| | | | | | OFF (closed) |  <p style="text-align: center;">Approx. 7.5 - 8.0 V</p> |

Terminal and Reference Value for IPDM E/R

INFOID:000000002956690

| Terminal No. | Wire color | Signal name | Measuring condition | | Reference value | |
|--------------|------------|--------------------|---------------------|--|-----------------|-----------------|
| | | | Ignition switch | Operation or condition | | |
| 20 | R | Headlamp low (RH) | ON | Lighting switch 2ND position | OFF | Approx. 0 V |
| | | | | | ON | Battery voltage |
| 27 | BR | Headlamp high (RH) | ON | Lighting switch HIGH or PASSING position | OFF | Approx. 0 V |
| | | | | | ON | Battery voltage |
| 28 | R/Y | Headlamp high (LH) | ON | Lighting switch HIGH or PASSING position | OFF | Approx. 0 V |
| | | | | | ON | Battery voltage |

HEADLAMP (FOR USA) - XENON TYPE -

< SERVICE INFORMATION >

| Terminal No. | Wire color | Signal name | Measuring condition | | Reference value |
|--------------|------------|-------------------|---------------------|------------------------------|-----------------------|
| | | | Ignition switch | Operation or condition | |
| 30 | R/B | Headlamp low (LH) | ON | Lighting switch 2ND position | OFF Approx. 0 V |
| | | | | | ON Battery voltage |
| 38 | B | Ground | ON | — | Approx. 0 V |
| 49 | L | CAN – H | — | — | — |
| 50 | P | CAN – L | — | — | — |
| 51 | B | Ground | ON | — | Approx. 0 V |

How to Perform Trouble Diagnosis

INFOID:000000002956691

1. Confirm the symptom or customer complaint.
2. Understand operation description and function description. Refer to [LT-34. "System Description"](#).
3. Perform the Preliminary Check. Refer to [LT-46. "Preliminary Check"](#).
4. Check symptom and repair or replace the cause of malfunction.
5. Does the headlamp operate normally? If YES, GO TO 6. If NO, GO TO 4.
6. INSPECTION END

Preliminary Check

INFOID:000000002956692

CHECK POWER SUPPLY AND GROUND CIRCUIT

1.CHECK FUSES AND FUSIBLE LINK

Check for blown fuses and fusible link.

| Unit | Power source | Fuse and fusible link No. |
|----------|--------------------------------------|---------------------------|
| BCM | Battery | F |
| | | 21 |
| | Ignition switch ON or START position | 1 |
| | Ignition switch ACC or ON position | 6 |
| IPDM E/R | Battery | 71 |
| | | 72 |
| | | 74 |
| | | 76 |
| | | 78 |
| | | 86 |

Refer to [LT-38. "Wiring Diagram - H/LAMP -"](#).

OK or NG

OK >> GO TO 2.

NG >> If fuse or fusible link is blown, be sure to eliminate cause of malfunction before installing new fuse or fusible link. Refer to [PG-4](#).

2.CHECK POWER SUPPLY CIRCUIT

HEADLAMP (FOR USA) - XENON TYPE -

< SERVICE INFORMATION >

1. Turn ignition switch OFF.
2. Disconnect BCM connector.
3. Check voltage between BCM harness connector and ground.

| Terminal (+) | | Terminal (-) | Ignition switch position | | |
|---------------|----------|--------------|--------------------------|-----------------|-----------------|
| BCM connector | Terminal | | OFF | ACC | ON |
| M1 | 11 | Ground | Approx. 0 V | Battery voltage | Battery voltage |
| | 38 | | Approx. 0 V | Approx. 0 V | Battery voltage |
| M2 | 42 | | Battery voltage | Battery voltage | Battery voltage |
| | 55 | | Battery voltage | Battery voltage | Battery voltage |

OK or NG

- OK >> GO TO 3.
 NG >> Repair harness or connector.

3. CHECK GROUND CIRCUIT

Check continuity between BCM harness connector and ground.

| BCM connector | Terminal | Ground | Continuity |
|---------------|----------|--------|------------|
| M2 | 52 | | Yes |

OK or NG

- OK >> INSPECTION END
 NG >> Repair harness or connector.

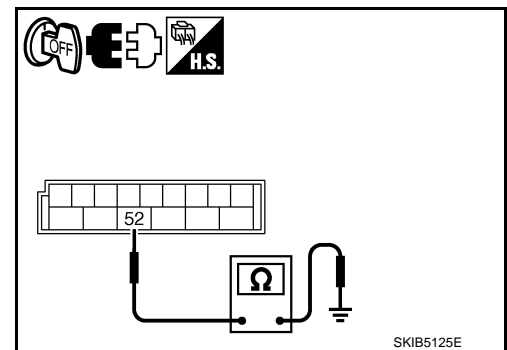
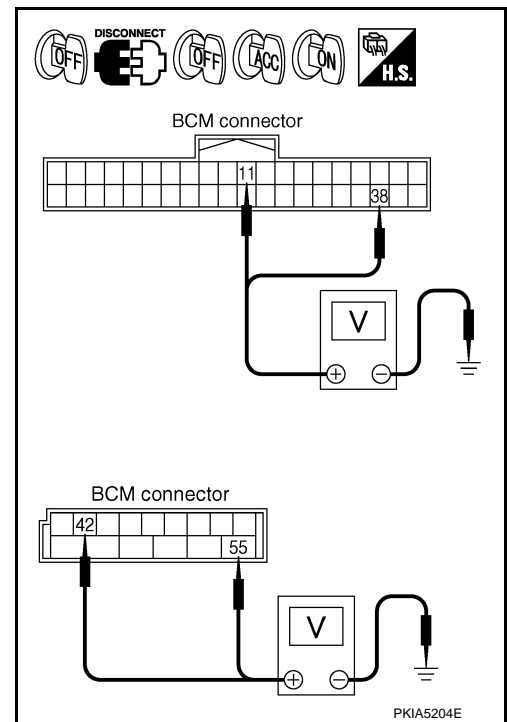

CONSULT-III Functions (BCM - HEAD LAMP)

INFOID:000000002956693

CONSULT-III can display each diagnostic item using the diagnostic test mode shown following.

| Diagnosis mode | Description |
|-----------------------|---|
| WORK SUPPORT | Changes the setting for each function. ^{NOTE} |
| DATA MONITOR | Displays BCM input data in real time. |
| ACTIVE TEST | Operation of electrical loads can be checked by sending drive signal to them. |
| SELF-DIAG RESULTS | BCM performs self-diagnosis of CAN communication. |
| CAN DIAG SUPPORT MNTR | The result of transmit/receive diagnosis of CAN communication can be read. |

NOTE:

Cannot change the setting for headlamp.

DATA MONITOR

Display Item List

| Monitor item | Contents |
|--------------------|--|
| IGN ON SW "On/Off" | Displays "IGN position (ON)/OFF, ACC position (OFF)" judged from the ignition switch signal. |
| ACC ON SW "On/Off" | Displays "ACC (ON)/OFF, Ignition OFF (OFF)" status judged from ignition switch signal. |

HEADLAMP (FOR USA) - XENON TYPE -

< SERVICE INFORMATION >

| Monitor item | Contents |
|------------------------------------|--|
| KEY ON SW "On/Off" | Displays "Intelligent Key inserted into key slot (ON)/Intelligent Key removed from key slot (OFF)" status judged from the key switch signal. |
| TURN SIGNAL R "On/Off" | Displays status (turn right: ON/others: OFF) as judged from lighting switch signal. |
| TURN SIGNAL L "On/Off" | Displays status (turn left: ON/others: OFF) as judged from lighting switch signal. |
| HI BEAM SW "On/Off" | Displays status (high beam switch: ON/others: OFF) of high beam switch judged from lighting switch signal. |
| HEAD LAMP SW 1 "On/Off" | Displays status (headlamp switch 1: ON/others: OFF) of headlamp switch 1 judged from lighting switch signal. |
| HEAD LAMP SW 2 "On/Off" | Displays status (headlamp switch 2: ON/others: OFF) of headlamp switch 2 judged from lighting switch signal. |
| TAIL LAMP SW "On/Off" | Displays status (lighting switch 1ST or 2ND position: ON/others: OFF) of lighting switch judged from lighting switch signal. |
| AUTO LIGHT SW "On/Off" | Displays status of the lighting switch as judged from the lighting switch signal. (AUTO position: ON/other than AUTO position: OFF) |
| PASSING SW "On/Off" | Displays status (flash-to-passing switch: ON/others: OFF) of flash-to-passing switch judged from lighting switch signal. |
| FR FOG SW "On/Off" | Displays status (front fog lamp switch: ON/others: OFF) of front fog lamp switch judged from lighting switch signal. |
| DOOR SW - DR "On/Off" | Displays status of the driver door as judged from the driver door switch signal. (door is open: ON/door is closed: OFF) |
| DOOR SW - AS "On/Off" | Displays status of the passenger door as judged from the passenger door switch signal. (door is open: ON/door is closed: OFF) |
| DOOR SW - RR "On/Off" | Displays status of the rear door as judged from the rear door switch (RH) signal. (door is open: ON/door is closed: OFF) |
| DOOR SW - RL "On/Off" | Displays status of the rear door as judged from the rear door switch (LH) signal. (door is open: ON/door is closed: OFF) |
| BACK DOOR SW ^{NOTE} "Off" | — |
| I - KEY LOCK "On/Off" | Displays "locked (ON)/other (OFF)" status, determined from lock signal. |
| OPTICAL SENSOR "0 - 5V" | Displays "outside brightness (close to 5 V when light/close to 0 V when dark)" judged from optical sensor signal. |
| VEHICLE SPEED "km/h" | Displays vehicle speed as judged from vehicle speed signal. |

NOTE:

This item is displayed, but cannot be monitored.

ACTIVE TEST

Display Item List

| Test item | Description |
|---------------------------------------|---|
| TAIL LAMP | Allows tail lamp relay to operate by switching ON-OFF. |
| FR FOG LAMP | Allows front fog lamp relay to operate by switching ON-OFF. |
| DAYTIME RUNNING LIGHT ^{NOTE} | — |
| HEAD LAMP (HI, LO) | Allows headlamp relay to operate by switching ON-OFF. |

NOTE:

This item is displayed, but cannot be tested.

CONSULT-III Functions (IPDM E/R)

INFOID:000000002956694

CONSULT-III can display each diagnostic item using the diagnostic test mode shown following.

HEADLAMP (FOR USA) - XENON TYPE -

< SERVICE INFORMATION >

| Diagnosis Mode | Description |
|-------------------------|--|
| SELF-DIAGNOSTIC RESULTS | Refer to PG-20. "CONSULT-III Function (IPDM E/R)" . |
| DATA MONITOR | The input/output data of IPDM E/R is displayed in real time. |
| CAN DIAG SUPPORT MNTR | The result of transmit/receive diagnosis of CAN communication can be read. |
| ACTIVE TEST | IPDM E/R sends a drive signal to electronic components to check their operation. |

DATA MONITOR

All Signals, Main Signals, Selection From Menu

| Item name | CONSULT-III screen display | Display or unit | Monitor item selection | | | Description |
|----------------------------|----------------------------|-----------------|------------------------|--------------|---------------------|------------------------------|
| | | | ALL SIGNALS | MAIN SIGNALS | SELECTION FROM MENU | |
| Position lights request | TAIL&CLR REQ | On/Off | × | × | × | Signal status input from BCM |
| Headlamp low beam request | HL LO REQ | On/Off | × | × | × | Signal status input from BCM |
| Headlamp high beam request | HL HI REQ | On/Off | × | × | × | Signal status input from BCM |
| Front fog lights request | FR FOG REQ | On/Off | × | × | × | Signal status input from BCM |

NOTE:

Perform monitoring of IPDM E/R data with the ignition switch ON. When the ignition switch is at ACC, the display may not be correct.

ACTIVE TEST

| Test item | CONSULT-III screen display | Description |
|--------------------------------|----------------------------|---|
| Tail lamp relay output | TAIL LAMP | Allows tail lamp relay to operate by switching operation ON-OFF at your option. |
| Headlamp relay (HI, LO) output | LAMPS | Allows headlamp relay (HI, LO) to operate by switching operation (OFF, HI ON, LO ON) at your option (Headlamp high beam repeats ON-OFF every 1 second). |
| Front fog lamp relay output | | Allows fog lamp relay to operate by switching operation ON-OFF at your option. |

Headlamp High Beam Does Not Illuminate (Both Sides)

INFOID:000000002956695

1. CHECK COMBINATION SWITCH INPUT SIGNAL

ⓂCONSULT-III DATA MONITOR

1. Select "HI BEAM SW" of BCM (HEAD LAMP) data monitor item.
2. With operating the lighting switch, check the monitor status.

When lighting switch is HIGH position : HI BEAM SW ON

ⓧCHECK THE COMBINATION SWITCH

Refer to [LT-202. "Combination Switch Inspection"](#).

OK or NG

OK >> GO TO 2.

NG >> Check combination switch (lighting switch). Refer to [LT-202. "Combination Switch Inspection"](#).

2. HEADLAMP ACTIVE TEST

ⓂCONSULT-III ACTIVE TEST

1. Select "LAMPS" of IPDM E/R active test item.
2. With operating the test item, check the headlamp high beam operation.

HI : Headlamp high beam ON
Off : Headlamp high beam OFF

NOTE:

Headlamp high beam repeats ON-OFF every 1 second.

HEADLAMP (FOR USA) - XENON TYPE -

< SERVICE INFORMATION >

⊗ IPDM E/R AUTO ACTIVE TEST

1. Activate auto active test. Refer to [PG-22. "Auto Active Test"](#).
2. Make sure headlamp high beam operation.

Headlamp high beam should operate.

OK or NG

- OK >> GO TO 3.
NG >> GO TO 4.

3. CHECK IPDM E/R

Ⓟ CONSULT-III DATA MONITOR

1. Select "HL LO REQ" and "HL HI REQ" of IPDM E/R data monitor item.
2. With operating the lighting switch is in HI position, check the monitor status.

**When lighting switch is HIGH position : HL LO REQ ON
: HL HI REQ ON**

OK or NG

- OK >> Replace IPDM E/R. Refer to [PG-27. "Removal and Installation of IPDM E/R"](#).
NG >> Replace BCM. Refer to [BCS-14. "Removal and Installation of BCM"](#).

4. CHECK HEADLAMP INPUT SIGNAL

Ⓟ CONSULT-III ACTIVE TEST

1. Turn ignition switch OFF.
2. Disconnect front combination lamp RH and LH connector.
3. Select "LAMPS" of IPDM E/R active test item.
4. Touch "HI" screen.
5. With operating the test item, check voltage between front combination lamp (RH and LH) harness connector and ground. (Headlamp high beam repeats ON-OFF every 1 second.)

| Terminal | | | (-) | Voltage (Approx.) |
|----------------------------------|-----|----------|--------|-------------------|
| (+) | | Terminal | | |
| Front combination lamp connector | | | | |
| RH | E47 | 6 | Ground | Battery voltage |
| LH | E54 | 6 | | |

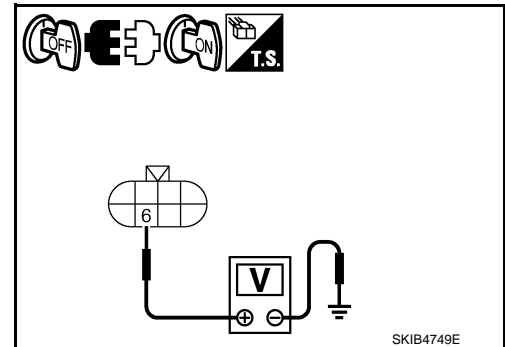

⊗ IPDM E/R AUTO ACTIVE TEST

1. Turn ignition switch OFF.
2. Disconnect front combination lamp connector.
3. Activate auto active test. Refer to [PG-22. "Auto Active Test"](#).
4. When headlamp high beam is operating, check voltage between front combination lamp (RH and LH) harness connector and ground.

| Terminal | | | (-) | Voltage (Approx.) |
|----------------------------------|-----|----------|--------|-------------------|
| (+) | | Terminal | | |
| Front combination lamp connector | | | | |
| RH | E47 | 6 | Ground | Battery voltage |
| LH | E54 | 6 | | |

OK or NG

- OK >> GO TO 5.
NG >> GO TO 7.

5. CHECK HEADLAMP GROUND

HEADLAMP (FOR USA) - XENON TYPE -

< SERVICE INFORMATION >

1. Turn ignition switch OFF.
2. Check continuity between front combination lamp (RH and LH) harness connector and ground.

| Front combination lamp connector | | Terminal | Ground | Continuity |
|----------------------------------|-----|----------|--------|------------|
| RH | E47 | 2 | | Yes |
| LH | E54 | 2 | | |

OK or NG

- OK >> GO TO 6.
 NG >> Repair harness or connector.

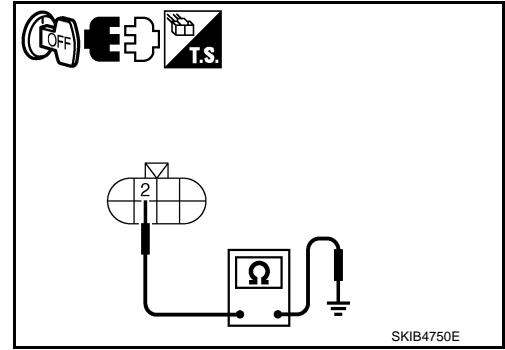

6.CHECK BULB

Check bulbs of lamp (both side).

OK or NG

- OK >> Check connecting condition headlamp harness connector.
 NG >> Replace headlamp bulb.

7.CHECK CIRCUIT BETWEEN IPDM E/R AND FRONT COMBINATION LAMP

1. Turn ignition switch OFF.
2. Disconnect IPDM E/R connector.
3. Check continuity between IPDM E/R harness connector (A) and front combination lamp (RH and LH) harness connector (B).

| Circuit | A | | B | | Continuity |
|---------|-----------|----------|-----------|----------|------------|
| | Connector | Terminal | Connector | Terminal | |
| RH | E7 | 27 | E47 | 6 | Yes |
| LH | | 28 | E54 | 6 | |

4. Check continuity between IPDM E/R harness connector (A) and ground.

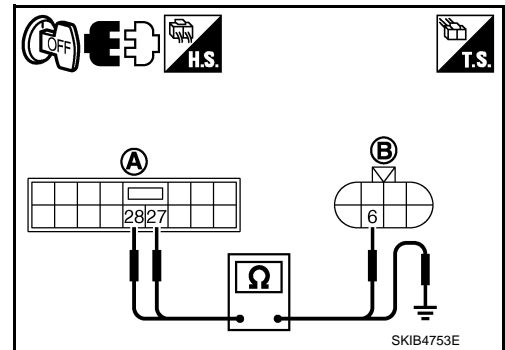

| A | | | Ground | Continuity |
|-----------|----------|----|--------|------------|
| Connector | Terminal | | | |
| RH | E7 | 27 | No | |
| LH | | 28 | | |

OK or NG

- OK >> Replace IPDM E/R. Refer to [PG-27. "Removal and Installation of IPDM E/R"](#).
 NG >> Repair harness or connector.

Headlamp High Beam Does Not Illuminate (One Side)

INFOID:000000002956696

1.CHECK BULB

Check bulb of lamp which does not illuminate.

OK or NG

- OK >> GO TO 2.
 NG >> Replace headlamp bulb.

2.CHECK HEADLAMP INPUT SIGNAL

CONSULT-III ACTIVE TEST

1. Turn ignition switch OFF.
2. Disconnect front combination lamp RH or LH connector.
3. Select "LAMPS" of IPDM E/R active test item.
4. Touch "HI" screen.

HEADLAMP (FOR USA) - XENON TYPE -

< SERVICE INFORMATION >

- With operating the test item, check voltage between front combination lamp RH or LH harness connector and ground. (Headlamp high beam repeats ON-OFF every 1 second.)

| Terminal | | | (-) | Voltage (Approx.) |
|----------------------------------|-----|----------|--------|-------------------|
| (+) | | Terminal | | |
| Front combination lamp connector | | | | |
| RH | E47 | 6 | Ground | Battery voltage |
| LH | E54 | 6 | | |

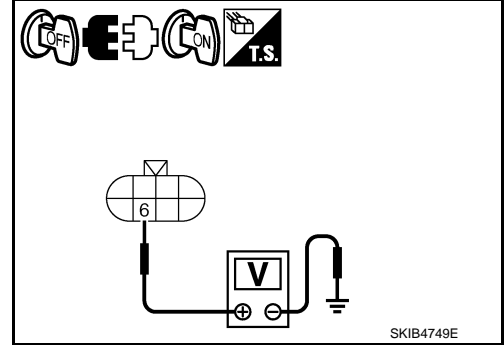

⊗ IPDM E/R AUTO ACTIVE TEST

- Turn ignition switch OFF.
- Disconnect front combination lamp RH or LH connector.
- Activate auto active test. Refer to [PG-22, "Auto Active Test"](#).
- When headlamp high beam is operating, check voltage between front combination lamp RH or LH harness connector and ground.

| Terminal | | | (-) | Voltage (Approx.) |
|----------------------------------|-----|----------|--------|-------------------|
| (+) | | Terminal | | |
| Front combination lamp connector | | | | |
| RH | E47 | 6 | Ground | Battery voltage |
| LH | E54 | 6 | | |

OK or NG

- OK >> GO TO 3.
NG >> GO TO 4.

3. CHECK HEADLAMP GROUND

- Turn ignition switch OFF.
- Check continuity between front combination lamp RH or LH harness connector and ground.

| Front combination lamp connector | Terminal | Ground | Continuity |
|----------------------------------|----------|--------|------------|
| RH | E47 | | 2 |
| LH | E54 | 2 | |

OK or NG

- OK >> Check connecting condition headlamp harness connector.
NG >> Repair harness or connector.

4. CHECK CIRCUIT BETWEEN IPDM E/R AND FRONT COMBINATION LAMP

- Turn ignition switch OFF.
- Disconnect IPDM E/R connector and front combination lamp RH or LH connector.

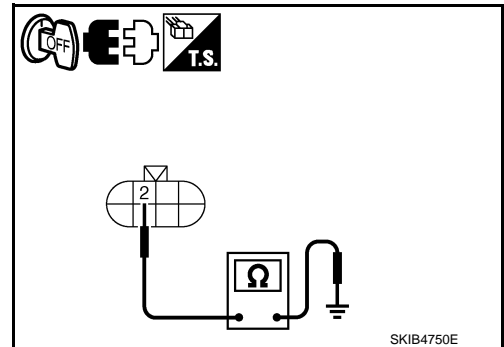

HEADLAMP (FOR USA) - XENON TYPE -

< SERVICE INFORMATION >

3. Check continuity between IPDM E/R harness connector (A) and front combination lamp RH or LH harness connector (B).

| Circuit | A | | B | | Continuity |
|---------|-----------|----------|-----------|----------|------------|
| | Connector | Terminal | Connector | Terminal | |
| RH | E7 | 27 | E47 | 6 | Yes |
| LH | | 28 | E54 | 6 | |

4. Check continuity between IPDM E/R harness connector (A) and ground.

| A | | | Ground | Continuity |
|-----------|----------|----|--------|------------|
| Connector | Terminal | | | |
| RH | E7 | 27 | Ground | No |
| LH | | 28 | | |

OK or NG

- OK >> Replace IPDM E/R. Refer to [PG-27, "Removal and Installation of IPDM E/R"](#).
 NG >> Repair harness or connector.

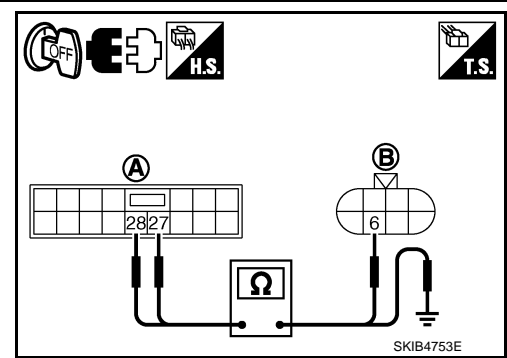

High Beam Indicator Lamp Does Not Illuminate

INFOID:000000002956697

1. CHECK UNIFIED METER AND A/C AMP.

CONSULT-III SELF-DIAGNOSIS

- Perform self-diagnosis for "METER A/C AMP" on CONSULT-III.
- Check if malfunction is indicated.

Is malfunction indicated?

- YES >> Repair or replace malfunctioning parts.
 NO >> GO TO 2.

2. CHECK COMBINATION METER INPUT SIGNAL

CONSULT-III DATA MONITOR

- Select "HI-BEAM IND" of METER A/C AMP data monitor item.
- With operating the lighting switch, check the monitor status.

When lighting switch is in the HIGH BEAM position : HI-BEAM IND ON

OK or NG

- OK >> Replace combination meter. Refer to [DI-25, "Disassembly and Assembly of Combination Meter"](#).
 NG >> Replace unified meter and A/C amp. Refer to [DI-33, "Removal and Installation of Unified Meter and A/C Amp"](#).

Headlamp Low Beam Does Not Illuminate (Both Sides)

INFOID:000000002956698

1. CHECK COMBINATION SWITCH INPUT SIGNAL

CONSULT-III DATA MONITOR

- Select "HEAD LAMP SW 1" and "HEAD LAMP SW 2" of BCM (HEAD LAMP) data monitor item.
- With operating the lighting switch, check the monitor status.

**When lighting switch is 2ND position : HEAD LAMP SW 1 ON
 : HEAD LAMP SW 2 ON**

CHECK THE COMBINATION SWITCH

Refer to [LT-202, "Combination Switch Inspection"](#).

OK or NG

- OK >> GO TO 2.

HEADLAMP (FOR USA) - XENON TYPE -

< SERVICE INFORMATION >

NG >> Check combination switch (lighting switch). Refer to [LT-202, "Combination Switch Inspection"](#).

2. HEADLAMP ACTIVE TEST

CONSULT-III ACTIVE TEST

1. Select "LAMPS" of IPDM E/R active test item.
2. With operating the test item, check the headlamp low beam operation.

LO : Headlamp low beam ON

Off : Headlamp low beam OFF

IPDM E/R AUTO ACTIVE TEST

1. Activate auto active test. Refer to [PG-22, "Auto Active Test"](#).
2. Make sure headlamp low beam operation.

Headlamp low beam should operate.

OK or NG

OK >> GO TO 3.

NG >> GO TO 4.

3. CHECK IPDM E/R

CONSULT-III DATA MONITOR

1. Select "HL LO REQ" of IPDM E/R data monitor item.
2. With operating the lighting switch is in 2ND position, check the monitor status.

When lighting switch is 2ND position : HL LO REQ ON

OK or NG

OK >> Replace IPDM E/R. Refer to [PG-27, "Removal and Installation of IPDM E/R"](#).

NG >> Replace BCM. Refer to [BCS-14, "Removal and Installation of BCM"](#).

4. CHECK HEADLAMP INPUT SIGNAL

CONSULT-III ACTIVE TEST

1. Turn ignition switch OFF.
2. Disconnect front combination lamp RH and LH connector.
3. Select "LAMPS" of IPDM E/R active test item.
4. Touch "LO" screen.
5. With operating the test item, check voltage between front combination lamp (RH and LH) harness connector and ground.

| Terminal | | | Voltage (Approx.) |
|----------------------------------|----------|-----|---------------------------|
| (+) | | (-) | |
| Front combination lamp connector | terminal | | |
| RH | E47 | 8 | Ground Battery voltage |
| LH | E54 | 8 | |

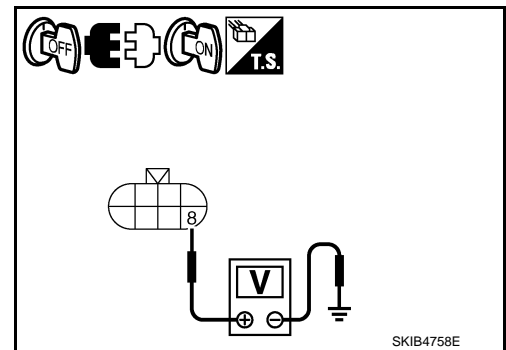

IPDM E/R AUTO ACTIVE TEST

1. Turn ignition switch OFF.
2. Disconnect front combination lamp RH and LH connector.
3. Activate auto active test. Refer to [PG-22, "Auto Active Test"](#).
4. When headlamp low beam is operating, check voltage between front combination lamp (RH and LH) harness connector and ground.

HEADLAMP (FOR USA) - XENON TYPE -

< SERVICE INFORMATION >

| Terminal | | | (-) | Voltage (Approx.) |
|----------------------------------|-----|----------|-----|-------------------|
| (+) | | terminal | | |
| Front combination lamp connector | | | | Ground |
| RH | E47 | 8 | | |
| LH | E54 | 8 | | |

OK or NG

- OK >> GO TO 5.
- NG >> GO TO 6.

5.CHECK HEADLAMP GROUND

1. Turn ignition switch OFF.
2. Check continuity between front combination lamp (RH and LH) harness connector and ground.

| Front combination lamp connector | | Terminal | Ground | Continuity |
|----------------------------------|-----|----------|--------|------------|
| RH | E47 | 4 | | Yes |
| LH | E54 | 4 | | |

OK or NG

- OK >> Check headlamp harness and connectors, ballasts (HID control unit), and xenon bulbs. Refer to [LT-58. "Xenon Headlamp Trouble Diagnosis"](#).
- NG >> Repair harness or connector.

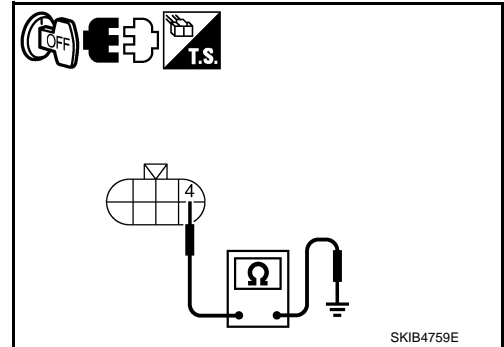

6.CHECK CIRCUIT BETWEEN IPDM E/R AND FRONT COMBINATION LAMP

1. Turn ignition switch OFF.
2. Disconnect IPDM E/R connector.
3. Check continuity between IPDM E/R harness connector (A) and front combination lamp (RH and LH) harness connector (B).

| Circuit | A | | B | | Continuity |
|---------|-----------|----------|-----------|----------|------------|
| | Connector | Terminal | Connector | Terminal | |
| RH | E7 | 20 | E47 | 8 | Yes |
| LH | | 30 | E54 | 8 | |

4. Check continuity between IPDM E/R harness connector (A) and ground.

| A | | | Ground | Continuity |
|-----------|----------|----|--------|------------|
| Connector | Terminal | | | |
| RH | E7 | 20 | No | |
| LH | | 30 | | |

OK or NG

- OK >> Replace IPDM E/R. Refer to [PG-27. "Removal and Installation of IPDM E/R"](#).
- NG >> Repair harness or connector.

Headlamp Low Beam Does Not Illuminate (One Side)

INFOID:000000002956699

1.CHECK BULB

Check ballast (HID control unit) and xenon bulb of lamp which does not illuminate. Refer to [LT-58. "Xenon Headlamp Trouble Diagnosis"](#).

HEADLAMP (FOR USA) - XENON TYPE -

< SERVICE INFORMATION >

OK or NG

- OK >> GO TO 2.
- NG >> Repair malfunctioning part.

2. CHECK HEADLAMP INPUT SIGNAL

Ⓟ CONSULT-III ACTIVE TEST

1. Turn ignition switch OFF.
2. Disconnect front combination lamp RH or LH connector.
3. Select "LAMPS" of IPDM E/R active test item.
4. Touch "LO" screen.
5. With operating the test item, check voltage between front combination lamp RH or LH harness connector and ground.

| Terminal | | | (-) | Voltage (Approx.) |
|----------------------------------|-----|----------|--------|-------------------|
| (+) | | terminal | | |
| Front combination lamp connector | | | | |
| RH | E47 | 8 | Ground | Battery voltage |
| LH | E54 | 8 | | |

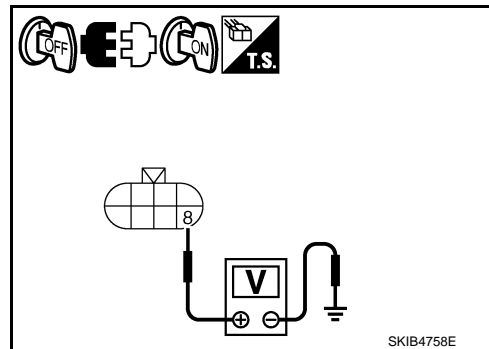

ⓧ IPDM E/R AUTO ACTIVE TEST

1. Turn ignition switch OFF.
2. Disconnect front combination lamp RH or LH connector.
3. Activate auto active test. Refer to [PG-22, "Auto Active Test"](#).
4. When headlamp low beam is operating, check voltage between front combination lamp RH or LH harness connector and ground.

| Terminal | | | (-) | Voltage (Approx.) |
|----------------------------------|-----|----------|--------|-------------------|
| (+) | | terminal | | |
| Front combination lamp connector | | | | |
| RH | E47 | 8 | Ground | Battery voltage |
| LH | E54 | 8 | | |

OK or NG

- OK >> GO TO 3.
- NG >> GO TO 4.

3. CHECK HEADLAMP GROUND

1. Turn ignition switch OFF.
2. Check continuity between front combination lamp RH or LH harness connector and ground.

| Front combination lamp connector | Terminal | Ground | Continuity |
|----------------------------------|----------|--------|------------|
| RH | E47 | | 4 |
| LH | E54 | 4 | |

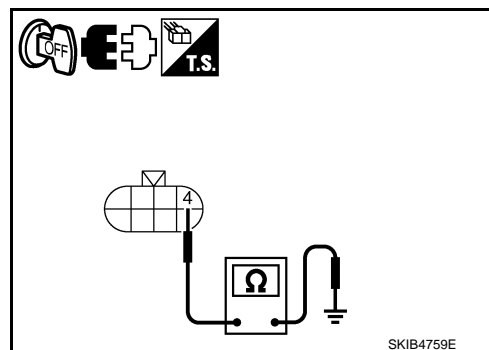

OK or NG

- OK >> Check headlamp harness and connectors.
- NG >> Repair harness or connector.

4. CHECK CIRCUIT BETWEEN IPDM E/R AND FRONT COMBINATION LAMP

1. Turn ignition switch OFF.
2. Disconnect IPDM E/R connector.

HEADLAMP (FOR USA) - XENON TYPE -

< SERVICE INFORMATION >

- Check continuity between IPDM E/R harness connector (A) and front combination lamp RH or LH harness connector (B).

| Circuit | A | | B | | Continuity |
|---------|-----------|----------|-----------|----------|------------|
| | Connector | Terminal | Connector | Terminal | |
| RH | E7 | 20 | E47 | 8 | Yes |
| LH | | 30 | E54 | 8 | |

- Check continuity between IPDM E/R harness connector (A) and ground.

| A | | | Ground | Continuity |
|-----------|----------|----|--------|------------|
| Connector | Terminal | | | |
| RH | E7 | 20 | | No |
| LH | | 30 | | |

OK or NG

- OK >> Replace IPDM E/R. Refer to [PG-27, "Removal and Installation of IPDM E/R"](#).
- NG >> Repair harness or connector.

Headlamps Do Not Turn OFF

INFOID:000000002956700

1. CHECK HEADLAMP TURN OFF

Make sure that lighting switch is OFF. And make sure headlamp turns off when ignition switch is turned OFF.

OK or NG

- OK >> GO TO 3.
- NG >> GO TO 2.

2. CHECK COMBINATION SWITCH INPUT SIGNAL

CONSULT-III DATA MONITOR

- Select "HEAD LAMP SW 2" of BCM (HEAD LAMP) data monitor item.
- With operating the lighting switch, check the monitor status.

When lighting switch is OFF position : HEAD LAMP SW 1 OFF
: HEAD LAMP SW 2 OFF

OK or NG

- OK >> Replace IPDM E/R. Refer to [PG-27, "Removal and Installation of IPDM E/R"](#).
- NG >> Check combination switch (lighting switch). Refer to [LT-202, "Combination Switch Inspection"](#).

3. CHECK CAN COMMUNICATIONS BETWEEN BCM AND IPDM E/R

CONSULT-III SELF-DIAGNOSIS

Perform self-diagnosis for "BCM".

Display of self-diagnosis results

- NO DTC >> Replace IPDM E/R. Refer to [PG-27, "Removal and Installation of IPDM E/R"](#).
- CAN COMM CIRCUIT >> Refer to [LAN-17, "CAN Diagnosis with CONSULT-III"](#).

General Information for Xenon Headlamp Trouble Diagnosis

INFOID:000000002956701

In most cases, malfunction of xenon headlamp - "does not illuminate", "flickers" or "dark" - is caused by a malfunctioning xenon bulb. A HID control unit or lamp housing, however, may be a cause of malfunction. Be sure to perform trouble diagnosis following the steps described below.

Caution:

INFOID:000000002956702

- Installation or removal of connector must be done with lighting switch OFF.
- Disconnect the battery cable from the negative terminal or remove power fuse.

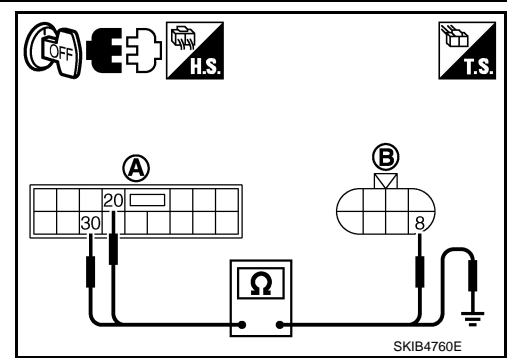

HEADLAMP (FOR USA) - XENON TYPE -

< SERVICE INFORMATION >

- When the lamp is illuminated (when lighting switch is ON), never touch harness, HID control unit, inside of lamp, or lamp metal parts.
- To check illumination, temporarily install lamp in vehicle. Be sure to connect power at vehicle side connector.
- If error can be traced directly to electrical system, first check for items such as blown fuses and fusible links, broken wires or loose connectors, dislocated terminals, and improper connections.
- Never work with wet hands.
- Using a tester for HID control unit circuit trouble diagnosis is prohibited.
- Disassembling HID control unit or harnesses (bulb socket harness, ECM harness) is prohibited.
- Immediately after illumination, light intensity and color will fluctuate, but there is nothing wrong.
- When bulb has come to end of its life, brightness will drop significantly, it will flash repeatedly, or light color will turn reddish.

Xenon Headlamp Trouble Diagnosis

INFOID:000000002956703

1.CHECK 1: XENON HEADLAMP LIGHTING

Install normal xenon bulb to corresponding xenon bulb headlamp, and check if lamp lights up.

OK or NG

- OK >> Replace xenon bulb.
- NG >> GO TO 2.

2.CHECK 2: XENON HEADLAMP LIGHTING

Install normal HID control unit to corresponding xenon headlamp, and check if lamp lights up.

OK or NG

- OK >> Replace HID control unit.
- NG >> GO TO 3.

3.CHECK 3: XENON HEADLAMP LIGHTING

Install normal xenon lamp housing assembly to corresponding xenon headlamp, and check if lamp lights up.

OK or NG

- OK >> Replace xenon headlamp housing assembly.
- NG >> INSPECTION END (Check the headlamp control system.)

Aiming Adjustment

INFOID:000000002956704

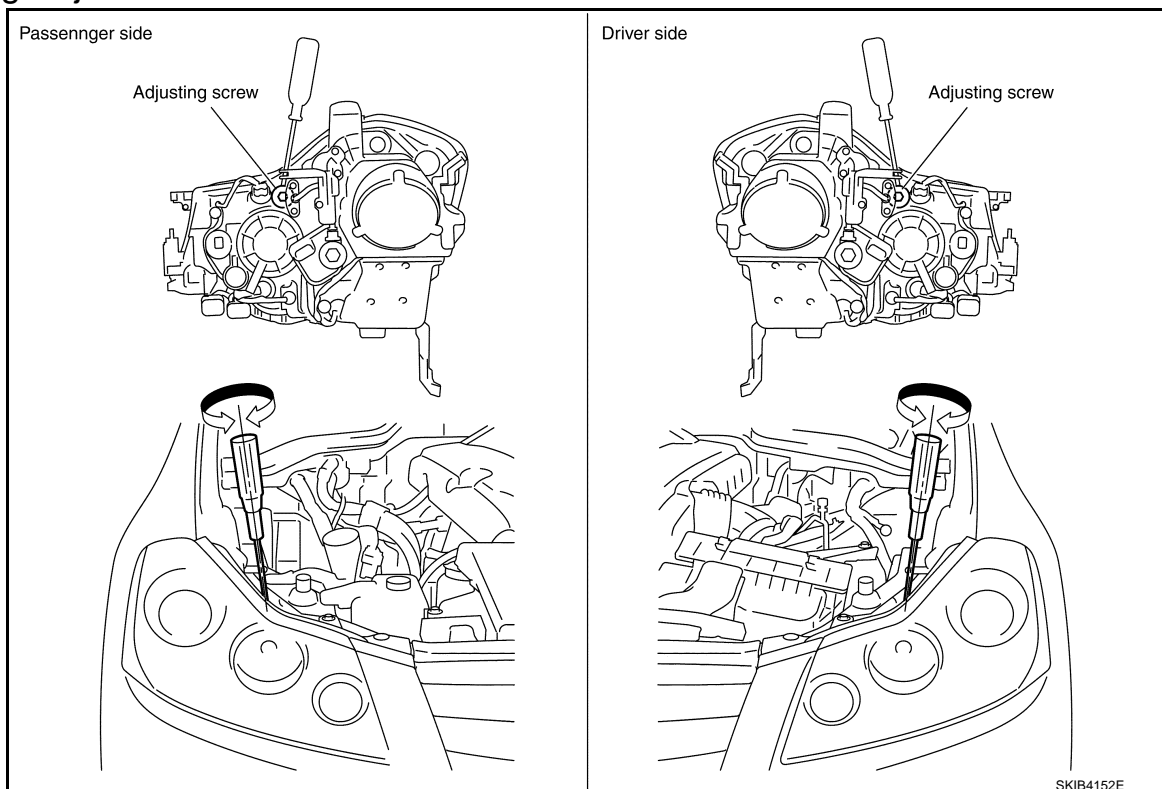

HEADLAMP (FOR USA) - XENON TYPE -

< SERVICE INFORMATION >

PREPARATION BEFORE ADJUSTING

For details, refer to the regulations in your own country.

Before performing aiming adjustment, check the following.

1. Keep all tires inflated to correct pressures.
2. Place vehicle on flat surface.
3. Set that there is no-load in vehicle other than the driver (or equivalent weight placed in driver's position). Coolant, engine oil filled up to correct level and full fuel tank.

LOW BEAM AND HIGH BEAM

1. Turn headlamp low beam ON.
2. Use adjusting screws to perform aiming adjustment.

ADJUSTMENT USING AN ADJUSTMENT SCREEN (LIGHT/DARK BORDERLINE)

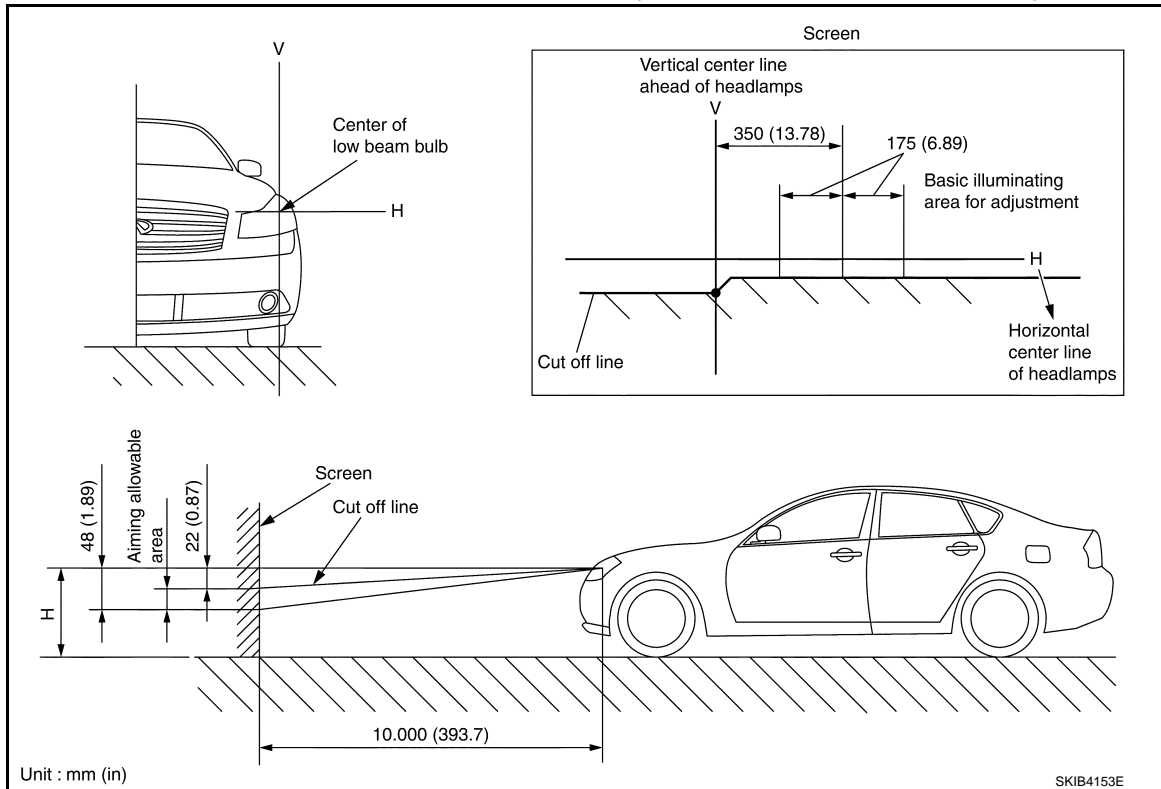

If the vehicle front body has been repaired and/or the headlamp assembly has been replaced, check aiming. Use the aiming chart shown in the figure.

- Basic illumination area for adjustment should be within the range shown on the aiming chart. Adjust headlamp accordingly.

Bulb Replacement

INFOID:000000002956705

CAUTION:

- **Disconnect the battery negative terminal or remove the fuse.**
- **Never touch the glass of bulb directly by hand. Keep grease and other oily matters away from it. Never touch bulb by hand while it is lit or right after being turned off.**
- **Never leave bulb out of lamp reflector for a long time because dust, moisture smoke, etc. may affect the performance of lamp. When replacing bulb, be sure to replace it with new one.**

HEADLAMP (INNER) HIGH BEAM

1. Remove air cleaner case when replacing bulb LH. Refer to [EM-18, "Removal and Installation"](#) (VQ35DE) or [EM-175, "Removal and Installation"](#) (VK45DE).
2. Remove washer tank inlet when replacing bulb RH. Refer to [WW-35, "Removal and Installation of Washer Tank"](#).
3. Turn plastic cap counterclockwise and unlock it.

HEADLAMP (FOR USA) - XENON TYPE -

< SERVICE INFORMATION >

4. Turn bulb socket counterclockwise and unlock it.
5. Disconnect connector, and remove bulb.

Headlamp (inner) high beam : 12V - 60W (HB3)

HEADLAMP (OUTER) LOW BEAM

1. Remove fender protector (front). Refer to [EI-31, "FENDER PROTECTOR : Component Parts Location"](#).
2. Turn plastic cap counterclockwise and unlock it.
3. Turn bulb socket (1) counterclockwise and unlock it.
4. Unlock retaining spring and remove bulb from headlamp.

Headlamp (outer) low beam : 12V - 35W (D2S)

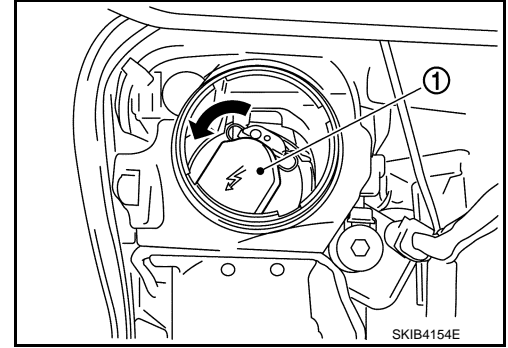

PARKING LAMP

1. Turn bulb socket counterclockwise and unlock it.
2. Remove bulb from its socket.

Parking lamp : 12V - 5W

FRONT TURN SIGNAL LAMP

1. Remove washer tank inlet when replacing bulb RH. Refer to [WW-35, "Removal and Installation of Washer Tank"](#).
2. Remove air cleaner case when replacing bulb LH. Refer to [EM-18, "Removal and Installation"](#) (VQ35DE) or [EM-175, "Removal and Installation"](#) (VK45DE).
3. Turn bulb socket counterclockwise and unlock it.
4. Remove bulb from its socket.

Front turn signal lamp : 12V - 21W (amber)

FRONT SIDE MARKER LAMP

1. Turn off the fender protector (front) to obtain work space between the fender protector and fender.
2. Turn bulb socket counterclockwise and unlock it.
3. Remove bulb from its socket.

Front side marker lamp : 12V - 5W

CAUTION:

After installing bulb, be sure to install plastic cap and bulb socket securely to insure watertightness.

HEADLAMP (FOR USA) - XENON TYPE -

< SERVICE INFORMATION >

Removal and Installation

INFOID:000000002956706

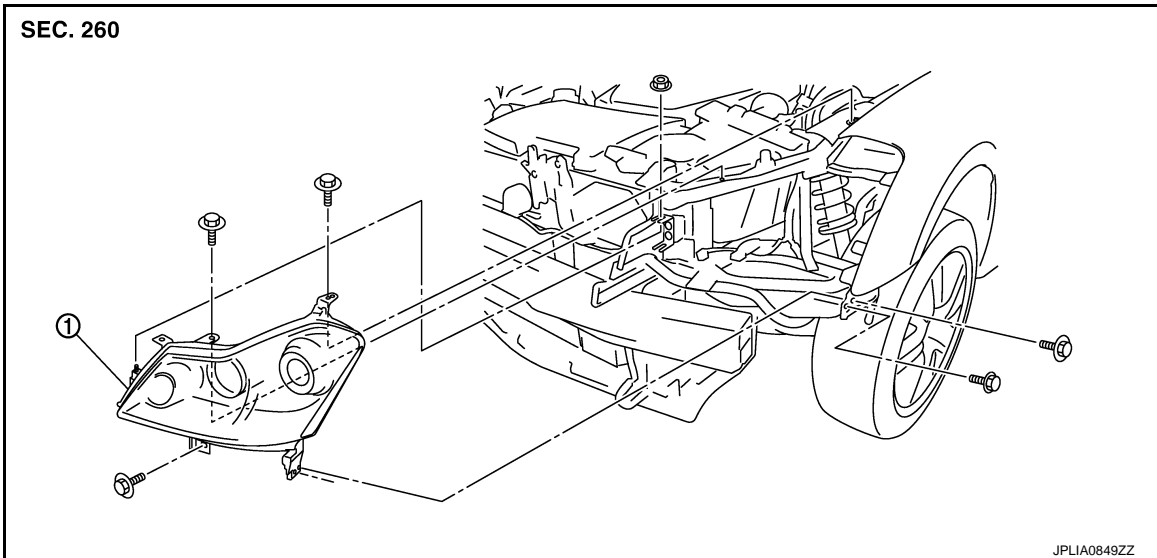

1. Headlamp assembly

REMOVAL

CAUTION:

Disconnect the battery negative terminal or remove the fuse.

1. Remove front bumper. Refer to [EI-12, "STANDARD TYPE : Component Parts Location"](#).
2. Remove front bumper retainer (upper). Refer to [EI-12, "STANDARD TYPE : Component Parts Location"](#).
3. Remove front bumper clips. Refer to [EI-12, "STANDARD TYPE : Component Parts Location"](#).
4. Remove headlamp mounting bolts and nuts.
5. Remove plastic bumper bracket, then pull headlamp toward vehicle front, disconnect connector, and remove headlamp.

INSTALLATION

Note the following, and installation is the reverse order of removal.

NOTE:

After installation, perform aiming adjustment. Refer to [LT-58, "Aiming Adjustment"](#).

Disassembly and Assembly

INFOID:000000002956707

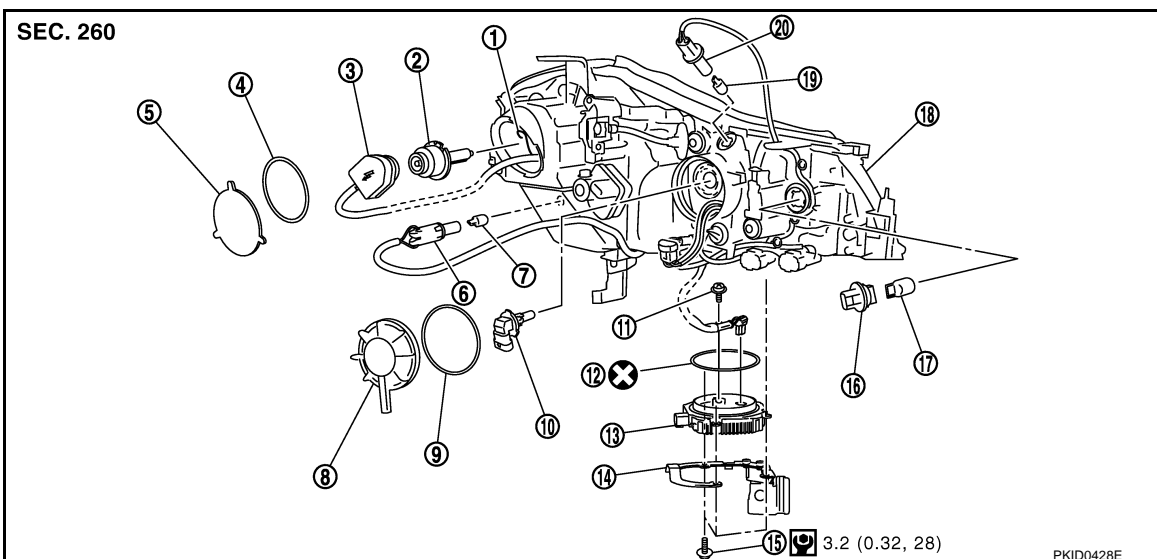

HEADLAMP (FOR USA) - XENON TYPE -

< SERVICE INFORMATION >

- | | | |
|--|---------------------------------|---------------------------------|
| 1. Retaining spring | 2. Xenon bulb (low) | 3. Xenon bulb socket (low) |
| 4. Seal packing | 5. Plastic cap | 6. Side marker lamp bulb socket |
| 7. Side marker lamp bulb | 8. Plastic cap | 9. Seal packing |
| 10. Halogen bulb (high) | 11. Screw | 12. Seal packing |
| 13. HID control unit | 14. Bracket | 15. Screw |
| 16. Front turn signal lamp bulb socket | 17. Front turn signal lamp bulb | 18. Headlamp housing assembly |
| 19. Parking lamp bulb | 20. Parking lamp bulb socket | |

Refer to [GI-9, "Component"](#) for symbols in the figure

DISASSEMBLY

1. Turn plastic cap counterclockwise and unlock it.
2. Turn xenon bulb (low) socket counterclockwise and unlock it.
3. Unlock retaining spring, and remove xenon bulb (low).
4. Remove HID control unit screws.
5. Remove bracket.
6. Remove screw and ground from HID control unit.
7. Disconnect connectors from HID control unit.
8. Turn halogen bulb (high) counterclockwise and unlock it.
9. Remove halogen bulb (high) and disconnect connector it.
10. Turn front turn signal lamp bulb socket counterclockwise and unlock it.
11. Remove front turn signal lamp bulb from its socket.
12. Turn parking lamp bulb from socket counterclockwise and unlock it.
13. Remove parking lamp bulb from its socket.
14. Turn front side marker lamp bulb socket counterclockwise and unlock it.
15. Remove front side marker lamp bulb from its socket.

ASSEMBLY

Note the following, and installation is the reverse order of removal.

CAUTION:

- **When HID control unit is removed, reinstall it securely and avoid any looseness.**
- **After installing bulb, be sure to install plastic cap and bulb socket securely to insure watertightness**

HEADLAMP (FOR CANADA) - DAYTIME LIGHT SYSTEM -

< SERVICE INFORMATION >

HEADLAMP (FOR CANADA) - DAYTIME LIGHT SYSTEM -

Component Parts and Harness Connector Location

INFOID:000000002956708

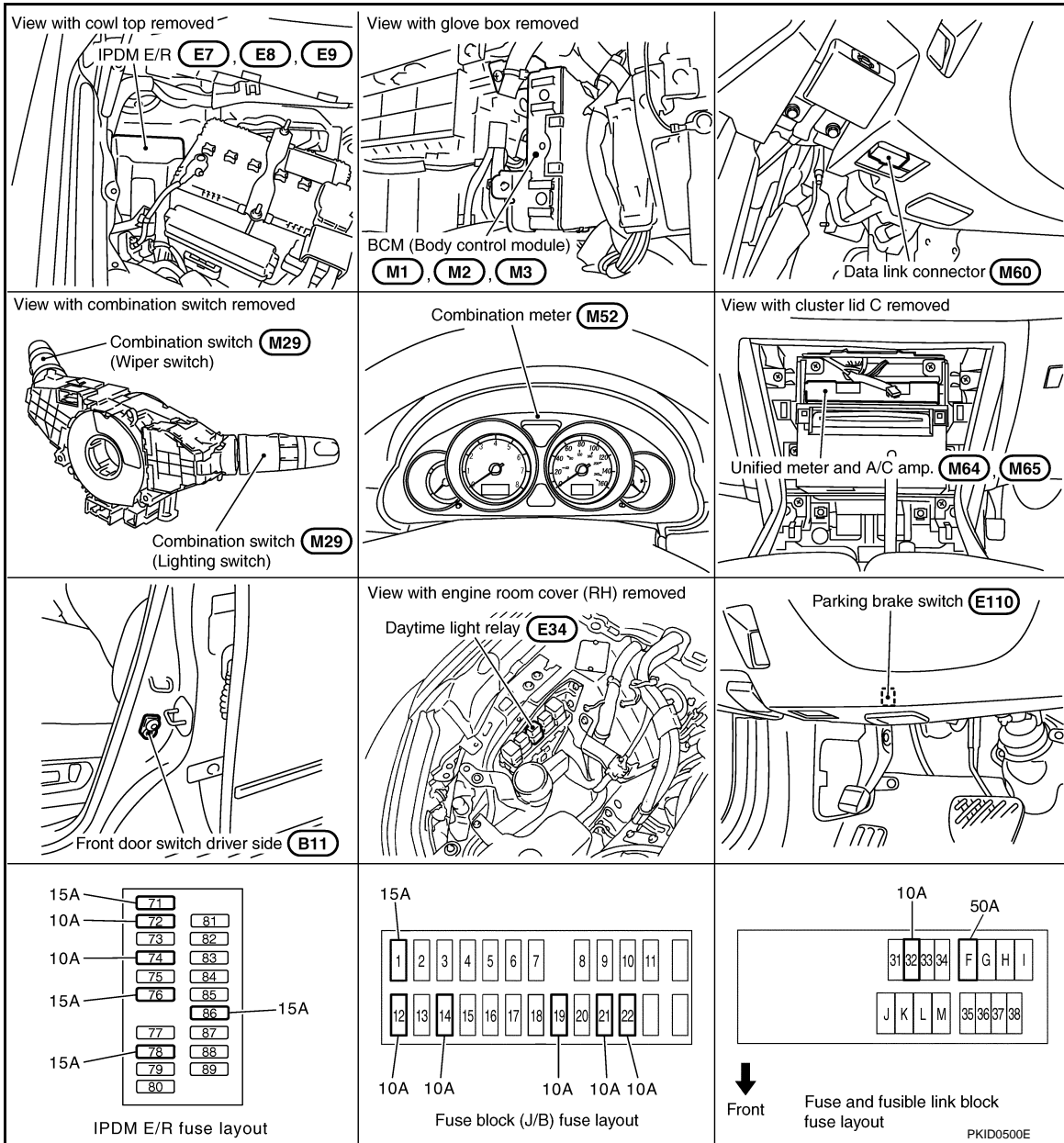

System Description

INFOID:000000002956709

DAYTIME LIGHT SYSTEM turns on daytime light lamps while driving. Daytime light lamps are not turned on if engine is activated with parking brake on. Take off parking brake to turn on daytime light lamps. The lamps turn off when lighting switch is in the 2ND position or AUTO position (Head lamp is "ON") and when lighting switch is in the PASSING position. (Daytime light lamps are not turned off only by parking brake itself.) A parking brake signal and engine run or stop signal are sent to BCM (body control module) by CAN communication line, and control daytime light system.

OUTLINE

Power is supplied at all times

- to headlamp high relay, located in IPDM E/R (intelligent power distribution module engine room) and
- to headlamp low relay, located in IPDM E/R, from battery direct,
- through 15A fuse (No. 71, located in IPDM E/R)
- to CPU (central processing unit), located in IPDM E/R,
- through 15A fuse (No. 78, located in IPDM E/R)

A
B
C
D
E
F
G
H
I
J
LT
L
M
N
O
P

HEADLAMP (FOR CANADA) - DAYTIME LIGHT SYSTEM -

< SERVICE INFORMATION >

- to CPU, located in IPDM E/R,
- through 50A fusible link (letter F, located in fuse and fusible link block)
- to BCM terminal 55,
- through 10A fuse [No. 21, located in fuse block (J/B)]
- to BCM terminal 42 and
- to combination meter terminal 23,
- through 10A fuse (No. 32, located in IPDM E/R)
- to daytime light relay terminals 2 and 5,
- through 10A fuse [No. 19, located in fuse block (J/B)]
- to unified meter and A/C amp. terminal 54,
- through 10A fuse [No. 22, located in fuse block (J/B)]
- to key slot terminal 1.

When the ignition switch is in ON or START position, power is supplied

- to CPU, located in IPDM E/R,
- through 15A fuse [No. 1, located in fuse block (J/B)]
- to BCM terminal 38,
- through 10A fuse [No. 14, located in fuse block (J/B)]
- to combination meter terminal 12,
- through 10A fuse [No. 12, located in fuse block (J/B)]
- to unified meter and A/C amp. terminal 53.

Ground is supplied

- to BCM terminal 52
- to combination meter terminals 9, 10, and 11
- to unified meter and A/C amp. terminal 55 and 71
- to push-button ignition switch (push switch) terminal 1
- to key slot terminal 8
- through grounds M16 and M70,
- to IPDM E/R terminals 38 and 51
- through grounds E22 and E43.

HEADLAMP OPERATION

Low Beam Operation

With the lighting switch in 2ND position, the BCM receives input signal requesting the headlamps to illuminate. This input signal is communicated to IPDM E/R across the CAN communication lines. The CPU located in the IPDM E/R controls the headlamp low relay coil, which when energized, directs power

- through 15A fuse (No. 76, located in IPDM E/R)
- through IPDM E/R terminal 20
- to front combination lamp RH terminal 8,
- through 15A fuse (No. 86, located in IPDM E/R)
- through IPDM E/R terminal 30
- to front combination lamp LH terminal 8.

Ground is supplied

- to front combination lamp RH terminal 4
- to front combination lamp LH terminal 4
- through grounds E22 and E43.

With power and ground supplied, low beam headlamps illuminate.

High Beam Operation (When Daytime Light Does Not Operate)/Flash-to-Pass Operation

With the lighting switch in 2ND position and placed in HIGH BEAM or PASSING position, the BCM receives input signal requesting headlamp high beams to illuminate. High beam request signal is communicated to the IPDM E/R across the CAN communication lines. The CPU located in the IPDM E/R controls headlamp high relay coil and low relay coil, which when energized, directs power

- through 10A fuse (No. 72, located in IPDM E/R)
- through IPDM E/R terminal 27
- through front combination lamp RH terminals 6 and 2
- to daytime light relay terminal 3,
- through 10A fuse (No. 74, located in IPDM E/R)
- through IPDM E/R terminal 28
- to front combination lamp LH terminal 6,
- through 15A fuse (No. 76, located in IPDM E/R)
- through IPDM E/R terminal 20

HEADLAMP (FOR CANADA) - DAYTIME LIGHT SYSTEM -

< SERVICE INFORMATION >

- to front combination lamp RH terminal 8,
- through 15A fuse (No. 86, located in IPDM E/R)
- through IPDM E/R terminal 30
- to front combination lamp LH terminal 8.

Ground is supplied

- to daytime light relay terminal 4
- to front combination lamp RH terminal 4
- to front combination lamp LH terminal 2
- to front combination lamp LH terminal 4
- through grounds E22 and E43.

With the power and ground supplied, the headlamp high beam and low headlamp illuminate.

High beam indicator illuminates when combination meter receives input signal requesting high beam indicator to illuminate. This is communicated to BCM across the CAN communication lines.

DAYTIME LIGHT OPERATION

With the engine running, the lighting switch in the OFF or AUTO position (headlamp is not illuminate) and parking brake released, the IPDM E/R receives input request signal from BCM to turn on daytime light. This input is communicated across the CAN communication lines. The CPU of the IPDM E/R controls the daytime light relay coil. When energized, this relay directs power

- through daytime light relay terminals 5 and 3
- through front combination lamp RH terminal 2
- through front combination lamp RH terminal 6
- through IPDM E/R terminal 27
- through 10A fuse (No. 72, located in IPDM E/R)
- through 10A fuse (No. 74, located in IPDM E/R)
- through IPDM E/R terminal 28
- to front combination lamp LH terminal 6.

Ground is supplied

- to combination lamp LH terminal 2
- through grounds E22 and E43.

With power and grounds supplied, the daytime lights illuminate. The high beam headlamps are now wired in series and illuminate at a reduced intensity.

COMBINATION SWITCH READING FUNCTION

Refer to [BCS-4, "System Description"](#).

AUTO LIGHT OPERATION

For auto light operation, refer to [LT-93, "System Description"](#).

CAN Communication System Description

INFOID:000000002956710

CAN (Controller Area Network) is a serial communication line for real time application. It is an on-vehicle multiplex communication line with high data communication speed and excellent error detection ability. Many electronic control units are equipped onto a vehicle, and each control unit shares information and links with other control units during operation (not independent). In CAN communication, control units are connected with 2 communication lines (CAN H line, CAN L line) allowing a high rate of information transmission with less wiring. Each control unit transmits/receives data but selectively reads required data only.

CAN Communication Unit

INFOID:000000002956711

Refer to [LAN-11, "System Description"](#).

A
B
C
D
E
F
G
H
I
J
LT
L
M
N
O
P

HEADLAMP (FOR CANADA) - DAYTIME LIGHT SYSTEM -

< SERVICE INFORMATION >

Wiring Diagram - DTRL -

INFOID:00000002956713

LT-DTRL-01

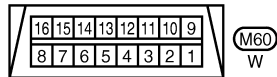
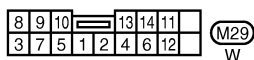
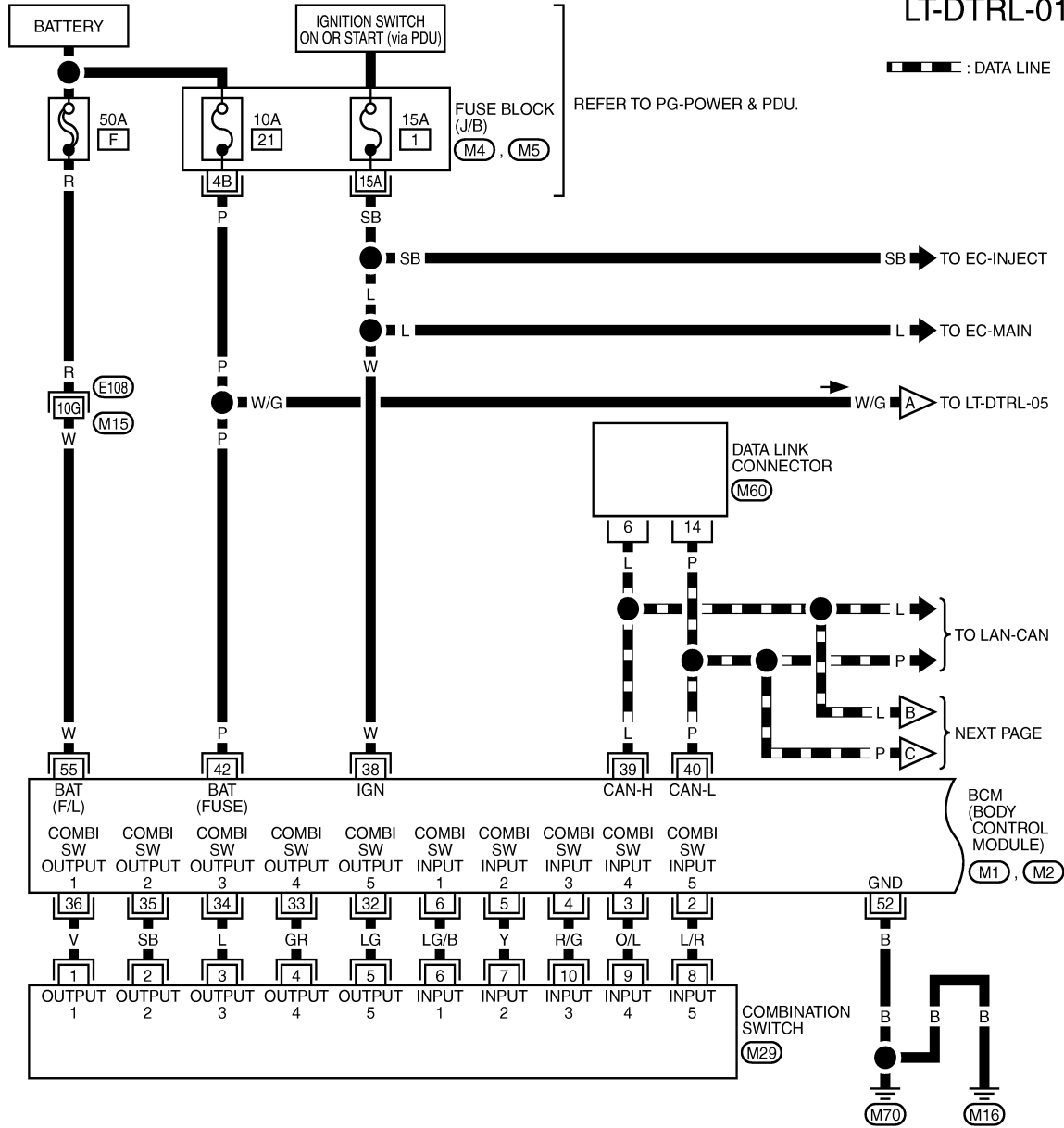

REFER TO THE FOLLOWING.

- (E108) - SUPER MULTIPLE JUNCTION (SMJ)
- (M4), (M5) - FUSE BLOCK - JUNCTION BOX (J/B)
- (M1), (M2) - ELECTRICAL UNITS

TKWT6806E

HEADLAMP (FOR CANADA) - DAYTIME LIGHT SYSTEM -

< SERVICE INFORMATION >

LT-DTRL-02

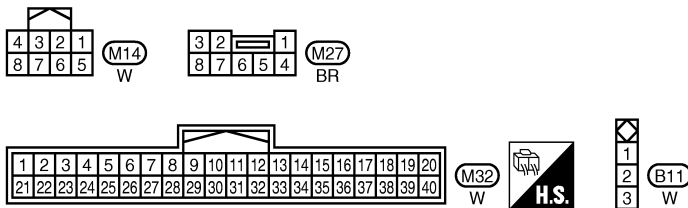
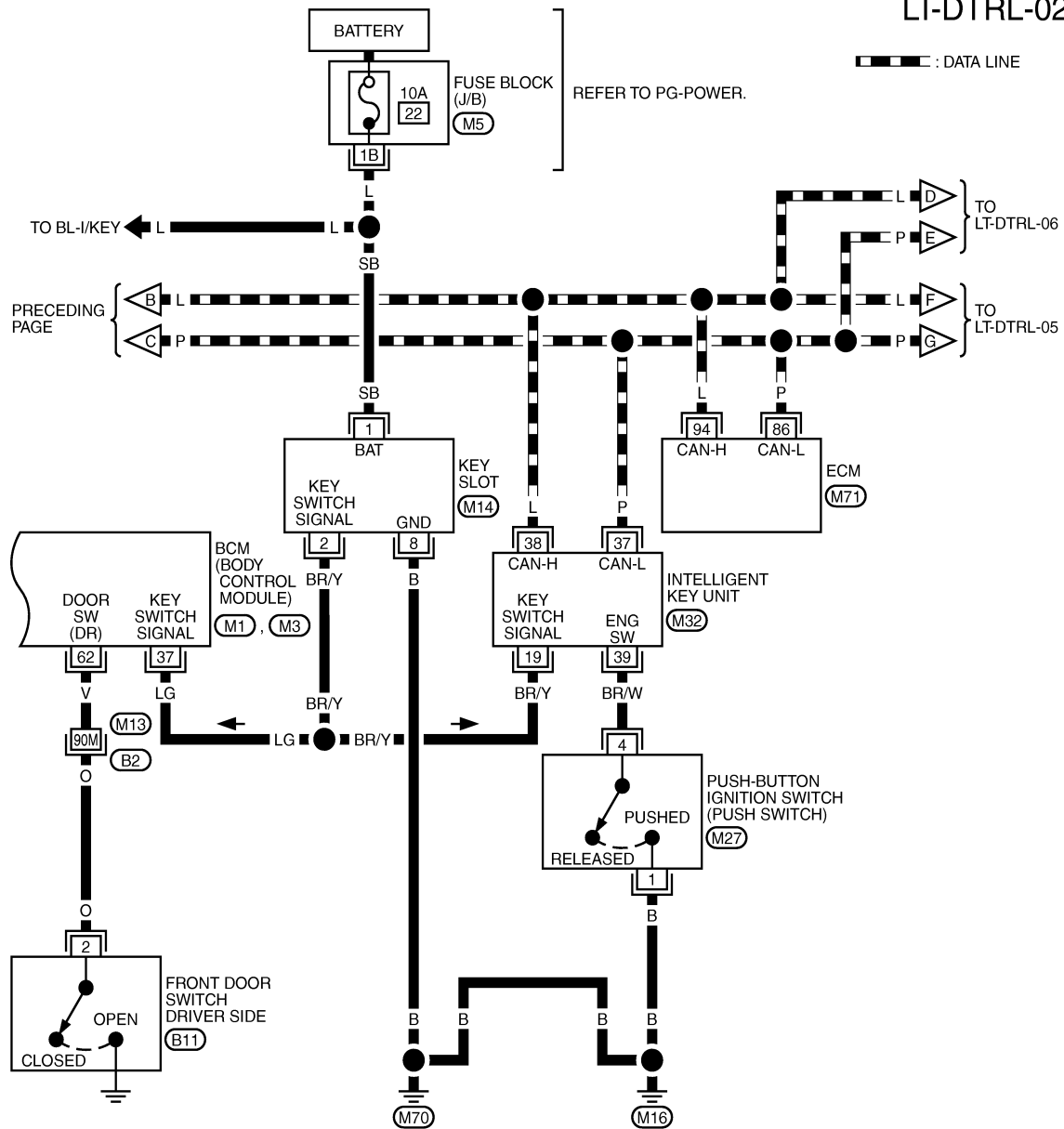

REFER TO THE FOLLOWING.

- (B2) - SUPER MULTIPLE JUNCTION (SMJ)
- (M5) - FUSE BLOCK-JUNCTION BOX (J/B)
- (M1), (M3), (M71) - ELECTRICAL UNITS

TKWT6807E

HEADLAMP (FOR CANADA) - DAYTIME LIGHT SYSTEM -

< SERVICE INFORMATION >

LT-DTRL-03

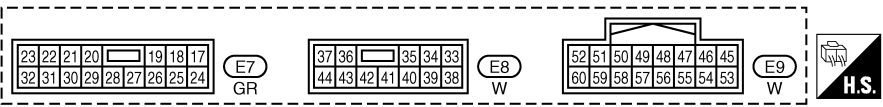
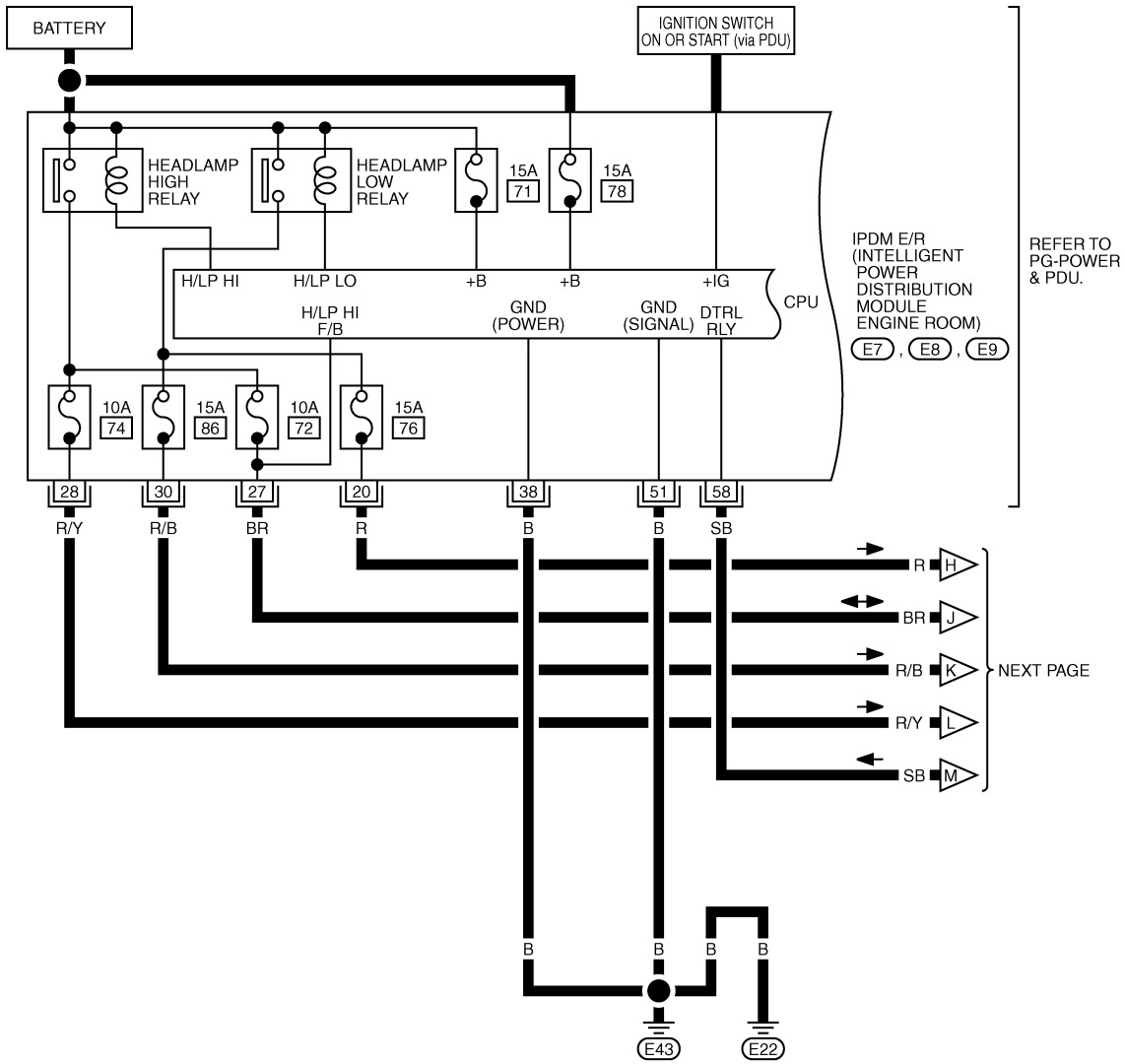

TKWT5259E

HEADLAMP (FOR CANADA) - DAYTIME LIGHT SYSTEM -

< SERVICE INFORMATION >

LT-DTRL-04

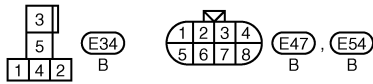
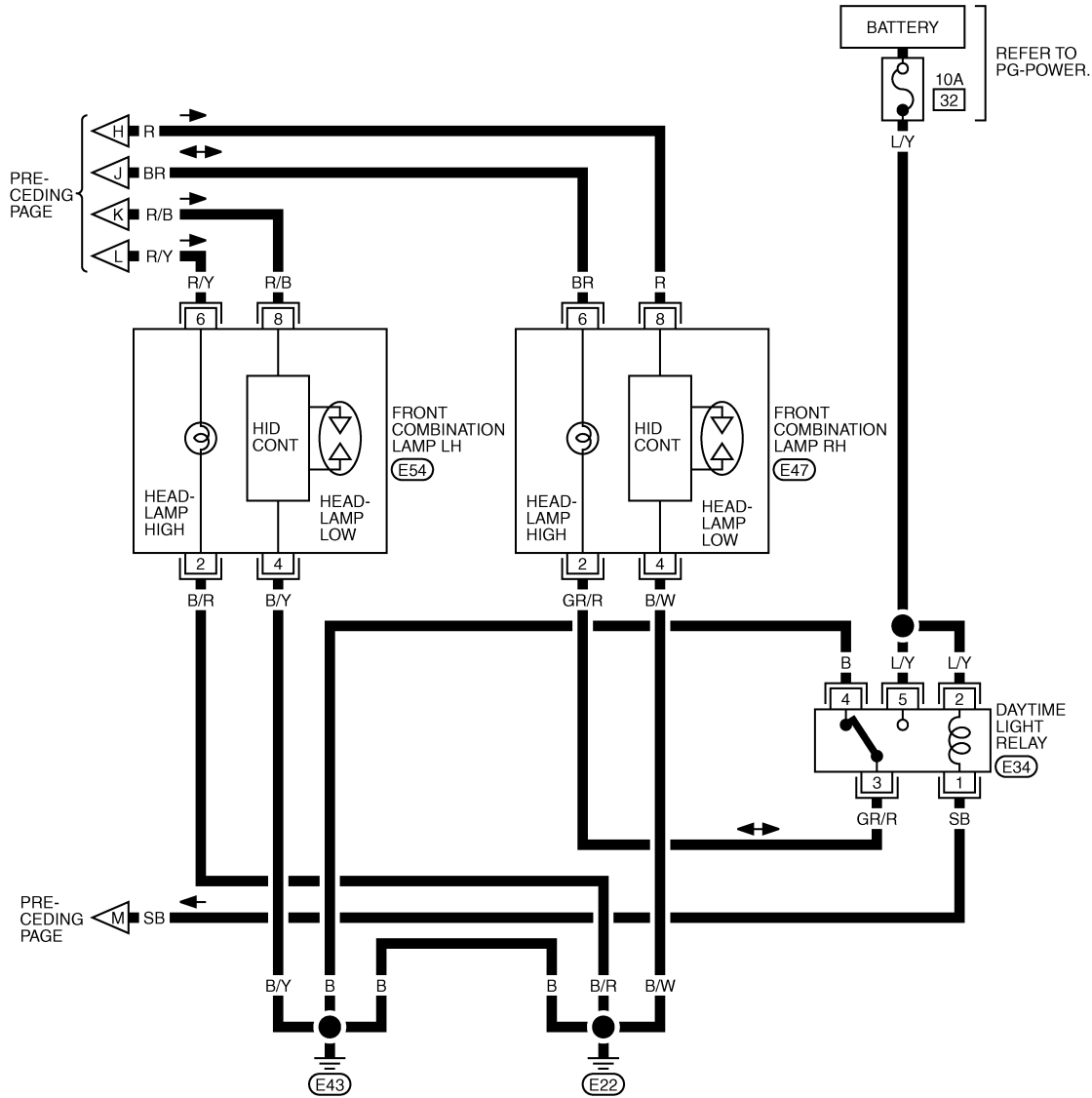

TKWT3366E

HEADLAMP (FOR CANADA) - DAYTIME LIGHT SYSTEM -

< SERVICE INFORMATION >

LT-DTRL-05

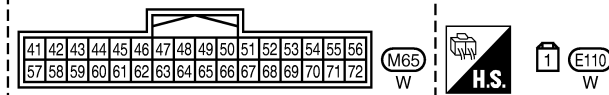
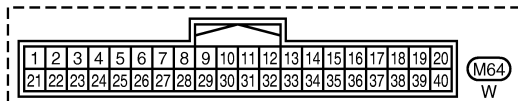
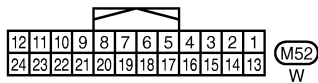
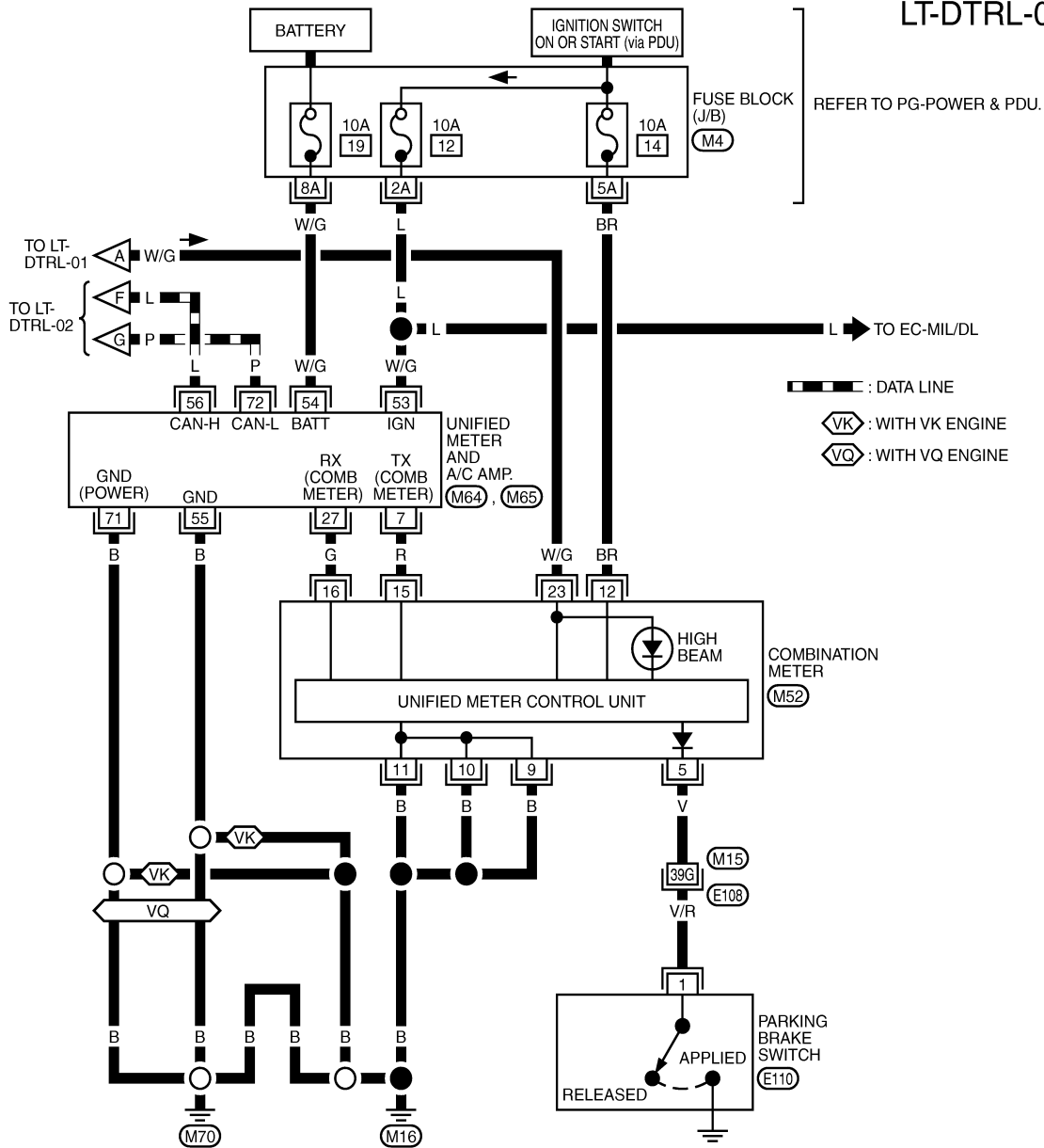

REFER TO THE FOLLOWING.
 (E108) - SUPER MULTIPLE JUNCTION (SMJ)
 (M4) - FUSE BLOCK - JUNCTION BOX (J/B)

TKWT6808E

A
B
C
D
E
F
G
H
I
J
LT
L
M
N
O
P

HEADLAMP (FOR CANADA) - DAYTIME LIGHT SYSTEM -

< SERVICE INFORMATION >

LT-DTRL-06

▬ : DATA LINE

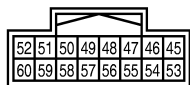
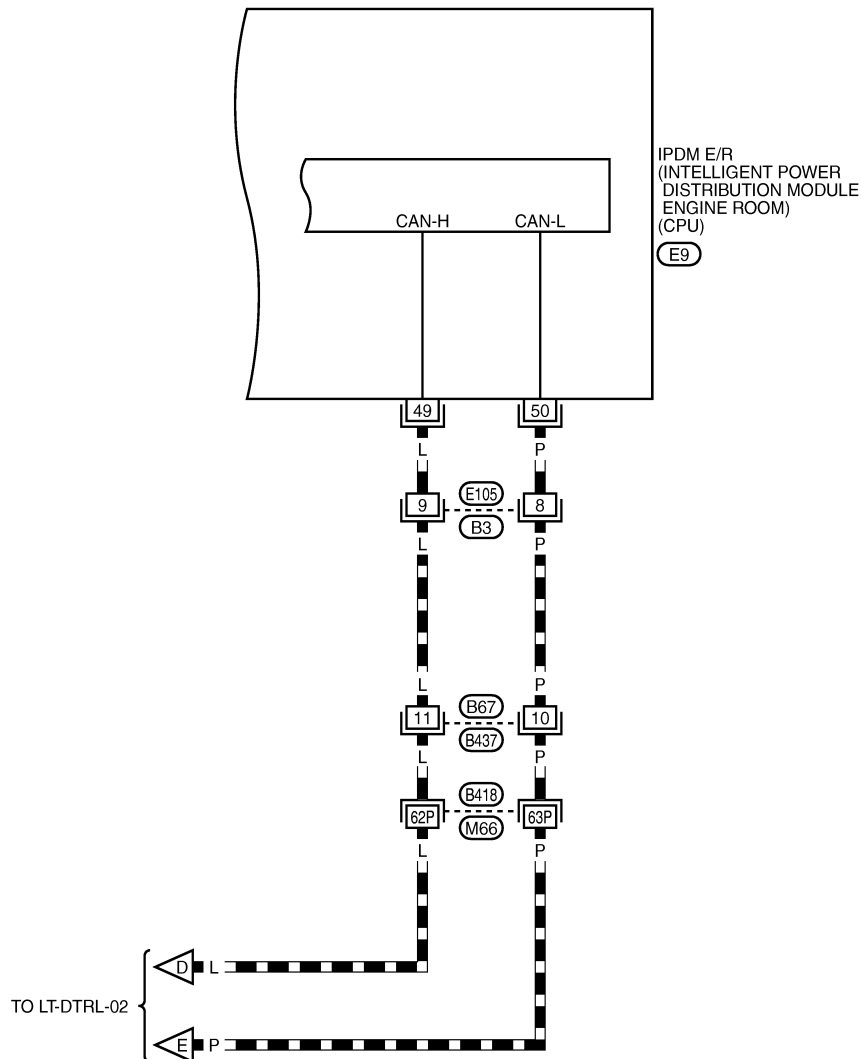

E9
W

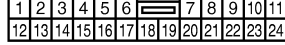

B3
W

B437
BR

REFER TO THE FOLLOWING.

B418 - SUPER MULTIPLE
JUNCTION (SMJ)

TKWT6809E

INFOID:000000002956714

Terminal and Reference Value for BCM

CAUTION:

- Check combination switch system terminal waveform under the loaded condition with lighting switch, turn signal switch and wiper switch OFF not to be fluctuated by overloaded.
- Turn wiper dial position to 4 except when checking waveform or voltage of wiper dial position. Wiper dial position can be confirmed on CONSULT-III. Refer to [LT-201, "CONSULT-III Functions \(BCM - COMB SW\)"](#).

HEADLAMP (FOR CANADA) - DAYTIME LIGHT SYSTEM -

< SERVICE INFORMATION >

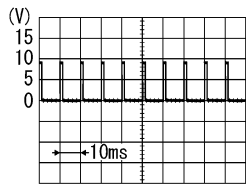
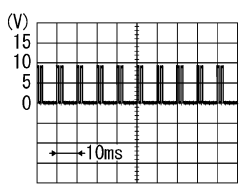
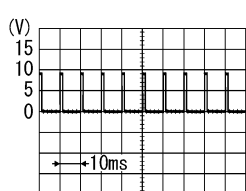
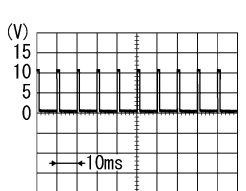
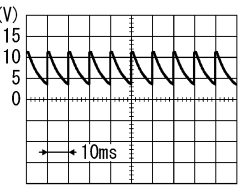
| Terminal No. | Wire color | Signal name | Measuring condition | | Reference value |
|--------------|------------|-----------------------------|---------------------|--|--|
| | | | Ignition switch | Operation or condition | |
| 2 | L/R | Combination switch input 5 | ON | Lighting, turn, wiper switch (Wiper dial position 4) |  <p style="text-align: right;">PKIB4957J</p> <p style="text-align: center;">Approx. 1.0 V</p> |
| | | | | Lighting switch 2ND |  <p style="text-align: right;">PKIB4953J</p> <p style="text-align: center;">Approx. 2.0 V</p> |
| | | | | OFF | Approx. 0 V |
| 3 | O/L | Combination switch input 4 | ON | Lighting, turn, wiper switch (Wiper dial position 4) <ul style="list-style-type: none"> • Lighting switch 2ND • Lighting switch PASSING (Operates only PASSING switch) |  <p style="text-align: right;">PKIB4957J</p> <p style="text-align: center;">Approx. 1.0 V</p> |
| | | | | OFF | Approx. 0 V |
| 34 | L | Combination switch output 3 | ON | Lighting, turn, wiper switch (Wiper dial position 4) <ul style="list-style-type: none"> • Lighting switch 2ND • Lighting switch HI beam (Operates only HI beam switch) |  <p style="text-align: right;">PKIB4958J</p> <p style="text-align: center;">Approx. 1.2 V</p> |
| | | | | OFF |  <p style="text-align: right;">PKIB4960J</p> <p style="text-align: center;">Approx. 7.0 - 7.5 V</p> |

A
B
C
D
E
F
G
H
I
J
LT
L
M
N
O
P

HEADLAMP (FOR CANADA) - DAYTIME LIGHT SYSTEM -

< SERVICE INFORMATION >

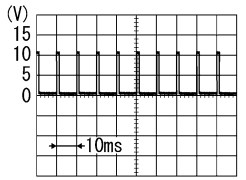
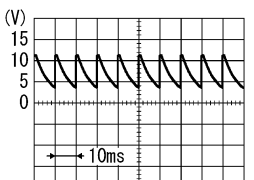
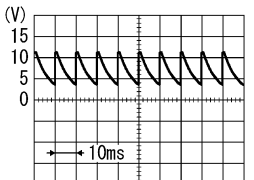
| Terminal No. | Wire color | Signal name | Measuring condition | | Reference value | |
|--------------|------------|--------------------------------------|---------------------|--|--|--|
| | | | Ignition switch | Operation or condition | | |
| 35 | SB | Combination switch output 2 | ON | Lighting, turn, wiper switch (Wiper dial position 4) | Any of several conditions below <ul style="list-style-type: none"> • Lighting switch 2ND • Lighting switch PASSING (Operates only PASSING switch)  <p style="text-align: right; font-size: small;">PKIB4958J</p> <p style="text-align: center;">Approx. 1.2 V</p> | |
| | | | | | OFF |  <p style="text-align: right; font-size: small;">PKIB4960J</p> <p style="text-align: center;">Approx. 7.0 - 7.5 V</p> |
| 37 | LG | Key switch signal | OFF | Intelligent Key is inserted into key slot. | Battery voltage | |
| | | | | Intelligent Key is removed from key slot. | Approx. 0 V | |
| 38 | W | Ignition switch (ON) | ON | — | Battery voltage | |
| 39 | L | CAN - H | — | — | — | |
| 40 | P | CAN - L | — | — | — | |
| 42 | P | Battery power supply | OFF | — | Battery voltage | |
| 52 | B | Ground | ON | — | Approx. 0 V | |
| 55 | W | Battery power supply | OFF | — | Battery voltage | |
| 62 | V | Front door switch driver side signal | OFF | Front door switch driver side | ON (open) | Approx. 0 V |
| | | | | | OFF (closed) |  <p style="text-align: right; font-size: small;">PKIB4960J</p> <p style="text-align: center;">Approx. 7.5 - 8.0 V</p> |

Terminal and Reference Value for IPDM E/R

INFOID:000000002956715

| Terminal No. | Wire color | Signal name | Measuring condition | | Reference value | |
|--------------|------------|--------------------|---------------------|--|-----------------|-----------------|
| | | | Ignition switch | Operation or condition | | |
| 20 | R | Headlamp low (RH) | ON | Lighting switch 2ND position | OFF | Approx. 0 V |
| | | | | | ON | Battery voltage |
| 27 | BR | Headlamp high (RH) | ON | Lighting switch HIGH or PASSING position | OFF | Approx. 0 V |
| | | | | | ON | Battery voltage |
| | | | | Daytime running light is operating ^{NOTE} | | |

HEADLAMP (FOR CANADA) - DAYTIME LIGHT SYSTEM -

< SERVICE INFORMATION >

| Terminal No. | Wire color | Signal name | Measuring condition | | Reference value |
|--------------|------------|----------------------------|---------------------|--|------------------------|
| | | | Ignition switch | Operation or condition | |
| 28 | R/Y | Headlamp high (LH) | ON | Lighting switch HIGH or PASSING position | OFF Battery voltage |
| | | | | Daytime running light is operating ^{NOTE} | ON Approx. 6.5 V |
| | | | | | |
| 30 | R/B | Headlamp low (LH) | ON | Lighting switch 2ND position | OFF Battery voltage |
| | | | | | ON Approx. 0 V |
| 38 | B | Ground | ON | — | Approx. 0 V |
| 49 | L | CAN – H | — | — | — |
| 50 | P | CAN – L | — | — | — |
| 51 | B | Ground | ON | — | Approx. 0 V |
| 58 | SB | Daytime light relay signal | ON | Daytime running light is operating ^{NOTE} | Approx. 0 V |
| | | | | Daytime running light is not operating | Battery voltage |

NOTE:

Daytime running light is operating: Lighting switch in OFF position with engine running and parking brake is released.

How to Perform Trouble Diagnosis

INFOID:000000002956716

1. Confirm the symptom or customer complaint.
2. Understand operation description and function description. Refer to [LT-63, "System Description"](#).
3. Perform the Preliminary Check. Refer to [LT-75, "Preliminary Check"](#).
4. Check symptom and repair or replace the cause of malfunction.
5. Does the headlamp operate normally? If YES: GO TO 6. If NO: GO TO 4.
6. INSPECTION END

Preliminary Check

INFOID:000000002956717

INSPECTION FOR POWER SUPPLY AND GROUND CIRCUIT

1. CHECK FUSES AND FUSIBLE LINK

Check for blown fuses and fusible link.

| Unit | Power source | Fuse No. |
|---------------------|--------------------------------------|----------|
| BCM | Battery | F |
| | | 21 |
| | Ignition switch ON or START position | 1 |
| Daytime light relay | Battery | 32 |

Refer to [LT-67, "Wiring Diagram - DTRL -"](#).

OK or NG

OK >> GO TO 2.

NG >> If fuse is blown, be sure to eliminate cause of malfunction before installing new fuse. Refer to [PG-4](#).

2. CHECK POWER SUPPLY CIRCUIT

HEADLAMP (FOR CANADA) - DAYTIME LIGHT SYSTEM -

< SERVICE INFORMATION >

1. Disconnect BCM connector.
2. Check voltage between BCM harness connector and ground.

| Terminals | | Ignition switch position | |
|---------------|----------|--------------------------|-----------------|
| (+) | | (-) | |
| BCM connector | Terminal | OFF | ON |
| M1 | 38 | Approx. 0 V | Battery voltage |
| M2 | 42 | Battery voltage | Battery voltage |
| | 55 | Battery voltage | Battery voltage |

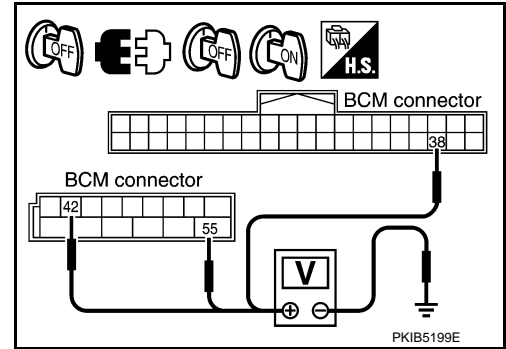

OK or NG

- OK >> GO TO 3.
 NG >> Repair harness or connector.

3.CHECK GROUND CIRCUIT

Check continuity between BCM harness connector and ground.

| BCM connector | Terminal | Ground | Continuity |
|---------------|----------|--------|------------|
| M2 | 52 | | Yes |

OK or NG

- OK >> INSPECTION END.
 NG >> Repair harness or connector.

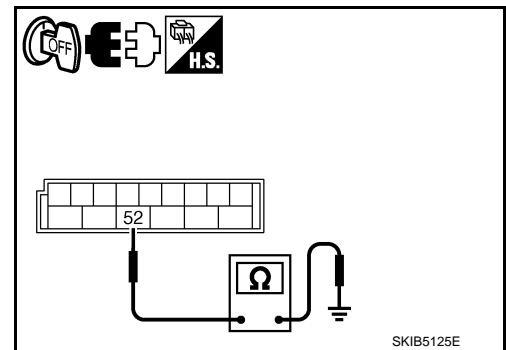

INSPECTION FOR PARKING BRAKE SWITCH CIRCUIT

1.CHECK BRAKE INDICATOR

1. Turn ignition switch ON.
2. When parking brake is switched ON/OFF, it checks whether the brake indicator lamp of combination meter lights up / puts out the light.

OK or NG

- OK >> INSPECTION END
 NG >> GO TO 2.

2.CHECK PARKING BRAKE SWITCH SIGNAL

1. Turn ignition switch OFF.
2. Disconnect parking brake switch connector.
3. Turn ignition switch ON.
4. Check voltage between parking brake switch harness connector and ground.

| Terminals | | Voltage (Approx.) | |
|--------------------------------|----------|-------------------|-----------------|
| (+) | | (-) | |
| Parking brake switch connector | Terminal | | |
| E110 | 1 | Ground | Battery voltage |

OK or NG

- OK >> Replace parking brake switch.
 NG >> GO TO 3.

3.CHECK PARKING BRAKE SWITCH CIRCUIT

1. Turn ignition switch OFF.
2. Disconnect combination meter connector.

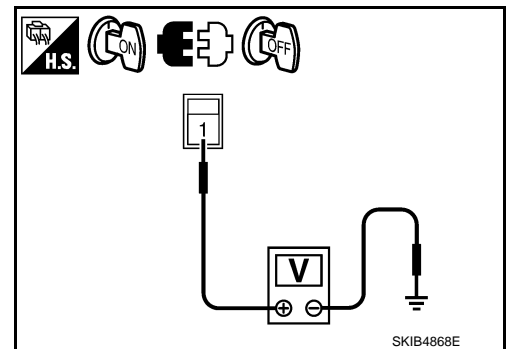

HEADLAMP (FOR CANADA) - DAYTIME LIGHT SYSTEM -

< SERVICE INFORMATION >

3. Check continuity between combination meter harness connector (A) and parking brake switch harness connector (B).

| A | | B | | Continuity |
|-----------|----------|-----------|----------|------------|
| Connector | Terminal | Connector | Terminal | |
| M52 | 5 | E110 | 1 | Yes |

OK or NG

- OK >> Replace combination meter.
 NG >> Repair harness or connector.

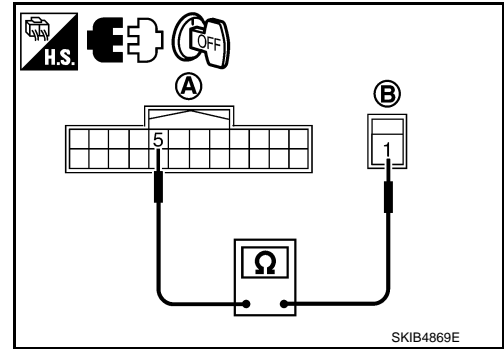

CONSULT-III Functions (BCM - HEAD LAMP)

INFOID:000000002956718

CONSULT-III can display each diagnostic item using the diagnostic test mode shown following.

| Diagnosis mode | Description |
|-----------------------|---|
| WORK SUPPORT | Changes the setting for each function. ^{NOTE} |
| DATA MONITOR | Displays BCM input data in real time. |
| ACTIVE TEST | Operation of electrical loads can be checked by sending drive signal to them. |
| SELF-DIAG RESULTS | BCM performs self-diagnosis of CAN communication. |
| CAN DIAG SUPPORT MNTR | The result of transmit/receive diagnosis of CAN communication can be read. |

NOTE:

Cannot change setting for headlamp.

DATA MONITOR

Display Item List

| Monitor item | Contents |
|----------------|---|
| IGN ON SW | "On/Off" Displays "IGN position (ON)/OFF, ACC position (OFF)" judged from the ignition switch signal. |
| ACC ON SW | "On/Off" Displays "ACC (ON)/OFF, Ignition OFF (OFF)" status judged from ignition switch signal. |
| KEY ON SW | "On/Off" Displays "Intelligent Key inserted into key slot (ON)/Intelligent Key removed from key slot (OFF)" status judged from the key switch signal. |
| TURN SIGNAL R | "On/Off" Displays status (turn right: ON/others: OFF) as judged from lighting switch signal. |
| TURN SIGNAL L | "On/Off" Displays status (turn left: ON/others: OFF) as judged from lighting switch signal. |
| HI BEAM SW | "On/Off" Displays status (high beam switch: ON/others: OFF) of high beam switch judged from lighting switch signal. |
| HEAD LAMP SW 1 | "On/Off" Displays status (headlamp switch 1: ON/others: OFF) of headlamp switch 1 judged from lighting switch signal. |
| HEAD LAMP SW 2 | "On/Off" Displays status (headlamp switch 2: ON/others: OFF) of headlamp switch 2 judged from lighting switch signal. |
| TAIL LAMP SW | "On/Off" Displays status (lighting switch 1ST or 2ND position: ON/others: OFF) of lighting switch judged from lighting switch signal. |
| AUTO LIGHT SW | "On/Off" Displays status of the lighting switch as judged from the lighting switch signal. (AUTO position: ON/other than AUTO position: OFF) |
| PASSING SW | "On/Off" Displays status (flash-to-passing switch: ON/others: OFF) of flash-to-passing switch judged from lighting switch signal. |
| FR FOG SW | "On/Off" Displays status (front fog lamp switch: ON/others: OFF) of front fog lamp switch judged from lighting switch signal. |
| DOOR SW - DR | "On/Off" Displays status of the driver door as judged from the driver door switch signal. (door is open: ON/door is closed: OFF) |
| DOOR SW - AS | "On/Off" Displays status of the passenger door as judged from the passenger door switch signal. (door is open: ON/door is closed: OFF) |

HEADLAMP (FOR CANADA) - DAYTIME LIGHT SYSTEM -

< SERVICE INFORMATION >

| Monitor item | Contents |
|------------------------------------|---|
| DOOR SW - RR "On/Off" | Displays status of the rear door as judged from the rear door switch (RH) signal. (door is open: ON/door is closed: OFF) |
| DOOR SW - RL "On/Off" | Displays status of the rear door as judged from the rear door switch (LH) signal. (door is open: ON/door is closed: OFF) |
| BACK DOOR SW ^{NOTE} "Off" | — |
| PKB SW "On/Off" | Displays status (parking brake released: ON/ parking brake applied: OFF) of parking brake switch judged from parking brake switch signal. |
| ENGINE RUN "On/Off" | Displays status (engine running: ON/ engine stopped: OFF) of engine judged from engine run signal. |
| I - KEY LOCK "On/Off" | Displays "locked (ON)/other (OFF)" status, determined from lock signal. |
| OPTICAL SENSOR "0 - 5V" | Displays "outside brightness (close to 5 V when light/close to 0 V when dark)" judged from optical sensor signal. |
| VEHICLE SPEED "km/h" | Displays vehicle speed as judged from vehicle speed signal. |

NOTE:

This item is displayed, but cannot be monitored.

ACTIVE TEST

Display Item List

| Test item | Description |
|-----------------------|---|
| TAIL LAMP | Allows tail lamp relay to operate by switching ON-OFF. |
| FR FOG LAMP | Allows front fog lamp relay to operate by switching ON-OFF. |
| DAYTIME RUNNING LIGHT | Allows daytime relay to operate by switching ON-OFF. |
| HEAD LAMP (HI, LO) | Allows headlamp relay to operate by switching ON-OFF. |

CONSULT-III Functions (IPDM E/R)

INFOID:000000002956719

CONSULT-III can display each diagnostic item using the diagnostic test mode shown following.

| Diagnosis Mode | Description |
|-------------------------|--|
| SELF-DIAGNOSTIC RESULTS | Refer to PG-20, "CONSULT-III Function (IPDM E/R)" . |
| DATA MONITOR | The input/output data of IPDM E/R is displayed in real time. |
| CAN DIAG SUPPORT MNTR | The result of transmit/receive diagnosis of CAN communication can be read. |
| ACTIVE TEST | IPDM E/R sends a drive signal to electronic components to check their operation. |

DATA MONITOR

All Signals, Main Signals, Selection From Menu

| Item name | CONSULT-III screen display | Display or unit | Monitor item selection | | | Description |
|-------------------------------|----------------------------|-----------------|------------------------|--------------|---------------------|------------------------------|
| | | | ALL SIGNALS | MAIN SIGNALS | SELECTION FROM MENU | |
| Position lights request | TAIL&CLR REQ | On/Off | × | × | × | Signal status input from BCM |
| Headlamp low beam request | HL LO REQ | On/Off | × | × | × | Signal status input from BCM |
| Headlamp high beam request | HL HI REQ | On/Off | × | × | × | Signal status input from BCM |
| Front fog lights request | FR FOG REQ | On/Off | × | × | × | Signal status input from BCM |
| Daytime running light request | DTRL REQ | On/Off | × | — | × | Signal status input from BCM |

NOTE:

Perform monitoring of IPDM E/R data with the ignition switch ON. When the ignition switch is at ACC, the display may not be correct.

ACTIVE TEST

HEADLAMP (FOR CANADA) - DAYTIME LIGHT SYSTEM -

< SERVICE INFORMATION >

| Test item | CONSULT-III screen display | Description |
|--------------------------------|----------------------------|---|
| Tail lamp relay output | TAIL LAMP | Allows tail lamp relay to operate by switching operation ON-OFF at your option. |
| Headlamp relay (HI, LO) output | LAMPS | Allows headlamp relay (HI, LO) to operate by switching operation (OFF, HI ON, LO ON) at your option (Headlamp high beam repeats ON-OFF every 1 second). |
| Front fog lamp relay output | | Allows fog lamp relay to operate by switching operation ON-OFF at your option. |

Daytime Light Control Does Not Operate Properly (Normal Headlamps Operate Properly)

INFOID:000000002956720

1. DAYTIME LIGHT ACTIVE TEST

Ⓜ CONSULT-III ACTIVE TEST

1. Select "DAYTIME RUNNING LIGHT" of BCM (HEAD LAMP) active test item.
2. With operating the test item, check the daytime light operation.

On : Daytime running light ON

Off : Daytime running light OFF

OK or NG

OK >> GO TO 2.

NG >> GO TO 4.

2. CHECK INPUT SIGNAL

Ⓜ CONSULT-III DATA MONITOR

1. Select "ENGINE RUN" of BCM (HEAD LAMP) data monitor item.
2. With operating the engine running or stop, check the monitor status.

Engine running : ENGINE RUN On

Engine stop : ENGINE RUN Off

3. Select "PKB SW" of BCM (HEAD LAMP) data monitor item.
4. With operating the parking brake, check the monitor status.

Parking brake ON : PKB SW On

Parking brake OFF : PKB SW Off

OK or NG

OK >> GO TO 3.

NG >> Check BCM CAN communication system. Refer to [LAN-17, "CAN Diagnosis with CONSULT-III"](#).

3. CHECK INPUT SIGNAL

Ⓜ CONSULT-III DATA MONITOR

1. Start engine and release parking brake. Headlamp switch OFF.
2. Select "DTRL REQ" of IPDM E/R data monitor item.
3. With operating the parking brake, check the monitor status.

Parking brake ON : DTRL REQ On

Parking brake OFF : DTRL REQ Off

OK or NG

OK >> Replace IPDM E/R. Refer to [PG-27, "Removal and Installation of IPDM E/R"](#).

NG >> Replace BCM. Refer to [BCS-14, "Removal and Installation of BCM"](#).

4. CHECK DAYTIME LIGHT RELAY POWER SUPPLY CIRCUIT

1. Turn ignition switch OFF.
2. Remove daytime light relay.

HEADLAMP (FOR CANADA) - DAYTIME LIGHT SYSTEM -

< SERVICE INFORMATION >

- Check voltage between daytime light relay harness connector and ground.

| Terminals | | (-) | Voltage (Approx.) |
|---|----------|--------|-------------------|
| (+) <table border="1"> <tr> <td>Daytime light relay connector</td> <td>Terminal</td> </tr> </table> | | | |
| Daytime light relay connector | Terminal | | |
| E34 | 2 | Ground | Battery voltage |
| | 5 | | |

OK or NG

- OK >> GO TO 5.
- NG >> Repair harness or connector.

5. CHECK DAYTIME LIGHT RELAY

Check continuity between daytime light relay terminals.

| Daytime light relay terminals | | Condition | Continuity |
|-------------------------------|---|---|------------|
| 3 | 5 | Applying battery voltage to between daytime light relay terminals 1 and 2 | Yes |
| | | No battery voltage | No |

OK or NG

- OK >> GO TO 6.
- NG >> Replace daytime light relay.

6. CHECK CIRCUIT BETWEEN DAYTIME LIGHT RELAY AND IPDM E/R

- Disconnect IPDM E/R connector.
- Check continuity between IPDM E/R harness connector (A) and daytime light relay harness connector (B).

| A | | B | | Continuity |
|-----------|----------|-----------|----------|------------|
| Connector | Terminal | Connector | Terminal | |
| E9 | 58 | E34 | 1 | Yes |

OK or NG

- OK >> GO TO 7.
- NG >> Repair harness or connector.

7. CHECK DAYTIME LIGHT RELAY SIGNAL

- Connect IPDM E/R connector.
- Install daytime light relay.
- Turn ignition switch ON.
- Applied parking brake.
- Check voltage between IPDM E/R harness connector and ground.

| Terminals | | (-) | Voltage (Approx.) |
|--|----------|--------|-------------------|
| (+) <table border="1"> <tr> <td>IPDM E/R connector</td> <td>Terminal</td> </tr> </table> | | | |
| IPDM E/R connector | Terminal | | |
| E9 | 58 | Ground | Battery voltage |

- Start engine and release parking break. Headlamp switch OFF.
- Check voltage between IPDM E/R harness connector and ground.

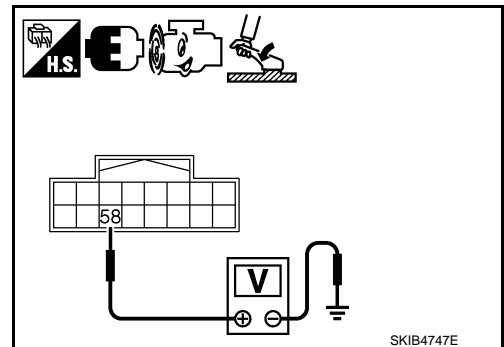
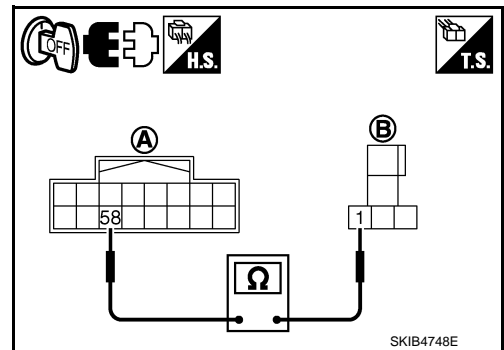
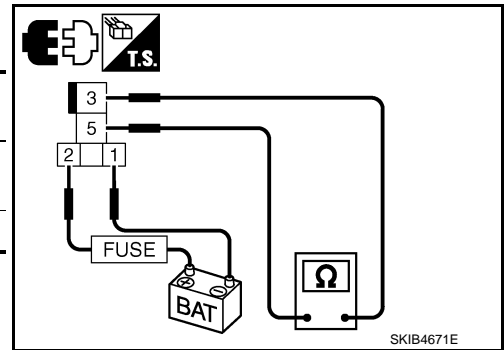
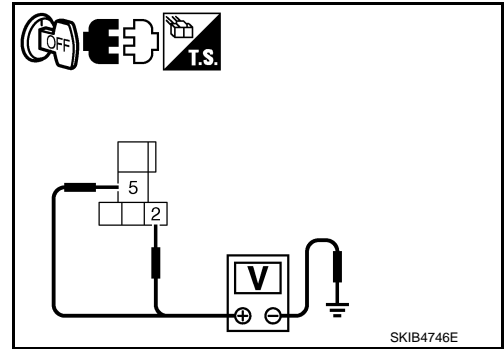

HEADLAMP (FOR CANADA) - DAYTIME LIGHT SYSTEM -

< SERVICE INFORMATION >

| Terminals | | Voltage (Approx.) |
|--------------------|----------|-------------------|
| (+) | (-) | |
| IPDM E/R connector | Terminal | 0 V |
| E9 | 58 | |
| | Ground | |

OK or NG

- OK >> Check connecting condition daytime light relay harness connector.
- NG >> GO TO 8.

8. CHECK CAN COMMUNICATIONS

CONSULT-III SELF-DIAGNOSIS

Perform self-diagnosis for "BCM" on CONSULT-III.

Displayed self-diagnosis results

- NO DTC>>Replace BCM. Refer to [BCS-14, "Removal and Installation of BCM"](#).
- CAN COMM CIRCUIT>>Check BCM CAN communication system. Refer to [LAN-17, "CAN Diagnosis with CONSULT-III"](#).

Headlamp High Beam Does Not Illuminate (Both Sides)

INFOID:000000002956721

1. CHECK COMBINATION SWITCH INPUT SIGNAL

CONSULT-III DATA MONITOR

1. Select "HI BEAM SW" of BCM (HEAD LAMP) data monitor item.
2. With operating the lighting switch, check the monitor status.

**When lighting switch is : HI BEAM SW ON
HIGH BEAM position**

CHECK THE COMBINATION SWITCH

Refer to [LT-202, "Combination Switch Inspection"](#).

OK or NG

- OK >> GO TO 2.
- NG >> Check combination switch (lighting switch). Refer to [LT-202, "Combination Switch Inspection"](#).

2. HEADLAMP ACTIVE TEST

CONSULT-III ACTIVE TEST

1. Select "LAMPS" of IPDM E/R active test item.
2. With operating the test item, check the headlamp high beam operation.

**HI : Headlamp high beam ON
Off : Headlamp high beam OFF**

NOTE:

Headlamp high beam repeats ON-OFF every 1 second.

IPDM E/R AUTO ACTIVE TEST

1. Activate auto active test. Refer to [PG-22, "Auto Active Test"](#).
2. Make sure headlamp high beam operation.

Headlamp high beam should operate.

OK or NG

- OK >> GO TO 3.
- NG >> GO TO 4.

3. CHECK IPDM E/R

CONSULT-III DATA MONITOR

1. Select "HL LO REQ" and "HL HI REQ" of IPDM E/R data monitor item.
2. With operating the lighting switch is in HIGH BEAM position, check the monitor status.

HEADLAMP (FOR CANADA) - DAYTIME LIGHT SYSTEM -

< SERVICE INFORMATION >

When lighting switch is HIGH BEAM position : HL LO REQ ON
: HL HI REQ ON

OK or NG

- OK >> Replace IPDM E/R. Refer to [PG-27, "Removal and Installation of IPDM E/R"](#).
- NG >> Replace BCM. Refer to [BCS-14, "Removal and Installation of BCM"](#).

4. CHECK HEADLAMP INPUT SIGNAL

Ⓟ CONSULT-III ACTIVE TEST

1. Turn ignition switch OFF.
2. Disconnect front combination lamp RH and LH connector.
3. Select "LAMPS" of IPDM E/R active test item.
4. Touch "HI" screen.
5. With operating the test item, check voltage between front combination lamp (RH and LH) harness connector and ground. (Headlamp high beam repeats ON-OFF every 1 second.)

| Terminal | | | (-) | Voltage (Approx.) |
|----------------------------------|-----|----------|-----|-------------------|
| (+) | | Terminal | | |
| Front combination lamp connector | | | | Ground |
| RH | E47 | 6 | | |
| LH | E54 | 6 | | |

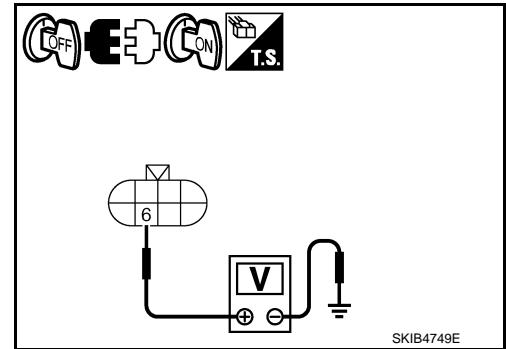

ⓧ IPDM E/R AUTO ACTIVE TEST

1. Turn ignition switch OFF.
2. Disconnect front combination lamp RH and LH connector.
3. Activate auto active test. Refer to [PG-22, "Auto Active Test"](#).
4. When headlamp high beam is operating, check voltage between front combination lamp (RH and LH) harness connector and ground.

| Terminal | | | (-) | Voltage (Approx.) |
|----------------------------------|-----|----------|-----|-------------------|
| (+) | | Terminal | | |
| Front combination lamp connector | | | | Ground |
| RH | E47 | 6 | | |
| LH | E54 | 6 | | |

OK or NG

- OK >> GO TO 5.
- NG >> GO TO 8.

5. CHECK HEADLAMP (LH SIDE) GROUND

1. Turn ignition switch OFF.
2. Check continuity between front combination lamp LH harness connector and ground.

| Front combination lamp LH connector | Terminal | Ground | Continuity |
|-------------------------------------|----------|--------|------------|
| E54 | 2 | | Yes |

OK or NG

- OK >> GO TO 6.
- NG >> Repair harness or connector.

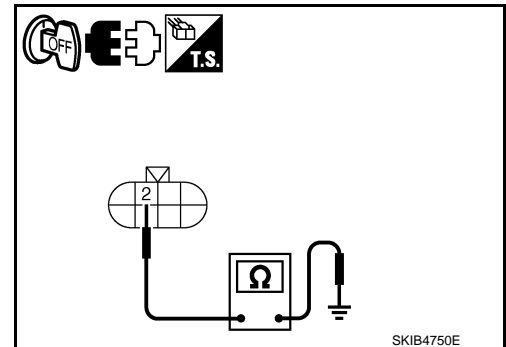

6. CHECK HEADLAMP (RH SIDE) GROUND

HEADLAMP (FOR CANADA) - DAYTIME LIGHT SYSTEM -

< SERVICE INFORMATION >

1. Remove daytime light relay.
2. Check continuity between front combination lamp RH harness connector (A) and daytime light relay harness connector (B).

| A | | B | | Continuity |
|-----------|----------|-----------|----------|------------|
| Connector | Terminal | Connector | Terminal | |
| E47 | 2 | E34 | 3 | Yes |

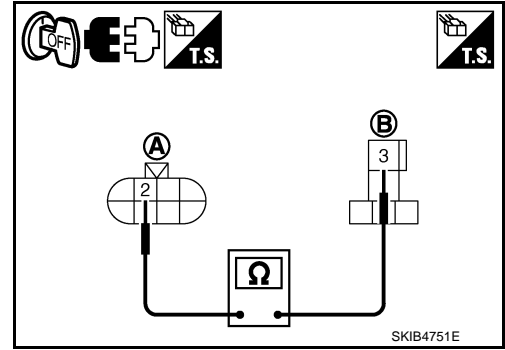

3. Check continuity between daytime light relay harness connector and ground.

| Daytime light re- lay connector | Terminal | Ground | Continuity |
|------------------------------------|----------|--------|------------|
| E34 | 4 | | Yes |

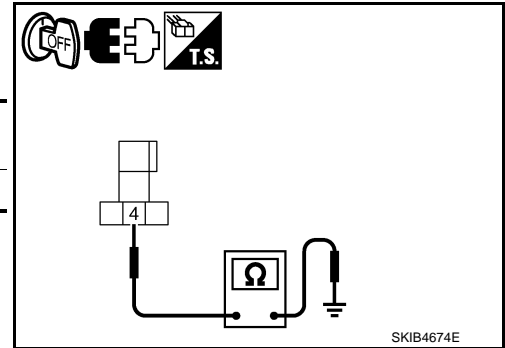

OK or NG

- OK >> GO TO 7.
- NG >> Repair harness or connector.

7. CHECK DAYTIME LIGHT RELAY

Check continuity between daytime light relay terminals.

| Daytime light relay terminals | | Continuity |
|-------------------------------|---|------------|
| 3 | 4 | Yes |

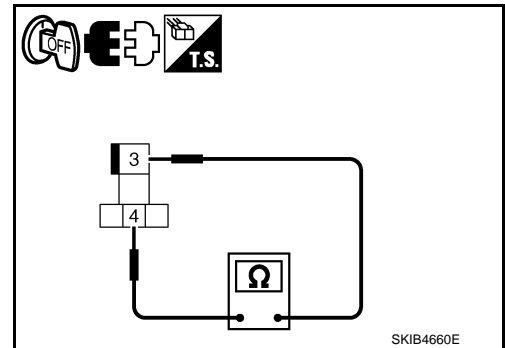

- OK >> Check headlamp bulb and connecting condition combination lamp terminal connector.
- NG >> Replace daytime light relay.

8. CHECK CIRCUIT BETWEEN IPDM E/R AND FRONT COMBINATION LAMP

1. Turn ignition switch OFF.
2. Disconnect IPDM E/R connector.
3. Check continuity between IPDM E/R harness connector (A) and front combination lamp (RH and LH) harness connector (B).

| Circuit | A | | B | | Continuity |
|---------|-----------|----------|-----------|----------|------------|
| | Connector | Terminal | Connector | Terminal | |
| RH | E7 | 27 | E47 | 6 | Yes |
| LH | | 28 | E54 | 6 | |

4. Check continuity between IPDM E/R harness connector (A) and ground.

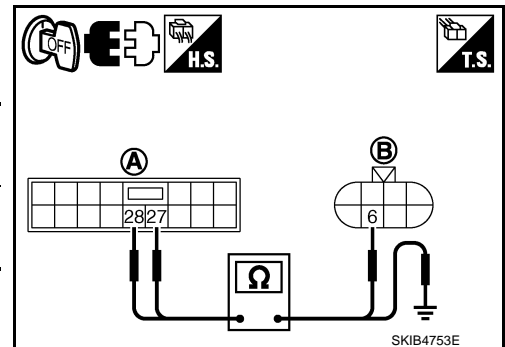

| A | | Ground | Continuity |
|-----------|----------|--------|------------|
| Connector | Terminal | | |
| RH | E7 | 27 | No |
| LH | | 28 | |

HEADLAMP (FOR CANADA) - DAYTIME LIGHT SYSTEM -

< SERVICE INFORMATION >

OK or NG

- OK >> Replace IPDM E/R. Refer to [PG-27, "Removal and Installation of IPDM E/R"](#).
- NG >> Repair harness or connector.

RH High Beam Does Not Illuminate But LH High Beam Illuminates

INFOID:000000002956722

1. CHECK BULB

Check bulb of lamp.

OK or NG

- OK >> GO TO 2.
- NG >> Replace headlamp bulb.

2. CHECK HEADLAMP INPUT SIGNAL

CONSULT-III ACTIVE TEST

1. Disconnect front combination lamp RH connector.
2. Select "LAMPS" of IPDM E/R active test item.
3. Touch "HI" screen.
4. With operating the test item, check voltage between front combination lamp RH harness connector and ground. (Headlamp high beam repeats ON-OFF every 1 second.)

| Terminals | | | Voltage (Approx.) |
|-------------------------------------|----------|--------|-------------------|
| (+) | | (-) | |
| Front combination lamp RH connector | Terminal | | |
| E47 | 6 | Ground | Battery voltage |

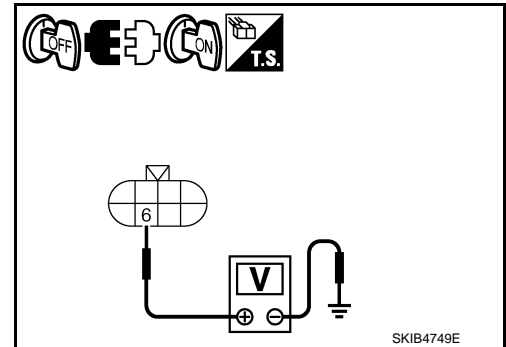

IPDM E/R AUTO ACTIVE TEST

1. Disconnect front combination lamp RH connector.
2. Activate auto active test. Refer to [PG-22, "Auto Active Test"](#).
3. When headlamp HI is operating, check voltage between front combination lamp RH harness connector and ground.

| Terminals | | | Voltage (Approx.) |
|-------------------------------------|----------|--------|-------------------|
| (+) | | (-) | |
| Front combination lamp RH connector | Terminal | | |
| E47 | 6 | Ground | Battery voltage |

OK or NG

- OK >> GO TO 4.
- NG >> GO TO 3.

3. CHECK CONTINUITY BETWEEN IPDM E/R AND FRONT COMBINATION LAMP

1. Turn ignition switch OFF.
2. Disconnect IPDM E/R connector.
3. Check continuity between IPDM E/R harness connector (A) and front combination lamp RH harness connector (B).

| A | | B | | Continuity |
|-----------|----------|-----------|----------|------------|
| Connector | Terminal | Connector | Terminal | |
| E7 | 27 | E47 | 6 | Yes |

4. Check continuity between IPDM E/R harness connector (A) and ground.

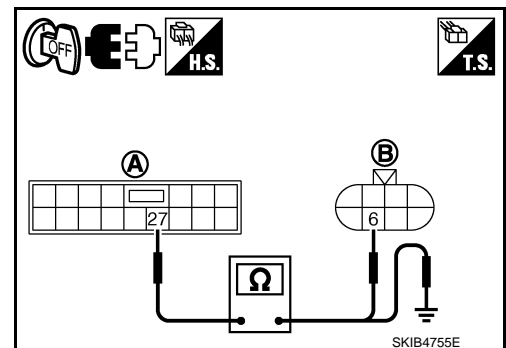

HEADLAMP (FOR CANADA) - DAYTIME LIGHT SYSTEM -

< SERVICE INFORMATION >

| A | | Ground | Continuity |
|-----------|----------|--------|------------|
| Connector | Terminal | | |
| E7 | 27 | | No |

OK or NG

- OK >> Replace IPDM E/R. Refer to [PG-27, "Removal and Installation of IPDM E/R"](#).
- NG >> Repair harness or connector.

4.CHECK HEADLAMP GROUND (1)

1. Turn ignition switch OFF.
2. Remove daytime light relay.
3. Check continuity between front combination lamp RH harness connector (A) and daytime light relay harness connector (B).

| A | | B | | Continuity |
|-----------|----------|-----------|----------|------------|
| Connector | Terminal | Connector | Terminal | |
| E47 | 2 | E34 | 3 | Yes |

OK or NG

- OK >> GO TO 5.
- NG >> Repair harness or connector.

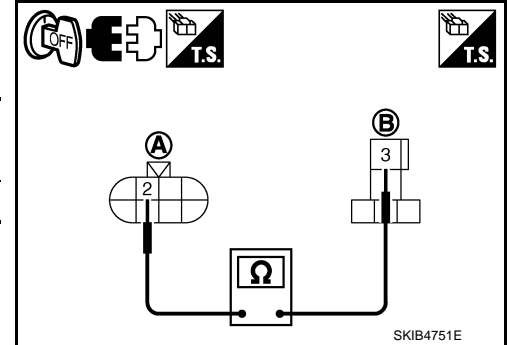

5. CHECK HEADLAMP GROUND (2)

Check continuity between daytime light relay harness connector and ground.

| Daytime light relay connector | Terminal | Ground | Continuity |
|-------------------------------|----------|--------|------------|
| E34 | 4 | | |

OK or NG

- OK >> GO TO 6.
- NG >> Repair harness or connector.

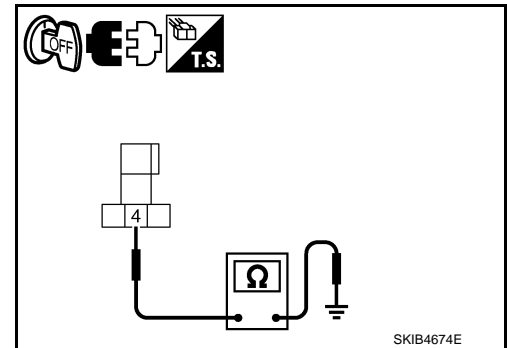

6.CHECK DAYTIME RELAY

Check continuity between daytime light relay terminals.

| Daytime light relay terminals | | Continuity |
|-------------------------------|---|------------|
| 3 | 4 | Yes |

- OK >> Check connecting condition front combination lamp RH harness connector.
- NG >> Replace daytime light relay.

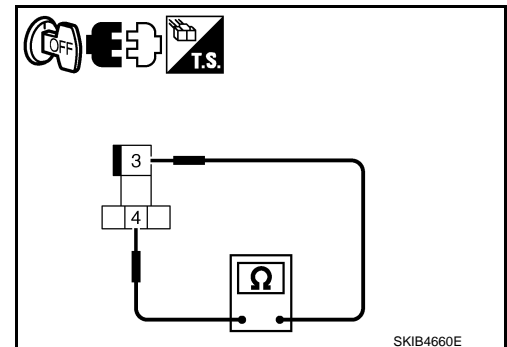

LH High Beam Does Not Illuminate But RH High Beam Illuminates

INFOID:000000002956723

1.CHECK BULB

Check bulb of lamp.

OK or NG

- OK >> GO TO 2.
- NG >> Replace bulb of lamp.

HEADLAMP (FOR CANADA) - DAYTIME LIGHT SYSTEM -

< SERVICE INFORMATION >

2. CHECK HEADLAMP INPUT SIGNAL

CONSULT-III ACTIVE TEST

1. Disconnect front combination lamp LH connector.
2. Select "LAMPS" of IPDM E/R active test item.
3. Touch "HI" screen.
4. With operating the test item, check voltage between front combination lamp LH harness connector and ground. (Headlamp high beam repeats ON-OFF every 1 second.)

| Terminals | | | Voltage (Approx.) |
|-------------------------------------|----------|--------|-------------------|
| (+) | | (-) | |
| Front combination lamp LH connector | Terminal | | |
| E54 | 6 | Ground | Battery voltage |

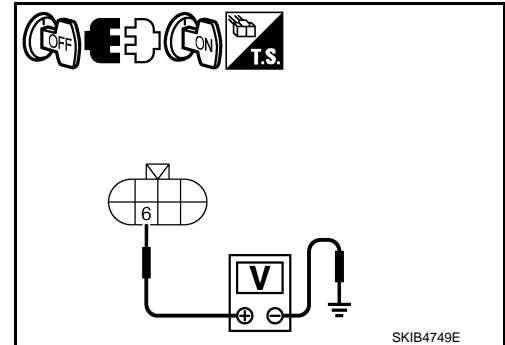

IPDM E/R AUTO ACTIVE TEST

1. Disconnect front combination lamp LH connector.
2. Activate auto active test. Refer to [PG-22, "Auto Active Test"](#).
3. When headlamp high beam is operating, check voltage between front combination lamp LH harness connector and ground.

| Terminals | | | Voltage (Approx.) |
|-------------------------------------|----------|--------|-------------------|
| (+) | | (-) | |
| Front combination lamp LH connector | Terminal | | |
| E54 | 6 | Ground | Battery voltage |

OK or NG

- OK >> GO TO 3.
 NG >> GO TO 4.

3. CHECK HEADLAMP GROUND

1. Turn ignition switch OFF.
2. Check continuity front combination lamp harness connector and ground.

| Front combination lamp LH connector | Terminal | Ground | Continuity |
|-------------------------------------|----------|--------|------------|
| E54 | 2 | | Yes |

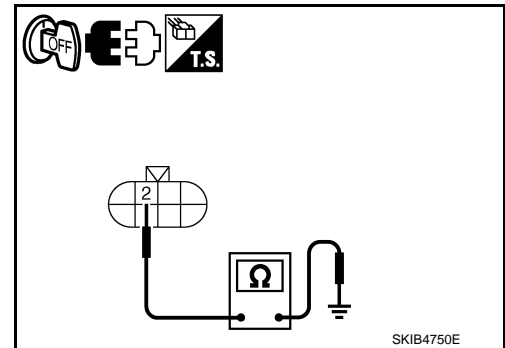

OK or NG

- OK >> Check connecting condition front headlamp LH connector harness.
 NG >> Repair harness or connector.

4. CHECK CIRCUIT BETWEEN IPDM E/R AND FRONT COMBINATION LAMP

1. Turn ignition switch OFF.
2. Disconnect IPDM E/R connector and front combination lamp LH connector.

HEADLAMP (FOR CANADA) - DAYTIME LIGHT SYSTEM -

< SERVICE INFORMATION >

OK or NG

- OK >> Replace IPDM E/R. Refer to [PG-27, "Removal and Installation of IPDM E/R"](#).
 NG >> Replace BCM. Refer to [BCS-14, "Removal and Installation of BCM"](#).

4. CHECK HEADLAMP INPUT SIGNAL

Ⓟ CONSULT-III ACTIVE TEST

1. Turn ignition switch OFF.
2. Disconnect front combination lamp RH and LH connector.
3. Select "LAMPS" of IPDM E/R active test item.
4. Touch "LO" screen.
5. With operating the test item, check voltage between front combination lamp (RH and LH) harness connector and ground.

| Terminal | | | (-) | Voltage (Approx.) |
|----------------------------------|-----|----------|-----|-------------------|
| (+) | | terminal | | |
| Front combination lamp connector | | | | Ground |
| RH | E47 | 8 | | |
| LH | E54 | 8 | | |

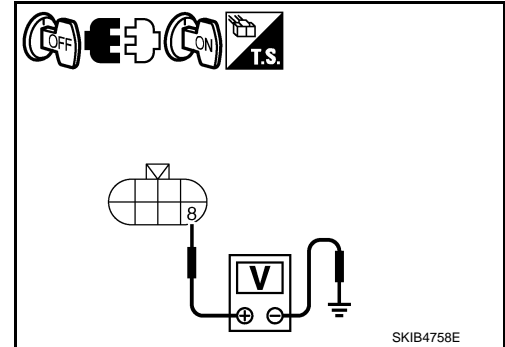

ⓧ IPDM E/R AUTO ACTIVE TEST

1. Turn ignition switch OFF.
2. Disconnect front combination lamp RH and LH connector.
3. Activate auto active test. Refer to [PG-22, "Auto Active Test"](#).
4. When headlamp low beam is operating, check voltage between front combination lamp (RH and LH) harness connector and ground.

| Terminal | | | (-) | Voltage (Approx.) |
|----------------------------------|-----|----------|-----|-------------------|
| (+) | | terminal | | |
| Front combination lamp connector | | | | Ground |
| RH | E47 | 8 | | |
| LH | E54 | 8 | | |

OK or NG

- OK >> GO TO 5.
 NG >> GO TO 6.

5. CHECK HEADLAMP GROUND

1. Turn ignition switch OFF.
2. Check continuity between front combination lamp (RH and LH) harness connector and ground.

| Front combination lamp connector | | Terminal | Ground | Continuity |
|----------------------------------|-----|----------|--------|------------|
| RH | E47 | 4 | | Ground |
| LH | E54 | 4 | | |

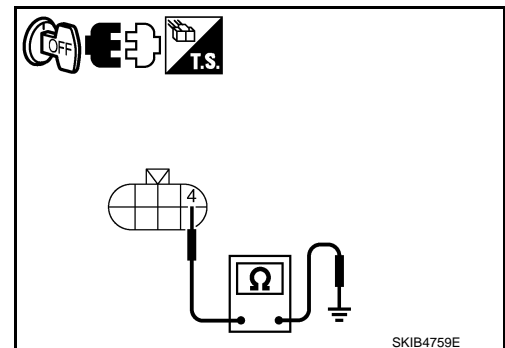

OK or NG

- OK >> Check headlamp harness, connectors, ballasts (HID control unit), and xenon bulbs. Refer to [LT-91, "Xenon Headlamp Trouble Diagnosis"](#).
 NG >> Repair harness or connector.

6. CHECK CIRCUIT BETWEEN IPDM E/R AND FRONT COMBINATION LAMP

1. Turn ignition switch OFF.
2. Disconnect IPDM E/R connector.

HEADLAMP (FOR CANADA) - DAYTIME LIGHT SYSTEM -

< SERVICE INFORMATION >

- Check continuity between IPDM E/R harness connector (A) and front combination lamp (RH and LH) harness connector (B).

| Circuit | A | | B | | Continuity |
|---------|-----------|----------|-----------|----------|------------|
| | Connector | Terminal | Connector | Terminal | |
| RH | E7 | 20 | E47 | 8 | Yes |
| LH | | 30 | E54 | 8 | |

- Check continuity between IPDM E/R harness connector (A) and ground.

| A | | | Ground | Continuity |
|-----------|----|----------|--------|------------|
| Connector | | Terminal | | |
| RH | E7 | 20 | Ground | No |
| LH | | 30 | | |

OK or NG

- OK >> Replace IPDM E/R. Refer to [PG-27, "Removal and Installation of IPDM E/R"](#).
 NG >> Repair harness or connector.

Headlamp Low Beam Does Not Illuminate (One Side)

INFOID:000000002956725

1. CHECK BULB

Check ballast (HID control unit) and xenon bulb of lamp which does not illuminate. Refer to [LT-91, "Xenon Headlamp Trouble Diagnosis"](#).

OK or NG

- OK >> GO TO 2.
 NG >> Repair malfunctioning part.

2. CHECK HEADLAMP INPUT SIGNAL

CONSULT-III ACTIVE TEST

- Turn ignition switch OFF.
- Disconnect front combination lamp RH or LH connector.
- Select "LAMPS" of IPDM E/R active test item.
- Touch "LO" screen.
- With operating the test item, check voltage between front combination lamp RH or LH harness connector and ground.

| Terminal | | | (-) | Voltage (Approx.) |
|--------------------------------------|-----|----------|--------|-------------------|
| (+) Front combination lamp connector | | Terminal | | |
| RH | E47 | 8 | Ground | Battery voltage |
| LH | E54 | 8 | | |

IPDM E/R AUTO ACTIVE TEST

- Turn ignition switch OFF.
- Disconnect front combination lamp RH or LH connector.
- Activate auto active test. Refer to [PG-22, "Auto Active Test"](#).
- When headlamp low beam is operating, check voltage between front combination lamp RH or LH harness connector and ground.

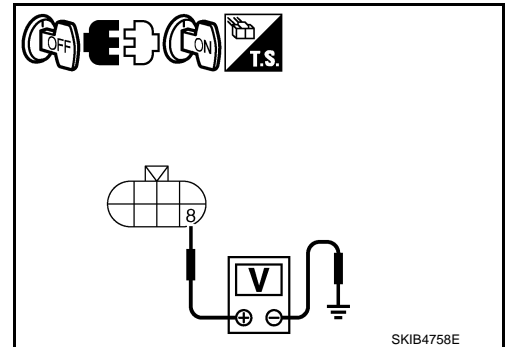
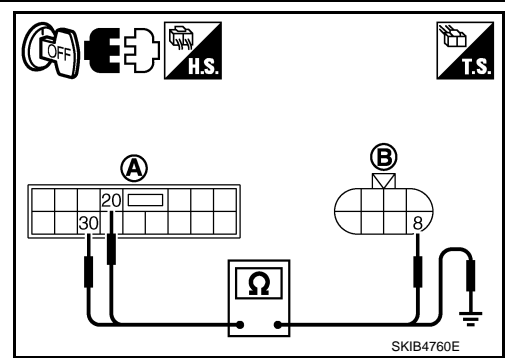

HEADLAMP (FOR CANADA) - DAYTIME LIGHT SYSTEM -

< SERVICE INFORMATION >

| Terminal | | | (-) | Voltage (Approx.) |
|----------------------------------|-----|----------|-----|-------------------|
| (+) | | Terminal | | |
| Front combination lamp connector | | | | Ground |
| RH | E47 | 8 | | |
| LH | E54 | 8 | | |

OK or NG

- OK >> GO TO 3.
- NG >> GO TO 4.

3.CHECK HEADLAMP GROUND

1. Turn ignition switch OFF.
2. Check continuity between front combination lamp RH or LH harness connector and ground.

| Front combination lamp connector | Terminal | Ground | Continuity |
|----------------------------------|----------|--------|------------|
| RH | E47 | | 4 |
| LH | E54 | 4 | |

OK or NG

- OK >> Check connecting condition headlamp harness connector.
- NG >> Repair harness or connector.

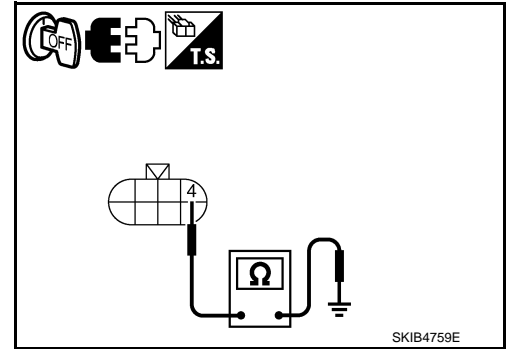

4.CHECK CIRCUIT BETWEEN IPDM E/R AND FRONT COMBINATION LAMP

1. Turn ignition switch OFF.
2. Disconnect IPDM E/R connector.
3. Check continuity between IPDM E/R harness connector (A) and front combination lamp RH or LH harness connector (B).

| Circuit | A | | B | | Continuity |
|---------|-----------|----------|-----------|----------|------------|
| | Connector | Terminal | Connector | Terminal | |
| RH | E7 | 20 | E47 | 8 | Yes |
| LH | | 30 | E54 | 8 | |

4. Check continuity between IPDM E/R harness connector (A) and ground.

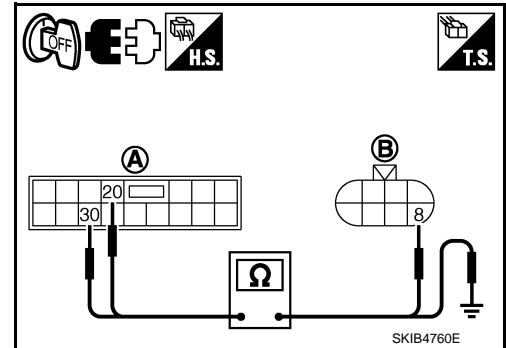

| A | | Ground | Continuity |
|-----------|----------|--------|------------|
| Connector | Terminal | | |
| RH | E7 | 20 | No |
| LH | | 30 | |

OK or NG

- OK >> Replace IPDM E/R. Refer to [PG-27. "Removal and Installation of IPDM E/R"](#).
- NG >> Repair harness or connector.

Headlamps Do Not Turn OFF

INFOID:00000002956726

1.CHECK HEADLAMP TURN OFF

Make sure that lighting switch is OFF. And make sure is headlamp turns off when ignition switch is turned OFF.

OK or NG

- OK >> GO TO 3.

HEADLAMP (FOR CANADA) - DAYTIME LIGHT SYSTEM -

< SERVICE INFORMATION >

NG >> GO TO 2.

2.CHECK COMBINATION SWITCH INPUT SIGNAL

CONSULT-III DATA MONITOR

1. Select "HEAD LAMP SW 1" and "HEAD LAMP SW 2" of BCM (HEAD LAMP) data monitor item.
2. With operating the lighting switch, check the monitor status.

When lighting switch is OFF : HEAD LAMP SW 1 OFF
position : HEAD LAMP SW 2 OFF

OK or NG

OK >> Replace IPDM E/R. Refer to [PG-27, "Removal and Installation of IPDM E/R"](#).

NG >> Check lighting switch. Refer to [LT-202, "Combination Switch Inspection"](#).

3.CHECK CAN COMMUNICATIONS BETWEEN BCM AND IPDM E/R

CONSULT-III SELF-DIAGNOSIS

Perform self-diagnosis for "BCM".

Display of self-diagnosis results

NO DTC>> Replace IPDM E/R. Refer to [PG-27, "Removal and Installation of IPDM E/R"](#).

CAN COMM CIRCUIT>> Refer to [LAN-17, "CAN Diagnosis with CONSULT-III"](#).

General Information for Xenon Headlamp Trouble Diagnosis

INFOID:000000002956727

In most cases, malfunction of xenon headlamp - "does not illuminate", "flickers" or "dark" - is caused by a malfunctioning xenon bulb. A HID control unit or lamp housing, however, may be a cause of malfunction. Be sure to perform trouble diagnosis following the steps described below.

Caution

INFOID:000000002956728

- Installation or removal of connector must be done with lighting switch OFF.
- When lamp is illuminated (when lighting switch is ON), do not touch harness, HID control unit, inside of lamp, or lamp metal parts.
- To check illumination, temporarily install lamp in the vehicle. Be sure to connect power at the vehicle-side connector.
- If the error can be traced directly to the electrical system, first check for items such as burned-out fuses and fusible links, broken wires or loose connectors, pulled-out terminals, and improper connections.
- Do not work with wet hands.
- Using a tester for HID control unit circuit trouble diagnosis is prohibited.
- Disassembling the HID control unit or harnesses (bulb socket harness, ECM harness) is prohibited.
- Immediately after illumination, the light intensity and color will fluctuate, but there is nothing wrong.
- When the bulb has reached the end of its lifetime, the brightness may drop significantly, it may flash repeatedly, or the light may turn a reddish color.

Xenon Headlamp Trouble Diagnosis

INFOID:000000002956729

1.CHECK 1: XENON HEADLAMP LIGHTING

Install normal xenon bulb to corresponding xenon bulb headlamp, and check if lamp lights up.

OK or NG

OK >> Replace xenon bulb.

NG >> GO TO 2.

2.CHECK 2: XENON HEADLAMP LIGHTING

Install normal HID control unit to corresponding xenon headlamp, and check if lamp lights up.

OK or NG

OK >> Replace HID control unit.

NG >> GO TO 3.

3.CHECK 3: XENON HEADLAMP LIGHTING

Install normal xenon lamp housing assembly to corresponding xenon headlamp, and check if lamp lights up.

HEADLAMP (FOR CANADA) - DAYTIME LIGHT SYSTEM -

< SERVICE INFORMATION >

OK or NG

OK >> Replace xenon headlamp housing assembly.
NG >> INSPECTION END

Aiming Adjustment

INFOID:000000002956730

Refer to [LT-30, "Aiming Adjustment"](#) in "HEADLAMP -CONVENTIONAL TYPE-".
Refer to [LT-58, "Aiming Adjustment"](#) in "HEADLAMP -XENON TYPE-".

Bulb Replacement

INFOID:000000002956731

Refer to [LT-31, "Bulb Replacement"](#) in "HEADLAMP -CONVENTIONAL TYPE-".
Refer to [LT-59, "Bulb Replacement"](#) in "HEADLAMP -XENON TYPE-".

Removal and Installation

INFOID:000000002956732

Refer to [LT-32, "Removal and Installation"](#) in "HEADLAMP -CONVENTIONAL TYPE-".
Refer to [LT-61, "Removal and Installation"](#) in "HEADLAMP -XENON TYPE-".

Disassembly and Assembly

INFOID:000000002956733

Refer to [LT-33, "Disassembly and Assembly"](#) in "HEADLAMP -CONVENTIONAL TYPE-".
Refer to [LT-61, "Disassembly and Assembly"](#) in "HEADLAMP -XENON TYPE-".

AUTO LIGHT SYSTEM

< SERVICE INFORMATION >

AUTO LIGHT SYSTEM

Component Parts and Harness Connector Location

INFOID:000000002956734

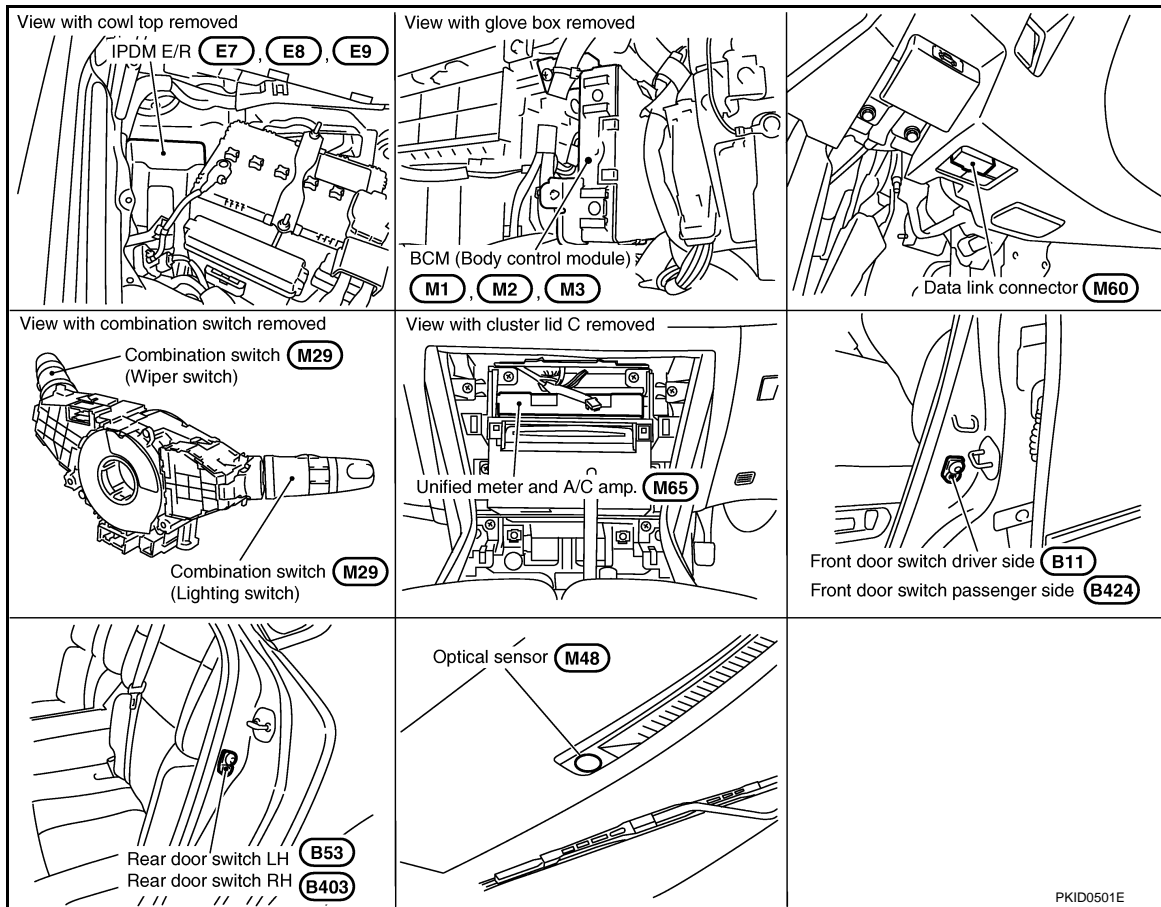

System Description

INFOID:000000002956735

Automatically turns ON/OFF the parking lamps and the headlamps in accordance with ambient light. Timing for when lamps turn ON/OFF can be selected using four modes.

OUTLINE

The auto light control system has an optical sensor inside it that detects outside brightness.

When the lighting switch is in AUTO position, it automatically turns ON/OFF the parking lamps and the headlamps in accordance with ambient light. Sensitivity can be adjusted in four steps. For the details of the setting, Refer to [LT-103, "Preliminary Check"](#).

Optical sensor, power is supplied

- from BCM (body control module) terminal 17
- to optical sensor terminal 1.

Optical sensor, ground is supplied

- to optical sensor terminal 3
- through BCM terminal 18.

When ignition switch is turn to ON position, and

When outside brightness is darker than prescribed level, input is supplied

- from optical sensor terminal 2
- to BCM terminal 14.

The headlamps will then illuminate. For a description of headlamp operation, Refer to "System Description".

COMBINATION SWITCH READING FUNCTION

Refer to [BCS-4, "System Description"](#).

EXTERIOR LAMP BATTERY SAVER CONTROL

When the combination switch (lighting switch) is in the 2ND position (or if auto light system is activated), and the ignition switch is turned from ON or ACC to OFF, the battery saver control function is activated.

AUTO LIGHT SYSTEM

< SERVICE INFORMATION >

Under this condition, the headlamps remain illuminated for 5 minutes, then the headlamps are turned off. Exterior lamp battery saver control mode can be changed by the function setting of CONSULT-III.

DELAY TIMER FUNCTION

Delay timer function carries out a function that BCM activates the timer and controls lights out of headlamps by door switch signal and lightning switch signal when turning the Ignition switch OFF while it is ON and headlamps are ON by the auto light function.

Timer types are a 5 minutes timer and a 45 seconds timer

- When opening any door (door switch is ON), the 5 minutes timer starts and then headlamps go out five minutes later
- When all the doors are closed (from door switch ON to OFF), the 45 second timer starts and then headlamps go out 45 seconds later. If any door is opened (door switch ON) while the 45 seconds timer is in operation, the 5 minutes timer starts again
- The timer stops when turning on the ignition switch or turning off the auto light switch under the above conditions.

Delay timer control mode can be changed by the function setting of CONSULT-III.

CAN Communication System Description

INFOID:000000002956736

CAN (Controller Area Network) is a serial communication line for real time application. It is an on-vehicle multiplex communication line with high data communication speed and excellent error detection ability. Many electronic control units are equipped onto vehicle, and each control unit shares information and links with other control units during operation (not independent). In CAN communication, control units are connected with 2 communication lines (CAN H line, CAN L line) allowing the high rate of information transmission with less wiring. Each control unit transmits/receives data but selectively reads required data only.

CAN Communication Unit

INFOID:000000002956737

Refer to [LAN-11. "System Description"](#).

Major Component and Functions

INFOID:000000002956738

| Components | Functions |
|----------------|--|
| BCM | <ul style="list-style-type: none">• Turns on/off circuits of tail light and headlamp according to signals from optical sensor, lighting switch (AUTO), driver door switch, passenger door switch, rear door switch, and ignition switch (ON, OFF). |
| Optical sensor | <ul style="list-style-type: none">• Converts outside brightness (lux) to voltage, and sends it to BCM. (Detects brightness of 50 to 1,300 lux) |

AUTO LIGHT SYSTEM

< SERVICE INFORMATION >

Schematic

INFOID:00000002956739

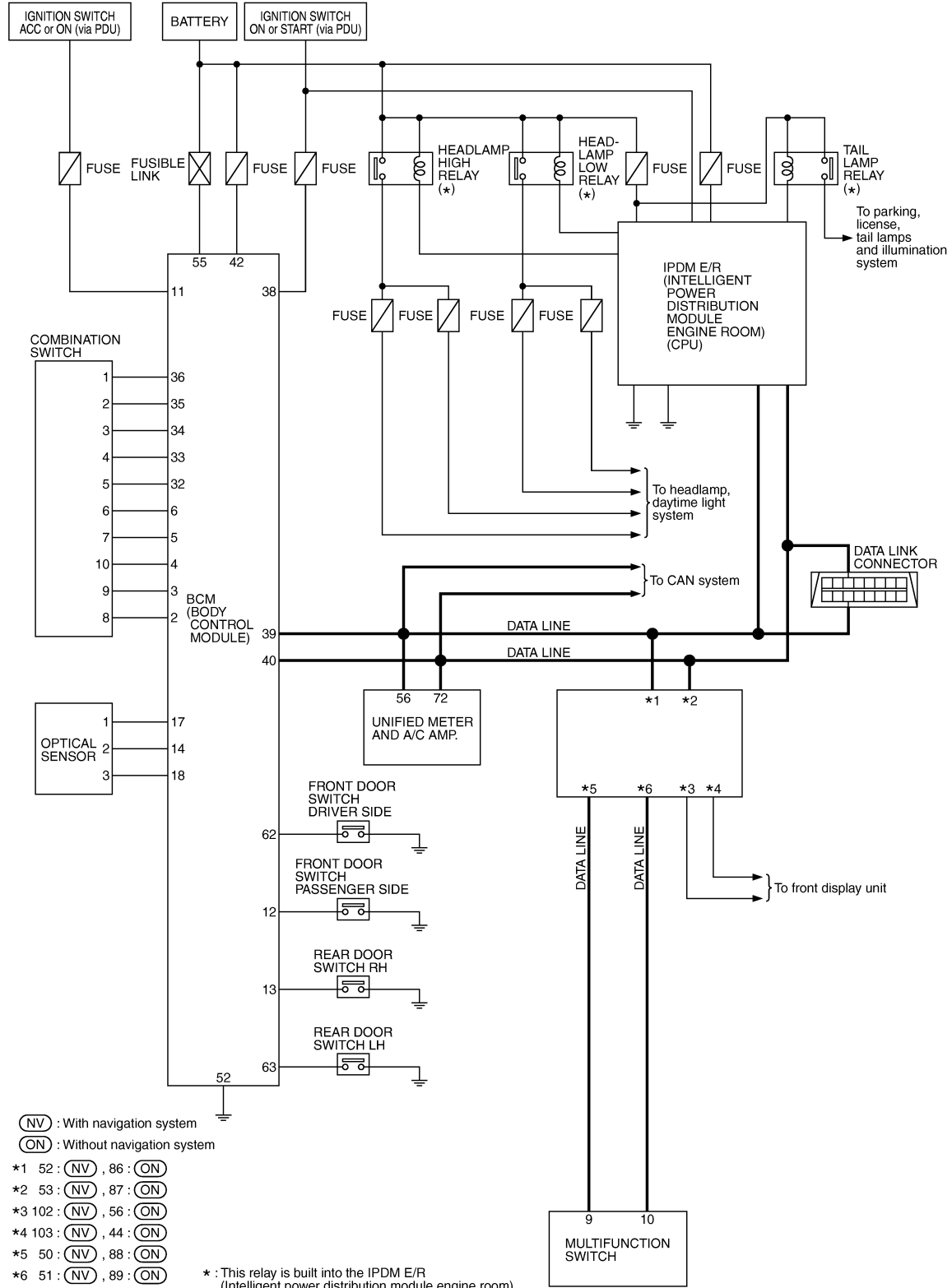

TKWT6810E

A
B
C
D
E
F
G
H
I
J
LT
L
M
N
O
P

AUTO LIGHT SYSTEM

< SERVICE INFORMATION >

Wiring Diagram - AUTO/L -

INFOID:00000002956740

LT-AUTO/L-01

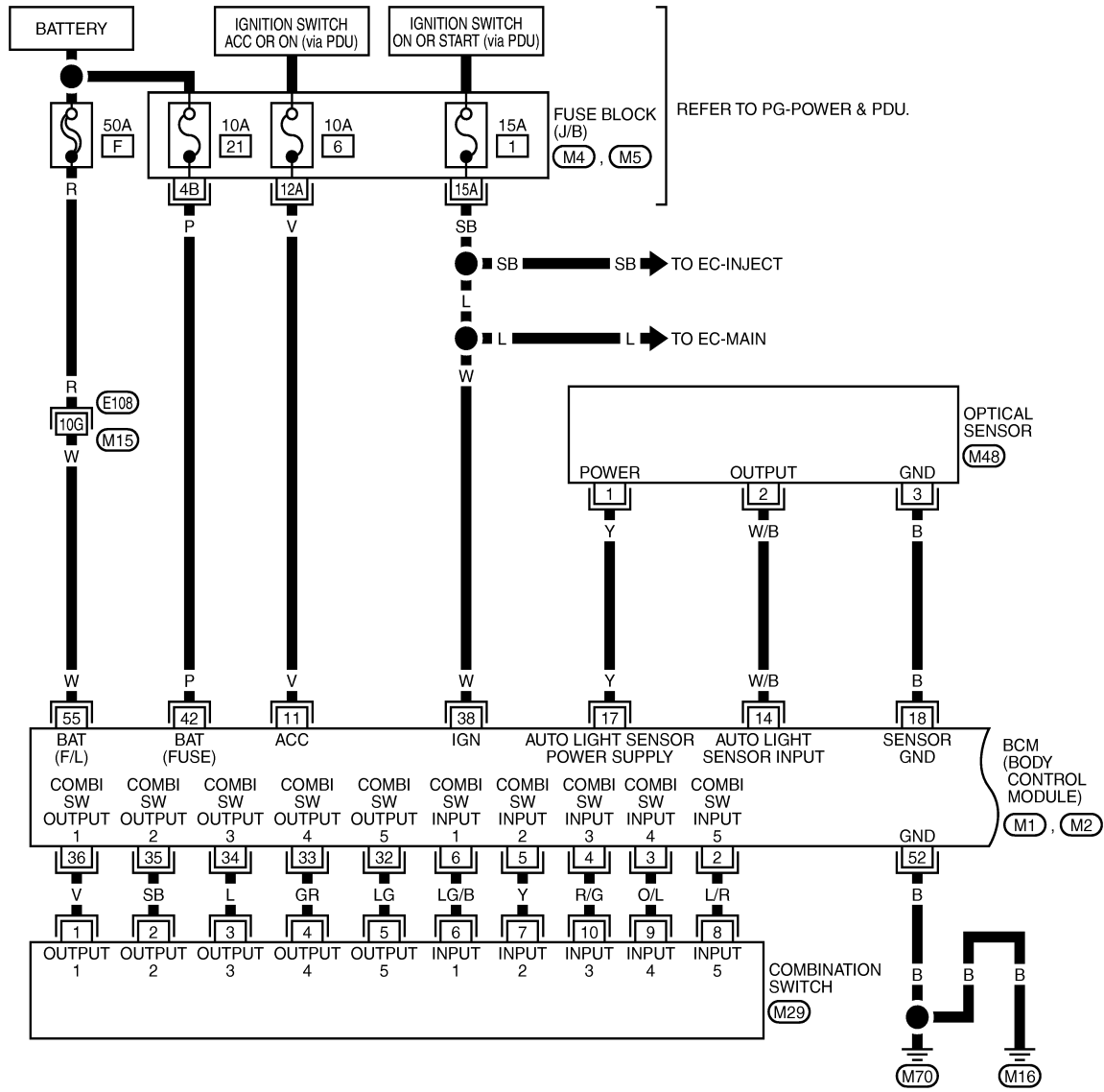

REFER TO THE FOLLOWING.

- (E108) - SUPER MULTIPLE JUNCTION (SMJ)
- (M4), (M5) - FUSE BLOCK-JUNCTION BOX (J/B)
- (M1), (M2) - ELECTRICAL UNITS

TKWT6811E

AUTO LIGHT SYSTEM

< SERVICE INFORMATION >

LT-AUTO/L-02

▬ : DATA LINE

(NV) : WITH NAVIGATION SYSTEM

(ON) : WITHOUT NAVIGATION SYSTEM

*1 52 : (NV), 86 : (ON)

*2 53 : (NV), 87 : (ON)

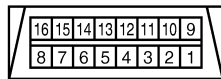
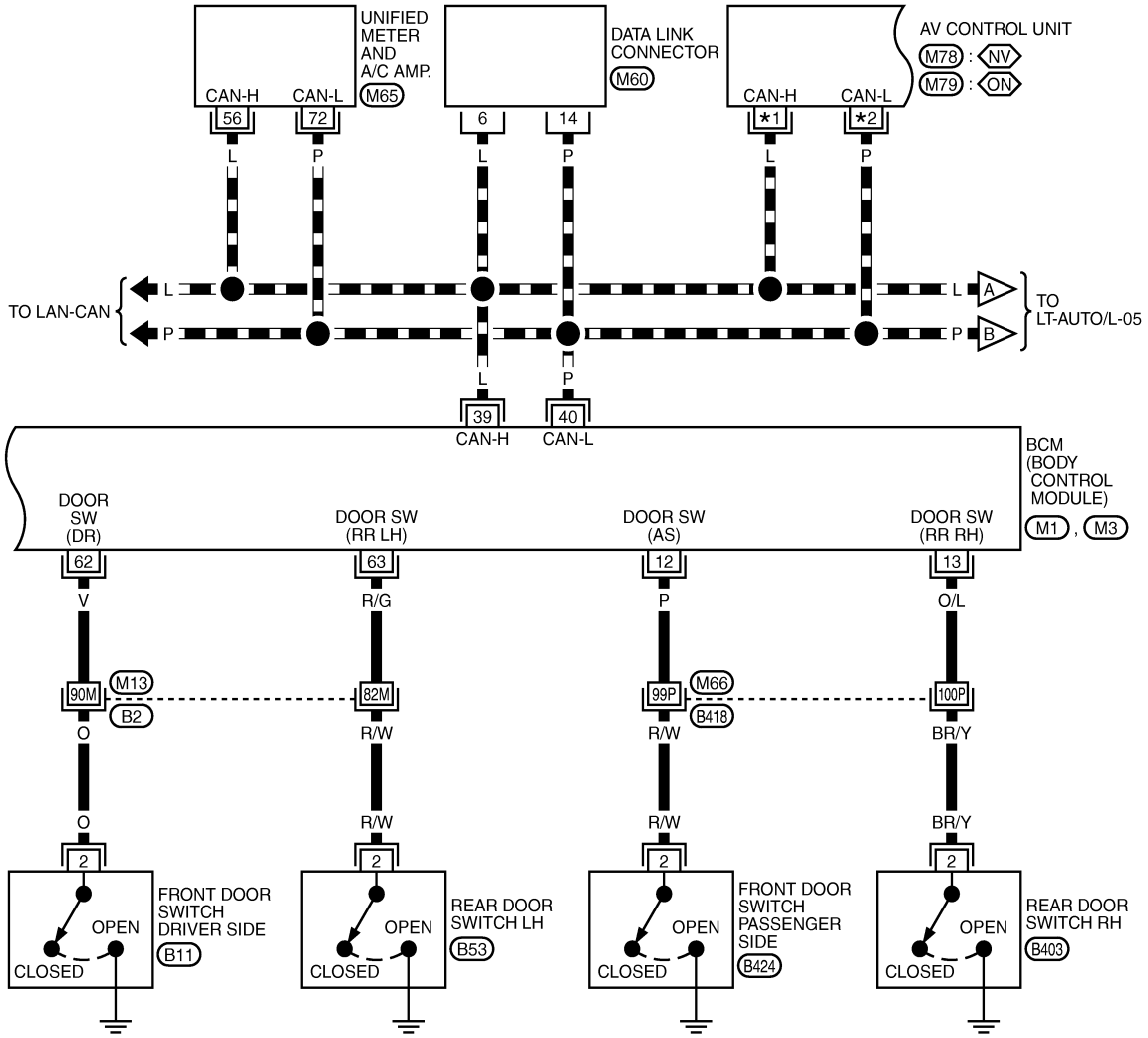

(M60)
W

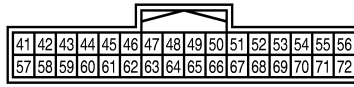

(M65)
W

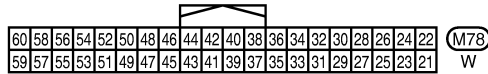

(M78)
W

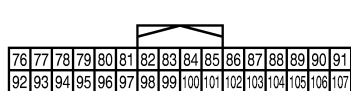

(M79)
W



1
2 (B11), (B53), (B403), (B424)
3 W W W W

REFER TO THE FOLLOWING.

(B2), (B418) - SUPER MULTIPLE JUNCTION (SMJ)

(M1), (M3) - ELECTRICAL UNITS

TKWT6812E

A
B
C
D
E
F
G
H
I
J
K
L
M
N
O
P

LT

AUTO LIGHT SYSTEM

< SERVICE INFORMATION >

LT-AUTO/L-03

▬ : DATA LINE

◊(NV) : WITH NAVIGATION SYSTEM

◊(ON) : WITHOUT NAVIGATION SYSTEM

*1 102 : ◊(NV) , 56 : ◊(ON)

*2 103 : ◊(NV) , 44 : ◊(ON)

*3 50 : ◊(NV) , 88 : ◊(ON)

*4 51 : ◊(NV) , 89 : ◊(ON)

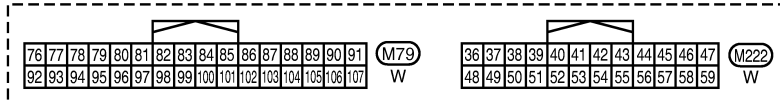
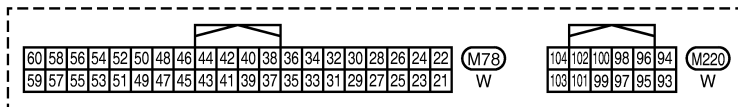
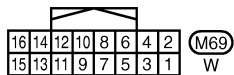
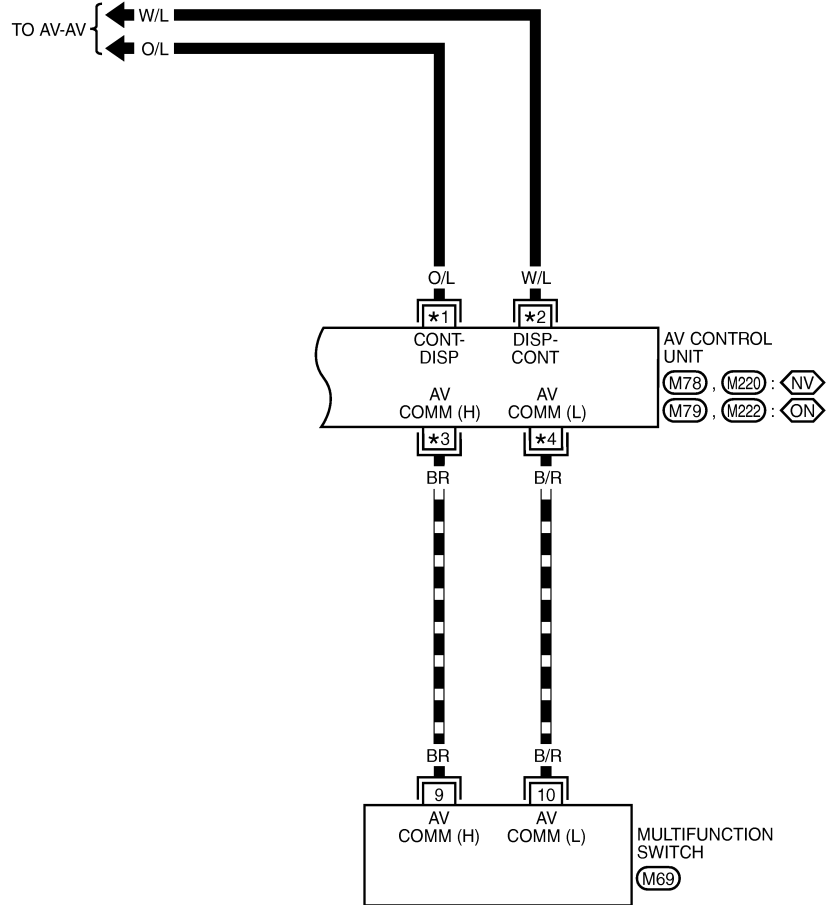

TKWT6813E

AUTO LIGHT SYSTEM

< SERVICE INFORMATION >

LT-AUTO/L-04

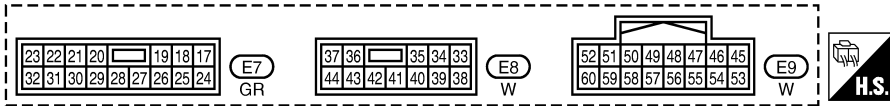
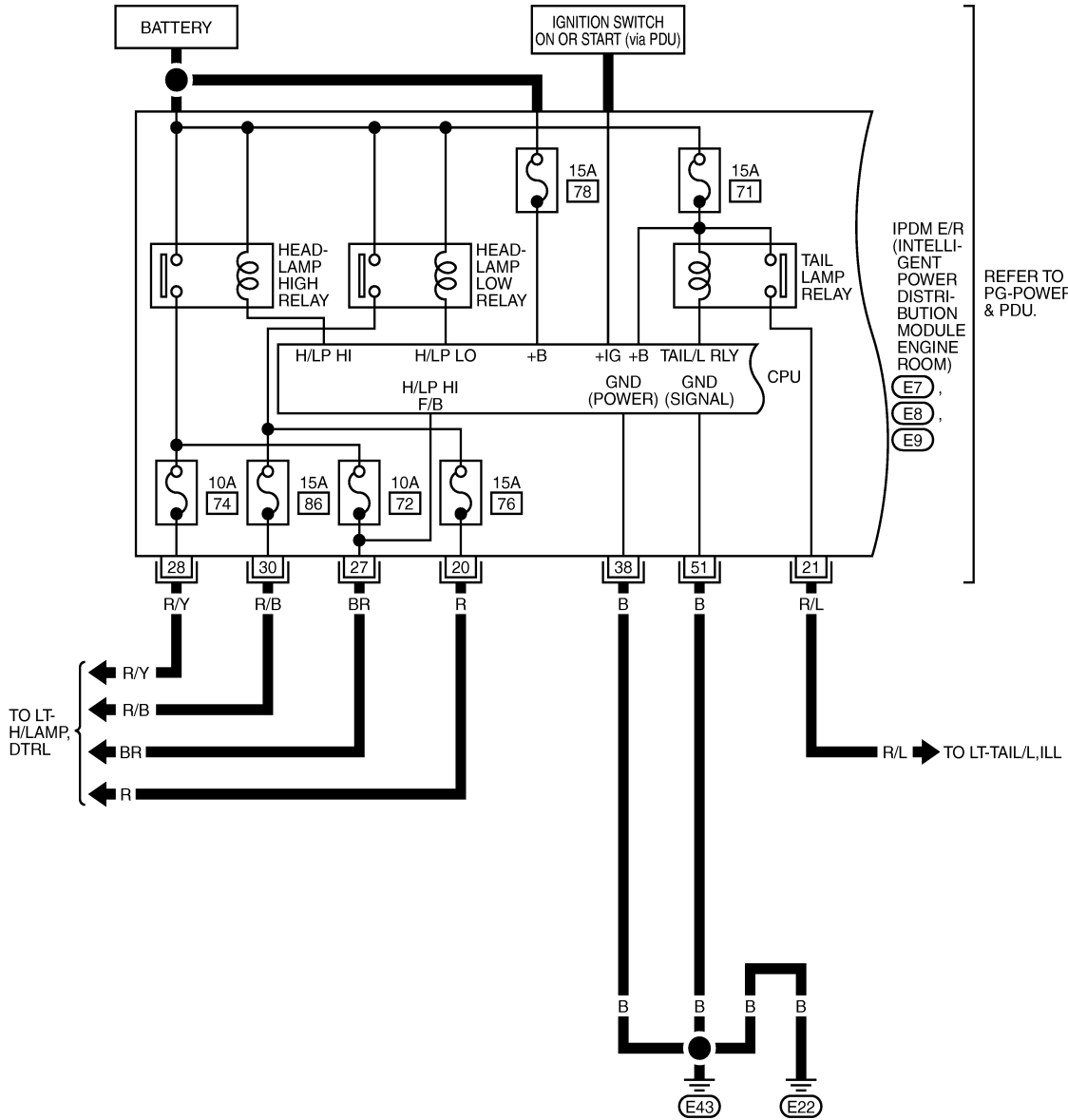

TKWT6814E

A
B
C
D
E
F
G
H
I
J
L
M
N
O
P

LT

AUTO LIGHT SYSTEM

< SERVICE INFORMATION >

LT-AUTO/L-05

▬▬▬ : DATA LINE

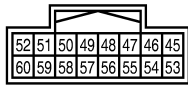
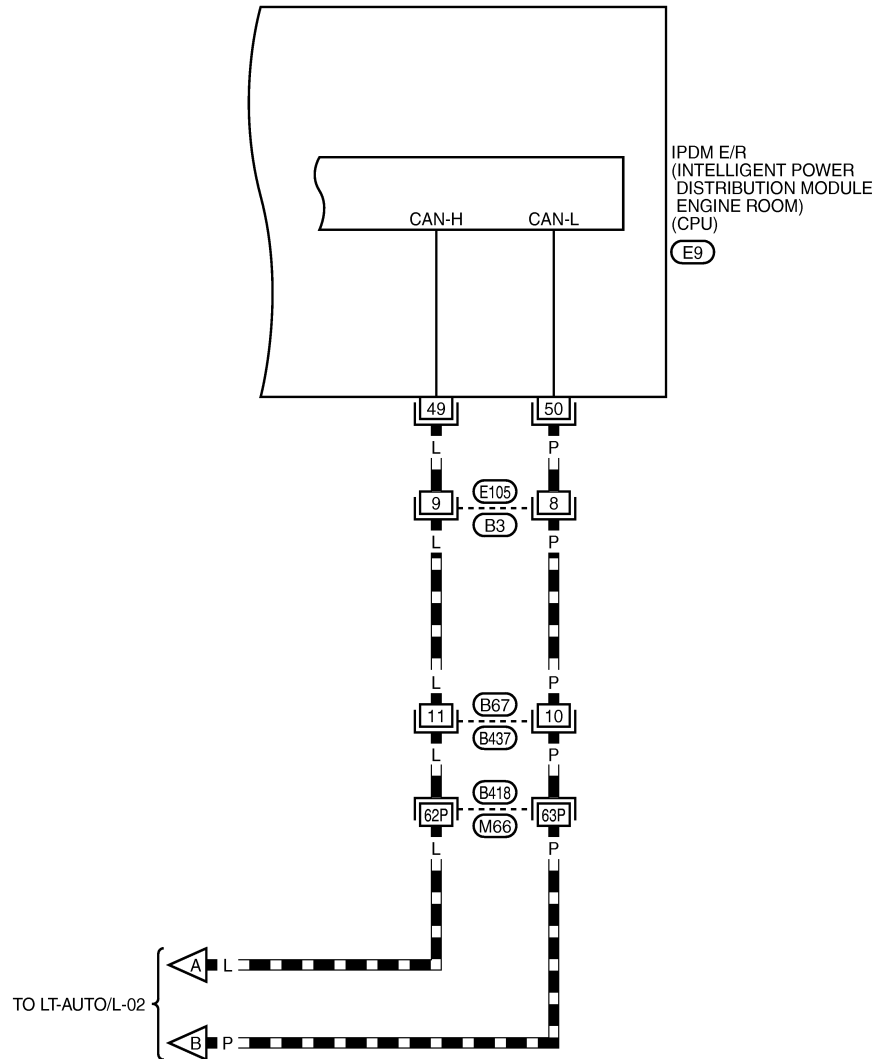

(E9)
W

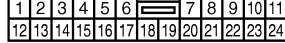

(B3) (B437)
W BR

REFER TO THE FOLLOWING.

(B418) - SUPER MULTIPLE JUNCTION (SMJ)

TKWT6815E

INFOID:000000002956741

Terminal and Reference Value for BCM

CAUTION:

- Check combination switch system terminal waveform under the loaded condition with lighting switch, turn signal switch and wiper switch OFF not to be fluctuated by overloaded.
- Turn wiper dial position to 4 except when checking waveform or voltage of wiper dial position. Wiper dial position can be confirmed on CONSULT-III. Refer to [LT-201, "CONSULT-III Functions \(BCM - COMB SW\)"](#).

AUTO LIGHT SYSTEM

< SERVICE INFORMATION >

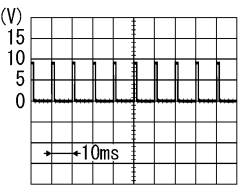
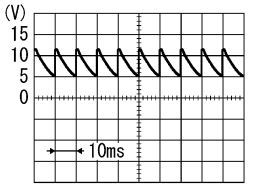
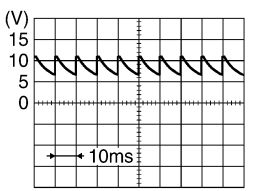
| Terminal No. | Wire color | Signal name | Measuring condition | | Reference value |
|--------------|------------|---|---------------------|--|--|
| | | | Ignition switch | Operation or condition | |
| 4 | R/G | Combination switch input 3 | ON | Lighting, turn, wiper OFF (Wiper dial position 4) | Lighting switch AUTO  Approx. 1.0 V |
| | | | | | OFF |
| 11 | V | Ignition switch (ACC) | ACC | — | Battery voltage |
| 12 | P | Front door switch passenger side signal | OFF | Front door switch pas-senger side | ON (open) Approx. 0 V |
| | | | | | OFF (closed)  Approx. 8.0 - 8.5 V |
| 13 | O/L | Rear door switch RH signal | OFF | Rear door switch RH | ON (open) Approx. 0 V |
| | | | | | OFF (closed)  Approx. 8.5 - 9.0 V |
| 14 | W/B | Optical sensor sig-nal | ON | When optical sensor is illuminated. | 3.1 V or more ^{NOTE} |
| | | | | When optical sensor is not illuminated. | 0.6 V or less |
| 17 | Y | Optical sensor power supply | ON | — | Approx. 5 V |
| 18 | B | Optical sensor ground | ON | — | Approx. 0 V |

A
B
C
D
E
F
G
H
I
J
LT
L
M
N
O
P

AUTO LIGHT SYSTEM

< SERVICE INFORMATION >

| Terminal No. | Wire color | Signal name | Measuring condition | | Reference value |
|--------------|------------|--------------------------------------|---------------------|--|--|
| | | | Ignition switch | Operation or condition | |
| 33 | GR | Combination switch output 4 | ON | Lighting, turn, wiper OFF (Wiper dial position 4) | Lighting switch AUTO PKIB4958J Approx. 1.2 V |
| | | | | | OFF PKIB4960J Approx. 7.0 - 7.5 V |
| 38 | W | Ignition switch (ON) | ON | — | Battery voltage |
| 39 | L | CAN - H | — | — | — |
| 40 | P | CAN - L | — | — | — |
| 42 | P | Battery power supply | OFF | — | Battery voltage |
| 52 | B | Ground | ON | — | Approx. 0 V |
| 55 | W | Battery power supply | OFF | — | Battery voltage |
| 62 | V | Front door switch driver side signal | OFF | Front door switch driver side | ON (open) Approx. 0 V |
| | | | | | OFF (closed) PKIB4960J Approx. 7.5 - 8.0 V |
| 63 | R/G | Rear door switch LH signal | OFF | Rear door switch LH | ON (open) Approx. 0V |
| | | | | | OFF (closed) PKIB4960J Approx. 7.5 - 8.0 V |

NOTE:

Optical sensor must be securely subjected to work lamp light. If the optical sensor is insufficiently illuminated, the measured value may not satisfy standard.

AUTO LIGHT SYSTEM

< SERVICE INFORMATION >

Terminal and Reference Value for IPDM E/R

INFOID:000000002956742

| Terminal No. | Wire color | Signal name | Measuring condition | | Reference value | |
|--------------|------------|---------------------------------------|---------------------|--|-----------------|-----------------|
| | | | Ignition switch | Operation or condition | | |
| 20 | R | Headlamp low (RH) | ON | Lighting switch 2ND position | OFF | Approx. 0 V |
| | | | | | ON | Battery voltage |
| 21 | R/L | Parking, license plate, and tail lamp | ON | Lighting switch 1ST position | OFF | Approx. 0 V |
| | | | | | ON | Battery voltage |
| 27 | BR | Headlamp high (RH) | ON | Lighting switch HIGH or PASSING position | OFF | Approx. 0 V |
| | | | | | ON | Battery voltage |
| 28 | R/Y | Headlamp high (LH) | ON | Lighting switch HIGH or PASSING position | OFF | Approx. 0 V |
| | | | | | ON | Battery voltage |
| 30 | R/B | Headlamp low (LH) | ON | Lighting switch 2ND position | OFF | Approx. 0 V |
| | | | | | ON | Battery voltage |
| 38 | B | Ground | ON | — | Approx. 0 V | |
| 49 | L | CAN – H | — | — | — | |
| 50 | P | CAN – L | — | — | — | |
| 51 | B | Ground | ON | — | Approx. 0 V | |

How to Perform Trouble Diagnosis

INFOID:000000002956743

1. Confirm the symptom or customer complaint.
2. Understand operation description and function description. Refer to [LT-93, "System Description"](#).
3. Perform the Preliminary Check. Refer to [LT-103, "Preliminary Check"](#).
4. Check symptom and repair or replace the cause of malfunction. Refer to [LT-106, "Symptom Chart"](#).
5. Does the auto light system operate normally? If YES, GO TO 6. If NO, GO TO 4.
6. INSPECTION END.

Preliminary Check

INFOID:000000002956744

SETTING CHANGE FUNCTIONS

- Sensitivity of auto light system can be adjusted using CONSULT-III. Refer to [LT-104, "CONSULT-III Functions \(BCM - HEAD LAMP\)"](#).

CHECK POWER SUPPLY AND GROUND CIRCUIT

1. CHECK FUSE AND FUSIBLE LINK

Check for blown fuses and fusible link.

| Unit | Power source | Fuse and fusible link No. |
|------|--------------------------------------|---------------------------|
| BCM | Battery | F |
| | | 21 |
| | Ignition switch ON or START position | 1 |
| | Ignition switch ACC or ON position | 6 |

AUTO LIGHT SYSTEM

< SERVICE INFORMATION >

| Unit | Power source | Fuse and fusible link No. |
|----------|--------------|---------------------------|
| IPDM E/R | Battery | 71 |
| | | 72 |
| | | 74 |
| | | 76 |
| | | 78 |
| | | 86 |

Refer to [LT-96, "Wiring Diagram - AUTO/L -"](#).

OK or NG

OK >> GO TO 2.

NG >> If fuse or fusible link is blown, be sure to eliminate cause of malfunction before installing new fuse or fusible link. Refer to [PG-4](#).

2. CHECK POWER SUPPLY CIRCUIT

1. Turn ignition switch OFF.
2. Disconnect BCM connector.
3. Check voltage between BCM harness connector and ground.

| Terminal (+) | | Terminal (-) | Ignition switch position | | |
|---------------|----------|--------------|--------------------------|--------------------|--------------------|
| BCM connector | Terminal | | OFF | ACC | ON |
| M1 | 11 | Ground | Approx. 0 V | Battery voltage | Battery voltage |
| | 38 | | Approx. 0 V | Approx. 0 V | Battery voltage |
| M2 | 42 | | Battery voltage | Battery voltage | Battery voltage |
| | 55 | | Battery voltage | Battery voltage | Battery voltage |

OK or NG

OK >> GO TO 3.

NG >> Repair harness or connector.

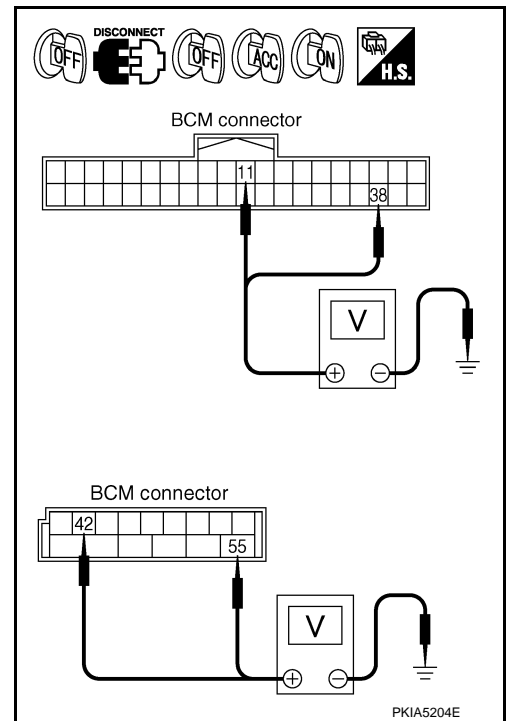

3. CHECK GROUND CIRCUIT

Check continuity between BCM harness connector and ground.

| BCM connector | Terminal | Ground | Continuity |
|---------------|----------|--------|------------|
| M2 | 52 | | Yes |

OK or NG

OK >> INSPECTION END

NG >> Repair harness or connector.

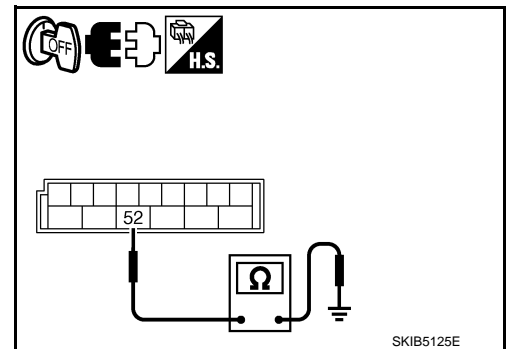

CONSULT-III Functions (BCM - HEAD LAMP)

INFOID:000000002956745

CONSULT-III can display each diagnostic item using the diagnostic test mode shown following.

AUTO LIGHT SYSTEM

< SERVICE INFORMATION >

| Diagnosis mode | Description |
|-----------------------|---|
| WORK SUPPORT | Changes the setting for each function. |
| DATA MONITOR | Displays BCM input data in real time. |
| ACTIVE TEST | Operation of electrical loads can be checked by sending drive signal to them. |
| SELF-DIAG RESULTS | BCM performs self-diagnosis of CAN communication. |
| CAN DIAG SUPPORT MNTR | The result of transmit/receive diagnosis of CAN communication can be read. |

WORK SUPPORT

Work Support Setting Item

- Customizing Auto Light Setting

| Work item | Description |
|------------------------|---|
| CUSTOM A/LIGHT SETTING | Auto light sensitivity can be changed in this mode. Sensitivity can be adjusted in four modes. <ul style="list-style-type: none"> • Mode 1 (Factory settings)/Mode 2 (More sensitive Mode 1)/ Mode 3 (More sensitive than Mode 2)/Mode 4 (Less sensitive than Mode 1) |
| ILL DELAY SET | Auto light delay off timer period can be changed in this mode. Selects Auto light delay off timer period among eight modes. <ul style="list-style-type: none"> • Mode 1 (45 sec.)^{NOTE}/Mode 2 (OFF)/Mode 3 (30 sec.)/Mode 4 (60 sec.)/ Mode 5 (90 sec.)/Mode 6 (120 sec.)/Mode 7 (150 sec.)/Mode 8 (180 sec.) |

NOTE:

Factory settings

DATA MONITOR

Display Item List

| Monitor item | Contents |
|----------------|---|
| IGN ON SW | "On/Off" Displays "IGN position (ON)/OFF, ACC position (OFF)" judged from the ignition switch signal. |
| ACC ON SW | "On/Off" Displays "ACC (ON)/OFF, Ignition OFF (OFF)" status judged from ignition switch signal. |
| KEY ON SW | "On/Off" Displays "Intelligent Key inserted into key slot (ON)/Intelligent Key removed from key slot (OFF)" status judged from the key switch signal. |
| TURN SIGNAL R | "On/Off" Displays status (turn right: ON/others: OFF) as judged from lighting switch signal. |
| TURN SIGNAL L | "On/Off" Displays status (turn left: ON/others: OFF) as judged from lighting switch signal. |
| HI BEAM SW | "On/Off" Displays status (high beam switch: ON/others: OFF) of high beam switch judged from lighting switch signal. |
| HEAD LAMP SW 1 | "On/Off" Displays status (headlamp switch 1: ON/others: OFF) of headlamp switch 1 judged from lighting switch signal. |
| HEAD LAMP SW 2 | "On/Off" Displays status (headlamp switch 2: ON/others: OFF) of headlamp switch 2 judged from lighting switch signal. |
| TAIL LAMP SW | "On/Off" Displays status (lighting switch 1ST or 2ND position: ON/others: OFF) of lighting switch judged from lighting switch signal. |
| AUTO LIGHT SW | "On/Off" Displays status of the lighting switch as judged from the lighting switch signal. (AUTO position: ON/other than AUTO position: OFF) |
| PASSING SW | "On/Off" Displays status (flash-to-passing switch: ON/others: OFF) of flash-to-passing switch judged from lighting switch signal. |
| FR FOG SW | "On/Off" Displays status (front fog lamp switch: ON/others: OFF) of front fog lamp switch judged from lighting switch signal. |
| DOOR SW - DR | "On/Off" Displays status of the driver door as judged from the driver door switch signal. (door is open: ON/door is closed: OFF) |
| DOOR SW - AS | "On/Off" Displays status of the passenger door as judged from the passenger door switch signal. (door is open: ON/door is closed: OFF) |
| DOOR SW - RR | "On/Off" Displays status of the rear door as judged from the rear door switch (RH) signal. (door is open: ON/door is closed: OFF) |

AUTO LIGHT SYSTEM

< SERVICE INFORMATION >

| Monitor item | Contents |
|------------------------------------|--|
| DOOR SW - RL "On/Off" | Displays status of the rear door as judged from the rear door switch (LH) signal. (door is open: ON/door is closed: OFF) |
| BACK DOOR SW ^{NOTE} "Off" | — |
| I - KEY LOCK "On/Off" | Displays "locked (ON)/other (OFF)" status, determined from lock signal. |
| OPTICAL SENSOR "0 - 5V" | Displays "outside brightness (close to 5 V when light/close to 0 V when dark)" judged from optical sensor signal. |
| VEHICLE SPEED "km/h" | Displays vehicle speed as judged from vehicle speed signal. |

NOTE:

This item is displayed, but cannot be monitored.

ACTIVE TEST

Display Item List

| Test item | Description |
|---------------------------------------|---|
| TAIL LAMP | Allows tail lamp relay to operate by switching ON-OFF. |
| FR FOG LAMP | Allows front fog lamp relay to operate by switching ON-OFF. |
| DAYTIME RUNNING LIGHT ^{NOTE} | Allows daytime light relay to operate by switching ON-OFF. |
| HEAD LAMP (HI, LO) | Allows headlamp relay to operate by switching ON-OFF. |

NOTE:

This item is tested only for CANADA models.

Symptom Chart

INFOID:000000002956746

| Phenomenon | Malfunction system and reference |
|--|---|
| <ul style="list-style-type: none"> Parking lamps and headlamps will not illuminate when outside of the vehicle becomes dark. (Lighting switch 1ST position and 2ND position operate normally.) Parking lamps and headlamp will not go out when outside of the vehicle becomes light. (Lighting switch 1ST position and 2ND position operate normally.) Headlamps go out when outside of the vehicle becomes light, but parking lamps stay on. | <ul style="list-style-type: none"> Refer to LT-104, "CONSULT-III Functions (BCM - HEAD LAMP)". Refer to LT-106, "Lighting Switch Inspection". Refer to LT-107, "Optical Sensor System Inspection". If above systems are normal, replace BCM. |
| Parking lamps illuminate when outside of the vehicle becomes dark, but headlamps stay off. (Lighting switch 1ST position and 2ND position operate normally.) | <ul style="list-style-type: none"> Refer to LT-104, "CONSULT-III Functions (BCM - HEAD LAMP)". Refer to LT-107, "Optical Sensor System Inspection". If above systems are normal, replace BCM. |
| With the ignition key in ACC position, headlamps, parking lamps, tail lamps, etc. will not go out when the driver's door is opened. | <ul style="list-style-type: none"> Refer to BL-86, "Check Door Switch". If above system is normal, replace BCM. |
| Auto light adjustment system will not operate. (Lighting switch AUTO, 1ST position and 2ND position operate normally.) | <ul style="list-style-type: none"> Refer to LT-107, "Optical Sensor System Inspection". If above system is normal, replace BCM. |
| Auto light adjustment system of combination meter will not operate. | <ul style="list-style-type: none"> CAN communication line inspection between BCM and combination meter: Refer to LAN-17, "CAN Diagnosis with CONSULT-III". |

Lighting Switch Inspection

INFOID:000000002956747

1. CHECK LIGHTING SWITCH INPUT SIGNAL

ⓅCONSULT-III DATA MONITOR

- Select "AUTO LIGHT SW" of BCM (HEAD LAMP) data monitor item.
- With operating the lighting switch, check the monitor status.

When lighting switch is AUTO : AUTO LIGHT SW ON position

AUTO LIGHT SYSTEM

< SERVICE INFORMATION >

⊗CHECK THE COMBINATION SWITCH
Refer to [LT-202. "Combination Switch Inspection"](#).

OK or NG

- OK >> INSPECTION END
- NG >> Replace combination switch (lighting switch). Refer to [LT-202. "Combination Switch Inspection"](#).

Optical Sensor System Inspection

INFOID:000000002956748

1. CHECK OPTICAL SENSOR INPUT SIGNAL

ⓂCONSULT-III DATA MONITOR

1. Select "OPTICAL SENSOR" of BCM (HEAD LAMP) data monitor item.
2. Check difference in the voltage when optical sensor is illuminated and not illuminated.

Illuminated

OPTICAL SENSOR : 3.1 V or more

Not illuminated

OPTICAL SENSOR : 0.6 V or less

CAUTION:

Optical sensor must be securely subjected to work lamp light. If the optical sensor is insufficiently illuminated, the measured value may not satisfy the standard.

⊗CHECK THE OPTICAL SENSOR INPUT SIGNAL

1. Turn ignition switch ON.
2. Check voltage between BCM harness connector and ground.

| Terminal | | Condition | Voltage (Approx.) |
|---------------|----------|--------------------------------|-------------------|
| (+) | (-) | | |
| BCM connector | Terminal | | |
| M1 | 14 | Illuminated Optical sensor | 3.1 V or more |
| | | Not illuminated Optical sensor | 0.6 V or less |

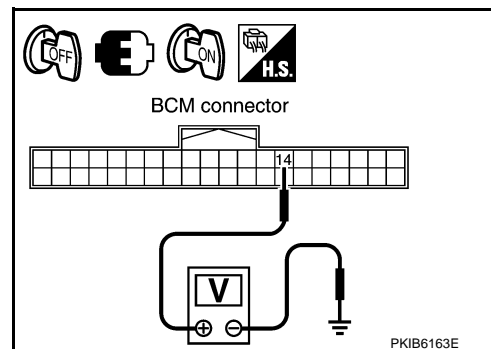

CAUTION:

Optical sensor must be securely subjected to work lamp light. If the optical sensor is insufficiently illuminated, the measured value may not satisfy the standard.

OK or NG

- OK >> INSPECTION END
- NG >> GO TO 2.

2. CHECK OPTICAL SENSOR POWER SUPPLY CIRCUIT

1. Turn ignition switch OFF.
2. Disconnect BCM connector and optical sensor connector.
3. Check continuity (open circuit) between BCM harness connector and optical sensor harness connector.

| BCM | | Optical sensor | | Continuity |
|-----------|----------|----------------|----------|------------|
| Connector | Terminal | Connector | Terminal | |
| M1 | 17 | M48 | 1 | Yes |

4. Check continuity (short circuit) between BCM harness connector and ground.

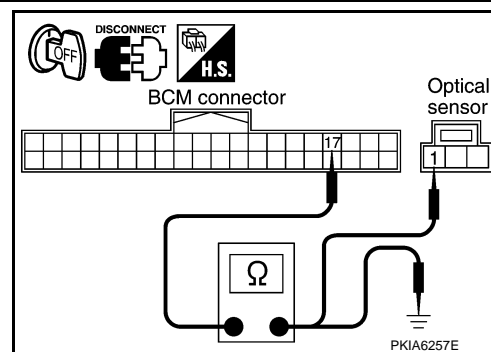

| BCM connector | Terminal | Ground | Continuity |
|---------------|----------|--------|------------|
| M1 | 17 | | No |

AUTO LIGHT SYSTEM

< SERVICE INFORMATION >

OK or NG

- OK >> GO TO 3.
- NG >> Repair harness or connector.

3. CHECK OPTICAL SENSOR SIGNAL CIRCUIT

1. Check continuity (open circuit) between BCM harness connector and optical sensor harness connector.

| BCM | | Optical sensor | | Continuity |
|-----------|----------|----------------|----------|------------|
| Connector | Terminal | Connector | Terminal | |
| M1 | 14 | M48 | 2 | Yes |

2. Check continuity between (short circuit) BCM harness connector and ground.

| BCM connector | Terminal | Ground | Continuity |
|---------------|----------|--------|------------|
| M1 | 14 | | No |

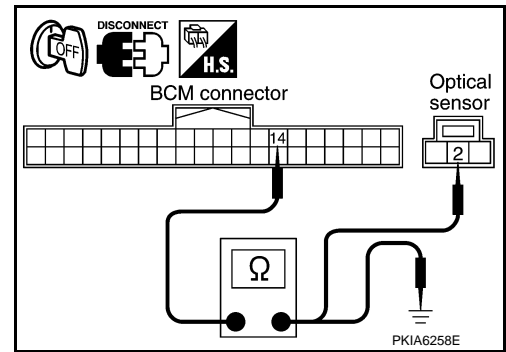

OK or NG

- OK >> GO TO 4.
- NG >> Repair harness or connector.

4. CHECK OPTICAL SENSOR GROUND CIRCUIT

1. Check continuity (open circuit) between BCM harness connector and optical sensor harness connector.

| BCM | | Optical sensor | | Continuity |
|-----------|----------|----------------|----------|------------|
| Connector | Terminal | Connector | Terminal | |
| M1 | 18 | M48 | 3 | Yes |

2. Check continuity (short circuit) between BCM harness connector and ground.

| BCM connector | Terminal | Ground | Continuity |
|---------------|----------|--------|------------|
| M1 | 18 | | No |

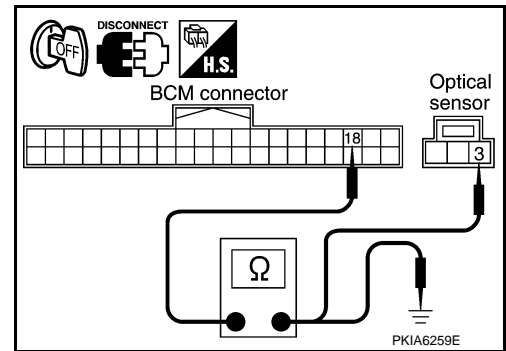

OK or NG

- OK >> GO TO 5.
- NG >> Repair harness or connector.

5. CHECK OPTICAL SENSOR VOLTAGE

1. Connect BCM connector.
2. Turn ignition switch ON.
3. Check voltage between BCM harness connector and ground.

| Terminal (+) | | Terminal (-) | Voltage (Approx.) |
|---------------|----------|--------------|-------------------|
| BCM connector | Terminal | | |
| M1 | 17 | Ground | 5.0 V |

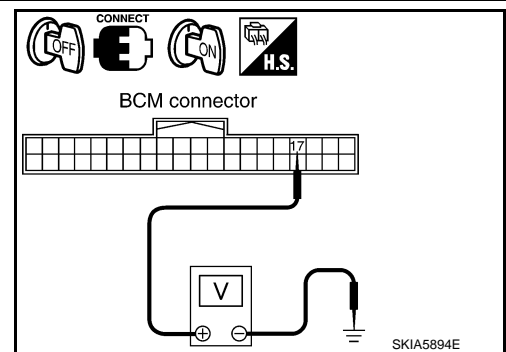

OK or NG

- OK >> Replace optical sensor. Refer to [LT-108, "Removal and Installation for Optical Sensor"](#).
- NG >> Replace BCM. Refer to [BCS-14, "Removal and Installation of BCM"](#).

Removal and Installation for Optical Sensor

INFOID:000000002956749

REMOVAL

AUTO LIGHT SYSTEM

< SERVICE INFORMATION >

1. Disengage the tab (A) and disconnect connector.
2. Remove optical sensor (1).

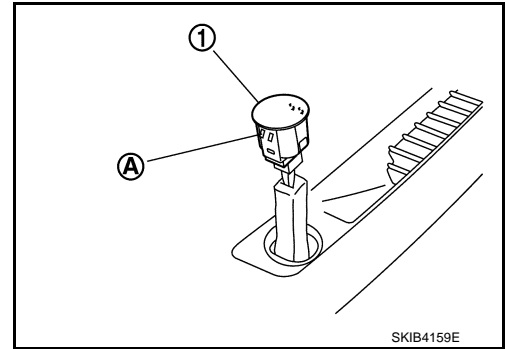

INSTALLATION

Installation is the reverse order of removal.

A
B
C
D
E
F
G
H
I
J
LT
L
M
N
O
P

ACTIVE AFS

< SERVICE INFORMATION >

ACTIVE AFS

Component Parts and Harness Connector Location

INFOID:000000002956750

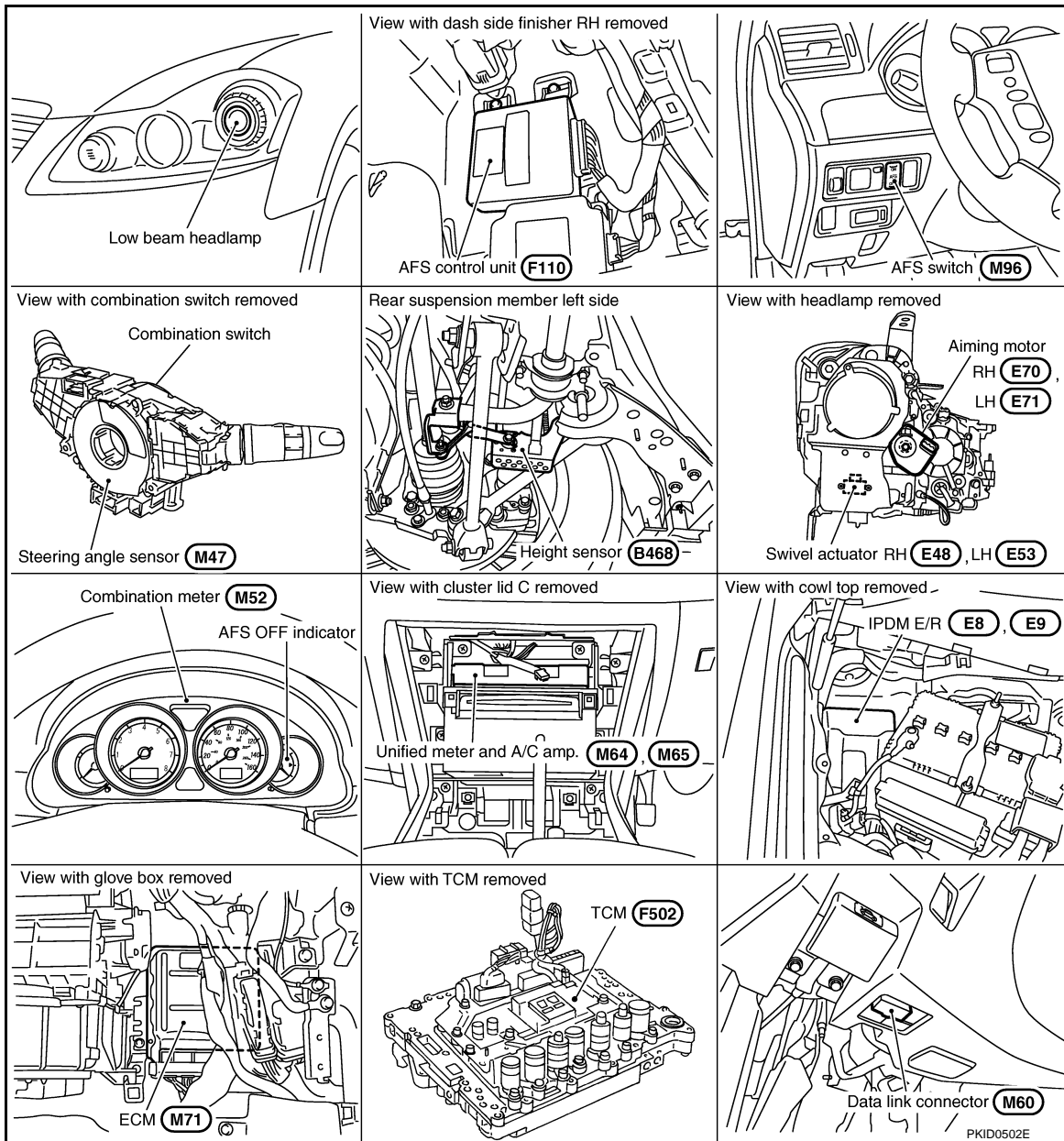

System Description

INFOID:000000002956751

AFS control unit controls AFS and headlamp auto aiming.

The following signals are input to AFS control unit via CAN communication:

- Steering angle sensor signal
- A/T position indicator signal
- Low beam status signal
- Vehicle speed signal
- Engine speed signal

Other signals are input as follows:

- AFS switch signal from AFS switch connected to AFS control unit
- Height sensor signal from height sensor connected to AFS control unit
- Swivel position sensor signal from swivel position sensor built into both right and left swivel actuators connected to AFS control unit

ACTIVE AFS

< SERVICE INFORMATION >

In response to the state of control, AFS control unit switches commands of AFS off indicator signal sent to unified meter and A/C amp. via CAN communication; and then turns on/off or blinks AFS off indicator lamp built in the combination meter.

AFS (ADAPTIVE FRONT-LIGHTING SYSTEM)

AFS increases viewability of cornering direction by changing light axis automatically to the direction of travel with low beam headlamps during vehicle's cornering.

AFS switch allows AFS function to be stopped.

AFS control unit determines the current vehicle conditions by each received signals, and sends commands to the low beam headlamp to swivel. With the headlamps (HIGH/LOW) illuminated, the AFS switch on, engine running and the A/T select lever in any position but range P or range R, the low beam headlamps are operative by AFS control unit commands.

As the steering wheel is turned to the left (right), the left (right) low beam headlamp will automatically swivel angle in accordance with the steering angle and vehicle speed, and stop the operation when the steering wheel is returned to the straight-ahead position.

Swivel operation allows drive signal to be sent to the swivel actuator on the side that AFS control unit is actuated. Step motor built in swivel actuator adjusts low beam projector of headlamp to swivel angle that matches drive signal. Swivel position sensor built in swivel actuator detects swivel angle and transmits a swivel position sensor signal to the AFS control unit. AFS control unit monitors if swivel operation is performed normally via swivel position sensor signal.

• Swivel operation

| | Low beam status | A/T selector lever position | Vehicle speed | AFS switch | Engine speed | Low beam headlamp LH (swivel) | Low beam headlamp RH (swivel) |
|------------|-----------------|-----------------------------|---------------|------------|------------------------|-------------------------------|-------------------------------|
| Left turn | Illuminated*1 | Except P, R | Running*2 | ON | While engine running*3 | × | |
| Right turn | Illuminated*1 | Except P, R | Irrespective | ON | While engine running*3 | | × |

*1: Included high beam illuminated.

*2: The swivel operates when running at approx. 25 km/h (15.5 MPH). When swivel operation is started, it works on until vehicle stops.

*3: The low beam headlamps perform small movements when AFS control unit detects start of the engine. This is normal with initialization of swivel actuator by AFS control unit.

HEADLAMP AUTO AIMING

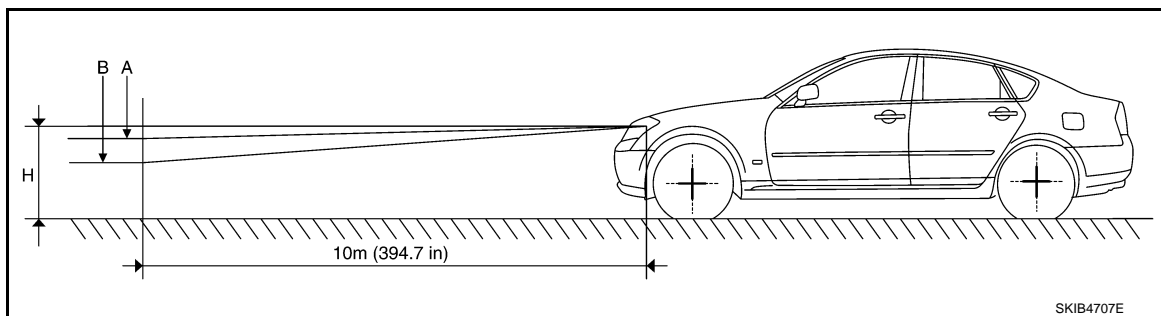

| Operating range | With 18-inch wheel (Reference value) | With 19-inch wheel (Reference value) | Vehicle height |
|-----------------|--------------------------------------|--------------------------------------|---------------------------|
| A | 0 mm (Standard position) | 0 mm (Standard position) | Unloaded vehicle position |
| B | Approx. 200 mm (7.9 in) | Approx.180 mm (7.1 in) | Low |

Headlamp auto aiming control automatically corrects vertical deviation of light axis that is brought by the change of vehicle height with changing number of passenger and laden weight, and relieves dazzle to oncoming vehicles.

AFS control unit determines the current vehicle conditions by each received signals, and sends commands to the low beam headlamps to auto aiming. With the headlamps (HIGH/LOW) illuminated and engine running, the low beam headlamps are operative by AFS control unit commands.

The height sensor is located on the left side of the rear suspension member and detects rear vehicle height change by sensing the displacement of the rear suspension arm. And transmits a height sensor signal to the AFS control unit.

ACTIVE AFS

< SERVICE INFORMATION >

With reference to the rear vehicle height under the empty condition, light axis of low beam with low rear vehicle height is relatively higher than that with the empty condition. AFS control unit switches drive signal corrects height of low beam axis to maintain height of light axis with empty condition.

Light axis of low beam with high rear vehicle height is relatively lower than that with empty condition. Light axis of low beam with empty condition is set as upper limit of headlamp auto aiming control operation. Control to correct deviation is not performed when light axis of low beam gets relatively higher than that with empty condition. Timing of control is switched in accordance with driving conditions.

- Headlamp auto aiming operation

| Low beam status | Vehicle speed | Engine speed | AFS switch |
|-----------------|--|----------------------|----------------|
| Illuminated*1 | Control switch by driving conditions*2 | While engine running | Irrespective*3 |

*1: Included high beam illuminated

*2: Control timing of drive signal is switched by vehicle speed and accelerating/decelerating vehicle.

*3: Control is performed without regard to the condition of AFS switch. Headlamp auto aiming control function cannot be cancelled.

OUTLINE

Power is supplied

When the ignition switch is ON or START position, power is supplied

- through 10A fuse [No.12, located in fuse block (J/B)]
- to AFS control unit terminal 1
- to front combination lamp LH and RH terminal 13
- to AFS switch terminal 1
- to unified meter and A/C amp. terminal 53.

Ground is supplied

- to AFS control unit terminal 25
- through grounds M16 and M70,
- to front combination lamp LH and RH terminal 11
- through grounds E22 and E43.

AFS OPERATION

When The Steering Wheel Is Turned To The Left

Swivel motor driving signal (1-phase) is transmitted when the steering wheel is turned to left approximately more than 10* degrees (pre-determined), with vehicle speed at approximately 25 km/h (15.5 MPH) or more, headlamps (HIGH/LOW) illuminated, AFS switch ON and the engine running and the A/T select lever in any position except range P or R.

*: Slightly different from the case when it is turned to the right.

Swivel motor driving signal (1-phase) is sent

- to front combination lamp LH terminal 17
- through AFS control unit terminal 15,
- to AFS control unit terminal 38
- through front combination lamp LH terminal 21.

And swivel motor driving signal (2-phase) is sent:

- to front combination lamp LH terminal 16
- through AFS control unit terminal 17,
- to AFS control unit terminal 36
- through front combination lamp LH terminal 20.

Swivel position sensor detects swivel angle during ignition switch ON, and transmits swivel position sensor signals to the AFS control unit:

When ignition switch is turn to ON position, power is supplied

- to front combination lamp LH terminal 15
- through AFS control unit terminal 24.

When ignition switch is turn to ON position, swivel position sensor signal input is supplied

- to AFS control unit terminal 29
- through front combination lamp LH terminal 14.

Ground is supplied

- to front combination lamp LH terminal 19
- through AFS control unit terminal 27.

The low beam headlamp LH starts to swivel to the left.

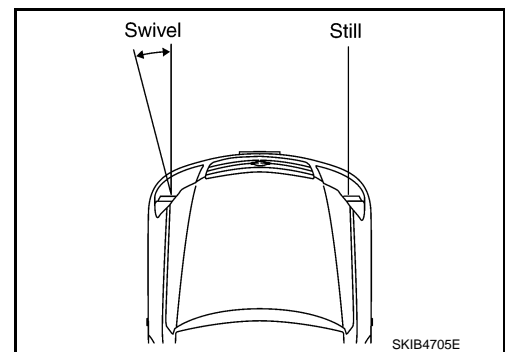

ACTIVE AFS

< SERVICE INFORMATION >

The swivel motor driving signals are blocked and the swivel motion stops when the steering angle reaches approximately more than 80 degrees (predetermined). The low beam headlamp will not swivel any further no matter how further left. As the steering wheel is turned back to the right, the swivel motor driving signals (both 1-phase and 2-phase) will be reversed, causing low beam headlamp LH to start swiveling to the right. When steering angle becomes smaller than predetermined value, the low beam headlamp is set in the straight-ahead position, swivel motor driving signals are blocked and low beam headlamps stop swiveling.

When The Steering Wheel Is Turned To The Right

Swivel motor driving signal (1-phase) is transmitted when the steering wheel is turned to right approximately more than 10° degrees (predetermined), with headlamps (HIGH/LOW) illuminated, AFS switch ON, the engine running and the A/T select lever in any position except range P or R.

*: Slightly different from the case when it is turned to the left.

Swivel motor driving signal (1-phase) is sent

- to front combination lamp RH terminal 16
- through AFS control unit terminal 34,
- to AFS control unit terminal 11
- through front combination lamp RH terminal 20.

And swivel motor driving signal (2-phase) is sent

- to front combination lamp RH terminal 17
- through AFS control unit terminal 32,
- to AFS control unit terminal 13
- through front combination lamp RH terminal 21.

Swivel position sensor detects swivel angle during ignition switch ON, and transmits swivel position sensor signals to the AFS control unit:

When ignition switch is turn to ON position, power is supplied

- to front combination lamp RH terminal 15
- through AFS control unit terminal 4.

When ignition switch is turn to ON position, swivel position sensor input signal is supplied

- to AFS control unit terminal 9
- through front combination lamp RH terminal 14.

Ground is supplied

- to front combination lamp RH terminal 19
- through AFS control unit terminal 2.

The low beam headlamp RH starts to swivel to the right.

The swivel motor driving signals are blocked and the swivel motion stops when the steering angle reaches approximately more than 80 degrees (predetermined). The low beam headlamp will not swivel any further no matter how further right. As the steering wheel is turned back to the left, the swivel motor driving signals (both 1-phase and 2-phase) will be reversed, causing low beam headlamp RH to start swiveling to the left. When steering angle becomes smaller than predetermined value, the low beam headlamp is set in the straight-ahead position, swivel motor driving signals are blocked and low beam headlamps stop swiveling.

AFS OFF INDICATOR OPERATION

In response to the state of control, AFS control unit switches commands of AFS off indicator signal sent to unified meter and A/C amp. via CAN communication; and then turns on/off or blinks AFS off indicator lamp built in the combination meter depending on the following condition.

- Bulb check operation

AFS off indicator lamp is turned off after illuminating for one second as a bulb check for AFS off indicator lamp when turn ignition switch ON is detected.

NOTE:

AFS off indicator lamp is turned off without a lapse of one second when start of the engine is detected.

- AFS switch operation

AFS off indicator lamp is illuminated while AFS switch is OFF.

AFS off indicator lamp is turned off while AFS switch is ON.

- System warning operation

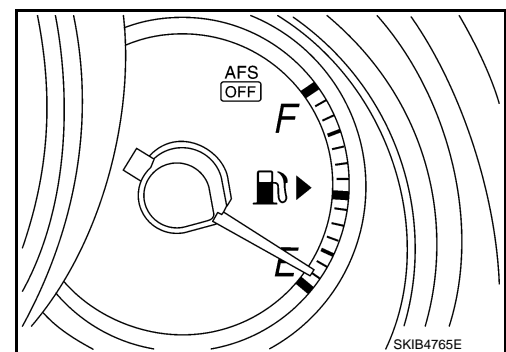
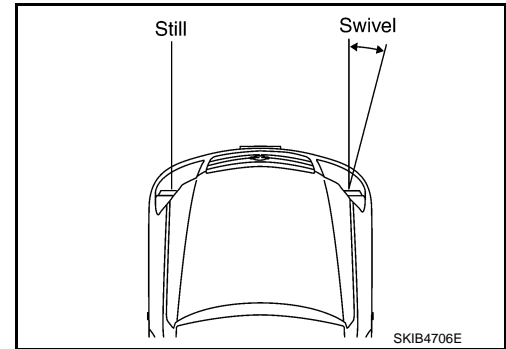

ACTIVE AFS

< SERVICE INFORMATION >

AFS off indicator lamp illuminates at intervals of approximately one second when AFS control unit detects any specific DTC (diagnosis trouble code), or when unified meter and A/C amp. cannot receive AFS off indicator signals.

NOTE:

Unified meter and A/C amp. transmits a command to combination meter to blink AFS off indicator lamp when they cannot receive AFS off indicator signal.

SWIVEL ACTUATOR INITIALIZATION

AFS control unit performs swivel operation to initialize swivel actuator when start of the engine is detected. Straight-ahead position of low beam headlamps is adjusted by turning low beam headlamps to outside vehicle with specified swivel angle after turning it to the center of vehicle and making sure that it reaches the stopper. Swivel actuator initialization shall be performed every time when start of the engine is detected.

HEADLAMP AUTO AIMING OPERATION

The height sensor detects a change in height of rear vehicle with ignition switch ON, and transmits signals to the AFS control unit:

When ignition switch is turn to ON position, power is supplied

- to height sensor terminal 1
- through AFS control unit terminal 6.

When ignition switch is turned to ON position, height sensor input signal is supplied

- to AFS control unit terminal 28
- through height sensor terminal 2.

Ground is supplied

- to height sensor terminal 3
- through AFS control unit terminal 8.

Aiming motor driving signal (voltage signal that corresponds to the vehicle height) is transmitted depending on the height sensor signal at the start of the engine

- to front combination lamp LH (aiming motor) terminal 12
- through AFS control unit terminal 40,
- to front combination lamp RH (aiming motor) terminal 12
- through AFS control unit terminal 19.

Output of aiming motor driving signal is maintained unless headlamp (HIGH/LOW) illuminate detected.

Auto aiming control operation starts when headlamps (HIGH/LOW) illuminate detected.

When headlamps (HIGH/LOW) illuminate, output of aiming motor driving signal is changed according to the height sensor signal. After the change, it is changed according to height sensor signals with predetermined timing based on driving condition while headlamps are ON.

Auto Aiming Operation

AFS control unit starts outputting aiming motor drive signal when the engine starts, and continues to output it until the engine stops. Aiming motor drive signal changes output when the specified conditions described below are met.

Headlamp aiming motors set the low beam projectors according to aiming motor drive signals received from AFS control unit, both headlamp aiming motors cause the low beam projectors to move to the position commanded by the signal.

The aiming motor drive signal level retains when the following conditions are not met.

- AFS control unit operation when the vehicle is stopped (low beam headlamps illuminated)
Headlamp aiming motor drive signal is changed when vehicle height is stabilized with a parked condition, depending on the height sensor signal detected with height sensor signal by AFS control unit.
- AFS control unit operation when the vehicle is running (low beam headlamps illuminated)
When vehicle is running, headlamp aiming motor drive signal is changed depending on the height sensor signal which is detected when AFS control unit detects constant steady speed of vehicle.
When the vehicle is accelerating or decelerating, AFS control unit keeps headlamp aiming motor drive signal voltage level rather than changing it, so that the low beam projectors of both headlamps do not operate.

CAN COMMUNICATION SYSTEM DESCRIPTION

CAN (Controller Area Network) is a serial communication line for real time application. It is an on-vehicle multiplex communication line with high data communication speed and excellent error detection ability. Many electronic control units are equipped onto a vehicle, and each control unit shares information and links with other control units during operation (not independent). In CAN communication, control units are connected with 2 communication lines (CAN H line, CAN L line) allowing a high rate of information transmission with less wiring. Each control unit transmits/receives data but selectively reads required data only.

CAN COMMUNICATION UNIT

ACTIVE AFS

< SERVICE INFORMATION >

Refer to [LAN-11, "System Description"](#).

Component Parts Description

INFOID:000000002956752

AFS CONTROL UNIT

AFS control unit determines current vehicle conditions by received signals and controls AFS and headlamp auto aiming.

SWIVEL ACTUATOR

Swivel actuator is configured with swivel motor and swivel position sensor and is built in headlamps.

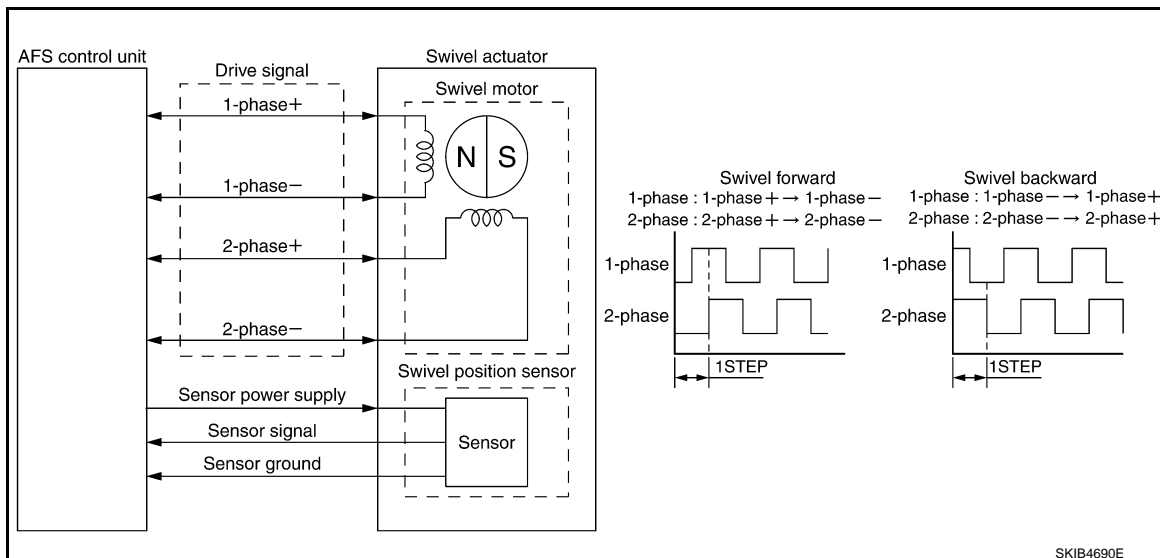
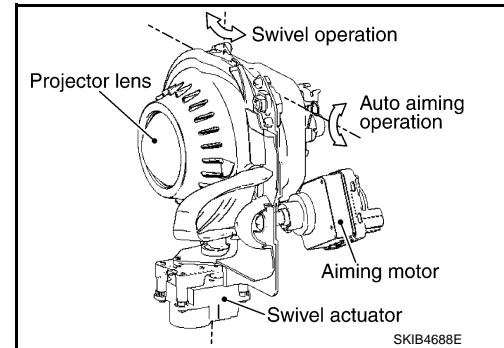

- Swivel motor (step motor)
Swivel motor is a two-phase step motor. It is driven according to drive signals from AFS control unit when two drive windings are energized in set sequences, and adjusts low beam projector of headlamp. The direction of actuator rotation can be changed as desired by selecting appropriate energizing sequences.
- Swivel position sensor
Swivel position sensor detects swivel angle and transmits a swivel position sensor signal to the AFS control unit.

AIMING MOTOR

Aiming motor is installed outside the headlamps. Headlamp aiming motors set the low beam projectors according to headlamp aiming motor drive signals received from AFS control unit.

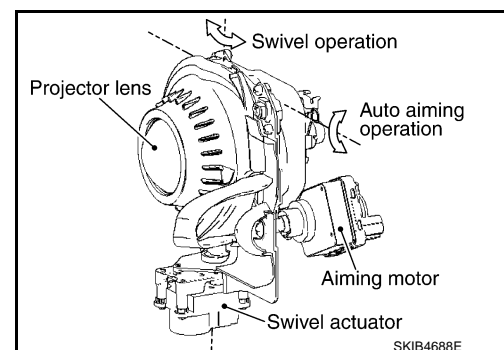

ACTIVE AFS

< SERVICE INFORMATION >

AFS SWITCH

AFS switch transmits state of ON/OFF as AFS switch signals to AFS control unit.

- AFS control unit performs AFS operation when AFS switch is ON and turns off AFS off indicator lamp.
- AFS control unit does not perform AFS operation when AFS switch is OFF, and turns on AFS off indicator lamp.

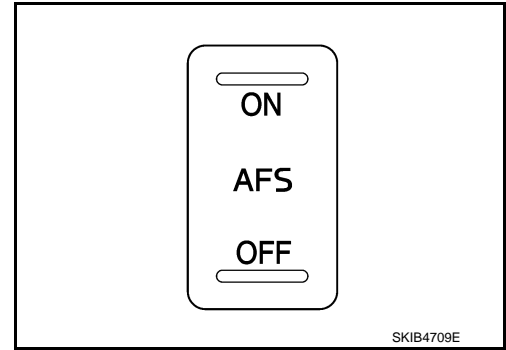

HEIGHT SENSOR

The height sensor is located on the left side of the rear suspension member and detects rear vehicle height change by sensing the displacement of the rear suspension arm. And transmits a height sensor signal to the AFS control unit.

| | Sensor angle | Vehicle height |
|---|---|-----------------------------------|
| A | Approx. -103° (Link stopper angle) | Low side |
| B | 0° (Standard position) | Approx. unloaded vehicle position |
| C | Approx. 46° (Link stopper angle) | High side |

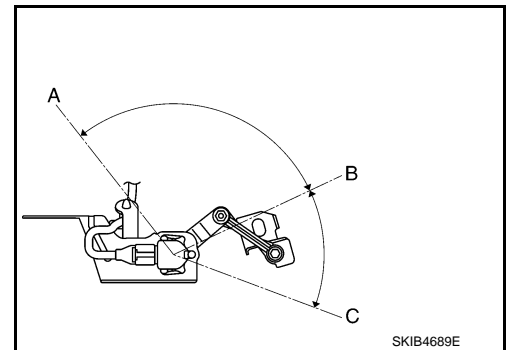

STEERING ANGLE SENSOR

The steering angle sensor is located combination switch and detects steering angle. And transmits a steering angle sensor signal to the AFS control unit.

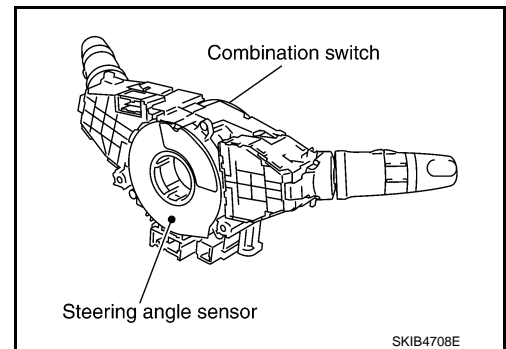

IPDM E/R

IPDM E/R detects ON/OFF state of low beam headlamps. It transmits a low beam state signal to the AFS control unit.

ECM

ECM transmits an engine speed signal to the AFS control unit.

TCM

TCM transmits an A/T position indicator signal to the AFS control unit.

UNIFIED METER AND A/C AMP.

- Unified meter and A/C amp. transmits vehicle speed signals to the AFS control unit.
- Unified meter and A/C amp. transmits AFS off indicator signals received from the AFS control unit to the combination meter.

COMBINATION METER

Combination meter turns on/off or blinks built-in AFS off indicator lamp depending on AFS off indicator signal received from unified meter and A/C amp.

ACTIVE AFS

< SERVICE INFORMATION >

Schematic

INFOID:000000002956753

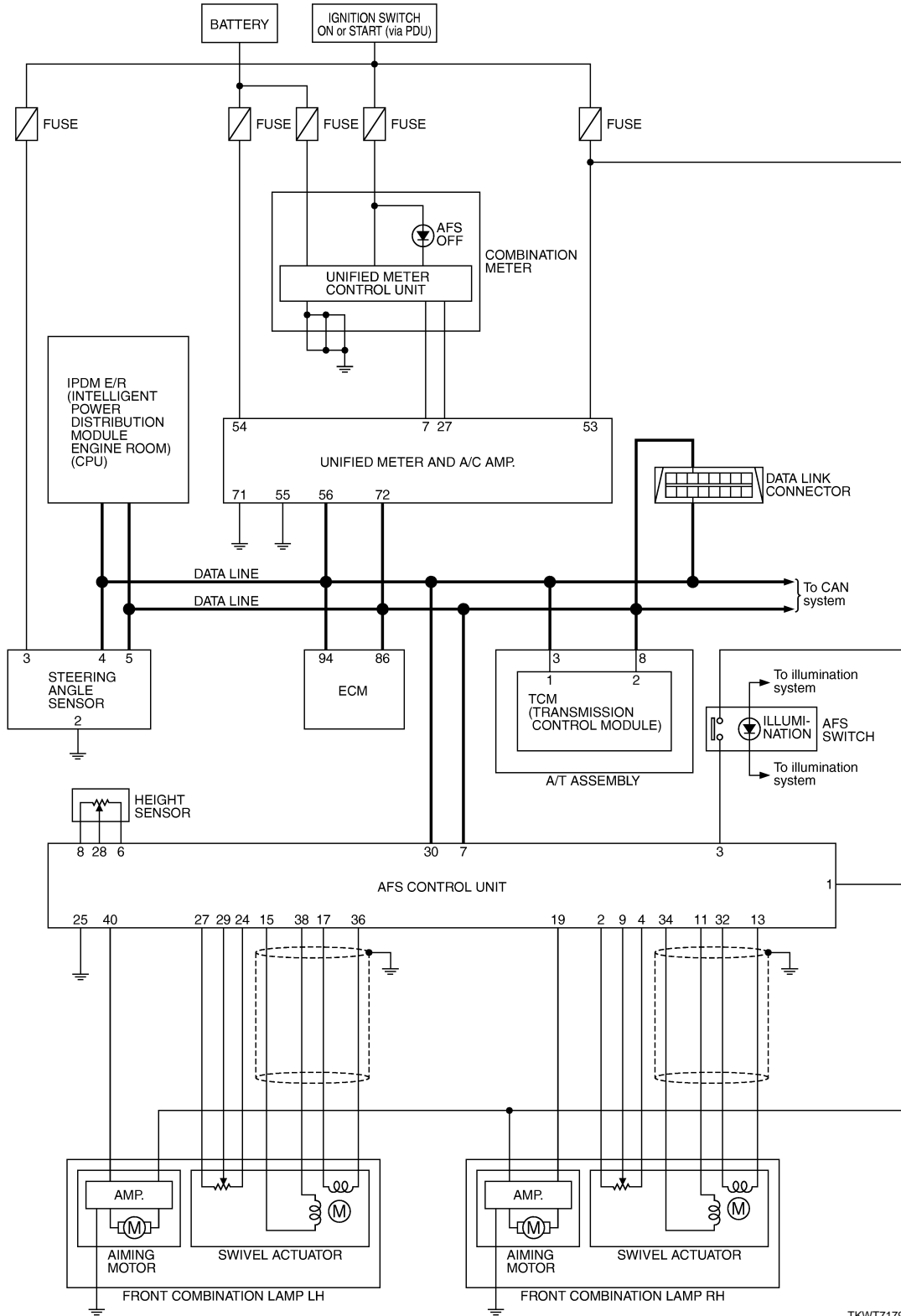

TKWT7179E

A
B
C
D
E
F
G
H
I
J
LT
L
M
N
O
P

ACTIVE AFS

< SERVICE INFORMATION >

Wiring Diagram - AFS -

INFOID:00000002956754

LT-AFS-01

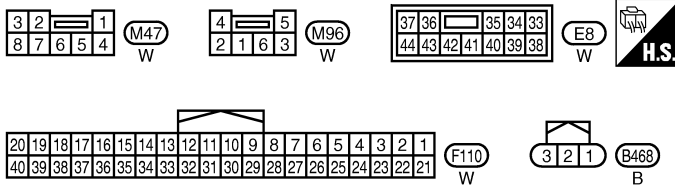
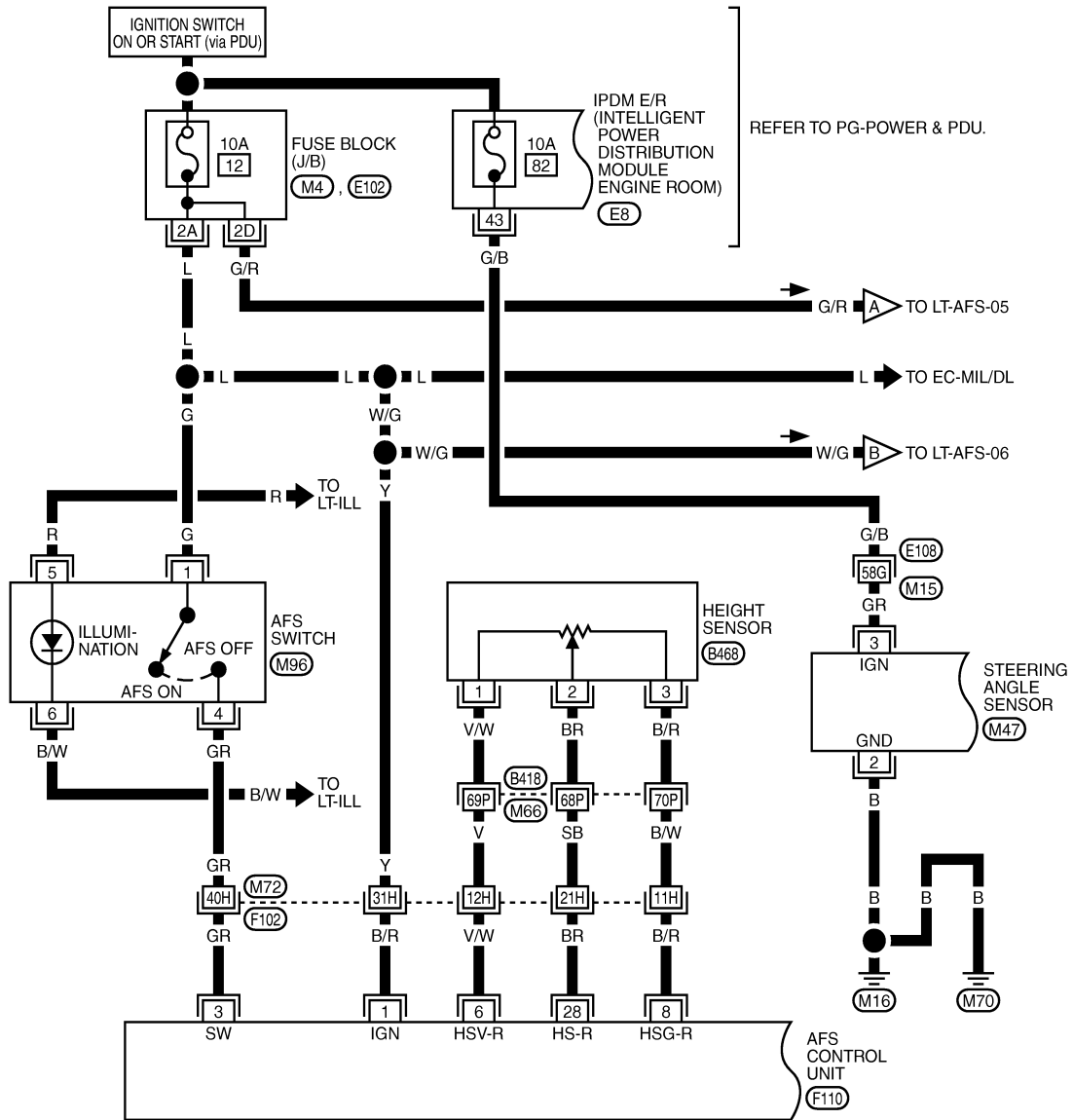

REFER TO THE FOLLOWING.
 (E108), (F102), (B418) - SUPER MULTIPLE JUNCTION (SMJ)
 (M4), (E102) - FUSE BLOCK - JUNCTION BOX (J/B)

TKWT6816E

ACTIVE AFS

< SERVICE INFORMATION >

LT-AFS-02

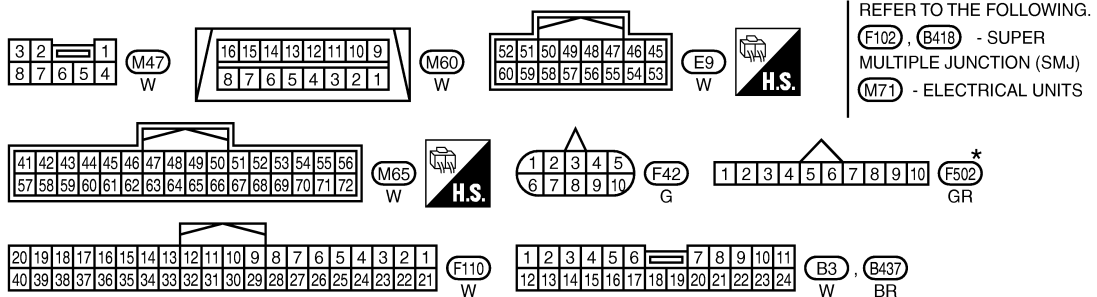
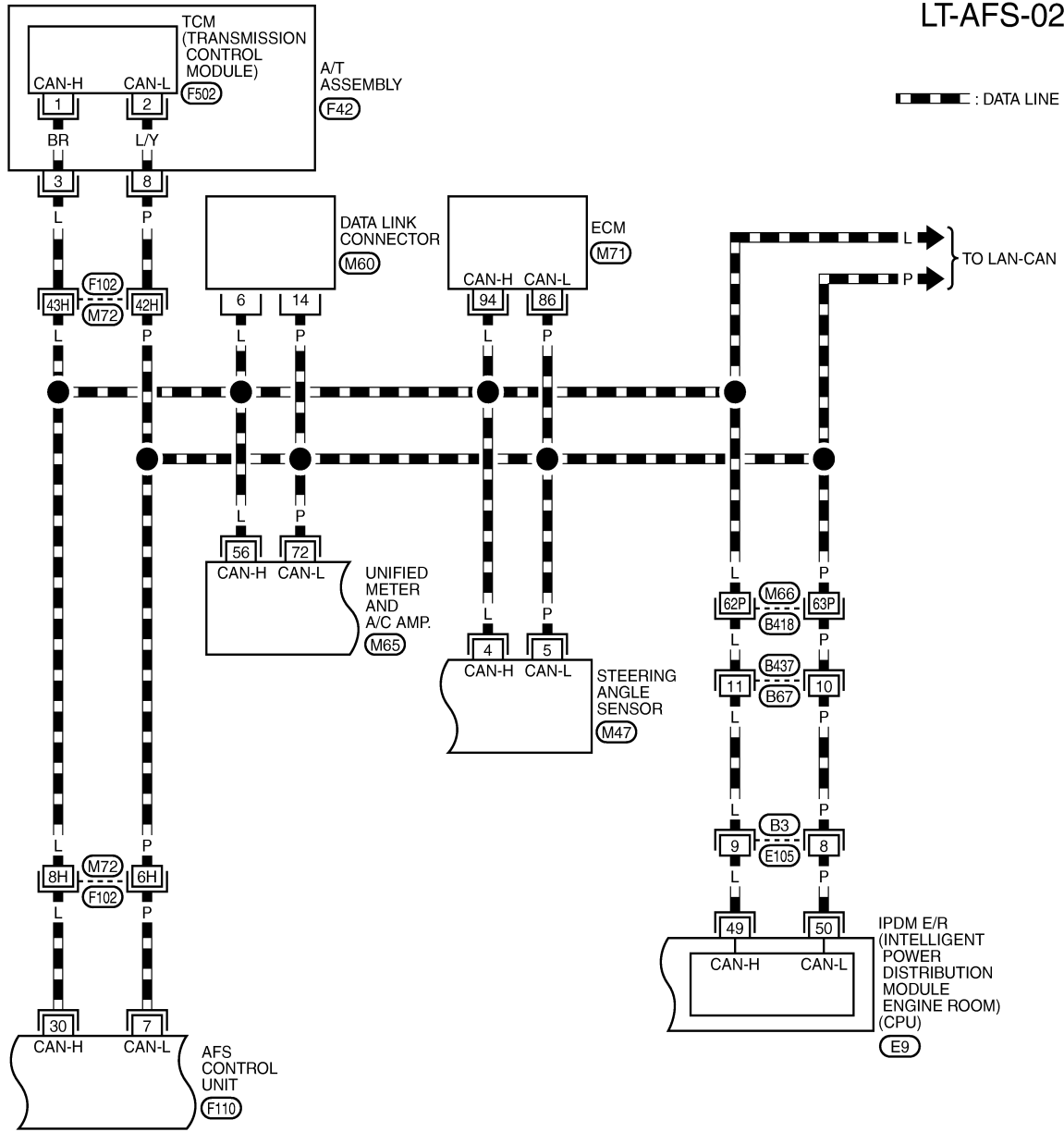

* : THIS CONNECTOR IS NOT SHOWN IN "HARNESS LAYOUT", PG SECTION.

TKWT6817E

ACTIVE AFS

< SERVICE INFORMATION >

LT-AFS-03

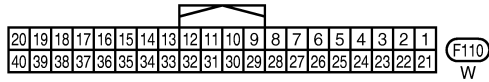
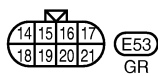
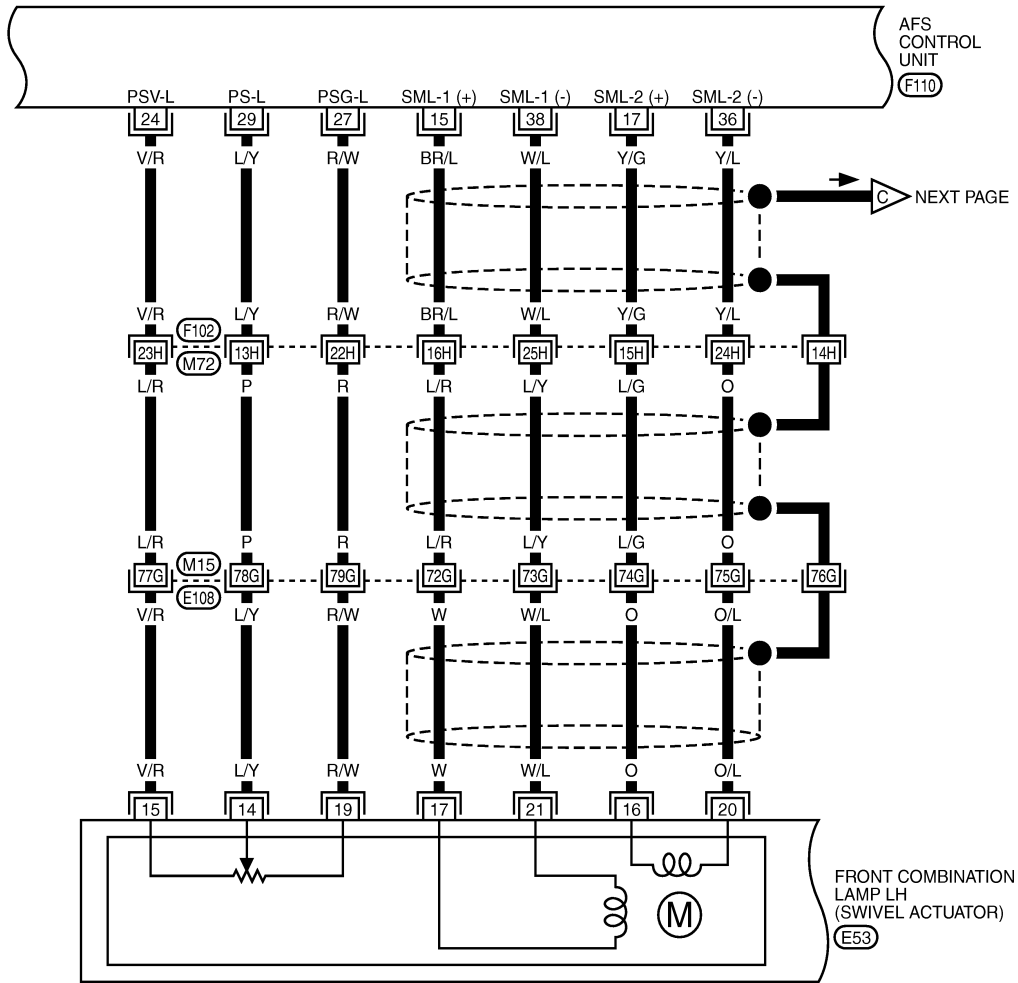

REFER TO THE FOLLOWING.
 (E108), (F102) - SUPER MULTIPLE
 JUNCTION (SMJ)

TKWT6818E

ACTIVE AFS

< SERVICE INFORMATION >

LT-AFS-04

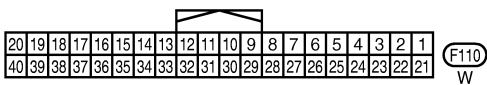
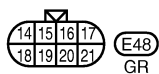
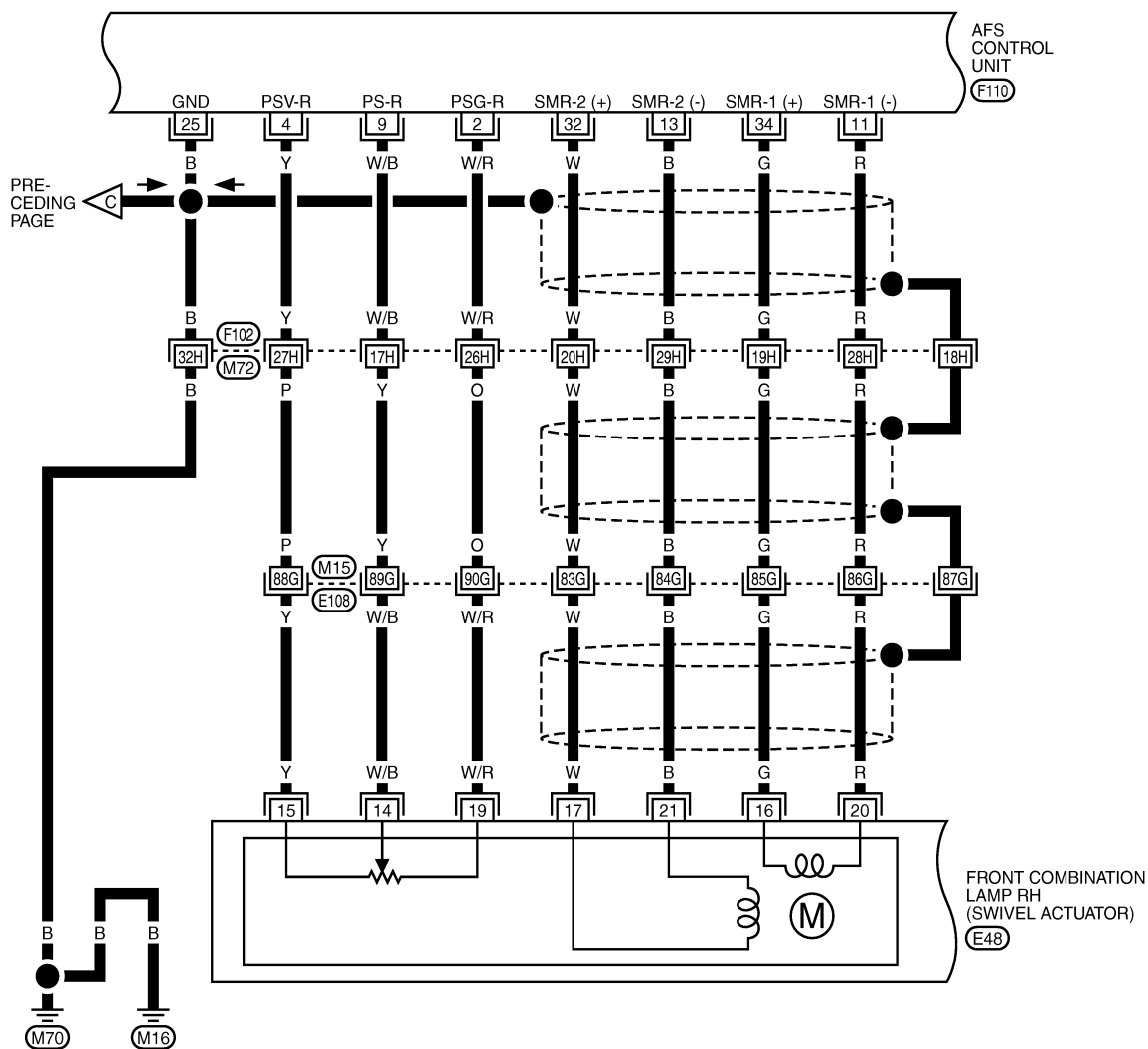

REFER TO THE FOLLOWING.
 (E108), (F102) - SUPER MULTIPLE JUNCTION (SMJ)

TKWT6819E

A
B
C
D
E
F
G
H
I
J
LT
L
M
N
O
P

ACTIVE AFS

< SERVICE INFORMATION >

LT-AFS-05

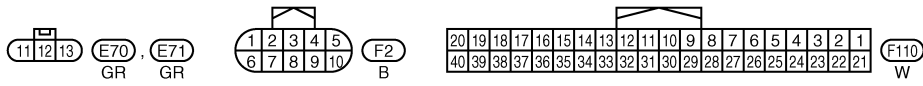
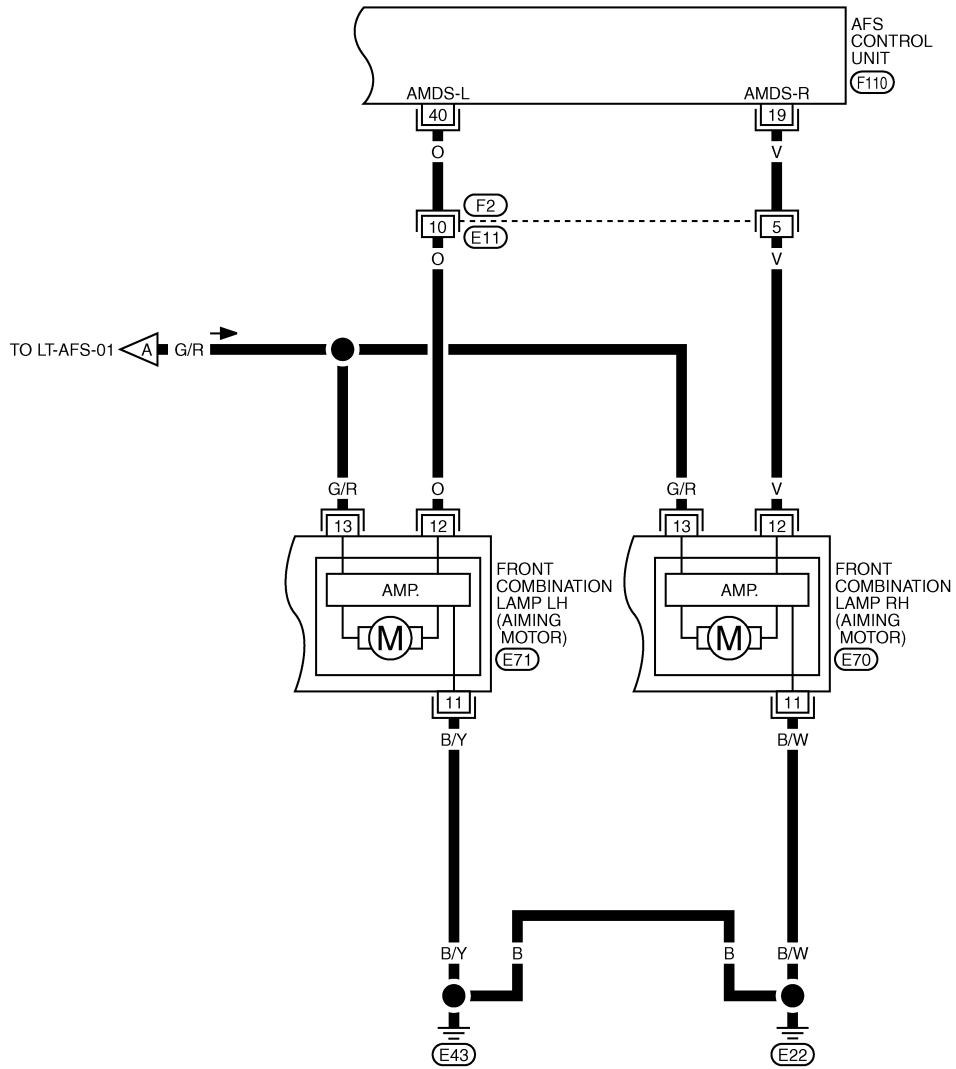

TKWT3378E

ACTIVE AFS

< SERVICE INFORMATION >

LT-AFS-06

VK : WITH VK ENGINE
VQ : WITH VQ ENGINE

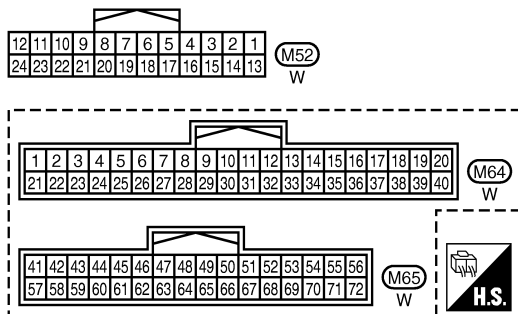
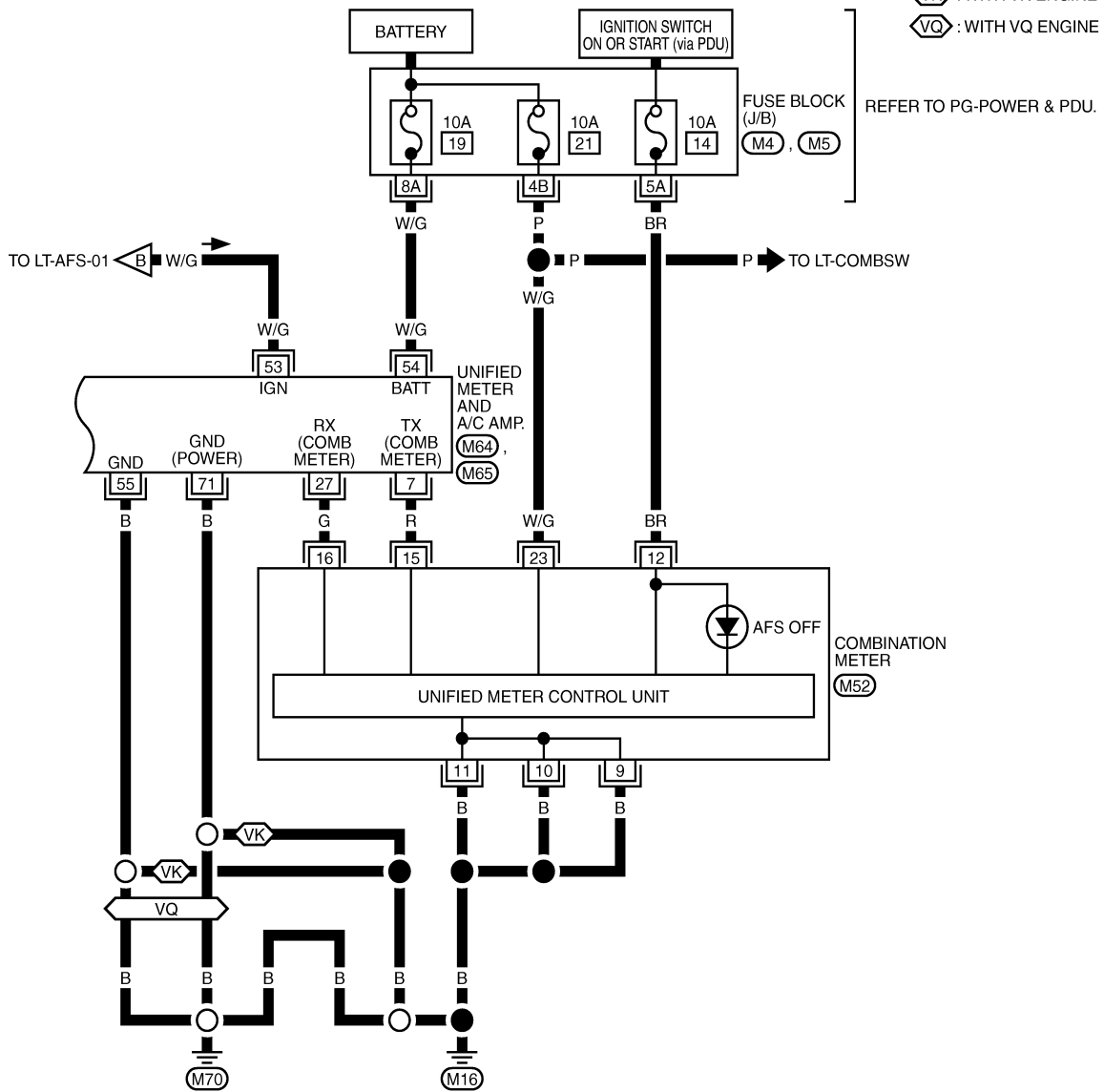

REFER TO THE FOLLOWING.
 (M4), (M5) - FUSE BLOCK - JUNCTION BOX (J/B)

TKWT7180E

A
B
C
D
E
F
G
H
I
J
LT
L
M
N
O
P

ACTIVE AFS

< SERVICE INFORMATION >

Terminal and Reference Value for AFS Control Unit

INFOID:00000002956755

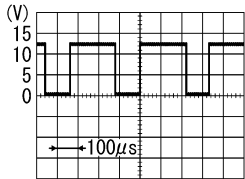
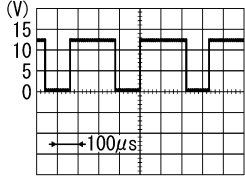
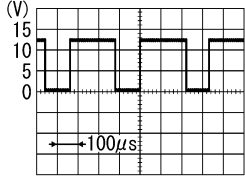
| Terminal No. | Wire color | Item | Measuring condition | | Reference value | |
|--------------|------------|---|---------------------|--|---------------------------|--|
| | | | Ignition switch | Operation or condition | | |
| 1 | B/R | IGN power supply | ON | — | Battery voltage | |
| 2 | W/R | Swivel position sensor ground (right) | ON | — | Approx. 0 V | |
| 3 | GR | AFS switch signal | ON | AFS switch | ON | Approx. 0 V |
| | | | | | OFF | Battery voltage |
| 4 | Y | Swivel position sensor power supply (right) | ON | — | Approx. 5 V | |
| 6 | V/W | Height sensor power supply | ON | — | Approx. 5 V | |
| 7 | P | CAN-L | — | — | — | |
| 8 | B/R | Height sensor ground | ON | — | Approx. 0 V | |
| 9 | W/B | Swivel position sensor signal (right) | ON | Low beam headlamp (right) swivel angle | 0° | Approx. 1.5 V |
| | | | | | Maximum angle | Approx. 2.5 V |
| 11 | R | Swivel motor 1 phase- (right) | ON | Low beam headlamp (right) swivel | ON | Reference waveform  SKIB2408J Approx. 8 - 12 V |
| | | | | | | OFF |
| 13 | B | Swivel motor 2 phase- (right) | ON | Low beam headlamp (left) swivel | ON | Reference waveform  SKIB2408J Approx. 8 - 12 V |
| | | | | | | OFF |
| 15 | BR/L | Swivel motor 1 phase+ (left) | ON | Low beam headlamp (left) swivel | ON | Reference waveform  SKIB2408J Approx. 8 - 12 V |
| 17 | Y/G | Swivel motor 2 phase+ (left) | ON | Low beam headlamp (right) auto aiming | OFF | Approx. 9.5 - 11.5 V |
| 19 | V | Aiming motor drive signal (right) | ON | Low beam headlamp (right) auto aiming | Unloaded vehicle position | Approx. 9 V |
| | | | | | Maximum laden condition | Approx. 4.8 V (With 18-inch wheel) Approx. 5.2 V (With 19-inch wheel) |
| 24 | V/R | Swivel position sensor power supply (left) | ON | — | Approx. 5 V | |
| 25 | B | Ground | ON | — | Approx. 0 V | |
| 27 | R/W | Swivel position sensor ground (left) | ON | — | Approx. 0 V | |

ACTIVE AFS

< SERVICE INFORMATION >

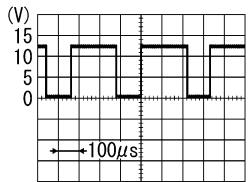
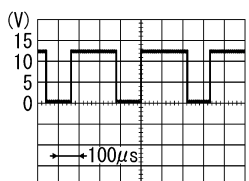
| Ter- mi- nal No. | Wire color | Item | Measuring condition | | Reference value | |
|---------------------------|---------------|---|---------------------|--|-----------------------------------|---|
| | | | Ignition switch | Operation or condition | | |
| 28 | BR | Height sensor signal | ON | Vehicle height | Unloaded vehicle posi- tion | Approx. 2.5 V |
| | | | | | Maximum laden condi- tion | Approx. 1.0 V (With 18- inch wheel) Approx. 1.3 V (With 19- inch wheel) |
| 29 | L/Y | Swivel position sensor signal (left) | ON | Low beam headlamp (left) swivel angle | 0° | Approx. 1.5 V |
| | | | | | Maximum angle | Approx. 3.5 V |
| 30 | L | CAN-H | — | — | — | |
| 32 | W | Swivel motor 2 phase+ (right) | ON | Low beam headlamp (right) swivel | ON | Reference waveform  SKIB2408J Approx. 8 - 12 V |
| | | | | | OFF | Approx. 9.5 - 11.5V |
| 36 | Y/L | Swivel motor 2 phase- (left) | ON | Low beam headlamp (left) swivel | ON | Reference waveform  SKIB2408J Approx. 8 - 12 V |
| | | | | | OFF | Approx. 9.5 - 11.5 V |
| 38 | W/L | Swivel motor 1 phase- (left) | ON | | Approx. 9.5 - 11.5 V | |
| 40 | O | Aiming motor drive signal (left) | ON | Low beam headlamp (left) auto aiming | Unloaded vehicle posi- tion | Approx. 9 V |
| | | | | | Maximum laden condi- tion | Approx. 4.8 V (With 18- inch wheel) Approx. 5.2 V (With 19- inch wheel) |

How to Proceed with Trouble Diagnosis

INFOID:000000002956756

1. Confirm the symptom or customer complaint.
2. Understand operation description and function description. Refer to [LT-110, "System Description"](#).
3. Perform the preliminary check. Refer to [LT-125, "Preliminary Check"](#).
4. Perform self-diagnosis by CONSULT-III. Refer to [LT-126, "CONSULT-III Function \(ADAPTIVE LIGHT\)"](#).
5. Check symptom and repair or replace the cause of malfunction.
6. Does the AFS operate normally? If YES: GO TO 7. If NO: GO TO 4.
7. INSPECTION END

Preliminary Check

INFOID:000000002956757

1. CHECK FUSES AND FUSIBLE LINK

Check for blown fuses and fusible link.

ACTIVE AFS

< SERVICE INFORMATION >

| Unit | Power source | Fuse No. |
|------------------|-----------------------------|----------|
| AFS control unit | Ignition switch ON or START | 12 |

Refer to [LT-118, "Wiring Diagram - AFS -"](#).

OK or NG

OK >> GO TO 2.

NG >> If the fuse is brown be sure to eliminate cause of malfunction before installing new fuse. Refer to [PG-4](#).

2. CHECK AFS CONTROL UNIT VOLTAGE

1. Turn ignition switch ON.
2. Check voltage between AFS control unit harness connector and ground.

| Terminals | | Voltage (Approx.) |
|----------------------------|----------|-------------------|
| (+) | | |
| AFS control unit connector | Terminal | (-) |
| F110 | 1 | Ground |
| | | Battery voltage |

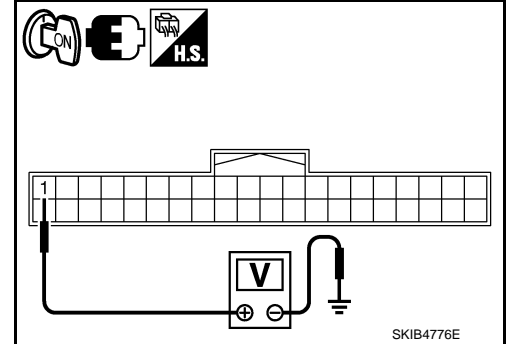

OK or NG

OK >> GO TO 3.

NG >> Repair harness or connector.

3. CHECK GROUND CIRCUIT

1. Turn ignition switch OFF.
2. Check continuity between AFS control unit harness connector and ground.

| AFS control unit connector | Terminal | Ground | Continuity |
|----------------------------|----------|--------|------------|
| F110 | 25 | | Yes |

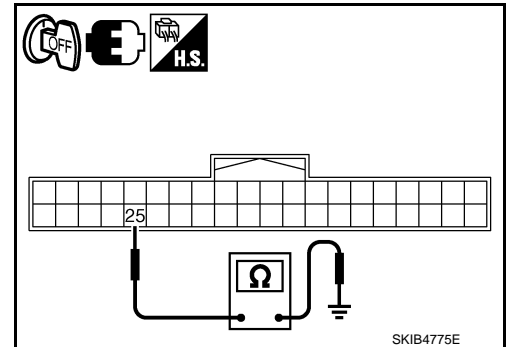

OK or NG

OK >> INSPECTION END

NG >> Repair harness or connector.

CONSULT-III Function (ADAPTIVE LIGHT)

INFOID:000000002956758

CONSULT-III can display each diagnostic item using diagnostic test modes shown following.

| Check item, diagnosis mode | Description |
|----------------------------|--|
| WORK SUPPORT | Adjusts steering angle sensor (Never use this function but on VDC side) and adjusts levelizer. |
| SELF-DIAG RESULTS | Displays self-diagnosis |
| DATA MONITOR | Displays AFS control unit inputs and outputs in real time. |
| CAN DIAG SUPPORT MNTR | The result of transmit/receive diagnosis of CAN communication can be read. |
| ACTIVE TEST | AFS control unit sends a drive signal to electronic components to check their operation. |
| ECU PART NUMBER | AFS control unit part number can be read. |

WORK SUPPORT (STEERING ANGLE SENSOR ADJUSTMENT)

Work Support Item List

| Item | Description |
|-----------------------|---|
| ST ANG SEN ADJUSTMENT | Adjust steering angle sensor neutral point (straight-ahead position). |

ACTIVE AFS

< SERVICE INFORMATION >

CAUTION:

Never use this function but on VDC side.

Notes on Steering Angle Sensor (Neutral Point) Adjustment

- Be sure to adjust steering angle sensor neutral point before driving if any of the following has been removed/ installed or replaced: Steering angle sensor; Steering system part, Suspension system part.
- On vehicle with VDC, perform steering angle sensor neutral point adjustment only on VDC side. Never perform the adjustment on ADAPTIVE LIGHT side as this may lead to VDC malfunctions. If the adjustment has been performed on AFS side, readjust on VDC side. For steering angle sensor neutral point adjustment procedures on VDC side, refer to [BRC-8, "Adjustment of Steering Angle Sensor Neutral Position"](#) in "ON-VEHICLE SERVICE".
- When replaced steering angle sensor, AFS control unit detects "DTC B2515 ST ANG SEN SIG". Delete the malfunction history after adjust steering angle sensor on VDC side.
- Steering angle sensor neutral point adjustment should be performed using CONSULT-III. (The adjustment will not be possible without CONSULT-III.)

Operation Procedure

Refer to [BRC-8, "Adjustment of Steering Angle Sensor Neutral Position"](#).

WORK SUPPORT (LEVELIZER ADJUSTMENT)

Work Support Item List

| Item | Description |
|----------------------|--|
| LEVELIZER ADJUSTMENT | Adjust the height sensor signal value at unloaded vehicle position recognized by AFS control unit. |

CAUTION:

When "CAN NOT BE TESTED" is displayed, AFS control unit stops levelizer adjustment as it detected the change of height sensor signal. AFS control unit detects "DTC B2519 LEVELIZER CALIB". Turn ignition switch OFF not to change the vehicle height. Then turn ignition switch ON and perform levelizer adjustment again.

- When "ADJUSTMENT COMPLETE" is displayed, and "NO DTC IS DETECTED" is displayed on self-diagnosis results, levelizer adjustment is completed.
- When "ADJUSTMENT COMPLETE" is displayed, and "B2514 HI SEN UNUSUAL" is displayed on self-diagnosis results, refer to [LT-144, "DTC B2514 HI SEN UNUSUAL RR"](#).

SELF-DIAG RESULTS

CAUTION:

DTC B2503 and B2504 cannot be detected before the swivel operation. Thus, perform swivel operation first, and then check the display in self-diagnostic results.

Description of DTC and Solutions after Detection

CONSULT-III can detect DTC (Diagnosis trouble code). The descriptions and solutions of DTC are listed below.

ACTIVE AFS

< SERVICE INFORMATION >

| Details of error indication detected by CONSULT-III | Conditions of error detection | Fail-safe | Reference |
|---|--|---|---|
| CAN COMM CIRCUIT [U1000] | CAN communication system. | <ol style="list-style-type: none"> 1. Swivel operation 2. Auto aiming operation 3. AFS OFF indicator operation 4. Cancellation | Reference |
| CONTROL UNIT (CAN) [U1010] | AFS control unit malfunctions. | <ol style="list-style-type: none"> 1. Stop the swivel motor RH and LH when the malfunction occurred. 2. Stop the aiming motors when the malfunction occurred. 3. Flash at intervals of approx. 1 second when keeping error state for 2 seconds or longer. 4. Turn ignition switch OFF. | LAN-20, "Trouble Diagnosis Flow Chart". |
| SWIVEL ACTUATOR [RH] [B2503] | <p>Any of several statuses below</p> <ul style="list-style-type: none"> • Large difference between swivel motor drive signal (swivel angle command signal) transmitted by AFS control unit and swivel position sensor signal (swivel angle feed back signal) by swivel position sensor exists for 2 seconds or longer. Or swivel position sensor signal does not change for 2 seconds or longer even when AFS control unit transmit swivel motor drive signal. <p>CAUTION: Detects when swivel operating (excludes initialization).</p> <ul style="list-style-type: none"> • Short or open circuit exists for 2 seconds or longer on one of swivel motor circuits (AFS control unit terminals 11, 13, 32 or 34). <p>CAUTION: Detects when swivel operating (excludes initialization).</p> <ul style="list-style-type: none"> • Voltage of swivel position sensor power supply (AFS control unit terminal 4) had more than 6 V or had less than 4 V for 2 seconds or longer. • Voltage of swivel position sensor signal (AFS control unit terminal 9) had more than 4.75 V or had less than 0.25 V for 2 seconds or longer. | <ol style="list-style-type: none"> 1. Stop the swivel motor RH and LH when the malfunction occurred. 2. Reduce approx. 2 V of the aiming motor drive signal value from that of when error is detected. 3. Flash at intervals of approx. 1 second when keeping error state for 2 seconds or longer. 4. Turn ignition switch OFF. | LT-134, "DTC B2503 SWIVEL ACTUATOR RH" |
| SWIVEL ACTUATOR [LH] [B2504] | <p>Any of several statuses below</p> <ul style="list-style-type: none"> • Large difference between swivel motor drive signal (swivel angle command signal) transmitted by AFS control unit and swivel position sensor signal (swivel angle feed back signal) by swivel position sensor exists for 2 seconds or longer. Or swivel position sensor signal does not change for 2 seconds or longer even when AFS control unit transmit swivel motor drive signal. <p>CAUTION: Detects when swivel operating (excludes initialization).</p> <ul style="list-style-type: none"> • Short or open circuit exists for 2 seconds or longer on one of swivel motor circuits (AFS control unit terminals 15, 17, 36 or 38). <p>CAUTION: Detects when swivel operating (excludes initialization).</p> <ul style="list-style-type: none"> • Voltage of swivel position sensor power supply (AFS control unit terminal 24) had more than 6 V or had less than 4 V for 2 seconds or longer. • Voltage of swivel position sensor signal (AFS control unit terminal 29) had more than 4.75 V or had less than 0.25 V for 2 seconds or longer. | <ol style="list-style-type: none"> 1. Stop the swivel motor RH and LH when the malfunction occurred. 2. Reduce approx. 2 V of the aiming motor drive signal value from that of when error is detected. 3. Flash at intervals of approx. 1 second when keeping error state for 2 seconds or longer. 4. Turn ignition switch OFF. | LT-139, "DTC B2504 SWIVEL ACTUATOR LH" |

ACTIVE AFS

< SERVICE INFORMATION >

| Details of error indication detected by CONSULT-III | Conditions of error detection | Fail-safe 1. Swivel operation 2. Auto aiming operation 3. AFS OFF indicator operation 4. Cancellation | Reference | A B C D E F G H I J LT L M N O P |
|---|--|---|--|---|
| HI SEN UNUSUAL [RR] [B2514] | Any of several statuses below <ul style="list-style-type: none"> • Voltage of height sensor power supply (AFS control unit terminal 6) had more than 6 V or had less than 4 V for 2 seconds or longer. • Voltage of height sensor signal (AFS control unit terminal 28) had more than 4.75 V or had less than 0.25 V for 2 seconds or longer. | 1. Normal operation 2. Stop aiming motors when the malfunction occurred. 3. Remains OFF. 4. Turn ignition switch OFF. | LT-144. "DTC B2514 HI SEN UNUSUAL RR" | |
| ST ANG SEN SIG [B2515] | Any of several statuses below <ul style="list-style-type: none"> • Cannot receive steering angle sensor signal. • Receives steering angle sensor error. • Receives steering angle sensor signal except -943° to +943°. | 1. Back to the initial position. 2. Normal operation 3. Flash at intervals of approx. 1 second when keeping error state for 2 seconds or longer. 4. Turn ignition switch OFF. | LT-126. "CONSULT-III Function (ADAPTIVE LIGHT)". If above system is normal, replace AFS control unit. | |
| SHIFT SIG [P, R] [B2516] | Cannot receive A/T position indicator signal. | 1. Back to the initial position. 2. Normal operation 3. Flash at intervals of approx. 1 second when keeping error state for 2 seconds or longer. 4. Turn ignition switch OFF. | LT-126. "CONSULT-III Function (ADAPTIVE LIGHT)". If above system is normal, replace AFS control unit. | |
| VEHICLE SPEED SIG [B2517] | Cannot receive vehicle speed signal. | 1. Back to the initial position. 2. Stop when the malfunction occurred. 3. Flash at intervals of approx. 1 second when keeping error state for 2 seconds or longer. 4. Turn ignition switch OFF. | DI-27. "CONSULT-III Function (METER/M&A)". If above system is normal, replace AFS control unit. | |
| HEAD LAMP SIG [B2518] | Cannot receive low beam status signal. | 1. Back to the initial position. 2. Stop aiming motors when the malfunction occurred. 3. Flash at intervals of approx. 1 second when keeping error state for 2 seconds or longer. 4. Turn ignition switch OFF. | PG-20. "CONSULT-III Function (IPDM E/R)". If above system is normal, replace AFS control unit. | |
| LEVELIZER CALIB [B2519] | Cannot recognize height sensor signal value at unloaded vehicle position. | 1. Normal operation 2. Stop aiming motors when the malfunction occurred. 3. Remains OFF. 4. When levelizer adjustment is completed | "WORK SUPPORT (LEVELIZER ADJUSTMENT)" | |
| ST ANGLE SEN CALIB [B2520] | Cannot recognize steering angle sensor neutral point (straight-ahead position). | 1. Back to the initial position. 2. Normal operation 3. Flash at intervals of approx. 1 second when keeping error state for 2 seconds or longer. 4. When steering angle sensor adjustment is completed | BRC-8. "Adjustment of Steering Angle Sensor Neutral Position". | |

ACTIVE AFS

< SERVICE INFORMATION >

| Details of error indication detected by CONSULT-III | Conditions of error detection | Fail-safe | Reference |
|---|---|--|---|
| ECU CIRC [B2521] | Any of several statuses below <ul style="list-style-type: none"> • Short circuit exists for 2 seconds or longer on power supply (approx. 12 V) or ground of swivel position sensor (RH) power supply (AFS control unit terminal 4). • Short circuit exists for 2 seconds or longer on power supply (approx. 12 V) of swivel position sensor (RH) signal (AFS control unit terminal 9). • Short circuit exists for 2 seconds or longer on power supply (approx. 12 V) or ground of swivel position sensor (LH) power supply (AFS control unit terminal 24). • Short circuit exists for 2 seconds or longer on power supply (approx. 12 V) of swivel position sensor (LH) signal (AFS control unit terminal 29). • Short circuit exists for 2 seconds or longer on power supply (approx. 12 V) or ground of height sensor power supply (AFS control unit terminal 6). • Short circuit exists for 2 seconds or longer on power supply (approx. 12 V) of height sensor signal (AFS control unit terminal 28). • AFS control unit (RAM/ROM) malfunctions. | 1. Swivel operation 2. Auto aiming operation 3. AFS OFF indicator operation 4. Cancellation | Reference |
| ECM SIG [B2522] | Cannot receive engine speed signal. | 1. Stop the swivel motor RH and LH when the malfunction occurred. 2. Stop aiming motors when the malfunction occurred. 3. Flash at intervals of approx. 1 second when keeping error state for 2 seconds or longer. 4. Turn ignition switch OFF. | LT-149, "DTC B2521 ECU CIRC" EC-116, "CONSULT-III Function (ENGINE)" . If above system is normal, replace AFS control unit. |
| AFS SIG [B2523] | Cannot transmit AFS off indicator signal. | 1. Back to the initial position. 2. Normal operation 3. Flashes at intervals of approx. 1 second when keeping error state for 2 seconds or longer. 4. Turn ignition switch OFF. | Replace AFS control unit LT-160 |

CAUTION:

- If DTC relating to CAN communication [U1000] and other components are displayed at the same time, diagnose CAN communication first.
 - Make sure of the normal operation after the parts (except AFS control unit) replacement according to the self-diagnosis results. Delete the malfunction history.
- Display Results**
- **0:** There is malfunction now.
 - **1 – 39:** Displays when it is normal at present and finds malfunction in the past. It increases in order of 0→1→2...38→39 after returning to the normal condition whenever IGN OFF→ON. If it is over 39, it is fixed to 39 until the self-diagnostic results are erased. It returns to 0 when malfunction is detected again in the process.

DATA MONITOR

Data Monitor item

| Monitors item | Measuring condition | | | Description | |
|---------------|------------------------|-----------------|-----------------|-----------------------|---|
| | Operation or condition | Reference value | Reference value | | |
| STR ANGLE SIG | " ° " | Steering wheel | Straight-ahead | Approx. 0° | Displays steering angle based on steering angle sensor signals. |
| | | | Turned | Approx. -550° to 550° | |

ACTIVE AFS

< SERVICE INFORMATION >

| Monitors item | Measuring condition | | | Description | |
|----------------|------------------------|--|---------------------------|--|--|
| | Operation or condition | Reference value | | | |
| VHCL SPD | " km/h " | — | | Displays vehicle speed based on vehicle speed sensor signals. | |
| SLCT LVR POSI | " P – 1 " | — | | Displays A/T selector lever position based on AT position indicator signals. | |
| HEAD LAMP | " On/Off " | Lighting switch | 2ND | ON | Displays low beam headlamps on/off status based on low beam status signal. |
| | | | Out of 2ND | OFF | |
| AFS SW | " On/Off " | AFS switch | ON | ON | Displays AFS switch ON/OFF position based on AFS switch signals. |
| | | | OFF | OFF | |
| HI SEN OTP RR | " V " | Vehicle height (With 18-inch wheel) | Unloaded vehicle position | Approx. 2.5 V | Displays vehicle height value based on height sensor signals. |
| | | | Maximum laden condition | Approx. 1.0 V | |
| | | Vehicle height (With 19-inch wheel) | Unloaded vehicle position | Approx. 2.5 V | |
| | | | Maximum laden condition | Approx. 1.3 V | |
| LEV ACTR VLTG | "% " | Low beam headlamp auto aiming (With 18-inch wheel) | Unloaded vehicle position | Approx. 70.0% | Displays aiming motor drive signal based on AFS control unit interpretation of various vehicle sensor signals. The value is a ratio to IGN power supply. |
| | | | Maximum laden condition | Approx. 38.0% | |
| | | Low beam headlamp auto aiming (With 19-inch wheel) | Unloaded vehicle position | Approx. 70.0% | |
| | | | Maximum laden condition | Approx. 41.8% | |
| SWVL SEN RH* | " ° " | Low beam headlamp (right) swivel | OFF | Approx. 0° | Displays low beam headlamp (right) swivel angle based on swivel position sensor signals (right). |
| | | | ON | +° | |
| SWVL SEN LH* | " ° " | Low beam headlamp (left) swivel | OFF | Approx. 0° | Displays low beam headlamp (left) swivel angle based on swivel position sensor signals (left). |
| | | | ON | +° | |
| SWVL ANGLE RH* | " ° " | Low beam headlamp (right) swivel | OFF | Approx. 0° | Displays swivel motor drive signal (right) based on AFS control unit interpretation of various vehicle sensor signals. |
| | | | ON | +° | |
| SWVL ANGLE LH* | " ° " | Low beam headlamp (left) swivel | OFF | Approx. 0° | Displays swivel motor drive signal (left) based on AFS control unit interpretation of various vehicle sensor signals. |
| | | | ON | +° | |

CAUTION:

*: The value can be slightly different between that is displayed on "SWVL SEN RH/LH" and that on "SWVL ANGLE RH/LH".

ACTIVE TEST

CAUTION:

Can be tested only when swivel actuator initialization is completed. If initialization is not completed, "RETRY COMMAND" is displayed and cannot be tested.

- **LOW BEAM TEST RIGHT**
Low beam headlamp (right) can be operated to swivel angle 0° by touching "ORIGIN", and to maximum angle by "PEAK".

| Test Item | Swivel Speed | Mode |
|--------------------|--------------------------|------------------|
| ORIGIN/PEAK - FAST | Three times fast as SLOW | Normal operation |
| ORIGIN/PEAK - SLOW | — | Initialization |

ACTIVE AFS

< SERVICE INFORMATION >

- **LOW BEAM TEST LEFT**

Low beam headlamp (left) can be operated to swivel angle 0° by touching "ORIGIN", and to maximum angle by "PEAK".

| Test Item | Swivel Speed | Mode |
|--------------------|--------------------------|------------------|
| ORIGIN/PEAK - FAST | Three times fast as SLOW | Normal operation |
| ORIGIN/PEAK - SLOW | — | Initialization |

- **LEVELIZER TEST**

Aiming motor drive signal can be changed to approx. 85% (ratio to IGN power supply) by touching "ORIGIN", and to approx. 15% by "PEAK". That angles headlamp LO up and down.

| Test Item | Aiming Motor Drive Signal | | Light Axis (Reference Value) |
|-----------|---------------------------|----------------|--|
| | Ratio to IGN power supply | Voltage | |
| ORIGIN | Approx. 85% | Approx. 10.6 V | 0° |
| PEAK | Approx. 15% | Approx. 1.9 V | Approx. 2.5° (Relatively lower than that of origin) |

Symptom Chart

INFOID:000000002956759

CAUTION:

The low beam headlamps performs small movements when AFS control unit detects the engine start. This is normal with initialization of swivel actuator by AFS control unit.

| Symptom | AFS OFF indicator | Causal system | Reference |
|--|-------------------|---|---|
| • AFS operates, but cannot judge normal/abnormal. (AFS function test) | Normal | Check swivel operation. | LT-152, "AFS Operation Check (Function Test)" |
| | | Check steering angle sensor neutral point (straight-ahead position). | |
| • Auto aiming operates, but cannot judge normal/abnormal. (Auto aiming function test) | Normal | Check auto aiming operation. | LT-153, "Auto Aiming Operation Check (Function Test)" |
| | | Check height sensor signal value recognized by AFS control unit at unloaded vehicle position. | |
| | | Check height sensor signal and aiming motor drive signal. | |
| • Neither AFS operates nor auto aiming operates. | Blinking | Check AFS control unit self-diagnostic results. | LT-126, "CONSULT-III Function (ADAPTIVE LIGHT)" |
| | | Check AFS control unit power supply and ground circuit. NOTE: Check only when "ADAPTIVE LIGHT" is not displayed on CONSULT-III "SELECT SYSTEM" screen. | |
| • AFS does not operate. (Auto aiming operation is normal.) | Blinking | Check AFS control unit self-diagnostic results. | LT-126, "CONSULT-III Function (ADAPTIVE LIGHT)" |
| | Illuminated | Check AFS switch system circuit. | LT-155, "AFS Switch Does Not Operate" |

ACTIVE AFS

< SERVICE INFORMATION >

| Symptom | AFS OFF indicator | Causal system | Reference |
|--|-------------------|---|--|
| <ul style="list-style-type: none"> Auto aiming does not operate. (AFS operation is normal.) | Normal | Check AFS control unit self-diagnostic results. | LT-126, "CONSULT-III Function (ADAPTIVE LIGHT)" |
| | | Check aiming motor system circuit. | LT-157, "Auto Aiming Does Not Operate (Check Aiming Motor System Circuit)" |
| <ul style="list-style-type: none"> Auto aiming operates in the reverse way. (Lowering vehicle height angles light axis up.) | Normal | Replace AFS control unit. | LT-160, "Removal and Installation of AFS Control Unit" |
| <ul style="list-style-type: none"> AFS OFF indicator does not illuminate. (AFS operation and auto aiming operation are normal.) | Not illuminated | Check circuit between unified meter and A/C amp. and combination meter. | LT-159, "AFS OFF Indicator Does Not Operate" |
| <ul style="list-style-type: none"> AFS OFF indicator blinks. (AFS operation and auto aiming operation are normal.) | Blinking | Check receive state of AFS off indicator signal from unified meter and A/C amp. | |
| <ul style="list-style-type: none"> AFS cannot be cancelled. (AFS switch does not operate.) | Normal | Check AFS switch system circuit. | LT-155, "AFS Switch Does Not Operate" |

DTC U1000 CAN COMM CIRCUIT

INFOID:00000002989266

| Details of error indication detected by CONSULT-III | Conditions of error detection | Fail-safe 1. Swivel operation 2. Auto aiming operation 3. AFS OFF indicator operation 4. Cancellation | Reference |
|---|-------------------------------|--|--|
| CANCOMM CIRCUIT [U1000] | CAN communication system. | <ol style="list-style-type: none"> Stop the swivel motor RH and LH when the malfunction occurred. Stop the aiming motors when the malfunction occurred. Flash at intervals of approx. 1 second when keeping error state for 2 seconds or longer. Turn ignition switch OFF. | LAN-20, "Trouble Diagnosis Flow Chart" |

ACTIVE AFS

< SERVICE INFORMATION >

DTC U1010 CONTROL UNIT (CAN)

INFOID:000000002989271

| Details of error indication detected by CONSULT-III | Conditions of error detection | Fail-safe | Reference |
|---|--------------------------------|--|---|
| CONTROL UNIT (CAN) [U1010] | AFS control unit malfunctions. | 1. Swivel operation 2. Auto aiming operation 3. AFS OFF indicator operation 4. Cancellation | Reference Replace AFS control unit. LT-160 |

DTC B2503 SWIVEL ACTUATOR RH

INFOID:000000002956760

1. CHECK SWIVEL POSITION SENSOR SIGNAL

1. Turn ignition switch ON.
2. Check voltage between AFS control unit harness connector and ground.

| Terminals | | | Voltage (Approx.) |
|----------------------------|----------|--------|-------------------|
| (+) | | (-) | |
| AFS control unit connector | Terminal | | |
| F110 | 9 | Ground | 0.25 - 4.75 V |

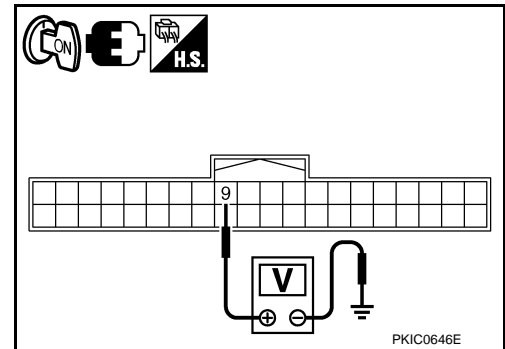

OK or NG

- OK >> GO TO 2.
 NG >> • If voltage is less than approx. 0.25V, GO TO 3.
 • If voltage is more than approx. 4.75V, GO TO 6.

2. CHECK SWIVEL POSITION SENSOR POWER SUPPLY

Check voltage between AFS control unit harness connector and ground.

| Terminals | | | Voltage (Approx.) |
|----------------------------|----------|--------|-------------------|
| (+) | | (-) | |
| AFS control unit connector | Terminal | | |
| F110 | 4 | Ground | 4.0 - 6.0 V |

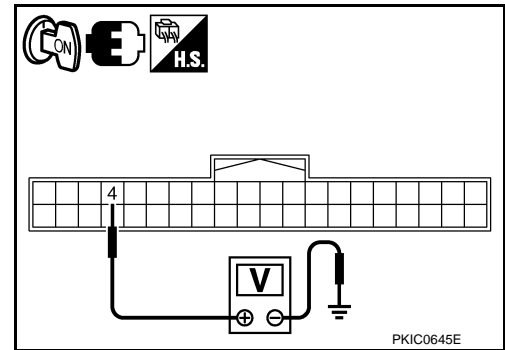

OK or NG

- OK >> GO TO 12.
 NG >> Replace AFS control unit. Refer to [LT-160, "Removal and Installation of AFS Control Unit"](#).

3. CHECK SWIVEL POSITION SENSOR POWER SUPPLY

ACTIVE AFS

< SERVICE INFORMATION >

Check voltage between AFS control unit harness connector and ground.

| Terminals | | (-) | Voltage (Approx.) |
|----------------------------|----------|--------|-------------------|
| (+) | | | |
| AFS control unit connector | Terminal | | |
| F110 | 4 | Ground | 4.0 - 6.0 V |

OK or NG

OK >> GO TO 4.

NG >> GO TO 8.

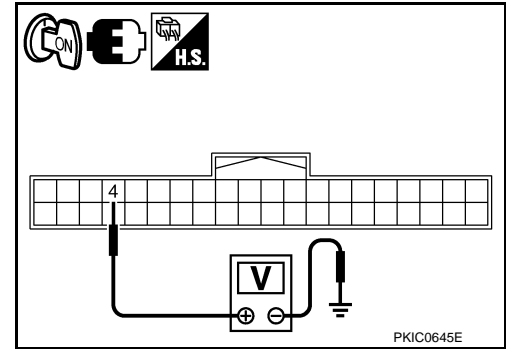

4. CHECK SWIVEL POSITION SENSOR POWER SUPPLY CIRCUIT

1. Turn ignition switch OFF.
2. Disconnect front combination lamp RH connector.
3. Turn ignition switch ON.
4. Check voltage between front combination lamp RH harness connector and ground.

| Terminals | | (-) | Voltage (Approx.) |
|-------------------------------------|----------|--------|-------------------|
| (+) | | | |
| Front combination lamp RH connector | Terminal | | |
| E48 | 15 | Ground | 4.0 - 6.0 V |

OK or NG

OK >> GO TO 5.

NG >> Repair harness or connector.

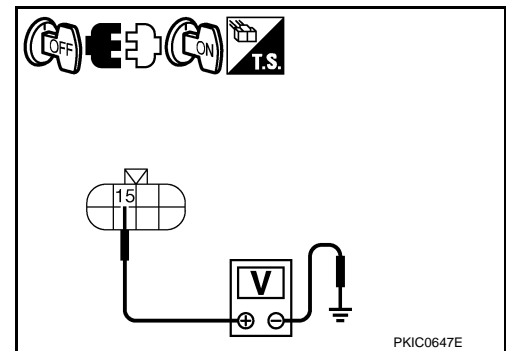

5. CHECK SWIVEL POSITION SENSOR SIGNAL CIRCUIT

1. Turn ignition switch OFF.
2. Disconnect AFS control unit connector.
3. Check continuity between AFS control unit harness connector (A) and front combination lamp RH harness connector (B).

| A | | B | | Continuity |
|-----------|----------|-----------|----------|------------|
| Connector | Terminal | Connector | Terminal | |
| F110 | 9 | E48 | 14 | Yes |

OK or NG

OK >> Replace front combination lamp RH (swivel position sensor malfunction). Refer to [LT-160, "Removal and Installation of Front Combination Lamp"](#).

NG >> Repair harness or connector.

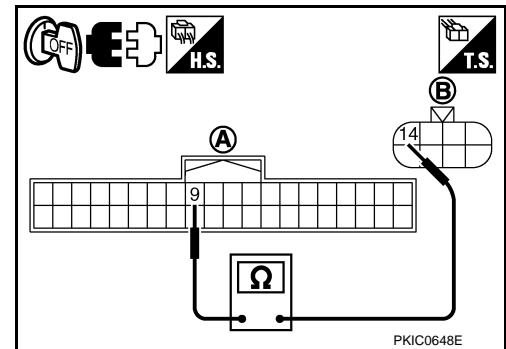

6. CHECK SWIVEL POSITION SENSOR GROUND

Check voltage between AFS control unit harness connector and ground.

| Terminals | | (-) | Voltage (Approx.) |
|----------------------------|----------|--------|-------------------|
| (+) | | | |
| AFS control unit connector | Terminal | | |
| F110 | 2 | Ground | 0 V |

OK or NG

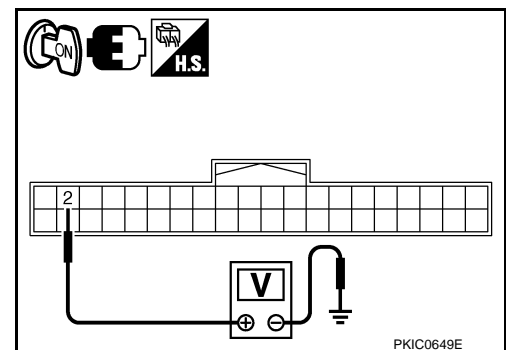

ACTIVE AFS

< SERVICE INFORMATION >

- OK >> GO TO 7.
 NG >> Check connector for connection, bend and loose fit. If it is normal, replace AFS control unit. Refer to [LT-160. "Removal and Installation of AFS Control Unit"](#).

7. CHECK SWIVEL POSITION SENSOR GROUND CIRCUIT

1. Turn ignition switch OFF.
2. Disconnect AFS control unit connector and front combination lamp RH connector.
3. Check continuity between AFS control unit harness connector (A) and front combination lamp RH harness connector (B).

| A | | B | | Continuity |
|-----------|----------|-----------|----------|------------|
| Connector | Terminal | Connector | Terminal | |
| F110 | 2 | E48 | 19 | Yes |

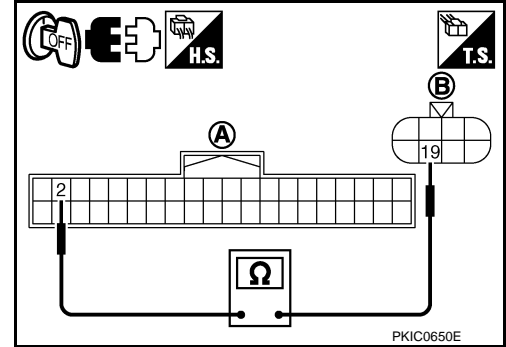

OK or NG

- OK >> Replace front combination lamp RH (swivel position sensor malfunction). Refer to [LT-160. "Removal and Installation of Front Combination Lamp"](#).
 NG >> Repair harness or connector.

8. CHECK DIAGNOSIS RESULT

Select "ADAPTIVE LIGHT" on CONSULT-III. Select "SELF-DIAG RESULTS" on "SELECT DIAG MODE" screen.

Is DTC B2521 ECU CIRC detected?

- YES >> Refer to [LT-149. "DTC B2521 ECU CIRC"](#).
 NO >> GO TO 9.

9. CHECK SWIVEL POSITION SENSOR POWER SUPPLY CIRCUIT

1. Turn ignition switch OFF.
2. Disconnect front combination lamp RH connector.
3. Turn ignition switch ON.
4. Check voltage between AFS control unit harness connector and ground.

| Terminals | | | Voltage (Approx.) |
|----------------------------|----------|--------|-------------------|
| (+) | | (-) | |
| AFS control unit connector | Terminal | | |
| F110 | 4 | Ground | 4.0 - 6.0 V |

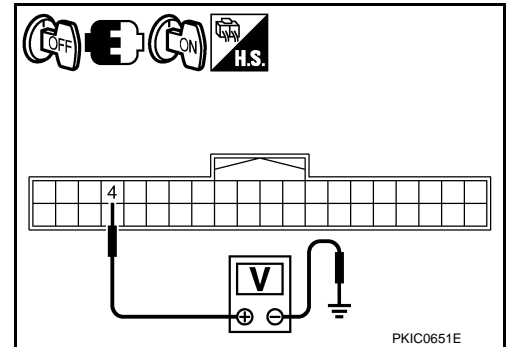

OK or NG

- OK >> GO TO 10.
 NG >> GO TO 11.

10. CHECK SWIVEL POSITION SENSOR SIGNAL CIRCUIT (SHORT CIRCUIT)

1. Turn ignition switch OFF.
2. Disconnect AFS control unit connector.
3. Check continuity between AFS control unit harness connector and ground.

| AFS control unit connector | Terminal | Ground | Continuity |
|----------------------------|----------|--------|------------|
| F110 | 9 | | No |

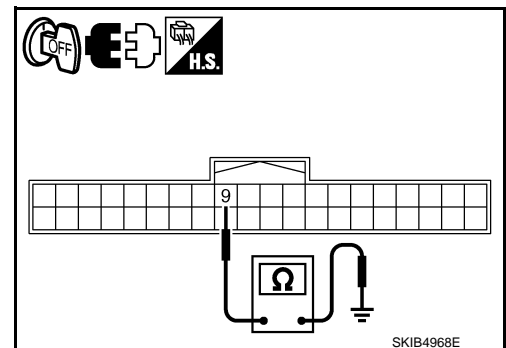

OK or NG

- OK >> Replace front combination lamp RH (swivel position sensor malfunction). Refer to [LT-160. "Removal and Installation of Front Combination Lamp"](#).

ACTIVE AFS

< SERVICE INFORMATION >

NG >> Repair harness or connector.

11. CHECK SWIVEL POSITION SENSOR POWER SUPPLY CIRCUIT (SHORT CIRCUIT)

1. Turn ignition switch OFF.
2. Disconnect AFS control unit connector.
3. Check continuity between AFS control unit harness connector and ground.

| AFS control unit connector | Terminal | Ground | Continuity |
|----------------------------|----------|--------|------------|
| F110 | 4 | | No |

OK or NG

OK >> Replace AFS control unit. Refer to [LT-160, "Removal and Installation of AFS Control Unit"](#).

NG >> Repair harness or connector.

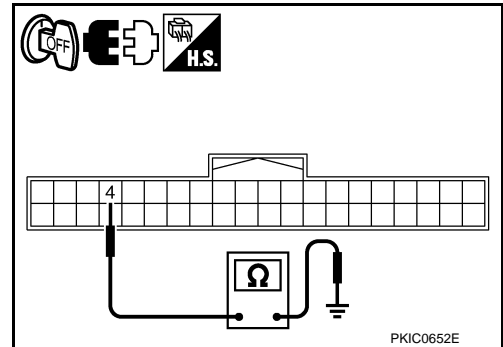

12. CHECK SWIVEL MOTOR

1. Turn ignition switch OFF.
2. Disconnect front combination lamp RH connector.
3. Check continuity between front combination lamp RH connector terminals.

| Front combination lamp RH terminals (1 phase) | Resistance |
|---|---------------|
| 16 20 | Approx. 7.4 Ω |

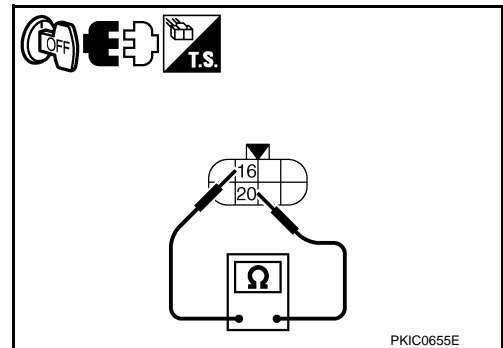

4. Check continuity between front combination lamp RH connector terminals.

| Front combination lamp RH terminals (2 phase) | Resistance |
|---|---------------|
| 17 21 | Approx. 7.4 Ω |

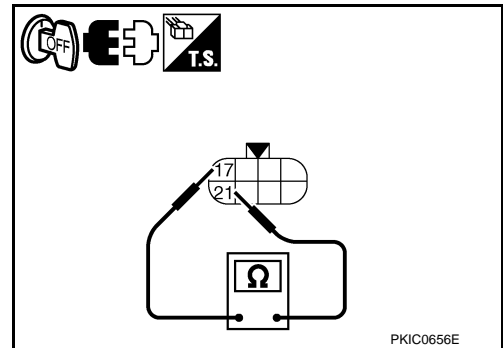

5. Check continuity between front combination lamp RH connector terminals (insulation resistance).

| Front combination lamp RH terminals | Resistance |
|-------------------------------------|----------------------|
| 16 17 | Approx. 1 MΩ or more |

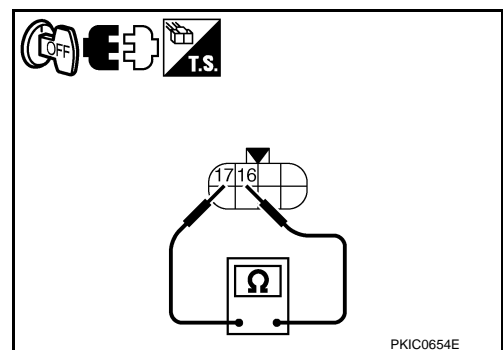

OK or NG

OK >> GO TO 13.

NG >> Replace front combination lamp RH (swivel motor malfunction). Refer to [LT-160, "Removal and Installation of Front Combination Lamp"](#).

13. CHECK SWIVEL MOTOR CIRCUIT 1

1. Connect front combination lamp RH connector.
2. Turn ignition switch ON.

ACTIVE AFS

< SERVICE INFORMATION >

- Check voltage between AFS control unit harness connector and ground.

| (+) | | (-) | Voltage (Approx.) |
|----------------------------|----------|--------|-------------------|
| AFS control unit connector | Terminal | | |
| F110 | 11 | Ground | 9.5 - 11.5 V |
| | 13 | | |
| | 32 | | |
| | 34 | | |

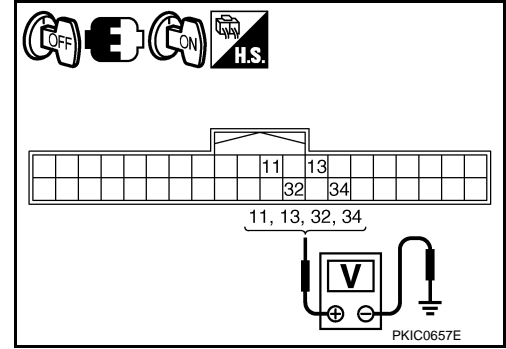

OK or NG

OK >> GO TO 14.

NG >> GO TO 16.

14. CHECK DIAGNOSIS RESULT 1

Select "ADAPTIVE LIGHT" on CONSULT-III. Select "SELF-DIAG RESULTS" on "SELECT DIAG MODE" screen.

Is DTC of present malfunction detected?

- YES >>
- If detect DTC B2503 and B2504, refer to [LT-139, "DTC B2504 SWIVEL ACTUATOR LH"](#).
 - If detect DTC B2503 only, replace AFS control unit. Refer to [LT-160, "Removal and Installation of AFS Control Unit"](#).
 - If detect any DTC except B2503 and B2504, refer to [LT-126, "CONSULT-III Function \(ADAPTIVE LIGHT\)"](#).

NO >> GO TO 15.

15. CHECK DIAGNOSIS RESULT 2

Select "ADAPTIVE LIGHT" on CONSULT-III, check "SELF-DIAG RESULTS" with steering turning 180° or more to right under swivel operative condition to keep more than 2 seconds.

Is DTC B2503 of present malfunction detected?

YES >> Replace front combination lamp RH (swivel actuator malfunction). Refer to [LT-160, "Removal and Installation of Front Combination Lamp"](#).

NO >> The swivel actuator system RH is normal at present.

16. CHECK SWIVEL MOTOR CIRCUIT 2

- Turn ignition switch OFF.
- Disconnect AFS control unit connector and front combination lamp RH connector.
- Check continuity between AFS control unit harness connector (A) and front combination lamp RH harness connector (B).

| A | | B | | Continuity |
|-----------|----------|-----------|----------|------------|
| Connector | Terminal | Connector | Terminal | |
| F110 | 11 | E48 | 20 | Yes |
| | 13 | | 21 | |
| | 32 | | 17 | |
| | 34 | | 16 | |

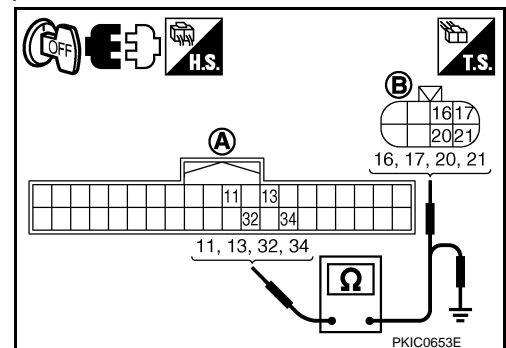

- Check continuity between AFS control unit harness connector (A) and ground.

ACTIVE AFS

< SERVICE INFORMATION >

| A | | Ground | Continuity |
|-----------|----------|--------|------------|
| Connector | Terminal | | |
| F110 | 11 | Ground | No |
| | 13 | | |
| | 32 | | |
| | 34 | | |

OK or NG

- OK >> Replace AFS control unit. Refer to [LT-160, "Removal and Installation of AFS Control Unit"](#).
 NG >> Repair or replace harness or connector.

DTC B2504 SWIVEL ACTUATOR LH

INFOID:000000002956761

1. CHECK SWIVEL POSITION SENSOR SIGNAL

- Turn ignition switch ON.
- Check voltage between AFS control unit harness connector and ground.

| Terminals | | | Voltage (Approx.) |
|----------------------------|----------|--------|-------------------|
| (+) | | (-) | |
| AFS control unit connector | Terminal | | |
| F110 | 29 | Ground | 0.25 - 4.75 V |

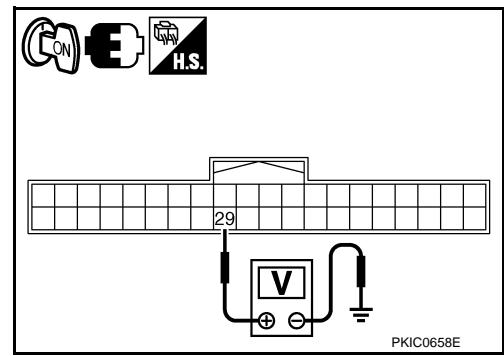

OK or NG

- OK >> GO TO 2.
 NG >> • If voltage is less than approx. 0.25V, GO TO 3.
 • If voltage is more than approx. 4.75V, GO TO 6.

2. CHECK SWIVEL POSITION SENSOR POWER SUPPLY

Check voltage between AFS control unit harness connector and ground.

| Terminals | | | Voltage (Approx.) |
|----------------------------|----------|--------|-------------------|
| (+) | | (-) | |
| AFS control unit connector | Terminal | | |
| F110 | 24 | Ground | 4.0 - 6.0 V |

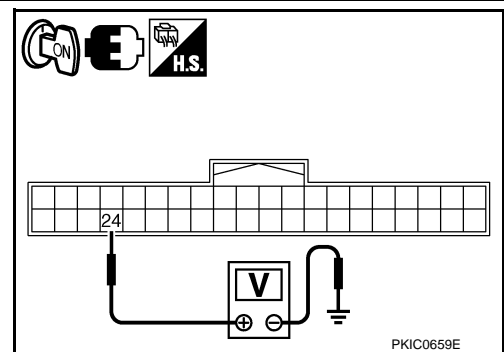

OK or NG

- OK >> GO TO 12.
 NG >> Replace AFS control unit. Refer to [LT-160, "Removal and Installation of AFS Control Unit"](#).

3. CHECK SWIVEL POSITION SENSOR POWER SUPPLY

Check voltage between AFS control unit harness connector and ground.

| Terminals | | | Voltage (Approx.) |
|----------------------------|----------|--------|-------------------|
| (+) | | (-) | |
| AFS control unit connector | Terminal | | |
| F110 | 24 | Ground | 4.0 - 6.0 V |

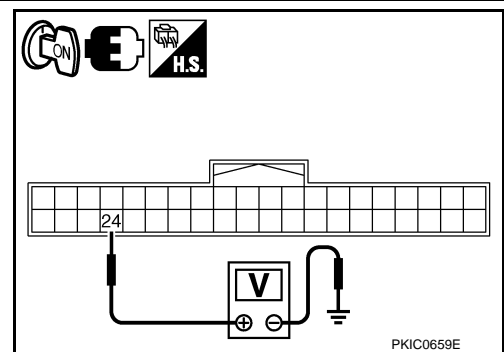

OK or NG

- OK >> GO TO 4.

ACTIVE AFS

< SERVICE INFORMATION >

NG >> GO TO 8.

4. CHECK SWIVEL POSITION SENSOR POWER SUPPLY CIRCUIT

1. Turn ignition switch OFF.
2. Disconnect front combination lamp LH connector.
3. Turn ignition switch ON.
4. Check voltage between front combination lamp LH harness connector and ground.

| Terminals | | | Voltage (Approx.) |
|-------------------------------------|----------|--------|-------------------|
| (+) | | (-) | |
| Front combination lamp LH connector | Terminal | | |
| E53 | 15 | Ground | 4.0 - 6.0 V |

OK or NG

OK >> GO TO 5.

NG >> Repair harness or connector.

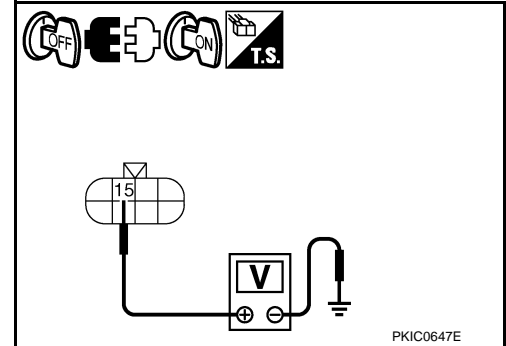

5. CHECK SWIVEL POSITION SENSOR SIGNAL CIRCUIT

1. Turn ignition switch OFF.
2. Disconnect AFS control unit connector.
3. Check continuity between AFS control unit harness connector (A) and front combination lamp LH harness connector (B).

| A | | B | | Continuity |
|-----------|----------|-----------|----------|------------|
| Connector | Terminal | Connector | Terminal | |
| F110 | 29 | E53 | 14 | Yes |

OK or NG

OK >> Replace front combination lamp LH (swivel position sensor malfunction). Refer to [LT-160, "Removal and Installation of Front Combination Lamp"](#).

NG >> Repair harness or connector.

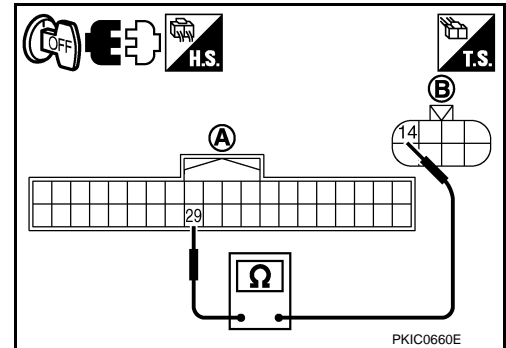

6. CHECK SWIVEL POSITION SENSOR GROUND

Check voltage between AFS control unit harness connector and ground.

| Terminals | | | Voltage (Approx.) |
|----------------------------|----------|--------|-------------------|
| (+) | | (-) | |
| AFS control unit connector | Terminal | | |
| F110 | 27 | Ground | 0 V |

OK or NG

OK >> GO TO 7.

NG >> Check connector for connection, bend and loose fit. If it is normal, replace AFS control unit. Refer to [LT-160, "Removal and Installation of AFS Control Unit"](#).

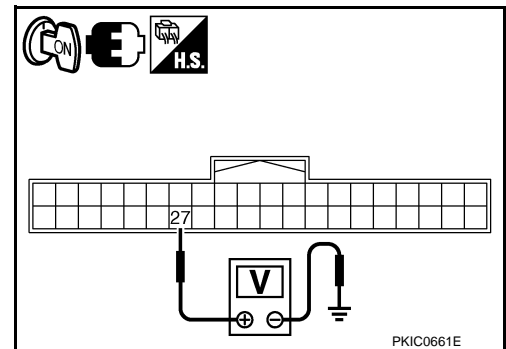

7. CHECK SWIVEL POSITION SENSOR GROUND CIRCUIT

1. Turn ignition switch OFF.
2. Disconnect AFS control unit connector and front combination lamp LH connector.

ACTIVE AFS

< SERVICE INFORMATION >

- Check continuity between AFS control unit harness connector (A) and front combination lamp LH harness connector (B).

| A | | B | | Continuity |
|-----------|----------|-----------|----------|------------|
| Connector | Terminal | Connector | Terminal | |
| F110 | 27 | E53 | 19 | Yes |

OK or NG

- OK >> Replace front combination lamp LH (swivel position sensor malfunction). Refer to [LT-160, "Removal and Installation of Front Combination Lamp"](#).
- NG >> Repair harness or connector.

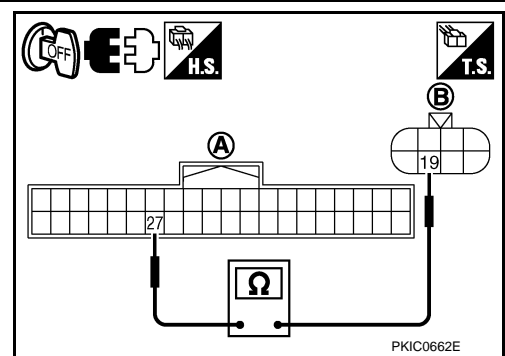

8. CHECK DIAGNOSIS RESULT

Select "ADAPTIVE LIGHT" on CONSULT-III. Select "SELF-DIAG RESULTS" on "SELECT DIAG MODE" screen.

Is DTC B2521 ECU CIRC detected?

- YES >> Refer to [LT-149, "DTC B2521 ECU CIRC"](#).
- NO >> GO TO 9.

9. CHECK SWIVEL POSITION SENSOR POWER SUPPLY CIRCUIT

- Turn ignition switch OFF.
- Disconnect front combination lamp LH connector.
- Turn ignition switch ON.
- Check voltage between AFS control unit harness connector and ground.

| Terminals | | | Voltage (Approx.) |
|----------------------------|----------|--------|-------------------|
| (+) | | (-) | |
| AFS control unit connector | Terminal | | |
| F110 | 24 | Ground | 4.0 - 6.0 V |

OK or NG

- OK >> GO TO 10.
- NG >> GO TO 11.

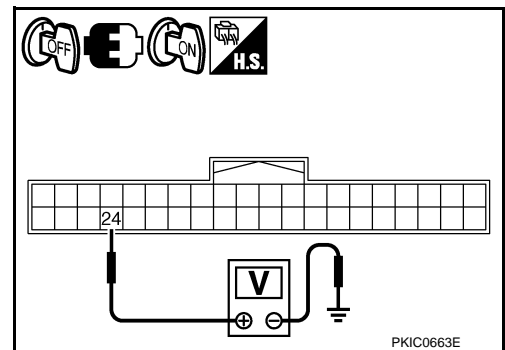

10. CHECK SWIVEL POSITION SENSOR SIGNAL CIRCUIT (SHORT CIRCUIT)

- Turn ignition switch OFF.
- Disconnect AFS control unit connector.
- Check continuity between AFS control unit harness connector and ground.

| AFS control unit connector | Terminal | Ground | Continuity |
|----------------------------|----------|--------|------------|
| F110 | 29 | | No |

OK or NG

- OK >> Replace front combination lamp LH (swivel position sensor malfunction). Refer to [LT-160, "Removal and Installation of Front Combination Lamp"](#).
- NG >> Repair harness or connector.

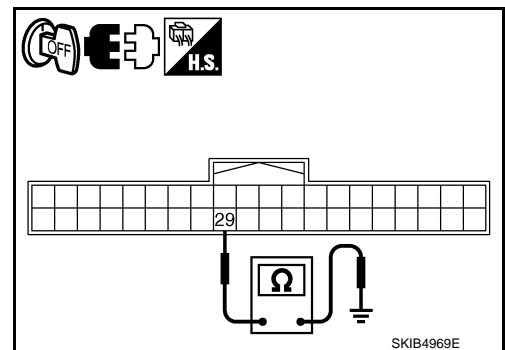

11. CHECK SWIVEL POSITION SENSOR POWER SUPPLY CIRCUIT (SHORT CIRCUIT)

- Turn ignition switch OFF.
- Disconnect AFS control unit connector.

ACTIVE AFS

< SERVICE INFORMATION >

- Check continuity between AFS control unit harness connector and ground.

| AFS control unit connector | Terminal | Ground | Continuity |
|----------------------------|----------|--------|------------|
| F110 | 24 | | No |

OK or NG

- OK >> Replace AFS control unit. Refer to [LT-160, "Removal and Installation of AFS Control Unit"](#).
- NG >> Repair harness or connector.

12.CHECK SWIVEL MOTOR

- Turn ignition switch OFF.
- Disconnect front combination lamp LH connector.
- Check continuity between front combination lamp LH connector terminals.

| Front combination lamp LH terminals (2 phase) | Resistance |
|---|---------------|
| 16 20 | Approx. 7.4 Ω |

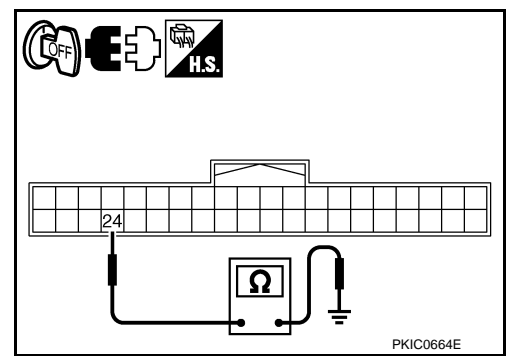

PKIC0664E

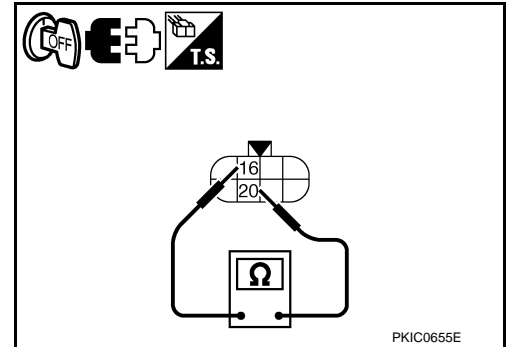

PKIC0655E

- Check continuity between front combination lamp LH connector terminals.

| Front combination lamp LH terminals (1 phase) | Resistance |
|---|---------------|
| 17 21 | Approx. 7.4 Ω |

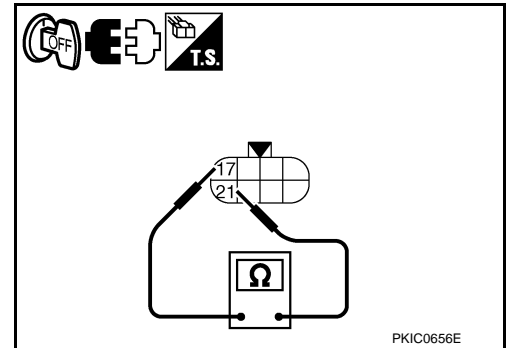

PKIC0656E

- Check continuity between front combination lamp LH connector terminals (insulation resistance).

| Front combination lamp LH terminals | Resistance |
|-------------------------------------|----------------------|
| 16 17 | Approx. 1 MΩ or more |

OK or NG

- OK >> GO TO 13.
- NG >> Replace front combination lamp LH (swivel motor malfunction). Refer to [LT-160, "Removal and Installation of Front Combination Lamp"](#).

13.CHECK SWIVEL MOTOR CIRCUIT 1

- Connect front combination lamp LH connector.
- Turn ignition switch ON.

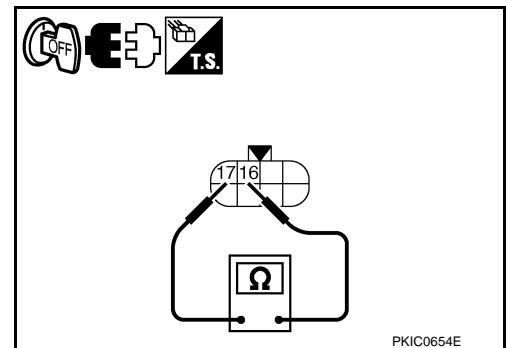

PKIC0654E

ACTIVE AFS

< SERVICE INFORMATION >

- Check voltage between AFS control unit harness connector and ground.

| (+) | | (-) | Voltage (Approx.) |
|----------------------------|----------|--------|-------------------|
| AFS control unit connector | Terminal | | |
| F110 | 15 | Ground | 9.5 - 11.5 V |
| | 17 | | |
| | 36 | | |
| | 38 | | |

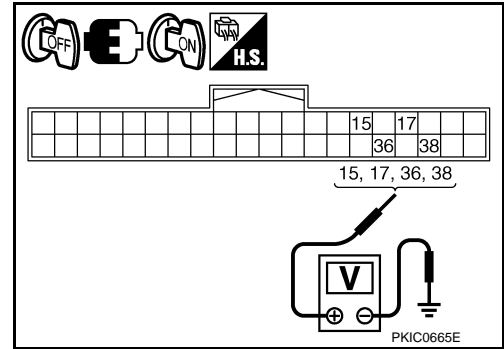

OK or NG

OK >> GO TO 14.

NG >> GO TO 16.

14. CHECK DIAGNOSIS RESULT 1

Select "ADAPTIVE LIGHT" on CONSULT-III. Select "SELF-DIAG RESULTS" on "SELECT DIAG MODE" screen.

Is DTC of present malfunction detected?

- YES >>
- If detect DTC B2503 and B2504, refer to "DTC B2504 SWIVEL ACTUATOR LH".
 - If detect DTC B2504 only, replace AFS control unit. Refer to [LT-160. "Removal and Installation of AFS Control Unit"](#).
 - If detect any DTC except B2503 and B2504, refer to [LT-126. "CONSULT-III Function \(ADAPTIVE LIGHT\)"](#).

NO >> GO TO 15.

15. CHECK DIAGNOSIS RESULT 2

Select "ADAPTIVE LIGHT" on CONSULT-III, check "SELF-DIAG RESULTS" with steering turning 180° or more to left under swivel operative condition to keep more than 2 seconds.

Is DTC B2504 of present malfunction detected?

YES >> Replace front combination lamp LH (swivel actuator malfunction). Refer to [LT-160. "Removal and Installation of Front Combination Lamp"](#).

NO >> The swivel actuator system LH is normal at present.

16. CHECK SWIVEL MOTOR CIRCUIT 2

- Turn ignition switch OFF.
- Disconnect AFS control unit connector and front combination lamp LH connector.
- Check continuity between AFS control unit harness connector (A) and front combination lamp LH harness connector (B).

| A | | B | | Continuity |
|-----------|----------|-----------|----------|------------|
| Connector | Terminal | Connector | Terminal | |
| F110 | 15 | E53 | 17 | Yes |
| | 17 | | 16 | |
| | 36 | | 20 | |
| | 38 | | 21 | |

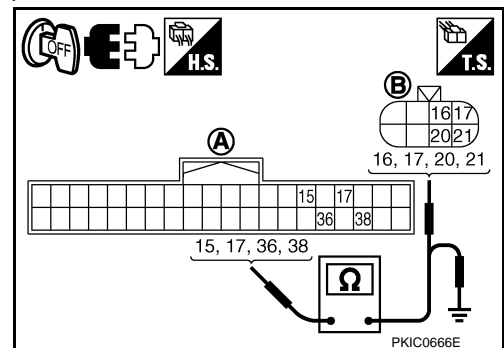

- Check continuity between AFS control unit harness connector (A) and ground.

ACTIVE AFS

< SERVICE INFORMATION >

| A | | Ground | Continuity |
|-----------|----------|--------|------------|
| Connector | Terminal | | |
| F110 | 15 | | No |
| | 17 | | |
| | 36 | | |
| | 38 | | |

OK or NG

- OK >> Replace AFS control unit. Refer to [LT-160, "Removal and Installation of AFS Control Unit"](#).
 NG >> Repair or replace harness or connector.

DTC B2514 HI SEN UNUSUAL RR

INFOID:000000002956762

1. CHECK HEIGHT SENSOR SIGNAL

CONSULT-III DATA MONITOR

- Turn ignition switch ON.
- Select "HI SEN OTP RR" of ADAPTIVE LIGHT data monitor item.
- Check the monitor status.

HI SEN OTP RR : Approx. 0.25 – 4.75 V

OK or NG

- OK >> GO TO 2.
 NG >> • If voltage is less than approx. 0.25V, GO TO 3.
 • If voltage is more than approx. 4.75V, GO TO 7.

2. CHECK HEIGHT SENSOR POWER SUPPLY

Check voltage between AFS control unit harness connector and ground.

| Terminals | | (-) | Voltage (Approx.) |
|----------------------------|----------|--------|-------------------|
| (+) | Terminal | | |
| AFS control unit connector | | | |
| F110 | 6 | Ground | 4.0 - 6.0 V |

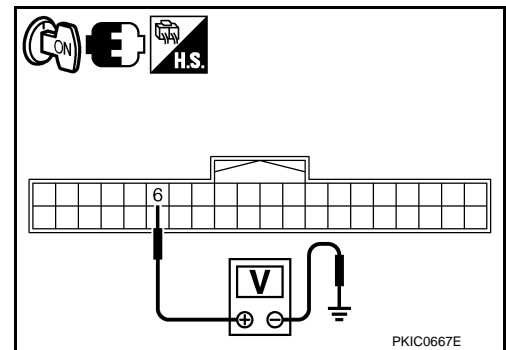

OK or NG

- OK >> The height sensor system is normal at present.
 NG >> Replace AFS control unit. Refer to [LT-160, "Removal and Installation of AFS Control Unit"](#).

3. CHECK HEIGHT SENSOR SIGNAL

Check voltage between AFS control unit harness connector and ground.

| Terminals | | (-) | Voltage (Approx.) |
|----------------------------|----------|--------|-------------------|
| (+) | Terminal | | |
| AFS control unit connector | | | |
| F110 | 28 | Ground | 0.25 - 4.75 V |

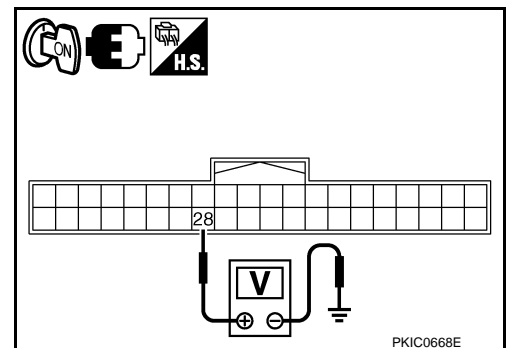

OK or NG

- OK >> Replace AFS control unit. Refer to [LT-160, "Removal and Installation of AFS Control Unit"](#).
 NG >> • If voltage is less than approx. 0.25V, GO TO 4.
 • If voltage is more than approx. 4.75V, GO TO 7.

ACTIVE AFS

< SERVICE INFORMATION >

4. CHECK HEIGHT SENSOR POWER SUPPLY

Check voltage between AFS control unit harness connector and ground.

| Terminals | | | Voltage (Approx.) |
|----------------------------|----------|--------|-------------------|
| (+) | | (-) | |
| AFS control unit connector | Terminal | | |
| F110 | 6 | Ground | 4.0 - 6.0 V |

OK or NG

- OK >> GO TO 5.
- NG >> GO TO 9.

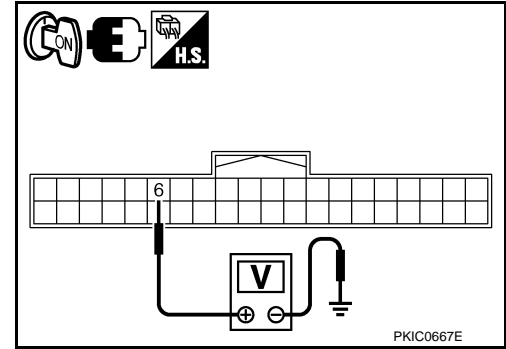

5. CHECK HEIGHT SENSOR POWER SUPPLY CIRCUIT

1. Turn ignition switch OFF.
2. Disconnect height sensor connector.
3. Turn ignition switch ON.
4. Check voltage between height sensor harness connector and ground.

| Terminals | | | Voltage (Approx.) |
|-------------------------|----------|--------|-------------------|
| (+) | | (-) | |
| Height sensor connector | Terminal | | |
| B468 | 1 | Ground | 4.0 - 6.0 V |

OK or NG

- OK >> GO TO 6.
- NG >> Repair harness or connector.

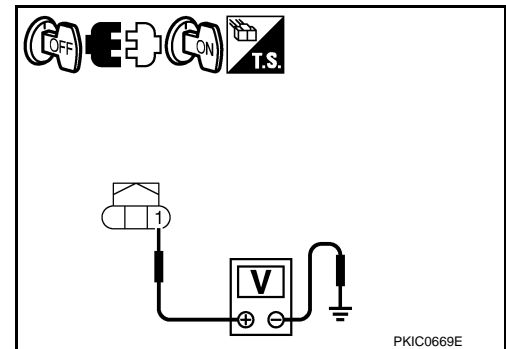

6. CHECK HEIGHT SENSOR SIGNAL CIRCUIT

1. Disconnect AFS control unit connector.
2. Check continuity between AFS control unit harness connector (A) and height sensor harness connector (B).

| A | | B | | Continuity |
|-----------|----------|-----------|----------|------------|
| Connector | Terminal | Connector | Terminal | |
| F110 | 28 | B468 | 2 | Yes |

OK or NG

- OK >> Replace height sensor. Refer to [LT-161, "Removal and Installation of Height Sensor"](#).
- NG >> Repair harness or connector.

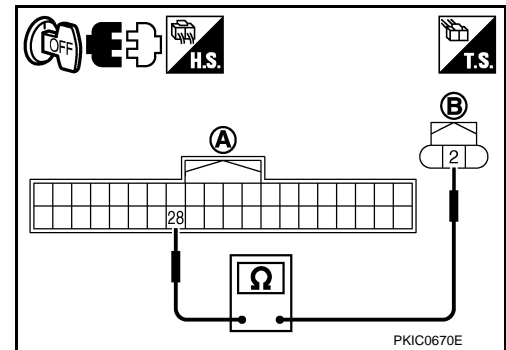

7. CHECK HEIGHT SENSOR GROUND

Check voltage between AFS control unit harness connector and ground.

| Terminals | | | Voltage (Approx.) |
|----------------------------|----------|--------|-------------------|
| (+) | | (-) | |
| AFS control unit connector | Terminal | | |
| F110 | 8 | Ground | 0 V |

OK or NG

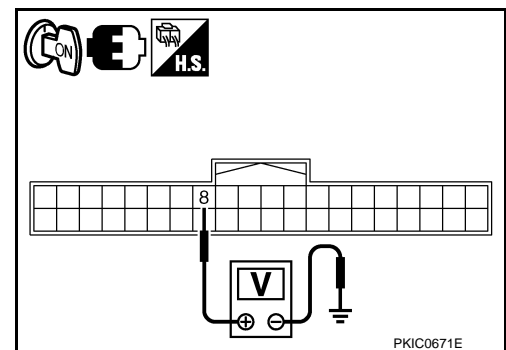

A
B
C
D
E
F
G
H
I
J
LT
L
M
N
O
P

ACTIVE AFS

< SERVICE INFORMATION >

- OK >> GO TO 8.
 NG >> Check connector for connection, bend and loose fit. If it is normal, replace AFS control unit. Refer to [LT-160. "Removal and Installation of AFS Control Unit"](#).

8. CHECK HEIGHT SENSOR GROUND CIRCUIT

1. Turn ignition switch OFF.
2. Disconnect AFS control unit connector and height sensor connector.
3. Check continuity between AFS control unit harness connector (A) and height sensor harness connector (B).

| A | | B | | Continuity |
|-----------|----------|-----------|----------|------------|
| Connector | Terminal | Connector | Terminal | |
| F110 | 8 | B468 | 3 | Yes |

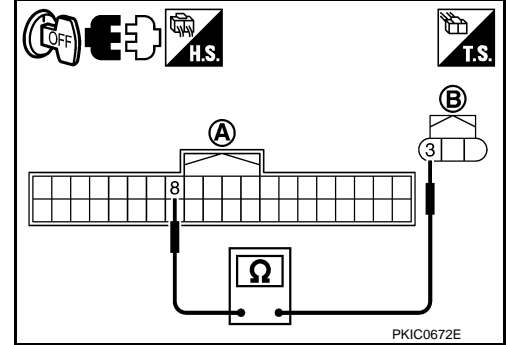

OK or NG

- OK >> Replace height sensor. Refer to [LT-161. "Removal and Installation of Height Sensor"](#).
 NG >> Repair harness or connector.

9. CHECK DIAGNOSIS RESULT

Select "ADAPTIVE LIGHT" on CONSULT-III. Select "SELF-DIAG RESULTS" on "SELECT DIAG MODE" screen.

Is DTC B2521 ECU CIRC detected?

- YES >> Refer to [LT-149. "DTC B2521 ECU CIRC"](#).
 NO >> GO TO 10.

10. CHECK HEIGHT SENSOR POWER SUPPLY CIRCUIT

1. Turn ignition switch OFF.
2. Disconnect height sensor connector.
3. Turn ignition switch ON.
4. Check voltage between AFS control unit harness connector and ground.

| Terminals | | | Voltage (Approx.) |
|----------------------------|----------|--------|-------------------|
| (+) | | (-) | |
| AFS control unit connector | Terminal | | |
| F110 | 6 | Ground | 4.0 - 6.0 V |

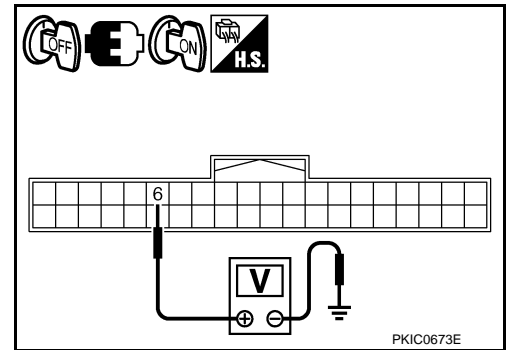

OK or NG

- OK >> GO TO 11.
 NG >> GO TO 12.

11. CHECK HEIGHT SENSOR SIGNAL CIRCUIT (SHORT CIRCUIT)

1. Disconnect AFS control unit connector.
2. Check continuity between AFS control unit harness connector and ground.

| AFS control unit connector | Terminal | Ground | Continuity |
|----------------------------|----------|--------|------------|
| F110 | 28 | | No |

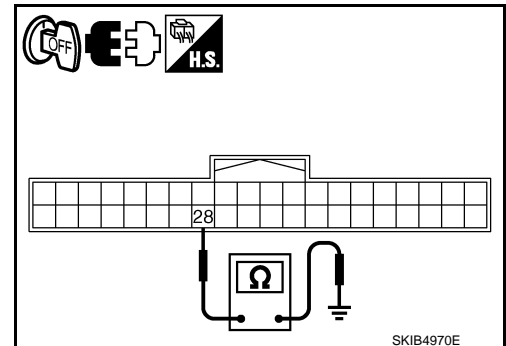

OK or NG

- OK >> Replace height sensor. Refer to [LT-161. "Removal and Installation of Height Sensor"](#).
 NG >> Repair harness or connector.

12. CHECK HEIGHT SENSOR POWER SUPPLY CIRCUIT (SHORT CIRCUIT)

ACTIVE AFS

< SERVICE INFORMATION >

1. Turn ignition switch OFF.
2. Disconnect AFS control unit connector.
3. Check continuity between AFS control unit harness connector and ground.

| AFS control unit connector | Terminal | Ground | Continuity |
|----------------------------|----------|--------|------------|
| F110 | 6 | | No |

OK or NG

- OK >> Replace AFS control unit. Refer to [LT-160, "Removal and Installation of AFS Control Unit"](#).
- NG >> Repair harness or connector.

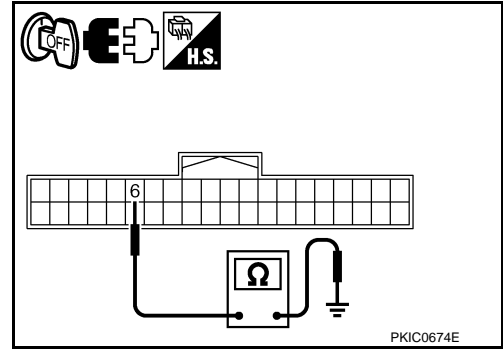

DTC B2515 ST ANG SEN SIG

INFOID:000000002989273

| Details of error indication detected by CONSULT-III | Conditions of error detection | Fail-safe | Reference |
|---|---|--|--|
| ST ANG SEN SIG [B2515] | Any of several statuses below <ul style="list-style-type: none"> Cannot receive steering angle sensor signal. Receives steering angle sensor error. Receives steering angle sensor signal except -943° to $+943^{\circ}$. | <ol style="list-style-type: none"> 1. Swivel operation 2. Auto aiming operation 3. AFS OFF indicator operation 4. Cancellation | Reference LT-126, "CONSULT-III Function (ADAPTIVE LIGHT)" . If above system is normal, replace AFS control unit. |

DTC B2516 SIFT SIG [P,R]

INFOID:000000002989275

| Details of error indication detected by CONSULT-III | Conditions of error detection | Fail-safe | Reference |
|---|---|--|---|
| SHIFT SIG [P, R] [B2516] | Cannot receive A/T position indicator signal. | <ol style="list-style-type: none"> 1. Swivel operation 2. Auto aiming operation 3. AFS OFF indicator operation 4. Cancellation | Reference AT-85, "CONSULT-III Function (TRANSMISSION)" . If above system is normal, replace AFS control unit. |

ACTIVE AFS

< SERVICE INFORMATION >

DTC B2517 VEHICLE SPEED SIG

INFOID:000000002989274

| Details of error indication detected by CONSULT-III | Conditions of error detection | Fail-safe | Reference |
|---|--------------------------------------|---|--|
| | | 1. Swivel operation 2. Auto aiming operation 3. AFS OFF indicator operation 4. Cancellation | |
| VEHICLE SPEED SIG [B2517] | Cannot receive vehicle speed signal. | 1. Back to the initial position. 2. Stop when the malfunction occurred. 3. Flash at intervals of approx. 1 second when keeping error state for 2 seconds or longer. 4. Turn ignition switch OFF. | DI-27. "CONSULT-III Function (METER/M&A)". If above system is normal, replace AFS control unit. |

DTC B2518 HEADLAMP SIG

INFOID:000000002989276

| Details of error indication detected by CONSULT-III | Conditions of error detection | Fail-safe | Reference |
|---|--|---|---|
| | | 1. Swivel operation 2. Auto aiming operation 3. AFS OFF indicator operation 4. Cancellation | |
| HEAD LAMP SIG [B2518] | Cannot receive low beam status signal. | 1. Back to the initial position. 2. Stop aiming motors when the malfunction occurred. 3. Flash at intervals of approx. 1 second when keeping error state for 2 seconds or longer. 4. Turn ignition switch OFF. | PG-20. "CONSULT-III Function (IPDM E/R)". If above system is normal, replace AFS control unit. |

DTC B2519 LEVELIZER CALIB

INFOID:000000002994885

| Details of error indication detected by CONSULT-III | Conditions of error detection | Fail-safe | Reference |
|---|---|---|---------------------------------------|
| | | 1. Swivel operation 2. Auto aiming operation 3. AFS OFF indicator operation 4. Cancellation | |
| LEVELIZER CALIB [B2519] | Cannot recognize height sensor signal value at unloaded vehicle position. | 1. Normal operation 2. Stop aiming motors when the malfunction occurred. 3. Remains OFF. 4. When levelizer adjustment is completed | "WORK SUPPORT (LEVELIZER ADJUSTMENT)" |

ACTIVE AFS

< SERVICE INFORMATION >

DTC B2520 ST ANGLE SEN CALIB

INFOID:00000002994886

| Details of error indication detected by CONSULT-III | Conditions of error detection | Fail-safe | Reference |
|---|---|--|---|
| ST ANGLE SEN CALIB [B2520] | Cannot recognize steering angle sensor neutral point (straight-ahead position). | 1. Swivel operation 2. Auto aiming operation 3. AFS OFF indicator operation 4. Cancellation | Reference BRC-8, "Adjustment of Steering Angle Sensor Neutral Position". |

DTC B2521 ECU CIRC

INFOID:00000002956763

1. CHECK SENSOR POWER SUPPLY

- Turn ignition switch ON.
- Check voltage between AFS control unit harness connector and ground.

| (+) | | (-) | Voltage (Approx.) |
|----------------------------|----------|--------|-------------------|
| AFS control unit connector | Terminal | | |
| F110 | 4 | Ground | 4.0 - 6.0 V |
| | 6 | | |
| | 24 | | |

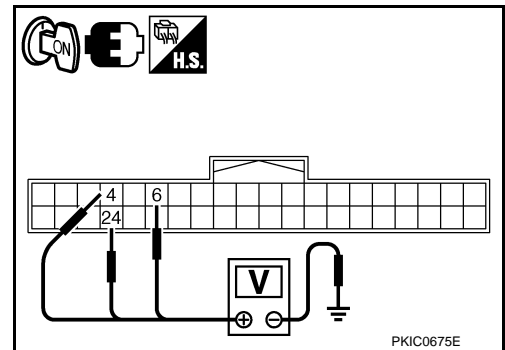

OK or NG

- OK >> GO TO 2.
 NG >> • If voltage is less than approx. 4 V, GO TO 3.
 • If voltage is more than approx. 6 V, GO TO 4.

2. CHECK SENSOR SIGNAL

Check voltage between AFS control unit harness connector and ground.

| (+) | | (-) | Voltage (Approx.) |
|----------------------------|----------|--------|-------------------|
| AFS control unit connector | Terminal | | |
| F110 | 9 | Ground | 0.25 - 4.75 V |
| | 28 | | |
| | 29 | | |

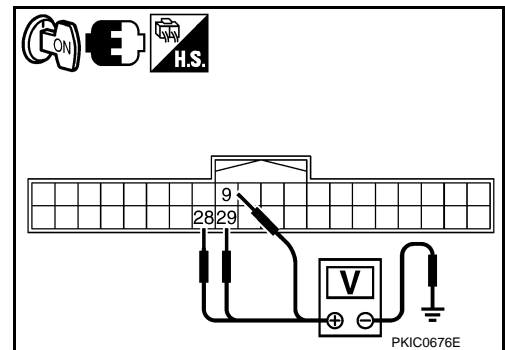

OK or NG

- OK >> Replace AFS control unit. Refer to [LT-160, "Removal and Installation of AFS Control Unit"](#).
 NG >> • If voltage is less than approx. 0.25 V, GO TO 5.
 • If voltage is more than approx. 4.75 V, GO TO 6.

3. CHECK SENSOR POWER SUPPLY CIRCUIT (GROUND SHORT CIRCUIT)

- Turn ignition switch OFF.
- Disconnect AFS control unit connector.

ACTIVE AFS

< SERVICE INFORMATION >

3. Check continuity between AFS control unit harness connector and ground.

| AFS control unit connector | Terminal | | Continuity |
|----------------------------|----------|--------|------------|
| F110 | 4 | Ground | No |
| | 6 | | |
| | 24 | | |

OK or NG

- OK >> Replace AFS control unit. Refer to [LT-160, "Removal and Installation of AFS Control Unit"](#).
- NG >> GO TO 7.

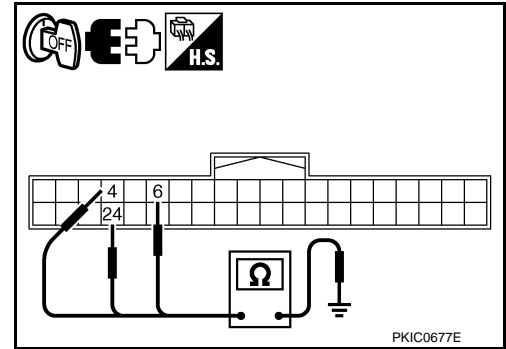

4. CHECK SENSOR POWER SUPPLY CIRCUIT (IGN POWER SUPPLY SHORT CIRCUIT)

1. Turn ignition switch OFF.
2. Disconnect AFS control unit connector.
3. Turn ignition switch ON.
4. Check voltage between AFS control unit harness connector and ground.

| (+) | | (-) | Voltage (Approx.) |
|----------------------------|----------|--------|-------------------|
| AFS control unit connector | Terminal | | |
| F110 | 4 | Ground | 0 V |
| | 6 | | |
| | 24 | | |

OK or NG

- OK >> Replace AFS control unit. Refer to [LT-160, "Removal and Installation of AFS Control Unit"](#).
- NG >> GO TO 8.

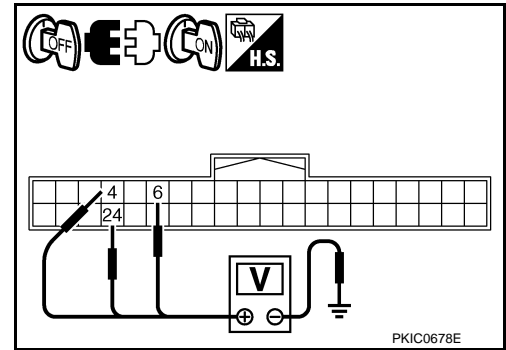

5. CHECK SENSOR SIGNAL CIRCUIT (GROUND SHORT CIRCUIT)

1. Turn ignition switch OFF.
2. Disconnect AFS control unit connector.
3. Check continuity between AFS control unit harness connector and ground.

| AFS control unit connector | Terminal | | Continuity |
|----------------------------|----------|--------|------------|
| F110 | 9 | Ground | No |
| | 28 | | |
| | 29 | | |

OK or NG

- OK >> Replace AFS control unit. Refer to [LT-160, "Removal and Installation of AFS Control Unit"](#).
- NG >> GO TO 7.

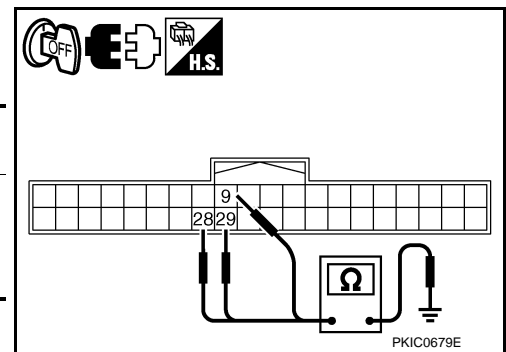

6. CHECK SENSOR SIGNAL CIRCUIT (IGN POWER SUPPLY SHORT CIRCUIT)

1. Turn ignition switch OFF.
2. Disconnect AFS control unit connector.
3. Turn ignition switch ON.

ACTIVE AFS

< SERVICE INFORMATION >

- Check voltage between AFS control unit harness connector and ground.

| (+) | | (-) | Voltage (Approx.) |
|----------------------------|----------|--------|-------------------|
| AFS control unit connector | Terminal | | |
| F110 | 9 | Ground | 0 V |
| | 28 | | |
| | 29 | | |

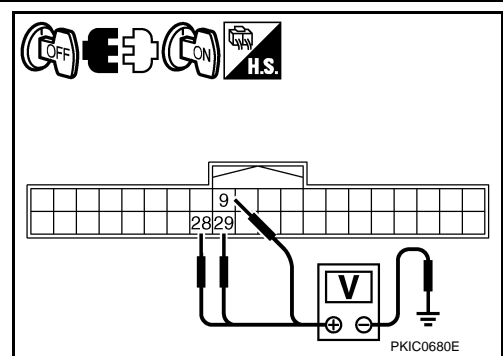

OK or NG

- OK >> Replace AFS control unit. Refer to [LT-160, "Removal and Installation of AFS Control Unit"](#).
 NG >> GO TO 8.

7. CHECK SENSOR SIGNAL AND POWER SUPPLY CIRCUIT (GROUND SHORT CIRCUIT)

- Disconnect height sensor connector, front combination lamp LH and RH connector.
- Check continuity between AFS control unit harness connector and ground.

| AFS control unit connector | Terminal | (-) | Continuity |
|----------------------------|----------|-----|------------|
| F110 | 4 | | |
| | 6 | | |
| | 9 | | |
| | 24 | | |
| | 28 | | |
| | 29 | | |

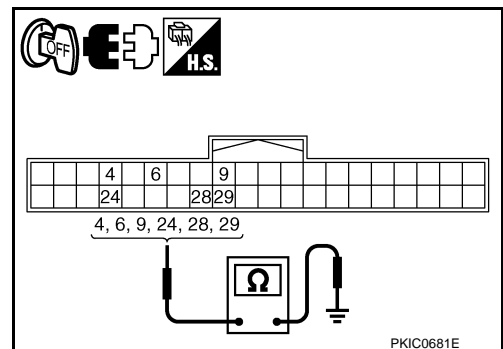

OK or NG

- OK >> Replace height sensor, front combination lamp LH or RH with malfunction at the preceding process 3 or 5. Refer to [LT-161, "Removal and Installation of Height Sensor"](#) or [LT-160, "Removal and Installation of Front Combination Lamp"](#).
 NG >> Repair harness or connector.

8. CHECK SENSOR SIGNAL AND POWER SUPPLY CIRCUIT (IGN POWER SUPPLY SHORT CIRCUIT)

- Turn ignition switch OFF.
- Disconnect height sensor connector, front combination lamp LH and RH connector.
- Turn ignition switch ON.
- Check voltage between AFS control unit harness connector and ground.

| (+) | | (-) | Voltage (Approx.) |
|----------------------------|----------|--------|-------------------|
| AFS control unit connector | Terminal | | |
| F110 | 4 | Ground | 0 V |
| | 6 | | |
| | 9 | | |
| | 24 | | |
| | 28 | | |
| | 29 | | |

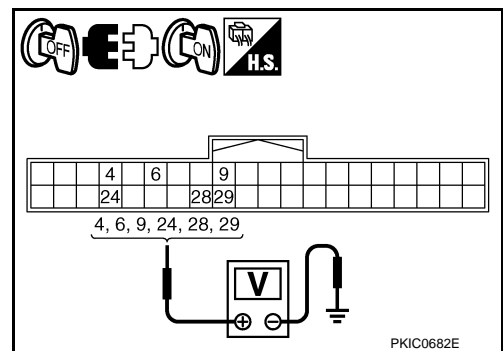

OK or NG

- OK >> Replace height sensor, front combination lamp LH or RH with malfunction at the preceding process 4 or 6. Refer to [LT-161, "Removal and Installation of Height Sensor"](#) or [LT-160, "Removal and Installation of Front Combination Lamp"](#).

ACTIVE AFS

< SERVICE INFORMATION >

NG >> Repair harness or connector.

DTC B2522 ECM SIG

INFOID:000000002994889

| Details of error indication detected by CONSULT-III | Conditions of error detection | Fail-safe | Reference |
|---|-------------------------------------|--|--|
| ECM SIG [B2522] | Cannot receive engine speed signal. | 1. Swivel operation 2. Auto aiming operation 3. AFS OFF indicator operation 4. Cancellation | EC-116, "CONSULT-III Function (ENGINE)". If above system is normal, replace AFS control unit. |

DTC B2523 AFS SIG

INFOID:000000002994890

| Details of error indication detected by CONSULT-III | Conditions of error detection | Fail-safe | Reference |
|---|---|--|---|
| AFS SIG [B2523] | Cannot transmit AFS off indicator signal. | 1. Swivel operation 2. Auto aiming operation 3. AFS OFF indicator operation 4. Cancellation | Replace AFS control unit LT-160 |

AFS Operation Check (Function Test)

INFOID:000000002956764

1. CHECK SWIVEL ACTUATOR

CONSULT-III ACTIVE TEST

1. Start engine and turn lighting switch to 2ND position.
2. Select "LOW BEAM TEST RIGHT" or "LOW BEAM TEST LEFT" of ADAPTIVE LIGHT active test item.
3. Touch "ORIGIN-FAST/SLOW" and "PEAK-FAST/SLOW" screen.
4. Make sure of swivel operation.

| TEST ITEM | ORIGIN | PEAK | Light axis range at 10 m (394.7 in) off (Reference value) |
|---------------------|-----------------|-------------------------|--|
| LOW BEAM TEST RIGHT | Swivel angle 0° | Swivel angle 7° to 13° | Approx. 1.200 to 2.300 mm (48 to 90 in) |
| LOW BEAM TEST LEFT | Swivel angle 0° | Swivel angle 17° to 23° | Approx. 3.000 to 4.200 mm (120 to 167 in) |

OK or NG

OK >> GO TO 2.

- NG >>
- When interference or poor fitment is found, perform aiming adjustment. Refer to [LT-58, "Aiming Adjustment"](#). If it is normal, replace headlamp. Refer to [LT-160, "Removal and Installation of Front Combination Lamp"](#).
 - When the operation range is irregular, perform aiming adjustment. Refer to [LT-58, "Aiming Adjustment"](#). If it is normal, GO TO 3.

2. CHECK STEERING ANGLE SENSOR

CONSULT-III DATA MONITOR

Check "STR ANGLE SIG" in "Data Monitor" when driving straight and steering turn 90° to right or left.

ACTIVE AFS

< SERVICE INFORMATION >

| Steering condition | STR ANGLE SIG (Data monitor) |
|--------------------|---------------------------------|
| Driving straight | - 5.0 ° to + 5.0° |
| Turn 90° to right | Approx. + 90° |
| Turn 90° to left | Approx. - 90° |

OK or NG

OK >> GO TO 3.

- NG >>
- When steering is out of range while driving straight, perform steering angle sensor adjustment. Refer to [BRC-8, "Adjustment of Steering Angle Sensor Neutral Position"](#) in "ON-VEHICLE SERVICE".
 - When the function is normal while driving straight but the displayed value is different from actual steering position with turning to right or left, replace steering angle sensor. Refer to [LT-160, "Removal and Installation of Steering Angle Sensor"](#).

3. CHECK SWIVEL ACTUATOR AND AFS CONTROL UNIT

ⓂCONSULT-III DATA MONITOR

Check "SWVL SEN RH/LH" and "SWVL ANGLE RH/LH" in "Data Monitor" with steering turning to right or left under swivel operative condition.

| TEST ITEM | Turn 180° or more to left | Turn 180° or more to right |
|--|---------------------------|----------------------------|
| <ul style="list-style-type: none"> • SWVL SEN RH • SWVL ANGLE RH | Approx. 0° | 7° to 13° |
| <ul style="list-style-type: none"> • SWVL SEN LH • SWVL ANGLE LH | 17° to 23° | Approx. 0° |

NOTE:

The angle can be slightly different between the displayed value on "SWVL SEN" and that on "SWVL ANGLE" even when AFS operation is normal.

OK or NG

OK >> AFS function is normal.

- NG >>
- When the difference is 4.5° or more between the displayed value on "SWVL ANGLE" and that on "SWVL SEN", replace headlamp.
 - When the displayed angle on "SWVL ANGLE" is irregular, replace AFS control unit.

Auto Aiming Operation Check (Function Test)

INFOID:000000002956765

1. CHECK AIMING MOTOR

ⓂCONSULT-III ACTIVE TEST

1. Start engine and turn lighting switch to 2ND position.
2. Select "LEVELIZER TEST" of ADAPTIVE LIGHT active test item.
3. Touch "ORIGIN" and "PEAK" screen.
4. Make sure of auto aiming operation.

| TEST ITEM | ORIGIN | PEAK (Reference value) | Light axis range at 10 m (394.7 in) off (Reference value) |
|----------------|---------------------|-------------------------------|--|
| LEVELIZER TEST | Light axis angle 0° | Light axis angle approx. 2.5° | Approx. 450 mm (17.7 in) |

OK or NG

OK >> GO TO 2.

- NG >>
- When interference or poor fitment is found, perform aiming adjustment. Refer to [LT-58, "Aiming Adjustment"](#). If it is normal, replace headlamp. Refer to [LT-160, "Removal and Installation of Front Combination Lamp"](#).
 - When the operation range is irregular, perform aiming adjustment. Refer to [LT-58, "Aiming Adjustment"](#). If it is normal, GO TO 4.

ACTIVE AFS

< SERVICE INFORMATION >

2. PERFORM STATE LEVELIZER ADJUSTMENT 1

CONSULT-III DATA MONITOR

Check "LEV ACTR VLTG" in "Data Monitor" with unloaded vehicle position. (Remove all loads in driver, passenger and trunk rooms.)

| TEST ITEM | Unloaded vehicle position |
|---------------|---------------------------|
| LEV ACTR VLTG | Approx. 70% |

OK or NG

OK >> GO TO 3.

NG >> Perform LEVELIZER ADJUSTMENT. Refer to [LT-126. "CONSULT-III Function \(ADAPTIVE LIGHT\)"](#).

3. PERFORM STATE LEVELIZER ADJUSTMENT 2

CONSULT-III DATA MONITOR

Check if "LEV ACTR VLTG" changes approx. 3 seconds after lowering vehicle height as low as approx. -0.5V from the value of "HI SEN OTP RR" in "Data Monitor" at unloaded vehicle position. (Remove all loads in driver, passenger and trunk rooms.)

OK or NG

OK >> GO TO 4.

NG >> Perform LEVELIZER ADJUSTMENT. Refer to [LT-126. "CONSULT-III Function \(ADAPTIVE LIGHT\)"](#).

4. CHECK HEIGHT SENSOR SIGNAL AND AIMING MOTOR DRIVE SIGNAL

CONSULT-III DATA MONITOR

Remove height sensor link bracket mounting nuts (rear stabilizer side). For details, refer to [LT-161. "Removal and Installation of Height Sensor"](#). Change sensor angle from the basic point of sensor angle 0° (standard position) and check "HI SEN OTP RR" and "LEV ACTR VLTG" of "Data Monitor".

| | Sensor angle | Vehicle height |
|---|------------------------------------|---------------------------|
| A | Approx. -103° (Link stopper angle) | Low side |
| B | 0° (Standard position) | Unloaded vehicle position |
| C | Approx. 46° (Link stopper angle) | High side |

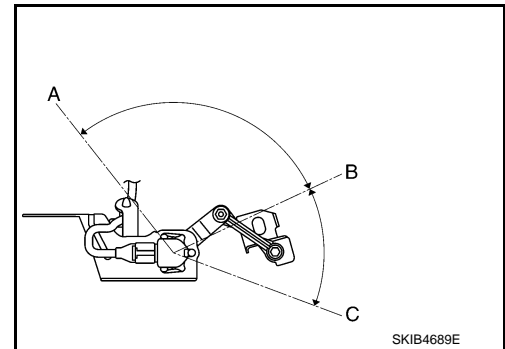

With 18-inch wheel

| | Sensor angle | "HI SEN OTP RR" | "LEV ACTR VLTG" | Light axis range at 10 m (394.7 in) off (Reference value) |
|---|--------------|--------------------------------|-----------------|---|
| Limit value of vehicle height (high side) | Approx. 45° | Approx. 4.5 V | Approx. 70.0% | — |
| Maximum angle of auto aiming operation ^{NOTE1} (Unloaded vehicle position) | Approx. 0° | Approx. 2.5 V | Approx. 70.0% | 0 |
| Minimum angle of auto aiming operation ^{NOTE1} (Maximum laden condition) | Approx. -35° | Approx. 1.0 V ^{NOTE2} | Approx. 38.0% | Approx. 200 mm (7.9 in) |
| Limit value of vehicle height (low side) | Approx. -45° | Approx. 0.5 V | Approx. 38.0% | — |

NOTE:

- Reference value. The value can be different from that of sensor angle and HI SEN OTP RR of maximum/minimum angle of auto aiming operation depending on LEVELIZER ADJUSTMENT state.
- Reference value. Approx. -1.5 V from the LEVELIZER ADJUSTMENT value.

ACTIVE AFS

< SERVICE INFORMATION >

With 19-inch wheel

| | Sensor angle | "HI SEN OTP RR" | "LEV ACTR VLTG" | Light axis range at 10m (394.7 in) off (Reference value) |
|--|--------------|------------------------------|-----------------|--|
| Limit value of vehicle height (high side) | Approx. 45° | Approx. 4.5 V | Approx. 70.0% | — |
| Maximum angle of auto aiming operation ^{NOTE1} (Unloaded vehicle position) | Approx. 0° | Approx. 2.5 V | Approx. 70.0% | 0 |
| Minimum angle of auto aiming operation ^{NOTE1} (Maximum laden condition) | Approx. -27° | Approx. 1.3 ^{NOTE2} | Approx. 41.8% | Approx. 180 mm (7.1 in) |
| Limit value of vehicle height (low side) | Approx. -45° | Approx. 0.5 V | Approx. 41.8% | — |

NOTE:

- Reference value. The value can be different from that of sensor angle and HI SEN OTP RR of maximum/minimum angle of auto aiming operation depending on LEVELIZER ADJUSTMENT state.
- Reference value. Approx. -1.2 V from LEVELIZER ADJUSTMENT value.

OK or NG

- OK >> Auto aiming operation function is normal.
- NG >> • When approx. 4.5 V or 0.5 V is not displayed on "HI SEN OTP RR" screen with sensor angle approx. 45° or -45°, check connector for connection, bend and loose fit. If it is normal, replace height sensor. Refer to [LT-161, "Removal and Installation of Height Sensor"](#).
- When "HI SEN OTP RR" value is normal but "LEV ACTR VLTG" value differs from maximum/minimum angle of auto aiming operation, replace AFS control unit. Refer to [LT-160, "Removal and Installation of AFS Control Unit"](#).
- When "LEV ACTR VLTG" value is normal but operation range is irregular, check aiming motor system circuit. Refer to [LT-157, "Auto Aiming Does Not Operate \(Check Aiming Motor System Circuit\)"](#).

AFS Switch Does Not Operate

INFOID:000000002956766

1.CHECK AFS SWITCH SIGNAL 1

CONSULT-III DATA MONITOR

- Turn ignition switch ON.
- Select "AFS SW" of ADAPTIVE LIGHT data monitor item.
- With operating the AFS switch, check the monitor status.

OK or NG

- OK >> Replace AFS control unit. Refer to [LT-160, "Removal and Installation of AFS Control Unit"](#).
- NG >> GO TO 2.

2.CHECK AFS SWITCH

- Turn ignition switch OFF.
- Disconnect AFS switch connector.
- Check continuity AFS switch.

| AFS switch | | Condition | Continuity |
|------------|---|--------------------|------------|
| Terminal | | | |
| 1 | 4 | AFS switch is ON. | No |
| | | AFS switch is OFF. | Yes |

OK or NG

- OK >> GO TO 3.
- NG >> Replace AFS switch. Refer to [LT-160, "Removal and Installation of AFS Switch"](#).

3.CHECK AFS SWITCH SIGNAL 2

- Connect AFS switch connector.
- Turn ignition switch ON.

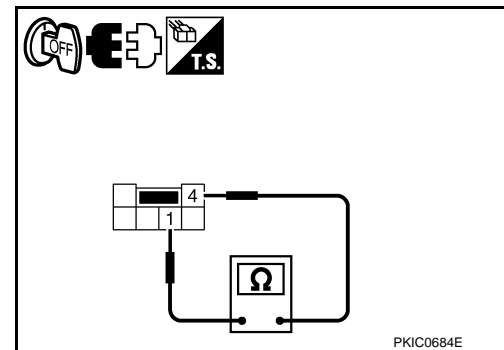

ACTIVE AFS

< SERVICE INFORMATION >

- Check voltage between AFS control unit harness connector and ground according to AFS switch operation.

| (+) | | (-) | Condition | Voltage (Approx.) |
|----------------------------|----------|--------|--------------------|-------------------|
| AFS control unit connector | Terminal | | | |
| F110 | 3 | Ground | AFS switch is ON. | 0 V |
| | | | AFS switch is OFF. | Battery voltage |

OK or NG

- OK >> Replace AFS control unit. Refer to [LT-160. "Removal and Installation of AFS Control Unit"](#).
- NG >> • If voltage is approx. 0 V and stays unchanged, GO TO 4.
• If voltage is battery voltage and stays unchanged, GO TO 6.

4. CHECK AFS SWITCH POWER SUPPLY CIRCUIT

- Turn ignition switch OFF.
- Disconnect AFS switch connector.
- Turn ignition switch ON.
- Check voltage between AFS switch harness connector and ground.

| Terminals | | (-) | Voltage (Approx.) |
|----------------------|----------|--------|-------------------|
| (+) | | | |
| AFS switch connector | Terminal | Ground | Battery voltage |
| M96 | 1 | | |

OK or NG

- OK >> GO TO 5.
- NG >> Repair harness or connector.

5. CHECK AFS SWITCH CIRCUIT

- Turn ignition switch OFF.
- Disconnect AFS control unit connector.
- Check continuity between AFS switch harness connector (A) and AFS control unit harness connector (B).

| A | | B | | Continuity |
|-----------|----------|-----------|----------|------------|
| Connector | Terminal | Connector | Terminal | |
| M96 | 4 | F110 | 3 | Yes |

OK or NG

- OK >> Check connector for connection, bend and loose fit.
- NG >> Repair harness or connector.

6. CHECK AFS SWITCH CIRCUIT (IGN POWER SUPPLY SHORT CIRCUIT)

- Turn ignition switch OFF.
- Disconnect AFS control unit connector and AFS switch connector.
- Turn ignition switch ON.

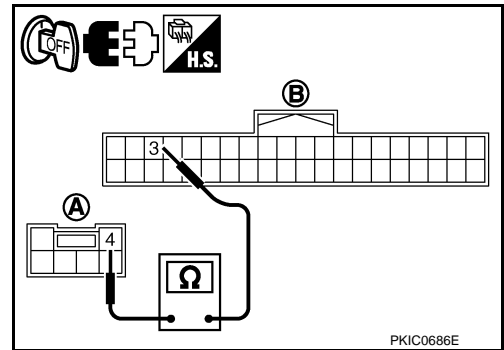
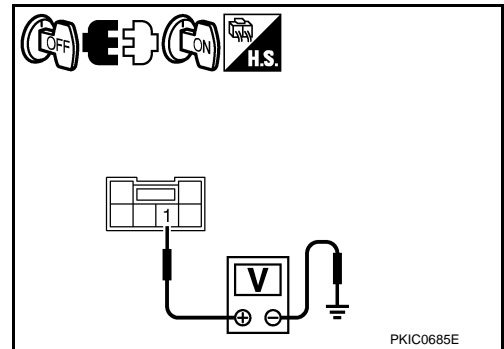
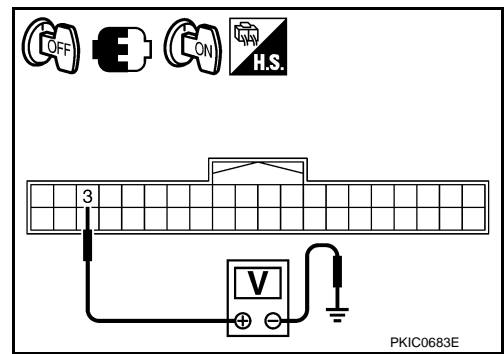

ACTIVE AFS

< SERVICE INFORMATION >

- Check voltage between AFS control unit harness connector and ground.

| Terminals | | (-) | Voltage (Approx.) |
|--------------------------------|----------|--------|-------------------|
| (+) AFS control unit connector | | | |
| | Terminal | | |
| F110 | 3 | Ground | Battery voltage |

OK or NG

- OK >> Replace AFS control unit. Refer to [LT-160. "Removal and Installation of AFS Control Unit"](#).
- NG >> Repair harness or connector.

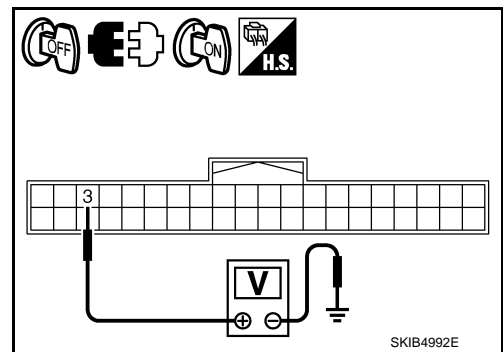

Auto Aiming Does Not Operate (Check Aiming Motor System Circuit)

INFOID:000000002956767

1. CHECK AIMING MOTOR

CONSULT-III ACTIVE TEST

- Start engine and turn lighting switch to 2ND position.
- Select "LEVELIZER TEST" of ADAPTIVE LIGHT active test item.
- Touch "ORIGIN" or "PEAK" screen.
- Make sure of aiming motor operation.

OK or NG

- OK >> Replace AFS control unit. Refer to [LT-160. "Removal and Installation of AFS Control Unit"](#).
- NG >> GO TO 2.

2. CHECK AIMING MOTOR DRIVE SIGNAL

CONSULT-III ACTIVE TEST

- Start engine and turn lighting switch to 2ND position.
- Select "LEVELIZER TEST" of ADAPTIVE LIGHT active test item.
- Touch "ORIGIN" or "PEAK" screen.
- Check voltage between AFS control unit harness connector and ground.

| (+) | | (-) | Condition | Voltage (Approx.) |
|----------------------------|----------|--------|-----------|-------------------|
| AFS control unit connector | Terminal | | | |
| RH | F110 | Ground | ORIGIN | 10.6 V |
| | | | 19 | PEAK |
| LH | 40 | | ORIGIN | 10.6 V |
| | | | PEAK | 1.9 V |

OK or NG

- OK >> GO TO 3.
- NG >> GO TO 6.

3. CHECK AIMING MOTOR DRIVE SIGNAL CIRCUIT

CONSULT-III ACTIVE TEST

- Turn ignition switch OFF.
- Disconnect front combination lamp RH and LH connector.
- Start engine and turn lighting switch to 2ND position.
- Select "LEVELIZER TEST" of ADAPTIVE LIGHT active test item.
- Touch "ORIGIN" or "PEAK" screen.

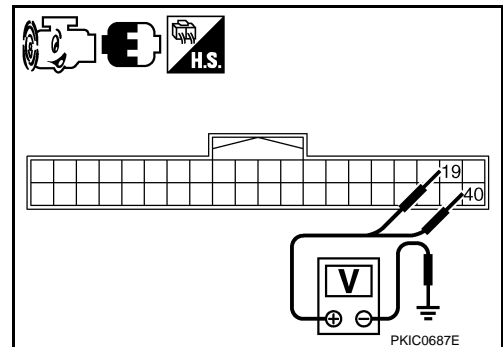

ACTIVE AFS

< SERVICE INFORMATION >

- Check voltage between front combination lamp (LH and RH) harness connector and ground.

| | | (+) | | (-) | Condition | Voltage (Approx.) |
|----------------------------------|-----|----------|--------|--------|-----------|-------------------|
| Front combination lamp connector | | Terminal | | | | |
| RH | E70 | 12 | Ground | ORIGIN | 10.6 V | |
| | | | | PEAK | 1.9 V | |
| LH | E71 | 12 | | ORIGIN | 10.6 V | |
| | | | | PEAK | 1.9 V | |

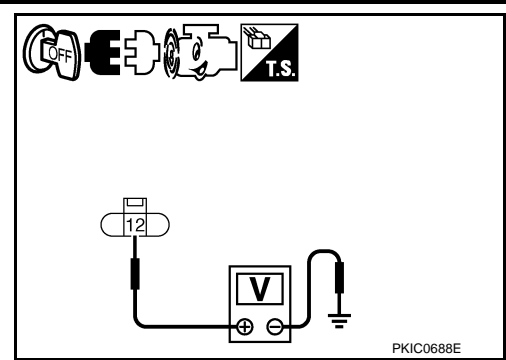

OK or NG

- OK >> GO TO 4.
- NG >> Repair harness or connector.

4. CHECK AIMING MOTOR POWER SUPPLY

- Turn ignition switch OFF.
- Turn ignition switch ON.
- Check voltage between front combination lamp (RH and LH) harness connector and ground.

| | | (+) | | (-) | Voltage (Approx.) |
|----------------------------------|-----|----------|--------|-----------------|-------------------|
| Front combination lamp connector | | Terminal | | | |
| RH | E70 | 13 | Ground | Battery voltage | |
| LH | E71 | 13 | | | |

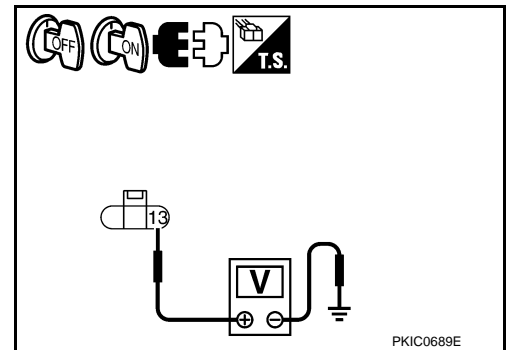

OK or NG

- OK >> GO TO 5.
- NG >> Repair harness or connector.

5. CHECK AIMING MOTOR GROUND

- Turn ignition switch OFF.
- Check continuity between front combination lamp (RH and LH) harness connector and ground.

| Front combination lamp connector | | Terminal | Ground | Continuity |
|----------------------------------|-----|----------|--------|------------|
| RH | E70 | 11 | | Yes |
| LH | E71 | 11 | | |

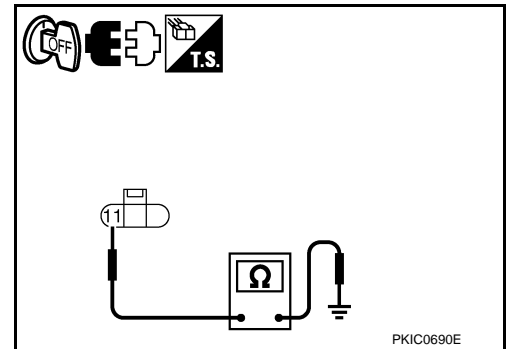

OK or NG

- OK >> Replace front combination lamp RH and LH (aiming motor malfunction). Refer to [LT-160, "Removal and Installation of Front Combination Lamp"](#).
- NG >> Repair harness or connector.

6. CHECK AIMING MOTOR DRIVE SIGNAL CIRCUIT

ⓑ CONSULT-III ACTIVE TEST

- Turn ignition switch OFF.
- Disconnect front combination lamp RH and LH connector.
- Start engine and turn lighting switch to 2ND position.
- Select "LEVELIZER TEST" of ADAPTIVE LIGHT active test item.
- Touch "ORIGIN" or "PEAK" screen.

ACTIVE AFS

< SERVICE INFORMATION >

6. Check voltage between AFS control unit harness connector and ground.

| (+) | | Terminal | (-) | Condition | Voltage (Approx.) |
|----------------------------|------|----------|--------|-----------|-------------------|
| AFS control unit connector | | | | | |
| RH | F110 | 19 | Ground | ORIGIN | 10.6 V |
| | | PEAK | | 1.9 V | |
| LH | 40 | ORIGIN | | 10.6 V | |
| | | PEAK | | 1.9 V | |

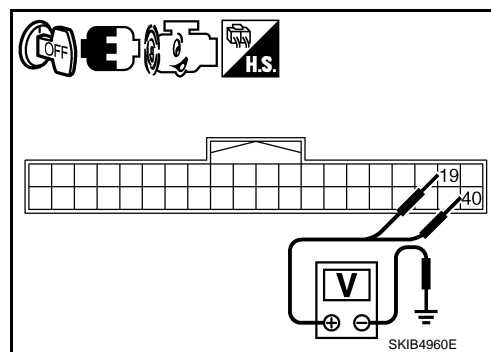

OK or NG

- OK >> Replace front combination lamp RH and LH (aiming motor malfunction). Refer to [LT-160, "Removal and Installation of Front Combination Lamp"](#).
 NG >> GO TO 7.

7. CHECK AIMING MOTOR DRIVE SIGNAL CIRCUIT

- Turn ignition switch OFF.
- Disconnect AFS control unit connector.
- Check continuity between AFS control unit harness connector (A) and front combination lamp (LH or RH) harness connector (B).

| Circuit | A | | B | | Continuity |
|---------|-----------|----------|-----------|----------|------------|
| | Connector | Terminal | Connector | Terminal | |
| RH | F110 | 19 | E70 | 12 | Yes |
| LH | | 40 | E71 | 12 | |

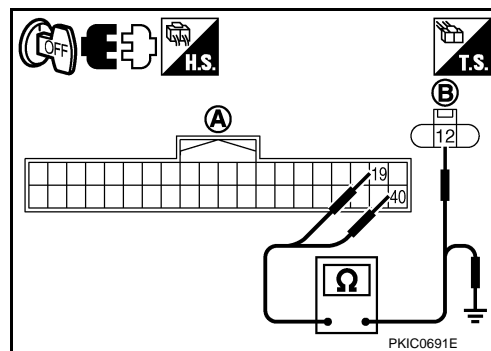

4. Check continuity between AFS control unit harness connector (A) and ground.

| A | | Ground | Continuity |
|-----------|----------|--------|------------|
| Connector | Terminal | | |
| F110 | 19 | | No |
| | 40 | | |

OK or NG

- OK >> Replace AFS control unit. Refer to [LT-160, "Removal and Installation of AFS Control Unit"](#).
 NG >> Repair harness or connector.

AFS OFF Indicator Does Not Operate

INFOID:000000002956768

1. CHECK DIAGNOSIS RESULT (AFS CONTROL UNIT)

Select "ADAPTIVE LIGHT" on CONSULT-III. Select "SELF-DIAG RESULTS" on "SELECT DIAG MODE" screen.

Is DTC detected?

- YES >> Refer to [LT-126, "CONSULT-III Function \(ADAPTIVE LIGHT\)"](#).
 NO >> GO TO 2.

2. CHECK DIAGNOSIS RESULT (UNIFIED METER AND A/C AMP.)

Select "METER A/C AMP" on CONSULT-III. Select "SELF-DIAG RESULTS" on "SELECT DIAG MODE" screen.

Is DTC detected?

- YES >> Refer to [DI-27, "CONSULT-III Function \(METER/M&A\)"](#).
 NO >> GO TO 3.

ACTIVE AFS

< SERVICE INFORMATION >

3. CHECK AFS OFF INDICATOR SIGNAL (UNIFIED METER AND A/C AMP.)

CONSULT-III DATA MONITOR

1. Select "AFS OFF IND" of METER A/C AMP data monitor item
2. With operating the AFS switch, check the monitor status.

| Condition | "AFS OFF IND" |
|--------------------|---------------|
| AFS switch is OFF. | On |
| AFS switch is ON. | Off |

OK or NG

- OK >> Replace combination meter.
NG >> Replace unified meter and A/C amp.

Removal and Installation of Steering Angle Sensor

INFOID:000000002956769

Refer to [BRC-64](#).

Removal and Installation of Front Combination Lamp

INFOID:000000002956770

Refer to [LT-61, "Removal and Installation"](#).

Removal and Installation of AFS Control Unit

INFOID:000000002956771

REMOVAL

1. Remove dash side finisher RH. Refer to [EI-48](#).
2. Remove screw (A).
3. Disconnect AFS control unit connector.
4. Remove AFS control unit (1).

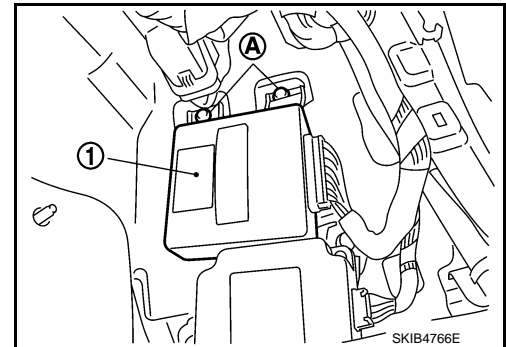

INSTALLATION

Installation is the reverse order of removal.

Removal and Installation of AFS Switch

INFOID:000000002956772

REMOVAL

1. Remove instrument lower driver panel. Refer to [IP-11](#).
2. Press AFS switch fixing pawls (A), And remove AFS switch (1) from instrument lower driver panel.

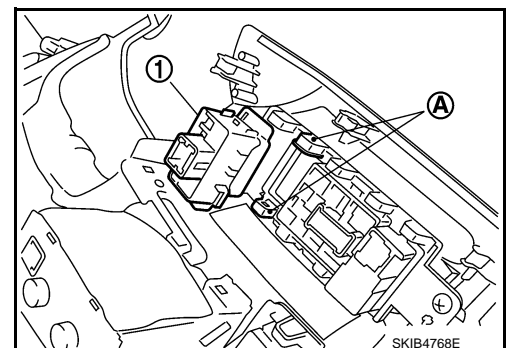

INSTALLATION

Installation is the reverse order of removal.

ACTIVE AFS

< SERVICE INFORMATION >

Removal and Installation of Height Sensor

INFOID:00000002956773

REMOVAL

1. Disconnect height sensor connector.
2. Remove height sensor link bracket mounting nut. (rear stabilizer side)
CAUTION:
Never remove from the installation nut of height sensor link bracket (height sensor link side).
3. Remove bolts, and remove height sensor.

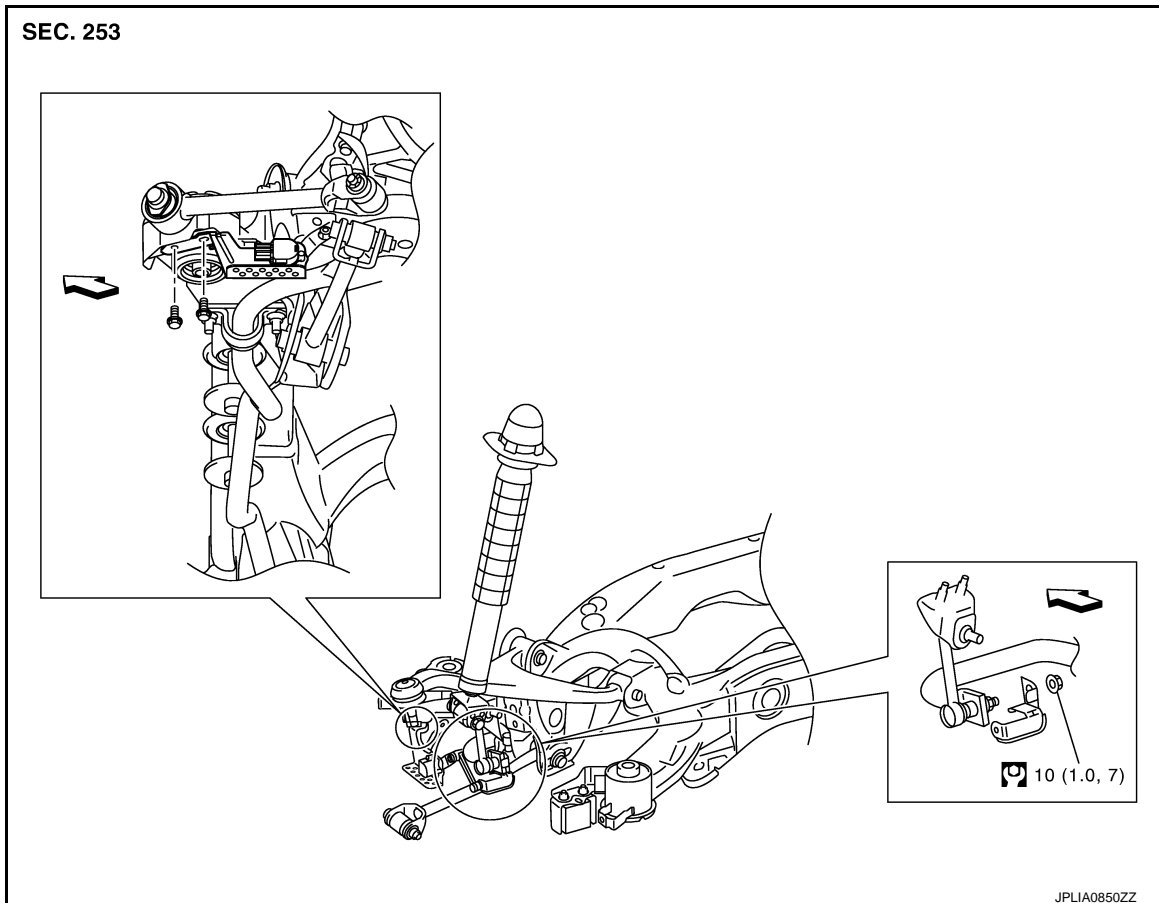

← :Vehicle front

Refer to [GI-9, "Component"](#) for symbols in the figure

INSTALLATION

Installation is the reverse order of removal.

CAUTION:

Tighten the bracket while pushing onto rear stabilizer when installing the installation nut of height sensor link bracket (stabilizer side).

← :Presses

NOTE:

Adjust levelizer when replacing height sensor. For details, refer to [LT-126, "CONSULT-III Function \(ADAPTIVE LIGHT\)"](#).

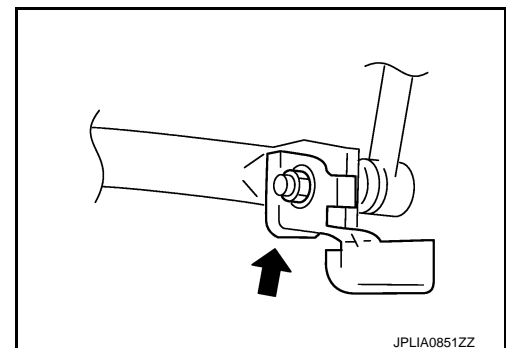

FRONT FOG LAMP

< SERVICE INFORMATION >

FRONT FOG LAMP

Component Parts and Harness Connector Location

INFOID:00000002956774

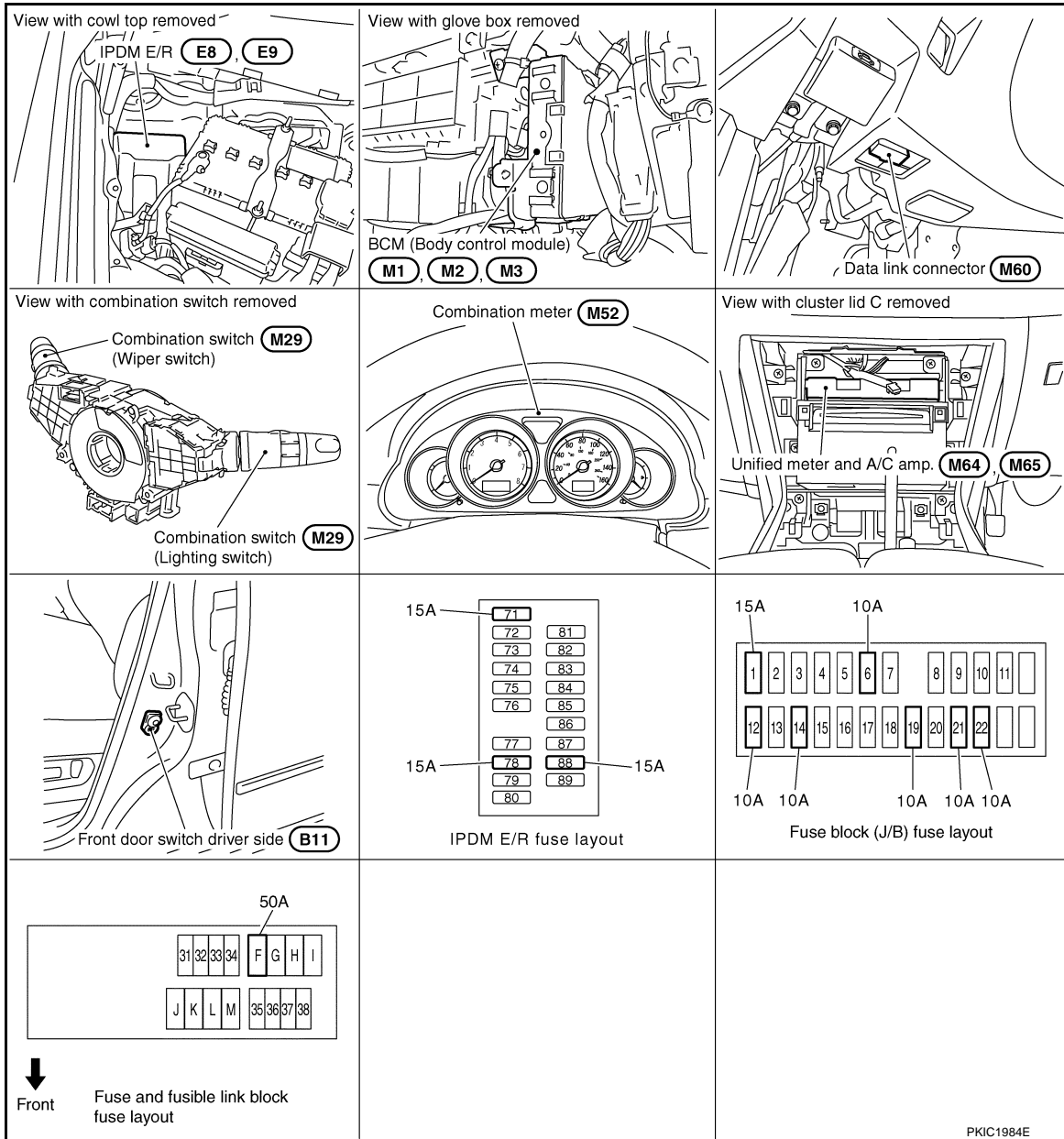

System Description

INFOID:00000002956775

The control of the fog lamps is dependent upon the position of the combination switch (lighting switch). The lighting switch must be in the 2ND position or AUTO position (headlamp is ON) for front fog lamp operation. When the lighting switch is placed in fog lamp position, the BCM (body control module) receives input signal requesting the fog lamps to illuminate. When the headlamps are illuminated, this input signal is communicated to the IPDM E/R (intelligent power distribution module engine room) across the CAN communication lines. The CPU (central processing unit) located in the IPDM E/R controls the front fog lamp relay coil. When activated, this relay directs power to the front fog lamps.

OUTLINE

Power is supplied at all times

- through 15A fuse (No. 88, located in IPDM E/R)
- to front fog lamp relay, located in IPDM E/R,
- through 15A fuse (No. 78, located in IPDM E/R)
- to CPU, located in IPDM E/R,

FRONT FOG LAMP

< SERVICE INFORMATION >

- through 15A fuse (No. 71, located in IPDM E/R)
- to CPU, located in IPDM E/R,
- through 50A fusible link (letter F, located in fuse fusible link and relay block)
- to BCM terminal 55,
- through 10A fuse [No. 21, located in fuse block (J/B)]
- to BCM terminal 42, and
- to combination meter terminal 23,
- through 10A fuse [No. 19, located in fuse block (J/B)]
- to unified meter and A/C amp. terminal 54,
- through 10A fuse [No. 22, located in fuse block (J/B)]
- to key slot terminal 1.

With the ignition switch in the ON or START position, power is supplied

- to CPU, located in IPDM E/R,
- through 15A fuse [No. 1, located in fuse block (J/B)]
- to BCM terminal 38,
- through 10A fuse [No. 14, located in fuse block (J/B)]
- to combination meter terminal 12,
- through 10A fuse [No. 12, located in fuse block (J/B)]
- to unified meter and A/C amp. terminal 53.

With the ignition switch in the ACC or ON position, power is supplied

- through 10A fuse [No. 6, located in fuse block (J/B)]
- to BCM terminal 11.

Ground is supplied

- to BCM terminal 52
- to combination meter terminals 9, 10 and 11
- to unified meter and A/C amp. terminals 55 and 71
- to push-button ignition switch (push switch) terminal 1
- to key slot terminal 8
- through grounds M16 and M70,
- to IPDM E/R terminals 38 and 51
- through grounds E22 and E43.

FOG LAMP OPERATION

The fog lamp switch is built in combination switch. The lighting switch must be in 2ND position or AUTO position (headlamp is ON) and fog lamp switch must be ON for fog lamp operation.

With the fog lamp switch in the ON position, the CPU located in IPDM E/R grounds coil side of the fog lamp relay. Fog lamp relay then directs power

- through IPDM E/R terminal 37
- to front fog lamp RH terminal 1,
- through IPDM E/R terminal 36
- to front fog lamp LH terminal 1.

Ground is supplied

- to front fog lamp RH terminal 2
- through grounds E22 and E43,
- to front fog lamp LH terminal 2
- through grounds E22 and E43.

With power and grounds supplied, the front fog lamps illuminate.

The unified meter and A/C amp. that received the front fog lamp request signal by BCM across the CAN communication makes a front fog lamp indicator lamp turn on in combination meter.

COMBINATION SWITCH READING FUNCTION

Refer to [BCS-4, "System Description"](#).

EXTERIOR LAMP BATTERY SAVER CONTROL

When the combination switch (lighting switch) is in the 2ND position (ON), and the ignition switch is turned from ON or ACC to OFF, the battery saver control function is activated.

Under this condition, the headlamps remain illuminated for 5 minutes, then the headlamps are turned off. Exterior lamp battery saver control mode can be changed by the function setting of CONSULT-III.

CAN Communication System Description

INFOID:000000002956776

CAN (Controller Area Network) is a serial communication line for real time application. It is an on-vehicle multiplex communication line with high data communication speed and excellent error detection ability. Many elec-

A

B

C

D

E

F

G

H

I

J

LT

L

M

N

O

P

FRONT FOG LAMP

< SERVICE INFORMATION >

tronic control units are equipped onto a vehicle, and each control unit shares information and links with other control units during operation (not independent). In CAN communication, control units are connected with 2 communication lines (CAN H line, CAN L line) allowing a high rate of information transmission with less wiring. Each control unit transmits/receives data but selectively reads required data only.

CAN Communication Unit

INFOID:000000002956777

Refer to [LAN-11. "System Description"](#).

Schematic

INFOID:000000002956778

* : This relay is built into the IPDM E/R
(Intelligent power distribution module engine room).

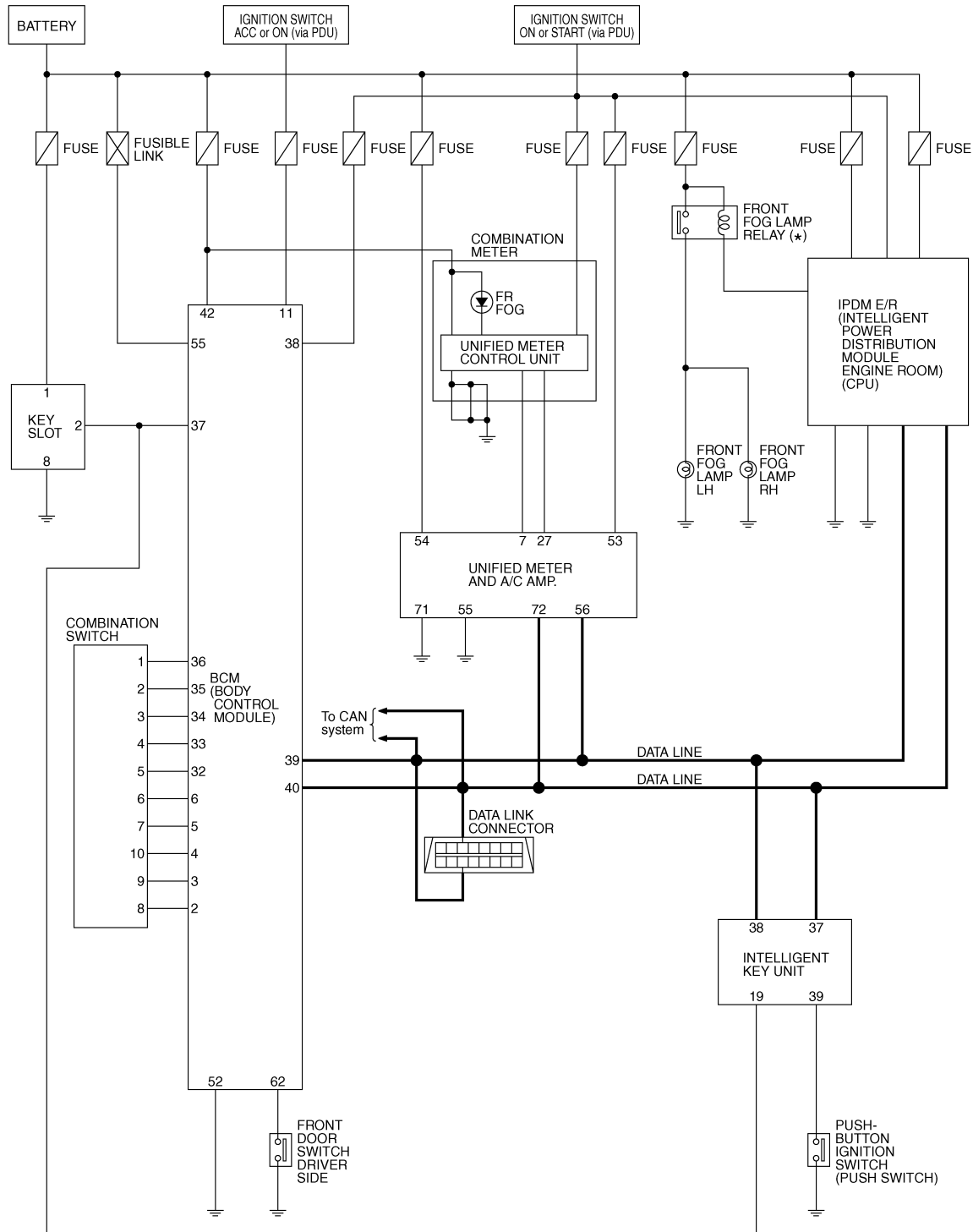

TKWT3386E

FRONT FOG LAMP

< SERVICE INFORMATION >

Wiring Diagram - F/FOG -

INFOID:00000002956779

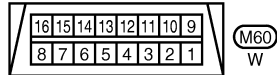
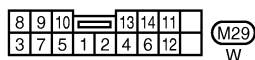
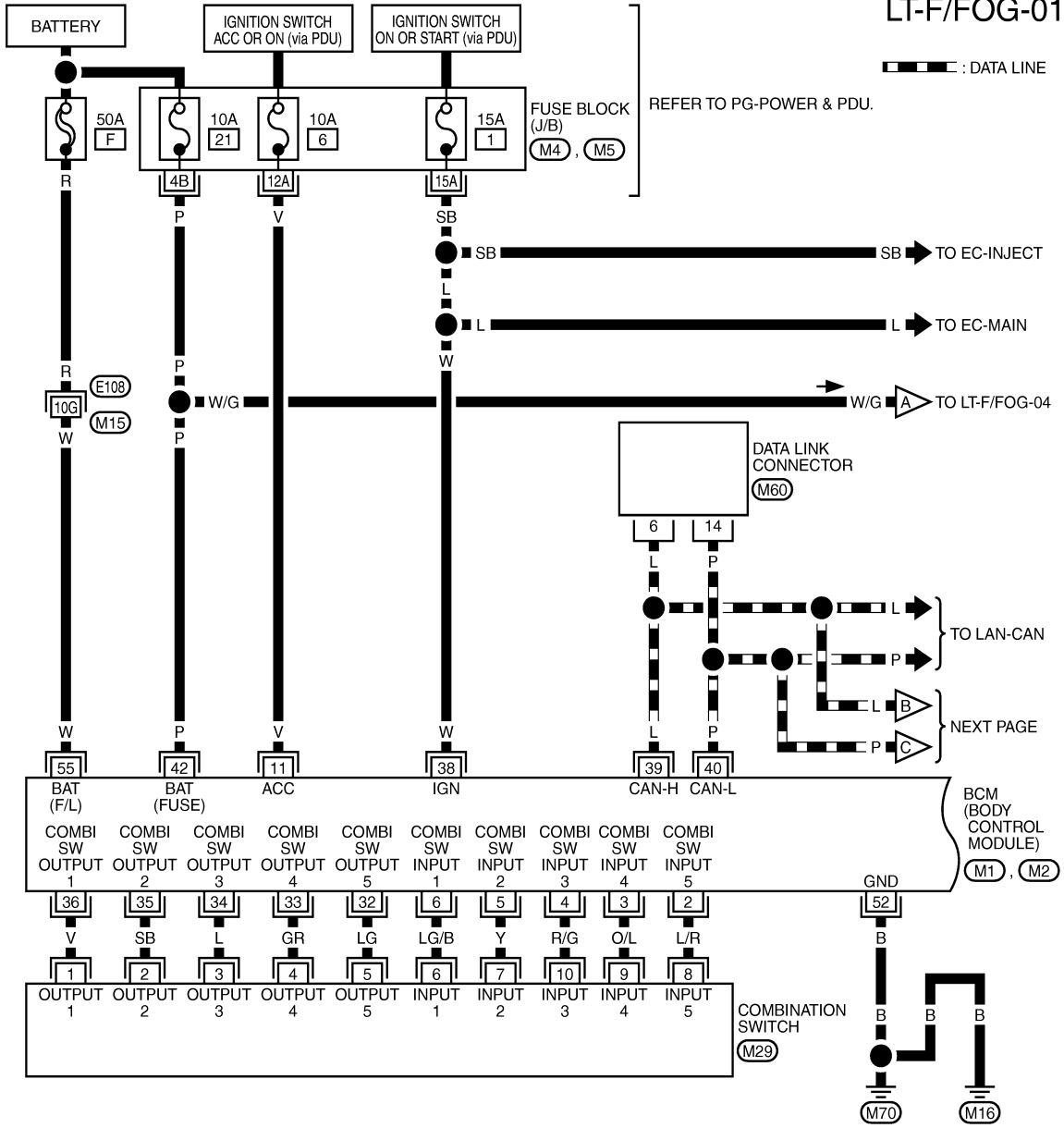

REFER TO THE FOLLOWING.

- (E108) - SUPER MULTIPLE JUNCTION (SMJ)
- (M4), (M5) - FUSE BLOCK - JUNCTION BOX (J/B)
- (M1), (M2) - ELECTRICAL UNITS

TKWT6820E

A
B
C
D
E
F
G
H
I
J
K
L
M
N
O
P

LT

FRONT FOG LAMP

< SERVICE INFORMATION >

LT-F/FOG-02

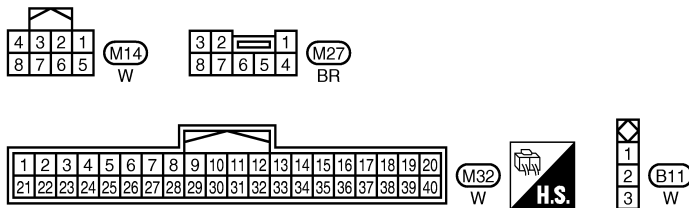
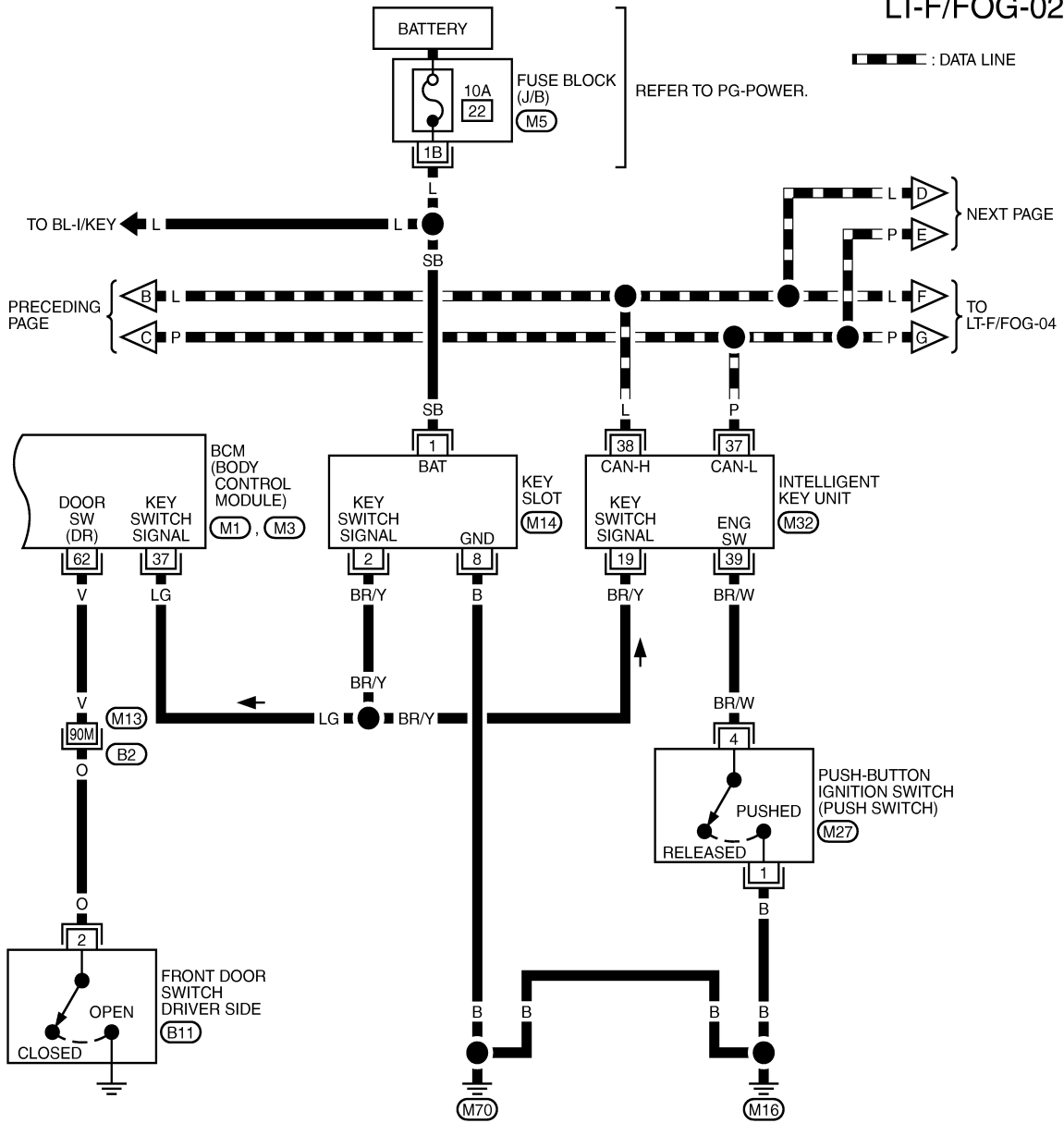

REFER TO THE FOLLOWING.
 (B2) - SUPER MULTIPLE JUNCTION (SMJ)
 (M5) - FUSE BLOCK-JUNCTION BOX (J/B)
 (M1), (M3) - ELECTRICAL UNITS

TKWT6821E

FRONT FOG LAMP

< SERVICE INFORMATION >

LT-F/FOG-03

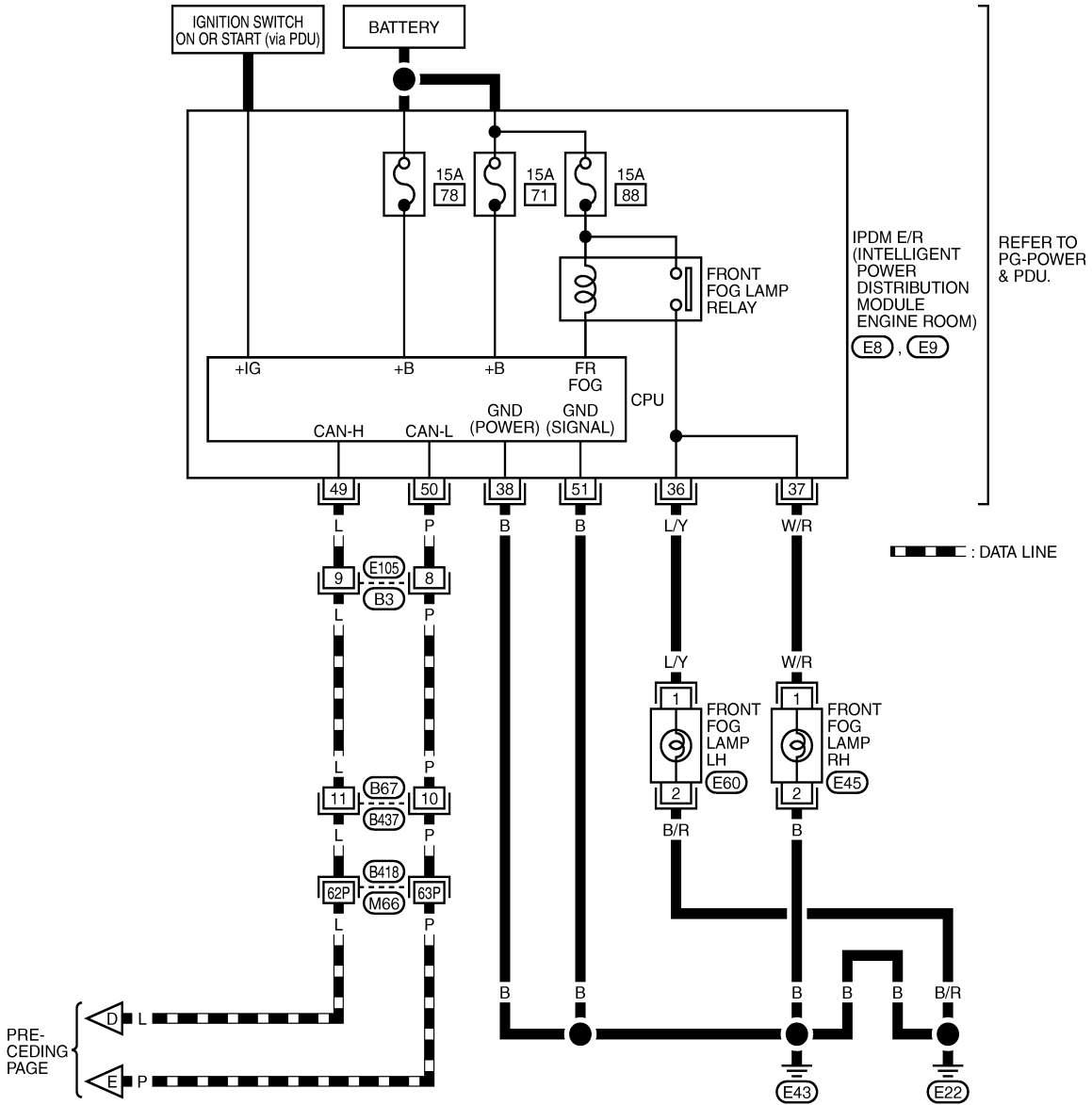

PRE-
CEDING
PAGE

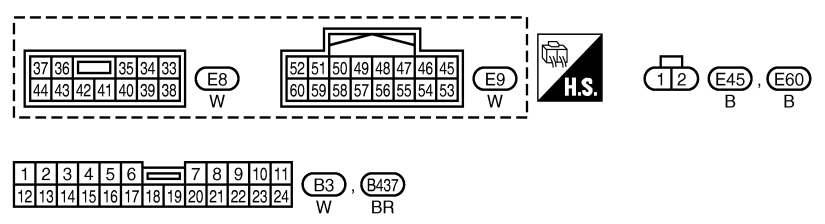

REFER TO THE FOLLOWING.
B418 - SUPER MULTIPLE JUNCTION (SMJ)

TKWT6822E

A
B
C
D
E
F
G
H
I
J
K
L
M
N
O
P

LT

FRONT FOG LAMP

< SERVICE INFORMATION >

LT-F/FOG-04

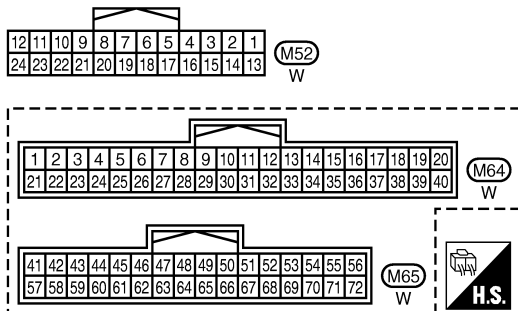
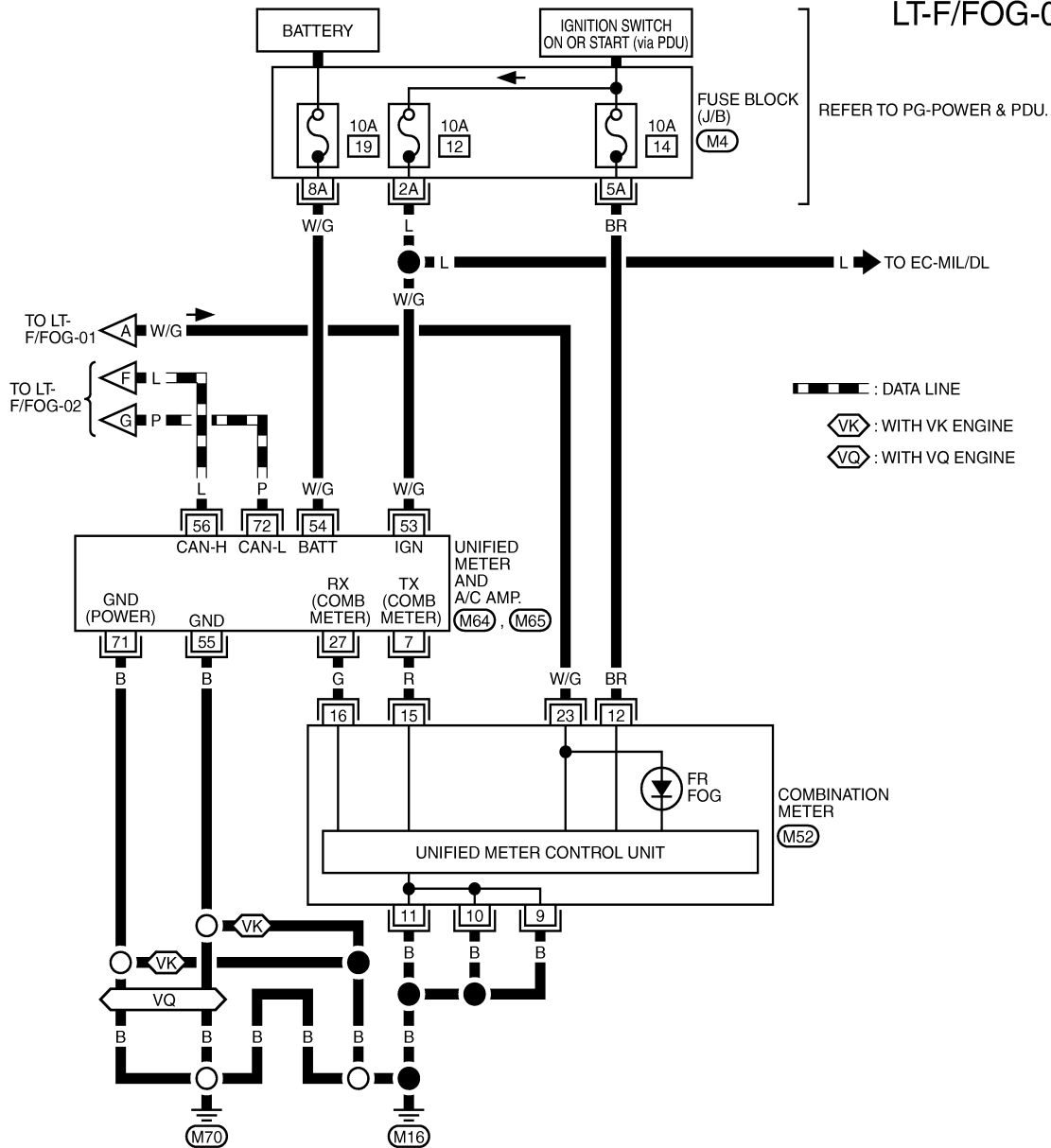

REFER TO THE FOLLOWING.
 (M4) - FUSE BLOCK - JUNCTION BOX (J/B)

TKWT6823E

INFOID:000000002956780

Terminal and Reference Value for BCM

CAUTION:

- Check combination switch system terminal waveform under the loaded condition with lighting switch, turn signal switch and wiper switch OFF not to be fluctuated by overloaded.
- Turn wiper dial position to 4 except when checking waveform or voltage of wiper dial position. Wiper dial position can be confirmed on CONSULT-III. Refer to [LT-201, "CONSULT-III Functions \(BCM - COMB SW\)"](#).

FRONT FOG LAMP

< SERVICE INFORMATION >

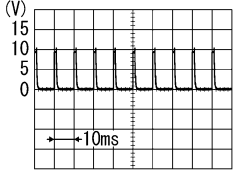
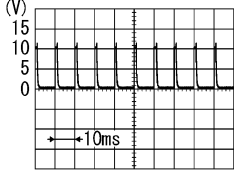
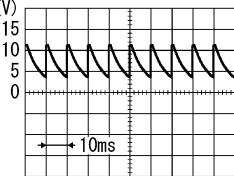
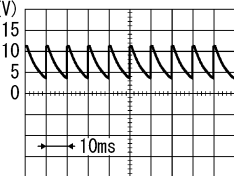
| Terminal No. | Wire color | Signal name | Measuring condition | | Reference value | |
|--------------|------------|--------------------------------------|---------------------|--|--|--|
| | | | Ignition switch | Operation or condition | | |
| 3 | O/L | Combination switch input 4 | ON | Lighting, turn, wiper switch (Wiper dial position 4) |  <p style="text-align: right;">PKIB4955J</p> <p style="text-align: center;">Approx. 0.8 V</p> | |
| | | | | | OFF | Approx. 0 V |
| 11 | V | Ignition switch (ACC) | ACC | — | Battery voltage | |
| 32 | LG | Combination switch output 5 | ON | Lighting, turn, wiper switch (Wiper dial position 4) |  <p style="text-align: right;">PKIB4956J</p> <p style="text-align: center;">Approx. 1.0 V</p> | |
| | | | | | OFF |  <p style="text-align: right;">PKIB4960J</p> <p style="text-align: center;">Approx. 7.0 - 7.5 V</p> |
| 37 | LG | Key switch signal | OFF | Intelligent Key is inserted into key slot. | Battery voltage | |
| | | | | Intelligent Key is removed from key slot. | Approx. 0 V | |
| 38 | W | Ignition switch (ON) | ON | — | Battery voltage | |
| 39 | L | CAN - H | — | — | — | |
| 40 | P | CAN - L | — | — | — | |
| 42 | P | Battery power supply | OFF | — | Battery voltage | |
| 52 | B | Ground | ON | — | Approx. 0 V | |
| 55 | W | Battery power supply | OFF | — | Battery voltage | |
| 62 | V | Front door switch driver side signal | OFF | Front door switch driver side | ON (open) | Approx. 0 V |
| | | | | | OFF (closed) |  <p style="text-align: right;">PKIB4960J</p> <p style="text-align: center;">Approx. 7.5 - 8.0 V</p> |

A
B
C
D
E
F
G
H
I
J

LT

L
M
N
O
P

FRONT FOG LAMP

< SERVICE INFORMATION >

Terminal and Reference Value for IPDM E/R

INFOID:000000002956781

| Terminal No. | Wire color | Signal name | Measuring condition | | Reference value | |
|--------------|------------|---------------------|---------------------|---|----------------------------|-----------------|
| | | | Ignition switch | Operation or condition | | |
| 36 | L/Y | Front fog lamp (LH) | ON | Lighting switch must be in the 2ND position or AUTO position (headlamp is ON) | Front fog lamp switch: OFF | Approx. 0 V |
| | | | | | Front fog lamp switch: ON | Battery voltage |
| 37 | W/R | Front fog lamp (RH) | ON | Lighting switch must be in the 2ND position or AUTO position (headlamp is ON) | Front fog lamp switch: OFF | Approx. 0 V |
| | | | | | Front fog lamp switch: ON | Battery voltage |
| 38 | B | Ground | ON | — | — | Approx. 0 V |
| 49 | L | CAN – H | — | — | — | — |
| 50 | P | CAN – L | — | — | — | — |
| 51 | B | Ground | ON | — | — | Approx. 0 V |

How to Perform Trouble Diagnosis

INFOID:000000002956782

1. Confirm the symptom or customer complaint.
2. Understand operation description and function description. Refer to [LT-162, "System Description"](#).
3. Perform the Preliminary Check. Refer to [LT-170, "Preliminary Check"](#).
4. Check symptom and repair or replace the cause of malfunction.
5. Does the front fog lamp operate normally? If YES, GO TO 6. If NO, GO TO 4.
6. INSPECTION END

Preliminary Check

INFOID:000000002956783

CHECK POWER SUPPLY AND GROUND CIRCUIT

1. CHECK FUSES AND FUSIBLE LINK

Check for blown fuses and fusible link.

| Unit | Power source | Fuse and fusible link No. |
|----------|--------------------------------------|---------------------------|
| BCM | Battery | F |
| | | 21 |
| | Ignition switch ON or START position | 1 |
| | Ignition switch ACC or ON position | 6 |
| IPDM E/R | Battery | 71 |
| | | 88 |
| | | 78 |

Refer to [LT-165, "Wiring Diagram - F/FOG -"](#).

OK or NG

OK >> GO TO 2.

NG >> If fuse or fusible link is blown, be sure to eliminate cause of malfunction before installing new fuse or fusible link. Refer to [PG-4](#).

2. CHECK POWER SUPPLY CIRCUIT

FRONT FOG LAMP

< SERVICE INFORMATION >

1. Turn ignition switch OFF.
2. Disconnect BCM connector.
3. Check voltage between BCM harness connector and ground.

| Terminal | | Ignition switch position | | | |
|---------------|----------|--------------------------|-----------------|-----------------|-----------------|
| (+) | | (-) | OFF | ACC | ON |
| BCM connector | Terminal | | | | |
| M1 | 11 | Ground | Approx. 0 V | Battery voltage | Battery voltage |
| | 38 | | Approx. 0 V | Approx. 0 V | Battery voltage |
| M2 | 42 | | Battery voltage | Battery voltage | Battery voltage |
| | 55 | | Battery voltage | Battery voltage | Battery voltage |

OK or NG

- OK >> GO TO 3.
 NG >> Check harness for open or short between BCM and fuse.

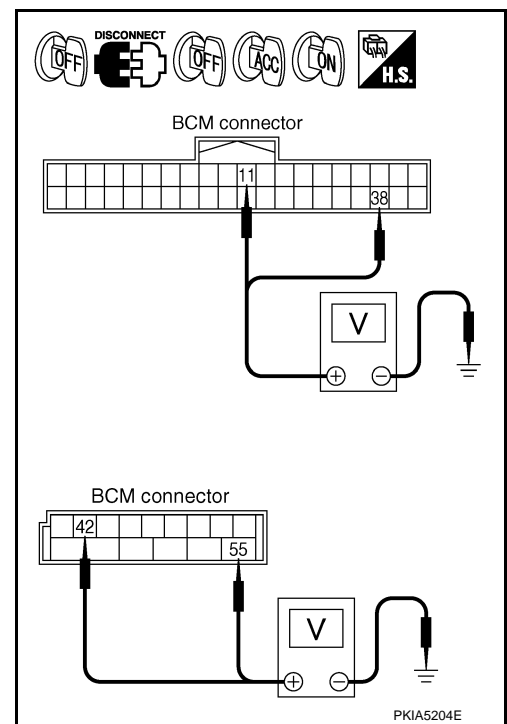

3. CHECK GROUND CIRCUIT

Check continuity between BCM harness connector and ground.

| BCM connector | Terminal | Ground | Continuity |
|---------------|----------|--------|------------|
| M2 | 52 | | Yes |

OK or NG

- OK >> INSPECTION END
 NG >> Check harness ground circuit.

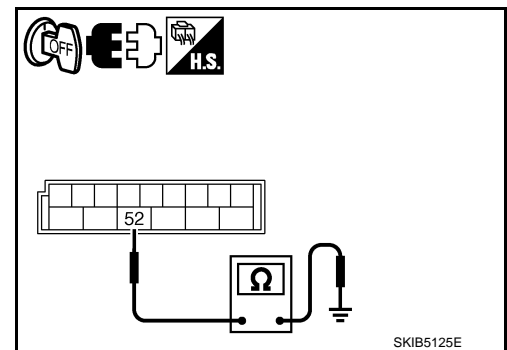

CONSULT-III Functions (BCM - HEAD LAMP)

INFOID:000000002956784

Refer to [LT-47, "CONSULT-III Functions \(BCM - HEAD LAMP\)"](#) in HEADLAMP (FOR USA) -XENON TYPE-.
 Refer to [LT-19, "CONSULT-III Functions \(BCM - HEAD LAMP\)"](#) in HEADLAMP (FOR USA) -CONVENTIONAL TYPE-.

Refer to [LT-77, "CONSULT-III Functions \(BCM - HEAD LAMP\)"](#) in HEADLAMP (FOR CANADA).

CONSULT-III Functions (IPDM E/R)

INFOID:000000002956785

Refer to [LT-48, "CONSULT-III Functions \(IPDM E/R\)"](#) in HEADLAMP (FOR USA) -XENON TYPE-.
 Refer to [LT-20, "CONSULT-III Functions \(IPDM E/R\)"](#) in HEADLAMP (FOR USA) -CONVENTIONAL TYPE-.
 Refer to [LT-78, "CONSULT-III Functions \(IPDM E/R\)"](#) in HEADLAMP (FOR CANADA).

Front Fog Lamps Do Not Illuminate (Both Sides)

INFOID:000000002956786

1. CHECK COMBINATION SWITCH INPUT SIGNAL

CONSULT-III DATA MONITOR

1. Select "FR FOG SW" of BCM (HEAD LAMP) data monitor item.
2. With operating the front fog lamp switch, check the monitor status.

When fog lamp switch is ON : FR FOG SW ON

CHECK THE COMBINATION SWITCH

Refer to [LT-202, "Combination Switch Inspection"](#).

FRONT FOG LAMP

< SERVICE INFORMATION >

OK or NG

OK >> GO TO 2.

NG >> Check combination switch (lighting switch). Refer to [LT-202. "Combination Switch Inspection"](#).

2. FRONT FOG LAMP ACTIVE TEST

Ⓟ CONSULT-III ACTIVE TEST

1. Select "LAMPS" of IPDM E/R active test item.
2. With operating the test item, check the fog lamp operation.

FOG : Front fog lamps ON
Off : Front fog lamps OFF

ⓧ IPDM E/R AUTO ACTIVE TEST

1. Activate auto active test. Refer to [PG-22. "Auto Active Test"](#).
2. Make sure fog lamp operation.

Front fog lamp should operate.

OK or NG

OK >> GO TO 3.

NG >> GO TO 4.

3. CHECK IPDM E/R

Ⓟ CONSULT-III DATA MONITOR

1. Select "FR FOG REQ" of IPDM E/R data monitor item.
2. With operating the fog lamp switch is in ON position, check the monitor status.

When lighting switch is ON position : FR FOG REQ ON

OK or NG

OK >> Replace IPDM E/R. Refer to [PG-27. "Removal and Installation of IPDM E/R"](#).

NG >> Replace BCM. Refer to [BCS-14. "Removal and Installation of BCM"](#).

4. CHECK FOG LAMP INPUT SIGNAL

Ⓟ CONSULT-III ACTIVE TEST

1. Turn ignition switch OFF.
2. Disconnect front fog lamp RH and LH connector.
3. Select "LAMPS" of IPDM E/R active test item.
4. Touch "FOG" screen.
5. With operating the test item, check voltage between front fog lamp (RH and LH) harness connector and ground.

| Terminal | | | Voltage (Approx.) |
|--------------------------|----------|-----|-------------------|
| (+) | | (-) | |
| Front fog lamp connector | Terminal | | |
| RH | E45 | 1 | Battery voltage |
| LH | E60 | 1 | |

ⓧ IPDM E/R AUTO ACTIVE TEST

1. Turn ignition switch OFF.
2. Disconnect front fog lamp RH and LH connector.
3. Activate auto active test. Refer to [PG-22. "Auto Active Test"](#).
4. When fog lamp is operating, check voltage between front fog lamp (RH and LH) harness connector and ground.

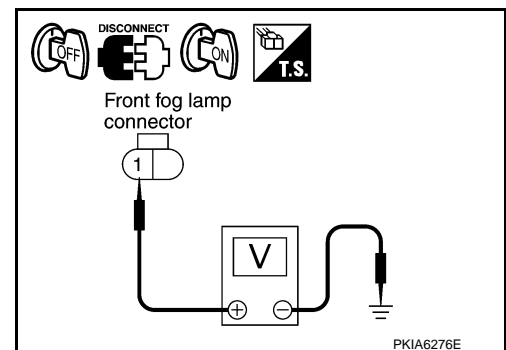

FRONT FOG LAMP

< SERVICE INFORMATION >

| Terminal | | | Voltage (Approx.) | |
|--------------------------|----------|--------|-------------------|---|
| (+) | | (-) | | |
| Front fog lamp connector | Terminal | Ground | Battery voltage | |
| RH | E45 | | | 1 |
| LH | E60 | | | 1 |

OK or NG

- OK >> GO TO 5.
NG >> GO TO 6.

5. CHECK FOG LAMP GROUND CIRCUIT

- Turn ignition switch OFF.
- Check continuity between front fog lamp (RH and LH) harness connector and ground.

| Front fog lamp connector | Terminal | Ground | Continuity |
|--------------------------|----------|--------|------------|
| RH | E45 | | 2 |
| LH | E60 | 2 | |

OK or NG

- OK >> Check front fog lamp bulbs.
NG >> Repair harness or connector.

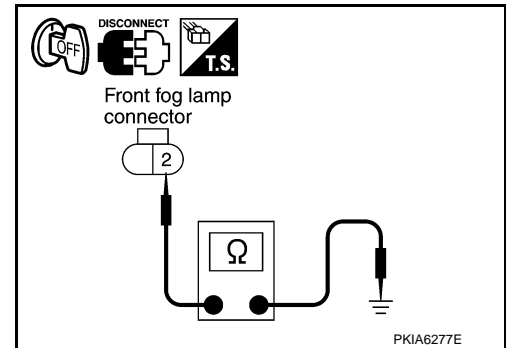

6. CHECK FRONT FOG LAMP CIRCUIT

- Turn ignition switch OFF.
- Disconnect IPDM E/R connector.
- Check continuity between IPDM E/R harness connector (A) and front fog lamp (RH and LH) harness connector (B).

| Circuit | A | | B | | Continuity |
|---------|-----------|----------|-----------|----------|------------|
| | Connector | Terminal | Connector | Terminal | |
| RH | E8 | 37 | E45 | 1 | Yes |
| LH | | 36 | E60 | 1 | |

- Check continuity between IPDM E/R harness connector (A) and ground.

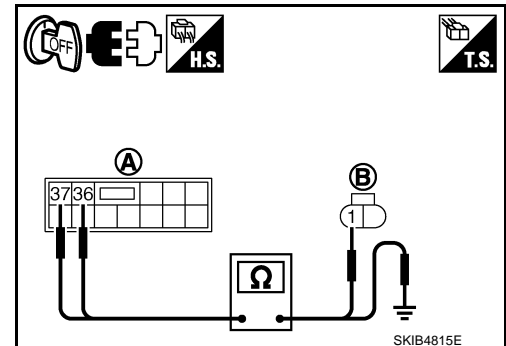

| A | | | Ground | Continuity |
|-----------|----------|----|--------|------------|
| Connector | Terminal | | | |
| RH | E8 | 37 | | No |
| LH | | 38 | | |

OK or NG

- OK >> Replace IPDM E/R. Refer to [PG-27, "Removal and Installation of IPDM E/R"](#).
NG >> Repair harness or connector.

Front Fog Lamp Does Not Illuminate (One Side)

INFOID:000000002956787

1. CHECK BULB

Check bulb of fog lamp which does not illuminate.

OK or NG

- OK >> GO TO 2.
NG >> Replace front fog lamp bulb.

FRONT FOG LAMP

< SERVICE INFORMATION >

2. CHECK FOG LAMP INPUT SIGNAL

1. Turn ignition switch OFF.
2. Disconnect front fog lamp RH or LH connector.
3. Turn ignition switch ON.
4. Lighting switch is turned 2ND position and fog lamp ON position.
5. Check voltage between front fog lamp RH or LH harness connector and ground.

| Terminal | | | (-) | Voltage (Approx.) |
|--------------------------|-----|----------|-----|-------------------|
| (+) | | Terminal | | |
| Front fog lamp connector | | | | Ground |
| RH | E45 | 1 | | |
| LH | E60 | 1 | | |

OK or NG

- OK >> GO TO 3.
 NG >> GO TO 4.

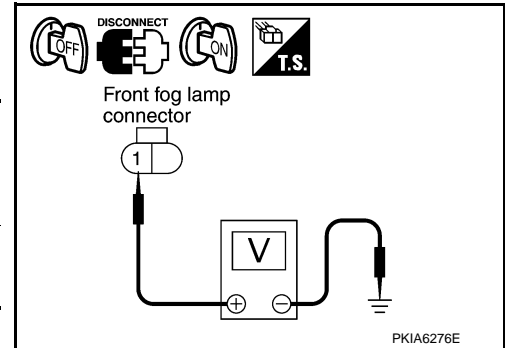

3. CHECK FRONT FOG LAMP GROUND CIRCUIT

1. Turn ignition switch OFF.
2. Check continuity between front fog lamp RH or LH harness connector and ground.

| Front fog lamp connector | Terminal | Ground | Continuity |
|--------------------------|----------|--------|------------|
| RH | E45 | | 2 |
| LH | E60 | 2 | |

OK or NG

- OK >> Check connecting condition front fog lamp harness connector.
 NG >> Repair harness or connector.

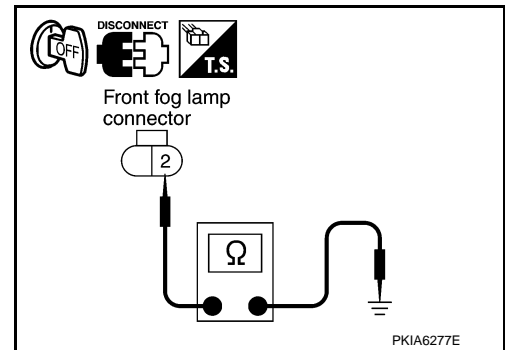

4. CHECK FOG LAMP CIRCUIT

1. Turn ignition switch OFF.
2. Disconnect IPDM E/R connector.
3. Check continuity between IPDM E/R harness connector (A) and front fog lamp RH or LH harness connector (B).

| Circuit | A | | B | | Continuity |
|---------|-----------|----------|-----------|----------|------------|
| | Connector | Terminal | Connector | Terminal | |
| RH | E8 | 37 | E45 | 1 | Yes |
| LH | | 36 | E60 | 1 | |

4. Check continuity between IPDM E/R harness connector (A) and ground.

| A | | | Ground | Continuity |
|-----------|----------|----|--------|------------|
| Connector | Terminal | | | |
| RH | E8 | 37 | No | |
| LH | | 36 | | |

OK or NG

- OK >> Replace IPDM E/R. Refer to [PG-27, "Removal and Installation of IPDM E/R"](#).
 NG >> Repair harness or connector.

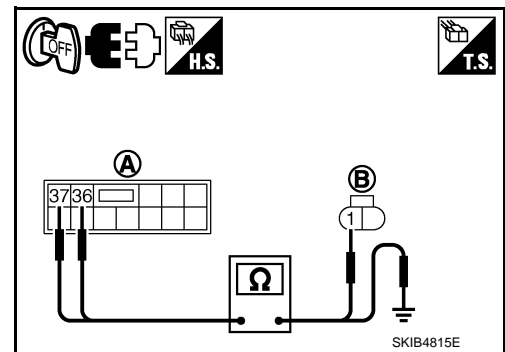

FRONT FOG LAMP

< SERVICE INFORMATION >

Front Fog Lamps Do Not Turn OFF

INFOID:000000002956788

1. CHECK FRONT FOG LAMP TURN OFF

Make sure that lighting switch is OFF. And make sure front fog lamp turns off when ignition switch is turned OFF.

OK or NG

- OK >> GO TO 3.
- NG >> GO TO 2.

2. CHECK COMBINATION SWITCH INPUT SIGNAL

CONSULT-III DATA MONITOR

1. Select "FR FOG SW" of BCM (HEAD LAMP) data monitor item.
2. With operating the front fog lamp switch, check the monitor status.

When fog lamp switch is OFF position : FR FOG SW OFF

OK or NG

- OK >> Replace IPDM E/R. Refer to [PG-27, "Removal and Installation of IPDM E/R"](#).
- NG >> Check combination switch (lighting switch). Refer to [LT-202, "Combination Switch Inspection"](#).

3. CHECK CAN COMMUNICATIONS BETWEEN BCM AND IPDM E/R

CONSULT-III SELF-DIAGNOSIS

Perform self-diagnosis for "BCM" on CONSULT-III.

Display of self-diagnosis results

- NO DTC>> Replace IPDM E/R. Refer to [PG-27, "Removal and Installation of IPDM E/R"](#).
- CAN COMM CIRCUIT>> Refer to [LAN-17, "CAN Diagnosis with CONSULT-III"](#).

Aiming Adjustment

INFOID:000000002956789

The fog lamp is a semi-sealed beam type which uses a replaceable halogen bulb. Before performing aiming adjustment, make sure of the following.

- Keep all tires inflated to correct pressure.
- Place vehicle on level ground.

Adjust aiming in the vertical direction by turning the adjusting screw.

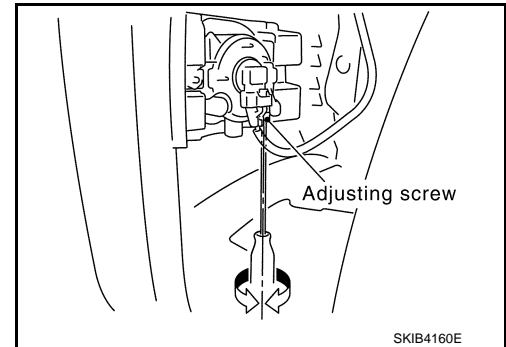

FRONT FOG LAMP

< SERVICE INFORMATION >

1. Set the distance between the screen and the center of fog lamp lens as shown.
2. Turn front fog lamps ON.
3. Adjust front fog lamps using adjusting screw so that the top edge of the high intensity zone is in the figure.
When performing adjustment, if necessary, cover the headlamps and opposite fog lamp.

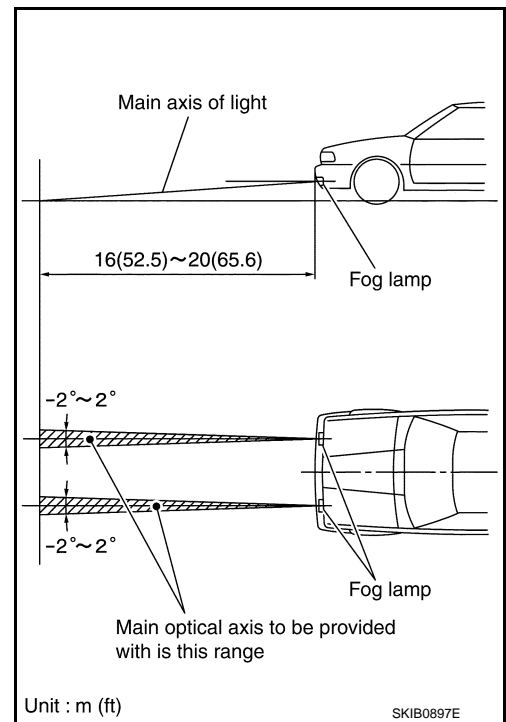

Bulb Replacement

INFOID:000000002956790

CAUTION:

- Disconnect the battery negative terminal or remove the fuse.
- Never touch the glass of bulb directly by hand. Keep grease and other oily matters away from it. Never touch bulb by hand while it is lit or right after being turned off.
- Never leave bulb out of lamp reflector for a long time because dust, moisture smoke, etc. may affect the performance of lamp. When replacing bulb, be sure to replace it with new one.

1. Remove fender protector (front). Refer to [EI-31](#).
2. Turn bulb (1) counterclockwise and unlock it.
3. Disconnect connector (2), and remove bulb (1).

Front fog lamp : 12V - 55W (H11)

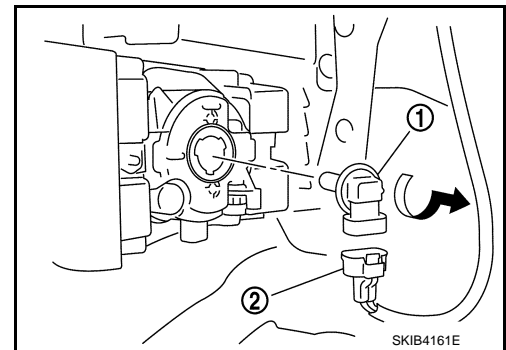

STANDARD TYPE

FRONT FOG LAMP

< SERVICE INFORMATION >

STANDARD TYPE : Removal and Installation

INFOID:000000003303501

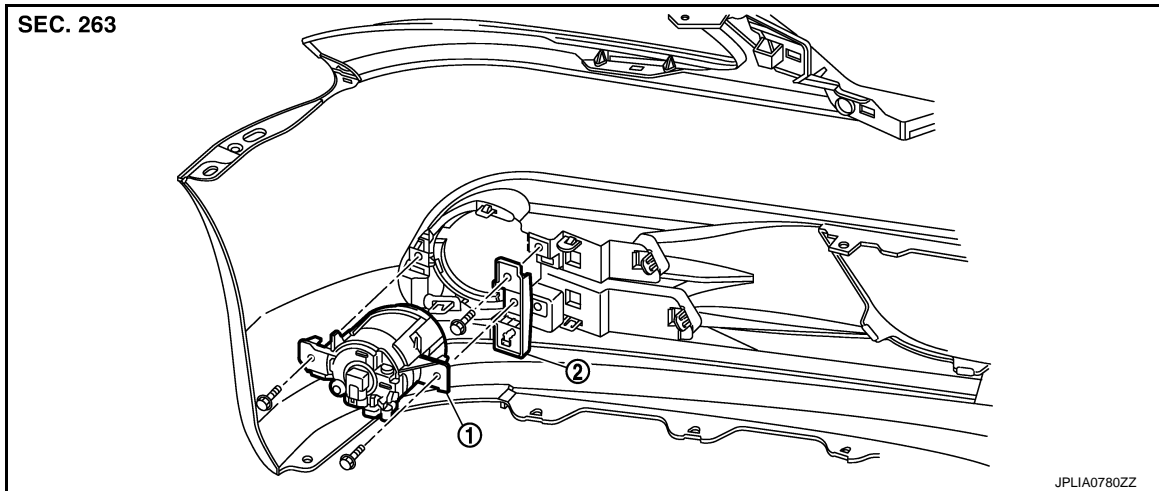

1. Front fog lamp
2. Fog lamp bracket

REMOVAL

CAUTION:

Disconnect the battery negative terminal or remove the fuse.

1. Remove fender protector (front). Refer to [EI-31, "FENDER PROTECTOR : Removal and Installation"](#).
2. Remove front fog lamp connector.
3. Remove screws and remove front fog lamp.

INSTALLATION

Installation is the reverse order of removal.

SPORTS TYPE

SPORTS TYPE : Removal and Installation

INFOID:000000002956791

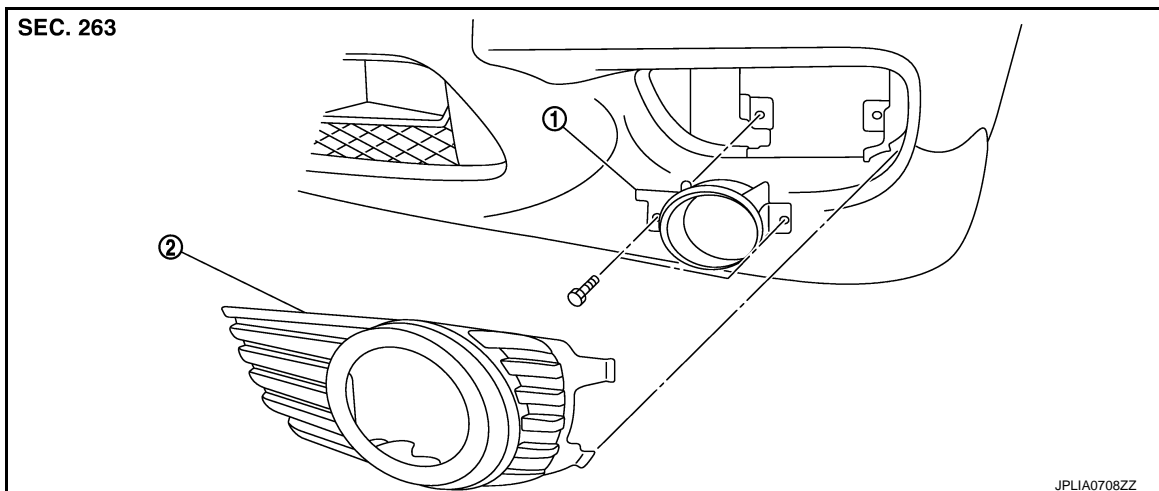

1. Front fog lamp
2. Front bumper grille

REMOVAL

CAUTION:

Disconnect the battery negative terminal or remove the fuse.

1. Remove front bumper grille. Refer to [EI-27, "Removal and Installation"](#).
2. Remove screws and remove front fog lamp.

A
B
C
D
E
F
G
H
I
J
LT
L
M
N
O
P

FRONT FOG LAMP

< SERVICE INFORMATION >

INSTALLATION

Installation is the reverse order of removal.

TURN SIGNAL AND HAZARD WARNING LAMPS

< SERVICE INFORMATION >

TURN SIGNAL AND HAZARD WARNING LAMPS

Component Parts and Harness Connector Location

INFOID:000000002956792

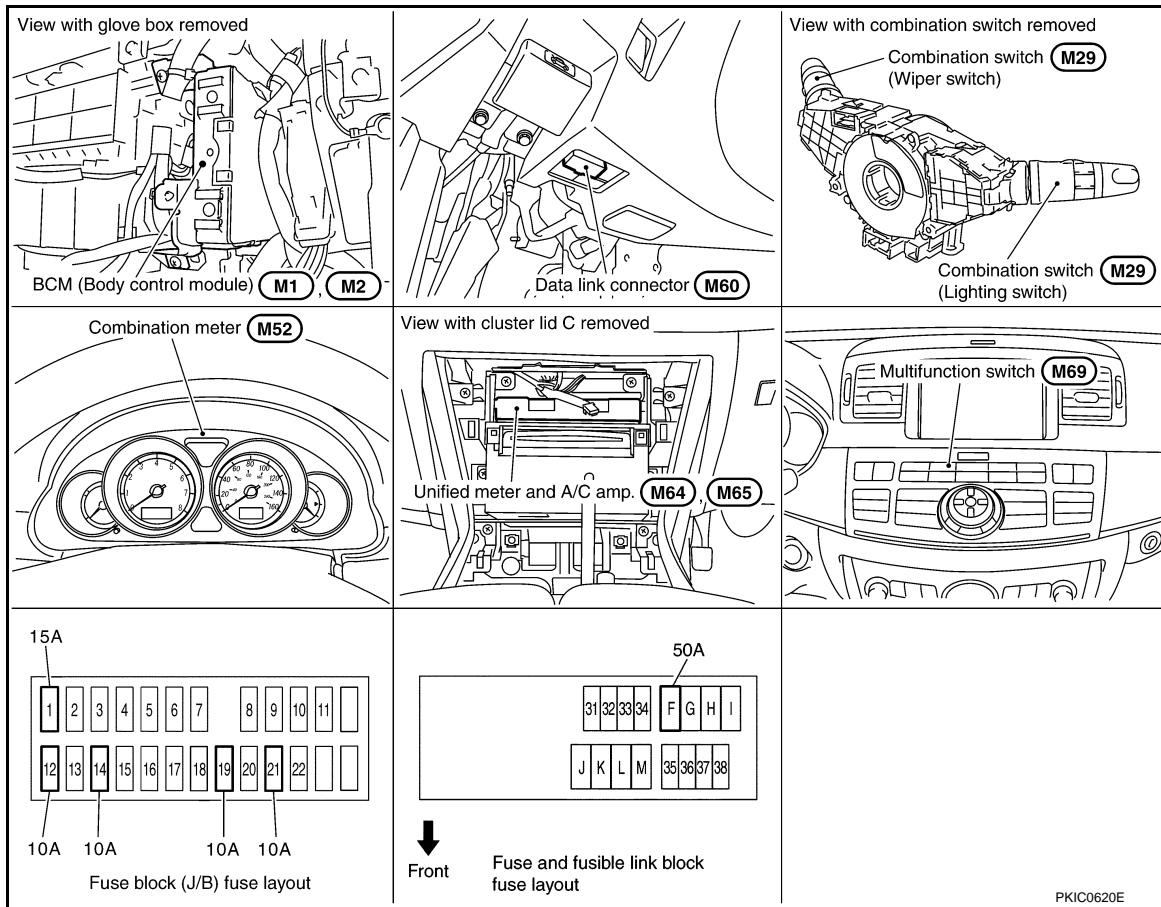

System Description

INFOID:000000002956793

TURN SIGNAL OPERATION

With the ignition switch is in the ON or START position, power is supplied

- through 15A fuse [No. 1, located in fuse block (J/B)]
- to BCM (body control module) terminal 38,
- through 10A fuse [No. 14, located in fuse block (J/B)]
- to combination meter terminal 12,
- through 10A fuse [No. 12, located in fuse block (J/B)]
- to unified meter and A/C amp. terminal 53.

Ground is supplied

- to BCM terminal 52
- to combination meter terminals 9, 10 and 11
- to unified meter and A/C amp. terminals 55 and 71
- through grounds M16 and M70.

LH Turn Signal Lamp

When turn signal switch is moved to left position, BCM receives input signal requesting left turn signals to flash. BCM then supplies power

- through BCM terminal 45
- to front combination lamp LH (turn signal) terminal 10
- to side turn signal lamp LH terminal 1, and
- to rear combination lamp LH (turn signal) terminal 3.

Ground is supplied

- to front combination lamp LH (turn signal) terminal 9
- to side turn signal lamp LH terminal 2
- through grounds E22 and E43,

A
B
C
D
E
F
G
H
I
J

LT

L
M
N
O
P

TURN SIGNAL AND HAZARD WARNING LAMPS

< SERVICE INFORMATION >

- to rear combination lamp LH (turn signal) terminal 4
- through grounds B5, B40 and B131.

The BCM also supplies input to unified meter and A/C amp. terminals 56 and 72 across the CAN communication lines.

The unified meter and A/C amp. which received the turn indicator signal makes the left turn signal indicator turn on in combination meter.

With power and input supplied, the BCM controls the flashing of the LH turn signal lamps.

RH Turn Signal Lamp

When turn signal switch is moved to right position, BCM receives input signal requesting right turn signals to flash. BCM then supplies power

- through BCM terminal 46
- to front combination lamp RH (turn signal) terminal 10
- to side turn signal lamp RH terminal 1, and
- to rear combination lamp RH (turn signal) terminal 3.

Ground is supplied

- to front combination lamp RH (turn signal) terminal 9
- to side turn signal lamp RH terminal 2
- through grounds E22 and E43,
- to rear combination lamp RH (turn signal) terminal 4
- through grounds B5, B40 and B131.

The BCM also supplies input to unified meter and A/C amp. terminals 56 and 72 across the CAN communication lines.

The unified meter and A/C amp. which received the turn indicator signal makes the right turn signal indicator turn on in combination meter.

With power and input supplied, the BCM controls the flashing of the RH turn signal lamps.

HAZARD LAMP OPERATION

Power is supplied at all times

- through 50A fusible link (letter F, located in fuse, fusible link and relay block)
- to BCM terminal 55,
- through 10A fuse [No. 21, located in fuse block (J/B)]
- to BCM terminal 42
- to combination meter terminal 23,
- through 10A fuse [No. 19, located in fuse block (J/B)]
- to unified meter and A/C amp. terminal 54.

When the hazard switch is depressed, ground is supplied

- to BCM terminal 29
- through multifunction switch terminal 6.

Ground is supplied

- to multifunction switch terminal 14
- to BCM terminal 52
- to combination meter terminals 9, 10 and 11
- to unified meter and A/C amp. terminals 55 and 71
- through grounds M16 and M70.

BCM then supplies power

- through BCM terminal 45
- to front combination lamp LH (turn signal) terminal 10
- to side turn signal lamp LH terminal 1
- to rear combination lamp LH (turn signal) terminal 3,
- through BCM terminal 46
- to front combination lamp RH (turn signal) terminal 10
- to side turn signal lamp RH terminal 1
- to rear combination lamp RH (turn signal) terminal 3.

Ground is supplied

- to front combination lamp LH (turn signal) terminal 9
- to front combination lamp RH (turn signal) terminal 9
- to side turn signal lamp LH terminal 2
- to side turn signal lamp RH terminal 2
- through grounds E22 and E43,
- to rear combination lamp LH (turn signal) terminal 4
- to rear combination lamp RH (turn signal) terminal 4

TURN SIGNAL AND HAZARD WARNING LAMPS

< SERVICE INFORMATION >

- through grounds B5, B40 and B131.

The BCM also supplies input to unified meter and A/C amp. terminals 56 and 72 across the CAN communication lines.

The unified meter and A/C amp. which received the turn indicator signal makes the left and right turn signal indicator turn on in combination meter.

With power and input supplied, the BCM controls the flashing of the hazard warning lamps.

COMBINATION SWITCH READING FUNCTION

Refer to [BCS-4, "System Description"](#).

CAN Communication System Description

INFOID:000000002956794

CAN (Controller Area Network) is a serial communication line for real time application. It is an on-vehicle multiplex communication line with high data communication speed and excellent error detection ability. Many electronic control units are equipped onto a vehicle, and each control unit shares information and links with other control units during operation (not independent). In CAN communication, control units are connected with 2 communication lines (CAN H line, CAN L line) allowing a high rate of information transmission with less wiring. Each control unit transmits/receives data but selectively reads required data only.

CAN Communication Unit

INFOID:000000002956795

Refer to [LAN-11, "System Description"](#).

A
B
C
D
E
F
G
H
I
J
LT
L
M
N
O
P



TURN SIGNAL AND HAZARD WARNING LAMPS

< SERVICE INFORMATION >

Schematic

INFOID:00000002956796

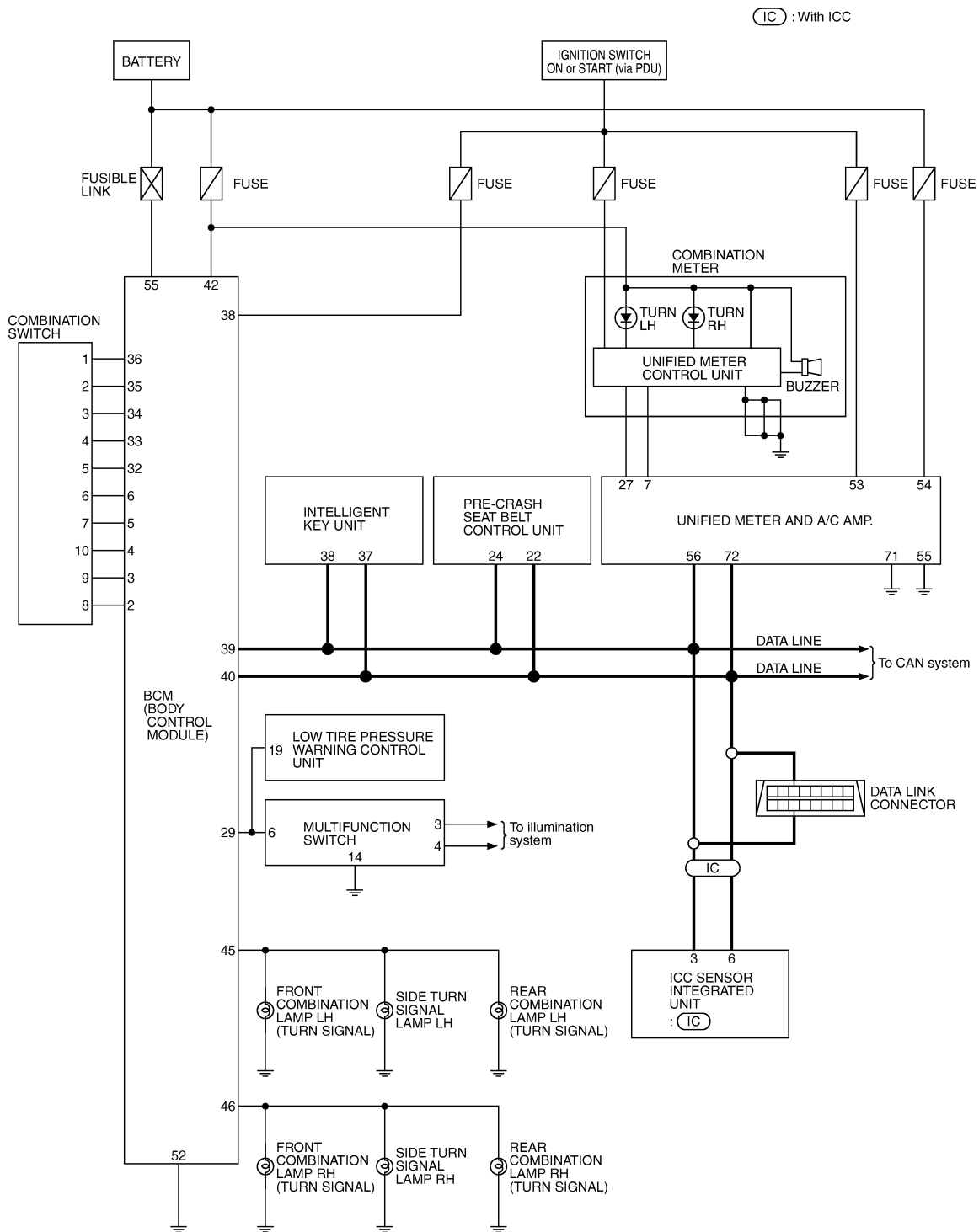

TKWT6824E

TURN SIGNAL AND HAZARD WARNING LAMPS

< SERVICE INFORMATION >

Wiring Diagram - TURN -

INFOID:00000002956797

LT-TURN-01

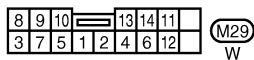
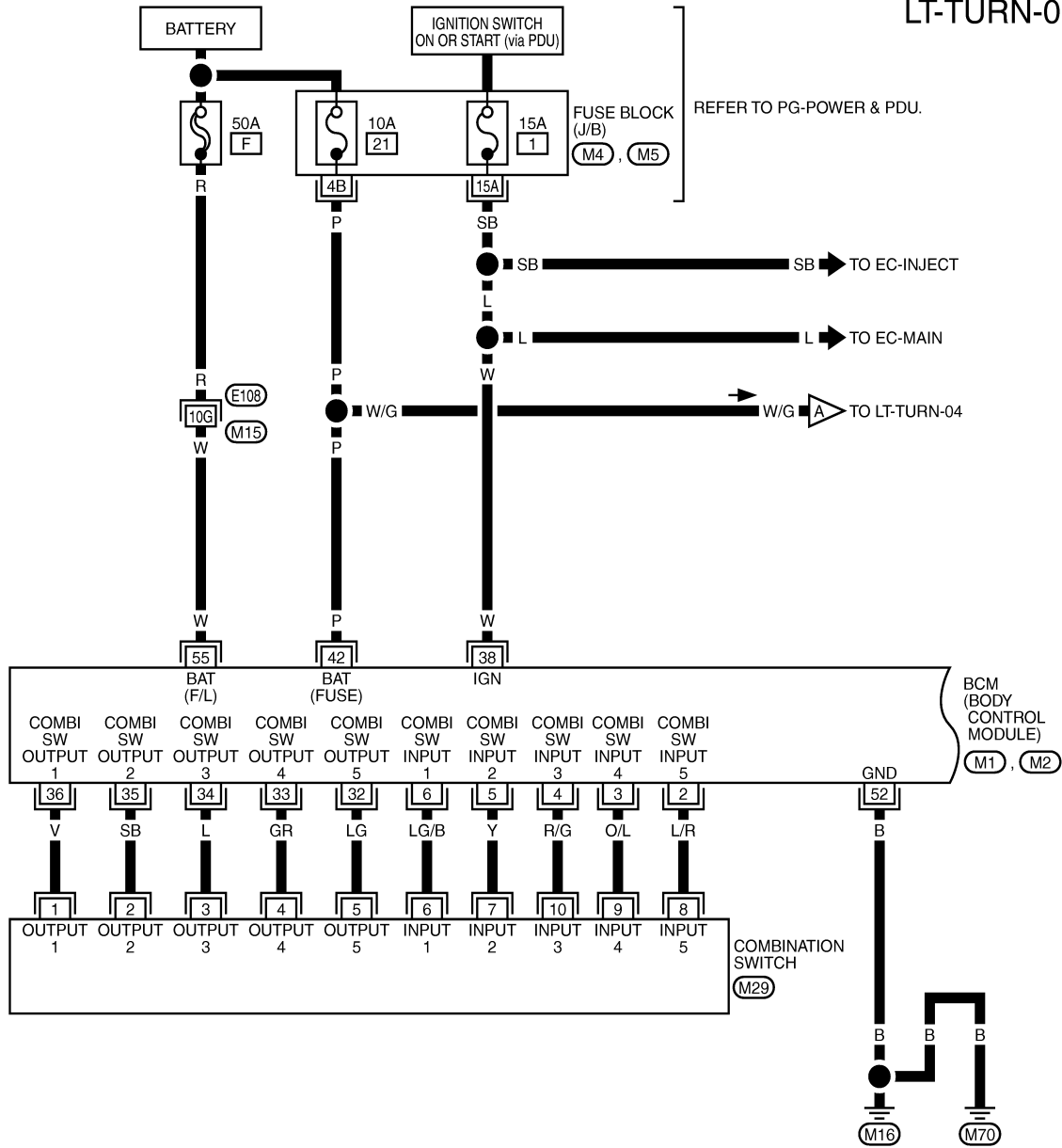

REFER TO THE FOLLOWING.
 (E108) - SUPER MULTIPLE JUNCTION (SMJ)
 (M4), (M5) - FUSE BLOCK - JUNCTION BOX (J/B)
 (M1), (M2) - ELECTRICAL UNITS

TKWT6825E

A
B
C
D
E
F
G
H
I
J
K
L
M
N
O
P

LT

TURN SIGNAL AND HAZARD WARNING LAMPS

< SERVICE INFORMATION >

LT-TURN-02

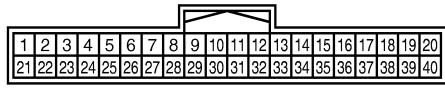
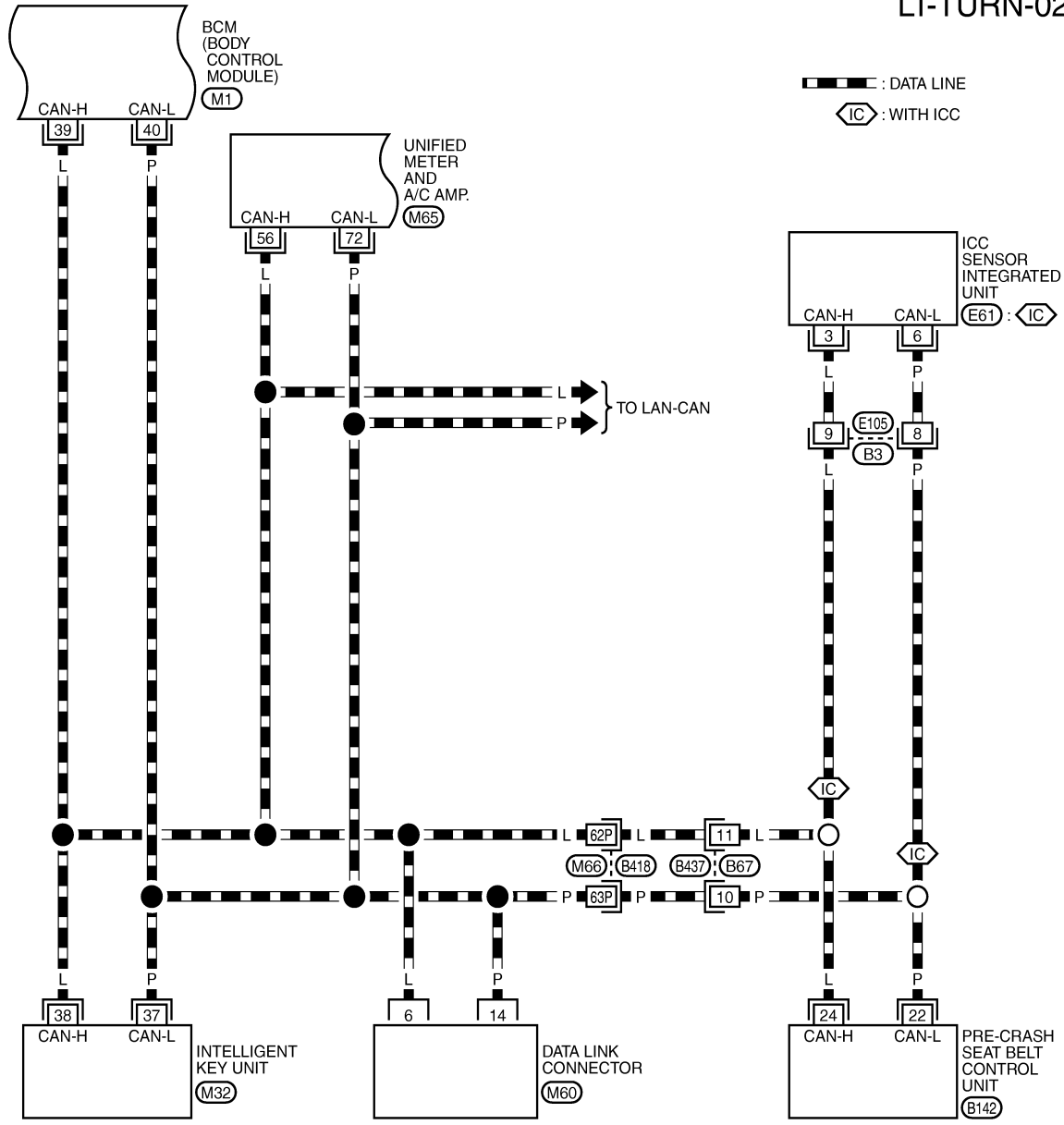

(M32)
W

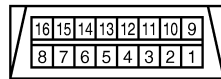

(M60)
W

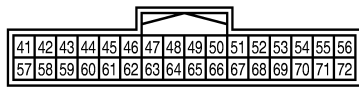

(M65)
W

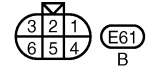

(E61)
B

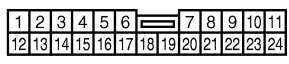

(B3)
W

(B437)
BR

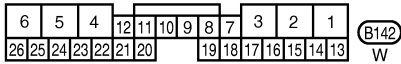

(B142)
W

REFER TO THE FOLLOWING.

- (B418) - SUPER MULTIPLE JUNCTION (SMJ)
- (M1) - ELECTRICAL UNITS

TKWT6826E

TURN SIGNAL AND HAZARD WARNING LAMPS

< SERVICE INFORMATION >

LT-TURN-03

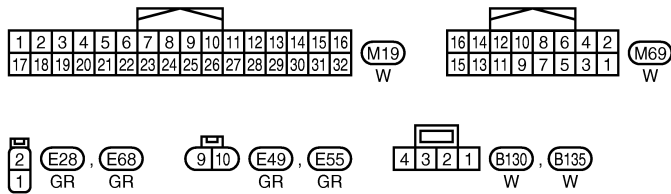
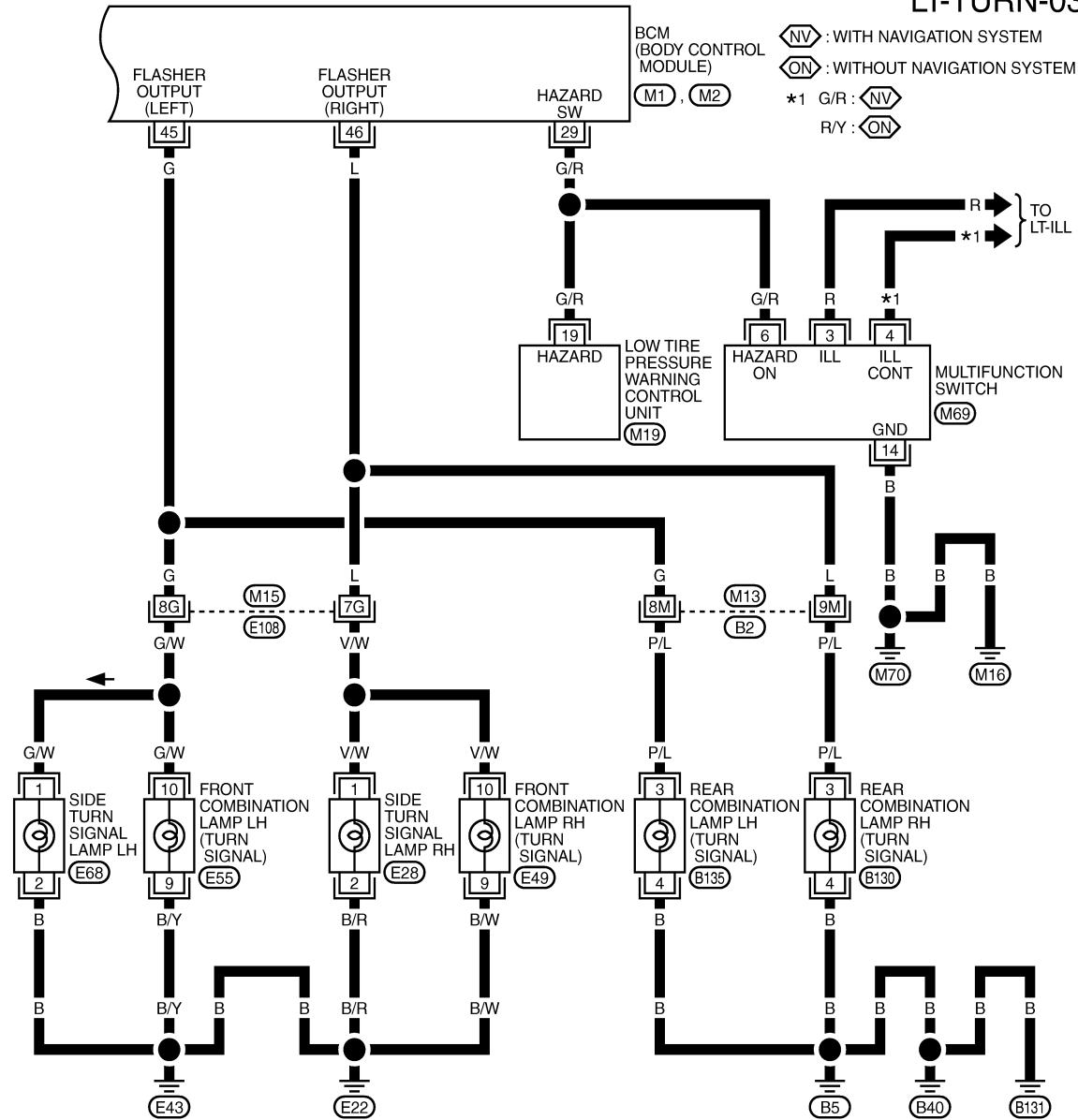

REFER TO THE FOLLOWING.
 (E108), (B2) - SUPER MULTIPLE JUNCTION (SMJ)
 (M1), (M2) - ELECTRICAL UNITS

TKWT6827E

A
B
C
D
E
F
G
H
I
J
K
L
M
N
O
P

LT

TURN SIGNAL AND HAZARD WARNING LAMPS

< SERVICE INFORMATION >

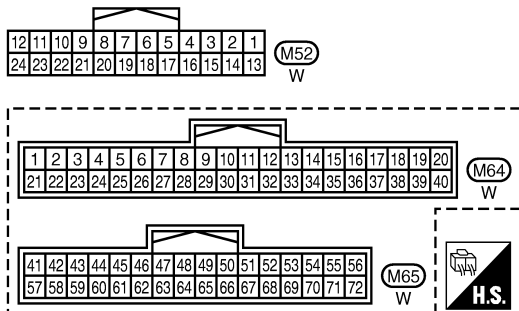
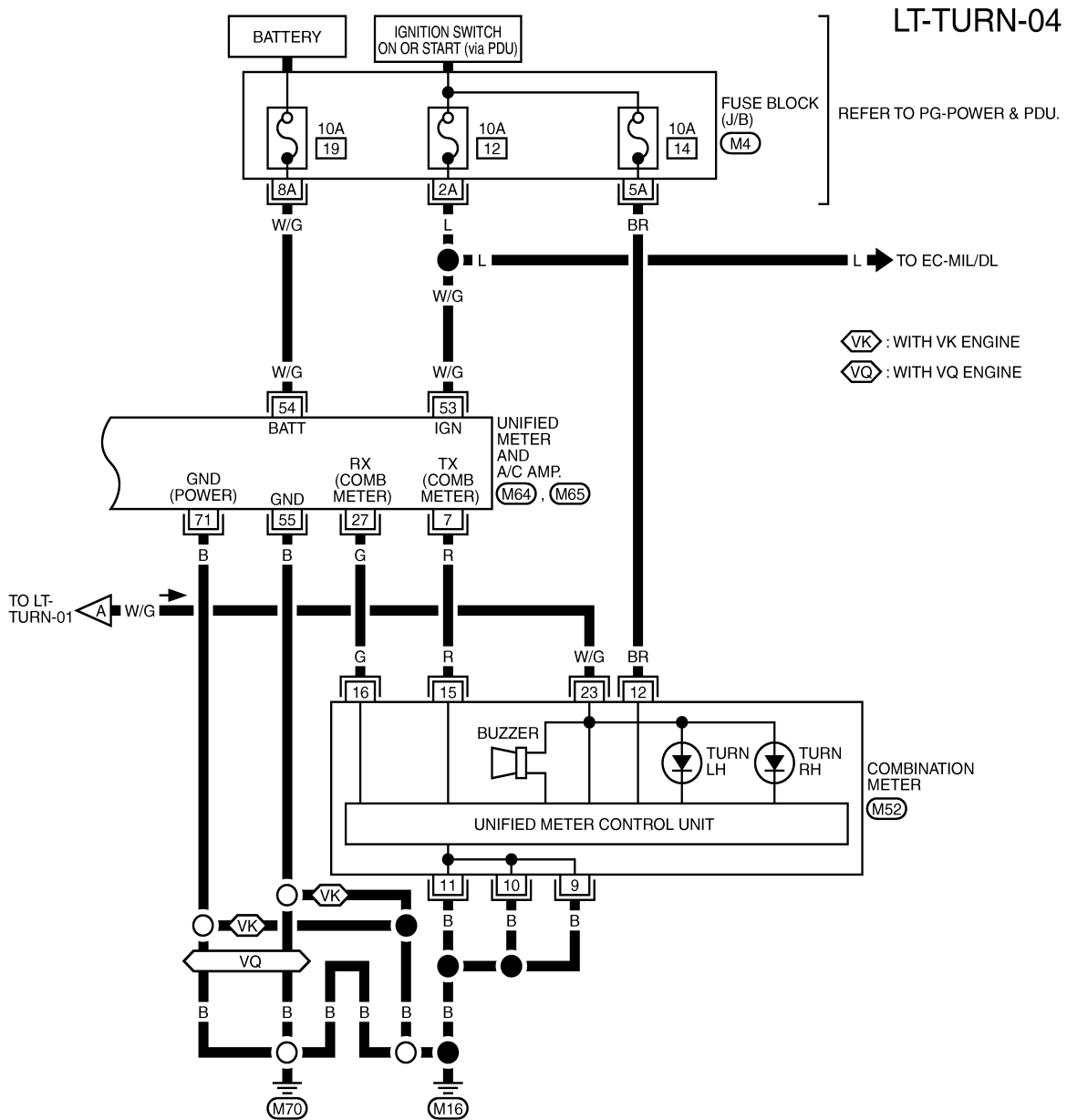

REFER TO THE FOLLOWING.
 (M4) - FUSE BLOCK - JUNCTION BOX (J/B)

TKWT6828E

INFOID:000000002956798

Terminal and Reference Value for BCM

CAUTION:

- Check combination switch system terminal waveform under the loaded condition with lighting switch, turn signal switch and wiper switch OFF not to be fluctuated by overloaded.
- Turn wiper dial position to 4 except when checking waveform or voltage of wiper dial position. Wiper dial position can be confirmed on CONSULT-III. Refer to [LT-201, "CONSULT-III Functions \(BCM - COMB SW\)"](#).

TURN SIGNAL AND HAZARD WARNING LAMPS

< SERVICE INFORMATION >

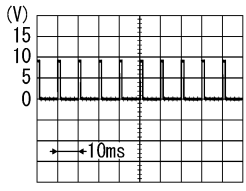
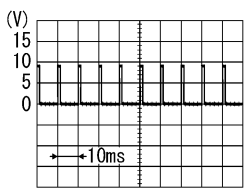
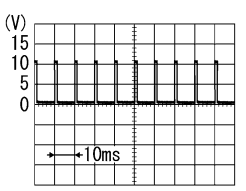
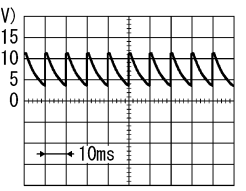
| Terminal No. | Wire color | Signal name | Measuring condition | | Reference value |
|--------------|------------|-----------------------------|---------------------|--|--|
| | | | Ignition switch | Operation or condition | |
| 2 | L/R | Combination switch input 5 | ON | Lighting, turn, wiper switch (Wiper dial position 4) Turn signal switch to right |  <p style="text-align: right; font-size: small;">PKIB4957J</p> <p style="text-align: center;">Approx. 1.0 V</p> |
| | | | | OFF | Approx. 0 V |
| 3 | O/L | Combination switch input 4 | ON | Lighting, turn, wiper switch (Wiper dial position 4) Turn signal switch to left |  <p style="text-align: right; font-size: small;">PKIB4957J</p> <p style="text-align: center;">Approx. 1.0 V</p> |
| | | | | OFF | Approx. 0 V |
| 29 | G/R | Hazard switch signal | OFF | Hazard switch | ON Approx. 0 V |
| | | | | OFF | Battery voltage |
| 36 | V | Combination switch output 1 | ON | Lighting, turn, wiper switch (Wiper dial position 4) Any of several conditions below • Turn signal switch to right • Turn signal switch to left |  <p style="text-align: right; font-size: small;">PKIB4958J</p> <p style="text-align: center;">Approx. 1.2 V</p> |
| | | | | OFF |  <p style="text-align: right; font-size: small;">PKIB4960J</p> <p style="text-align: center;">Approx. 7.0 - 7.5 V</p> |
| 38 | W | Ignition switch (ON) | ON | — | Battery voltage |
| 39 | L | CAN - H | — | — | — |
| 40 | P | CAN - L | — | — | — |
| 42 | P | Battery power supply | OFF | — | Battery voltage |

A
B
C
D
E
F
G
H
I
J
LT
L
M
N
O
P

TURN SIGNAL AND HAZARD WARNING LAMPS

< SERVICE INFORMATION >

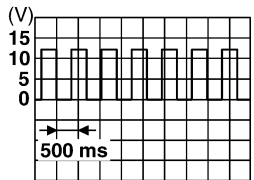
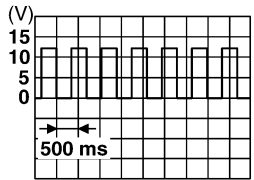
| Terminal No. | Wire color | Signal name | Measuring condition | | Reference value |
|--------------|------------|------------------------|---------------------|------------------------|---|
| | | | Ignition switch | Operation or condition | |
| 45 | G | Flasher output (Left) | ON | Turn signal switch |  <p style="text-align: right; font-size: small;">SKIA3009J</p> |
| | | | | OFF | Approx. 0 V |
| 46 | L | Flasher output (Right) | ON | Turn signal switch |  <p style="text-align: right; font-size: small;">SKIA3009J</p> |
| | | | | OFF | Approx. 0 V |
| 52 | B | Ground | ON | — | Approx. 0 V |
| 55 | W | Battery power supply | OFF | — | Battery voltage |

How to Perform Trouble Diagnosis

INFOID:000000002956799

1. Confirm the symptom or customer complaint.
2. Understand operation description and function description. Refer to [LT-179, "System Description"](#).
3. Perform the Preliminary Check. Refer to [LT-188, "Preliminary Check"](#).
4. Check symptom and repair or replace the cause of malfunction.
5. Do turn signal and hazard warning lamps operate normally? If YES, GO TO 6. If NO, GO TO 4.
6. INSPECTION END

Preliminary Check

INFOID:000000002956800

CHECK POWER SUPPLY AND GROUND CIRCUIT

1. CHECK FUSES AND FUSIBLE LINK

Check for blown fuses and fusible link.

| Unit | Power source | Fuse and fusible link No. |
|----------------------------|--------------------------------------|---------------------------|
| BCM | Battery | F |
| | Ignition switch ON or START position | 21 |
| Combination meter | Battery | 21 |
| | Ignition switch ON or START position | 14 |
| Unified meter and A/C amp. | Battery | 19 |
| | Ignition switch ON or START position | 12 |

Refer to [LT-183, "Wiring Diagram - TURN -"](#).

OK or NG

OK >> GO TO 2.

NG >> If fuse or fusible link is blown, be sure to eliminate cause of malfunction before installing new fuse or fusible link. Refer to [PG-4](#).

TURN SIGNAL AND HAZARD WARNING LAMPS

< SERVICE INFORMATION >

2. CHECK POWER SUPPLY CIRCUIT

1. Turn ignition switch OFF.
2. Disconnect BCM connector.
3. Check voltage between BCM harness connector and ground.

| Terminal (+) | | Terminal (-) | Ignition switch position | |
|---------------|----------|--------------|--------------------------|-----------------|
| BCM connector | Terminal | | OFF | ON |
| M1 | 38 | Ground | Approx. 0 V | Battery voltage |
| M2 | 42 | | Battery voltage | Battery voltage |
| | 55 | | Battery voltage | Battery voltage |

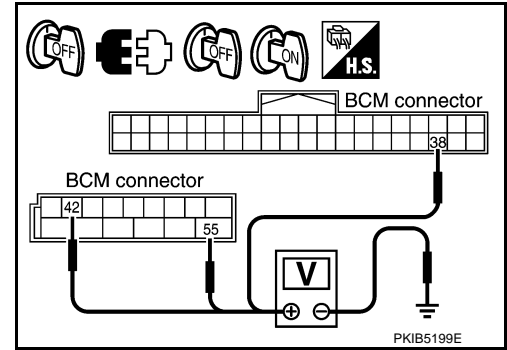

OK or NG

- OK >> GO TO 3.
 NG >> Repair harness or connector.

3. CHECK GROUND CIRCUIT

Check continuity between BCM harness connector and ground.

| BCM connector | Terminal | Ground | Continuity |
|---------------|----------|--------|------------|
| M2 | 52 | | Yes |

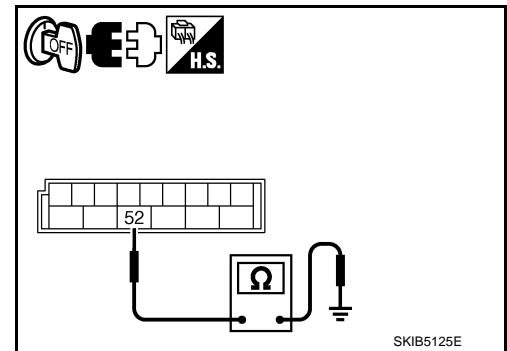

OK or NG

- OK >> INSPECTION END
 NG >> Repair harness or connector.

CONSULT-III Functions (BCM - FLASHER)

INFOID:000000002956801

CONSULT-III can display each diagnostic item using the diagnostic test mode shown following.

| Diagnosis mode | Description |
|----------------|---|
| DATA MONITOR | Displays BCM input data in real time. |
| ACTIVE TEST | Operation of electrical loads can be checked by sending driving signal to them. |

DATA MONITOR

Display Item List

| Monitor item | Contents |
|---------------|---|
| IGN ON SW | "On/Off" Displays "IGN position (ON)/OFF, ACC position (OFF)" judged from the ignition switch signal. |
| HAZARD SW | "On/Off" Displays "hazard ON (ON)/hazard OFF (OFF)" status, determined from hazard switch signal. |
| TURN SIGNAL R | "On/Off" Displays "turn right (ON)/other (OFF)" status, determined from lighting switch signal. |
| TURN SIGNAL L | "On/Off" Displays "turn left (ON)/other (OFF)" status, determined from lighting switch signal. |

ACTIVE TEST

Display Item List

| Test item | Description |
|-----------------|--|
| FLASHER (RIGHT) | Turn signal lamp (right) can be operated by any ON-OFF operations. |
| FLASHER (LEFT) | Turn signal lamp (left) can be operated by any ON-OFF operations. |

TURN SIGNAL AND HAZARD WARNING LAMPS

< SERVICE INFORMATION >

Turn Signal Lamp Does Not Operate

INFOID:00000002956802

1. CHECK BULB

Check bulb standard of each turn signal lamp is correct.

OK or NG

- OK >> GO TO 2.
- NG >> Replace turn signal lamp bulb.

2. CHECK COMBINATION SWITCH INPUT SIGNAL

CONSULT-III DATA MONITOR

1. Select "TURN SIGNAL R" and "TURN SIGNAL L" of BCM (FLASHER) data monitor item.
2. With operating the lighting switch, check the monitor status.

**When lighting switch is : TURN SIGNAL R On
TURN RH position**

**When lighting switch is : TURN SIGNAL L On
TURN LH position**

CHECK THE COMBINATION SWITCH

Refer to [LT-202, "Combination Switch Inspection"](#).

OK or NG

- OK >> GO TO 3.
- NG >> Check combination switch (lighting switch). Refer to [LT-202, "Combination Switch Inspection"](#).

3. ACTIVE TEST

CONSULT-III ACTIVE TEST

1. Select "FLASHER" of BCM (FLASHER) active test item.
2. With operating the test item, check the turn signal lamps operation.

Turn signal lamp should operate.

CHECK TURN SIGNAL LAMP CIRCUIT

GO TO 4.

OK or NG

- OK >> Replace BCM. Refer to [BCS-14, "Removal and Installation of BCM"](#).
- NG >> GO TO 4.

4. CHECK TURN SIGNAL LAMP CIRCUIT

1. Turn ignition switch OFF.
2. Disconnect BCM connector, front combination lamp RH and LH connector, side turn signal lamp RH and LH connector, rear combination lamp RH and LH connector.
3. Check continuity between BCM harness connector (A) and front combination lamp (RH and LH) harness connector (B).

| Circuit | A | | B | | Continuity |
|---------|-----------|----------|-----------|----------|------------|
| | Connector | Terminal | Connector | Terminal | |
| LH | M2 | 45 | E55 | 10 | Yes |
| RH | | 46 | E49 | 10 | |

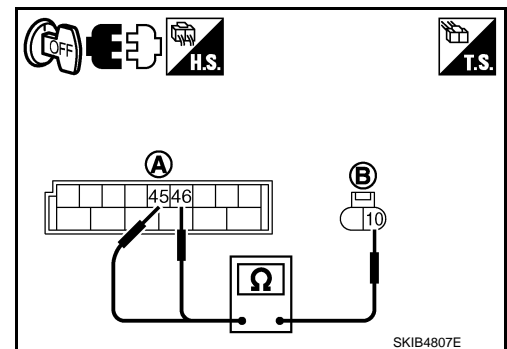

4. Check continuity between BCM harness connector (A) and side turn signal lamp (RH and LH) harness connector (B).

TURN SIGNAL AND HAZARD WARNING LAMPS

< SERVICE INFORMATION >

| Circuit | A | | B | | Continuity |
|---------|-----------|----------|-----------|----------|------------|
| | Connector | Terminal | Connector | Terminal | |
| LH | M2 | 45 | E68 | 1 | Yes |
| RH | | 46 | E28 | 1 | |

5. Check continuity between BCM harness connector (A) and rear combination lamp (RH and LH) harness connector (B).

| Circuit | A | | B | | Continuity |
|---------|-----------|----------|-----------|----------|------------|
| | Connector | Terminal | Connector | Terminal | |
| LH | M2 | 45 | B135 | 3 | Yes |
| RH | | 46 | B130 | 3 | |

OK or NG

OK >> GO TO 5.

NG >> Repair harness or connector.

5.CHECK SIGNAL LAMP CIRCUIT (SHORT CIRCUIT)

Check continuity between BCM harness connector and ground.

| BCM connector | Terminal | Ground | Continuity |
|---------------|----------|--------|------------|
| M2 | 45 | | No |
| | 46 | No | |

OK or NG

OK >> Replace BCM. Replace BCM if turn signal lamp does not work after setting the connector again. Refer to [BCS-14. "Removal and Installation of BCM"](#).

NG >> Repair harness or connector.

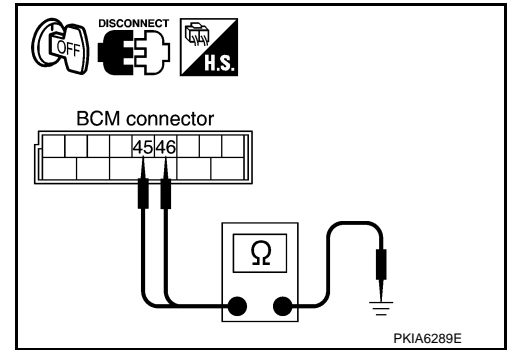
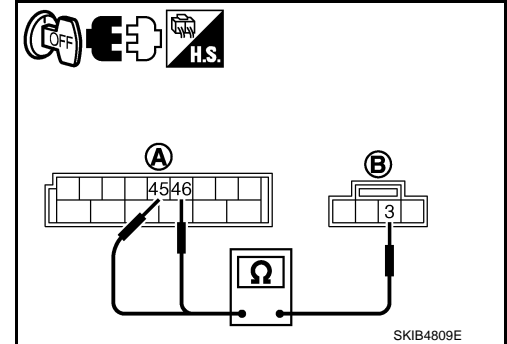

Hazard Warning Lamp Does Not Operate But Turn Signal Lamp Operates

INFOID:000000002956803

1.CHECK CIRCUIT BETWEEN HAZARD SWITCH AND BCM

CONSULT-III DATA MONITOR

1. Select "HAZARD SW" of BCM (FLASHER) data monitor item.
2. With operating the multifunction switch (hazard switch), check the monitor status.

When hazard switch is ON position : HAZARD SW ON

CHECK CIRCUIT BETWEEN HAZARD SWITCH AND BCM

Check voltage between BCM harness connector and ground.

| Terminal | | Condition | Voltage (Approx.) |
|-----------|----------|-----------------------|-------------------|
| (+) | (-) | | |
| Connector | Terminal | | |
| M1 | 29 | Hazard switch is ON. | 0 V |
| | | Hazard switch is OFF. | Battery Voltage |

OK or NG

OK >> Replace BCM. Refer to [BCS-14. "Removal and Installation of BCM"](#).

NG >> GO TO 2.

2.CHECK HAZARD SWITCH BCM CIRCUIT

1. Turn ignition switch OFF.

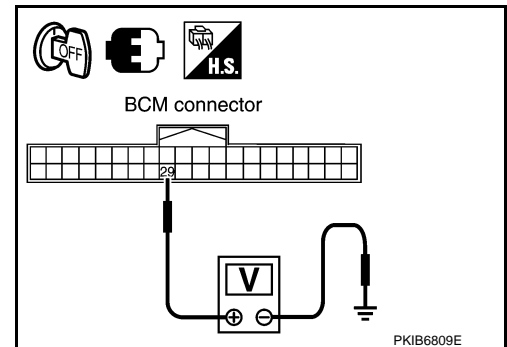

TURN SIGNAL AND HAZARD WARNING LAMPS

< SERVICE INFORMATION >

- Disconnect BCM connector and multifunction switch connector.
- Check continuity between BCM harness connector (A) and multifunction switch harness connector (B).

| A | | B | | Continuity |
|-----------|----------|-----------|----------|------------|
| Connector | Terminal | Connector | Terminal | |
| M1 | 29 | M69 | 6 | Yes |

OK or NG

- OK >> GO TO 3.
 NG >> Repair harness or connector.

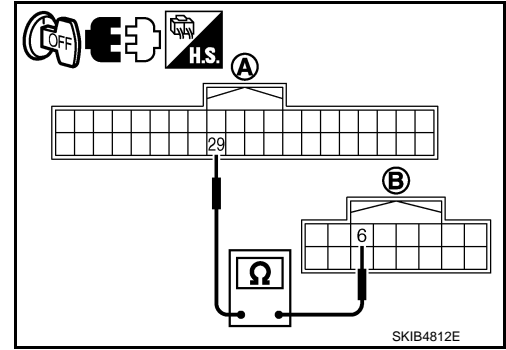

3.CHECK HAZARD SWITCH GROUND CIRCUIT

Check continuity between multifunction switch harness connector and ground.

| Multifunction switch connector | Terminal | Ground | Continuity |
|--------------------------------|----------|--------|------------|
| M69 | 14 | | Yes |

OK or NG

- OK >> GO TO 4.
 NG >> Repair harness or connector.

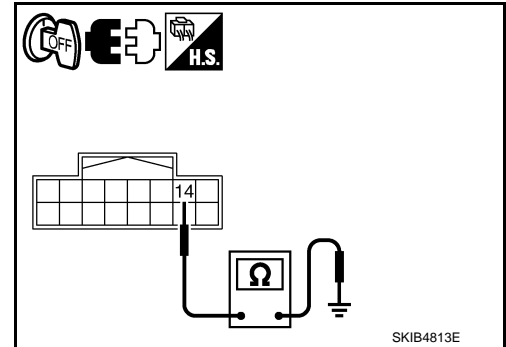

4.CHECK HAZARD SWITCH

Check continuity multifunction switch (hazard switch).

| Multifunction switch (Hazard switch) | | Condition | Continuity |
|--------------------------------------|----|-----------------------|------------|
| Terminal | | | |
| 6 | 14 | Hazard switch is ON. | Yes |
| | | Hazard switch is OFF. | No |

OK or NG

- OK >> Replace BCM. Replace BCM if turn signal lamp does not work after setting the connector again. Refer to [BCS-14, "Removal and Installation of BCM"](#).
 NG >> Replace multifunction switch. Refer to [AV-1077, "Exploded View"](#).

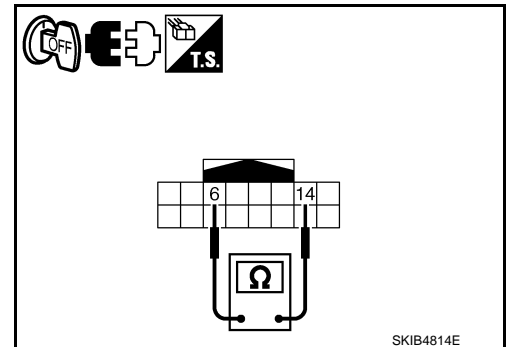

Turn Signal Indicator Lamp Does Not Operate

INFOID:000000002956804

1.CHECK UNIFIED METER AND A/C AMP.

CONSULT-III SELF-DIAGNOSIS

- Perform self-diagnosis for "METER A/C AMP" on CONSULT-III.
- Check if malfunction is indicated.

Is malfunction indicated?

- YES >> Repair or replace malfunctioning parts.
 NO >> GO TO 2.

2.CHECK CIRCUIT BETWEEN COMBINATION SWITCH AND BCM

CONSULT-III DATA MONITOR

- Select "TURN IND" of METER A/C AMP data monitor item.
- With operating the turn signal switch, check the monitor status.

**When turn signal switch is in : TURN IND ON
 the RH or LH position**

TURN SIGNAL AND HAZARD WARNING LAMPS

< SERVICE INFORMATION >

OK or NG

- OK >> Replace combination meter. Refer to [DI-25, "Removal and Installation of Combination Meter"](#).
NG >> Replace unified meter and A/C amp. Refer to [DI-33, "Removal and Installation of Unified Meter and A/C Amp"](#).

Bulb Replacement (Front Turn Signal Lamp)

INFOID:000000002956806

Refer to [LT-31, "Bulb Replacement"](#) in "HEADLAMP -CONVENTIONAL TYPE-".

Refer to [LT-59, "Bulb Replacement"](#) in "HEADLAMP -XENON TYPE-".

Bulb Replacement (Side Turn Signal Lamp)

INFOID:000000002956805

Bulb Replacement

Replace the side turn signal lamp as an assembly because it cannot be disassembled.

Bulb Replacement (Rear Turn Signal Lamp)

INFOID:000000002956807

Refer to [LT-227, "Bulb Replacement"](#).

Removal and Installation of Front Turn Signal Lamp

INFOID:000000002956808

Refer to [LT-32, "Removal and Installation"](#) in "HEADLAMP -CONVENTIONAL TYPE-".

Refer to [LT-61, "Removal and Installation"](#) in "HEADLAMP -XENON TYPE-".

Removal and Installation of Side Turn Signal Lamp

INFOID:000000002987600

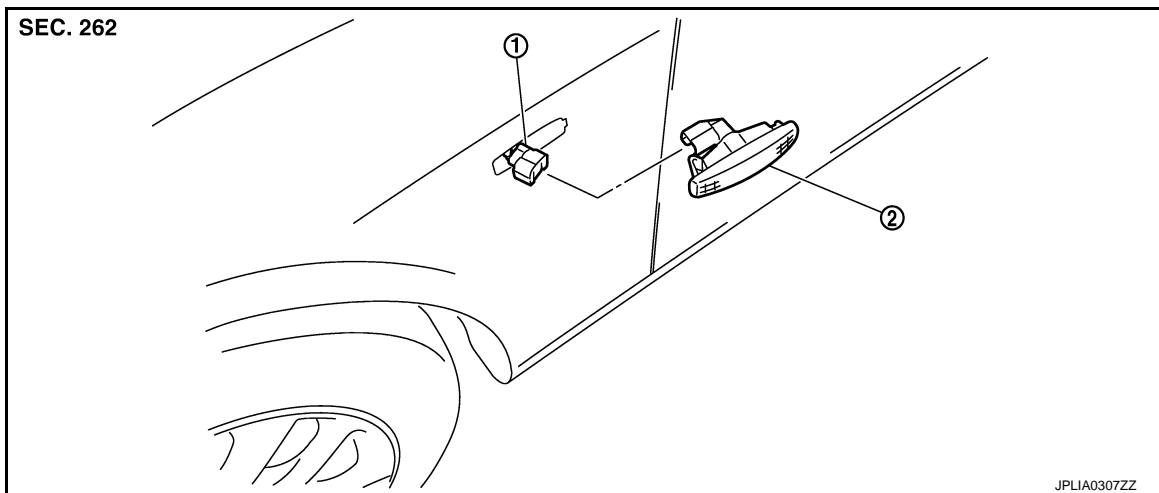

1. Side turn signal lamp connector 2. Side turn signal lamp

NOTE:

Replace as an assembly because it cannot be disassembled.

CAUTION:

Disconnect battery negative terminal or remove the fuse.

REMOVAL

1. Remove the side turn signal lamp in numerical order shown in the figure.

← : Vehicle front (side turn signal lamp LH)
: Vehicle rear (side turn signal lamp RH)

2. Disconnect side turn signal lamp connector.

NOTE:

Support the vehicle-side harness of the side turn signal lamp with tape so that it does not drop inside the front fender.

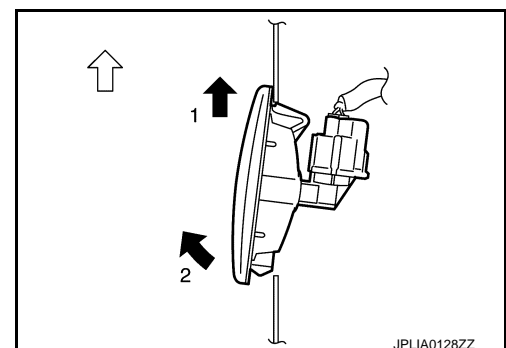

TURN SIGNAL AND HAZARD WARNING LAMPS

< SERVICE INFORMATION >

INSTALLATION

1. Connect the connector.
2. Fix the pawl-side behind the side turn signal lamp housing first, then push the resin clip-side.

Removal and Installation of Rear Turn Signal Lamp

INFOID:000000002956809

Refer to [LT-227, "Removal and Installation"](#).

LIGHTING AND TURN SIGNAL SWITCH

< SERVICE INFORMATION >

LIGHTING AND TURN SIGNAL SWITCH

Removal and Installation

INFOID:000000002956810

REMOVAL

1. Remove steering column lower cover. Refer to [IP-11](#).
2. While pressing pawls (A) in direction as shown in the figure, pull lighting and turn signal switch (1) toward driver door and disconnect from the base.

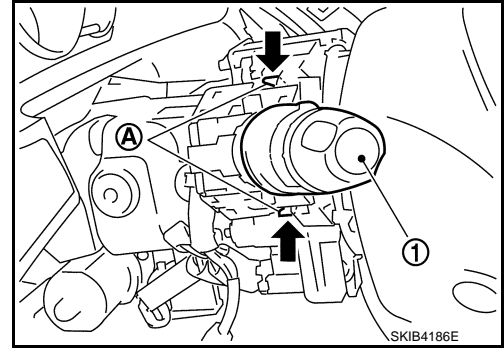

INSTALLATION

Installation is the reverse order of removal.

Switch Circuit Inspection

INFOID:000000002956811

Refer to [LT-202, "Combination Switch Inspection"](#).

A
B
C
D
E
F
G
H
I
J
LT
L
M
N
O
P

HAZARD SWITCH

< SERVICE INFORMATION >

HAZARD SWITCH

Removal and Installation

INFOID:000000002956812

REMOVAL

The hazard warning switch is integrated in the multifunction switch. Refer to [AV-1077, "Exploded View"](#).

COMBINATION SWITCH

< SERVICE INFORMATION >

COMBINATION SWITCH

Wiring Diagram - COMB SW -

INFOID:000000002956813

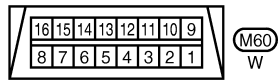
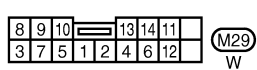
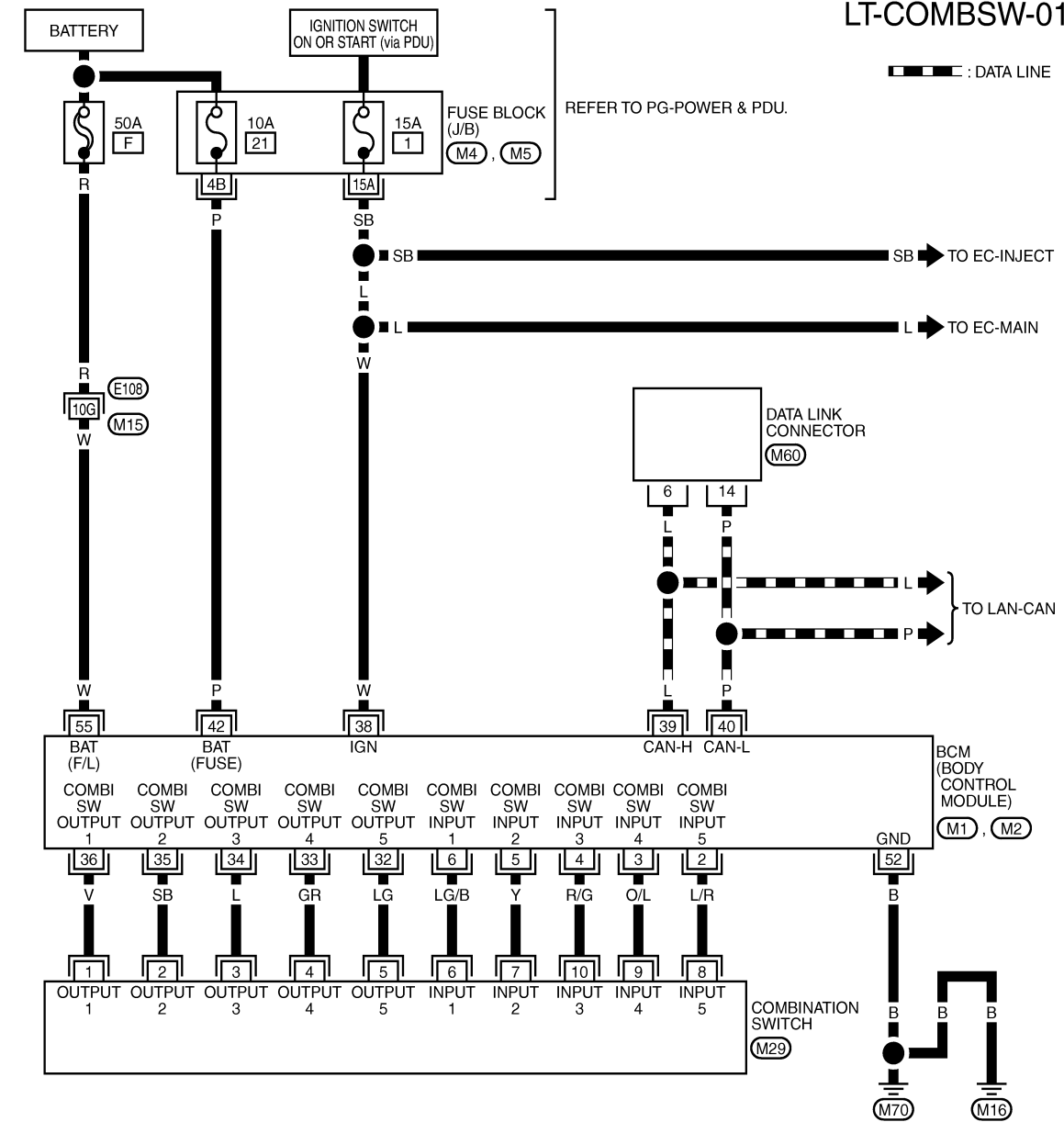

REFER TO THE FOLLOWING.

- (E108) - SUPER MULTIPLE JUNCTION (SMJ)
- (M4), (M5) - FUSE BLOCK-JUNCTION BOX (J/B)
- (M1), (M2) - ELECTRICAL UNITS

TKWT6829E

Combination Switch Reading Function

For details, refer to [BCS-4, "System Description"](#).

INFOID:000000002956814

COMBINATION SWITCH

< SERVICE INFORMATION >

Terminal and Reference Value for BCM

INFOID:000000002956815

CAUTION:

- Check combination switch system terminal waveform under the loaded condition with lighting switch, turn signal switch and wiper switch OFF not to be fluctuated by overloaded.
- Turn wiper dial position to 4 except when checking waveform or voltage of wiper dial position. Wiper dial position can be confirmed on CONSULT-III. Refer to [LT-201, "CONSULT-III Functions \(BCM - COMB SW\)"](#).

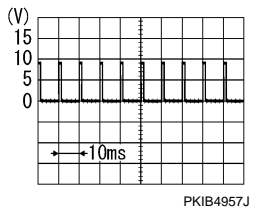
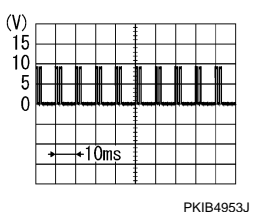
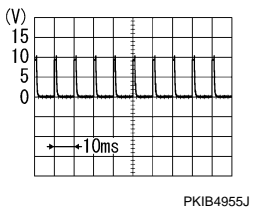
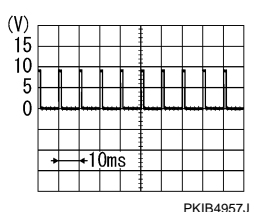
| Terminal No. | Wire color | Signal name | Measuring condition | | Reference value | |
|--------------|------------|----------------------------|---------------------|---|---|--|
| | | | Ignition switch | Operation or condition | | |
| 2 | L/R | Combination switch input 5 | ON | Lighting, turn, wiper switch (Wiper dial position 4) | Any of several conditions below <ul style="list-style-type: none"> • Lighting switch 1ST • Turn signal switch to right • Lighting switch HI beam (Operates only HI beam switch)  | |
| | | | | | Lighting switch 2ND |  |
| | | | | | OFF | Approx. 0 V |
| 3 | O/L | Combination switch input 4 | ON | Lighting, turn, wiper switch (Wiper dial position 4) | Front fog lamp switch ON  | |
| | | | | | Any of several conditions below <ul style="list-style-type: none"> • Lighting switch 2ND • Lighting switch PASSING (Operates only PASSING switch) • Turn signal switch to left  | |
| | | | | | OFF | Approx. 0 V |

COMBINATION SWITCH

< SERVICE INFORMATION >

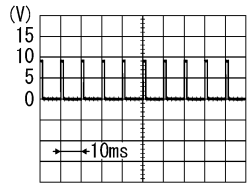
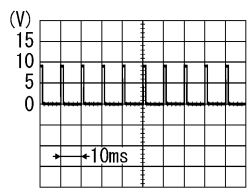
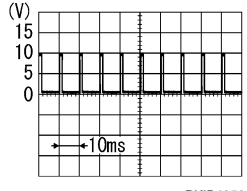
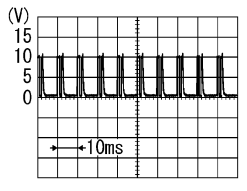
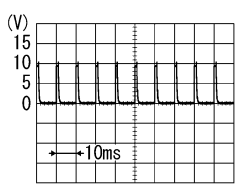
| Terminal No. | Wire color | Signal name | Measuring condition | | Reference value | |
|--------------|------------|----------------------------|---------------------|--|--|--|
| | | | Ignition switch | Operation or condition | | |
| 4 | R/G | Combination switch input 3 | ON | Lighting, turn, wiper switch (Wiper dial position 4) | Any of several conditions below <ul style="list-style-type: none"> • Lighting switch AUTO • Front wiper switch MIST • Front wiper switch INT • Front wiper switch LO |  <p style="text-align: center;">Approx. 1.0 V</p> |
| | | | | OFF | Approx. 0 V | |
| 5 | Y | Combination switch input 2 | ON | Lighting, turn, wiper switch | Any of several conditions below <ul style="list-style-type: none"> • Front washer switch (Wiper dial position 4) • Wiper dial position 1 • Wiper dial position 5 • Wiper dial position 6 |  <p style="text-align: center;">Approx. 1.0 V</p> |
| | | | | OFF (Wiper dial position 4) | Approx. 0 V | |
| 6 | LG/B | Combination switch input 1 | ON | Lighting, turn, wiper switch | Any of several conditions below <ul style="list-style-type: none"> • Front wiper switch HI (Wiper dial position 4) • Wiper dial position 3 |  <p style="text-align: center;">Approx. 1.0 V</p> |
| | | | | | Any of several conditions below <ul style="list-style-type: none"> • Wiper dial position 1 • Wiper dial position 2 |  <p style="text-align: center;">Approx. 1.7 V</p> |
| | | | | Any of several conditions below <ul style="list-style-type: none"> • Wiper dial position 6 • Wiper dial position 7 |  <p style="text-align: center;">Approx. 0.8 V</p> | |
| | | | | OFF (Wiper dial position 4) | Approx. 0 V | |

A
B
C
D
E
F
G
H
I
J
LT
L
M
N
O
P

COMBINATION SWITCH

< SERVICE INFORMATION >

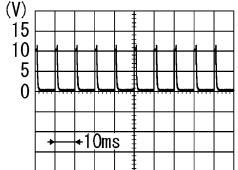
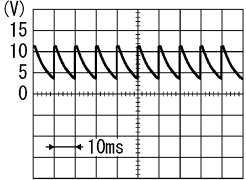
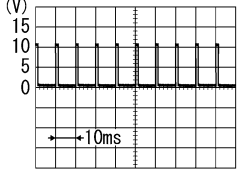
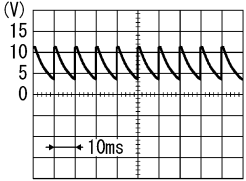
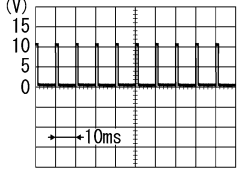
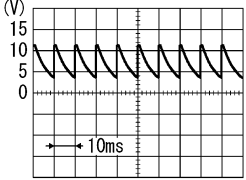
| Terminal No. | Wire color | Signal name | Measuring condition | | Reference value | |
|--------------|------------|-----------------------------|---------------------|--------------------------------|---|--|
| | | | Ignition switch | Operation or condition | | |
| 32 | LG | Combination switch output 5 | ON | Lighting, turn, wiper switch | Any of several conditions below <ul style="list-style-type: none"> • Front fog lamp switch (Operates only front fog lamp switch) (Wiper dial position 4) • Wiper dial position 1 • Wiper dial position 2 • Wiper dial position 6 • Wiper dial position 7 |  <p style="text-align: right; font-size: small;">PKIB4956J</p> <p style="text-align: center;">Approx. 1.0 V</p> |
| | | | | OFF (Wiper dial position 4) |  <p style="text-align: right; font-size: small;">PKIB4960J</p> <p style="text-align: center;">Approx. 7.0 - 7.5 V</p> | |
| 33 | GR | Combination switch output 4 | ON | Lighting, turn, wiper switch | Any of several conditions below <ul style="list-style-type: none"> • Lighting switch AUTO (Wiper dial position 4) • Lighting switch 1ST (The same result with lighting switch 2ND) (Wiper dial position 4) • Wiper dial position 1 • Wiper dial position 5 • Wiper dial position 6 |  <p style="text-align: right; font-size: small;">PKIB4958J</p> <p style="text-align: center;">Approx. 1.2 V</p> |
| | | | | OFF (Wiper dial position 4) |  <p style="text-align: right; font-size: small;">PKIB4960J</p> <p style="text-align: center;">Approx. 7.0 - 7.5 V</p> | |
| 34 | L | Combination switch output 3 | ON | Lighting, turn, wiper switch | Any of several conditions below <ul style="list-style-type: none"> • Lighting switch 2ND (Wiper dial position 4) • Lighting switch HI beam (Operates only HI beam switch) (Wiper dial position 4) • Wiper dial position 1 • Wiper dial position 2 • Wiper dial position 3 |  <p style="text-align: right; font-size: small;">PKIB4958J</p> <p style="text-align: center;">Approx. 1.2 V</p> |
| | | | | OFF (Wiper dial position 4) |  <p style="text-align: right; font-size: small;">PKIB4960J</p> <p style="text-align: center;">Approx. 7.0 - 7.5 V</p> | |

COMBINATION SWITCH

< SERVICE INFORMATION >

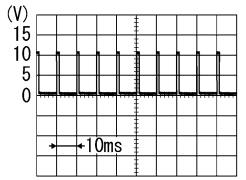
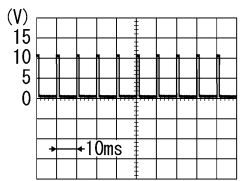
| Terminal No. | Wire color | Signal name | Measuring condition | | Reference value |
|--------------|------------|-----------------------------|---------------------|--|---|
| | | | Ignition switch | Operation or condition | |
| 35 | SB | Combination switch output 2 | ON | Lighting, turn, wiper switch (Wiper dial position 4) | Any of several conditions below <ul style="list-style-type: none"> • Lighting switch 2ND • Lighting switch PASSING (Operates only PASSING switch) • Front wiper switch INT • Front wiper switch HI  |
| | | | | | OFF |
| 36 | V | Combination switch output 1 | ON | Lighting, turn, wiper switch (Wiper dial position 4) | Any of several conditions below <ul style="list-style-type: none"> • Turn signal switch right • Turn signal switch left • Front wiper switch MIST • Front wiper switch LO • Front washer switch  |
| | | | | | OFF (Wiper dial position 4) |
| 38 | W | Ignition switch (ON) | ON | — | Battery voltage |
| 39 | L | CAN - H | — | — | — |
| 40 | P | CAN - L | — | — | — |
| 42 | P | Battery power supply | OFF | — | Battery voltage |
| 52 | B | Ground | ON | — | Approx. 0 V |
| 55 | W | Battery power supply | OFF | — | Battery voltage |

CONSULT-III Functions (BCM - COMB SW)

INFOID:000000002956816

CONSULT-III can display each diagnostic item using the diagnostic test mode shown following.

| Diagnosis mode | Description |
|----------------|---------------------------------------|
| DATA MONITOR | Displays BCM input data in real time. |

DATA MONITOR

Display Item List

COMBINATION SWITCH

< SERVICE INFORMATION >

| Monitor item name | Contents |
|-------------------------|--|
| TURN SIGNAL R "On/Off" | Displays "turn right (ON)/other (OFF)" status, determined from lighting switch signal. |
| TURN SIGNAL L "On/Off" | Displays "turn left (ON)/other (OFF)" status, determined from lighting switch signal. |
| HI BEAM SW "On/Off" | Displays status (high beam switch: ON/others: OFF) of high beam switch judged from lighting switch signal. |
| HEAD LAMP SW 1 "On/Off" | Displays status (headlamp switch 1: ON/others: OFF) of headlamp switch 1 judged from lighting switch signal. |
| HEAD LAMP SW 2 "On/Off" | Displays status (headlamp switch 2: ON/others: OFF) of headlamp switch 2 judged from lighting switch signal. |
| TAIL LAMP SW "On/Off" | Displays status (lighting switch 1ST or 2ND position: ON/others: OFF) of lighting switch judged from lighting switch signal. |
| PASSING SW "On/Off" | Displays status (flash-to-pass switch: ON/others: OFF) of flash-to-pass switch judged from lighting switch signal. |
| AUTO LIGHT SW "On/Off" | Displays "auto light switch (ON)/other (OFF)" status, determined from lighting switch signal. |
| FR FOG SW "On/Off" | Displays "front fog lamp switch (ON)/other (OFF)" status, determined from lighting switch signal. |
| FR WIPER HI "On/Off" | Displays "front wiper HI (ON)/other (OFF)" status, determined from wiper switch signal. |
| FR WIPER LOW "On/Off" | Displays "front wiper LOW (ON)/other (OFF)" status, determined from wiper switch signal. |
| FR WIPER INT "On/Off" | Displays "front wiper INT (ON)/other (OFF)" status, determined from wiper switch signal. |
| FR WASHER SW "On/Off" | Displays "front washer switch (ON)/other (OFF)" status, determined from wiper switch signal. |
| INT VOLUME "1 - 7" | Displays intermittent operation knob setting (1 - 7), determined from wiper switch signal. |

Combination Switch Inspection

INFOID:000000002956817

1.SYSTEM CHECK

Referring to table below, check the system to which malfunctioning switch belongs.

| System 1 | System 2 | System 3 | System 4 | System 5 |
|--------------|--------------|--------------|------------|--------------|
| — | FR WASHER | FR WIPER LO | TURN LH | TURN RH |
| FR WIPER HI | — | FR WIPER INT | PASSING | HEAD LAMP1 |
| INT VOLUME 1 | — | — | HEAD LAMP2 | HI BEAM |
| — | INT VOLUME 3 | AUTO LIGHT | — | LIGHT SW 1ST |
| INT VOLUME 2 | — | — | FR FOG | — |

>> Check the system to which malfunctioning switch belongs, and then GO TO 2.

2.SYSTEM CHECK

ⓐCONSULT-III DATA MONITOR

- Select COMB SW data monitor item.
- Confirm that other switches in malfunctioning system operate normally.
Example: When the HI BEAM switch is malfunctioning, confirm that "TURN RH", "HEAD LAMP 1" and "TAIL LAMP SW" in System 5, to which the HI BEAM switch belongs, turn ON-OFF normally.

ⓧSYSTEM CHECK

Operating combination switch, and confirm that other switches in malfunctioning system operate normally.
Example: When the HI BEAM switch is malfunctioning, confirm that "TURN RH", "HEAD LAMP 1" and "TAIL LAMP SW" in System 5, to which HI BEAM switch belongs, turn ON-OFF normally.

Check results

Other switches in malfunctioning system operate normally.>>Replace lighting switch or wiper switch.

Other switches in malfunctioning system do not operate normally.>>GO TO 3.

3.CHECK HARNESS

- Turn ignition switch OFF.

COMBINATION SWITCH

< SERVICE INFORMATION >

2. Disconnect BCM and combination switch connectors.
3. Check for continuity between BCM harness connector (A) of the suspect system and the corresponding combination switch connector (B).

| Suspect system | A | | B | | Continuity |
|----------------|-----------|----------|-----------|----------|------------|
| | Connector | Terminal | Connector | Terminal | |
| 1 | M1 | Input 1 | 6 | M29 | 6 |
| | | Output 1 | 36 | | 1 |
| 2 | | Input 2 | 5 | | 7 |
| | | Output 2 | 35 | | 2 |
| 3 | | Input 3 | 4 | | 10 |
| | | Output 3 | 34 | | 3 |
| 4 | | Input 4 | 3 | | 9 |
| | | Output 4 | 33 | | 4 |
| 5 | | Input 5 | 2 | | 8 |
| | | Output 5 | 32 | | 5 |

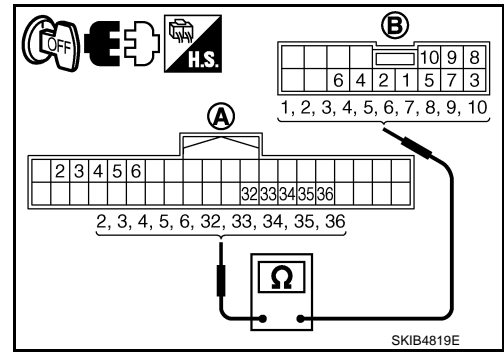

4. Check for continuity between each of BCM harness connector in suspect malfunctioning system and ground.

| Suspect system | BCM connector | Terminal | | Continuity |
|----------------|---------------|----------|----------|------------|
| 1 | M1 | Input 1 | 6 | |
| 2 | | Output 1 | 36 | |
| | | Input 2 | 5 | |
| 3 | | Output 2 | 35 | |
| | | Input 3 | 4 | |
| 4 | | Output 3 | 34 | |
| | | Input 4 | 3 | |
| 5 | | Output 4 | 33 | |
| | | Input 5 | 2 | |
| | | | Output 5 | 32 |

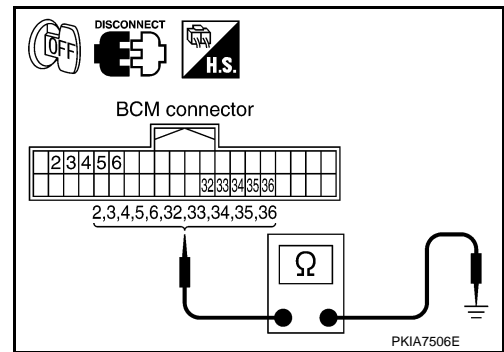

OK or NG

- OK >> GO TO 4.
- NG >> Check harness between BCM and combination switch for open or short circuit.

4. CHECK BCM OUTPUT TERMINAL

1. Connect BCM and combination switch connectors.
2. Turn ignition switch ON.
3. Turn lighting switch and wiper switch into OFF.
4. Set wiper dial position 4.
5. Check BCM output terminal voltage waveform of suspect malfunctioning system.

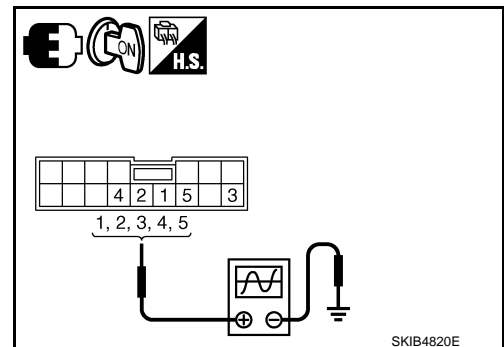

COMBINATION SWITCH

< SERVICE INFORMATION >

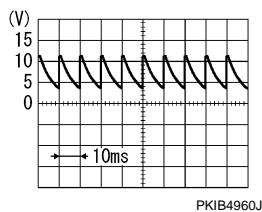
| Suspect system | Terminal (+) | | Terminal (-) | Reference value |
|----------------|------------------------------|----------|--------------|--|
| | Combination switch connector | Terminal | | |
| | | | | |
| 1 | M29 | 1 | Ground |  <p>PKIB4960J Approx. 7.0 - 7.5 V</p> |
| 2 | | 2 | | |
| 3 | | 3 | | |
| 4 | | 4 | | |
| 5 | | 5 | | |

OK or NG

OK >> Open circuit in combination switch, GO TO 5.

NG >> Replace BCM. Refer to [BCS-14, "Removal and Installation of BCM"](#).

5. CHECK COMBINATION SWITCH

Referring to table below, perform combination switch inspection.

| Procedure | | | | | | | | | |
|-------------------------|-----------------------|----|----------------------|-----------------------|----|---------------------|-----------------------|----|---------------------|
| 1 | 2 | | 3 | 4 | | 5 | 6 | | 7 |
| Replace lighting switch | Confirm check results | OK | INSPECTION END | Confirm check results | OK | INSPECTION END | Confirm check results | OK | INSPECTION END |
| | | NG | Replace wiper switch | | NG | Replace switch base | | NG | Check symptom again |

>> INSPECTION END

Removal and Installation

INFOID:000000002956818

Refer to [LT-195](#).

STOP LAMP

< SERVICE INFORMATION >

LT-STOP/L-02

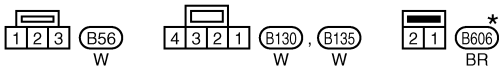
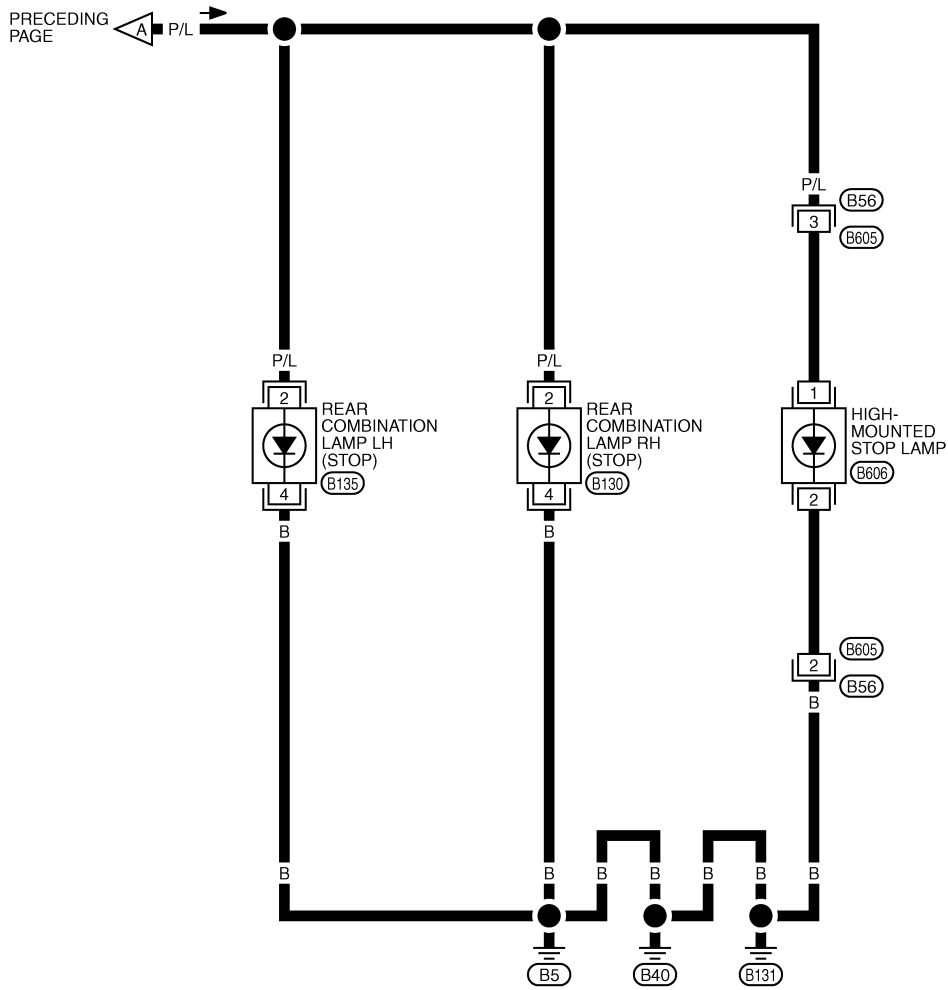

*: THIS CONNECTOR IS NOT SHOWN IN "HARNES LAYOUT", PG SECTION.

TKWT3398E

INFOID:000000002956820

High-Mounted Stop Lamp

BULB REPLACEMENT, REMOVAL AND INSTALLATION

1. Remove rear parcel shelf finisher. Refer to [EI-52](#).
2. Turned over protection sheet and disconnect connector.

STOP LAMP

< SERVICE INFORMATION >

3. Remove screws (A) and remove high-mounted stop lamp (1) from rear parcel shelf finisher.

High-mounted stop lamp : LED

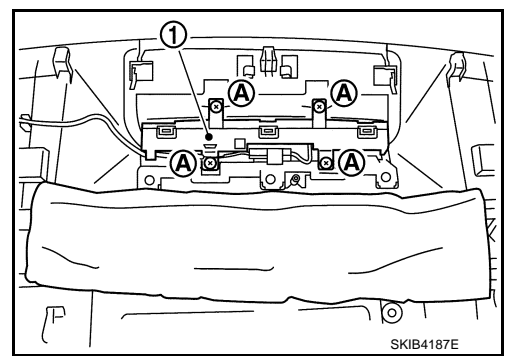

Stop Lamp

BULB REPLACEMENT

Refer to [LT-227, "Bulb Replacement"](#).

REMOVAL AND INSTALLATION

Refer to [LT-227, "Removal and Installation"](#).

INFOID:000000002956821

A
B
C
D
E
F
G
H
I
J
LT
L
M
N
O
P

BACK-UP LAMP

< SERVICE INFORMATION >

BACK-UP LAMP

Wiring Diagram - B/LAMP -

INFOID:000000002956822

LT-BACK/L-01

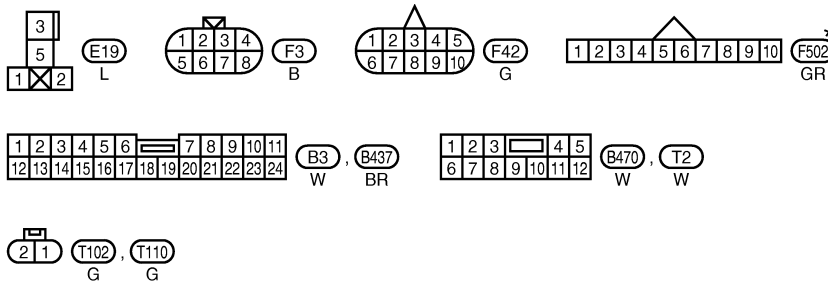
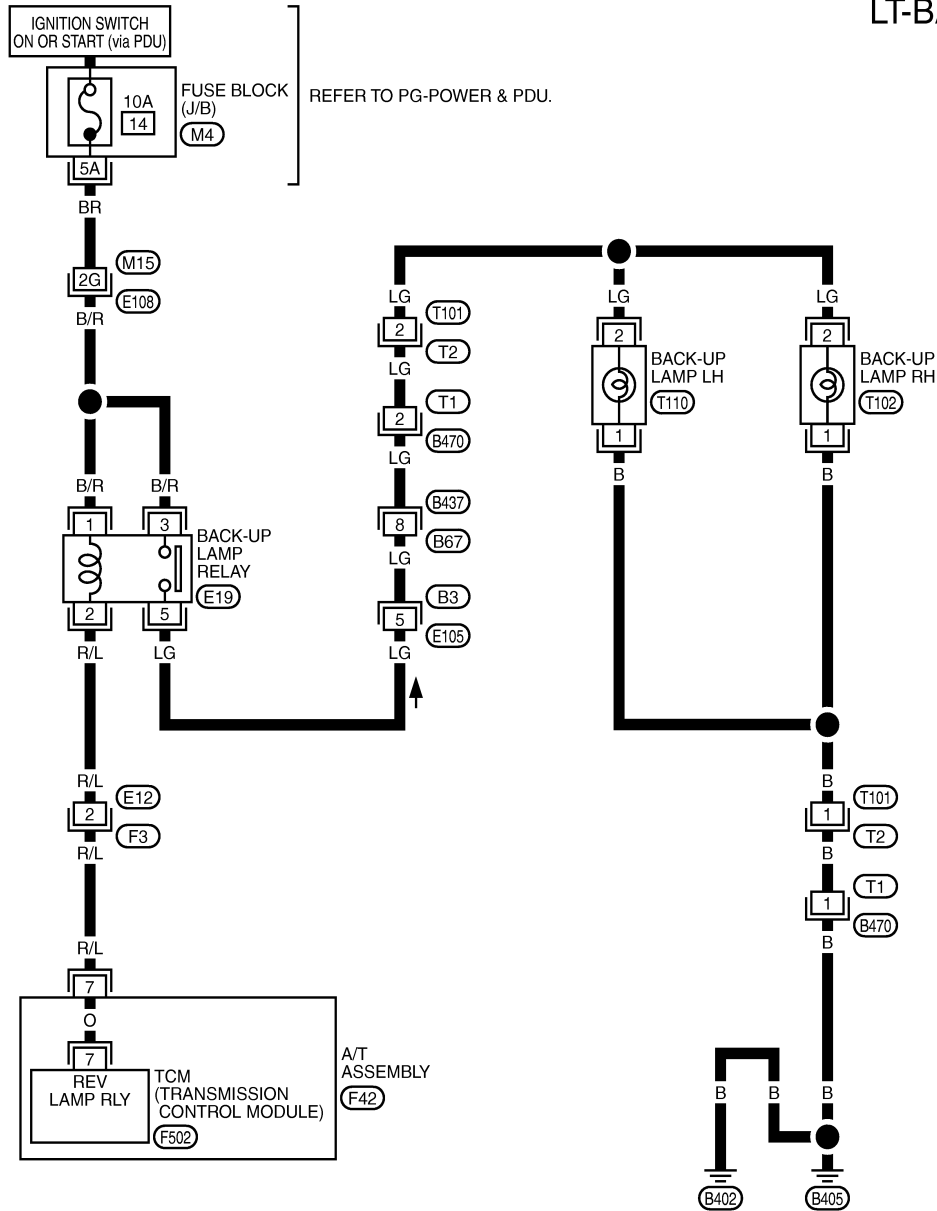

*: THIS CONNECTOR IS NOT SHOWN IN "HARNESS LAYOUT", PG SECTION.

REFER TO THE FOLLOWING.
 (E108) - SUPER MULTIPLE JUNCTION (SMJ)
 (M4) - FUSE BLOCK - JUNCTION BOX (J/B)

TKWT6831E

Bulb Replacement

INFOID:000000002956823

CAUTION:

- Disconnect the battery negative terminal or remove the fuse.

BACK-UP LAMP

< SERVICE INFORMATION >

- Never touch the glass of bulb directly by hand. Keep grease and other oily matters away from it. Never touch bulb by hand while it is lit or right after being turned off.
 - Never leave bulb out of lamp reflector for a long time because dust, moisture smoke, etc. may affect the performance of lamp. When replacing bulb, be sure to replace it with new one.
1. Remove trunk lid finisher inner. Refer to [EI-44](#).
 2. Turn bulb socket (1) counterclockwise and unlock it.
 3. Remove bulb (2) from its socket.

Back-up lamp

: 12V - 16W

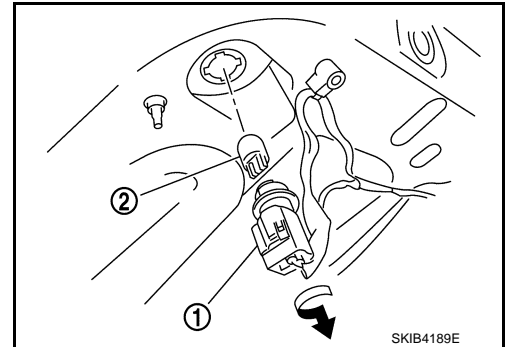

Removal and Installation

INFOID:000000002956824

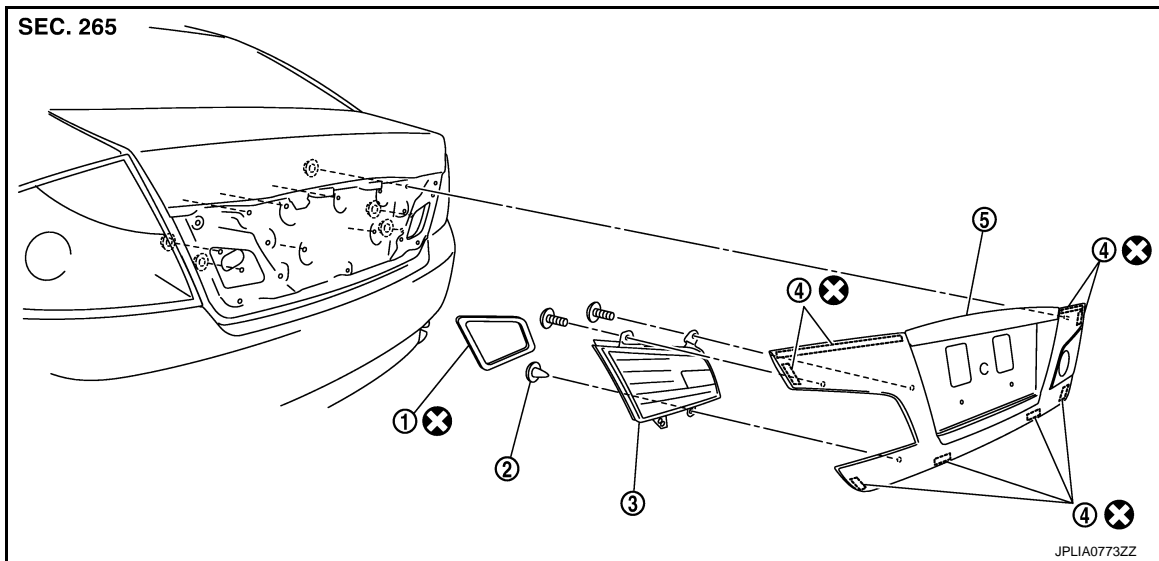

1. Seal packing
2. Clip
3. Back up lamp
4. Two-sided tape
5. Trunk lid finisher outer

Refer to [GI-9, "Component"](#) for symbols in the figure.

REMOVAL

CAUTION:

Disconnect the battery negative terminal or remove the fuse.

1. Remove trunk lid finisher inner. Refer to [EI-44](#).
2. Disconnect back up lamp and trunk lid request switch connector.
3. Remove trunk lid finisher outer. Refer to [EI-44](#).
4. Remove screws and clip, and then remove back up lamp.
5. Remove seal packing from back up lamp.

INSTALLATION

Installation is the reverse order of removal.
Install a new seal packing to the back up lamp.

CAUTION:

Seal packing cannot be reused.

PARKING, LICENSE PLATE AND TAIL LAMPS

< SERVICE INFORMATION >

PARKING, LICENSE PLATE AND TAIL LAMPS

Component Parts and Harness Connector Location

INFOID:000000002956825

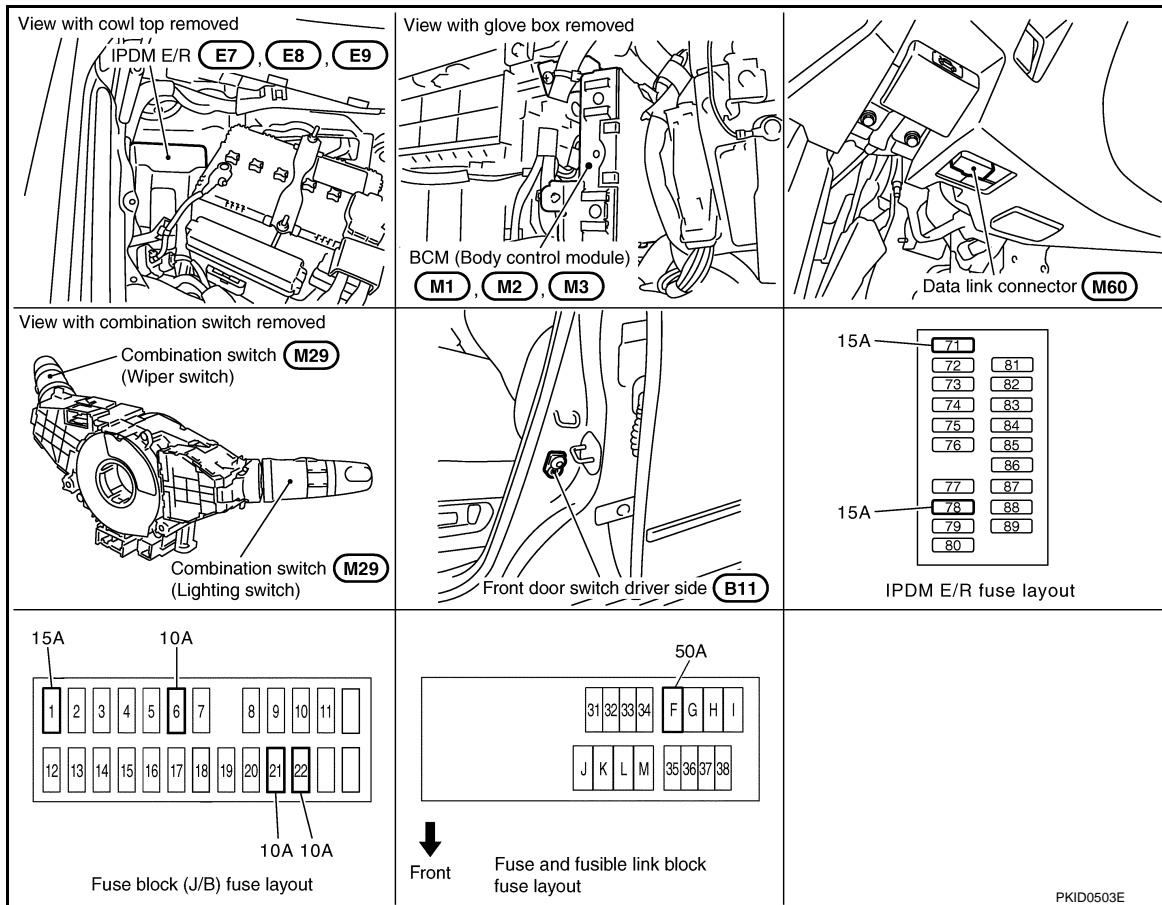

System Description

INFOID:000000002956826

The control of the parking, license plate and tail lamp operation is dependent upon the position of the lighting switch (combination switch). When the lighting switch is placed in the 1ST position, the BCM (body control module) receives input signal requesting the parking, license plate and tail lamps to illuminate. This input signal is communicated to the IPDM E/R (intelligent power distribution module engine room) across the CAN communication lines. The CPU (central processing unit) located in the IPDM E/R controls the tail lamp relay coil. This relay, when energized, directs power to parking, license plate and tail lamps, which then illuminate.

OUTLINE

Power is supplied at all times

- through 15A fuse (No. 71, located in IPDM E/R)
- to CPU located in IPDM E/R, and
- to tail lamp relay located in IPDM E/R,
- through 15A fuse (No. 78, located in IPDM E/R)
- to CPU located in IPDM E/R,
- through 50A fusible link (letter F, located in fuse, fusible link and relay block)
- to BCM terminal 55,
- through 10A fuse [No. 21, located in fuse block (J/B)]
- to BCM terminal 42,
- through 10A fuse [No. 22, located in fuse block (J/B)]
- to key slot terminal 1.

With the ignition switch in the ON or START position, power is supplied

- to CPU located in IPDM E/R,
- through 15A fuse [No. 1, located in fuse block (J/B)]
- to BCM terminal 38.

With the ignition switch in the ACC or ON position, power is supplied

PARKING, LICENSE PLATE AND TAIL LAMPS

< SERVICE INFORMATION >

- through 10A fuse [No. 6, located in fuse block (J/B)]
- to BCM terminal 11.

Ground is supplied

- to BCM terminal 52
- through grounds M16 and M70,
- to IPDM E/R terminals 38 and 51
- through grounds E22 and E43.

OPERATION BY LIGHTING SWITCH

With the lighting switch in the 1ST or 2ND position (or if the auto light system is activated), the BCM receives input signal requesting the parking, license plate and tail lamps to illuminate. This input signal is communicated to the IPDM E/R across the CAN communication lines. The CPU located in the IPDM E/R controls the tail lamp relay coil, which when energized, directs power

- through IPDM E/R terminal 21
- to front combination lamp LH and RH terminals 5 (parking)
- to front combination lamp LH and RH terminals 7 (side marker)
- to rear combination lamp LH and RH terminals 1 (tail and side marker)
- to license plate lamp LH and RH terminals 1.

Ground is supplied at all times

- to front combination lamp LH and RH terminals 1 (parking and side marker)
- through grounds E22 and E43,
- to rear combination lamp LH and RH terminals 4 (tail and side marker)
- through grounds B5, B40 and B131.
- to license plate lamp LH and RH terminals 2
- through grounds B402 and B405.

With power and ground supplied, the parking, license plate and tail lamps illuminate.

The unified meter and A/C amp. that received the position light request signal by BCM across the CAN communication makes a tail lamp indicator lamp turn on in the combination meter.

COMBINATION SWITCH READING FUNCTION

Refer to [BCS-4, "System Description"](#).

EXTERIOR LAMP BATTERY SAVER CONTROL

When the combination switch (lighting switch) is in the 1ST (or 2ND) position, and ignition switch is turned from ON or ACC to OFF, battery saver control feature is activated.

Under this condition, parking, license plate, side marker and tail lamps remain illuminated for 5 minutes, then the parking, license plate, side marker and tail lamps are turned off.

Exterior lamp battery saver control mode can be changed by the function setting of CONSULT-III.

CAN Communication System Description

INFOID:000000002956827

CAN (Controller Area Network) is a serial communication line for real time application. It is an on-vehicle multiplex communication line with high data communication speed and excellent error detection ability. Many electronic control units are equipped onto a vehicle, and each control unit shares information and links with other control units during operation (not independent). In CAN communication, control units are connected with 2 communication lines (CAN H line, CAN L line) allowing a high rate of information transmission with less wiring. Each control unit transmits/receives data but selectively reads required data only.

CAN Communication Unit

INFOID:000000002956828

Refer to [LAN-11, "System Description"](#).

A
B
C
D
E
F
G
H
I
J
LT
L
M
N
O
P

PARKING, LICENSE PLATE AND TAIL LAMPS

< SERVICE INFORMATION >

Schematic

INFOID:00000002956829

* : This relay is built into the IPDM E/R
(Intelligent power distribution module engine room).

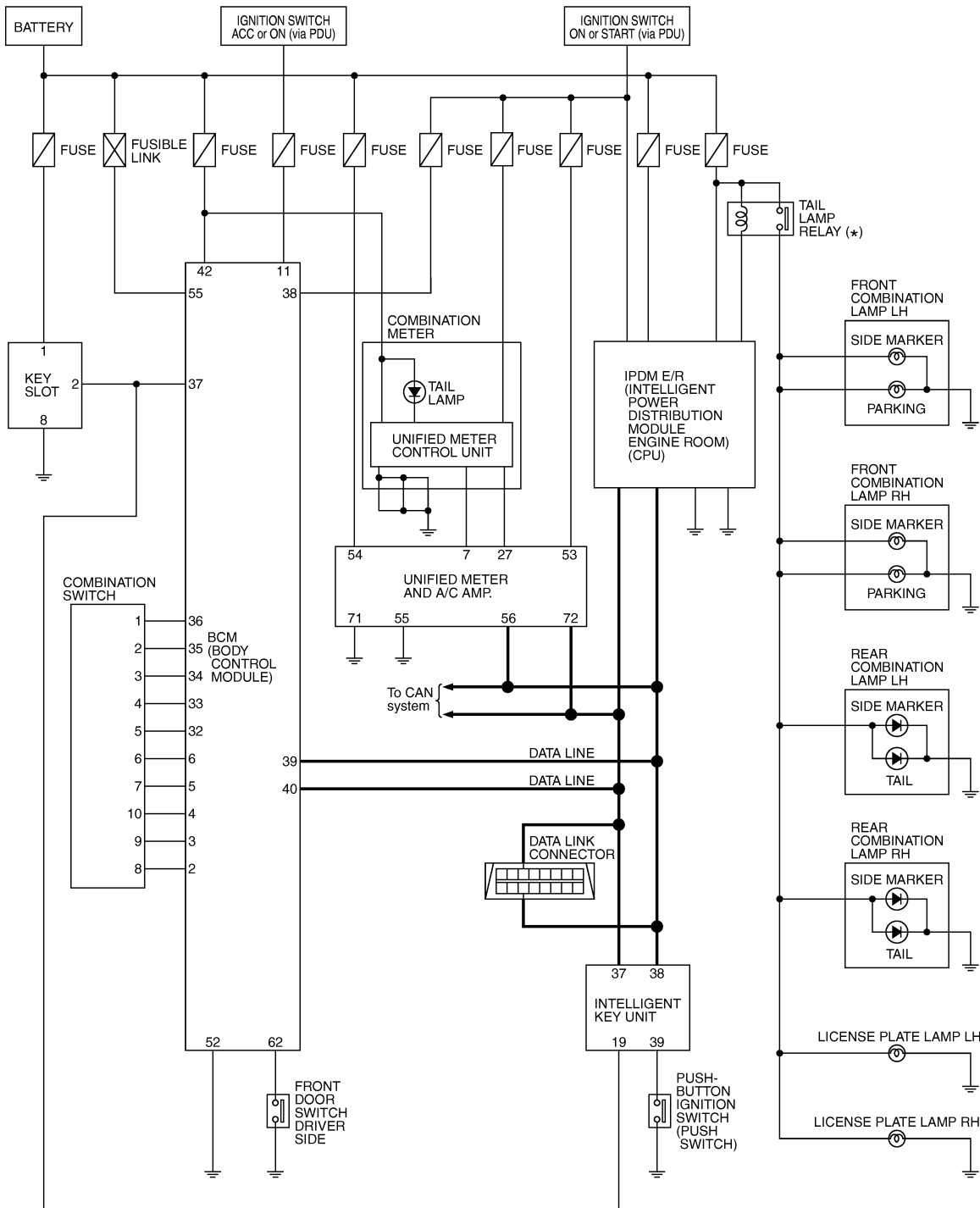

TKWB4889E

PARKING, LICENSE PLATE AND TAIL LAMPS

< SERVICE INFORMATION >

Wiring Diagram - TAIL/L -

INFOID:00000002956830

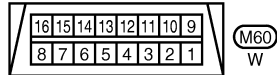
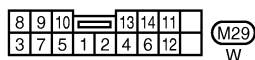
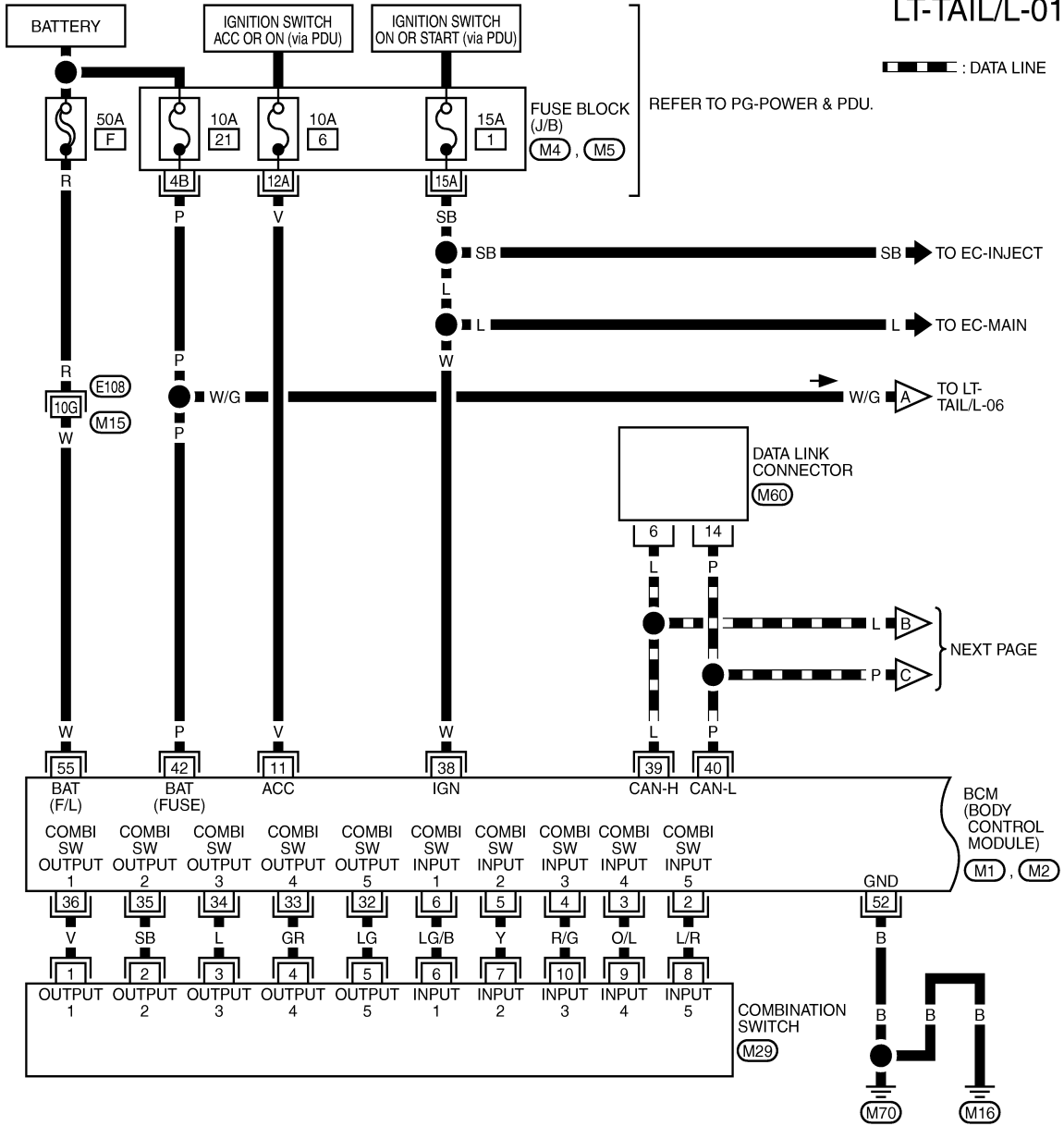

REFER TO THE FOLLOWING.

- (E108) - SUPER MULTIPLE JUNCTION (SMJ)
- (M4), (M5) - FUSE BLOCK - JUNCTION BOX (J/B)
- (M1), (M2) - ELECTRICAL UNITS

TKWT6832E

A
B
C
D
E
F
G
H
I
J
L
M
N
O
P

LT

PARKING, LICENSE PLATE AND TAIL LAMPS

< SERVICE INFORMATION >

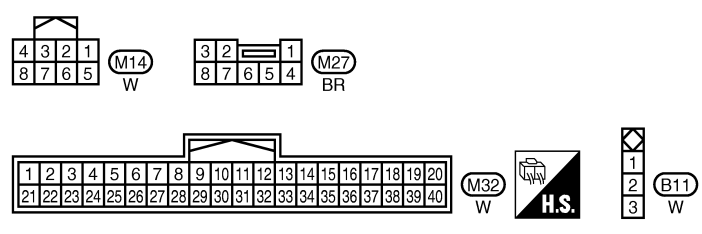
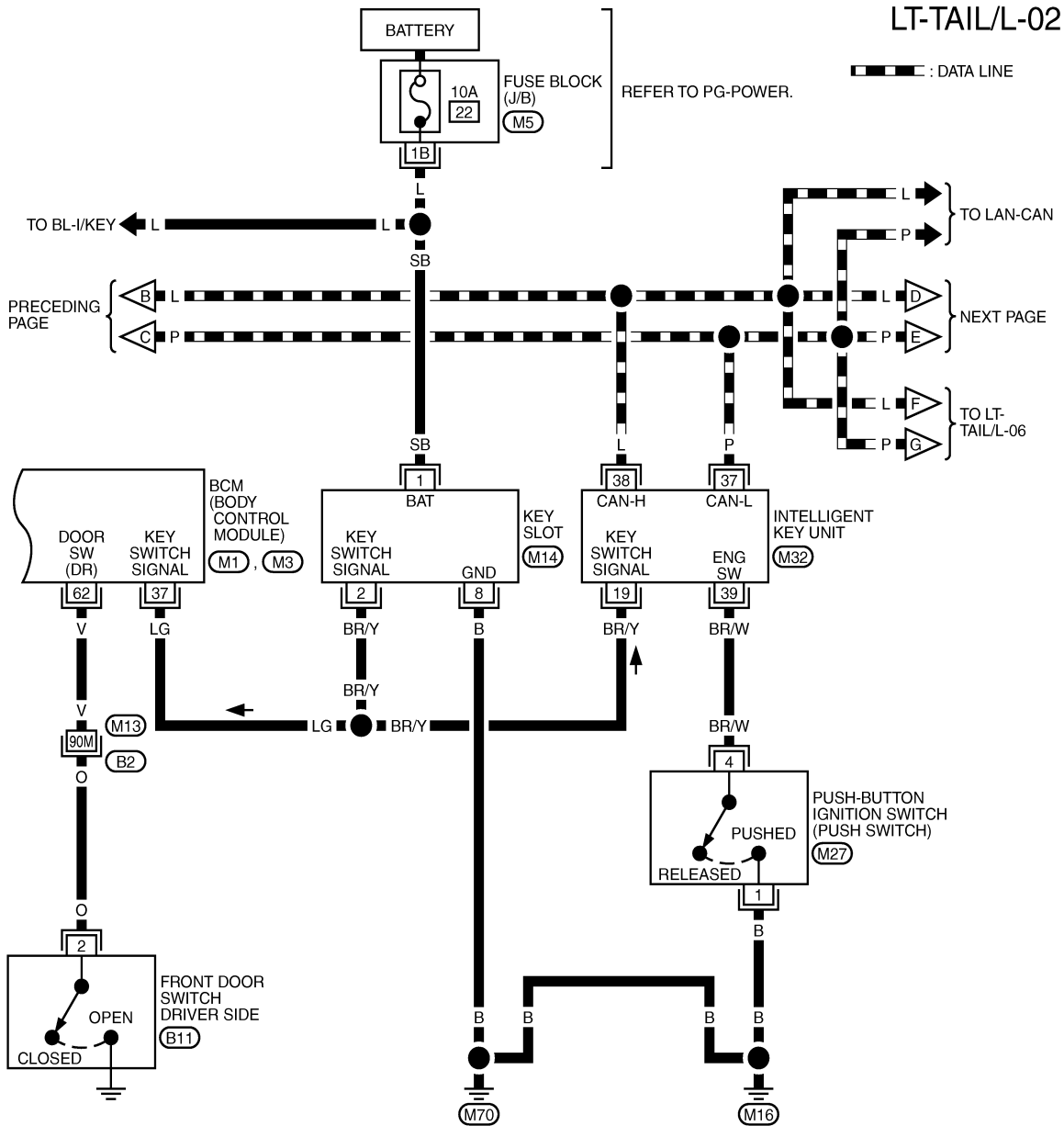

REFER TO THE FOLLOWING.

(B2) - SUPER MULTIPLE JUNCTION (SMJ)

(M5) - FUSE BLOCK - JUNCTION BOX (J/B)

(M1), (M3) - ELECTRICAL UNITS

TKWT6833E

PARKING, LICENSE PLATE AND TAIL LAMPS

< SERVICE INFORMATION >

LT-TAIL/L-04

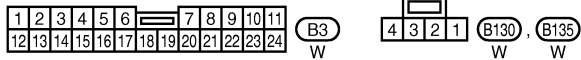
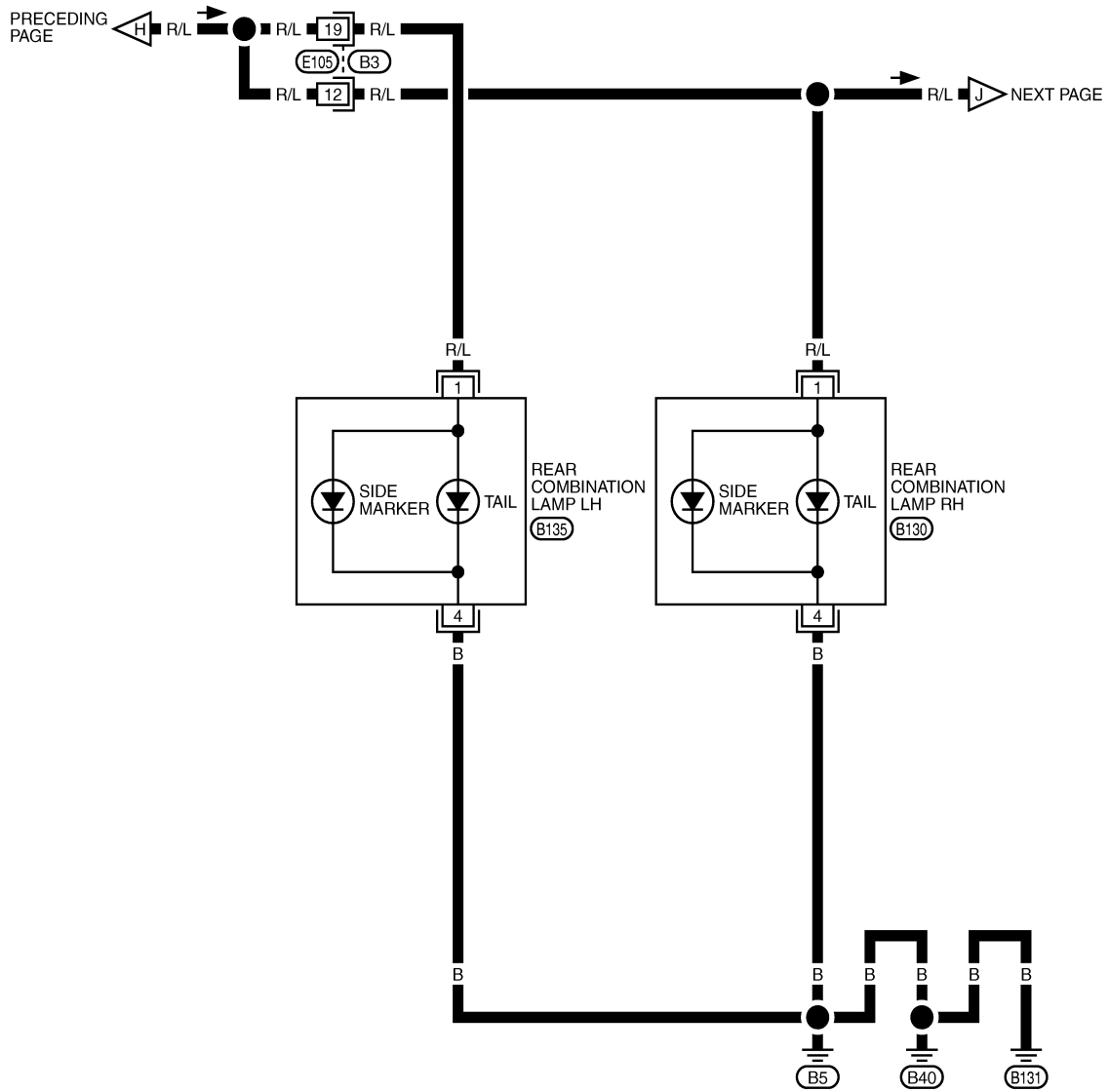

TKWT7181E

PARKING, LICENSE PLATE AND TAIL LAMPS

< SERVICE INFORMATION >

LT-TAIL/L-05

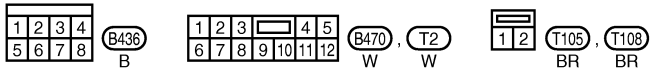
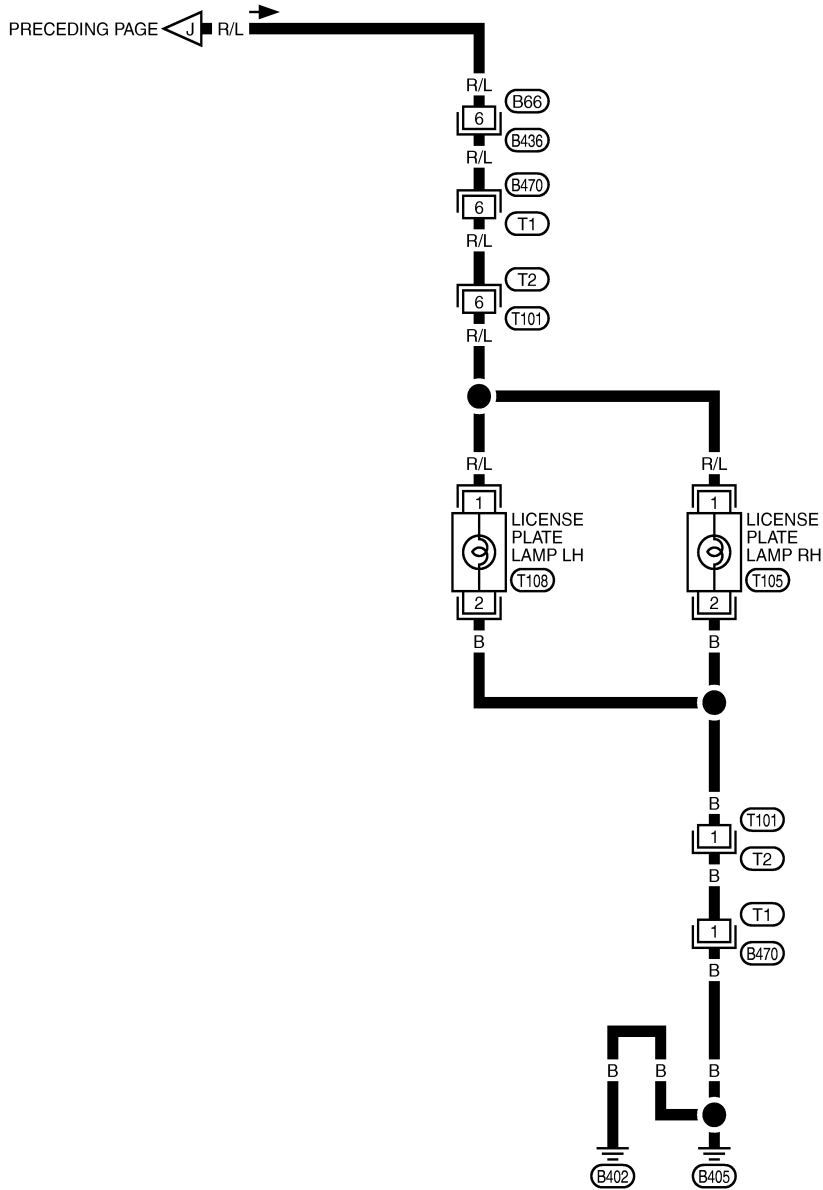

TKWT7182E

A
B
C
D
E
F
G
H
I
J
LT
L
M
N
O
P

LT

PARKING, LICENSE PLATE AND TAIL LAMPS

< SERVICE INFORMATION >

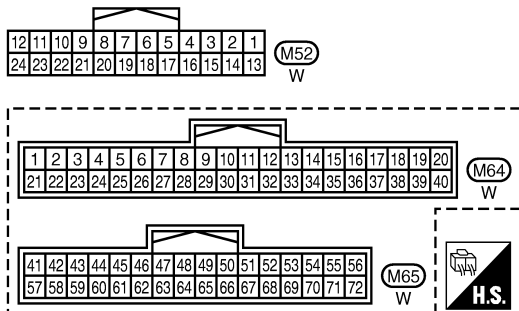
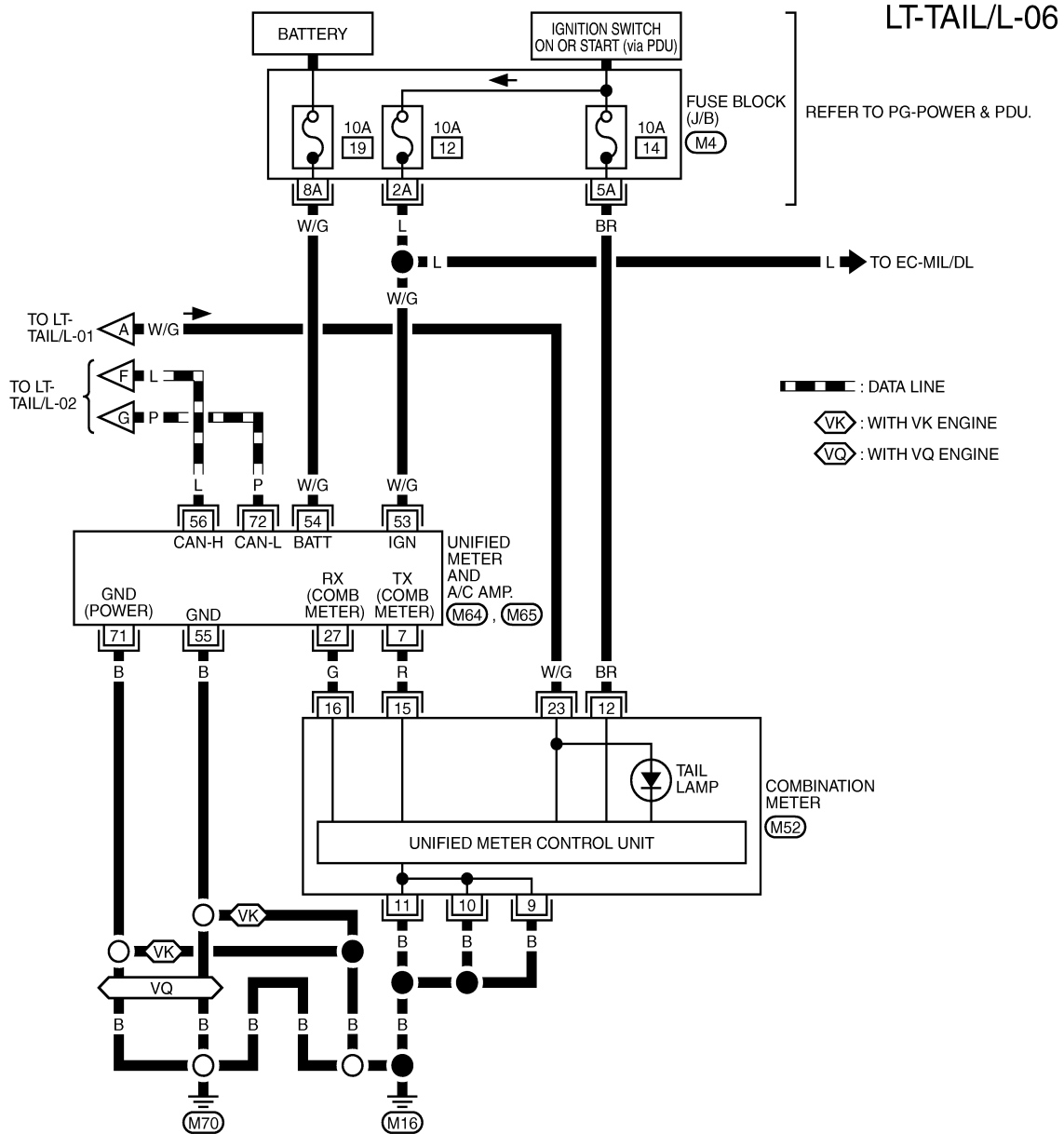

REFER TO THE FOLLOWING.
 (M4) - FUSE BLOCK - JUNCTION BOX (J/B)

TKWT7183E

INFOID:000000002956831

Terminal and Reference Value for BCM

CAUTION:

- Check combination switch system terminal waveform under the loaded condition with lighting switch, turn signal switch and wiper switch OFF not to be fluctuated by overloaded.
- Turn wiper dial position to 4 except when checking waveform or voltage of wiper dial position. Wiper dial position can be confirmed on CONSULT-III. Refer to [LT-201, "CONSULT-III Functions \(BCM - COMB SW\)"](#).

PARKING, LICENSE PLATE AND TAIL LAMPS

< SERVICE INFORMATION >

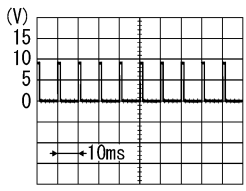
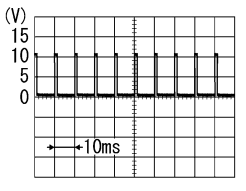
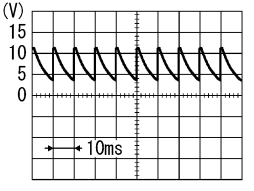
| Terminal No. | Wire color | Signal name | Measuring condition | | Reference value |
|--------------|------------|-----------------------------|---------------------|--|---|
| | | | Ignition switch | Operation or condition | |
| 2 | L/R | Combination switch input 5 | ON | Lighting, turn, wiper switch (Wiper dial position 4) Lighting switch 1ST |  Approx. 1.0 V |
| | | | | OFF | Approx. 0 V |
| 11 | V | Ignition switch (ACC) | ACC | — | Battery voltage |
| 33 | GR | Combination switch output 4 | ON | Lighting, turn, wiper switch (Wiper dial position 4) Lighting switch 1ST (The same result with lighting switch 2ND) |  Approx. 1.2 V |
| | | | | OFF |  Approx. 7.0 - 7.5 V |
| 38 | W | Ignition switch (ON) | ON | — | Battery voltage |
| 39 | L | CAN - H | — | — | — |
| 40 | P | CAN - L | — | — | — |
| 42 | P | Battery power supply | OFF | — | Battery voltage |
| 52 | B | Ground | ON | — | Approx. 0 V |
| 55 | W | Battery power supply | OFF | — | Battery voltage |

Terminal and Reference Value for IPDM E/R

INFOID:000000002956832

| Terminal No. | Wire color | Signal name | Measuring condition | | Reference value |
|--------------|------------|--|---------------------|------------------------|-----------------|
| | | | Ignition switch | Operation or condition | |
| 21 | R/L | Parking, license plate, and tail lamp output | ON | Lighting switch 1ST | OFF ON |
| | | | | OFF | Battery voltage |
| 38 | B | Ground | ON | — | Approx. 0 V |
| 49 | L | CAN - H | — | — | — |

PARKING, LICENSE PLATE AND TAIL LAMPS

< SERVICE INFORMATION >

| Terminal No. | Wire color | Signal name | Measuring condition | | Reference value |
|--------------|------------|-------------|---------------------|------------------------|-----------------|
| | | | Ignition switch | Operation or condition | |
| 50 | P | CAN – L | — | — | — |
| 51 | B | Ground | ON | — | Approx. 0 V |

How to Perform Trouble Diagnosis

INFOID:000000002956833

1. Confirm the symptom or customer complaint.
2. Understand operation description and function description. Refer to [LT-210, "System Description"](#).
3. Carry out the Preliminary Check. Refer to [LT-220, "Preliminary Check"](#).
4. Check symptom and repair or replace the cause of malfunction.
5. Do the parking, license plate and tail lamps operate normally? If YES, GO TO 6. If NO, GO TO 4.
6. INSPECTION END

Preliminary Check

INFOID:000000002956834

CHECK POWER SUPPLY AND GROUND CIRCUIT

1. CHECK FUSES AND FUSIBLE LINK

Check for blown fuses and fusible link.

| Unit | Power source | Fuse and fusible link No. |
|----------|--------------------------------------|---------------------------|
| BCM | Battery | F |
| | | 21 |
| | Ignition switch ON or START position | 1 |
| | Ignition switch ACC or ON position | 6 |
| IPDM E/R | Battery | 71 |
| | | 78 |

Refer to [LT-213, "Wiring Diagram - TAIL/L -"](#).

OK or NG

OK >> GO TO 2.

NG >> If fuse or fusible link is blown, be sure to eliminate cause of malfunction before installing new fuse or fusible link. Refer to [PG-4](#).

2. CHECK POWER SUPPLY CIRCUIT

PARKING, LICENSE PLATE AND TAIL LAMPS

< SERVICE INFORMATION >

1. Turn ignition switch OFF.
2. Disconnect BCM connector.
3. Check voltage between BCM harness connector and ground.

| Terminal (+) | | Terminal (-) | Ignition switch position | | |
|---------------|----------|--------------|--------------------------|-----------------|-----------------|
| BCM connector | Terminal | | OFF | ACC | ON |
| M1 | 11 | Ground | Approx. 0 V | Battery voltage | Battery voltage |
| | 38 | | Approx. 0 V | Approx. 0 V | Battery voltage |
| M2 | 42 | | Battery voltage | Battery voltage | Battery voltage |
| | 55 | | Battery voltage | Battery voltage | Battery voltage |

OK or NG

- OK >> GO TO 3.
 NG >> Repair harness or connector.

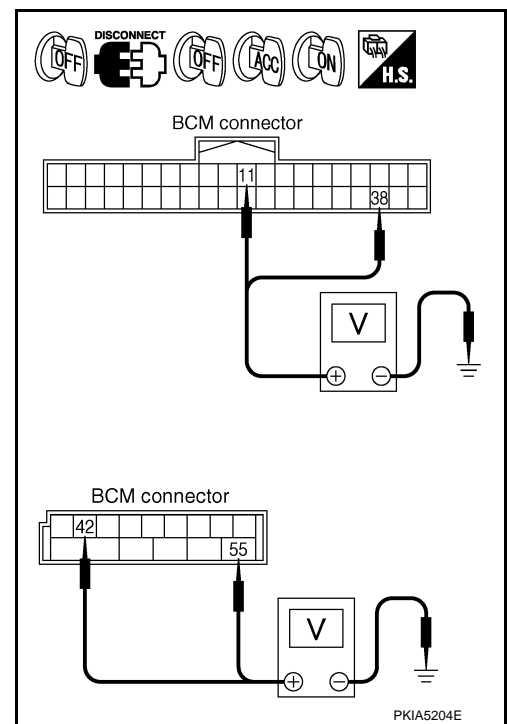

3. CHECK GROUND CIRCUIT

Check continuity between BCM harness connector and ground.

| BCM connector | Terminal | Ground | Continuity |
|---------------|----------|--------|------------|
| M2 | 52 | | Yes |

OK or NG

- OK >> INSPECTION END
 NG >> Repair harness or connector.

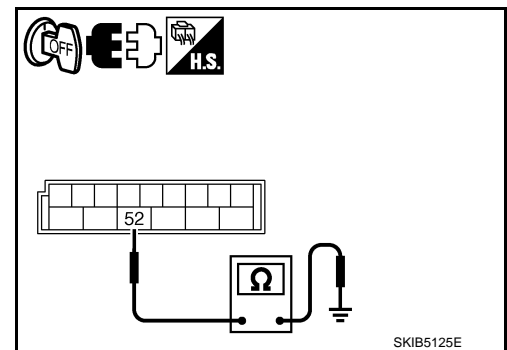

CONSULT-III Functions (BCM - HEAD LAMP)

INFOID:000000002956835

Refer to [LT-47, "CONSULT-III Functions \(BCM - HEAD LAMP\)"](#) in HEADLAMP (FOR USA) -XENON TYPE-.
 Refer to [LT-19, "CONSULT-III Functions \(BCM - HEAD LAMP\)"](#) in HEADLAMP (FOR USA) -CONVENTIONAL TYPE-.

Refer to [LT-77, "CONSULT-III Functions \(BCM - HEAD LAMP\)"](#) in HEADLAMP (FOR CANADA).

CONSULT-III Functions (IPDM E/R)

INFOID:000000002956836

Refer to [LT-48, "CONSULT-III Functions \(IPDM E/R\)"](#) in HEADLAMP (FOR USA) -XENON TYPE-.
 Refer to [LT-20, "CONSULT-III Functions \(IPDM E/R\)"](#) in HEADLAMP (FOR USA) -CONVENTIONAL TYPE-.
 Refer to [LT-78, "CONSULT-III Functions \(IPDM E/R\)"](#) in HEADLAMP (FOR CANADA).

Parking, License Plate and Tail Lamps Do Not Illuminate

INFOID:000000002956837

1. CHECK COMBINATION SWITCH INPUT SIGNAL

CONSULT-III DATA MONITOR

1. Select "TAIL LAMP SW" of BCM (HEAD LAMP) data monitor item.
2. With operating the lighting switch, check the monitor status.

When lighting switch is 1ST : TAIL LAMP SW ON position

CHECK THE COMBINATION SWITCH

PARKING, LICENSE PLATE AND TAIL LAMPS

< SERVICE INFORMATION >

Refer to [LT-202. "Combination Switch Inspection"](#).

OK or NG

OK >> GO TO 2.

NG >> Check combination switch (lighting switch). Refer to [LT-202. "Combination Switch Inspection"](#).

2.ACTIVE TEST

CONSULT-III ACTIVE TEST

1. Select "TAIL LAMP" of IPDM E/R active test item.
2. With operating the test item, check the parking, license plate and tail lamp operation.

On :Parking, license plate and tail lamps ON

Off :Parking, license plate and tail lamps OFF

IPDM E/R AUTO ACTIVE TEST

1. Activate auto active test. Refer to [PG-22. "Auto Active Test"](#).
2. Make sure parking, license plate and tail lamp operation.

Parking, license plate and tail lamps should operate.

OK or NG

OK >> GO TO 3.

NG >> GO TO 4.

3.CHECK IPDM E/R

CONSULT-III DATA MONITOR

1. Select "TAIL & CLR REQ" of IPDM E/R data monitor item.
2. With operating the lighting switch is in 1ST position, check the monitor status.

When lighting switch is 1ST position : TAIL & CLR REQ ON

OK or NG

OK >> Replace IPDM E/R. Refer to [PG-27. "Removal and Installation of IPDM E/R"](#).

NG >> Replace BCM. Refer to [BCS-14. "Removal and Installation of BCM"](#).

4.CHECK INPUT SIGNAL

CONSULT-III ACTIVE TEST

1. Turn ignition switch OFF.
2. Disconnect front combination lamp, license plate lamp and rear combination lamp connectors.
3. Select "TAIL LAMP" of IPDM E/R active test item.
4. With operating the test item, check voltage between front combination lamp, license plate lamp, rear combination lamp harness connector and ground.

IPDM E/R AUTO ACTIVE TEST

1. Turn ignition switch OFF.
2. Disconnect front combination lamp, license plate lamp and rear combination lamp connectors.
3. Activate auto active test. Refer to [PG-22. "Auto Active Test"](#).
4. When tail lamp relay is operating, check voltage between front combination lamp, license plate lamp, rear combination lamp harness connector and ground.

| Terminal (+) | | Terminal | (-) | Voltage (Approx.) |
|--|-----|----------|--------|-------------------|
| Front combination lamp (parking) connector | | | | |
| RH | E47 | 5 | Ground | Battery voltage |
| LH | E54 | | | |

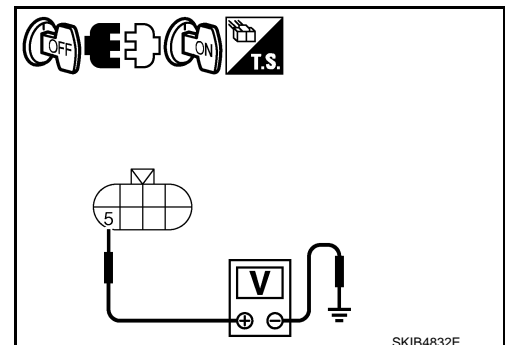

PARKING, LICENSE PLATE AND TAIL LAMPS

< SERVICE INFORMATION >

| Terminal | | | | Voltage (Approx.) |
|--|-----|----------|--------|-------------------|
| (+) | | Terminal | (-) | |
| Front combination lamp (side marker) connector | | | | |
| RH | E47 | 7 | Ground | Battery voltage |
| LH | E54 | | | |

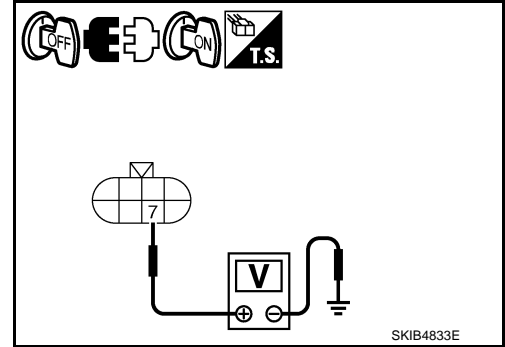

| Terminal | | | | Voltage (Approx.) |
|--|------|----------|--------|-------------------|
| (+) | | Terminal | (-) | |
| Rear combination lamp (tail) connector | | | | |
| RH | B130 | 1 | Ground | Battery voltage |
| LH | B135 | | | |

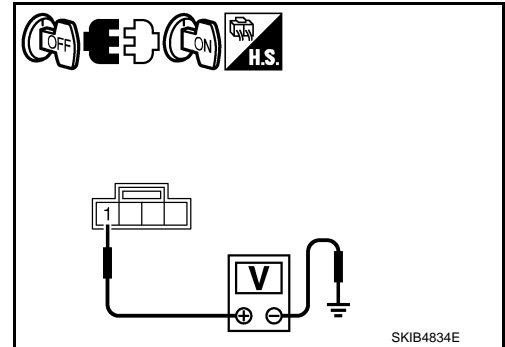

| Terminal | | | | Voltage (Approx.) |
|------------------------------|------|----------|--------|-------------------|
| (+) | | Terminal | (-) | |
| License plate lamp connector | | | | |
| RH | T105 | 1 | Ground | Battery voltage |
| LH | T108 | | | |

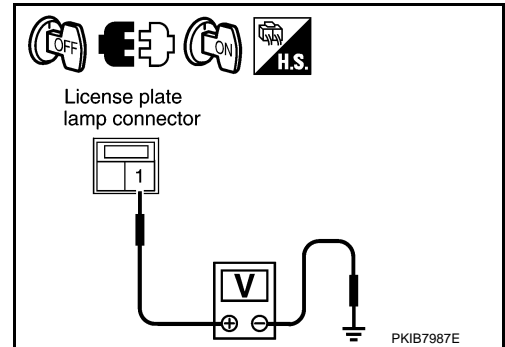

OK or NG

- OK >> GO TO 6.
- NG >> GO TO 5.

5. CHECK PARKING, LICENSE PLATE AND TAIL LAMP CIRCUIT

1. Turn ignition switch OFF.
2. Disconnect IPDM E/R connector.
3. Check continuity between IPDM E/R harness connector (A) and front combination lamp harness connector (B).

| A | | B | | Continuity |
|-----------|----------|-----------|----------|------------|
| Connector | Terminal | Connector | Terminal | |
| E7 | 21 | RH | E47 | Yes |
| | | LH | E54 | |

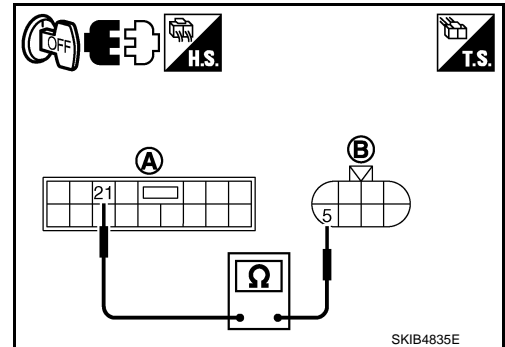

PARKING, LICENSE PLATE AND TAIL LAMPS

< SERVICE INFORMATION >

4. Check continuity between IPDM E/R harness connector (A) and front combination lamp harness connector (B).

| A | | B | | Continuity |
|-----------|----------|-----------|----------|------------|
| Connector | Terminal | Connector | Terminal | |
| E7 | 21 | RH | E47 | Yes |
| | | LH | E54 | |

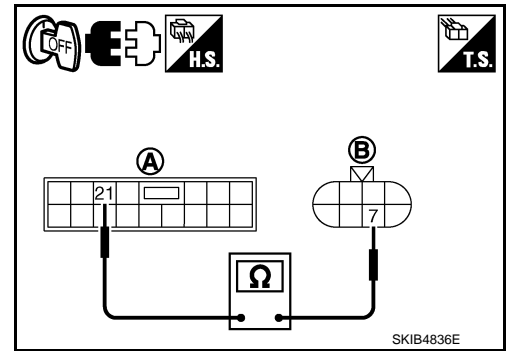

5. Check continuity between IPDM E/R harness connector (A) and rear combination lamp harness connector (B).

| A | | B | | Continuity |
|-----------|----------|-----------|----------|------------|
| Connector | Terminal | Connector | Terminal | |
| E7 | 21 | RH | B130 | Yes |
| | | LH | B135 | |

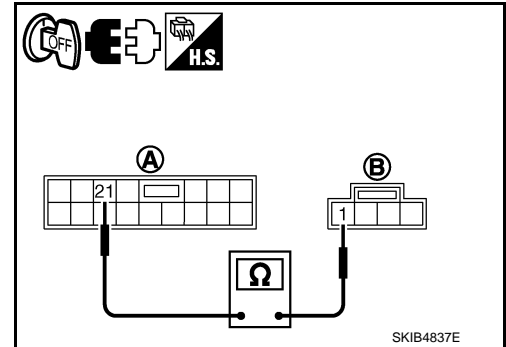

6. Check continuity between IPDM E/R harness connector (A) and license plate lamp harness connector (B).

| A | | B | | Continuity |
|-----------|----------|-----------|----------|------------|
| Connector | Terminal | Connector | Terminal | |
| E7 | 21 | RH | T105 | Yes |
| | | LH | T108 | |

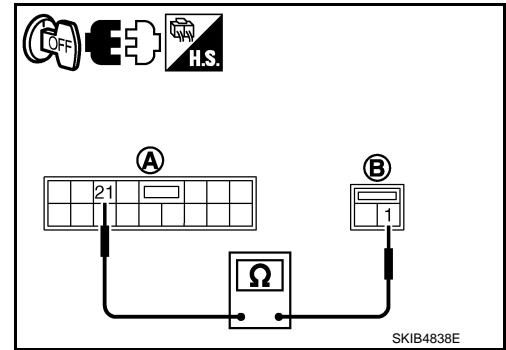

OK or NG

- OK >> Replace IPDM E/R. Refer to [PG-27. "Removal and Installation of IPDM E/R"](#).
 NG >> Repair harness or connector.

6. CHECK PARKING, LICENSE PLATE AND TAIL LAMPS GROUND CIRCUIT

1. Check continuity between front combination lamp harness connector and ground.

| Front combination lamp (parking and side marker) connector | | Terminal | Ground | Continuity |
|--|-----|----------|--------|------------|
| RH | E47 | 1 | | Yes |
| LH | E54 | | | |

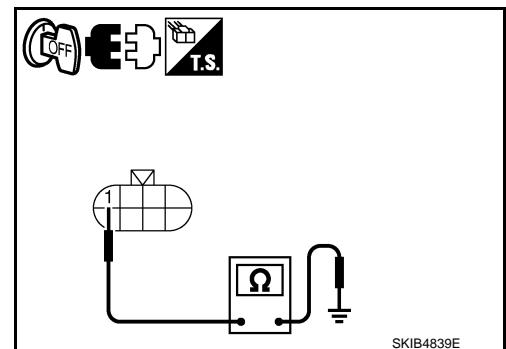

PARKING, LICENSE PLATE AND TAIL LAMPS

< SERVICE INFORMATION >

- Check continuity between rear combination lamp harness connector and ground.

| Rear combination lamp (tail and side marker) connector | | Terminal | Ground | Continuity |
|--|------|----------|--------|------------|
| RH | B130 | 4 | | Yes |
| LH | B135 | | | |

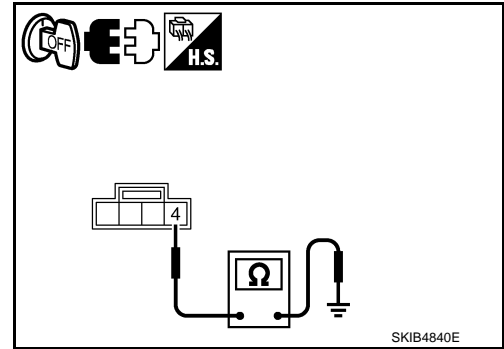

- Check continuity between license plate lamp harness connector and ground.

| License plate lamp connector | | Terminal | Ground | Continuity |
|------------------------------|------|----------|--------|------------|
| RH | T105 | 2 | | Yes |
| LH | T108 | | | |

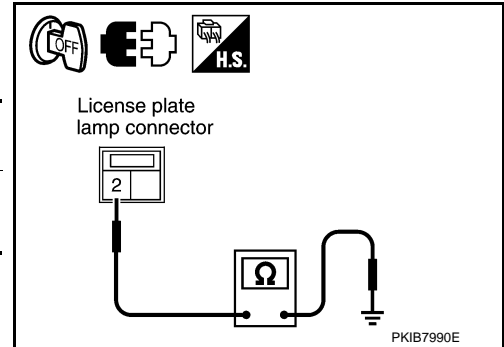

OK or NG

- OK >> Check bulbs.
- NG >> Repair harness or connector.

Parking, License Plate and Tail Lamps Do Not Turn OFF (After Approx. 10 Minutes)

INFOID:000000002956838

- This symptom indicates the malfunction of ignition relay in IPDM E/R. Refer to [PG-20, "Function of Detecting Ignition Relay Malfunction"](#).
- Select "LIGHT SW 1ST" of BCM (HEAD LAMP) data monitor item. If "LIGHT SW 1ST" is OFF when lighting switch is OFF, replace IPDM E/R.

License Plate Lamp

INFOID:000000002956839

BULB REPLACEMENT

CAUTION:

- Disconnect the battery negative terminal or remove the fuse.
- Never touch the glass of bulb directly by hand. Keep grease and other oily matters away from it. Never touch bulb by hand while it is lit or right after being turned off.
- Never leave bulb out of lamp reflector for a long time because dust, moisture smoke, etc. may affect the performance of lamp. When replacing bulb, be sure to replace it with new one.

- Remove trunk lid finisher inner. Refer to [EI-65, "Component Parts Location"](#).
- Turn bulb socket (1) counterclockwise and unlock it.
- Remove bulb (2) from its socket.

License plate lamp : 12V - 5W

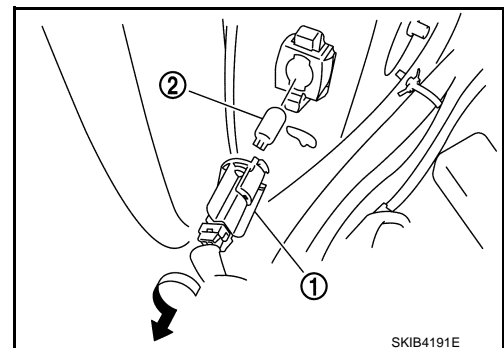

Removal and Installation

INFOID:000000002956840

REMOVAL

CAUTION:

Disconnect the battery negative terminal or remove the fuse.

PARKING, LICENSE PLATE AND TAIL LAMPS

< SERVICE INFORMATION >

1. Remove trunk lid finisher inner. Refer to [EI-65, "Component Parts Location"](#).
2. From the trunk room inside, push a lamp to outside while pushing a resin clip (A).
3. Disconnect connector and remove license plate lamp (1).

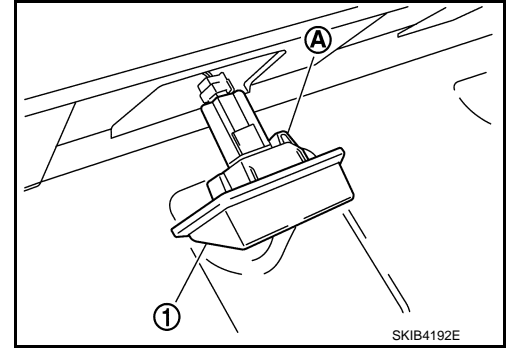

INSTALLATION

Installation is the reverse order of removal.

Parking Lamp

INFOID:000000002956841

BULB REPLACEMENT

Refer to [LT-31, "Bulb Replacement"](#) in "HEAD LAMP - CONVENTIONAL TYPE-".

Refer to [LT-59, "Bulb Replacement"](#) in "HEAD LAMP - XENON TYPE-".

REMOVAL AND INSTALLATION

Refer to [LT-32, "Removal and Installation"](#).

REAR COMBINATION LAMP

< SERVICE INFORMATION >

REAR COMBINATION LAMP

Bulb Replacement

INFOID:000000002956842

CAUTION:

- Disconnect the battery negative terminal or remove the fuse.
- Never touch the glass of bulb directly by hand. Keep grease and other oily matters away from it. Never touch bulb by hand while it is lit or right after being turned off.
- Never leave bulb out of lamp reflector for a long time because dust, moisture smoke, etc. may affect the performance of lamp. When replacing bulb, be sure to replace it with new one.

REAR TURN SIGNAL LAMP BULB

1. Remove rear combination lamp. Refer to [LT-227, "Removal and Installation"](#).
2. Rotate the resin cap (1) counterclockwise and unlock it.
3. Turn rear turn signal lamp bulb socket (2) counterclockwise and unlock it.
4. Remove bulb (3).

CAUTION:

Seal packing cannot be reused.

Rear turn signal lamp : 12V - 21W (amber bulb)

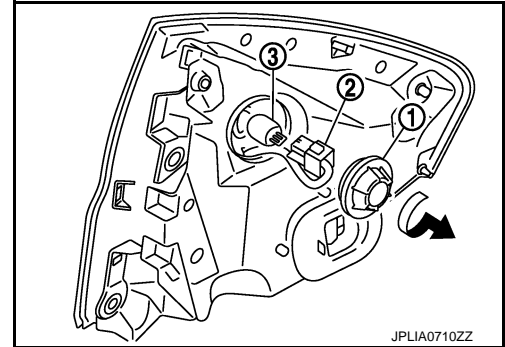

STOP/TAIL LAMP

Replacement integral with rear combination lamp.

Stop/tail lamp : LED

Removal and Installation

INFOID:000000002956843

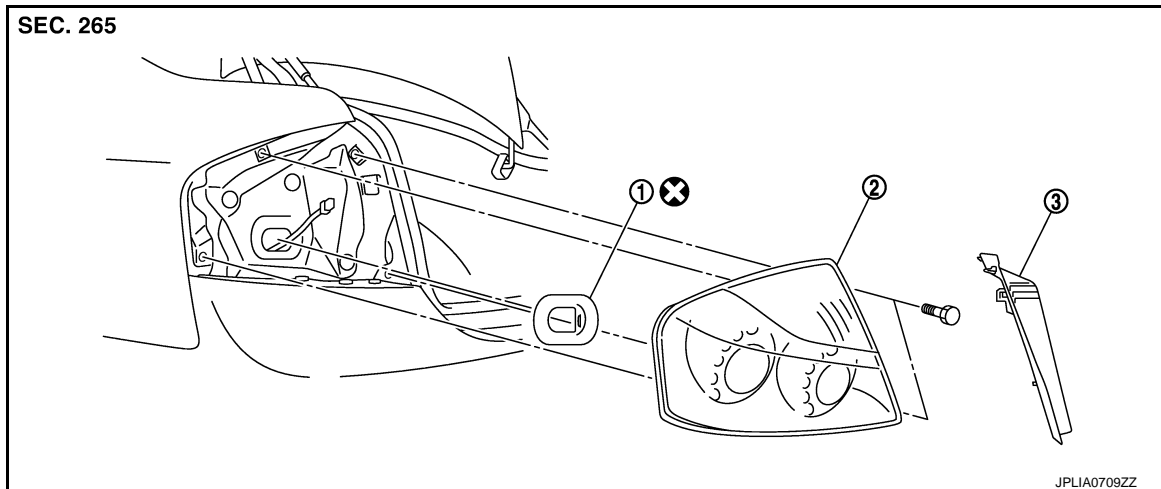

1. Seal packing
 2. Rear combination lamp assembly
 3. Rear combination lamp finisher
- Refer to [GI-9, "Component"](#) for symbols in the figure.

REMOVAL

CAUTION:

Disconnect the battery negative terminal or remove the fuse.

1. Remove trunk side finisher. Refer to [EI-65, "Component Parts Location"](#).
2. Disconnect rear combination lamp connector.

A
B
C
D
E
F
G
H
I
J
L
M
N
O
P

LT

REAR COMBINATION LAMP

< SERVICE INFORMATION >

3. Remove rear combination lamp finisher.
4. Remove rear combination lamp mounting bolts.
5. Pull the rear combination lamp toward rear of the vehicle and remove from the vehicle.
6. Remove seal packing from the vehicle.

INSTALLATION

Installation is the reverse order of removal.

CAUTION:

Seal packing cannot be reused.

INTERIOR ROOM LAMP

< SERVICE INFORMATION >

INTERIOR ROOM LAMP

Component Parts and Harness Connector Location

INFOID:000000002956844

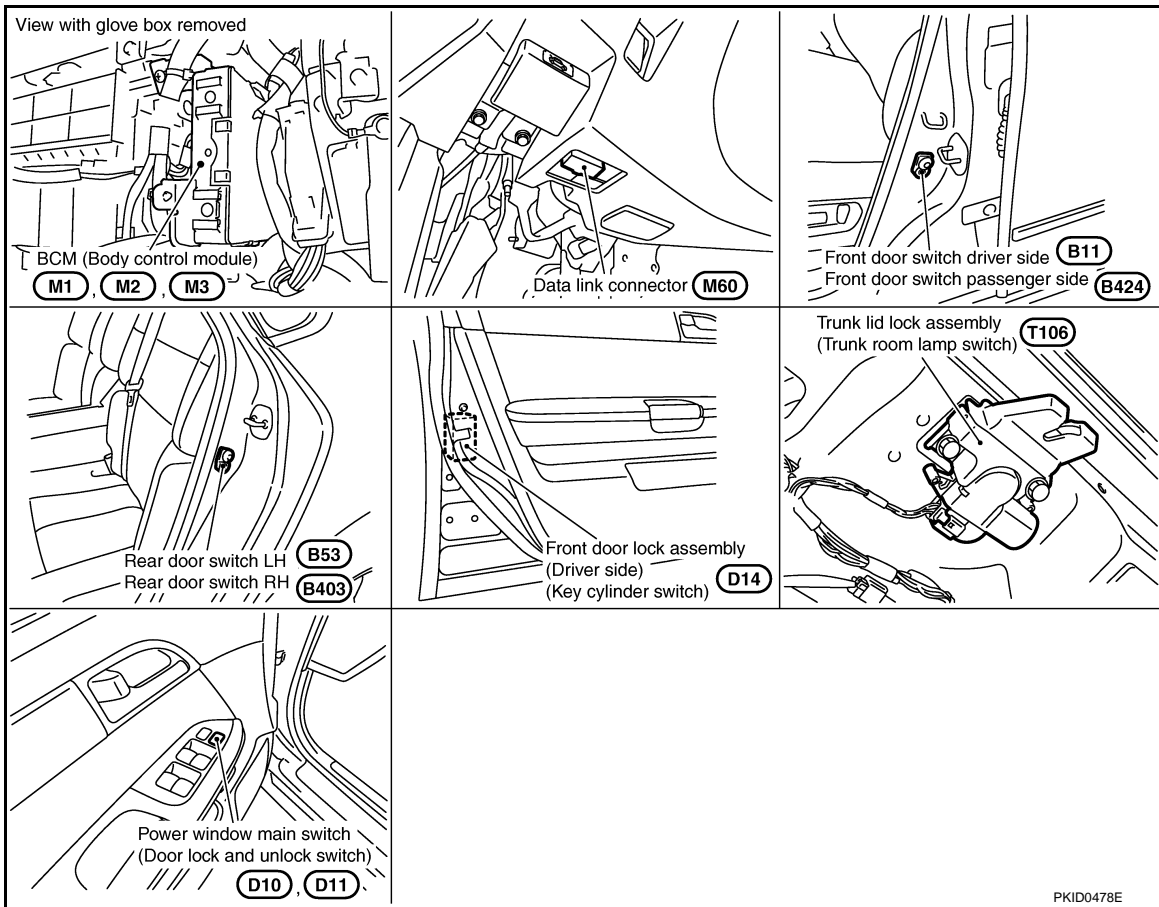

System Description

INFOID:000000002956845

BCM (body control module) controls interior lamp, room lamp timer and interior lamp battery saver. The following signals are input to BCM:

- Door lock/unlock trunk open request signal from the Intelligent Key unit via CAN communication
- Key cylinder switch status signal from power window main switch via power window serial link
- Door switch signal from door switches (driver side, passenger side, rear LH and RH)
- IGN power supply (signal) from PDU (power distribution unit)
- ACC power supply (signal) from PDU

ROOM LAMP TIMER BASIC OPERATION

Applicable lamps

- Room lamp system: map lamp, foot lamp (driver side and passenger side) and personal lamp (rear LH and rear RH).

1. When getting on the vehicle
 - Lamps illuminate by timer operation when driver side door or passenger side door is unlocked.*
 - Lamps illuminate by timer operation after any door is open and then all doors are closed.*
 - Timer operation stops and lamps are OFF, when driver side door is locked or the push-button ignition switch (push switch) is turned to ACC or ON from OFF.

*: This setting can be changed by CONSULT-III. Refer to [LT-245, "CONSULT-III Functions \(BCM - INT LAMP\)"](#).

2. When getting off the vehicle
 - Lamps illuminate by timer operation when the push-button ignition switch (push switch) is turned OFF.*

INTERIOR ROOM LAMP

< SERVICE INFORMATION >

- Lamps illuminate by timer operation after any door is open and then all doors are closed.*
 - Timer operation stops and lamps are OFF, when driver side door is locked.
- *: This setting can be changed by CONSULT-III. Refer to [LT-245. "CONSULT-III Functions \(BCM - INT LAMP\)".](#)

POWER SUPPLY AND GROUND

Power is supplied at all times

- through 50A fusible link (letter F, located in fuse and fusible link block)
- to BCM terminal 55,
- through 10A fuse [No. 21, located in fuse block (J/B)]
- to BCM (body control module) terminal 42,
- through 10A fuse [No. 22, located in fuse block (J/B)]
- to key slot terminal 1.

With the ignition switch in the ON or START position, power is supplied

- through 15A fuse [No. 1, located in fuse block (J/B)]
- to BCM terminal 38.

With the ignition switch in the ACC or ON position, power is supplied

- through 10A fuse [No. 6, located in fuse block (J/B)]
- to BCM terminal 11.

Ground is supplied

- to BCM terminal 52
- through grounds M16 and M70.

When the driver side door is opened, ground is supplied

- to BCM terminal 62
- through front door switch driver side terminal 2
- through case ground of front door switch driver side.

When the passenger side door is opened, ground is supplied

- to BCM terminal 12
- through front door switch passenger side terminal 2
- through case ground of front door switch passenger side.

When the rear door LH is opened, ground is supplied

- to BCM terminal 63
- through rear door switch LH terminal 2
- through case ground of rear door switch LH.

When the rear door RH is opened, ground is supplied

- to BCM terminal 13
- through rear door switch RH terminal 2
- through case ground of rear door switch RH.

When driver side door is unlocked by door lock and unlock switch, BCM receives a ground signal

- to BCM terminal 22
- through power window main switch (door lock and unlock switch) terminal 14 or power window sub-switch (front passenger side) (door lock and unlock switch) terminal 16
- through power window main switch (door lock and unlock switch) terminal 17 or power window sub-switch (front passenger side) (door lock and unlock switch) terminal 11
- through grounds M16 and M70.

When the driver side door is unlocked by the front door lock assembly (driver side) (key cylinder switch), BCM receives a ground signal

- to BCM terminal 22
- through power window main switch (door lock and unlock switch) terminals 14 and 6
- through front door lock assembly (driver side) (key cylinder switch) terminals 5 and 4
- through grounds M16 and M70.

When a signal, or combination of door open signals is received by BCM, ground is supplied

- to foot lamp driver side and passenger side terminals 2
- to personal lamp LH and RH terminals 1
- to map lamp terminal 2 and 5
- through BCM terminal 48,
- to step lamp (driver side, passenger side, rear LH and RH) terminals 2
- to kicking plate illumination (driver side and passenger side) terminals 2
- through BCM terminal 47.

With power and ground supplied, the interior lamps illuminate.

SWITCH OPERATION

INTERIOR ROOM LAMP

< SERVICE INFORMATION >

When any front door switch is ON (door is opened), ground is supplied

- to step lamp (driver side, passenger side, rear LH and RH) terminals 2
- to kicking plate illumination (driver side and passenger side) terminals 2
- through BCM terminal 47.

And power is supplied

- through BCM terminal 41
- to step lamp (driver side, passenger side, rear LH and RH) terminals 1
- to kicking plate illumination (driver side and passenger side) terminals 1.

When any door switch is ON (door is opened) and personal lamp and map lamp is DOOR position, ground is supplied

- to personal lamp LH and RH terminal 1
- to map lamp terminals 2 and 5
- through BCM terminal 48.

And power is supplied

- through BCM terminal 41
- to personal lamp LH and RH terminals 3
- to map lamp terminal 3.

When map lamp switch is ON, ground is supplied

- to map lamp terminal 1
- through grounds M16 and M70.

And power is supplied

- through BCM terminal 41
- to map lamp terminal 3.

When personal lamp LH and RH switch is ON, ground is supplied

- to personal lamp LH and RH terminals 2
- through grounds M16 and M70.

And power is supplied

- through BCM terminal 41
- to personal lamp LH and RH terminals 3.

When trunk lid lock assembly (trunk room lamp switch) is ON, ground is supplied

- to trunk room lamp (upper and lower) terminals 2
- through trunk lid lock assembly (trunk room lamp switch) terminals 1 and 2
- through grounds B405 and B402.

And power is supplied

- through BCM terminal 41
- to trunk room lamp (upper and lower) terminals 1.

When vanity mirror lamp LH and RH switch is ON, ground is supplied

- to vanity mirror lamp LH and RH terminals 2
- through grounds M16 and M70.

And power is supplied

- through BCM terminal 41
- to vanity mirror lamp (LH and RH) terminals 1.

ROOM LAMP TIMER OPERATION

BCM controls applicable lamps to illuminate for 15 seconds (can be set maximum 30 seconds) by timer operation under following conditions. BCM also controls applicable lamps to brighten for 1 second (can be set maximum 5 seconds) when turned ON, or to dim for 3 seconds (can be set maximum 5 seconds) when turned OFF. (Timer operating time and dimming/brightening time can be changed with CONSULT-III. Refer to [LT-245, "CONSULT-III Functions \(BCM - INT LAMP\)"](#).) This control operates as follows.

Applicable lamps

- Room lamp system: map lamp, foot lamp (driver side and passenger side) and personal lamp (rear LH and rear RH).

BCM controls room lamp timer operation under following condition.

- Condition 1: Door lock state changes.*

BCM judges as the door lock is unlocked under either case below.

- The Intelligent Key unit sends door lock/unlock trunk open request signal (driver side unlock or passenger side unlock) to BCM through CAN communication line by unlock operation of intelligent key, outside key antenna and front door request switch (driver side) or outside key antenna and front door request switch (passenger side).

A

B

C

D

E

F

G

H

I

J

LT

L

M

N

O

P

INTERIOR ROOM LAMP

< SERVICE INFORMATION >

- Key cylinder switch state (unlock) signal is sent to BCM through power window serial link when front door lock assembly (driver side) (key cylinder switch) is unlocked (ON) by power window main switch unlock operation.

And fulfills all the conditions below.

- The engine switch (push switch) is OFF.
- All the doors are closed.

*: This setting can be changed by CONSULT-III. Refer to [LT-245, "CONSULT-III Functions \(BCM - INT LAMP\)"](#).

- Condition 2: Any door switch state changes.*

The BCM terminal value of operated door switch is changed when any door is opened and then closed. From that BCM judges as the door is opened and then closed.

And fulfills all the conditions below.

- The engine switch (push switch) is OFF.
- All the doors are closed.

*: This setting can be changed by CONSULT-III. Refer to [LT-245, "CONSULT-III Functions \(BCM - INT LAMP\)"](#).

- Condition 3: Engine switch (push switch) state changes.*

The Intelligent Key unit judges as the engine switch (push switch) is OFF and sends push-button ignition switch (push switch) signal to PDU (power distribution unit) when push-button ignition switch (push switch) turned OFF. Then PDU (power distribution unit) turns OFF, IGN power supply and ACC power supply.

And fulfills the conditions below.

- All the doors are closed.

*: This setting can be changed by CONSULT-III. Refer to [LT-245, "CONSULT-III Functions \(BCM - INT LAMP\)"](#).

NOTE:

When timer operation signal is input during former timer operation, BCM goes for latter timer operation.

ROOM LAMP TIMER OPERATING TIME

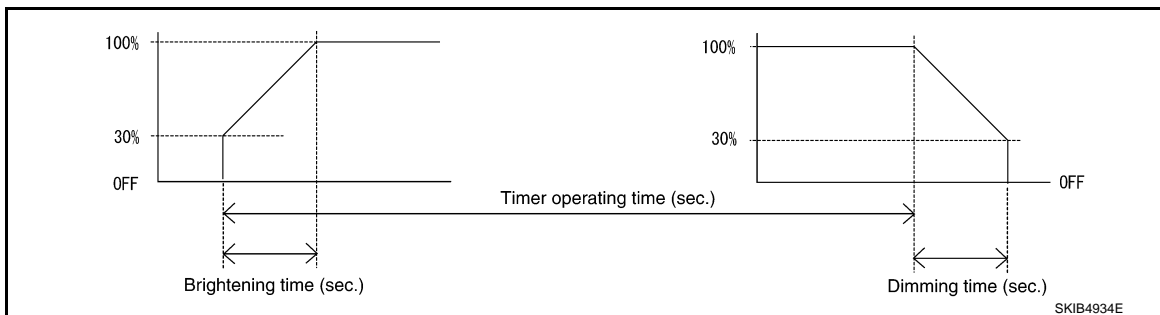

CONDITIONS FOR CANCELING TIMER

Timer operation is cancelled in any of the following conditions.

- Driver door is locked.
- Any door is opened.
- Turn ignition switch is ACC or ON.

ROOM LAMP TIMER INAPPLICABLE LAMPS OPERATION

- Step lamp system: step lamp (driver side, passenger side, rear LH and rear RH) and kicking plate illumination (driver side and passenger side).
Step lamp system lamps are ON/OFF linked with any door (driver side, passenger side, rear LH and rear RH) opened and then closed.
- Vanity mirror lamp LH and RH.
Operated side vanity mirror lamp is ON/OFF linked with vanity mirror opened and then closed.
- Trunk room lamp (lower) and trunk room lamp (upper).
Trunk room lamps (lower and upper) are ON/OFF linked with trunk opened and then closed.

INTERIOR ROOM LAMP BATTERY SAVER FUNCTION

Applicable lamps

- Room lamp system: map lamp, foot lamp (driver side and passenger side) and personal lamp (rear LH and rear RH).
- Step lamp system: step lamp (driver side, passenger side, rear LH and rear RH) and kicking plate illumination (driver side and passenger side).

INTERIOR ROOM LAMP

< SERVICE INFORMATION >

- Vanity mirror lamp LH and RH.
- Trunk room lamp (lower) and trunk room lamp (upper).

If the any applicable lamp is left illuminated, BCM turns OFF the battery saver output power supply 30 or 60 minutes to prevent run down of the battery. (Factory setting time is 30 minutes. And timer setting can be changed by CONSULT-III. Refer to [LT-245, "CONSULT-III Functions \(BCM - INT LAMP\)".](#))

- When the push-button ignition switch (push switch) is turned from ON to OFF, the timer is activated.
- If any of the following door switch signal condition is changed with the push-button ignition switch (push switch) in OFF position, the timer is activated when the change is occurred.

Door switch signals (driver side, passenger side, rear LH and RH), front door lock assembly (driver side) (key cylinder switch) signal and Intelligent Key unlock signal.

A

B

C

D

E

F

G

H

I

J

LT

L

M

N

O

P

INTERIOR ROOM LAMP

< SERVICE INFORMATION >

Schematic

INFOID:00000002956846

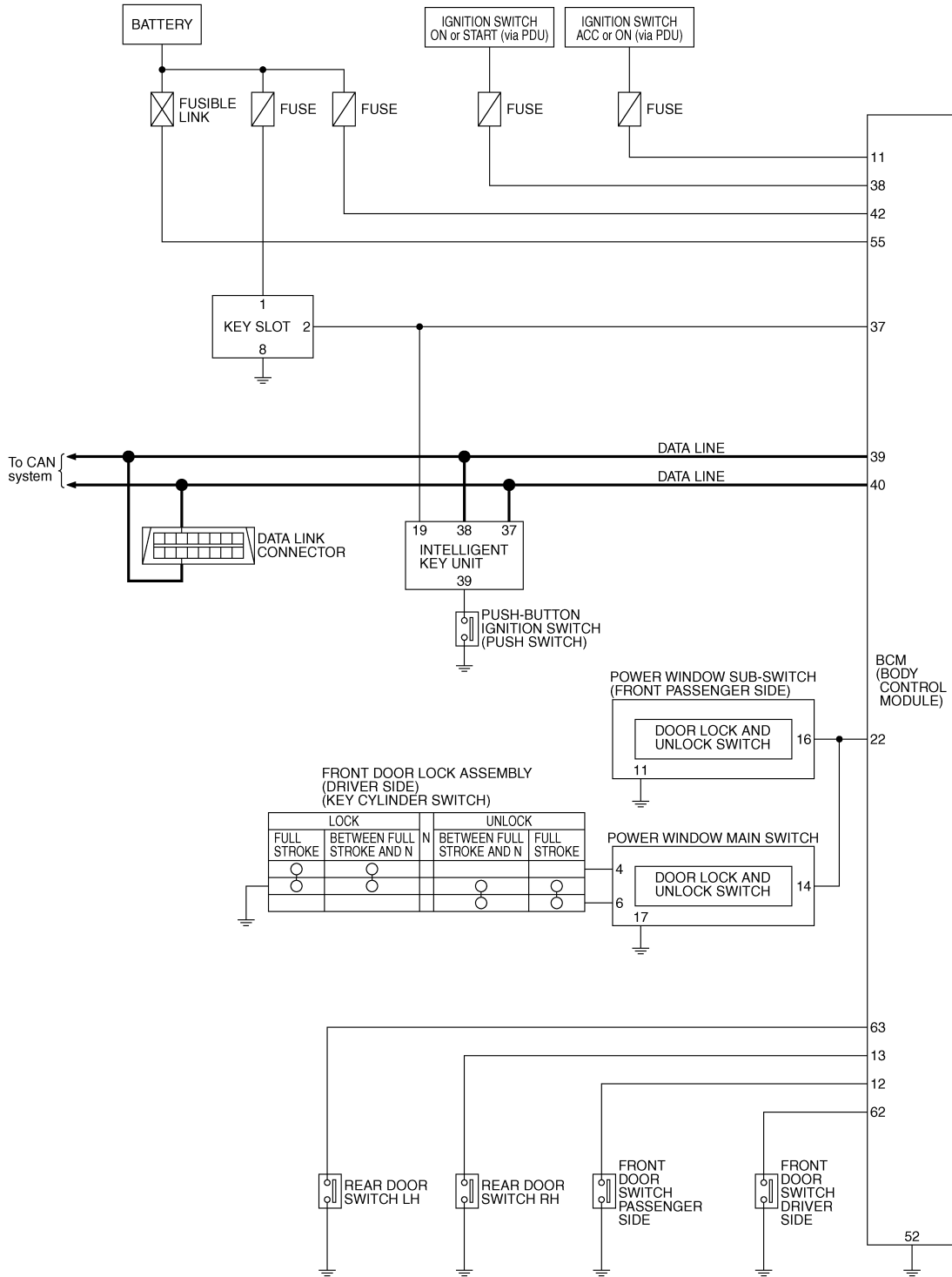

TKWT3400E

INTERIOR ROOM LAMP

< SERVICE INFORMATION >

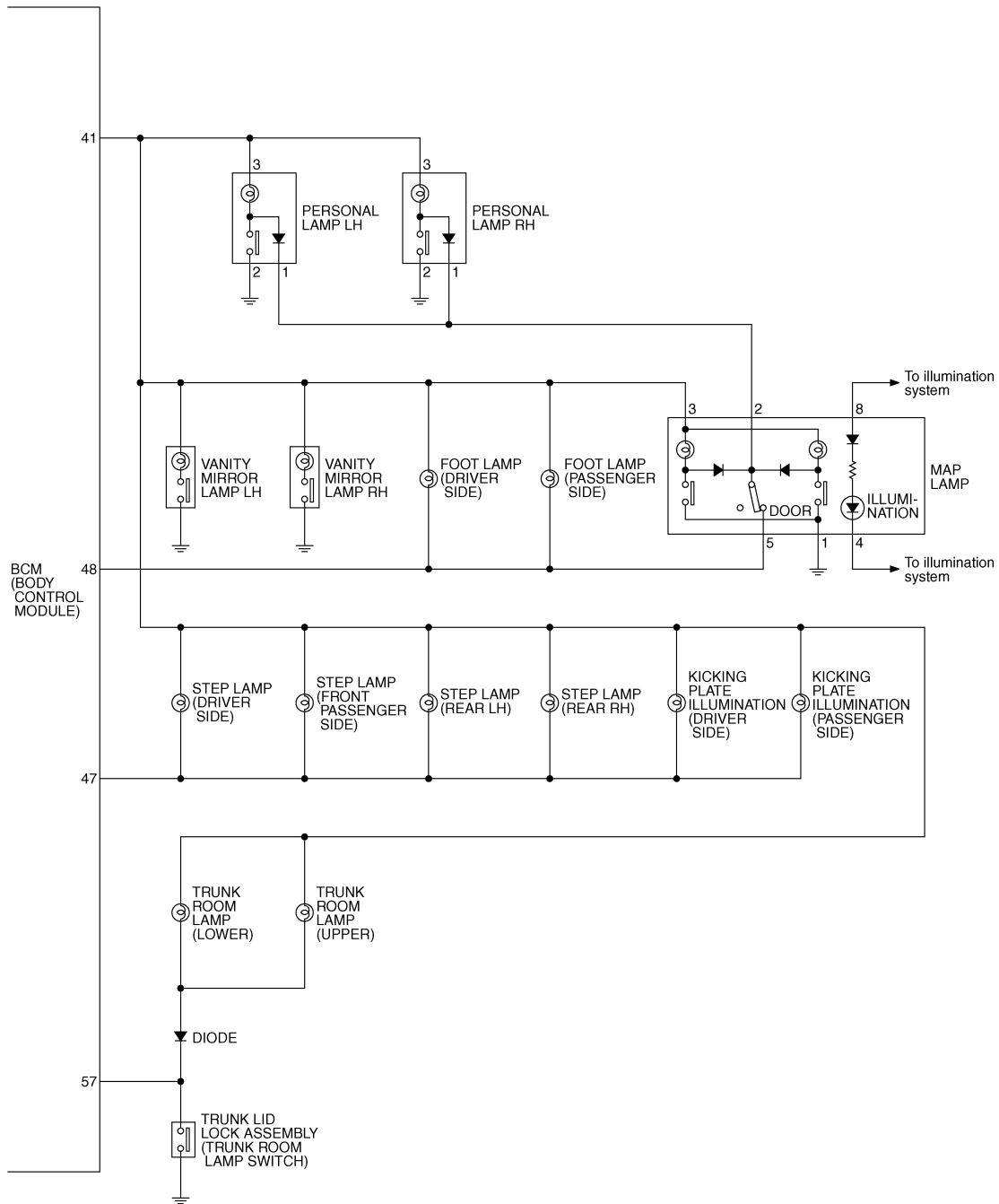

TKWT3401E

A
B
C
D
E
F
G
H
I
J
LT
L
M
N
O
P

INTERIOR ROOM LAMP

< SERVICE INFORMATION >

Wiring Diagram - ROOM/L -

INFOID:00000002956847

LT-ROOM/L-01

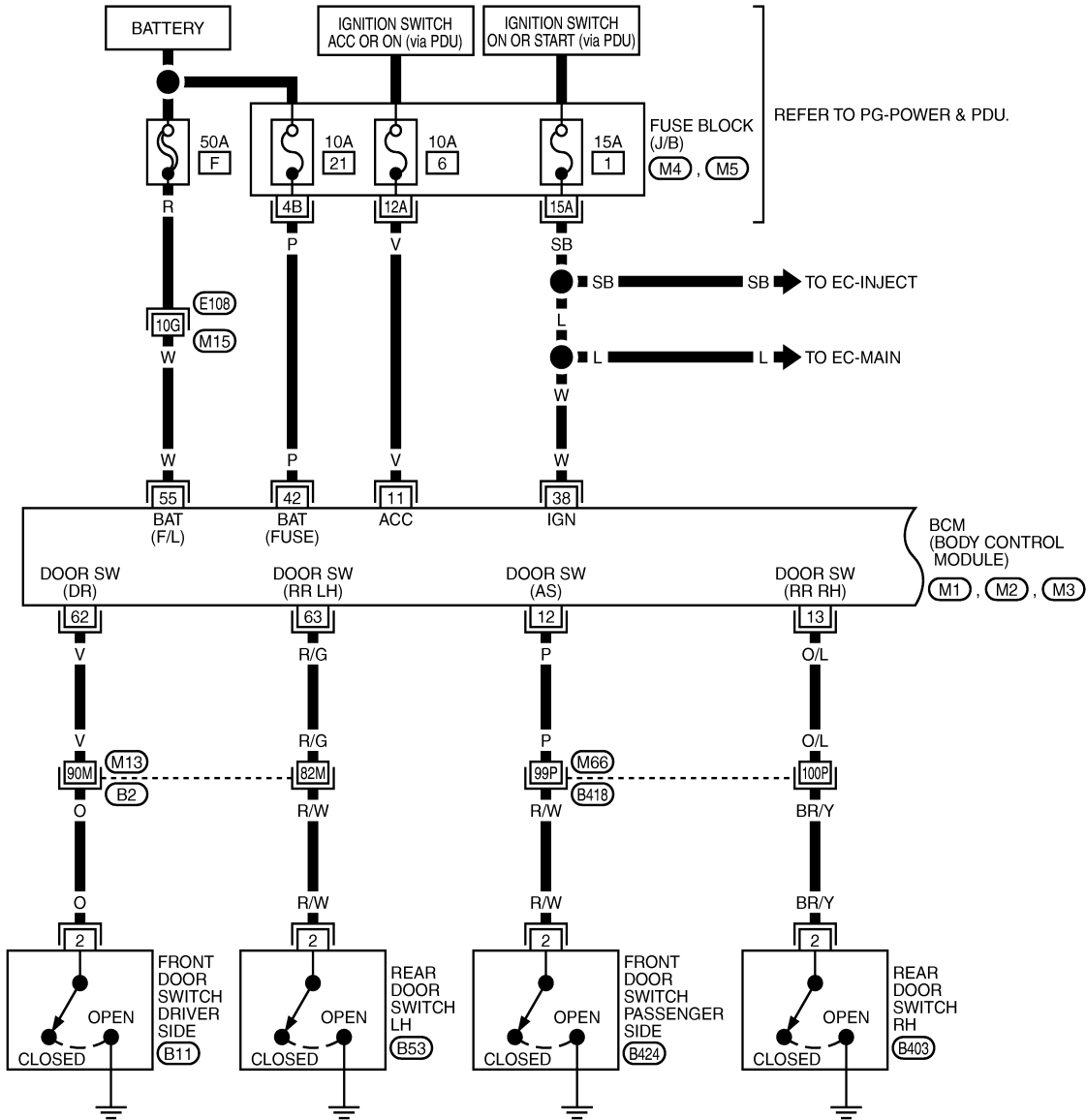

| | |
|---|------------------------------|
| 1 | |
| 2 | (B11), (B53), (B403), (B424) |
| 3 | W, W, W, W |

REFER TO THE FOLLOWING.
 (E108), (B2), (B418) - SUPER
 MULTIPLE JUNCTION (SMJ)
 (M4), (M5) - FUSE BLOCK -
 JUNCTION BOX (J/B)
 (M1), (M2), (M3)
 - ELECTRICAL UNITS

TKWT6835E

INTERIOR ROOM LAMP

< SERVICE INFORMATION >

LT-ROOM/L-02

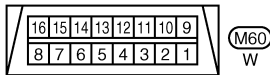
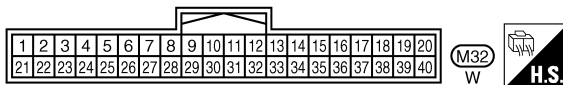
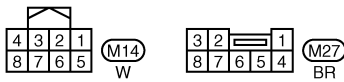
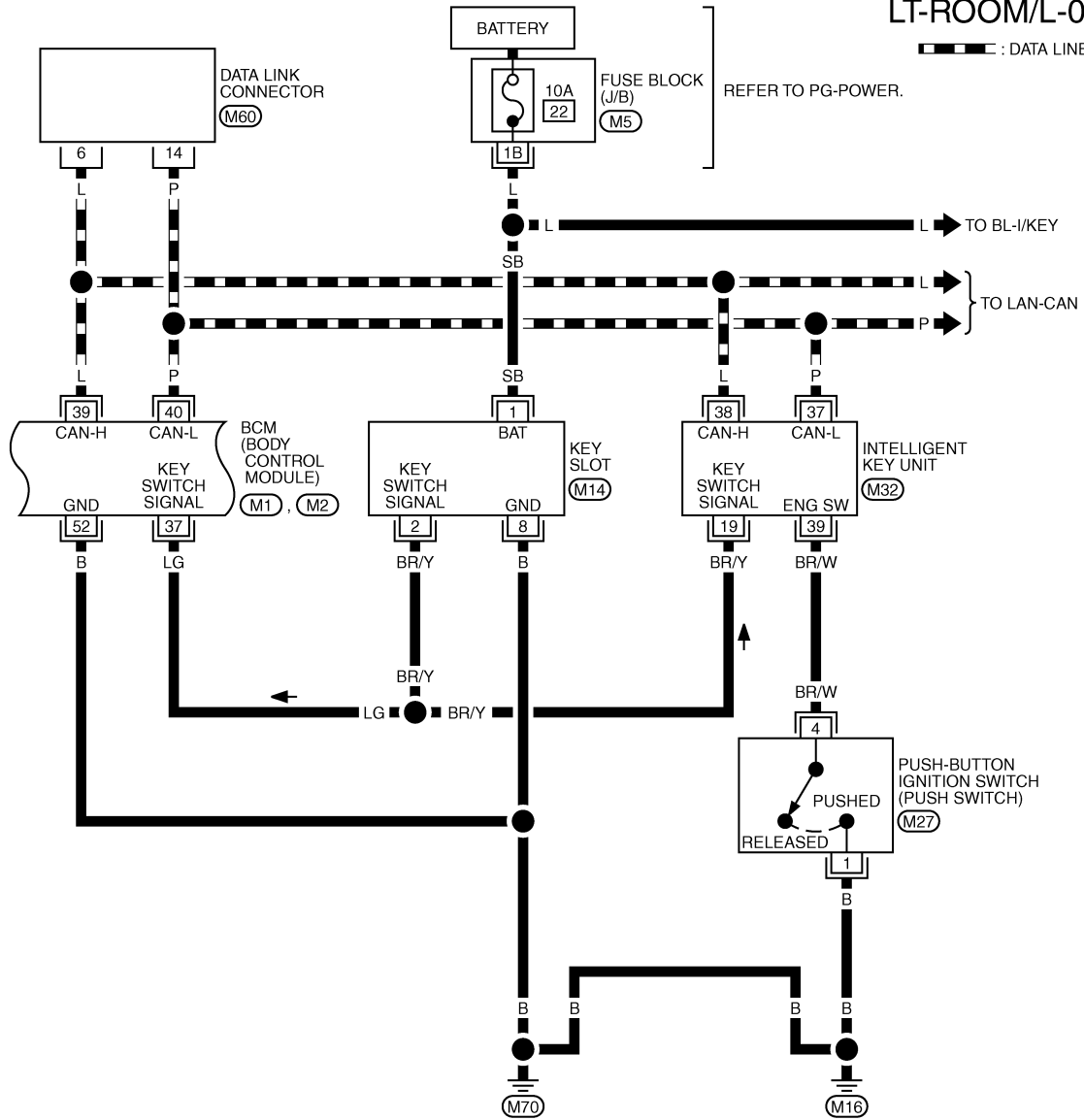

REFER TO THE FOLLOWING.

(M5) - FUSE BLOCK-JUNCTION BOX (J/B)

(M1), (M2) - ELECTRICAL UNITS

TKWT3403E

A
B
C
D
E
F
G
H
I
J
LT
L
M
N
O
P

INTERIOR ROOM LAMP

< SERVICE INFORMATION >

LT-ROOM/L-03

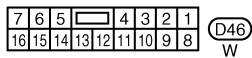
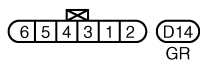
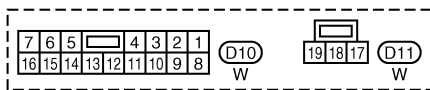
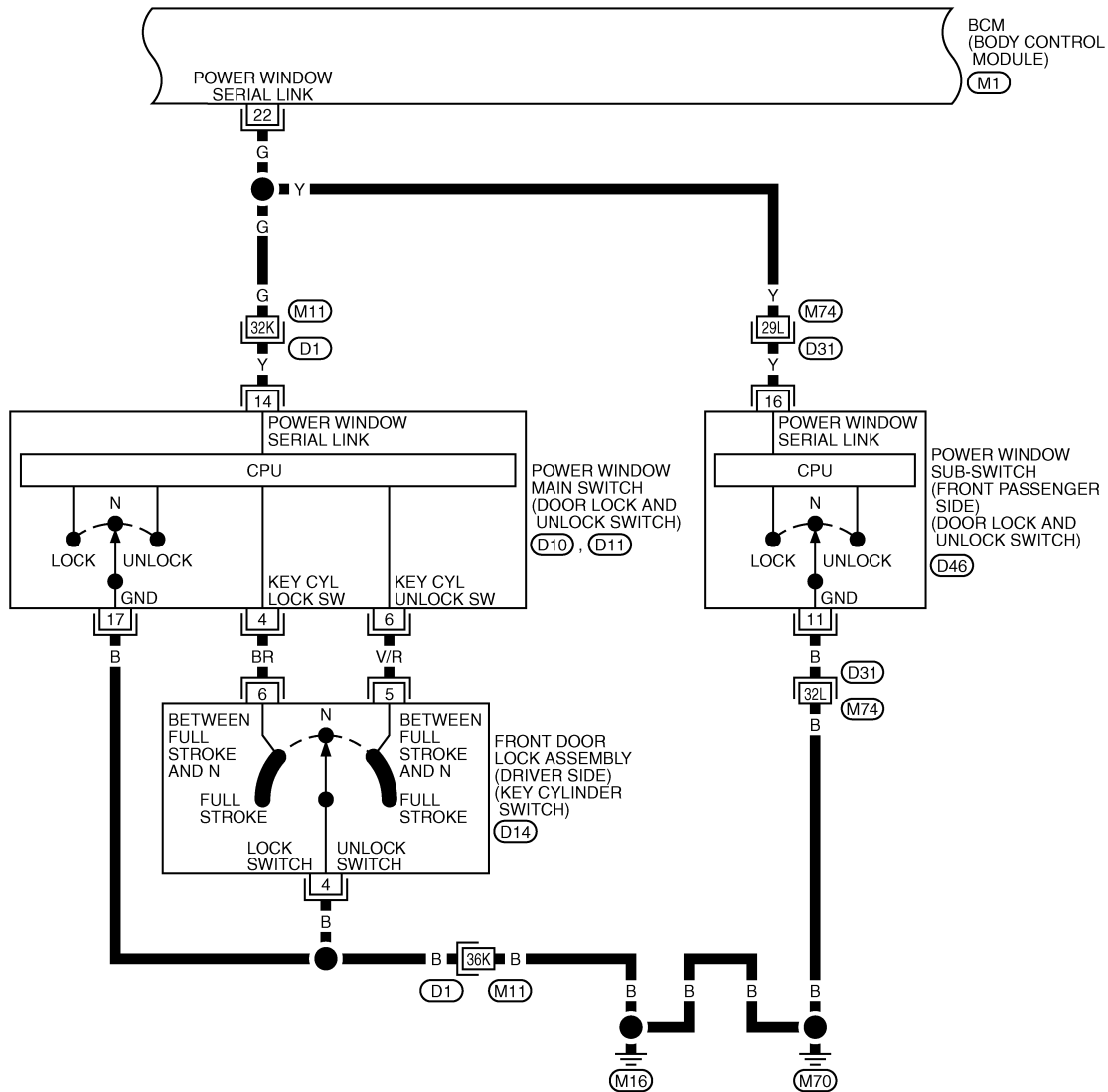

REFER TO THE FOLLOWING.
(D1), (D31) -SUPER MULTIPLE
JUNCTION (SMJ)
(M1) -ELECTRICAL UNITS

TKWT3404E

INTERIOR ROOM LAMP

< SERVICE INFORMATION >

LT-ROOM/L-05

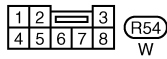
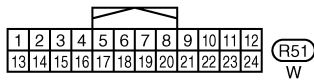
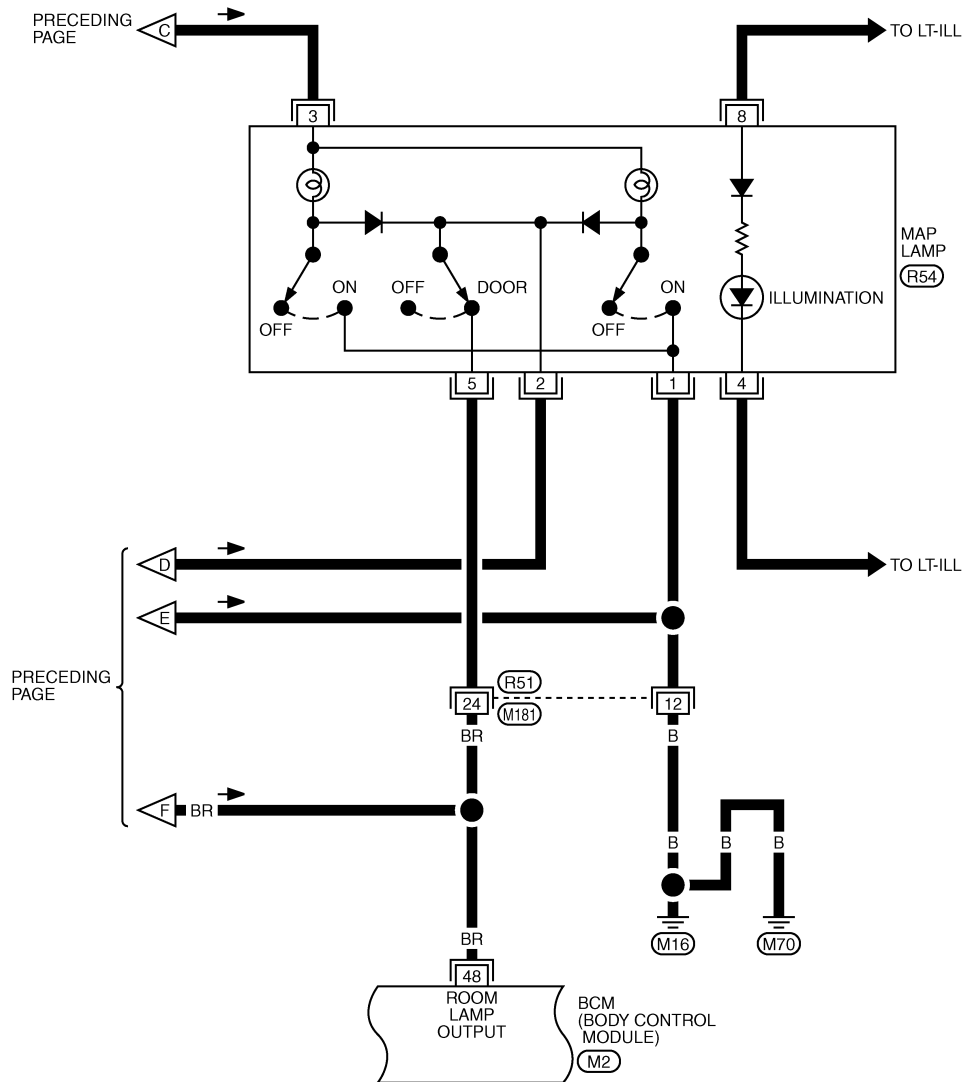

REFER TO THE FOLLOWING.
(M2) -ELECTRICAL UNITS

TKWT3406E

INTERIOR ROOM LAMP

< SERVICE INFORMATION >

LT-ROOM/L-07

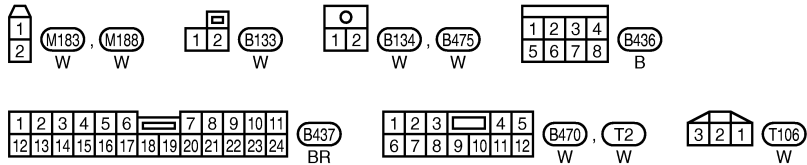
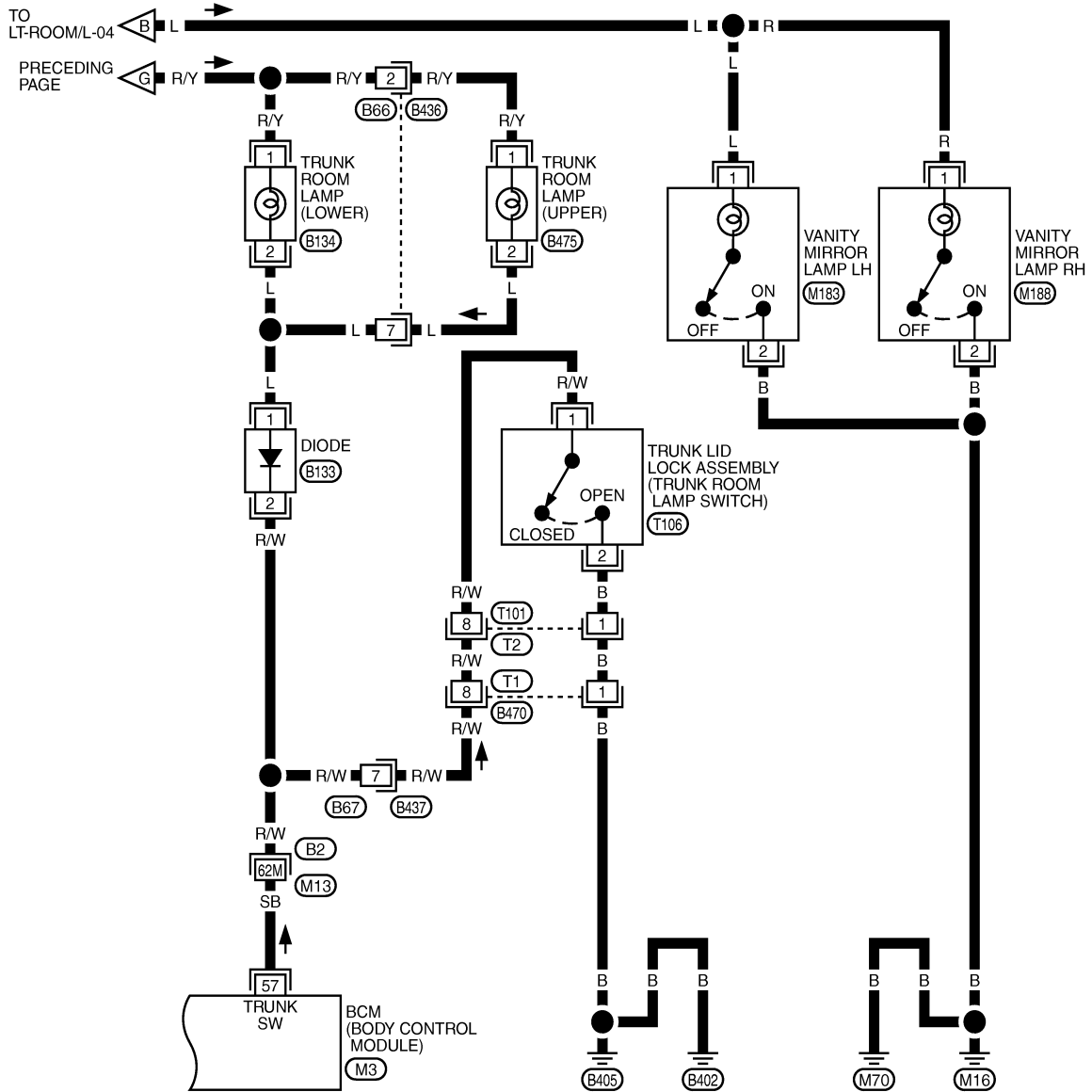

REFER TO THE FOLLOWING.

- (B2) - SUPER MULTIPLE JUNCTION (SMJ)
- (M3) - ELECTRICAL UNITS

TKWT6838E

INTERIOR ROOM LAMP

< SERVICE INFORMATION >

Terminal and Reference Value for BCM

INFOID:00000002956848

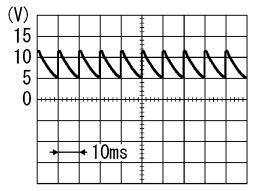
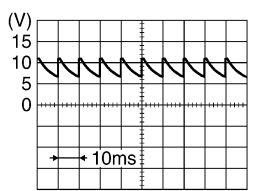
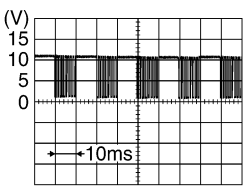
| Terminal No. | Wire color | Signal name | Measuring condition | | | Reference value |
|--------------|------------|---|---------------------|---|--|--|
| | | | Ignition switch | Operation or condition | | |
| 11 | V | Ignition switch (ACC) | ACC | — | | Battery voltage |
| 12 | P | Front door switch passenger side signal | OFF | Front door switch passenger side | ON (open) | Approx. 0 V |
| | | | | | OFF (closed) |  <p>Approx. 8.0 - 8.5 V</p> |
| 13 | O/L | Rear door switch RH signal | OFF | Rear door switch RH | ON (open) | Approx. 0 V |
| | | | | | OFF (closed) |  <p>Approx. 8.5 - 9.0 V</p> |
| 22 | G | Power window serial link | OFF | Power window main switch (door lock and unlock switch) and power window sub-switch (front passenger side) (door lock and unlock switch) | Lock or unlock switch ON NOTE: 10 seconds just after door lock and unlock switch (driver side and passenger side) is turned "LOCK" or "UNLOCK". |  |
| | | | | | OFF | Battery voltage |
| 37 | LG | Key switch signal | OFF | Intelligent Key is inserted into key slot. | Battery voltage | |
| | | | | Intelligent Key is removed from key slot. | Approx. 0 V | |
| 38 | W | Ignition power supply | ON | — | Battery voltage | |
| 39 | L | CAN - H | — | — | — | |
| 40 | P | CAN - L | — | — | — | |
| 41 | R | BAT saver output signal | OFF | — | Battery voltage | |
| 42 | P | Battery power supply | OFF | — | Battery voltage | |
| 47 | V | Step lamp output signal | OFF | Any door switch | ON (open) | Approx. 0 V |
| | | | | | OFF (close) | Battery voltage |
| 48 | BR | Room lamp output signal | ON | Any door switch | ON (open) | Approx. 0 V |
| | | | | | OFF (close) | Battery voltage |
| | | | — | All doors are closed | Turn ignition switch ON → OFF | Approx. 0 V (When room lamp timer is operating) |
| | | | | | Turn ignition switch ON | Battery voltage |

A
B
C
D
E
F
G
H
I
J
LT
L
M
N
O
P

INTERIOR ROOM LAMP

< SERVICE INFORMATION >

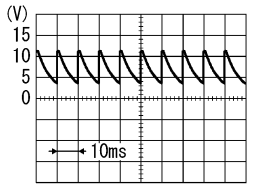
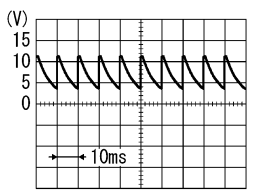
| Terminal No. | Wire color | Signal name | Measuring condition | | Reference value | |
|--------------|------------|--------------------------------------|---------------------|-------------------------------|-----------------|---|
| | | | Ignition switch | Operation or condition | | |
| 52 | B | Ground | ON | — | Approx. 0 V | |
| 55 | W | Battery power supply | OFF | — | Battery voltage | |
| 57 | SB | Trunk switch signal | OFF | Trunk room lamp switch | ON (open) | Approx. 0 V |
| | | | | | OFF (close) | Battery voltage |
| 62 | V | Front door switch driver side signal | OFF | Front door switch driver side | ON (open) | Approx. 0 V |
| | | | | | OFF (closed) |  <p style="text-align: center;">Approx. 7.5 - 8.0 V</p> |
| 63 | R/G | Rear door switch LH signal | OFF | Rear door switch LH | ON (open) | Approx. 0 V |
| | | | | | OFF (closed) |  <p style="text-align: center;">Approx. 7.5 - 8.0 V</p> |

How to Perform Trouble Diagnosis

INFOID:000000002956849

1. Confirm the symptom or customer complaint.
2. Understand operation description and function description. Refer to [LT-229, "System Description"](#).
3. Perform the Preliminary Check. Refer to [LT-244, "Preliminary Check"](#).
4. Check symptom and repair or replace the cause of malfunction.
5. Does the interior room lamp operate normally? If YES, GO TO 6. If NO, GO TO 4.
6. INSPECTION END

Preliminary Check

INFOID:000000002956850

CHECK POWER SUPPLY AND GROUND CIRCUIT

1. CHECK FUSES AND FUSIBLE LINK

Check for blown fuses and fusible link.

| Unit | Power source | Fuse or fusible link No. |
|----------|--------------------------------------|--------------------------|
| BCM | Battery | F |
| | | 21 |
| | Ignition switch ON or START position | 1 |
| | Ignition switch ACC or ON position | 6 |
| Key slot | Battery | 22 |

Refer to [LT-236, "Wiring Diagram - ROOM/L -"](#).

OK or NG

OK >> GO TO 2.

INTERIOR ROOM LAMP

< SERVICE INFORMATION >

NG >> If fuse or fusible link is blown, be sure to eliminate cause of malfunction before installing new fuse or fusible link. Refer to [PG-4](#).

2.CHECK POWER SUPPLY CIRCUIT

1. Turn ignition switch OFF.
2. Disconnect BCM connector.
3. Check voltage between BCM harness connector and ground.

| Terminal (+) | | Terminal (-) | Ignition switch position | | |
|---------------|----------|--------------|--------------------------|-----------------|-----------------|
| BCM connector | Terminal | | OFF | ACC | ON |
| M1 | 11 | Ground | Approx. 0 V | Battery voltage | Battery voltage |
| | 38 | | Approx. 0 V | Approx. 0 V | Battery voltage |
| M2 | 42 | | Battery voltage | Battery voltage | Battery voltage |
| | 55 | | Battery voltage | Battery voltage | Battery voltage |

OK or NG

OK >> GO TO 3.
 NG >> Repair harness or connector.

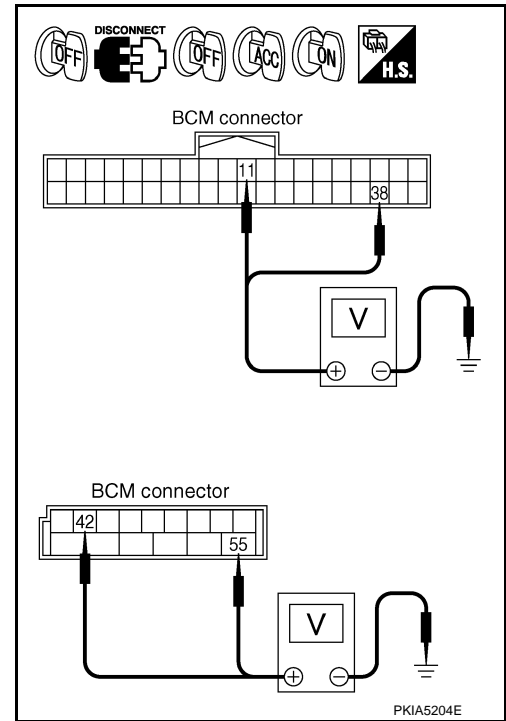

3.CHECK GROUND CIRCUIT

Check continuity between BCM harness connector and ground.

| BCM connector | Terminal | Ground | Continuity |
|---------------|----------|--------|------------|
| M2 | 52 | | Yes |

OK or NG

OK >> INSPECTION END
 NG >> Repair harness or connector.

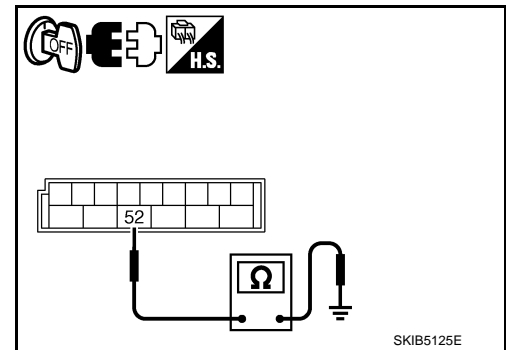

CONSULT-III Functions (BCM - INT LAMP)

INFOID:000000002956851

CONSULT-III can display each diagnostic item using the diagnostic test modes shown following.

| Diagnosis mode | Description |
|-----------------------|---|
| WORK SUPPORT | Changes the setting for each function. |
| DATA MONITOR | Displays BCM input data in real time. |
| ACTIVE TEST | Operation of electrical loads can be checked by sending driving signal to them. |
| SELF-DIAG RESULTS | BCM performs self-diagnosis of CAN communication. |
| CAN DIAG SUPPORT MNTR | The result of transmit/receive diagnosis of CAN communication can be read. |

WORK SUPPORT

Display Item List

INTERIOR ROOM LAMP

< SERVICE INFORMATION >

| Item | Description | CONSULT-III |
|------------------------|--|-------------|
| ROOM LAMP TIMER SET | The lighting time can be selected when the interior room lamps are unlocked by Intelligent Key or any door request switch. <ul style="list-style-type: none"> • Mode 1 (0 sec.)/Mode 2 (7.5 sec.)/Mode 3^{NOTE} (15 sec.)/Mode 4 (30 sec.) | MODE 1 – 4 |
| SET I/L D–UNLCK INTCON | Room lamp timer operation can be selected. <ul style="list-style-type: none"> • ON^{NOTE} (Room lamp timer operates)/OFF (Room lamp timer does not operates) | On/Off |
| ROOM LAMP ON TIME SET | The time to escalate illumination can be selected when the interior room lamp is turned on. <ul style="list-style-type: none"> • Mode 1 (0.5 sec.)/Mode 2^{NOTE} (1 sec.)/Mode 3 (2 sec.)/Mode 4 (3 sec.)/Mode 5 (4 sec.)/Mode 6 (5 sec.)/Mode 7 (0 sec.) | MODE 1 – 7 |
| ROOM LAMP OFF TIME SET | The time to diminish illumination can be selected when the interior room lamp is turned off. <ul style="list-style-type: none"> • Mode 1 (0.5 sec.)/Mode 2 (1 sec.)/Mode 3 (2 sec.)/Mode 4^{NOTE} (3 sec.)/Mode 5 (4 sec.)/Mode 6 (5 sec.)/Mode 7 (0 sec.) | MODE 1 – 7 |
| R LAMP TIMER LOGIC SET | The lighting condition of room lamp timer can be selected when the door is opened/closed. <ul style="list-style-type: none"> • Mode 1^{NOTE} (Connected with all doors)/Mode 2 (Connected with driver door only) | MODE 1 – 2 |
| ROOM LAMP ON AT LOCK | The connected operation with room lamp timer can be selected when engine switch (push switch) is turned OFF. <ul style="list-style-type: none"> • ON^{NOTE} (Connected with room lamp timer operation) /OFF (Disconnected with room lamp operation) | On/Off |

NOTE:

Factory setting

DATA MONITOR

Display Item List

| Monitor item | Contents |
|---------------------------------------|--|
| IGN ON SW "On/Off" | Displays "IGN ON position (ON)/OFF, ACC position (OFF)" judged from the ignition switch signal. |
| ACC ON SW "On/Off" | Displays "IGN ACC, ON position (ON)/OFF position (OFF)" status judged from the key switch signal. |
| KEY ON SW "On/Off" | Displays "Intelligent Key inserted into key slot (ON)/Intelligent Key removed from key slot (OFF)" status judged from the key switch signal. |
| DOOR SW - DR "On/Off" | Displays status of the driver door as judged from the driver door switch signal. (door is open: ON/door is closed: OFF) |
| DOOR SW - AS "On/Off" | Displays "door open (ON)/door closed (OFF)" status, determined from passenger door switch signal. |
| DOOR SW - RR "On/Off" | Displays "door open (ON)/door closed (OFF)" status, determined from rear door switch RH signal. |
| DOOR SW - RL "On/Off" | Displays "door open (ON)/door closed (OFF)" status, determined from rear door switch LH signal. |
| BACK DOOR SW ^{NOTE} "Off" | — |
| CDL LOCK SW "On/Off" | Displays "door locked (ON)/other (OFF)" status, determined from central door lock switch LOCK signal. |
| CDL UNLOCK SW "On/Off" | Displays "door unlocked (ON)/other (OFF)" status, determined from central door lock switch UNLOCK signal. |
| KEY CYL LK - SW "On/Off" | Displays "door locked (ON)" status, determined from key cylinder switch in driver door. |
| KEY CYL UN - SW "On/Off" | Displays "door unlocked (OFF)" status, determined from key cylinder switch in driver door. |
| I - KEY LOCK "On/Off" | Displays "locked (ON)/other (OFF)" status, determined from lock signal. |
| I - KEY UNLOCK "On/Off" | Displays "unlocked (ON)/other (OFF)" status, determined from unlock signal. |

INTERIOR ROOM LAMP

< SERVICE INFORMATION >

| Monitor item | Contents |
|-----------------|---|
| TRNK/HAT MNTR | "On/Off" Displays "trunk open (ON)/trunk close (OFF)" status, determined from trunk room lamp switch. |
| I - KEY DR UNLK | "On/Off" Displays "ON" when only driver door is unlocked or "OFF" other cases by intelligent Key or any door request switch, determined from unlock signal. |
| I - KEY AS UNLK | "On/Off" Displays "unlocked (ON)/locked (OFF)" states of passenger door by passenger side door request switch, determined from unlock signal. |

NOTE:

This item is displayed, but cannot be monitored.

ACTIVE TEST

Display Item List

| Test item | Description |
|----------------|--|
| INT LAMP | Personal lamps and map lamps can be operated by any ON-OFF operations. |
| STEP LAMP TEST | Step lamp can be operated by any ON-OFF operations. |

CONSULT-III Functions (BCM - BATTERY SAVER)

INFOID:000000002974907

CONSULT-III can display each diagnostic item using the diagnostic test modes shown following.

| Diagnosis mode | Description |
|-----------------------|---|
| WORK SUPPORT | Changes the setting for each function. |
| DATA MONITOR | Displays BCM input data in real time. |
| ACTIVE TEST | Operation of electrical loads can be checked by sending driving signal to them. |
| SELF-DIAG RESULTS | BCM performs self-diagnosis of CAN communication. |
| CAN DIAG SUPPORT MNTR | The result of transmit/receive diagnosis of CAN communication can be read. |

WORK SUPPORT

Display Item List

| Item | Description | CONSULT-III |
|---------------------|--|------------------------------------|
| ROOM LAMP TIMER SET | Interior room lamp battery saver timer setting can be changed. | MODE 1: 30 min. MODE 2: 60 min. |

DATA MONITOR

Display Item List

| Monitor item | Contents |
|------------------------------|---|
| IGN ON SW | "On/Off" Displays "IGN ON position (ON)/OFF, ACC position (OFF)" judged from the ignition switch signal. |
| ACC ON SW | "On/Off" Displays "IGN ACC, ON position (ON)/OFF position (OFF)" status judged from the key switch signal. |
| KEY ON SW | "On/Off" Displays "Intelligent Key inserted into key slot (ON)/Intelligent Key removed from key slot (OFF)" status judged from the key switch signal. |
| DOOR SW - DR | "On/Off" Displays status of the driver door as judged from the driver door switch signal. (door is open: ON/door is closed: OFF) |
| DOOR SW - AS | "On/Off" Displays "door open (ON)/door closed (OFF)" status, determined from passenger door switch signal. |
| DOOR SW - RR | "On/Off" Displays "door open (ON)/door closed (OFF)" status, determined from rear door switch RH signal. |
| DOOR SW - RL | "On/Off" Displays "door open (ON)/door closed (OFF)" status, determined from rear door switch LH signal. |
| BACK DOOR SW ^{NOTE} | "Off" — |

INTERIOR ROOM LAMP

< SERVICE INFORMATION >

| Monitor item | Contents |
|--------------------------|--|
| CDL LOCK SW "On/Off" | Displays "door locked (ON)/other (OFF)" status, determined from central door lock switch LOCK signal. |
| CDL UNLOCK SW "On/Off" | Displays "door unlocked (ON)/other (OFF)" status, determined from central door lock switch UNLOCK signal. |
| KEY CYL LK – SW "On/Off" | Displays "door locked (ON)" status, determined from key cylinder switch in driver door. |
| KEY CYL UN – SW "On/Off" | Displays "door unlocked (OFF)" status, determined from key cylinder switch in driver door. |
| I - KEY LOCK "On/Off" | Displays "locked (ON)/other (OFF)" status, determined from lock signal. |
| I - KEY UNLOCK "On/Off" | Displays "unlocked (ON)/other (OFF)" status, determined from unlock signal. |
| TRNK/HAT MNTR "On/Off" | Displays "trunk open (ON)/trunk close (OFF)" status, determined from trunk room lamp switch. |
| I - KEY DR UNLK "On/Off" | Displays "ON" when only driver door is unlocked or "OFF" other cases by Intelligent Key or any door request switch, determined from unlock signal. |
| I - KEY AS UNLK "On/Off" | Displays "unlocked (ON)/locked (OFF)" states of passenger door by passenger side door request switch, determined from unlock signal. |

NOTE:

This item is displayed, but cannot be monitored.

ACTIVE TEST

Display Item List

| Test item | Description |
|---------------|--|
| BATTERY SAVER | Personal lamps and map lamps can be operated by any ON-OFF operations. |

Interior Room Lamp Control Does Not Operate

INFOID:000000002956852

1. SELF-DIAGNOSIS

CONSULT-III SELF-DIAGNOSIS

Select "SELF-DIAG RESULTS" of BCM on CONSULT-III.

CHECK CIRCUIT BETWEEN EACH SWITCH AND BCM
GO TO 2.

Self-diagnostic result

NO DTC>>GO TO 2.

CAN communication>>Check CAN communication system of BCM. Refer to [LAN-17, "CAN Diagnosis with CONSULT-III"](#).

2. CHECK CIRCUIT BETWEEN EACH SWITCH AND BCM

CONSULT-III DATA MONITOR

1. Select "SELECT DIAG MODE" of BCM (INT LAMP) data monitor item.

2. With operating the switch, check the monitor status. Refer to [LT-245, "CONSULT-III Functions \(BCM - INT LAMP\)"](#) for switches and their functions.

CHECK THE EACH SWITCH

Check each switch. Refer to [BL-86, "Check Door Switch"](#).

OK or NG

OK >> GO TO 3.

NG >> Inspect malfunctioning switch system. Refer to [BL-86, "Check Door Switch"](#).

3. CHECK CIRCUIT BETWEEN BCM AND LAMP (1)

CONSULT-III ACTIVE TEST

1. Set map lamp switch and rear personal lamp switches to DOOR.

2. Select "INT LAMP" of BCM (INT LAMP) active test item.

3. With operating the test item, check the map lamps, personal lamps LH and RH operation.

Map lamps, personal lamps LH and RH operate normally.

INTERIOR ROOM LAMP

< SERVICE INFORMATION >

⊗ CHECK THE CIRCUIT

GO TO 4.

OK or NG

OK >> Replace BCM. Refer to [BCS-14, "Removal and Installation of BCM"](#).

NG >> GO TO 4.

4. CHECK CIRCUIT BETWEEN BCM AND MAP LAMP (2)

1. Turn ignition switch OFF.
2. Disconnect BCM connector and map lamp connector.
3. Check continuity between BCM harness connector (A) and map lamp harness connector (B).

| A | | B | | Continuity |
|-----------|----------|-----------|----------|------------|
| Connector | Terminal | Connector | Terminal | |
| M2 | 48 | R54 | 5 | Yes |

OK or NG

OK >> Replace BCM. Refer to [BCS-14, "Removal and Installation of BCM"](#). (Reconnect BCM connector and check the operation of map lamp. If it is faulty, replace BCM.)

NG >> Repair harness or connector between BCM and map lamp.

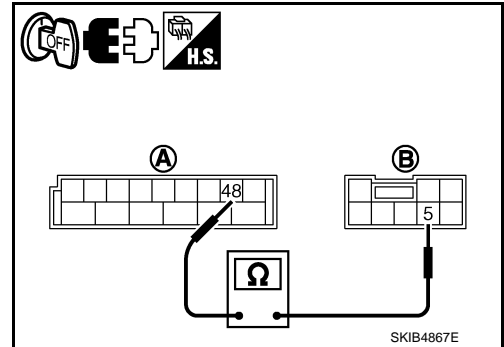

INFOID:000000002956853

Map Lamp

BULB REPLACEMENT

CAUTION:

Disconnect the battery negative terminal or remove the fuse.

1. Remove lens (1) using clip driver or suitable tool.
2. Remove bulb (2).

Map lamp : 12V - 8 W

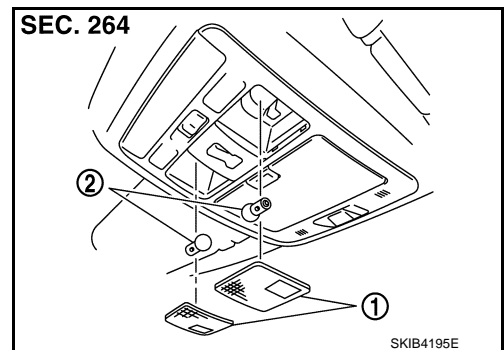

REMOVAL AND INSTALLATION

Refer to [EI-62](#).

Personal Lamp

INFOID:000000002956854

BULB REPLACEMENT

CAUTION:

Disconnect the battery negative terminal or remove the fuse.

1. Insert a screwdriver or similar tool and remove lens (1).
2. Remove bulb (2).

Personal lamp : 12V - 8W

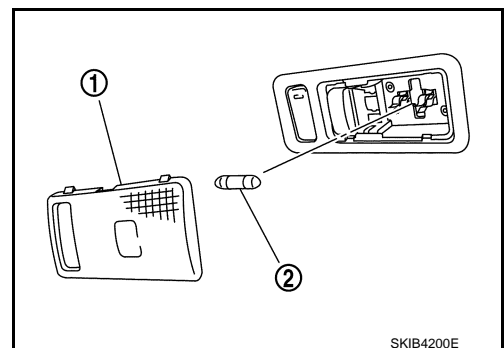

INTERIOR ROOM LAMP

< SERVICE INFORMATION >

REMOVAL AND INSTALLATION

Removal

1. Remove screw (A).
2. Use a clip driver or similar tool and remove personal lamp (1).
3. Disconnect connector.

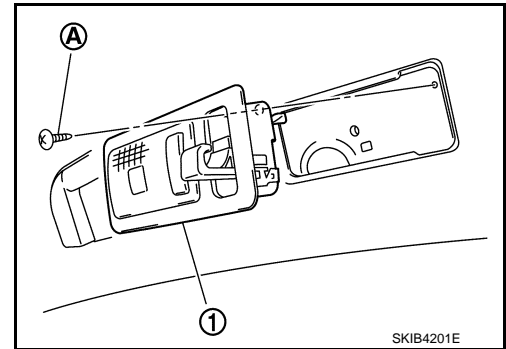

Installation

Installation is the reverse order of removal.

Foot Lamp (Driver Side)

INFOID:000000002956855

BULB REPLACEMENT

CAUTION:

Disconnect the battery negative terminal or remove the fuse.

1. Insert a screwdriver or similar tool and remove lens (1).
2. Remove bulb (2).

Foot lamp (Driver side) : 12V - 3.4W

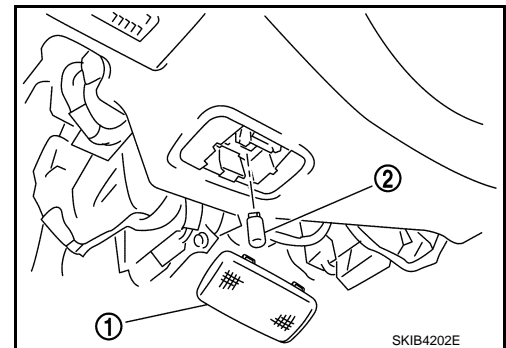

REMOVAL AND INSTALLATION

Removal

1. Use a clip driver or similar tool and remove foot lamp (driver side) (1).
2. Disconnect connector.

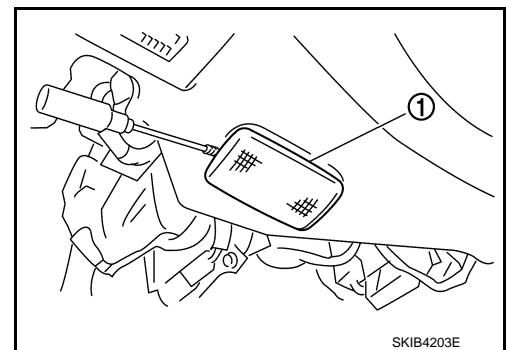

Installation

Installation is the reverse order of removal.

Foot Lamp (Passenger Side)

INFOID:000000002956856

BULB REPLACEMENT

CAUTION:

Disconnect the battery negative terminal or remove the fuse.

INTERIOR ROOM LAMP

< SERVICE INFORMATION >

1. Insert a screwdriver or similar tool and remove lens (1).
2. Remove bulb (2).

Foot lamp (Passenger side) : 12V - 3.4W

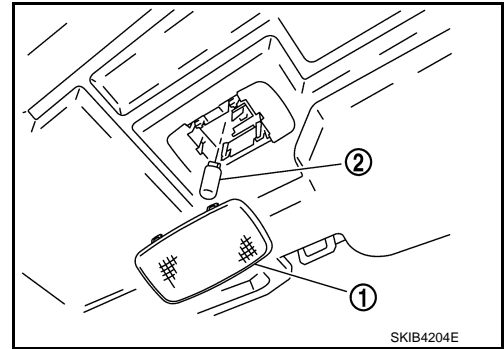

REMOVAL AND INSTALLATION

Removal

1. Use a clip driver or similar tool and remove foot lamp (passenger side) (1).
2. Disconnect connector.

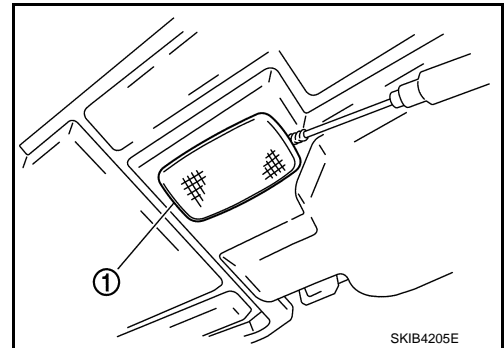

Installation

Installation is the reverse order of removal.

Vanity Mirror Lamp

INFOID:000000002956857

BULB REPLACEMENT

CAUTION:

Disconnect the battery negative terminal or remove the fuse.

1. Insert a thin screwdriver in the lens end and remove lens (1).
2. Remove bulb (2).

Vanity mirror lamp : 12V - 1.8 W

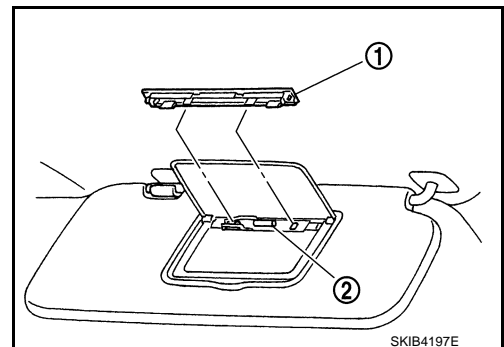

Step Lamp

INFOID:000000002956858

BULB REPLACEMENT

CAUTION:

Disconnect the battery negative terminal or remove the fuse.

A
B
C
D
E
F
G
H
I
J
LT
L
M
N
O
P

INTERIOR ROOM LAMP

< SERVICE INFORMATION >

1. Insert a screwdriver or similar tool and remove lens (1).
2. Remove bulb.

Step lamp : 12V - 5W

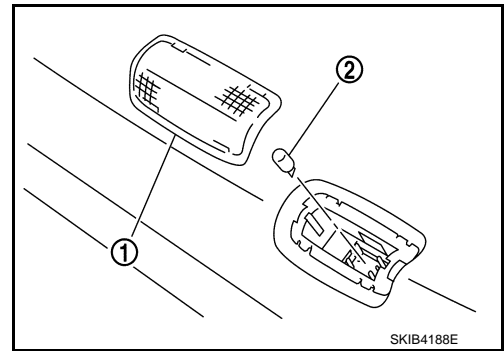

REMOVAL AND INSTALLATION

Remove step lamp integral with door trim. Refer to [EI-48. "Component Parts Location"](#).

Kicking Plate Illumination

INFOID:000000002956859

BULB REPLACEMENT

Replacement integral with front kicking plate inner.

REMOVAL AND INSTALLATION

Remove integral with front kicking plate inner. Refer to [EI-48. "Component Parts Location"](#).

Trunk Room Lamp (Upper/Lower)

INFOID:000000002956860

BULB REPLACEMENT

CAUTION:

Disconnect the battery negative terminal or remove the fuse.

1. Insert a screwdriver or similar tool and remove lens (1).
2. Remove bulb (2).

Trunk room lamp (upper/lower) : 12V - 5W

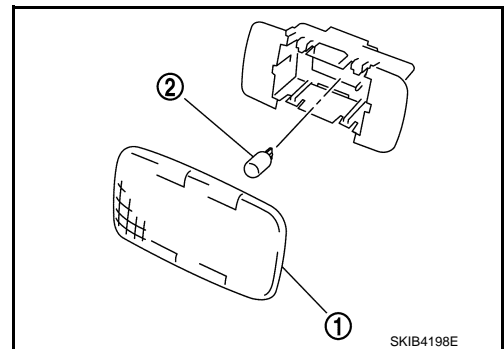

REMOVAL AND INSTALLATION

Removal

1. Insert a screwdriver or similar tool and remove trunk room lamp (1).
2. Disconnect connector.

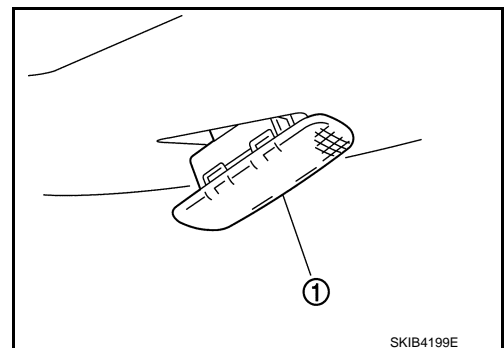

Installation

Installation is the reverse order of removal.

ILLUMINATION

< SERVICE INFORMATION >

ILLUMINATION

System Description

INFOID:00000002956861

Control of the illumination lamps operation is dependent upon the position of the lighting switch (combination switch). When the lighting switch is placed in the 1ST or 2ND position (or if the auto light system is activated) the BCM (body control module) receives input signal requesting the illumination lamps to illuminate. This input signal is communicated to the IPDM E/R (intelligent power distribution module engine room) across the CAN communication lines. The CPU (central processing unit) located in the IPDM E/R controls the tail lamp relay coil. This relay, when energized, directs power to the illumination lamps, which then illuminate.

OUTLINE

Power is supplied at all times

- through 15A fuse (No. 71, located in IPDM E/R)
- to tail lamp relay, located in IPDM E/R, and
- to CPU located in IPDM E/R,
- through 15A fuse (No. 78, located in IPDM E/R)
- to CPU located in IPDM E/R,
- through 50A fusible link (letter F, located in fuse, fusible link and relay block)
- to BCM terminal 55,
- through 10A fuse [No. 21, located in fuse block (J/B)]
- to BCM terminal 42 and
- to combination meter terminal 23,
- through 10A fuse [No. 19, located in fuse block (J/B)]
- to unified meter and A/C amp. terminal 54,
- through 10A fuse [No. 22, located in fuse block (J/B)]
- to intelligent key unit terminals 1, 41 and 57.

With the ignition switch in the ON or START position, power is supplied

- through 15A fuse [No. 1, located in fuse block (J/B)]
- to BCM terminal 38,
- through 10A fuse [No. 14, located in fuse block (J/B)]
- to combination meter terminal 12,
- through 10A fuse [No. 12, located in fuse block (J/B)]
- to unified meter and A/C amp. terminal 53 and
- to rear sunshade cancel relay terminal 1.

With the ignition switch in the ACC or ON position, power is supplied

- through 10A fuse [No. 6, located in fuse block (J/B)]
- to BCM terminal 11
- to unified meter and A/C amp. terminal 41 and
- to combination meter terminal 2.

Ground is supplied

- to BCM terminal 52
- to unified meter and A/C amp. terminals 55 and 71
- to combination meter terminals 9, 10, and 11
- to Intelligent Key unit terminals 20, 40, 56 and 72, and
- to illumination control switch terminal 3
- through grounds M16 and M70,
- to IPDM E/R terminals 38 and 51
- through grounds E22 and E43.

ILLUMINATION OPERATION BY LIGHTING SWITCH

With the lighting switch in the 1ST or 2ND position (or if the auto light system is activated), the BCM receives input signal requesting the illumination lamps to illuminate. This input signal is communicated to the IPDM E/R across the CAN communication lines. The CPU located in the IPDM E/R controls the tail lamp relay coil, which, when energized, directs power

- through IPDM E/R terminal 21
- to combination meter terminal 13
- to LDW switch (illumination) terminal 5 (with lane departure prevention)
- to VDC off switch (illumination) terminal 3
- to trunk lid opener switch (illumination) terminal 3
- to combination switch (spiral cable) terminal 25
- to door mirror remote control switch (illumination) terminal 16

A

B

C

D

E

F

G

H

I

J

LT

L

M

N

O

P

ILLUMINATION

< SERVICE INFORMATION >

- to AFS switch (illumination) terminal 5 (with AFS)
- to rear sunshade front switch (illumination) terminal 5 (with rear control switch)
- to A/T illumination terminal 1
- to snow mode switch (illumination) terminal 5 (AWD models)
- to rear control cancel switch (illumination) terminal 4 (with rear control switch)
- to clock terminal 3
- to multifunction switch terminal 3
- to DVD player terminal 18 (with DVD player)
- to AV control unit terminal 9
- to climate controlled seat switch driver side (illumination) terminal 7
- to climate controlled seat switch passenger side (illumination) terminal 7
- to ashtray illumination (rear LH) terminal 1
- to ashtray illumination (rear RH) terminal 1
- to illumination control switch terminal 1
- to cigarette lighter socket (illumination) terminal 2
- to map lamp (illumination) terminal 8
- to power window main switch illumination terminal 1
- to glove box lamp terminal 1
- to rear control switch terminal 2 (with rear control switch)
- to rear power seat switch RH (illumination) terminal 4 (with rear control switch)
- to rear heated seat switch RH (illumination) terminal 7 (with rear control switch)
- to rear sunshade cancel relay terminal 6 (with rear control switch)
- to automatic return cancel switch (illumination) terminal 4 (with rear control switch)
- to rear power seat switch LH (illumination) terminal 4 (with rear control switch) and
- to rear heated seat switch LH (illumination) terminal 7 (with rear control switch),
- through Intelligent Key unit terminal 64
- to push button ignition switch (illumination) terminal 3.

Ground is supplied

- to combination meter terminal 9, 10 and 11
- through grounds M16 and M70,
- to combination meter terminal 14
- to push button ignition switch (illumination) terminal 2
- to LDW switch (illumination) terminal 4 (with lane departure prevention)
- to VDC off switch (illumination) terminal 4
- to trunk lid opener switch (illumination) terminal 4
- to combination switch (spiral cable) terminal 24
- to door mirror remote control switch (illumination) terminal 15
- to AFS switch (illumination) terminal 6 (with AFS)
- to rear sunshade front switch (illumination) terminal 6 (with rear control switch)
- to A/T illumination terminal 2
- to snow mode switch (illumination) terminal 6 (AWD models)
- to rear control cancel switch (illumination) terminal 5 (with rear control switch)
- to clock terminal 4
- to multifunction switch terminal 4
- to AV control unit terminal 8 (with navigation system)
- to AV control unit terminal 18 (without navigation system)
- to climate controlled seat switch driver side (illumination) terminal 8 and
- to climate controlled seat switch passenger side (illumination) terminal 8
- through illumination control switch terminal 2
- to illumination control switch terminal 3
- through grounds M16 and M70,
- to DVD player terminal 17 (with DVD player)
- through grounds M16 and M70,
- to cigarette lighter socket (illumination) terminal 1
- to map lamp (illumination) terminal 4
- to power window main switch illumination terminal 2 and
- to glove box lamp terminal 2
- through grounds M16 and M70,
- to ashtray illumination (rear RH) terminal 2
- through grounds B402, B405,
- to ashtray illumination (rear LH) terminal 2

ILLUMINATION

< SERVICE INFORMATION >

- through grounds B5, B40 and B131,
- to automatic return cancel switch (illumination) terminal 2 (with rear control switch)
- to rear power seat switch LH (illumination) terminal 3 (with rear control switch)
- to rear heated seat switch LH (illumination) terminal 8 (with rear control switch)
- through grounds B5, B40 and B131,
- to rear sunshade cancel relay terminal 7(with rear control switch)
- to rear sunshade rear switch (illumination) terminal 5 (with rear control switch)
- to rear control switch terminal 4 (with rear control switch)
- through grounds B5, B40, B131 and B559.
- to rear power seat switch RH (illumination) terminal 3 (with rear control switch)
- to rear heated seat switch RH (illumination) terminal 8 (with rear control switch)
- through grounds B5, B40, B131 and B559.

With power and ground supplied, illumination lamps illuminate.

EXTERIOR LAMP BATTERY SAVER CONTROL

BCM activates the exterior lamp battery saver control function and turns off the exterior lamps to prevent battery from over discharge when the combination switch (lighting switch) is in 1ST or 2ND position and/or the front fog lamp switch ON and the door lock operation is performed by keyless entry system.

CAN Communication System Description

INFOID:000000002956862

CAN (Controller Area Network) is a serial communication line for real time application. It is an on-vehicle multiplex communication line with high data communication speed and excellent error detection ability. Many electronic control units are equipped onto a vehicle, and each control unit shares information and links with other control units during operation (not independent). In CAN communication, control units are connected with 2 communication lines (CAN H line, CAN L line) allowing a high rate of information transmission with less wiring. Each control unit transmits/receives data but selectively reads required data only.

CAN Communication Unit

INFOID:000000002956863

Refer to [LAN-11, "System Description"](#).

A
B
C
D
E
F
G
H
I
J
LT
L
M
N
O
P



ILLUMINATION

< SERVICE INFORMATION >

Schematic

INFOID:00000002956864

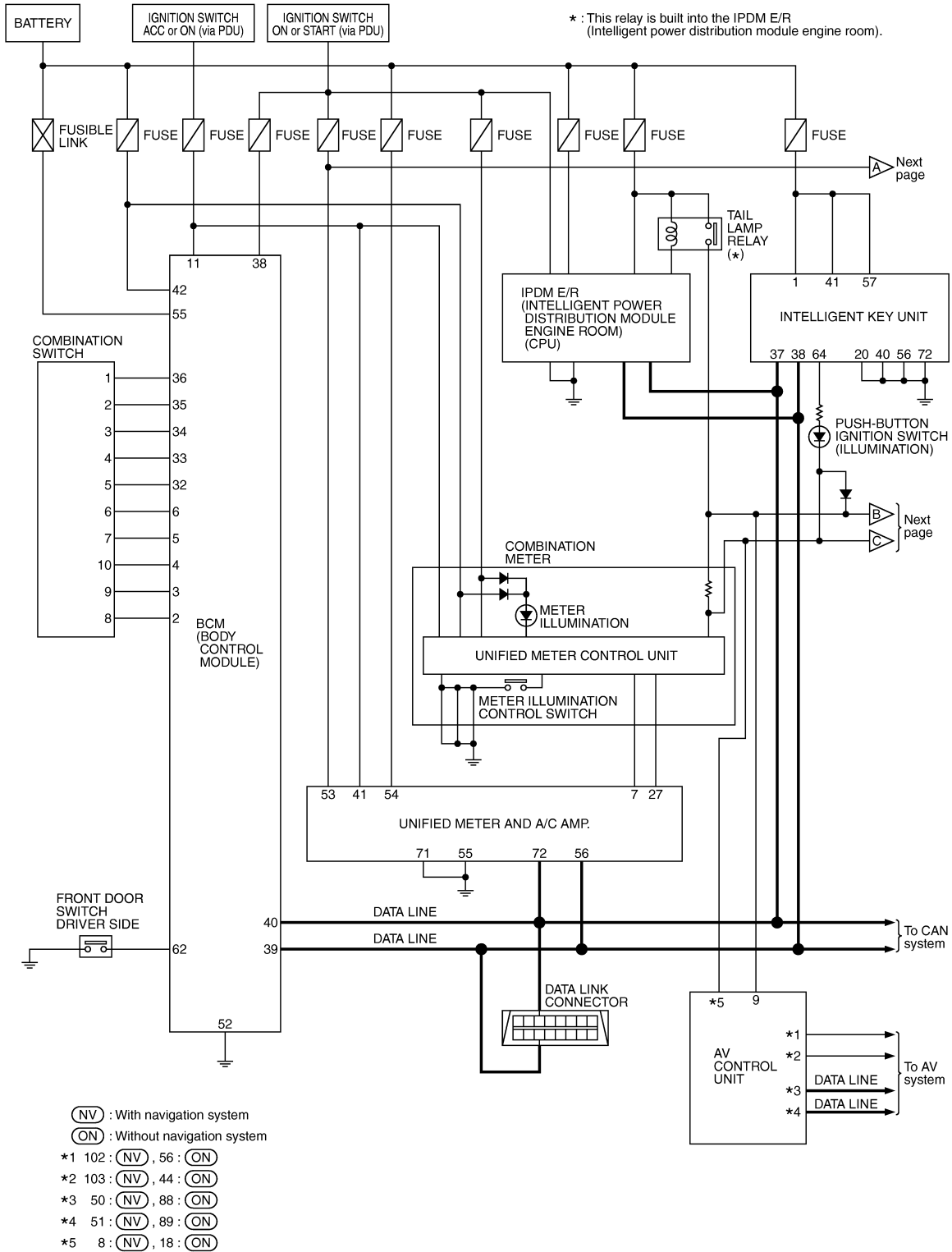

TKWT6839E

ILLUMINATION

< SERVICE INFORMATION >

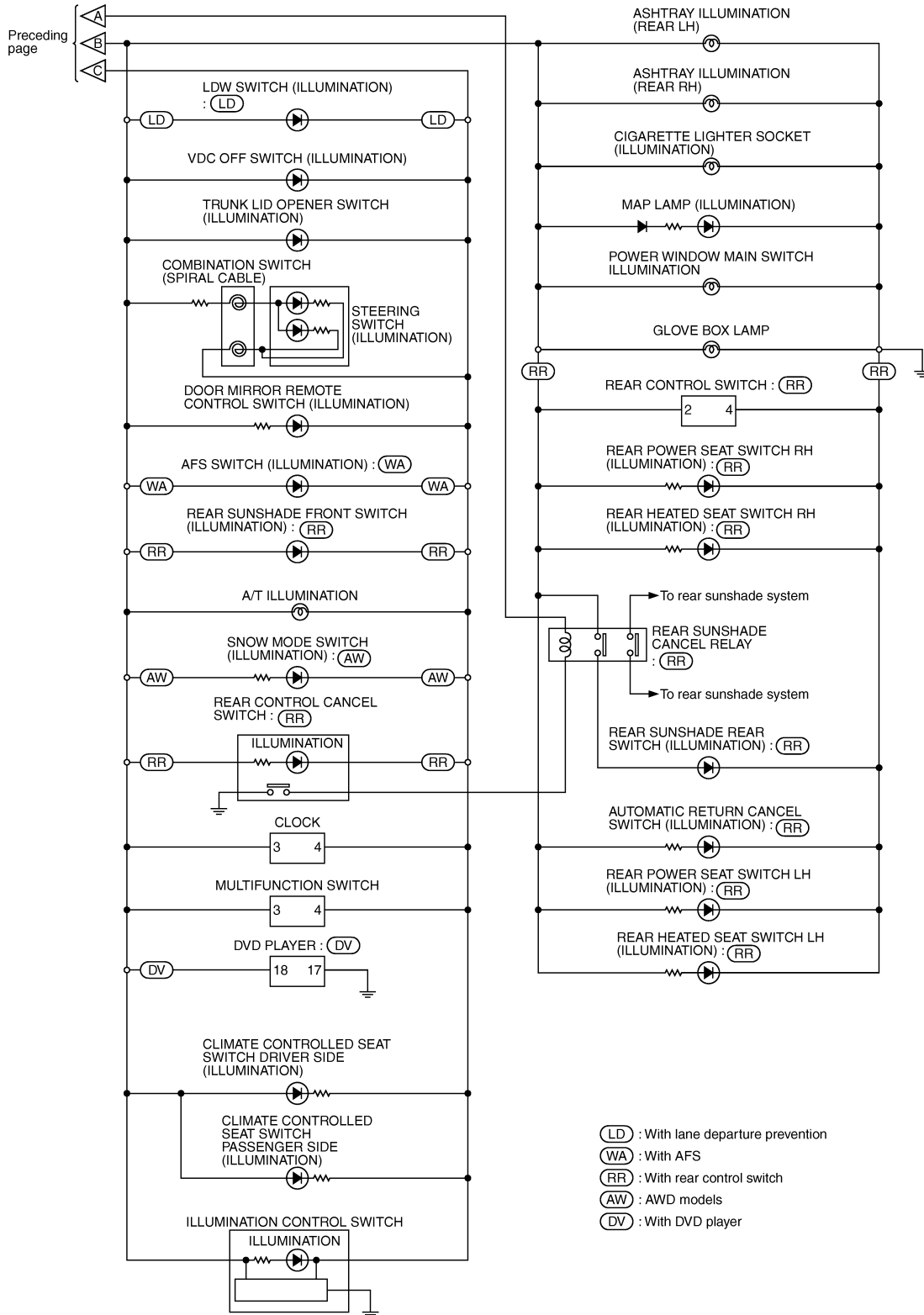



TKWT6840E

A
B
C
D
E
F
G
H
I
J
LT
L
M
N
O
P

ILLUMINATION

< SERVICE INFORMATION >

LT-ILL-03

 : WITH VK ENGINE
 : WITH VQ ENGINE

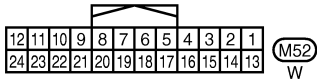
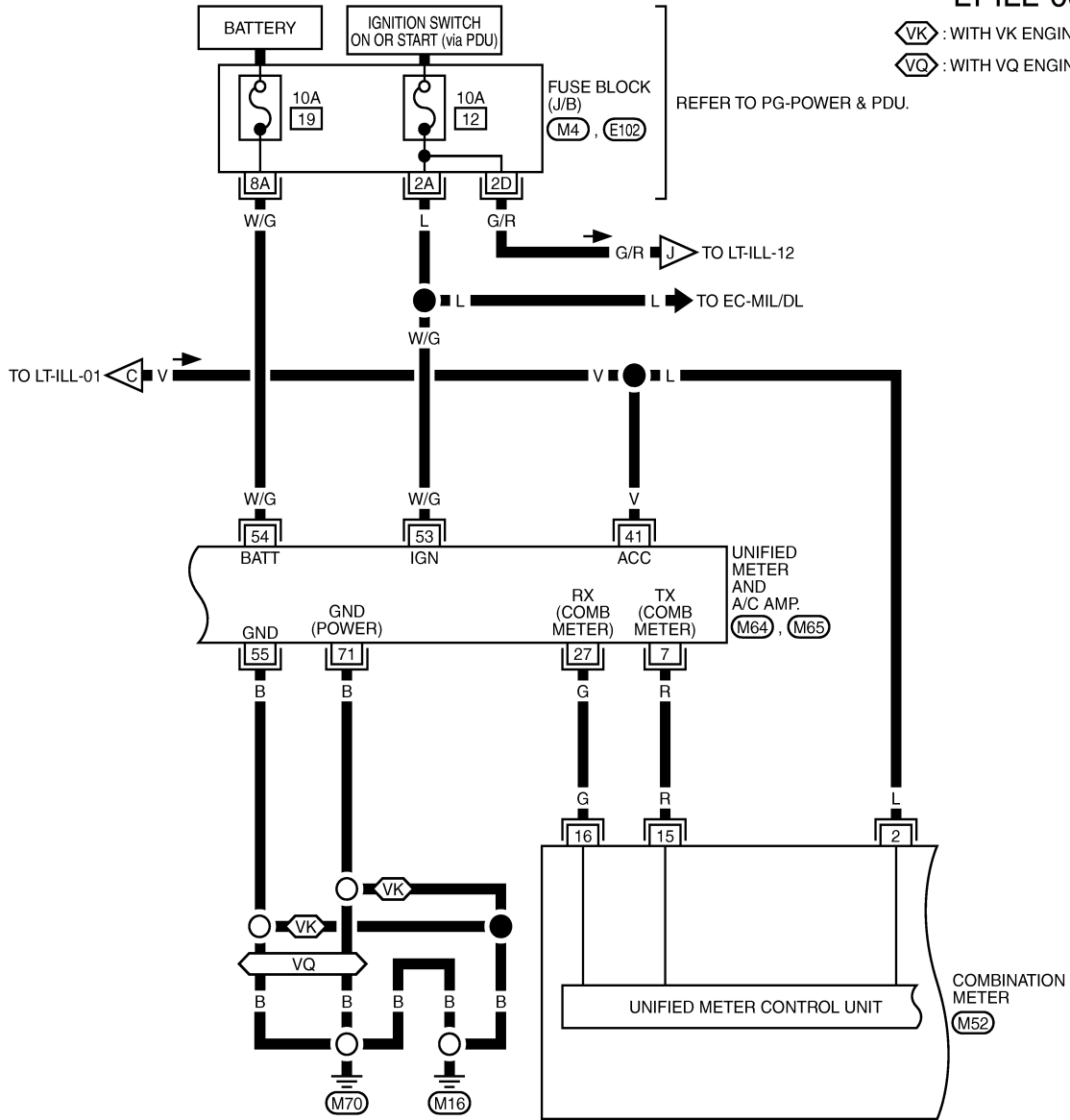

REFER TO THE FOLLOWING.
 M4, E102 - FUSE BLOCK - JUNCTIONBOX (J/B)

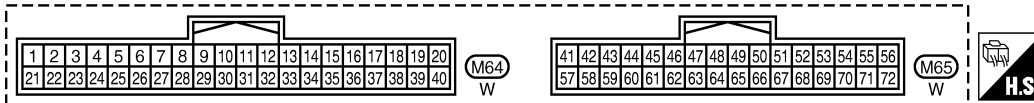

TKWT6843E

ILLUMINATION

< SERVICE INFORMATION >

LT-ILL-05

— : DATA LINE

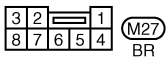
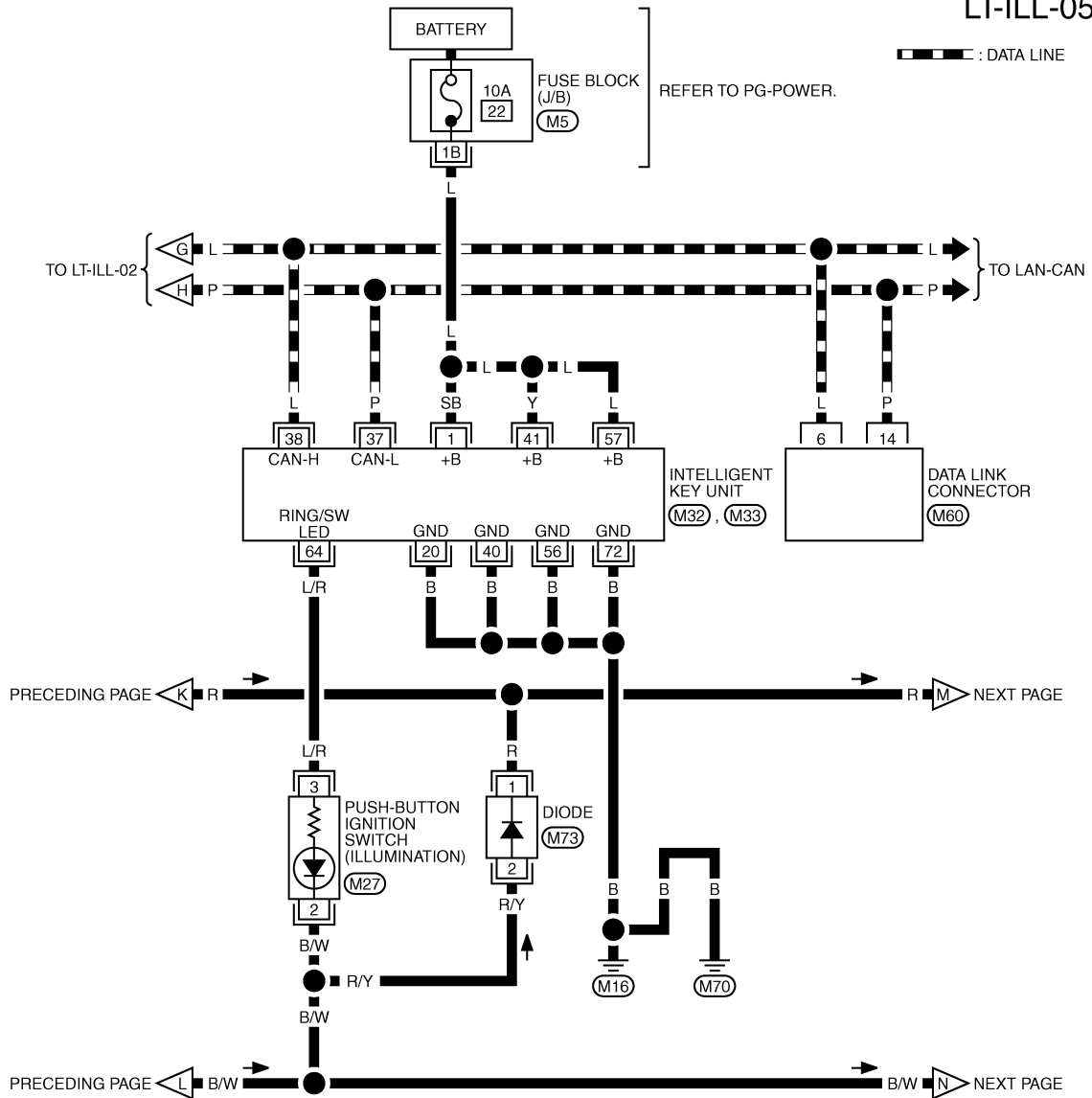

REFER TO THE FOLLOWING.
M5 - FUSE BLOCK-JUNCTION BOX (J/B)

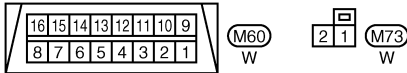
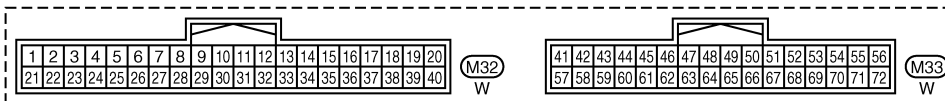

TKWT5075E

ILLUMINATION

< SERVICE INFORMATION >

LT-ILL-06

◊LD◊ : WITH LANE DEPARTURE PREVENTION

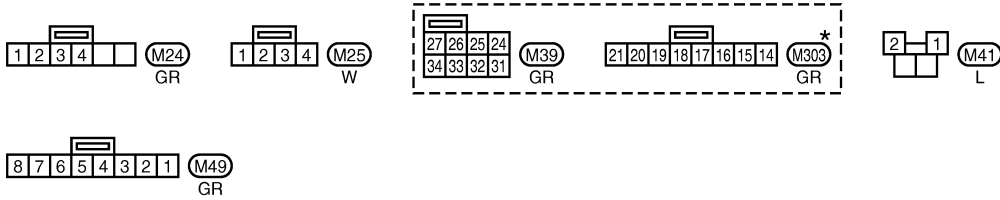
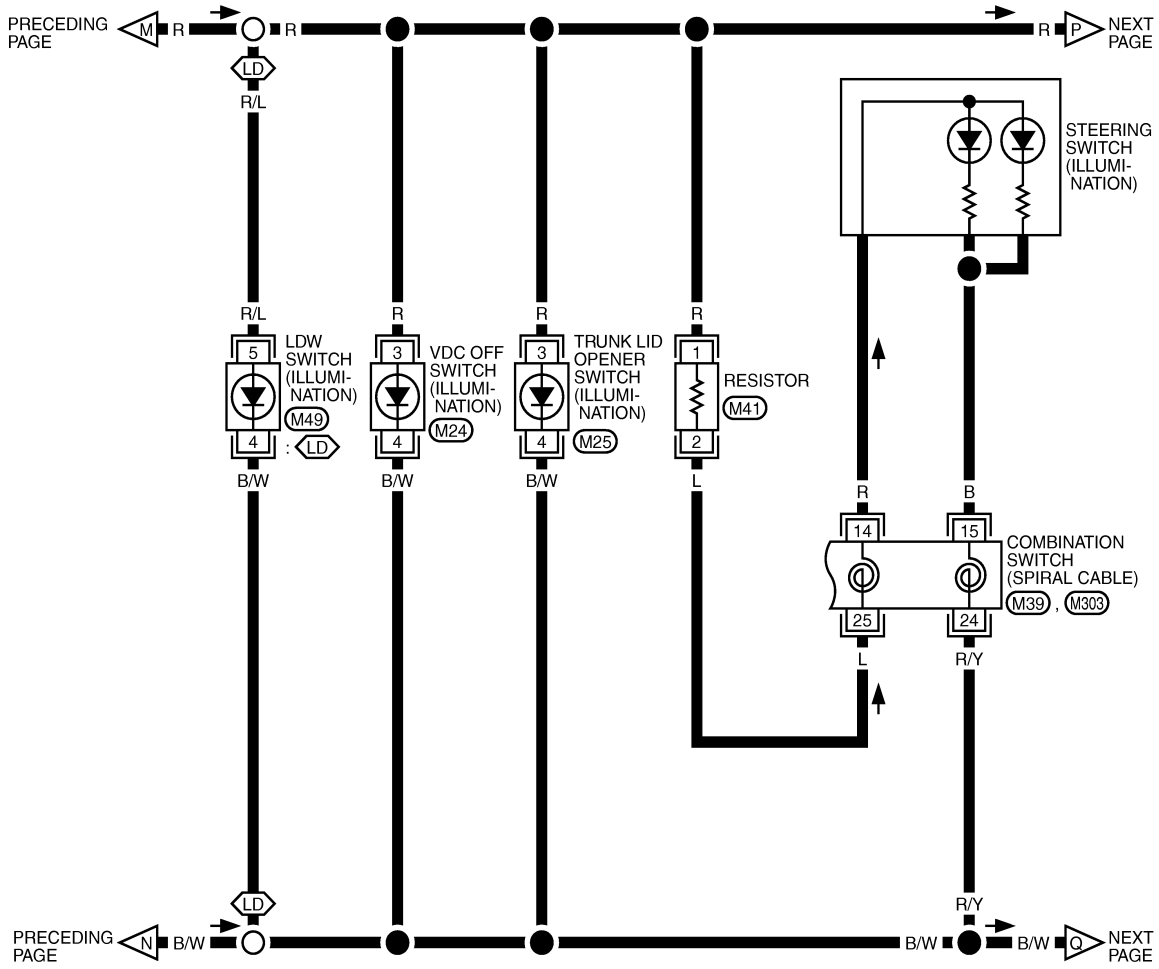

*: THIS CONNECTOR IS NOT SHOWN IN "HARNESS LAYOUT", PG SECTION.

TKWT6844E

A
B
C
D
E
F
G
H
I
J
LT
L
M
N
O
P

ILLUMINATION

< SERVICE INFORMATION >

LT-ILL-07

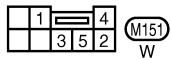
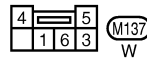
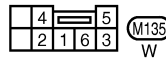
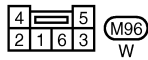
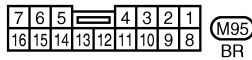
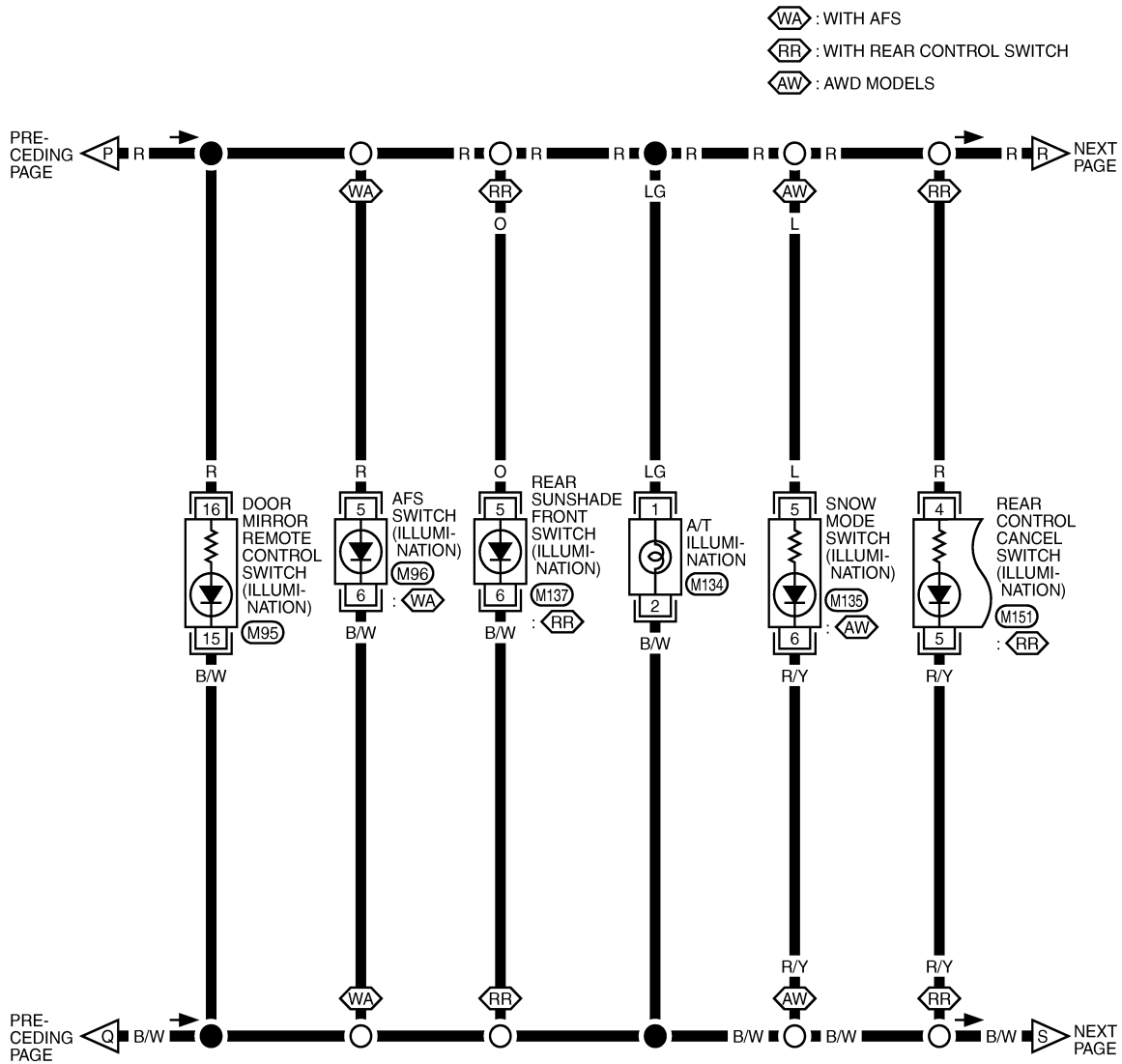

TKWT6845E

ILLUMINATION

< SERVICE INFORMATION >

LT-ILL-08

— : DATA LINE

⬡ NV : WITH NAVIGATION SYSTEM

⬡ ON : WITHOUT NAVIGATION SYSTEM

⬡ DV : WITH DVD PLAYER

*1 G/R : ⬡ NV, R/Y : ⬡ ON

*2 50 : ⬡ NV, 88 : ⬡ ON

*3 51 : ⬡ NV, 89 : ⬡ ON

*4 102 : ⬡ NV, 56 : ⬡ ON

*5 103 : ⬡ NV, 44 : ⬡ ON

*6 8 : ⬡ NV, 18 : ⬡ ON

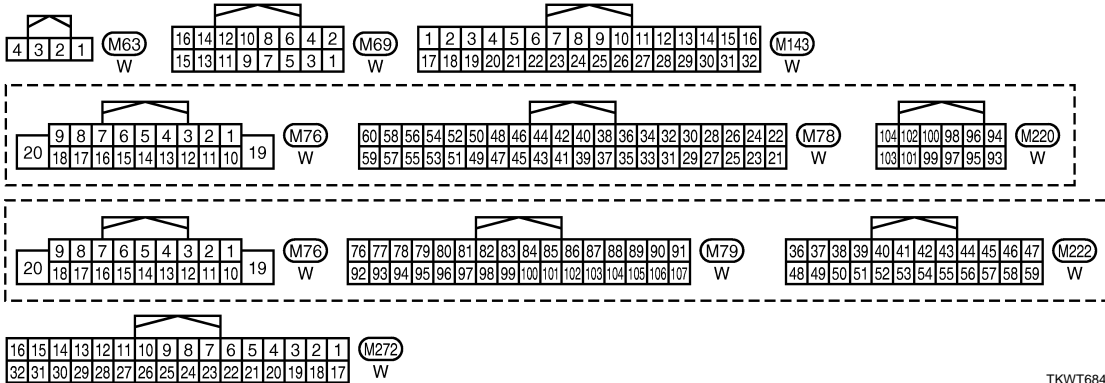
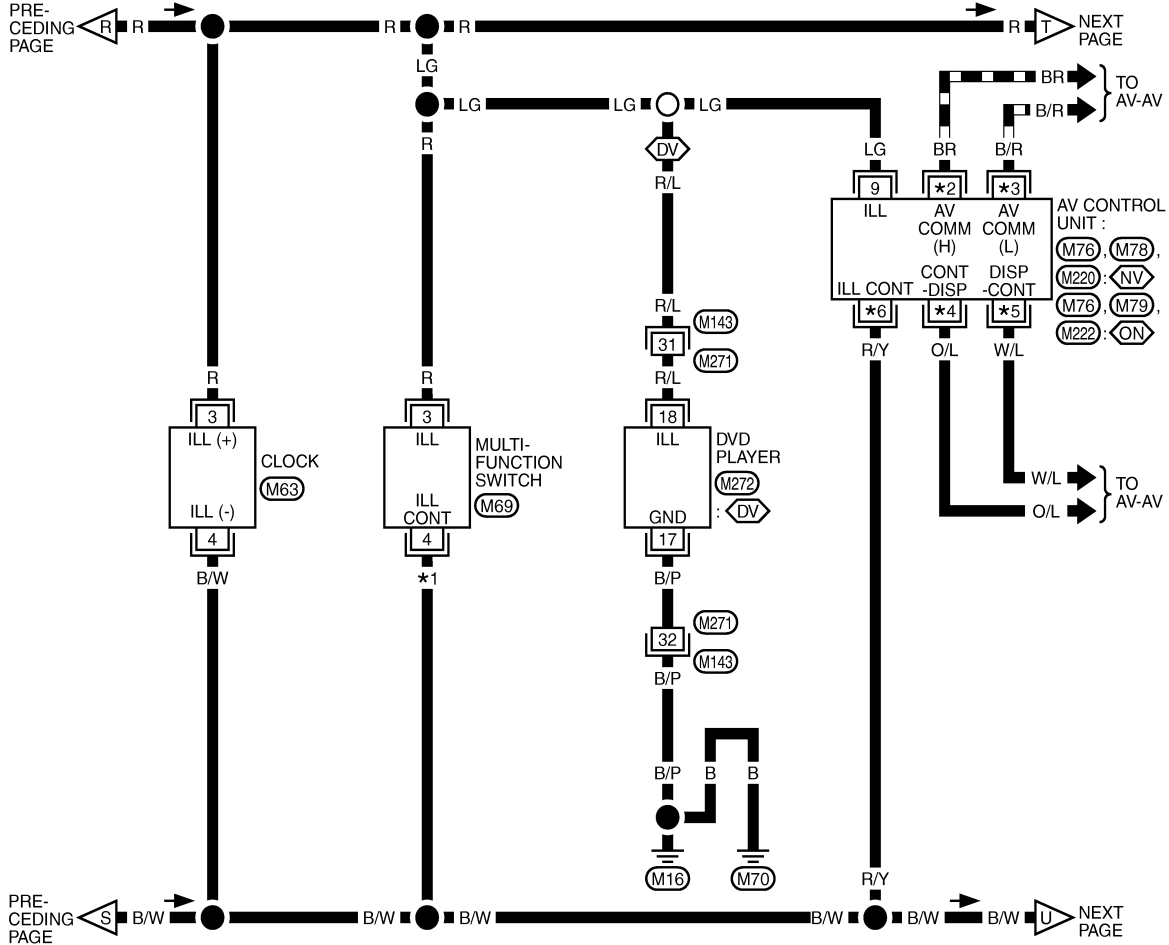

TKWT6846E

ILLUMINATION

< SERVICE INFORMATION >

LT-ILL-10

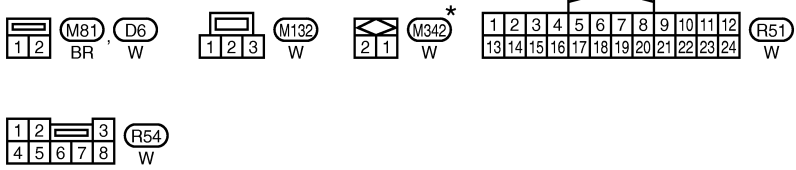
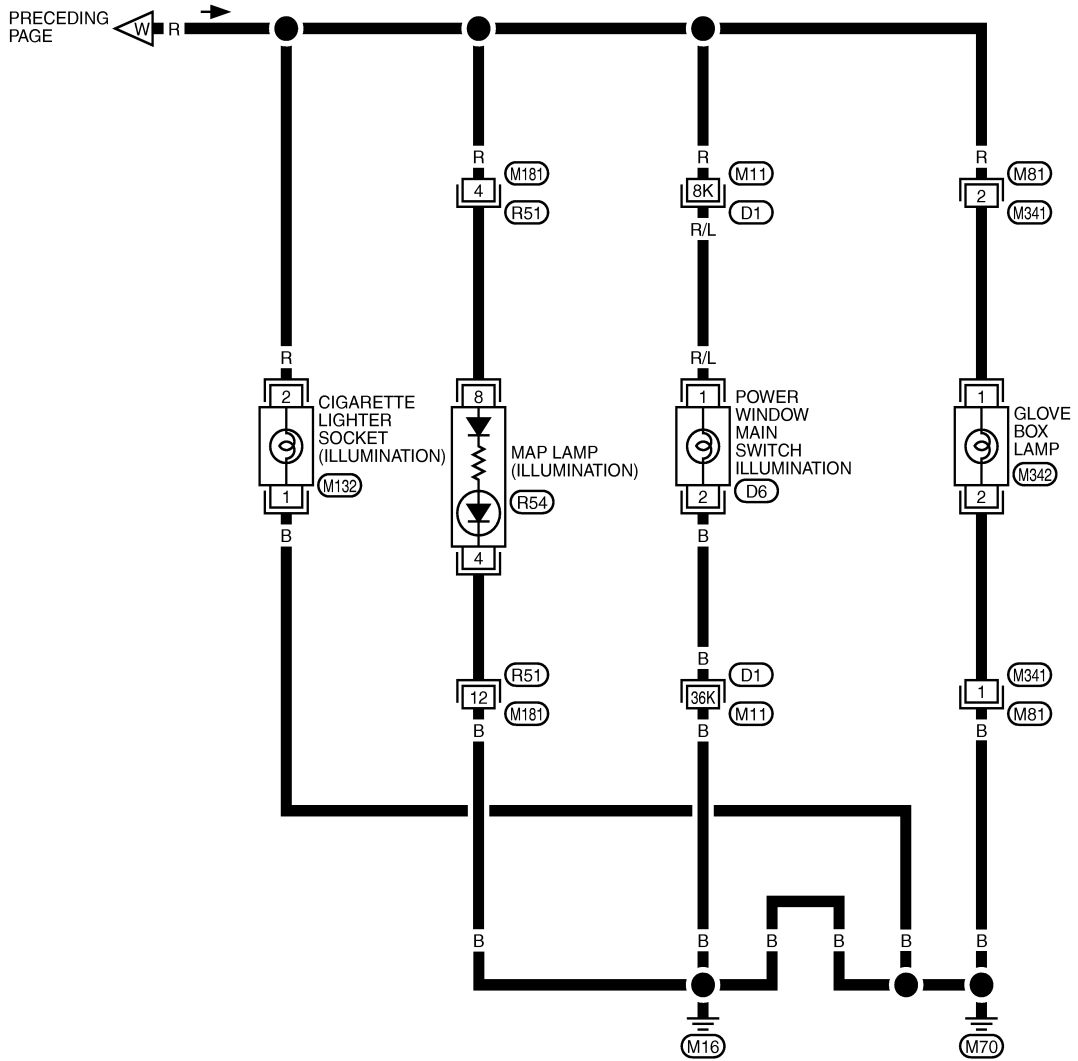

*: THIS CONNECTOR IS NOT SHOWN IN "HARNESS LAYOUT", PG SECTION.

REFER TO THE FOLLOWING.

(D1) - SUPER MULTIPLE JUNCTION (SMJ)

TKWT6848E

ILLUMINATION

< SERVICE INFORMATION >

LT-ILL-11

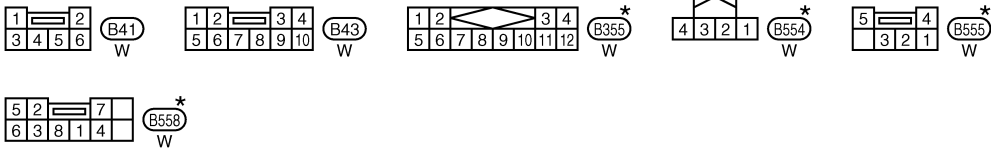
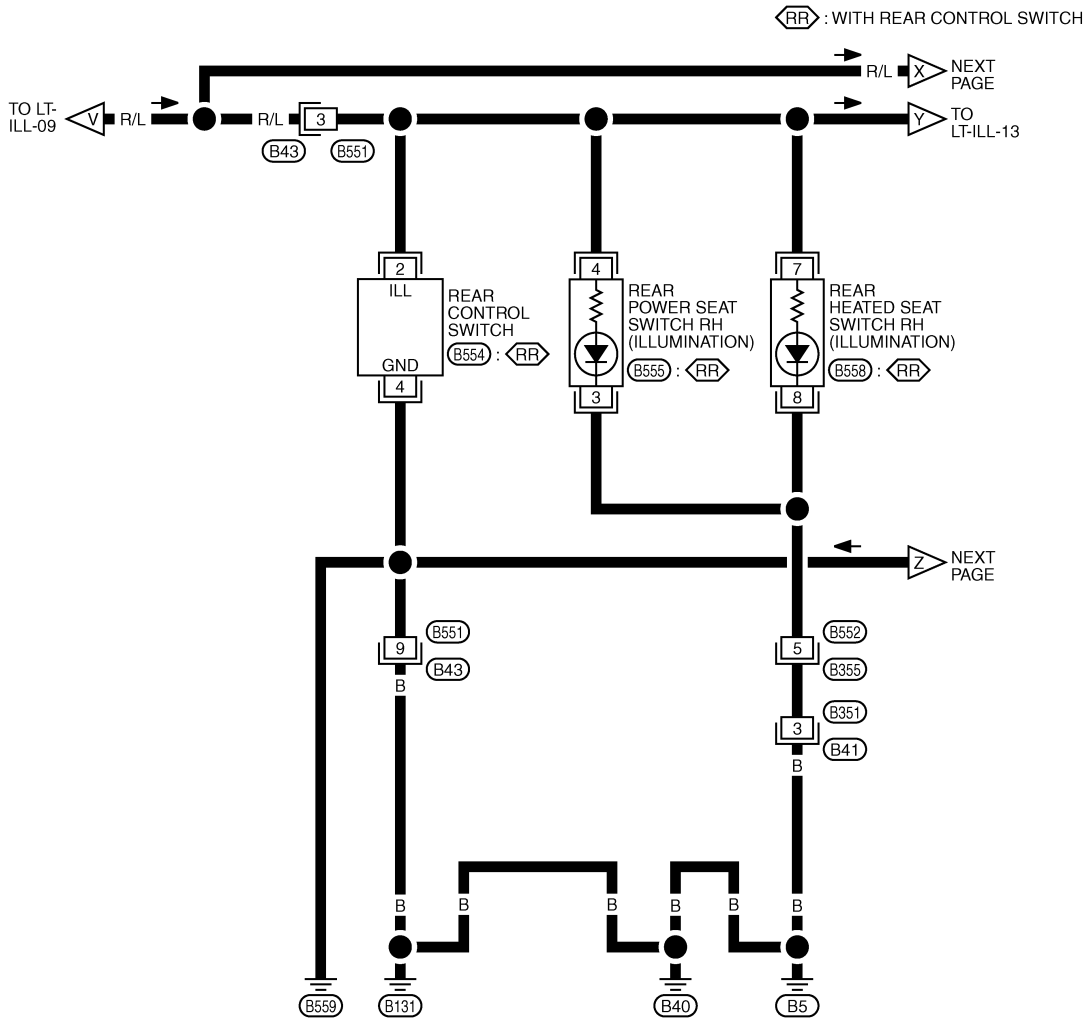

*: THIS CONNECTOR IS NOT SHOWN IN "HARNESS LAYOUT", PG SECTION.

TKWT3593E

ILLUMINATION

< SERVICE INFORMATION >

LT-ILL-12

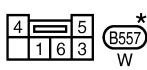
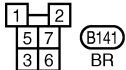
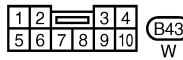
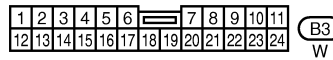
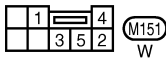
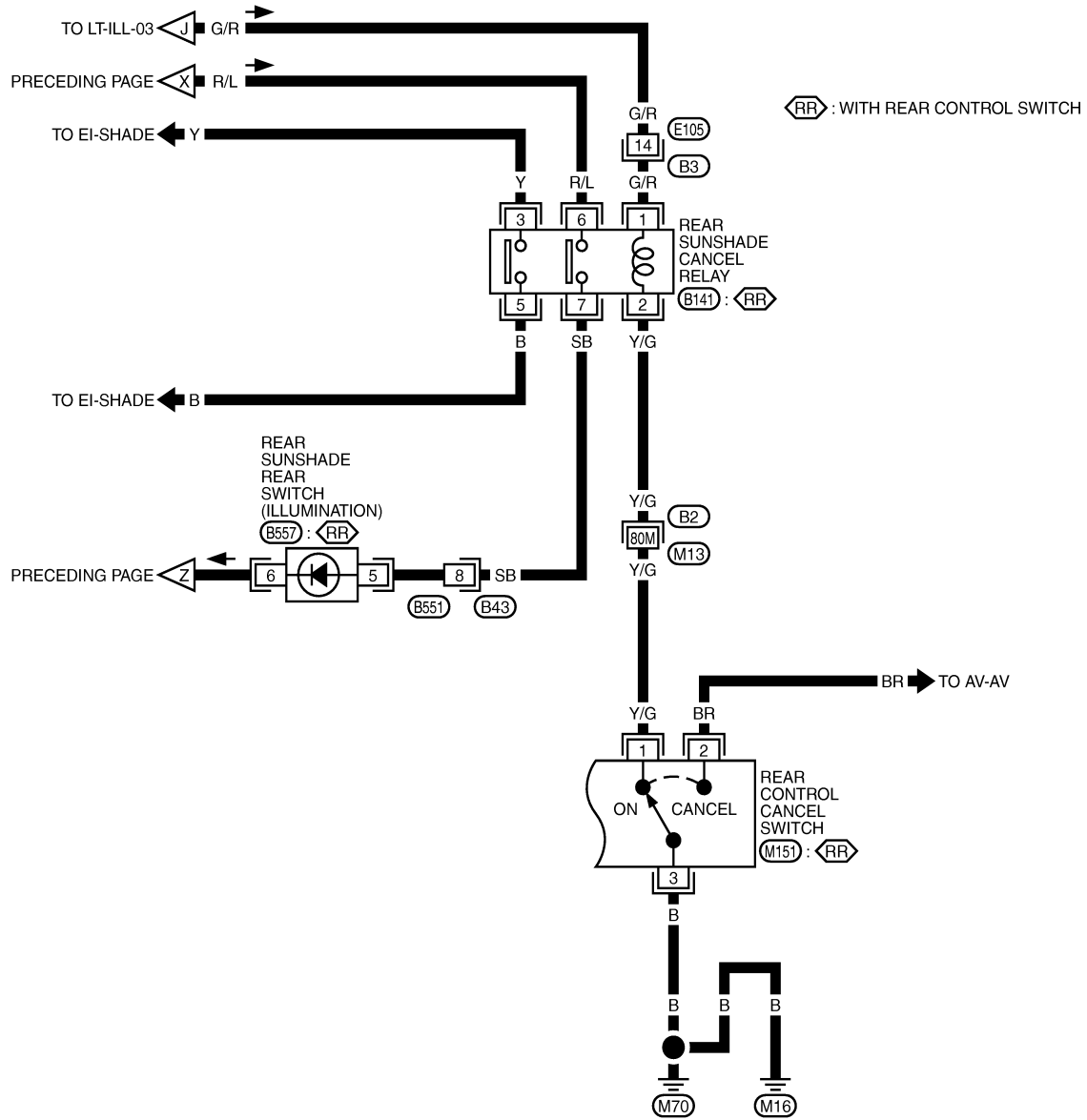

*: THIS CONNECTOR IS NOT SHOWN IN "HARNESS LAYOUT", PG SECTION.

REFER TO THE FOLLOWING.

(B2) - SUPER MULTIPLE JUNCTION (SMJ)

TKWT6849E

A
B
C
D
E
F
G
H
I
J
LT
L
M
N
O
P

ILLUMINATION

< SERVICE INFORMATION >

LT-ILL-13

◊(RR) : WITH REAR CONTROL SWITCH

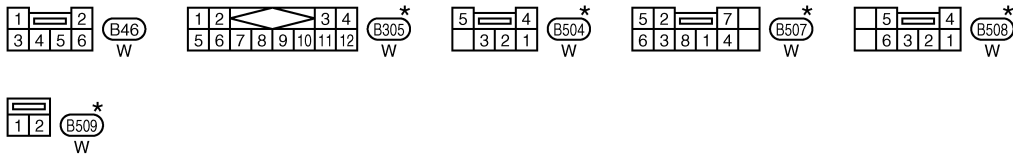
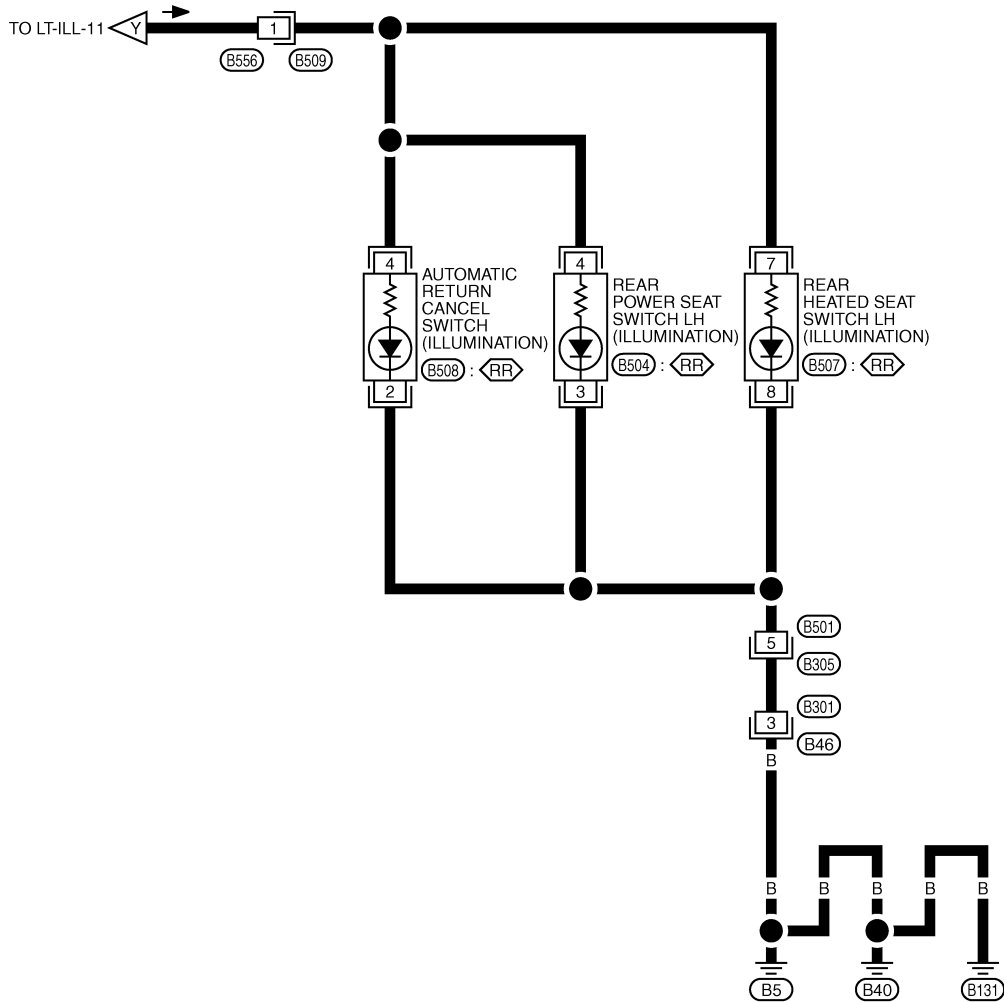

*: THIS CONNECTOR IS NOT SHOWN IN "HARNESS LAYOUT", PG SECTION.

TKWT3594E

INFOID:000000002956866

Glove Box Lamp

BULB REPLACEMENT, REMOVAL AND INSTALLATION

CAUTION:

Disconnect the battery negative terminal or remove the fuse.

Removal

1. Remove glove box cover. Refer to [IP-11](#).

ILLUMINATION

< SERVICE INFORMATION >

2. Turn globe box lamp bulb socket (1) counterclockwise and unlock it.
3. Remove bulb (2).

Glove box lamp : 12V - 1.4W

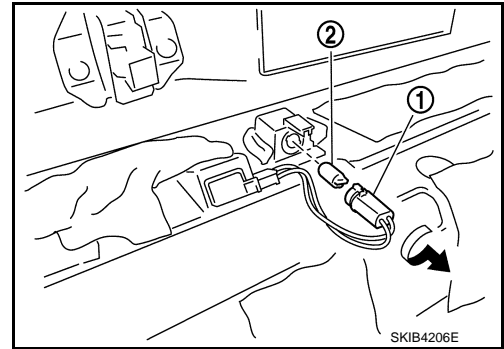

Installation

Installation is the reverse order of removal.

Cigarette Lighter Illumination

INFOID:000000002956867

BULB REPLACEMENT, REMOVAL AND INSTALLATION

CAUTION:

Disconnect the battery negative terminal or remove the fuse.

Removal

1. Remove A/T console finisher. Refer to [IP-12, "INSTRUMENT PANEL : Removal and Installation"](#).
2. Remove screws (A).

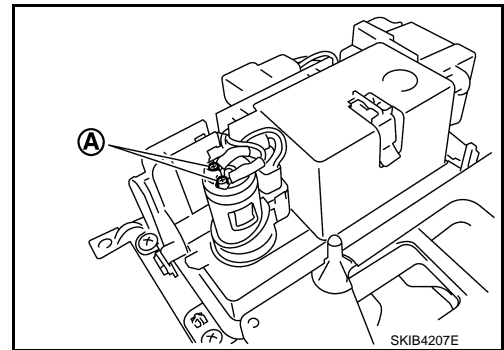

3. Use a screwdriver to undo hooks, remove bulb sockets (1).
4. Remove bulb (2).

Front ashtray and cigarette lighter illumination : 12V - 1.4W

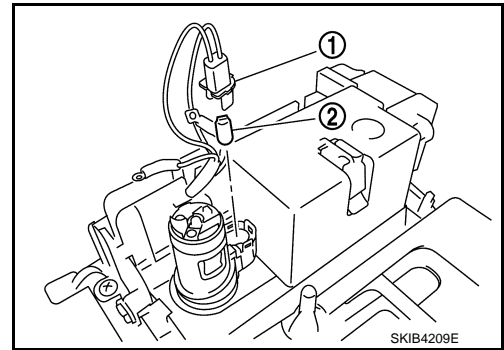

Installation

Installation is the reverse order of removal.

Front Ashtray Illumination

INFOID:000000002956868

BULB REPLACEMENT, REMOVAL AND INSTALLATION

Refer to [LT-271, "Cigarette Lighter Illumination"](#).

Rear Ashtray Illumination

INFOID:000000002956869

REMOVAL AND INSTALLATION

CAUTION:

Disconnect the battery negative terminal or remove the fuse.

A
B
C
D
E
F
G
H
I
J
LT
L
M
N
O
P

ILLUMINATION

< SERVICE INFORMATION >

1. Remove rear door finisher. Refer to [EI-45](#).
2. Turn rear ashtray illumination bulb socket (1) counterclockwise and unlock it.
3. Remove bulb (2).

Rear ashtray illumination : 12V - 1.4W

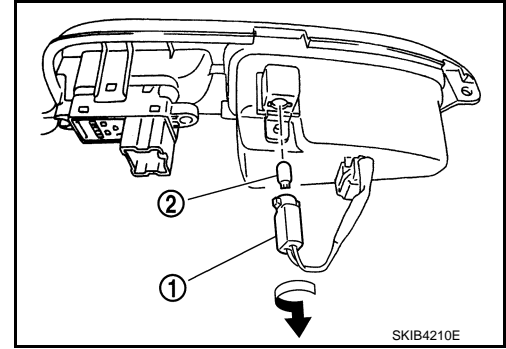

INSTALLATION

Installation is the reverse order of removal.

BULB SPECIFICATIONS

< SERVICE INFORMATION >

BULB SPECIFICATIONS

Headlamp

INFOID:000000002956870

| Item | Wattage (W) |
|--------------------|-------------|
| Low (Halogen type) | 55 (H1) |
| Low (Xenon type) | 35 (D2S) |
| High | 60 (HB3) |

Exterior Lamp

INFOID:000000002956871

| Item | Wattage (W) | |
|------------------------|---|------------|
| Front combination lamp | Front turn signal lamp | 21 (amber) |
| | Parking lamp | 5 |
| | Front side marker lamp | 5 |
| Rear combination lamp | Stop/Tail lamp | LED |
| | Rear turn signal lamp | 21 (amber) |
| | Rear side marker lamp | LED |
| Back-up lamp | 16 | |
| Side turn signal lamp | Replace as an assembly because it cannot be disassembled. | |
| Front fog lamp | 55 (H11) | |
| License plate lamp | 5 | |
| High-mounted stop lamp | LED | |

Interior Lamp/Illumination

INFOID:000000002956872

| Item | Wattage (W) | |
|--|----------------|-----|
| Map lamp | 8 | |
| Personal lamp | 8 | |
| Trunk room lamp | Upper | 5 |
| | Lower | |
| Front ashtray and front cigarette lighter illumination ^{NOTE} | 1.4 | |
| Rear ashtray illumination | 1.4 | |
| Step lamp | 5 | |
| Vanity mirror lamp | 1.8 | |
| Center console indirect illumination | LED | |
| Glove box lamp | 1.4 | |
| Foot lamp | Driver side | 3.4 |
| | Passenger side | |
| Kicking plate | Driver side | LED |
| | Passenger side | |
| Power window indirect illumination | LED | |

NOTE:

This lamp is used as both front ashtray and front cigarette lighter.