

A
LU
C
D
E
F
G
H
I
J
K
L
M
N
O
P

SECTION LU

ENGINE LUBRICATION SYSTEM

CONTENTS

<p style="text-align: center;">VQ35HR</p> <p>SERVICE INFORMATION 2</p> <p>PRECAUTIONS 2 Caution for Liquid Gasket 2</p> <p>PREPARATION 3 Special Service Tool 3 Commercial Service Tool 3</p> <p>LUBRICATION SYSTEM 4 Lubrication Circuit 4 System Chart 4</p> <p>ENGINE OIL 5 Inspection 5 Changing Engine Oil 7</p> <p>OIL FILTER 8 Removal and Installation 8</p> <p>OIL FILTER BRACKET (AWD) 10 Component 10 Removal and Installation 10</p> <p>OIL COOLER 12 Component 12 Removal and Installation 13</p> <p>OIL PUMP 16 Component 16 Removal and Installation 16 Disassembly and Assembly 16</p>	<p>SERVICE DATA AND SPECIFICATIONS (SDS) 19 Standard and Limit 19</p> <p style="text-align: center;">VK45DE</p> <p>SERVICE INFORMATION 20</p> <p>PRECAUTIONS 20 Caution for Liquid Gasket 20</p> <p>PREPARATION 21 Special Service Tool 21 Commercial Service Tool 21</p> <p>LUBRICATION SYSTEM 22 Lubrication Circuit 22 System Chart 23</p> <p>ENGINE OIL 24 Inspection 24 Changing Engine Oil 25</p> <p>OIL FILTER 27 Removal and Installation 27</p> <p>OIL PUMP 28 Component 28 Removal and Installation 28 Disassembly and Assembly 29</p> <p>SERVICE DATA AND SPECIFICATIONS (SDS) 31 Standard and Limit 31</p>
---	---

SERVICE INFORMATION

PRECAUTIONS

Precaution for Liquid Gasket

INFOID:000000004159548

LIQUID GASKET APPLICATION PROCEDURE

1. Remove old liquid gasket adhering to the liquid gasket application surface and the mating surface.
 - Remove liquid gasket completely from the liquid gasket application surface, mounting bolts, and bolt holes.
2. Wipe the liquid gasket application surface and the mating surface with white gasoline (lighting and heating use) to remove adhering moisture, grease and foreign materials.
3. Apply liquid gasket to the liquid gasket application surface.
Use Genuine RTV Silicone Sealant or equivalent. Refer to GI-46.
 - Within five minutes of liquid gasket application, install the mating component.
 - If liquid gasket protrudes, wipe it off immediately.
 - Do not retighten mounting bolts or nuts after the installation.
 - After 30 minutes or more have passed from the installation, fill engine oil and engine coolant.

PREPARATION

< SERVICE INFORMATION >

[VQ35HR]

PREPARATION

Special Service Tool

INFOID:000000004159549

The actual shapes of Kent-Moore tools may differ from those of special service tools illustrated here.

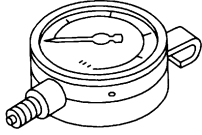
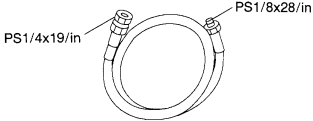
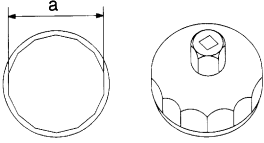
Tool number (Kent-Moore No.) Tool name	Description
ST25051001 (J25695-1) Oil pressure gauge  NT050	Measuring oil pressure Maximum measuring range: 2,452 kPa (25 kg/cm², 356 psi)
ST25052000 (J25695-2) Hose  S-NT559	Adapting oil pressure gauge to oil pan (upper)
KV10115801 (J38956) Oil filter wrench  S-NT375	Removing and installing oil filter a: 64.3 mm (2.531 in)

Commercial Service Tool

INFOID:000000004159550

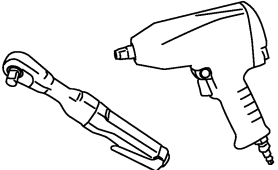
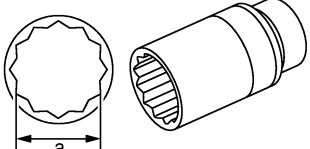
Tool name	Description
Power tools  PBIC0190E	Loosening nuts and bolts
Deep socket  PBIC2072E	Removing and installing oil pressure switch a: 26 mm (1.02 in)

LUBRICATION SYSTEM

< SERVICE INFORMATION >

[VQ35HR]

LUBRICATION SYSTEM

Lubrication Circuit

INFOID:000000004159551

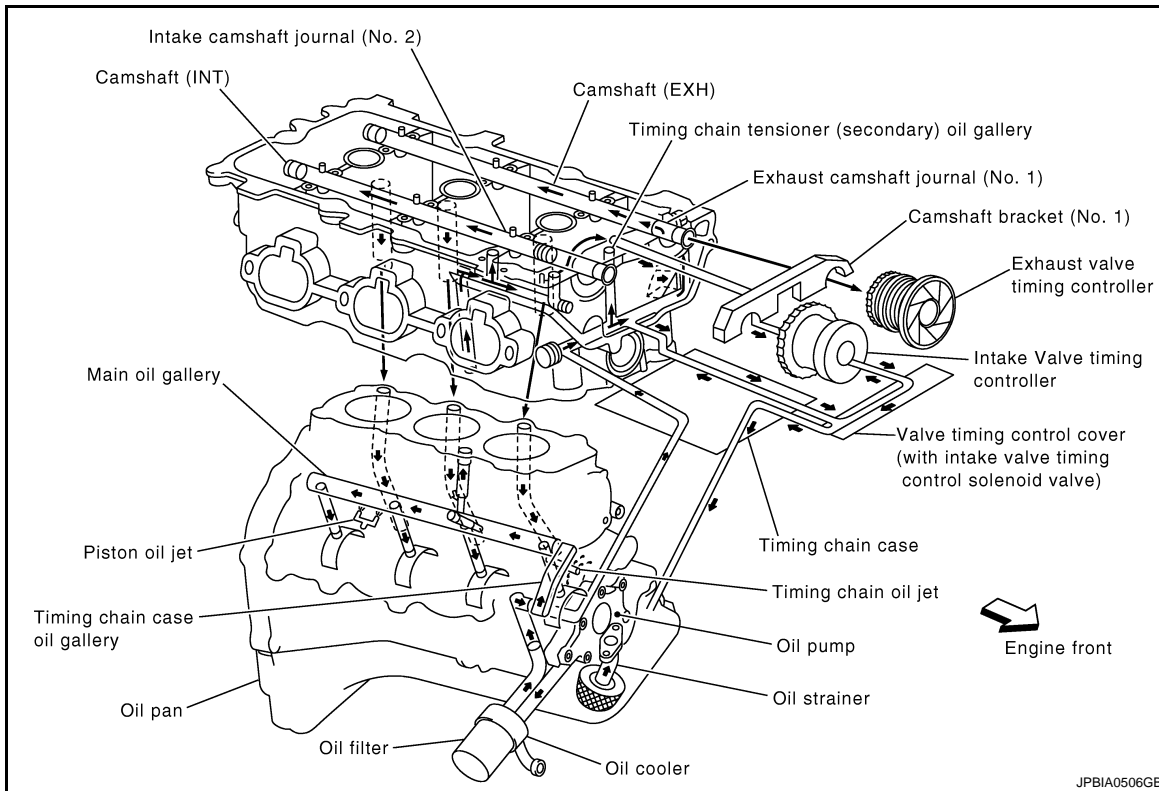

JPBIA0506GB

System Chart

INFOID:000000004159552

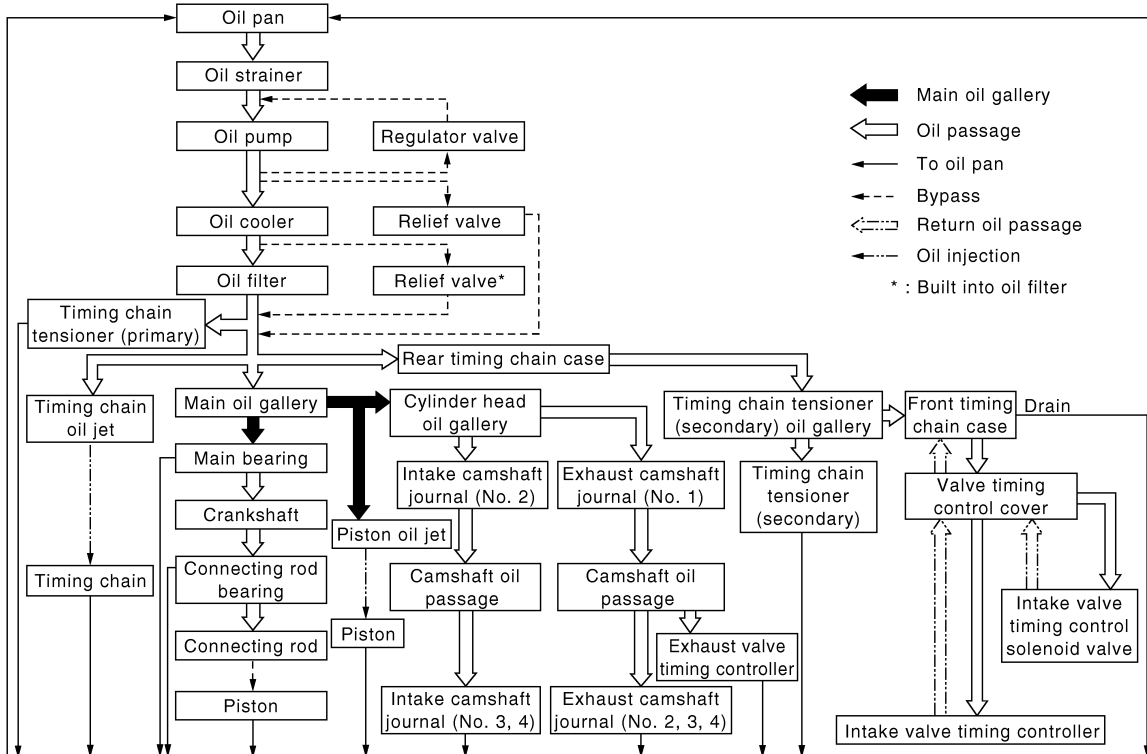

JPBIA0266GB

ENGINE OIL

Inspection

INFOID:000000004159553

ENGINE OIL LEVEL

NOTE:

Before starting engine, put vehicle horizontally and check the engine oil level. If engine is already started, stop it and allow 10 minutes before checking.

1. Pull out oil level gauge and wipe it clean.
2. Insert oil level gauge and check the engine oil level is within the range (A) shown in the figure.
3. If it is out of range, adjust it.

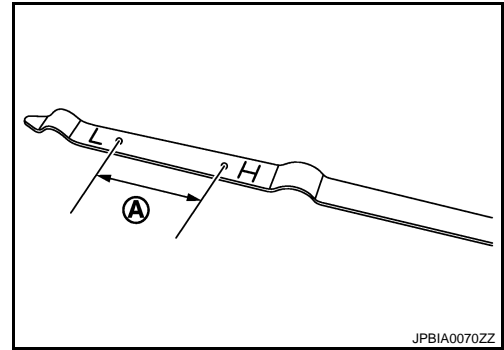

NOTE:

When checking the engine oil level, insert oil level gauge (1) with its tip aligned with oil level gauge guide.

- 2 : Engine cover
- ⇐ : Engine front

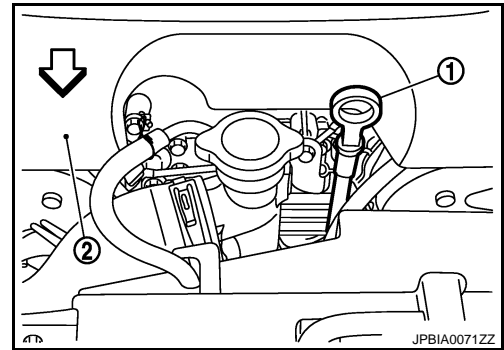

ENGINE OIL APPEARANCE

- Check engine oil for white turbidity or heavy contamination.
- If engine oil becomes turbid and white, it is highly probable that it is contaminated with engine coolant. Repair or replace damaged parts.

ENGINE OIL LEAKAGE

Check for engine oil leakage around the following areas:

- Oil pans (lower and upper)
- Oil pan drain plug
- Oil pressure switch
- Oil filter
- Oil filter bracket (AWD models)
- Oil cooler
- Valve timing control cover
- Mating surface between cylinder head and rocker cover
- Mating surface between front timing chain case and rear timing chain case
- Mating surface between rear timing chain case and cylinder head
- Mating surface between rear timing chain case and cylinder block
- Mating surface between rear timing chain case and oil pan (upper)
- Mating surface between cylinder block and cylinder head
- Mating surface between lower cylinder block and cylinder block
- Crankshaft oil seals (front and rear)
- Camshaft position sensor (PHASE) and exhaust valve timing control position sensor

OIL PRESSURE CHECK

A
LU
C
D
E
F
G
H
I
J
K
L
M
N
O
P

ENGINE OIL

[VQ35HR]

< SERVICE INFORMATION >

WARNING:

- Be careful not to get burn yourself, as engine oil may be hot.
 - Oil pressure check should be done in "Parking position".
1. Check the engine oil level. Refer to "ENGINE OIL LEVEL".
 2. Remove front engine undercover with power tool.
 3. Disconnect harness connector at oil pressure switch, and remove oil pressure switch using deep socket (commercial service tool).

- 1 : Oil pressure switch
 A : 2WD
 ⇐ : Engine front

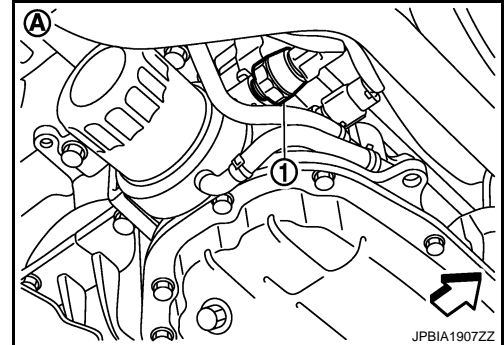

- 1 : Oil pressure switch
 A : AWD
 ⇐ : Engine front

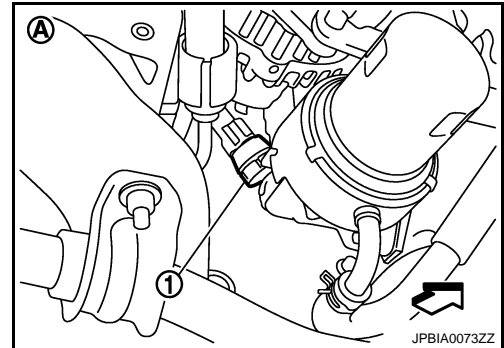

CAUTION:

Never drop or shock oil pressure switch.

4. Install the oil pressure gauge [SST: ST25051001 (J25695-1)] (A) and hose [SST: ST25052000 (J25695-2)] (B).

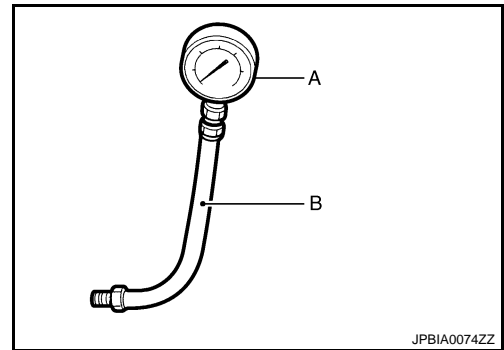

5. Start the engine and warm it up to normal operating temperature.
6. Check the engine oil pressure with engine running under no-load.

NOTE:

When the engine oil temperature is low, the engine oil pressure becomes high.

Engine oil pressure [Engine oil temperature at 80°C (176°F)]

Unit: kPa (kg/cm², psi)

Engine speed	Approximate discharge pressure
Idle speed	More than 98 (1.0, 14)
2,000 rpm	More than 294 (3.0, 43)

If difference is extreme, check engine oil passage and oil pump for engine oil leakage.

7. After the inspections, install oil pressure switch as follows:
 - a. Remove old liquid gasket adhering to oil pressure switch and the mating surface.
 - b. Apply liquid gasket and tighten oil pressure switch to the specification.
Use Genuine RTV Silicone Sealant or equivalent. Refer to [GI-46](#).

Oil pressure switch:

: 14.7 N·m (1.5 kg-m, 11 ft-lb)

- c. After warming up engine, check there is no leakage of engine oil with running engine.

Changing Engine Oil

INFOID:000000004159554

WARNING:

- Be careful not to get burn yourself, as engine oil may be hot.
- Prolonged and repeated contact with used engine oil may cause skin cancer. Try to avoid direct skin contact with used engine oil. If skin contact is made, wash thoroughly with soap or hand cleaner as soon as possible.

1. Warm up the engine, and check for engine oil leakage from engine components. Refer to [LU-5, "Inspection"](#).
2. Stop the engine and wait for 10 minutes.
3. Loosen oil filler cap.
4. Remove mounting bolts, and then pull down the rear of front engine undercover (1) and secure it using clip.
5. Remove drain plug (2) and then drain engine oil.

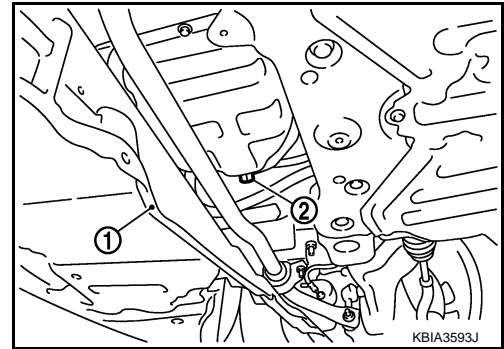

6. Install drain plug with new drain plug washer. Refer to [EM-28, "2WD : Component"](#).

CAUTION:

Be sure to clean drain plug and install with new drain plug washer.

Oil pan drain plug:

: 34.3 N·m (3.5 kg-m, 25 ft-lb)

7. Refill with new engine oil.
Engine oil specification and viscosity: Refer to [MA-9, "Fluids and Lubricants"](#).

Engine oil capacity (Approximate):

Unit: ℓ (US qt, Imp qt)

Drain and refill	With oil filter change	4.9 (5-1/8, 4-1/4)
	Without oil filter change	4.6 (4-7/8, 4)
Dry engine (Overhaul)		5.7 (6, 5)

CAUTION:

- When filling engine oil, never pull out oil level gauge.
 - The refill capacity depends on the engine oil temperature and drain time. Use these specifications for reference only.
 - Always use oil level gauge to determine the proper amount of engine oil in engine.
8. Warm up the engine and check area around drain plug and oil filter for engine oil leakage.
 9. Stop the engine and wait for 10 minutes.
 10. Check the engine oil level. Refer to [LU-5, "Inspection"](#).

OIL FILTER

Removal and Installation

INFOID:000000004159555

REMOVAL

1. Remove front engine undercover with power tool.
2. Using oil filter wrench [SST: KV10115801 (J38956)] (B), remove oil filter.

A : 2WD

⇐ : Engine front

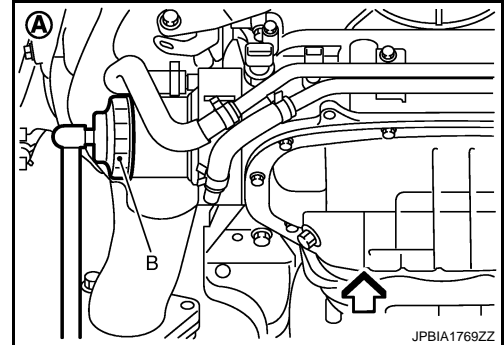

A : AWD

⇐ : Engine front

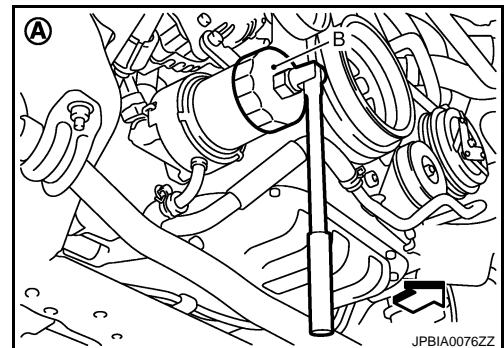

CAUTION:

- Oil filter is provided with relief valve. Use Genuine NISSAN Oil Filter or equivalent.
- Be careful not to get burned when engine and engine oil may be hot.
- When removing, prepare a shop cloth to absorb any engine oil leakage or spillage.
- Never allow engine oil to adhere to drive belt.
- Completely wipe off any engine oil that adheres to engine and vehicle.

INSTALLATION

1. Remove foreign materials adhering to oil filter installation surface.
2. Apply engine oil to the oil seal contact surface of new oil filter.

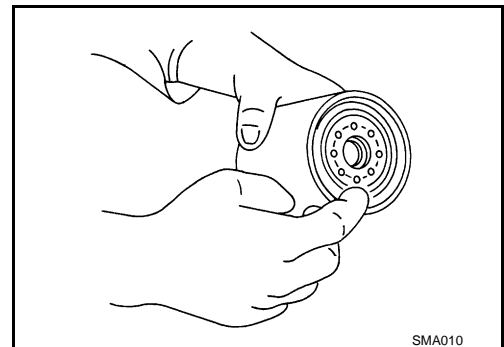

OIL FILTER

[VQ35HR]

< SERVICE INFORMATION >

3. Screw oil filter manually until it touches the installation surface, then tighten it by 2/3 turn (A). Or tighten to the specification.

Oil filter:

: 17.7 N·m (1.8 kg·m, 13 ft·lb)

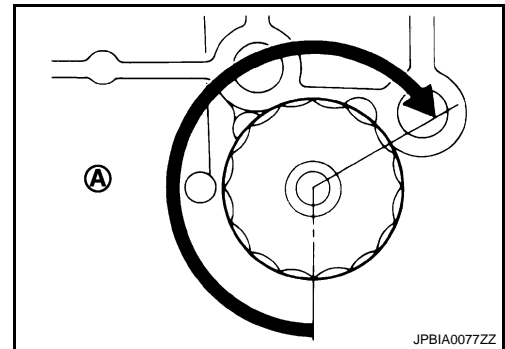

A

LU

C

D

INSPECTION AFTER INSTALLATION

1. Check the engine oil level. Refer to [LU-5](#).
2. Start the engine, and check there is no leakage of engine oil.
3. Stop the engine and wait for 10 minutes.
4. Check the engine oil level, and adjust the level. Refer to [LU-5](#).

E

F

G

H

I

J

K

L

M

N

O

P

OIL FILTER BRACKET (AWD)

[VQ35HR]

< SERVICE INFORMATION >

- Apply liquid gasket and install oil pressure switch.

Use Genuine RTV Silicone Sealant or equivalent. Refer to [GI-46](#).

- Align cutout on oil cooler with protrusion on oil filter bracket. Refer to [LU-13](#), "[Removal and Installation](#)".

INSPECTION AFTER INSTALLATION

1. Check the engine oil level and add engine oil. Refer to [LU-5](#).
2. Start the engine, and check there is no leakage of engine oil.
3. Stop the engine and wait for 10 minutes.
4. Check the engine oil level again. Refer to [LU-5](#).

A

LU

C

D

E

F

G

H

I

J

K

L

M

N

O

P

OIL COOLER

< SERVICE INFORMATION >

[VQ35HR]

OIL COOLER

Component

INFOID:000000004159558

2WD models

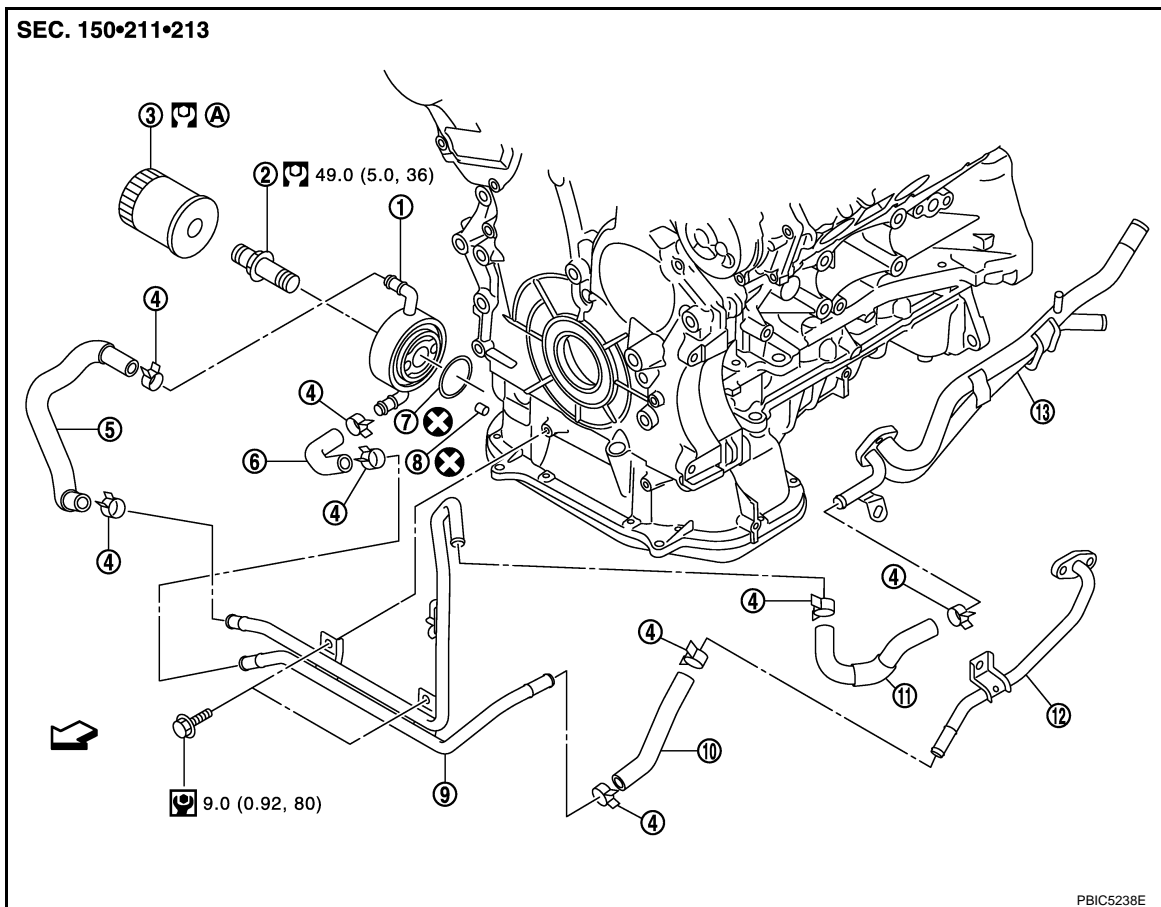

- | | | |
|-----------------|--------------------|----------------|
| 1. Oil cooler | 2. Connecting bolt | 3. Oil filter |
| 4. Clamp | 5. Water hose | 6. Water hose |
| 7. O-ring | 8. Relief valve | 9. Water pipe |
| 10. Water hose | 11. Water hose | 12. Water pipe |
| 13. Heater pipe | | |

A. Refer to [LU-8](#)

⇨ : Engine front

- Refer to [GI-9, "Component"](#) for symbols in the figure.

OIL COOLER

< SERVICE INFORMATION >

[VQ35HR]

AWD models

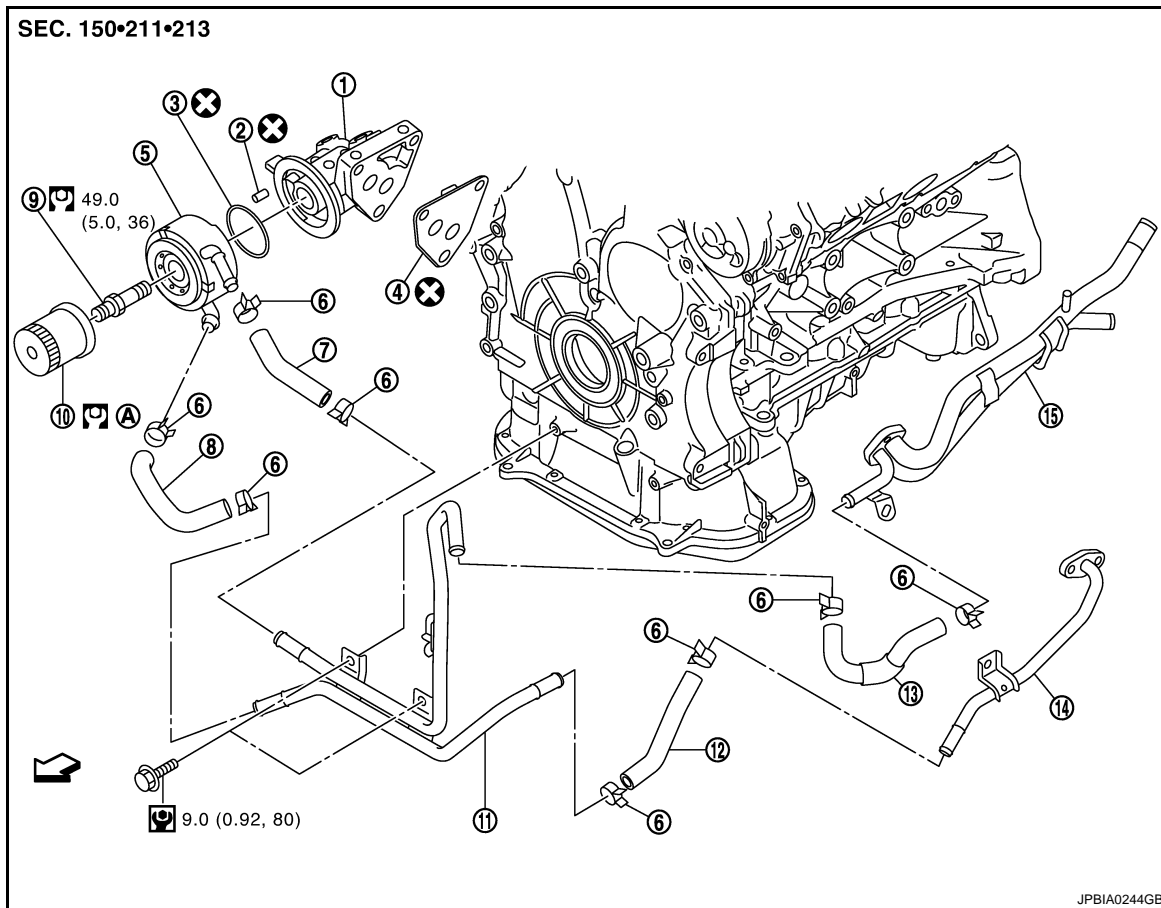

- | | | |
|-----------------------|-----------------|--------------------|
| 1. Oil filter bracket | 2. Relief valve | 3. O-ring |
| 4. Gasket | 5. Oil cooler | 6. Clamp |
| 7. Water hose | 8. Water hose | 9. Connecting bolt |
| 10. Oil filter | 11. Water pipe | 12. Water hose |
| 13. Water hose | 14. Water pipe | 15. Heater pipe |
- A. Refer to [LU-8](#)
- ↶ : Engine front

- Refer to [GI-9, "Component"](#) for symbols in the figure.

Removal and Installation

INFOID:000000004159559

REMOVAL

WARNING:

Be careful not to get burn yourself, as engine oil and engine coolant may be hot.

NOTE:

When removing oil cooler only, step 2 is unnecessary.

1. Remove front engine undercover with power tool.
2. Drain engine coolant from radiator and cylinder block. Refer to [CO-10, "Changing Engine Coolant"](#) and [EM-120, "Disassembly and Assembly"](#).

NOTE:

Perform this step when removing water pipes.

3. Disconnect water hoses from oil cooler.
 - When removing oil cooler only, pinching water hoses near oil cooler to prevent engine coolant from spilling out.
 - Remaining engine coolant in piping will come out. Use a tray to collect it.

CAUTION:

- Perform this step when the engine is cold.

OIL COOLER

[VQ35HR]

< SERVICE INFORMATION >

- **Never spill engine coolant on drive belt.**
- Using oil filter wrench [SST: KV10115801 (J38956)], remove oil filter. Refer to [LU-8](#).
CAUTION:
Never spill engine oil on drive belt.
 - Remove connector bolt, and remove oil cooler.
CAUTION:
Never spill engine oil to rubber parts such as drive belt and engine mounting insulator.
 - Remove water pipes if necessary.

INSPECTION AFTER REMOVAL

Oil Cooler

Check oil cooler for cracks. Check oil cooler for clogging by blowing through engine coolant inlet. If necessary, replace oil cooler.

Relief Valve

Check relief valve with the following procedure.

- Press steel ball of relief valve using a clean plastic stick. Check that valve moves smoothly and proper spring repulsion is felt.
- Replace relief valve, if necessary, with the following procedure.
- Remove the relief valve by prying using a screwdriver.

CAUTION:

Be careful not to damage the mounting hole.

- Press in the relief valve until it reaches a depth of 7 mm (0.28 in) from end surface of oil pan (upper) using approximately 10 mm (0.39 in) diameter drift.

CAUTION:

Carefully press in the relief valve by aligning its mounting hole side with the axle center so as not to cause deformation.

INSTALLATION

Note the following, and install in the reverse order of removal.

- Check that no foreign objects are adhering to the installation planes of oil filter and oil cooler bracket.

2WD Models

Align cutout (B) on oil cooler (1) with protrusion (C) on oil filter bracket side, and tighten connector bolt.

A : Engine right side

⇐ : Engine front

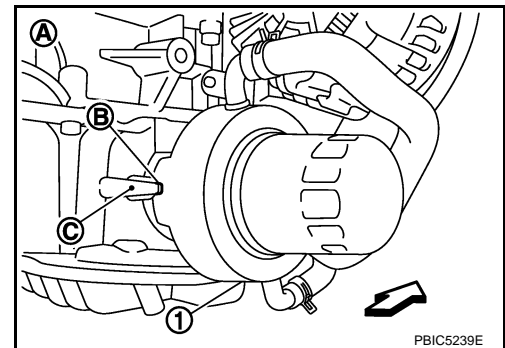

AWD Models

Align cutout (B) on oil cooler (1) with protrusion (A) on oil filter bracket side, and tighten connector bolt (3).

2 : Oil filter bracket

⇐ : Engine front

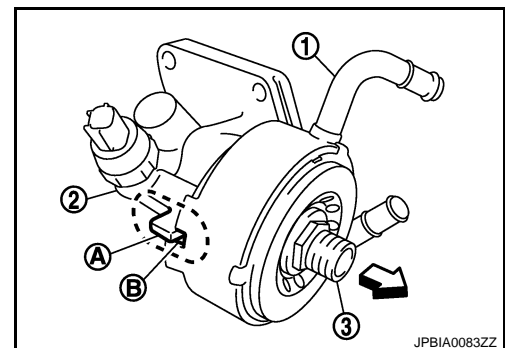

INSPECTION AFTER INSTALLATION

- Check the engine oil level and the engine coolant level and add engine oil and engine coolant. Refer to [LU-5](#) and [CO-10](#).

OIL COOLER

[VQ35HR]

< SERVICE INFORMATION >

2. Start the engine, and check there is no leakage of engine oil or engine coolant.
3. Stop the engine and wait for 10 minutes.
4. Check the engine oil level and the engine coolant level again. Refer to [LU-5](#) and [CO-10](#).

A

LU

C

D

E

F

G

H

I

J

K

L

M

N

O

P

OIL PUMP

< SERVICE INFORMATION >

[VQ35HR]

OIL PUMP

Component

INFOID:000000004159560

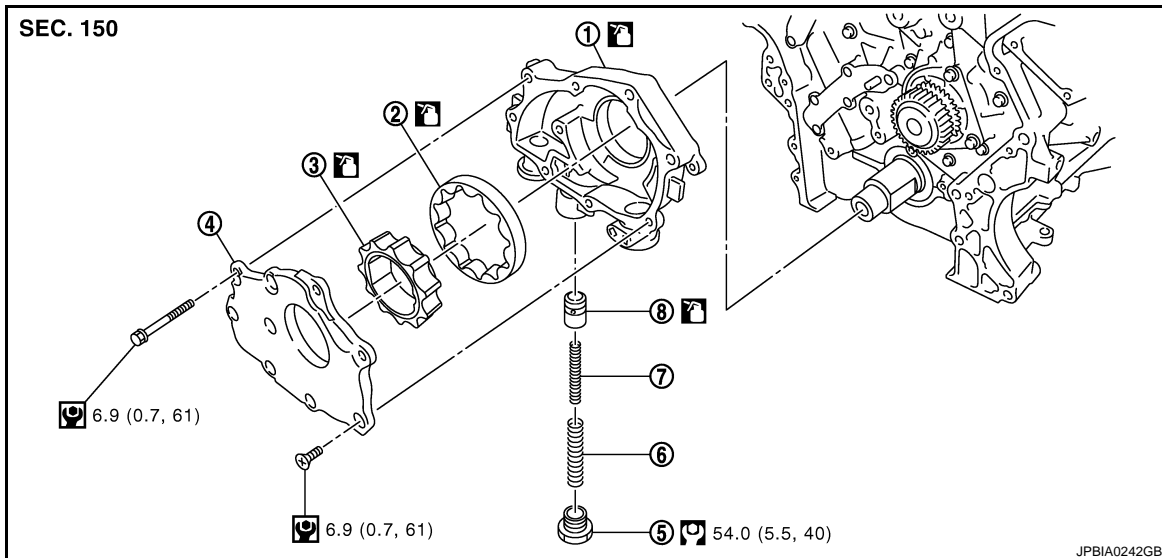

- | | | |
|---------------------------|-------------------------|---------------------------|
| 1. Oil pump body | 2. Oil pump outer rotor | 3. Oil pump inner rotor |
| 4. Oil pump cover | 5. Regulator valve plug | 6. Regulator valve spring |
| 7. Regulator valve spring | 8. Regulator valve | |

- Refer to [GI-9. "Component"](#) for symbols in the figure.

Removal and Installation

INFOID:000000004159561

REMOVAL

1. Remove oil pan (lower) and oil strainer. Refer to [EM-28. "2WD : Component"](#) (2WD models) or [EM-32. "AWD : Component"](#) (AWD models).
2. Remove front timing chain case and timing chain (primary). Refer to [EM-59. "Component"](#).
3. Remove oil pump assembly.

INSTALLATION

CAUTION:

Before installation, apply new engine oil to the parts as instructed in the figure.

Note the following, and install in the reverse order of removal.

- When installing, align crankshaft flat faces with oil pump inner rotor flat faces.

INSPECTION AFTER INSTALLATION

1. Check the engine oil level. Refer to [LU-5](#).
2. Start the engine, and check there is no leakage of engine oil.
3. Stop the engine and wait for 10 minutes.
4. Check the engine oil level and adjust the level. Refer to [LU-5](#).

Disassembly and Assembly

INFOID:000000004159562

DISASSEMBLY

1. Remove oil pump cover.
2. Remove oil pump inner rotor and oil pump outer rotor from oil pump body.
3. After removing regulator valve plug, remove regulator valve spring and regulator valve.

INSPECTION AFTER DISASSEMBLY

OIL PUMP

[VQ35HR]

< SERVICE INFORMATION >

Oil Pump Clearance

- Measure the clearance with feeler gauge (C).
- Clearance between oil pump outer rotor and oil pump body [Position (B)]

Standard : 0.114 - 0.260 mm (0.0045 - 0.0102 in)

- Tip clearance between oil pump inner rotor and oil pump outer rotor [Position (A)]

Standard : Below 0.180 mm (0.0071 in)

- If out of the standard, replace inner rotor and outer rotor.

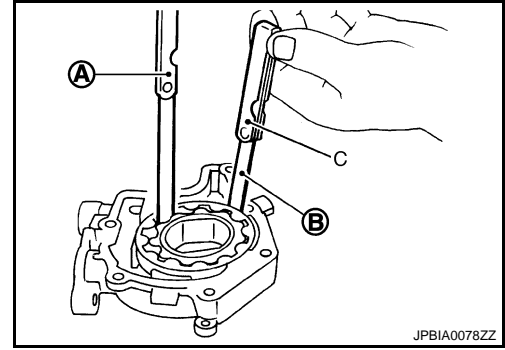

- Measure the clearance with feeler gauge and straightedge (A).
- Side clearance between oil pump inner rotor and oil pump body [Position (C)]

Standard : 0.030 - 0.070 mm (0.0012 - 0.0028 in)

- Side clearance between oil pump outer rotor and oil pump body [Position (B)]

Standard : 0.030 - 0.090 mm (0.0012 - 0.0035 in)

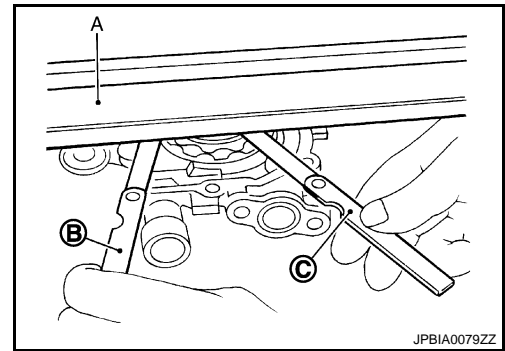

- Calculate the clearance between oil pump inner rotor and oil pump body as follows:

OIL PUMP BODY INNER DIAMETER

- Measure the inner diameter of oil pump body with inside micrometer. [Position (A)]

OIL PUMP INNER ROTOR OUTER DIAMETER

- Measure the outer diameter of protruded portion of oil pump inner rotor (1) with micrometer. [Position (B)]

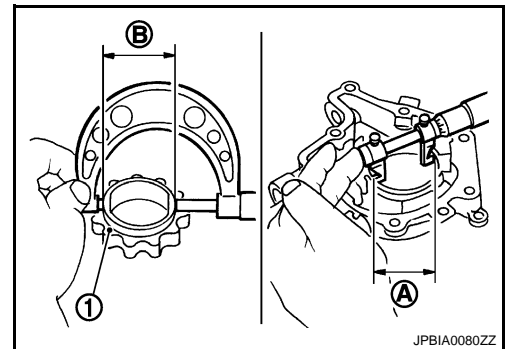

OIL PUMP INNER ROTOR TO OIL PUMP BODY CLEARANCE

- (Clearance) = (Oil pump body inner diameter) – (Oil pump inner rotor outer diameter)

Standard : 0.045 - 0.091 mm (0.0018 - 0.0036 in)

- If measured/calculated values are out of the standard, replace oil pump assembly.

Regulator Valve Clearance

- (Clearance) = (Regulator valve hole diameter) – (Regulator valve outer diameter)

1. Regulator valve
2. Oil pump body

Standard : 0.040 - 0.097 mm (0.0016 - 0.0038 in)

- If the calculated value is out of the standard, replace oil pump assembly.

CAUTION:

- Coat regulator valve with engine oil.

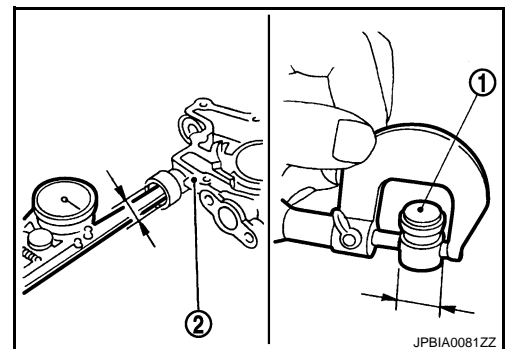

OIL PUMP

< SERVICE INFORMATION >

[VQ35HR]

- Check that it falls smoothly into valve hole by its own weight.

ASSEMBLY

Note the following, and assemble in the reverse order of disassembly.

- Install oil pump inner rotor with the groove faced to oil pump cover side.

- A : Oil pump body side
- B : Oil pump cover side
- C : Groove

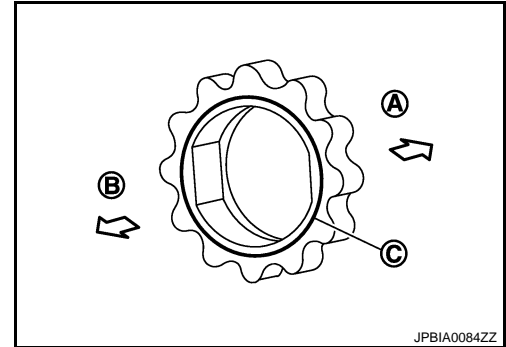

SERVICE DATA AND SPECIFICATIONS (SDS)

< SERVICE INFORMATION >

[VQ35HR]

SERVICE DATA AND SPECIFICATIONS (SDS)

Standard and Limit

INFOID:000000004159563

ENGINE OIL PRESSURE

Unit: kPa (kg/cm², psi)

Engine speed	Approximate discharge pressure*
Idle speed	More than 98 (1.0, 14)
2,000 rpm	More than 294 (3.0, 43)

*: Engine oil temperature at 80°C (176°F)

ENGINE OIL CAPACITY (APPROXIMATE)

Unit: ℓ (US qt, Imp qt)

Drain and refill	With oil filter change	4.9 (5-1/8, 4-1/4)
	Without oil filter change	4.6 (4-7/8, 4)
Dry engine (Overhaul)		5.7 (6, 5)

OIL PUMP

Unit: mm (in)

Oil pump body to oil pump outer rotor radial clearance	0.114 - 0.260 (0.0045 - 0.0102)
Oil pump inner rotor to oil pump outer rotor tip clearance	Below 0.180 (0.0071)
Oil pump body to oil pump inner rotor axial clearance	0.030 - 0.070 (0.0012 - 0.0028)
Oil pump body to oil pump outer rotor axial clearance	0.030 - 0.090 (0.0012 - 0.0035)
Oil pump inner rotor to brazed portion of housing clearance	0.045 - 0.091 (0.0018 - 0.0036)

REGULATOR VALVE

Unit: mm (in)

Regulator valve to oil pump cover clearance	0.040 - 0.097 (0.0016 - 0.0038)
---	---------------------------------

SERVICE INFORMATION

PRECAUTIONS

Precaution for Liquid Gasket

INFOID:000000004159564

LIQUID GASKET APPLICATION PROCEDURE

1. Remove old liquid gasket adhering to the liquid gasket application surface and the mating surface.
 - Remove liquid gasket completely from the liquid gasket application surface, mounting bolts, and bolt holes.
2. Wipe the liquid gasket application surface and the mating surface with white gasoline (lighting and heating use) to remove adhering moisture, grease and foreign materials.
3. Apply liquid gasket to the liquid gasket application surface.
Use Genuine RTV Silicone Sealant or equivalent. Refer to GI-46.
 - Within five minutes of liquid gasket application, install the mating component.
 - If liquid gasket protrudes, wipe it off immediately.
 - Do not retighten mounting bolts or nuts after the installation.
 - After 30 minutes or more have passed from the installation, fill engine oil and engine coolant.

PREPARATION

< SERVICE INFORMATION >

[VK45DE]

PREPARATION

Special Service Tool

INFOID:000000004159565

The actual shapes of Kent-Moore tools may differ from those of special service tools illustrated here.

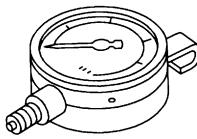
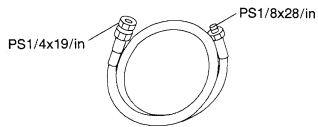
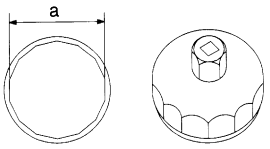
Tool number (Kent-Moore No.) Tool name	Description
ST25051001 (J25695-1) Oil pressure gauge  <p style="text-align: center;">S-NT050</p>	Measuring oil pressure Maximum measuring range: 2,452 kPa (25 kg/cm², 356 psi)
ST25052000 (J25695-2) Hose  <p style="text-align: center;">S-NT559</p>	Adapting oil pressure gauge to oil pan
KV10115801 (J38956) Oil filter wrench  <p style="text-align: center;">S-NT375</p>	Removing and installing oil filter a: 64.3 (2.531 in)

Commercial Service Tool

INFOID:000000004159566

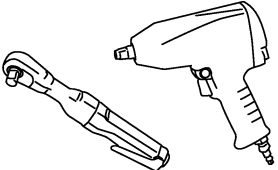
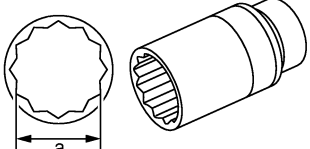
Tool name	Description
Power tool  <p style="text-align: center;">PBIC0190E</p>	Loosening nuts and bolts
Deep socket  <p style="text-align: center;">PBIC2072E</p>	Removing and installing oil pressure switch a: 26 mm (1.02 in)

LUBRICATION SYSTEM

< SERVICE INFORMATION >

[VK45DE]

LUBRICATION SYSTEM

Lubrication Circuit

INFOID:000000004159567

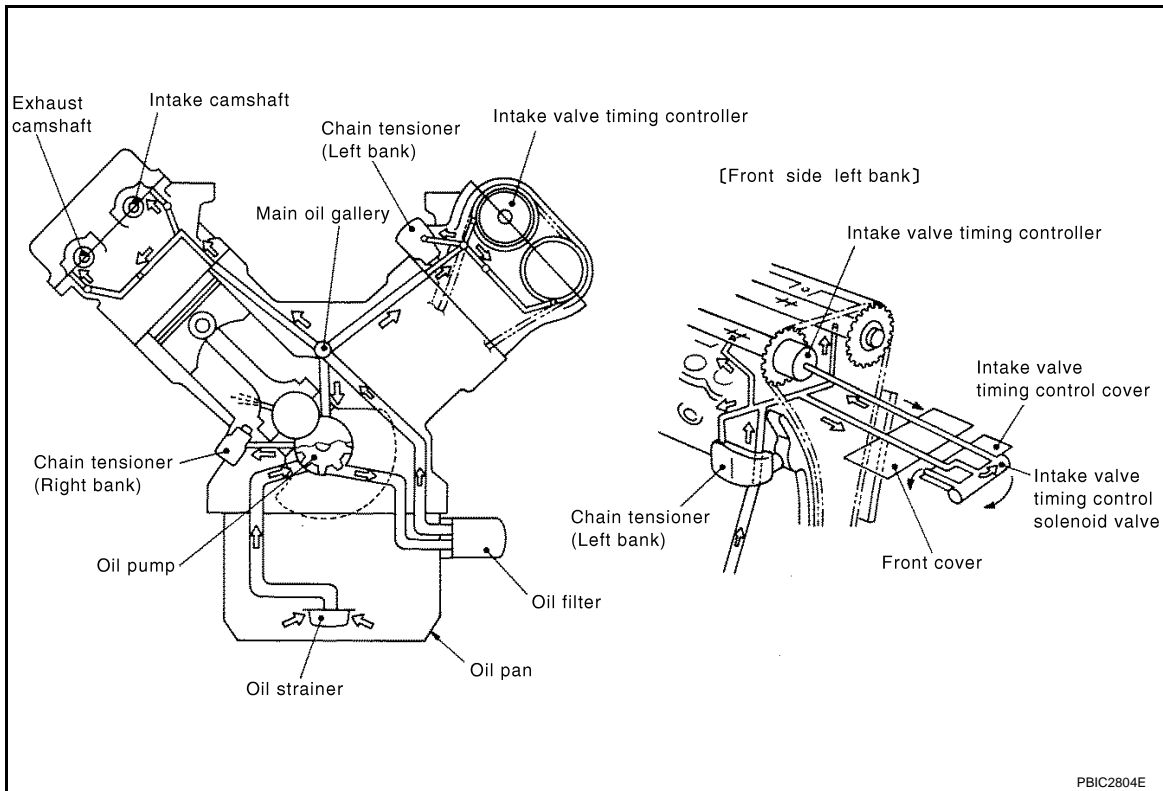

LUBRICATION SYSTEM

< SERVICE INFORMATION >

[VK45DE]

System Chart

INFOID:000000004159568

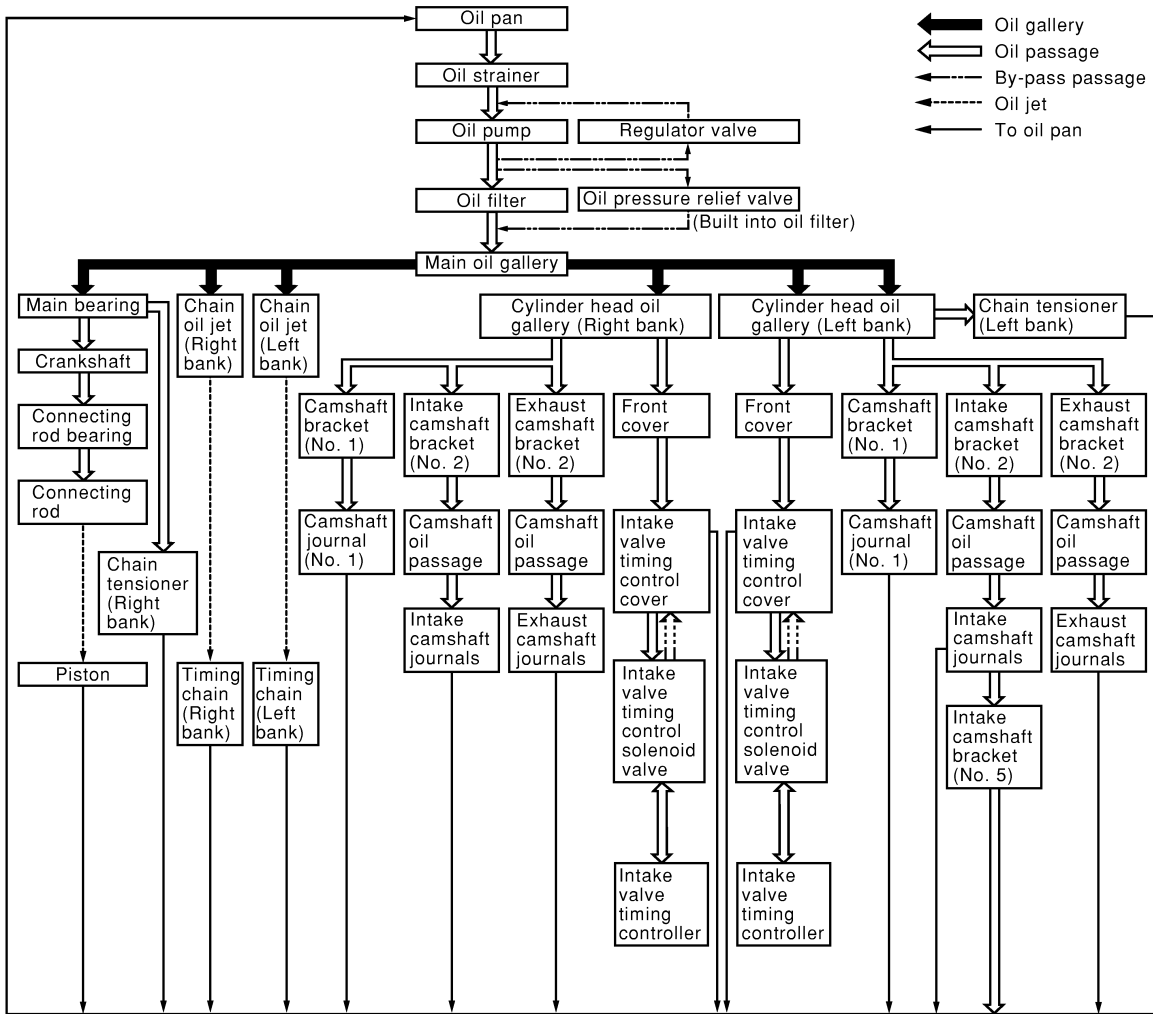

PBIC0134E

A
LU
C
D
E
F
G
H
I
J
K
L
M
N
O
P

ENGINE OIL

Inspection

INFOID:000000004159569

ENGINE OIL LEVEL

NOTE:

Before starting engine, put vehicle horizontally and check the engine oil level. If engine is already started, stop it and allow 15 minutes before checking.

1. Pull out oil level gauge and wipe it clean.
2. Insert oil level gauge and check the engine oil level is within the range shown in the figure.
3. If it is out of range, adjust it.

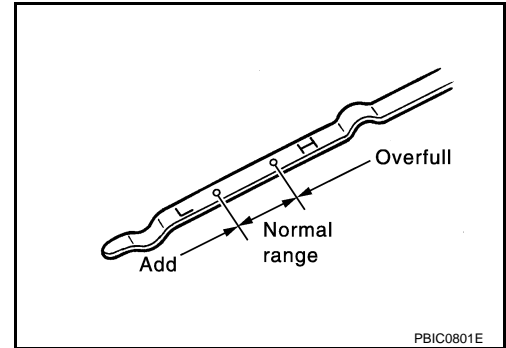

ENGINE OIL APPEARANCE

- Check engine oil for white turbidity or heavy contamination.
- If engine oil becomes turbid and white, it is highly probable that it is contaminated with engine coolant. Repair or replace damaged parts.

ENGINE OIL LEAKAGE

Check for oil leakage around the following areas:

- Oil pan
- Oil pan drain plug
- Oil pressure switch
- Oil filter
- Intake valve timing control cover
- Intake valve timing control solenoid valve
- Front cover
- Chain tensioner cover
- Mating surface between cylinder block and cylinder head
- Mating surface between cylinder head and rocker cover
- Crankshaft oil seals (front and rear)

OIL PRESSURE CHECK

WARNING:

- Be careful not to burn yourself, as engine oil may be hot.
- Oil pressure check should be done in "Parking position".

1. Check the engine oil level. Refer to "ENGINE OIL LEVEL".
2. Remove front engine undercover with power tool.
3. Disconnect harness connector at oil pressure switch, and remove oil pressure switch using deep socket (commercial service tool).

CAUTION:

Never drop or shock oil pressure switch.

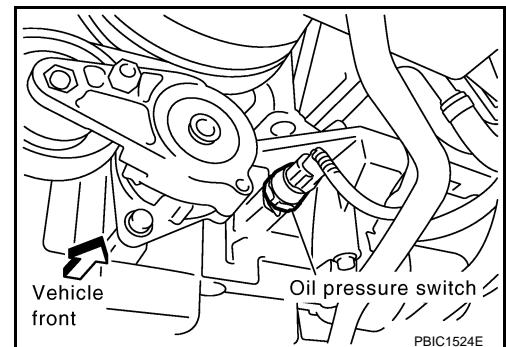

ENGINE OIL

< SERVICE INFORMATION >

[VK45DE]

4. Install oil pressure gauge and hose (SST).

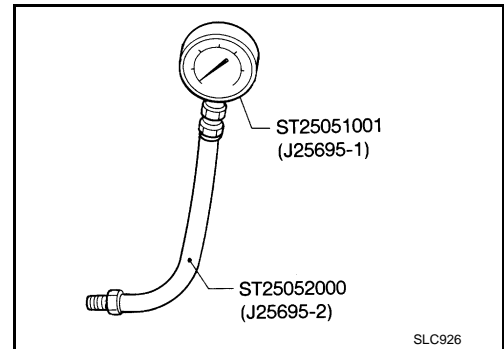

5. Start engine and warm it up to normal operating temperature.
6. Check the engine oil pressure with engine running under no-load.

NOTE:

When engine oil temperature is low, engine oil pressure becomes high.

Engine oil pressure [Engine oil temperature at 80°C (176°F)]

Unit: kPa (kg/cm², psi)

Engine speed	Approximate discharge pressure
Idle speed	More than 98 (1.0, 14)
2,000 rpm	More than 294 (3.0, 43)

If difference is extreme, check oil passage and oil pump for oil leakage.

7. After the inspections, install oil pressure switch as follows:
 - a. Remove old liquid gasket adhering to oil pressure switch and engine.
 - b. Apply liquid gasket and tighten oil pressure switch to the specification.
Use Genuine RTV Silicone Sealant or equivalent. Refer to [GI-46](#).

: **14.7 N·m (1.5 kg-m, 11 ft-lb)**

- c. After warming up engine, check there is no leakage of engine oil with running engine.

Changing Engine Oil

INFOID:000000004159570

WARNING:

- Be careful not to burn yourself, as engine oil may be hot.
- Prolonged and repeated contact with used engine oil may cause skin cancer. Try to avoid direct skin contact with used engine oil. If skin contact is made, wash thoroughly with soap or hand cleaner as soon as possible.

1. Warm up engine, put vehicle horizontally and check for engine oil leakage from engine components. Refer to [LU-24. "Inspection"](#).
2. Stop engine and wait for 15 minutes.
3. Loosen oil filler cap.

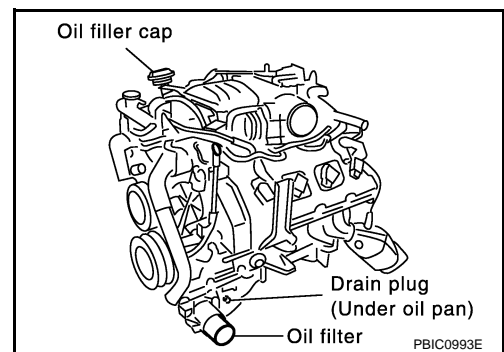

4. Remove mounting bolts, and then pull down the rear of front engine undercover and secure it using clip.
5. Remove drain plug and then drain engine oil.
6. Install drain plug with new drain plug washer. Refer to [EM-182](#).

ENGINE OIL

< SERVICE INFORMATION >

[VK45DE]

CAUTION:

Be sure to clean drain plug and install with new drain plug washer.

Oil pan drain plug:

: 34.3 N·m (3.5 kg-m, 25 ft-lb)

7. Refill with new engine oil.

Engine oil specification and viscosity: Refer to [MA-9, "Fluids and Lubricants"](#).

Engine oil capacity (Approximate):

Unit: ℓ (US qt, Imp qt)

Drain and refill	With oil filter change	5.5 (5-3/4, 4-7/8)
	Without oil filter change	4.9 (5-1/8, 4-1/4)
Dry engine (engine overhaul)		6.7 (7-1/8, 5-7/8)

CAUTION:

- The refill capacity depends on the engine oil temperature and drain time. Use these specifications for reference only.
- Always use oil level gauge to determine the proper amount of engine oil in engine.

8. Warm up engine and check area around drain plug and oil filter for oil leakage.
9. Stop engine and wait for 15 minutes.
10. Check the engine oil level. Refer to [LU-24, "Inspection"](#).

OIL FILTER

Removal and Installation

INFOID:000000004159571

REMOVAL

1. Remove front engine undercover with power tool.
2. Using the oil filter wrench (SST), remove the oil filter.

CAUTION:

- Oil filter is provided with relief valve. Use genuine NISSAN oil filter or equivalent.
- Be careful not to get burned when engine and engine oil may be hot.
- When removing, prepare a shop cloth to absorb any engine oil leakage or spillage.
- Never allow engine oil to adhere to drive belts.
- Completely wipe off any engine oil that adhere to engine and vehicle.

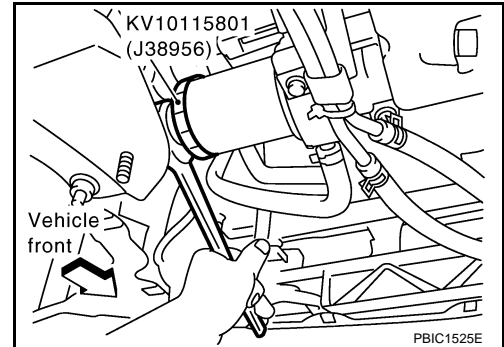

INSTALLATION

1. Remove foreign materials adhering to oil filter installation surface.
2. Apply new engine oil to the oil seal circumference of the new oil filter.

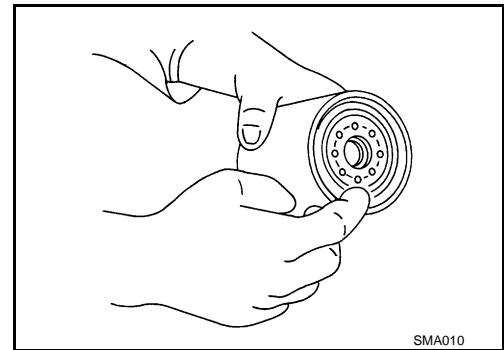

3. Screw oil filter manually until it touches the installation surface, then tighten it by 2/3 turn. Or tighten to specification.

Oil filter:

: 17.7 N·m (1.8 kg-m, 13 ft-lb)

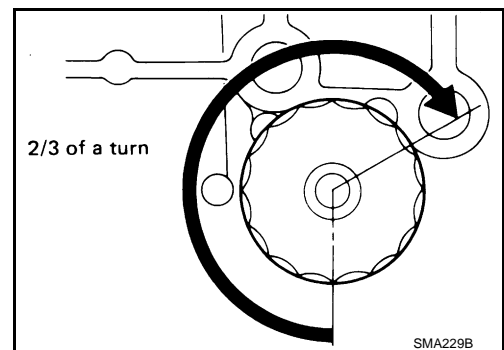

INSPECTION AFTER INSTALLATION

1. Check the engine oil level. Refer to [LU-24](#).
2. Start engine, and check there is no leakage of engine oil.
3. Stop engine and wait for 15 minutes.
4. Check the engine oil level and adjust engine oil. Refer to [LU-24](#).

OIL PUMP

< SERVICE INFORMATION >

[VK45DE]

OIL PUMP

Component

INFOID:000000004159572

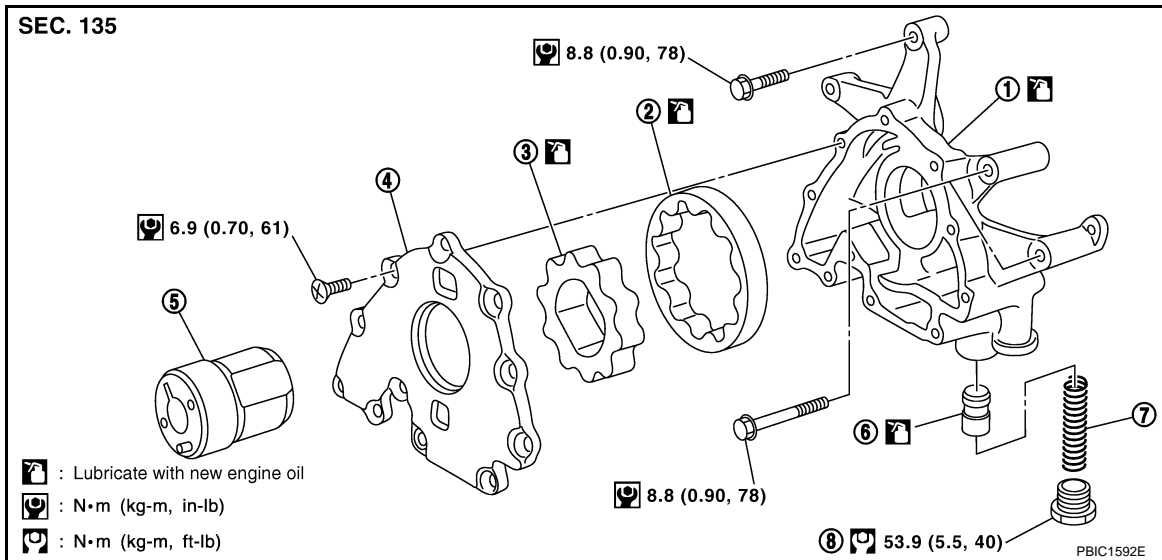

- | | | |
|---------------------------|--------------------------|-------------------------|
| 1. Oil pump body | 2. Oil pump outer rotor | 3. Oil pump inner rotor |
| 4. Oil pump cover | 5. Oil pump drive spacer | 6. Regulator valve |
| 7. Regulator valve spring | 8. Regulator valve plug | |

Removal and Installation

INFOID:000000004159573

REMOVAL

1. Remove engine assembly from vehicle. Refer to [EM-238, "2WD : Component"](#) (2WD models) or [EM-242, "AWD : Component"](#) (AWD models).
2. Remove front cover. Refer to [EM-199](#).
3. Remove oil pump drive spacer.
 - Set bolts in the two bolt holes [M6 × pitch 1.0 mm (0.039 in)] on the front surface. Using suitable puller, pull oil pump drive spacer off from crankshaft.

NOTE:

The dimension between the centers of the two bolt holes is 33 mm (1.30 in). In the figure, a commercial steering puller is used.

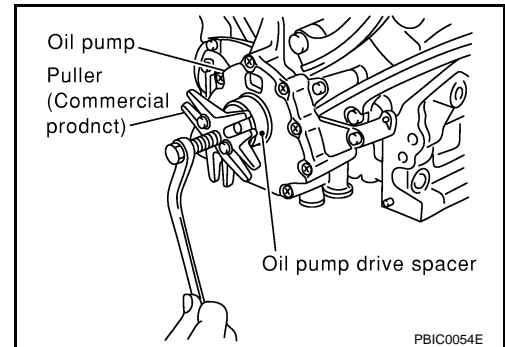

4. Remove oil pump.

INSTALLATION

1. Install the oil pump.
2. Install oil pump drive spacer as follows:

OIL PUMP

[VK45DE]

< SERVICE INFORMATION >

- a. Insert oil pump drive spacer according to the directions of crankshaft key and the two flat surfaces of oil pump inner rotor.
 - If the positional relationship does not allow the insertion, rotate oil pump inner rotor with a finger to allow spacer.
- b. After confirming that the position of each part is in correct condition to allow for spacer, force fit spacer by lightly tapping with plastic hammer until it contacts and does not go further.

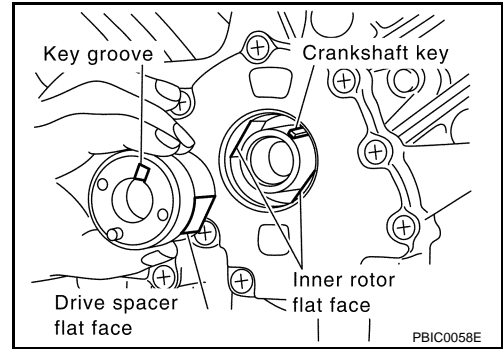

3. Install in the reverse order of removal after this step.

INSPECTION AFTER INSTALLATION

1. Check the engine oil level. Refer to [LU-24](#).
2. Start engine, and check there is no leakage of engine oil.
3. Stop engine and wait for 15 minutes.
4. Check the engine oil level and adjust engine oil. Refer to [LU-24](#).

Disassembly and Assembly

INFOID:000000004159574

DISASSEMBLY

1. Remove oil pump cover.
2. Remove oil pump inner rotor and oil pump outer rotor from oil pump body.
3. After removing regulator valve plug, remove regulator valve spring, and regulator valve.

INSPECTION AFTER DISASSEMBLY

Oil Pump Clearance

- Measure the clearance with feeler gauge.
 - Clearance between oil pump outer rotor and oil pump body (Position 1)
Standard : 0.114 - 0.200 mm (0.0045 - 0.0079 in)
 - Tip clearance between oil pump inner rotor and oil pump outer rotor (Position 2)
Standard : Below 0.180 mm (0.0071 in)
 - If out of the standard, replace inner rotor and outer rotor.

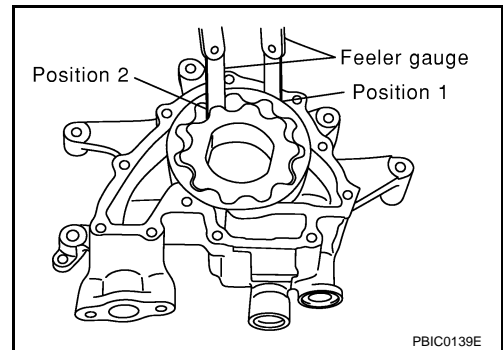

- Measure the clearance with feeler gauge and straightedge.
 - Side clearance between oil pump inner rotor and oil pump body (Position 3)
Standard : 0.030 - 0.070 mm (0.0012 - 0.0028 in)
 - Side clearance between oil pump outer rotor and oil pump body (Position 4)
Standard : 0.030 - 0.090 mm (0.0012 - 0.0035 in)

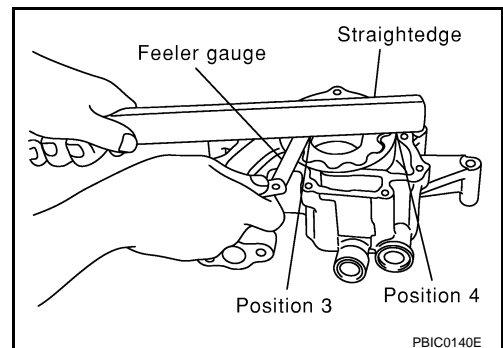

- Calculate the clearance between oil pump inner rotor and oil pump body as follows:

OIL PUMP INNER ROTOR OUTER DIAMETER

OIL PUMP

[VK45DE]

< SERVICE INFORMATION >

- Measure the outer diameter of protruded portion of oil pump inner rotor with micrometer. (Position 5)

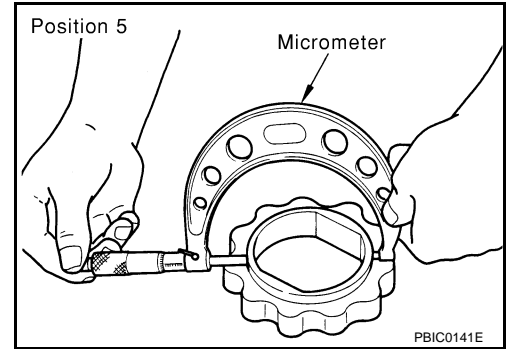

OIL PUMP BODY INNER DIAMETER

- Measure the inner diameter of oil pump body with inside micrometer. (Position 6)

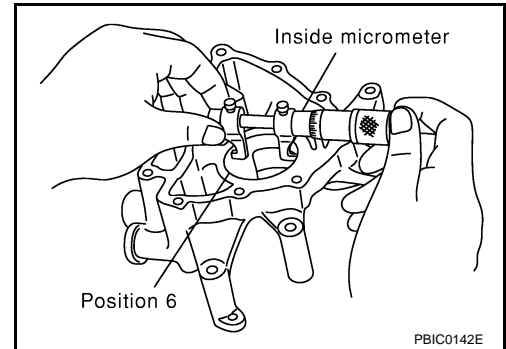

OIL PUMP INNER DIAMETER TO OIL PUMP BODY CLEARANCE

- (Clearance) = (Oil pump body inner diameter) – (Oil pump inner rotor outer diameter)

Standard : 0.045 - 0.091 mm (0.0018 - 0.0036 in)

- If the measured/calculated values are out of the standard, replace oil pump assembly.

Regulator Valve Clearance

- (Clearance) = D1 (Valve hole diameter) – D2 (Regulator valve outer diameter of valve)

Standard : 0.040 - 0.097 mm (0.0016 - 0.0038 in)

- If the calculated value is out of the standard, replace oil pump assembly.

CAUTION:

- Coat regulator valve with engine oil.
- Check that it falls smoothly into regulator valve hole by its own weight.

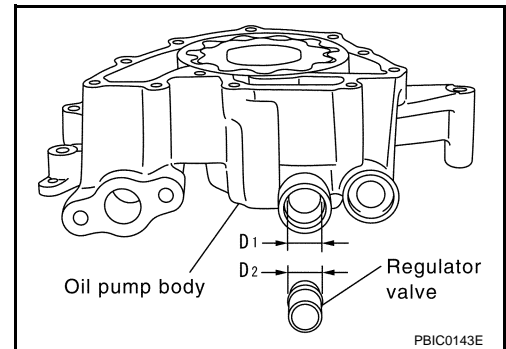

ASSEMBLY

Note the following, and assemble in the reverse order of disassembly.

- Install oil pump inner rotor and oil pump outer rotor with the punched marks on the oil pump cover side.

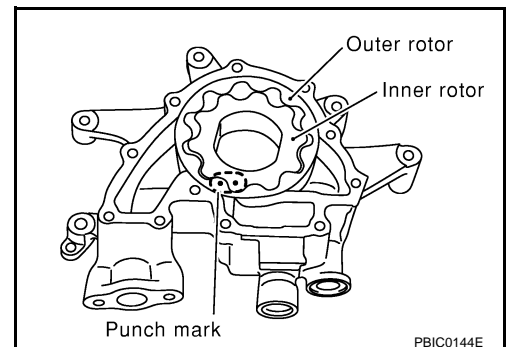

SERVICE DATA AND SPECIFICATIONS (SDS)

< SERVICE INFORMATION >

[VK45DE]

SERVICE DATA AND SPECIFICATIONS (SDS)

Standard and Limit

INFOID:000000004159575

ENGINE OIL PRESSURE

Unit: kPa (kg/cm²/psi)

Engine speed	Approximate discharge oil pressure*
Idle speed	More than 98 (1.0, 14)
2,000 rpm	More than 294 (3.0, 43)

*: Engine oil temperature at 80°C (176°F)

ENGINE OIL CAPACITY (APPROXIMATE)

Unit: ℓ (US qt, Imp qt)

Drain and refill	With oil filter change	5.5 (5-3/4, 4-7/8)
	Without oil filter change	4.9 (5-1/8, 4-1/4)
Dry engine (engine overhaul)		6.7 (7-1/8, 5-7/8)

OIL PUMP

Unit: mm (in)

Oil pump body to oil pump outer rotor radial clearance	0.114 - 0.200 (0.0045 - 0.0079)
Oil pump inner rotor to oil pump outer rotor tip clearance	Below 0.180 (0.0071)
Oil pump body to oil pump inner rotor axial clearance	0.030 - 0.070 (0.0012 - 0.0028)
Oil pump body to oil pump outer rotor axial clearance	0.030 - 0.090 (0.0012 - 0.0035)
Oil pump inner rotor to oil pump body clearance	0.045 - 0.091 (0.0018 - 0.0036)

REGULATOR VALVE

Unit: mm (in)

Regulator valve to oil pump body clearance	0.040 - 0.097 (0.0016 - 0.0038)
--	---------------------------------

A
LU
C
D
E
F
G
H
I
J
K
L
M
N
O
P