

# SECTION **ATC**

## AUTOMATIC AIR CONDITIONER

A  
B  
C  
D  
E  
F  
G  
H  
I  
J  
K  
L  
M  
N  
O  
P

### CONTENTS

<p><b>SERVICE INFORMATION</b> ..... 3</p> <p><b>PRECAUTIONS</b> ..... 3</p> <p style="padding-left: 20px;">Precaution for Supplemental Restraint System (SRS) "AIR BAG" and "SEAT BELT PRE-TENSIONER" .....3</p> <p style="padding-left: 20px;">Precaution Necessary for Steering Wheel Rotation after Battery Disconnect .....3</p> <p style="padding-left: 20px;">Precaution for Procedure without Cowl Top Cover.....4</p> <p style="padding-left: 20px;">Precaution for Working with HFC-134a (R-134a).....4</p> <p style="padding-left: 20px;">General Refrigerant Precaution .....4</p> <p style="padding-left: 20px;">Precaution for Refrigerant Connection .....5</p> <p style="padding-left: 20px;">Precaution for Service of Compressor .....9</p> <p style="padding-left: 20px;">Precaution for Service Equipment .....10</p> <p style="padding-left: 20px;">Precaution for Leak Detection Dye .....11</p> <p><b>PREPARATION</b> .....13</p> <p style="padding-left: 20px;">Special Service Tool .....13</p> <p style="padding-left: 20px;">Commercial Service Tool .....16</p> <p style="padding-left: 20px;">Sealant or/and Lubricant .....16</p> <p><b>REFRIGERATION SYSTEM</b> .....17</p> <p style="padding-left: 20px;">Refrigerant Cycle .....17</p> <p style="padding-left: 20px;">Refrigerant System Protection .....17</p> <p style="padding-left: 20px;">Variable Displacement Compressor .....17</p> <p style="padding-left: 20px;">Component Part Location .....21</p> <p><b>LUBRICANT</b> .....22</p> <p style="padding-left: 20px;">Maintenance of Lubricant Quantity in Compressor...22</p> <p><b>AIR CONDITIONER CONTROL</b> .....24</p> <p style="padding-left: 20px;">Description of Air Conditioner LAN Control System .....24</p> <p style="padding-left: 20px;">System Construction .....24</p> <p style="padding-left: 20px;">Description of Control System .....27</p> <p style="padding-left: 20px;">Control Operation .....27</p> <p style="padding-left: 20px;">Control Operation (Rear Control Switch) .....29</p> <p style="padding-left: 20px;">Fail-Safe Function .....30</p> <p style="padding-left: 20px;">Discharge Air Flow .....31</p> <p style="padding-left: 20px;">System Description .....32</p> <p style="padding-left: 20px;">CAN Communication System Description .....32</p>	<p><b>TROUBLE DIAGNOSIS</b> .....34</p> <p style="padding-left: 20px;">CONSULT-III Function (ECM) .....34</p> <p style="padding-left: 20px;">How to Perform Trouble Diagnosis for Quick and Accurate Repair .....34</p> <p style="padding-left: 20px;">Component Parts and Harness Connector Location .....36</p> <p style="padding-left: 20px;">Schematic .....38</p> <p style="padding-left: 20px;">Wiring Diagram - A/C - .....40</p> <p style="padding-left: 20px;">Auto Amp. Terminal and Reference Value .....47</p> <p style="padding-left: 20px;">Self-Diagnosis Function .....48</p> <p style="padding-left: 20px;">Operational Check .....56</p> <p style="padding-left: 20px;">Power Supply and Ground Circuit for Auto Amp. ....58</p> <p style="padding-left: 20px;">Rear Control Switch Circuit .....61</p> <p style="padding-left: 20px;">LAN System Circuit .....62</p> <p style="padding-left: 20px;">Mode Door Motor Circuit .....65</p> <p style="padding-left: 20px;">Upper Ventilator Door Motor Circuit .....68</p> <p style="padding-left: 20px;">Air Mix Door Motor Circuit .....71</p> <p style="padding-left: 20px;">Air Mix Door Motor PBR Circuit .....73</p> <p style="padding-left: 20px;">Intake Door Motor Circuit .....73</p> <p style="padding-left: 20px;">Blower Motor Circuit .....76</p> <p style="padding-left: 20px;">Magnet Clutch Circuit .....80</p> <p style="padding-left: 20px;">Insufficient Cooling .....84</p> <p style="padding-left: 20px;">Insufficient Heating .....93</p> <p style="padding-left: 20px;">Noise .....94</p> <p style="padding-left: 20px;">Self-Diagnosis .....95</p> <p style="padding-left: 20px;">Memory Function .....96</p> <p style="padding-left: 20px;">Ambient Sensor Circuit .....97</p> <p style="padding-left: 20px;">In-vehicle Sensor Circuit .....99</p> <p style="padding-left: 20px;">Sunload Sensor Circuit .....102</p> <p style="padding-left: 20px;">Intake Sensor Circuit .....105</p> <p><b>CONTROLLER</b> ..... 108</p> <p style="padding-left: 20px;">Removal and Installation of Multifunction Switch ..108</p> <p><b>AUTO AMP.</b> ..... 109</p> <p style="padding-left: 20px;">Removal and Installation of Unified Meter and A/C Amp. ....109</p> <p><b>AMBIENT SENSOR</b> ..... 110</p> <p style="padding-left: 20px;">Removal and Installation .....110</p>
---	--

ATC

<b>IN-VEHICLE SENSOR</b> .....	<b>111</b>	VQ35HR : Removal and Installation of High-pres-	
Removal and Installation .....	111	sure Pipe 1 .....	141
<b>SUNLOAD SENSOR</b> .....	<b>112</b>	VQ35HR : Removal and Installation of Low-pres-	
Removal and Installation .....	112	sure Pipe 1 and High-pressure Pipe 2 .....	142
<b>INTAKE SENSOR</b> .....	<b>113</b>	VQ35HR : Removal and Installation of Liquid Tank	
Removal and Installation .....	113	. 144	
<b>BLOWER UNIT</b> .....	<b>114</b>	VQ35HR : Removal and Installation of Condenser.	145
Removal and Installation .....	114	VQ35HR : Removal and Installation of Refrigerant	
Disassembly and Assembly .....	115	Pressure Sensor .....	147
<b>BLOWER MOTOR</b> .....	<b>116</b>	VQ35HR : Removal and Installation of Evaporator.	148
Removal and Installation .....	116	VQ35HR : Removal and Installation of Expansion	
<b>INTAKE DOOR MOTOR</b> .....	<b>117</b>	Valve .....	148
Removal and Installation .....	117	VQ35HR : Checking of Refrigerant Leaks .....	149
<b>IN-CABIN MICROFILTER</b> .....	<b>118</b>	VQ35HR : Checking System for Leaks Using the	
Removal and Installation .....	118	Fluorescent Leak Detector .....	149
<b>HEATER &amp; COOLING UNIT ASSEMBLY</b> .....	<b>119</b>	VQ35HR : Dye Injection .....	149
Removal and Installation .....	119	VQ35HR : Electrical Leak Detector .....	150
Disassembly and Assembly .....	122	<b>VK45DE</b> .....	<b>152</b>
<b>MODE DOOR MOTOR</b> .....	<b>124</b>	VK45DE : HFC-134a (R-134a) Service Procedure.	152
Removal and Installation .....	124	VK45DE : Component .....	155
<b>AIR MIX DOOR MOTOR</b> .....	<b>125</b>	VK45DE : Removal and Installation of Compres-	
Removal and Installation .....	125	sor .....	155
<b>UPPER VENTILATOR DOOR MOTOR</b> .....	<b>126</b>	VK45DE : Check Disc to Pulley Clearance .....	156
Removal and Installation .....	126	VK45DE : Removal and Installation of Low-pres-	
<b>HEATER CORE</b> .....	<b>127</b>	sure Flexible Hose and Pipe .....	156
Removal and Installation .....	127	VK45DE : Removal and Installation of High-pres-	
<b>DUCTS AND GRILLES</b> .....	<b>128</b>	sure Flexible Hose .....	157
Removal and Installation .....	128	VK45DE : Removal and Installation of High-pres-	
<b>REFRIGERANT LINES</b> .....	<b>135</b>	sure Pipe 1 .....	158
<b>VQ35HR</b> .....	<b>135</b>	VK45DE : Removal and Installation of Low-pres-	
VQ35HR : HFC-134a (R-134a) Service Procedure	.. 135	sure Pipe 1 and High-pressure Pipe 2 .....	160
VQ35HR : Component .....	136	VK45DE : Removal and Installation of Liquid Tank	
VQ35HR : Removal and Installation of Compres-		. 161	
sor .....	137	VK45DE : Removal and Installation of Condenser.	163
VQ35HR : Check Disc to Pulley Clearance .....	138	VK45DE : Removal and Installation of Refrigerant	
VQ35HR : Removal and Installation of Low-pres-		Pressure Sensor .....	165
sure Flexible Hose .....	138	VK45DE : Removal and Installation of Evaporator.	165
VQ35HR : Removal and Installation of Low-pres-		VK45DE : Removal and Installation of Expansion	
sure Pipe 2 .....	139	Valve .....	166
VQ35HR : Removal and Installation of High-pres-		VK45DE : Checking of Refrigerant Leaks .....	166
sure Flexible Hose .....	140	VK45DE : Checking System for Leaks Using the	
		Fluorescent Leak Detector .....	167
		VK45DE : Dye Injection .....	167
		VK45DE : Electrical Leak Detector .....	167
		<b>SERVICE DATA AND SPECIFICATIONS</b>	
		<b>(SDS)</b> .....	<b>171</b>
		Compressor .....	171
		Lubricant .....	171
		Refrigerant .....	171
		Engine Idling Speed .....	171
		Belt Tension .....	171

# PRECAUTIONS

< SERVICE INFORMATION >

## SERVICE INFORMATION

### PRECAUTIONS

#### Precaution for Supplemental Restraint System (SRS) "AIR BAG" and "SEAT BELT PRE-TENSIONER"

INFOID:000000005348485

The Supplemental Restraint System such as "AIR BAG" and "SEAT BELT PRE-TENSIONER", used along with a front seat belt, helps to reduce the risk or severity of injury to the driver and front passenger for certain types of collision. This system includes seat belt switch inputs and dual stage front air bag modules. The SRS system uses the seat belt switches to determine the front air bag deployment, and may only deploy one front air bag, depending on the severity of a collision and whether the front occupants are belted or unbelted. Information necessary to service the system safely is included in the "SUPPLEMENTAL RESTRAINT SYSTEM" and "SEAT BELTS" of this Service Manual.

#### **WARNING:**

- To avoid rendering the SRS inoperative, which could increase the risk of personal injury or death in the event of a collision which would result in air bag inflation, all maintenance must be performed by an authorized NISSAN/INFINITI dealer.
- Improper maintenance, including incorrect removal and installation of the SRS, can lead to personal injury caused by unintentional activation of the system. For removal of Spiral Cable and Air Bag Module, see the "SUPPLEMENTAL RESTRAINT SYSTEM".
- Do not use electrical test equipment on any circuit related to the SRS unless instructed to in this Service Manual. SRS wiring harnesses can be identified by yellow and/or orange harnesses or harness connectors.

#### PRECAUTIONS WHEN USING POWER TOOLS (AIR OR ELECTRIC) AND HAMMERS

#### **WARNING:**

- When working near the Air Bag Diagnosis Sensor Unit or other Air Bag System sensors with the ignition ON or engine running, DO NOT use air or electric power tools or strike near the sensor(s) with a hammer. Heavy vibration could activate the sensor(s) and deploy the air bag(s), possibly causing serious injury.
- When using air or electric power tools or hammers, always switch the ignition OFF, disconnect the battery, and wait at least 3 minutes before performing any service.

#### Precaution Necessary for Steering Wheel Rotation after Battery Disconnect

INFOID:000000005348486

#### **NOTE:**

- Before removing and installing any control units, first turn the push-button ignition switch to the LOCK position, then disconnect both battery cables.
- After finishing work, confirm that all control unit connectors are connected properly, then re-connect both battery cables.
- Always use CONSULT-III to perform self-diagnosis as a part of each function inspection after finishing work. If a DTC is detected, perform trouble diagnosis according to self-diagnosis results.

This vehicle is equipped with a push-button ignition switch and a steering lock unit.

If the battery is disconnected or discharged, the steering wheel will lock and cannot be turned.

If turning the steering wheel is required with the battery disconnected or discharged, follow the procedure below before starting the repair operation.

#### OPERATION PROCEDURE

1. Connect both battery cables.

#### **NOTE:**

Supply power using jumper cables if battery is discharged.

2. Turn the push-button ignition switch to ACC position.  
(At this time, the steering lock will be released.)
3. Disconnect both battery cables. The steering lock will remain released with both battery cables disconnected and the steering wheel can be turned.
4. Perform the necessary repair operation.

# PRECAUTIONS

## < SERVICE INFORMATION >

- When the repair work is completed, re-connect both battery cables. With the brake pedal released, turn the push-button ignition switch from ACC position to ON position, then to LOCK position. (The steering wheel will lock when the push-button ignition switch is turned to LOCK position.)
- Perform self-diagnosis check of all control units using CONSULT-III.

### Precaution for Procedure without Cowl Top Cover

INFOID:000000005348487

When performing the procedure after removing cowl top cover, cover the lower end of windshield with urethane, etc.

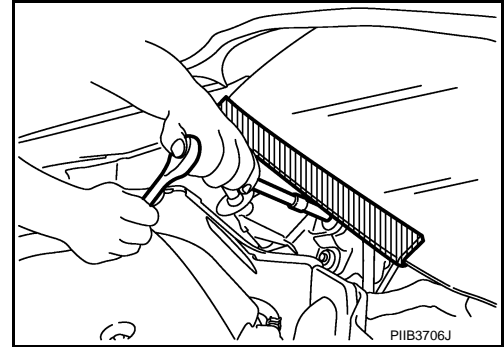

### Precaution for Working with HFC-134a (R-134a)

INFOID:000000005348488

#### CAUTION:

- CFC-12 (R-12) refrigerant and HFC-134a (R-134a) refrigerant are not compatible. Compressor malfunction is likely to occur if the refrigerants are mixed, refer to “CONTAMINATED REFRIGERANT” below. To determine the purity of HFC-134a (R-134a) in the vehicle and recovery tank, use Refrigerant recovery/recycling recharging equipment and Refrigerant Identifier.
- Use only specified lubricant for the HFC-134a (R-134a) A/C system and HFC-134a (R-134a) components. Compressor malfunction is likely to occur if lubricant other than that specified is used.
- The specified HFC-134a (R-134a) lubricant rapidly absorbs moisture from the atmosphere. The following handling precautions must be observed:
  - Cap (seal) immediately the component to minimize the entry of moisture from the atmosphere when removing refrigerant components from a vehicle.
  - Never remove the caps (unseal) until just before connecting the components when installing refrigerant components to a vehicle. Connect all refrigerant loop components as quickly as possible to minimize the entry of moisture into system.
  - Use only the specified lubricant from a sealed container. Reseal immediately containers of lubricant. Lubricant becomes moisture saturated and should not be used without proper sealing.
  - Never allow lubricant (NISSAN A/C System Oil Type S) to come in contact with styrene foam parts. Damage may result.

#### CONTAMINATED REFRIGERANT

Take appropriate steps shown below if a refrigerant other than pure HFC-134a (R-134a) is identified in a vehicle:

- Explain to the customer that environmental regulations prohibit the release of contaminated refrigerant into the atmosphere.
- Explain that recovery of the contaminated refrigerant could damage service equipment and refrigerant supply.
- Suggest the customer return the vehicle to the location of previous service where the contamination may have occurred.
- In case of repairing, recover the refrigerant using only **dedicated equipment and containers. Never recover contaminated refrigerant into the existing service equipment.** Contact a local refrigerant product retailer for available service if the facility does not have dedicated recovery equipment. This refrigerant must be disposed of in accordance with all federal and local regulations. In addition, replacement of all refrigerant system components on the vehicle is recommended.
- The air conditioner warranty is void if the vehicle is within the warranty period. Please contact Nissan Customer Affairs for further assistance.

### General Refrigerant Precaution

INFOID:000000005348489

#### WARNING:

- Never breathe A/C refrigerant and lubricant vapor or mist. Exposure may irritate eyes, nose and throat. Remove HFC-134a (R-134a) from the A/C system, using certified service equipment meeting

# PRECAUTIONS

## < SERVICE INFORMATION >

requirements of SAE J-2210 [HFC-134a (R-134a) recycling equipment], or J-2209 [HFC-134a (R-134a) recovery equipment]. Ventilate work area before resuming service if accidental system discharge occurs. Additional health and safety information may be obtained from refrigerant and lubricant manufacturers.

- Never release refrigerant into the air. Use approved recovery/recycling equipment to capture the refrigerant every time an air conditioning system is discharged.
- Wear always eye and hand protection (goggles and gloves) when working with any refrigerant or air conditioning system.
- Never store or heat refrigerant containers above 52°C (126°F).
- Never heat a refrigerant container with an open flame: Place the bottom of the container in a warm pail of water if container warming is required.
- Never intentionally drop, puncture, or incinerate refrigerant containers.
- Keep refrigerant away from open flames: poisonous gas will be produced if refrigerant burns.
- Refrigerant will displace oxygen, therefore be certain to work in well ventilated areas to prevent suffocation.
- Never pressure test or leakage test HFC-134a (R-134a) service equipment and/or vehicle air conditioning systems with compressed air during repair. Some mixtures of air and HFC-134a (R-134a) have been shown to be combustible at elevated pressures. These mixtures, if ignited, may cause injury or property damage. Additional health and safety information may be obtained from refrigerant manufacturers.

## Precaution for Refrigerant Connection

INFOID:000000005348490

A new type refrigerant connection has been introduced to all refrigerant lines except the following location.

- Expansion valve to evaporator
- Refrigerant pressure sensor to liquid tank

## ABOUT ONE-TOUCH JOINT

### Description

- One-touch joints are pipe joints which do not require tools during piping connection.
- Unlike conventional connection methods using union nuts and flanges, controlling tightening torque at connection point is not necessary.
- Use a disconnecter when removing a pipe joint.

### COMPONENT PARTS

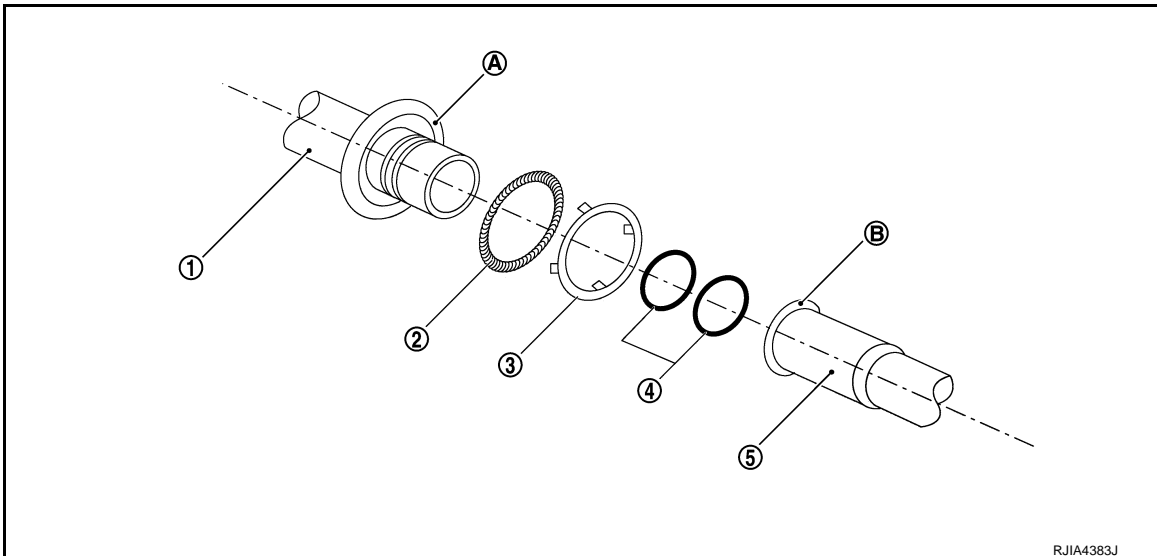

### FUNCTIONS OF COMPONENT PARTS

1	Pipe (Male-side)	<ul style="list-style-type: none"> <li>• Retains O-rings.</li> <li>• Retains garter spring in cage (A).</li> </ul>
2	Garter spring	Anchors female-side piping.
3	Indicator ring	When connection is made properly, this is ejected from male-side piping. (This part is no longer necessary after connection.)

# PRECAUTIONS

## < SERVICE INFORMATION >

4	O-ring	Seals connection point. (Not reusable)
5	Pipe (Female-side)	<ul style="list-style-type: none"> <li>Seals connection by compressing O-rings.</li> <li>Anchors piping connection using flare (B) and garter spring.</li> </ul>

### NOTE:

- Garter spring cannot be removed from cage of male-side piping.
- Indicator ring remains near piping connection point, however, this is not a malfunction. (This is to check piping connection during factory assembly.)

### REMOVAL

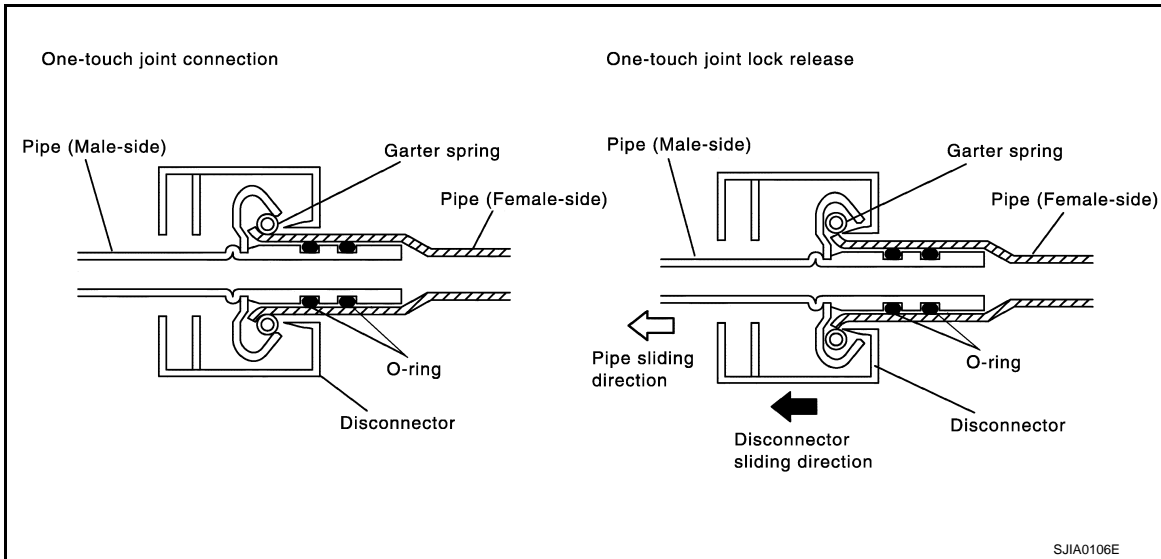

- Clean piping connection point, and set a disconnecter.
- Slide disconnecter in axial direction of piping, and stretch garter spring with tapered point of disconnecter.
- Slide disconnecter farther so that inside diameter of garter spring becomes larger than outside diameter of female-side piping flare. Then male-side piping can be disconnected.

### INSTALLATION

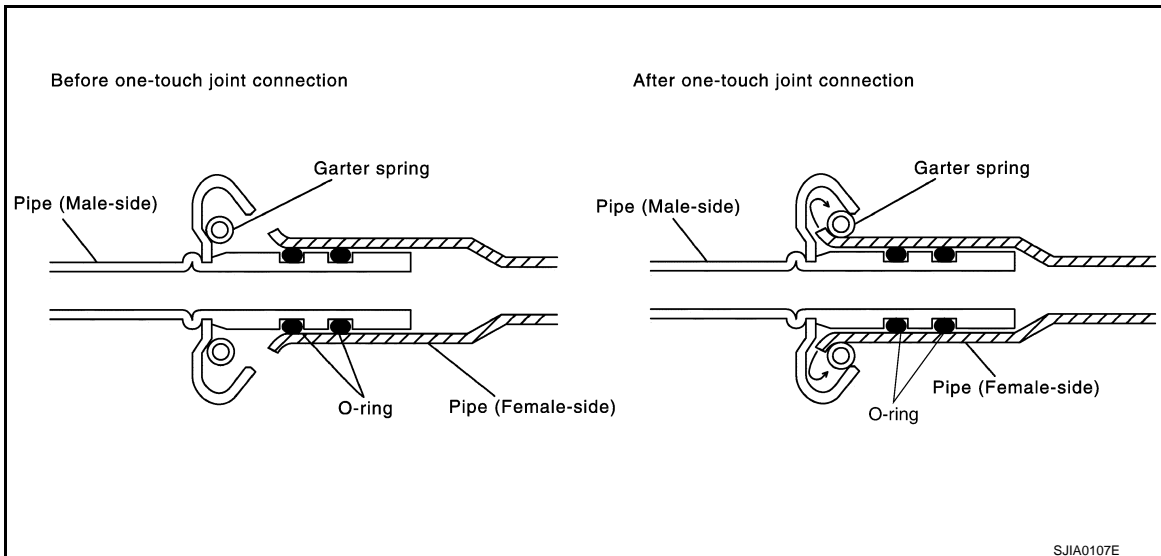

- Clean piping connection points, and insert male-side piping into female-side piping.
- Push inserted male-side piping harder so that female-side piping flare stretches garter spring.
- Garter spring seats on flare if inside diameter of garter spring becomes larger than outside diameter of female-side piping flare. Then, it fits in between male-side piping cage and female-side piping flare to anchor piping connection point.

### NOTE:

When garter spring seats on flare, and fits in between male-side piping cage and female-side piping flare, it clicks.

### CAUTION:

# PRECAUTIONS

## < SERVICE INFORMATION >

- Female-side piping connection point is thin and easy to deform. Slowly insert the male-side piping straight in axial direction.
- Insert piping securely until a click is heard.
- After piping connection is completed, pull male-side piping by hand to check that connection does not come loose.

## FEATURES OF NEW TYPE REFRIGERANT CONNECTION

- The O-ring has been relocated. It has also been provided with a groove for proper installation. This eliminates the possibility of the O-ring being caught in, or damaged by, the mating part. The sealing direction of the O-ring is now set vertically in relation to the contacting surface of the mating part to improve sealing characteristics.
- The reaction force of the O-ring will not occur in the direction that causes the joint to pull out, thereby facilitating piping connections.

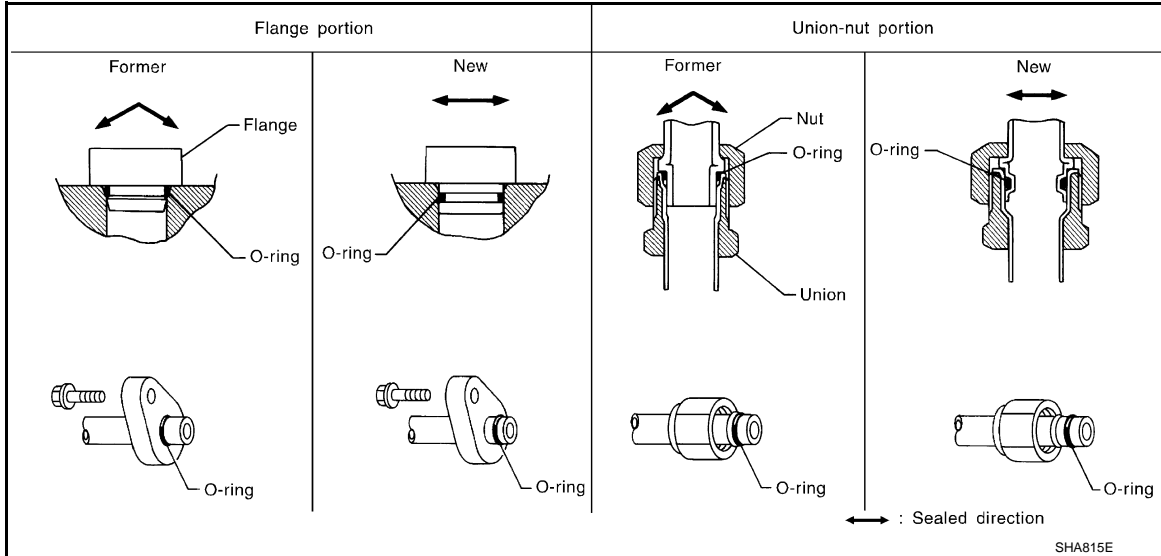

## O-RING AND REFRIGERANT CONNECTION

VQ35HR

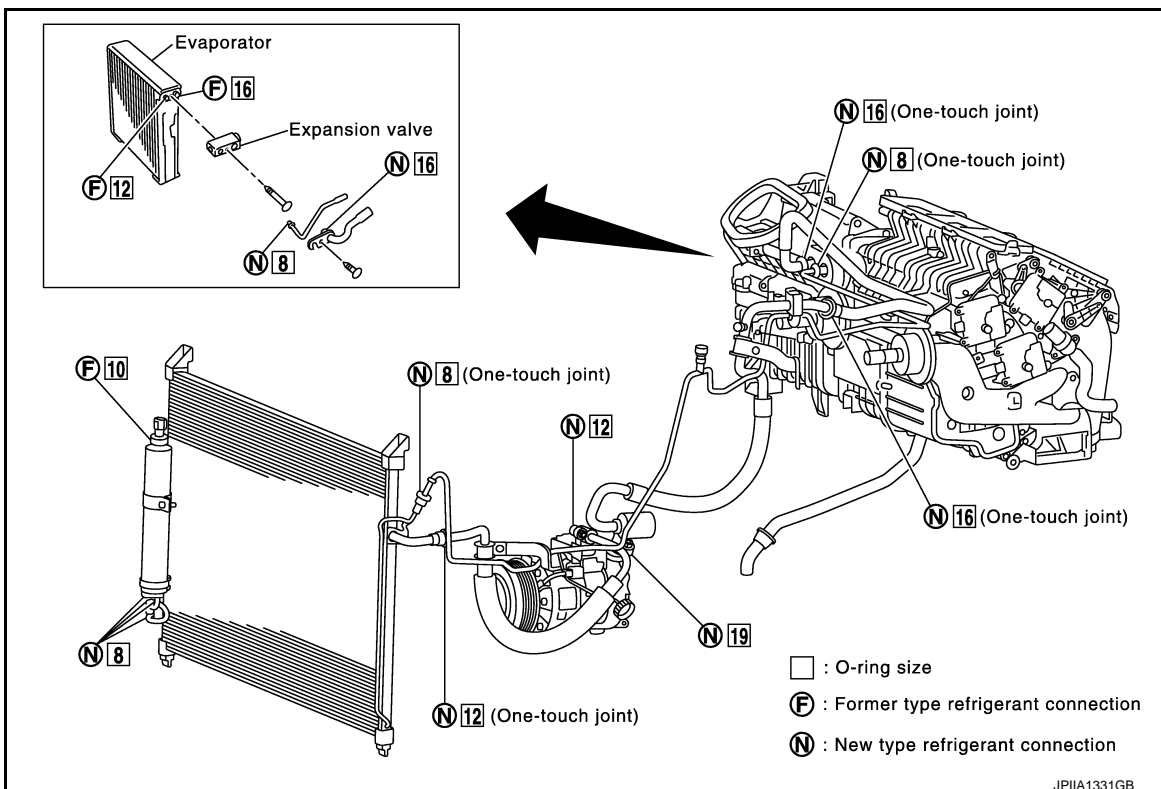

# PRECAUTIONS

< SERVICE INFORMATION >

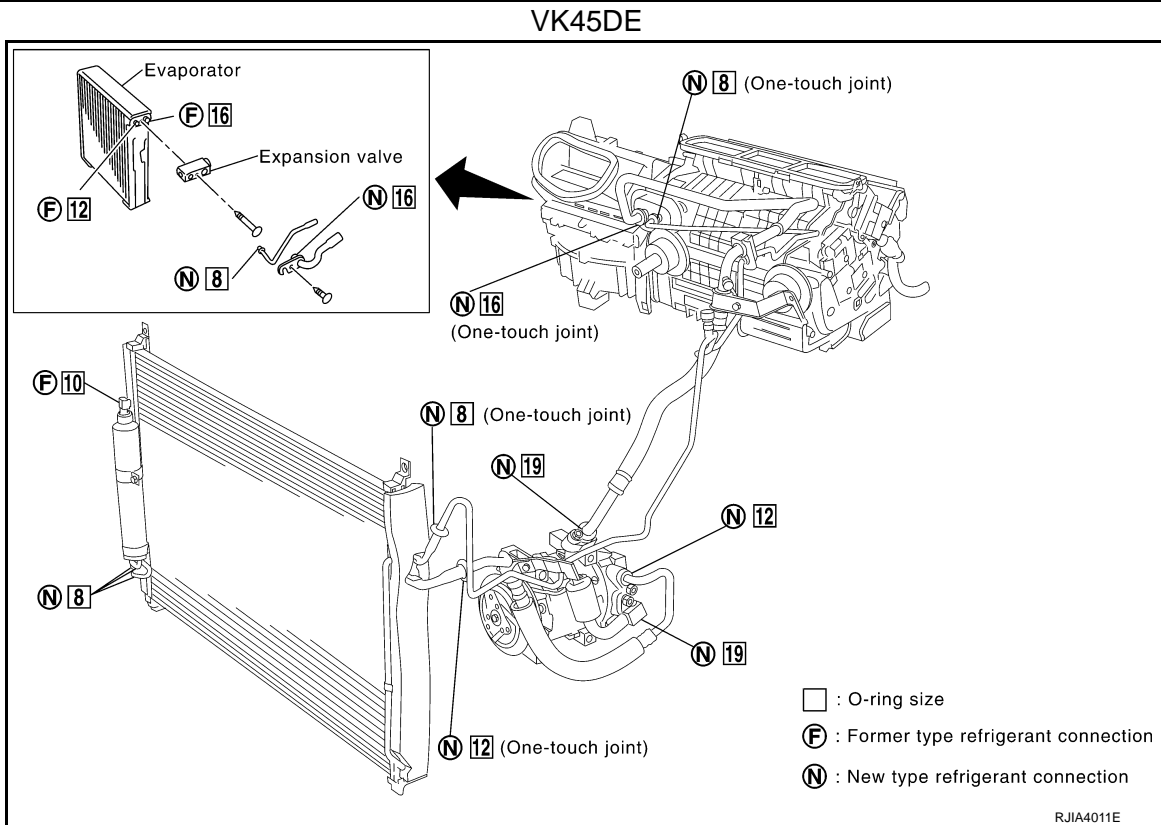

**CAUTION:**

The new and former refrigerant connections use different O-ring configurations. Never confuse O-rings since they are not interchangeable. Refrigerant may leak at the connection if a wrong O-ring is installed.

O-Ring Part Numbers and Specifications

Connection type	Piping connection point		Part number	QTY	O-ring size	
One-touch joint	Low-pressure flexible hose to low-pressure pipe 1 (VK45DE)		92473 N8221	2	φ16	
	Low-pressure flexible hose to low-pressure pipe 2 (VQ35HR)		92473 N8221	2	φ16	
	Low-pressure pipe 1 to low-pressure pipe 2 (VQ35HR)		92473 N8221	2	φ16	
	High-pressure pipe 1 to high-pressure pipe 2		92471 N8221	2	φ8	
	Condenser to high-pressure flexible hose		92472 N8221	2	φ12	
	Condenser to high-pressure pipe 1		92471 N8221	2	φ8	
New	Low-pressure pipe to low-pressure flexible hose (VK45DE)		92474 N8210	1	φ19	
	Low-pressure pipe 1 to expansion valve		92473 N8210	1	φ16	
	High-pressure pipe 2 to expansion valve		92471 N8210	1	φ8	
	Compressor to low-pressure flexible hose (VQ35HR)		92474 N8210	1	φ19	
	Compressor to low-pressure pipe (VK45DE)					
	Compressor to high-pressure flexible hose		92472 N8210	1	φ12	
	Condenser to condenser pipe		Inlet	92471 N8210	1	φ8
			Outlet		1	
	Liquid tank to condenser pipe		Inlet	92471 N8210	1	φ8
Outlet			1			
Former	Refrigerant pressure sensor to liquid tank		J2476 89956	1	φ10	
	Expansion valve to evaporator		Inlet	92475 71L00	1	φ12
			Outlet	92475 72L00	1	φ16



# PRECAUTIONS

## < SERVICE INFORMATION >

### WARNING:

Check that all refrigerant is discharged into the recycling equipment and the pressure in the system is less than atmospheric pressure. Then gradually loosen the discharge side hose fitting and remove it.

### CAUTION:

Observe the following when replacing or cleaning refrigerant cycle components.

- Store it in the same way as it is when mounted on the car when the compressor is removed. Failure to do so will cause lubricant to enter the low-pressure chamber.
- Use always a torque wrench and a back-up wrench when connecting tubes.
- Plug immediately all openings to prevent entry of dust and moisture after disconnecting tubes.
- Connect the pipes at the final stage of the operation when installing an air conditioner in the vehicle. Never remove the seal caps of pipes and other components until just before required for connection.
- Allow components stored in cool areas to warm to working area temperature before removing seal caps. This prevents condensation from forming inside A/C components.
- Remove thoroughly moisture from the refrigeration system before charging the refrigerant.
- Replace always used O-rings.
- Apply lubricant to circle of the O-rings shown in illustration when connecting tube. Be careful not to apply lubricant to threaded portion.

Name : NISSAN A/C System Oil Type S

- O-ring must be closely attached to the groove portion of tube.
- Be careful not to damage O-ring and tube when replacing the O-ring.
- Connect tube until a click can be heard. Then tighten the nut or bolt by hand. Check that the O-ring is installed to tube correctly.
- Perform leakage test and check that there is no leakage from connections after connecting line. Disconnect that line and replace the O-ring when the refrigerant leaking point is found. Then tighten connections of seal seat to the specified torque.

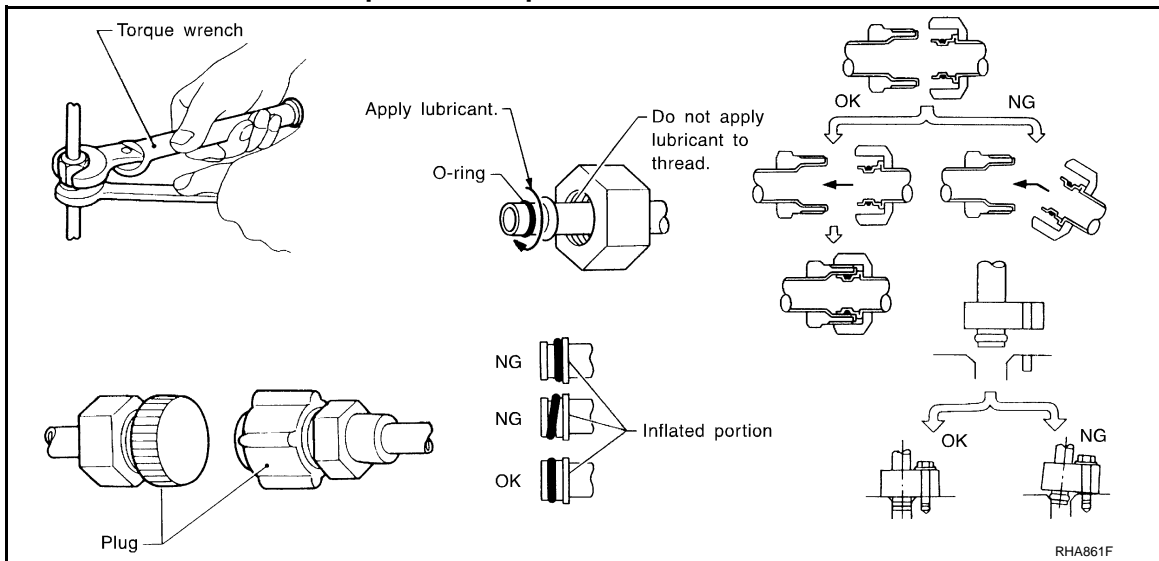

## Precaution for Service of Compressor

INFOID:000000005348491

- Plug all openings to prevent moisture and foreign matter from entering.
- Store it in the same way as it is when mounted on the car when the compressor is removed.
- Follow "Maintenance of Lubricant Quantity in Compressor" exactly when replacing or repairing compressor. Refer to [ATC-22. "Maintenance of Lubricant Quantity in Compressor"](#).
- Keep friction surfaces between clutch and pulley clean. Wipe it off by using a clean waste cloth moistened with thinner if the surface is contaminated with lubricant.
- Turn the compressor shaft by hand more than five turns in both directions after compressor service operation. This distributes equally lubricant inside the compressor. Let the engine idle and operate the compressor for one hour after the compressor is installed.
- Apply voltage to the new one and check for normal operation after replacing the compressor magnet clutch.

# PRECAUTIONS

## < SERVICE INFORMATION >

### Precaution for Service Equipment

INFOID:000000005348492

#### RECOVERY/RECYCLING RECHARGING EQUIPMENT

Be certain to follow the manufacturer's instructions for machine operation and machine maintenance. Never introduce any refrigerant other than that specified into the machine.

#### ELECTRICAL LEAK DETECTOR

Be certain to follow the manufacturer's instructions for tester operation and tester maintenance.

#### VACUUM PUMP

The lubricant contained inside the vacuum pump is not compatible with the specified lubricant for HFC-134a (R-134a) A/C systems. The vent side of the vacuum pump is exposed to atmospheric pressure. So the vacuum pump lubricant may migrate out of the pump into the service hose. This is possible when the pump is switched OFF after evacuation (vacuuming) and hose is connected to it. To prevent this migration, use a manual valve placed near the hose-to-pump connection, as per the following.

- Vacuum pumps usually have a manual isolator valve as part of the pump. Close this valve to isolate the service hose from the pump.
- Use a hose equipped with a manual shut-off valve near the pump end for pumps without an isolator. Close the valve to isolate the hose from the pump.
- Disconnect the hose from the pump if the hose has an automatic shut-off valve. As long as the hose is connected, the valve is open and lubricating oil may migrate.

Some one-way valves open when vacuum is applied and close under no vacuum condition. Such valves may restrict the pump's ability to pull a deep vacuum and are not recommended.

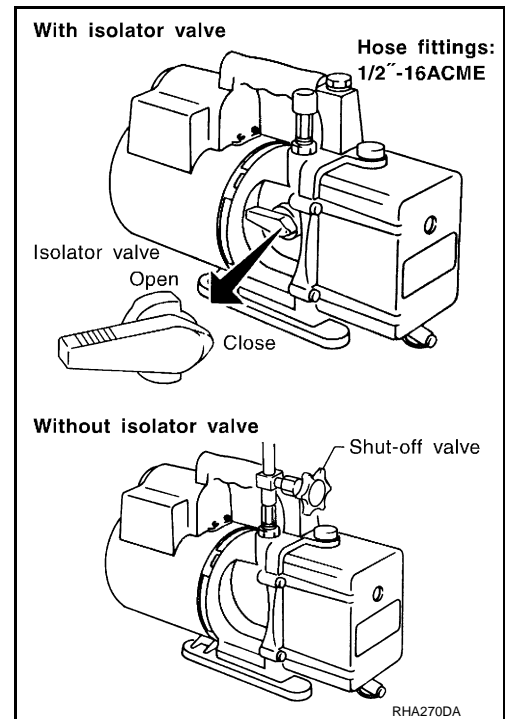

#### MANIFOLD GAUGE SET

Be certain that the gauge face indicates HFC-134a or R-134a. Be sure the gauge set has 1/2"-16 ACME threaded connections for service hoses. Confirm the set has been used only with refrigerant HFC-134a (R-134a) and specified lubricants.

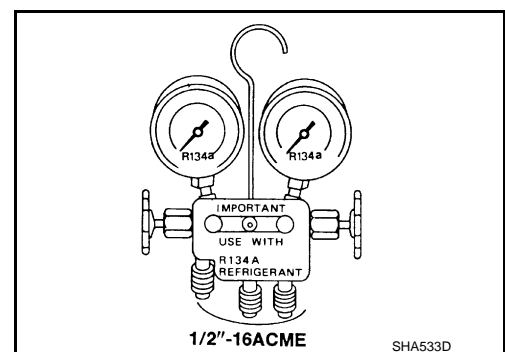

#### SERVICE HOSES

Be certain that the service hoses display the markings described (colored hose with black stripe). All hoses must equip positive shut-off devices (either manual or automatic) near the end of the hoses opposite to the manifold gauge.

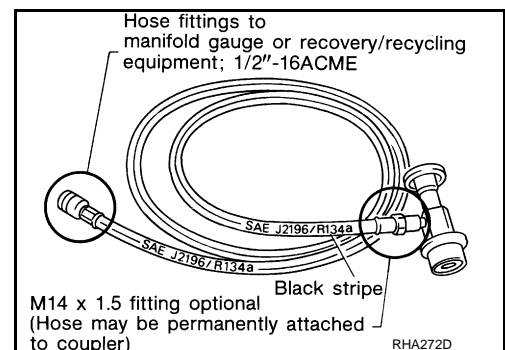

#### SERVICE COUPLERS

# PRECAUTIONS

## < SERVICE INFORMATION >

Never attempt to connect HFC-134a (R-134a) service couplers to the CFC-12 (R-12) A/C system. The HFC-134a (R-134a) couplers do not properly connect to the CFC-12 (R-12) system. However, if an improper connection is attempted, discharging and contamination may occur.

Shut-off valve rotation	A/C service valve
Clockwise	Open
Counterclockwise	Close

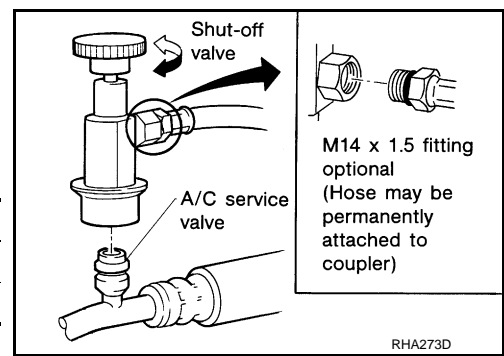

## REFRIGERANT WEIGHT SCALE

Verify that no refrigerant other than HFC-134a (R-134a) and specified lubricants have been used with the scale. The hose fitting must be 1/2"-16 ACME if the scale controls refrigerant flow electronically.

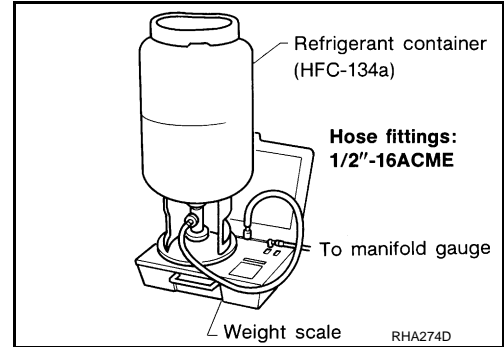

## CHARGING CYLINDER

Using a charging cylinder is not recommended. Refrigerant may be vented into air from cylinder's top valve when filling the cylinder with refrigerant. Also, the accuracy of the cylinder is generally less than that of an electronic scale or of quality recycle/recharge equipment.

## Precaution for Leak Detection Dye

INFOID:000000005348493

### CAUTION:

- The A/C system contains a fluorescent leak detection dye used for locating refrigerant leakages. An ultraviolet (UV) lamp is required to illuminate the dye when inspecting for leakages.
- Wear always fluorescence enhancing UV safety goggles to protect eyes and enhance the visibility of the fluorescent dye.
- The fluorescent dye leak detector is not a replacement for an electrical leak detector (SST: J-41995). The fluorescent dye leak detector should be used in conjunction with an electrical leak detector (SST: J-41995) to pinpoint refrigerant leakages.
- Read and follow all manufacturer's operating instructions and precautions prior to performing the work for the purpose of safety and customer's satisfaction.
- A compressor shaft seal should not necessarily be repaired because of dye seepage. The compressor shaft seal should only be repaired after confirming the leakage with an electrical leak detector (SST: J-41995).
- Remove always any remaining dye from the leakage area after repairs are completed to avoid a misdiagnosis during a future service.
- Never allow dye to come into contact with painted body panels or interior components. Clean immediately with the approved dye cleaner if dye is spilled. Fluorescent dye left on a surface for an extended period of time cannot be removed.
- Never spray the fluorescent dye cleaning agent on hot surfaces (engine exhaust manifold, etc.).
- Never use more than one refrigerant dye bottle [1/4 ounce (7.4 cc)] per A/C system.
- Leak detection dyes for HFC-134a (R-134a) and CFC-12 (R-12) A/C systems are different. Never use HFC-134a (R-134a) leak detection dye in CFC-12 (R-12) A/C system, or CFC-12 (R-12) leak detection dye in HFC-134a (R-134a) A/C system, or A/C system damage may result.
- The fluorescent properties of the dye remain for three or more years unless a compressor malfunction occurs.

## IDENTIFICATION

### NOTE:

Vehicles with factory installed fluorescent dye have a green label.

A  
B  
C  
D  
E  
F  
G  
H  
I

ATC

K  
L  
M  
N  
O  
P

## **PRECAUTIONS**

### **< SERVICE INFORMATION >**

---

Vehicles without factory installed fluorescent dye have a blue label.

#### **IDENTIFICATION LABEL FOR VEHICLE**

Vehicles with factory installed fluorescent dye have the identification label on the front side of hood.

# PREPARATION

< SERVICE INFORMATION >

## PREPARATION



### Special Service Tool

INFOID:000000005348494

The actual shapes of Kent-Moore tools may differ from those of special service tools illustrated here.



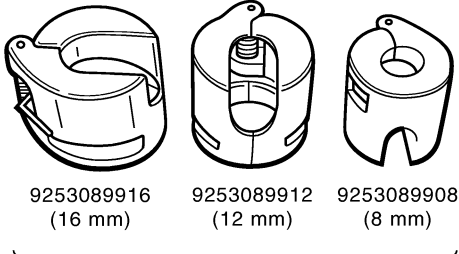

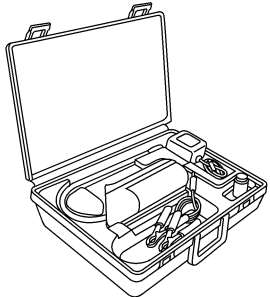
HFC-134a (R-134a) Service Tool and Equipment

- Never mix HFC-134a (R-134a) refrigerant and/or its specified lubricant with CFC-12 (R-12) refrigerant and/or its lubricant.
- Separate and non-interchangeable service equipment must be used for handling each type of refrigerant/lubricant.
- Refrigerant container fittings, service hose fittings and service equipment fittings (equipment which handles refrigerant and/or lubricant) are different between CFC-12 (R-12) and HFC-134a (R-134a). This is to avoid mixed use of the refrigerants/lubricant.
- Never use adapters that convert one size fitting to another: refrigerant/lubricant contamination occurs and compressor malfunction may result.

Tool number (Kent-Moore No.) Tool name	Description
<p>9253089908 (for high-pressure pipe 1) (—)</p> <p>9253089912 (for high-pressure flexible hose) (—)</p> <p>9253089916 (for low-pressure pipe 2 and low-pressure flexible hose) (—)</p> <p>Disconnecter tool set (J-45815)</p>	 <p>9253089916 (16 mm)    9253089912 (12 mm)    9253089908 (8 mm)</p> <p>Disconnecter tool set : J-45815</p> <p style="text-align: right;">SJIA1274E</p>
<p>(ACR2005-NI) ACR5 A/C Service Center</p>	 <p style="text-align: center;">WJIA0293E</p> <p>Function: Refrigerant recovery, recycling and recharging</p>
<p>(J-41995) Electrical leak detector</p>	 <p style="text-align: center;">AHA281A</p> <p>Power supply: DC 12 V (Battery terminal)</p>

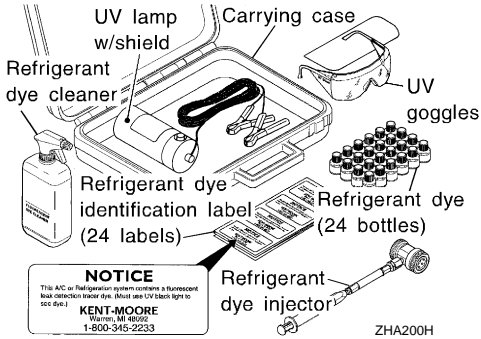
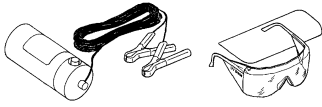
# PREPARATION

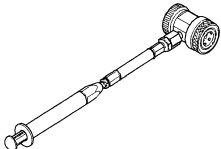
## < SERVICE INFORMATION >

Tool number (Kent-Moore No.) Tool name	Description
<p>(J-43926) Refrigerant dye leak detection kit Kit includes: (J-42220) UV lamp and UV safety goggles (J-41459) HFC-134a (R-134a) dye injector Use with J-41447, 1/4 ounce bottle (J-41447) HFC-134a (R-134a) fluorescent leak detection dye (Box of 24, 1/4 ounce bottles) (J-43872) Refrigerant dye cleaner</p>	 <p style="text-align: right;">Power supply: DC 12 V (Battery terminal)</p>
<p>(J-42220) UV lamp and UV safety goggles</p>	 <p style="text-align: right;">Power supply: DC 12 V (Battery terminal) For checking refrigerant leakage when fluorescent dye is equipped in A/C system Includes: UV lamp and UV safety goggles</p>
<p>(J-41447) HFC-134a (R-134a) fluorescent leak detection dye (Box of 24, 1/4 ounce bottles)</p>	 <p style="text-align: right;">Application: For HFC-134a (R-134a) PAG oil Container: 1/4 ounce (7.4 cc) bottle (Includes self-adhesive dye identification labels for affixing to vehicle after charging system with dye.)</p>
<p>(J-41459) HFC-134a (R-134a) dye injector Use with J-41447, 1/4 ounce bottle</p>	 <p style="text-align: right;">For injecting 1/4 ounce of fluorescent leak detection dye into A/C system</p>
<p>(J-43872) Refrigerant dye cleaner</p>	 <p style="text-align: right;">For cleaning dye spills</p>

# PREPARATION

## < SERVICE INFORMATION >

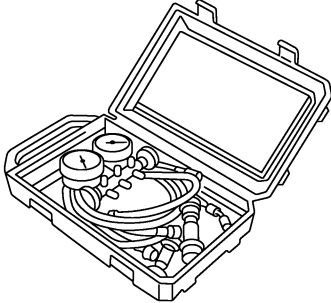
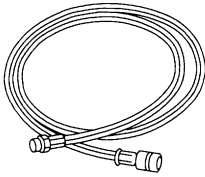
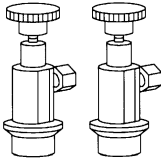
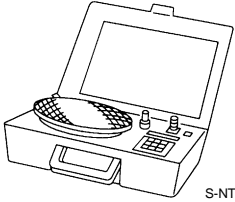
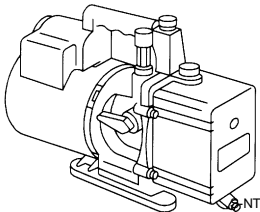
Tool number (Kent-Moore No.) Tool name	Description	A
<p>(J-39183) Manifold gauge set (with hoses and couplers)</p>  <p style="text-align: right; font-size: small;">RJIA0196E</p>	<p>Identification:</p> <ul style="list-style-type: none"> <li>The gauge face indicates HFC-134a (R-134a).</li> </ul> <p>Fitting size: Thread size</p> <ul style="list-style-type: none"> <li>1/2" -16 ACME</li> </ul>	B C D
<p>Service hoses</p> <ul style="list-style-type: none"> <li>High-pressure side hose (J-39501-72)</li> <li>Low-pressure side hose (J-39502-72)</li> <li>Utility hose (J-39476-72)</li> </ul>  <p style="text-align: right; font-size: small;">S-NT201</p>	<p>Hose color:</p> <ul style="list-style-type: none"> <li>Low-pressure side hose: Blue with black stripe</li> <li>High-pressure side hose: Red with black stripe</li> <li>Utility hose: Yellow with black stripe or green with black stripe</li> </ul> <p>Hose fitting to gauge:</p> <ul style="list-style-type: none"> <li>1/2" -16 ACME</li> </ul>	E F G
<p>Service couplers</p> <ul style="list-style-type: none"> <li>High-pressure side coupler (J-39500-20)</li> <li>Low-pressure side coupler (J-39500-24)</li> </ul>  <p style="text-align: right; font-size: small;">S-NT202</p>	<p>Hose fitting to service hose: M14 x 1.5 fitting is optional or permanently attached.</p>	H I
<p>(J-39650) Refrigerant weight scale</p>  <p style="text-align: right; font-size: small;">S-NT200</p>	<p>For measuring of refrigerant</p> <p>Fitting size: Thread size</p> <p>1/2" -16 ACME</p>	ATC K L
<p>(J-39649) Vacuum pump (Including the isolator valve)</p>  <p style="text-align: right; font-size: small;">S-NT203</p>	<p>Capacity:</p> <ul style="list-style-type: none"> <li>Air displacement: 4 CFM</li> <li>Micron rating: 20 microns</li> <li>Oil capacity: 482 g (17 oz.)</li> </ul> <p>Fitting size: Thread size</p> <ul style="list-style-type: none"> <li>1/2" -16 ACME</li> </ul>	M N O P

# PREPARATION

< SERVICE INFORMATION >

## Commercial Service Tool

INFOID:000000005348495

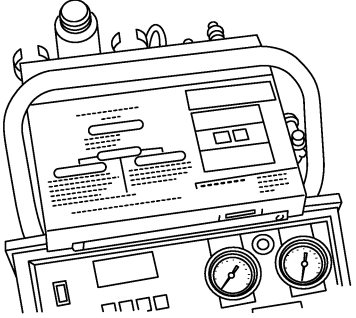
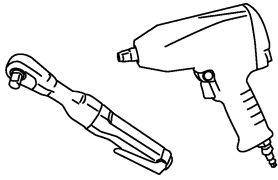

Tool name	Description
<p>Refrigerant identifier equipment</p>  <p style="text-align: right; font-size: small;">RJIA0197E</p>	<p>Checking for refrigerant purity and system contamination</p>
<p>Power tool</p>  <p style="text-align: right; font-size: small;">PBIC0190E</p>	<p>For loosening bolts and nuts</p>

## Sealant or/and Lubricant

INFOID:000000005348496

### HFC-134a (R-134a) Service Tool and Equipment

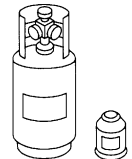
- Never mix HFC-134a (R-134a) refrigerant and/or its specified lubricant with CFC-12 (R-12) refrigerant and/or its lubricant.
- Separate and non-interchangeable service equipment must be used for handling each type of refrigerant/lubricant.
- Refrigerant container fittings, service hose fittings and service equipment fittings (equipment which handles refrigerant and/or lubricant) are different between CFC-12 (R-12) and HFC-134a (R-134a). This is to avoid mixed use of the refrigerants/lubricant.
- Never use adapters that convert one size fitting to another: refrigerant/lubricant contamination occurs and compressor malfunction may result.

Tool name	Description
<p>HFC-134a (R-134a) refrigerant</p>  <p style="text-align: right; font-size: small;">S-NT196</p>	<p>Container color: Light blue            Container marking: HFC-134a (R-134a)            Fitting size: Thread size</p> <ul style="list-style-type: none"> <li>• Large container 1/2" -16 ACME</li> </ul>
<p>NISSAN A/C System Oil Type S (DH-PS)</p>  <p style="text-align: right; font-size: small;">S-NT197</p>	<p>Type: Polyalkylene glycol oil (PAG), type S (DH-PS)            Application: HFC-134a (R-134a) swash plate compressors (NISSAN only)            Capacity: 40 mℓ (1.4 US fl oz., 1.4 Imp fl oz.)</p>



# REFRIGERATION SYSTEM

< SERVICE INFORMATION >

## REFRIGERATION SYSTEM

### Refrigerant Cycle

INFOID:000000005348497

#### REFRIGERANT FLOW

The refrigerant flows from the compressor, through the condenser with liquid tank, through the evaporator, and back to the compressor. The refrigerant evaporation in the evaporator is controlled by an externally equalized expansion valve, located inside the evaporator case.

#### FREEZE PROTECTION

To prevent evaporator frozen up, the evaporator air temperature is monitored, and the voltage signal to the unified meter and A/C amp. will make the A/C relay go OFF and stop the compressor.

### Refrigerant System Protection

INFOID:000000005348498

#### REFRIGERANT PRESSURE SENSOR

The refrigerant system is protected against excessively high- or low-pressures by the refrigerant pressure sensor, located on the liquid tank. If the system pressure rises above, or falls below the specifications, the refrigerant pressure sensor detects the pressure inside the refrigerant line and sends the voltage signal to the ECM. ECM makes the A/C relay go OFF and stops the compressor when pressure on the high-pressure side detected by refrigerant pressure sensor is over about 3,119 kPa (31.8 kg/cm<sup>2</sup>, 452 psi), or below about 118 kPa (1.2 kg/cm<sup>2</sup>, 17 psi).

#### PRESSURE RELIEF VALVE

The refrigerant system is also protected by a pressure relief valve, located in the rear head of the compressor. When the pressure of refrigerant in the system increases to an unusual level [more than 3,628 kPa (37 kg/cm<sup>2</sup>, 526 psi)], the release port on the pressure relief valve automatically opens and releases refrigerant into the atmosphere.

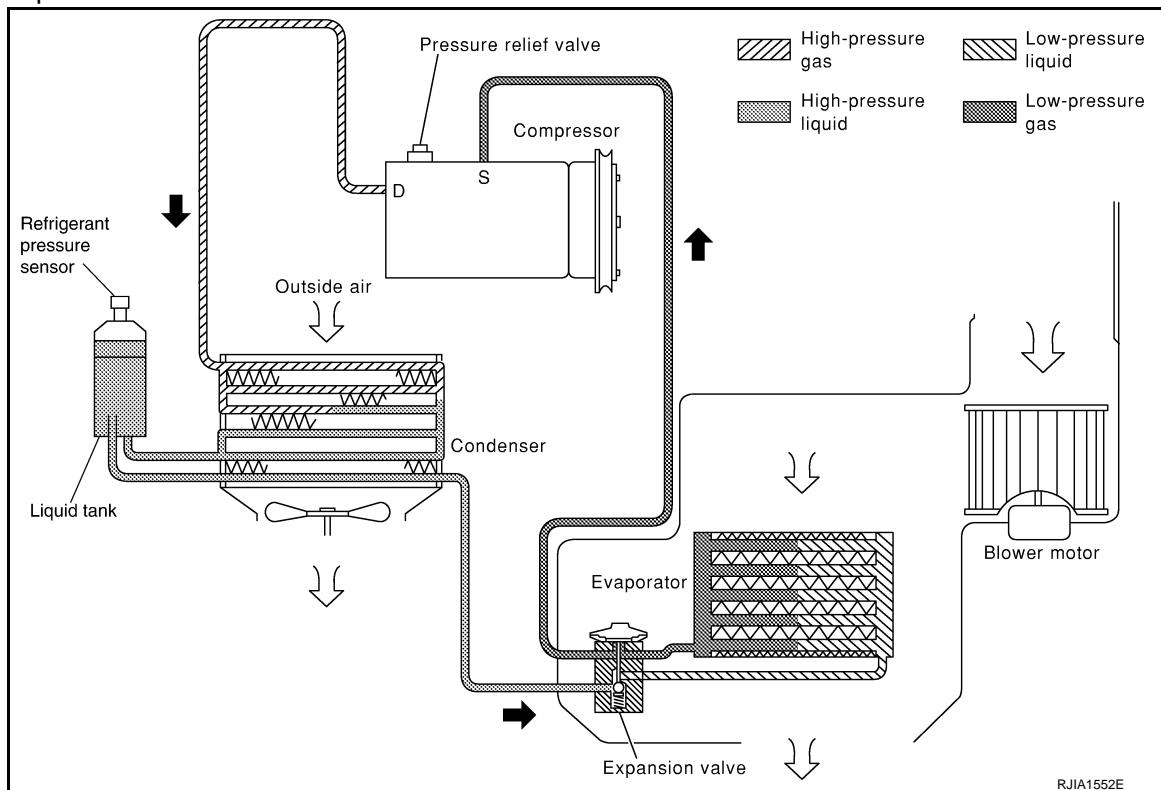

### Variable Displacement Compressor

INFOID:000000005348499

#### GENERAL INFORMATION

A  
B  
C  
D  
E  
F  
G  
H  
I  
K  
L  
M  
N  
O  
P

ATC

# REFRIGERATION SYSTEM

## < SERVICE INFORMATION >

1. The variable compressor provides refrigerant control under varying conditions. During cold winters, it may not produce high refrigerant pressure discharge (compared to previous units) when used with air conditioning systems.
2. For air conditioning systems with the compressor, the clutch remains engaged unless: the system main switch, fan switch or ignition switch is turned OFF. When ambient (outside) temperatures are low or when the amount of refrigerant is insufficient, the clutch is disengaged to protect the compressor.

## DESCRIPTION

### General

The variable compressor is a swash plate type that changes piston stroke in response to the required cooling capacity.

The tilt of the swash plate allows the piston's stroke to change so that refrigerant discharge continuously change from approx. 0 to 171 cm<sup>3</sup> (0 to 10.4 cu in).

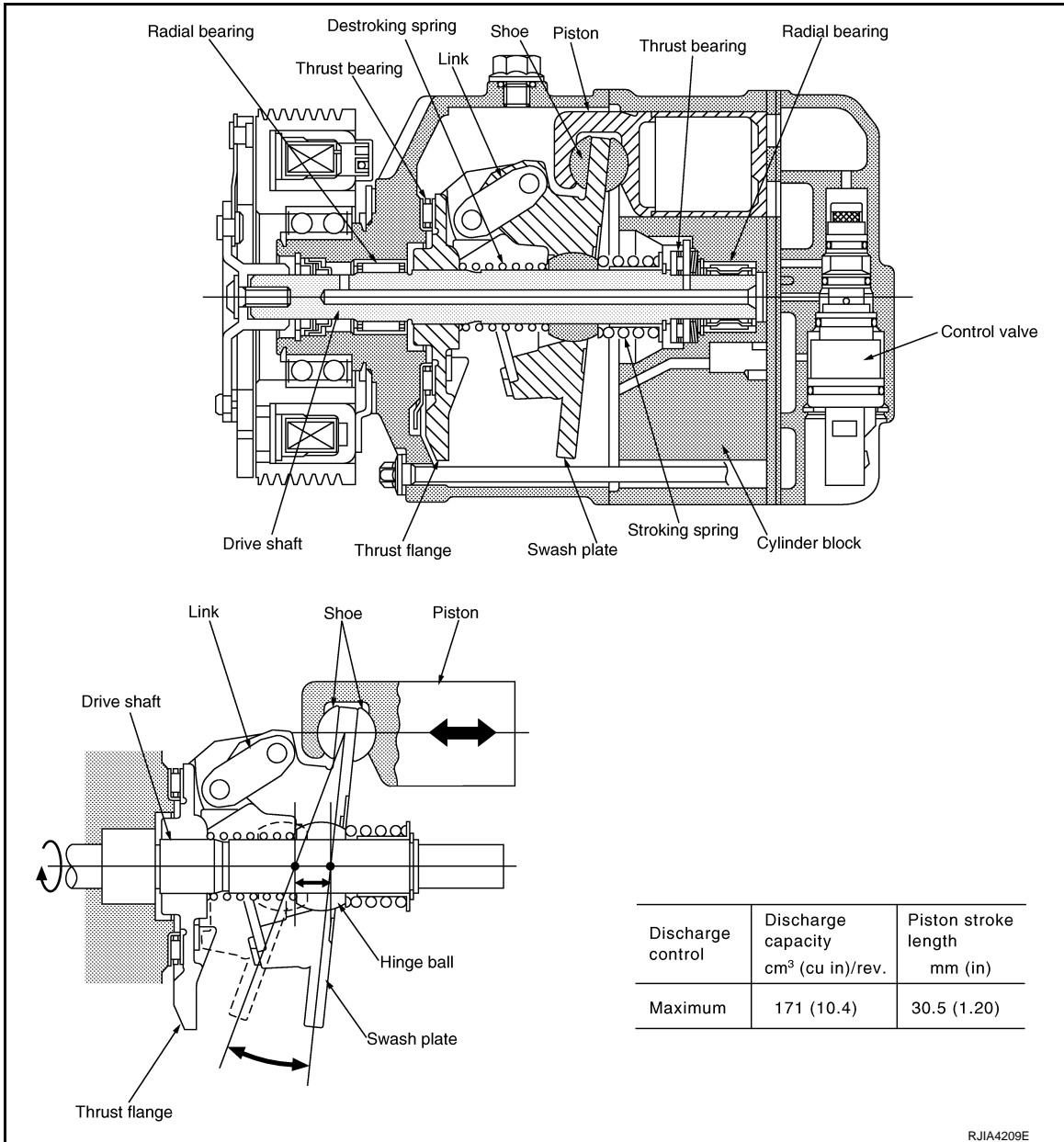

### Operation

1. Control Valve
  - By changing high-pressure valve lift amount, built-in electronic control valve executes the following:
    - Controls high-pressure valve discharge amount.
    - Changes crankcase pressure in compressor.

# REFRIGERATION SYSTEM

## < SERVICE INFORMATION >

- Changes angle of swash plate.
  - Amount of high-pressure valve lift is determined by factors below.
  - Low-pressure applied to diaphragm
  - Spring load of set spring
  - Balance of magnetic force generated in magnet coil
  - Electronic control valve (ECV) magnet coil receives electric signal (duty control) from unified meter and A/C amp. Then, magnetic force generated by electric current is changed to control high-pressure valve lift amount.
2. Maximum Cooling
- High-pressure valve is closed by magnetic force generated by electric signal sent from unified meter and A/C amp. At this time, cylinder moves full stroke due to pressure balance between inside crankcase ( $P_c$ ) and suction line ( $P_s$ ).

Under this condition, the swash plate is set to the maximum stroke position.

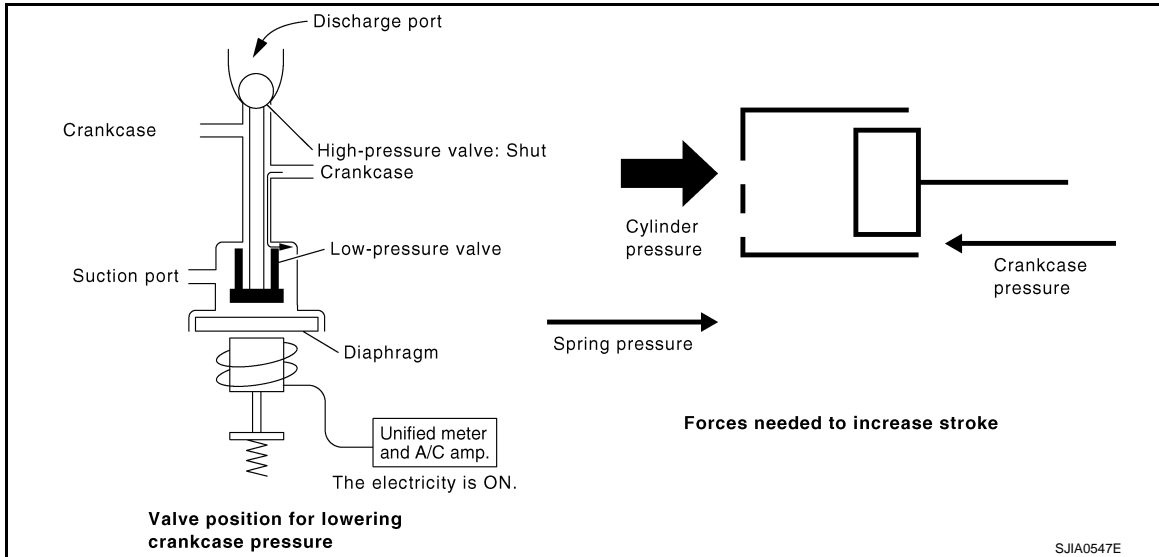

3. Capacity Control
- When no electric signal is sent from unified meter and A/C amp. (current: OFF), high-pressure valve is opened by spring force. Since suction pressure is low, it makes the suction port close and the discharge port open. Thus, crankcase pressure becomes high as high-pressure enters the crankcase.
- The force acts around the link near the swash plate, and is generated by the pressure difference before and behind the piston.
  - The thrust flange and link are located where the piston generates the highest pressure. Piston pressure is between suction pressure  $P_s$  and discharge pressure  $P_d$ , which is close to suction pressure  $P_s$ . If crankcase pressure  $P_c$  rises due to capacity control, the force around the link makes the swash plate angle decrease and also the piston stroke decrease. In other words, crankcase pressure increase triggers pres-

# REFRIGERATION SYSTEM

## < SERVICE INFORMATION >

sure difference between the piston and the crankcase. The pressure difference changes the angle of the swash plate.

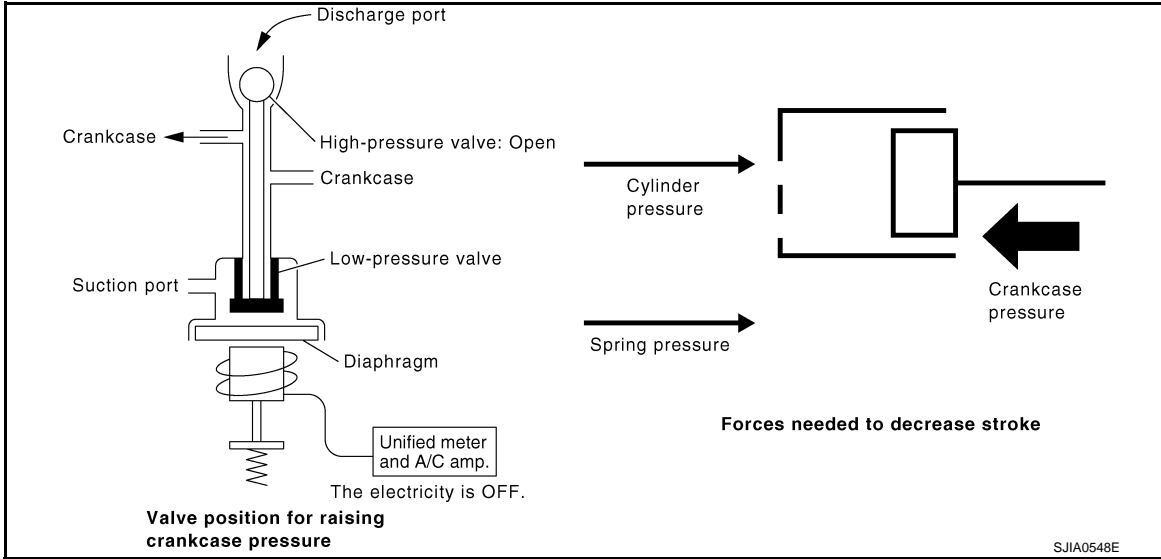

# REFRIGERATION SYSTEM

< SERVICE INFORMATION >

## Component Part Location

INFOID:000000005348500

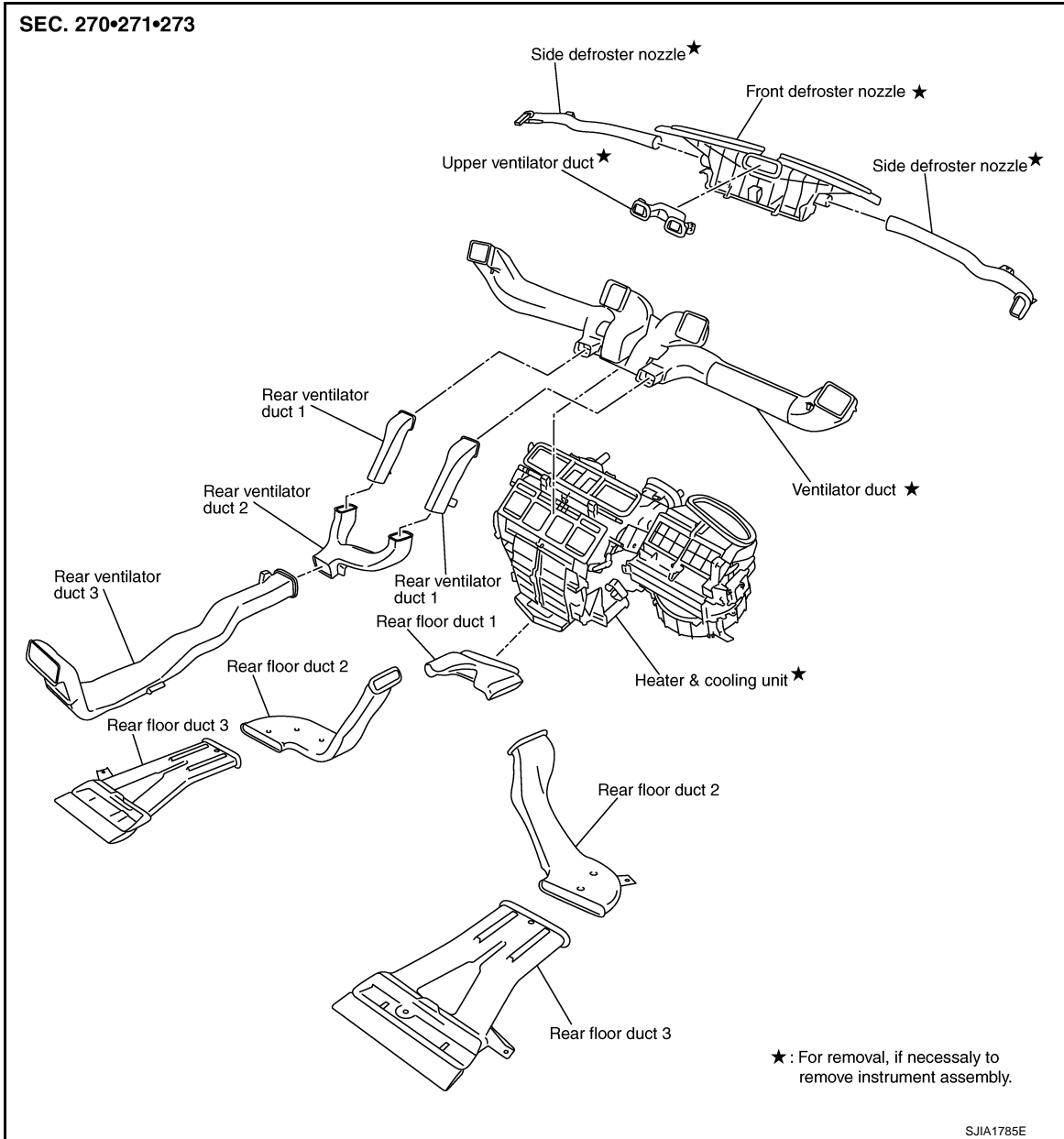

A  
B  
C  
D  
E  
F  
G  
H  
I  
ATC  
K  
L  
M  
N  
O  
P

# LUBRICANT

< SERVICE INFORMATION >

## LUBRICANT

### Maintenance of Lubricant Quantity in Compressor

INFOID:000000005348501

The lubricant in the compressor circulates through the system with the refrigerant. Add lubricant to compressor when replacing any component or after a large refrigerant leakage occurred. It is important to maintain the specified amount.

If lubricant quantity is not maintained properly, the following malfunctions may result:

- Lack of lubricant: May lead to a seized compressor.
- Excessive lubricant: Inadequate cooling (thermal exchange interference)

## LUBRICANT

**Name** : NISSAN A/C System Oil Type S

### LUBRICANT RETURN OPERATION

Adjust the lubricant quantity according to the test group shown below.

#### 1. CHECK LUBRICANT RETURN OPERATION

Can lubricant return operation be performed?

- A/C system works properly.
- There is no evidence of a large amount of lubricant leakage.

**CAUTION:**

**If excessive lubricant leakage is noted, never perform the lubricant return operation.**

OK or NG

- OK >> GO TO 2.
- NG >> GO TO 3.

#### 2. PERFORM LUBRICANT RETURN OPERATION, PROCEEDING AS FOLLOWS

1. Start the engine, and set to the following conditions:
  - Engine speed: Idle – 1,200 rpm
  - A/C switch: ON
  - Fan speed: Maximum position
  - Set temperature: Full hot
  - Intake position: Recirculation (REC)
2. Perform lubricant return operation for approximately 10 minutes.
3. Stop the engine.

>> GO TO 3.

#### 3. CHECK REPLACEMENT PART

Should the compressor be replaced?

- YES >> Go to "LUBRICANT ADJUSTING PROCEDURE FOR COMPRESSOR REPLACEMENT".
- NO >> Go to "LUBRICANT ADJUSTING PROCEDURE FOR COMPONENTS REPLACEMENT EXCEPT COMPRESSOR".

### LUBRICANT ADJUSTING PROCEDURE FOR COMPONENTS REPLACEMENT EXCEPT COMPRESSOR

Add the correct amount of lubricant to the system after replacing any of the following major components.

Amount of lubricant to be added:

Part replaced	Lubricant to be added to system		Remarks
	Amount of lubricant m ℓ (US fl oz., Imp fl oz.)		
Evaporator	75 (2.5, 2.6)		—
Condenser	35 (1.2, 1.2)		—
Liquid tank	10 (0.3, 0.4)		—

# LUBRICANT

## < SERVICE INFORMATION >

Part replaced	Lubricant to be added to system	Remarks
	Amount of lubricant m ℓ (US fl oz., Imp fl oz.)	
In case of refrigerant leak	30 (1.0, 1.1)	Large leak
	—	Small leak <sup>*1</sup>

\*1: If the refrigerant leak is small, no addition of lubricant is needed.

### LUBRICANT ADJUSTING PROCEDURE FOR COMPRESSOR REPLACEMENT

1. Check recovery/recycling recharging equipment gauges before connecting recovery/recycling recharging equipment to vehicle. No refrigerant pressure should be displayed. Recover refrigerant from equipment lines if NG.
2. Connect recovery/recycling recharging equipment to vehicle. Confirm refrigerant purity in supply tank using recovery/recycling recharging equipment and refrigerant identifier. Refer to [ATC-4, "Precaution for Working with HFC-134a \(R-134a\)"](#) if NG.
3. Confirm refrigerant purity in vehicle A/C system using recovery/recycling recharging equipment and refrigerant identifier. If NG, refer to [ATC-4, "Precaution for Working with HFC-134a \(R-134a\)"](#).
4. Discharge refrigerant into the recovery/recycling recharging equipment. Measure lubricant discharged into the recovery/recycling recharging equipment.
5. Drain the lubricant from the old (removed) compressor into a graduated container and recover the amount of lubricant drained.
6. Drain the lubricant from the new compressor into a separate. Then clean container.
7. Measure an amount of new lubricant installed equal to amount drained from old compressor. Add this lubricant to new compressor through the suction port opening.
8. Measure an amount of new lubricant equal to the amount recovered during discharging. Add this lubricant to new compressor through the suction port opening.
9. Add another 5 m ℓ (0.2 US fl oz., 0.2 Imp fl oz.) of lubricant at this time if the liquid tank also needs to be replaced.

Do not add this 5 m ℓ (0.2 US fl oz., 0.2 Imp fl oz.) of lubricant when replacing the compressor only.

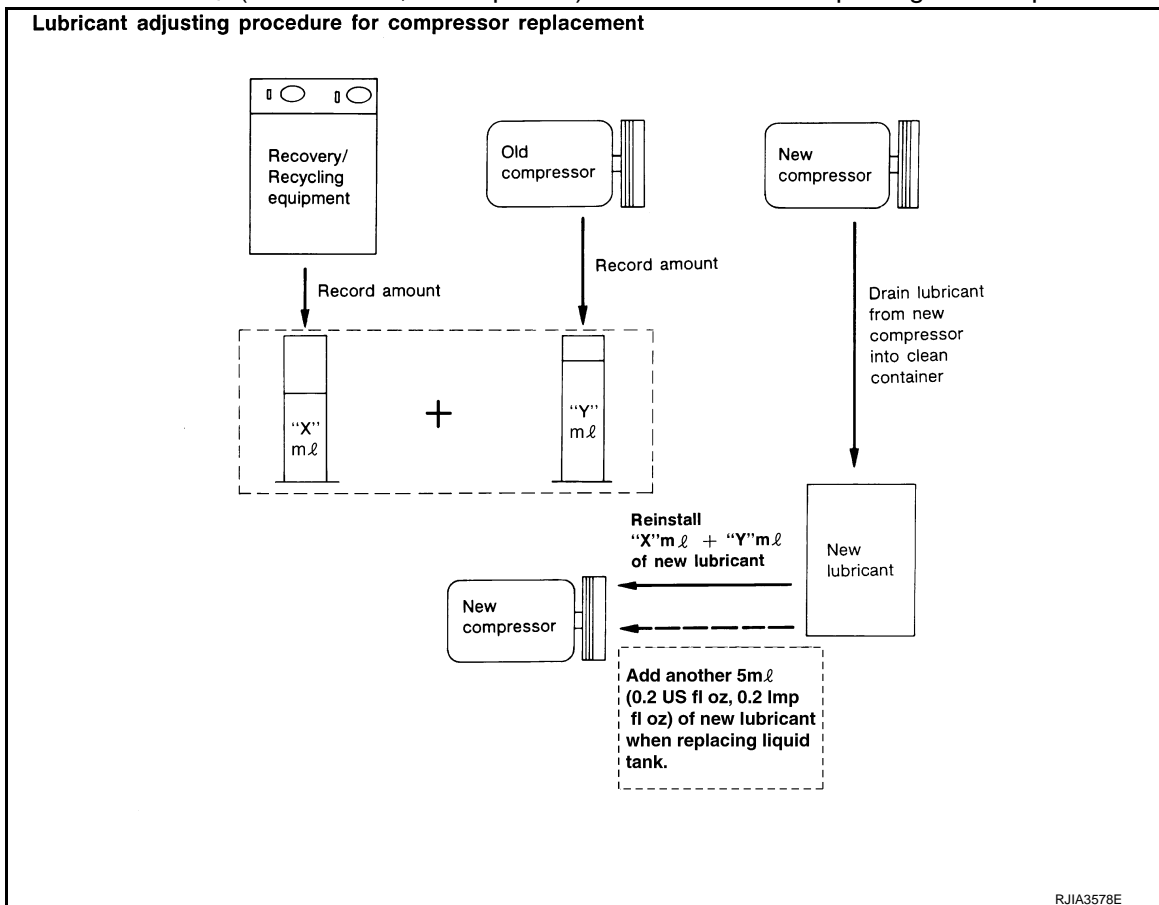

# AIR CONDITIONER CONTROL

< SERVICE INFORMATION >

## AIR CONDITIONER CONTROL

### Description of Air Conditioner LAN Control System

INFOID:000000005348502

The LAN (Local Area Network) system consists of unified meter and A/C amp., mode door motors, air mix door motors, upper ventilator door motor and intake door motor. A configuration of these components is shown in the figure below.

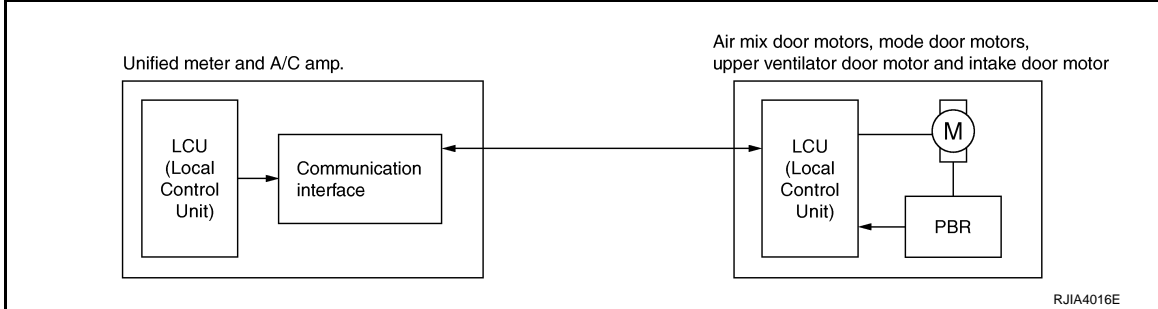

### System Construction

INFOID:000000005348503

A small network is constructed between the unified meter and A/C amp., mode door motors, air mix door motors, upper ventilator door motor and intake door motor. The unified meter and A/C amp. and motors are connected by data transmission lines and motor power supply lines. The LAN network is built through the ground circuits of each door motor.

Addresses, motor opening angle signals, motor stop signals and error checking messages are all transmitted through the data transmission lines connecting the unified meter and A/C amp. and each door motor.

The following functions are contained in LCUs built into the mode door motors, the air mix door motors, the upper ventilator door motor and the intake door motor.

- Address
- Motor opening angle signals
- Data transmission
- Motor stop and drive decision
- Opening angle sensor (PBR function)
- Comparison
- Decision (Unified meter and A/C amp. indicated value and motor opening angle comparison)

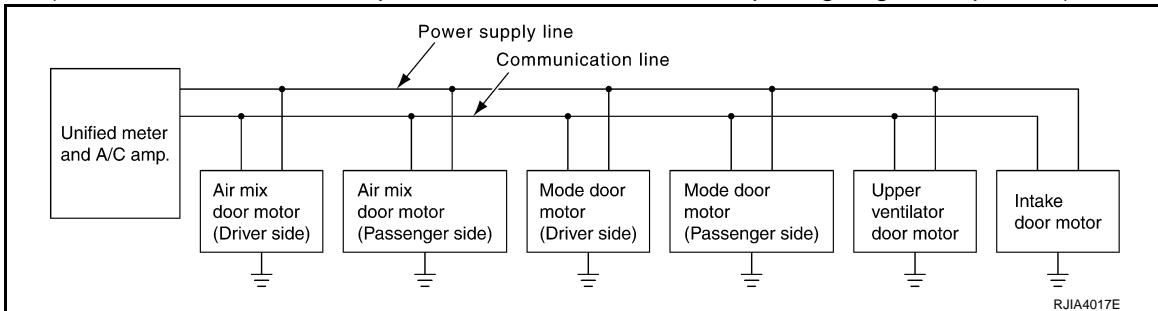

### OPERATION

The unified meter and A/C amp. receives data from each of the sensors. The unified meter and A/C amp. sends mode door, air mix door, upper ventilator door and intake door opening angle data to the mode door motor LCUs, air mix door motor LCUs, upper ventilator door motor LCU and intake door motor LCU.

The mode door motors, air mix door motors, upper ventilator door motor and intake door motor read their respective signals according to the address signal. Opening angle indication signals received from the unified meter and A/C amp. and each of the motor position sensors is compared by the LCUs in each door motor with



# AIR CONDITIONER CONTROL

## < SERVICE INFORMATION >

the existing decision and opening angles. Subsequently, HOT/COLD, DEF/VENT, OPEN/SHUT and FRE/REC operation is selected. The new selection data is returned to the unified meter and A/C amp.

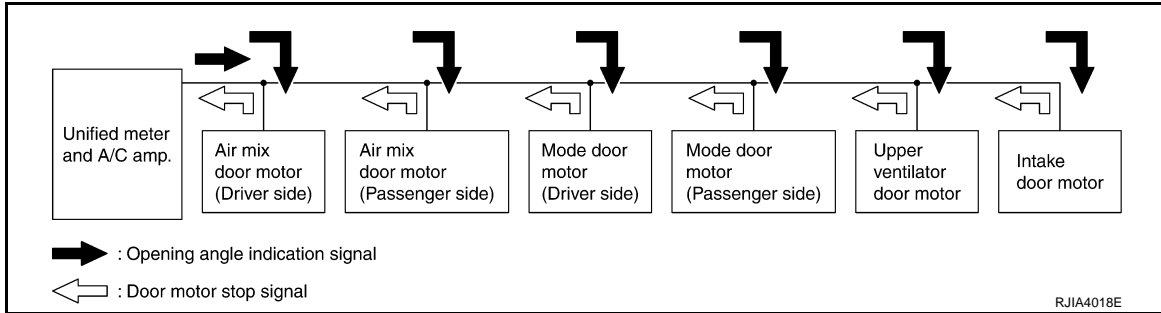

## TRANSMISSION DATA AND TRANSMISSION ORDER

Unified meter and A/C amp. data is transmitted consecutively to each of the door motors following the form shown in figure below.

Start:

Initial compulsory signal is sent to each of the door motors.

Address:

- Data sent from the unified meter and A/C amp. are selected according to data-based decisions made by the mode door motors, air mix door motors, upper ventilator door motor and intake door motor.
- If the addresses are identical, the opening angle data and error check signals are received by the door motor LCUs. The LCUs then make the appropriate error decision. If the opening angle data have no error, door control begins.
- If an error exists, the received data are rejected and corrected data received. Finally, door control is based upon the corrected opening angle data.

Opening angle:

Data that shows the indicated door opening angle of each door motor.

Error Check:

In this procedure, transmitted and received data is checked for errors. Error data are then compiled. The error check prevents corrupted data from being used by the mode door motors, the air mix door motors, the upper ventilator door motor and the intake door motor. Error data can be related to the following symptoms.

- Malfunction of electrical frequency
- Poor electrical connections
- Signal leakage from transmission lines
- Signal level fluctuation

Stop signal:

At the end of each transmission, a stop operation, in-operation, or internal malfunction message is delivered to the unified meter and A/C amp. This completes one data transmission and control cycle.

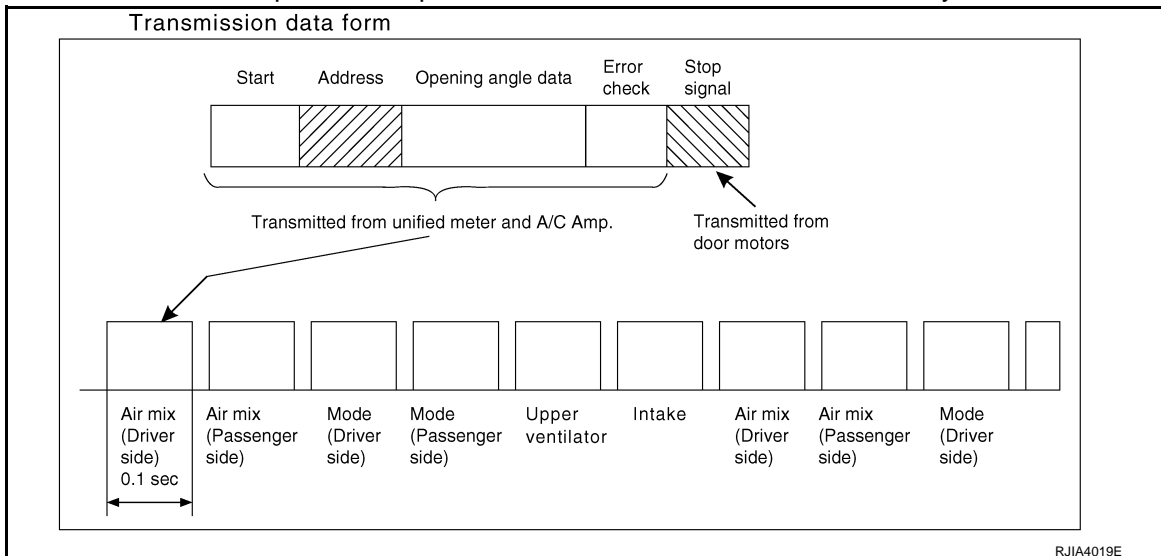

## AIR MIX DOOR CONTROL (AUTOMATIC TEMPERATURE CONTROL)

# AIR CONDITIONER CONTROL

## < SERVICE INFORMATION >

The air mix doors are automatically controlled so that in-vehicle temperature is maintained at a predetermined value by the temperature setting, ambient temperature, in-vehicle temperature and amount of sunload.

### FAN SPEED CONTROL

- Fan speed is automatically controlled by the temperature setting, ambient temperature, in-vehicle temperature, intake temperature, amount of sunload and air mix door position.
- With pressing AUTO switch, the blower motor starts to gradually increase air flow volume.
- When engine coolant temperature is low, the blower motor operation is delayed to prevent cool air from flowing.

### INTAKE DOOR CONTROL

The intake doors are automatically controlled by the temperature setting, ambient temperature, in-vehicle temperature, intake temperature, amount of sunload and ON/OFF operation of the compressor.

### MODE DOOR CONTROL

The mode doors are automatically controlled by the temperature setting, ambient temperature, in-vehicle temperature, intake temperature and amount of sunload.

### UPPER VENTILATOR DOOR CONTROL

The upper ventilator door is automatically controlled by the mode setting, and amount of sunload.

### MAGNET CLUTCH CONTROL

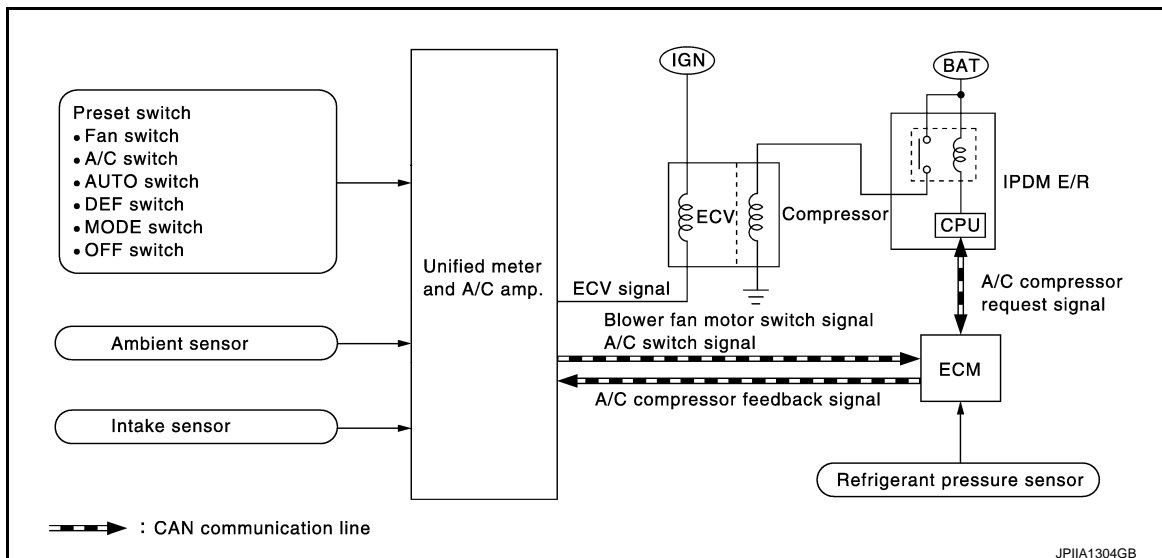

- When A/C switch, AUTO switch, DEF switch is pressed or when shifting mode position D/F, unified meter and A/C amp. transmits A/C switch signal and blower fan motor switch signal to ECM, via CAN communication.
- ECM judges whether compressor can be turned ON, based on each sensor status (refrigerant-pressure sensor signal, throttle angle, etc.). If it judges compressor can be turned ON, it sends A/C compressor request signal to IPDM E/R, via CAN communication.
- Upon receipt of A/C compressor request signal from ECM, IPDM E/R turns A/C relay ON to operate compressor.
- When sending A/C compressor request signal to IPDM E/R via CAN communication line, ECM simultaneously sends A/C compressor feedback signal to unified meter and A/C amp. via CAN communication line.
- ECM sends A/C compressor feedback signal to unified meter and A/C amp., then, uses input A/C compressor feedback signal to control air inlet.

### SELF-DIAGNOSIS SYSTEM

The self-diagnosis system is built into the unified meter and A/C amp. to quickly locate the cause of malfunctions.

# AIR CONDITIONER CONTROL

< SERVICE INFORMATION >

## Description of Control System

INFOID:000000005348504

The control system consists of input sensors, switches, the unified meter and A/C amp. (microcomputer) and outputs. The relationship of these components is shown in the figure below:

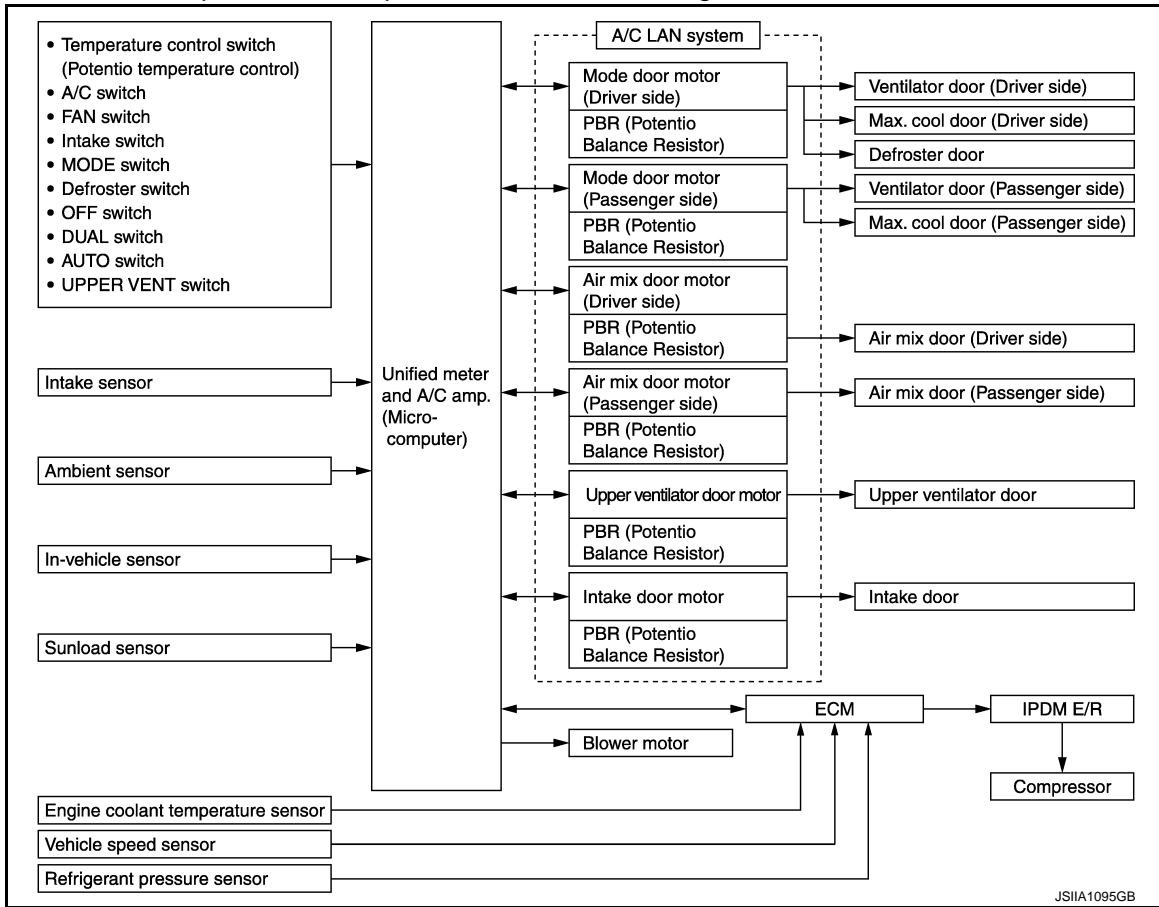

## Control Operation

INFOID:000000005348505

## DISPLAY SCREEN

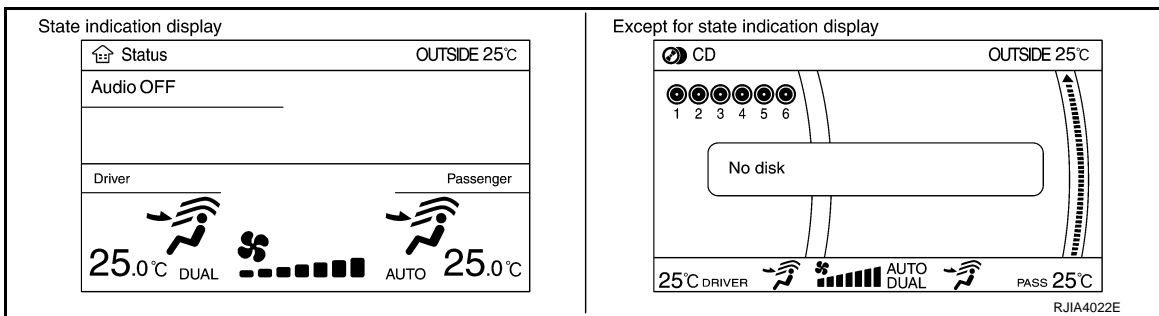

## MULTIFUNCTION SWITCH

A  
B  
C  
D  
E  
F  
G  
H  
I  
K  
L  
M  
N  
O  
P

ATC

# AIR CONDITIONER CONTROL

< SERVICE INFORMATION >

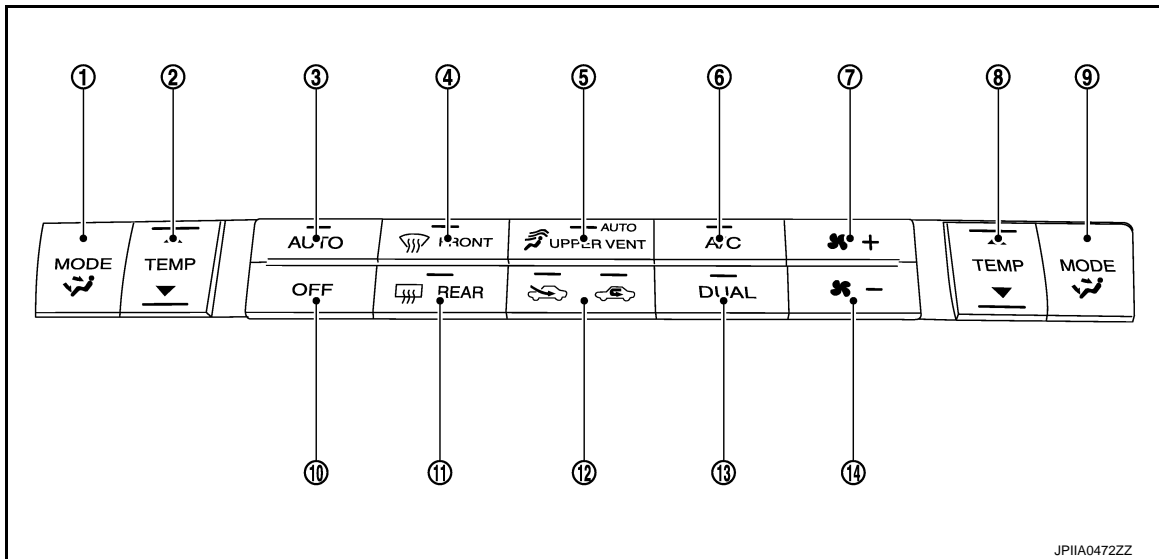

- |                              |  |                                 |
|------------------------------|--|---------------------------------|
| 1. MODE switch (driver side) | 2. Temperature control switch (driver side)    | 3. AUTO switch                  |
| 4. Defroster (DEF) switch    | 5. UPPER VENT switch                           | 6. A/C switch                   |
| 7. FAN (UP) switch           | 8. Temperature control switch (passenger side) | 9. MODE switch (passenger side) |
| 10. OFF switch               | 11. Rear window defogger switch                | 12. Intake switch               |
| 13. DUAL switch              | 14. FAN (DOWN) switch                          |                                 |

## DISPLAY SCREEN

The operation status of the system is displayed on the screen.

## MODE SWITCH (DRIVER SIDE)

- Controls the air discharge outlets.
- When the DUAL switch indicator lamp turns OFF, the driver side and passenger side outlets are switched together.
- When the DUAL switch indicator lamp turns ON, only the driver side outlet is switched.

## MODE SWITCH (PASSENGER SIDE)

When the MODE switch (passenger side) is pressed, the DUAL switch indicator lamp turns ON, and only the passenger side outlet is switched.

## TEMPERATURE CONTROL SWITCH (POTENTIAL TEMPERATURE CONTROL) (DRIVER SIDE)

The set temperature is increased or decreased with this switch.

## TEMPERATURE CONTROL SWITCH (POTENTIAL TEMPERATURE CONTROL) (PASSENGER SIDE)

- The set temperature is increased or decreased with this switch.
- When the temperature switch is pressed, the DUAL switch indicator lamp will automatically turn ON.

## AUTO SWITCH

- The compressor, intake doors, air mix doors, mode doors and fan speed are automatically controlled so that the in-vehicle temperature will reach, and be maintained at the set temperature selected by the operator.
- When pressing AUTO switch, air inlet, air outlet, fan speed, and discharge air temperature are automatically controlled.

## DEFROSTER (DEF) SWITCH

Mode doors are set to the defrost position with this switch. Also, intake doors are set to the outside air position, and compressor turns ON.

## UPPER VENT SWITCH

- When UPPER VENT switch is ON, UPPER VENT switch indicator lamp turns ON, and upper ventilator door is automatically controlled.

### NOTE:

# AIR CONDITIONER CONTROL

## < SERVICE INFORMATION >

The upper ventilator door operation depend on the sunload.

- When DEFROSTER (DEF) switch is ON, upper ventilator door is shut.
- When MODE position (driver side) is FOOT or D/F, upper ventilation door is shut.
- When UPPER VENT switch is OFF, UPPER VENT switch indicator lamp turns OFF, and upper ventilator door is shut.

### A/C SWITCH

Compressor is ON or OFF with this switch.

(Pressing the A/C switch when the A/C switch is ON will turn OFF the A/C switch and compressor.)

### FAN SWITCHES

The fan speed is manually controlled with this switch. Seven speeds are available for manual control (as shown on the display screen).

### OFF SWITCH

Compressor and blower are OFF, air inlet is set to FRE, and mode position is set to foot position.

### REAR WINDOW DEFOGGER SWITCH

When indicator lamp turns ON, rear window is defogged.

### INTAKE SWITCH

- When intake switch is ON, FRE indicator lamp turns ON, and air inlet is fixed to FRE.
- When press intake switch again, REC indicator lamp turns ON, and air inlet is fixed to REC.
- When intake switch is pressed for approximately 1.5 seconds or longer, FRE and REC indicator lamps blink twice. Then, automatic control mode is entered. Inlet status is displayed by indicator lamp even during automatic controlled.
- When FRE indicator lamp turned ON, shifting mode position to D/F, pressing DEF switch or when compressor is turned from ON to OFF, intake switch is automatically turned OFF (fixed to FRE mode). REC mode can be re-entered by pressing intake switch again, and then compressor is turned ON. (Except D/F or DEF position)

### DUAL SWITCH

- When the DUAL switch indicator lamp turns ON, the driver side and passenger side temperature can each be set independently.
- When the DUAL switch indicator lamp turns OFF, the driver side outlet and setting temperature is applied to both sides.

## Control Operation (Rear Control Switch)

INFOID:000000005348506

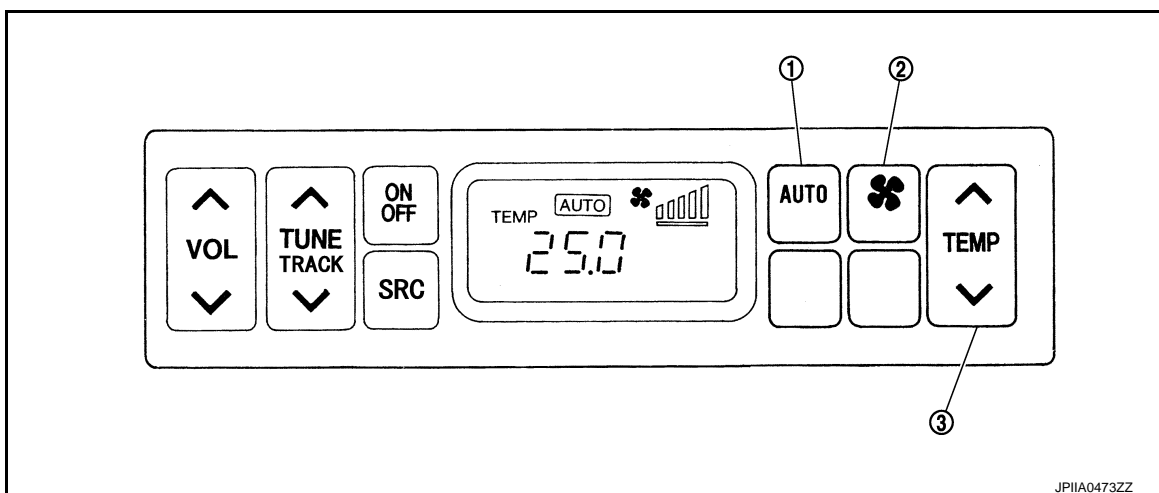

1. AUTO switch

2. FAN switch

3. Rear temperature control switch

### AUTO SWITCH

- When pressing AUTO switch, display for turned on AUTO and fan speed is automatically controlled.
- When pressing AUTO switch, air inlet, air outlet, fan speed, and discharge air temperature are automatically controlled.

# AIR CONDITIONER CONTROL

## < SERVICE INFORMATION >

---

### FAN SWITCH

The fan speed is manually controlled with this switch. Five speeds are available for manual control (as shown on the display screen).

### REAR TEMPERATURE CONTROL SWITCH

- Increases or decreases the set temperature.
- A temperature for the rear seat with respect to a set temperature for the front seat can be adjusted by operating switch.
- Rear temperature control switch allows to select a temperature every 0.5°C (1°F) in the 18°C (60°F) to 32°C (90°F) range.
- When the DUAL switch is ON, temperature for the rear seat changes keeping the temperature difference between two front seats. [e.g. When lowering the set temperature for the rear seat 1°C (2°F) by operating rear control switch at a set temperature of 25°C (77°F) for the driver's seat and 26°C (79°F) for the passenger's seat, the set temperature for the driver's seat and passenger's seat lower 1°C (2°F) and become 24°C (75°F) for the driver's seat and 25°C (77°F) for the passenger's seat.]

#### NOTE:

A set temperature for the rear seat is tied to a set temperature for the passenger's seat. Therefore, a set temperature for the rear seat changes in conjunction with a set temperature for the passenger's seat (When the set temperature of front seats are independent).

### Fail-Safe Function

INFOID:000000005348507

- If a communication error exists between the unified meter and A/C amp., and the AV control unit and multi-function switch for 30 seconds or longer, air conditioner is controlled under the following conditions:

<b>Compressor</b>	<b>: ON</b>
<b>Air outlet</b>	<b>: AUTO</b>
<b>Air inlet</b>	<b>: FRE (Fresh air intake)</b>
<b>Fan speed</b>	<b>: AUTO</b>
<b>Set temperature</b>	<b>: Setting before communication error occurs</b>

# AIR CONDITIONER CONTROL

< SERVICE INFORMATION >

## Discharge Air Flow

INFOID:000000005348508

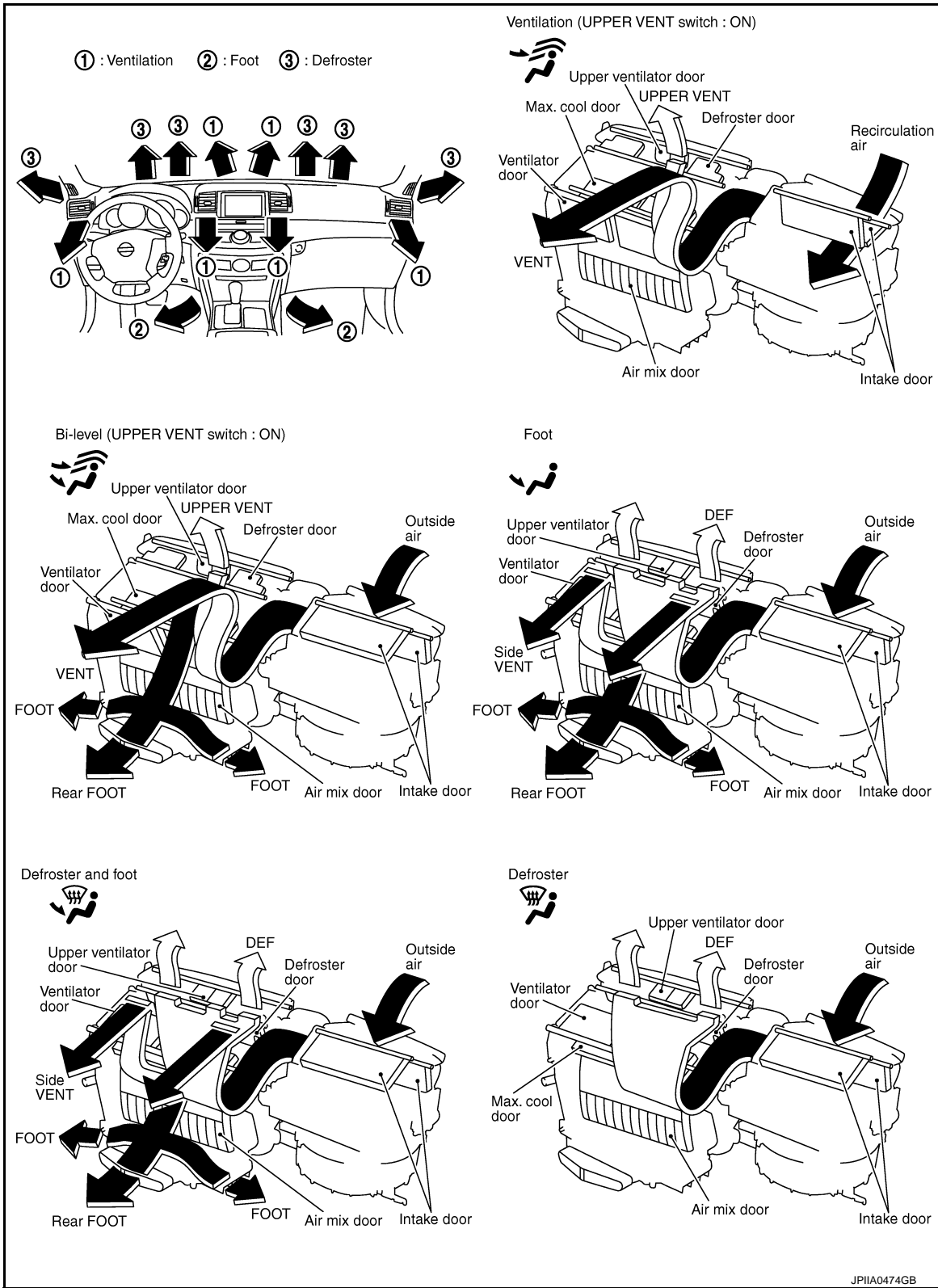

A  
B  
C  
D  
E  
F  
G  
H  
I  
ATC  
K  
L  
M  
N  
O  
P

# AIR CONDITIONER CONTROL

< SERVICE INFORMATION >

## System Description

INFOID:000000005348509

### SWITCHES AND THEIR CONTROL FUNCTION

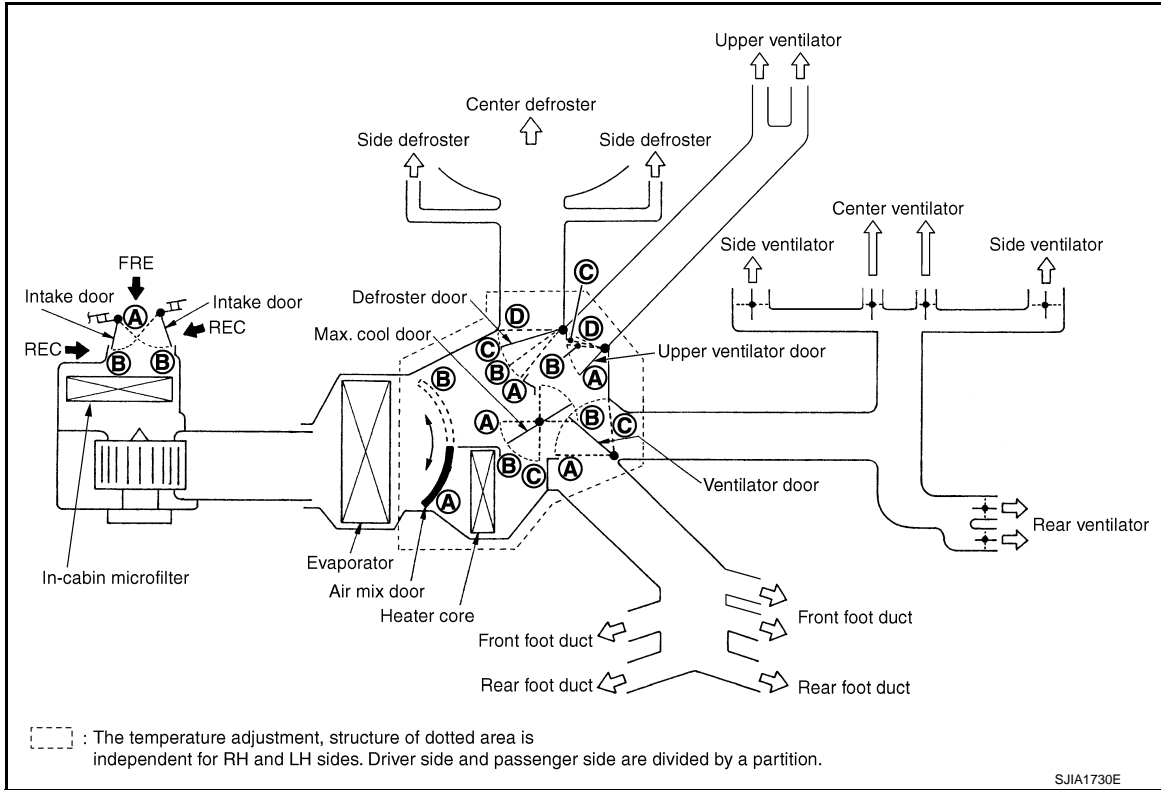

Door	DUAL switch		MODE switch				DEF switch		UPPER VENT switch		AUTO switch	Intake switch		Temperature control switch (Driver side)		Temperature control switch (Passenger side)		OFF switch
	ON	OFF	VENT	B/L	FOOT	D/F <sup>*1</sup>	ON	OFF	AUTO	OFF		FRE	REC	TEMP		TEMP		OFF
	DUAL		MODE				FRONT		UPPER VENT		AUTO	TEMP		TEMP		OFF		
	☀ ☐		☂ ☂ ☂ ☂				☀ ☐		☂ ☂		☀ ☐	18°C (60°F) ↔ 32°C (90°F)		18°C (60°F) ↔ 32°C (90°F)		☐		
Ventilator door (Driver side)	—		A	B	C	C												C
Ventilator door (Passenger side)	ON		A	B	C	—	C											C
	OFF		—															—
Max. cool door (Driver side)	—		A	B	B	B	C				AUTO							B
Max. cool door (Passenger side)	ON		A	B	B	—	C											B
	OFF		—															—
Defroster door	—		D	D	C/D <sup>*2</sup>	B	A											C/D <sup>*2</sup>
Upper ventilator door	—		A—D <sup>*3</sup>	D	D	D			AUTO	D								D
Intake door 1,2	—		—				B											B
Air mix door (Driver side)	—		—											A	AUTO	B		
Air mix door (Passenger side)	ON		—							AUTO					A	AUTO	B	—
	OFF		—											A	AUTO	B		—

\*1 When the DUAL switch is ON, passenger cannot select the D/F mode.  
 \*2 This position is selected only when the mode door is automatically controlled.  
 \*3 When the MODE switch (Driver side) is VENT or B/L position, upper ventilator door is automatically controlled from A to D.  
 \*4 Inlet status is displayed by indicator lamp during automatic control.

JPIIA0475GB

## CAN Communication System Description

INFOID:000000005348510

CAN (Controller Area Network) is a serial communication line for real time application. It is an on-vehicle multiplex communication line with high data communication speed and excellent error detection ability. Many elec-



# AIR CONDITIONER CONTROL

## < SERVICE INFORMATION >

tronic control units are equipped onto a vehicle, and each control unit shares information and links with other control units during operation (not independent). In CAN communication, control units are connected with 2 communication lines (CAN-H line, CAN-L line) allowing a high rate of information transmission with less wiring. Each control unit transmits/receives data but selectively reads required data only. For details, refer to [LAN-29, "CAN System Specification Chart"](#).

A  
B  
C  
D  
E  
F  
G  
H  
I  
K  
L  
M  
N  
O  
P

ATC

# TROUBLE DIAGNOSIS

< SERVICE INFORMATION >

## TROUBLE DIAGNOSIS

### CONSULT-III Function (ECM)

INFOID:000000005348511

CONSULT-III can display each diagnosis item using the diagnosis test modes shown following.

System part	Check item, diagnosis mode	Description
ECM	Data monitor	Displays ECM input data in real time.

### DATA MONITOR

#### Display Item List

Monitor item name "operation or unit"	Contents
AIR COND SIG "On/Off"	Displays "COMP (On)/COMP (Off)" status as judged from air conditioner switch signal.
HEATER FAN SW "On/Off"	Displays "FAN (On)/FAN (Off)" status as judged from blower fan motor switch signal.
IGNITION SW "On/Off"	Displays "IGN position (On)/OFF, ACC position (Off)" status as judged from ignition switch signal.
AC PRESS SEN "V"	Displays "Refrigerant pressure sensor for voltage" status as inputted from refrigerant pressure sensor.

### How to Perform Trouble Diagnosis for Quick and Accurate Repair

INFOID:000000005348512

#### WORK FLOW

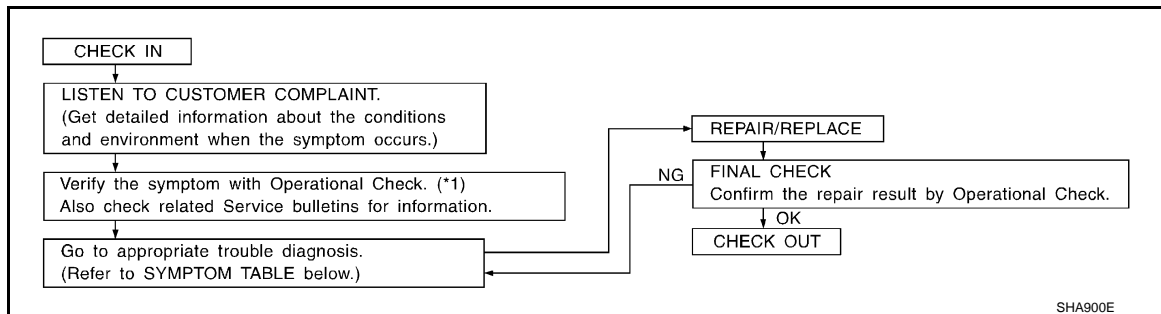

\*1 [ATC-56, "Operational Check"](#)

#### SYMPTOM TABLE

# TROUBLE DIAGNOSIS

## < SERVICE INFORMATION >

Symptom	Reference Page		A
A/C system does not activate.	Go to Trouble Diagnosis Procedure for A/C System.	<a href="#">ATC-58, "Power Supply and Ground Circuit for Auto Amp."</a>	B
A/C system cannot be controlled.	Go to Multifunction Switch System.	<a href="#">AV-461, "WITHOUT NAVIGATION : Symptom Table"</a> [Without mobile entertainment system (WITHOUT NAVIGATION)], <a href="#">AV-464, "WITH NAVIGATION : Symptom Table"</a> [Without mobile entertainment system (WITH NAVIGATION)] or <a href="#">AV-1048, "Symptom Table"</a> (With mobile entertainment system)	C D E F
Air outlet does not change.	Go to Trouble Diagnosis Procedure for Mode Door Motor. (LAN)	<a href="#">ATC-65, "Mode Door Motor Circuit"</a>	G
Mode door motor does not operate normally.			
Upper ventilator outlet does not change.	Go to Trouble Diagnosis Procedure for Upper Ventilator Door Motor. (LAN)	<a href="#">ATC-68, "Upper Ventilator Door Motor Circuit"</a>	H
Upper ventilator door motor does not operate normally.			
Discharge air temperature does not change.	Go to Trouble Diagnosis Procedure for Air Mix Door Motor. (LAN)	<a href="#">ATC-71, "Air Mix Door Motor Circuit"</a>	I
Air mix door motor does not operate normally.			
Intake door does not change.	Go to Trouble Diagnosis Procedure for Intake Door Motor. (LAN)	<a href="#">ATC-73, "Intake Door Motor Circuit"</a>	ATC
Intake door motor does not operate normally.			
Blower motor operation is malfunctioning.	Go to Trouble Diagnosis Procedure for Blower Motor.	<a href="#">ATC-76, "Blower Motor Circuit"</a>	K
Magnet clutch does not engage.	Go to Trouble Diagnosis Procedure for Magnet Clutch.	<a href="#">ATC-80, "Magnet Clutch Circuit"</a>	L
Insufficient cooling	Go to Trouble Diagnosis Procedure for Insufficient Cooling.	<a href="#">ATC-84, "Insufficient Cooling"</a>	M
Insufficient heating	Go to Trouble Diagnosis Procedure for Insufficient Heating.	<a href="#">ATC-93, "Insufficient Heating"</a>	N
Noise	Go to Trouble Diagnosis Procedure for Noise.	<a href="#">ATC-94, "Noise"</a>	O
Self-diagnosis cannot be performed.	Go to Trouble Diagnosis Procedure for Self-diagnosis.	<a href="#">ATC-95, "Self-Diagnosis"</a>	P
Memory function does not operate.	Go to Trouble Diagnosis Procedure for Memory Function.	<a href="#">ATC-96, "Memory Function"</a>	
Rear control switch does not operate.	Go to Trouble Diagnosis Procedure for Rear Control Switch.	<a href="#">ATC-61, "Rear Control Switch Circuit"</a>	

# TROUBLE DIAGNOSIS

< SERVICE INFORMATION >

## Component Parts and Harness Connector Location

INFOID:00000005348513

### ENGINE COMPARTMENT

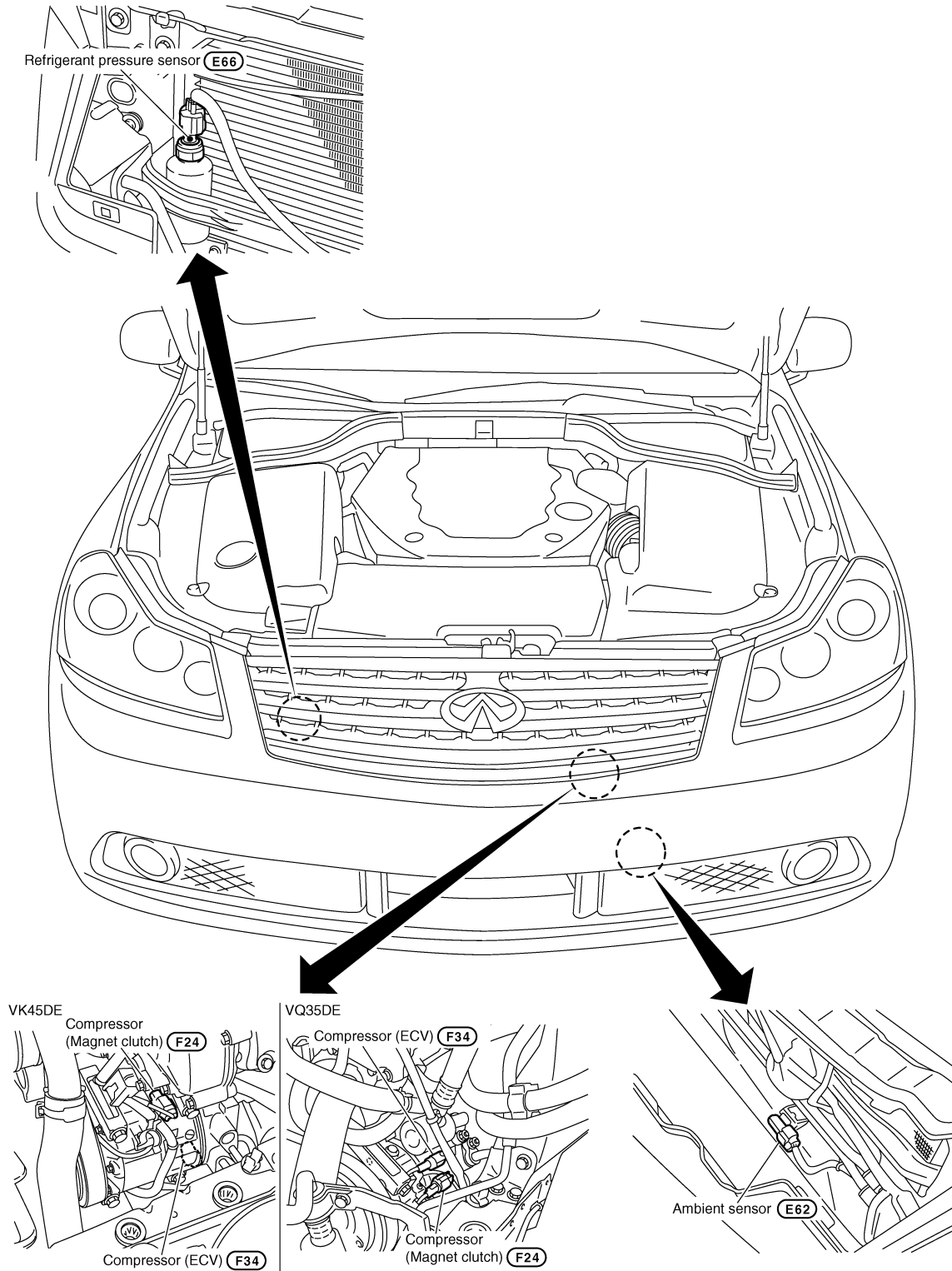

RJIA4030E

# TROUBLE DIAGNOSIS

## < SERVICE INFORMATION > PASSENGER COMPARTMENT

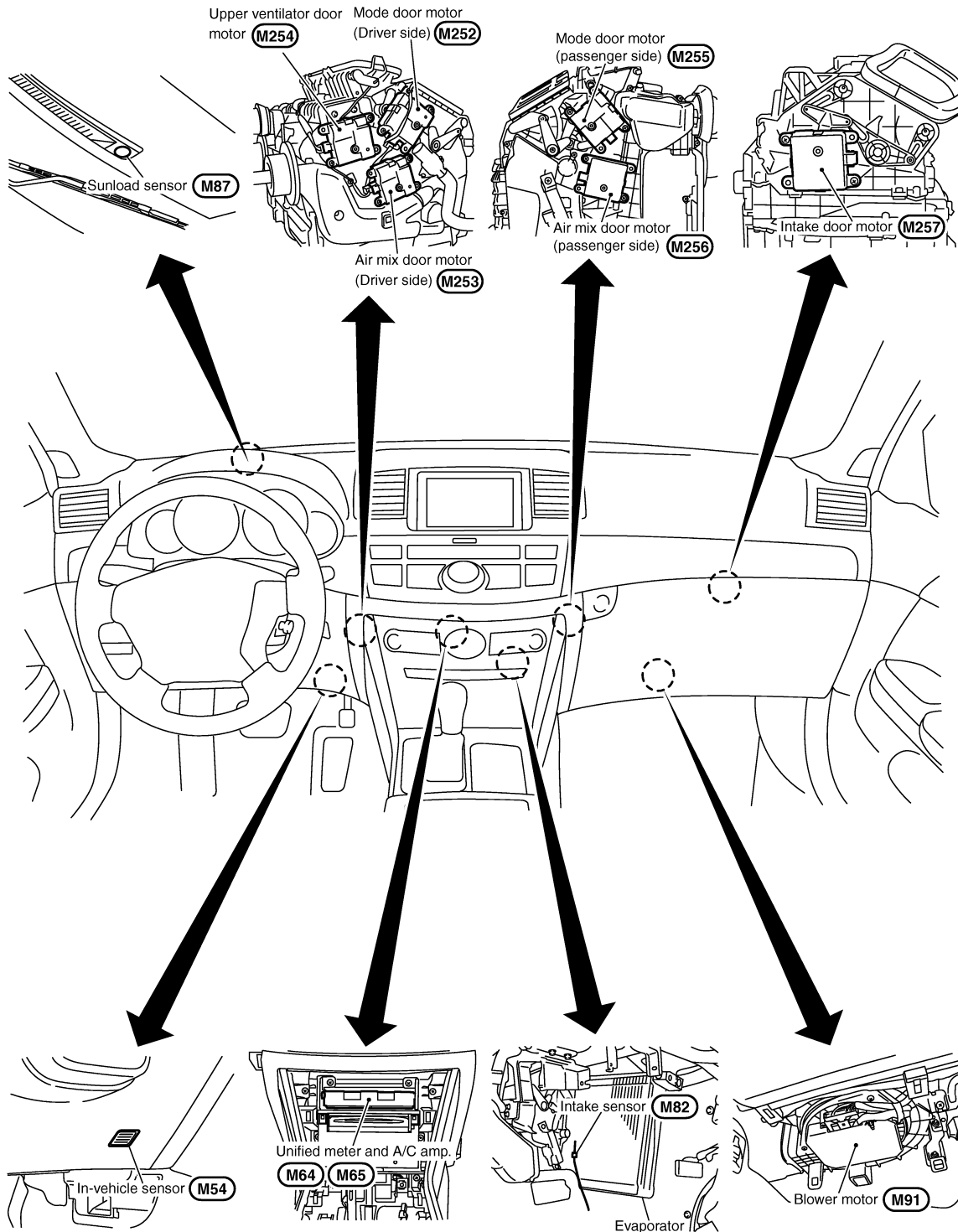

A  
B  
C  
D  
E  
F  
G  
H  
I  
ATC  
K  
L  
M  
N  
O  
P

JSIIA0906GB

# TROUBLE DIAGNOSIS

< SERVICE INFORMATION >

## Schematic

INFOID:00000005348514

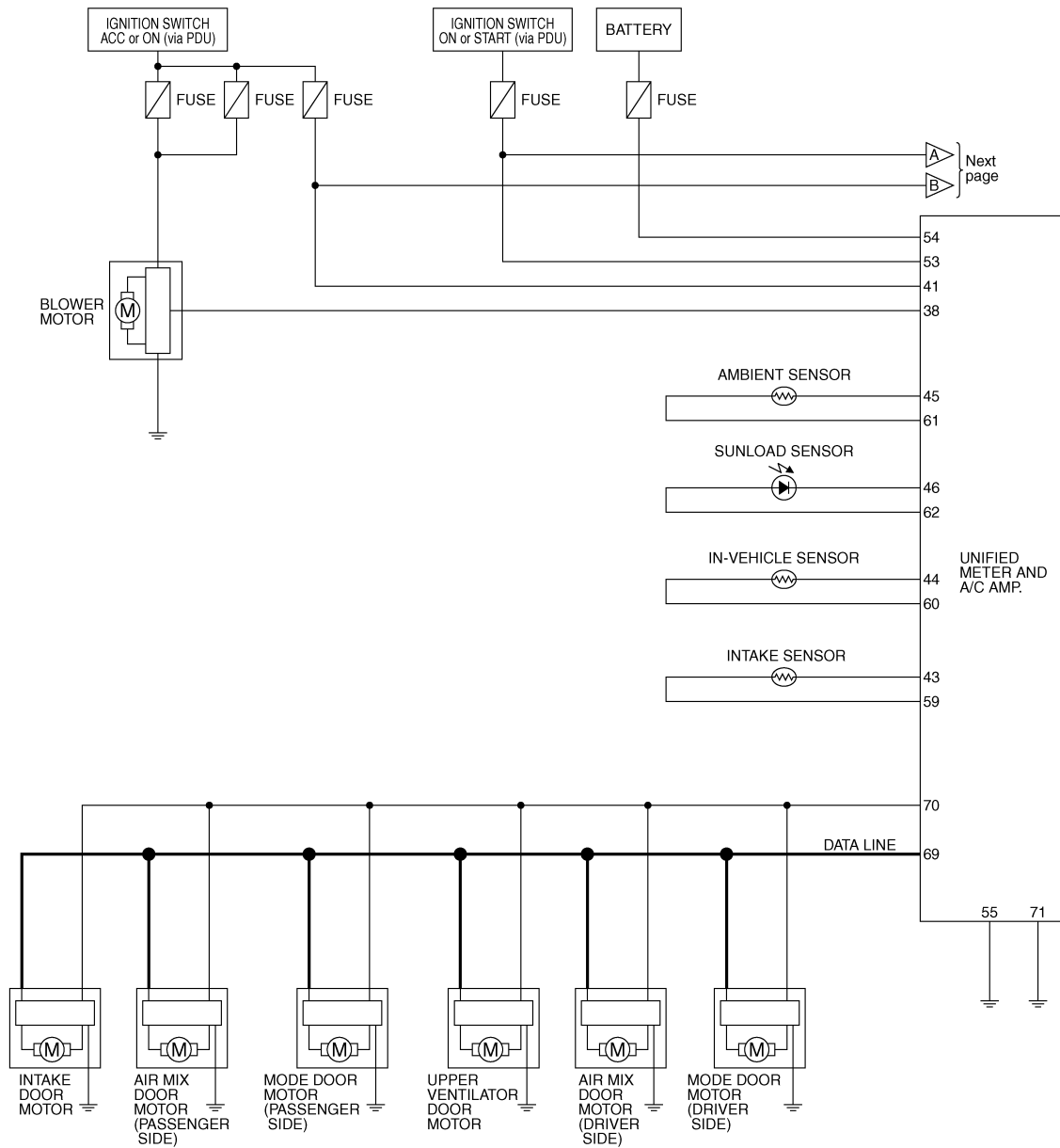

TJWT0141E

# TROUBLE DIAGNOSIS

< SERVICE INFORMATION >

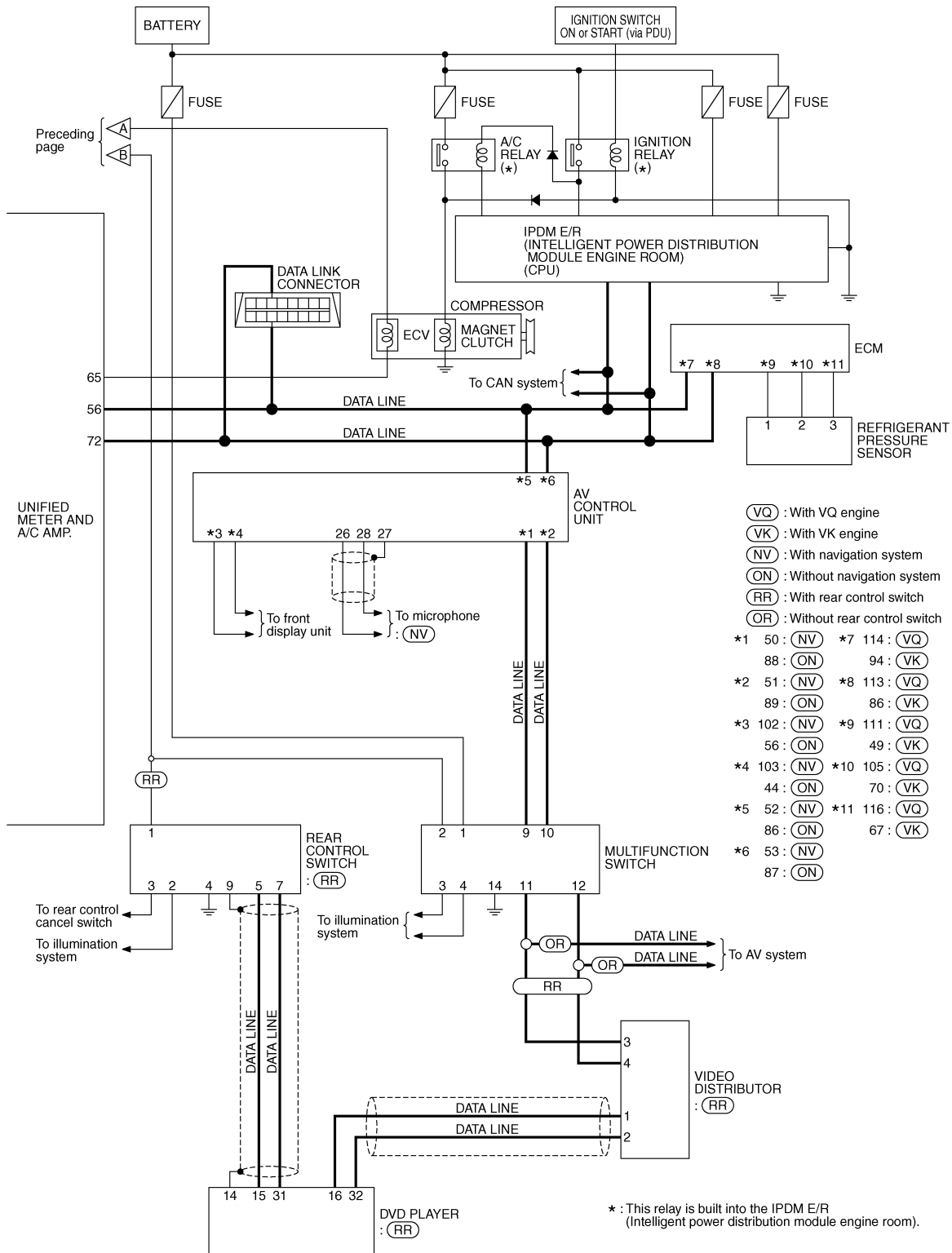

TJW0435E

A  
B  
C  
D  
E  
F  
G  
H  
I  
ATC  
K  
L  
M  
N  
O  
P

# TROUBLE DIAGNOSIS

< SERVICE INFORMATION >

## Wiring Diagram - A/C -

INFOID:000000005348515

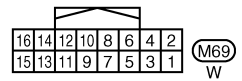
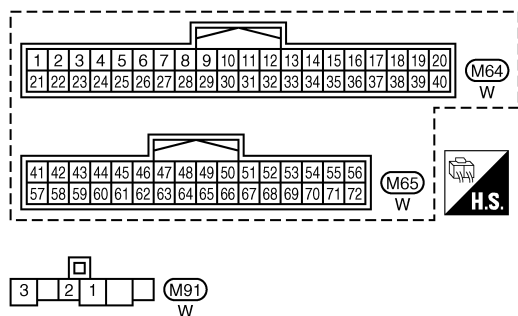
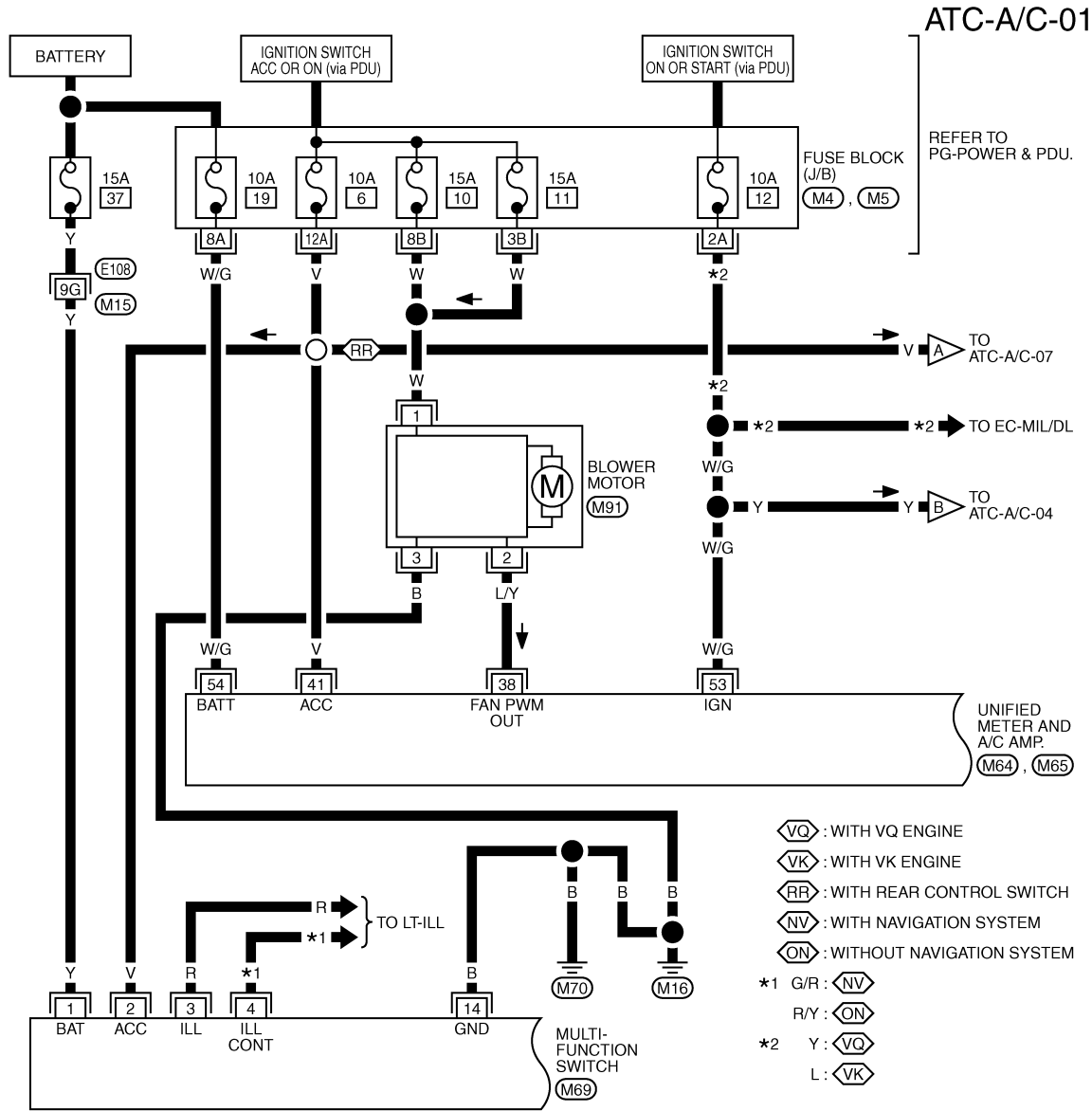

REFER TO THE FOLLOWING.  
(E108) -SUPER MULTIPLE JUNCTION (SMJ)  
(M4), (M5) -FUSE BLOCK-JUNCTION BOX (J/B)

TJW0436E



# TROUBLE DIAGNOSIS

< SERVICE INFORMATION >

ATC-A/C-02

▬ : DATA LINE

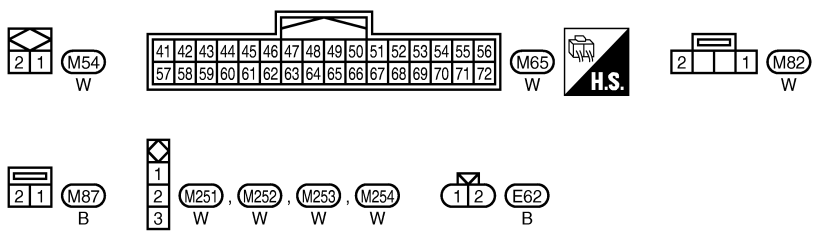
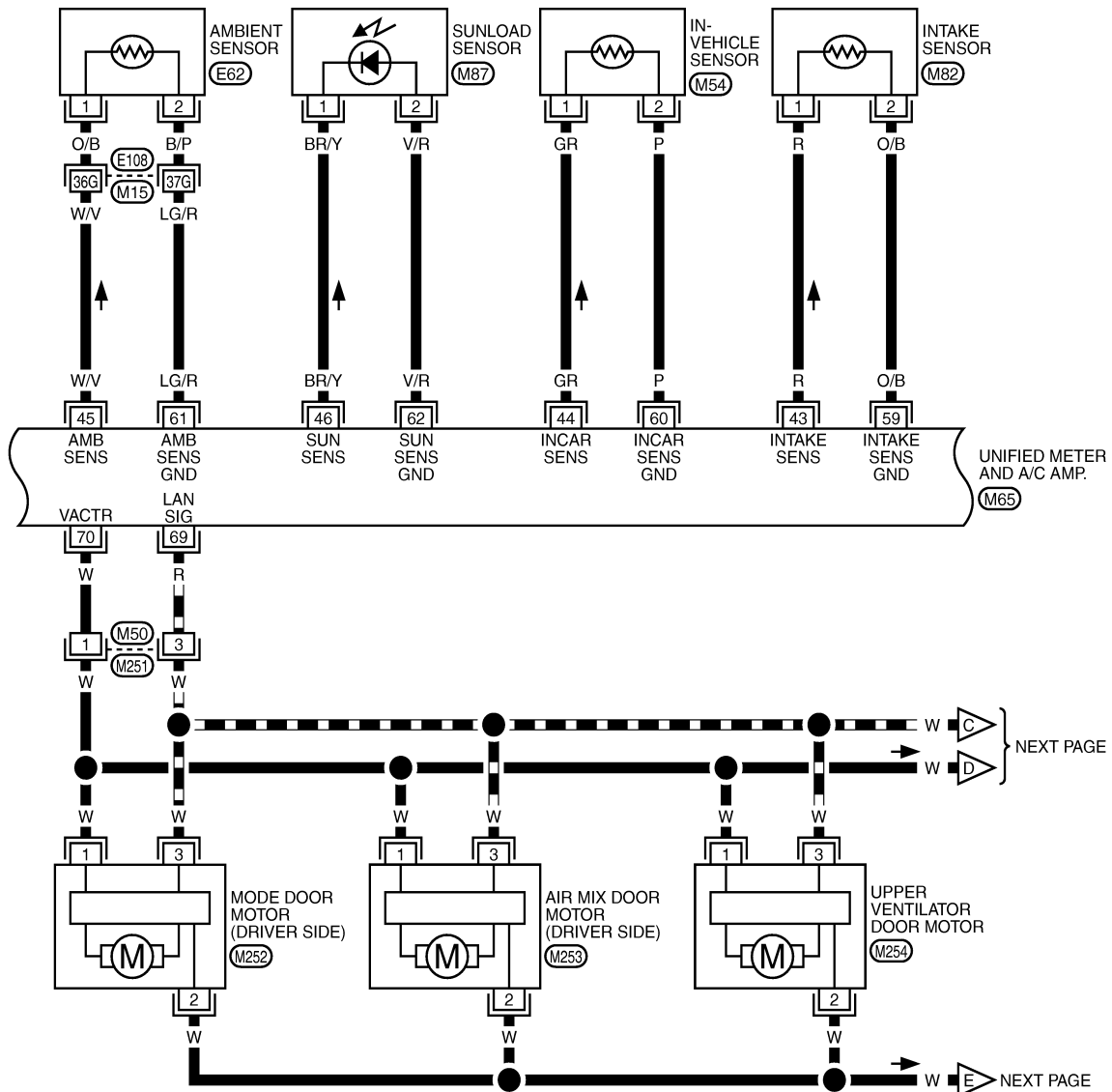

REFER TO THE FOLLOWING.  
 (E108) - SUPER MULTIPLE JUNCTION (SMJ)

TJW0325E

A  
B  
C  
D  
E  
F  
G  
H  
I  
J  
K  
L  
M  
N  
O  
P

ATC

# TROUBLE DIAGNOSIS

< SERVICE INFORMATION >

ATC-A/C-03

▬ : DATA LINE

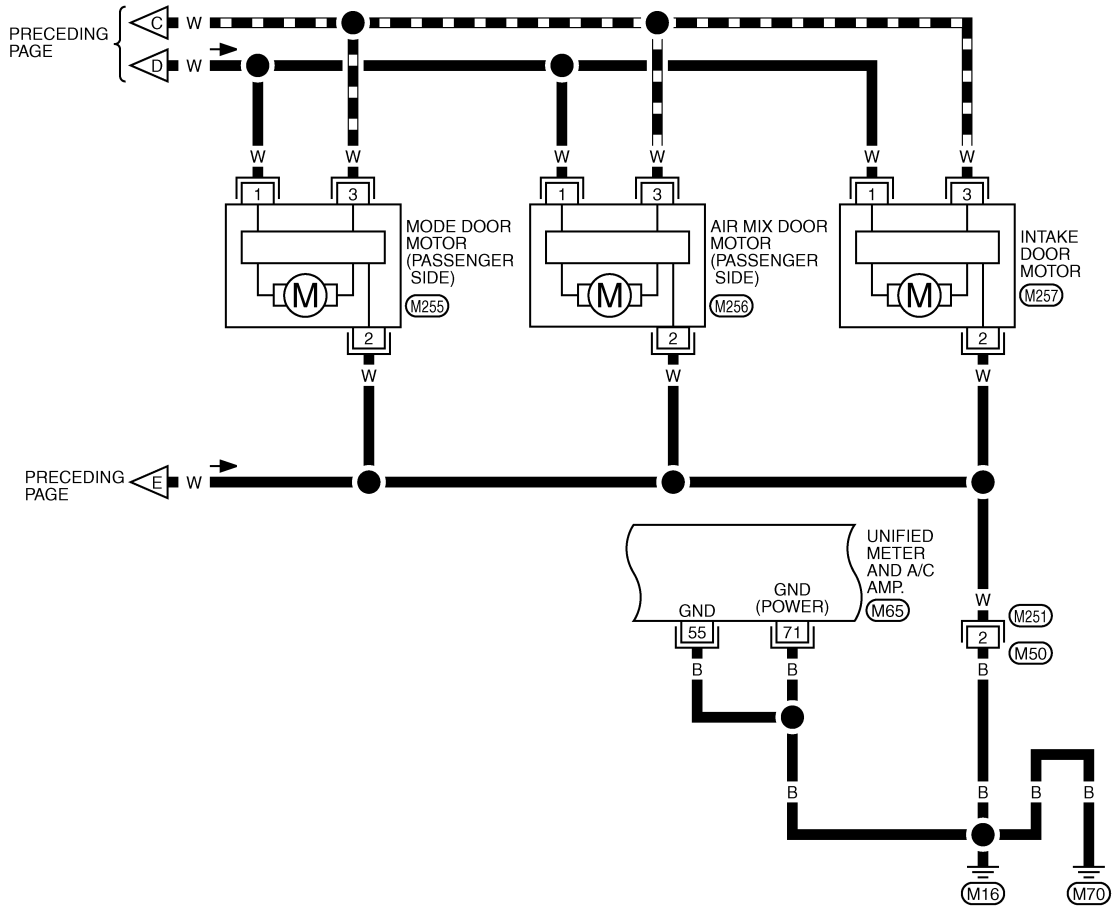

TJW0437E

# TROUBLE DIAGNOSIS

< SERVICE INFORMATION >

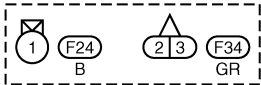
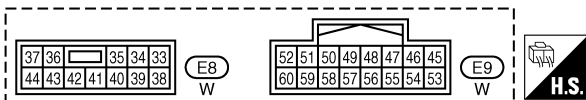
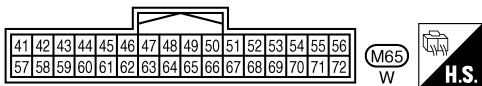
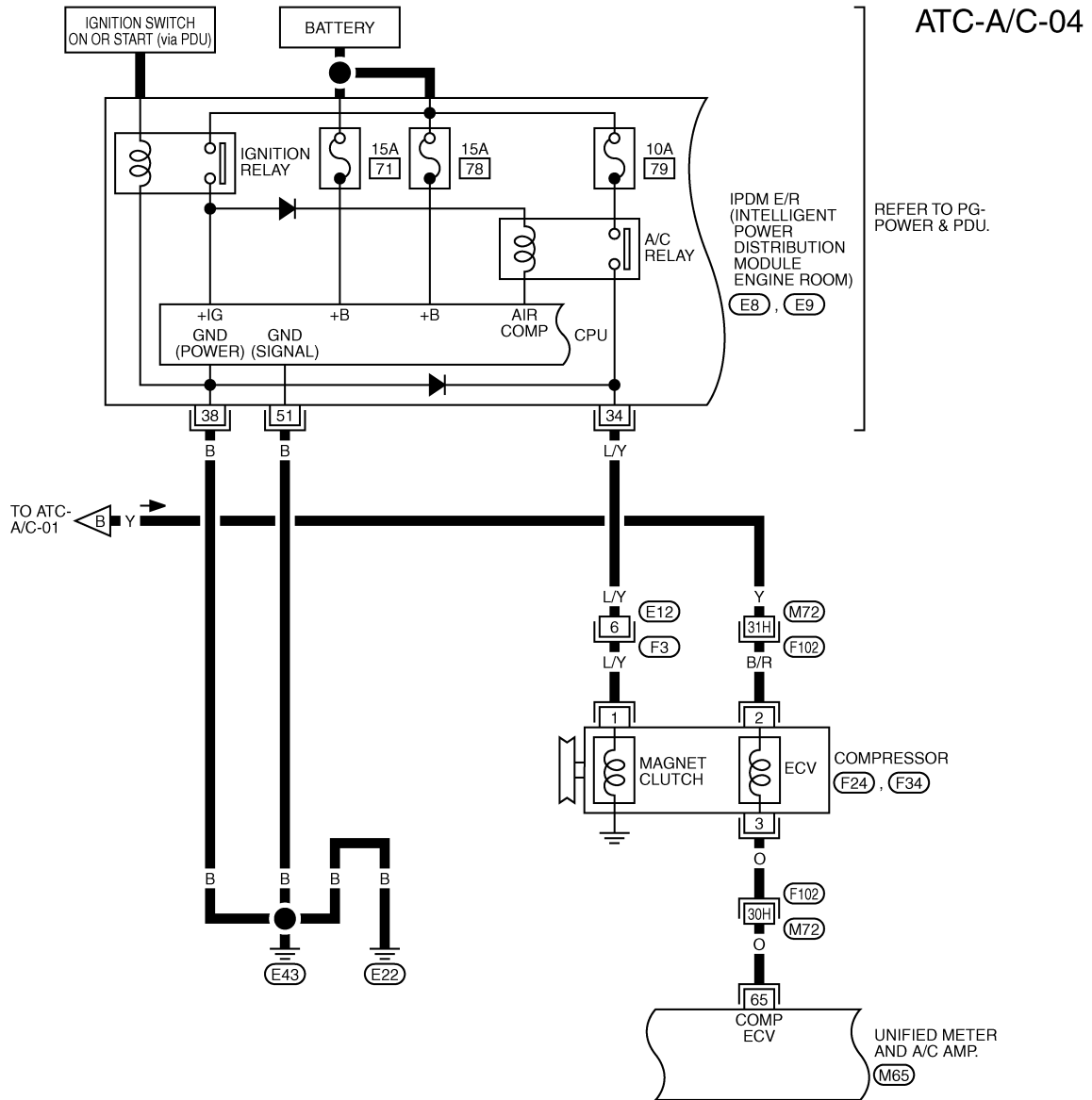

REFER TO THE FOLLOWING.  
(F102) -SUPER MULTIPLE JUNCTION (SMJ)

TJW0438E

A  
B  
C  
D  
E  
F  
G  
H  
I  
J  
K  
L  
M  
N  
O  
P

ATC

# TROUBLE DIAGNOSIS

< SERVICE INFORMATION >

ATC-A/C-05

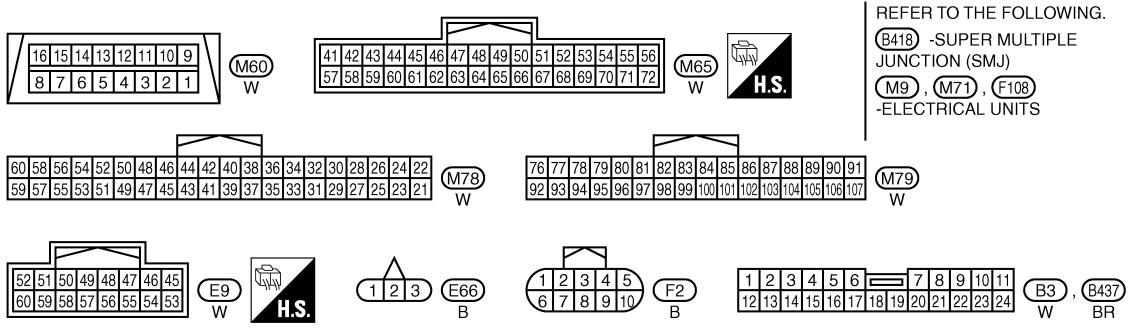
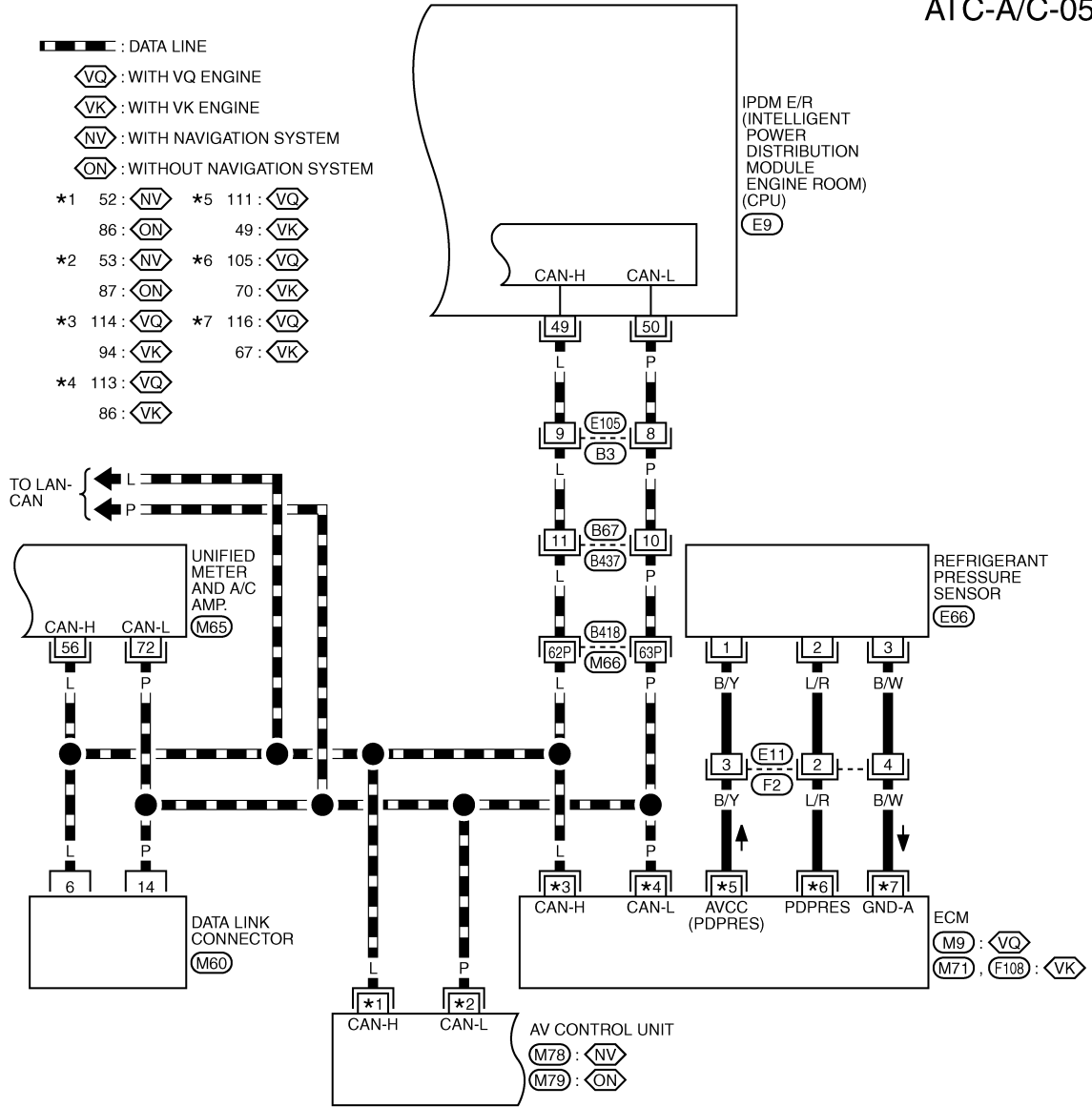

TJW0439E

# TROUBLE DIAGNOSIS

< SERVICE INFORMATION >

ATC-A/C-06

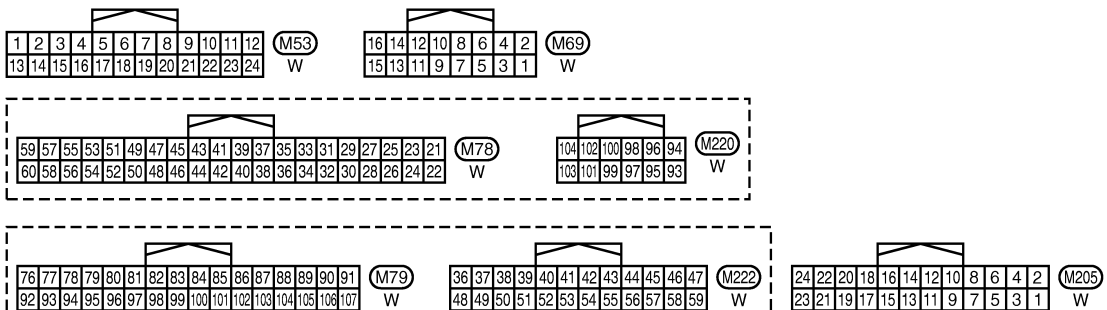
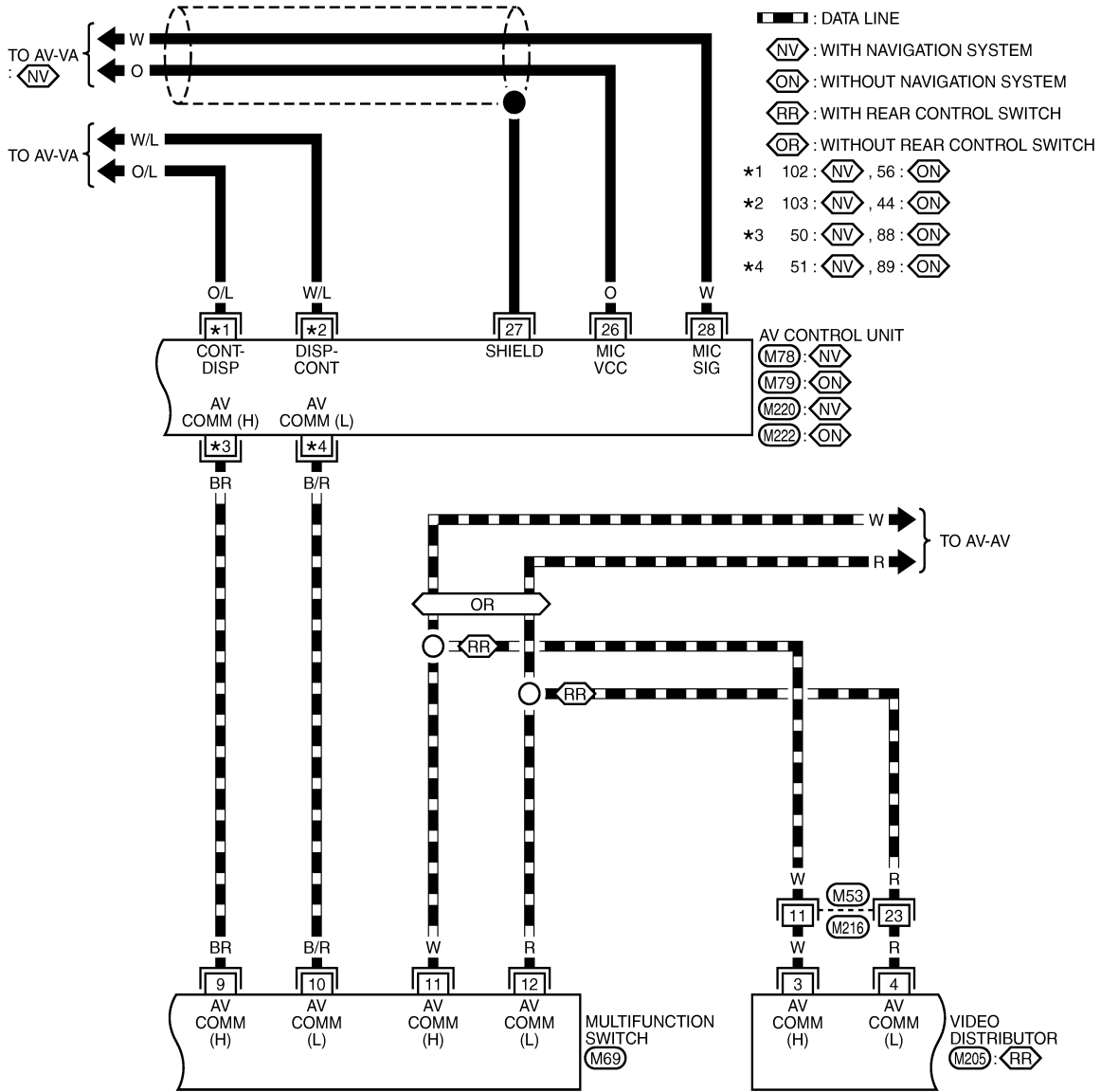

TJW0327E

A  
B  
C  
D  
E  
F  
G  
H  
I  
J  
K  
L  
M  
N  
O  
P

ATC

# TROUBLE DIAGNOSIS

< SERVICE INFORMATION >

ATC-A/C-07

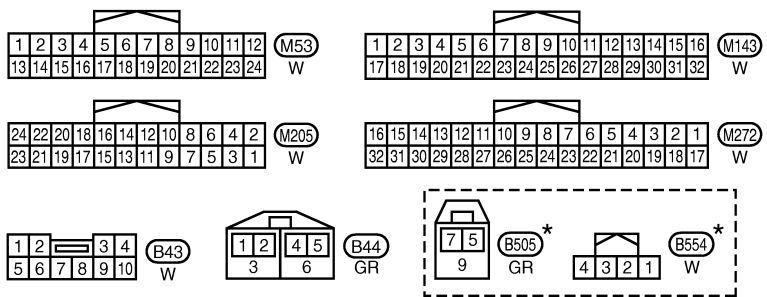
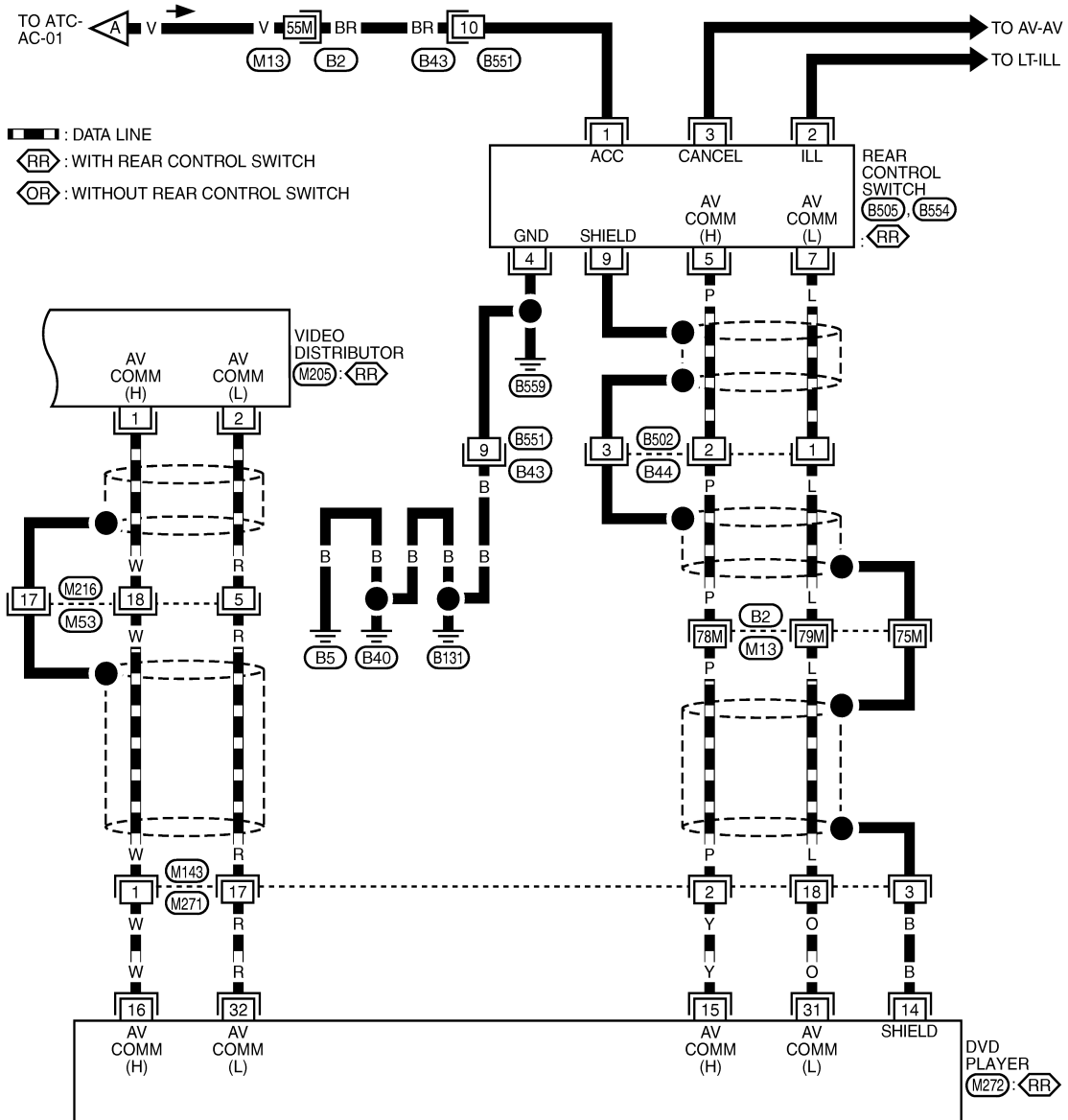

REFER TO THE FOLLOWING.  
 (B2) - SUPER MULTIPLE JUNCTION (SMJ)

\* : THIS CONNECTOR IS NOT SHOWN IN "HARNESS LAYOUT", PG. SECTION.

TJW0328E

# TROUBLE DIAGNOSIS

< SERVICE INFORMATION >

## Auto Amp. Terminal and Reference Value

INFOID:000000005348516

Measure voltage between each terminal and ground by referring terminals and reference value for unified meter and A/C amp.

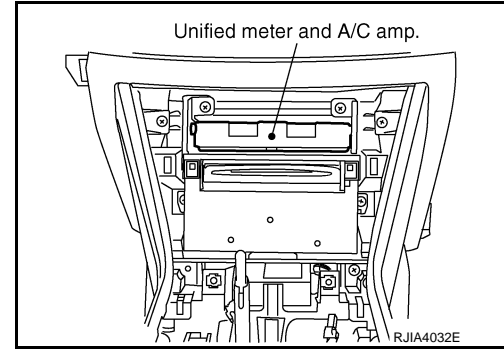

### PIN CONNECTOR TERMINAL LAYOUT

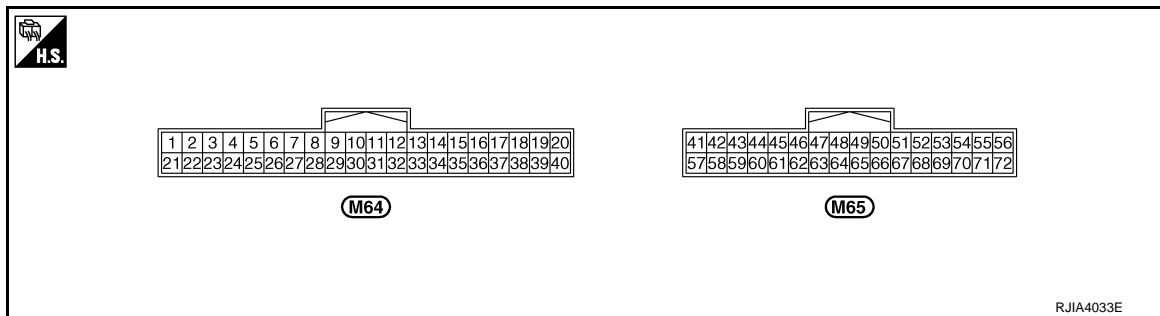

### TERMINALS AND REFERENCE VALUE FOR UNIFIED METER AND A/C AMP.

Terminal No.	Wire color	Item	Ignition switch	Condition	Voltage (V)
38	L/Y	Blower motor control signal	ON	Fan speed: 1st speed (manual)	<p>SJIA1454J</p>
41	V	Power supply from ACC	ACC	—	Battery voltage
43	R	Intake sensor	—	—	—
44	GR	In-vehicle sensor	—	—	—
45	W/V	Ambient sensor	—	—	—
46	BR/Y	Sunload sensor	—	—	—
53	W/G	Power supply from IGN	ON	—	Battery voltage
54	W/G	Power supply from BATT	OFF	—	Battery voltage
55	B	Ground	ON	—	Approx. 0
56	L	CAN-H	—	—	—
59	O/B	Intake sensor ground	ON	—	Approx. 0
60	P	In-vehicle sensor ground	ON	—	Approx. 0
61	LG/R	Ambient sensor ground	ON	—	Approx. 0
62	V/R	Sunload sensor ground	ON	—	Approx. 0

# TROUBLE DIAGNOSIS

## < SERVICE INFORMATION >

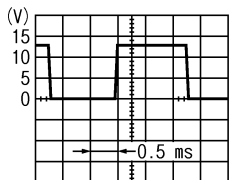
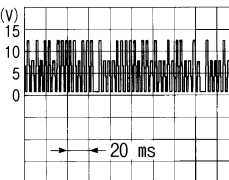
Terminal No.	Wire color	Item	Ignition switch	Condition	Voltage (V)
65	O	ECV (Electric Control Valve) signal	ON	Self-diagnosis. STEP-4 (Code No. 45)	 SJA1607E
69	R	A/C LAN signal	ON	—	 SJA1453J
70	W	Power supply for each door motor	ON	—	Battery voltage
71	B	Ground (Power)	ON	—	Approx. 0
72	P	CAN-L	—	—	—

## Self-Diagnosis Function

INFOID:000000005348517

### DESCRIPTION

The self-diagnosis system diagnoses sensors, door motors, blower motor, etc. by system line. Refer to applicable sections (items) for details. Shifting from normal control to the self-diagnosis system is accomplished by starting the engine (turning the ignition switch ON) and pressing OFF switch for at least 5 seconds. The OFF switch must be pressed within 10 seconds after starting the engine (ignition switch is turned ON). This system will be canceled by either pressing AUTO switch or turning the ignition switch OFF. Shifting from one step is accomplished by means of pressing temperature control switch (driver side), as required.



# TROUBLE DIAGNOSIS

## < SERVICE INFORMATION >

Shifting from STEP-5 to AUXILIARY MECHANISM is accomplished by means of pressing fan (UP: +) switch.

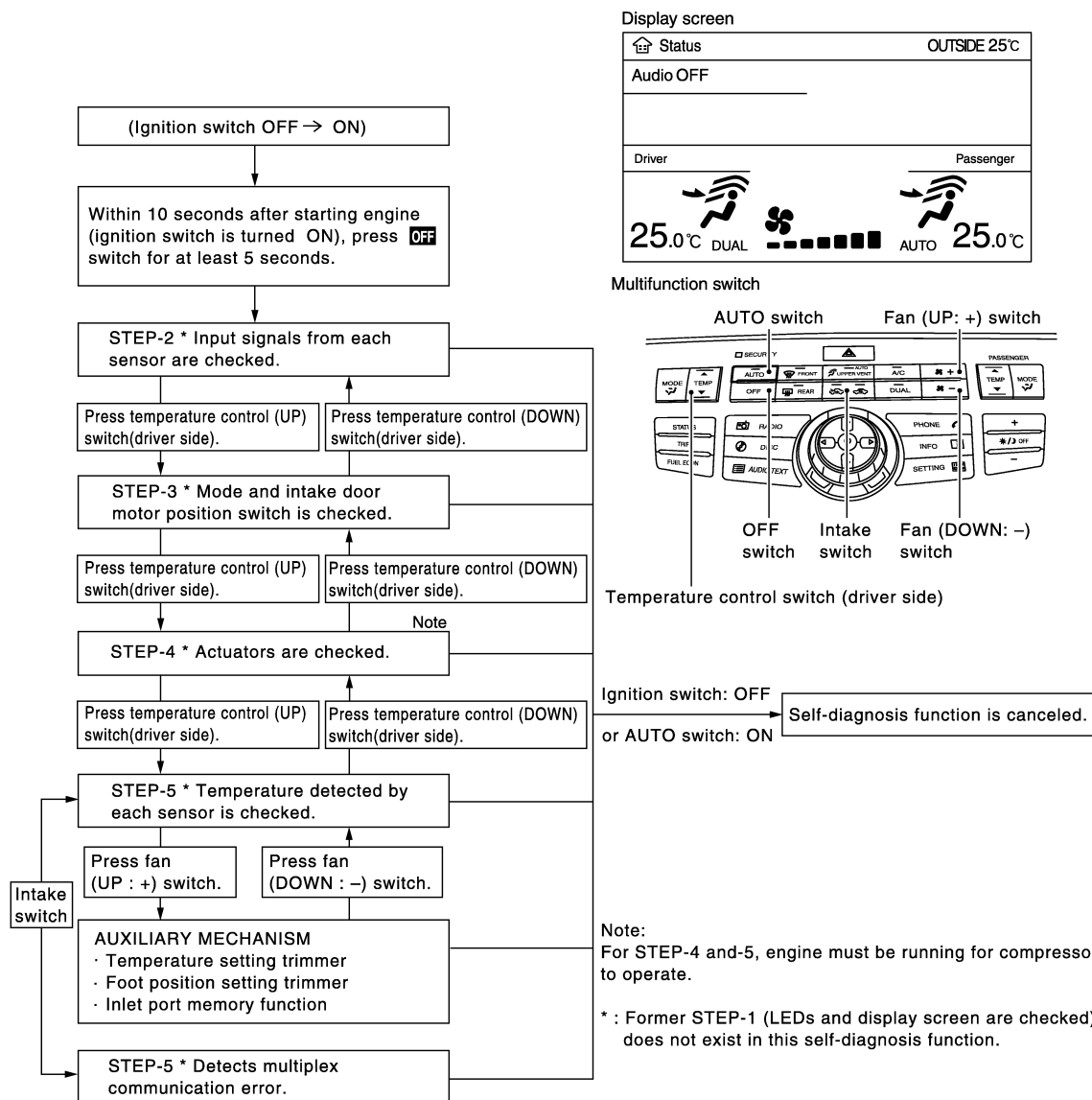

## FUNCTION CONFIRMATION PROCEDURE

### 1. SET IN SELF-DIAGNOSIS MODE

1. Turn ignition switch ON.
2. Set in self-diagnosis mode as per the following. Press OFF switch for at least 5 seconds Within 10 seconds after starting engine (ignition switch is turned ON).

#### NOTE:

- If battery voltage drops below 12 V during diagnosis STEP-3, door motor speed becomes slower and as a result, the system may generate an error even when operation is normal. To avoid this, start engine before performing this diagnosis.
- Former STEP-1 (LEDs and display screen are checked) does not exist in this self-diagnosis function.

>> GO TO 2.

### 2. STEP-2: SENSOR AND DOOR MOTOR CIRCUITS ARE CHECKED FOR OPEN OR SHORT CIRCUIT

# TROUBLE DIAGNOSIS

## < SERVICE INFORMATION >

Does code No. 20 appear on the display?

- YES >> GO TO 3.  
NO >> GO TO 13.

**Display (when all sensors are in good order)**

Indicates 25 seconds after "2" is indicated.

Indicates

SJIA1778E

### 3.CHECK TO ADVANCE SELF-DIAGNOSIS STEP-3

Press temperature control (UP) switch (driver side).

Advance to self-diagnosis STEP-3?

- YES >> GO TO 4.  
NO >> Replace Multifunction switch. (Temperature control switch is malfunctioning.)

### 4.CHECK TO RETURN SELF-DIAGNOSIS STEP-2

Press temperature control (DOWN) switch (driver side).

Return to self-diagnosis STEP-2?

- YES >> GO TO 5.  
NO >> Malfunctioning multifunction switch or unified meter and A/C amp. Refer to [ATC-95. "Self-Diagnosis"](#).

### 5.STEP-3: MODE DOOR AND INTAKE DOOR POSITIONS ARE CHECKED

Press temperature control (UP) switch (driver side).

Does code No. 30 appear on the display?

- YES >> GO TO 6.  
NO >> GO TO 14.

**Display (when all doors are in good order)**

Indicates 50 seconds after "3" is indicated.

Indicates

SJIA1779E

### 6.STEP-4: OPERATION OF EACH DOOR MOTOR IS CHECKED

1. Press temperature control (UP) switch (driver side).
2. Press DEF (🌀) switch. Code No. of each door motor test is indicated on the display.

>> GO TO 7.

Changes from "1" to "6"

Indicates

SJIA1780E

### 7.CHECK ACTUATORS

# TROUBLE DIAGNOSIS

## < SERVICE INFORMATION >

Refer to the following chart and check discharge air flow, air temperature, blower motor duty ratio and compressor operation.

Discharge air flow		Condition	Air outlet/distribution				
Mode position indication			VENT		FOOT		DEF
Driver side	Passenger side		Front	Rear	Front	Rear	
		DUAL switch: OFF Upper ventilator door: SHUT Rear ventilator door: OPEN	85%	15%	—	—	—
			47%	14%	23%	16%	—
			10%	9%	35%	23%	23%
			10%	8%	27%	19%	36%
			—	—	—	—	100%

JSIIA0907GB

Code No.	41	42	43	44	45	46
Mode door position	VENT	B/L 1	B/L 2	FOOT*	D/F	DEF
Upper ventilator door position	OPEN	SHUT	SHUT	SHUT	SHUT	SHUT
Intake door position	REC	REC	20% FRE	FRE	FRE	FRE
Air mix door position	FULL COLD	FULL COLD	FULL HOT	FULL HOT	FULL HOT	FULL HOT
Blower motor duty ratio	37%	91%	65%	65%	65%	91%
Compressor	ON	ON	OFF	OFF	ON	ON
Electronic control valve (ECV) duty ratio	100%	100%	0%	0%	50%	100%

Checks must be made visually, by listening the sound, or by touching air outlets with hand, etc. for improper operation.

\*: Mode door position is in a condition of FOOT position setting trimmer (automatic control). Refer to "FOOT POSITION SETTING TRIMMER".

### Is this inspection result normal?

YES >> GO TO 8.

NO-1 >> Air outlet does not change. Refer to [ATC-65, "Mode Door Motor Circuit"](#).

NO-2 >> Upper ventilator outlet does not change. Refer to [ATC-68, "Upper Ventilator Door Motor Circuit"](#).

NO-3 >> Intake door does not change. Refer to [ATC-73, "Intake Door Motor Circuit"](#).

NO-4 >> Discharge air temperature does not change. Refer to [ATC-71, "Air Mix Door Motor Circuit"](#).

NO-5 >> Blower motor operation is malfunctioning. Refer to [ATC-76, "Blower Motor Circuit"](#).

NO-6 >> Magnet clutch does not engage. Refer to [ATC-80, "Magnet Clutch Circuit"](#).

## 8. STEP-5: TEMPERATURE OF EACH SENSOR IS CHECKED

1. Press temperature control (UP) switch (driver side).
2. Code No. 51 appears on the display.

>> GO TO 9.

## 9. CHECK AMBIENT SENSOR

# TROUBLE DIAGNOSIS

## < SERVICE INFORMATION >

Press DEF (  ) switch one time. Temperature detected by ambient sensor is indicated on the display.

**NOTE:**

Check sensor circuit first if the temperature indicated on the display greatly differs from the actual temperature, and then check sensor.

Is this inspection result normal?

YES >> GO TO 10.

NO >> Go to Ambient Sensor Circuit. Refer to [ATC-97, "Ambient Sensor Circuit"](#).

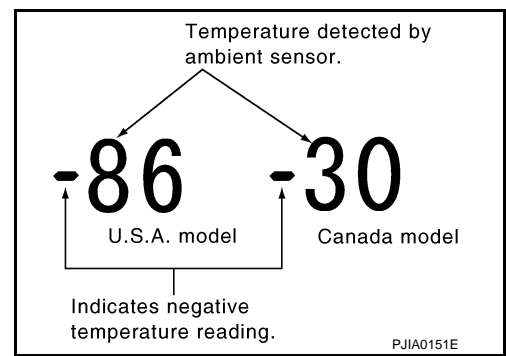

## 10.CHECK IN-VEHICLE SENSOR

Press DEF (  ) switch for the second time. Temperature detected by in-vehicle sensor is indicated on the display.

**NOTE:**

Check sensor circuit first if the temperature indicated on the display greatly differs from the actual temperature, and then check sensor.

Is this inspection result normal?

YES >> GO TO 11.

NO >> Go to In-vehicle Sensor Circuit. Refer to [ATC-99, "In-vehicle Sensor Circuit"](#).

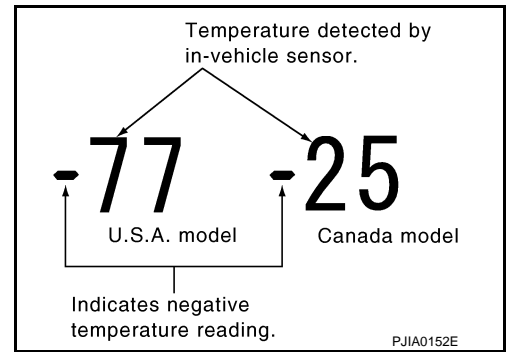

## 11.CHECK INTAKE SENSOR

Press DEF (  ) switch for the third time. Temperature detected by intake sensor is indicated on the display.

**NOTE:**

Check sensor circuit first if the temperature indicated on the display greatly differs from the actual temperature, and then check sensor.

Is this inspection result normal?

YES >> GO TO 12.

NO >> Go to Intake Sensor Circuit. Refer to [ATC-105, "Intake Sensor Circuit"](#).

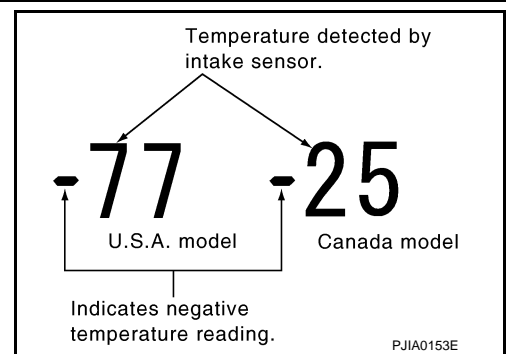



## 12.CHECK CAN COMMUNICATION ERROR

1. Press intake switch.
2. CAN communication error between each unit that uses the unified meter and A/C amp. can be detected as self-diagnosis results. (If plural errors occur, the display of each error will blink twice for 0 - 5 second intervals.)

Is this inspection result normal?

YES >> INSPECTION END

NO >> Go to CAN communication (Unified meter and A/C amp. – AV control unit). Refer to [DI-31, "DTC \[U1000\] CAN Communication Circuit"](#).

Display	CAN communication error
52	In good order
52 	AV control unit ⇨ Unified meter and A/C amp.
52 	Unified meter and A/C amp. ⇨ All unit

JPIIA0476GB

## 13.CHECK MALFUNCTIONING SENSOR AND DOOR MOTOR

Refer to the following chart for malfunctioning code No.

(Corresponding code Nos. indicates 1 second each if two or more sensors and door motors malfunction.)

(Corresponding code Nos. indicates 0.5 second each if two door motors malfunction.)

# TROUBLE DIAGNOSIS

## < SERVICE INFORMATION >

Code No.	Malfunctioning sensor and door motor (Including circuits)	Reference page
21 / -21	Ambient sensor	<a href="#">ATC-97, "Ambient Sensor Circuit".</a>
22 / -22	In-vehicle sensor	<a href="#">ATC-99, "In-vehicle Sensor Circuit".</a>
24 / -24	Intake sensor	<a href="#">ATC-105, "Intake Sensor Circuit".</a>
25 / -25	Sunload sensor *	<a href="#">ATC-102, "Sunload Sensor Circuit".</a>
26 / -26	Air mix door motor PBR (Driver side)	<a href="#">ATC-73, "Air Mix Door Motor PBR Circuit".</a>
27 / -27	Air mix door motor PBR (Passenger side)	

\*: Perform self-diagnosis STEP-2 under sunshine.

When performing indoors, aim a light (more than 60 W) at sunload sensor, otherwise code No. 25 will indicate despite that sunload sensor is functioning properly.

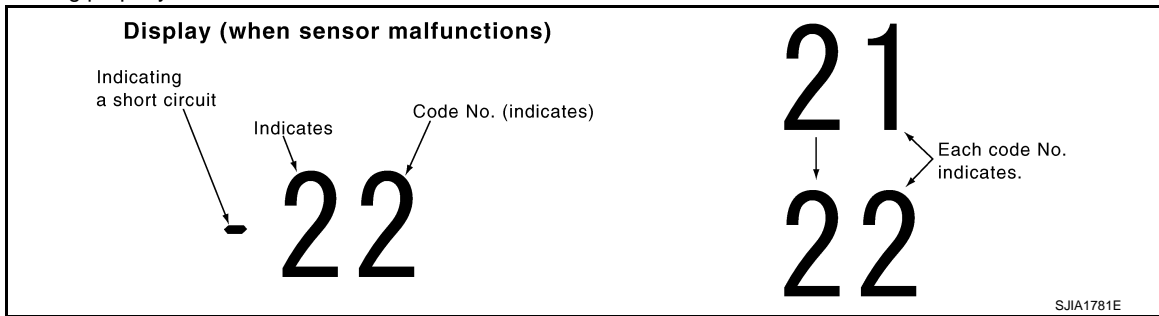

>> INSPECTION END

## 14. CHECK MALFUNCTIONING DOOR MOTOR POSITION SWITCH

Door motor PBR is malfunctioning.

Code No. *1 *2 *3	Door position	Reference page	
31	VENT (Driver side)	<a href="#">ATC-65, "Mode Door Motor Circuit".</a>	
32	DEF (Driver side)		
33	VENT (Passenger side)		
34	DEF (Passenger side)		
35	UPPER VENT (Open)	Upper ventilator door motor	<a href="#">ATC-68, "Upper Ventilator Door Motor Circuit".</a>
36	UPPER VENT (Shut)		
37	FRE	Intake door motor	<a href="#">ATC-73, "Intake Door Motor Circuit".</a>
38	20% FRE		
39	REC		

(If two or more door motors malfunction, corresponding code Nos. indicates 1 second each.)

\*1: If mode door motor (driver and passenger side) harness connector is disconnected, the following display pattern will appear.

31→32→33→34→Return to 31

\*2: If upper ventilator door motor harness connector is disconnected, the following display pattern will appear.

35→36→Return to 35

\*3: If intake door motor harness connector is disconnected, the following display pattern will appear.

## TROUBLE DIAGNOSIS

### < SERVICE INFORMATION >

37→38→39→Return to 37

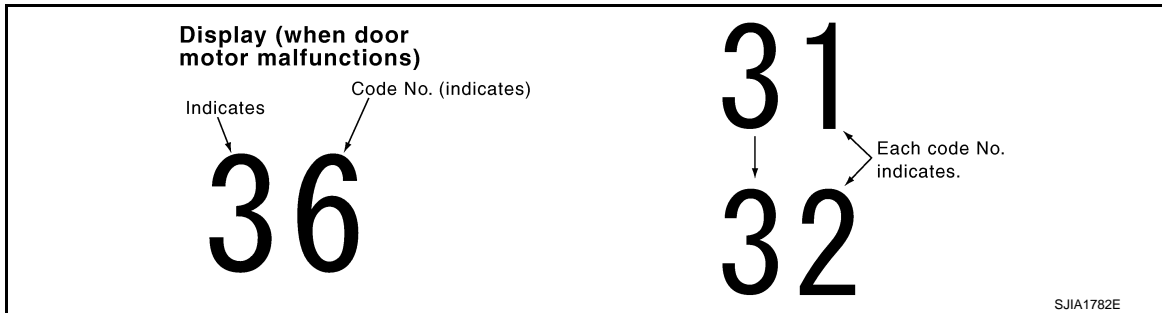

>> INSPECTION END

### AUXILIARY MECHANISM: TEMPERATURE SETTING TRIMMER

The trimmer compensates for differences in range of  $\pm 3^{\circ}\text{C}$  ( $\pm 6^{\circ}\text{F}$ ) between temperature setting (displayed digitally) and temperature felt by customer.

Operating procedures for this trimmer are as follows:

1. Begin self-diagnosis STEP-5 mode. Refer to "Self-diagnosis Function".
2. Press fan (UP: +) switch to set system in auxiliary mode.
3. Display shows "61" in auxiliary mechanism. It takes approximately 3 seconds to enable setting operation.
4. Press temperature control switch (driver side) as desired. Temperature will change at a rate of  $0.5^{\circ}\text{C}$  ( $1.0^{\circ}\text{F}$ ) each time a switch is pressed.

**CAUTION:**

# TROUBLE DIAGNOSIS

< SERVICE INFORMATION >

**A decimal point is not indicated on the display.**

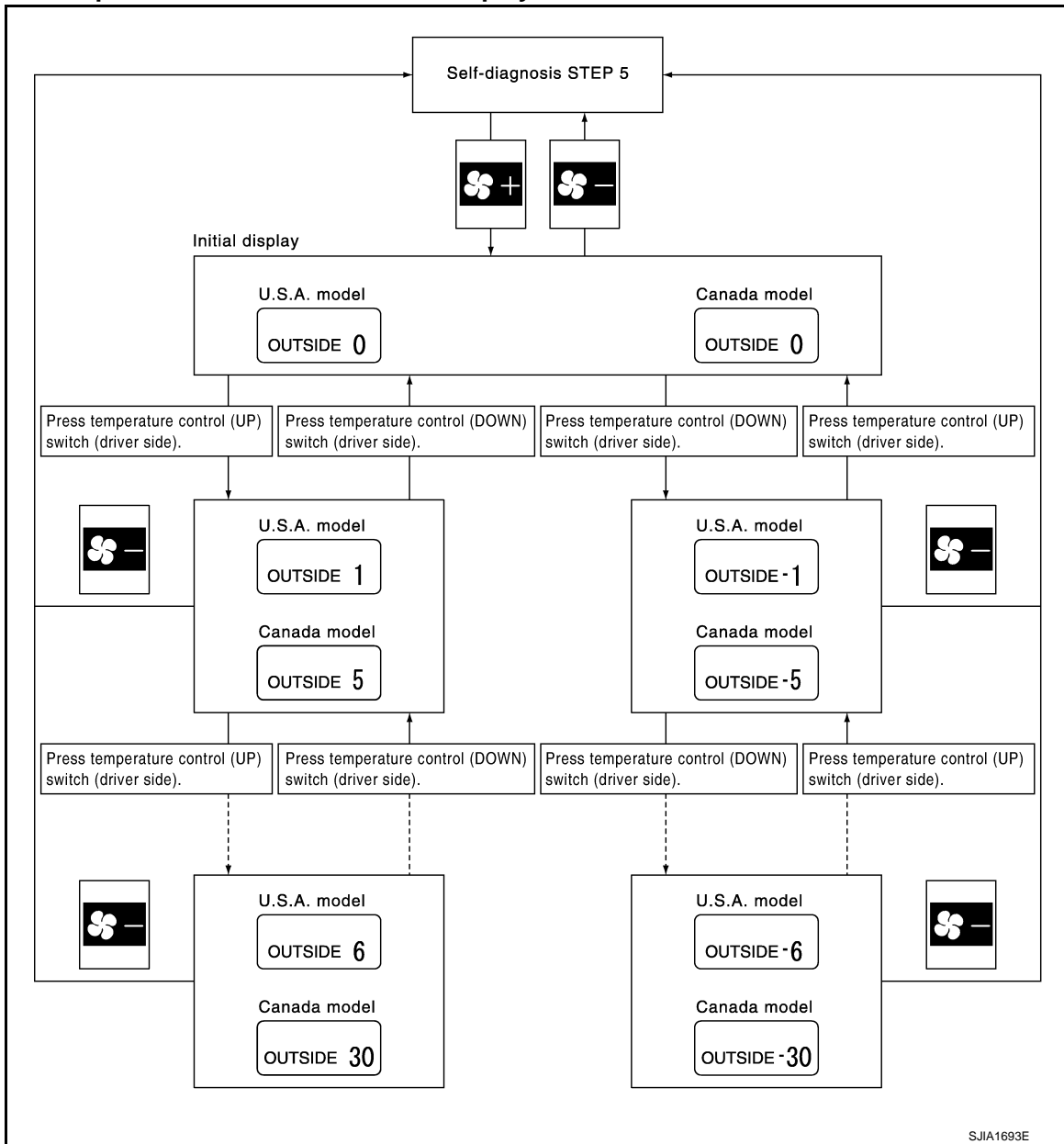

**NOTE:**

When battery cable is disconnected or battery voltage is below 10 V, trimmer operation is canceled. Temperature set becomes that of initial condition, i.e. 0°C (0°F).

## AUXILIARY MECHANISM: FOOT POSITION SETTING TRIMMER

Wind distribution ratio in FOOT mode can be set.

Operating procedures for this trimmer are as follows:

1. Begin self-diagnosis STEP-5 mode. Refer to "Self-diagnosis Function".
2. Press fan (UP: +) switch to set system in auxiliary mode.
3. Display shows "61" in auxiliary mechanism. It takes approximately 3 seconds to enable setting operation.

# TROUBLE DIAGNOSIS

## < SERVICE INFORMATION >

4. Press the mode switch as desired.

Display	Discharge air flow / Upper ventilator door : SHUT									
	Automatically controls the mode door					Manually controls the mode door				
	VENT		FOOT		DEF	VENT		FOOT		DEF
	Front	Rear	Front	Rear		Front	Rear	Front	Rear	
	10%	9%	35%	23%	23%	10%	9%	35%	23%	23%
	10%	9%	35%	23%	23%	13%	12%	45%	30%	—
	13%	12%	45%	30%	—	10%	9%	35%	23%	23%
	13%	12%	45%	30%	—	13%	12%	45%	30%	—

JPIIA0507GB

**NOTE:**

When battery cable is disconnected or battery voltage is below 10 V, trimmer operation is canceled. Wind distribution ratio set becomes that of initial condition.

**AUXILIARY MECHANISM: INLET PORT MEMORY FUNCTION**

When ignition switch is turned from OFF to ON, inlet port memory function at manual mode can be set.

Operating procedures for this trimmer are as follows:

1. Begin self-diagnosis STEP-5 mode. Refer to "Self-diagnosis Function".
2. Press fan (UP: +) switch to set system in auxiliary mode.
3. Press the intake switch as desired.

LED status of FRE position	LED status of REC position	Setting status		Setting changeover method
		FRE	REC	
OFF	OFF	AUTO control	AUTO control	Intake switch: ON
OFF	ON	AUTO control (Initial setting)	Manual REC status is memorized. (Initial setting)	
ON	ON	Manual FRE status is memorized.	Manual REC status is memorized.	
ON	OFF	Manual FRE status is memorized.	AUTO control	

**NOTE:**

When battery cable is disconnected or battery voltage is below 10 V, memory function is canceled. Memory function set becomes that of initial condition.

## Operational Check

INFOID:000000005348518

The purpose of the operational check is to check if the individual system operates properly.

**Conditions : Engine running at normal operating temperature**

### CHECKING MEMORY FUNCTION

1. Press the temperature control (UP) switch (driver side) until 32°C (90°F) is displayed.
2. Press OFF switch.
3. Turn ignition switch OFF.
4. Turn ignition switch ON.
5. Press AUTO switch.
6. Confirm that the set temperature remains at previous temperature.
7. Press OFF switch.

If NG, go to trouble diagnosis procedure for [ATC-96. "Memory Function"](#).



# TROUBLE DIAGNOSIS

## < SERVICE INFORMATION >

If OK, continue the check.

### CHECKING BLOWER

1. Press fan (UP: +) switch. Blower should operate on low speed. The fan symbol should have one blade lit.
2. Press fan (UP: +) switch again, and continue checking fan speed and fan symbol until all speeds are checked.
3. Leave blower on maximum speed.

If NG, go to trouble diagnosis procedure for [ATC-76, "Blower Motor Circuit"](#).

If OK, continue the check.

### CHECKING DISCHARGE AIR (MODE SWITCH AND DEF SWITCH)

1. Press MODE switch and DEF switch.
2. Each position indicator should change shape.
3. Confirm that discharge air comes out according to the air distribution table. Refer to [ATC-31, "Discharge Air Flow"](#).

Discharge air flow							
Mode position indication		Condition	Air outlet/distribution				
Driver side	Passenger side		VENT		FOOT		DEF
			Front	Rear	Front	Rear	
		DUAL switch: OFF Upper ventilator door: SHUT Rear ventilator door: OPEN	85%	15%	—	—	—
			47%	14%	23%	16%	—
			10%	9%	35%	23%	23%
			10%	8%	27%	19%	36%
			—	—	—	—	100%

JSIIA0907GB

If NG, go to trouble diagnosis procedure for [ATC-65, "Mode Door Motor Circuit"](#).

If OK, continue the check.

#### NOTE:

Confirm that the compressor clutch is engaged (sound or visual inspection) and intake door position is at FRE when the D/F or DEF is selected.

### CHECKING DISCHARGE AIR (UPPER VENT SWITCH)

1. Press temperature control (UP) switch (driver side) until 32°C (90°F) is displayed.
2. Press fan (UP: +) switch until maximum speed.
3. Set MODE switch (driver side) to VENT position.
4. Press UPPER VENT switch. UPPER VENT switch indicator lamp turns ON.
5. Press temperature control (DOWN) switch (driver side) until 18°C (60°F) is displayed.
6. Confirm that discharger air come out.
7. Press UPPER VENT switch again. UPPER VENT switch indicator lamp turns OFF.

If NG, go to trouble diagnosis procedure for [ATC-68, "Upper Ventilator Door Motor Circuit"](#).

If OK, continue the check.

### CHECKING INTAKE AIR

1. Press intake switch. REC indicator lamp turns ON.
2. Press intake switch again. FRE indicator lamp turns ON.
3. Listen for intake door position change. (Slight change of blower sound can be heard.)

If NG, go to trouble diagnosis procedure for [ATC-73, "Intake Door Motor Circuit"](#).

If OK, continue the check.

#### NOTE:

Confirm that the compressor clutch is engaged (sound or visual inspection) and intake door position is at FRE when the D/F or DEF is selected.

# TROUBLE DIAGNOSIS

## < SERVICE INFORMATION >

---

### CHECKING A/C SWITCH

1. Press AUTO switch and A/C switch.
2. A/C switch indicator lamp turns ON.
  - Confirm that the compressor clutch engages (sound or visual inspection).

If NG, go to trouble diagnosis procedure for [ATC-80, "Magnet Clutch Circuit"](#).

If OK, continue the check.

### CHECKING TEMPERATURE DECREASE

1. Press temperature control (DOWN) switch (driver side) until 18°C (60°F) is displayed.
2. Check for cool air at discharge air outlets.

If NG, go to trouble diagnosis procedure for [ATC-84, "Insufficient Cooling"](#).

If OK, continue the check.

### CHECKING TEMPERATURE INCREASE

1. Press temperature control (UP) switch (driver side) until 32°C (90°F) is displayed.
2. Check for warm air at discharge air outlets.

If NG, go to trouble diagnosis procedure for [ATC-93, "Insufficient Heating"](#).

If OK, continue the check.

### CHECKING AUTO MODE

1. Press AUTO switch.
2. Display should indicate AUTO.
  - Confirm that discharge air and fan speed will depend on ambient, in-vehicle, and set temperatures.

If NG, go to trouble diagnosis procedure for [ATC-58, "Power Supply and Ground Circuit for Auto Amp."](#), then if necessary, trouble diagnosis procedure for [ATC-80, "Magnet Clutch Circuit"](#).

If all operational checks are OK (symptom cannot be duplicated), go to Incident Simulation Tests in [GI-26, "How to Perform Efficient Diagnosis for an Electrical Incident"](#) and perform tests as outlined to simulate driving conditions environment. If symptom appears, refer to [ATC-34, "How to Perform Trouble Diagnosis for Quick and Accurate Repair"](#) and perform applicable trouble diagnosis procedures.

## Power Supply and Ground Circuit for Auto Amp.

INFOID:000000005348519

SYMPTOM: A/C system does not activate.

### INSPECTION FLOW

# TROUBLE DIAGNOSIS

## < SERVICE INFORMATION >

1. Confirm symptom by performing the following operational check.

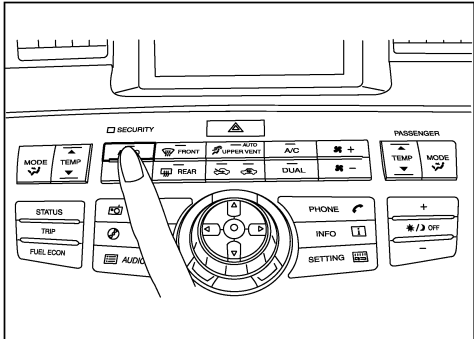

**OPERATIONAL CHECK – AUTO mode**

- Press AUTO switch and A/C switch.
- Display should indicate AUTO.

Confirm that the compressor clutch engages (sound or visual inspection).  
(Discharge air and blower speed will depend on ambient, in-vehicle and set temperatures.)

**If OK (symptom cannot be duplicated), perform complete operational check (\*2).**  
**If NG (symptom is confirmed), continue with STEP-2 following.**

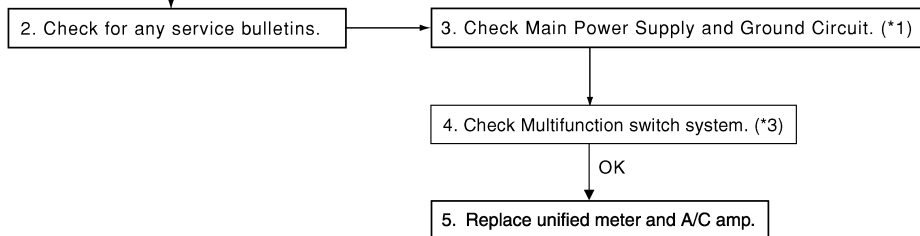

RJIA4047E

\*1 "DIAGNOSIS PROCEDURE FOR A/C SYSTEM"

\*2 [ATC-56, "Operational Check"](#)

\*3 [AV-48, "WITHOUT NAVIGATION : Diagnosis Description"](#) [Without mobile entertainment system (WITHOUT NAVIGATION)], [AV-57, "WITH NAVIGATION : Diagnosis Description"](#) [Without mobile entertainment system (WITH NAVIGATION)] or [AV-545, "Diagnosis Description"](#) (With mobile entertainment system)

## COMPONENT DESCRIPTION

### Unified Meter and A/C Amp. (Automatic Amplifier)

- The unified meter and A/C amp. has a built-in microcomputer which processes information sent from various sensors needed for air conditioner operation. The air mix door motor, mode door motor, upper ventilator door motor, intake door motor, blower motor and compressor are then controlled.
- When the various switches and temperature control switch are operated, data is input to the unified meter and A/C amp. from the AV control unit using CAN communication.
- Self-diagnosis functions are also built into unified meter and A/C amp. to provide quick check of malfunctions in the auto air conditioner system.

### Potential Temperature Control (PTC)

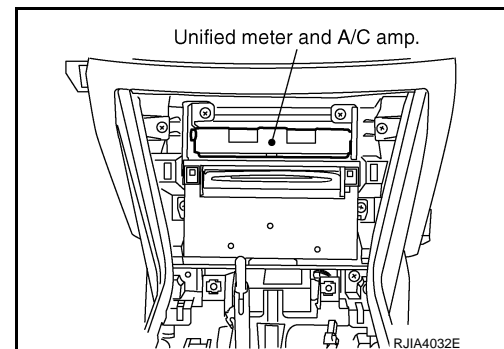

# TROUBLE DIAGNOSIS

## < SERVICE INFORMATION >

The PTC is built into the multifunction switch. It can be set at an interval of 0.5°C (1.0°F) in the 18°C (60°F) to 32°C (90°F) temperature range by pressing temperature control switch. The set temperature is displayed.

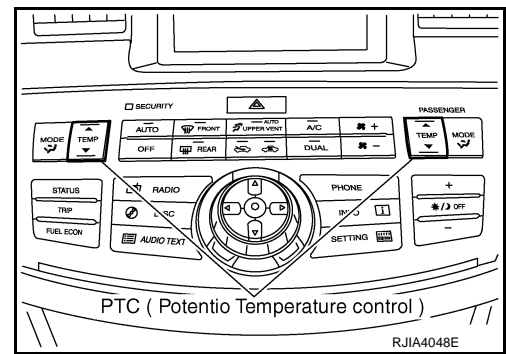

## DIAGNOSIS PROCEDURE FOR A/C SYSTEM

SYMPTOM: A/C system does not come on.

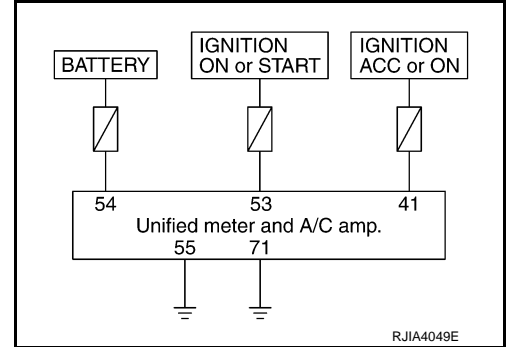

### 1. CHECK POWER SUPPLY CIRCUIT FOR UNIFIED METER AND A/C AMP.

1. Disconnect unified meter and A/C amp. connector.
2. Check voltage between unified meter and A/C amp. harness connector M65 terminals 41, 53 and 54 and ground.

Terminals		Ignition switch position			
(+)		(-)	OFF	ACC	ON
Unified meter and A/C amp. connector	Terminal No.				
M65	41	Ground	Approx. 0 V	Battery voltage	Battery voltage
	53		Approx. 0 V	Approx. 0 V	Battery voltage
	54		Battery voltage	Battery voltage	Battery voltage

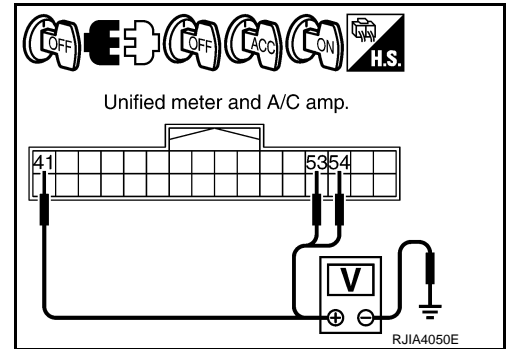

### OK or NG

OK >> GO TO 2.

NG >> Check 10A fuses [Nos. 6, 12 and 19, located in the fuse block (J/B)]. Refer to [PG-84, "Terminal Arrangement"](#).

- If fuses are OK, check harness for open circuit. Repair or replace if necessary.
- If fuses are NG, check harness for short circuit and replace fuse.

### 2. CHECK GROUND CIRCUIT FOR UNIFIED METER AND A/C AMP.

1. Turn ignition switch OFF.

# TROUBLE DIAGNOSIS

## < SERVICE INFORMATION >

2. Check continuity between unified meter and A/C amp. harness connector M65 terminal 55, 71 and ground.

**55, 71 – Ground : Continuity should exist.**

### OK or NG

- OK >> Replace unified meter and A/C amp.  
NG >> Repair harness or connector.

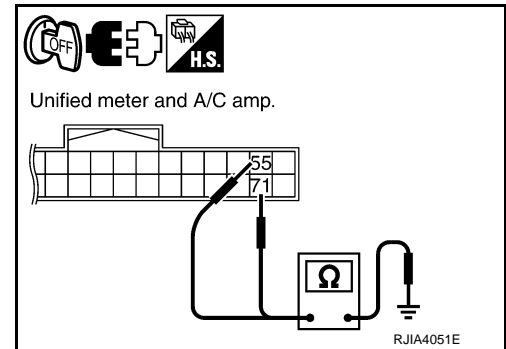

INFOID:000000005348520

## Rear Control Switch Circuit

### DIAGNOSIS PROCEDURE FOR REAR CONTROL SWITCH

SYMPTOM: Rear control switch does not operate.

#### 1.CHECK A/C SYSTEM

Check multifunction switch, confirm A/C system operation.

### OK or NG

- OK >> GO TO 2.  
NG >> Go to trouble diagnosis procedure for A/C system. Refer to [ATC-58, "Power Supply and Ground Circuit for Auto Amp."](#)

#### 2.CHECK REAR CONTROL SWITCH

Check rear control switch, except for A/C switch (audio) operation.

### OK or NG

- OK >> GO TO 5.  
NG >> GO TO 3.

#### 3.CHECK POWER SUPPLY FOR REAR CONTROL SWITCH

1. Turn ignition switch OFF.
2. Disconnect rear control switch connector.
3. Turn ignition switch ACC.
4. Check voltage between rear control switch harness connector B554 terminal 1 and ground.

**1 – Ground : Battery voltage**

### OK or NG

- OK >> GO TO 4.  
NG >> Check 10A fuse [No. 6 located in the fuse block (J/B)]. Refer to [PG-84, "Terminal Arrangement"](#).
- If fuse is OK, check harness for open circuit. Repair or replace if necessary.
  - If fuse is NG, check harness for short circuit and replace fuse.

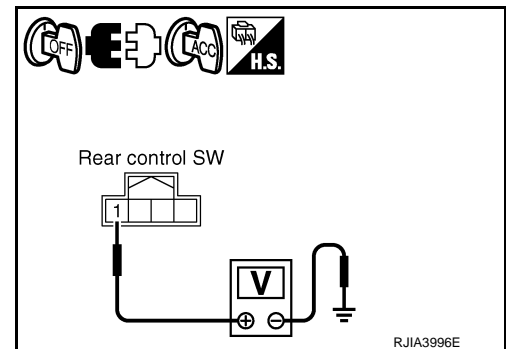

#### 4.CHECK GROUND CIRCUIT FOR REAR CONTROL SWITCH

1. Turn ignition switch OFF.

# TROUBLE DIAGNOSIS

## < SERVICE INFORMATION >

- Check continuity between rear control switch harness connector B554 terminal 4 and ground.

**4 – Ground : Continuity should exist.**

### OK or NG

- OK >> GO TO 5.  
 NG >> Repair harness or connector.

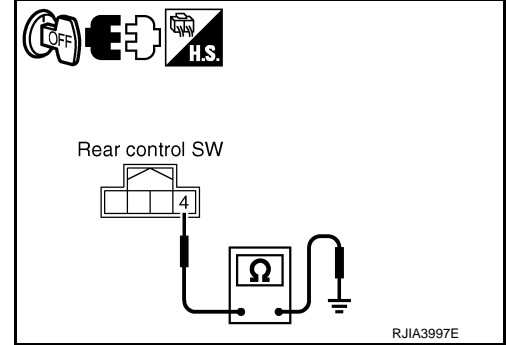

## 5. CHECK REAR CONTROL SWITCH, AV CONTROL UNIT

Check circuit between rear control switch and AV control unit. Refer to [AV-545, "Diagnosis Description"](#).

### OK or NG

- OK >> Replace rear control switch.  
 NG >> Replace part or repair for result trouble diagnosis.

## LAN System Circuit

INFOID:000000005348521

SYMPTOM: Mode door motors, upper ventilator door motor, air mix door motors and intake door motor does not operate normally.

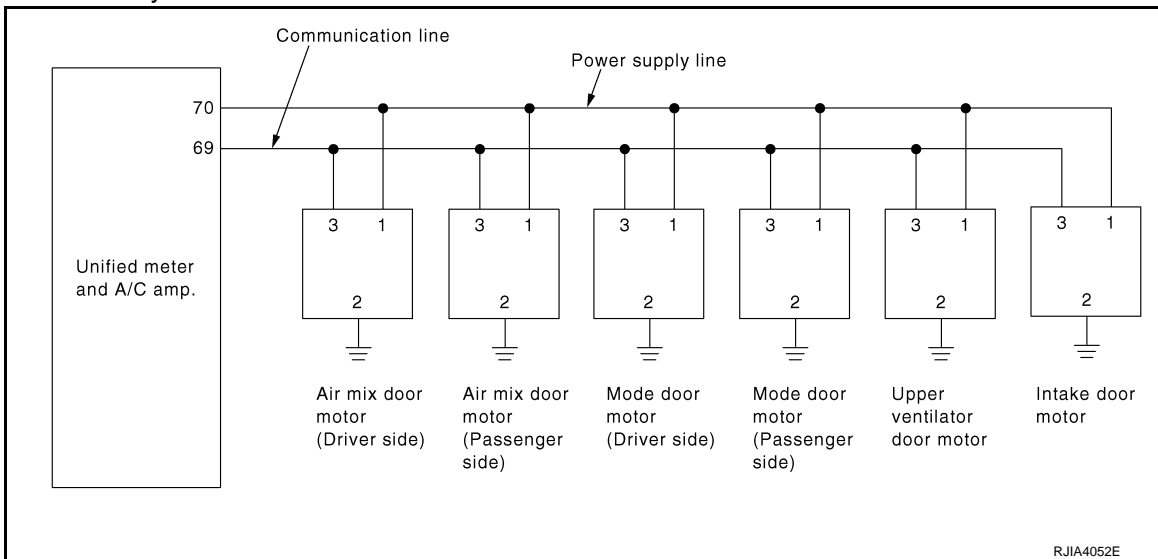

## DIAGNOSIS PROCEDURE FOR LAN CIRCUIT

### 1. CHECK POWER SUPPLY FOR UNIFIED METER AND A/C AMP.

- Turn ignition switch ON.
- Check voltage between unified meter and A/C amp. harness connector M65 terminal 70 and ground.

**70 – Ground : Battery voltage**

### OK or NG

- OK >> GO TO 2.  
 NG >> Replace unified meter and A/C amp.

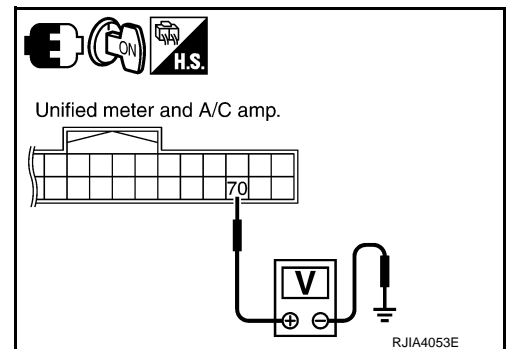

### 2. CHECK SIGNAL FOR UNIFIED METER AND A/C AMP.

# TROUBLE DIAGNOSIS

## < SERVICE INFORMATION >

Confirm A/C LAN signal between unified meter and A/C amp. harness connector M65 terminal 69 and ground using an oscilloscope.

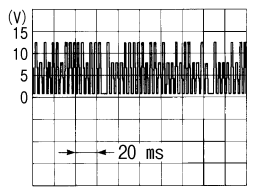
Terminals		(-)	Output waveform
(+) Terminal No.			
Unified meter and A/C amp. connector	Terminal No.		
M65	69	Ground	 <p style="text-align: right;">SJIA1453J</p>

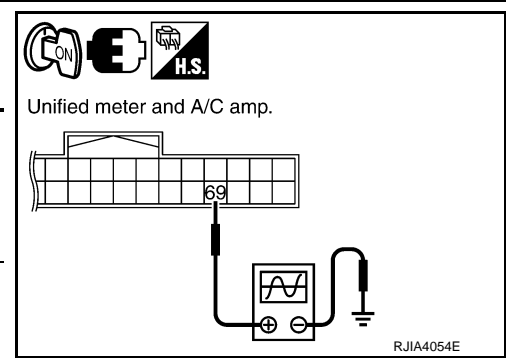

### OK or NG

- OK >> GO TO 3.
- NG >> Replace unified meter and A/C amp.

## 3. CHECK POWER SUPPLY FOR EACH DOOR MOTOR

Check voltage between each door motor harness connector terminal 1 and ground.

**1 – Ground : Battery voltage**

### OK or NG

- OK >> GO TO 4.
- NG >> Repair harness or connector.

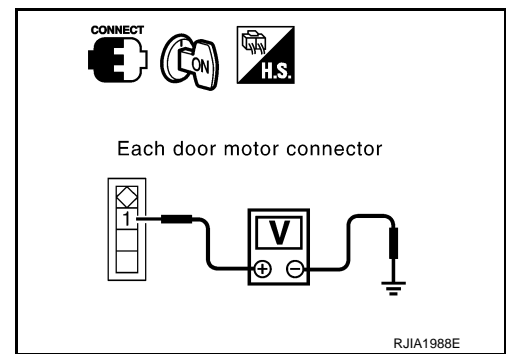

## 4. CHECK SIGNAL FOR EACH DOOR MOTOR

Confirm A/C LAN signal between each door motor harness connector terminal 3 and ground using an oscilloscope.

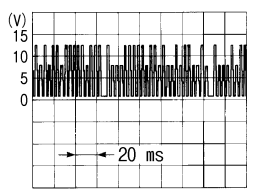
Door motor	Terminals		(-)	Output waveform
	(+) Terminal No.			
	Con-connector	Terminal No.		
Mode (Driver side)	M252	3	Ground	 <p style="text-align: right;">SJIA1453J</p>
Mode (Passenger side)	M255	3		
Upper ventilator	M254	3		
Air mix (Driver side)	M253	3		
Air mix (Passenger side)	M256	3		
Intake	M257	3		

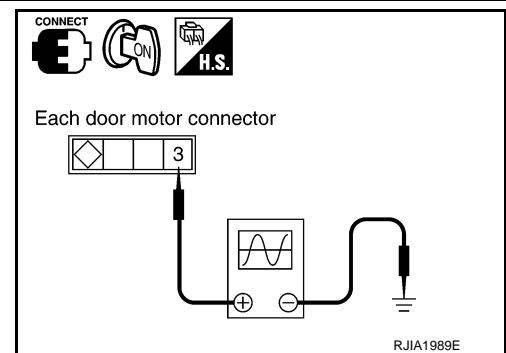

### OK or NG

- OK >> GO TO 5.
- NG >> Repair harness or connector.

A  
B  
C  
D  
E  
F  
G  
H  
I  
ATC  
K  
L  
M  
N  
O  
P

# TROUBLE DIAGNOSIS

## < SERVICE INFORMATION >

### 5. CHECK MOTOR GROUND CIRCUIT

1. Turn ignition switch OFF.
2. Disconnect each door motor connector.
3. Check continuity between each door motor harness connector terminal 2 and ground.

**2 – Ground : Continuity should exist.**

#### OK or NG

- OK >> GO TO 6.  
NG >> Repair harness or connector.

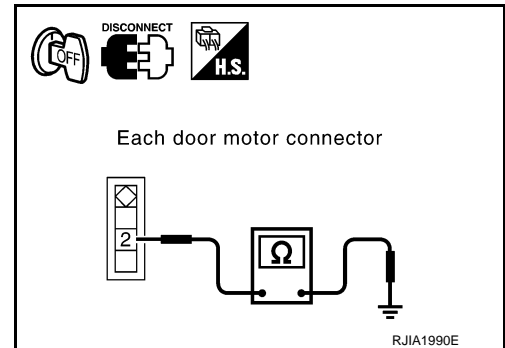

### 6. CHECK MOTOR OPERATION

1. Reconnect each door motor connector.
2. Turn ignition switch ON.
3. Confirm operation of each door motor.

#### OK or NG

- OK >> (Return to operate normally.)  
• Poor contact in motor connector.  
NG >> (Does not operate normally.)  
• GO TO 7.

### 7. CHECK UPPER VENTILATOR DOOR MOTOR, AIR MIX DOOR MOTOR AND INTAKE DOOR MOTOR OPERATION

1. Turn ignition switch OFF.
2. Disconnect mode (driver side, passenger side), upper ventilator, air mix (driver side, passenger side), and intake door motor connectors.
3. Reconnect upper ventilator, air mix (driver side, passenger side) and intake door motor connectors.
4. Turn ignition switch ON.
5. Confirm operation of upper ventilator, air mix door motor (driver side, passenger side) and intake door motor.

#### OK or NG

- OK >> [Upper ventilator, air mix (driver side, passenger side) and intake door motors operate normally.]  
• GO TO 11.  
NG >> [Upper ventilator, air mix (driver side, passenger side) and intake door motors does not operate normally.]  
• GO TO 8.

### 8. CHECK MODE DOOR MOTOR, AIR MIX DOOR MOTOR AND INTAKE DOOR MOTOR OPERATION

1. Turn ignition switch OFF.
2. Disconnect upper ventilator door motor connector.
3. Reconnect mode door motor (driver side, passenger side) connectors.
4. Turn ignition switch ON.
5. Confirm operation of mode door motor (driver side, passenger side), air mix door motor (driver side, passenger side) and intake door motor.

#### OK or NG

- OK >> [Mode (driver side, passenger side), air mix (driver side, passenger side) and intake door motors operate normally.]  
• Replace upper ventilator door motor.  
NG >> [Mode (driver side, passenger side), air mix (driver side, passenger side) and intake door motors does not operate normally.]  
• GO TO 9.

### 9. CHECK MODE DOOR MOTOR, UPPER VENTILATOR DOOR MOTOR AND INTAKE DOOR MOTOR OPERATION



# TROUBLE DIAGNOSIS

## < SERVICE INFORMATION >

---

1. Turn ignition switch OFF.
2. Disconnect air mix door motor (driver side, passenger side) connectors. A
3. Reconnect upper ventilator door motor connector.
4. Turn ignition switch ON.
5. Confirm operation of mode door motor (driver side, passenger side), upper ventilator door motor and intake door motor. B

### OK or NG

- OK >> [Mode (driver side, passenger side), upper ventilator and intake door motors operate normally.] C
- GO TO 12.
- NG >> [Mode (driver side, passenger side), upper ventilator and intake door motors does not operate normally.] D
- GO TO 10.

## 10. CHECK MODE DOOR MOTOR, UPPER VENTILATOR DOOR MOTOR AND AIR MIX DOOR MOTOR OPERATION

---

1. Turn ignition switch OFF. E
2. Disconnect intake door motor connector.
3. Reconnect air mix door motor (driver side, passenger side) connectors.
4. Turn ignition switch ON. F
5. Confirm operation of mode door motor (driver side, passenger side), upper ventilator door motor and air mix door motor (driver side, passenger side). G

### OK or NG

- OK >> [Mode (driver side, passenger side), upper ventilator and air mix door motor (driver side, passenger side) operate normally.] H
- Replace intake door motor.
- NG >> [Mode (driver side, passenger side), upper ventilator and air mix door motor (driver side, passenger side) does not operate normally.] I
- Replace unified meter and A/C amp.

## 11. CHECK MODE DOOR MOTOR OPERATION

---

1. Turn ignition switch OFF.
2. Reconnect mode door motor (passenger side) connector. ATC
3. Turn ignition switch ON.
4. Confirm operation of mode door motor (passenger side).

### OK or NG

- OK >> [Mode door motor (passenger side) operates normally.] K
- Replace mode door motor (driver side).
- NG >> [Mode door motor (passenger side) does not operate normally.] L
- Replace mode door motor (passenger side).

## 12. CHECK AIR MIX DOOR MOTOR OPERATION

---

1. Turn ignition switch OFF. M
2. Reconnect air mix door motor (passenger side) connector.
3. Turn ignition switch ON.
4. Confirm operation of air mix door motor (passenger side). N

### OK or NG

- OK >> [Air mix door motor (passenger side) operates normally.] O
- Replace air mix door motor (driver side).
- NG >> [Air mix door motor (passenger side) does not operate normally.] P
- Replace air mix door motor (passenger side).

## Mode Door Motor Circuit

INFOID:000000005348522

### SYMPTOM

- Air outlet does not change.
- Mode door motor does not operate normally.

### INSPECTION FLOW

# TROUBLE DIAGNOSIS

## < SERVICE INFORMATION >

1. Confirm symptom by performing the following operational check.

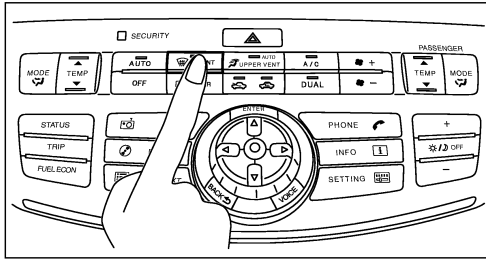

### OPERATIONAL CHECK – Discharge air

- Press MODE switch and DEF switch.
  - Each position indicator should change shape.
  - Confirm that discharge air comes out according to the air distribution table at below.
- Refer to "Discharge Air Flow" (\*1).

#### NOTE:

- If OK (symptom cannot be duplicated), perform complete operational check (\*2).
- If NG (symptom is confirmed), continue with STEP-2 following.
- Confirm that the compressor clutch is engaged (Sound or visual inspection) and intake door position is at FRESH when DEF or D/F is selected.

Discharge air flow							
Mode position indication		Condition	Air outlet/distribution				
Driver side	Passenger side		VENT		FOOT		DEF
			Front	Rear	Front	Rear	
		DUAL switch: OFF Upper ventilator door: SHUT Rear ventilator door: OPEN	85%	15%	—	—	—
			47%	14%	23%	16%	—
			10%	9%	35%	23%	23%
			10%	8%	27%	19%	36%
			—	—	—	—	100%

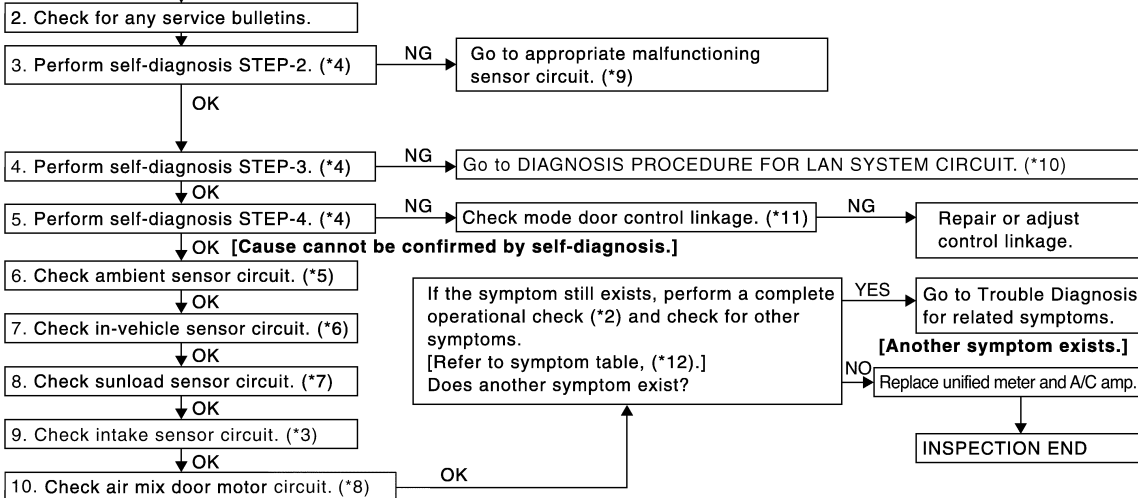

JSIIA0908GB

- |   |   |  |
|---|---|--|
| *1 <a href="#">ATC-31, "Discharge Air Flow"</a>                       | *2 <a href="#">ATC-56, "Operational Check"</a>          | *3 <a href="#">ATC-105, "Intake Sensor Circuit"</a>  |
| *4 <a href="#">ATC-48, "Self-Diagnosis Function", see No. 2 to 6.</a> | *5 <a href="#">ATC-97, "Ambient Sensor Circuit"</a>     | *6 <a href="#">ATC-99, "In-vehicle Sensor Circuit"</a>                                       |
| *7 <a href="#">ATC-102, "Sunload Sensor Circuit"</a>                  | *8 <a href="#">ATC-71, "Air Mix Door Motor Circuit"</a> | *9 <a href="#">ATC-48, "Self-Diagnosis Function", see No. 13.</a>                            |
| *10 <a href="#">ATC-62, "LAN System Circuit"</a>                      | *11 <a href="#">ATC-124, "Removal and Installation"</a> | *12 <a href="#">ATC-34, "How to Perform Trouble Diagnosis for Quick and Accurate Repair"</a> |

## SYSTEM DESCRIPTION

### Component Parts

# TROUBLE DIAGNOSIS

## < SERVICE INFORMATION >

Mode door control system components are:

- Unified meter and A/C amp.
- Mode door motor (LCU)
- A/C LAN system (PBR built-in mode door motor, upper ventilator door motor, air mix door motor and intake door motor)
- In-vehicle sensor
- Ambient sensor
- Sunload sensor
- Intake sensor

### System Operation

- The unified meter and A/C amp. receives data from each of the sensors. The unified meter and A/C amp. sends air mix door, mode door, upper ventilator door and intake door opening angle data to the air mix door motor LCUs, mode door motor LCUs, upper ventilator door motor LCU and intake door motor LCU.
- The air mix door motors, mode door motors, upper ventilator door motor and intake door motor read their respective signals according to the address signal. Opening angle indication signals received from the unified meter and A/C amp. and each of the motor position sensors are compared by the LCUs in each door motor with the existing decision and opening angles.
- Subsequently, HOT/COLD, DEF/VENT, OPEN/SHUT and FRE/REC operation is selected. The new selection data are returned to the unified meter and A/C amp.

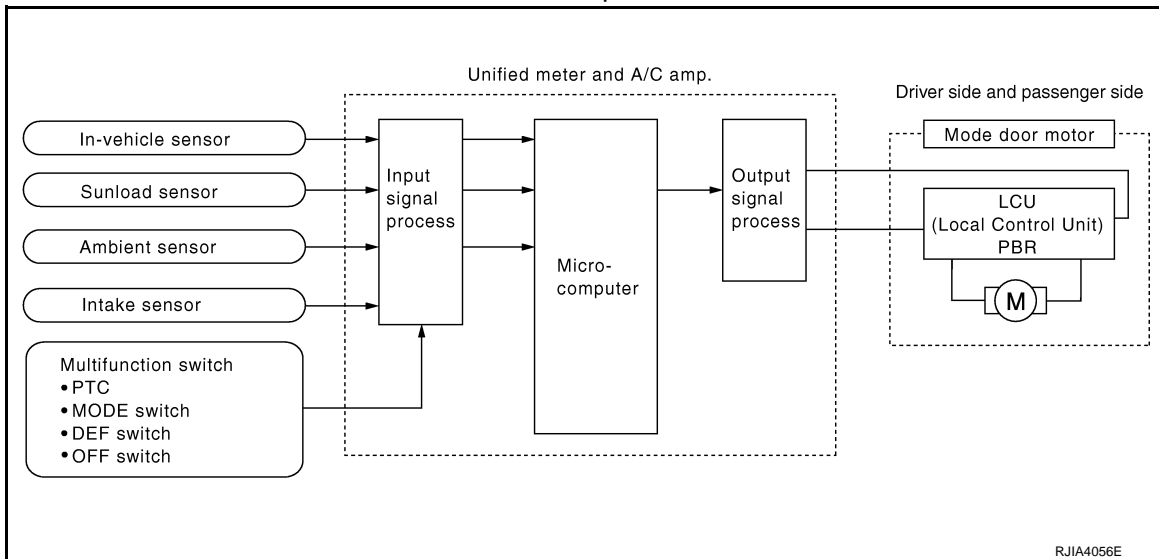

### Mode Door Control Specification

Mode position can be selected manually by pressing MODE switch or DEF switch of the preset switch. This enables to fix a mode position. Automatic control by unified meter and A/C amp. Pressing AUTO switch allows automatic control by unified meter and A/C amp. During the automatic control of mode position, a mode door position (VENT, B/L, FOOT, or D/F) is selected based on a target air mix door opening angle and sunload depending on a temperature calculated by unified meter and A/C amp. In addition, D/F is selected to prevent windshield fogging only when ambient temperature is extremely low with mode position FOOT.

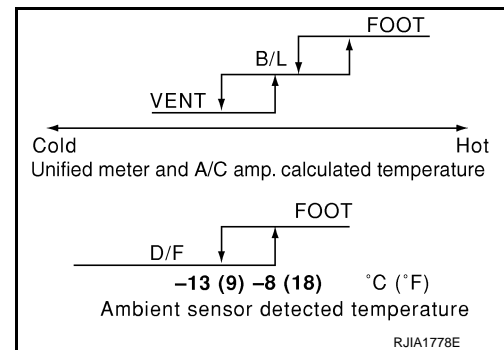

## COMPONENT DESCRIPTION

### Mode Door Motor

# TROUBLE DIAGNOSIS

## < SERVICE INFORMATION >

The mode door motors are attached to the heater & cooling unit assembly. It rotates so that air is discharged from the outlet set by the unified meter and A/C amp. Motor rotation is conveyed to a link which activates the mode door.

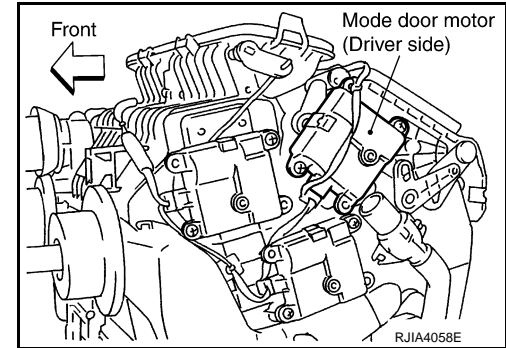
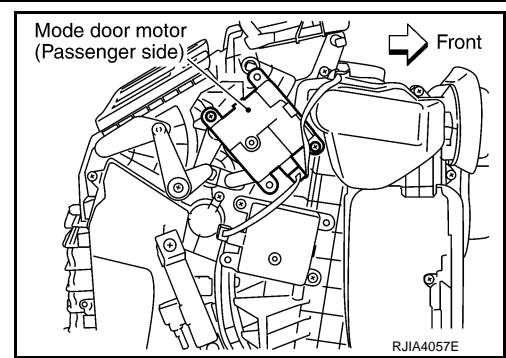

## DIAGNOSIS PROCEDURE FOR MODE DOOR MOTOR

SYMPTOM: Mode door motor does not operate normally.

Perform diagnosis procedure. Refer to [ATC-62. "LAN System Circuit"](#).

## Upper Ventilator Door Motor Circuit

INFOID:000000005348523

### SYMPTOM

- Upper ventilator outlet does not change.
- Upper ventilator door motor does not operate normally.

## INSPECTION FLOW

# TROUBLE DIAGNOSIS

## < SERVICE INFORMATION >

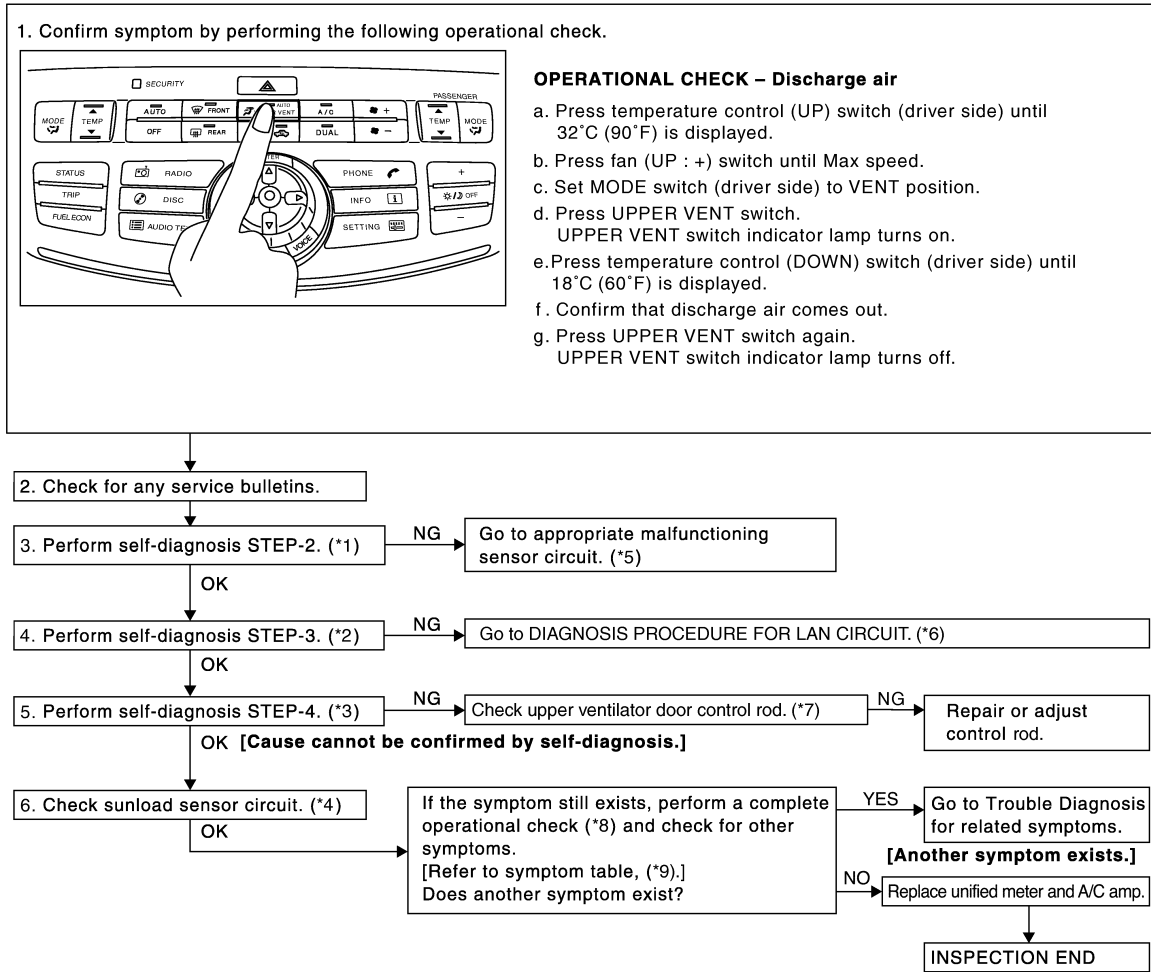

JPIIA0518GB

\*1 [ATC-48, "Self-Diagnosis Function"](#), see No. 2.

\*2 [ATC-48, "Self-Diagnosis Function"](#), see No. 5.

\*3 [ATC-48, "Self-Diagnosis Function"](#), see No. 6.

\*4 [ATC-102, "Sunload Sensor Circuit"](#)

\*5 [ATC-48, "Self-Diagnosis Function"](#), see No. 13.

\*6 [ATC-62, "LAN System Circuit"](#)

\*7 [ATC-126, "Removal and Installation"](#)

\*8 [ATC-56, "Operational Check"](#)

\*9 [ATC-34, "How to Perform Trouble Diagnosis for Quick and Accurate Repair"](#)

## SYSTEM DESCRIPTION

### Component Parts

Upper ventilator door control system components are:

- Unified meter and A/C amp.
- Upper ventilator door motor (LCU)
- A/C LAN system (PBR built-in mode door motor, upper ventilator door motor, air mix door motor and intake door motor)
- Sunload sensor

### System Operation

- The unified meter and A/C amp. receives data from each of the sensors. The unified meter and A/C amp. sends air mix door, mode door, upper ventilator door and intake door opening angle data to the air mix door motor LCUs, mode door motor LCUs, upper ventilator door motor LCU and intake door motor LCU.
- The air mix door motors, mode door motors, upper ventilator door motor and intake door motor read their respective signals according to the address signal. Opening angle indication signals received from the uni-

# TROUBLE DIAGNOSIS

## < SERVICE INFORMATION >

fied meter and A/C amp. and each of the motor position sensors are compared by the LCUs in each door motor with the existing decision and opening angles.

- Subsequently, HOT/COLD, DEF/VENT, OPEN/SHUT and FRE/REC operation is selected. The new selection data are returned to the unified meter and A/C amp.

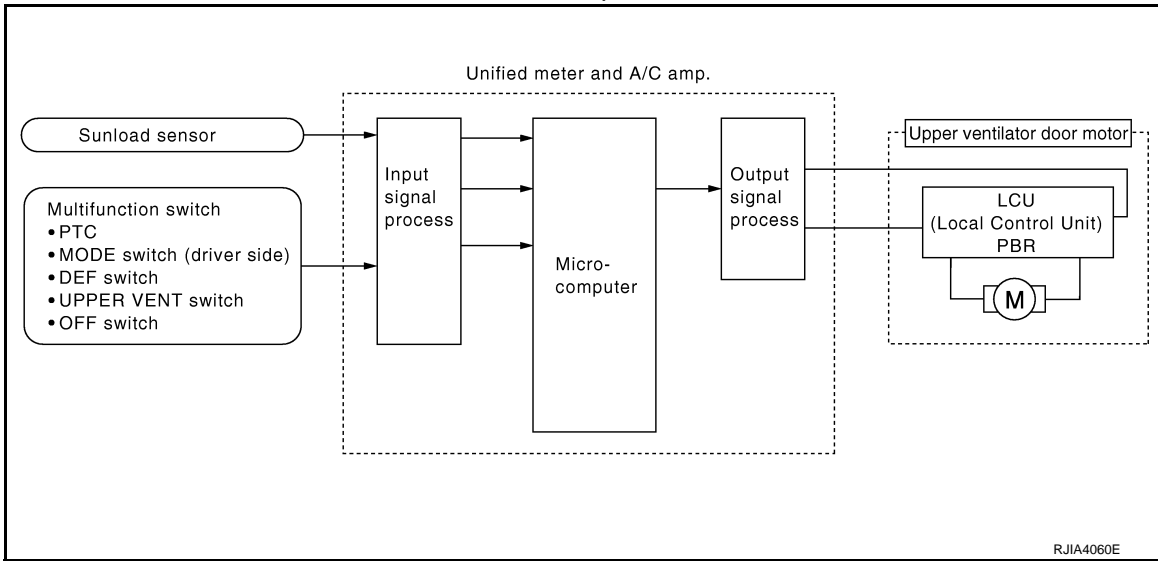

### Upper Ventilator Door Control Specification

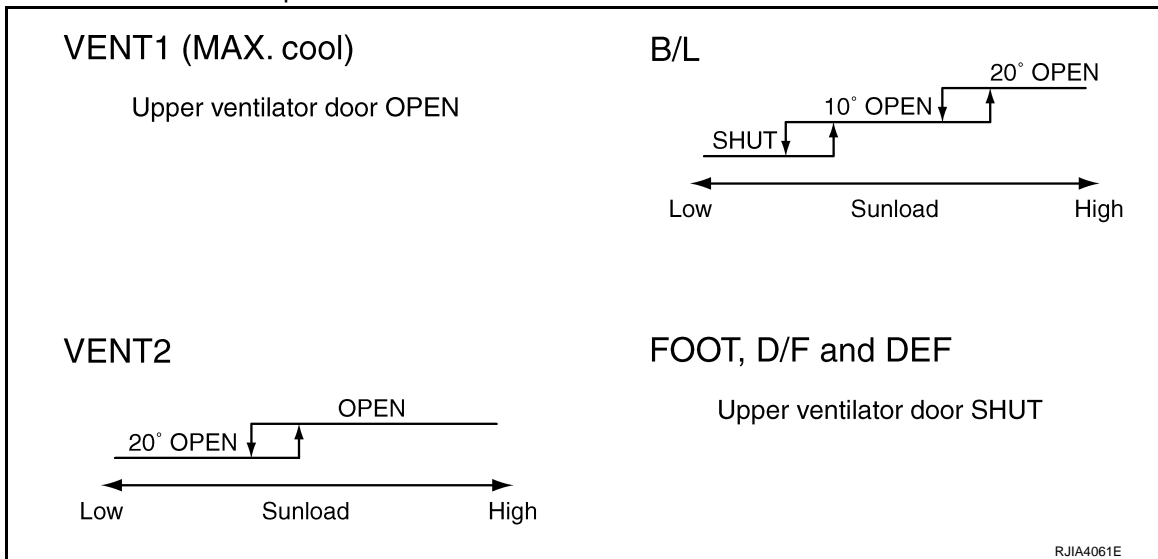

## COMPONENT DESCRIPTION

### Upper Ventilator Door Motor

The upper ventilator door motor is attached to the heater & cooling unit assembly. It rotates so that air is discharged from the outlet set by the unified meter and A/C amp. Motor rotation is conveyed to a rod which activates the upper ventilator door.

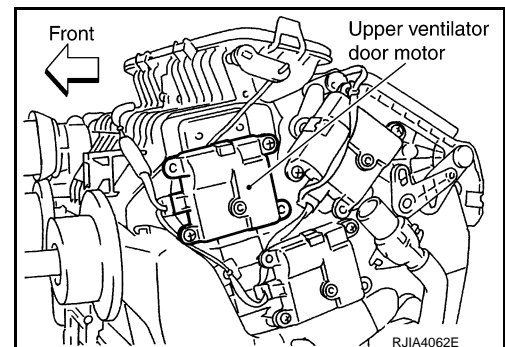

## DIAGNOSIS PROCEDURE FOR UPPER VENTILATOR DOOR MOTOR

SYMPTOM: Upper ventilator door motor does not operate normally.  
Perform diagnosis procedure. Refer to [ATC-62. "LAN System Circuit"](#).

# TROUBLE DIAGNOSIS

< SERVICE INFORMATION >

## Air Mix Door Motor Circuit

INFOID:000000005348524

### SYMPTOM

- Discharge air temperature does not change.
- Air mix door motor does not operate normally.

### INSPECTION FLOW

1. Confirm symptom by performing the following operational check.

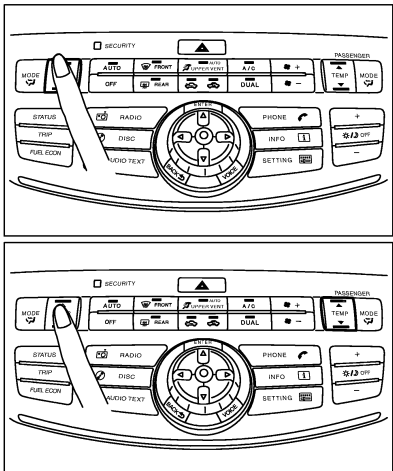

**OPERATIONAL CHECK**

**Temperature increase**

- Press temperature control (UP) switch (driver side) until 32°C (90°F) is displayed.
- Check for hot air at discharge air outlets.

**Temperature decrease**

- Press temperature control (DOWN) switch (driver side) until 18°C (60°F) is displayed.
- Check for cold air at discharge air outlets.

**If OK (symptom cannot be duplicated), perform complete operational check (\*8).  
If NG (symptom is confirmed), continue with STEP-2 following.**

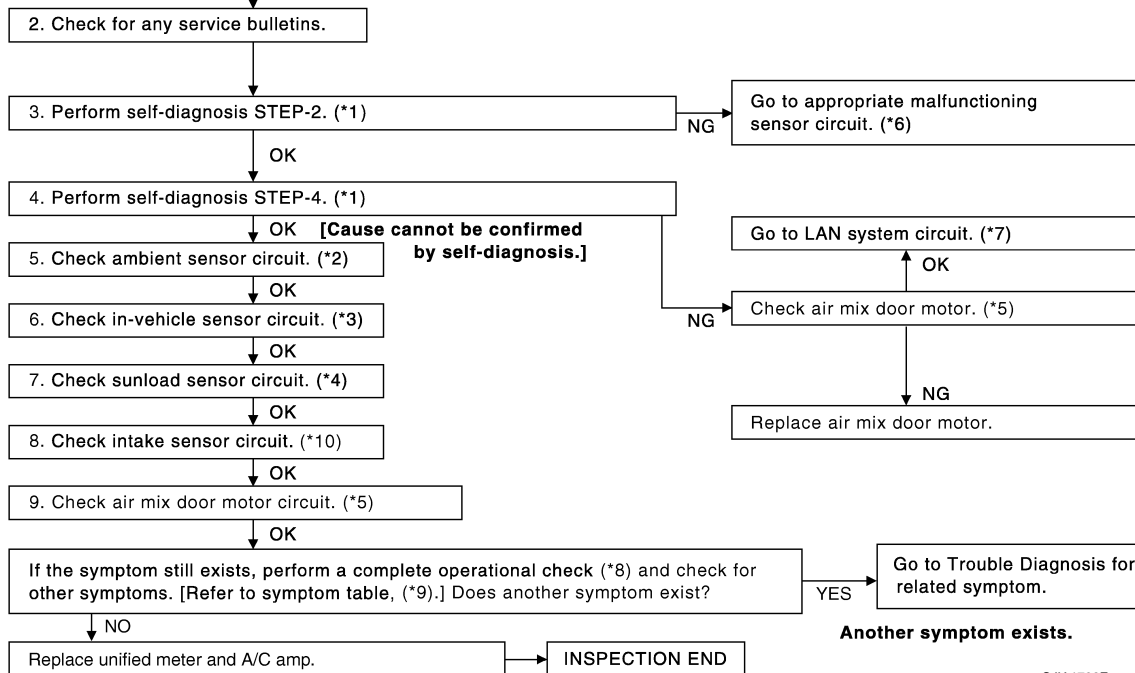

\*1 [ATC-48, "Self-Diagnosis Function"](#), see No. 2 to 6.

\*4 [ATC-102, "Sunload Sensor Circuit"](#)

\*7 [ATC-62, "LAN System Circuit"](#)

\*10 [ATC-105, "Intake Sensor Circuit"](#)

\*2 [ATC-97, "Ambient Sensor Circuit"](#)

\*5 "Air Mix Door Motor Circuit"

\*8 [ATC-56, "Operational Check"](#)

\*3 [ATC-99, "In-vehicle Sensor Circuit"](#)

\*6 [ATC-48, "Self-Diagnosis Function"](#), see No. 13.

\*9 [ATC-34, "How to Perform Trouble Diagnosis for Quick and Accurate Repair"](#)

SJIA1762E

### SYSTEM DESCRIPTION

#### Component Parts

Revision: 2009 June

**ATC-71**

2010 M35/M45

A

B

C

D

E

F

G

H

I

ATC

K

L

M

N

O

P

# TROUBLE DIAGNOSIS

## < SERVICE INFORMATION >

Air mix door control system components are:

- Unified meter and A/C amp.
- Air mix door motor (LCU)
- A/C LAN system (PBR built-in mode door motor, upper ventilator door motor, air mix door motor and intake door motor)
- In-vehicle sensor
- Ambient sensor
- Sunload sensor
- Intake sensor

### System Operation

- The unified meter and A/C amp. receives data from each of the sensors. The unified meter and A/C amp. sends air mix door, mode door, upper ventilator door and intake door opening angle data to the air mix door motor LCUs, mode door motor LCUs, upper ventilator door motor LCU and intake door motor LCU.
- The air mix door motors, mode door motors, upper ventilator door motor and intake door motor read their respective signals according to the address signal. Opening angle indication signals received from the unified meter and A/C amp. and each of the motor position sensors are compared by the LCUs in each door motor with the existing decision and opening angles.
- Subsequently, HOT/COLD, DEF/VENT, OPEN/SHUT and FRE/REC operation is selected. The new selection data are returned to the unified meter and A/C amp.

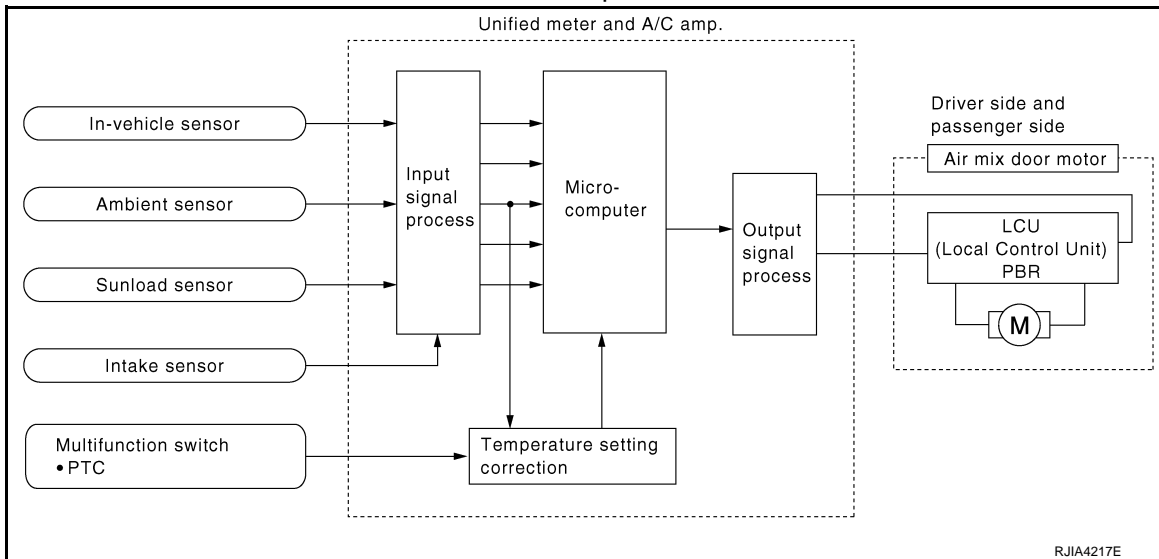

### Air Mix Door Control Specification

When ignition switch is ON, unified meter and A/C amp. continuously and automatically controls temperatures regardless of air conditioner operational condition. When setting a target temperature with temperature control switch, unified meter and A/C amp. corrects the set temperature and decides a target air mix door opening angle. Unified meter and A/C amp. controls air mix door according to the target air mix door opening angle and current air mix door opening angle for keeping an optimum air mix door opening angle. When a temperature is set at 18°C (60°F), air mix door is fixed at full cold, and when a temperature is set at 32°C (90°F), it is set at full hot.

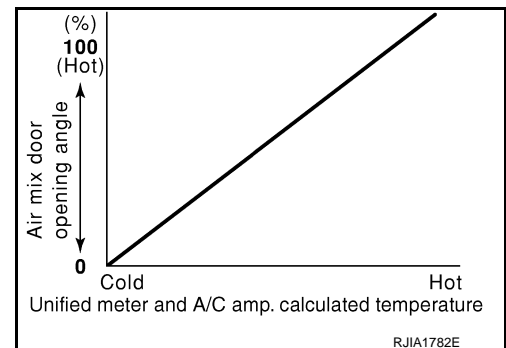

## COMPONENT DESCRIPTION

### Air Mix Door Motor



# TROUBLE DIAGNOSIS

## < SERVICE INFORMATION >

The air mix door motors are attached to the heater & cooling unit assembly. It rotates so that the air mix door is opened or closed to a position set by the unified meter and A/C amp. Motor rotation is then conveyed through a shaft and the air mix door position feedback is then sent to the unified meter and A/C amp. by PBR built-in air mix door motor.

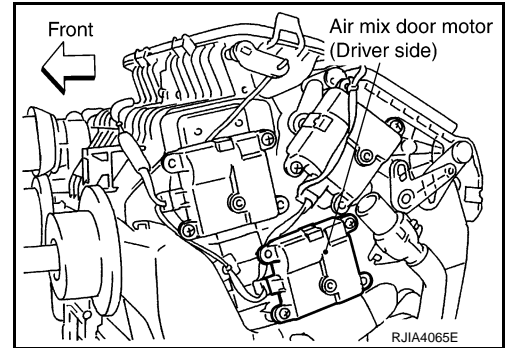
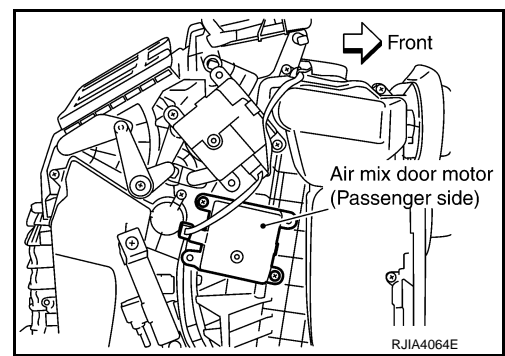

### DIAGNOSIS PROCEDURE FOR AIR MIX DOOR MOTOR

SYMPTOM: Discharge air temperature does not change.

Perform diagnosis procedure. Refer to [ATC-62, "LAN System Circuit"](#).

### Air Mix Door Motor PBR Circuit

INFOID:000000005348525

#### SYMPTOM

- Discharge air temperature does not change.
- PBR circuit is open or shorted.

### DIAGNOSIS PROCEDURE FOR AIR MIX DOOR MOTOR PBR

Perform diagnosis procedure. Refer to [ATC-62, "LAN System Circuit"](#).

### Intake Door Motor Circuit

INFOID:000000005348526

#### SYMPTOM

- Intake door does not change.
- Intake door motor does not operate normally.

### INSPECTION FLOW

A  
B  
C  
D  
E  
F  
G  
H  
I  
K  
L  
M  
N  
O  
P

ATC

# TROUBLE DIAGNOSIS

## < SERVICE INFORMATION >

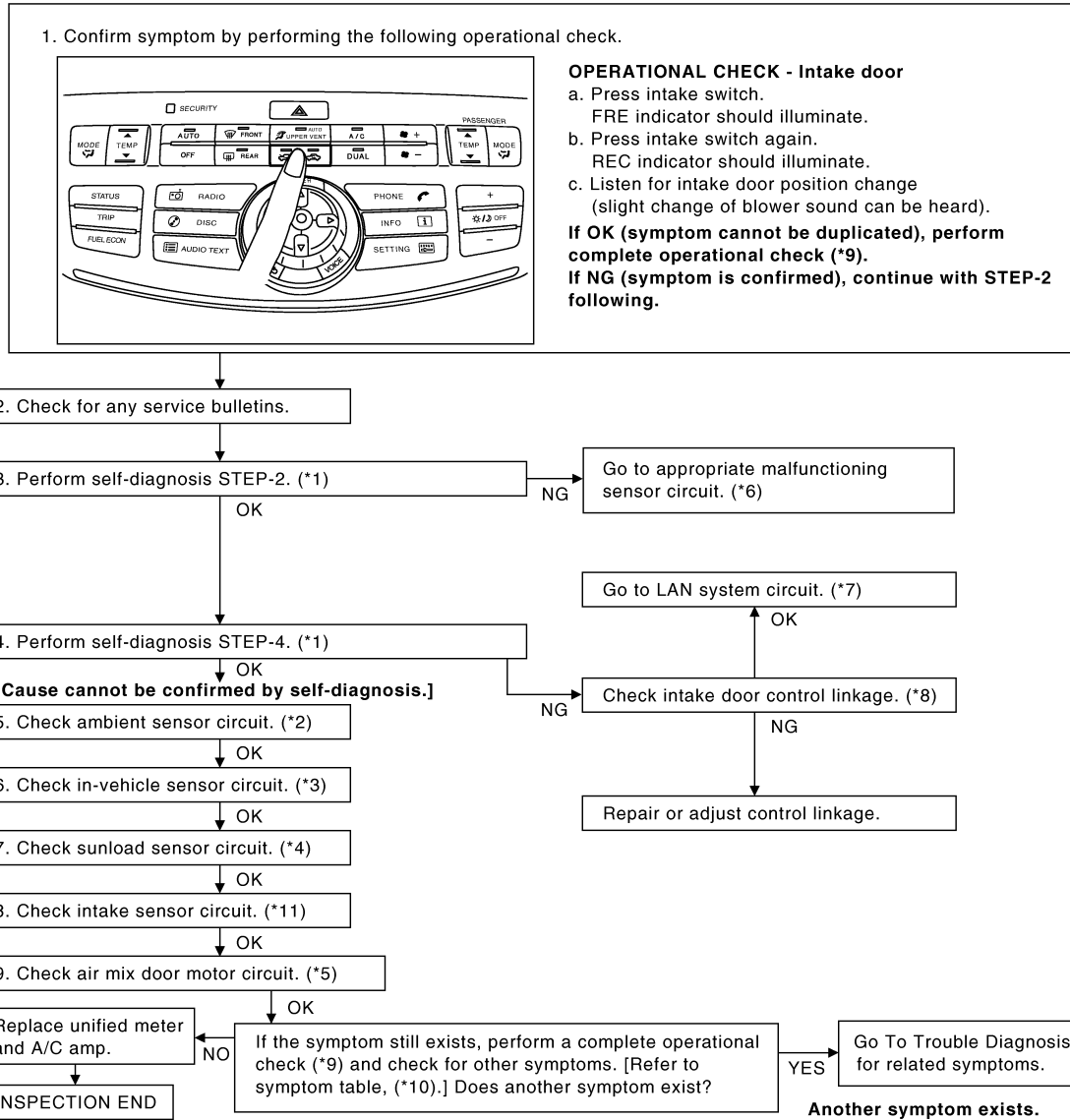

RJA4066E

- |  |   |   |
|--|---|---|
| *1 <a href="#">ATC-48, "Self-Diagnosis Function",</a> see No. 2 to 6.                        | *2 <a href="#">ATC-97, "Ambient Sensor Circuit"</a>     | *3 <a href="#">ATC-99, "In-vehicle Sensor Circuit"</a>            |
| *4 <a href="#">ATC-102, "Sunload Sensor Circuit"</a>   | *5 <a href="#">ATC-71, "Air Mix Door Motor Circuit"</a> | *6 <a href="#">ATC-48, "Self-Diagnosis Function",</a> see No. 13. |
| *7 <a href="#">ATC-62, "LAN System Circuit"</a>  | *8 <a href="#">ATC-117, "Removal and Installation"</a>  | *9 <a href="#">ATC-56, "Operational Check"</a>                    |
| *10 <a href="#">ATC-34, "How to Perform Trouble Diagnosis for Quick and Accurate Repair"</a> | *11 <a href="#">ATC-105, "Intake Sensor Circuit"</a>    |   |

## SYSTEM DESCRIPTION

### Component Parts

Intake door control system components are:

- Unified meter and A/C amp.
- Intake door motor (LCU)
- A/C LAN system (PBR built-in mode door motor, upper ventilator door motor, air mix door motor and intake door motor)

# TROUBLE DIAGNOSIS

## < SERVICE INFORMATION >

- In-vehicle sensor
- Ambient sensor
- Sunload sensor
- Intake sensor

### System Operation

The intake door control determines intake door position based on the ambient temperature, the intake air temperature and the in-vehicle temperature. When shifting mode position D/F, when the DEF or OFF switches are pressed, or when A/C switch is OFF, the unified meter and A/C amp. sets the intake door at the FRE position.

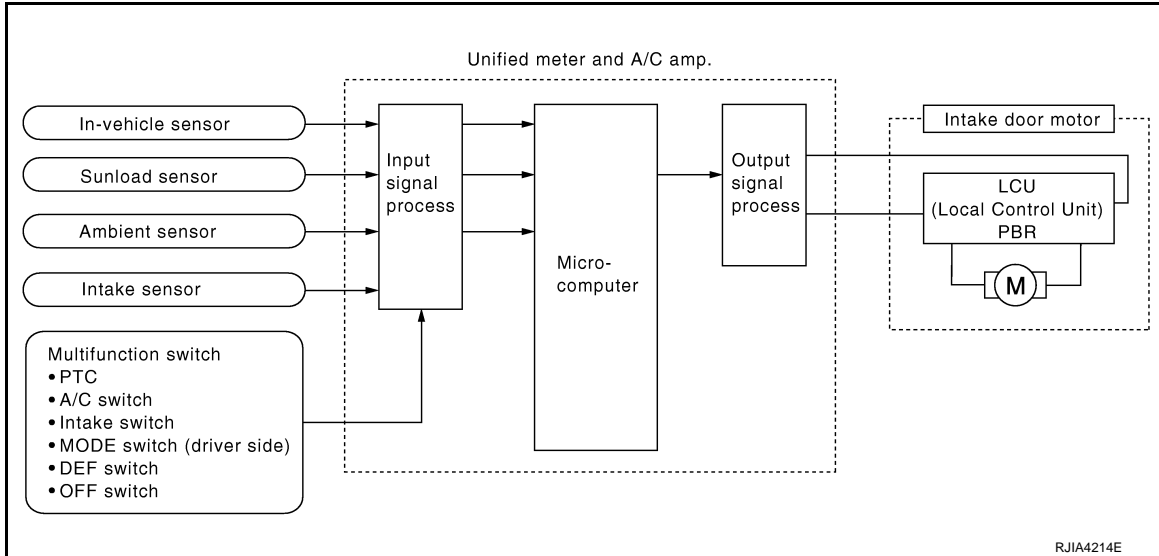

### Intake Door Control Specification

- Intake door position is basically fixed at FRE when FRE indicator of FRE switch is ON or DEF switch is ON.
- Intake door position is basically fixed at REC when REC indicator of REC switch is ON.
- Intake door automatic control selects FRE, 20 – 80% FRE, or REC depending on a target air mix door opening angle, based on in-vehicle temperature, ambient temperature, and sunload amount.

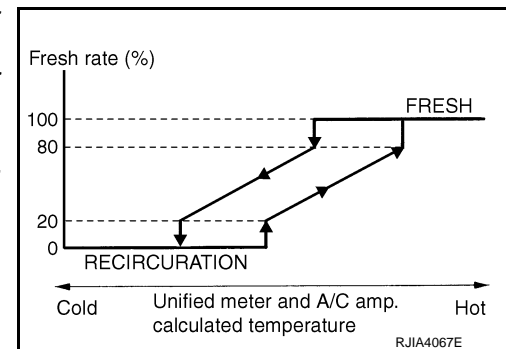

## COMPONENT DESCRIPTION

### Intake Door Motor

The intake door motor is attached to the blower unit. It rotates so that air is drawn from inlets set by the unified meter and A/C amp. Motor rotation is conveyed to a lever which activates the intake door.

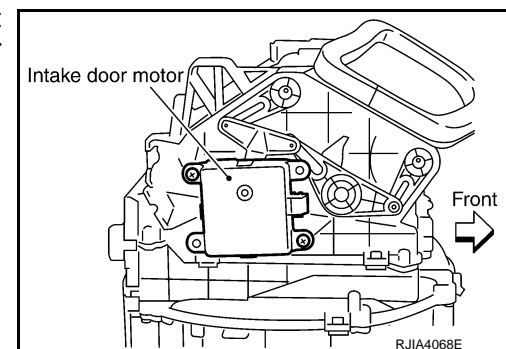

## DIAGNOSIS PROCEDURE FOR INTAKE DOOR MOTOR

SYMPTOM: Intake door motor does not operate normally.

Perform diagnosis procedure. Refer to [ATC-62. "LAN System Circuit"](#).

# TROUBLE DIAGNOSIS

< SERVICE INFORMATION >

## Blower Motor Circuit

INFOID:000000005348527

SYMPTOM: Blower motor operation is malfunctioning.

### INSPECTION FLOW

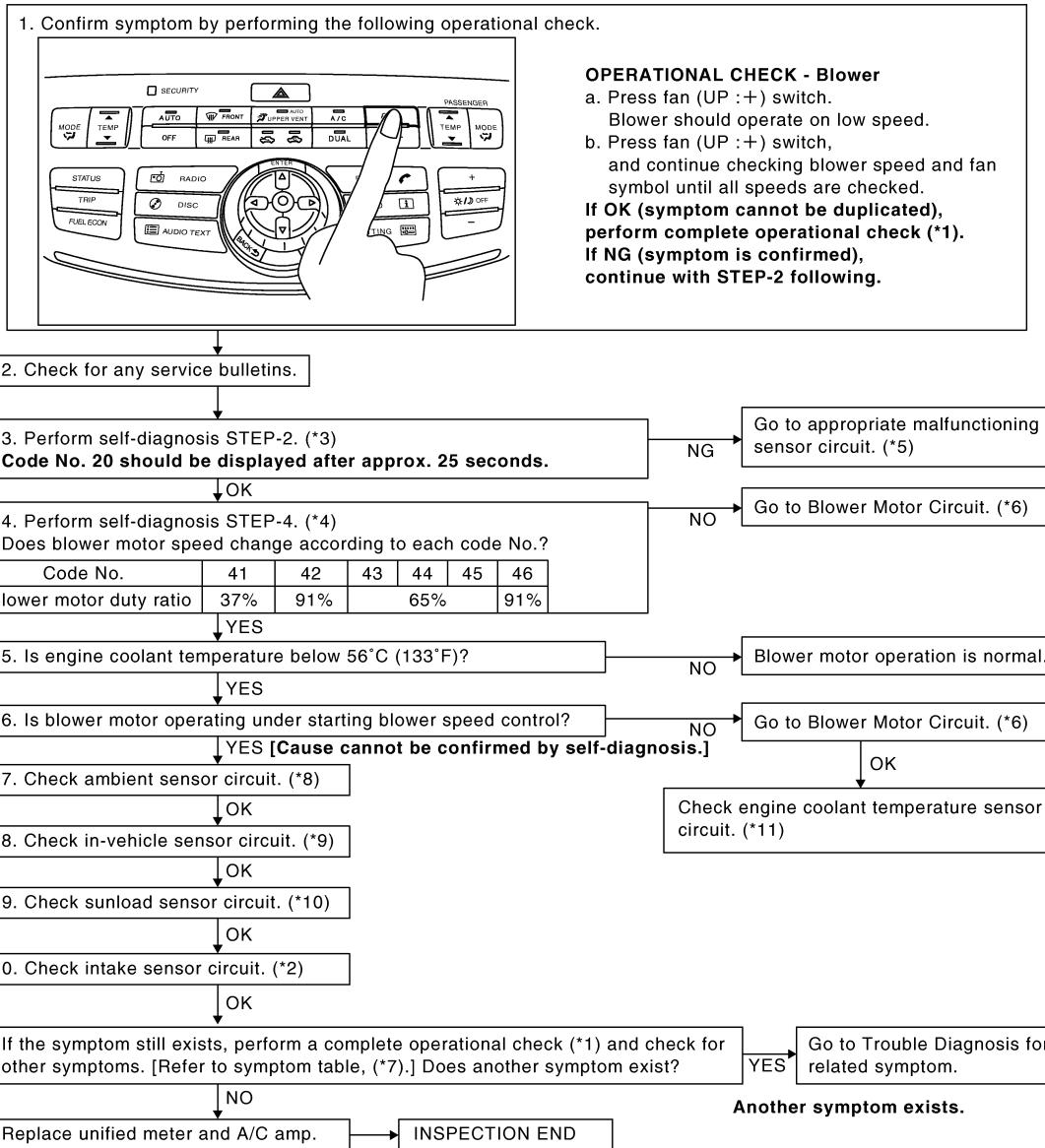

RJIA4069E

\*1 [ATC-56, "Operational Check"](#)

\*2 [ATC-105, "Intake Sensor Circuit"](#)

\*3 [ATC-48, "Self-Diagnosis Function", see No. 2.](#)

\*4 [ATC-48, "Self-Diagnosis Function", see No. 6.](#)

\*5 [ATC-48, "Self-Diagnosis Function", see No. 13.](#)

\*6 "DIAGNOSIS PROCEDURE FOR BLOWER MOTOR"

\*7 [ATC-34, "How to Perform Trouble Diagnosis for Quick and Accurate Repair"](#)

\*8 [ATC-97, "Ambient Sensor Circuit"](#)

\*9 [ATC-99, "In-vehicle Sensor Circuit"](#)

\*10 [ATC-102, "Sunload Sensor Circuit"](#)

\*11 [EC-219, "Diagnosis Procedure" \(VQ35HR\) or EC-900, "Diagnosis Procedure" \(VK45DE\)](#)

## SYSTEM DESCRIPTION

### Component Parts

# TROUBLE DIAGNOSIS

## < SERVICE INFORMATION >

Fan speed control system components are:

- Unified meter and A/C amp.
- A/C LAN system (PBR built-in mode door motor, upper ventilator door motor, air mix door motor and intake door motor)
- In-vehicle sensor
- Ambient sensor
- Sunload sensor
- Intake sensor

### System Operation

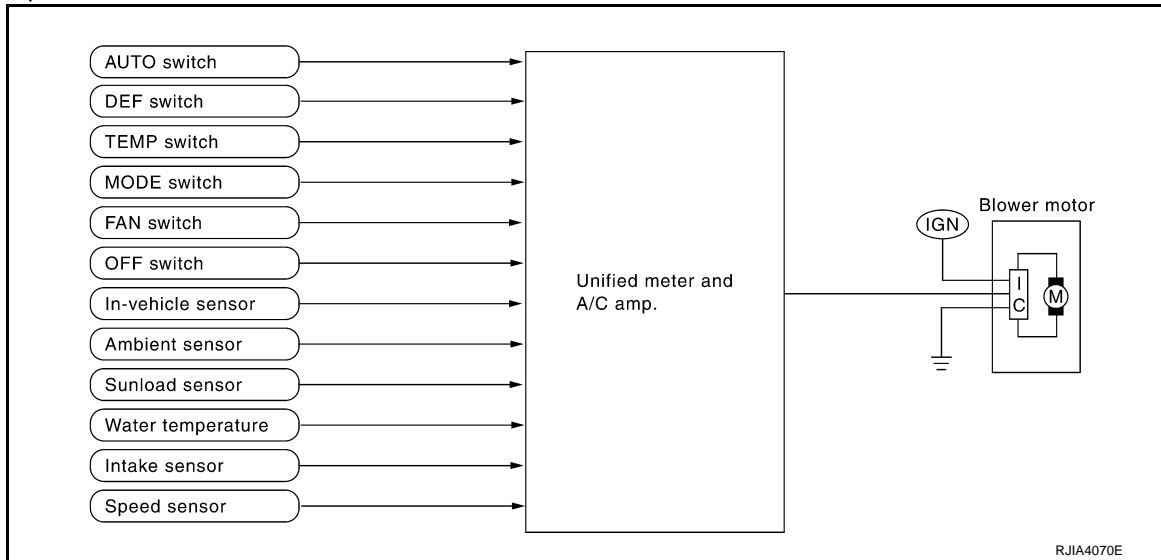

### Automatic Mode

In the automatic mode, the blower motor speed is calculated by the unified meter and A/C amp. based on the input from the PBR, in-vehicle sensor, sunload sensor, intake sensor and ambient sensor.

When the air flow is increased, the duty ratio of the blower fan motor's drive signal is changed at 8%/sec. to prevent a sudden increase in air flow.

In addition to manual air flow control and the usual automatic air flow control, starting air flow control, low water temperature starting control and high passenger compartment temperature starting control are available.

### Starting Fan Speed Control

#### Start up from COLD SOAK Condition (Automatic mode)

In a cold start up condition where the engine coolant temperature is below 56°C (133°F), the blower will not operate for a short period of time (up to 150 seconds). The exact start delay time varies depending on the ambient and engine coolant temperature.

In the most extreme case (very low ambient) the blower starting delay will be 150 seconds as described above. After this delay, the blower will operate at low speed until the engine coolant temperature rises above 56°C (133°F), and then the fan speed will increase to the objective speed.

#### Start up from usual or HOT SOAK Condition (Automatic mode)

The blower will begin operation momentarily after the AUTO switch is pressed. The fan speed will gradually rise to the objective speed over a time period of 3 seconds or less (actual time depends on the objective fan speed).

### Fan Speed Compensation

#### Sunload

When the in-vehicle temperature and the set temperature are very close, the blower will be operating at low speed. The low speed will vary depending on the sunload. During conditions of low or no sunload, the fan speed is at duty ratio 25%. During high sunload conditions, the unified meter and A/C amp. raise the fan speed (duty ratio 49%).

# TROUBLE DIAGNOSIS

## < SERVICE INFORMATION >

### Fan Speed Control Specification

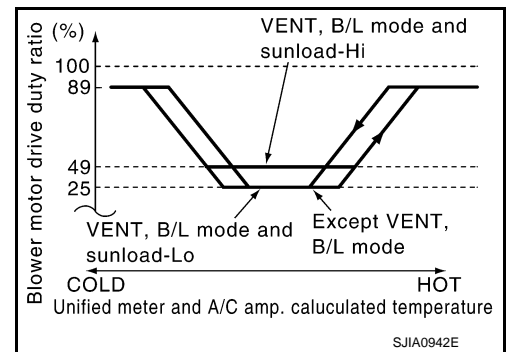

## COMPONENT DESCRIPTION

### Brush-less Motor

The blower motor utilizes a brush-less motor with a rotating magnet. Quietness is improved over previous motors where the brush was the point of contact and the coil rotated.

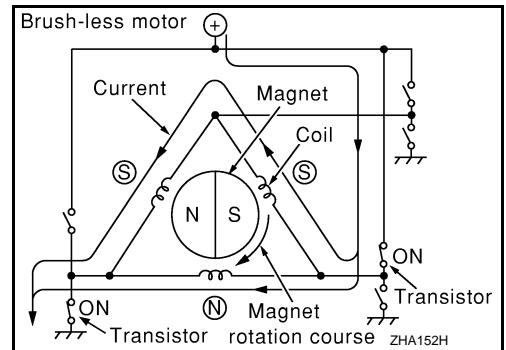

## DIAGNOSIS PROCEDURE FOR BLOWER MOTOR

SYMPTOM: Blower motor operation is malfunctioning.

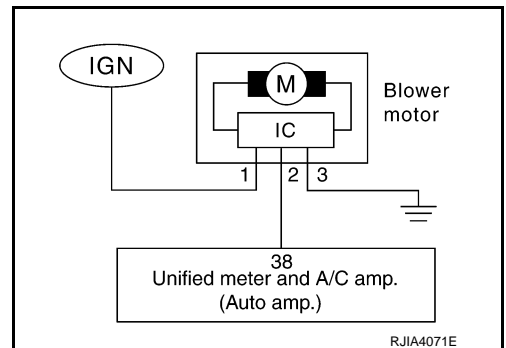

## 1. CHECK POWER SUPPLY FOR BLOWER MOTOR

1. Disconnect blower motor connector.
2. Turn ignition switch ON.
3. Check voltage between blower motor harness connector M91 terminal 1 and ground.

**1 – Ground** : **Battery voltage**

### OK or NG

- OK >> GO TO 2.
- NG >> Check power supply circuit and 15A fuses [Nos. 10 and 11, located in the fuse block (J/B)]. Refer to [PG-84. "Terminal Arrangement"](#).
- If fuses are OK, check harness for open circuit. Repair or replace if necessary.
  - If fuses are NG, check harness for short circuit and replace fuse.

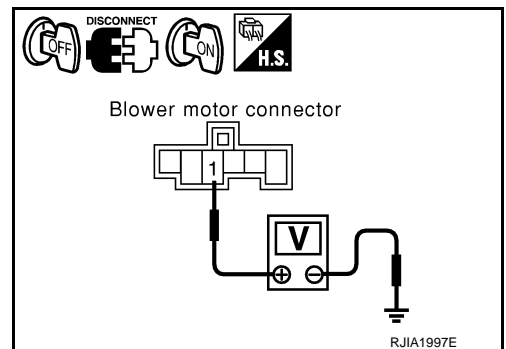

## 2. CHECK BLOWER MOTOR GROUND CIRCUIT

1. Turn ignition switch OFF.

# TROUBLE DIAGNOSIS

## < SERVICE INFORMATION >

- Check continuity between blower motor harness connector M91 terminal 3 and ground.

**3 – Ground : Continuity should exist.**

### OK or NG

- OK >> GO TO 3.
- NG >> Repair harness or connector.

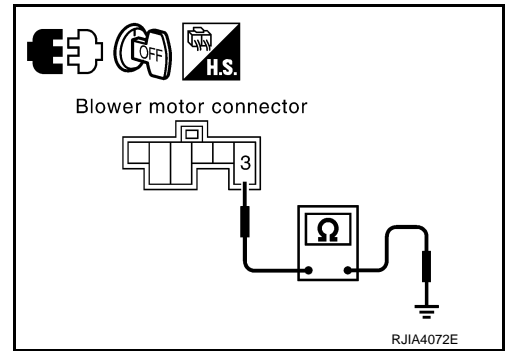

## 3. CHECK CIRCUIT CONTINUITY BETWEEN BLOWER MOTOR AND UNIFIED METER AND A/C AMP.

- Disconnect unified meter and A/C amp. connector.
- Check continuity between blower motor harness connector M91 terminal 2 and unified meter and A/C amp. harness connector M64 terminal 38.

**2 – 38 : Continuity should exist.**

### OK or NG

- OK >> GO TO 4.
- NG >> Repair harness or connector.

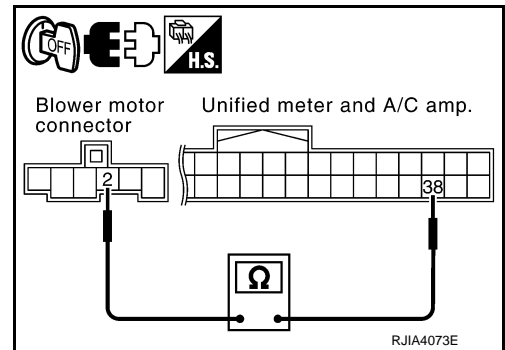

## 4. CHECK UNIFIED METER AND A/C AMP. OUTPUT SIGNAL

- Reconnect blower motor connector and unified meter and A/C amp. connector.
- Turn ignition switch ON.
- Set MODE switch to VENT position.
- Change fan speed from 1 to 7, and check duty ratios between blower motor harness connector and ground by using an oscilloscope.

### NOTE:

Calculate the drive signal duty ratio as shown in the figure.  
 $T_2 = 1.6 \text{ ms}$

Blower motor		Fan speed (manual)	Duty ratio (Approx.)
Connector	Terminal		
M91	2	1st	25 %
		2nd	33 %
		3rd	41 %
		4th	51 %
		5th	61 %
		6th	71 %
		7th	85 %

Condition: VENT mode

### OK or NG

- OK >> Replace blower motor after confirming the fan air flow does not change.
- NG >> Replace unified meter and A/C amp.

## COMPONENT INSPECTION

Blower Motor

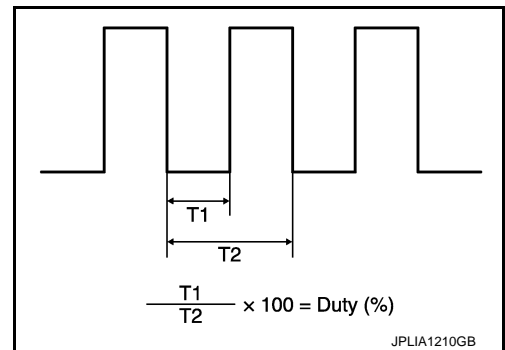

A  
B  
C  
D  
E  
F  
G  
H  
I  
K  
L  
M  
N  
O  
P

ATC

# TROUBLE DIAGNOSIS

## < SERVICE INFORMATION >

Confirm smooth rotation of the blower motor.

- Ensure that there are no foreign particles inside the blower unit.

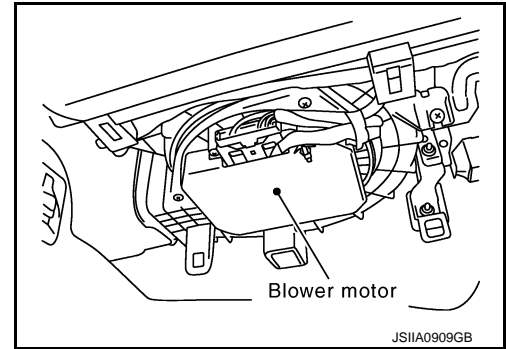

## Magnet Clutch Circuit

INFOID:000000005348528

SYMPTOM: Magnet clutch does not engage.

## INSPECTION FLOW

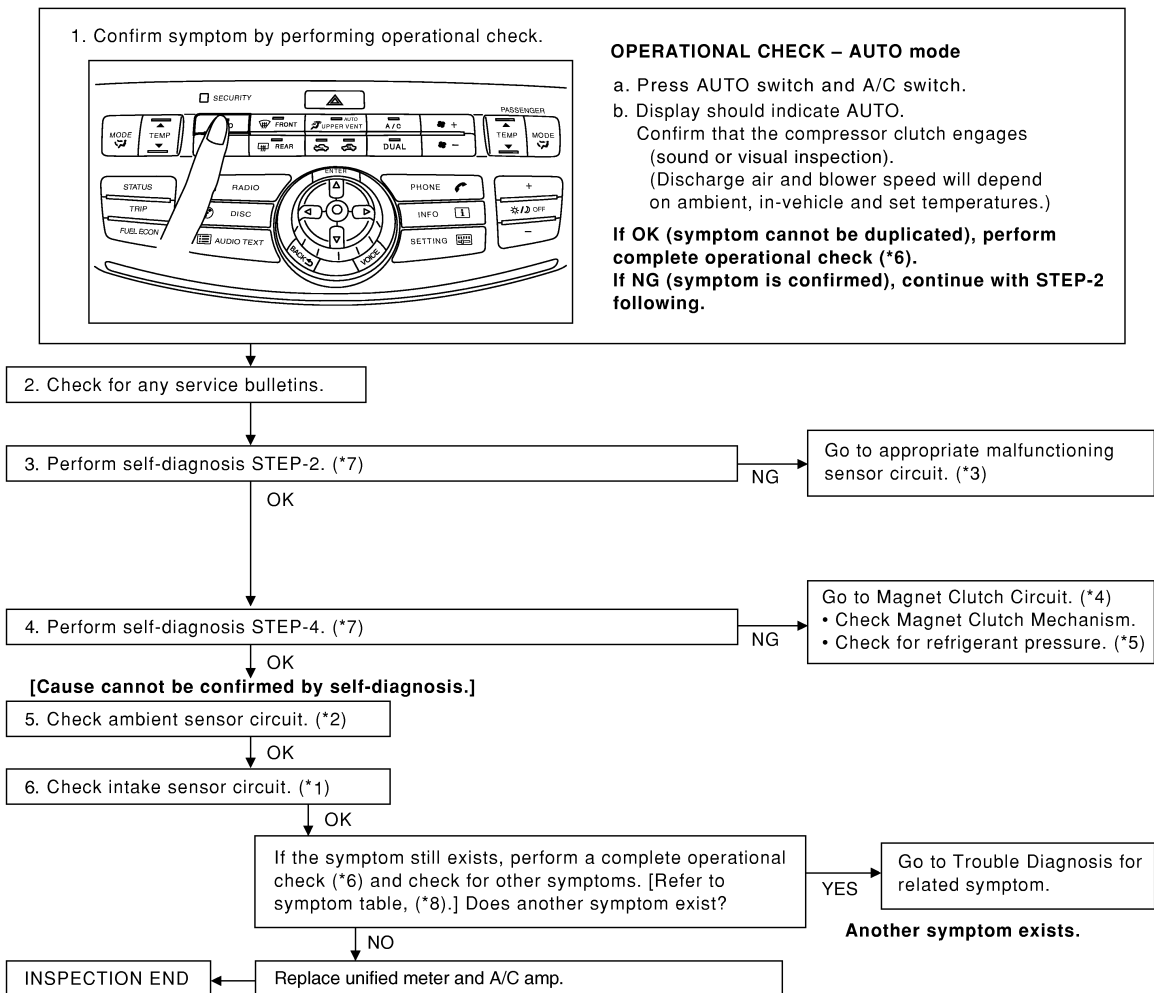

RJIA4077E

\*1 [ATC-105, "Intake Sensor Circuit"](#)

\*2 [ATC-97, "Ambient Sensor Circuit"](#)

\*3 [ATC-48, "Self-Diagnosis Function"](#), see No. 13.



# TROUBLE DIAGNOSIS

## < SERVICE INFORMATION >

\*4 "DIAGNOSIS PROCEDURE FOR MAGNET CLUTCH"

\*7 [ATC-48, "Self-Diagnosis Function"](#), see No. 2 to 6.

\*5 [ATC-84, "Insufficient Cooling"](#)

\*8 [ATC-34, "How to Perform Trouble Diagnosis for Quick and Accurate Repair"](#)

\*6 [ATC-56, "Operational Check"](#)

## SYSTEM DESCRIPTION

Unified meter and A/C amp. controls compressor operation by ambient temperature, intake air temperature and signal from ECM.

### Low Temperature Protection Control

- Unified meter and A/C amp. will turn compressor ON or OFF as determined by a signal detected by ambient sensor and intake sensor.
- When ambient temperature is higher than  $-2^{\circ}\text{C}$  ( $28^{\circ}\text{F}$ ), the compressor turns ON. The compressor turns OFF when ambient temperature is lower than  $-5^{\circ}\text{C}$  ( $23^{\circ}\text{F}$ ).

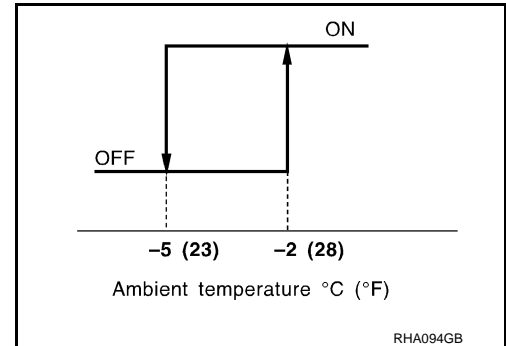

- When intake air temperature is higher than  $1^{\circ}\text{C}$  ( $34^{\circ}\text{F}$ ), the compressor turns ON. The compressor turns OFF when intake air temperature is lower than  $-5^{\circ}\text{C}$  ( $23^{\circ}\text{F}$ ).

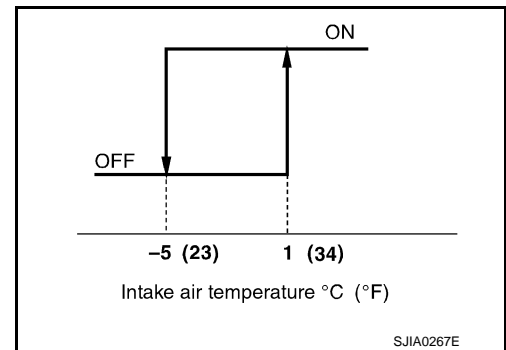

## DIAGNOSIS PROCEDURE FOR MAGNET CLUTCH

SYMPTOM: Magnet clutch does not engage when A/C switch is ON.

### VQ35HR

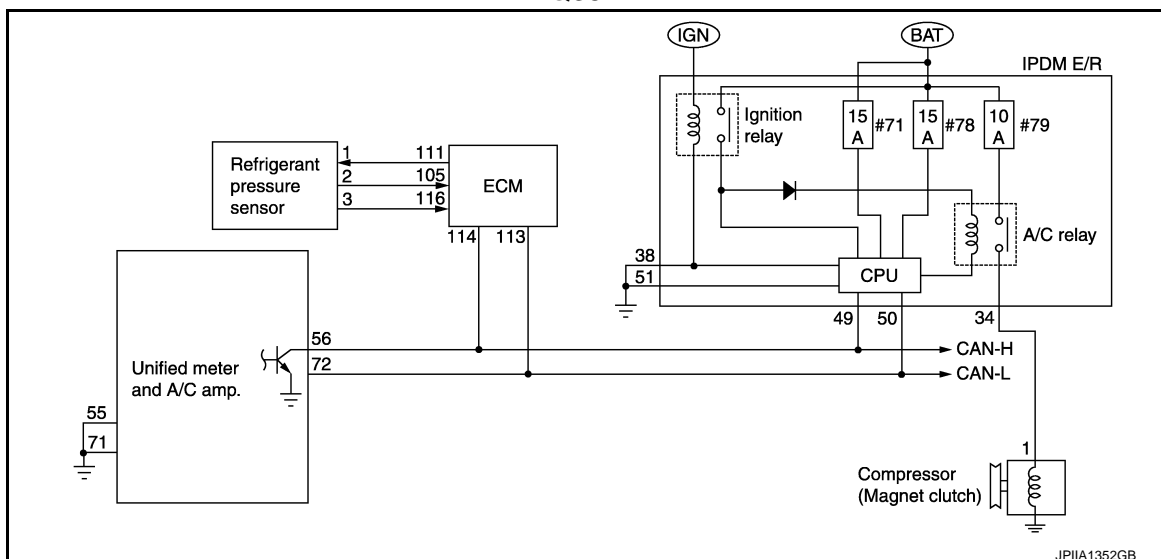

# TROUBLE DIAGNOSIS

< SERVICE INFORMATION >

VK45DE

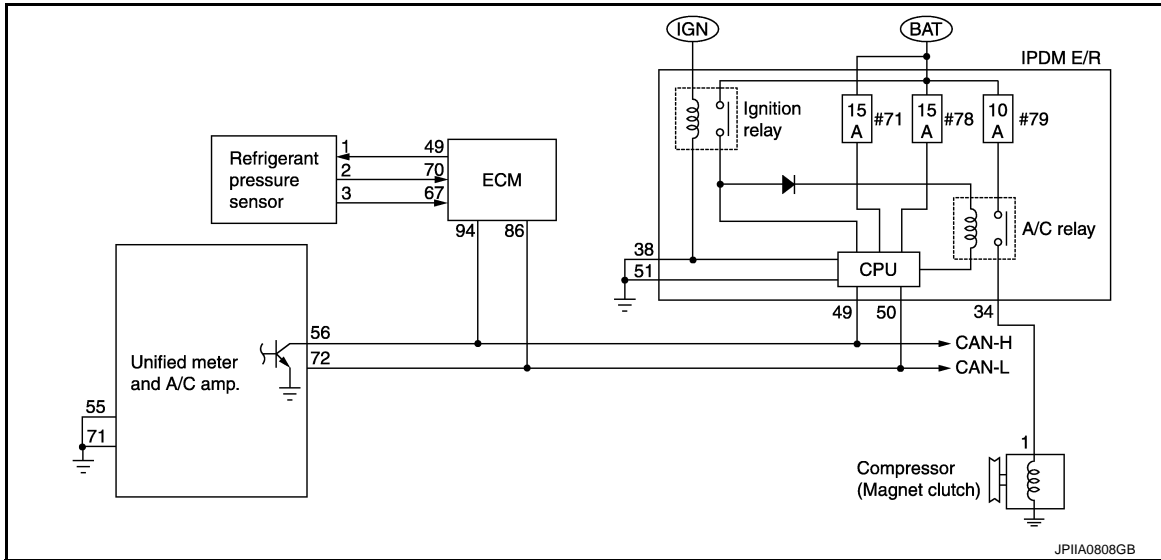

## 1. CHECK AMBIENT SENSOR AND INTAKE SENSOR CIRCUIT

Check ambient sensor and intake sensor. Refer to [ATC-48, "Self-Diagnosis Function"](#), see No. 9 and 11.

**OK or NG**

OK >> GO TO 2.

NG-1 >> Malfunctioning ambient sensor: Refer to [ATC-97, "Ambient Sensor Circuit"](#).

NG-2 >> Malfunctioning intake sensor: Refer to [ATC-105, "Intake Sensor Circuit"](#).

## 2. PERFORM AUTO ACTIVE TEST

Perform IPDM E/R auto active test. Refer to [PG-22, "Auto Active Test"](#).

Does the magnet clutch operate?

YES-1 >>  WITH CONSULT-III: GO TO 5.

YES-2 >>  WITHOUT CONSULT-III: GO TO 6.

NO >> Check 10A fuse (No. 79, located in IPDM E/R). Refer to [PG-26, "IPDM E/R Terminal Arrangement"](#), and GO TO 3.

## 3. CHECK CIRCUIT CONTINUITY BETWEEN IPDM E/R AND COMPRESSOR

1. Turn ignition switch OFF.
2. Disconnect IPDM E/R connector and compressor connector.
3. Check continuity between IPDM E/R harness connector E8 terminal 34 and compressor harness connector F24 terminal 1.

**34 - 1 : Continuity should exist.**

**OK or NG**

OK >> GO TO 4.

NG >> Repair harness or connector.

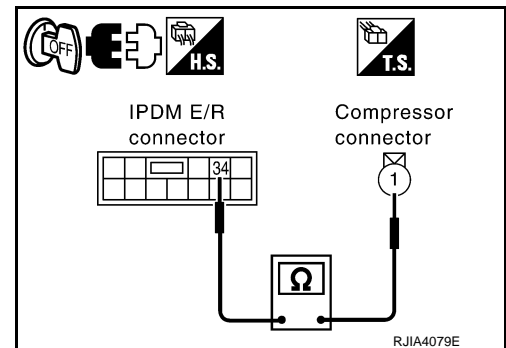

## 4. CHECK MAGNET CLUTCH CIRCUIT

# TROUBLE DIAGNOSIS

## < SERVICE INFORMATION >

Check for operation sound when applying battery voltage direct current to terminal.

### OK or NG

- OK >> 1. Replace IPDM E/R.  
 2. Go to self-diagnosis procedure [ATC-48, "Self-Diagnosis Function"](#) and perform self-diagnosis STEP-4. Confirm that magnet clutch operation normal.
- NG >> 1. Replace compressor.  
 2. Go to self-diagnosis procedure [ATC-48, "Self-Diagnosis Function"](#) and perform self-diagnosis STEP-4. Confirm that magnet clutch operation normal.

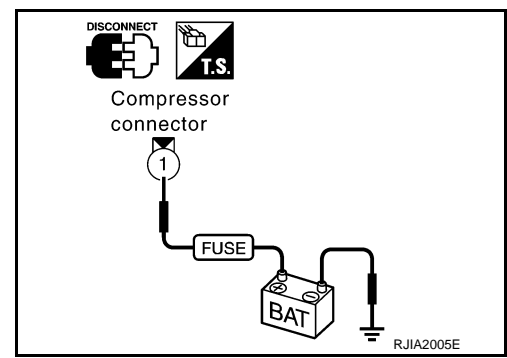

## 5. CHECK BCM INPUT (COMPRESSOR ON) SIGNAL

Check compressor ON/OFF signal in "Data monitor". Refer to [ATC-34, "CONSULT-III Function \(ECM\)"](#).

- A/C SWITCH ON : AIR COND SIG On**  
**A/C SWITCH OFF : AIR COND SIG Off**

### OK or NG

- OK >> GO TO 8.  
 NG >> GO TO 6.

## 6. CHECK REFRIGERANT PRESSURE SENSOR

### ⓐ WITH CONSULT-III

- Start the engine.
- Check voltage of refrigerant pressure sensor in "Data monitor". Refer to [EC-645, "Reference Value" \(VQ35HR\)](#) or [EC-810, "CONSULT-III Reference Value in Data Monitor Mode" \(VK45DE\)](#).

### ⓧ WITHOUT CONSULT-III

- Start the engine.
- Check voltage between ECM harness connector and ground.

VQ35HR

Terminals			Condition	Voltage
(+)		(-)		
ECM connector	Terminal No.			
M9	105	Ground	A/C switch: ON (Blower motor operates.)	Approx. 1.0 - 4.0 V

VK45DE

Terminals			Condition	Voltage
(+)		(-)		
ECM connector	Terminal No.			
F108	70	Ground	A/C switch: ON (Blower motor operates.)	Approx. 1.0 - 4.0 V

### OK or NG

- OK-1 >> ⓐ WITH CONSULT-III: GO TO 7.  
 OK-2 >> ⓧ WITHOUT CONSULT-III: Repair harness or connector.  
 NG >> Check refrigerant pressure sensor. Refer to [EC-638, "Diagnosis Procedure" \(VQ35HR\)](#) or [EC-1320, "Diagnosis Procedure" \(VK45DE\)](#).

## 7. CHECK ECM INPUT (FAN ON) SIGNAL

Check FAN ON/OFF signal in "Data monitor". Refer to [ATC-34, "CONSULT-III Function \(ECM\)"](#).

- FAN SWITCH ON : HEATER FAN SW On**  
**FAN SWITCH OFF : HEATER FAN SW Off**

A  
B  
C  
D  
E  
F  
G  
H  
I  
K  
L  
M  
N  
O  
P

ATC

# TROUBLE DIAGNOSIS

## < SERVICE INFORMATION >

### OK or NG

- OK >> GO TO 8.
- NG >> Repair harness or connector.

## 8. CHECK CAN COMMUNICATION

Check CAN communication. Refer to [EC-463, "Description"](#) (VQ35HR) or [EC-829, "Description"](#) (VK45DE).

- ECM – IPDM E/R
- ECM – Unified meter and A/C amp.

### OK or NG

- OK >> Replace ECM.
- NG >> Repair or replace malfunctioning part(s).

## COMPONENT INSPECTION

### Refrigerant Pressure Sensor

The refrigerant pressure sensor is attached to the liquid tank. Check that the A/C refrigerant pressure and the sensor output voltage are within the specified range as shown in the A/C operating condition figure. Refer to [EC-637, "Description"](#) (VQ35HR) or [EC-1318, "Component Description"](#) (VK45DE).

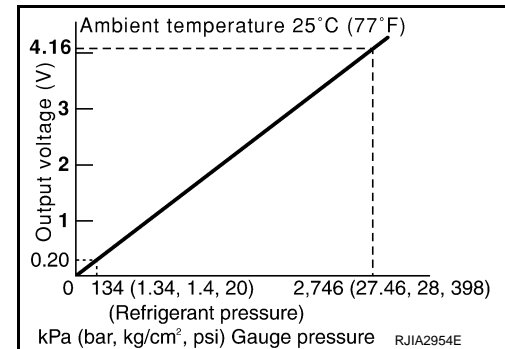
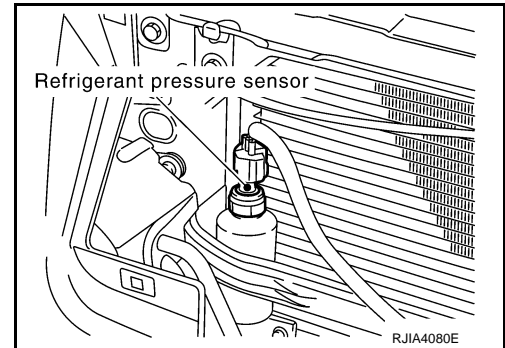

## Insufficient Cooling

SYMPTOM: Insufficient cooling

INSPECTION FLOW

INFOID:000000005348529

# TROUBLE DIAGNOSIS

## < SERVICE INFORMATION >

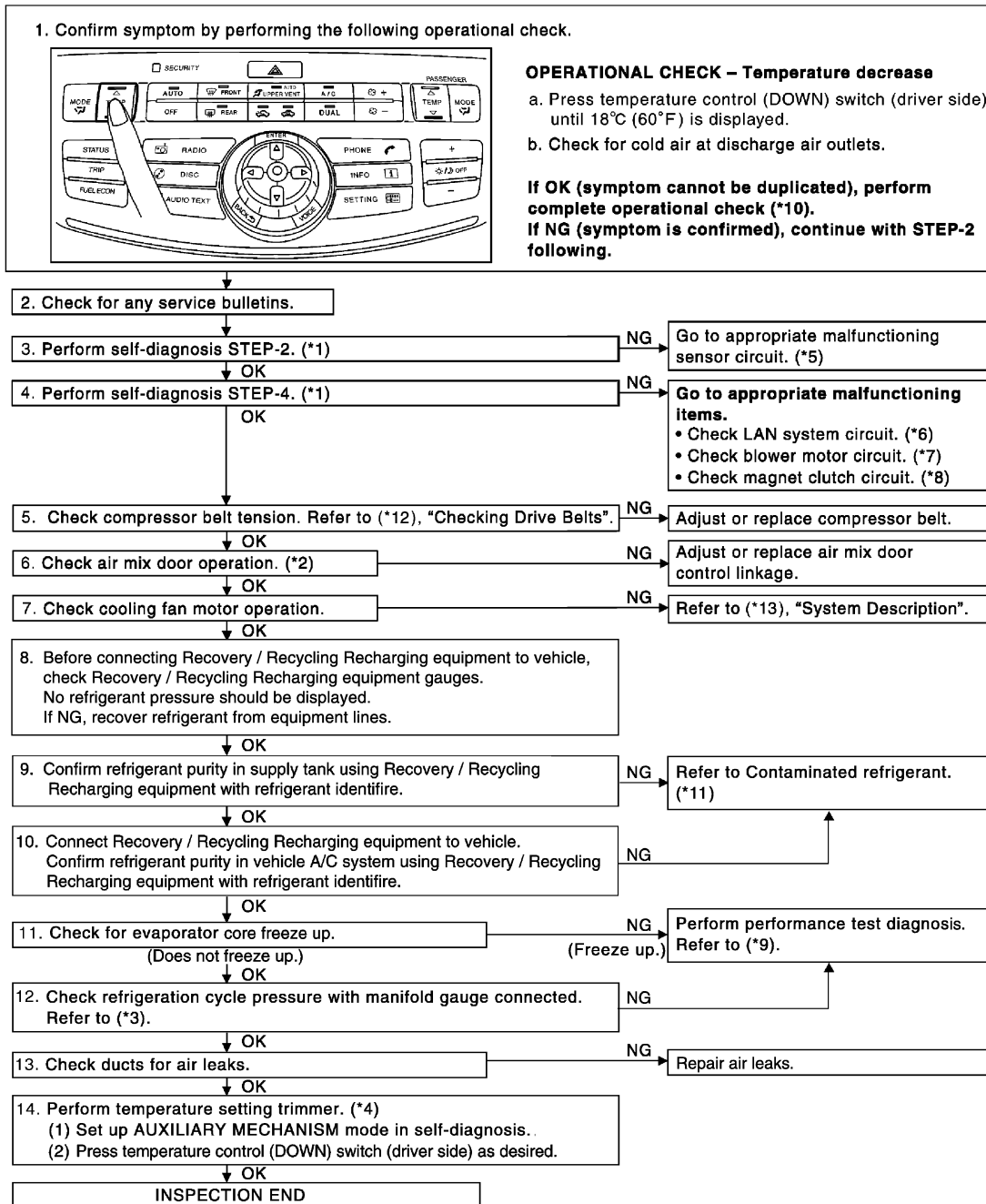

JPIIA1353GB

\*1 [ATC-48, "Self-Diagnosis Function"](#), see No. 2 to 6.

\*4 [ATC-48, "Self-Diagnosis Function"](#)

\*7 [ATC-76, "Blower Motor Circuit"](#)

\*2 [ATC-71, "Air Mix Door Motor Circuit"](#)

\*5 [ATC-48, "Self-Diagnosis Function"](#), see No. 13.

\*8 [ATC-80, "Magnet Clutch Circuit"](#)

\*3 "Test Reading (VQ35HR)" or "Test Reading (VK45DE)"

\*6 [ATC-62, "LAN System Circuit"](#)

\*9 "PERFORMANCE TEST DIAGNOSIS"

# TROUBLE DIAGNOSIS

## < SERVICE INFORMATION >

\*10 [ATC-56, "Operational Check"](#)

\*11 [ATC-4, "Precaution for Working with HFC-134a \(R-134a\)"](#)

\*12 [EM-15, "Checking Drive Belt" \(VQ35HR\)](#) or [EM-169, "Checking Drive Belts" \(VK45DE\)](#)

\*13 [EC-464, "DTC Logic" \(VQ35HR\)](#) or [EC-1142, "Description" \(VK45DE\)](#)

## PERFORMANCE TEST DIAGNOSIS

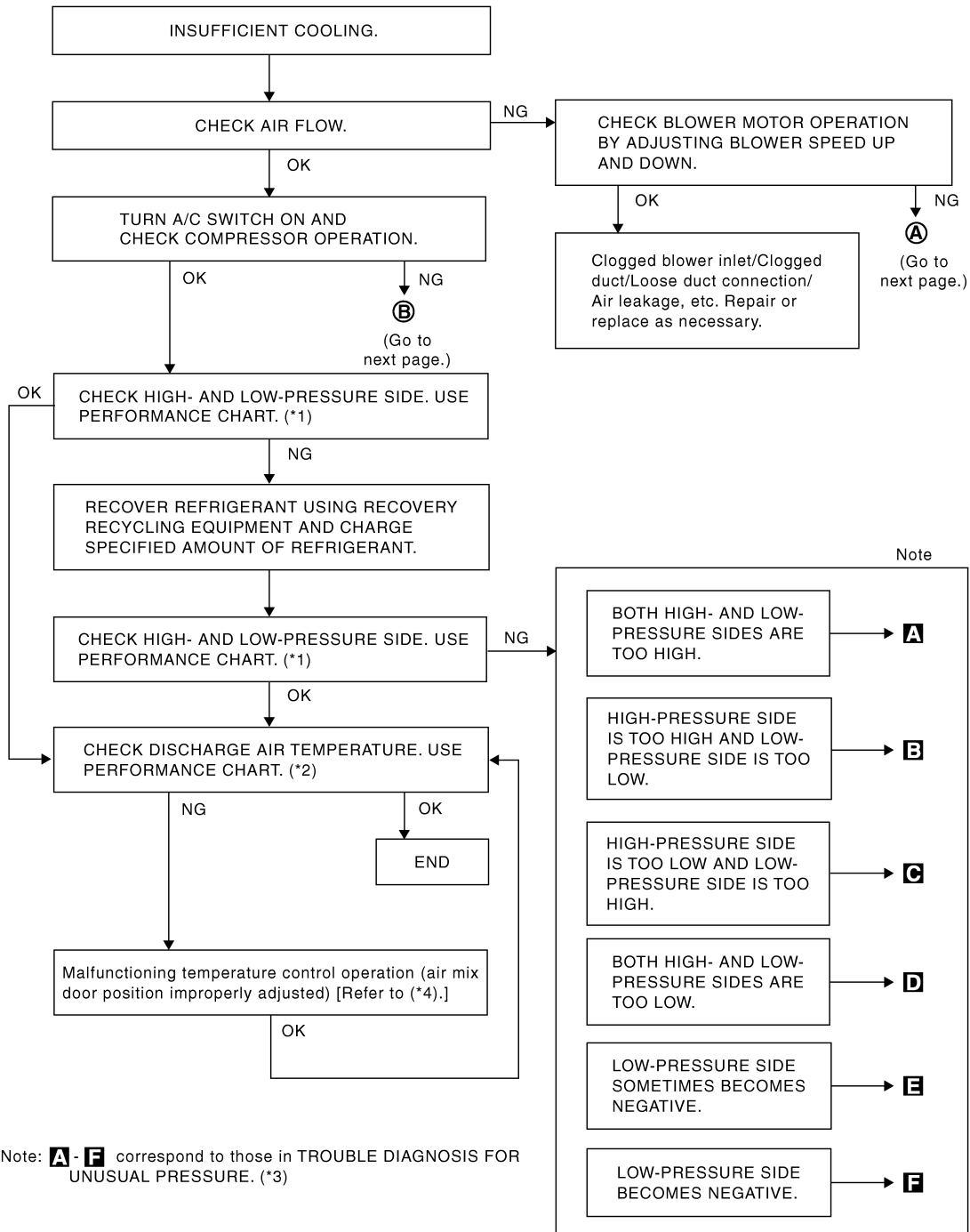

SJA1226E

\*1 "PERFORMANCE CHART"

\*2 "PERFORMANCE CHART"

\*3 "TROUBLE DIAGNOSIS FOR UNUSUAL PRESSURE"

\*4 [ATC-71, "Air Mix Door Motor Circuit"](#)

# TROUBLE DIAGNOSIS

< SERVICE INFORMATION >

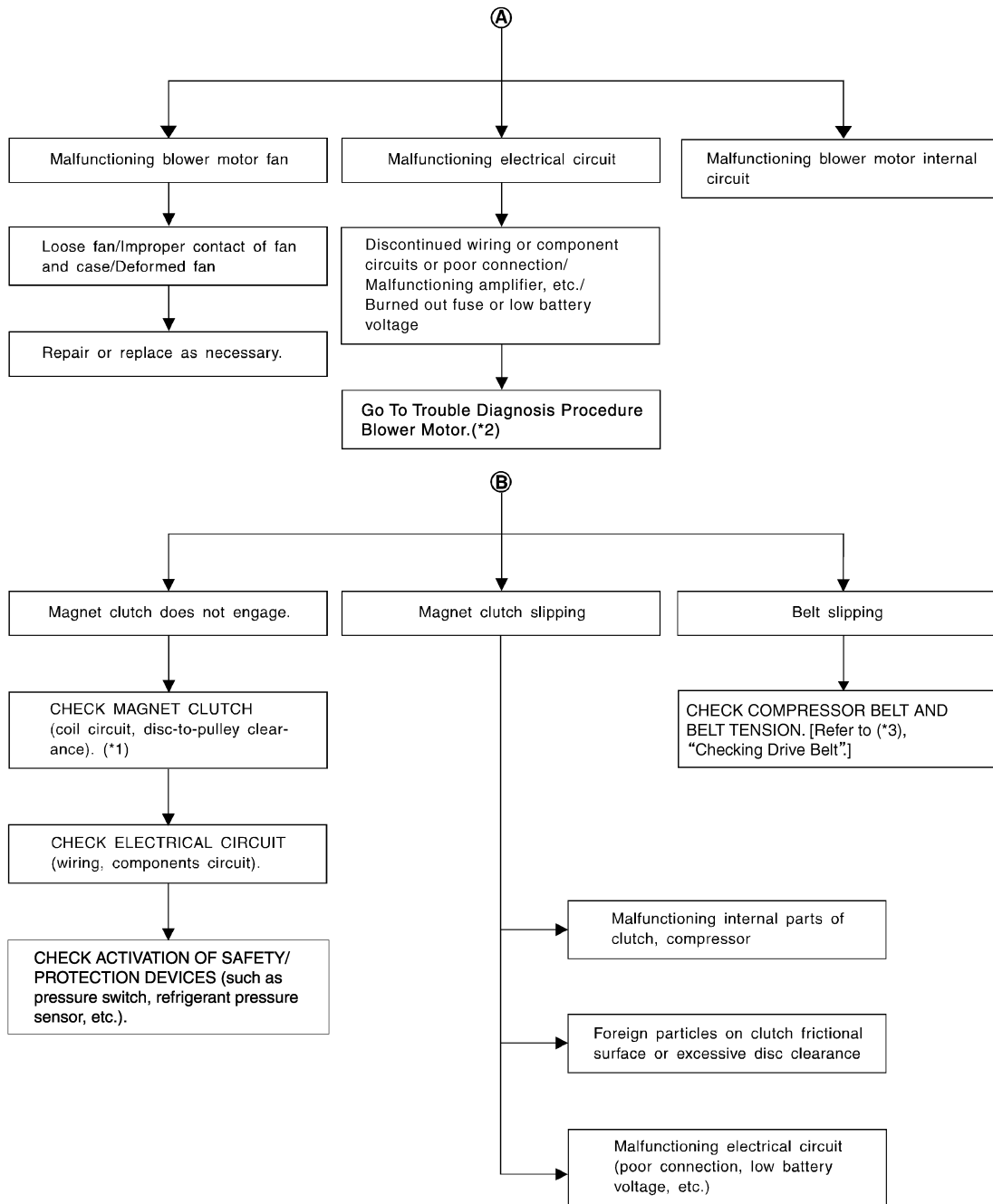

SJIA1642E

\*1 [ATC-138, "VQ35HR : Check Disc to Pulley Clearance"](#) (VQ35HR) or [ATC-156, "VK45DE : Check Disc to Pulley Clearance"](#) (VK45DE)

\*2 [ATC-76, "Blower Motor Circuit"](#)

\*3 [EM-15, "Checking Drive Belt"](#) (VQ35HR) or [EM-169, "Checking Drive Belts"](#) (VK45DE)



## PERFORMANCE CHART

Test Condition

Testing must be performed as follows:

# TROUBLE DIAGNOSIS

## < SERVICE INFORMATION >

Vehicle condition	Indoors or in the shade (in a well-ventilated place)
Doors	Closed
Door windows	Open
Hood	Open
Temperature control switch	Maximum COLD
Mode switch	 (Ventilation) set
Intake switch	 (Recirculation) set
Fan speed	Maximum speed set
Engine speed	Idle speed

Operate the air conditioning system for 10 minutes before taking measurements.

### Test Reading (VQ35HR)

Recirculating-to-discharge Air Temperature Table

Inside air (Recirculating air) at blower assembly inlet		Discharge air temperature at center ventilator °C (°F)
Relative humidity %	Air temperature °C (°F)	
50 – 60	20 (68)	5.5 – 7.2 (42 – 45)
	25 (77)	8.5 – 10.9 (47 – 52)
	30 (86)	12.3 – 15.1 (54 – 59)
	35 (95)	16.5 – 19.8 (62 – 68)
	40 (104)	21.0 – 25.0 (70 – 77)
60 – 70	20 (68)	7.2 – 9.0 (45 – 48)
	25 (77)	10.9 – 13.4 (52 – 56)
	30 (86)	15.1 – 18.0 (59 – 64)
	35 (95)	19.8 – 23.0 (68 – 73)
	40 (104)	25.0 – 29.0 (77 – 84)

Ambient Air Temperature-to-operating Pressure Table

Ambient air		High-pressure (Discharge side) kPa (kg/cm <sup>2</sup> , psi)	Low-pressure (Suction side) kPa (kg/cm <sup>2</sup> , psi)
Relative humidity %	Air temperature °C (°F)		
50 – 70	20 (68)	733 – 895 (7.5 – 9.1, 106.3 – 129.8)	180 – 220 (1.8 – 2.2, 26.1 – 31.9)
	25 (77)	838 – 1,025 (8.5 – 10.5, 121.5 – 148.6)	210 – 257 (2.1 – 2.6, 30.5 – 37.3)
	30 (86)	985 – 1,204 (10.0 – 12.3, 142.8 – 174.6)	239 – 293 (2.4 – 3.0, 34.7 – 42.5)
	35 (95)	1,115 – 1,363 (11.4 – 13.9, 161.7 – 197.6)	270 – 330 (2.8 – 3.4, 39.2 – 47.9)
	40 (104)	1,294 – 1,581 (13.2 – 16.1, 187.6 – 229.2)	331 – 405 (3.4 – 4.1, 48.0 – 58.7)

### Test Reading (VK45DE)



# TROUBLE DIAGNOSIS

## < SERVICE INFORMATION >

**Recirculating-to-discharge Air Temperature Table**

Inside air (Recirculating air) at blower assembly inlet		Discharge air temperature at center ventilator °C (°F)
Relative humidity %	Air temperature °C (°F)	
50 – 60	20 (68)	6.0 – 7.4 (43 – 45)
	25 (77)	8.9 – 10.6 (48 – 51)
	30 (86)	12.5 – 14.6 (55 – 58)
	35 (95)	16.7 – 19.4 (62 – 67)
60 – 70	20 (68)	7.4 – 8.7 (45 – 48)
	25 (77)	10.6 – 12.2 (51 – 54)
	30 (86)	14.6 – 16.7 (58 – 62)
	35 (95)	19.4 – 22.1 (67 – 72)

**Ambient Air Temperature-to-operating Pressure Table**

Ambient air		High-pressure (Discharge side) kPa (kg/cm <sup>2</sup> , psi)	Low-pressure (Suction side) kPa (kg/cm <sup>2</sup> , psi)
Relative humidity %	Air temperature °C (°F)		
50 – 70	20 (68)	907 – 1,106 (9.3 – 11.3, 131.5 – 160.4)	192 – 238 (2.0 – 2.4, 27.8 – 34.5)
	25 (77)	987 – 1,207 (10.1 – 12.3, 143.1 – 175.0)	210 – 262 (2.1 – 2.7, 30.5 – 38.0)
	30 (86)	1,072 – 1,312 (10.9 – 13.4, 155.4 – 190.2)	233 – 284 (2.4 – 2.9, 33.8 – 41.2)
	35 (95)	1,168 – 1,425 (11.9 – 14.5, 169.4 – 206.6)	258 – 320 (2.6 – 3.3, 37.4 – 46.4)
	40 (104)	1,272 – 1,550 (13.0 – 15.8, 184.4 – 224.8)	288 – 356 (2.9 – 3.6, 41.8 – 51.6)

### TROUBLE DIAGNOSIS FOR UNUSUAL PRESSURE

Whenever system's high and/or low side pressure(s) is/are unusual, diagnose using a manifold gauge. The marker above the gauge scale in the following tables indicates the standard (usual) pressure range. Since the standard (usual) pressure, however, differs from vehicle to vehicle, refer to above table (Ambient air temperature-to-operating pressure table).

Both High- and Low-pressure Sides are Too High

A  
B  
C  
D  
E  
F  
G  
H  
I  
K  
L  
M  
N  
O  
P

**ATC**

# TROUBLE DIAGNOSIS

## < SERVICE INFORMATION >

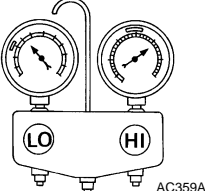
Gauge indication	Refrigerant cycle	Probable cause	Corrective action
<p>Both high- and low-pressure sides are too high.</p> 	<p>The pressure returns to normal soon after water is splashed on condenser.</p>	<p>Excessive refrigerant charge in refrigeration cycle.</p>	<p>Reduce refrigerant until specified pressure is obtained.</p>
	<p>Air suction by cooling fan is insufficient.</p>	<p>Insufficient condenser cooling performance. ↓ 1. Condenser fins are clogged. 2. Improper fan rotation of cooling fan.</p>	<ul style="list-style-type: none"> <li>Clean condenser.</li> <li>Check and repair cooling fan as necessary.</li> </ul>
	<ul style="list-style-type: none"> <li>Low-pressure pipe is not cold.</li> <li>When compressor is stopped high-pressure value quickly drops by approximately 196 kPa (2 kg/cm<sup>2</sup>, 28 psi). It then decreases gradually thereafter.</li> </ul>	<p>Poor heat exchange in condenser (After compressor operation stops, high-pressure decreases too slowly.) ↓ Air in refrigeration cycle.</p>	<p>Evacuate repeatedly and re-charge system.</p>
	<p>Engine tends to overheat.</p>	<p>Engine cooling systems malfunction.</p>	<p>Check and repair each engine cooling system.</p>
	<ul style="list-style-type: none"> <li>An area of the low-pressure pipe is colder than areas near the evaporator outlet.</li> <li>Low-pressure pipe is sometimes covered with frost.</li> </ul>	<ul style="list-style-type: none"> <li>Excessive liquid refrigerant on low-pressure side.</li> <li>Excessive refrigerant discharge flow.</li> <li>Expansion valve is open a little compared with the specification.</li> </ul> <p>↓ Improper expansion valve adjustment.</p>	<p>Replace expansion valve.</p>

### High-pressure Side is Too High and Low-pressure Side is Too Low

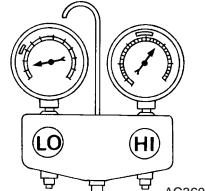
Gauge indication	Refrigerant cycle	Probable cause	Corrective action
<p>High-pressure side is too high and low-pressure side is too low.</p> 	<p>Upper side of condenser and high-pressure side are hot, however, liquid tank is not so hot.</p>	<p>High-pressure tube or parts located between compressor and condenser are clogged or crushed.</p>	<ul style="list-style-type: none"> <li>Check and repair or replace malfunctioning parts.</li> <li>Check lubricant for contamination.</li> </ul>

### High-pressure Side is Too Low and Low-pressure Side is Too High

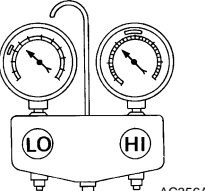
Gauge indication	Refrigerant cycle	Probable cause	Corrective action
<p>High-pressure side is too low and low-pressure side is too high.</p> 	<p>High- and low-pressure sides become equal soon after compressor operation stops.</p>	<p>Compressor pressure operation is improper. ↓ Damaged inside compressor packings.</p>	<p>Replace compressor.</p>
	<p>No temperature difference between high- and low-pressure sides.</p>	<p>Compressor pressure operation is improper. ↓ Damaged inside compressor packings.</p>	<p>Replace compressor.</p>

### Both High- and Low-pressure Sides are Too Low

# TROUBLE DIAGNOSIS

## < SERVICE INFORMATION >

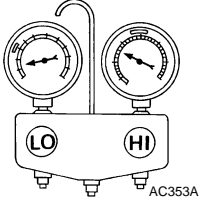
Gauge indication	Refrigerant cycle	Probable cause	Corrective action
<p>Both high- and low-pressure sides are too low.</p> 	<ul style="list-style-type: none"> <li>There is a big temperature difference between liquid tank outlet and inlet. Outlet temperature is extremely low.</li> <li>Liquid tank inlet and expansion valve are frosted.</li> </ul>	Liquid tank inside is slightly clogged.	<ul style="list-style-type: none"> <li>Replace liquid tank.</li> <li>Check lubricant for contamination.</li> </ul>
	<ul style="list-style-type: none"> <li>Temperature of expansion valve inlet is extremely low as compared with areas near liquid tank.</li> <li>Expansion valve inlet is frosted.</li> <li>Temperature difference occurs somewhere in high-pressure side.</li> </ul>	High-pressure pipe located between liquid tank and expansion valve is clogged.	<ul style="list-style-type: none"> <li>Check and repair malfunctioning parts.</li> <li>Check lubricant for contamination.</li> </ul>
	Expansion valve and liquid tank are warm or slightly cool when touched.	Low refrigerant charge. ↓ Leaking fittings or components.	Check refrigerant for leaks. Refer to <a href="#">ATC-149, "VQ35HR : Checking of Refrigerant Leaks"</a> (VQ35HR) or <a href="#">ATC-166, "VK45DE : Checking of Refrigerant Leaks"</a> (VK45DE).
	There is a big temperature difference between expansion valve inlet and outlet while the valve itself is frosted.	Expansion valve closes a little compared with the specification. ↓ 1. Improper expansion valve adjustment. 2. Malfunctioning expansion valve. 3. Outlet and inlet may be clogged.	<ul style="list-style-type: none"> <li>Remove foreign particles by using compressed air.</li> <li>Replace expansion valve.</li> <li>Check lubricant for contamination.</li> </ul>
	An area of the low-pressure pipe is colder than areas near the evaporator outlet.	Low-pressure pipe is clogged or crushed.	<ul style="list-style-type: none"> <li>Check and repair malfunctioning parts.</li> <li>Check lubricant for contamination.</li> </ul>
	Air flow volume is not enough or is too low.	Evaporator is frozen.	<ul style="list-style-type: none"> <li>Check intake sensor circuit. Refer to <a href="#">ATC-105, "Intake Sensor Circuit"</a>.</li> <li>Replace compressor.</li> <li>Repair evaporator fins.</li> <li>Replace evaporator.</li> <li>Check blower motor circuit. Refer to <a href="#">ATC-76, "Blower Motor Circuit"</a>.</li> </ul>

A  
B  
C  
D  
E  
F  
G  
H  
I  
K  
L  
M  
N

ATC

### Low-pressure Side Sometimes Becomes Negative

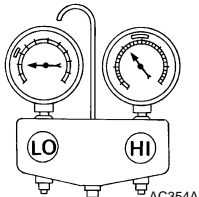
Gauge indication	Refrigerant cycle	Probable cause	Corrective action
<p>Low-pressure side sometimes becomes negative.</p> 	<ul style="list-style-type: none"> <li>Air conditioning system does not function and does not cyclically cool the compartment air.</li> <li>The system constantly functions for a certain period of time after compressor is stopped and restarted.</li> </ul>	Refrigerant does not discharge cyclically. ↓ Moisture is frozen at expansion valve outlet and inlet. ↓ Water is mixed with refrigerant.	<ul style="list-style-type: none"> <li>Drain water from refrigerant or replace refrigerant.</li> <li>Replace liquid tank.</li> </ul>

### Low-pressure Side Becomes Negative

O  
P

# TROUBLE DIAGNOSIS

## < SERVICE INFORMATION >

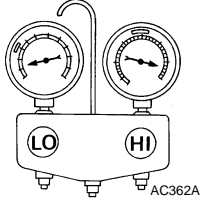
Gauge indication	Refrigerant cycle	Probable cause	Corrective action
<p>Low-pressure side becomes negative.</p> 	<p>Liquid tank or front/rear side of expansion valve's pipe is frosted or wet with dew.</p>	<p>High-pressure side is closed and refrigerant does not flow. ↓ Expansion valve or liquid tank is frosted.</p>	<p>Leave the system at rest until no frost is present. Start it again to check whether or not the malfunction is caused by water or foreign particles.</p> <ul style="list-style-type: none"> <li>• If water is the cause, initially cooling is okay. Then the water freezes causing a blockage. Drain water from refrigerant or replace refrigerant.</li> <li>• If due to foreign particles, remove expansion valve and remove the particles with dry and compressed air (not shop air).</li> <li>• If either of the above methods cannot correct the malfunction, replace expansion valve.</li> <li>• Replace liquid tank.</li> <li>• Check lubricant for contamination.</li> </ul>

### DIAGNOSIS PROCEDURE FOR INSUFFICIENT COOLING

SYMPTOM: Insufficient cooling

#### 1. CHECK POWER SUPPLY FOR ECV (ELECTRONIC CONTROL VALVE)

1. Disconnect compressor (ECV) connector.
2. Turn ignition switch ON.
3. Check voltage between compressor (ECV) harness connector F34 terminal 2 and ground.

**2 – ground : Battery voltage**

**OK or NG**

OK >> GO TO 2.

NG >> Check power supply circuit and 10A fuse [No. 12, located in the fuse block (J/B)]. Refer to [PG-84, "Terminal Arrangement"](#).

- If fuse is OK, check harness for open circuit. Repair or replace if necessary.
- If fuse is NG, check harness for short circuit and replace fuse.

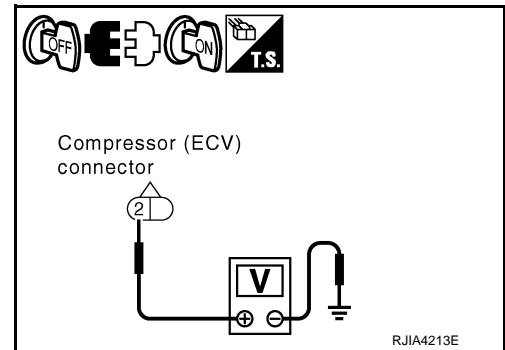

#### 2. CHECK ECV CONTROL SIGNAL

1. Turn ignition switch OFF.
2. Reconnect compressor (ECV) connector.
3. Perform self-diagnosis. Refer to [ATC-48, "Self-Diagnosis Function"](#).
4. Set in self-diagnosis STEP-4 (Code No. 45). Refer to [ATC-48, "Self-Diagnosis Function"](#).
5. Confirm ECV control signal between unified meter and A/C amp. harness connector M65 terminal 65 and ground using an oscilloscope.

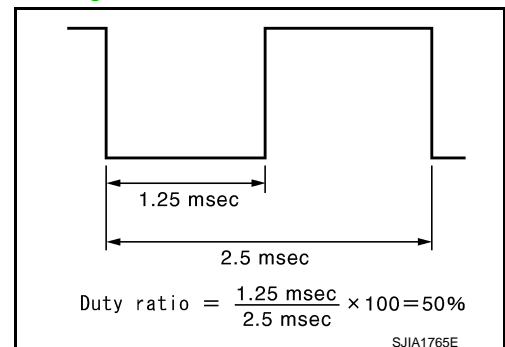

# TROUBLE DIAGNOSIS

## < SERVICE INFORMATION >

### OK or NG

- OK >> Replace compressor.
- NG >> GO TO 3.

### 3. CHECK CIRCUIT CONTINUITY BETWEEN ECV AND UNIFIED METER AND A/C AMP.

1. Turn ignition switch OFF.
2. Disconnect compressor (ECV) and unified meter and A/C amp. connector.
3. Check continuity between compressor (ECV) harness connector F34 terminal 3 and unified meter and A/C amp. harness connector M65 terminal 65.

**3 – 65 : Continuity should exist.**

### OK or NG

- OK >> GO TO 4.
- NG >> Repair harness or connector.

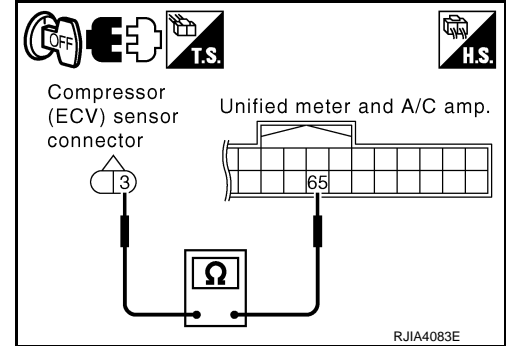

### 4. CHECK ECV

Check continuity between compressor (ECV) connector F34 terminals 2 and 3.

**2 – 3 : Continuity should exist.**

### OK or NG

- OK >> Replace unified meter and A/C amp.
- NG >> Replace compressor.

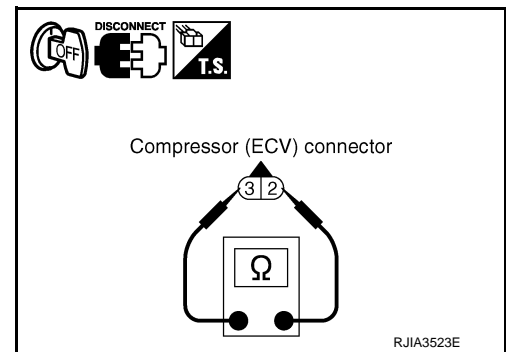

INFOID:000000005348530

## Insufficient Heating

SYMPTOM: Insufficient heating

INSPECTION FLOW

A  
B  
C  
D  
E  
F  
G  
H  
I  
ATC  
K  
L  
M  
N  
O  
P

# TROUBLE DIAGNOSIS

## < SERVICE INFORMATION >

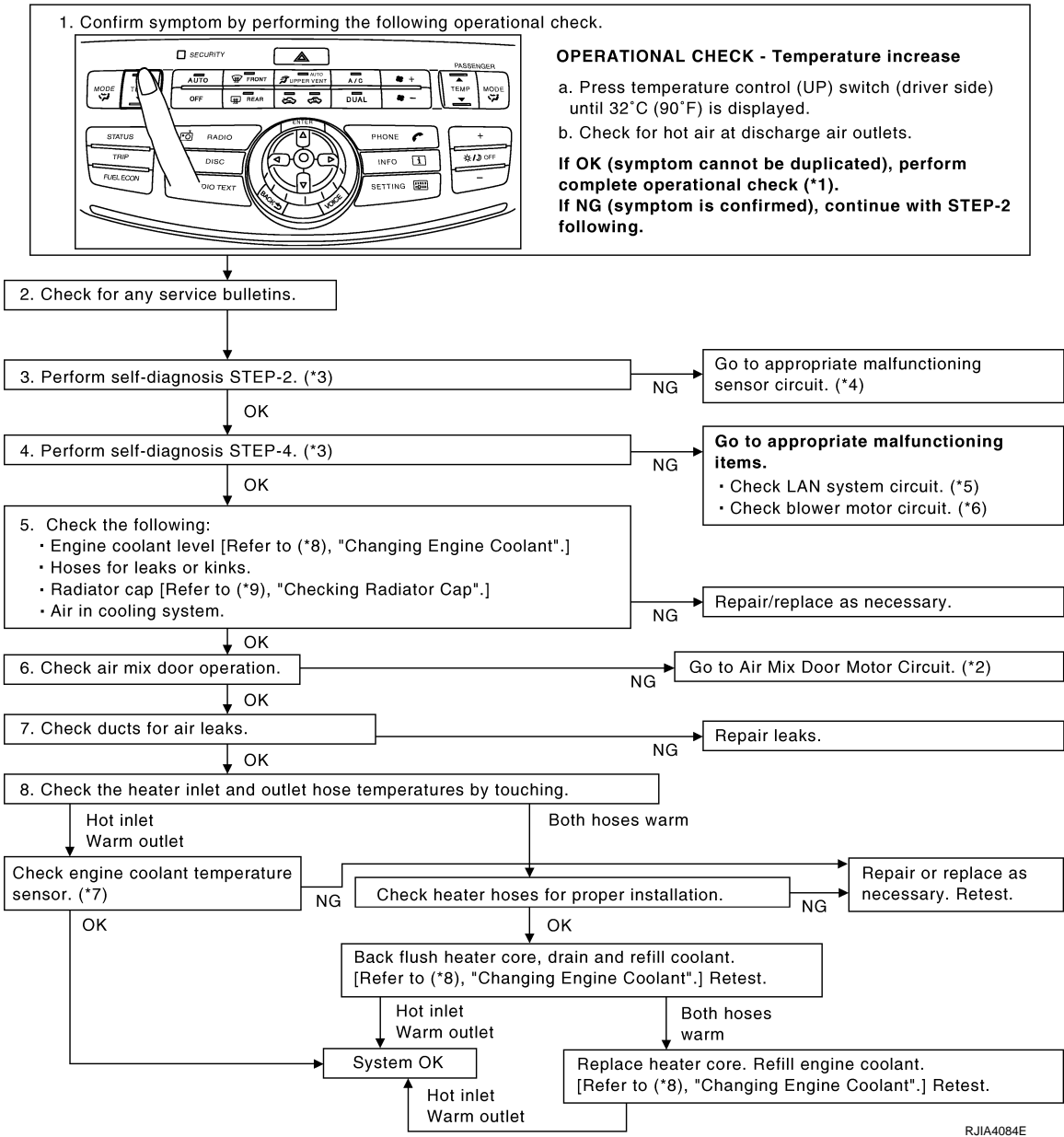

\*1 [ATC-56, "Operational Check"](#)

\*2 [ATC-71, "Air Mix Door Motor Circuit"](#)

\*3 [ATC-48, "Self-Diagnosis Function"](#), see No. 2 to 6.

\*4 [ATC-48, "Self-Diagnosis Function"](#), see No. 13.

\*5 [ATC-62, "LAN System Circuit"](#)

\*6 [ATC-76, "Blower Motor Circuit"](#)

\*7 [EC-220, "Description"](#) (VQ35HR) or [EC-888, "Component Description"](#) (VK45DE)

\*8 [CO-10, "Changing Engine Coolant"](#) (VQ35HR) or [CO-36, "Changing Engine Coolant"](#) (VK45DE)

\*9 [CO-15, "Checking Radiator Cap"](#) (VQ35HR) or [CO-41, "Checking Radiator Cap"](#) (VK45DE)

## Noise

INFOID:000000005348531

SYMPTOM: Noise

## INSPECTION FLOW

# TROUBLE DIAGNOSIS

< SERVICE INFORMATION >

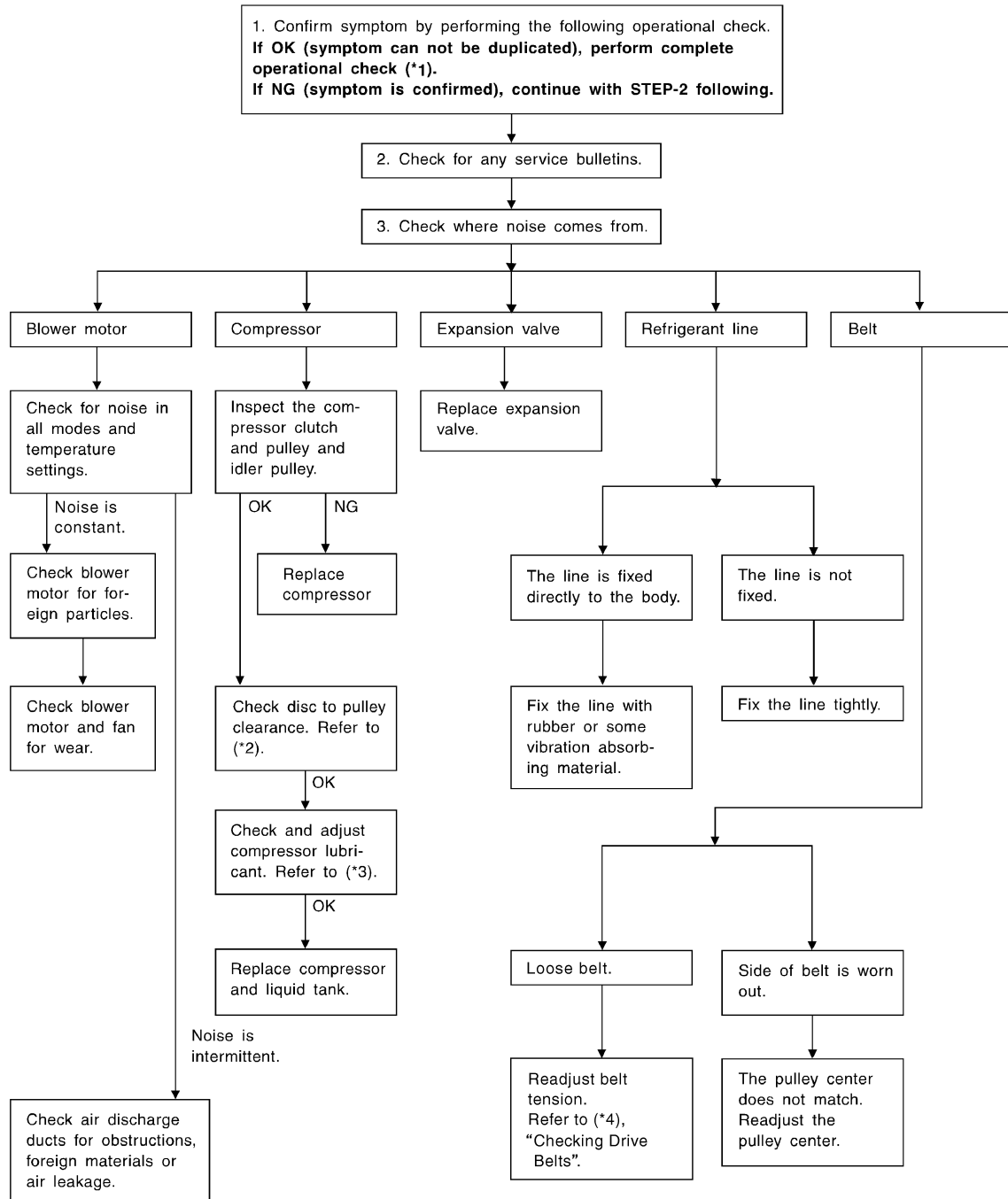

SJIA0843E

\*1 [ATC-56, "Operational Check"](#)

\*2 [ATC-138, "VQ35HR : Check Disc to Pulley Clearance"](#) (VQ35HR) or [ATC-156, "VK45DE : Check Disc to Pulley Clearance"](#) (VK45DE)

\*3 [ATC-22, "Maintenance of Lubricant Quantity in Compressor"](#)

\*4 [EM-15, "Checking Drive Belt"](#) (VQ35HR) or [EM-169, "Checking Drive Belts"](#) (VK45DE)

## Self-Diagnosis

SYMPTOM: Self-diagnosis cannot be performed.

## INSPECTION FLOW

A  
B  
C  
D  
E  
F  
G  
H  
I  
ATC  
K  
L  
M  
N  
O  
P

# TROUBLE DIAGNOSIS

< SERVICE INFORMATION >

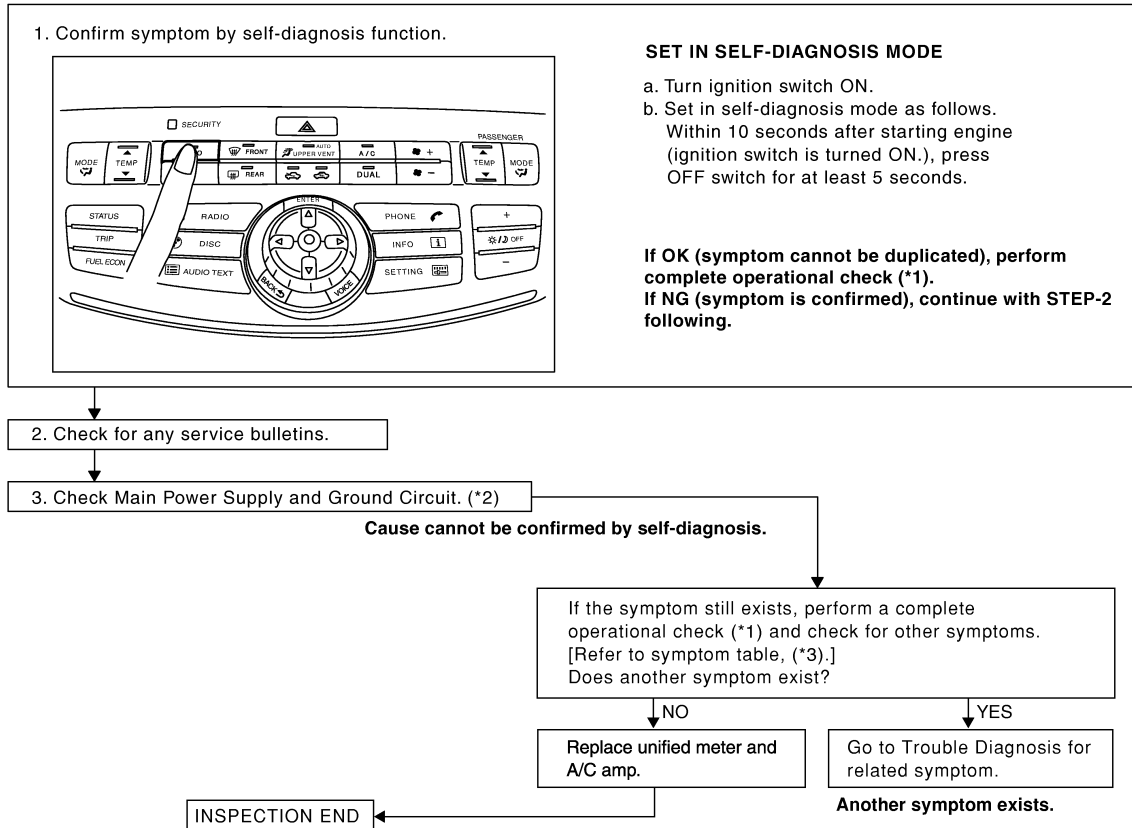

SJIA1796E

\*1 [ATC-56, "Operational Check"](#)

\*2 [ATC-58, "Power Supply and Ground Circuit for Auto Amp."](#)

\*3 [ATC-34, "How to Perform Trouble Diagnosis for Quick and Accurate Repair"](#)

## Memory Function

INFOID:000000005348533

SYMPTOM: Memory function does not operate.

INSPECTION FLOW



# TROUBLE DIAGNOSIS

## < SERVICE INFORMATION >

1. Confirm symptom by performing the following operational check.

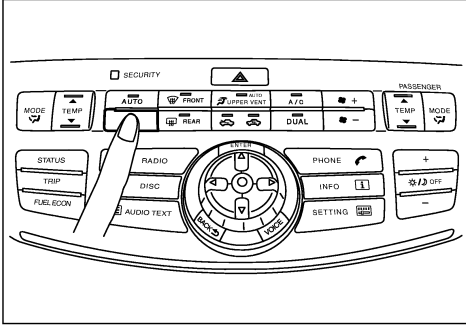

**OPERATIONAL CHECK – Memory function**

- Set the temperature 32°C (90°F).
- Press OFF switch.
- Turn the ignition OFF.
- Turn the ignition ON.
- Press the AUTO switch.
- Confirm that the set temperature remains at previous temperature.
- Press OFF switch.

**If OK (symptom cannot be duplicated), perform complete operational check (\*2).**  
**If NG (symptom is confirmed), continue with STEP-2 following.**

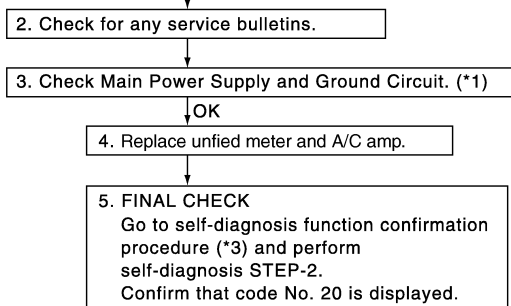

RJIA4086E

\*1 [ATC-58. "Power Supply and Ground Circuit for Auto Amp."](#) \*2 [ATC-56. "Operational Check"](#)

\*3 [ATC-48. "Self-Diagnosis Function"](#)

ATC

## Ambient Sensor Circuit

INFOID:000000005348534

### COMPONENT DESCRIPTION

#### Ambient Sensor

The ambient sensor is attached on the radiator core support (left side). It detects ambient temperature and converts it into a resistance value which is then input into the unified meter and A/C amp.

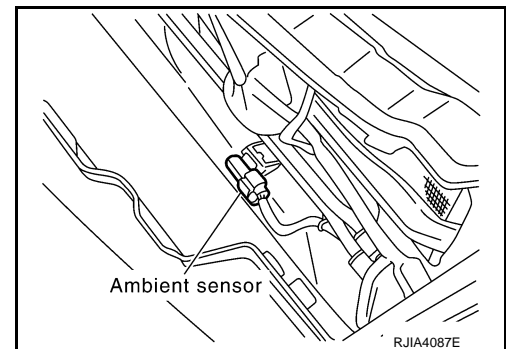

# TROUBLE DIAGNOSIS

## < SERVICE INFORMATION >

### Ambient Sensor Circuit

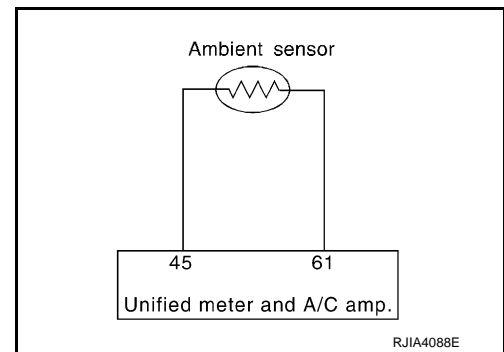

### AMBIENT TEMPERATURE INPUT PROCESS

- The unified meter and A/C amp. includes a processing circuit for the ambient sensor input. However, when the temperature detected by the ambient sensor increases quickly, the processing circuit retards the unified meter and A/C amp. function. It only allows the unified meter and A/C amp. to recognize an ambient temperature increase of 0.33°C (0.6°F) per 100 seconds.
- As an example, consider stopping for a few minutes after high speed driving. Although the actual ambient temperature has not changed, the temperature detected by the ambient sensor will increase. This is because the heat from the engine compartment can radiate to the front bumper area, location of the ambient sensor.

### DIAGNOSIS PROCEDURE FOR AMBIENT SENSOR

SYMPTOM: Ambient sensor circuit is open or shorted. (21 or -21 is indicated on unified meter and A/C amp. as a result of performing self-diagnosis STEP-2.)

## 1. CHECK VOLTAGE BETWEEN AMBIENT SENSOR AND GROUND

1. Disconnect ambient sensor connector.
2. Turn ignition switch ON.
3. Check voltage between ambient sensor harness connector E62 terminal 1 and ground.

**1 – Ground : Approx. 5 V**

#### OK or NG

- OK >> GO TO 2.
- NG >> GO TO 4.

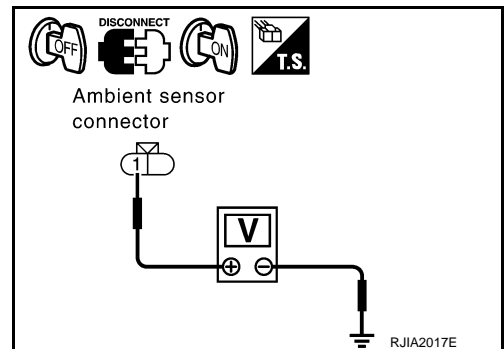

## 2. CHECK CIRCUIT CONTINUITY BETWEEN AMBIENT SENSOR AND UNIFIED METER AND A/C AMP.

1. Turn ignition switch OFF.
2. Disconnect unified meter and A/C amp. connector.
3. Check continuity between ambient sensor harness connector E62 terminal 2 and unified meter and A/C amp. harness connector M65 terminal 61.

**2 – 61 : Continuity should exist.**

#### OK or NG

- OK >> GO TO 3.
- NG >> Repair harness or connector.

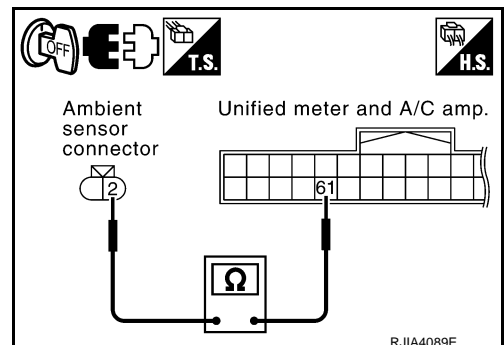

## 3. CHECK AMBIENT SENSOR

Refer to "COMPONENT INSPECTION (Ambient Sensor)".

# TROUBLE DIAGNOSIS

## < SERVICE INFORMATION >

### OK or NG

- OK >> 1. Replace unified meter and A/C amp.  
 2. Go to self-diagnosis [ATC-48. "Self-Diagnosis Function"](#) and perform self-diagnosis STEP-2. Confirm that code No. 20 is displayed.
- NG >> 1. Replace ambient sensor.  
 2. Go to self-diagnosis [ATC-48. "Self-Diagnosis Function"](#) and perform self-diagnosis STEP-2. Confirm that code No. 20 is displayed.

### 4. CHECK CIRCUIT CONTINUITY BETWEEN AMBIENT SENSOR AND UNIFIED METER AND A/C AMP.

- Turn ignition switch OFF.
- Disconnect unified meter and A/C amp. connector.
- Check continuity between ambient sensor harness connector E62 terminal 1 and unified meter and A/C amp. harness connector M65 terminal 45.

**1 – 45 : Continuity should exist.**

- Check continuity between ambient sensor harness connector E62 terminal 1 and ground.

**1 – Ground : Continuity should not exist.**

### OK or NG

- OK >> 1. Replace unified meter and A/C amp.  
 2. Go to self-diagnosis [ATC-48. "Self-Diagnosis Function"](#) and perform self-diagnosis STEP-2. Confirm that code No. 20 is displayed.
- NG >> Repair harness or connector.

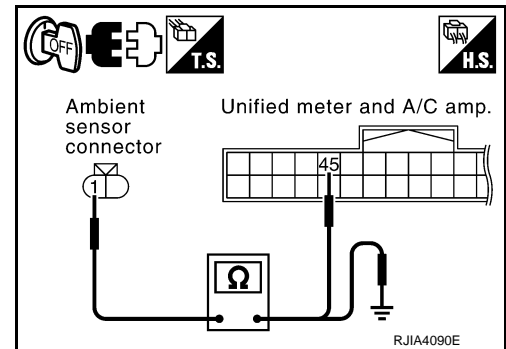

## COMPONENT INSPECTION

### Ambient Sensor

After disconnecting ambient sensor connector E62, measure resistance between terminals 1 and 2 at sensor side. Refer to the table below.

Temperature °C (°F)	Resistance kΩ
-15 (5)	12.73
-10 (14)	9.92
-5 (23)	7.80
0 (32)	6.19
5 (41)	4.95
10 (50)	3.99
15 (59)	3.24
20 (68)	2.65
25 (77)	2.19
30 (86)	1.81
35 (95)	1.51
40 (104)	1.27
45 (113)	1.07

If NG, replace ambient sensor.

### In-vehicle Sensor Circuit

## COMPONENT DESCRIPTION

In-vehicle Sensor

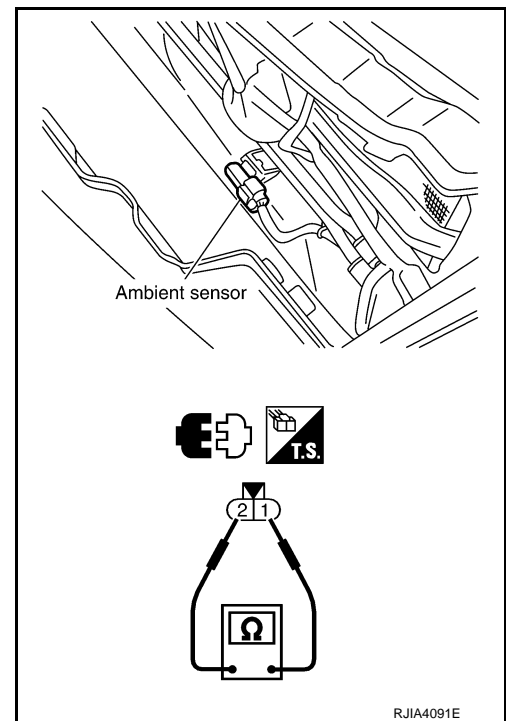

INFOID:000000005348535

# TROUBLE DIAGNOSIS

## < SERVICE INFORMATION >

The in-vehicle sensor is located on instrument driver lower panel. It converts variations in temperature of compartment air drawn from the aspirator into a resistance value. It is then input into the unified meter and A/C amp.

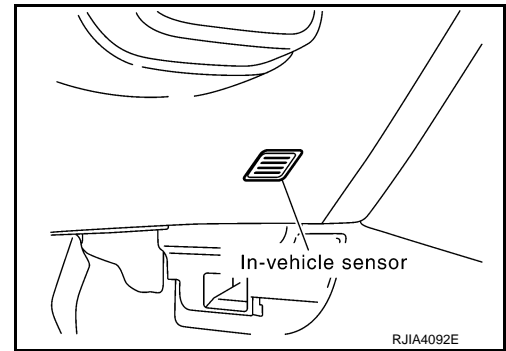

### Aspirator

The aspirator is located on driver's side of heater & cooling unit assembly. It produces vacuum pressure due to air discharged from the heater & cooling unit assembly, continuously taking compartment air in the aspirator.

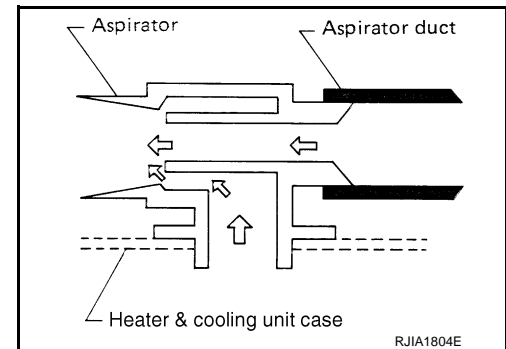
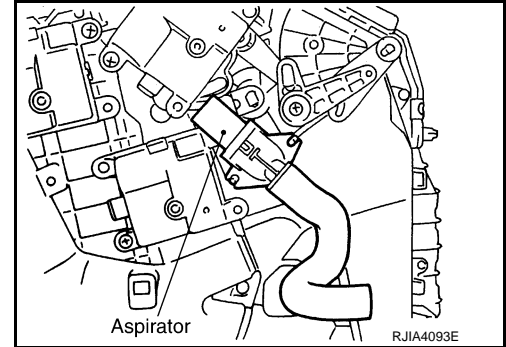

### In-vehicle Sensor Circuit

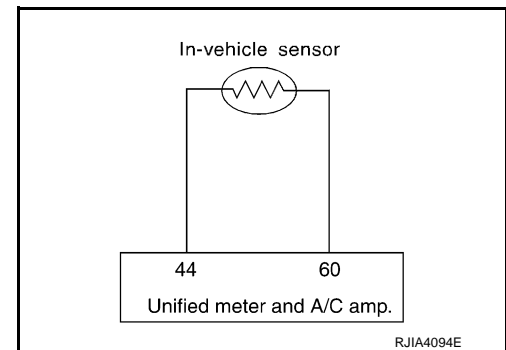

## DIAGNOSIS PROCEDURE FOR IN-VEHICLE SENSOR

SYMPTOM: In-vehicle sensor circuit is open or shorted. (22 or -22 is indicated on unified meter and A/C amp. as a result of performing self-diagnosis STEP-2.)

### 1. CHECK VOLTAGE BETWEEN IN-VEHICLE SENSOR AND GROUND

1. Disconnect in-vehicle sensor connector.
2. Turn ignition switch ON.

# TROUBLE DIAGNOSIS

## < SERVICE INFORMATION >

3. Check voltage between in-vehicle sensor harness connector M54 terminal 1 and ground.

**1 – Ground : Approx. 5 V**

### OK or NG

- OK >> GO TO 2.
- NG >> GO TO 4.

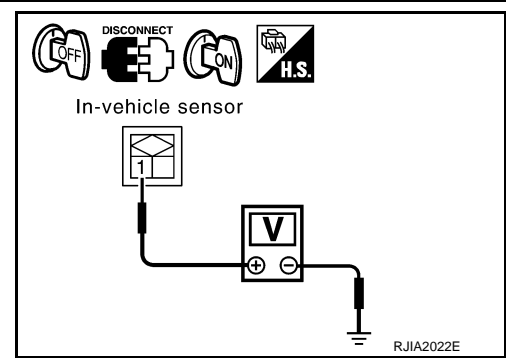

## 2. CHECK CIRCUIT CONTINUITY BETWEEN IN-VEHICLE SENSOR AND UNIFIED METER AND A/C AMP.

1. Turn ignition switch OFF.
2. Disconnect unified meter and A/C amp. connector.
3. Check continuity between in-vehicle sensor harness connector M54 terminal 2 and unified meter and A/C amp. harness connector M65 terminal 60.

**2 – 60 : Continuity should exist.**

### OK or NG

- OK >> GO TO 3.
- NG >> Repair harness or connector.

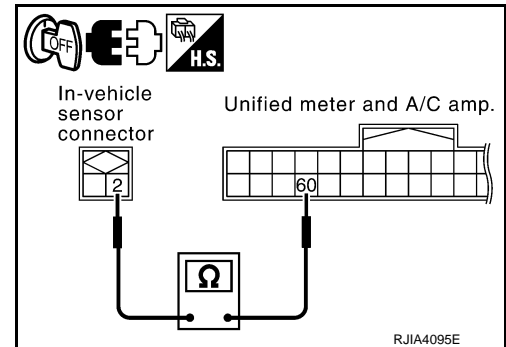

## 3. CHECK IN-VEHICLE SENSOR

Refer to "COMPONENT INSPECTION (In-vehicle Sensor)".

### OK or NG

- OK >> 1. Replace unified meter and A/C amp.  
2. Go to self-diagnosis [ATC-48. "Self-Diagnosis Function"](#) and perform self-diagnosis STEP-2. Confirm that code No. 20 is displayed.
- NG >> 1. Replace in-vehicle sensor.  
2. Go to self-diagnosis [ATC-48. "Self-Diagnosis Function"](#) and perform self-diagnosis STEP-2. Confirm that code No. 20 is displayed.

## 4. CHECK CIRCUIT CONTINUITY BETWEEN IN-VEHICLE SENSOR AND UNIFIED METER AND A/C AMP.

1. Turn ignition switch OFF.
2. Disconnect unified meter and A/C amp. connector.
3. Check continuity between in-vehicle sensor harness connector M54 terminal 1 and unified meter and A/C amp. harness connector M65 terminal 44.

**1 – 44 : Continuity should exist.**

4. Check continuity between in-vehicle sensor harness connector M54 terminal 1 and ground.

**1 – Ground : Continuity should not exist.**

### OK or NG

- OK >> 1. Replace unified meter and A/C amp.  
2. Go to self-diagnosis [ATC-48. "Self-Diagnosis Function"](#) and perform self-diagnosis STEP-2. Confirm that code No. 20 is displayed.
- NG >> Repair harness or connector.

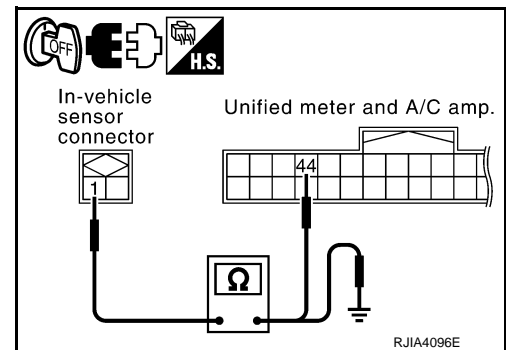

## COMPONENT INSPECTION

In-vehicle Sensor

# TROUBLE DIAGNOSIS

## < SERVICE INFORMATION >

After disconnecting in-vehicle sensor connector M54, measure resistance between terminals 1 and 2 at sensor side. Refer to the table below.

Temperature °C (°F)	Resistance kΩ
-15 (5)	12.73
-10 (14)	9.92
-5 (23)	7.80
0 (32)	6.19
5 (41)	4.95
10 (50)	3.99
15 (59)	3.24
20 (68)	2.65
25 (77)	2.19
30 (86)	1.81
35 (95)	1.51
40 (104)	1.27
45 (113)	1.07

If NG, replace in-vehicle sensor.

## Sunload Sensor Circuit

### COMPONENT DESCRIPTION

#### Sunload Sensor

The sunload sensor is located on the driver's side front defroster grille. It detects sunload entering through windshield by means of a photo diode. The sensor converts the sunload into a current value which is then input into the unified meter and A/C amp.

#### Sunload Sensor Circuit

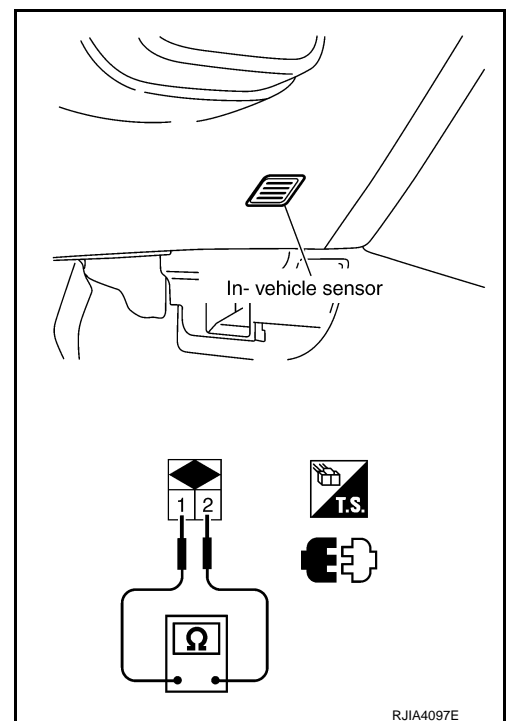

INFOID:000000005348536

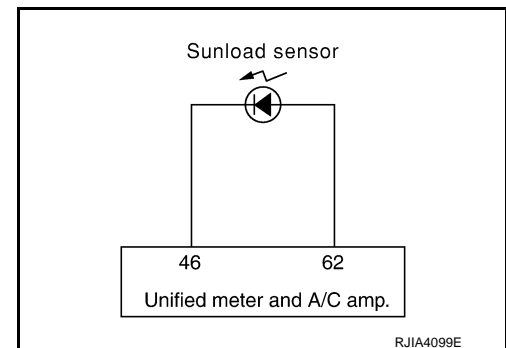
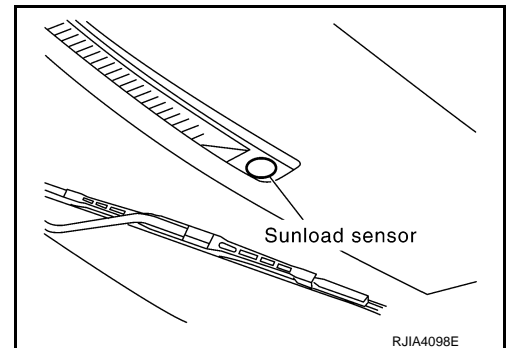

### SUNLOAD INPUT PROCESS

- The unified meter and A/C amp. also includes a processing circuit which averages the variations in detected sunload over a period of time. This prevents drastic swings in the ATC system operation due to small or quick variations in detected sunload.
- For example, consider driving along a road bordered by an occasional group of large trees. The sunload detected by the sunload sensor will vary whenever the trees obstruct the sunlight. The processing circuit

# TROUBLE DIAGNOSIS

## < SERVICE INFORMATION >

averages the detected sunload over a period of time, so that the (insignificant) effect of the trees momentarily obstructing the sunlight does not cause any change in the ATC system operation. On the other hand, shortly after entering a long tunnel, the system will recognize the change in sunload, and the system will react accordingly.

### DIAGNOSIS PROCEDURE FOR SUNLOAD SENSOR

SYMPTOM: Sunload sensor circuit is open or shorted. (25 or -25 is indicated on unified meter and A/C amp. as a result of performing self-diagnosis STEP-2.)

#### 1. CHECK VOLTAGE BETWEEN SUNLOAD SENSOR AND GROUND

1. Disconnect sunload sensor connector.
2. Turn ignition switch ON.
3. Check voltage between sunload sensor harness connector M87 terminal 1 and ground.

**1 – Ground : Approx. 5 V**

##### OK or NG

- OK >> GO TO 2.  
NG >> GO TO 4.

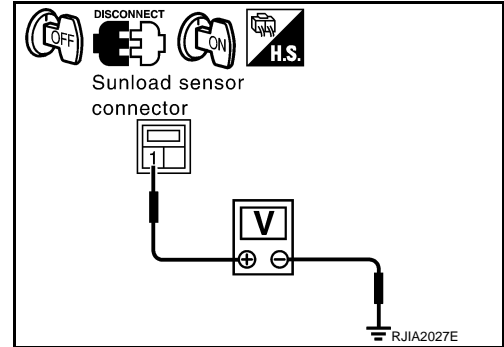

#### 2. CHECK CIRCUIT CONTINUITY BETWEEN SUNLOAD SENSOR AND UNIFIED METER AND A/C AMP.

1. Turn ignition switch OFF.
2. Disconnect unified meter and A/C amp. connector.
3. Check continuity between sunload sensor harness connector M87 terminal 2 and unified meter and A/C amp. harness connector M65 terminal 62.

**2 – 62 : Continuity should exist.**

##### OK or NG

- OK >> GO TO 3.  
NG >> Repair harness or connector.

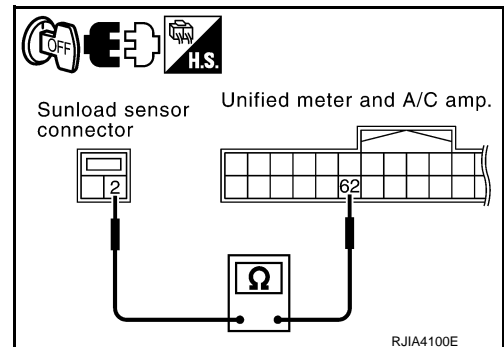

#### 3. CHECK SUNLOAD SENSOR

1. Reconnect sunload sensor connector and unified meter and A/C amp. connector.
2. Refer to "COMPONENT INSPECTION (Sunload Sensor)".

##### OK or NG

- OK >> 1. Replace unified meter and A/C amp.  
2. Go to self-diagnosis [ATC-48, "Self-Diagnosis Function"](#) and perform self-diagnosis STEP-2. Confirm that code No. 20 is displayed.
- NG >> 1. Replace sunload sensor.  
2. Go to self-diagnosis [ATC-48, "Self-Diagnosis Function"](#) and perform self-diagnosis STEP-2. Confirm that code No. 20 is displayed.

#### 4. CHECK CIRCUIT CONTINUITY BETWEEN SUNLOAD SENSOR AND UNIFIED METER AND A/C AMP.

1. Turn ignition switch OFF.
2. Disconnect unified meter and A/C amp. connector.

# TROUBLE DIAGNOSIS

## < SERVICE INFORMATION >

3. Check continuity between sunload sensor harness connector M87 terminal 1 and unified meter and A/C amp. harness connector M65 terminal 46.

**1 – 46 : Continuity should exist.**

4. Check continuity between sunload sensor harness connector M87 terminal 1 and ground.

**1 – Ground : Continuity should not exist.**

### OK or NG

- OK >> 1. Replace unified meter and A/C amp.  
2. Go to self-diagnosis [ATC-48. "Self-Diagnosis Function"](#) and perform self-diagnosis STEP-2.  
Confirm that code No. 20 is displayed.
- NG >> Repair harness or connector.

## COMPONENT INSPECTION

### Sunload Sensor

Measure voltage between unified meter and A/C amp. harness connector M65 terminal 46 and ground.

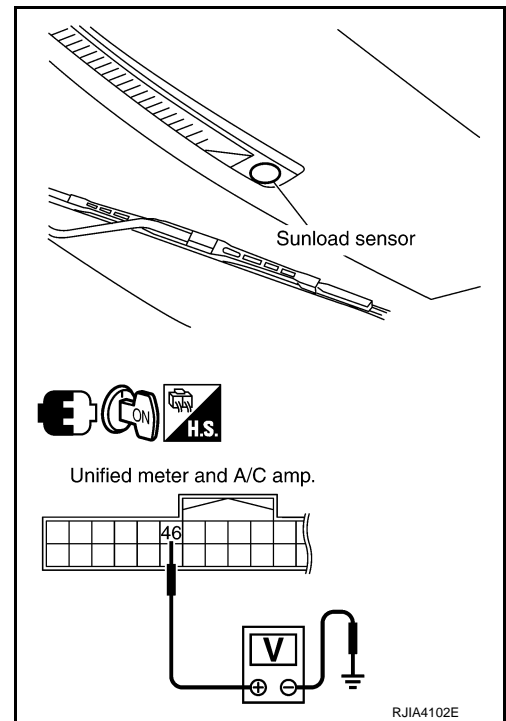
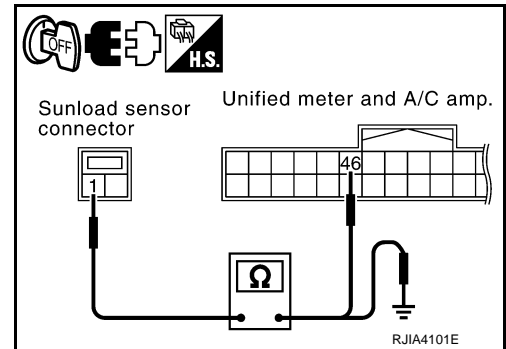



# TROUBLE DIAGNOSIS

## < SERVICE INFORMATION >

- When checking sunload sensor, select a place where sunshine directly on it.

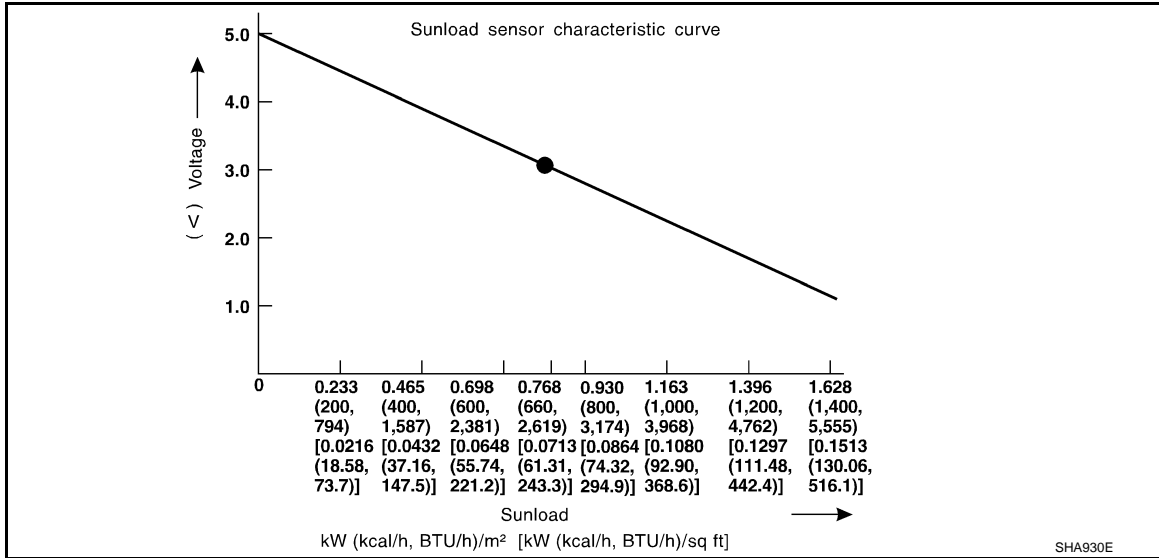

If NG, replace sunload sensor.

## Intake Sensor Circuit

INFOID:000000005348537

## COMPONENT DESCRIPTION

### Intake Sensor

The intake sensor is located on the evaporator assembly. It converts temperature of air after it passes through the evaporator into a resistance value which is then input to the unified meter and A/C amp.

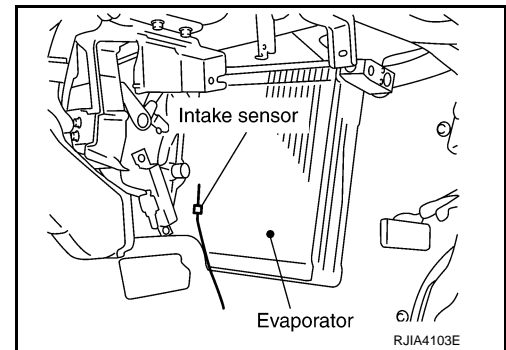

### Intake Sensor Circuit

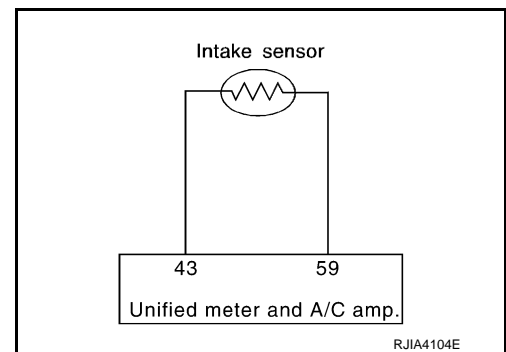

## DIAGNOSIS PROCEDURE FOR INTAKE SENSOR

SYMPTOM: Intake sensor circuit is open or shorted. (24 or -24 is indicated on unified meter and A/C amp. as a result of performing self-diagnosis STEP-2.)

### 1. CHECK VOLTAGE BETWEEN INTAKE SENSOR AND GROUND

1. Disconnect intake sensor connector.
2. Turn ignition switch ON.

# TROUBLE DIAGNOSIS

## < SERVICE INFORMATION >

3. Check voltage between intake sensor harness connector M82 terminal 1 and ground.

**1 – Ground : Approx. 5 V**

### OK or NG

- OK >> GO TO 2.
- NG >> GO TO 4.

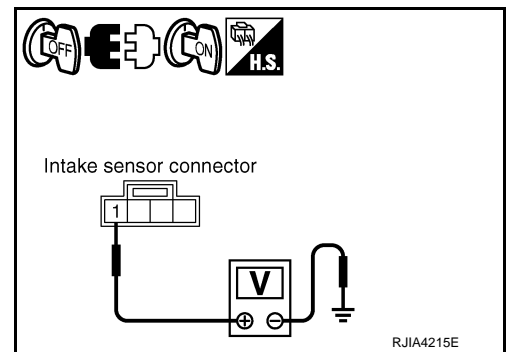

## 2. CHECK CIRCUIT CONTINUITY BETWEEN INTAKE SENSOR AND UNIFIED METER AND A/C AMP.

1. Turn ignition switch OFF.
2. Disconnect unified meter and A/C amp. connector.
3. Check continuity between intake sensor harness connector M82 terminal 2 and unified meter and A/C amp. harness connector M65 terminal 59.

**2 – 59 : Continuity should exist.**

### OK or NG

- OK >> GO TO 3.
- NG >> Repair harness or connector.

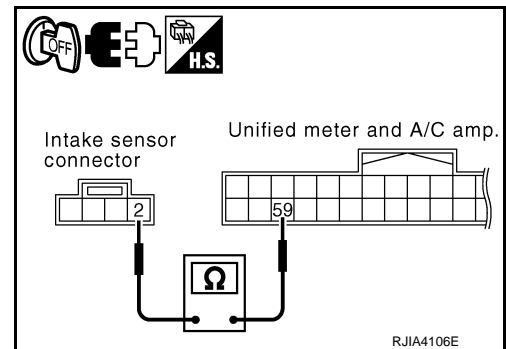

## 3. CHECK INTAKE SENSOR

Refer to "COMPONENT INSPECTION (Intake Sensor)".

### OK or NG

- OK >> 1. Replace unified meter and A/C amp.  
2. Go to self-diagnosis [ATC-48. "Self-Diagnosis Function"](#) and perform self-diagnosis STEP-2. Confirm that code No. 20 is displayed.
- NG >> 1. Replace intake sensor.  
2. Go to self-diagnosis [ATC-48. "Self-Diagnosis Function"](#) and perform self-diagnosis STEP-2. Confirm that code No. 20 is displayed.

## 4. CHECK CIRCUIT CONTINUITY BETWEEN INTAKE SENSOR AND UNIFIED METER AND A/C AMP.

1. Turn ignition switch OFF.
2. Disconnect unified meter and A/C amp. connector.
3. Check continuity between intake sensor harness connector M82 terminal 1 and unified meter and A/C amp. harness connector M65 terminal 43.

**1 – 43 : Continuity should exist.**

4. Check continuity between intake sensor harness connector M82 terminal 1 and ground.

**1 – Ground : Continuity should not exist.**

### OK or NG

- OK >> 1. Replace unified meter and A/C amp.  
2. Go to self-diagnosis [ATC-48. "Self-Diagnosis Function"](#) and perform self-diagnosis STEP-2. Confirm that code No. 20 is displayed.
- NG >> Repair harness or connector.

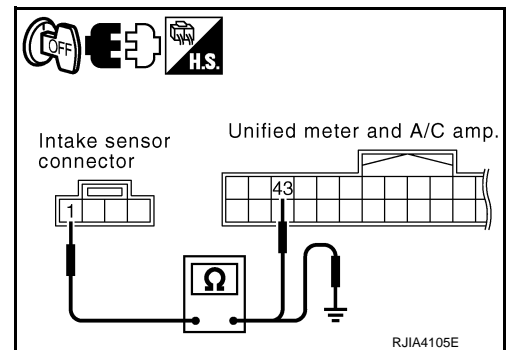

## COMPONENT INSPECTION

Intake Sensor

# TROUBLE DIAGNOSIS

## < SERVICE INFORMATION >

After disconnecting intake sensor connector M82, measure resistance between terminals 1 and 2 at sensor side. Refer to the table below.

Temperature °C (°F)	Resistance kΩ
-15 (5)	12.84
-10 (14)	10.02
-5 (23)	7.90
0 (32)	6.28
5 (41)	5.03
10 (50)	4.06
15 (59)	3.30
20 (68)	2.71
25 (77)	2.23
30 (86)	1.85
35 (95)	1.55
40 (104)	1.30
45 (113)	1.10

If NG, replace intake sensor.

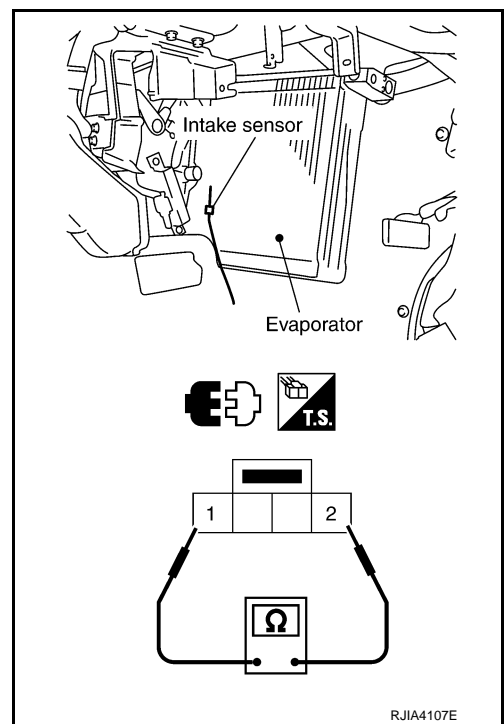

A  
B  
C  
D  
E  
F  
G  
H  
I

ATC

K  
L  
M  
N  
O  
P

# CONTROLLER

< SERVICE INFORMATION >

---

## CONTROLLER

### Removal and Installation of Multifunction Switch

INFOID:000000005348538

#### REMOVAL

Refer to [AV-493. "Exploded View"](#) (WITHOUT MOBILE ENTERTAINMENT SYSTEM) or [AV-1077. "Exploded View"](#) (WITH MOBILE ENTERTAINMENT SYSTEM).

#### INSTALLATION

Installation is basically the reverse order of removal.

# AUTO AMP.

< SERVICE INFORMATION >

## AUTO AMP.

### Removal and Installation of Unified Meter and A/C Amp.

INFOID:000000005348539

#### REMOVAL

1. Remove AV control unit. Refer to [AV-482, "Exploded View"](#) (WITHOUT MOBILE ENTERTAINMENT SYSTEM) or [AV-1064, "Exploded View"](#) (WITH MOBILE ENTERTAINMENT SYSTEM).
2. Remove mounting screws, and then remove unified meter and A/C amp.

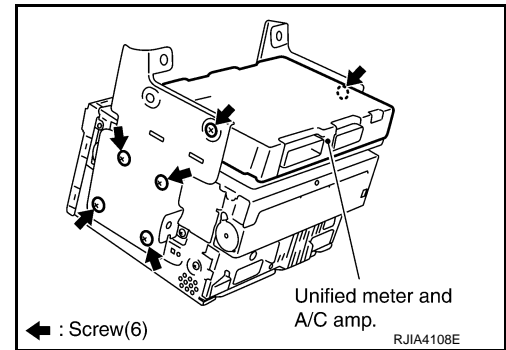

#### INSTALLATION

Installation is basically the reverse order of removal.

A  
B  
C  
D  
E  
F  
G  
H  
I

ATC

K  
L  
M  
N  
O  
P

# AMBIENT SENSOR

< SERVICE INFORMATION >

## AMBIENT SENSOR

### Removal and Installation

INFOID:000000005348540

#### REMOVAL

1. Remove front grille. Refer to [EI-27, "Component Parts Location"](#).
2. Disconnect ambient sensor connector, and then remove ambient sensor.

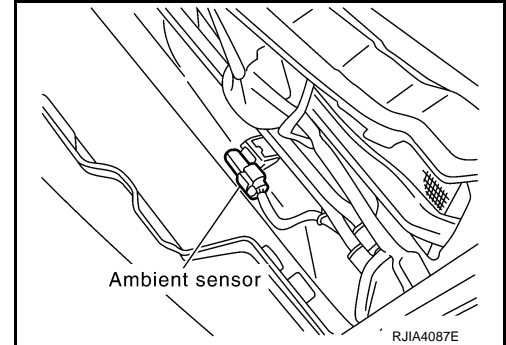

#### INSTALLATION

Installation is basically the reverse order of removal.

# IN-VEHICLE SENSOR

< SERVICE INFORMATION >

## IN-VEHICLE SENSOR

### Removal and Installation

INFOID:000000005348541

#### REMOVAL

1. Remove instrument driver lower panel. Refer to [IP-11, "INSTRUMENT PANEL : Component Parts Location"](#).
2. Remove mounting screw, and then remove in-vehicle sensor.

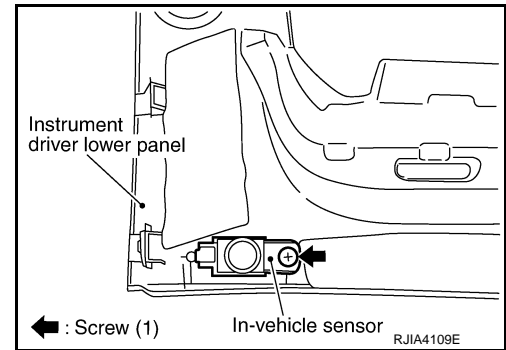

#### INSTALLATION

Installation is basically the reverse order of removal.

A  
B  
C  
D  
E  
F  
G  
H  
I  
K  
L  
M  
N  
O  
P

ATC

# SUNLOAD SENSOR

< SERVICE INFORMATION >

## SUNLOAD SENSOR

### Removal and Installation

INFOID:000000005348542

#### REMOVAL

1. Remove front defroster grille (left). Refer to [IP-11, "INSTRUMENT PANEL : Component Parts Location"](#).
2. Disconnect sunload sensor connector, and then remove sunload sensor.

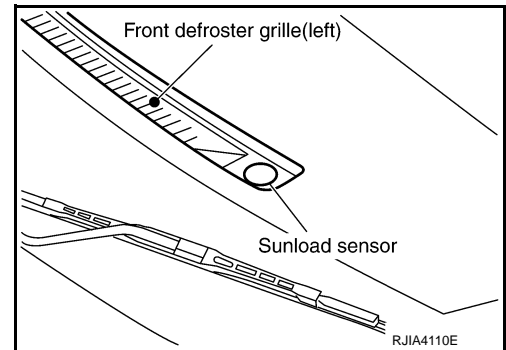

#### INSTALLATION

Installation is basically the reverse order of removal.



# INTAKE SENSOR

< SERVICE INFORMATION >

## INTAKE SENSOR

### Removal and Installation

INFOID:000000005348543

#### REMOVAL

1. Remove low-pressure pipe 1 and high-pressure pipe 2. Refer to [ATC-142, "VQ35HR : Removal and Installation of Low-pressure Pipe 1 and High-pressure Pipe 2"](#) (VQ35HR) or [ATC-160, "VK45DE : Removal and Installation of Low-pressure Pipe 1 and High-pressure Pipe 2"](#) (VK45DE).

**CAUTION:**

Cap or wrap the joint of the A/C piping with suitable material such as vinyl tape to avoid the entry of air.

2. Slide evaporator to passenger side, and then remove intake sensor.

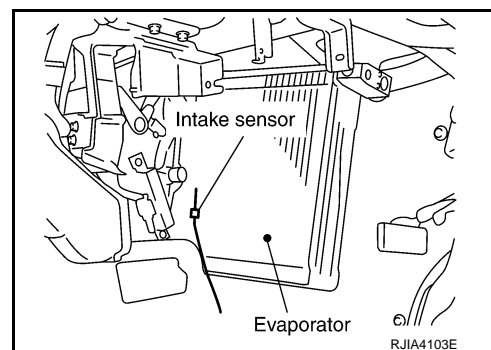

#### INSTALLATION

Installation is basically the reverse order of removal.

**CAUTION:**

- Replace O-rings with new ones. Then apply compressor oil to them when installing.
- Mark the mounting position of intake sensor bracket prior to removal so that the reinstalled sensor can be located in the same position.
- Female-side piping connection is thin and easy to deform. Slowly insert the male-side piping straight in axial direction.
- Insert piping securely until a click is heard.
- After piping connection is completed, pull male-side piping by hand to check that connection does not come loose.
- Check for leakages when recharging refrigerant.

A  
B  
C  
D  
E  
F  
G  
H  
I  
K  
L  
M  
N  
O  
P

ATC

# BLOWER UNIT

< SERVICE INFORMATION >

## BLOWER UNIT

### Removal and Installation

INFOID:000000005348544

#### REMOVAL

1. Remove instrument passenger lower cover and glove box cover. Refer to [IP-11. "INSTRUMENT PANEL : Component Parts Location"](#).
2. Remove BCM. Refer to [BCS-14. "Removal and Installation of BCM"](#).
3. Remove mounting bolt (A) and nut (B), and then remove ECM (1) with bracket attached.
4. Disconnect intake door motor connector and blower fan motor connector.
5. Remove mounting bolt (C) and screw (D) from blower unit (2).

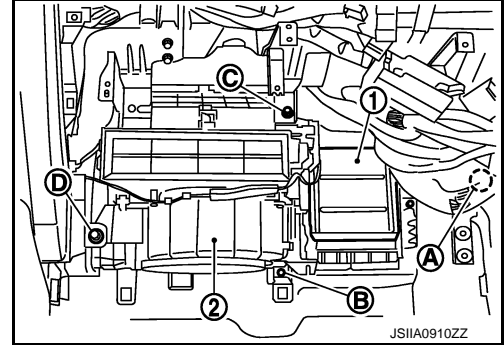

6. Remove blower unit.  
**CAUTION:**  
Move blower unit rightward, and remove locating pin (1 part) and joint. Then remove blower unit downward.

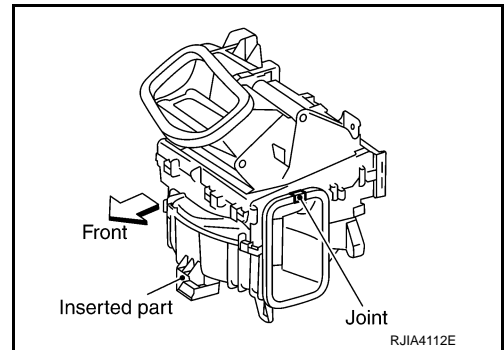

#### INSTALLATION

Installation is basically the reverse order of removal.

**CAUTION:**  
Check locating pin (1 part) and joint are securely inserted.

# BLOWER UNIT

< SERVICE INFORMATION >

## Disassembly and Assembly

INFOID:000000005348545

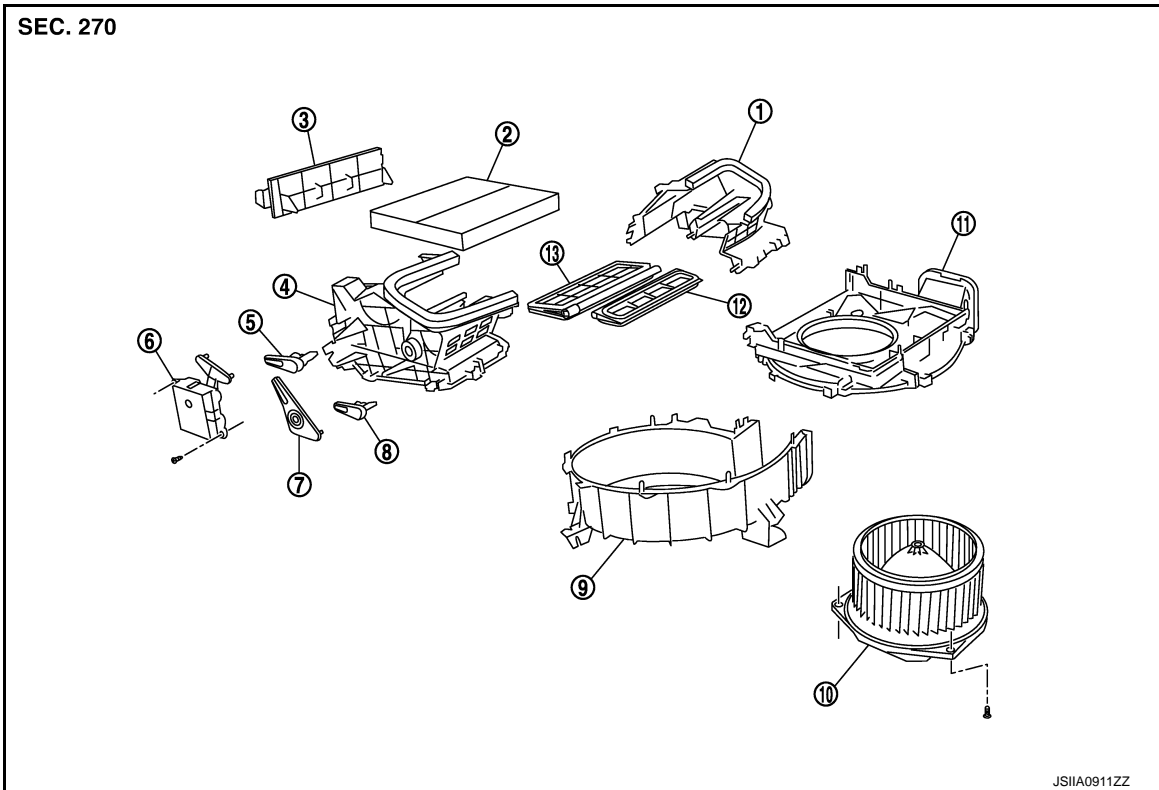

- |                           |                         |                      |
|---------------------------|-------------------------|----------------------|
| 1. Intake box (left)      | 2. In-cabin microfilter | 3. Filter cover      |
| 4. Intake box (right)     | 5. Intake door lever 2  | 6. Intake door motor |
| 7. Intake door link       | 8. Intake door lever 1  | 9. Intake lower case |
| 10. Blower motor assembly | 11. Intake upper case   | 12. Intake door 1    |
| 13. Intake door 2         |                         |                      |

A  
B  
C  
D  
E  
F  
G  
H  
I  
K  
L  
M  
N  
O  
P

ATC

# BLOWER MOTOR

< SERVICE INFORMATION >

## BLOWER MOTOR

### Removal and Installation

INFOID:000000005348546

#### REMOVAL

1. Remove instrument passenger lower cover. Refer to [IP-11. "INSTRUMENT PANEL : Component Parts Location"](#).
2. Disconnect blower motor connector.
3. Remove mounting screws, and then remove blower motor.

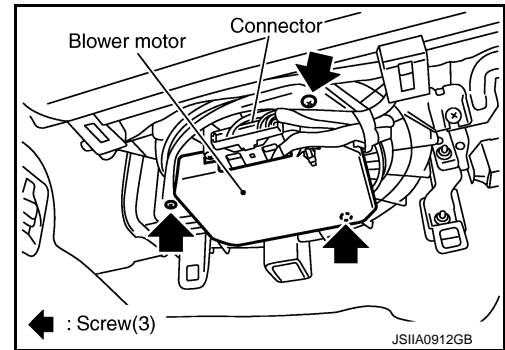

#### INSTALLATION

Installation is basically the reverse order of removal.

# INTAKE DOOR MOTOR

< SERVICE INFORMATION >

## INTAKE DOOR MOTOR

### Removal and Installation

INFOID:000000005348547

#### REMOVAL

1. Remove ECM with bracket attached. Refer to [ATC-114, "Removal and Installation"](#).
2. Remove mounting screws, and then remove intake door motor from blower unit.
3. Disconnect intake door motor connector.

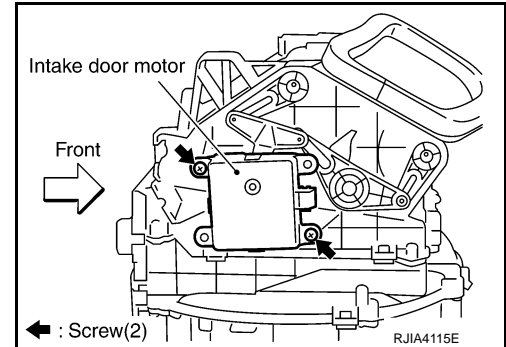

#### INSTALLATION

Installation is basically the reverse order of removal.

A  
B  
C  
D  
E  
F  
G  
H  
I  
K  
L  
M  
N  
O  
P

ATC

# IN-CABIN MICROFILTER

< SERVICE INFORMATION >

## IN-CABIN MICROFILTER

### Removal and Installation

INFOID:000000005348548

#### FUNCTION

Air inside passenger compartment is kept clean at either recirculation or fresh mode by installing in-cabin microfilter into blower unit.

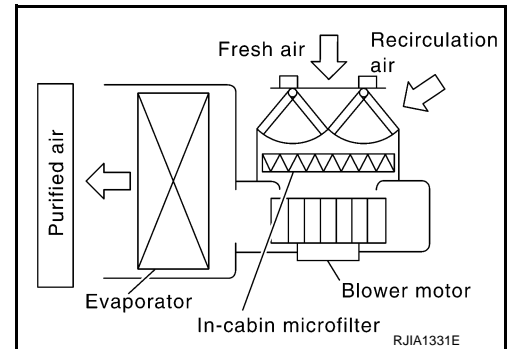

#### REPLACEMENT TIMING

Replace in-cabin microfilter.

Refer to [MA-5, "Schedule 1"](#) in Schedule 1 and [MA-7, "Schedule 2"](#) in Schedule 2.

When replacing filter, affix a caution label inside the glove box.

#### REPLACEMENT PROCEDURES

1. Remove glove box. Refer to [IP-11, "INSTRUMENT PANEL : Component Parts Location"](#).

2. Remove filter cover, and then remove in-cabin microfilter.

**CAUTION:**

**If the filter is deformed/damaged when removing, replace it with a new one. Deformed/damaged filter may deteriorate the dust collecting performance.**

3. Take out in-cabin microfilter from blower unit.

4. Replace with new one and reinstall on blower unit.

**CAUTION:**

**When installing, handle the filter with extreme care to avoid deforming/damaging.**

5. Reinstall glove box.

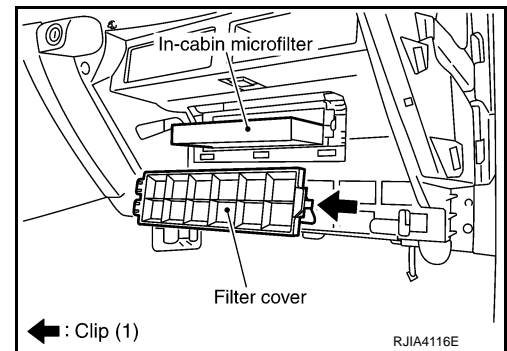

# HEATER & COOLING UNIT ASSEMBLY

< SERVICE INFORMATION >

## HEATER & COOLING UNIT ASSEMBLY

### Removal and Installation

INFOID:000000005348549

#### REMOVAL

1. Use a refrigerant collecting equipment (for HFC-134a) to discharge the refrigerant.
2. Drain coolant from cooling system. Refer to [CO-10, "Changing Engine Coolant"](#) (VQ35HR) or [CO-36, "Changing Engine Coolant"](#) (VK45DE).
3. Remove cowl top cover. Refer to [EI-29, "Component Parts Location"](#).
4. Remove engine cover. Refer to [EM-19, "Removal and Installation"](#) (VQ35HR) or [EM-175, "Removal and Installation"](#) (VK45DE).
5. Disconnect one-touch joint between low-pressure pipe 1 (1) and low-pressure pipe 2 (2) (VQ35HR) or low-pressure flexible hose (2) (VK45DE) with disconnecter (SST: 9253089916) (A).

**CAUTION:**

Cap or wrap the joint of the A/C piping with suitable material such as vinyl tape to avoid the entry of air.

6. Disconnect one-touch joint between high-pressure pipe 1 (3) and high-pressure pipe 2 (4) with disconnecter (SST: 9253089908).

**CAUTION:**

Cap or wrap the joint of the A/C piping with suitable material such as vinyl tape to avoid the entry of air.

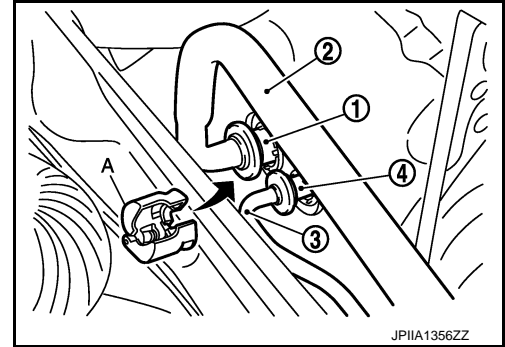

7. Remove clamps (A), and then disconnect heater hoses (1). (VQ35HR)

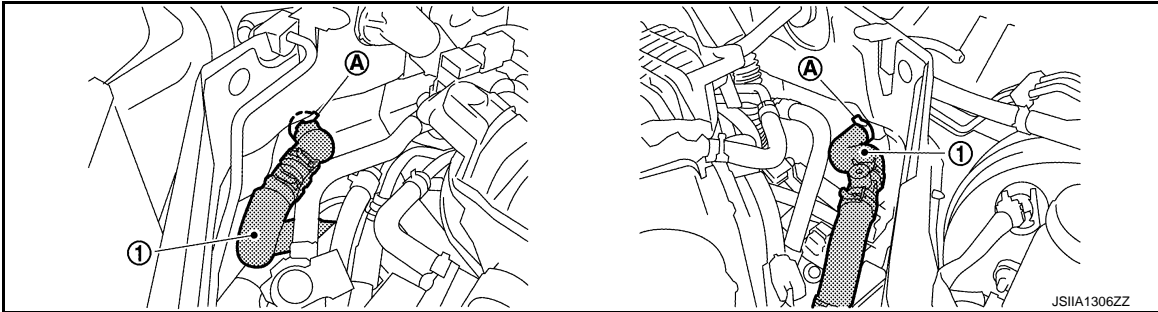

8. Remove clamps, and then disconnect heater hoses. (VK45DE)

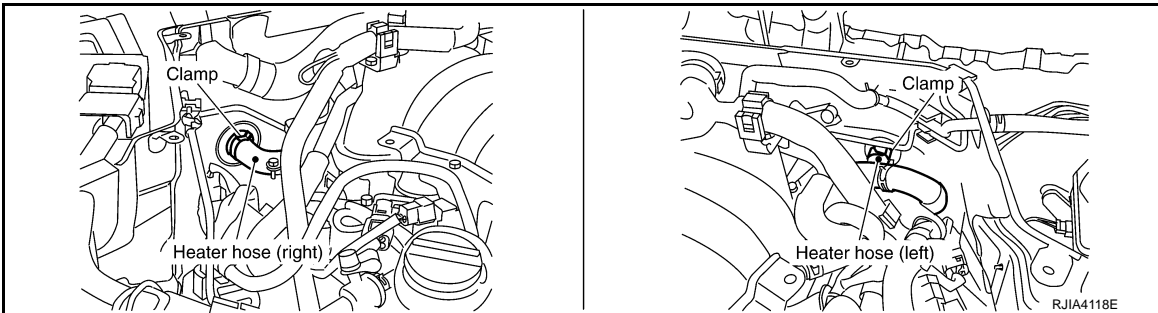

9. Remove instrument panel & pad. Refer to [IP-11, "INSTRUMENT PANEL : Component Parts Location"](#).
10. Remove blower unit. Refer to [ATC-114, "Removal and Installation"](#).
11. Remove clips of vehicle harness from steering member.

A  
B  
C  
D  
E  
F  
G  
H  
I  
K  
L  
M  
N  
O  
P

ATC

# HEATER & COOLING UNIT ASSEMBLY

## < SERVICE INFORMATION >

12. Remove mounting nuts and bolts, and then remove instrument stays.

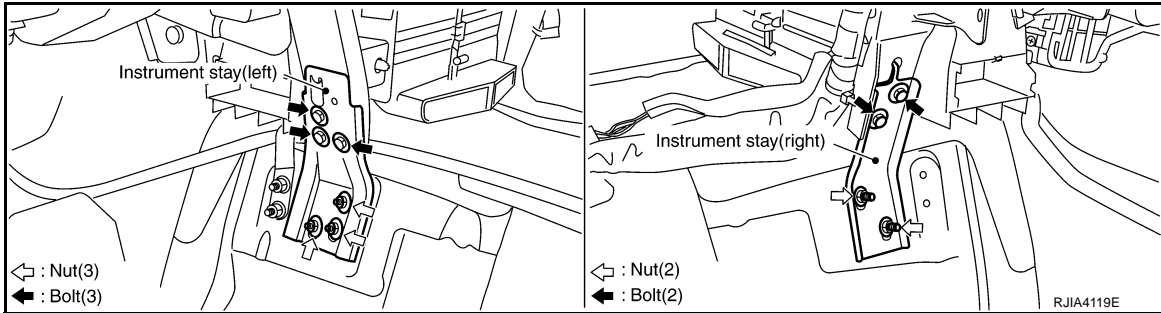

13. Disconnect drain hose.

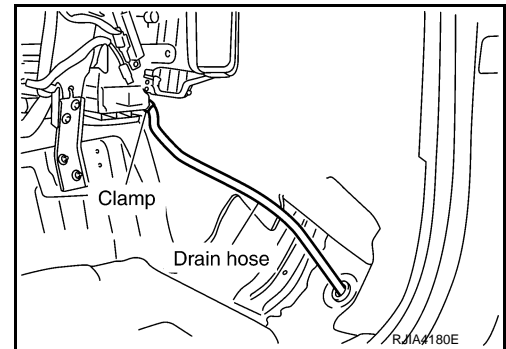

14. Remove mounting bolts from heater & cooling unit.

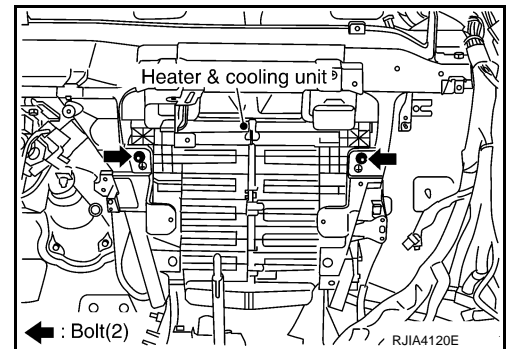



# HEATER & COOLING UNIT ASSEMBLY

## < SERVICE INFORMATION >

### 15. Remove side defroster nozzles.

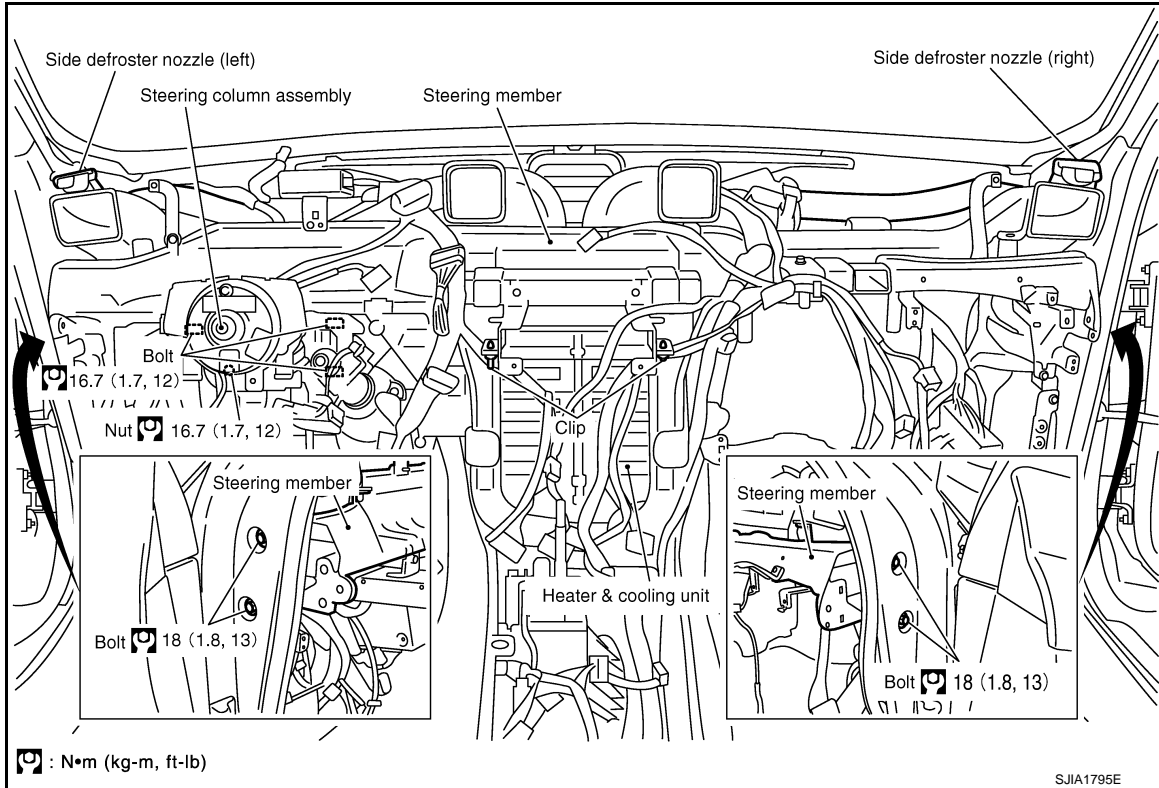

16. Remove steering column assembly mounting bolts and nut.

17. Remove steering member mounting bolts.

18. Remove steering member, and then remove heater & cooling unit.

## INSTALLATION

Installation is basically the reverse order of removal.

### CAUTION:

- Replace O-rings with new ones. Then apply compressor oil to them when installing.
- Female-side piping connection is thin and easy to deform. Slowly insert the male-side piping straight in axial direction.
- Insert piping securely until a click is heard.
- After piping connection is completed, pull male-side piping by hand to check that connection does not come loose.
- Check for leakages when recharging refrigerant.

### NOTE:

- When filling radiator with coolant, refer to [CO-10, "Changing Engine Coolant"](#) (VQ35HR) or [CO-36, "Changing Engine Coolant"](#) (VK45DE).
- Recharge the refrigerant.

### Heater & cooling unit assembly mounting bolt

: 6.9 N•m (0.7 kg-m, 61 in-lb)

### Instrument stay mounting nut and bolt

: 12 N•m (1.2 kg-m, 9 ft-lb)

# HEATER & COOLING UNIT ASSEMBLY

< SERVICE INFORMATION >

## Disassembly and Assembly

INFOID:000000005348550

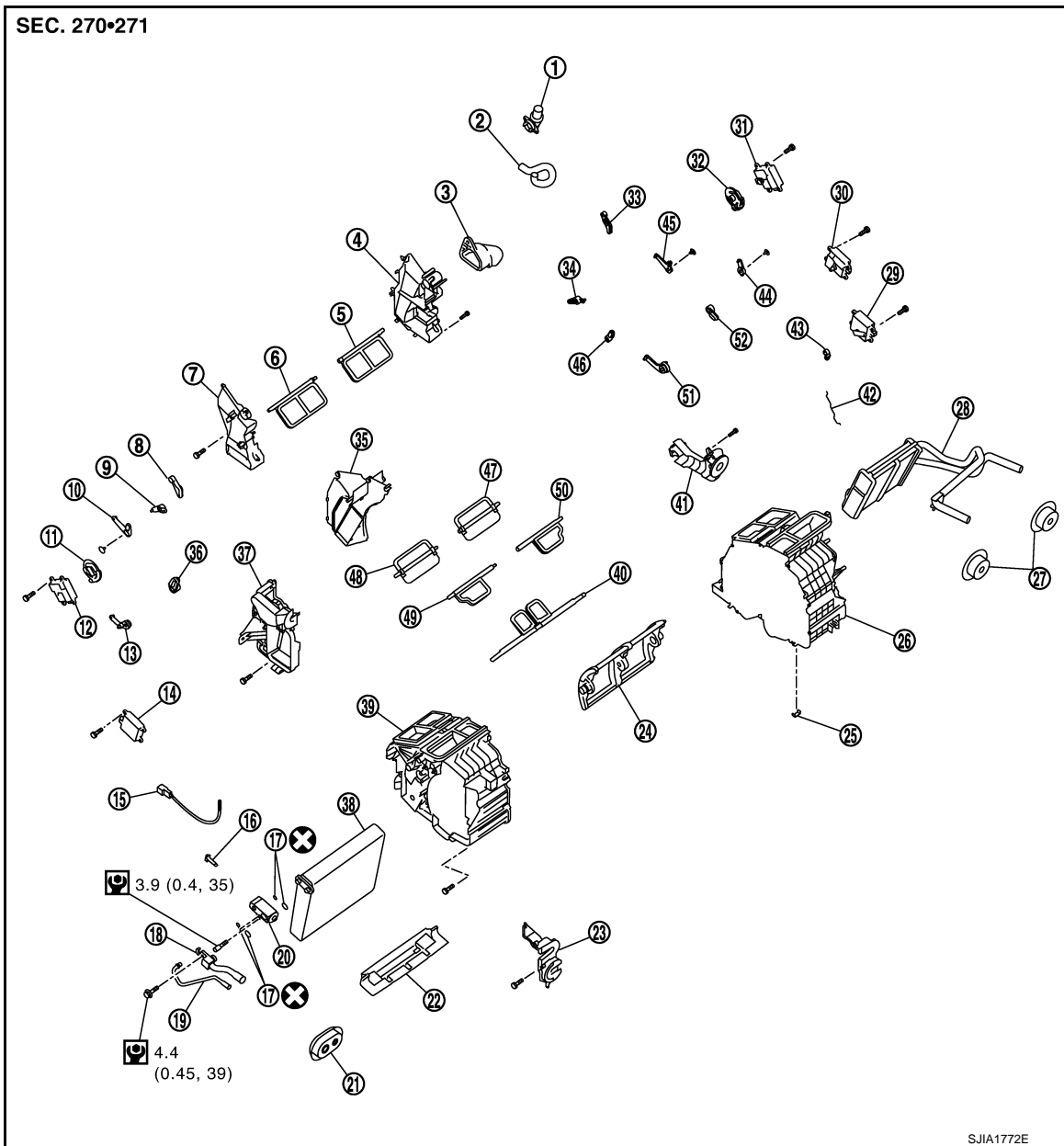

- |                                   |   |  |
|-----------------------------------|---|--|
| 1. Aspirator                      | 2. Aspirator hose                       | 3. Front heater duct (left)            |
| 4. Foot duct (left)               | 5. Ventilator door (left)               | 6. Ventilator door (right)             |
| 7. Foot duct (right)              | 8. Main link sub (right)                | 9. Ventilator door lever (right)       |
| 10. Ventilator door link (right)  | 11. Main link (right)                   | 12. Mode door motor (passenger side)   |
| 13. Max. cool door link (right)   | 14. Air mix door motor (passenger side) | 15. Intake sensor                      |
| 16. Intake sensor bracket         | 17. O-ring                              | 18. Low-pressure pipe 1                |
| 19. High-pressure pipe 2          | 20. Expansion valve                     | 21. Cooler pipe grommet                |
| 22. Insulator                     | 23. Evaporator cover adapter            | 24. Air mix door (Slide door)          |
| 25. Clip                          | 26. Heater & cooling unit case (left)   | 27. Heater pipe grommet                |
| 28. Heater core                   | 29. Upper ventilator door motor         | 30. Air mix door motor (driver side)   |
| 31. Mode door motor (driver side) | 32. Main link (left)                    | 33. Main link sub (left)               |
| 34. Ventilator door lever (left)  | 35. Center case                         | 36. Max. cool door lever (right)       |
| 37. Evaporator cover              | 38. Evaporator                          | 39. Heater & cooling unit case (right) |
| 40. Upper ventilator door         | 41. Heater pipe cover                   | 42. Upper ventilator door rod          |

# HEATER & COOLING UNIT ASSEMBLY

## < SERVICE INFORMATION >

---

- |                                 |                           |                                 |
|---------------------------------|---------------------------|---------------------------------|
| 43. Upper ventilator door lever | 44. Defroster door link   | 45. Ventilator door link (left) |
| 46. Max. cool door lever (left) | 47. Max. cool door (left) | 48. Max. cool door (right)      |
| 49. Defroster door (right)      | 50. Defroster door (left) | 51. Max. cool door link (left)  |
| 52. Defroster door lever        |                           |                                 |

Refer to [GI-9, "Component"](#) for symbols in the figure.

A

B

C

D

E

F

G

H

I

ATC

K

L

M

N

O

P

# MODE DOOR MOTOR

< SERVICE INFORMATION >

## MODE DOOR MOTOR

### Removal and Installation

INFOID:000000005348551

#### REMOVAL

##### Driver Side

1. Remove heater & cooling unit assembly. Refer to [ATC-119. "Removal and Installation"](#).
2. Remove mounting screws, and then remove mode door motor.
3. Disconnect mode door motor connector.

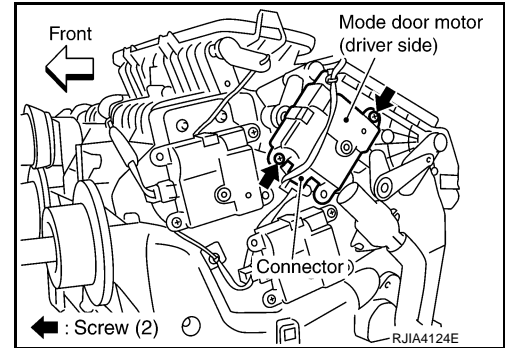

##### Passenger Side

1. Remove blower unit. Refer to [ATC-114. "Removal and Installation"](#).
2. Remove mounting screws, and then remove mode door motor.
3. Disconnect mode door motor connector.

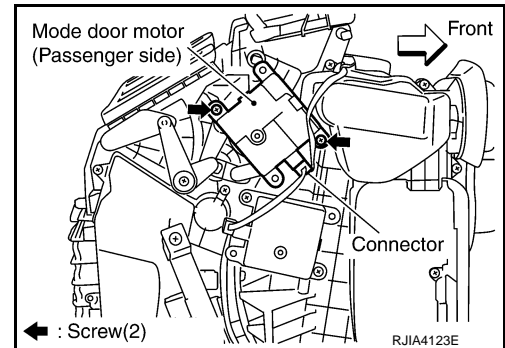

#### INSTALLATION

Installation is basically the reverse order of removal.

# AIR MIX DOOR MOTOR

< SERVICE INFORMATION >

## AIR MIX DOOR MOTOR

### Removal and Installation

INFOID:000000005348552

#### REMOVAL

##### Driver Side

1. Set the temperature control switch (driver side) at 18°C (60°F).  
**CAUTION:**  
**The angle may be out, when installing the air mix door motor to the air mix door, unless the above procedure is performed.**
2. Disconnect the battery cable from the negative terminal.
3. Remove heater & cooling unit assembly. Refer to [ATC-119, "Removal and Installation"](#).
4. Remove mounting screws, and then remove air mix door motor.
5. Disconnect air mix door motor connector.

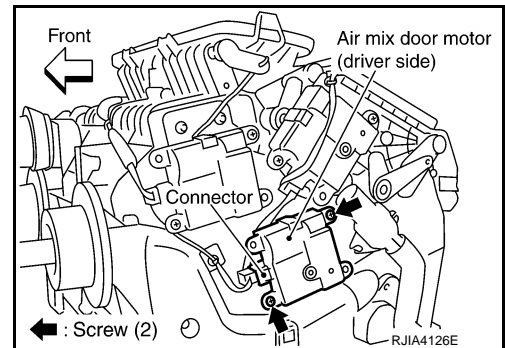

##### Passenger Side

1. Set the temperature control switch (passenger side) at 18°C (60°F).  
**CAUTION:**  
**The angle may be out, when installing the air mix door motor to the air mix door, unless the above procedure is performed.**
2. Disconnect the battery cable from the negative terminal.
3. Remove blower unit. Refer to [ATC-114, "Removal and Installation"](#).
4. Remove mounting screws, and then remove air mix door motor.
5. Disconnect air mix door motor connector.

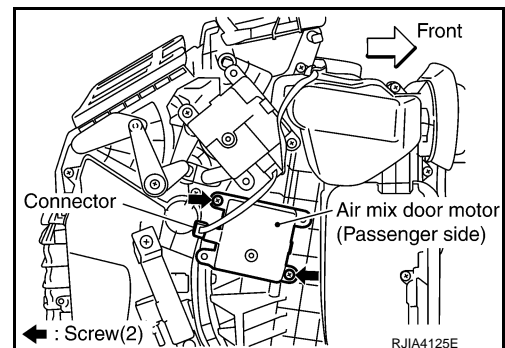

#### INSTALLATION

Installation is basically the reverse order of removal.

A  
B  
C  
D  
E  
F  
G  
H  
I  
K  
L  
M  
N  
O  
P

ATC

# UPPER VENTILATOR DOOR MOTOR

< SERVICE INFORMATION >

## UPPER VENTILATOR DOOR MOTOR

### Removal and Installation

INFOID:000000005348553

#### REMOVAL

1. Remove heater & cooling unit assembly. Refer to [ATC-119. "Removal and Installation"](#).
2. Remove mounting screws.
3. Disconnect upper ventilator door motor connector.
4. Disconnect upper ventilator door rod, and then remove upper ventilator door motor.

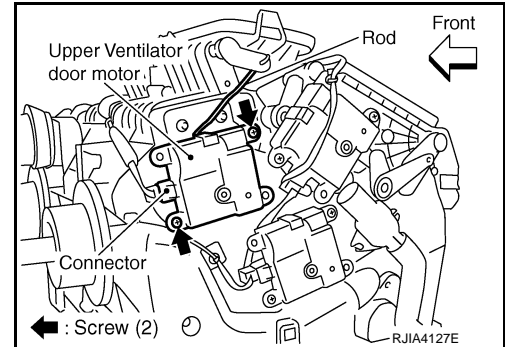

#### INSTALLATION

Installation is basically the reverse order of removal.

# HEATER CORE

< SERVICE INFORMATION >

## HEATER CORE

### Removal and Installation

INFOID:000000005348554

#### REMOVAL

1. Remove heater & cooling unit assembly. Refer to [ATC-119. "Removal and Installation"](#).
2. Remove mounting screws, and then remove heater pipe cover.
3. Remove mounting screws, and then remove foot duct (left).
4. Slide heater core (shown in the figure) to leftward.

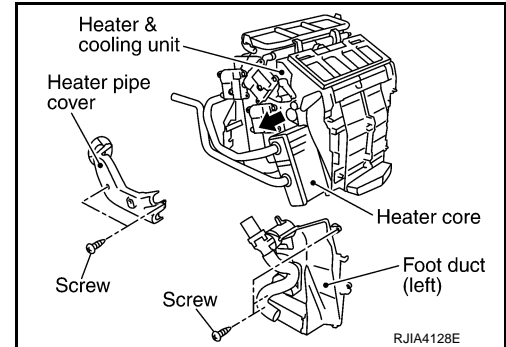

#### INSTALLATION

Installation is basically the reverse order of removal.

#### NOTE:

Refer to [CO-10. "Changing Engine Coolant"](#) (VQ35HR) or [CO-36. "Changing Engine Coolant"](#) (VK45DE) when filling radiator with engine coolant.

A  
B  
C  
D  
E  
F  
G  
H  
I  
K  
L  
M  
N  
O  
P

ATC

# DUCTS AND GRILLES

< SERVICE INFORMATION >

## DUCTS AND GRILLES

### Removal and Installation

INFOID:000000005348555

### COMPONENT LAYOUT

Grilles, Ducts and Nozzles

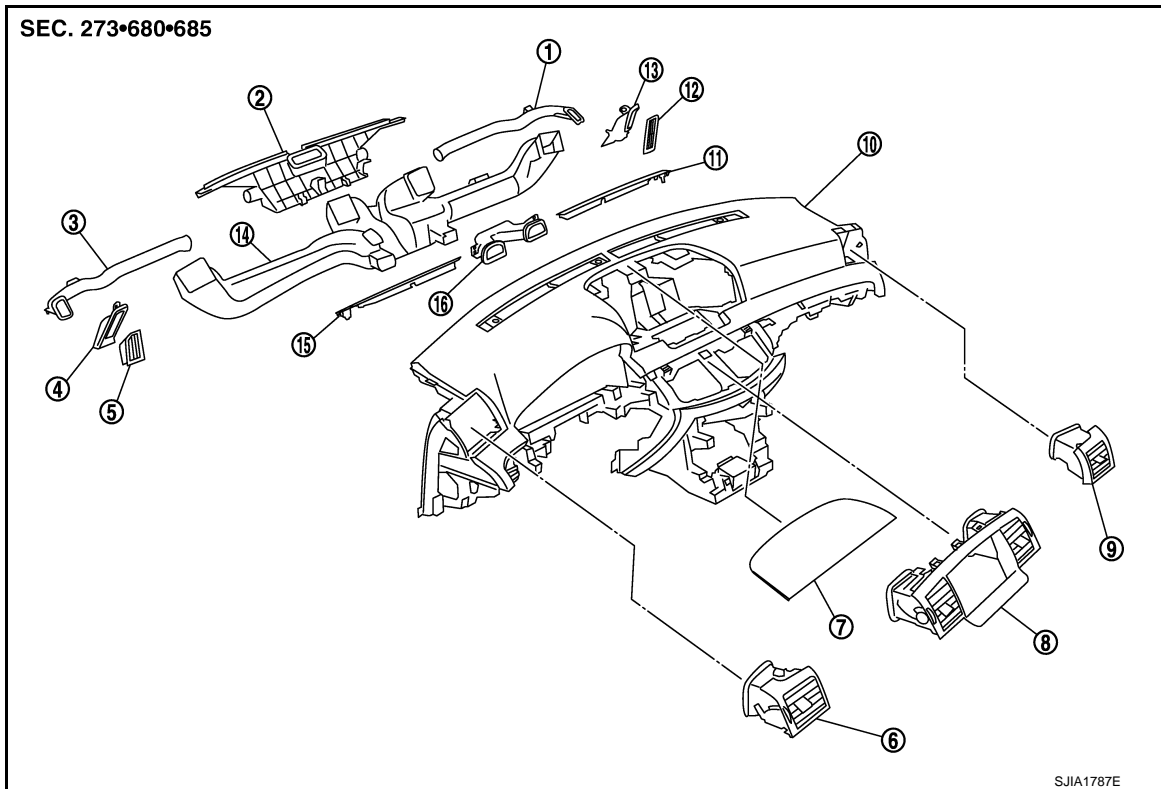

- |                                  |                                    |                                   |
|----------------------------------|------------------------------------|-----------------------------------|
| 1. Side defroster nozzle (right) | 2. Front defroster nozzle          | 3. Side defroster nozzle (left)   |
| 4. Side defroster duct (left)    | 5. Side defroster grille (left)    | 6. Side ventilator grille (left)  |
| 7. Upper ventilator grille       | 8. Center ventilator grille        | 9. Side ventilator grille (right) |
| 10. Instrument panel & pad       | 11. Front defroster grille (right) | 12. Side defroster grille (right) |
| 13. Side defroster duct (right)  | 14. Ventilator duct                | 15. Front defroster grille (left) |
| 16. Upper ventilator duct        |                                    |                                   |

### Rear Ventilator Ducts and Grilles



# DUCTS AND GRILLES

< SERVICE INFORMATION >

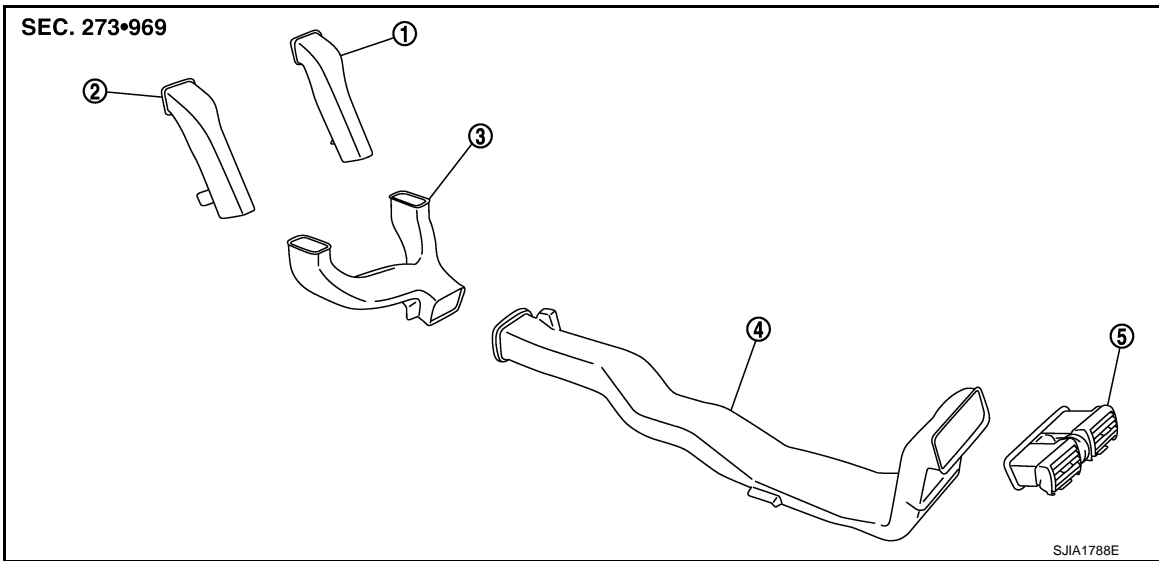

1. Rear ventilator duct 1 (right)
2. Rear ventilator duct 1 (left)
3. Rear ventilator duct 2
4. Rear ventilator duct 3
5. Rear ventilator grille

## Rear Floor Ducts and Grilles

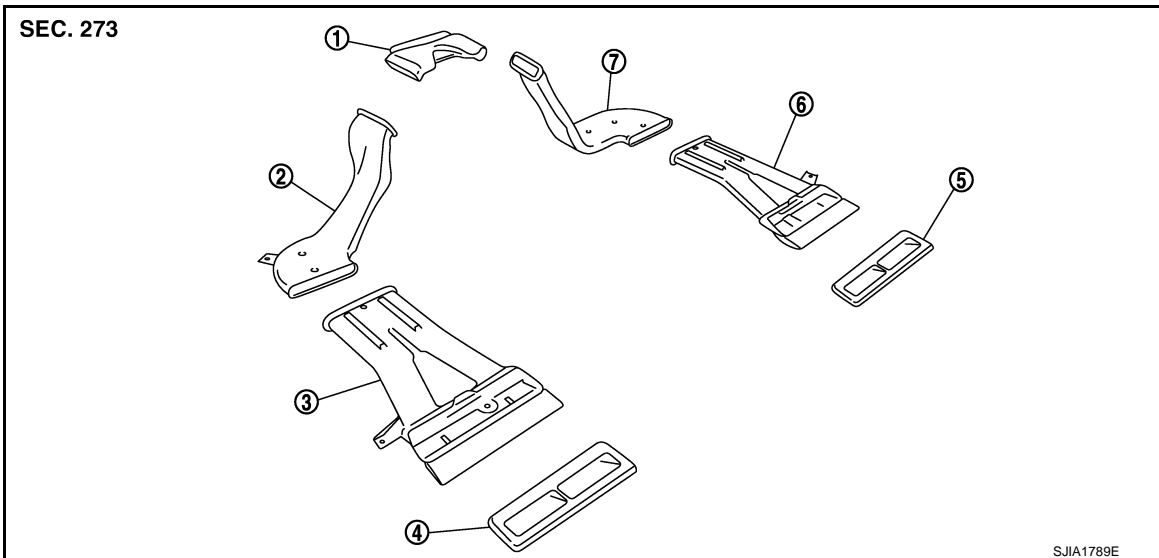

1. Rear floor duct 1
2. Rear floor duct 2 (left)
3. Rear floor duct 3 (left)
4. Rear floor grille (left)
5. Rear floor grille (right)
6. Rear floor duct 3 (right)
7. Rear floor duct 2 (right)

## REMOVAL

### Removal of Center Ventilator Grilles

Remove center ventilator assembly. Refer to [IP-11, "INSTRUMENT PANEL : Component Parts Location"](#).

### Removal of Side Ventilator Grilles

Remove side ventilator assembly. Refer to [IP-11, "INSTRUMENT PANEL : Component Parts Location"](#).

### Removal of Upper Ventilator Grille

A  
B  
C  
D  
E  
F  
G  
H  
I  
ATC  
K  
L  
M  
N  
O  
P

## DUCTS AND GRILLES

### < SERVICE INFORMATION >

Remove mounting metal clips, and then remove upper ventilator grille.

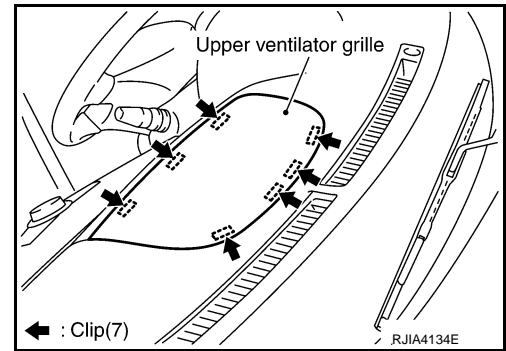

### Removal of Upper Ventilator Duct

1. Remove instrument panel & pad. Refer to [IP-11, "INSTRUMENT PANEL : Component Parts Location"](#).
2. Remove mounting screws, and then remove upper ventilator duct, using power tools.

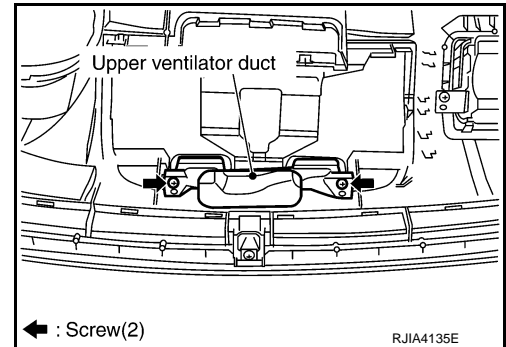

### Removal of Front Defroster Nozzle, Side Defroster Nozzles and Ventilator Duct

1. Remove instrument panel & pad. Refer to [IP-11, "INSTRUMENT PANEL : Component Parts Location"](#).
2. Remove mounting clips, and then remove side defroster nozzles.

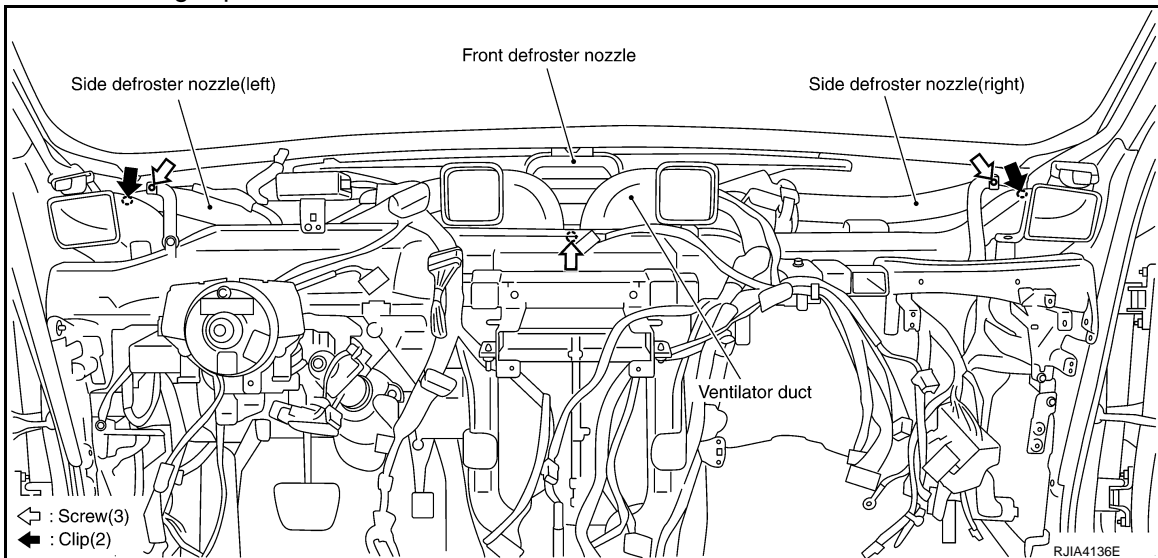

3. Remove front defroster nozzle.
4. Remove mounting screws, and then remove ventilator duct, using power tools.

### Removal of Side Defroster Grilles

1. Remove front pillar garnish. Refer to [EI-48, "Component Parts Location"](#).

# DUCTS AND GRILLES

## < SERVICE INFORMATION >

2. Press side defroster grill pawls (A), and then remove side defroster grilles (1).

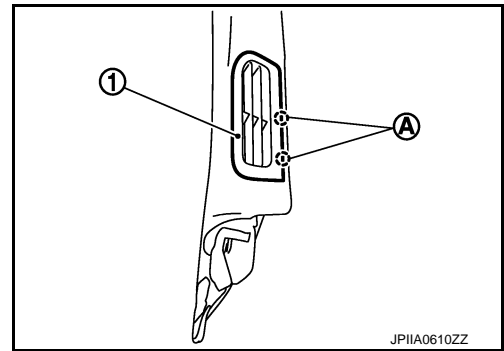

### Removal of Side Defroster Ducts

1. Remove front pillar garnish. Refer to [EI-48, "Component Parts Location"](#).
2. Remove mounting screws, and then remove side defroster ducts.

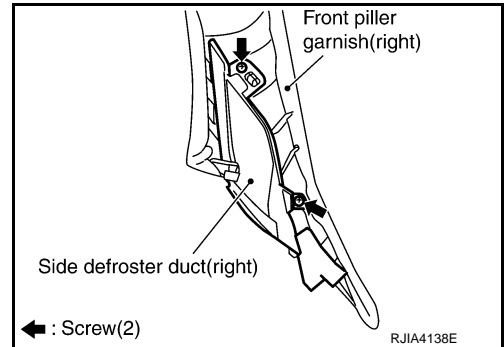

### Removal of Rear Ventilator Grille

1. Remove console rear finisher. Refer to [IP-21, "CENTER CONSOLE : Component Parts Location"](#).
2. Remove mounting clips, and then remove rear ventilator grille.

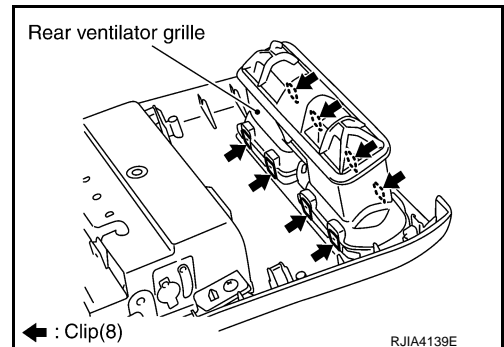

### Removal of Rear Ventilator Ducts

1. Remove center console. Refer to [IP-21, "CENTER CONSOLE : Component Parts Location"](#).
2. Remove mounting clip, and then remove rear ventilator duct 2.

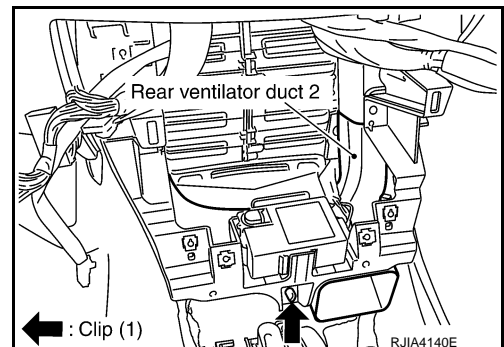

A  
B  
C  
D  
E  
F  
G  
H  
I  
ATC  
K  
L  
M  
N  
O  
P

## DUCTS AND GRILLES

### < SERVICE INFORMATION >

3. Remove mounting clips, and then remove rear ventilator ducts 1.

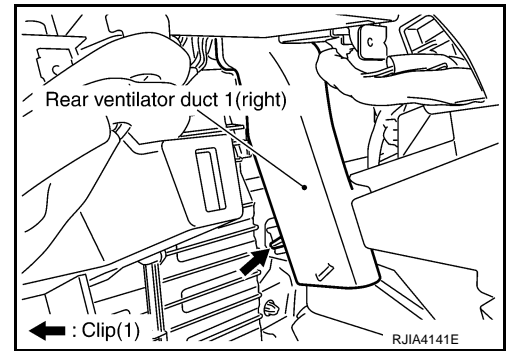

4. Remove mounting screws, and then remove rear ventilator duct 3.

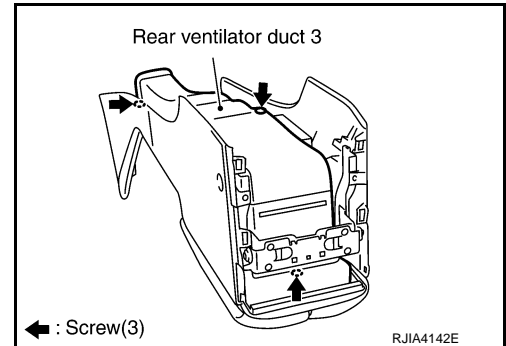

### Removal of Foot Grilles

1. Remove mounting clips, and then remove foot grille (left).

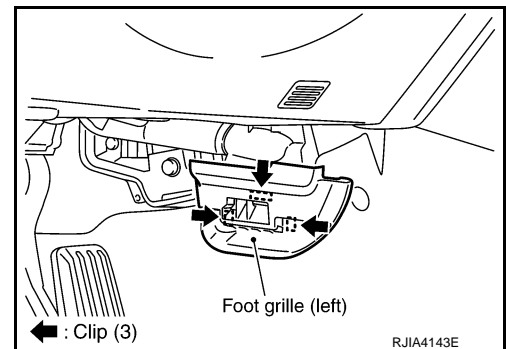

2. Remove mounting clips, and then remove foot grille (right).

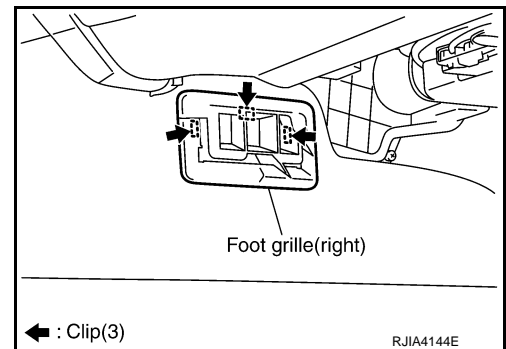

### Removal of Foot Duct (driver side)

1. Remove instrument driver lower panel. Refer to [IP-11, "INSTRUMENT PANEL : Component Parts Location"](#).

# DUCTS AND GRILLES

## < SERVICE INFORMATION >

2. Remove mounting screws, and then remove heater pipe cover.
3. Remove mounting screws, and then remove foot duct (left).

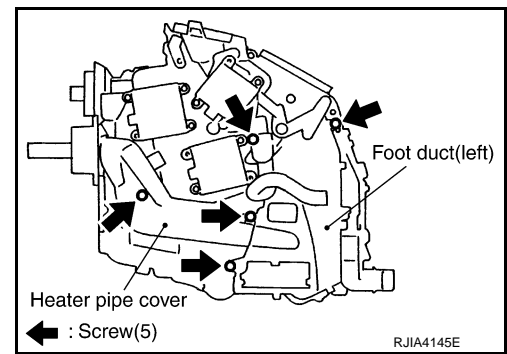

### Removal of Foot Duct (passenger side)

1. Remove air mix door motor (passenger side). Refer to [ATC-125, "Removal and Installation"](#).
2. Remove mode door motor (passenger side). Refer to [ATC-125, "Removal and Installation"](#).
3. Remove mounting screws, and then remove evaporator cover.
4. Remove mounting screws, and then remove foot duct (right).

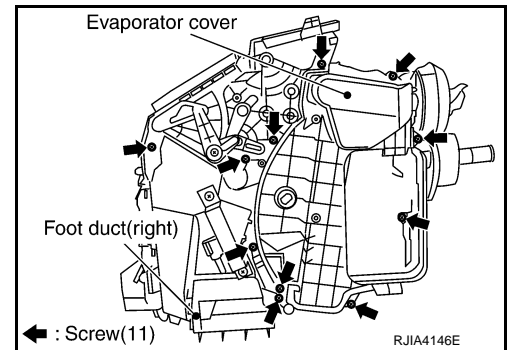

### Removal of Rear Floor Grilles

1. Slide front seats toward vehicle front.
2. Remove mounting clips, and then remove rear floor grilles.

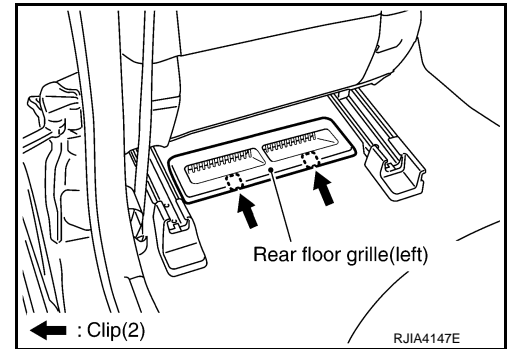

### Removal of Rear Floor Ducts

1. Remove center console. Refer to [IP-21, "CENTER CONSOLE : Component Parts Location"](#).
2. Remove rear floor duct 1.

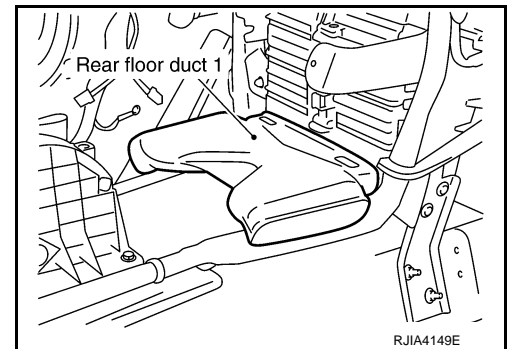

3. Remove front seats. Refer to [SE-143, "Driver's Seat Component"](#) (driver side) and [SE-145, "Passenger's Seat Component"](#) (passenger side).
4. Peel back floor trim to a point where rear floor duct is visible.

## DUCTS AND GRILLES

### < SERVICE INFORMATION >

5. Remove mounting screws and clip, and then remove rear floor ducts 2 and 3.

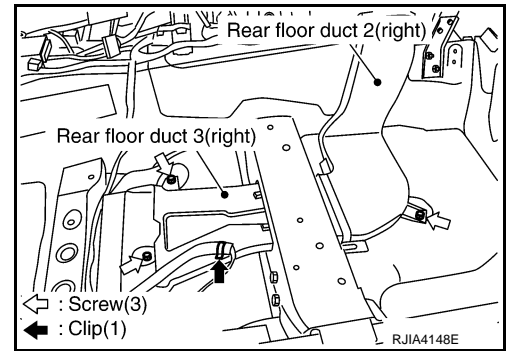

### INSTALLATION

Installation is basically the reverse order of removal.

# REFRIGERANT LINES

< SERVICE INFORMATION >

## REFRIGERANT LINES

VQ35HR

VQ35HR : HFC-134a (R-134a) Service Procedure

INFOID:000000005348556

### SETTING OF SERVICE TOOLS AND EQUIPMENT

Discharging Refrigerant

**WARNING:**

Never breath A/C refrigerant and lubricant vapor or mist. Exposure may irritate eyes, nose and throat. Remove HFC-134a (R-134a) from A/C system using certified service equipment meeting requirements of SAE J-2210 [HFC-134a (R-134a) recycling equipment] or J-2209 [HFC-134a (R-134a) recovery equipment]. Ventilate work area before resuming service if accidental system discharge occurs. Additional health and safety information may be obtained from refrigerant and lubricant manufacturers.

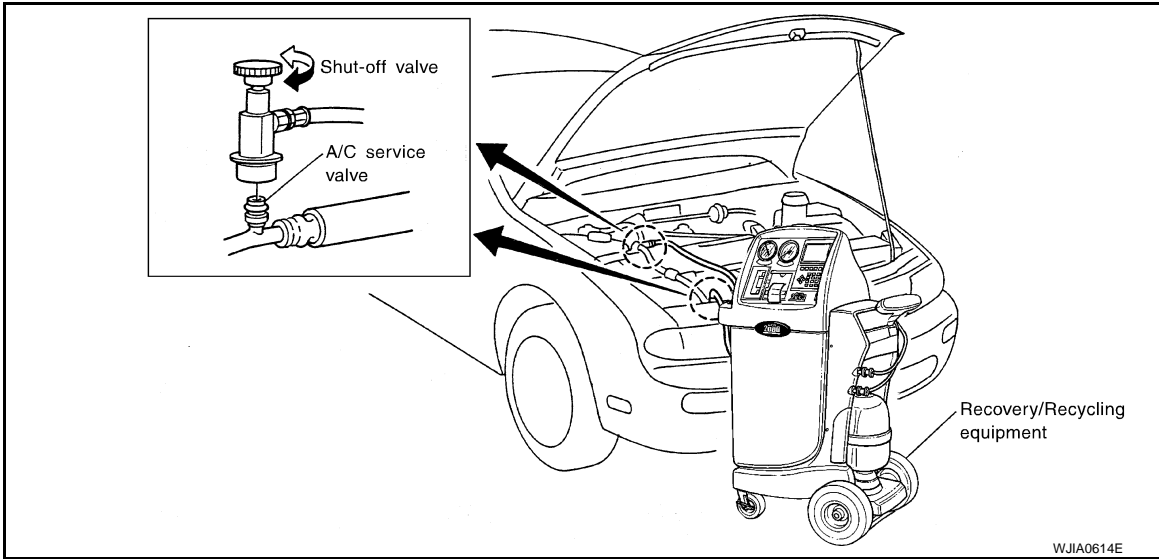

### Evacuating System and Charging Refrigerant

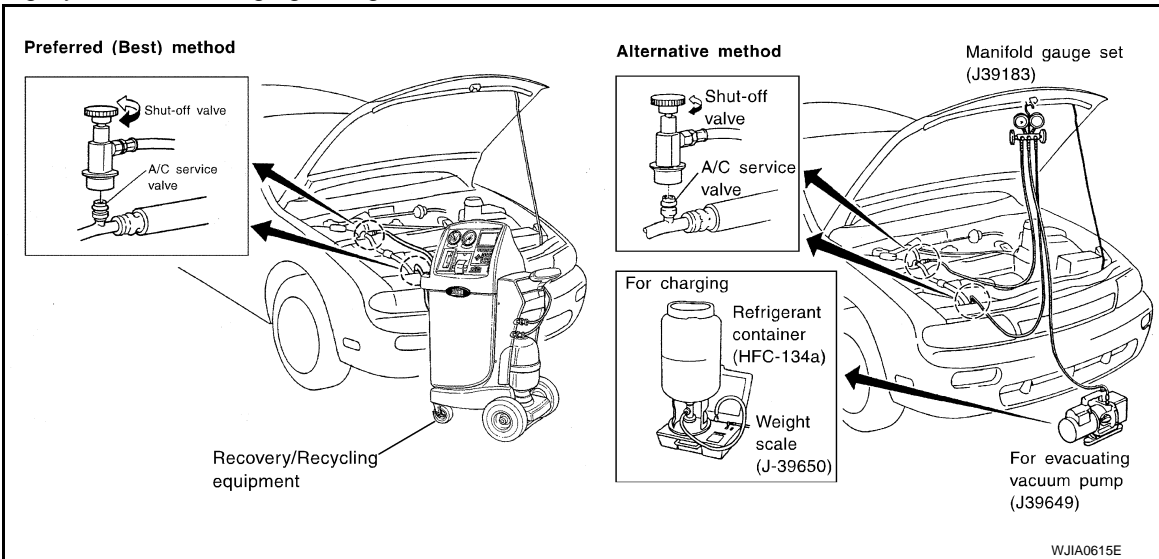

A  
B  
C  
D  
E  
F  
G  
H  
I  
ATC  
K  
L  
M  
N  
O  
P

# REFRIGERANT LINES

## < SERVICE INFORMATION >

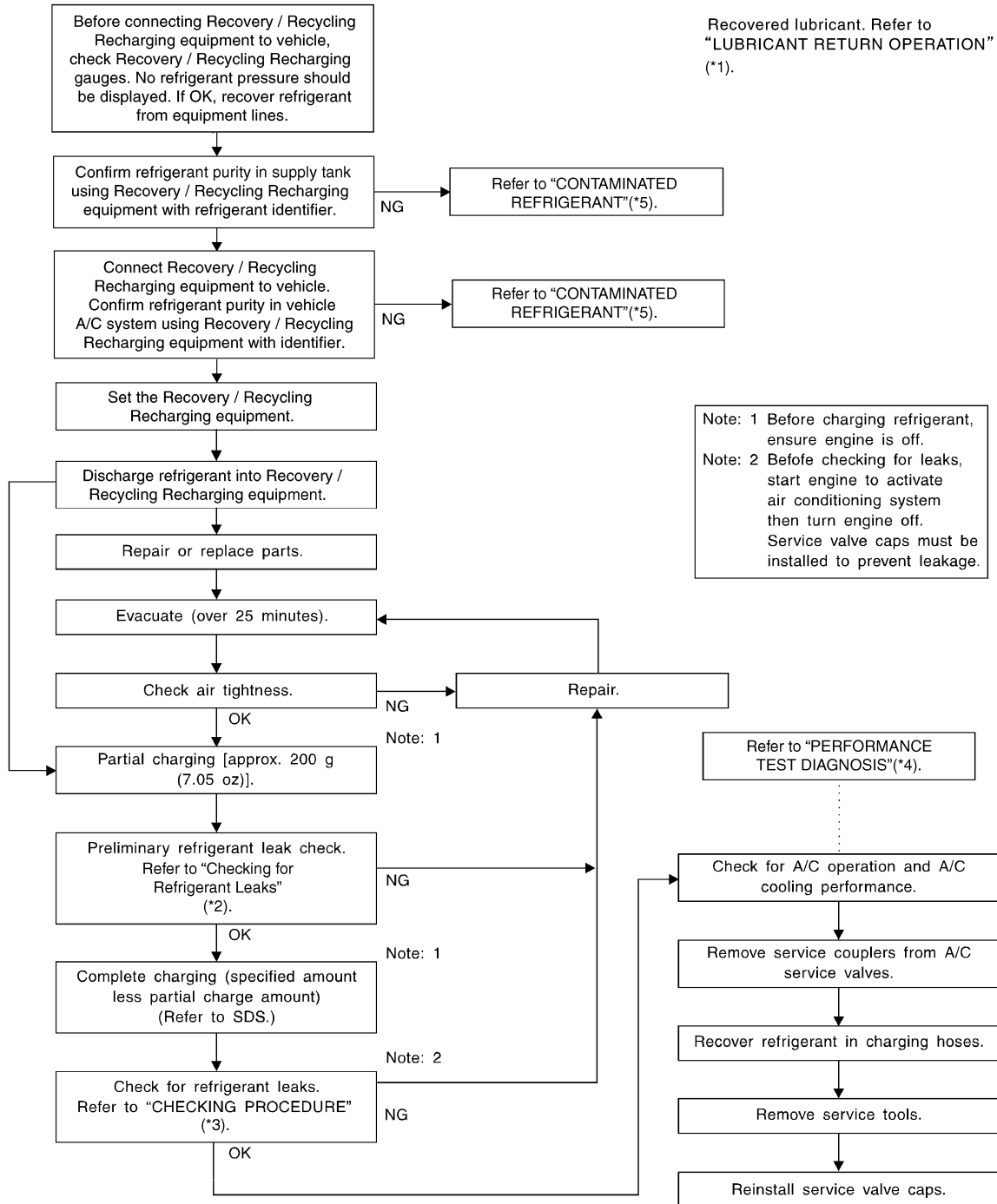

SJIA1275E

\*1 [ATC-22, "Maintenance of Lubricant Quantity in Compressor"](#)

\*2 [ATC-149, "VQ35HR : Checking of Refrigerant Leaks"](#)

\*3 [ATC-150, "VQ35HR : Electrical Leak Detector"](#)

\*4 [ATC-84, "Insufficient Cooling"](#)

\*5 [ATC-4, "Precaution for Working with HFC-134a \(R-134a\)"](#)

VQ35HR : Component

INFOID:000000005348557

Refer to [ATC-5, "Precaution for Refrigerant Connection"](#).



# REFRIGERANT LINES

< SERVICE INFORMATION >

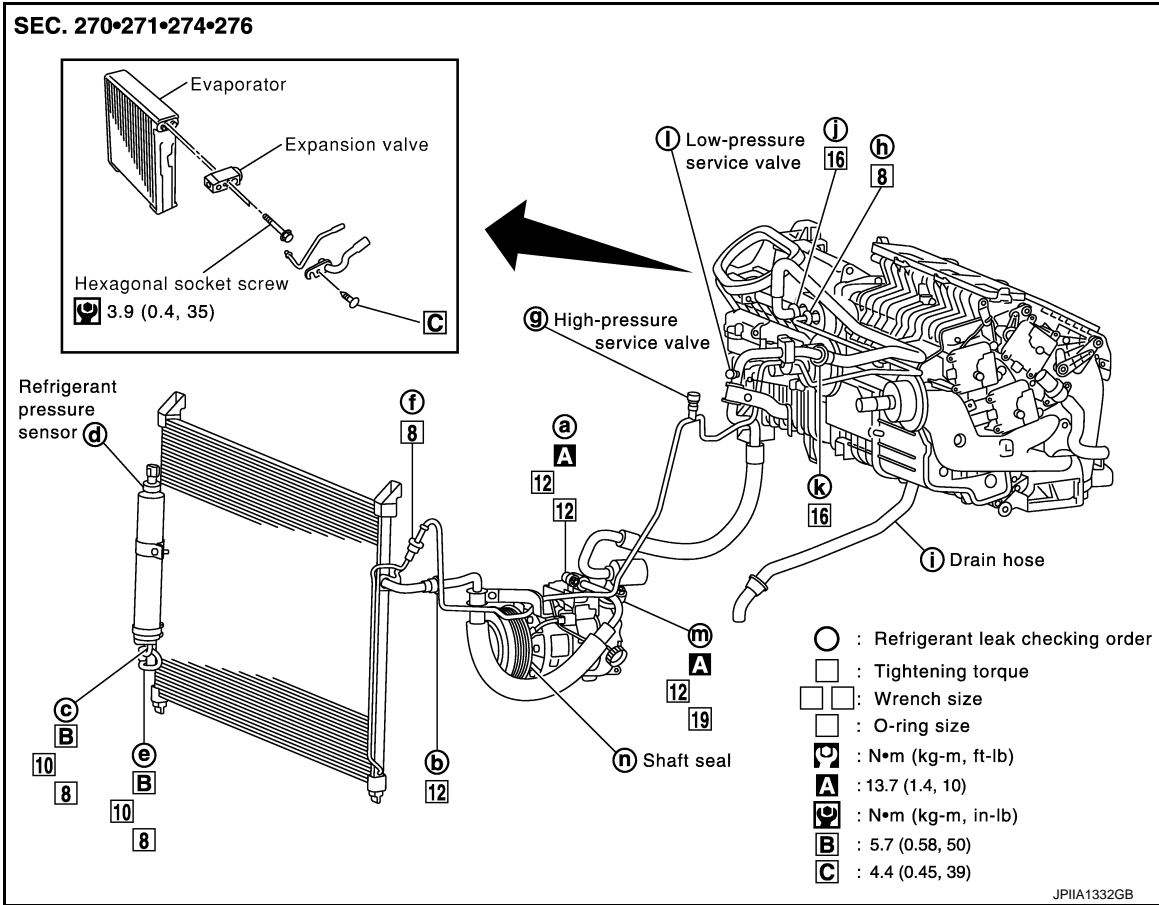

## VQ35HR : Removal and Installation of Compressor

INFOID:000000005348558

ATC

### REMOVAL

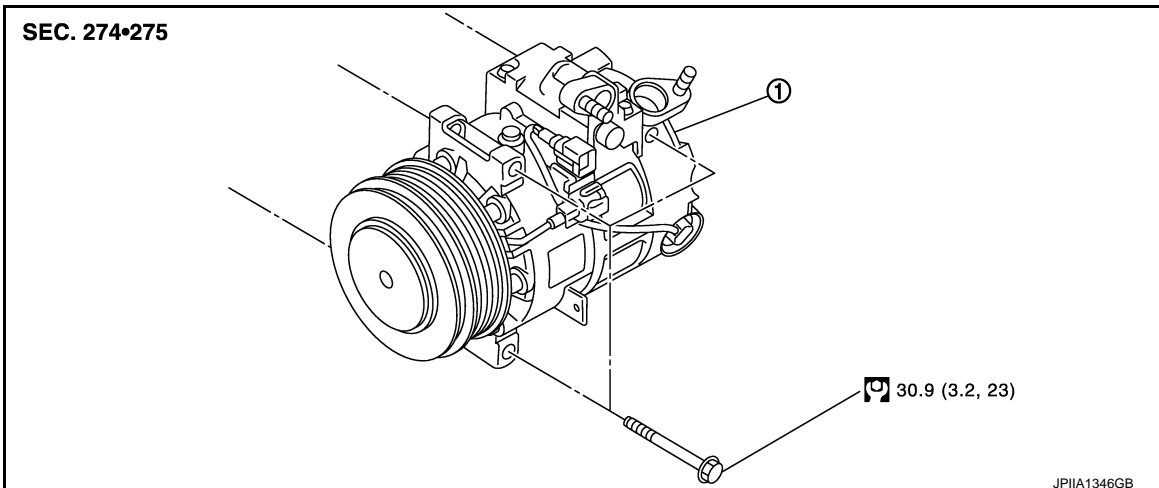

1. Compressor

Refer to [GI-9, "Component"](#) for symbols in the figure.

1. Use a refrigerant collecting equipment (for HFC-134a) to discharge the refrigerant.
2. Remove air cleaner case (LH) and air duct (LH). Refer to [EM-17, "Component"](#).
3. Remove engine undercover, using power tools.
4. Remove drive belt. Refer to [EM-15, "Removal and Installation"](#).

# REFRIGERANT LINES

## < SERVICE INFORMATION >

5. Remove mounting nuts (A) from low-pressure flexible hose (1) and high-pressure flexible hose (2).

**CAUTION:**

Cap or wrap the joint of the A/C piping and compressor with suitable material such as vinyl tape to avoid the entry of air.

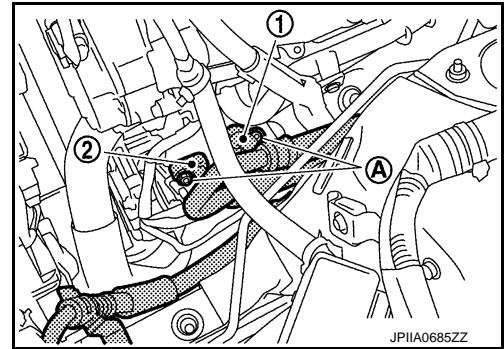

6. Disconnect compressor (ECV) connector (A).
7. Disconnect compressor (magnet clutch) connector (B).
8. Remove harness clip (C).

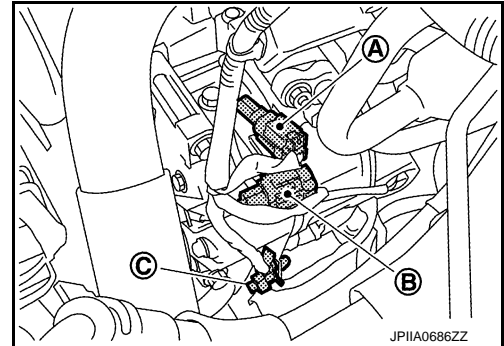

9. Remove mounting bolts (A), and then remove harness bracket.
10. Remove mounting bolts (B) from compressor (1), using power-tools.
11. Remove compressor downward of the vehicle.

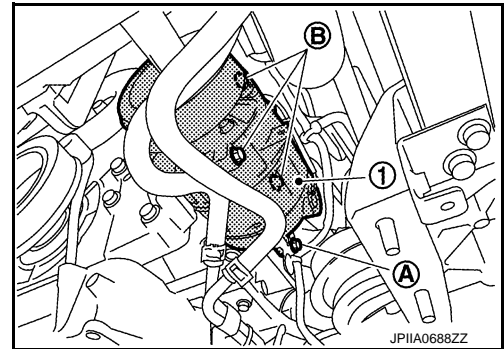

## INSTALLATION

Installation is basically the reverse order of removal.

**CAUTION:**

- Replace O-rings with new ones. Then apply compressor oil to them when installing.
- Check for leakages when recharging refrigerant.
- Check tension of the drive belt after installing compressor. Refer to [EM-15, "Checking Drive Belt"](#).

## VQ35HR : Check Disc to Pulley Clearance

INFOID:000000005348559

Check the clearance (B) between pulley assembly (1) and clutch disc (2) along the entire periphery with a feeler gauge (A).

**Clearance : 0.3 - 0.6 mm (0.012 - 0.024 in)**

Replace compressor if specified clearance is not obtained.

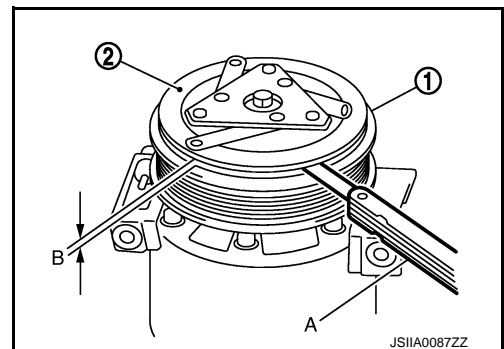

## VQ35HR : Removal and Installation of Low-pressure Flexible Hose

INFOID:000000005348560

## REMOVAL

# REFRIGERANT LINES

## < SERVICE INFORMATION >

1. Use a refrigerant collecting equipment (for HFC-134a) to discharge the refrigerant.
2. Remove cowl top cover. Refer to [EI-29, "Component Parts Location"](#).
3. Remove mounting bolt (A) from low-pressure flexible hose bracket (1).
4. Disconnect one-touch joint between low-pressure flexible hose (2) and low-pressure pipe 2 (3) with disconnecter (B) (SST: 9253089916).

**CAUTION:**

Cap or wrap the joint of the A/C piping with suitable material such as vinyl tape to avoid the entry of air.

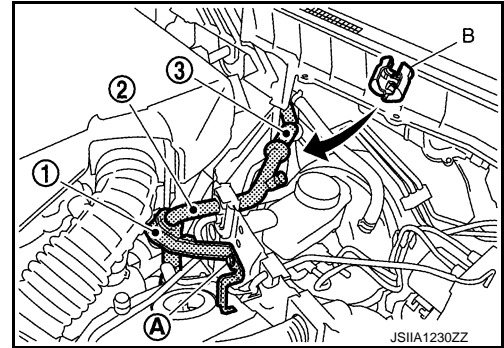

5. Remove engine cover. Refer to [EM-19, "Removal and Installation"](#).
6. Remove air cleaner case (LH) and air duct (LH). Refer to [EM-17, "Component"](#).
7. Remove mounting nut (A) from low-pressure flexible hose (1).

**CAUTION:**

Cap or wrap the joint of the A/C piping and compressor with suitable material such as vinyl tape to avoid the entry of air.

8. Remove low-pressure flexible hose.

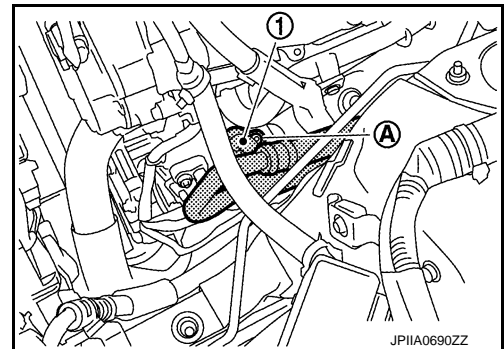

## INSTALLATION

Installation is basically the reverse order of removal.

**CAUTION:**

- Replace O-rings with new ones. Then apply compressor oil to them when installing.
- Female-side piping connection is thin and easy to deform. Slowly insert the male-side piping straight in axial direction.
- Insert piping securely until a click is heard.
- After piping connection is completed, pull male-side piping by hand to check that connection does not come loose.
- Check for leakages when recharging refrigerant.

### Low-pressure flexible hose bracket mounting bolt

 : 4.2 N·m (0.43 kg·m, 37 in·lb)

## VQ35HR : Removal and Installation of Low-pressure Pipe 2

INFOID:000000005348561

## REMOVAL

1. Use a refrigerant collecting equipment (for HFC-134a) to discharge the refrigerant.
2. Remove cowl top cover. Refer to [EI-29, "Component Parts Location"](#).

A  
B  
C  
D  
E  
F  
G  
H  
I  
K  
L  
M  
N  
O  
P

ATC

# REFRIGERANT LINES

## < SERVICE INFORMATION >

3. Remove mounting bolt (A) from low-pressure flexible hose bracket (1).
4. Disconnect one-touch joint between low-pressure flexible hose (2) and low-pressure pipe 2 (3) with disconnecter (B) (SST: 9253089916).

**CAUTION:**

Cap or wrap the joint of the A/C piping with suitable material such as vinyl tape to avoid the entry of air.

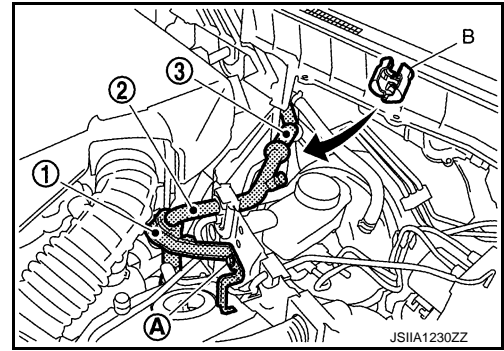

5. Disconnect one-touch joint between low-pressure pipe 1 (1) and low-pressure pipe 2 (2) with disconnecter (A) (SST: 9253089916).

**CAUTION:**

Cap or wrap the joint of the A/C piping with suitable material such as vinyl tape to avoid the entry of air.

6. Remove low-pressure pipe 2.

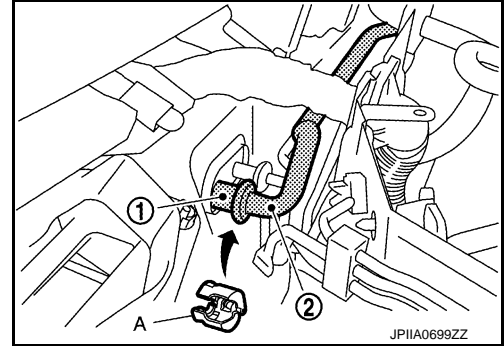

## INSTALLATION

Installation is basically the reverse order of removal.

**CAUTION:**

- Replace O-rings with new ones. Then apply compressor oil to them when installing.
- Female-side piping connection is thin and easy to deform. Slowly insert the male-side piping straight in axial direction.
- Insert piping securely until a click is heard.
- After piping connection is completed, pull male-side piping by hand to check that connection does not come loose.
- Check for leakages when recharging refrigerant.

### Low-pressure flexible hose bracket mounting bolt

 : 4.2 N·m (0.43 kg·m, 37 in·lb)

## VQ35HR : Removal and Installation of High-pressure Flexible Hose

INFOID:000000005348562

### REMOVAL

1. Use a refrigerant collecting equipment (for HFC-134a) to discharge the refrigerant.
2. Remove engine cover. Refer to [EM-19, "Removal and Installation"](#).
3. Remove air cleaner case (LH) and air duct (LH). Refer to [EM-17, "Component"](#).
4. Remove mounting bolt from high-pressure flexible hose bracket.

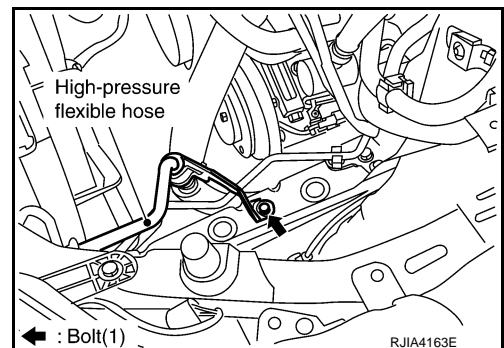

# REFRIGERANT LINES

## < SERVICE INFORMATION >

5. Disconnect one-touch joint between high-pressure flexible hose and condenser.
  - a. Set a disconnecter (SST: 9253089912) on A/C piping.
  - b. Slide a disconnecter backward until it clicks.
  - c. Slide A/C piping backward and disconnect it.

**CAUTION:**

Cap or wrap the joint of the A/C piping with suitable material such as vinyl tape to avoid the entry of air.

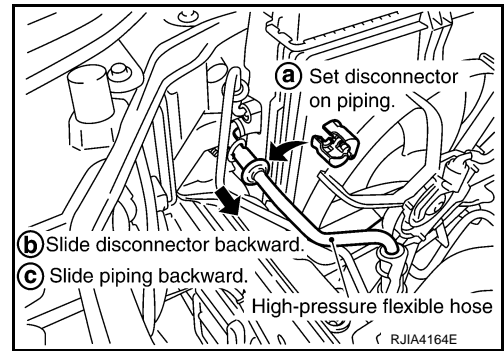

6. Remove mounting nut (A) from high-pressure flexible hose (1).
7. Remove high-pressure flexible hose.

**CAUTION:**

Cap or wrap the joint of the A/C piping and compressor with suitable material such as vinyl tape to avoid the entry of air.

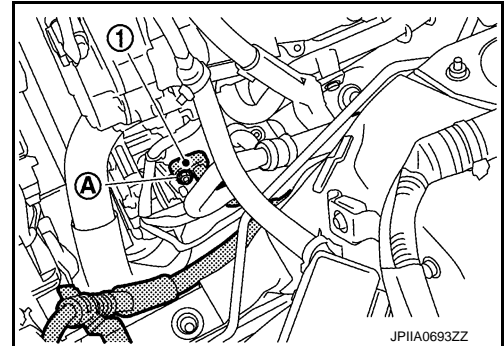

## INSTALLATION

Installation is basically the reverse order of removal.

**CAUTION:**

- Replace O-rings with new ones. Then apply compressor oil to them when installing.
- Female-side piping connection is thin and easy to deform. Slowly insert the male-side piping straight in axial direction.
- Insert piping securely until a click is heard.
- After piping connection is completed, pull male-side piping by hand to check that connection does not come loose.
- Check for leakages when recharging refrigerant.

### High-pressure flexible hose bracket mounting bolt

 : 4.2 N·m (0.43 kg·m, 37 in·lb)

## VQ35HR : Removal and Installation of High-pressure Pipe 1

INFOID:000000005348563

### REMOVAL

1. Remove low-pressure flexible hose. Refer to [ATC-138, "VQ35HR : Removal and Installation of Low-pressure Flexible Hose"](#).
2. Remove low-pressure pipe 2. Refer to [ATC-139, "VQ35HR : Removal and Installation of Low-pressure Pipe 2"](#).
3. Remove mounting bolt from high-pressure flexible hose bracket.

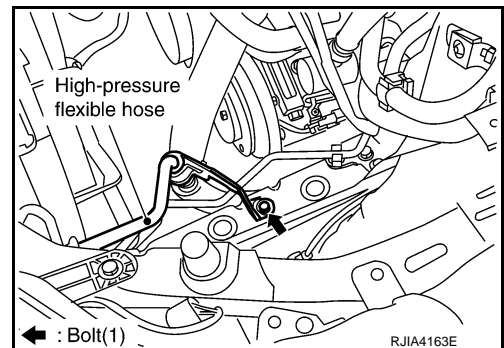



# REFRIGERANT LINES

## < SERVICE INFORMATION >

4. Remove high-pressure pipe 1 (1) from vehicle clips (A).

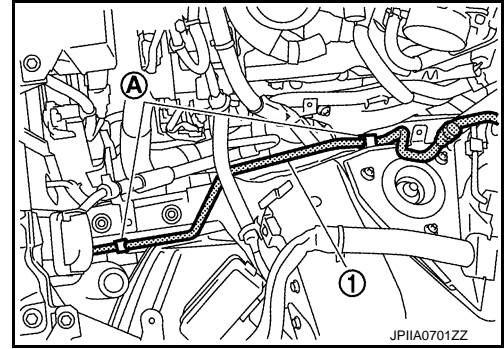

5. Disconnect one-touch joints of high-pressure pipe 1.
  - a. Set a disconnecter (SST: 9253089908) on A/C piping.
  - b. Slide a disconnecter toward (or upward) vehicle front until it clicks.
  - c. Slide A/C piping toward (or upward) vehicle front and disconnect it.

### CAUTION:

Cap or wrap the joint of condenser, evaporator and the A/C piping with suitable material such as vinyl tape to avoid the entry of air.

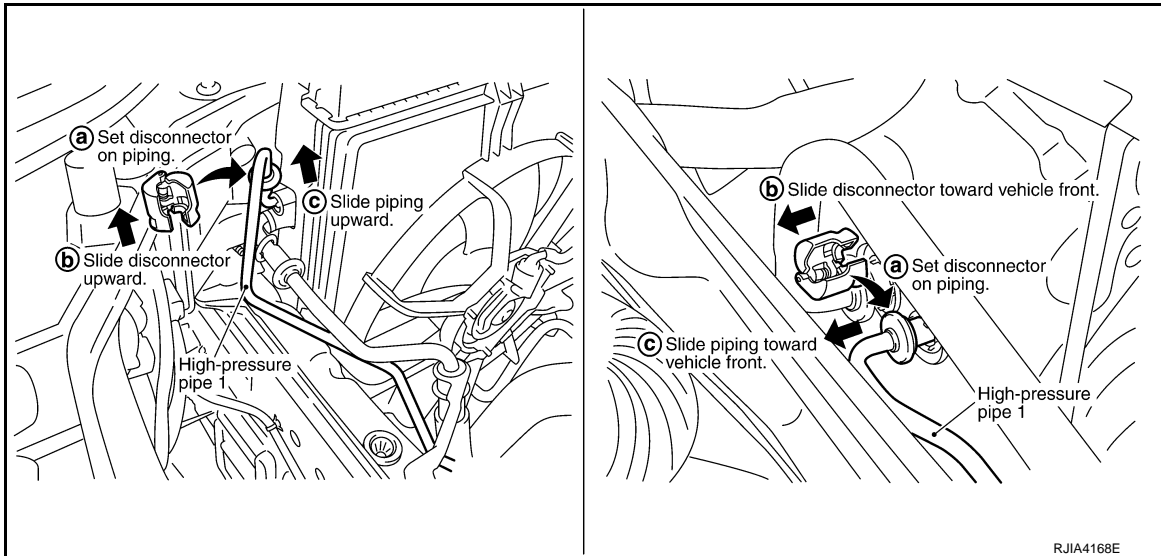

6. Remove high-pressure pipe 1.

## INSTALLATION

Installation is basically the reverse order of removal.

### CAUTION:

- Replace O-rings with new ones. Then apply compressor oil to them when installing.
- Female-side piping connection is thin and easy to deform. Slowly insert the male-side piping straight in axial direction.
- Insert piping securely until a click is heard.
- After piping connection is completed, pull male-side piping by hand to check that connection does not come loose.
- Check for leakages when recharging refrigerant.

### High-pressure flexible hose bracket mounting bolt

 : 4.2 N·m (0.43 kg·m, 37 in·lb)

## VQ35HR : Removal and Installation of Low-pressure Pipe 1 and High-pressure Pipe 2

INFOID:000000005348564

## REMOVAL

1. Set the temperature control switch (passenger side) at 18°C (60°F).

# REFRIGERANT LINES

## < SERVICE INFORMATION >

### CAUTION:

The angle may be out, when installing the air mix door motor to the air mix door, unless the above procedure is performed.

2. Disconnect the battery cable from the negative terminal.
3. Use a refrigerant collecting equipment (for HFC-134a) to discharge the refrigerant.
4. Remove cowl top cover. Refer to [EI-29, "Component Parts Location"](#).
5. Remove mounting bolt from low-pressure flexible hose bracket.
6. Remove high-pressure pipe 1 from vehicle clip.

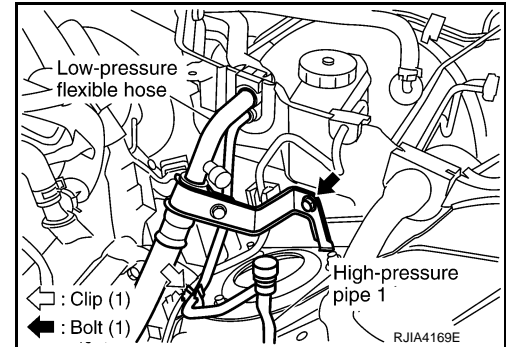

7. Disconnect one-touch joints.
  - a. Set a disconnecter [high-pressure side (SST: 9253089908), low-pressure side (SST: 9253089916)] on A/C piping.
  - b. Slide a disconnecter toward vehicle front until it clicks.
  - c. Slide A/C piping toward vehicle front and disconnect it.

### CAUTION:

Cap or wrap the joint of the A/C piping with suitable material such as vinyl tape to avoid the entry of air.

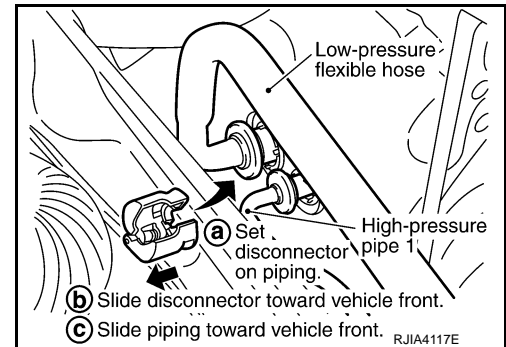

8. Remove instrument passenger lower panel and glove box. Refer to [IP-11, "INSTRUMENT PANEL : Component Parts Location"](#).
9. Remove foot grille (right). Refer to [ATC-128, "Removal and Installation"](#).
10. Remove air mix door motor (passenger side). Refer to [ATC-125, "Removal and Installation"](#).
11. Remove mode door motor (passenger side). Refer to [ATC-124, "Removal and Installation"](#).
12. Remove main link (right) and max. cool door link (right). Refer to [ATC-119, "Removal and Installation"](#).
13. Remove mounting screws, and then remove evaporator cover.

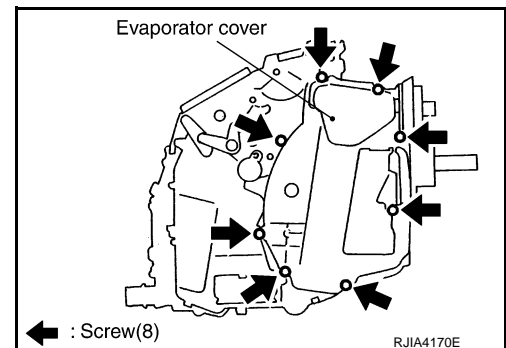

# REFRIGERANT LINES

## < SERVICE INFORMATION >

14. Remove mounting bolt, and then remove low-pressure pipe 1 and high-pressure pipe 2.

**CAUTION:**

Cap or wrap the joint of the A/C piping and expansion valve with suitable material such as vinyl tape to avoid the entry of air.

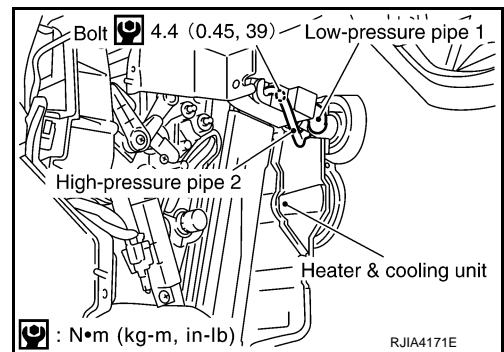

## INSTALLATION

Installation is basically the reverse order of removal.

**CAUTION:**

- Replace O-rings with new ones. Then apply compressor oil to them when installing.
- Female-side piping connection is thin and easy to deform. Slowly insert the male-side piping straight in axial direction.
- Insert piping securely until a click is heard.
- After piping connection is completed, pull male-side piping by hand to check that connection does not come loose.
- Check for leakages when recharging refrigerant.

**Low-pressure flexible hose bracket mounting bolt**

**Ⓜ** : 4.2 N•m (0.43 kg-m, 37 in-lb)

## VQ35HR : Removal and Installation of Liquid Tank

INFOID:000000005348565

## DISASSEMBLY AND ASSEMBLY

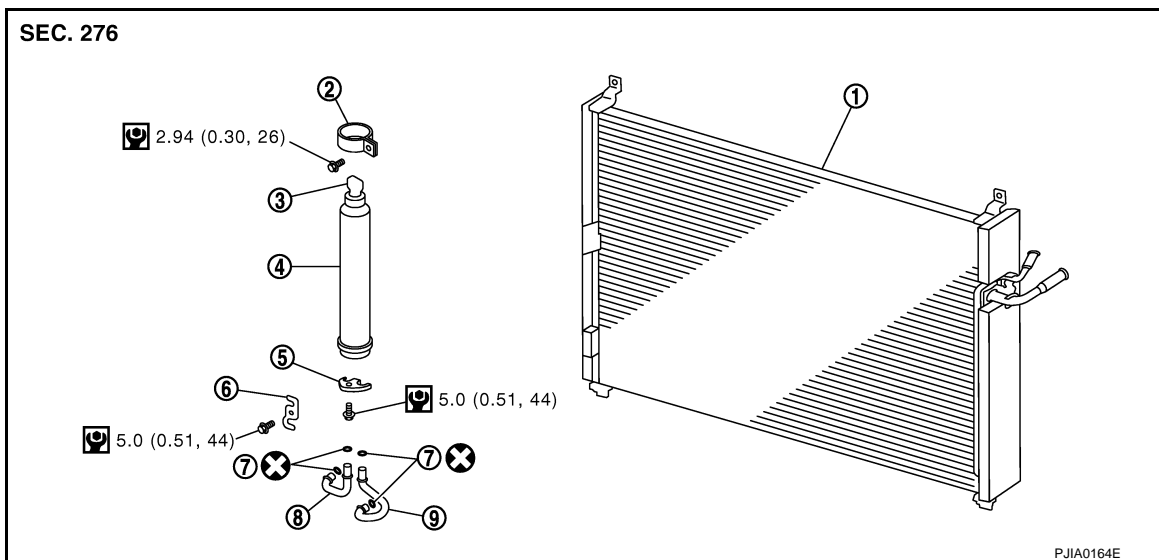

- |                |                               |                                |
|----------------|-------------------------------|--------------------------------|
| 1. Condenser   | 2. Liquid tank bracket        | 3. Refrigerant pressure sensor |
| 4. Liquid tank | 5. Bracket (liquid tank side) | 6. Bracket (condenser side)    |
| 7. O-ring      | 8. Inside pipe                | 9. Outside pipe                |

Refer to [GI-9, "Component"](#) for symbols in the figure.

## REMOVAL

1. Remove condenser. Refer to [ATC-145, "VQ35HR : Removal and Installation of Condenser"](#).
2. Clean liquid tank and its surrounding area, and remove dust and rust from liquid tank.

**CAUTION:**

Be sure to clean carefully.



# REFRIGERANT LINES

## < SERVICE INFORMATION >

- Remove mounting bolts from liquid tank.

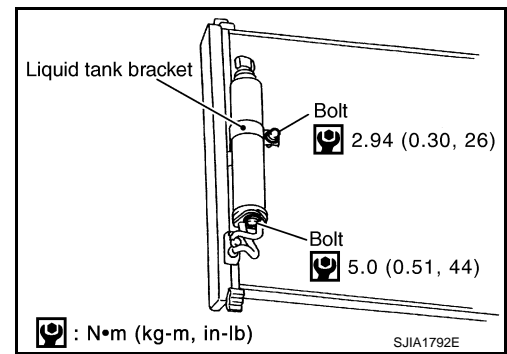

- Lift liquid tank bracket upward. Remove liquid tank bracket from protruding part of condenser.
- Slide liquid tank upward, and then remove liquid tank.

**CAUTION:**

Cap or wrap the joint of the A/C piping and liquid tank with suitable material such as vinyl tape to avoid the entry of air.

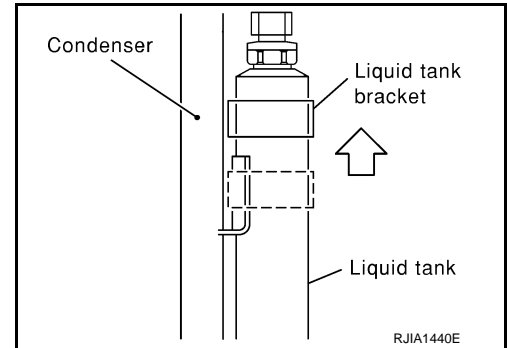

## INSTALLATION

Install liquid tank, and then install liquid tank bracket on condenser.

**CAUTION:**

- Check liquid tank bracket is securely installed at protrusion of condenser. (Check liquid tank bracket does not move to a position below center of liquid tank.)
- Replace O-rings of the A/C piping with new ones. Then apply compressor oil to them when installing.
- Check for leakages when recharging refrigerant.

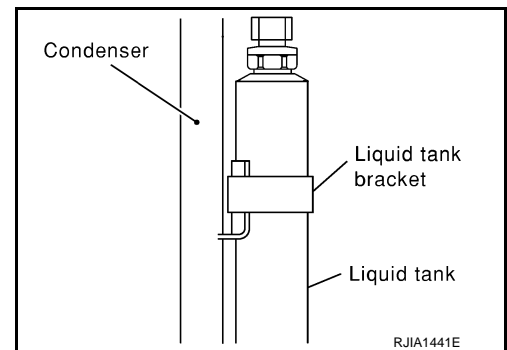

## VQ35HR : Removal and Installation of Condenser

INFOID:000000005348566

### REMOVAL

- Use a refrigerant collecting equipment (for HFC-134a) to discharge the refrigerant.
- Remove air cleaner case and air duct (RH/LH). Refer to [EM-17. "Component"](#).
- Remove front grille. Refer to [EI-27. "Component Parts Location"](#).
- Remove mounting clips and bolts, and then remove bracket.
- Remove radiator upper mount, move radiator and condenser to the engine side.

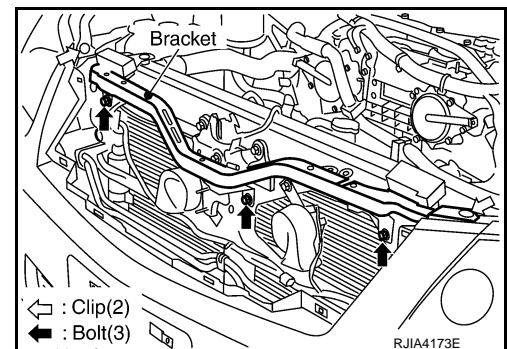

## REFRIGERANT LINES

### < SERVICE INFORMATION >

6. Remove mounting bolt from high-pressure flexible hose bracket.
7. Remove high-pressure pipe1 from vehicle clip.

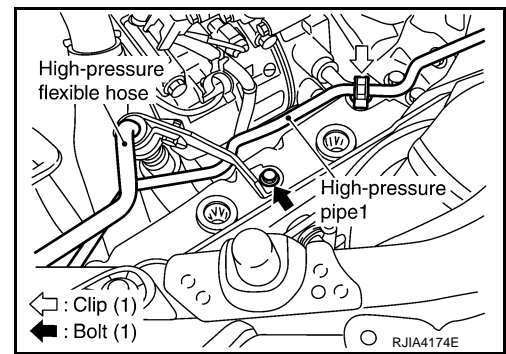

8. Disconnect high-pressure flexible hose from condenser.
  - a. Set a disconnecter (SST: 9253089912) on A/C piping.
  - b. Slide a disconnecter backward until it clicks.
  - c. Slide A/C piping backward and disconnect it.

**CAUTION:**

Cap or wrap the joint of condenser and the A/C piping with suitable material such as vinyl tape to avoid the entry of air.

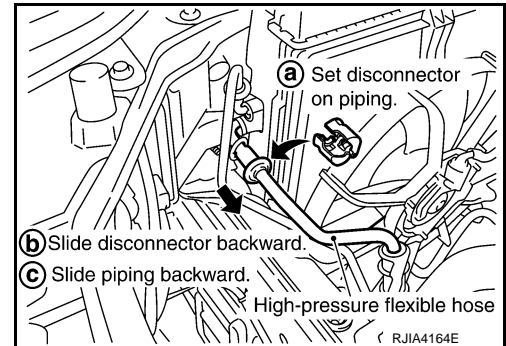

9. Disconnect high-pressure pipe 1 from condenser.
  - a. Set a disconnecter (SST: 9253089908) on A/C piping.
  - b. Slide a disconnecter upward until it clicks.
  - c. Slide A/C piping upward and disconnect it.

**CAUTION:**

Cap or wrap the joint of condenser and the A/C piping with suitable material such as vinyl tape to avoid the entry of air.

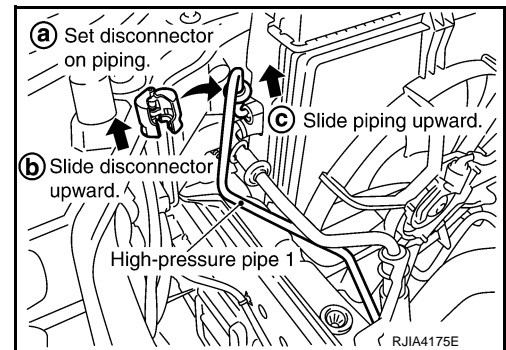

10. Disconnect refrigerant pressure sensor connector.

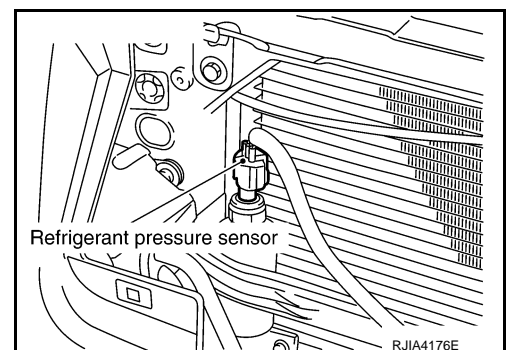

11. Disconnect hood rock switch connector.
12. Remove radiator reservoir tank. Refer to [CO-13. "Component"](#).

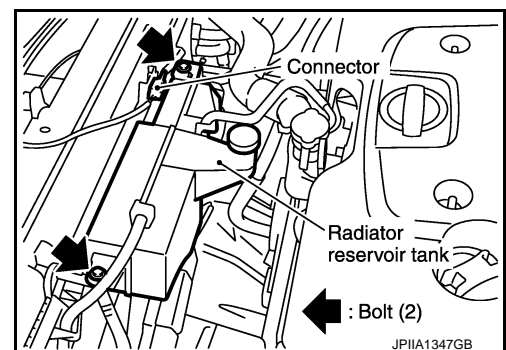

# REFRIGERANT LINES

## < SERVICE INFORMATION >

13. Remove mounting screws from condenser.

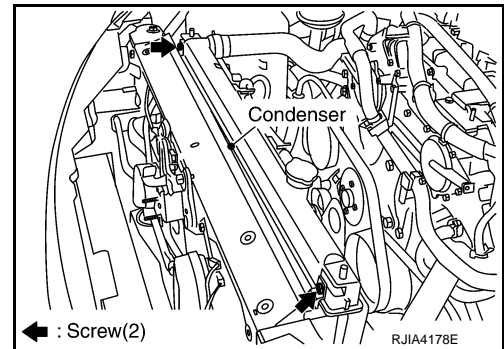

14. Pull condenser forward at an angle. Remove condenser from radiator.

**CAUTION:**

**Be careful not to damage the core surface of condenser and radiator.**

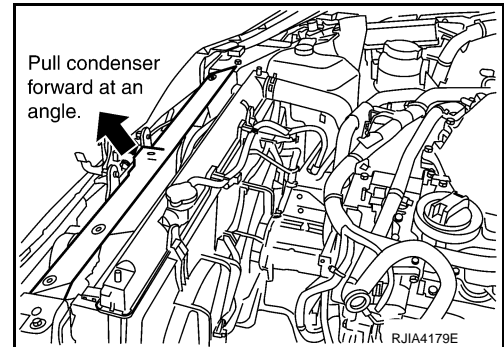

## INSTALLATION

Installation is basically the reverse order of removal.

**CAUTION:**

- Replace O-rings with new ones. Then apply compressor oil to them when installing.
- Female-side piping connection is thin and easy to deform. Slowly insert the male-side piping straight in axial direction.
- Insert piping securely until a click is heard.
- After piping connection is completed, pull male-side piping by hand to check that connection does not come loose.
- Check for leakages when recharging refrigerant.

**High-pressure flexible hose bracket mounting bolt**

 : 4.2 N·m (0.43 kg-m, 37 in-lb)

## VQ35HR : Removal and Installation of Refrigerant Pressure Sensor

INFOID:000000005348567

## REMOVAL

1. Remove liquid tank. Refer to [ATC-144, "VQ35HR : Removal and Installation of Liquid Tank"](#).
2. Using a vice, secure liquid tank, and remove refrigerant pressure sensor.

**CAUTION:**

**Be careful not to damage liquid tank.**

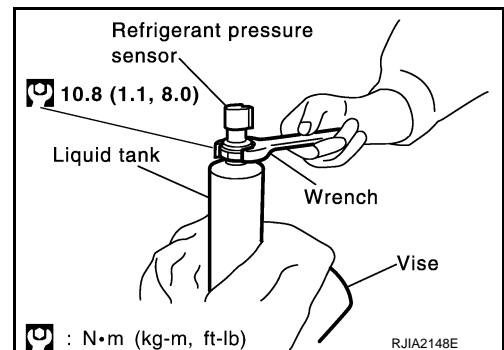

## INSTALLATION

Installation is basically the reverse order of removal.

**CAUTION:**

- Apply compressor oil to O-ring of refrigerant pressure sensor when installing it.
- Check for leakages when recharging refrigerant.

# REFRIGERANT LINES

< SERVICE INFORMATION >

## VQ35HR : Removal and Installation of Evaporator

INFOID:000000005348568

### REMOVAL

1. Remove low-pressure pipe 1 and high-pressure pipe 2. Refer to [ATC-142, "VQ35HR : Removal and Installation of Low-pressure Pipe 1 and High-pressure Pipe 2"](#).

**CAUTION:**

Cap or wrap the joint of the A/C piping and expansion valve with suitable material such as vinyl tape to avoid the entry of air.

2. Slide evaporator, and then remove it from heater & cooling unit assembly.
3. Remove intake sensor from evaporator, and then remove evaporator.

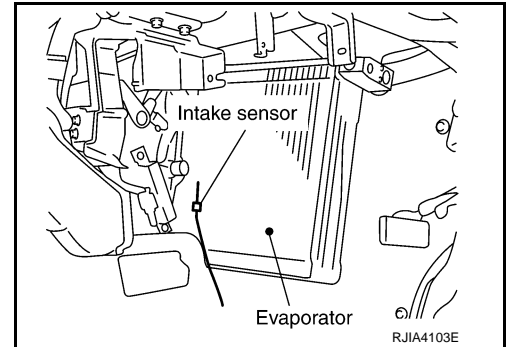

4. Remove mounting bolts, and then remove expansion valve.

**CAUTION:**

Cap or wrap the joint of evaporator and expansion valve with suitable material such as vinyl tape to avoid the entry of air.

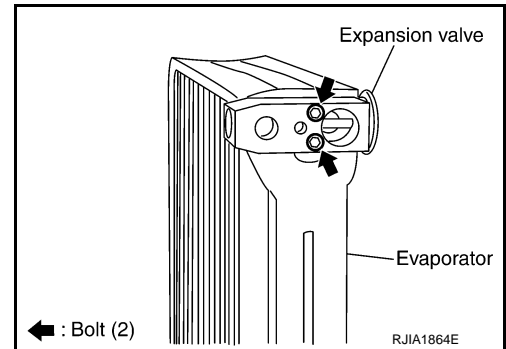

### INSTALLATION

Installation is basically the reverse order of removal.

**CAUTION:**

- Replace O-rings with new ones. Then apply compressor oil to them when installing.
- Female-side piping connection is thin and easy to deform. Slowly insert the male-side piping straight in axial direction.
- Insert piping securely until a click is heard.
- After piping connection is completed, pull male-side piping by hand to check that connection does not come loose.
- O-rings are different from low-pressure pipe 2 (high-pressure pipe 1) and low-pressure pipe 1 (high-pressure pipe 2).
- Mark the mounting position of intake sensor bracket prior to removal so that the reinstalled sensor can be located in the same position.
- Check for leakages when recharging refrigerant.

Low-pressure flexible hose bracket mounting bolt

 : 4.2 N·m (0.43 kg·m, 37 in·lb)

## VQ35HR : Removal and Installation of Expansion Valve

INFOID:000000005348569

### REMOVAL

1. Remove evaporator. Refer to [ATC-148, "VQ35HR : Removal and Installation of Evaporator"](#).

# REFRIGERANT LINES

## < SERVICE INFORMATION >

- Remove mounting bolts, and then remove expansion valve.

### **CAUTION:**

**Cap or wrap the joint of evaporator and expansion valve with suitable material such as vinyl tape to avoid the entry of air.**

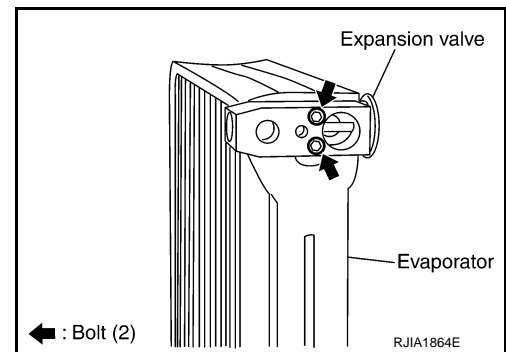

## INSTALLATION

Installation is basically the reverse order of removal.

### **CAUTION:**

- **Replace O-rings with new ones. Then apply compressor oil to them when installing.**
- **Check for leakages when recharging refrigerant.**
- **O-rings are different from low-pressure pipe 2 (high-pressure pipe 1) and low-pressure pipe 1 (high-pressure pipe 2).**

## VQ35HR : Checking of Refrigerant Leaks

INFOID:000000005348570

Perform a visual inspection of all refrigeration parts, fittings, hoses and components for signs of A/C lubricant leakage, damage and corrosion. A/C lubricant leakage may indicate an area of refrigerant leakage. Allow extra inspection time in these areas when using either an electrical leak detector (SST: J-41995) or UV lamp and UV safety goggles (SST: J-42220).

Confirm the leakage with an electrical leak detector if dye is observed. It is possible a prior leakage was repaired and not properly cleaned.

If a leakage is found but continue checking for additional leakages at all system components and connections when searching for leakages.

Move the probe along the suspected leakage area at 1 to 2 inches per second and no further than 1/4 inch from the component when searching for refrigerant leakages using an electrical leak detector.

### **CAUTION:**

**Moving the electrical leak detector probe slower and closer to the suspected leakage area improves the chances of finding a leakage.**

## VQ35HR : Checking System for Leaks Using the Fluorescent Leak Detector

INFOID:000000005348571

1. Check A/C system for leakages using the UV lamp and safety goggles (SST: J-42220) in a low sunlight area (area without windows preferable). Illuminate all components, fittings and lines. The dye will appear as a bright green/yellow area at the point of leakage. Fluorescent dye observed at the evaporator drain opening indicates an evaporator core assembly (tubes, core or expansion valve) leakage.
2. Use an adjustable mirror or wipe the area with a clean shop rag or cloth, with the UV lamp for dye residue if the suspected area is difficult to see.
3. Remove any residual dye using dye cleaner (SST: J-43872) to prevent future misdiagnosis after the leakage is repaired.
4. Perform a system performance check and verify the leakage repair with an approved electrical leak detector (SST: J-41995).

### **NOTE:**

Other gases in the work area or substances on the A/C components, for example, anti-freeze, windshield washer fluid, solvents and lubricants, may falsely trigger the leak detector. Check the surfaces to be checked are clean.

Clean with a dry cloth or blow off with shop air.

Do not allow the sensor tip of the detector to contact with any substance. This can also cause false readings and may damage the detector.

## VQ35HR : Dye Injection

INFOID:000000005348572

(This procedure is only necessary when recharging the system or when the compressor has seized and was replaced.)

# REFRIGERANT LINES

## < SERVICE INFORMATION >

1. Check A/C system static (at rest) pressure. Pressure must be at least 345 kPa (3.52 kg/cm<sup>2</sup>, 50 psi).
2. Pour one bottle [1/4 ounce (7.4 cc)] of the A/C refrigerant dye into the injector tool (SST: J-41459).
3. Connect the injector tool to the A/C low-pressure side service valve.
4. Start the engine. Then switch A/C ON.
5. Inject one bottle [1/4 ounce (7.4 cc)] of fluorescent dye through the low-pressure service valve using dye injector tool (SST: J-41459) (refer to the manufacture's operating instructions) when the A/C operating (compressor running).
6. Disconnect the injector tool from the service valve with the engine still running.  
**CAUTION:**  
**Be careful when replacing the A/C system or a component, pour the dye directly into the open system connection and proceed with the service procedures.**
7. Operate the A/C system for a minimum of 20 minutes to mix the dye with the system oil. Depending on the leakage size, operating conditions and location of the leakage, it may take from minutes to days for the dye to penetrate a leakage and become visible.
8. Attach a blue label as necessary.

## VQ35HR : Electrical Leak Detector

INFOID:000000005348573

### PRECAUTIONS FOR HANDLING LEAK DETECTOR

Use an electrical leak detector (SST: J-41995) or equivalent when performing a refrigerant leakage check. Ensure that the instrument is calibrated and set properly per the operating instructions. The leak detector is a delicate device. Read the operating instructions and perform any specified maintenance for using the leak detector properly.

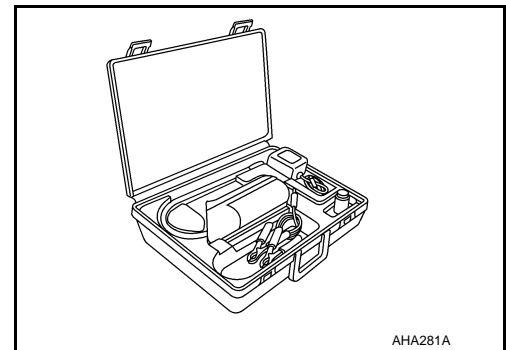

1. Position probe approximately 3 mm (0.12 in) away from point to be checked.

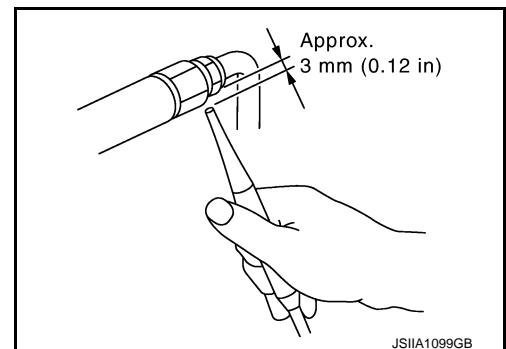

2. Circle each fitting completely with probe when testing.

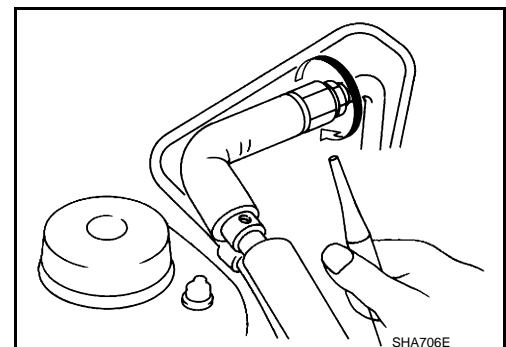



# REFRIGERANT LINES

## < SERVICE INFORMATION >

3. Move probe along component approximately 25 to 50 mm (1 to 2 in)/sec.

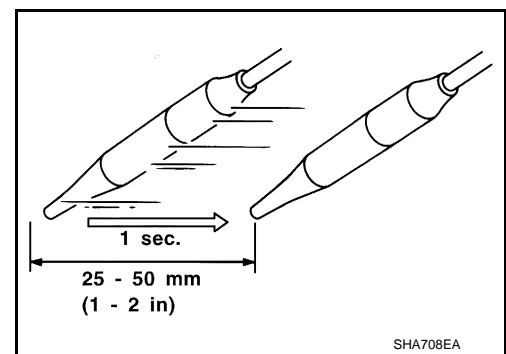

## CHECKING PROCEDURE

Check that there is no refrigerant vapor, shop chemicals, or cigarette smoke in the vicinity of the vehicle to prevent inaccurate or false readings. Perform the leakage test in calm area (low air/wind movement) so that the leaking refrigerant is not dispersed.

1. Stop the engine.
2. Connect a suitable manifold gauge set (SST: J-39183) to the A/C service valves.
3. Check if the A/C refrigerant pressure is at least 345 kPa (3.52 kg/cm<sup>2</sup>, 50 psi) above 16°C (61°F). Recover/evacuate and recharge the system with the specified amount of refrigerant if less than specification.

### NOTE:

Leakages may not be detected since the system may not reach 345 kPa (3.52 kg/cm<sup>2</sup>, 50 psi) at temperatures below 16°C (61°F).

4. Perform the leak test from the high-pressure side (compressor discharge “a” to evaporator inlet “h”) to the low-pressure side (evaporator drain hose “i” to shaft seal “n”). Refer to [ATC-136, "VQ35HR : Component"](#). Perform a leak check for the following areas carefully. Clean the component to be checked and move the leak detected probe completely around the connection/component.

### Compressor

Check the fitting of high- and low-pressure flexible hoses, relief valve and shaft seal.

### Condenser

Check the fitting of high-pressure flexible hose and pipe.

### Liquid tank

Check the fitting of refrigerant pressure sensor.

### Service valves

Check all around the service valves. Ensure service valve caps are secured on the service valves (to prevent leaks).

### NOTE:

After removing A/C manifold gauge set from service valves, wipe any residue from valves to prevent any false readings by leak detector.

### Cooling unit (Evaporator)

With engine OFF, turn blower fan on “High” for at least 15 seconds to dissipate any refrigerant trace in the cooling unit. Wait a minimum of 10 minutes accumulation time (refer to the manufacturer’s recommended procedure for actual wait time) before inserting the leak detector probe into the drain hose.

Keep the probe inserted for at least 10 seconds. Use caution not to contaminate the probe tip with water or dirt that may be in the drain hose.

5. Verify at least once by blowing compressed air into area of suspected leakage, then repeat check as outlined above if a leak detector detects a leakage.
6. If a leakage is found, but continue checking for additional leakages at all system components. When leakages are not found, go to next step.
7. Start the engine.
8. Set the A/C control as per the following:
  - a. A/C switch: ON
  - b. Air flow: VENT (Ventilation)
  - c. Intake door position: Recirculation
  - d. Temperature setting: Maximum cold
  - e. Fan speed: High

# REFRIGERANT LINES

## < SERVICE INFORMATION >

9. Run engine at 1,500 rpm for at least 2 minutes.
10. Stop the engine and perform leakage check again, steps 4 – 6. Refrigerant leakages should be checked immediately after stopping the engine. Begin with the leak detector at the compressor. The pressure on the high-pressure side drops gradually after refrigerant circulation stops and pressure on the low-pressure side rises gradually, as shown in the graph. Some leakages are more easily detected when pressure is high.

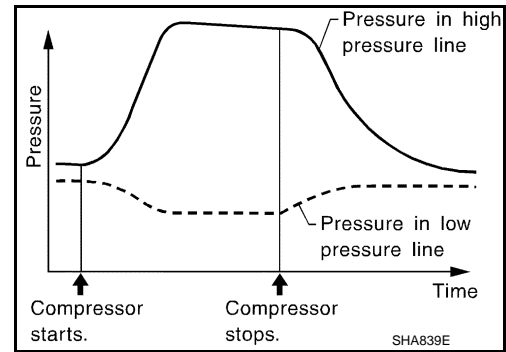

11. Check recovery/recycling recharging equipment gauges before connecting recovery/recycling recharging equipment to vehicle. No refrigerant pressure should be displayed. Recover refrigerant from equipment lines if pressure is displayed.
12. Confirm refrigerant purity in supply tank using recovery/recycling recharging equipment and refrigerant identifier.
13. Confirm refrigerant purity in vehicle A/C system using recovery/recycling recharging equipment and refrigerant identifier.
14. Discharge A/C system using approved refrigerant recovery equipment. Repair the leaking fitting or component if necessary.
15. Evacuate and recharge A/C system and perform the leakage test to confirm no refrigerant leakages.
16. Perform A/C performance test to ensure system works properly.

VK45DE

VK45DE : HFC-134a (R-134a) Service Procedure

INFOID:000000005348574

## SETTING OF SERVICE TOOLS AND EQUIPMENT

Discharging Refrigerant

### **WARNING:**

**Never breath A/C refrigerant and lubricant vapor or mist. Exposure may irritate eyes, nose and throat. Remove HFC-134a (R-134a) from A/C system using certified service equipment meeting requirements of SAE J-2210 [HFC-134a (R-134a) recycling equipment] or J-2209 [HFC-134a (R-134a) recovery equipment]. Ventilate work area before resuming service if accidental system discharge occurs. Additional health and safety information may be obtained from refrigerant and lubricant manufacturers.**

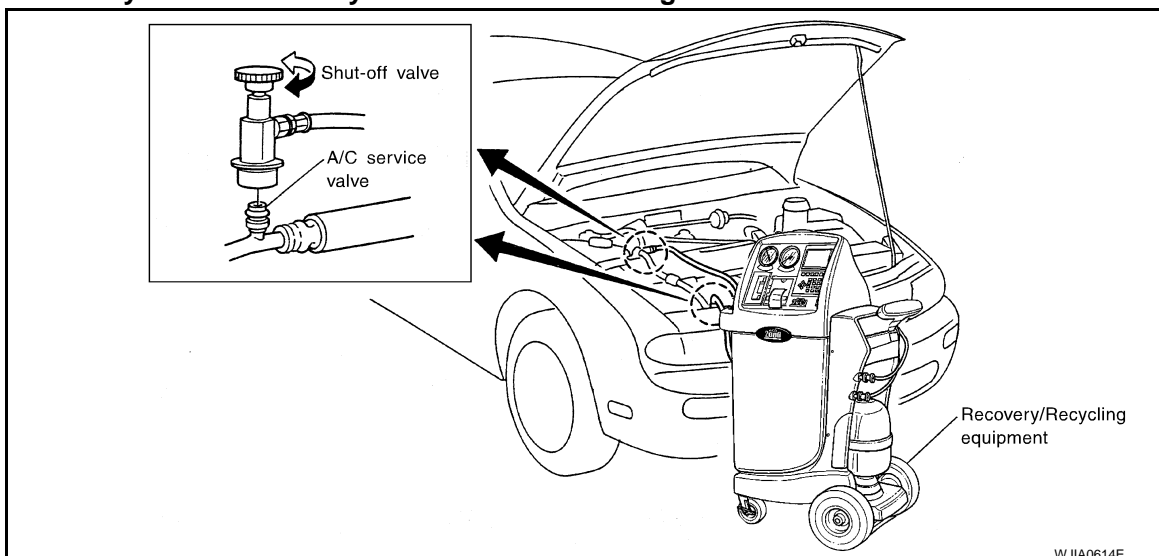



# REFRIGERANT LINES

## < SERVICE INFORMATION >

### Evacuating System and Charging Refrigerant

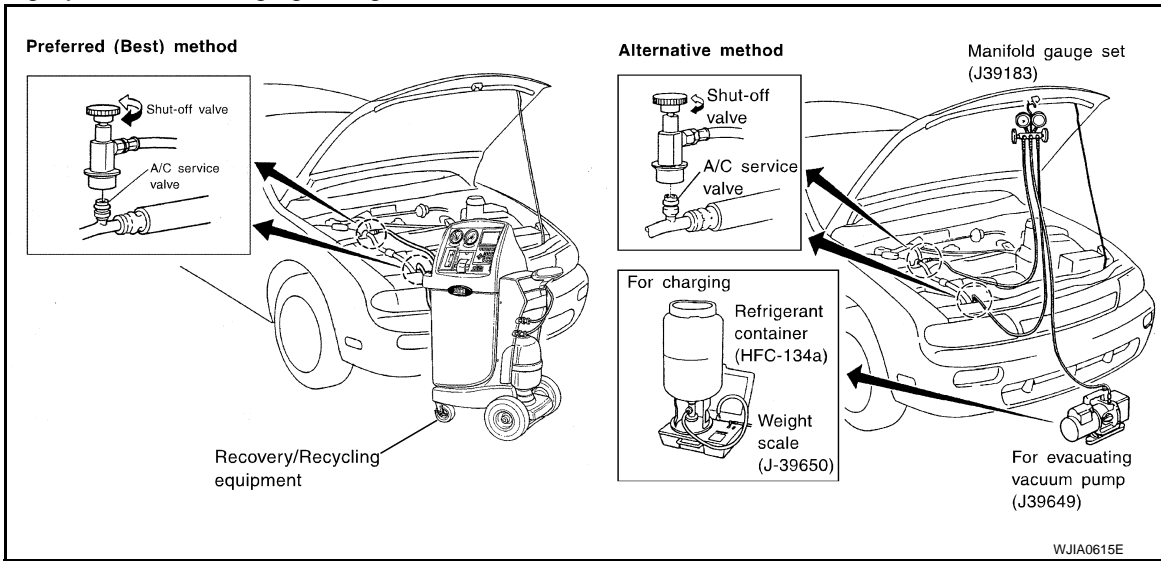

A  
B  
C  
D  
E  
F  
G  
H  
I  
K  
L  
M  
N  
O  
P

ATC

# REFRIGERANT LINES

## < SERVICE INFORMATION >

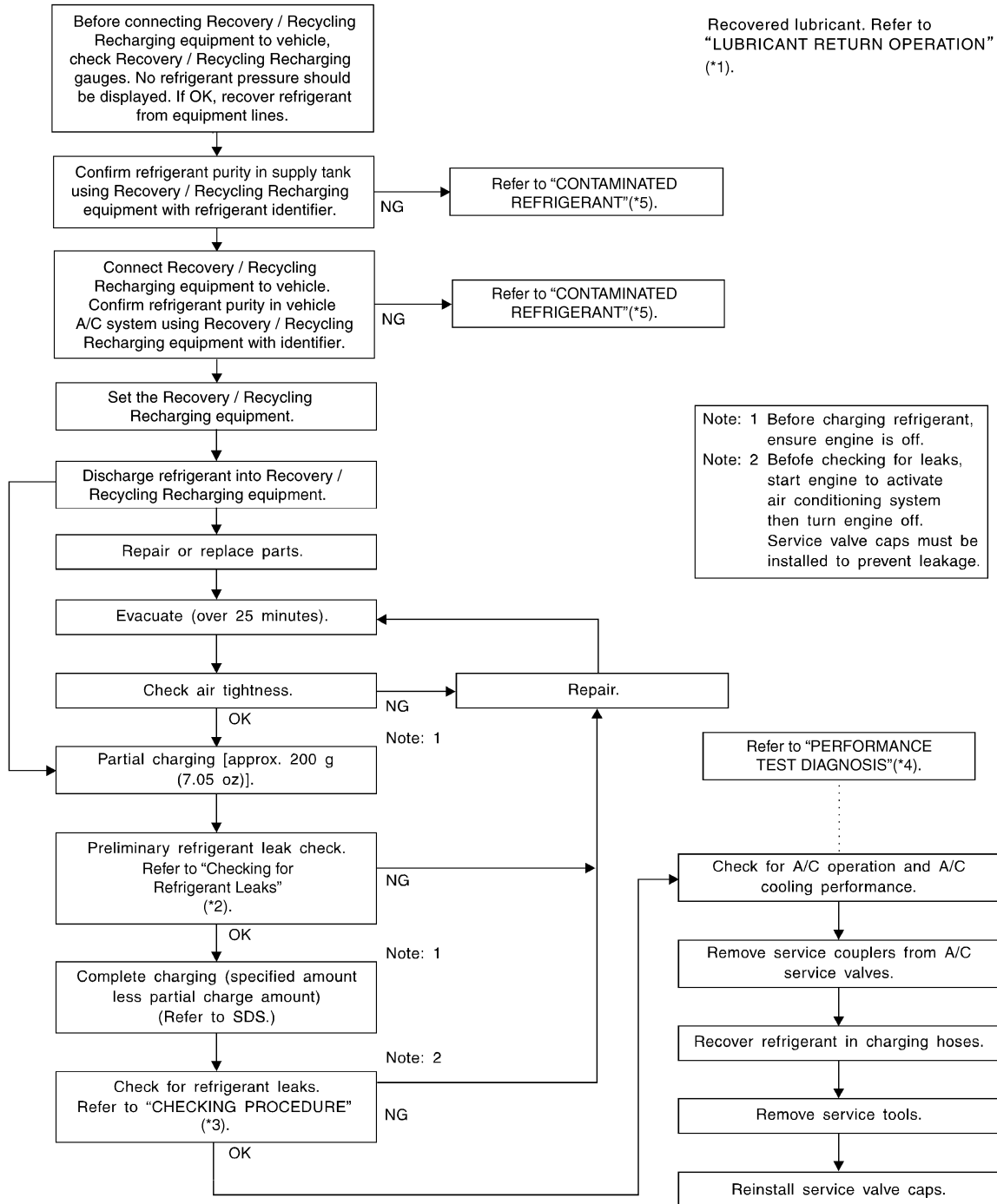

SJIA1275E

\*1 [ATC-22, "Maintenance of Lubricant Quantity in Compressor"](#)

\*2 [ATC-166, "VK45DE : Checking of Refrigerant Leaks"](#)

\*3 [ATC-167, "VK45DE : Electrical Leak Detector"](#)

\*4 [ATC-84, "Insufficient Cooling"](#)

\*5 [ATC-4, "Precaution for Working with HFC-134a \(R-134a\)"](#)

# REFRIGERANT LINES

< SERVICE INFORMATION >

VK45DE : Component

INFOID:000000005348575

Refer to [ATC-5, "Precaution for Refrigerant Connection"](#).

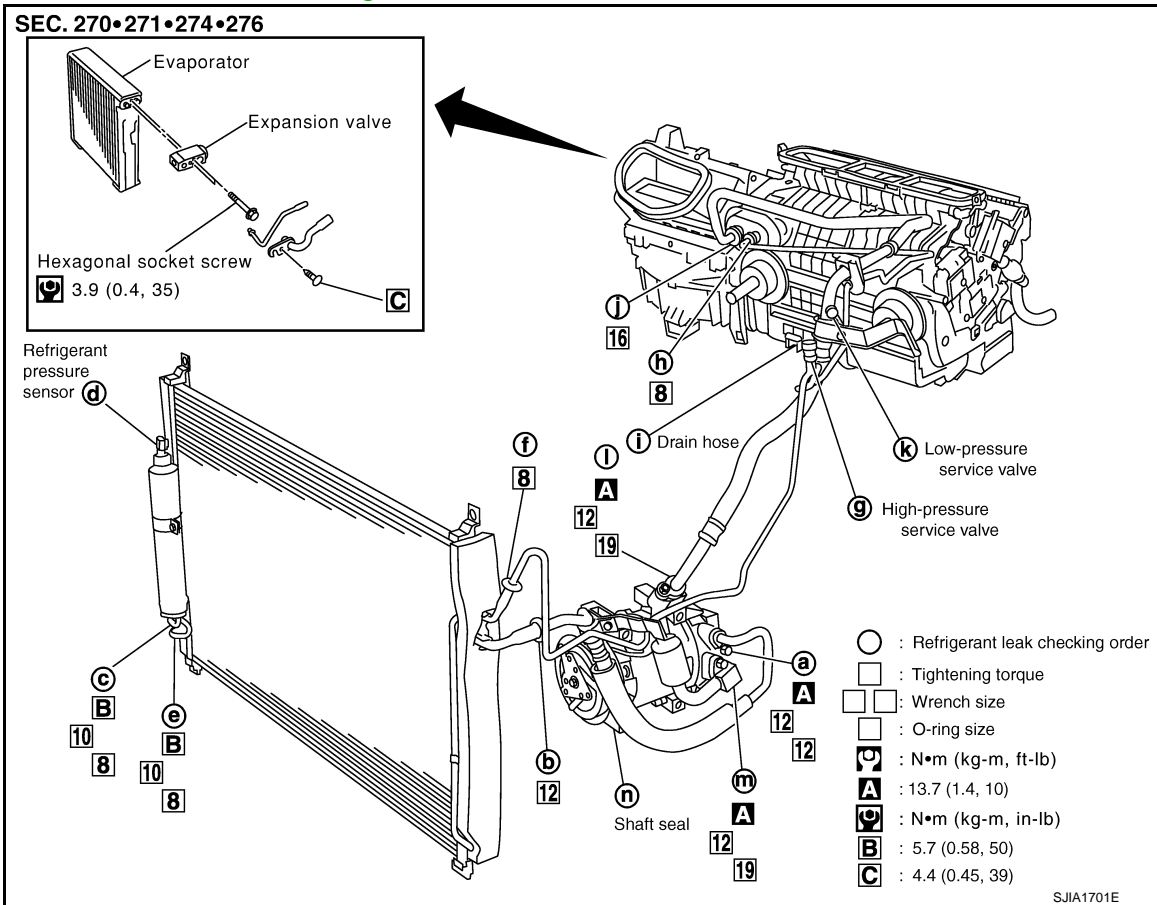

VK45DE : Removal and Installation of Compressor

INFOID:000000005348576

REMOVAL

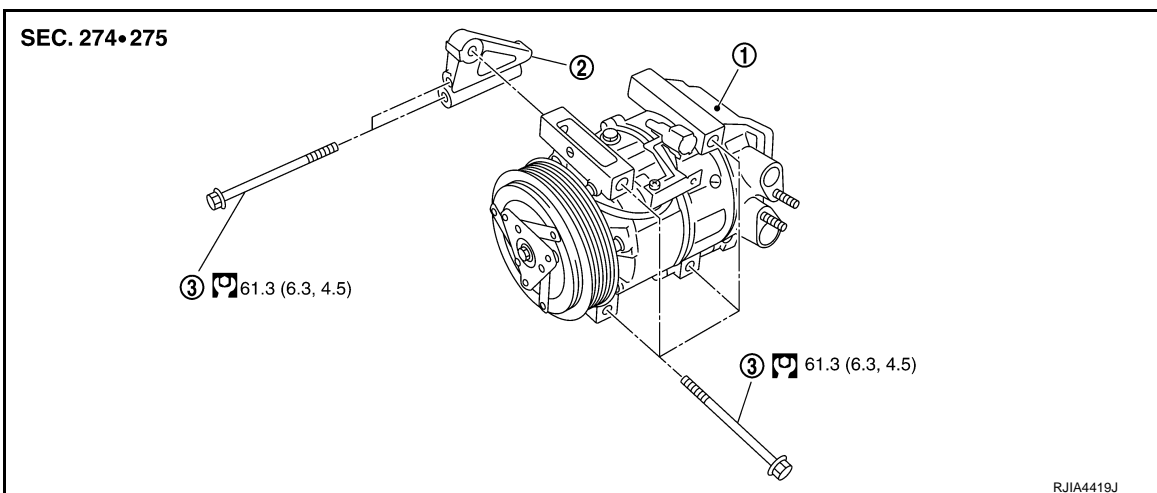

1. Compressor
2. Compressor bracket
3. Bolt

Refer to [GI-9, "Component"](#) for symbols in the figure.

1. Use a refrigerant collecting equipment (for HFC-134a) to discharge the refrigerant.
2. Remove air cleaner case and air duct. Refer to [EM-172, "Component"](#).
3. Remove engine undercover, using power tools.

# REFRIGERANT LINES

## < SERVICE INFORMATION >

4. Remove mounting nut between low-pressure flexible hose and low-pressure pipe. Refer to [ATC-156. "VK45DE : Removal and Installation of Low-pressure Flexible Hose and Pipe"](#).
5. Remove mounting nuts from low-pressure pipe and high-pressure flexible hose.

**CAUTION:**

Cap or wrap the joint of the A/C piping and compressor with suitable material such as vinyl tape to avoid the entry of air.

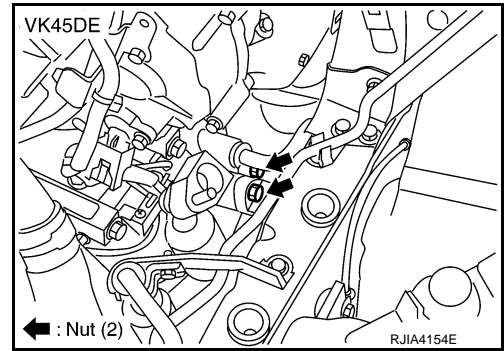

6. Remove drive belt. Refer to [EM-169. "Component"](#).
7. Disconnect compressor (magnet clutch and ECV) connectors.
8. Remove mounting bolts from compressor, using power tools.
9. Remove compressor downward of the vehicle.

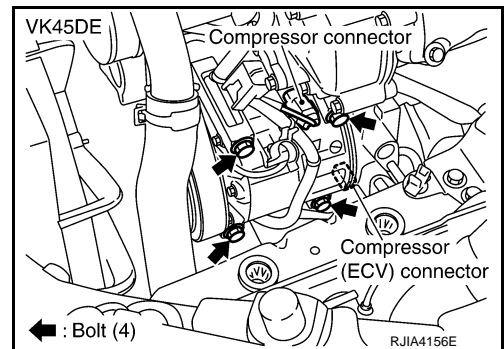

## INSTALLATION

Installation is basically the reverse order of removal.

**CAUTION:**

- Replace O-rings with new ones. Then apply compressor oil to them when installing.
- When recharging refrigerant, check for leaks.
- Check tension of the drive belt after installing compressor. Refer to [EM-169. "Checking Drive Belts"](#).

## VK45DE : Check Disc to Pulley Clearance

INFOID:000000005348577

Check the clearance (B) between pulley assembly (1) and clutch disc (2) along the entire periphery with a feeler gauge (A).

**Clearance : 0.3 - 0.6 mm (0.012 - 0.024 in)**

Replace compressor if specified clearance is not obtained.

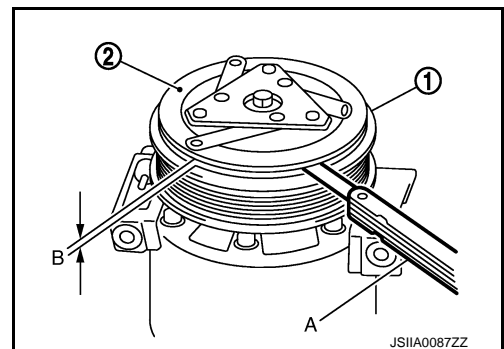

## VK45DE : Removal and Installation of Low-pressure Flexible Hose and Pipe

INFOID:000000005348578

## REMOVAL

1. Use a refrigerant collecting equipment (for HFC-134a) to discharge the refrigerant.
2. Remove engine cover. Refer to [EM-175. "Removal and Installation"](#).
3. Remove air cleaner case and air duct. Refer to [EM-172. "Component"](#).
4. Remove cowl top cover. Refer to [EI-29. "Component Parts Location"](#).

# REFRIGERANT LINES

## < SERVICE INFORMATION >

5. Remove mounting bolt from low-pressure flexible hose bracket.

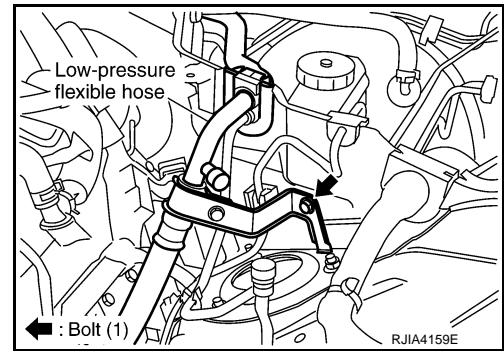

6. Disconnect one-touch joint between low-pressure flexible hose and low-pressure pipe 1.
- Set a disconnecter (SST: 9253089916) on A/C piping.
  - Slide a disconnecter toward vehicle front until it clicks.
  - Slide A/C piping toward vehicle front and disconnect it.

**CAUTION:**

Cap or wrap the joint of the A/C piping with suitable material such as vinyl tape to avoid the entry of air.

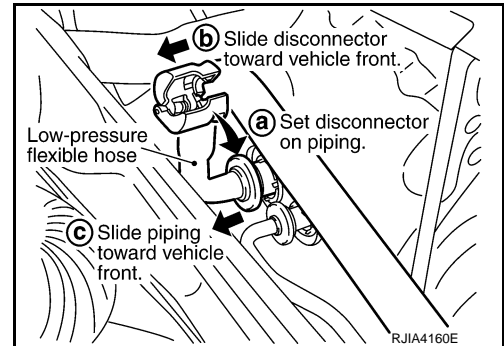

7. Remove mounting nuts from low-pressure flexible hose and low-pressure pipe.

**CAUTION:**

Cap or wrap the joint of the A/C piping and compressor with suitable material such as vinyl tape to avoid the entry of air.

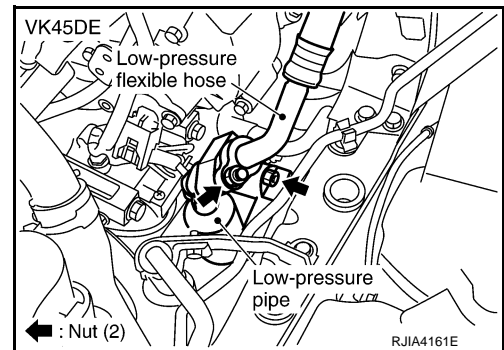

## INSTALLATION

Installation is basically the reverse order of removal.

**CAUTION:**

- Replace O-rings with new ones. Then apply compressor oil to them when installing.
- Female-side piping connection is thin and easy to deform. Slowly insert the male-side piping straight in axial direction.
- Insert piping securely until a click is heard.
- After piping connection is completed, pull male-side piping by hand to check that connection does not come loose.
- Check for leakages when recharging refrigerant.

### Low-pressure flexible hose bracket mounting bolt

 : 4.2 N·m (0.43 kg·m, 37 in·lb)

## VK45DE : Removal and Installation of High-pressure Flexible Hose

INFOID:000000005348579

## REMOVAL

- Use a refrigerant collecting equipment (for HFC-134a) to discharge the refrigerant.
- Remove engine cover. Refer to [EM-175. "Removal and Installation"](#).
- Remove air cleaner case and air duct. Refer to [EM-172. "Component"](#).

# REFRIGERANT LINES

## < SERVICE INFORMATION >

4. Remove mounting bolt from high-pressure flexible hose bracket.

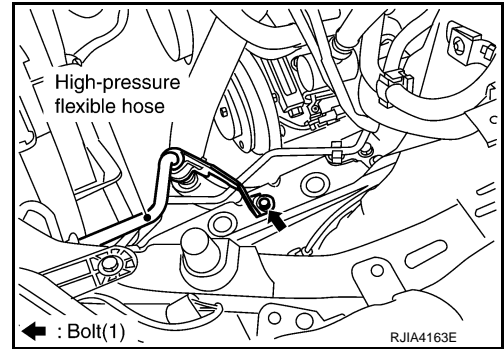

5. Disconnect one-touch joint between high-pressure flexible hose and condenser.

- Set a disconnecter (SST: 9253089912) on A/C piping.
- Slide a disconnecter backward until it clicks.
- Slide A/C piping backward and disconnect it.

**CAUTION:**

Cap or wrap the joint of the A/C piping with suitable material such as vinyl tape to avoid the entry of air.

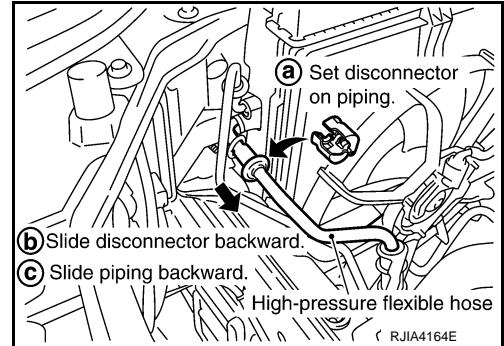

6. Remove low-pressure pipe. Refer to [ATC-156, "VK45DE : Removal and Installation of Low-pressure Flexible Hose and Pipe"](#).

7. Remove mounting nut from high-pressure flexible hose, and then remove high-pressure flexible hose.

**CAUTION:**

Cap or wrap the joint of the A/C piping and compressor with suitable material such as vinyl tape to avoid the entry of air.

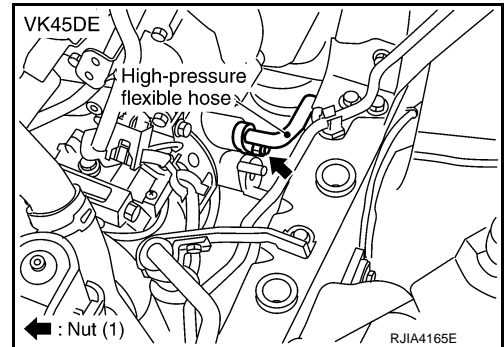

## INSTALLATION

Installation is basically the reverse order of removal.

**CAUTION:**

- Replace O-rings with new ones. Then apply compressor oil to them when installing.
- Female-side piping connection is thin and easy to deform. Slowly insert the male-side piping straight in axial direction.
- Insert piping securely until a click is heard.
- After piping connection is completed, pull male-side piping by hand to check that connection does not come loose.
- Check for leakages when recharging refrigerant.

### High-pressure flexible hose bracket mounting bolt

 : 4.2 N·m (0.43 kg·m, 37 in·lb)

## VK45DE : Removal and Installation of High-pressure Pipe 1

INFOID:000000005348580

## REMOVAL

1. Remove low-pressure flexible hose. Refer to [ATC-156, "VK45DE : Removal and Installation of Low-pressure Flexible Hose and Pipe"](#).

# REFRIGERANT LINES

## < SERVICE INFORMATION >

2. Remove mounting bolt from high-pressure flexible hose bracket.

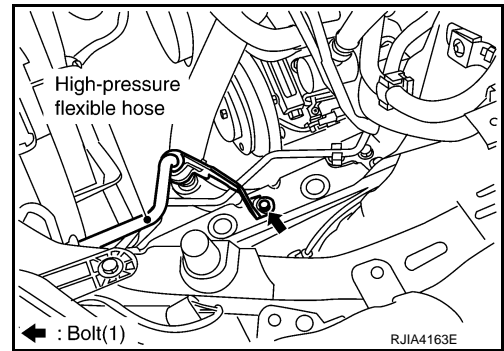

3. Remove high-pressure pipe 1 from vehicle clips.

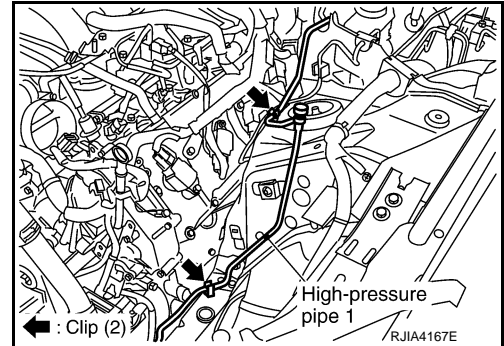

4. Disconnect one-touch joints of high-pressure pipe 1.
  - a. Set a disconnecter (SST: 9253089908) on A/C piping.
  - b. Slide a disconnecter toward (or upward) vehicle front until it clicks.
  - c. Slide A/C piping toward (or upward) vehicle front and disconnect it.

**CAUTION:**

Cap or wrap the joint of the A/C piping with suitable material such as vinyl tape to avoid the entry of air.

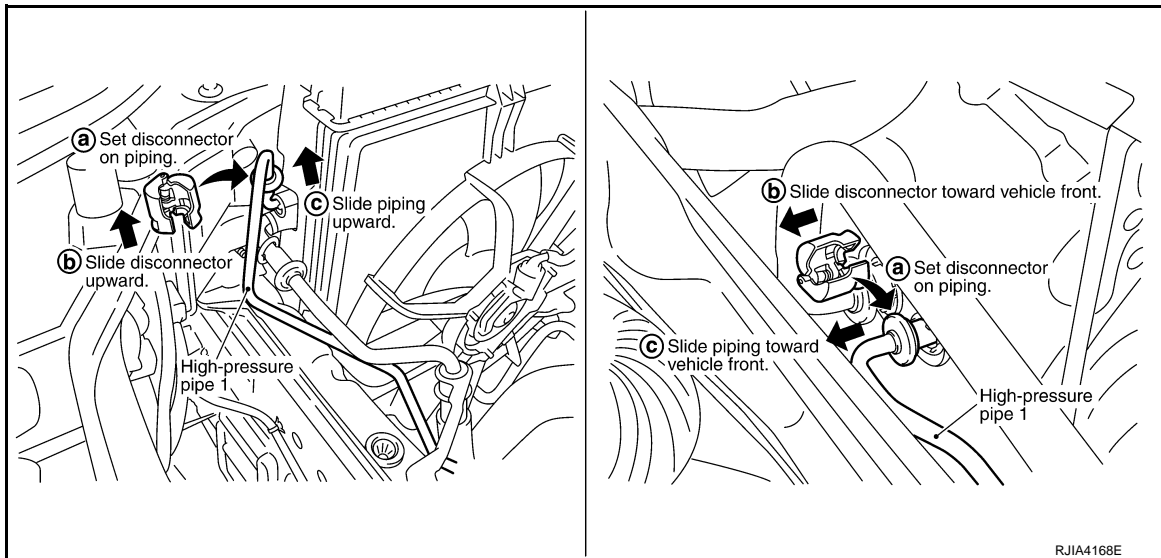

5. Remove high-pressure pipe 1.

## INSTALLATION

Installation is basically the reverse order of removal.

**CAUTION:**

- Replace O-rings with new ones. Then apply compressor oil to them when installing.
- Female-side piping connection is thin and easy to deform. Slowly insert the male-side piping straight in axial direction.
- Insert piping securely until a click is heard.
- After piping connection is completed, pull male-side piping by hand to check that connection does not come loose.

A  
B  
C  
D  
E  
F  
G  
H  
I  
K  
L  
M  
N  
O  
P

ATC



# REFRIGERANT LINES

## < SERVICE INFORMATION >

- Check for leakages when recharging refrigerant.

### High-pressure flexible hose bracket mounting bolt

 : 4.2 N·m (0.43 kg·m, 37 in·lb)

## VK45DE : Removal and Installation of Low-pressure Pipe 1 and High-pressure Pipe 2

INFOID:000000005348581

### REMOVAL

1. Set the temperature control switch (passenger side) at 18°C (60°F).

#### CAUTION:

The angle may be out, when installing the air mix door motor to the air mix door, unless the above procedure is performed.

2. Disconnect the battery cable from the negative terminal.
3. Use a refrigerant collecting equipment (for HFC-134a) to discharge the refrigerant.
4. Remove cowl top cover. Refer to [EI-29. "Component Parts Location"](#).
5. Remove mounting bolt from low-pressure flexible hose bracket.
6. Remove high-pressure pipe 1 from vehicle clip.

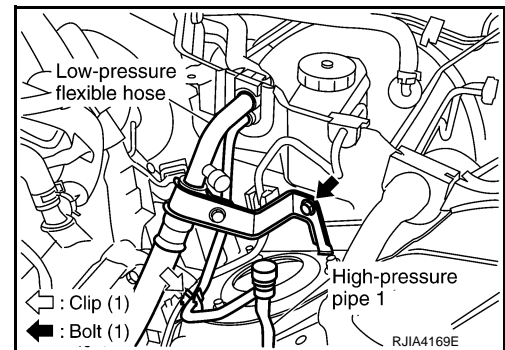

7. Disconnect one-touch joints.
  - a. Set a disconnecter [high-pressure side (SST: 9253089908), low-pressure side (SST: 9253089916)] on A/C piping.
  - b. Slide a disconnecter toward vehicle front until it clicks.
  - c. Slide A/C piping toward vehicle front and disconnect it.

#### CAUTION:

Cap or wrap the joint of the A/C piping with suitable material such as vinyl tape to avoid the entry of air.

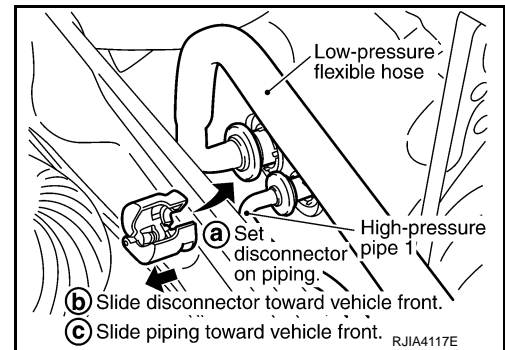

8. Remove instrument passenger lower panel and glove box. Refer to [IP-11. "INSTRUMENT PANEL : Component Parts Location"](#).
9. Remove foot grille (right). Refer to [ATC-128. "Removal and Installation"](#).
10. Remove air mix door motor (passenger side). Refer to [ATC-125. "Removal and Installation"](#).
11. Remove mode door motor (passenger side). Refer to [ATC-124. "Removal and Installation"](#).
12. Remove main link (right) and max. cool door link (right). Refer to [ATC-119. "Removal and Installation"](#).



# REFRIGERANT LINES

## < SERVICE INFORMATION >

13. Remove mounting screws, and then remove evaporator cover.

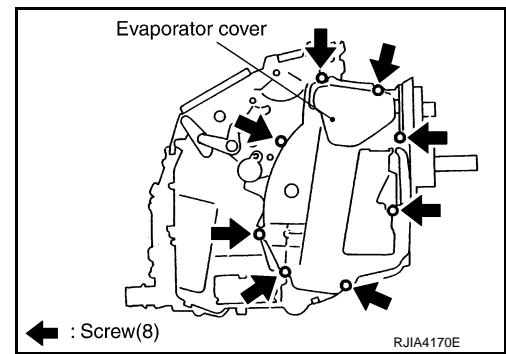

14. Remove mounting bolt, and then remove low-pressure pipe 1 and high-pressure pipe 2.

**CAUTION:**

Cap or wrap the joint of the A/C piping and expansion valve with suitable material such as vinyl tape to avoid the entry of air.

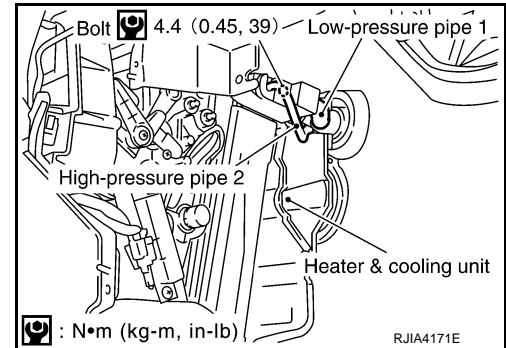

## INSTALLATION

Installation is basically the reverse order of removal.

**CAUTION:**

- Replace O-rings with new ones. Then apply compressor oil to them when installing.
- Female-side piping connection is thin and easy to deform. Slowly insert the male-side piping straight in axial direction.
- Insert piping securely until a click is heard.
- After piping connection is completed, pull male-side piping by hand to check that connection does not come loose.
- Check for leakages when recharging refrigerant.

### Low-pressure flexible hose bracket mounting bolt

⊗ : 4.2 N·m (0.43 kg·m, 37 in·lb)

VK45DE : Removal and Installation of Liquid Tank

INFOID:000000005348582

DISASSEMBLY AND ASSEMBLY

# REFRIGERANT LINES

< SERVICE INFORMATION >

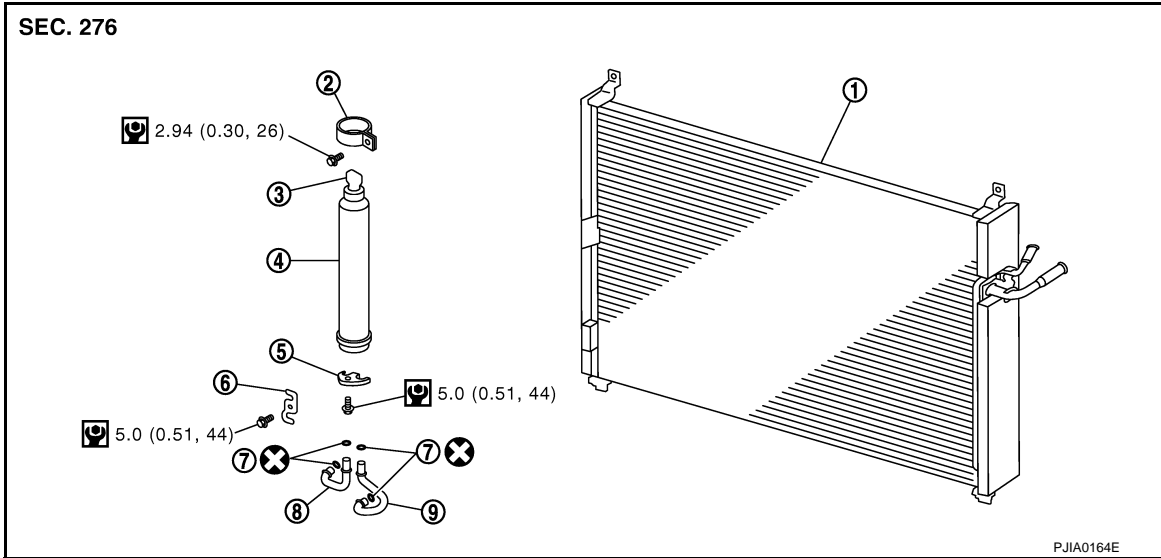

- |                |                               |                                |
|----------------|-------------------------------|--------------------------------|
| 1. Condenser   | 2. Liquid tank bracket        | 3. Refrigerant pressure sensor |
| 4. Liquid tank | 5. Bracket (liquid tank side) | 6. Bracket (condenser side)    |
| 7. O-ring      | 8. Inside pipe                | 9. Outside pipe                |

Refer to [GI-9, "Component"](#) for symbols in the figure.

## REMOVAL

- Remove condenser. Refer to [ATC-163, "VK45DE : Removal and Installation of Condenser"](#).
- Clean liquid tank and its surrounding area, and remove dust and rust from liquid tank.  
**CAUTION:**  
**Be sure to clean carefully.**
- Remove mounting bolts from liquid tank.

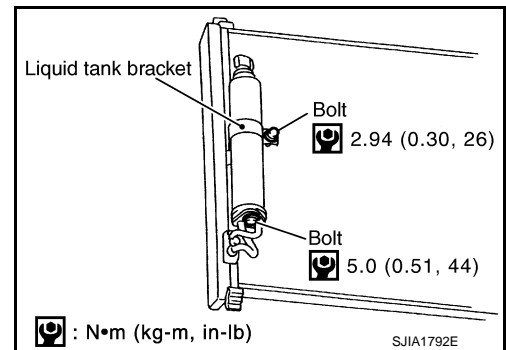

- Lift liquid tank bracket upward. Remove liquid tank bracket from protruding part of condenser.
- Slide liquid tank upward, and then remove liquid tank.  
**CAUTION:**  
**Cap or wrap the joint of the A/C piping and liquid tank with suitable material such as vinyl tape to avoid the entry of air.**

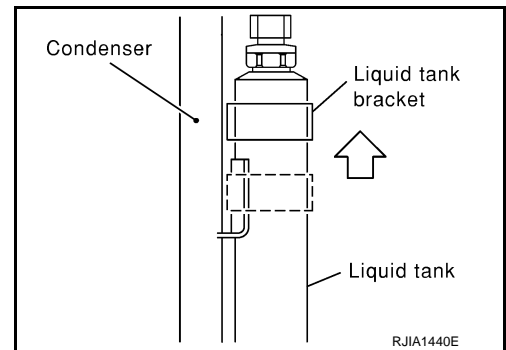

## INSTALLATION

# REFRIGERANT LINES

## < SERVICE INFORMATION >

Install liquid tank, and then install liquid tank bracket on condenser.

### CAUTION:

- Check liquid tank bracket is securely installed at protrusion of condenser. (Check liquid tank bracket does not move to a position below center of liquid tank.)
- Replace O-rings of the A/C piping with new ones. Then apply compressor oil to them when installing.
- Check for leakages when recharging refrigerant.

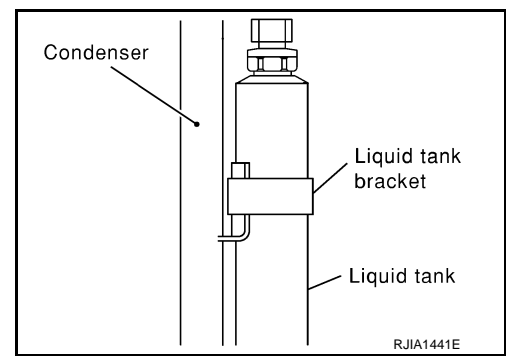

## VK45DE : Removal and Installation of Condenser

INFOID:000000005348583

### REMOVAL

1. Use a refrigerant collecting equipment (for HFC-134a) to discharge the refrigerant.
2. Remove engine cover. Refer to [EM-175. "Removal and Installation"](#).
3. Remove air cleaner case, air hose and air duct. Refer to [EM-172. "Component"](#).
4. Remove front grille. Refer to [EI-27. "Component Parts Location"](#).
5. Remove radiator fan shroud with cooling fan. Refer to [CO-47. "Component"](#).
6. Remove mounting clips and bolts, and then remove bracket.
7. Remove radiator upper mount, move radiator and condenser to the engine side.

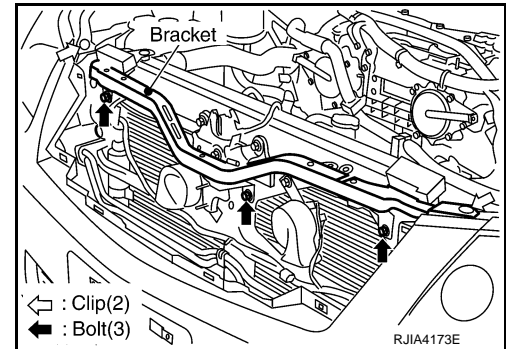

8. Remove mounting bolt from high-pressure flexible hose bracket.
9. Remove high-pressure pipe1 from vehicle clip.

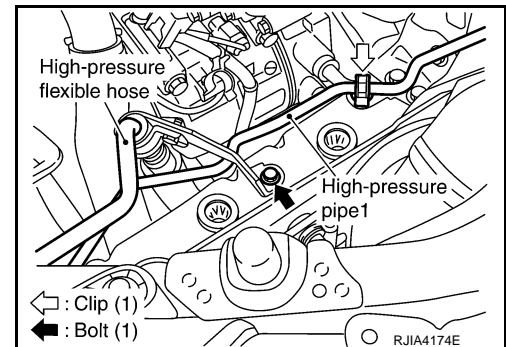

10. Disconnect high-pressure flexible hose from condenser.
  - a. Set a disconnecter (SST: 9253089912) on A/C piping.
  - b. Slide a disconnecter backward until it clicks.
  - c. Slide A/C piping backward and disconnect it.

### CAUTION:

Cap or wrap the joint of condenser and high-pressure flexible hose with suitable material such as vinyl tape to avoid the entry of air.

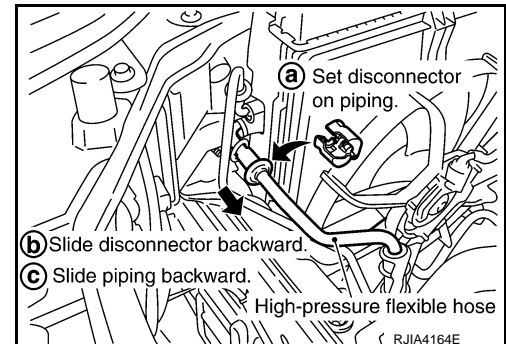

# REFRIGERANT LINES

## < SERVICE INFORMATION >

11. Disconnect high-pressure pipe 1 from condenser.
  - a. Set a disconnecter (SST: 9253089908) on A/C piping.
  - b. Slide a disconnecter upward until it clicks.
  - c. Slide A/C piping upward and disconnect it.

**CAUTION:**

Cap or wrap the joint of condenser and high-pressure pipe 1 with suitable material such as vinyl tape to avoid the entry of air.

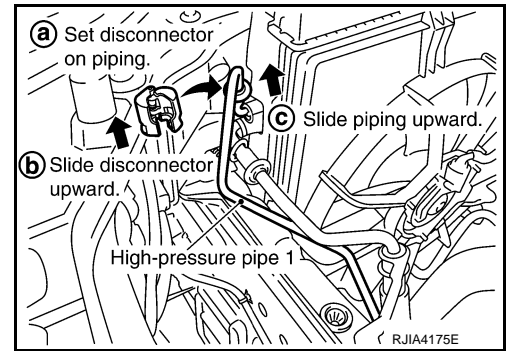

12. Disconnect refrigerant pressure sensor connector.

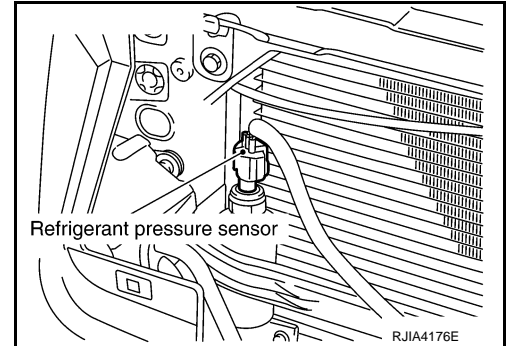

13. Disconnect hood rock switch connector.
14. Remove radiator reservoir tank. Refer to [CO-39, "Component"](#).

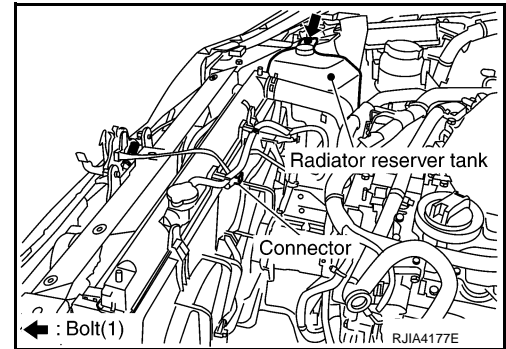

15. Remove mounting screws from condenser.

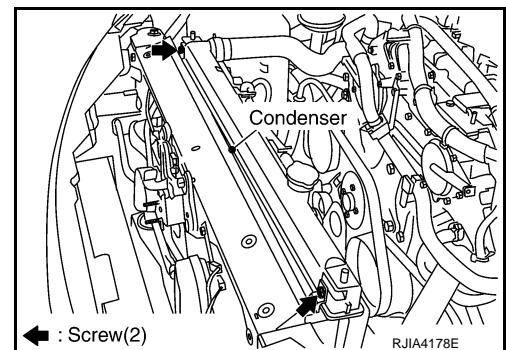

16. Pull condenser forward at an angle. Remove condenser from radiator.

**CAUTION:**

Be careful not to damage the core surface of condenser and radiator.

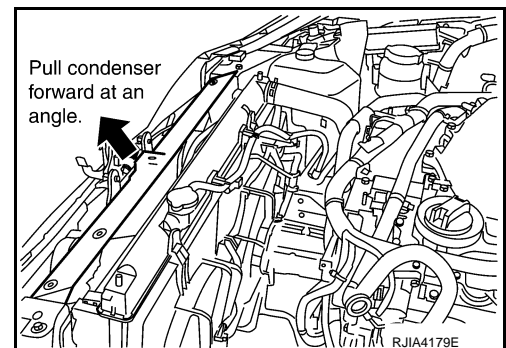

# REFRIGERANT LINES

## < SERVICE INFORMATION >

### INSTALLATION

Installation is basically the reverse order of removal.

#### **CAUTION:**

- Replace O-rings with new ones. Then apply compressor oil to them when installing.
- Female-side piping connection is thin and easy to deform. Slowly insert the male-side piping straight in axial direction.
- Insert piping securely until a click is heard.
- After piping connection is completed, pull male-side piping by hand to check that connection does not come loose.
- Check for leakages when recharging refrigerant.

### VK45DE : Removal and Installation of Refrigerant Pressure Sensor

INFOID:000000005348584

#### REMOVAL

1. Remove liquid tank. Refer to [ATC-161, "VK45DE : Removal and Installation of Liquid Tank"](#).
2. Using a vice, secure liquid tank, and remove refrigerant pressure sensor.

#### **CAUTION:**

Be careful not to damage liquid tank.

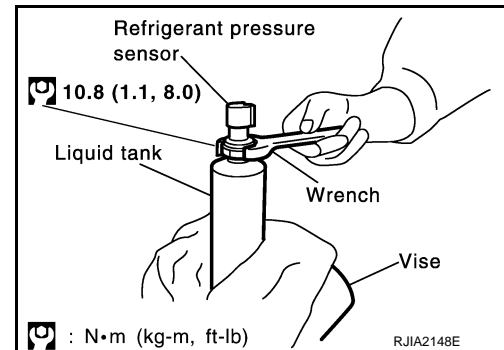

#### INSTALLATION

Installation is basically the reverse order of removal.

#### **CAUTION:**

- Apply compressor oil to O-ring of refrigerant pressure sensor when installing it.
- Check for leakages when recharging refrigerant.

### VK45DE : Removal and Installation of Evaporator

INFOID:000000005348585

#### REMOVAL

1. Remove low-pressure pipe 1 and high-pressure pipe 2. Refer to [ATC-160, "VK45DE : Removal and Installation of Low-pressure Pipe 1 and High-pressure Pipe 2"](#).

#### **CAUTION:**

Cap or wrap the joint of the A/C piping and expansion valve with suitable material such as vinyl tape to avoid the entry of air.

2. Slide evaporator, and then remove it from heater & cooling unit assembly.
3. Remove intake sensor from evaporator, and then remove evaporator.

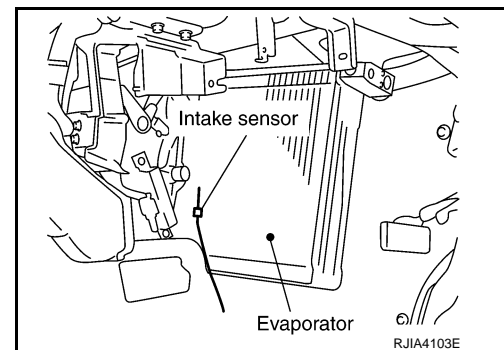

A  
B  
C  
D  
E  
F  
G  
H  
I  
K  
L  
M  
N  
O  
P

ATC

# REFRIGERANT LINES

## < SERVICE INFORMATION >

- Remove mounting bolts, and then remove expansion valve.

**CAUTION:**

Cap or wrap the joint of evaporator and expansion valve with suitable material such as vinyl tape to avoid the entry of air.

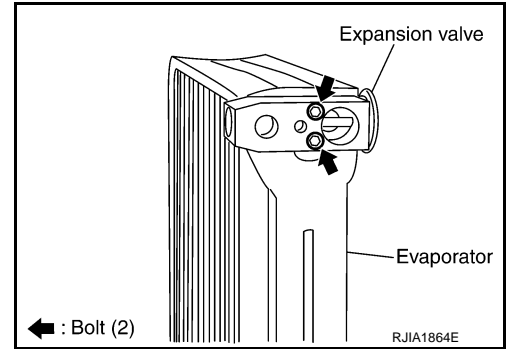

## INSTALLATION

Installation is basically the reverse order of removal.

**CAUTION:**

- Replace O-rings with new ones. Then apply compressor oil to them when installing.
- Female-side piping connection is thin and easy to deform. Slowly insert the male-side piping straight in axial direction.
- Insert piping securely until a click is heard.
- After piping connection is completed, pull male-side piping by hand to check that connection does not come loose.
- O-rings are different from low-pressure flexible hose (high-pressure pipe 1) and low-pressure pipe 1 (high-pressure pipe 2).
- Mark the mounting position of intake sensor bracket prior to removal so that the reinstalled sensor can be located in the same position.
- Check for leakages when recharging refrigerant.

### Low-pressure flexible hose bracket mounting bolt

 : 4.2 N·m (0.43 kg·m, 37 in·lb)

## VK45DE : Removal and Installation of Expansion Valve

INFOID:000000005348586

### REMOVAL

- Remove evaporator. Refer to [ATC-165, "VK45DE : Removal and Installation of Evaporator"](#).
- Remove mounting bolts, and then remove expansion valve.

**CAUTION:**

Cap or wrap the joint of evaporator and expansion valve with suitable material such as vinyl tape to avoid the entry of air.

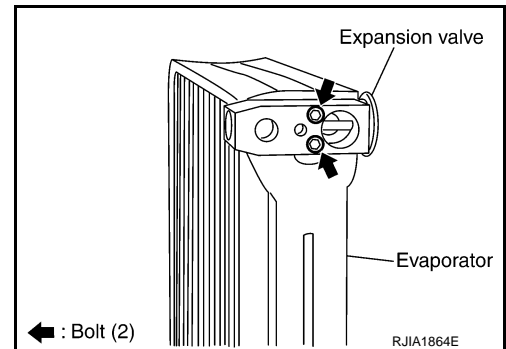

### INSTALLATION

Installation is basically the reverse order of removal.

**CAUTION:**

- Replace O-rings with new ones. Then apply compressor oil to them when installing.
- Check for leakages when recharging refrigerant.
- O-rings are different from low-pressure pipe 2 (high-pressure pipe 1) and low-pressure pipe 1 (high-pressure pipe 2).

## VK45DE : Checking of Refrigerant Leaks

INFOID:000000005348587

Perform a visual inspection of all refrigeration parts, fittings, hoses and components for signs of A/C lubricant leakage, damage and corrosion. A/C lubricant leakage may indicate an area of refrigerant leakage. Allow



# REFRIGERANT LINES

## < SERVICE INFORMATION >

extra inspection time in these areas when using either an electrical leak detector (SST: J-41995) or UV lamp and UV safety goggles (SST: J-42220).

Confirm the leakage with an electrical leak detector if dye is observed. It is possible a prior leakage was repaired and not properly cleaned.

If a leakage is found but continue checking for additional leakages at all system components and connections when searching for leakages.

Move the probe along the suspected leakage area at 1 to 2 inches per second and no further than 1/4 inch from the component when searching for refrigerant leakages using an electrical leak detector.

### **CAUTION:**

**Moving the electrical leak detector probe slower and closer to the suspected leakage area improves the chances of finding a leakage.**

## VK45DE : Checking System for Leaks Using the Fluorescent Leak Detector

INFOID:000000005348588

1. Check A/C system for leakages using the UV lamp and safety goggles (SST: J-42220) in a low sunlight area (area without windows preferable). Illuminate all components, fittings and lines. The dye will appear as a bright green/yellow area at the point of leakage. Fluorescent dye observed at the evaporator drain opening indicates an evaporator core assembly (tubes, core or expansion valve) leakage.
2. Use an adjustable mirror or wipe the area with a clean shop rag or cloth, with the UV lamp for dye residue if the suspected area is difficult to see.
3. Remove any residual dye using dye cleaner (SST: J-43872) to prevent future misdiagnosis after the leakage is repaired.
4. Perform a system performance check and verify the leakage repair with an approved electrical leak detector (SST: J-41995).

### **NOTE:**

Other gases in the work area or substances on the A/C components, for example, anti-freeze, windshield washer fluid, solvents and lubricants, may falsely trigger the leak detector. Check the surfaces to be checked are clean.

Clean with a dry cloth or blow off with shop air.

Do not allow the sensor tip of the detector to contact with any substance. This can also cause false readings and may damage the detector.

## VK45DE : Dye Injection

INFOID:000000005348589

(This procedure is only necessary when recharging the system or when the compressor has seized and was replaced.)

1. Check A/C system static (at rest) pressure. Pressure must be at least 345 kPa (3.52 kg/cm<sup>2</sup>, 50 psi).
2. Pour one bottle [1/4 ounce (7.4 cc)] of the A/C refrigerant dye into the injector tool (SST: J-41459).
3. Connect the injector tool to the A/C low-pressure side service valve.
4. Start the engine. Then switch A/C ON.
5. Inject one bottle [1/4 ounce (7.4 cc)] of fluorescent dye through the low-pressure service valve using dye injector tool (SST: J-41459) (refer to the manufacturer's operating instructions) when the A/C operating (compressor running).
6. Disconnect the injector tool from the service valve with the engine still running.

### **CAUTION:**

**Be careful when replacing the A/C system or a component, pour the dye directly into the open system connection and proceed with the service procedures.**

7. Operate the A/C system for a minimum of 20 minutes to mix the dye with the system oil. Depending on the leakage size, operating conditions and location of the leakage, it may take from minutes to days for the dye to penetrate a leakage and become visible.
8. Attach a blue label as necessary.

## VK45DE : Electrical Leak Detector

INFOID:000000005348590

## PRECAUTIONS FOR HANDLING LEAK DETECTOR

# REFRIGERANT LINES

## < SERVICE INFORMATION >

Use an electrical leak detector (SST: J-41995) or equivalent when performing a refrigerant leakage check. Ensure that the instrument is calibrated and set properly per the operating instructions. The leak detector is a delicate device. Read the operating instructions and perform any specified maintenance for using the leak detector properly.

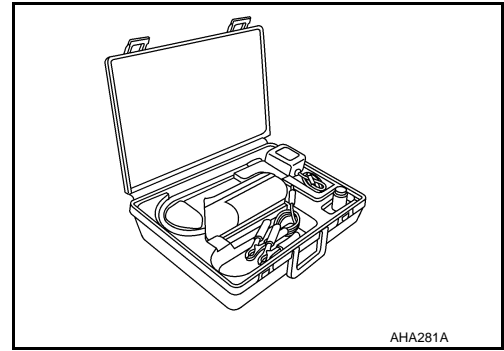

1. Position probe approximately 3 mm (0.12 in) away from point to be checked.

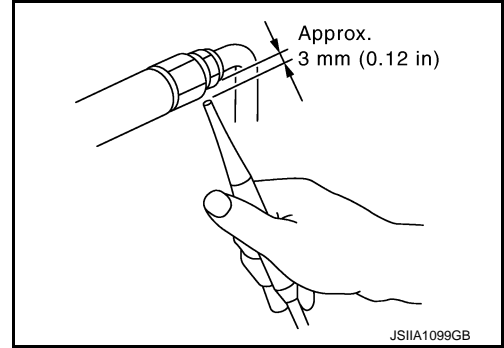

2. Circle each fitting completely with probe when testing.

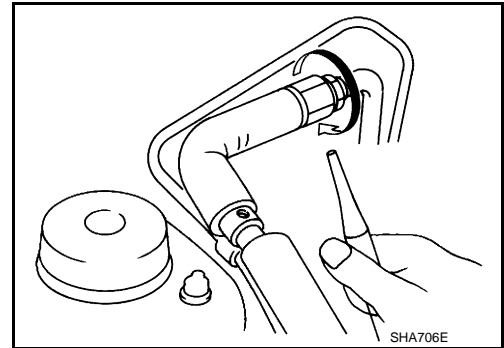

3. Move probe along component approximately 25 to 50 mm (1 to 2 in)/sec.

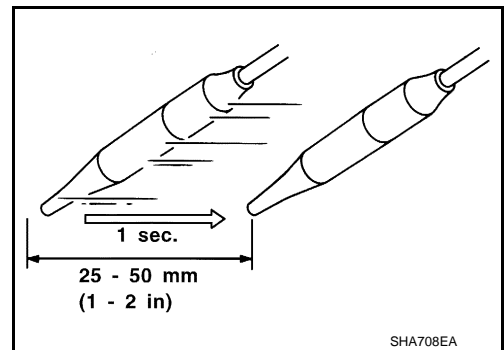

## CHECKING PROCEDURE

Check that there is no refrigerant vapor, shop chemicals, or cigarette smoke in the vicinity of the vehicle to prevent inaccurate or false readings. Perform the leakage test in calm area (low air/wind movement) so that the leaking refrigerant is not dispersed.

1. Stop the engine.
2. Connect a suitable manifold gauge set (SST: J-39183) to the A/C service valves.
3. Check if the A/C refrigerant pressure is at least 345 kPa (3.52 kg/cm<sup>2</sup>, 50 psi) above 16°C (61°F). Recover/evacuate and recharge the system with the specified amount of refrigerant if less than specification.

### NOTE:



# REFRIGERANT LINES

## < SERVICE INFORMATION >

Leakages may not be detected since the system may not reach 345 kPa (3.52 kg/cm<sup>2</sup>, 50 psi) at temperatures below 16°C (61°F).

4. Perform the leak test from the high-pressure side (compressor discharge “a” to evaporator inlet “h”) to the low-pressure side (evaporator drain hose “i” to shaft seal “n”). Refer to [ATC-155, "VK45DE : Component"](#). Perform a leak check for the following areas carefully. Clean the component to be checked and move the leak detected probe completely around the connection/component.

### Compressor

Check the fitting of high- and low-pressure flexible hoses, relief valve and shaft seal.

### Condenser

Check the fitting of high-pressure flexible hose and pipe.

### Liquid tank

Check the fitting of refrigerant pressure sensor.

### Service valves

Check all around the service valves. Ensure service valve caps are secured on the service valves (to prevent leaks).

### NOTE:

After removing A/C manifold gauge set from service valves, wipe any residue from valves to prevent any false readings by leak detector.

### Cooling unit (Evaporator)

With engine OFF, turn blower fan on “High” for at least 15 seconds to dissipate any refrigerant trace in the cooling unit. Wait a minimum of 10 minutes accumulation time (refer to the manufacturer’s recommended procedure for actual wait time) before inserting the leak detector probe into the drain hose.

Keep the probe inserted for at least 10 seconds. Use caution not to contaminate the probe tip with water or dirt that may be in the drain hose.

5. Verify at least once by blowing compressed air into area of suspected leakage, then repeat check as outlined above if a leak detector detects a leakage.
6. If a leakage is found, but continue checking for additional leakages at all system components. When leakages are not found, go to next step.
7. Start the engine.
8. Set the A/C control as per the following:
  - a. A/C switch: ON
  - b. Air flow: VENT (Ventilation)
  - c. Intake door position: Recirculation
  - d. Temperature setting: Maximum cold
  - e. Fan speed: High
9. Run engine at 1,500 rpm for at least 2 minutes.

10. Stop the engine and perform leakage check again, steps 4 – 6. Refrigerant leakages should be checked immediately after stopping the engine. Begin with the leak detector at the compressor. The pressure on the high-pressure side drops gradually after refrigerant circulation stops and pressure on the low-pressure side rises gradually, as shown in the graph. Some leakages are more easily detected when pressure is high.

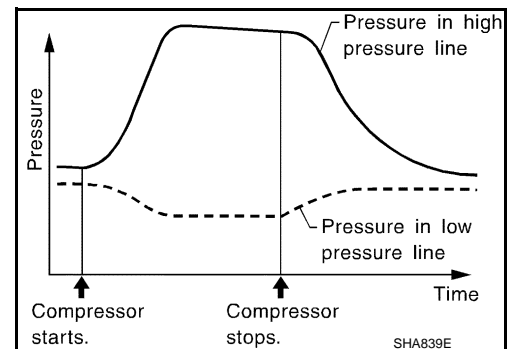

11. Check recovery/recycling recharging equipment gauges before connecting recovery/recycling recharging equipment to vehicle. No refrigerant pressure should be displayed. Recover refrigerant from equipment lines if pressure is displayed.
12. Confirm refrigerant purity in supply tank using recovery/recycling recharging equipment and refrigerant identifier.
13. Confirm refrigerant purity in vehicle A/C system using recovery/recycling recharging equipment and refrigerant identifier.
14. Discharge A/C system using approved refrigerant recovery equipment. Repair the leaking fitting or component if necessary.

## REFRIGERANT LINES

### < SERVICE INFORMATION >

---

15. Evacuate and recharge A/C system and perform the leakage test to confirm no refrigerant leakages.
16. Perform A/C performance test to ensure system works properly.

# SERVICE DATA AND SPECIFICATIONS (SDS)

< SERVICE INFORMATION >

## SERVICE DATA AND SPECIFICATIONS (SDS)

### Compressor

INFOID:000000005348591

Model	VALEO THERMAL SYSTEMS JAPAN make DCS-17EC	
Type	Variable displacement swash plate	
Displacement cm <sup>3</sup> (cu in)/rev	Max.	171 (10.4)
Cylinder bore × stroke (Max.) mm (in)	32 (1.26) × 30.5 (1.20)	
Direction of rotation	Clockwise (viewed from clutch)	
Drive belt	Poly V	

### Lubricant

INFOID:000000005348592

Name	NISSAN A/C System Oil Type S (DH-PS)	
Capacity m ℓ (US fl oz, Imp fl oz)	Total in system	150 (5.03, 5.3)
	Compressor (Service part) charging amount	150 (5.03, 5.3)

### Refrigerant

INFOID:000000005348593

Type	HFC-134a (R-134a)	
Capacity kg (lb)	0.55 (1.21)	

### Engine Idling Speed

INFOID:000000005348594

Refer to [EC-697, "Idle Speed"](#) (VQ35HR) or [EC-1337, "Idle Speed and Ignition Timing"](#) (VK45DE).

### Belt Tension

INFOID:000000005348595

Refer to [EM-15, "Checking Drive Belt"](#) (VQ35HR) or [EM-169, "Checking Drive Belts"](#) (VK45DE).

A  
B  
C  
D  
E  
F  
G  
H  
I  
ATC  
K  
L  
M  
N  
O  
P