

SECTION **EM**

ENGINE MECHANICAL

CONTENTS

VQ35HR

SERVICE INFORMATION	4	
PRECAUTIONS	4	
Precaution for Procedure without Cowl Top Cover.....	4	
Precaution Necessary for Steering Wheel Rotation After Battery Disconnect	4	
Precaution for Supplemental Restraint System (SRS) "AIR BAG" and "SEAT BELT PRE-TENSIONER"	4	
Precaution for Drain Engine Coolant and Engine Oil	5	
Precaution for Disconnecting Fuel Piping	5	
Precaution for Removal and Disassembly	5	
Precaution for Inspection, Repair and Replacement	5	
Precaution for Assembly and Installation	5	
Parts Requiring Angle Tightening	6	
Precaution for Liquid Gasket	6	
Definitions of Bank Names	7	
PREPARATION	8	
Special Service Tool	8	
Commercial Service Tool	9	
NOISE, VIBRATION AND HARSHNESS (NVH) TROUBLESHOOTING	12	
NVH Troubleshooting - Engine Noise	12	
Use the Chart Below to Help You Find the Cause of the Symptom	12	
ENGINE ROOM COVER	14	
Component	14	
Removal and Installation	14	
DRIVE BELT	15	
Checking Drive Belt	15	
Tension Adjustment	15	
Removal and Installation	15	
Component	16	
Removal and Installation of Drive Belt Auto Tensioner	16	
AIR CLEANER AND AIR DUCT	17	
Component	17	
Removal and Installation	17	
Changing Air Cleaner Filter	18	
INTAKE MANIFOLD COLLECTOR	19	
Component	19	
Removal and Installation	19	
INTAKE MANIFOLD	22	
Component	22	
Removal and Installation	22	
EXHAUST MANIFOLD AND THREE WAY CATALYST	24	
Component	24	
Removal and Installation	24	
OIL PAN AND OIL STRAINER	28	
2WD	28	
2WD : Component	28	
2WD : Removal and Installation	28	
AWD	32	
AWD : Component	32	
AWD : Removal and Installation	32	
IGNITION COIL	37	
Component	37	
Removal and Installation	37	
SPARK PLUG (IRIDIUM-TIPPED TYPE)	38	
Component	38	
Removal and Installation	38	
FUEL INJECTOR AND FUEL TUBE	40	
Component	40	
Removal and Installation	40	

ROCKER COVER	46	Precaution for Removal and Disassembly	159
Component	46	Precaution for Inspection, Repair and Replacement	159
Removal and Installation	46	Precaution for Assembly and Installation	159
FRONT TIMING CHAIN CASE	49	Parts Requiring Angle Tightening	160
Removal and Installation	49	Precaution for Liquid Gasket	160
TIMING CHAIN	59	PREPARATION	162
Component	59	Special Service Tool	162
Removal and Installation	60	Commercial Service Tool	163
CAMSHAFT	79	NOISE, VIBRATION AND HARSHNESS (NVH) TROUBLESHOOTING	166
Component	79	NVH Troubleshooting - Engine Noise	166
Removal and Installation	79	Use the Chart Below to Help You Find the Cause of the Symptom	166
Valve Clearance	88	ENGINE ROOM COVER	168
OIL SEAL	93	Component	168
Removal and Installation of Valve Oil Seal	93	Removal and Installation	168
Removal and Installation of Front Oil Seal	93	DRIVE BELTS	169
Removal and Installation of Rear Oil Seal	94	Component	169
CYLINDER HEAD	96	Checking Drive Belts	169
On-Vehicle Service	96	Tension Adjustment	169
Component	97	Removal and Installation	169
Removal and Installation	97	Component	170
Disassembly and Assembly	101	Drive Belt Auto Tensioner and Idler Pulley	171
Inspection After Disassembly	103	AIR CLEANER AND AIR DUCT	172
ENGINE ASSEMBLY	108	Component	172
2WD	108	Removal and Installation	172
2WD : Component	108	Changing Air Cleaner Filter	173
2WD : Removal and Installation	108	INTAKE MANIFOLD	174
AWD	112	Component	174
AWD : Component	113	Removal and Installation	175
AWD : Removal and Installation	113	EXHAUST MANIFOLD AND THREE WAY CATALYST	178
CYLINDER BLOCK	119	Component	178
Component	119	Removal and Installation	178
Disassembly and Assembly	120	OIL PAN AND OIL STRAINER	182
How to Select Piston and Bearing	130	Component	182
Inspection After Disassembly	136	Removal and Installation	183
SERVICE DATA AND SPECIFICATIONS (SDS)	147	IGNITION COIL	186
Standard and Limit	147	Component	186
		Removal and Installation	186
		SPARK PLUG (PLATINUM-TIPPED TYPE) ...	187
		Component	187
		Removal and Installation	187
		FUEL INJECTOR AND FUEL TUBE	189
		Component	189
		Removal and Installation	189
		ROCKER COVER	195
		Component	195
		Removal and Installation	195

VK45DE

TIMING CHAIN	199	ENGINE ASSEMBLY	238	A
Component	199	2WD	238	
Removal and Installation	200	2WD : Component	238	
CAMSHAFT	211	2WD : Removal and Installation	238	EM
Component	211	AWD	241	
Removal and Installation	211	AWD : Component	242	
Valve Clearance	219	AWD : Removal and Installation	242	C
OIL SEAL	223	CYLINDER BLOCK	246	
Removal and Installation of Valve Oil Seal	223	Component	246	D
Removal and Installation of Front Oil Seal	224	Disassembly and Assembly	247	
Removal and Installation of Rear Oil Seal	225	How to Select Piston and Bearing	256	
CYLINDER HEAD	227	Inspection After Disassembly	262	E
On-Vehicle Service	227	SERVICE DATA AND SPECIFICATIONS		
Component	228	(SDS)	272	F
Removal and Installation	228	Standard and Limit	272	
Disassembly and Assembly	231			G
Inspection After Disassembly	233			H
				I
				J
				K
				L
				M
				N
				O
				P

SERVICE INFORMATION

PRECAUTIONS

Precaution for Procedure without Cowl Top Cover

INFOID:000000005347949

When performing the procedure after removing cowl top cover, cover the lower end of windshield with urethane, etc.

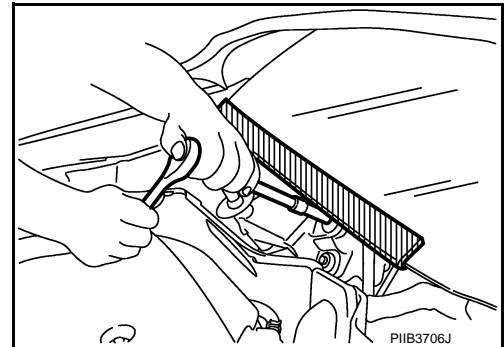

Precaution Necessary for Steering Wheel Rotation After Battery Disconnect

INFOID:000000005347950

NOTE:

- This Procedure is applied only to models with Intelligent Key system and NVIS/IVIS (NISSAN/INFINITI VEHICLE IMMOBILIZER SYSTEM - NATS).
- Remove and install all control units after disconnecting both battery cables with the ignition knob in the "LOCK" position.
- Always use CONSULT-III to perform self-diagnosis as a part of each function inspection after finishing work. If DTC is detected, perform trouble diagnosis according to self-diagnostic results.

For models equipped with the Intelligent Key system and NVIS/IVIS, an electrically controlled steering lock mechanism is adopted on the key cylinder.

For this reason, if the battery is disconnected or if the battery is discharged, the steering wheel will lock and steering wheel rotation will become impossible.

If steering wheel rotation is required when battery power is interrupted, follow the procedure below before starting the repair operation.

OPERATION PROCEDURE

1. Connect both battery cables.
NOTE:
Supply power using jumper cables if battery is discharged.
2. Use the Intelligent Key or mechanical key to turn the ignition switch to the "ACC" position. At this time, the steering lock will be released.
3. Disconnect both battery cables. The steering lock will remain released and the steering wheel can be rotated.
4. Perform the necessary repair operation.
5. When the repair work is completed, return the ignition switch to the "LOCK" position before connecting the battery cables. (At this time, the steering lock mechanism will engage.)
6. Perform a self-diagnosis check of all control units using CONSULT-III.

Precaution for Supplemental Restraint System (SRS) "AIR BAG" and "SEAT BELT PRE-TENSIONER"

INFOID:000000005347951

The Supplemental Restraint System such as "AIR BAG" and "SEAT BELT PRE-TENSIONER", used along with a front seat belt, helps to reduce the risk or severity of injury to the driver and front passenger for certain types of collision. This system includes seat belt switch inputs and dual stage front air bag modules. The SRS system uses the seat belt switches to determine the front air bag deployment, and may only deploy one front air bag, depending on the severity of a collision and whether the front occupants are belted or unbelted. Information necessary to service the system safely is included in the "SUPPLEMENTAL RESTRAINT SYSTEM" and "SEAT BELTS" of this Service Manual.

WARNING:

PRECAUTIONS

< SERVICE INFORMATION >

[VQ35HR]

- To avoid rendering the SRS inoperative, which could increase the risk of personal injury or death in the event of a collision which would result in air bag inflation, all maintenance must be performed by an authorized NISSAN/INFINITI dealer.
- Improper maintenance, including incorrect removal and installation of the SRS, can lead to personal injury caused by unintentional activation of the system. For removal of Spiral Cable and Air Bag Module, see the "SUPPLEMENTAL RESTRAINT SYSTEM".
- Do not use electrical test equipment on any circuit related to the SRS unless instructed to in this Service Manual. SRS wiring harnesses can be identified by yellow and/or orange harnesses or harness connectors.

PRECAUTIONS WHEN USING POWER TOOLS (AIR OR ELECTRIC) AND HAMMERS

WARNING:

- When working near the Air Bag Diagnosis Sensor Unit or other Air Bag System sensors with the ignition ON or engine running, DO NOT use air or electric power tools or strike near the sensor(s) with a hammer. Heavy vibration could activate the sensor(s) and deploy the air bag(s), possibly causing serious injury.
- When using air or electric power tools or hammers, always switch the ignition OFF, disconnect the battery, and wait at least 3 minutes before performing any service.

Precaution for Drain Engine Coolant and Engine Oil

INFOID:000000005347952

Drain engine coolant and engine oil when engine is cooled.

Precaution for Disconnecting Fuel Piping

INFOID:000000005347953

- Before starting work, check no fire or spark producing items are in the work area.
- Release fuel pressure before disconnecting and disassembly.
- After disconnecting pipes, plug openings to stop fuel leakage.

Precaution for Removal and Disassembly

INFOID:000000005347954

- When instructed to use special service tools, use specified tools. Always be careful to work safely, avoid forceful or uninstructed operations.
- Exercise maximum care to avoid damage to mating or sliding surfaces.
- Cover openings of engine system with tape or equivalent, if necessary, to seal out foreign materials.
- Mark and arrange disassembly parts in an organized way for easy troubleshooting and reassembly.
- When loosening bolts and nuts, as a basic rule, start with the one furthest outside, then the one diagonally opposite, and so on. If the order of loosening is specified, do exactly as specified. Power tools may be used in the step.

Precaution for Inspection, Repair and Replacement

INFOID:000000005347955

Before repairing or replacing, thoroughly inspect parts. Inspect new replacement parts in the same way, and replace if necessary.

Precaution for Assembly and Installation

INFOID:000000005347956

- Use torque wrench to tighten bolts or nuts to specification.
- When tightening bolts and nuts, as a basic rule, equally tighten in several different steps starting with the ones in center, then ones on inside and outside diagonally in this order. If the order of tightening is specified, do exactly as specified.
- Replace with new gasket, packing, oil seal or O-ring.
- Dowel pins are used for several parts alignment. When replacing and reassembling with dowel pins, check that dowel pins are installed in the original portion.
- Thoroughly wash, clean, and air-blow each part. Carefully check engine oil or engine coolant passages for any restriction and blockage.
- Avoid damaging sliding or mating surfaces. Completely remove foreign materials such as cloth lint or dust. Before assembly, oil sliding surfaces well.
- Release air within route when refilling after draining engine coolant.
- After repairing, start engine and increase engine speed to check engine coolant, fuel, engine oil, and exhaust gases for leakage.

PRECAUTIONS

< SERVICE INFORMATION >

[VQ35HR]

INFOID:000000005347957

Parts Requiring Angle Tightening

- Use angle wrench [SST: KV10112100 (BT8653-A)] for the final tightening of the following engine parts:
 - Cylinder head bolts
 - Lower cylinder block bolts
 - Connecting rod cap bolts
- Do not use a torque value for final tightening.
- The torque value for these parts are for a preliminary step.
- Ensure thread and seat surfaces are clean and coated with engine oil.

Precaution for Liquid Gasket

INFOID:000000005347958

REMOVAL OF LIQUID GASKET SEALING

- After removing mounting bolts and nuts, separate the mating surface using seal cutter [SST: KV10111100 (J37228)] (A) and remove old liquid gasket sealing.

CAUTION:

Be careful not to damage the mating surfaces.

- Tap (B) seal cutter [SST: KV10111100 (J37228)] to insert it, and then slide (C) it by tapping on the side as shown in the figure.
- In areas where seal cutter [SST: KV10111100 (J37228)] is difficult to use, use plastic hammer to lightly tap the parts, to remove it.

CAUTION:

If for some unavoidable reason tool such as screwdriver is used, be careful not to damage the mating surfaces.

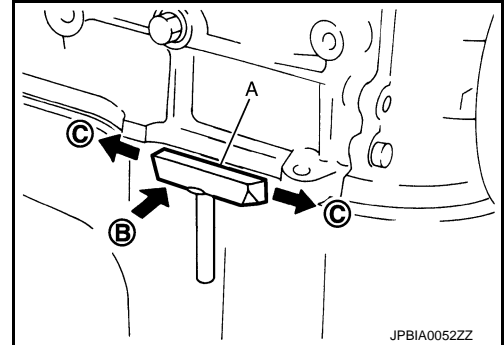

LIQUID GASKET APPLICATION PROCEDURE

1. Using scraper (A), remove old liquid gasket adhering to the gasket application surface and the mating surface.
 - Remove liquid gasket completely from the groove of the gasket application surface, mounting bolts, and bolt holes.
2. Wipe the liquid gasket application surface and the mating surface with white gasoline (lighting and heating use) to remove adhering moisture, grease and foreign materials.

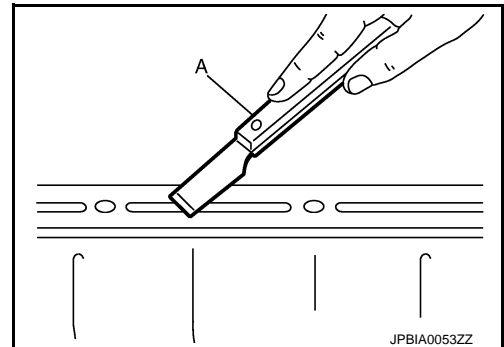

3. Attach liquid gasket tube to tube presser (commercial service tool).

Use Genuine RTV Silicone Sealant or equivalent. Refer to [GI-46, "Recommended Chemical Product and Sealant"](#).
4. Apply liquid gasket without breaks to the specified location with the specified dimensions.
 - If there is a groove for liquid gasket application, apply liquid gasket to the groove.

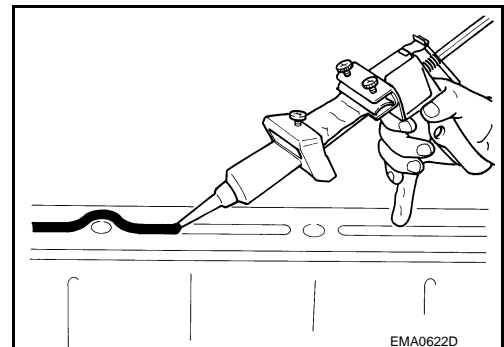

PRECAUTIONS

[VQ35HR]

< SERVICE INFORMATION >

- As for bolt holes (B), normally apply liquid gasket inside the holes. Occasionally, it should be applied outside the holes. Check to read the text of this manual.

A : Groove

⇐ : Inside

- Within five minutes of liquid gasket application, install the mating component.
- If liquid gasket protrudes, wipe it off immediately.
- Do not retighten mounting bolts or nuts after the installation.
- After 30 minutes or more have passed from the installation, fill engine oil and engine coolant.

CAUTION:

If there are specific instructions in this manual, observe them.

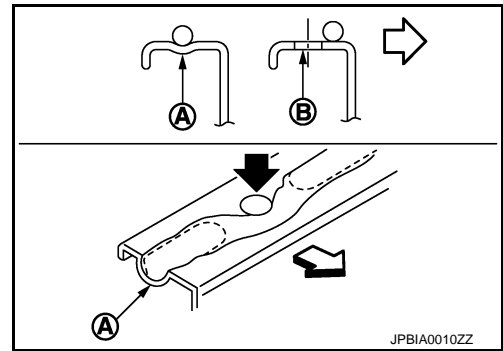

Definitions of Bank Names

INFOID:000000005347959

- In this manual, each bank name is defined as follows:

A : Bank 1 (The conventional right bank)

B : Bank 2 (The conventional left bank)

⇐ : Engine front

- For cylinder numbers and bank layout, refer to the illustration.

Bank 1 : The bank side including cylinder No. 1 (odd-numbered cylinder side)

Bank 2 : The other bank side of the above (even-numbered cylinder side)

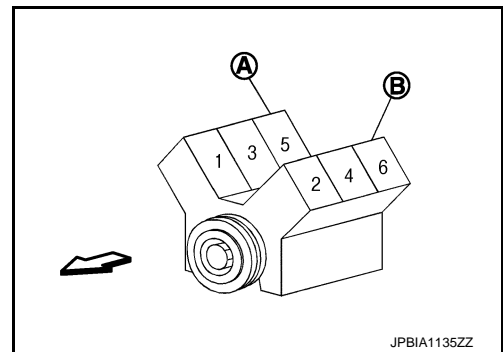

PREPARATION

< SERVICE INFORMATION >

[VQ35HR]

PREPARATION

Special Service Tool

INFOID:000000005347960

The actual shapes of Kent-Moore tools may differ from those of special service tools illustrated here.

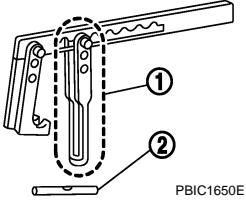
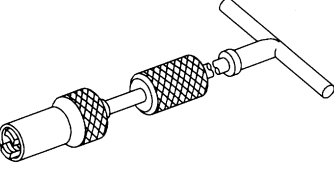
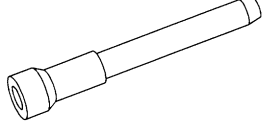
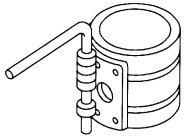
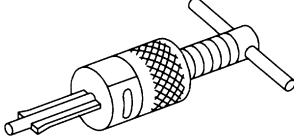
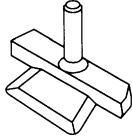
Tool number (Kent-Moore No.) Tool name	Description
KV10116200 (J26336-A) Valve spring compressor 1. KV10115900 (J26336-20) Attachment 2. KV10109220 (—) Adapter	 Disassembling valve mechanism Part (1) is a component of KV10116200 (J26336-A), but Part (2) is not so.
KV10107902 (J38959) Valve oil seal puller	 Replacing valve oil seal
— (J39386) Valve oil seal drift	 Installing valve oil seal
EM03470000 (J8037) Piston ring compressor	 Installing piston assembly into cylinder bore
ST16610001 (J23907) Pilot bushing puller	 Removing pilot converter
KV10111100 (J37228) Seal cutter	 Removing oil pan (lower and upper), front and rear timing chain case, etc.

PREPARATION

< SERVICE INFORMATION >

[VQ35HR]

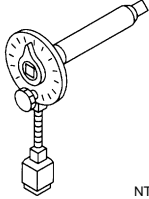
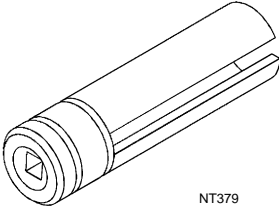
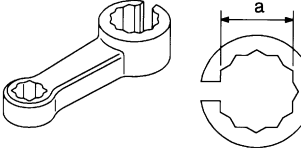
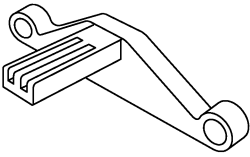
Tool number (Kent-Moore No.) Tool name	Description
KV10112100 (BT8653-A) Angle wrench  NT014	Tightening bolts for bearing cap, cylinder head, etc. in angle
KV10117100 (J3647-A) Heated oxygen sensor wrench  NT379	Loosening or tightening heated oxygen sensor 2 For 22 mm (0.87 in) width hexagon nut
KV10114400 (J38365) Heated oxygen sensor wrench  NT636	Loosening or tightening air fuel ratio sensor 1 a: 22 mm (0.87 in)
KV10118600 (J-48641) Ring gear stopper  PBIC5052E	Removing and installing crankshaft pulley

Commercial Service Tool

INFOID:000000005347961

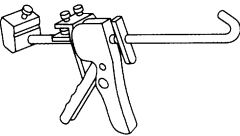
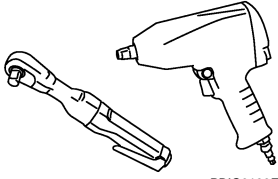
(Kent-Moore No.) Tool name	Description
(—) Tube presser  NT052	Pressing the tube of liquid gasket
(—) Power tool  PBIC0190E	Loosening bolts and nuts

PREPARATION

< SERVICE INFORMATION >

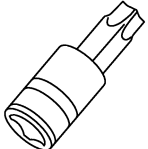
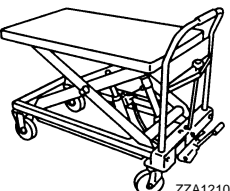
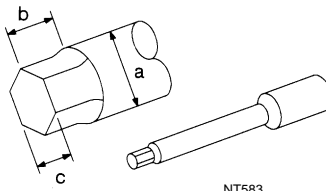
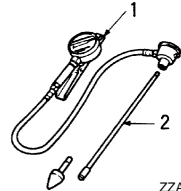
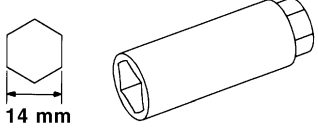
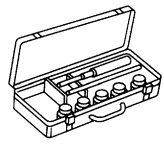
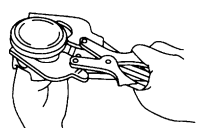

[VQ35HR]

(Kent-Moore No.) Tool name	Description
(—) TORX socket	Removing and installing flywheel Size: T55
 P81C1113E	
(—) Manual lift table caddy	Removing and installing engine
 ZZA1210D	
(J24239-01) Cylinder head bolt wrench	Loosening and tightening cylinder head bolt, and used with angle wrench [SST: KV10112100 (BT8653-A)] a: 13 (0.51) dia. b: 12 (0.47) c: 10 (0.39) Unit: mm (in)
 NT583	
(—) 1. Compression gauge 2. Adapter	Checking compression pressure
 ZZA0008D	
(—) Spark plug wrench	Removing and installing spark plug
 14 mm (0.55 in) P81C3874E	
(—) Valve seat cutter set	Finishing valve seat dimensions
 NT048	
(—) Piston ring expander	Removing and installing piston ring
 NT030	

PREPARATION

< SERVICE INFORMATION >

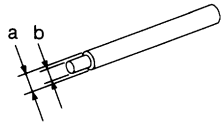
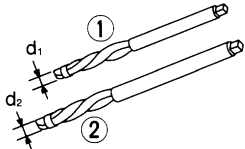
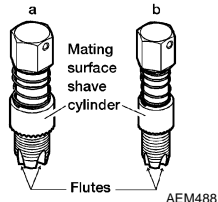
[VQ35HR]

(Kent-Moore No.) Tool name	Description
(—) Valve guide drift  <p style="text-align: center;">NT015</p>	Removing and installing valve guide Intake and Exhaust: a: 9.5 mm (0.374 in) dia. b: 5.5 mm (0.217 in) dia.
(—) Valve guide reamer  <p style="text-align: center;">NT016</p>	(1): Reaming valve guide inner hole (2): Reaming hole for oversize valve guide Intake and Exhaust: d1: 6.0 mm (0.236 in) dia. d2: 10.2 mm (0.402 in) dia.
(J-43897-18) (J-43897-12) Oxygen sensor thread cleaner  <p style="text-align: center;">AEM488</p>	Reconditioning the exhaust system threads before installing a new air fuel ratio and heated oxygen sensor (Use with anti-seize lubricant shown below.) a: J-43897-18 [18 mm (0.71 in) dia.] for zirconia heated oxygen sensor and air fuel ratio sensor b: J-43897-12 [12 mm (0.47 in) dia.] for titania heated oxygen sensor
(—) Anti-seize lubricant (Permatex 133AR or equivalent meeting MIL specification MIL-A-907)  <p style="text-align: center;">AEM489</p>	Lubricating oxygen sensor thread cleaning tool when reconditioning exhaust system threads

A
EM
C
D
E
F
G
H
I
J
K
L
M
N
O
P

NOISE, VIBRATION AND HARSHNESS (NVH) TROUBLESHOOTING

< SERVICE INFORMATION >

[VQ35HR]

NOISE, VIBRATION AND HARSHNESS (NVH) TROUBLESHOOTING

NVH Troubleshooting - Engine Noise

INFOID:000000005347962

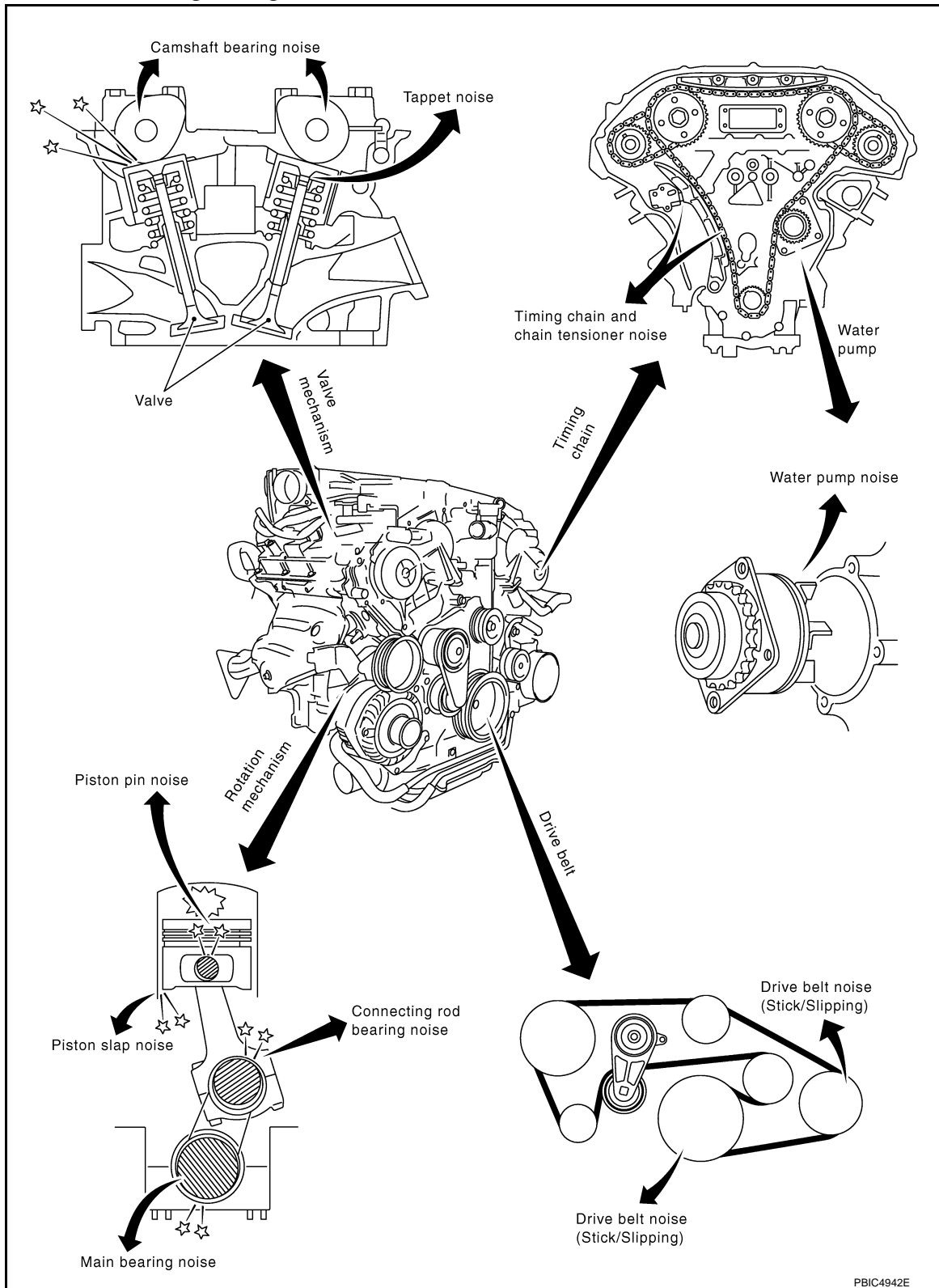

Use the Chart Below to Help You Find the Cause of the Symptom

INFOID:000000005347963

1. Locate the area where noise occurs.
2. Confirm the type of noise.

NOISE, VIBRATION AND HARSHNESS (NVH) TROUBLESHOOTING

< SERVICE INFORMATION >

[VQ35HR]

3. Specify the operating condition of engine.

4. Check specified noise source.

If necessary, repair or replace these parts.

Location of noise	Type of noise	Operating condition of engine						Source of noise	Check item	Reference page
		Before warm-up	After warm-up	When starting	When idling	When racing	While driving			
Top of engine Rocker cover Cylinder head	Ticking or clicking	C	A	—	A	B	—	Tappet noise	Valve clearance	EM-88
	Rattle	C	A	—	A	B	C	Camshaft bearing noise	Camshaft runout Camshaft journal oil clearance	EM-79
Crankshaft pulley Cylinder block (Side of engine) Oil pan	Slap or knock	—	A	—	B	B	—	Piston pin noise	Piston to piston pin oil clearance Connecting rod bushing oil clearance	EM-136
	Slap or rap	A	—	—	B	B	A	Piston slap noise	Piston to cylinder bore clearance Piston ring side clearance Piston ring end gap Connecting rod bend and torsion	EM-136
	Knock	A	B	C	B	B	B	Connecting rod bearing noise	Connecting rod bushing oil clearance Connecting rod bearing oil clearance	EM-136
	Knock	A	B	—	A	B	C	Main bearing noise	Main bearing oil clearance Crankshaft runout	EM-136
Front of engine Timing chain case	Tapping or ticking	A	A	—	B	B	B	Timing chain and chain tensioner noise	Timing chain cracks and wear Timing chain tensioner operation	EM-59
Front of engine	Squeaking or fizzing	A	B	—	B	—	C	Drive belt (Sticking or slipping)	Drive belt deflection	EM-15
	Creaking	A	B	A	B	A	B	Drive belt (Slipping)	Idler pulley bearing operation	
	Squall Creak	A	B	—	B	A	B	Water pump noise	Water pump operation	CO-23 "Component"

A: Closely related B: Related C: Sometimes related —: Not related

ENGINE ROOM COVER

Component

INFOID:000000005347964

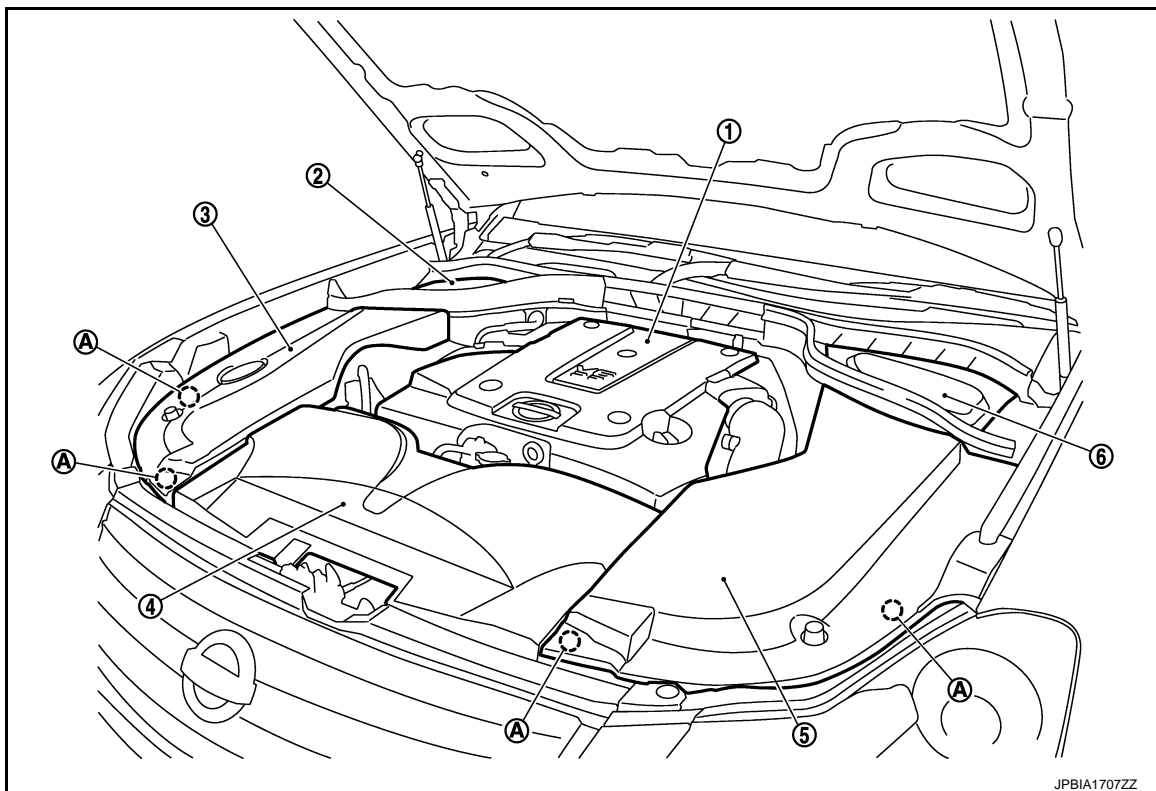

- | | | |
|----------------------------------|--------------------------------|---------------------------|
| 1. Engine cover | 2. Brake master cylinder cover | 3. Engine room cover (RH) |
| 4. Air duct (inlet) | 5. Engine room cover (LH) | 6. Battery cover |
| A. Clip (secure at back surface) | | |

Removal and Installation

INFOID:000000005347965

REMOVAL

CAUTION:

Never damage or scratch cover when installing or removing.

- Refer to [EM-19, "Removal and Installation"](#) for removal and installation of engine cover.
- Refer to [EM-17, "Component"](#) for removal and installation of air duct (inlet).
- Remove the washer tank cap before removing the engine room cover (RH).
- Remove the engine room covers (RH and LH) by lifting the clipped point using a clip driver.
- Major parts and inspection points under each cover are as follows: (numbered as in figure)

1. Upper side of engine assembly
2. Brake master cylinder, brake booster
3. Power steering fluid reservoir tank, engine coolant reservoir tank, Mass air flow sensor, air cleaner case, relay box
4. Engine assembly front side, drive belt, cooling fan
5. Mass air flow sensor, air cleaner case
6. Battery, relay box

INSTALLATION

Install in the reverse order of removal.

DRIVE BELT

Checking Drive Belt

INFOID:000000005347966

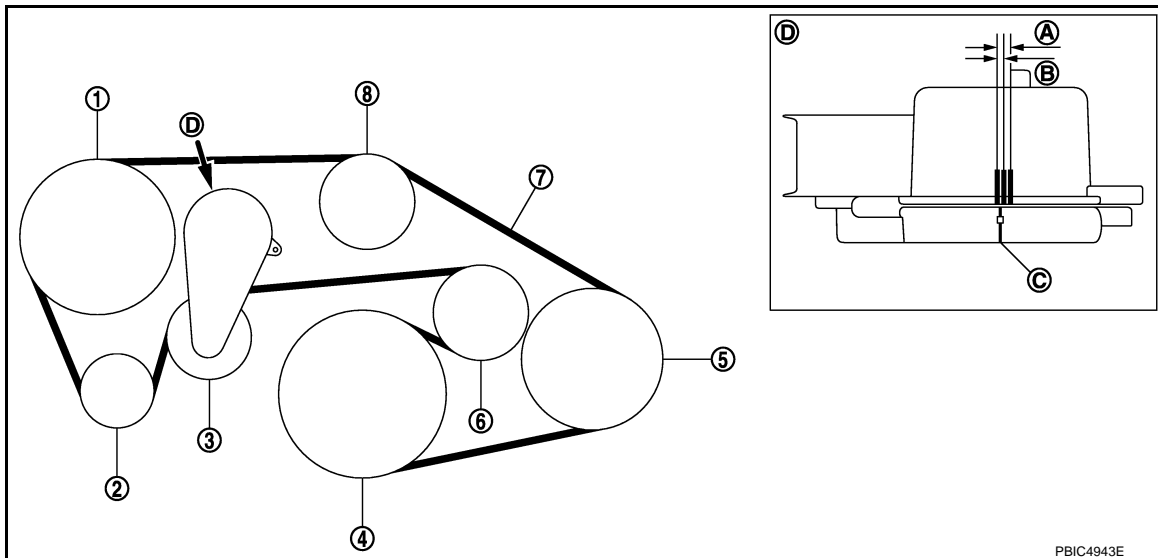

- | | | |
|----------------------------|-------------------|------------------------------|
| 1. Power steering oil pump | 2. Alternator | 3. Drive belt auto-tensioner |
| 4. Crankshaft pulley | 5. A/C compressor | 6. Idler pulley |
| 7. Drive belt | 8. Idler pulley | |
-
- | | | |
|-----------------------|---|--------------|
| A. Possible use range | B. Range when new drive belt is installed | C. Indicator |
| D. View D | | |

WARNING:

Be sure to perform this step when engine is stopped.

- Check that the indicator (notch on fixed side) of drive belt auto-tensioner is within the possible use range (A).

NOTE:

Check the drive belt auto-tensioner indication when the engine is cold.

- When new drive belt is installed, the indicator (notch on fixed side) should be within the range (B) in the figure.
- Visually check entire drive belt for wear, damage or cracks.
- If the indicator (notch on fixed side) is out of the possible use range or belt is damaged, replace drive belt.

Tension Adjustment

INFOID:000000005347967

Belt tension is not necessary, as it is automatically adjusted by drive belt auto-tensioner.

Removal and Installation

INFOID:000000005347968

REMOVAL

1. Remove front engine undercover with power tool.
2. While securely holding the square hole (A) in pulley center of auto tensioner (1) with a spinner handle, move spinner handle in the direction of arrow (loosening direction of drive belt).

← : Loosing direction of drive belt

CAUTION:

Avoid placing hand in a location where pinching may occur if the holding tool accidentally comes off.

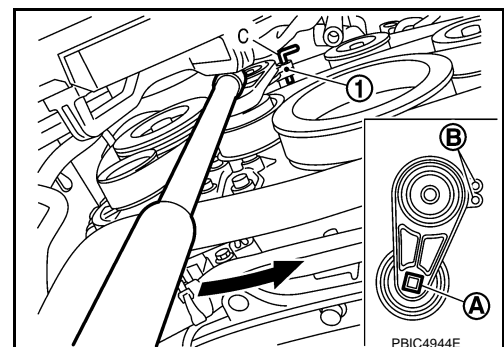

PBIC4944E

DRIVE BELT

[VQ35HR]

< SERVICE INFORMATION >

- Under the above condition, insert a metallic bar of approximately 6 mm (0.24 in) diameter [hexagonal wrench (C) shown as example in the figure] through the holding boss (B) to lock auto-tensioner pulley arm.
- Remove drive belt.

INSTALLATION

Note the following, and install in the reverse order of removal.

CAUTION:

- Check drive belt is securely installed around all pulleys.
- Check drive belt is correctly engaged with the pulley groove.
- Check for engine oil and engine coolant are not adhered drive belt and pulley groove.

INSPECTION AFTER INSTALLATION

Turn crankshaft pulley clockwise several times to equalize tension between each pulley, and then confirm tension of drive belt at indicator (notch on fixed side) is within the possible use range. Refer to [EM-15, "Checking Drive Belt"](#).

Component

INFOID:000000005347969

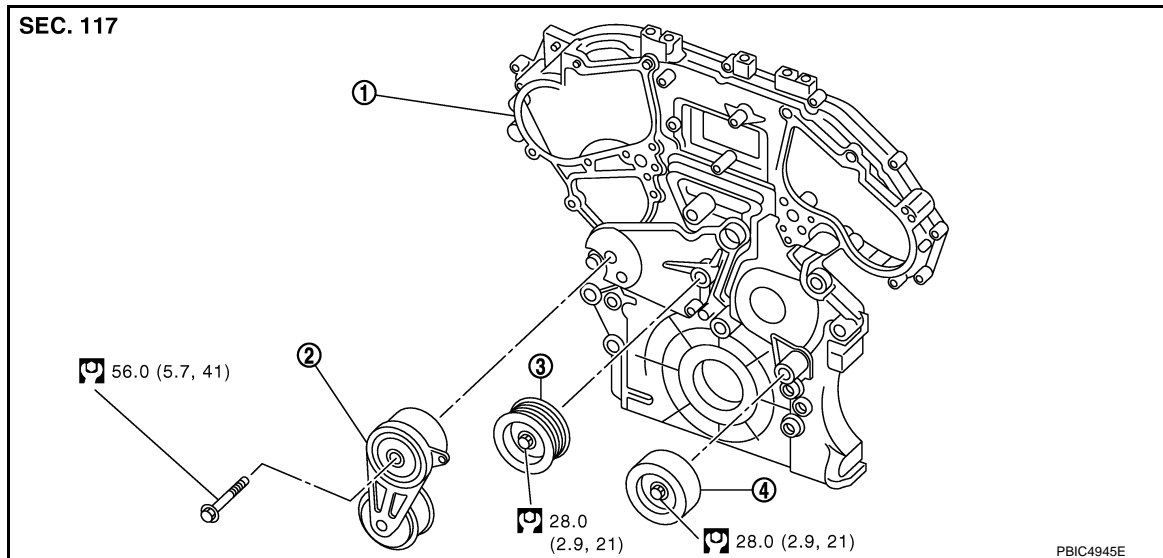

1. Front timing chain case
2. Drive belt auto-tensioner
3. Idler pulley
4. Idler pulley

- Refer to [GI-9, "Component"](#) for symbols in the figure.

Removal and Installation of Drive Belt Auto Tensioner

INFOID:000000005347970

REMOVAL

- Remove drive belt. Refer to [EM-15, "Removal and Installation"](#).
 - Keep auto-tensioner pulley arm locked after drive belt is removed.
- Remove auto-tensioner and idler pulley.
 - Keep auto-tensioner pulley arm locked to install or remove auto-tensioner.

INSTALLATION

Install in the reverse order of removal.

CAUTION:

If there is damage greater than peeled paint, replace drive belt auto-tensioner.

AIR CLEANER AND AIR DUCT

< SERVICE INFORMATION >

[VQ35HR]

AIR CLEANER AND AIR DUCT

Component

INFOID:000000005347971

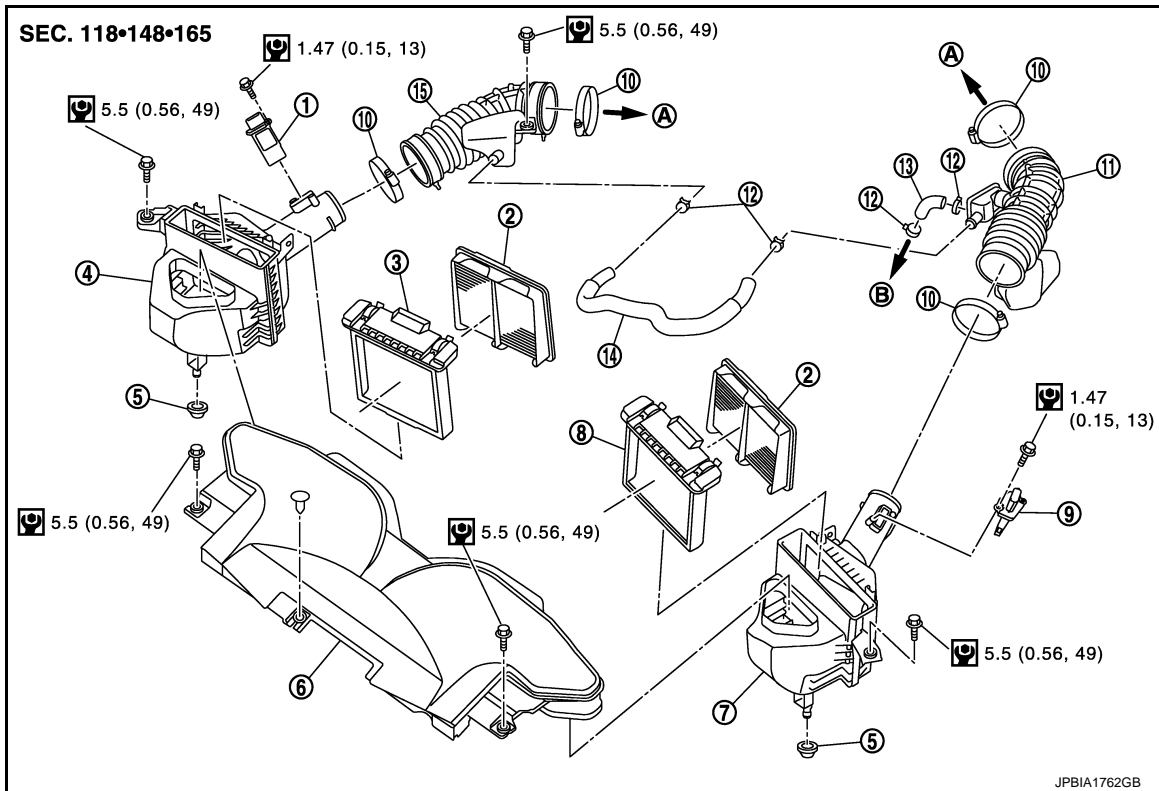

- | | | |
|--|-----------------------------|----------------------------------|
| 1. Mass air flow sensor (bank 1) | 2. Air cleaner filter | 3. Holder (LH) |
| 4. Air cleaner case (RH) | 5. Grommet | 6. Air duct |
| 7. Air cleaner case (LH) | 8. Holder (LH) | 9. Mass air flow sensor (bank 2) |
| 10. Clamp | 11. Air duct (LH) | 12. Clamp |
| 13. PCV hose | 14. PCV hose | 15. Air duct (RH) |
| A. To electric throttle control actuator | B. To rocker cover (bank 2) | |

- Refer to [GI-9. "Component"](#) for symbols in the figure.

Removal and Installation

INFOID:000000005347972

REMOVAL

NOTE:

Mass air flow sensor is removable under the car-mounted condition.

1. Remove engine room cover (RH and LH). Refer to [EM-14. "Component"](#).
2. Remove air duct (inlet).
3. Disconnect mass air flow sensor harness connector.
4. Disconnect PCV hose.
5. Remove air cleaner case with mass air flow sensor assembly and air duct assembly disconnecting their joints.
 - Add marks if necessary for easier installation.
6. Remove mass air flow sensor from air cleaner case if necessary.

CAUTION:

Handle the mass air flow sensor with care.

- Never shock the mass air flow sensor.
- Never disassemble the mass air flow sensor.
- Never touch the sensor of the mass air flow sensor.

AIR CLEANER AND AIR DUCT

[VQ35HR]

< SERVICE INFORMATION >

INSTALLATION

Note the following, and install in the reverse order of removal.

- Align marks. Attach each joint. Screw clamps firmly.

Changing Air Cleaner Filter

INFOID:000000005347973

REMOVAL

1. Unhook clips (A).

- 1 : Holder
- 2 : Air cleaner case

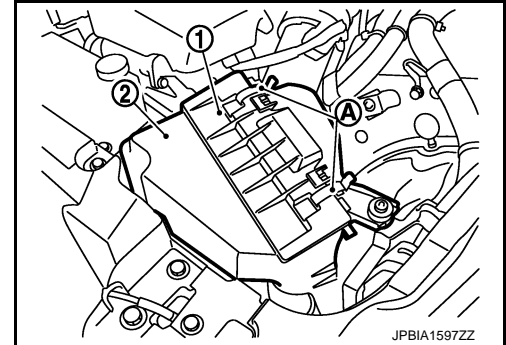

2. Remove air cleaner filter (1) from air cleaner case (2).

- 3 : Holder

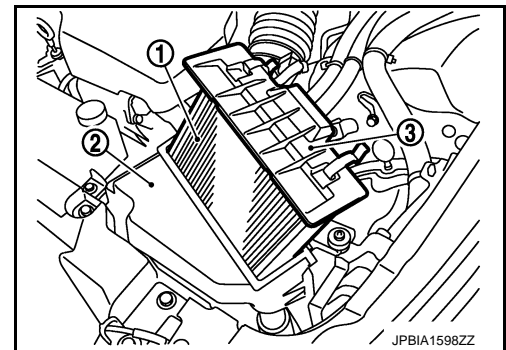

INSTALLATION

Note the following, and install in the reverse order of removal.

- Install the air cleaner filter by aligning the seal with the notch of air cleaner case.

INTAKE MANIFOLD COLLECTOR

< SERVICE INFORMATION >

[VQ35HR]

INTAKE MANIFOLD COLLECTOR

Component

INFOID:000000005347974

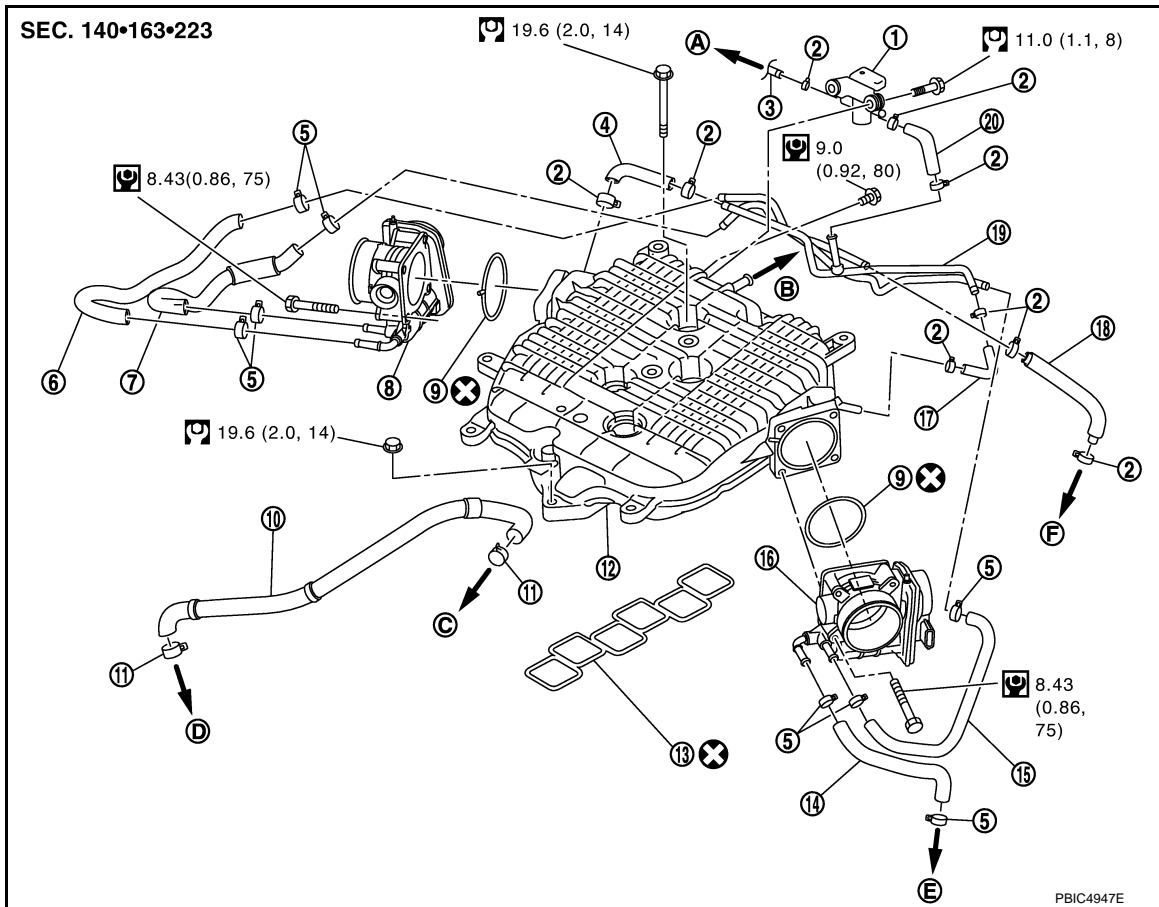

- | | | |
|---|--|---------------------------------|
| 1. EVAP canister purge control solenoid valve | 2. Clamp | 3. EVAP hose |
| 4. EVAP hose | 5. Clamp | 6. Water hose |
| 7. Water hose | 8. Electric throttle control actuator (bank 1) | 9. Gasket |
| 10. PCV hose | 11. Clamp | 12. Intake manifold collector |
| 13. Gasket | 14. Water hose | 15. Water hose |
| 16. Electric throttle control actuator (bank 2) | 17. EVAP hose | 18. Water hose |
| 19. EVAP tube assembly | 20. EVAP hose | |
| A. To vacuum pipe | B. To brake booster | C. To intake manifold collector |
| D. To PCV valve | E. To heater pipe | F. To water outlet (rear) |

- Refer to [GI-9, "Component"](#) for symbols in the figure.

Removal and Installation

INFOID:000000005347975

REMOVAL

WARNING:

To avoid the danger of being scalded, never drain the engine coolant when the engine is hot.

- Remove engine room cover (RH and LH). Refer to [EM-14, "Component"](#).

INTAKE MANIFOLD COLLECTOR

[VQ35HR]

< SERVICE INFORMATION >

2. Remove engine cover (1) and (2) with power tool.

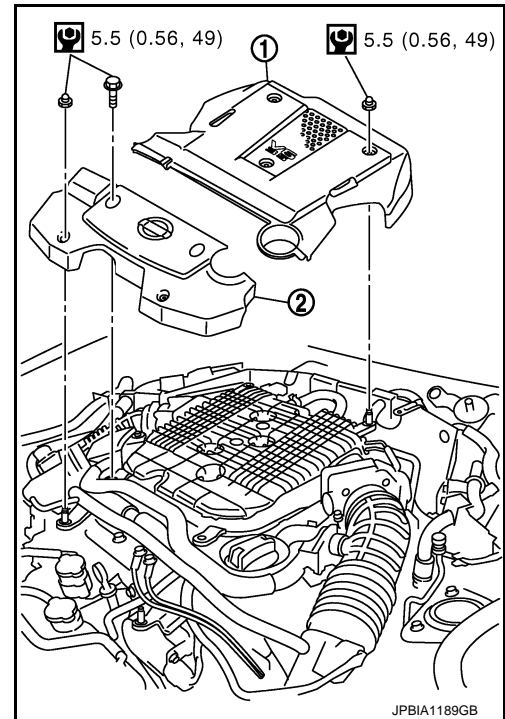

3. Remove air cleaner case and air duct (RH and LH). Refer to [EM-17](#).
4. Remove electric throttle control actuator (bank 1 and bank 2) as follows:
NOTE:
When removing only intake manifold collector, move electric throttle control actuator without disconnecting water hose.
 - a. Drain engine coolant.
CAUTION:
Perform this step when engine is cold.
 - b. Disconnect water hoses from electric throttle control actuator. When engine coolant is not drained from radiator, attach plug to water hoses to prevent engine coolant leakage.
CAUTION:
Never spill engine coolant on drive belt.
 - c. Disconnect harness connector.
 - d. Loosen mounting bolts in reverse order as shown in the figure.

- CAUTION:**
- Handle carefully to avoid any shock to electric throttle control actuator.
 - Never disassemble.
- NOTE:**
- Figure shows electric throttle control actuator (bank 1) viewed from the air duct side.
 - Viewed from the air duct side, order of loosening mounting bolts of electric throttle control actuator (bank 2) is the same as that of the electric throttle control actuator (bank 1).

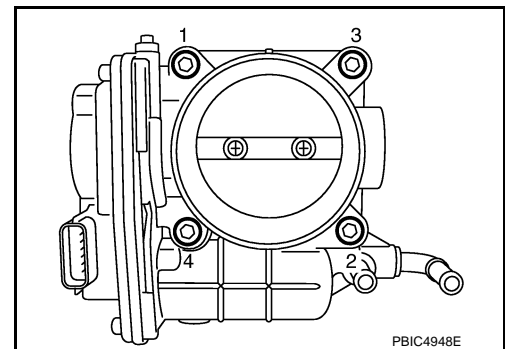

5. Disconnect vacuum hose, PCV hose and EVAP hose from intake manifold collector.
6. Remove EVAP canister purge volume control solenoid valve and EVAP tube assembly from intake manifold collector.

INTAKE MANIFOLD COLLECTOR

[VQ35HR]

< SERVICE INFORMATION >

- Loosen mounting bolts with power tool in reverse order as shown in the figure to remove intake manifold collector.

← : Engine front

CAUTION:
Cover engine openings to avoid entry of foreign materials.

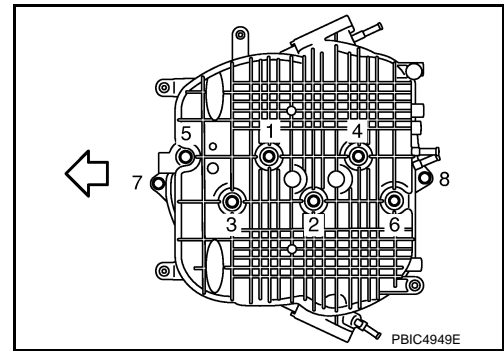

- Remove PCV hose [between intake manifold collector and rocker cover (bank 1)].

INSTALLATION

Note the following, and install in the reverse order of removal.

Intake Manifold Collector

If stud bolts were removed, install them and tighten to the specified torque below.

: **10.8 N·m (1.1 kg·m, 8 ft·lb)**

- Tighten mounting bolts in numerical order as shown in the figure.

← : Engine front

NOTE:

Tighten mounting bolts to secure gasket and intake manifold collector.

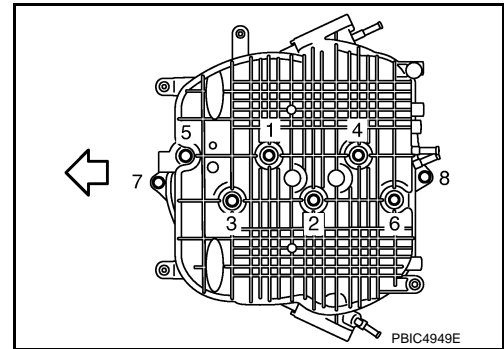

Water Hose

- Insert hose by 27 to 32 mm (1.06 to 1.26 in) from connector end.
- Clamp hose at location of 3 to 7 mm (0.12 to 0.28 in) from hose end.

Electric Throttle Control Actuator

- Install in the reverse order of removal.
- Tighten mounting bolts in numerical order as shown in the figure.

CAUTION:

- Handle carefully to avoid any shock to electric throttle control actuator.
- Never disassemble.
- The figure shows the electric throttle control actuator (bank 1) viewed from the air duct side.
- Viewed from the air duct side, order of tightening mounting bolts of electric throttle control actuator (bank 2) is the same as that of the electric throttle control actuator (bank 1).

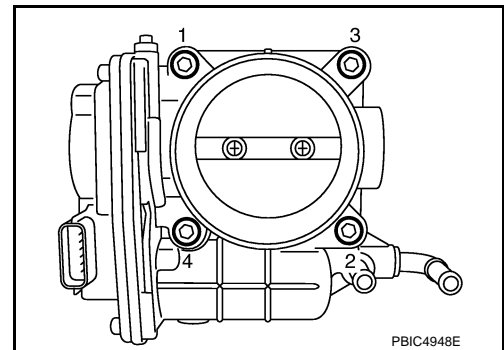

- Perform the "Throttle Valve Closed Position Learning" when harness connector of electric throttle control actuator is disconnected. Refer to [EC-27, "THROTTLE VALVE CLOSED POSITION LEARNING : Description"](#).
- Perform the "Idle Air Volume Learning" and "Throttle Valve Closed Position Learning" when electric throttle control actuator is replaced. Refer to [EC-27, "IDLE AIR VOLUME LEARNING : Description"](#) and [EC-27, "THROTTLE VALVE CLOSED POSITION LEARNING : Description"](#).

INTAKE MANIFOLD

< SERVICE INFORMATION >

[VQ35HR]

INTAKE MANIFOLD

Component

INFOID:000000005347976

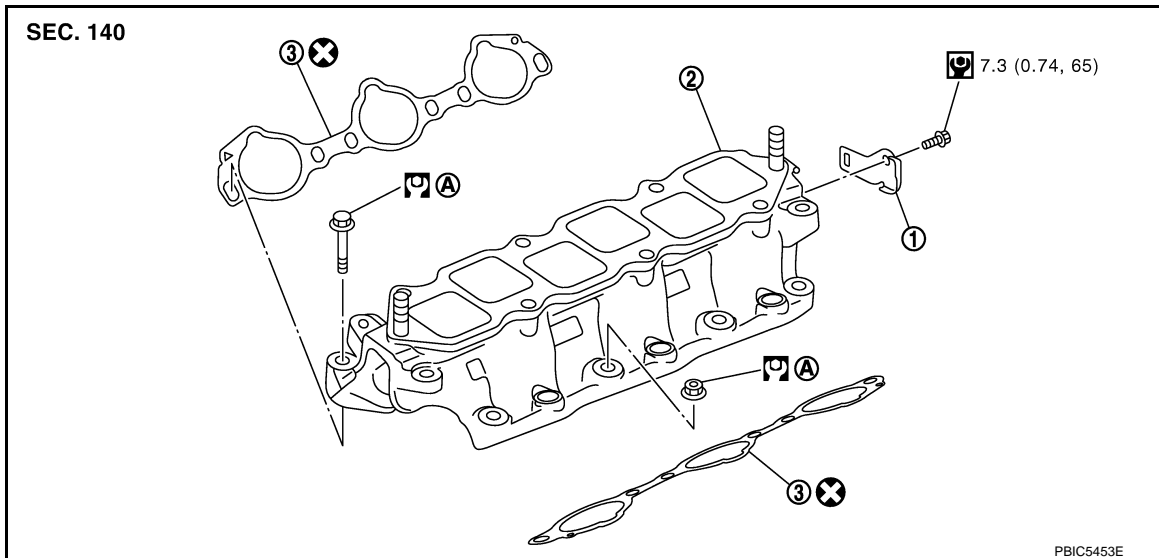

1. Harness bracket

2. Intake manifold

3. Gasket

A. Refer to [EM-22](#)

- Refer to [GI-9. "Component"](#) for symbols in the figure.

Removal and Installation

INFOID:000000005347977

REMOVAL

1. Release fuel pressure. Refer to [EC-692. "Inspection"](#).
2. Remove intake manifold collector. Refer to [EM-19](#).
3. Remove fuel tube and fuel injector assembly. Refer to [EM-40](#).
4. Remove harness bracket.
5. Loosen mounting nuts and bolts with power tool in reverse order as shown in the figure to remove intake manifold.

← : Engine front

CAUTION:

- Cover engine openings to avoid entry of foreign materials.
- Put a mark on the intake manifold and the cylinder head with paint before removal because they need installed in the specified direction.
- Loosen mounting bolts and nuts from the inside of manifold to the outside.

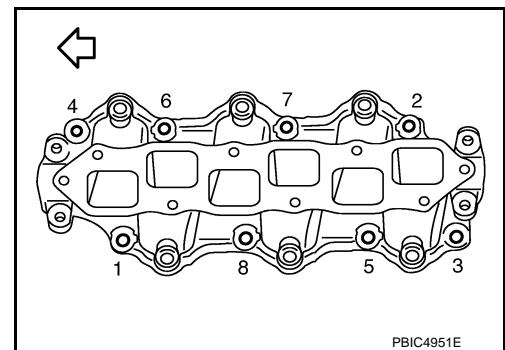

6. Remove gaskets.

INSPECTION AFTER REMOVAL

Surface Distortion

INTAKE MANIFOLD

[VQ35HR]

< SERVICE INFORMATION >

- Check the surface distortion of the intake manifold mating surface with straightedge (A) and feeler gauge (B).

Limit : 0.1 mm (0.004 in)

- If it exceeds the limit, replace intake manifold.

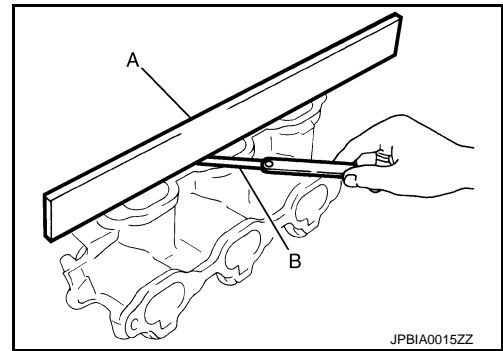

INSTALLATION

Note the following, and install in the reverse order of removal.

Intake Manifold

- If stud bolts were removed, install them and tighten to the specified torque below.

: **10.8 N·m (1.1 kg·m, 96 in·lb)**

- Tighten all mounting nuts and bolts to the specified torque in two or more steps in numerical order shown in the figure.

 : Engine front

CAUTION:

- Install intake manifold with the marks (put on the intake manifold and the cylinder head before removal) aligned.
- Tighten mounting bolts and nuts from the outside of manifold to the inside.

 **1st step: 7.4 N·m (0.75 kg·m, 5 ft·lb)**

 **2nd step and after: 25.5 N·m (2.6 kg·m, 19 ft·lb)**

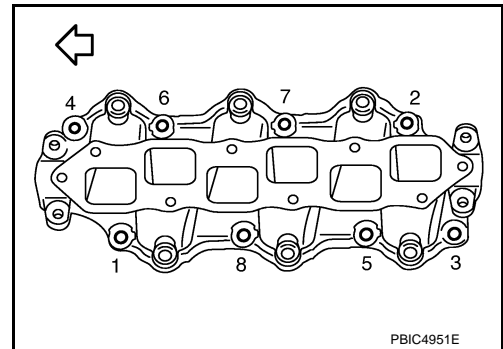

A
EM
C
D
E
F
G
H
I
J
K
L
M
N
O
P

EXHAUST MANIFOLD AND THREE WAY CATALYST

< SERVICE INFORMATION >

[VQ35HR]

EXHAUST MANIFOLD AND THREE WAY CATALYST

Component

INFOID:000000005347978

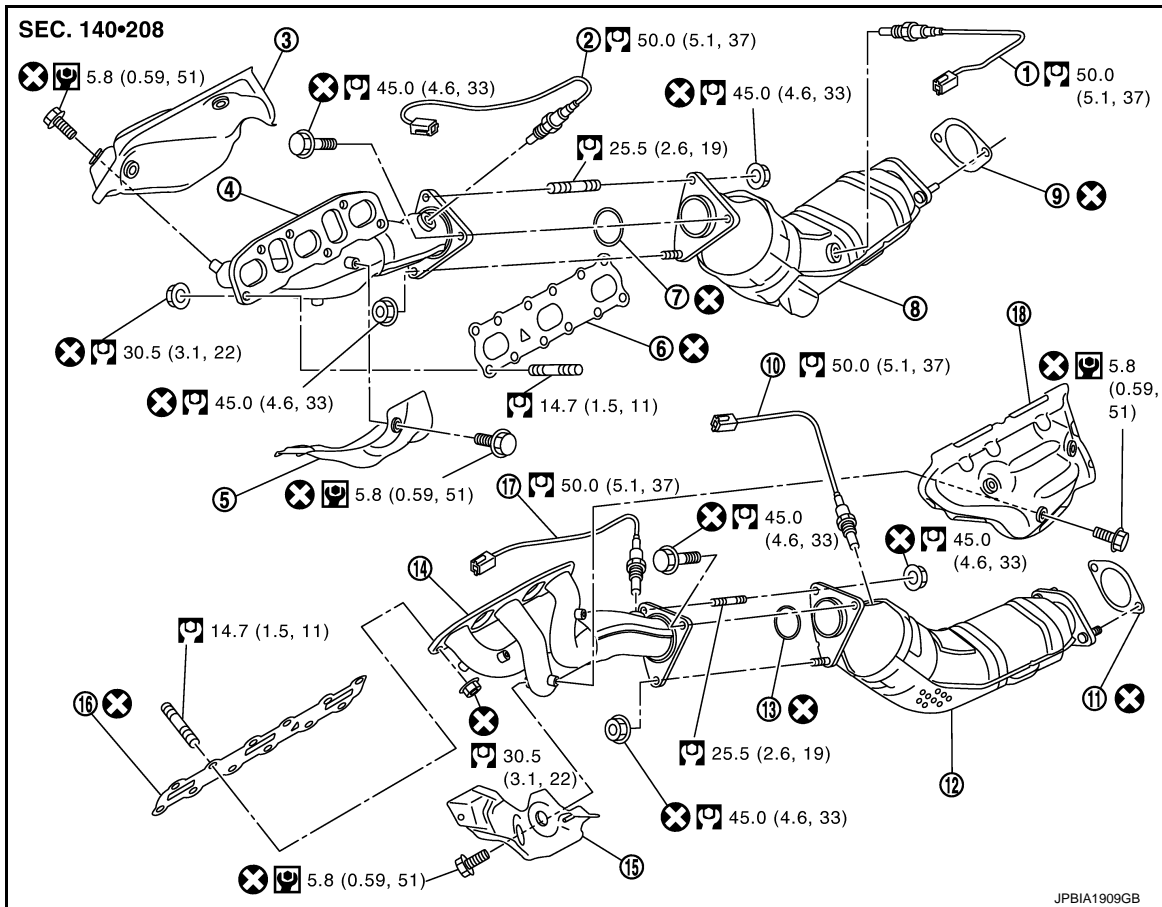

- | | | |
|-------------------------------------|--------------------------------------|------------------------------------|
| 1. Heated oxygen sensor 2 (bank 1) | 2. Air fuel ratio sensor 1 (bank 1) | 3. Exhaust manifold cover (upper) |
| 4. Exhaust manifold (bank 1) | 5. Exhaust manifold cover (lower) | 6. Gasket |
| 7. Ring gasket | 8. Three way catalyst (bank 1) | 9. Gasket |
| 10. Heated oxygen sensor 2 (bank 2) | 11. Gasket | 12. Three way catalyst (bank 2) |
| 13. Ring gasket | 14. Exhaust manifold (bank 2) | 15. Exhaust manifold cover (lower) |
| 16. Gasket | 17. Air fuel ratio sensor 1 (bank 2) | 18. Exhaust manifold cover (upper) |

- Refer to [GI-9. "Component"](#) for symbols in the figure.

Removal and Installation

INFOID:000000005347979

REMOVAL

WARNING:

Perform the work when the exhaust and cooling system have completely cooled down.

NOTE:

When removing bank 1 side parts only, step 3, 10 and 11 are unnecessary.

1. Remove engine room cover (RH and LH). Refer to [EM-14. "Component"](#).
2. Remove engine cover with power tool. Refer to [EM-19](#).
3. Drain engine coolant. Refer to [CO-10. "Inspection"](#).

CAUTION:

- Perform this step when engine is cold.
- Never spill engine coolant on drive belt.

4. Remove air cleaner case and air duct. Refer to [EM-17](#).

EXHAUST MANIFOLD AND THREE WAY CATALYST

[VQ35HR]

< SERVICE INFORMATION >

- Remove front and rear undercover with power tool.
- Disconnect heated oxygen sensor harness connectors.
CAUTION:
 - Be careful not to damage heated oxygen sensor 2.
 - Discard any heated oxygen sensor 2 which has been dropped onto a hard surface such as a concrete floor. Replace with a new sensor.
- Remove exhaust mounting bracket between three way catalysts (bank 1 and bank 2) and transmission. Refer to [EX-3, "Component"](#).
- Remove exhaust front tube and three way catalysts (bank 1 and bank 2).
- Disconnect harness connector and remove air fuel ratio sensor 1 on both banks using heated oxygen sensor wrench [SST: KV10114400 (J38365)] (C).

A : Bank 1

B : Bank 2

- Put marks to identify installation positions of each air fuel ratio sensor 1.

CAUTION:

- Be careful not to damage air fuel ratio sensor 1.
- Discard any air fuel ratio sensor 1 which has been dropped onto a hard surface such as a concrete floor. Replace with a new sensor.

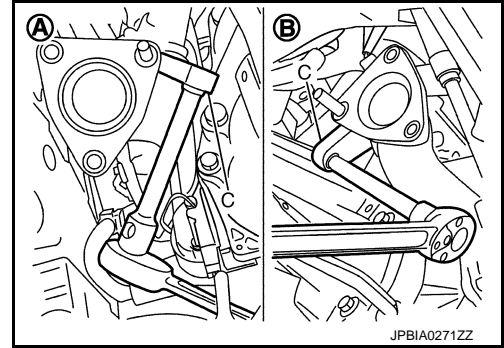

- Disconnect steering lower joint at power steering gear assembly side, and release steering lower shaft. Refer to [PS-12, "Removal and Installation"](#).
- Remove water bypass pipe and heater pipe. Refer to [CO-28, "Component"](#).
- Remove exhaust manifold cover.
- Loosen mounting nuts in reverse order as shown in the figure to remove exhaust manifold.

A : Bank 1

B : Bank 2

← : Engine front

NOTE:

Disregard the numerical order No. 7 and 8 in removal.

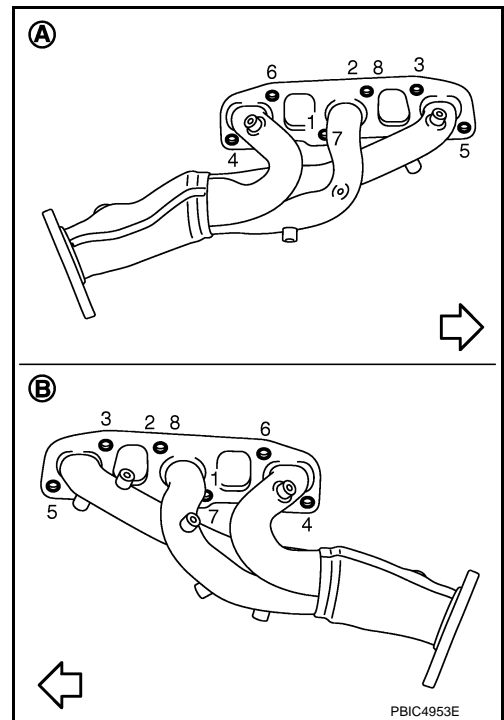

- Remove gaskets.

CAUTION:

Cover engine openings to avoid entry of foreign materials.

INSPECTION AFTER REMOVAL

Surface Distortion

EXHAUST MANIFOLD AND THREE WAY CATALYST

[VQ35HR]

< SERVICE INFORMATION >

- Check the surface distortion of the exhaust manifold mating surface with straightedge (A) and feeler gauge (B).

Limit : 0.7 mm (0.028 in)

- If it exceeds the limit, replace exhaust manifold.

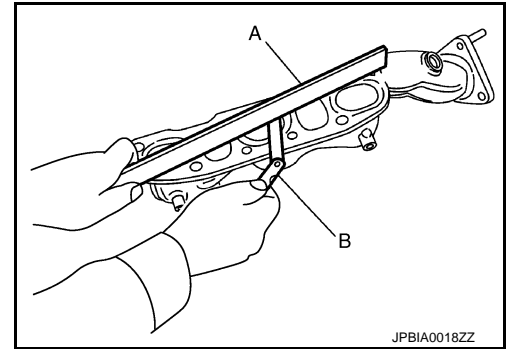

INSTALLATION

Note the following, and install in the reverse order of removal.

Exhaust Manifold Gasket

- Install exhaust manifold gasket in direction shown in the figure.

- A : Bank 1
B : Triangle press
C : Bank 2
⇐ : Engine front

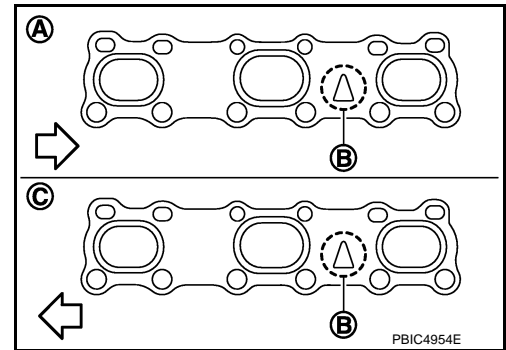

Exhaust Manifold

- If stud bolts were removed, install them and tighten to the specified torque below.

: **14.7 N·m (1.5 kg-m, 11 ft-lb)**

- Install mounting exhaust manifold in numerical order as shown in the figure.

- A : Bank 1
B : Bank 2
⇐ : Engine front

NOTE:

Tighten nuts No. 1 and 2 in two steps. The numerical order No. 7 and 8 shown second step.

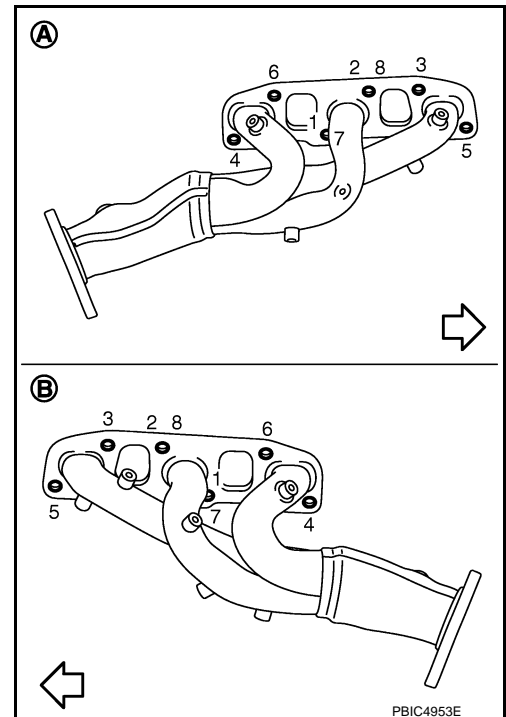

Air Fuel Ratio Sensor 1 and Heated Oxygen Sensor 2

CAUTION:

- Before installing a new air fuel ratio sensor 1 and heated oxygen sensor 2, clean exhaust system threads using oxygen sensor thread cleaner (commercial service tool: J-43897-18 or J43897-12) and apply anti-seize lubricant (commercial service tool).

EXHAUST MANIFOLD AND THREE WAY CATALYST

< SERVICE INFORMATION >

[VQ35HR]

- Never over torque air fuel ratio sensor 1 and heated oxygen sensor 2. Doing so may cause damage to air fuel ratio sensor 1 and heated oxygen sensor 2, resulting in the "MIL" coming on.

A

EM

C

D

E

F

G

H

I

J

K

L

M

N

O

P

OIL PAN AND OIL STRAINER

< SERVICE INFORMATION >

[VQ35HR]

OIL PAN AND OIL STRAINER

2WD

2WD : Component

INFOID:000000005347980

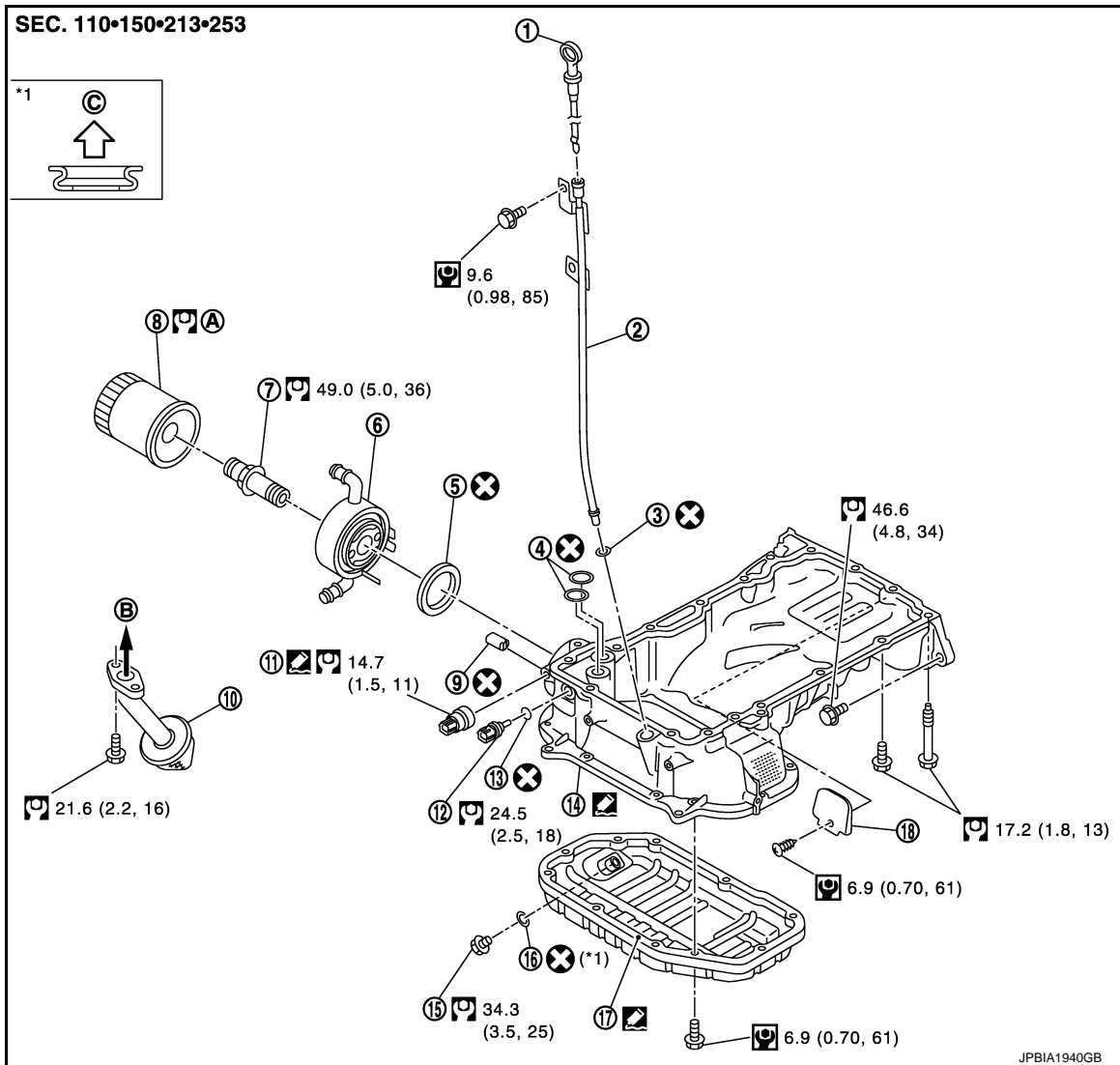

- | | | |
|--|--------------------------|----------------------------|
| 1. Oil level gauge | 2. Oil level gauge guide | 3. O-ring |
| 4. O-ring | 5. O-ring | 6. Oil cooler |
| 7. Connector bolt | 8. Oil filter | 9. Relief valve |
| 10. Oil strainer | 11. Oil pressure switch | 12. Oil temperature sensor |
| 13. Washer | 14. Oil pan (upper) | 15. Drain plug |
| 16. Drain plug washer | 17. Oil pan (lower) | 18. Rear plate cover |
| A. Refer to LU-8, "Removal and Installation" | B. To oil pump | C. Oil pan (lower) side |

- Refer to [GI-9, "Component"](#) for symbols in the figure.

2WD : Removal and Installation

INFOID:000000005347981

REMOVAL

WARNING:

To avoid the danger of being scalded, never drain engine oil when engine is hot.

CAUTION:

OIL PAN AND OIL STRAINER

< SERVICE INFORMATION >

[VQ35HR]

To remove oil pan (upper), remove engine assembly first.

NOTE:

When removing oil pan (lower) only, remove engine assembly is not necessary. Perform step 1, 2 and 10.

1. Remove front and rear undercover with power tool.
2. Drain engine oil. Refer to [LU-7, "Changing Engine Oil"](#).
CAUTION:
 - Perform this step when engine is cold.
 - Never spill engine oil on drive belt.
3. Remove engine assembly from the vehicle, and separate front suspension member and transmission from engine. Refer to [EM-108, "2WD : Component"](#).
4. Lift the engine with hoist, and mount it onto widely use engine stand. Refer to [EM-119, "Component"](#).
5. Remove alternator. Refer to [SC-29, "Removal and Installation"](#).
6. Remove starter motor. Refer to [SC-13, "Removal and Installation"](#).
7. Remove idler pulley and bracket assembly. Refer to [EM-59](#).
8. Remove oil filter, if necessary. Refer to [LU-8, "Removal and Installation"](#).
9. Remove oil temperature sensor, if necessary.
10. Remove oil pan (lower) as follows:
 - a. Loosen mounting bolts with power tool in reverse order as shown in the figure to remove.

← : Engine front

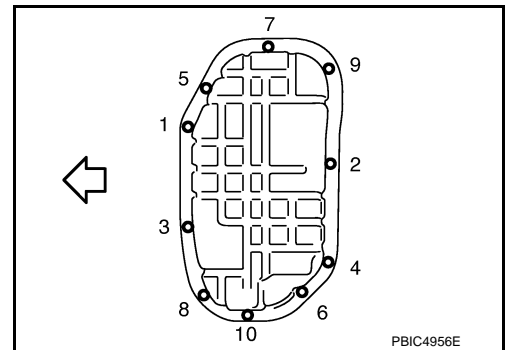

- b. Insert seal cutter [SST: KV10111100 (J37228)] (A) between oil pan (upper) and oil pan (lower).

CAUTION:

- Be careful not to damage the mating surfaces.
- Never insert screwdriver, this will damage the mating surface.

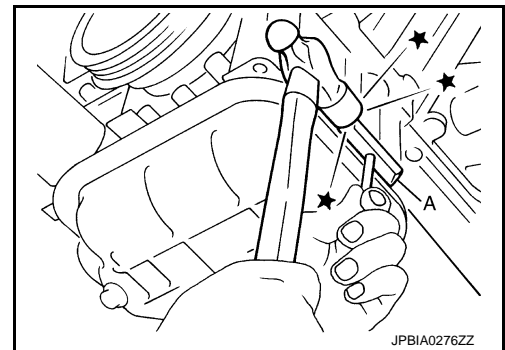

11. Remove oil strainer.
12. Remove rear cover plate.
13. Loosen mounting bolts with power tool in reverse order as shown in the figure to remove oil pan (upper).

← : Engine front

- Insert seal cutter [SST: KV10111100 (J37228)] between oil pan (upper) and cylinder block. Slide seal cutter by tapping on the side of tool with hammer. Remove oil pan (upper).

CAUTION:

- Be careful not to damage mating surfaces.
- Never insert screwdriver, this will damage the mating surface.

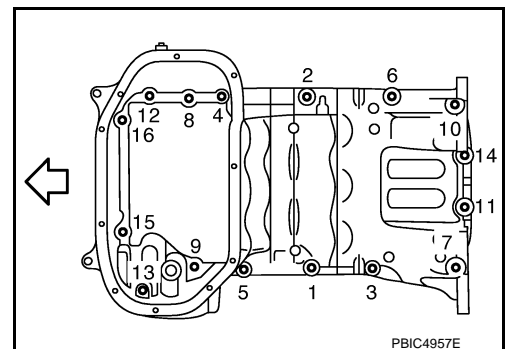

OIL PAN AND OIL STRAINER

[VQ35HR]

< SERVICE INFORMATION >

14. Remove O-rings (2) from bottom of lower cylinder block (1) and oil pump (3).

⇐ : Engine front

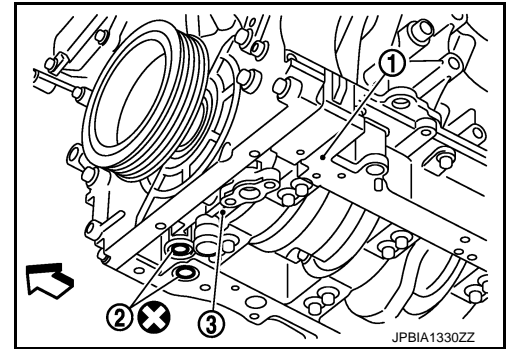

INSPECTION AFTER REMOVAL

Clean oil strainer if any object attached.

INSTALLATION

1. Install oil pan (upper) as follows:
- a. Use scraper (A) to remove old liquid gasket from mating surfaces.
- Also remove the old liquid gasket from mating surface of lower cylinder block.
 - Remove old liquid gasket from the bolt holes and threads.

CAUTION:

Never scratch or damage the mating surfaces when cleaning off old liquid gasket.

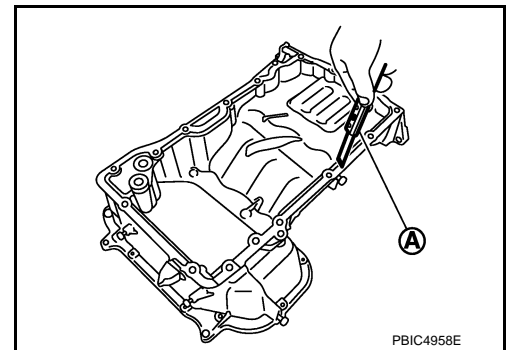

- b. Install new O-rings (2) on the bottom of lower cylinder block (1) and oil pump (3).

⇐ : Engine front

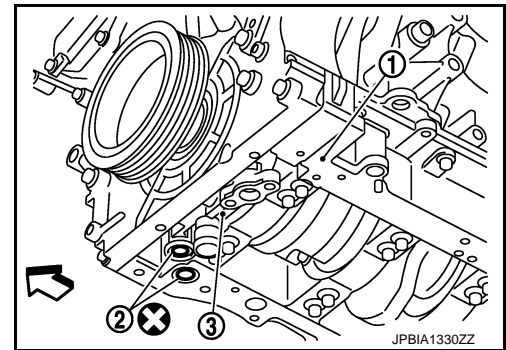

- c. Apply a continuous bead of liquid gasket with tube presser (commercial service tool) to the lower cylinder block mating surface of oil pan (upper) to a limited portion as shown in the figure. **Use Genuine RTV Silicone Sealant or equivalent. Refer to [GI-46. "Recommended Chemical Product and Sealant"](#).**

a : $\phi 4.0 - 5.0$ mm (0.157 - 0.197 in)

⇐ : Engine front

CAUTION:

- For bolt holes (B) (7 locations), apply liquid gasket outside the holes.
- Attaching should be done within 5 minutes after coating.

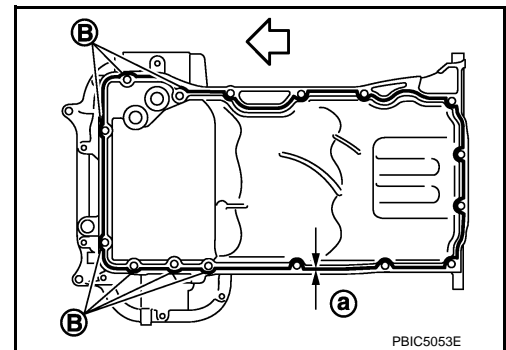

- d. Install oil pan (upper).

CAUTION:

Install avoiding misalignment of both oil pan gasket and O-rings.

OIL PAN AND OIL STRAINER

[VQ35HR]

< SERVICE INFORMATION >

- Tighten mounting bolts in numerical order as shown in the figure.

← : Engine front

- There are two types of mounting bolts. Refer to the following for locating bolts.

M8 × 92 mm (3.62 in) : 7, 10, 13
M8 × 25 mm (0.98 in) : Except the above

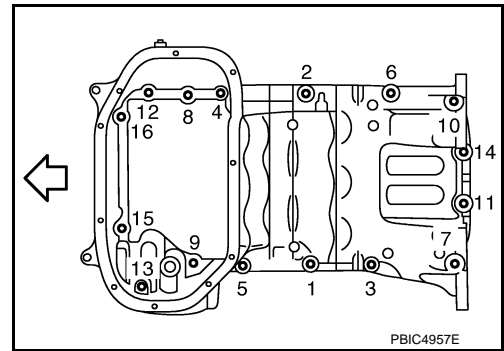

- Tighten transmission joint bolts. Refer to [EM-28, "2WD : Component"](#).
- Install oil strainer to oil pump.
 - Apply locking sealant to the thread of mounting bolts.
Use genuine high strength thread locking sealant or equivalent. Refer to [GI-46, "Recommended Chemical Product and Sealant"](#).

- Install oil pan (lower) as follows:

- Use scraper (A) to remove old liquid gasket from mating surfaces.
 - Also remove old liquid gasket from mating surface of oil pan (upper).
 - Remove old liquid gasket from the bolt holes and thread.

CAUTION:

Never scratch or damage the mating surfaces when cleaning off old liquid gasket.

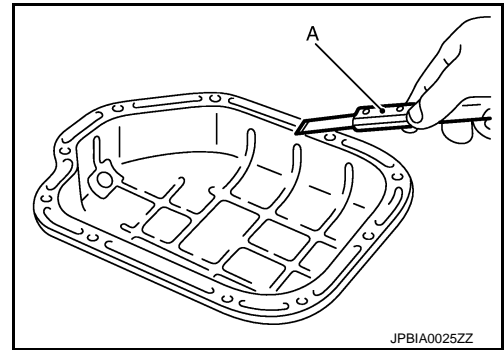

- Apply a continuous bead of liquid gasket with tube presser (commercial service tool) (A) to the oil pan (lower) as shown in the figure.

b : $\phi 4.0 - 5.0$ mm (0.157 - 0.197 in)

Use Genuine RTV Silicone Sealant or equivalent. Refer to [GI-46, "Recommended Chemical Product and Sealant"](#).

CAUTION:

Attaching should be done within 5 minutes after coating.

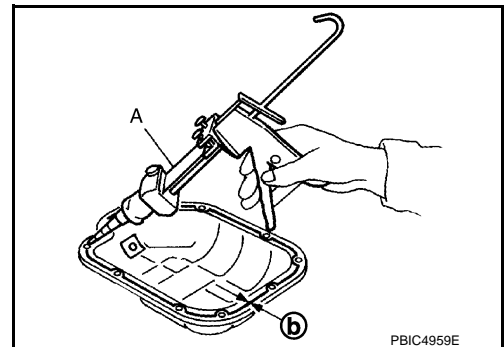

- Install oil pan (lower).

- Tighten mounting bolts in numerical order as shown in the figure.

← : Engine front

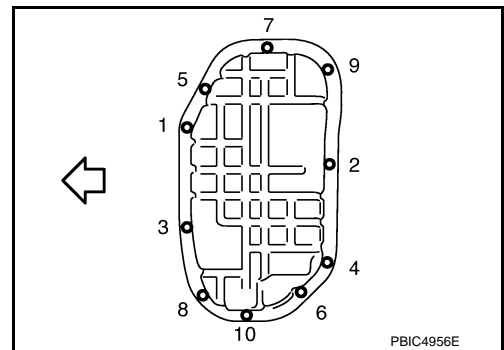

- Install oil pan drain plug.

- Refer to the figure of components of former page for installation direction of drain plug washer. Refer to [EM-28, "2WD : Component"](#).

- Install in the reverse order of removal after this step.

OIL PAN AND OIL STRAINER

[VQ35HR]

< SERVICE INFORMATION >

NOTE:

At least 30 minutes after oil pan is installed, pour engine oil.

INSPECTION AFTER INSTALLATION

1. Check engine oil level and adjust engine oil. Refer to [LU-5, "Inspection"](#).
2. Start engine, and check there is no leakage of engine oil.
3. Stop engine and wait for 10 minutes.
4. Check engine oil level again. Refer to [LU-5, "Inspection"](#).

AWD

AWD : Component

INFOID:000000005347982

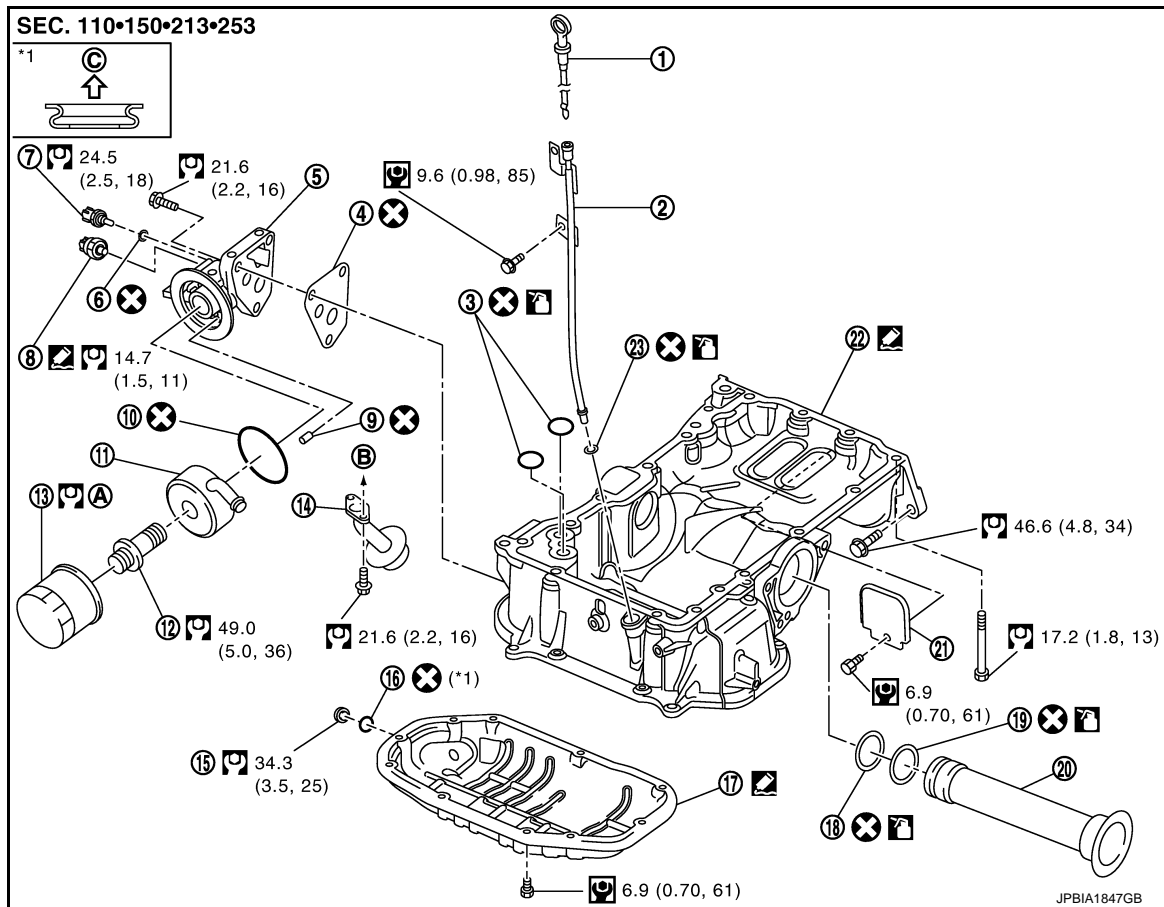

- | | | |
|---------------------------|--------------------------|----------------------|
| 1. Oil level gauge | 2. Oil level gauge guide | 3. O-ring |
| 4. Gasket | 5. Oil filter bracket | 6. Washer |
| 7. Oil temperature sensor | 8. Oil pressure switch | 9. Relief valve |
| 10. O-ring | 11. Oil cooler | 12. Connector bolt |
| 13. Oil filter | 14. Oil strainer | 15. Drain plug |
| 16. Drain plug washer | 17. Oil pan (lower) | 18. O-ring (small) |
| 19. O-ring (large) | 20. Axle pipe | 21. Rear plate cover |
| 22. Oil pan (upper) | 23. O-ring | |
- A. Refer to [LU-8, "Removal and Installation"](#)
B. To oil pump
C. Oil pan (lower) side

- Refer to [GI-9, "Component"](#) for symbols in the figure.

AWD : Removal and Installation

INFOID:000000005347983

REMOVAL

OIL PAN AND OIL STRAINER

< SERVICE INFORMATION >

[VQ35HR]

WARNING:

To avoid the danger of being scalded, never drain engine oil when engine is hot.

CAUTION:

To remove oil pan (upper), remove engine assembly first.

NOTE:

When removing oil pan (lower) only, remove engine assembly is not necessary. Perform step 1, 2 and 10.

1. Remove front and rear undercover with power tool.
2. Drain engine oil. Refer to [LU-7, "Changing Engine Oil"](#).
CAUTION:
 - Perform this step when engine is cold.
 - Never spill engine oil on drive belt.
3. Remove engine assembly from the vehicle, and separate front suspension member and transmission from engine. Refer to [EM-113, "AWD : Component"](#).
4. Lift the engine with hoist, and mount it onto widely use engine stand. Refer to [EM-119, "Component"](#).
5. Remove alternator. Refer to [SC-29, "Removal and Installation"](#).
6. Remove starter motor. Refer to [SC-13, "Removal and Installation"](#).
7. Remove idler pulley and bracket assembly. Refer to [EM-59](#).
8. Remove oil filter, if necessary. Refer to [LU-8, "Removal and Installation"](#).
9. Remove oil temperature sensor, if necessary.
10. Remove oil pan (lower) as follows:
 - a. Loosen mounting bolts with power tool in reverse order as shown in the figure to remove.

← : Engine front

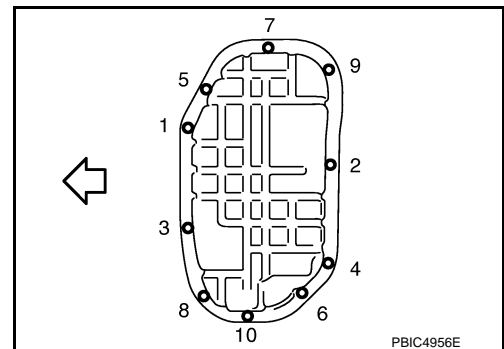

- b. Insert seal cutter [SST: KV10111100 (J37228)] (A) between oil pan (upper) and oil pan (lower).

CAUTION:

- Be careful not to damage the mating surfaces.
- Never insert screwdriver, this will damage the mating surface.

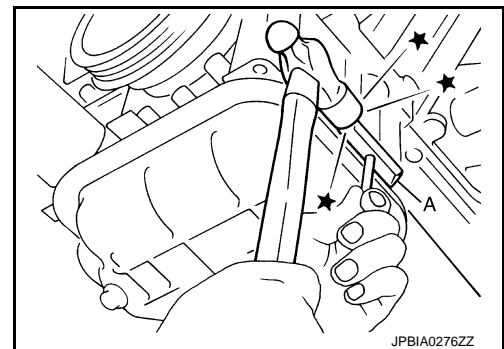

11. Remove oil strainer.
12. Remove rear cover plate.
13. Loosen mounting bolts with power tool in reverse order as shown in the figure to remove oil pan (upper).

← : Engine front

- Insert seal cutter [SST: KV10111100 (J37228)] between oil pan (upper) and cylinder block. Slide seal cutter by tapping on the side of tool with hammer. Remove oil pan (upper).

CAUTION:

- Be careful not to damage mating surfaces.

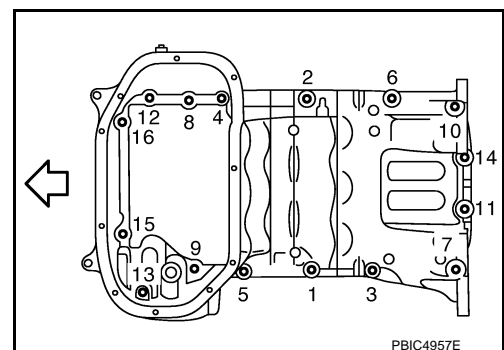

OIL PAN AND OIL STRAINER

[VQ35HR]

< SERVICE INFORMATION >

- Never insert screwdriver, this will damage the mating surface.

14. Remove O-rings (2) from bottom of lower cylinder block (1) and oil pump (3).

⇐ : Engine front

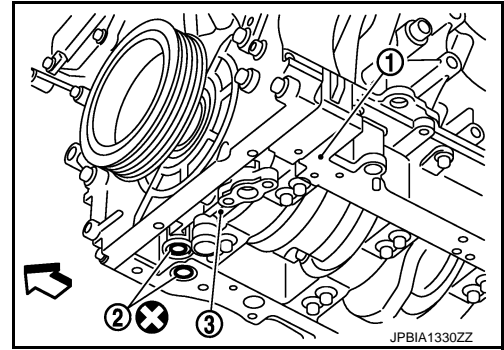

15. Remove axle pipe, if necessary.

- Remove axle pipe from oil pan (upper) using a suitable drift (A) [outer diameter: 37 mm (1.46 in)].

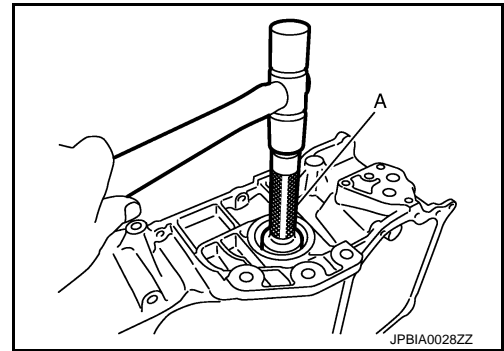

INSPECTION AFTER REMOVAL

Clean oil strainer if any object attached.

INSTALLATION

1. Install axle pipe (3) to oil pan (upper), if removed.

- Lubricate O-ring groove of axle pipe, O-rings (1), (2), and O-ring joint of oil pan with new engine oil.

Unit: mm (in)

Items	O-ring inner diameter
Final drive side (right side)	31.4 (1.236)
Axle pipe flange side (left side)	33.6 (1.323)

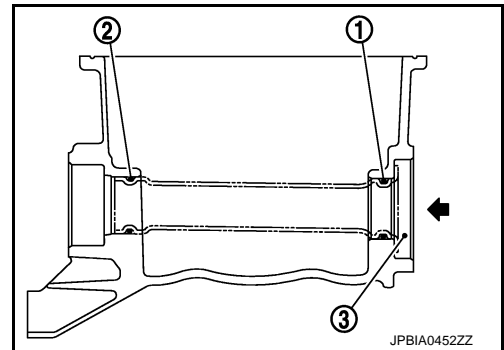

- Install axle pipe (1) to oil pan (upper) from axle pipe flange side (left side) using a suitable drift (A) [outer diameter: 43 to 57 mm (1.69 to 2.24 in)].

CAUTION:
Insert it with care to prevent O-ring from sliding.

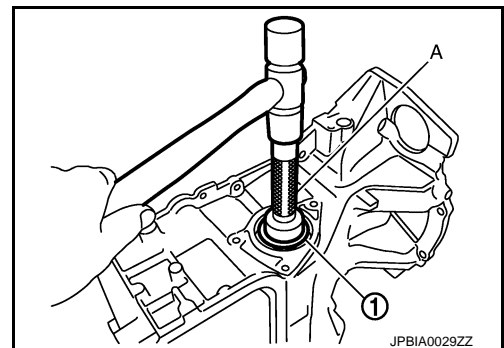

2. Install oil pan (upper) as follows:

OIL PAN AND OIL STRAINER

[VQ35HR]

< SERVICE INFORMATION >

- a. Use scraper (A) to remove old liquid gasket from mating surfaces.
 - Also remove the old liquid gasket from mating surface of lower cylinder block.
 - Remove old liquid gasket from the bolt holes and threads.

CAUTION:

Never scratch or damage the mating surfaces when cleaning off old liquid gasket.

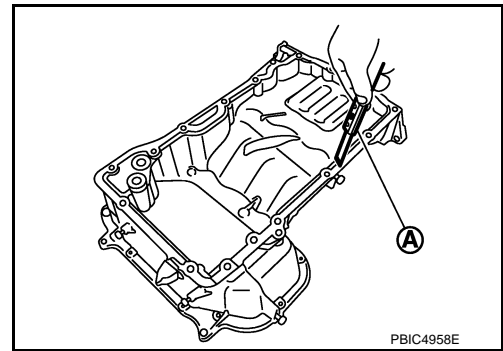

- b. Install new O-rings (2) on the bottom of lower cylinder block (1) and oil pump (3).

⇐ : Engine front

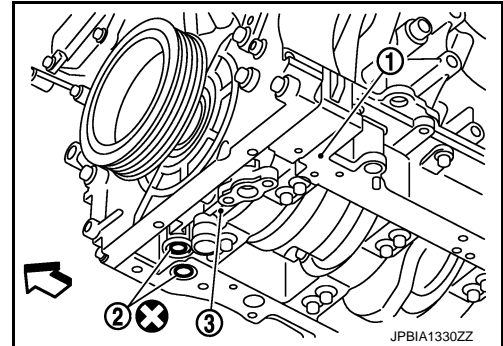

- c. Apply a continuous bead of liquid gasket with tube presser (commercial service tool) to the lower cylinder block mating surface of oil pan (upper) to a limited portion as shown in the figure. **Use Genuine RTV Silicone Sealant or equivalent. Refer to GI-46, "Recommended Chemical Product and Sealant".**

a : $\phi 4.0 - 5.0$ mm (0.157 - 0.197 in)

⇐ : Engine front

CAUTION:

- For bolt holes (B) (7 locations), apply liquid gasket outside the holes.
- Attaching should be done within 5 minutes after coating.

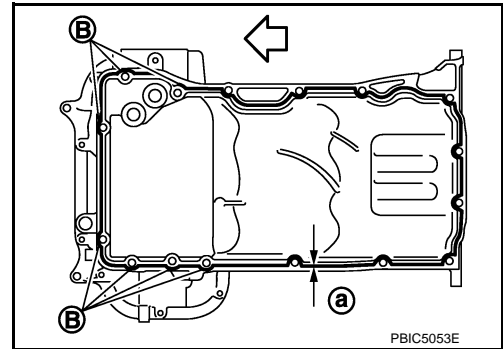

- d. Install oil pan (upper).

CAUTION:

Install avoiding misalignment of both oil pan gasket and O-rings.

- Tighten mounting bolts in numerical order as shown in the figure.

⇐ : Engine front

- There are three types of mounting bolts. Refer to the following for locating bolts.

M8 × 25 mm (0.98 in) : 3, 6, 8, 9, 11, 12, 14, 15, 16

M8 × 50 mm (1.97 in) : 2

M8 × 90 mm (3.54 in) : 1, 4, 5, 7, 10, 13

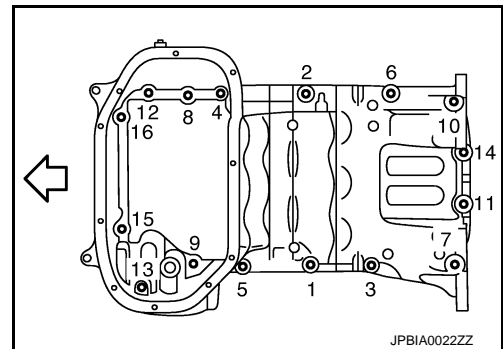

- e. Tighten transmission joint bolts. Refer to [EM-32, "AWD : Component"](#).

3. Install oil strainer to oil pump.

- Apply locking sealant to the thread of mounting bolts.

Use genuine high strength thread locking sealant or equivalent. Refer to [GI-46, "Recommended Chemical Product and Sealant"](#).

4. Install oil pan (lower) as follows:

OIL PAN AND OIL STRAINER

[VQ35HR]

< SERVICE INFORMATION >

- a. Use scraper (A) to remove old liquid gasket from mating surfaces.
- Also remove old liquid gasket from mating surface of oil pan (upper).
 - Remove old liquid gasket from the bolt holes and thread.

CAUTION:

Never scratch or damage the mating surfaces when cleaning off old liquid gasket.

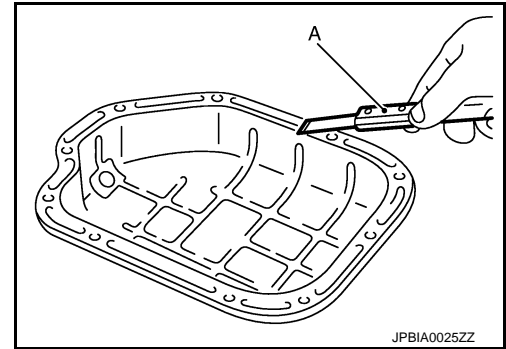

- b. Apply a continuous bead of liquid gasket with tube presser (commercial service tool) (A) to the oil pan (lower) as shown in the figure.

b : $\phi 4.0 - 5.0$ mm (0.157 - 0.197 in)

Use Genuine RTV Silicone Sealant or equivalent. Refer to [GI-46, "Recommended Chemical Product and Sealant"](#).

CAUTION:

Attaching should be done within 5 minutes after coating.

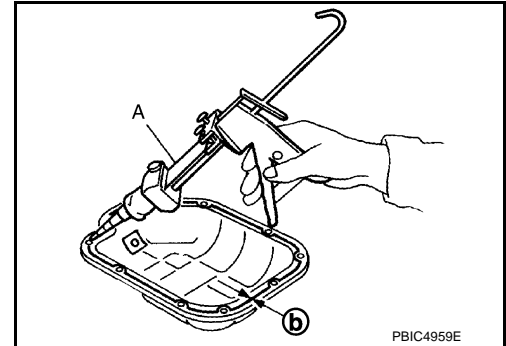

- c. Install oil pan (lower).
- Tighten mounting bolts in numerical order as shown in the figure.

⇐ : Engine front

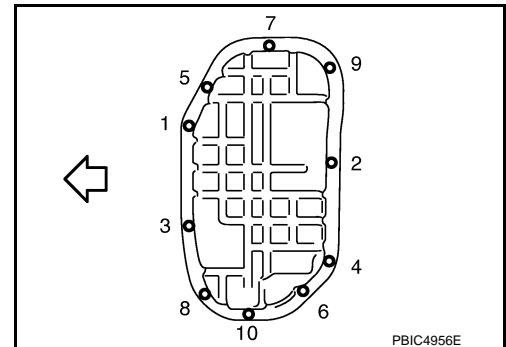

5. Install oil pan drain plug.
- Refer to the figure of components of former page for installation direction of drain plug washer. Refer to [EM-32, "AWD : Component"](#).

6. Install in the reverse order of removal after this step.

NOTE:

At least 30 minutes after oil pan is installed, pour engine oil.

INSPECTION AFTER INSTALLATION

1. Check engine oil level and adjust engine oil. Refer to [LU-5, "Inspection"](#).
2. Start engine, and check there is no leakage of engine oil.
3. Stop engine and wait for 10 minutes.
4. Check engine oil level again. Refer to [LU-5, "Inspection"](#).

IGNITION COIL

< SERVICE INFORMATION >

[VQ35HR]

IGNITION COIL

Component

INFOID:000000005347984

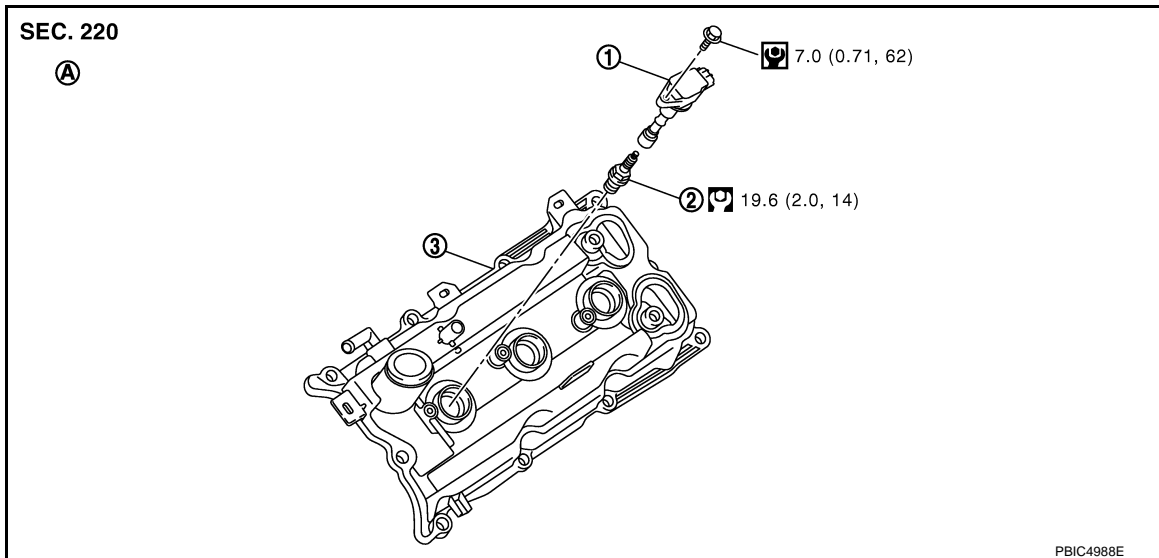

1. Ignition coil
2. Spark plug
3. Rocker cover
A. Bank 2

- Refer to [GI-9. "Component"](#) for symbols in the figure.

Removal and Installation

INFOID:000000005347985

REMOVAL

1. Remove engine room cover (RH and LH). Refer to [EM-14. "Component"](#).
2. Remove engine cover with power tool. Refer to [EM-19](#).
3. Remove air cleaner case and air duct. Refer to [EM-17](#).
4. Move aside harness, harness bracket, and hoses located above ignition coil.
5. Remove electric throttle control actuator. Refer to [EM-19. "Component"](#).
6. Disconnect harness connector from ignition coil.
7. Remove ignition coil.

CAUTION:

Never shock ignition coil.

INSTALLATION

Install in the reverse order of removal.

SPARK PLUG (IRIDIUM-TIPPED TYPE)

< SERVICE INFORMATION >

[VQ35HR]

SPARK PLUG (IRIDIUM-TIPPED TYPE)

Component

INFOID:000000005347986

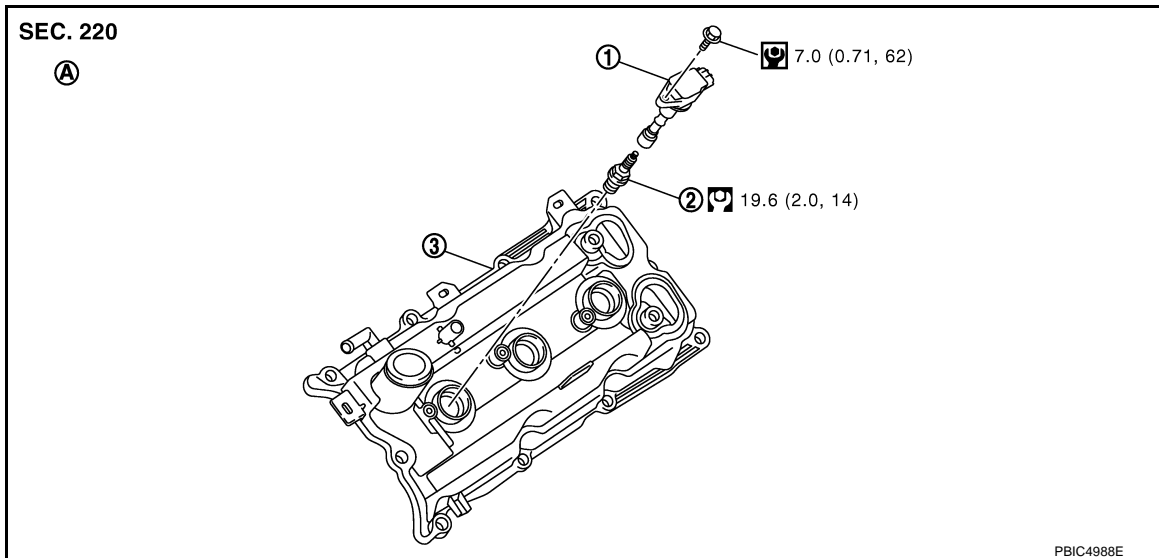

1. Ignition coil
 2. Spark plug
 3. Rocker cover
- A. Bank 2

- Refer to [GI-9. "Component"](#) for symbols in the figure.

Removal and Installation

INFOID:000000005347987

REMOVAL

1. Remove engine cover with power tool. Refer to [EM-19](#).
2. Remove ignition coil. Refer to [EM-37](#).
3. Remove spark plug using spark plug wrench (commercial service tool).

a : 14 mm (0.55 in)

CAUTION:
Never drop or shock spark plug.

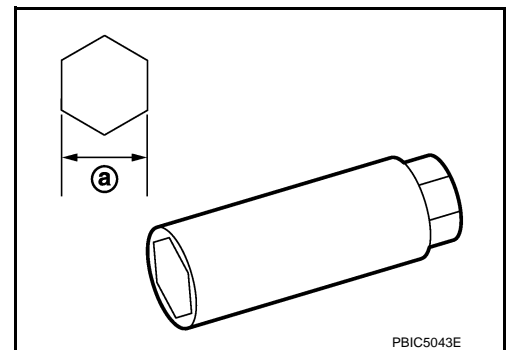

INSPECTION AFTER REMOVAL

Make	DENSO
Standard type	FXE22HR-11

Gap (Nominal) : 1.1 mm (0.043 in)

- CAUTION:**
- Never drop or shock spark plug.

SPARK PLUG (IRIDIUM-TIPPED TYPE)

[VQ35HR]

< SERVICE INFORMATION >

- Never use wire brush for cleaning.
- If plug tip is covered with carbon, spark plug cleaner may be used.

Cleaner air pressure:

Less than 588 kPa (6 kg/cm², 85 psi)

Cleaning time:

Less than 20 seconds

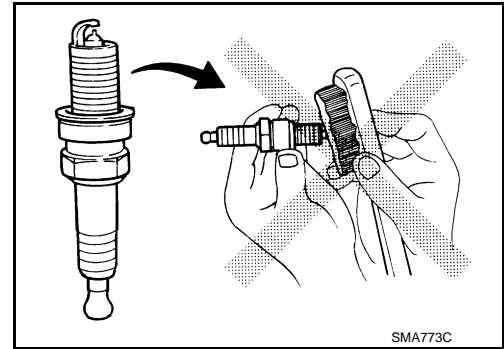

- Checking and adjusting plug gap is not required between change intervals.

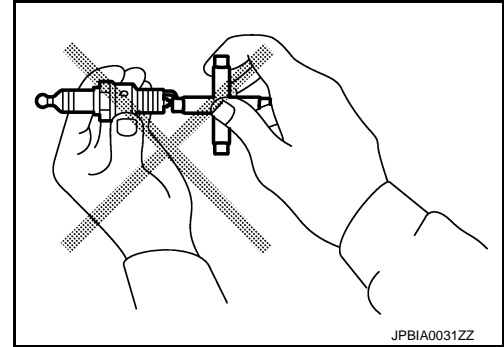

INSTALLATION

Install in the reverse order of removal.

A

EM

C

D

E

F

G

H

I

J

K

L

M

N

O

P

FUEL INJECTOR AND FUEL TUBE

< SERVICE INFORMATION >

[VQ35HR]

FUEL INJECTOR AND FUEL TUBE

Component

INFOID:000000005347988

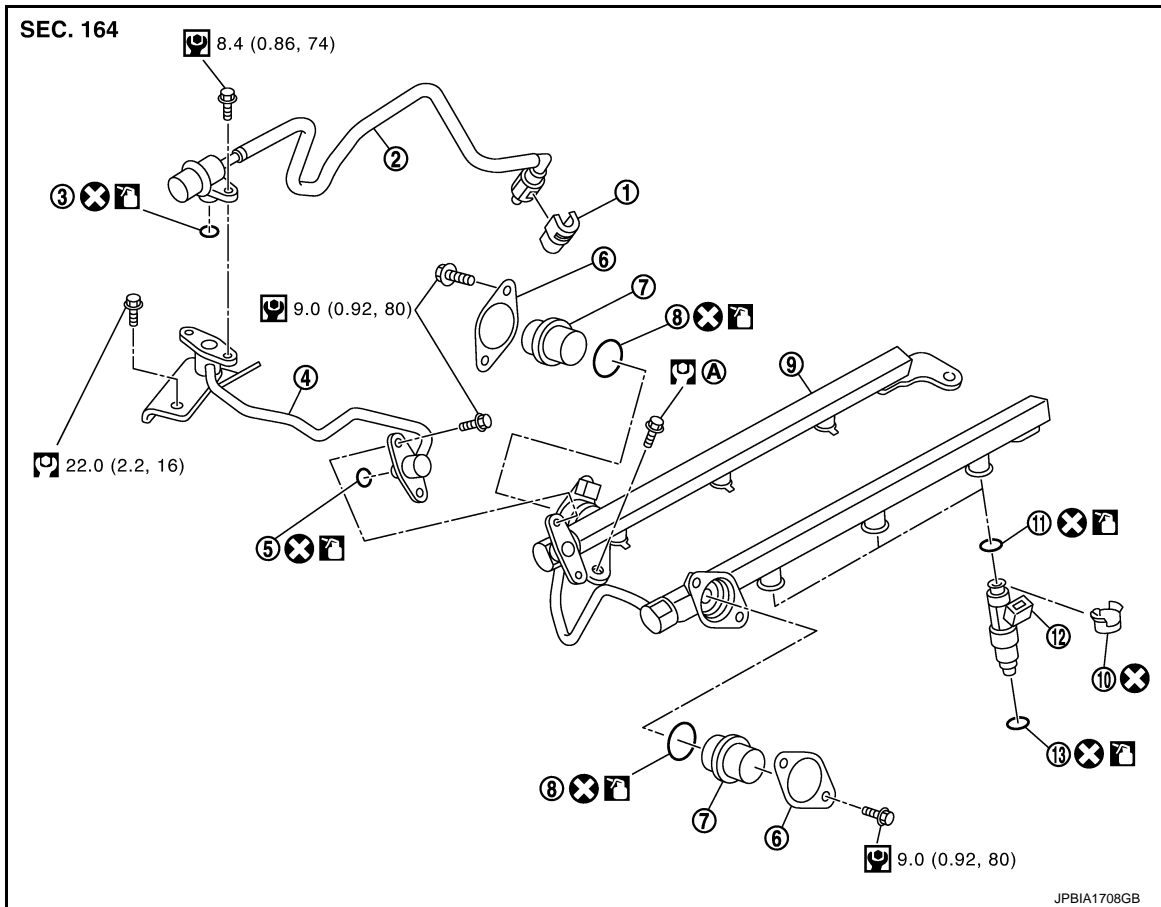

- | | | |
|-----------------------------------|---------------------------------|--------------------|
| 1. Quick connector cap | 2. Fuel feed hose (with damper) | 3. O-ring |
| 4. Fuel sub tube | 5. O-ring | 6. Fuel damper cap |
| 7. Fuel damper | 8. O-ring | 9. Fuel tube |
| 10. Clip | 11. O-ring (black) | 12. Fuel injector |
| 13. O-ring (green) | | |
| A. Refer to EM-40 | | |

• Refer to [GI-9. "Component"](#) for symbols in the figure.

CAUTION:

Never remove or disassemble parts unless instructed as shown in the figure.

Removal and Installation

INFOID:000000005347989

REMOVAL

WARNING:

- Put a "CAUTION: FLAMMABLE" sign in the workshop.
- Be sure to work in a well ventilated area and furnish workshop with a CO2 fire extinguisher.
- Never smoke while servicing fuel system. Keep open flames and sparks away from the work area.
- To avoid the danger of being scalded, never drain engine coolant when engine is hot.

1. Remove engine room cover (RH and LH). Refer to [EM-14. "Component"](#).
2. Remove engine cover with power tool. Refer to [EM-19](#).
3. Release fuel pressure. Refer to [EC-692. "Inspection"](#).
4. Drain engine coolant, or when water hoses are disconnected, attach plug to prevent engine coolant leakage. Refer to [CO-10. "Changing Engine Coolant"](#) and [EM-19](#).

FUEL INJECTOR AND FUEL TUBE

[VQ35HR]

< SERVICE INFORMATION >

CAUTION:

Perform this step when engine is cold.

5. Remove intake manifold collector. Refer to [EM-19](#).
6. Remove fuel feed hose (with damper) (1) from fuel sub-tube (2) and harness bracket (3).

⇐ : Engine front

NOTE:

There is no fuel return route.

CAUTION:

- While hoses are disconnected, plug them to prevent fuel from draining.
- Never separate fuel damper and fuel feed hose.

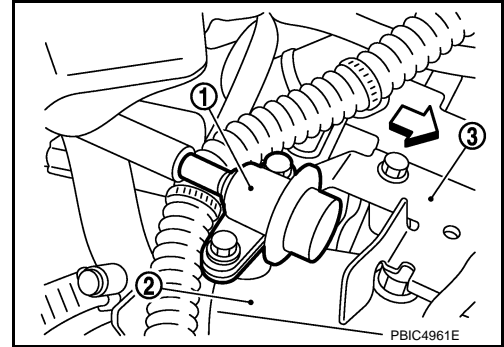

7. When separating fuel feed hose (with damper) and centralized under-floor piping connection, disconnect quick connector as follows:

- a. Remove quick connector cap (2) from quick connector connection on right member side.
- b. Disconnect fuel feed hose (with damper) (1) from bracket hose clamp.

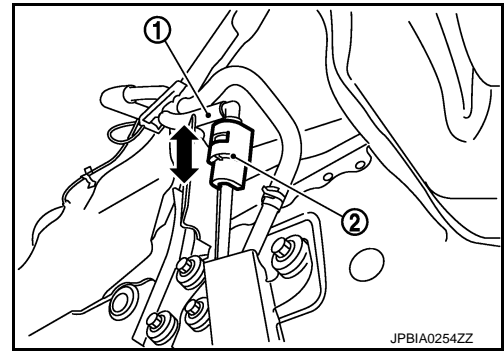

- c. Push in retainer tabs (2).
- d. Draw and pull out quick connector (1) straight from centralized under-floor piping (3).

CAUTION:

- Pull quick connector holding (A) position as shown in the figure.
- Never pull with lateral force applied. O-ring inside quick connector may be damaged.
- Prepare container and cloth beforehand because fuel will leakage out.
- Avoid fire and sparks.
- Keep parts away from heat source. Especially, be careful when welding is performed around them.
- Never expose parts to battery electrolyte or other acids.
- Never bend or twist connection between quick connector and fuel feed hose (with damper) during installation/removal.
- To keep clean the connecting portion and to avoid damage and foreign materials, cover them completely with plastic bags, etc. (A) or something similar.

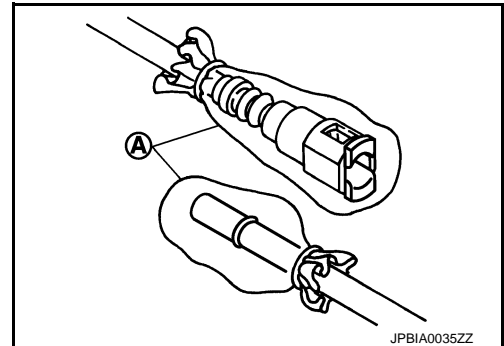
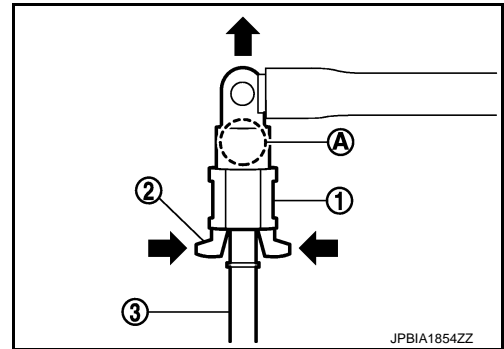

8. Disconnect harness connector from fuel injector.

A
EM
C
D
E
F
G
H
I
J
K
L
M
N
O
P

FUEL INJECTOR AND FUEL TUBE

[VQ35HR]

< SERVICE INFORMATION >

9. Loosen mounting bolts in reverse order as shown in the figure, and remove fuel tube and fuel injector assembly.

← : Engine front

CAUTION:

Never tilt it, or remaining fuel in pipes may flow out from pipes.

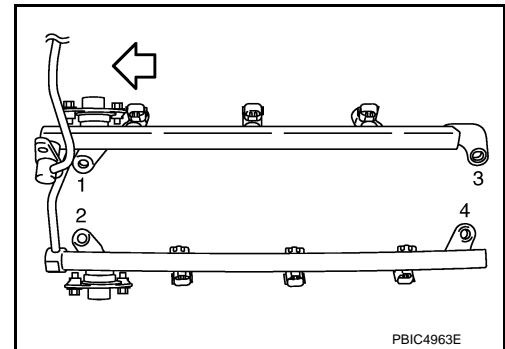

10. Remove fuel injector (2) from fuel tube (4) as follows:

3 : O-ring

A : Installed condition

B : Clip mounting groove

- a. Open and remove clip (1).
b. Remove fuel injector from fuel tube by pulling straight.

CAUTION:

- Be careful with remaining fuel that may go out from fuel tube.
- Be careful not to damage injector nozzles during removal.
- Never bump or drop fuel injector.
- Never disassemble fuel injector.

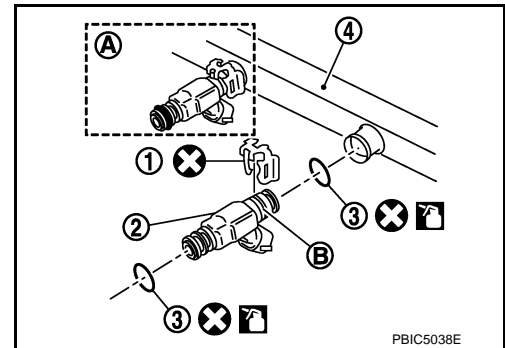

11. Remove fuel sub-tube and fuel damper, if necessary.

INSTALLATION

1. Install fuel damper (4) as follows:

- a. Install new O-ring (2) to fuel tube (1) as shown.

- When handling new O-ring, be careful of the following caution:

CAUTION:

- Handle O-ring with bare hands. Never wear gloves.
- Lubricate O-ring with new engine oil.
- Never clean O-ring with solvent.
- Check that O-ring and its mating part are free of foreign material.
- When installing O-ring, be careful not to scratch it with tool or fingernails. Also be careful not to twist or stretch O-ring. If O-ring was stretched while it was being attached, never insert it quickly into fuel tube.
- Insert new O-ring straight into fuel tube. Never twist it.

- b. Install spacer (3) to fuel damper.

- c. Insert fuel damper straight into fuel tube.

CAUTION:

- Insert straight, checking that the axis is lined up.
- Never pressure-fit with excessive force.

Reference value : 130 N (13.3 kg, 29.2 lb)

- Insert fuel damper unit (B) is touching (A) of fuel tube.

- d. Tighten bolts evenly in turn.

- After tightening bolts, check that there is no gap between fuel damper cap (5) and fuel tube.

2. Install fuel sub-tube.

- When handling new O-ring, be careful of the following caution:

CAUTION:

- Handle O-ring with bare hands. Never wear gloves.

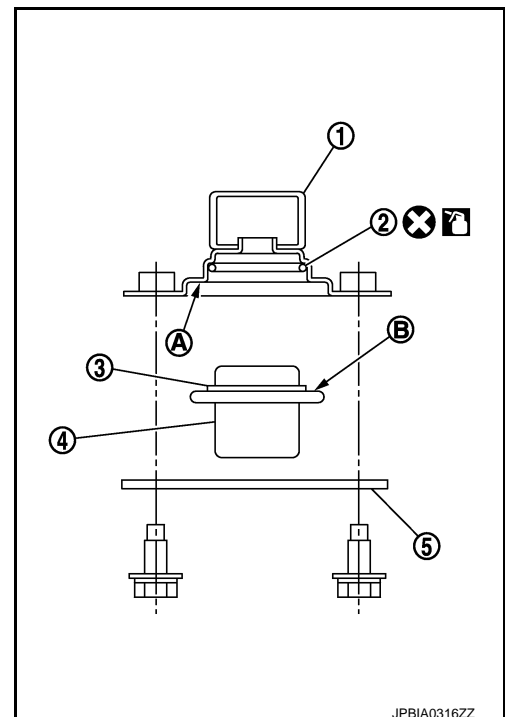

FUEL INJECTOR AND FUEL TUBE

[VQ35HR]

< SERVICE INFORMATION >

- Lubricate O-ring with new engine oil.
 - Never clean O-ring with solvent.
 - Check that O-ring and its mating part are free of foreign material.
 - When installing O-ring, be careful not to scratch it with tool or fingernails. Also be careful not to twist or stretch O-ring. If O-ring was stretched while it was being attached, never insert it quickly into fuel tube.
 - Insert O-ring straight into fuel tube. Never decenter or twist it.
- Insert fuel sub-tube straight into fuel tube.
- Tighten mounting bolts evenly in turn.
- After tightening mounting bolts, check that there is no gap between flange and fuel sub-tube.
3. Install O-rings to fuel injector, paying attention to the following.
- CAUTION:**
- Upper and lower O-ring are different. Be careful not to confuse them.

Fuel tube side : Black

Nozzle side : Green

- Handle O-ring with bare hands. Never wear gloves.
 - Lubricate O-ring with new engine oil.
 - Never clean O-ring with solvent.
 - Check that O-ring and its mating part are free of foreign material.
 - When installing O-ring, be careful not to scratch it with tool or fingernails. Also be careful not to twist or stretch O-ring. If O-ring was stretched while it was being attached, never insert it quickly into fuel tube.
 - Insert O-ring straight into fuel injector. Never decenter or twist it.
4. Install fuel injector (5) to fuel tube (1) as follows:

2 : O-ring (Black)

4 : O-ring (Green)

- a. Insert clip (3) into clip mounting groove (D) on fuel injector.
- CAUTION:**
- Never reuse clip. Replace it with a new one.
 - Be careful to keep clip from interfering with O-ring. If interference occurs, replace O-ring.
- b. Insert fuel injector into fuel tube with clip attached.
- Insert it while matching it to the axial center.
 - Insert fuel injector so that protrusion (A) of fuel tube matches cutout (B) of clip.
 - Check that fuel tube flange (E) is securely fixed in flange fixing groove (C) on clip.
- c. Check that installation is complete by checking that fuel injector does not rotate or come off.
- Check that protrusions of fuel injectors are aligned with cut-outs of clips after installation.

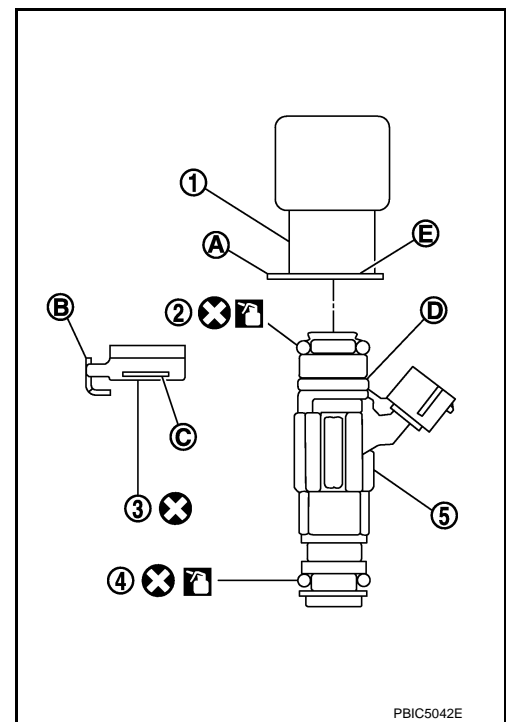

5. Install fuel tube and fuel injector assembly to intake manifold.
- CAUTION:**
- Be careful not to let tip of injector nozzle come in contact with other parts.

FUEL INJECTOR AND FUEL TUBE

[VQ35HR]

< SERVICE INFORMATION >

- Tighten mounting bolts in two steps in numerical order as shown in the figure.

← : Engine front

 **1st step** : 10.1 N-m (1.0 kg-m, 7 ft-lb)

 **2nd step** : 23.6 N-m (2.4 kg-m, 17 ft-lb)

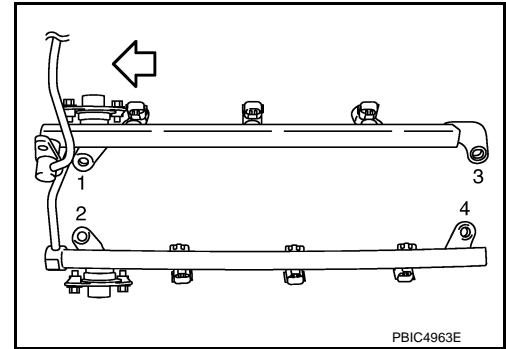

6. Connect fuel injector harness connector.
7. Connect fuel feed hose (with damper).
 - Handling procedure of O-ring is the same as that of fuel damper and fuel sub-tube.
 - Insert fuel damper straight into fuel sub-tube.
 - Tighten mounting bolts evenly in turn.
 - After tightening mounting bolts, check that there is no gap between flange and fuel sub-tube.
8. Connect quick connector between fuel feed hose (with damper) and centralized under-floor piping connection as follows:
 - a. Check no foreign substances are deposited in and around centralized under-floor piping and quick connector, and no damage on them.
 - b. Thinly apply new engine oil around centralized under-floor piping from tip end to spool end.
 - c. Align center to insert quick connector straightly into centralized under-floor piping.
 - Insert quick connector to centralized under-floor piping until top spool is completely inside quick connector, and 2nd level spool exposes right below quick connector.

CAUTION:

- **Hold align center to avoid inclined insertion to prevent to O-ring inside quick connector.**
- **Insert until you hear a “click” sound and actually feel the engagement.**
- **To avoid misidentification of engagement with a similar sound, be sure to perform the next step.**

- d. Pull quick connector by hand holding position (A). Check it is completely engaged (connected) so that it does not come out from centralized under-floor piping (1).

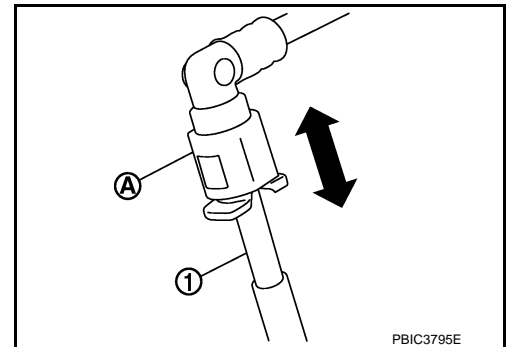

- e. Install quick connector cap (3) to quick connector connection.

- 1 : Centralized under-floor piping
- 2 : Fuel feed hose
- B : Under view

- Install quick connector cap with arrow (A) on surface facing in direction of quick connector (fuel feed hose side).

CAUTION:

If quick connector cap cannot be installed smoothly, quick connector may have not been installed correctly. Check the connection again.

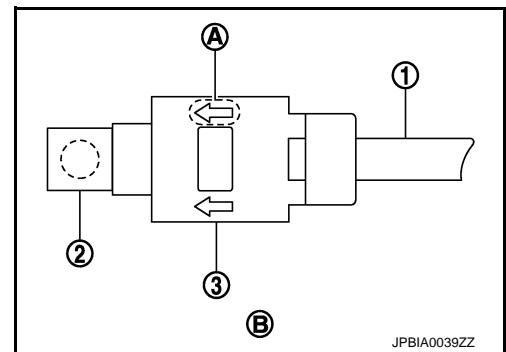

9. Install in the reverse order of removal after this step.

INSPECTION AFTER INSTALLATION

Check on Fuel Leakage

FUEL INJECTOR AND FUEL TUBE

[VQ35HR]

< SERVICE INFORMATION >

1. Turn ignition switch "ON" (with engine stopped). With fuel pressure applied to fuel piping, check for fuel leakage at connection points.

NOTE:

Use mirrors for checking at points out of clear sight.

2. Start engine. With engine speed increased, check again for fuel leakage at connection points.

CAUTION:

Never touch engine immediately after stopped, as engine becomes extremely hot.

A

EM

C

D

E

F

G

H

I

J

K

L

M

N

O

P

ROCKER COVER

< SERVICE INFORMATION >

[VQ35HR]

ROCKER COVER

Component

INFOID:000000005347990

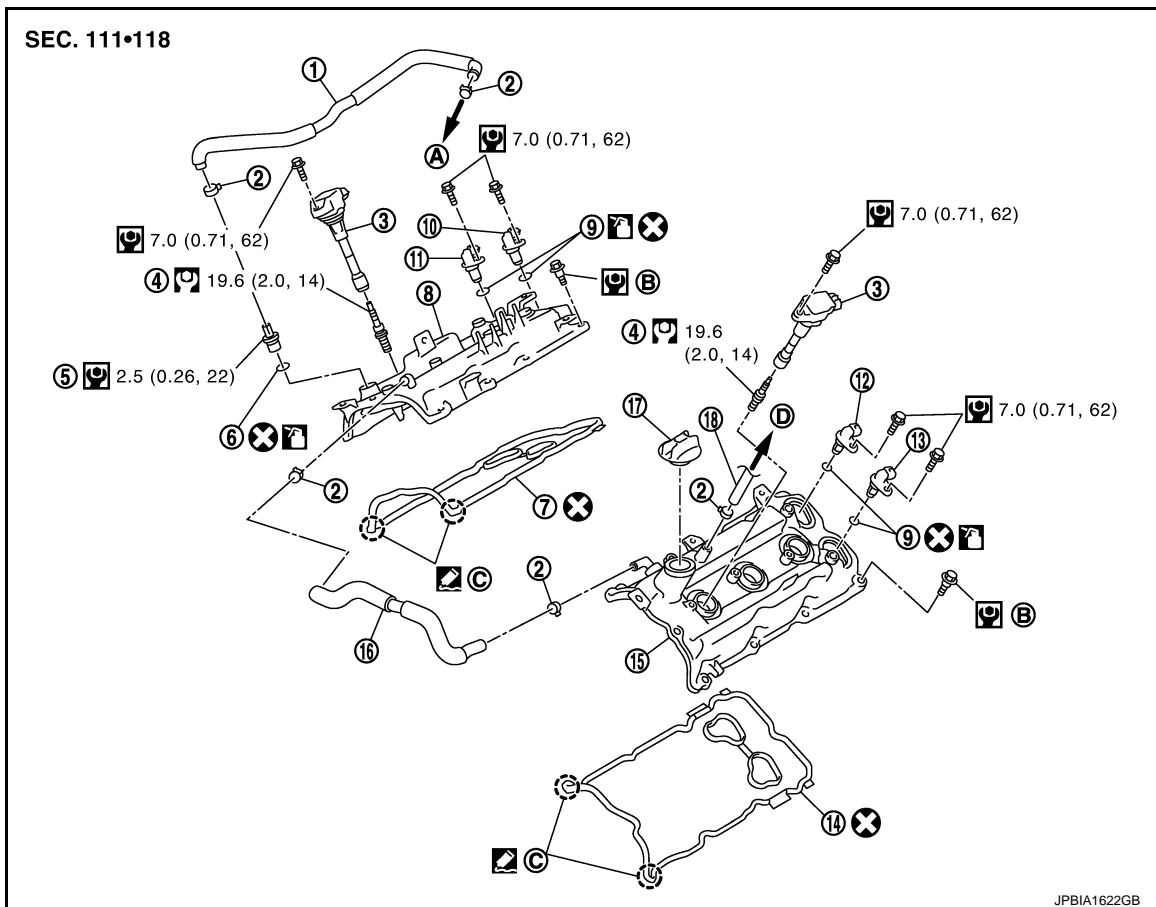

- | | | |
|---|---|---------------------------------------|
| 1. PCV hose | 2. Clamp | 3. Ignition coil |
| 4. Spark plug | 5. PCV valve | 6. O-ring |
| 7. Rocker cover gasket (bank 1) | 8. Rocker cover (bank 1) | 9. O-ring |
| 10. Camshaft position sensor (bank 1) | 11. Exhaust valve timing control position sensor (bank 1) | 12. Camshaft position sensor (bank 2) |
| 13. Exhaust valve timing control position sensor (bank 2) | 14. Rocker cover gasket (bank 2) | 15. Rocker cover (bank 2) |
| 16. PCV hose | 17. Oil filler cap | 18. PCV hose |
| A. To intake manifold collector | B. Refer to EM-46 | C. Camshaft bracket side |
| D. To air duct | | |

- Refer to [GI-9. "Component"](#) for symbols in the figure.

Removal and Installation

INFOID:000000005347991

REMOVAL

1. Remove engine room cover (RH and LH). Refer to [EM-14. "Component"](#).
2. Remove engine cover. Refer to [EM-19](#).
3. Remove intake manifold collector. Refer to [EM-19](#).
4. Separate engine harness removing their brackets from rocker covers.
5. Remove ignition coil. Refer to [EM-37](#).

ROCKER COVER

[VQ35HR]

< SERVICE INFORMATION >

- Remove camshaft position sensor and exhaust valve timing control position sensor.

A : Keep off any magnetic materials

CAUTION:

- Handle carefully to avoid dropping and shocks.
- Never disassemble.
- Never allow metal powder to adhere to magnetic part at sensor tip.
- Never place sensors in a location where they are exceed to magnetism.

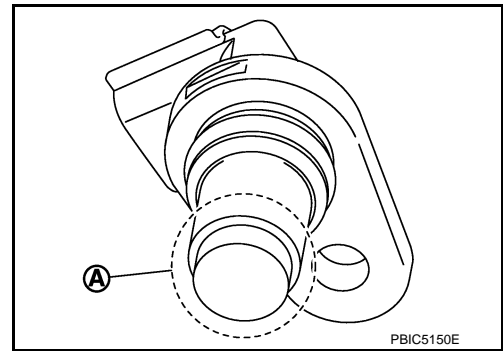

- Remove PCV hoses from rocker covers.
- Remove PCV valve and O-ring from rocker cover, if necessary.
- Remove oil filler cap from rocker cover, if necessary.
- Loosen mounting bolts with power tool in reverse order as shown in the figure.

← : Engine front

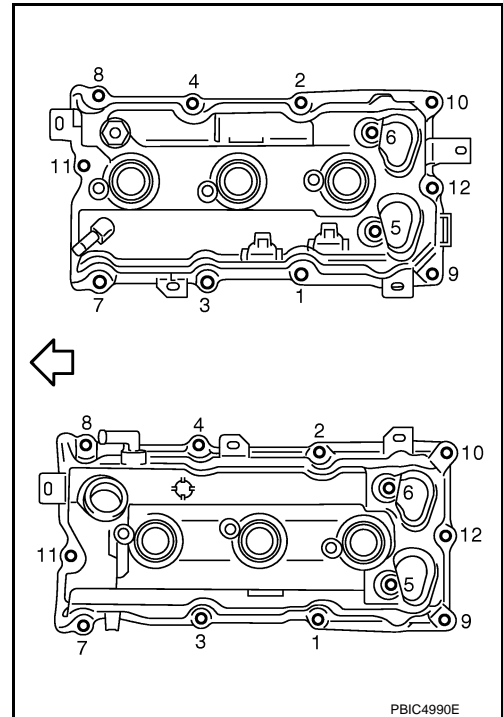

- Remove rocker cover gaskets from rocker covers.
- Use scraper to remove all traces of liquid gasket from cylinder head and camshaft bracket (No. 1).

CAUTION:

Never scratch or damage the mating surface when cleaning off old liquid gasket.

INSTALLATION

ROCKER COVER

[VQ35HR]

< SERVICE INFORMATION >

1. Apply liquid gasket with tube presser (commercial service tool) to joint part among rocker cover, cylinder head and camshaft bracket (No. 1) as follows:

- A : Liquid gasket application point
- F : View F
- I : End surface of camshaft bracket (No. 1)
- b : 4 mm (0.16 in)
- c : $\phi 2.5 - 3.5$ mm (0.098 - 0.138 in)
- d : 5 mm (0.20 in)
- g : 10 mm (0.39 in)
- ⇐ : Engine front

Use Genuine RTV Silicone Sealant or equivalent. Refer to [GI-46, "Recommended Chemical Product and Sealant"](#).

NOTE:

The figure shows an example of bank 2 side [zoomed in shows camshaft bracket (No. 1)].

- a. Refer to the figure (E) to apply liquid gasket to joint part of camshaft bracket (No. 1) (1) and cylinder head.
- b. Refer to the figure (H) to apply liquid gasket in 90 degrees to figure.

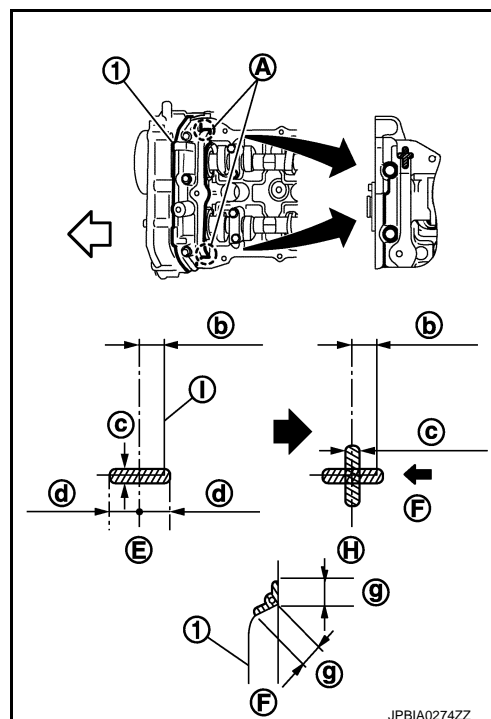

2. Install new rocker cover gasket to rocker cover.
3. Install rocker cover.
 - Check if rocker cover gasket is not dropped from installation groove of rocker cover.
4. Tighten bolts in two steps separately in numerical order as shown in the figure.

⇐ : Engine front

- 1st step** : 2.0 N·m (0.2 kg·m, 18 in·lb)
- 2nd step** : 8.3 N·m (0.85 kg·m, 73 in·lb)

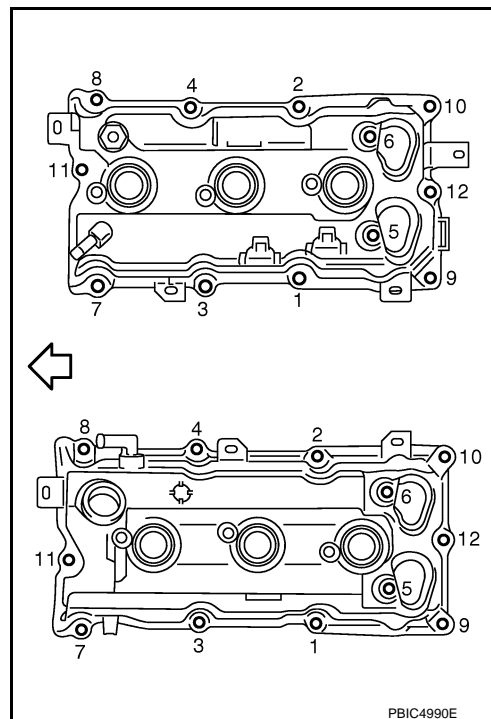

5. Install oil filler cap to rocker cover (bank 2), if removed.
6. Install new O-ring and PCV valve to rocker cover (bank 1), if removed.
7. Install PCV hose.
 - Insert PCV hose by 25 to 30 mm (0.98 to 1.18 in) from connector end.
 - When installing, be careful not to twist or come in contact with other parts.
 - Install PCV hose between bank 1 and bank 2 rocker covers with its identification paint facing upward [rocker cover (bank 1) side]. Refer to component figure in [EM-46, "Component"](#).
8. Install in the reverse order of removal after this step.

FRONT TIMING CHAIN CASE

Removal and Installation

INFOID:000000005347992

NOTE:

- This section describes removal/installation procedure of front timing chain case and timing chain related parts without removing oil pan (upper) on vehicle.
- When oil pan (upper) needs to be removed or installed, or when rear timing chain case is removed or installed, remove oil pans (upper and lower) first. Then remove front timing chain case, timing chain related parts, and rear timing chain case in this order, and install in the reverse order of removal. Refer to [EM-59](#).
- Refer to [EM-59](#) for component parts location.

REMOVAL

1. Remove engine cover with power tool. Refer to [EM-19, "Removal and Installation"](#).
2. Remove front and rear undercover with power tool.
3. Release the fuel pressure. Refer to [EC-692, "Inspection"](#).
4. Disconnect the battery cable from the negative terminal.
5. Drain engine oil. Refer to [LU-7, "Changing Engine Oil"](#).
CAUTION:
 - Perform this step when engine is cold.
 - Never spill engine oil on drive belt.
6. Drain engine coolant from radiator. Refer to [CO-10, "Changing Engine Coolant"](#).
CAUTION:
 - Perform this step when engine is cold.
 - Never spill engine coolant on drive belt.
7. Remove radiator cooling fan assembly. Refer to [CO-13, "Component"](#).
8. Separate engine harnesses removing their brackets from front timing chain case.
9. Remove drive belt. Refer to [EM-15](#).
10. Remove intake manifold collector. Refer to [EM-19](#).
11. Remove harness bracket and fuel sub tube mounting bolt on front timing chain case.
12. Remove oil level gauge and guide.
13. Remove power steering oil pump from bracket with piping connected, and temporarily secure it to aside. Refer to [PS-36, "Removal and Installation"](#).
14. Remove power steering oil pump bracket. Refer to [EM-59, "Component"](#).
15. Remove alternator. Refer to [SC-29, "Removal and Installation"](#).
16. Remove water outlet and water piping. Refer to [CO-28, "Component"](#).
17. Remove left and right valve timing control covers with the following procedure.
 - a. Disconnect valve timing control harness connector.
 - b. Loosen mounting bolts in reverse order as shown in the figure.

- A : Bank 1
- B : Bank 2
- C : Dowel pin hole

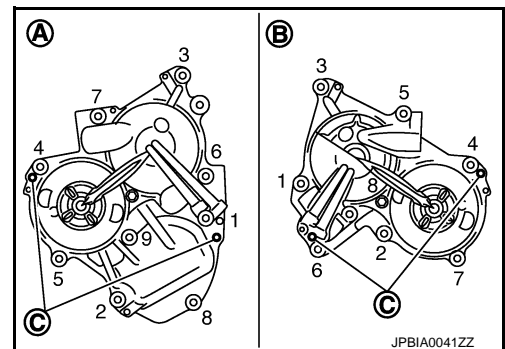

- c. Shaft is engaged with intake side camshaft sprocket center hole on inside. Pull straight out so as not to tilt until the joint is disengaged.

FRONT TIMING CHAIN CASE

[VQ35HR]

< SERVICE INFORMATION >

- The mating surface of magnet retarder (2) may be fitted with the exhaust side camshaft sprocket via the engine oil. Open valve timing control cover (1) carefully.
- If the mating surface of magnet retarder is fitted with the camshaft sprocket, open the cover within the range that the load is not applied to the harness. And then, remove it so as to prevent magnet retarder from dropping.

CAUTION:

- **Be careful not to damage magnet retarder.**
- **When carrying valve timing control cover, face the magnet retarder side up to prevent the cover from falling from magnet retarder.**
- **Never remove magnet retarder from valve timing control cover. (Disassembly prohibited parts)**

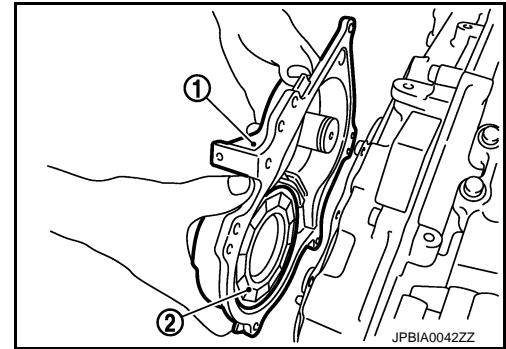

18. Remove rocker covers (bank 1 and bank 2). Refer to [EM-46](#).

NOTE:

When only timing chain (primary) is removed, rocker cover does not need to be removed.

19. Obtain No. 1 cylinder at TDC of its compression stroke as follows:

NOTE:

When timing chain is not removed/installed, this step is not required.

- a. Rotate crankshaft pulley clockwise to align timing mark (grooved line without color) with timing indicator.

← : Timing mark (grooved without color)

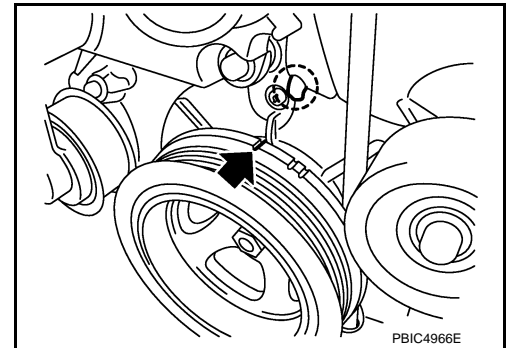

- b. Check that intake and exhaust cam noses on No. 1 cylinder (engine front side of bank 1) are located as shown in the figure.

⇐ : Engine front

- If not, turn crankshaft one revolution (360 degrees) and align as shown in the figure.

NOTE:

When only timing chain (primary) is removed, rocker cover does not need to be removed. To check that No. 1 cylinder is at its compression TDC, remove front timing chain case first. Then check mating marks on camshaft sprockets. Refer to [EM-59](#), "[Component](#)".

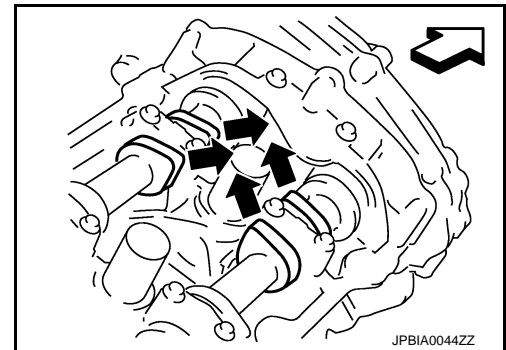

20. Remove crankshaft pulley as follows:

- a. Remove rear cover plate and set ring gear stopper [SST: KV10118600 (J-48641)] (A) as shown in the figure.

1 : Oil pan (upper)

2 : Drive plate

⇐ : Vehicle front

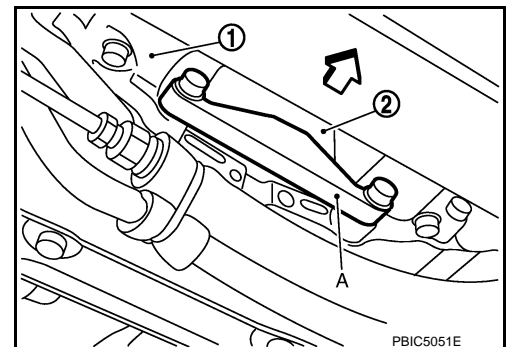

FRONT TIMING CHAIN CASE

[VQ35HR]

< SERVICE INFORMATION >

- b. Loosen crankshaft pulley bolt and locate bolt seating surface as 10 mm (0.39 in) from its original position.

1 : Crankshaft pulley

CAUTION:

Never remove crankshaft pulley bolt as it will be used as a supporting point for suitable puller.

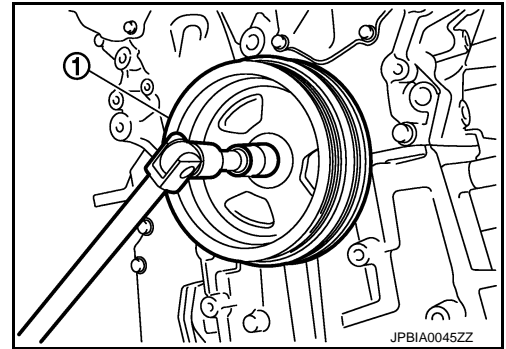

- c. Place suitable puller tab on holes of crankshaft pulley, and pull crankshaft pulley through.

CAUTION:

Never put suitable puller tab on crankshaft pulley periphery, as this will damage internal damper.

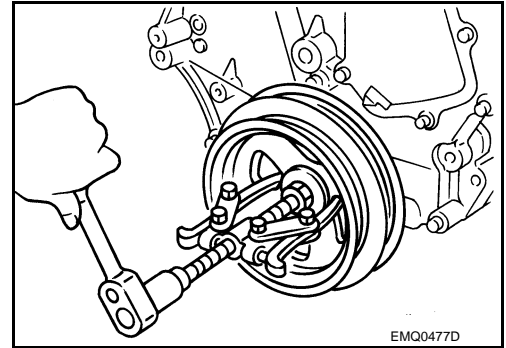

21. Remove oil pan (lower). Refer to [EM-28](#).
 22. Loosen two mounting bolts in front of oil pan (upper) in reverse order as shown in the figure.

← : Engine front

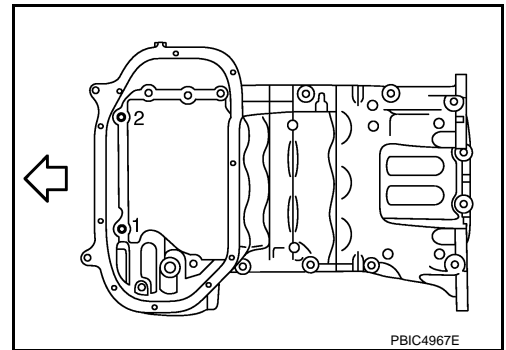

23. Remove front timing chain case as follows:
 a. Loosen mounting bolts in reverse order as shown in the figure.

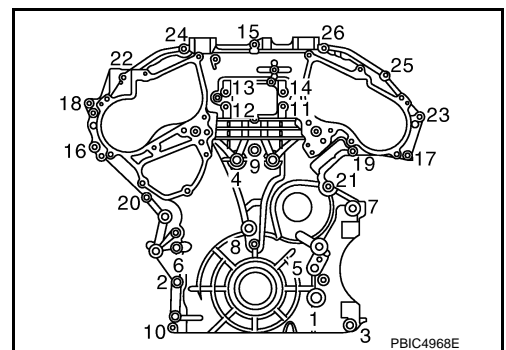

A
EM
C
D
E
F
G
H
I
J
K
L
M
N
O
P

FRONT TIMING CHAIN CASE

[VQ35HR]

< SERVICE INFORMATION >

- b. Insert suitable tool (A) into the notch at the top of the front timing chain case as shown.
- c. Pry off case by moving tool as shown.
- Use seal cutter [SST: KV10111100 (J37228)] to cut liquid gasket for removal.

CAUTION:

- Never use screwdriver or something similar.
- After removal, handle front timing chain case carefully so it never tilt, cant, or warp under a load.

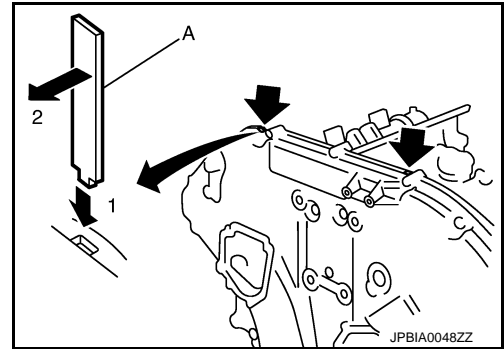

24. Remove O-ring (1) from rear timing chain case.

A : Bank 1

B : Bank 2

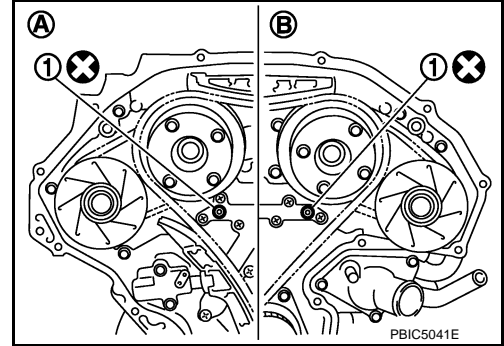

25. Remove front oil seal from front timing chain case using suitable tool.

- Use screwdriver for removal.

CAUTION:

Be careful not to damage front timing chain case.

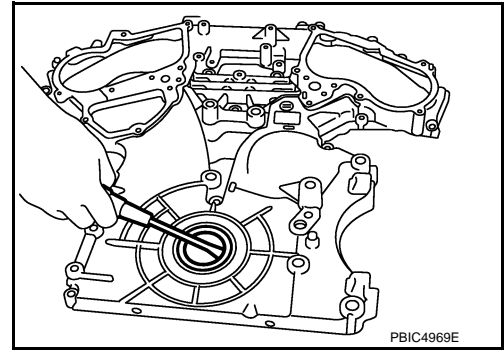

26. Remove timing chain and related parts. Refer to [EM-59](#).
27. Use scraper to remove all traces of old liquid gasket from front and rear timing chain cases and oil pan (upper), and liquid gasket mating surfaces.

CAUTION:

Be careful not to allow gasket fragments to enter oil pan.

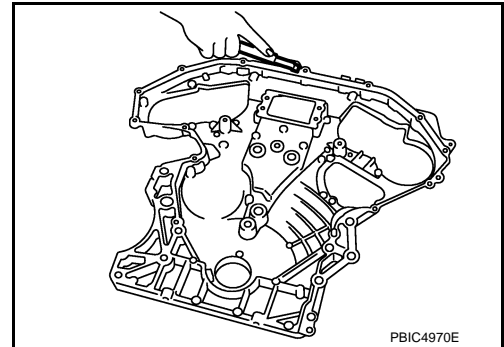

FRONT TIMING CHAIN CASE

[VQ35HR]

< SERVICE INFORMATION >

- Remove old liquid gasket from bolt hole and thread.

- A : Remove sticking old liquid gasket
- B : Bolt hole

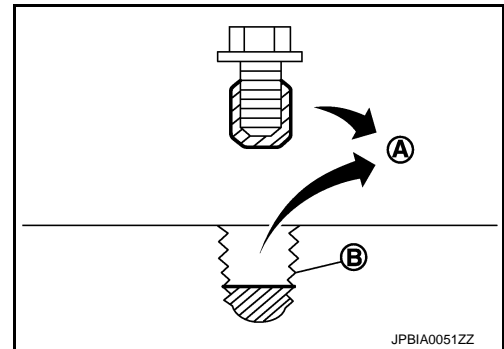

INSTALLATION

- Install timing chain and related parts. Refer to [EM-59](#).
- Install new O-ring (1) on rear timing chain case.

- A : Bank 1
- B : Bank 2

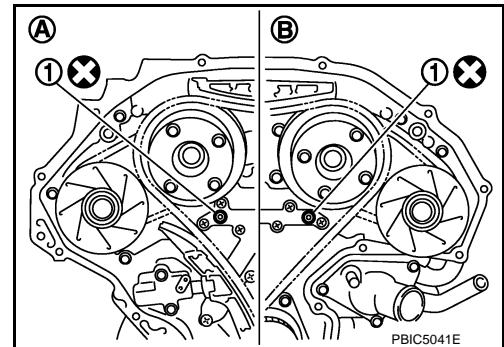

- Hammer dowel pins (right and left) (A) into front timing chain case (1) up to a point close to taper in order to shorten protrusion length.

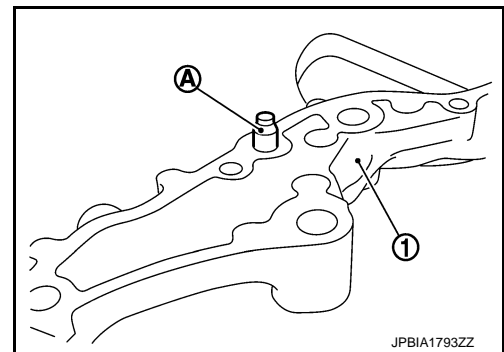

- Install new front oil seal on the front timing chain case.
 - Apply new engine oil to both oil seal lip (A) and dust seal lip (B).

- ↔ : Engine inside
- ← : Engine outside

- Install it so that each seal lip is oriented as shown in the figure.

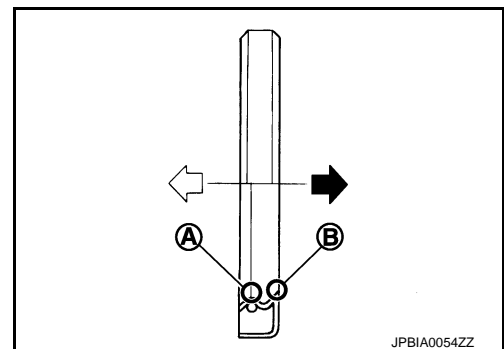

A
EM
C
D
E
F
G
H
I
J
K
L
M
N
O
P

FRONT TIMING CHAIN CASE

[VQ35HR]

< SERVICE INFORMATION >

- Using suitable drift [outer diameter: 60 mm (2.36 in)] (A), press-fit oil seal until it becomes flush with front timing chain case end face.
- Check the garter spring is in position and seal lip is not inverted.

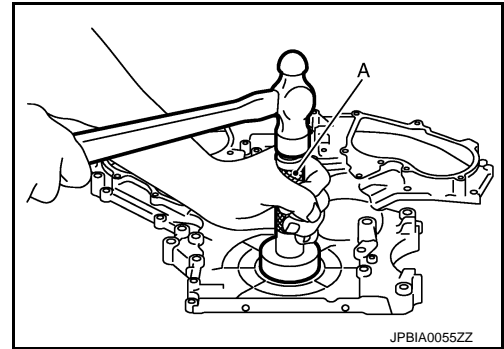

5. Install front timing chain case as follows:

- a. Apply a continuous bead of liquid gasket with tube presser (commercial service tool) to front timing chain case back side as shown in the figure.

B : Protrusion

c : $\phi 3.4 - 4.4$ mm (0.134 - 0.173 in)

d : $\phi 2.6 - 3.6$ mm (0.102 - 0.142 in)

e : 4.0 - 5.6 mm (0.157 - 0.220 in)

Use Genuine RTV Silicone Sealant or equivalent. Refer to [GI-46. "Recommended Chemical Product and Sealant"](#).

NOTE:

Apply liquid gasket, start and end up application at the portions (A) shown in the figure.

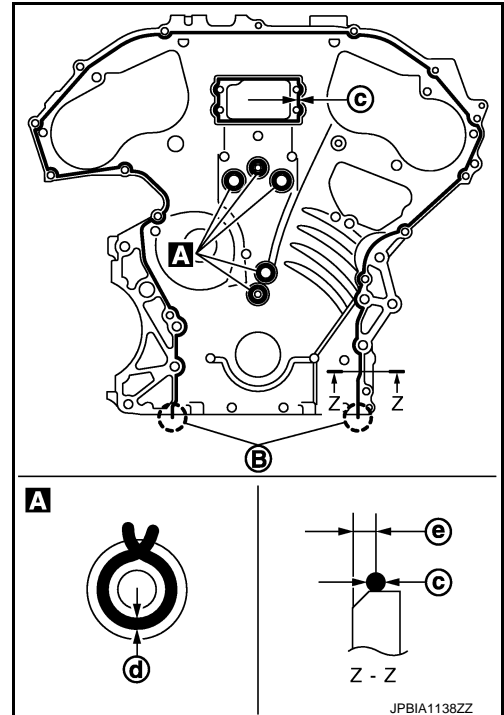

- Apply liquid gasket with tube presser (commercial service tool) to top surface of oil pan (upper) as shown in the figure.

A : $\phi 4.0 - 5.0$ mm (0.157 - 0.197 in)

Use Genuine RTV Silicone Sealant or equivalent. Refer to [GI-46. "Recommended Chemical Product and Sealant"](#).

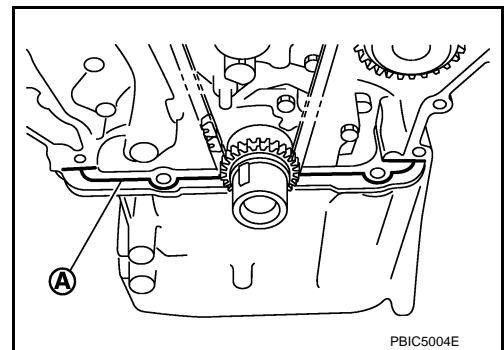

b. Assemble front timing chain case as follows:

FRONT TIMING CHAIN CASE

[VQ35HR]

< SERVICE INFORMATION >

Fit lower end of front timing chain case (1) tightly onto top face of oil pan (upper). From the fitting point, make entire front timing chain case contact rear timing chain case completely.

2 : Oil pan (upper)

3 : Cylinder block

⇐ : Engine front

CAUTION:

- Be careful not to damage front oil seal by interference with front end of crankshaft.
- Attaching should be done within 5 minutes after liquid gasket application.

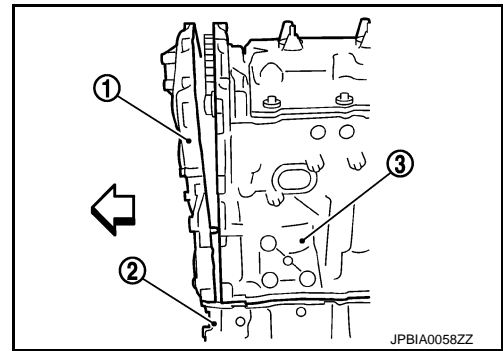

c. Install front timing chain case as to fit its dowel pin hole together dowel pin on rear timing chain case.

d. Tighten mounting bolts to the specified torque in numerical order as shown in the figure.

- There are two types of mounting bolts. Refer to the following for locating bolts.

M10 bolts : 1, 2, 3, 4, 5, 6, 7

: 55.0 N·m (5.6 kg-m, 41 ft-lb)

M6 bolts : Except the above

: 12.7 N·m (1.3 kg-m, 9 ft-lb)

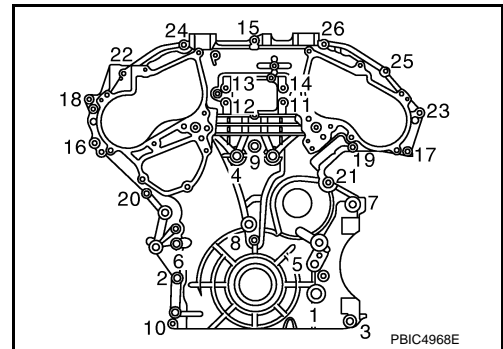

e. After all bolts tightened, retighten them to the specified torque in numerical order as shown in the figure.

6. Install two mounting bolts in front of oil pan (upper) in numerical order as shown in the figure.

⇐ : Engine front

: 17.2 N·m (1.8 kg-m, 13 ft-lb)

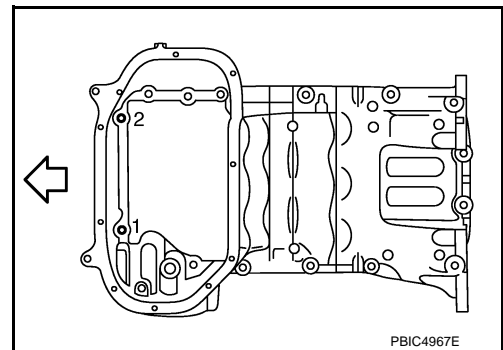

7. Install oil pan (lower). Refer to [EM-28](#).

8. Install right and left valve timing control covers as follows.

a. Install new seal rings (1) in shaft grooves.

A : Bank 2

CAUTION:

When replacing seal ring, replace all rings with new one.

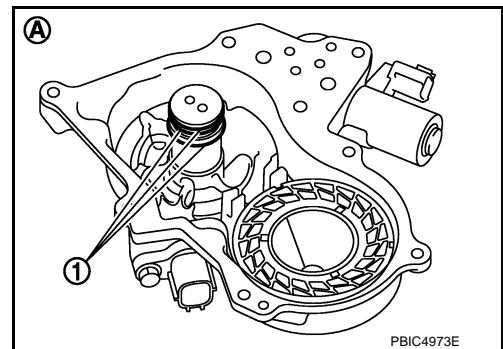

FRONT TIMING CHAIN CASE

[VQ35HR]

< SERVICE INFORMATION >

- b. To check the joint between dowel pins and dowel pin holes, check the looseness in the axle direction by pushing the mating surface of magnet retarder (A) at several places and the circumferential looseness (between dowel pins and dowel pin holes) by twisting in the circumferential direction.

- B : Moves slightly
C : Not shaken

CAUTION:

Always perform this procedure when removing because the gap between dowel pins and dowel pin holes may not be caused on purpose.

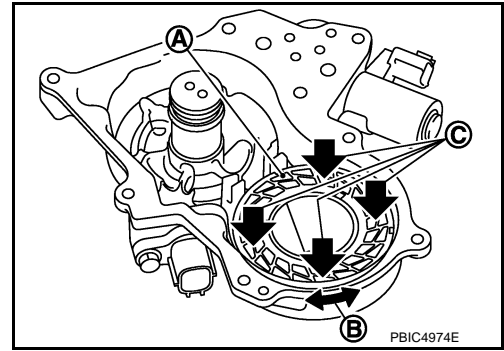

- c. Install valve timing control cover (1) with new gasket to front timing chain case.

- 2 : Magnet retarder

CAUTION:

- Never face the magnet retarder side down to prevent magnet retarder from dropping.
- Check the mating surface of magnet retarder and the drum of exhaust side camshaft sprocket for foreign materials.
- Align the center of both shaft holes of the shaft and the intake side camshaft sprocket, and then insert them.
- Be careful not to drop the seal ring from the shaft groove.
- When setting the valve timing control cover in position by hand, if valve timing control cover is not contacting with the front timing chain case, the dowel pin of magnet retarder may not be aligned with the dowel pin holes of cover. In this case, return to step "b".

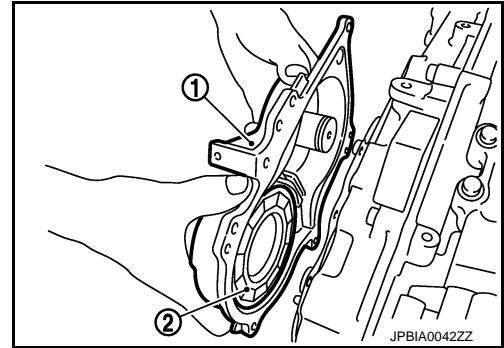

- d. Tighten mounting bolts in numerical order as shown in the figure.

- A : Bank 1
B : Bank 2
C : Dowel pin hole

CAUTION:

Completely tighten the mounting bolts with the seat surface of valve timing control cover contacting with front timing chain case.

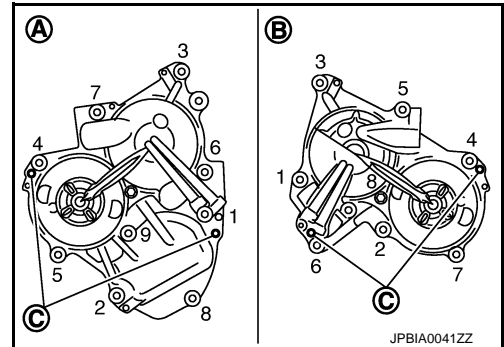

: 11.3 N·m (1.2 kg-m, 8 ft-lb)

- After all bolt are tightened, tighten No. 1 bolt to the specified torque again.

9. Install crankshaft pulley as follows:

- Fix crankshaft using ring gear stopper [SST: KV10118600 (J-48641)].
- Install crankshaft pulley, taking care not to damage front oil seal.
 - When press-fitting crankshaft pulley with plastic hammer, tap on its center portion (not circumference).

- c. Tighten crankshaft pulley bolt.

: 44.1 N·m (4.5 kg-m, 33 ft-lb)

FRONT TIMING CHAIN CASE

[VQ35HR]

< SERVICE INFORMATION >

- d. Tighten the bolt 90 degrees (one mark) (b).
- Place a matching mark (A) on crankshaft pulley (2) aligning with the matching (C) of crankshaft pulley bolt (1).

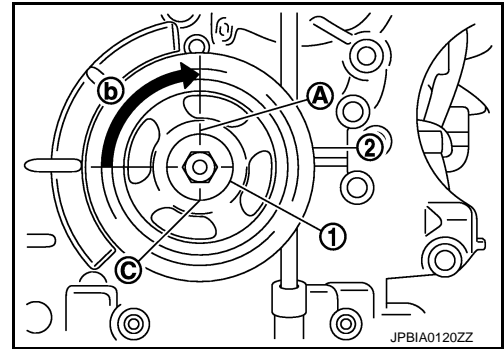

- e. Rotate crankshaft pulley in normal direction (clockwise when viewed from front) to confirm it turns smoothly.

10. Install power steering oil pump bracket and idler pulley bracket as follows:

- a. Tighten mounting bolts in numerical order as shown in the figure. (temporarily)

- 1 : Idler pulley bracket
- 2 : Power steering oil pump bracket
- 3 : Crankshaft pulley
- A : Engine front side
- B : Engine right side
- ↔ : Engine front

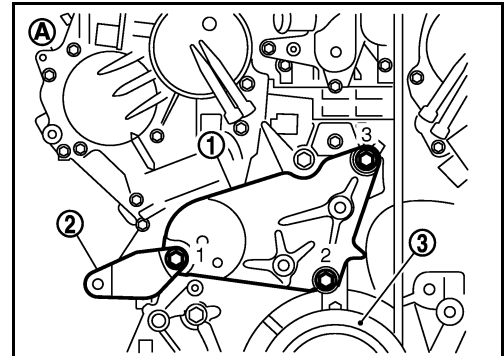

- b. Tighten mounting bolts to specified torque in numerical order as shown in the figure.

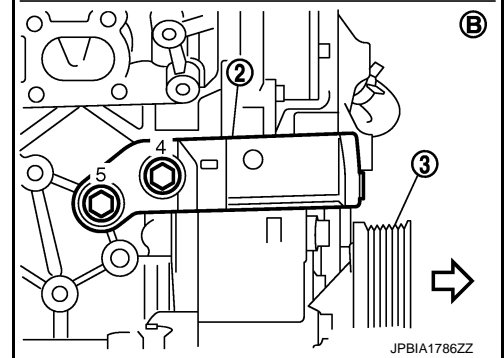

11. For the following operations, perform steps in the reverse order of removal.

INSPECTION AFTER INSTALLATION

Inspection for Leakage

The following are procedures for checking fluid leakage, lubricates leakage, and exhaust gases leakage.

- Before starting engine, check oil/fluid levels including engine coolant and engine oil. If less than required quantity, fill to the specified level. Refer to [MA-9. "Fluids and Lubricants"](#).
- Run engine to check for unusual noise and vibration.

NOTE:

If hydraulic pressure inside timing chain tensioner drops after removal/installation, slack in the guide may generate a pounding noise during and just after engine start. However, this is normal. Noise will stop after hydraulic pressure rises.

- Warm up engine thoroughly to check there is no leakage of exhaust gases, or any oil/fluids including engine oil and engine coolant.
- Bleed air from lines and hoses of applicable lines, such as in cooling system.
- After cooling down engine, again check oil/fluid levels including engine oil and engine coolant. Refill to the specified level, if necessary.

FRONT TIMING CHAIN CASE

< SERVICE INFORMATION >

[VQ35HR]

Summary of the inspection items:

Items	Before starting engine	Engine running	After engine stopped
Engine coolant	Level	Leakage	Level
Engine oil	Level	Leakage	Level
Other oils and fluid*	Level	Leakage	Level

*: Transmission/transaxle/CVT fluid, power steering fluid, brake fluid, etc.

TIMING CHAIN

< SERVICE INFORMATION >

[VQ35HR]

TIMING CHAIN

Component

INFOID:000000005347993

A

EM

C

D

E

F

G

H

I

J

K

L

M

N

O

P

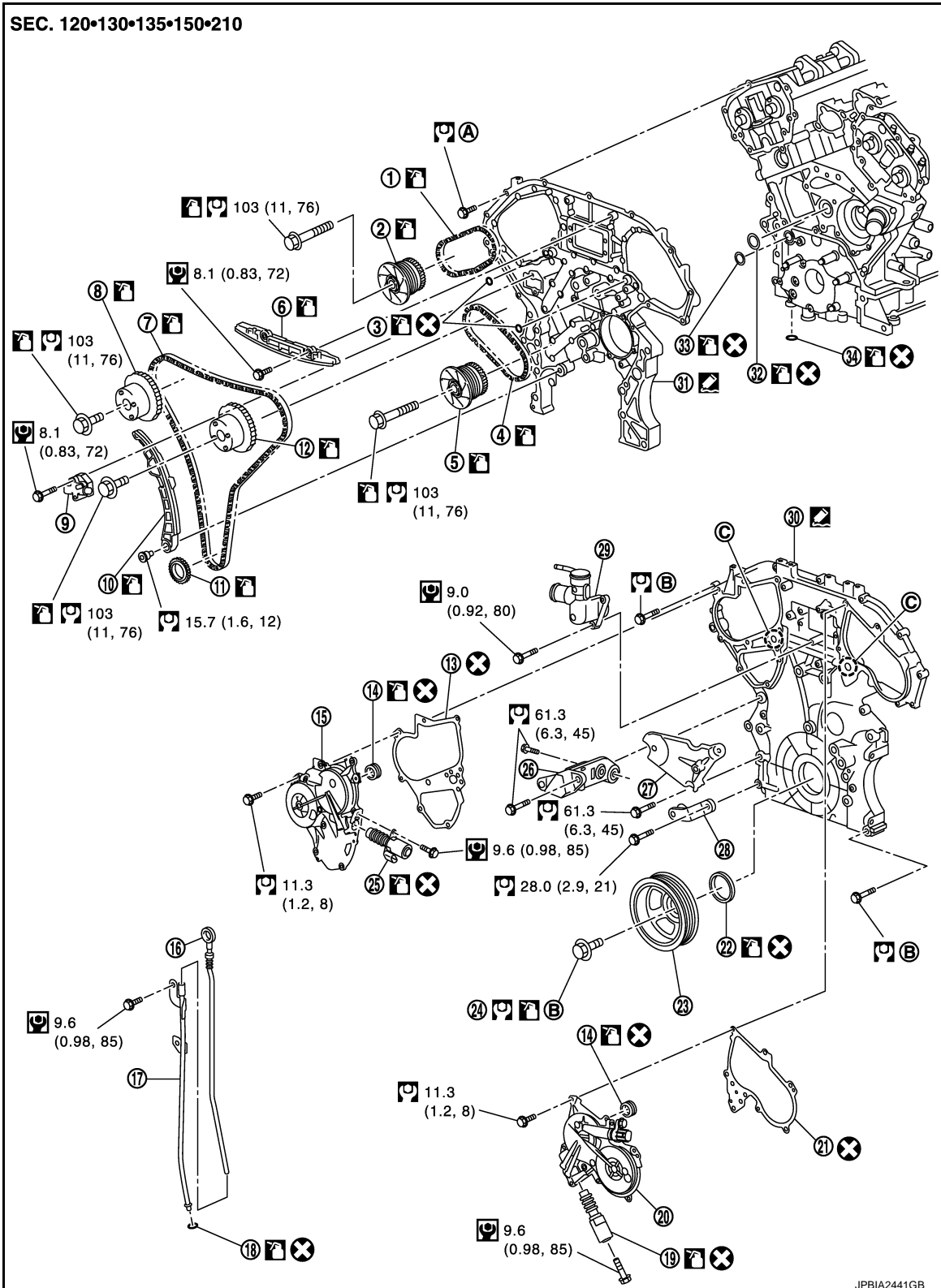

JPBIA2441GB

- | | | |
|-----------------------------|----------------------------|-------------------------------------|
| 1. Timing chain (secondary) | 2. Camshaft sprocket (EXH) | 3. O-ring |
| 4. Timing chain (secondary) | 5. Camshaft sprocket (EXH) | 6. Internal chain guide |
| 7. Timing chain (primary) | 8. Camshaft sprocket (INT) | 9. Timing chain tensioner (primary) |

TIMING CHAIN

[VQ35HR]

< SERVICE INFORMATION >

- | | | |
|---|---|--|
| 10. Slack guide | 11. Crankshaft sprocket | 12. Camshaft sprocket (INT) |
| 13. Valve timing control cover gasket (bank 1) | 14. Seal ring | 15. Valve timing control cover (bank 1) |
| 16. Oil level gauge | 17. Oil level gauge guide | 18. O-ring |
| 19. Intake valve timing control solenoid valve (bank 2) | 20. Valve timing control cover (bank 2) | 21. Valve timing control cover gasket (bank 2) |
| 22. Front oil seal | 23. Crankshaft pulley | 24. Crankshaft pulley bolt |
| 25. Intake valve timing control solenoid valve (bank 1) | 26. Power steering oil pump bracket | 27. Idler pulley bracket |
| 28. Alternator bracket | 29. Water outlet (front) | 30. Front timing chain case |
| 31. Rear timing chain case | 32. O-ring | 33. O-ring |
| 34. O-ring | | |
| A. Refer to EM-60 | B. Refer to EM-49 | C. Oil filter |

- Refer to [GI-9, "Component"](#) for symbols in the figure.

Removal and Installation

INFOID:000000005347994

NOTE:

- This section describes procedures for removing/installing front timing chain case and timing chain related parts, and rear timing chain case, when oil pan (upper) needs to be removed/installed for engine overhaul, etc.
- To remove/install front timing chain case, timing chain, and its related parts without removing oil pan (upper), refer to [EM-49](#).

REMOVAL

1. Remove engine assembly from the vehicle, and separate front suspension member and transmission from engine. Refer to [EM-108, "2WD : Component"](#) (2WD models) or [EM-113, "AWD : Component"](#) (AWD models).
2. Lift the engine with hoist and mount it onto widely use engine stand. Refer to [EM-120, "Disassembly and Assembly"](#).
3. Remove intake manifold collector. Refer to [EM-19](#).
4. Remove power steering oil pump bracket. Refer to [EM-59, "Component"](#).
5. Remove alternator. Refer to [SC-29, "Removal and Installation"](#).
6. Remove water bypass hose, water hose clamp and idler pulley bracket from front timing chain case.
7. Remove left and right valve timing control covers (including magnet retarder and cover) with the following procedure.
 - a. Loosen mounting bolts in reverse order as shown in the figure.

- A : Bank 1
B : Bank 2
C : Dowel pin hole

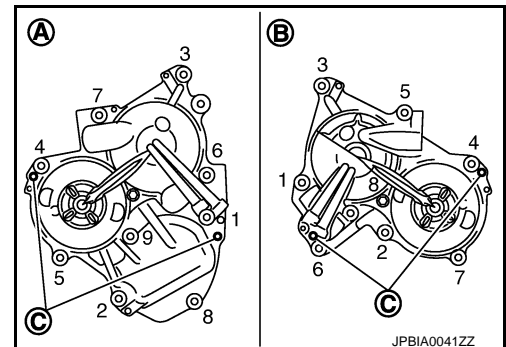

TIMING CHAIN

[VQ35HR]

< SERVICE INFORMATION >

- b. Shaft is engaged with intake side camshaft sprocket center hole on inside. Pull straight out so as not to tilt until the joint is disengaged.
- The mating surface of magnet retarder (2) may be fitted with the exhaust side camshaft sprocket via the engine oil. Open valve timing control cover (1) carefully.
 - If the mating surface of magnet retarder is fitted with the camshaft sprocket, open the cover within the range that the load is not applied to the harness. And then, remove it so as to prevent magnet retarder from dropping.

CAUTION:

- **Be careful not to damage magnet retarder.**
- **When carrying valve timing control cover, face the magnet retarder side up to prevent the cover from falling from magnet retarder.**
- **Never remove magnet retarder from valve timing control cover. (Disassembly prohibited parts)**

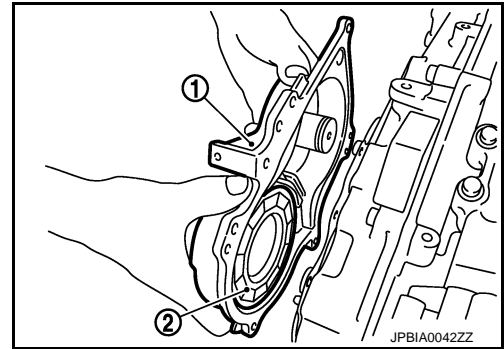

8. Remove rocker covers (bank 1 and bank 2). Refer to [EM-46](#).
9. Obtain No. 1 cylinder at TDC of its compression stroke as follows:
- a. Rotate crankshaft pulley clockwise to align timing mark (grooved line without color) with timing indicator.

← : Timing mark (grooved line without color)

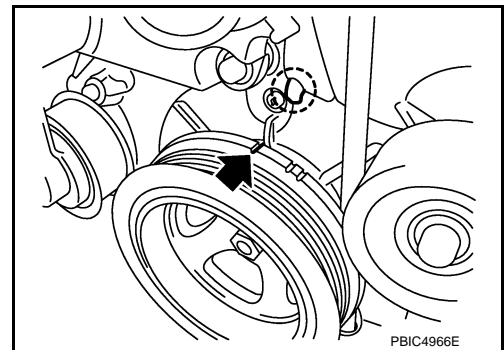

- b. Check that intake and exhaust cam noses on No. 1 cylinder (engine front side of bank 1) are located as shown in the figure.

⇐ : Engine front

- If not, turn crankshaft one revolution (360 degrees) and align as shown in the figure.

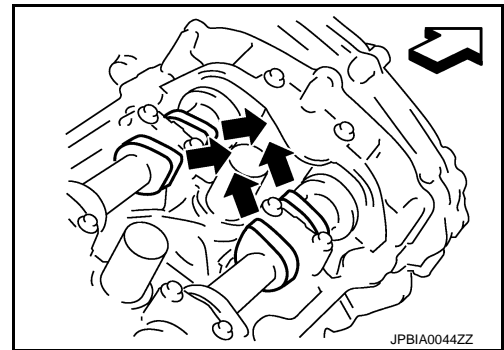

10. Remove crankshaft pulley as follows:

- a. Remove rear cover plate and set ring gear stopper [SST: KV10118600 (J-48641)] (A) as shown in the figure.

- 1 : Oil pan
- 2 : Drive plate
- ⇐ : Vehicle front

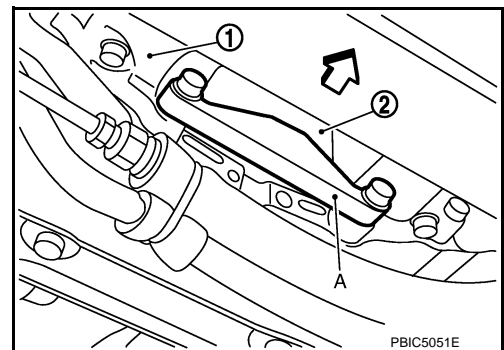

A
EM
C
D
E
F
G
H
I
J
K
L
M
N
O
P

TIMING CHAIN

[VQ35HR]

< SERVICE INFORMATION >

- b. Loosen crankshaft pulley bolt and rotate bolt seating surface at 10 mm (0.39 in) from its original position.

1 : Crankshaft pulley

CAUTION:

Never remove crankshaft pulley bolt as it will be used as a supporting point for suitable puller.

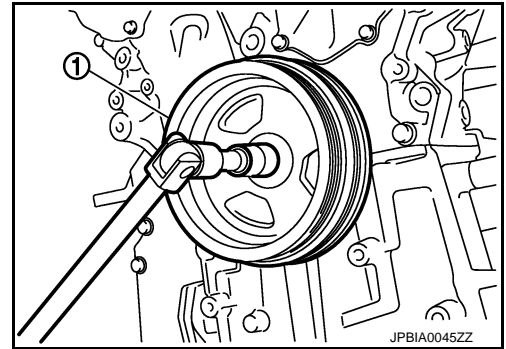

- c. Place suitable puller tab on holes of crankshaft pulley, and pull crankshaft pulley through.

CAUTION:

Never put suitable puller tab on crankshaft pulley periphery, as this will damage internal damper.

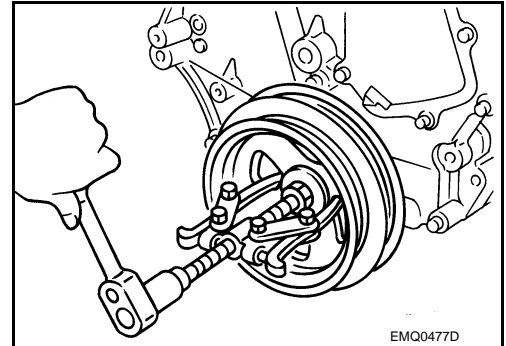

11. Remove oil pans (upper and lower). Refer to [EM-28](#).

12. Remove front timing chain case as follows:

- a. Loosen mounting bolts in reverse order as shown in the figure.

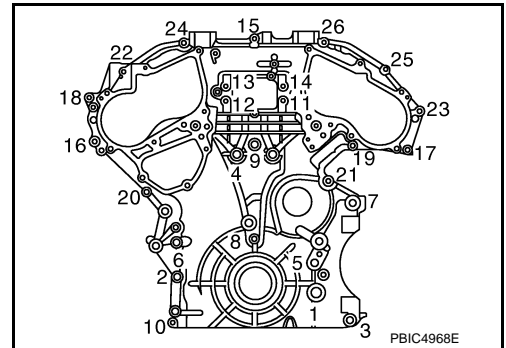

- b. Insert suitable tool (A) into the notch at the top of the front timing chain case as shown.

- c. Pry off case by moving the tool as shown.

- Use seal cutter [SST: KV10111100 (J37228)] to cut liquid gasket for removal.

CAUTION:

- Never use screwdriver or something similar.
- After removal, handle front timing chain case carefully so it never tilt, cant, or warp under a load.

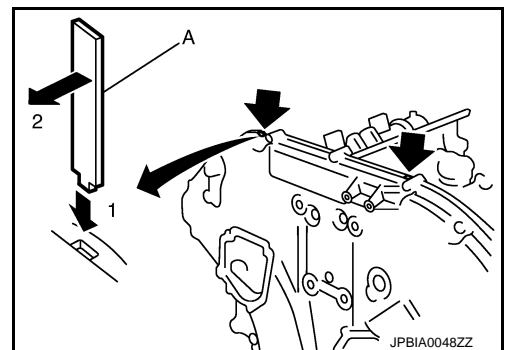

TIMING CHAIN

< SERVICE INFORMATION >

[VQ35HR]

13. Remove O-ring (1) from rear timing chain case.

- A : Bank 1
- B : Bank 2

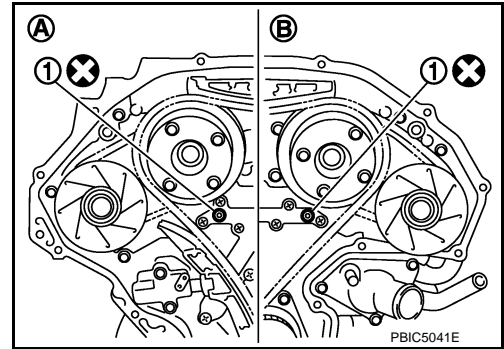

14. Remove front oil seal from front timing chain case using suitable tool.

- Use screwdriver for removal.

CAUTION:

Be careful not to damage front timing chain case.

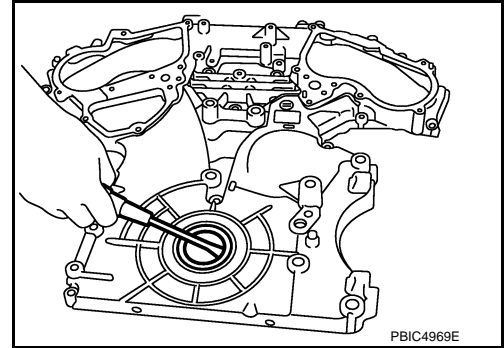

15. Remove timing chain tensioner (primary) as follows:

- a. Remove lower mounting bolt (A).
- b. Loosen upper mounting bolt (B) slowly, and then turn timing chain tensioner (primary) (1) on the mounting bolt so that plunger (C) is fully expanded.

NOTE:

Even if plunger is fully expanded, it is not dropped from the body of timing chain tensioner (primary).

- c. Remove upper mounting bolt, and then remove timing chain tensioner (primary).

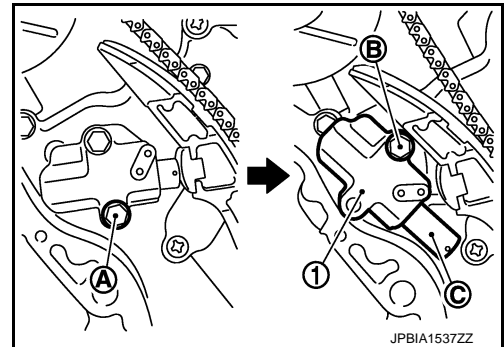

A
EM
C
D
E
F
G
H
I
J
K
L
M
N
O
P

TIMING CHAIN

< SERVICE INFORMATION >

[VQ35HR]

16. Remove internal chain guide (1) and slack guide (2).

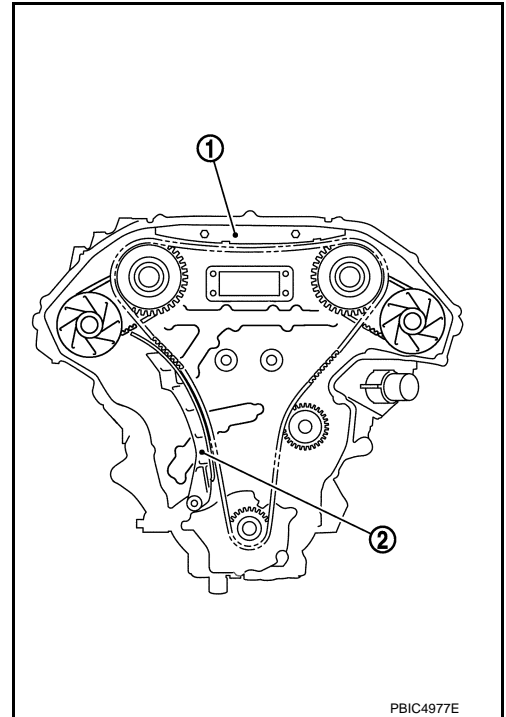

17. Remove timing chain (primary) and crankshaft sprocket.

CAUTION:

After removing timing chain (primary), never turn crankshaft and camshaft separately, or valves will strike the piston heads.

18. Remove timing chain (secondary) and camshaft sprockets as follows:

- a. Attach suitable stopper pin (2) to the right and left timing chain tensioners (secondary) (1).

- A : Bank 1
B : Bank 2

NOTE:

- Use approximately 0.5 mm (0.020 in) dia. hard metal pin as a stopper pin.
- For removal of timing chain tensioner (secondary), refer to [EM-79](#). [Removing camshaft bracket (No. 1) is required.]

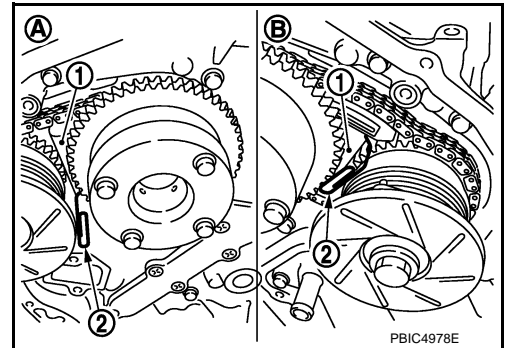

- b. Remove intake and exhaust camshaft sprocket bolts.
- Secure the hexagonal portion of camshaft using wrench to loosen mounting bolts.

CAUTION:

Never loosen mounting bolts with securing anything other than the camshaft hexagonal portion or with tensioning the timing chain.

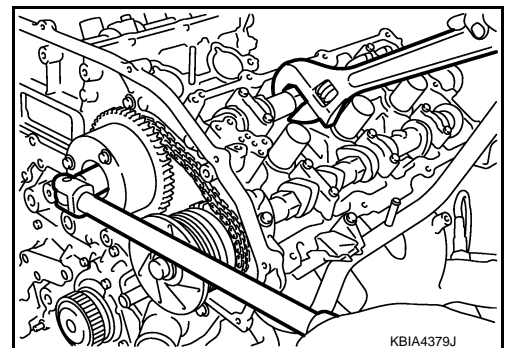

- c. Remove timing chain (secondary) together with camshaft sprockets.

CAUTION:

- Handle carefully to avoid any shock to camshaft sprocket.

TIMING CHAIN

[VQ35HR]

< SERVICE INFORMATION >

- **Never disassemble.** [Never loosen bolts (A) and (B) as shown in the figure.]

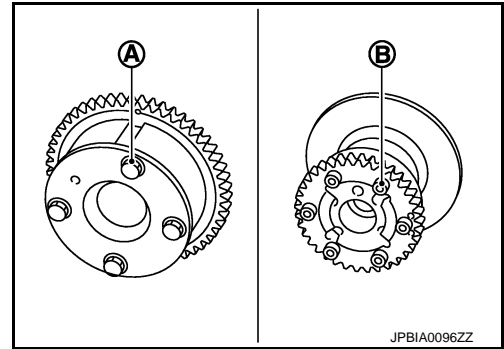

A

EM

C

D

19. Remove water pump. Refer to [CO-23. "Component"](#).
20. Remove rear timing chain case as follows:
 - a. Loosen and remove mounting bolts in reverse order as shown in the figure.
 - b. Cut liquid gasket using seal cutter [SST: KV10111100 (J37228)] and remove rear timing chain case.

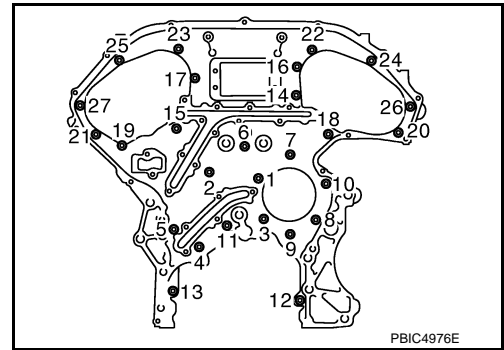

E

F

G

H

CAUTION:

- **Never remove plate metal cover (1) of oil passage.**
- **After removal, handle rear timing chain case carefully so it never tilt, cant, or warp under a load.**

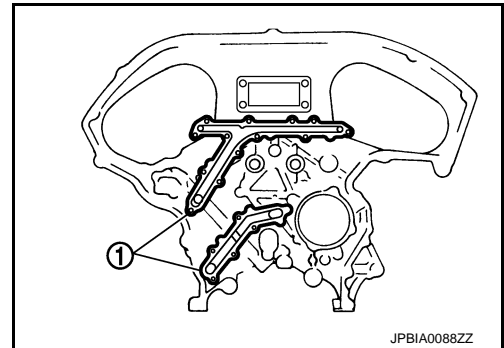

I

J

K

L

21. Remove O-rings (1) from cylinder block.

← : Engine front

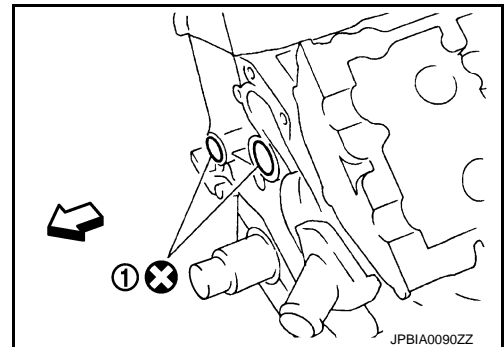

M

N

O

22. Remove timing chain tensioners (secondary) from cylinder head as follows, if necessary.
 - a. Remove camshaft brackets (No. 1). Refer to [EM-79. "Removal and Installation"](#).

P

TIMING CHAIN

[VQ35HR]

< SERVICE INFORMATION >

- b. Remove timing chain tensioners (secondary) with stopper pin (A) attached.

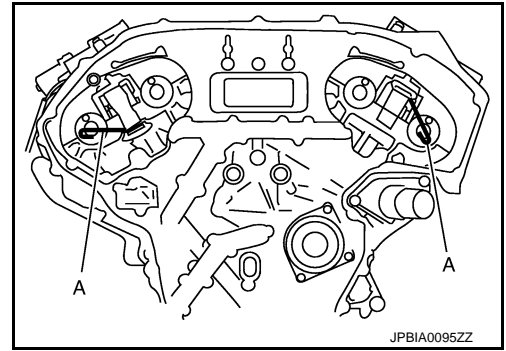

23. Use scraper to remove all traces of old liquid gasket from front and rear timing chain cases, and opposite mating surfaces.

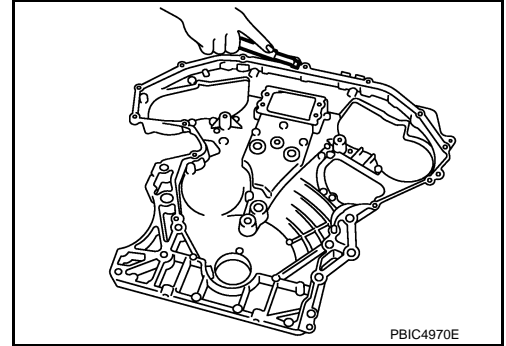

- Remove old liquid gasket from bolt hole and thread.

- A : Remove sticking old liquid gasket
B : Bolt hole

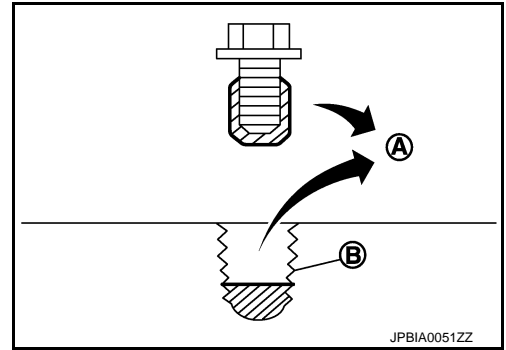

INSPECTION AFTER REMOVAL

Timing Chain

Check for cracks (A) and any excessive wear (B) at link plates and roller links of timing chain. Replace timing chain if necessary.

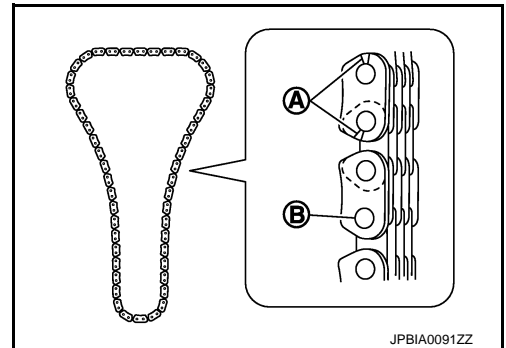

INSTALLATION

NOTE:

- The below figure shows the relationship between the mating mark on each timing chain and that on the corresponding sprocket, with the components installed.

TIMING CHAIN

< SERVICE INFORMATION >

[VQ35HR]

- In this figure, the drum of exhaust side camshaft sprocket has been omitted.

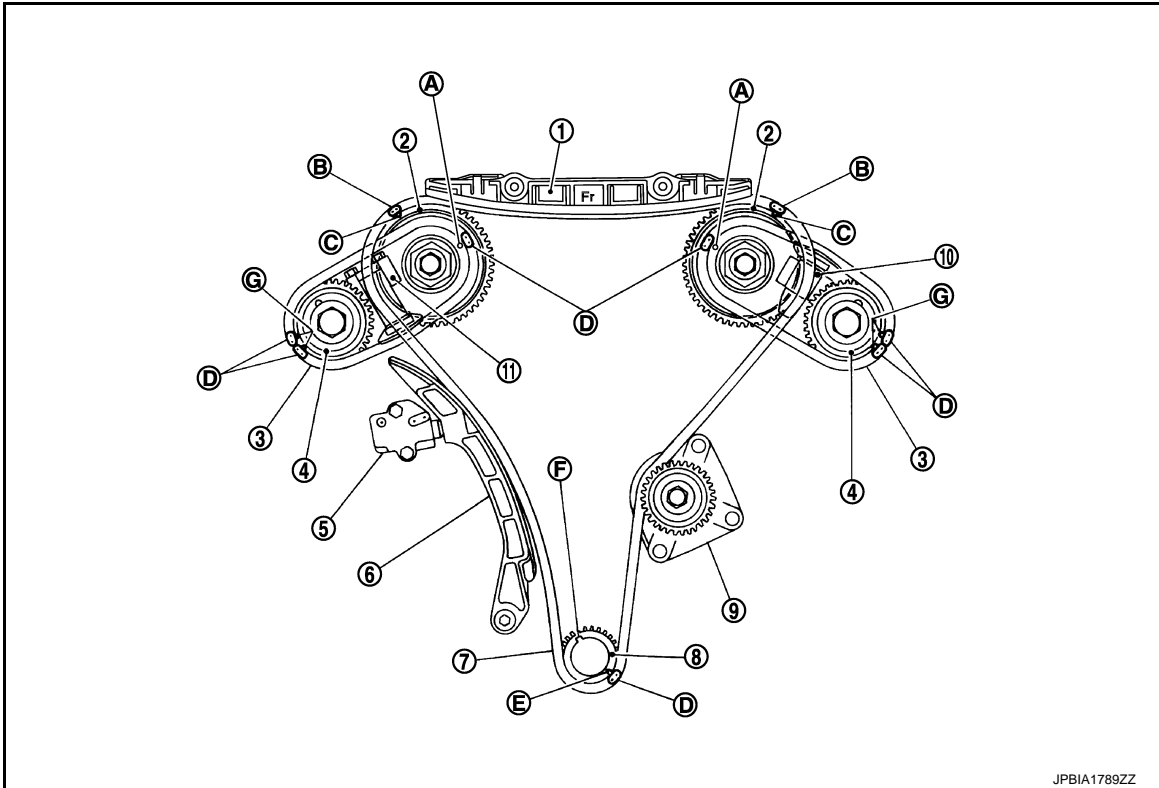

- | | | |
|---|---|-----------------------------|
| 1. Internal chain guide | 2. Camshaft sprocket (INT) | 3. Timing chain (secondary) |
| 4. Camshaft sprocket (EXH) | 5. Timing chain tensioner (primary) | 6. Slack guide |
| 7. Timing chain (primary) | 8. Crankshaft sprocket | 9. Water pump |
| 10. Timing chain tensioner (secondary) (bank 2) | 11. Timing chain tensioner (secondary) (bank 1) | |
| A. Mating mark [punched (back side)] | B. Mating mark (colored link) | C. Mating mark (punched) |
| D. Mating mark (colored link) | E. Mating mark (notched) | F. Crankshaft key |

- Install timing chain tensioners (secondary) to cylinder head as follows if removed. Refer to [EM-79, "Removal and Installation"](#).
 - Install timing chain tensioners (secondary) with stopper pin attached and new O-ring.
 - Install camshaft brackets (No. 1). Refer to [EM-79, "Removal and Installation"](#).
- Measure difference in levels between front end faces of camshaft bracket (No. 1) and cylinder head.

Standard : -0.14 to 0.14 mm (-0.0055 to 0.0055 in)

- Measure two positions (Both intake and exhaust side) for a single bank.
- If the measured value is out of the standard, reinstall camshaft bracket (No. 1).

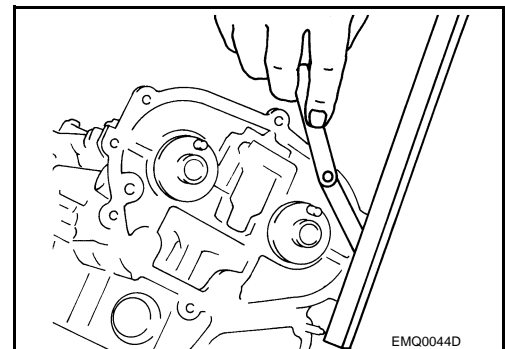

- Install rear timing chain case as follows:

TIMING CHAIN

[VQ35HR]

< SERVICE INFORMATION >

a. Install new O-rings (1) onto cylinder block.

↶ : Engine front

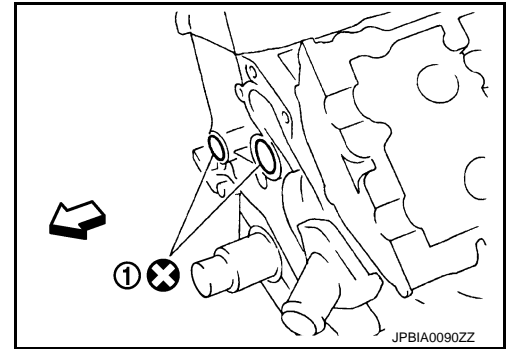

b. Apply liquid gasket with tube presser (commercial service tool) to rear timing chain case back side as shown in the figure.

Use Genuine RTV Silicone Sealant or equivalent. Refer to [GI-46, "Recommended Chemical Product and Sealant"](#).

CAUTION:

- For "A" in the figure, completely wipe out liquid gasket extended on a portion touching at engine coolant.
- Apply liquid gasket on installation position of water pump and cylinder head very completely.

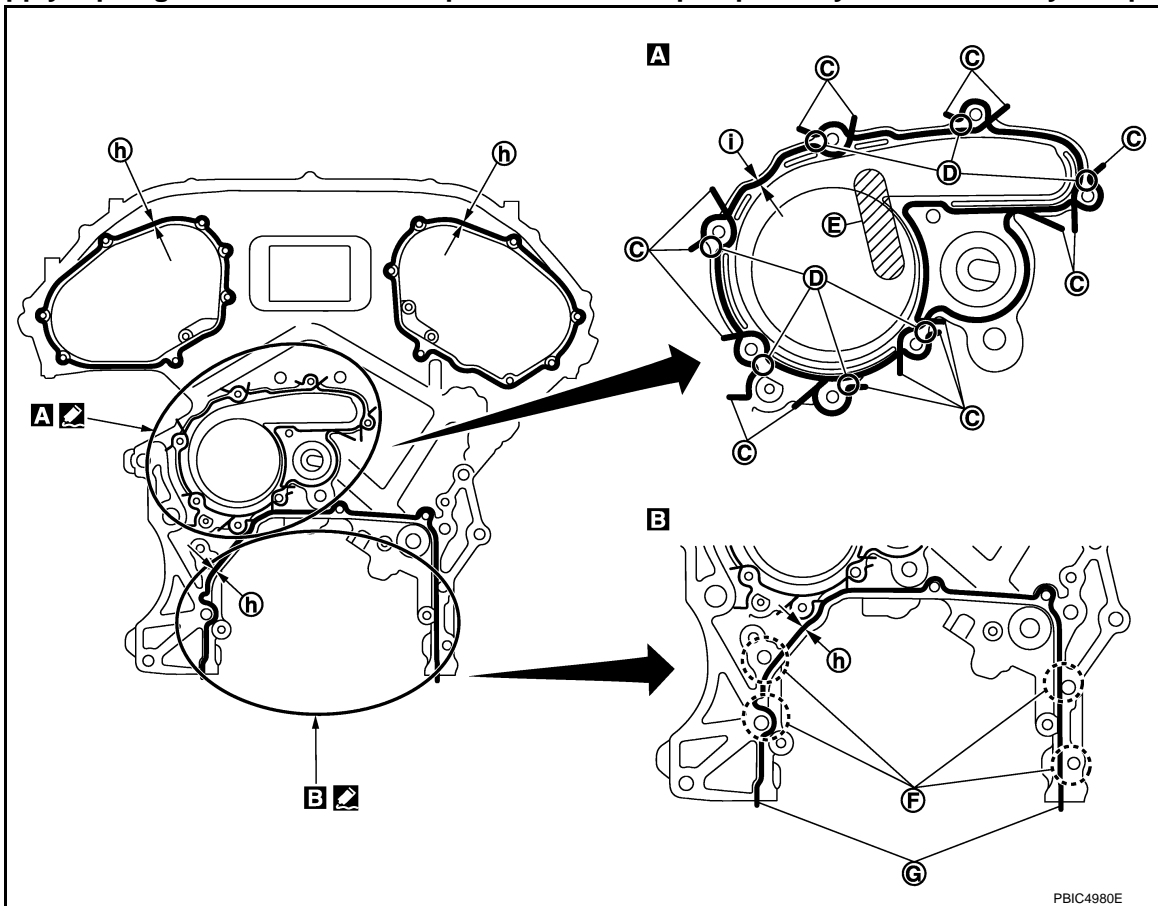

- | | | |
|-----------------------------------|---|---------------------------------|
| C. Protrusion | D. Clearance 1 mm (0.04 in) | E. Do not protrude in this area |
| F. Run along bolt hole inner side | G. Protrusions at beginning and end of gasket | |
| h. ϕ 3.9 mm (0.154 in) | i. ϕ 2.7 mm (0.106 in) | |

• Refer to [GI-9, "Component"](#) for symbols in the figure.

c. Align rear timing chain case and water pump assembly with dowel pins (right and left) on cylinder block and install rear timing chain case.

- Check O-rings stay in place during installation to cylinder block.

TIMING CHAIN

[VQ35HR]

< SERVICE INFORMATION >

- d. Tighten mounting bolts in numerical order as shown in the figure.
- There are two types of mounting bolts. Refer to the following for locating bolts.

Bolt length:	Bolt position
20 mm (0.79 in)	: 1, 2, 3, 6, 7, 8, 9, 10
16 mm (0.63 in)	: 4, 5, 11, 12, 13

: 12.7 N·m (1.3 kg·m, 9 ft·lb)

16 mm (0.63 in) : Except the above

: 15.0 N·m (1.5 kg·m, 11 ft·lb)

- e. After all bolts are tightened, retighten them to the specified in numerical order shown in the figure.
- If liquid gasket protrudes, wipe it off immediately.

- f. After installing rear timing chain case, check the surface height difference between following parts on oil pan (upper) mounting surface.

- 1 : Rear timing chain case
2 : Lower cylinder block

Standard

Rear timing chain case to cylinder block:
-0.24 to 0.14 mm (-0.0094 to 0.0055 in)

- If not within standard, repeat the installation procedure.

4. Install water pump with new O-rings. Refer to [CO-23. "Component"](#).
5. Check that dowel pin (A) and crankshaft key (1) are located as shown in the figure. (No. 1 cylinder at compression TDC)

NOTE:

Though camshaft does not stop at the position as shown in the figure, for the placement of cam nose, it is generally accepted camshaft is placed for the same direction of the figure.

Camshaft dowel pin

: At cylinder head upper face side in each bank.

Crankshaft key

: At cylinder head side of bank 1.

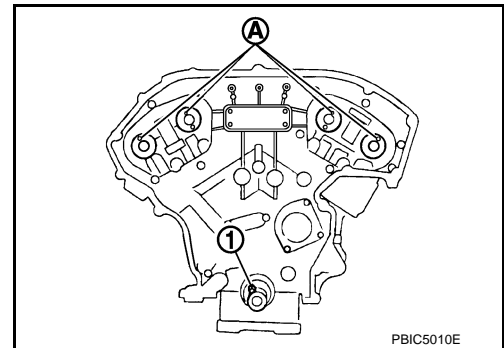
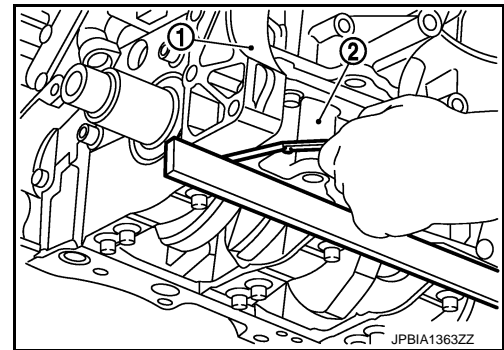
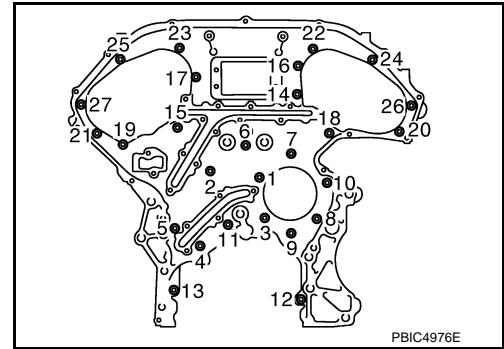

6. Install timing chains (secondary) and camshaft sprockets as follows:

CAUTION:

- When replacing camshaft sprocket (EXH), replace valve timing control cover (including magnet retarder and cover).
- Mating marks between timing chain and sprockets slip easily. Confirm all mating mark positions repeatedly during the installation process.

A
EM
C
D
E
F
G
H
I
J
K
L
M
N
O
P

TIMING CHAIN

[VQ35HR]

< SERVICE INFORMATION >

- a. Push plunger of timing chain tensioner (secondary) and keep it pressed in with stopper pin (A).

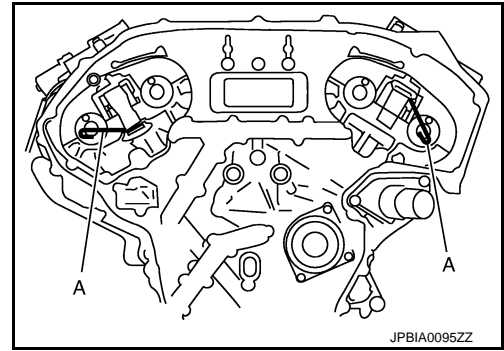

- b. Install timing chains (secondary) and camshaft sprockets.

NOTE:

Figure shows bank 1 (rear view).

- A : Camshaft sprocket (INT) back face
- B : Colored link
- C : Mating mark (circle)
- D : Mating mark (oval)
- E : Dowel groove
- F : Mating mark (2 oval)
- G : Camshaft sprocket (EXH) back face
- H : Mating mark (2 circle)
- I : Dowel pin hole
- J : Timing chain (secondary)

- Align the mating marks on timing chain (secondary) (orange link) with the ones on intake and exhaust camshaft sprockets (punched), and install them.

NOTE:

- Mating marks for intake camshaft sprocket are on the back side of camshaft sprocket (secondary).
- There are two types of mating marks, circle and oval types. They should be used for the bank 1 and bank 2, respectively.

Bank 1 : Use circle type

Bank 2 : Use oval type

- Align dowel pin hole on the small diameter side of the camshaft front end with dowel pin on the back side of camshaft sprockets, and install them.
- In case that positions of each mating mark and each dowel pin are not fit on mating parts, make fine adjustment to the position holding the hexagonal portion on camshaft with wrench or equivalent.
- Mounting bolts for camshaft sprockets must be tightened in the step "d". Tightening them by hand is enough to prevent the dislocation of dowel pins.

- c. Check that timing chain (secondary) is not loose from each camshaft sprocket.

- Check the mating marks (punched) (D) on each camshaft sprocket are positioned on the mating marks (orange link) (C) on timing chain (secondary).

- A : Intake side
- B : Exhaust side

NOTE:

Mating mark (punched) in the figure is for checking loose at this step.

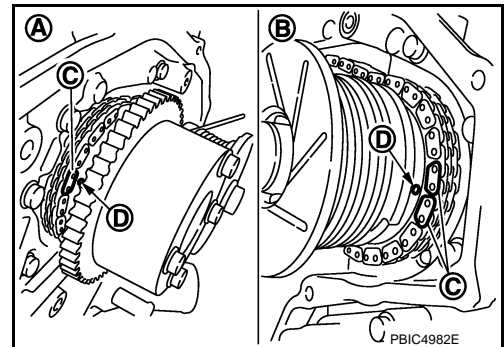
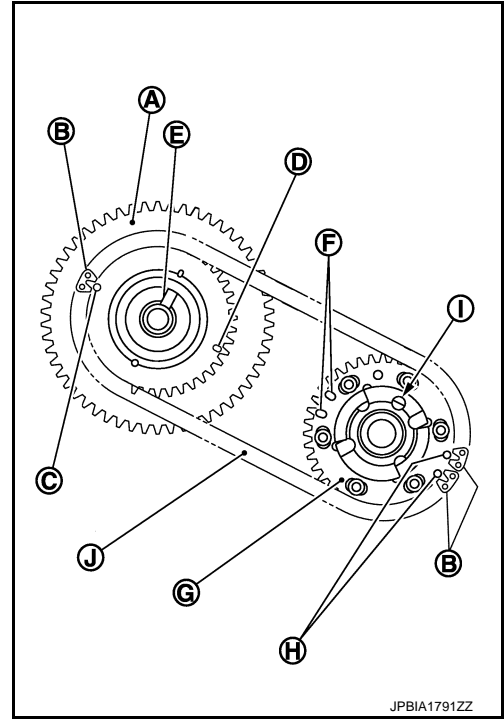

- d. Tighten camshaft sprocket mounting bolts.

TIMING CHAIN

[VQ35HR]

< SERVICE INFORMATION >

- Secure camshaft using wrench at the hexagonal portion to tighten mounting bolts.

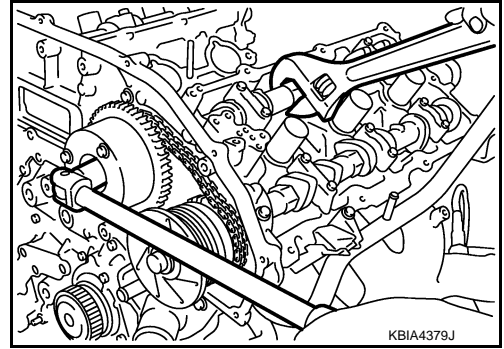

- e. Pull stopper pins (2) out from timing chain tensioners (secondary) (1).

- A : Bank 1
B : Bank 2

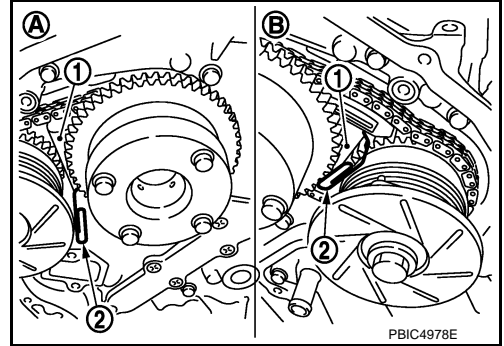

7. Install timing chain (primary) as follows:

- a. Install crankshaft sprocket (1).

- A : Crankshaft side
B : Engine front
C : Mating mark (Front side)

- Check the mating marks on crankshaft sprocket face the front of engine.

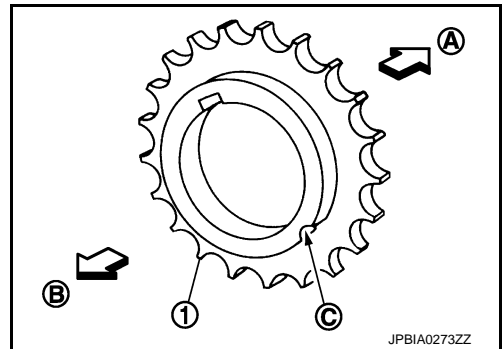

- b. Install timing chain (primary).

A
EM
C
D
E
F
G
H
I
J
K
L
M
N
O
P

TIMING CHAIN

[VQ35HR]

< SERVICE INFORMATION >

- Install timing chain (primary) so the mating mark (punched) (B) on camshaft sprocket (INT) (1) is aligned with the yellow link (A) on timing chain, while the mating mark (notched) (C) on crankshaft sprocket (2) is aligned with the orange link (D) on timing chain, as shown in the figure.

3 : Water pump

- When it is difficult to align mating marks of timing chain (primary) with each sprocket, gradually turn camshaft using wrench on the hexagonal portion to align it with the mating marks.
- During alignment, be careful to prevent dislocation of mating mark alignments of timing chains (secondary).

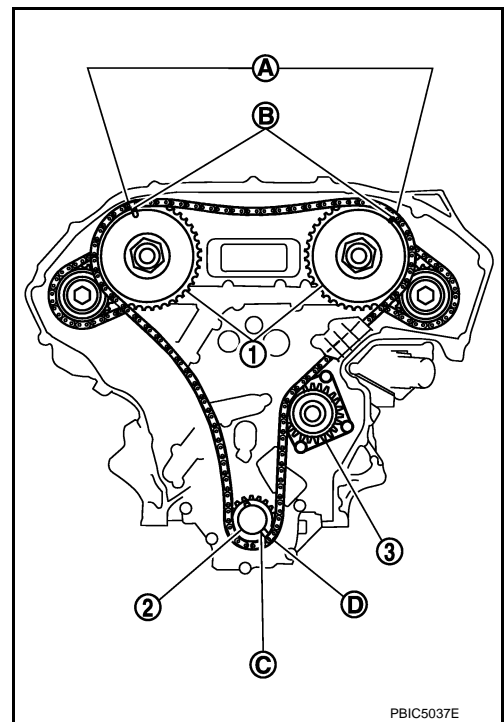

8. Install internal chain guide (1) and slack guide (2).

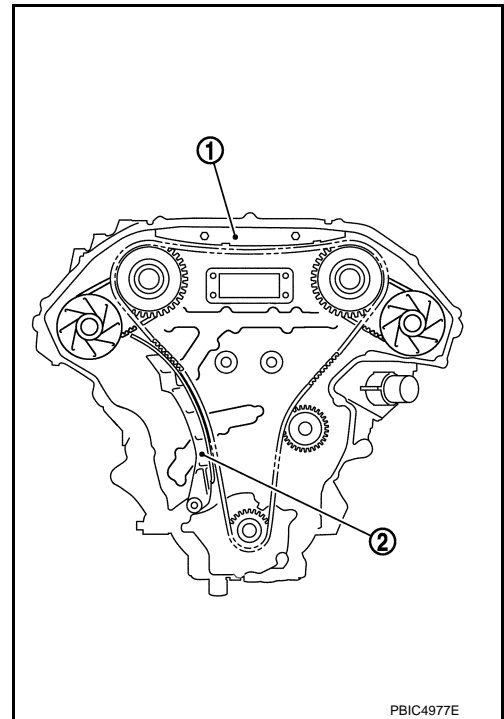

CAUTION:

TIMING CHAIN

[VQ35HR]

< SERVICE INFORMATION >

Never over tighten slack guide mounting bolts (2). It is normal for a gap (A) to exist under the bolt seats when mounting bolts are tightened to specification.

- 1 : Slack guide
- 2 : Cylinder block

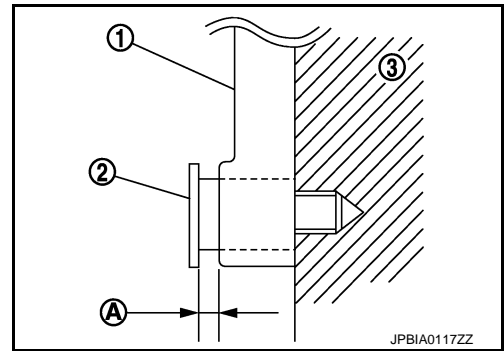

9. Install the timing chain tensioner (primary) with the following procedure:

- a. Pull plunger stopper tab (A) up (or turn lever downward) so as to remove plunger stopper tab from the ratchet of plunger (D).

NOTE:

Plunger stopper tab and lever (C) are synchronized.

- b. Push plunger into the inside of tensioner body.
 - c. Hold plunger in the fully compressed position by engaging plunger stopper tab with the tip of ratchet.
 - d. To secure lever, insert stopper pin (E) through hole of lever into tensioner body hole (B).
- The lever parts and the tab are synchronized. Therefore, the plunger will be secured under this condition.

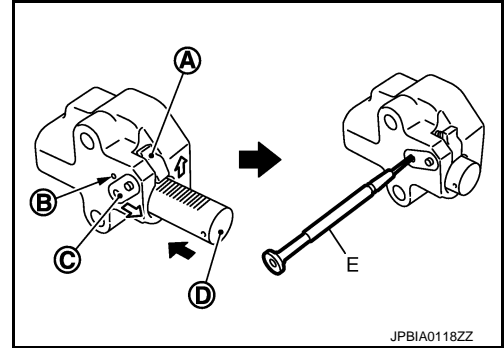

NOTE:

Figure shows the example of 1.2 mm (0.047 in) diameter thin screwdriver being used as the stopper pin.

- e. Install timing chain tensioner (primary) (1).
- Remove any dirt and foreign materials completely from the back and the mounting surfaces of timing chain tensioner (primary).
- f. Pull out stopper pin (A) after installing, and then release plunger.

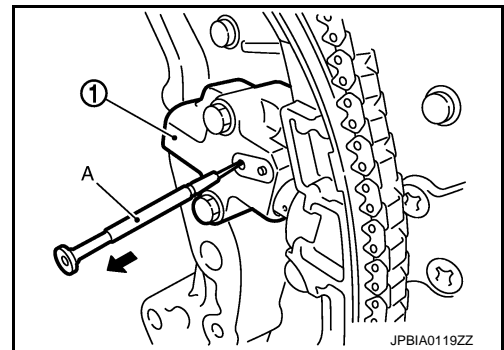

10. Check again that the mating marks on sprockets and timing chain have not slipped out of alignment.

11. Install new O-ring (1) on rear timing chain case.

- A : Bank 1
- B : Bank 2

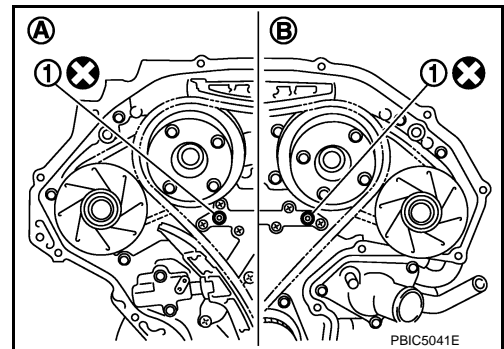

TIMING CHAIN

[VQ35HR]

< SERVICE INFORMATION >

12. Hammer dowel pins (right and left) (A) into front timing chain case (1) up to a point close to taper in order to shorten protrusion length.

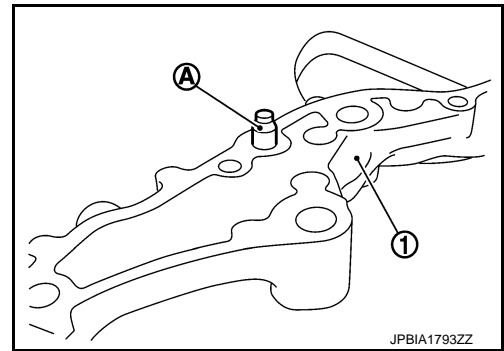

13. Install new front oil seal on front timing chain case.
- Apply new engine oil to both oil seal lip (A) and dust seal lip (B).

⇐ : Engine inside

➡ : Engine outside

- Install it so that each seal lip is oriented as shown in the figure.

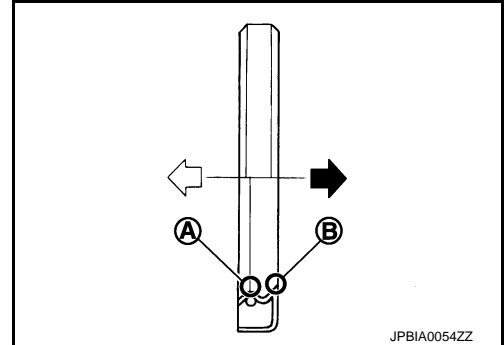

- Using suitable drift (1), press-fit oil seal until it becomes flush with front timing chain case end face.
- Check the garter spring is in position and seal lip is not inverted.

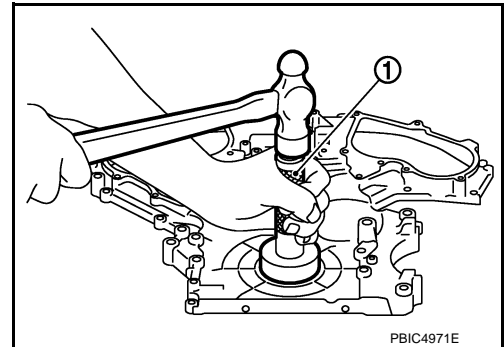

14. Install front timing chain case as follows:

TIMING CHAIN

[VQ35HR]

< SERVICE INFORMATION >

- a. Apply a continuous bead of liquid gasket with tube presser (commercial service tool) to front timing chain case back side as shown in the figure.

- B : Protrusion
 c : $\phi 3.4 - 4.4$ mm (0.134 - 0.173 in)
 d : $\phi 2.6 - 3.6$ mm (0.102 - 0.142 in)
 e : 4.0 - 5.6 mm (0.157 - 0.220 in)

Use Genuine RTV Silicone Sealant or equivalent. Refer to [GI-46, "Recommended Chemical Product and Sealant"](#).

NOTE:

Apply liquid gasket, start and end up application at the portions (A) shown in the figure.

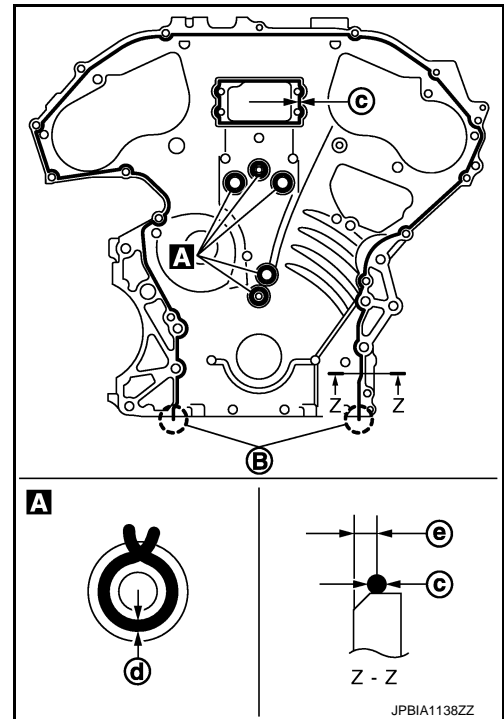

- b. Install front timing chain case as to fit its dowel pin hole together with dowel pin on rear timing chain case.

- c. Tighten mounting bolts to the specified torque in numerical order as shown in the figure.

- There are two types of mounting bolts. Refer to the following for locating bolts.

M8 bolts : 1, 2, 3, 4, 5, 6, 7

: **55.0 N·m (5.6 kg-m, 41 ft-lb)**

M6 bolts : Except the above

: **12.7 N·m (1.3 kg-m, 9 ft-lb)**

- d. After all bolts are tightened, retighten them to the specified torque in numerical order shown in the figure.

CAUTION:

Be sure to wipe off any excessive liquid gasket leaking on surface mating with oil pan (upper).

- e. After installing front timing chain case, check the surface height difference between the following parts on the oil pan (upper) mounting surface.

- 1 : Front timing chain case
 2 : Rear timing chain case
 3 : Lower cylinder block

Standard

**Front timing chain case to rear timing chain case:
 -0.24 to 0.14 mm (-0.0094 to 0.0055 in)**

- If not within standard, repeat the installation procedure.

15. Install right and left valve timing control covers as follows:

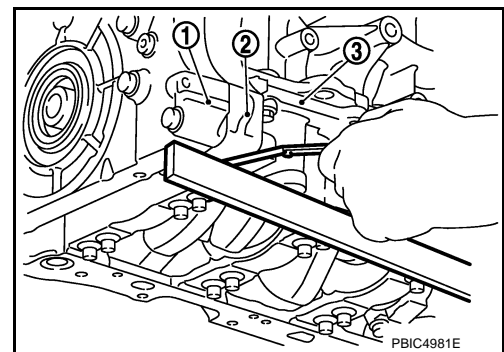
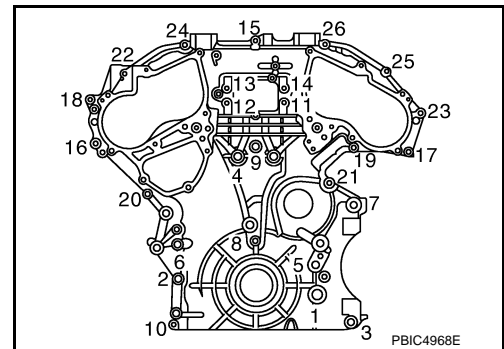

A
EM
C
D
E
F
G
H
I
J
K
L
M
N
O
P

TIMING CHAIN

[VQ35HR]

< SERVICE INFORMATION >

- a. Install new seal rings (1) in shaft grooves.

A : Bank 2

CAUTION:

When replacing seal rings, replace all rings with new one.

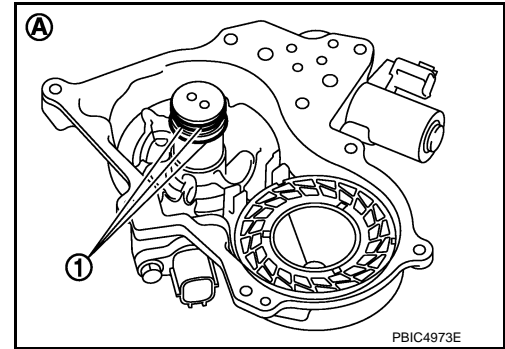

- b. To check the joint between dowel pins and dowel pin holes, check the looseness in the axle direction by pushing the mating surface of magnet retarder (A) at several places and the circumferential looseness (between dowel pins and dowel pin holes) by twisting in the circumferential direction.

B : Moves slightly

C : Not shaken

CAUTION:

Always perform this procedure when removing because the gap between dowel pins and dowel pin holes may not be caused on purpose.

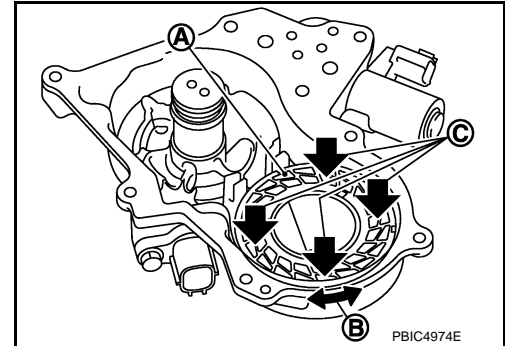

- c. Install valve timing control cover (1) to front timing chain case.

2 : Magnet retarder

CAUTION:

- Never face the magnet retarder side down to prevent magnet retarder from dropping.
- Check the mating surface of magnet retarder and the drum of exhaust side camshaft sprocket for foreign materials.
- Align the center of both shaft holes of the shaft and the intake side camshaft sprocket, and then insert them.
- Be careful not to drop the seal ring from the shaft groove.
- When setting the valve timing control cover in position by hand, if valve timing control cover is not contacting with the front timing chain case, the dowel pin of magnet retarder may not be aligned with the dowel pin holes of cover. In this case, return to step "b".

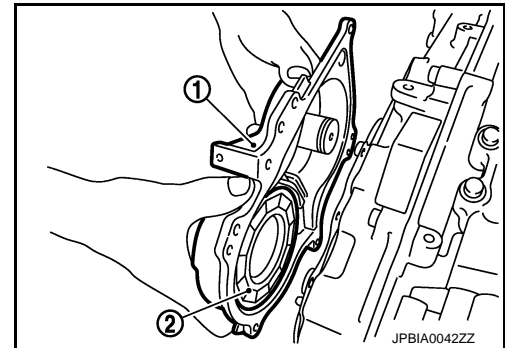

- d. Tighten mounting bolts in numerical order as shown in the figure.

A : Bank 1

B : Bank 2

C : Dowel pin hole

: 11.3 N·m (1.2 kg·m, 8 ft·lb)

CAUTION:

Completely tighten the mounting bolts with the seat surface of valve timing control cover contacting with front timing chain case.

- After all bolts are tightened, tighten No. 1 bolt to the specified torque again.

16. Install oil pans (upper and lower). Refer to [EM-28](#).

17. Install rocker covers (bank 1 and bank 2). Refer to [EM-46](#).

18. Install crankshaft pulley as follows:

- a. Fix crankshaft using ring gear stopper [SST: KV10118600 (J-48641)].

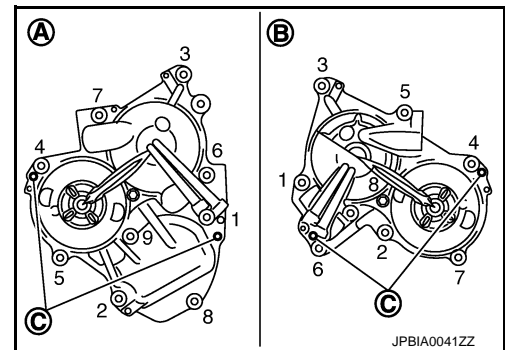

TIMING CHAIN

[VQ35HR]

< SERVICE INFORMATION >

- b. Install crankshaft pulley, taking care not to damage front oil seal.
 - When press-fitting crankshaft pulley with plastic hammer, tap on its center portion (not circumference).
- c. Tighten crankshaft pulley bolt.

: **44.1 N·m (4.5 kg·m, 33 ft·lb)**

- d. Tighten the bolt 90 degrees (one mark) (b).
 - Place a matching mark (A) on crankshaft pulley (2) aligning with the matching (C) of crankshaft pulley bolt (1).

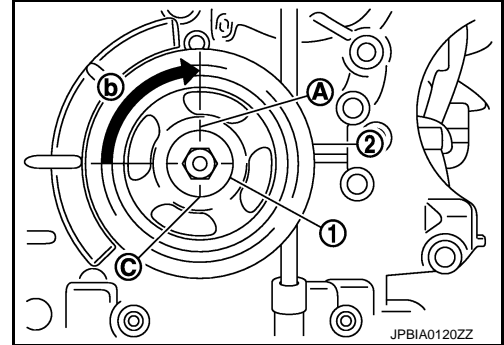

- e. Rotate crankshaft pulley in normal direction (clockwise when viewed from front) to confirm it turns smoothly.
19. Install power steering oil pump bracket and idler pulley bracket as follows:

- a. Tighten mounting bolts in numerical order as shown in the figure. (temporarily)

- 1 : Idler pulley bracket
- 2 : Power steering oil pump bracket
- 3 : Crankshaft pulley
- A : Engine front side
- B : Engine right side
- ⇐ : Engine front

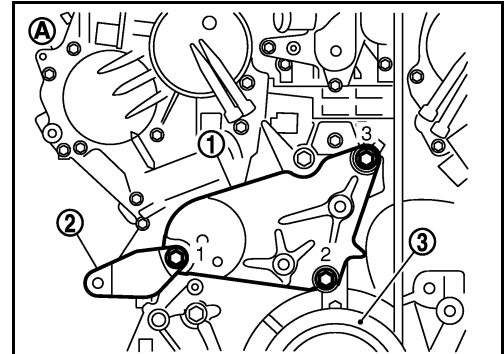

- b. Tighten mounting bolts to specified torque in numerical order as shown in the figure.

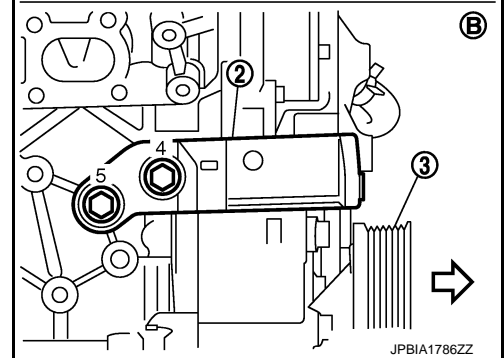

20. For the following operations, perform steps in the reverse order of removal.

INSPECTION AFTER INSTALLATION

Inspection for Leakage

The following are procedures for checking fluids leakage, lubricates leakage, and exhaust gases leakage.

- Before starting engine, check oil/fluid levels including engine coolant and engine oil. If less than required quantity, fill to the specified level. Refer to [MA-9. "Fluids and Lubricants"](#).
- Use procedure below to check for fuel leakage.
 - Turn ignition switch "ON" (with engine stopped). With fuel pressure applied to fuel piping, check for fuel leakage at connection points.
 - Start engine. With engine speed increased, check again for fuel leakage at connection points.
- Run engine to check for unusual noise and vibration.

NOTE:

TIMING CHAIN

[VQ35HR]

< SERVICE INFORMATION >

If hydraulic pressure inside timing chain tensioner drops after removal/installation, slack in the guide may generate a pounding noise during and just after engine start. However, this is normal. Noise will stop after hydraulic pressure rises.

- Warm up engine thoroughly to check there is no leakage of fuel, exhaust gases, or any oil/fluids including engine oil and engine coolant.
- Bleed air from lines and hoses of applicable lines, such as in cooling system.
- After cooling down engine, again check oil/fluid levels including engine oil and engine coolant. Refill to the specified level, if necessary.

Summary of the inspection items:

Items	Before starting engine	Engine running	After engine stopped
Engine coolant	Level	Leakage	Level
Engine oil	Level	Leakage	Level
Other oils and fluid*	Level	Leakage	Level
Fuel	Leakage	Leakage	Leakage
Exhaust gases	—	Leakage	—

*: Transmission/transaxle/CVT fluid, power steering fluid, brake fluid, etc.

CAMSHAFT

< SERVICE INFORMATION >

[VQ35HR]

CAMSHAFT

Component

INFOID:000000005347995

A

EM

C

D

E

F

G

H

I

J

K

L

M

N

O

P

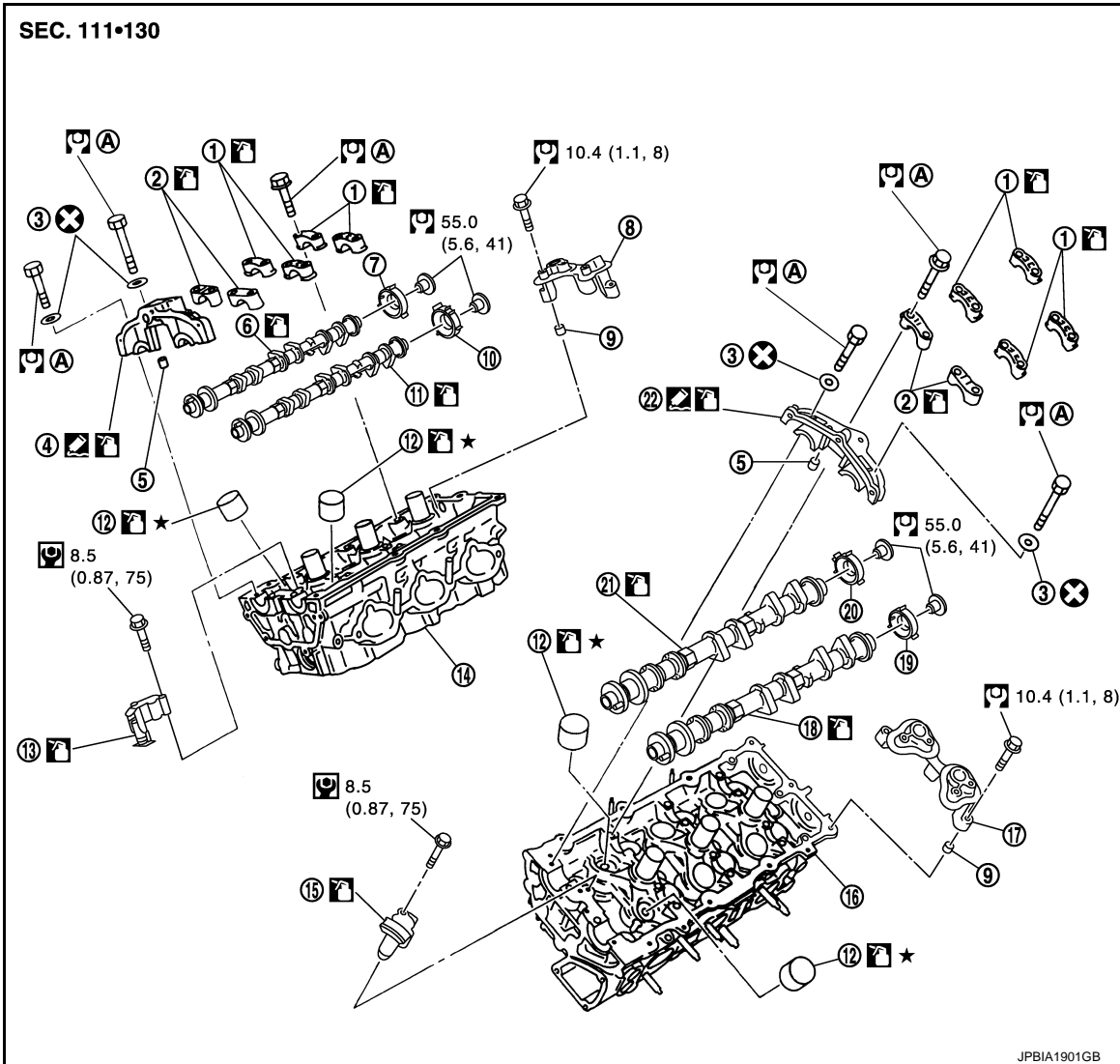

- | | | |
|---|-------------------------------------|---|
| 1. Camshaft bracket (No. 3, 4) | 2. Camshaft bracket (No. 2) | 3. Seal washer |
| 4. Camshaft bracket (No. 1) (bank 1) | 5. Dowel pin | 6. Camshaft (EXH) (bank 1) |
| 7. Camshaft signal plate (EXH) | 8. Camshaft sensor bracket (bank 1) | 9. Dowel pin |
| 10. Camshaft signal plate (INT) | 11. Camshaft (INT) (bank 1) | 12. Valve lifter |
| 13. Timing chain tensioner (secondary) (bank 1) | 14. Cylinder head (bank 1) | 15. Timing chain tensioner (secondary) (bank 2) |
| 16. Cylinder head (bank 2) | 17. Camshaft sensor bracket | 18. Camshaft (EXH) |
| 19. Camshaft signal plate (EXH) | 20. Camshaft signal plate (INT) | 21. Camshaft (INT) |
| 22. Camshaft bracket (No. 1) (bank 2) | | |
- A. Refer to [EM-79](#)

• Refer to [GI-9. "Component"](#) for symbols in the figure.

Removal and Installation

INFOID:000000005347996

REMOVAL

1. Remove front timing chain case, camshaft sprocket, and timing chain. Refer to [EM-60](#).
2. Remove fuel sub tube. Refer to [EM-40](#).

CAMSHAFT

[VQ35HR]

< SERVICE INFORMATION >

- Remove camshaft sensor bracket bolts in reverse order as shown in the figure.

↔ : Engine front

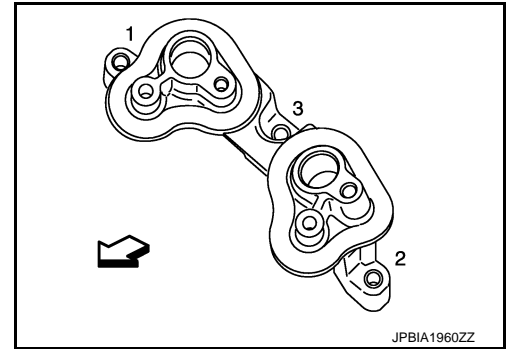

- Remove intake and exhaust camshaft brackets.
 - Mark camshafts, camshaft brackets and bolts so they are placed in the same position and direction for installation.
 - Equally loosen camshaft bracket bolts in several steps in reverse order as shown in the figure.

↔ : Engine front

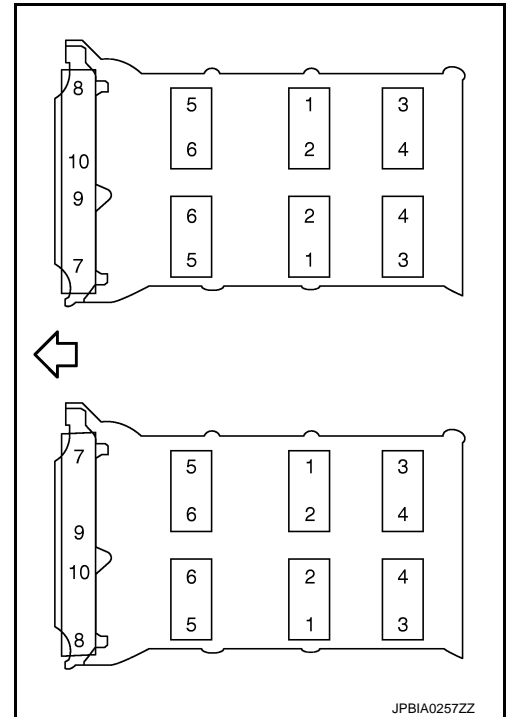

- Remove camshaft.
- Remove valve lifter.
 - Identify installation positions, and store them without mixing them up.
- Remove timing chain tensioner (secondary) (1) from cylinder head.

A : Bank 1
B : Bank 2

- Remove timing chain tensioner (secondary) with its stopper pin (C) attached.

NOTE:

Stopper pin was attached when timing chain (secondary) was removed.

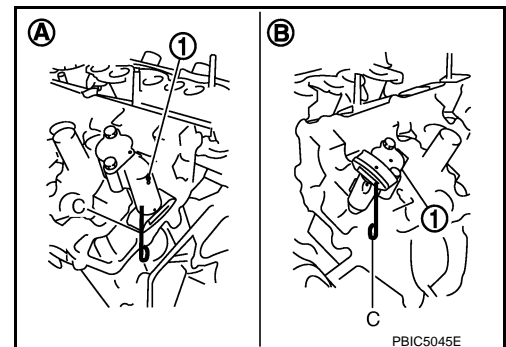

INSPECTION AFTER REMOVAL

Camshaft Runout

- Put V-block on precise flat table, and support No. 2 and 4 journals of camshaft.

CAUTION:

CAMSHAFT

[VQ35HR]

< SERVICE INFORMATION >

Never support journal No. 1 (on the side of camshaft sprocket) because it has a different diameter from the other three locations.

2. Set dial indicator vertically to No. 3 journal.
3. Turn camshaft to one direction with hands, and measure the camshaft runout on a dial indicator. (Total indicator reading)

Standard : Less than 0.02 mm (0.0008 in)

Limit : 0.05 mm (0.0020 in)

4. If it exceeds the limit, replace camshaft.

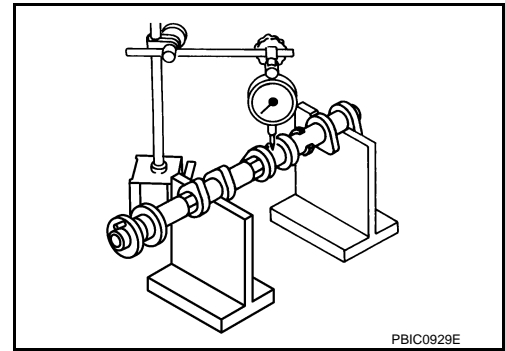

Camshaft Cam Height

1. Measure the camshaft cam height with a micrometer.

Standard cam height:

Intake : 45.865 - 46.055 mm (1.8057 - 1.8132 in)

Exhaust : 45.875 - 46.065 mm (1.8061 - 1.8136 in)

Cam wear limit

: 0.2 mm (0.008 in)

2. If wear is beyond the limit, replace camshaft.

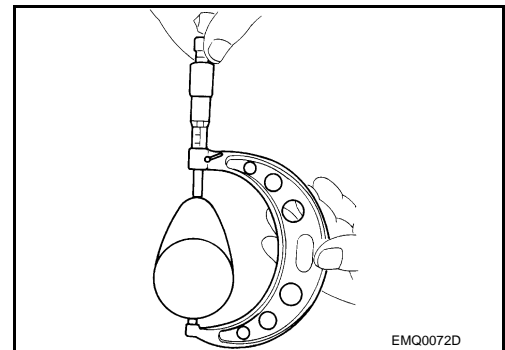

Camshaft Journal Oil Clearance

CAMSHAFT JOURNAL DIAMETER

- Measure the outer diameter of camshaft journal with a micrometer (A).

Standard:

No. 1 : 25.935 - 25.955 mm (1.0211 - 1.0218 in)

No. 2, 3, 4 : 23.445 - 23.465 mm (0.9230 - 0.9238 in)

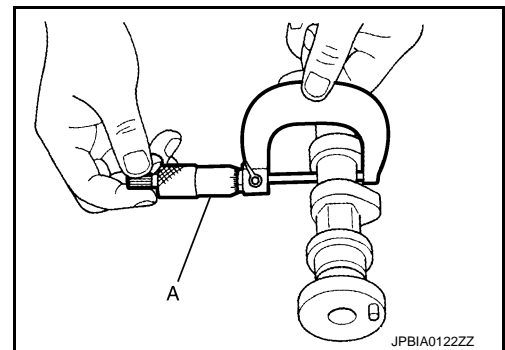

CAMSHAFT BRACKET INNER DIAMETER

- Tighten camshaft bracket bolt with the specified torque. Refer to [EM-79, "Component"](#) for the tightening procedure.
- Measure the inner diameter "A" of camshaft bracket with a bore gauge.

Standard:

No. 1 : 26.000 - 26.021 mm (1.0236 - 1.0244 in)

No. 2, 3, 4 : 23.500 - 23.521 mm (0.9252 - 0.9260 in)

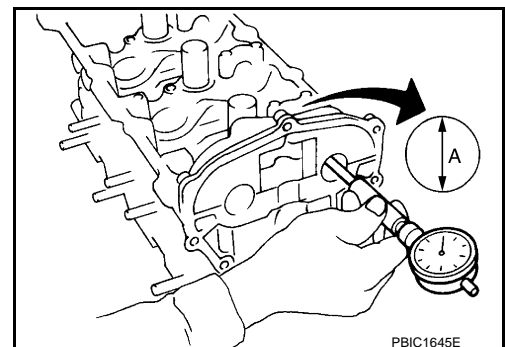

CAMSHAFT JOURNAL OIL CLEARANCE

- (Oil clearance) = (Camshaft bracket inner diameter) – (Camshaft journal diameter)

Standard:

No. 1 : 0.045 - 0.086 mm (0.0018 - 0.0034 in)

No. 2, 3, 4 : 0.035 - 0.076 mm (0.0014 - 0.0030 in)

Limit : 0.15 mm (0.0059 in)

- If it exceeds the limit, replace either or both camshaft and cylinder head.

NOTE:

Camshaft brackets cannot be replaced as single parts, because there are machined together with cylinder head. Replace whole cylinder head assembly.

Camshaft End Play

- Install a dial indicator in thrust direction on front end of camshaft. Measure the end play of a dial indicator when camshaft is moved forward/backward (in direction to axis).

Standard : 0.115 - 0.188 mm (0.0045 - 0.0074 in)

Limit : 0.24 mm (0.0094 in)

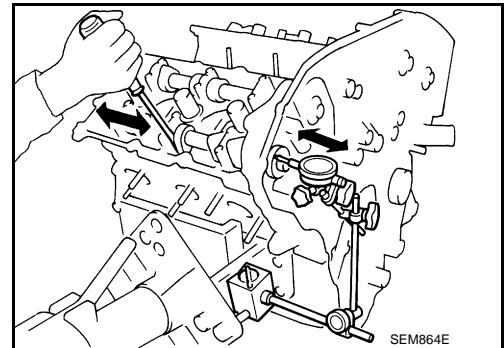

- Measure the following parts if out of the limit.
 - Dimension "A" for camshaft No. 1 journal

Standard : 27.500 - 27.548 mm (1.0827 - 1.0846 in)

- Dimension "B" for cylinder head No. 1 journal bearing

Standard : 27.360 - 27.385 mm (1.0772 - 1.0781 in)

- Refer to the standards above, and then replace camshaft and/or cylinder head.

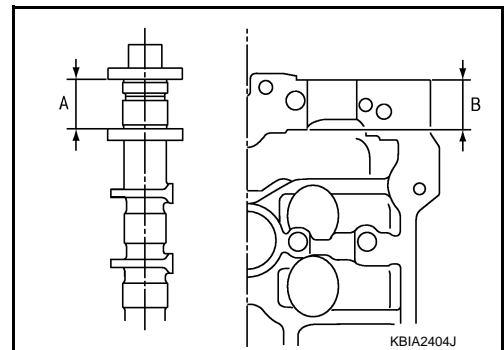

Camshaft Sprocket Runout

1. Put V-block on precise flat table, and support No. 2 and 4 journal of camshaft.

CAUTION:

Never support journal No. 1 (on the side of camshaft sprocket) because it has a different diameter from the other three locations.

2. Measure the camshaft sprocket runout with a dial indicator. (Total indicator reading)

Limit : 0.15 mm (0.0059 in)

- If it exceeds the limit, replace camshaft sprocket.

CAUTION:

When replacing camshaft sprocket (EXH), replace valve timing control cover (including magnet retarder and cover).

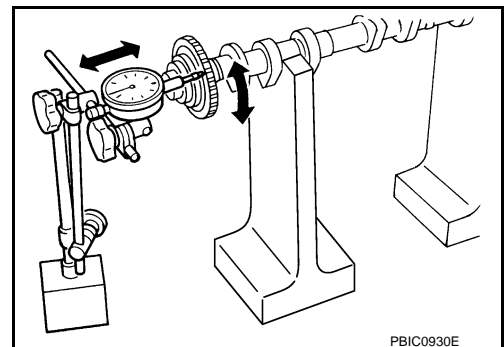

Valve Lifter

CAMSHAFT

[VQ35HR]

< SERVICE INFORMATION >

Check if surface of valve lifter has any wear or cracks.

- If anything above is found, replace valve lifter. Refer to [EM-147](#), "[Standard and Limit](#)".

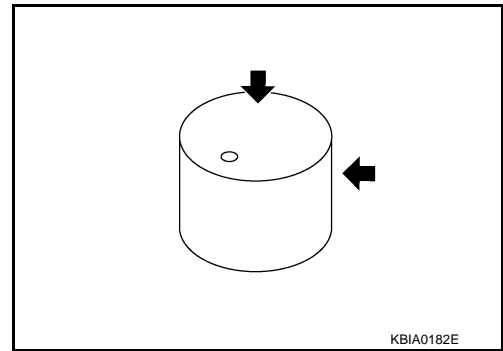

Valve Lifter Clearance

VALVE LIFTER OUTER DIAMETER

- Measure the outer diameter at 1/2 height of valve lifter with a micrometer (A) since valve lifter is in barrel shape.

Standard (Intake and exhaust)

: 33.980 - 33.990 mm (1.3378 - 1.3382 in)

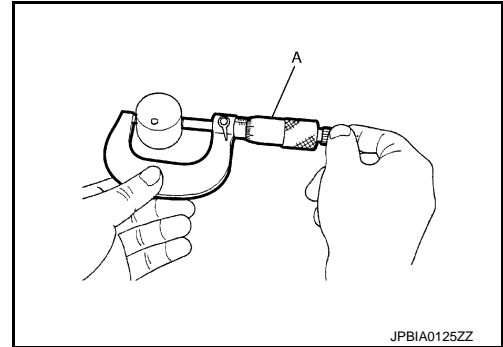

VALVE LIFTER HOLE DIAMETER

- Measure the inner diameter of valve lifter hole of cylinder head with an inside micrometer.

Standard (Intake and exhaust)

: 34.000 - 34.016 mm (1.3386 - 1.3392 in)

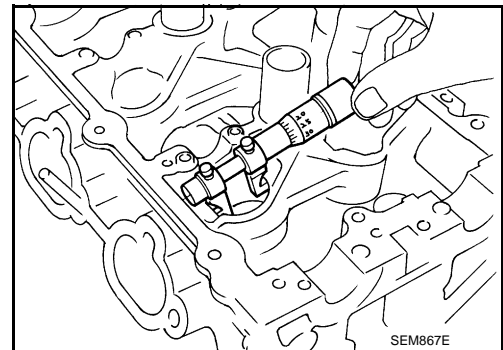

VALVE LIFTER CLEARANCE

- (Valve lifter clearance) = (Valve lifter hole diameter) – (Valve lifter outer diameter)

Standard (Intake and exhaust)

: 0.010 - 0.036 mm (0.0004 - 0.0014 in)

- If the calculated value is out of the standard, referring to each standard of valve lifter outer diameter and valve lifter hole diameter, replace either or both valve lifter and cylinder head.

INSTALLATION

CAMSHAFT

[VQ35HR]

< SERVICE INFORMATION >

1. Install timing chain tensioners (secondary) (1) on both sides of cylinder head.

A : Bank 1
B : Bank 2

- Install timing chain tensioner with its stopper pin (C) attached.
- Install timing chain tensioner with sliding part facing downward on right-side cylinder head, and with sliding part facing upward on left-side cylinder head.

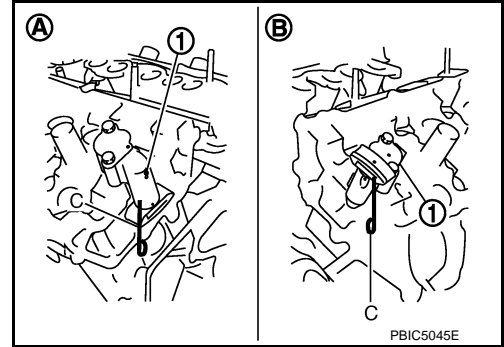

2. Install valve lifter.
 - Install it in the original position.
3. Install camshafts.
 - Follow your identification marks made during removal, or follow the identification marks that are present on new camshafts for proper placement and direction.

← : Engine front

Bank	INT/EXH	Dowel pin (1)	Paint marks			Identification mark (C)
			M1 (E)	M2 (F)	M3 (D)	
1	EXH (B)	Yes	No	Green	Light blue	1F
	INT (A)	Yes	Green	No	Light blue	1E
2	INT (A)	Yes	Green	No	Light blue	1G
	EXH (B)	Yes	No	Green	Light blue	1H

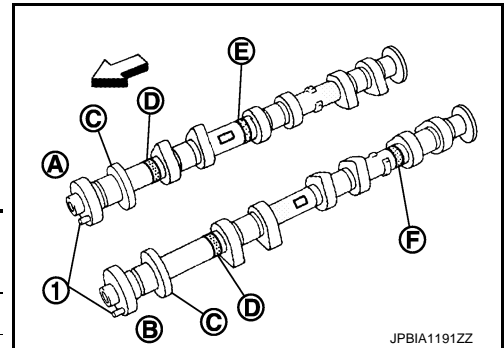

- Install camshaft so that and dowel pin (A) on front end face are positioned as shown in the figure. (No. 1 cylinder TDC on its compression stroke)

1 : Crankshaft key

NOTE:

Though camshaft does not stop at the portion as shown in the figure, for the placement of cam nose, it is generally accepted camshaft is placed for the same direction of the figure.

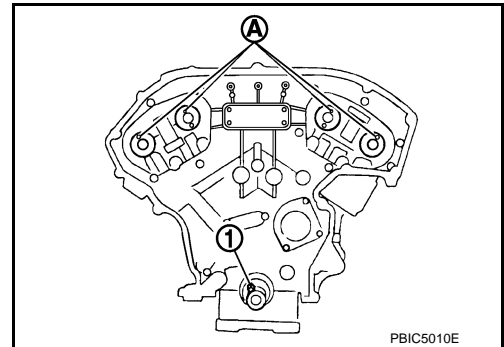

CAMSHAFT

[VQ35HR]

< SERVICE INFORMATION >

4. Install camshaft brackets.

- A : No. 1
- B : No. 2
- C : No. 3
- D : No. 4
- E : Right camshaft bracket
- F : Exhaust side
- G : Intake side
- H : Left camshaft bracket
- I : Intake side
- J : Exhaust side
- ⇐ : Engine front

- Remove foreign material completely from camshaft bracket backside and from cylinder head installation face.
- Install camshaft bracket in original position and direction as shown in the figure.

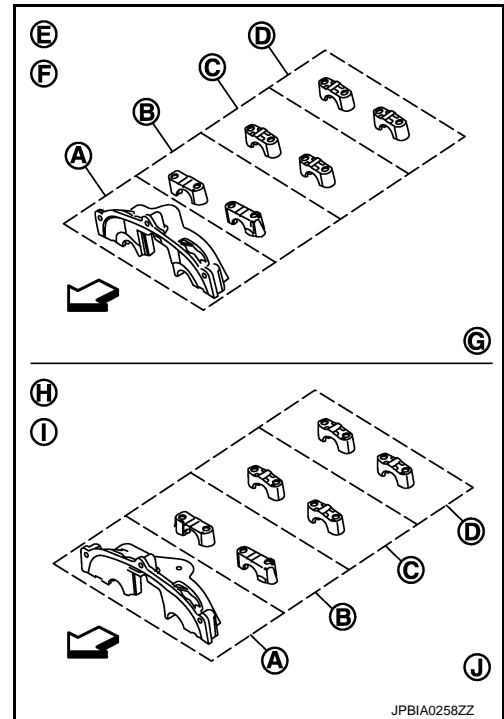

- Install camshaft brackets (No. 2 to 4) aligning the stamp marks (A) as shown in the figure.

- B : Bank 1
- C : Bank 2
- ⇐ : Engine front

NOTE:

There are no identification marks indicating left and right for camshaft bracket (No. 1).

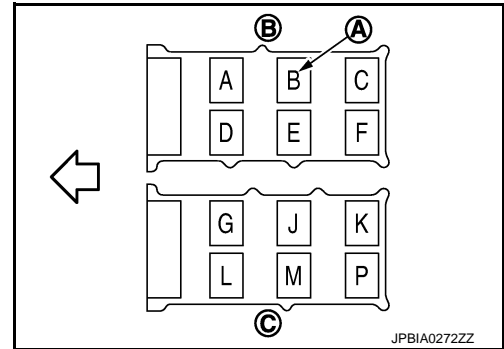

- Apply liquid gasket to mating surface of camshaft bracket (No. 1) as shown on bank 1 and bank 2.

- a : 8.5 mm (0.335 in)
- b : 2.0 mm
- c : Clearance 5.0 mm (0.20 in)
- d : ϕ 2.5 mm (0.098 in)
- * : Apply liquid gasket to rear timing chain side

Use Genuine RTV Silicone Sealant or equivalent. Refer to [GI-46, "Recommended Chemical Product and Sealant"](#).

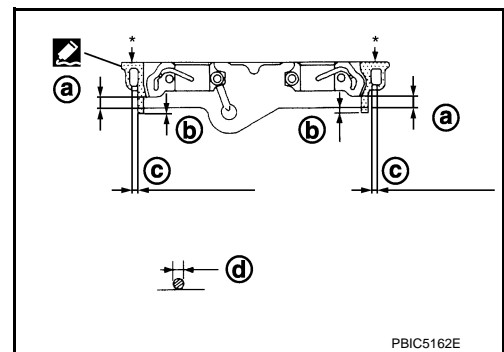

CAMSHAFT

[VQ35HR]

< SERVICE INFORMATION >

- Apply liquid gasket to camshaft bracket (No. 1) contact surface on the rear timing chain case backside as shown on both bank 1 and bank 2.

1 : Rear timing chain case

a : $\phi 3.9$ mm (0.154 in)

Use Genuine RTV Silicone Sealant or equivalent. Refer to [GI-46, "Recommended Chemical Product and Sealant"](#).

CAUTION:

For camshaft bracket (No. 1) near installation position, and install it without disturbing the liquid gasket applied to the surfaces.

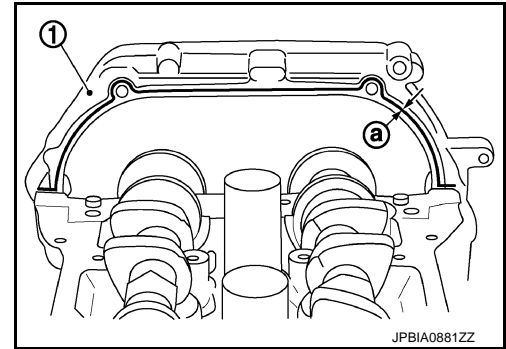

- Tighten camshaft bracket bolts in the following steps, in numerical order as shown in the figure.

- Tighten No. 7 to 10 in numerical order as shown.

: **1.96 N·m (0.2 kg-m, 1 ft-lb)**

- Tighten No. 1 to 6 in numerical order as shown.

: **1.96 N·m (0.2 kg-m, 1 ft-lb)**

- Tighten No. 1 to 10 in numerical order as shown.

: **5.88 N·m (0.6 kg-m, 4 ft-lb)**

- Tighten No. 1 to 10 in numerical order as shown.

: **10.4 N·m (1.1 kg-m, 8 ft-lb)**

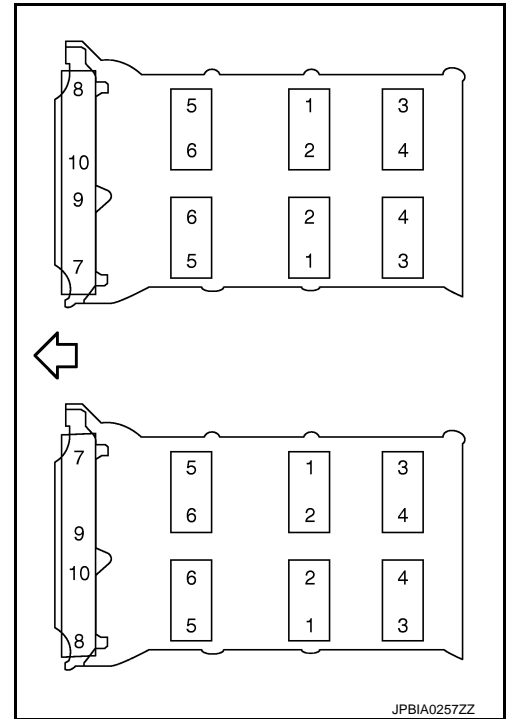

CAUTION:

After tightening mounting bolts of camshaft brackets (No. 1), be sure to wipe off excessive liquid gasket from the parts list below.

- Mating surface of rocker cover
- Mating surface of rear timing chain case

- Inspect and adjust the valve clearance. Refer to [EM-88, "Valve Clearance"](#).

- Install camshaft sensor bracket.

- Tighten camshaft sensor bracket bolts in numerical order as shown in the figure.

: Engine front

NOTE:

The order of tightening bolts is the same for bank 1 and bank 2.

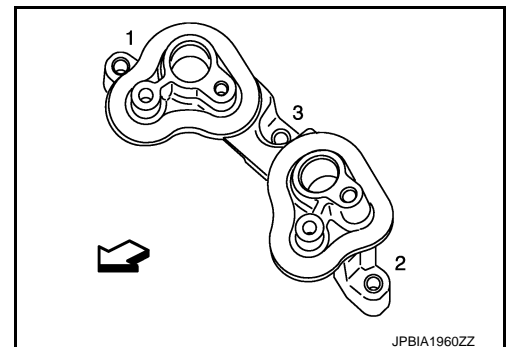

- Install in the reverse order of removal after this step.

INSPECTION AFTER INSTALLATION

Inspection of Camshaft Sprocket (INT) Oil Groove

CAUTION:

- Perform this inspection only when DTC P0011 or P0021 are detected in self-diagnostic results of CONSULT-III and it is directed according to inspection procedure of EC section. Refer to [EC-121, "Diagnosis Description"](#).

• **Check when engine is cold so as to prevent burns from any splashing engine oil.**

1. Check the engine oil level. Refer to [LU-5, "Inspection"](#).
2. Perform the following procedure so as to prevent the engine from being unintentionally started while checking.
 - a. Release fuel pressure. Refer to [EC-692, "Inspection"](#).
 - b. Disconnect ignition coil and injector harness connectors.
3. Remove intake valve timing control solenoid valve. Refer to [EM-59, "Component"](#).
4. Crank the engine, and then check that engine oil comes out from valve timing control solenoid valve hole (A). End crank after checking.

1 : Valve timing control solenoid valve

↶ : Engine front

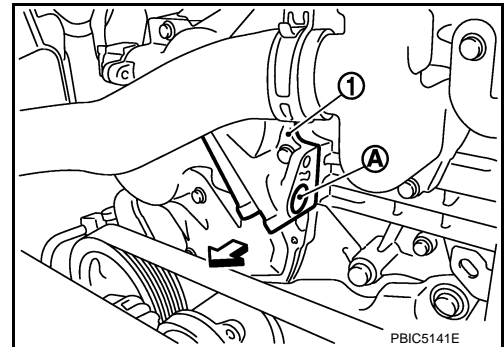

WARNING:

Be careful not to touch rotating parts (drive belt, idler pulley, and crankshaft pulley, etc.).

CAUTION:

Engine oil may squirt from intake valve timing control solenoid valve installation hole during cranking. Use a shop cloth to prevent the engine components and the vehicle. Never allow engine oil to get on rubber components such as drive belt or engine mount insulators. Immediately wipe off any splashed engine oil.

- Clean oil groove between oil strainer and intake valve timing control solenoid valve if engine oil does not come out from valve timing control solenoid valve hole. Refer to [LU-4, "Lubrication Circuit"](#).
5. Remove components between intake valve timing control solenoid valve and camshaft sprocket (INT), and then check each oil groove for clogging.
 - Clean oil groove if necessary. Refer to [LU-4, "Lubrication Circuit"](#).
 6. After inspection, install removed parts.

Inspection for Leakage

The following are procedures for checking fluids leakage, lubricates leakage, and exhaust gases leakage.

- Before starting engine, check oil/fluid levels including engine coolant and engine oil. If less than required quantity, fill to the specified level. Refer to [MA-9, "Fluids and Lubricants"](#).
- Use procedure below to check for fuel leakage.
 - Turn ignition switch "ON" (with engine stopped). With fuel pressure applied to fuel piping, check for fuel leakage at connection points.
 - Start engine. With engine speed increased, check again for fuel leakage at connection points.
- Run engine to check for unusual noise and vibration.

NOTE:

If hydraulic pressure inside timing chain tensioner drops after removal/installation, slack in the guide may generate a pounding noise during and just after engine start. However, this is normal. Noise will stop after hydraulic pressure rises.

- Warm up engine thoroughly to check there is no leakage of fuel, exhaust gases, or any oil/fluids including engine oil and engine coolant.
- Bleed air from lines and hoses of applicable lines, such as in cooling system.
- After cooling down engine, again check oil/fluid levels including engine oil and engine coolant. Refill to the specified level, if necessary.

Summary of the inspection items:

Items	Before starting engine	Engine running	After engine stopped
Engine coolant	Level	Leakage	Level
Engine oil	Level	Leakage	Level
Other oils and fluid*	Level	Leakage	Level
Fuel	Leakage	Leakage	Leakage
Exhaust gases	—	Leakage	—

*: Transmission/transaxle/CVT fluid, power steering fluid, brake fluid, etc.

Valve Clearance

INSPECTION

Perform inspection as follows after removal, installation or replacement of camshaft or valve-related parts, or if there is unusual engine conditions regarding valve clearance.

In cases of removing/installing or replacing camshaft and valve-related parts, or of unusual engine conditions due to changes in valve clearance (found malfunctions during starting, idling or causing noise), perform inspection as follows:

⇐ : Engine front

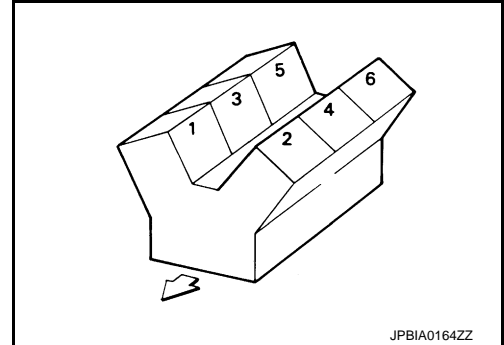

1. Remove rocker covers (bank 1 and bank 2). Refer to [EM-46](#).
2. Measure the valve clearance as follows:
 - a. Set No. 1 cylinder at TDC of its compression stroke.
 - Rotate crankshaft pulley clockwise to align timing mark (grooved line without color) with timing indicator.

← : Timing mark (grooved line without color)

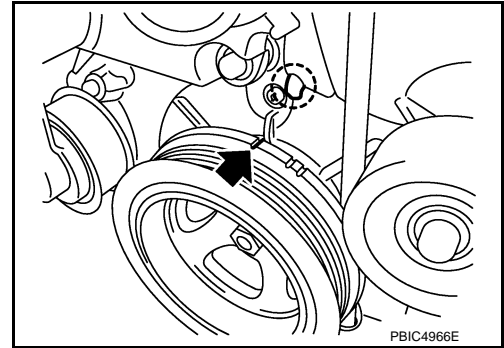

- Check that intake and exhaust cam nose on No. 1 cylinder (engine front side of bank 1) are located as shown in the figure.

⇐ : Engine front

- If not, turn crankshaft one revolution (360 degrees) and align as shown in the figure.

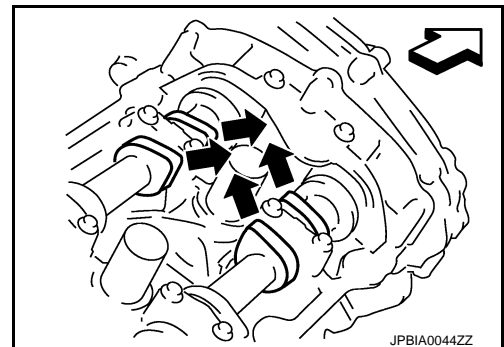

- b. Use a feeler gauge, measure the clearance between valve lifter and camshaft.

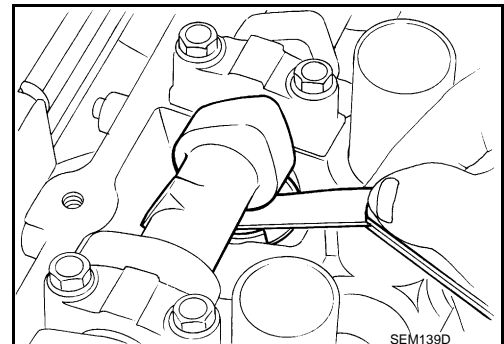

Valve clearance:

CAMSHAFT

< SERVICE INFORMATION >

[VQ35HR]

Unit: mm (in)

Items	Cold	Hot * (reference data)
Intake	0.26 - 0.34 (0.010 - 0.013)	0.304 - 0.416 (0.012 - 0.016)
Exhaust	0.29 - 0.37 (0.011 - 0.015)	0.308 - 0.432 (0.012 - 0.017)

*: Approximately 80°C (176°F)

- By referring to the figure, measure the valve clearances at locations marked "x" as shown in the table below (locations indicated in the figure).

← : Engine front

- No. 1 cylinder at compression TDC

Measuring position [bank 1 (A)]		No. 1 CYL.	No. 3 CYL.	No. 5 CYL.
No. 1 cylinder at compression TDC	EXH (C)		x (B)	
	INT (D)	x (E)		
Measuring position [bank 2 (H)]		No. 2 CYL.	No. 4 CYL.	No. 6 CYL.
No. 1 cylinder at compression TDC	INT (D)			x (F)
	EXH (C)	x (G)		

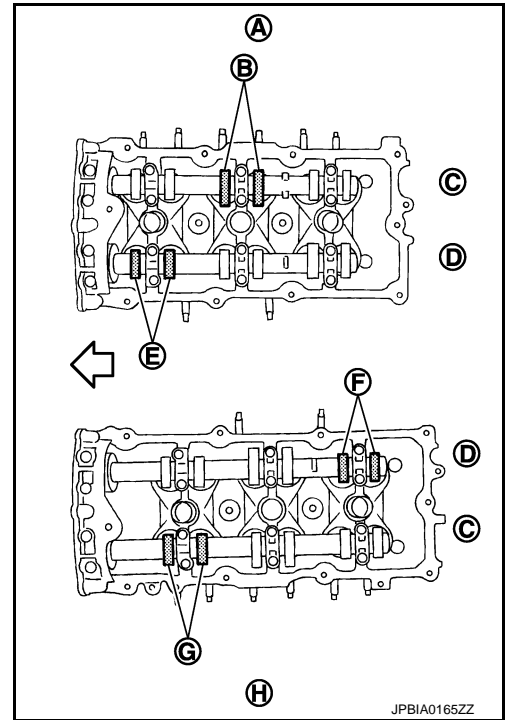

- c. Rotate crankshaft by 240 degrees clockwise (when viewed from engine front) to align No. 3 cylinder at TDC of its compression stroke.

NOTE:

Mark a position 240 degrees (b) from a corner of the hexagonal part of crankshaft pulley mounting bolt as shown in the figure. Use the hexagonal part as a guide.

- 1 : Crankshaft pulley
- A : Paint mark

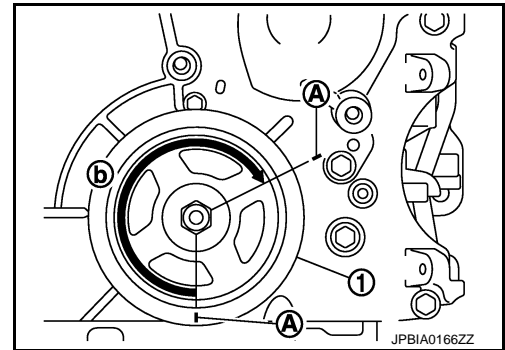

CAMSHAFT

[VQ35HR]

< SERVICE INFORMATION >

- By referring to the figure, measure the valve clearances at locations marked "x" as shown in the table below (locations indicated in the figure).

← : Engine front

- No. 3 cylinder at compression TDC

Measuring position [bank 1 (A)]		No. 1 CYL.	No. 3 CYL.	No. 5 CYL.
No. 3 cylinder at compression TDC	EXH (C)			x (B)
	INT (D)		x (E)	
Measuring position [bank 2 (H)]		No. 2 CYL.	No. 4 CYL.	No. 6 CYL.
No. 3 cylinder at compression TDC	INT (D)	x (F)		
	EXH (C)		x (G)	

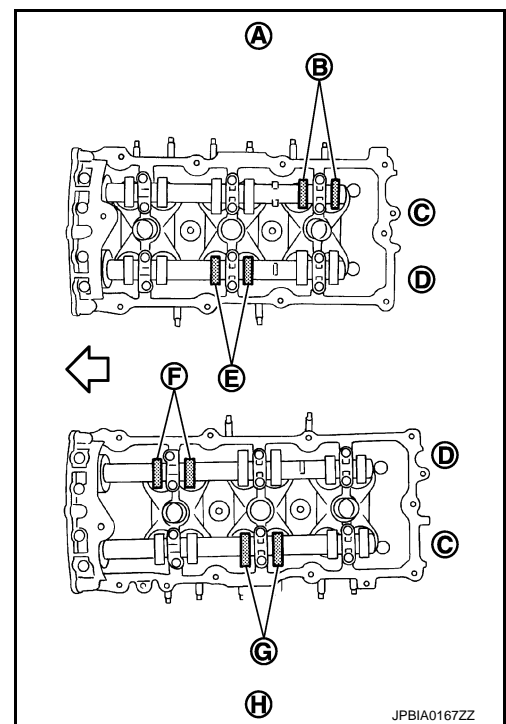

- d. Rotate crankshaft by 240 degrees clockwise (when viewed from engine front) to align No. 5 cylinder at TDC of its compression stroke.

NOTE:

Mark a position 240 degrees (b) from a corner of the hexagonal part of crankshaft pulley mounting bolt as shown in the figure. Use the hexagonal part as a guide.

- 1 : Crankshaft pulley
- A : Paint mark

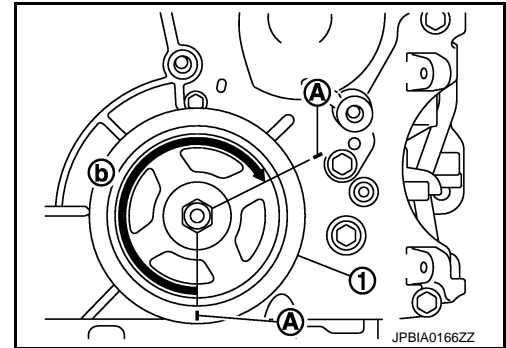

CAMSHAFT

[VQ35HR]

< SERVICE INFORMATION >

- By referring to the figure, measure the valve clearances at locations marked "x" as shown in the table below (locations indicated in the figure).

← : Engine front

- No. 5 cylinder at compression TDC

Measuring position [bank 1 (A)]		No. 1 CYL.	No. 3 CYL.	No. 5 CYL.
No. 5 cylinder at compression TDC	EXH (C)	x (B)		
	INT (D)			x (E)
Measuring position [bank 2 (H)]		No. 2 CYL.	No. 4 CYL.	No. 6 CYL.
No. 5 cylinder at compression TDC	INT (D)		x (F)	
	EXH (C)			x (G)

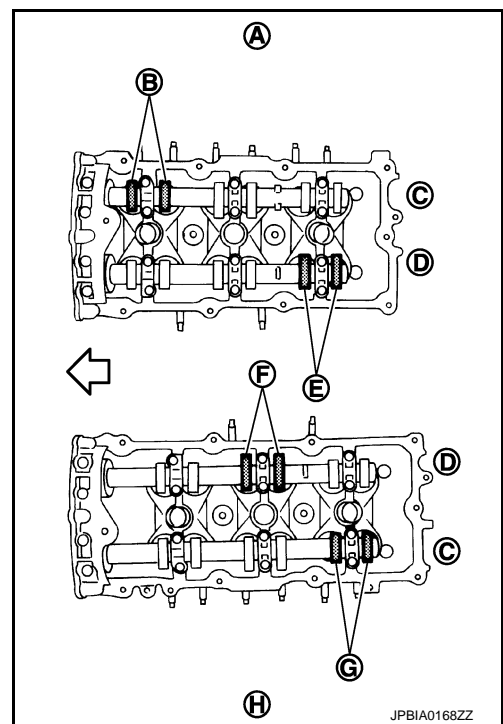

- If the measured values are out of the standard, perform adjustment. Refer to "ADJUSTMENT".

ADJUSTMENT

- Perform adjustment depending on selected head thickness of valve lifter.
 - Measure the valve clearance. Refer to "INSPECTION".
 - Remove camshaft. Refer to [EM-79. "Component"](#).
 - Remove valve lifters at the locations that are out of the standard.
 - Measure the center thickness of removed valve lifters with a micrometer (A).

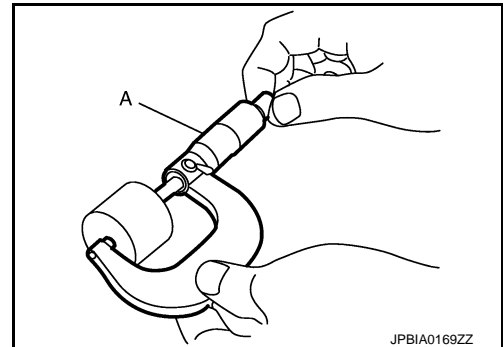

- Use the equation below to calculate valve lifter thickness for replacement.

Valve lifter thickness calculation: $t = t_1 + (C_1 - C_2)$

t = Valve lifter thickness to be replaced

t₁ = Removed valve lifter thickness

C₁ = Measured valve clearance

C₂ = Standard valve clearance:

Intake : 0.30 mm (0.012 in)*

Exhaust : 0.33 mm (0.013 in)*

*: Approximately 20°C (68°F)

CAMSHAFT

[VQ35HR]

< SERVICE INFORMATION >

- Thickness of new valve lifter can be identified by stamp marks on the reverse side (inside the cylinder).

A : Stamp

B : Thickness of valve lifter

Stamp mark 788 indicates 7.88 mm (0.3102 in) in thickness.

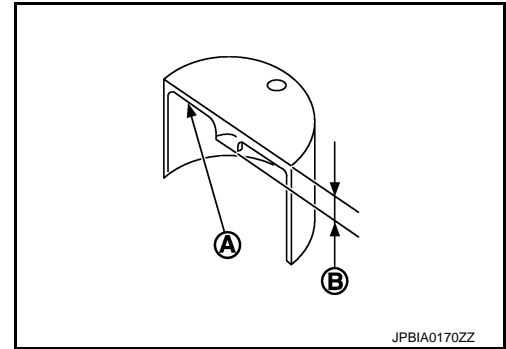

Available thickness of valve lifter: 27 sizes with range 7.88 to 8.40 mm (0.3102 to 0.3307 in) in steps of 0.02 mm (0.0008 in) (when manufactured at factory). Refer to [EM-147. "Standard and Limit"](#).

6. Install selected valve lifter.
7. Install camshaft. Refer to [EM-79. "Component"](#).
8. Manually turn crankshaft pulley a few turns.
9. Check that the valve clearances for cold engine are within the specifications by referring to the specified values. Refer to "INSPECTION".
10. Install all removal parts in the reverse order of removal. Refer to [EM-79. "Component"](#).
11. Warm up the engine, and check for unusual noise and vibration.

OIL SEAL

Removal and Installation of Valve Oil Seal

INFOID:000000005347998

REMOVAL

1. Remove camshaft relating to valve oil seal to be removed. Refer to [EM-79](#).
2. Remove valve lifters. Refer to [EM-79](#).
3. Turn crankshaft until the cylinder requiring new oil seals is at TDC. This will prevent valve from dropping into cylinder.
4. Remove valve collet.
 - Compress valve spring with valve spring compressor [SST: KV10116200 (J26336-A)] (A), attachment [SST: KV10115900 (J26336-20)] (C), adapter [SST: KV10109220 (—)] (B). Remove valve collet with magnet hand.

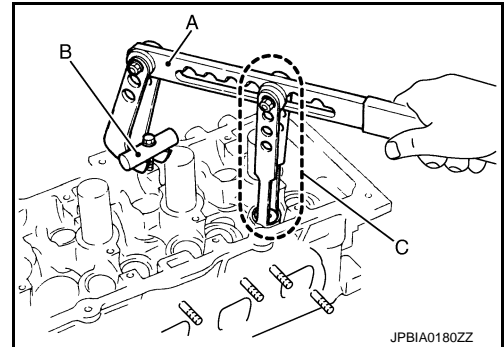
CAUTION:**When working, take care not to damage valve lifter holes.**

5. Remove valve spring retainer, valve spring and valve spring seat.
6. Remove valve oil seal using valve oil seal puller [SST: KV10107902 (J38959)] (A).

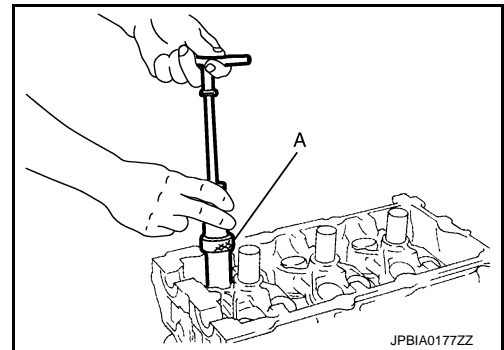

INSTALLATION

1. Apply engine oil on new valve oil seal joint and seal lip.
2. Using valve oil seal drift [SST: KV10115600 (J38958)] (A), press fit valve oil seal to height (b) shown in the figure.

NOTE:

Dimension: Height measured before valve spring seat installation

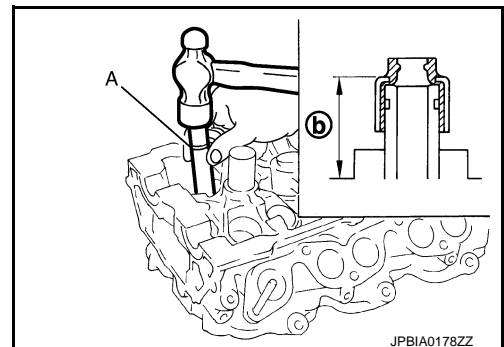
Intake and exhaust : 14.3 - 14.9 mm (0.563 - 0.587 in)

3. Install in the reverse order of removal after this step.

Removal and Installation of Front Oil Seal

INFOID:000000005347999

REMOVAL

1. Remove the following parts:
 - Front engine undercover
 - Drive belt: Refer to [EM-15](#).
 - Radiator cooling fan assembly: Refer to [CO-13, "Component"](#).

< SERVICE INFORMATION >

- Crankshaft pulley: Refer to [EM-59](#).
2. Remove front oil seal using suitable tool.

CAUTION:

Be careful not to damage front timing chain case and crankshaft.

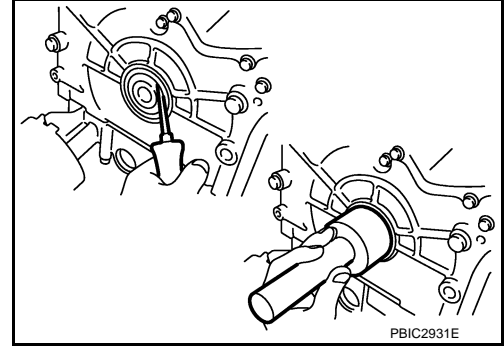

INSTALLATION

1. Apply engine oil to both oil seal lip and dust seal lip of new front oil seal.
2. Install front oil seal.
 - Install front oil seal so that each seal lip is oriented as shown in the figure.

- A : Oil seal lip
- B : Dust seal lip
- ⇐ : Engine inside
- ➡ : Engine outside

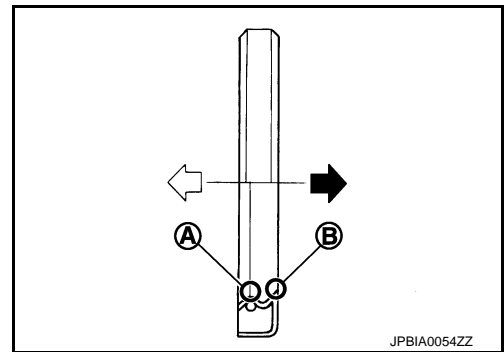

- Using suitable drift, press-fit until the height of front oil seal is level with the mounting surface.
- Suitable drift: outer diameter 60 mm (2.36 in), inner diameter 50 mm (1.97 in).

CAUTION:

- **Be careful not to damage front timing chain case and crankshaft.**
- **Press-fit straight and avoid causing burrs or tilting oil seal.**

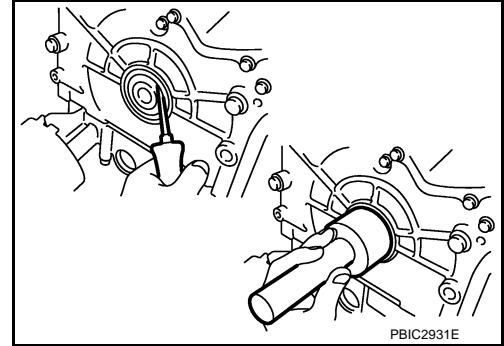

3. Install in the reverse order of removal after this step.

Removal and Installation of Rear Oil Seal

INFOID:000000005348000

REMOVAL

1. Remove transmission assembly. Refer to [AT-243, "Removal and Installation \(2WD Models\)"](#) or [AT-245, "Removal and Installation \(AWD Models\)"](#), [AT-501, "Exploded View"](#).
2. Remove drive plate. Refer to [EM-119](#).

OIL SEAL

< SERVICE INFORMATION >

[VQ35HR]

3. Remove rear oil seal with a suitable tool.

CAUTION:

Be careful not to damage crankshaft and cylinder block.

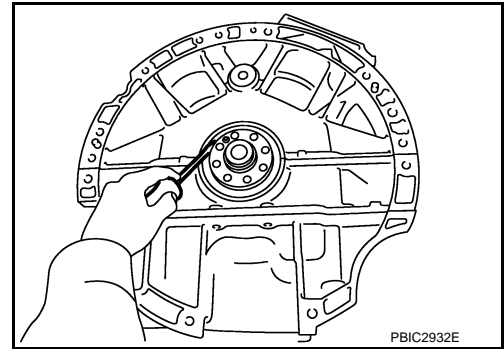

INSTALLATION

1. Apply new engine oil to new rear oil seal joint surface and seal lip.
2. Install rear oil seal so that each seal lip is oriented as shown in the figure.

- A : Oil seal lip
- B : Dust seal lip
- ⇐ : Engine inside
- ⇐ : Engine outside

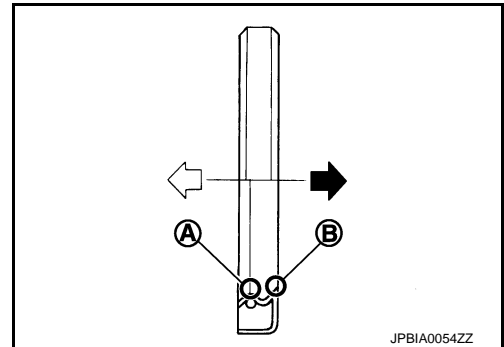

- Press in rear oil seal (1) to the position as shown in the figure.

- B : Cylinder block rear end face
- a : 0 - 0.5 mm (0 - 0.020 in)

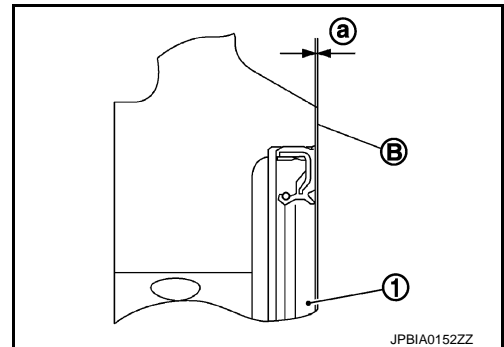

- Using suitable drift (A), press-fit until the height of front oil seal is level with the mounting surface.
- Suitable drift: outer diameter 100 mm (3.94 in), inner diameter 85 mm (3.35 in).

CAUTION:

- **Be careful not to damage crankshaft and cylinder block.**
- **Press-fit oil seal straight to avoid causing burrs or tilting.**

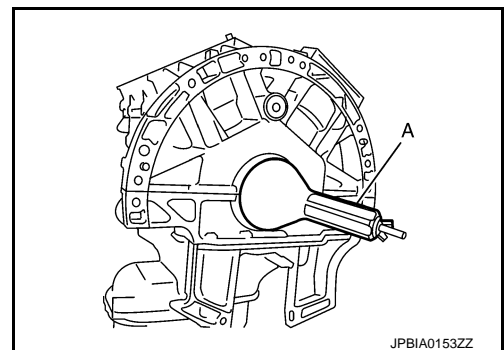

3. Install in the reverse order of removal after this step.

CYLINDER HEAD

< SERVICE INFORMATION >

[VQ35HR]

CYLINDER HEAD

On-Vehicle Service

INFOID:000000005348001

CHECKING COMPRESSION PRESSURE

1. Warm up engine thoroughly. Then, stop it.
2. Release fuel pressure. Refer to [EC-692, "Inspection"](#).
3. Disconnect fuel pump fuse (1) from IPDM E/R (2) to avoid fuel injection during measurement.

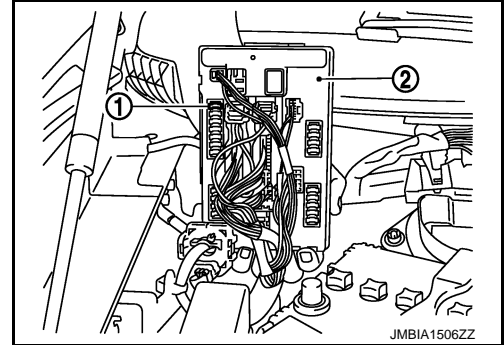

4. Remove engine cover with power tool. Refer to [EM-19, "Removal and Installation"](#).
5. Remove ignition coil and spark plug from each cylinder. Refer to [EM-37](#) and [EM-38](#).
6. Connect engine tachometer (not required in use of CONSULT-III).
7. Install compression tester (commercial service tool) with adapter onto spark plug hole.

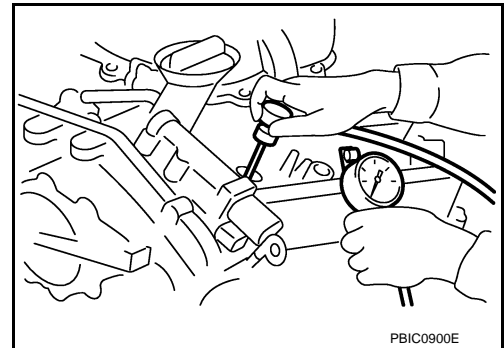

- Use the adapter whose picking up end inserted to spark plug hole is smaller than 20 mm (0.79 in) in diameter. Otherwise, it may be caught by cylinder head during removal.

a : 20 mm (0.79 in)

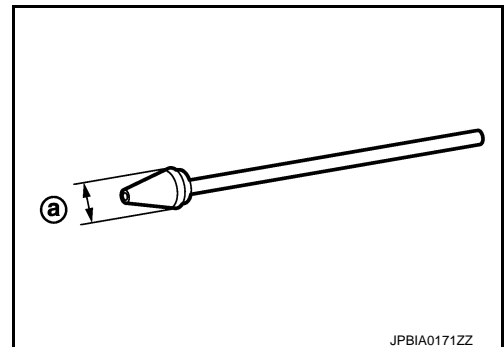

8. With accelerator pedal fully depressed, turn ignition switch to "START" for cranking. When the gauge pointer stabilizes, read the compression pressure and engine rpm. Perform these steps to check each cylinder.

Compression pressure:

Unit: kPa (kg/cm², psi)/rpm

Standard	Minimum	Differential limit between cylinders
1,275 (13.0, 185)/300	981 (10.0, 142)/300	98 (1.0, 14)/300

CAUTION:

Always use a fully charged battery to obtain specified engine speed.

CYLINDER HEAD

< SERVICE INFORMATION >

[VQ35HR]

- If the engine speed is out of specified range, check battery liquid for proper gravity. Check engine speed again with normal battery gravity.
 - If compression pressure is below minimum value, check valve clearances and parts associated with combustion chamber (valve, valve seat, piston, piston ring, cylinder bore, cylinder head, cylinder head gasket). After the checking, measure compression pressure again.
 - If some cylinders have low compression pressure, pour small amount of engine oil into the spark plug hole of the cylinder to recheck it for compression.
 - If the added engine oil improves the compression, piston rings may be worn out or damaged. Check the piston rings and replace if necessary.
 - If the compression pressure remains at low level despite the addition of engine oil, valves may be malfunctioning. Check valves for damage. Replace valve or valve seat accordingly.
 - If two adjacent cylinders have respectively low compression pressure and their compression remains low even after the addition of engine oil, cylinder head gaskets are leaking. In such a case, replace cylinder head gaskets.
9. After inspection is completed, install removed parts.
10. Start engine, and check that engine runs smoothly.
11. Perform trouble diagnosis. If DTC appears, erase it. Refer to [EC-146, "Description"](#).

Component

INFOID:000000005348002

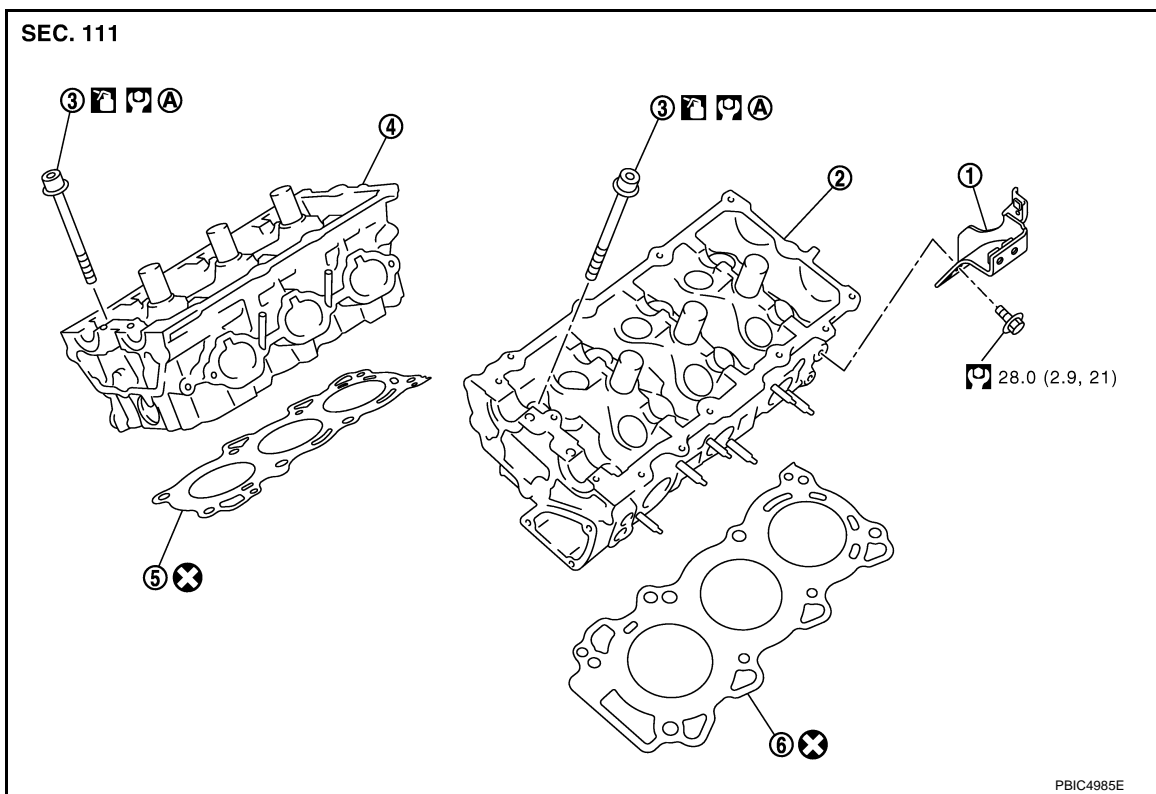

- | | | |
|-----------------------------------|----------------------------------|----------------------------------|
| 1. Engine rear lower slinger | 2. Cylinder head (bank 2) | 3. Cylinder head bolt |
| 4. Cylinder head (bank 1) | 5. Cylinder head gasket (bank 1) | 6. Cylinder head gasket (bank 2) |
| A. Refer to EM-97 | | |

- Refer to [GI-9, "Component"](#) for symbols in the figure.

Removal and Installation

INFOID:000000005348003

REMOVAL

1. Remove engine assembly from vehicle, and separate front suspension member and transmission from engine. Refer to [EM-108, "2WD : Component"](#) (2WD models) or [EM-113, "AWD : Component"](#) (AWD models).

CYLINDER HEAD

[VQ35HR]

< SERVICE INFORMATION >

2. Remove the following parts:
 - Fuel tube and fuel injector assembly: Refer to [EM-40](#).
 - Intake manifold: Refer to [EM-22](#).
 - Exhaust manifold: Refer to [EM-24](#).
 - Water inlet and thermostat assembly: Refer to [CO-26](#), "Component".
 - Water outlet and water pipe: Refer to [CO-28](#), "Component".
 - Front and rear timing chain case: Refer to [EM-60](#).
3. Remove camshaft (INT and EXH). Refer to [EM-79](#).
4. Remove cylinder head bolts in reverse order as shown in the figure with cylinder head bolt wrench (commercial service tool).

- A : Bank 1
 B : Bank 2
 ⇐ : Engine front

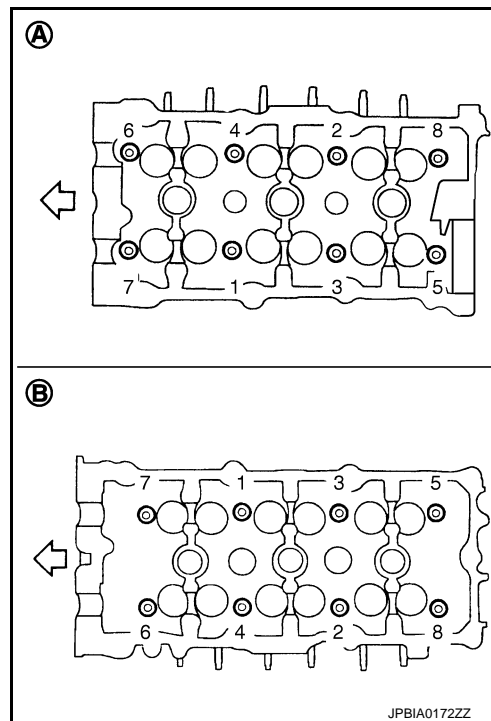

5. Remove cylinder head gaskets.

INSPECTION AFTER REMOVAL

Cylinder Head Bolts Outer Diameter

- Cylinder head bolts are tightened by plastic zone tightening method. Whenever the size difference between (C) and (B) exceeds the limit, replace them with new one.

- A : Measurement point
 e : 48 mm (1.89 in)
 d : 11 mm (0.43 in)

Limit (C – B) : 0.18 mm (0.0071 in)

- If reduction of outer diameter appears in a position other than (B), use it as (B) point.

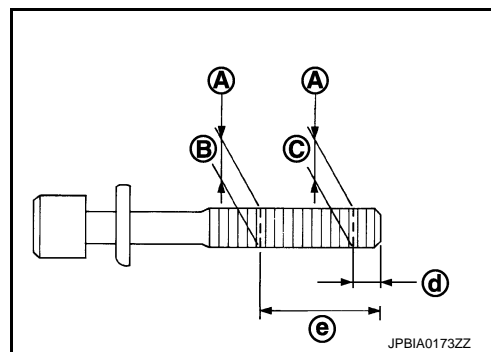

Cylinder Head Distortion

NOTE:

When performing this inspection, cylinder block distortion should be also checked. Refer to [EM-136](#), "Inspection After Disassembly".

1. Using scraper, wipe off oil, scale, gasket, sealant and carbon deposits from surface of cylinder head.

CAUTION:

Never allow gasket fragments to enter engine oil or engine coolant passages.

CYLINDER HEAD

[VQ35HR]

< SERVICE INFORMATION >

- At each of several locations on bottom surface of cylinder head, measure the distortion in six directions (A), (B), (C), (D), (E), and (F).

Limit : 0.1 mm (0.004 in)

- If it exceeds the limit, replace cylinder head.

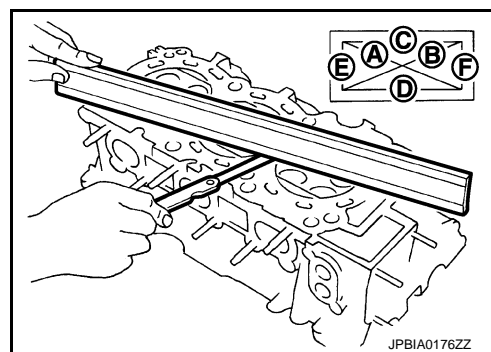

INSTALLATION

- Install new cylinder head gaskets.
- Turn crankshaft until No. 1 piston is set at TDC.
 - Crankshaft key (1) should line up with the bank 1 cylinder center line as shown in the figure.

← : Bank 1 side

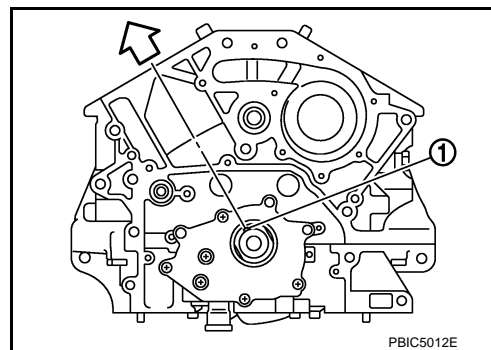

- Install cylinder head follow the steps below to tighten cylinder head bolts in numerical order as shown in the figure.

CAUTION:

If cylinder head bolts reused, check their outer diameters before installation. Refer to "Cylinder Head Bolts Outer Diameter".

- Apply new engine oil to threads and seat surfaces of cylinder head bolts.
- Tighten all cylinder head bolts.

: **105 N·m (11 kg-m, 77 ft-lb)**

- Completely loosen all cylinder head bolts.

: **0 N·m (0 kg-m, 0 ft-lb)**

CAUTION:

In step "c", loosen bolts in reverse order of that indicated in the figure.

- Tighten all cylinder head bolts.

: **40.0 N·m (4.1 kg-m, 30 ft-lb)**

- Turn all bolts 95 degrees clockwise (angle tightening).

CAUTION:

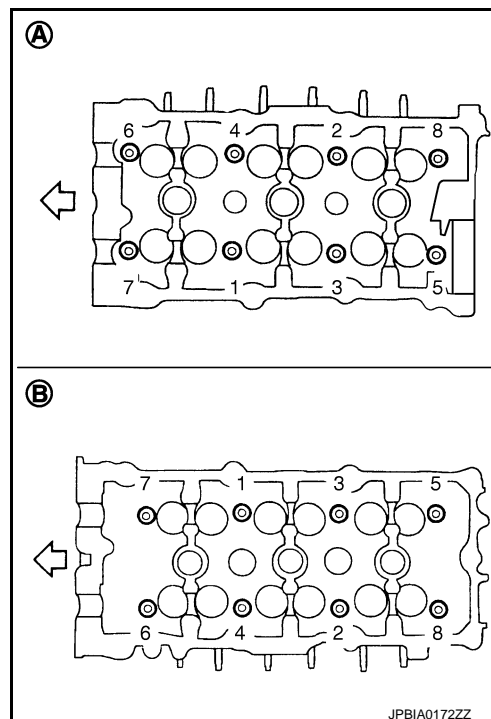

CYLINDER HEAD

[VQ35HR]

< SERVICE INFORMATION >

Check the tightening angle by using angle wrench [SST: KV10112100 (BT8653-A)] (A). Avoid judgment by visual inspection without tool.

- Check tightening angle indicated on angle wrench (SST) indicator plate.

f. Turn all bolts 95 degrees clockwise again (angle tightening).

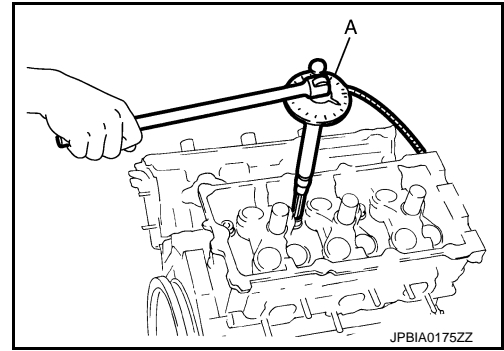

4. After installing cylinder head, measure distance between front end faces of cylinder block and cylinder head (bank 1 and bank 2).

Standard : 14.1 - 14.9 mm (0.555 - 0.587 in)

- If the measured value is out of the standard, reinstall cylinder head.

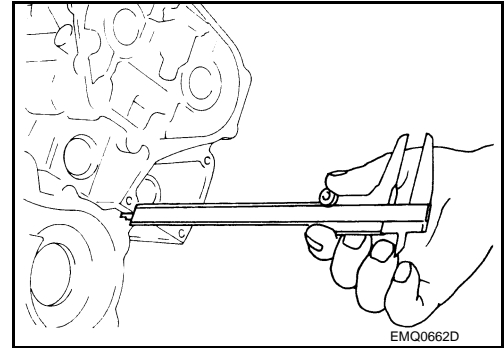

5. Install in the reverse order of removal after this step.

INSPECTION AFTER INSTALLATION

Inspection for Leakage

The following are procedures for checking fluids leakage, lubricates leakage, and exhaust gases leakage.

- Before starting engine, check oil/fluid levels including engine coolant and engine oil. If less than required quantity, fill to the specified level. Refer to [MA-9, "Fluids and Lubricants"](#).
- Use procedure below to check for fuel leakage.
 - Turn ignition switch "ON" (with engine stopped). With fuel pressure applied to fuel piping, check for fuel leakage at connection points.
 - Start engine. With engine speed increased, check again for fuel leakage at connection points.
- Run engine to check for unusual noise and vibration.
- Warm up engine thoroughly to check there is no leakage of fuel, exhaust gases, or any oil/fluids including engine oil and engine coolant.
- Bleed air from lines and hoses of applicable lines, such as in cooling system.
- After cooling down engine, again check oil/fluid levels including engine oil and engine coolant. Refill to the specified level, if necessary.

Summary of the inspection items:

Items	Before starting engine	Engine running	After engine stopped
Engine coolant	Level	Leakage	Level
Engine oil	Level	Leakage	Level
Other oils and fluid*	Level	Leakage	Level
Fuel	Leakage	Leakage	Leakage
Exhaust gases	—	Leakage	—

*: Transmission/transaxle/CVT fluid, power steering fluid, brake fluid, etc.

CYLINDER HEAD

< SERVICE INFORMATION >

[VQ35HR]

Disassembly and Assembly

INFOID:000000005348004

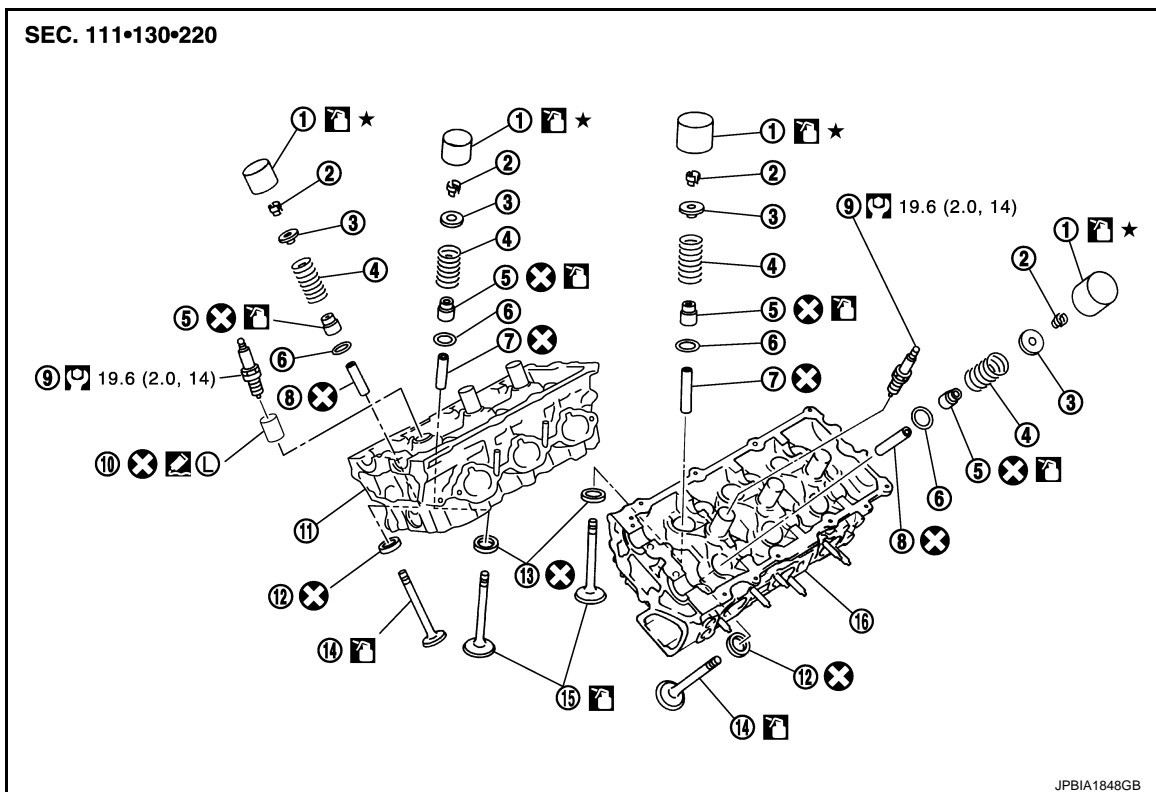

- | | | |
|----------------------------|----------------------------|--------------------------|
| 1. Valve lifter | 2. Valve collet | 3. Valve spring retainer |
| 4. Valve spring | 5. Valve oil seal | 6. Valve spring seat |
| 7. Valve guide (INT) | 8. Valve guide (EXH) | 9. Spark plug |
| 10. Spark plug tube | 11. Cylinder head (bank 1) | 12. Valve seat (EXH) |
| 13. Valve seat (INT) | 14. Valve (EXH) | 15. Valve (INT) |
| 16. Cylinder head (bank 2) | | |

- Refer to [GI-9. "Component"](#) for symbols in the figure.

DISASSEMBLY

- Remove spark plug with spark plug wrench (commercial service tool).
- Remove valve lifter.
 - Identify installation positions, and store them without mixing them up.
- Remove valve collet.
 - Compress valve spring with valve spring compressor [SST: KV10116200 (J26336-A)] (A), attachment [SST: KV10115900 (J26336-20)] (C) and adapter [SST: KV10109220 (—)] (B). Remove valve collet with magnet hand.

CAUTION:

When working, take care not to damage valve lifter holes.

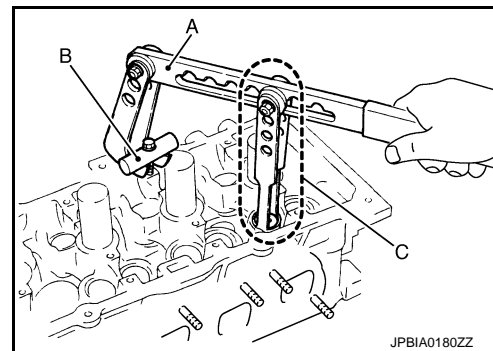

- Remove valve spring retainer, valve spring and valve spring seat.
- Push valve stem to combustion chamber side, and remove valve.
 - Identify installation positions, and store them without mixing them up.

CYLINDER HEAD

[VQ35HR]

< SERVICE INFORMATION >

- Remove valve oil seals using valve oil seal puller [SST: KV10107902 (J38959)] (A).

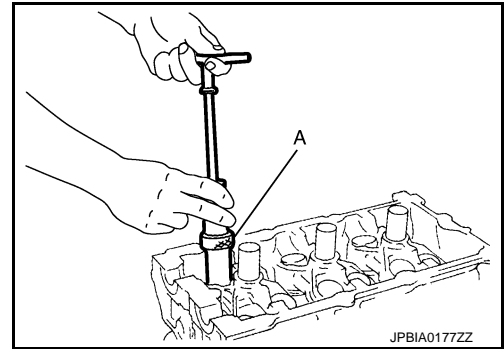

- If valve seat must be replaced, refer to [EM-103, "Inspection After Disassembly"](#).
- If valve guide must be replaced, refer to [EM-103, "Inspection After Disassembly"](#).
- Remove spark plug tube, if necessary.
 - Using pair of pliers, pull spark plug tube out of cylinder head.**CAUTION:**
 - Take care not to damage cylinder head.
 - Once removed, spark plug tube will be deformed and cannot be reused. Never remove it unless absolutely necessary.

ASSEMBLY

- When valve guide is removed, install it. Refer to [EM-103, "Inspection After Disassembly"](#).
- When valve seat is removed, install it. Refer to [EM-103, "Inspection After Disassembly"](#).
- Install valve oil seals.
 - Install with valve oil seal drift [SST: KV10115600 (J38958)] (A) to match dimension in the figure.

Height (b) (Without valve spring seat installed)
Intake and exhaust : 14.3 - 14.9 mm (0.563 - 0.587 in)

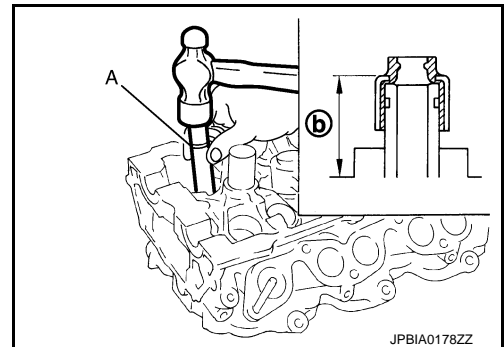

- Install valve spring seat.
- Install valves.**NOTE:**
Larger diameter valves are for intake side.
- Install valve spring (uneven pitch type).
 - Install narrow pitch (B) end [paint mark (C)] to cylinder head side (valve spring seat side).

A : Wide pitch
⇐ : Cylinder head side

Paint mark color : Yellowish green

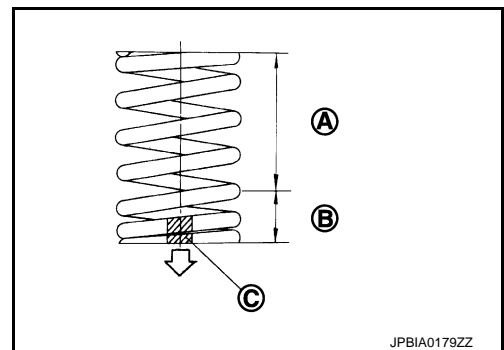

- Install valve spring retainer.
- Install valve collet.

CYLINDER HEAD

< SERVICE INFORMATION >

[VQ35HR]

- Compress valve spring with valve spring compressor [SST: KV10116200 (J26336-A)] (A), attachment [SST: KV10115900 (J26336-20)] (C) and adapter [SST: KV10109220 (—)] (B). Install valve collet with magnet hand.

CAUTION:

When working, take care not to damage valve lifter holes.

- Tap valve stem edge lightly with plastic hammer after installation to check its installed condition.

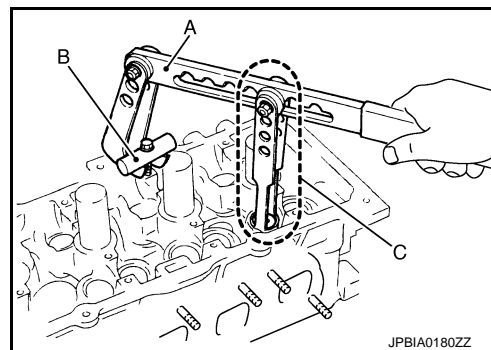

9. Install valve lifter.

- Install it in the original position.

10. Install spark plug tube.

- Press-fit spark plug tube as follows:

a. Remove old liquid gasket adhering to cylinder head mounting hole.

b. Apply liquid gasket to area within approximately 12 mm (0.47 in) from edge of spark plug tube press-fit side.

Use genuine high strength thread locking sealant or equivalent. Refer to [GI-46, "Recommended Chemical Product and Sealant"](#).

c. Using drift, press-fit spark plug tube so that its height (A) is as specified in the figure.

B : Genuine high strength thread locking sealant application area

Standard press-fit height

: 37.7 - 38.7 mm (1.484 - 1.524 in)

CAUTION:

- When press-fitting, take care not to deform spark plug tube.**
- After press-fitting, wipe off liquid gasket protruding onto cylinder-head upper face.**

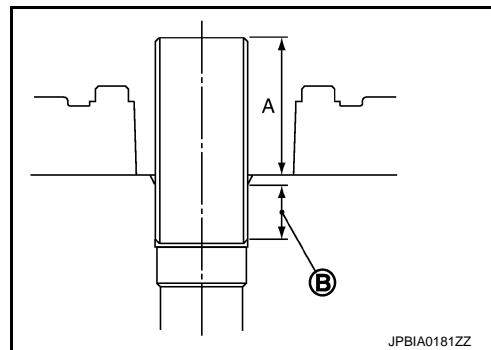

11. Install spark plug with spark plug wrench (commercial service tool).

Inspection After Disassembly

INFOID:000000005348005

VALVE DIMENSIONS

- Check dimensions of each valve. For dimensions, refer to [EM-147, "Standard and Limit"](#).
- If dimensions are out of the standard, replace valve and check valve seat contact. Refer to "VALVE SEAT CONTACT".

VALVE GUIDE CLEARANCE

Valve Stem Diameter

Measure diameter of valve stem with micrometer (A).

Standard

Intake : 5.965 - 5.980 mm (0.2348 - 0.2354 in)

Exhaust : 5.962 - 5.970 mm (0.2347 - 0.2350 in)

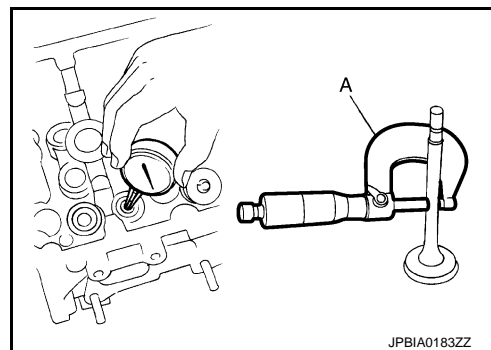

Valve Guide Inner Diameter

Measure inner diameter of valve guide with inside micrometer.

CYLINDER HEAD

< SERVICE INFORMATION >

[VQ35HR]

Standard

Intake and Exhaust : 6.000 - 6.018 mm (0.2362 - 0.2369 in)

Valve Guide Clearance

(Valve guide clearance) = (Valve guide inner diameter) – (Valve stem diameter)

Valve guide clearance:

Standard

Intake : 0.020 - 0.053 mm (0.0008 - 0.0021 in)

Exhaust : 0.030 - 0.056 mm (0.0012 - 0.0022 in)

Limit

Intake : 0.08 mm (0.0031 in)

Exhaust : 0.09 mm (0.0035 in)

- If it exceeds the limit, replace valve and/or valve guide. When valve guide must be replaced, refer to "VALVE GUIDE REPLACEMENT".

VALVE GUIDE REPLACEMENT

When valve guide is removed, replace with Oversize (Service) [0.2 mm (0.008 in)] valve guide.

1. To remove valve guide, heat cylinder head to 110 to 130°C (230 to 266°F) by soaking in heated oil (A).

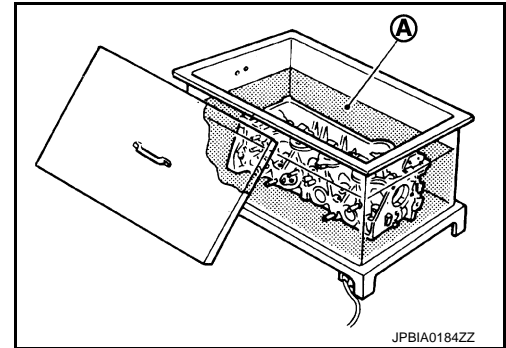

2. Drive out valve guide with a press [under a 20 kN (2 ton, 2.2 US ton, 2.0 Imp ton) pressure] or hammer and suitable tool.

WARNING:

Cylinder head contains heat. When working, wear protective equipment to avoid getting burned.

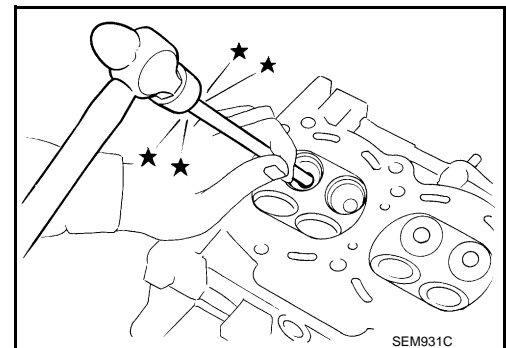

3. Using valve guide reamer (commercial service tool) (A), ream cylinder head valve guide hole.

Valve guide hole diameter (for service parts):

Intake and exhaust

: 10.175 - 10.196 mm (0.4006 - 0.4014 in)

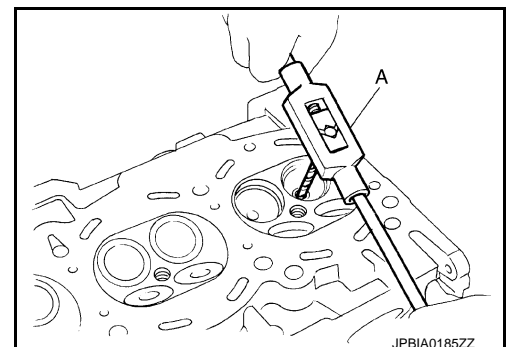

CYLINDER HEAD

[VQ35HR]

< SERVICE INFORMATION >

4. Heat cylinder head to 110 to 130°C (230 to 266°F) by soaking in heated oil (A).

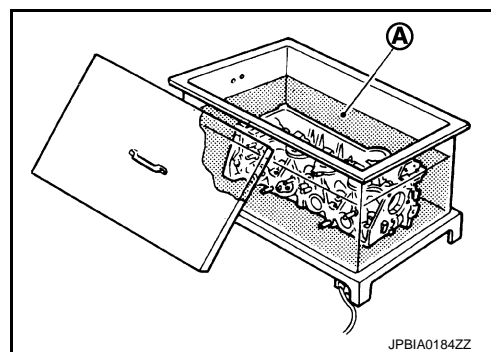

5. Using valve guide drift (commercial service tool), press valve guide from camshaft side to the dimensions as in the figure.

Projection "L"

Intake and exhaust

: 12.6 - 12.8 mm (0.496 - 0.504 in)

WARNING:

Cylinder head contains heat. When working, wear protective equipment to avoid getting burned.

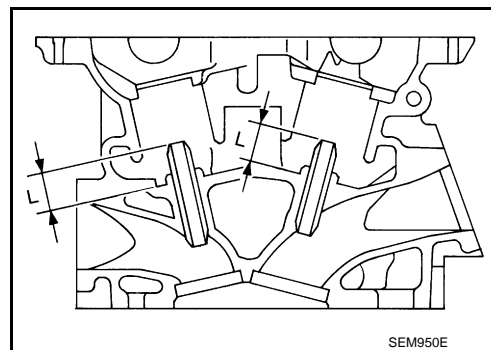

6. Using valve guide reamer (commercial service tool) (A), apply reamer finish to valve guide.

Standard:

Intake and exhaust

: 6.000 - 6.018 mm (0.2362 - 0.2369 in)

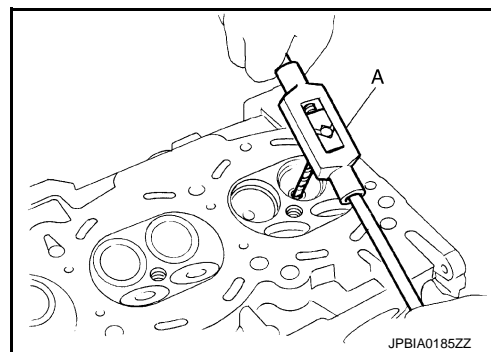

VALVE SEAT CONTACT

- After confirming that the dimensions of valve guides and valves are within the specifications, perform this procedure.
- Apply prussian blue (or white lead) onto contacting surface of valve seat to check the condition of the valve contact on the surface.
- Check if the contact area band is continuous all around the circumference.
- If not, grind to adjust valve fitting and check again. If the contacting surface still has "NG" conditions (B) even after the recheck, replace valve seat. Refer to "VALVE SEAT REPLACEMENT".

A : OK

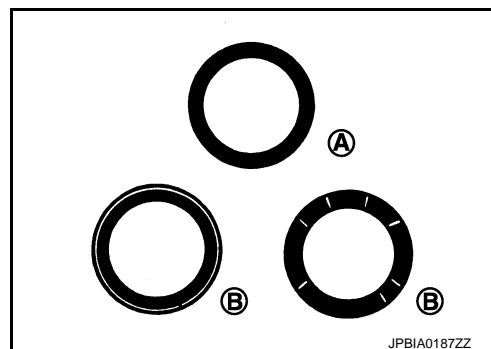

VALVE SEAT REPLACEMENT

When valve seat is removed, replace with Oversize (Service) [0.5 mm (0.020 in)] valve seat.

1. Bore out old seat until it collapses. Boring should not continue beyond the bottom face of the seat recess in cylinder head. Set the machine depth stop to ensure this. Refer to [EM-147, "Standard and Limit"](#).

CAUTION:

Prevent to scratch cylinder head by excessive boring.

CYLINDER HEAD

[VQ35HR]

< SERVICE INFORMATION >

2. Ream cylinder head recess diameter (a) for service valve seat.

Oversize (Service) [0.5 mm (0.020 in)]

Intake : 38.500 - 38.516 mm (1.5157 - 1.5164 in)

Exhaust : 32.100 - 32.116 mm (1.2638 - 1.2644 in)

- Be sure to ream in circles concentric to valve guide center. This will enable valve to fit correctly.

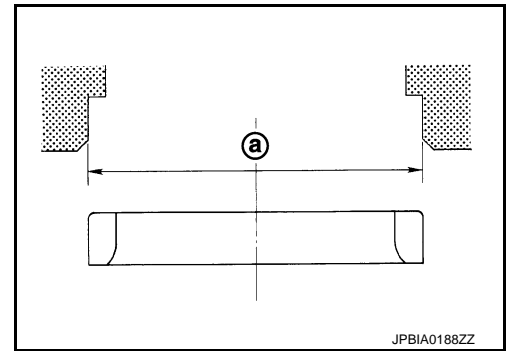

JPBIA0188ZZ

3. Heat cylinder head to 110 to 130°C (230 to 266°F) by soaking in heated oil (A).

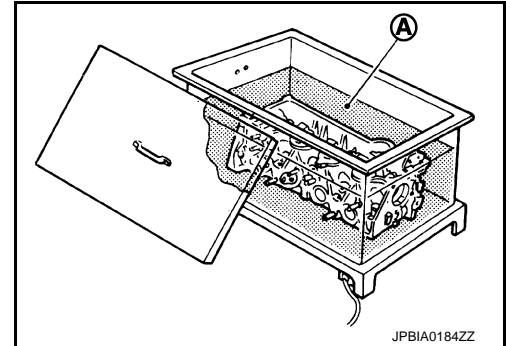

JPBIA0184ZZ

4. Provide valve seats cooled well with dry ice. Force fit valve seat into cylinder head.

WARNING:

- Avoid directly touching cold valve seats.
- Cylinder head contains heat. When working, wear protective equipment to avoid getting burned.

5. Using valve seat cutter set (commercial service tool) or valve seat grinder, finish seat to the specified dimensions. Refer to [EM-147, "Standard and Limit"](#).

CAUTION:

When using valve seat cutter, firmly grip cutter handle with both hands. Then, press on the contacting surface all around the circumference to cut in a single drive. Improper pressure on with cutter or cutting many different times may result in stage valve seat.

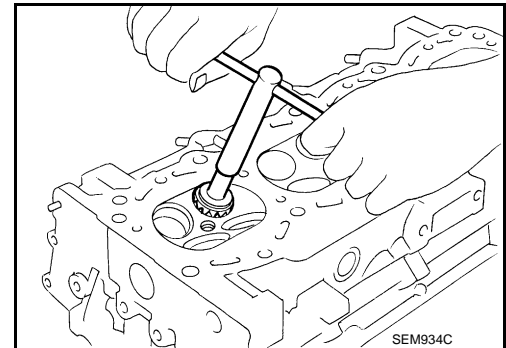

SEM934C

6. Using compound, grind to adjust valve fitting.
7. Check again for normal contact. Refer to "VALVE SEAT CONTACT".

VALVE SPRING SQUARENESS

- Set try square (A) along the side of valve spring and rotate spring. Measure the maximum clearance between the top face of spring and try square.

B : Contact

Limit : 1.9 mm (0.075 in)

- If it exceeds the limit, replace valve spring.

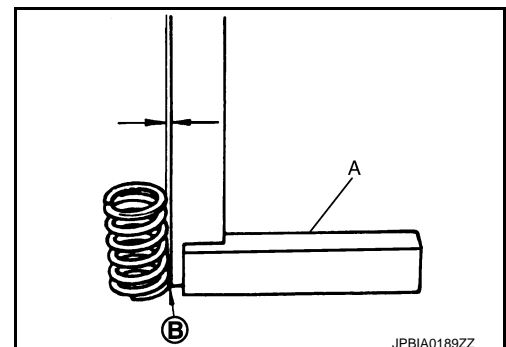

JPBIA0189ZZ

VALVE SPRING DIMENSIONS AND VALVE SPRING PRESSURE LOAD

CYLINDER HEAD

[VQ35HR]

< SERVICE INFORMATION >

- Check valve spring pressure at specified spring height.

Standard:

Intake and exhaust

Free height	: 43.85 mm (1.7264 in)
Installation height	: 37.00 mm (1.4567 in)
Installation load	: 166 - 188 N (16.9 - 19.2 kg, 37 - 42 lb)
Height during valve open	: 26.8 mm (1.055 in)
Load with valve open	: 502 - 566 N (51.2 - 57.7 kg, 113 - 127 lb)

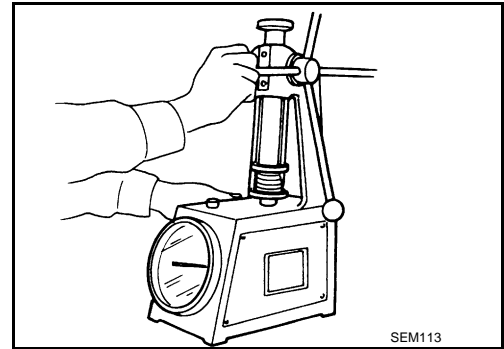

- If the installation load or load with valve open is out of the standard, replace valve spring.

A

EM

C

D

E

F

G

H

I

J

K

L

M

N

O

P

ENGINE ASSEMBLY

2WD

2WD : Component

INFOID:000000005348006

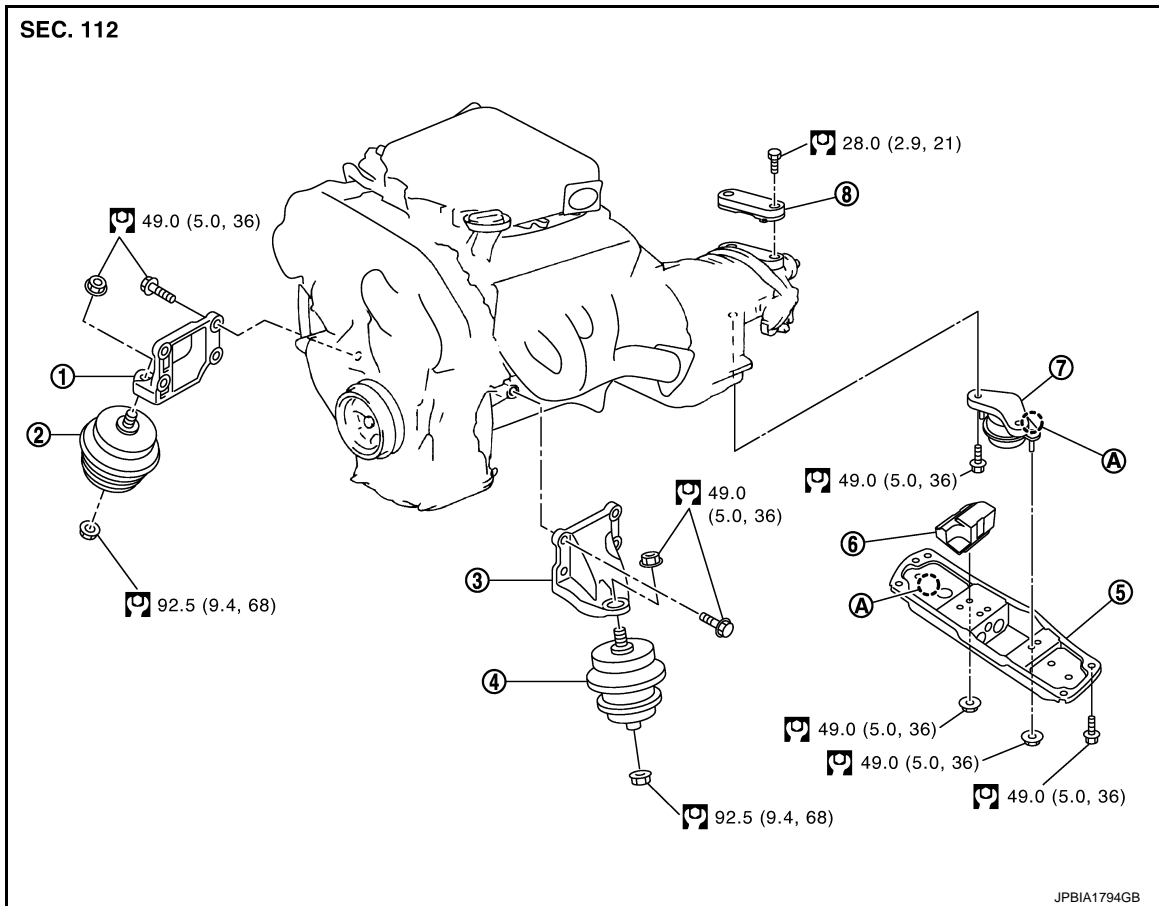

- | | | |
|-------------------------------------|-----------------------------------|---------------------------------|
| 1. Engine mounting bracket (RH) | 2. Engine mounting insulator (RH) | 3. Engine mounting bracket (LH) |
| 4. Engine mounting insulator (LH) | 5. Rear engine mounting member | 6. Dynamic damper |
| 7. Engine mounting insulator (rear) | 8. Dynamic damper | |

- Refer to [GI-9, "Component"](#) for symbols in the figure.

2WD : Removal and Installation

INFOID:000000005348007

WARNING:

- Situate the vehicle on a flat and solid surface.
- Place chocks at front and back of rear wheels.
- For engines not equipped with engine slingers, attach proper slingers and bolts described in PARTS CATALOG.

CAUTION:

- Always be careful to work safely, avoid forceful or uninstructed operations.
- Never start working until exhaust system and engine coolant are cool enough.
- If items or work required are not covered by the engine section, refer to the applicable sections.
- Always use the support point specified for lifting.
- Use either 2-pole lift type or separate type lift as best you can. If board-on type is used for unavoidable reasons, support at rear axle jacking point with transmission jack or similar tool before starting work, in preparation for the backward shift of center of gravity.
- For supporting points for lifting and jacking point at rear axle, refer to [GI-38, "Garage Jack and Safety Stand and 2-Pole Lift"](#).

REMOVAL

Outline

At first, remove the engine and the transmission assembly with front suspension member downward. Then separate the engine from transmission.

Preparation

1. Release fuel pressure. Refer to [EC-692, "Inspection"](#).
2. Disconnect both battery cables. Refer to [SC-4, "How to Handle Battery"](#).
3. Drain engine coolant from radiator. Refer to [CO-10, "Changing Engine Coolant"](#).
CAUTION:
 - Perform this step when engine is cold.
 - Never spill engine coolant on drive belt.
4. Remove the following parts:
 - Engine room cover (RH and LH): Refer to [EM-14, "Component"](#).
 - Radiator reservoir tank: Refer to [CO-13, "Component"](#).
 - Engine cover: Refer to [EM-19, "Removal and Installation"](#).
 - Front road wheel and tires (power tool)
 - Front and rear engine undercover (power tool)
 - Cowl top cover: Refer to [EI-29, "Component Parts Location"](#).
 - Air duct and air cleaner case assembly (RH and LH): Refer to [EM-17, "Component"](#).
 - Drive belt: Refer to [EM-15, "Removal and Installation"](#).
5. Discharge refrigerant from A/C circuit. Refer to [ATC-136, "VQ35HR : Component"](#).
6. Remove radiator hoses (upper and lower). Refer to [CO-13, "Component"](#).

Engine Room LH

1. Disconnect heater hose from vehicle-side, and fit a plug onto hose end to prevent engine coolant leakage.
2. Disconnect ground cable.
3. Disconnect A/C piping from A/C compressor, and temporarily fasten it on vehicle with a rope. Refer to [ATC-137, "VQ35HR : Removal and Installation of Compressor"](#).

Engine Room RH

1. Disconnect battery positive cable at vehicle side and temporarily fasten it on engine.
2. Disconnect brake booster vacuum hose.
3. Disconnect all clips and connector of the engine room harness from engine back side.
4. Disconnect fuel feed hose (with damper) and EVAP hose. Refer to [EM-40, "Component"](#).
CAUTION:
Fit plugs onto disconnected hoses to prevent fuel leakage.
5. Remove reservoir tank of power steering oil pump and piping from vehicle, and temporarily secure them on engine. Refer to [PS-36, "Removal and Installation"](#).
CAUTION:
When temporarily securing, keep the reservoir tank upright to avoid a fluid leakage.

Vehicle Inside

Follow procedure below to disconnect engine room harness connectors at passenger room side, and temporarily secure them on engine.

1. Remove passenger-side kicking plate and dash side finisher. Refer to [EI-48, "Component Parts Location"](#).
2. Disconnect engine room harness connectors at unit sides TCM, ECM and other.
3. Disengage intermediate fixing point. Pull out engine room harnesses to engine room side, and temporarily secure them on engine.
CAUTION:
 - When pulling out harnesses, take care not to damage harnesses and connectors.
 - After temporarily securing, cover connectors with vinyl or similar material to protect against foreign material adhesion.

Vehicle Underbody

1. Remove A/T fluid cooler hoses and power steering oil pump oil cooler hoses.
 - Install plug to avoid leakage of A/T fluid and power steering fluid.
2. Disconnect heated oxygen sensor 2 harness.

ENGINE ASSEMBLY

[VQ35HR]

< SERVICE INFORMATION >

3. Remove three way catalyst and exhaust front tube. Refer to [EX-3, "Component"](#).
4. Disconnect steering lower joint at power steering gear assembly side, and release steering lower shaft. Refer to [PS-12, "Removal and Installation"](#).
5. Remove rear propeller shaft. Refer to [PR-8, "Component"](#).
6. Disengage A/T control rod at A/T shift selector side. Then, temporarily secure it on the transmission assembly, so that it does not sag. Refer to [AT-205, "A/T Shift Selector Removal and Installation"](#) or [AT-493, "Exploded View"](#).
7. Remove rear plate cover from oil pan (upper). Then remove bolts fixing drive plate to torque converter. Refer to [EM-28, "2WD : Component"](#).
8. Remove transmission joint bolts which pierce at oil pan (upper) lower rear side. Refer to [EM-28, "2WD : Component"](#).
9. Remove front stabilizer connecting rod from transverse link. Refer to [FSU-7, "Component"](#).
10. Remove lower ends of left and right steering knuckle from transverse link. Refer to [FSU-7, "Component"](#).
11. Separate steering outer sockets from steering knuckle. Refer to [PS-18, "Removal and Installation"](#).
12. Remove transverse links mounting bolts at suspension member side. Refer to [FSU-7, "Component"](#).

Removal Work

1. Use a manual lift table caddy (commercial service tool) or equivalently rigid tool such as a transmission jack. Securely support bottom of suspension member and the transmission assembly.

CAUTION:

Put a piece of wood or something similar as the supporting surface, secure a completely stable condition.

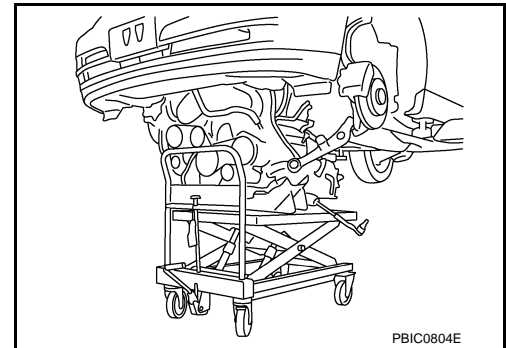

PBIC0804E

2. Remove rear engine mounting member bolts.
3. Remove front suspension member mounting bolts and nuts. Refer to [FSU-7, "Component"](#).
4. Carefully lower jack, or raise lift to remove the engine, the transmission assembly and front suspension member. When performing work, observe the following caution:

CAUTION:

- Confirm there is no interference with the vehicle.
- Check that all connection points have been disconnected.
- Keep in mind the center of vehicle gravity changes. If necessary, use jack(s) to support the vehicle at rear jacking point(s) to prevent it from falling off the lift.

Separation Work

1. Install engine slingers into front of cylinder head (bank 1) and rear of cylinder head (bank 2).

- 1 : Engine front slinger
- 2 : Engine rear upper slinger
- 3 : Spacer
- 4 : Engine rear lower slinger
- A : Bank 1
- B : Bank 2
- ⇐ : Engine front

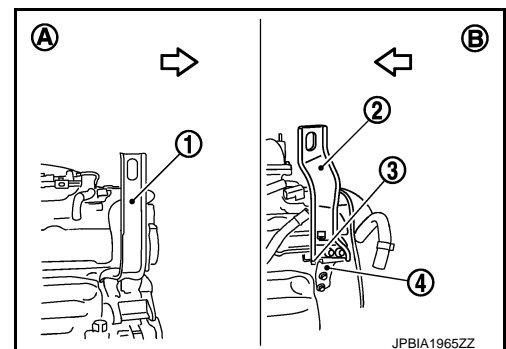

JPBIA1965ZZ

Slinger bolts:

: 28.0 N·m (2.9 kg·m, 21 ft·lb)

ENGINE ASSEMBLY

[VQ35HR]

< SERVICE INFORMATION >

- To protect rocker cover against damage caused by tilting of engine slinger, insert spacer between cylinder head and engine rear lower slinger (3), in direction shown in the figure.

1 : Engine rear upper slinger

⇐ : Engine front

NOTE:

Spacer (2) is a component part of engine rear upper slinger assembly.

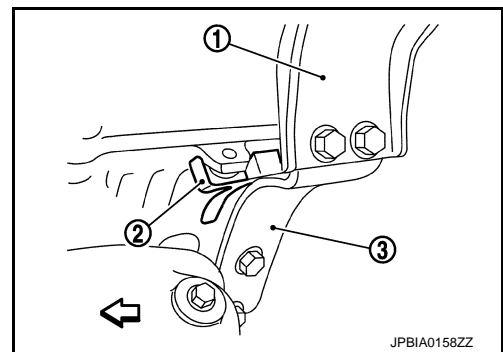

- Remove power steering oil pump from engine side. Refer to [PS-36, "Removal and Installation"](#).
- Remove engine mounting insulators (RH and LH) under side nuts with power tool.
- Lift with hoist and separate the engine and the transmission assembly from front suspension member.
CAUTION:
 - Before and during this lifting, always check that any harnesses are left connected.
 - Avoid damage to and oil/grease smearing or spills onto engine mounting insulator.
- Remove alternator. Refer to [SC-29, "Removal and Installation"](#).
- Remove starter motor. Refer to [SC-13, "Removal and Installation"](#).
- Separate the engine from the transmission assembly. Refer to [AT-245, "Removal and Installation \(AWD Models\)"](#) or [AT-501, "Exploded View"](#).
- Remove each engine mounting insulator and each engine mounting bracket from the engine with power tool.

INSTALLATION

Note the following, and install in the reverse order of removal.

- Do not allow engine mounting insulator to be damage and careful no oil gets on it.
- For a location with a positioning pin, insert it securely into hole of mating part.
- For a part with a specified installation orientation, refer to component figure in [EM-108, "2WD : Component"](#).
- When installing engine mounting bracket (RH and LH) on cylinder block, tighten two upper bolts [shown as (B) in the figure] first. Then tighten two lower bolts [shown as (C) in the figure].

A : Example Left

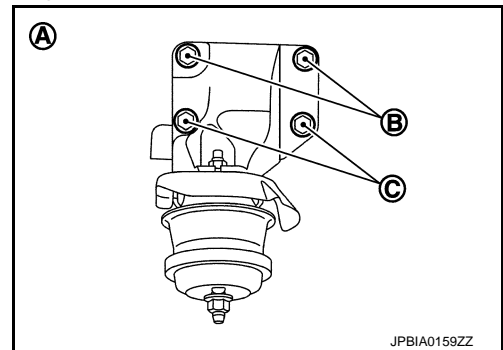

- Check all engine mounting insulators are seated properly, then tighten mounting nuts.
- Tighten rear engine mounting member bolts in numerical order as shown in the figure.

⇐ : Vehicle front

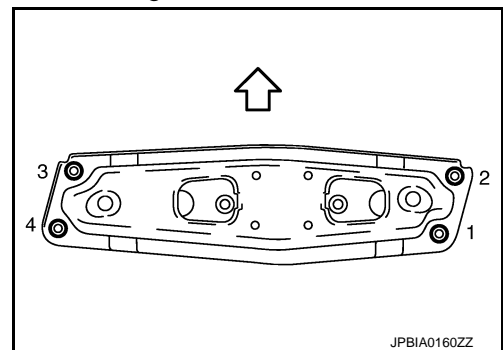

INSPECTION AFTER INSTALLATION

Inspection for Leakage

The following are procedures for checking fluids leakage, lubricates leakage, and exhaust gases leakage.

ENGINE ASSEMBLY

[VQ35HR]

< SERVICE INFORMATION >

- Before starting engine, check oil/fluid levels including engine coolant and engine oil. If less than required quantity, fill to the specified level. Refer to [MA-9, "Fluids and Lubricants"](#).
- Use procedure below to check for fuel leakage.
 - Turn ignition switch "ON" (with engine stopped). With fuel pressure applied to fuel piping, check for fuel leakage at connection points.
 - Start engine. With engine speed increased, check again for fuel leakage at connection points.
- Run engine to check for unusual noise and vibration.
- Warm up engine thoroughly to check there is no leakage of fuel, exhaust gases, or any oil/fluids including engine oil and engine coolant.
- Bleed air from lines and hoses of applicable lines, such as in cooling system.
- After cooling down engine, again check oil/fluid levels including engine oil and engine coolant. Refill to the specified level, if necessary.

Summary of the inspection items:

Items	Before starting engine	Engine running	After engine stopped
Engine coolant	Level	Leakage	Level
Engine oil	Level	Leakage	Level
Other oils and fluid*	Level	Leakage	Level
Fuel	Leakage	Leakage	Leakage
Exhaust gases	—	Leakage	—

*: Transmission/transaxle/CVT fluid, power steering fluid, brake fluid, etc.

AWD

ENGINE ASSEMBLY

< SERVICE INFORMATION >

[VQ35HR]

AWD : Component

INFOID:000000005348008

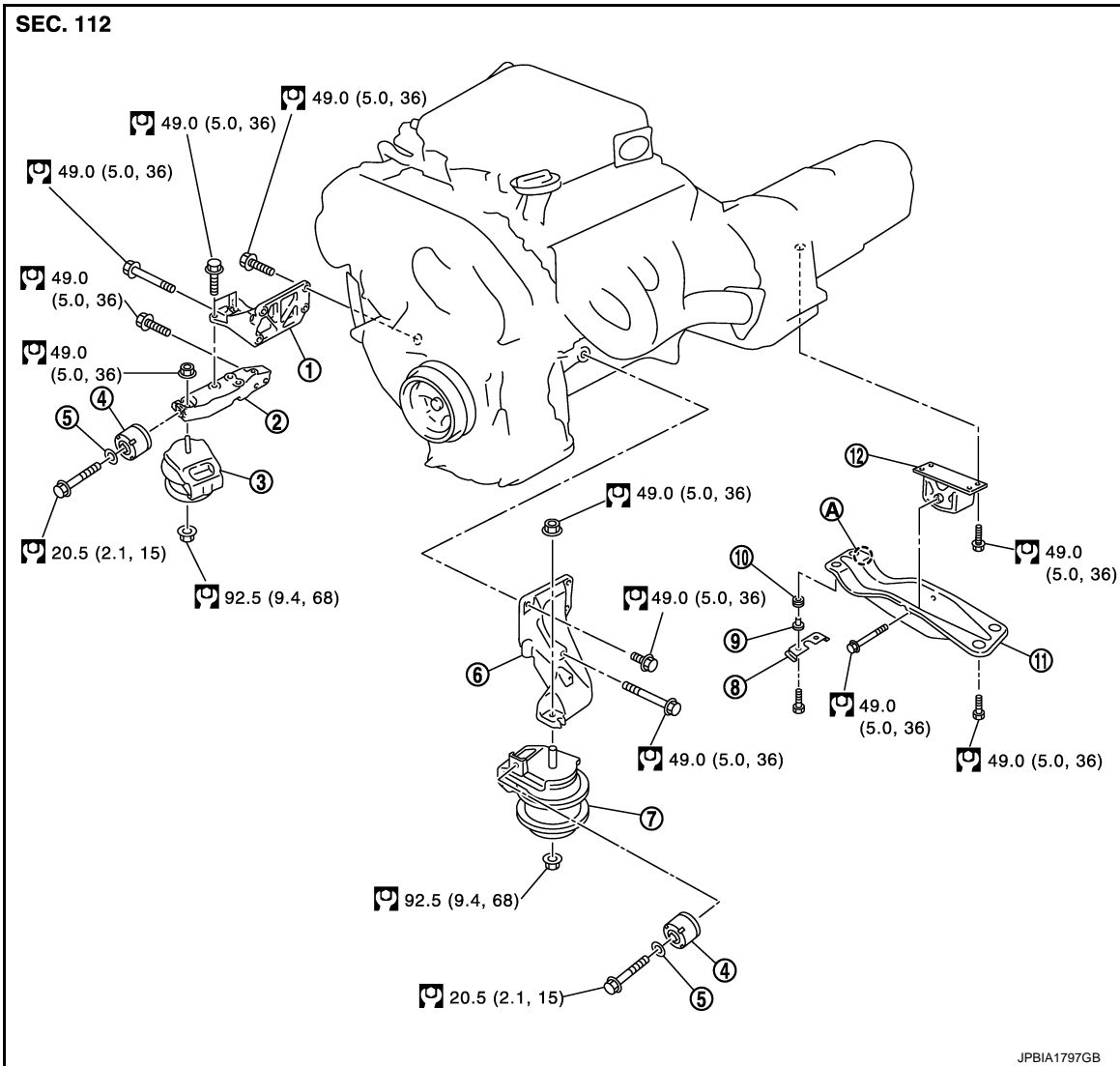

- | | | |
|-----------------------------------|---|--------------------------------------|
| 1. Engine mounting bracket (RH) | 2. Engine mounting bracket (RH) (lower) | 3. Engine mounting insulator (RH) |
| 4. Dynamic damper | 5. Washer | 6. Engine mounting bracket (LH) |
| 7. Engine mounting insulator (LH) | 8. Heat insulator | 9. Caller |
| 10. Bush | 11. Rear engine mounting member | 12. Engine mounting insulator (rear) |
| A. Front mark | | |

- Refer to [GI-9. "Component"](#) for symbols in the figure.

AWD : Removal and Installation

INFOID:000000005348009

WARNING:

- Situate the vehicle on a flat and solid surface.
- Place chocks at front and back of rear wheels.
- For engines not equipped with engine slingers, attach proper slingers and bolts described in PARTS CATALOG.

CAUTION:

- Always be careful to work safely, avoid forceful or uninstructed operations.
- Never start working until exhaust system and engine coolant are cool enough.
- If items or work required are not covered by the engine section, refer to the applicable sections.
- Always use the support point specified for lifting.

ENGINE ASSEMBLY

[VQ35HR]

< SERVICE INFORMATION >

- Use either 2-pole lift type or separate type lift as best you can. If board-on type is used for unavoidable reasons, support at rear axle jacking point with transmission jack or similar tool before starting work, in preparation for the backward shift of center of gravity.
- For supporting points for lifting and jacking point at rear axle, refer to [GI-38, "Garage Jack and Safety Stand and 2-Pole Lift"](#).

REMOVAL

Outline

At first, remove the engine, the transmission assembly, the transfer assembly and the front final drive assembly with front suspension member downward. Then separate the engine, the transmission assembly, the transfer and the front final drive assembly.

Preparation

1. Release fuel pressure. Refer to [EC-692, "Inspection"](#).
2. Disconnect both battery terminals. Refer to [SC-4, "How to Handle Battery"](#).
3. Drain engine coolant from radiator. Refer to [CO-10, "Changing Engine Coolant"](#).
CAUTION:
 - Perform this step when engine is cold.
 - Never spill engine coolant on drive belt.
4. Remove the following parts:
 - Engine room cover (RH and LH): Refer to [EM-14, "Component"](#).
 - Radiator reservoir tank: Refer to [CO-13, "Component"](#).
 - Engine cover: Refer to [EM-19, "Removal and Installation"](#).
 - Front road wheel and tires (power tool)
 - Front and rear engine undercover (power tool)
 - Front cross bar: Refer to [FSU-24, "Component"](#).
 - Cowl top cover: Refer to [EI-29, "Component Parts Location"](#).
 - Air duct and air cleaner case assembly (RH and LH): Refer to [EM-17, "Component"](#).
 - Drive belt: Refer to [EM-15, "Removal and Installation"](#).
5. Discharge refrigerant from A/C circuit. Refer to [ATC-136, "VQ35HR : Component"](#).
6. Remove radiator hoses (upper and lower). Refer to [CO-13, "Component"](#).

Engine Room LH

1. Disconnect heater hose from vehicle-side, and fit a plug onto hose end to prevent engine coolant leakage.
2. Disconnect A/C piping from A/C compressor, and temporarily fasten it on vehicle with a rope. Refer to [ATC-137, "VQ35HR : Removal and Installation of Compressor"](#).
3. Disconnect ground cables.

Engine Room RH

1. Disconnect battery positive cable vehicle side and temporarily fasten it on engine.
2. Disconnect brake booster vacuum hose.
3. Disconnect all clips and connectors of the engine room harness from engine back side.
4. Disconnect fuel feed hose (with damper) and EVAP hose. Refer to [EM-40, "Component"](#).
CAUTION:
Fit plugs onto disconnected hoses to prevent fuel leakage.
5. Remove reservoir tank of power steering oil pump and piping from vehicle, and temporarily secure them on engine. Refer to [PS-36, "Removal and Installation"](#).
CAUTION:
When temporarily securing, keep the reservoir tank upright to avoid a fluid leakage.

Vehicle Inside

Follow procedure below to disconnect engine room harness connectors at passenger room side, and temporarily secure them on engine.

1. Remove passenger-side kicking plate and dash side finisher. Refer to [EI-48, "Component Parts Location"](#).
2. Disconnect engine room harness connectors at unit sides TCM, ECM and other.
3. Disengage intermediate fixing point. Pull out engine room harnesses to engine room side, and temporarily secure them on engine.
CAUTION:

ENGINE ASSEMBLY

[VQ35HR]

< SERVICE INFORMATION >

- **When pulling out harnesses, take care not to damage harnesses and connectors.**
- **After temporarily securing, cover connectors with vinyl or similar material to protect against foreign material adhesion.**

Vehicle Underbody

1. Remove A/T fluid cooler hoses and power steering oil pump oil cooler hoses.
 - Install plug to avoid leakage of A/T fluid and power steering fluid.
2. Disconnect heated oxygen sensor 2 harness. Refer to [EX-3, "Component"](#).
3. Remove three way catalyst and exhaust front tube. Refer to [EX-3, "Component"](#).
4. Disconnect steering lower joint at power steering gear assembly side, and release steering lower shaft. Refer to [PS-12, "Removal and Installation"](#) (without 4WAS models).
5. Remove rear propeller shaft. Refer to [PR-4, "Component"](#).
6. Remove front drive shaft (both side). Refer to [FAX-12, "Removal and Installation"](#).
7. Disconnect harness connector from transmission assembly and transfer assembly.
8. Disengage A/T control rod at A/T shift selector side. Then, temporarily secure it on the transmission assembly, so that it does not sag. Refer to [AT-205, "A/T Shift Selector Removal and Installation"](#).
9. Remove rear plate cover from oil pan (upper). Then remove bolts fixing drive plate to torque converter. Refer to [EM-32, "AWD : Component"](#).
10. Remove bolts fixing the transmission assembly to lower rear side of oil pan (upper). Refer to [AT-245, "Removal and Installation \(AWD Models\)"](#).
11. Remove front stabilizer connecting rod from transverse link. Refer to [FSU-24, "Component"](#).
12. Remove lower ends of left and right steering knuckle from transverse link. Refer to [FSU-24, "Component"](#).
13. Separate steering outer sockets from steering knuckle. Refer to [PS-18, "Removal and Installation"](#).
14. Remove transverse links mounting bolts at suspension member side. Refer to [FSU-24, "Component"](#).

Removal Work

1. Use a manual lift table caddy (commercial service tool) or equivalently rigid tool such as a transmission jack. Securely support bottom of suspension member and transmission.

CAUTION:

Put a piece of wood or something similar as the supporting surface, secure a completely stable condition.

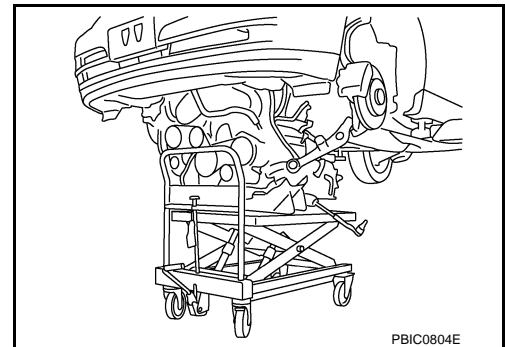

2. Remove rear engine mounting member bolts.
3. Remove front suspension member mounting bolts and nuts. Refer to [FSU-24, "Component"](#).
4. Carefully lower jack, or raise lift to remove the engine, transmission assembly, transfer, front final drive assembly and front suspension member. When performing work, observe the following caution:

CAUTION:

- **Confirm there is no interference with the vehicle.**
- **Check that all connection points have been disconnected.**
- **Keep in mind the center of the vehicle gravity changes. If necessary, use jack(s) to support the vehicle at rear jacking point(s) to prevent it from falling it off the lift.**

Separation Work

ENGINE ASSEMBLY

[VQ35HR]

< SERVICE INFORMATION >

1. Install engine slingers into front of cylinder head (bank 1) and rear of cylinder head (bank 2).

- 1 : Engine front slinger
- 2 : Engine rear upper slinger
- 3 : Spacer
- 4 : Engine rear lower slinger
- A : Bank 1
- B : Bank 2
- ⇐ : Engine front

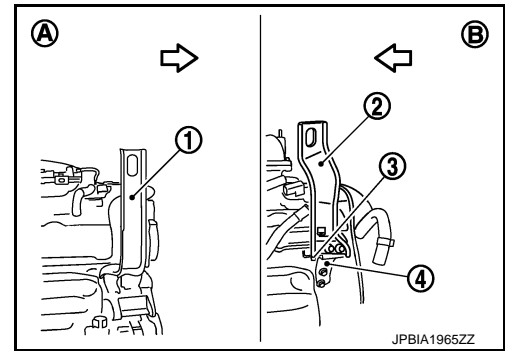

Slinger bolts:

: 28.0 N·m (2.9 kg·m, 21 ft·lb)

- To protect rocker cover against damage caused by tilting of engine slinger, insert spacer between cylinder head and engine rear lower slinger (3), in direction shown in the figure.

- 1 : Engine rear upper slinger
- ⇐ : Engine front

NOTE:

Spacer (2) is a component part of engine rear upper slinger assembly.

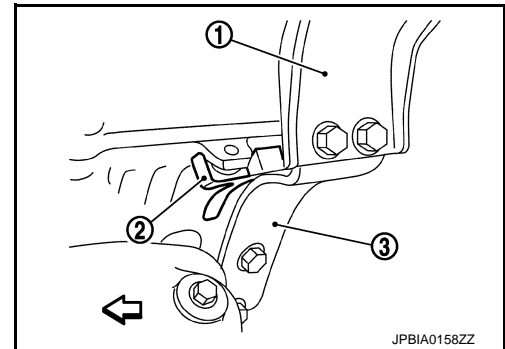

2. Remove power steering oil pump from engine side. Refer to [PS-36, "Removal and Installation"](#) (without 4WAS models).
3. Remove engine mounting insulators (RH and LH) under side nuts with power tool.
4. Lift with hoist and separate the engine, the transmission assembly, the transfer assembly and the front final drive assembly from front suspension member.

CAUTION:

- Before and during this lifting, always check if any harnesses are left connected.
- Avoid damage to and oil/grease smearing or spills onto engine mounting insulator.

5. Remove alternator. Refer to [SC-29, "Removal and Installation"](#).
6. Remove starter motor. Refer to [SC-13, "Removal and Installation"](#).
7. Remove front propeller shaft from the front final drive assembly side. Refer to [PR-4, "Component"](#).
8. Separate the engine from the transmission assembly. Refer to [AT-245, "Removal and Installation \(AWD Models\)"](#).
9. Remove the front final drive assembly from oil pan (upper). Refer to [FFD-14, "Removal and Installation \(VQ35HR\)"](#).
10. Remove each engine mounting insulator and each engine mounting bracket from the engine with power tool.

INSTALLATION

Note the following, and install in the reverse order of removal.

- Do not allow engine mounting insulator to be damage and careful no engine oil gets on it.
- For a location with a positioning pin, insert it securely into hole of mating part.
- For a part with a specified installation orientation, refer to component figure in [EM-113, "AWD : Component"](#).

ENGINE ASSEMBLY

[VQ35HR]

< SERVICE INFORMATION >

- When installing engine mounting bracket (RH and LH) on cylinder block, tighten two upper bolts [shown as (B) in the figure] first. Then tighten two lower bolts [shown as (C) in the figure].

3 : Engine mounting bracket (LH)

A : Right side

G : Left side

- Install engine mounting bracket (RH) (lower) (2) as follows:
 - Temporarily tighten mounting bolts [shown as (D), (E) and (F) in the figure].
 - Tighten mounting bolts to the specified torque with following mounting surfaces touched.
- Engine mounting bracket (RH) (1) to engine mounting bracket (RH) (lower) [shown as and in figure].
- Front final drive to engine mounting bracket (RH) (lower) [shown as in figure].
- Check all engine mounting insulators are seated properly, then tighten mounting nuts.

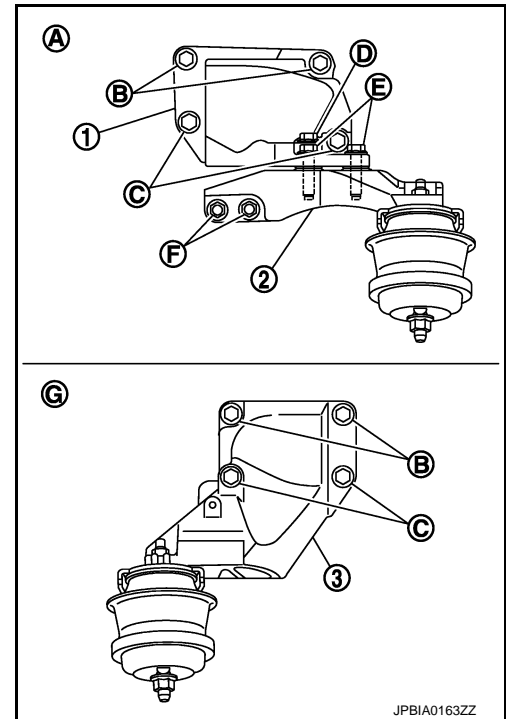

- Tighten rear engine mounting member bolts in numerical order as shown in the figure.

← : Vehicle front

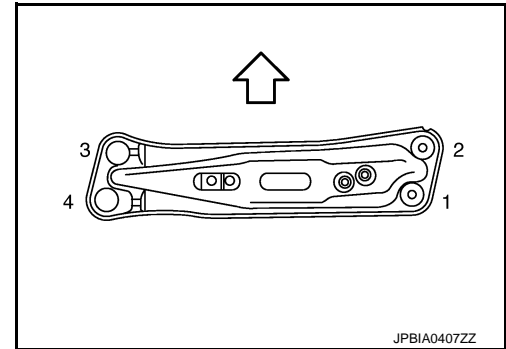

INSPECTION AFTER INSTALLATION

Inspection for Leakage

The following are procedures for checking fluids leakage, lubricates leakage, and exhaust gases leakage.

- Before starting engine, check oil/fluid levels including engine coolant and engine oil. If less than required quantity, fill to the specified level. Refer to [MA-9. "Fluids and Lubricants"](#).
- Use procedure below to check for fuel leakage.
 - Turn ignition switch "ON" (with engine stopped). With fuel pressure applied to fuel piping, check for fuel leakage at connection points.
 - Start engine. With engine speed increased, check again for fuel leakage at connection points.
- Run engine to check for unusual noise and vibration.
- Warm up engine thoroughly to check there is no leakage of fuel, exhaust gases, or any oil/fluids including engine oil and engine coolant.
- Bleed air from lines and hoses of applicable lines, such as in cooling system.
- After cooling down engine, again check oil/fluid levels including engine oil and engine coolant. Refill to the specified level, if necessary.

Summary of the inspection items:

Items	Before starting engine	Engine running	After engine stopped
Engine coolant	Level	Leakage	Level
Engine oil	Level	Leakage	Level
Other oils and fluid*	Level	Leakage	Level

ENGINE ASSEMBLY

< SERVICE INFORMATION >

[VQ35HR]

Fuel	Leakage	Leakage	Leakage
Exhaust gases	—	Leakage	—

*: Transmission/transaxle/CVT fluid, power steering fluid, brake fluid, etc.

CYLINDER BLOCK

< SERVICE INFORMATION >

[VQ35HR]

CYLINDER BLOCK

Component

INFOID:000000005348010

A

EM

C

D

E

F

G

H

I

J

K

L

M

N

O

P

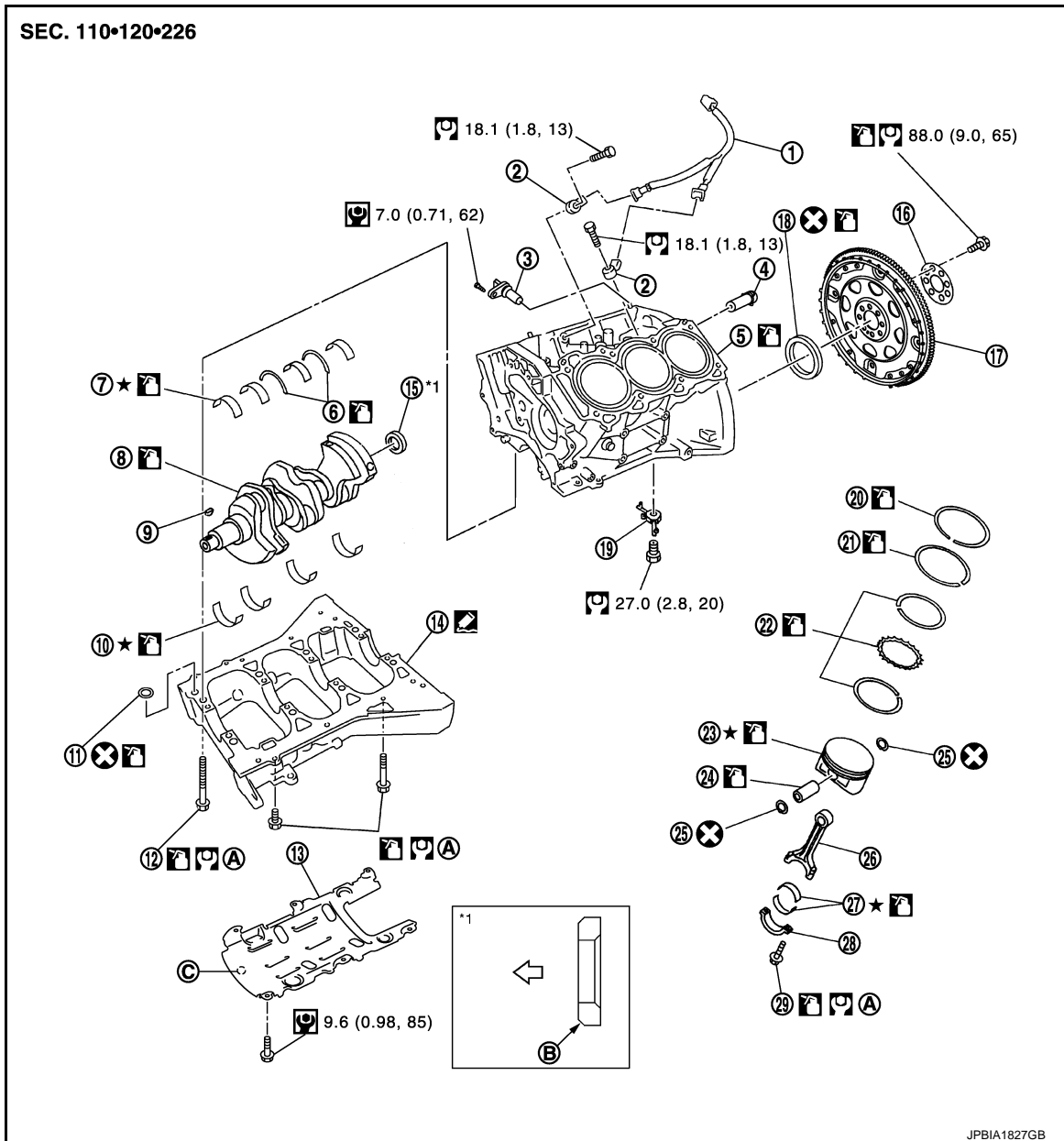

- | | | |
|---------------------------------------|--------------------------|-------------------------------|
| 1. Sub harness | 2. Knock sensor | 3. Crankshaft position sensor |
| 4. Cylinder block heater (for Canada) | 5. Cylinder block | 6. Thrust bearing |
| 7. Main bearing (upper) | 8. Crankshaft | 9. Crankshaft key |
| 10. Main bearing (lower) | 11. O-ring | 12. Lower cylinder block bolt |
| 13. Baffle plate | 14. Lower cylinder block | 15. Pilot converter |
| 16. Reinforcement plate | 17. Drive plate | 18. Rear oil seal |
| 19. Oil jet | 20. Top ring | 21. Second ring |
| 22. Oil ring | 23. Piston | 24. Piston pin |
| 25. Snap ring | 26. Connecting rod | 27. Connecting rod bearing |
| 28. Connecting rod bearing cap | 29. Connecting rod bolt | |
- A. Refer to [EM-120](#)
 B. Chamfered
 C. Front mark

← : Crankshaft side

CYLINDER BLOCK

[VQ35HR]

< SERVICE INFORMATION >

- Refer to [GI-9, "Component"](#) for symbols in the figure.

Disassembly and Assembly

INFOID:000000005348011

DISASSEMBLY

1. Remove engine assembly from vehicle, and separate front suspension member and transmission from engine. Refer to [EM-108, "2WD : Component"](#) (2WD models) or [EM-113, "AWD : Component"](#) (AWD models).
2. Remove engine mounting brackets (RH and LH). Refer to [EM-108, "2WD : Component"](#) (2WD models) or [EM-113, "AWD : Component"](#) (AWD models).
3. Remove the parts that may restrict installation of engine to widely use engine stand.

NOTE:

The procedure is described assuming that you use a widely use engine stand holding the surface, to which transmission is installed.

- Remove drive plate. Fix crankshaft with a ring gear stopper [SST: KV10118600 (J-48641)], and remove mounting bolts.
- Loosen mounting bolts in diagonal order.
- Check for deformation or damage.

CAUTION:

- **Never disassemble drive plate.**
- **Never place drive plate with signal plate facing down.**
- **When handling signal plate, take care not to damage or scratch it.**
- **Handle signal plate in a manner that prevents it from becoming magnetized.**

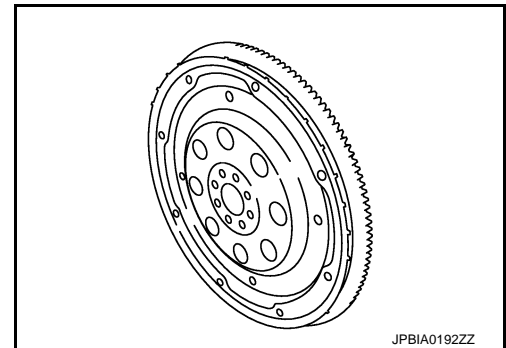

4. Remove pilot converter using pilot bushing puller [SST: ST16610001 (J23907)] (A) or suitable tool if necessary.

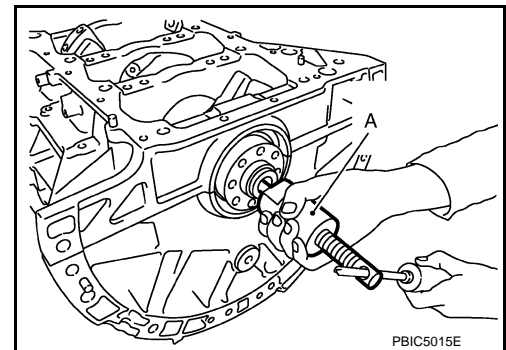

5. Lift the engine with hoist to install it onto the widely use engine stand.
 - A widely use engine stand (A) can be used.

CAUTION:

Use engine stand that has a load capacity [approximately 220 kg (485 lb) or more] large enough for supporting the engine weight.

NOTE:

This example is engine stand for holding at transmission mounting side with drive plate removed.

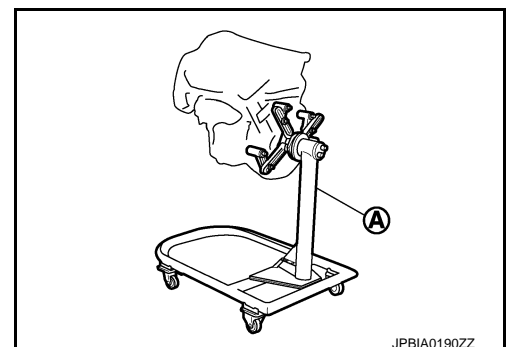

6. Drain engine oil. Refer to [LU-7, "Changing Engine Oil"](#).

CYLINDER BLOCK

[VQ35HR]

< SERVICE INFORMATION >

7. Drain engine coolant by removing water drain plugs (1) from cylinder block both sides as shown in the figure.

- 2 : Washer
3 : Plug
4 : Plug
⇐ : Engine front

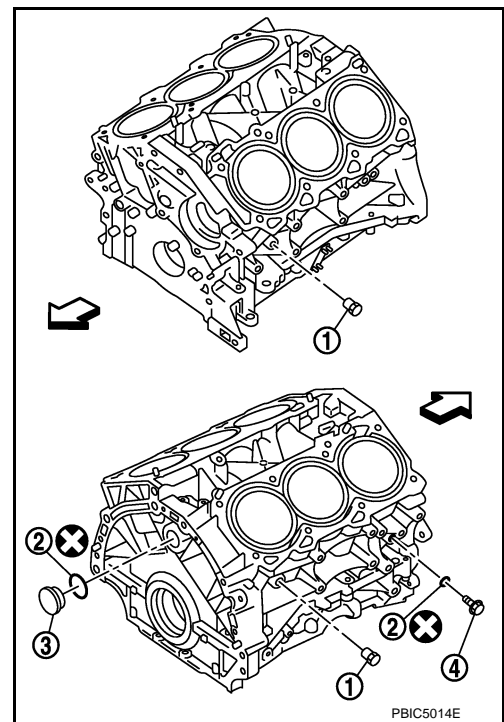

8. Remove oil pan (upper and lower). Refer to [EM-28](#).
9. Remove front timing chain case, timing chain and rear timing chain case. Refer to [EM-60](#).
10. Remove cylinder head. Refer to [EM-97. "Component"](#).
11. Remove knock sensor.
CAUTION:
Carefully handle sensor avoiding shocks.
12. Remove rear oil seal.
13. Remove baffle plate from lower cylinder block.
14. Remove piston and connecting rod assembly as follows:
- Before removing piston and connecting rod assembly, check the connecting rod side clearance. Refer to [EM-136. "Inspection After Disassembly"](#).
- a. Position crankshaft pin corresponding to connecting rod to be removed onto the bottom dead center.
- b. Remove connecting rod bearing cap.
- c. Using hammer handle or similar tool, push piston and connecting rod assembly out to the cylinder head side.

CAUTION:

Be careful not to damage the cylinder wall and crankshaft pin, resulting from an interference of the connecting rod big end.

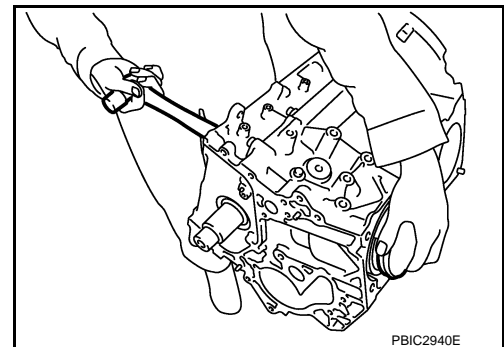

15. Remove connecting rod bearings from connecting rod and connecting rod bearing cap.
CAUTION:
Identify installation position, and store them without mixing them up.
16. Remove piston rings from piston.
- Before removing piston rings, check the piston ring side clearance. Refer to [EM-136. "Inspection After Disassembly"](#).

CYLINDER BLOCK

[VQ35HR]

< SERVICE INFORMATION >

- Use piston ring expander (commercial service tool) (A).

CAUTION:

- When removing piston rings, be careful not to damage piston.
- Be careful not to damage piston rings by expanding them excessively.

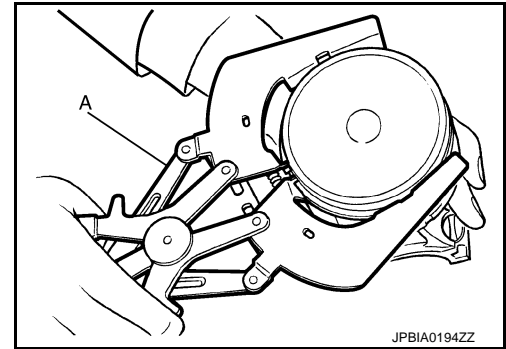

17. Remove piston from connecting rod as follows:

a. Using snap ring pliers (A), remove snap ring.

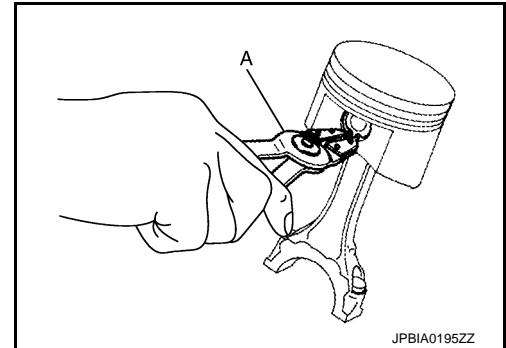

b. Heat piston to 60 to 70°C (140 to 158°F) with industrial use drier (A) or equivalent.

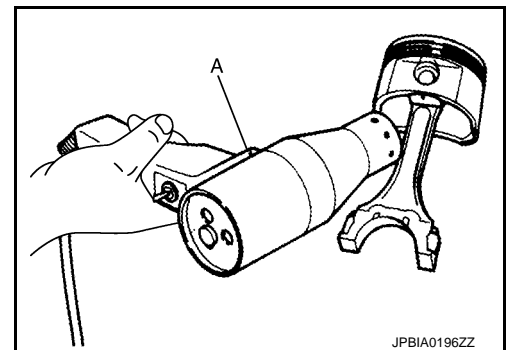

c. Push out piston pin with stick of outer diameter approximately 20 mm (0.79 in).

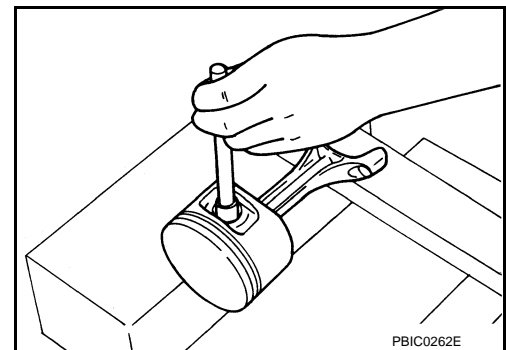

18. Remove lower cylinder block bolts.

NOTE:

Use TORX socket (size E14).

- Before loosening lower cylinder block bolts, measure the crankshaft end play. Refer to [EM-136. "Inspection After Disassembly"](#).

CYLINDER BLOCK

[VQ35HR]

< SERVICE INFORMATION >

- Loosen lower cylinder block bolts in reverse order shown in the figure in several different steps.

← : Engine front

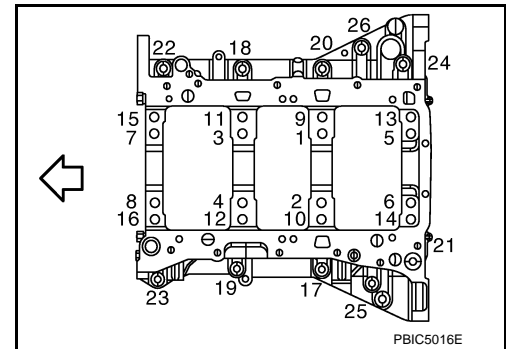

19. Remove lower cylinder block as follows:
Screw M8 bolt [Pitch: 1.25 mm (0.0492 in), Length: approximately 50 mm (1.97 in)] into bolt holes (A) shown in the figure. Then equally tighten each bolt, and remove lower cylinder block.

← : Engine front

CAUTION:

- Be careful not to damage the mating surface.
- Never tighten bolts too much.
- Never insert screw driver, this will damage the mating surface.

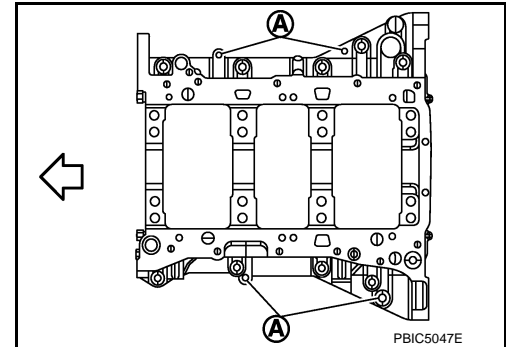

20. Remove crankshaft.
21. Pull rear oil seal out from rear end of crankshaft.
22. Remove main bearings and thrust bearings from cylinder block and lower cylinder block.
CAUTION:
 - Identify installation positions, and store them without mixing them up.
 - Be careful not to drop main bearing, and to scratch the surface.
23. Remove oil jet.

ASSEMBLY

1. Fully air-blow engine coolant and engine oil passages in cylinder block, cylinder bore and crankcase to remove any foreign material.

CAUTION:

Use a goggles to protect your eye.

A
EM
C
D
E
F
G
H
I
J
K
L
M
N
O
P

CYLINDER BLOCK

[VQ35HR]

< SERVICE INFORMATION >

2. Install each plug to cylinder block as shown in the figure.

↔ : Engine front

- Apply sealant to the thread of water drain plug (1).
Use Genuine RTV Silicone Sealant or equivalent. Refer to [GI-46, "Recommended Chemical Product and Sealant"](#).
- Apply sealant to the thread of plugs (3) and (4).
Use genuine high strength thread locking sealant or equivalent. Refer to [GI-46, "Recommended Chemical Product and Sealant"](#).
- Replace washers (2) with new one.

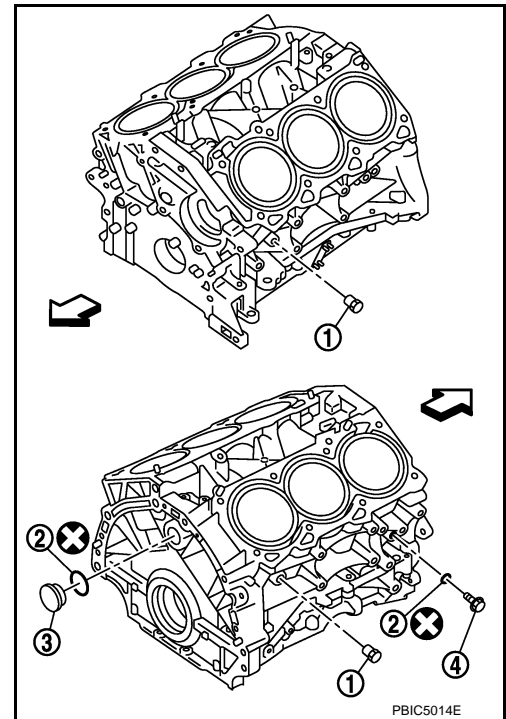

- Tighten each plug as specified below.

Part	Washer	Tightening torque
1	No	19.6 N·m (2.0 kg·m, 14 in·lb)
3	Yes	78.0 N·m (8.0 kg·m, 58 ft·lb)
4	Yes	12.3 N·m (1.3 kg·m, 9 ft·lb)

3. Install oil jet.

- Insert oil jet dowel pin (A) into cylinder block dowel pin hole, and tighten mounting bolts.

↔ : Engine front

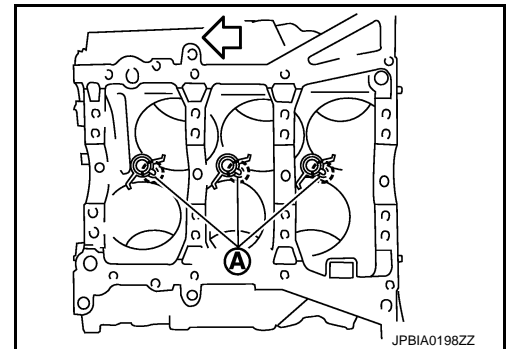

4. Install main bearings and thrust bearings as follows:

- Remove dust, dirt, and engine oil on bearing mating surfaces of cylinder block and lower cylinder block.
- Install thrust bearings to the both sides of the No. 3 journal housing on cylinder block.
 - Install thrust bearings (1) with the oil groove (E) facing crankshaft arm (outside).

- A : No. 1
- B : No. 2
- C : No. 3
- D : No. 4
- F : Thrust bearing installation position

↔ : Engine front

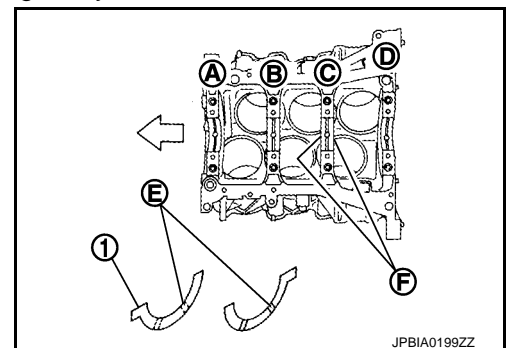

CYLINDER BLOCK

[VQ35HR]

< SERVICE INFORMATION >

- Install thrust bearing with a protrusion on one end on cylinder block. Align each protrusion with mating notch.

c. Install main bearings paying attention to the direction.

- A : Cylinder block side
- D : Lower cylinder block side
- ↔ : Engine front

- Main bearing with oil hole (B) and groove (C) goes on cylinder block. The one without them goes on lower cylinder block.
- Before installing main bearings, apply engine oil to the bearing surface (inside). Do not apply engine oil to the back surface, but thoroughly clean it.
- When installing, align main bearing stopper protrusion to cut-out of cylinder block and lower cylinder block.
- Ensure the oil holes on cylinder block and those on the corresponding bearing are aligned.

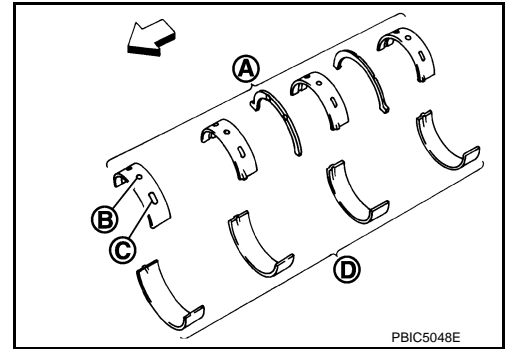

5. Install crankshaft to cylinder block.
 - While turning crankshaft by hand, check that it turns smoothly.
6. Install lower cylinder block.

NOTE:

Lower cylinder block cannot be replaced as a single part, because it is machined together with cylinder block.

- Apply a continuous bead of liquid gasket with the tube presser (commercial service tool) to lower cylinder block as shown in the figure.

- B** : Apply to end
- a** : $\phi 4.0 - 5.0$ mm (0.157 - 0.197 in) dia

Use genuine high strength thread locking sealant or equivalent. Refer to [GI-46, "Recommended Chemical Product and Sealant"](#).

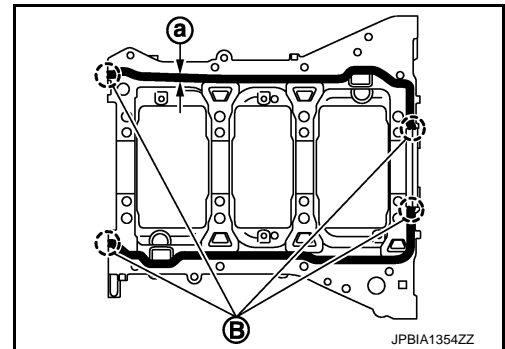

7. Inspect the outer diameter of lower cylinder block bolt. Refer to [EM-136, "Inspection After Disassembly"](#).
8. Install lower cylinder block bolts in numerical order as shown in the figure as follows:
 - a. Apply new engine oil to threads and seat surfaces of lower cylinder block bolts.
 - b. Tighten lower cylinder block bolt (No. 17 to 26) in numerical order as shown in the figure.

- ↔ : Engine front

: **25.0 N·m (2.6 kg·m, 18 ft·lb)**

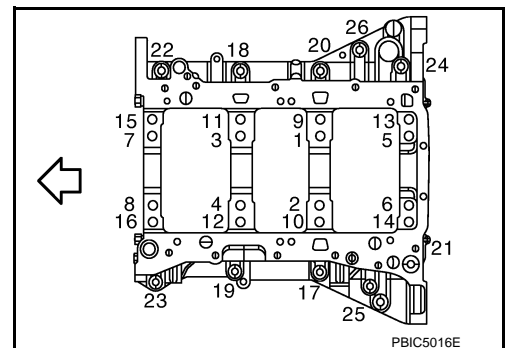

c. Repeat step b.

A
EM
C
D
E
F
G
H
I
J
K
L
M
N
O
P

CYLINDER BLOCK

[VQ35HR]

< SERVICE INFORMATION >

- d. Tighten lower cylinder block bolts (No. 1 to 16) in numerical order as shown in the figure.

← : Engine front

NOTE:

Use TORX socket (size E14) for bolts No. 1 to 16.

: 35.3 N·m (3.6 kg-m, 26 ft-lb)

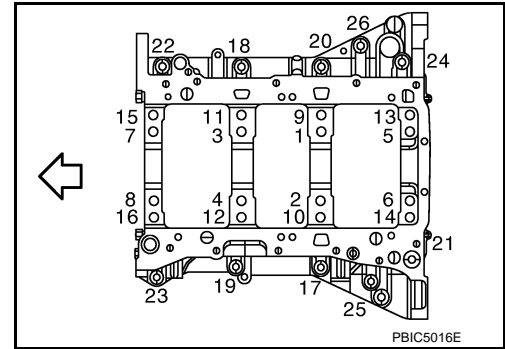

- e. Turn lower cylinder block bolts (No. 1 to 16) 90 degrees clockwise (angle tightening).

CAUTION:

Use the angle wrench [SST: KV10112100 (BT8653-A)] (A) to check tightening angle. Never make judgment by visual inspection.

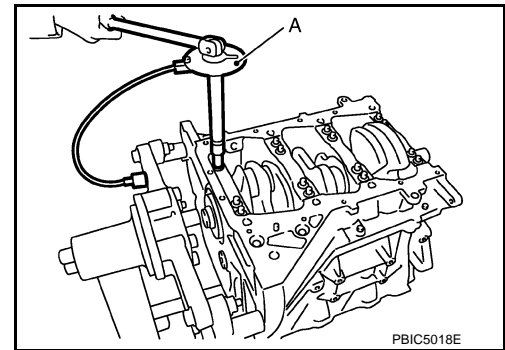

- After installing lower cylinder block bolts, check that crankshaft can be rotated smoothly by hand.
- Check the crankshaft end play. Refer to [EM-136, "Inspection After Disassembly"](#).

9. Install piston to connecting rod as follows:

- Using snap ring pliers, install new snap ring to the groove of piston rear side.
 - Insert it fully into groove to install.
- Install piston to connecting rod.
 - Using industrial use drier or similar tool, heat piston until piston pin can be pushed in by hand without excess force [approximately 60 to 70°C (140 to 158°F)]. From the front to the rear, insert piston pin into piston and connecting rod.
 - Assemble so that the front mark on the piston head and the cylinder number on connecting rod are positioned as shown in the figure.

A : Piston grade number

B : Front mark

C : Pin grade number

D : Cylinder number

E : Front mark

← : Engine front

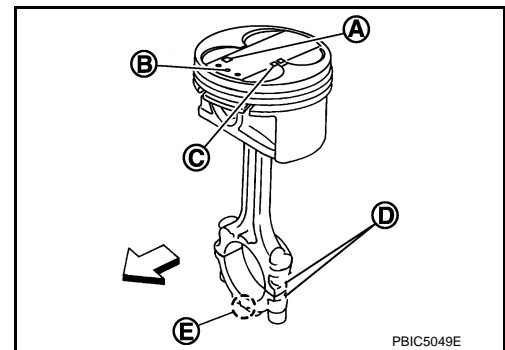

- Install new snap ring to the groove of the piston front side.
 - Insert it fully into groove to install.
 - After installing, check that connecting rod moves smoothly.

CYLINDER BLOCK

[VQ35HR]

< SERVICE INFORMATION >

10. Using piston ring expander (commercial service tool) (A), install piston rings.

CAUTION:

- When installing piston rings, be careful not to damage piston.
- Be careful not to damage piston rings by expanding them excessively.

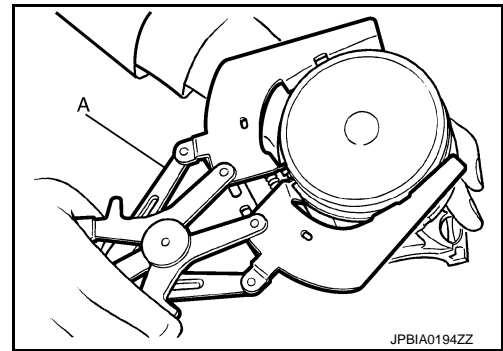

- If there is stamped mark on ring, mount it with marked side up.

Stamped mark:

- Top ring (A) : 1 N
- Second ring (B) : 2 N

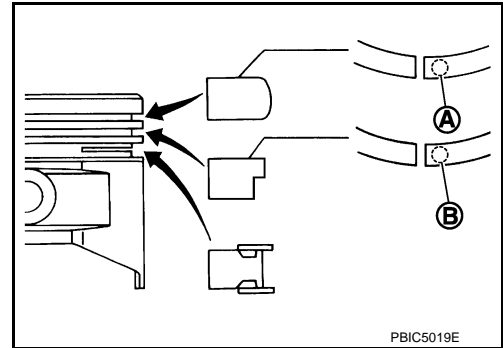

- Mount second ring with cut out side down.
- Position each ring with the gap as shown in the figure referring to the piston front mark (D).

- C : Top ring gap
- E : Oil ring upper or lower rail gap
- F : Second ring and oil ring spacer gap
- a : 90 degrees
- b : 45 degrees

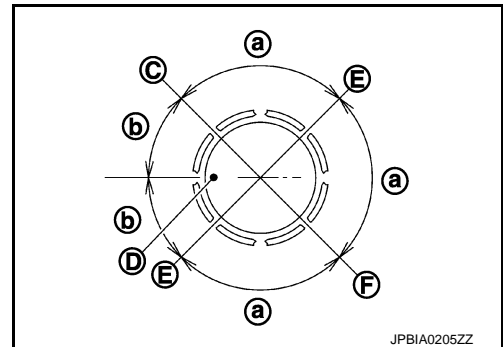

- Check the piston ring side clearance. Refer to [EM-136. "Inspection After Disassembly"](#).

11. Install connecting rod bearings to connecting rod and connecting rod bearing cap.

- Before installing connecting rod bearings, apply engine oil to the bearing surface (inside). Do not apply engine oil to the back surface, but thoroughly clean it.
- When installing, align connecting rod bearing stopper protrusion (B) with cutout (C) of connecting rods and connecting rod bearing caps to install.
- Ensure the oil hole (A) on connecting rod and that on the corresponding bearing are aligned.

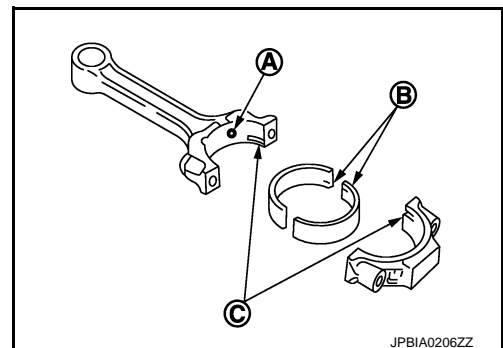

12. Install piston and connecting rod assembly to crankshaft.

- Position crankshaft pin corresponding to connecting rod to be installed onto the bottom dead center.
- Apply engine oil sufficiently to the cylinder bore, piston and crankshaft pin journal.
- Match the cylinder position with the cylinder number on connecting rod to install.
- Be sure that front mark on piston head is facing front of engine.

CYLINDER BLOCK

[VQ35HR]

< SERVICE INFORMATION >

- Using piston ring compressor [SST: EM03470000 (J8037)] (A) or suitable tool, install piston with the front mark on the piston head facing the front of engine.

CAUTION:

Be careful not to damage the cylinder wall and crankshaft pin, resulting from an interference of the connecting rod big end.

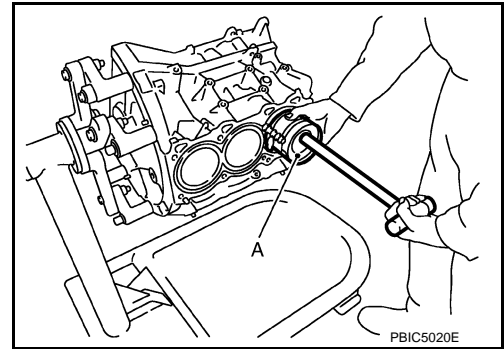

13. Install connecting rod bearing cap.

- Match the stamped cylinder number marks on connecting rod with those on connecting rod bearing cap to install.
- Be sure that front mark (H) on connecting rod bearing cap is facing front of engine.

- A : Sample code
- B : Bearing stopper groove
- C : Small-end diameter grade
- D : Big end diameter grade
- E : Weight grade
- F : Cylinder No.
- G : Management code
- I : Management code

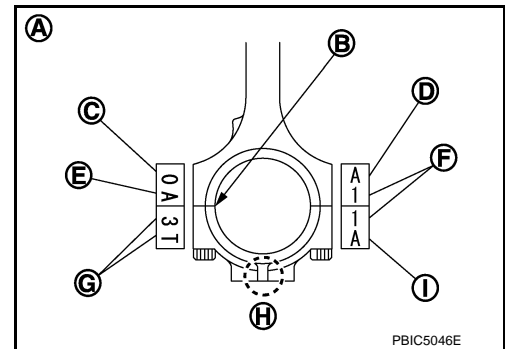

14. Inspect the outer diameter of connecting rod bolt. Refer to [EM-136, "Inspection After Disassembly"](#).

15. Tighten connecting rod bolts as follows:

- Apply engine oil to the threads and seats of connecting rod bolts.
- Tighten connecting rod bolts.

: 28.4 N·m (2.9 kg-m, 21 ft-lb)

- Completely loosen connecting rod bolts.

: 0 N·m (0 kg-m, 0 ft-lb)

- Tighten connecting rod bolts.

: 24.5 N·m (2.5 kg-m, 18 ft-lb)

- Then turn connecting rod bolts 90 degrees clockwise (angle tightening).

CAUTION:

Use angle wrench [SST: KV10112100 (BT8653-A)] (A) to check tightening angle. Never make judgment by visual inspection.

- After tightening connecting rod bolts, check that crankshaft rotates smoothly.
- Check the connecting rod side clearance. Refer to [EM-136, "Inspection After Disassembly"](#).

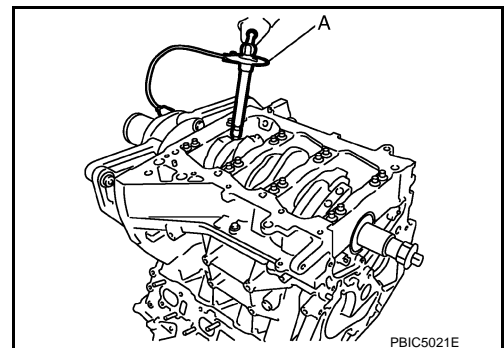

16. Install baffle plate.

CYLINDER BLOCK

[VQ35HR]

< SERVICE INFORMATION >

17. Install new rear oil seal. Refer to [EM-94, "Removal and Installation of Rear Oil Seal"](#).
18. Install pilot converter.
 - With drift of the following outer diameter, press-fit as far as it will go.

Pilot converter : Approximately 33 mm (1.30 in)

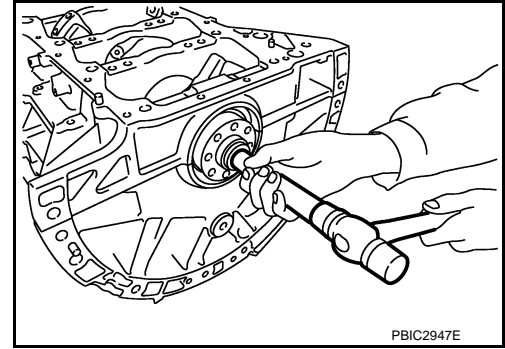

- Press-fit pilot converter with its chamfer facing crankshaft as shown in the figure.

← : Crankshaft side

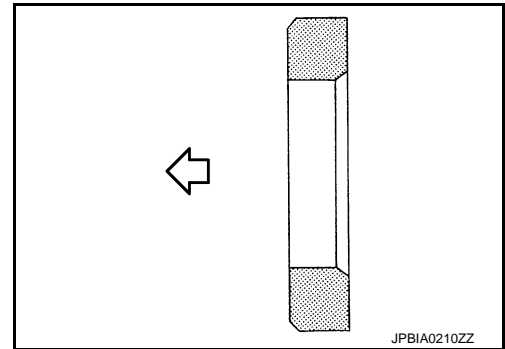

19. Install cylinder head. Refer to [EM-97, "Component"](#).
20. Install rear timing chain case. Refer to [EM-60](#).
21. Install oil pan (upper). Refer to [EM-28](#).
22. Install knock sensors.

A : Bank 1
B : Bank 2
← : Engine front

- Install knock sensor so that connector faces rear of engine.
- After installing knock sensor, connect harness connector, and lay it out to rear of engine.

CAUTION:

- **Never tighten mounting bolts while holding connector.**
- **If any impact by dropping is applied to knock sensor, replace it with new one.**

NOTE:

- Check that there is no foreign material on the cylinder block mating surface and the back surface of knock sensor.
- Check that knock sensor does not interfere with other parts.

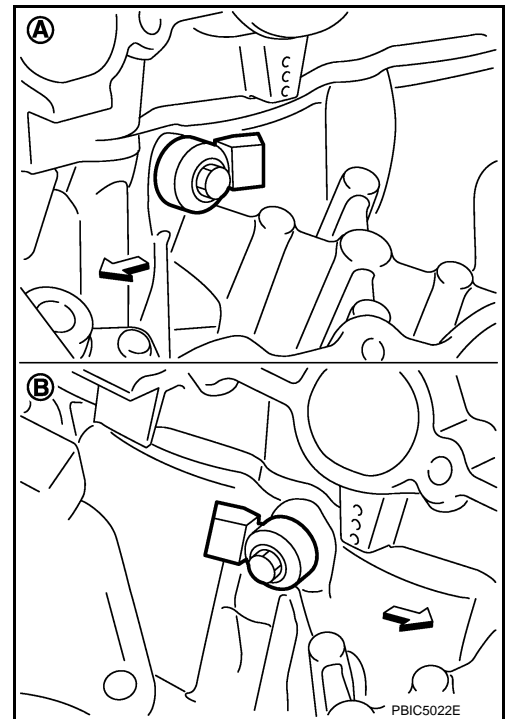

23. Note the following, assemble in the reverse order of disassembly after this step.

Drive plate

- When installing drive plate to crankshaft, be sure to correctly align crankshaft side dowel pin and drive plate side dowel pin hole.

CAUTION:

If these are not aligned correctly, engine runs roughly and "MIL" turns on.

CYLINDER BLOCK

[VQ35HR]

< SERVICE INFORMATION >

- Install drive plate (2) and reinforcement plate (3) as shown in the figure.

- 1 : Ring gear
- 4 : Pilot converter
- 5 : Crankshaft
- A : Rounded
- ⇐ : Engine front

- Holding ring gear with ring gear stopper [SST: KV10118600 (J-48641)].
- Tighten the mounting bolts crosswise over several times.

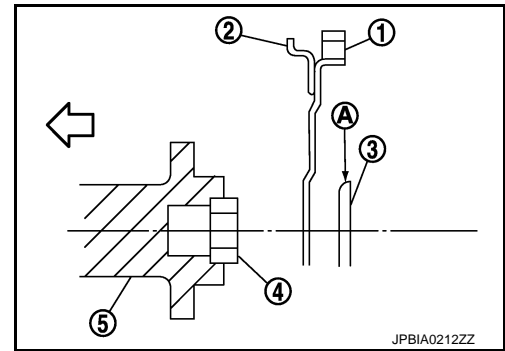

How to Select Piston and Bearing

INFOID:000000005348012

DESCRIPTION

Selection points	Selection parts	Selection items	Selection methods
Between cylinder block to crankshaft	Main bearing	Main bearing grade (bearing thickness)	Determined by match of cylinder block bearing housing grade (inner diameter of housing) and crankshaft journal grade (outer diameter of journal)
Between crankshaft to connecting rod	Connecting rod bearing	Connecting rod bearing grade (bearing thickness)	Combining service grades for connecting rod big end diameter and crankshaft pin outer diameter determine connecting rod bearing selection.
Between cylinder block to piston	Piston and piston pin assembly (Piston is available together with piston pin as assembly.)	Piston grade (piston skirt diameter)	Piston grade = cylinder bore grade (inner diameter of bore)
Between piston to connecting rod*	—	—	—

*: For the service parts, the grade for fitting cannot be selected between piston pin and connecting rod. (Only "0" grade is available.) The information at the shipment from the plant is described as a reference.

- The identification grade stamped on each part is the grade for the dimension measured in new condition. This grade cannot apply to reused parts.
- For reused or repaired parts, measure the dimension accurately. Determine the grade by comparing the measurement with the values of each selection table.
- For details of the measurement method of each part, the reuse standards and the selection method of the selective fitting parts, refer to the text.

HOW TO SELECT PISTON

When New Cylinder Block is Used

Check the cylinder bore grade ("1", "2" or "3") on rear side of cylinder block, and select piston of the same grade.

- A : Bearing housing grade No. 1
- B : Bearing housing grade No. 2
- C : Bearing housing grade No. 3
- D : Bearing housing grade No. 4
- E : Cylinder bore grade No. 1
- F : Cylinder bore grade No. 2
- G : Cylinder bore grade No. 3
- H : Cylinder bore grade No. 4
- I : Cylinder bore grade No. 5
- J : Cylinder bore grade No. 6

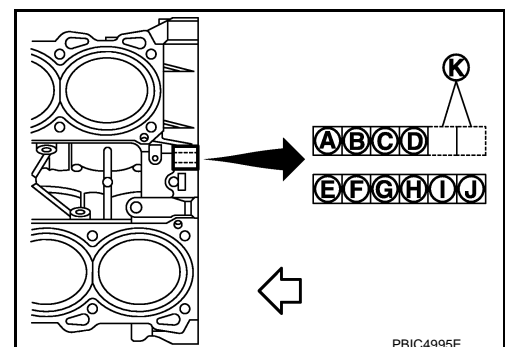

CYLINDER BLOCK

[VQ35HR]

< SERVICE INFORMATION >

K : Identification code

↩ : Engine front

NOTE:

Piston is available with piston pin as a set for the service part. (Only "0" grade piston pin is available.)

When Cylinder Block is Reused

1. Measure the cylinder bore inner diameter. Refer to [EM-136, "Inspection After Disassembly"](#).
2. Determine the bore grade by comparing the measurement with the values under the cylinder bore inner diameter of the "Piston Selection Table".

A : Piston grade number

B : Front mark

C : Piston pin grade number

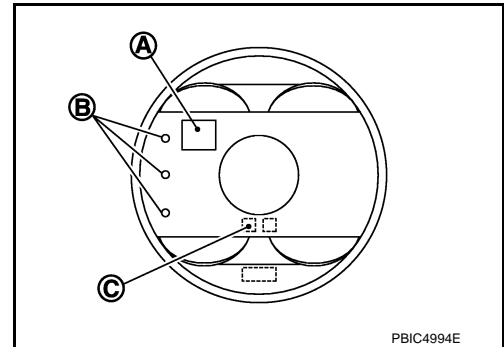

3. Select piston of the same grade.

Piston Selection Table

Unit: mm (in)

Grade	1	2	3
Cylinder bore inner diameter	95.500 - 95.510 (3.7598 - 3.7602)	95.510 - 95.520 (3.7602 - 3.7606)	95.520 - 95.530 (3.7606 - 3.7610)
Piston skirt diameter	95.480 - 95.490 (3.7590 - 3.7594)	95.490 - 95.500 (3.7594 - 3.7598)	95.500 - 95.510 (3.7598 - 3.7602)

NOTE:

- Piston is available together with piston pin as assembly.
- Piston pin (piston pin hole) grade is provided only for the parts installed at the plant. For service parts, no piston pin grades can be selected. (Only "0" grade is available.)
- No second grade mark is available on piston.

HOW TO SELECT CONNECTING ROD BEARING

When New Connecting Rod and Crankshaft are Used

1. "Connecting Rod Bearing Selection Table" rows correspond to connecting rod big end diameter grade (D) stamped on side face of connecting rod.

A : Sample code

B : Bearing stopper groove

C : Small end diameter grade

E : Weight grade

F : Cylinder No.

G : Management code

H : Front mark

I : Management code

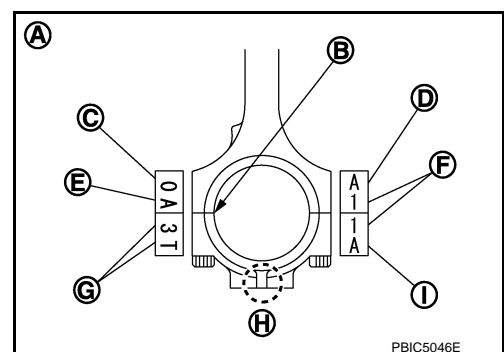

CYLINDER BLOCK

[VQ35HR]

< SERVICE INFORMATION >

2. "Connecting Rod Bearing Selection Table" columns correspond to pin journal diameter grade on front side of crankshafts.

- A : Main journal diameter grade No. 1
- B : Main journal diameter grade No. 2
- C : Main journal diameter grade No. 3
- D : Main journal diameter grade No. 4
- E : Pin diameter grade No. 1
- F : Pin diameter grade No. 2
- G : Pin diameter grade No. 3
- H : Pin diameter grade No. 4
- I : Pin diameter grade No. 5
- J : Pin diameter grade No. 6
- K : Identification code

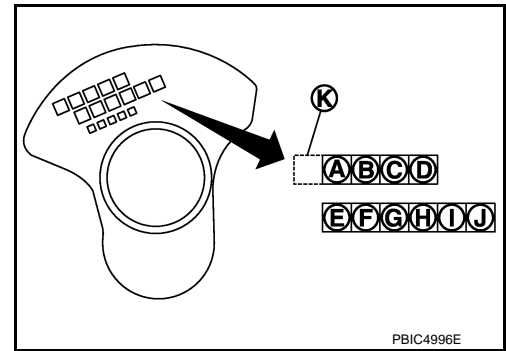

3. Select connecting rod bearing grade at the point where selected row and column meet in "Connecting Rod Bearing Selection Table".

When Crankshaft and Connecting Rod are Reused

1. Measure the connecting rod big end diameter and crankshaft pin journal diameter. Refer to [EM-136. "Inspection After Disassembly"](#).
2. Correspond the measured dimension in "Connecting rod big end diameter" row of "Connecting Rod Bearing Selection Table".
3. Correspond the measured dimension in "Crankshaft pin journal diameter" column of "Connecting Rod Bearing Selection Table".
4. Select connecting rod bearing grade at the point where selected row and column meet in following selection table.

CYLINDER BLOCK

[VQ35HR]

< SERVICE INFORMATION >

Connecting Rod Bearing Selection Table

Mark	Axle diameter	Connecting rod big end diameter Unit: mm (in)		Crankshaft pin journal diameter Unit: mm (in)													
		Mark	Hole diameter	A	B	C	D	E	F	G	H	J	K	L	M	N	
A	53.974 - 53.973 (2.1250 - 2.1249)	0	0	0	0	0	0	0	0	1	1	1	1	1	1	2	
B	53.973 - 53.972 (2.1249 - 2.1249)	0	0	0	0	0	0	0	1	1	1	1	1	1	1	2	
C	53.972 - 53.971 (2.1249 - 2.1248)	0	0	0	0	0	1	1	1	1	1	1	1	2	2	2	
D	53.971 - 53.970 (2.1248 - 2.1248)	0	0	0	1	1	1	1	1	1	1	1	2	2	2	2	
E	53.970 - 53.969 (2.1248 - 2.1248)	0	0	1	1	1	1	1	1	1	2	2	2	2	2	2	
F	53.969 - 53.968 (2.1248 - 2.1247)	0	1	1	1	1	1	1	1	2	2	2	2	2	2	2	
G	53.968 - 53.967 (2.1247 - 2.1247)	1	1	1	1	1	1	1	2	2	2	2	2	2	2	3	
H	53.967 - 53.966 (2.1247 - 2.1246)	1	1	1	1	1	1	2	2	2	2	2	2	2	3	3	
J	53.966 - 53.965 (2.1246 - 2.1246)	1	1	1	1	2	2	2	2	2	2	2	3	3	3	3	
K	53.965 - 53.964 (2.1246 - 2.1246)	1	1	1	2	2	2	2	2	2	2	3	3	3	3	3	
L	53.964 - 53.963 (2.1246 - 2.1245)	1	1	2	2	2	2	2	2	2	3	3	3	3	3	3	
M	53.963 - 53.962 (2.1245 - 2.1245)	1	2	2	2	2	2	2	2	3	3	3	3	3	3	3	
N	53.962 - 53.961 (2.1245 - 2.1244)	2	2	2	2	2	2	2	3	3	3	3	3	3	3	4	
P	53.961 - 53.960 (2.1244 - 2.1244)	2	2	2	2	2	3	3	3	3	3	3	3	4	4	4	
R	53.960 - 53.959 (2.1244 - 2.1244)	2	2	2	2	3	3	3	3	3	3	3	4	4	4	4	
S	53.959 - 53.958 (2.1244 - 2.1243)	2	2	2	3	3	3	3	3	3	3	4	4	4	4	4	
T	53.958 - 53.957 (2.1243 - 2.1243)	2	2	3	3	3	3	3	3	3	4	4	4	4	4	4	
U	53.957 - 53.956 (2.1243 - 2.1242)	2	3	3	3	3	3	3	3	4	4	4	4	4	4	4	

PBIC5435E

Connecting Rod Bearing Grade Table

Unit: mm (in)

Grade number	Thickness	Identification color (mark)
0	1.497 - 1.500 (0.0589 - 0.0591)	Black
1	1.500 - 1.503 (0.0591 - 0.0592)	Brown
2	1.503 - 1.506 (0.0592 - 0.0593)	Green
3	1.506 - 1.509 (0.0593 - 0.0594)	Yellow
4	1.509 - 1.512 (0.0594 - 0.0595)	Blue

Undersize Bearings Usage Guide

- When the specified connecting rod bearing oil clearance is not obtained with standard size connecting rod bearings, use undersize (US) bearings.
- When using undersize (US) bearing, measure the connecting rod bearing inner diameter with bearing installed, and grind crankshaft pin so that the connecting rod bearing oil clearance satisfies the standard.

CAUTION:

CYLINDER BLOCK

< SERVICE INFORMATION >

[VQ35HR]

In grinding crankshaft pin to use undersize bearings, keep the fillet R (A) [1.5 – 1.7 mm (0.059 – 0.067 in)].

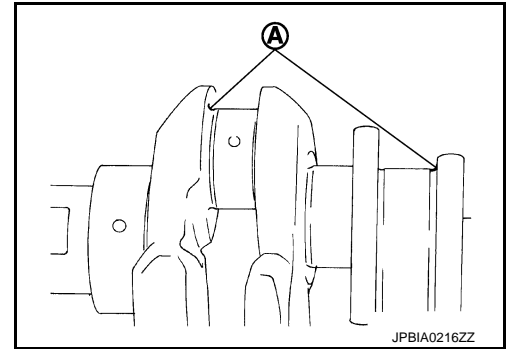

Bearing undersize table

Unit: mm (in)

Size	Thickness
US 0.25 (0.0098)	1.626 - 1.634 (0.0640 - 0.0643)

HOW TO SELECT MAIN BEARING

When New Cylinder Block and Crankshaft are Used

1. "Main Bearing Selection Table" rows correspond to bearing housing grade on rear left side of cylinder block.

- A : Bearing housing grade No. 1
- B : Bearing housing grade No. 2
- C : Bearing housing grade No. 3
- D : Bearing housing grade No. 4
- E : Cylinder bore grade No. 1
- F : Cylinder bore grade No. 2
- G : Cylinder bore grade No. 3
- H : Cylinder bore grade No. 4
- I : Cylinder bore grade No. 5
- J : Cylinder bore grade No. 6
- K : Identification code
- ⇐ : Engine front

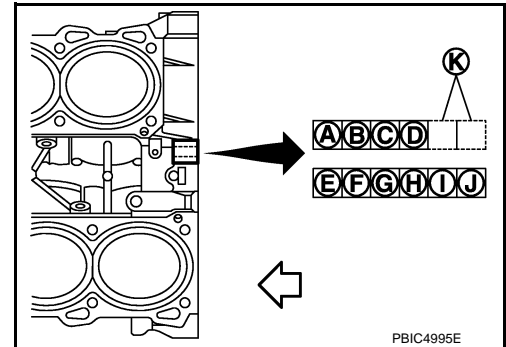

2. "Main Bearing Selection Table" columns correspond to journal diameter grade on front side of crankshaft.

- A : Main journal diameter grade No. 1
- B : Main journal diameter grade No. 2
- C : Main journal diameter grade No. 3
- D : Main journal diameter grade No. 4
- E : Pin diameter grade No. 1
- F : Pin diameter grade No. 2
- G : Pin diameter grade No. 3
- H : Pin diameter grade No. 4
- I : Pin diameter grade No. 5
- J : Pin diameter grade No. 6
- K : Identification code

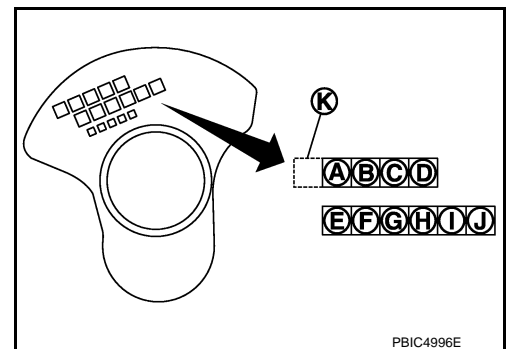

3. Select main bearing grade at the point where selected row and column meet in "Main Bearing Selection Table".

When Cylinder Block and Crankshaft are Reused

1. Measure cylinder block main bearing housing inner diameter and crankshaft main journal diameter. Refer to [EM-136, "Inspection After Disassembly"](#).

CYLINDER BLOCK

[VQ35HR]

< SERVICE INFORMATION >

- Correspond the measured dimension in "Cylinder block main bearing housing inner diameter" row of "Main Bearing Selection Table".
- Correspond the measured dimension in "Crankshaft main journal diameter" column of "Main Bearing Selection Table".
- Select main bearing grade at the point where selected row and column meet in following selection table.

Main Bearing Selection Table

Cylinder block main bearing housing inner diameter Unit: mm (in)		Crankshaft main journal diameter Unit: mm (in)		Hole diameter																											
				Mark																											
Mark	Axle diameter	69.993 - 69.994 (2.7556 - 2.7557)	A	B	C	D	E	F	G	H	J	K	L	M	N	P	R	S	T	U	V	W	X	Y	4	7					
A	64.975 - 64.974 (2.5581 - 2.5580)	0	0	0	0	0	1	0	1	1	1	1	1	1	1	1	1	1	1	1	1	1	1	1	1	1	1	1			
B	64.974 - 64.973 (2.5580 - 2.5580)	0	0	0	1	0	1	0	1	1	1	1	1	1	1	1	1	1	1	1	1	1	1	1	1	1	1	1			
C	64.973 - 64.972 (2.5580 - 2.5579)	0	0	1	0	1	0	1	1	1	1	1	1	1	1	1	1	1	1	1	1	1	1	1	1	1	1	1			
D	64.972 - 64.971 (2.5579 - 2.5579)	0	1	0	1	0	1	1	1	1	1	1	1	1	1	1	1	1	1	1	1	1	1	1	1	1	1	1			
E	64.971 - 64.970 (2.5579 - 2.5579)	0	1	0	1	1	1	1	1	1	1	1	1	1	1	1	1	1	1	1	1	1	1	1	1	1	1	1			
F	64.970 - 64.969 (2.5579 - 2.5578)	0	1	1	1	1	1	1	1	1	1	1	1	1	1	1	1	1	1	1	1	1	1	1	1	1	1	1			
G	64.969 - 64.968 (2.5578 - 2.5578)	1	1	1	1	1	1	1	1	1	1	1	1	1	1	1	1	1	1	1	1	1	1	1	1	1	1	1			
H	64.968 - 64.967 (2.5578 - 2.5578)	1	1	1	1	1	1	1	1	1	1	1	1	1	1	1	1	1	1	1	1	1	1	1	1	1	1	1			
J	64.967 - 64.966 (2.5578 - 2.5577)	1	1	1	1	1	1	1	1	1	1	1	1	1	1	1	1	1	1	1	1	1	1	1	1	1	1	1			
K	64.966 - 64.965 (2.5577 - 2.5577)	1	1	1	1	1	1	1	1	1	1	1	1	1	1	1	1	1	1	1	1	1	1	1	1	1	1	1			
L	64.965 - 64.964 (2.5577 - 2.5576)	1	1	1	1	1	1	1	1	1	1	1	1	1	1	1	1	1	1	1	1	1	1	1	1	1	1	1			
M	64.964 - 64.963 (2.5576 - 2.5576)	1	1	1	1	1	1	1	1	1	1	1	1	1	1	1	1	1	1	1	1	1	1	1	1	1	1	1			
N	64.963 - 64.962 (2.5576 - 2.5576)	1	1	1	1	1	1	1	1	1	1	1	1	1	1	1	1	1	1	1	1	1	1	1	1	1	1	1			
P	64.962 - 64.961 (2.5576 - 2.5575)	1	1	1	1	1	1	1	1	1	1	1	1	1	1	1	1	1	1	1	1	1	1	1	1	1	1	1			
R	64.961 - 64.960 (2.5575 - 2.5575)	1	1	1	1	1	1	1	1	1	1	1	1	1	1	1	1	1	1	1	1	1	1	1	1	1	1	1			
S	64.960 - 64.959 (2.5575 - 2.5574)	1	1	1	1	1	1	1	1	1	1	1	1	1	1	1	1	1	1	1	1	1	1	1	1	1	1	1			
T	64.959 - 64.958 (2.5574 - 2.5574)	1	1	1	1	1	1	1	1	1	1	1	1	1	1	1	1	1	1	1	1	1	1	1	1	1	1	1			
U	64.958 - 64.957 (2.5574 - 2.5574)	1	1	1	1	1	1	1	1	1	1	1	1	1	1	1	1	1	1	1	1	1	1	1	1	1	1	1			
V	64.957 - 64.956 (2.5574 - 2.5573)	1	1	1	1	1	1	1	1	1	1	1	1	1	1	1	1	1	1	1	1	1	1	1	1	1	1	1			
W	64.956 - 64.955 (2.5573 - 2.5573)	1	1	1	1	1	1	1	1	1	1	1	1	1	1	1	1	1	1	1	1	1	1	1	1	1	1	1			
X	64.955 - 64.954 (2.5573 - 2.5572)	1	1	1	1	1	1	1	1	1	1	1	1	1	1	1	1	1	1	1	1	1	1	1	1	1	1	1			
Y	64.954 - 64.953 (2.5572 - 2.5572)	1	1	1	1	1	1	1	1	1	1	1	1	1	1	1	1	1	1	1	1	1	1	1	1	1	1	1			
4	64.953 - 64.952 (2.5572 - 2.5572)	1	1	1	1	1	1	1	1	1	1	1	1	1	1	1	1	1	1	1	1	1	1	1	1	1	1	1			
7	64.952 - 64.951 (2.5572 - 2.5571)	1	1	1	1	1	1	1	1	1	1	1	1	1	1	1	1	1	1	1	1	1	1	1	1	1	1	1			

PBIC5024E

Main Bearing Grade Table (All Journals)

CYLINDER BLOCK

< SERVICE INFORMATION >

[VQ35HR]

Grade number	UPR/LWR	Thickness	Width	Identification color	Remarks
0	—	2.500 - 2.503 (0.0984 - 0.0985)	19.9 - 20.1 (0.783 - 0.791)	Black	Grade and color are the same for upper and lower bearings.
1	—	2.503 - 2.506 (0.0985 - 0.0987)		Brown	
2	—	2.506 - 2.509 (0.0987 - 0.0988)		Green	
3	—	2.509 - 2.512 (0.0988 - 0.0989)		Yellow	
4	—	2.512 - 2.515 (0.0989 - 0.0990)		Blue	
5	—	2.515 - 2.518 (0.0990 - 0.0991)		Pink	
6	—	2.518 - 2.521 (0.0991 - 0.0993)		Purple	
7	—	2.521 - 2.524 (0.0993 - 0.0994)		White	Grade and color are different for upper and lower bearings.
01	UPR	2.503 - 2.506 (0.0985 - 0.0987)		Brown	
	LWR	2.500 - 2.503 (0.0984 - 0.0985)		Black	
12	UPR	2.506 - 2.509 (0.0987 - 0.0988)		Green	
	LWR	2.503 - 2.506 (0.0985 - 0.0987)		Brown	
23	UPR	2.509 - 2.512 (0.0988 - 0.0989)		Yellow	
	LWR	2.506 - 2.509 (0.0987 - 0.0988)		Green	
34	UPR	2.512 - 2.515 (0.0989 - 0.0990)	Blue		
	LWR	2.509 - 2.512 (0.0988 - 0.0989)	Yellow		
45	UPR	2.515 - 2.518 (0.0990 - 0.0991)	Pink		
	LWR	2.512 - 2.515 (0.0989 - 0.0990)	Blue		
56	UPR	2.518 - 2.521 (0.0991 - 0.0993)	Purple		
	LWR	2.515 - 2.518 (0.0990 - 0.0991)	Pink		
67	UPR	2.521 - 2.524 (0.0993 - 0.0994)	White		
	LWR	2.518 - 2.521 (0.0991 - 0.0993)	Purple		

Undersize Bearing Usage Guide

- When the specified main bearing oil clearance is not obtained with standard size main bearings, use undersize (US) bearing.
- When using undersize (US) bearing, measure the main bearing inner diameter with bearing installed, and grind main journal so that the main bearing oil clearance satisfies the standard.

CAUTION:

In grinding crankshaft main journal to use undersize bearings, keep the fillet R (A) [1.5 – 1.7 mm (0.059 – 0.067 in)].

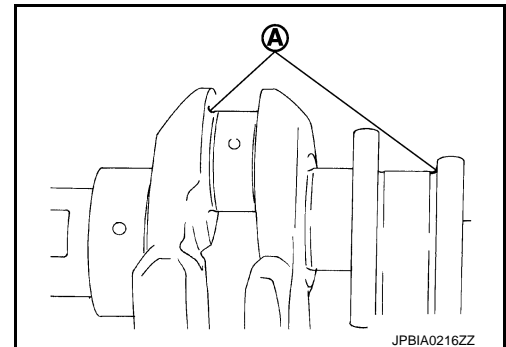

Bearing undersize table

Unit: mm (in)

Size	Thickness
US 0.25 (0.0098)	2.633 - 2.641 (0.1037 - 0.1040)

Inspection After Disassembly

INFOID:000000005348013

CRANKSHAFT END PLAY

CYLINDER BLOCK

[VQ35HR]

< SERVICE INFORMATION >

- Measure the clearance between thrust bearings and crankshaft arm when crankshaft is moved fully forward or backward with dial indicator.

Standard : 0.10 - 0.25 mm (0.0039 - 0.0098 in)

Limit : 0.30 mm (0.0118 in)

- If the measured value exceeds the limit, replace thrust bearings, and measure again. If it still exceeds the limit, replace crankshaft also.

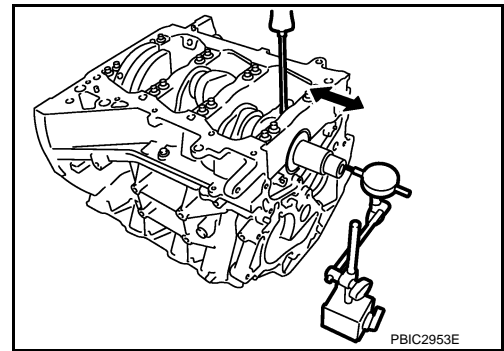

CONNECTING ROD SIDE CLEARANCE

- Measure the side clearance between connecting rod and crankshaft arm with feeler gauge.

Standard : 0.20 - 0.35 mm (0.0079 - 0.0138 in)

Limit : 0.40 mm (0.0157 in)

- If the measured value exceeds the limit, replace connecting rod, and measure again. If it still exceeds the limit, replace crankshaft also.

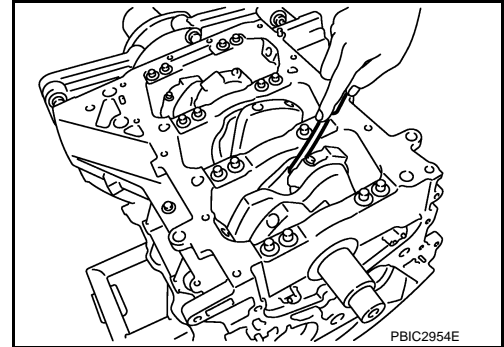

PISTON TO PISTON PIN OIL CLEARANCE

Piston Pin Hole Diameter

Measure the inner diameter of piston pin hole with inside micrometer (A).

Standard : 21.993 - 22.005 mm (0.8659 - 0.8663 in)

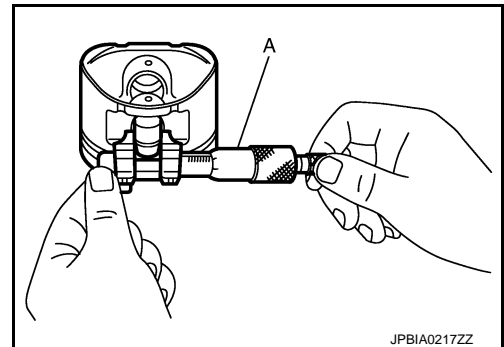

Piston Pin Outer Diameter

Measure the outer diameter of piston pin with micrometer (A).

Standard : 21.989 - 22.001 mm (0.8657 - 0.8662 in)

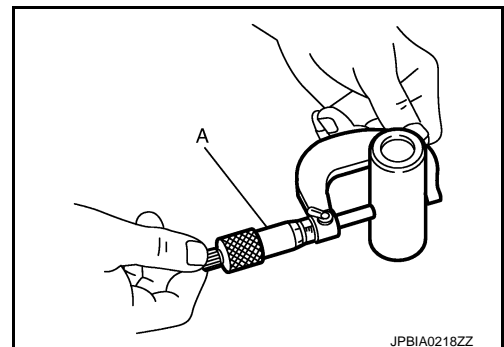

Piston to Piston Pin Oil Clearance

(Piston to piston pin oil clearance) = (Piston pin hole diameter) – (Piston pin outer diameter)

Standard : 0.002 - 0.006 mm (0.0001 - 0.0002 in)

- If the calculated value is out of the standard, replace piston and piston pin assembly.
- When replacing piston and piston pin assembly, refer to [EM-130, "How to Select Piston and Bearing"](#).

NOTE:

- Piston is available together with piston pin as assembly.

A
EM
C
D
E
F
G
H
I
J
K
L
M
N
O
P

CYLINDER BLOCK

[VQ35HR]

< SERVICE INFORMATION >

- Piston pin (piston pin hole) grade is provided only for the parts installed at the plant. For service parts, no piston pin grades can be selected. (Only "0" grade is available.)

PISTON RING SIDE CLEARANCE

- Measure the side clearance of piston ring (1) and piston ring groove with feeler gauge (C).

A : NG

B : OK

Standard:

Top ring : 0.040 - 0.080 mm (0.0016 - 0.0031 in)

2nd ring : 0.030 - 0.070 mm (0.0012 - 0.0028 in)

Oil ring : 0.055 - 0.155 mm (0.0022 - 0.0061 in)

Limit

Top ring : 0.11 mm (0.0043 in)

2nd ring : 0.10 mm (0.0039 in)

Oil ring : —

- If the measured value exceeds the limit replace piston ring, and measure again. If it still exceeds the limit replace piston also.

PISTON RING END GAP

- Check that cylinder bore inner diameter is within the specification. Refer to "Cylinder Bore Inner Diameter".
- Lubricate with new engine oil to piston (1) and piston ring (2), and then insert piston ring until middle of cylinder with piston, and measure the piston ring end gap with feeler gauge (B).

A : Press-fit

C : Measuring point

Standard:

Top ring : 0.23 - 0.33 mm (0.0091 - 0.0130 in)

2nd ring : 0.33 - 0.48 mm (0.0130 - 0.0189 in)

Oil ring : 0.17 - 0.47 mm (0.0067 - 0.0185 in)

Limit:

Top ring : 0.42 mm (0.0165 in)

2nd ring : 0.57 mm (0.0224 in)

Oil ring : 0.63 mm (0.0248 in)

- If the measured value exceeds the limit, replace piston ring, and measure again. If it still exceeds the limit, rebore cylinder and use oversize piston and piston rings.

CONNECTING ROD BEND AND TORSION

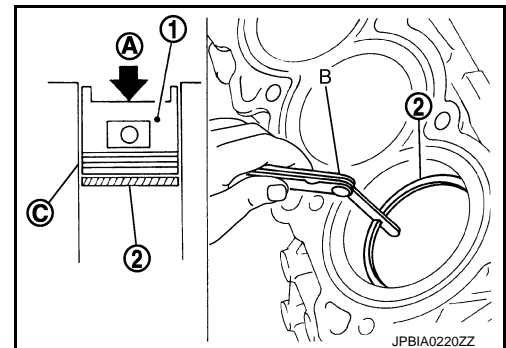
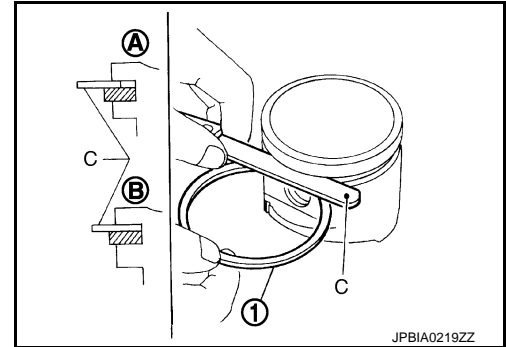

CYLINDER BLOCK

[VQ35HR]

< SERVICE INFORMATION >

- Check with connecting rod aligner.

A : Bend
B : Torsion
C : Feeler gauge

Bend:

Limit: 0.15 mm (0.0059 in) per 100 mm (3.94 in) length

Torsion:

Limit: 0.30 mm (0.0118 in) per 100 mm (3.94 in) length

- If it exceeds the limit, replace connecting rod assembly.

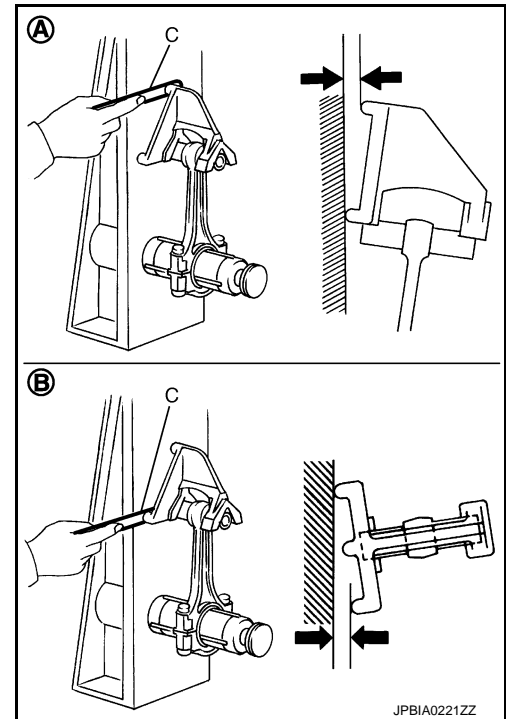

CONNECTING ROD BIG END DIAMETER

- Install connecting rod bearing cap without installing connecting rod bearing, and tightening connecting rod bolts to the specified torque. Refer to [EM-119. "Component"](#) for the tightening procedure.

1 : Connecting rod

- Measure the inner diameter of connecting rod big end with inside micrometer.

Standard : 57.000 - 57.013 mm (2.2441 - 2.2446 in)

- If out of the standard, replace connecting rod assembly.

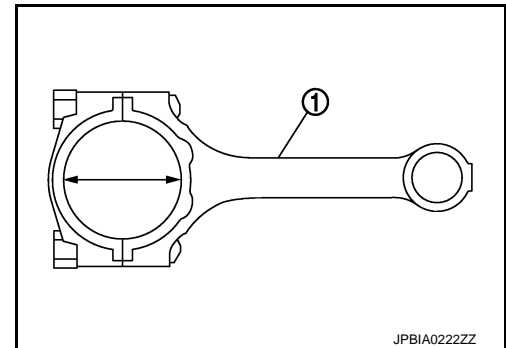

CONNECTING ROD BUSHING OIL CLEARANCE

Connecting Rod Bushing Inner Diameter

Measure the inner diameter of connecting rod bushing with inside micrometer (A).

Standard : 22.000 - 22.012 mm (0.8661 - 0.8666 in)

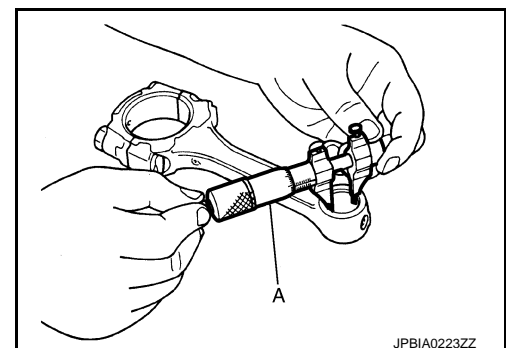

Piston Pin Outer Diameter

CYLINDER BLOCK

[VQ35HR]

< SERVICE INFORMATION >

Measure the outer diameter of piston pin with micrometer (A).

Standard : 21.989 - 22.001 mm (0.8657 - 0.8662 in)

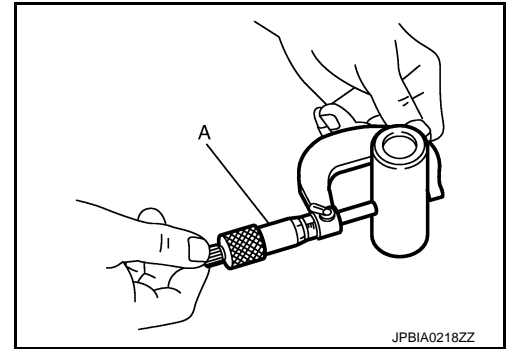

Connecting Rod Bushing Oil Clearance

(Connecting rod bushing oil clearance) = (Connecting rod bushing inner diameter) – (Piston pin outer diameter)

Standard : 0.005 - 0.017 mm (0.0002 - 0.0007 in)

Limit : 0.030 mm (0.0012 in)

- If the measured value exceeds the limit, replace connecting rod assembly and/or piston and piston pin assembly.
- If replacing piston and piston pin assembly, refer to [EM-130. "How to Select Piston and Bearing"](#).
- If replacing connecting rod assembly, refer to "CONNECTING ROD BEARING OIL CLEARANCE" to select the connecting rod bearing.

- A : Sample code
- B : Bearing stopper groove
- C : Small end diameter grade
- D : Big end diameter grade
- E : Weight grade
- F : Cylinder No.
- G : Management code
- H : Front mark
- I : Management code

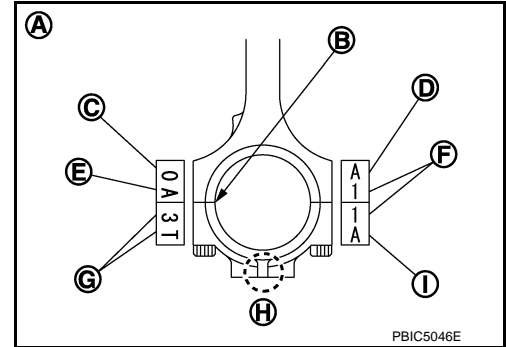

Factory installed parts grading:

- Service parts apply only to grade "0".

- A : Piston grade number
- B : Front mark
- C : Piston pin grade number

Unit: mm (in)

Grade	0	1
Connecting rod bushing inner diameter *	22.000 - 22.006 (0.8661 - 0.8664)	22.006 - 22.012 (0.8664 - 0.8666)
Piston pin hole diameter	21.993 - 21.999 (0.8659 - 0.8661)	21.999 - 22.005 (0.8661 - 0.8663)
Piston pin outer diameter	21.989 - 21.995 (0.8657 - 0.8659)	21.995 - 22.001 (0.8659 - 0.8662)

*: After installing in connecting rod

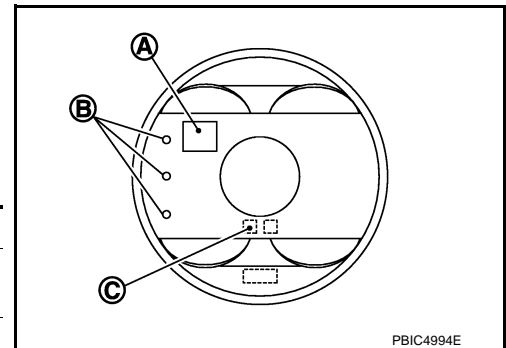

CYLINDER BLOCK DISTORTION

- Using scraper, remove gasket on the cylinder block surface, and also remove engine oil, scale, carbon, or other contamination.

CAUTION:

Be careful not to allow gasket flakes to enter engine oil or engine coolant passages.

CYLINDER BLOCK

[VQ35HR]

< SERVICE INFORMATION >

- Measure the distortion on the cylinder block upper face at some different points in six directions (C), (D), (E), (F), (G), and (H) with a straightedge (A) and feeler gauge (B).

Limit : 0.1 mm (0.004 in)

- If it exceeds the limit, replace cylinder block.

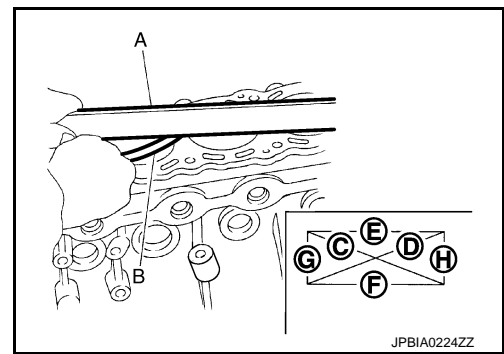

MAIN BEARING HOUSING INNER DIAMETER

- Install lower cylinder block (2) without installing main bearings, and tighten lower cylinder block bolts to the specified torque. Refer to [EM-119, "Component"](#) for the tightening procedure.
- Measure the inner diameter of main bearing housing with bore gauge.

Standard : 69.993 - 70.017 mm (2.7556 - 2.7566 in)

- If out of the standard, replace cylinder block (1) and lower cylinder block as assembly.

NOTE:

Cylinder block cannot be replaced as a single part, because it is machined together with lower cylinder block.

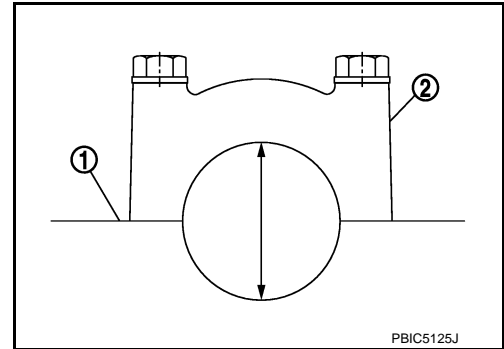

PISTON TO CYLINDER BORE CLEARANCE

Cylinder Bore Inner Diameter

- Using bore gauge, measure cylinder bore for wear, out-of-round and taper at six different points on each cylinder. [(A) and (B) directions at (C), (D) and (E)] is in longitudinal direction of engine).

- f : 10 mm (0.39 in)
- g : 60 mm (2.36 in)
- h : 125 mm (4.92 in)

Standard inner diameter:

95.500 - 95.530 mm (3.7598 - 3.7610 in)

Wear limit:

0.2 mm (0.008 in)

Out-of-round (Difference between "A" and "B"):

0.015 mm (0.0006 in)

Taper limit (Difference between "C" and "E"):

0.01 mm (0.0004 in)

- If the measured value exceeds the limit, or if there are scratches and/or seizure on the cylinder inner wall, hone or rebore the inner wall.
- Oversize piston is provided. When using oversize piston, rebore cylinder so that the clearance of the piston-to-cylinder bore satisfies the standard.

CAUTION:

When using oversize piston, use over size pistons for all cylinders with oversize piston rings.

Oversize (O/S) : 0.2 mm (0.008 in)

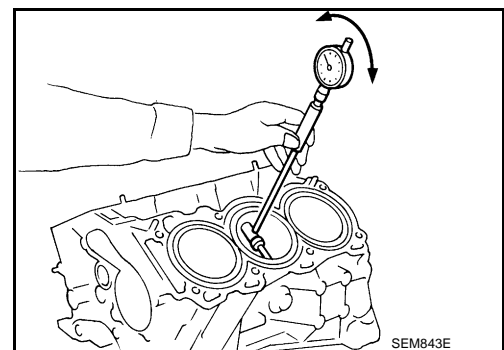
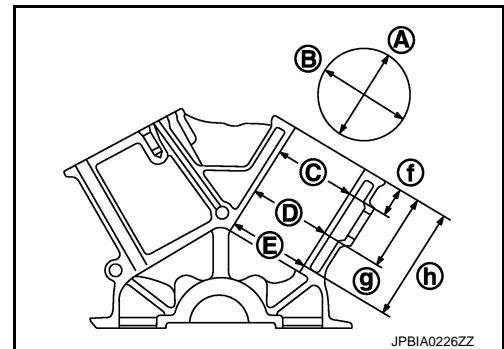

CYLINDER BLOCK

[VQ35HR]

< SERVICE INFORMATION >

Piston Skirt Diameter

Measure the outer diameter of piston skirt with micrometer (A).

Measure point

: Distance from the top 38.8 mm (1.528 in)

Standard

: 95.480 - 95.510 mm (3.7590 - 3.7602 in)

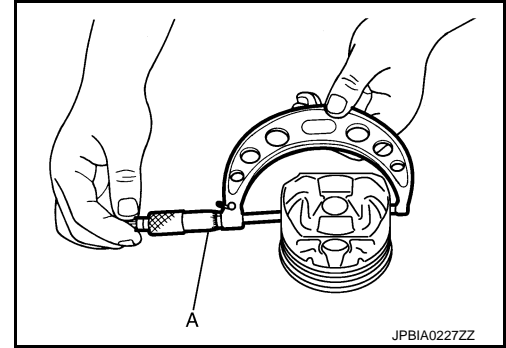

Piston to Cylinder Bore Clearance

Calculate by piston skirt diameter and cylinder bore inner diameter [direction (B), position (C)].

A : Direction A

C : Position C

E : Position E

f : 10 mm (0.39 in)

g : 60 mm (2.36 in)

h : 125 mm (4.92 in)

(Clearance) = (Cylinder bore inner diameter) – (Piston skirt diameter).

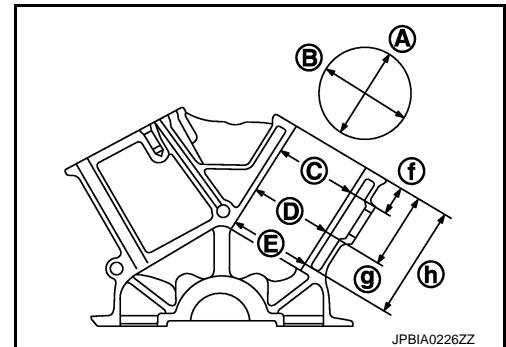

Standard : 0.010 - 0.030 mm (0.0004 - 0.0012 in)

Limit : 0.08 mm (0.0031 in)

- If calculated value exceeds the limit, replace piston and piston pin assembly. Refer to [EM-130. "How to Select Piston and Bearing"](#).

Reboring Cylinder Bore

1. Cylinder bore size is determined by adding piston to cylinder bore clearance to piston skirt diameter.

Rebored size calculation: $D = A + B - C$

where,

A: Piston skirt diameter as measured

B: Piston to cylinder bore clearance (standard value)

C: Honing allowance 0.02 mm (0.0008 in)

D: Bored diameter

2. Install lower cylinder block, and tighten to the specified torque. Otherwise, cylinder bores may be distorted in final assembly.

3. Cut cylinder bores.

NOTE:

- When any cylinder needs boring, all other cylinders must also be bored.
- Do not cut too much out of cylinder bore at a time. Cut only 0.05 mm (0.0020 in) or so in diameter at a time.

- 4.hone cylinders to obtain the specified piston to cylinder bore clearance.

5. Measure finished cylinder bore for the out-of-round and taper.

NOTE:

Measurement should be done after cylinder bore cools down.

CRANKSHAFT MAIN JOURNAL DIAMETER

- Measure the outer diameter of crankshaft main journals with micrometer.

Standard : 64.951 - 64.975 mm (2.5571 - 2.5581 in) dia.

CYLINDER BLOCK

[VQ35HR]

< SERVICE INFORMATION >

- If out of the standard, measure the main bearing oil clearance. Then use undersize bearing. Refer to "MAIN BEARING OIL CLEARANCE".

CRANKSHAFT PIN JOURNAL DIAMETER

- Measure the outer diameter of crankshaft pin journal with micrometer (A).

Standard : 53.956 - 53.974 mm (2.1242 - 2.1250 in) dia.

- If out of the standard, measure the connecting rod bearing oil clearance. Then use undersize bearing. Refer to "CONNECTING ROD BEARING OIL CLEARANCE".

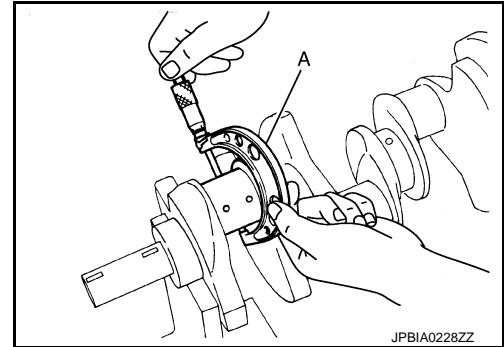

CRANKSHAFT OUT-OF-ROUND AND TAPER

- Measure the dimensions at four different points as shown in the figure on each main journal and pin journal with micrometer.
- Out-of-round is indicated by the difference in the dimensions between (c) and (d) at (a) and (b).
- Taper is indicated by the difference in the dimensions between.

Limit:

**Out-of-round (Difference between "X" and "Y")
: 0.0025 mm (0.0001 in)**

**Taper (Difference between "A" and "B")
: 0.0025 mm (0.0001 in)**

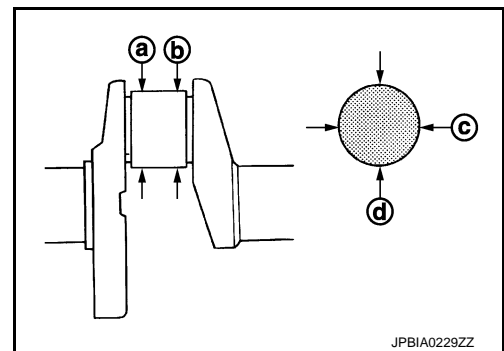

- If the measured value exceeds the limit, correct or replace crankshaft.
- If corrected, measure the bearing oil clearance of the corrected main journal and/or pin journal. Then select the main bearing and/or connecting rod bearing. Refer to "MAIN BEARING OIL CLEARANCE" and/or "CONNECTING ROD BEARING OIL CLEARANCE".

CRANKSHAFT RUNOUT

- Place V-block on precise flat table, and support the journals on the both end of crankshaft.
- Place dial indicator straight up on the No. 3 journal.
- While rotating crankshaft, read the movement of the pointer on dial indicator. (Total indicator reading)

Standard : Less than 0.05 mm (0.0020 in)

Limit : 0.10 mm (0.0039 in)

- If it exceeds the limit, replace crankshaft.

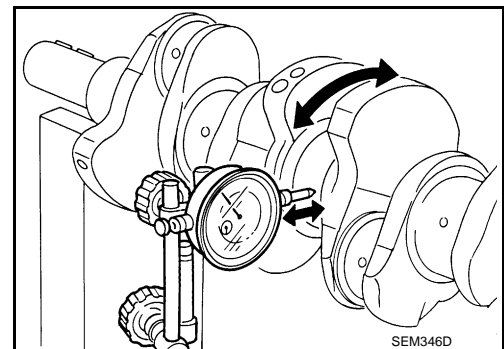

CONNECTING ROD BEARING OIL CLEARANCE

Method by Calculation

- Install connecting rod bearings (1) to connecting rod (2) and cap, and tighten connecting rod bolts to the specified torque. Refer to [EM-119. "Component"](#) for the tightening procedure.
- Measure the inner diameter of connecting rod bearing with inside micrometer.

(Bearing oil clearance) = (Connecting rod bearing inner diameter) – (Crankshaft pin journal diameter)

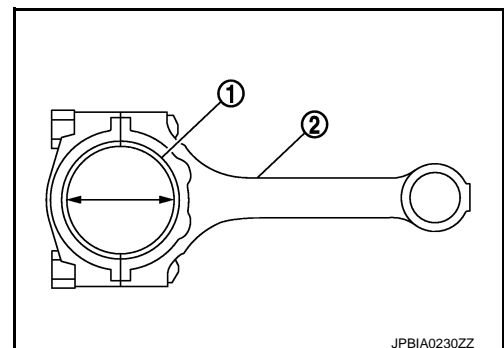

CYLINDER BLOCK

< SERVICE INFORMATION >

[VQ35HR]

Standard : 0.040 - 0.053 mm (0.0016 - 0.0021 in) (actual clearance)

Limit : 0.070 mm (0.0028 in)

- If the calculated value exceeds the limit, select proper connecting rod bearing according to connecting rod big end diameter and crankshaft pin journal diameter to obtain the specified bearing oil clearance. Refer to [EM-130. "How to Select Piston and Bearing"](#).

Method of Using Plastigage

- Remove oil and dust on crankshaft pin journal and the surfaces of each bearing completely.
- Cut plastigage slightly shorter than the bearing width, and place it in crankshaft axial direction, avoiding oil holes.
- Install connecting rod bearings to connecting rod and cap, and tighten connecting rod bolts to the specified torque. Refer to [EM-119. "Component"](#) for the tightening procedure.

CAUTION:

Never rotate crankshaft.

- Remove connecting rod bearing cap and bearing, and using scale on plastigage bag, measure the plastigage width.

NOTE:

The procedure when the measured value exceeds the limit is same as that described in the "Method by Calculation".

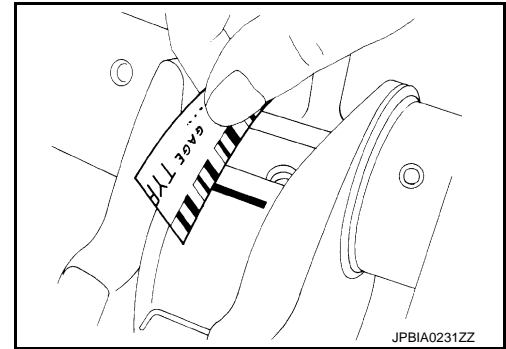

MAIN BEARING OIL CLEARANCE

Method by Calculation

- Install main bearings (3) to cylinder block (1) and lower cylinder block (2), and tighten lower cylinder block bolts to the specified torque. Refer to [EM-119. "Component"](#) for the tightening procedure.
- Measure the inner diameter of main bearing with bore gauge.
(Bearing clearance) = (Main bearing inner diameter) – (Crankshaft main journal diameter)

Standard : 0.035 - 0.045 mm (0.0014 - 0.0018 in) (actual clearance)

Limit : 0.065 mm (0.0026 in)

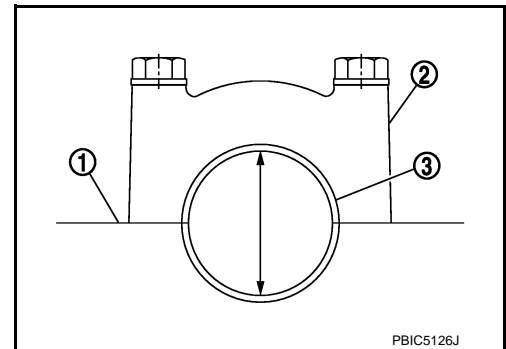

- If the clearance exceeds the limit, select proper main bearing according to main bearing inner diameter and crankshaft main journal diameter to obtain the specified bearing oil clearance. Refer to [EM-130. "How to Select Piston and Bearing"](#).

Method of Using Plastigage

- Remove oil and dust on crankshaft main journal and the surfaces of each bearing completely.
- Cut plastigage slightly shorter than the bearing width, and place it in crankshaft axial direction, avoiding oil holes.
- Install main bearings to cylinder block and lower cylinder block, and tighten lower cylinder block bolts with lower cylinder block to the specified torque. Refer to [EM-119. "Component"](#) for the tightening procedure.

CAUTION:

Never rotate crankshaft.

CYLINDER BLOCK

[VQ35HR]

< SERVICE INFORMATION >

- Remove lower cylinder block and bearings, and using scale on plastigage bag, measure the plastigage width.

NOTE:

The procedure when the measured value exceeds the limit is same as that described in the "Method by Calculation".

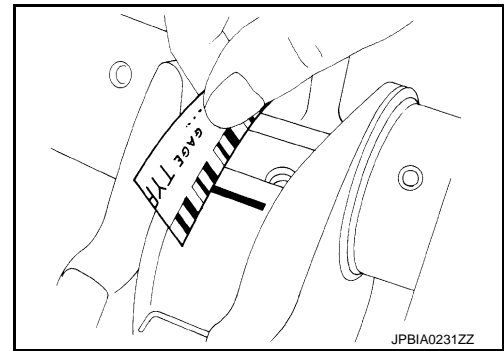

A

EM

C

D

CRUSH HEIGHT OF MAIN BEARING

- When lower cylinder block is removed after being tightened to the specified torque with main bearings (1) installed, the tip end of bearing must protrude. Refer to [EM-119, "Component"](#) for the tightening procedure.

A : Crush height

Standard : There must be crush height.

- If the standard is not met, replace main bearings.

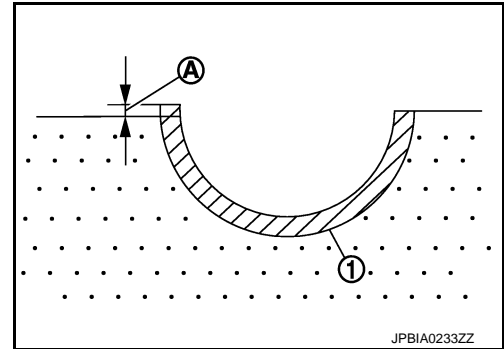

E

F

G

CRUSH HEIGHT OF CONNECTING ROD BEARING

- When connecting rod bearing cap is removed after being tightened to the specified torque with connecting rod bearings (1) installed, the tip end of bearing must protrude. Refer to [EM-119, "Component"](#) for the tightening procedure.

A : Crush height

Standard : There must be crush height.

- If the standard is not met, replace connecting rod bearings.

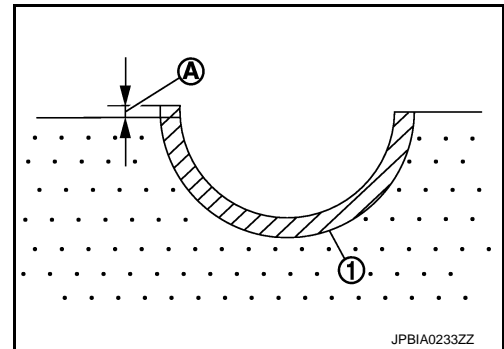

H

I

J

K

LOWER CYLINDER BLOCK BOLT OUTER DIAMETER

- Measure the outer diameters (c), (d) at two positions as shown in the figure.

a : 20 mm (0.79 in)

b : 30 mm (1.18 in)

e : 10 mm (0.39 in)

- If reduction appears in (a) range, regard it as "d2".

Limit [(d) – (c)] : 0.11 mm (0.0043 in)

- If it exceeds the limit (large difference in dimensions), replace lower cylinder block bolt with new one.

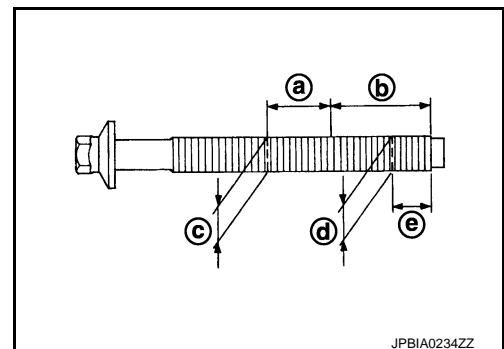

L

M

N

O

CONNECTING ROD BOLT OUTER DIAMETER

P

CYLINDER BLOCK

[VQ35HR]

< SERVICE INFORMATION >

- Measure the outer diameter [(a), (b) and (c)] at the position shown in the figure.

- a : Value at the end of the smaller diameter of the bolt
- b : Value at the end of the smaller diameter of the bolt [opposite side (a)]
- c : Value of the smallest diameter of the smaller of the bolt

- Obtain a mean value (d) of (a) and (b).
- Subtract (c) from (d).

Limit [(d) – (c)] : 0.09 mm (0.0035 in)

- If it exceeds the limit (large difference in dimensions), replace the bolt with new one.

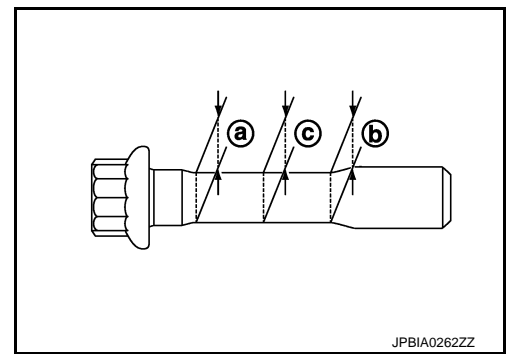

DRIVE PLATE

- Check drive plate and signal plate for deformation or cracks.

CAUTION:

- **Never disassemble drive plate.**
- **Never place drive plate with signal plate facing down.**
- **When handling signal plate, take care not to damage or scratch it.**
- **Handle signal plate in a manner that prevents it from becoming magnetized.**
- If anything is found, replace drive plate.

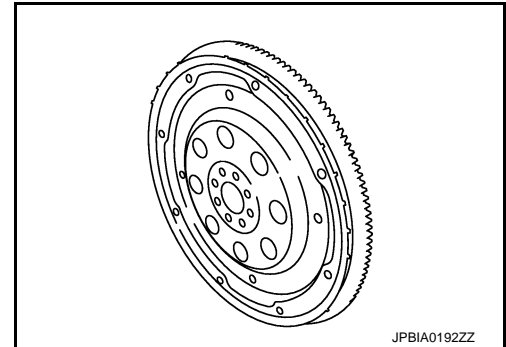

OIL JET

- Check nozzle for deformation and damage.
- Blow compressed air from nozzle, and check for clogs.
- If it is not satisfied, clean or replace oil jet.

OIL JET RELIEF VALVE

- Using clean plastic stick, press check valve in oil jet relief valve. Check that valve moves smoothly with proper reaction force.
- If it is not satisfied, replace oil jet relief valve.

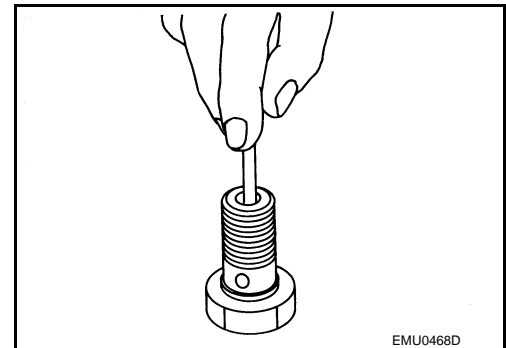

SERVICE DATA AND SPECIFICATIONS (SDS)

< SERVICE INFORMATION >

[VQ35HR]

SERVICE DATA AND SPECIFICATIONS (SDS)

Standard and Limit

INFOID:000000005348014

GENERAL SPECIFICATIONS

Cylinder arrangement		V-6
Displacement cm ³ (cu in)		3,498 (213.45)
Bore and stroke mm (in)		95.5 x 81.4 (3.760 x 3.205)
Valve arrangement		DOHC
Firing order		1-2-3-4-5-6
Number of piston rings	Compression	2
	Oil	1
Number of main bearings		4
Compression ratio		10.6
Compression pressure kPa (kg/cm ² , psi)/300 rpm	Standard	1,275 (13.0, 185)
	Minimum	981 (10.0, 142)
	Differential limit between cylinders	98 (1.0, 14)

Cylinder number

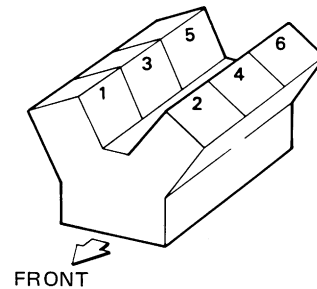

SEM713A

Valve timing (Intake valve timing control - "OFF")						
	Unit: degree					

a	b	c	d	e	f
248	248	2	66	0	68

DRIVE BELT

Tension of drive belt	Auto adjustment by auto tensioner
-----------------------	-----------------------------------

INTAKE MANIFOLD COLLECTOR, INTAKE MANIFOLD AND EXHAUST MANIFOLD

SERVICE DATA AND SPECIFICATIONS (SDS)

< SERVICE INFORMATION >

[VQ35HR]

Unit: mm (in)

	Items	Limit
Surface distortion	Intake manifold	0.1 (0.004)
	Exhaust manifold	0.7 (0.028)

SPARK PLUG

Unit: mm (in)

Make	DENSO
Standard type	FXE22HR11
Gap (Nominal)	1.1 (0.043)

CAMSHAFT AND CAMSHAFT BEARING

Unit: mm (in)

Items		Standard	Limit
Camshaft journal oil clearance	No. 1	0.045 - 0.086 (0.0018 - 0.0034)	0.15 (0.0059)
	No. 2, 3, 4	0.035 - 0.076 (0.0014 - 0.0030)	
Camshaft bracket inner diameter	No. 1	26.000 - 26.021 (1.0236 - 1.0244)	—
	No. 2, 3, 4	23.500 - 23.521 (0.9252 - 0.9260)	—
Camshaft journal diameter	No. 1	25.935 - 25.955 (1.0211 - 1.0218)	—
	No. 2, 3, 4	23.445 - 23.465 (0.9230 - 0.9238)	—
Camshaft end play		0.115 - 0.188 (0.0045 - 0.0074)	0.24 (0.0094)
Camshaft cam height "A"	Intake	45.865 - 46.055 (1.8057 - 1.8132)	0.2 (0.008)*1
	Exhaust	45.875 - 46.065 (1.8061 - 1.8136)	
Camshaft runout (TIR*2)		Less than 0.02 (0.0008)	0.05 (0.0020)
Camshaft sprocket runout (TIR*2)		—	0.15 (0.0059)

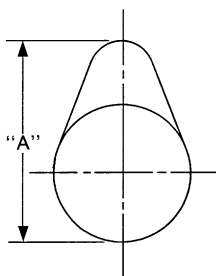

SEM671

*1: Cam wear limit

*2: Total indicator reading

VALVE LIFTER

Unit: mm (in)

Items	Standard
Valve lifter outer diameter	33.980 - 33.990 (1.3378 - 1.3382)
Valve lifter hole diameter	34.000 - 34.016 (1.3386 - 1.3392)
Valve lifter clearance	0.010 - 0.036 (0.0004 - 0.0014)

VALVE CLEARANCE

Unit: mm (in)

Items	Cold	Hot* (reference data)

SERVICE DATA AND SPECIFICATIONS (SDS)

< SERVICE INFORMATION >

[VQ35HR]

Intake	0.26 - 0.34 (0.010 - 0.013)	0.304 - 0.416 (0.012 - 0.016)
Exhaust	0.29 - 0.37 (0.011 - 0.015)	0.308 - 0.432 (0.012 - 0.017)

*: Approximately 80°C (176°F)

AVAILABLE VALVE LIFTER

Unit: mm (in)

Identification (stamped) mark	Thickness
788	7.88 (0.3102)
790	7.90 (0.3110)
792	7.92 (0.3118)
794	7.94 (0.3126)
796	7.96 (0.3134)
798	7.98 (0.3142)
800	8.00 (0.3150)
802	8.02 (0.3157)
804	8.04 (0.3165)
806	8.06 (0.3173)
808	8.08 (0.3181)
810	8.10 (0.3189)
812	8.12 (0.3197)
814	8.14 (0.3205)
816	8.16 (0.3213)
818	8.18 (0.3220)
820	8.20 (0.3228)
822	8.22 (0.3236)
824	8.24 (0.3244)
826	8.26 (0.3252)
828	8.28 (0.3260)
830	8.30 (0.3268)
832	8.32 (0.3276)
834	8.34 (0.3283)
836	8.36 (0.3291)
838	8.38 (0.3299)
840	8.40 (0.3307)

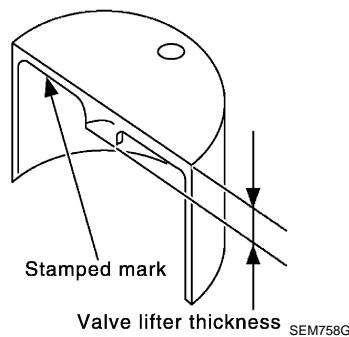

CYLINDER HEAD

SERVICE DATA AND SPECIFICATIONS (SDS)

< SERVICE INFORMATION >

[VQ35HR]

Unit: mm (in)

Items	Standard	Limit
Head surface distortion	Less than 0.03 (0.0012)	0.1 (0.004)
Normal cylinder head height "H"	126.3 - 126.5 (4.97 - 4.98)	—

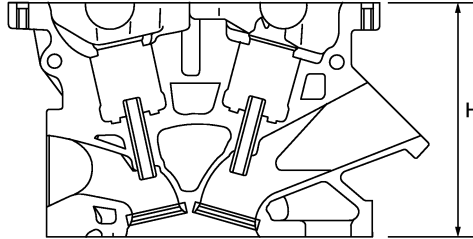

PBIC0924E

VALVE DIMENSIONS

Unit: mm (in)

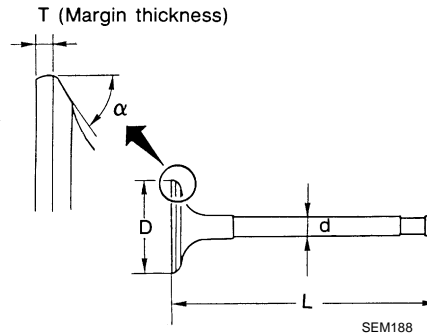

Valve head diameter "D"	Intake	36.6 - 36.9 (1.441 - 1.453)
	Exhaust	30.2 - 30.5 (1.189 - 1.201)
Valve length "L"	Intake	97.13 (3.8240)
	Exhaust	94.67 (3.7272)
Valve stem diameter "d"	Intake	5.965 - 5.980 (0.2348 - 0.2354)
	Exhaust	5.962 - 5.970 (0.2347 - 0.2350)
Valve seat angle " α "	Intake	45°15' - 45°45'
	Exhaust	
Valve margin "T"	Intake	1.1 (0.043)
	Exhaust	1.3 (0.051)
Valve margin "T" limit		0.5 (0.020)
Valve stem end surface grinding limit		0.2 (0.008)

VALVE GUIDE

SERVICE DATA AND SPECIFICATIONS (SDS)

< SERVICE INFORMATION >

[VQ35HR]

Unit: mm (in)

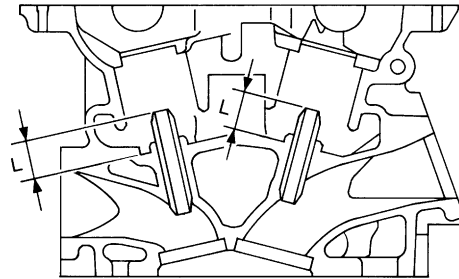

SEM950E

Items		Standard	Oversize (Service) [0.2 (0.008)]
Valve guide	Outer diameter	10.023 - 10.034 (0.3946 - 0.3950)	10.223 - 10.234 (0.4025 - 0.4029)
	Inner diameter (Finished size)	6.000 - 6.018 (0.2362 - 0.2369)	
Cylinder head valve guide hole diameter		9.975 - 9.996 (0.3927 - 0.3935)	10.175 - 10.196 (0.4006 - 0.4014)
Interference fit of valve guide		0.027 - 0.059 (0.0011 - 0.0023)	
Items		Standard	Limit
Valve guide clearance	Intake	0.020 - 0.053 (0.0008 - 0.0021)	0.08 (0.0031)
	Exhaust	0.030 - 0.056 (0.0012 - 0.0022)	0.09 (0.0035)
Projection length "L"		12.6 - 12.8 (0.496 - 0.504)	

VALVE SEAT

Unit: mm (in)

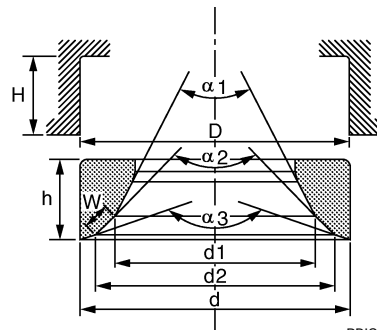

PBIC2745E

Items		Standard	Oversize (Service) [0.5 (0.020)]
Cylinder head seat recess diameter "D"	Intake	38.000 - 38.016 (1.4961 - 1.4967)	38.500 - 38.516 (1.5157 - 1.5164)
	Exhaust	31.600 - 31.616 (1.2441 - 1.2447)	32.100 - 32.116 (1.2638 - 1.2644)
Valve seat outer diameter "d"	Intake	38.097 - 38.113 (1.4999 - 1.5005)	38.597 - 38.613 (1.5196 - 1.5202)
	Exhaust	31.680 - 31.696 (1.2472 - 1.2479)	32.180 - 32.196 (1.2669 - 1.2676)
Valve seat interference fit	Intake	0.081 - 0.113 (0.0032 - 0.0044)	
	Exhaust	0.064 - 0.096 (0.0025 - 0.0038)	
Diameter "d1"*1	Intake	34.6 (1.362)	
	Exhaust	27.7 (1.091)	
Diameter "d2"*2	Intake	35.9 - 36.4 (1.413 - 1.433)	
	Exhaust	29.3 - 29.8 (1.154 - 1.173)	
Angle "alpha1"	Intake	60°	
	Exhaust	60°	
Angle "alpha2"	Intake	88°45' - 90°15'	
	Exhaust	88°45' - 90°15'	

SERVICE DATA AND SPECIFICATIONS (SDS)

< SERVICE INFORMATION >

[VQ35HR]

Angle "α3"	Intake	120°	
	Exhaust	120°	
Contacting width "W" ^{*3}	Intake	1.0 - 1.4 (0.039 - 0.055)	
	Exhaust	1.2 - 1.6 (0.047 - 0.063)	
Height "h"	Intake	5.9 - 6.0 (0.232 - 0.236)	5.05 - 5.15 (0.1988 - 0.2028)
	Exhaust	5.9 - 6.0 (0.232 - 0.236)	4.95 - 5.05 (0.1949 - 0.1988)
Depth "H"	6.0 (0.236)		

*1: Diameter made by intersection point of conic angles "α1" and "α2"

*2: Diameter made by intersection point of conic angles "α2" and "α3"

*3: Machining data

VALVE SPRING

Unit: mm (in)

Items	Standard
Free height	43.85 (1.7264)
Installation height	37.00 (1.4567)
Installation load	166 - 188 N (16.9 - 19.2 kg, 37 - 42 lb)
Height during valve open	26.8 (1.055)
Load with valve open	502 - 566 N (51.2 - 57.7 kg, 113 - 127 lb)
Items	Limit
squareness	1.9 (0.075)

CYLINDER BLOCK

Unit: mm (in)

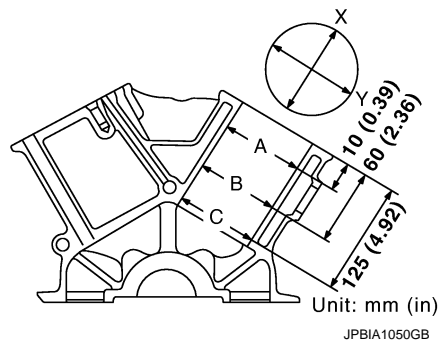

Surface distortion	Standard	Less than 0.03 (0.0012)		
	Limit	0.1 (0.004)		
Main bearing housing inner diameter	Standard	69.993 - 70.017 (2.7556 - 2.7566)		
Cylinder bore	Inner diameter	Standard	Grade No. 1	95.500 - 95.510 (3.7598 - 3.7602)
			Grade No. 2	95.510 - 95.520 (3.7602 - 3.7606)
			Grade No. 3	95.520 - 95.530 (3.7606 - 3.7610)
		Wear limit	0.2 (0.008)	
Out-of-round (Difference between "X" and "Y")	Limit	0.015 (0.0006)		
Taper (Difference between "A" and "C")		0.010 (0.0004)		

SERVICE DATA AND SPECIFICATIONS (SDS)

< SERVICE INFORMATION >

[VQ35HR]

Main bearing housing inner diameter (Without bearing)	Grade No. A	69.993 - 69.994 (2.7556 - 2.7557)	A EM C D E F G
	Grade No. B	69.994 - 69.995 (2.7557 - 2.7557)	
	Grade No. C	69.995 - 69.996 (2.7557 - 2.7557)	
	Grade No. D	69.996 - 69.997 (2.7557 - 2.7558)	
	Grade No. E	69.997 - 69.998 (2.7558 - 2.7558)	
	Grade No. F	69.998 - 69.999 (2.7558 - 2.7559)	
	Grade No. G	69.999 - 70.000 (2.7559 - 2.7559)	
	Grade No. H	70.000 - 70.001 (2.7559 - 2.7559)	
	Grade No. J	70.001 - 70.002 (2.7559 - 2.7560)	
	Grade No. K	70.002 - 70.003 (2.7560 - 2.7560)	
	Grade No. L	70.003 - 70.004 (2.7560 - 2.7561)	
	Grade No. M	70.004 - 70.005 (2.7561 - 2.7561)	
	Grade No. N	70.005 - 70.006 (2.7561 - 2.7561)	
	Grade No. P	70.006 - 70.007 (2.7561 - 2.7562)	
	Grade No. R	70.007 - 70.008 (2.7562 - 2.7562)	
	Grade No. S	70.008 - 70.009 (2.7562 - 2.7563)	
	Grade No. T	70.009 - 70.010 (2.7563 - 2.7563)	
	Grade No. U	70.010 - 70.011 (2.7563 - 2.7563)	
	Grade No. V	70.011 - 70.012 (2.7563 - 2.7564)	
Grade No. W	70.012 - 70.013 (2.7564 - 2.7564)		
Grade No. X	70.013 - 70.014 (2.7564 - 2.7565)		
Grade No. Y	70.014 - 70.015 (2.7565 - 2.7565)		
Grade No. 4	70.015 - 70.016 (2.7565 - 2.7565)		
Grade No. 7	70.016 - 70.017 (2.7565 - 2.7566)		
Difference in inner diameter between cylinders	Standard	Less than 0.03 (0.0012)	

PISTON, PISTON RING AND PISTON PIN

AVAILABLE PISTON

Unit: mm (in)

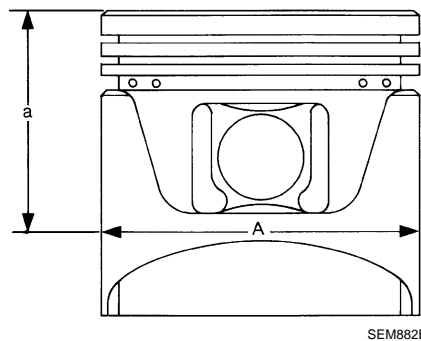

Items	Standard	Oversize (Service) [0.2 (0.008)]
"a" dimension	38.8 (1.528)	
Piston skirt diameter "A"	Grade No. 1	95.480 - 95.490 (3.7590 - 3.7594)
	Grade No. 2	95.490 - 95.500 (3.7594 - 3.7598)
	Grade No. 3	95.500 - 95.510 (3.7598 - 3.7602)
	Service	—
95.680 - 95.710 (3.7669 - 3.7681)		
Items	Standard	Limit
Piston pin hole diameter	Grade No. 0	21.993 - 21.999 (0.8659 - 0.8661)
	Grade No. 1	21.999 - 22.005 (0.8661 - 0.8663)
Piston to cylinder bore clearance	0.010 - 0.030 (0.0004 - 0.0012)	0.08 (0.0031)

PISTON RING

SERVICE DATA AND SPECIFICATIONS (SDS)

< SERVICE INFORMATION >

[VQ35HR]

Unit: mm (in)

Items		Standard	Limit
Side clearance	Top	0.040 - 0.080 (0.0016 - 0.0031)	0.11 (0.0043)
	2nd	0.030 - 0.070 (0.0012 - 0.0028)	0.10 (0.0039)
	Oil ring	0.055 - 0.155 (0.0022 - 0.0061)	—
End gap	Top	0.23 - 0.33 (0.0091 - 0.0130)	0.42 (0.0165)
	2nd	0.33 - 0.48 (0.0130 - 0.0189)	0.57 (0.0224)
	Oil (rail ring)	0.17 - 0.47 (0.0067 - 0.0185)	0.63 (0.0248)

PISTON PIN

Unit: mm (in)

Items		Standard	Limit
Piston pin outer diameter	Grade No. 0	21.989 - 21.995 (0.8657 - 0.8659)	—
	Grade No. 1	21.995 - 22.001 (0.8659 - 0.8662)	—
Piston to piston pin oil clearance		0.002 - 0.006 (0.0001 - 0.0002)	—
Connecting rod bushing oil clearance		0.005 - 0.017 (0.0002 - 0.0007)	0.030 (0.0012)

CONNECTING ROD

Unit: mm (in)

Items		Standard	Limit
Center distance		144.15 - 144.25 (5.68 - 5.68)	—
Bend [per 100 (3.94)]		—	0.15 (0.0059)
Torsion [per 100 (3.94)]		—	0.30 (0.0118)
Connecting rod bushing inner diameter*	Grade No. 0	22.000 - 22.006 (0.8661 - 0.8664)	—
	Grade No. 1	22.006 - 22.012 (0.8664 - 0.8666)	—
Connecting rod big end diameter (Without bearing)		57.000 - 57.013 (2.2441 - 2.2446)	—
Side clearance		0.20 - 0.35 (0.0079 - 0.0138)	0.40 (0.0157)

*: After installing in connecting rod

CRANKSHAFT

SERVICE DATA AND SPECIFICATIONS (SDS)

< SERVICE INFORMATION >

[VQ35HR]

Unit: mm (in)

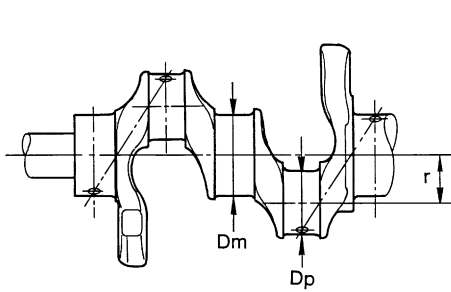

SEM645

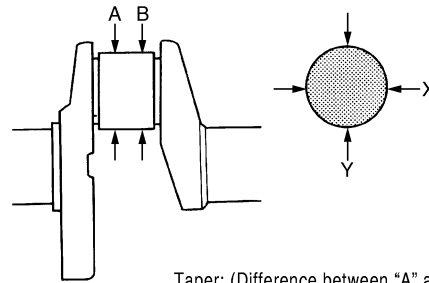

Taper: (Difference between "A" and "B")
Out-of-round: (Difference between "X" and "Y")

SBIA0535E

Main journal diameter. "Dm" grade	Standard	Grade No. A	64.975 - 64.974 (2.5581 - 2.5580)		
		Grade No. B	64.974 - 64.973 (2.5580 - 2.5580)		
		Grade No. C	64.973 - 64.972 (2.5580 - 2.5579)		
		Grade No. D	64.972 - 64.971 (2.5579 - 2.5579)		
		Grade No. E	64.971 - 64.970 (2.5579 - 2.5579)		
		Grade No. F	64.970 - 64.969 (2.5579 - 2.5578)		
		Grade No. G	64.969 - 64.968 (2.5578 - 2.5578)		
		Grade No. H	64.968 - 64.967 (2.5578 - 2.5578)		
		Grade No. J	64.967 - 64.966 (2.5578 - 2.5577)		
		Grade No. K	64.966 - 64.965 (2.5577 - 2.5577)		
		Grade No. L	64.965 - 64.964 (2.5577 - 2.5576)		
		Grade No. M	64.964 - 64.963 (2.5576 - 2.5576)		
		Grade No. N	64.963 - 64.962 (2.5576 - 2.5576)		
		Grade No. P	64.962 - 64.961 (2.5576 - 2.5575)		
		Grade No. R	64.961 - 64.960 (2.5575 - 2.5575)		
		Grade No. S	64.960 - 64.959 (2.5575 - 2.5574)		
		Grade No. T	64.959 - 64.958 (2.5574 - 2.5574)		
		Grade No. U	64.958 - 64.957 (2.5574 - 2.5574)		
		Pin journal diameter. "Dp" grade	Standard	Grade No. A	53.974 - 53.973 (2.1250 - 2.1249)
				Grade No. B	53.973 - 53.972 (2.1249 - 2.1249)
Grade No. C	53.972 - 53.971 (2.1249 - 2.1248)				
Grade No. D	53.971 - 53.970 (2.1248 - 2.1248)				
Grade No. E	53.970 - 53.969 (2.1248 - 2.1248)				
Grade No. F	53.969 - 53.968 (2.1248 - 2.1247)				
Grade No. G	53.968 - 53.967 (2.1247 - 2.1247)				
Grade No. H	53.967 - 53.966 (2.1247 - 2.1246)				
Grade No. J	53.966 - 53.965 (2.1246 - 2.1246)				
Grade No. K	53.965 - 53.964 (2.1246 - 2.1246)				
Grade No. L	53.964 - 53.963 (2.1246 - 2.1245)				
Grade No. M	53.963 - 53.962 (2.1245 - 2.1245)				
Grade No. N	53.962 - 53.961 (2.1245 - 2.1244)				
Grade No. P	53.961 - 53.960 (2.1244 - 2.1244)				
Grade No. R	53.960 - 53.959 (2.1244 - 2.1244)				
Grade No. S	53.959 - 53.958 (2.1244 - 2.1243)				
Grade No. T	53.958 - 53.957 (2.1243 - 2.1243)				
Grade No. U	53.957 - 53.956 (2.1243 - 2.1242)				
Center distance "r"		40.66 - 40.74 (1.6008 - 1.6039)			

SERVICE DATA AND SPECIFICATIONS (SDS)

< SERVICE INFORMATION >

[VQ35HR]

Out-of-round (Difference between "X" and "Y")	Limit	0.0025 (0.0001)
Taper (Difference between "A" and "B")		0.0025 (0.0001)
Crankshaft runout (TIR*)	Standard	Less than 0.05 (0.0020)
	Limit	0.10 (0.0039)
Crankshaft end play	Standard	0.10 - 0.25 (0.0039 - 0.0098)
	Limit	0.30 (0.0118)

*: Total indicator reading

MAIN BEARING

Unit: mm (in)

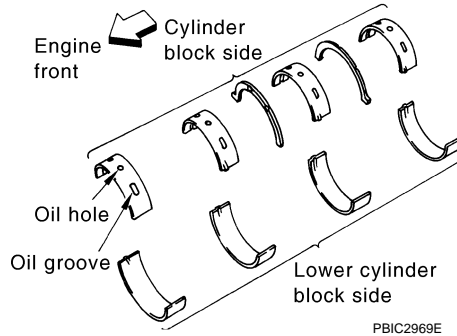

Grade number	UPR/LWR	Thickness	Width	Identification color	Remarks
0	—	2.500 - 2.503 (0.0984 - 0.0985)	19.9 - 20.1 (0.783 - 0.791)	Black	Grade is the same for upper and lower bearings.
1	—	2.503 - 2.506 (0.0985 - 0.0987)		Brown	
2	—	2.506 - 2.509 (0.0987 - 0.0988)		Green	
3	—	2.509 - 2.512 (0.0988 - 0.0989)		Yellow	
4	—	2.512 - 2.515 (0.0989 - 0.0990)		Blue	
5	—	2.515 - 2.518 (0.0990 - 0.0991)		Pink	
6	—	2.518 - 2.521 (0.0991 - 0.0993)		Purple	
7	—	2.521 - 2.524 (0.0993 - 0.0994)		White	Grade is different for upper and lower bearings.
01	UPR	2.503 - 2.506 (0.0985 - 0.0987)		Brown	
	LWR	2.500 - 2.503 (0.0984 - 0.0985)		Black	
12	UPR	2.506 - 2.509 (0.0987 - 0.0988)		Green	
	LWR	2.503 - 2.506 (0.0985 - 0.0987)		Brown	
23	UPR	2.509 - 2.512 (0.0988 - 0.0989)		Yellow	
	LWR	2.506 - 2.509 (0.0987 - 0.0988)		Green	
34	UPR	2.512 - 2.515 (0.0989 - 0.0990)	Blue		
	LWR	2.509 - 2.512 (0.0988 - 0.0989)	Yellow		
45	UPR	2.515 - 2.518 (0.0990 - 0.0991)	Pink		
	LWR	2.512 - 2.515 (0.0989 - 0.0990)	Blue		
56	UPR	2.518 - 2.521 (0.0991 - 0.0993)	Purple		
	LWR	2.515 - 2.518 (0.0990 - 0.0991)	Pink		
67	UPR	2.521 - 2.524 (0.0993 - 0.0994)	White		
	LWR	2.518 - 2.521 (0.0991 - 0.0993)	Purple		

UNDERSIZE

Unit: mm (in)

Items	Thickness	Main journal diameter
0.25 (0.0098)	2.633 - 2.641 (0.1037 - 0.1040)	Grind so that bearing clearance is the specified value.

SERVICE DATA AND SPECIFICATIONS (SDS)

< SERVICE INFORMATION >

[VQ35HR]

MAIN BEARING OIL CLEARANCE

Unit: mm (in)

Items	Standard	Limit
Main bearing oil clearance	0.035 - 0.045 (0.0014 - 0.0018)*	0.065 (0.0026)

*: Actual clearance

CONNECTING ROD BEARING

Unit: mm (in)

Grade number	Thickness	Identification color (mark)
0	1.497 - 1.500 (0.0589 - 0.0591)	Black
1	1.500 - 1.503 (0.0591 - 0.0592)	Brown
2	1.503 - 1.506 (0.0592 - 0.0593)	Green
3	1.506 - 1.509 (0.0593 - 0.0594)	Yellow
4	1.509 - 1.512 (0.0594 - 0.0595)	Blue

UNDERSIZE

Unit: mm (in)

Items	Thickness	Crank pin journal diameter
0.25 (0.0098)	1.626 - 1.634 (0.0640 - 0.0643)	Grind so that bearing clearance is the specified value.

CONNECTING ROD BEARING OIL CLEARANCE

Unit: mm (in)

Items	Standard	Limit
Connecting rod bearing oil clearance	0.040 - 0.053 (0.0016 - 0.0021)*	0.070 (0.0028)

*: Actual clearance

SERVICE INFORMATION

PRECAUTIONS

Precaution for Procedure without Cowl Top Cover

INFOID:000000005348015

When performing the procedure after removing cowl top cover, cover the lower end of windshield with urethane, etc.

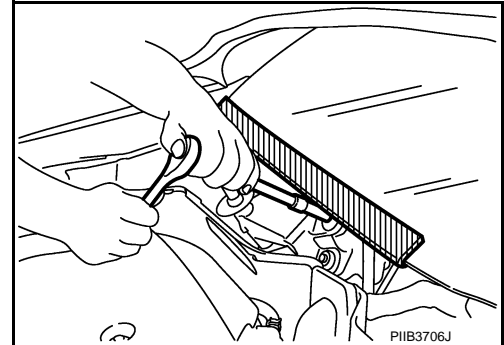

Precaution Necessary for Steering Wheel Rotation after Battery Disconnect

INFOID:000000005348016

NOTE:

- Before removing and installing any control units, first turn the push-button ignition switch to the LOCK position, then disconnect both battery cables.
- After finishing work, confirm that all control unit connectors are connected properly, then re-connect both battery cables.
- Always use CONSULT-III to perform self-diagnosis as a part of each function inspection after finishing work. If a DTC is detected, perform trouble diagnosis according to self-diagnosis results.

This vehicle is equipped with a push-button ignition switch and a steering lock unit. If the battery is disconnected or discharged, the steering wheel will lock and cannot be turned.

If turning the steering wheel is required with the battery disconnected or discharged, follow the procedure below before starting the repair operation.

OPERATION PROCEDURE

1. Connect both battery cables.
 - NOTE:**
Supply power using jumper cables if battery is discharged.
2. Turn the push-button ignition switch to ACC position.
(At this time, the steering lock will be released.)
3. Disconnect both battery cables. The steering lock will remain released with both battery cables disconnected and the steering wheel can be turned.
4. Perform the necessary repair operation.
5. When the repair work is completed, re-connect both battery cables. With the brake pedal released, turn the push-button ignition switch from ACC position to ON position, then to LOCK position. (The steering wheel will lock when the push-button ignition switch is turned to LOCK position.)
6. Perform self-diagnosis check of all control units using CONSULT-III.

Precaution for Supplemental Restraint System (SRS) "AIR BAG" and "SEAT BELT PRE-TENSIONER"

INFOID:000000005348017

The Supplemental Restraint System such as "AIR BAG" and "SEAT BELT PRE-TENSIONER", used along with a front seat belt, helps to reduce the risk or severity of injury to the driver and front passenger for certain types of collision. This system includes seat belt switch inputs and dual stage front air bag modules. The SRS system uses the seat belt switches to determine the front air bag deployment, and may only deploy one front air bag, depending on the severity of a collision and whether the front occupants are belted or unbelted. Information necessary to service the system safely is included in the "SUPPLEMENTAL RESTRAINT SYSTEM" and "SEAT BELTS" of this Service Manual.

WARNING:

PRECAUTIONS

< SERVICE INFORMATION >

[VK45DE]

- To avoid rendering the SRS inoperative, which could increase the risk of personal injury or death in the event of a collision which would result in air bag inflation, all maintenance must be performed by an authorized NISSAN/INFINITI dealer.
- Improper maintenance, including incorrect removal and installation of the SRS, can lead to personal injury caused by unintentional activation of the system. For removal of Spiral Cable and Air Bag Module, see the "SUPPLEMENTAL RESTRAINT SYSTEM".
- Do not use electrical test equipment on any circuit related to the SRS unless instructed to in this Service Manual. SRS wiring harnesses can be identified by yellow and/or orange harnesses or harness connectors.

PRECAUTIONS WHEN USING POWER TOOLS (AIR OR ELECTRIC) AND HAMMERS

WARNING:

- When working near the Air Bag Diagnosis Sensor Unit or other Air Bag System sensors with the ignition ON or engine running, DO NOT use air or electric power tools or strike near the sensor(s) with a hammer. Heavy vibration could activate the sensor(s) and deploy the air bag(s), possibly causing serious injury.
- When using air or electric power tools or hammers, always switch the ignition OFF, disconnect the battery, and wait at least 3 minutes before performing any service.

Precaution for Drain Engine Coolant and Engine Oil

INFOID:000000005348018

Drain engine coolant and engine oil when engine is cooled.

Precaution for Disconnecting Fuel Piping

INFOID:000000005348019

- Before starting work, check no fire or spark producing items are in the work area.
- Release fuel pressure before disconnecting and disassembly.
- After disconnecting pipes, plug openings to stop fuel leakage.

Precaution for Removal and Disassembly

INFOID:000000005348020

- When instructed to use SST, use specified tools. Always be careful to work safely, avoid forceful or uninstructed operations.
- Exercise maximum care to avoid damage to mating or sliding surfaces.
- Cover openings of engine system with tape or the equivalent, if necessary, to seal out foreign materials.
- Mark and arrange disassembly parts in an organized way for easy troubleshooting and assembly.
- When loosening nuts and bolts, as a basic rule, start with the one furthest outside, then the one diagonally opposite, and so on. If the order of loosening is specified, do exactly as specified. Power tools may be used where noted in the step.

Precaution for Inspection, Repair and Replacement

INFOID:000000005348021

Before repairing or replacing, thoroughly inspect parts. Inspect new replacement parts in the same way, and replace if necessary.

Precaution for Assembly and Installation

INFOID:000000005348022

- Use torque wrench to tighten bolts or nuts to specification.
- When tightening nuts and bolts, as a basic rule, equally tighten in several different steps starting with the ones in center, then ones on inside and outside diagonally in this order. If the order of tightening is specified, do exactly as specified.
- Replace with new gasket, packing, oil seal or O-ring.
- Thoroughly wash, clean, and air-blow each part. Carefully check engine oil or engine coolant passages for any restriction and blockage.
- Guide pins are used for several parts alignment. When replacing and reassembling parts with guide pins, check that guide pins are installed in the original position.
- Avoid damaging sliding or mating surfaces. Completely remove foreign materials such as cloth lint or dust. Before assembly, oil sliding surfaces well.
- Release air within route when refilling after draining engine coolant.
- After repairing, start engine and increase engine speed to check engine coolant, fuel, engine oil, and exhaust gases for leakage.

PRECAUTIONS

< SERVICE INFORMATION >

[VK45DE]

Parts Requiring Angle Tightening

INFOID:000000005348023

- Use angle wrench [SST: KV101112100 (BT8653-A)] for the final tightening of the following engine parts:
 - Cylinder head bolts
 - Main bearing cap bolts
 - Connecting rod cap nuts
 - Crankshaft pulley bolt (No angle wrench is required as the bolt flange is provided with notches for angle tightening)
- Do not use a torque value for final tightening.
- The torque value for these parts are for a preliminary step.
- Ensure thread and seat surfaces are clean and coated with engine oil.

Precaution for Liquid Gasket

INFOID:000000005348024

REMOVAL OF LIQUID GASKET SEALING

- After removing mounting nuts and bolts, separate the mating surface using seal cutter (SST) and remove old liquid gasket sealing.

CAUTION:

Be careful not to damage the mating surfaces.

- Tap seal cutter (SST) to insert it, and then slide it by tapping on the side as shown in the figure.
- In areas where seal cutter (SST) is difficult to use, use plastic hammer to lightly tap the parts, to remove it.

CAUTION:

If for some unavoidable reason tool such as screwdriver is used, be careful not to damage the mating surfaces.

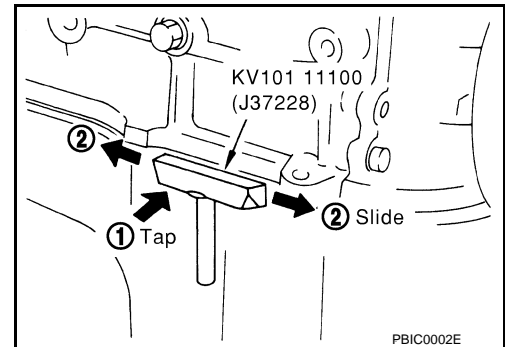

LIQUID GASKET APPLICATION PROCEDURE

1. Using scraper, remove old liquid gasket adhering to the liquid gasket application surface and the mating surface.
 - Remove liquid gasket completely from the groove of the liquid gasket application surface, mounting bolts, and bolt holes.
2. Wipe the liquid gasket application surface and the mating surface with white gasoline (lighting and heating use) to remove adhering moisture, grease and foreign materials.

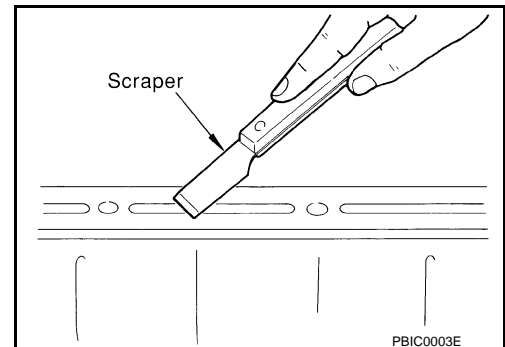

3. Attach liquid gasket tube to tube presser (commercial service tool).

Use Genuine RTV Silicone Sealant or equivalent. Refer to [GI-46](#).

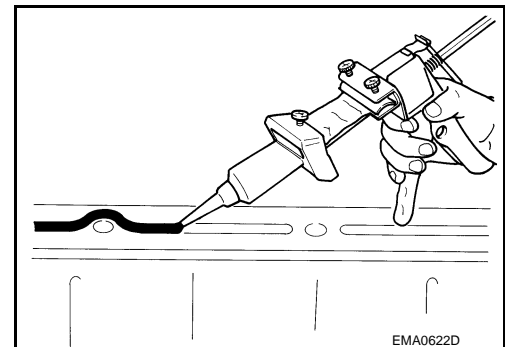

PRECAUTIONS

< SERVICE INFORMATION >

[VK45DE]

4. Apply liquid gasket without breaks to the specified location with the specified dimensions.
 - If there is a groove for the liquid gasket application, apply liquid gasket to the groove.
 - As for the bolt holes, normally apply liquid gasket inside the holes. Occasionally, it should be applied outside the holes. Check to read the text of this manual.
 - Within five minutes of liquid gasket application, install the mating component.
 - If liquid gasket protrudes, wipe it off immediately.
 - Do not retighten mounting bolts and nuts after the installation.
 - Wait 30 minutes or more after installation before refilling engine with engine oil and engine coolant.

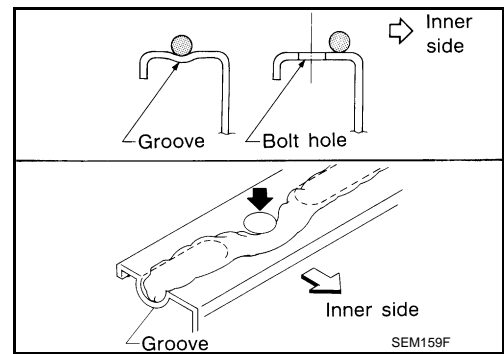

CAUTION:

If there are specific instructions in this manual, observe them.

A
EM
C
D
E
F
G
H
I
J
K
L
M
N
O
P

PREPARATION



< SERVICE INFORMATION >

[VK45DE]

PREPARATION

Special Service Tool

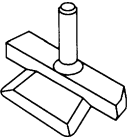
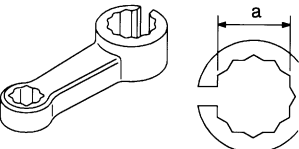
INFOID:00000005348025

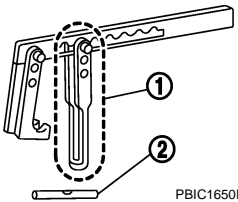
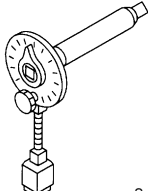
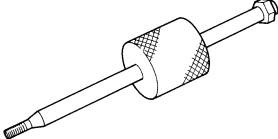
Tool number (Kent-Moore No.) Tool name	Description
KV10111100 (J-37228) Seal cutter  <p style="text-align: center;">S-NT046</p>	Removing steel oil pan and front cover
KV10114400 (J-38365) Heated oxygen sensor wrench  <p style="text-align: center;">S-NT636</p>	Loosening or tightening air fuel ratio sensor 1 a: 22 mm (0.87 in)
EG15050500 (J-45402) Compression gauge adapter  <p style="text-align: center;">ZZA1225D</p>	Inspecting of compression pressure
KV10116200 (J26336-A) Valve spring compressor 1. KV10115900 (J26336-20) Attachment 2. KV10109220 (—) Adapter  <p style="text-align: center;">PBIC1650E</p>	Disassembling valve mechanism Part (1) is a component of KV10116200 (J26336-A), but part (2) is not so.
KV10112100 (BT8653-A) Angle wrench  <p style="text-align: center;">S-NT014</p>	Tightening bolts for bearing cap, cylinder head, etc.
KV10114700 (J-38139) Main bearing cap remover  <p style="text-align: center;">ZZA0023D</p>	Removing crankshaft main bearing cap

PREPARATION

< SERVICE INFORMATION >

[VK45DE]

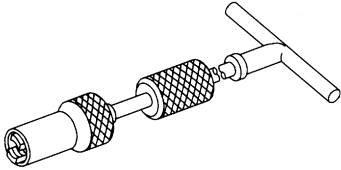
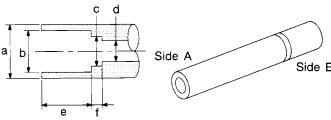
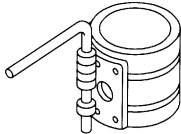
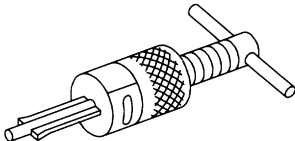
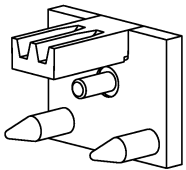
Tool number (Kent-Moore No.) Tool name	Description
KV10107902 (J-38959) Valve oil seal puller  <p style="text-align: center;">S-NT011</p>	Removing valve oil seal
KV10115600 (J-38958) Valve oil seal drift  <p style="text-align: center;">S-NT603</p>	Installing valve oil seal Use side A. a: 20 (0.79) dia. d: 8 (0.31) dia. b: 13 (0.51) dia. e: 10.7 (0.421) c: 10.3 (0.406) dia. f: 5 (0.20) Unit: mm (in)
EM03470000 (J-8037) Piston ring compressor  <p style="text-align: center;">S-NT044</p>	Installing piston assembly into cylinder bore
ST16610001 (J-23907) Pilot bushing puller  <p style="text-align: center;">S-NT045</p>	Removing crankshaft pilot converter
— (J-45476) Ring gear stopper  <p style="text-align: center;">PBIC1655E</p>	Removing and installing crankshaft pulley

A
EM
C

D

E

F

G

H

I

J

K

L

M

Commercial Service Tool

INFOID:000000005348026

N

O

P

PREPARATION

< SERVICE INFORMATION >

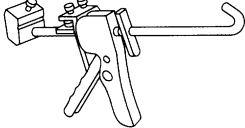
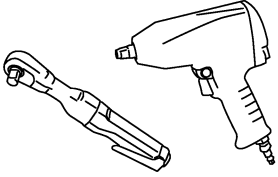
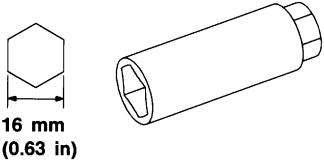
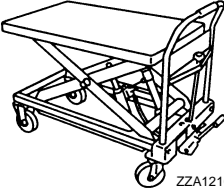
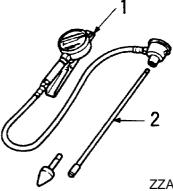
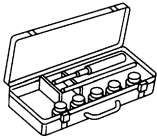

[VK45DE]

(Kent-Moore No.) Tool name	Description
(J-45488) Quick connector release <div style="text-align: center; margin-top: 20px;">  <p>PBIC0198E</p> </div>	Removing fuel tube quick connectors in engine room
(—) Tube presser <div style="text-align: center; margin-top: 20px;">  <p>S-NT052</p> </div>	Pressing the tube of liquid gasket
(—) Power tool <div style="text-align: center; margin-top: 20px;">  <p>PBIC0190E</p> </div>	Loosening nuts and bolts
(—) Spark plug wrench <div style="text-align: center; margin-top: 20px;">  <p>16 mm (0.63 in)</p> <p>S-NT047</p> </div>	Removing and installing spark plug
(—) Manual lift table caddy <div style="text-align: center; margin-top: 20px;">  <p>ZZA1210D</p> </div>	Removing and installing engine
(—) 1.Compression gauge 2.Adapter <div style="text-align: center; margin-top: 20px;">  <p>ZZA0008D</p> </div>	Checking compression pressure
(—) Valve seat cutter set <div style="text-align: center; margin-top: 20px;">  <p>S-NT048</p> </div>	Finishing valve seat dimensions

PREPARATION

< SERVICE INFORMATION >

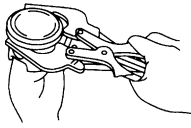
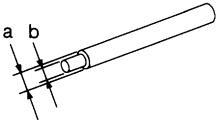
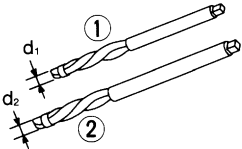
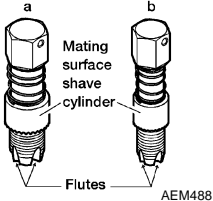
[VK45DE]

(Kent-Moore No.) Tool name	Description
(—) Piston ring expander  <p style="text-align: center;">S-NT030</p>	Removing and installing piston ring
(—) Valve guide drift  <p style="text-align: center;">S-NT015</p>	Removing and installing valve guide Intake and Exhaust: a: 9.5 mm (0.374 in) dia. b: 5.5 mm (0.217 in) dia.
(—) Valve guide reamer  <p style="text-align: center;">S-NT016</p>	(1): Reaming valve guide inner hole (2): Reaming hole for oversize valve guide Intake and Exhaust: d1: 6.0 mm (0.236 in) dia. d2: 10.2 mm (0.402 in) dia.
a: (J-43897-18) b: (J-43897-12) Oxygen sensor thread cleaner  <p style="text-align: center;">AEM488</p>	Reconditioning the exhaust system threads before installing a new air fuel ratio sensor (Use with anti-seize lubricant shown below.) a: J-43897-18 [18 mm (0.71 in) dia.] for zirconia air fuel ratio sensor b: J-43897-12 [12 mm (0.47 in) dia.] for titania air fuel ratio sensor
(—) Anti-seize lubricant (Permatex 133AR or equivalent meeting MIL specification MIL-A-907)  <p style="text-align: center;">AEM489</p>	Lubricating oxygen sensor thread cleaning tool when reconditioning exhaust system threads

A

EM

C

D

E

F

G

H

I

J

K

L

M

N

O

P

NOISE, VIBRATION AND HARSHNESS (NVH) TROUBLESHOOTING

< SERVICE INFORMATION >

[VK45DE]

NOISE, VIBRATION AND HARSHNESS (NVH) TROUBLESHOOTING

NVH Troubleshooting - Engine Noise

INFOID:000000005348027

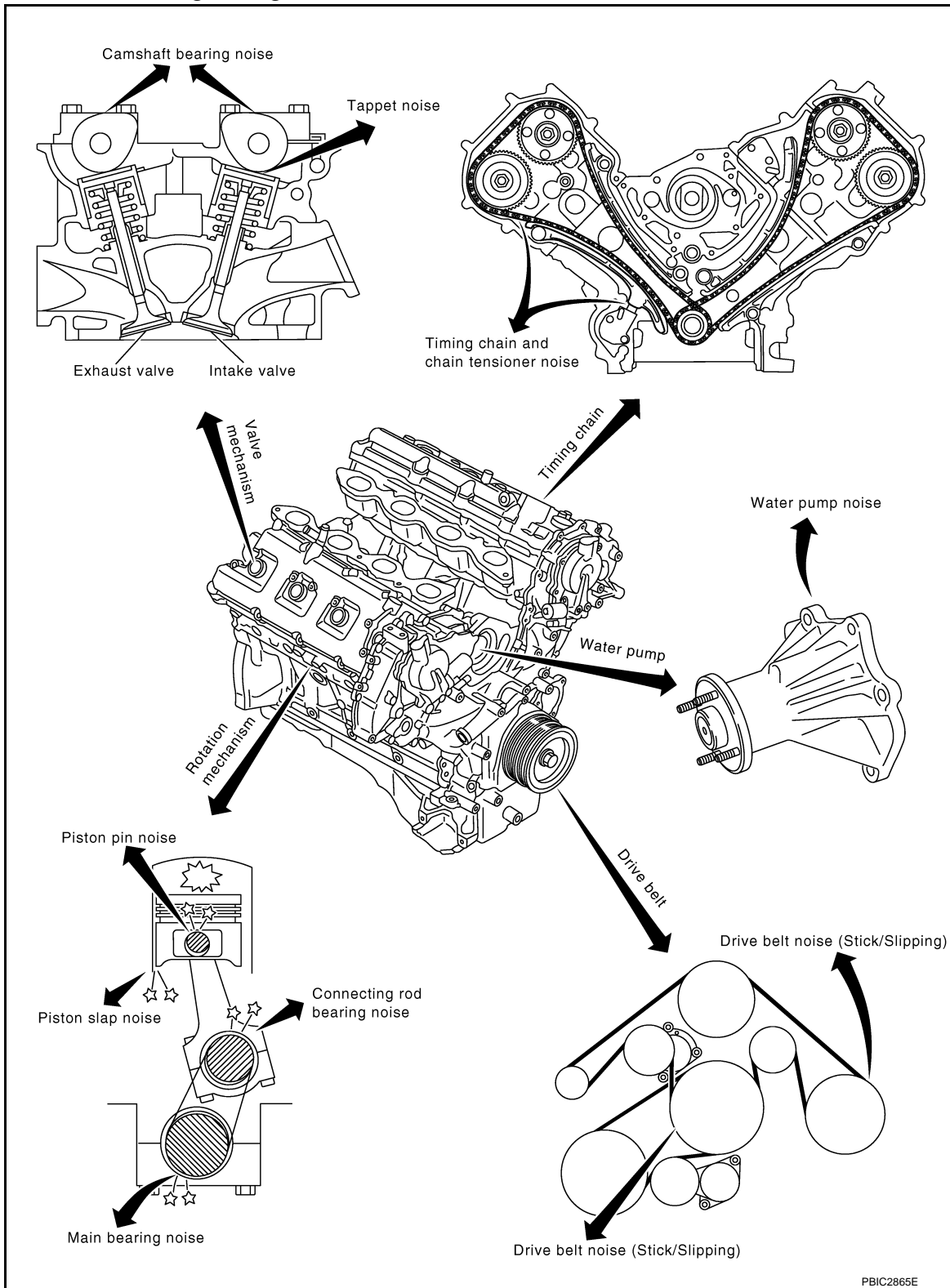

Use the Chart Below to Help You Find the Cause of the Symptom

INFOID:000000005348028

1. Locate the area where noise occurs.
2. Confirm the type of noise.

NOISE, VIBRATION AND HARSHNESS (NVH) TROUBLESHOOTING

< SERVICE INFORMATION >

[VK45DE]

3. Specify the operating condition of engine.

4. Check specified noise source.

If necessary, repair or replace these parts.

Location of noise	Type of noise	Operating condition of engine						Source of noise	Check item	Reference page
		Before warm-up	After warm-up	When starting	When idling	When racing	While driving			
Top of engine Rocker cover Cylinder head	Ticking or clicking	C	A	—	A	B	—	Tappet noise	Valve clearance	EM-219
	Rattle	C	A	—	A	B	C	Camshaft bearing noise	Camshaft journal oil clearance Camshaft runout	EM-211
Crankshaft pulley Cylinder block (Side of engine) Oil pan	Slap or knock	—	A	—	B	B	—	Piston pin noise	Piston to piston pin oil clearance Connecting rod bushing oil clearance	EM-262
	Slap or rap	A	—	—	B	B	A	Piston slap noise	Piston to cylinder bore clearance Piston ring side clearance Piston ring end gap Connecting rod bend and torsion	EM-262
	Knock	A	B	C	B	B	B	Connecting rod bearing noise	Connecting rod bushing oil clearance Connecting rod bearing oil clearance	EM-262
	Knock	A	B	—	A	B	C	Main bearing noise	Main bearing oil clearance Crankshaft runout	EM-262
Front of engine front cover	Tapping or ticking	A	A	—	B	B	B	Timing chain and chain tensioner noise	Timing chain cracks and wear Timing chain tensioner operation	EM-200 EM-199
Front of engine	Squeaking or fizzing	A	B	—	B	—	C	Drive belts (Sticking or slipping)	Drive belts deflection	EM-169
	Creaking	A	B	A	B	A	B	Drive belts (Slipping)	Idler pulley bearing operation	
	Squall Creak	A	B	—	B	A	B	Water pump noise	Water pump operation	CO-49 , "Component"

A: Closely related B: Related C: Sometimes related —: Not related

ENGINE ROOM COVER

< SERVICE INFORMATION >

[VK45DE]

ENGINE ROOM COVER

Component

INFOID:000000005348029

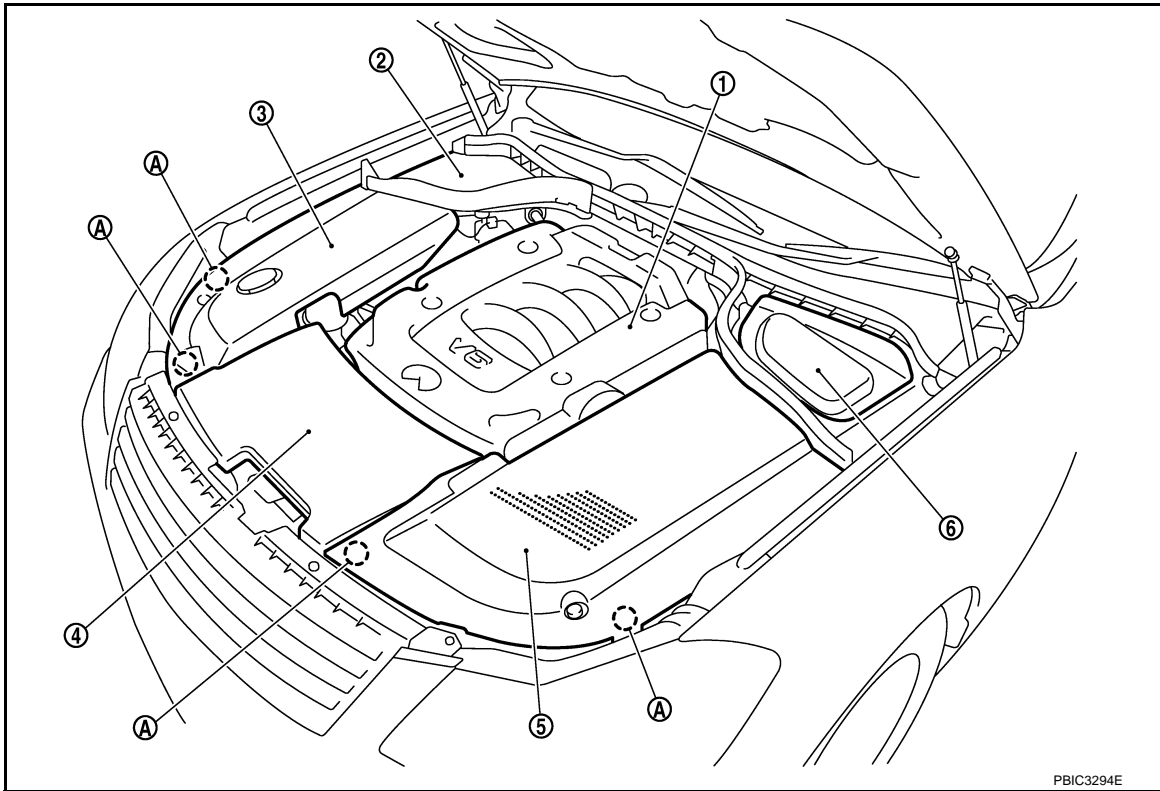

PBIC3294E

- | | | |
|----------------------------------|---------------------------|--------------------------------|
| 1. Engine cover | 2. Battery cover | 3. Engine room cover (RH) |
| 4. Air duct (inlet) | 5. Engine room cover (LH) | 6. Brake master cylinder cover |
| A. Clip (secure at back surface) | | |

Removal and Installation

INFOID:000000005348030

REMOVAL

CAUTION:

Never damage or scratch cover when installing or removing.

- Refer to [EM-175, "Removal and Installation"](#) for removal and installation of engine cover.
- Refer to [EM-172](#) for removal and installation of air duct (inlet).
- Remove the washer tank cap before removing the engine room cover (RH).
- Remove the engine room covers (RH and LH) by lifting the clipped point using a clip driver.
- Major parts and inspection points under each cover are as follows: (numbered as in the figure)

1. Upper side of engine assembly
2. Battery, relay box
3. Power steering fluid reservoir tank, engine coolant reservoir tank, relay box
4. Engine assembly front side, drive belts, cooling fan
5. Mass air flow sensor, air cleaner case
6. Brake master cylinder, brake booster

INSTALLATION

Install in the reverse order of removal.

DRIVE BELTS

Component

INFOID:000000005348031

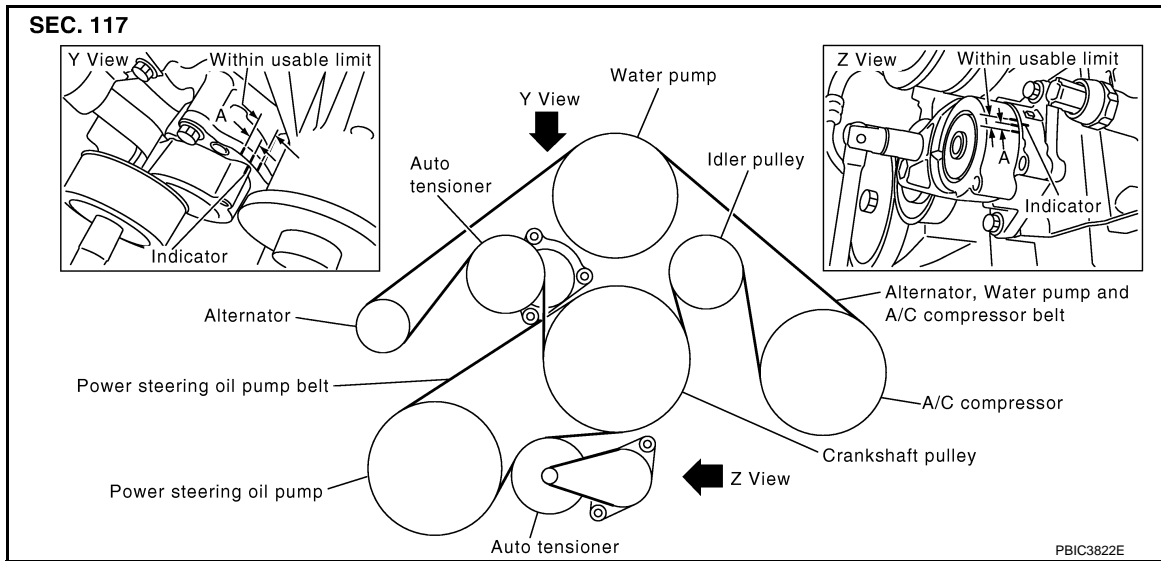

Checking Drive Belts

INFOID:000000005348032

WARNING:

Be sure to perform when engine is stopped.

- Remove air duct (inlet) when inspecting drive belt for alternator, water pump and A/C compressor.
- Remove front engine undercover with power tool when inspecting power steering oil pump belt.
- Check that indicator (single line notch) of each auto tensioner is within the allowable working range (between three line notches).

NOTE:

- Check auto tensioner indication when engine is cold.
- When new drive belt is installed, the range should be "A".
- The indicator notch is located on the moving side of auto tensioner for alternator, water pump and A/C compressor belt, while it is found on the fixed side for power steering oil pump belt.
- Visually check entire belt for wear, damage or cracks.
- If the indicator is out of allowable working range or belt is damaged, replace belt.

Tension Adjustment

INFOID:000000005348033

Belt tensioning is not necessary, as it is automatically adjusted by auto tensioner.

Removal and Installation

INFOID:000000005348034

REMOVAL

Alternator, Water Pump and A/C Compressor Belt

1. Remove air duct (inlet). Refer to [EM-172](#).
2. With box wrench, and while securely holding the hexagonal part in pulley center of auto tensioner, move wrench handle in the direction of arrow (loosening direction of tensioner).

CAUTION:

- Avoid placing hand in a location where pinching may occur if the holding tool accidentally comes off.
- Never loosen the hexagonal part in center of drive belt auto tensioner pulley (Never turn it clockwise). If turned clockwise, the complete drive belt auto tensioner must be replaced as a unit, including the pulley.

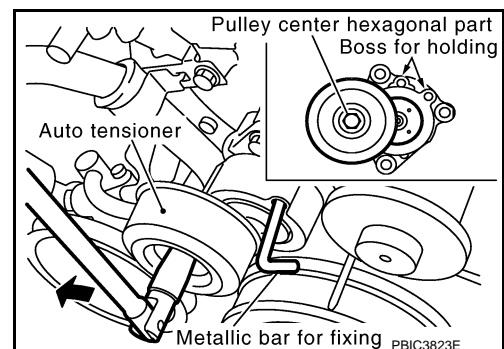

DRIVE BELTS

[VK45DE]

< SERVICE INFORMATION >

- Under the above condition, insert a metallic bar of approximately 6 mm (0.24 in) in diameter (hexagonal bar wrench shown as example in the figure) through the holding boss to lock auto tensioner pulley arm.
 - Leave auto tensioner pulley arm locked until belt is installed again.
- Remove alternator, water pump and A/C compressor belt.

Power Steering Oil Pump Belt

- Remove air duct (inlet). Refer to [EM-172](#).
- Remove front engine undercover with power tool.
- Remove alternator, water pump and A/C compressor belt. Refer to "Alternator, Water Pump and A/C Compressor Belt".
- While securely holding the hexagonal protrusion part of auto tensioner pulley with box wrench, move wrench handle in the direction of arrow (loosening direction of tensioner).

CAUTION:

Avoid placing hand in a location where pinching may occur if holding tool accidentally comes off.

- Under the above condition, insert a metallic bar of approximately 6 mm (0.24 in) in diameter (hexagonal bar wrench shown as example in the figure) through the holding boss to lock auto tensioner pulley arm.
 - Leave auto tensioner pulley arm locked until belt is installed again.
- Remove power steering oil pump belt.

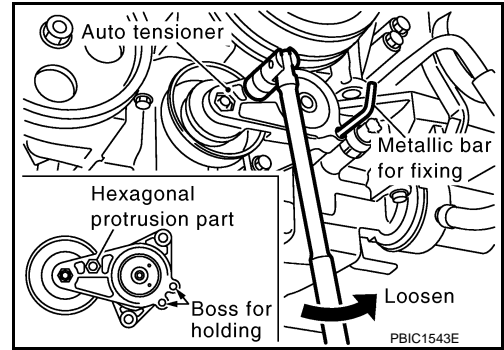

INSTALLATION

Note the following, and install in the reverse order of removal.

CAUTION:

- Check belt is securely installed around all pulleys.
- Check belt is correctly engaged with the pulley groove.
- Check for engine oil and engine coolant are not adhered belt and pulley groove.
- Check that belt tension is within the allowable working range, using indicator notch on auto tensioner. Refer to [EM-169, "Checking Drive Belts"](#).

Component

INFOID:000000005348035

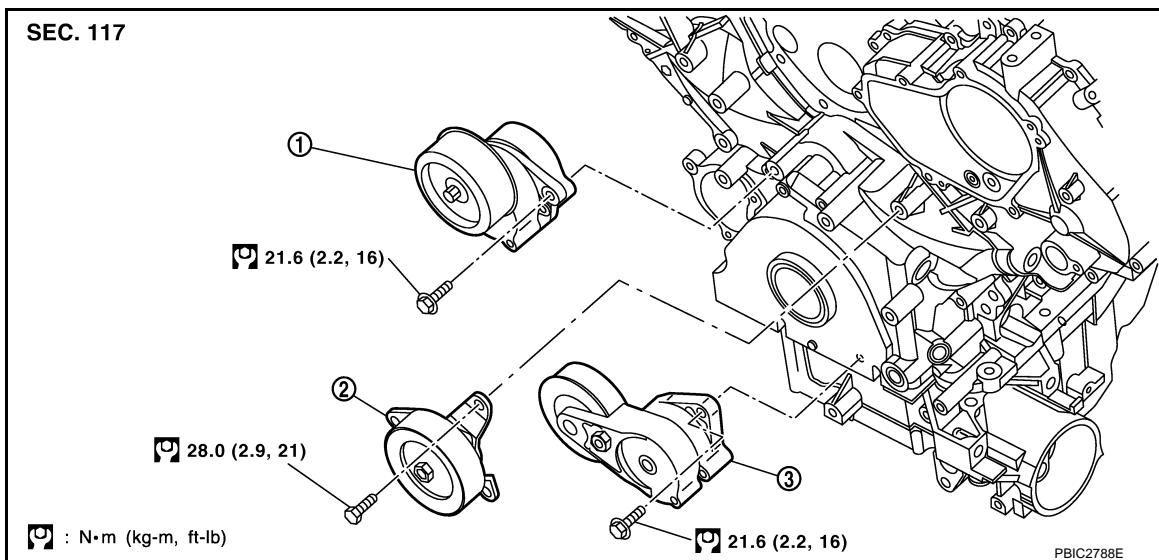

- Auto tensioner (Used for alternator, water pump and A/C compressor)
- Idler pulley
- Auto tensioner (Used for power steering oil pump belt)

CAUTION:

The complete drive belt auto tensioner must be replaced as a unit, including the pulley.

DRIVE BELTS

< SERVICE INFORMATION >

[VK45DE]

Drive Belt Auto Tensioner and Idler Pulley

INFOID:000000005348036

A

REMOVAL

1. Remove air duct (inlet). Refer to [EM-172](#).
2. Remove front engine undercover with power tool.
3. Remove drive belts. Refer to [EM-169. "Removal and Installation"](#).
 - Keep auto tensioner pulley arm locked after belt is removed.
4. Remove auto tensioner and idler pulley with power tool.
 - Keep auto tensioner pulley arm locked to install or remove auto tensioner.

EM

C

CAUTION:

Never loosen the hexagonal part in center of drive belt auto tensioner pulley (Never turn it clockwise). If turned clockwise, the complete drive belt auto tensioner must be replaced as a unit, including the pulley.

D

INSTALLATION

Install in the reverse order of removal.

CAUTION:

Never swap the pulley between new and old drive belt auto tensioner.

E

F

G

H

I

J

K

L

M

N

O

P

AIR CLEANER AND AIR DUCT

< SERVICE INFORMATION >

[VK45DE]

AIR CLEANER AND AIR DUCT

Component

INFOID:000000005348037

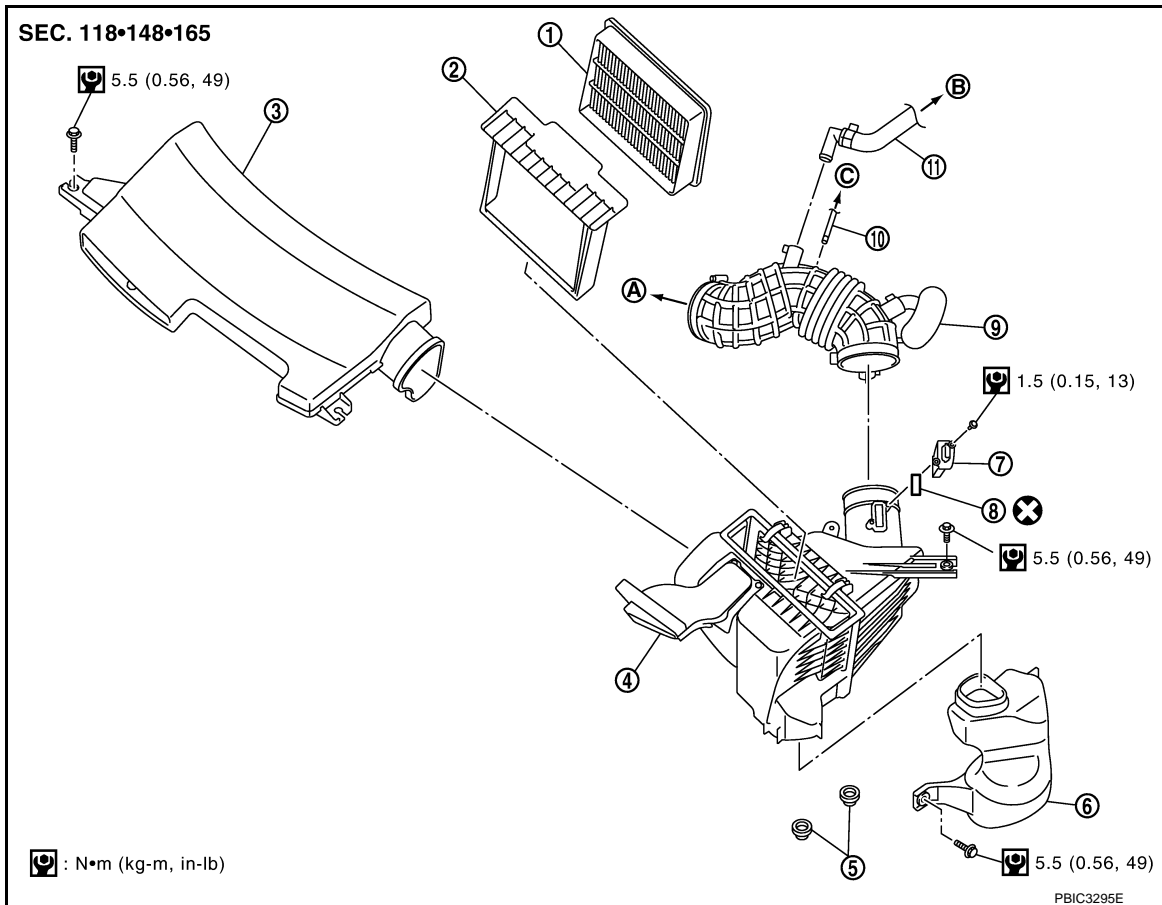

- | | | |
|--|--------------------------------|------------------------------------|
| 1. Air cleaner filter | 2. Holder | 3. Air duct (inlet) |
| 4. Air cleaner case | 5. Mounting rubber | 6. Resonator |
| 7. Mass air flow sensor | 8. O-ring | 9. Air duct and resonator assembly |
| 10. Vacuum hose | 11. PCV hose | |
| A. To electric throttle control actuator | B. To rocker cover (left bank) | C. To VIAS control solenoid valve |

- Refer to [GI-9. "Component"](#) for symbols in the figure.

Removal and Installation

INFOID:000000005348038

REMOVAL

NOTE:

Mass air flow sensor is removable under the car-mounted condition.

- Remove engine room cover (RH and LH). Refer to [EM-168](#).
- Disconnect harness connector from mass air flow sensor.
- Disconnect vacuum hose and PCV hose.
- Remove air duct (inlet), air cleaner case and mass air flow sensor assembly, and air duct and resonator assembly disconnecting their joints.
 - Add marks if necessary for easier installation.
- Remove mass air flow sensor from air cleaner case if necessary.

CAUTION:

Handle mass air flow sensor with following cares.

- Never shock mass air flow sensor.
- Never disassemble mass air flow sensor.

AIR CLEANER AND AIR DUCT

[VK45DE]

< SERVICE INFORMATION >

- **Never touch the sensor of the mass air flow sensor.**

6. Remove resonator in fender lifting front fender protector (LH). Refer to [EI-31](#).

INSPECTION AFTER REMOVAL

Inspect air duct and resonator assembly for crack or tear.

- If anything found, replace air duct and resonator assembly.

INSTALLATION

Note the following, and install in the reverse order of removal.

- Align marks. Attach each joint. Screw clamps firmly.

Changing Air Cleaner Filter

INFOID:000000005348039

REMOVAL

1. Remove engine room cover (LH). Refer to [EM-168](#).
2. Unhook clips (1).

- 2 : Air cleaner case
- 3 : Holder

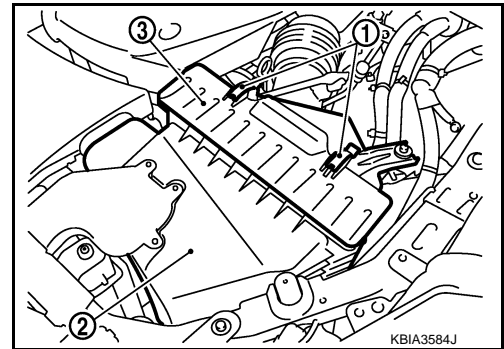

3. Remove holder and air cleaner filter assembly (2) from air cleaner case (1).

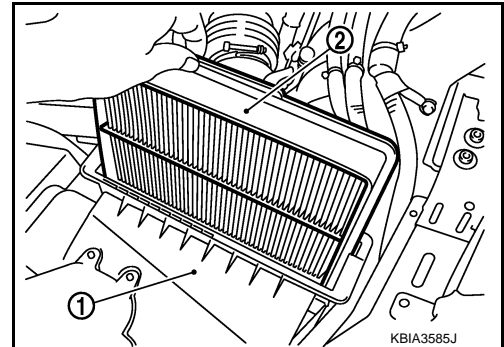

INSTALLATION

Note the following, and install in the reverse order of removal.

- Install the air cleaner filter by aligning the seal with the notch of air cleaner case.

INTAKE MANIFOLD

< SERVICE INFORMATION >

[VK45DE]

INTAKE MANIFOLD

Component

INFOID:00000005348040

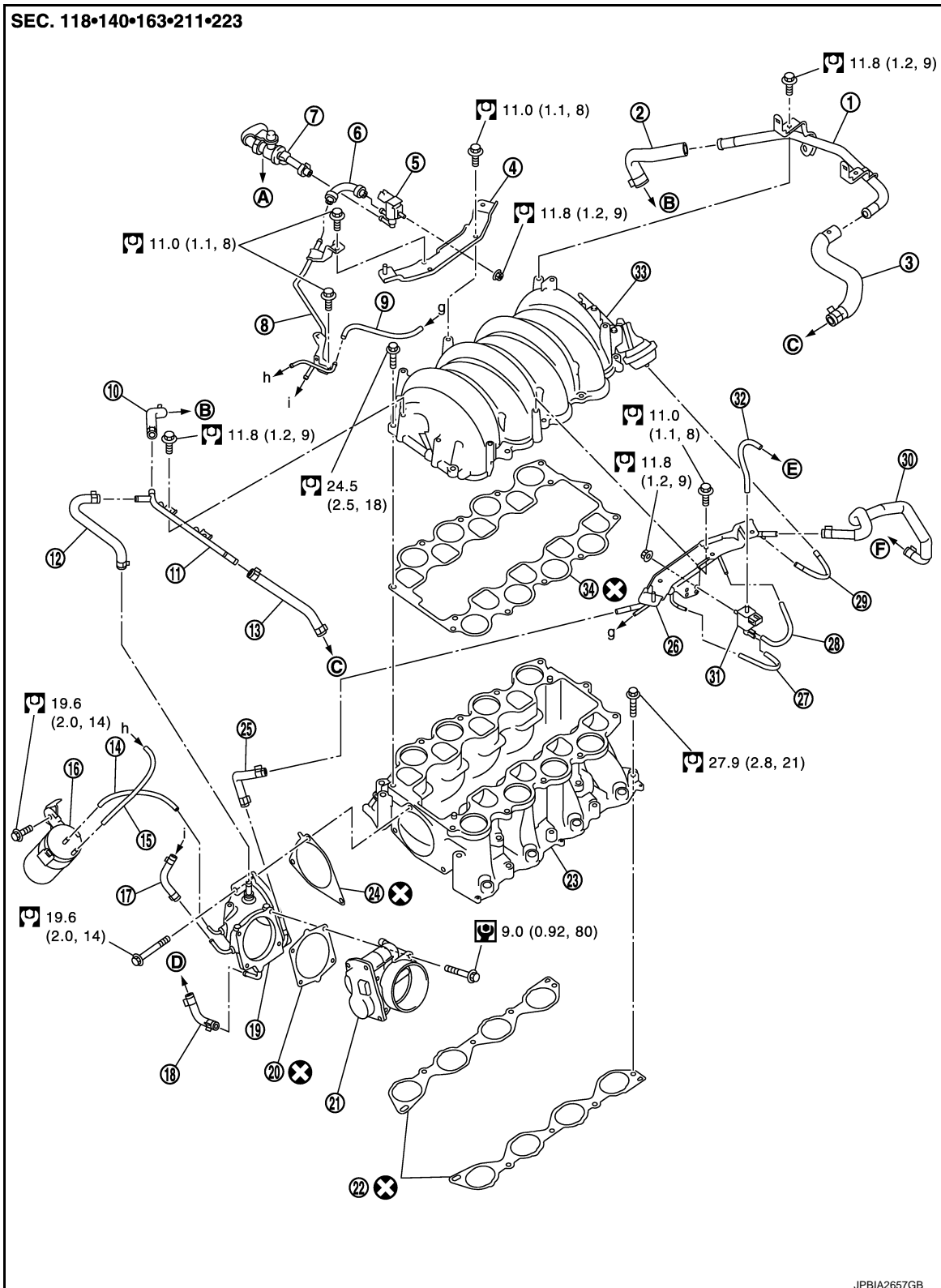

INTAKE MANIFOLD

[VK45DE]

< SERVICE INFORMATION >

- | | | |
|---------------------------------|-------------------------------|--|
| 7. EVAP service port | 8. EVAP tube | 9. Vacuum hose |
| 10. PCV hose | 11. PCV tube | 12. PCV hose |
| 13. PCV hose | 14. Vacuum hose | 15. Vacuum hose |
| 16. Vacuum tank | 17. EVAP hose | 18. Water hose |
| 19. Intake manifold adapter | 20. Gasket | 21. Electric throttle control actuator |
| 22. Gasket | 23. Intake manifold (lower) | 24. Gasket |
| 25. Water hose | 26. Engine cover bracket (LH) | 27. Vacuum hose |
| 28. Vacuum hose | 29. Vacuum hose | 30. Water hose |
| 31. VIAS control solenoid valve | 32. Vacuum hose | 33. Intake manifold (upper) |
| 34. Gasket | | |
- A. To centralized under-floor piping B. To rocker cover (right bank) C. To rocker cover (left bank)
D. To thermostat housing E. To air duct and resonator assembly F. To heater pipe

- Refer to [GI-9, "Component"](#) for symbols in the figure.

Removal and Installation

INFOID:000000005348041

REMOVAL

WARNING:

To avoid the danger of being scalded, never drain the engine coolant when the engine is hot.

1. Remove engine room cover (RH and LH). Refer to [EM-168](#).
2. Remove engine cover with power tool.

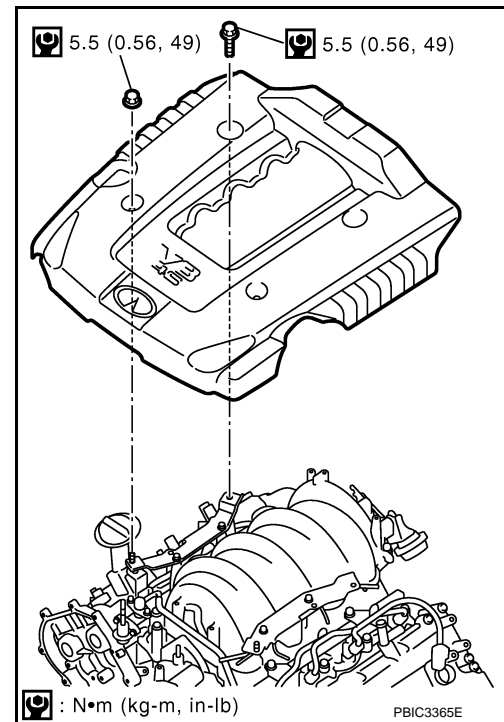

3. Release fuel pressure. Refer to [EC-766, "Fuel Pressure Check"](#).
4. Remove air duct (inlet), air cleaner case, and air duct and resonator assembly. Refer to [EM-172](#).
5. Drain engine coolant from radiator. Refer to [CO-36, "Changing Engine Coolant"](#).

CAUTION:

- Perform this step when the engine is cold.
- Never spill engine coolant on drive belts.

INTAKE MANIFOLD

[VK45DE]

< SERVICE INFORMATION >

6. Disconnect fuel feed hose quick connector (1) on engine side.
Refer to [EM-189](#).

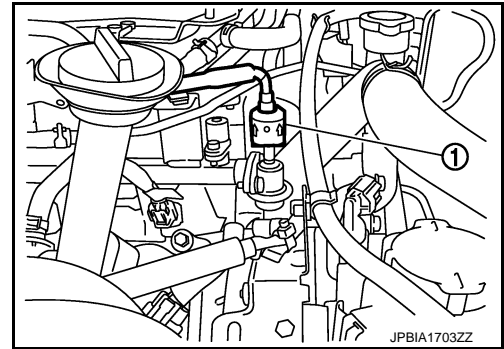

7. Remove fuel damper and fuel hose assembly. Refer to [EM-189](#).
CAUTION:
 - While hoses are disconnected, plug them to prevent fuel from draining.
 - Never separate fuel damper and fuel hose.
8. Remove or disconnect harnesses, engine cover bracket (RH and LH), vacuum hose, EVAP tube and hose and PCV hose and tube from intake manifold (upper).
9. Loosen mounting bolts in reverse order as shown in the figure to remove intake manifold (upper) with power tool.

⇐ : Engine front

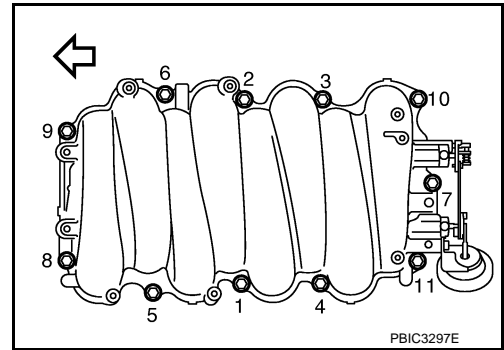

10. Remove electric throttle control actuator as follows:
 - a. Disconnect harness connector.
 - b. Loosen mounting bolts diagonally.**CAUTION:**
 - Handle carefully to avoid any shock to electric throttle control actuator.
 - Never disassemble.
11. Remove fuel injector and fuel tube assembly. Refer to [EM-189](#).
12. Disconnect water hoses from intake manifold adaptor.
13. Loosen mounting bolts in reverse order as shown in the figure to remove intake manifold (lower) with power tool.

⇐ : Engine front

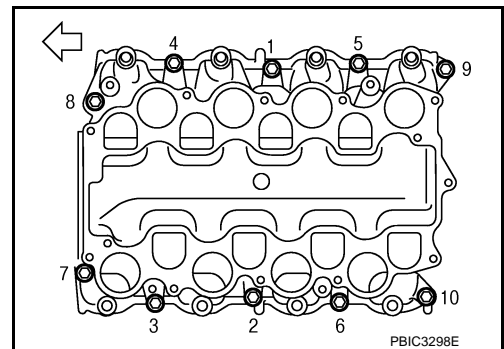

14. Remove intake manifold adaptor from intake manifold (lower).
15. Remove vacuum tank.
16. Remove intake manifold gaskets.
CAUTION:
 - Cover engine openings to avoid entry of foreign materials.

INSPECTION AFTER REMOVAL

INTAKE MANIFOLD

[VK45DE]

< SERVICE INFORMATION >

Surface Distortion

- Check the surface distortion of both the intake manifold (upper and lower) mating surfaces with straightedge and feeler gauge.

Limit : 0.1 mm (0.004 in)

- If it exceeds the limit, replace intake manifolds (lower and/or upper).

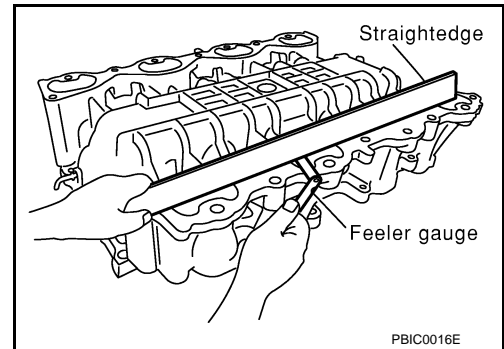

INSTALLATION

Note the following, and install in the reverse order of removal.

Intake Manifold (Lower)

Tighten in numerical order as shown in the figure.

↩ : Engine front

- There are two types of mounting bolts. Refer to the following for locating bolts.

M8 × 90 mm (3.54 in) : 7, 8

M8 × 35 mm (1.38 in) : Except the above

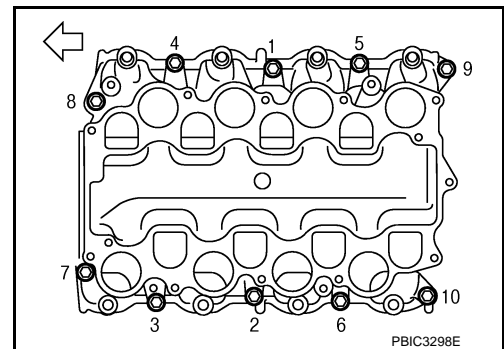

Intake Manifold (Upper)

Tighten in numerical order as shown in the figure.

↩ : Engine front

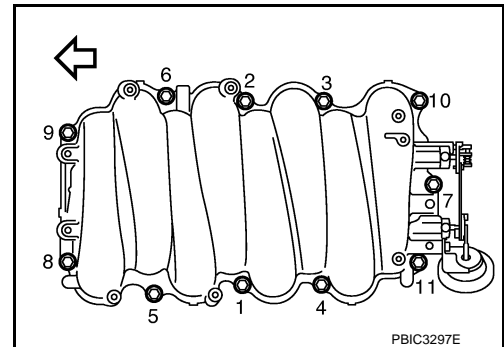

Electric Throttle Control Actuator

- Install gasket with its directional protrusion set up/downward.
- Tighten mounting bolts of electric throttle control actuator equally and diagonally in several steps.
- After installation perform procedure in "INSPECTION AFTER INSTALLATION".

Water Hose

Insert hose by 27 to 32 mm (1.06 to 1.26 in) from connector end.

Vacuum Hose

Refer to [EC-788. "Vacuum Hose Drawing"](#).

INSPECTION AFTER INSTALLATION

- Perform the "Throttle Valve Closed Position Learning" when harness connector of electric throttle control actuator is disconnected. Refer to [EC-764. "Throttle Valve Closed Position Learning"](#).
- Perform the "Idle Air Volume Learning" and "Throttle Valve Closed Position Learning" when electric throttle control actuator is replaced. Refer to [EC-765. "Idle Air Volume Learning"](#).

EXHAUST MANIFOLD AND THREE WAY CATALYST

< SERVICE INFORMATION >

[VK45DE]

EXHAUST MANIFOLD AND THREE WAY CATALYST

Component

INFOID:000000005348042

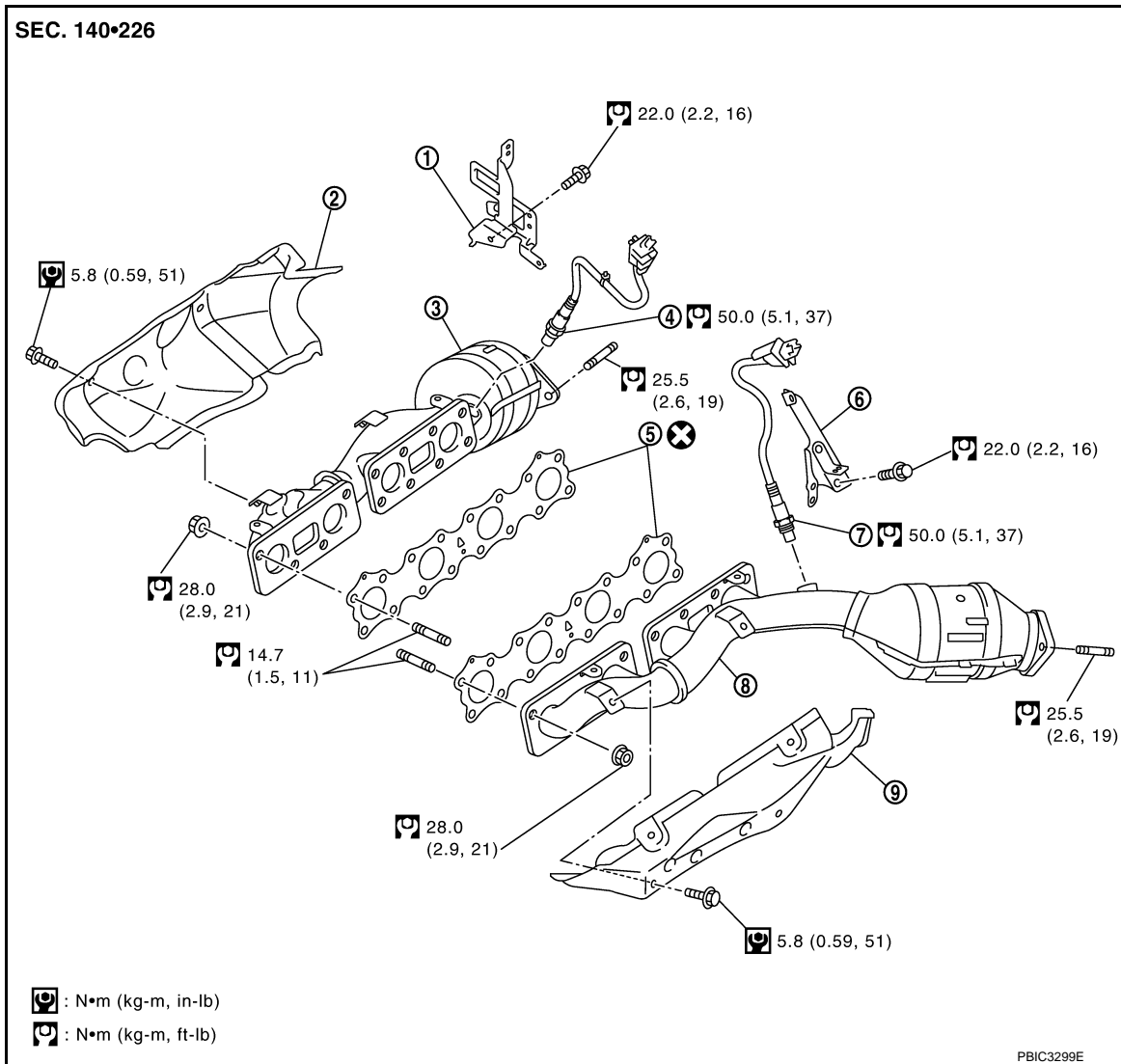

- | | | |
|-------------------------------------|--|---|
| 1. Harness bracket | 2. Exhaust manifold cover (right bank) | 3. Exhaust manifold and three way catalyst (right bank) |
| 4. Air fuel ratio sensor 1 (bank 2) | 5. Gasket | 6. Harness bracket |
| 7. Air fuel ratio sensor 1 (bank 1) | 8. Exhaust manifold and three way catalyst (left bank) | 9. Exhaust manifold cover (left bank) |

• Refer to [GI-9, "Component"](#) for symbols in the figure.

Removal and Installation

INFOID:000000005348043

REMOVAL

WARNING:

Perform the work when the exhaust and cooling system have completely cooled down.

1. Remove engine room cover (RH and LH). Refer to [EM-168](#).
2. Remove engine cover with power tool. Refer to [EM-175, "Removal and Installation"](#).
3. Remove air duct (inlet), air cleaner case and air duct and resonator assembly. Refer to [EM-172](#).
4. Remove front and rear engine undercovers with power tool.
5. Drain engine coolant from radiator. Refer to [CO-36, "Changing Engine Coolant"](#).

EXHAUST MANIFOLD AND THREE WAY CATALYST

< SERVICE INFORMATION >

[VK45DE]

CAUTION:

- Perform this step when engine is cold.
- Never spill engine coolant on drive belts.

- Remove radiator. Refer to [CO-39](#).
- Remove drive belts. Refer to [EM-169](#).
- Remove exhaust front tube with power tool. Refer to [EX-3](#).
- Remove each air fuel ratio sensor 1 as follows:
 - Disconnect harness connector of each air fuel ratio sensor 1.
 - Remove each air fuel ratio sensor 1 on both bank with heated oxygen sensor wrench (SST).

CAUTION:

- Be careful not to damage air fuel ratio sensor 1.
- Discard any air fuel ratio sensor 1 which has been dropped onto a hard surface such as a concrete floor. Replace with a new one.

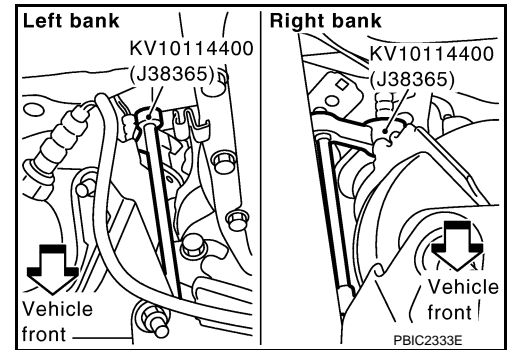

- Remove exhaust manifold and three way catalyst (left bank) as follows:
 - Disconnect A/C piping from A/C compressor, then remove A/C compressor with power tool. Refer to [ATC-135](#).
 - Remove steering lower joint to enable steering shaft to move freely. Refer to [PS-12](#).
 - Remove starter motor. Refer to [SC-13, "Removal and Installation"](#).
 - Remove nuts on bottom of engine mounting insulator (LH), and lift up left side of engine approximately 3 cm (1.18 in) with transmission jack. Refer to [EM-238, "2WD : Component"](#) (2WD models) or [EM-242, "AWD : Component"](#) (AWD models).
 - Remove exhaust manifold cover (left bank).
 - Loosen nuts in the reverse order of figure to remove exhaust manifold and three way catalyst (left bank) with power tool.

- A : Left bank
- B : Right bank
- ⇐ : Engine front

NOTE:

Disregard No. 9 to No. 12 when loosening.

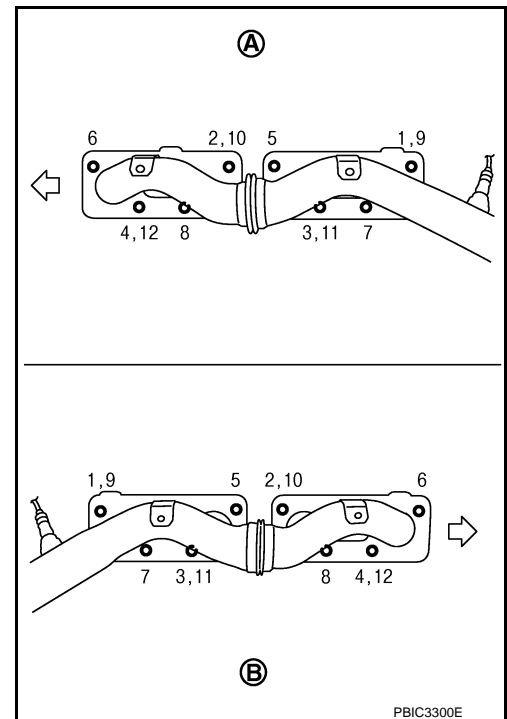

- Remove exhaust manifold and three way catalyst (right bank) as follows:
 - Remove alternator and bracket. Refer to [SC-21](#).

EXHAUST MANIFOLD AND THREE WAY CATALYST

[VK45DE]

< SERVICE INFORMATION >

- b. Remove nuts on bottom of engine mounting insulator (RH), and lift up right side of engine approximately 3 cm (1.18 in) with transmission jack. Refer to [EM-238, "2WD : Component"](#) (2WD models) or [EM-242, "AWD : Component"](#) (AWD models).
- c. Remove exhaust manifold cover (right bank).
- d. Loosen nuts in the reverse order of figure to remove exhaust manifold and three way catalyst (right bank) with power tool.

- A : Left bank
B : Right bank
⇐ : Engine front

NOTE:

Disregard No. 9 to No. 12 when loosening.

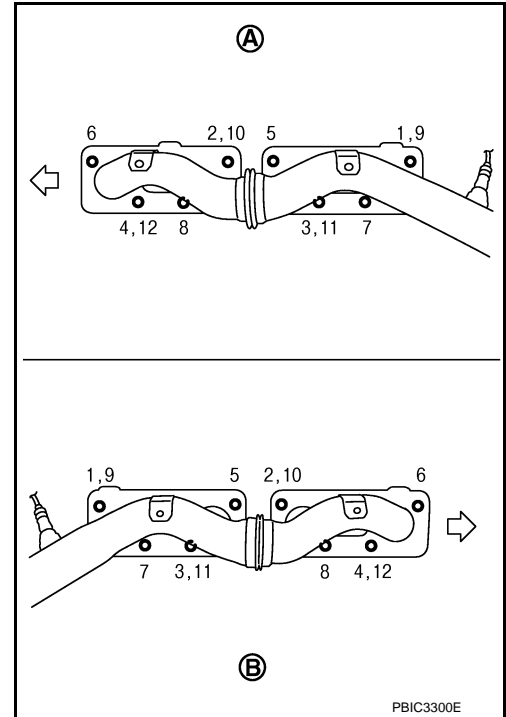

12. Remove exhaust manifold gaskets.

CAUTION:

Cover engine openings to avoid entry of foreign materials.

INSPECTION AFTER REMOVAL

Surface Distortion

- Check the surface distortion of the each exhaust manifold flange mating surface with straightedge and feeler gauge.

Limit : 0.3 mm (0.012 in)

- If it exceeds the limit, replace exhaust manifold and three way catalyst.

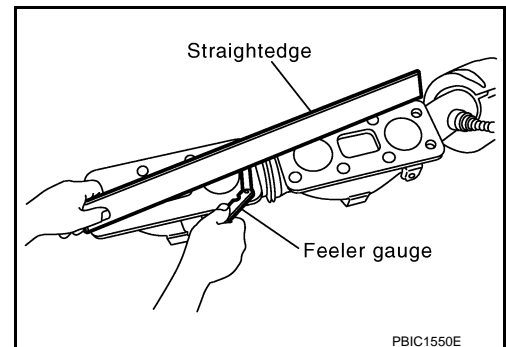

INSTALLATION

Note the following, and install in the reverse order of removal.

Exhaust Manifold Gasket

EXHAUST MANIFOLD AND THREE WAY CATALYST

< SERVICE INFORMATION >

[VK45DE]

Install exhaust manifold gasket with its directional protrusion set upward.

A : Protrusion for confirming installation

↖ : Above

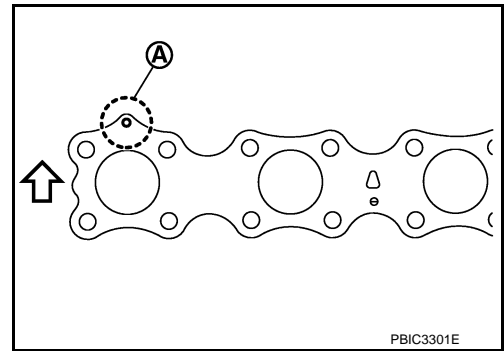

Exhaust Manifold

- Install exhaust manifold and tighten mounting nuts in numerical order as shown in the figure.

A : Left bank

B : right bank

↖ : Engine front

NOTE:

Tighten mounting nuts No. 1 to 4 in two steps. The numerical order No. 9 to 12 shown second steps.

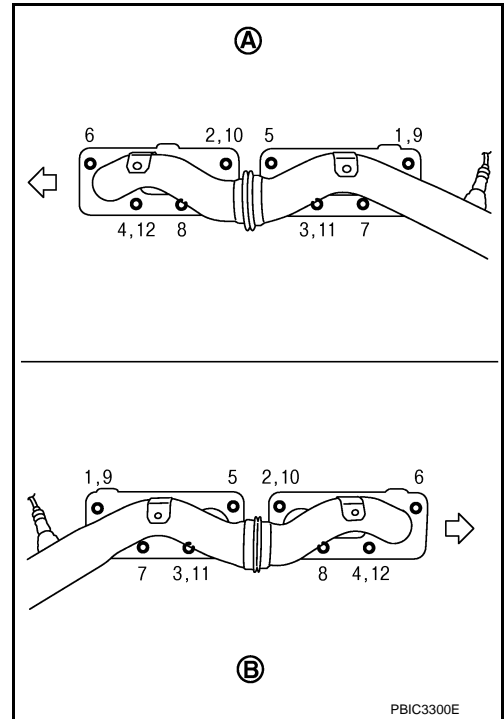

Air Fuel Ratio Sensor 1

CAUTION:

- Before installing a new air fuel ratio sensor 1, clean exhaust system threads using oxygen sensor thread cleaner (commercial service tool: J-43897-18 or J-43897-12), and apply anti-seize lubricant (commercial service tool).
- Never over torque air fuel ratio sensor 1. Doing so may cause damage to the air fuel ratio sensor 1, resulting in "MIL" coming on.

OIL PAN AND OIL STRAINER

< SERVICE INFORMATION >

[VK45DE]

OIL PAN AND OIL STRAINER

Component

INFOID:000000005348044

2WD models

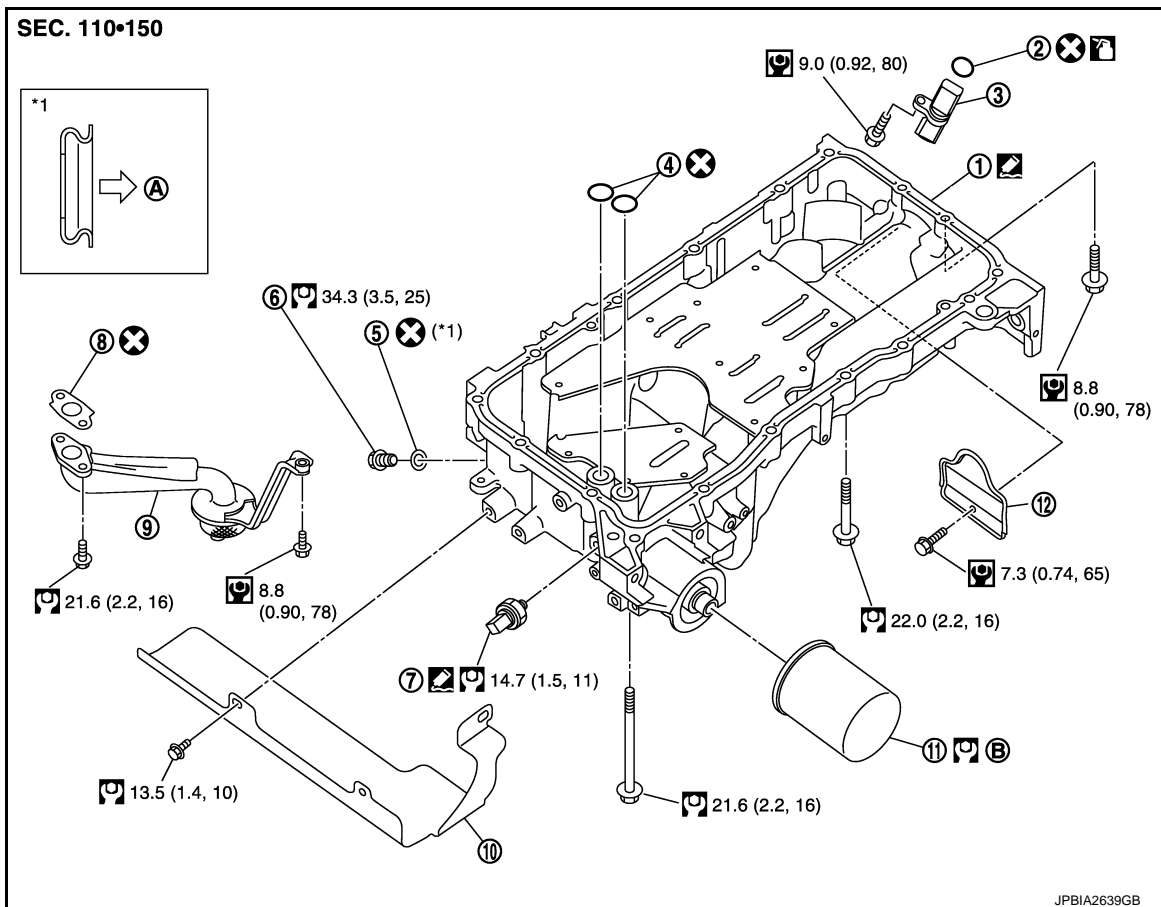

- | | | |
|------------------------|-----------------------------------|-------------------------------------|
| 1. Oil pan | 2. O-ring | 3. Crankshaft position sensor (POS) |
| 4. O-ring | 5. Drain plug washer | 6. Drain plug |
| 7. Oil pressure switch | 8. Gasket | 9. Oil strainer |
| 10. Harness bracket | 11. Oil filter | 12. Rear plate cover |
| A. Oil pan side | B. Refer to LU-27 | |

- Refer to [GI-9. "Component"](#) for symbols in the figure.

OIL PAN AND OIL STRAINER

< SERVICE INFORMATION >

[VK45DE]

AWD models

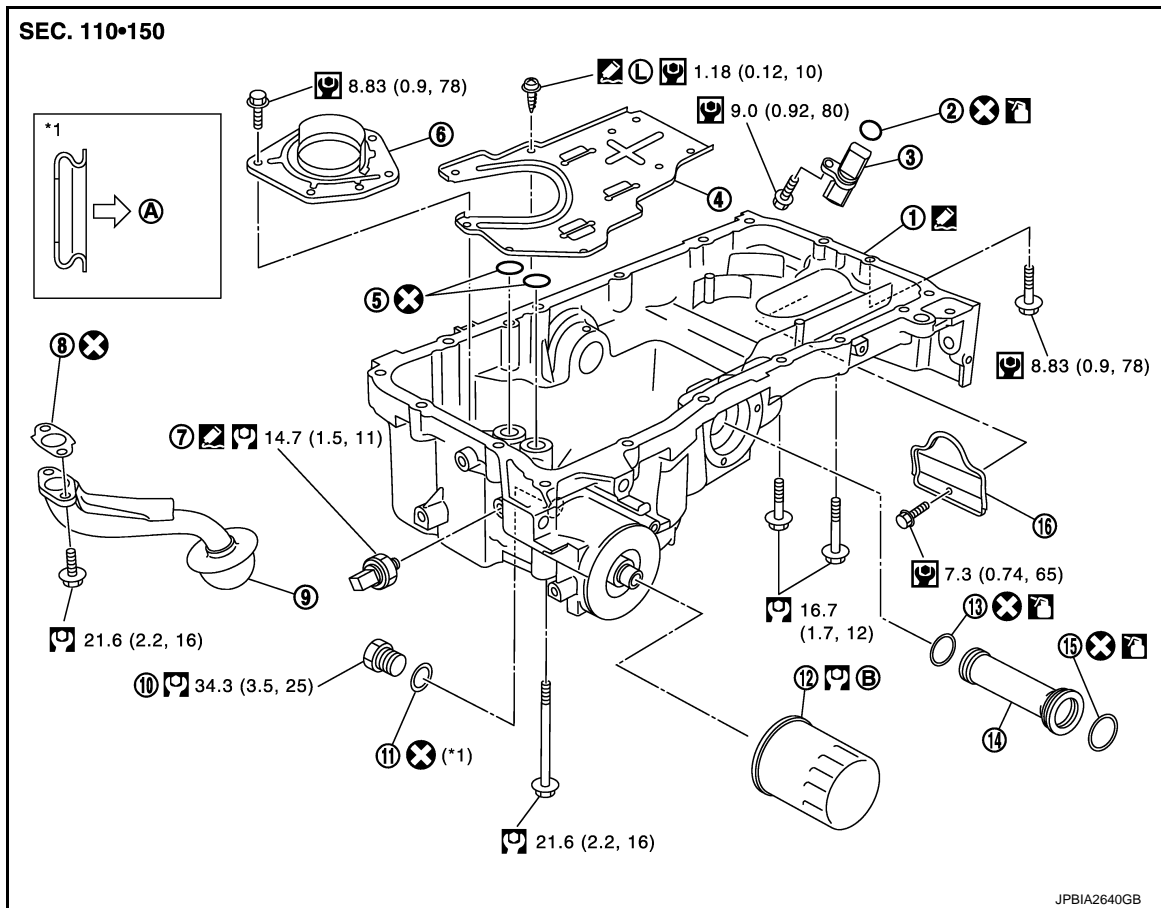

- | | | |
|------------------------|-----------------------------------|-------------------------------------|
| 1. Oil pan | 2. O-ring | 3. Crankshaft position sensor (POS) |
| 4. Baffle plate | 5. O-ring | 6. Baffle plate |
| 7. Oil pressure switch | 8. Gasket | 9. Oil strainer |
| 10. Drain plug | 11. Drain plug washer | 12. Oil filter |
| 13. O-ring | 14. Axle pipe | 15. O-ring |
| 16. Rear plate cover | | |
| A. Oil pan side | B. Refer to LU-27 | |

: Apply Genuine High Strength Thread Locking Sealant or equivalent.

• Refer to [GI-9. "Component"](#) for symbols not described on the above.

Removal and Installation

INFOID:000000005348045

REMOVAL

WARNING:

To avoid the danger of being scalded, never drain engine oil when engine is hot.

1. Remove front and rear engine undercovers with power tool.
2. Drain engine oil. Refer to [LU-25. "Changing Engine Oil"](#).

CAUTION:

- Perform this step when engine is cold.
 - Never spill engine oil on drive belts.
3. Remove engine assembly from vehicle. Refer to [EM-238. "2WD : Component"](#) (2WD models) or [EM-242. "AWD : Component"](#) (AWD models).

OIL PAN AND OIL STRAINER

< SERVICE INFORMATION >

[VK45DE]

4. Install engine slingers into front of cylinder head (left bank) and front of cylinder head (right bank).

Slinger bolts:

: 33.4 N·m (3.4 kg·m, 25 ft·lb)

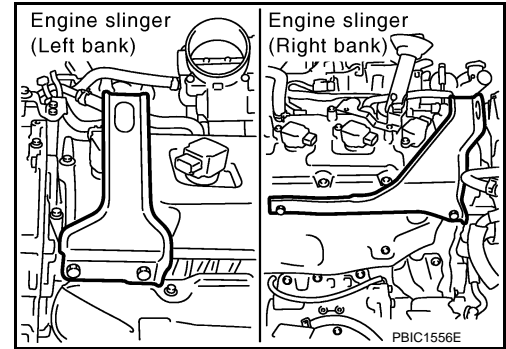

5. Remove engine mounting insulators (RH and LH) under side nut with power tool.
6. Lift with hoist and separate engine and transmission assembly from front suspension member.

CAUTION:

Avoid damage to and oil/grease smearing or spills onto engine mounting insulator.

7. Remove harness bracket from oil pan. (2WD models)
8. Remove oil filter. Refer to [LU-27](#).
9. Remove oil pan as the follows:
 - a. Remove rear plate cover.
 - b. Remove transmission joint bolts which pierce oil pan. Refer to [EM-182, "Component"](#).
 - c. Loosen mounting bolts with power tool in reverse order as shown in the figure.

NOTE:

Disregard the numerical order No. 11 and 17 in removal.

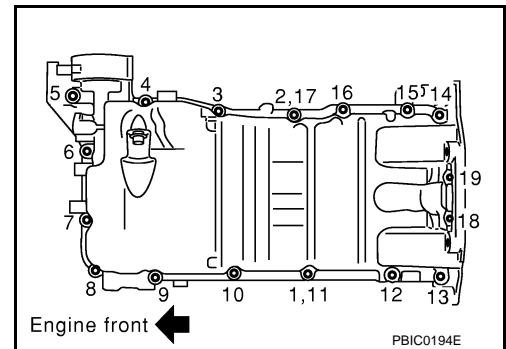

- d. Insert seal cutter (SST) between oil pan and cylinder block. Slide seal cutter (SST) by tapping on the side of seal cutter (SST) with hammer. Remove oil pan.

CAUTION:

- Be careful not to damage the mating surfaces.
- Never insert screwdriver, this will damage the mating surface.

- e. Remove O-rings from bottom of oil pump and front cover.

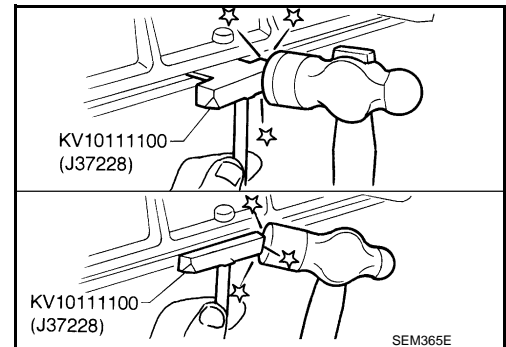

10. Remove oil pressure switch if necessary. Refer to [LU-24, "Inspection"](#).
11. If necessary, pull axle pipe from oil pan. (AWD models)
 - Hold pipes and pull them out to front drive shaft (left) installing side.
12. Remove oil strainer.

INSPECTION AFTER REMOVAL

Clean oil strainer if any object attached.

INSTALLATION

1. Install oil strainer.

OIL PAN AND OIL STRAINER

[VK45DE]

< SERVICE INFORMATION >

2. Install axle pipe to oil pan, if removed. (AWD models)
 - Lubricate O-ring groove of axle pip, O-ring, and O-ring joint of oil pan with new engine oil.
 - Right/left O-ring diameters differ from each other. O-ring with identification paint mark is installed on front drive shaft (left) installing side.
 - Install axle pipe to oil pan from left side.

CAUTION:
Insert it with care to prevent O-ring from sliding.

3. Install oil pan as follows:

- a. Use scraper to remove old liquid gasket from mating surfaces.
 - Also remove the old liquid gasket from mating surface of cylinder block.
 - Remove old liquid gasket from the bolt holes and threads.

CAUTION:
Never scratch or damage the mating surfaces when cleaning off old liquid gasket.

- b. Install new O-rings to oil pump and front cover side.
- c. Apply a continuous bead of liquid gasket with tube presser (commercial service tool) to the cylinder block mating surfaces of oil pan to a limited portion as shown in the figure.

Use Genuine RTV Silicone Sealant or equivalent. Refer to [GI-46](#).

CAUTION:
Attaching should be done within 5 minutes after coating.

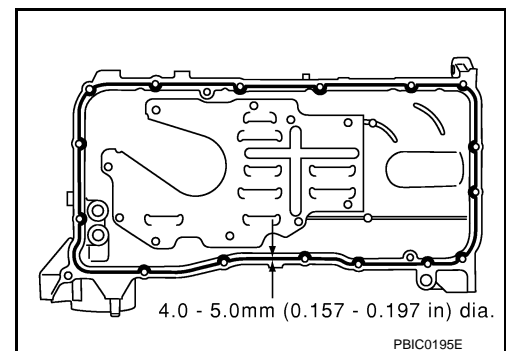
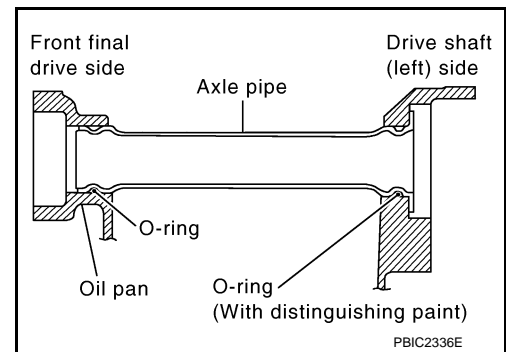

- d. Install oil pan.

CAUTION:
Install avoiding misalignment of O-rings.

- Tighten mounting bolts in numerical order as shown in the figure.

NOTE:

Tighten mounting bolts No. 1 and 2 in two steps. The numerical order No. 11 and 17 shown second steps.

- There are three types of mounting bolts. Refer to the following for locating bolts.

M6 × 30 mm. (1.18 in) : 18, 19

M8 × 100 mm (3.94 in) : 5, 9

M8 × 45 mm (1.77 in) : Except the above

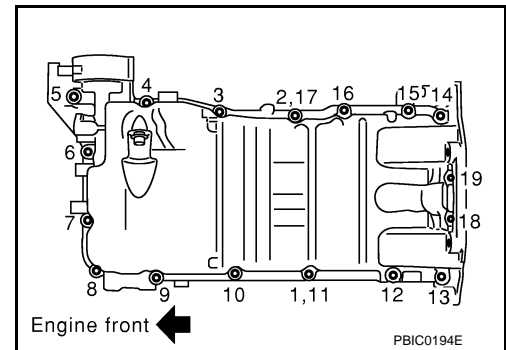

- e. Tighten transmission joint bolts. Refer to [EM-182, "Component"](#).
- f. Install rear plate cover.
4. Install oil pan drain plug with new drain plug washer.
 - Refer to the figure of components of former page for installation direction of drain plug washer. Refer to [EM-182, "Component"](#).
5. Install in the reverse order of removal after this step.

NOTE:
At least 30 minutes after oil pan is installed, pour engine oil.

INSPECTION AFTER INSTALLATION

1. Check engine oil level and adjust engine oil. Refer to [LU-24](#).
2. Start engine, and check there is no leakage of engine oil.
3. Stop engine and wait for 15 minutes.
4. Check engine oil level again. Refer to [LU-24](#).

IGNITION COIL

< SERVICE INFORMATION >

[VK45DE]

IGNITION COIL

Component

INFOID:000000005348046

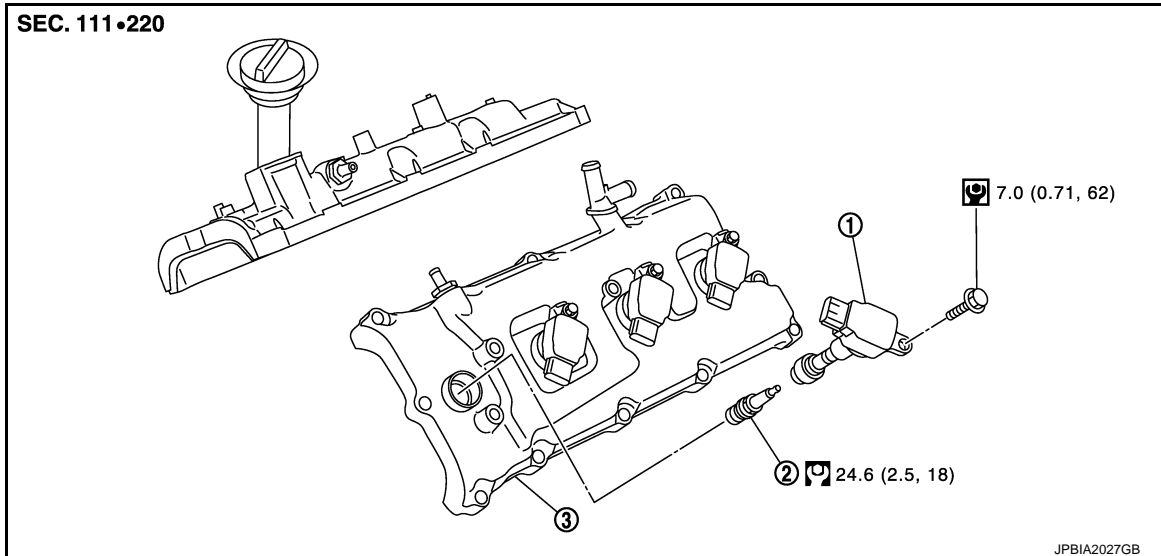

1. Ignition coil

2. Spark plug

3. Rocker cover

- Refer to [GI-9. "Component"](#) for symbols in the figure.

Removal and Installation

INFOID:000000005348047

REMOVAL

1. Remove engine room cover (RH and LH). Refer to [EM-168](#).
2. Remove engine cover with power tool. Refer to [EM-175. "Removal and Installation"](#).
3. Remove air duct (inlet), air cleaner case, and air duct and resonator assembly. Refer to [EM-172](#).
4. Disconnect harness connector from ignition coil.
5. Remove ignition coil.

CAUTION:

Never shock ignition coil.

INSTALLATION

Install in the reverse order of removal.

SPARK PLUG (PLATINUM-TIPPED TYPE)

< SERVICE INFORMATION >

[VK45DE]

SPARK PLUG (PLATINUM-TIPPED TYPE)

Component

INFOID:000000005348048

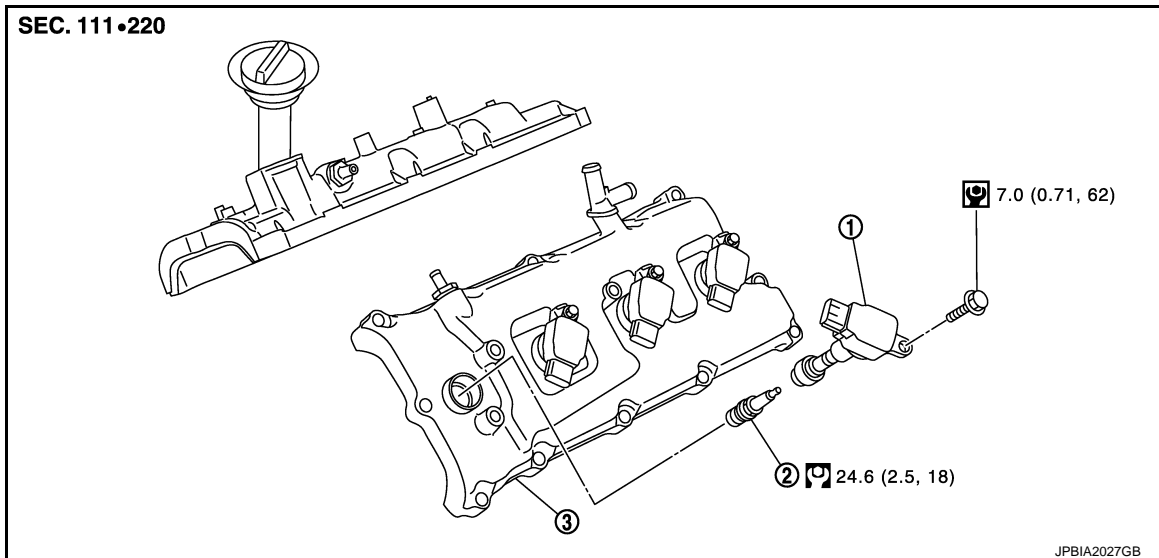

1. Ignition coil

2. Spark plug

3. Rocker cover

- Refer to [GI-9. "Component"](#) for symbols in the figure.

Removal and Installation

INFOID:000000005348049

REMOVAL

1. Remove ignition coil. Refer to [EM-186](#).
2. Remove spark plug with spark plug wrench (commercial service tool).

CAUTION:

Never drop or shock spark plug.

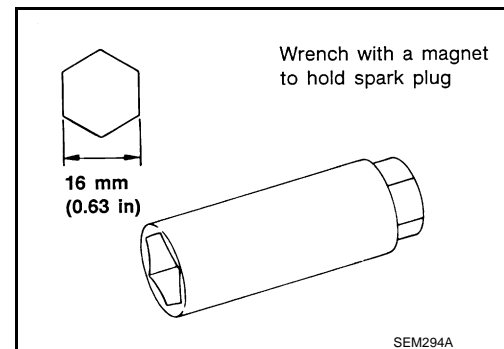

INSPECTION AFTER REMOVAL

Use standard type spark plug for normal condition.

Hot type spark plug is suitable when fouling occurs with standard type spark plug under conditions such as:

- Frequent engine starts
- Low ambient temperatures

Cold type spark plug is suitable when spark plug knock occurs with standard type spark plug under conditions such as:

- Extended highway driving
- Frequent high engine revolution

Make	NGK
Standard type	PLFR5A-11
Hot type	PLFR4A-11
Cold type	PLFR6A-11

SPARK PLUG (PLATINUM-TIPPED TYPE)

< SERVICE INFORMATION >

[VK45DE]

Gap (Nominal) : 1.1 mm (0.043 in)

CAUTION:

- Never drop or shock spark plug.
- Never use wire brush for cleaning.
- If plug tip is covered with carbon, spark plug cleaner may be used.

Cleaner air pressure:

Less than 588 kPa (6 kg/cm², 85 psi)

Cleaning time:

Less than 20 seconds

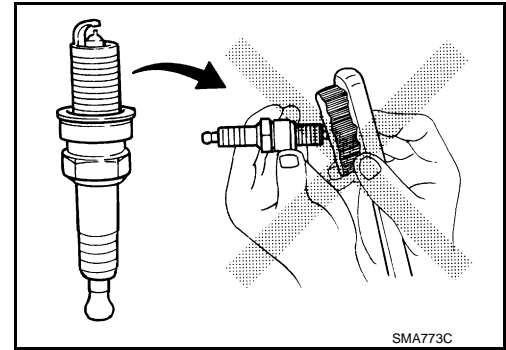

- Checking and adjusting plug gap is not required between change intervals.

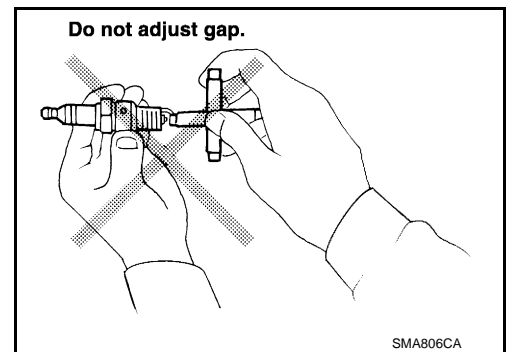

INSTALLATION

Install in the reverse order of removal.

FUEL INJECTOR AND FUEL TUBE

< SERVICE INFORMATION >

[VK45DE]

FUEL INJECTOR AND FUEL TUBE

Component

INFOID:000000005348050

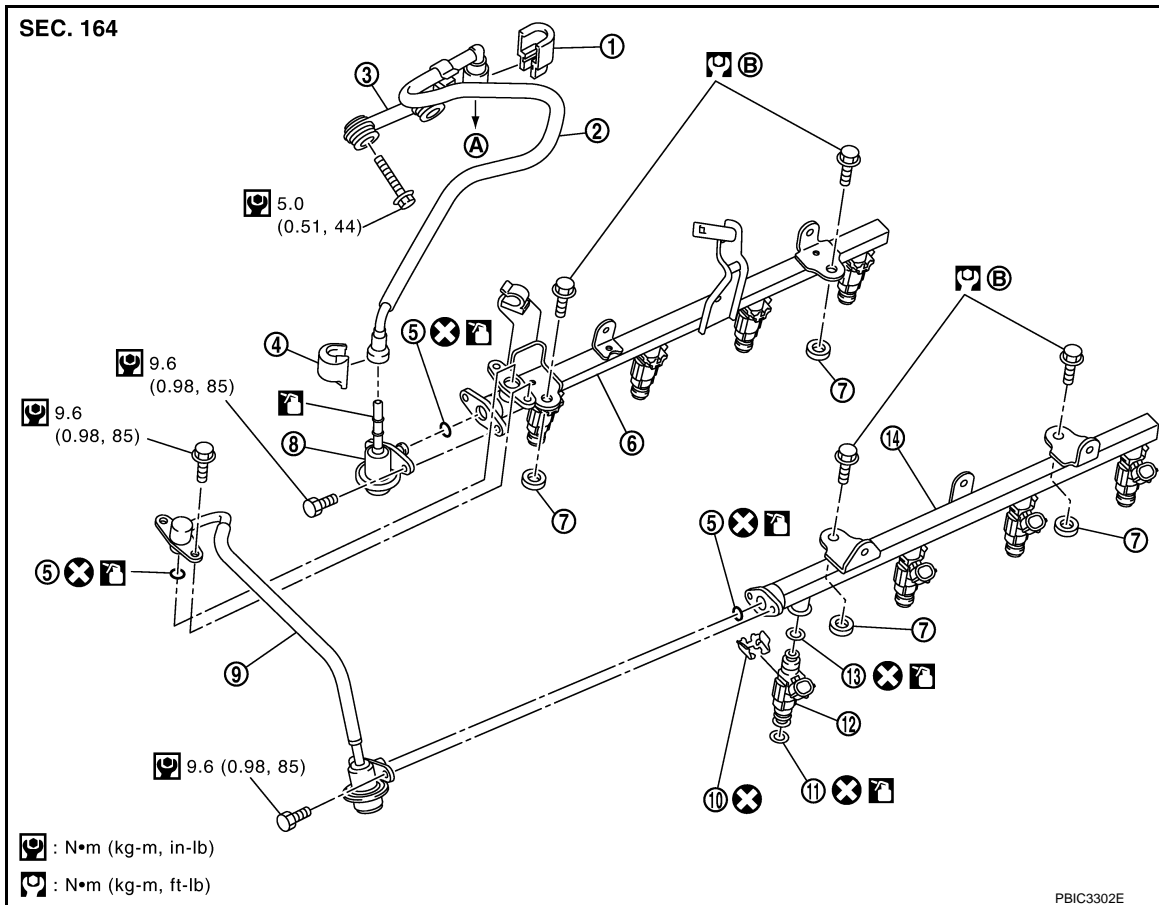

- | | | |
|--------------------------------------|------------------------------------|---------------------------------------|
| 1. Quick connector cap | 2. Fuel feed hose | 3. Fuel feed hose bracket |
| 4. Quick connector cap | 5. O-ring | 6. Fuel tube (RH) |
| 7. Spacer | 8. Fuel feed damper | 9. Fuel damper and fuel hose assembly |
| 10. Clip | 11. O-ring (green) | 12. Fuel injector |
| 13. O-ring (black) | 14. Fuel tube (LH) | |
| A. To centralized under-floor piping | B. Refer to EM-189 | |

• Refer to [GI-9, "Component"](#) for symbols in the figure.

CAUTION:

Never remove or disassemble parts unless instructed as shown in the figure.

Removal and Installation

INFOID:000000005348051

REMOVAL

WARNING:

- Put a "CAUTION: FLAMMABLE" sign in the workshop.
- Be sure to work in a well ventilated area and furnish workshop with a CO2 fire extinguisher.
- Never smoke while servicing fuel system. Keep open flames and sparks away from the work area.
- To avoid the danger of being scalded, never drain engine coolant when engine is hot.

1. Remove engine room cover (RH and LH). Refer to [EM-168](#).
2. Remove engine cover with power tool. Refer to [EM-175, "Removal and Installation"](#).
3. Release fuel pressure. Refer to [EC-766, "Fuel Pressure Check"](#).

FUEL INJECTOR AND FUEL TUBE

[VK45DE]

< SERVICE INFORMATION >

4. Disconnect fuel feed hose (1) on engine side as follows: (Perform same procedure for the side of centralized under-floor piping as well.)

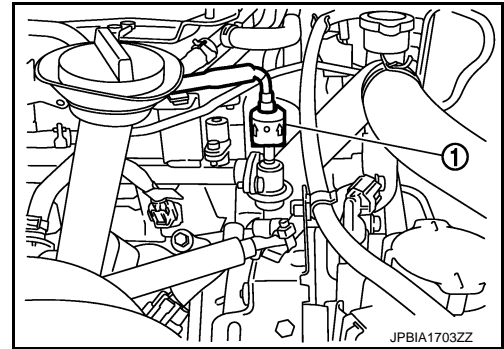

- a. Remove quick connector cap from quick connector connection.

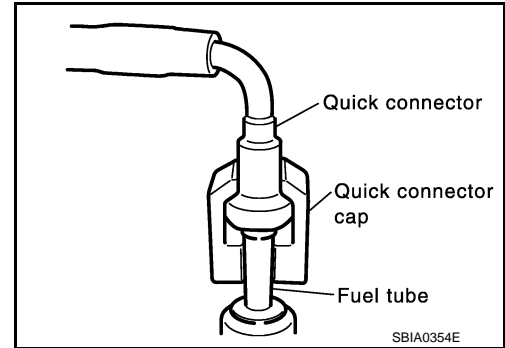

- b. Disconnect quick connector from fuel feed damper as follows:

CAUTION:

Disconnect quick connector by using quick connector release (commercial service tool: J-45488), not by picking out retainer tabs (centralized under-floor piping side).

- i. With the sleeve side of quick connector release facing to quick connector, install quick connector release onto fuel tube.
- ii. Insert quick connector release into quick connector until sleeve contacts and goes no further. Hold quick connector release on that position.

CAUTION:

Inserting quick connector release hard will not disconnect quick connector. Hold quick connector release where it contacts and goes no further.

- iii. Draw and pull out quick connector straight from fuel feed damper.

CAUTION:

• Pull quick connector holding "A" position as shown in the figure.

• Never pull with lateral force applied. O-ring inside quick connector may be damaged.

• Prepare container and cloth beforehand as fuel will leakage out.

• Avoid fire and sparks.

• Keep parts away from heat source. Especially, be careful when welding is performed around them.

• Never expose parts to battery electrolyte or other acids.

• Never bend or twist connection between quick connector and fuel feed hose during installation/removal.

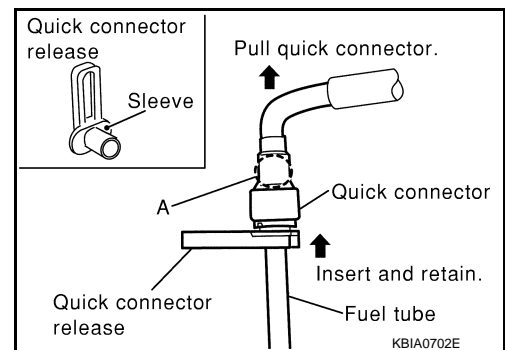

FUEL INJECTOR AND FUEL TUBE

[VK45DE]

< SERVICE INFORMATION >

- To keep clean the connecting portion and to avoid damage and foreign materials, cover them completely with plastic bags or something similar.

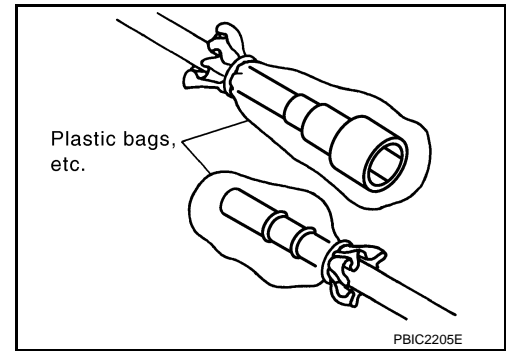

5. Disconnect fuel damper and fuel hose assembly from fuel tubes (RH and LH).

CAUTION:

- While hoses are disconnected, plug them to prevent fuel from draining.
- Never separate fuel damper and fuel hose.

6. Disconnect harness connector from fuel injector.

7. Loosen mounting bolts in reverse order as shown in the figure, and remove fuel tube and fuel injector assembly.

- A. : Right bank
- B. : Left bank
- ⇐ : Engine front

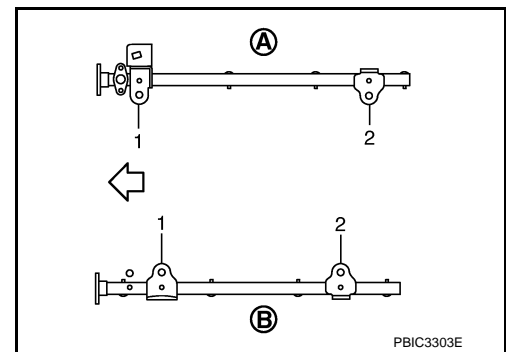

CAUTION:

Never tilt it, or remaining fuel in pipes may flow out from pipes.

8. Remove spacers on intake manifold (lower).
9. Remove fuel injector from fuel tube as follows:
 - a. Open and remove clip.
 - b. Remove fuel injector from fuel tube by pulling straight.

CAUTION:

- Be careful with remaining fuel that may go out from fuel tube.
- Be careful not to damage injector nozzles during removal.
- Never bump or drop fuel injector.
- Never disassemble fuel injector.

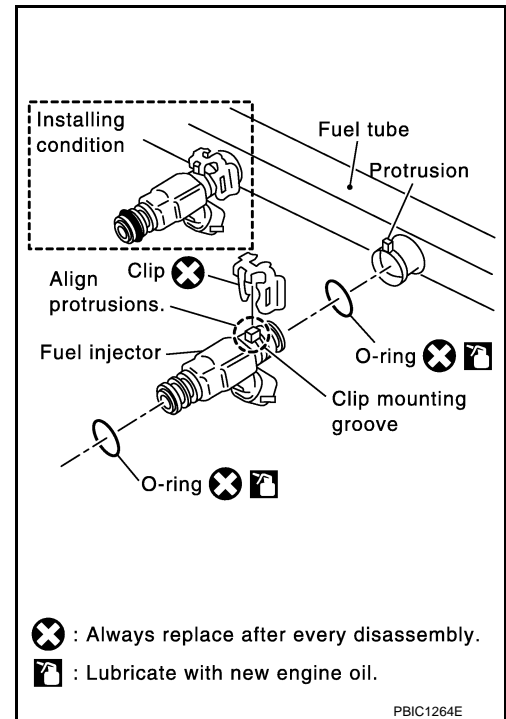

10. Remove fuel feed damper.

INSTALLATION

1. Install fuel feed damper.

FUEL INJECTOR AND FUEL TUBE

[VK45DE]

< SERVICE INFORMATION >

- When handling new O-rings, be careful of the following caution.

CAUTION:

- Handle O-ring with bare hands. Never wear gloves.
- Lubricate O-ring with new engine oil.
- Never clean O-ring with solvent.
- Check that O-ring and its mating part are free of foreign material.
- When installing O-ring, be careful not to scratch it with tool or fingernails. Also be careful not to twist or stretch O-ring. If O-ring was stretched while it was being attached, never insert it quickly into fuel tube.
- Insert new O-ring straight into fuel tube. Never decenter or twist it.

- Insert fuel feed damper straight into fuel tube (RH).
- Tighten mounting bolts evenly in turn.
- After tightening mounting bolts, check that there is no gap between flange and fuel tube (RH).

- Install new O-rings to fuel injector paying attention to the following caution.

CAUTION:

- Upper and lower O-ring are different. Be careful not to confuse them.

Fuel tube side : Black

Nozzle side : Green

- Handle O-ring with bare hands. Never wear gloves.
- Lubricate O-ring with new engine oil.
- Never clean O-ring with solvent.
- Check that O-ring and its mating part are free of foreign material.
- When installing O-ring, be careful not to scratch it with tool or fingernails. Also be careful not to twist or stretch O-ring. If O-ring was stretched while it was being attached, never insert it quickly into fuel tube.
- Insert O-ring straight into fuel injector. Never decenter or twist it.

- Install fuel injector to fuel tube as follows:

- Insert clip into clip mounting groove on fuel injector.
 - Insert clip so that "protrusion A" of fuel injector matches "cutout A" of clip.

CAUTION:

- Never reuse clip. Replace it with a new one.
- Be careful to keep clip from interfering with O-ring. If interference occurs, replace O-ring.

- Insert fuel injector into fuel tube with clip attached.
 - Insert it while matching it to the axial center.
 - Insert fuel injector so that "protrusion B" of fuel tube matches "cutout B" of clip.
 - Check that fuel tube flange is securely fixed in flange fixing groove on clip.
- Check that installation is complete by checking that fuel injector does not rotate or come off.
 - Check that protrusions of fuel injectors are aligned with cutouts of clips after installation.

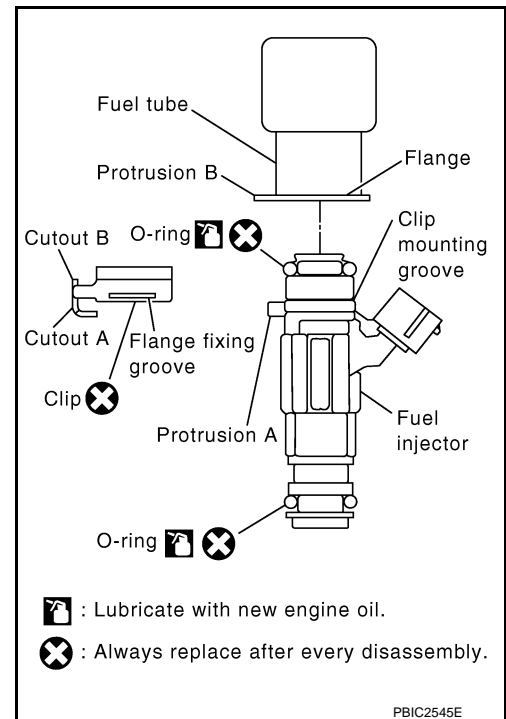

- Install spacers on intake manifold (lower).
- Install fuel tube and fuel injector assembly to intake manifold (lower).

CAUTION:

- Be careful not to let tip of injector nozzle come in contact with other parts.

FUEL INJECTOR AND FUEL TUBE

[VK45DE]

< SERVICE INFORMATION >

- Tighten mounting bolts in two steps in numerical order as shown in the figure.

A : Right bank
 B : Left bank
 : Engine front

 **1st step** : 10.1 N-m (1.0 kg-m, 7 ft-lb)

 **2nd step** : 23.5 N-m (2.4 kg-m, 17 ft-lb)

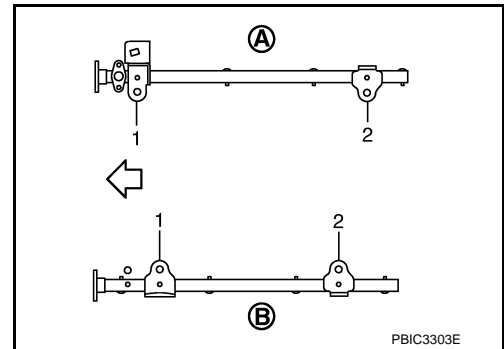

6. Connect fuel feed hose on engine side as follows: (Unless otherwise indicated, the installation to the engine side and centralized under-floor piping side is exactly alike.)
 - a. Check no foreign substances are deposited in and around fuel tube and quick connector, and no damage on them.
 - b. Thinly apply new engine oil around fuel tube from tip end to spool end.
 - c. Align center to insert quick connector straightly into fuel tube.

Engine side:

- Insert fuel tube into quick connector until top spool is completely inside quick connector, and 2nd level spool exposes right below quick connector.

CAUTION:

- Hold "A" position as shown in the figure when inserting fuel tube into quick connector.
- Carefully align center to avoid inclined insertion to prevent damage to O-ring inside quick connector.
- Insert until you hear a "click" sound and actually feel the engagement.
- To avoid misidentification of engagement with a similar sound, be sure to perform the next step.

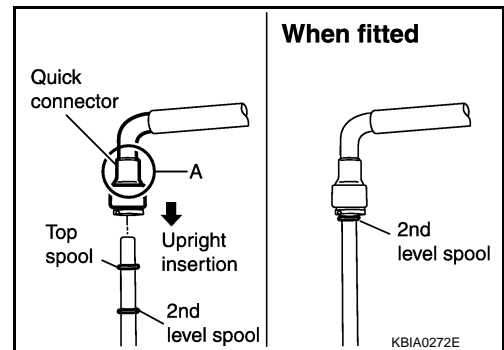

Centralized under-floor piping side:

- Visually confirm that the two retainer tabs are connected to the connector.

CAUTION:

- Carefully align center to avoid inclined insertion to prevent damage to O-ring inside quick connector.
- Insert until you hear a "click" sound and actually feel the engagement.
- To avoid misidentification of engagement with a similar sound, be sure to perform the next step.

- d. Pull quick connector by hand holding position. Check it is completely engaged (connected) so that it does not come out from fuel tube.
- e. Install quick connector cap on quick connector connection.

CAUTION:

If cap cannot be installed smoothly, quick connector may have not been installed correctly. Check connection again.

- f. Install fuel feed hose to hose clamps.

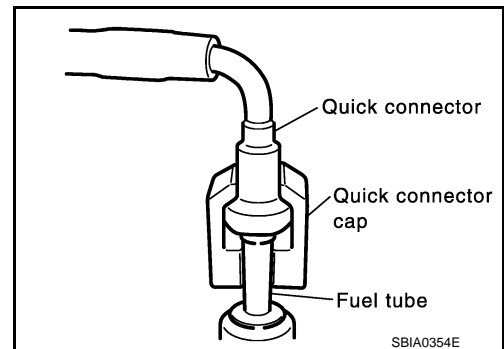

7. Install in the reverse order of removal after this step.

INSPECTION AFTER INSTALLATION

Check on Fuel Leakage

1. Turn ignition switch "ON" (with engine stopped). With fuel pressure applied to fuel piping, check for fuel leakage at connection points.

NOTE:

FUEL INJECTOR AND FUEL TUBE

< SERVICE INFORMATION >

[VK45DE]

Use mirrors for checking at points out of clear sight.

2. Start engine. With engine speed increased, check again for fuel leakage at connection points.

CAUTION:

Never touch engine immediately after stopped, as engine becomes extremely hot.

ROCKER COVER

< SERVICE INFORMATION >

[VK45DE]

ROCKER COVER

Component

INFOID:000000005348052

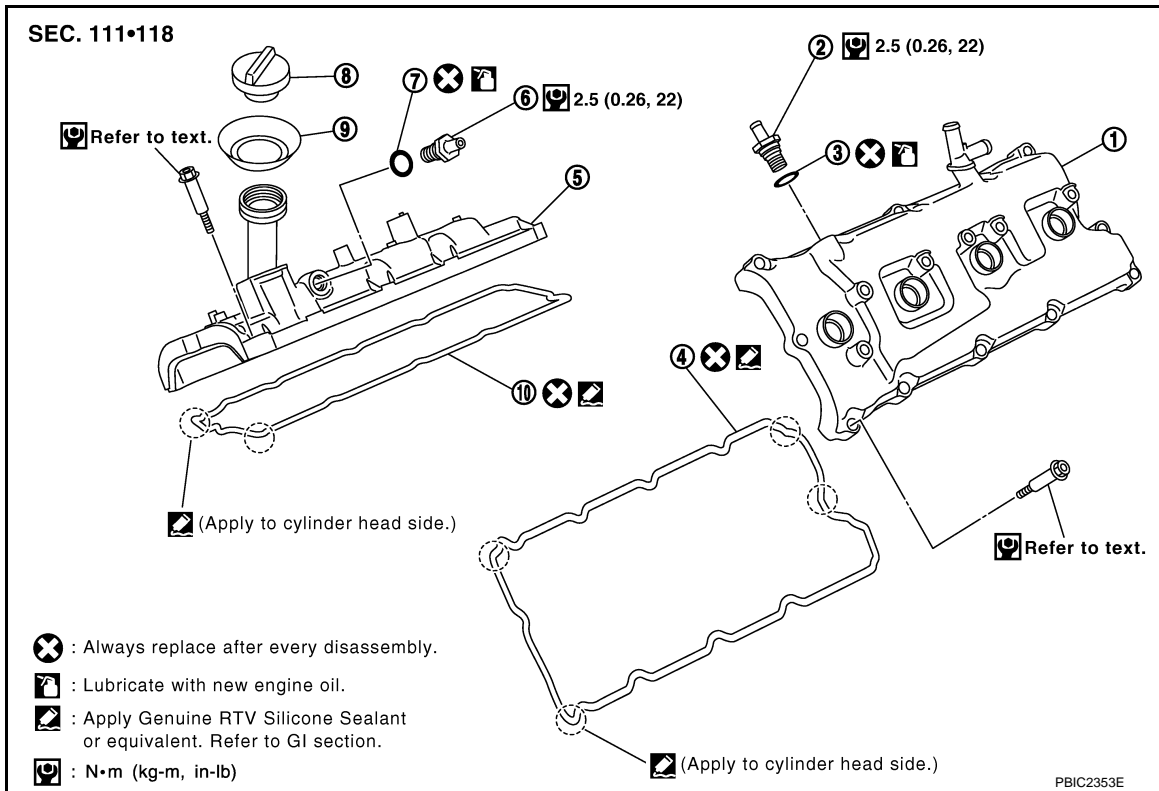

- | | | |
|--------------------------------------|------------------------------|----------------|
| 1. Rocker cover (left bank) | 2. PCV valve | 3. O-ring |
| 4. Rocker cover gasket (left bank) | 5. Rocker cover (right bank) | 6. PCV valve |
| 7. O-ring | 8. Oil filler cap | 9. Oil catcher |
| 10. Rocker cover gasket (right bank) | | |

Removal and Installation

INFOID:000000005348053

REMOVAL

1. Remove engine room cover (RH and LH). Refer to [EM-168](#).
2. Remove engine cover with power tool. Refer to [EM-175, "Removal and Installation"](#).
3. Refer to the following for incidental works related to left bank.
 - a. Remove air duct (inlet), air cleaner case, and air duct and resonator assembly. Refer to [EM-172](#).
 - b. Move harness on upper rocker cover and its peripheral aside.
 - c. Remove harness bracket from camshaft bracket (No. 6). Refer to [EM-211](#).
 - d. Remove ignition coil. Refer to [EM-186](#).
 - e. Remove PCV hose from PCV valve.
4. Refer to the following for incidental works related to right bank.
 - a. Move harness on upper rocker cover and its peripheral aside.
 - b. Remove ignition coil. Refer to [EM-186](#).
 - c. Remove PCV hose from PCV valve.
5. Remove PCV valves and O-rings from rocker covers (right bank and left bank), if necessary.
6. Remove oil filler cap and oil catcher from rocker cover (right bank), if necessary.
7. Remove rocker cover (right bank) as follows:
 - a. Remove battery cover. Refer to [EM-168](#).

ROCKER COVER

[VK45DE]

< SERVICE INFORMATION >

- b. Remove battery and battery tray. Refer to [SC-4](#).
- c. Remove grommet (2) from cowl top panel hole (RH).

- 1 : Relay box
 ⇐ : Engine front

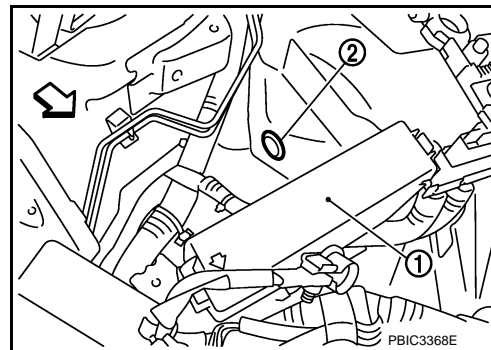

- d. Loosen mounting bolts in reverse order as that shown in the figure.

CAUTION:

Never hold oil filler neck (right bank) so as not to damage it.

NOTE:

Loosen No. 10 bolt of right bank from cowl top panel hole using tool.

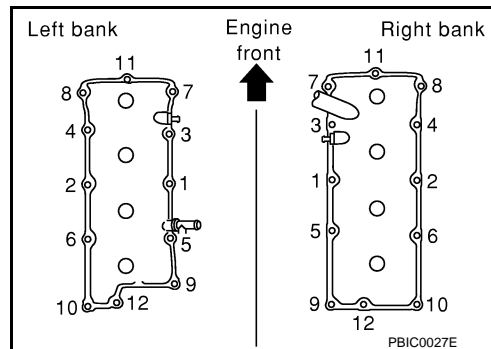

8. Remove rocker cover (left bank) as follows:
 - a. Remove brake master cylinder cover. Refer to [EM-168](#).
 - b. Remove two grommets (1) from cowl top panel hole (LH).

- 2 : Brake master cylinder
 ⇐ : Engine front

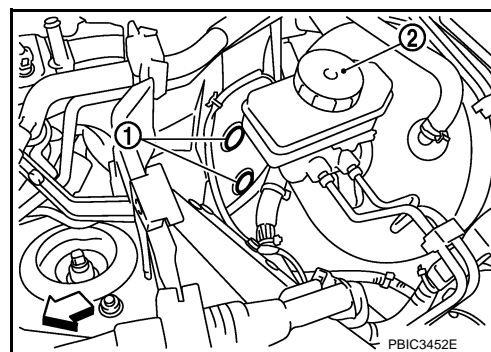

- c. Loosen mounting bolts in reverse order as that shown in the figure.

NOTE:

Loosen No. 10 and 12 bolts of the left bank from cowl top panel hole using tool.

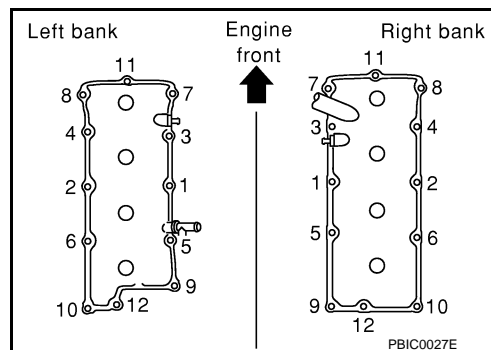

- Refer to the following procedure for removal of mounting bolts No. 10 and 12. (For ICC models)

CAUTION:

Never bend or damage brake piping by tools.

ROCKER COVER

[VK45DE]

< SERVICE INFORMATION >

- No. 10 bolt. See the figure and remove them using a 300 mm (11.81 in) expansion bar.

A : Cowl top panel hole

↔ : Engine front

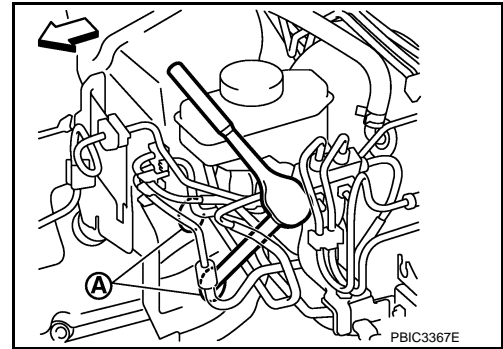

- No. 12 bolt. See the figure and remove them using a 300 mm (11.81 in) expansion bar.

A : Cowl top panel hole

↔ : Engine front

NOTE:

Slide the brake piping forward to obtain working space.

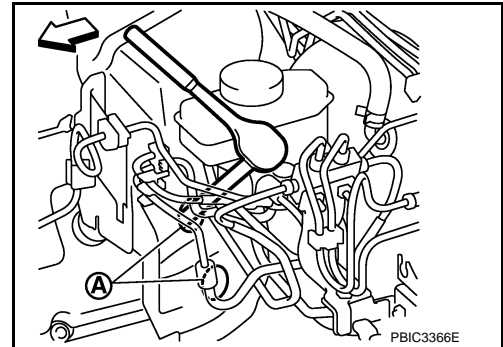

- Remove rocker cover gaskets from rocker covers.
- Use scraper to remove all traces of liquid gasket from cylinder head and camshaft bracket (No. 1 and 6).

CAUTION:

Never scratch or damage the mating surface when cleaning off oil liquid gasket.

INSTALLATION

- Apply liquid gasket with tube presser (commercial service tool) to joint among rocker cover, cylinder head and camshaft bracket (No. 1 and 6) as follows:

Use Genuine RTV Silicone Sealant or equivalent. Refer to GI-46.

NOTE:

The figure shows an example of left bank side [zoomed in shows camshaft bracket (No. 1)]. Apply only to camshaft bracket (No. 1) for right bank side.

- Refer to the figure "a" to apply liquid gasket to joint part of camshaft bracket (both No. 1 and 6) and cylinder head.
- Refer to the figure "b" to apply liquid gasket to the figure "a" squarely.

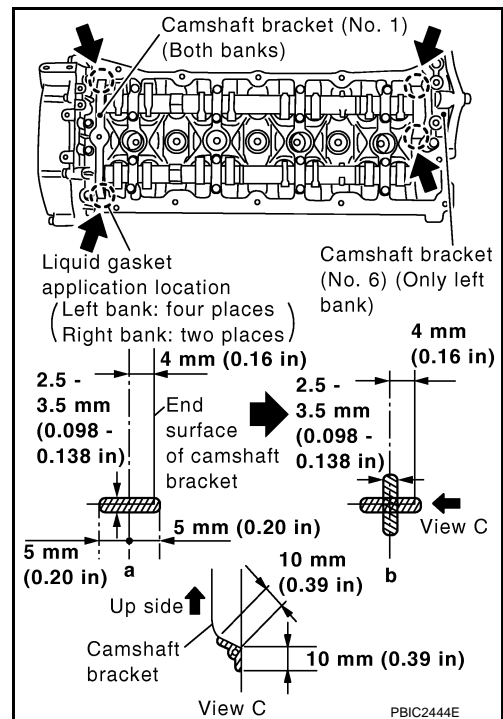

- Install new rocker cover gaskets to rocker covers.
- Install rocker cover.
 - Check if rocker cover gasket is not dropped from installation groove of rocker cover.

ROCKER COVER

[VK45DE]

< SERVICE INFORMATION >

4. Tighten mounting bolts in two steps separately in numerical order as shown in the figure.

CAUTION:

- Never hold oil filler neck (right bank) so as not to damage it.
- Never bend or damage brake piping by tools. (ICC models)

NOTE:

Tighten No. 10 bolt of the right bank and No. 10 and 12 bolts of the bank 1 from cowl top panel hole with using tool.

 **1st step** : 2.0 N·m (0.20 kg·m, 18 in-lb)

 **2nd step** : 8.3 N·m (0.85 kg·m, 73 in-lb)

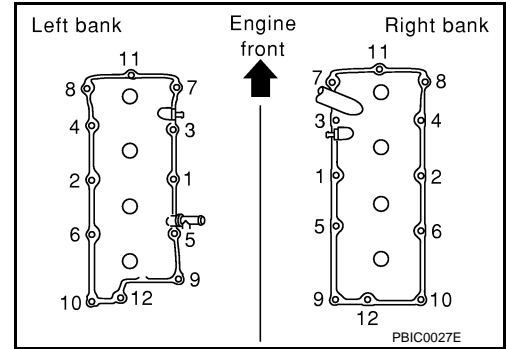

5. Install oil filler cap and oil catcher to rocker cover (right bank), if removed.
6. Install new O-rings and PCV valves to rocker covers (right bank and left bank), if removed.
7. Install in the reverse order of removal.

TIMING CHAIN

< SERVICE INFORMATION >

[VK45DE]

TIMING CHAIN

Component

INFOID:000000005348054

A

EM

C

D

E

F

G

H

I

J

K

L

M

N

O

P

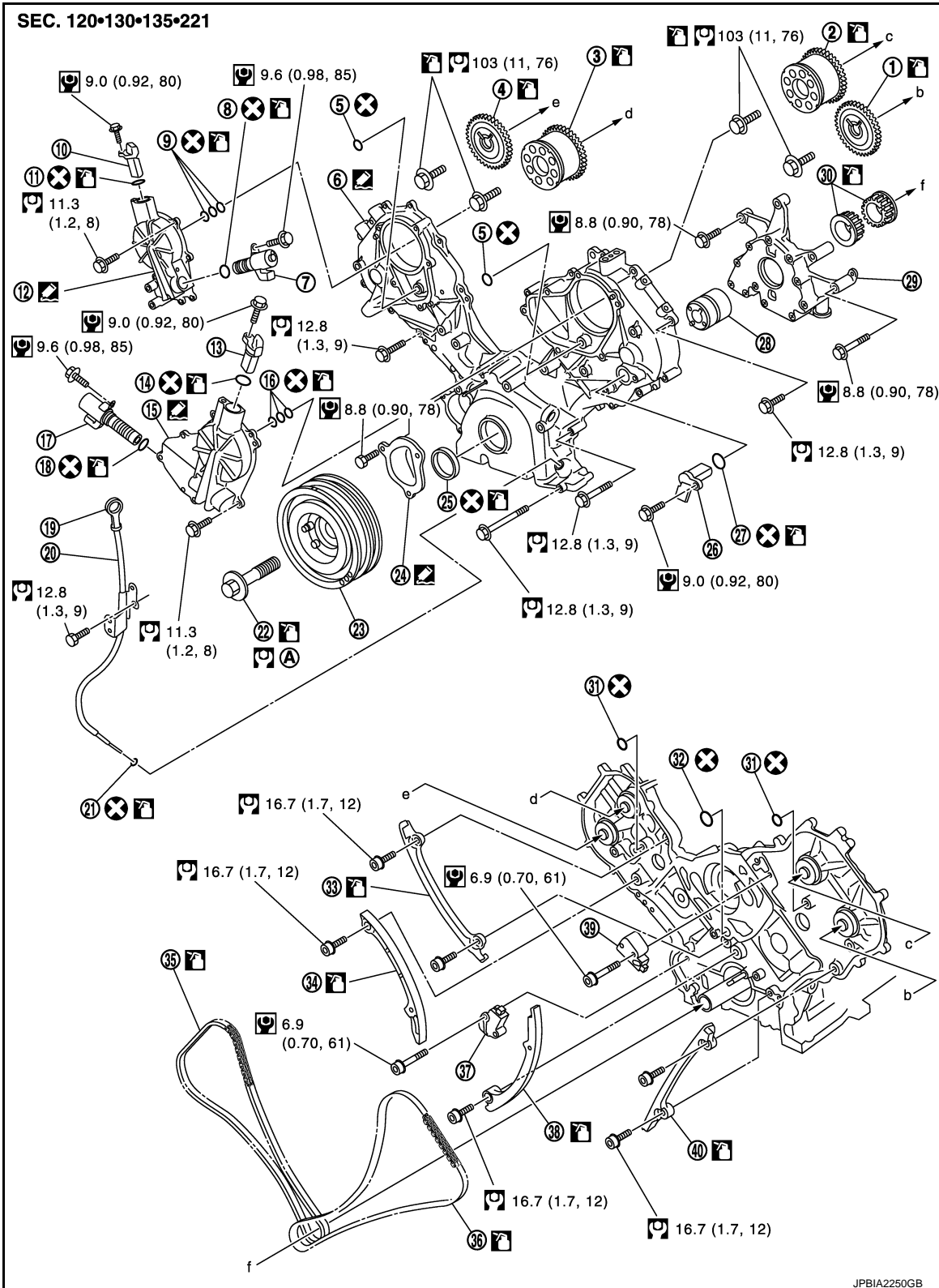

JPBIA2250GB

- | | | |
|---|--|---|
| 1. Camshaft sprocket (EXH) (left bank) | 2. Camshaft sprocket (INT) (left bank) | 3. Camshaft sprocket (INT) (right bank) |
| 4. Camshaft sprocket (EXH) (right bank) | 5. O-ring | 6. Front cover |

TIMING CHAIN

[VK45DE]

< SERVICE INFORMATION >

- | | | |
|--|---|--|
| 7. Intake valve timing control solenoid valve (bank 2) | 8. O-ring | 9. Seal ring |
| 10. Intake valve timing control position sensor (bank 2) | 11. O-ring | 12. Intake valve timing control cover (right bank) |
| 13. Intake valve timing control position sensor (bank 1) | 14. O-ring | 15. Intake valve timing control cover (left bank) |
| 16. Seal ring | 17. Intake valve timing control solenoid valve (bank 1) | 18. O-ring |
| 19. Oil level gauge | 20. Oil level gauge guide | 21. O-ring |
| 22. Crankshaft pulley bolt | 23. Crankshaft pulley | 24. Chain tensioner cover |
| 25. Front oil seal | 26. Camshaft position sensor (PHASE) | 27. O-ring |
| 28. Oil pump drive spacer | 29. Oil pump assembly | 30. Crankshaft sprocket |
| 31. O-ring | 32. O-ring | 33. Timing chain tension guide (right bank) |
| 34. Timing chain slack guide (right bank) | 35. Timing chain (right bank) | 36. Timing chain (left bank) |
| 37. Chain tensioner (left bank) | 38. Timing chain slack guide (left bank) | 39. Chain tensioner (right bank) |
| 40. Timing chain tension guide (left bank) | | |
- A. Refer to [EM-200](#)

- Refer to [GI-9, "Component"](#) for symbols in the figure.

Removal and Installation

INFOID:000000005348055

REMOVAL

1. Remove engine assembly from vehicle. Refer to [EM-238, "2WD : Component"](#) (2WD models) or [EM-242, "AWD : Component"](#) (AWD models).
2. Remove the following components and related parts:
 - Drive belt auto tensioner and idler pulley: Refer to [EM-171, "Drive Belt Auto Tensioner and Idler Pulley"](#).
 - Thermostat housing and hoses: Refer to [CO-51](#).
 - Ignition coil: Refer to [EM-186](#).
 - Rocker cover: Refer to [EM-195](#).
3. If necessary, remove intake valve timing control position sensor (right bank and left bank) and camshaft position sensor (PHASE) from intake valve timing control cover and front cover.

CAUTION:

- Handle carefully to avoid dropping and shocks.
- Never disassemble.

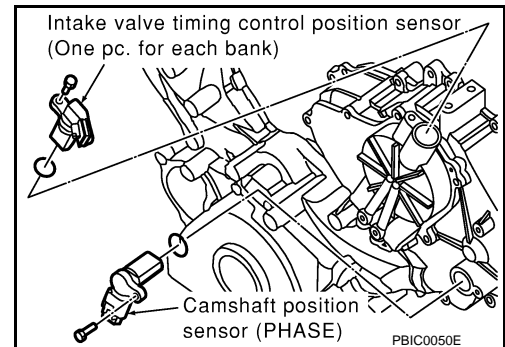

4. If necessary, remove intake valve timing control solenoid valve from intake valve timing control cover.
CAUTION:
 - Handle components and parts carefully to avoid dropping and shocks.
 - Never disassemble.
 - Never allow metal powder to adhere to magnetic part at sensor tip.
 - Never place sensors in a location where they are exposed to magnetism.
5. Remove intake valve timing control cover as follows:

TIMING CHAIN

[VK45DE]

< SERVICE INFORMATION >

- a. Loosen and remove mounting bolts in the reverse order as shown in the figure.
- b. Use seal cutter [SST: KV10111100 (J-37228)] to cut liquid gasket for removal.

CAUTION:

- Exercise care not to damage mating surfaces.
- Pull out cover keeping levelness without an angle, as inner part of cover is engaged with the center of camshaft sprocket (INT).

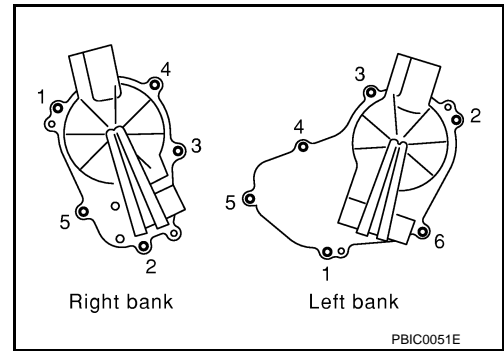

6. Remove O-rings from front cover.

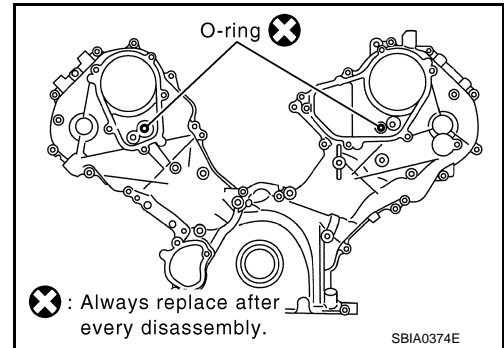

7. Obtain No. 1 cylinder at TDC of its compression stroke as follows:

- a. Rotate crankshaft pulley clockwise to align the TDC identification notch (without paint mark) with timing indicator on front cover.

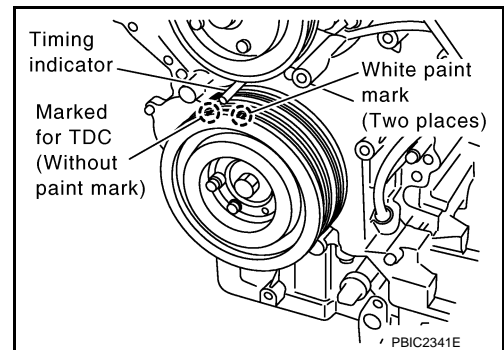

- b. Check that both intake and exhaust cam noses of No. 1 cylinder (engine front side of left bank) are located as shown in the figure.
 - If not, turn crankshaft one revolution (360 degrees) and align as shown in the figure.

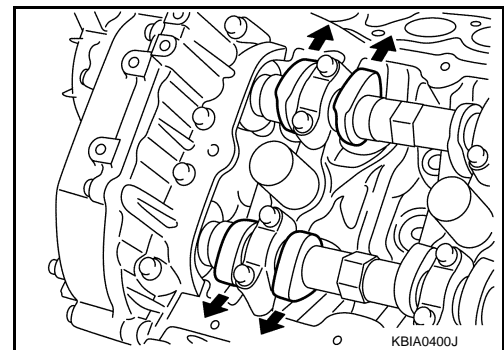

8. Remove crankshaft pulley as follows:

A
EM
C
D
E
F
G
H
I
J
K
L
M
N
O
P

TIMING CHAIN

[VK45DE]

< SERVICE INFORMATION >

- a. Remove rear plate cover, and set ring gear stopper (SST).
- b. Loosen crankshaft pulley bolt, and then pull crankshaft pulley with both hands to remove it.
CAUTION:
 - Never remove crankshaft pulley bolt. Keep loosened crankshaft pulley bolt in place to protect removed crankshaft pulley from dropping.
 - Never remove balance weight (inner hexagon bolt) at the front of crankshaft pulley.

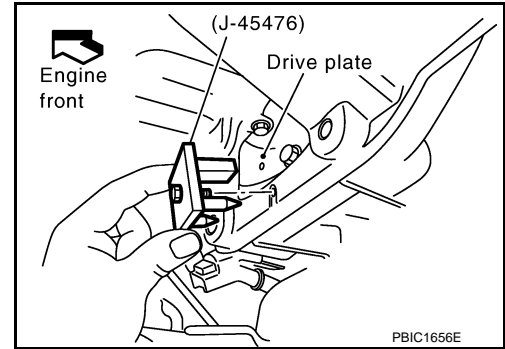

9. Remove oil pan and oil strainer. Refer to [EM-182](#).
10. Remove front cover as follows:
 - a. Loosen mounting bolts in reverse order as shown in the figure.
 - b. Use seal cutter [SST: KV10111100 (J-37228)] to cut liquid gasket for removal.
CAUTION:
 - Exercise care not to damage mating surfaces.
 - After removal, handle front cover carefully so it never tilt, cant, or warp under a load.

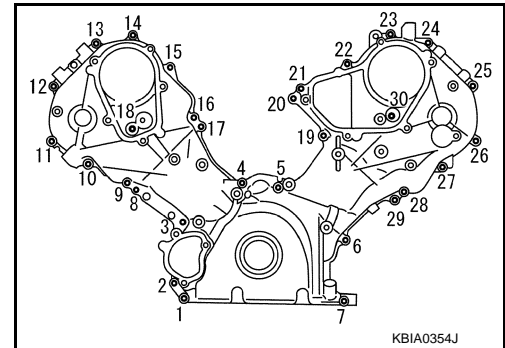

11. Remove front oil seal from front cover using suitable tool.
 - Use screwdriver for removal.
CAUTION:
Be careful not to damage front cover.
12. Remove O-rings from cylinder heads (right bank and left bank) and cylinder block.

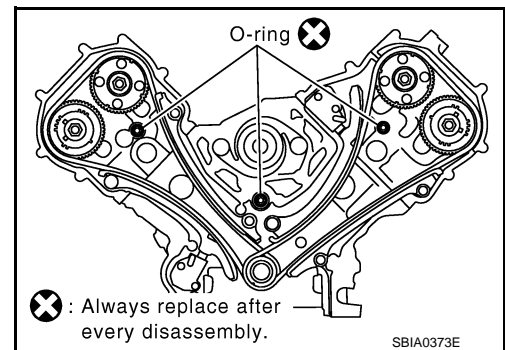

13. Remove chain tensioner cover from front cover.
 - Use seal cutter [SST: KV10111100 (J-37228)] to cut liquid gasket for remove.
14. Remove oil pump drive spacer.
 - Set bolts in the two bolt holes [M6 × pitch 1.0 mm (0.039 in)] on front surface. Using suitable puller, pull oil pump drive spacer off from crankshaft.
NOTE:
The dimension between the centers of the two bolt holes is 33 mm (1.30 in).
In the figure, a commercial steering puller is used.

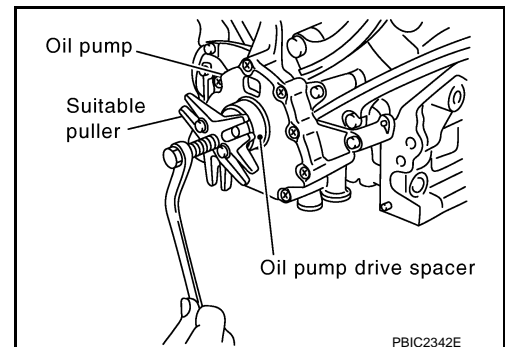

15. Remove oil pump. Refer to [LU-28](#).

TIMING CHAIN

[VK45DE]

< SERVICE INFORMATION >

16. Remove chain tensioner (left bank) as follows:

NOTE:

To remove timing chain and related parts, start with those on left bank. The procedure for removing parts on right bank is omitted because it is the same as that for left bank.

- a. Press tab in the direction of arrow (or turn lever in the direction of arrow) to unlock the locking with the groove that stops tensioner plunger from returning.
 - Lightly press tensioner plunger to release the tension of spring for this operation.
- b. Push in tensioner plunger to align the hole on lever and that on pump main body.
 - Pushing in tensioner too far does not allow the holes to align. Therefore, push in plunger to the degree at which the start of stopper groove and tab engages.
- c. Insert stopper pin [hard wire with approximately 0.5 mm (0.020 in) diameter or similar tool] to fix plunger. With plunger fixed, remove chain tensioner.

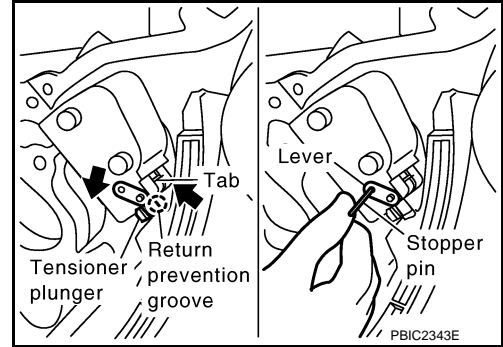

17. Remove chain tension guide and timing chain slack guide.

18. Remove timing chain and crankshaft sprocket.

CAUTION:

After removing timing chain, never turn crankshaft and camshaft separately, or valves will strike the piston head.

19. With hexagonal part of camshaft locked with wrench, loosen mounting bolts securing camshaft sprocket to remove camshaft sprocket.

CAUTION:

Never loosen mounting bolts with securing anything other than the camshaft hexagonal portion or with tensioning the timing chain.

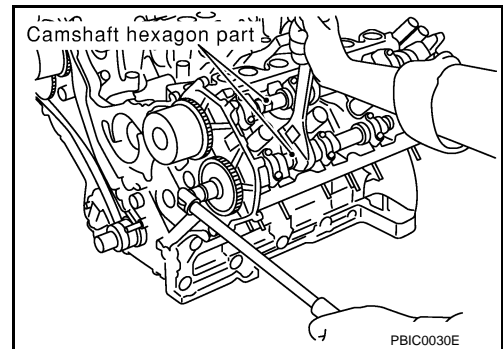

20. Perform same procedure as for left bank, remove timing chain and related parts on right side.

21. Use scraper to remove all traces of old liquid gasket from front cover and opposite mating surfaces.

- Remove oil liquid gasket from bolt hole and thread.

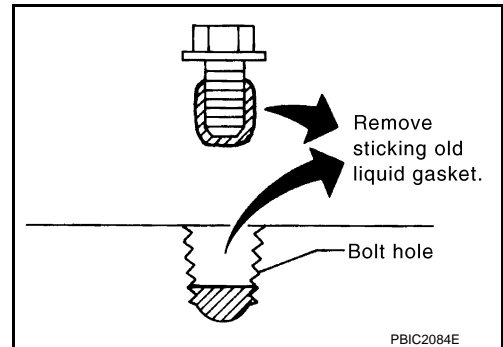

22. Use scraper to remove all trace of liquid gasket from chain tensioner cover and intake valve timing control covers.

INSPECTION AFTER REMOVAL

Timing Chain

TIMING CHAIN

[VK45DE]

< SERVICE INFORMATION >

Check for cracks and any excessive wear at link plates and roller links of timing chain. Replace timing chain if necessary.

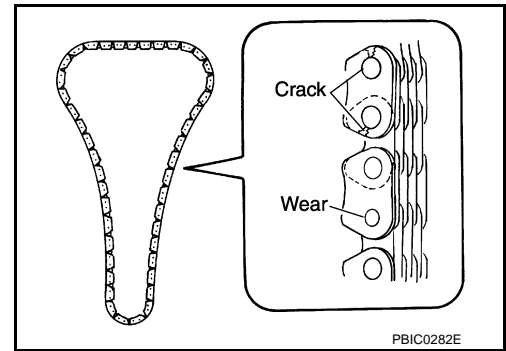

INSTALLATION

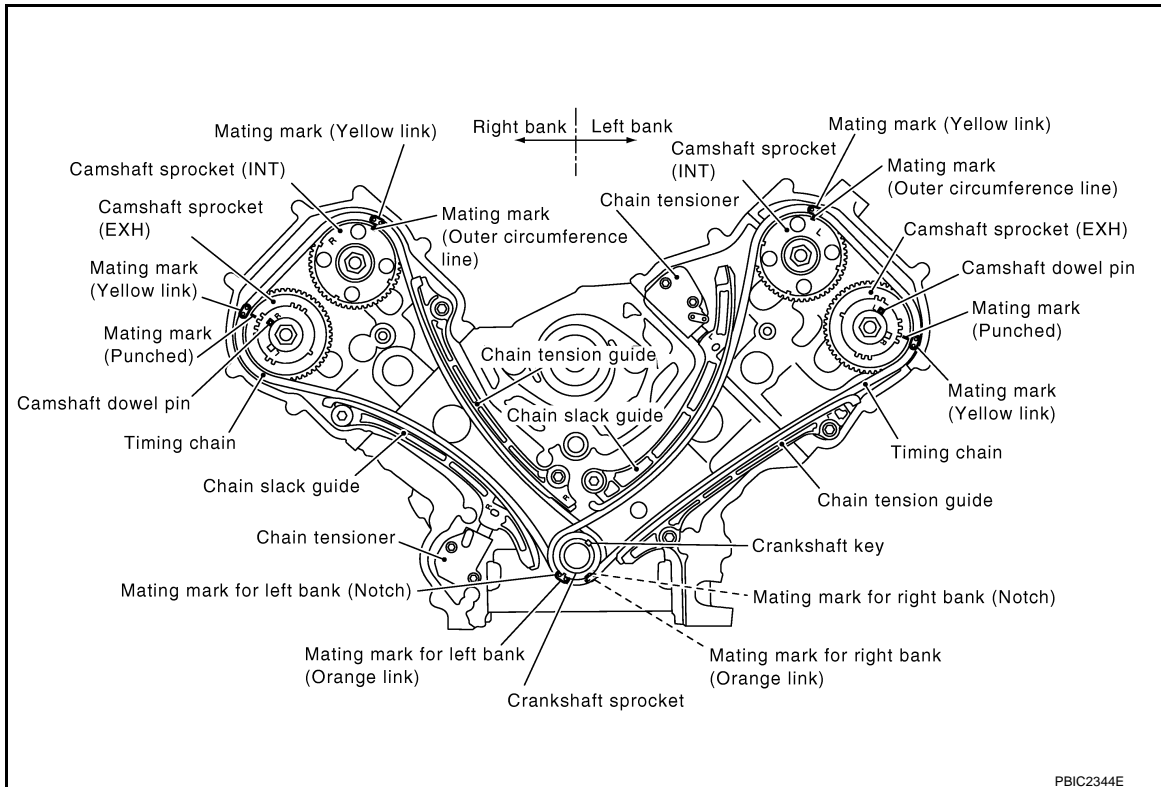

NOTE:

- The above figure shows the relationship between the mating mark on each timing chain and that on the corresponding sprocket, with the components installed.
- Parts with an identification mark (R or L) should be installed on the corresponding bank according to the mark.
Parts with an identification mark:
 - Camshaft sprocket (INT)
 - Dowel pin groove of camshaft sprocket (EXH) (camshaft sprocket is same part both banks)
 - Chain tension guide
 - Chain slack guide
- To install timing chain and related parts, start with those on right bank. The procedure for installing parts on left bank is omitted because it is the same as that for installation on right bank.

TIMING CHAIN

[VK45DE]

< SERVICE INFORMATION >

1. Check that crankshaft key and dowel pin of each camshaft are located as shown in the figure. (No. 1 cylinder at compression TDC)

NOTE:

Though camshaft does not stop at the position as shown in the figure, for the placement of cam nose, it is generally accepted camshaft is placed for the same direction of the figure.

Camshaft dowel pin

: At cylinder head upper face side in each bank

Crankshaft key

: At cylinder head side of left bank

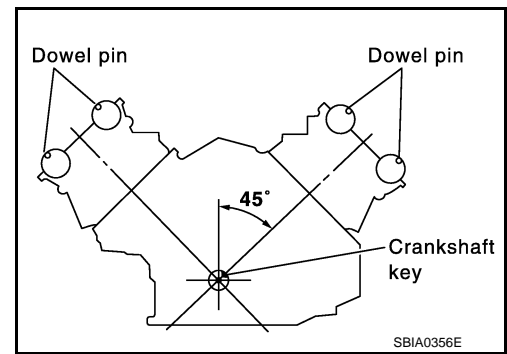

2. Install camshaft sprockets.
 - Install onto correct side by checking with identification mark on surface.
 - Install camshaft sprocket (EXH) by selectively using the groove of dowel pin according to the bank. (Common part used for both banks.)
 - Lock the hexagonal part of camshaft in the same procedure as for removal, and tighten mounting bolts.

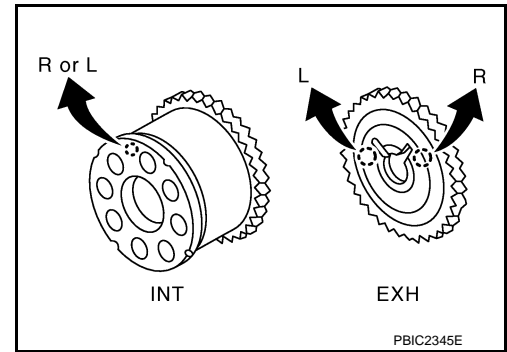

3. Install crankshaft sprockets for both banks.
 - Install each crankshaft sprocket so that its flange side (the larger diameter side without teeth) faces in the direction shown in the figure.

NOTE:

The same parts are used but facing directions are different.

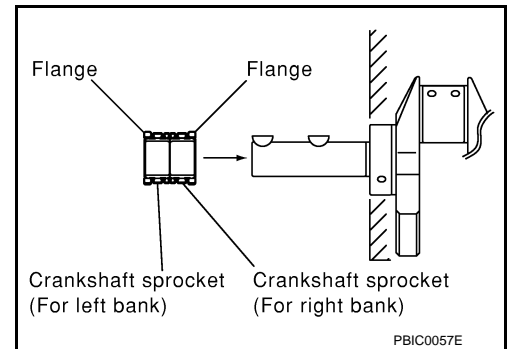

A
EM
C
D
E
F
G
H
I
J
K
L
M
N
O
P

TIMING CHAIN

< SERVICE INFORMATION >

[VK45DE]

4. Install timing chains and related parts.

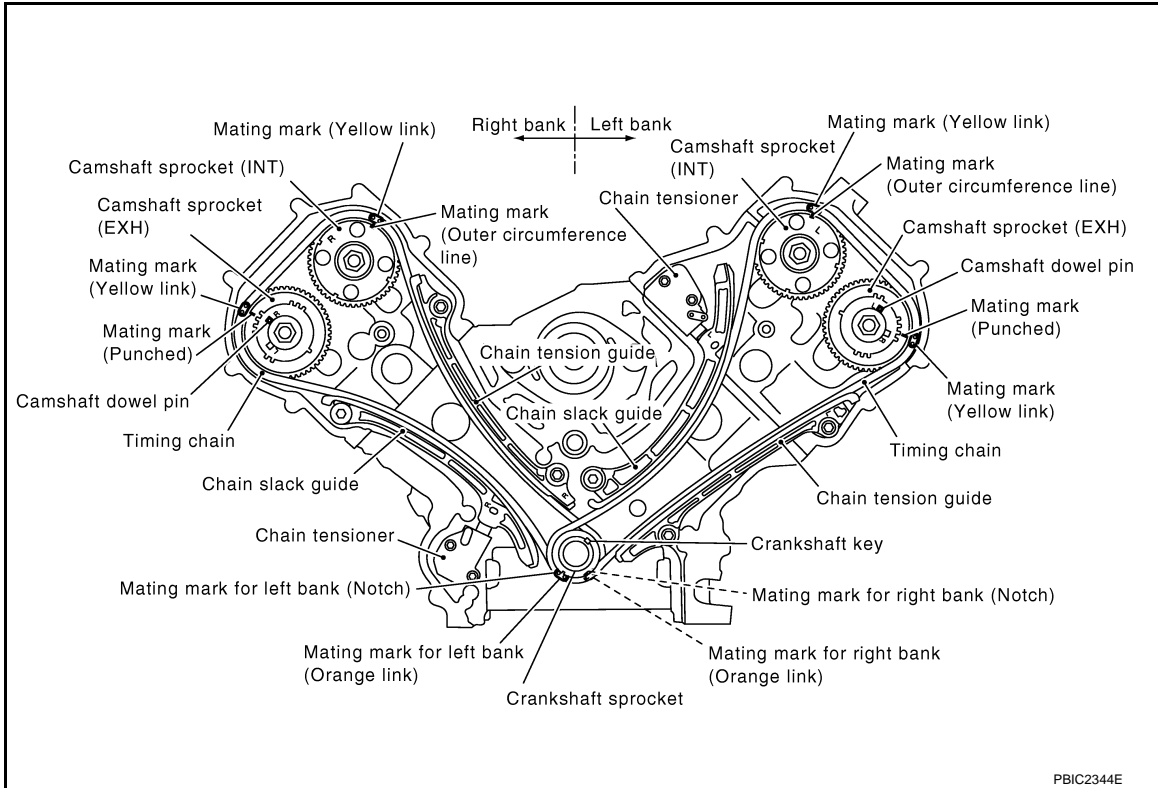

- Align the mating mark on each sprocket and timing chain for installation.

NOTE:

Before installing chain tensioner, it is possible to change the position of mating mark on timing chain for that on each sprocket for alignment.

CAUTION:

For the above reason, after the mating marks are aligned, keep them aligned by holding them with a hand.

- Install slack guides and tension guides onto correct side by checking with identification mark on surface.
- Install chain tensioner with plunger fixed as described in its removal.

CAUTION:

- **Before and after the installation of chain tensioner, check that the mating mark on timing chain is not out of alignment.**
- **After installing chain tensioner, remove stopper pin to release tensioner. Check tensioner is released.**
- **To avoid chain-link skipping of timing chain, never move crankshaft or camshafts until front cover is installed.**

5. Perform the same procedure as for right bank, install timing chain and related parts on left side.

6. Install oil pump. Refer to [LU-28](#).

7. Install oil pump drive spacer as follows:

- Insert oil pump drive spacer according to the directions of crankshaft key and the two flat surfaces of oil pump inner rotor.
 - If the positional relationship does not allow the insertion, rotate oil pump inner rotor with a finger to allow spacer.
- After confirming that the position of each part is in correct condition to allow for spacer, force fit spacer by lightly tapping with plastic hammer until it contacts and does not go further.

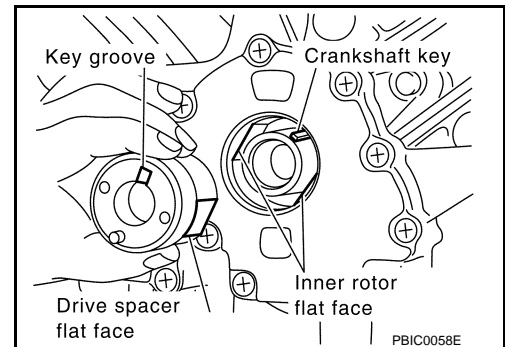

8. Install front oil seal on front cover.

TIMING CHAIN

[VK45DE]

< SERVICE INFORMATION >

- Apply new engine oil to both oil seal lip and dust seal lip.
- Install it so that each seal lip is oriented as shown in the figure.
CAUTION:
Be careful not to scratch or make burrs on circumference of oil seal.

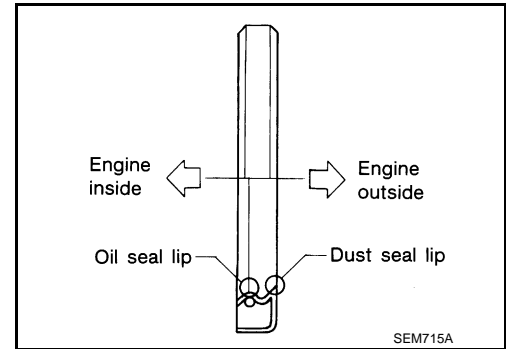

- Using front oil seal drift (commercial service tool), press fit until the height of front oil seal is level with the mounting surface.

Front oil seal drift

Outer diameter : 56 mm (2.20 in)

Inner diameter : 49 mm (1.93 in)

- Check the garter spring is in position and seal lips not inverted.

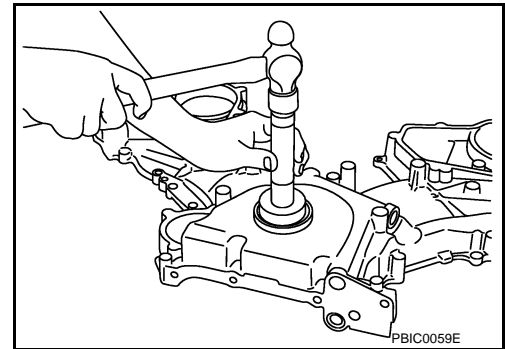

9. Install chain tensioner cover to front cover.

- Apply a continuous bead of liquid gasket with tube presser (commercial service tool) to front cover as shown in the figure.

1 : Chain tensioner cover

2 : Front cover

a : $\phi 2.6 - 3.6$ mm (0.102 - 0.142 in)

Use Genuine RTV Silicone Sealant or equivalent. Refer to [GI-46](#).

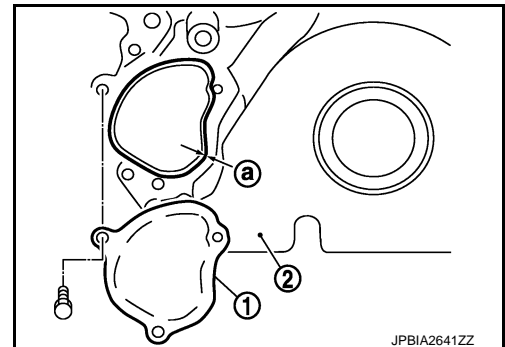

10. Install front cover as follows:

- a. Install new O-rings onto cylinder heads (right bank and left bank) and cylinder block.

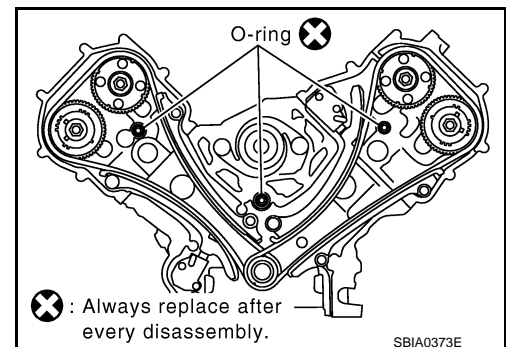

TIMING CHAIN

[VK45DE]

< SERVICE INFORMATION >

- b. Apply a continuous bead of liquid gasket with tube presser (commercial service tool) to front cover as shown in the figure.
Use Genuine RTV Silicone Sealant or equivalent. Refer to GI-46.
- c. Check again that the mating marks on timing chain and that on each sprocket are aligned. Then, install front cover.
CAUTION:
Be careful to avoid interference with the front end of oil pump drive spacer. Such interference may damage front oil seal.

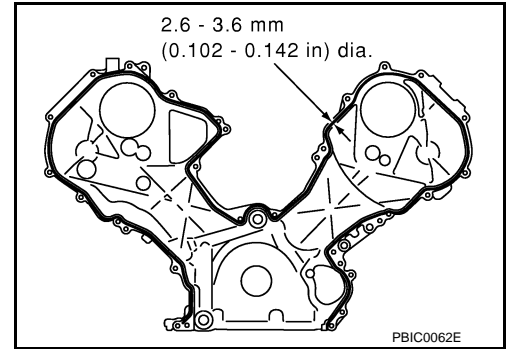

- d. Tighten mounting bolts in numerical order as shown in the figure.

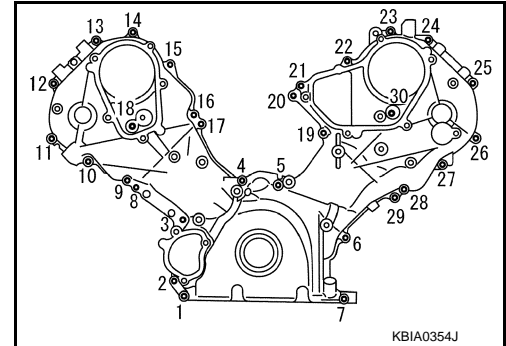

- There are four types of mounting bolts.

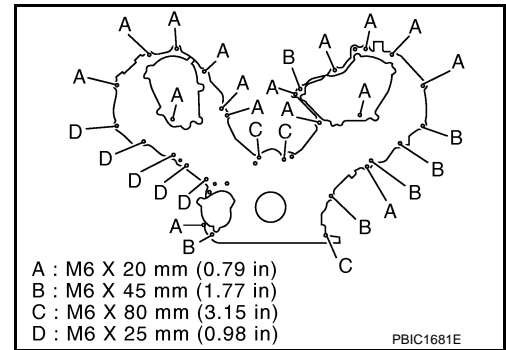

- e. After all mounting bolts are tightened, retighten them in numerical order as shown in the figure.
CAUTION:
Be sure to wipe off any excessive liquid gasket leaking onto surface mating with oil pan.
11. Install intake valve timing control cover as follows:
- a. At the back of intake valve timing control cover, install new seal rings (three for each bank) to the area to be inserted into camshaft sprocket (INT).
CAUTION:
Never spread seal ring excessively to avoid breaks and deformation.
- b. Install new O-rings on front cover.

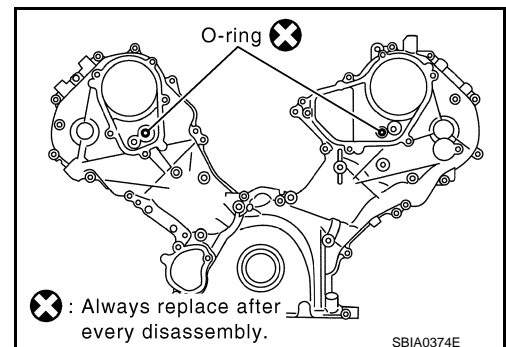

TIMING CHAIN

[VK45DE]

< SERVICE INFORMATION >

- c. Apply a continuous bead of liquid gasket with tube presser (commercial service tool) to intake valve timing control covers as shown in the figure.
Use Genuine RTV Silicone Sealant or equivalent. Refer to [GI-46](#).

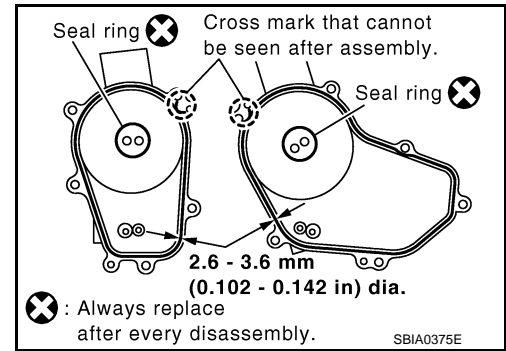

- d. Tighten mounting bolts in numerical order as shown in the figure.

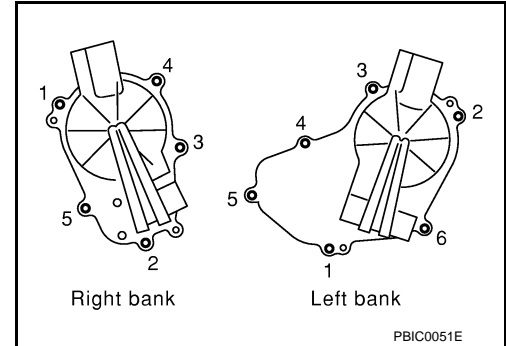

12. Install intake valve timing control position sensor, intake valve timing control solenoid valve and camshaft position sensor (PHASE) to intake valve timing control cover and front cover if removed.
- Be sure to tighten mounting bolts with flanges completely seated.
13. Install oil pan and oil strainer. Refer to [EM-182](#).
14. Install crankshaft pulley as follows:
- Fix crankshaft with ring gear stopper [SST: — (J-45476)].
 - Install crankshaft pulley, taking care not to damage front oil seal.
 - Install according to dowel pin of oil pump drive spacer.
 - Lightly tapping its center with plastic hammer, insert pulley.
- CAUTION:**
Never tap pulley on the side surface where belt is installed (outer circumference).
- Apply engine oil onto threaded parts of crankshaft pulley bolt and seating area.
 - Tighten crankshaft pulley bolt.

: **93.1 N·m (9.5 kg·m, 69 ft·lb)**

- Put a paint mark on crankshaft pulley aligning with angle mark on crankshaft pulley bolt.
- Further tighten by 90 degrees. (angle tightening)
 - Check the tightening angle by referencing to the notches. The angle between two notches is 90 degrees.

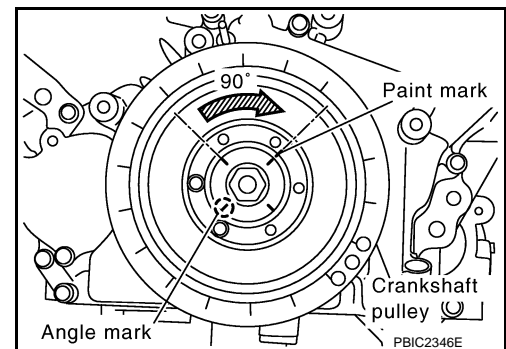

15. Rotate crankshaft pulley in normal direction (clockwise when viewed from engine front) to confirm it turns smoothly.
16. Install in the reverse order of removal after this step.

INSPECTION AFTER INSTALLATION

TIMING CHAIN

[VK45DE]

< SERVICE INFORMATION >

Inspection for Leakage

The following are procedures for checking fluids leakage, lubricates leakage, and exhaust gases leakage.

- Before starting engine, check oil/fluid levels including engine coolant and engine oil. If less than required quantity, fill to the specified level. Refer to [MA-9](#).
- Use procedure below to check for fuel leakage.
 - Turn ignition switch "ON" (with engine stopped). With fuel pressure applied to fuel piping, check for fuel leakage at connection points.
 - Start engine. With engine speed increased, check again for fuel leakage at connection points.
- Run engine to check for unusual noise and vibration.

NOTE:

If hydraulic pressure inside timing chain tensioner drops after removal/installation, slack in guide may generate a pounding noise during and just after engine start. However, this does not indicate an unusualness. Noise will stop after hydraulic pressure rises.

- Warm up engine thoroughly to check there is no leakage of fuel, exhaust gases, or any oil/fluids including engine oil and engine coolant.
- Bleed air from lines and hoses of applicable lines, such as in cooling system.
- After cooling down engine, again check oil/fluid levels including engine oil and engine coolant. Refill to the specified level, if necessary.

Summary of the inspection items:

Items	Before starting engine	Engine running	After engine stopped
Engine coolant	Level	Leakage	Level
Engine oil	Level	Leakage	Level
Other oils and fluid*	Level	Leakage	Level
Fuel	Leakage	Leakage	Leakage
Exhaust gases	—	Leakage	—

*: Transmission/transaxle/CVT fluid, power steering fluid, brake fluid, etc.

CAMSHAFT

< SERVICE INFORMATION >

[VK45DE]

CAMSHAFT

Component

INFOID:000000005348056

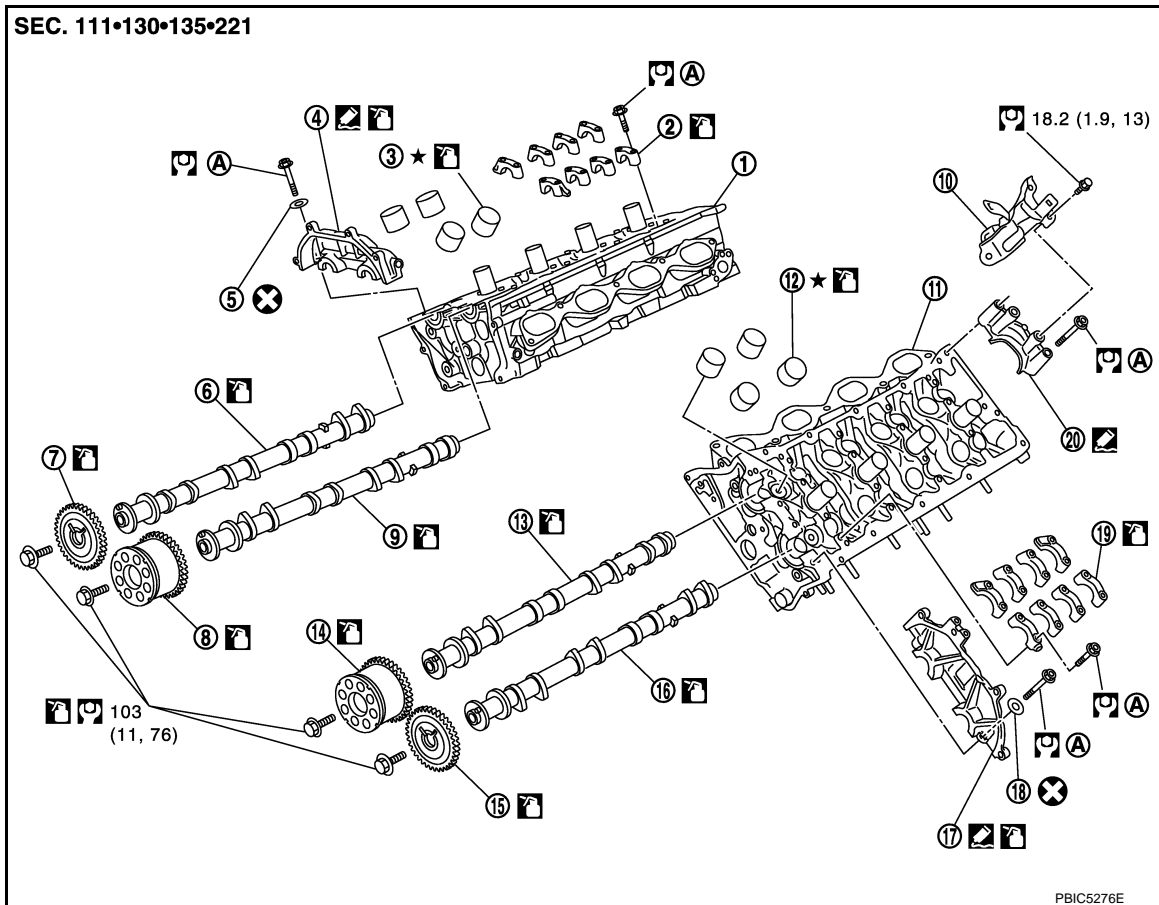

- | | | |
|---|---|---|
| 1. Cylinder head (right bank) | 2. Camshaft bracket (No. 2 to 5) (right bank) | 3. Valve lifter |
| 4. Camshaft bracket (No. 1) (right bank) | 5. Washer | 6. Camshaft (EXH) (right bank) |
| 7. Camshaft sprocket (EXH) (right bank) | 8. Camshaft sprocket (INT) (right bank) | 9. Camshaft (INT) (right bank) |
| 10. Bracket | 11. Cylinder head (left bank) | 12. Valve lifter |
| 13. Camshaft (INT) (left bank) | 14. Camshaft sprocket (INT) (left bank) | 15. Camshaft sprocket (EXH) (left bank) |
| 16. Camshaft (EXH) (left bank) | 17. Camshaft bracket (No. 1) (left bank) | 18. Washer |
| 19. Camshaft bracket (No. 2 to 5) (left bank) | 20. Camshaft bracket (No. 6) (left bank) | |

A. Refer to [EM-211](#)

• Refer to [GI-9, "Component"](#) for symbols in the figure.

Removal and Installation

INFOID:000000005348057

REMOVAL

1. Remove engine assembly from vehicle. Refer to [EM-238, "2WD : Component"](#) (2WD models) or [EM-242, "AWD : Component"](#) (AWD models).
2. Remove timing chain. Refer to [EM-199](#).

CAMSHAFT

[VK45DE]

< SERVICE INFORMATION >

- With hexagonal part of camshaft locked with wrench, loosen bolts securing camshaft sprocket to remove camshaft sprocket.

CAUTION:

- Never loosen mounting bolts with securing anything other than the camshaft hexagonal portion or with tensioning the timing chain.
- After removing timing chain, never turn crankshaft and camshaft separately, or valves will strike the piston head.

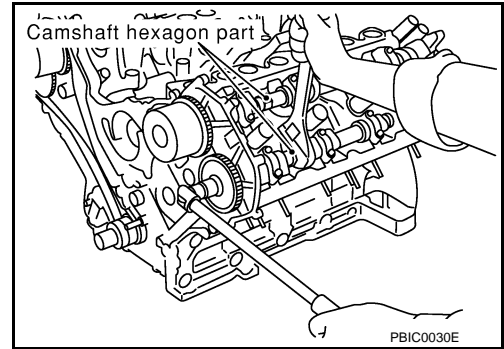

- Remove intake and exhaust camshaft brackets.
 - Mark camshafts, camshaft brackets and bolts so placed in the same position and direction for installation.
 - Equally loosen camshaft brackets and bolts in several steps in reverse order as shown in the figure.
 - Lightly tapping with plastic hammer, remove camshaft bracket (No. 1) and camshaft bracket (No. 6).

NOTE:

The bottom surface of each bracket will be stuck to cylinder head because of liquid gasket.

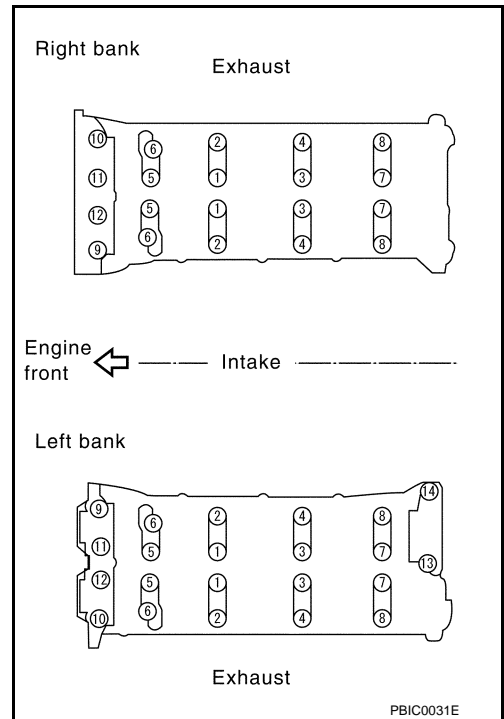

- Remove camshaft.
- Remove valve lifter.
 - Identify installation positions, and store them without mixing them up.

INSPECTION AFTER REMOVAL

Camshaft Runout

- Put V-block on precise flat table, and support No. 2 and 5 journal of camshaft.

CAUTION:

Never support journal No. 1 (on the side of camshaft sprocket) because it has a different diameter from the other four locations.

CAMSHAFT

[VK45DE]

< SERVICE INFORMATION >

- Set dial indicator vertically to No. 3 journal.
- Turn camshaft to one direction with hands, and measure the camshaft runout on dial indicator (total indicator reading).

Standard:

0.02 mm (0.0008 in)

Limit:

0.05 mm (0.0020 in)

- If it exceeds the limit, replace camshaft.

Camshaft Cam Height

- Measure the camshaft cam height with micrometer.

Standard cam height

Intake : 44.865 - 45.055 mm (1.7663 - 1.7738 in)

Exhaust : 43.925 - 44.115 mm (1.7293 - 1.7368 in)

Cam wear limit

: 0.2 mm (0.008 in)

- If wear exceeds the limit, replace camshaft.

Camshaft Journal Oil Clearance

CAMSHAFT JOURNAL DIAMETER

- Measure the outer diameter of camshaft journal with micrometer.

Standard:

No. 1 : 25.938 - 25.955 mm (1.0212 - 1.0218 in)

No. 2, 3, 4, 5 : 25.953 - 25.970 mm (1.0218 - 1.0224 in)

CAMSHAFT BRACKET INNER DIAMETER

- Tighten camshaft bracket bolt with the specified torque. Refer to "INSTALLATION" for the tightening procedure.
- Measure the inner diameter "A" of camshaft bracket with bore gauge.

Standard:

26.000 - 26.021 mm (1.0236 - 1.0244 in)

CAMSHAFT JOURNAL OIL CLEARANCE

- (Oil clearance) = (Camshaft bracket inner diameter) – (Camshaft journal diameter).

Standard:

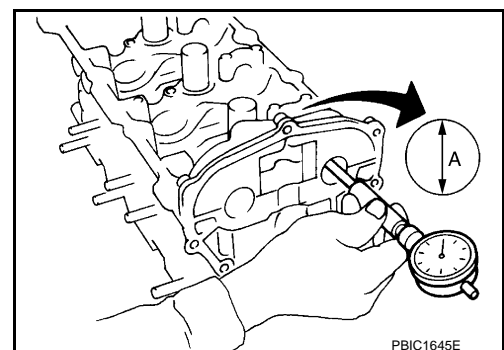
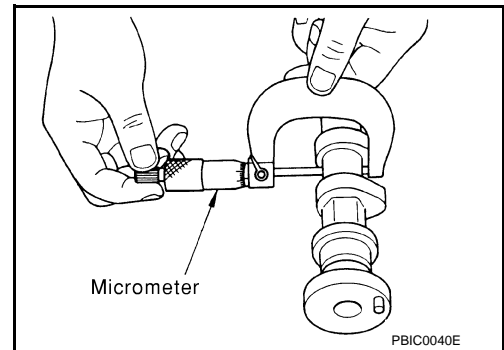
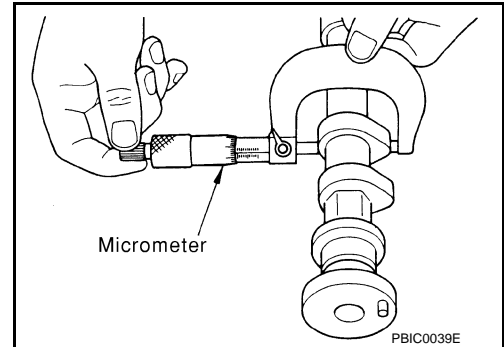
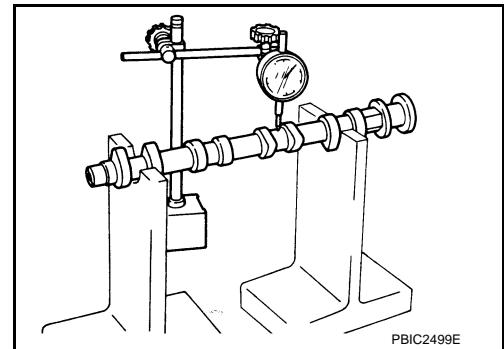

A
EM
C
D
E
F
G
H
I
J
K
L
M
N
O
P

CAMSHAFT

[VK45DE]

< SERVICE INFORMATION >

No. 1 : 0.045 - 0.083 mm (0.0018 - 0.0033 in)

No. 2, 3, 4, 5 : 0.030 - 0.068 mm (0.0012 - 0.0027 in)

- If the calculated value out of the standard, replace either or both camshaft and cylinder head.

NOTE:

Camshaft bracket cannot be replaced as a single part, because it is machined together with cylinder head. Replace whole cylinder head assembly.

Camshaft End Play

- Install dial indicator in thrust direction on front end of camshaft. Measure the end play of dial indicator when camshaft is moved forward/backward (in direction to axis).

Standard:

0.115 - 0.188 mm (0.0045 - 0.0074 in)

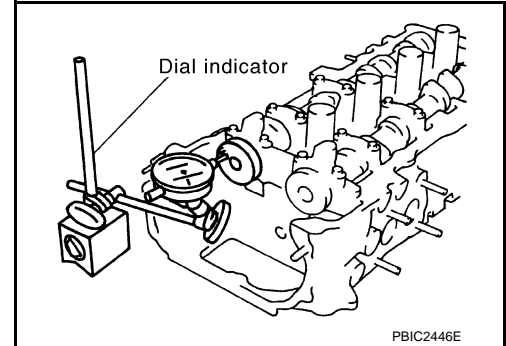

- Measure the following parts if out of the standard.

- Dimension "A" for camshaft No. 1 journal

Standard : 30.500 - 30.548 mm (1.2008 - 1.2027 in)

- Dimension "B" for cylinder head No. 1 journal bearing

Standard : 30.360 - 30.385 mm (1.1953 - 1.1963 in)

- Refer to the standards above, and then replace camshaft and/or cylinder head.

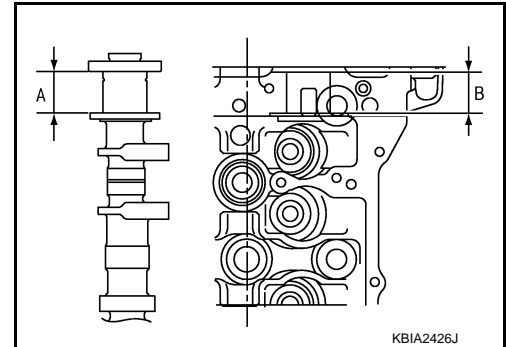

Camshaft Sprocket Runout

1. Put V-block on precise flat table, and support No. 2 and 5 journal of camshaft.

CAUTION:

Never support journal No. 1 (on the side of camshaft sprocket) because it has a different diameter from the other four locations.

2. Measure the camshaft sprocket runout with dial indicator. (Total indicator reading)

Limit : 0.15 mm (0.0059 in)

- If it exceeds the limit, replace camshaft sprocket.

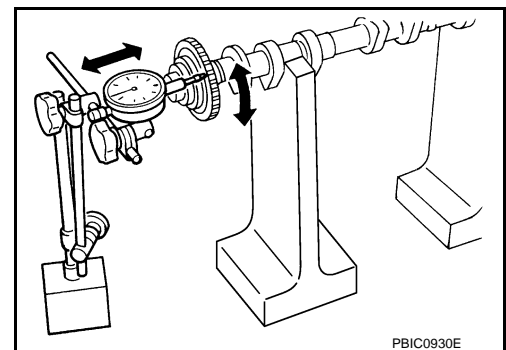

Valve Lifter

CAMSHAFT

[VK45DE]

< SERVICE INFORMATION >

Check if surface of valve lifter has any wear or cracks.

- If anything above is found, replace valve lifter. Refer to [EM-219](#), "[Valve Clearance](#)".

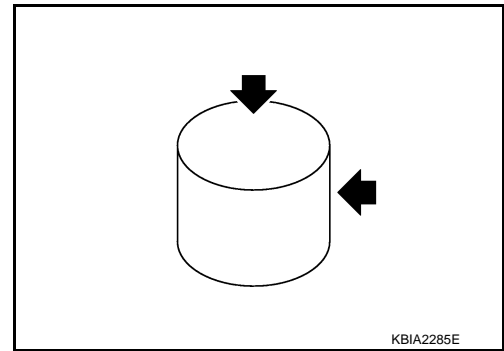

Valve Lifter Clearance

VALVE LIFTER OUTER DIAMETER

- Measure the outer diameter of valve lifter with micrometer.

Standard : 33.977 - 33.987 mm (1.3377 - 1.3381 in)

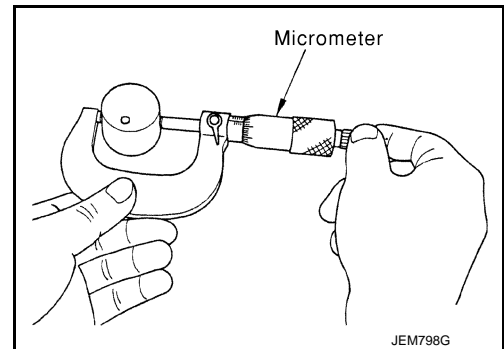

VALVE LIFTER HOLE DIAMETER

- Measure the inner diameter of valve lifter hole of cylinder head with inside micrometer.

Standard : 34.000 - 34.016 mm (1.3386 - 1.3392 in)

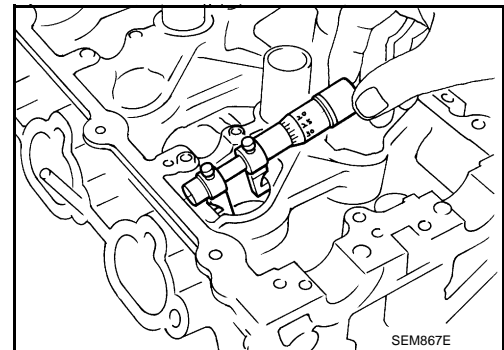

VALVE LIFTER CLEARANCE

- (Valve lifter clearance) = (Valve lifter hole diameter) – (Valve lifter outer diameter)

Standard : 0.013 - 0.039 mm (0.0005 - 0.0015 in)

- If the calculated value is out of the standard, referring to each standard of valve lifter outer diameter and valve lifter hole diameter, replace either or both valve lifter and cylinder head.

INSTALLATION

1. Install valve lifters if removed.
 - Install it in the original position.
2. Install camshafts.

CAMSHAFT

[VK45DE]

< SERVICE INFORMATION >

- Follow your identification marks made during removal, or follow the identification marks that are present on new camshafts for proper placement and direction.

Bank	INT/EXH	Identification rib	Paint marks		Identification mark
			M1	M2	
RH	EXH	Yes	No	White	RH
	INT	Yes	White	No	RH
LH	INT	No	White	No	LH
	EXH	No	No	White	LH

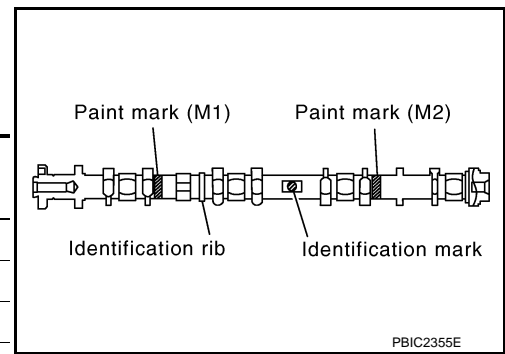

- Install camshaft so that dowel pin on front end face are positioned as shown in the figure. (No. 1 cylinder TDC on its compression stroke)

NOTE:

Though camshaft does not stop at the position as shown in the figure, for the placement of cam nose, it is generally accepted camshaft is placed for the same direction of the figure.

Camshaft dowel pin

: At cylinder head upper face side in each bank

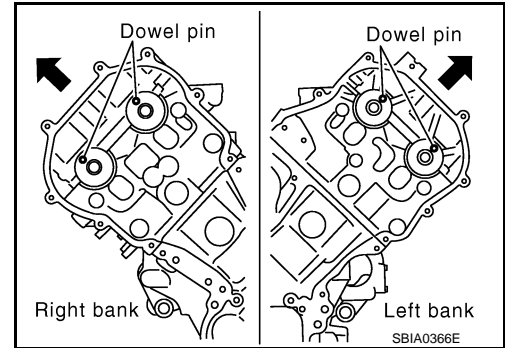

3. Install camshaft brackets.

- Remove foreign material completely from camshaft bracket backside and from cylinder head installation face.
- Install by referring to installation location mark on upper surface and front mark.
- Install so that installation location mark can be correctly read when viewed from the side of left exhaust bank.

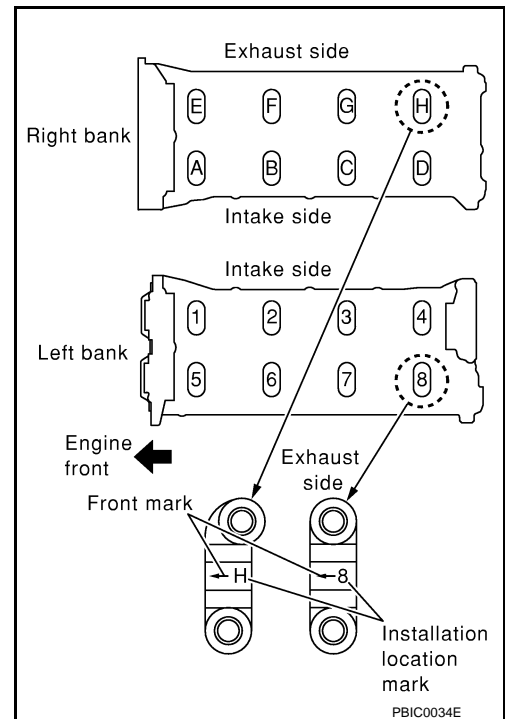

CAMSHAFT

[VK45DE]

< SERVICE INFORMATION >

- Apply liquid gasket to mating surface of camshaft bracket (No. 1) as shown in the figure.

Use Genuine RTV Silicone Sealant or equivalent. Refer to GI-46.

CAUTION:

- After installation, be sure to wipe off any excessive liquid gasket leaking from part "A" and "B" (both on right and left sides).
- Remove completely any excess of liquid gasket inside bracket.

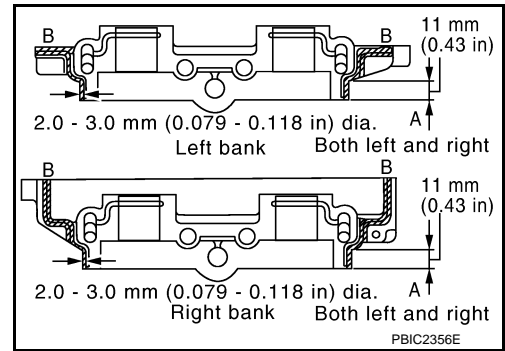

- Apply liquid gasket to mating surface of camshaft bracket (No. 6) on left bank intake as shown in the figure.

Use Genuine RTV Silicone Sealant or equivalent. Refer to GI-46.

CAUTION:

- After installation, be sure to wipe off any excessive liquid gasket leaking from part "A" and "B" (both on right and left sides).
- Remove completely any excess of liquid gasket inside bracket.

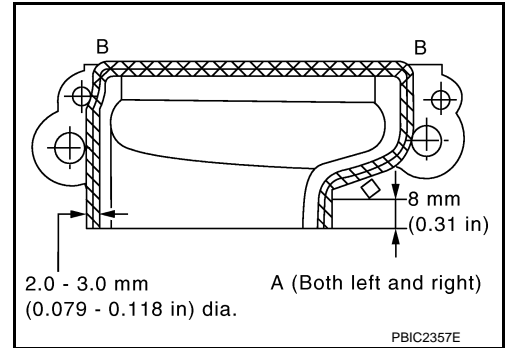

- Tighten camshaft bracket bolts in the following steps, in numerical order as shown in the figure.

- Tighten No. 9 to 12 in numerical order as shown.

: **1.96 N-m (0.20 kg-m, 1 ft-lb)**

- Tighten No. 1 to 8 in numerical order as shown.

: **1.96 N-m (0.20 kg-m, 1 ft-lb)**

- Tighten No. 13 to 14 in numerical order as shown. (left bank only)

: **1.96 N-m (0.20 kg-m, 1 ft-lb)**

- Tighten all bolts in numerical order as shown.

: **5.88 N-m (0.60 kg-m, 4 ft-lb)**

- Tighten No. 1 to 12 in numerical order as shown.

: **10.41 N-m (1.1 kg-m, 8 ft-lb)**

- Tighten No. 13 to 14 in numerical order as shown. (left bank only)

: **31.35 N-m (3.2 kg-m, 23 ft-lb)**

CAUTION:

After tightening mounting bolts of camshaft brackets, be sure to wipe off excessive liquid gasket from the parts listed below.

- Mating surface of rocker cover
- Mating surface of front cover

- Install camshaft sprockets.

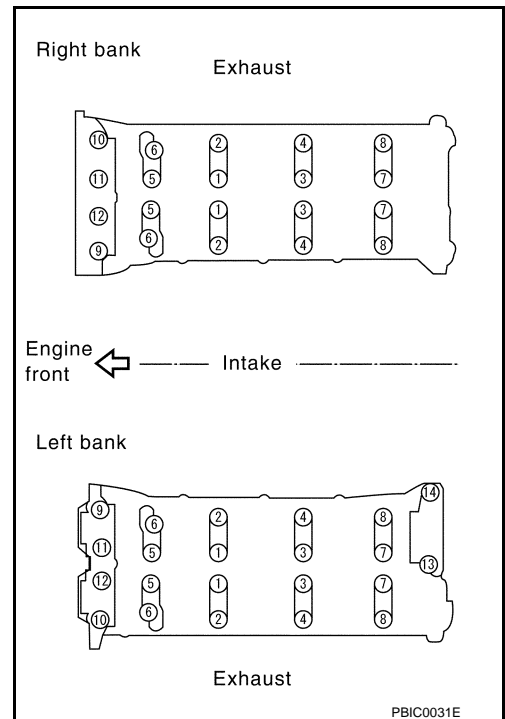

CAMSHAFT

[VK45DE]

< SERVICE INFORMATION >

- Install by checking with identification mark on surface.
- Install camshaft sprocket (EXH) by selectively using the groove of dowel pin according to the bank. (Common part used for both banks.)
- Lock the hexagonal part of camshaft in the same way as for removal, and tighten mounting bolts.

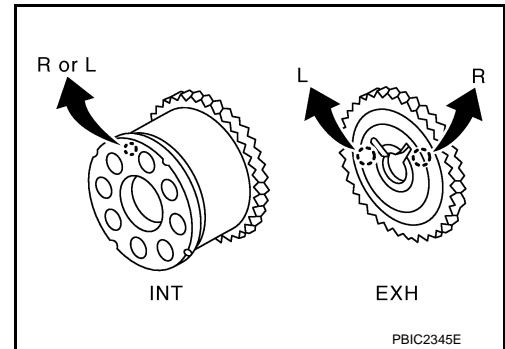

6. Check and adjust the valve clearance. Refer to [EM-219, "Valve Clearance"](#).
7. Install in the reverse order of removal after this step.

INSPECTION AFTER INSTALLATION

Inspection of Camshaft Sprocket (INT) Oil Groove

CAUTION:

- Perform this inspection only when DTC P0011 and/or P0021 are detected in self-diagnostic results of CONSULT-III and it is directed according to inspection procedure of EC section. Refer to [EC-833, "Description"](#).
- Check when the engine is cold so as to prevent burns from any splashing engine oil.

1. Check the engine oil level. Refer to [LU-24](#).
2. Perform the following procedure so as to prevent the engine from being unintentionally started while checking.
 - a. Release fuel pressure. Refer to [EC-766, "Fuel Pressure Check"](#).
 - b. Disconnect ignition coil and injector harness connectors.
3. Remove intake valve timing control solenoid valve. Refer to [EM-199](#).
4. Crank the engine, and then check that engine oil comes out from intake valve timing control cover oil hole. End crank after checking.

WARNING:

Be careful not to touch rotating parts (drive belt, idler pulley, and crankshaft pulley, etc.).

CAUTION:

Engine oil may squirt from intake valve timing control solenoid valve installation hole during cranking. Use a shop cloth to prevent the engine components and the vehicle. Never allow engine oil to get on rubber components such as drive belt or engine mount insulators. Immediately wipe off any splashed engine oil.

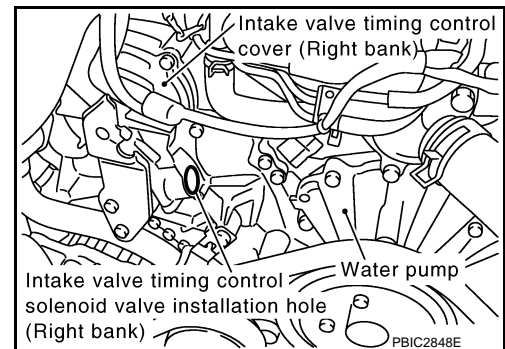

- Clean oil groove between oil strainer and intake valve timing control solenoid valve if engine oil does not come out from intake valve timing control cover oil hole. Refer to [LU-22](#).
5. Remove components between intake valve timing control solenoid valve and camshaft sprocket (INT), and then check each oil groove for clogging.
 - Clean oil groove if necessary. Refer to [LU-22](#).
 6. After inspection, install removed parts.

INSPECTION AFTER INSTALLATION

Inspection for Leakage

The following are procedures for checking fluids leakage, lubricates leakage, and exhaust gases leakage.

- Before starting engine, check oil/fluid levels including engine coolant and engine oil. If less than required quantity, fill to the specified level. Refer to [MA-9](#).
- Use procedure below to check for fuel leakage.
 - Turn ignition switch "ON" (with engine stopped). With fuel pressure applied to fuel piping, check for fuel leakage at connection points.
 - Start engine. With engine speed increased, check again for fuel leakage at connection points.

CAMSHAFT

< SERVICE INFORMATION >

[VK45DE]

- Run engine to check for unusual noise and vibration.

NOTE:

If hydraulic pressure inside timing chain tensioner drops after removal/installation, slack in guide may generate a pounding noise during and just after engine start. However, this does not indicate an unusualness. Noise will stop after hydraulic pressure rises.

- Warm up engine thoroughly to check there is no leakage of fuel, exhaust gases, or any oil/fluids including engine oil and engine coolant.
- Bleed air from lines and hoses of applicable lines, such as in cooling system.
- After cooling down engine, again check oil/fluid levels including engine oil and engine coolant. Refill to the specified level, if necessary.

Summary of the inspection items:

Items	Before starting engine	Engine running	After engine stopped
Engine coolant	Level	Leakage	Level
Engine oil	Level	Leakage	Level
Other oils and fluid*	Level	Leakage	Level
Fuel	Leakage	Leakage	Leakage
Exhaust gases	—	Leakage	—

*: Transmission/transaxle/CVT fluid, power steering fluid, brake fluid, etc.

Valve Clearance

INFOID:000000005348058

INSPECTION

In cases of removing/installing or replacing camshaft and valve-related parts, or of unusual engine conditions due to changes in valve clearance (found malfunctions during starting, idling or causing noise), perform inspection as follows:

1. Remove rocker covers (right bank and left bank). Refer to [EM-195](#).
2. Measure the valve clearance as follows:
 - a. Set No. 1 cylinder at TDC of its compression stroke.
 - Rotate crankshaft pulley in clockwise to align TDC identification notch (without paint mark) with timing indicator on front cover.

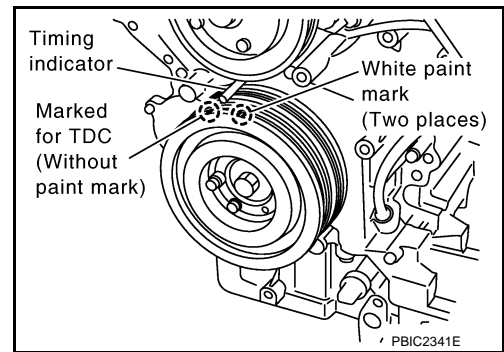

- Check that both intake and exhaust cam noses of No. 1 cylinder (engine front side of left bank) are located as shown in the figure.
- If not, turn crankshaft one revolution (360 degrees) and align as shown in the figure.

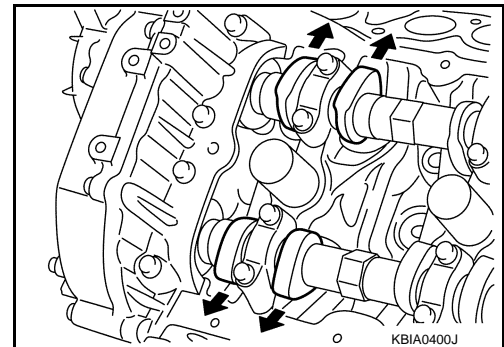

CAMSHAFT

[VK45DE]

< SERVICE INFORMATION >

- b. Use feeler gauge, measure the clearance between valve lifter and camshaft.

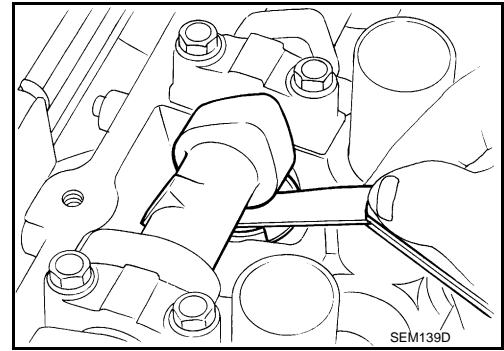

Valve clearance:

Unit: mm (in)

	Cold	Hot * (reference data)
Intake	0.26 - 0.34 (0.010 - 0.013)	0.304 - 0.416 (0.012 - 0.016)
Exhaust	0.29 - 0.37 (0.011 - 0.015)	0.308 - 0.432 (0.012 - 0.017)

*: Approximately 80°C (176°F)

- By referring to the figure, measure the valve clearances at locations marked "x" as shown in the table below (locations indicated with black arrow in figure).

NOTE:

Firing order 1-8-7-3-6-5-4-2

- No.1 cylinder at compression TDC

Measuring position (right bank)		No. 2 CYL.	No. 4 CYL.	No. 6 CYL.	No. 8 CYL.
No. 1 cylinder at compression TDC	EXH				x
	INT	x	x		
Measuring position (left bank)		No. 1 CYL.	No. 3 CYL.	No. 5 CYL.	No. 7 CYL.
No. 1 cylinder at compression TDC	INT	x		x	
	EXH	x			x

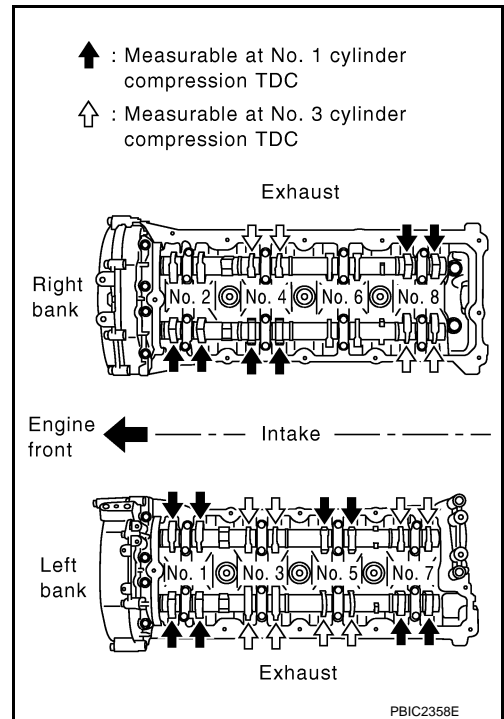

- c. Rotate crankshaft pulley clockwise (when view from engine front) by 270 degrees from the position of No. 1 cylinder compression TDC to align No. 3 cylinder at TDC of its compression stroke.

NOTE:

Crankshaft pulley mounting bolt flange has a angle mark every 90 degrees. They can be used as a guide to rotation angle.

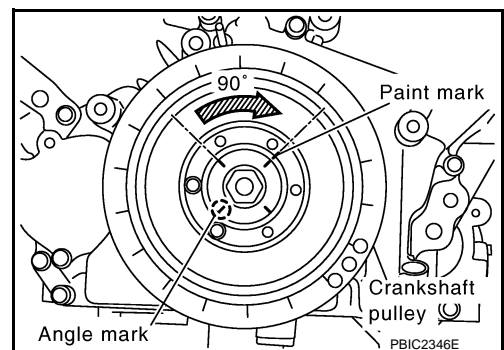

CAMSHAFT

[VK45DE]

< SERVICE INFORMATION >

- By referring to the figure, measure the valve clearances at locations marked "x" as shown in the table below (locations indicated with white arrow in figure).
- No. 3 cylinder at compression TDC

Measuring position (right bank)		No. 2 CYL.	No. 4 CYL.	No. 6 CYL.	No. 8 CYL.
No. 3 cylinder at compression TDC	EXH		x		
	INT				x
Measuring position (left bank)		No. 1 CYL.	No. 3 CYL.	No. 5 CYL.	No. 7 CYL.
No. 3 cylinder at compression TDC	INT		x		x
	EXH		x	x	

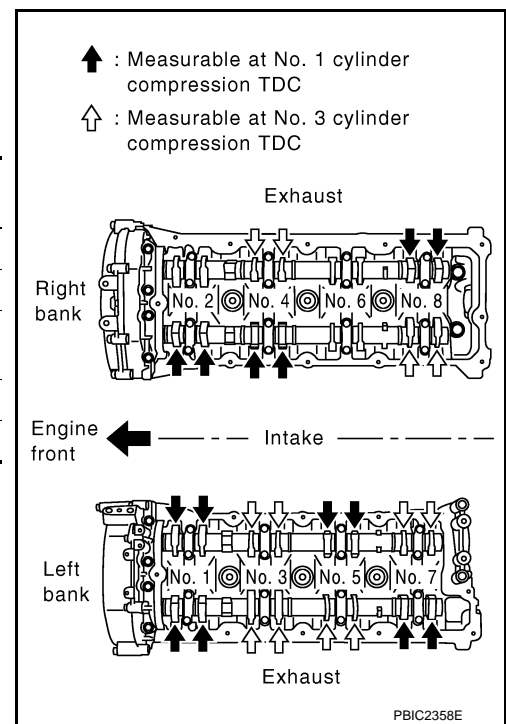

- d. Rotate crankshaft pulley clockwise (when view from engine front) by 90 degrees from the position of No. 3 cylinder compression TDC to align No. 6 cylinder at TDC of its compression stroke.

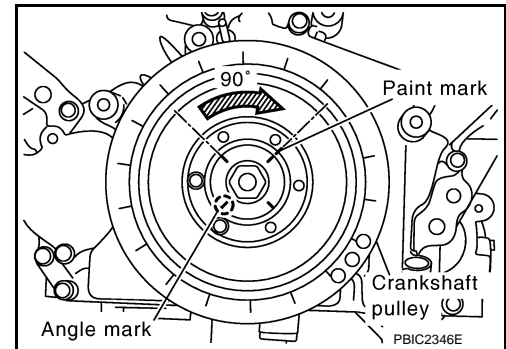

- By referring to the figure, measure the valve clearances at locations marked "x" as shown in the table below.
- No. 6 cylinder at compression TDC

Measuring position (right bank)		No. 2 CYL.	No. 4 CYL.	No. 6 CYL.	No. 8 CYL.
No. 6 cylinder at compression TDC	EXH	x		x	
	INT			x	

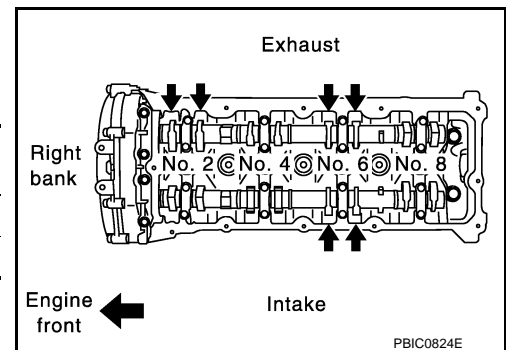

3. Perform adjustment if the measured value is out of the standard. Refer to "ADJUSTMENT".

ADJUSTMENT

Perform adjustment depending on selected head thickness of valve lifter.

1. Measure the valve clearance. Refer to [EM-219, "Valve Clearance"](#).
2. Remove camshaft. Refer to [EM-211, "Removal and Installation"](#).
3. Remove valve lifters at the locations that are out of the standard.

CAMSHAFT

[VK45DE]

< SERVICE INFORMATION >

4. Measure the center thickness of removed valve lifters with a micrometer.

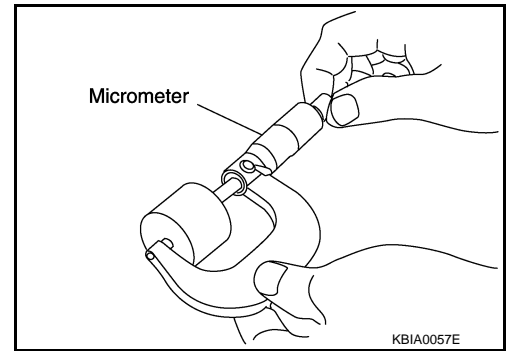

5. Use the equation below to calculate valve lifter thickness for replacement.

Valve lifter thickness calculation: $t = t_1 + (C_1 - C_2)$

t = Valve lifter thickness to be replaced

t₁ = Removed valve lifter thickness

C₁ = Measured valve clearance

C₂ = Standard valve clearance:

Intake : 0.30 mm (0.012 in)*

Exhaust : 0.33 mm (0.013 in)*

***: Approximately 20°C (68°F)**

- Thickness of new valve lifter can be identified by stamp marks on the reverse side (inside the cylinder). Stamp mark 788 indicates 7.88 mm (0.3102 in) in thickness.

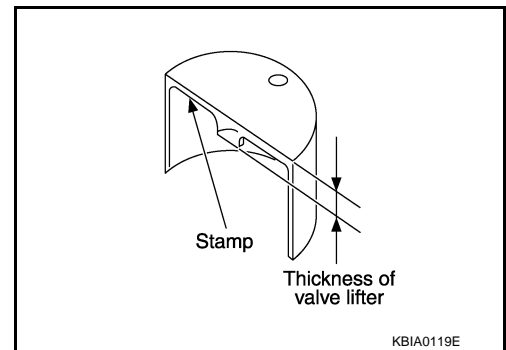

Unit: mm (in)

Stamp mark	Thickness
788	7.88 (0.3102)
790	7.90 (0.3110)
.	.
.	.
840	8.40 (0.3307)

NOTE:

Available thickness of valve lifter: 27 sizes with range 7.88 to 8.40 mm (0.3102 to 0.3307 in) in steps of 0.02 mm (0.0008 in) (when manufactured at factory). Refer to [EM-272, "Standard and Limit"](#).

6. Install selected valve lifter.
7. Install camshaft. Refer to [EM-211, "Removal and Installation"](#).
8. Manually turn crankshaft pulley a few turns.
9. Check that the valve clearances for cold engine are within the specifications by referring to the specified values. Refer to [EM-219, "Valve Clearance"](#).
10. Install all removal parts in the reverse order of removal. Refer to [EM-211, "Removal and Installation"](#).
11. Warm up the engine, and check for unusual noise and vibration.

OIL SEAL

Removal and Installation of Valve Oil Seal

INFOID:000000005348059

REMOVAL

1. Remove engine assembly from vehicle. Refer to [EM-238. "2WD : Component"](#) (2WD models) or [EM-242. "AWD : Component"](#) (AWD models).
2. Remove camshaft relating to valve oil seal to be removed. Refer to [EM-211](#).
3. Remove valve lifters. Refer to [EM-211](#).
 - Identify installation positions, and store them without mixing them up.
4. Turn crankshaft until the cylinder requiring new oil seals is at TDC. This will prevent valve from dropping into cylinder.
5. Remove valve collet.
 - Compress valve spring with valve spring compressor (SST), attachment (SST), and adapter (SST). Remove valve collet with magnetic hand.

CAUTION:

When working, take care not to damage valve lifter holes.

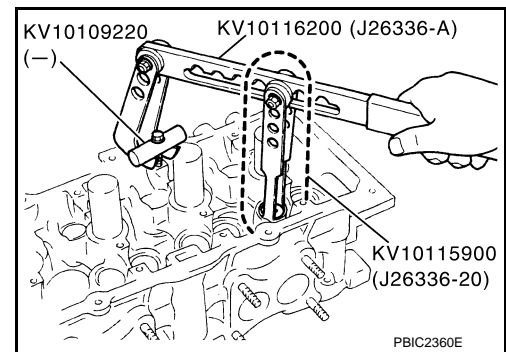

6. Remove valve spring retainer and valve spring (with valve spring seat).

CAUTION:

Never remove valve spring seat from valve spring.

7. Remove valve oil seal using valve oil seal puller (SST).

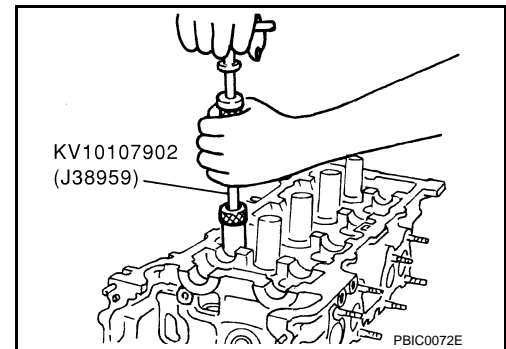

INSTALLATION

1. Apply new engine oil on new valve oil seal joint and seal lip.
2. Install valve oil seal.
 - Install with valve oil seal drift (SST) to match dimension in the figure.

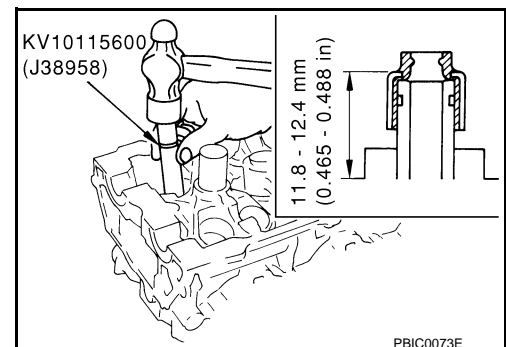

3. Install in the reverse order of removal.

Removal and Installation of Front Oil Seal

INFOID:000000005348060

REMOVAL

1. Remove the following parts:
 - Front engine undercover (power tool)
 - Radiator: Refer to [CO-39](#).
 - Drive belts: Refer to [EM-169](#).
 - Rear plate cover: Refer to [EM-182](#).
2. Remove crankshaft pulley as follows:
 - a. Set ring gear stopper (SST).

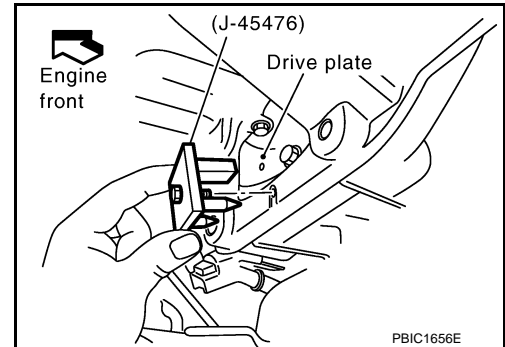

- b. Loosen crankshaft pulley bolt, and then pull crankshaft pulley with both hands to remove it.

CAUTION:

- Never remove crankshaft pulley bolt. Keep loosened crankshaft pulley bolt in place to protect removed crankshaft pulley from dropping.
- Never remove balance weight (inner hexagon bolt) at the front of crankshaft pulley.

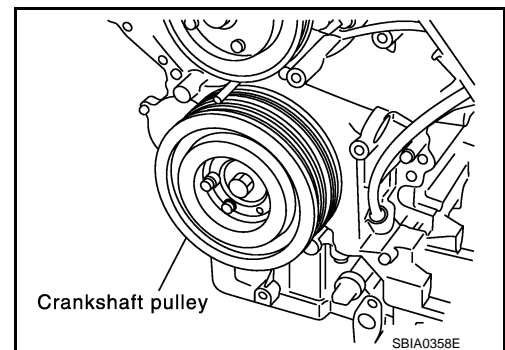

3. Remove front oil seal using suitable tool.

CAUTION:

Be careful not to damage front cover and oil pump drive spacer.

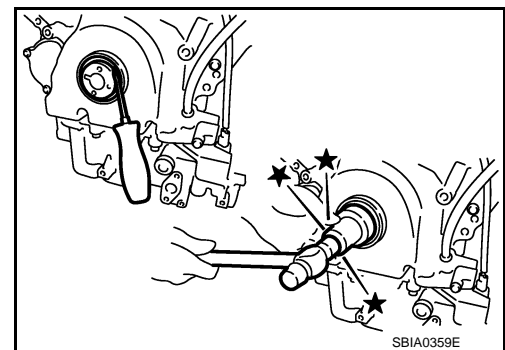

INSTALLATION

1. Apply new engine oil to both oil seal lip and dust seal lip of new front oil seal.
2. Install front oil seal.

OIL SEAL

[VK45DE]

< SERVICE INFORMATION >

- Install front oil seal so that each seal lip is oriented as shown in the figure.

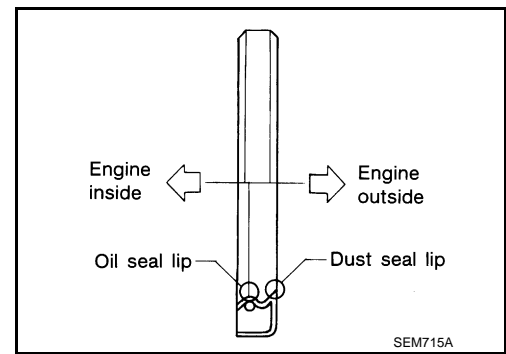

- Using suitable drift, press fit until the height of front oil seal is level with the mounting surface.

Suitable drift

Outer diameter : 56 mm (2.20 in)

Inner diameter : 49 mm (1.93 in)

- Check the garter spring is in position and seal lips not inverted.
- CAUTION:**
- Be careful not to damage front cover and oil pump drive spacer.
 - Press fit straight and avoid causing burrs or tilting oil seal.

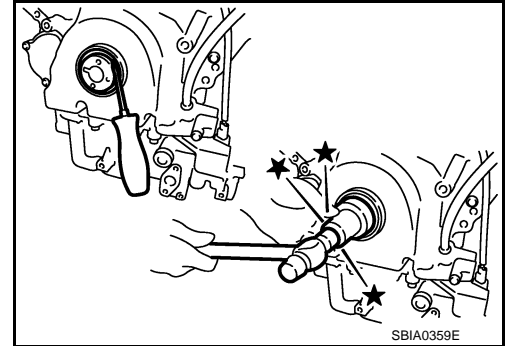

3. Install in the reverse order of removal.

Removal and Installation of Rear Oil Seal

INFOID:000000005348061

REMOVAL

1. Remove transmission assembly. Refer to [AT-243](#).
 - a. Remove drive plate. Refer to [EM-246](#).
 - b. Remove rear plate. Refer to [EM-246](#).
2. Remove rear oil seal using suitable tool.

CAUTION:

Be careful not to damage crankshaft and oil seal retainer surface.

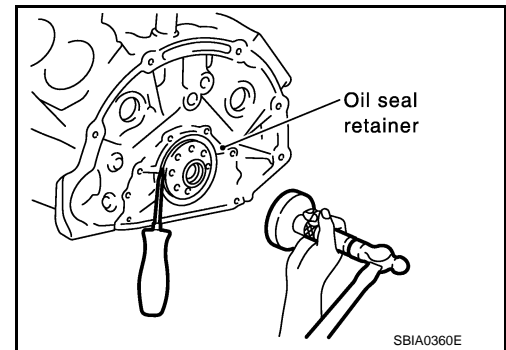

INSTALLATION

1. Apply new engine oil to both oil seal lip and dust seal lip of new rear oil seal.
2. Install rear oil seal.

OIL SEAL

[VK45DE]

< SERVICE INFORMATION >

- Install rear oil seal so that each seal lip is oriented as shown in the figure.

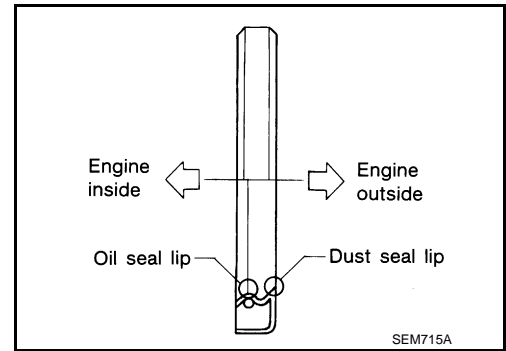

- Using suitable drift, press fit until the height of rear oil seal is level with the mounting surface.

Suitable drift

Outer diameter : 102 mm (4.02 in)

Inner diameter : 86 mm (3.39 in)

- Check the garter spring is in position and seal lips not inverted.
- CAUTION:**
- **Be careful not to damage crankshaft and rear oil seal retainer.**
 - **Press fit straight and avoid causing burrs or tilting oil seal.**

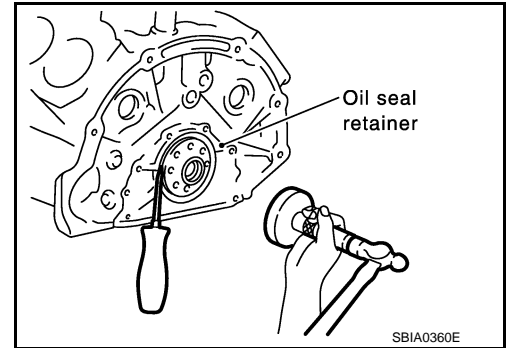

3. Install in the reverse order of removal.

CYLINDER HEAD

< SERVICE INFORMATION >

[VK45DE]

CYLINDER HEAD

On-Vehicle Service

INFOID:000000005348062

CHECKING COMPRESSION PRESSURE

1. Warm up engine thoroughly. Then, stop it.
2. Release fuel pressure. Refer to [EC-766, "Fuel Pressure Check"](#).
- a. Remove fuel pump fuse to avoid fuel injection during measurement.

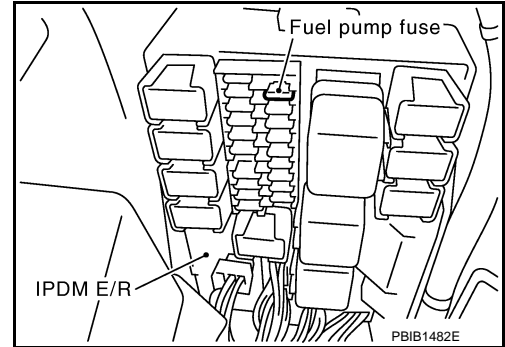

3. Remove engine cover with power tool. Refer to [EM-168](#).
4. Remove ignition coil and spark plug from each cylinder. Refer to [EM-186, "Component"](#) and [EM-187, "Component"](#).
5. Connect engine tachometer (not required in use of CONSULT-III).
6. Install compression gauge with adapter (SST or commercial service tool) onto spark plug hole.
 - Use compression gauge adapter (SST) which is required on No. 7 and 8 cylinders.

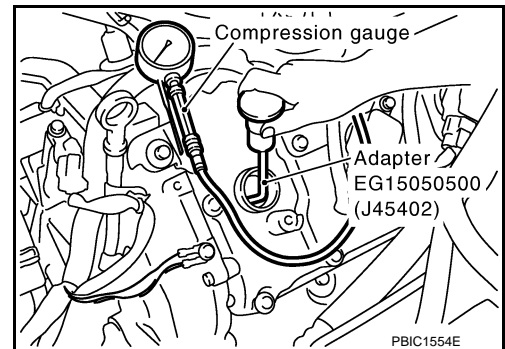

- Use compression gauge adapter (if no SST is used) whose picking up end inserted to spark plug hole is smaller than 20 mm (0.79 in) in diameter. Otherwise, it may be caught by cylinder head during removal.

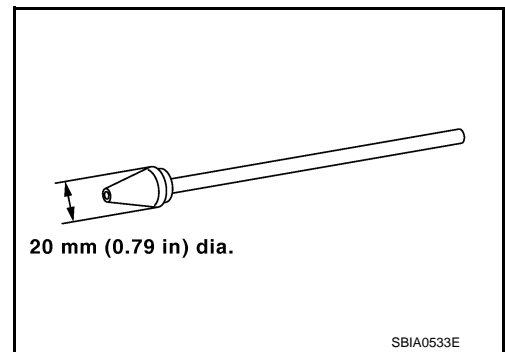

7. With accelerator pedal fully depressed, turn ignition switch to "START" for cranking. When the gauge pointer stabilizes, read the compression pressure and engine rpm. Perform these steps to check each cylinder.

Compression pressure:

Unit: kPa (kg/cm², psi)/rpm

Standard	Minimum	Deferential limit between cylinders
1,320 (13.5, 191)/300	1,130 (11.5, 164)/300	98 (1.0, 14)/300

CAUTION:

Always use a fully charged battery to obtain the specified engine speed.

CYLINDER HEAD

[VK45DE]

< SERVICE INFORMATION >

- If the engine speed is out of specified range, check battery liquid for proper gravity. Check engine speed again with normal battery gravity.
 - If compression pressure is below minimum value, check valve clearances and parts associated with combustion chamber (valve, valve seat, piston, piston ring, cylinder bore, cylinder head, cylinder head gasket). After the checking, measure compression pressure again.
 - If some cylinders have low compression pressure, pour small amount of engine oil into the spark plug hole of the cylinder to recheck it for compression.
 - If the added engine oil improves the compression, piston rings may be worn out or damaged. Check the piston rings and replace if necessary.
 - If the compression pressure remains at low level despite the addition of engine oil, valves may be malfunctioning. Check valves for damage. Replace valve or valve seat accordingly.
 - If two adjacent cylinders have respectively low compression pressure and their compression remains low even after the addition of engine oil, cylinder head gaskets are leaking. In such a case, replace cylinder head gaskets.
8. After inspection is completed, install removed parts in the reverse order of removal.
 9. Start engine, and check that engine runs smoothly.
 10. Perform trouble diagnosis. If DTC appears, erase it. Refer to [EC-768](#).

Component

INFOID:000000005348063

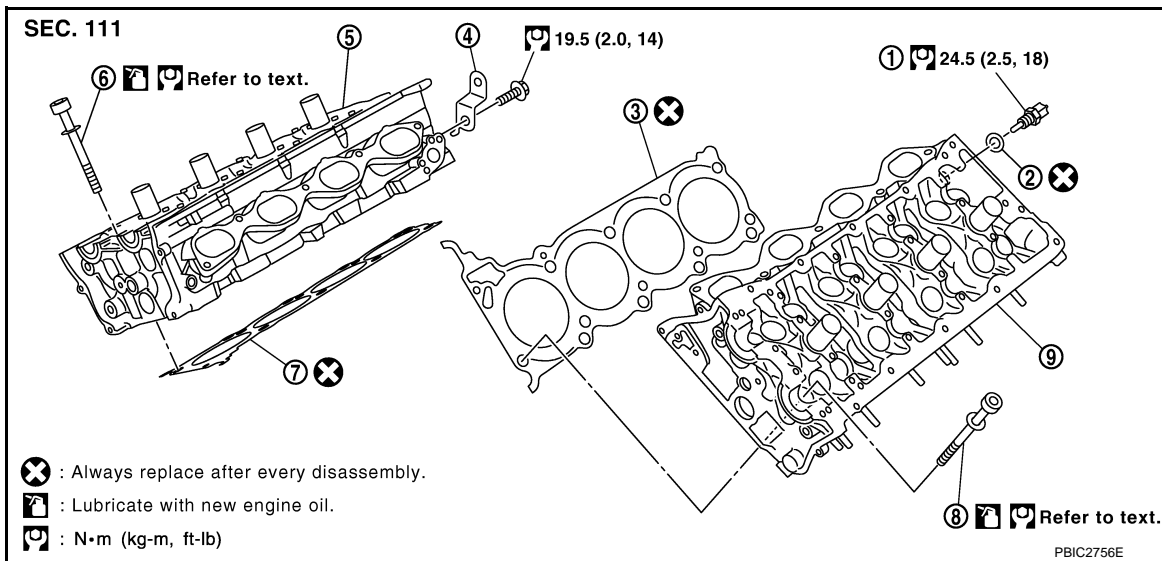

- | | | |
|--------------------------------------|-------------------------------|-------------------------------------|
| 1. Engine coolant temperature sensor | 2. Washer | 3. Cylinder head gasket (left bank) |
| 4. Harness bracket | 5. Cylinder head (right bank) | 6. Cylinder head bolt |
| 7. Cylinder head gasket (right bank) | 8. Cylinder head bolt | 9. Cylinder head (left bank) |

CAUTION:

Never use washer bolt together with flange bolt, when replacing cylinder head bolts, because there are two kinds of cylinder head bolts.

NOTE:

Figure is shown as an example of washer bolt.

Removal and Installation

INFOID:000000005348064

REMOVAL

1. Remove engine assembly from vehicle. Refer to [EM-238, "2WD : Component"](#) (2WD models) or [EM-242, "AWD : Component"](#) (AWD models).
2. Remove exhaust manifold. Refer to [EM-178](#).
3. Remove camshaft. Refer to [EM-211](#).

CYLINDER HEAD

[VK45DE]

< SERVICE INFORMATION >

- Remove cylinder head bolts in reverse order as shown in the figure to remove cylinder heads (right bank and left bank).

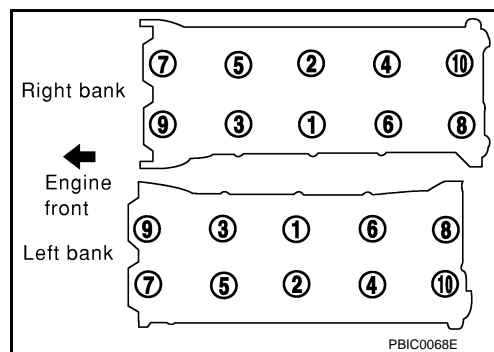

- Remove cylinder head gaskets.

INSPECTION AFTER REMOVAL

Cylinder Head Bolts Outer Diameter

- Cylinder head bolts are tightened by plastic zone tightening method. Whenever the size difference between “d1” and “d2” exceeds the limit, replace them with new one.

CAUTION:

Never use washer bolt together with flange bolt, when replacing cylinder head bolts.

NOTE:

Figure is shown as an example of washer bolt.

Limit (“d1” – “d2”) : 0.18 mm (0.0071 in)

- If reduction of outer diameter appears in a position other than “d2”, use it as “d2” point.

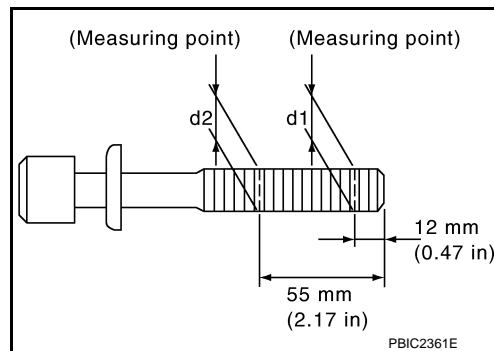

Cylinder Head Distortion

NOTE:

When performing this inspection, cylinder block distortion should be also checking. Refer to [EM-262. "Inspection After Disassembly"](#).

- Using scraper, wipe off oil, scale, gasket, sealant, and carbon deposits from surface of cylinder head.

CAUTION:

Never allow gasket fragments to enter engine oil or engine coolant passages.

- At each of several locations on bottom surface of cylinder head, measure the distortion in six directions.

Limit : 0.1 mm (0.004 in)

- If it exceeds the limit, replace cylinder head.

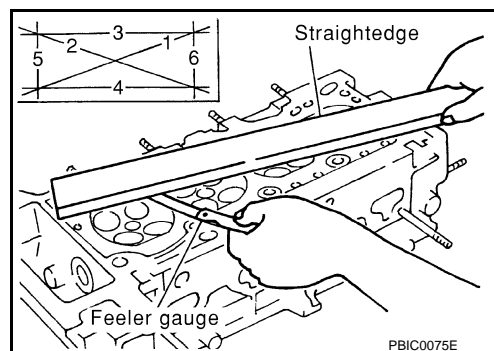

INSTALLATION

- Install new cylinder head gasket.
- Turn crankshaft until No. 1 piston is set at TDC.

CYLINDER HEAD

[VK45DE]

< SERVICE INFORMATION >

- Crankshaft key should line up with the left bank cylinder center line as shown in the figure.

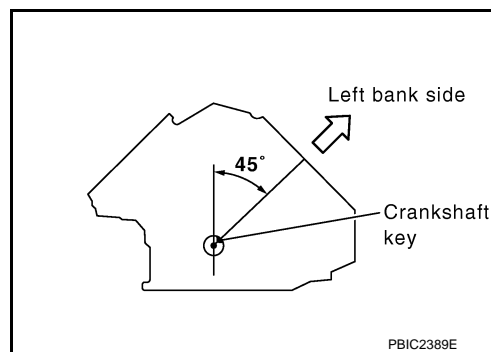

3. Install cylinder head follow the steps below to tighten cylinder head bolts in numerical order as shown in the figure.

CAUTION:

If cylinder head bolts are reused, check their outer diameters before installation. Refer to "Cylinder Head Bolts Outer Diameter".

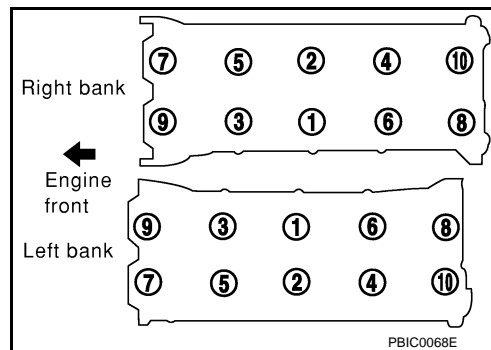

- a. Apply new engine oil to threads and seating surface of cylinder head bolts.
- b. Tighten all cylinder head bolts.

: 44.1 N·m (4.5 kg·m, 33 ft·lb)

- c. Turn all cylinder head bolts 70 degrees clockwise. (angle tightening)

CAUTION:

Check the tightening angle by using angle wrench (SST). Avoid judgment by visual inspection without SST.

- Check tightening angle indicated on angle wrench indicator plate.

- d. Completely loosen all cylinder head bolts.

: 0 N·m (0 kg·m, 0 ft·lb)

CAUTION:

In step "d", loosen cylinder head bolts in reverse order of that indicated in the figure.

- e. Tighten all cylinder head bolts.

: 44.1 N·m (4.5 kg·m, 33 ft·lb)

- f. Turn all cylinder head bolts 60 degrees clockwise. (angle tightening)

CAUTION:

Check the tightening angle by using angle wrench (SST). Avoid judgment by visual inspection without SST.

- Check tightening angle indicated on angle wrench indicator plate.

- g. Turn all cylinder head bolts 60 degrees clockwise again. (angle tightening)

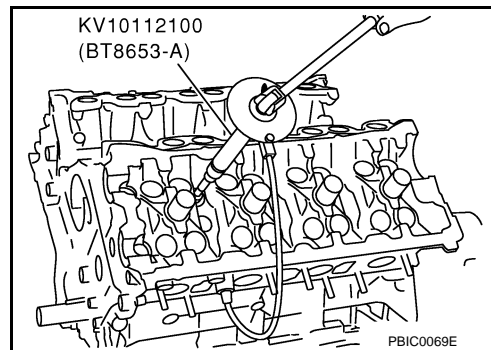
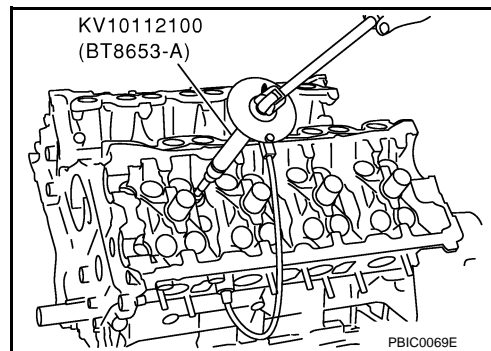

CYLINDER HEAD

< SERVICE INFORMATION >

[VK45DE]

4. Install in the reverse order of removal.

Disassembly and Assembly

INFOID:000000005348065

COMPONENTS

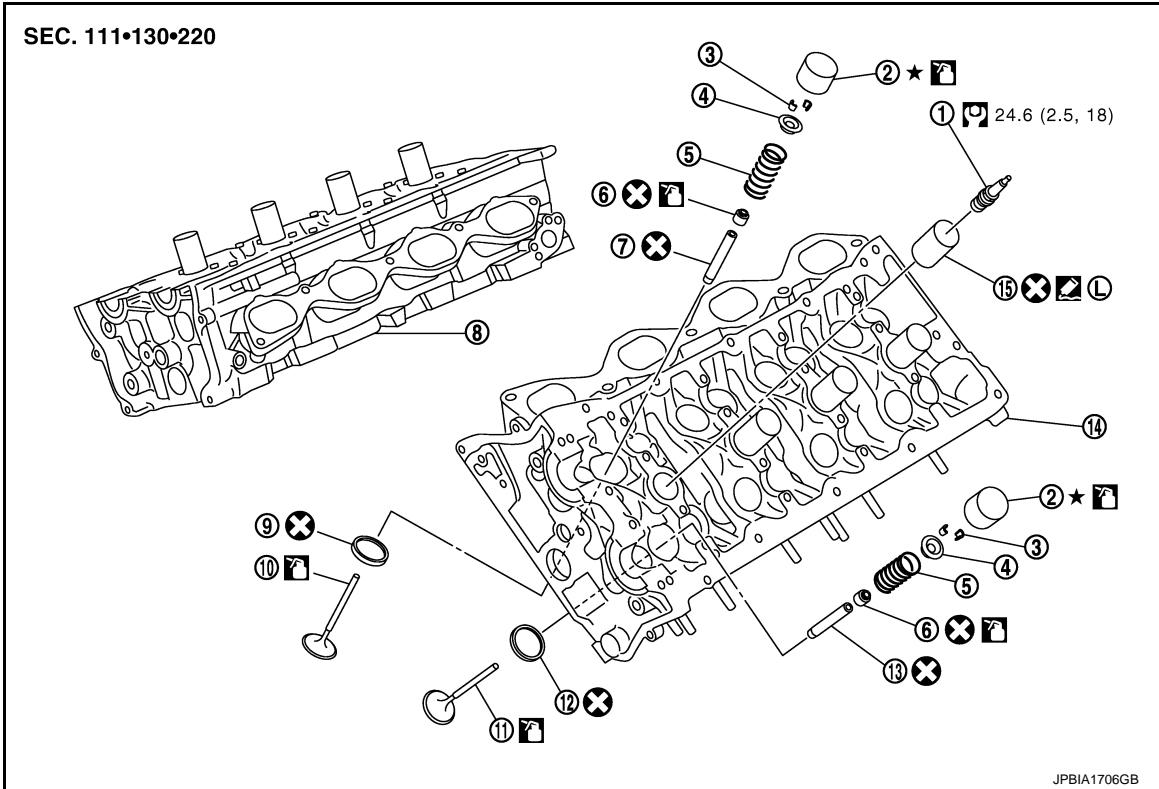

- | | | |
|--------------------------|--|----------------------|
| 1. Spark plug | 2. Valve lifter | 3. Valve collet |
| 4. Valve spring retainer | 5. Valve spring (with valve spring seat) | 6. Valve oil seal |
| 7. Valve guide (INT) | 8. Cylinder head (right bank) | 9. Valve seat (INT) |
| 10. Valve (INT) | 11. Valve (EXH) | 12. Valve seat (EXH) |
| 13. Valve guide (EXH) | 14. Cylinder head (left bank) | 15. Spark plug tube |

: Apply Genuine High Strength Thread Locking Sealant or equivalent.

• Refer to [GI-9. "Component"](#) for symbols not described on the above.

DISASSEMBLY

- Remove spark plug with spark plug wrench (commercial service tool).
- Remove valve lifter.
 - Identify installation positions, and store them without mixing them up.
- Remove valve collet.
 - Compress valve spring with valve spring compressor (SST), attachment (SST), and adapter (SST). Remove valve collet with magnetic hand.

CAUTION:

When working, take care not to damage valve lifter holes.

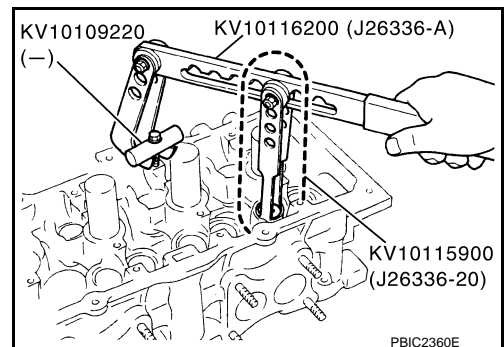

CYLINDER HEAD

[VK45DE]

< SERVICE INFORMATION >

4. Remove valve spring retainer and valve spring (with valve spring seat).

CAUTION:

Never remove valve spring seat from valve spring.

5. Push valve stem to combustion chamber side, and remove valve.
 - Identify installation positions, and store them without mixing them up.
6. Remove valve oil seal with valve oil seal puller (SST).

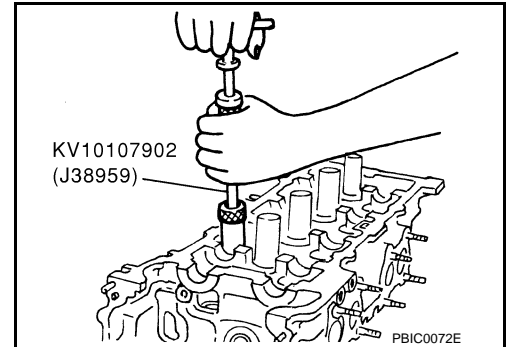

7. If valve seat must be replaced, refer to [EM-233, "Inspection After Disassembly"](#).
8. If valve guide must be replaced, refer to [EM-233, "Inspection After Disassembly"](#).
9. Remove spark plug tube if necessary.
 - Using pair of pliers, pull spark plug tube out of cylinder head.

CAUTION:

 - **Take care not to damage cylinder head.**
 - **Once removed, spark plug tube will be deformed and cannot be reused. Never remove it unless absolutely necessary.**

ASSEMBLY

1. When valve guide is removed, install it. Refer to [EM-233, "Inspection After Disassembly"](#).
2. When valve seat is removed, install it. Refer to [EM-233, "Inspection After Disassembly"](#).
3. Install new valve oil seal as follows:
 - a. Apply new engine oil on valve oil seal joint and seal lip.
 - b. Install with valve oil seal drift (SST) to match dimension in the figure.

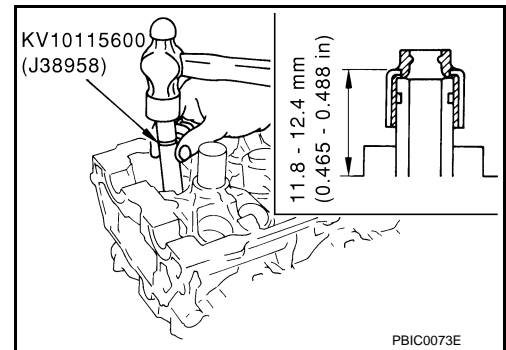

4. Install valve.
 - Install in the original position.

NOTE:

Larger diameter valves are for intake side.
5. Install valve spring (with valve spring seat).

CYLINDER HEAD

[VK45DE]

< SERVICE INFORMATION >

- Install smaller pitch (valve spring seat side) to cylinder head side.

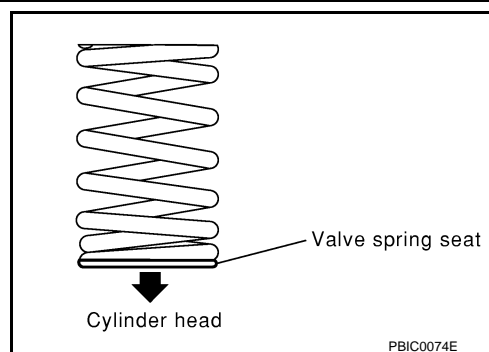

6. Install valve spring retainer.
7. Install valve collet.
 - Compress valve spring with valve spring compressor (SST), attachment (SST) and adapter (SST). Install valve collet with magnetic hand.

CAUTION:

When working, take care not to damage valve lifter holes.

- Tap stem edge lightly with plastic hammer after installation to check its installed condition.

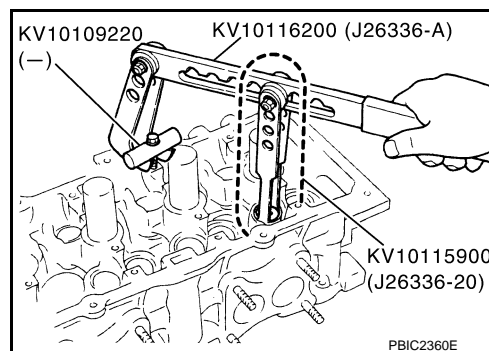

8. Install valve lifter.
 - Install it in the original position.
9. Install spark plug tube.
 - Press-fit spark plug tube as follows:
 - a. Remove old liquid gasket adhering to cylinder-head mounting hole.
 - b. Apply sealant to area within approximately 12 mm (0.47 in) from edge of spark plug tube press-fit side. **Use genuine high strength thread locking sealant or equivalent. Refer to GI-46.**
 - c. Using drift, press-fit spark plug tube so that its height "H" is as specified in the figure.

Standard press-fit height "H"
: 38.4 - 39.4 mm (1.512 - 1.551 in)

CAUTION:

- **When press-fitting, take care not to deform spark plug tube.**
- **After press-fitting, wipe off liquid gasket protruding onto cylinder head upper face.**

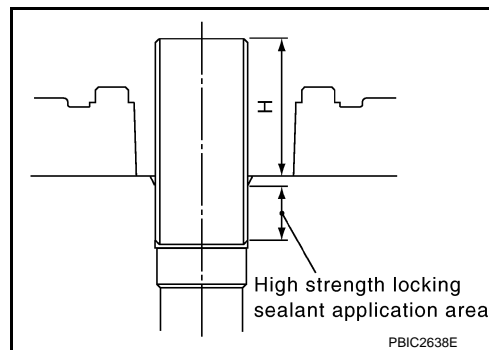

10. Install spark plug with spark plug wrench (commercial service tool).

Inspection After Disassembly

INFOID:000000005348066

VALVE DIMENSIONS

CYLINDER HEAD

[VK45DE]

< SERVICE INFORMATION >

- Check the dimensions of each valve. For the dimensions, refer to [EM-272, "Standard and Limit"](#).
- If the dimensions are out of the standard, replace valve and check the valve seat contact. Refer to "VALVE SEAT CONTACT".

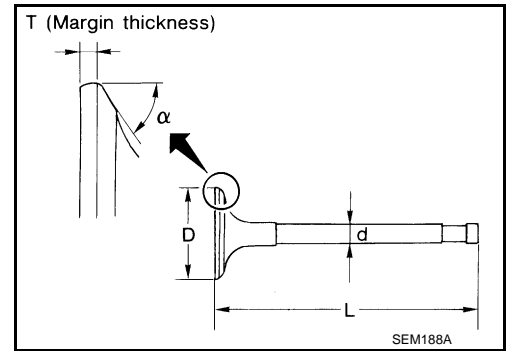

VALVE GUIDE CLEARANCE

Valve Stem Diameter

Measure the diameter of valve stem with micrometer.

Standard

Intake : 5.972 - 5.980 mm (0.2351 - 0.2354 in)

Exhaust : 5.962 - 5.970 mm (0.2347 - 0.2350 in)

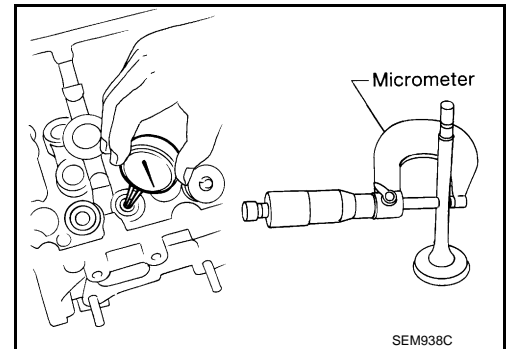

Valve Guide Inner Diameter

Measure the inner diameter of valve guide with bore gauge.

Standard

Intake and Exhaust : 6.000 - 6.018 mm (0.2362 - 0.2369 in)

Valve Guide Clearance

(Valve guide clearance) = (Valve guide inner diameter) – (Valve stem diameter).

Valve guide clearance:

Standard

Intake : 0.020 - 0.046 mm (0.0008 - 0.0018 in)

Exhaust : 0.030 - 0.056 mm (0.0012 - 0.0022 in)

Limit

Intake : 0.08 mm (0.0031 in)

Exhaust : 0.1 mm (0.004 in)

- If the calculated value exceeds the limit, replace valve and/or valve guide. When valve guide must be replaced, refer to "VALVE GUIDE REPLACEMENT".

VALVE GUIDE REPLACEMENT

When valve guide is removed, replace with oversized [0.2 mm (0.008 in)] valve guide.

CYLINDER HEAD

[VK45DE]

< SERVICE INFORMATION >

1. To remove valve guide, heat cylinder head to 110 to 130°C (230 to 266°F) by soaking in heated oil.

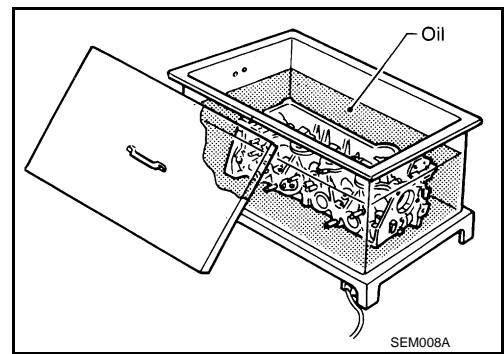

2. Drive out valve guide with a press [under a 20 kN (2 ton, 2.2 US ton, 2.0 Imp ton) pressure] or hammer and valve guide drift (commercial service tool).

WARNING:

Cylinder head contains heat. When working, wear protective equipment to avoid getting burned.

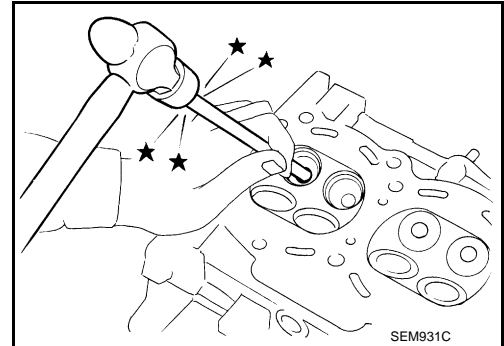

3. Using valve guide reamer (commercial service tool), ream cylinder head valve guide hole.

Valve guide hole diameter (for service parts):

Intake and exhaust

: 10.175 - 10.196 mm (0.4006 - 0.4014 in)

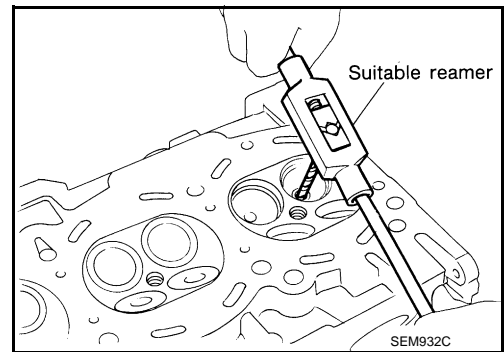

4. Heat cylinder head to 110 to 130°C (230 to 266°F) by soaking in heated oil.

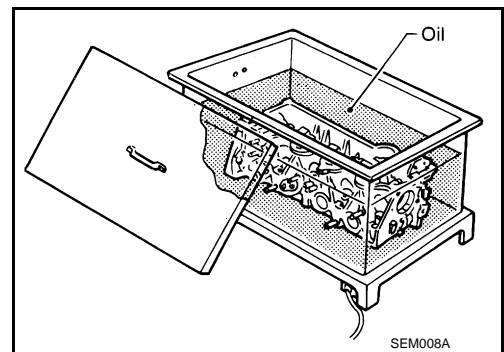

5. Using valve guide drift (commercial service tool), press valve guide from camshaft side to the dimensions as in the figure.

WARNING:

Cylinder head contains heat. When working, wear protective equipment to avoid getting burned.

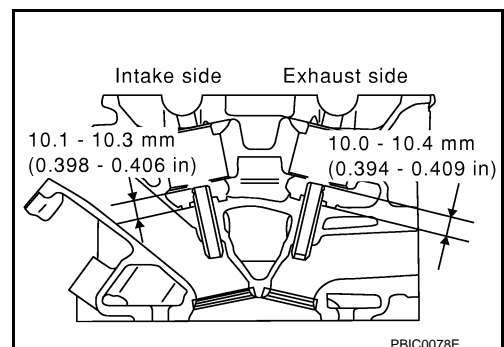

A

EM

C

D

E

F

G

H

I

J

K

L

M

N

O

P

CYLINDER HEAD

[VK45DE]

< SERVICE INFORMATION >

- Using valve guide reamer (commercial service tool), apply reamer finish to valve guide.

Standard:

Intake and exhaust

: 6.000 - 6.018 mm (0.2362 - 0.2369 in)

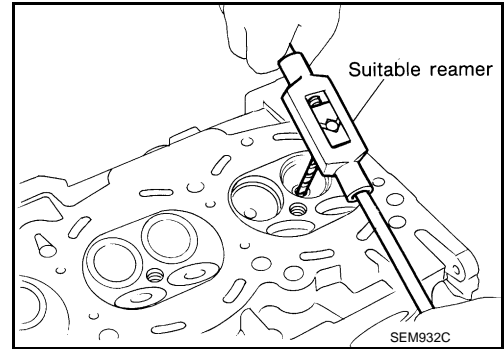

VALVE SEAT CONTACT

- After confirming that the dimensions of valve guides and valves are within the specifications, perform this procedure.
- Apply prussian blue (or white lead) onto contacting surface of valve seat to check the condition of the valve contact on the surface.
- Check if the contact area band is continuous all around the circumference.
- If not, grind to adjust valve fitting and check again. If the contacting surface still has "NG" conditions even after the recheck, replace valve seat. Refer to "VALVE SEAT REPLACEMENT".

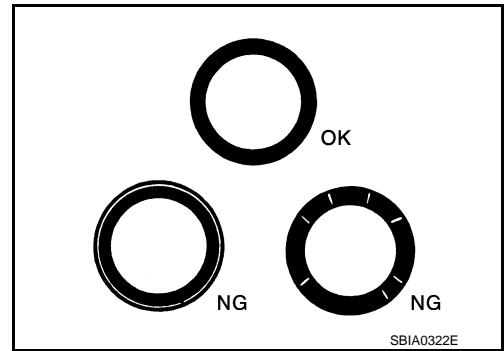

VALVE SEAT REPLACEMENT

When valve seat is removed, replace with oversized [0.5 mm (0.020 in)] valve seat.

- Bore out old seat until it collapses. Boring should not continue beyond the bottom face of the seat recess in cylinder head. Set the machine depth stop to ensure this. Refer to [EM-272, "Standard and Limit"](#).

CAUTION:

Prevent to scratch cylinder head by excessive boring.

- Ream cylinder head recess diameter for service valve seat.

Oversize [0.5 mm (0.020 in)]

Intake : 37.500 - 37.516 mm (1.4764 - 1.4770 in)

Exhaust : 32.700 - 32.716 mm (1.2874 - 1.2880 in)

- Be sure to ream in circles concentric to valve guide center. This will enable valve to fit correctly.

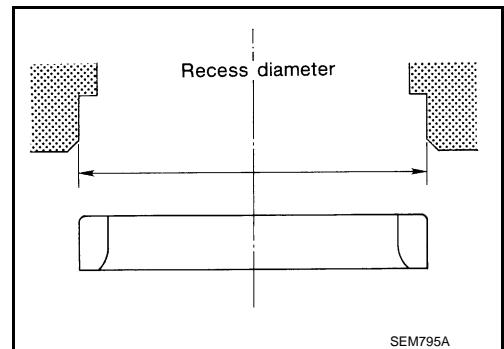

- Heat cylinder head to 110 to 130°C (230 to 266°F) by soaking in heated oil.

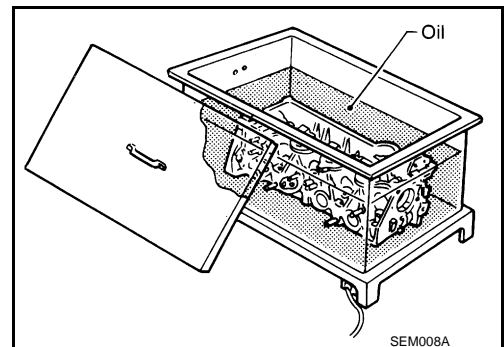

CYLINDER HEAD

< SERVICE INFORMATION >

[VK45DE]

4. Provide valve seats cooled well with dry ice. Force fit valve seat into cylinder head.

WARNING:

Cylinder head contains heat. When working, wear protective equipment to avoid getting burned.

CAUTION:

Avoid directly touching cold valve seats.

5. Using valve seat cutter set (commercial service tool) or valve seat grinder, finish seat to the specified dimensions. Refer to [EM-272, "Standard and Limit"](#).

CAUTION:

When using valve seat cutter, firmly grip cutter handle with both hands. Then, press on the contacting surface all around the circumference to cut in a single drive. Improper pressure on with cutter or cutting many different times may result in stage valve seat.

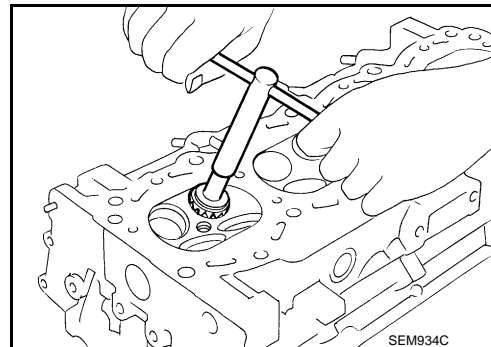

6. Using compound, grind to adjust valve fitting.
7. Check again for normal contact. Refer to "VALVE SEAT CONTACT".

VALVE SPRING SQUARENESS

- Set try square along the side of valve spring and rotate spring. Measure the maximum clearance between the top face of spring and try square.

Limit : 2.0 mm (0.079 in)

- If it exceeds the limit, replace valve spring.

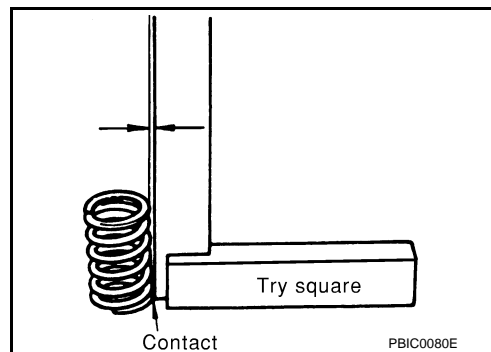

VALVE SPRING DIMENSIONS AND VALVE SPRING PRESSURE LOAD

- Check valve spring pressure at the specified spring height.

Standard:

Intake and exhaust

Free height

: 46.35 - 46.85 mm (1.8248 - 1.8445 in)

Installation height

: 33.8 mm (1.331 in)

Installation load

: 165 - 189 N (16.8 - 19.3 kg, 37 - 42 lb)

Height during valve open

: 24.4 mm (0.961 in)

Load with valve open

: 290 - 330 N (29.6 - 33.7 kg, 65 - 74 lb)

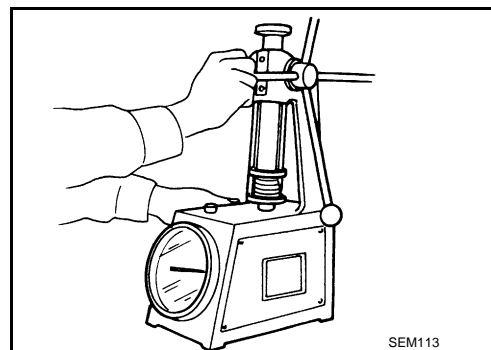

- If the installation load or load with valve open is out of the standard, replace valve spring.

ENGINE ASSEMBLY

[VK45DE]

< SERVICE INFORMATION >

ENGINE ASSEMBLY

2WD

2WD : Component

INFOID:000000005348067

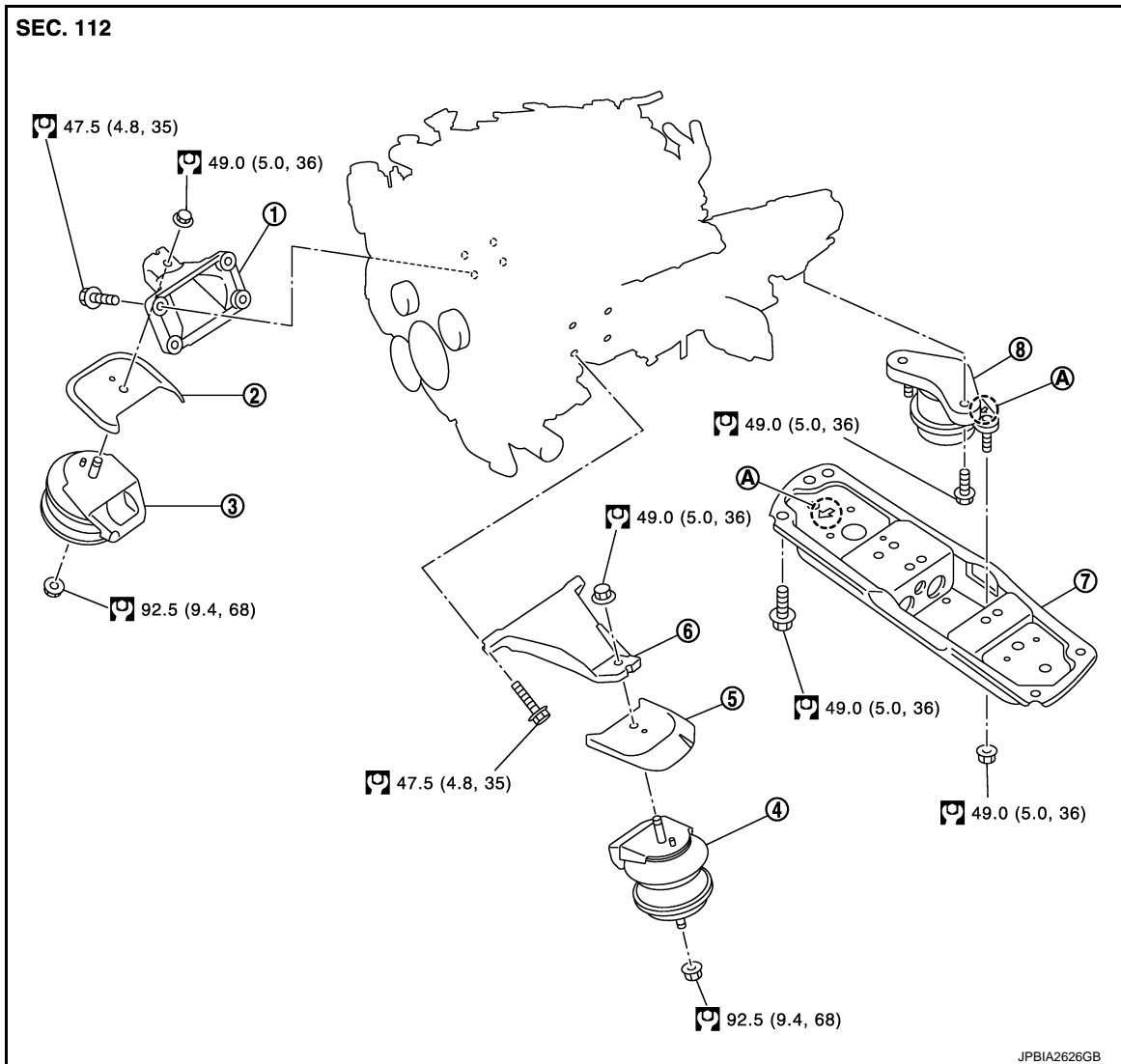

- | | | |
|-----------------------------------|-------------------------------------|-----------------------------------|
| 1. Engine mounting bracket (RH) | 2. Heat insulator (RH) | 3. Engine mounting insulator (RH) |
| 4. Engine mounting insulator (LH) | 5. Heat insulator (LH) | 6. Engine mounting bracket (LH) |
| 7. Rear engine mounting member | 8. Engine mounting insulator (rear) | |
| A. Front mark | | |

- Refer to [GI-9, "Component"](#) for symbols in the figure.

2WD : Removal and Installation

INFOID:000000005348068

WARNING:

- Situate vehicle on a flat and solid surface.
- Place chocks at front and back of rear wheels.
- For engines not equipped with engine slingers, attach proper slingers and bolts described in PARTS CATALOG.

CAUTION:

- Always be careful to work safely, avoid forceful or uninstructed operations.
- Never start working until exhaust system and engine coolant are cool enough.
- If items or work required are not covered by the engine section, refer to the applicable sections.

ENGINE ASSEMBLY

[VK45DE]

< SERVICE INFORMATION >

- Always use the support point specified for lifting.
- Use either 2-pole lift type or separate type lift as best you can. If board-on type is used for unavoidable reasons, support at the rear axle jacking point with transmission jack or similar tool before starting work, in preparation for the backward shift of center of gravity.
- For supporting points for lifting and jacking point at rear axle, refer to [GI-38, "Garage Jack and Safety Stand and 2-Pole Lift"](#).

REMOVAL

Outline

At first, remove the engine and the transmission assembly with front suspension member from vehicle downward. Then separate the engine from the transmission.

Preparation

1. Release fuel pressure. Refer to [EC-766, "Fuel Pressure Check"](#).
2. Drain engine coolant from radiator. Refer to [CO-36, "Changing Engine Coolant"](#).
CAUTION:
 - Perform this step when engine is cold.
 - Never spill engine coolant on drive belts.
3. Disconnect both battery cables. Refer to [SC-4](#).
4. Remove crankshaft position sensor (POS) from transmission. Refer to [EM-182, "Component"](#).
CAUTION:
 - Handle carefully to avoid dropping and shocks.
 - Never disassemble.
 - Never allow metal powder to adhere to magnetic part at sensor tip.
 - Never place sensors in a location where they are exposed to magnetism.
5. Remove the following parts:
 - Front and rear engine undercover (power tool)
 - Air duct (inlet), air duct and air cleaner case assembly: Refer to [EM-172](#).
 - Front road wheels and tires (power tool)

Engine Room LH

1. Disconnect heater hoses, and install plugs to avoid leakage of engine coolant. Refer to [CO-51, "Component"](#).
2. Disconnect wire bonding from exhaust manifold cover to vehicle.
3. Disconnect vacuum hose between vehicle and engine and set it aside.
4. Discharge refrigerant from A/C circuit. Refer to [ATC-135](#).
5. Remove A/C piping from A/C compressor, and temporarily fasten it on vehicle with a rope. Refer to [ATC-135](#).

Engine Room RH

1. Disconnect fuel feed hose and EVAP hose. Refer to [EM-189](#).
CAUTION:
Fit plugs onto disconnected hose to prevent fuel leakage.
2. Disconnect ground cable [between vehicle and cylinder head (right bank)].
3. Disconnect vacuum hose between vehicle and engine and set it aside.
4. Disconnect reservoir tank of power steering oil pump from engine, and move it aside for easier work.
CAUTION:
When temporarily securing, keep reservoir tank upright to avoid a fluid leakage.

Vehicle inside

Follow procedure below to disconnect engine room harness connectors at passenger room side, and temporarily secure them on engine.

1. Remove passenger-side kicking plate, dash side finisher, and glove box. Refer to [EI-48](#) and [IP-11](#).
2. Disconnect engine room harness connectors at unit sides TCM, ECM, and other.
3. Disengage intermediate fixing point. Pull out engine room harnesses to engine room side, and temporarily secure them on engine.
CAUTION:
 - When pulling out harnesses, take care not to damage harnesses and connectors.

ENGINE ASSEMBLY

[VK45DE]

< SERVICE INFORMATION >

- After temporarily securing, cover connectors with vinyl or similar material to protect against foreign material adhesion.

Vehicle Underbody

1. Remove A/T fluid cooler hoses and power steering oil pump oil cooler hoses.
 - Install plug to avoid leakage of A/T fluid and power steering fluid.
2. Disconnect heated oxygen sensor 2 harness. Refer to [EX-3](#).
3. Remove exhaust front tube with power tool. Refer to [EX-3](#).
4. Disconnect steering lower joint at power steering gear assembly side, and release steering lower shaft. Refer to [PS-12](#).
5. Separate steering outer sockets from steering knuckle. Refer to [PS-18](#).
6. Remove A/T control rod at A/T shift selector side. Then temporarily secure it on transmission, so that it does not sag. Refer to [AT-205](#).
7. Remove rear plate cover from oil pan. Then remove bolts fixing drive plate to torque converter. Refer to [EM-182](#) and [AT-243](#).
8. Remove transmission joint bolts which pierce at oil pan lower rear side. Refer to [EM-182, "Component"](#).
9. Remove lower ends of left and right strut from transverse link. Refer to [FSU-7, "Component"](#).
10. Remove transverse link mounting bolts at knuckle side. Refer to [FSU-7, "Component"](#).
11. Remove front stabilizer at transverse link side. Refer to [FSU-7, "Component"](#).
12. Remove rear propeller shaft. Refer to [PR-8, "Component"](#).

Removal Work

1. Use manual lift table caddy (commercial service tool) or equivalently rigid tool such as transmission jack. Securely support bottom of suspension member and transmission assembly.

CAUTION:

Put a piece of wood or something similar as the supporting surface, secure a completely stable condition.

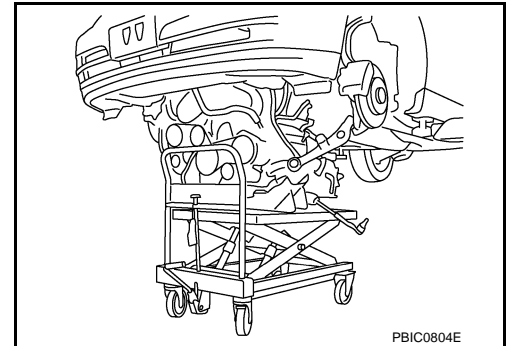

2. Remove engine rear member mounting bolts.
3. Remove front suspension member mounting nuts and bolts with power tool. Refer to [FSU-7, "Component"](#).
4. Carefully lower jack, or raise lift to remove engine, transmission and front suspension member assembly. When performing work, observe the following caution:

CAUTION:

- Confirm there is no interference with vehicle.
- Check that all connection points have been disconnected.
- Keep in mind the center of vehicle gravity changes. If necessary, use jack(s) to support vehicle at rear jacking point(s) to prevent it from falling off the lift.

Separation Work

1. Install engine slingers into front of cylinder head (left bank) and front of cylinder head (right bank).

Slinger bolts:

: 33.4 N·m (3.4 kg·m, 25 ft·lb)

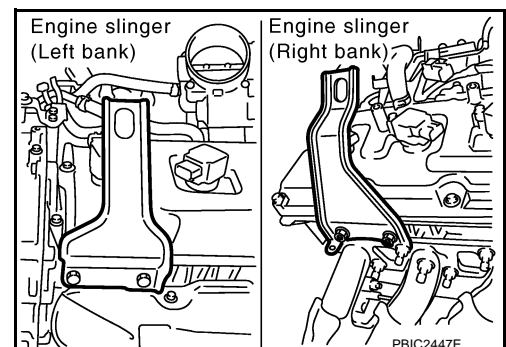

ENGINE ASSEMBLY

[VK45DE]

< SERVICE INFORMATION >

2. Remove engine mounting insulators (RH and LH) under side nut with power tool.
3. Lift with hoist and separate engine and transmission assembly from front suspension member.
CAUTION:
Avoid damage to and oil/grease smearing or spills onto engine mounting insulator.
4. Remove alternator. Refer to [SC-29, "Removal and Installation"](#).
5. Remove starter motor. Refer to [SC-13, "Removal and Installation"](#).
6. Separate engine from transmission assembly. Refer to [AT-243](#).
7. Remove engine mounting insulators (RH and LH) and brackets (RH and LH) from engine with power tool.
8. Remove rear engine mounting member and engine mounting insulator (rear) from transmission.

INSTALLATION

Note the following, and install in the reverse order of removal.

- Do not allow engine mounting insulator to be damage and careful no engine oil gets on it.
- For a location with a positioning pin, insert it securely into hole of mating part.
- For a part with a specified installation orientation, refer to component figure in [EM-238, "2WD : Component"](#).
- When installing engine mounting brackets (RH and LH) on cylinder block, tighten two upper bolts (shown as "A" in the figure) first. Then tighten two lower bolts (shown as "B" in the figure).

NOTE:

Figure shows left bank.

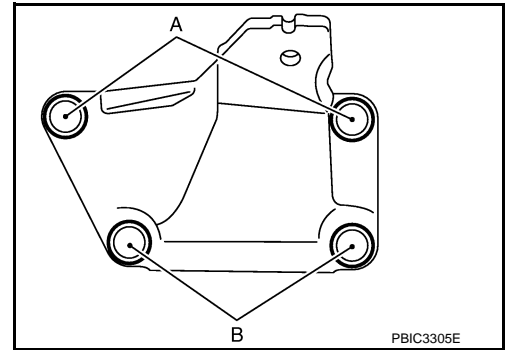

INSPECTION AFTER INSTALLATION

Inspection for Leakage

The following are procedure for checking fluids leakage, lubricates leakage, and exhaust gases leakage.

- Before starting engine, check oil/fluid levels including engine coolant and engine oil. If less than required quantity, fill to the specified level. Refer to [MA-9](#).
- Use procedure below to check for fuel leakage.
 - Turn ignition switch "ON" (with engine stopped). With fuel pressure applied to fuel piping, check for fuel leakage at connection points.
 - Start engine. With engine speed increased, check again for fuel leakage at connection points.
- Run engine to check for unusual noise and vibration.
- Warm up engine thoroughly to check there is no leakage of fuel, exhaust gases, or any oil/fluids including engine oil and engine coolant.
- Bleed air from lines and hoses of applicable lines, such as in cooling system.
- After cooling down engine, again check oil/fluid levels including engine oil and engine coolant. Refill to the specified level, if necessary.

Summary of the inspection items:

Items	Before starting engine	Engine running	After engine stopped
Engine coolant	Level	Leakage	Level
Engine oil	Level	Leakage	Level
Other oils and fluid*	Level	Leakage	Level
Fuel	Leakage	Leakage	Leakage
Exhaust gases	—	Leakage	—

*: Transmission/transaxle/CVT fluid, power steering fluid, brake fluid, etc.

AWD

ENGINE ASSEMBLY

< SERVICE INFORMATION >

[VK45DE]

AWD : Component

INFOID:000000005348069

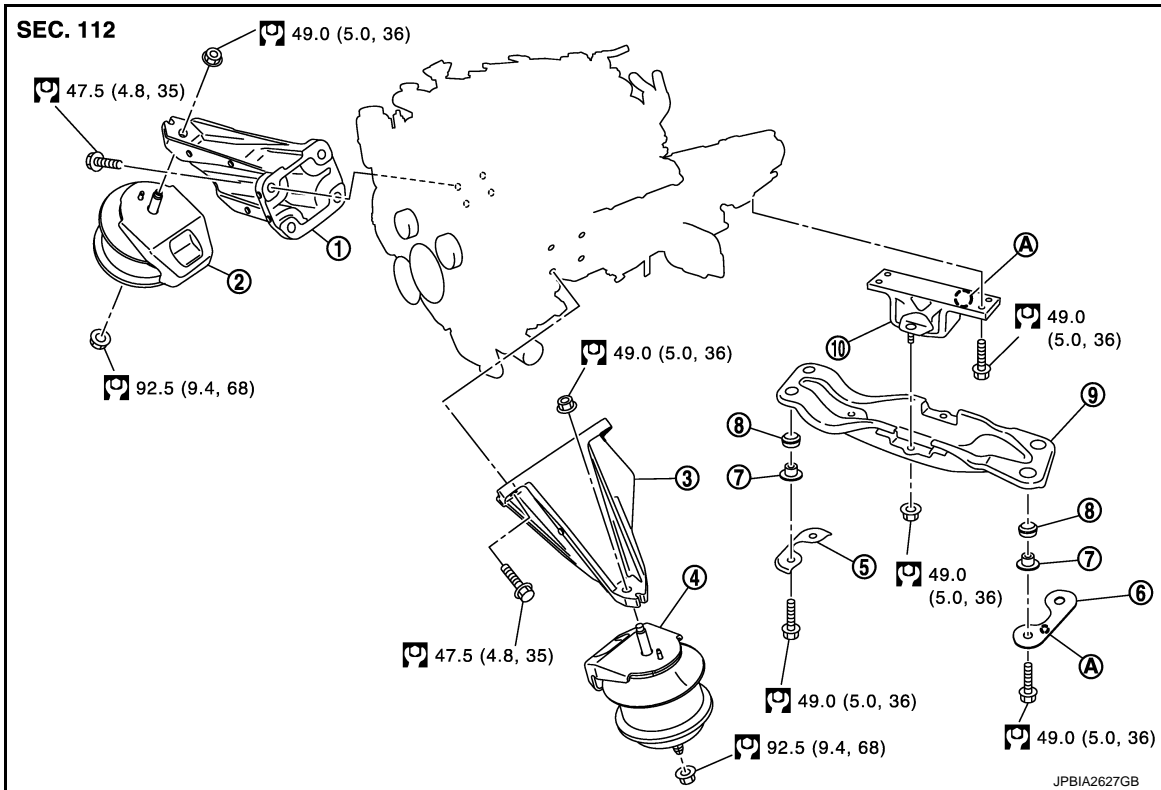

- | | | |
|--------------------------------------|-----------------------------------|---------------------------------|
| 1. Engine mounting bracket (RH) | 2. Engine mounting insulator (RH) | 3. Engine mounting bracket (LH) |
| 4. Engine mounting insulator (LH) | 5. Plate (RH) | 6. Plate (LH) |
| 7. Spacer | 8. Pad | 9. Rear engine mounting member |
| 10. Engine mounting insulator (rear) | | |
| A. Front mark | | |

- Refer to [GI-9, "Component"](#) for symbols in the figure.

AWD : Removal and Installation

INFOID:000000005348070

WARNING:

- Situate vehicle on a flat and solid surface.
- Place chocks at front and back of rear wheels.
- For engines not equipped with engine slingers, attach proper slingers and bolts described in PARTS CATALOG.

CAUTION:

- Always be careful to work safely, avoid forceful or uninstructed operations.
- Never start working until exhaust system and engine coolant are cool enough.
- If items or work required are not covered by the engine section, refer to the applicable sections.
- Always use the support point specified for lifting.
- Use either 2-pole lift type or separate type lift as best you can. If board-on type is used for unavoidable reasons, support at the rear axle jacking point with transmission jack or similar tool before starting work, in preparation for the backward shift of center of gravity.
- For supporting points for lifting and jacking point at rear axle, refer to [GI-38, "Garage Jack and Safety Stand and 2-Pole Lift"](#).

REMOVAL

Outline

At first, remove the engine and the transmission assembly, and front final drive with front suspension member from vehicle downward. Then separate the engine from the transmission.

ENGINE ASSEMBLY

[VK45DE]

< SERVICE INFORMATION >

Preparation

1. Release fuel pressure. Refer to [EC-766, "Fuel Pressure Check"](#).
2. Drain engine coolant from radiator. Refer to [CO-36, "Changing Engine Coolant"](#).
CAUTION:
 - Perform this step when engine is cold.
 - Never spill engine coolant on drive belts.
3. Disconnect both battery cables. Refer to [SC-4](#).
4. Remove crankshaft position sensor (POS) from transmission. Refer to [EM-182, "Component"](#).
CAUTION:
 - Handle carefully to avoid dropping and shocks.
 - Never disassemble.
 - Never allow metal powder to adhere to magnetic part at sensor tip.
 - Never place sensors in a location where they are exposed to magnetism.
5. Remove the following parts:
 - Front and rear engine undercover (power tool)
 - Air duct (inlet), air duct and air cleaner case assembly: Refer to [EM-172](#).
 - Front road wheels and tires (power tool)
 - Front cross bar: Refer to [FSU-24, "Component"](#).

Engine Room LH

1. Disconnect heater hoses, and install plugs to avoid leakage of engine coolant. Refer to [CO-51, "Component"](#).
2. Disconnect wire bonding from exhaust manifold cover to vehicle.
3. Disconnect vacuum hose between vehicle and engine and set it aside.
4. Discharge refrigerant from A/C circuit. Refer to [ATC-135](#).
5. Remove A/C piping from A/C compressor, and temporarily fasten it on vehicle with a rope. Refer to [ATC-135](#).

Engine Room RH

1. Disconnect fuel feed hose and EVAP hose. Refer to [EM-189](#).
CAUTION:
Fit plugs onto disconnected hose to prevent fuel leakage.
2. Disconnect ground cable (between vehicle and right bank cylinder head).
3. Disconnect vacuum hose between vehicle and engine and set it aside.
4. Disconnect reservoir tank of power steering oil pump from engine, and move it aside for easier work.
CAUTION:
When temporarily securing, keep reservoir tank upright to avoid a fluid leakage.

Vehicle inside

Follow procedure below to disconnect engine room harness connectors at passenger room side, and temporarily secure them on engine.

1. Remove passenger-side kicking plate, dash side finisher, and glove box. Refer to [EI-48](#) and [IP-11](#).
2. Disconnect engine room harness connectors at unit sides TCM, ECM, and other.
3. Disengage intermediate fixing point. Pull out engine room harnesses to engine room side, and temporarily secure them on engine.
CAUTION:
 - When pulling out harnesses, take care not to damage harnesses and connectors.
 - After temporarily securing, cover connectors with vinyl or similar material to protect against foreign material adhesion.

Vehicle Underbody

1. Remove A/T fluid cooler hoses and power steering oil pump oil cooler hoses.
 - Install plug to avoid leakage of A/T fluid and power steering fluid.
2. Disconnect heated oxygen sensor 2 harness. Refer to [EX-3](#).
3. Remove exhaust front tube with power tool. Refer to [EX-3](#).
4. Disconnect steering lower joint at power steering gear assembly side, and release steering lower shaft. Refer to [PS-12](#).

ENGINE ASSEMBLY

[VK45DE]

< SERVICE INFORMATION >

5. Separate steering outer sockets from steering knuckle. Refer to [PS-18](#).
6. Remove A/T control rod at A/T shift selector side. Then temporarily secure it on transmission, so that it does not sag. Refer to [AT-205](#).
7. Remove rear plate cover from oil pan. Then remove bolts fixing drive plate to torque converter. Refer to [EM-182](#) and [AT-243](#).
8. Remove bolts fixing the transmission assembly to lower rear side of oil pan. Refer to [EM-182](#), "[Component](#)".
9. Remove lower ends of left and right strut from transverse link. Refer to [FSU-24](#), "[Component](#)".
10. Remove transverse link mounting bolts at knuckle side. Refer to [FSU-24](#), "[Component](#)".
11. Remove front stabilizer at transverse link side. Refer to [FSU-24](#), "[Component](#)".
12. Remove rear propeller shaft. Refer to [PR-8](#), "[Component](#)".
13. Remove front drive shaft (both side). Refer to [FAX-12](#), "[Removal and Installation](#)".

Removal Work

1. Use manual lift table caddy (commercial service tool) or equivalently rigid tool such as transmission jack. Securely support bottom of suspension member and transmission assembly.

CAUTION:

Put a piece of wood or something similar as the supporting surface, secure a completely stable condition.

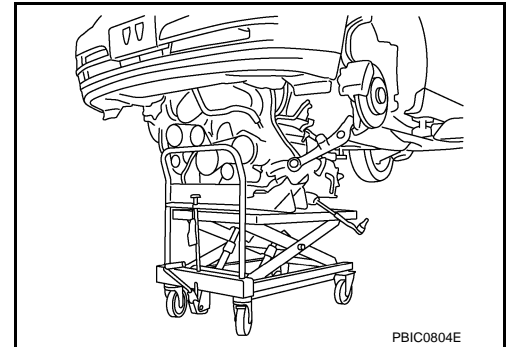

2. Remove engine rear member mounting bolts.
3. Remove front suspension member mounting nuts and bolts with power tool. Refer to [FSU-24](#), "[Component](#)".
4. Carefully lower jack, or raise lift to remove engine, transmission and front suspension member assembly. When performing work, observe the following caution:

CAUTION:

- Confirm there is no interference with vehicle.
- Check that all connection points have been disconnected.
- Keep in mind the center of vehicle gravity changes. If necessary, use jack(s) to support vehicle at rear jacking point(s) to prevent it from falling off the lift.

Separation Work

1. Install engine slingers into front of cylinder head (left bank) and front of cylinder head (right bank).

Slinger bolts:

: 33.4 N·m (3.4 kg·m, 25 ft·lb)

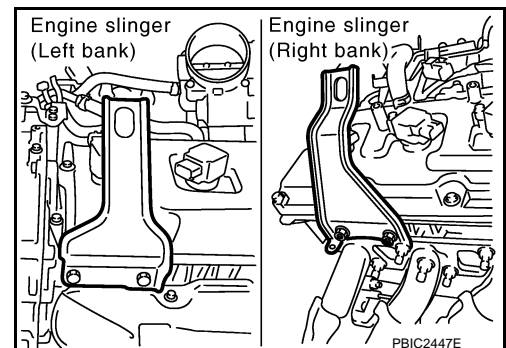

2. Remove engine mounting insulators (RH and LH) under side nut with power tool.
3. Lift with hoist and separate engine, transmission assembly, the transfer assembly and the front final drive assembly from front suspension member.

CAUTION:

Avoid damage to and oil/grease smearing or spills onto engine mounting insulator.

4. Remove alternator. Refer to [SC-29](#), "[Removal and Installation](#)".
5. Remove starter motor. Refer to [SC-17](#), "[Disassembly and Assembly](#)".

ENGINE ASSEMBLY

[VK45DE]

< SERVICE INFORMATION >

6. Remove front propeller shaft from the front final drive assembly. Refer to [PR-4. "Component"](#).
7. Separate engine from transmission assembly. Refer to [AT-243](#).
8. Remove the front final drive assembly from oil pan. Refer to [FFD-15. "Removal and Installation \(VK45DE\)"](#).
9. Remove engine mounting insulators (RH and LH) and brackets (RH and LH) from engine with power tool.
10. Remove rear engine mounting member and engine mounting insulator (rear) from transmission.

INSTALLATION

Note the following, and install in the reverse order of removal.

- Do not allow engine mounting insulator to be damage and careful no engine oil gets on it.
- For a location with a positioning pin, insert it securely into hole of mating part.
- For a part with a specified installation orientation, refer to component figure in [EM-242. "AWD : Component"](#).
- When installing engine mounting brackets (RH and LH) on cylinder block, tighten two upper bolts (shown as "A" in the figure) first. Then tighten two lower bolts (shown as "B" in the figure).

NOTE:

Figure shows left bank.

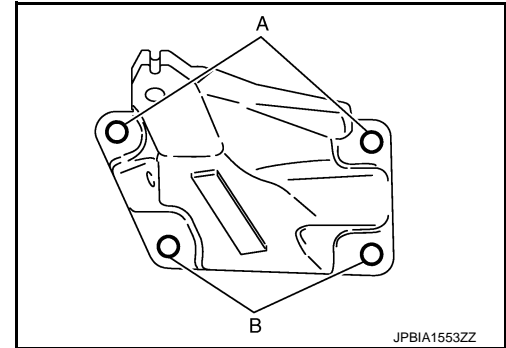

INSPECTION AFTER INSTALLATION

Inspection for Leakage

The following are procedure for checking fluids leakage, lubricates leakage, and exhaust gases leakage.

- Before starting engine, check oil/fluid levels including engine coolant and engine oil. If less than required quantity, fill to the specified level. Refer to [MA-9](#).
- Use procedure below to check for fuel leakage.
 - Turn ignition switch "ON" (with engine stopped). With fuel pressure applied to fuel piping, check for fuel leakage at connection points.
 - Start engine. With engine speed increased, check again for fuel leakage at connection points.
- Run engine to check for unusual noise and vibration.
- Warm up engine thoroughly to check there is no leakage of fuel, exhaust gases, or any oil/fluids including engine oil and engine coolant.
- Bleed air from lines and hoses of applicable lines, such as in cooling system.
- After cooling down engine, again check oil/fluid levels including engine oil and engine coolant. Refill to the specified level, if necessary.

Summary of the inspection items:

Items	Before starting engine	Engine running	After engine stopped
Engine coolant	Level	Leakage	Level
Engine oil	Level	Leakage	Level
Other oils and fluid*	Level	Leakage	Level
Fuel	Leakage	Leakage	Leakage
Exhaust gases	—	Leakage	—

*: Transmission/transaxle/CVT fluid, power steering fluid, brake fluid, etc.

CYLINDER BLOCK

< SERVICE INFORMATION >

[VK45DE]

CYLINDER BLOCK

Component

INFOID:000000005348071

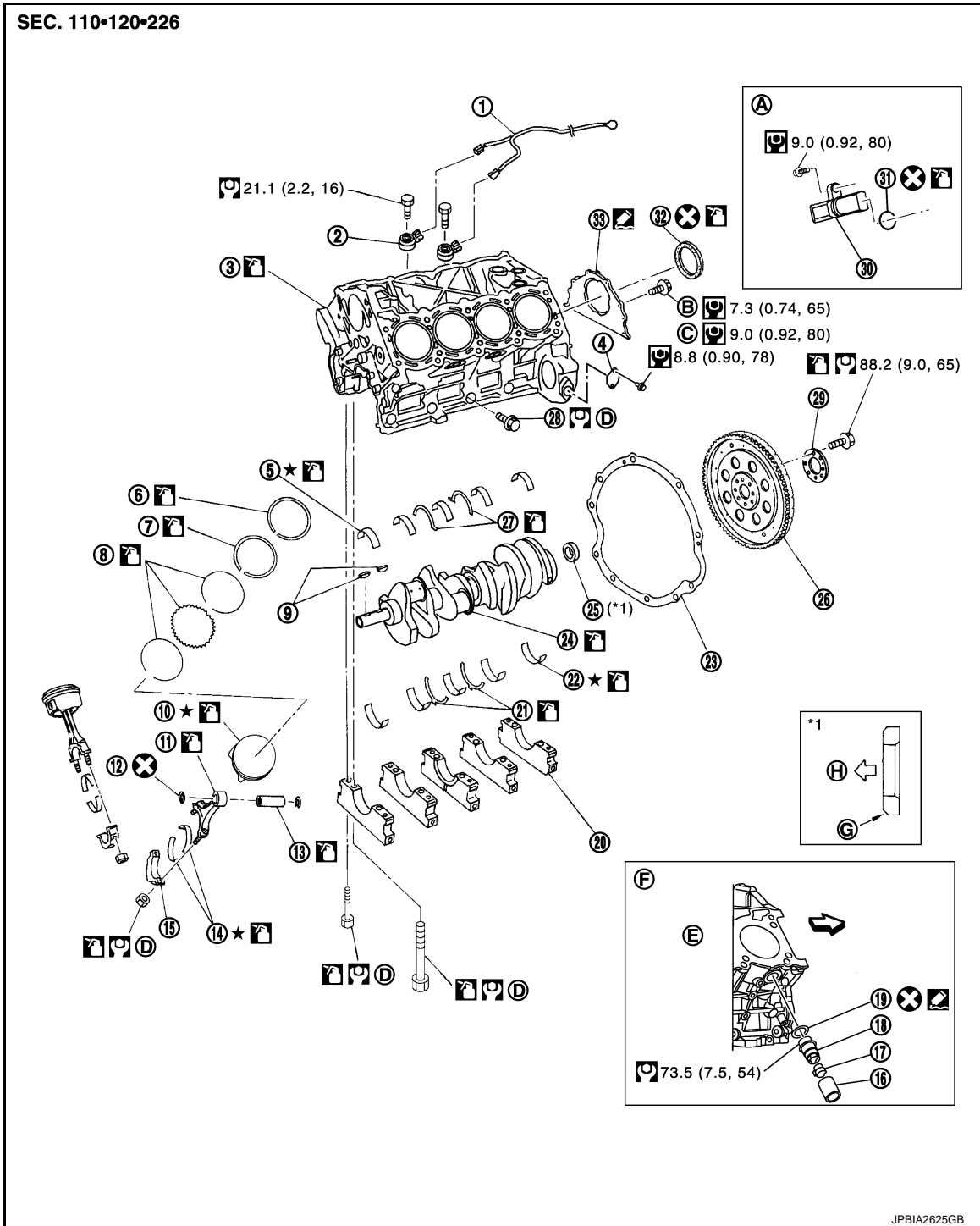

JPBIA2625GB

- | | | |
|-------------------------------------|----------------------------|--------------------------------|
| 1. Knock sensor sub harness | 2. Knock sensor | 3. Cylinder block |
| 4. Cover | 5. Main bearing (upper) | 6. Top ring |
| 7. Second ring | 8. Oil ring | 9. Crankshaft key |
| 10. Piston | 11. Connecting rod | 12. Snap ring |
| 13. Piston pin | 14. Connecting rod bearing | 15. Connecting rod bearing cap |
| 16. Cylinder block heater protector | 17. Connector cap | 18. Cylinder block heater |
| 19. Gasket | 20. Main bearing cap | 21. Thrust bearing (lower) |

CYLINDER BLOCK

[VK45DE]

< SERVICE INFORMATION >

- | | | |
|---|-------------------------|---------------------------------------|
| 22. Main bearing (lower) | 23. Rear plate | 24. Crankshaft |
| 25. Pilot converter | 26. Drive plate | 27. Thrust bearing (upper) |
| 28. Side bolt | 29. Reinforcement plate | 30. Crankshaft position sensor (POS) |
| 31. O-ring | 32. Rear oil seal | 33. Rear oil seal retainer |
| A. Reference: Installed on transmission | B. Washer bolt | C. Flange bolt |
| D. Refer to EM-247 | E. left bank | F. Cylinder block heater (for Canada) |
| G. Chamfered | H. Crankshaft side | |

↶ : Engine front

- Refer to [GI-9](#) for symbols in the figure.

Disassembly and Assembly

INFOID:000000005348072

DISASSEMBLY

NOTE:

Explained here is how to disassemble with engine stand supporting transmission surface. When using different type of engine stand, note with difference in steps and etc.

1. Remove engine assembly from vehicle, and separate front suspension member, transmission from engine. Refer to [EM-238, "2WD : Component"](#) (2WD models) or [EM-242, "AWD : Component"](#) (AWD models).
2. Remove the parts that may restrict installation of engine to widely use engine stand.

NOTE:

The procedure is described assuming that you use widely use engine holding the surface, to which transmission is installed.

- a. Remove drive plate.
 - Holding ring gear with ring gear stopper (SST).
 - Loosen mounting bolts diagonally order.

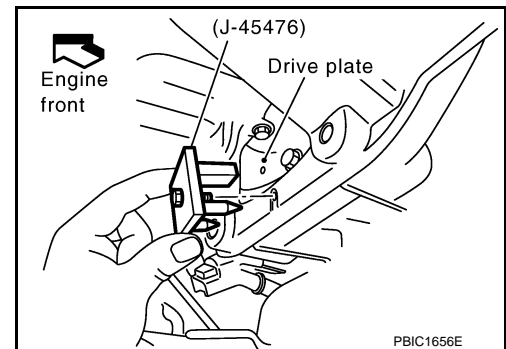

CAUTION:

- Never disassemble drive plate.
- Never place drive plate with signal plate facing down.
- When handling signal plate, take care not to damage or scratch it.
- Handle signal plate in a manner that prevents it from becoming magnetized.

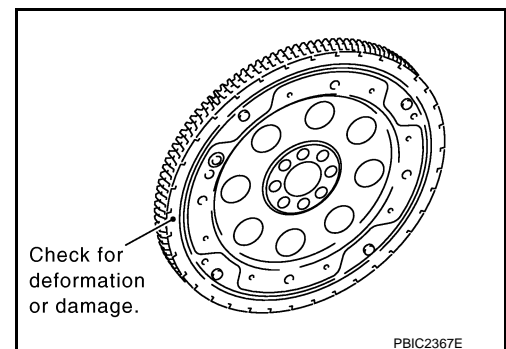

- b. Remove rear plate.
3. Lift engine with hoist to install it onto widely use engine stand.

CAUTION:

Use engine stand that has a load capacity [approximately 240 kg (529 lb) or more] large enough for supporting the engine weight.

- If the load capacity of stand is not adequate, remove the following parts beforehand to reduce the potential risk of overturning stand.

CYLINDER BLOCK

[VK45DE]

< SERVICE INFORMATION >

- Intake manifolds (upper and lower): Refer to [EM-174. "Component"](#).
- Exhaust manifold and three way catalyst: Refer to [EM-178](#).
- Fuel tube and fuel injector assembly: Refer to [EM-189](#).
- Ignition coil: Refer to [EM-186](#).
- Rocker cover: Refer to [EM-195](#).
- Other removable brackets

NOTE:

The figure shows an example of widely use engine stand that can hold mating surface of transmission with drive plate and rear plate removed.

CAUTION:

Before removing the hanging chains, check the engine stand is stable and there is no risk of overturning.

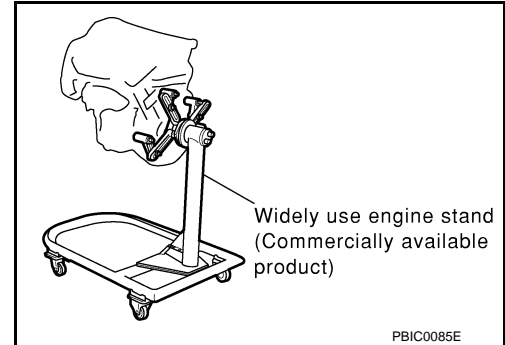

4. Drain engine oil. Refer to [LU-25. "Changing Engine Oil"](#).
5. Drain engine coolant from inside engine by removing water drain plugs (B) as shown in the figure.

- A : Plug
- C : Plug (except for Canada models)
- D : Block heater (for Canada models)
- D : Plug

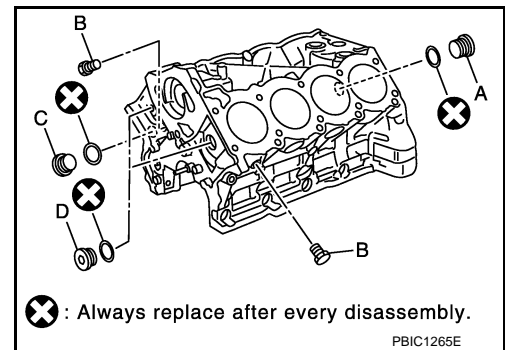

6. Remove oil pan and oil strainer. Refer to [EM-182](#).
7. Remove crankshaft pulley as follows:
 - a. Lock crankshaft with a hammer handle or similar tool to loosen crankshaft bolt.
 - b. Pull crankshaft pulley with both hands to remove it.

CAUTION:

- **Never remove crankshaft pulley bolt. Keep loosened crankshaft pulley bolt in place to protect removed crankshaft pulley from dropping.**
- **Never remove balance weight (inner hexagon bolt) at the front of crankshaft pulley.**

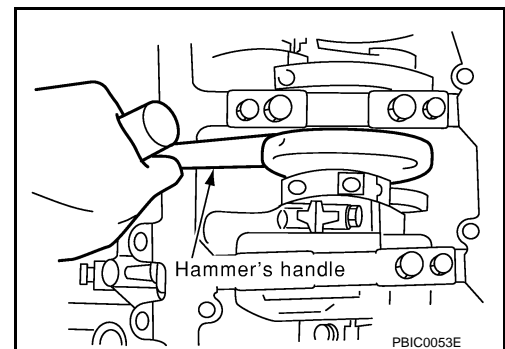

8. Remove the following parts and related parts (The parts listed in step 3 are not included here).
 - Front cover and timing chain: Refer to [EM-199](#).
 - Camshaft: Refer to [EM-211](#).
 - Cylinder head: Refer to [EM-228. "Component"](#).
9. Remove knock sensor.

CAUTION:

Carefully handle sensor, avoiding shocks.
10. Remove piston and connecting rod assembly as follows:
 - Before removing piston and connecting rod assembly, check the connecting rod side clearance. Refer to [EM-262. "Inspection After Disassembly"](#).
 - a. Position crankshaft pin corresponding to connecting rod to be removed onto the bottom dead center.
 - b. Remove connecting rod bearing cap.

CYLINDER BLOCK

[VK45DE]

< SERVICE INFORMATION >

- c. Using hammer handle or similar tool, push piston and connecting rod assembly out to the cylinder head side.

CAUTION:

Be careful not to damage the cylinder wall and crankshaft pin, resulting from an interference of the connecting rod big end.

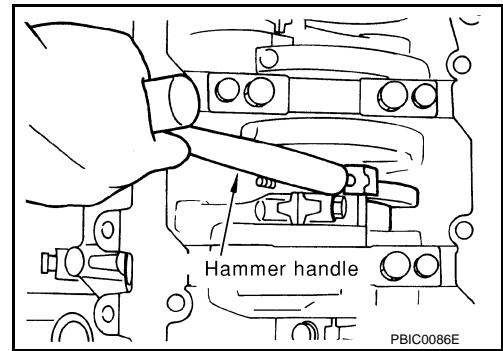

11. Remove connecting rod bearings from connecting rod and connecting rod bearing cap.

CAUTION:

Identify installation positions, and store them without mixing them up.

12. Remove piston rings from piston.

• Before removing the piston rings, check the piston ring side clearance. Refer to [EM-262, "Inspection After Disassembly"](#).

• Use piston ring expander (commercial service tool).

CAUTION:

- **When removing piston rings, be careful not to damage piston.**
- **Be careful not to damage piston rings by expanding them excessively.**

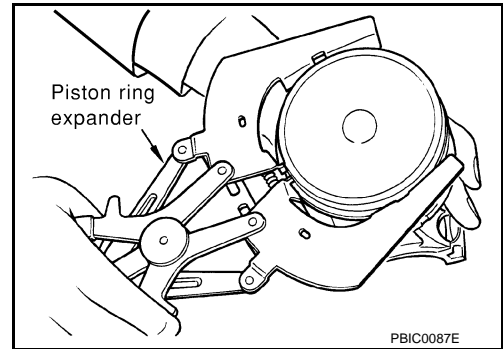

13. Remove piston from connecting rod as follows:

- a. Using snap ring pliers, remove the snap rings.

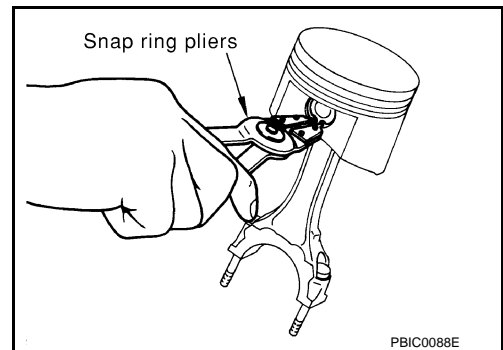

- b. Heat piston to 60 to 70°C (140 to 158°F) with industrial use drier or equivalent.

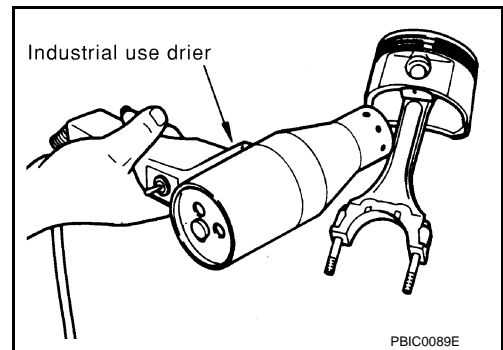

A
EM
C
D
E
F
G
H
I
J
K
L
M
N
O
P

CYLINDER BLOCK

[VK45DE]

< SERVICE INFORMATION >

- c. Push out piston pin with stick of outer diameter approximately 20 mm (0.79 in).

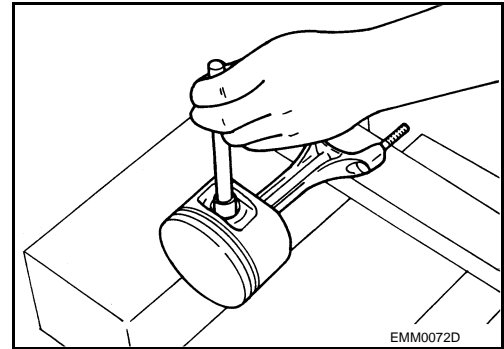

14. Remove rear oil seal retainer from cylinder block.
- Insert screwdriver or similar tool between rear end of crankshaft counter weight and rear oil seal retainer, and separate liquid gasket to remove.

CAUTION:

Be careful not to damage the mating surfaces.

15. Using screwdriver or similar tool, and lever off rear oil seal from rear oil seal retainer.
16. Remove main bearing cap as follows:
- Before loosening main bearing cap bolts, measure the crankshaft end play. Refer to [EM-262, "Inspection After Disassembly"](#).
 - Loosen main bearing cap bolts in several different steps.

- a. Remove cover attached to the rear left side of cylinder block (next to the starter motor housing).

NOTE:

Bolts (No. 27 shown in the figure) are installed on the inside of cover.

- b. Loosen side bolts (M10) starting from 30 to 21 to remove.
- c. Loosen main bearing cap sub bolts (M9) starting from 20 to 11 to remove.
- d. Loosen main bearing cap bolts (M12) starting from 10 to 1 to remove.

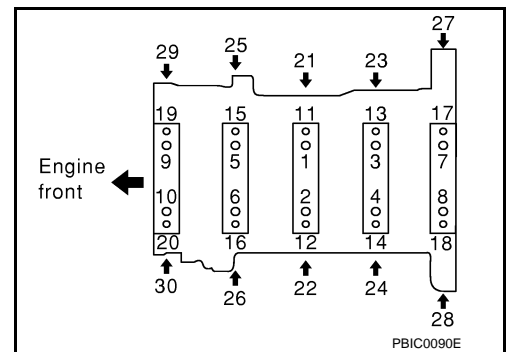

- e. Using main bearing cap remover (SST), remove main bearing cap.

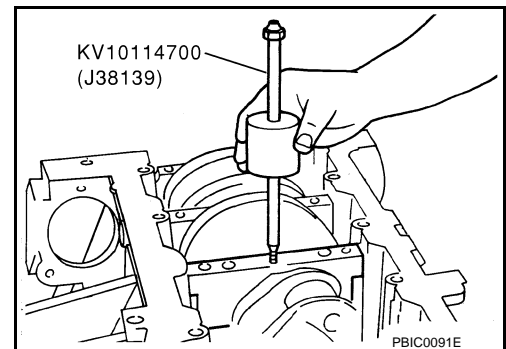

17. Remove crankshaft.
18. Remove main bearings and thrust bearings from cylinder block and main bearing caps.

CAUTION:

Identify installation positions, and store them without mixing them up.

CYLINDER BLOCK

[VK45DE]

< SERVICE INFORMATION >

19. If pilot converter must be removed, remove it from the rear end of the crankshaft using pilot bushing puller (SST).

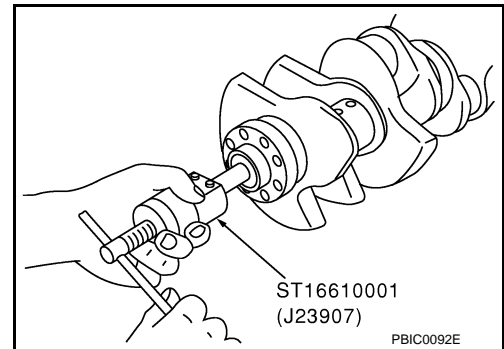

ASSEMBLY

1. Fully air-blow engine coolant and engine oil passages in cylinder block, cylinder bore and crankcase to remove any foreign material.

CAUTION:

Use a goggles to protect your eye.

2. Install each plug to the cylinder block. (Only screwed-type plugs are shown in the figure.)

- Apply sealant to the thread of each plug "A" and "D".
Use genuine high strength thread locking sealant or equivalent. Refer to GI-46.
- Apply sealant to the thread of each plug "B" and "C".
Use Anaerobic Liquid Gasket or equivalent. Refer to GI-46.

NOTE:

For Canada models, "C" in the figure is not plug but block heater. Refer to EM-246. "Component".

- Replace copper washers with new ones.
- Tighten each plug as specified below.

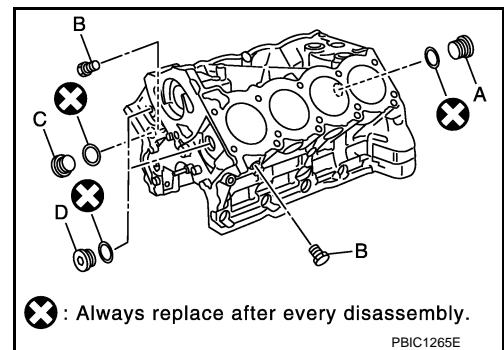

Part	Washer	Tightening torque
A	Yes	53.9 N·m (5.5 kg-m, 40 ft-lb)
B	No	19.6 N·m (2.0 kg-m, 14 ft-lb)
C	Yes	62.7 N·m (6.4 kg-m, 46 ft-lb)
D	Yes	62.7 N·m (6.4 kg-m, 46 ft-lb)

3. Install main bearings and thrust bearings as follows:
- Remove dust, dirt and oil on the bearing mating surfaces of cylinder block and main bearing caps.
 - Install thrust bearings to the both sides of the No. 3 journal housing on cylinder block and main bearing cap.
 - Install thrust bearings with the oil groove facing the crankshaft arm (outside).
 - Install thrust bearing with a protrusion on one end on cylinder block, and thrust bearing with a protrusion at center on main bearing cap. Align each protrusion with mating notch.

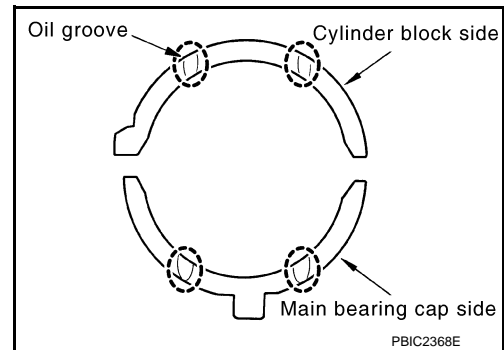

CYLINDER BLOCK

[VK45DE]

< SERVICE INFORMATION >

- c. Install main bearings paying attention to the direction.
- Main bearing with oil hole and groove goes on cylinder block. The one without them goes on main bearing cap.
 - Before installing main bearings, apply engine oil to the bearing surface (inside). Do not apply engine oil to the back surface, but thoroughly clean it.
 - When installing, align main bearing stopper protrusion to cut-out of cylinder block and main bearing caps.
 - Ensure the oil holes on cylinder block and those on the corresponding bearing are aligned.

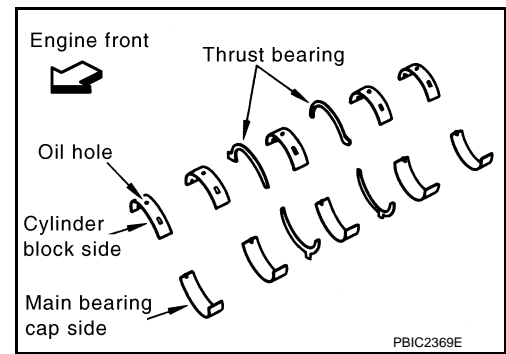

4. Install pilot converter to crankshaft, if removed.
- With drift [outer diameter: approximately 35 mm (1.38 in)], press-fit as far as it will go.

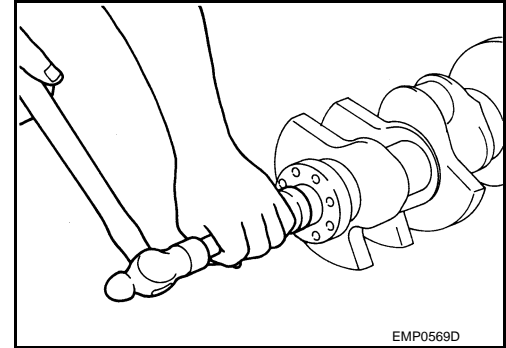

- Press-fit pilot converter with its chamfering side facing crankshaft as shown in the figure.
- It is possible to remove pilot converter without hoisting engine with engine stand.

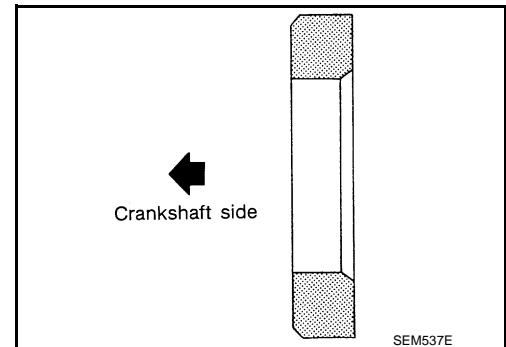

5. Install crankshaft to cylinder block.
- While turning crankshaft by hand, check it turns smoothly.
6. Install main bearing caps.
- Align the identification number to the journal position to install.
 - Install the upper side of the identification number facing the front of engine. (The number shall be read correctly from the rear of engine.)
 - Using plastic hammer or similar tool, tap them lightly to seat them on the installation position.

NOTE:

Main bearing cap cannot be replaced as a single parts, because it is machined together with cylinder block.

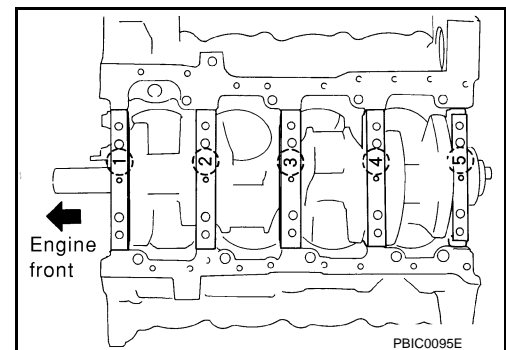

7. Install each main bearing cap bolt as follows:
- a. Apply new engine oil to threads and seating surface of main bearing cap bolts, and tighten all bolts temporarily.

CYLINDER BLOCK

[VK45DE]

< SERVICE INFORMATION >

- b. Tighten main bearing cap bolt (M12) in order of 1 to 10.

: **39.2 N·m (4.0 kg-m, 29 ft-lb)**

- c. Tighten main bearing cap sub bolt (M9) in order of 11 to 20.

: **29.4 N·m (3.0 kg-m, 22 ft-lb)**

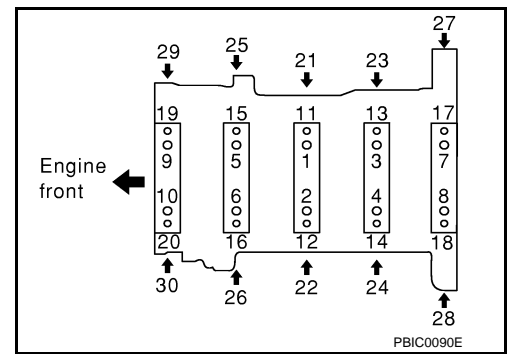

- d. Tighten main bearing cap bolt (M12) to 40 degrees clockwise in order of 1 to 10. (angle tightening)

CAUTION:

Use angle wrench (SST) to check tightening angle in step “d” and “e”. Never make judgment by visual inspection.

- e. Tighten main bearing cap sub bolt (M9) to 30 degrees clockwise in order of 11 to 20. (angle tightening)

CAUTION:

Use angle wrench (SST) to check tightening angle in step “d” and “e”. Never make judgment by visual inspection.

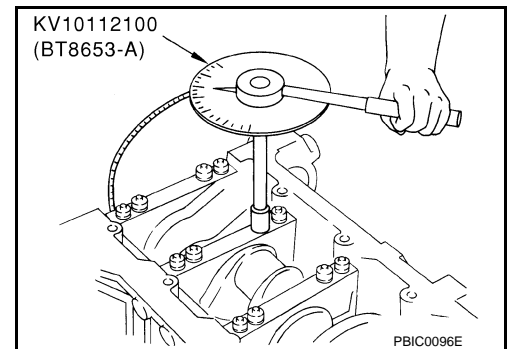

- f. Tighten side bolt (M10) in order of 21 to 30.

: **49.0 N·m (5.0 kg-m, 36 ft-lb)**

- After installing main bearing cap bolts, check that crankshaft can be rotated smoothly.
- Check the crankshaft end play. Refer to [EM-262, "Inspection After Disassembly"](#).

- g. Install cover of cylinder block rear left side (next to the starter motor housing).
8. Install new rear oil seal on rear oil seal retainer.

- Install new rear oil seal so that each seal lip is oriented as shown in the figure.

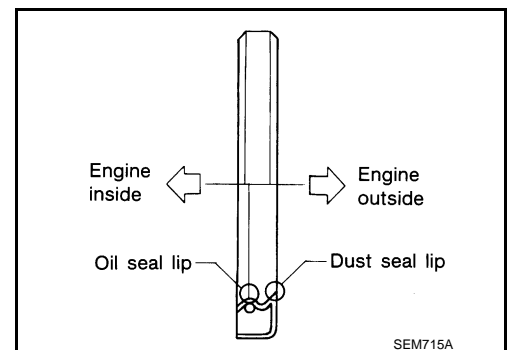

- Install rear oil seal to rear oil seal retainer with rear oil seal drift (commercial service tool).

Rear oil seal drift

Outer diameter : 102 mm (4.02 in)

Inner diameter : 86 mm (3.39 in)

- Tap until flattened with front edge of rear oil seal retainer. Do not damage or scratch outer circumference of oil seal.
- Check the garter spring is in position and seal lips not inverted.

9. Install rear oil seal retainer.

- Apply new engine oil to both oil seal lip and dust seal lip.

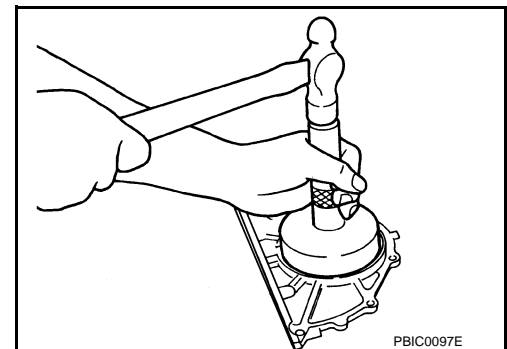

CYLINDER BLOCK

[VK45DE]

< SERVICE INFORMATION >

- Apply a continuous bead of liquid gasket with tube presser (commercial service tool) to rear oil seal retainer as shown in the figure.
Use Genuine RTV Silicone Sealant or equivalent. Refer to [GI-46](#).

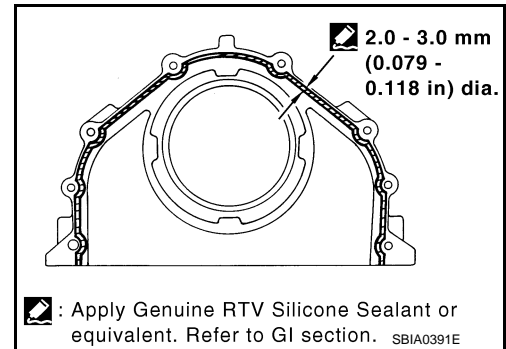

10. Install piston to connecting rod.
 - a. Using snap ring pliers, install new snap ring to the groove of the piston rear side.
 - Insert it fully into groove to install.
 - b. Install piston to connecting rod.
 - Using industrial use drier or similar tool, heat piston until piston pin can be pushed in by hand without excess force [approximately 60 to 70°C (140 to 158°F)]. From the front to the rear, insert piston pin into piston and connecting rod.
 - Assemble so that the front mark on the piston head and the oil holes and the cylinder No. on connecting rod are positioned as shown in the figure.
 - c. Using snap ring pliers, install new snap rings to the groove of the piston front side.
 - Insert it fully into groove to install.
 - After installing, check that connecting rod moves smoothly.

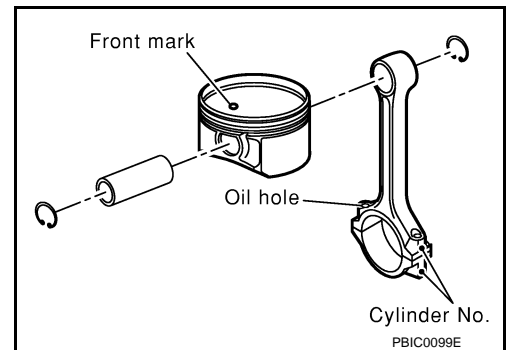

11. Using piston ring expander (commercial service tool), install piston rings.

CAUTION:

 - **When installing piston rings, be careful not to damage piston.**
 - **Be careful not to damage piston rings by expanding them excessively.**

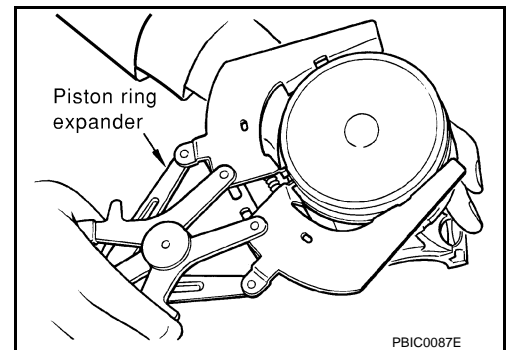

- Position each ring with the gap as shown in the figure, referring to the piston front mark.
- Install top ring and second ring with the stamped surface facing upward.

Stamped mark

- Top ring : R**
- Second ring : 2 R**

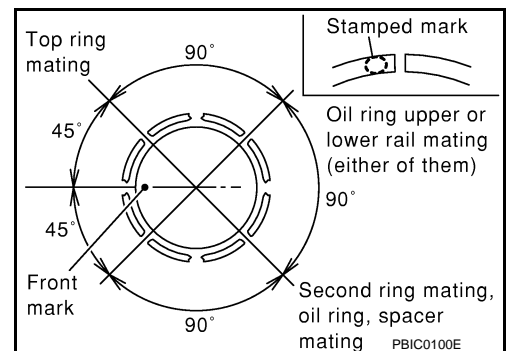

12. Install connecting rod bearings to connecting rod and connecting rod bearing cap.
 - Before installing connecting rod bearings, apply engine oil to the bearing surface (inside). Do not apply engine oil to the back surface, but thoroughly clean it.

CYLINDER BLOCK

[VK45DE]

< SERVICE INFORMATION >

- When installing, align the connecting rod bearing stopper protrusion with the cutout of connecting rod and connecting rod bearing cap to install.
- Ensure the oil holes on connecting rod and that on the corresponding bearing are aligned.

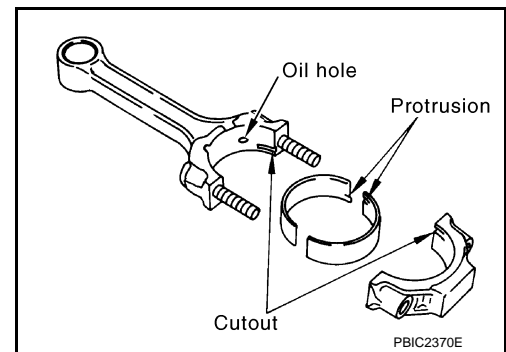

13. Install piston and connecting rod assembly to crankshaft.
- Position the crankshaft pin corresponding to connecting rod to be installed onto the bottom dead center.
 - Apply engine oil sufficiently to the cylinder bore, piston and crankshaft pin journal.
 - Match the cylinder position with the cylinder No. on connecting rod to install.
 - Be sure that front mark on piston head is facing front of engine.
 - Using piston ring compressor [SST: EM03470000 (J8037)], install piston with the front mark on the piston head facing the front of engine.

CAUTION:

Be careful not to damage cylinder wall and crankshaft pin, resulting from an interference of the connecting rod big end.

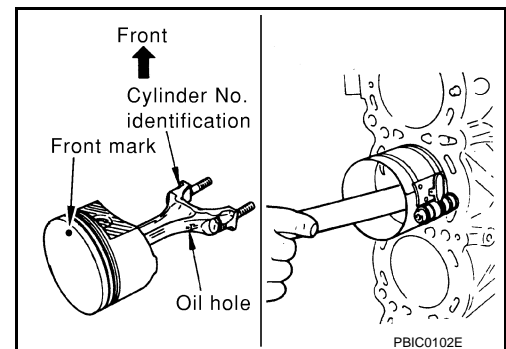

14. Install connecting rod bearing cap.
- Match the stamped cylinder number marks on connecting rod with those on cap to install.

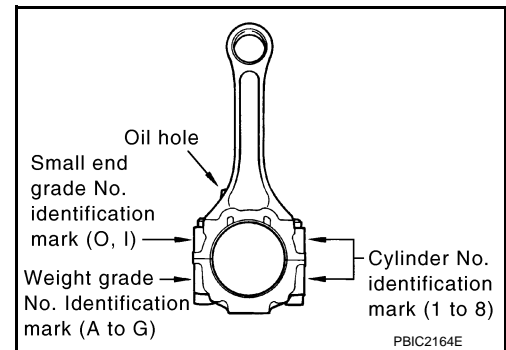

15. Tighten connecting rod nuts as follows:
- a. Apply new engine oil to the threads and seats of connecting rod bolts and nuts.
 - b. Tighten connecting rod nuts.

: 14.7 N·m (1.5 kg-m, 11 ft-lb)

- c. Then tighten all connecting rod nuts 60 degrees clockwise. (angle tightening)

CAUTION:

CYLINDER BLOCK

[VK45DE]

< SERVICE INFORMATION >

Use angle wrench (SST) to check tightening angle. Never make judgment by visual inspection.

- After tightening connecting rod nuts, check that crankshaft rotates smoothly.
- Check the connecting rod side clearance. Refer to [EM-262](#), "Inspection After Disassembly".

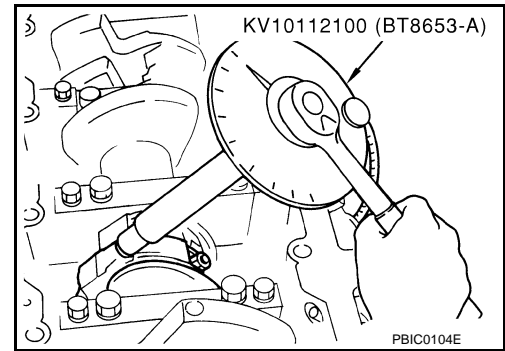

16. Install knock sensor.

- Install it with its connector facing the rear of engine.
- Install the sub-harness with its shorter branch line to the left bank.

CAUTION:

- **Never tighten mounting bolts while holding connector.**
- **If any impact by dropping is applied to knock sensor, replace it with new one.**

NOTE:

- Check that there is no foreign material on the cylinder block mating surface and the back surface of knock sensor.
- Check that knock sensor does not interfere with other parts.

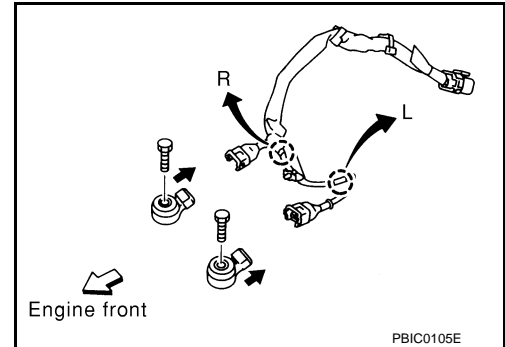

17. Note the following, and assemble in the reverse order of disassembly after this step.

Drive plate

- When installing drive plate to crankshaft, be sure to correctly align crankshaft side guide pin and drive plate side guide pin hole.

CAUTION:

If these are not aligned correctly, engine runs roughly and "MIL" turns on.

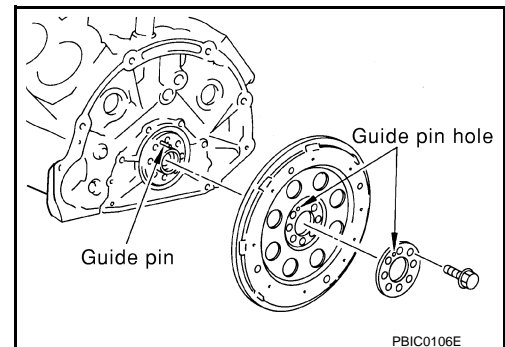

- Install drive plate, reinforcement plate and pilot converter (if not installed in step 4) as shown in the figure.
- Face chamfered or rounded edge side to crankshaft.
- Holding ring gear with ring gear stopper [SST: — (J-45476)].
- Tighten mounting bolts crosswise over several times.
- When install pilot converter, using drift [outer diameter: approximately 35 mm (1.38 in)]. Press-fit as far as it will go.

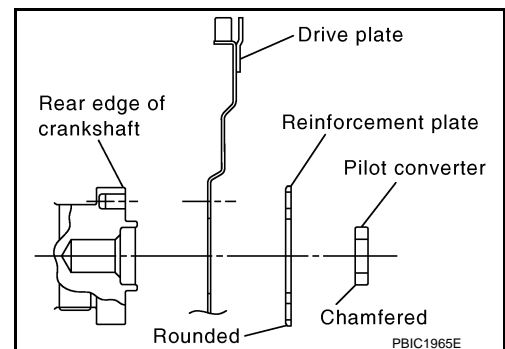

How to Select Piston and Bearing

INFOID:000000005348073

DESCRIPTION

CYLINDER BLOCK

< SERVICE INFORMATION >

[VK45DE]

Selection points	Selection parts	Selection items	Selection methods
Between cylinder block and crankshaft	Main bearing	Main bearing grade (bearing thickness)	Determined by match of cylinder block bearing housing grade (inner diameter of housing) and crankshaft journal grade (outer diameter of journal)
Between crankshaft and connecting rod	Connecting rod bearing	Connecting rod bearing grade (bearing thickness)	Combining service grades for connecting rod big end diameter and crankshaft pin outer diameter determine connecting rod bearing selection.
Between cylinder block and piston	Piston and piston pin assembly (Piston is available together with piston pin as assembly.)	Piston grade (piston skirt diameter)	Piston grade = cylinder bore grade (inner diameter of bore)
Between piston and connecting rod*	—	—	—

*: For the service parts, the grade for fitting cannot be selected between piston pin and connecting rod. (Only "0" grade is available.) The information at the shipment from the plant is described as a reference.

- The identification grade stamped on each part is the grade for the dimension measured in new condition. This grade cannot apply to reused parts.
- For reused or repaired parts, measure the dimension accurately. Determine the grade by comparing the measurement with the values of each selection table.
- For details of the measurement method of each part, the reuse standards, and the selection method of the selective fitting parts, refer to the text.

HOW TO SELECT PISTON

When New Cylinder Block is Used

Check the cylinder bore grade ("1", "2" or "3") on the rear upper side between cylinder block banks, and select piston of the same grade.

NOTE:

Piston is available with piston pin as a set for the service part. (Only "0" grade piston pin is available.)

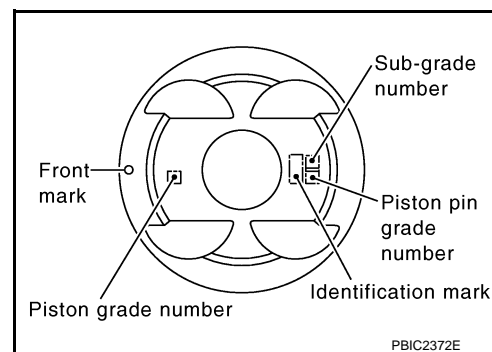
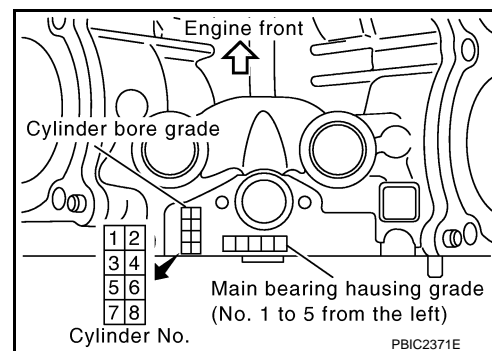

When Cylinder Block is Reused

1. Measure the cylinder bore inner diameter. Refer to [EM-262, "Inspection After Disassembly"](#).
2. Determine the bore grade by comparing the measurement with the values the "Cylinder bore inner diameter" of the "Piston Selection Table". Select piston of the same grade.

Piston Selection Table

CYLINDER BLOCK

< SERVICE INFORMATION >

[VK45DE]

Unit: mm (in)

Grade	1	2 (or no mark)	3
Cylinder bore inner diameter	93.000 - 93.010 (3.6614 - 3.6618)	93.010 - 93.020 (3.6618 - 3.6622)	93.020 - 93.030 (3.6622 - 3.6626)
Piston skirt diameter	92.980 - 92.990 (3.6606 - 3.6610)	92.990 - 93.000 (3.6610 - 3.6614)	93.000 - 93.010 (3.6614 - 3.6618)

NOTE:

- Piston is available together with piston pin as assembly.
- Piston pin (piston pin hole) grade is provided only for the parts installed at the plant. For service parts, no piston pin grades can be selected. (Only "0" grade is available.)
- No second grade mark is available on piston.

HOW TO SELECT CONNECTING ROD BEARING

When New Connecting Rod and Crankshaft are Used

Check pin diameter grade ("0", "1" or "2") on front of crankshaft, and select connecting rod bearing of the same grade.

NOTE:

There is no grading for connecting rod big end diameter.

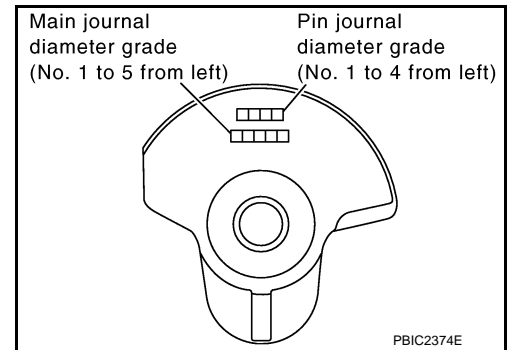

When Crankshaft and Connecting Rod are Reused

1. Measure the connecting rod big end diameter. Refer to [EM-262, "Inspection After Disassembly"](#).
2. Check that the connecting rod big end diameter is within the standard value.
3. Measure the crankshaft pin journal diameter. Refer to [EM-262, "Inspection After Disassembly"](#).
4. Determine the grade of crankshaft pin diameter grade by corresponding to the measured dimension in "Crankshaft pin journal diameter" column of "Connecting Rod Bearing Selection Table".
5. Select connecting rod bearing of the same grade.

Connecting Rod Bearing Selection Table

Unit: mm (in)

Connecting rod big end diameter	55.000 - 55.013 (2.1654 - 2.1659)
---------------------------------	-----------------------------------

Unit: mm (in)

Crankshaft		Connecting rod bearing		
Crankshaft pin journal diameter	Grade (Mark)	Dimension (Bearing thickness range)	Bearing grade No.	Color
51.968 - 51.974 (2.0460 - 2.0462)	0	1.500 - 1.503 (0.0591 - 0.0592)	STD 0	No color
51.962 - 51.968 (2.0457 - 2.0460)	1	1.503 - 1.506 (0.0592 - 0.0593)	STD 1	Brown
51.956 - 51.962 (2.0455 - 2.0457)	2	1.506 - 1.509 (0.0593 - 0.0594)	STD 2	Green

Under Size Bearings Usage Guide

- When the specified connecting rod bearing oil clearance is not obtained with standard size connecting rod bearings, use undersize (US) bearings.
- When using undersize (US) bearing, measure the connecting rod bearing inner diameter with bearing installed, and grind crankshaft pin so that the connecting rod bearing oil clearance satisfies the standard.

CAUTION:

CYLINDER BLOCK

< SERVICE INFORMATION >

[VK45DE]

In grinding crankshaft pin to use undersize bearings, keep the fillet R [1.5 mm (0.059 in)].

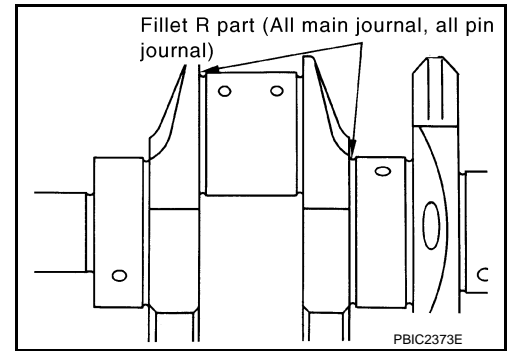

Bearing undersize table

Unit: mm (in)

Size	Thickness
US 0.25 (0.0098)	1.626 - 1.634 (0.0640 - 0.0643)

HOW TO SELECT MAIN BEARING

When New Cylinder Block and Crankshaft are Used

1. "Main Bearing Selection Table" rows correspond to main bearing housing grade on rear upper side between cylinder block banks.

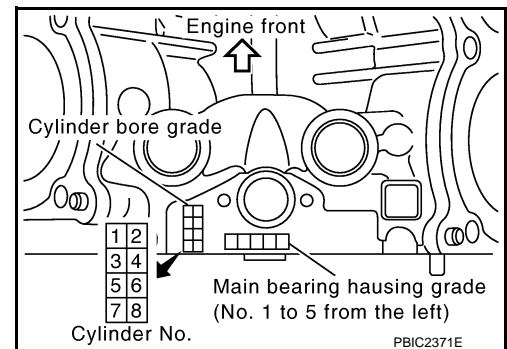

2. "Main Bearing Selection Table" columns correspond to main journal diameter grade on front side of crankshaft.

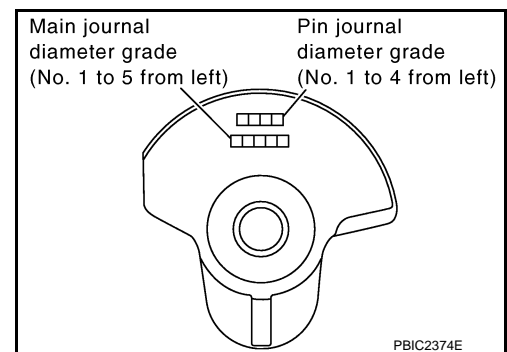

3. Select main bearing grade at the point where selected row and column meet in "Main Bearing Selection Table".

CAUTION:

- Initial clearance for No. 1, 5 journal and No. 2, 3, 4 journal is different. Use two different selection table for each part.
- No. 1, 5 journal and No. 2, 3, 4 journal have the same signs but different measures. Never confuse.

4. Apply sign at crossing in above step 3 to "Main Bearing Grade Table".

NOTE:

- "Main Bearing Grade Table" applies to all journals.
- Service parts is available as a set of both upper and lower.

When Cylinder Block and Crankshaft are Reused

1. Measure the cylinder block main bearing housing inner diameter and the crankshaft main journal diameter. Refer to [EM-262. "Inspection After Disassembly"](#).

A
EM
C
D
E
F
G
H
I
J
K
L
M
N
O
P

CYLINDER BLOCK

[VK45DE]

< SERVICE INFORMATION >

2. Correspond the measured dimension in “Cylinder block main bearing housing inner diameter” row of “Main Bearing Selection Table”.
3. Correspond the measured dimension in “Crankshaft main journal diameter” column of “Main Bearing Selection Table”.
4. Follow step 3 and later in “When New Cylinder Block and Crankshaft are Used”.

Main Bearing Selection Table (No. 1 and 5 Journal)

			Cylinder block main bearing housing inner diameter		Crankshaft main journal diameter		I.D. mark		Hole diameter Unit: mm (in)																	
			A	B	C	D	E	F	G	H	J	K	L	M	N	P	R	S	T	U	V	W	X	Y	1	2
I.D. mark	Axle diameter Unit: mm (in)		68.944 - 68.945 (2.7143 - 2.7144)	68.945 - 68.946 (2.7144 - 2.7144)	68.946 - 68.947 (2.7144 - 2.7144)	68.947 - 68.948 (2.7144 - 2.7145)	68.948 - 68.949 (2.7145 - 2.7145)	68.949 - 68.950 (2.7145 - 2.7146)	68.950 - 68.951 (2.7146 - 2.7146)	68.951 - 68.952 (2.7146 - 2.7146)	68.952 - 68.953 (2.7146 - 2.7147)	68.953 - 68.954 (2.7147 - 2.7147)	68.954 - 68.955 (2.7147 - 2.7148)	68.955 - 68.956 (2.7148 - 2.7148)	68.956 - 68.957 (2.7148 - 2.7148)	68.957 - 68.958 (2.7148 - 2.7149)	68.958 - 68.959 (2.7149 - 2.7149)	68.959 - 68.960 (2.7149 - 2.7150)	68.960 - 68.961 (2.7150 - 2.7150)	68.961 - 68.962 (2.7150 - 2.7150)	68.962 - 68.963 (2.7150 - 2.7151)	68.963 - 68.964 (2.7151 - 2.7151)	68.964 - 68.965 (2.7151 - 2.7152)	68.965 - 68.966 (2.7152 - 2.7152)	68.966 - 68.967 (2.7152 - 2.7152)	68.967 - 68.968 (2.7152 - 2.7153)
G	63.964 - 63.963 (2.5183 - 2.5182)		1	1	12	12	12	2	2	2	23	23	23	3	3	3	34	34	34	4	4	4	45	45	45	5
H	63.963 - 63.962 (2.5182 - 2.5182)		1	12	12	12	2	2	2	23	23	23	3	3	3	34	34	34	4	4	4	45	45	45	5	5
J	63.962 - 63.961 (2.5182 - 2.5181)		12	12	12	2	2	2	23	23	23	3	3	3	34	34	34	4	4	4	45	45	45	5	5	5
K	63.961 - 63.960 (2.5181 - 2.5181)		12	12	2	2	2	23	23	23	3	3	3	34	34	34	4	4	4	45	45	45	5	5	5	56
L	63.960 - 63.959 (2.5181 - 2.5181)		12	2	2	2	23	23	23	3	3	3	34	34	34	4	4	4	45	45	45	5	5	5	56	56
M	63.959 - 63.958 (2.5181 - 2.5180)		2	2	2	23	23	23	3	3	3	34	34	34	4	4	4	45	45	45	5	5	5	56	56	56
N	63.958 - 63.957 (2.5180 - 2.5180)		2	2	23	23	23	3	3	3	34	34	34	4	4	4	45	45	45	5	5	5	56	56	56	6
P	63.957 - 63.956 (2.5180 - 2.5179)		2	23	23	23	3	3	3	34	34	34	4	4	4	45	45	45	5	5	5	56	56	56	6	6
R	63.956 - 63.955 (2.5179 - 2.5179)		23	23	23	3	3	3	34	34	34	4	4	4	45	45	45	5	5	5	56	56	56	6	6	6
S	63.955 - 63.954 (2.5179 - 2.5179)		23	23	3	3	3	34	34	34	4	4	4	45	45	45	5	5	5	56	56	56	6	6	6	67
T	63.954 - 63.953 (2.5179 - 2.5178)		23	3	3	3	34	34	34	4	4	4	45	45	45	5	5	5	56	56	56	6	6	6	67	67
U	63.953 - 63.952 (2.5178 - 2.5178)		3	3	3	34	34	34	4	4	4	45	45	45	5	5	5	56	56	56	6	6	6	67	67	67
V	63.952 - 63.951 (2.5178 - 2.5178)		3	3	34	34	34	4	4	4	45	45	45	5	5	5	56	56	56	6	6	6	67	67	67	7
W	63.951 - 63.950 (2.5178 - 2.5177)		3	34	34	34	4	4	4	45	45	45	5	5	5	56	56	56	6	6	6	67	67	67	7	7
X	63.950 - 63.949 (2.5177 - 2.5177)		34	34	34	4	4	4	45	45	45	5	5	5	56	56	56	6	6	6	67	67	67	7	7	7
Y	63.949 - 63.948 (2.5177 - 2.5176)		34	34	4	4	4	45	45	45	5	5	5	56	56	56	6	6	6	67	67	67	7	7	7	78
1	63.948 - 63.947 (2.5176 - 2.5176)		34	4	4	4	45	45	45	5	5	5	56	56	56	6	6	6	67	67	67	7	7	7	78	78
2	63.947 - 63.946 (2.5176 - 2.5176)		4	4	4	45	45	45	5	5	5	56	56	56	6	6	6	67	67	67	7	7	7	78	78	78
3	63.946 - 63.945 (2.5176 - 2.5175)		4	4	45	45	45	5	5	5	56	56	56	6	6	6	67	67	67	7	7	7	78	78	78	8
4	63.945 - 63.944 (2.5175 - 2.5175)		4	45	45	45	5	5	5	56	56	56	6	6	6	67	67	67	7	7	7	78	78	78	8	8
5	63.944 - 63.943 (2.5175 - 2.5174)		45	45	45	5	5	5	56	56	56	6	6	6	67	67	67	7	7	7	78	78	78	8	8	8
6	63.943 - 63.942 (2.5174 - 2.5174)		45	45	5	5	5	56	56	56	6	6	6	67	67	67	7	7	7	78	78	78	8	8	8	8
7	63.942 - 63.941 (2.5174 - 2.5174)		45	5	5	5	56	56	56	6	6	6	67	67	67	7	7	7	78	78	78	8	8	8	8	8
9	63.941 - 63.940 (2.5174 - 2.5173)		5	5	5	56	56	56	6	6	6	67	67	67	7	7	7	78	78	78	8	8	8	8	8	8

PBIC2375E

CYLINDER BLOCK

< SERVICE INFORMATION >

[VK45DE]

Main Bearing Selection Table (No. 2, 3 and 4 Journal)

I.D. mark	Axle diameter Unit: mm (in)	Cylinder block main bearing housing inner diameter	Crankshaft main journal diameter	I.D. mark																									
				A	B	C	D	E	F	G	H	J	K	L	M	N	P	R	S	T	U	V	W	X	Y	1	2		
				68.944 - 68.945 (2.7143 - 2.7144)	68.945 - 68.946 (2.7144 - 2.7144)	68.946 - 68.947 (2.7144 - 2.7144)	68.947 - 68.948 (2.7144 - 2.7145)	68.948 - 68.949 (2.7145 - 2.7145)	68.949 - 68.950 (2.7145 - 2.7146)	68.950 - 68.951 (2.7146 - 2.7146)	68.951 - 68.952 (2.7146 - 2.7146)	68.952 - 68.953 (2.7146 - 2.7147)	68.953 - 68.954 (2.7147 - 2.7147)	68.954 - 68.955 (2.7147 - 2.7148)	68.955 - 68.956 (2.7148 - 2.7148)	68.956 - 68.957 (2.7148 - 2.7148)	68.957 - 68.958 (2.7148 - 2.7149)	68.958 - 68.959 (2.7149 - 2.7149)	68.959 - 68.960 (2.7149 - 2.7150)	68.960 - 68.961 (2.7150 - 2.7150)	68.961 - 68.962 (2.7150 - 2.7150)	68.962 - 68.963 (2.7150 - 2.7151)	68.963 - 68.964 (2.7151 - 2.7151)	68.964 - 68.965 (2.7151 - 2.7152)	68.965 - 68.966 (2.7152 - 2.7152)	68.966 - 68.967 (2.7152 - 2.7152)	68.967 - 68.968 (2.7152 - 2.7153)		
A	63.964 - 63.963 (2.5183 - 2.5182)	0	0	01	01	01	1	1	1	1	12	12	12	2	2	2	23	23	23	3	3	3	3	34	34	34	4	4	
B	63.963 - 63.962 (2.5182 - 2.5182)	0	01	01	01	1	1	1	1	12	12	12	2	2	2	23	23	23	3	3	3	3	34	34	34	4	4		
C	63.962 - 63.961 (2.5182 - 2.5181)	01	01	01	1	1	1	12	12	12	12	2	2	2	23	23	23	3	3	3	3	34	34	34	4	4			
D	63.961 - 63.960 (2.5181 - 2.5181)	01	01	1	1	1	12	12	12	2	2	2	23	23	23	3	3	3	3	34	34	34	4	4	4	4			
E	63.960 - 63.959 (2.5181 - 2.5181)	01	1	1	1	12	12	12	2	2	2	23	23	23	3	3	3	3	34	34	34	4	4	4	4				
F	63.959 - 63.958 (2.5181 - 2.5180)	1	1	1	12	12	12	2	2	2	23	23	23	3	3	3	34	34	34	4	4	4	4	4	4				
G	63.958 - 63.957 (2.5180 - 2.5180)	1	1	12	12	12	2	2	2	23	23	23	3	3	3	34	34	34	4	4	4	4	4	4	4				
H	63.957 - 63.956 (2.5180 - 2.5179)	1	12	12	12	2	2	2	23	23	23	3	3	3	34	34	34	4	4	4	4	4	4	4	4				
J	63.956 - 63.955 (2.5179 - 2.5179)	12	12	12	2	2	2	23	23	23	3	3	3	34	34	34	4	4	4	4	4	4	4	4	4				
K	63.955 - 63.954 (2.5179 - 2.5179)	12	12	2	2	2	23	23	23	3	3	3	34	34	34	4	4	4	4	4	4	4	4	4	4				
L	63.954 - 63.953 (2.5179 - 2.5178)	12	2	2	2	23	23	23	3	3	3	34	34	34	4	4	4	4	4	4	4	4	4	4	4				
M	63.953 - 63.952 (2.5178 - 2.5178)	2	2	2	23	23	23	3	3	3	34	34	34	4	4	4	4	4	4	4	4	4	4	4	4				
N	63.952 - 63.951 (2.5178 - 2.5178)	2	2	23	23	23	3	3	3	34	34	34	4	4	4	4	4	4	4	4	4	4	4	4	4				
P	63.951 - 63.950 (2.5178 - 2.5177)	2	23	23	23	3	3	3	34	34	34	4	4	4	4	4	4	4	4	4	4	4	4	4	4				
R	63.950 - 63.949 (2.5177 - 2.5177)	23	23	23	3	3	3	34	34	34	4	4	4	4	4	4	4	4	4	4	4	4	4	4	4				
S	63.949 - 63.948 (2.5177 - 2.5176)	23	23	3	3	3	34	34	34	4	4	4	4	4	4	4	4	4	4	4	4	4	4	4	4				
T	63.948 - 63.947 (2.5176 - 2.5176)	23	3	3	3	34	34	34	4	4	4	4	4	4	4	4	4	4	4	4	4	4	4	4	4				
U	63.947 - 63.946 (2.5176 - 2.5176)	3	3	3	34	34	34	4	4	4	4	4	4	4	4	4	4	4	4	4	4	4	4	4	4				
V	63.946 - 63.945 (2.5176 - 2.5175)	3	3	34	34	34	4	4	4	4	4	4	4	4	4	4	4	4	4	4	4	4	4	4	4				
W	63.945 - 63.944 (2.5175 - 2.5175)	3	34	34	34	4	4	4	4	4	4	4	4	4	4	4	4	4	4	4	4	4	4	4	4				
X	63.944 - 63.943 (2.5175 - 2.5174)	34	34	34	4	4	4	4	4	4	4	4	4	4	4	4	4	4	4	4	4	4	4	4	4				
Y	63.943 - 63.942 (2.5174 - 2.5174)	34	34	4	4	4	4	4	4	4	4	4	4	4	4	4	4	4	4	4	4	4	4	4	4				
1	63.942 - 63.941 (2.5174 - 2.5174)	34	4	4	4	4	4	4	4	4	4	4	4	4	4	4	4	4	4	4	4	4	4	4	4				
2	63.941 - 63.940 (2.5174 - 2.5173)	4	4	4	4	4	4	4	4	4	4	4	4	4	4	4	4	4	4	4	4	4	4	4	4				

PBIC2376E

Main Bearing Grade Table (All Journals)

Unit: mm (in)

Grade number	Thickness	Identification color	Remarks
0	2.483 - 2.486 (0.0978 - 0.0979)	Black	Grade and color are the same for upper and lower bearings.
1	2.486 - 2.489 (0.0979 - 0.0980)	Brown	
2	2.489 - 2.492 (0.0980 - 0.0981)	Green	
3	2.492 - 2.495 (0.0981 - 0.0982)	Yellow	
4	2.495 - 2.498 (0.0982 - 0.0983)	Blue	
5	2.498 - 2.501 (0.0983 - 0.0985)	Pink	
6	2.501 - 2.504 (0.0985 - 0.0986)	Purple	
7	2.504 - 2.507 (0.0986 - 0.0987)	White	
8	2.507 - 2.510 (0.0987 - 0.0988)	Red	

CYLINDER BLOCK

[VK45DE]

< SERVICE INFORMATION >

01	UPR	2.483 - 2.486 (0.0978 - 0.0979)	Black	Grade and color are different for upper and lower bearings.
	LWR	2.486 - 2.489 (0.0979 - 0.0980)	Brown	
12	UPR	2.486 - 2.489 (0.0979 - 0.0980)	Brown	
	LWR	2.489 - 2.492 (0.0980 - 0.0981)	Green	
23	UPR	2.489 - 2.492 (0.0980 - 0.0981)	Green	
	LWR	2.492 - 2.495 (0.0981 - 0.0982)	Yellow	
34	UPR	2.492 - 2.495 (0.0981 - 0.0982)	Yellow	
	LWR	2.495 - 2.498 (0.0982 - 0.0983)	Blue	
45	UPR	2.495 - 2.498 (0.0982 - 0.0983)	Blue	
	LWR	2.498 - 2.501 (0.0983 - 0.0985)	Pink	
56	UPR	2.498 - 2.501 (0.0983 - 0.0985)	Pink	
	LWR	2.501 - 2.504 (0.0985 - 0.0986)	Purple	
67	UPR	2.501 - 2.504 (0.0985 - 0.0986)	Purple	
	LWR	2.504 - 2.507 (0.0986 - 0.0987)	White	
78	UPR	2.504 - 2.507 (0.0986 - 0.0987)	White	
	LWR	2.507 - 2.510 (0.0987 - 0.0988)	Red	

Use Undersize Bearing Usage Guide

- When the specified main bearing oil clearance is not obtained with standard size main bearings, use undersize (US) bearing.
- When using undersize (US) bearing, measure the main bearing inner diameter with bearing installed, and grind main journal so that the main bearing oil clearance satisfies the standard.

CAUTION:

In grinding crankshaft main journal to use undersize bearings, keep the fillet R [1.5 mm (0.059 in)].

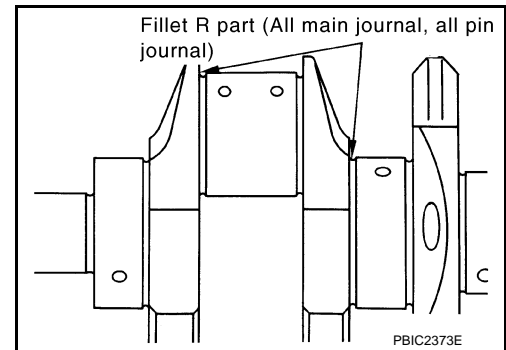

Bearing undersize table

Unit: mm (in)

Size	Thickness
US 0.25 (0.0098)	2.618 - 2.626 (0.1031 - 0.1034)

Inspection After Disassembly

INFOID:000000005348074

CRANKSHAFT END PLAY

- Measure the clearance between thrust bearings and crankshaft arm when crankshaft is moved fully forward or backward with dial indicator.

Standard : 0.10 - 0.25 mm (0.0039 - 0.0098 in)

Limit : 0.30 mm (0.0118 in)

- If the measured value exceeds the limit, replace thrust bearings, and measure again. If it still exceeds the limit, replace crankshaft also.

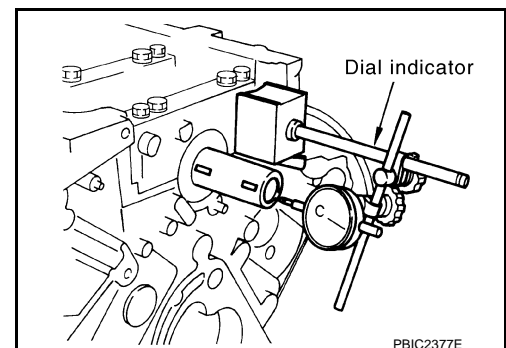

CYLINDER BLOCK

[VK45DE]

< SERVICE INFORMATION >

CONNECTING ROD SIDE CLEARANCE

- Measure the side clearance between connecting rod and crankshaft arm with feeler gauge.

Standard : 0.20 - 0.35 mm (0.0079 - 0.0138 in)

Limit : 0.40 mm (0.0157 in)

- If the measured value exceeds the limit, replace connecting rod, and measure again. If it still exceeds the limit, replace crankshaft also.

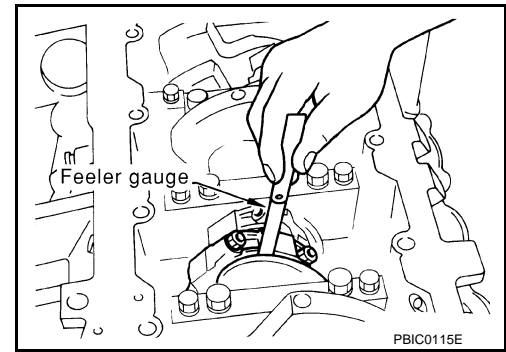

PISTON TO PISTON PIN OIL CLEARANCE

Piston Pin Hole Diameter

Measure the inner diameter of piston pin hole with inside micrometer.

Standard : 21.993 - 22.005 mm (0.8659 - 0.8663 in)

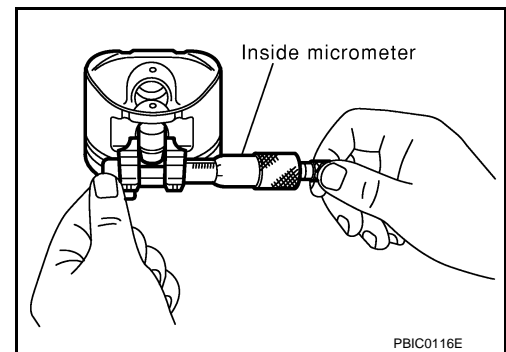

Piston Pin Outer Diameter

Measure the outer diameter of piston pin with micrometer.

Standard : 21.989 - 22.001 mm (0.8657 - 0.8662 in)

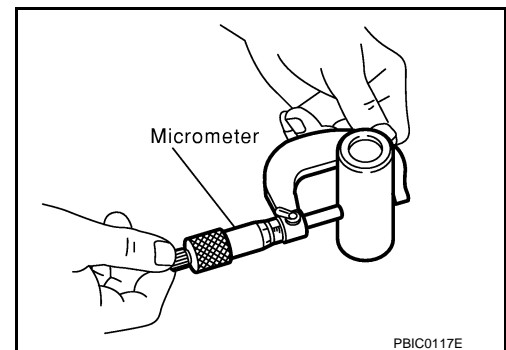

Piston to Piston Pin Oil Clearance

(Piston to piston pin oil clearance) = (Piston pin hole diameter) – (Piston pin outer diameter)

Standard : 0.002 - 0.006 mm (0.0001 - 0.0002 in)

- If the calculated value is out of the standard, replace piston and piston pin assembly.
- When replacing piston and piston pin assembly, refer to [EM-256. "How to Select Piston and Bearing"](#).

NOTE:

- Piston is available together with piston pin as assembly.
- Piston pin (piston pin hole) grade is provided only for the parts installed at the plant. For service parts, no piston pin grades can be selected. (Only "0" grade is available.)

PISTON RING SIDE CLEARANCE

CYLINDER BLOCK

[VK45DE]

< SERVICE INFORMATION >

- Measure the side clearance of piston ring and piston ring groove with feeler gauge.

Standard:

Top ring	: 0.045 - 0.080 mm (0.0018 - 0.0031 in)
2nd ring	: 0.030 - 0.070 mm (0.0012 - 0.0028 in)
Oil ring	: 0.065 - 0.135 mm (0.0026 - 0.0053 in)

Limit:

Top ring	: 0.11 mm (0.0043 in)
2nd ring	: 0.10 mm (0.0039 in)

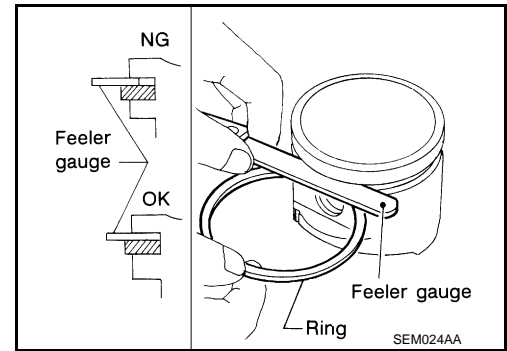

- If the measured value exceeds the limit, replace piston ring, and measure again. If it still exceeds the limit, replace piston also.

PISTON RING END GAP

- Check that the cylinder bore inner diameter is within the specification. Refer to "Cylinder Bore Inner Diameter".
- Lubricate with new engine oil to piston and piston ring, and then insert piston ring until middle of cylinder with piston, and measure the piston ring end gap with feeler gauge.

Standard:

Top ring	: 0.22 - 0.32 mm (0.0087 - 0.0126 in)
2nd ring	: 0.22 - 0.32 mm (0.0087 - 0.0126 in)
Oil ring	: 0.20 - 0.50 mm (0.0079 - 0.0197 in)

Limit:

Top ring	: 0.56 mm (0.0220 in)
2nd ring	: 0.56 mm (0.0220 in)
Oil ring	: 0.96 mm (0.0378 in)

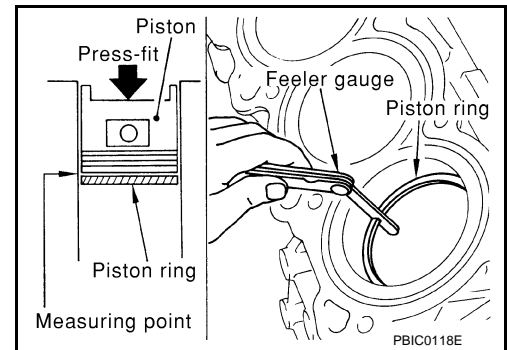

- If the measured value exceeds the limit, replace piston ring, and measure again. If it still exceeds the limit, rebore cylinder and use oversize piston and piston rings.

CONNECTING ROD BEND AND TORSION

- Check with connecting rod aligner.

Bend:

Limit: 0.15 mm (0.0059 in) per 100 mm (3.94 in) length

Torsion:

Limit: 0.30 mm (0.0118 in) per 100 mm (3.94 in) length

- If it exceeds the limit, replace connecting rod assembly.

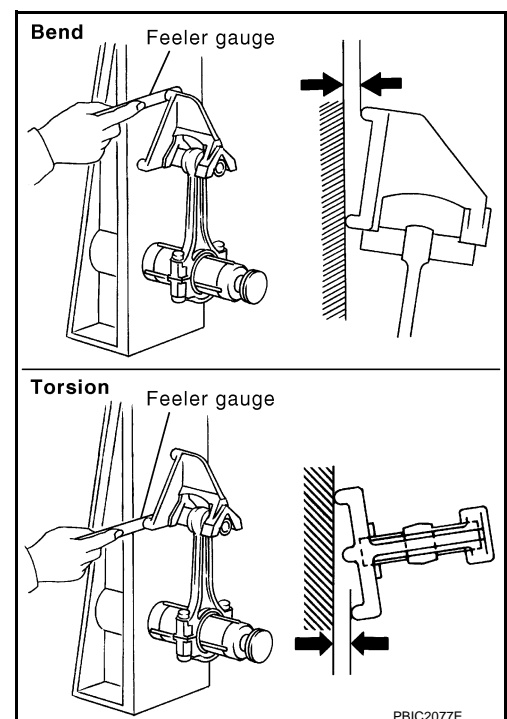

CYLINDER BLOCK

[VK45DE]

< SERVICE INFORMATION >

CONNECTING ROD BIG END DIAMETER

- Install connecting rod bearing cap without installing connecting rod bearing, and tightening connecting rod bolts to the specified torque. Refer to [EM-247, "Disassembly and Assembly"](#) for the tightening procedure.
- Measure the inner diameter of connecting rod big end with inside micrometer.

Standard : 55.000 - 55.013 mm (2.1654 - 2.1659 in)

- If out of the standard, replace connecting rod assembly.

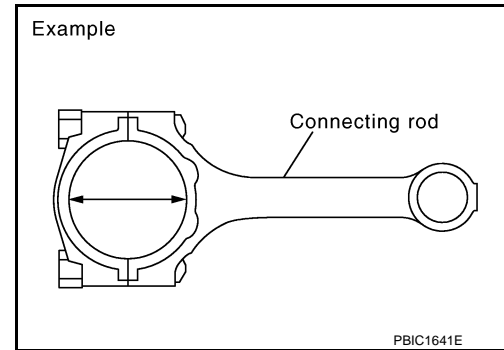

CONNECTING ROD BUSHING OIL CLEARANCE

Connecting Rod Bushing Inner Diameter

Measure the inner diameter of connecting rod bushing with inside micrometer.

Standard : 22.000 - 22.012 mm (0.8661 - 0.8666 in)

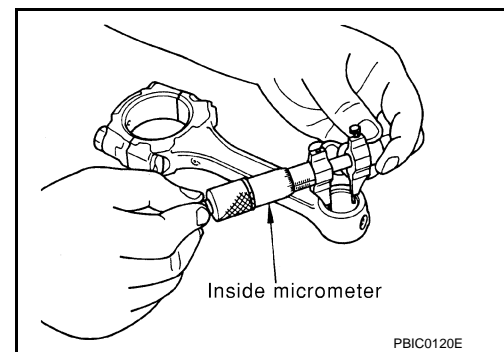

Piston Pin Outer Diameter

Measure the outer diameter of piston pin with micrometer.

Standard : 21.989 - 22.001 mm (0.8657 - 0.8662 in)

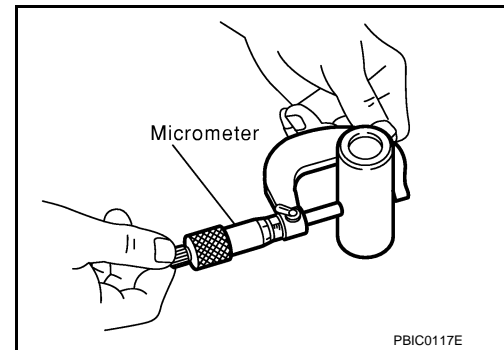

Connecting Rod Bushing Oil Clearance

(Connecting rod bushing oil clearance) = (Connecting rod bushing inner diameter) – (Piston pin outer diameter)

Standard : 0.005 - 0.017 mm (0.0002 - 0.0007 in)

Limit : 0.030 mm (0.0012 in)

- If the calculated value exceeds the limit, replace connecting rod assembly and/or piston and piston pin assembly.
- If replacing piston and piston pin assembly, refer to [EM-256, "How to Select Piston and Bearing"](#).

CYLINDER BLOCK

[VK45DE]

< SERVICE INFORMATION >

- If replacing connecting rod assembly, refer to "CONNECTING ROD BEARING OIL CLEARANCE" to select the connecting rod bearing.

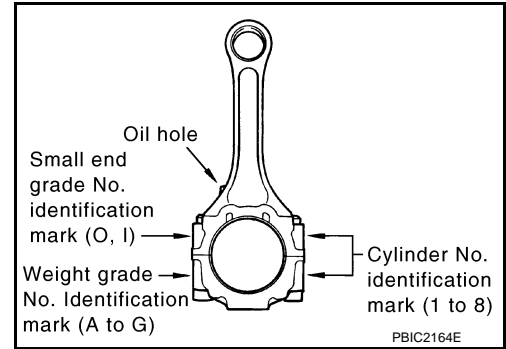

Factory installed parts grading:

- Service parts apply only to grade "0".

Grade	Unit: mm (in)	
	0	1
Connecting rod bushing inner diameter *	22.000 - 22.006 (0.8661 - 0.8664)	22.006 - 22.012 (0.8664 - 0.8666)
Piston pin hole diameter	21.993 - 21.999 (0.8659 - 0.8661)	21.999 - 22.005 (0.8661 - 0.8663)
Piston pin outer diameter	21.989 - 21.995 (0.8657 - 0.8659)	21.995 - 22.001 (0.8659 - 0.8662)

*: After installing in connecting rod

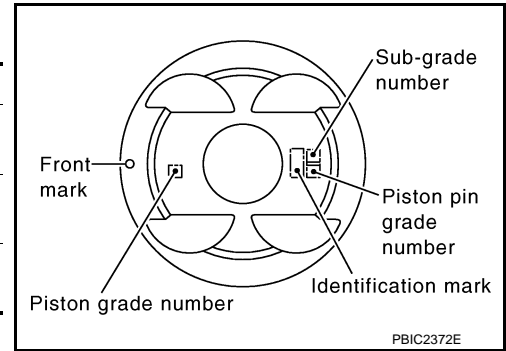

CYLINDER BLOCK DISTORTION

- Using scraper, remove gasket on the cylinder block surface, and also remove engine oil, scale, carbon, or other contamination.

CAUTION:

Be careful not to allow gasket flakes to enter engine oil or engine coolant passages.

- Measure the distortion on the cylinder block upper face at some different points in six directions with straightedge and feeler gauge.

Limit : 0.1 mm (0.004 in)

- If it exceeds the limit, replace cylinder block.

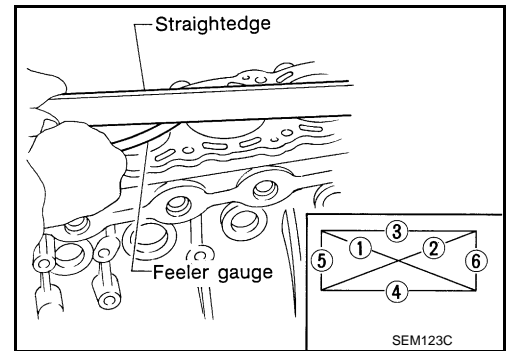

MAIN BEARING HOUSING INNER DIAMETER

- Install main bearing caps and main bearing without installing main bearings, and tighten main bearing cap bolts to the specified torque. Refer to [EM-247. "Disassembly and Assembly"](#) for the tightening procedure.
- Measure the inner diameter of main bearing housing with bore gauge.

Standard : 68.944 - 68.968 mm (2.7143 - 2.7153 in)

- If out of the standard, replace cylinder block and main bearing caps as assembly.

NOTE:

Cylinder block cannot be replaced as a single part, because it is machined together with main bearing caps.

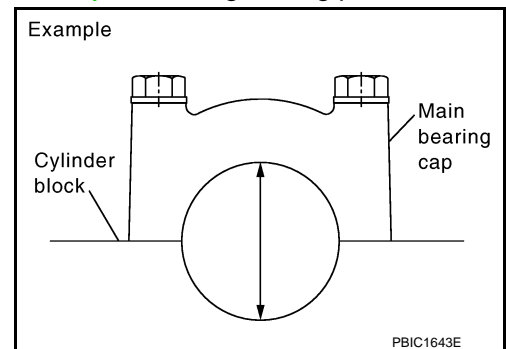

PISTON TO CYLINDER BORE CLEARANCE

Cylinder Bore Inner Diameter

CYLINDER BLOCK

[VK45DE]

< SERVICE INFORMATION >

- Using bore gauge, measure cylinder bore for wear, out-of-round and taper at six different points on each cylinder. ("X" and "Y" directions at "A", "B" and "C") ("X" is in longitudinal direction of engine)

Standard inner diameter:

93.000 - 93.030 mm (3.6614 - 3.6626 in)

Wear limit:

0.2 mm (0.008 in)

Out-of-round (Difference between "X" and "Y"):

0.015 mm (0.0006 in)

Taper limit (Difference between "A" and "C"):

0.01 mm (0.0004 in)

- If the measured value exceeds the limit, or if there are scratches and/or seizure on the cylinder inner wall, hone or rebore the inner wall.
- Oversize piston is provided. When using oversize piston, rebore cylinder so that the clearance of the piston-to-cylinder bore satisfies the standard.

CAUTION:

When using oversize piston, use oversize pistons for all cylinders with oversize piston rings.

Oversize (O/S) : 0.2 mm (0.008 in)

Piston Skirt Diameter

- Measure the outer diameter of piston skirt with micrometer.

Standard

: 92.980 - 93.010 mm (3.6606 - 3.6618 in)

- Measure point "H" (Distance from the top): 42 mm (1.65 in)

Piston to Cylinder Bore Clearance

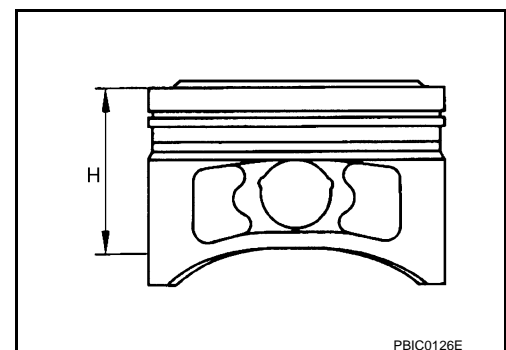
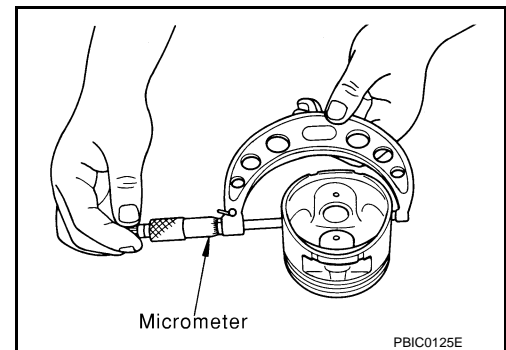
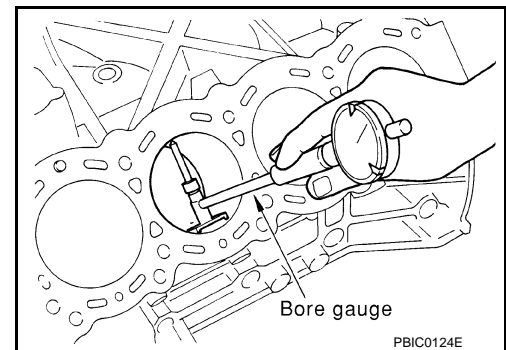
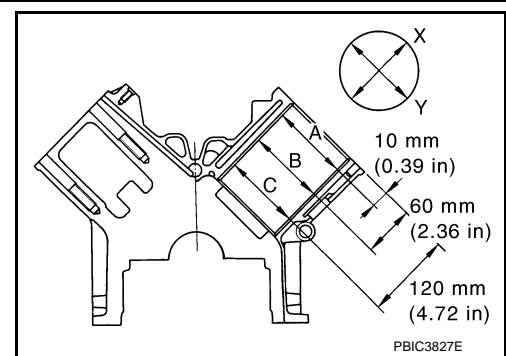

A
EM
C
D
E
F
G
H
I
J
K
L
M
N
O
P

CYLINDER BLOCK

[VK45DE]

< SERVICE INFORMATION >

Calculate by piston skirt diameter and cylinder bore inner diameter (direction "Y", position "B").
(Clearance) = (Cylinder bore inner diameter) – (Piston skirt diameter)

Standard : 0.010 - 0.030 mm (0.0004 - 0.0012 in)
Limit : 0.08 mm (0.0031 in)

- If the calculated value exceeds the limit, replace piston and piston pin assembly. Refer to [EM-256. "How to Select Piston and Bearing"](#).

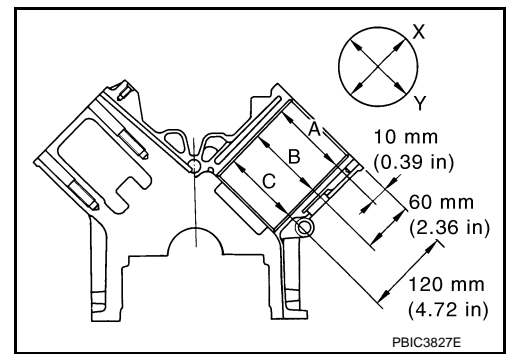

Reboring Cylinder Bore

1. Cylinder bore size is determined by adding piston to cylinder bore clearance to piston skirt diameter.

Rebored size calculation: $D = A + B - C$

where,

A: Piston skirt diameter as measured

B: Piston to cylinder bore clearance (standard value)

C: Honing allowance 0.02 mm (0.0008 in)

D: Bored diameter

2. Install main bearing caps and main bearing, and tighten to the specified torque. Otherwise, cylinder bores may be distorted in final assembly.
3. Cut cylinder bores.
NOTE:
 - When any cylinder needs boring, all other cylinders must also be bored.
 - Do not cut too much out of cylinder bore at a time. Cut only 0.05 mm (0.0020 in) or so in diameter at a time.
- 4.hone cylinders to obtain the specified piston to cylinder bore clearance.
5. Measure finished cylinder bore for the out-of-round and taper.

NOTE:

Measurement should be done after cylinder bore cools down.

CRANKSHAFT MAIN JOURNAL DIAMETER

- Measure the outer diameter of crankshaft main journals with micrometer.

Standard : 63.940 - 63.964 mm (2.5173 - 2.5183 in) dia.

- If out of the standard, measure the main bearing oil clearance. Then use undersize bearing. Refer to "MAIN BEARING OIL CLEARANCE".

CRANKSHAFT PIN JOURNAL DIAMETER

- Measure the outer diameter of crankshaft pin journal with micrometer.

Standard : 51.956 - 51.974 mm (2.0455 - 2.0462 in) dia.

- If out of the standard, measure the connecting rod bearing oil clearance. Then use undersize bearing. Refer to "CONNECTING ROD BEARING OIL CLEARANCE".

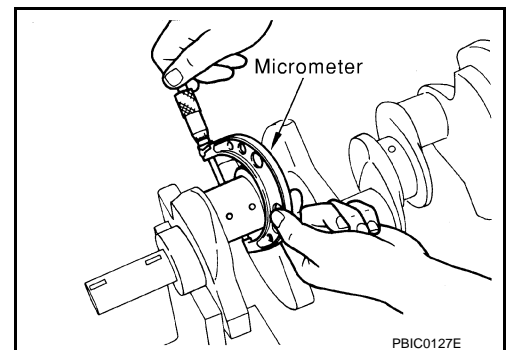

CRANKSHAFT OUT-OF-ROUND AND TAPER

CYLINDER BLOCK

[VK45DE]

< SERVICE INFORMATION >

- Measure the dimensions at four different points as shown in the figure on each main journal and pin journal with micrometer.
- Out-of-round is indicated by the difference in the dimensions between "X" and "Y" at "A" and "B".
- Taper is indicated by the difference in the dimensions between "A" and "B" at "X" and "Y".

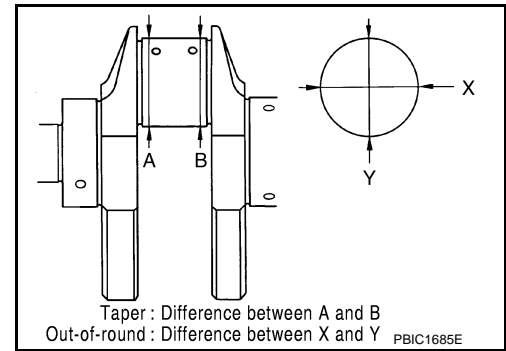

Limit:

Out-of-round (Difference between "X" and "Y")

: 0.015 mm (0.0006 in)

Taper (Difference between "A" and "B")

: 0.010 mm (0.0004 in)

- If the measured value exceeds the limit, correct or replace crankshaft.
- If corrected, measure the bearing oil clearance of the corrected main journal and/or pin journal. Then select the main bearing and/or connecting rod bearing. Refer to "MAIN BEARING OIL CLEARANCE" and/or "CONNECTING ROD BEARING OIL CLEARANCE".

CRANKSHAFT RUNOUT

- Place V-block on precise flat table, and support the journals on the both end of crankshaft.
- Place dial indicator straight up on the No. 3 journal.
- While rotating crankshaft, read the movement of the pointer on dial indicator (total indicator reading).

Standard : Less than 0.05 mm (0.0020 in)

Limit : 0.10 mm (0.0039 in)

- If it exceeds the limit, replace crankshaft.

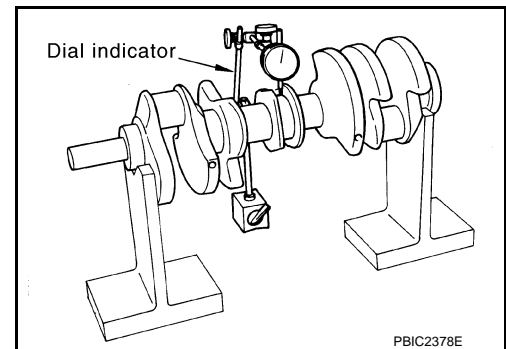

CONNECTING ROD BEARING OIL CLEARANCE

Method by Calculation

- Install connecting rod bearings to connecting rod and cap, and tighten connecting rod bolts to the specified torque. Refer to [EM-247, "Disassembly and Assembly"](#) for the tightening procedure.
 - Measure the inner diameter of connecting rod bearing with inside micrometer.
- (Bearing oil clearance) = (Connecting rod bearing inner diameter) – (Crankshaft pin journal diameter)

Standard : 0.020 - 0.045 mm (0.0008 - 0.0018 in) (actual clearance)

Limit : 0.055 mm (0.0022 in)

- If the calculated value exceeds the limit, select proper connecting rod bearing according to connecting rod big end diameter and crankshaft pin journal diameter to obtain the specified bearing oil clearance. Refer to [EM-256, "How to Select Piston and Bearing"](#).

Method of Using Plastigage

- Remove oil and dust on crankshaft pin journal and the surfaces of each bearing completely.
- Cut plastigage slightly shorter than the bearing width, and place it in crankshaft axial direction, avoiding oil holes.
- Install connecting rod bearings to connecting rod and cap, and tighten connecting rod bolts to the specified torque. Refer to [EM-247, "Disassembly and Assembly"](#) for the tightening procedure.

CAUTION:

Never rotate crankshaft.

CYLINDER BLOCK

[VK45DE]

< SERVICE INFORMATION >

- Remove connecting rod bearing cap and bearing, and using scale on plastigage bag, measure the plastigage width.

NOTE:

The procedure when the measured value exceeds the limit is same as that described in the "Method by Calculation".

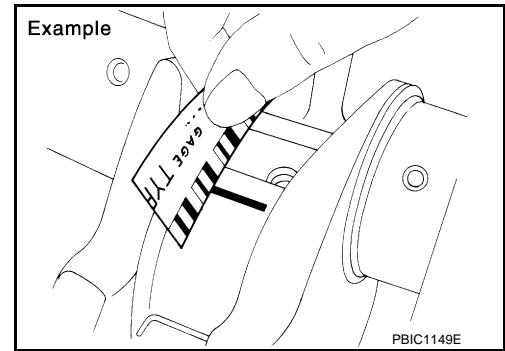

MAIN BEARING OIL CLEARANCE

Method by Calculation

- Install main bearings to cylinder block and main bearing caps, and tighten main bearing cap bolts with main bearing to the specified torque. Refer to [EM-247. "Disassembly and Assembly"](#) for the tightening procedure.
- Measure the inner diameter of main bearing with bore gauge.

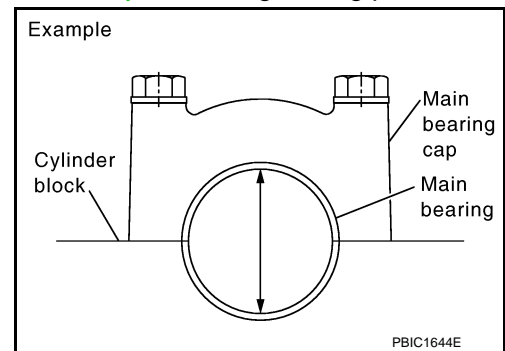

$$(\text{Bearing clearance}) = (\text{Main bearing inner diameter}) - (\text{Crankshaft main journal diameter})$$

Standard

No. 1 and 5 journal : 0.001 - 0.011 mm (0.00004 - 0.0004 in)

No. 2, 3 and 4 journal : 0.007 - 0.017 mm (0.0003 - 0.0007 in)

Limit

No. 1 and 5 journal : 0.021 mm (0.0008 in)

No. 2, 3 and 4 journal : 0.027 mm (0.0011 in)

- If the calculated value exceeds the limit, select proper main bearing according to main bearing inner diameter and crankshaft main journal diameter to obtain the specified bearing oil clearance. Refer to [EM-256. "How to Select Piston and Bearing"](#).

Method of Using Plastigage

- Remove oil and dust on crankshaft main journal and the surfaces of each bearing completely.
- Cut plastigage slightly shorter than the bearing width, and place it in crankshaft axial direction, avoiding oil holes.
- Install main bearings to cylinder block and main bearing caps, and tighten main bearing bolts with main bearing to the specified torque. Refer to [EM-247. "Disassembly and Assembly"](#) for the tightening procedure.

CAUTION:

Never rotate crankshaft.

CYLINDER BLOCK

[VK45DE]

< SERVICE INFORMATION >

- Remove main bearing caps and bearings, and using scale on plastigage bag, measure the plastigage width.

NOTE:

The procedure when the measured value exceeds the limit is same as that described in the "Method by Calculation".

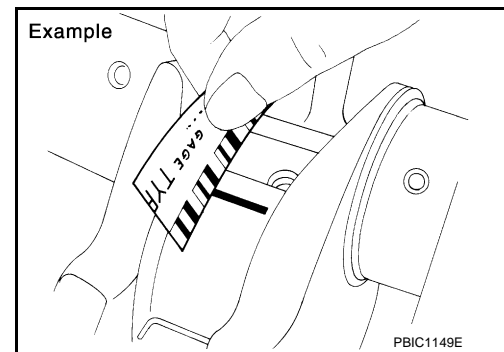

CRUSH HEIGHT OF MAIN BEARING

- When main bearing cap is removed after being tightened to the specified torque with main bearings installed, the tip end of bearing must protrude. Refer to [EM-247, "Disassembly and Assembly"](#) for the tightening procedure.

Standard : There must be crush height.

- If the standard is not met, replace main bearings.

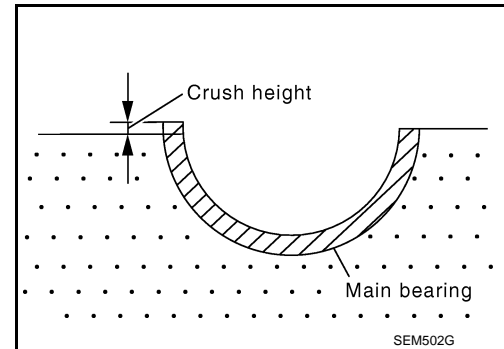

CRUSH HEIGHT OF CONNECTING ROD BEARING

- When connecting rod bearing cap is removed after being tightened to the specified torque with connecting rod bearings installed, the tip end of bearing must protrude. Refer to [EM-247, "Disassembly and Assembly"](#) for the tightening procedure.

Standard : There must be crush height.

- If the standard is not met, replace connecting rod bearings.

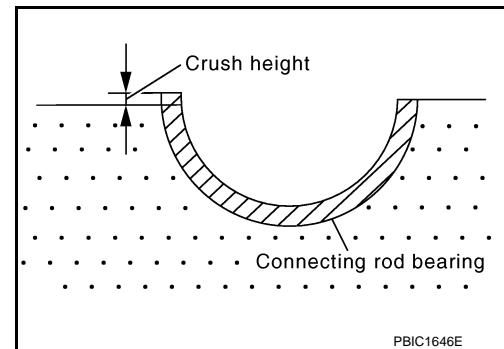

DRIVE PLATE

- Check drive plate and signal plate for deformation or cracks.

CAUTION:

- Never disassemble drive plate.
- Never place drive plate with signal plate facing down.
- When handling signal plate, take care not to damage or scratch it.
- Handle signal plate in a manner that prevents it from becoming magnetized.
- If anything is found, replace drive plate.

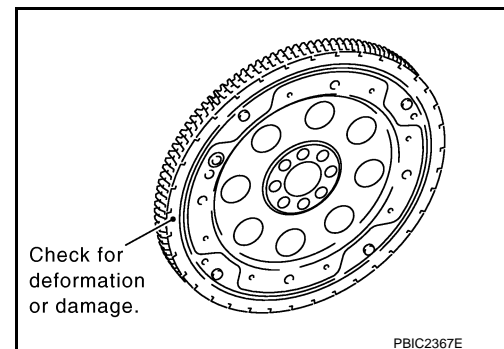

SERVICE DATA AND SPECIFICATIONS (SDS)

< SERVICE INFORMATION >

[VK45DE]

SERVICE DATA AND SPECIFICATIONS (SDS)

Standard and Limit

INFOID:000000005348075

GENERAL SPECIFICATIONS

Cylinder arrangement		V-8
Displacement cm ³ (cu in)		4,494 (274.22)
Bore and stroke mm (in)		93 x 82.7 (3.66 x 3.256)
Valve arrangement		DOHC
Firing order		1-8-7-3-6-5-4-2
Number of piston rings	Compression	2
	Oil	1
Number of main bearings		5
Compression ratio		10.5
Compression pressure kPa (kg/cm ² , psi)/300 rpm	Standard	1,320 (13.5, 191)
	Minimum	1,130 (11.5, 164)
	Differential limit between cylinders	98 (1.0, 14)

Cylinder number

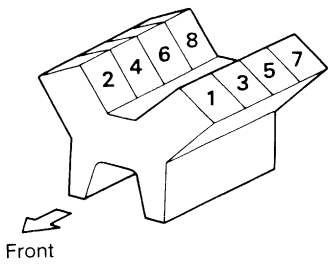

SEM957C

Valve timing

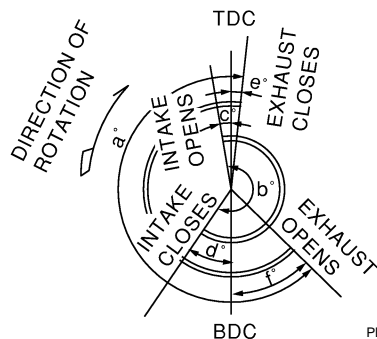

PBIC0187E

Unit: degree

a	b	c	d	e	f
228	240	-2	62	4	44

DRIVE BELTS

Tension of drive belts	Auto adjustment by auto tensioner
------------------------	-----------------------------------

INTAKE MANIFOLD AND EXHAUST MANIFOLD

SERVICE DATA AND SPECIFICATIONS (SDS)

< SERVICE INFORMATION >

[VK45DE]

Unit: mm (in)

	Items	Limit
Surface distortion	Intake manifold (upper)	0.1 (0.004)
	Intake manifold (lower)	0.1 (0.004)
	Exhaust manifold	0.3 (0.012)

SPARK PLUG

Unit: mm (in)

Make	NGK
Standard type	PLFR5A-11
Hot type	PLFR4A-11
Cold type	PLFR6A-11
Gap (Nominal)	1.1 (0.043)

CAMSHAFT AND CAMSHAFT BEARING

Unit: mm (in)

	Items	Standard	Limit
Camshaft journal oil clearance	No. 1	0.045 - 0.083 (0.0018 - 0.0033)	—
	No. 2, 3, 4, 5	0.030 - 0.068 (0.0012 - 0.0027)	—
Camshaft journal diameter	No. 1	25.938 - 25.955 (1.0212 - 1.0218)	—
	No. 2, 3, 4, 5	25.953 - 25.970 (1.0218 - 1.0224)	—
Camshaft bracket inner diameter		26.000 - 26.021 (1.0236 - 1.0244)	—
Camshaft end play		0.115 - 0.188 (0.0045 - 0.0074)	—
Cam height "A"	Intake	44.865 - 45.055 (1.7663 - 1.7738)	0.2 (0.008)
	Exhaust	43.925 - 44.115 (1.7293 - 1.7368)	0.2 (0.008)
Camshaft runout (TIR*)		0.02 (0.0008)	0.05 (0.0020)
Camshaft sprocket runout (TIR*)		—	0.15 (0.0059)

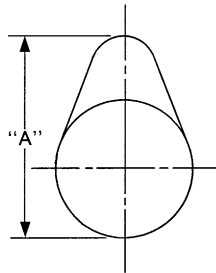

*: Total indicator reading

VALVE CLEARANCE

Unit: mm (in)

Items	Cold	Hot* (reference data)
Intake	0.26 - 0.34 (0.010 - 0.013)	0.304 - 0.416 (0.012 - 0.016)
Exhaust	0.29 - 0.37 (0.011 - 0.015)	0.308 - 0.432 (0.012 - 0.017)

*: Approximately 80°C (176°F)

AVAILABLE VALVE LIFTER

SERVICE DATA AND SPECIFICATIONS (SDS)

< SERVICE INFORMATION >

[VK45DE]

Unit: mm (in)

Identification (stamped) mark	Thickness
788	7.88 (0.3102)
790	7.90 (0.3110)
792	7.92 (0.3118)
794	7.94 (0.3126)
796	7.96 (0.3134)
798	7.98 (0.3142)
800	8.00 (0.3150)
802	8.02 (0.3157)
804	8.04 (0.3165)
806	8.06 (0.3173)
808	8.08 (0.3181)
810	8.10 (0.3189)
812	8.12 (0.3197)
814	8.14 (0.3205)
816	8.16 (0.3213)
818	8.18 (0.3220)
820	8.20 (0.3228)
822	8.22 (0.3236)
824	8.24 (0.3244)
826	8.26 (0.3252)
828	8.28 (0.3260)
830	8.30 (0.3268)
832	8.32 (0.3276)
834	8.34 (0.3283)
836	8.36 (0.3291)
838	8.38 (0.3299)
840	8.40 (0.3307)

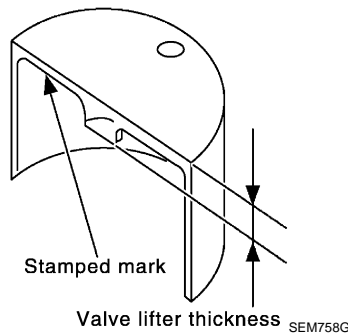

VALVE LIFTER

Unit: mm (in)

Items	Standard
Valve lifter outer diameter	33.977 - 33.987 (1.3377 - 1.3381)
Valve lifter hole diameter	34.000 - 34.016 (1.3386 - 1.3392)
Valve lifter clearance	0.013 - 0.039 (0.0005 - 0.0015)

CYLINDER HEAD

SERVICE DATA AND SPECIFICATIONS (SDS)

< SERVICE INFORMATION >

[VK45DE]

Unit: mm (in)

Items	Standard	Limit
Surface distortion	Less than 0.03 (0.0012)	0.1 (0.004)

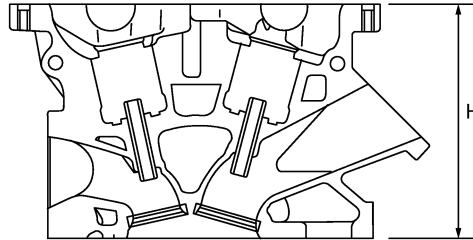

Nominal cylinder head height:
H = 126.4 mm (4.98 in)

PBIC0183E

VALVE DIMENSIONS

Unit: mm (in)

Items	Standard	
Valve head diameter "D"	Intake	36.0 - 36.3 (1.417 - 1.429)
	Exhaust	31.2 - 31.5 (1.228 - 1.240)
Valve length "L"	Intake	96.57 (3.8020)
	Exhaust	94.50 (3.7205)
Valve stem diameter "d"	Intake	5.972 - 5.980 (0.2351 - 0.2354)
	Exhaust	5.962 - 5.970 (0.2347 - 0.2350)
Valve seat angle "α"	Intake	45°15' - 45°45'
	Exhaust	
Valve margin "T"	Intake	1.15 - 1.45 (0.0453 - 0.0571)
	Exhaust	1.85 - 2.15 (0.0728 - 0.0846)

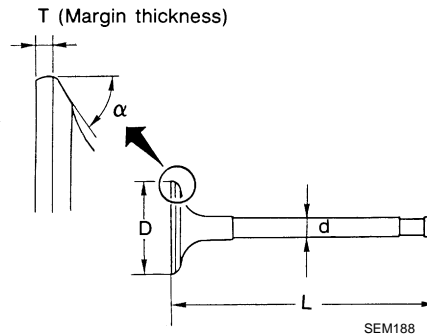

VALVE GUIDE

Unit: mm (in)

Items	Standard	Oversize (Service) [0.2 (0.008)]
Valve guide	Outer diameter	10.023 - 10.034 (0.3946 - 0.3950)
	Inner diameter (Finished size)	6.000 - 6.018 (0.2362 - 0.2369)
Cylinder head valve guide hole diameter	9.975 - 9.996 (0.3927 - 0.3935)	10.175 - 10.196 (0.4006 - 0.4014)
Interference fit of valve guide	0.027 - 0.059 (0.0011 - 0.0023)	
Items	Standard	Limit
Valve guide clearance	Intake	0.020 - 0.046 (0.0008 - 0.0018)
	Exhaust	0.030 - 0.056 (0.0012 - 0.0022)
		0.1 (0.004)

SERVICE DATA AND SPECIFICATIONS (SDS)

< SERVICE INFORMATION >

[VK45DE]

Items	Standard	Oversize (Service) [0.2 (0.008)]
Projection length "L"	Intake	10.1 - 10.3 (0.398 - 0.406)
	Exhaust	10.0 - 10.4 (0.394 - 0.409)

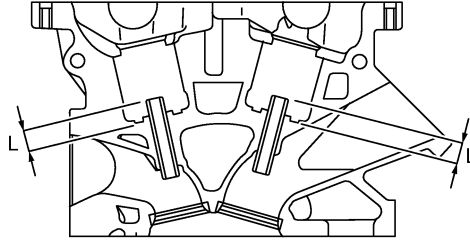

PBIC0184E

VALVE SEAT

Unit: mm (in)

* : Machining data
 *1 : 44°45'±22'
 Contacting width (W)
 ; 1.0 - 1.4 (0.039 - 0.055)

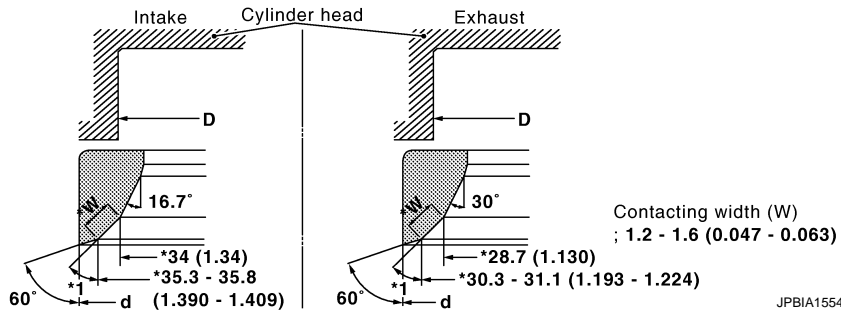

JPBIA1554GB

Items	Standard	Oversize (Service) [0.5 (0.020)]
Cylinder head seat recess diameter "D"	Intake	37.000 - 37.016 (1.4567 - 1.4573)
	Exhaust	32.200 - 32.216 (1.2677 - 1.2683)
Valve seat interference fit	Intake	0.081 - 0.113 (0.0032 - 0.0044)
	Exhaust	0.064 - 0.096 (0.0025 - 0.0038)
Valve seat outer diameter "d"	Intake	37.097 - 37.113 (1.4605 - 1.4611)
	Exhaust	32.280 - 32.296 (1.2709 - 1.2715)

VALVE SPRING

Free height	mm (in)	46.35 - 46.85 (1.8248 - 1.8445)
Pressure	N (kg, lb) at height mm (in)	Installation 165 - 189 (16.8 - 19.3, 37 - 42) at 33.8 (1.331)
		Valve open 290 - 330 (29.6 - 33.7, 65 - 74) at 24.4 (0.961)
Out-of-square	mm (in)	Limit 2.0 (0.079)

CYLINDER BLOCK

SERVICE DATA AND SPECIFICATIONS (SDS)

< SERVICE INFORMATION >

[VK45DE]

Unit: mm (in)

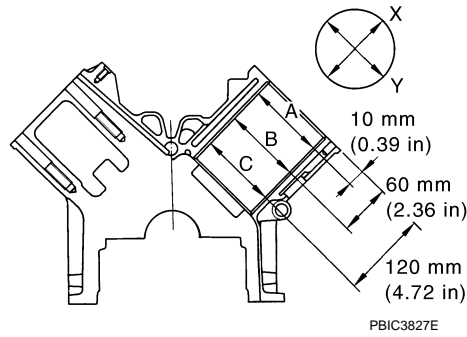

Surface distortion	Standard	Less than 0.03 (0.0012)	
	Limit	0.1 (0.004)	
Main bearing housing inner diameter	Standard	68.944 - 68.968 (2.7143 - 2.7153)	
Cylinder bore inner diameter	Standard	Grade No. 1	93.000 - 93.010 (3.6614 - 3.6618)
		Grade No. 2	93.010 - 93.020 (3.6618 - 3.6622)
		Grade No. 3	93.020 - 93.030 (3.6622 - 3.6626)
	Wear limit	0.2 (0.008)	
Out-of-round (Difference between "X" and "Y")	Limit	0.015 (0.0006)	
Taper (Difference between "A" and "C")		0.01 (0.0004)	
Main bearing housing inner diameter (Without bearing)	Grade No. A	68.944 - 68.945 (2.7143 - 2.7144)	
	Grade No. B	68.945 - 68.946 (2.7144 - 2.7144)	
	Grade No. C	68.946 - 68.947 (2.7144 - 2.7144)	
	Grade No. D	68.947 - 68.948 (2.7144 - 2.7145)	
	Grade No. E	68.948 - 68.949 (2.7145 - 2.7145)	
	Grade No. F	68.949 - 68.950 (2.7145 - 2.7146)	
	Grade No. G	68.950 - 68.951 (2.7146 - 2.7146)	
	Grade No. H	68.951 - 68.952 (2.7146 - 2.7146)	
	Grade No. J	68.952 - 68.953 (2.7146 - 2.7147)	
	Grade No. K	68.953 - 68.954 (2.7147 - 2.7147)	
	Grade No. L	68.954 - 68.955 (2.7147 - 2.7148)	
	Grade No. M	68.955 - 68.956 (2.7148 - 2.7148)	
	Grade No. N	68.956 - 68.957 (2.7148 - 2.7148)	
	Grade No. P	68.957 - 68.958 (2.7148 - 2.7149)	
	Grade No. R	68.958 - 68.959 (2.7149 - 2.7149)	
	Grade No. S	68.959 - 68.960 (2.7149 - 2.7150)	
	Grade No. T	68.960 - 68.961 (2.7150 - 2.7150)	
	Grade No. U	68.961 - 68.962 (2.7150 - 2.7150)	
	Grade No. V	68.962 - 68.963 (2.7150 - 2.7151)	
	Grade No. W	68.963 - 68.964 (2.7151 - 2.7151)	
Grade No. X	68.964 - 68.965 (2.7151 - 2.7152)		
Grade No. Y	68.965 - 68.966 (2.7152 - 2.7152)		
Grade No. 1	68.966 - 68.967 (2.7152 - 2.7152)		
Grade No. 2	68.967 - 68.968 (2.7152 - 2.7153)		
Difference in inner diameter between cylinders	Standard	Less than 0.03 (0.0012)	

PISTON, PISTON RING AND PISTON PIN

AVAILABLE PISTON

SERVICE DATA AND SPECIFICATIONS (SDS)

< SERVICE INFORMATION >

[VK45DE]

Unit: mm (in)

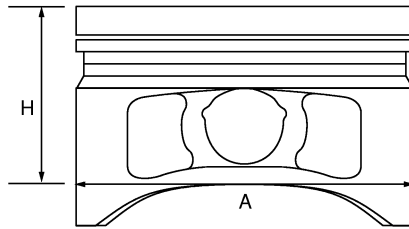

PBIC0188E

Items		Standard	Oversize (Service) [0.2 (0.008)]
Piston skirt diameter "A"	Grade No. 1	92.980 - 92.990 (3.6606 - 3.6610)	—
	Grade No. 2	92.990 - 93.000 (3.6610 - 3.6614)	—
	Grade No. 3	93.000 - 93.010 (3.6614 - 3.6618)	—
	Service	—	93.180 - 93.210 (3.6685 - 3.6697)
"H" dimension		42 (1.65)	
Piston pin hole diameter	Grade No. 0	21.993 - 21.999 (0.8659 - 0.8661)	
	Grade No. 1	21.999 - 22.005 (0.8661 - 0.8663)	
Piston to cylinder bore clearance	Standard	0.010 - 0.030 (0.0004 - 0.0012)	
	Limit	0.08 (0.0031)	

PISTON RING

Unit: mm (in)

Items		Standard	Limit
Side clearance	Top	0.045 - 0.080 (0.0018 - 0.0031)	0.11 (0.0043)
	2nd	0.030 - 0.070 (0.0012 - 0.0028)	0.10 (0.0039)
	Oil ring	0.065 - 0.135 (0.0026 - 0.0053)	—
End gap	Top	0.22 - 0.32 (0.0087 - 0.0126)	0.56 (0.0220)
	2nd	0.22 - 0.32 (0.0087 - 0.0126)	0.56 (0.0220)
	Oil (rail ring)	0.20 - 0.50 (0.0079 - 0.0197)	0.96 (0.0378)

PISTON PIN

Unit: mm (in)

Items		Standard	Limit
Piston pin outer diameter	Grade No. 0	21.989 - 21.995 (0.8657 - 0.8659)	—
	Grade No. 1	21.995 - 22.001 (0.8659 - 0.8662)	—
Piston to piston pin oil clearance		0.002 - 0.006 (0.0001 - 0.0002)	—
Connecting rod bushing oil clearance		0.005 - 0.017 (0.0002 - 0.0007)	0.030 (0.0012)

CONNECTING ROD

Unit: mm (in)

Items		Standard	Limit
Center distance		146.95 - 147.05 (5.79 - 5.79)	—
Bend [per 100 (3.94)]		—	0.15 (0.0059)
Torsion [per 100 (3.94)]		—	0.30 (0.0118)
Connecting rod bushing inner diameter*	Grade No. 0	22.000 - 22.006 (0.8661 - 0.8664)	—
	Grade No. 1	22.006 - 22.012 (0.8664 - 0.8666)	—

SERVICE DATA AND SPECIFICATIONS (SDS)

< SERVICE INFORMATION >

[VK45DE]

Items	Standard	Limit
Connecting rod big end diameter (without bearing)	55.000 - 55.013 (2.1654 - 2.1659)	—
Side clearance	0.20 - 0.35 (0.0079 - 0.0138)	0.40 (0.0157)

*: After installing in connecting rod

CRANKSHAFT

Unit: mm (in)

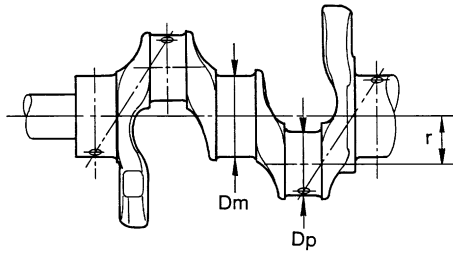

SEM645

Out-of-round : Difference between X and Y.
Taper : Difference between A and B.

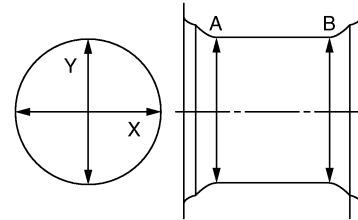

PBIC1686E

A
EM
C
D
E
F
G
H
I
J
K
L
M
N
O
P

SERVICE DATA AND SPECIFICATIONS (SDS)

< SERVICE INFORMATION >

[VK45DE]

Main journal diameter "Dm" (No. 1 and 5 journal)	Standard	Grade No. G	63.963 - 63.964 (2.5182 - 2.5183)
		Grade No. H	63.962 - 63.963 (2.5182 - 2.5182)
		Grade No. J	63.961 - 63.962 (2.5181 - 2.5182)
		Grade No. K	63.960 - 63.961 (2.5181 - 2.5181)
		Grade No. L	63.959 - 63.960 (2.5181 - 2.5181)
		Grade No. M	63.958 - 63.959 (2.5180 - 2.5181)
		Grade No. N	63.957 - 63.958 (2.5180 - 2.5180)
		Grade No. P	63.956 - 63.957 (2.5179 - 2.5180)
		Grade No. R	63.955 - 63.956 (2.5179 - 2.5179)
		Grade No. S	63.954 - 63.955 (2.5179 - 2.5179)
		Grade No. T	63.953 - 63.954 (2.5178 - 2.5179)
		Grade No. U	63.952 - 63.953 (2.5178 - 2.5178)
		Grade No. V	63.951 - 63.952 (2.5178 - 2.5178)
		Grade No. W	63.950 - 63.951 (2.5177 - 2.5178)
		Grade No. X	63.949 - 63.950 (2.5177 - 2.5177)
		Grade No. Y	63.948 - 63.949 (2.5176 - 2.5177)
		Grade No. 1	63.947 - 63.948 (2.5176 - 2.5176)
		Grade No. 2	63.946 - 63.947 (2.5176 - 2.5176)
		Main journal diameter "Dm" (No. 2, 3 and 4 journal)	Standard
Grade No. B	63.962 - 63.963 (2.5182 - 2.5182)		
Grade No. C	63.961 - 63.962 (2.5181 - 2.5182)		
Grade No. D	63.960 - 63.961 (2.5181 - 2.5181)		
Grade No. E	63.959 - 63.960 (2.5181 - 2.5181)		
Grade No. F	63.958 - 63.959 (2.5180 - 2.5181)		
Grade No. G	63.957 - 63.958 (2.5180 - 2.5180)		
Grade No. H	63.956 - 63.957 (2.5179 - 2.5180)		
Grade No. J	63.955 - 63.956 (2.5179 - 2.5179)		
Grade No. K	63.954 - 63.955 (2.5179 - 2.5179)		
Grade No. L	63.953 - 63.954 (2.5178 - 2.5179)		
Grade No. M	63.952 - 63.953 (2.5178 - 2.5178)		
Grade No. N	63.951 - 63.952 (2.5178 - 2.5178)		
Grade No. P	63.950 - 63.951 (2.5177 - 2.5178)		
Grade No. R	63.949 - 63.950 (2.5177 - 2.5177)		
Grade No. S	63.948 - 63.949 (2.5176 - 2.5177)		
Grade No. T	63.947 - 63.948 (2.5176 - 2.5176)		
Grade No. U	63.946 - 63.947 (2.5176 - 2.5176)		
Grade No. V	63.945 - 63.946 (2.5175 - 2.5176)		
Grade No. W	63.944 - 63.945 (2.5175 - 2.5175)		
Grade No. X	63.943 - 63.944 (2.5174 - 2.5175)		
Grade No. Y	63.942 - 63.943 (2.5174 - 2.5174)		
Grade No. 1	63.941 - 63.942 (2.5174 - 2.5174)		
Grade No. 2	63.940 - 63.941 (2.5173 - 2.5174)		
Pin journal diameter "Dp"	Grade No. 0	51.968 - 51.974 (2.0460 - 2.0462)	
	Grade No. 1	51.962 - 51.968 (2.0457 - 2.0460)	
	Grade No. 2	51.956 - 51.962 (2.0455 - 2.0457)	
Center distance "r"		41.31 - 41.39 (1.6264 - 1.6295)	
Out-of-round (Difference between "X" and "Y")	Limit	0.015 (0.0006)	
Taper (Difference between "A" and "B")	Limit	0.010 (0.0004)	
Runout (TIR*)	Standard	Less than 0.05 (0.0020)	
	Limit	0.10 (0.0039)	
Crankshaft end play	Standard	0.10 - 0.25 (0.0039 - 0.0098)	
	Limit	0.30 (0.0118)	

*: Total indicator reading

MAIN BEARING

SERVICE DATA AND SPECIFICATIONS (SDS)

< SERVICE INFORMATION >

[VK45DE]

Unit: mm (in)

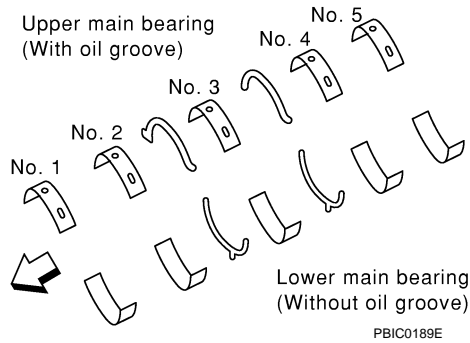

Grade number		Thickness	Identification color	Remarks
0		2.483 - 2.486 (0.0978 - 0.0979)	Black	Grade and color are the same for upper and lower bearings.
1		2.486 - 2.489 (0.0979 - 0.0980)	Brown	
2		2.489 - 2.492 (0.0980 - 0.0981)	Green	
3		2.492 - 2.495 (0.0981 - 0.0982)	Yellow	
4		2.495 - 2.498 (0.0982 - 0.0983)	Blue	
5		2.498 - 2.501 (0.0983 - 0.0985)	Pink	
6		2.501 - 2.504 (0.0985 - 0.0986)	Purple	
7		2.504 - 2.507 (0.0986 - 0.0987)	White	
8		2.507 - 2.510 (0.0987 - 0.0988)	Red	
01	UPR	2.483 - 2.486 (0.0978 - 0.0979)	Black	Grade and color are different for upper and lower bearings.
	LWR	2.486 - 2.489 (0.0979 - 0.0980)	Brown	
12	UPR	2.486 - 2.489 (0.0979 - 0.0980)	Brown	
	LWR	2.489 - 2.492 (0.0980 - 0.0981)	Green	
23	UPR	2.489 - 2.492 (0.0980 - 0.0981)	Green	
	LWR	2.492 - 2.495 (0.0981 - 0.0982)	Yellow	
34	UPR	2.492 - 2.495 (0.0981 - 0.0982)	Yellow	
	LWR	2.495 - 2.498 (0.0982 - 0.0983)	Blue	
45	UPR	2.495 - 2.498 (0.0982 - 0.0983)	Blue	
	LWR	2.498 - 2.501 (0.0983 - 0.0985)	Pink	
56	UPR	2.498 - 2.501 (0.0983 - 0.0985)	Pink	
	LWR	2.501 - 2.504 (0.0985 - 0.0986)	Purple	
67	UPR	2.501 - 2.504 (0.0985 - 0.0986)	Purple	
	LWR	2.504 - 2.507 (0.0986 - 0.0987)	White	
78	UPR	2.504 - 2.507 (0.0986 - 0.0987)	White	
	LWR	2.507 - 2.510 (0.0987 - 0.0988)	Red	

UNDERSIZE

Unit: mm (in)

Undersize	Thickness	Main journal diameter
0.25 (0.0098)	2.618 - 2.626 (0.1031 - 0.1034)	Grind so that bearing clearance is the specified value.

MAIN BEARING OIL CLEARANCE

SERVICE DATA AND SPECIFICATIONS (SDS)

< SERVICE INFORMATION >

[VK45DE]

Unit: mm (in)

Main bearing oil clearance	Standard	No. 1 and 5	0.001 - 0.011 (0.00004 - 0.0004)
		No. 2, 3 and 4	0.007 - 0.017 (0.0003 - 0.0007)
	Limit	No. 1 and 5	0.021 (0.0008)
		No. 2, 3 and 4	0.027 (0.0011)

CONNECTING ROD BEARING

Unit: mm (in)

Grade number	Thickness	Identification color (mark)
0	1.500 - 1.503 (0.0591 - 0.0592)	No color
1	1.503 - 1.506 (0.0592 - 0.0593)	Brown
2	1.506 - 1.509 (0.0593 - 0.0594)	Green

UNDERSIZE

Unit: mm (in)

Undersize	Thickness	Pin journal diameter
0.25 (0.0098)	1.626 - 1.634 (0.0640 - 0.0643)	Grind so that bearing clearance is the specified value.

CONNECTING ROD BEARING OIL CLEARANCE

Unit: mm (in)

Connecting rod bearing oil clearance	Standard	0.020 - 0.045 (0.0008 - 0.0018)
	Limit	0.055 (0.0022)