

SECTION **EX**
EXHAUST SYSTEM

A
EX
C
D
E
F
G
H
I
J
K
L
M
N
O
P

CONTENTS

SERVICE INFORMATION	2	EXHAUST SYSTEM	3
PREPARATION	2	Checking Exhaust System	3
Special Service Tool	2	Component	3
Commercial Service Tool	2	Removal and Installation	4
		Component	5
		Removal and Installation	6

PREPARATION

< SERVICE INFORMATION >

SERVICE INFORMATION

PREPARATION

Special Service Tool

INFOID:000000005349303

The actual shapes of Kent-Moore tools may differ from those of special service tools illustrated here.

Tool number (Kent-Moore No.) Tool name	Description
KV10114400 (J38365) Heated oxygen sensor wrench	Loosening or tightening heated oxygen sensor 2 a: For 22 mm (0.87 in) width hexagon nut

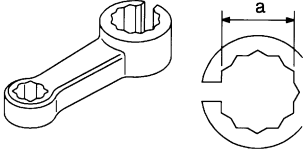

S-NT636

Commercial Service Tool

INFOID:000000005349304

(Kent-Moore No.) Tool name	Description
a: (J-43897-18) b: (J-43897-12) Heated oxygen sensor thread cleaner	Reconditioning the exhaust system threads before installing a new heated oxygen sensor (Use with anti-seize lubricant shown below.) a: J-43897-18 [18 mm (0.71 in) dia.] for zirconia heated oxygen sensor b: J-43897-12 [12 mm (0.47 in) dia.] for titania heated oxygen sensor
(—) Anti-seize lubricant (Permatex 133AR or equivalent meeting MIL specification MIL-A-907)	Lubricating heated oxygen sensor thread cleaner when reconditioning exhaust system threads
(—) Power tool	Loosening bolts and nuts

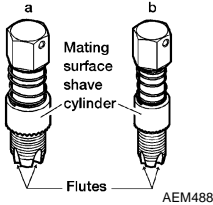

AEM488

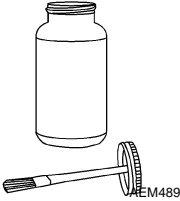

AEM489

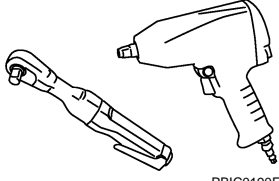

PBIC0190E

EXHAUST SYSTEM

< SERVICE INFORMATION >

EXHAUST SYSTEM

Checking Exhaust System

INFOID:000000005349305

Check exhaust pipes, muffler and mounting for improper attachment, leakage, cracks, damage or deterioration.

- If anything is found, repair or replace damaged parts.

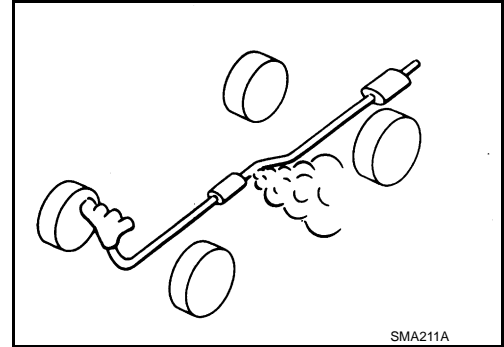

Component

INFOID:000000005349306

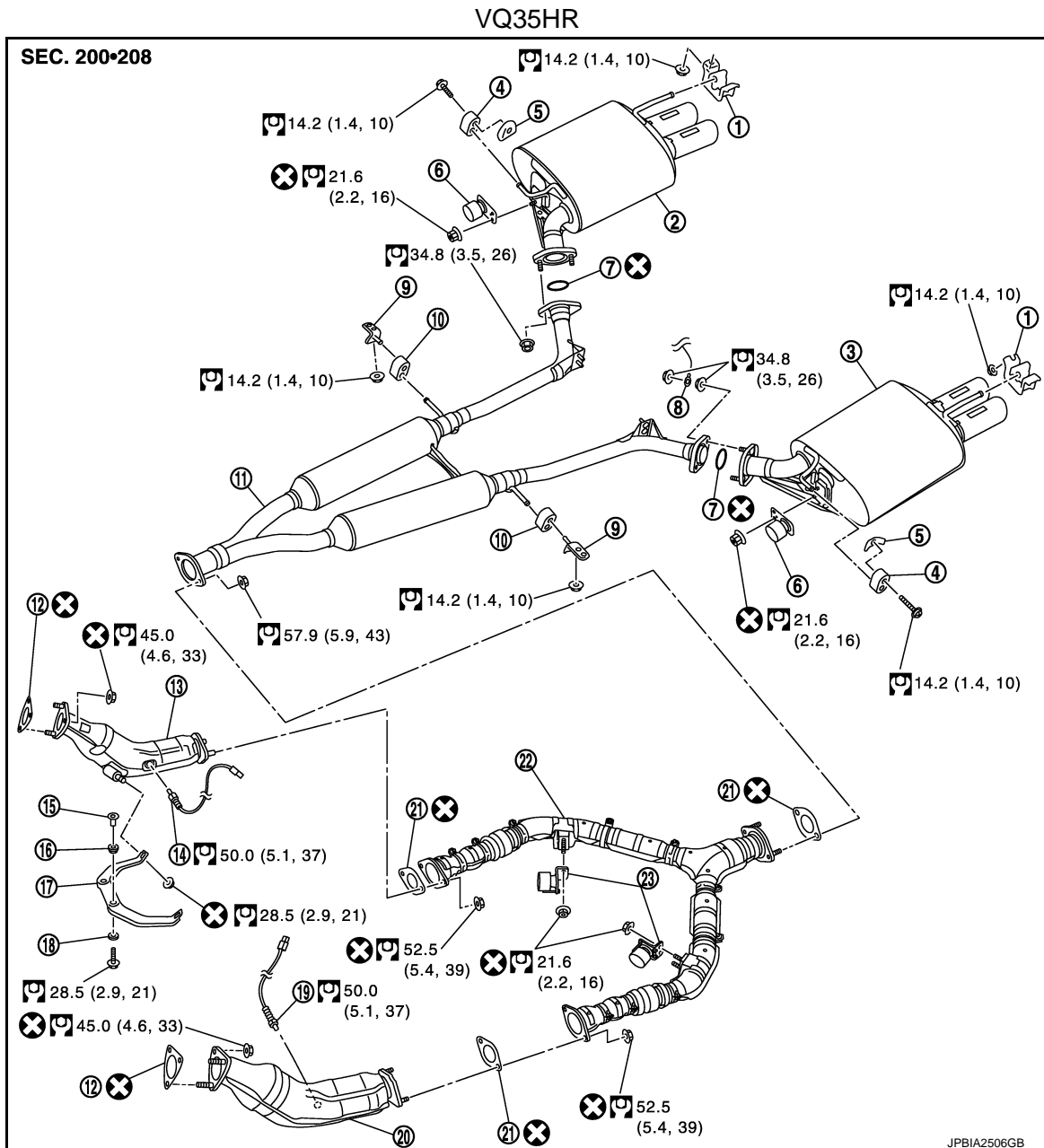

EXHAUST SYSTEM

< SERVICE INFORMATION >

- | | | |
|-------------------------------------|-------------------------------------|----------------------|
| 1. Mounting bracket | 2. Main muffler (RH) | 3. Main muffler (LH) |
| 4. Mounting rubber | 5. Collar | 6. Dynamic damper |
| 7. Ring gasket | 8. Bonding wire | 9. Mounting bracket |
| 10. Mounting rubber | 11. Center muffler | 12. Gasket |
| 13. Three way catalyst (bank 1) | 14. Heated oxygen sensor 2 (bank 1) | 15. Collar |
| 16. Grommet | 17. Exhaust mounting bracket | 18. Grommet |
| 19. Heated oxygen sensor 2 (bank 2) | 20. Three way catalyst (bank 2) | 21. Gasket |
| 22. Exhaust front tube | 23. Dynamic damper | |

- Refer to [GI-9, "Component"](#) for symbols in the figure.

Removal and Installation

INFOID:000000005349307

CAUTION:

- Be sure to use genuine exhaust system parts or equivalents which are specially designed for heat resistance, corrosion resistance, and shape.
- Perform the operation with the exhaust system fully cooled down because the system will be hot just after engine stops.
- Be careful not to cut your hand on the heat insulator edge.

REMOVAL

- Disconnect each joint and mounting using power tool.
- Remove heated oxygen sensor 2 as follows:
 - Using heated oxygen sensor wrench [SST: KV10114400 (J38365)] (C), removal heated oxygen sensor 2.

- A : Bank 1
B : Bank 2
⇐ : Vehicle front

CAUTION:

Be careful not to damage heated oxygen sensor 2.

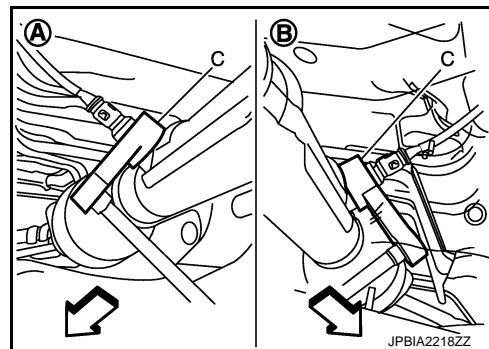

INSTALLATION

Note the following, and install in the reverse order of removal.

- Check for deformation of the grommets (16 and 18 of Components).
- Insert the collar (15 of Components) vertically.
- Install the collar (5 of Components) with its lower surface horizontal.
- Temporarily tighten nuts and bolts when installing exhaust pipe assembly. Tighten them to the specified torque when connecting the vehicle rear to the vehicle front.

CAUTION:

- Always replace exhaust tube gaskets with new ones when reassembling.
- Discard any heated oxygen sensor 2 which has been dropped onto a hard surface such as a concrete floor. Use a new one.
- Before installing a new heated oxygen sensor 2, clean exhaust system threads using the heated oxygen sensor thread cleaner (commercial service tool: J-43897-18 or J-43897-12), and apply the anti-seize lubricant (commercial service tool).
- Never over torque heated oxygen sensor 2. Doing so may cause damage to heated oxygen sensor 2, resulting in the "MIL" coming on.
- If heat insulator is badly deformed, repair or replace it. If deposits such as mud pile up on the heat insulator, remove them.
- When installing heat insulator avoid large gaps or interference between heat insulator and each exhaust pipe.
- Remove deposits from the sealing surface of each connection. Connect them securely to avoid gases leakage.
- Temporarily tighten mounting nuts on the exhaust manifold side and mounting bolts on the vehicle side. Check each part for unusual interference, and then tighten them to the specified torque.

EXHAUST SYSTEM

< SERVICE INFORMATION >

- When installing each mounting rubber, avoid twisting or unusual extension in up/down and right/left directions.

INSPECTION AFTER INSTALLATION

- Check clearance between tail tube and rear bumper is even.
- With engine running, check exhaust tube joints for gas leakage and unusual noises.
- Check to ensure that mounting brackets and mounting rubbers are installed properly and free from undue stress. Improper installation could result in excessive noise and vibration.

Component

INFOID:000000005349308

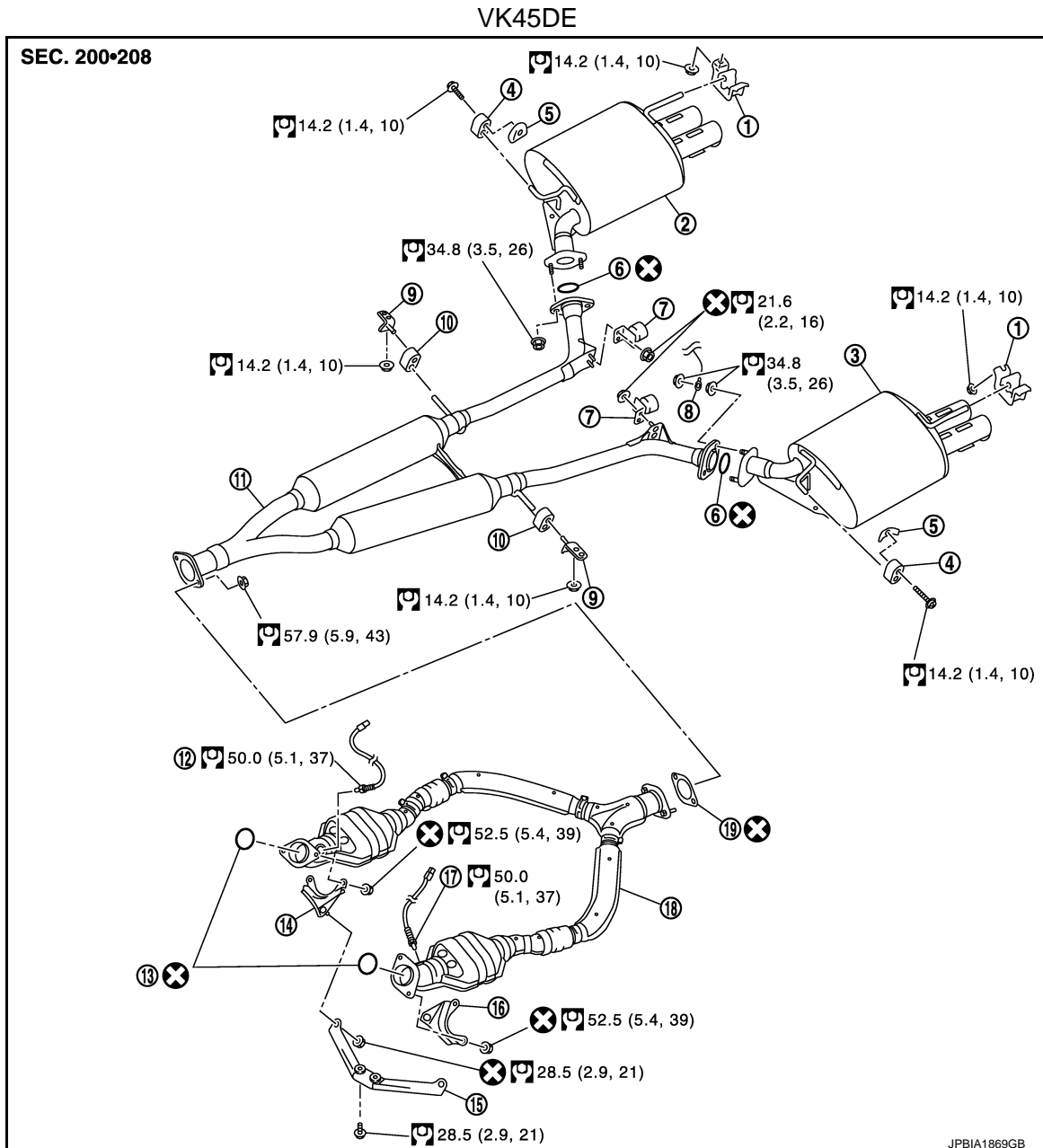

- | | | |
|----------------------|-------------------------------------|-------------------------------------|
| 1. Mounting bracket | 2. Main muffler (RH) | 3. Main muffler (LH) |
| 4. Mounting rubber | 5. Collar | 6. Ring gasket |
| 7. Dynamic damper | 8. Bonding wire | 9. Mounting bracket |
| 10. Mounting rubber | 11. Center muffler | 12. Heated oxygen sensor 2 (bank 2) |
| 13. Ring gasket | 14. Mounting bracket | 15. Exhaust mounting bracket |
| 16. Mounting bracket | 17. Heated oxygen sensor 2 (bank 1) | 18. Exhaust front tube |
| 19. Gasket | | |

EXHAUST SYSTEM

< SERVICE INFORMATION >

- Refer to [GI-9, "Component"](#) for symbols in the figure.

Removal and Installation

INFOID:000000005349309

CAUTION:

- Be sure to use genuine exhaust system parts or equivalents which are specially designed for heat resistance, corrosion resistance, and shape.
- Perform the operation with the exhaust system fully cooled down because the system will be hot just after engine stops.
- Be careful not to cut your hand on the heat insulator edge.

REMOVAL

- Disconnect each joint and mounting using power tool.
- Remove heated oxygen sensor 2 as follows:
 - Using heated oxygen sensor wrench (SST), removal heated oxygen sensor 2.

CAUTION:

Be careful not to damage heated oxygen sensor 2.

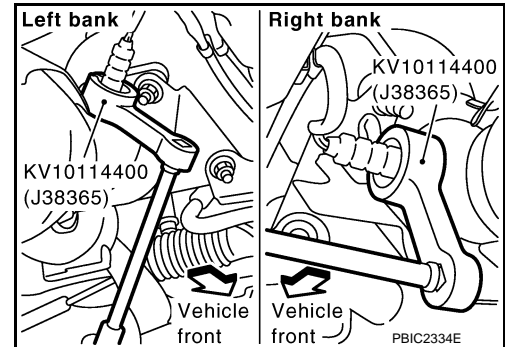

INSTALLATION

Note the following, and install in the reverse order of removal.

- Install the collar (5 of Components) with its lower surface horizontal.
- Temporarily tighten nuts and bolts when installing exhaust pipe assembly. Tighten them to the specified torque when connecting the vehicle rear to the vehicle front.

CAUTION:

- Always replace exhaust tube gaskets with new ones when reassembling.
- Discard any heated oxygen sensor 2 which has been dropped onto a hard surface such as a concrete floor. Use a new one.
- Before installing a new heated oxygen sensor 2, clean exhaust system threads using the heated oxygen sensor thread cleaner (commercial service tool: J-43897-18 or J-43897-12), and apply the anti-seize lubricant (commercial service tool).
- Never over torque heated oxygen sensor 2. Doing so may cause damage to heated oxygen sensor 2, resulting in the "MIL" coming on.
- If heat insulator is badly deformed, repair or replace it. If deposits such as mud pile up on the heat insulator, remove them.
- When installing heat insulator avoid large gaps or interference between heat insulator and each exhaust pipe.
- Remove deposits from the sealing surface of each connection. Connect them securely to avoid gases leakage.
- Check each part for unusual interference, and then tighten them to the specified torque.
- When installing each mounting rubber, avoid twisting or unusual extension in up/down and right/left directions.

INSPECTION AFTER INSTALLATION

- Check clearance between tail tube and rear bumper is even.
- With engine running, check exhaust tube joints for gas leakage and unusual noises.
- Check to ensure that mounting brackets and mounting rubbers are installed properly and free from undue stress. Improper installation could result in excessive noise and vibration.