

SECTION **PR**  
PROPELLER SHAFT

A

B

C

PR

CONTENTS

E

<b>SERVICE INFORMATION</b> .....	2	Removal and Installation .....	5	F
<b>PREPARATION</b> .....	2	<b>REAR PROPELLER SHAFT</b> .....	7	G
Commercial Service Tool .....	2	On-Vehicle Inspection .....	7	
<b>NOISE, VIBRATION AND HARSHNESS</b>		Component .....	8	
<b>(NVH) TROUBLESHOOTING</b> .....	3	Removal and Installation .....	9	
NVH Troubleshooting Chart .....	3	<b>SERVICE DATA AND SPECIFICATIONS</b>		H
<b>FRONT PROPELLER SHAFT</b> .....	4	<b>(SDS)</b> .....	12	
On-Vehicle Inspection .....	4	General Specification .....	12	I
Component .....	4	Journal Axial Play .....	13	
		Propeller Shaft Runout .....	13	J

J

K

L

M

N

O

P

# PREPARATION

< SERVICE INFORMATION >

## SERVICE INFORMATION

### PREPARATION

#### Commercial Service Tool

INFOID:000000005347017

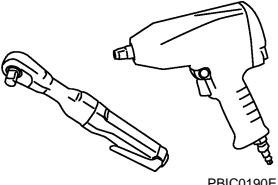
Tool name	Description
<p data-bbox="162 415 272 441">Power tool</p>  <p data-bbox="828 630 901 651">PBIC0190E</p>	<p data-bbox="1015 415 1263 441">Loosening bolts and nuts</p>

# NOISE, VIBRATION AND HARSHNESS (NVH) TROUBLESHOOTING

< SERVICE INFORMATION >

## NOISE, VIBRATION AND HARSHNESS (NVH) TROUBLESHOOTING

### NVH Troubleshooting Chart

INFOID:000000005347018

Use the chart below to help you find the cause of the symptom. If necessary, repair or replace these parts.

Reference page	Front	PR-4	—	—	—	—	PR-4	PR-5	NVH in FFD and RFD section	NVH in FAX, RAX, FSU and RSU section	NVH in WT section	NVH in WT section	NVH in RAX section	NVH in BR section	NVH in PS section
	Rear	PR-7	PR-9	—	PR-8	—	PR-7	PR-9							
Possible cause and SUSPECTED PARTS	Uneven rotating torque														
	Center bearing improper installation														
	Excessive center bearing axial end play														
	Center bearing mounting (insulator) cracks, damage or deterioration														
	Excessive joint angle														
	Rotation imbalance														
	Excessive runout														
	DIFFERENTIAL														
	AXLE AND SUSPENSION														
	TIRE														
	ROAD WHEEL														
	DRIVE SHAFT														
	BRAKE														
	STEERING														
Symptom	Noise	x	x	x	x	x	x	x	x	x	x	x	x	x	x
	Shake		x							x	x	x	x	x	x
	Vibration	x	x	x	x	x	x	x		x	x		x		x

x: Applicable

A  
B  
C  
PR  
E  
F  
G  
H  
I  
J  
K  
L  
M  
N  
O  
P

# FRONT PROPELLER SHAFT

< SERVICE INFORMATION >

## FRONT PROPELLER SHAFT

### On-Vehicle Inspection

INFOID:000000005347019

#### APPEARANCE AND NOISE INSPECTION

- Check the propeller shaft tube surface for dents or cracks. If damaged, replace propeller shaft assembly.

#### PROPELLER SHAFT VIBRATION

If vibration is present at high speed, inspect propeller shaft runout first.

1. With a dial indicator, measure propeller shaft runout at runout measuring point by rotating final drive companion flange with hands. For measuring point, refer to "Propeller Shaft Runout Measuring Point".

**Propeller shaft runout limit : 0.8 mm (0.031 in)**

2. If runout still exceeds specifications, separate propeller shaft at final drive companion flange; then rotate companion flange 90, 180, 270 degrees and install propeller shaft.
3. Check runout again. If runout still exceeds specifications, replace propeller shaft assembly.
4. Check the vibration by driving vehicle.

#### Propeller Shaft Runout Measuring Point

- Propeller shaft runout measuring point (Point "Δ")

**Dimension A: 381.5 mm (15.01 in)**

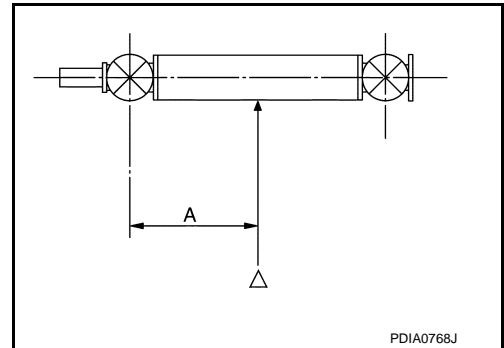
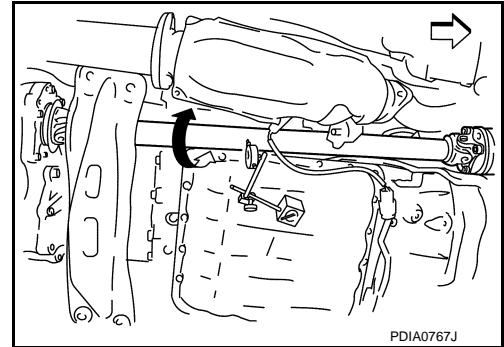

### Component

INFOID:000000005347020

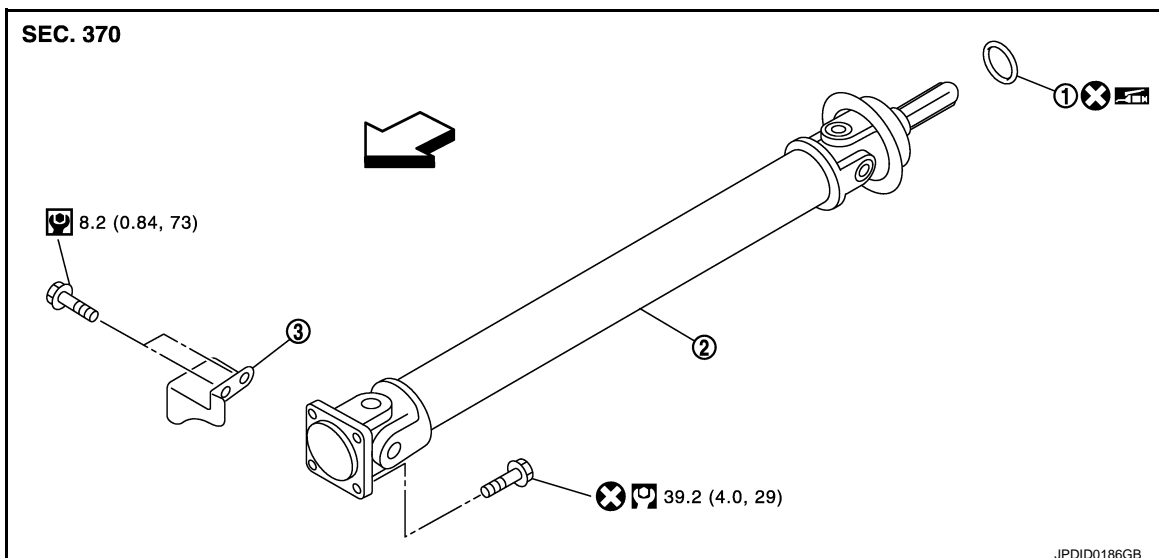

1. O-ring

2. Propeller shaft assembly

3. Heat bracket

# FRONT PROPELLER SHAFT

## < SERVICE INFORMATION >

: Apply multi-purpose grease.

: Vehicle front

Refer to [GI-9, "Component"](#) for symbols not described above.

## Removal and Installation

INFOID:000000005347021

### REMOVAL

1. Remove engine undercover with a power tool.
2. If necessary, remove heat bracket.
3. Remove the three way catalyst (right bank) with a power tool. Refer to [EX-3](#).
4. Put matching marks onto propeller shaft flange yoke and final drive companion flange.

#### **CAUTION:**

**For matching marks, use paint. Never damage propeller shaft flange and companion flange.**

5. Remove the propeller shaft fixing bolts.
6. Remove propeller shaft from the front final drive and transfer.

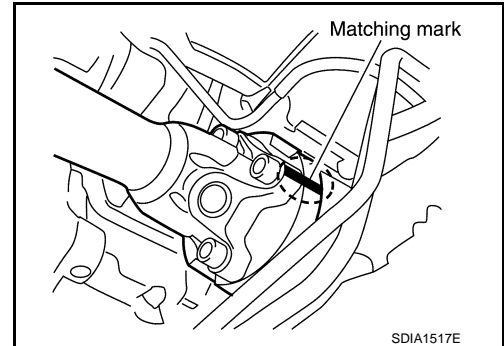

### INSPECTION

- Check propeller shaft runout at measuring point with a dial indicator. If runout exceeds specifications, replace propeller shaft assembly. For measuring point, refer to [PR-4, "On-Vehicle Inspection"](#).

**Propeller shaft runout limit : 0.8 mm (0.031 in)**

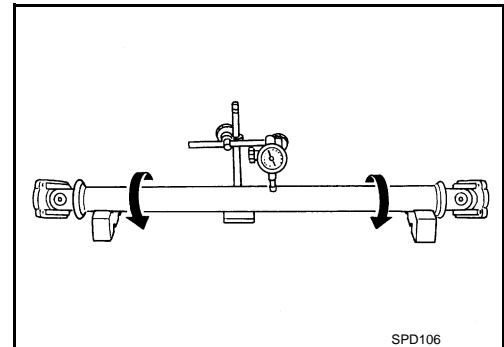

- As shown in the figure, while fixing yoke on one side, check axial play of joint. If outside the standard, replace propeller shaft assembly.

**Journal axial play : 0 mm (0 in)**

- Check propeller shaft for bend and damage. If damage is detected, replace propeller shaft assembly.

#### **CAUTION:**

**Never disassemble joints.**

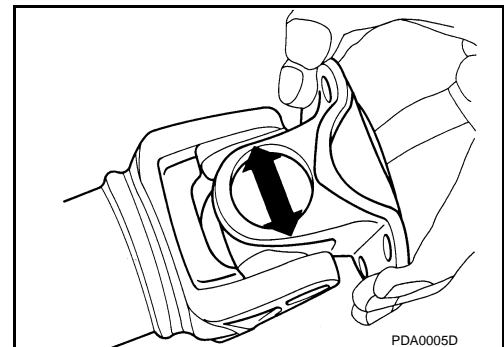

### INSTALLATION

Note the following, install in the reverse order of removal.

A  
B  
C  
PR  
E  
F  
G  
H  
I  
J  
K  
L  
M  
N  
O  
P

## FRONT PROPELLER SHAFT

### < SERVICE INFORMATION >

- Align matching marks to install propeller shaft to final drive companion flange, and then tighten to specified torque. Refer to [PR-4, "Component"](#).

**CAUTION:**

**Never reuse the bolts.**

- After assembly, perform a driving test to check propeller shaft vibration. If vibration occurred, separate propeller shaft from final drive or transfer. Reinstall companion flange after rotating it by 90, 180, 270 degrees. Then perform driving test and check propeller shaft vibration again at each point.

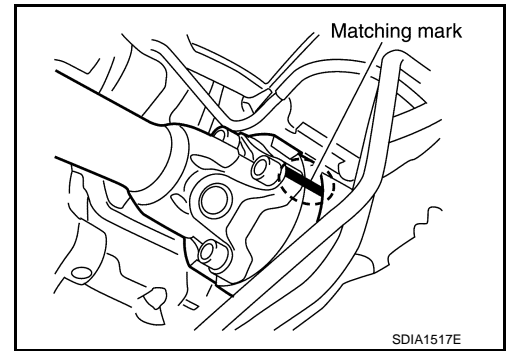

# REAR PROPELLER SHAFT

< SERVICE INFORMATION >

## REAR PROPELLER SHAFT

### On-Vehicle Inspection

INFOID:000000005347022

#### APPEARANCE AND NOISE INSPECTION

- Check the propeller shaft tube surface for dents or cracks. If damaged, replace propeller shaft assembly.
- If center bearing is noisy or damaged, replace center bearing.

#### PROPELLER SHAFT VIBRATION

If vibration is present at high speed, inspect propeller shaft runout first.

1. With a dial indicator, measure propeller shaft runout at runout measuring points by rotating final drive companion flange with hands. For measuring point, refer to "Propeller Shaft Runout Measuring Point".

**Propeller shaft runout limit : 0.8 mm (0.031 in)**

2. If runout still exceeds specifications, separate propeller shaft at final drive companion flange; then rotate companion flange 60, 120, 180, 240, 300 degrees and install propeller shaft.
3. Check runout again. If runout still exceeds specifications, replace propeller shaft assembly.
4. Check the vibration by driving vehicle.

#### Propeller Shaft Runout Measuring Point

- Propeller shaft runout measuring point (Point "△")
- VQ35HR 2WD models (3S80A-1VL107 type)

**Dimension**    **A: 192 mm (7.56 in)**  
                      **B: 172 mm (6.77 in)**  
                      **C: 185 mm (7.28 in)**

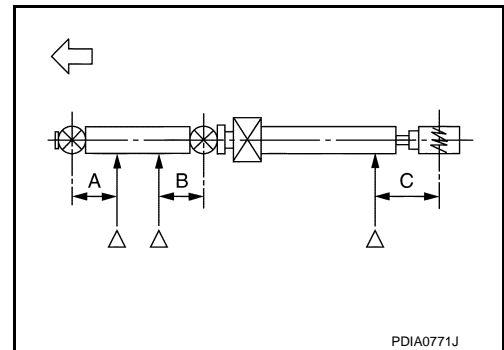
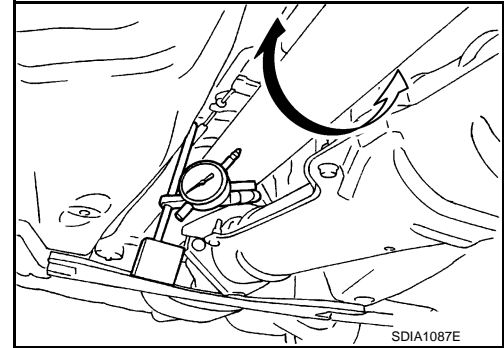

- VK45DE 2WD models (3F-R-2VL107 type)

**Dimension**    **A: 162 mm (6.38 in)**  
                      **B: 160 mm (6.30 in)**  
                      **C: 185 mm (7.28 in)**

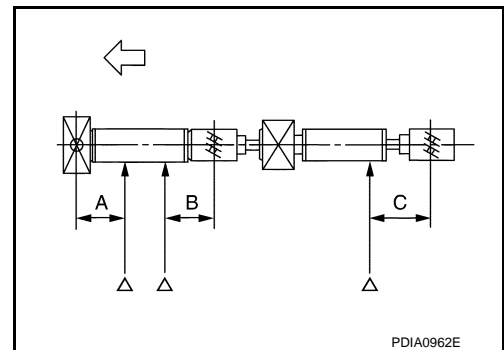

A  
B  
C  
PR  
E  
F  
G  
H  
I  
J  
K  
L  
M  
N  
O  
P

# REAR PROPELLER SHAFT

< SERVICE INFORMATION >

- VQ35HR AWD models (3F80A-1VL107 type)

**Dimension**    **A: 162 mm (6.38 in)**  
                       **B: 245 mm (9.65 in)**  
                       **C: 185 mm (7.28 in)**

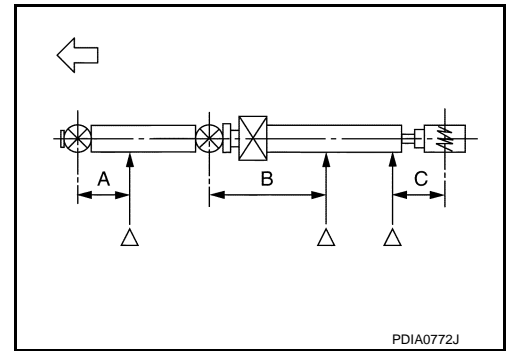

- VK45DE AWD models (3F-R-2VL107 type)

**Dimension**    **A: 162 mm (6.38 in)**  
                       **B: 270 mm (10.63 in)**  
                       **C: 185 mm (7.28 in)**

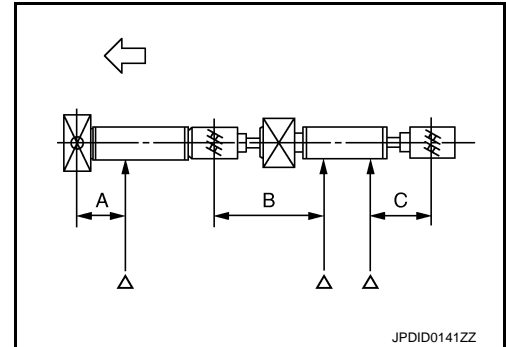

## Component

INFOID:000000005347023

### VQ35HR 2WD MODELS (3S80A-1VL107 TYPE)

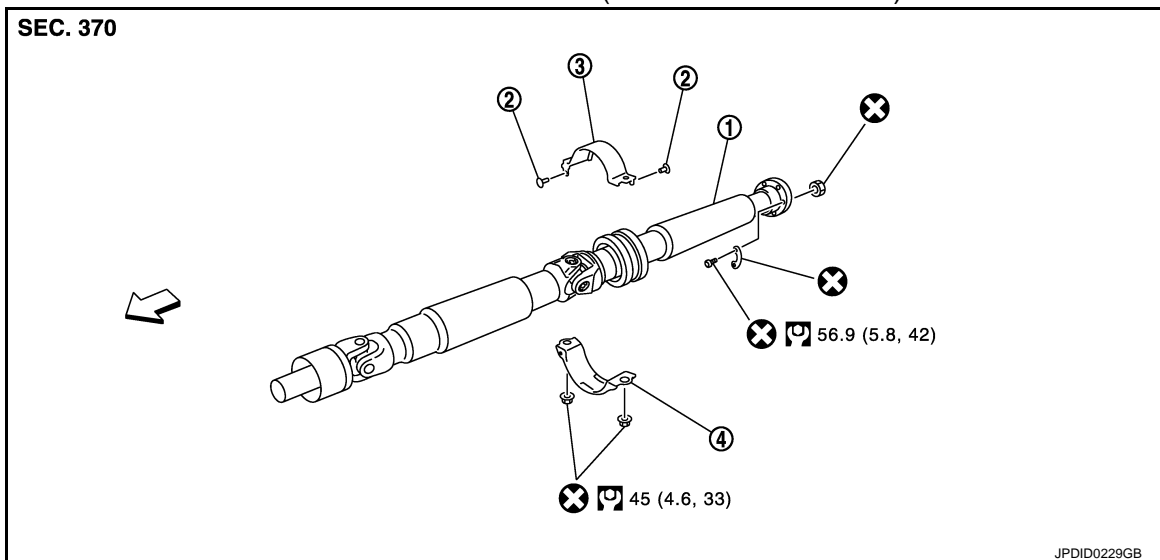

- 1. Propeller shaft assembly
- 2. Clip
- 3. Center bearing mounting bracket (Upper)
- 4. Center bearing mounting bracket (Lower)

← : Vehicle front

Refer to [GI-9, "Component"](#), for the symbols in the figure.



# REAR PROPELLER SHAFT

< SERVICE INFORMATION >

VQ35HR AWD MODELS (3F80A-1VL107 TYPE)

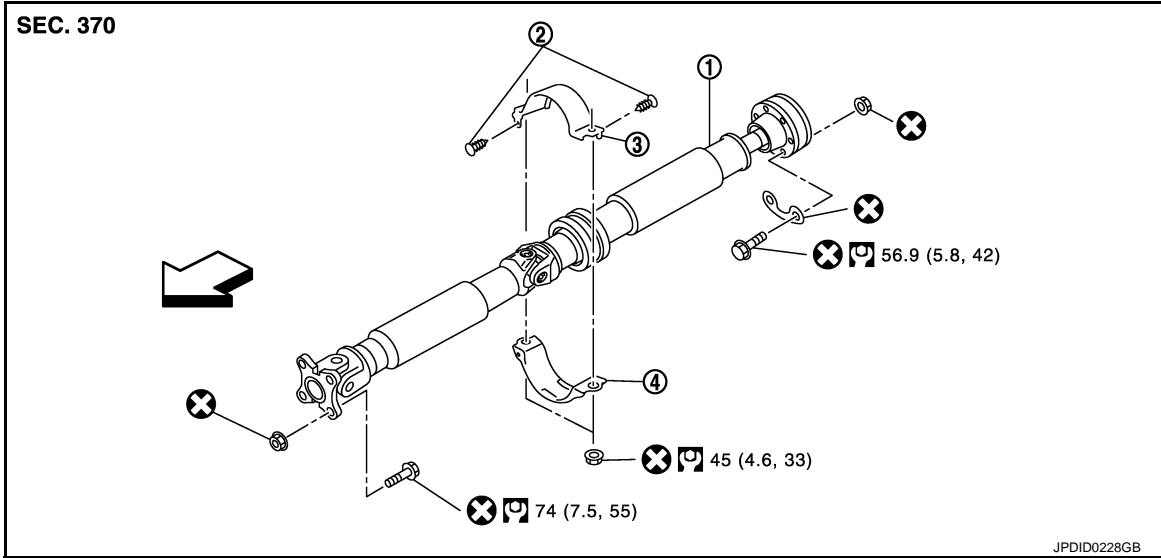

- 1. Propeller shaft assembly
- 2. Clip
- 3. Center bearing mounting bracket (Upper)
- 4. Center bearing mounting bracket (Lower)

← :Vehicle front

Refer to [GI-9, "Component"](#), for the symbols in the figure.

VK45DE MODELS (3F-R-2VL107 TYPE)

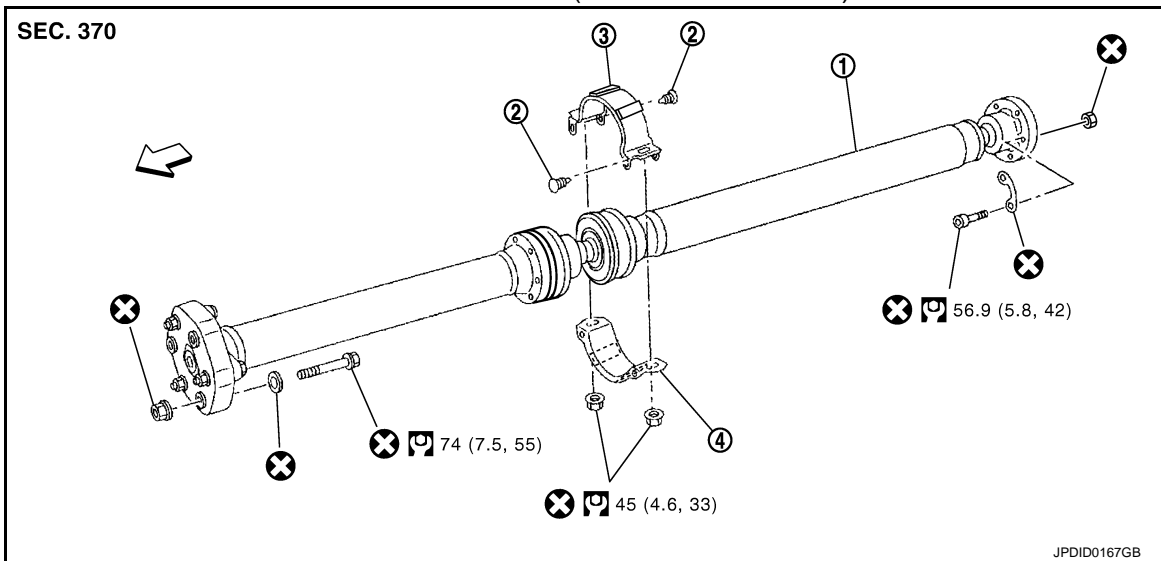

- 1. Propeller shaft assembly
- 2. Clip
- 3. Center bearing mounting bracket (Upper)
- 4. Center bearing mounting bracket (Lower)

← :Vehicle front

Refer to [GI-9, "Component"](#), for the symbols in the figure.

## Removal and Installation

INFOID:000000005347024

### REMOVAL

1. Move the A/T select lever to N position and release the parking brake.
2. Remove the floor reinforcement.

A  
B  
C  
PR  
E  
F  
G  
H  
I  
J  
K  
L  
M  
N  
O  
P

# REAR PROPELLER SHAFT

## < SERVICE INFORMATION >

3. Remove the center muffler with power tool. Refer to [EX-3](#).

4. **For VQ35HR 2WD models**

- Put matching marks on propeller shaft rebro joint with final drive companion flange.

**CAUTION:**

**For matching marks, use paint. Never damage propeller shaft rebro joint and companion flange.**

**For VK45DE models**

- Put matching marks on propeller shaft rubber coupling with transmission companion flange and on rebro joint with final drive companion flange.

**CAUTION:**

**For matching marks, use paint. Never damage rubber coupling, rebro joint and companion flanges.**

**For VQ35HR AWD models**

- Put matching marks on propeller shaft flange yoke with transfer companion flange and on rebro joint with final drive companion flange.

**CAUTION:**

**For matching marks, use paint. Never damage propeller shaft flange yoke, rebro joint and companion flanges.**

5. Loosen mounting nuts of center bearing mounting brackets.

**CAUTION:**

**Tighten mounting nuts temporarily.**

6. Remove propeller shaft fixing bolts and nuts.

7. Remove center bearing mounting bracket fixing nuts.

8. Remove propeller shaft.

**CAUTION:**

**If constant velocity joint was bent during propeller shaft assembly removal, installation, or transportation, its boot may be damaged. Wrap boot interference area to metal part with shop cloth or rubber to protect boot from breakage.**

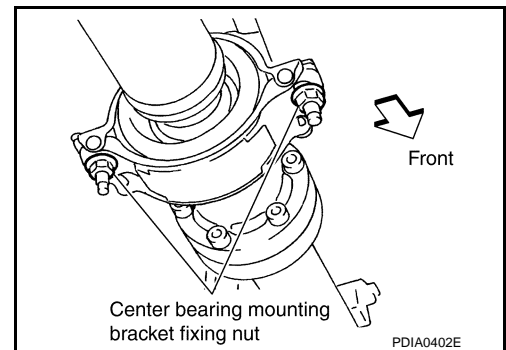
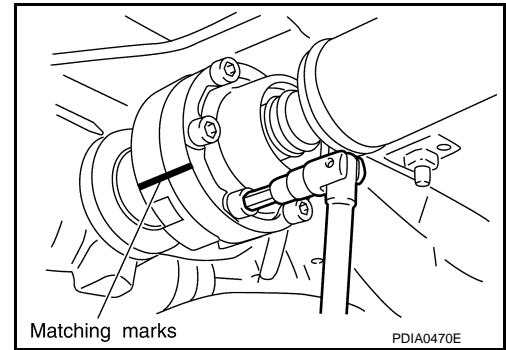

## INSPECTION

- Check propeller shaft runout at measuring points with a dial indicator. If runout exceeds specifications, replace propeller shaft assembly. For measuring point, refer to [PR-7. "On-Vehicle Inspection"](#).

**Propeller shaft runout limit : 0.8 mm (0.031 in)**

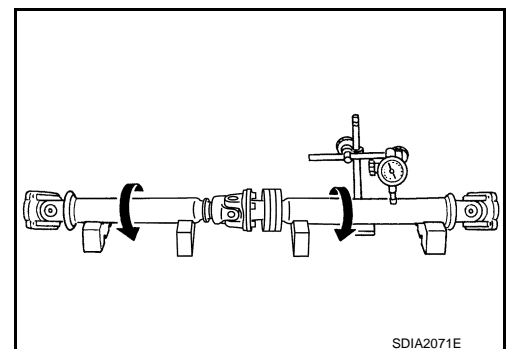

- As shown in the figure, while fixing yoke on one side, check axial play of joint. If outside the standard, replace relevant propeller shaft.

**Journal axial play : 0 mm (0 in)**

- Check propeller shaft for bend and damage. If damage is detected, replace relevant propeller shaft assembly.

**CAUTION:**

**Never disassemble joints.**

- Check center bearing for noise and damage. If noise or damage is detected, replace center bearing. Refer to [PR-9. "Removal and Installation"](#).

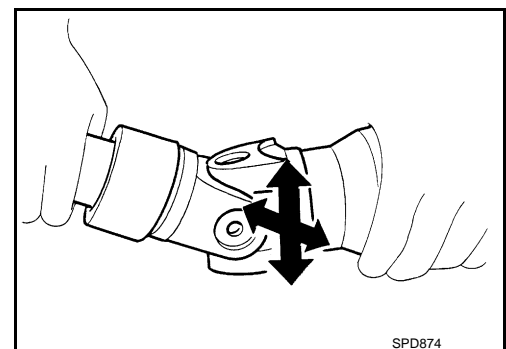

## INSTALLATION

# REAR PROPELLER SHAFT

## < SERVICE INFORMATION >

Note the following, and install in the reverse order of removal.

### CAUTION:

- Avoid damaging the rebro joint boot, protect it with a shop towel or equivalent.
- Tighten mounting bolt and nut in the order shown in the figure.
- Align matching marks to install propeller shaft to final drive and transfer (AWD models only) companion flanges, and then tighten to specified torque. Refer to [PR-8, "Component"](#).

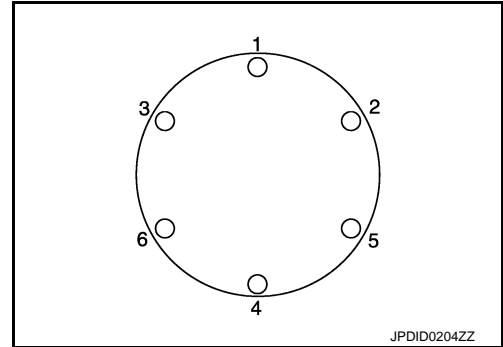

- Install center bearing mounting bracket (Upper) with its arrow mark facing forward.
- Adjust position of mounting bracket sliding back and forth to prevent play in thrust direction of center bearing insulator. Install bracket to vehicle.
- After assembly, perform a driving test to check propeller shaft vibration. If vibration occurred, separate propeller shaft from final drive. Reinstall companion flange after rotating it by 60, 120, 180, 240, 300 degrees. Then perform driving test and check propeller shaft vibration again at each point.

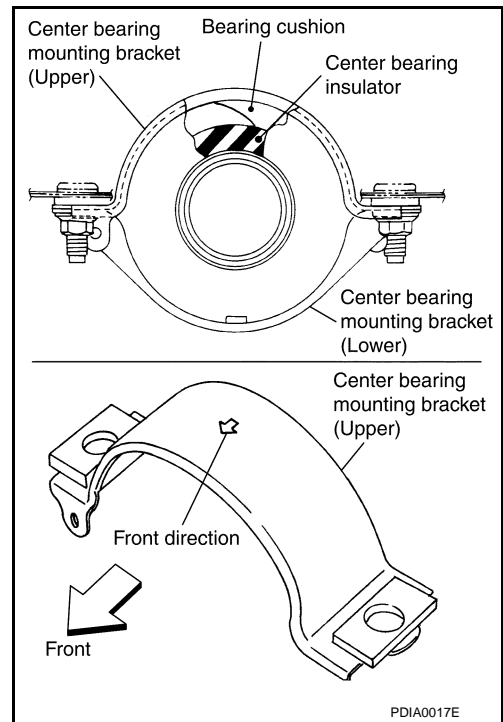

- If propeller shaft or final drive has been replaced, connect them as follows:

1. Install the propeller shaft while aligning its matching mark A with the matching mark B on the joint as close as possible.
2. Tighten the joint bolts to the specified torque. Refer to [PR-8, "Component"](#).

### CAUTION:

Never reuse the bolts, nuts and washers.

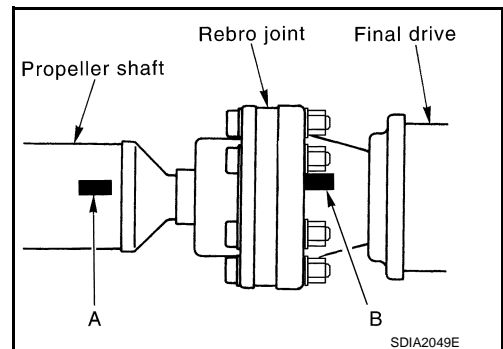

A  
B  
C  
PR  
E  
F  
G  
H  
I  
J  
K  
L  
M  
N  
O  
P

# SERVICE DATA AND SPECIFICATIONS (SDS)

< SERVICE INFORMATION >

## SERVICE DATA AND SPECIFICATIONS (SDS)

### General Specification

INFOID:000000005347025

#### 2WD MODELS

Applied model		VQ35HR	VK45DE
Propeller shaft model		3S80A-1VL107	3F-R-2VL107
Number of joints		3	
Type of journal bearings (Non-disassembly type)	1st joint	Shell type	Rubber coupling type
	2nd joint	Shell type	Rebro joint type
	3rd joint	Rebro joint type	Rebro joint type
Coupling method with transmission		Sleeve type	Flange type
Coupling method with rear final drive		Flange type	
Shaft length	1st	718 mm (28.27 in) <sup>*1</sup>	739 mm (29.09 in) <sup>*3</sup>
	2nd	786 mm (30.94 in) <sup>*2</sup>	802 mm (31.57 in) <sup>*4</sup>
Shaft outer diameter	1st	82.6 mm (3.25 in)	
	2nd	82.6 mm (3.25 in)	

\*1: Spider to spider

\*2: Spider to rebro joint center

\*3: Rubber coupling center to rebro joint center

\*4: Rebro joint center to rebro joint center

#### AWD MODELS

Applied model		VQ35HR	VK45DE	
Front	Propeller shaft model	2S56A		
	Number of joints	2		
	Type of journal bearings (Non-disassembly type)	Shell type		
	Coupling method with transfer	Sleeve type		
	Coupling method with front final drive	Flange type		
	Shaft length (Spider to spider)	763 mm (30.04 in)		
	Shaft outer diameter	42.7 mm (1.68 in)		
Rear	Propeller shaft model	3F80A-1VL107	3F-R-2VL107	
	Number of joints	3		
	Type of journal bearings (Non-disassembly type)	1st joint	Shell type	Rubber coupling type
		2nd joint	Shell type	Rebro joint type
		3rd joint	Rebro joint type	
	Coupling method with transfer	Flange type		
	Coupling method with rear final drive	Flange type		
	Shaft length	1st (Spider to spider)	415 mm (16.34 in)	404 mm (15.91 in)
		2nd (Spider to rebro joint center)	786 mm (30.94 in)	802 mm (31.57 in)
	Shaft outer diameter	1st	82.6 mm (3.25 in)	
2nd		82.6 mm (3.25 in)		

# SERVICE DATA AND SPECIFICATIONS (SDS)

< SERVICE INFORMATION >

## Journal Axial Play

INFOID:000000005347026

Model	Front propeller shaft	Rear propeller shaft		
	VQ35HR, VK45DE	VQ35HR		VK45DE
	AWD	2WD	AWD	2WD, AWD
	2S56A	3S80A-1VL107	3F80A-1VL107	3F-R-2VL107
Journal axial play	0 mm (0 in)			—

## Propeller Shaft Runout

INFOID:000000005347027

Model	Front propeller shaft	Rear propeller shaft		
	VQ35HR, VK45DE	VQ35HR		VK45DE
	AWD	2WD	AWD	2WD, AWD
	2S56A	3S80A-1VL107	3F80A-1VL107	3F-R-2VL107
Propeller shaft runout limit	0.8 mm (0.031 in)			

A  
B  
C  
PR  
E  
F  
G  
H  
I  
J  
K  
L  
M  
N  
O  
P