

SECTION **RF**  
ROOF

A  
B  
C  
D  
E  
F  
G  
H  
RF  
J  
K  
L  
M  
N  
O  
P

CONTENTS

<b>SERVICE INFORMATION</b> .....	2	Component Parts and Harness Connector Location .....	10
<b>PRECAUTIONS</b> .....	2	System Description .....	10
Precaution for Supplemental Restraint System (SRS) "AIR BAG" and "SEAT BELT PRE-TENSIONER" .....	2	Wiring Diagram - SROOF - .....	12
Precaution .....	2	Terminal and Reference Value for BCM .....	13
<b>PREPARATION</b> .....	3	Terminal and Reference Value for Sunroof Motor Assembly .....	14
Special Service Tool .....	3	CONSULT-III Function (BCM) .....	14
Commercial Service Tool .....	3	Work Flow .....	15
<b>SQUEAK AND RATTLE TROUBLE DIAGNOSIS</b> .....	4	Diagnosis Symptom Chart .....	15
Work Flow .....	4	Check BCM Power Supply and Ground Circuit .....	15
Inspection Procedure .....	6	Check Sunroof Motor Assembly Power Supply and Ground Circuit .....	16
Diagnostic Worksheet .....	8	Check Sunroof Switch .....	17
<b>SUNROOF</b> .....	10	Check Door Switch .....	19
		Fitting Adjustment .....	21
		Removal and Installation .....	21
		Disassembly and Assembly .....	24

# PRECAUTIONS

< SERVICE INFORMATION >

## SERVICE INFORMATION

### PRECAUTIONS

#### Precaution for Supplemental Restraint System (SRS) "AIR BAG" and "SEAT BELT PRE-TENSIONER"

INFOID:000000005348463

The Supplemental Restraint System such as "AIR BAG" and "SEAT BELT PRE-TENSIONER", used along with a front seat belt, helps to reduce the risk or severity of injury to the driver and front passenger for certain types of collision. This system includes seat belt switch inputs and dual stage front air bag modules. The SRS system uses the seat belt switches to determine the front air bag deployment, and may only deploy one front air bag, depending on the severity of a collision and whether the front occupants are belted or unbelted. Information necessary to service the system safely is included in the "SUPPLEMENTAL RESTRAINT SYSTEM" and "SEAT BELTS" of this Service Manual.

#### **WARNING:**

- To avoid rendering the SRS inoperative, which could increase the risk of personal injury or death in the event of a collision which would result in air bag inflation, all maintenance must be performed by an authorized NISSAN/INFINITI dealer.
- Improper maintenance, including incorrect removal and installation of the SRS, can lead to personal injury caused by unintentional activation of the system. For removal of Spiral Cable and Air Bag Module, see the "SUPPLEMENTAL RESTRAINT SYSTEM".
- Do not use electrical test equipment on any circuit related to the SRS unless instructed to in this Service Manual. SRS wiring harnesses can be identified by yellow and/or orange harnesses or harness connectors.

#### PRECAUTIONS WHEN USING POWER TOOLS (AIR OR ELECTRIC) AND HAMMERS

#### **WARNING:**

- When working near the Air Bag Diagnosis Sensor Unit or other Air Bag System sensors with the ignition ON or engine running, DO NOT use air or electric power tools or strike near the sensor(s) with a hammer. Heavy vibration could activate the sensor(s) and deploy the air bag(s), possibly causing serious injury.
- When using air or electric power tools or hammers, always switch the ignition OFF, disconnect the battery, and wait at least 3 minutes before performing any service.

#### Precaution

INFOID:000000005348464

- Disconnect both battery cables in advance.
- Disconnect air bag system line in advance.
- Do not tamper with or force air bag lid open, as this may adversely affect air bag performance.
- Be careful not to scratch pad and other parts.
- When removing or disassembling any part, be careful not to damage or deform it. Protect parts, which may get in the way with cloth.
- When removing parts with a screwdriver or other tool, protect parts by wrapping them with vinyl or tape.
- Keep removed parts protected with cloth.
- If a clip is deformed or damaged, replace it.
- If an un reusable part is removed, replace it with a new one.
- Tighten bolts and nuts firmly to the specified torque.
- After re-assembly has been completed, make sure each part functions correctly.
- Remove stains in the following way.

Water-soluble stains:

Dip a soft cloth in warm water, and then squeeze it tightly. After wiping the stain, wipe with a soft dry cloth.

Oil stain:

Dissolve a synthetic detergent in warm water (density of 2 to 3% or less), dip the cloth, then clean off the stain with the cloth. Next, dip the cloth in fresh water and squeeze it tightly. Then clean off the detergent completely. Then wipe the area with a soft dry cloth.

- Do not use any organic solvent, such as thinner or benzene.

# PREPARATION

< SERVICE INFORMATION >

## PREPARATION

### Special Service Tool

INFOID:000000005348465

The actual shapes of Kent-Moore tools may differ from those of special service tools illustrated here.

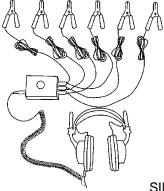
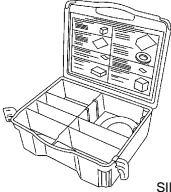
Tool number (Kent-Moore No.) Tool name	Description
(J-39570) Chassis ear   <p style="text-align: center;">SIIA0993E</p>	Locating the noise
(J-43980) NISSAN Squeak and Rattle Kit   <p style="text-align: center;">SIIA0994E</p>	Repairing the cause of noise

### Commercial Service Tool

INFOID:000000005348466

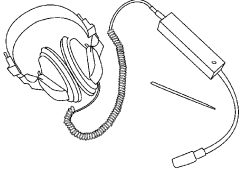
Tool name	Description
Engine ear   <p style="text-align: center;">SIIA0995E</p>	Locating the noise

# SQUEAK AND RATTLE TROUBLE DIAGNOSIS

< SERVICE INFORMATION >

## SQUEAK AND RATTLE TROUBLE DIAGNOSIS

### Work Flow

INFOID:000000005348467

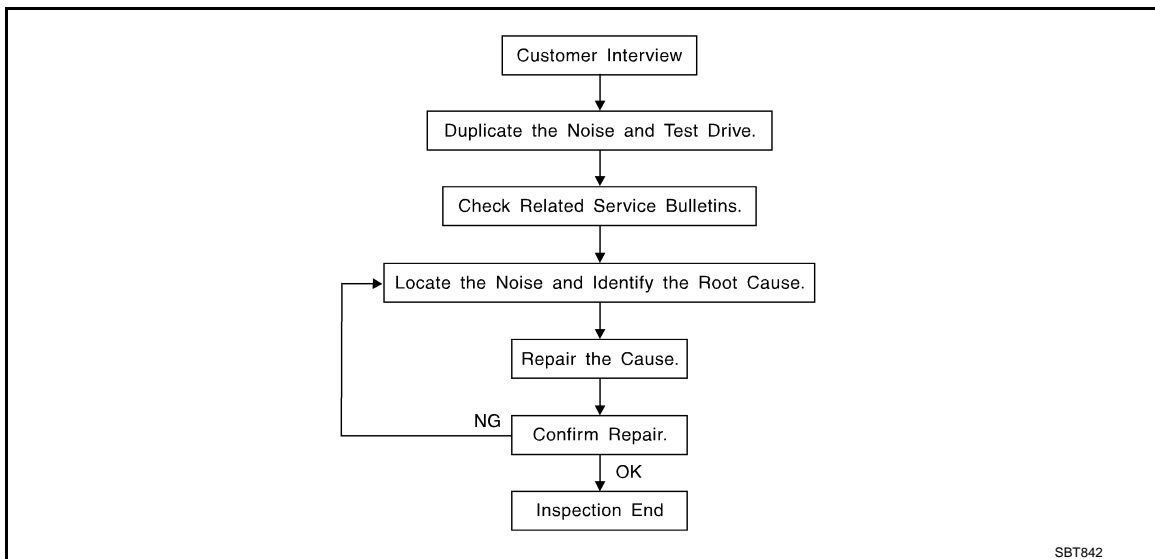

### CUSTOMER INTERVIEW

Interview the customer if possible, to determine the conditions that exist when the noise occurs. Use the Diagnostic Worksheet during the interview to document the facts and conditions when the noise occurs and any of customer's comments; refer to [RF-8, "Diagnostic Worksheet"](#). This information is necessary to duplicate the conditions that exist when the noise occurs.

- The customer may not be able to provide a detailed description or the location of the noise. Attempt to obtain all the facts and conditions that exist when the noise occurs (or does not occur).
- If there is more than one noise in the vehicle, perform a diagnosis and repair the noise that the customer is concerned about. This can be accomplished by performing a cruise test on the vehicle with the customer.
- After identifying the type of noise, isolate the noise in terms of its characteristics. The noise characteristics are provided so the customer, service adviser and technician are all speaking the same language when defining the noise.
- Squeak —(Like tennis shoes on a clean floor)  
Squeak characteristics include the light contact/fast movement/brought on by road conditions/hard surfaces=higher pitch noise/softer surfaces=lower pitch noises/edge to surface=chirping
- Creak—(Like walking on an old wooden floor)  
Creak characteristics include firm contact/slow movement/twisting with a rotational movement/pitch dependent on materials/often brought on by activity.
- Rattle—(Like shaking a baby rattle)  
Rattle characteristics include the fast repeated contact/vibration or similar movement/loose parts/missing clip or fastener/incorrect clearance.
- Knock —(Like a knock on a door)  
Knock characteristics include hollow sounding/sometimes repeating/often brought on by driver action.
- Tick—(Like a clock second hand)  
Tick characteristics include gentle contacting of light materials/loose components/can be caused by driver action or road conditions.
- Thump—(Heavy, muffled knock noise)  
Thump characteristics include softer knock/dead sound often brought on by activity.
- Buzz—(Like a bumblebee)  
Buzz characteristics include high frequency rattle/firm contact.
- Often the degree of acceptable noise level will vary depending up on the person. A noise that you may judge as acceptable may be very irritating to the customer.
- Weather conditions, especially humidity and temperature, may have a great effect on noise level.

### DUPLICATE THE NOISE AND TEST DRIVE

If possible, drive the vehicle with the customer until the noise is duplicated. Note any additional information on the Diagnostic Worksheet regarding the conditions or location of the noise. This information can be used to duplicate the same conditions when you confirm the repair.

# SQUEAK AND RATTLE TROUBLE DIAGNOSIS

## < SERVICE INFORMATION >

If the noise can be duplicated easily during the test drive, to help identify the source of the noise, try to duplicate the noise with the vehicle stopped by doing one or all of the following:

- 1) Close a door.
  - 2) Tap or push/pull around the area where the noise appears to be coming from.
  - 3) Rev the engine.
  - 4) Use a floor jack to recreate vehicle "twist".
  - 5) At idle, apply engine load (electrical load, half-clutch on M/T models, drive position on A/T models).
  - 6) Raise the vehicle on a hoist and hit a tire with a rubber hammer.
- Drive the vehicle and attempt to duplicate the conditions the customer states exist when the noise occurs.
  - If it is difficult to duplicate the noise, drive the vehicle slowly on an undulating or rough road to stress the vehicle body.

## CHECK RELATED SERVICE BULLETINS

After verifying the customer concern or symptom, check ASIST for Technical Service Bulletins (TSBs) related to that concern or symptom.

If a TSB relates to the symptom, follow the procedure to repair the noise.

## LOCATE THE NOISE AND IDENTIFY THE ROOT CAUSE

1. Narrow down the noise to a general area. To help pinpoint the source of the noise, use a listening tool (Chassis Ear: J-39570, Engine Ear and mechanics stethoscope).
2. Narrow down the noise to a more specific area and identify the cause of the noise by:
  - removing the components in the area that you suspect the noise is coming from.  
Do not use too much force when removing clips and fasteners, otherwise clips and fastener can be broken or lost during the repair, resulting in the creation of new noise.
  - tapping or pushing/pulling the component that you suspect is causing the noise.  
Do not tap or push/pull the component with excessive force, otherwise the noise will be eliminated only temporarily.
  - feeling for a vibration with your hand by touching the component(s) that you suspect is (are) causing the noise.
  - placing a piece of paper between components that you suspect are causing the noise.
  - looking for loose components and contact marks.  
Refer to [RF-6. "Inspection Procedure"](#).

## REPAIR THE CAUSE

- If the cause is a loose component, tighten the component securely.
- If the cause is insufficient clearance between components:
  - separate components by repositioning or loosening and retightening the component, if possible.
  - insulate components with a suitable insulator such as urethane pads, foam blocks, felt cloth tape or urethane tape. A Nissan Squeak and Rattle Kit (J-43980) is available through your authorized Nissan Parts Department.

### **CAUTION:**

**Do not use excessive force as many components are constructed of plastic and may be damaged.**

### **NOTE:**

Always check with the Parts Department for the latest parts information.

The following materials are contained in the Nissan Squeak and Rattle Kit (J-43980). Each item can be ordered separately as needed.

URETHANE PADS [1.5 mm (0.059 in) thick]

Insulates connectors, harness, etc.

76268-9E005: 100 × 135 mm (3.94 × 5.31 in)/76884-71L01: 60 × 85 mm (2.36 × 3.35 in)/76884-71L02: 15 × 25 mm (0.59 × 0.98 in)

INSULATOR (Foam blocks)

Insulates components from contact. Can be used to fill space behind a panel.

73982-9E000: 45 mm (1.77 in) thick, 50 × 50 mm (1.97 × 1.97 in)/73982-

50Y00: 10 mm (0.39 in) thick, 50 × 50 mm (1.97 × 1.97 in)

INSULATOR (Light foam block)

80845-71L00: 30 mm (1.18 in) thick, 30 × 50 mm (1.18 × 1.97in)

FELT CLOTHTAPE

Used to insulate where movement does not occur. Ideal for instrument panel applications.

68370-4B000: 15 × 25 mm (0.59 × 0.98 in) pad/68239-13E00: 5 mm (0.20 in) wide tape roll

The following materials, not found in the kit, can also be used to repair squeaks and rattles.

UHMW (TEFLON) TAPE

# SQUEAK AND RATTLE TROUBLE DIAGNOSIS

## < SERVICE INFORMATION >

---

Insulates where slight movement is present. Ideal for instrument panel applications.

### SILICONE GREASE

Used in place of UHMW tape that will be visible or not fit. Will only last a few months.

### SILICONE SPRAY

Use when grease cannot be applied.

### DUCT TAPE

Use to eliminate movement.

## CONFIRM THE REPAIR

Confirm that the cause of a noise is repaired by test driving the vehicle. Operate the vehicle under the same conditions as when the noise originally occurred. Refer to the notes on the Diagnostic Worksheet.

## Inspection Procedure

INFOID:000000005348468

Refer to Table of Contents for specific component removal and installation information.

## INSTRUMENT PANEL

Most incidents are caused by contact and movement between:

1. The cluster lid A and instrument panel
2. Acrylic lens and combination meter housing
3. Instrument panel to front pillar garnish
4. Instrument panel to windshield
5. Instrument panel mounting pins
6. Wiring harnesses behind the combination meter
7. A/C defroster duct and duct joint

These incidents can usually be located by tapping or moving the components to duplicate the noise or by pressing on the components while driving to stop the noise. Most of these incidents can be repaired by applying felt cloth tape or silicon spray (in hard to reach areas). Urethane pads can be used to insulate wiring harness.

### **CAUTION:**

**Do not use silicone spray to isolate a squeak or rattle. If you saturate the area with silicone, you will not be able to recheck the repair.**

## CENTER CONSOLE

Components to pay attention to include:

1. Shifter assembly cover to finisher
2. A/C control unit and cluster lid C
3. Wiring harnesses behind audio and A/C control unit

The instrument panel repair and isolation procedures also apply to the center console.

## DOORS

Pay attention to the:

1. Finisher and inner panel making a slapping noise
2. Inside handle escutcheon to door finisher
3. Wiring harnesses tapping
4. Door striker out of alignment causing a popping noise on starts and stops

Tapping or moving the components or pressing on them while driving to duplicate the conditions can isolate many of these incidents. You can usually insulate the areas with felt cloth tape or insulator foam blocks from the Nissan Squeak and Rattle Kit (J-43980) to repair the noise.

## TRUNK

Trunk noises are often caused by a loose jack or loose items put into the trunk by the owner.

In addition look for:

1. Trunk lid dumpers out of adjustment
2. Trunk lid striker out of adjustment
3. The trunk lid torsion bars knocking together
4. A loose license plate or bracket

# SQUEAK AND RATTLE TROUBLE DIAGNOSIS

## < SERVICE INFORMATION >

Most of these incidents can be repaired by adjusting, securing or insulating the item(s) or component(s) causing the noise.

### SUNROOF/HEADLINING

Noises in the sunroof/headlining area can often be traced to one of the following:

1. Sunroof lid, rail, linkage or seals making a rattle or light knocking noise
2. Sunvisor shaft shaking in the holder
3. Front or rear windshield touching headlining and squeaking

Again, pressing on the components to stop the noise while duplicating the conditions can isolate most of these incidents. Repairs usually consist of insulating with felt cloth tape.

### SEATS

When isolating seat noise it's important to note the position the seat is in and the load placed on the seat when the noise is present. These conditions should be duplicated when verifying and isolating the cause of the noise.

Cause of seat noise include:

1. Headrest rods and holder
2. A squeak between the seat pad cushion and frame
3. The rear seatback lock and bracket

These noises can be isolated by moving or pressing on the suspected components while duplicating the conditions under which the noise occurs. Most of these incidents can be repaired by repositioning the component or applying urethane tape to the contact area.

### UNDERHOOD

Some interior noise may be caused by components under the hood or on the engine wall. The noise is then transmitted into the passenger compartment.

Causes of transmitted underhood noise include:

1. Any component mounted to the engine wall
2. Components that pass through the engine wall
3. Engine wall mounts and connectors
4. Loose radiator mounting pins
5. Hood bumpers out of adjustment
6. Hood striker out of adjustment

These noises can be difficult to isolate since they cannot be reached from the interior of the vehicle. The best method is to secure, move or insulate one component at a time and test drive the vehicle. Also, engine RPM or load can be changed to isolate the noise. Repairs can usually be made by moving, adjusting, securing, or insulating the component causing the noise.

A  
B  
C  
D  
E  
F  
G  
H  
J  
K  
L  
M  
N  
O  
P

RF

# SQUEAK AND RATTLE TROUBLE DIAGNOSIS

< SERVICE INFORMATION >

## Diagnostic Worksheet

INFOID:000000005348469



### SQUEAK & RATTLE DIAGNOSTIC WORKSHEET

Dear Infiniti Customer:

We are concerned about your satisfaction with your Infiniti vehicle. Repairing a squeak or rattle sometimes can be very difficult. To help us fix your Infiniti right the first time, please take a moment to note the area of the vehicle where the squeak or rattle occurs and under what conditions. You may be asked to take a test drive with a service consultant or technician to ensure we confirm the noise you are hearing.

#### I. WHERE DOES THE NOISE COME FROM? (circle the area of the vehicle)

The illustrations are for reference only, and may not reflect the actual configuration of your vehicle.

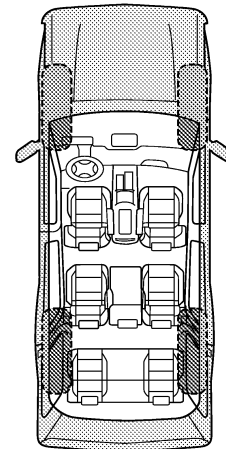
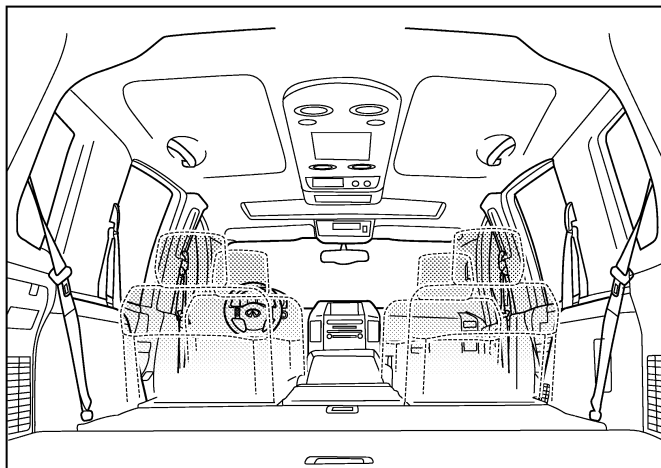
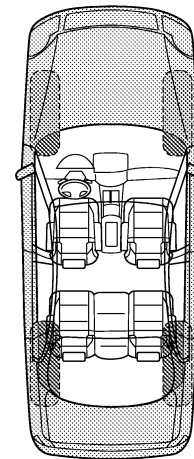
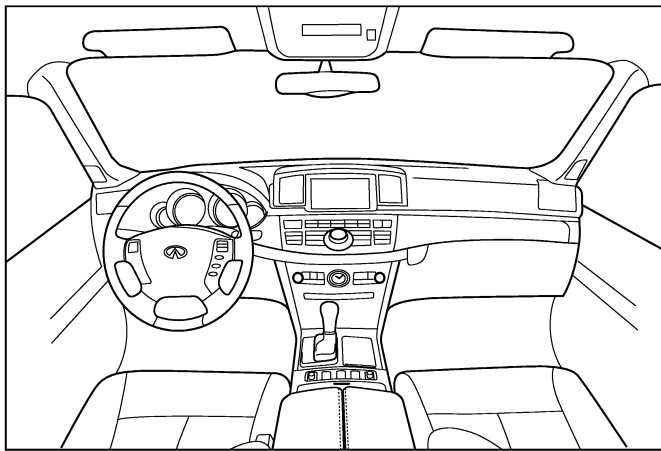

Continue to page 2 of the worksheet and briefly describe the location of the noise or rattle. In addition, please indicate the conditions which are present when the noise occurs.

PIIB8741E



# SQUEAK AND RATTLE TROUBLE DIAGNOSIS

< SERVICE INFORMATION >

## SQUEAK & RATTLE DIAGNOSTIC WORKSHEET - page 2

Briefly describe the location where the noise occurs:

---

---

### II. WHEN DOES IT OCCUR? (please check the boxes that apply)

- |   |  |
|---|--|
| <input type="checkbox"/> anytime                      | <input type="checkbox"/> after sitting out in the rain |
| <input type="checkbox"/> 1st time in the morning      | <input type="checkbox"/> when it is raining or wet     |
| <input type="checkbox"/> only when it is cold outside | <input type="checkbox"/> dry or dusty conditions       |
| <input type="checkbox"/> only when it is hot outside  | <input type="checkbox"/> other:                        |

### III. WHEN DRIVING:

- through driveways
- over rough roads
- over speed bumps
- only about \_\_\_\_ mph
- on acceleration
- coming to a stop
- on turns: left, right or either (circle)
- with passengers or cargo
- other: \_\_\_\_\_
- after driving \_\_\_\_ miles or \_\_\_\_ minutes

### IV. WHAT TYPE OF NOISE

- squeak (like tennis shoes on a clean floor)
- creak (like walking on an old wooden floor)
- rattle (like shaking a baby rattle)
- knock (like a knock at the door)
- tick (like a clock second hand)
- thump (heavy, muffled knock noise)
- buzz (like a bumble bee)

### TO BE COMPLETED BY DEALERSHIP PERSONNEL

#### Test Drive Notes:

---

---

---

	YES	NO	Initials of person performing
Vehicle test driven with customer	<input type="checkbox"/>	<input type="checkbox"/>	_____
- Noise verified on test drive	<input type="checkbox"/>	<input type="checkbox"/>	_____
- Noise source located and repaired	<input type="checkbox"/>	<input type="checkbox"/>	_____
- Follow up test drive performed to confirm repair	<input type="checkbox"/>	<input type="checkbox"/>	_____

VIN: \_\_\_\_\_ Customer Name: \_\_\_\_\_  
W.O.# \_\_\_\_\_ Date: \_\_\_\_\_

This form must be attached to Work Order

PIIB8742E

A  
B  
C  
D  
E  
F  
G  
H  
RF  
J  
K  
L  
M  
N  
O  
P

# SUNROOF

< SERVICE INFORMATION >

## SUNROOF

### Component Parts and Harness Connector Location

INFOID:000000005348470

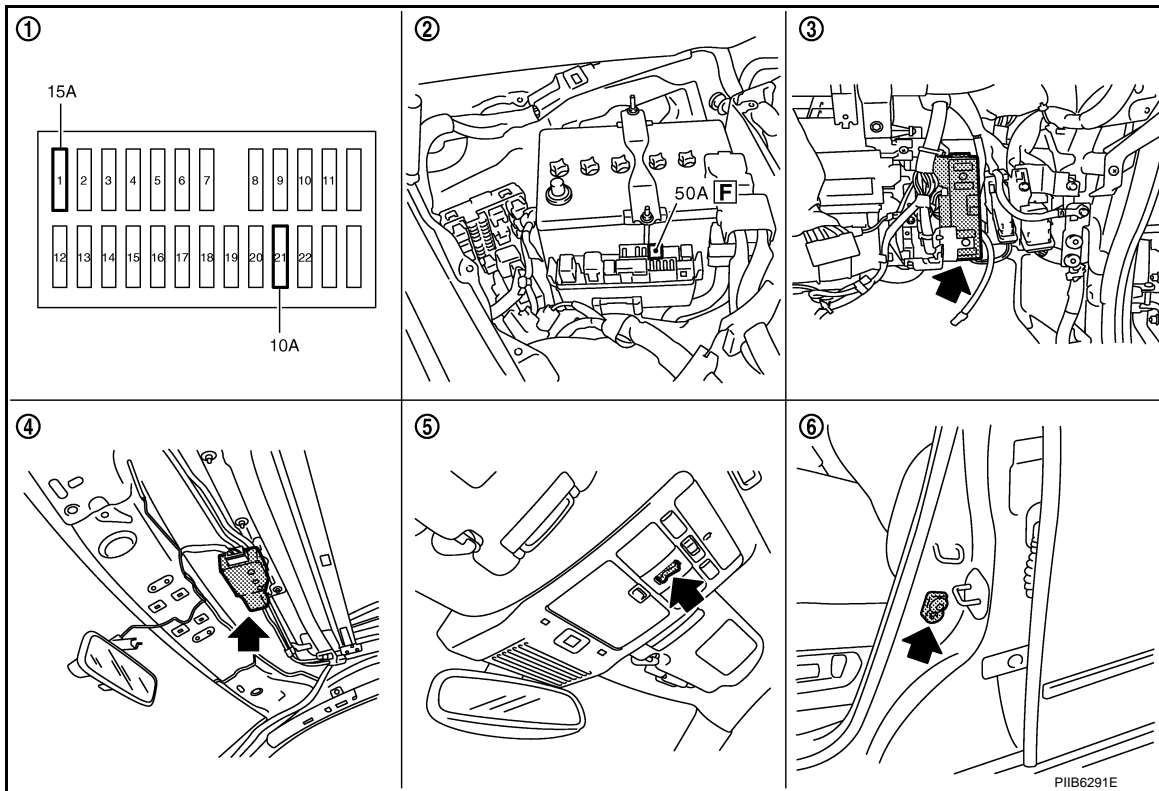

- |                                |                              |   |
|--------------------------------|------------------------------|---|
| 1. Fuse block (J/B)            | 2. Fuse and fusible link box | 3. BCM M1, M2, M3<br>(View with the glove box assembly removed) |
| 4. Sunroof motor assembly M186 | 5. Sunroof switch R53        | 6. Front door switch driver side B11                            |

### System Description

INFOID:000000005348471

Power supplied at all time

- through 50A fusible link (letter **F**, located in the fuse and fusible link box)
- to BCM terminal 55
- through 10A fuse [No.21, located in the fuse block (J/B)]

• to BCM terminal 42

• through BCM terminal 54

• to sunroof motor assembly terminal 1

When ignition switch ON or START position,

Power is supplied

• through 15A fuse [No.1, located in the fuse block (J/B)]

• to BCM terminal 38

• through BCM terminal 53

• to sunroof motor assembly terminal 6

Ground is supplied

• to BCM terminal 52

• through body grounds M16 and M70

• to sunroof motor assembly terminal 8

• through body ground M16 and M70

### TILT UP / SLIDE CLOSE OPERATION

When tilt up / slide close switch is pressed,

Ground is supplied

• to sunroof motor assembly terminal 11

• through sunroof switch terminal 3

# SUNROOF

## < SERVICE INFORMATION >

---

- through sunroof switch terminal 2
  - through sunroof motor assembly terminal 9
- Then, the sunroof tilt up / slide close.

A

### TILT DOWN / SLIDE OPEN OPERATION

When tilt down / slide open switch is pressed,  
Ground is supplied

B

- to sunroof motor assembly terminal 4
- through sunroof switch terminal 1
- through sunroof switch terminal 2
- through sunroof motor assembly terminal 9

C

Then, the sunroof tilt down / slide open.

D

### AUTO OPERATION

The power sunroof AUTO feature makes it possible to slide open and slide close or tilt up and tilt down the sunroof without holding the sunroof switch in the SLIDE OPEN/TILT DOWN or SLIDE CLOSE/TILT UP position.

E

### RETAINED POWER OPERATION

When the ignition switch is turned to OFF position from ON position, power is supplied for 45 seconds.

F

- through BCM terminal 53.
- to sunroof motor assembly terminal 6.

When power is supplied, the sunroof can be operated.

The retained power operation is canceled when the driver or passenger side door is opened.

G

RAP signal period can be changed by CONSULT-III. Refer to [RF-14. "CONSULT-III Function \(BCM\)".](#)

### ANTI-PINCH FUNCTION

The CPU of sunroof motor assembly monitors the sunroof motor operation and the sunroof position (fully-closed or other) by the signals from sunroof motor.

H

When sunroof motor detects an interruption during the following slide close and tilt down operation, sunroof motor assembly controls the motor until full up position (when tilt down operate) or 125 mm (4.92 in) or more to open direction (when slide close operate).

RF

The function is operated in the following conditions.

- close operation and tilt down when ignition switch is in the ON position.
- close operation and tilt down during retained power operation.

J

### INITIALIZATION PROCEDURE

If the battery is disconnected, the sunroof motor connector is disconnected sunroof does not close or open automatically, use the following procedure to return sunroof operation to normal.

K

1. Close the sunroof if it is not in the closed position. It may be necessary to repeatedly push the switch to close the sunroof.
2. Press the SLIDE OPEN/TILT DOWN switch for approximately 1 second or more.
3. Initialization procedure is completed. Confirm proper operation of the sunroof (slide open, slide close, tilt up, tilt down.)

L

M

N

O

P

# SUNROOF

< SERVICE INFORMATION >

## Wiring Diagram - SROOF -

INFOID:000000005348472

### RF-SROOF-01

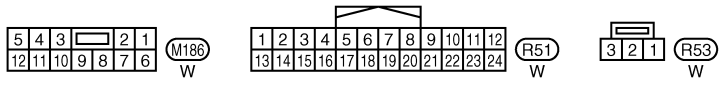
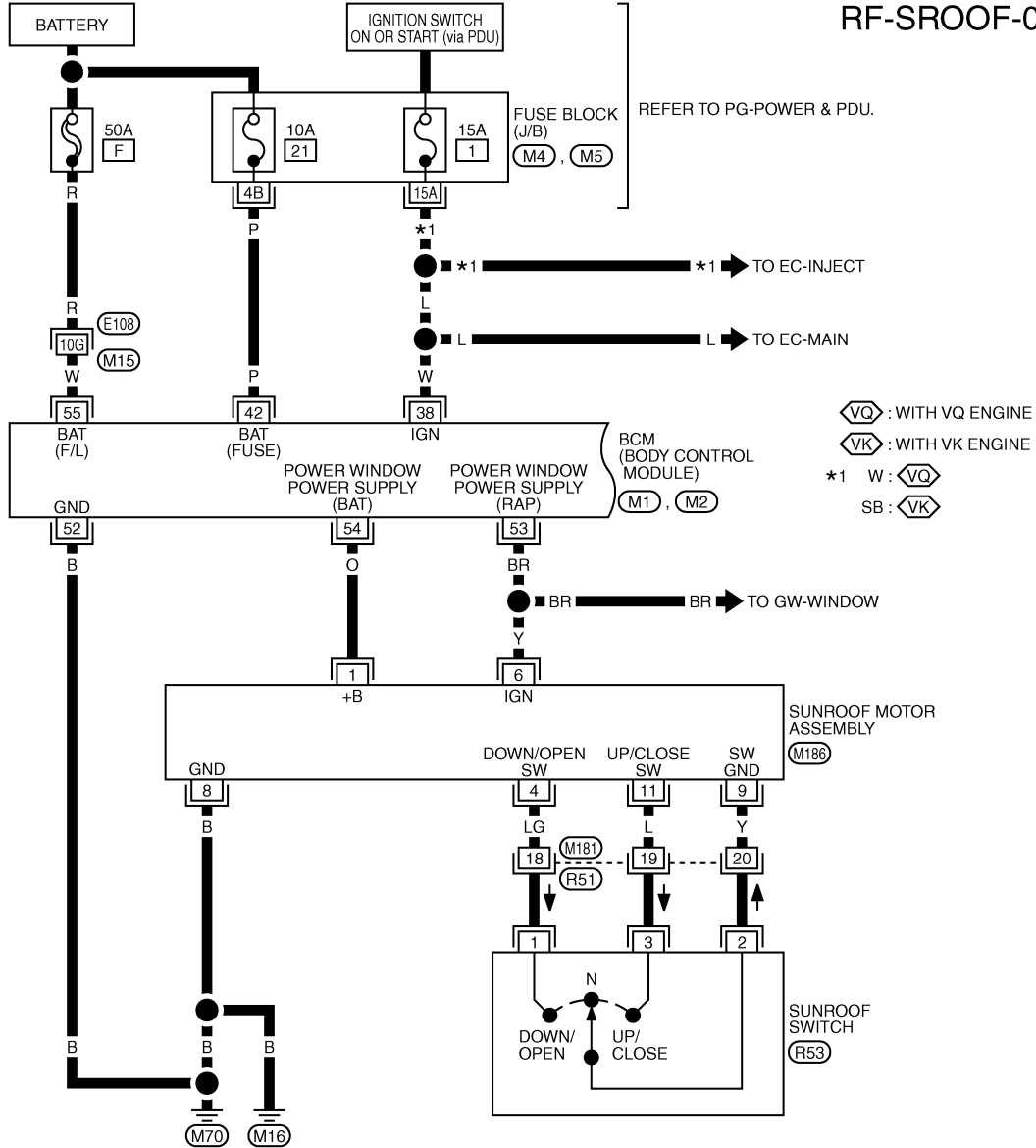

REFER TO THE FOLLOWING.

(E108) -SUPER MULTIPLE JUNCTION (SMJ)

(M4), (M5) -FUSE BLOCK-JUNCTION BOX (J/B)

(M1), (M2) -ELECTRICAL UNITS

TIWT3169E

# SUNROOF

< SERVICE INFORMATION >

RF-SROOF-02

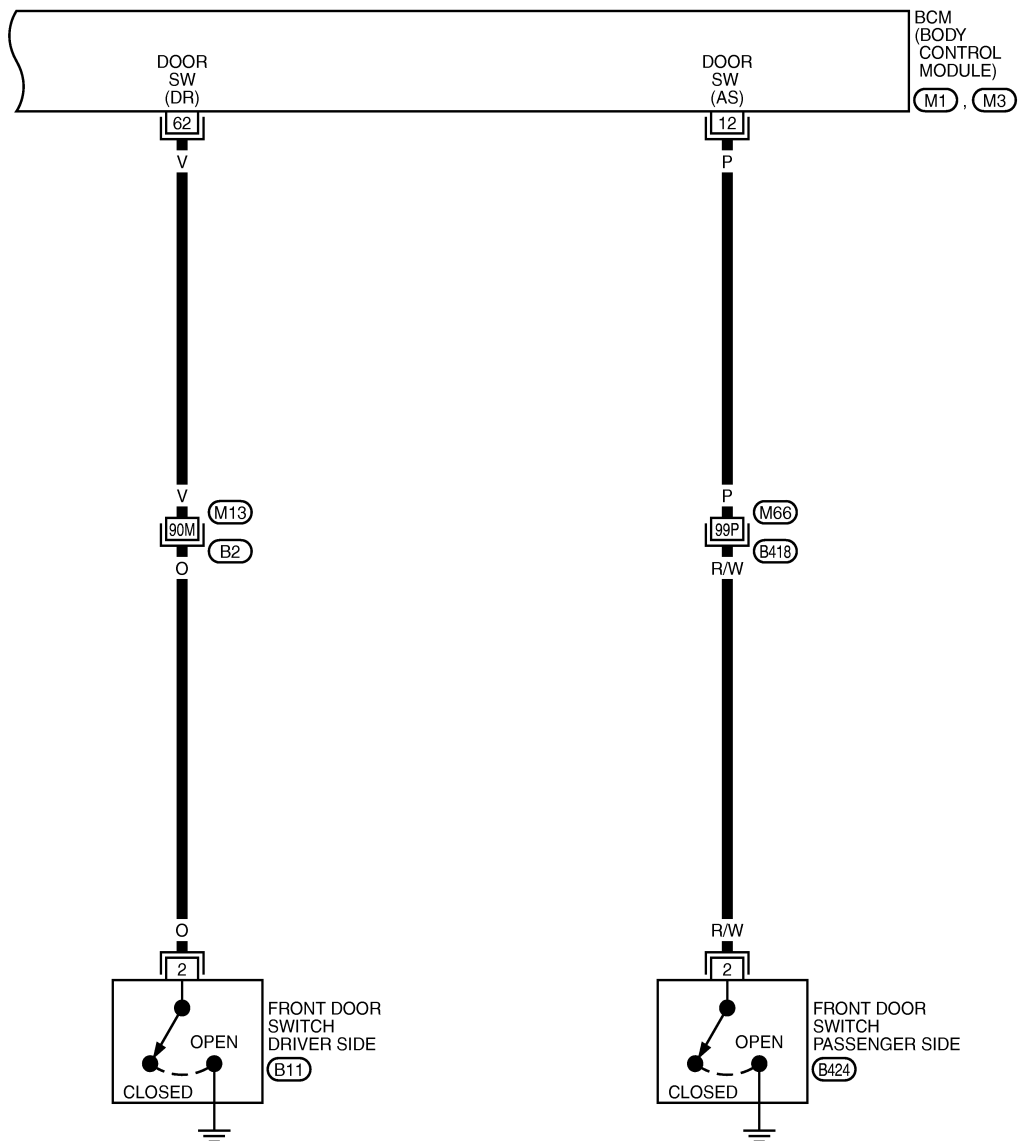

1	
2	(B11), (B424)
3	W, W

REFER TO THE FOLLOWING.  
 (B2), (B418) - SUPER MULTIPLE JUNCTION (SMJ)  
 (M1), (M3) - ELECTRICAL UNITS

TIWT2647E

## Terminal and Reference Value for BCM

INFOID:000000005348473

Terminal	Wire color	Item	Signal Input/Output	Condition	Voltage (V) (Approx.)
12	P	Front door switch (passenger side)	Input	OPEN (ON)	0
				CLOSE (OFF)	Battery voltage

# SUNROOF

## < SERVICE INFORMATION >

Terminal	Wire color	Item	Signal Input/Output	Condition	Voltage (V) (Approx.)
38	W	Power source (IGN)	Input	Ignition switch (ON or START) position	Battery voltage
42	P	Power source (Fuse)	Input	—	Battery voltage
52	B	Ground (power)	—	—	0
53	BR	RAP signal	Output	Ignition switch ON	Battery voltage
				Within 45 seconds after ignition switch is turned to OFF position	Battery voltage
				When driver side or passenger side door is opened during retained power operation.	0
54	O	Power window power supply (BAT)	Output	—	Battery voltage
55	W	Power source (Fusible link)	Input	—	Battery voltage
62	V	Front door switch (driver side)	Input	OPEN (ON)	0
				CLOSE (OFF)	Battery voltage

## Terminal and Reference Value for Sunroof Motor Assembly

INFOID:000000005348474

Terminal	Wire color	Item	Signal Input/Output	Condition	Voltage (V) (Approx.)
1	O	BAT power supply (BCM)	Input	—	Battery voltage
4	LG	Sunroof (TILT DOWN/SLIDE OPEN) switch signal	Input	Ignition switch ON and sunroof switch in TILT DOWN / SLIDE OPEN position	0
				Other than above	Battery voltage
6	Y	RAP signal	Input	Ignition switch ON	Battery voltage
				Within 45 seconds after ignition switch is turned to OFF position	Battery voltage
				When driver side or passenger side door is opened during retained power operation.	0
8	B	Ground	—	—	0
9	Y	Sunroof switch ground	—	—	0
11	L	Sunroof (TILT UP/SLIDE CLOSE) switch signal	Input	Ignition switch ON and sunroof switch in TILT UP / SLIDE CLOSE position	0
				Other than above	Battery voltage

## CONSULT-III Function (BCM)

INFOID:000000005348475

CONSULT-III can display each diagnostic item using the diagnostic test modes shown following.

BCM diagnostic test item	Check item diagnostic test mode	Content
RETAINED PWR	Work support	Changes setting of each function.
	Data monitor	Displays the input data of BCM in real time.
	Active test	Gives a drive signal to a load to check the operation.

## ACTIVE TEST

Test Item	Description
RETAINED PWR	This test is able to supply RAP signal (power) from BCM (body control module) to power window system and power sunroof system (if equipped). Those systems can be operated when turning on "RETAINED PWR" on CONSULT-III screen even if the ignition switch is turned OFF.

## WORK SUPPORT

# SUNROOF

## < SERVICE INFORMATION >

Work item	Description
RETAINED PWR	Rap signal's power supply period can be changed by mode setting. Selects rap signal's power supply period between three steps <ul style="list-style-type: none"> <li>• MODE1 (45 sec.) / MODE2 (OFF) / MODE3 (2 min.).</li> </ul>

## DATA MONITOR

Work item	Description
IGN ON SW	Indicates (ON / OFF) condition of ignition switch
DOOR SW-DR	Indicates (ON / OFF) condition of front door switch driver side
DOOR SW-AS	Indicates (ON / OFF) condition of front door switch passenger side

## Work Flow

INFOID:000000005348476

1. Check the symptom and customer's requests.
2. Understand the outline of system. Refer to [RF-10, "System Description"](#).
3. According to the trouble diagnosis chart, repair or replace the cause of the malfunction. Refer to [RF-15, "Diagnosis Symptom Chart"](#).
4. Does sunroof system operate normally? If Yes, GO TO 5. If No, GO TO 3.
5. INSPECTION END.

## Diagnosis Symptom Chart

INFOID:000000005348477

Symptom	Diagnostic procedure and repair order	Refer to page
Sunroof does not operate properly.	1. Check BCM power supply and ground circuit	<a href="#">RF-15</a>
	2. Check sunroof motor assembly power supply and ground circuit	<a href="#">RF-16</a>
	3. Check sunroof switch	<a href="#">RF-17</a>
	4. Replace sunroof motor assembly	<a href="#">RF-21</a>
Automatic operation dose not operate.	1. Check initialization procedure	<a href="#">RF-10</a>
	2. Replace sunroof motor assembly	<a href="#">RF-21</a>
Motor does not stop at sunroof fully -open or fully- closed position.	1. Check initialization procedure	<a href="#">RF-10</a>
	2. Replace sunroof motor assembly	<a href="#">RF-21</a>
Retained power operation does not operate properly.	1. Check the retained power operation mode setting	<a href="#">RF-14</a>
	2. Check door switch	<a href="#">RF-19</a>
	3. Replace sunroof motor assembly	<a href="#">RF-21</a>
Sunroof does not operate anti-pinch function.	1. Check initialization procedure	<a href="#">RF-10</a>
	2. Replace sunroof motor assembly	<a href="#">RF-21</a>

## Check BCM Power Supply and Ground Circuit

INFOID:000000005348478

### 1.CHECK FUSE

- Check 50A fusible link (letter **F**, located in the fuse and fusible link box).
- Check 15A fuse [No.1, located in the fuse block (J/B)]
- Check 10A fuse [No.21, located in the fuse block (J/B)]

#### NOTE:

Refer to [RF-10, "Component Parts and Harness Connector Location"](#).

#### OK or NG

OK >> GO TO 2.

NG >> If fuse is blown out, be sure to eliminate cause of malfunction before installing new fuse. Refer to [PG-4](#).

# SUNROOF

< SERVICE INFORMATION >

## 2. CHECK POWER SUPPLY CIRCUIT

1. Turn ignition switch ON.
2. Check voltage between BCM connector and ground.

Terminals		Condition of ignition switch	Voltage (V) (Approx.)
(+)			
BCM connector	Terminal		
M1	38	Ground	Battery voltage
M2	42		
	55	OFF	

**OK or NG**

- OK >> GO TO 3.  
 NG >> Repair or replace harness.

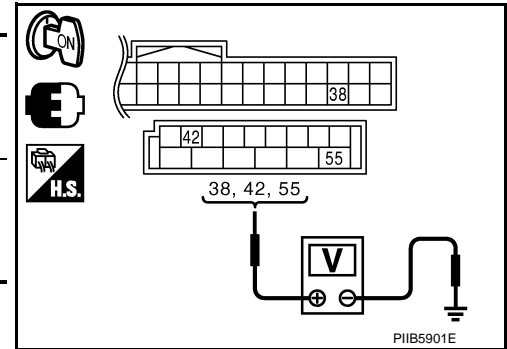

## 3. CHECK GROUND CIRCUIT

1. Turn ignition switch OFF.
2. Disconnect BCM connector.
3. Check continuity between BCM connector and ground.

BCM connector	Terminal	Ground	Continuity
M2	52		Yes

**OK or NG**

- OK >> Power supply and ground circuit are OK.  
 NG >> Repair or replace harness.

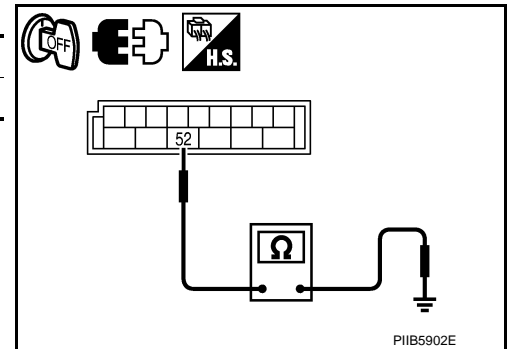

## Check Sunroof Motor Assembly Power Supply and Ground Circuit

INFOID:000000005348479

## 1. CHECK POWER SUPPLY CIRCUIT

1. Turn ignition switch OFF.
2. Disconnect sunroof motor assembly connector.
3. Turn ignition switch ON.
4. Check voltage between sunroof motor assembly connector and ground.

Terminal		Condition of ignition switch	Voltage (V) (Approx.)
(+)			
Sunroof motor assembly connector	Terminal		
M186	1	Ground	Battery voltage
	6		

**OK or NG**

- OK >> GO TO 2.  
 NG >> GO TO 3.

## 2. CHECK GROUND CIRCUIT

1. Turn ignition switch OFF.
2. Check continuity between sunroof motor assembly connector and ground.

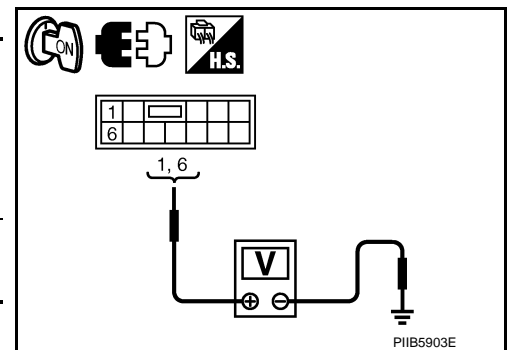



# SUNROOF

## < SERVICE INFORMATION >

Sunroof motor assembly connector	Terminal	Ground	Continuity
M186	8		Yes

### OK or NG

- OK >> Sunroof motor assembly power supply and ground circuit are OK. Further inspection is necessary. Refer to [RF-15. "Diagnosis Symptom Chart"](#).
- NG >> Repair or replace harness.

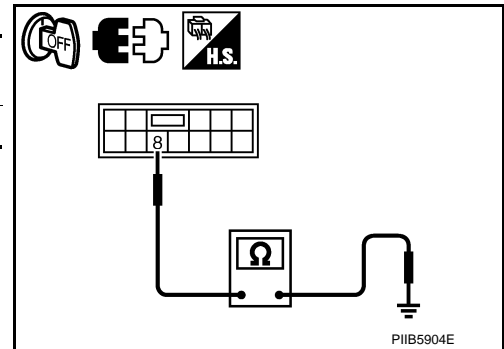

## 3.CHECK SONROOF MOTOR CIRCUIT

- Turn ignition switch OFF.
- Disconnect BCM connector.
- Check continuity between BCM connector and sunroof motor assembly connector.

A		B		Continuity
BCM connector	Terminal	Sunroof motor assembly connector	Terminal	
M2	53	M186	6	Yes
	54		1	

- Check continuity between BCM connector and ground.

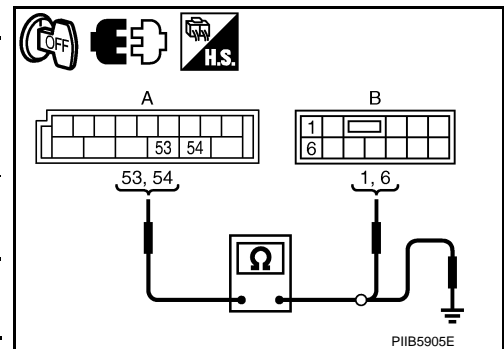

A		Ground	Continuity
BCM connector	Terminal		
M2	53		No
	54		

### OK or NG

- OK >> GO TO 4.
- NG >> Repair or replace harness.

## 4.CHECK BCM OUTPUT SIGNAL

- Connect BCM connector.
- Turn ignition switch ON.
- Check voltage between BCM connector and ground.

Terminals		Voltage (V) (Approx.)	
(+)			
BCM connector	Terminal	(-)	
M2	53	Ground	Battery voltage
	54		

### OK or NG

- OK >> Replace sunroof motor assembly.
- NG >> Replace BCM.

## Check Sunroof Switch

### 1.CHECK SUNROOF SWITCH INPUT SIGNAL

- Turn ignition switch ON.
- Check voltage between sunroof motor assembly connector and ground.

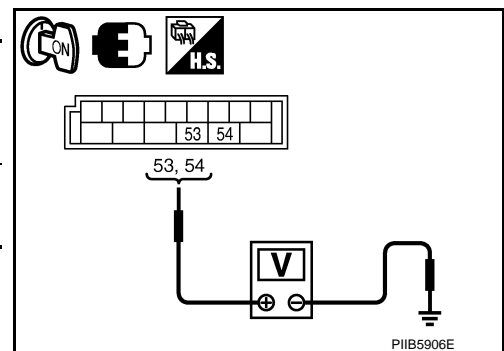

INFOID:000000005348480

# SUNROOF

## < SERVICE INFORMATION >

Sunroof motor as-assembly connector	Terminals		Condition	Voltage (V) (Approx.)
	(+)	(-)		
M186	4	Ground	Sunroof switch is operated TILT DOWN or SLIDE OPEN	0
			Other than above	Battery voltage
	11		Sunroof switch is operated TILT UP or SLIDE CLOSE	0
			Other than above	Battery voltage

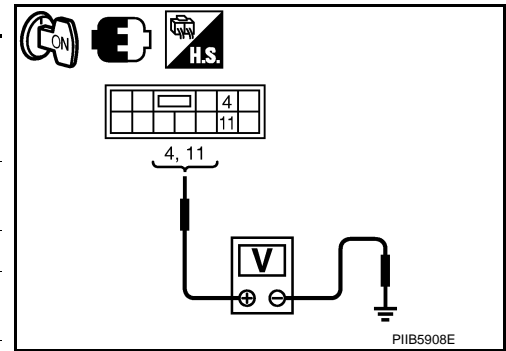

### OK or NG

OK >> Sunroof switch system is OK.

NG >> GO TO 2.

## 2. CHECK SUNROOF SWITCH CIRCUIT

1. Turn ignition switch OFF.
2. Disconnect sunroof motor assembly and sunroof switch connector.
3. Check continuity between sunroof motor assembly connector and sunroof switch connector.

A		B		Continuity
Sunroof motor as-assembly connector	Terminal	Sunroof switch connector	Terminal	
M186	4	R53	1	Yes
	11		3	

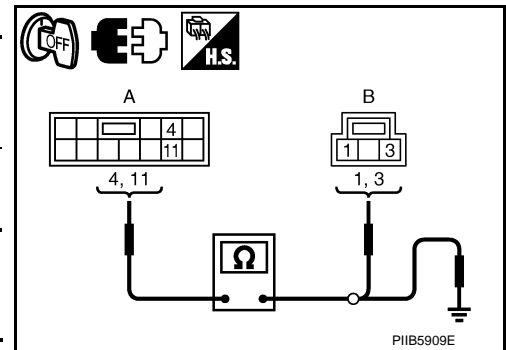

4. Check continuity between sunroof motor assembly connector and ground.

A		Ground	Continuity
Sunroof motor assembly connector	Terminal		
M186	4		No
	11		

### OK or NG

OK >> GO TO 3.

NG >> Repair or replace harness.

## 3. CHECK SUNROOF SWITCH GROUND CIRCUIT

Check continuity between sunroof switch connector and ground.

Sunroof switch connector	Terminal	Ground	Continuity
R53	2		Yes

### OK or NG

OK >> GO TO 4.

NG >> Repair or replace harness.

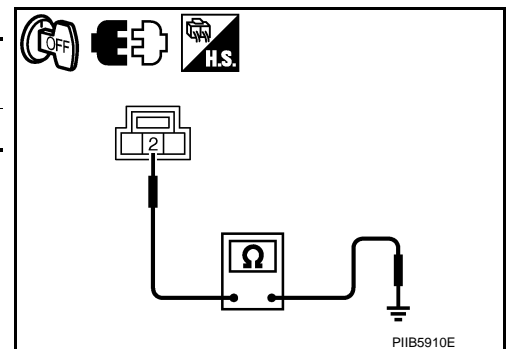

## 4. CHECK SUNROOF SWITCH GROUND CIRCUIT

Check continuity between sunroof motor connector and sunroof switch connector.

# SUNROOF

## < SERVICE INFORMATION >

A		B		Continuity
Sunroof switch connector	Terminal	Sunroof motor assembly connector	Terminal	
R53	2	M186	9	Yes

### OK or NG

- OK >> GO TO 5.
- NG >> Repair or replace harness.

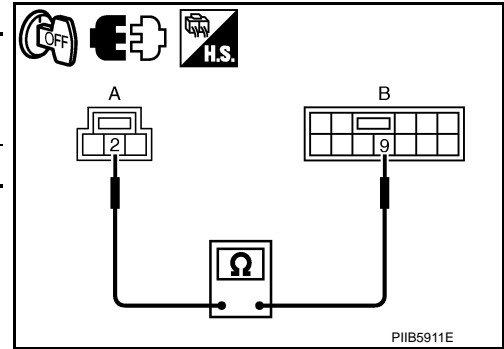

## 5. CHECK SUNROOF SWITCH

Check continuity between sunroof switch terminals.

Terminals	Condition	Continuity	
1	2	Sunroof switch is operated TILT DOWN or SLIDE OPEN	Yes
		Other than above	No
3	2	Sunroof switch is operated TILT UP or SLIDE CLOSE	Yes
		Other than above	No

### OK or NG

- OK >> Replace sunroof motor assembly.
- NG >> Replace sunroof switch.

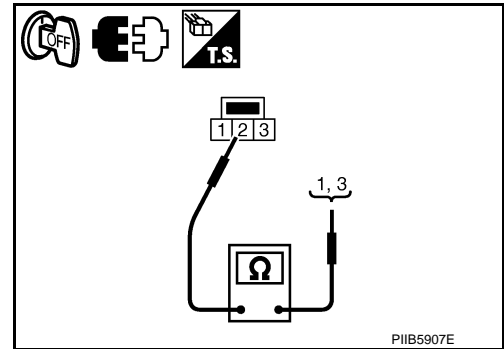

## Check Door Switch

INFOID:000000005348481

### 1. CHECK DOOR SWITCH INPUT SIGNAL

Check voltage between BCM connector and ground.

BCM connector	Item	Terminals		Condition	Voltage (V) (Approx.)
		(+)	(-)		
M1	Passenger side	12	Ground	OPEN	0
				CLOSE	Battery voltage
M3	Driver side	62	Ground	OPEN	0
				CLOSE	Battery voltage

### OK or NG

- OK >> Door switch circuit is OK.
- NG >> GO TO 2.

### 2. CHECK DOOR SWITCH CIRCUIT

1. Turn ignition switch OFF.
2. Disconnect door switch and BCM connector.
3. Check continuity between BCM connector and door switch connector.

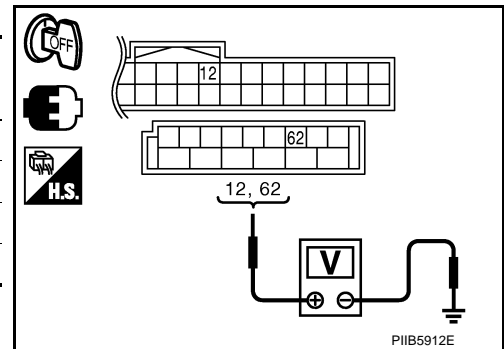

# SUNROOF

## < SERVICE INFORMATION >

A		B		Continuity
BCM connector	Terminal	Driver side door switch connector	Terminal	
M3	62	B11	2	Yes
A		C		Continuity
BCM connector	Terminal	Passenger side door switch connector	Terminal	
M1	12	B424	2	Yes

4. Check continuity between BCM connector and ground.

A			Ground	Continuity
BCM connector	Item	Terminal		
M3	Driver side	62	Ground	No
M1	Passenger side	12		

**OK or NG**

OK >> GO TO 3.

NG >> Repair or replace harness.

### 3. CHECK DOOR SWITCH

Check continuity between door switches and ground part of door switch.

Terminal	Door switch	Continuity
2	Pushed	No
	Released	Yes

**OK or NG**

OK >> GO TO 4.

NG >> Replace malfunction door switch.

### 4. CHECK BCM OUTPUT SIGNAL

1. Connect BCM connector.
2. Check voltage between BCM connector and ground.

Terminals			(-)	Voltage (V) (Approx.)
(+)				
BCM connector	Item	Terminal	Ground	Battery voltage
M3	Driver side	62		
M1	Passenger side	12		

**OK or NG**

OK >> Check the condition of the harness and the connector.

NG >> Replace BCM.

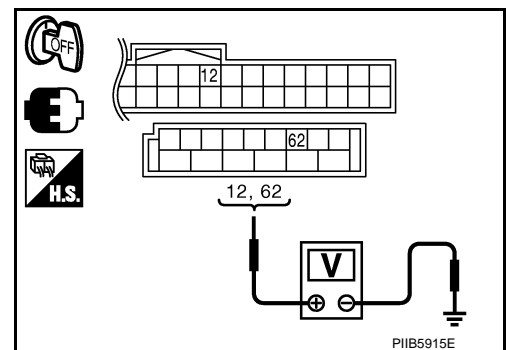
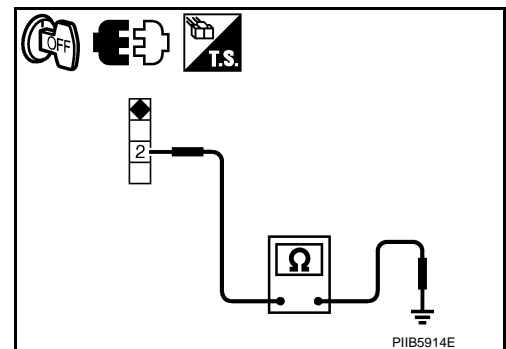
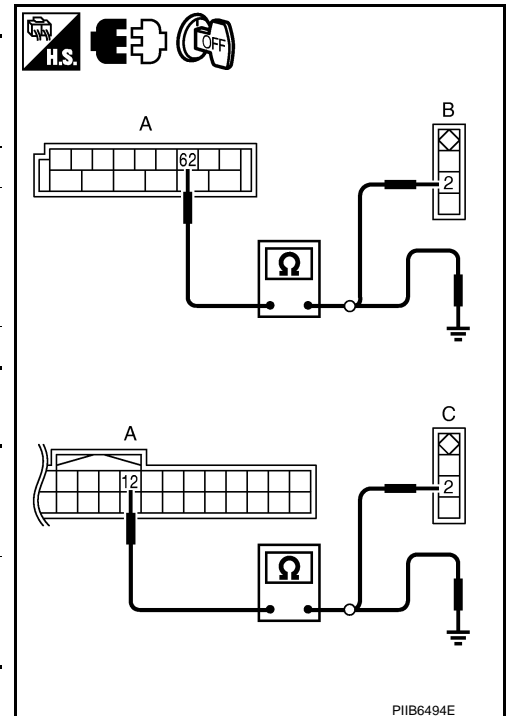

# SUNROOF

< SERVICE INFORMATION >

## Fitting Adjustment

INFOID:000000005348482

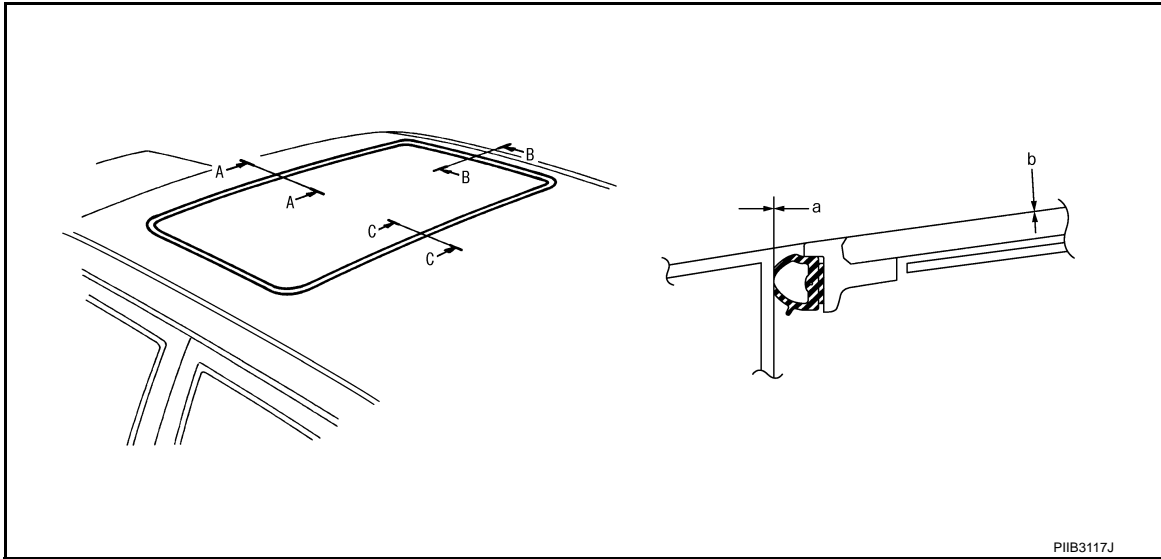

### RID WEATHERSTRIP OVERLAP ADJUSTMENT AND SURFACE MISMATCH ADJUSTMENT

1. Tilt up glass lid then remove side trim.
2. After loosening glass lid from bolts (left and right), tilt down glass lid.
3. Adjust glass lid from outside of vehicle so it resembles "A-A" "B-B" "C-C" as shown in the figure.

	a	b
<b>A-A</b>	<b>1.4 ± 0.8 mm (0.055 ± 0.031 in)</b>	<b>0 ± 1.5 mm (0 ± 0.059 in)</b>
<b>B-B</b>	<b>1.2 ± 0.8 mm (0.047 ± 0.031 in)</b>	<b>0 ± 1.5 mm (0 ± 0.059 in)</b>
<b>C-C</b>	<b>1.4 ± 0.8 mm (0.055 ± 0.031 in)</b>	<b>0 ± 1.5 mm (0 ± 0.059 in)</b>

4. To prevent glass lid from moving after adjustment, first tighten the bolts of front left, and then tighten the bolts of rear right.
5. Tighten remaining bolts, being careful to prevent glass lid from moving.
6. Tilt glass lid up and down several times to check that it moves smoothly.

### Removal and Installation

INFOID:000000005348483

- After any adjustment, check sunroof operation and glass lid alignment.
- Handle finisher plate and glass lid with care so not to cause damage.
- It is desirable for easy installation to mark each point before removal.

#### **CAUTION:**

- **Always work with a helper.**
- **Fully close the glass lid assembly, before removal, then do not operate sunroof motor assembly after removal.**

# SUNROOF

< SERVICE INFORMATION >

SEC. 736

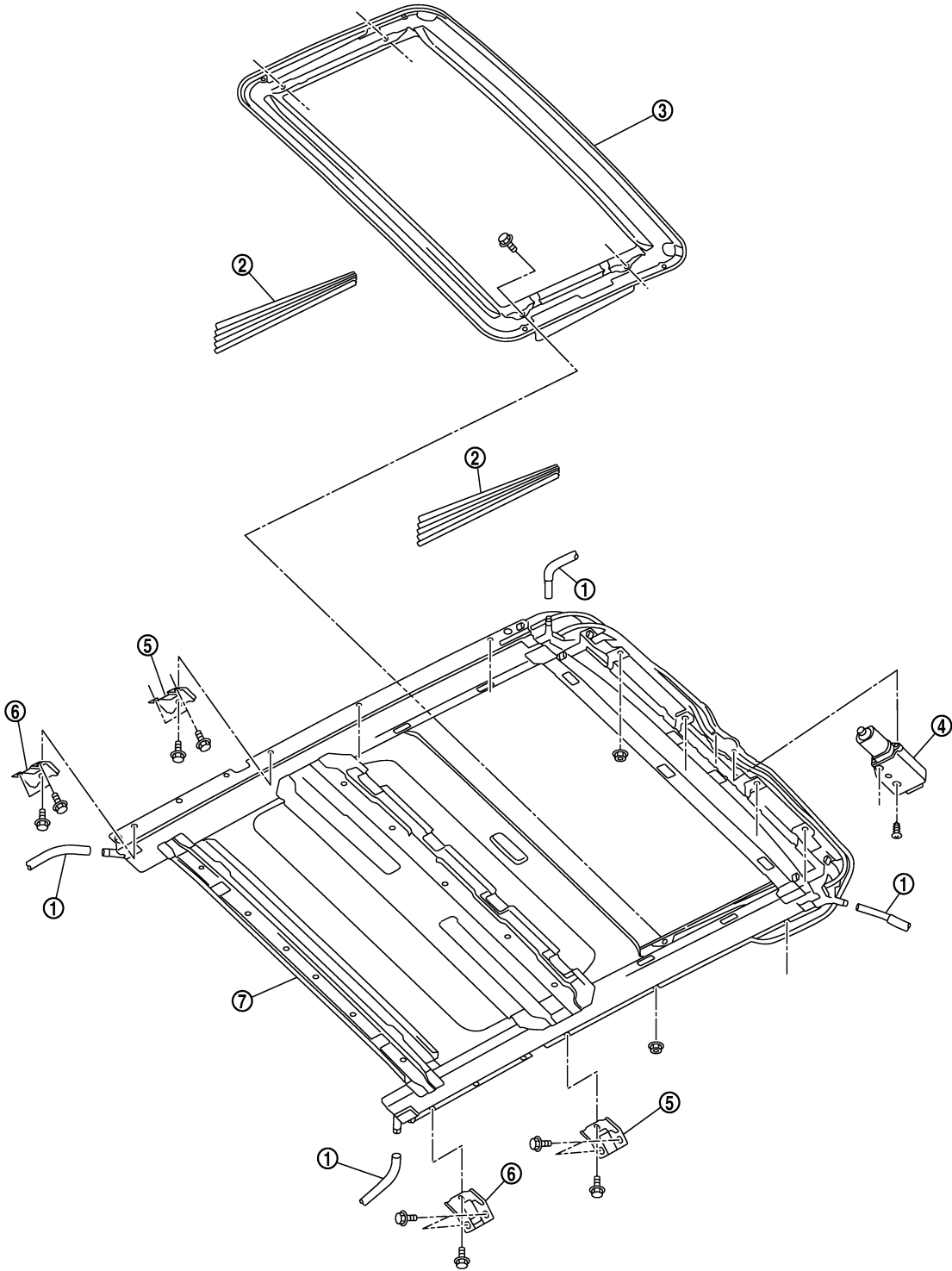

PIIB3115E

- 1. Drain hose
- 2. Side trim (LH/RH)
- 3. Glass lid
- 4. Sunroof motor assembly
- 5. Front sunroof bracket (LH/RH)
- 6. Rear sunroof bracket (LH/RH)
- 7. Sunroof unit assembly

## SUNROOF UNIT

Removal

# SUNROOF

## < SERVICE INFORMATION >

### CAUTION:

- Always work with a helper.
- When taking sunroof unit out, use clothes to protect the seats and trim from damage.
- After installing the sunroof unit and glass lid, be sure to carry out the leak test and check that there is no malfunction.

1. Remove the headlining. Refer to [EI-62](#).
2. Disconnect drain hoses.
3. Tilt up glass lid, and then remove glass lid.
4. Remove sunroof motor assembly mounting screws. Disconnect connector from sunroof motor assembly and then remove sunroof motor assembly.

### CAUTION:

- Before removing sunroof motor, make sure that sunroof lid is fully closed.
  - After removing sunroof motor, do not attempt to rotate sunroof motor assembly as a single unit.
5. Remove nuts from the front end and side rail.
  6. Remove front sunroof bracket bolts.
  7. Remove rear sunroof bracket bolts, and then remove sunroof unit assembly from roof panel.
  8. Remove sunroof unit assembly through the passenger compartment while being careful not to damage the seats and trim.

### Installation

1. Temporarily tighten the mounting bolts to the rear sunroof brackets (RH/LH).
2. Bring sunroof unit into passenger compartment, and then place the rear end of the rail onto the rear sunroof brackets.
3. Temporarily tighten the mounting nuts to the front end of sunroof unit assembly.
4. Tighten the installation points diagonally excluding the installation point of the sunroof bracket around the roof opening.
5. Tighten the front sunroof bracket bolts of the vehicle side, and then tighten the bolt of the rail side.
6. Tighten the rear sunroof bracket bolts of the vehicle side, and then tighten the bolt of the rail side.
7. Tighten the mounting nuts to the front end and side rail.
8. Move the sunroof motor assembly laterally by little by little so that the gear is completely engaged into the wire on the sunroof unit assembly and mounting surface becomes parallel. Then secure the sunroof motor assembly with screws.

### CAUTION:

Before installing the sunroof motor assembly, be sure to the place the link and wire assembly in the symmetrical and fully closed position.

9. Install glass lid.
10. Connect drain hoses.
11. Install headlining. Refer to [EI-62](#).

A  
B  
C  
D  
E  
F  
G  
H  
RF  
J  
K  
L  
M  
N  
O  
P

# SUNROOF

< SERVICE INFORMATION >

## Disassembly and Assembly

INFOID:00000005348484

SEC. 736

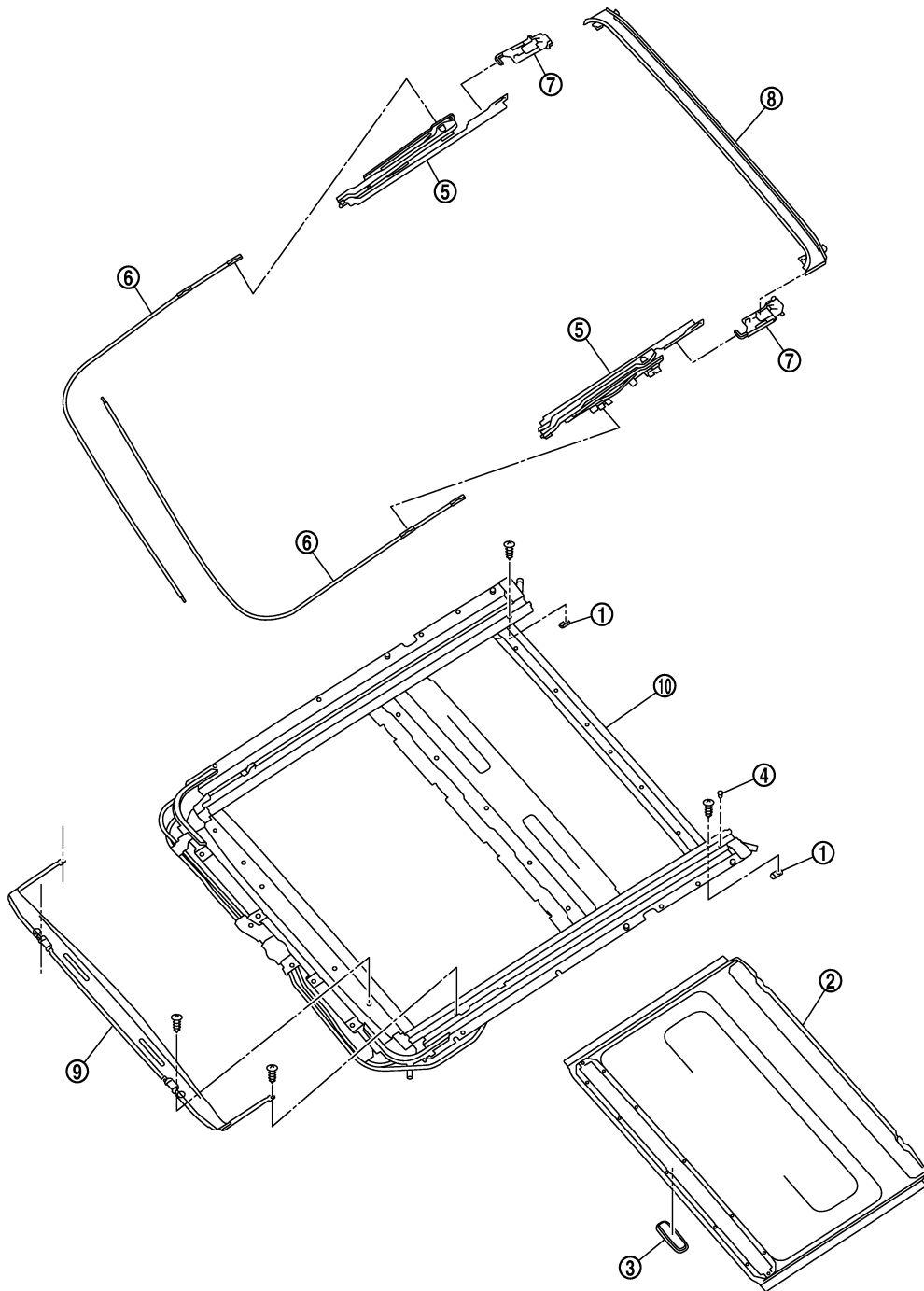

PIIB3116J

- |                        |                                   |                                |
|------------------------|-----------------------------------|--------------------------------|
| 1. Sunshade stopper    | 2. Sunshade                       | 3. Sunshade knob               |
| 4. Guide stopper       | 5. Sunroof guide assembly (LH/RH) | 6. Guide wire assembly (LH/RH) |
| 7. Drain guide (LH/RH) | 8. Rear drain assembly            | 9. Wind deflector assembly     |
| 10. Sunroof frame      |                                   |                                |



# SUNROOF

## < SERVICE INFORMATION >

---

### DISASSEMBLY

1. Remove sunshade stopper mounting screws from the rear end of sunroof frame, and then remove sunshade stopper. A
2. Remove sunshade from the rear end of sunroof frame. B  
**NOTE:**  
Removing is possible even by the on vehicle.
3. Remove sunshade knob from the sunshade. C
4. Remove guide stopper from the rear end of sunroof frame. C
5. Remove sunroof guide assembly from the rear end of sunroof frame. D
6. Remove guide wire assembly from sunroof guide assembly. D
7. Remove rear drain assembly and drain guide from sunroof guide assembly. D
8. Remove screws from left and right sides of each wind deflector holder. Extract pawls through rail holes, then remove left and right sides of wind deflector holder. E
9. Remove screws from front end of sunroof unit. Extract pawls through frame holes, then remove wind deflector from frame assembly. E

**NOTE:**

Removing is possible even by the on vehicle. F

### ASSEMBLY

Assemble in the reverse order of disassembly. G

**CAUTION:**

**Be sure to place the sunroof guide assembly in the symmetrical and fully close position.** H

RF

J

K

L

M

N

O

P