

SECTION **BRM**
BODY REPAIR

CONTENTS

VEHICLE INFORMATION	2	Hoodledge	23	F
BODY EXTERIOR PAINT COLOR	2	Front Side Member (2WD)	26	
Body Exterior Paint Color	2	Front Side Member (AWD)	29	
PRECAUTION	3	Front Side Member (Partial Replacement)	32	G
REPAIRING HIGH STRENGTH STEEL	3	Front Pillar	33	
High Strength Steel (HSS)	3	Side Body	35	
Handling of Ultra High Strength Steel Plate Parts.....	5	Center Pillar	39	H
PREPARATION	6	Outer Sill (Partial Replacement)	43	
REPAIRING MATERIAL	6	Outer Sill	44	
Foam Repair	6	Rear Fender	49	I
BODY COMPONENT PARTS	8	Rear Fender Extension	52	
Underbody Component Parts	8	Outer Rear Wheelhouse	52	
Body Component Parts	10	Rear Panel	58	J
REMOVAL AND INSTALLATION	13	Rear Floor Rear	58	
CORROSION PROTECTION	13	Rear Side Member Extension	59	
Description	13	SERVICE DATA AND SPECIFICATIONS		
Undercoating	13	(SDS)	61	BRM
Body Sealing	14	BODY ALIGNMENT	61	
BODY CONSTRUCTION	18	Body Center Marks	61	L
Body Construction	18	Description	62	
Rear Fender Hemming Process	19	Engine Compartment	62	
REPLACEMENT OPERATIONS	21	Underbody (2WD)	64	M
Description	21	Underbody (AWD)	67	
Radiator Core Support	23	Passenger Compartment	70	
		Rear Body	72	N
		LOCATION OF PLASTIC PARTS	75	
		Precautions for Plastics	75	O
		Location of Plastic Parts	76	

A
B
C
D
E
F
G
H
I
J
L
M
N
O
P

BODY EXTERIOR PAINT COLOR

< VEHICLE INFORMATION >

VEHICLE INFORMATION

BODY EXTERIOR PAINT COLOR

Body Exterior Paint Color

INFOID:000000005927129

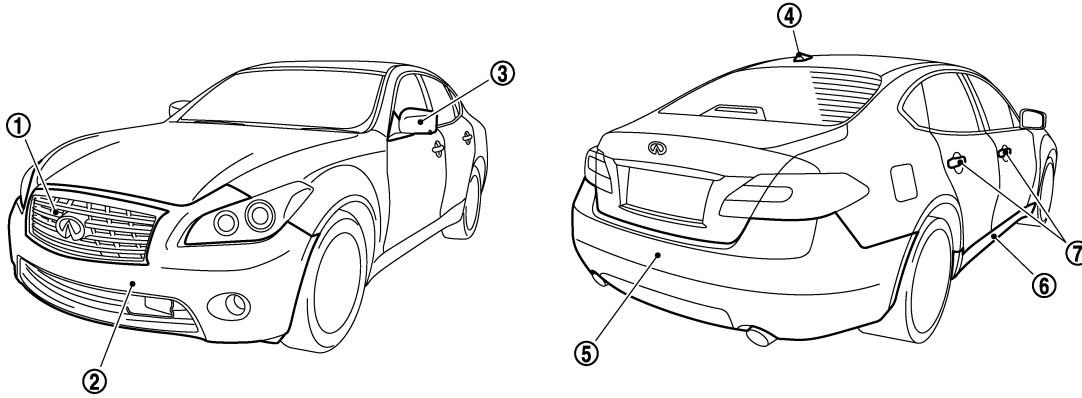

JSKIA1870ZZ

Component	Color code	BQAA	BK23	BKH3	BK51	BK52	BGAC	BKAT	BRAM	BKBB	
	Description	White	Silver	Black	Gray	Dark Gray	Black	Gray	Grayish Blue	Silver	
	Paint type ^{note}	3P	M	2S	M	PM	P	TPM	P	TM	
	Hard clear coat	-	-	×	-	×	×	×	×	-	
1	Front grille	Chromium plate	Cr	Cr	Cr	Cr	Cr	Cr	Cr	Cr	
2	Front bumper fascia	Body color	BQAA	BK23	BKH3	BK51	BK52	BGAC	BKAT	BRAM	BKBB
3	Door outside mirror cover	Body color	BQAA	BK23	BKH3	BK51	BK52	BGAC	BKAT	BRAM	BKBB
4	Antenna base cover	Body color	BQAA	BK23	BKH3	BK51	BK52	BGAC	BKAT	BRAM	BKBB
5	Rear bumper fascia	Body color	BQAA	BK23	BKH3	BK51	BK52	BGAC	BKAT	BRAM	BKBB
6	Sill cover	Body color	BQAA	BK23	BKH3	BK51	BK52	BGAC	BKAT	BRAM	BKBB
7	Door outside handle	Chromium plate	Cr	Cr	Cr	Cr	Cr	Cr	Cr	Cr	

NOTE:

- S: Solid
- 2S: Solid + Clear
- CS: Color clear solid
- M: Metallic
- P: 2-Coat pearl
- 3P: 3-Coat pearl
- FPM: Iron oxide pearl
- RM, RPM: Multi flex color
- TPM: Titanium pearl metallic
- TM: Micro titanium metallic
- PM: Pearl metallic

REPAIRING HIGH STRENGTH STEEL

< PRECAUTION >

PRECAUTION

REPAIRING HIGH STRENGTH STEEL

High Strength Steel (HSS)

INFOID:000000005927130

High strength steel is used for body panels in order to reduce vehicle weight. Accordingly, precautions in repairing automotive bodies made of high strength steel are described below:

Tensile strength	Major applicable parts
440 - 780 MPa	<ul style="list-style-type: none"> • Hoodledge reinforcement • Upper front hoodledge • Front strut housing • Rear floor seat belt anchor reinforcement • Rear seat crossmember reinforcement assembly • 2nd and 3rd crossmember (Front floor component part) • Inner sill • Center front floor • Lower dash • Lower dash crossmember assembly • Front side member assembly • Front side member closing plate assembly • Front side member outrigger assembly • Rear seat crossmember • Rear tie down hook • Rear side member assembly • Rear side member extension • Inner front roof side rail (Side body assembly component part) • Outer front pillar reinforcement (Lower) (Side body assembly component part) • Outer sill reinforcement • Center pillar reinforcement • Outer rear wheelhouse extension (Upper) • Outer rear wheelhouse extension (Lower rear) • Front roof rail • Rear roof rail • Other reinforcements
980 - 1350 MPa	<ul style="list-style-type: none"> • Front side member stiffener (Front floor component part) • Front side member rear extension • Inner roof side rail (Front) (Side body assembly component part) • Outer roof side rail (Side body assembly component part) • Inner center pillar (Side body assembly component part) • Outer front pillar reinforcement (Upper) (Side body assembly component part) • Outer sill extension (Outer sill reinforcement component part) • Center pillar reinforcement (Upper) • Center pillar seat belt reinforcement (Center pillar reinforcement component part) • Outer rear wheelhouse extension (Lower front)

Read the following precautions when repairing HSS:

1. Additional points to consider

REPAIRING HIGH STRENGTH STEEL

< PRECAUTION >

- The repair of reinforcements (such as side members) by heating is not recommended, because it may weaken the component. When heating is unavoidable, never heat HSS parts above 550°C (1,022°F). Verify heating temperature with a thermometer. (Crayon-type and other similar type thermometer are appropriate.)

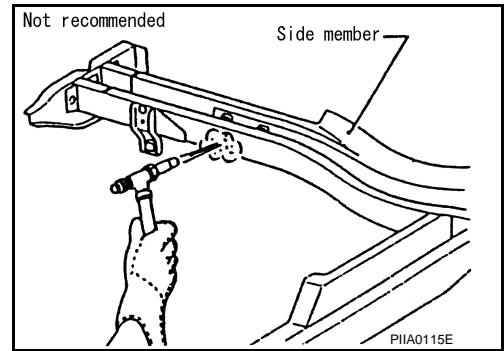

- When straightening body panels, use caution in pulling any HSS panel. Because HSS is very strong, pulling may cause deformation in adjacent sections of the body. In this case, increase the number of measuring points, and carefully pull the HSS panel.
- When cutting HSS panels, avoid gas (torch) cutting if possible. Instead, use a saw to avoid weakening surrounding areas due to heat. If gas (torch) cutting is unavoidable, allow a minimum margin of 50 mm (1.97 in).

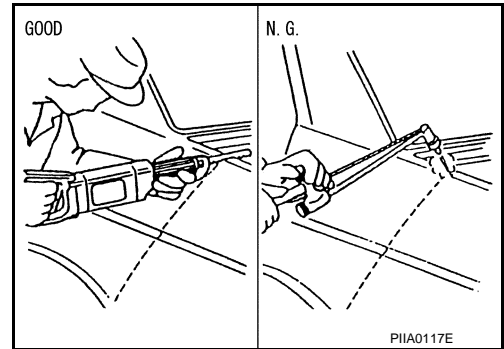

- When welding HSS panels, use spot welding whenever possible in order to minimize weakening surrounding areas due to heat. If spot welding is impossible, use MIG. welding. Do not use gas (torch) for welding because it is inferior in welding strength.

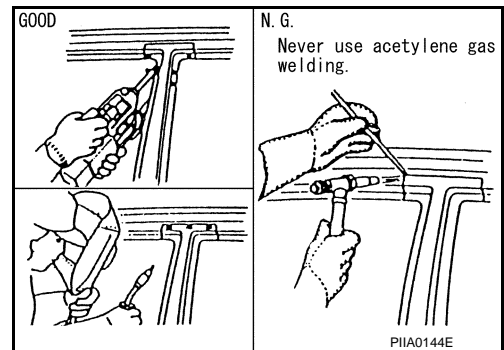

- Spot welding on HSS panels is harder than that of an ordinary steel panel. Therefore, when cutting spot welds on a HSS panel, use a low speed high torque drill (1,000 to 1,200 rpm) to increase drill bit durability and facilitate the operation.

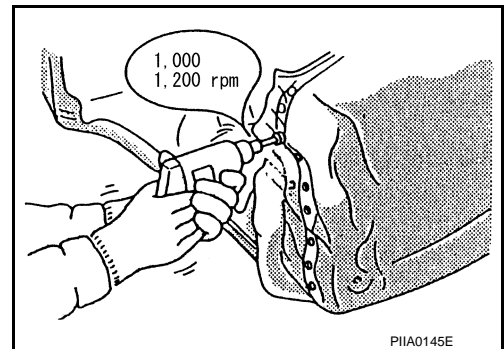

REPAIRING HIGH STRENGTH STEEL

< PRECAUTION >

2. Precautions in spot welding HSS

This work should be performed under standard working conditions. Always note the following when spot welding HSS:

- The electrode tip diameter must be sized properly according to the metal thickness.

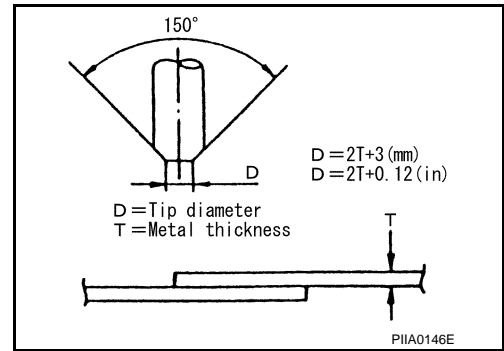

- The panel surfaces must fit flush to each other, leaving no gaps.

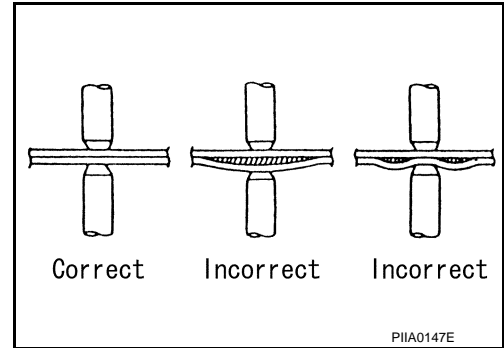

- Follow the specifications for the proper welding pitch.

Unit: mm (in)

Thickness (T)	Minimum pitch (L)
0.6 (0.024)	10 (0.39) or more
0.8 (0.031)	12 (0.47) or more
1.0 (0.039)	18 (0.71) or more
1.2 (0.047)	20 (0.79) or more
1.6 (0.063)	27 (1.06) or more
1.8 (0.071)	31 (1.22) or more

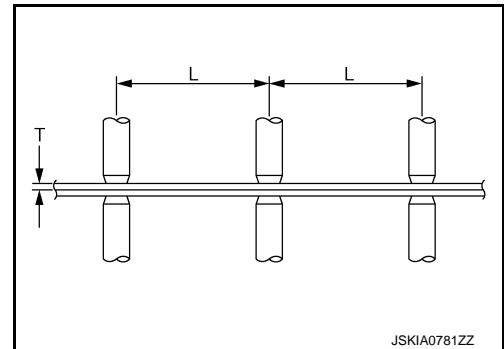

Handling of Ultra High Strength Steel Plate Parts

INFOID:0000000005927131

PROHIBITION OF CUT AND CONNECTION

Never cut and joint the lower lock pillar reinforcement (center pillar reinforcement inside frame parts) because its material is high strength steel plate (ultra high strength steel plate).

The center pillar reinforcement must be replaced if this part is damaged.

A
B
C
D
E
F
G
H
I
J
L
M
N
O
P

BRM

REPAIRING MATERIAL

< PREPARATION >

PREPARATION

REPAIRING MATERIAL

Foam Repair

INFOID:000000005927132

During factory body assembly, foam insulators are installed in certain body panels and locations around the vehicle. Use the following procedure(s) to replace any factory-installed foam insulators.

URETHANE FOAM APPLICATIONS

Use commercially available Urethane foam for sealant (foam material) repair of material used on vehicle.

<Urethane foam for foaming agent>

3M™ Automix™ Flexible Foam 08463 or equivalent

Read instructions on product for fill procedures.

Example of foaming agent filling operation procedure

1. Fill procedures after installation of service part.
 - a. Eliminate foam material remaining on vehicle side.
 - b. Clean area after eliminating form insulator and foam material.
 - c. Install service part.
 - d. Insert nozzle into hole near fill area and fill foam material or fill enough to close gap with the service part.

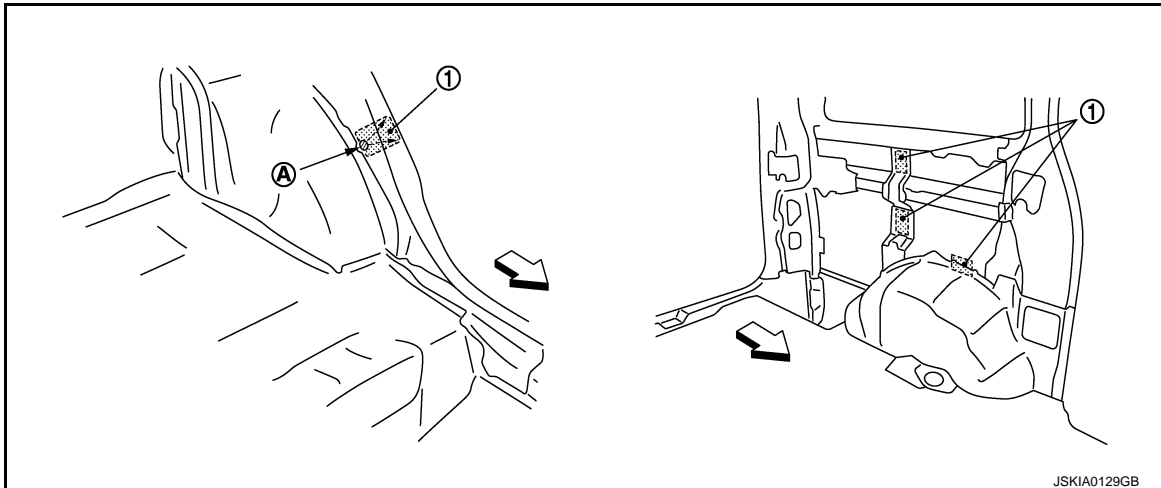

1. Urethane foam
- A. Nozzle insert hole

↔: Vehicle front

2. Fill procedures before installation of service part.
 - a. Eliminate foam material remaining on vehicle side.
 - b. Clean area after eliminating foam insulator and foam material.
 - c. Fill foam material on wheelhouse outer side.

REPAIRING MATERIAL

< PREPARATION >

- 1. Urethane foam
- A. Fill while avoiding flange area

←: Vehicle front

NOTE:

Fill enough to close gap with service part while avoiding flange area.

- d. Install service part.

NOTE:

Refer to label for information on working times.

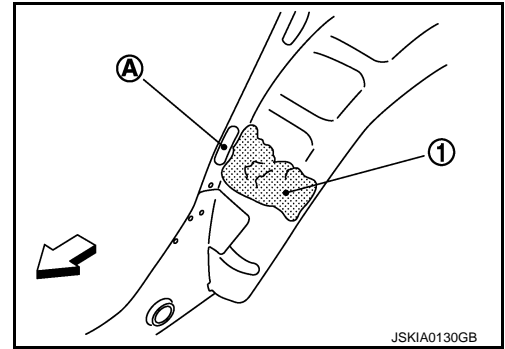

A
B
C
D
E
F
G
H
I
J
L
M
N
O
P

BRM

BODY COMPONENT PARTS



< PREPARATION >

BODY COMPONENT PARTS

Underbody Component Parts

INFOID:000000005927133



-  Both sided anti-corrosive pre-coated steel sections
-  High strength steel (HSS) sections
-  Both sided anti-corrosive steel and HSS sections

JSKIA1871ZZ

BODY COMPONENT PARTS

< PREPARATION >

No.	Parts name		Tensile strength (MPa)	Both sided anti-corrosive precoated steel sections
1.	Hoodledge reinforcement (RH & LH)		440	×
2.	Upper front hoodledge (RH & LH)		440	×
3.	Side radiator core support (RH & LH)		Under 440	×
4.	Front strut housing (RH & LH)		440	×
5.	Lower rear hoodledge (RH & LH)		Under 440	×
6.	Upper side cowl top (RH & LH)		Under 440	×
7.	Upper rear hoodledge (RH & LH)		Under 440	×
8.	Rear floor rear		440	×
9.	Rear floor side (RH & LH)		Under 440	×
10.	Rear floor front		Under 440	×
11.	Rear floor seat belt anchor reinforcement (RH & LH)		590	×
12.	Rear seat crossmember reinforcement assembly		590	×
13.	Front floor (RH & LH)	a. T=1.6 mm (0.063 in)	1350 ^{caution}	×
14.	Inner sill (RH & LH)		590	×
15.	Lower dash reinforcement		440	×
16.	Lower dash		440	×
17.	Upper dash		Under 440	×
18.	Lower dash crossmember assembly		590	×
19.	Front cowl top		Under 440	×
20.	Front side member assembly (RH & LH)		590	×
21.	Front side member connector assembly (RH & LH)		Under 440	×
22.	Front side member front extension (RH & LH)		440	×
23.	Front side member closing plate assembly (RH & LH)		590	×
24.	Front side member center closing plate (RH & LH)		440	×
25.	Front side member front closing plate (RH & LH)		590	×
26.	Front side member outrigger assembly (RH & LH)		590	×
27.	Front side member rear extension (RH & LH)	T=1.2 mm (0.047 in)	980 ^{caution}	×
28.	Rear seat crossmember		590	×
29.	2nd rear crossmember		590	—
30.	Rear crossmember		Under 440	×
31.	Rear tie down hook		440	×
32.	Rear side member assembly (RH & LH)		780	×
33.	Rear side member extension (RH & LH)		780	×

NOTE:

- For the parts without a number described in the figure, it is supplied only with the assembly part that the part is included with.
- Tensile strength column shows the largest strength value of a part in the component part.

CAUTION:

If the high strength steel (ultra high strength steel) of this is broken, replace by assembly for the supply part.

BODY COMPONENT PARTS

< PREPARATION >

Body Component Parts

INFOID:000000005927134

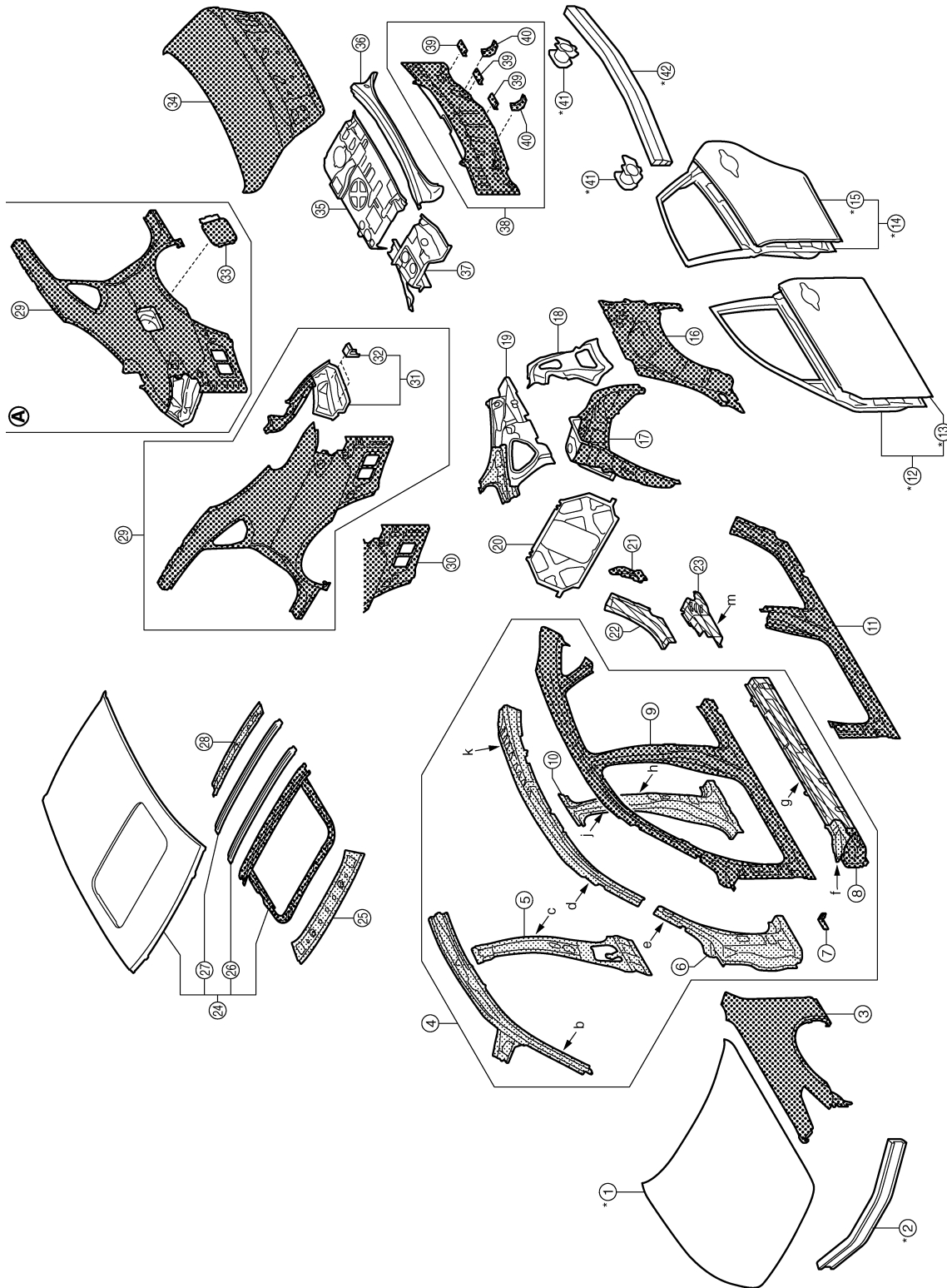

JSKIA1872ZZ

A. Right side

Both sided anti-corrosive pre-coated steel sections

High strength steel (HSS) sections

Both sided anti-corrosive steel and HSS sections

BODY COMPONENT PARTS

< PREPARATION >

No.	Parts name	Tensile strength (MPa)	Both sided anti-corrosive pre-coated steel sections	Aluminum portion			
1.	Hood	—	—	×	A		
2.	Front bumper armature assembly	—	—	×	B		
3.	Front fender (RH & LH)	Under 440	×	—	C		
4.	Side body assembly (RH & LH)	Refer to No.5-10					
		c.	T=1.6mm (0.063 in)	1350 ^{caution}		D	
		d.	T=1.2mm (0.047 in)	980 ^{caution}	—	E	
		j.	T=1.2mm (0.047 in)	980 ^{caution}			
	5.	Inner center pillar (RH & LH)	o.	T=1.0mm (0.039 in)	1350 ^{caution}	—	F
	6.	Outer front pillar reinforcement (RH&LH)	b.	T=1.2mm (0.047 in)	980 ^{caution}	—	
	7.	Front fender bracket (RH & LH)			Under 440	×	G
	8.	Outer sill reinforcement (RH & LH)	g.	T=1.2mm (0.047 in)	980 ^{caution}		H
			h.	T=1.2mm (0.047 in)	980 ^{caution}	×	
	9.	Outer front side body (RH & LH)			Under 440	×	I
10.	Center pillar reinforcement (RH & LH)	e.	T=1.2mm (0.047 in)	980 ^{caution}		J	
		f.	T=1.6mm (0.063 in)	1350 ^{caution}	—		
11.	Outer sill (RH & LH)			Under 440	×		
12.	Front door assembly (RH & LH)			—	—		
13.	Outer front door panel (RH & LH)			—	—	BRM	
14.	Rear door assembly (RH & LH)			—	—		
15.	Outer rear door panel (RH & LH)			—	—	L	
16.	Outer rear wheelhouse (RH & LH)			Under 440	×		
17.	Inner rear wheelhouse (RH & LH)			Under 440	×		
18.	Inner rear pillar reinforcement (RH & LH)			Under 440	—	M	
19.	Inner rear pillar (RH & LH)			590	—		
20.	Seat back support			Under 440	—		
21.	Inner rear wheelhouse front extension (RH & LH)			Under 440	×	N	
22.	Outer rear wheelhouse extension (RH & LH Upper)			590	×		
23.	Outer rear wheelhouse extension (RH & LH Lower)	k.	T=1.2mm (0.047 in)	980 ^{caution}	×	O	
24.	Roof			Under 440	×		
25.	Front roof rail			Under 440	—	P	
26.	Roof bow No. 3			Under 440	—		
27.	Roof bow No. 4			Under 440	—		
28.	Rear roof rail			Under 440	—		
29.	Rear fender assembly (RH & LH)			Under 440	×		
30.	Rear fender extension (RH & LH)			Under 440	×		

BODY COMPONENT PARTS

< PREPARATION >

No.	Parts name	Tensile strength (MPa)	Both sided anti-corrosive pre-coated steel sections	Aluminum portion
31.	Rear fender extension assembly (RH & LH)	Under 440	—	—
32.	Rear bumper side bracket (RH & LH)	Under 440	—	—
33.	Fuel filler lid	Under 440	×	—
34.	Trunk lid	Under 440	×	—
35.	Parcel shelf with rear waist	Under 440	—	—
36.	Rear waist	Under 440	—	—
37.	Parcel shelf side (RH & LH)	Under 440	—	—
38.	Rear panel assembly	Under 440	×	—
39.	Rear bumper bracket	Under 440	×	—
40.	Rear side bumper bracket	Under 440	×	—
41.	Rear bumper stay (RH & LH)	Under 440	—	×
42.	Inner center rear bumper reinforcement assembly	Under 440	—	×

NOTE:

- For the parts without a number described in the figure, it is supplied only with the assembly part that the part is included with.
- Tensile strength column shows the largest strength value of a part in the component part.

CAUTION:

If the high strength steel (ultra high strength steel) of this is broken, replace by assembly for the supply part.

CORROSION PROTECTION

< REMOVAL AND INSTALLATION >

REMOVAL AND INSTALLATION

CORROSION PROTECTION

Description

INFOID:000000005927135

To provide improved corrosion prevention, the following anti-corrosive measures have been implemented in NISSAN production plants. When repairing or replacing body panels, it is necessary to use the same anti-corrosive measures.

Anti-Corrosive Precoated Steel (Galvannealed Steel)

To improve repairability and corrosion resistance, a new type of anti-corrosive precoated steel sheet is adopted replacing conventional zinc-coated steel sheet.

Galvannealed steel is electroplated and heated to form Zinc-iron alloy, which provides excellent and long term corrosion resistance with cationic electrodeposition primer.

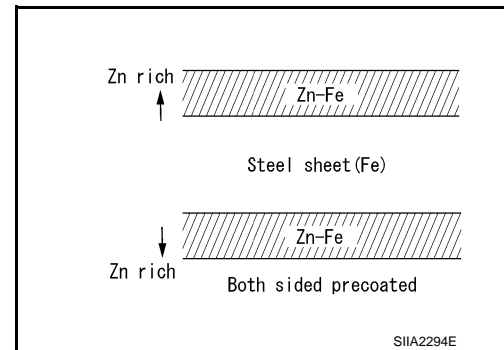

NISSAN genuine parts are fabricated from galvannealed steel. Therefore, it is recommended that NISSAN genuine parts or an equivalent be used for panel replacement to maintain the anti-corrosive performance built into the vehicle at the factory.

Phosphate Coating Treatment and Cationic Electrodeposition Primer

A phosphate coating treatment and a cationic electrodeposition primer, which provide excellent corrosion protection, are applied to all body components.

CAUTION:

Confine paint removal during welding operation to an absolute minimum.

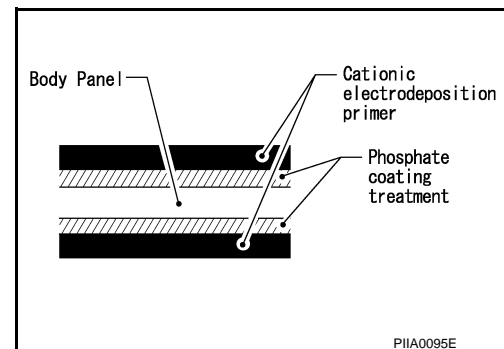

NISSAN genuine parts are also treated in the same manner. Therefore, it is recommended that NISSAN genuine parts or an equivalent be used for panel replacement to maintain anti-corrosive performance built into the vehicle at the factory.

Undercoating

INFOID:000000005927137

The underside of the floor and wheelhouse are undercoated to prevent rust, vibration, noise and stone chipping. Therefore, when such a panel is replaced or repaired, apply undercoating to that part. Use an undercoating which is rust resistant, soundproof, vibration-proof, shock-resistant, adhesive, and durable.

Precautions in Undercoating

1. Never apply undercoating to any place unless specified (such as the areas above the muffler and three way catalyst that are subjected to heat).
2. Never undercoat the exhaust pipe or other parts that become hot.
3. Never undercoat rotating parts.
4. Apply bitumen wax after applying undercoating.
5. After putting seal on the vehicle, put undercoating on it.

CORROSION PROTECTION

< REMOVAL AND INSTALLATION >

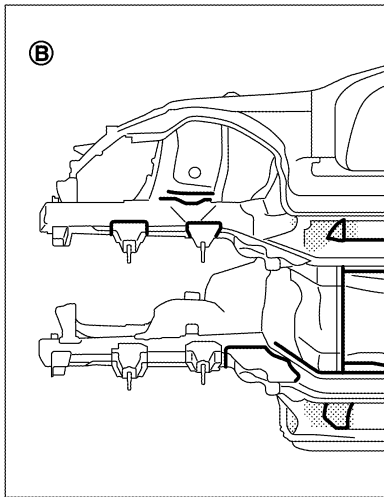
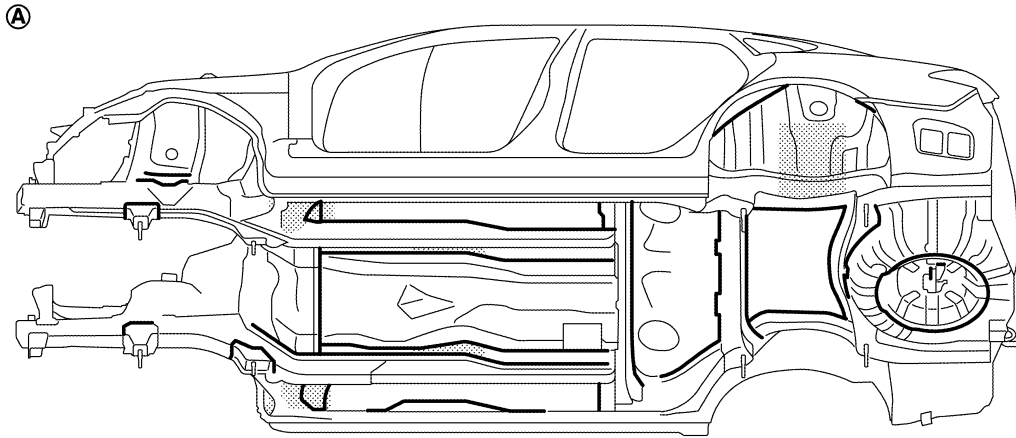

JSKIA1677ZZ

A. 2WD

B. AWD

 Undercoated areas

 Sealed portions

Body Sealing

INFOID:000000005927139

The following figure shows the areas that are sealed at the factory. Sealant that is applied to these areas should be smooth and free from cuts or gaps. Care should be taken not to apply an excess amount of sealant and not to allow other unaffected parts to come into contact with the sealant.

CORROSION PROTECTION

< REMOVAL AND INSTALLATION >

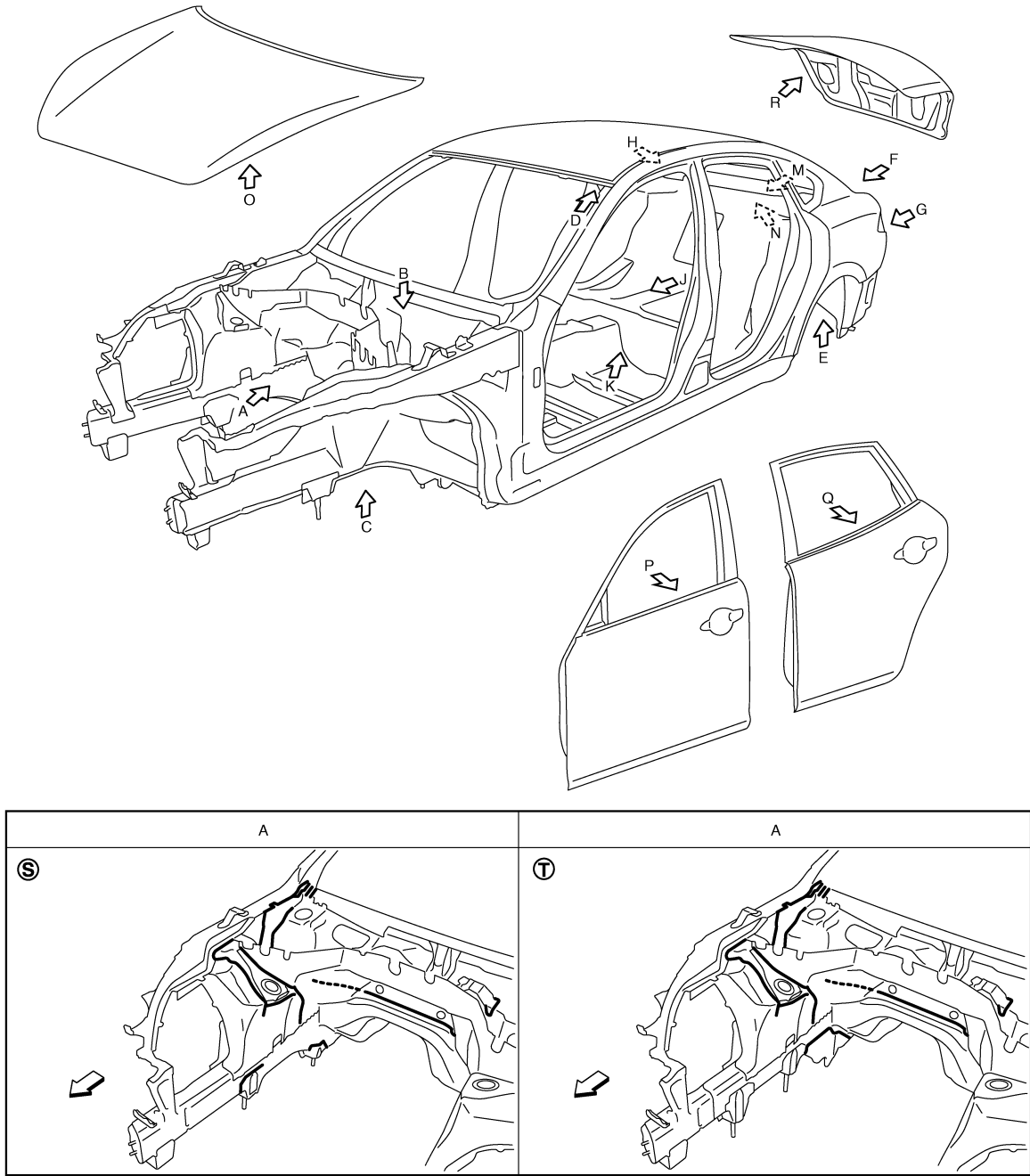

JSKIA1873ZZ

S. 2WD

T. AWD

⇐: Vehicle front

—: Sealed portions

A
B
C
D
E
F
G
H
I
J
K
L
M
N
O
P

BRM

CORROSION PROTECTION

< REMOVAL AND INSTALLATION >

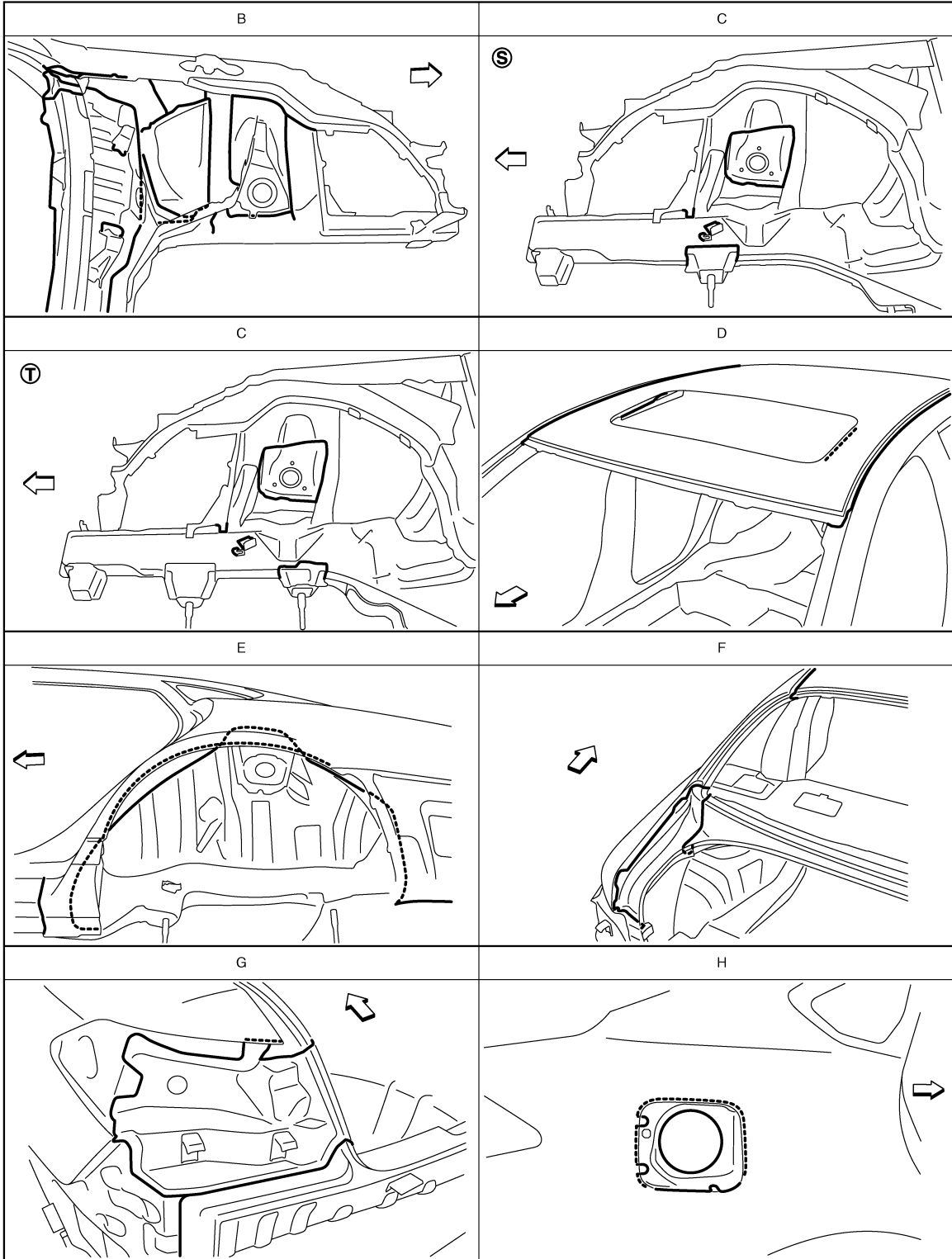

JSKIA1874ZZ

S. 2WD

T. AWD

↔: Vehicle front

—: Sealed portions

CORROSION PROTECTION

< REMOVAL AND INSTALLATION >

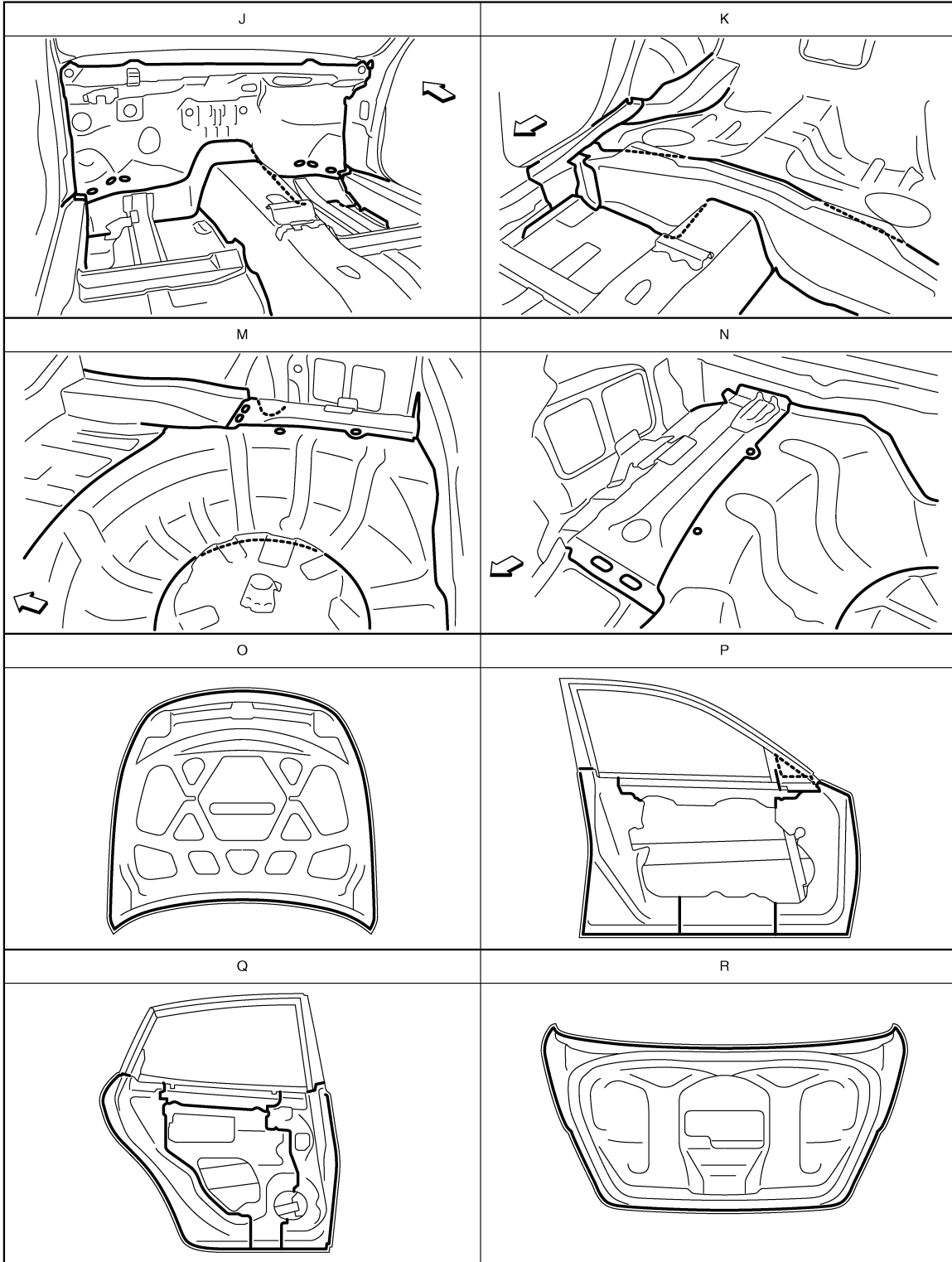

JSKIA1875ZZ

↔: Vehicle front
 —: Sealed portions

A
B
C
D
E
F
G
H
I
J
K
L
M
N
O
P

BRM

BODY CONSTRUCTION

< REMOVAL AND INSTALLATION >

BODY CONSTRUCTION

Body Construction

INFOID:000000005927140

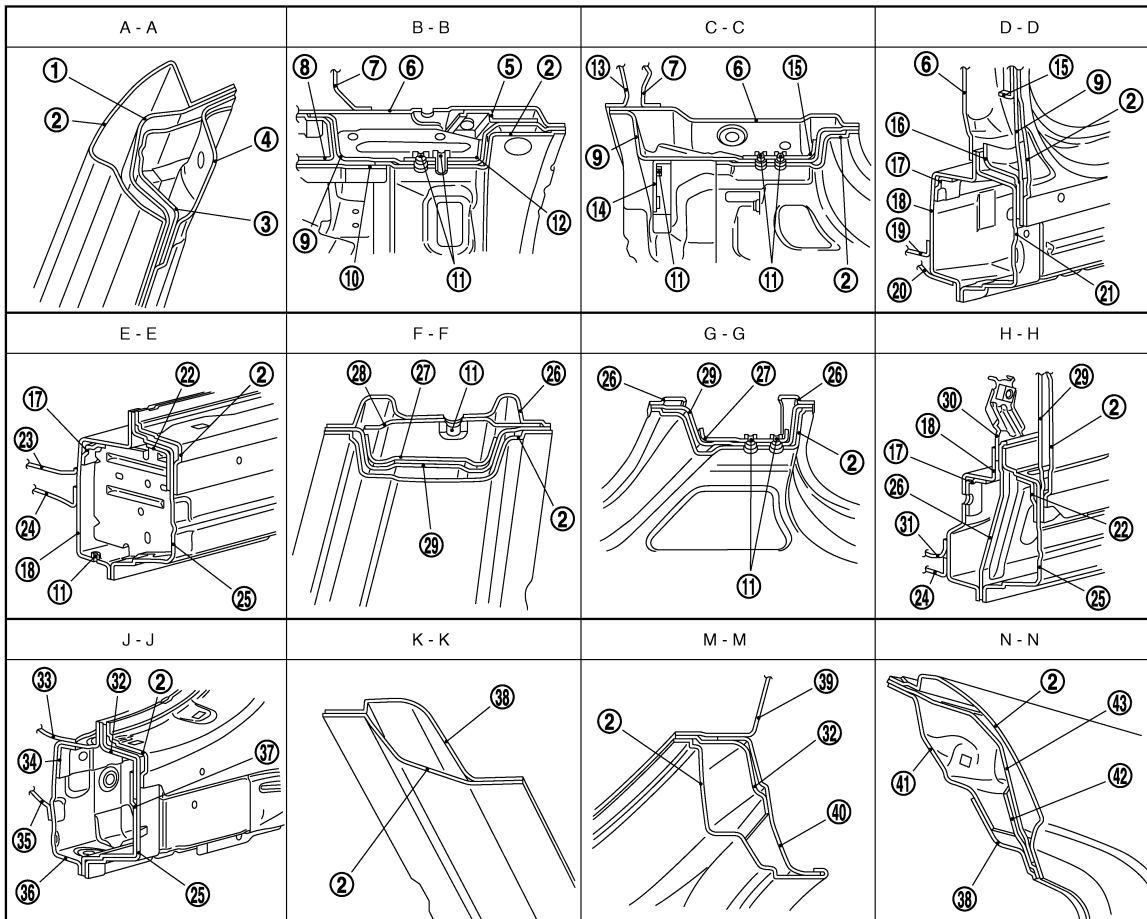
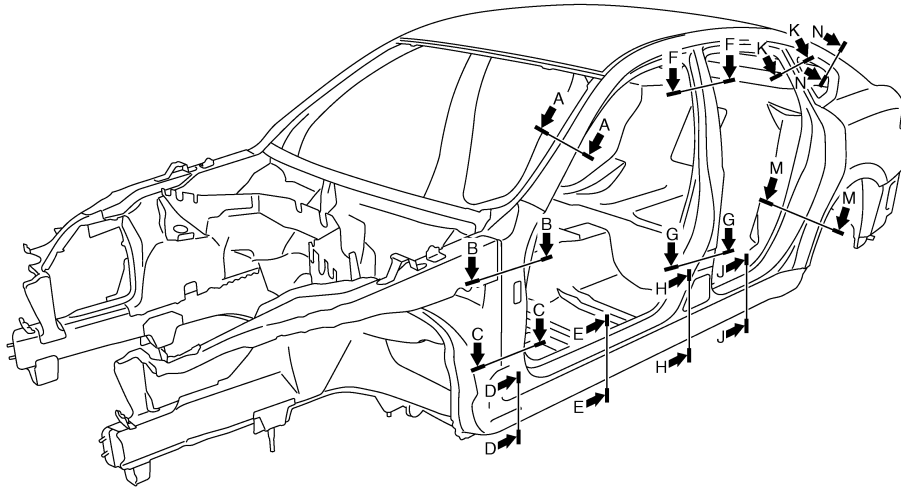

JSKIA1626ZZ

- | | | |
|-------------------------|-----------------------------------|-------------------------------------|
| 1. Outer roof side rail | 2. Outer side body | 3. Outer front pillar reinforcement |
| 4. Inner roof side rail | 5. Outer front pillar bracket | 6. Upper rear hoodledge |
| 7. Upper dash | 8. Hoodledge reinforcement gusset | 9. Front pillar hinge brace |

BODY CONSTRUCTION

< REMOVAL AND INSTALLATION >

- | | | |
|--|-------------------------------------|---|
| 10. Hoodledge reinforcement | 11. Weld nut | 12. Upper hinge plate |
| 13. Lower dash crossmember | 14. Front pillar bracket | 15. Lower hinge plate |
| 16. Lower front pillar gusset | 17. Center sill reinforcement | 18. Inner sill |
| 19. Lower dash | 20. Front side member outrigger | 21. Outer front sill brace |
| 22. Outer sill extension | 23. 2nd crossmember | 24. Front floor |
| 25. Outer sill reinforcement | 26. Inner center pillar | 27. Center pillar seat belt reinforcement |
| 28. Inner center pillar reinforcement | 29. Center pillar reinforcement | 30. Seat belt anchor |
| 31. 3rd crossmember | 32. Outer rear wheelhouse extension | 33. Rear seat crossmember reinforcement |
| 34. Rear side member front reinforcement | 35. Rear seat crossmember | 36. Rear side member front |
| 37. Outer sill rear reinforcement | 38. Inner rear pillar | 39. Inner rear wheelhouse |
| 40. Outer rear wheelhouse | 41. Rear roof rail brace | 42. Inner rear pillar reinforcement |
| 43. Outer roof side rail reinforcement | | |

Rear Fender Hemming Process

INFOID:000000005927141

1. A wheel arch is to be installed and hemmed over the left and right outer wheel houses.
2. In order to hem the wheel arch, it is necessary to repair any damaged or defaced parts around outer wheel house.

CAUTION:

Ensure that the area that is to be glued around the outer wheelhouse is undamaged or defaced.

PROCEDURE OF THE HEMMING PROCESS

- Peel off old bonding material on the surface of the outer wheelhouse and clean thoroughly.
- Peel off a primer coat in the specified area where new adhesive is to be applied on rear fender (the replacing part).
- Apply new adhesive to both specified areas of the outer wheelhouse and rear fender.

<Adhesive> 3M™ Automix™ Panel Bonding Adhesive 08115 or equivalent

- Attach rear fender to the body of the car, and weld the required part except the hemming part.

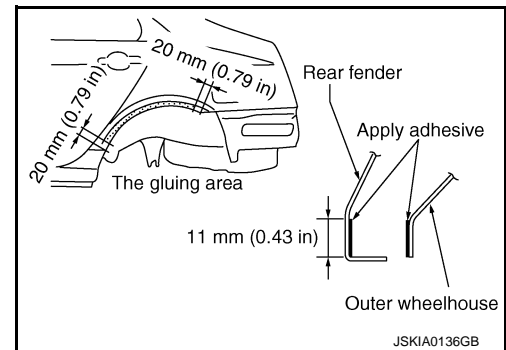

- Bend the welded part starting from the center of the wheel arch gradually with a hammer and a dolly. (Also hem the end of the flange.)
- Hemming with a hammer is conducted to an approximate angle of 80 degrees.

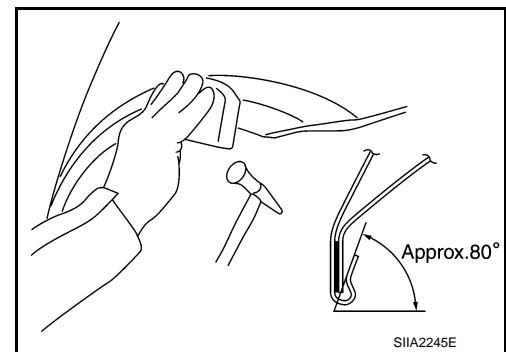

BODY CONSTRUCTION

< REMOVAL AND INSTALLATION >

- Starting from the center, hem the wheel arch gradually, using slight back and forth motion with a hemming tool.

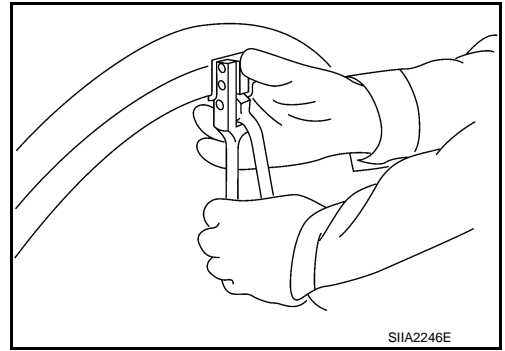

- Seal up the area around the hemmed end of the flange.

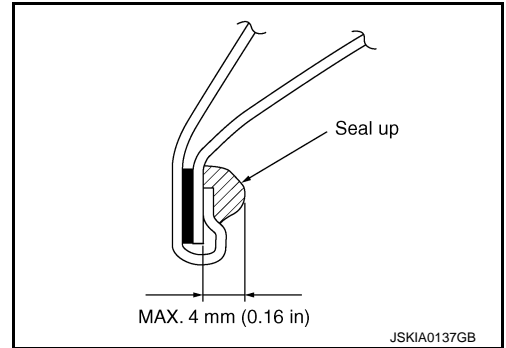

REPLACEMENT OPERATIONS

< REMOVAL AND INSTALLATION >



REPLACEMENT OPERATIONS

Description

INFOID:000000005927142

- This section is prepared for technicians who have attained a high level of skill and experience in repairing collision-damaged vehicles and also use modern service tools and equipment. Persons unfamiliar with body repair techniques should not attempt to repair collision-damaged vehicles by using this section.
- Technicians are also encouraged to read the Body Repair Manual (Fundamentals) in order to ensure that the original functions and quality of the vehicle are maintained. The Body Repair Manual (Fundamentals) contains additional information, including cautions and warnings, that are not including in this manual. Technicians should refer to both manuals to ensure proper repair.
- Please note that this information is prepared for worldwide usage, and as such, certain procedures might not apply in some regions or countries.

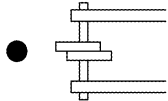
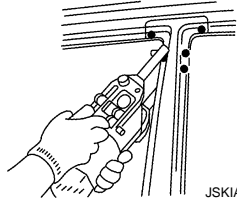
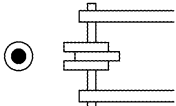
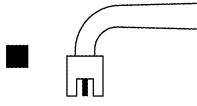
The symbols used in this section for welding operations are shown below.

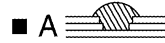
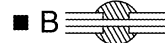
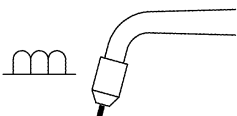
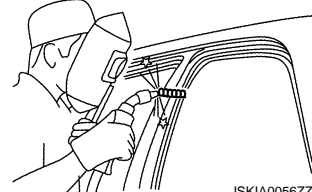
Symbol marks	Description	Description
 <p>JSKIA0049ZZ</p>	2-spot welds	 <p>JSKIA0053ZZ</p>
 <p>JSKIA0050ZZ</p>	3-spot welds	
 <p>JSKIA0051ZZ</p>	MIG plug weld	 <p>JSKIA0054ZZ</p> <p>For 3 panels plug weld method</p> <p>■ A </p> <p>■ B </p> <p>JSKIA0055ZZ</p>
 <p>JSKIA0052ZZ</p>	MIG seam weld / Point weld	 <p>JSKIA0056ZZ</p>

A
B
C
D
E
F
G
H
I
J
L
M
N
O
P

BRM

REPLACEMENT OPERATIONS

< REMOVAL AND INSTALLATION >

- Front pillar butt joint can be determined anywhere within shaded area as shown in the figure. The best location for the butt joint is at position A due to the construction of the vehicle.

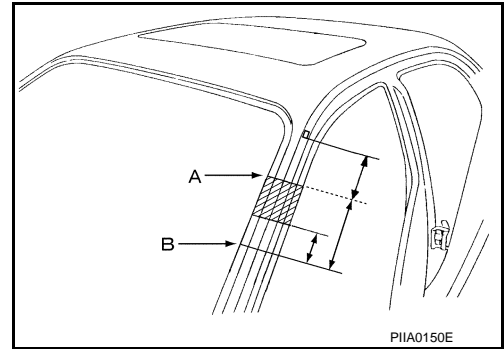

- Determine cutting position and record distance from the locating indent. Use this distance when cutting the service part. Cut outer front pillar over 60 mm (2.36 in) above the inner front pillar cut position.

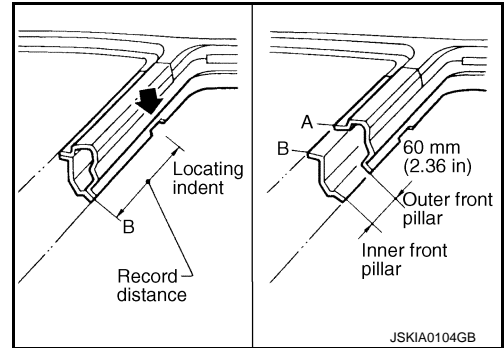

- Prepare a cutting jig to make outer pillar easier to cut. Also, this will permit the service part to be accurately cut at the joint position.

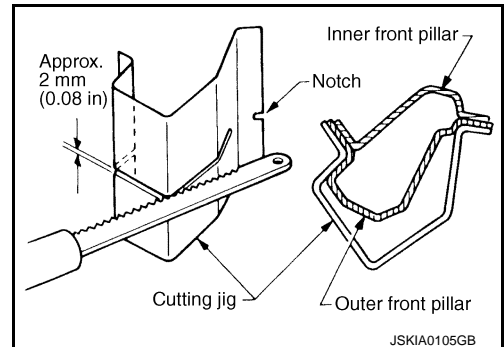

- An example of cutting operation using a cutting jig is as per the following.

1. Mark cutting lines.
A: Cut position of outer pillar
B: Cut position of inner pillar
2. Align cutting line with notch on jig. Clamp jig to pillar.
3. Cut outer pillar along groove of jig (at position A).
4. Remove jig and cut remaining portions.
5. Cut inner pillar at position B in same manner.

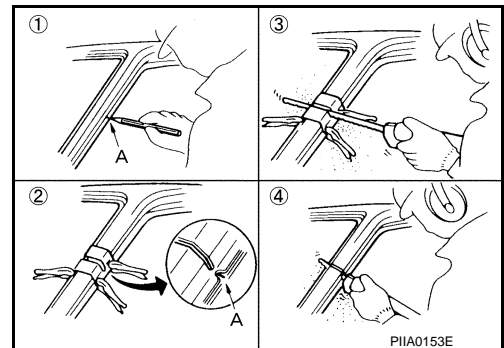

REPLACEMENT OPERATIONS

< REMOVAL AND INSTALLATION >

Radiator Core Support

INFOID:000000005927143

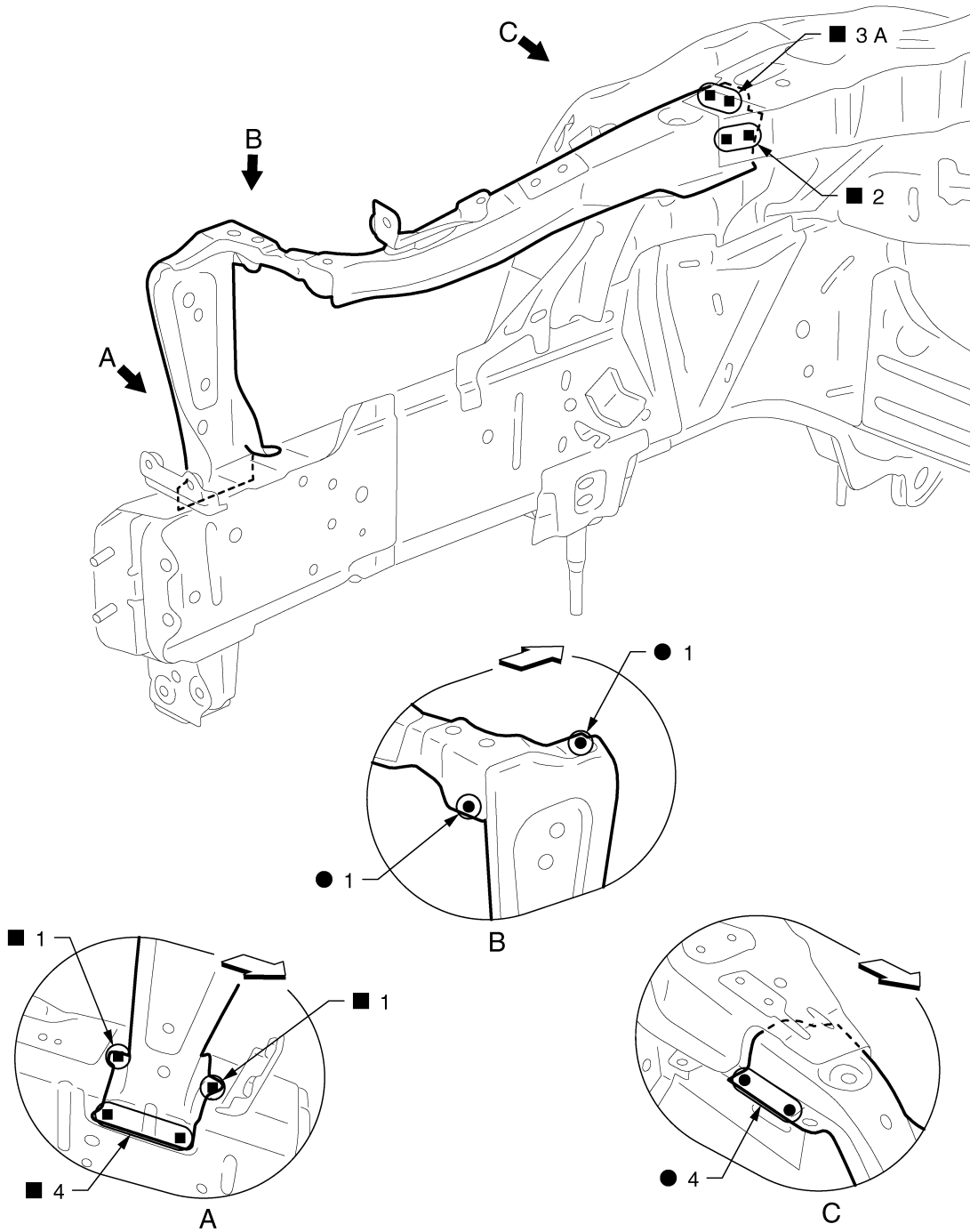

A
B
C
D
E
F
G
H
I
J
K
L
M
N
O
P

BRM

← Vehicle front

Replacement parts

- Radiator core support assembly (LH)
- Front side member connector assembly (LH)

Hoodledge

INFOID:000000005927144

Work after radiator core support is removed.

REPLACEMENT OPERATIONS

< REMOVAL AND INSTALLATION >

Remove the front side member extension front reinforcement (reusable) and front side member center closing plate (reusable).

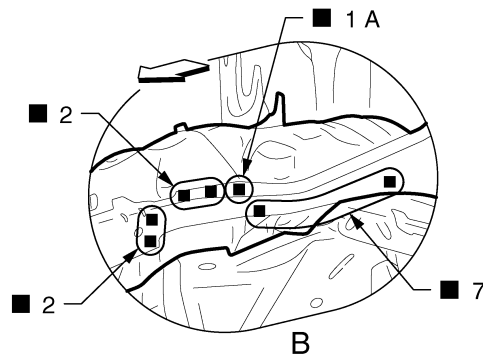
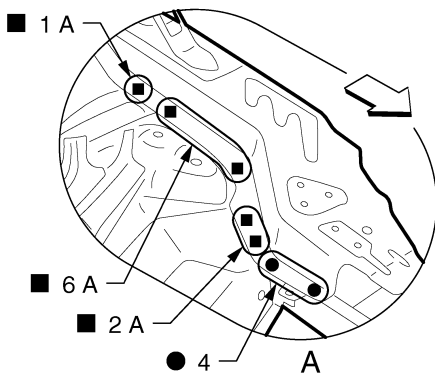
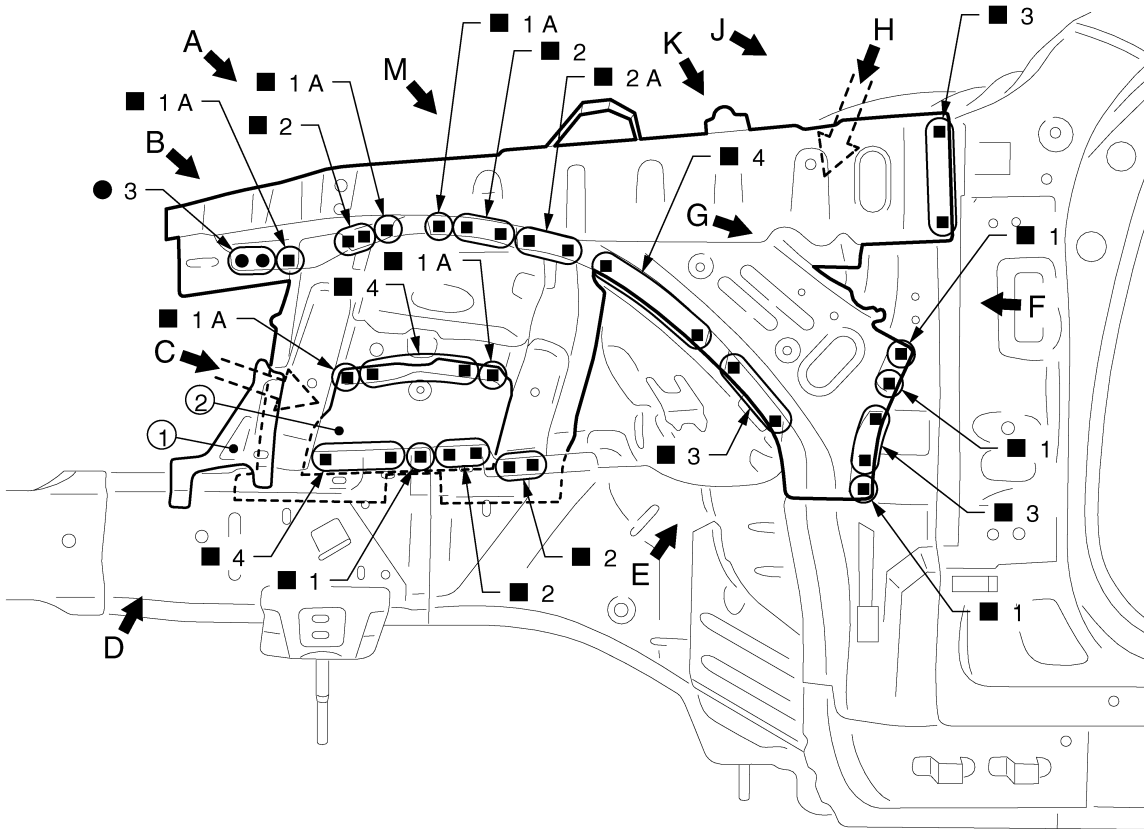

JSKIA1629ZZ

1. Front side member extension front reinforcement

2. Front side member center closing plate

←: Vehicle front

Replacement parts

● Upper front hoodledge (LH)

● Hoodledge reinforcement (LH)

● Front strut housing (LH)

View B: Before installing hoodledge reinforcement

REPLACEMENT OPERATIONS

< REMOVAL AND INSTALLATION >

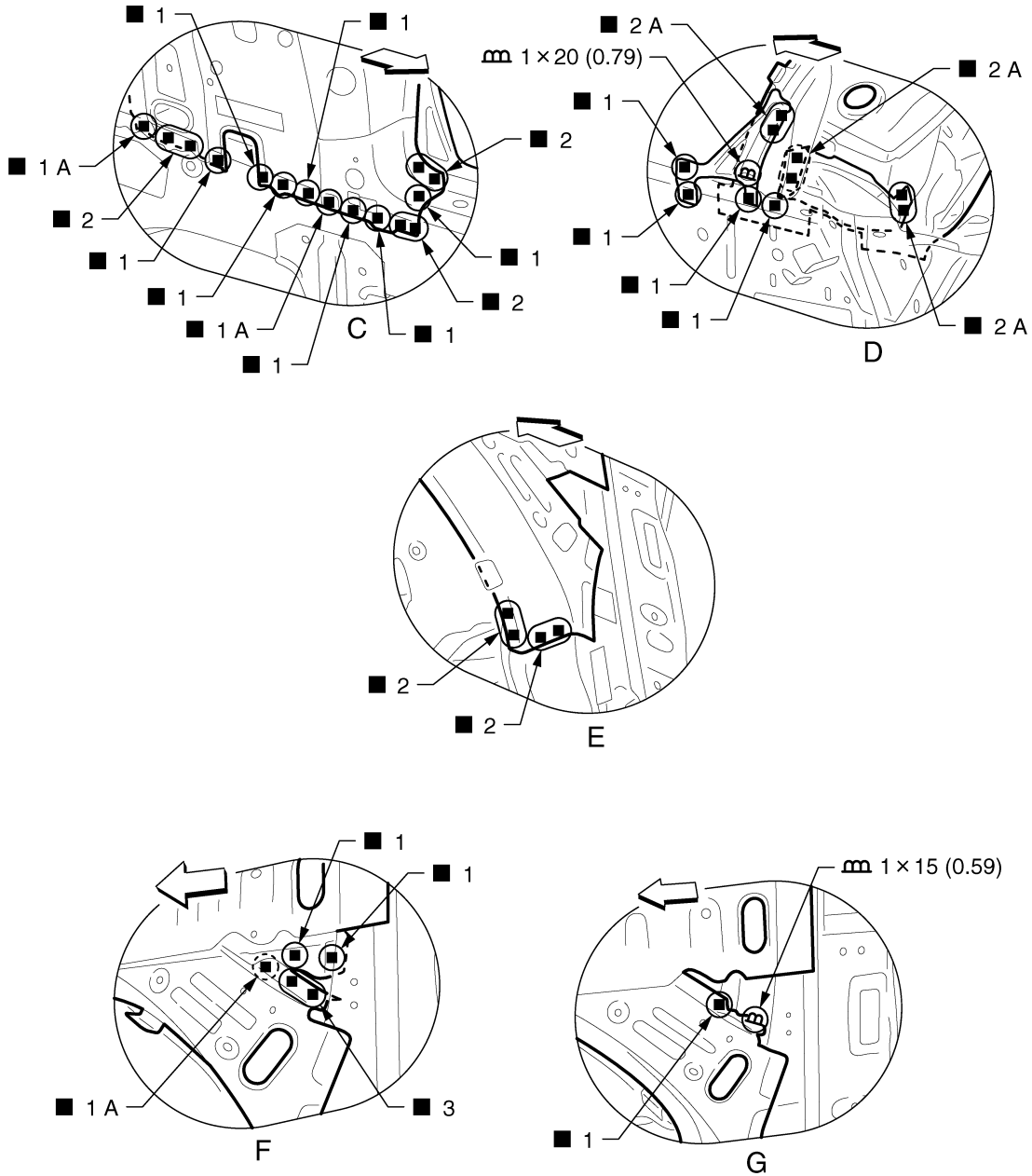

Unit: mm (in)

← Vehicle front

○: Weld the parts onto the back of the component part.

A
B
C
D
E
F
G
H
I
J
K
L
M
N
O
P

BRM

JSKIA1630GB

REPLACEMENT OPERATIONS

< REMOVAL AND INSTALLATION >

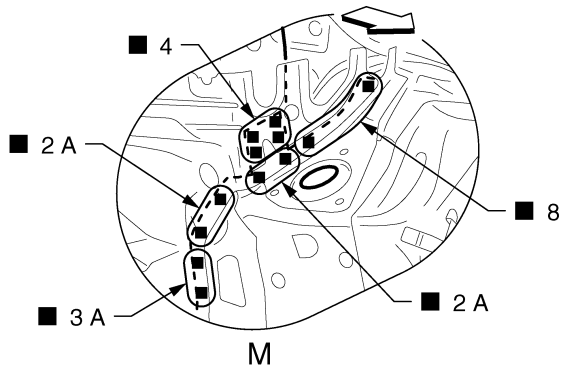
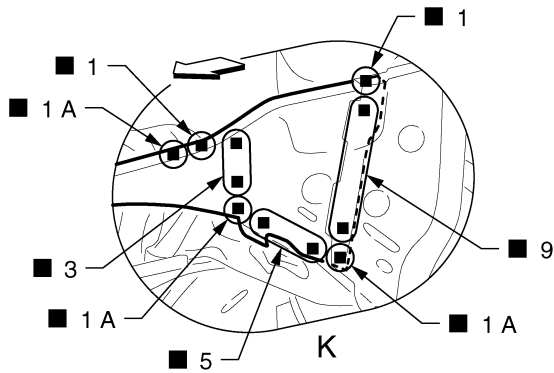
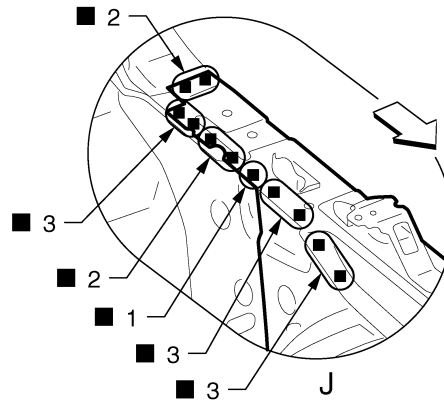
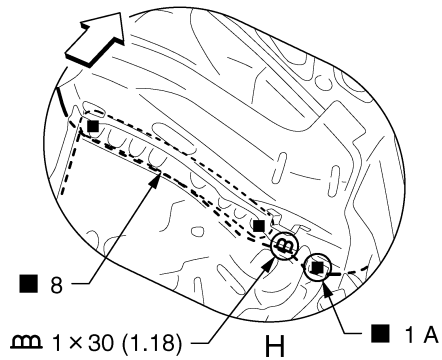

JSKIA1631GB

Unit: mm (in)

↔: Vehicle front

○: Weld the parts onto the back of the component part.

View K: Before installing hoodledge reinforcement

Front Side Member (2WD)

INFOID:000000005927147

Work after radiator core support and hoodledge are removed.

Remove the front side member extension front reinforcement (reusable) and front side member center closing plate (reusable) from the service part "front side member closing plate assembly" for easier installation of hoodledge.

REPLACEMENT OPERATIONS

< REMOVAL AND INSTALLATION >

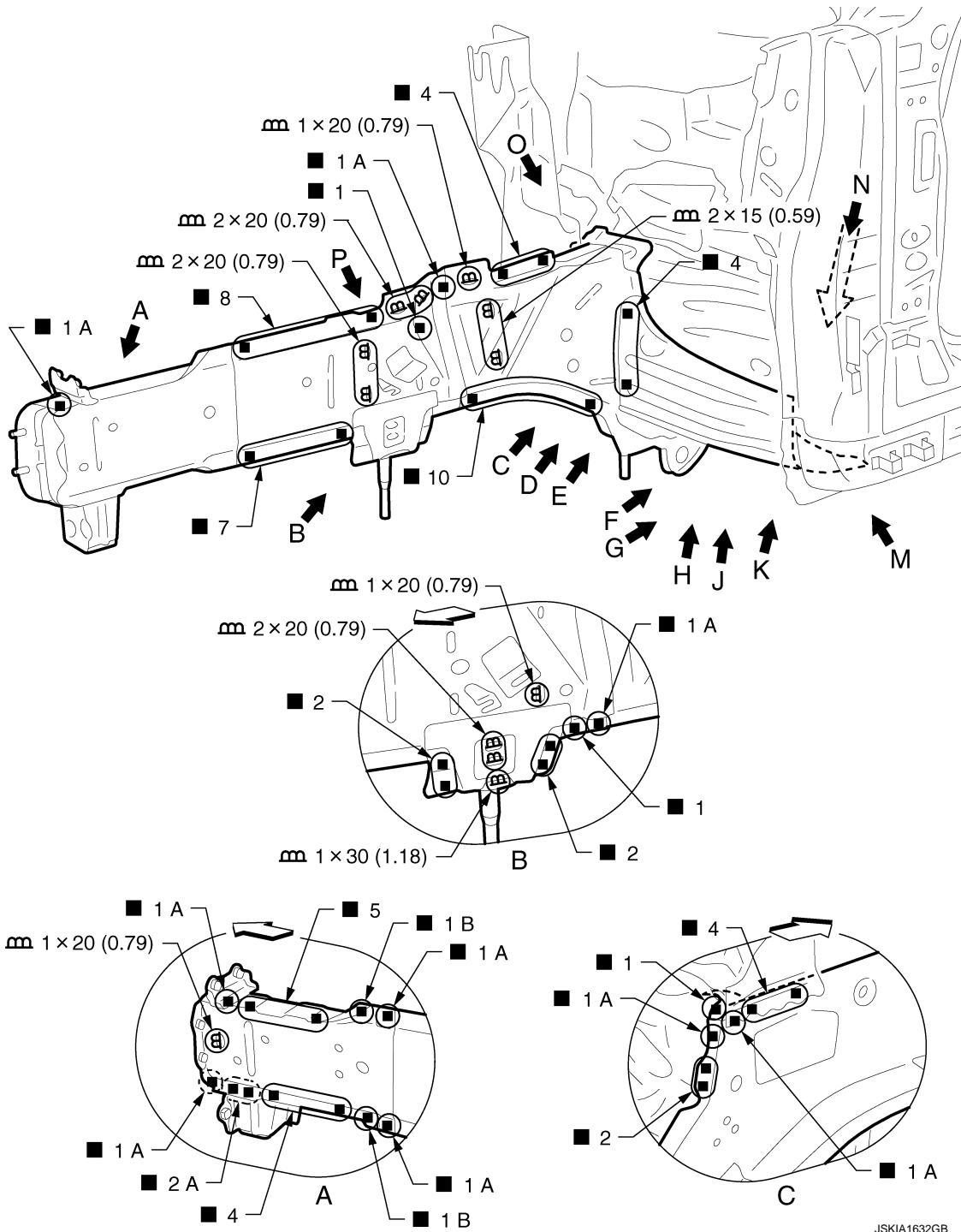

JSKIA1632GB

Unit: mm (in)

⇐: Vehicle front

⊙: Weld the parts onto the back of the component part.

Replacement parts

- Front side member assembly (LH)
- Front side member closing plate assembly (LH)
- Front side member outrigger assembly (LH)

A
B
C
D
E
F
G
H
I
J
K
L
M
N
O
P

BRM

REPLACEMENT OPERATIONS

< REMOVAL AND INSTALLATION >

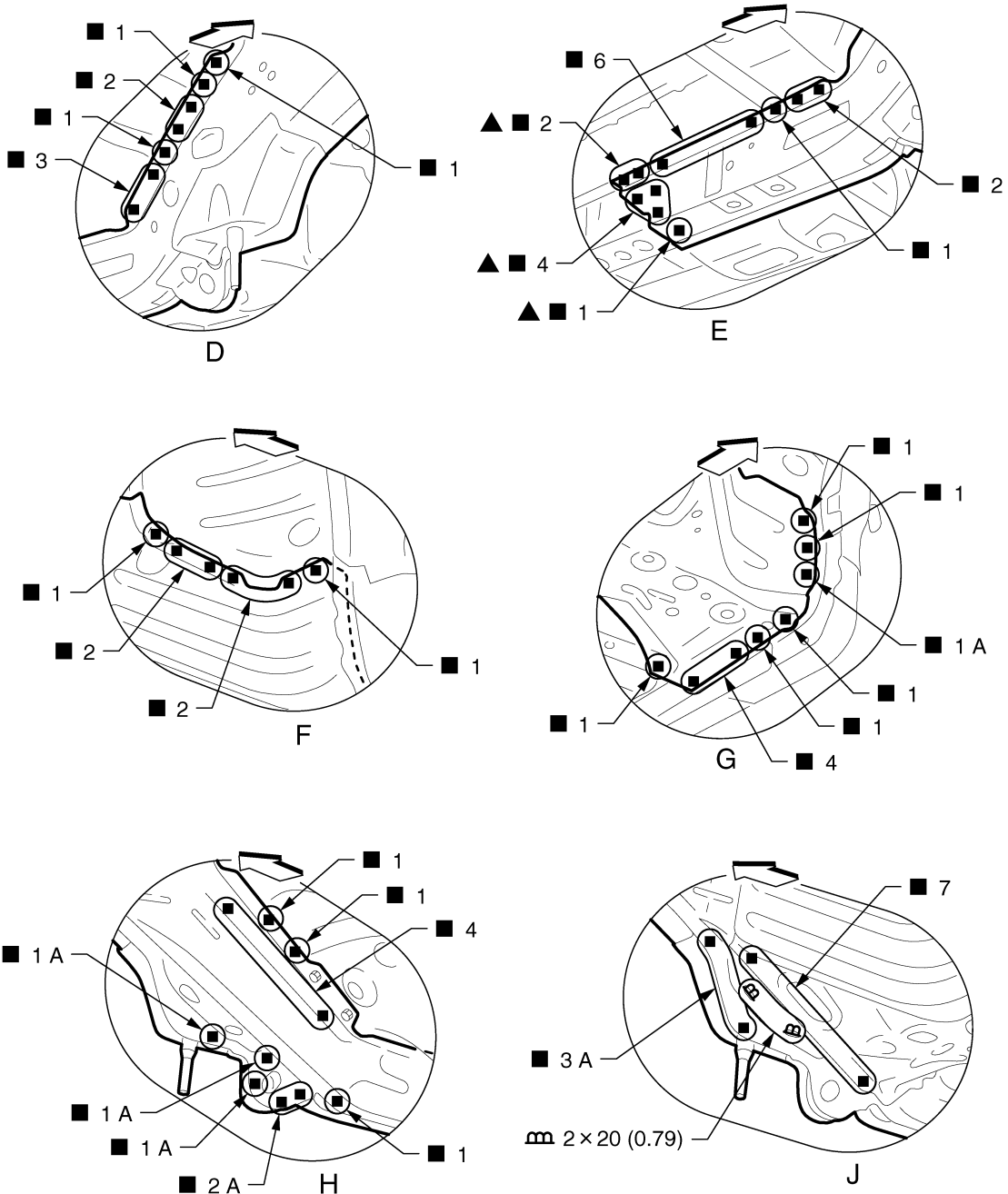

JSKIA1633GB

Unit: mm (in)

↔: Vehicle front

▲: Drill $\phi 8$ mm (0.31 in) hole for the plug welding hole (ultra high strength steel plate).

View H: Before installing front side member outrigger assembly

REPLACEMENT OPERATIONS

< REMOVAL AND INSTALLATION >

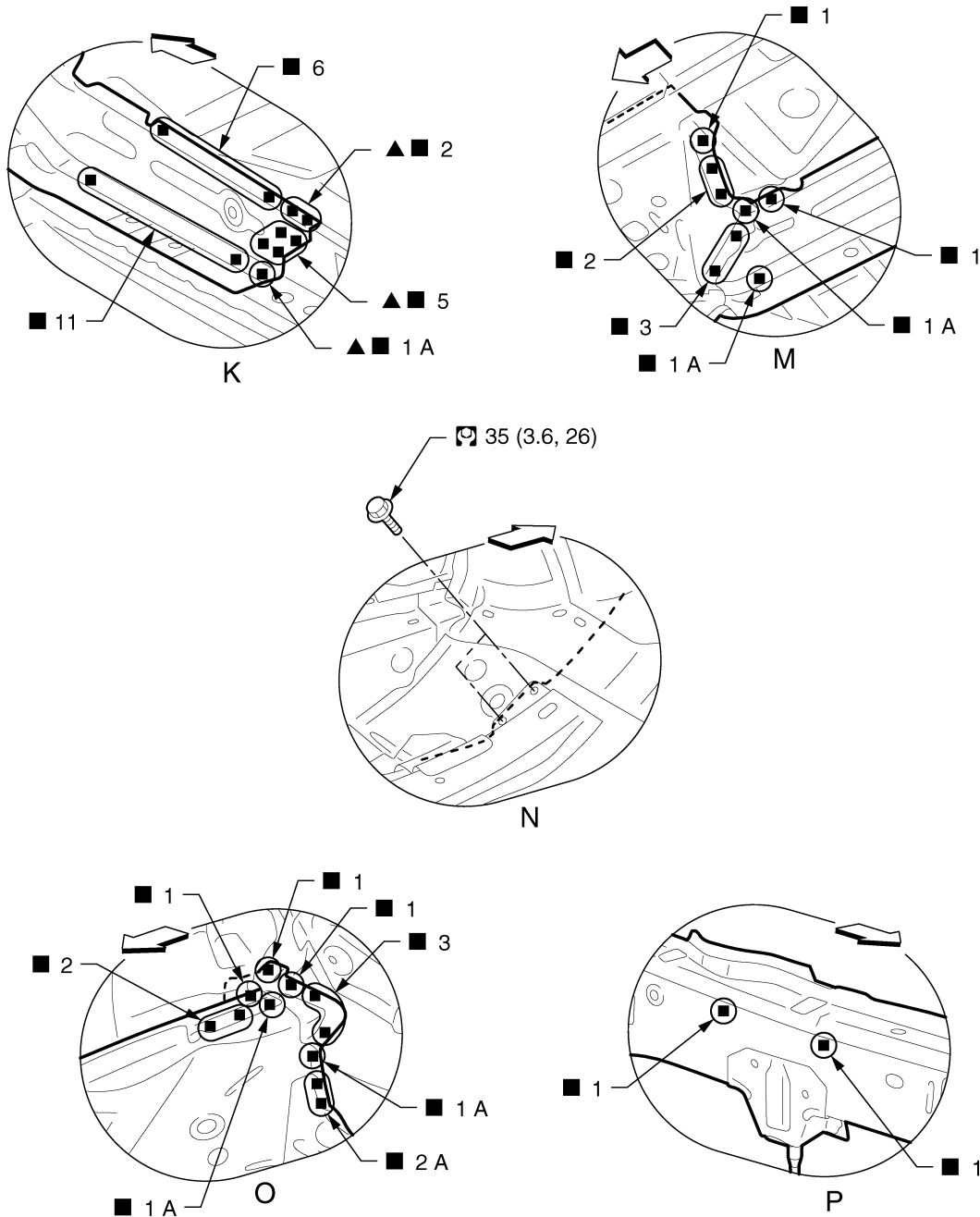

JSKIA1634GB

←: Vehicle front

▲: Drill $\phi 8$ mm (0.31 in) hole for the plug welding hole (ultra high strength steel plate).
Refer to [GI-4. "Components"](#) for symbols in the figure.

View K: Before installing front side member outrigger assembly

Front Side Member (AWD)

INFOID:000000005931544

Work after radiator core support and hoodledge are removed.

Remove the front side member extension front reinforcement (reusable) and front side member center closing plate (reusable) from the service part "front side member closing plate assembly" for easier installation of hoodledge.

A
B
C
D
E
F
G
H
I
J
K
L
M
N
O
P

BRM

REPLACEMENT OPERATIONS

< REMOVAL AND INSTALLATION >

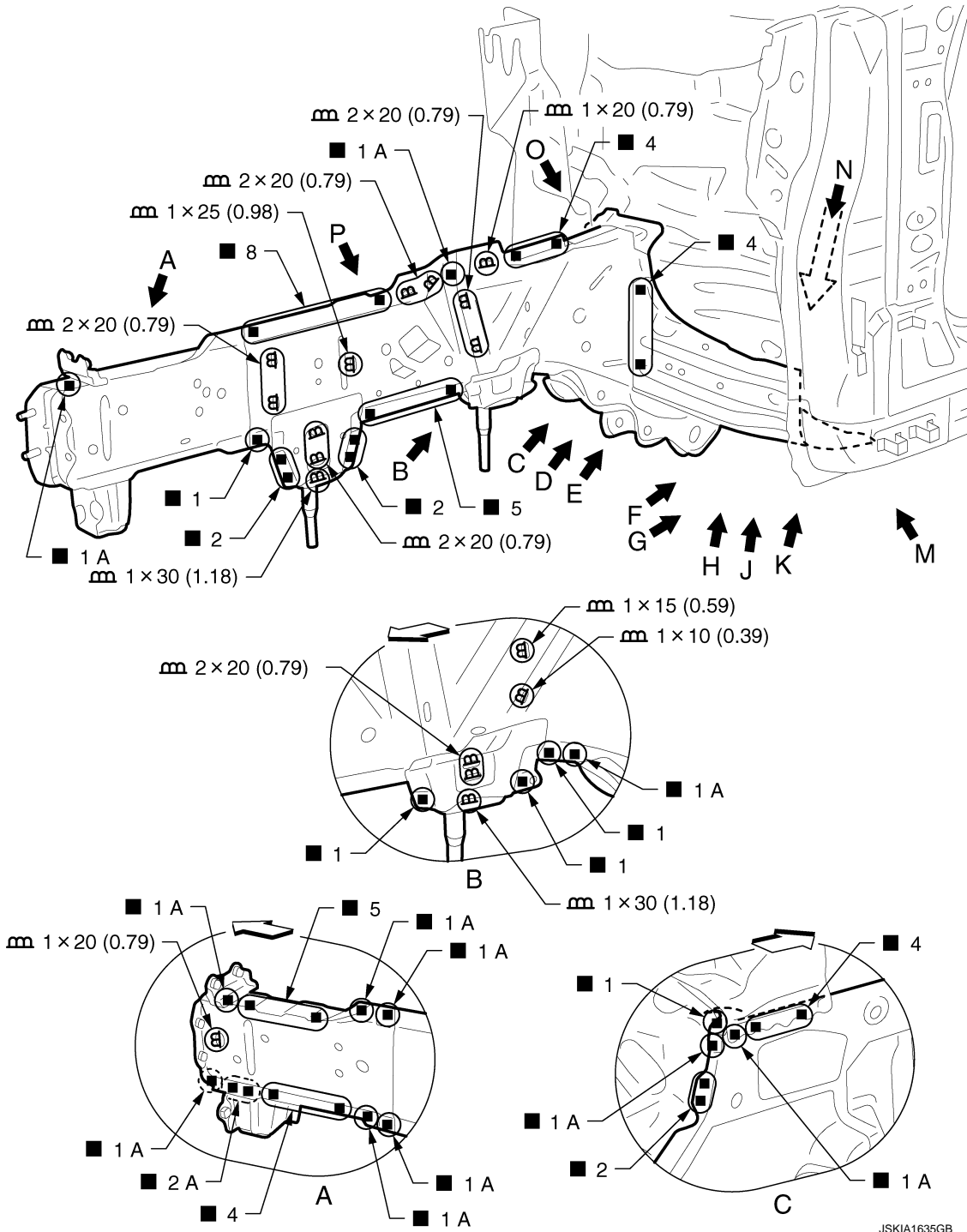

JSKIA1635GB

Unit: mm (in)

↔: Vehicle front

○: Weld the parts onto the back of the component part.

Replacement parts

- Front side member assembly (LH)
- Front side member closing plate assembly (LH)
- Front side member outrigger assembly (LH)

REPLACEMENT OPERATIONS

< REMOVAL AND INSTALLATION >

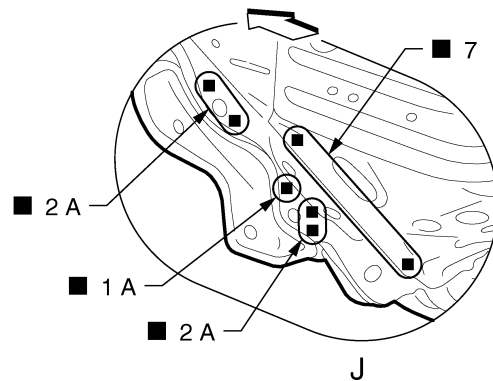
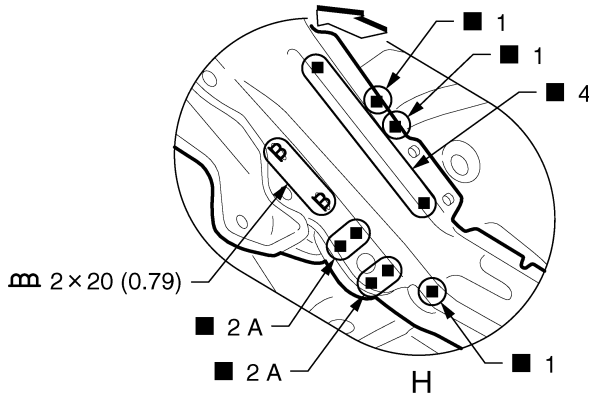
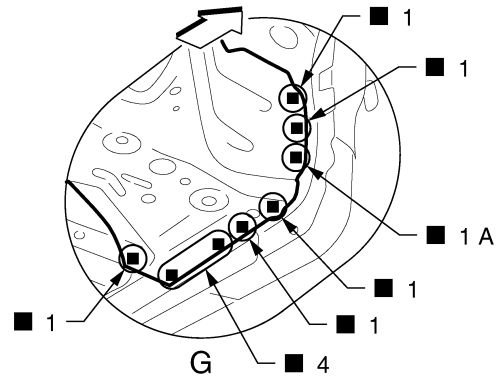
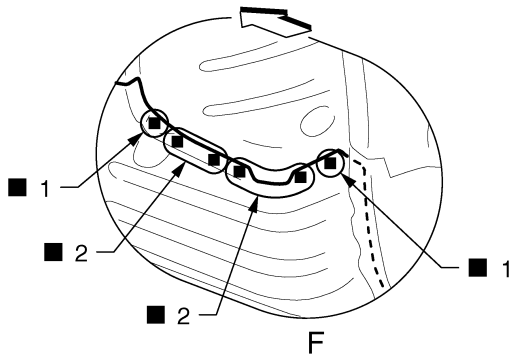
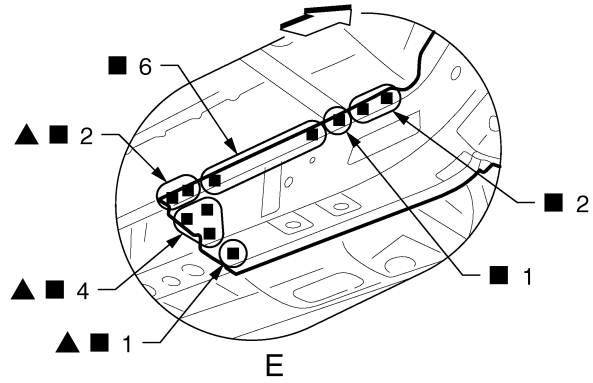
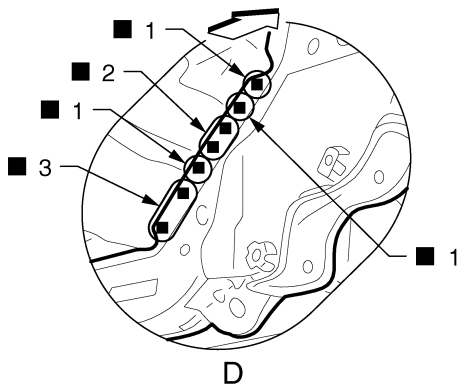

JSKIA1636GB

Unit: mm (in)

↔: Vehicle front

▲: Drill $\phi 8$ mm (0.31 in) hole for the plug welding hole (ultra high strength steel plate).

View H: Before installing front side member outrigger assembly

A
B
C
D
E
F
G
H
I
J
BRM
L
M
N
O
P

REPLACEMENT OPERATIONS

< REMOVAL AND INSTALLATION >

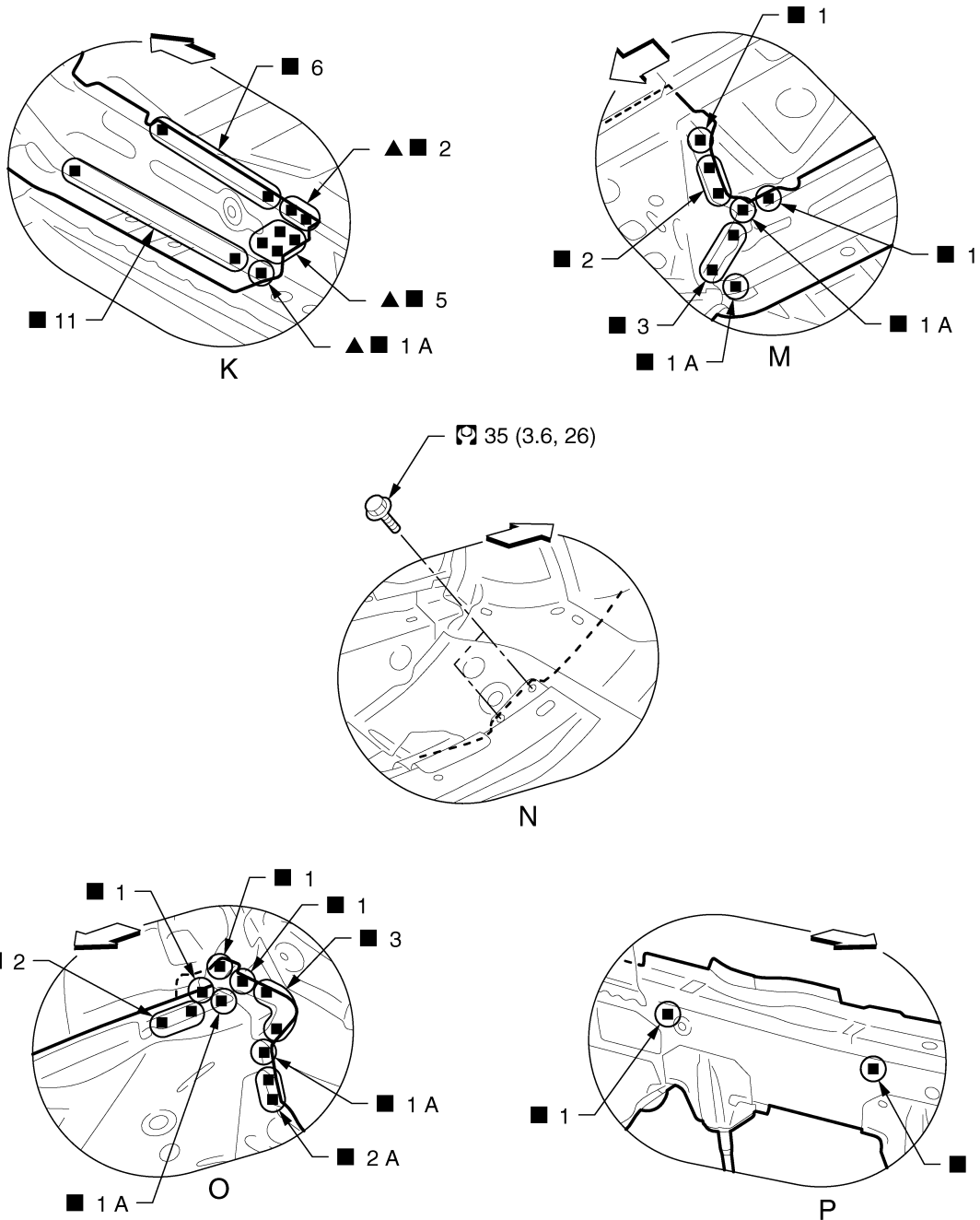

JSKIA1637GB

↔: Vehicle front

▲: Drill $\phi 8$ mm (0.31 in) hole for the plug welding hole (ultra high strength steel plate).
Refer to [GI-4. "Components"](#) for symbols in the figure.

View K: Before installing front side member outrigger assembly
Front Side Member (Partial Replacement)

INFOID:000000005927148

Work after radiator core support is removed.

REPLACEMENT OPERATIONS

< REMOVAL AND INSTALLATION >

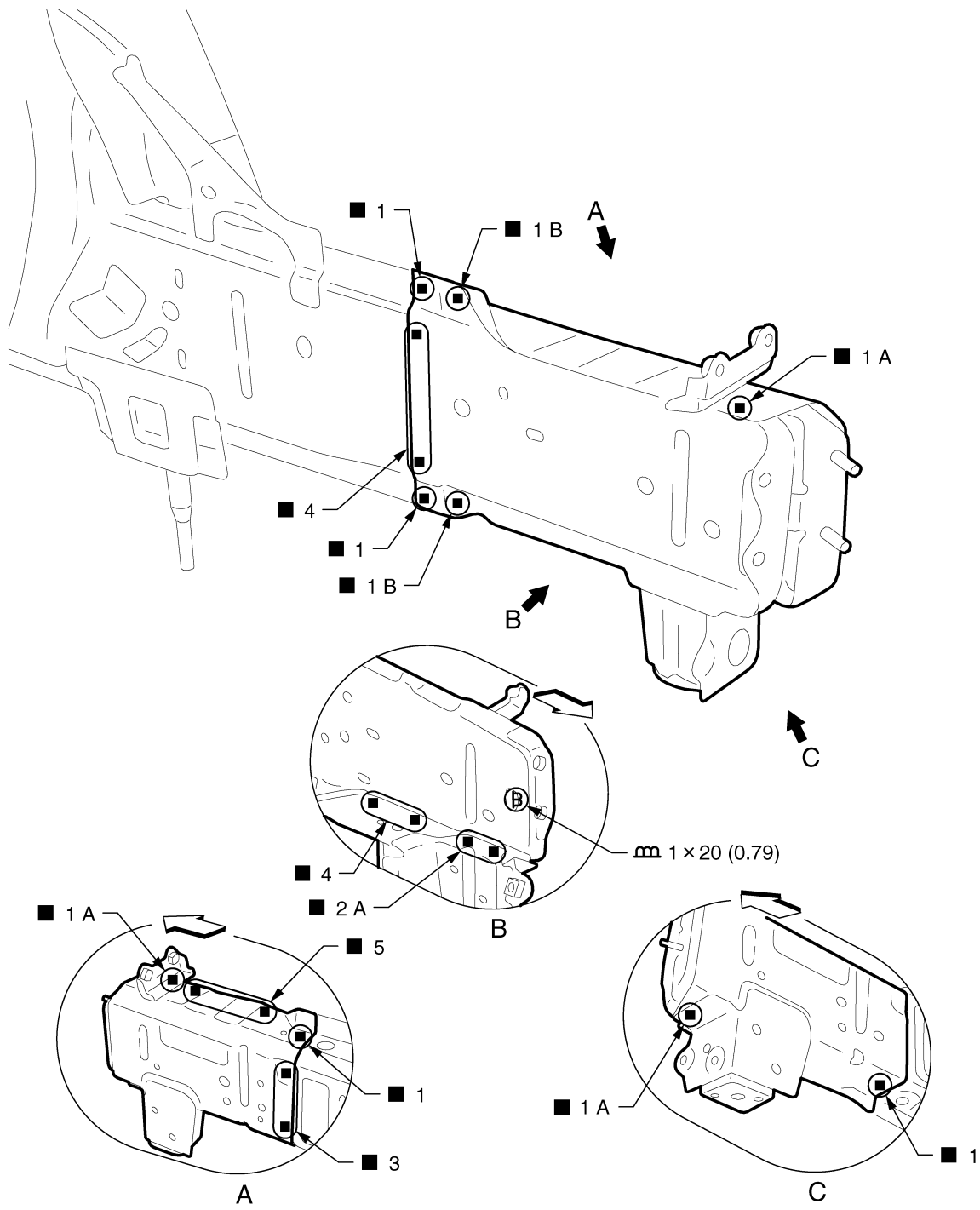

A
B
C
D
E
F
G
H
I
J
BRM
L
M
N
O
P

Unit: mm (in)

⇐: Vehicle front

Replacement parts

- Front side member front extension (LH)
- Front side member front closing plate (LH)

Front Pillar

INFOID:000000005927149

Work after hoodledge reinforcement and roof are removed.

REPLACEMENT OPERATIONS

< REMOVAL AND INSTALLATION >

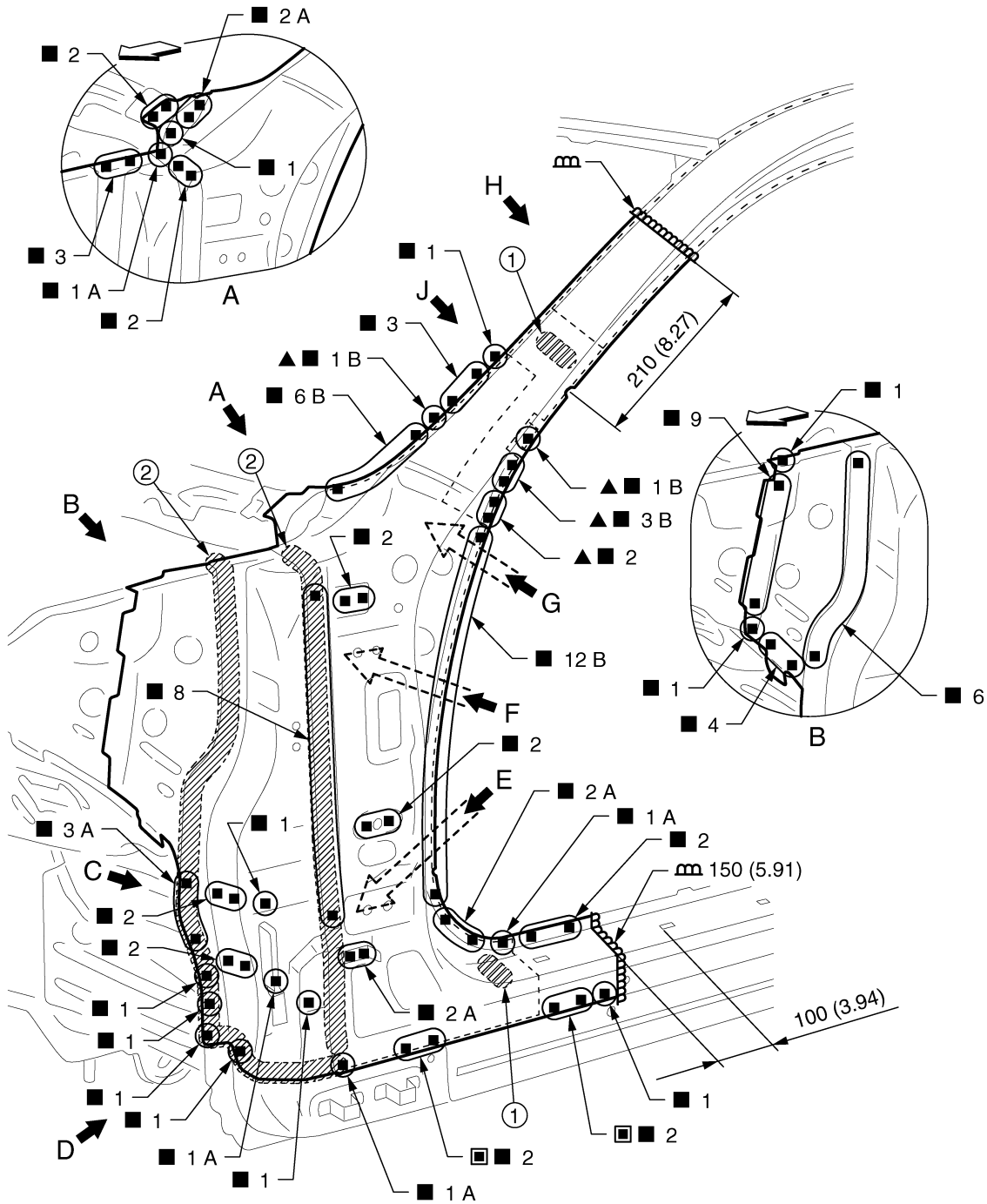

JSKIA1639GB

1. Urethane foam

2. Body sealing

Unit: mm (in)

◁: Vehicle front

■: Perform the plug welding instead of the laser welding.

▲: Drill $\phi 8$ mm (0.31 in) hole for the plug welding hole (ultra high strength steel plate).

Replacement parts

- Outer front side body (LH)
- Outer front pillar reinforcement (LH)
- Upper rear hoodledge (LH)
- Front fender bracket

REPLACEMENT OPERATIONS

< REMOVAL AND INSTALLATION >

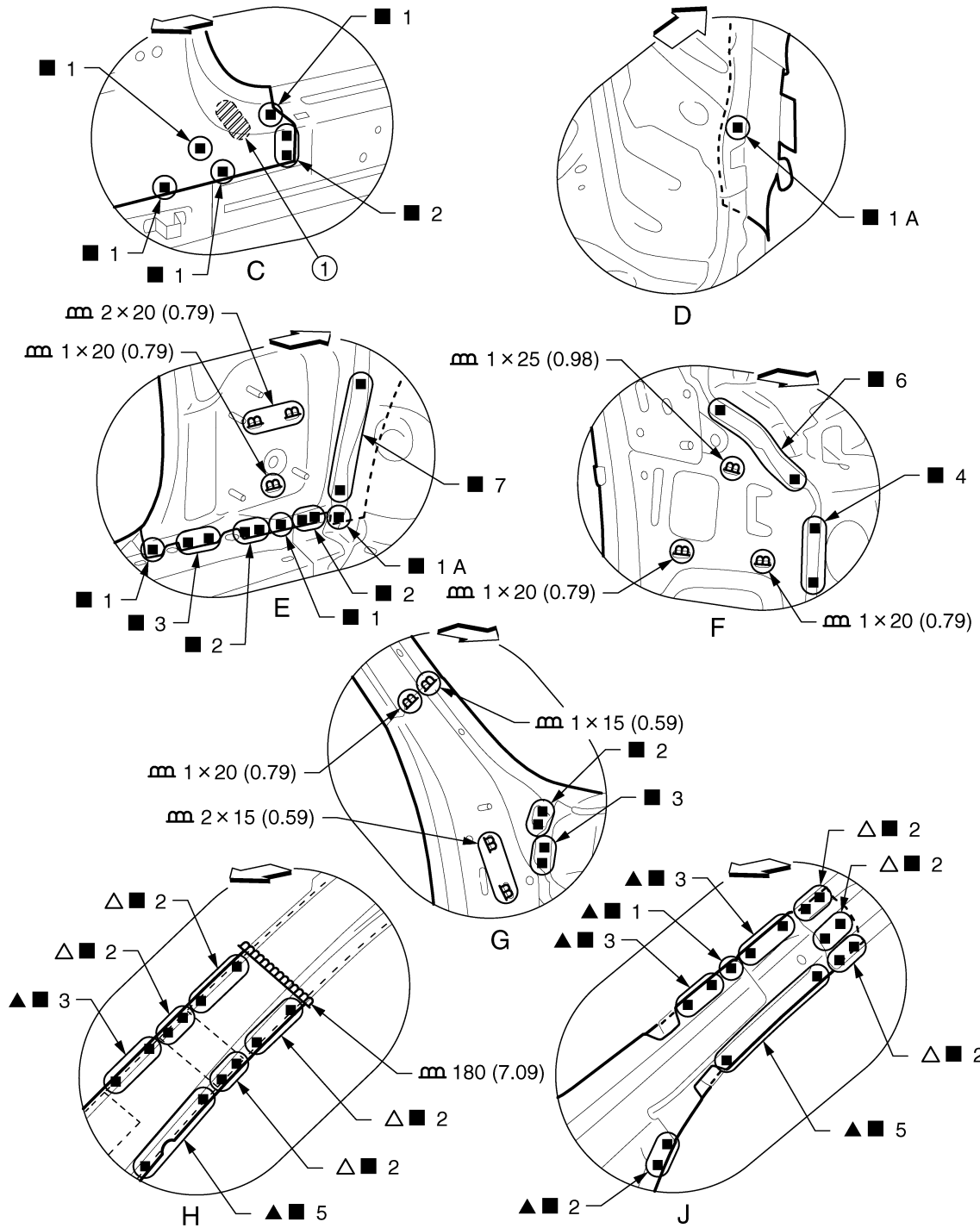

1. Urethane foam

Unit: mm (in)

◁: Vehicle front

▲: Drill $\phi 8$ mm (0.31 in) hole for the plug welding hole (ultra high strength steel plate).

△: Drill $\phi 10$ mm (0.39 in) hole for the plug welding hole (ultra high strength steel plate).

View C and J: Before installing outer front side body

Side Body

Work after hoodledge reinforcement and roof are removed.

JSKIA1868GB

A
B
C
D
E
F
G
H
I
J
L
M
N
O
P

BRM

REPLACEMENT OPERATIONS

< REMOVAL AND INSTALLATION >

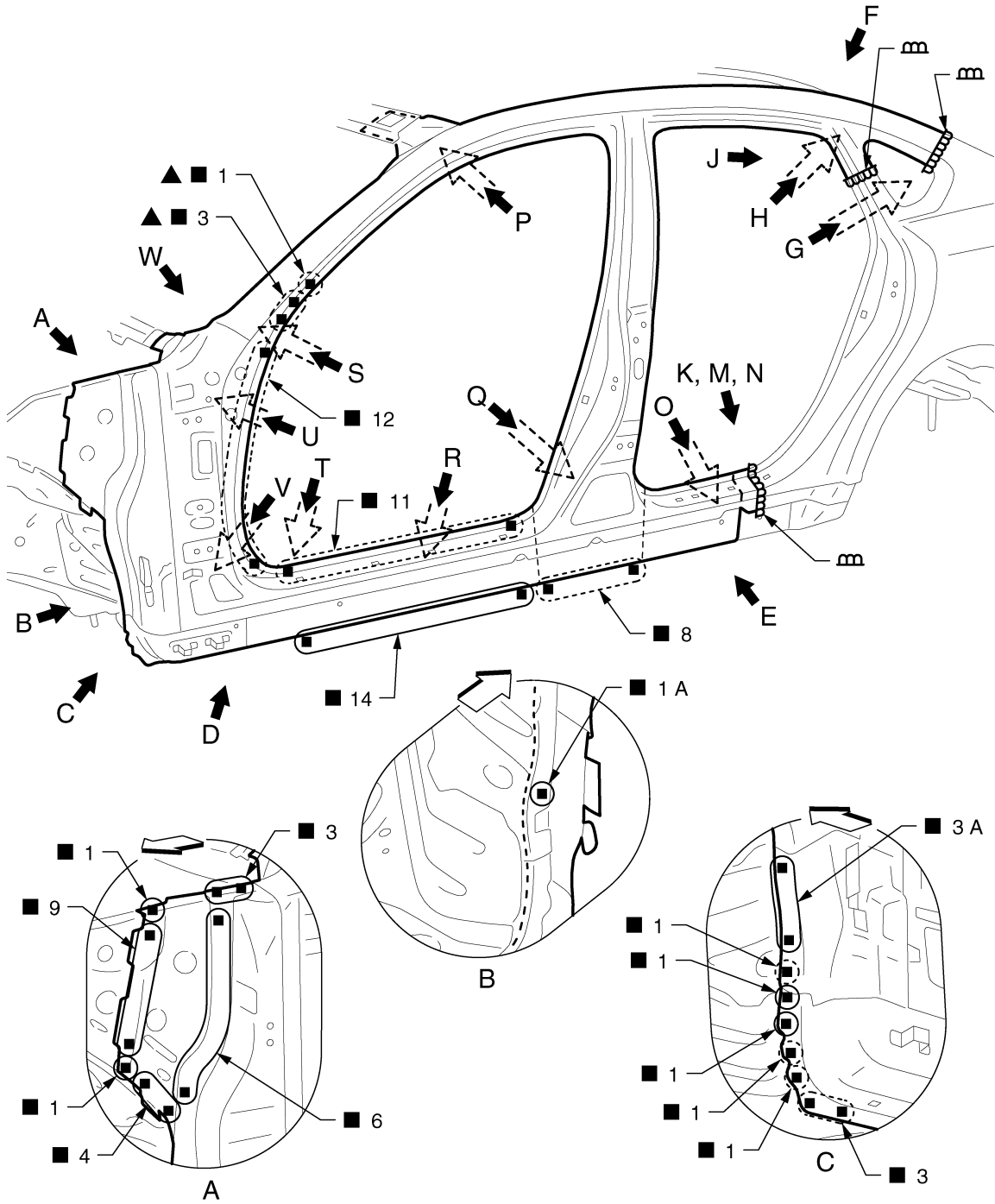

JSKIA1641ZZ

← Vehicle front

▲: Drill $\phi 8$ mm (0.31 in) hole for the plug welding hole (ultra high strength steel plate).

○: Weld the parts onto the back of the component part.

Replacement parts

- Side body assembly (LH)
- Upper rear hoodledge (LH)

REPLACEMENT OPERATIONS

< REMOVAL AND INSTALLATION >

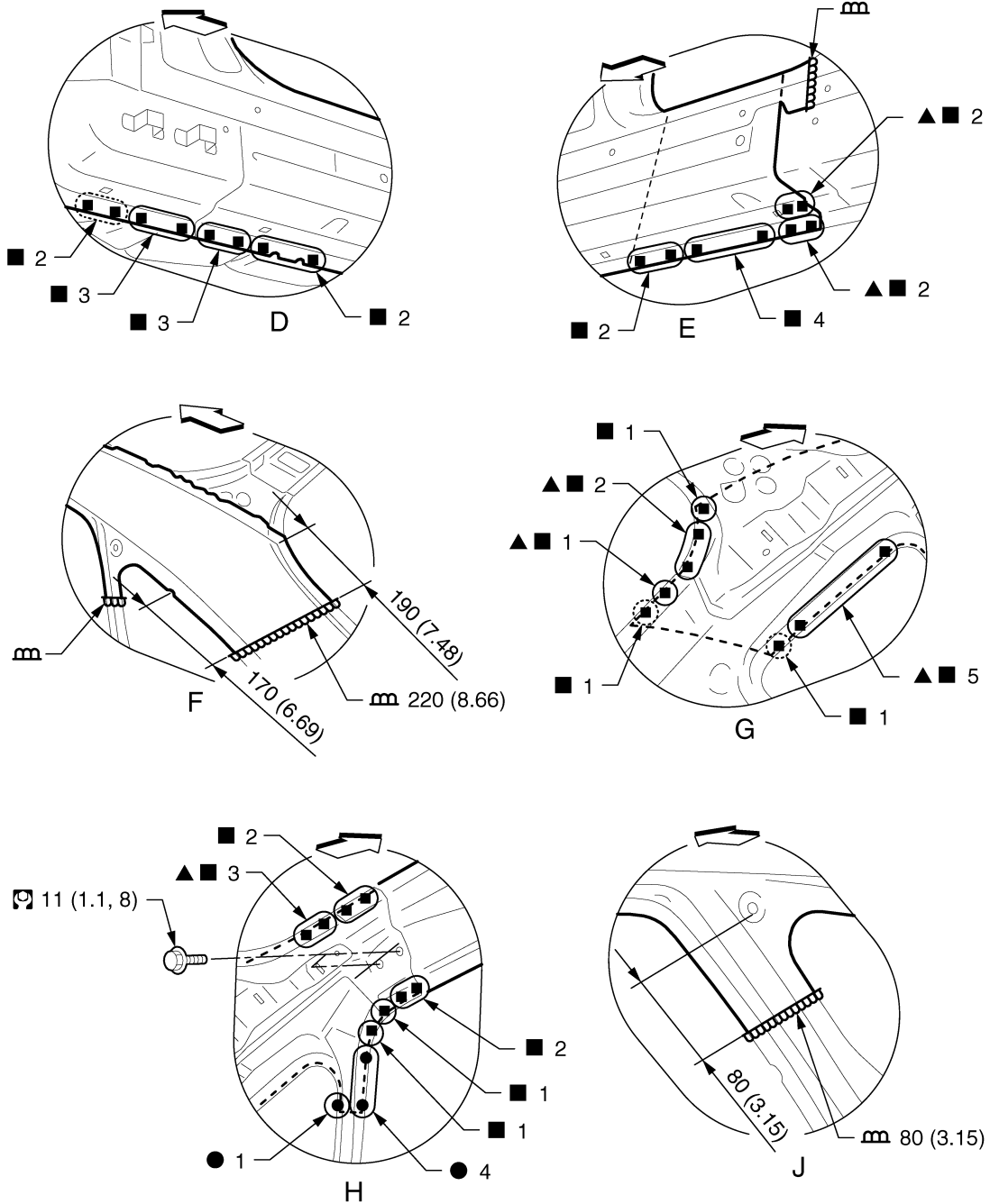

Unit: mm (in)

← Vehicle front

▲: Drill $\phi 8$ mm (0.31 in) hole for the plug welding hole (ultra high strength steel plate).

○: Weld the parts onto the back of the component part.

Refer to [GI-4, "Components"](#) for symbols in the figure.

A
B
C
D
E
F
G
H
I
J
BRM
L
M
N
O
P

JSKIA1642GB

REPLACEMENT OPERATIONS

< REMOVAL AND INSTALLATION >

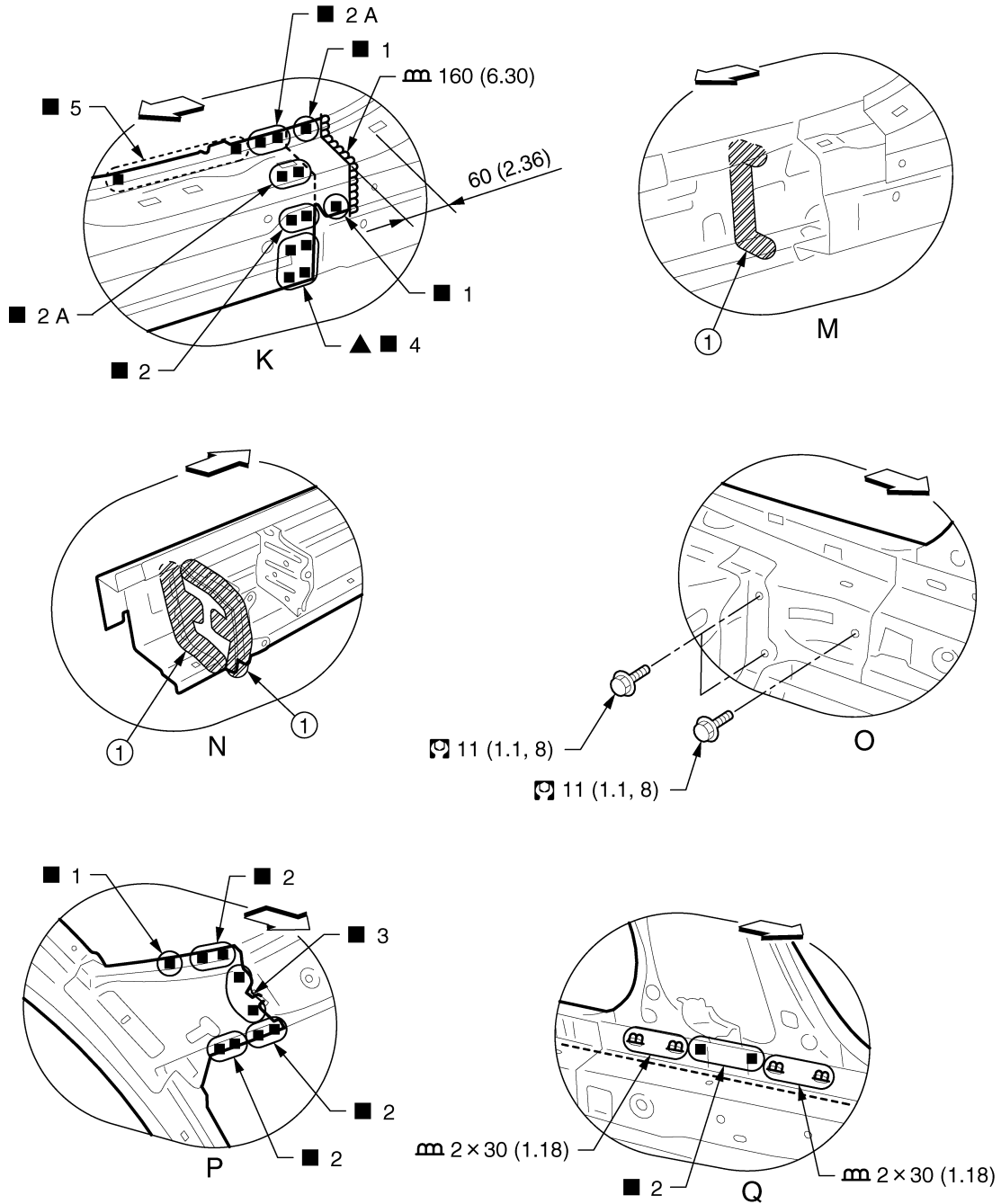

JSKIA1643GB

1. Urethane foam

Unit: mm (in)

↔: Vehicle front

▲: Drill $\phi 8$ mm (0.31 in) hole for the plug welding hole (ultra high strength steel plate).

⊕: Weld the parts onto the back of the component part.
Refer to [GI-4, "Components"](#) for symbols in the figure.

View M: Before installing side body assembly
View N: Side body assembly (replacement parts)

REPLACEMENT OPERATIONS

< REMOVAL AND INSTALLATION >

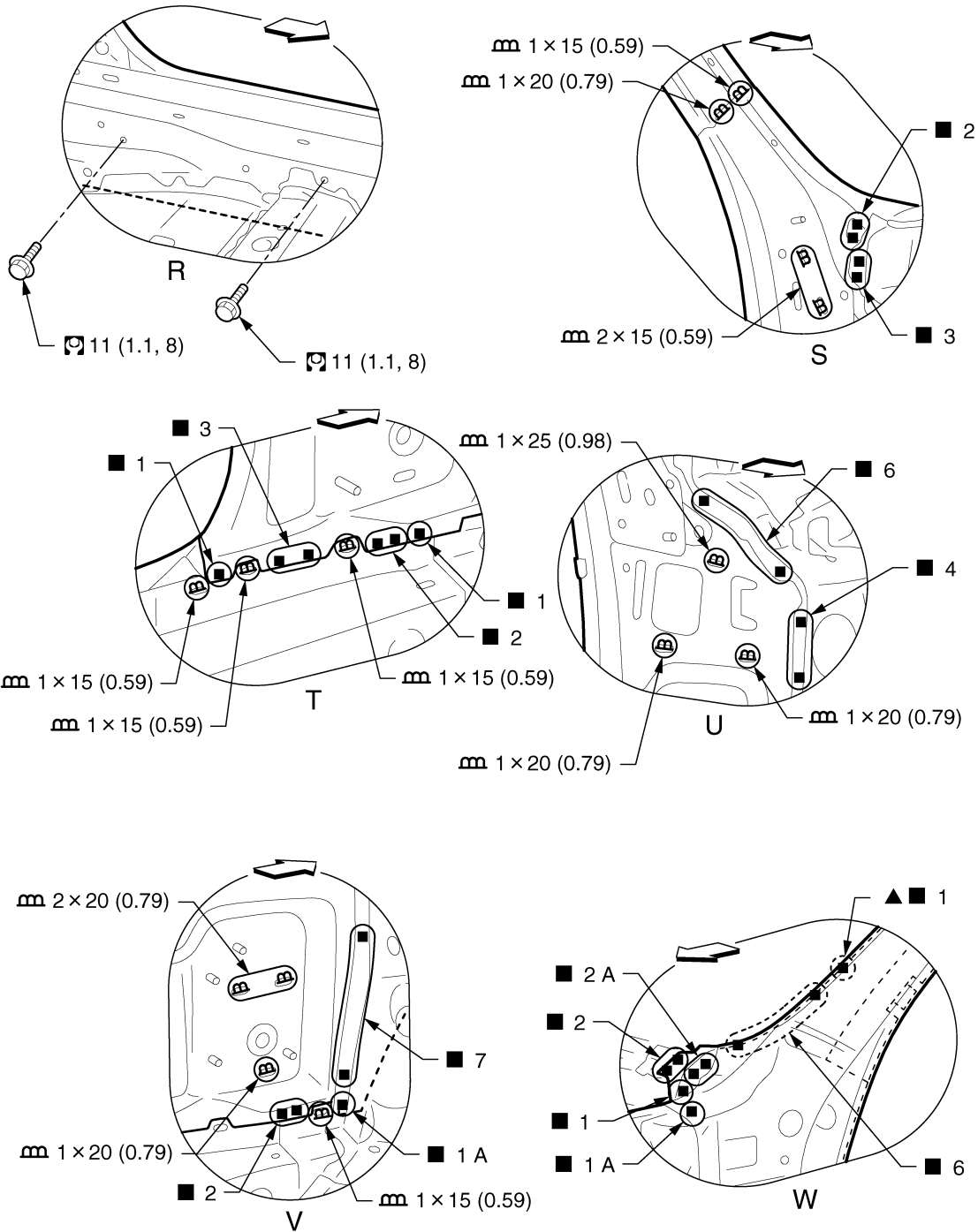

JSKIA1869GB

Unit: mm (in)

⇐: Vehicle front

▲: Drill $\phi 8$ mm (0.31 in) hole for the plug welding hole (ultra high strength steel plate).

⊙: Weld the parts onto the back of the component part.

Refer to [GI-4, "Components"](#) for symbols in the figure.

Center Pillar

Work after roof is removed.

INFOID:000000005927997

A
B
C
D
E
F
G
H
I
J
K
L
M
N
O
P

BRM

REPLACEMENT OPERATIONS

< REMOVAL AND INSTALLATION >

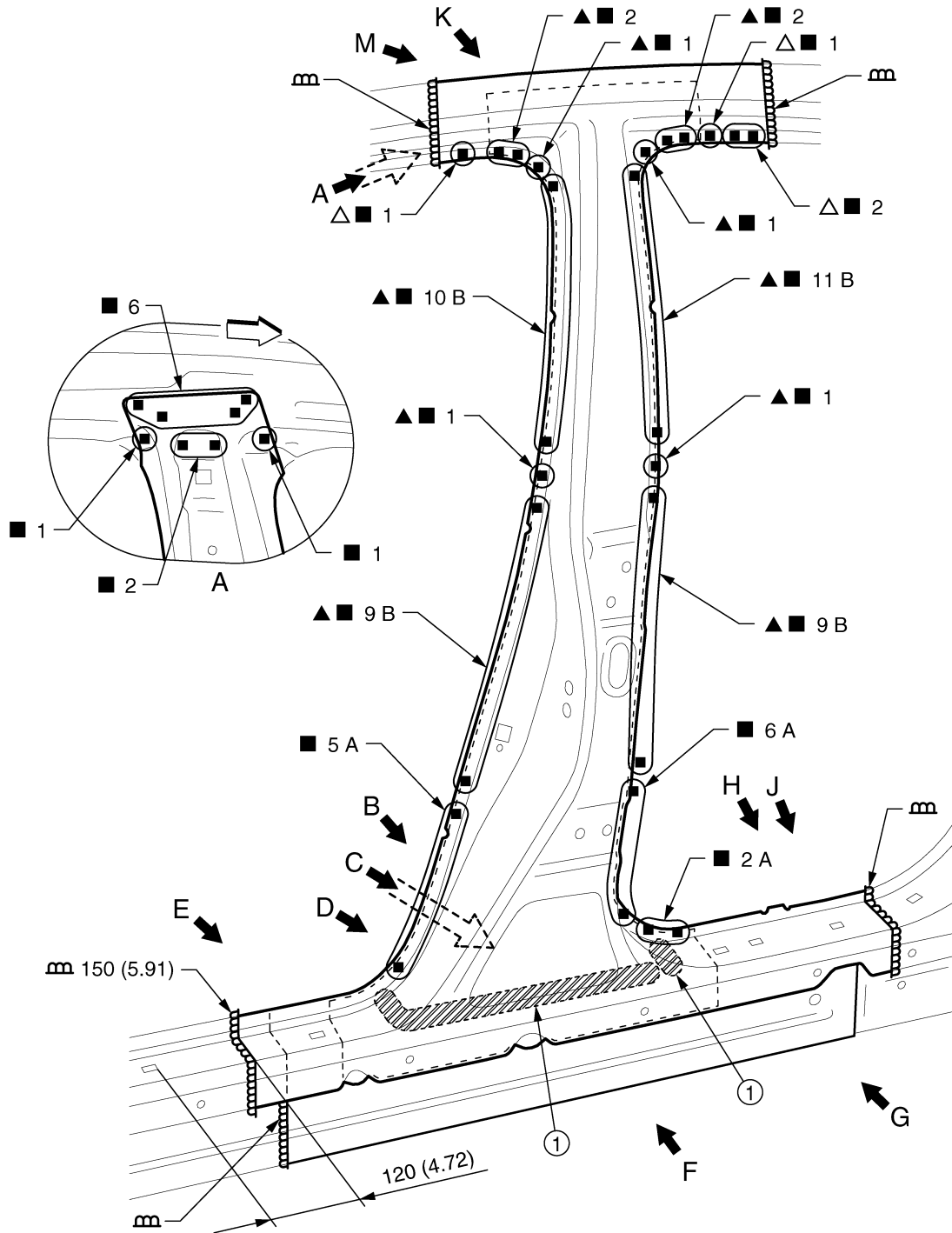

JSKIA1645GB

1. Urethane foam

Unit: mm (in)

↔: Vehicle front

▲: Drill $\phi 8$ mm (0.31 in) hole for the plug welding hole (ultra high strength steel plate).

△: Drill $\phi 10$ mm (0.39 in) hole for the plug welding hole (ultra high strength steel plate).

Replacement parts

- Outer front side body (LH)
- Center pillar reinforcement (LH)
- Inner center pillar (LH)

REPLACEMENT OPERATIONS

< REMOVAL AND INSTALLATION >

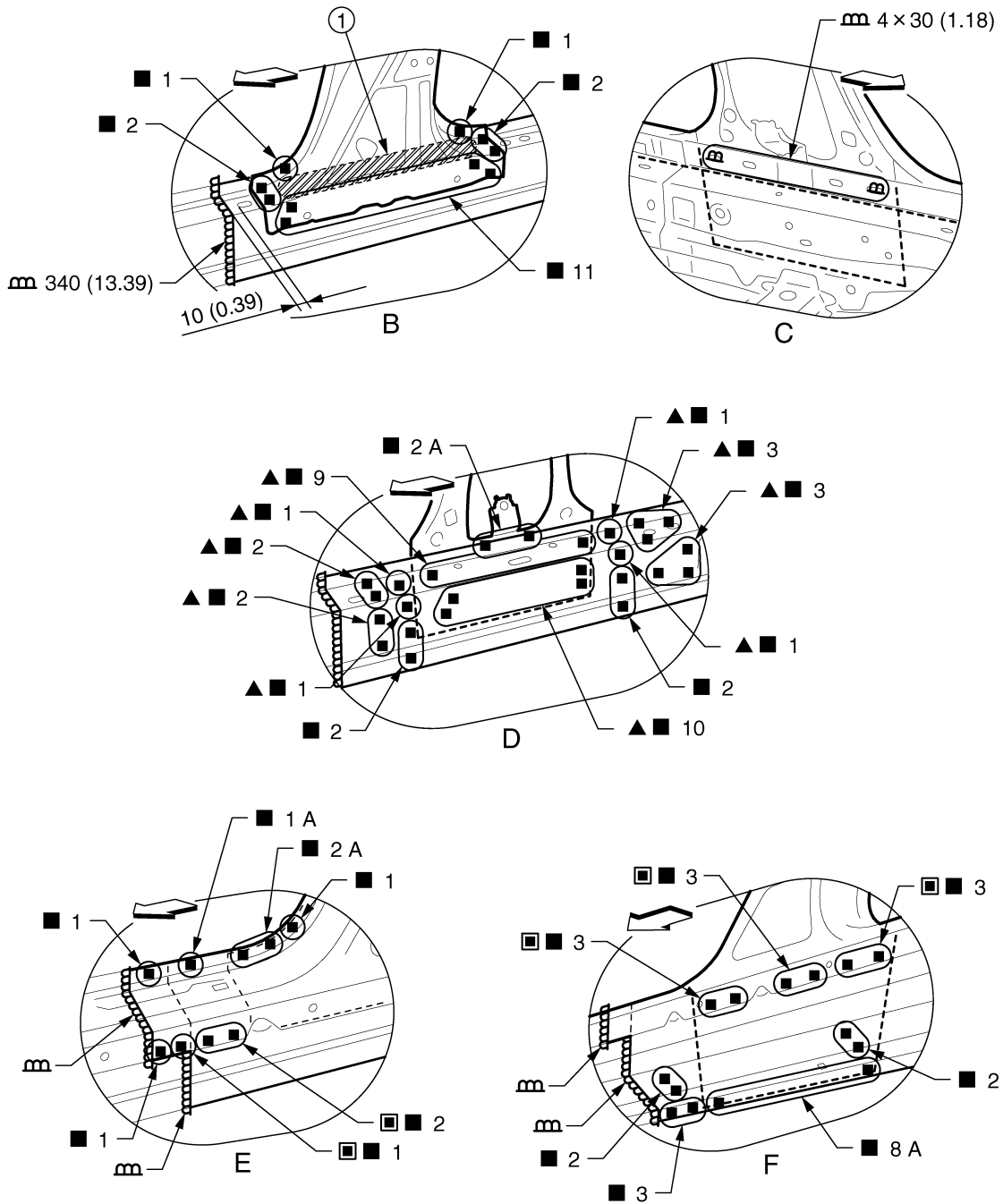

JSKIA1646GB

1. Urethane foam

Unit: mm (in)

←: Vehicle front

■: Perform the plug welding instead of the laser welding.

▲: Drill $\phi 8$ mm (0.31 in) hole for the plug welding hole (ultra high strength steel plate).

View B: Before installing outer front side body

View D: Before installing outer front side body and center pillar reinforcement

REPLACEMENT OPERATIONS

< REMOVAL AND INSTALLATION >

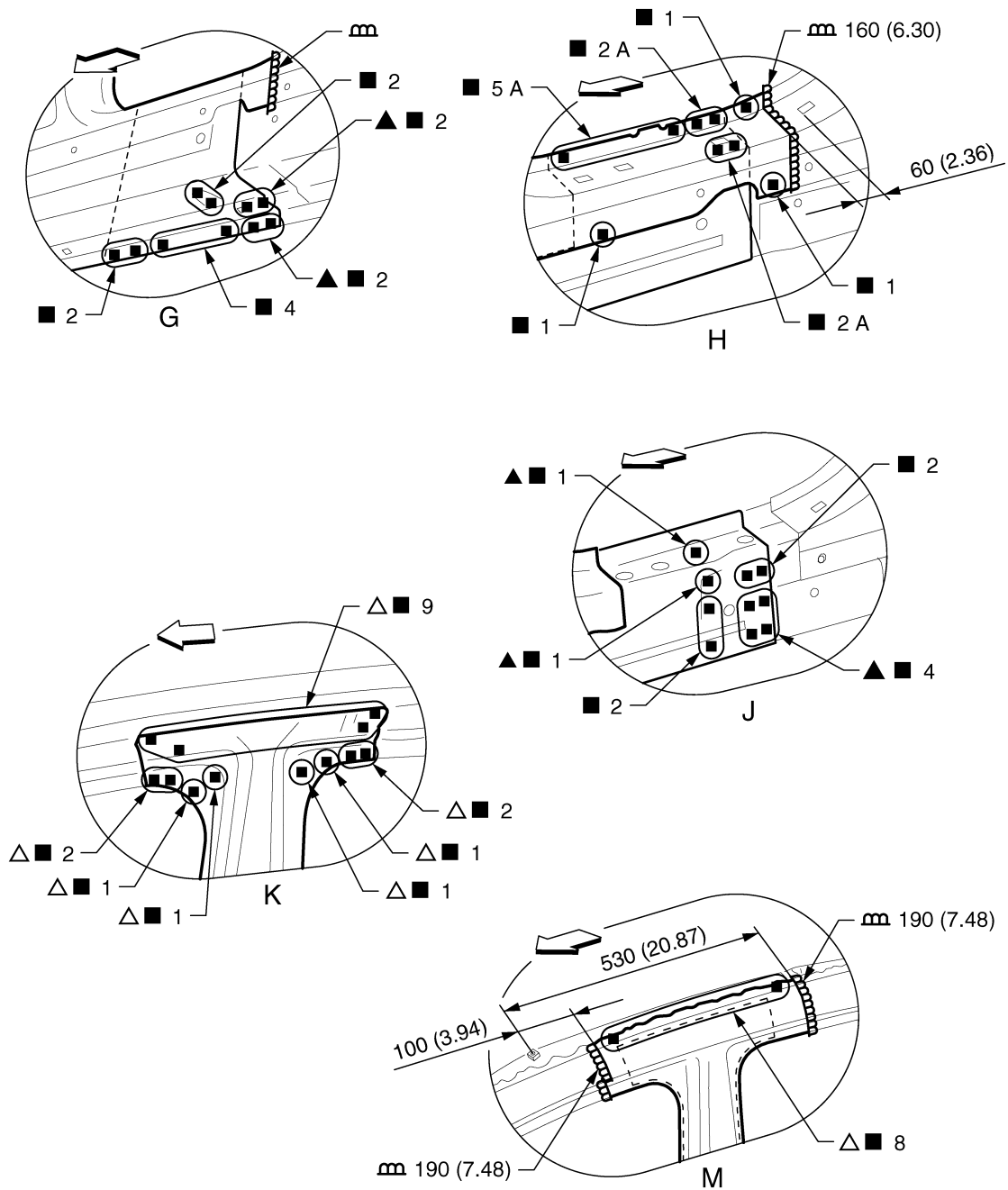

JSKIA1647GB

Unit: mm (in)

↔: Vehicle front

▲: Drill $\phi 8$ mm (0.31 in) hole for the plug welding hole (ultra high strength steel plate).

△: Drill $\phi 10$ mm (0.39 in) hole for the plug welding hole (ultra high strength steel plate).

View J and K: Before installing outer front side body

REPLACEMENT OPERATIONS

< REMOVAL AND INSTALLATION >

Outer Sill (Partial Replacement)

INFOID:000000005927151

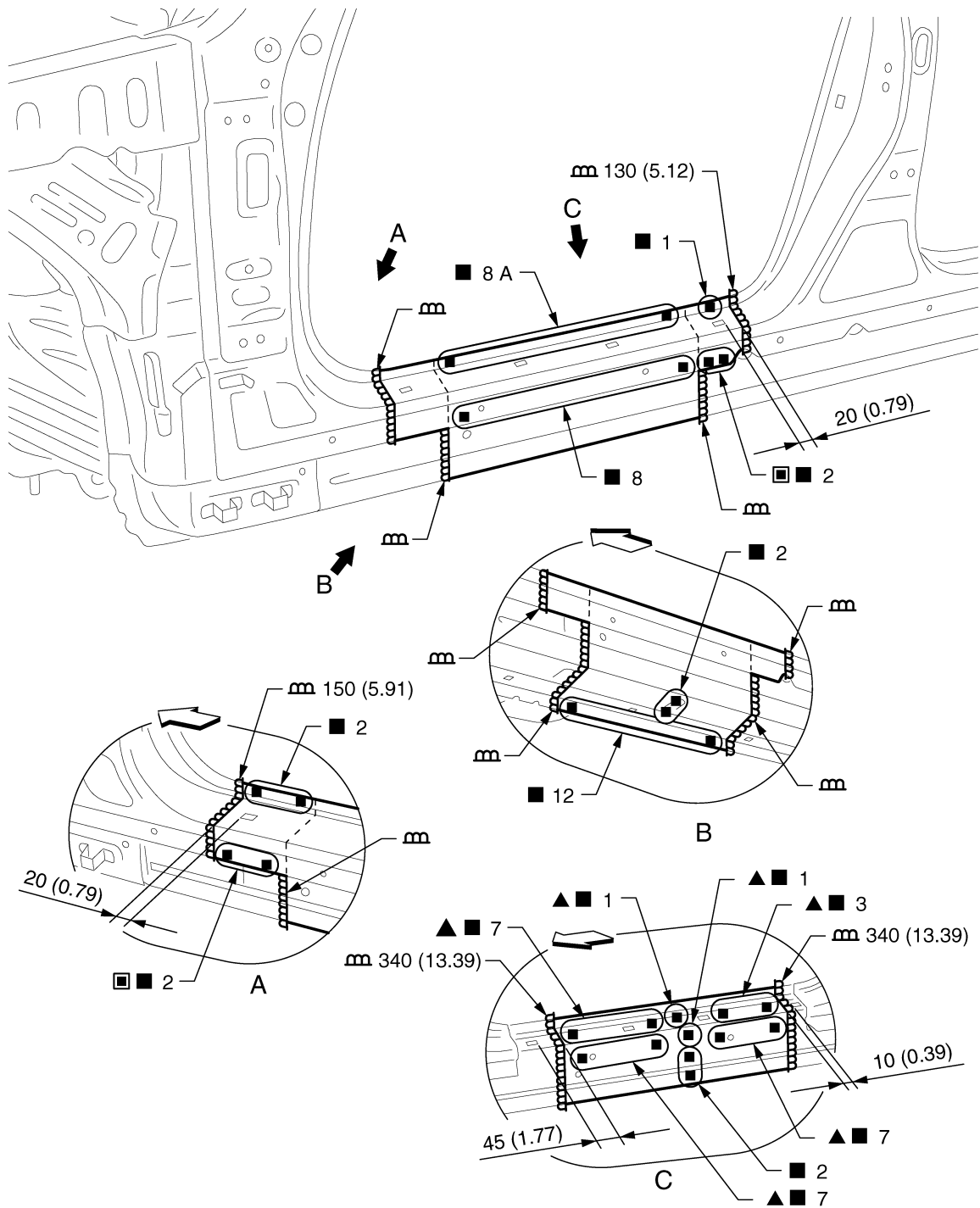

A
B
C
D
E
F
G
H
I
J
K
L
M
N
O
P

BRM

Unit: mm (in)

↔: Vehicle front

■: Perform the plug welding instead of the laser welding.

▲: Drill $\phi 8$ mm (0.31 in) hole for the plug welding hole (ultra high strength steel plate).

Replacement parts

- Outer sill (LH)
- Outer sill reinforcement (LH)

View C: Before installing outer sill

JSKIA1648GB

REPLACEMENT OPERATIONS

< REMOVAL AND INSTALLATION >

INFOID:000000005927152

Outer Sill

Work after hoodledge reinforcement is removed.

Remove the outer front pillar reinforcement (reusable) and center pillar reinforcement (reusable) for easier installation.

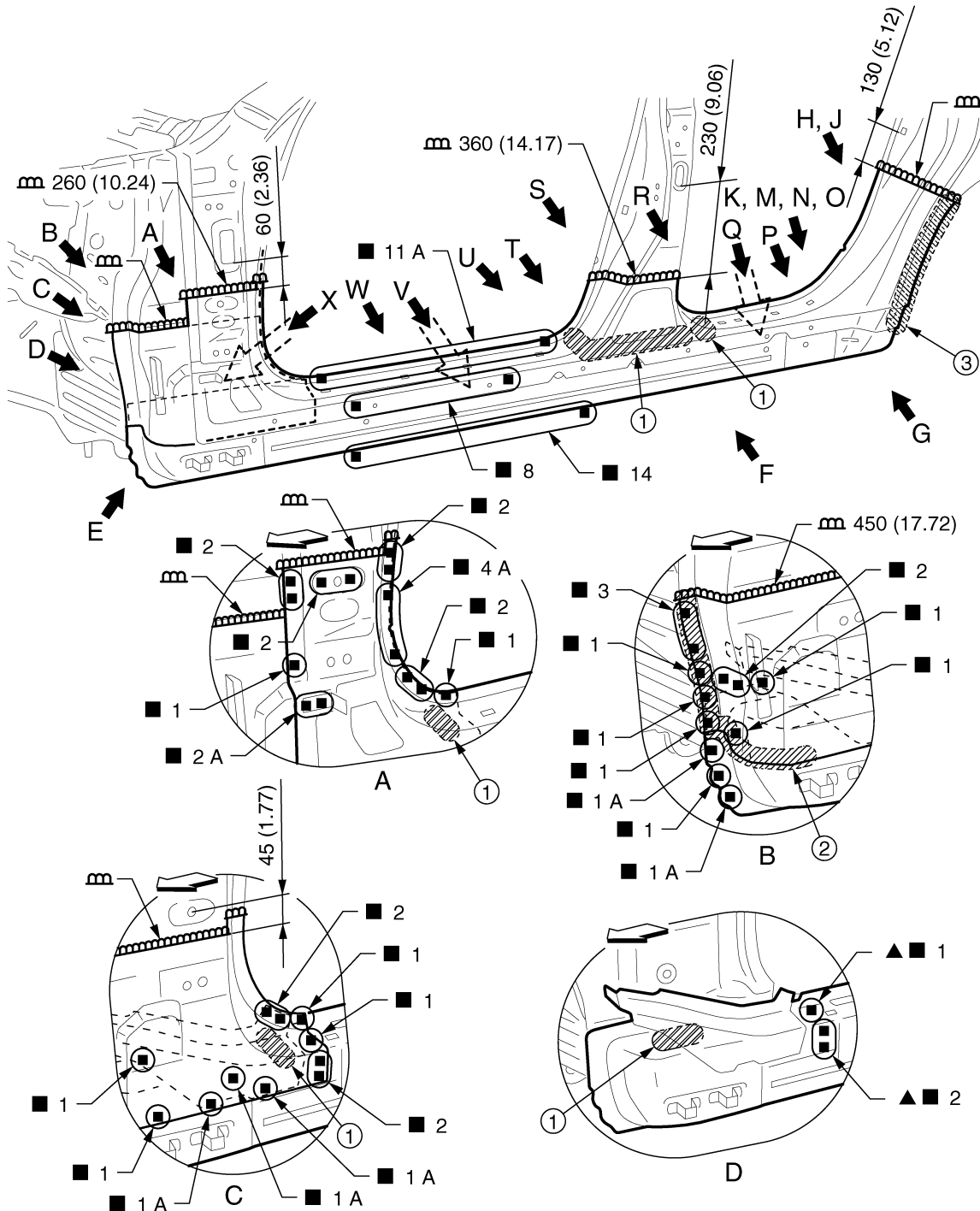

JSKIA1649GB

1. Urethane foam

2. Body sealing

3. Adhesive

Unit: mm (in)

◁: Vehicle front

▲: Drill $\phi 8$ mm (0.31 in) hole for the plug welding hole (ultra high strength steel plate).

Replacement parts

REPLACEMENT OPERATIONS

< REMOVAL AND INSTALLATION >

- Outer sill (LH)
- Outer sill reinforcement (LH)
- Outer rear wheelhouse extension (LH, Upper)
- Outer rear wheelhouse extension (LH, Lower)
- Front fender bracket

View B and C: Before installing outer sill

View D: Before installing outer sill and outer front pillar reinforcement

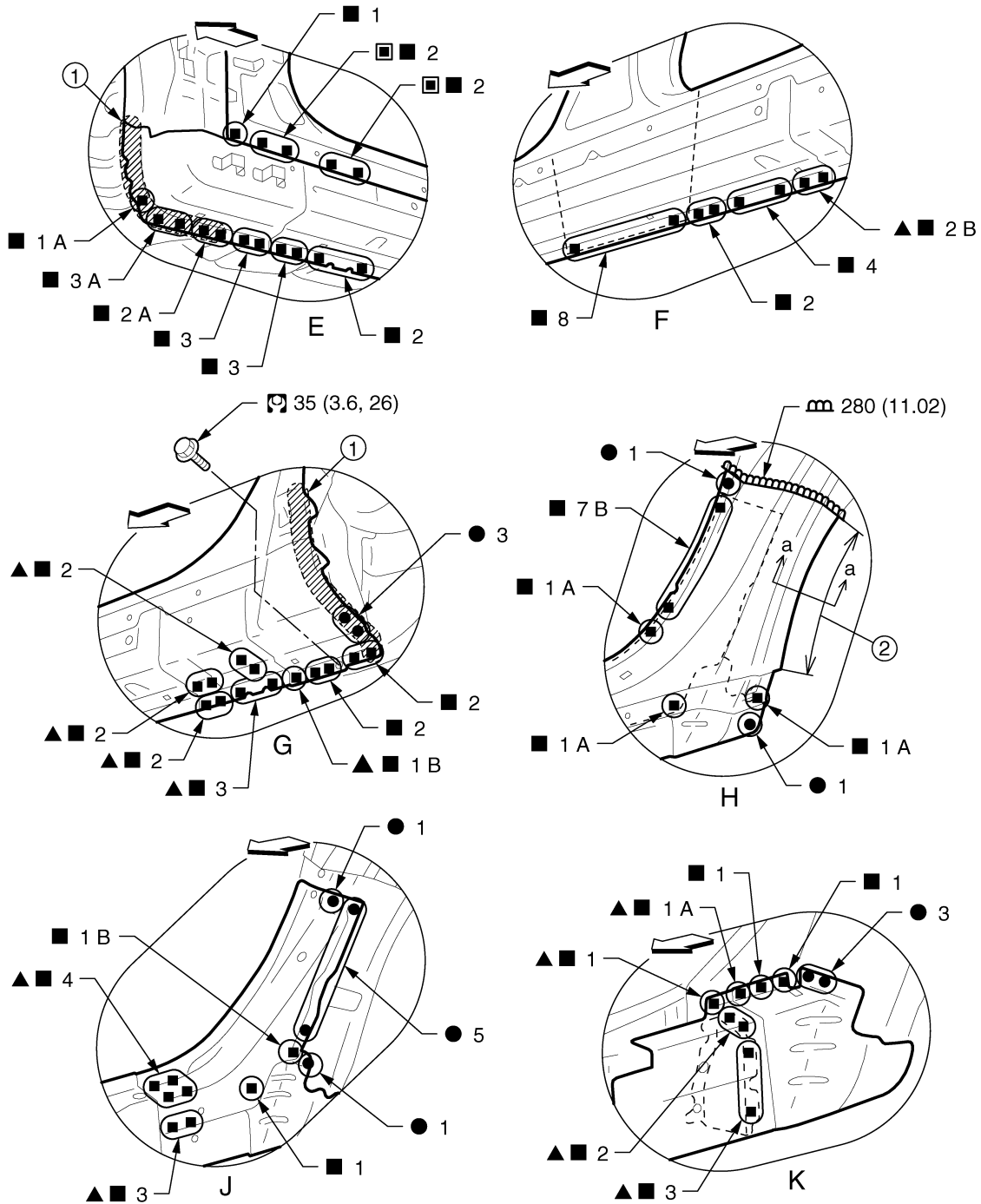

A
B
C
D
E
F
G
H
I
J
K
L
M
N
O
P

BRM

1. Body sealing

2. Hemming portion

JSKIA1650ZZ

REPLACEMENT OPERATIONS

< REMOVAL AND INSTALLATION >

Unit: mm (in)

↔: Vehicle front

■: Perform the plug welding instead of the laser welding.

▲: Drill $\phi 8$ mm (0.31 in) hole for the plug welding hole (ultra high strength steel plate).

Refer to [GI-4. "Components"](#) for symbols in the figure.

View J: Before installing outer sill

View K: Before installing outer sill, outer sill reinforcement, and outer rear wheelhouse extension (upper)

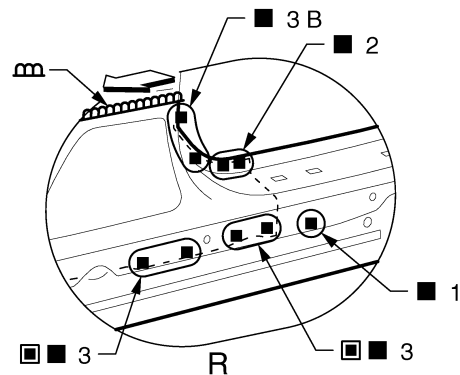
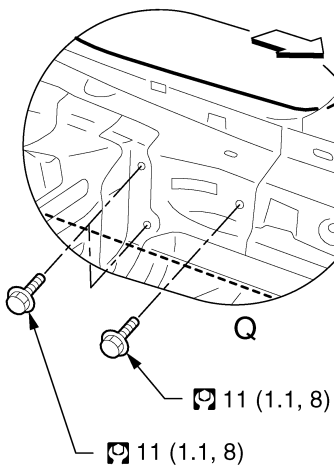
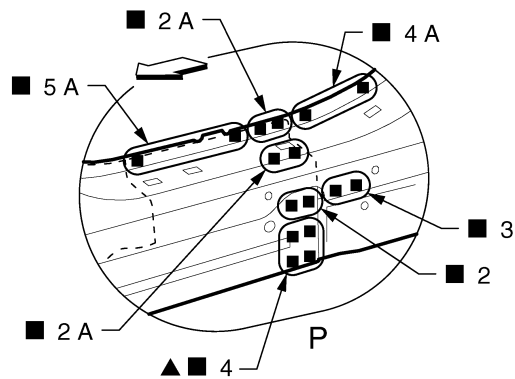
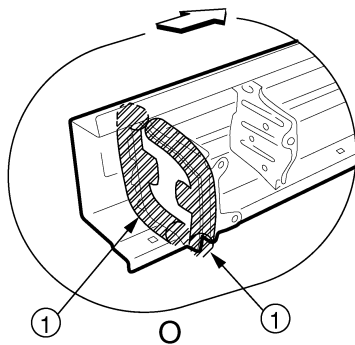
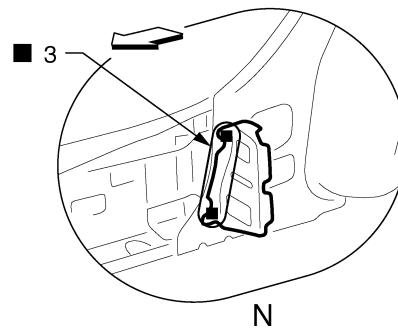
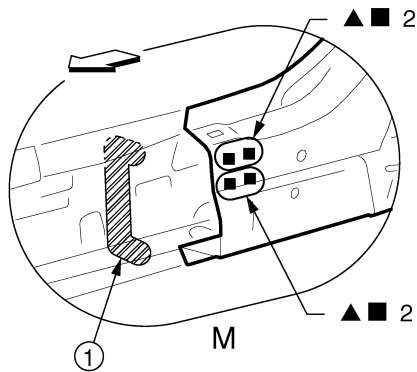

JSKIA1651GB

REPLACEMENT OPERATIONS

< REMOVAL AND INSTALLATION >

1. Urethane foam

↔: Vehicle front

■: Perform the plug welding instead of the laser welding.

▲: Drill $\phi 8$ mm (0.31 in) hole for the plug welding hole (ultra high strength steel plate).

Refer to [GI-4, "Components"](#) for symbols in the figure.

View M: Before installing outer sill and outer sill reinforcement

View N: Before installing outer sill, outer sill reinforcement, outer rear wheelhouse extension (upper), and outer rear wheelhouse extension (lower)

View O: Outer sill reinforcement (replacement parts)

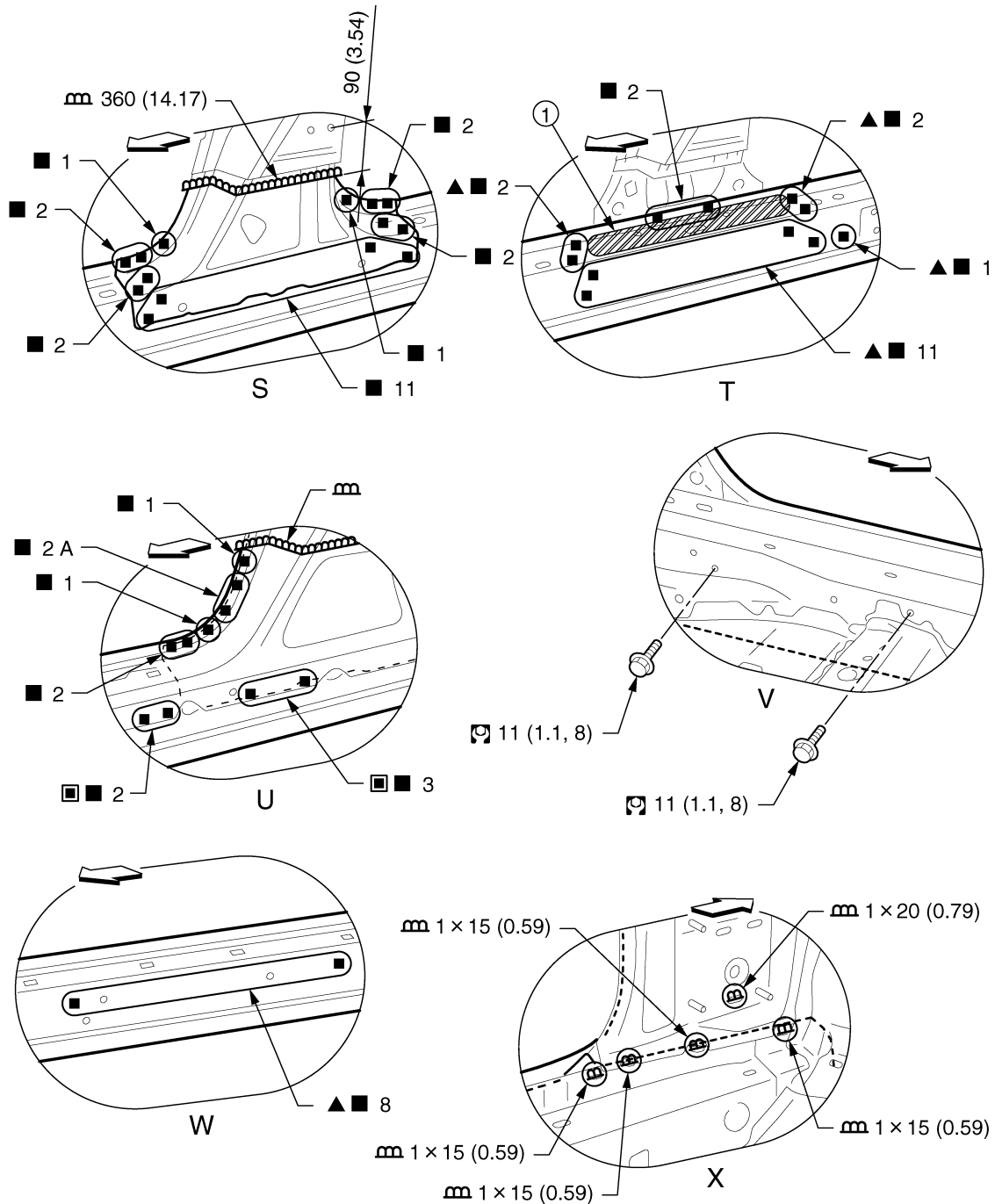

A
B
C
D
E
F
G
H
I
J
L
M
N
O
P

BRM

JSKIA1652GB

REPLACEMENT OPERATIONS

< REMOVAL AND INSTALLATION >

1. Urethane foam

Unit: mm (in)

↶: Vehicle front

■: Perform the plug welding instead of the laser welding.

▲: Drill $\phi 8$ mm (0.31 in) hole for the plug welding hole (ultra high strength steel plate).

Refer to [GI-4, "Components"](#) for symbols in the figure.

View S and W: Before installing outer sill

View T: Before installing outer sill and center pillar reinforcement

POINT

- Perform the hemming to the flange of wheelarch after applying the adhesive.
- Apply the sealing to the flange end.
- Refer to [BRM-19, "Rear Fender Hemming Process"](#).

1. Outer rear wheelhouse
2. Rear fender
3. Adhesive
4. Sealant

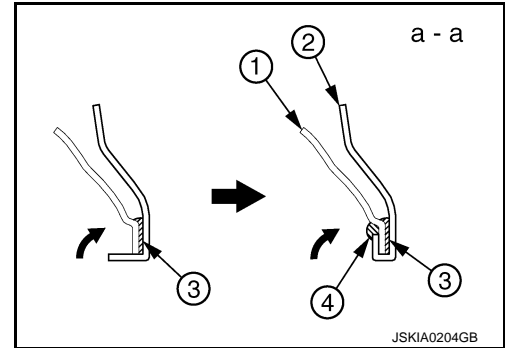

REPLACEMENT OPERATIONS

< REMOVAL AND INSTALLATION >

Rear Fender

INFOID:000000005927155

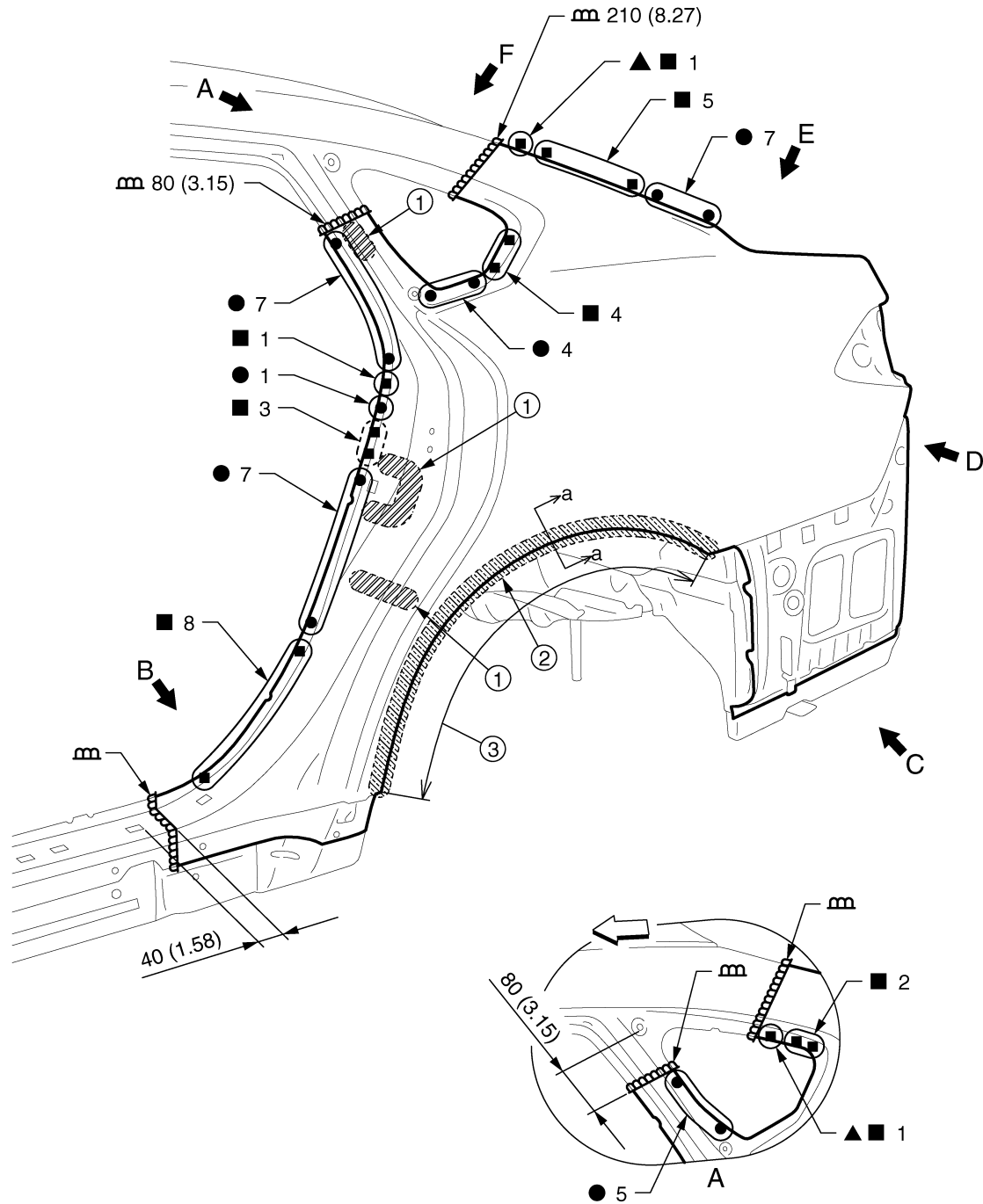

A
B
C
D
E
F
G
H
I
J
K
L
M
N
O
P

BRM

1. Urethane foam

2. Adhesive

3. Hemming portion

Unit: mm (in)

←: Vehicle front

▲: Drill $\phi 8$ mm (0.31 in) hole for the plug welding hole (ultra high strength steel plate).

○: Weld the parts onto the back of the component part.

Replacement parts

- Rear fender assembly (LH)

JSKIA1653GB

REPLACEMENT OPERATIONS

< REMOVAL AND INSTALLATION >

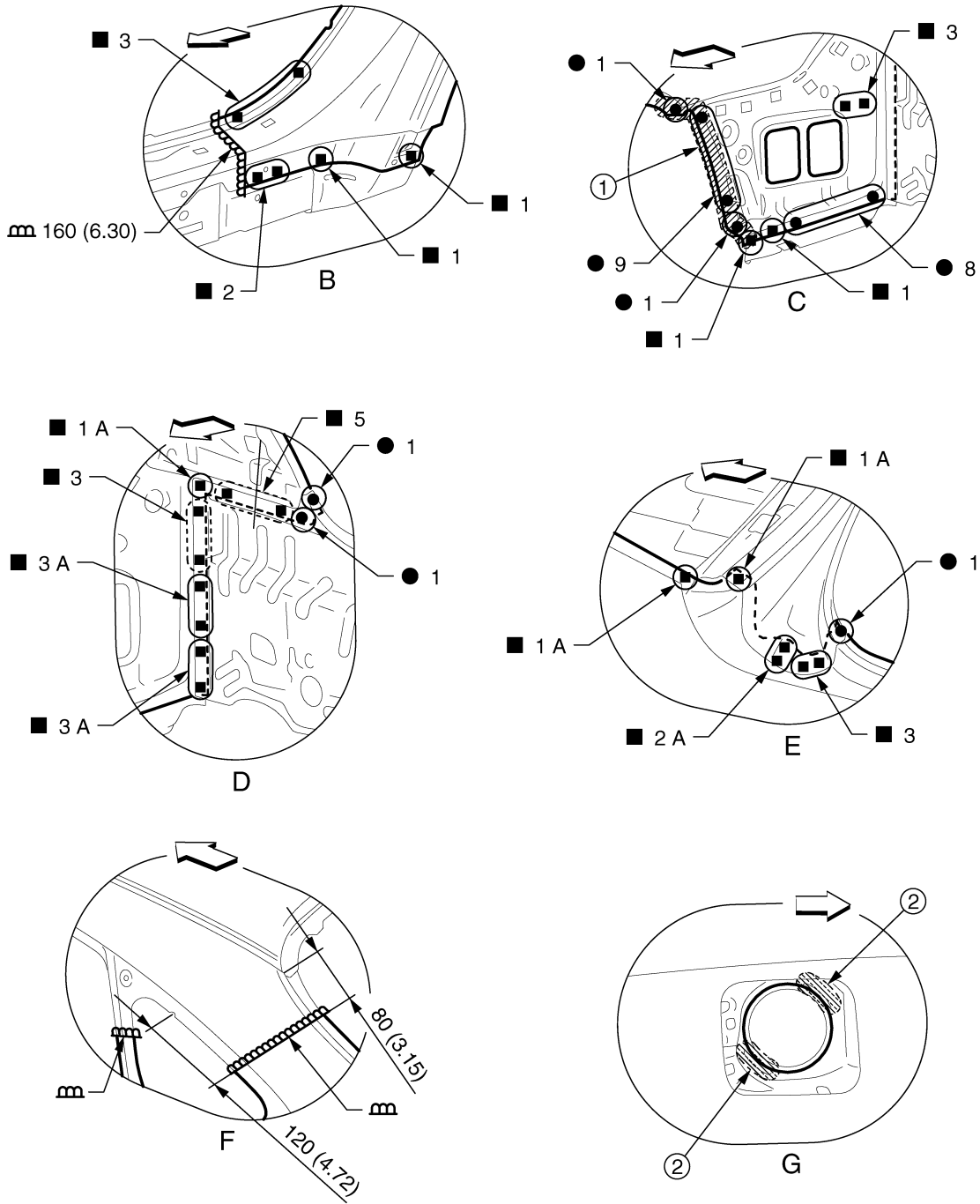

JSKIA1654GB

- 1. Body sealing
 - 2. Adhesive
- Unit: mm (in)
- ◀: Vehicle front
- ⊙: Weld the parts onto the back of the component part.

View G: Right side rear fender

POINT

REPLACEMENT OPERATIONS

< REMOVAL AND INSTALLATION >

- Perform the hemming to the flange of wheelarch after applying the adhesive.
- Apply the sealing to the flange end.
- Refer to [BRM-19. "Rear Fender Hemming Process"](#).

1. Outer rear wheelhouse
2. Rear fender
3. Adhesive
4. Sealant

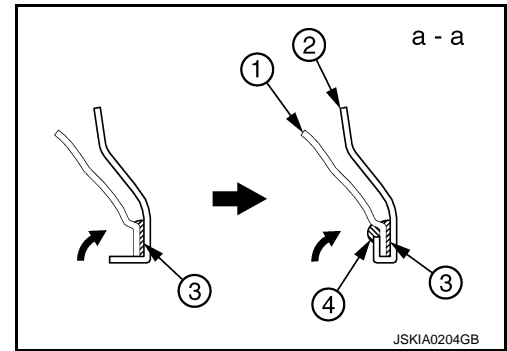

A
B
C
D
E
F
G
H
I
J
L
M
N
O
P

BRM

REPLACEMENT OPERATIONS

< REMOVAL AND INSTALLATION >

Rear Fender Extension

INFOID:000000005928006

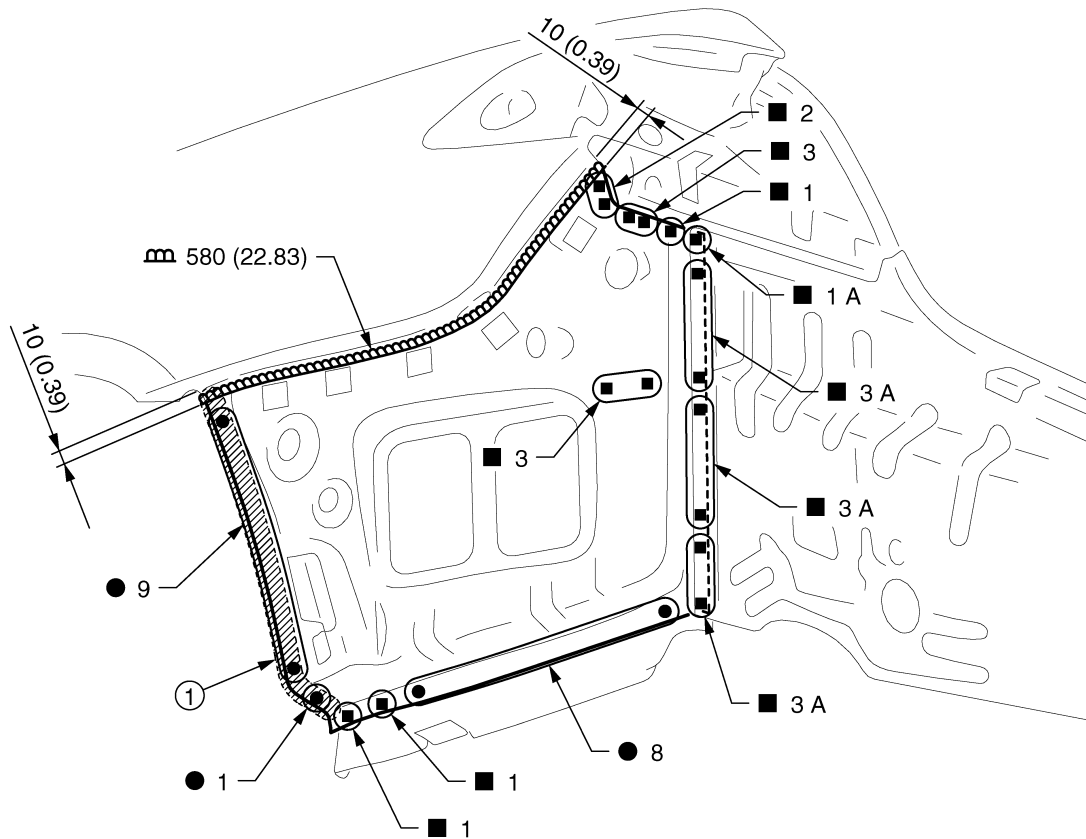

JSKIA1655GB

1. Body sealing

Unit: mm (in)

Replacement parts

- Rear fender extension (LH)

Outer Rear Wheelhouse

INFOID:000000005928005

Work after rear fender is removed.

CAUTION:

REPLACEMENT OPERATIONS

< REMOVAL AND INSTALLATION >

Refer to **SUPPLEMENTARY WORK** to replace or reuse outer rear wheelhouse.

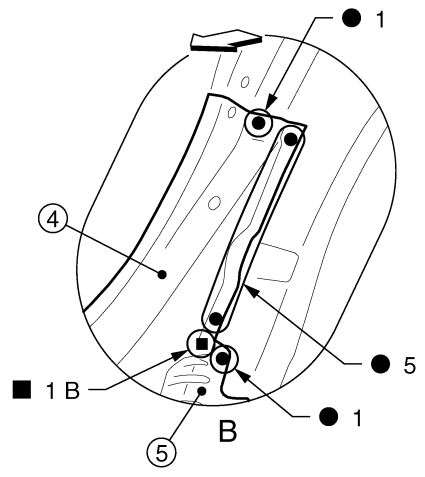
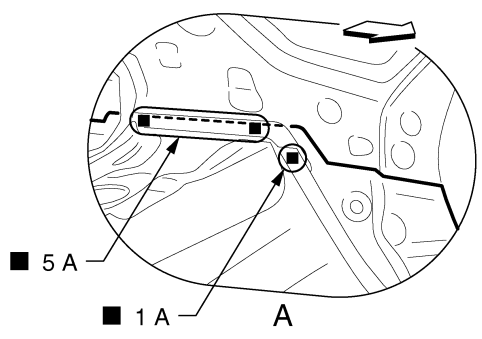
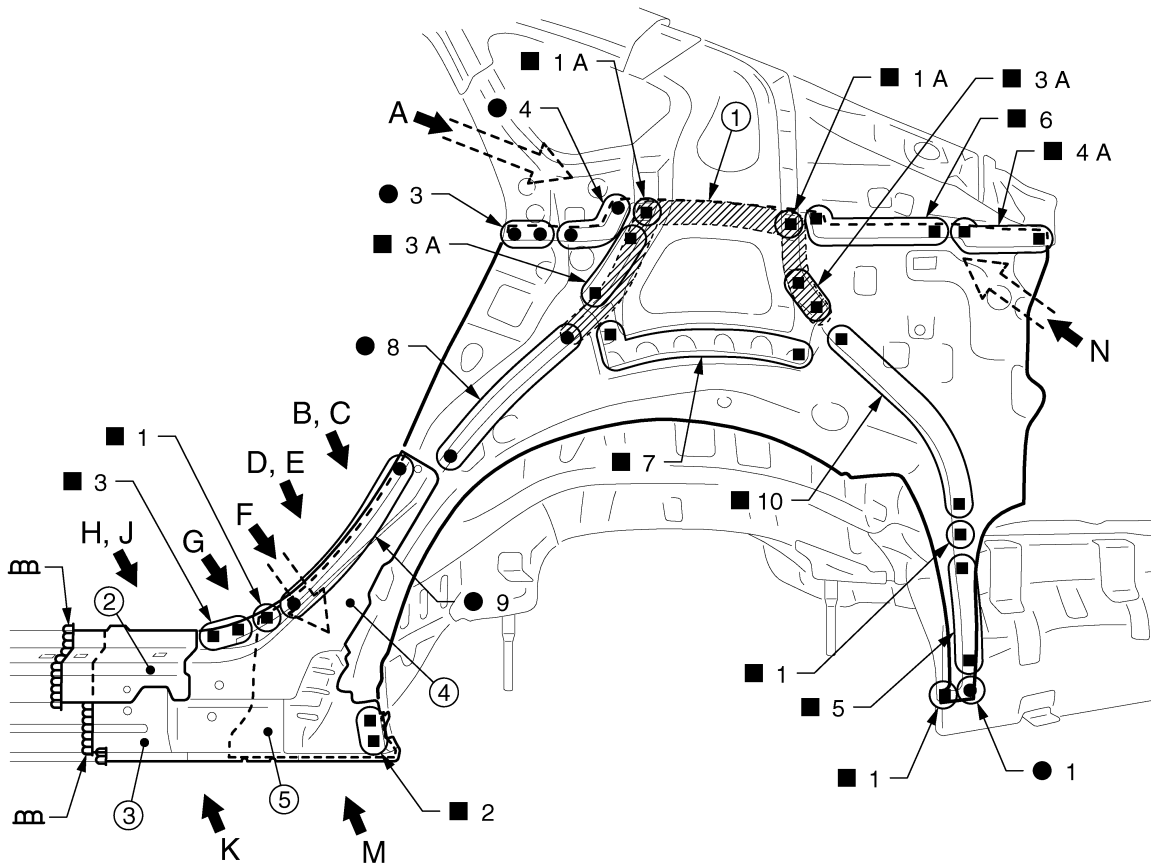

JSKIA1656ZZ

- | | | |
|--|--|-----------------------------|
| 1. Body sealing | 2. Outer front side body | 3. Outer sill reinforcement |
| 4. Outer rear wheelhouse extension (Upper) | 5. Outer rear wheelhouse extension (Lower) | |

← Vehicle front

Replacement parts

- Outer rear wheelhouse (LH)

A
B
C
D
E
F
G
H
I
J
K
L
M
N
O
P

BRM

REPLACEMENT OPERATIONS

< REMOVAL AND INSTALLATION >

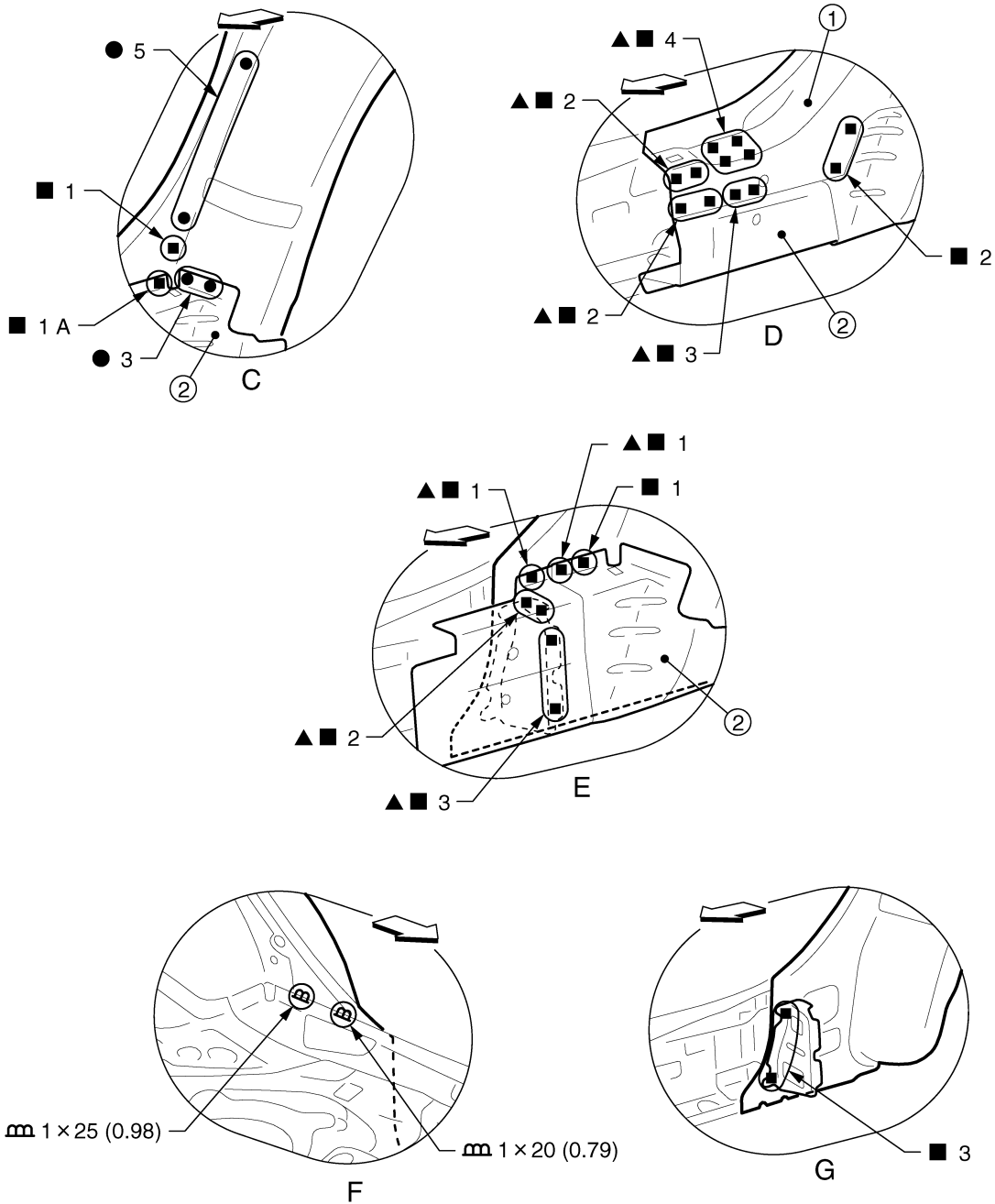

JSKIA1657GB

1. Outer rear wheelhouse extension (Upper) 2. Outer rear wheelhouse extension (Lower)

Unit: mm (in)

↔: Vehicle front

▲: Drill $\phi 8$ mm (0.31 in) hole for the plug welding hole (ultra high strength steel plate).

View C and E: Before installing outer front side body, outer sill reinforcement, and outer rear wheelhouse extension (Upper)

View D: Before installing outer front side body and outer sill reinforcement

View G: Before installing outer front side body, outer sill reinforcement, outer rear wheelhouse extension (upper), and outer rear wheelhouse extension (Lower)

REPLACEMENT OPERATIONS

< REMOVAL AND INSTALLATION >

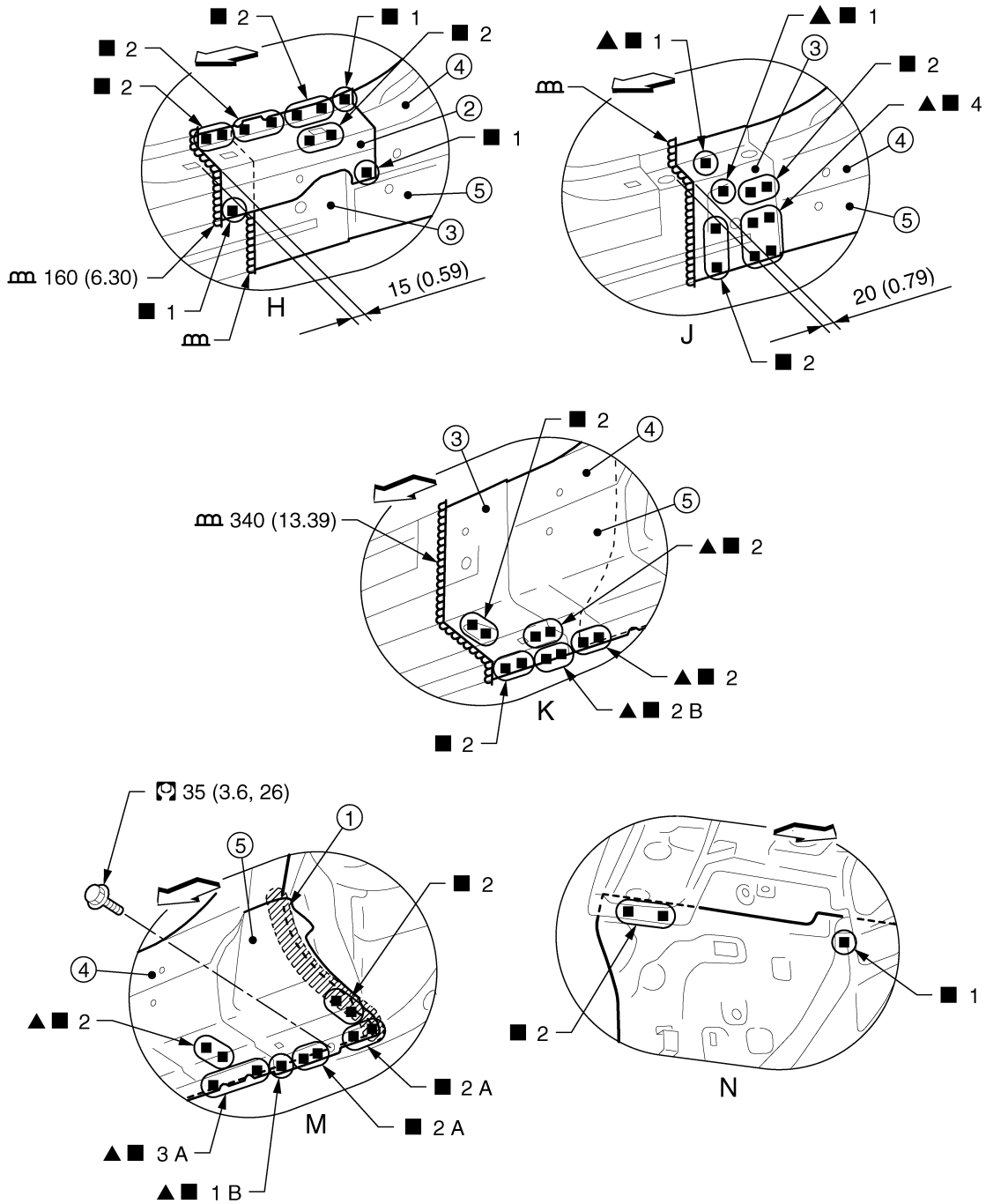

JSKIA1658GB

- | | | |
|--|--|-----------------------------|
| 1. Body sealing | 2. Outer front side body | 3. Outer sill reinforcement |
| 4. Outer rear wheelhouse extension (Upper) | 5. Outer rear wheelhouse extension (Lower) | |

Unit: mm (in)

←: Vehicle front

▲: Drill $\phi 8$ mm (0.31 in) hole for the plug welding hole (ultra high strength steel plate). Refer to [GI-4, "Components"](#) for symbols in the figure.

View J and K: Before installing outer front side body

SUPPLEMENTARY WORK

A
B
C
D
E
F
G
H
I
J
K
L
M
N
O
P

BRM

REPLACEMENT OPERATIONS

< REMOVAL AND INSTALLATION >

Remove the following parts first according to the instruction because the outer rear wheelhouse cannot be removed due to the existence of hidden welding points.

1. Cut the outer front side body as shown in the figure.

1. Cut position

Unit: mm (in)

←: Vehicle front

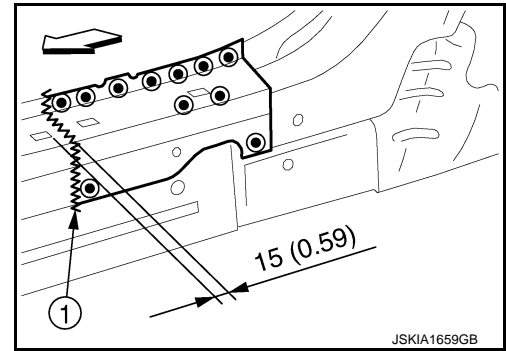

2. Cut the outer sill reinforcement as shown in the figure.

1. Cut position

Unit: mm (in)

←: Vehicle front

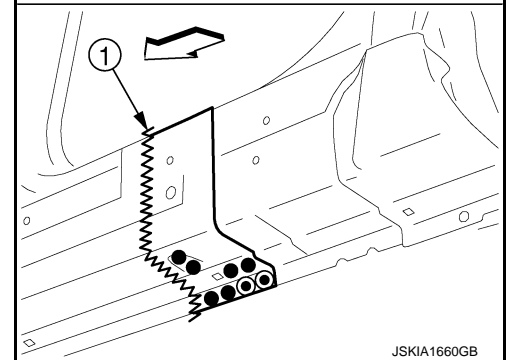
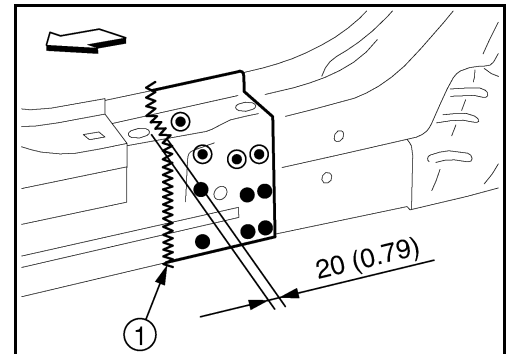

3. Remove the outer rear wheelhouse extension (Upper).

←: Vehicle front

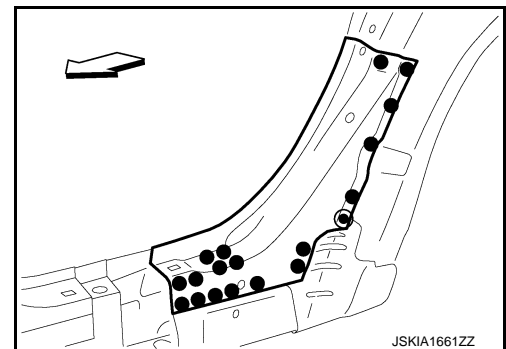

REPLACEMENT OPERATIONS

< REMOVAL AND INSTALLATION >

4. Remove the outer rear wheelhouse extension (Lower).

←: Vehicle front

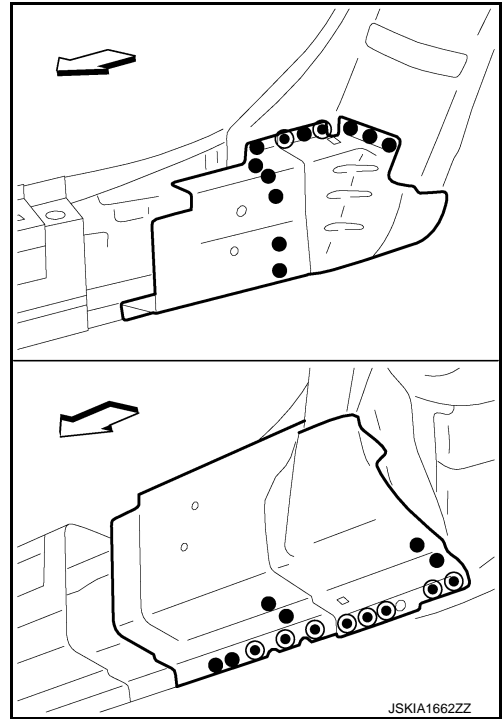

5. Remove the outer rear wheelhouse brace.

←: Vehicle front

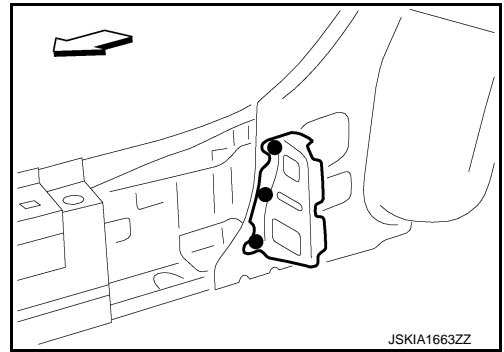

A
B
C
D
E
F
G
H
I
J
L
M
N
O
P

BRM

REPLACEMENT OPERATIONS

< REMOVAL AND INSTALLATION >

Rear Panel

INFOID:000000005927160

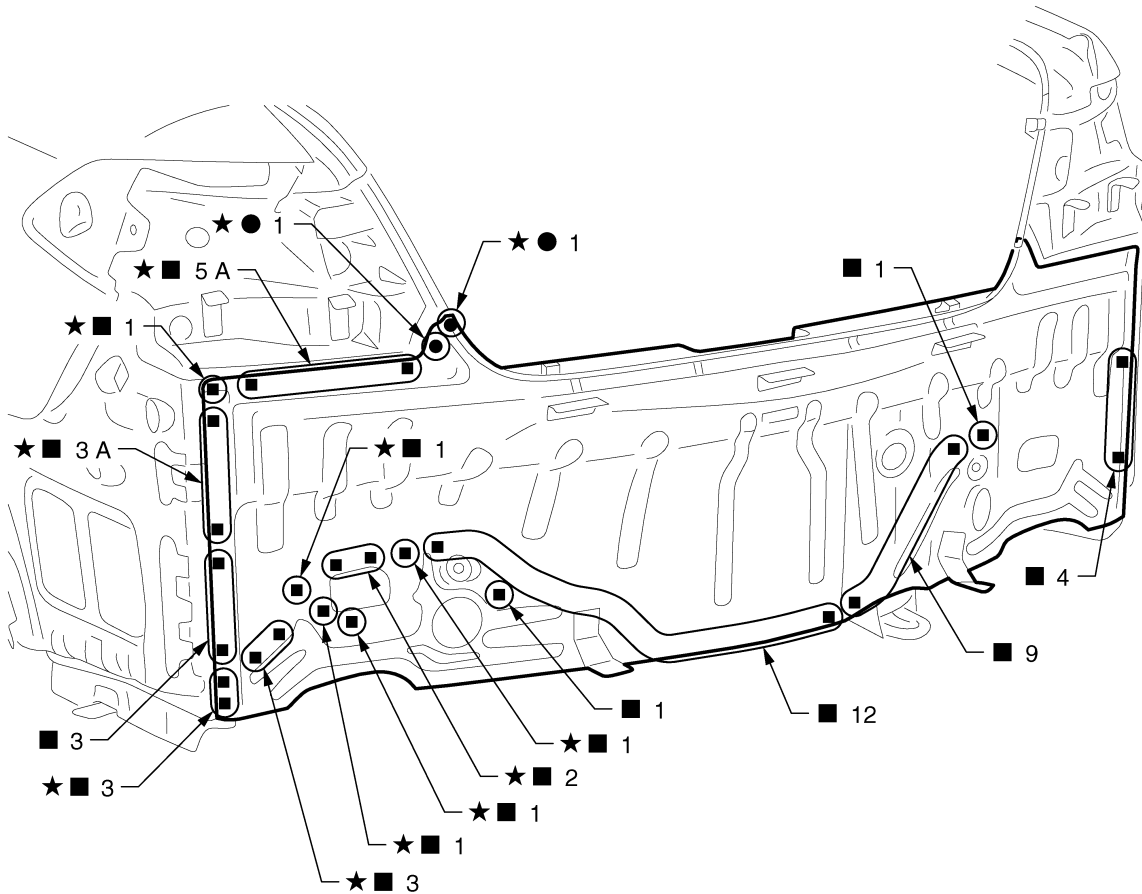

JSKIA1664ZZ

★: Welding method and the number of welding points apply to both side of the vehicle.

Replacement parts

- Rear panel assembly

Rear Floor Rear

INFOID:000000005927161

Work after rear panel is removed.

REPLACEMENT OPERATIONS

< REMOVAL AND INSTALLATION >

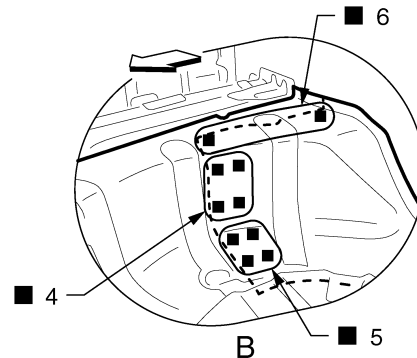
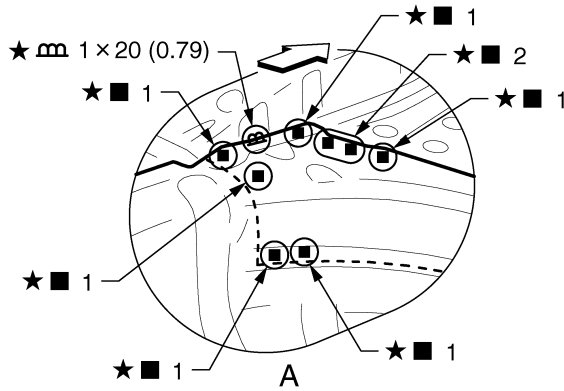
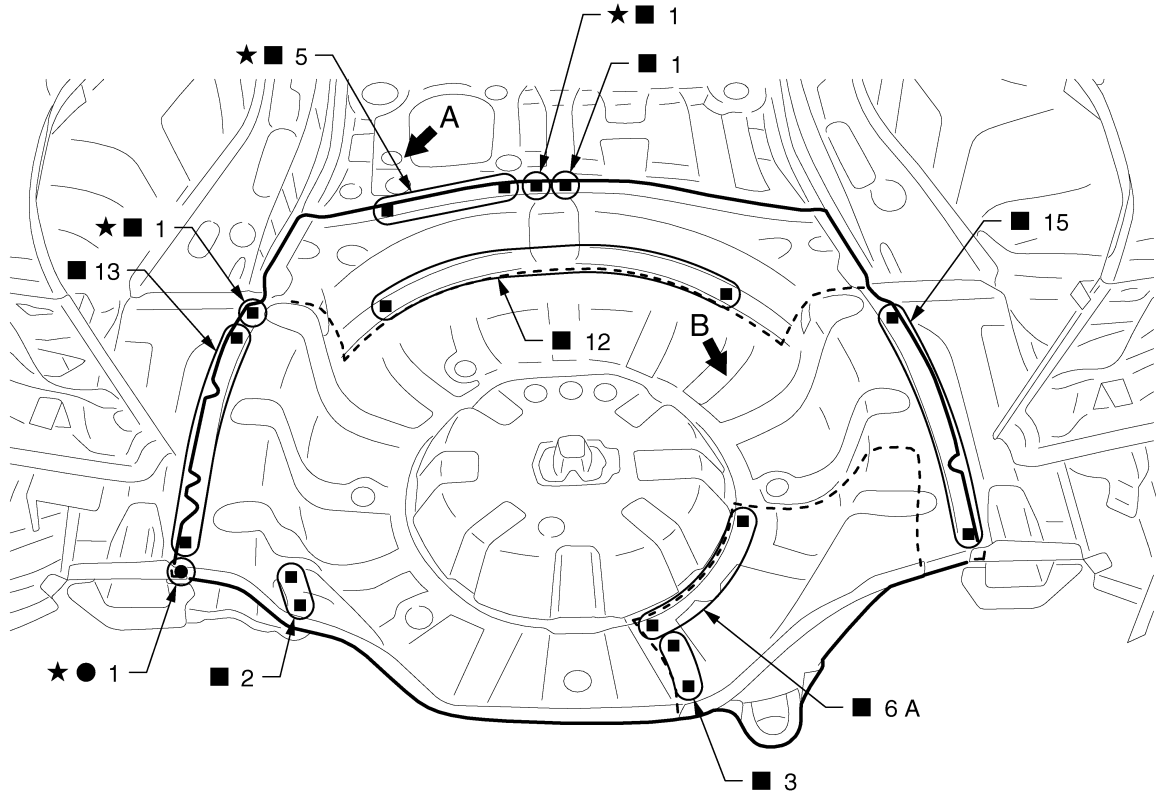

Unit: mm (in)

↔: Vehicle front

★: Welding method and the number of welding points apply to both side of the vehicle.

Replacement parts

● Rear floor rear

● Rear tie down hook

Rear Side Member Extension

Work after rear panel is removed.

JSKIA1665GB

INFOID:000000005927162

A
B
C
D
E
F
G
H
I
J
BRM
L
M
N
O
P

REPLACEMENT OPERATIONS

< REMOVAL AND INSTALLATION >

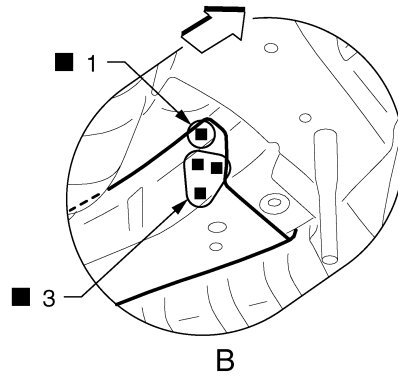
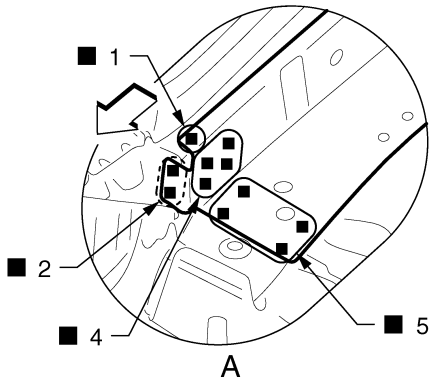
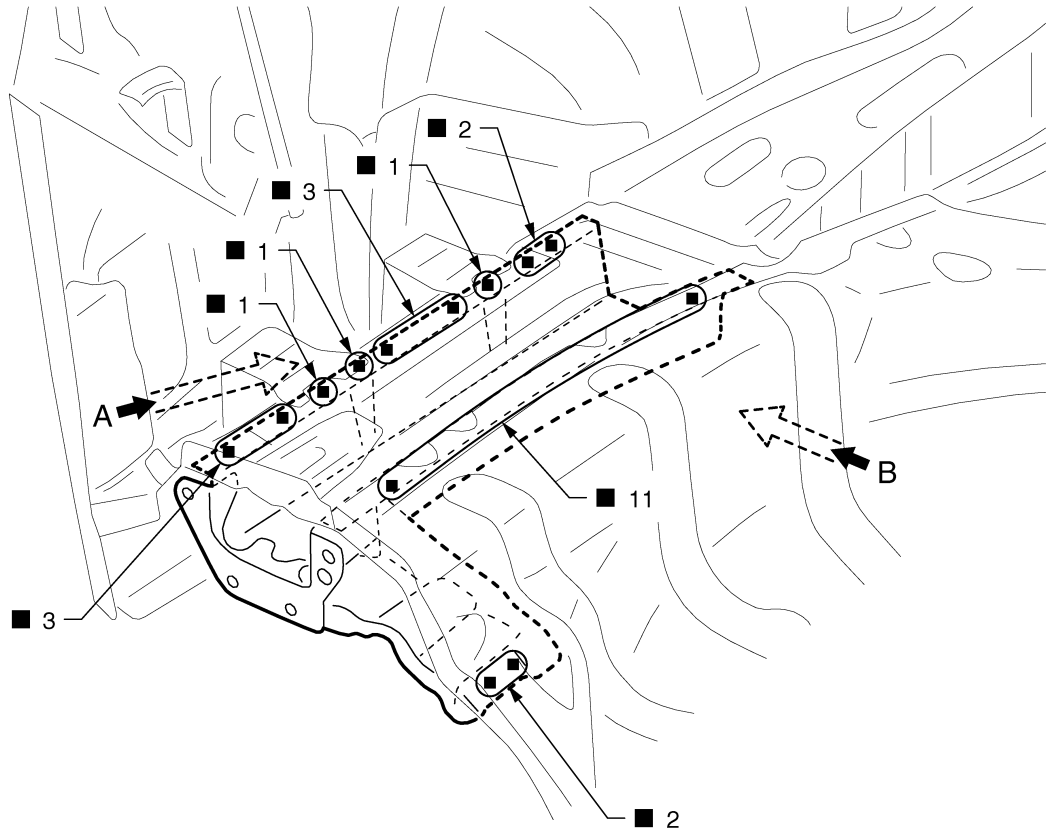

JSKIA1668ZZ

←: Vehicle front

(○): Weld the parts onto the back of the component part.

Replacement parts

- Rear side member extension assembly (LH)

BODY ALIGNMENT

< SERVICE DATA AND SPECIFICATIONS (SDS)

SERVICE DATA AND SPECIFICATIONS (SDS)

BODY ALIGNMENT

Body Center Marks

INFOID:000000005927166

A mark is placed on each part of the body to indicate the vehicle center. When repairing the vehicle frame (members, pillars, etc.) damaged by an accident which it enables more accurate and effective repair by using these marks together with body alignment specifications.

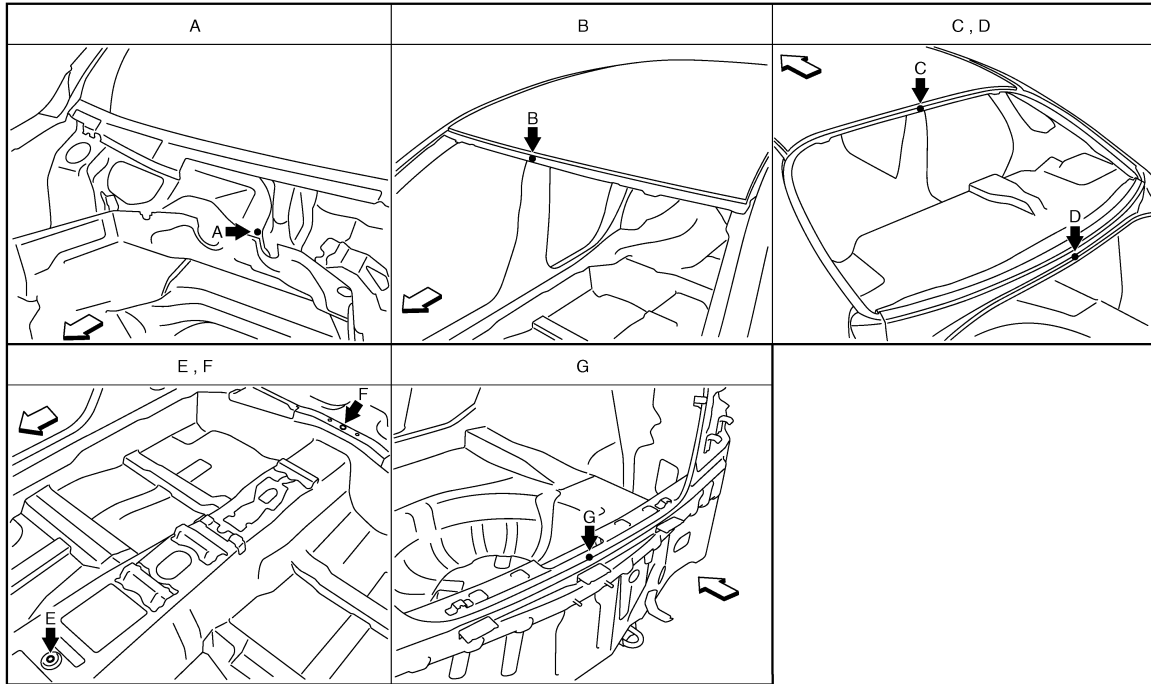
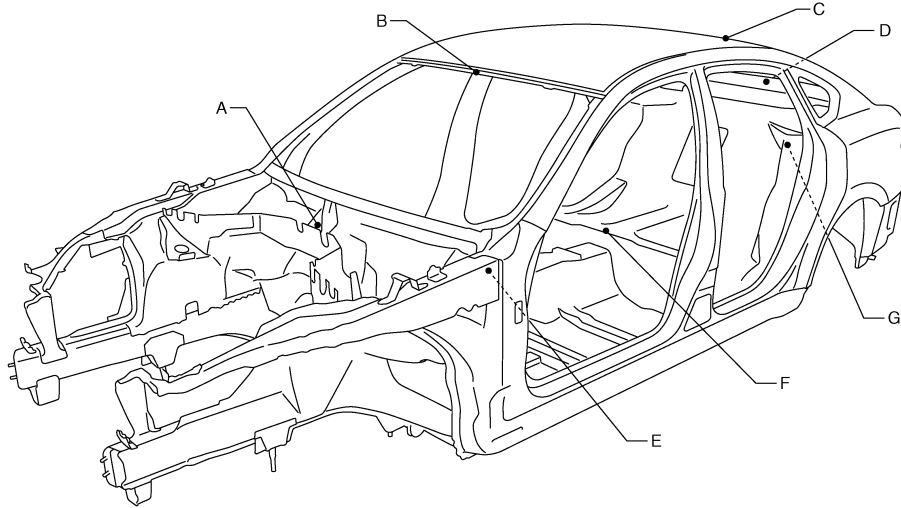

JSKIA1876ZZ

↶: Vehicle front

Unit: mm (in)

Points	Portion	Marks
A	Upper dash	Embossment
B	Front roof	Embossment
C	Rear roof	Embossment
D	Rear waist	Bead

A
B
C
D
E
F
G
H
I
J
K
L
M
N
O
P

BRM

BODY ALIGNMENT

< SERVICE DATA AND SPECIFICATIONS (SDS)

Points	Portion	Marks
E	Trans control reinforcement	Hole 14×12 (0.55×0.47)
F	Rear seat crossmember reinforcement	Hole ϕ 5 (0.20)
G	Rear panel	Indent

Description

INFOID:000000005927167

- All dimensions indicated in the figures are actual.
- When using a tracking gauge, adjust both pointers to equal length. Then check the pointers and gauge itself to make sure there is no free play.
- When a measuring tape is used, check to be sure there is no elongation, twisting or bending.
- Measurements should be taken at the center of the mounting holes.
- An asterisk (*) following the value at the measuring point indicates that the measuring point on the other side is symmetrically the same value.
- The coordinates of the measurement points are the distances measured from the standard line of "X", "Y" and "Z".
- "Z": Imaginary base line [200 mm (7.87 in) below datum line ("0Z" at design plan)]

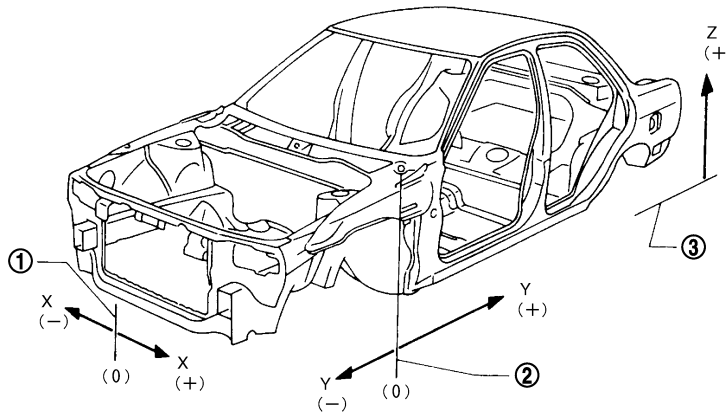

JSKIA0073GB

1. Vehicle center

2. Front axle center

3. Imaginary base line

Engine Compartment

INFOID:000000005927168

Measurement

Dimensions marked with "*" indicate symmetrically identical dimensions on both the right and left hand of the vehicle.

BODY ALIGNMENT

< SERVICE DATA AND SPECIFICATIONS (SDS)

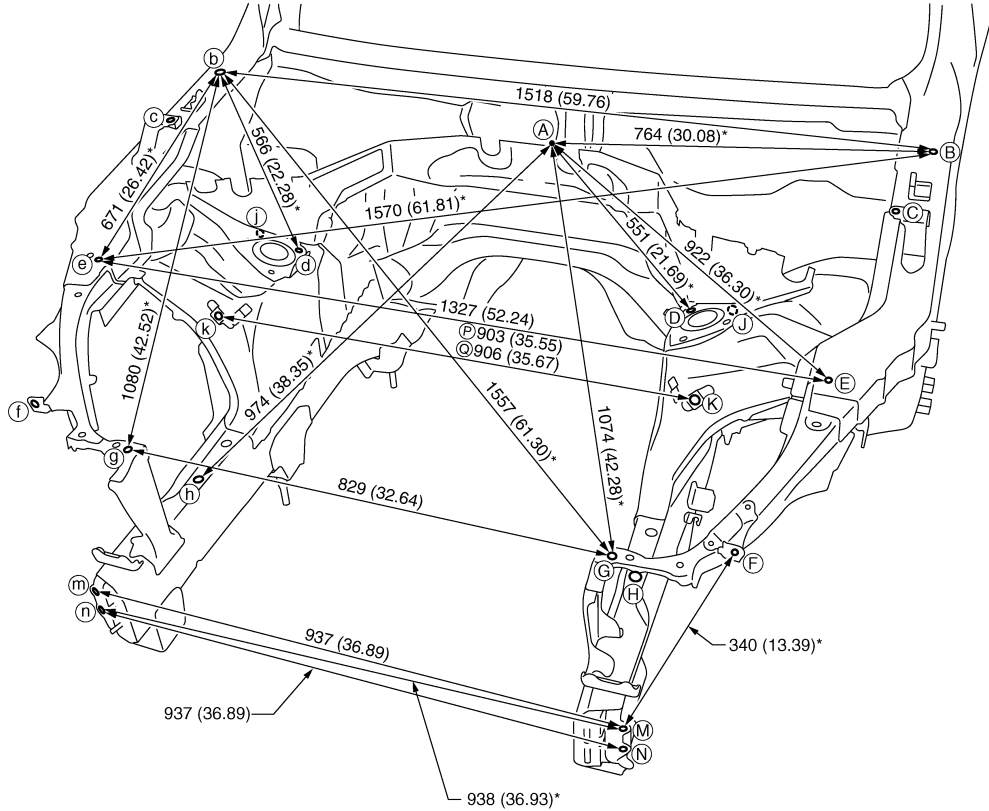

JSKIA1877GB

P. 2WD

Q. AWD

Unit: mm (in)

«The others»

Unit: mm (in)

Point	Dimension	Memo	Point	Dimension	Memo	Point	Dimension	Memo	Point	Dimension	Memo
A - C	767 (30.20)*		D - k 2WD	875 (34.45)*		E - G	442 (17.40)*		J - j 2WD	903 (35.55)	
B - d	1231 (48.46)*				E - g	1138 (44.80)*					
C - c	1431 (56.34)		D - k AWD	878 (34.57)*		F - f	1178 (46.38)		J - j AWD	906 (35.67)	
D - d	787 (30.98)				H - h	826 (32.52)					

Measurement Points

BODY ALIGNMENT

< SERVICE DATA AND SPECIFICATIONS (SDS)

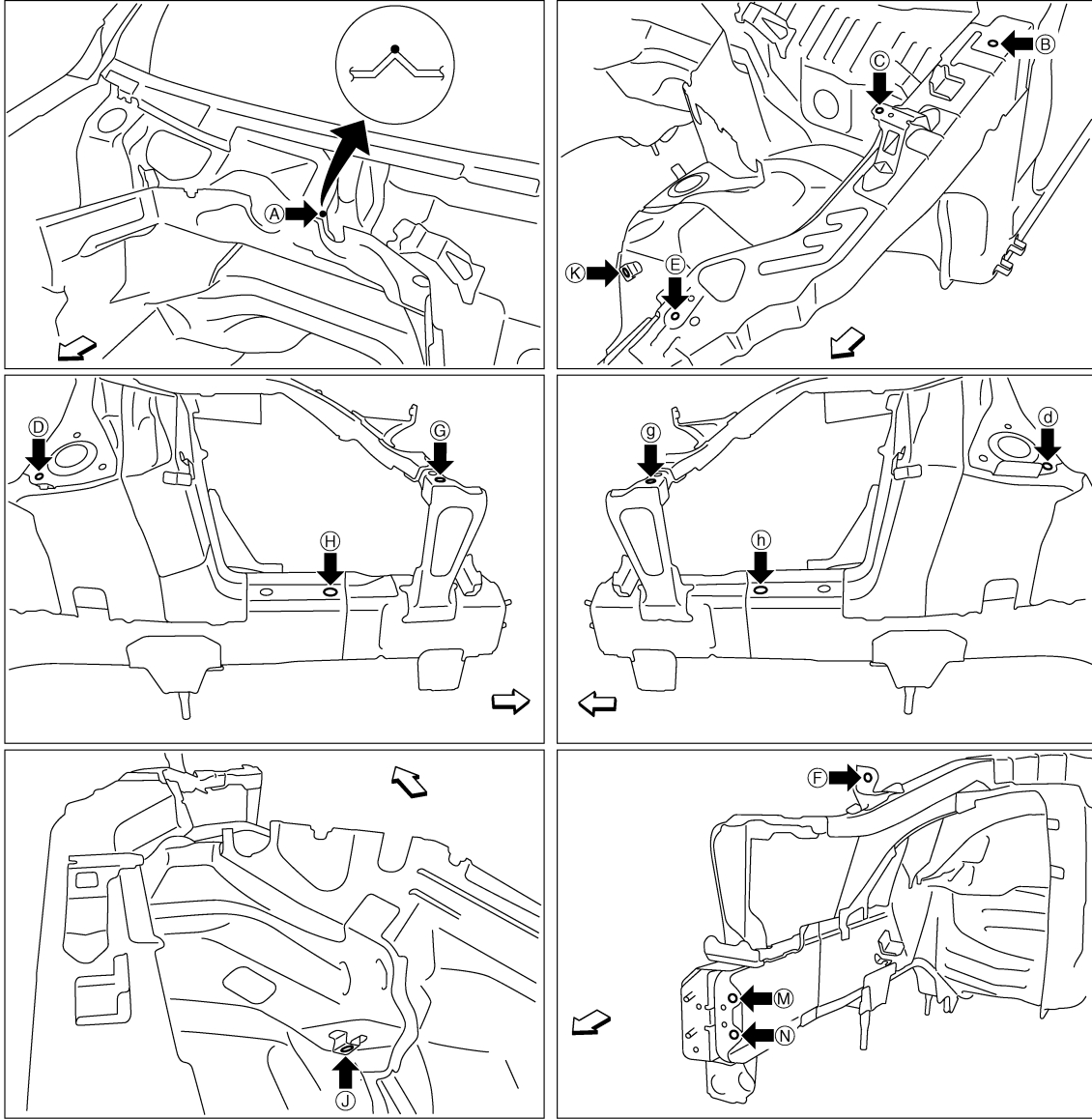

JSKIA1878ZZ

↶: Vehicle front

Unit: mm (in)

Point	Material	Point	Material
A	Upper dash positioning mark of center positioning mark	G, g	Side radiator core stay hole center $\phi 12$ (0.47)
B, b	Hood hinge installing hole center $\phi 12$ (0.47)	H, h	Front side member hole center $\phi 20$ (0.79)
C, c, F, f	Front fender installing hole center $\phi 7$ (0.28)	J, j, K, k	Nut holder hole center $\phi 16$ (0.63)
D, d	Front strut installing hole center $\phi 11$ (0.43)	M, m, N, n	Front bumper reinforcement installing hole center $\phi 11$ (0.43)
E, e	Hoodledge reinforcement hole center $\phi 7$ (0.28)		

Underbody (2WD)

INFOID:000000006044185

Measurement

Dimensions marked with "*" indicate symmetrically identical dimensions on both the right and left hand of the vehicle.

BODY ALIGNMENT

< SERVICE DATA AND SPECIFICATIONS (SDS)

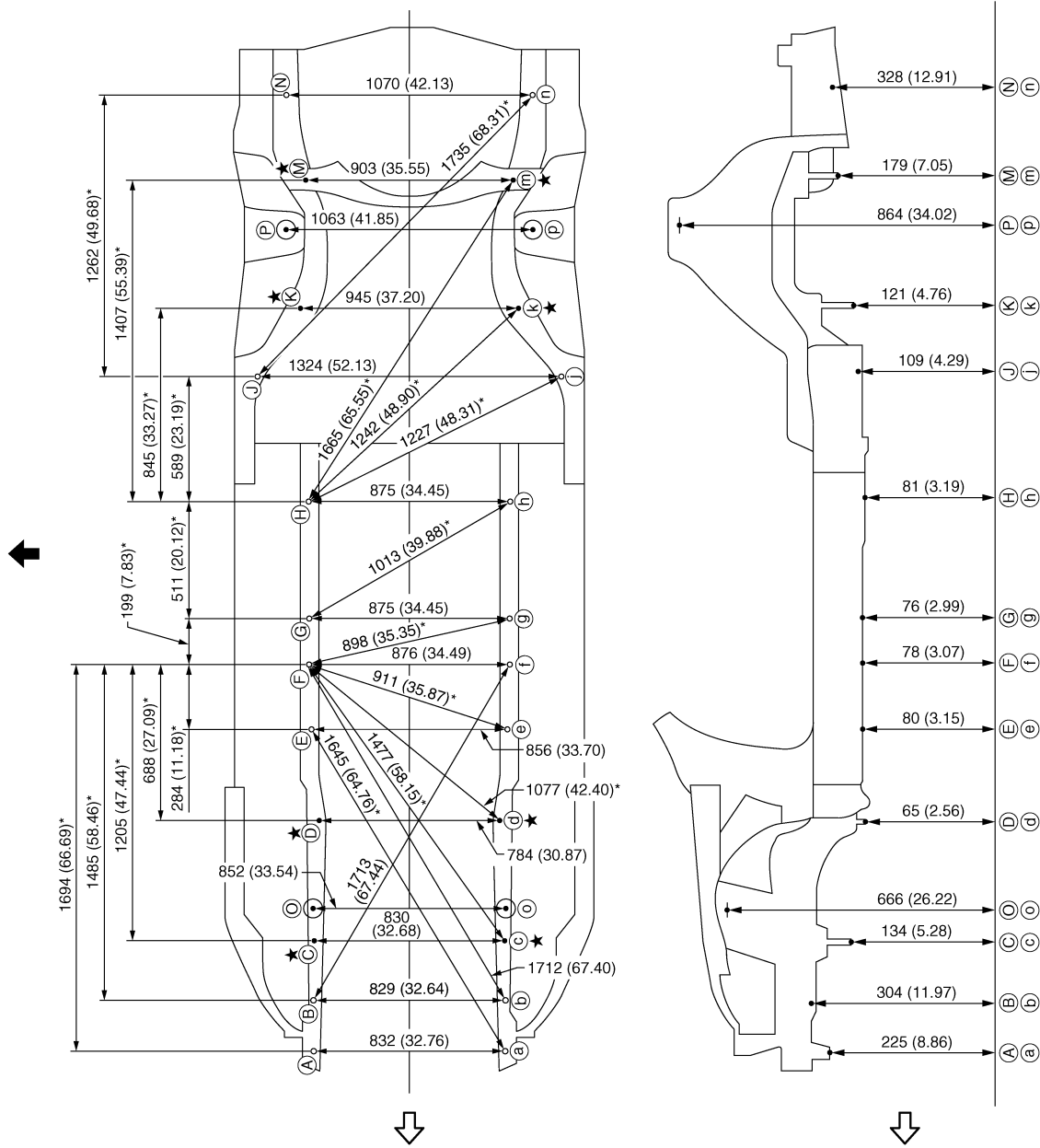

A
B
C
D
E
F
G
H
I
J
K
L
M
N
O
P

BRM

- Unit: mm (in)
- ↔: Vehicle front
- ↔: Vehicle left side
- ★: Bolt head

Measurement Points

BODY ALIGNMENT

< SERVICE DATA AND SPECIFICATIONS (SDS)

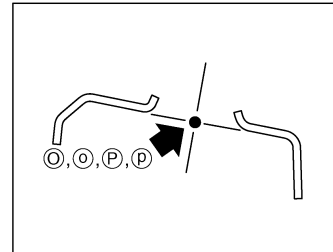
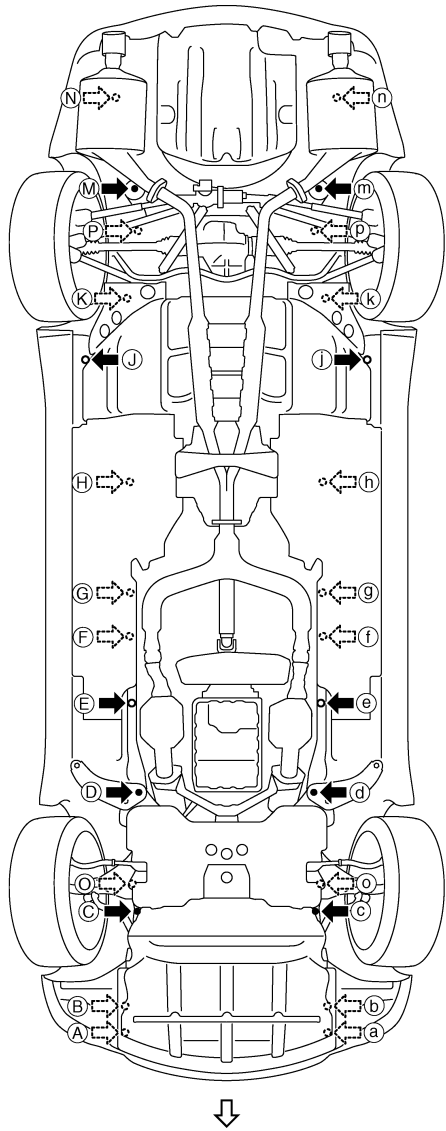

JSKIA1879ZZ

←: Vehicle front

BODY ALIGNMENT

< SERVICE DATA AND SPECIFICATIONS (SDS)

Unit: mm (in)

Points	Coordinates			Remarks	Points	Coordinates			Remarks
	X	Y	Z			X	Y	Z	
A, a	±415.8 (±16.370)	-588.0 (-23.150)	224.6 (8.843)	Hole φ13 (0.51)	H, h	±437.5 (±17.224)	1810.0 (71.260)	81.2 (3.197)	Hole φ16 (0.63)
B	416.2 (16.386)	-368.0 (-14.488)	303.5 (11.949)	Hole φ16 (0.63)	J, j	±662.0 (±26.063)	2354.0 (92.677)	108.5 (4.272)	Hole φ8 (0.31)
b	-413.0 (-16.260)	-368.0 (-14.488)	303.5 (11.949)	Hole φ16 (0.63)	K, k	±472.6 (±18.606)	2653.8 (104.480)	120.8 (4.756)	Bolt head
C, c	±415.0 (±16.339)	-104.0 (-4.094)	133.5 (5.256)	Bolt head	M, m	±451.5 (±17.776)	3213.9 (126.531)	179.0 (7.047)	Bolt head
D, d	±392.0 (±15.433)	414.0 (16.299)	64.5 (2.539)	Bolt head	N, n	±535.0 (±21.063)	3590.0 (141.338)	328.3 (12.925)	Hole 18×16 (0.71×0.63)
E, e	±428.0 (±16.850)	816.6 (32.150)	80.0 (3.150)	Hole 18×16 (0.71×0.63)	O, o	±426.1 (±16.776)	37.1 (1.461)	665.8 (26.213)	Hole φ50.1 (1.972)
F, f	±438.0 (±17.244)	1100.0 (43.307)	78.0 (3.071)	Hole φ16 (0.63)	P, p	±531.3 (±20.917)	2995.8 (117.945)	864.1 (34.020)	Hole φ68 (2.677)
G, g	±437.5 (±17.224)	1299.0 (51.142)	76.0 (2.992)	Hole φ16 (0.63)					

Underbody (AWD)

INFOID:000000006044186

Measurement

Dimensions marked with "*" indicate symmetrically identical dimensions on both the right and left hand of the vehicle.

A
B
C
D
E
F
G
H
I
J

BRM

L
M
N
O
P

BODY ALIGNMENT

< SERVICE DATA AND SPECIFICATIONS (SDS)

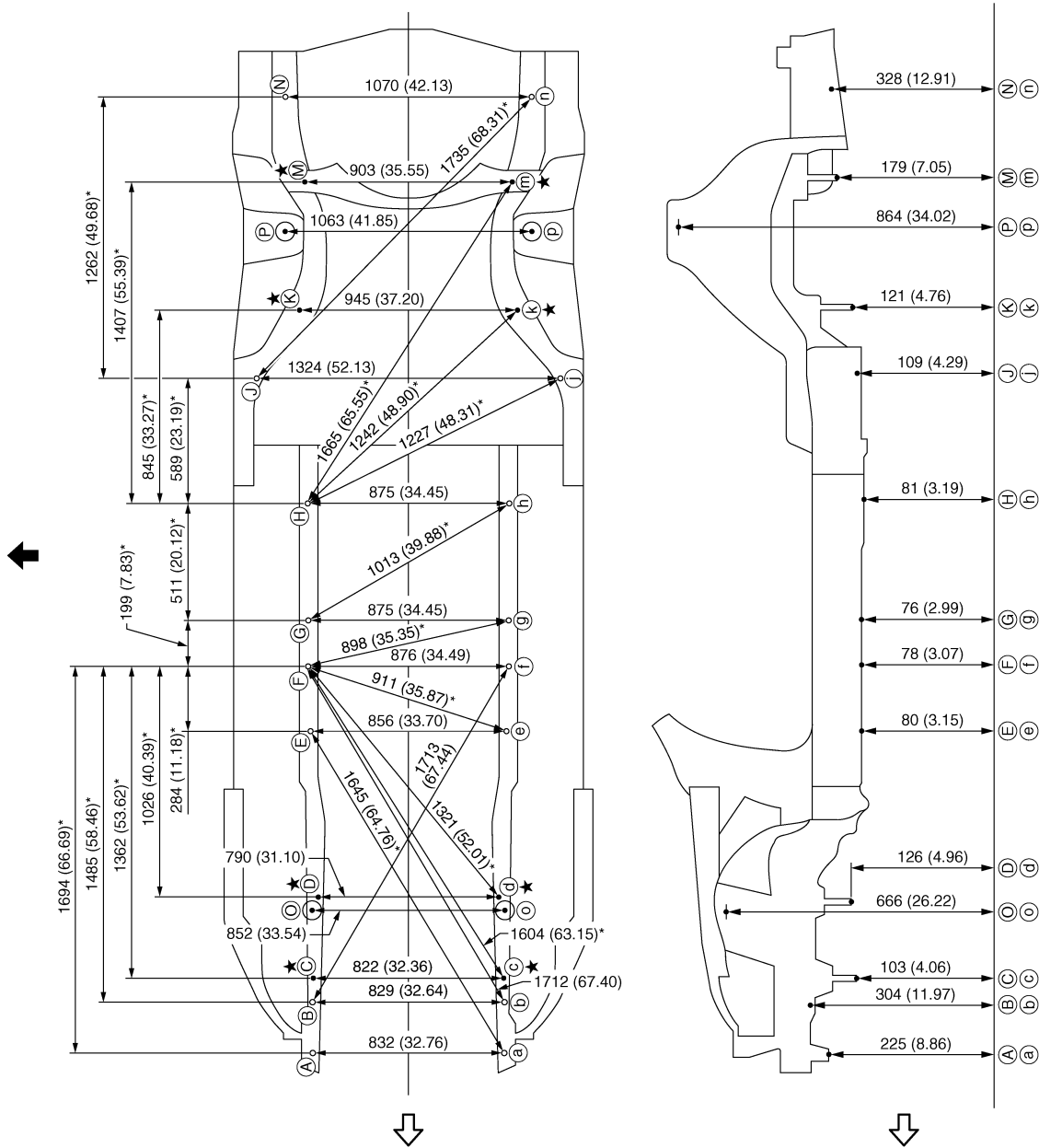

JSKIA1617GB

Unit: mm (in)

↳ Vehicle front

← Vehicle left side

★ Bolt head

Measurement Points

BODY ALIGNMENT

< SERVICE DATA AND SPECIFICATIONS (SDS)

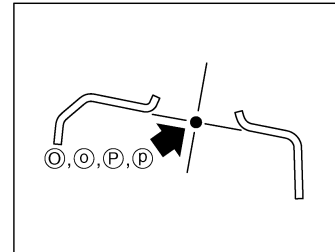
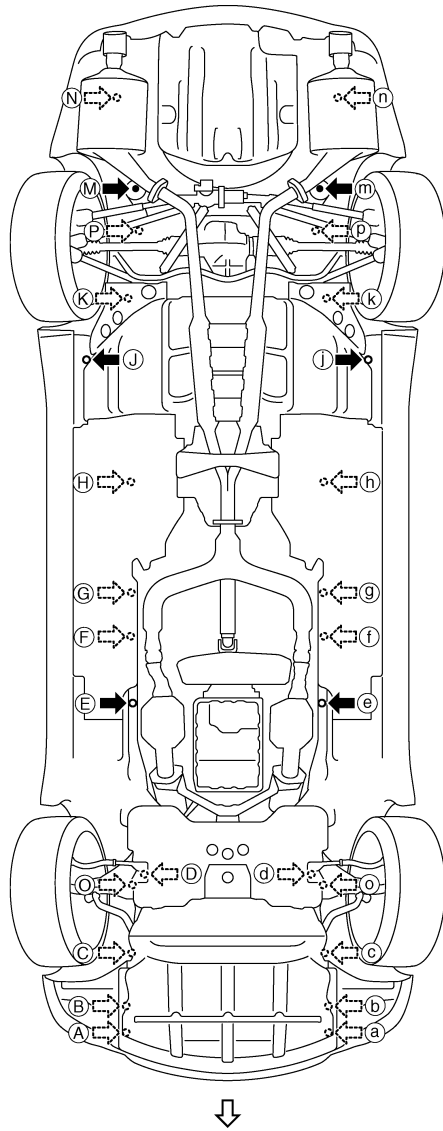

←: Vehicle front

JSKIA1880ZZ

A
B
C
D
E
F
G
H
I
J
K
L
M
N
O
P

BRM

BODY ALIGNMENT

< SERVICE DATA AND SPECIFICATIONS (SDS)

Unit: mm (in)

Points	Coordinates			Remarks	Points	Coordinates			Remarks
	X	Y	Z			X	Y	Z	
A, a	±415.8 (±16.370)	-588.0 (-23.150)	224.6 (8.843)	Hole φ13 (0.51)	H, h	±437.5 (±17.224)	1810.0 (71.260)	81.2 (3.197)	Hole φ16 (0.63)
B	416.2 (16.386)	-368.0 (-14.488)	303.5 (11.949)	Hole φ16 (0.63)	J, j	±662.0 (±26.063)	2354.0 (92.677)	108.5 (4.272)	Hole φ8 (0.31)
b	-413.0 (-16.260)	-368.0 (-14.488)	303.5 (11.949)	Hole φ16 (0.63)	K, k	±472.6 (±18.606)	2653.8 (104.480)	120.8 (4.756)	Bolt head
C, c	±411.0 (±16.181)	-261.0 (-10.276)	103.3 (4.067)	Bolt head	M, m	±451.5 (±17.776)	3213.9 (126.531)	179.0 (7.047)	Bolt head
D, d	±395.0 (±15.551)	76.0 (2.992)	126.3 (4.972)	Bolt head	N, n	±535.0 (±21.063)	3590.0 (141.338)	328.3 (12.925)	Hole 18×16 (0.71×0.63)
E, e	±428.0 (±16.850)	816.6 (32.150)	80.0 (3.150)	Hole 18×16 (0.71×0.63)	O, o	±426.1 (±16.776)	37.1 (1.461)	665.8 (26.213)	Hole φ50.1 (1.972)
F, f	±438.0 (±17.244)	1100.0 (43.307)	78.0 (3.071)	Hole φ16 (0.63)	P, p	±531.3 (±20.917)	2995.8 (117.945)	864.1 (34.020)	Hole φ68 (2.677)
G, g	±437.5 (±17.224)	1299.0 (51.142)	76.0 (2.992)	Hole φ16 (0.63)					

Passenger Compartment

INFOID:000000005927170

Measurement

Dimensions marked with "*" indicate symmetrically identical dimensions on both the right and left hand of the vehicle.

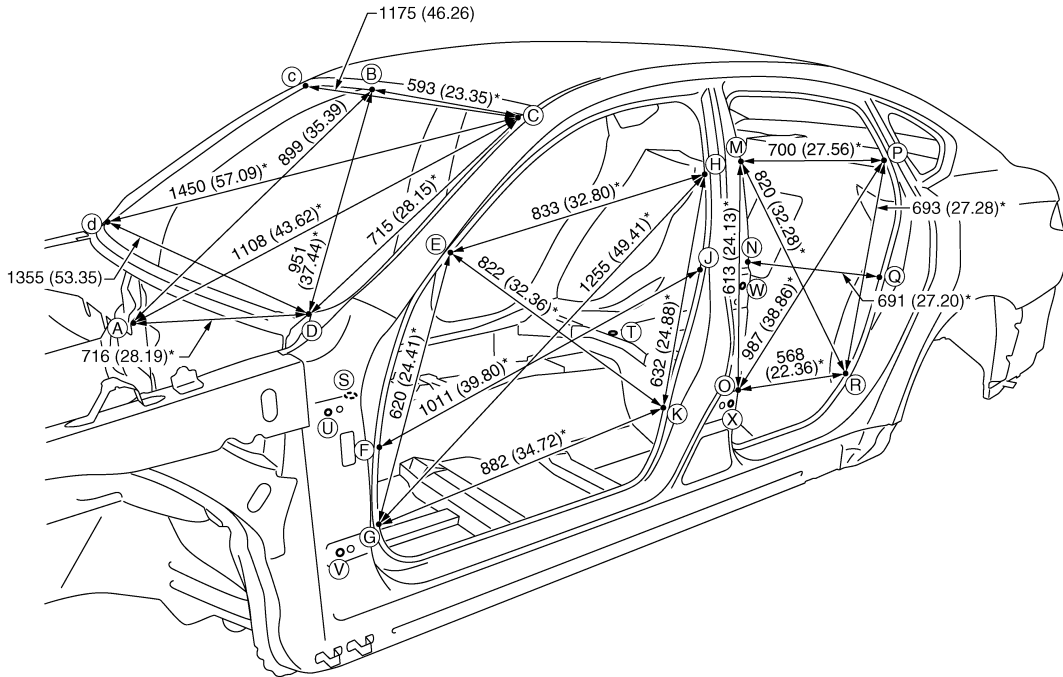

JSKIA1622GB

Unit: mm (in)

BODY ALIGNMENT

< SERVICE DATA AND SPECIFICATIONS (SDS)

«The others»

Unit: mm (in)

Point	Dimension	Memo	Point	Dimension	Memo	Point	Dimension	Memo	Point	Dimension	Memo
E - e	1431 (56.34)		J - j	1485 (58.46)		P - p	1338 (52.68)		T - N	871 (34.29)*	
E - g	1597 (62.87)*		K - k	1501 (59.09)		P - r	1586 (62.44)*		T - O	796 (31.34)*	
E - h	1627 (64.05)*		M - m	1361 (53.58)		Q - q	1468 (57.80)		T - P	1076 (42.36)*	
E - k	1681 (66.18)*		M - o	1555 (61.22)*		R - r	1522 (59.92)		T - Q	923 (36.34)*	
F - f	1494 (58.82)		M - p	1521 (59.88)*		S - E	930 (36.61)*		T - R	821 (32.32)*	
F - j	1800 (70.87)*		M - r	1657 (65.24)*		S - F	766 (30.16)*		U - W	1220 (48.03)*	
G - g	1513 (59.57)		N - n	1485 (58.46)		S - G	758 (29.84)*		U - X	1206 (47.48)*	
G - h	1908 (75.12)*		N - q	1630 (64.17)*		S - H	1390 (54.72)*		V - W	1278 (50.31)*	
G - k	1746 (68.74)*		O - o	1501 (59.09)		S - J	1279 (50.35)*		V - X	1183 (46.57)*	
H - h	1365 (53.74)		O - p	1727 (67.99)*		S - K	1125 (44.29)*				
H - k	1565 (61.61)*		O - r	1614 (63.54)*		T - M	968 (38.11)*				

Measurement Points

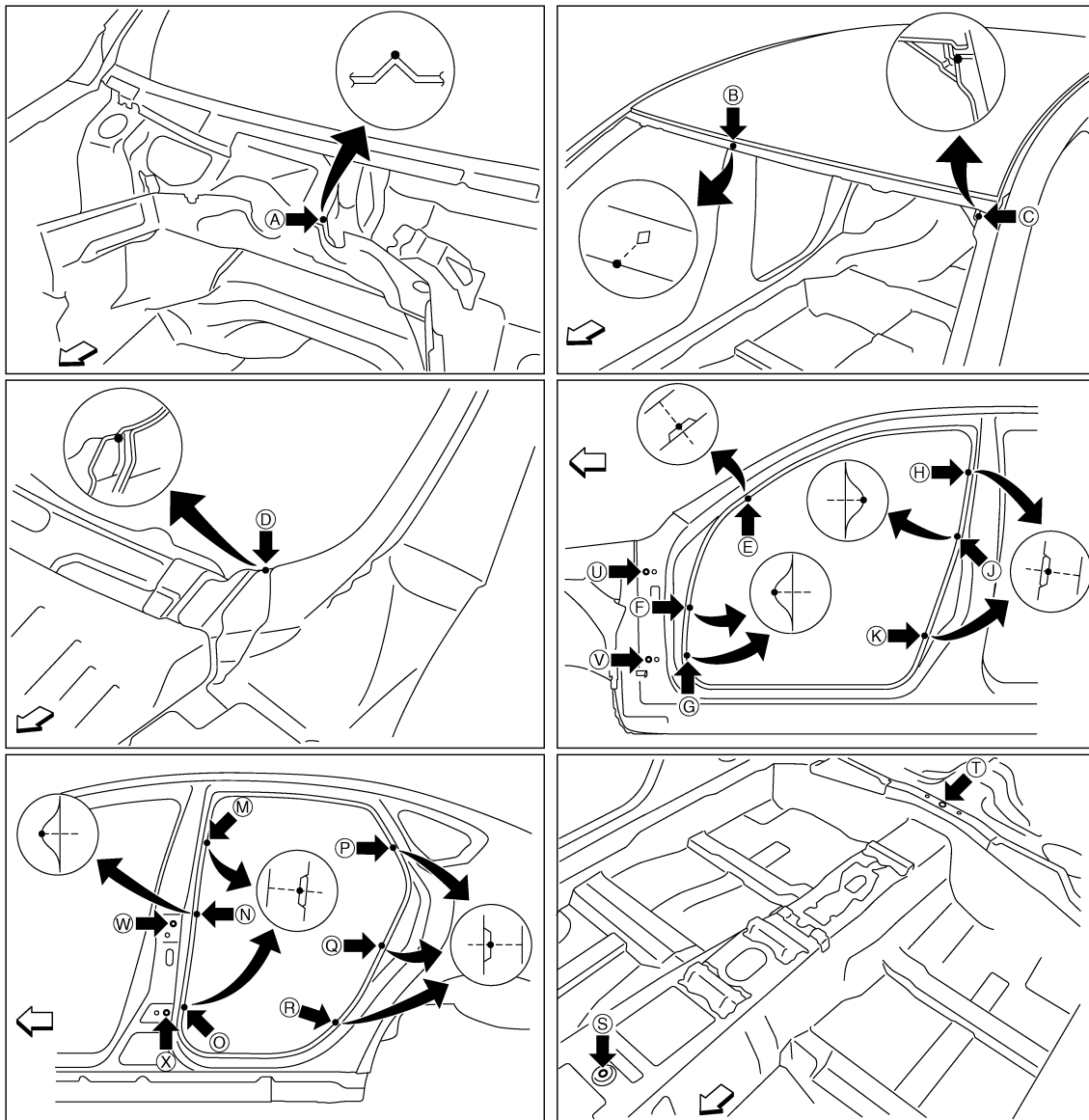

A
B
C
D
E
F
G
H
I
J
L
M
N
O
P

BRM

JSKIA1881ZZ

BODY ALIGNMENT

< SERVICE DATA AND SPECIFICATIONS (SDS)

↶: Vehicle front

Unit: mm (in)

Point	Material	Point	Material
A	Upper dash positioning mark of center positioning mark	H, h, J, j, K, k, M, m, N, n, O, o	Center pillar indent
B	Roof flange end of center positioning mark	P, p, Q, q, R, r	Rear fender indent
C, c	Front pillar joggle	S	Trans control reinforcement hole center of center positioning mark 14×12 (0.55×0.47)
D, d	Front pillar hinge brace joggle	T	Rear seat crossmember reinforcement hole center of center positioning mark ϕ 5 (0.20)
E, e, F, f, G, g	Front pillar indent	U, u, V, v, W, w, X, x	Door hinge installing hole center U, u, V, v, X, x: ϕ 12 (0.47) W, w: 11×9 (0.43×0.35)

Rear Body

INFOID:000000005927171

Measurement

Dimensions marked with "*" indicate symmetrically identical dimensions on both the right and left hand of the vehicle.

BODY ALIGNMENT

< SERVICE DATA AND SPECIFICATIONS (SDS)

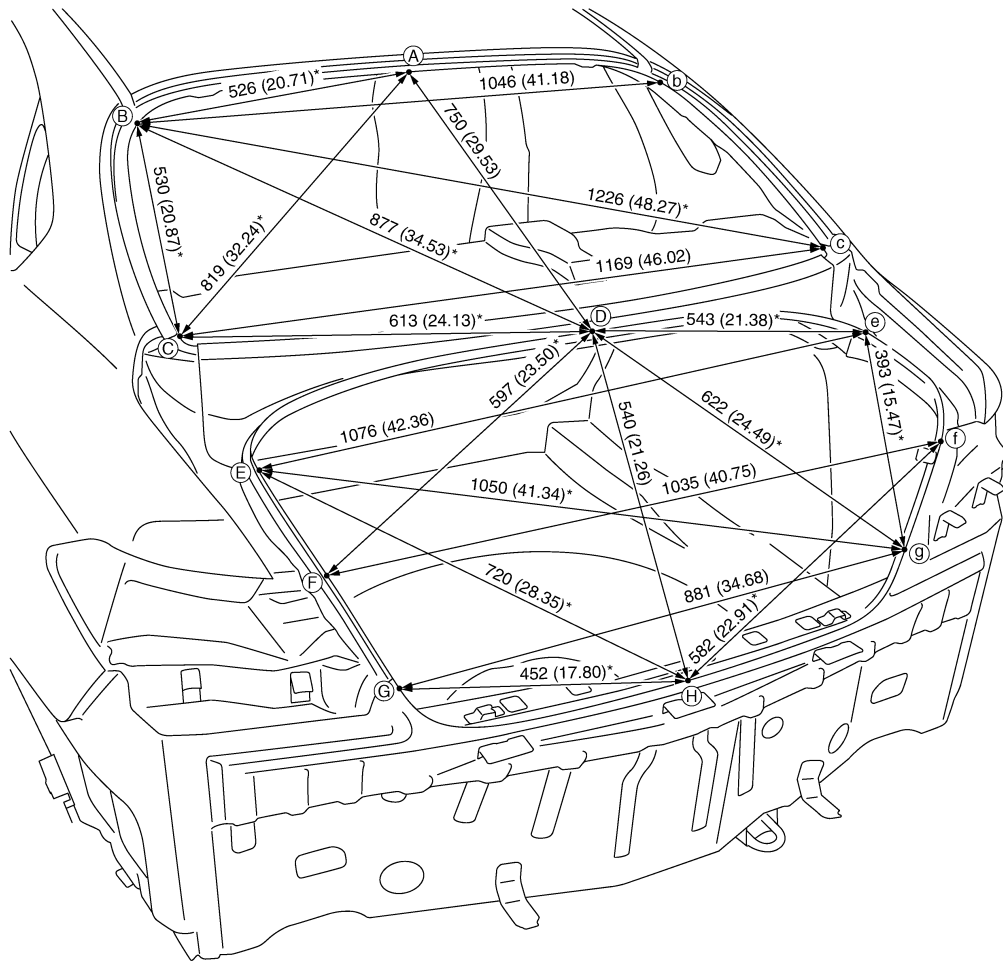

A
B
C
D
E
F
G
H
I
J

BRM

L
M
N
O
P

JSKIA1624GB

Unit: mm (in)

Measurement Points

BODY ALIGNMENT

< SERVICE DATA AND SPECIFICATIONS (SDS)

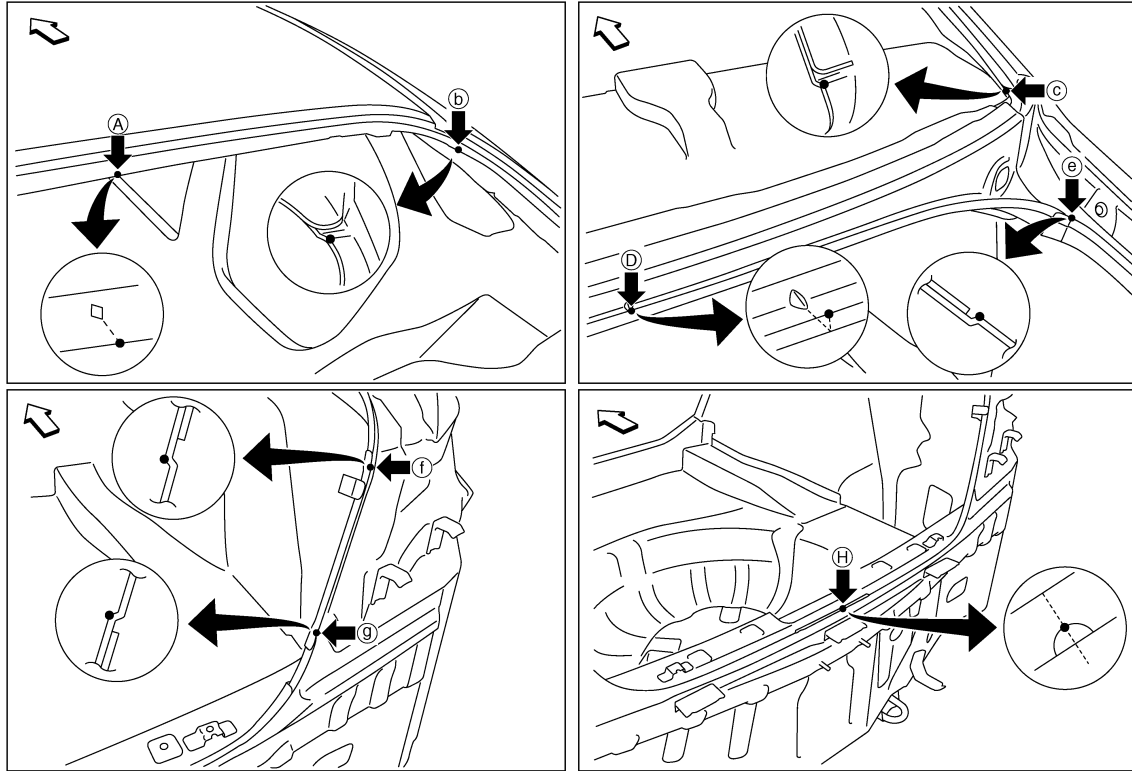

JSKIA1625ZZ

↶: Vehicle front

Point	Material	Point	Material
A	Roof flange end of center positioning mark	D	Rear waist flange end of center positioning mark
B, b	Outer side body joggle	F, f, G, g	Rear combination lamp base joggle
C, c, E, e	Rear fender corner joggle	H	Upper rear panel indent of center positioning mark

LOCATION OF PLASTIC PARTS

< SERVICE DATA AND SPECIFICATIONS (SDS)

LOCATION OF PLASTIC PARTS

Precautions for Plastics

INFOID:000000005927172

Abbreviation	Material name	Heatresisting temperature °C (°F)	Resistance to gasoline and solvents	Other cautions
PE	Polyethylene	60 (140)	Gasoline and most solvents are harmless if applied for a very short time (wipe out quickly).	Flammable
ABS	Acrylonitrile Butadiene Styrene	80 (176)	Avoid gasoline and solvents.	—
EPM/EPDM	Ethylene Propylene (Diene) copolymer	80 (176)	Gasoline and most solvents are harmless if applied for a very short time (wipe out quickly).	Flammable
PS	Polystyrene	80 (176)	Avoid solvents.	Flammable
PVC	Poly Vinyl Chloride	80 (176)	Gasoline and most solvents are harmless if applied for a very short time (wipe out quickly).	Poisonous gas is emitted when burned.
TPO	Thermoplastic Olefine	80 (176)	↑	Flammable
AAS	Acrylonitrile Acrylic Styrene	85 (185)	Avoid gasoline and solvents.	—
PMMA	Poly Methyl Methacrylate	85 (185)	↑	—
EVAC	Ethylene Vinyl Acetate	90 (194)	↑	—
PP	Polypropylene	90 (194)	Gasoline and most solvents are harmless if applied for a very short time (wipe out quickly).	Flammable, avoid battery acid.
PUR	Polyurethane	90 (194)	Avoid gasoline and solvents.	—
UP	Unsaturated Polyester	90 (194)	↑	Flammable
ASA	Acrylonitrile Styrene Acrylate	100 (212)	↑	Flammable
PPE	Poly Phenylene Ether	110 (230)	↑	—
TPU	Thermoplastic Urethane	110 (230)	↑	—
PBT+PC	Poly Butylene Terephthalate + Polycarbonate	120 (248)	↑	Flammable
PC	Polycarbonate	120 (248)	↑	—
POM	Poly Oxymethylene	120 (248)	↑	Avoid battery acid.
PA	Polyamide	140 (284)	↑	Avoid immersing in water.
PBT	Poly Butylene Terephthalate	140 (284)	↑	—
PAR	Polyarylate	180 (356)	↑	—
PET	Polyethylene terephthalate	180 (356)	↑	—
PEI	Polyetherimide	200 (392)	↑	—

CAUTION:

- When repairing and painting a portion of the body adjacent to plastic parts, consider their characteristics (influence of heat and solvent) and remove them if necessary or take suitable measures to protect them.
- Plastic parts should be repaired and painted using methods suiting the materials' characteristics.

LOCATION OF PLASTIC PARTS

< SERVICE DATA AND SPECIFICATIONS (SDS)

Location of Plastic Parts

INFOID:000000005927173

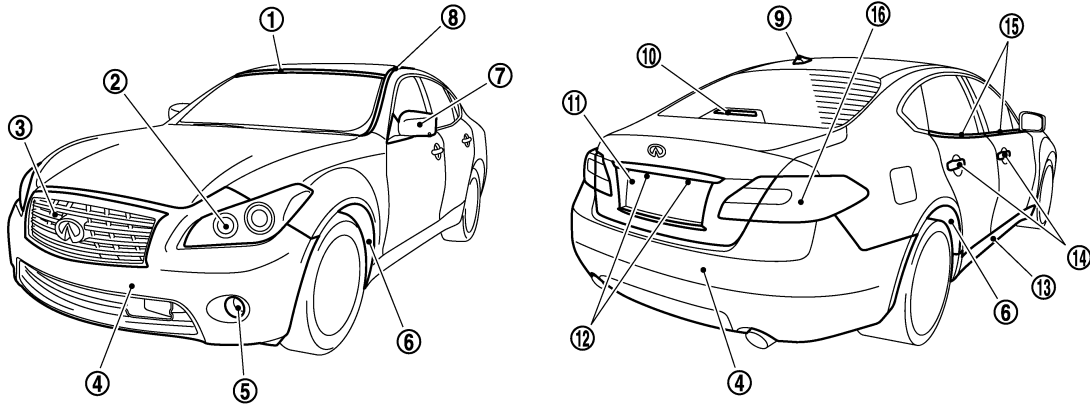

JSKIA1882ZZ

Component		Material	Component		Material		
1	Upper windshield molding	TPO	11	Trunk lid finisher	Base	ABS	
2	Front combination lamp	Lens			PC	Upper finisher molding	ABS
		Housing			PP	Lower finisher molding	ABS
3	Front grille	ABS	12	License plate lamp	Lens	PC	
4	Bumper fascia	PP + EPM			Housing	PA	
5	Front fog lamp	Lens	Glass	13	Sill cover	PP + EPDM	
		Housing	PBT + ASA + Glass fiber	14	Door outside handle	PC + ABS	
6	Fender protector	Front	PP	15	Door outside molding	PVC + Stainless	
		Rear	PUR	16	Rear combination lamp (Rear fender)	Lens	PMMA
7	Door outside mirror	Housing	ABS			Housing	ASA
8	Roof side molding	PVC + Stainless	Rear combination lamp (Trunk lid)		Lens	PMMA	
9	Antenna base cover	ASA + PC	Housing	ASA			
10	High mount stop lamp	Lens	PC				
		Housing	PA				

LOCATION OF PLASTIC PARTS

< SERVICE DATA AND SPECIFICATIONS (SDS)

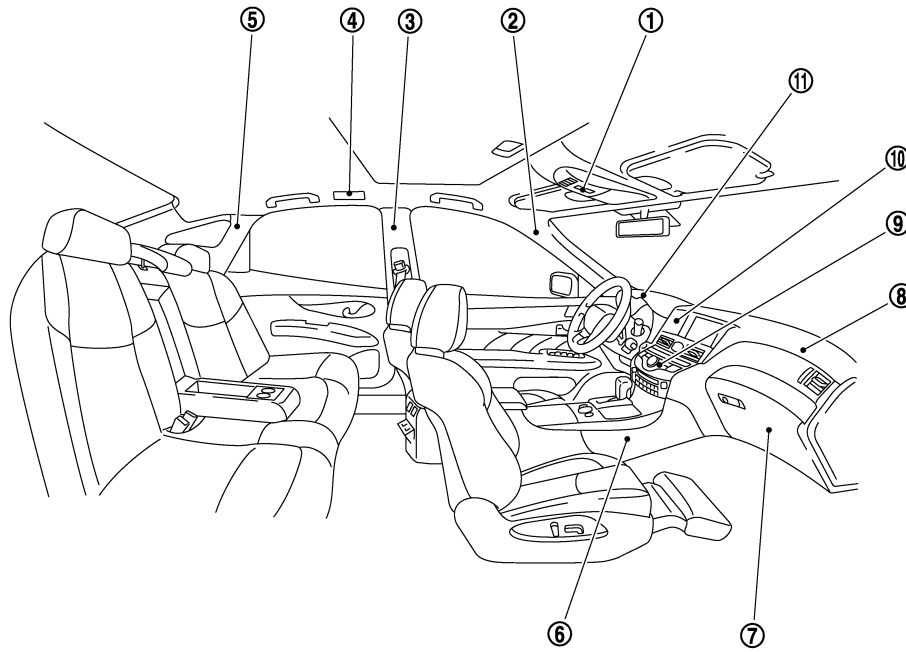

JSKIA1883ZZ

Component		Material	Component		Material		
1	Map lamp	Lens	PC	7	Glove box	Core	ABS
		Housing	PP			Pad	PUR
						Skin	PVC
2	Front pillar garnish		PP	8	Instrument panel		PP
3	Center pillar garnish		PP	9	Cluster lid D		ABS + Glass fiber
4	Personal lamp	Lens	PC	10	Center ventilator ASSY		PC + ABS
		Housing	PP	11	Cluster lid A		ABS
5	Rear pillar garnish		PP				
6	Center console		ABS				

A
B
C
D
E
F
G
H
I
J
K
L
M
N
O
P

BRM