

A
B
C

EXL

SECTION EXL

EXTERIOR LIGHTING SYSTEM

D
E

CONTENTS

XENON TYPE		
PRECAUTION	5	
PRECAUTIONS	5	
Precaution for Supplemental Restraint System (SRS) "AIR BAG" and "SEAT BELT PRE-TENSIONER"	5	
Precautions Necessary for Steering Wheel Rotation After Battery Disconnection	5	
Precautions For Xenon Headlamp Service	6	
SYSTEM DESCRIPTION	7	
COMPONENT PARTS	7	
EXTERIOR LIGHTING SYSTEM	7	
EXTERIOR LIGHTING SYSTEM : Component Parts Location	7	
EXTERIOR LIGHTING SYSTEM : Component Description	9	
FRONT COMBINATION LAMP	9	
FRONT COMBINATION LAMP : Xenon Headlamp	9	
FRONT COMBINATION LAMP : HID control unit... ..	10	
FRONT COMBINATION LAMP : High Beam Solenoid	10	
FRONT COMBINATION LAMP : Aiming Motor	11	
FRONT COMBINATION LAMP : Swivel Actuator... ..	11	
SYSTEM	12	
HEADLAMP SYSTEM (WITHOUT DTRL)	12	
HEADLAMP SYSTEM (WITHOUT DTRL) : System Diagram	12	
HEADLAMP SYSTEM (WITHOUT DTRL) : System Description	12	
HEADLAMP SYSTEM (WITHOUT DTRL) : Fail-safe	12	
HEADLAMP SYSTEM (WITH DTRL)	13	
		F
	HEADLAMP SYSTEM (WITH DTRL) : System Diagram	13
	HEADLAMP SYSTEM (WITH DTRL) : System Description	13
	HEADLAMP SYSTEM (WITH DTRL) : Fail-safe	13
	AUTO LIGHT SYSTEM (WITHOUT DTRL)	14
	AUTO LIGHT SYSTEM (WITHOUT DTRL) : System Diagram	14
	AUTO LIGHT SYSTEM (WITHOUT DTRL) : System Description	14
	AUTO LIGHT SYSTEM (WITH DTRL)	15
	AUTO LIGHT SYSTEM (WITH DTRL) : System Diagram	15
	AUTO LIGHT SYSTEM (WITH DTRL) : System Description	16
	DAYTIME RUNNING LIGHT SYSTEM	16
	DAYTIME RUNNING LIGHT SYSTEM : System Diagram	16
	DAYTIME RUNNING LIGHT SYSTEM : System Description	17
	ACTIVE ADAPTIVE FRONT-LIGHTING SYSTEM	17
	ACTIVE ADAPTIVE FRONT-LIGHTING SYSTEM : System Diagram	17
	ACTIVE ADAPTIVE FRONT-LIGHTING SYSTEM : System Description	17
	FRONT FOG LAMP SYSTEM	19
	FRONT FOG LAMP SYSTEM : System Diagram....	19
	FRONT FOG LAMP SYSTEM : System Description	19
	TURN SIGNAL AND HAZARD WARNING LAMP SYSTEM	20
	TURN SIGNAL AND HAZARD WARNING LAMP SYSTEM : System Diagram	20
	TURN SIGNAL AND HAZARD WARNING LAMP SYSTEM : System Description	20

EXL

PARKING, LICENSE PLATE, SIDE MARKER AND TAIL LAMP SYSTEM (WITHOUT DTRL)	20	WIRING DIAGRAM	44
PARKING, LICENSE PLATE, SIDE MARKER AND TAIL LAMP SYSTEM (WITHOUT DTRL) : System Diagram	20	EXTERIOR LIGHTING SYSTEM	44
PARKING, LICENSE PLATE, SIDE MARKER AND TAIL LAMP SYSTEM (WITHOUT DTRL) : System Description	21	EXTERIOR LIGHTING SYSTEM	44
PARKING, LICENSE PLATE, SIDE MARKER AND TAIL LAMP SYSTEM (WITHOUT DTRL) : Fail-safe	21	EXTERIOR LIGHTING SYSTEM : Wiring Diagram	44
PARKING, LICENSE PLATE, SIDE MARKER AND TAIL LAMP SYSTEM (WITH DTRL)	21	ACTIVE ADAPTIVE FRONT-LIGHTING SYSTEM ...	46
PARKING, LICENSE PLATE, SIDE MARKER AND TAIL LAMP SYSTEM (WITH DTRL) : System Diagram	21	ACTIVE ADAPTIVE FRONT-LIGHTING SYSTEM : Wiring Diagram	47
PARKING, LICENSE PLATE, SIDE MARKER AND TAIL LAMP SYSTEM (WITH DTRL) : System Description	22	BASIC INSPECTION	49
PARKING, LICENSE PLATE, SIDE MARKER AND TAIL LAMP SYSTEM (WITH DTRL) : Fail-safe	22	DIAGNOSIS AND REPAIR WORKFLOW	49
EXTERIOR LAMP BATTERY SAVER SYSTEM	22	Work Flow	49
EXTERIOR LAMP BATTERY SAVER SYSTEM : System Diagram	23	INSPECTION AND ADJUSTMENT	52
EXTERIOR LAMP BATTERY SAVER SYSTEM : System Description	23	ADDITIONAL SERVICE WHEN REPLACING CONTROL UNIT (AFS CONTROL UNIT)	52
DIAGNOSIS SYSTEM (BCM)	25	ADDITIONAL SERVICE WHEN REPLACING CONTROL UNIT (AFS CONTROL UNIT) : Description	52
COMMON ITEM	25	ADDITIONAL SERVICE WHEN REPLACING CONTROL UNIT (AFS CONTROL UNIT) : Special Repair Requirement	52
COMMON ITEM : CONSULT Function (BCM - COMMON ITEM)	25	ADDITIONAL SERVICE WHEN REPLACING CONTROL UNIT (HEIGHT SENSOR)	52
HEADLAMP	26	ADDITIONAL SERVICE WHEN REPLACING CONTROL UNIT (HEIGHT SENSOR) : Description	52
HEADLAMP : CONSULT Function (BCM - HEAD LAMP)	26	ADDITIONAL SERVICE WHEN REPLACING CONTROL UNIT (HEIGHT SENSOR) : Special Repair Requirement	52
FLASHER	29	LEVELIZER ADJUSTMENT	52
FLASHER : CONSULT Function (BCM - FLASHER)	29	LEVELIZER ADJUSTMENT : Description	52
DIAGNOSIS SYSTEM (IPDM E/R)	31	LEVELIZER ADJUSTMENT : Special Repair Requirement	52
Diagnosis Description	31	DTC/CIRCUIT DIAGNOSIS	54
CONSULT Function (IPDM E/R)	33	B2503, B2504 SWIVEL ACTUATOR	54
DIAGNOSIS SYSTEM (AFS)	36	DTC Logic	54
CONSULT Function (ADAPTIVE LIGHT)	36	Diagnosis Procedure	55
ECU DIAGNOSIS INFORMATION	38	Component Inspection	58
BCM, IPDM E/R	38	B2514 HEIGHT SENSOR UNUSUAL [RR]	59
List of ECU Reference	38	DTC Logic	59
AFS CONTROL UNIT	39	Diagnosis Procedure	59
Reference Value	39	B2516 SHIFT SIGNAL [P, R]	62
Fail-Safe	41	DTC Logic	62
DTC Inspection Priority Chart	42	Diagnosis Procedure	62
DTC Index	43	B2517 VEHICLE SPEED SIGNAL	63
		DTC Logic	63
		Diagnosis Procedure	63
		B2519 LEVELIZER CALIBRATION	64
		DTC Logic	64

Diagnosis Procedure	64	Diagnosis Procedure	89	A
B2521 ECU CIRCUIT	65	HAZARD SWITCH	92	B
DTC Logic	65	Component Function Check	92	
Diagnosis Procedure	65	Diagnosis Procedure	92	
C0126 STEERING ANGLE SENSOR SIGNAL...	68	SYMPTOM DIAGNOSIS	94	C
DTC Logic	68	EXTERIOR LIGHTING SYSTEM SYMPTOMS...	94	D
Diagnosis Procedure	68	Symptom Table	94	
C0428 STEERING ANGLE SENSOR CALI-		NORMAL OPERATING CONDITION	97	E
BRATION	69	Description	97	
DTC Logic	69	BOTH SIDE HEADLAMPS DO NOT SWITCH		F
Diagnosis Procedure	69	TO HIGH BEAM	98	G
U1000 CAN COMM CIRCUIT	70	Description	98	
DTC Logic	70	Diagnosis Procedure	98	
Diagnosis Procedure	70	BOTH SIDE HEADLAMPS (LO) ARE NOT		H
U1010 CONTROL UNIT (CAN)	71	TURNED ON	99	I
DTC Logic	71	Description	99	
Diagnosis Procedure	71	Diagnosis Procedure	99	J
POWER SUPPLY AND GROUND CIRCUIT	72	PARKING, LICENSE PLATE AND TAIL		K
AFS CONTROL UNIT	72	LAMPS ARE NOT TURNED ON	100	
AFS CONTROL UNIT : Diagnosis Procedure	72	Description	100	
EXTERIOR LAMP FUSE	73	Diagnosis Procedure	100	
Diagnosis Procedure	73	BOTH SIDE FRONT FOG LAMPS ARE NOT		
HEADLAMP (HI) CIRCUIT	74	TURNED ON	101	
Component Function Check	74	Description	101	
Diagnosis Procedure	74	Diagnosis Procedure	101	
HEADLAMP (LO) CIRCUIT	76	PERIODIC MAINTENANCE	102	
Component Function Check	76	HEADLAMP AIMING ADJUSTMENT	102	
Diagnosis Procedure	76	Description	102	
XENON HEADLAMP	78	Aiming Adjustment Procedure	103	
Diagnosis Procedure	78	FRONT FOG LAMP AIMING ADJUSTMENT .	104	EXL
DAYTIME RUNNING LIGHT RELAY CIRCUIT		Description	104	
.....	79	Aiming Adjustment Procedure	104	
Component Function Check	79	REMOVAL AND INSTALLATION	106	M
Diagnosis Procedure	79	FRONT COMBINATION LAMP	106	
Component Inspection	80	Exploded View	106	
HEADLAMP LEVELIZER CIRCUIT	82	Removal and Installation	107	
Component Function Check	82	Replacement	107	
Diagnosis Procedure	82	Disassembly and Assembly	108	
FRONT FOG LAMP CIRCUIT	84	FRONT FOG LAMP	109	N
Component Function Check	84	Exploded View	109	
Diagnosis Procedure	84	Removal and Installation	109	
TURN SIGNAL LAMP CIRCUIT	86	Replacement	109	P
Description	86	OPTICAL SENSOR	111	
Component Function Check	86	Exploded View	111	
Diagnosis Procedure	86	Removal and Installation	111	
OPTICAL SENSOR	89	LIGHTING AND TURN SIGNAL SWITCH	112	
Component Function Check	89			

Exploded View	112	Exploded View	118
HAZARD SWITCH	113	Removal and Installation	118
Exploded View	113	BACK-UP LAMP	119
AFS CONTROL UNIT	114	Exploded View	119
Exploded View	114	Removal and Installation	119
Removal and Installation	114	Replacement	119
STEERING ANGLE SENSOR	115	LICENSE PLATE LAMP	120
Removal and Installation	115	Exploded View	120
HEIGHT SENSOR	116	Removal and Installation	120
Exploded View	116	Replacement	120
Removal and Installation	116	SERVICE DATA AND SPECIFICATIONS	
REAR COMBINATION LAMP	117	(SDS)	121
Exploded View	117	SERVICE DATA AND SPECIFICATIONS	
Removal and Installation	117	(SDS)	121
HIGH-MOUNTED STOP LAMP	118	Bulb Specifications	121

PRECAUTION

PRECAUTIONS

Precaution for Supplemental Restraint System (SRS) "AIR BAG" and "SEAT BELT PRE-TENSIONER"

INFOID:000000007222009

The Supplemental Restraint System such as "AIR BAG" and "SEAT BELT PRE-TENSIONER", used along with a front seat belt, helps to reduce the risk or severity of injury to the driver and front passenger for certain types of collision. This system includes seat belt switch inputs and dual stage front air bag modules. The SRS system uses the seat belt switches to determine the front air bag deployment, and may only deploy one front air bag, depending on the severity of a collision and whether the front occupants are belted or unbelted. Information necessary to service the system safely is included in the "SRS AIR BAG" and "SEAT BELT" of this Service Manual.

WARNING:

Always observe the following items for preventing accidental activation.

- To avoid rendering the SRS inoperative, which could increase the risk of personal injury or death in the event of a collision that would result in air bag inflation, all maintenance must be performed by an authorized NISSAN/INFINITI dealer.
- Improper maintenance, including incorrect removal and installation of the SRS, can lead to personal injury caused by unintentional activation of the system. For removal of Spiral Cable and Air Bag Module, see "SRS AIR BAG".
- Never use electrical test equipment on any circuit related to the SRS unless instructed to in this Service Manual. SRS wiring harnesses can be identified by yellow and/or orange harnesses or harness connectors.

PRECAUTIONS WHEN USING POWER TOOLS (AIR OR ELECTRIC) AND HAMMERS

WARNING:

Always observe the following items for preventing accidental activation.

- When working near the Air Bag Diagnosis Sensor Unit or other Air Bag System sensors with the ignition ON or engine running, never use air or electric power tools or strike near the sensor(s) with a hammer. Heavy vibration could activate the sensor(s) and deploy the air bag(s), possibly causing serious injury.
- When using air or electric power tools or hammers, always switch the ignition OFF, disconnect the battery, and wait at least 3 minutes before performing any service.

Precautions Necessary for Steering Wheel Rotation After Battery Disconnection

INFOID:000000007222011

CAUTION:

Comply with the following cautions to prevent any error and malfunction.

- Before removing and installing any control units, first turn the ignition switch to the LOCK position, then disconnect both battery cables.
- After finishing work, confirm that all control unit connectors are connected properly, then re-connect both battery cables.
- Always use CONSULT to perform self-diagnosis as a part of each function inspection after finishing work. If a DTC is detected, perform trouble diagnosis according to self-diagnosis results.

For vehicle with steering lock unit, if the battery is disconnected or discharged, the steering wheel will lock and cannot be turned.

If turning the steering wheel is required with the battery disconnected or discharged, follow the operation procedure below before starting the repair operation.

OPERATION PROCEDURE

1. Connect both battery cables.

NOTE:

Supply power using jumper cables if battery is discharged.

2. Turn the ignition switch to ACC position.
(At this time, the steering lock will be released.)
3. Disconnect both battery cables. The steering lock will remain released with both battery cables disconnected and the steering wheel can be turned.

A
B
C
D
E
F
G
H
I
J
K
L
M
N
O
P

EXL

PRECAUTIONS

< PRECAUTION >

[XENON TYPE]

4. Perform the necessary repair operation.
5. When the repair work is completed, re-connect both battery cables. With the brake pedal released, turn the ignition switch from ACC position to ON position, then to LOCK position. (The steering wheel will lock when the ignition switch is turned to LOCK position.)
6. Perform self-diagnosis check of all control units using CONSULT.

Precautions For Xenon Headlamp Service

INFOID:000000007222012

WARNING:

Comply with the following warnings to prevent any serious accident.

- Disconnect the battery cable (negative terminal) or the power supply fuse before installing, removing, or touching the xenon headlamp (bulb included). The xenon headlamp contains high-voltage generated parts.
- Never work with wet hands.
- Check the xenon headlamp ON-OFF status after assembling it to the vehicle. Never turn the xenon headlamp ON in other conditions. Connect the power supply to the vehicle-side connector. (Turning it ON outside the lamp case may cause fire or visual impairments.)
- Never touch the bulb glass immediately after turning it OFF. It is extremely hot.

CAUTION:

Comply with the following cautions to prevent any error and malfunction.

- Install the xenon bulb securely. (Insufficient bulb socket installation may melt the bulb, the connector, the housing, etc. by high-voltage leakage or corona discharge.)
- Never perform HID circuit inspection with a tester.
- Never touch the xenon bulb glass with hands. Never put oil and grease on it.
- Dispose of the used xenon bulb after packing it in thick vinyl without breaking it.
- Never wipe out dirt and contamination with organic solvent (thinner, gasoline, etc.).

SYSTEM DESCRIPTION

COMPONENT PARTS

EXTERIOR LIGHTING SYSTEM

EXTERIOR LIGHTING SYSTEM : Component Parts Location

INFOID:000000006887828

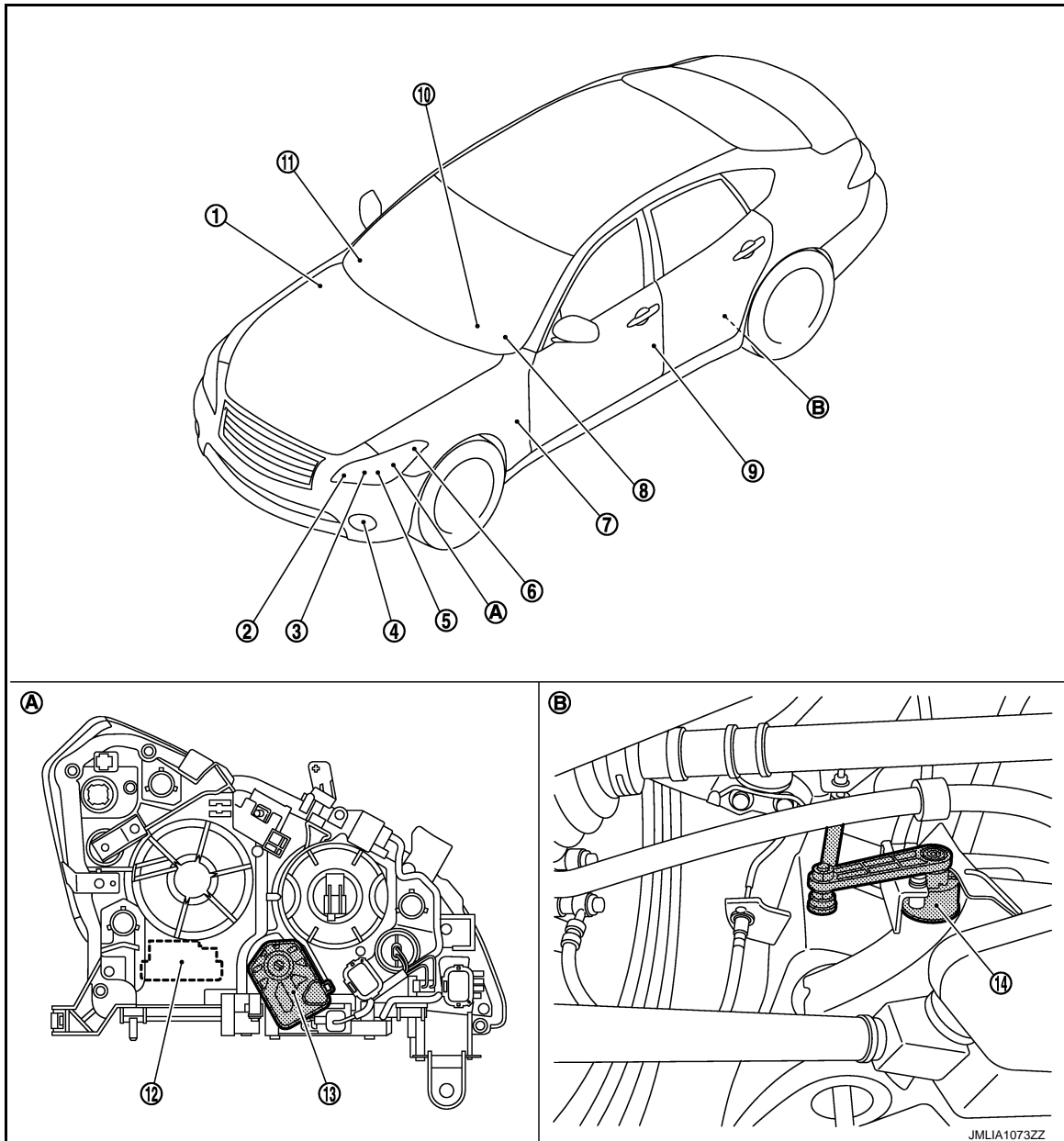

- | | | |
|--|---------------------------|---------------------------|
| 1. IPDM E/R
Refer to PCS-5, "IPDM E/R : Component Parts Location" | 2. Front turn signal lamp | 3. Parking lamp |
| 4. Front fog lamp | 5. Headlamp | 6. Front side marker lamp |
| 7. BCM
Refer to BCS-4, "BODY CONTROL SYSTEM : Component Parts Location" | 8. Combination switch | 9. Door switch |
| 10. Combination meter | 11. Optical sensor | 12. Swivel actuator |

A
B
C
D
E
F
G
H
I
J
K
EXL
M
N
O
P

COMPONENT PARTS

[XENON TYPE]

< SYSTEM DESCRIPTION >

- | | |
|----------------------------------|--------------------------------|
| 13. Aiming motor | 14. Height sensor |
| A. Front combination lamp (back) | B. Rear suspension member (LH) |

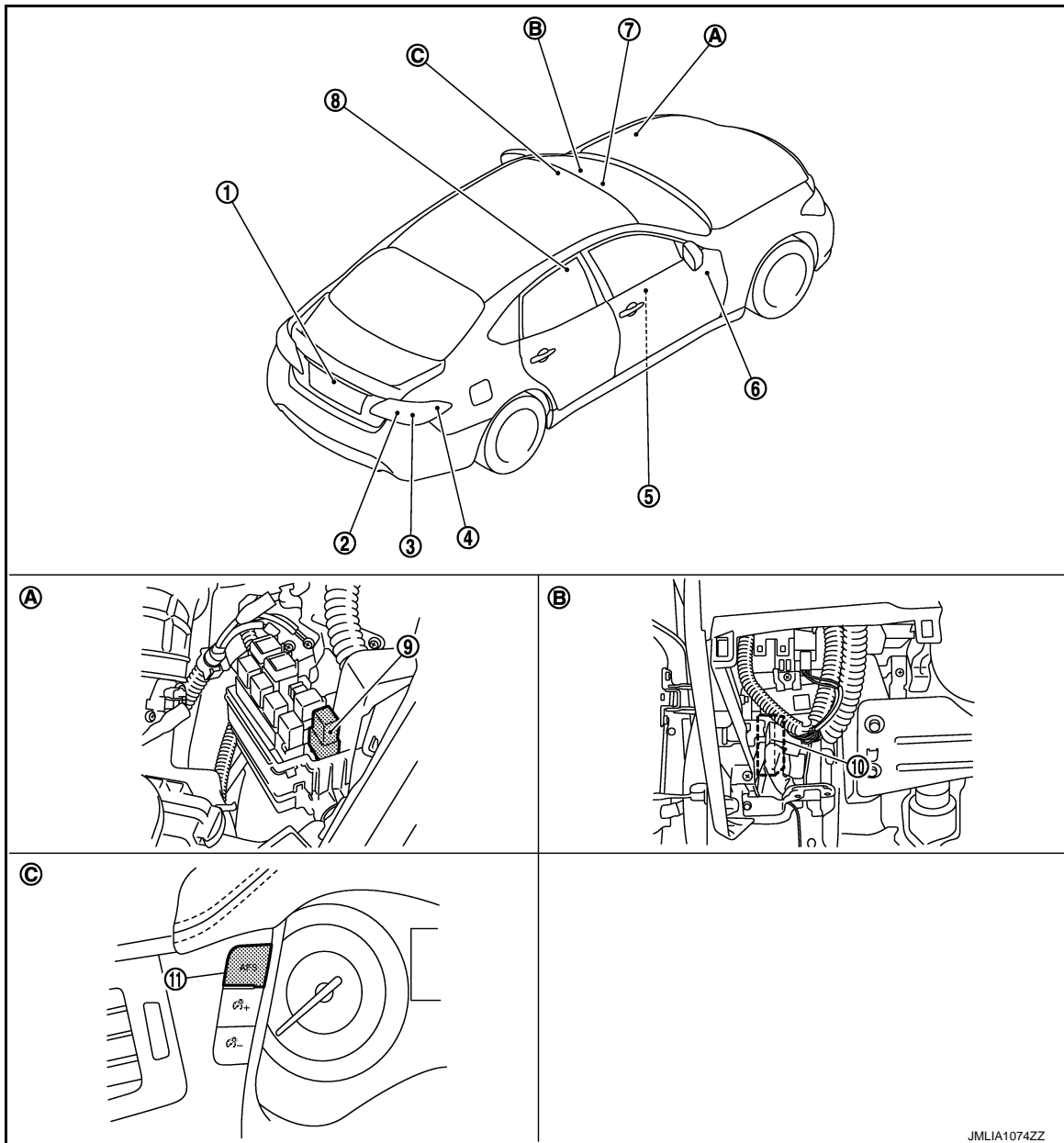

- | | | |
|--------------------------|--|--|
| 1. License plate lamp | 2. Rear turn signal lamp | 3. Tail lamp |
| 4. Rear side marker lamp | 5. TCM
Refer to TM-10. "A/T CONTROL SYSTEM : Component Parts Location" | 6. ECM
Refer to EC-38. "ENGINE CONTROL SYSTEM : Component Parts Location" |
| 7. Steering angle sensor | 8. Air bag diagnosis sensor unit
Refer to SRC-7. "Component Parts Location" | 9. Daytime running light relay* |
| 10. AFS control unit | 11. AFS switch | |
| A. Engine room (LH) | B. Behind the instrument driver lower panel | C. Cluster lid A |

*: With Daytime running light system

JMLIA1074ZZ

COMPONENT PARTS

< SYSTEM DESCRIPTION >

[XENON TYPE]

EXTERIOR LIGHTING SYSTEM : Component Description

INFOID:000000006887829

A
B
C
D
E
F
G
H
I
J
K
EXL
M
N
O
P

Part	Description	
BCM	Controls the exterior lighting system.	
ECM	Transmits engine speed signal to AFS control unit. (via CAN communication)	
TCM	Transmits Shift position signal to AFS control unit. (via CAN communication)	
Air bag diagnosis sensor unit	Transmits air bag signal to BCM.	
IPDM E/R	Controls the integrated relay, and supplies voltage to the load according to the request from BCM (via CAN communication).	
AFS control unit	AFS control unit judges the vehicle condition from each signal. AFS control unit controls AFS function and the headlamp aiming.	
Combination meter	<ul style="list-style-type: none"> Outputs the vehicle speed signal (8-pulse) to AFS control unit. Blinks the turn signal indicator lamp and outputs the turn signal operating sound with integrated buzzer according to the request from BCM (via CAN communication). Turns the tail lamp indicator lamp, high beam indicator lamp and front fog lamp indicator lamp ON according to the request from BCM (via CAN communication). Turns the AFS OFF indicator lamp ON/OFF/blinking according to the request from AFS control unit (via CAN communication). 	
Headlamp assembly	Xenon bulb	Refer to EXL-9. "FRONT COMBINATION LAMP : Xenon Headlamp" .
	HID control unit	Refer to EXL-10. "FRONT COMBINATION LAMP : HID control unit" .
	High beam solenoid	Refer to EXL-10. "FRONT COMBINATION LAMP : High Beam Solenoid" .
	Aiming motor	Refer to EXL-11. "FRONT COMBINATION LAMP : Aiming Motor" .
	Swivel actuator	Refer to EXL-11. "FRONT COMBINATION LAMP : Swivel Actuator" .
Height sensor	The sensor angle of the unloaded vehicle position is the reference value.	
Optical sensor	Optical sensor converts the outside brightness (lux) to voltage and transmits the optical sensor signal to BCM.	
Steering angle sensor	Transmits Steering angle sensor signal to AFS control unit. (via CAN communication)	
Combination switch (Lighting & turn signal switch)	Refer to BCS-8. "COMBINATION SWITCH READING SYSTEM : System Description" .	
AFS switch	<ul style="list-style-type: none"> AFS switch is integrated in meter control switch. Inputs the AFS switch signal to AFS control unit. 	
Door switch	Inputs the door switch signal to BCM.	
Hazard switch	Inputs the hazard switch signal to BCM.	

FRONT COMBINATION LAMP

FRONT COMBINATION LAMP : Xenon Headlamp

INFOID:000000006887830

OUTLINE

- The lamp light source is by the arch discharge by applying high voltage into the xenon gas-filled bulb instead of the halogen bulb filament.
- Sight becomes more natural and brighter because the amount of light are gained adequately and the color of light is sunshine-like white.
- The xenon bulb drops the amount of light, repeats blinking, and illuminates in red if the bulb reaches the service life.

ILLUMINATION PRINCIPLE

COMPONENT PARTS

[XENON TYPE]

< SYSTEM DESCRIPTION >

1. Discharging starts in high voltage pulse between bulb electrodes.
2. Xenon gas is activated by current between electrodes. Pale light is emitted.
3. The luminous tube (bulb) temperature elevates. Evaporated halide is activated by discharge. The color of light changes into white.

NOTE:

- Brightness and the color of light may change slightly immediately after the headlamp turned ON until the xenon bulb becomes stable. This is not malfunction.
- Illumination time lag may occur between right and left. This is not malfunction.

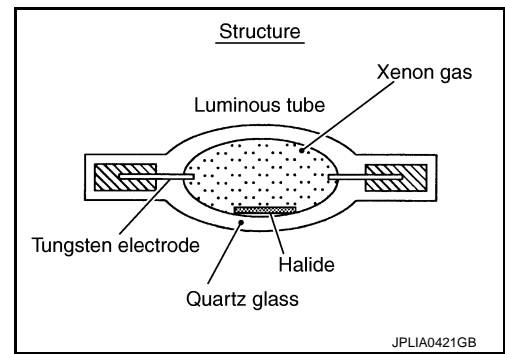

PRECAUTIONS FOR TROUBLE DIAGNOSIS

Representative malfunction examples are; "Light does not turn ON", "Light blinks", and "Brightness is inadequate." The cause often be the xenon bulb. Such malfunctions, however, are occurred occasionally by HID control unit malfunction or lamp case malfunction. Specify the malfunctioning part with diagnosis procedure.

WARNING:

- **Never touch the harness, HID control unit, the inside and metal part of lamp when turning the headlamp ON or operating the lighting switch.**
- **Never work with wet hands.**

CAUTION:

- **Never perform HID control unit circuit diagnosis with a circuit tester or an equivalent.**
- **Temporarily install the headlamps on the vehicle. Connect the battery to the connector (vehicle side) when checking ON/OFF status.**
- **Disconnect the battery negative terminal before disconnecting the lamp socket connector or the harness connector.**
- **Check for fusing of the fusible link(s), open around connector, short, disconnection if the symptom is caused by electric error.**

NOTE:

- Turn the switch OFF once before turning ON, if the ON/OFF is inoperative.
- The xenon bulb drops the amount of light, repeats blinking, and illuminates in red if the bulb reaches the service life.

FRONT COMBINATION LAMP : HID control unit

INFOID:000000006887831

Headlamp (LO) circuit is connected to HID control unit integrated in the headlamp. Headlamp (LO) circuit turns xenon headlamp ON.

For the details of HID control unit and the xenon headlamp, refer to [EXL-9. "FRONT COMBINATION LAMP : Xenon Headlamp"](#).

FRONT COMBINATION LAMP : High Beam Solenoid

INFOID:000000006887832

The high beam solenoid drives the mobile valve shade. And the mobile valve shade switches the high beam and low beam of headlamp.

COMPONENT PARTS

[XENON TYPE]

< SYSTEM DESCRIPTION >

- When the headlamp high relay is turned ON, magnetic force is applied to the high beam solenoid (1) by a current. The mobile valve shade (2) is switched to the high beam position.
- When the headlamp high relay is turned OFF, the current stops. The mobile valve shade returns to the low beam position automatically.

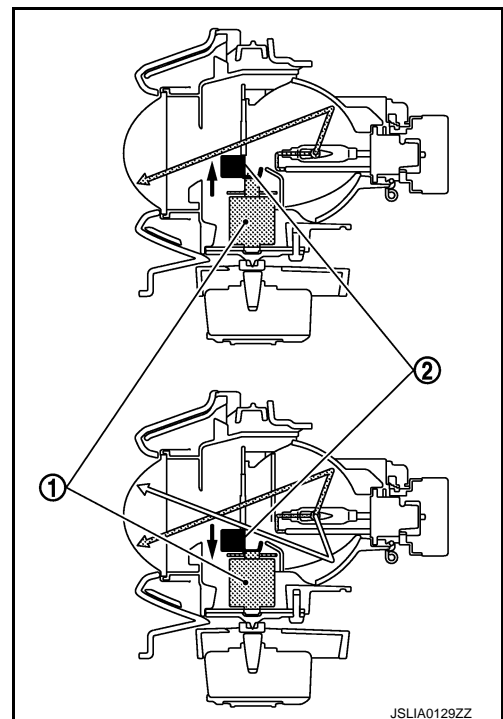

FRONT COMBINATION LAMP : Aiming Motor

INFOID:000000006887833

The headlamp levelizer adjusts the headlamp light axis upward and downward with the aiming motor integrated in the front combination lamp.

FRONT COMBINATION LAMP : Swivel Actuator

INFOID:000000006887834

SWIVEL ACTUATOR

The swivel actuator is installed in the headlamp unit. The swivel actuator consists of the swivel motor and the swivel position sensor.

SWIVEL MOTOR

- The swivel motor is the two-phase step motor.
- The swivel motor drives headlamp by exciting the two drive coils according to the drive signal from AFS control unit.
- The rotation direction of the swivel motor is changeable by changing the exciting pattern.

SWIVEL POSITION SENSOR

The swivel position sensor detects the headlamp swivel angle to transmit the swivel position sensor signal to AFS control unit.

A
B
C
D
E
F
G
H
I
J
K
EXL
M
N
O
P

SYSTEM

HEADLAMP SYSTEM (WITHOUT DTRL)

HEADLAMP SYSTEM (WITHOUT DTRL) : System Diagram

INFOID:000000006887835

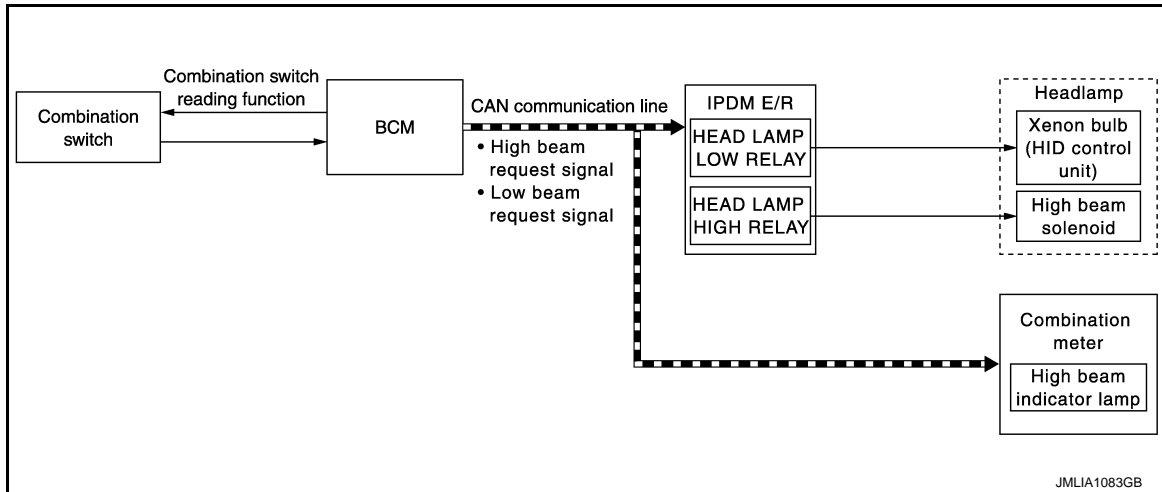

HEADLAMP SYSTEM (WITHOUT DTRL) : System Description

INFOID:000000006887836

OUTLINE

Headlamp is controlled by combination switch reading function and headlamp control function of BCM, and relay control function of IPDM E/R.

HEADLAMP (LO) OPERATION

- BCM detects the combination switch condition with the combination switch reading function.
- BCM transmits the low beam request signal to IPDM E/R via CAN communication according to the headlamp (LO) ON condition.

Headlamp (LO) ON condition

- Lighting switch 2ND
- Lighting switch AUTO (auto light function ON judgment)
- Lighting switch AUTO, with the front fog lamp switch ON and the ignition switch ON
- Lighting switch PASS

- IPDM E/R turns the integrated headlamp low relay ON, and turns the headlamp ON according to the low beam request signal.

HEADLAMP (HI) OPERATION

- BCM transmits the high beam request signal to IPDM E/R and the combination meter via CAN communication according to the headlamp (HI) ON condition.

Headlamp (HI) ON condition

- Lighting switch HI with the lighting switch 2ND or AUTO (auto light function ON judgment)
- Lighting switch PASS
- Lighting switch AUTO, with the front fog lamp switch ON, the ignition switch ON and lighting switch HI
- Combination meter turns the high beam indicator lamp ON according to the high beam request signal.
- IPDM E/R turns the integrated headlamp high relay ON, and turns the headlamp ON according to the high beam request signal.

HEADLAMP SYSTEM (WITHOUT DTRL) : Fail-safe

INFOID:000000006887837

CAN COMMUNICATION CONTROL

When CAN communication with BCM is impossible, IPDM E/R performs fail-safe control. After CAN communication recovers normally, it also returns to normal control.

If No CAN Communication Is Available With BCM

SYSTEM

< SYSTEM DESCRIPTION >

[XENON TYPE]

Control part	Fail-safe operation
Headlamp	<ul style="list-style-type: none"> • Turns ON the headlamp low relay when the ignition switch is turned ON • Turns OFF the headlamp low relay when the ignition switch is turned OFF • Headlamp high relay OFF

HEADLAMP SYSTEM (WITH DTRL)

HEADLAMP SYSTEM (WITH DTRL) : System Diagram

INFOID:0000000006887838

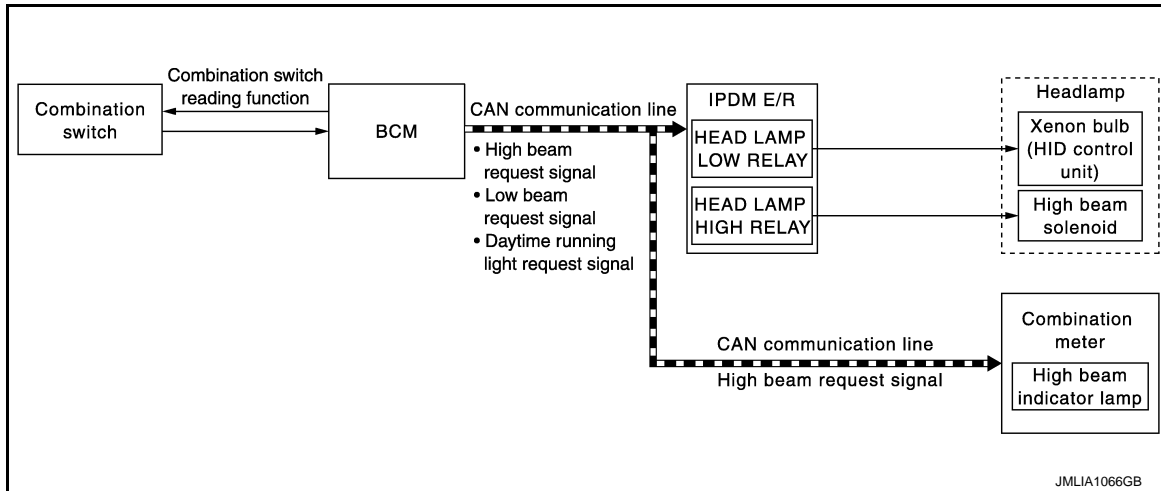

HEADLAMP SYSTEM (WITH DTRL) : System Description

INFOID:0000000006887839

OUTLINE

Headlamp is controlled by combination switch reading function and headlamp control function of BCM, and relay control function of IPDM E/R.

HEADLAMP (LO) OPERATION

- BCM detects the combination switch condition with the combination switch reading function.
- BCM transmits the low beam request signal or daytime running light request signal to IPDM E/R via CAN communication according to the headlamp (LO) ON condition.

Headlamp (LO) ON condition

- Lighting switch 2ND
- Lighting switch is in the other positions than 2ND (daytime running light ON judgment).
- Lighting switch AUTO (auto light function ON judgment)
- Lighting switch AUTO, with the front fog lamp switch ON and the ignition switch ON
- Lighting switch PASS

- IPDM E/R turns the integrated headlamp low relay ON, and turns the headlamp ON according to the low beam request signal or daytime running light request signal.

HEADLAMP (HI) OPERATION

- BCM transmits the high beam request signal to IPDM E/R and the combination meter via CAN communication according to the headlamp (HI) ON condition.

Headlamp (HI) ON condition

- Lighting switch HI with the lighting switch 2ND or AUTO (auto light function ON judgment)
- Lighting switch PASS
- Lighting switch AUTO, with the front fog lamp switch ON, the ignition switch ON and lighting switch HI
- Combination meter turns the high beam indicator lamp ON according to the high beam request signal.
- IPDM E/R turns the integrated headlamp high relay ON, and turns the headlamp ON according to the high beam request signal.

HEADLAMP SYSTEM (WITH DTRL) : Fail-safe

INFOID:0000000006887840

CAN COMMUNICATION CONTROL

A
B
C
D
E
F
G
H
I
J
K
M
N
O
P

EXL

SYSTEM

< SYSTEM DESCRIPTION >

[XENON TYPE]

When CAN communication with BCM is impossible, IPDM E/R performs fail-safe control. After CAN communication recovers normally, it also returns to normal control.

If No CAN Communication Is Available With BCM

Control part	Fail-safe operation
Headlamp	<ul style="list-style-type: none"> • Turns ON the headlamp low relay when the ignition switch is turned ON • Turns OFF the headlamp low relay when the ignition switch is turned OFF • Headlamp high relay OFF

AUTO LIGHT SYSTEM (WITHOUT DTRL)

AUTO LIGHT SYSTEM (WITHOUT DTRL) : System Diagram

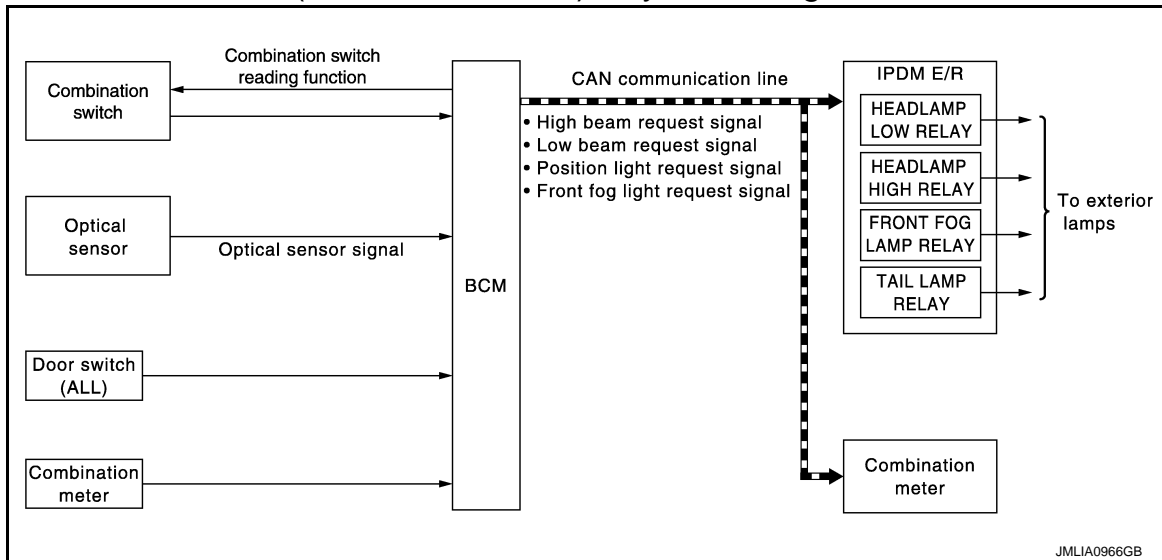

AUTO LIGHT SYSTEM (WITHOUT DTRL) : System Description

INFOID:000000006887842

OUTLINE

- Auto light system is controlled by each function of BCM and IPDM E/R.

Control by BCM

- Combination switch reading function
- Headlamp control function
- Auto light function
- Delay timer function
- Wiper linked auto lighting function
- Auto light adjustment system

Control by IPDM E/R

- Relay control function
- Auto light system has the auto light function (with twilight lighting function), wiper linked auto lighting function and delay timer function.
- Auto light function automatically turns ON/OFF the exterior lamps* and each illumination automatically, depending on the outside brightness.
- Wiper linked auto lighting function automatically turns ON/OFF the exterior lamps* and each illumination when the light switch is in the AUTO position, according to a front wiper operation.
- When auto light system turns the exterior lamps ON with the ignition switch OFF, delay timer function turns the exterior lamps OFF, depending on the vehicle condition with the auto light function after a certain period of time.

*: Headlamp (LO/HI), parking lamp, license plate lamp, side marker lamp, tail lamp and front fog lamp (Headlamp HI and front fog lamp depend on the combination switch condition.)

NOTE:

The settings of the twilight lighting function and the wiper linked auto lighting function can be changed with CONSULT. Refer to [EXL-26, "HEADLAMP : CONSULT Function \(BCM - HEAD LAMP\)"](#).

AUTO LIGHT FUNCTION (WITH TWILIGHT LIGHTING FUNCTION)

Description

- BCM detects the combination switch condition with the combination switch reading function.
- BCM supplies voltage to the optical sensor when the ignition switch is turned ON or ACC.
- Optical sensor converts outside brightness (lux) to voltage and transmits the optical sensor signal to BCM.
- When ignition switch is turned ON, BCM detects outside brightness from the optical sensor signal and judges ON/OFF condition of the exterior lamp and each illumination, depending on the outside brightness condition (standard or twilight).
- BCM transmits each request signal to IPDM E/R via CAN communication, according to ON/OFF condition by the auto light function.

NOTE:

As to ON/OFF timing, the sensitivity depends on settings. The settings can be changed with CONSULT. Refer to [EXL-26, "HEADLAMP : CONSULT Function \(BCM - HEAD LAMP\)"](#).

WIPER LINKED AUTO LIGHTING FUNCTION

BCM turns the exterior lamp ON when detecting 4 operations of the front wiper work the light switch in AUTO position.

NOTE:

BCM turns OFF the headlamps 3 seconds after the front wiper switch is turned from HI⇒OFF.

AUTO LIGHT ADJUSTMENT SYSTEM

The auto light adjustment system automatically, dims/brightens the display and combination meter, according to brightness outside the vehicle, when lighting switch 1ST or lighting switch 2ND is operated. Refer to [INL-11, "AUTO LIGHT ADJUSTMENT SYSTEM : System Description"](#).

DELAY TIMER FUNCTION

BCM turns the exterior lamp OFF depending on the vehicle condition with the auto light function when the ignition switch is turned OFF.

- Turns the exterior lamp OFF 5 minutes after detecting that any door opens excepting back door. (Door switch ON).
- Turns the exterior lamp OFF a certain period of time* after closing all doors excepting back door. (Door switch ON⇒OFF).
- Turns the exterior lamp OFF with the ignition switch ACC or the light switch OFF.

*: The preset time is 45 seconds. The timer operating time can be set by CONSULT. Refer to [EXL-26, "HEADLAMP : CONSULT Function \(BCM - HEAD LAMP\)"](#).

NOTE:

When any position other than the light switch AUTO is set, the auto light system function switches to the exterior lamp battery saver function.

AUTO LIGHT SYSTEM (WITH DTRL)

AUTO LIGHT SYSTEM (WITH DTRL) : System Diagram

INFOID:000000006887843

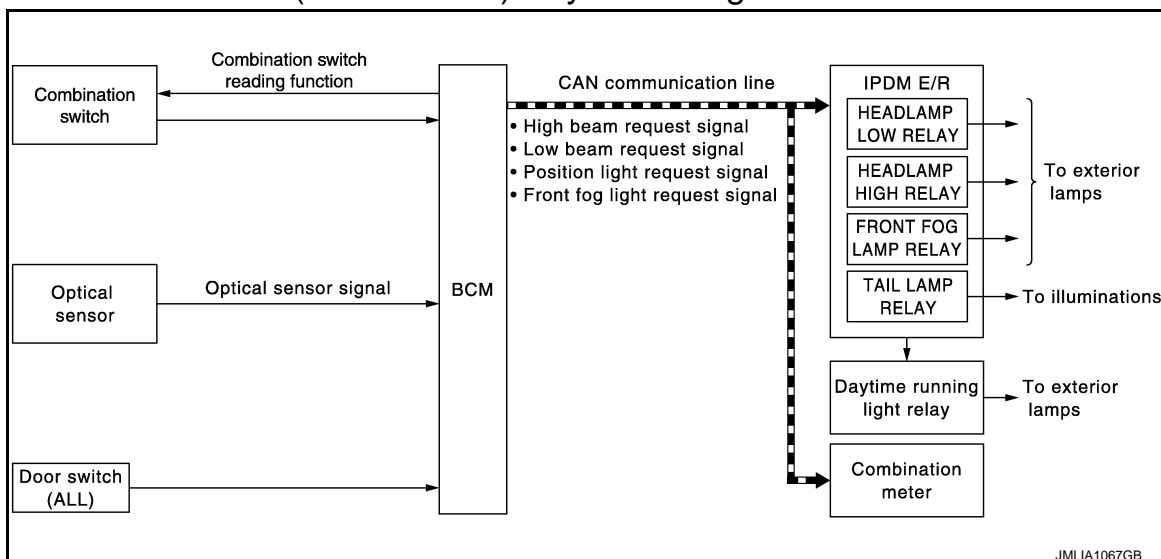

A
B
C
D
E
F
G
H
I
J
K

EXL

M
N
O
P

AUTO LIGHT SYSTEM (WITH DTRL) : System Description

INFOID:00000006887844

OUTLINE

- Auto light system is controlled by each function of BCM and IPDM E/R.

Control by BCM

- Combination switch reading function
- Headlamp control function
- Auto light function
- Delay timer function
- Auto light adjustment system

Control by IPDM E/R

- Relay control function
- Auto light system has the auto light function and delay timer function.
- Auto light function automatically turns ON/OFF the exterior lamps* and each illumination automatically, depending on the outside brightness.
- When auto light system turns the exterior lamps ON with the ignition switch OFF, delay timer function turns the exterior lamps OFF, depending on the vehicle condition with the auto light function after a certain period of time.

*: Headlamp (LO/HI), parking lamp, license plate lamp, side marker lamp, tail lamp and front fog lamp (Headlamp HI and front fog lamp depend on the combination switch condition.)

AUTO LIGHT ADJUSTMENT SYSTEM

The auto light adjustment system automatically, dims/brightens the display and combination meter, according to brightness outside the vehicle, when lighting switch 1ST or lighting switch 2ND is operated. Refer to [INL-11, "AUTO LIGHT ADJUSTMENT SYSTEM : System Description"](#).

DELAY TIMER FUNCTION

BCM turns the exterior lamp OFF depending on the vehicle condition with the auto light function when the ignition switch is turned OFF.

- Turns the exterior lamp OFF 5 minutes after detecting that any door opens excepting back door. (Door switch ON).
- Turns the exterior lamp OFF a certain period of time* after closing all doors excepting back door. (Door switch ON→OFF).
- Turns the exterior lamp OFF with the ignition switch ACC or the light switch OFF.

*: The preset time is 45 seconds. The timer operating time can be set by CONSULT. Refer to [EXL-26, "HEADLAMP : CONSULT Function \(BCM - HEAD LAMP\)"](#).

NOTE:

When any position other than the light switch AUTO is set, the auto light system function switches to the exterior lamp battery saver function.

DAYTIME RUNNING LIGHT SYSTEM

DAYTIME RUNNING LIGHT SYSTEM : System Diagram

INFOID:00000006887845

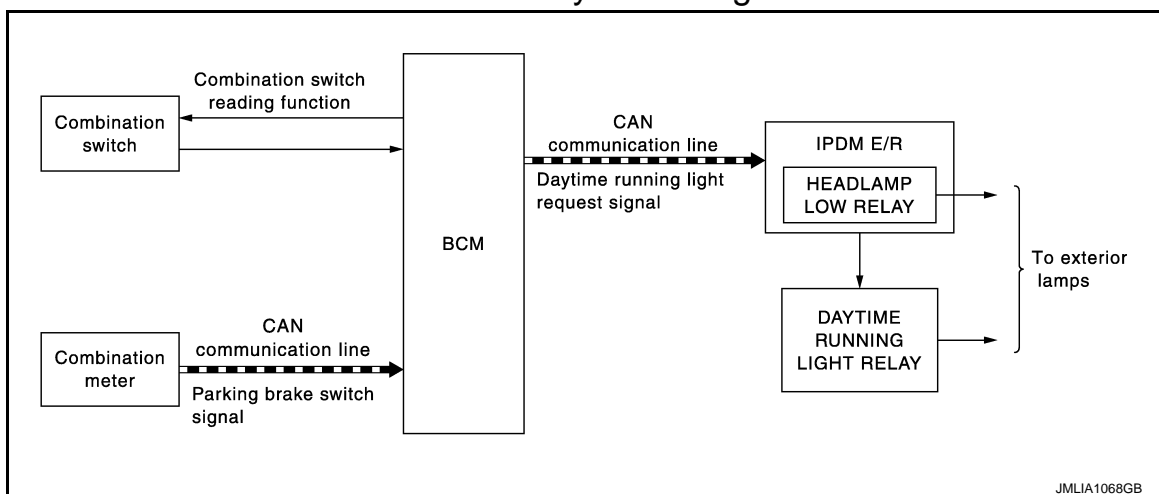

DAYTIME RUNNING LIGHT SYSTEM : System Description

INFOID:000000006887846

OUTLINE

- Turns the following exterior lamps ON as the daytime running light.
 - Headlamp (LO)
 - Parking, license plate, side marker and tail lamps.
- Daytime running light is controlled by daytime running light control function and combination switch reading function of BCM, and relay control function of IPDM E/R.

DAYTIME RUNNING LIGHT OPERATION

- BCM detects the combination switch condition by the combination switch reading function.
- BCM detects vehicle condition depending on the following signals.
 - Parking brake switch signal (received from combination meter via CAN communication)
- BCM transmits the daytime running light request signal to IPDM E/R via CAN communication according to the daytime running light ON condition.

Daytime running light ON condition

- While the engine running with the parking brake released.
- Lighting switch is in the other positions than 2ND.
- IPDM E/R turns the integrated headlamp low relay and daytime running light relay ON according to the daytime running light request signal. And it turns each lamps ON.

ACTIVE ADAPTIVE FRONT-LIGHTING SYSTEM

ACTIVE ADAPTIVE FRONT-LIGHTING SYSTEM : System Diagram

INFOID:000000006887847

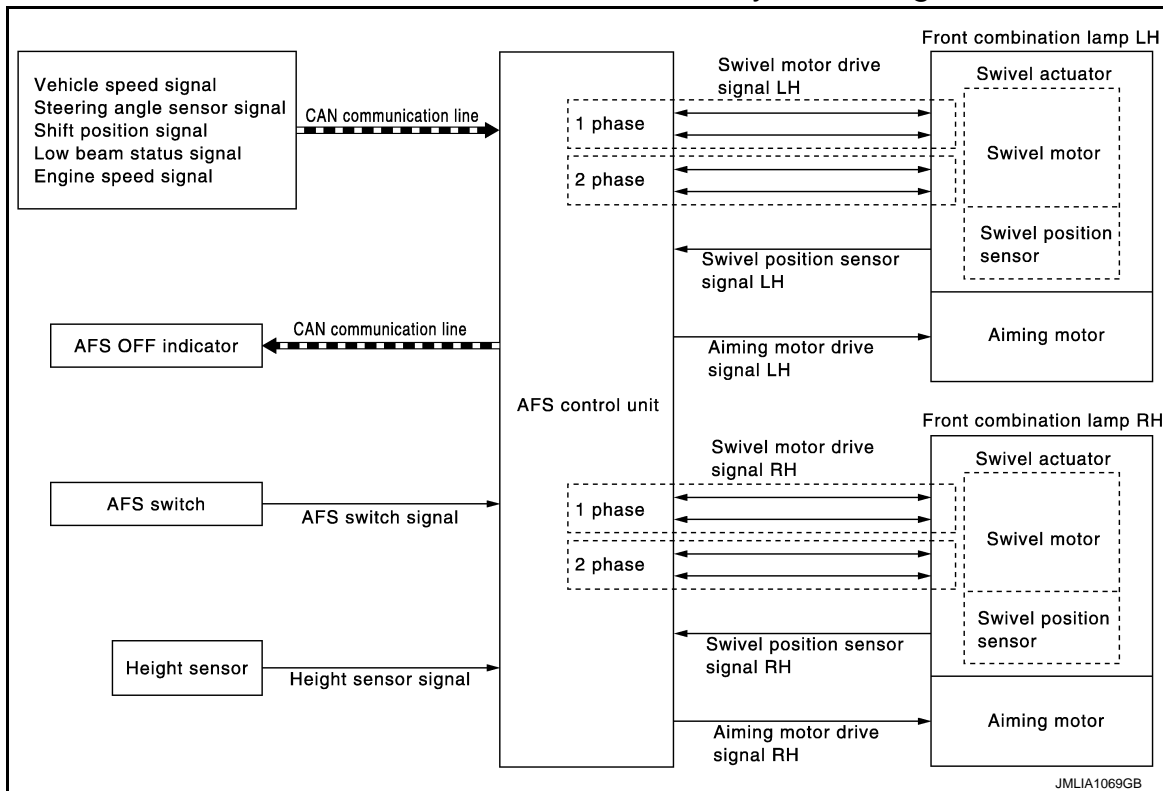

ACTIVE ADAPTIVE FRONT-LIGHTING SYSTEM : System Description

INFOID:000000006887848

OUTLINE

- AFS (ACTIVE ADAPTIVE FRONT-LIGHTING SYSTEM) is controlled by AFS control unit.
- AFS has AFS control (swivel control) and the headlamp auto aiming control.
 - AFS control swivels the headlamp to the steering direction.
 - Headlamp auto aiming control moves the headlamp light axis up/down according to the vehicle height.

AFS (ADAPTIVE FRONT-LIGHTING SYSTEM)

< SYSTEM DESCRIPTION >

AFS Control Description

- AFS control unit controls the headlamp (right) only when the steering wheel is turned rightward, and the headlamp (left) only when the steering wheel is turned leftward.
- AFS control unit detects the vehicle condition necessary for AFS control with the following signals.
 - AFS switch signal
 - Vehicle speed signal (received from combination meter via CAN communication)
 - Steering angle sensor signal (received from steering angle sensor via CAN communication)
 - Shift position signal (received from TCM via CAN communication)
 - Low beam status signal (received from IPDM E/R via CAN communication)
 - Engine speed signal (received from ECM via CAN communication)
- When the operation conditions are satisfied, AFS control unit controls the swivel angle depending on the steering angle and the vehicle speed.

AFS operation condition

- Swivel actuator initialization completed
- AFS "ON" (AFS OFF indicator lamp "OFF")
- Headlamp ON
- While the engine running
- Selector lever position other than "P" or "R"
- Vehicle speed approximately 25 km/h (15.5 MPH) or more
(Left swivel only; Right swivel activates regardless of the vehicle speed.)

Swivel Actuator Initialization

- AFS control unit performs the swivel actuator initialization when detecting that the engine starts.
- Swivels the headlamp to the vehicle-center side until it hits the stopper.
- Returns the swivel angle from the stopper. Completes the initialization with regarding the returned position as the swivel angle 0° (straight-forward position).

Swivel Operation

- AFS control unit transmits the drive signal to the swivel actuator when activation conditions are satisfied. And swivels the headlamp.
- The swivel starts after steering approximately 20° or more from straight-forward position.
 - NOTE:**
The steering angle differs between right turn and left turn.
- The swivel angle becomes the maximum angle toward the driving direction if the steering angle is approximately 90° or more depending on the vehicle speed. The swivel angle is maintained by shutting off the drive signal.
- The swivel starts, and returns to the swivel angle 0° (straight-forward position) when the steering is returned to the straight-forward position.
- AFS control unit returns the swivel angle to the straight-forward position, and stops the swivel regardless of the steering angle if the operation condition is not satisfied while the swivel angle is 0°.

AFS OFF Indicator Lamp

- AFS control unit transmits AFS OFF indicator lamp signal to the combination meter via CAN communication.
- Combination meter turns AFS OFF indicator lamp ON/OFF/blinking according to AFS OFF indicator lamp signal.
- AFS OFF indicator lamp is turned ON for 1 second for the AFS OFF indicator lamp bulb check when the ignition switch is turned ON. AFS OFF indicator lamp is turned OFF within 1 second when the engine starts.
- AFS OFF indicator lamp turns ON when AFS is switched to "OFF" by operating AFS switch.
- AFS OFF indicator lamp blinks (1 second each) if AFS control unit detects a specific DTC.

NOTE:

Combination meter blinks AFS OFF indicator lamp (approximately 1 second each) if AFS OFF indicator lamp signal is not received from AFS control unit.

HEADLAMP AUTO AIMING

Headlamp Auto Aiming Control Description

- AFS control unit controls the headlamp light axis height appropriately according to the vehicle height.
- AFS control unit detects the vehicle condition necessary for headlamp auto aiming control with the following signals.
 - Height sensor signal
 - Vehicle speed signal (received from combination meter via CAN communication)
 - Low beam status signal (received from IPDM E/R via CAN communication)
 - Engine speed signal (received from ECM via CAN communication)

SYSTEM

< SYSTEM DESCRIPTION >

[XENON TYPE]

- When the operation conditions are satisfied, AFS control unit transmits the aiming motor drive signal for adjusting the headlamp axis height.

Headlamp auto aiming operation condition

- Headlamp ON
- While the engine running
- Vehicle speed (Control mode is switched according to the driving condition.)

Headlamp Auto Aiming Operation

- AFS control unit calculates the vehicle pitch angle from the height sensor signal. AFS control unit judges the angle for adjusting the axis gap from the preset position.
- AFS control unit controls the headlamp axis by changing the aiming motor drive signal output according to the vehicle-rearward height when detecting the following vehicle condition. Output is maintained if other condition than following is detected.
- Engine starts.
- Headlamp is turned ON.
- Vehicle posture becomes stable after changing the vehicle posture change is detected with the headlamp ON and the vehicle stopped.
- Vehicle speed is maintained with the headlamp ON and the vehicle driven.

CAUTION:

Adjusted axis position may differ from the preset position although the headlamp auto aiming activates properly if the suspension is replaced or worn.

FRONT FOG LAMP SYSTEM

FRONT FOG LAMP SYSTEM : System Diagram

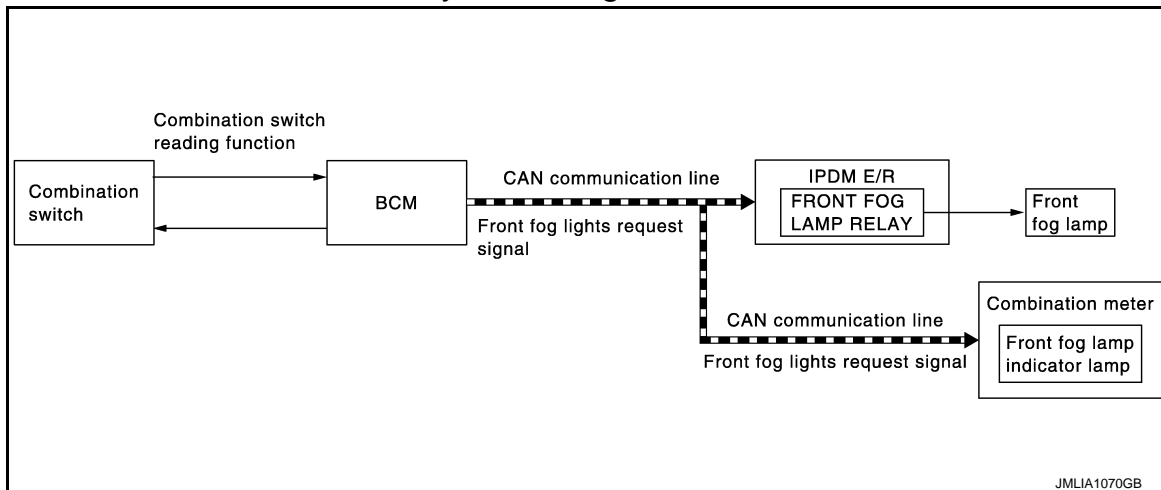

FRONT FOG LAMP SYSTEM : System Description

INFOID:000000006887850

OUTLINE

Front fog lamp is controlled by combination switch reading function and front fog lamp control function of BCM, and relay control function of IPDM E/R.

FRONT FOG LAMP OPERATION

- BCM detects the combination switch condition by the combination switch reading function.
- BCM transmits the front fog lights request signal to IPDM E/R and the combination meter via CAN communication according to the front fog lamp ON condition.

Front fog lamp ON condition

- Front fog lamp switch ON and any of the followings. (except for the high beam ON)
- Lighting switch 2ND
- Lighting switch AUTO and the ignition switch ON

NOTE:

- Headlamp, front fog lamp, parking lamp, licence plate lamp, side marker lamp and tail lamp are turned ON.
- IPDM E/R turns the integrated front fog lamp relay ON, and turns the front fog lamp ON according to the front fog lights request signal.

SYSTEM

< SYSTEM DESCRIPTION >

[XENON TYPE]

- Combination meter turns the front fog lamp indicator lamp ON according to the front fog lights request signal.

TURN SIGNAL AND HAZARD WARNING LAMP SYSTEM

TURN SIGNAL AND HAZARD WARNING LAMP SYSTEM : System Diagram

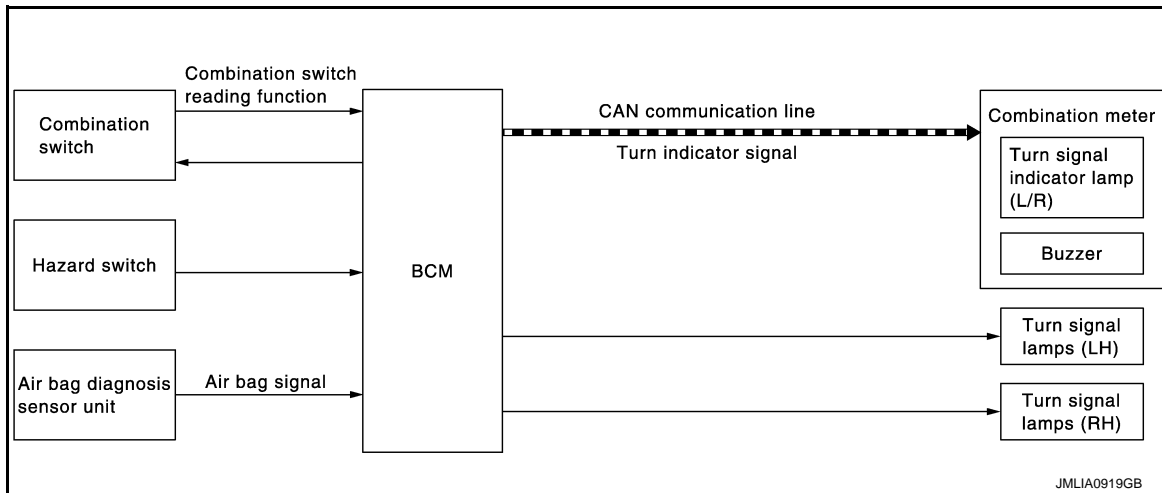

TURN SIGNAL AND HAZARD WARNING LAMP SYSTEM : System Description

INFOID:000000006887852

OUTLINE

Turn signal and the hazard warning lamp is controlled by combination switch reading function, flasher control function and auto hazard function of BCM.

TURN SIGNAL LAMP OPERATION

- BCM detects the combination switch condition by the combination switch reading function.
- BCM supplies voltage to the right (left) turn signal lamp circuit when the ignition switch is turned ON and the turn signal switch is in the right (left) position. BCM blinks the turn signal lamp.

HAZARD WARNING LAMP OPERATION

BCM supplies voltage to both turn signal lamp circuit when the hazard switch is turned ON. BCM blinks the hazard warning lamp.

TURN SIGNAL INDICATOR LAMP AND TURN SIGNAL SOUND OPERATION

- BCM transmits the turn indicator signal to the combination meter via CAN communication while the turn signal lamp and the hazard warning lamp operating.
- Combination meter outputs the turn signal sound with the integrated buzzer while blinking the turn signal indicator lamp according to the turn indicator signal.

HIGH FLASHER OPERATION

- BCM detects the turn signal lamp circuit status from the current value.
- BCM increases the turn signal lamp blinking speed if the bulb or harness open is detected with the turn signal lamp operating.

NOTE:

The blinking speed is normal while operating the hazard warning lamp.

AUTO HAZARD FUNCTION

- Air bag diagnosis sensor unit transmits air bag signal to BCM, when air bag diagnosis sensor unit detects strong impact to the vehicle body while ignition switch is ON.
- When air bag signal from air bag diagnosis sensor unit is detected, BCM supplies voltage to each turn signal lamp system and hazard lamp blinks.

PARKING, LICENSE PLATE, SIDE MARKER AND TAIL LAMP SYSTEM (WITHOUT DTRL)

PARKING, LICENSE PLATE, SIDE MARKER AND TAIL LAMP SYSTEM (WITHOUT

DTRL) : System Diagram

INFOID:000000006887853

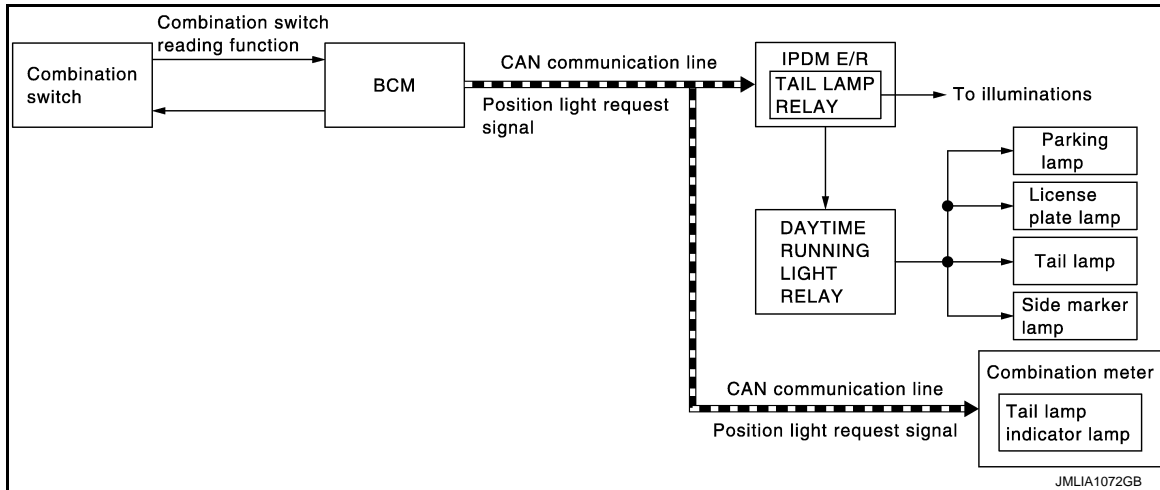

PARKING, LICENSE PLATE, SIDE MARKER AND TAIL LAMP SYSTEM (WITHOUT DTRL) : System Description

INFOID:000000006887854

OUTLINE

Parking, license plate, side marker and tail lamps are controlled by combination switch reading function and headlamp control function of BCM, and relay control function of IPDM E/R.

PARKING, LICENSE PLATE AND TAIL LAMPS OPERATION

- BCM detects the combination switch condition by the combination switch reading function.
- BCM transmits the position light request signal to IPDM E/R and the combination meter via CAN communication according to the ON/OFF condition of the parking, license plate and tail lamps.

Parking, license plate and tail lamps ON condition

- Lighting switch 1ST
- Lighting switch 2ND
- Lighting switch AUTO, and the auto light function ON judgment
- Lighting switch AUTO, with the front fog lamp switch ON and the ignition switch ON
- IPDM E/R turns the daytime running light relay ON and turns the parking, license plate, side marker and tail lamps ON according to the position light request signal.
- Combination meter turns the tail lamp indicator lamp ON according to the position light request signal.

PARKING, LICENSE PLATE, SIDE MARKER AND TAIL LAMP SYSTEM (WITHOUT DTRL) : Fail-safe

INFOID:000000006887855

CAN COMMUNICATION CONTROL

When CAN communication with BCM is impossible, IPDM E/R performs fail-safe control. After CAN communication recovers normally, it also returns to normal control.

If No CAN Communication Is Available With BCM

Control part	Fail-safe operation
<ul style="list-style-type: none"> • Parking lamps • License plate lamps • Illuminations • Tail lamps 	<ul style="list-style-type: none"> • Turns ON the daytime running light relay when the ignition switch is turned ON • Turns OFF the daytime running light relay when the ignition switch is turned OFF

PARKING, LICENSE PLATE, SIDE MARKER AND TAIL LAMP SYSTEM (WITH DTRL)

PARKING, LICENSE PLATE, SIDE MARKER AND TAIL LAMP SYSTEM (WITH

SYSTEM

< SYSTEM DESCRIPTION >

[XENON TYPE]

DTRL) : System Diagram

INFOID:000000006887856

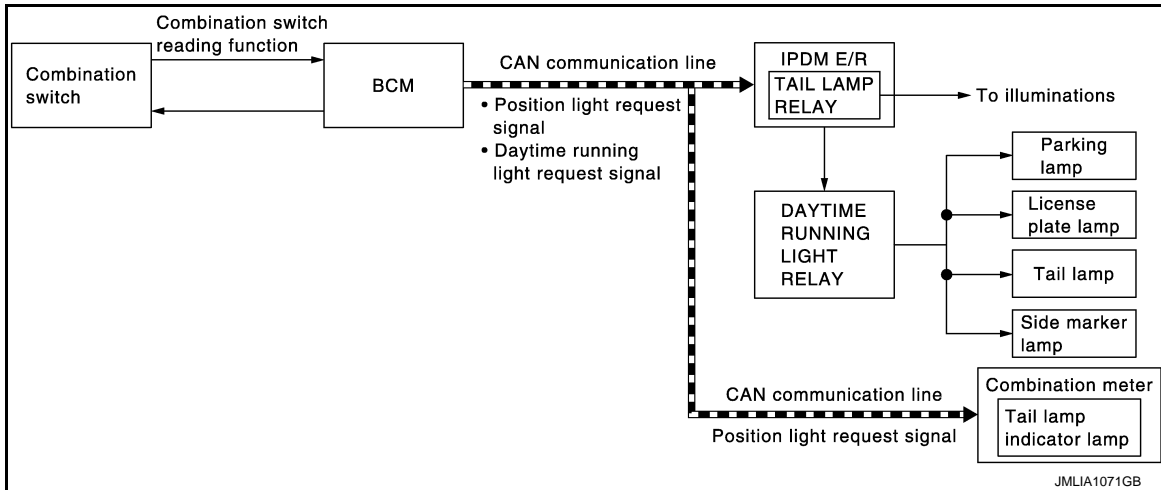

PARKING, LICENSE PLATE, SIDE MARKER AND TAIL LAMP SYSTEM (WITH DTRL) : System Description

INFOID:000000006887857

OUTLINE

Parking, license plate, side marker and tail lamps are controlled by combination switch reading function and headlamp control function of BCM, and relay control function of IPDM E/R.

PARKING, LICENSE PLATE AND TAIL LAMPS OPERATION

- BCM detects the combination switch condition by the combination switch reading function.
- BCM transmits the daytime running light request signal or position light request signal to IPDM E/R and the combination meter via CAN communication according to the ON/OFF condition of the parking, license plate, side marker and tail lamps.

Parking, license plate and tail lamps ON condition

- Lighting switch 1ST
- Lighting switch 2ND
- Lighting switch is in the other positions than 2ND (daytime running light ON judgement).
- Lighting switch AUTO, and the auto light function ON judgment
- Lighting switch AUTO, with the front fog lamp switch ON and the ignition switch ON
- IPDM E/R turns the daytime running light relay ON and turns the parking, license plate, side marker and tail lamps ON according to the day time running request signal or position light request signal.
- Combination meter turns the tail lamp indicator lamp ON according to the position light request signal.

PARKING, LICENSE PLATE, SIDE MARKER AND TAIL LAMP SYSTEM (WITH DTRL) : Fail-safe

INFOID:000000006887858

CAN COMMUNICATION CONTROL

When CAN communication with BCM is impossible, IPDM E/R performs fail-safe control. After CAN communication recovers normally, it also returns to normal control.

If No CAN Communication Is Available With BCM

Control part	Fail-safe operation
<ul style="list-style-type: none"> • Parking lamps • License plate lamps • Illuminations • Tail lamps 	<ul style="list-style-type: none"> • Turns ON the tail lamp relay and daytime running light relay when the ignition switch is turned ON • Turns OFF the tail lamp relay and daytime running light relay when the ignition switch is turned OFF

EXTERIOR LAMP BATTERY SAVER SYSTEM

SYSTEM

< SYSTEM DESCRIPTION >

[XENON TYPE]

EXTERIOR LAMP BATTERY SAVER SYSTEM : System Diagram

INFOID:000000006887859

WITHOUT DAYTIME RUNNING LIGHT SYSTEM

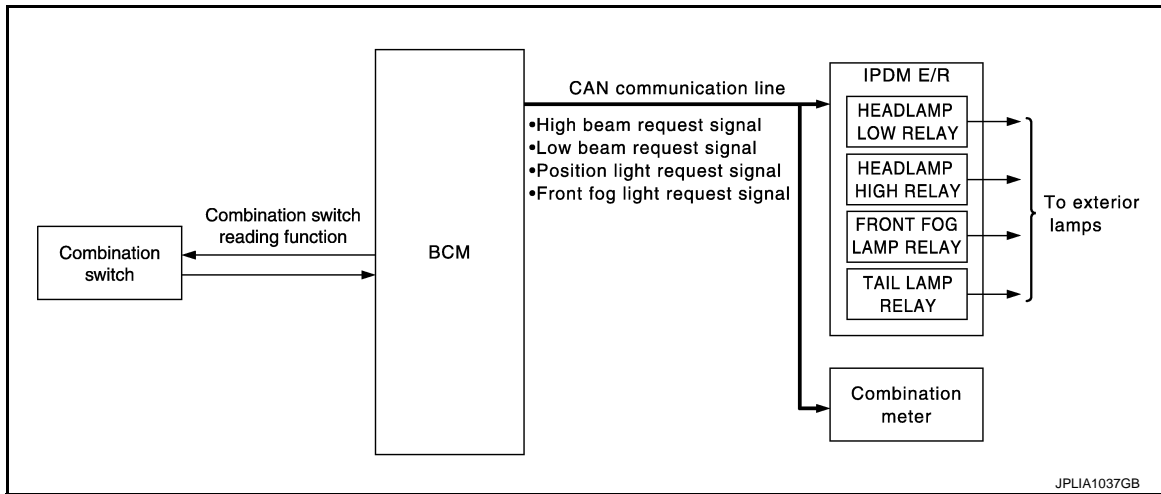

WITH DAYTIME RUNNING LIGHT SYSTEM

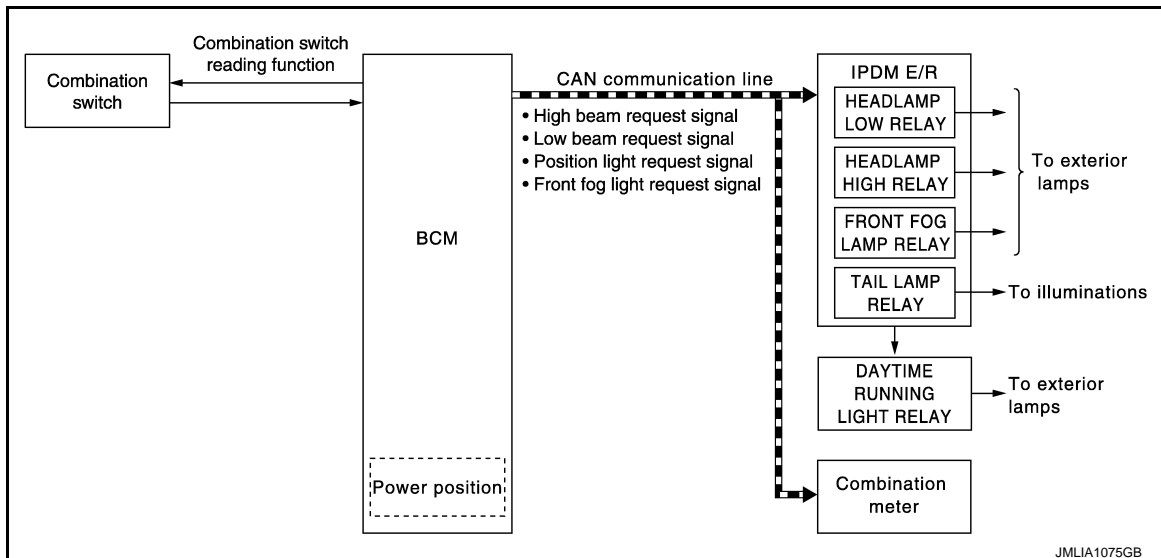

EXTERIOR LAMP BATTERY SAVER SYSTEM : System Description

INFOID:000000006887860

OUTLINE

- Exterior lamp battery saver system is controlled by each function of BCM and IPDM E/R.

Control by BCM

- Combination switch reading function
- Headlamp control function
- Exterior lamp battery saver function

Control by IPDM E/R

- Relay control function
 - BCM turns the exterior lamp* OFF after a period of time to prevent the battery from over-discharge when the ignition switch is turned OFF with the exterior lamp ON.
- *: Headlamp (LO/Hi), parking lamp, tail lamp, license plate lamp, side marker lamp and front fog lamp

EXTERIOR LAMP BATTERY SAVER ACTIVATION

BCM activates the timer and turns the exterior lamp OFF 5 minutes after the ignition switch is turned from ON → OFF with the exterior lamps ON.

NOTE:

- Headlamp control function turns the exterior lamps ON normally when the ignition switch is turned ACC or the engine started (both before and after the exterior lamp battery saver is turned OFF).

A
B
C
D
E
F
G
H
I
J
K

EXL

SYSTEM

< SYSTEM DESCRIPTION >

[XENON TYPE]

- The timer starts at the time that the lighting switch is turned from OFF → 1ST or 2ND with the exterior lamp OFF.

DIAGNOSIS SYSTEM (BCM)

[XENON TYPE]

< SYSTEM DESCRIPTION >

DIAGNOSIS SYSTEM (BCM)

COMMON ITEM

COMMON ITEM : CONSULT Function (BCM - COMMON ITEM)

INFOID:000000007216252

APPLICATION ITEM

CONSULT performs the following functions via CAN communication with BCM.

Diagnosis mode	Function Description
Work Support	Changes the setting for each system function.
Self Diagnostic Result	Displays the diagnosis results judged by BCM.
CAN Diag Support Monitor	Monitors the reception status of CAN communication viewed from BCM.
Data Monitor	The BCM input/output signals are displayed.
Active Test	The signals used to activate each device are forcibly supplied from BCM.
Ecu Identification	The BCM part number is displayed.
Configuration	<ul style="list-style-type: none"> Read and save the vehicle specification. Write the vehicle specification when replacing BCM.

SYSTEM APPLICATION

BCM can perform the following functions for each system.

NOTE:

It can perform the diagnosis modes except the following for all sub system selection items.

x: Applicable item

System	Sub system selection item	Diagnosis mode		
		Work Support	Data Monitor	Active Test
Door lock	DOOR LOCK	×	×	×
Rear window defogger	REAR DEFOGGER		×	×
Warning chime	BUZZER		×	×
Interior room lamp timer	INT LAMP	×	×	×
Exterior lamp	HEAD LAMP	×	×	×
Wiper and washer	WIPER	×	×	×
Turn signal and hazard warning lamps	FLASHER	×	×	×
—	AIR CONDITONER*		×	×
<ul style="list-style-type: none"> Intelligent Key system Engine start system 	INTELLIGENT KEY	×	×	×
Combination switch	COMB SW		×	
Body control system	BCM	×		
IVIS - NATS	IMMU	×	×	×
Interior room lamp battery saver	BATTERY SAVER	×	×	×
Trunk lid open	TRUNK		×	
Vehicle security system	THEFT ALM	×	×	×
RAP system	RETAINED PWR		×	
Signal buffer system	SIGNAL BUFFER		×	×
—	AIR PRESSURE MONITOR*	×	×	×

*: This item is not used.

FREEZE FRAME DATA (FFD)

The BCM records the following vehicle condition at the time a particular DTC is detected, and displays on CONSULT.

DIAGNOSIS SYSTEM (BCM)

< SYSTEM DESCRIPTION >

[XENON TYPE]

CONSULT screen item	Indication/Unit	Description	
Vehicle Speed	km/h	Vehicle speed of the moment a particular DTC is detected	
Odo/Trip Meter	km	Total mileage (Odometer value) of the moment a particular DTC is detected	
Vehicle Condition	SLEEP>LOCK	Power position status of the moment a particular DTC is detected	While turning BCM status from low power consumption mode to normal mode (Power supply position is "LOCK"*)
	SLEEP>OFF		While turning BCM status from low power consumption mode to normal mode (Power supply position is "OFF".)
	LOCK>ACC		While turning power supply position from "LOCK" *to "ACC"
	ACC>ON		While turning power supply position from "ACC" to "IGN"
	RUN>ACC		While turning power supply position from "RUN" to "ACC" (Vehicle is stopping and selector lever is except P position.)
	CRANK>RUN		While turning power supply position from "CRANKING" to "RUN" (From cranking up the engine to run it)
	RUN>URGENT		While turning power supply position from "RUN" to "ACC" (Emergency stop operation)
	ACC>OFF		While turning power supply position from "ACC" to "OFF"
	OFF>LOCK		While turning power supply position from "OFF" to "LOCK"*
	OFF>ACC		While turning power supply position from "OFF" to "ACC"
	ON>CRANK		While turning power supply position from "IGN" to "CRANKING"
	OFF>SLEEP		While turning BCM status from normal mode (Power supply position is "OFF".) to low power consumption mode
	LOCK>SLEEP		While turning BCM status from normal mode (Power supply position is "LOCK"*.) to low power consumption mode
	LOCK		Power supply position is "LOCK" (Ignition switch OFF with steering is locked.)*
	OFF		Power supply position is "OFF" (Ignition switch OFF with steering is unlocked.)
	ACC		Power supply position is "ACC" (Ignition switch ACC)
	ON		Power supply position is "IGN" (Ignition switch ON with engine stopped)
	ENGINE RUN		Power supply position is "RUN" (Ignition switch ON with engine running)
CRANKING	Power supply position is "CRANKING" (At engine cranking)		
IGN Counter	0 - 39	The number of times that ignition switch is turned ON after DTC is detected <ul style="list-style-type: none"> • The number is 0 when a malfunction is detected now. • The number increases like 1 → 2 → 3...38 → 39 after returning to the normal condition whenever ignition switch OFF → ON. • The number is fixed to 39 until the self-diagnosis results are erased if it is over 39. 	

NOTE:

*: For models without steering lock unit, power supply position changes from "OFF" to "LOCK" when steering lock conditions are satisfied.

HEADLAMP

HEADLAMP : CONSULT Function (BCM - HEAD LAMP)

INFOID:000000006887862

WORK SUPPORT

DIAGNOSIS SYSTEM (BCM)

< SYSTEM DESCRIPTION >

[XENON TYPE]

Service item	Setting item	Setting
CUSTOM A/LIGHT SETTING	MODE 1 [*]	Normal
	MODE 2	More sensitive setting than normal setting (Turns ON earlier than normal operation.)
	MODE 3	More sensitive setting than MODE 2 (Turns ON earlier than MODE 2.)
	MODE 4	Less sensitive setting than normal setting (Turns ON later than normal operation.)
AUTO LIGHT LOGIC SET [*]	MODE 1 [*]	With twilight ON custom & with wiper INT, LO and HI
	MODE 2	With twilight ON custom & with wiper LO and HI
	MODE 3	With twilight ON custom & without
	MODE 4	Without twilight ON custom & with wiper INT, LO and HI
	MODE 5	Without twilight ON custom & with wiper LO and HI
	MODE 6	Without twilight ON custom & without
BATTERY SAVER SET	On [*]	With the exterior lamp battery saver function
	Off	Without the exterior lamp battery saver function
ILL DELAY SET	MODE 1 [*]	45 sec.
	MODE 2	Without the function
	MODE 3	30 sec.
	MODE 4	60 sec.
	MODE 5	90 sec.
	MODE 6	120 sec.
	MODE 7	150 sec.
	MODE 8	180 sec.
		Sets delay timer function timer operation time. (All doors closed)

^{*1}: For models with daytime running light system, this item is not displayed.

^{*2}: Factory setting

DATA MONITOR

Monitor item [Unit]	Description
PUSH SW [On/Off]	The switch status input from push-button ignition switch
ENGINE STATE [Stop/Stall/Crank/Run]	The engine status received from ECM via CAN communication
VEH SPEED 1 [km/h]	The value of the vehicle speed received from combination meter via CAN communication

DIAGNOSIS SYSTEM (BCM)

< SYSTEM DESCRIPTION >

[XENON TYPE]

Monitor item [Unit]	Description
TURN SIGNAL R [On/Off]	Each switch status that BCM judges from the combination switch reading function
TURN SIGNAL L [On/Off]	
TAIL LAMP SW [On/Off]	
HI BEAM SW [On/Off]	
HEAD LAMP SW1 [On/Off]	
HEAD LAMP SW2 [On/Off]	
PASSING SW [On/Off]	
AUTO LIGHT SW [On/Off]	
FR FOG SW [On/Off]	
RR FOG SW [On/Off]	NOTE: The item is indicated, but not monitored.
DOOR SW-DR [On/Off]	The switch status input from front door switch (driver side)
DOOR SW-AS [On/Off]	The switch status input from front door switch (passenger side)
DOOR SW-RR [On/Off]	The switch status input from rear door switch RH
DOOR SW- RL [On/Off]	The switch status input from rear door switch LH
DOOR SW-BK [On/Off]	NOTE: The item is indicated, but not monitored.
OPTICAL SENSOR [On/Off/NG]	NOTE: The item is indicated, but not monitored.
OPTICAL SEN (DTCT) [V]	The value of outside brightness voltage input from the optical sensor
OPTICAL SEN (FLIT) [V]	The sensor outside brightness voltage filtered by BCM.

ACTIVE TEST

Test item	Operation	Description
TAIL LAMP	On	Transmits the position light request signal to IPDM E/R via CAN communication to turn the tail lamp ON.
	Off	Stops the tail lamp request signal transmission.
HEAD LAMP	Hi	Transmits the high beam request signal via CAN communication to turn the headlamp (HI).
	Low	Transmits the low beam request signal via CAN communication to turn the headlamp (LO).
	Off	Stops the high & low beam request signal transmission.
FR FOG LAMP	On	Transmits the front fog lights request signal to IPDM E/R via CAN communication to turn the front fog lamp ON.
	Off	Stops the front fog lights request signal transmission.

DIAGNOSIS SYSTEM (BCM)

[XENON TYPE]

< SYSTEM DESCRIPTION >

Test item	Operation	Description
RR FOG LAMP	On	NOTE: The item is indicated, but cannot be tested.
	Off	
DAYTIME RUNNING LIGHT*	On	Transmits the daytime running light request signal via CAN communication to turn the headlamp (LO), parking, license plate, side marker and tail lamps ON.
	Off	Stop the daytime running light request signal transmission.
ILL DIM SIGNAL	On	<ul style="list-style-type: none"> Transmits the dimmer signal to combination meter via CAN communication and dims combination meter. Transmits the dimmer signal to AV control unit and dims display.
	Off	Stops the dimmer signal transmission.

*: For models without daytime running light system, This item is displayed but active test is not operated.

FLASHER

FLASHER : CONSULT Function (BCM - FLASHER)

INFOID:000000006887863

WORK SUPPORT

Service item	Setting item	Setting	
HAZARD ANSWER BACK	Lock Only	With locking only	Sets the hazard warning lamp answer back function when the door is lock/unlock with the request switch or the key fob.
	Unlock Only	With unlocking only	
	Lock&Unlock*	With locking/unlocking	
	Off	Without the function	

*: Factory setting

DATA MONITOR

Monitor item [Unit]	Description
REQ SW-DR [On/Off]	The switch status input from the request switch (driver side)
REQ SW-AS [On/Off]	The switch status input from the request switch (passenger side)
PUSH SW [On/Off]	The switch status input from the push-button ignition switch
TURN SIGNAL R [On/Off]	Each switch status that BCM detects from the combination switch reading function
TURN SIGNAL L [On/Off]	
HAZARD SW [On/Off]	The switch status input from the hazard switch
RKE-LOCK [On/Off]	Lock signal status received from the remote keyless entry receiver
RKE-UNLOCK [On/Off]	Unlock signal status received from the remote keyless entry receiver
RKE-PANIC [On/Off]	Panic alarm signal status received from the remote keyless entry receiver

ACTIVE TEST

DIAGNOSIS SYSTEM (BCM)

< SYSTEM DESCRIPTION >

[XENON TYPE]

Test item	Operation	Description
FLASHER	RH	Outputs the voltage to blink the right side turn signal lamps.
	LH	Outputs the voltage to blink the left side turn signal lamps.
	Off	Stops the voltage to turn the turn signal lamps OFF.

DIAGNOSIS SYSTEM (IPDM E/R)

Diagnosis Description

INFOID:000000007216253

AUTO ACTIVE TEST

Description

In auto active test, the IPDM E/R sends a drive signal to the following systems to check their operation.

- Oil pressure warning lamp (only for models with VQ37VHR engine)
- Front wiper (LO, HI)
- Parking lamp
- License plate lamp
- Tail lamp
- Side marker lamp
- Front fog lamp
- Headlamp (LO, HI)
- A/C compressor (magnet clutch)
- Cooling fan (cooling fan control module)

Operation Procedure

CAUTION:

Wiper arm interferes with hood when wiper is operated while wiper arm is in the raised position. Always perform auto active test without setting wiper arm in the raised position. Always pour water on front windshield glass in advance to auto active test so that damage on front windshield glass surface is prevented.

NOTE:

Never perform auto active test in the following condition.

- Engine is running
 - CONSULT is connected
1. Turn the ignition switch OFF.
 2. Turn the ignition switch ON, and within 20 seconds, press the front door switch (driver side) 10 times. Then turn the ignition switch OFF.

NOTE:

- Close passenger door.
- Within 5 seconds after ignition switch is turned to the ON position and when driver door switch is pressed 6 times or more within 4 seconds, self-diagnosis function for BOSE amp. activates and speaker sounds. After waiting for 5 seconds or more after ignition switch is turned to the ON position and when driver door switch is operated, self-diagnosis function for BOSE amp. does not activate.

3. Turn the ignition switch ON within 10 seconds. After that the horn sounds once and the auto active test starts.

NOTE:

Engine starts when ignition switch is turned ON while brake pedal is depressed.

4. The oil pressure warning lamp starts blinking when the auto active test starts.
5. After a series of the following operations is repeated 3 times, auto active test is completed.

NOTE:

- When auto active test has to be cancelled halfway through test, turn the ignition switch OFF.
- When auto active test is not activated, door switch may be the cause. Check door switch. Refer to [DLK-60, "Component Function Check"](#).

Inspection in Auto Active Test

When auto active test is actuated, the following 6 steps are repeated 3 times.

Operation sequence	Inspection location	Operation
1	Oil pressure warning lamp (only for models with VQ37VHR engine)	Blinks continuously during operation of auto active test
2	Front wiper motor	LO for 5 seconds → HI for 5 seconds

DIAGNOSIS SYSTEM (IPDM E/R)

[XENON TYPE]

< SYSTEM DESCRIPTION >

Operation sequence	Inspection location	Operation
3	<ul style="list-style-type: none"> • Parking lamp • License plate lamp • Tail lamp • Side marker lamp • Front fog lamp 	10 seconds
4	Headlamp	<ul style="list-style-type: none"> • LO 10 seconds • HI ON ⇔ OFF 5 times
5	A/C compressor (magnet clutch)	ON ⇔ OFF 5 times
6	Cooling fan	MID for 5 seconds → HI for 5 seconds

*: Outputs duty ratio of 50% for 5 seconds → duty ratio of 100% for 5 seconds on the cooling fan control module.

Concept of auto active test

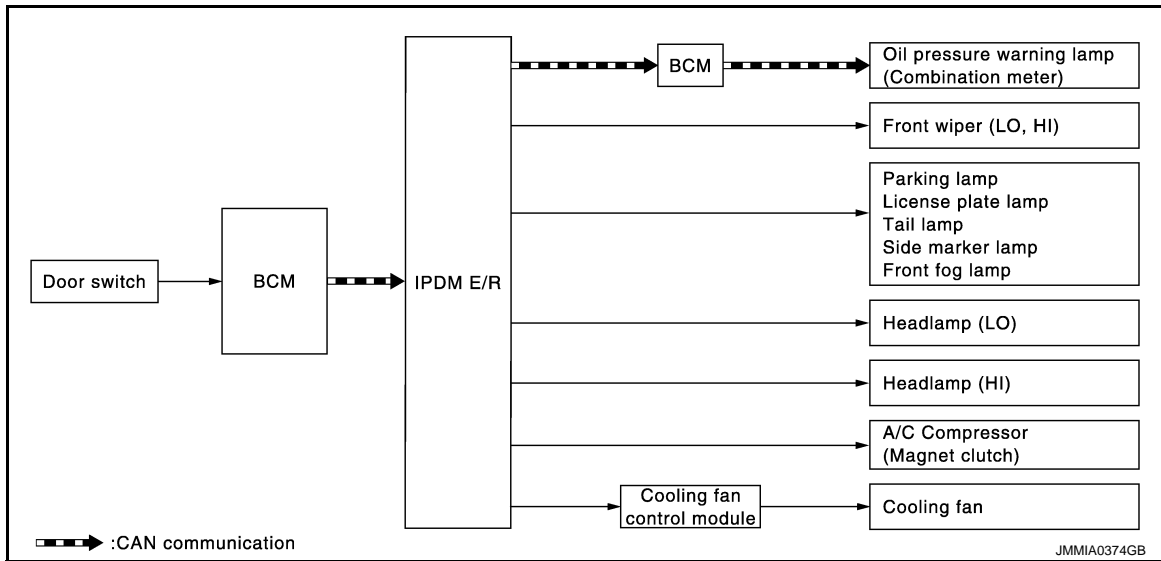

- IPDM E/R starts the auto active test with the door switch signals transmitted by BCM via CAN communication. Therefore, the CAN communication line between IPDM E/R and BCM is considered normal if the auto active test starts successfully.
- The auto active test facilitates troubleshooting if any systems controlled by IPDM E/R cannot be operated.

Diagnosis chart in auto active test

Symptom	Inspection contents	Possible cause
Any of the following components do not operate <ul style="list-style-type: none"> • Parking lamp • License plate lamp • Tail lamp • Side marker lamp • Front fog lamp • Headlamp (HI, LO) • Front wiper motor 	Perform auto active test. Does the applicable system operate?	YES BCM signal input circuit
		NO <ul style="list-style-type: none"> • Lamp or motor • Lamp or motor ground circuit • Harness or connector between IPDM E/R and applicable system • IPDM E/R
A/C compressor does not operate	Perform auto active test. Does the magnet clutch operate?	YES <ul style="list-style-type: none"> • Combination meter signal input circuit • CAN communication signal between Combination meter and ECM • CAN communication signal between ECM and IPDM E/R
		NO <ul style="list-style-type: none"> • Magnet clutch • Harness or connector between IPDM E/R and magnet clutch • IPDM E/R

DIAGNOSIS SYSTEM (IPDM E/R)

< SYSTEM DESCRIPTION >

[XENON TYPE]

Symptom	Inspection contents	Possible cause
Oil pressure warning lamp does not operate (only for models with VQ37VHR engine)	Perform auto active test. Does the oil pressure warning lamp blink?	YES <ul style="list-style-type: none"> • Harness or connector between IPDM E/R and oil pressure switch • Oil pressure switch • IPDM E/R
		NO <ul style="list-style-type: none"> • CAN communication signal between IPDM E/R and BCM • CAN communication signal between BCM and Combination meter • Combination meter
Cooling fan does not operate	Perform auto active test. Does the cooling fan operate?	YES <ul style="list-style-type: none"> • ECM signal input circuit • CAN communication signal between ECM and IPDM E/R
		NO <ul style="list-style-type: none"> • Cooling fan • Harness or connector between cooling fan and cooling fan control module • Cooling fan control module • Harness or connector between IPDM E/R and cooling fan control module • Cooling fan relay • Harness or connector between IPDM E/R and cooling fan relay • IPDM E/R

CONSULT Function (IPDM E/R)

INFOID:000000007216254

APPLICATION ITEM

CONSULT performs the following functions via CAN communication with IPDM E/R.

Diagnosis mode	Description
Ecu Identification	Allows confirmation of IPDM E/R part number.
Self Diagnostic Result	Displays the diagnosis results judged by IPDM E/R.
Data Monitor	Displays the real-time input/output data from IPDM E/R input/output data.
Active Test	IPDM E/R can provide a drive signal to electronic components to check their operations.
CAN Diag Support Monitor	The results of transmit/receive diagnosis of CAN communication can be read.

SELF DIAGNOSTIC RESULT

Refer to [PCS-25, "DTC Index"](#).

DATA MONITOR

Monitor item

Monitor Item [Unit]	MAIN SIGNALS	Description
RAD FAN REQ [%]	×	Displays the value of the cooling fan speed signal received from ECM via CAN communication.
AC COMP REQ [Off/On]	×	Displays the status of the A/C compressor request signal received from ECM via CAN communication.
TAIL&CLR REQ [Off/On]	×	Displays the status of the position light request signal received from BCM via CAN communication.
HL LO REQ [Off/On]	×	Displays the status of the low beam request signal received from BCM via CAN communication.
HL HI REQ [Off/On]	×	Displays the status of the high beam request signal received from BCM via CAN communication.
FR FOG REQ [Off/On]	×	Displays the status of the front fog light request signal received from BCM via CAN communication.

DIAGNOSIS SYSTEM (IPDM E/R)

[XENON TYPE]

< SYSTEM DESCRIPTION >

Monitor Item [Unit]	MAIN SIG- NALS	Description
FR WIP REQ [Stop/1LOW/Low/Hi]	×	Displays the status of the front wiper request signal received from BCM via CAN communication.
WIP AUTO STOP [STOP P/ACT P]	×	Displays the status of the front wiper stop position signal judged by IPDM E/R.
WIP PROT [Off/BLOCK]	×	Displays the status of the front wiper fail-safe operation judged by IPDM E/R.
IGN RLY1 -REQ [Off/On]		Displays the status of the ignition switch ON signal received from BCM via CAN communication.
IGN RLY [Off/On]	×	Displays the status of the ignition relay judged by IPDM E/R.
PUSH SW [Off/On]		Displays the status of the push-button ignition switch judged by IPDM E/R.
INTER/NP SW [Off/On]		Displays the status of the shift position judged by IPDM E/R.
ST RLY CONT [Off/On]		Displays the status of the starter relay status signal received from BCM via CAN communication.
IHBT RLY -REQ [Off/On]		Displays the status of the starter control relay signal received from BCM via CAN communication.
ST/INH RLY [Off/ ST /INH/UNKWN]		Displays the status of the starter relay and starter control relay judged by IPDM E/R.
DETENT SW [Off/On]		Displays the status of the A/T shift selector (detention switch) judged by IPDM E/R.
S/L RLY -REQ [Off/On]		Displays the status of the steering lock relay request received from BCM via CAN communication. NOTE: For models without steering lock unit, this item is not monitored.
S/L STATE [LOCK/UNLOCK/UNKWN]		Displays the status of the steering lock judged by IPDM E/R. NOTE: For models without steering lock unit, this item is not monitored.
DTRL REQ [Off/On]		Displays the status of the daytime running light request signal received from BCM via CAN communication. NOTE: This item is monitored only on the vehicle with daytime running light system.
OIL P SW [Open/Close]		Displays the status of the oil pressure switch judged by IPDM E/R. NOTE: This item is monitored only on the vehicle with VQ37VHR engine models.
HOOD SW [Off/On]		Displays the status of the hood switch judged by IPDM E/R.
HL WASHER REQ [Off/On]		NOTE: This item is indicated, but not monitored.
THFT HRN REQ [Off/On]		Displays the status of the theft warning horn request signal received from BCM via CAN communication.
HORN CHIRP [Off/On]		Displays the status of the horn reminder signal received from BCM via CAN communication.
CRNRNG LMP REQ [Off/On]		NOTE: This item is indicated, but not monitored.

ACTIVE TEST

Test item

DIAGNOSIS SYSTEM (IPDM E/R)

< SYSTEM DESCRIPTION >

[XENON TYPE]

Test item	Operation	Description
CORNERING LAMP	Off	NOTE: This item is indicated, but cannot be tested.
	LH	
	RH	
HORN	On	Operates horn relay for 20 ms.
FRONT WIPER	Off	OFF
	Lo	Operates the front wiper relay.
	Hi	Operates the front wiper relay and front wiper high relay.
MOTOR FAN	1	OFF
	2	Transmits 50% pulse duty signal (PWM signal) to the cooling fan control module.
	3	Transmits 75% pulse duty signal (PWM signal) to the cooling fan control module.
	4	Transmits 100% pulse duty signal (PWM signal) to the cooling fan control module.
HEAD LAMP WASHER	On	NOTE: This item is indicated, but cannot be tested.
EXTERNAL LAMPS	Off	OFF
	TAIL	Operates the tail lamp relay and the daytime running light relay.
	Lo	Operates the headlamp low relay.
	Hi	Operates the headlamp low relay and ON/OFF the headlamp high relay at 1 second intervals.
	Fog	Operates the front fog lamp relay.

A
B
C
D
E
F
G
H
I
J
K
L
M
N
O
P

EXL

DIAGNOSIS SYSTEM (AFS)

[XENON TYPE]

< SYSTEM DESCRIPTION >

DIAGNOSIS SYSTEM (AFS)

CONSULT Function (ADAPTIVE LIGHT)

INFOID:000000006887866

APPLICATION ITEM

Diagnostic mode	Description
Ecu Identification	Allows confirmation of AFS control unit part number.
Self Diagnostic Result	Displays the diagnosis results judged by AFS control unit.
Work support	Sets each sensor.
Data monitor	Indicates AFS control unit input data in real time.
Active test	Provides the drive signal to the load. Checks operation.

WORK SUPPORT

Service item	Description
ST ANG SEN ADJUSTMENT*	—
LEVELIZER ADJUSTMENT	Adjusts the height sensor signal output value (AFS control unit recognized) in the unloaded vehicle condition.

*: Adjusts the steering angle sensor neutral position on ABS actuator and electrical unit (control unit) side. Refer to [BRC-59, "Work Procedure"](#).

DATA MONITOR

Monitor item [Unit]	Description
STR ANGLS SIG [deg]	The steering angle value judged by the steering angle sensor signal received from the steering angle sensor via CAN communication
VHCL SPD [km/h]	The vehicle speed signal value from the combination metr via CAN communication
SLCT LVR POSI [P/R/N/D/M/FF]	The selector lever status judged by the position indicator signal received from TCM via CAN communication
HEAD LAMP [On/Off]	The headlamp On/Off status judged by the low beam headlamp (ON) signal received from IPDM E/R via CAN communication
AFS SW [On/Off]	The AFS ON/OFF status judged by AFS control unit
HI SEN OTP RR [V]	The height sensor signal voltage value input from the height sensor
LEV ACTR VLTG [%]	The ratio value to the battery voltage generated by the levelizer activation signal control value judged by AFS control unit
SWVL SEN RH* [deg]	The head lamp swivel angle value judged by AFS control unit received from the swivel position sensor signal input from the swivel actuator
SWVL SEN LH* [deg]	
SWVL ANGLE RH* [deg]	The swivel angle command value to the swivel motor judged by AFS control unit
SWVL ANGLE LH* [deg]	

*: The swivel angle "0°" (feedback value) of the swivel position sensor signal may differ from the swivel angle "0°" of the swivel motor (AFS control unit command value). This causes that the swivel motor initializes the value based on the step number from the stopper.

ACTIVE TEST

CAUTION:

Start the engine when using "ACTIVE TEST".

DIAGNOSIS SYSTEM (AFS)

< SYSTEM DESCRIPTION >

[XENON TYPE]

Test item	Operation Item	Description
LOW BEAM TEST RIGHT	Origin Fast	Swivels the right headlamp to the swivel angle 0° in the normal speed.
	Peak Fast	Swivels the right headlamp to the swivel angle approximately 15° in the normal speed.
	Origin Slow	Swivels the right headlamp to the swivel angle 0° in the speed at the initialization.
	Peak Slow	Swivels the right headlamp to the swivel angle approximately 15° in the speed at the initialization.
LOW BEAM TEST LEFT	Origin Fast	Swivels the left headlamp to the swivel angle 0° in the normal speed.
	Peak Fast	Swivels the left headlamp to the swivel angle approximately 17° in the normal speed.
	Origin Slow	Swivels the left headlamp to the swivel angle 0° in the speed at the initialization.
	Peak Slow	Swivels the left headlamp to the swivel angle approximately 17° in the speed at the initialization.
LEVELIZER TEST	Origin	Changes the aiming motor drive signal to approximately 70% of the battery voltage. Moves the headlamp upward and downward.
	Peak	Changes the aiming motor drive signal to approximately 15% of the battery voltage. Moves the headlamp upward and downward.

NOTE:

"Fast" operation speed is as three times fast as "Slow".

A
B
C
D
E
F
G
H
I
J
K
L
M
N
O
P

EXL

ECU DIAGNOSIS INFORMATION

BCM, IPDM E/R

List of ECU Reference

INFOID:000000006887867

ECU	Reference
BCM	BCS-34. "Reference Value"
	BCS-54. "Fail-safe"
	BCS-56. "DTC Inspection Priority Chart"
	BCS-57. "DTC Index"
IPDM E/R	PCS-17. "Reference Value"
	PCS-24. "Fail-safe"
	PCS-25. "DTC Index"

AFS CONTROL UNIT

< ECU DIAGNOSIS INFORMATION >

[XENON TYPE]

AFS CONTROL UNIT

Reference Value

INFOID:000000006887868

VALUES ON THE DIAGNOSIS TOOL

CONSULT MONITOR ITEM

Monitor Item	Condition		Value/Status
STR ANGLE SIG	Steering	Straight-forward	Approx. 0°
		Steering	Approx. -900° - +900°
VHCL SPD	Driving at 40 km/h (25 MPH)		40 km/h
SLCT LVR POSI	Selector lever operation		P - 1
HEAD LAMP	Light switch	2ND	On
		Other than 2ND	Off
AFS SW	AFS switch	ON	On
		OFF	Off
HI SEN OTP RR	Vehicle rear height	Unloaded vehicle condition	Approx. 2.5 V
		Low (Leveling operation downward edge)	Approx. 1.4 V
LEV ACTR VLTG	Headlamp leveling	Unloaded vehicle condition	Approx. 70.0%
		Low (Leveling operation downward edge)	Approx. 32.0%
SWVL SEN RH	Right headlamp swivel activation	Standard position	Approx. 0°
		Activation	Positive degree (+°)
SWVL SEN LH	Left headlamp swivel activation	Standard position	Approx. 0°
		Activation	Positive degree (+°)
SWVL ANGLE RH	Right headlamp swivel activation	Standard position	Approx. 0°
		Activation	Positive degree (+°)
SWVL ANGLE LH	Left headlamp swivel activation	Standard position	Approx. 0°
		Activation	Positive degree (+°)

TERMINAL LAYOUT

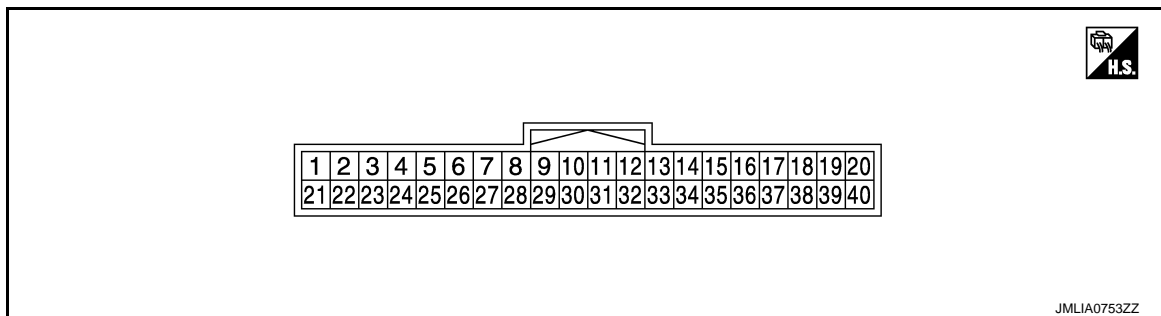

PHYSICAL VALUES

Terminal No. (Wire color)		Description		Condition	Value (Approx.)
+	-	Signal name	Input/ output		
1 (G)	Ground	Ignition power supply	Input	The ignition switch ON	Battery voltage
2 (O)	Ground	Right swivel position sensor ground	Input	The ignition switch ON	0 V

AFS CONTROL UNIT

< ECU DIAGNOSIS INFORMATION >

[XENON TYPE]

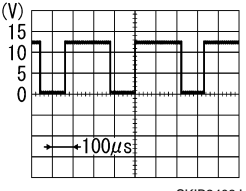
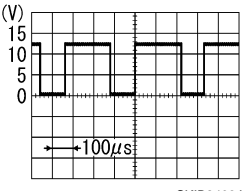
Terminal No. (Wire color)		Description		Condition		Value (Approx.)
+	-	Signal name	Input/ output			
3 (GR)	Ground	AFS switch signal	Input	AFS switch	ON	Battery voltage
					OFF	0 V
4 (BR)	Ground	Right swivel position sensor power supply	Output	The ignition switch ON		5 V
6 (V)	Ground	Height sensor power supply	Output	The ignition switch ON		5 V
7 (P)	Ground	CAN-L	Input/ output	—		—
8 (B)	Ground	Height sensor ground	Input	The ignition switch ON		0 V
9 (Y)	Ground	Right swivel position sensor signal	Output	Right headlamp swivel angle	0°	1.0 V
					15°	2.8 V
11 (R)	Ground	Right swivel motor 1-phase (-)	Output	Right headlamp swivel	Activation	Reference waveform 
						8 - 12 V
13 (B)	Ground	Right swivel motor 2-phase (-)	Output	Right headlamp swivel	Stopped	9.5 - 11.5 V
15 (W)	Ground	Left swivel motor 1-phase (+)	Output	Left headlamp swivel	Activation	Reference waveform 
						8 - 12 V
17 (G)	Ground	Left swivel motor 2-phase (+)	Output	Left headlamp swivel	Stopped	9.5 - 11.5 V
19 (W)	Ground	Right levelizer signal	Output	Right headlamp leveling	Unloaded vehicle condition	8.8 V
					Leveling operation downward edge	4.0 V
24 (LG)	Ground	Left swivel position sensor power supply	Output	The ignition switch ON		5 V
25 (B)	Ground	Ground	—	The ignition switch ON		0 V
27 (BR)	Ground	Left swivel position sensor ground	Input	The ignition switch ON		0 V
28 (SB)	Ground	Height sensor signal	Output	Vehicle rear height	Unloaded vehicle condition	2.5 V
					Low (Leveling operation downward edge)	1.4 V

AFS CONTROL UNIT

< ECU DIAGNOSIS INFORMATION >

[XENON TYPE]

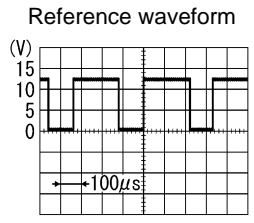
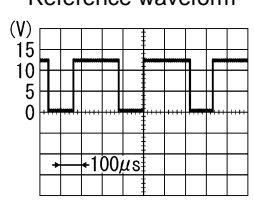
Terminal No. (Wire color)		Description		Condition		Value (Approx.)
+	-	Signal name	Input/ output			
29 (P)	Ground	Left swivel position sensor signal	Output	Left headlamp swivel angle	0°	1.0 V
					17°	3.0 V
30 (L)	Ground	CAN-H	Input/ output	—		—
32 (W)	Ground	Right swivel motor 2-phase (+)	Output	Right headlamp swivel	Activation	 <p style="text-align: center;">Reference waveform 8 - 12 V</p>
						8 - 12 V
34 (G)	Ground	Right swivel motor 1-phase (+)	Output	Right headlamp swivel	Stopped	9.5 - 11.5 V
						9.5 - 11.5 V
36 (R)	Ground	Left swivel motor 2-phase (-)	Output	Left headlamp swivel	Activation	 <p style="text-align: center;">Reference waveform 8 - 12 V</p>
						8 - 12 V
38 (B)	Ground	Left swivel motor 1-phase (-)	Output	Left headlamp swivel	Stopped	9.5 - 11.5 V
						9.5 - 11.5 V
40 (GR)	Ground	Left levelizer signal	Output	Right headlamp leveling	Unloaded vehicle condition	8.8 V
					Leveling operation downward edge	4.0 V

Fail-Safe

INFOID:000000006887869

EXL

DTC	Fail-safe	AFS OFF indicator lamp	Cancellation
U1000: CAN COMM CIRCUIT	<ul style="list-style-type: none"> Right and left swivel motors stop at the position when DTC is detected. Right and left aiming motors stop at the position when DTC is detected. 	Blinks 1 second each.	Ignition switch OFF
U1010: CONTROL UNIT (CAN)	<ul style="list-style-type: none"> Right and left swivel motors stop at the position when DTC is detected. Right and left aiming motors stop at the position when DTC is detected. 	Blinks 1 second each.	Ignition switch OFF
B2503: SWIVEL ACTUATOR [RH]	<ul style="list-style-type: none"> Right swivel motors stop at the position when DTC is detected. The signal, approximately 2 V decreased from the levelizer signal when DTC detected, is output. 	Blinks 1 second each.	Ignition switch OFF

AFS CONTROL UNIT

< ECU DIAGNOSIS INFORMATION >

[XENON TYPE]

DTC	Fail-safe	AFS OFF indicator lamp	Cancellation
B2504: SWIVEL ACTUATOR [LH]	<ul style="list-style-type: none"> Left swivel motors stop at the position when DTC is detected. The signal, approximately 2 V decreased from the levelizer signal when DTC detected, is output. 	Blinks 1 second each.	Ignition switch OFF
B2514: HI SEN UNUSUAL [RR]	<ul style="list-style-type: none"> Right and left aiming motors stop at the position when DTC is detected. 	—	Ignition switch OFF
C0126: ST ANG SEN SIG	<ul style="list-style-type: none"> Right and left swivel motor swivel angle returns to 0° and fixed. 	Blinks 1 second each.	Ignition switch OFF
B2516: SHIFT SIG [P, R]	<ul style="list-style-type: none"> Right and left swivel motor swivel angle returns to 0° and fixed. 	Blinks 1 second each.	Ignition switch OFF
B2517: VEHICLE SPEED SIG	<ul style="list-style-type: none"> Right and left swivel motor swivel angle returns to 0° and fixed. Right and left aiming motors stop at the position when DTC is detected. 	Blinks 1 second each.	Ignition switch OFF
B2519: LEVELIZER CALIB	<ul style="list-style-type: none"> Right and left aiming motors stop at the position when DTC is detected. 	—	When the levelizer adjustment is completed.
C0428: ST ANGLE SEN CALIB	<ul style="list-style-type: none"> Right and left swivel motor swivel angle returns to 0° and fixed. 	Blinks 1 second each.	When the steering angle sensor neutral position registration is completed.
B2521: ECU CIRC	<ul style="list-style-type: none"> Right and left swivel motors stop at the position when DTC is detected. Right and left aiming motors stop at the position when DTC is detected. 	Blinks 1 second each.	Ignition switch OFF

DTC Inspection Priority Chart

INFOID:000000006887870

If some DTCs are displayed at the same time, perform inspections one by one based on the following priority chart.

NOTE:

- If DTC U1000 is displayed with other DTC, first perform the trouble diagnosis for DTC U1000.
- If DTC U1010 is displayed with other DTC, first perform the trouble diagnosis for DTC U1010.

Priority	Detected items (DTC)
1	<ul style="list-style-type: none"> U1000: CAN COMM CIRCUIT U1010: CONTROL UNIT (CAN)
2	<ul style="list-style-type: none"> B2519: LEVELIZER CALIB B2521: ECU CIRC C0428: ST ANG SEN CALIB
3	<ul style="list-style-type: none"> B2503: SWIVEL ACTUATOR [RH] B2504: SWIVEL ACTUATOR [LH] B2514: HI SEN UNUSUAL [RR] B2516: SHIFT SIG [P, R] B2517: VEHICLE SPEED SIG C0126: ST ANG SEN SIG

AFS CONTROL UNIT

< ECU DIAGNOSIS INFORMATION >

[XENON TYPE]

DTC Index

INFOID:000000006887871

x: Applicable

CONSULT display	Fail-safe	AFS OFF indicator lamp	Reference
U1000: CAN COMM CIRCUIT	×	×	EXL-70
U1010: CONTROL UNIT (CAN)	×	×	EXL-71
B2503: SWIVEL ACTUATOR [RH]	×	×	EXL-54
B2504: SWIVEL ACTUATOR [LH]	×	×	EXL-54
B2514: HI SEN UNUSUAL [RR]	×		EXL-59
B2516: SHIFT SIG [P, R]	×	×	EXL-62
B2517: VEHICLE SPEED SIG	×	×	EXL-63
B2519: LEVELIZER CALIB	×		EXL-64
B2521: ECU CIRC	×	×	EXL-65
C0126: ST ANG SEN SIG	×	×	EXL-70
C0428: ST ANGLE SEN CALIB	×	×	EXL-69

A
B
C
D
E
F
G
H
I
J
K
EXL
M
N
O
P

EXL

EXTERIOR LIGHTING SYSTEM

[XENON TYPE]

< WIRING DIAGRAM >

WIRING DIAGRAM

EXTERIOR LIGHTING SYSTEM

EXTERIOR LIGHTING SYSTEM

EXTERIOR LIGHTING SYSTEM : Wiring Diagram

INFOID:000000006887872

For connector terminal arrangements, harness layouts, and alphabets in a  (option abbreviation; if not described in wiring diagram), refer to [GI-12, "Connector Information"](#).

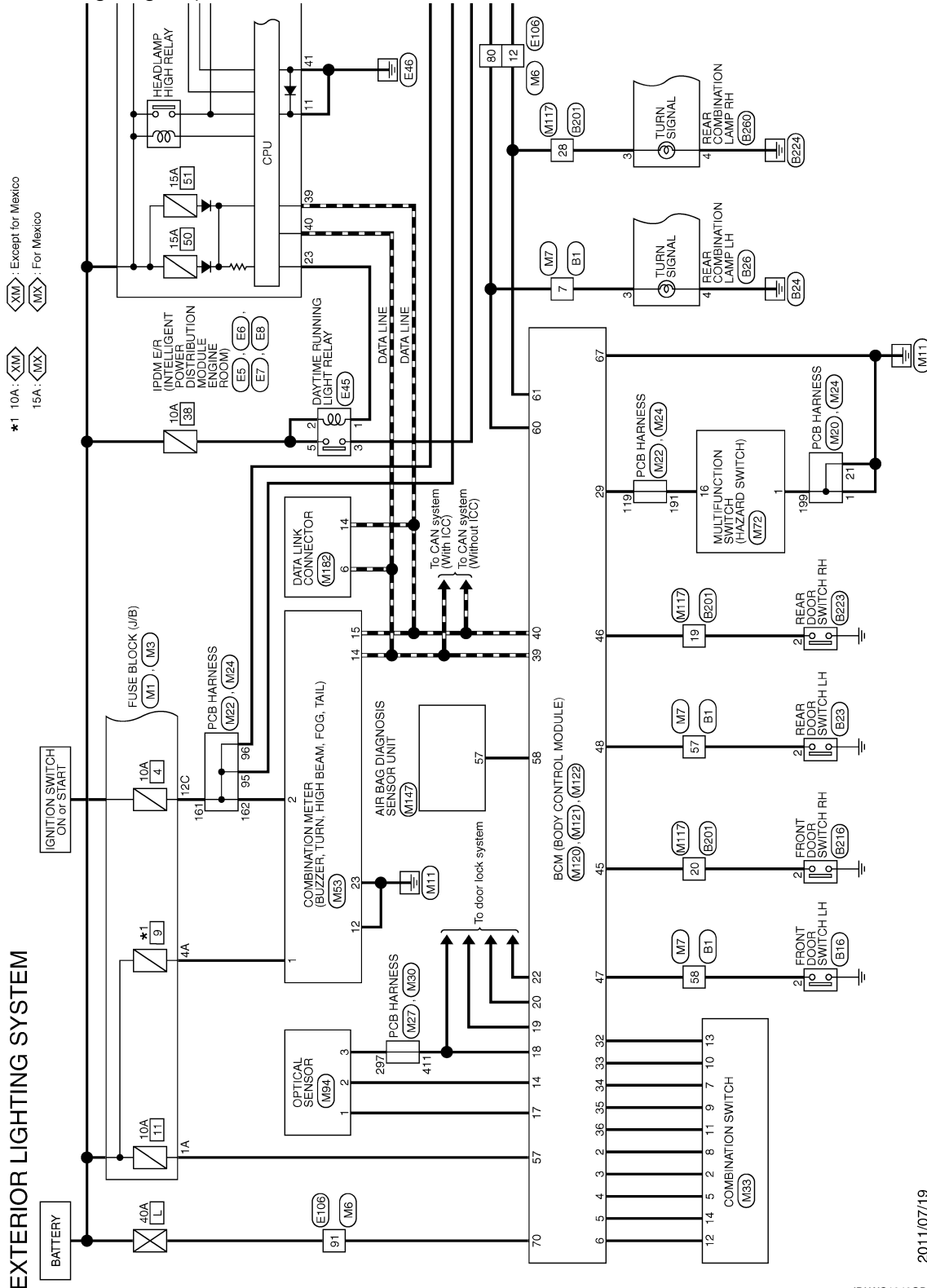

2011/07/19

JRLWC1046GB

EXTERIOR LIGHTING SYSTEM

< WIRING DIAGRAM >

[XENON TYPE]

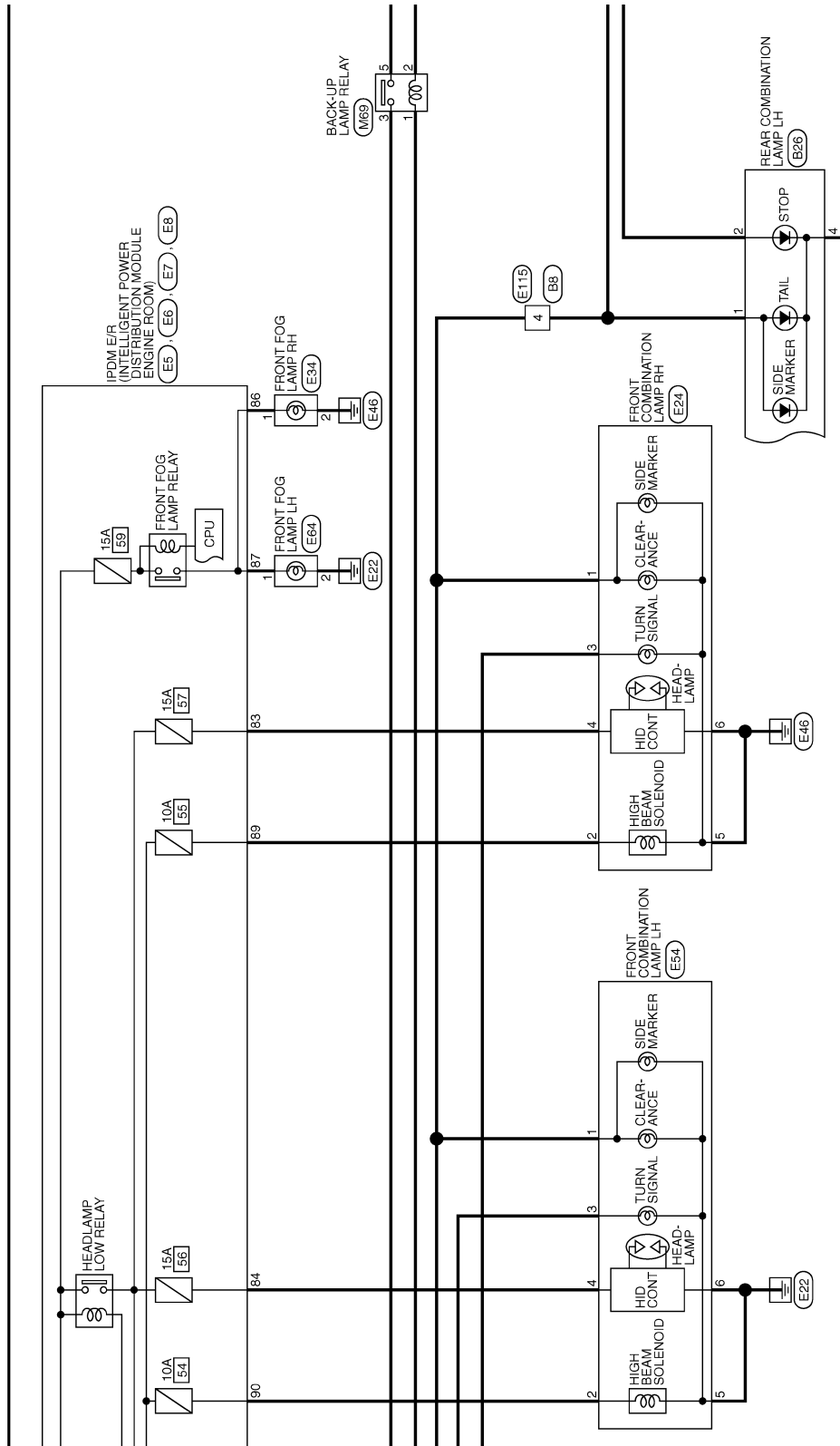

JRLWC1047GB

A
B
C
D
E
F
G
H
I
J
K
EXL
M
N
O
P

EXTERIOR LIGHTING SYSTEM

< WIRING DIAGRAM >

[XENON TYPE]

* This connector is not shown in "Harness Layout".

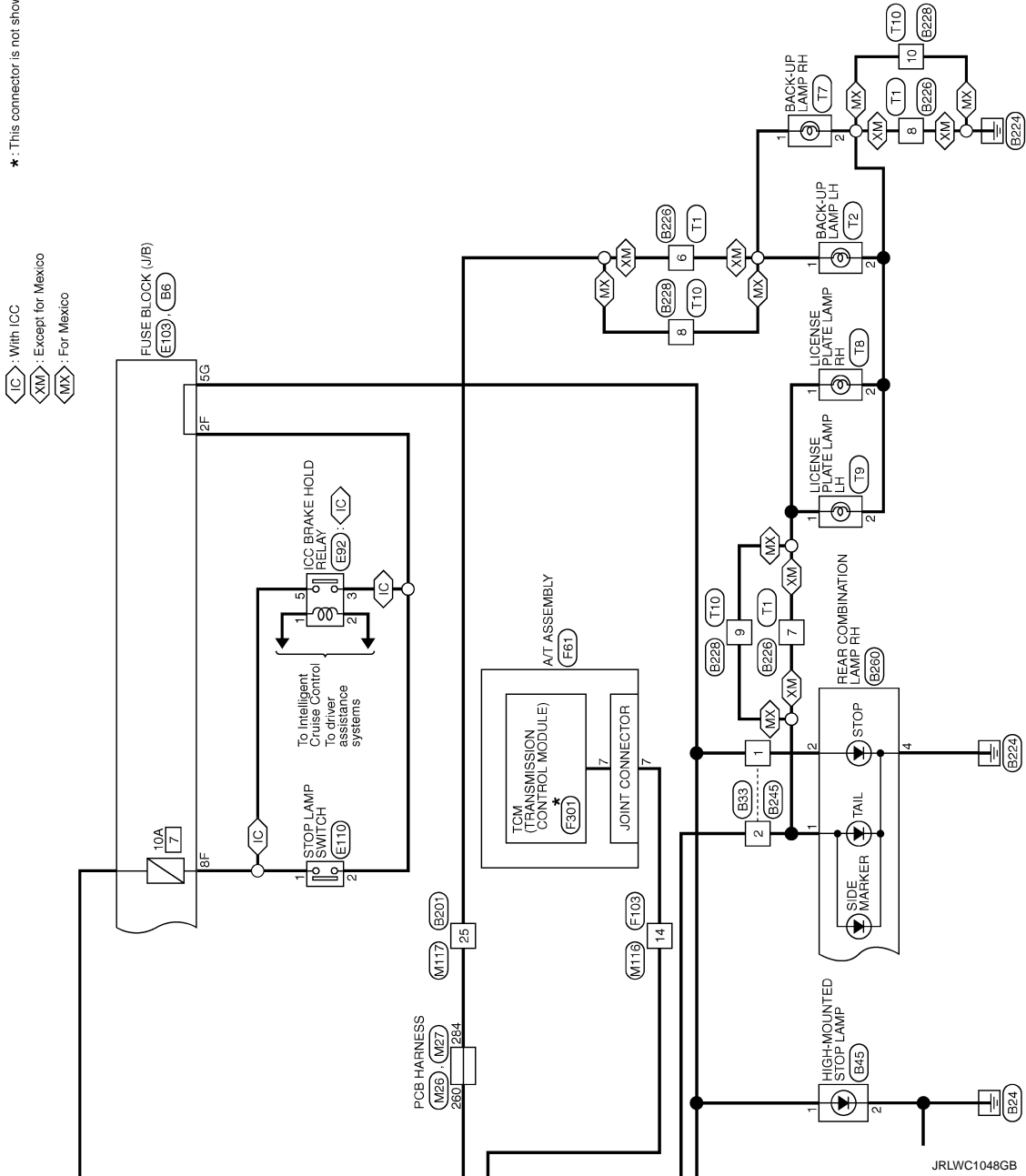

ACTIVE ADAPTIVE FRONT-LIGHTING SYSTEM

EXTERIOR LIGHTING SYSTEM

[XENON TYPE]

< WIRING DIAGRAM >

ACTIVE ADAPTIVE FRONT-LIGHTING SYSTEM : Wiring Diagram

INFOID:000000006887873

For connector terminal arrangements, harness layouts, and alphabets in a  (option abbreviation; if not described in wiring diagram), refer to [GI-12, "Connector Information"](#).

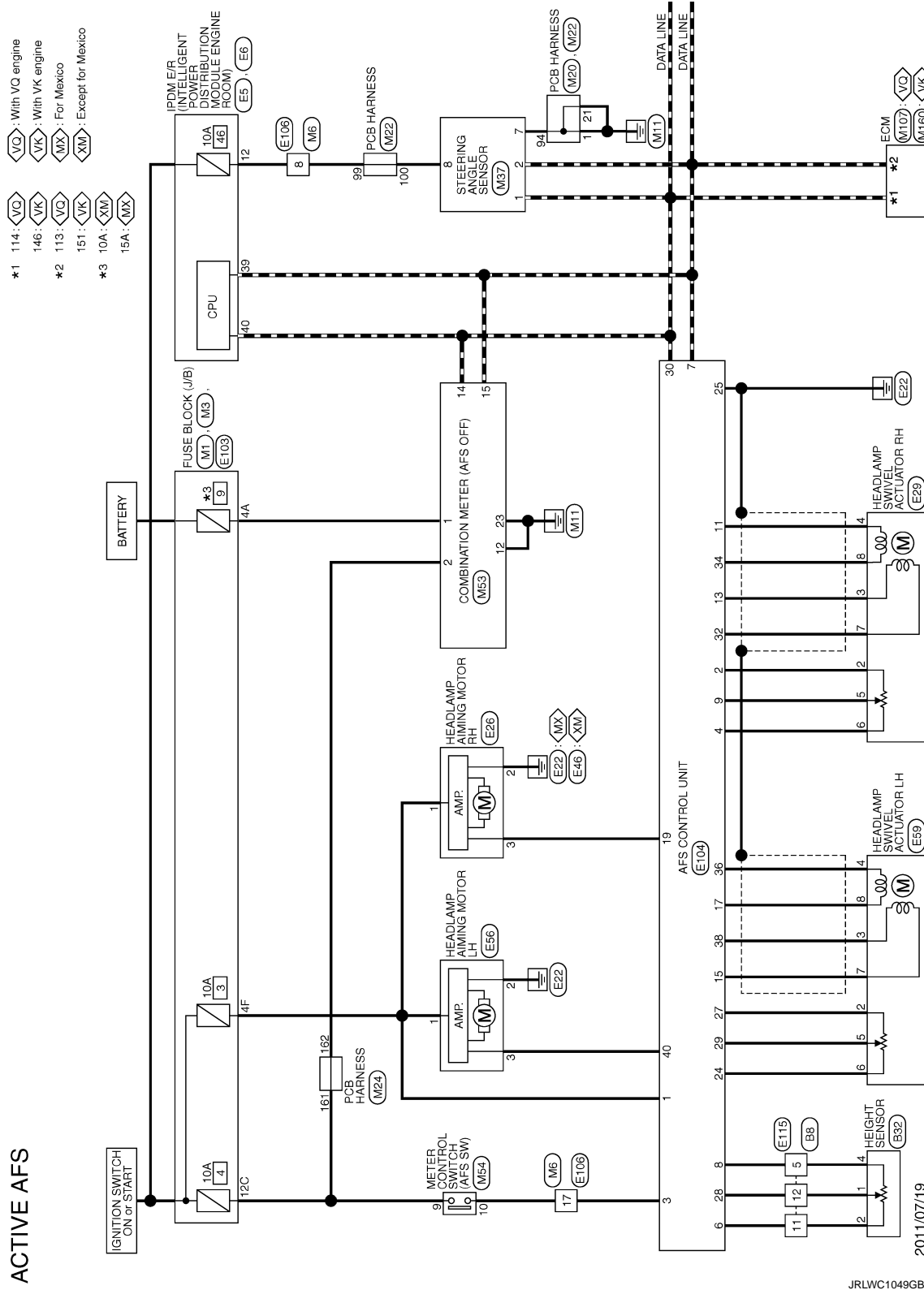

A
B
C
D
E
F
G
H
I
J
K
L
M
N
O
P

EXL

EXTERIOR LIGHTING SYSTEM

< WIRING DIAGRAM >

[XENON TYPE]

*: This connector is not shown in "Harness Layout".

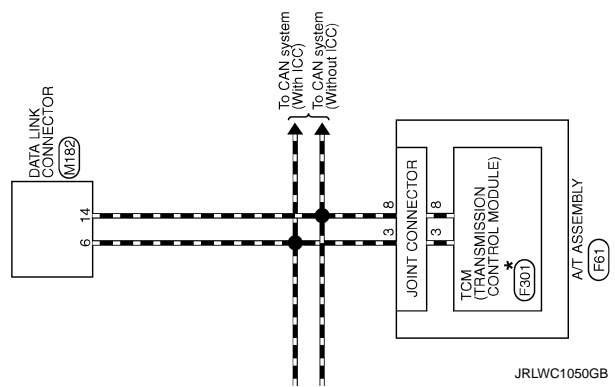

BASIC INSPECTION

DIAGNOSIS AND REPAIR WORKFLOW

Work Flow

INFOID:000000006887874

OVERALL SEQUENCE

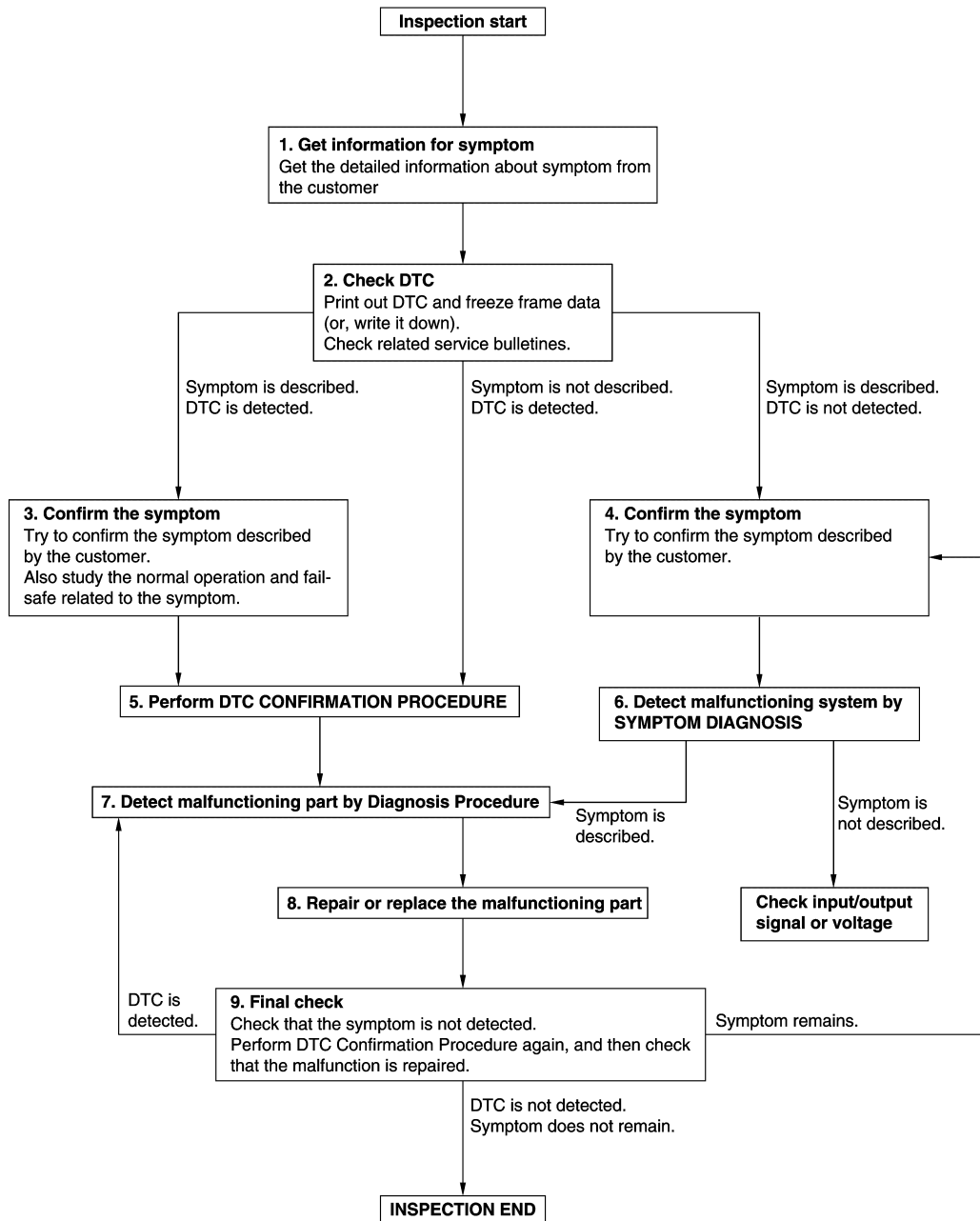

A
B
C
D
E
F
G
H
I
J
K
L
M
N
O
P

EXL

DETAILED FLOW

JMKIA8652GB

DIAGNOSIS AND REPAIR WORKFLOW

[XENON TYPE]

< BASIC INSPECTION >

1. GET INFORMATION FOR SYMPTOM

1. Get detailed information from the customer about the symptom (the condition and the environment when the incident/malfunction occurs).
2. Check operation condition of the function that is malfunctioning.

>> GO TO 2.

2. CHECK DTC

1. Check DTC.
2. Perform the following procedure if DTC is detected.
 - Record DTC and freeze frame data (Print them out using CONSULT.)
 - Erase DTC.
 - Study the relationship between the cause detected by DTC and the symptom described by the customer.
3. Check related service bulletins for information.

Are any symptoms described and any DTC detected?

Symptom is described, DTC is detected>>GO TO 3.

Symptom is described, DTC is not detected>>GO TO 4.

Symptom is not described, DTC is detected>>GO TO 5.

3. CONFIRM THE SYMPTOM

Try to confirm the symptom described by the customer.

Also study the normal operation and fail-safe related to the symptom.

Verify relation between the symptom and the condition when the symptom is detected.

>> GO TO 5.

4. CONFIRM THE SYMPTOM

Try to confirm the symptom described by the customer.

Verify relation between the symptom and the condition when the symptom is detected.

>> GO TO 6.

5. PERFORM DTC CONFIRMATION PROCEDURE

Perform DTC CONFIRMATION PROCEDURE for the detected DTC, and then check that DTC is detected again. At this time, always connect CONSULT to the vehicle, and check self diagnostic results in real time. If two or more DTCs are detected, refer to DTC INSPECTION PRIORITY CHART, and determine trouble diagnosis order.

NOTE:

- Freeze frame data is useful if the DTC is not detected.
- Perform Component Function Check if DTC CONFIRMATION PROCEDURE is not included on Service Manual. This simplified check procedure is an effective alternative though DTC cannot be detected during this check.
If the result of Component Function Check is NG, it is the same as the detection of DTC by DTC CONFIRMATION PROCEDURE.

Is DTC detected?

YES >> GO TO 7.

NO >> Check according to [GI-44. "Intermittent Incident"](#).

6. DETECT MALFUNCTIONING SYSTEM BY SYMPTOM DIAGNOSIS

Detect malfunctioning system according to SYMPTOM DIAGNOSIS based on the confirmed symptom in step 4, and determine the trouble diagnosis order based on possible causes and symptom.

Is the symptom described?

YES >> GO TO 7.

NO >> Monitor input data from related sensors or check voltage of related module terminals using CONSULT.

7. DETECT MALFUNCTIONING PART BY DIAGNOSIS PROCEDURE

DIAGNOSIS AND REPAIR WORKFLOW

[XENON TYPE]

< BASIC INSPECTION >

Inspect according to Diagnosis Procedure of the system.

Is malfunctioning part detected?

YES >> GO TO 8.

NO >> Check according to [GI-44. "Intermittent Incident"](#).

8. REPAIR OR REPLACE THE MALFUNCTIONING PART

1. Repair or replace the malfunctioning part.
2. Reconnect parts or connectors disconnected during Diagnosis Procedure again after repair and replacement.
3. Check DTC. If DTC is detected, erase it.

>> GO TO 9.

9. FINAL CHECK

When DTC is detected in step 2, perform DTC CONFIRMATION PROCEDURE again, and then check that the malfunction is repaired securely.

When symptom is described by the customer, refer to confirmed symptom in step 3 or 4, and check that the symptom is not detected.

Is DTC detected and does symptom remain?

YES-1 >> DTC is detected: GO TO 7.

YES-2 >> Symptom remains: GO TO 4.

NO >> Before returning the vehicle to the customer, always erase DTC.

A
B
C
D
E
F
G
H
I
J
K
EXL
M
N
O
P

INSPECTION AND ADJUSTMENT

< BASIC INSPECTION >

[XENON TYPE]

INSPECTION AND ADJUSTMENT

ADDITIONAL SERVICE WHEN REPLACING CONTROL UNIT (AFS CONTROL UNIT)

ADDITIONAL SERVICE WHEN REPLACING CONTROL UNIT (AFS CONTROL UNIT) : Description

INFOID:000000006887875

Perform "LEVELIZER ADJUSTMENT" with CONSULT when replacing the AFS control unit.

ADDITIONAL SERVICE WHEN REPLACING CONTROL UNIT (AFS CONTROL UNIT) : Special Repair Requirement

INFOID:000000006887876

1.LEVELIZER ADJUSTMENT

Perform "LEVELIZER ADJUSTMENT".

>> Refer to [EXL-52, "LEVELIZER ADJUSTMENT : Special Repair Requirement"](#).

ADDITIONAL SERVICE WHEN REPLACING CONTROL UNIT (HEIGHT SENSOR)

ADDITIONAL SERVICE WHEN REPLACING CONTROL UNIT (HEIGHT SENSOR) : Description

INFOID:000000006887877

Perform "LEVELIZER ADJUSTMENT" with CONSULT when replacing the height sensor.

ADDITIONAL SERVICE WHEN REPLACING CONTROL UNIT (HEIGHT SENSOR) : Special Repair Requirement

INFOID:000000006887878

1.LEVELIZER ADJUSTMENT

Perform "LEVELIZER ADJUSTMENT".

>> Refer to [EXL-52, "LEVELIZER ADJUSTMENT : Special Repair Requirement"](#).

LEVELIZER ADJUSTMENT

LEVELIZER ADJUSTMENT : Description

INFOID:000000006887879

Perform "LEVELIZER ADJUSTMENT" when installing, removing, and replacing the height sensor and the suspension components.

LEVELIZER ADJUSTMENT : Special Repair Requirement

INFOID:000000006887880

CAUTION:

If perform aiming adjustment after the levelizer initialization, be sure to start the engine running after turning ignition switch OFF.

1.CHECK VEHICLE CONDITION

1. Park the vehicle in the straight-forward position.
2. Unload the vehicle (no passenger aboard).

>> GO TO 2.

2.LEVELIZER ADJUSTMENT

ⓐCONSULT WORK SUPPORT

1. Select "LEVELIZER ADJUSTMENT" of ADAPTIVE LIGHT work support item.
2. Select "START".
3. When "ADJUSTMENT IS COMPLETED", select "END".

CAUTION:

INSPECTION AND ADJUSTMENT

< BASIC INSPECTION >

[XENON TYPE]

If "CAN NOT BE TESTED" is indicated, AFS control unit detects that the height sensor signal changes. The levelizer adjustment is cancelled. In this case, turn the ignition switch OFF to prevent the vehicle from the height change. Perform the levelizer adjustment again.

A

Is the levelizer adjustment completed?

YES >> GO TO 3.

NO >> Perform the levelizer adjustment again.

B

3.SELF-DIAGNOSIS RESULT CHECK

Perform self-diagnosis with CONSULT. Check that any DTC is not detected.

C

Is any DTC detected?

YES >> GO TO 2.

NO >> Levelizer adjustment completed

D

E

F

G

H

I

J

K

EXL

M

N

O

P

DTC/CIRCUIT DIAGNOSIS

B2503, B2504 SWIVEL ACTUATOR

DTC Logic

INFOID:000000006887881

DTC DETECTION LOGIC

- [B2503] Swivel actuator [RH]
- [B2504] Swivel actuator [LH]

DTC detection condition	DTC erase condition	Possible cause
<p>AFS control unit indicates an applicable DTC when detecting any of the following conditions continuously for 2 seconds or more.</p> <ul style="list-style-type: none"> • AFS control unit-recognized swivel position differs extremely from the swivel position sensor-input value while the swivel operating.* • The swivel position sensor signal does not change even though AFS control unit transmits the swivel motor driving signal while the swivel operating.* • The swivel motor short and open is detected while the swivel operating.* • The swivel position sensor power supply is 6 V or more, or 4 V or less. • The swivel position sensor signal is 0.25 V or less, or 4.75 V or more. 	<p>Ignition switch OFF</p>	<p>Swivel position sensor</p> <ul style="list-style-type: none"> • Swivel position sensor • Harness and connector <p>AFS control unit</p> <ul style="list-style-type: none"> • Swivel motor • Harness and connector • AFS control unit

*: Initialization is not included.

DTC CONFIRMATION PROCEDURE

1. DTC ERASE

Erase the DTC memory of AFS with CONSULT.

>> GO TO 2.

2. CONFIRMATION DTC SELECTION

Select "B2503" or "B2504" for confirmation.

Which DTC is confirmation?

B2503 >> GO TO 3.

B2504 >> GO TO 4.

3. DTC CONFIRMATION (B2503)

1. Steer to the straight-forward position.
2. Start the engine.
3. Turn AFS switch ON.
4. Turn the headlamp ON.
5. Shift the selector lever to "N".
6. Steer to the right. (Rotate it once or more.)
7. Perform the self-diagnosis with CONSULT.

Is DTC "B2503" detected?

YES >> Refer to [EXL-55, "Diagnosis Procedure"](#).

NO >> Refer to [GI-44, "Intermittent Incident"](#).

4. DTC CONFIRMATION (B2504)

1. Steer to the straight-forward position.
2. Start the engine.
3. Turn AFS switch ON.
4. Turn the headlamp ON.
5. Drive at 25 km/h (15.5 MPH) or more.
6. Steer to the left. (Rotate it once or more.)
7. Stop the vehicle.
8. Perform the self-diagnosis with CONSULT.

Is DTC "B2504" detected?

B2503, B2504 SWIVEL ACTUATOR

< DTC/CIRCUIT DIAGNOSIS >

[XENON TYPE]

- YES >> Refer to [EXL-55, "Diagnosis Procedure"](#).
 NO >> Refer to [GI-44, "Intermittent Incident"](#).

Diagnosis Procedure

INFOID:000000006887882

1. CHECK SWIVEL POSITION SENSOR SIGNAL INPUT

- Turn the ignition switch ON.
- Check the voltage between the AFS control unit harness connector and the ground.

Terminals				Voltage (Approx.)
(+)		(-)		
AFS control unit				
Connector		Terminal		
RH	E104	9		0.25 - 4.75 V
LH		29		
Ground				

Is the measurement value within the standard value?

- YES >> GO TO 2.
 Less than the standard value >>GO TO 6.
 Higher than the standard value>>GO TO 9.

2. CHECK SWIVEL MOTOR

Check the swivel motor. [EXL-58, "Component Inspection"](#).

Is the inspection result normal?

- YES >> GO TO 3.
 NO >> Replace the front combination lamp.

3. CHECK SWIVEL MOTOR OPEN CIRCUIT

- Turn the ignition switch OFF.
- Disconnect AFS control unit connector and the headlamp swivel actuator connector.
- Check continuity between the AFS control unit harness connector and the headlamp swivel actuator harness connector.

AFS control unit		Headlamp swivel actuator		Continuity	
Connector	Terminal	Connector	Terminal		
RH	E104	E29	11	4	Existed
			13	3	
			32	7	
			34	8	
LH	E104	E59	15	7	
			17	8	
			36	4	
			38	3	

Does continuity exist?

- YES >> GO TO 4.
 NO >> Repair the harnesses or connectors.

4. CHECK SWIVEL MOTOR SHORT CIRCUIT

Check continuity between the AFS control unit harness connector and the ground.

B2503, B2504 SWIVEL ACTUATOR

< DTC/CIRCUIT DIAGNOSIS >

[XENON TYPE]

AFS control unit			Ground	Continuity			
Connector		Terminal		Not existed			
RH	E104	11	Ground		Not existed		
		13					
		32					
		34					
LH		15				Ground	Not existed
		17					
		36					
		38					

Does continuity exist?

YES >> Repair the harnesses or connectors.

NO >> GO TO 5.

5. CHECK SWIVEL MOTOR CIRCUIT VOLTAGE OUTPUT

1. Connect AFS control unit connector.
2. Start the engine.
3. Turn the headlamp ON.
4. Select "LOW BEAM TEST RIGHT" or "LOW BEAM TEST LEFT" of ADAPTIVE LIGHT active test item.
5. With operating the test item, check the voltage between the AFS control unit harness connector and the ground.

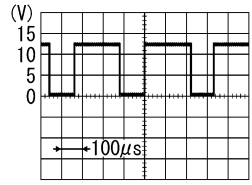
Terminals			Condition	Voltage (Approx.)								
(+)		(-)										
AFS control unit			Swivel motor									
Connector		Terminal										
RH	E104	11	Ground	Active	 <p>SKIB2408J</p>							
		32										
		15										
LH		36				Ground	Active	8 - 12 V				
		13										
		34										
RH		E104							17	Ground	Stop	9.5 - 11.5 V
									38			
LH	17		Ground	Stop	9.5 - 11.5 V							
	38											

Is the measurement value within the standard value?

YES >> Replace the front combination lamp.

NO >> Replace AFS control unit. Refer to [EXL-114, "Removal and Installation"](#)

6. CHECK SWIVEL POSITION SENSOR POWER SUPPLY CIRCUIT INPUT VOLTAGE

1. Turn the ignition switch OFF.
2. Disconnect the headlamp swivel actuator connector.
3. Turn the ignition switch ON.
4. Check the voltage between the headlamp swivel actuator harness connector and the ground.

B2503, B2504 SWIVEL ACTUATOR

< DTC/CIRCUIT DIAGNOSIS >

[XENON TYPE]

Terminals				Voltage (Approx.)
(+)		(-)		
Headlamp swivel actuator				
Connector		Terminal		Ground
RH	E29	6		
LH	E59	6		
5 V				

Is the measurement value normal?

YES >> GO TO 7.

NO >> GO TO 8.

7. CHECK SWIVEL POSITION SENSOR SIGNAL CIRCUIT

1. Turn the ignition switch OFF.
2. Disconnect AFS control unit connector.
3. Check continuity between the AFS control unit harness connector and the headlamp swivel actuator harness connector.

AFS control unit		Headlamp swivel actuator		Continuity
Connector	Terminal	Connector	Terminal	
RH	E104	9	E29	Existed
LH		29	E59	

4. Check continuity between the AFS control unit harness connector and the ground.

AFS control unit		Ground	Continuity
Connector	Terminal		
RH	E104	9	Not existed
LH		29	

Does continuity exist?

YES >> Replace the front combination lamp.

NO >> Repair the harnesses or connectors.

8. CHECK SWIVEL POSITION SENSOR POWER SUPPLY CIRCUIT

1. Turn the ignition switch OFF.
2. Disconnect AFS control unit connector.
3. Check continuity between the AFS control unit harness connector and the headlamp swivel actuator harness connector.

AFS control unit		Headlamp swivel actuator		Continuity
Connector	Terminal	Connector	Terminal	
RH	E104	4	E29	Existed
LH		24	E59	

4. Check continuity between the AFS control unit harness connector and the ground.

AFS control unit		Ground	Continuity
Connector	Terminal		
RH	E104	4	Not existed
LH		24	

Is the measurement value normal?

YES >> Replace AFS control unit. Refer to [EXL-114, "Removal and Installation"](#)

NO >> Repair the harnesses or connectors.

9. CHECK SWIVEL POSITION SENSOR GROUND CIRCUIT VOLTAGE OUTPUT

B2503, B2504 SWIVEL ACTUATOR

< DTC/CIRCUIT DIAGNOSIS >

[XENON TYPE]

Check the voltage between the AFS control unit harness connector and the ground.

Terminals				Voltage (Approx.)
(+)		(-)		
AFS control unit				Ground
Connector		Terminal		
RH	E104	2		
LH		27		
				0 V

Is the measurement value normal?

YES >> GO TO 10.

NO >> Replace AFS control unit. Refer to [EXL-114, "Removal and Installation"](#)

10.CHECK SWIVEL POSITION SENSOR GROUND OPEN CIRCUIT

1. Turn the ignition switch OFF.
2. Disconnect AFS control unit connector and the headlamp swivel actuator connector.
3. Check continuity between the AFS control unit harness connector and the headlamp swivel actuator harness connector.

AFS control unit		Headlamp swivel actuator		Continuity
Connector	Terminal	Connector	Terminal	
RH	E104	E29	2	Existed
LH		E59	2	

Does continuity exist?

YES >> Replace the front combination lamp.

NO >> Repair the harnesses or connectors.

Component Inspection

INFOID:000000006887883

1.CHECK SWIVEL MOTOR SINGLE PART

1. Disconnect the swivel actuator connector.
2. Check the resistance among each swivel actuator connector terminal.

Swivel actuator		Resistance (Approx.)
Terminal	Terminal	
3	7	7.2 Ω
4	8	7.2 Ω
3	4	10 MΩ or more

Is the measurement value normal?

YES >> Swivel actuator is normal.

NO >> Replace the front combination lamp.

B2514 HEIGHT SENSOR UNUSUAL [RR]

< DTC/CIRCUIT DIAGNOSIS >

[XENON TYPE]

B2514 HEIGHT SENSOR UNUSUAL [RR]

DTC Logic

INFOID:000000006887884

DTC DETECTION LOGIC

[B2514] Height sensor unusual [RR]

DTC detection condition	DTC erase condition	Possible cause
An applicable DTC is indicated when any of the following conditions is detected continuously for 2 seconds or more. <ul style="list-style-type: none">The height sensor power supply is 6 V or more, or 4 V or less.The height sensor signal is 0.25 V or less, or 4.75 V or more.	Ignition switch OFF	Height sensor <ul style="list-style-type: none">Height sensorHarness and connectorAFS control unit

DTC CONFIRMATION PROCEDURE

1. DTC ERASE

Erase the DTC memory of AFS with CONSULT.

>> GO TO 2.

2. DTC CONFIRMATION

- Start the engine.
- Turn the headlamp ON.
- Select the self-diagnosis with CONSULT.
- Check the self-diagnosis result. Refer to [EXL-43, "DTC Index"](#).

Is DTC "B2514" detected?

YES >> Refer to [EXL-59, "Diagnosis Procedure"](#).

NO >> Refer to [GI-44, "Intermittent Incident"](#).

Diagnosis Procedure

INFOID:000000006887885

1. CHECK HEIGHT SENSOR SIGNAL INPUT

- Turn the ignition switch ON.
- Check the voltage between the AFS control unit harness connector and the ground.

Terminals		Voltage (Approx.)
(+)	(-)	
AFS control unit		0.25 - 4.75 V
Connector	Terminal	
E104	28	

Is the measurement value within the standard value?

YES >> Replace AFS control unit. Refer to [EXL-114, "Removal and Installation"](#)

Less than the standard value >> GO TO 2.

Higher than the standard value >> GO TO 5.

2. CHECK HEIGHT SENSOR POWER SUPPLY CIRCUIT INPUT VOLTAGE

- Turn the ignition switch OFF.
- Disconnect the height sensor connector.
- Turn the ignition switch ON.
- Check the voltage between the height sensor harness connector and the ground.

B2514 HEIGHT SENSOR UNUSUAL [RR]

< DTC/CIRCUIT DIAGNOSIS >

[XENON TYPE]

Terminals		Voltage (Approx.)
(+)	(-)	
Height sensor		5 V
Connector	Terminal	
B32	2	

Is the measurement value within the standard value?

YES >> GO TO 3.

NO >> GO TO 4.

3.CHECK HEIGHT SENSOR SIGNAL CIRCUIT

1. Turn the ignition switch OFF.
2. Disconnect AFS control unit connector.
3. Check continuity between the AFS control unit harness connector and the height sensor harness connector.

AFS control unit		Height sensor		Continuity
Connector	Terminal	Connector	Terminal	
E104	28	B32	1	Existed

4. Check continuity between the AFS control unit harness connector and the ground.

AFS control unit		Ground	Continuity
Connector	Terminal		
E104	28		Not existed

Does continuity exist?

YES >> Replace the height sensor.

NO >> Repair the harnesses or connectors.

4.CHECK HEIGHT SENSOR POWER SUPPLY CIRCUIT

1. Turn the ignition switch OFF.
2. Disconnect AFS control unit connector.
3. Check continuity between the AFS control unit harness connector and the height sensor harness connector.

AFS control unit		Height sensor		Continuity
Connector	Terminal	Connector	Terminal	
E104	6	B32	2	Existed

4. Check continuity between the AFS control unit harness connector and the ground.

AFS control unit		Ground	Continuity
Connector	Terminal		
E104	6		Not existed

Does continuity exist?

YES >> Replace AFS control unit. Refer to [EXL-114, "Removal and Installation"](#)

NO >> Repair the harnesses or connectors.

5.CHECK HEIGHT SENSOR GROUND CIRCUIT VOLTAGE OUTPUT

Check the voltage between the AFS control unit harness connector and the ground.

B2514 HEIGHT SENSOR UNUSUAL [RR]

< DTC/CIRCUIT DIAGNOSIS >

[XENON TYPE]

Terminals		Voltage (Approx.)
(+)	(-)	
AFS control unit		
Connector	Terminal	Ground
E104	8	
		0 V

Is the measurement value within the standard value?

YES >> GO TO 6.

NO >> Replace AFS control unit. Refer to [EXL-114. "Removal and Installation"](#)

6. CHECK HEIGHT SENSOR GROUND OPEN CIRCUIT

1. Turn the ignition switch OFF.
2. Disconnect AFS control unit connector and the height sensor connector.
3. Check continuity between the AFS control unit harness connector and the height sensor harness connector.

AFS control unit		Height sensor		Continuity
Connector	Terminal	Connector	Terminal	
E104	8	B32	4	Existed

Does continuity exist?

YES >> Replace the height sensor.

NO >> Repair the harnesses or connectors.

A
B
C
D
E
F
G
H
I
J
K
L
M
N
O
P

EXL

B2516 SHIFT SIGNAL [P, R]

[XENON TYPE]

< DTC/CIRCUIT DIAGNOSIS >

B2516 SHIFT SIGNAL [P, R]

DTC Logic

INFOID:000000006887886

DTC DETECTION LOGIC

[B2516] Shift signal [P, R]

DTC detection condition	DTC erase condition	Possible causes
The shift position signal is not received.	Ignition switch OFF	<ul style="list-style-type: none">• TCM• AFS control unit

DTC CONFIRMATION PROCEDURE

1. DTC ERASE

Erase the DTC memory of AFS with CONSULT.

>> GO TO 2.

2. DTC CONFIRMATION

1. Turn ignition ON.
2. Select the self-diagnosis with CONSULT.
3. Check the self-diagnosis result. Refer to [EXL-43, "DTC Index"](#).

Is DTC "B2516" detected?

- YES >> Refer to [EXL-62, "Diagnosis Procedure"](#).
NO >> Refer to [GI-44, "Intermittent Incident"](#).

Diagnosis Procedure

INFOID:000000006887887

1. TCM SELF-DIAGNOSIS

Check the self-diagnosis result with CONSULT. Check that TCM does not detect any DTCs.

Is any DTC detected?

- YES >> Check TCM. Refer to [TM-60, "CONSULT Function"](#).
NO >> GO TO 2.

2. DTC ERASE

Erase the DTC memory of AFS with CONSULT.

Is the memory erased?

- YES >> INSPECTION END.
NO >> Replace AFS control unit. Refer to [EXL-114, "Removal and Installation"](#)

B2517 VEHICLE SPEED SIGNAL

< DTC/CIRCUIT DIAGNOSIS >

[XENON TYPE]

B2517 VEHICLE SPEED SIGNAL

DTC Logic

INFOID:000000006887888

DTC DETECTION LOGIC

[B2517] Vehicle speed signal

DTC detection condition	DTC erase condition	Possible causes
The vehicle speed signal is not received.	Ignition switch OFF	<ul style="list-style-type: none">• Combination meter• AFS control unit

DTC CONFIRMATION PROCEDURE

1. DTC ERASE

Erase the DTC memory of AFS with CONSULT.

>> GO TO 2.

2. DTC CONFIRMATION

1. Turn ignition ON.
2. Select the self-diagnosis with CONSULT.
3. Check the self-diagnosis result. Refer to [EXL-43, "DTC Index"](#).

Is DTC "B2517" detected?

- YES >> Refer to [EXL-63, "Diagnosis Procedure"](#).
NO >> Refer to [GI-44, "Intermittent Incident"](#).

Diagnosis Procedure

INFOID:000000006887889

1. COMBINATION METER SELF-DIAGNOSIS

Check the self-diagnosis result with CONSULT. Check that the combination meter does not detect any DTCs.

Is any DTC detected?

- YES >> Check the combination meter Refer to [MWI-31, "CONSULT Function"](#).
NO >> GO TO 2.

2. DTC ERASE

Erase the DTC memory of AFS with CONSULT.

Is the memory erased?

- YES >> INSPECTION END.
NO >> Replace AFS control unit. Refer to [EXL-114, "Removal and Installation"](#)

A
B
C
D
E
F
G
H
I
J
K
EXL
M
N
O
P

B2519 LEVELIZER CALIBRATION

< DTC/CIRCUIT DIAGNOSIS >

[XENON TYPE]

B2519 LEVELIZER CALIBRATION

DTC Logic

INFOID:000000006887890

[B2519] Levelizer calibration

DTC detection condition	DTC erase condition	Possible causes
The height sensor adjustment position is not recognized.	When the levelizer adjustment is completed	AFS control unit

Diagnosis Procedure

INFOID:000000006887891

1.LEVELIZER ADJUSTMENT

Perform the levelizer adjustment.

>> Refer to [EXL-52. "LEVELIZER ADJUSTMENT : Special Repair Requirement"](#).

B2521 ECU CIRCUIT

DTC Logic

INFOID:000000006887892

DTC DETECTION LOGIC

[B2521] ECU circuit

Error detection condition	DTC erase condition	Possible cause
<ul style="list-style-type: none"> • AFS control unit indicates an applicable DTC when detecting any of the following conditions continuously for 2 seconds or more. - The swivel position sensor is shorted to the power supply or the ground. - The swivel position sensor signal is shorted to the ground. - The height sensor power supply is shorted to the power supply or the ground. - The height sensor signal is shorted to the ground. • AFS control unit RAM/ROM error 	Ignition switch OFF	Swivel position sensor <ul style="list-style-type: none"> • Swivel position sensor • Harness and connector • AFS control unit Height sensor <ul style="list-style-type: none"> • Height sensor • Harness and connector • AFS control unit AFS control unit (RAM/ROM) <ul style="list-style-type: none"> • AFS control unit

DTC CONFIRMATION PROCEDURE

1.DTC ERASE

Erase the DTC memory of AFS with CONSULT.

>> GO TO 2.

2.DTC CONFIRMATION PROCEDURE

1. Turn ignition ON.
2. Select the self-diagnosis with CONSULT.
3. Check the self-diagnosis result. Refer to [EXL-43, "DTC Index"](#).

Is DTC "B2521" detected?

- YES >> Refer to [EXL-65, "Diagnosis Procedure"](#).
 NO >> Refer to [GI-44, "Intermittent Incident"](#).

Diagnosis Procedure

INFOID:000000006887893

1.CHECK EACH SENSOR POWER SUPPLY

1. Turn the ignition switch ON.
2. Check the voltage between the AFS control unit harness connector and the ground.

Terminals		Voltage (Approx.)
(+)	(-)	
AFS control unit		5 V
Connector	Terminal	
E104	4	
	6	
	24	
		Ground

Is the measurement value within the standard value?

- YES >> GO TO 2.
 Less than the standard value >>GO TO 3.
 Higher than the standard value>>GO TO 4.

2.CHECK EACH SENSOR SIGNAL

Check the voltage between the AFS control unit harness connector and the ground.

A
B
C
D
E
F
G
H
I
J
K
EXL
M
N
O
P

B2521 ECU CIRCUIT

< DTC/CIRCUIT DIAGNOSIS >

[XENON TYPE]

Terminals		Voltage (Approx.)
(+)	(-)	
AFS control unit		Ground
Connector	Terminal	
E104	9	
	28	
	29	
		0.25 - 4.75 V

Is the measurement value within the standard value?

YES >> Replace AFS control unit. Refer to [EXL-114, "Removal and Installation"](#)

Less than the standard value >>GO TO 5.

Higher than the standard value>>GO TO 6.

3.CHECK EACH SENSOR POWER SUPPLY SHORT CIRCUIT

1. Turn the ignition switch OFF.
2. Disconnect AFS control unit connector.
3. Check continuity between the AFS control unit harness connector and the ground.

AFS control unit		Ground	Continuity
Connector	Terminal		
E104	4		Not existed
	6		
	24		

Does continuity exist?

YES >> Repair the harnesses or connectors.

NO >> Replace AFS control unit. Refer to [EXL-114, "Removal and Installation"](#)

4.CHECK EACH SENSOR POWER SUPPLY SHORT CIRCUIT

1. Turn the ignition switch OFF.
2. Disconnect AFS control unit connector.
3. Check the voltage between the AFS control unit harness connector and the ground.

Terminals		Voltage (Approx.)
(+)	(-)	
AFS control unit		Ground
Connector	Terminal	
E104	4	
	6	
	24	
		0 V

Is the measurement value normal?

YES >> Replace AFS control unit. Refer to [EXL-114, "Removal and Installation"](#)

NO >> Repair the harnesses or connectors.

5.CHECK EACH SENSOR SIGNAL SHORT CIRCUIT

1. Turn the ignition switch OFF.
2. Disconnect AFS control unit connector.
3. Check continuity between the AFS control unit harness connector and the ground.

B2521 ECU CIRCUIT

< DTC/CIRCUIT DIAGNOSIS >

[XENON TYPE]

AFS control unit		Ground	Continuity
Connector	Terminal		
E104	9	Ground	Not existed
	28		
	29		

Does continuity exist?

YES >> Repair the harnesses or connectors.

NO >> Replace AFS control unit. Refer to [EXL-114. "Removal and Installation"](#)

6. CHECK EACH SENSOR SIGNAL SHORT CIRCUIT

1. Turn the ignition switch OFF.
2. Disconnect AFS control unit connector.
3. Turn the ignition switch ON.
4. Check the voltage between the AFS control unit harness connector and the ground.

AFS control unit		Ground	Voltage (Approx.)
Connector	Terminal		
E104	9	Ground	0 V
	28		
	29		

Is the measurement value normal?

YES >> Replace AFS control unit. Refer to [EXL-114. "Removal and Installation"](#)

NO >> Repair the harnesses or connectors.

A
B
C
D
E
F
G
H
I
J
K
L
M
N
O
P

EXL

C0126 STEERING ANGLE SENSOR SIGNAL

< DTC/CIRCUIT DIAGNOSIS >

[XENON TYPE]

C0126 STEERING ANGLE SENSOR SIGNAL

DTC Logic

INFOID:000000006887894

DTC DETECTION LOGIC

[C0126] Steering angle sensor signal

DTC detection condition	DTC erase condition	Possible causes
In any of the following conditions <ul style="list-style-type: none">The steering angle sensor signal is not received.The steering angle sensor signal error is received.Out-of-standard signal (-900°- +900°) is received.	The ignition switch OFF	<ul style="list-style-type: none">Steering angle sensorAFS control unit

DTC CONFIRMATION PROCEDURE

1. DTC ERASE

Erase the DTC memory of AFS with CONSULT.

>> GO TO 2.

2. DTC CONFIRMATION

1. Start the engine.
2. Turn the steering wheel to the maximum right/left.
3. Select the self-diagnosis with CONSULT.
4. Check the self-diagnosis result. Refer to [EXL-43, "DTC Index"](#).

Is DTC "C0126" detected?

- YES >> Refer to [EXL-68, "Diagnosis Procedure"](#).
NO >> Refer to [GI-44, "Intermittent Incident"](#).

Diagnosis Procedure

INFOID:000000006887895

1. ABS ACTUATOR AND ELECTRICAL UNIT (CONTROL UNIT) SELF-DIAGNOSIS

Check the self-diagnosis result with CONSULT. Check that ABS actuator and electrical unit (control unit) does not detect any DTCs.

Is any DTC detected?

- YES >> Check ABS actuator and electrical unit (control unit). Refer to [BRC-51, "DTC Index"](#).
NO >> GO TO 2.

2. DTC ERASE

Erase DTC memory of AFS with CONSULT.

Is the memory erased?

- YES >> Inspection end.
NO >> Replace AFS control unit. Refer to [EXL-114, "Removal and Installation"](#).

C0428 STEERING ANGLE SENSOR CALIBRATION

< DTC/CIRCUIT DIAGNOSIS >

[XENON TYPE]

C0428 STEERING ANGLE SENSOR CALIBRATION

DTC Logic

INFOID:000000006887896

[C0428] Steering angle sensor calibration

DTC detection condition	DTC erase condition	Possible causes
The steering angle sensor neutral position is not recognized.	When the steering angle sensor neutral position registration is completed	Steering angle sensor

Diagnosis Procedure

INFOID:000000006887897

1. STEERING ANGLE SENSOR NEUTRAL POSITION ADJUSTMENT

Perform the steering angle sensor neutral position adjustment.

CAUTION:

Perform the steering angle sensor neutral position adjustment on VDC side. VDC may activate incorrectly.

>> Refer to [BRC-59, "Work Procedure"](#).

A
B
C
D
E
F
G
H
I
J
K
EXL
M
N
O
P

U1000 CAN COMM CIRCUIT

< DTC/CIRCUIT DIAGNOSIS >

[XENON TYPE]

U1000 CAN COMM CIRCUIT

DTC Logic

INFOID:000000006887898

DTC DETECTION LOGIC

[U1000] CAN communication circuit

DTC detection condition	DTC erase condition	Possible causes
When AFS control unit does not transmit/receive CAN communication signal continuously for 2 seconds or more	Ignition switch OFF	CAN communication system

Diagnosis Procedure

INFOID:000000006887899

1. PERFORM SELF DIAGNOSTIC

1. Turn ignition switch ON and wait for 2 seconds or more.
2. Check "Self Diagnostic Result".

Is "CAN COMM CIRCUIT" displayed?

- YES >> Refer to [LAN-25, "Trouble Diagnosis Flow Chart"](#).
NO >> Refer to [GI-44, "Intermittent Incident"](#).

U1010 CONTROL UNIT (CAN)

< DTC/CIRCUIT DIAGNOSIS >

[XENON TYPE]

U1010 CONTROL UNIT (CAN)

DTC Logic

INFOID:000000006887901

DTC DETECTION LOGIC

[U1010] Control unit (CAN)

DTC detection condition	DTC erase condition	Possible cause
AFS control unit detected internal CAN communication circuit malfunction.	Ignition switch OFF	AFS control unit

Diagnosis Procedure

INFOID:000000006887901

1. REPLACE AFS CONTROL UNIT

When DTC [U1010] is detected, replace AFS control unit.

>> Replace AFS control unit. Refer to [EXL-114, "Removal and Installation"](#)

A
B
C
D
E
F
G
H
I
J
K
M
N
O
P

EXL

POWER SUPPLY AND GROUND CIRCUIT

< DTC/CIRCUIT DIAGNOSIS >

[XENON TYPE]

POWER SUPPLY AND GROUND CIRCUIT

AFS CONTROL UNIT

AFS CONTROL UNIT : Diagnosis Procedure

INFOID:000000006887902

1. FUSE INSPECTION

Check that the following fuses are not fusing.

Signal name	Connection position	Fuse No.	Capacity
Ignition power supply	FUSE BLOCK (J/B)	3	10 A

Is the fuse fusing?

YES >> Repair the applicable circuit. And then replace the fuse.

NO >> GO TO 2.

2. CHECK POWER SUPPLY CIRCUIT

1. Turn the ignition switch OFF.
2. Disconnect AFS control unit harness connector.
3. Turn the ignition switch ON.
4. Check voltage between the AFS control unit harness connector and the ground.

Terminals		Voltage (Approx.)
(+)	(-)	
AFS control unit		Ground
Connector	Terminal	
E104	1	
		Battery voltage

Is the measurement value normal?

YES >> GO TO 3.

NO >> Repair harness or connector.

3. CHECK GROUND CIRCUIT

1. Turn the ignition switch OFF.
2. Check continuity between the AFS control unit harness connectors and the ground.

AFS control unit		Ground	Continuity
Connector	Terminal		
E104	25		Existed

Does continuity exist?

YES >> Power supply and ground circuit are normal.

NO >> Repair harness or connector.

EXTERIOR LAMP FUSE

< DTC/CIRCUIT DIAGNOSIS >

[XENON TYPE]

EXTERIOR LAMP FUSE

Diagnosis Procedure

INFOID:000000006887903

1. CHECK FUSE

Check that the following fuses are not fusing.

Unit	Location	Fuse No.	Capacity
Headlamp HI (LH)	IPDM E/R	#54	10 A
Headlamp HI (RH)	IPDM E/R	#55	10 A
Headlamp LO (LH)	IPDM E/R	#56	15 A
Headlamp LO (RH)	IPDM E/R	#57	15 A
Front fog lamp	IPDM E/R	#59	15 A
Daytime running light relay • Parking lamp • License plate lamp • Side marker lamp • Tail lamp	Fuse and fusible link block	#38	10 A
Stop lamp	FUSE BLOCK (J/B)	#7	10 A
Back-up lamp	FUSE BLOCK (J/B)	#4	10 A

Is the measurement normal?

YES >> The fuse is normal.

NO >> Repair the applicable circuit. And then replace the fuse.

A
B
C
D
E
F
G
H
I
J
K
EXL
M
N
O
P

HEADLAMP (HI) CIRCUIT

< DTC/CIRCUIT DIAGNOSIS >

[XENON TYPE]

HEADLAMP (HI) CIRCUIT

Component Function Check

INFOID:000000006887904

1. CHECK HEADLAMP (HI) OPERATION

CONSULT ACTIVE TEST

1. Select "EXTERNAL LAMPS" of IPDM E/R active test item.
2. With operating the test items, check that the headlamp (HI) is turned ON.

Hi : Headlamp (HI) ON

Off : Headlamp (HI) OFF

NOTE:

ON/OFF is repeated 1 second each.

Is the measurement normal?

- YES >> Headlamp (HI) circuit is normal.
NO >> Refer to [EXL-74, "Diagnosis Procedure"](#).

Diagnosis Procedure

INFOID:000000006887905

1. CHECK HEADLAMP (HI) OUTPUT VOLTAGE

CONSULT ACTIVE TEST

1. Turn ignition switch OFF.
2. Disconnect front combination lamp connector.
3. Turn ignition switch ON.
4. Select "EXTERNAL LAMPS" of IPDM E/R active test item.
5. With operating the test items, check voltage between IPDM E/R harness connector and ground.

(+)		Terminal	(-)	Test item	Voltage (Approx.)
IPDM E/R					
Connector					
RH	E8	89	Ground	Hi	Battery voltage
					Off
LH		90		Hi	Battery voltage
				Off	0 V

Is the inspection result normal?

- YES >> GO TO 2.
NO >> GO TO 3.

2. CHECK HEADLAMP (HI) OPEN CIRCUIT

1. Turn ignition switch OFF.
2. Disconnect IPDM E/R connector.
3. Check continuity between IPDM E/R harness connector and front combination lamp harness connector.

IPDM E/R		Front combination lamp		Continuity
Connector	Terminal	Connector	Terminal	
RH	E8	E24	2	Existed
LH		90	E54	

Is the inspection result normal?

- YES >> GO TO 5.
NO >> Repair or replace harness.

3. CHECK HEADLAMP (HI) FUSE

1. Turn ignition switch OFF.

HEADLAMP (HI) CIRCUIT

[XENON TYPE]

< DTC/CIRCUIT DIAGNOSIS >

2. Check that the following fuses are not fusing.

Unit	Location	Fuse No.	Capacity
Headlamp HI (RH)	IPDM E/R	#55	10 A
Headlamp HI (LH)	IPDM E/R	#54	10 A

Is the inspection result normal?

YES >> Replace IPDM E/R.

NO >> GO TO 4.

4. CHECK HEADLAMP HIGH (HI) SHORT CIRCUIT

1. Disconnect IPDM E/R connector.
2. Check continuity between IPDM E/R harness connector and ground.

IPDM E/R		Ground	Continuity
Connector	Terminal		
RH	E8	89	Not existed
LH		90	

Is the inspection result normal?

YES >> Replace fuse. (Replace IPDM E/R if the fuse is fusing again.)

NO >> Repair or replace harness. And then replace the fuse.

5. CHECK HEADLAMP (HI) GROUND OPEN CIRCUIT

1. Turn ignition switch OFF.
2. Disconnect combination lamp connector.
3. Check continuity between front combination lamp harness connector and ground.

Front combination lamp		Ground	Continuity
Connector	Terminal		
RH	E24	5	Existed
LH	E54	5	

Is the inspection result normal?

YES >> Replace the front combination lamp.

NO >> Repair or replace harness.

A
B
C
D
E
F
G
H
I
J
K
M
N
O
P

EXL

HEADLAMP (LO) CIRCUIT

< DTC/CIRCUIT DIAGNOSIS >

[XENON TYPE]

HEADLAMP (LO) CIRCUIT

Component Function Check

INFOID:000000006887906

1. CHECK HEADLAMP (LO) OPERATION

CONSULT ACTIVE TEST

1. Select "EXTERNAL LAMPS" of IPDM E/R active test item.
2. With operating the test items, check that the headlamp (LO) is turned ON.

Lo : Headlamp (LO) ON

Off : Headlamp (LO) OFF

Is the measurement normal?

- YES >> Headlamp (LO) is normal.
NO >> Refer to [EXL-76, "Diagnosis Procedure"](#).

Diagnosis Procedure

INFOID:000000006887907

1. CHECK HEADLAMP (LO) OUTPUT VOLTAGE

CONSULT ACTIVE TEST

1. Turn ignition switch OFF.
2. Disconnect front combination lamp connector.
3. Turn ignition switch ON.
4. Select "EXTERNAL LAMPS" of IPDM E/R active test item.
5. With operating the test items, check voltage between IPDM E/R harness connector and ground.

(+)			(-)	Test item	Voltage (Approx.)		
IPDM E/R							
Connector		Terminal					
RH	E7	83	Ground	EXTERNAL LAMPS	Lo	Battery voltage	
						Off	0 V
LH				84		Lo	Battery voltage
						Off	0 V

Is the inspection result normal?

- YES >> GO TO 2.
NO >> GO TO 3.

2. CHECK HEADLAMP (LO) OPEN CIRCUIT

1. Turn ignition switch OFF.
2. Disconnect IPDM E/R connector.
3. Check continuity between IPDM E/R harness connector and front combination lamp harness connector.

IPDM E/R			Front combination lamp		Continuity
Connector		Terminal	Connector	Terminal	
RH	E7	83	E24	4	Existed
LH			84	E54	

Is the inspection result normal?

- YES >> GO TO 5.
NO >> Repair or replace harness.

3. CHECK HEADLAMP (LO) FUSE

1. Turn ignition switch OFF.
2. Check that the following fuses are not fusing.

HEADLAMP (LO) CIRCUIT

< DTC/CIRCUIT DIAGNOSIS >

[XENON TYPE]

Unit	Lotion	Fuse No.	Capacity
Headlamp LO (RH)	IPDM E/R	#57	15 A
Headlamp LO (LH)	IPDM E/R	#56	15 A

Is the inspection result normal?

YES >> Replace IPDM E/R.

NO >> GO TO 4.

4.CHECK HEADLAMP (LO) SHORT CIRCUIT

1. Disconnect IPDM E/R connector.
2. Check continuity between IPDM E/R harness connector and ground.

IPDM E/R			Ground	Continuity
Connector		Terminal		
RH	E7	83		Not existed
LH		84		

Is the inspection result normal?

YES >> Replace fuse. (Replace IPDM E/R if the fuse is fusing again.)

NO >> Repair or replace harness. And then replace the fuse.

5.CHECK HEADLAMP (LO) GROUND OPEN CIRCUIT

1. Turn ignition switch OFF.
2. Disconnect front combination lamp connector.
3. Check continuity between front combination lamp harness connector and ground.

Front combination lamp			Ground	Continuity
Connector		Terminal		
RH	E54	6		Existed
LH	E24	6		

Is the inspection result normal?

YES >> Perform the xenon headlamp diagnosis. Refer to [EXL-78, "Diagnosis Procedure"](#).

NO >> Repair or replace harness.

EXL

XENON HEADLAMP

< DTC/CIRCUIT DIAGNOSIS >

[XENON TYPE]

XENON HEADLAMP

Diagnosis Procedure

INFOID:000000006887908

1. CHECK XENON BULB

Install the normal bulb to the applicable headlamp. Check that the lighting switch is turned ON.

Is the headlamp turned ON?

- YES >> Replace xenon bulb.
- NO >> GO TO 2.

2. CHECK INSIDE OF XENON HEADLAMP HOUSING

Check the inside of applicable headlamp (upper surface of HID control unit) for exist the water or trace of the water intrusion.

Are there trace of the water intrusion in the headlamp?

- YES >> GO TO 3.
- NO >> Check headlamp control system. If result is normal, replace front combination headlamp.

3. CHECK OUTSIDE OF XENON HEADLAMP HOUSING

Check the outside of applicable headlamp for cracks, serious damage or install the resin cap and the bulb socket securely.

Is the outside of headlamp housing abnormality?

- YES >> Replace the front combination lamp.
- NO >> Dry water fully and then check that the lighting switch is turned ON. Refer to [EXL-108. "Disassembly and Assembly"](#)

DAYTIME RUNNING LIGHT RELAY CIRCUIT

< DTC/CIRCUIT DIAGNOSIS >

[XENON TYPE]

DAYTIME RUNNING LIGHT RELAY CIRCUIT

Component Function Check

INFOID:000000006887909

1. CHECK DAYTIME RUNNING LIGHT OPERATION

CONSULT ACTIVE TEST

1. Select "EXTERNAL LAMPS" of IPDM E/R active test item.
2. With operating the test item, check that parking lamp, license plate lamp, side marker lamp and tail lamp are turned ON.

TAIL : Parking lamp, license plate lamp, side marker lamp and tail lamp ON

Off : Parking lamp, license plate lamp, side marker lamp and tail lamp OFF

Are parking lamp and tail lamp turned ON?

- YES >> Daytime running light relay circuit is normal.
 NO >> Refer to [EXL-79. "Diagnosis Procedure"](#).

Diagnosis Procedure

INFOID:000000006887910

1. CHECK DAYTIME RUNNING LIGHT RELAY FUSE

Check that the following fuse is not fusing.

Unit	Location	Fuse No.	Capacity
Daytime running light relay	Fuse and fusible link block	#38	10 A

Is the fuse fusing?

- YES >> Replace the fuse after repairing the applicable circuit.
 NO >> GO TO 2.

2. CHECK DAYTIME RUNNING LIGHT RELAY POWER SUPPLY

1. Remove the daytime running light relay.
2. Check voltage between the daytime running light relay harness connector and the ground.

Terminals		Voltage (Approx.)
(+)	(-)	
Daytime running light relay		Battery voltage
Connector	Terminal	
E45	2 5	

Is the measurement value normal?

- YES >> GO TO 3.
 NO >> Repair harnesses or connectors.

3. CHECK DAYTIME RUNNING LIGHT RELAY

Check the daytime running light relay. Refer to [EXL-80. "Component Inspection"](#).

Is the daytime running light relay normal?

- YES >> GO TO 4.
 NO >> Replace the daytime running light relay.

4. CHECK DAYTIME RUNNING LIGHT RELAY CONTROL SIGNAL OUTPUT

CONSULT ACTIVE TEST

1. Install the daytime running light relay.
2. Turn the ignition switch ON.
3. Select "EXTERNAL LAMPS" of IPDM E/R active test item.

DAYTIME RUNNING LIGHT RELAY CIRCUIT

[XENON TYPE]

< DTC/CIRCUIT DIAGNOSIS >

4. With operating the test item, check voltage between the IPDM E/R harness connector and the ground.

Terminals		Test item	Voltage (Approx.)
(+)	(-)		
IPDM E/R		EXTERNAL LAMPS	0 V
Connector	Terminal		
E5	23		
		TAIL	Battery voltage
		Off	Battery voltage

Is the measurement value normal?

YES >> Check the parking lamp, license plate lamp, side marker lamp and tail lamp circuit. Refer to [EXL-44. "EXTERIOR LIGHTING SYSTEM : Wiring Diagram"](#).

Fixed at 0 V >> GO TO 5.

Fixed at battery voltage >> Replace IPDM E/R.

5. CHECK DAYTIME RUNNING LIGHT RELAY CONTROL SIGNAL OPEN CIRCUIT

1. Remove the daytime running light relay.
2. Disconnect IPDM E/R harness connector.
3. Check continuity between the IPDM E/R harness connector and the daytime running light relay harness connector.

IPDM E/R		Daytime running light relay		Continuity
Connector	Terminal	Connector	Terminal	
E5	23	E45	1	Existed

Does continuity exist?

YES >> GO TO 6.

NO >> Repair the harnesses or connectors.

6. CHECK DAYTIME RUNNING LIGHT RELAY CONTROL SIGNAL SHORT CIRCUIT

Check continuity between the IPDM E/R harness connector and the ground.

IPDM E/R		Ground	Continuity
Connector	Terminal		
E5	23		Not existed

Does continuity exist?

YES >> Repair the harnesses or connectors.

NO >> Replace IPDM E/R.

Component Inspection

INFOID:000000006887911

1. CHECK DAYTIME RUNNING LIGHT RELAY EXCITATION COIL SIDE

1. Turn the ignition switch OFF.
2. Remove the daytime running light relay.
3. Check continuity of the daytime running light relay excitation coil side.

Daytime running light relay		Continuity
Terminal		
1	2	Existed

Does continuity exist?

YES >> GO TO 2.

NO >> Replace the daytime running light relay.

2. CHECK DAYTIME RUNNING LIGHT RELAY CONTACT SIDE

1. Apply battery voltage to the daytime running light relay between the terminals 1 and 2.
2. Check continuity of the daytime running light relay.

DAYTIME RUNNING LIGHT RELAY CIRCUIT

< DTC/CIRCUIT DIAGNOSIS >

[XENON TYPE]

Daytime running light relay		Condition	Continuity
Terminal		Voltage	
3	5	Apply	Existed
		Not Apply	Not existed

A

B

Does continuity exist?

YES >> Daytime running light relay is normal.

NO >> Replace the daytime running light relay.

C

D

E

F

G

H

I

J

K

EXL

M

N

O

P

HEADLAMP LEVELIZER CIRCUIT

< DTC/CIRCUIT DIAGNOSIS >

[XENON TYPE]

HEADLAMP LEVELIZER CIRCUIT

Component Function Check

INFOID:000000006887912

1. CHECK AIMING MOTOR OPERATION

CONSULT ACTIVE TEST

1. Start the engine.
2. Turn the lighting switch 2ND.
3. Select "LEVELIZER TEST" of ADAPTIVE LIGHT active test item.
4. With operating the test item, check the operation.

Test item	Optical axis
LEVELIZER TEST	
Origin	Standard position
Peak	Lowest position

Is the operation normal?

- YES >> Headlamp levelizer circuit is normal.
 NO >> Refer to [EXL-82, "Diagnosis Procedure"](#).

Diagnosis Procedure

INFOID:000000006887913

1. CHECK AIMING MOTOR DRIVE SIGNAL OUTPUT

CONSULT ACTIVE TEST

1. Start the engine.
2. Turn the light switch 2ND.
3. Select "LEVELIZER TEST" of ADAPTIVE LIGHT active test item.
4. With operating the test item, check the voltage between the AFS control unit harness connector and the ground.

Terminals			Test item	Voltage (Approx.)		
(+)		(-)				
AFS control unit			LEVELIZER TEST			
Connector		Terminal				
RH	E104	19			Origin	8.8 V
		Peak			4.0 V	
LH		40			Origin	8.8 V
					Peak	4.0 V

Is the measurement value normal?

- YES >> GO TO 2.
 NO >> GO TO 3.

2. CHECK AIMING MOTOR DRIVE SIGNAL OPEN CIRCUIT

1. Turn the ignition switch OFF.
2. Disconnect AFS control unit connector and headlamp aiming motor connector.
3. Check continuity between AFS control unit harness connector and the aiming motor harness connector.

AFS control unit			Headlamp aiming motor		Continuity
Connector		Terminal	Connector	Terminal	
RH	E104	19	E26	3	Existed
		40	E56	3	
LH					

Does continuity exist?

- YES >> Replace the front combination lamp.
 NO >> Repair the harnesses and connectors.

HEADLAMP LEVELIZER CIRCUIT

< DTC/CIRCUIT DIAGNOSIS >

[XENON TYPE]

3. CHECK AIMING MOTOR DRIVE SIGNAL SHORT CIRCUIT

1. Turn the ignition switch OFF.
2. Disconnect AFS control unit connector and headlamp aiming motor connector.
3. Check continuity between AFS control unit harness connector and ground.

AFS control unit		Ground	Continuity
Connector	Terminal		
RH	E104	19	Not existed
LH		40	

Does continuity exist?

- YES >> Repair the harness and connectors.
NO >> Replace AFS control unit. Refer to [EXL-114, "Removal and Installation"](#)

A
B
C
D
E
F
G
H
I
J
K
M
N
O
P

EXL

FRONT FOG LAMP CIRCUIT

< DTC/CIRCUIT DIAGNOSIS >

[XENON TYPE]

FRONT FOG LAMP CIRCUIT

Component Function Check

INFOID:000000006887914

1.CHECK FRONT FOG LAMP OPERATION

ⓈCONSULT ACTIVE TEST

1. Select "EXTERNAL LAMPS" of IPDM E/R active test item.
2. With operating the test items, check that the front fog lamp is turned ON.

Fog : Front fog lamp ON
Off : Front fog lamp OFF

Is the measurement normal?

- YES >> Front fog lamp circuit is normal.
NO >> Refer to [EXL-84, "Diagnosis Procedure"](#).

Diagnosis Procedure

INFOID:000000006887915

1.CHECK FRONT FOG LAMP FUSE

1. Turn ignition switch OFF.
2. Check that the following fuse is not fusing.

Unit	Location	Fuse No.	Capacity
Front fog lamp	IPDM E/R	#59	15 A

Is the inspection result normal?

- YES >> GO TO 3.
NO >> GO TO 2.

2.CHECK FRONT FOG LAMP SHORT CIRCUIT

1. Disconnect front fog connector and IPDM E/R connector.
2. Check continuity between IPDM E/R harness connector and ground.

IPDM E/R		Ground	Continuity
Connector	Terminal		
RH	E8	86	Not existed
LH		87	

Is the inspection result normal?

- YES >> Replace fuse. (Replace IPDM E/R if the fuse is fusing again.)
NO >> Repair or replace harness. And then replace the fuse.

3.CHECK FRONT FOG LAMP BULB

Check the applicable lamp bulb.

Is the inspection result normal?

- YES >> GO TO 4.
NO >> Replace bulb.

4.CHECK FRONT FOG LAMP OUTPUT VOLTAGE

ⓈCONSULT ACTIVE TEST

1. Disconnect front fog lamp connector.
2. Turn ignition switch ON.
3. Select "EXTERNAL LAMPS" of IPDM E/R active test item.
4. With operating the test items, check the voltage between IPDM E/R harness connector and ground.

FRONT FOG LAMP CIRCUIT

< DTC/CIRCUIT DIAGNOSIS >

[XENON TYPE]

(+)		Terminal	(-)	Test item	Voltage (Approx.)		
IPDM E/R							
Connector							
RH	E8	86	Ground	EXTERNAL LAMPS	Fog	Battery voltage	
						Off	0 V
LH		87				Fog	Battery voltage
						Off	0 V

Is the inspection result normal?

YES >> GO TO 5.

NO >> Replace IPDM E/R.

5. CHECK FRONT FOG LAMP OPEN CIRCUIT

1. Turn ignition switch OFF.
2. Disconnect IPDM E/R connector.
3. Check continuity between IPDM E/R harness connector and front fog lamp harness connector.

IPDM E/R		Front fog lamp		Continuity
Connector	Terminal	Connector	Terminal	
RH	E8	86	E34	Existed
LH		87	E64	

Is the inspection result normal?

YES >> GO TO 6.

NO >> Repair or replace harness.

6. CHECK FRONT FOG LAMP GROUND CIRCUIT OPEN CIRCUIT

Check continuity between front fog lamp harness connector and ground.

Front fog lamp		Ground	Continuity
Connector	Terminal		
RH	E34	2	Existed
LH	E64		

Is the inspection result normal?

YES >> Replace front fog lamp.

NO >> Repair or replace harness.

A
B
C
D
E
F
G
H
I
J
K
M
N
O
P

EXL

TURN SIGNAL LAMP CIRCUIT

< DTC/CIRCUIT DIAGNOSIS >

[XENON TYPE]

TURN SIGNAL LAMP CIRCUIT

Description

INFOID:000000006887916

BCM performs the high flasher operation if any bulb or harness of the turn signal lamp circuit is open.

NOTE:

The turn signal lamp blinks at normal speed when using the hazard warning lamp.

Component Function Check

INFOID:000000006887917

1. CHECK TURN SIGNAL LAMP

Ⓟ CONSULT ACTIVE TEST

1. Select "FLASHER" of BCM (FLASHER) active test item.
2. With operating the test items, check that the turn signal lamp is turned ON.

LH : Turn signal lamps (LH) ON

RH : Turn signal lamps (RH) ON

Off : Turn signal lamps OFF

Is the inspection result normal?

- YES >> Turn signal lamp circuit is normal.
NO >> Refer to [EXL-86, "Diagnosis Procedure"](#).

Diagnosis Procedure

INFOID:000000006887918

1. CHECK TURN SIGNAL LAMP BULB

Check applicable lamp bulb.

Is the inspection result normal?

- YES >> GO TO 2.
NO >> Replace bulb.

2. CHECK TURN SIGNAL LAMP OUTPUT VOLTAGE

1. Turn ignition switch OFF.
2. Disconnect front combination lamp connector, door mirror connector or rear combination lamp connector.
3. Turn ignition switch ON.
4. With operating the turn signal switch, check voltage between BCM harness connector and ground.

TURN SIGNAL LAMP CIRCUIT

< DTC/CIRCUIT DIAGNOSIS >

[XENON TYPE]

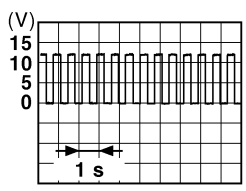
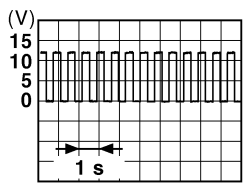
(+)		(-)	Condition	Voltage (Approx.)	
BCM					
Connector	Terminal				
M122	60	Ground	Turn signal switch	LH	 <small>PKID0926E</small>
			OFF	0 V	
	61		RH	 <small>PKID0926E</small>	
			OFF	0 V	

Is the inspection result normal?

YES >> GO TO 3.

NO >> GO TO 4.

3. CHECK TURN SIGNAL LAMP OPEN CIRCUIT

1. Turn ignition switch OFF.
2. Disconnect BCM connector.
3. Check continuity between BCM harness connector and front combination lamp, door mirror or rear combination lamp harness connector.

Front turn signal lamp

BCM		Front combination lamp		Continuity
Connector	Terminal	Connector	Terminal	
LH	M122	E54	3	Existed
RH		E24	3	

Rear turn signal lamp

BCM		Rear combination lamp		Continuity
Connector	Terminal	Connector	Terminal	
LH	M122	B26	3	Existed
RH		B260	3	

Is the inspection result normal?

YES >> GO TO 5.

NO >> Repair or replace harness.

4. CHECK TURN SIGNAL LAMP SHORT CIRCUIT

Check continuity between BCM harness connector and ground.

BCM		Ground	Continuity
Connector	Terminal		
M69	60		Not existed
	61		

Is the inspection result normal?

TURN SIGNAL LAMP CIRCUIT

[XENON TYPE]

< DTC/CIRCUIT DIAGNOSIS >

- YES >> Check each bulb socket for internal short, and if check result is normal, replace BCM. Refer to [BCS-82, "Removal and Installation"](#).
- NO >> Repair or replace harness.

5. CHECK TURN SIGNAL LAMP GROUND OPEN CIRCUIT

Check continuity between front combination lamp, door mirror or rear combination lamp and ground.

Front turn signal lamp

Front combination lamp			Ground	Continuity
Connector		Terminal		Existed
LH	E54	5		
RH	E24	5		

Rear turn signal lamp

Rear combination lamp			Ground	Continuity
Connector		Terminal		Existed
LH	B26	4		
RH	B260	4		

Is the inspection result normal?

- YES >> Replace front combination lamp, door mirror assembly or rear combination lamp.
- NO >> Repair or replace harness.

OPTICAL SENSOR

< DTC/CIRCUIT DIAGNOSIS >

[XENON TYPE]

OPTICAL SENSOR

Component Function Check

INFOID:000000006887919

1.CHECK OPTICAL SENSOR SIGNAL BY CONSULT

CONSULT DATA MONITOR

1. Turn ignition switch ON.
2. Select "OPTISEN (DTCT)" of BCM (HEADLAMP) data monitor item.
3. Turn lighting switch AUTO.
4. With the optical sensor illuminating, check the monitor status.

Monitor item	Condition		Voltage (Approx.)
OPTISEN (DTCT)	Optical sensor	When illuminating	3.1 V or more *
		When shutting off light	0.6 V or less

*: Illuminates the optical sensor. The value may be less than the standard value if brightness is weak.

Is the inspection result normal?

- YES >> Optical sensor is normal.
 NO >> Refer to [EXL-89, "Diagnosis Procedure"](#).

Diagnosis Procedure

INFOID:000000006887920

1.CHECK OPTICAL SENSOR POWER SUPPLY INPUT

1. Turn ignition switch ON.
2. Turn lighting switch AUTO.
3. Check voltage between optical sensor harness connector and ground.

(+)		(-)	Voltage (Approx.)
Optical sensor			
Connector	Terminal	Ground	5 V
M94	1		

Is the inspection result normal?

- YES >> GO TO 2.
 NO >> GO TO 4.

2.CHECK OPTICAL SENSOR GROUND INPUT

Check voltage between optical sensor harness connector and ground.

(+)		(-)	Voltage (Approx.)
Optical sensor			
Connector	Terminal	Ground	0 V
M94	3		

Is the inspection result normal?

- YES >> GO TO 3.
 NO >> GO TO 6.

3.CHECK OPTICAL SENSOR SIGNAL OUTPUT

With illuminating the optical sensor, check voltage between optical sensor harness connector and ground.

(+)		(-)	Condition	Voltage (Approx.)
Optical sensor				
Connector	Terminal			

OPTICAL SENSOR

[XENON TYPE]

< DTC/CIRCUIT DIAGNOSIS >

M94	2	Ground	Optical sensor	When illuminating	3.1 V or more *
				When shutting off light	0.6 V or less

*: Illuminate the optical sensor. The value may be less than the standard if brightness is weak.

Is the inspection result normal?

- YES >> GO TO 7.
 NO >> Replace the optical sensor.

4.CHECK OPTICAL SENSOR OPEN CIRCUIT

1. Turn ignition switch OFF.
2. Disconnect optical sensor connector and BCM connector.
3. Check continuity between optical sensor harness connector and BCM harness connector.

Optical sensor		BCM		Continuity
Connector	Terminal	Connector	Terminal	
M94	1	M120	17	Existed

Is the inspection result normal?

- YES >> GO TO 5.
 NO >> Repair or replace harness.

5.CHECK OPTICAL SENSOR SHORT CIRCUIT

Check continuity between optical sensor harness connector and ground.

Optical sensor		Ground	Continuity
Connector	Terminal		
M94	1		Not existed

Is the inspection result normal?

- YES >> Replace BCM. Refer to [BCS-82. "Removal and Installation"](#).
 NO >> Repair or replace harness.

6.CHECK OPTICAL SENSOR GROUND OPEN CIRCUIT

1. Turn ignition switch OFF.
2. Disconnect optical sensor connector and BCM connector.
3. Check continuity between optical sensor harness connector and BCM harness connector.

Optical sensor		BCM		Continuity
Connector	Terminal	Connector	Terminal	
M94	3	M120	18	Existed

Is the inspection result normal?

- YES >> Replace BCM. Refer to [BCS-82. "Removal and Installation"](#).
 NO >> Repair or replace harness.

7.CHECK OPTICAL SENSOR SIGNAL OPEN CIRCUIT

1. Turn ignition switch OFF.
2. Disconnect optical sensor connector and BCM connector.
3. Check continuity between optical sensor harness connector and BCM harness connector.

Optical sensor		BCM		Continuity
Connector	Terminal	Connector	Terminal	
M94	2	M120	14	Existed

Is the inspection result normal?

- YES >> GO TO 8.

OPTICAL SENSOR

< DTC/CIRCUIT DIAGNOSIS >

[XENON TYPE]

NO >> Repair or replace harness.

8. CHECK OPTICAL SENSOR SHORT CIRCUIT

Check continuity between optical sensor harness connector and ground.

Optical sensor		Ground	Continuity
Connector	Terminal		
M94	2		Not existed

Is the inspection result normal?

YES >> Replace BCM. Refer to [BCS-82. "Removal and Installation"](#).

NO >> Repair or replace harness.

A
B
C
D
E
F
G
H
I
J
K
EXL
M
N
O
P

HAZARD SWITCH

< DTC/CIRCUIT DIAGNOSIS >

[XENON TYPE]

HAZARD SWITCH

Component Function Check

INFOID:000000006887921

1. CHECK HAZARD SWITCH SIGNAL BY CONSULT

CONSULT DATA MONITOR

1. Turn ignition switch ON.
2. Select "HAZARD SW" of BCM (FLASHER) data monitor item.
3. With operating the hazard switch, check the monitor status.

Monitor item	Condition		Monitor status
HAZARD SW	Hazard switch	ON	On
		OFF	Off

Is the measurement normal?

- YES >> Hazard switch circuit is normal.
 NO >> Refer to [EXL-92. "Diagnosis Procedure"](#).

Diagnosis Procedure

INFOID:000000006887922

1. CHECK HAZARD SWITCH SIGNAL INPUT

1. Turn ignition switch OFF.
2. Disconnect multifunction switch connector.
3. Check voltage between multifunction switch harness connector and ground.

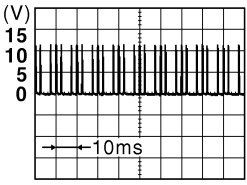
(+)		(-)	Voltage (Approx.)
Connector	Terminal		
M72	16	Ground	

Is the inspection result normal?

- YES >> GO TO 4.
 NO >> GO TO 2.

2. CHECK HAZARD SWITCH SIGNAL OPEN CIRCUIT

1. Turn ignition switch OFF.
2. Disconnect BCM connector.
3. Check continuity between multifunction harness connector and BCM harness connector.

Multifunction switch (Hazard switch)		BCM		Continuity
Connector	Terminal	Connector	Terminal	
M72	16	M120	29	Existed

Is the inspection result normal?

- YES >> GO TO 3.
 NO >> Repair or replace harness.

3. CHECK HAZARD SWITCH SIGNAL SHORT CIRCUIT

Check continuity between multifunction harness connector and ground.

HAZARD SWITCH

< DTC/CIRCUIT DIAGNOSIS >

[XENON TYPE]

Multifunction switch (Hazard switch)		Ground	Continuity
Connector	Terminal		
M72	16		Not existed

Is the inspection result normal?

YES >> Replace BCM. Refer to [BCS-82, "Removal and Installation"](#).

NO >> Repair or replace harness.

4. CHECK HAZARD SWITCH GROUND OPEN CIRCUIT

Check continuity between multifunction switch harness connector and ground.

Multifunction switch (Hazard switch)		Ground	Continuity
Connector	Terminal		
M72	1		Existed

Is the inspection result normal?

YES >> Replace multifunction switch.

NO >> Repair or replace harness.

A
B
C
D
E
F
G
H
I
J
K
L
M
N
O
P

EXL

EXTERIOR LIGHTING SYSTEM SYMPTOMS

< SYMPTOM DIAGNOSIS >

[XENON TYPE]

SYMPTOM DIAGNOSIS

EXTERIOR LIGHTING SYSTEM SYMPTOMS

Symptom Table

INFOID:000000006887923

CAUTION:

Perform the self-diagnosis with CONSULT before the symptom diagnosis. Perform the trouble diagnosis if any DTC is detected.

Symptom		Possible cause	Inspection item
Headlamp does not switch to the high beam.	One side	<ul style="list-style-type: none"> Fuse Harness between IPDM E/R and the front combination lamp Front combination lamp (High beam solenoid) IPDM E/R Harness between the front combination lamp and ground 	Headlamp (HI) circuit Refer to EXL-74 .
	Both sides	Symptom diagnosis "BOTH SIDE HEADLAMPS DO NOT SWITCH TO HIGH BEAM" Refer to EXL-98 .	
High beam indicator lamp is not turned ON. (Headlamp switches to the high beam.)		Combination meter	<ul style="list-style-type: none"> Combination meter Data monitor "HI-BEAM IND" BCM (HEAD LAMP) Active test "HEADLAMP"
Headlamp does not switch to the low beam.	One side	Front combination lamp (High beam solenoid)	—
	Both sides	<ul style="list-style-type: none"> Combination switch Harness between the combination switch and BCM BCM 	Combination switch Refer to BCS-8 .
		High beam request signal <ul style="list-style-type: none"> BCM IPDM E/R 	IPDM E/R Data monitor "HL HI REQ"
		IPDM E/R	—
Headlamp is not turned ON.	One side	<ul style="list-style-type: none"> Fuse Xenon bulb Harness between IPDM E/R and the front combination lamp Front combination lamp (xenon headlamp) IPDM E/R Harness between the front combination lamp and ground 	Headlamp (LO) circuit Refer to EXL-76 .
	Both sides	Symptom diagnosis "BOTH SIDE HEADLAMPS (LO) ARE NOT TURNED ON" Refer to EXL-99 .	
Headlamp is not turned OFF.	When the ignition switch is turned ON		
	The ignition switch is turned OFF (After activating the battery saver).	IPDM E/R	—

EXTERIOR LIGHTING SYSTEM SYMPTOMS

< SYMPTOM DIAGNOSIS >

[XENON TYPE]

Symptom	Possible cause	Inspection item
Headlamp is not turned ON/OFF with the lighting switch AUTO.	<ul style="list-style-type: none"> • Combination switch • Harness between the combination switch and BCM • BCM 	Combination switch Refer to BCS-8 .
	<ul style="list-style-type: none"> • Optical sensor • Harness between the optical sensor and BCM • BCM 	Optical sensor Refer to EXL-89 .
Front fog lamp is not turned ON.	One side <ul style="list-style-type: none"> • Front fog lamp bulb • Harness between IPDM E/R and the front combination lamp • Front combination lamp • IPDM E/R 	Front fog lamp circuit Refer to EXL-84 .
	Both side	Symptom diagnosis "BOTH SIDE FRONT FOG LAMPS ARE NOT TURNED ON" Refer to EXL-101 .
Front fog lamp indicator is not turned ON. (Front fog lamp is turned ON.)	Combination meter	<ul style="list-style-type: none"> • Combination meter • Data monitor "FR FOG IND" • BCM (HEAD LAMP) • Active test "FR FOG LAMP"
<ul style="list-style-type: none"> • Parking lamp, the tail lamp, side marker lamp and the license plate lamp are not turned ON. • Parking lamp, the tail lamp, side marker lamp and the license plate lamp are not turned OFF. 	Each illumination is turned ON/OFF	<ul style="list-style-type: none"> • Fuse • Harness between IPDM E/R and the daytime running light relay • daytime running light relay • IPDM E/R Daytime running light relay circuit Refer to EXL-79 .
	Each illumination is not turned ON/OFF	Symptom diagnosis "PARKING, LICENSE PLATE AND TAIL LAMPS ARE NOT TURNED ON" Refer to EXL-100 .
Tail lamp indicator is not turned ON. (Parking and tail lamps are turned ON.)	Combination meter	<ul style="list-style-type: none"> • Combination meter • Data monitor "LIGHT IND" • BCM (HEAD LAMP) • Active test "TAIL LAMP"
Turn signal lamp does not blink.	Indicator lamp is normal. (The applicable side performs the high flasher activation.)	<ul style="list-style-type: none"> • Harness between BCM and each turn signal lamp • Turn signal lamp bulb Turn signal lamp circuit Refer to EXL-86 .
	Indicator lamp is included	<ul style="list-style-type: none"> • Combination switch • Harness between the combination switch and BCM • BCM Combination switch Refer to BCS-8 .
Turn signal indicator lamp does not blink. (The turn signal lamp is normal.)	One side	Combination meter —
	Both sides (Always)	<ul style="list-style-type: none"> • Turn signal indicator lamp signal - Combination meter - BCM • Combination meter <ul style="list-style-type: none"> • Combination meter • Data monitor "TURN IND" • BCM (FLASHER) • Active test "FLASHER"
	Both sides (Only when activating the hazard warning lamp with the ignition switch OFF.)	<ul style="list-style-type: none"> • The combination meter power supply and the ground circuit • Combination meter Combination meter Power supply and the ground circuit Refer to MWI-59 .
<ul style="list-style-type: none"> • Hazard warning lamp does not activate. • Hazard warning lamp continues activating. (Turn signal is normal.) 	<ul style="list-style-type: none"> • Hazard switch • Harness between the hazard switch and BCM • BCM Hazard switch Refer to EXL-92 .	

A
B
C
D
E
F
G
H
I
J
K
EXL
M
N
O
P



EXTERIOR LIGHTING SYSTEM SYMPTOMS

< SYMPTOM DIAGNOSIS >

[XENON TYPE]

Symptom	Possible cause	Inspection item
Headlamp auto aiming does not activate. (AFS is normal.)	<ul style="list-style-type: none">• Harness between AFS control unit and aiming motor• Front combination lamp (Aiming motor)• AFS control unit	Headlamp levelizer circuit Refer to EXL-82 .
AFS OFF indicator lamp is not turned ON.	<ul style="list-style-type: none">• AFS OFF indicator lamp signal- Combination meter- AFS control unit• Combination meter	Combination meter Data monitor "AFS OFF IND"

NORMAL OPERATING CONDITION

< SYMPTOM DIAGNOSIS >

[XENON TYPE]

NORMAL OPERATING CONDITION

Description

INFOID:000000006887924

XENON HEADLAMP

- Brightness and the color of light may change slightly immediately after turning the headlamp ON until the xenon bulb becomes stable. This is normal.
- Illumination time lag may occur between right and left. This is normal.

AUTO LIGHT SYSTEM

The headlamp may not be turned ON/OFF immediately after passing dark area or bright area (short tunnel, sky bridge, shadowed area etc.) while using the auto light system. This causes for the control difference. This is normal.

A
B
C
D
E
F
G
H
I
J
K
EXL
M
N
O
P

EXL

BOTH SIDE HEADLAMPS DO NOT SWITCH TO HIGH BEAM

< SYMPTOM DIAGNOSIS >

[XENON TYPE]

BOTH SIDE HEADLAMPS DO NOT SWITCH TO HIGH BEAM

Description

INFOID:000000006887925

Both side headlamps (HI) are not turned ON when setting to the lighting switch HI or PASS.

Diagnosis Procedure

INFOID:000000006887926

1.COMBINATION SWITCH INSPECTION

Check combination switch. Refer to [BCS-80, "Symptom Table"](#).

Is the inspection result normal?

YES >> GO TO 2.

NO >> Repair or replace the malfunctioning part.

2.CHECK HEADLAMP (HI) REQUEST SIGNAL INPUT

ⓑCONSULT DATA MONITOR

1. Select "HL HI REQ" of IPDM E/R data monitor item.
2. With operating the lighting switch, check the monitor status.

Monitor item	Condition		Monitor status
HL HI REQ	Lighting switch (2ND)	HI or PASS	On
		LO	Off

Is the inspection result normal?

YES >> GO TO 3.

NO >> Replace BCM. Refer to [BCS-82, "Removal and Installation"](#).

3.HEADLAMP (HI) CIRCUIT INSPECTION

Check headlamp (HI) circuit. Refer to [EXL-74, "Component Function Check"](#).

Is the inspection result normal?

YES >> Replace IPDM E/R.

NO >> Repair or replace the malfunctioning part.

BOTH SIDE HEADLAMPS (LO) ARE NOT TURNED ON

< SYMPTOM DIAGNOSIS >

[XENON TYPE]

BOTH SIDE HEADLAMPS (LO) ARE NOT TURNED ON

Description

INFOID:000000006887927

Both side headlamps (LO) are not turned ON in any condition.

Diagnosis Procedure

INFOID:000000006887928

1. CHECK COMBINATION SWITCH

Check combination switch. Refer to [BCS-80, "Symptom Table"](#).

Is the inspection result normal?

YES >> GO TO 2.

NO >> Repair or replace the malfunctioning part.

2. CHECK HEADLAMP (LO) REQUEST SIGNAL INPUT

 CONSULT DATA MONITOR

1. Select "HL LO REQ" of IPDM E/R data monitor item.

2. With operating the lighting switch, check the monitor status.

Monitor item	Condition		Monitor status
HL LO REQ	Lighting switch	2ND	On
		OFF	Off

Is the inspection result normal?

YES >> GO TO 3.

NO >> Replace BCM. Refer to [BCS-82, "Removal and Installation"](#).

3. HEADLAMP (LO) CIRCUIT INSPECTION

Check headlamp (LO) circuit. Refer to [EXL-76, "Component Function Check"](#).

Is the inspection result normal?

YES >> Replace IPDM E/R.

NO >> Repair or replace the malfunctioning part.

A
B
C
D
E
F
G
H
I
J
K
M
N
O
P

EXL

PARKING, LICENSE PLATE AND TAIL LAMPS ARE NOT TURNED ON

< SYMPTOM DIAGNOSIS >

[XENON TYPE]

PARKING, LICENSE PLATE AND TAIL LAMPS ARE NOT TURNED ON

Description

INFOID:000000006887929

The parking, license plate, tail lamps and each illumination are not turned ON in any condition.

Diagnosis Procedure

INFOID:000000006887930

1.COMBINATION SWITCH INSPECTION

Check combination switch. Refer to [BCS-80. "Symptom Table"](#).

Is the combination switch normal?

YES >> GO TO 2.

NO >> Repair or replace the malfunctioning part.

2.CHECK TAIL LAMP RELAY REQUEST SIGNAL INPUT

ⓅCONSULT DATA MONITOR

1. Select "TAIL & CLR REQ" of IPDM E/R data monitor item.
2. With operating the lighting switch, check the monitor status.

Monitor item	Condition	Monitor status	
TAIL & CLR REQ	Lighting switch	1ST	On
		OFF	Off

Is the inspection result normal?

YES >> GO TO 3.

NO >> Replace BCM. Refer to [BCS-82. "Removal and Installation"](#).

3.DAYTIME RUNNING LIGHT RELAY CIRCUIT INSPECTION

Check the daytime running light relay circuit. Refer to [EXL-79. "Component Function Check"](#).

Is the inspection result normal?

YES >> Replace IPDM E/R.

NO >> Repair or replace the malfunctioning part.

BOTH SIDE FRONT FOG LAMPS ARE NOT TURNED ON

< SYMPTOM DIAGNOSIS >

[XENON TYPE]

BOTH SIDE FRONT FOG LAMPS ARE NOT TURNED ON

Description

INFOID:000000006887931

The front fog lamps are not turned ON in any condition.

Diagnosis Procedure

INFOID:000000006887932

1.CHECK FUSE

Check that the following fuse is not fusing.

Unit	Location	Fuse No.	Capacity
Front fog lamp	IPDM E/R	#59	15 A

Is the inspection result normal?

YES >> GO TO 2.

NO >> Repair the applicable circuit. And then replace the fuse.

2.COMBINATION SWITCH INSPECTION

Check combination switch. Refer to [BCS-80. "Symptom Table"](#).

Is the inspection result normal?

YES >> GO TO 3.

NO >> Repair or replace the malfunctioning part.

3.CHECK FRONT FOG LAMP REQUEST SIGNAL INPUT

CONSULT DATA MONITOR

1. Select "FR FOG REQ" of IPDM E/R data monitor item.

2. With operating the front fog lamp switch, check the monitor status.

Monitor item	Condition	Monitor status	
FR FOG REQ	Front fog lamp switch (With lighting switch 1ST)	ON	On
		OFF	Off

Is the item status normal?

YES >> GO TO 4.

NO >> Replace BCM. Refer to [BCS-82. "Removal and Installation"](#).

4.FRONT FOG LAMP CIRCUIT INSPECTION

Check the front fog lamp circuit. Refer to [EXL-84. "Component Function Check"](#).

Is the inspection result normal?

YES >> Replace IPDM E/R.

NO >> Repair or replace the malfunctioning part.

A
B
C
D
E
F
G
H
I
J
K
EXL
M
N
O
P

HEADLAMP AIMING ADJUSTMENT

< PERIODIC MAINTENANCE >

[XENON TYPE]

PERIODIC MAINTENANCE

HEADLAMP AIMING ADJUSTMENT

Description

INFOID:000000006887933

PREPARATION BEFORE ADJUSTING

NOTE:

- For details, refer to the regulations in your own country.
- Perform aiming if the vehicle front body has been repaired and/or the headlamp assembly has been replaced.

Before performing aiming adjustment, check the following.

- Adjust the tire pressure to the specification.
- Fill with fuel, engine coolant and each oil.
- Maintain the unloaded vehicle condition. (Remove luggage from the passenger compartment and the trunk room.)

NOTE:

Do not remove the temporary tire, jack and on-vehicle tool.

- Wipe out dirt on the headlamp.

CAUTION:

Never use organic solvent (thinner, gasoline etc.)

- Ride alone on the driver seat.

AIMING ADJUSTMENT SCREW

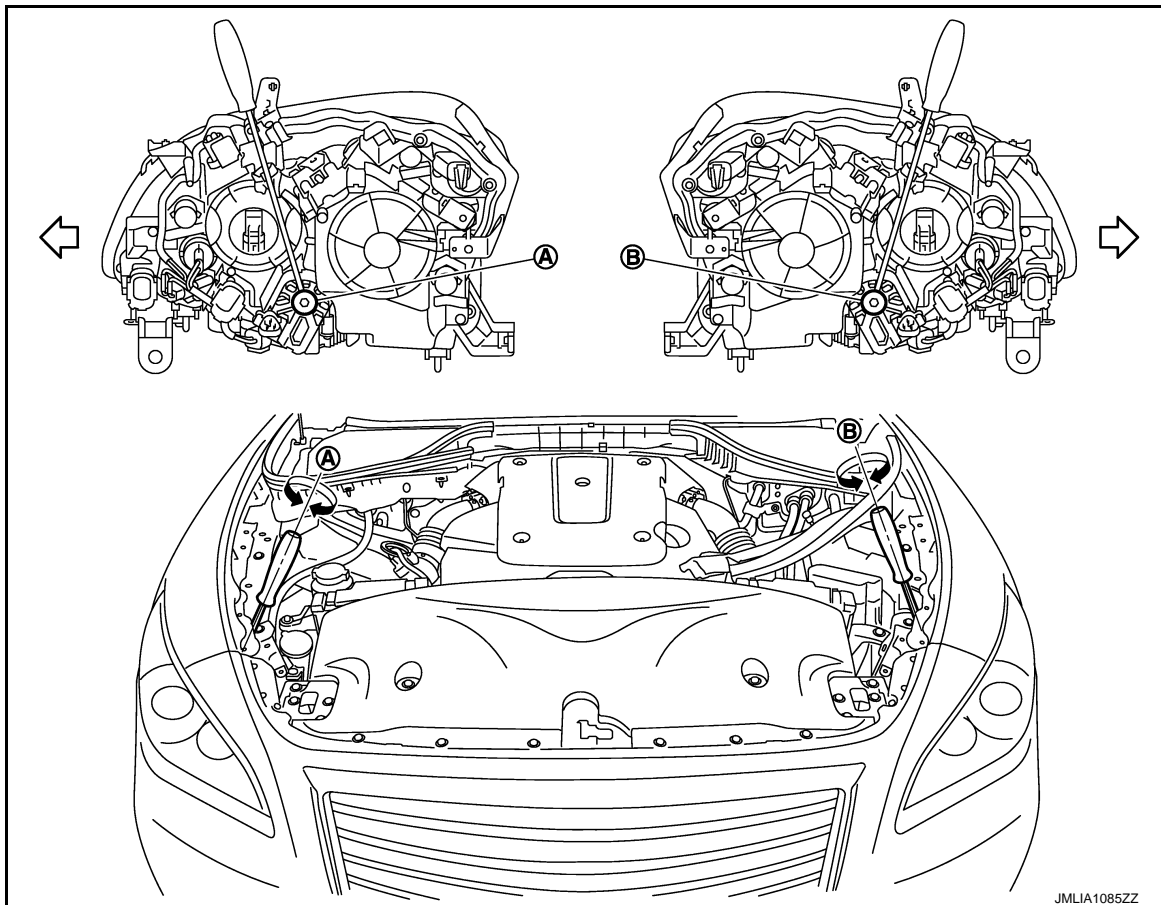

A Headlamp RH (UP/DOWN) adjustment screw B. Headlamp LH (UP/DOWN) adjustment screw

←: Vehicle center

NOTE:

HEADLAMP AIMING ADJUSTMENT

< PERIODIC MAINTENANCE >

[XENON TYPE]

The figure is the vehicle without AFS. Each adjustment screw is applied to the vehicle with AFS.

Adjustment screw	Screw driver rotation	Facing direction
A Headlamp RH (UP/DOWN)	Clockwise	UP
	Counterclockwise	DOWN
B Headlamp LH (UP/DOWN)	Clockwise	UP
	Counterclockwise	DOWN

Aiming Adjustment Procedure

INFOID:000000006887934

- Place the screen.
 - NOTE:**
 - Stop the vehicle facing the wall.
 - Place the board on a plain road vertically.
- Face the vehicle with the screen. Maintain 10 m (32.8 ft) between the headlamp center and the screen.
- Start the engine. Turn the headlamp (LO) ON.
 - NOTE:** Shut off the headlamp light with the board to prevent from illuminating the adjustment screen.
 - CAUTION:** Never cover the lens surface with a tape etc. The lens is made of resin.
- Measure the distance (X) between the horizontal center line of headlamp (H) and the cutoff line (A) within the light axis measurement range (R) from the vertical center line ahead of headlamp (V).

Light axis measurement range (R) : 350 ± 175 mm (13.78 ± 6.89 in)

Low beam distribution on the screen

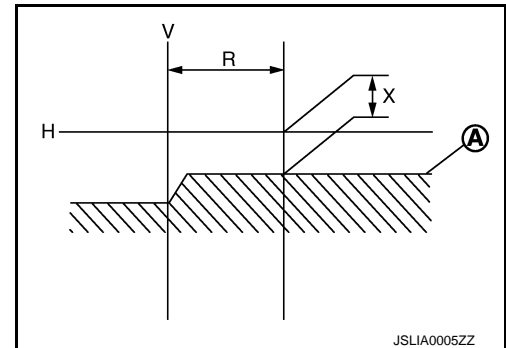

- Adjust the cutoff line height (X) with the aiming adjustment screw so as to enter in the adjustment range (M–N) according to the horizontal center line of headlamp (H).

unit: mm (in)

Horizontal center line of headlamp (H)	Highest cutoff line height (M)	Lowest cutoff line height (N)
700 (27.56) or less	4 (0.16)	30 (1.18)
701(27.60) – 800 (31.50)	4 (0.16)	30 (1.18)
801 (31.54) or more	17 (0.67)	44 (1.73)

Side view

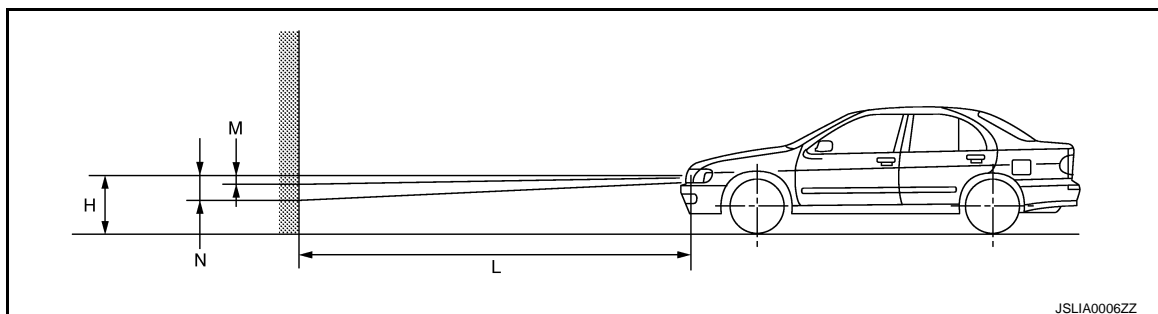

Distance between the headlamp center and the screen (L) : 10 m (32.8 ft)

FRONT FOG LAMP AIMING ADJUSTMENT

< PERIODIC MAINTENANCE >

[XENON TYPE]

FRONT FOG LAMP AIMING ADJUSTMENT

Description

INFOID:000000006887935

PREPARATION BEFORE ADJUSTING

NOTE:

- For details, refer to the regulations in your own country.
- Perform aiming if the vehicle front body has been repaired and/or the headlamp assembly has been replaced.

Before performing aiming adjustment, check the following.

- Adjust the tire pressure to the specification.
- Fill with fuel, engine coolant and each oil.
- Maintain the unloaded vehicle condition. (Remove luggage from the passenger compartment and the trunk room.)

NOTE:

Do not remove the temporary tire, jack and on-vehicle tool.

- Wipe out dirt on the headlamp.

CAUTION:

Never use organic solvent (thinner, gasoline etc.)

- Ride alone on the driver seat.

AIMING ADJUSTMENT SCREW

- Turn the aiming adjusting screw for adjustment.

A: UP

B: DOWN

- For the position and direction of the adjusting screw, refer to the figure.

NOTE:

A screwdriver or hexagonal wrench [6 mm (0.24 in)] can be used for adjustment.

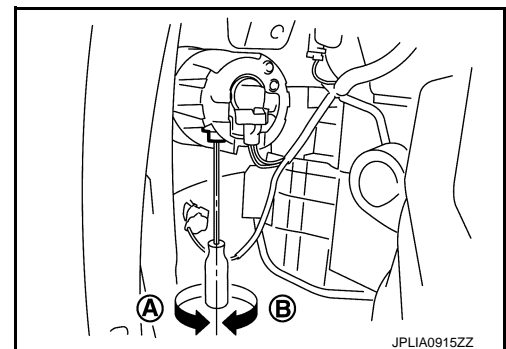

Aiming Adjustment Procedure

INFOID:000000006887936

1. Place the screen.

NOTE:

- Stop the vehicle facing the wall.
- Place the board on a plain road vertically.

2. Face the vehicle with the screen. Maintain 10 m (32.8 ft) between the front fog lamp center and the screen.

3. Start the engine. Turn the front fog lamp ON.

NOTE:

Shut off the headlamp light with the board to prevent from illuminating the adjustment screen.

CAUTION:

Never cover the lens surface with a tape etc. The lens is made of resin.

4. Adjust the cutoff line height (A) with the aiming adjustment screw so that the distance (X) between the horizontal center line of front fog lamp (H) and (A) becomes 200 mm (7.87 in).

FRONT FOG LAMP AIMING ADJUSTMENT

< PERIODIC MAINTENANCE >

[XENON TYPE]

Front fog lamp light distribution on the screen

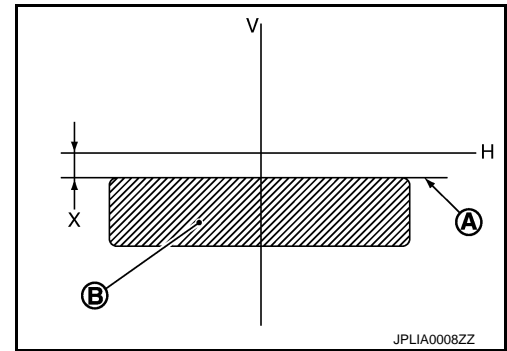

- A : Cutoff line
- B : High illuminance area
- H : Horizontal center line of front fog lamp
- V : Vertical center line of front fog lamp
- X : Cutoff line height

A
B
C
D
E
F
G
H
I
J
K
L
M
N
O
P

EXL

FRONT COMBINATION LAMP

< REMOVAL AND INSTALLATION >

[XENON TYPE]

REMOVAL AND INSTALLATION

FRONT COMBINATION LAMP

Exploded View

INFOID:000000006887937

REMOVAL

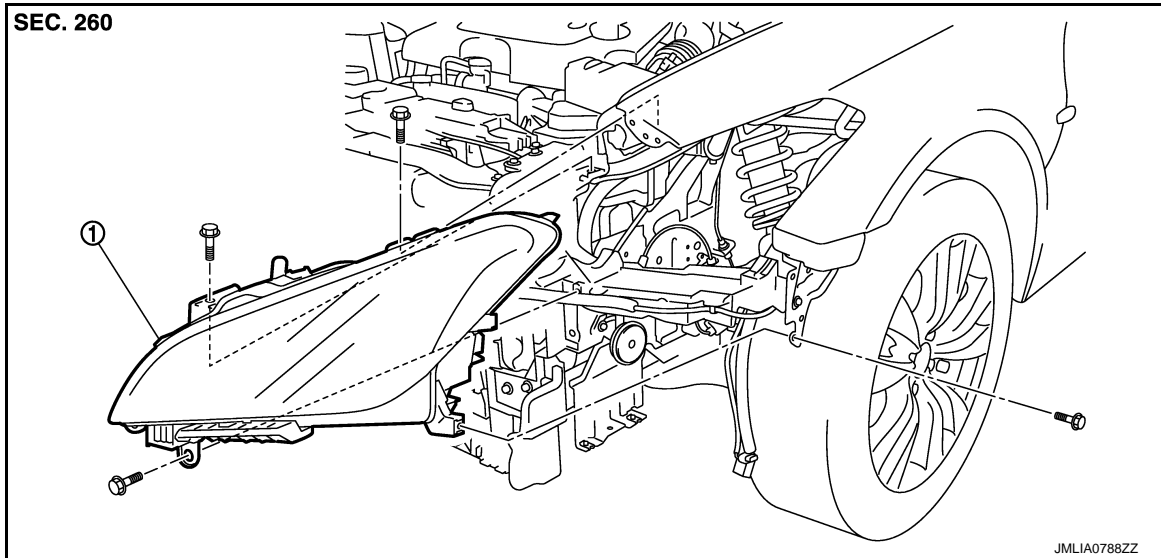

1. Front combination lamp

DISASSEMBLY

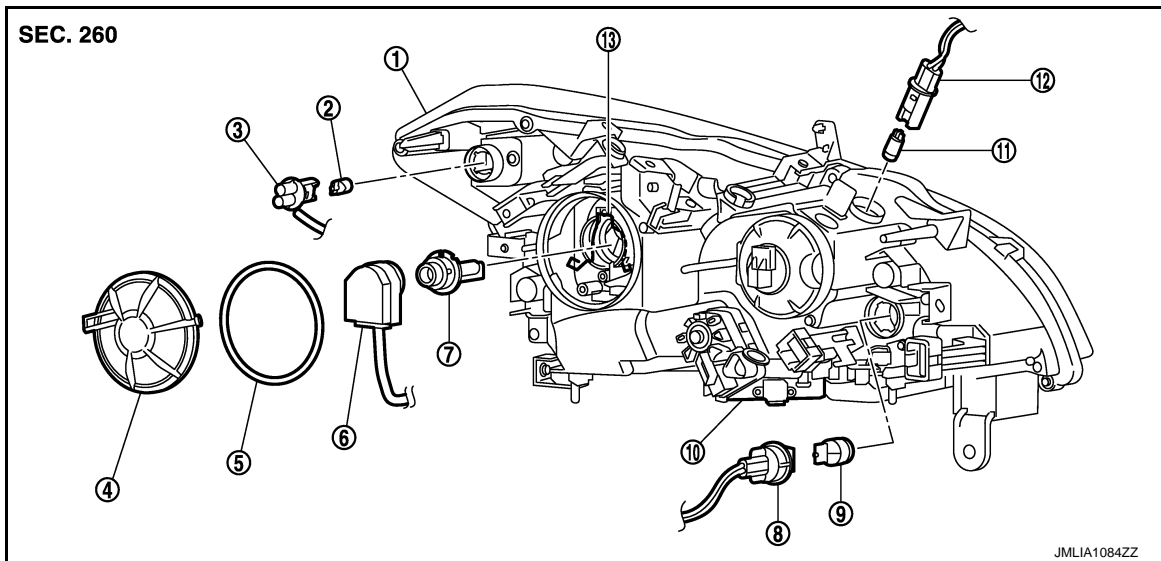

- | | | |
|------------------------------|---------------------------------------|---------------------------------------|
| 1. Headlamp housing assembly | 2. Front side marker lamp bulb | 3. Front side marker lamp bulb socket |
| 4. Resin cap | 5. Seal packing | 6. Xenon bulb socket |
| 7. Xenon bulb | 8. Front turn signal lamp bulb socket | 9. Front turn signal lamp bulb |
| 10. HID control unit | 11. Parking lamp bulb | 12. Parking lamp bulb socket |
| 13. Retaining spring | | |

CAUTION:
HID control unit and xenon bulb socket cannot be disassembled.

FRONT COMBINATION LAMP

< REMOVAL AND INSTALLATION >

[XENON TYPE]

Removal and Installation

INFOID:000000006887938

REMOVAL

CAUTION:

Disconnect the battery negative terminal or remove the fuse.

1. Remove the front bumper fascia. Refer to [EXT-14, "Removal and Installation"](#).
2. Remove the washer inlet tube.
3. Remove the headlamp mounting bolts and clips.
4. Remove the harness clip and the holding clip (A)*.
*: Left side only.

← : Vehicle front

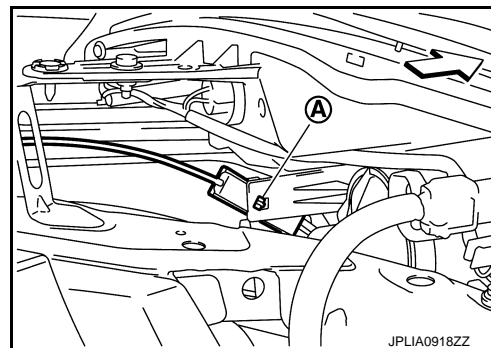

5. Pull out the headlamp assembly forward the vehicle, and then disconnect the connector before removing the headlamp assembly.

INSTALLATION

Note the following item and then, install in the reverse order of removal.

NOTE:

After installation, perform aiming adjustment. Refer to [EXL-102, "Description"](#).

Replacement

INFOID:000000006887939

CAUTION:

- Disconnect the battery negative terminal or remove the fuse.
- After installing the bulb, install the resin cap and the bulb socket securely for watertightness.
- Never touch the glass of bulb directly by hand. Keep grease and other oily matters away from it. Never touch bulb by hand while it is lit or right after being turned off.
- Never leave bulb out of lamp reflector for a long time because dust, moisture smoke, etc. may affect the performance of lamp. When replacing bulb, be sure to replace it with new one.

HEADLAMP BULB

1. Remove the fender protector front side. Keep a service area.
2. Rotate the resin cap counterclockwise and unlock it.
3. Rotate the bulb socket counterclockwise and unlock it.
4. Remove the retaining spring lock. And then remove the bulb from the headlamp housing assembly.

CAUTION:

Never break the xenon bulb ceramic tube when replacing the bulb.

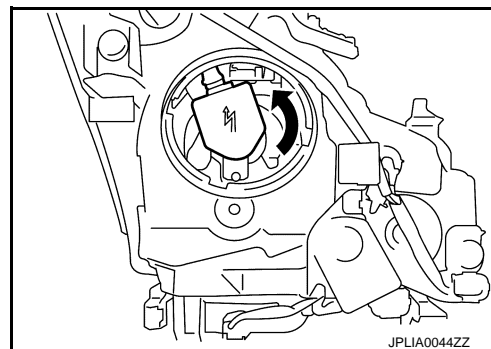

FRONT TURN SIGNAL LAMP BULB

1. Rotate the bulb socket counterclockwise and unlock it.
2. Remove the bulb from the bulb socket.

PARKING LAMP BULB

1. Remove the fender protector front side. Keep a service area.

A
B
C
D
E
F
G
H
I
J
K
EXL
M
N
O
P

FRONT COMBINATION LAMP

[XENON TYPE]

< REMOVAL AND INSTALLATION >

2. Rotate the bulb socket counterclockwise and unlock it.
3. Remove the bulb from the bulb socket.

FRONT SIDE MARKER LAMP BULB

1. Remove the fender protector front side. Keep a service area.
2. Rotate the bulb socket counterclockwise and unlock it.
3. Remove the bulb from the bulb socket.

Disassembly and Assembly

INFOID:000000006887940

CAUTION:

HID control unit and xenon bulb socket cannot be disassembled.

DISASSEMBLY

1. Rotate the resin cap counterclockwise and unlock it.
2. Rotate the xenon bulb socket counterclockwise and unlock it.
3. Remove the retaining spring lock. Remove the xenon bulb.
4. Remove the bumper bracket.
5. Rotate the parking lamp bulb socket counterclockwise and unlock it.
6. Remove the bulb from the parking lamp bulb socket.
7. Rotate the front turn signal lamp bulb socket counterclockwise and unlock it.
8. Remove the bulb from the front turn signal lamp bulb socket.
9. Rotate the front side marker lamp bulb socket counterclockwise and unlock it.
10. Remove the bulb from the front side marker lamp bulb socket.

ASSEMBLY

Note the following item, and then assemble in the reverse order of disassembly.

CAUTION:

After installing the bulb, install the resin cap and the bulb socket securely for watertightness.

FRONT FOG LAMP

< REMOVAL AND INSTALLATION >

[XENON TYPE]

FRONT FOG LAMP

Exploded View

INFOID:000000006887941

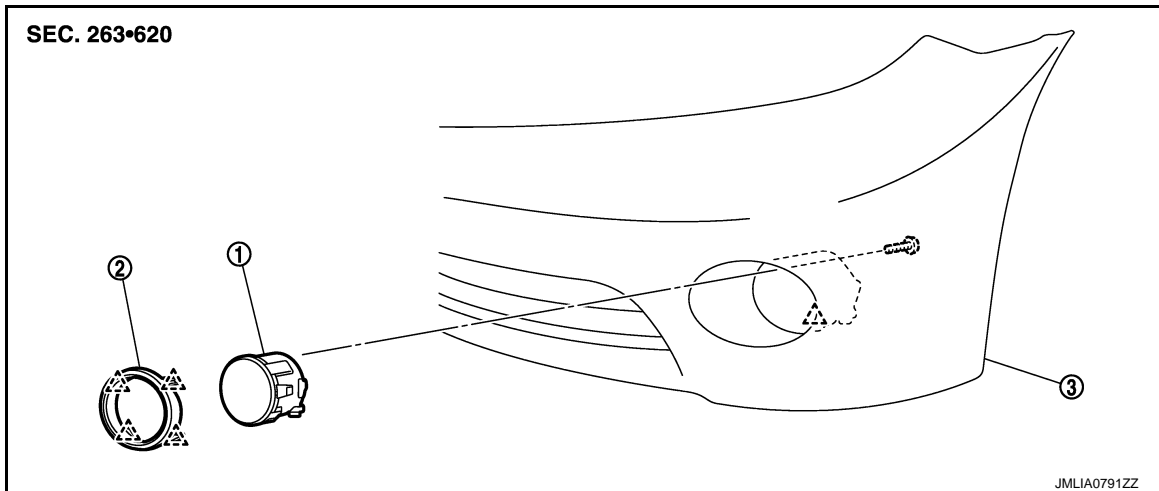

1. Front fog lamp

2. Front fog lamp finisher

3. Front bumper fascia

△ : Pawl

Removal and Installation

INFOID:000000006887942

CAUTION:

Disconnect the battery negative terminal or remove the fuse.

REMOVAL

1. Remove the front fender protector. Keep a service area. Refer to [EXT-24, "FENDER PROTECTOR : Removal and Installation"](#).
2. Remove the front fog lamp finisher.
3. Disconnect the front fog lamp connector.
4. Remove the bolt.
5. Disengage the pawl, and then remove the front fog lamp.

INSTALLATION

Note the following item, and then installation is the reverse order of removal.

NOTE:

After installation, perform aiming adjustment. Refer to [EXL-104, "Description"](#)

Replacement

INFOID:000000006887943

CAUTION:

- Disconnect the battery negative terminal or remove the fuse.
- Never touch the glass of bulb directly by hand. Keep grease and other oily matters away from it. Never touch bulb by hand while it is lit or right after being turned off.
- Never leave bulb out of lamp reflector for a long time because dust, moisture smoke, etc. may affect the performance of lamp. When replacing bulb, be sure to replace it with new one.

FRONT FOG LAMP BULB

1. Remove the front fender protector. Keep the service area. Refer to [EXT-24, "FENDER PROTECTOR : Removal and Installation"](#).

FRONT FOG LAMP

[XENON TYPE]

< REMOVAL AND INSTALLATION >

2. Remove the front fog lamp bulb connector (1).
3. Rotate the bulb (2) counterclockwise and unlock it.

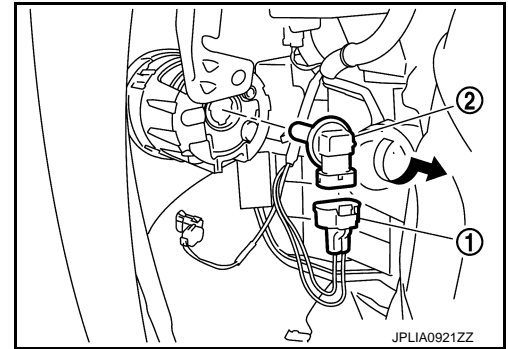

OPTICAL SENSOR

< REMOVAL AND INSTALLATION >

[XENON TYPE]

OPTICAL SENSOR

Exploded View

INFOID:000000006887944

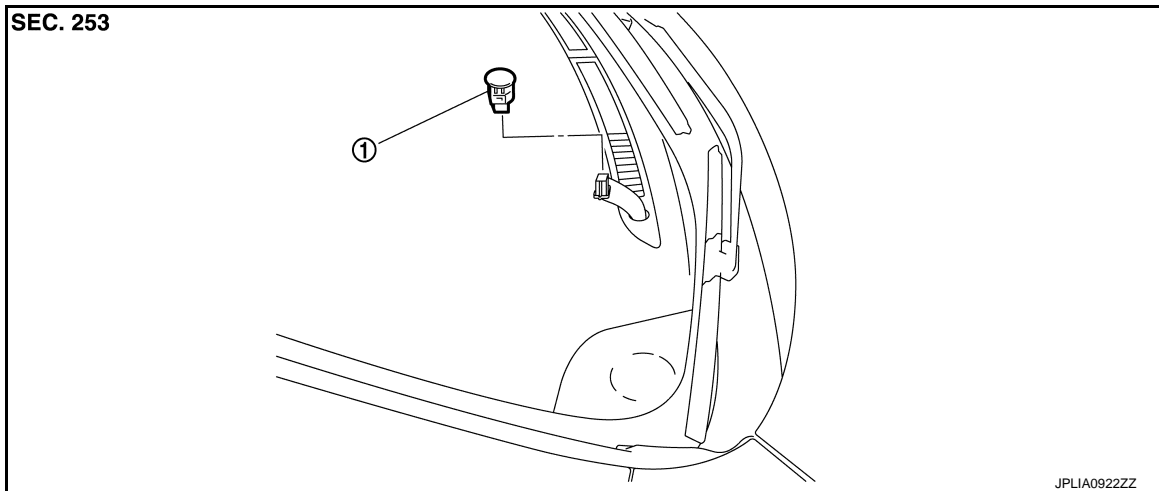

1. Optical sensor

Removal and Installation

INFOID:000000006887945

REMOVAL

1. Insert an appropriate tool between the optical sensor and the instrument upper panel. Pull out the optical sensor upward.
2. Disconnect the optical sensor connector. And then remove the optical sensor.

INSTALLATION

Install in the reverse order of removal.

A
B
C
D
E
F
G
H
I
J
K

EXL

M
N
O
P

LIGHTING AND TURN SIGNAL SWITCH

< REMOVAL AND INSTALLATION >

[XENON TYPE]

LIGHTING AND TURN SIGNAL SWITCH

Exploded View

INFOID:000000006887946

Lighting and turn signal switch is integrated in the combination switch. [BCS-83. "Removal and Installation"](#).

HAZARD SWITCH

< REMOVAL AND INSTALLATION >

[XENON TYPE]

HAZARD SWITCH

Exploded View

INFOID:000000006887947

The hazard warning switch is integrated in the multifunction switch. Refer to [AV-114. "Removal and Installation"](#).

A
B
C
D
E
F
G
H
I
J
K
EXL
M
N
O
P

EXL

AFS CONTROL UNIT

< REMOVAL AND INSTALLATION >

[XENON TYPE]

AFS CONTROL UNIT

Exploded View

INFOID:000000006887948

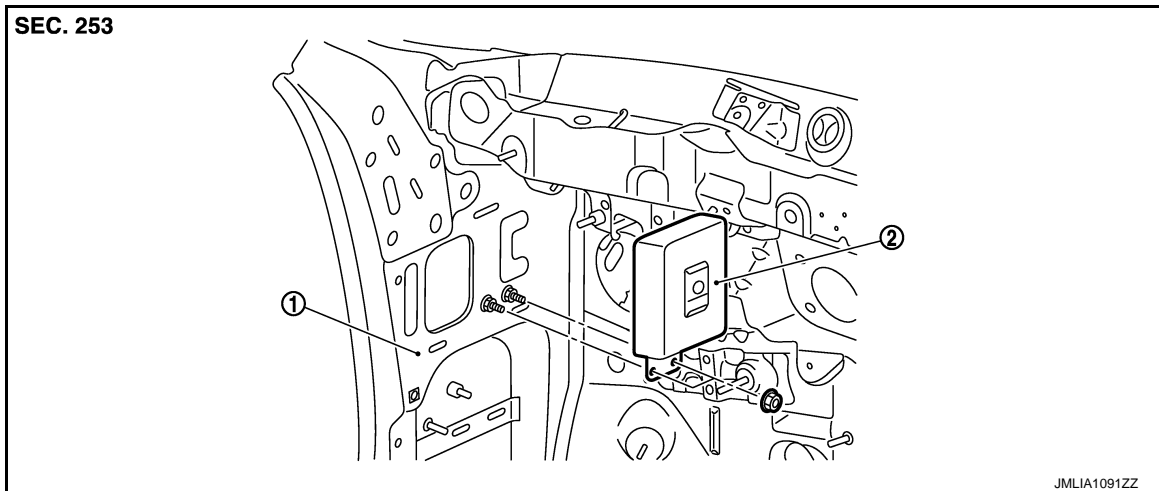

1. Dash side panel

2. AFS control unit

Removal and Installation

INFOID:000000006887949

REMOVAL

1. Remove the instrument lower panel LH. Refer to [IP-13. "Removal and Installation"](#).
2. Remove the AFS control unit mounting nuts.
3. Disconnect the AFS control unit connector.
4. Remove the AFS control unit.

INSTALLATION

Install in the reverse order of removal.

STEERING ANGLE SENSOR

< REMOVAL AND INSTALLATION >

[XENON TYPE]

STEERING ANGLE SENSOR

Removal and Installation

INFOID:000000006887950

Refer to [SR-14. "Removal and Installation"](#).

A

B

C

D

E

F

G

H

I

J

K

EXL

M

N

O

P

HEIGHT SENSOR

< REMOVAL AND INSTALLATION >

[XENON TYPE]

HEIGHT SENSOR

Exploded View

INFOID:000000006887951

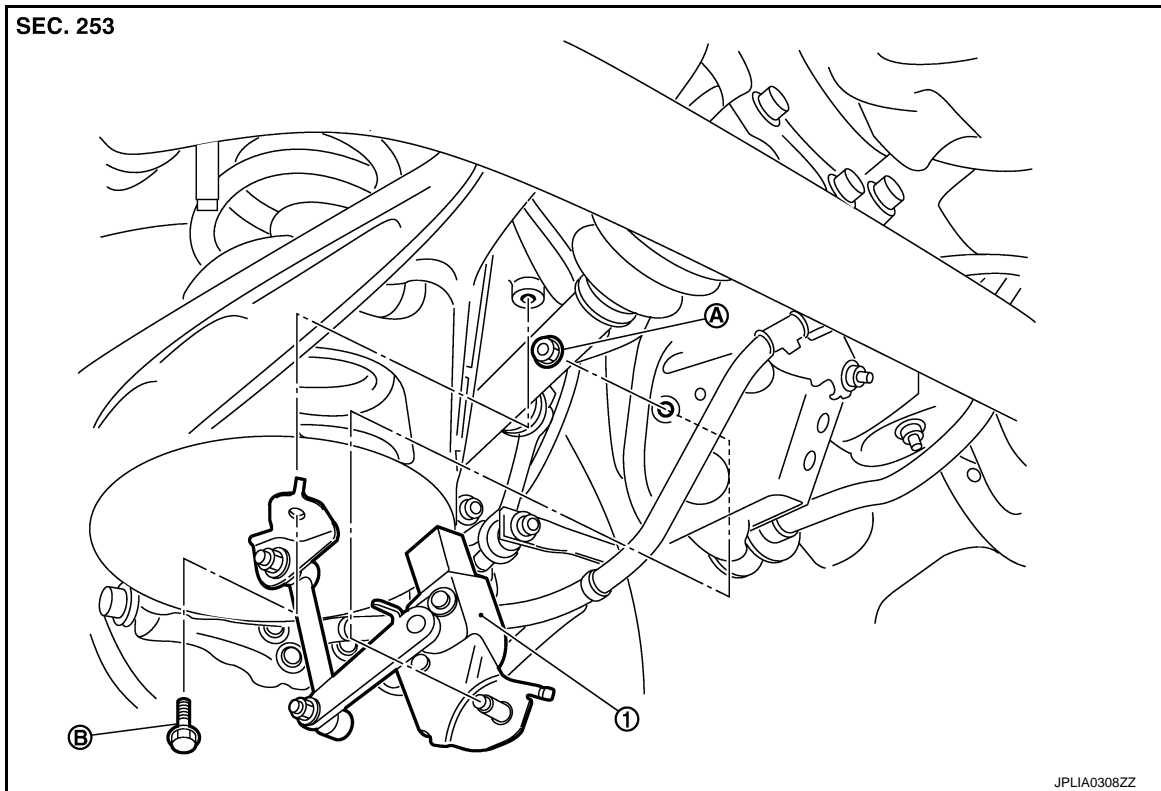

- 1. Height sensor
- A Height sensor mounting nut
- B. Height sensor lever link bracket mounting bolt

Removal and Installation

INFOID:000000006887952

REMOVAL

1. Remove the height sensor mounting nut.
2. Remove the height sensor lever link bracket mounting bolt.
3. Disconnect the height sensor connector.
4. Remove the height sensor.

INSTALLATION

Install in the reverse order of removal.

CAUTION:

Perform the levelizer adjustment when removing the height sensor. Refer to [EXL-52, "LEVELIZER ADJUSTMENT : Special Repair Requirement"](#).

REAR COMBINATION LAMP

< REMOVAL AND INSTALLATION >

[XENON TYPE]

REAR COMBINATION LAMP

Exploded View

INFOID:000000006887953

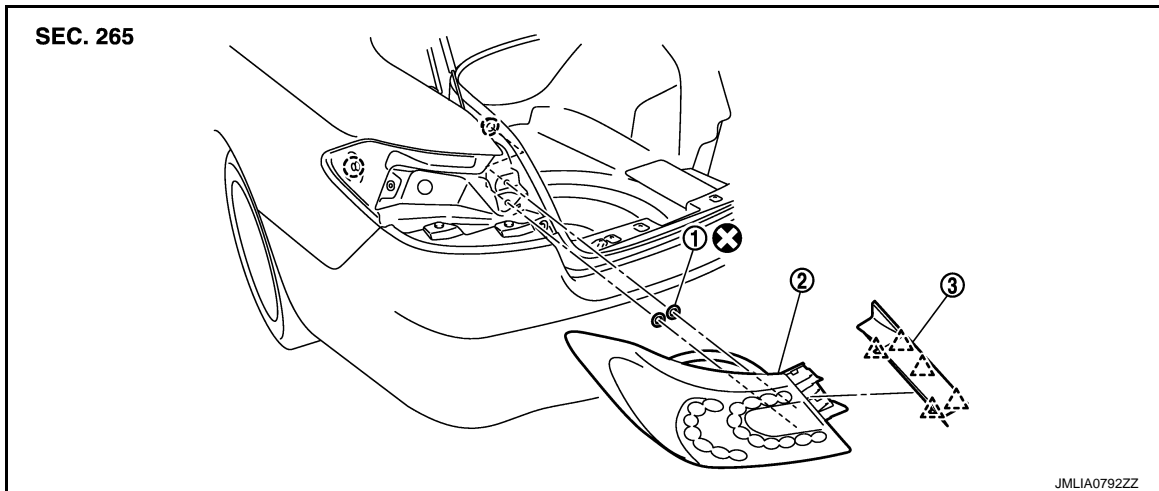

1. Seal packing
2. Rear combination lamp
3. Rear combination lamp finisher

Refer to [GI-4, "Components"](#) for symbols in the figure.

Removal and Installation

INFOID:000000006887954

CAUTION:

Disconnect the battery negative terminal or remove the fuse.

REMOVAL

1. Remove the rear combination lamp finisher.
2. Remove the trunk side finisher. Refer to [INT-51, "TRUNK SIDE FINISHER : Removal and Installation"](#).
3. Disconnect the rear combination lamp connector.
4. Remove the rear combination lamp mounting nuts.
5. Pull the rear combination lamp toward outside of the vehicle, and then remove the rear combination lamp.
6. Remove the seal packing.

INSTALLATION

Install in the reverse order of removal.

CAUTION:

Seal packing cannot be reused.

A
B
C
D
E
F
G
H
I
J
K
EXL
M
N
O
P

HIGH-MOUNTED STOP LAMP

< REMOVAL AND INSTALLATION >

[XENON TYPE]

HIGH-MOUNTED STOP LAMP

Exploded View

INFOID:000000006887955

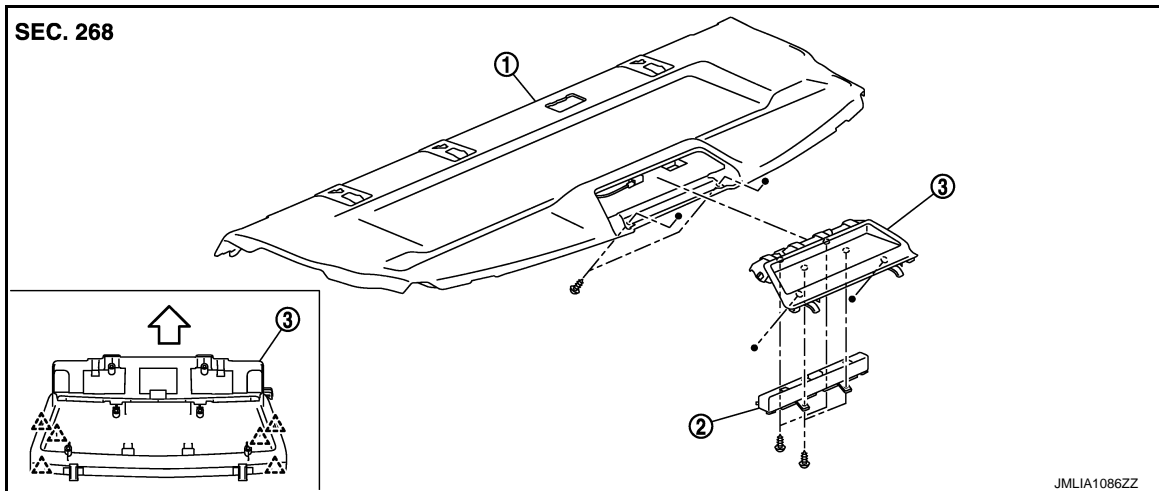

1. Rear parcel shelf finisher

2. High-mounted stop lamp

3. High-mounted stop lamp cover

↔ : Vehicle front

Refer to [GI-4, "Components"](#) for symbols in the figure.

Removal and Installation

INFOID:000000006887956

REMOVAL

1. Remove the rear parcel shelf finisher. Refer to [INT-40, "Removal and Installation"](#).
2. Remove the high-mounted stop lamp cover fixing screws.
3. Remove the high-mounted stop lamp.

INSTALLATION

Install in the reverse order of removal.

BACK-UP LAMP

< REMOVAL AND INSTALLATION >

[XENON TYPE]

BACK-UP LAMP

Exploded View

INFOID:000000006887957

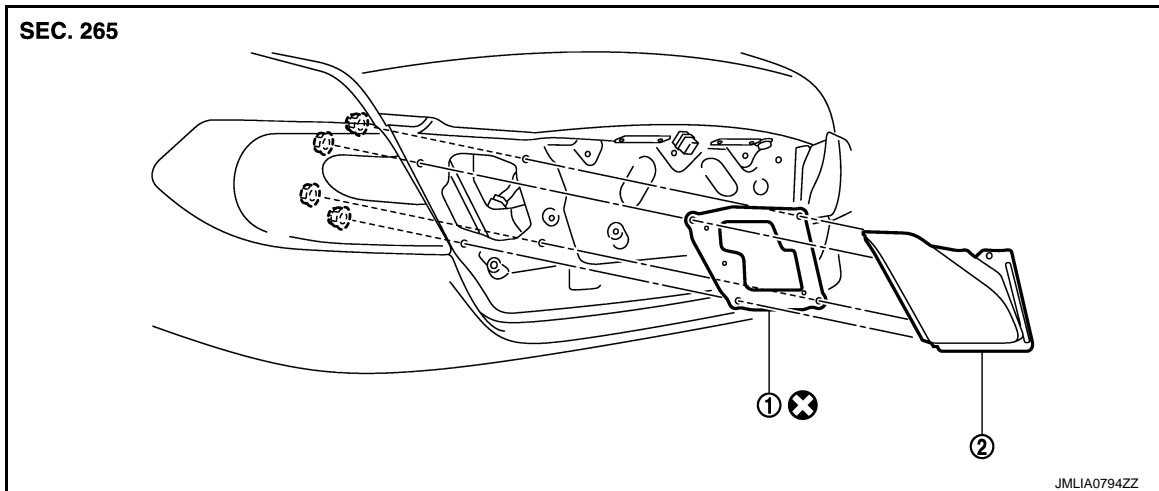

1. Seal packing
2. Back-up lamp

Refer to [GI-4, "Components"](#) for symbols in the figure.

Removal and Installation

INFOID:000000006887958

CAUTION:

Disconnect the battery negative terminal or remove the fuse.

REMOVAL

1. Remove the trunk lid trim. Refer to [INT-53, "Removal and Installation"](#).
2. Disconnect the back-up lamp connector.
3. Remove the back-up lamp mounting nuts, and then remove the back-up lamp.

INSTALLATION

Install in the reverse order of removal.

Replacement

INFOID:000000006887959

CAUTION:

- **Disconnect the battery negative terminal or remove the fuse.**
- **Never touch the glass of bulb directly by hand. Keep grease and other oily matters away from it. Never touch bulb by hand while it is lit or right after being turned off.**
- **Never leave bulb out of lamp reflector for a long time because dust, moisture smoke, etc. may affect the performance of lamp. When replacing bulb, be sure to replace it with new one.**

BACK-UP LAMP BULB

1. Remove the trunk lid trim. Refer to [INT-53, "Removal and Installation"](#).
2. Turn the bulb socket (2) counterclockwise and unlock it.
3. Remove the bulb (1) from the socket.

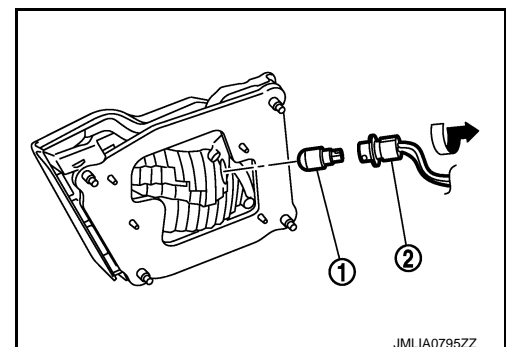

A
B
C
D
E
F
G
H
I
J
K
EXL
M
N
O
P

LICENSE PLATE LAMP

< REMOVAL AND INSTALLATION >

[XENON TYPE]

LICENSE PLATE LAMP

Exploded View

INFOID:000000006887960

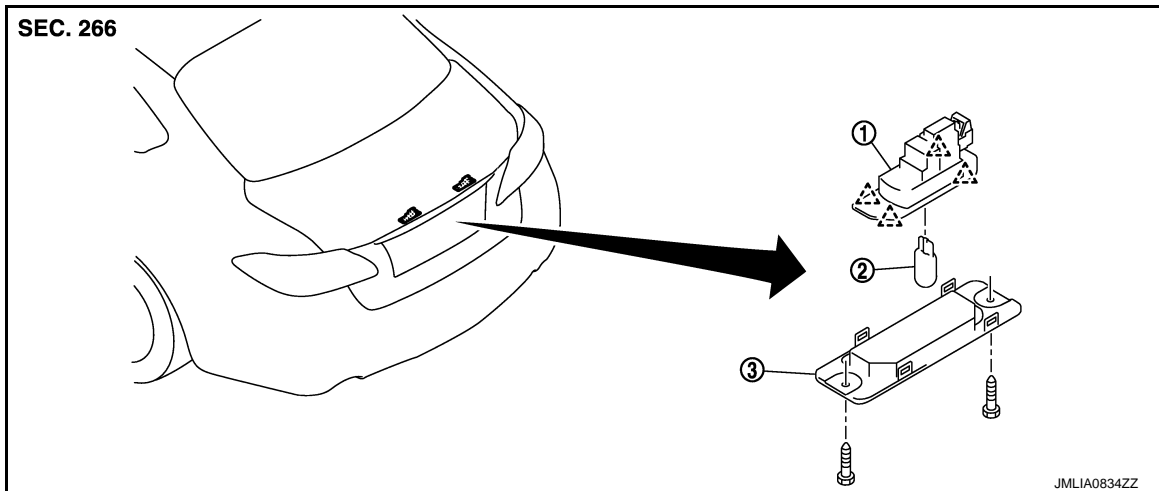

1. License plate lamp

2. License plate lamp bulb

3. License plate lamp lens

Removal and Installation

INFOID:000000006887961

CAUTION:

Disconnect the battery negative terminal or remove the fuse.

REMOVAL

1. Remove the screw, and then remove the license plate lamp.
2. Disconnect the license plate lamp connector.

INSTALLATION

Install in the reverse order of removal.

Replacement

INFOID:000000006887962

CAUTION:

- **Disconnect the battery negative terminal or remove the fuse.**
- **Never touch the glass of bulb directly by hand. Keep grease and other oily matters away from it. Never touch bulb by hand while it is lit or right after being turned off.**
- **Never leave bulb out of lamp reflector for a long time because dust, moisture smoke, etc. may affect the performance of lamp. When replacing bulb, be sure to replace it with new one.**

LICENSE PLATE LAMP BULB

1. Remove the license lamp. Refer to [EXL-120, "Removal and Installation"](#).
2. Disengage license lamp lens (1) fixing pawls, with a flat-bladed screwdriver (A).
3. Remove the bulb.

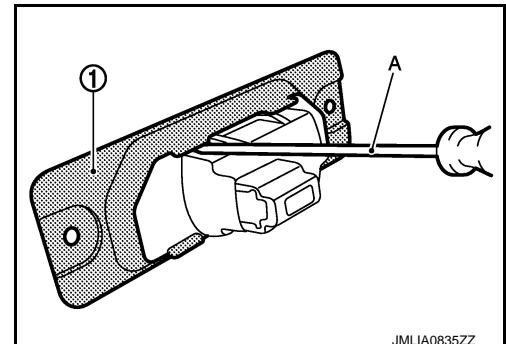

JMLIA0835ZZ

SERVICE DATA AND SPECIFICATIONS (SDS)

< SERVICE DATA AND SPECIFICATIONS (SDS)

[XENON TYPE]

SERVICE DATA AND SPECIFICATIONS (SDS)

SERVICE DATA AND SPECIFICATIONS (SDS)

Bulb Specifications

INFOID:0000000006887963

Item	Type	Wattage (W)	
Front combination lamp	Headlamp (HI/LO)	D2S (Xenon)	35
	Front turn signal lamp	WY21W (Amber)	21
	Parking lamp	W5W	5
	Front side marker lamp	W5W	5
Front fog lamp	H8	35	
Rear combination lamp	Stop lamp/Tail lamp	LED	—
	Rear side marker lamp	LED	—
	Rear turn signal lamp	WY21W	21W
Back-up lamp	W16W	16	
License plate lamp	W5W	5	
High-mounted stop lamp	LED	—	

A
B
C
D
E
F
G
H
I
J
K
L
M
N
O
P

EXL