

SECTION BR
BRAKE SYSTEM

A
B
C
D
E

CONTENTS

<p>PRECAUTION 5</p> <p>PRECAUTIONS 5</p> <p style="padding-left: 20px;">Precaution for Supplemental Restraint System (SRS) "AIR BAG" and "SEAT BELT PRE-TENSIONER"5</p> <p style="padding-left: 20px;">Precaution Necessary for Steering Wheel Rotation after 12V Battery Disconnect5</p> <p style="padding-left: 20px;">Precaution for Procedure without Cowl Top Cover.....6</p> <p style="padding-left: 20px;">Precautions Concerning On-board Servicing of Hybrid Systems6</p> <p style="padding-left: 20px;">Precaution for Removing 12V Battery6</p> <p style="padding-left: 20px;">Precaution for Brake System6</p> <p>PREPARATION 9</p> <p>PREPARATION 9</p> <p style="padding-left: 20px;">Commercial Service Tools9</p> <p>SYSTEM DESCRIPTION10</p> <p>COMPONENT PARTS10</p> <p style="padding-left: 20px;">Component Parts Location10</p> <p style="padding-left: 20px;">Electrically-driven Intelligent Brake12</p> <p style="padding-left: 20px;">ADAS Control Unit12</p> <p style="padding-left: 20px;">Master Cylinder Pressure Sensor112</p> <p style="padding-left: 20px;">Pedal Stroke Sensor13</p> <p style="padding-left: 20px;">Stop Lamp OFF Relay 113</p> <p style="padding-left: 20px;">Stop Lamp OFF Relay 213</p> <p style="padding-left: 20px;">Warning Buzzer13</p> <p style="padding-left: 20px;">Brake Power Supply Backup Unit13</p> <p>SYSTEM14</p> <p style="padding-left: 20px;">System Description14</p> <p style="padding-left: 20px;">Fail-Safe17</p> <p>COOPERATIVE REGENERATIVE BRAKE FUNCTION19</p> <p style="padding-left: 20px;">COOPERATIVE REGENERATIVE BRAKE FUNCTION : System Description19</p> <p>HILL START ASSIST FUNCTION23</p>	<p style="padding-left: 20px;">Hill start assist FUNCTION : System Description....23</p> <p>ACTIVE STABILITY ASSIST25</p> <p style="padding-left: 20px;">ACTIVE STABILITY ASSIST : System Description25</p> <p style="padding-left: 20px;">ACTIVE STABILITY ASSIST : Rise-up & Build-up Function28</p> <p style="padding-left: 20px;">ACTIVE STABILITY ASSIST : Active Trace Control Function28</p> <p>DIAGNOSIS SYSTEM (ELECTRICALLY-DRIVEN INTELLIGENT BRAKE UNIT)30</p> <p style="padding-left: 20px;">CONSULT Function30</p> <p>ECU DIAGNOSIS INFORMATION33</p> <p>ELECTRICALLY-DRIVEN INTELLIGENT BRAKE UNIT33</p> <p style="padding-left: 20px;">Reference Value33</p> <p style="padding-left: 20px;">Fail-Safe35</p> <p style="padding-left: 20px;">DTC Inspection Priority Chart37</p> <p style="padding-left: 20px;">DTC Index38</p> <p>ADAS CONTROL UNIT39</p> <p style="padding-left: 20px;">List of ECU Reference39</p> <p>WIRING DIAGRAM40</p> <p>BRAKE SYSTEM40</p> <p style="padding-left: 20px;">Wiring Diagram40</p> <p>BASIC INSPECTION43</p> <p>DIAGNOSIS AND REPAIR WORK FLOW43</p> <p style="padding-left: 20px;">Work Flow43</p> <p style="padding-left: 20px;">Diagnostic Work Sheet44</p> <p>ADDITIONAL SERVICE WHEN REPLACING ELECTRICALLY-DRIVEN INTELLIGENT BRAKE UNIT46</p> <p style="padding-left: 20px;">Description46</p> <p>STROKE SENSOR 0 POINT LEARNING47</p>
--	---

BR

G
H
I
J
K
L
M
N
O
P

Description	47	C1A6D BRAKE POWER SUPPLY BACKUP UNIT	180
Work Procedure	47	DTC Logic	180
DTC/CIRCUIT DIAGNOSIS	50	Diagnosis Procedure	180
C1A60 CONTROL MODULE	50	C1A6E HEV SYSTEM	188
DTC Logic	50	DTC Logic	188
Diagnosis Procedure	50	Diagnosis Procedure	188
C1A61 MOTOR	58	C1A6F TCM SYSTEM	196
DTC Logic	58	DTC Logic	196
Diagnosis Procedure	58	Diagnosis Procedure	196
C1A62 CONTROL MODULE	66	C1A70 BRAKE CONTROL SYSTEM	204
DTC Logic	66	DTC Logic	204
Diagnosis Procedure	66	Diagnosis Procedure	204
C1A63 BRAKE POWER SUPPLY BACKUP UNIT	75	C1A71 INTEGRATED CONTROL SYSTEM ...	212
DTC Logic	75	DTC Logic	212
Diagnosis Procedure	75	Diagnosis Procedure	212
C1A64 STROKE SENSOR	84	C1A74 STEERING ANGLE SENSOR	220
DTC Logic	84	DTC Logic	220
Diagnosis Procedure	84	Diagnosis Procedure	220
C1A65 INCOMPLETE STROKE SENSOR	96	U1000 CAN COMM CIRCUIT	228
DTC Logic	96	Description	228
Diagnosis Procedure	96	DTC Logic	228
C1A66 PRESSURE SENSOR	108	Diagnosis Procedure	229
DTC Logic	108	U1010 CONTROL UNIT (CAN)	230
Diagnosis Procedure	108	Description	230
C1A67 STOP LAMP SWITCH	119	DTC Logic	230
DTC Logic	119	Diagnosis Procedure	231
Diagnosis Procedure	119	U0424 HVAC CAN CIRCUIT 1	232
Component Inspection	130	Description	232
C1A68 STOP LAMP SWITCH RELAY	132	DTC Logic	232
DTC Logic	132	Diagnosis Procedure	232
Diagnosis Procedure	132	U1510 ABS ACTUATOR AND ELECTRIC UNIT (CONTROL UNIT) COMMUNICATION ..	233
Component Inspection	141	DTC Logic	233
C1A69 MOTOR	143	Diagnosis Procedure	233
DTC Logic	143	U1511 BRAKE POWER SUPPLY BACKUP UNIT COMMUNICATION	241
Diagnosis Procedure	143	DTC Logic	241
C1A6A CONTROL MODULE	152	Diagnosis Procedure	241
DTC Logic	152	POWER SUPPLY AND GROUND CIRCUIT ...	251
Diagnosis Procedure	152	Diagnosis Procedure	251
C1A6B BRAKE POWER SUPPLY BACKUP UNIT	161	WARNING BUZZER	255
DTC Logic	161	Diagnosis Procedure	255
Diagnosis Procedure	161	Component Inspection	255
C1A6C BRAKE POWER SUPPLY BACKUP UNIT	172	BRAKE WARNING LAMP	257
DTC Logic	172	Component Function Check	257
Diagnosis Procedure	172	Diagnosis Procedure	257
		BRAKE SYSTEM WARNING LAMP	258

Component Function Check	258	FRONT	282	
Diagnosis Procedure	258	FRONT : Exploded View	282	A
SYMPTOM DIAGNOSIS	259	FRONT : Hydraulic Piping	283	
NOISE, VIBRATION AND HARSHNESS		FRONT : Removal and Installation	283	
(NVH) TROUBLESHOOTING	259	FRONT : Inspection	284	B
NVH Troubleshooting Chart	259	REAR	284	
UNEXPECTED BRAKE PEDAL REACTION ..	260	REAR : Exploded View	285	C
Description	260	REAR : Hydraulic Piping	285	
Diagnosis Procedure	260	REAR : Removal and Installation	286	
THE BRAKING DISTANCE IS LONG	261	REAR : Inspection	287	
Description	261	ELECTRICALLY-DRIVEN INTELLIGENT		D
Diagnosis Procedure	261	BRAKE UNIT	288	
VEHICLE JERKS DURING	268	Exploded View	288	E
Description	268	Removal and installation	288	
Diagnosis Procedure	268	Inspection and Adjustment	289	
NORMAL OPERATING CONDITION	269	BRAKE POWER SUPPLY BACKUP UNIT	290	BR
Description	269	Exploded View	290	
PERIODIC MAINTENANCE	270	Removal and Installation	290	
BRAKE PEDAL	270	FRONT DISC BRAKE	291	G
Inspection and Adjustment	270	BRAKE PAD	291	
BRAKE FLUID	273	BRAKE PAD : Exploded View	291	H
Inspection	273	BRAKE PAD : Removal and Installation	291	
Draining	273	BRAKE PAD : Inspection	292	I
Refilling	273	BRAKE CALIPER ASSEMBLY	292	
Bleeding Brake System	274	BRAKE CALIPER ASSEMBLY : Exploded View ..	292	J
ELECTRICALLY-DRIVEN INTELLIGENT		BRAKE CALIPER ASSEMBLY : Removal and In-	293	
BRAKE UNIT	275	stallation	293	
Inspection	275	BRAKE CALIPER ASSEMBLY : Disassembly and	294	K
FRONT DISC BRAKE	276	Assembly	294	
BRAKE PAD	276	BRAKE CALIPER ASSEMBLY : Inspection	296	
BRAKE PAD : Inspection and Adjustment	276	REAR DISC BRAKE	297	L
DISC ROTOR	276	BRAKE PAD	297	
DISC ROTOR : Inspection and Adjustment	276	BRAKE PAD : Exploded View	297	M
REAR DISC BRAKE	278	BRAKE PAD : Removal and Installation	297	
BRAKE PAD	278	BRAKE PAD : Inspection	298	
BRAKE PAD : Inspection and Adjustment	278	BRAKE CALIPER ASSEMBLY	298	N
DISC ROTOR	278	BRAKE CALIPER ASSEMBLY : Exploded View ..	298	
DISC ROTOR : Inspection and Adjustment	278	BRAKE CALIPER ASSEMBLY : Removal and In-	299	
REMOVAL AND INSTALLATION	280	stallation	299	
BRAKE PEDAL	280	BRAKE CALIPER ASSEMBLY : Disassembly and	300	O
Exploded View	280	Assembly	300	
Removal and Installation	280	BRAKE CALIPER ASSEMBLY : Inspection	302	
Inspection and Adjustment	281	SERVICE DATA AND SPECIFICATIONS		P
BRAKE PIPING	282	(SDS)	304	
		SERVICE DATA AND SPECIFICATIONS		
		(SDS)	304	
		General Specifications	304	
		Brake Pedal	304	
		Electrically-driven Intelligent Brake	304	
		Front Disc Brake	304	

PRECAUTIONS

< PRECAUTION >

PRECAUTION

PRECAUTIONS

Precaution for Supplemental Restraint System (SRS) "AIR BAG" and "SEAT BELT PRE-TENSIONER"

INFOID:000000008139772

The Supplemental Restraint System such as "AIR BAG" and "SEAT BELT PRE-TENSIONER", used along with a front seat belt, helps to reduce the risk or severity of injury to the driver and front passenger for certain types of collision. This system includes seat belt switch inputs and dual stage front air bag modules. The SRS system uses the seat belt switches to determine the front air bag deployment, and may only deploy one front air bag, depending on the severity of a collision and whether the front occupants are belted or unbelted. Information necessary to service the system safely is included in the "SRS AIR BAG" and "SEAT BELT" of this Service Manual.

WARNING:

Always observe the following items for preventing accidental activation.

- To avoid rendering the SRS inoperative, which could increase the risk of personal injury or death in the event of a collision that would result in air bag inflation, all maintenance must be performed by an authorized NISSAN/INFINITI dealer.
- Improper maintenance, including incorrect removal and installation of the SRS, can lead to personal injury caused by unintentional activation of the system. For removal of Spiral Cable and Air Bag Module, see "SRS AIR BAG".
- Never use electrical test equipment on any circuit related to the SRS unless instructed to in this Service Manual. SRS wiring harnesses can be identified by yellow and/or orange harnesses or harness connectors.

PRECAUTIONS WHEN USING POWER TOOLS (AIR OR ELECTRIC) AND HAMMERS

WARNING:

Always observe the following items for preventing accidental activation.

- When working near the Air Bag Diagnosis Sensor Unit or other Air Bag System sensors with the ignition ON or engine running, never use air or electric power tools or strike near the sensor(s) with a hammer. Heavy vibration could activate the sensor(s) and deploy the air bag(s), possibly causing serious injury.
- When using air or electric power tools or hammers, always switch the ignition OFF, disconnect the 12V battery, and wait at least 3 minutes before performing any service.

Precaution Necessary for Steering Wheel Rotation after 12V Battery Disconnect

INFOID:000000008139773

For vehicle with steering lock unit, if the 12V battery is disconnected or discharged, the steering wheel will lock and cannot be turned.

If turning the steering wheel is required with the 12V battery disconnected or discharged, follow the operation procedure below before starting the repair operation.

OPERATION PROCEDURE

1. Connect both 12V battery cables.
NOTE:
Supply power using jumper cables if 12V battery is discharged.
2. Turn the ignition switch to ACC position.
(At this time, the steering lock will be released.)
3. Disconnect both 12V battery cables. The steering lock will remain released with both 12V battery cables disconnected and the steering wheel can be turned.
4. Perform the necessary repair operation.
5. When the repair work is completed, re-connect both 12V battery cables. With the brake pedal released, turn the ignition switch from ACC position to ON position, then to LOCK position. (The steering wheel will lock when the ignition switch is turned to LOCK position.)
6. Perform All DTC Reading using CONSULT and delete DTC.
NOTE:
Multiple DTCs are detected when 12V battery cable is disconnected while ignition switch is in ACC position.

PRECAUTIONS

< PRECAUTION >

Precaution for Procedure without Cowl Top Cover

INFOID:000000008139774

When performing the procedure after removing cowl top cover, cover the lower end of windshield with urethane, etc to prevent damage to windshield.

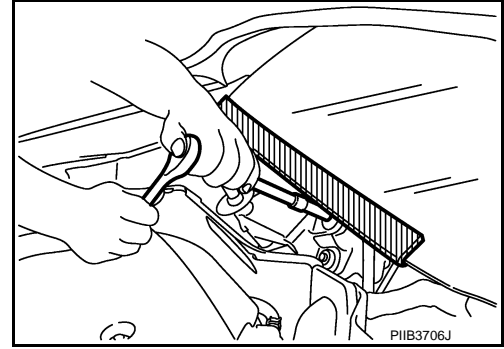

Precautions Concerning On-board Servicing of Hybrid Systems

INFOID:000000008139775

CAUTION:

Be sure to turn the ignition switch OFF before performing inspection and servicing inside the engine compartment or underneath the vehicle. If the ignition switch is ON (vehicle READY state), even if the engine is stopped, the conditions of the vehicle may cause the engine to start automatically. If it is necessary to continually operate the engine during inspection or servicing, use the designated inspection mode. [HBC-89, "Description"](#).

Precaution for Removing 12V Battery

INFOID:000000008139776

CAUTION:

When the 12V battery is removed, plural DTC may be detected. After installing 12V battery, always perform "All DTC" with CONSULT and delete DTC.

Precaution for Brake System

INFOID:000000008139777

WARNING:

Since dust covering the front and rear brakes has an affect on human body, the dust must be removed with a dust collector. Never splatter the dust with an air blow gun.

- Brake fluid use refer to [MA-10, "Fluids and Lubricants"](#).
- Never reuse drained brake fluid.
- Never spill or splash brake fluid on painted surfaces. Brake fluid may seriously damage paint. Wipe it off immediately and wash with water if it gets on a painted surface. For brake component parts, never wash them with water.
- Always confirm the specified tightening torque when installing the brake pipes.
- After pressing the brake pedal more deeply or harder than normal driving, such as air bleeding, check each item of brake pedal. Adjust brake pedal if it is outside the standard value.
- Always clean with new brake fluid when cleaning the brake caliper and other components.
- Never use mineral oils such as gasoline or light oil to clean. They may damage rubber parts and cause improper operation.
- Always loosen the brake tube flare nut with a flare nut wrench.
- Tighten the brake tube flare nut to the specified torque with a crow-foot (A) and torque wrench (B).
- Turn the ignition switch OFF to exit CONSULT. Get out of the vehicle, close all doors (including trunk lid), and wait for 3 minutes or more without opening these doors. Disconnect the electrically-driven intelligent brake unit, the ABS actuator and electric unit (control unit) harness connector or the 12V battery negative terminal before performing the work. Refer to [BR-6, "Precaution for Removing 12V Battery"](#).

CAUTION:

Never operate the vehicle and CONSULT while waiting.

- Check that no brake fluid leakage is present after replacing the parts.
- Burnish the brake contact surfaces after refinishing or replacing rotors, after replacing pads, or if a soft pedal occurs at very low mileage.

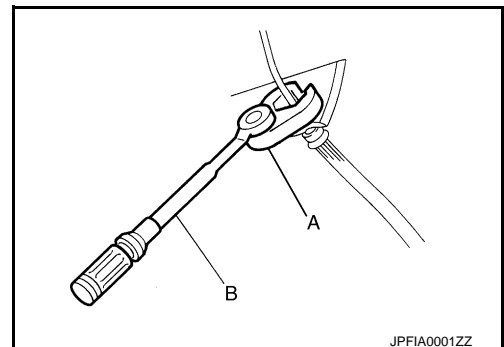

PRECAUTIONS

< PRECAUTION >

- Front brake pad: Refer to [BR-276. "BRAKE PAD : Inspection and Adjustment"](#).
- Front disc rotor: Refer to [BR-276. "DISC ROTOR : Inspection and Adjustment"](#).
- Rear brake pad: Refer to [BR-278. "BRAKE PAD : Inspection and Adjustment"](#).
- Rear disc rotor: Refer to [BR-278. "DISC ROTOR : Inspection and Adjustment"](#).
- When the brake pedal is operated, an operating sound may be heard from the electrically-driven intelligent brake unit. This occurs when the electrically-driven intelligent brake unit is operating normally and is not a malfunction.
- When the brake pedal is depressed when the hybrid system is not started, the brake pedal will feel heavy and the stroke will be shorter. When the unfamiliar feeling disappears and the brake warning lamp is OFF after the brake pedal was depressed, then this is not a malfunction. When the brake warning lamp is ON, use CONSULT and perform the "BRAKE" self diagnosis.
- When there is a malfunction in the power system of the electrically-driven intelligent brake unit (no voltage is generated), voltage is temporarily supplied to the electrically-driven intelligent brake unit from the brake power supply backup unit. At the same time, the brake warning lamp (red) and brake system warning lamp (yellow) turn ON, and the warning buzzer sounds.
- When a malfunction occurs in the electrically-driven intelligent brake unit, the VDC function performs control (boost operation).
- When a malfunction occurs in the DC/DC-J/B and 12V battery, the braking force is determined by the force pressing on the brake pedal (no boost operation). At the same time, the brake warning lamp (red) and the brake system warning lamp (yellow) turns ON.
- When a malfunction occurs in the electrically-driven intelligent brake and in the VDC function, the braking force is determined by the force pressing on the brake pedal (no boost operation). At the same time, the brake warning lamp (red) and brake system warning lamp (yellow) turn ON.
- When a malfunction occurs in the electrically-driven intelligent brake, VDC function, and power system, then cooperative regenerative brake control, hill start assist function, Rise-up & Build-up function, Active Trace Control function and Brake force distribution function [function of the ABS actuator and electric unit (control unit)] are not performed.
- When a malfunction occurs in the brake power supply backup unit, the brake system warning lamp (yellow) turns ON.
- Slight vibrations are felt on the brake pedal and the operation noises occur, when hill start assist function, Rise-up & Build-up function, Active Trace Control function or Brake force distribution function [function of the ABS actuator and electric unit (control unit)] operates. This is not a malfunction because it is caused by hill start assist function, Rise-up & Build-up function, Active Trace Control function or Brake force distribution function [function of the ABS actuator and electric unit (control unit)] that is normally operated.
- The optimum performance is achieved by control for hill start assist function, Rise-up & Build-up function, Active Trace Control function and Brake force distribution function [function of the ABS actuator and electric unit (control unit)], when all of brakes, suspensions and tires installed on the vehicle are the specified size and parts. Brake performance and controllability may be negatively affected when other parts than the specified are installed.
- When a radio (including wiring), antenna and antenna lead line are located near electrically-driven intelligent brake unit (control unit), a malfunction or improper operation may occur for the control of hill start assist function, Rise-up & Build-up function, Active Trace Control function and Brake force distribution function [function of the ABS actuator and electric unit (control unit)].
- When the following items are replaced by other parts than genuine parts or modified, brake warning lamp (red) and brake system warning lamp (yellow) may turn ON, and the control may not operate normally for hill start assist function, Rise-up & Build-up function, Active Trace Control function and Brake force distribution function [function of the ABS actuator and electric unit (control unit)].
 - Suspension component parts (shock absorber, spring, bushing and others)
 - Tire and wheel (other than the specified size)
 - Brake component parts (brake pad, disc rotor, brake caliper and others)
 - Engine component parts (ECM, muffler and others)
 - Body reinforcement component parts (rollover bar, tower bar and others)
- When suspension, tire and brake related parts are excessively worn or deteriorated and the vehicle is driven, brake warning lamp (red) and brake system warning (yellow) lamp may turn ON, and the control may not operate normally for hill start assist function, Rise-up & Build-up function, Active Trace Control function and Brake force distribution function [function of the ABS actuator and electric unit (control unit)].
- Brake pedal vibrates and operation sound occurs during sudden acceleration and cornering, when Rise-up & Build-up function, Active Trace Control function or Brake force distribution function [function of the ABS actuator and electric unit (control unit)] are operated. This is not a malfunction because it is caused by Rise-up & Build-up function, Active Trace Control function or Brake force distribution function [function of the ABS actuator and electric unit (control unit)] that is operated normally.

A

B

C

D

E

BR

G

H

I

J

K

L

M

N

O

P

PRECAUTIONS

< PRECAUTION >

- Brake warning lamp (red) and brake system warning lamp (yellow) may turn ON and Rise-up & Build-up function, Active Trace Control function and Brake force distribution function [function of the ABS actuator and electric unit (control unit)] may not normally operate, when driving on a special road that is extremely slanted (bank in a circuit course). This is not a malfunction if the status returns to normal for Rise-up & Build-up function, Active Trace Control function and Brake force distribution function [function of the ABS actuator and electric unit (control unit)] after the engine is started again. In this case, perform self-diagnosis, check self-diagnosis results, and erase memory.

CAUTION:

After erase self-diagnosis result, turn the ignition switch OFF, to exit CONSULT. Get out of the vehicle, close all doors (including trunk lid), and wait for 3 minutes or more without opening these doors. Never operate the vehicle and CONSULT while waiting.

- A malfunction in yaw rate/side/decel G sensor system may be detected when the vehicle sharply turns during a spin turn, acceleration turn or drift driving while Rise-up & Build-up function, Active Trace Control function and Brake force distribution function [function of the ABS actuator and electric unit (control unit)] are OFF (VDC OFF switch is pressed and VDC OFF indicator lamp is in ON status). This is not a malfunction if the status returns to normal for Rise-up & Build-up function, Active Trace Control function and Brake force distribution function [function of the ABS actuator and electric unit (control unit)] after the engine is started again. In this case, perform self-diagnosis, check self-diagnosis results, and erase memory.

CAUTION:

After erase self-diagnosis result, turn the ignition switch OFF, to exit CONSULT. Get out of the vehicle, close all doors (including trunk lid), and wait for 3 minutes or more without opening these doors. Never operate the vehicle and CONSULT while waiting.

PREPARATION

< PREPARATION >

PREPARATION

PREPARATION

Commercial Service Tools

INFOID:000000008139778

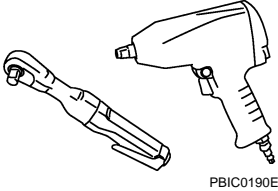
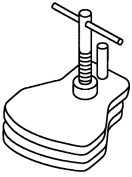
Tool name	Description
<p data-bbox="155 520 261 541">Power tool</p>  <p data-bbox="867 632 938 646">PBIC0190E</p>	<p data-bbox="1052 520 1300 541">Loosening bolts and nuts</p>
<p data-bbox="155 772 367 793">Brake caliper wrench</p>  <p data-bbox="867 884 954 898">NNFIA0040ZZ</p>	<p data-bbox="1052 772 1219 793">Return the piston</p>

A
B
C
D
E
BR
G
H
I
J
K
L
M
N
O
P

COMPONENT PARTS

< SYSTEM DESCRIPTION >

SYSTEM DESCRIPTION

COMPONENT PARTS

Component Parts Location

INFOID:000000008139779

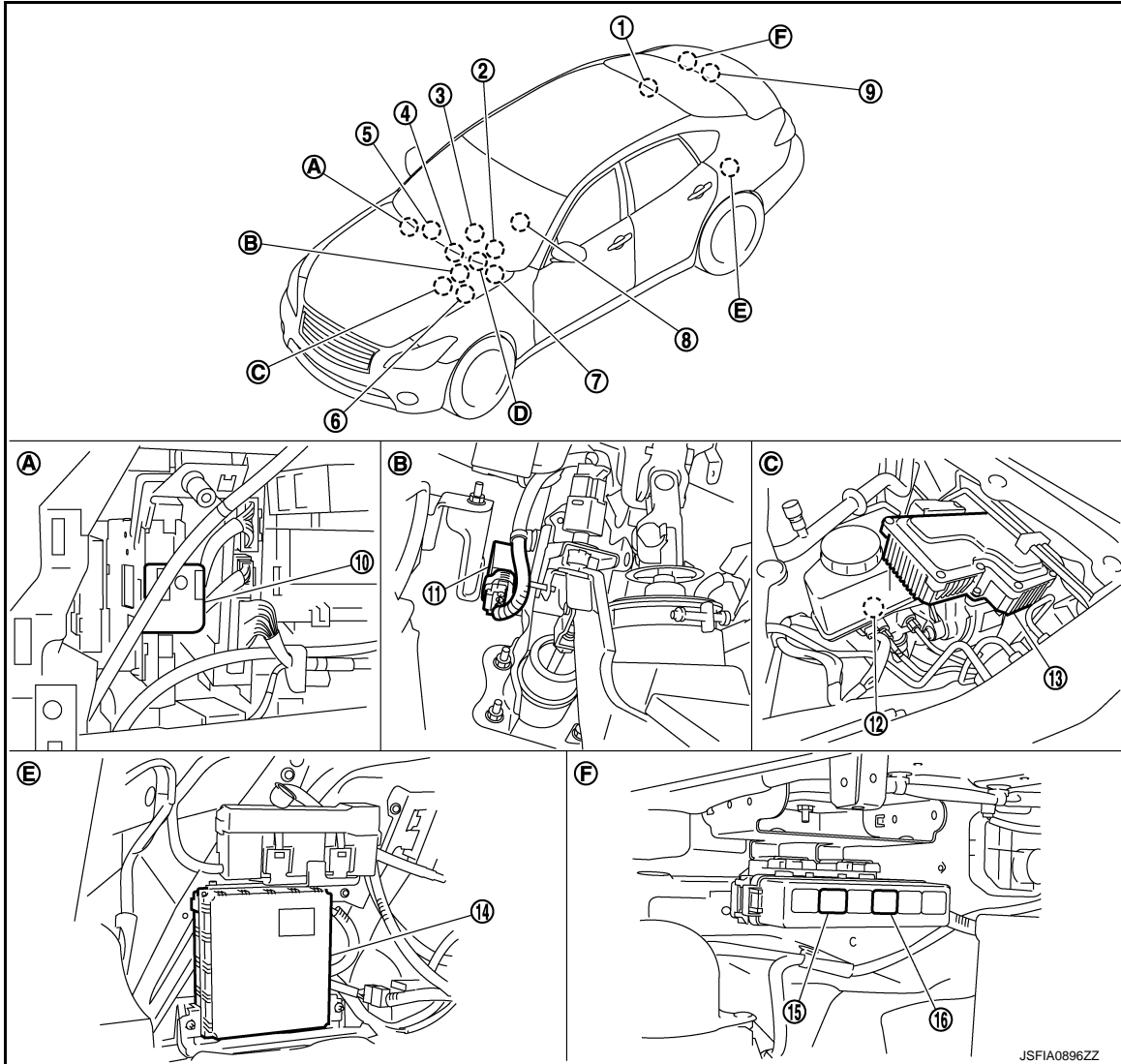

- A. View with the glove box assembly removed
 B. Brake pedal
 C. Inside of brake master cylinder cover
 D. Brake warning lamp (in combination meter, Brake system warning lamp (in combination meter)
 E. Inside of trunk side finisher (left)
 F. Trunk side of rear parcel shelf finisher

COMPONENT DESCRIPTION

No.	Component parts	Function
1.	HPCM	Mainly transmits the following signals to electrically-driven intelligent brake unit via CAN communication. • HPCM control signal
2.	Steering angle sensor	Mainly transmits the following signals to electrically-driven intelligent brake unit via CAN communication. • Steering angle sensor signal

COMPONENT PARTS

< SYSTEM DESCRIPTION >

No.	Component parts	Function	
3.	Drive mode select switch	Mainly transmits the following signals to A/C auto AMP. <ul style="list-style-type: none"> • ECO mode signal • SNOW mode signal • SPORT mode signal • STANDARD mode signal 	A
4.	BCM	Mainly transmits the following signals to electrically-driven intelligent brake unit via CAN communication. <ul style="list-style-type: none"> • Ignition switch ON signal • Door switch signal 	B
5.	A/C auto AMP.	Mainly transmits the following signals to ADAS control unit via CAN communication. <ul style="list-style-type: none"> • ECO mode signal • SNOW mode signal • SPORT mode signal • STANDARD mode signal 	C
6.	ABS actuator and electric unit (control unit)	Mainly transmits the following signals to electrically-driven intelligent brake unit via CAN communication. <ul style="list-style-type: none"> • Stop lamp switch signal • ABS actuator and electric unit (control unit) control signal • Vehicle speed signal (ABS) • Stop lamp OFF relay signal • Decel G signal • Front LH wheel speed signal • Rear LH wheel speed signal • Front RH wheel speed signal • Rear RH wheel speed signal • Yaw rate signal • Side G signal Mainly receives the following signals from ABS actuator and electric unit (control unit) via CAN communication. <ul style="list-style-type: none"> • Brake assist request signal • Brake backup operation signal • Brake fluid pressure command signal • Electrically-driven intelligent brake control signal 	D
7.	Traction Motor Inverter	Mainly transmits the following signals to electrically-driven intelligent brake unit via CAN communication. <ul style="list-style-type: none"> • Required braking force calculation signal Mainly receives the following signals to traction motor inverter via CAN communication. <ul style="list-style-type: none"> • Regenerative braking force calculation signal 	E
8.	Control valve & TCM	Mainly transmits the following signals to electrically-driven intelligent brake unit via CAN communication. <ul style="list-style-type: none"> • TCM malfunction signal • Current gear position signal 	BR
9.	ADAS control unit*	Mainly transmits the following signals to electrically-driven intelligent brake unit via CAN communication. <ul style="list-style-type: none"> • Active trace control signal 	G
10.	Warning buzzer	BR-13, "Warning Buzzer"	H
11.	Pedal stroke sensor	BR-13, "Pedal Stroke Sensor"	I
12.	Master cylinder pressure sensor1	BR-12, "Master Cylinder Pressure Sensor1"	J
13.	Electrically-driven intelligent brake unit	BR-12, "Electrically-driven Intelligent Brake"	K
14.	Brake power supply backup unit	BR-13, "Brake Power Supply Backup Unit"	L
15.	Stop lamp OFF relay 1*	BR-13, "Stop Lamp OFF Relay 1"	M
16.	Stop lamp OFF relay 2*	BR-13, "Stop Lamp OFF Relay 2"	N

*: Models with ICC

COMPONENT PARTS

< SYSTEM DESCRIPTION >

Electrically-driven Intelligent Brake

INFOID:000000008139780

Integrates the control module, master cylinder, and brake booster, and it controls the fluid pressure that is sent to the ABS actuator and electric unit (control unit).

CONTROL MODULE

- Controls the fluid pressure that is applied to the brake calipers, based on the signals from each sensor and unit.
- Performs cooperative regenerative brake control.
- When a malfunction is detected, the system enters fail-safe mode.

MASTER CYLINDER

- Generates brake fluid pressure according to the amount of piston movement.
- The fluid pressure generated by the master cylinder is sent to the ABS actuator and electric unit (control unit).

BRAKE BOOSTER

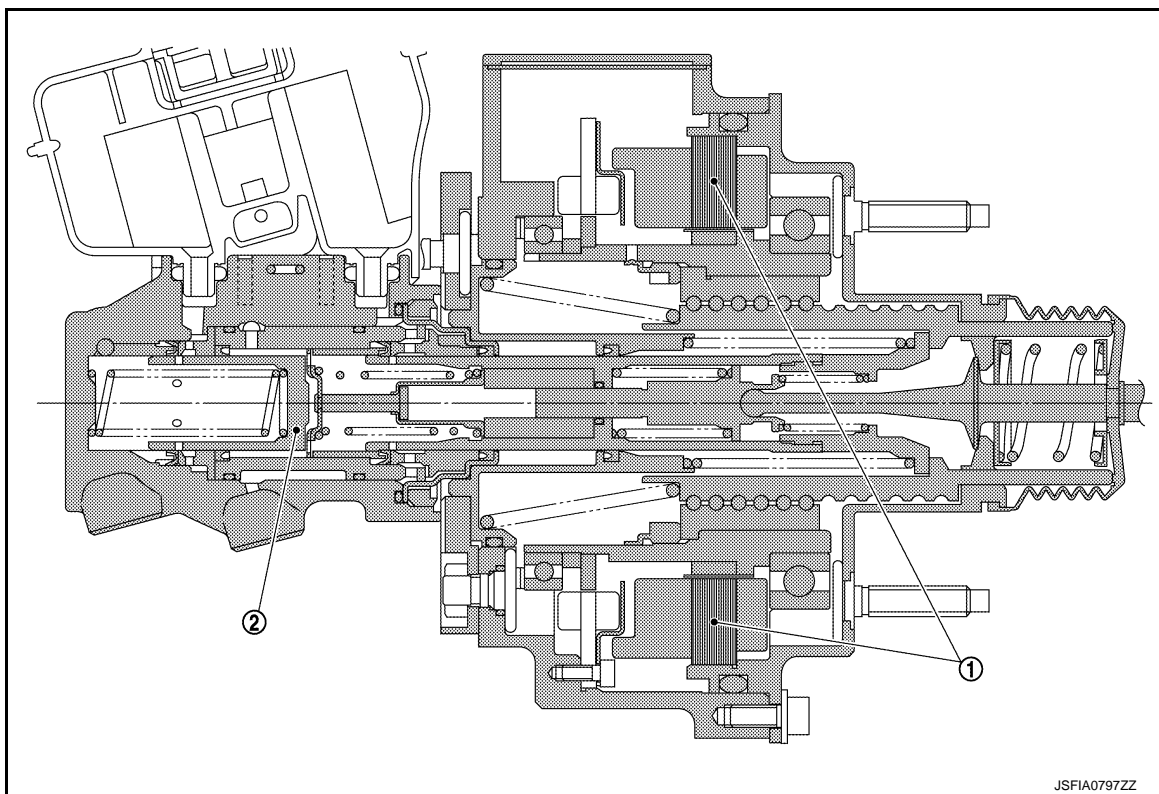

1. Motor

2. Piston

- Contains a motor and generates boost force according to the amount that the brake pedal is depressed and the amount of cooperative regenerative brake control.
- Uses the boost force to generate fluid pressure in the master cylinder.

ADAS Control Unit

INFOID:000000008139781

Controls Active Trace Control function in ADAS control unit and transmits Active trace control signal to ABS actuator and electric unit (control unit) via CAN communication.

NOTE:

Models with ICC

Master Cylinder Pressure Sensor1

INFOID:000000008139782

Detects the brake fluid pressure and transmits signals to the electrically-driven intelligent brake unit.

COMPONENT PARTS

< SYSTEM DESCRIPTION >

Pedal Stroke Sensor

INFOID:000000008139783

Detects the amount that the brake pedal is depressed and sends it to the electrically-driven intelligent brake unit.

A

Stop Lamp OFF Relay 1

INFOID:000000008139784

During LDW/LDP control, switches the relay to turn OFF the stop lamp.

NOTE:

- During LDW/LDP control, shuts off the stop lamp circuit.
- Models with ICC

B

C

Stop Lamp OFF Relay 2

INFOID:000000008139785

Stop lamp OFF relay 2 starts up in conjunction with Stop lamp OFF relay 1 during LDW/LDP control and transmits a brake switch signal to the ABS actuator and electric unit (control unit).

NOTE:

: Models with ICC

D

E

Warning Buzzer

INFOID:000000008139786

The warning buzzer operates based on the signal from the electrically-driven intelligent brake unit to notify the driver of the change in power supply circuits.

BR

G

Brake Power Supply Backup Unit

INFOID:000000008139787

When there is a malfunction in the power system of the electrically-driven intelligent brake unit (no voltage is generated), this unit temporarily supplies voltage to the electrically-driven intelligent brake unit.

H

I

J

K

L

M

N

O

P

SYSTEM

< SYSTEM DESCRIPTION >

SYSTEM

System Description

INFOID:000000008139788

- An electrically-driven intelligent brake is a booster system that generates assist force by using an internal motor to operate a piston inside the master cylinder.
- When the brake pedal is depressed during driving, cooperative control of the braking force from the friction brake (regular brake) and the regenerative brake from the traction motor is used.
- The system performs cooperative control of the regenerative brake and friction brake (same brake as in conventional vehicles) and enables highly efficient energy recovery.
- The fluid pressure which is applied to each brake caliper is controlled according to the amount of traction motor regeneration.
- The amount of brake pedal operation is detected by the pedal stroke sensor, and sent to the control module of the electrically-driven intelligent brake unit.
- Based on the commands from the control module of the electrically-driven intelligent brake unit, the motor inside the electrically-driven intelligent brake unit is operated and presses the master cylinder piston.
- Pressing the master cylinder piston, and brake fluid is sent to the ABS actuator and electric unit (control unit).
- CONSULT can be used to diagnose the system diagnosis.
- When there is a malfunction in the power system of the electrically-driven intelligent brake unit (no voltage is generated), voltage is temporarily supplied to the electrically-driven intelligent brake unit from the brake power supply backup unit. At the same time, the brake warning lamp (red) and brake system warning lamp (yellow) turn ON, and the warning buzzer sounds.
- When a malfunction occurs in the electrically-driven intelligent brake unit, the VDC function performs control (boost operation). At the same time, the brake warning lamp (red) and brake system warning lamp (yellow) turn ON.
- When a malfunction occurs in the DC/DC-J-B and 12V battery, the braking force is determined by the force pressing on the brake pedal (no boost operation). At the same time, the brake warning lamp (red) and the brake system warning lamp (yellow) turns ON.
- When a malfunction occurs in the brake power supply backup unit, the brake system warning lamp (yellow) turns ON.
- When a malfunction occurs in the electrically-driven intelligent brake and in the VDC function, the braking force is determined by the force pressing on the brake pedal (no boost operation). At the same time, the brake warning lamp (red) and brake system warning lamp (yellow) turn ON.
- When a malfunction occurs in the electrically-driven intelligent brake, the VDC function, and the power system, then cooperative regenerative brake control is not performed.
- A fail-safe function is available and is activated when a system malfunction occurs. Refer to [BR-17, "Fail-Safe"](#).

SYSTEM DIAGRAM

NOTE:

ADAS control unit is applied to models with ICC.

SYSTEM

< SYSTEM DESCRIPTION >

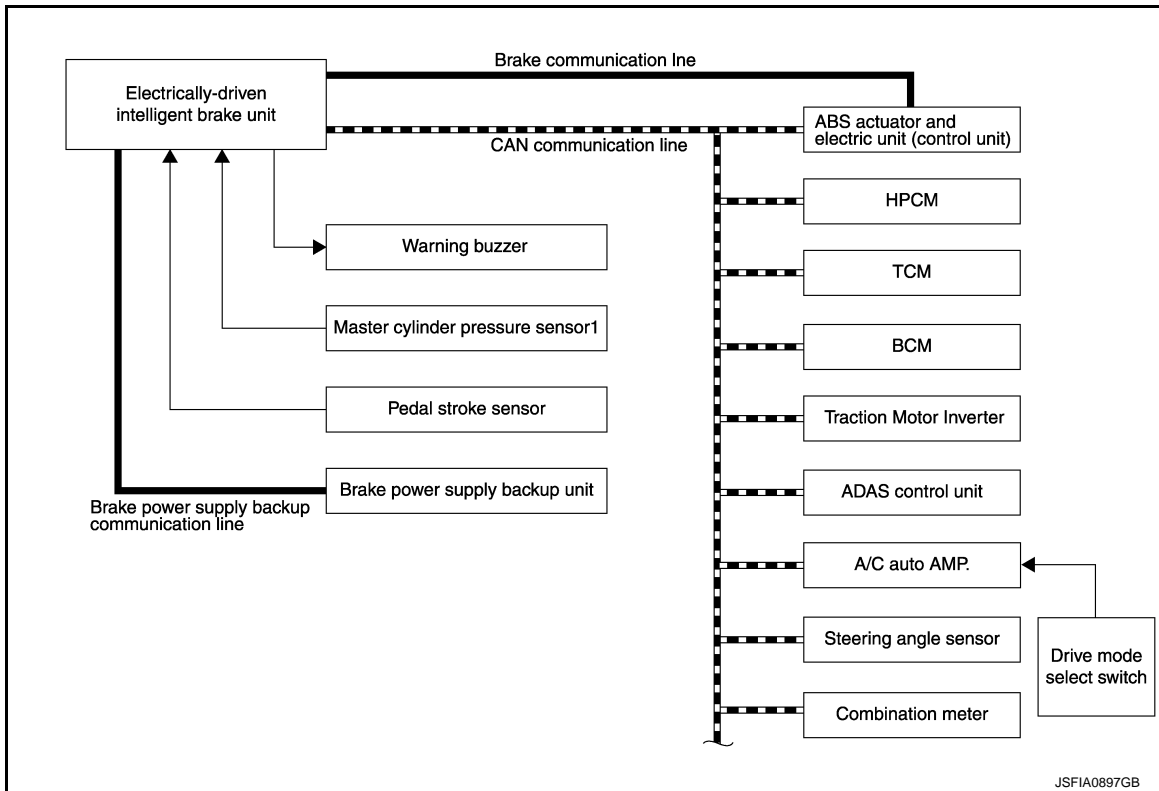

INPUT SIGNAL AND OUTOUT SIGNAL

Major signal transmission between each unit via communication lines is shown in the following table.

Ordinary brake control, Cooperative regenerative brake control, hill start assist function, Rise-up & Build-up function

Component	Signal description
HPCM	Mainly transmits the following signals to electrically-driven intelligent brake unit via CAN communication. <ul style="list-style-type: none"> • HPCM control signal
Steering angle sensor	Mainly transmits the following signals to electrically-driven intelligent brake unit via CAN communication. <ul style="list-style-type: none"> • Steering angle sensor signal
ABS actuator and electric unit (control unit)	Mainly transmits the following signals to electrically-driven intelligent brake unit via CAN communication. <ul style="list-style-type: none"> • Stop lamp switch signal • ABS actuator and electric unit (control unit) control signal • Vehicle speed signal (ABS) • Stop lamp OFF relay signal* • Decel G signal • Front LH wheel speed signal • Rear LH wheel speed signal • Front RH wheel speed signal • Rear RH wheel speed signal • Yaw rate signal • Side G signal Mainly receives the following signals from electrically-driven intelligent brake unit via CAN communication. <ul style="list-style-type: none"> • Brake assist request signal • Brake backup operation signal • Brake fluid pressure command signal • Electrically-driven intelligent brake control signal
BCM	Mainly transmits the following signals to electrically-driven intelligent brake unit via CAN communication. <ul style="list-style-type: none"> • Ignition switch ON signal • Door switch signal

SYSTEM

< SYSTEM DESCRIPTION >

Component	Signal description
Traction Motor Inverter	<p>Mainly transmits the following signals to electrically-driven intelligent brake unit via CAN communication.</p> <ul style="list-style-type: none"> • Required braking force calculation signal <p>Mainly receives the following signals from electrically-driven intelligent brake unit via CAN communication.</p> <ul style="list-style-type: none"> • Regenerative braking force calculation signal
Control valve & TCM	<p>Mainly transmits the following signals to electrically-driven intelligent brake unit via CAN communication.</p> <ul style="list-style-type: none"> • TCM malfunction signal • Current gear position signal
Combination meter	<p>Mainly receives the following signals from electrically-driven intelligent brake unit via CAN communication.</p> <ul style="list-style-type: none"> • Brake warning lamp signal • Brake system warning lamp signal

***: Models with ICC**

Active Trace Control function

Component	Signal description
ADAS control unit	<p>Mainly transmits the following signals to electrically-driven intelligent brake unit via CAN communication.</p> <ul style="list-style-type: none"> • Active trace control signal
ECM	<p>Mainly transmits the following signals to electrically-driven intelligent brake unit via CAN communication.</p> <ul style="list-style-type: none"> • Accelerator pedal position signal • Engine speed signal <p>Mainly receives the following signals from electrically-driven intelligent brake unit via CAN communication.</p> <ul style="list-style-type: none"> • Target throttle position signal
HPCM	<p>Mainly transmits the following signals to electrically-driven intelligent brake unit via CAN communication.</p> <ul style="list-style-type: none"> • HPCM control signal
ABS actuator and electric unit (control unit)	<p>Mainly transmits the following signals to electrically-driven intelligent brake unit via CAN communication.</p> <ul style="list-style-type: none"> • Stop lamp switch signal • ABS actuator and electric unit (control unit) control signal • Vehicle speed signal (ABS) • Yaw rate signal • Side G signal • Decel G signal • VDC OFF switch signal • Steering angle sensor signal
Electrically-driven intelligent brake unit	<p>Mainly transmits the following signals to ADAS control unit via CAN communication.</p> <ul style="list-style-type: none"> • Stop lamp switch signal • Vehicle speed signal (ABS) • VDC OFF switch signal • Yaw rate signal • Side G signal • Decel G signal • Steering angle sensor signal
Drive mode select switch	<p>Outputs ON/OFF status of STANDARD, SPORT, ECO, SNOW mode to A/C auto AMP.</p>
A/C auto AMP.	<p>Mainly transmits the following signals to ADAS control unit via CAN communication.</p> <ul style="list-style-type: none"> • Drive mode select switch signal
Combination meter	<p>Mainly receives the following signals from electrically-driven intelligent brake unit via CAN communication.</p> <ul style="list-style-type: none"> • Brake warning lamp signal • Brake system warning lamp signal <p>Mainly receives the following signals from ADAS control unit via CAN communication.</p> <ul style="list-style-type: none"> • IBA OFF indicator lamp signal

CONDITION FOR TURN ON THE WARNING LAMP AND OPERATION THE WARNING BUZZER

SYSTEM

< SYSTEM DESCRIPTION >

Turns ON when ignition switch ON and OFF when the system is normal, for bulb check purposes.

Condition (status)	Brake warning lamp (red)	Brake system warning lamp (yellow)	Warning buzzer
Ignition switch OFF	OFF	OFF	OFF
For several seconds after the ignition switch is ON	ON	ON	OFF
Several seconds after ignition switch ON (when the system is in normal operation)	OFF	OFF	OFF
When the power supply of the electrically-driven intelligent brake is changed to the brake power supply backup unit	ON	ON	ON
Brake power supply backup unit is malfunctioning	OFF	ON	OFF
Electrically-driven intelligent brake is malfunctioning	ON	ON	OFF
hill start assist function is malfunctioning	ON	ON	OFF
Rise-up & Build-up function is malfunctioning	ON	ON	OFF

CONDITION FOR TURN ON THE INDICATOR LAMP

IBA OFF indicator lamp (Models with ICC)

Turns ON when Active Trace Control function is malfunctioning.

NOTE:

Lamp ON condition of intelligent brake assistance OFF indicator lamp is that intelligent brake assistance OFF switch is in the pressed and not turned ON status.

Fail-Safe

INFOID:000000008139789

- When there is a malfunction in the power system of the electrically-driven intelligent brake unit (no voltage is generated), voltage is temporarily supplied to the electrically-driven intelligent brake unit from the brake power supply backup unit. At the same time, the brake warning lamp (red) and brake system warning lamp (yellow) turn ON and the buzzer sounds.
- When a malfunction occurs in the electrically-driven intelligent brake unit, the VDC function performs control (boost operation).
- When a malfunction occurs in the DC/DC-J/B and 12V battery, the braking force is determined by the force pressing on the brake pedal (no boost operation). At the same time, brake warning lamp (red) and the brake system warning lamp (yellow) turns ON.
- When a malfunction occurs in the electrically-driven intelligent brake and in the VDC function, the braking force is determined by the force pressing on the brake pedal (no boost operation). At the same time, the brake warning lamp (red) and brake system warning lamp (yellow) turn ON.
- When a malfunction occurs in the brake power supply backup unit, the brake system warning lamp (yellow) turns ON.
- When a malfunction occurs in the electrically-driven intelligent brake, VDC function, and power system, cooperative regenerative brake control, hill start assist function, Rise-up & Build-up function, Active Trace Control function and Brake force distribution function [function of the ABS actuator and electric unit (control unit)] are not performed.
- Brake warning lamp (red) and brake system warning lamp (yellow) in combination meter turn ON when a malfunction occurs in system (electrically-driven intelligent brake unit). The control is suspended for cooperative regenerative brake control, hill start assist function, Rise-up & Build-up function, Active Trace Control function and Brake force distribution function [function of the ABS actuator and electric unit (control unit)]. The vehicle status becomes the same as models without cooperative regenerative brake control, hill start assist function, Rise-up & Build-up function, Active Trace Control function and Brake force distribution function [function of the ABS actuator and electric unit (control unit)].
- IBA indicator lamp in combination meter turn ON when a malfunction occurs in system (ADAS control unit). The control is suspended for Active Trace Control function and Brake force distribution function [function of the ABS actuator and electric unit (control unit)]. The vehicle status becomes the same as models without Active Trace Control function and Brake force distribution function [function of the ABS actuator and electric unit (control unit)].

CAUTION:

Lamp ON condition of IBA OFF indicator lamp is that IBA OFF switch is in the pressed and not turned ON status.

SYSTEM

< SYSTEM DESCRIPTION >

- Mode is fixed to the mode when a malfunction occurs if CAN communication malfunction (DTC “U1000”, DTC “U1010”, DTC “U0424”) occurs between ADAS control unit and A/C auto AMP. The mode is fixed to STANDARD mode after ignition switch turns OFF to ON.

DTC	Vehicle condition
C1A60	The following functions are suspended.
C1A61	<ul style="list-style-type: none"> • Boost operation by the electrically-driven intelligent brake • Cooperative regenerative brake control
C1A62	<ul style="list-style-type: none"> • Power supply from the brake power supply backup unit • hill start assist function • Rise-up & Build-up function • Active Trace Control function • Brake force distribution function [function of the ABS actuator and electric unit (control unit)]
C1A63	The following functions are suspended. <ul style="list-style-type: none"> • Power supply from the brake power supply backup unit • Rise-up & Build-up function
C1A64	The following functions are suspended.
C1A65	<ul style="list-style-type: none"> • Boost operation by the electrically-driven intelligent brake • Cooperative regenerative brake control • Power supply from the brake power supply backup unit • hill start assist function • Rise-up & Build-up function • Active Trace Control function • Brake force distribution function [function of the ABS actuator and electric unit (control unit)]
C1A66	The following functions are suspended. <ul style="list-style-type: none"> • Cooperative regenerative brake control • hill start assist function • Rise-up & Build-up function • Active Trace Control function • Brake force distribution function [function of the ABS actuator and electric unit (control unit)]
C1A67	The following functions are suspended.
C1A68*1	<ul style="list-style-type: none"> • Rise-up & Build-up function
C1A69	The following functions are suspended.
C1A6A	<ul style="list-style-type: none"> • Boost operation by the electrically-driven intelligent brake • Cooperative regenerative brake control • Power supply from the brake power supply backup unit • hill start assist function • Rise-up & Build-up function • Active Trace Control function • Brake force distribution function [function of the ABS actuator and electric unit (control unit)]
C1A6B	The following functions are suspended.
C1A6C	<ul style="list-style-type: none"> • Backup power supply from the brake power supply backup unit
C1A6D	<ul style="list-style-type: none"> • Rise-up & Build-up function
C1A6E	The following functions are suspended. <ul style="list-style-type: none"> • Cooperative regenerative brake control • hill start assist function
C1A6F	The following functions are suspended. <ul style="list-style-type: none"> • hill start assist function
C1A70	The following functions are suspended. <ul style="list-style-type: none"> • Cooperative regenerative brake control • hill start assist function • Rise-up & Build-up function • Active Trace Control function • Brake force distribution function [function of the ABS actuator and electric unit (control unit)]
C1A71	Normal control
C1A74	The following functions are suspended. <ul style="list-style-type: none"> • Cooperative regenerative brake control

SYSTEM

< SYSTEM DESCRIPTION >

DTC	Vehicle condition
U1000	The following functions are suspended.
U1010	<ul style="list-style-type: none"> Cooperative regenerative brake control hill start assist function Rise-up & Build-up function Active Trace Control function Brake force distribution function [function of the ABS actuator and electric unit (control unit)]
U0424*2	Mode is fixed to the mode when a malfunction of drive mode selector occurs. The mode is fixed to STANDARD mode after ignition switch turns OFF to ON.
U1510	The following functions are suspended.
U1511	<ul style="list-style-type: none"> Rise-up & Build-up function

*1: Models with ICC

*: This is DTC that is detected in ADAS control unit side.

COOPERATIVE REGENERATIVE BRAKE FUNCTION

COOPERATIVE REGENERATIVE BRAKE FUNCTION : System Description

INFOID:000000008139790

A
B
C
D
E

BR

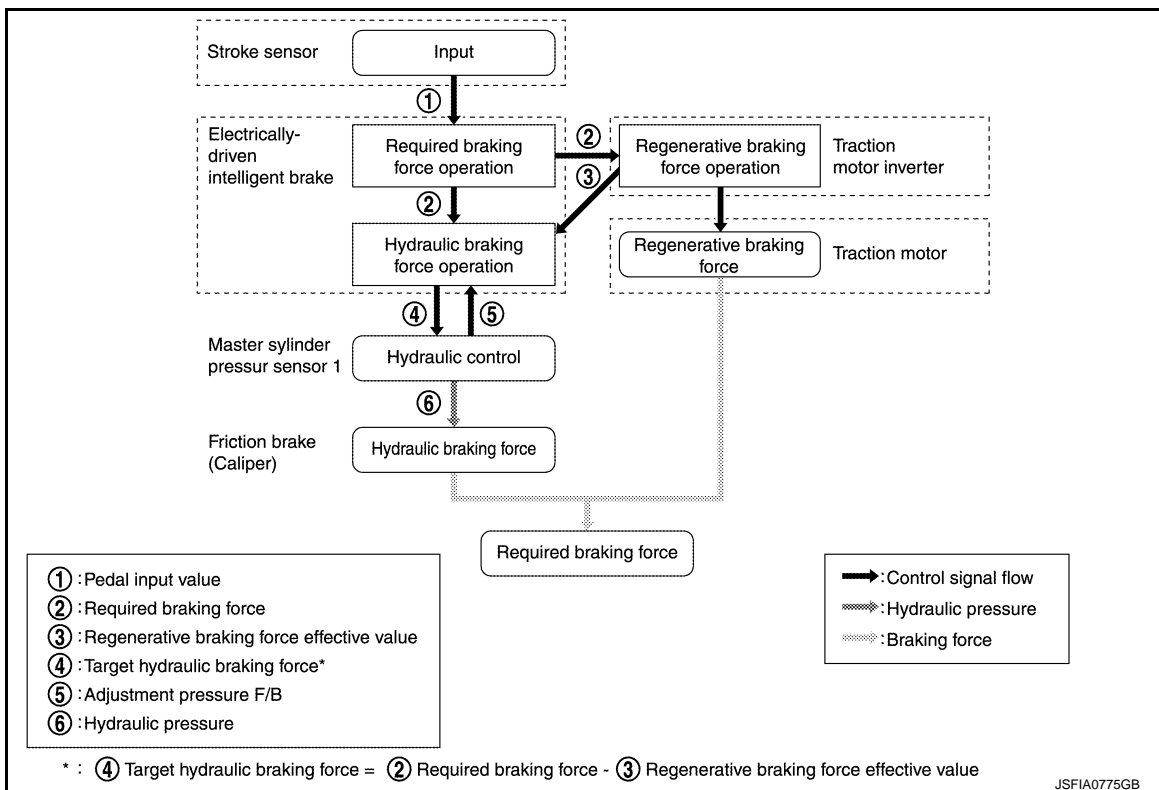

G
H
I
J
K
L
M

- A regenerative brake drives the traction motor to act as an alternator, and converts the kinetic energy produced by rotation of the tires into electrical energy. The converted electrical energy charges the Li-ion battery. In the same way as engine braking, this can also reduce the load on the ordinary brakes.
- When the brakes are operated (during driving), the electrically-driven intelligent brake unit calculates the required braking force based on the input value from the stroke sensor (indicating the amount of brake pedal operation), and it sends the result to the traction motor inverter. At the same time, it calculates the hydraulic braking force needed to produce the required braking force.
- The traction motor inverter calculates the regenerative braking force needed to produce the required braking force, and it sends the result to the electrically-driven intelligent brake unit. At the same time, the traction motor inverter uses the traction motor to perform regenerative braking.
- The electrically-driven intelligent brake unit calculates the hydraulic braking force again based on the regenerative braking force result from the tracking motor inverter and the calculated result for hydraulic braking force.
- Based on the calculated result for hydraulic braking force, the electrically-driven intelligent brake unit uses the motor inside the electrically-driven intelligent brake unit to move the master cylinder piston, adjusting the

N
O
P

SYSTEM

< SYSTEM DESCRIPTION >

fluid pressure inside the master cylinder to the master fluid pressure. It also performs adjustment so that the fluid pressure that is actually applied matches the target fluid pressure.

NOTE:

The fluid pressure applied to the master cylinder is detected by master cylinder pressure sensor1.

- The fluid pressure generated by the master cylinder is sent to each brake caliper via the ABS actuator and electric unit (control unit).
- When the cooperative regenerative brake is operating, the motor inside the electrically-driven intelligent brake unit moves the master cylinder piston according to the amount of regeneration.
- Moving the master cylinder piston increases the fluid pressure applied to the ABS actuator and electric unit (control unit). (The brake pedal stroke does not change.)
- When brake control is stopped (immediately before vehicle stop or while vehicle is stopped), cooperative regenerative brake control is not performed.

SYSTEM DIAGRAM

NOTE:

ADAS control unit is applied to models with ICC.

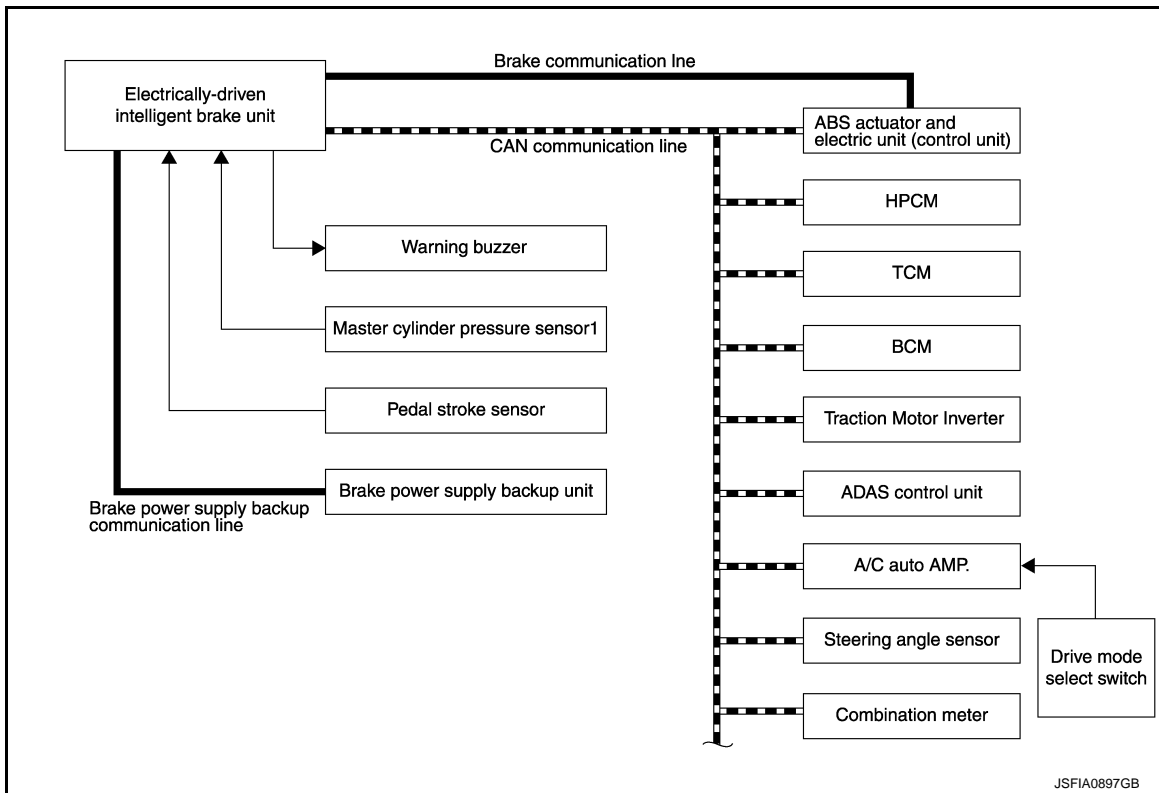

INPUT SIGNAL AND OUTOUT SIGNAL

Major signal transmission between each unit via communication lines is shown in the following table.

Component	Signal description
HPCM	Mainly transmits the following signals to electrically-driven intelligent brake unit via CAN communication. <ul style="list-style-type: none"> • HPCM control signal
Steering angle sensor	Mainly transmits the following signals to electrically-driven intelligent brake unit via CAN communication. <ul style="list-style-type: none"> • Steering angle sensor signal

SYSTEM

< SYSTEM DESCRIPTION >

Component	Signal description
ABS actuator and electric unit (control unit)	<p>Mainly transmits the following signals to electrically-driven intelligent brake unit via CAN communication.</p> <ul style="list-style-type: none"> • Stop lamp switch signal • ABS actuator and electric unit (control unit) control signal • Vehicle speed signal (ABS) • Stop lamp OFF relay signal* • Decel G signal • Front LH wheel speed signal • Rear LH wheel speed signal • Front RH wheel speed signal • Rear RH wheel speed signal • Yaw rate signal • Side G signal <p>Mainly receives the following signals from electrically-driven intelligent brake unit via CAN communication.</p> <ul style="list-style-type: none"> • Brake assist request signal • Brake backup operation signal • Brake fluid pressure command signal • Electrically-driven intelligent brake control signal
BCM	<p>Mainly transmits the following signals to electrically-driven intelligent brake unit via CAN communication.</p> <ul style="list-style-type: none"> • Ignition switch ON signal • Door switch signal
Traction Motor Inverter	<p>Mainly transmits the following signals to electrically-driven intelligent brake unit via CAN communication.</p> <ul style="list-style-type: none"> • Required braking force calculation signal <p>Mainly receives the following signals from electrically-driven intelligent brake unit via CAN communication.</p> <ul style="list-style-type: none"> • Regenerative braking force calculation signal
Control valve & TCM	<p>Mainly transmits the following signals to electrically-driven intelligent brake unit via CAN communication.</p> <ul style="list-style-type: none"> • TCM malfunction signal • Current gear position signal
Combination meter	<p>Mainly receives the following signals from electrically-driven intelligent brake unit via CAN communication.</p> <ul style="list-style-type: none"> • Brake warning lamp signal • Brake system warning lamp signal

*: Models with ICC

OPERATION

During Normal Braking

A
B
C
D
E
BR
G
H
I
J
K
L
M
N
O
P

SYSTEM

< SYSTEM DESCRIPTION >

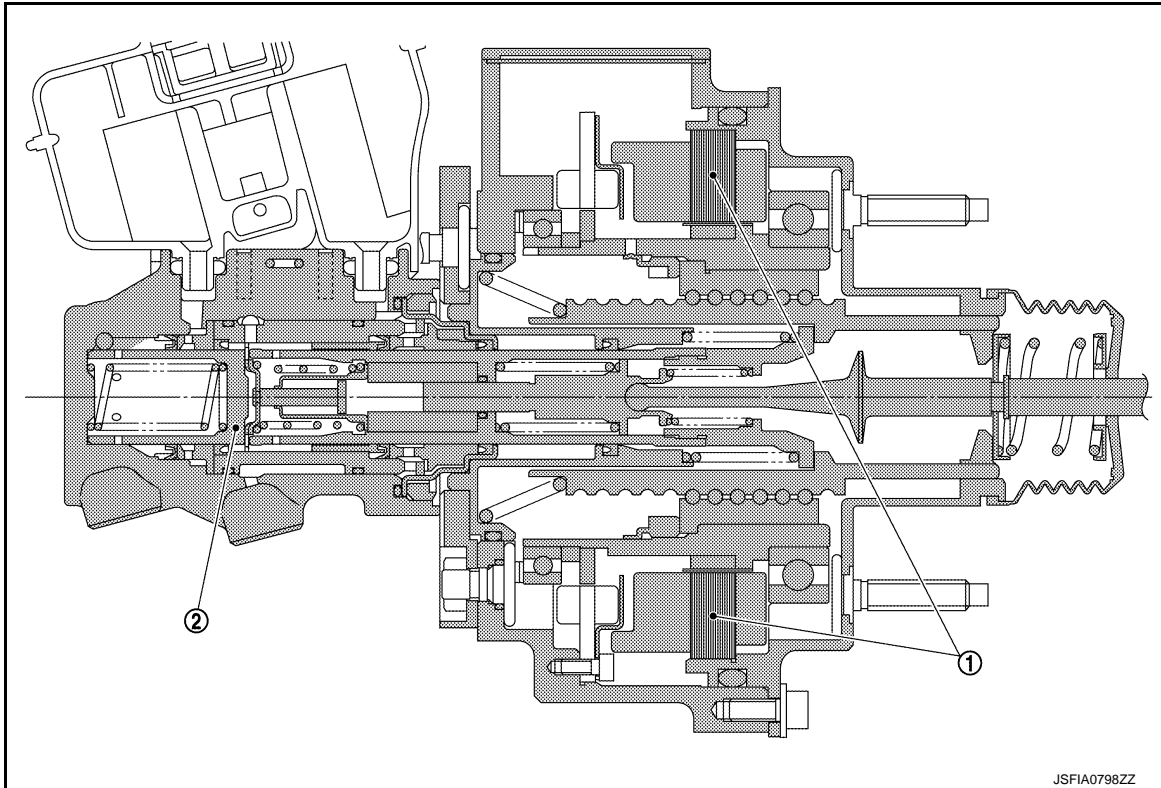

1. Motor

2. Piston

The stroke sensor detects the brake pedal stroke, and the motor inside the electrically-driven intelligent brake unit presses the master cylinder piston, generating boost operation (brake pedal assist force) and increasing the fluid pressure.

When Cooperative Regenerative Brake Control Is Operating

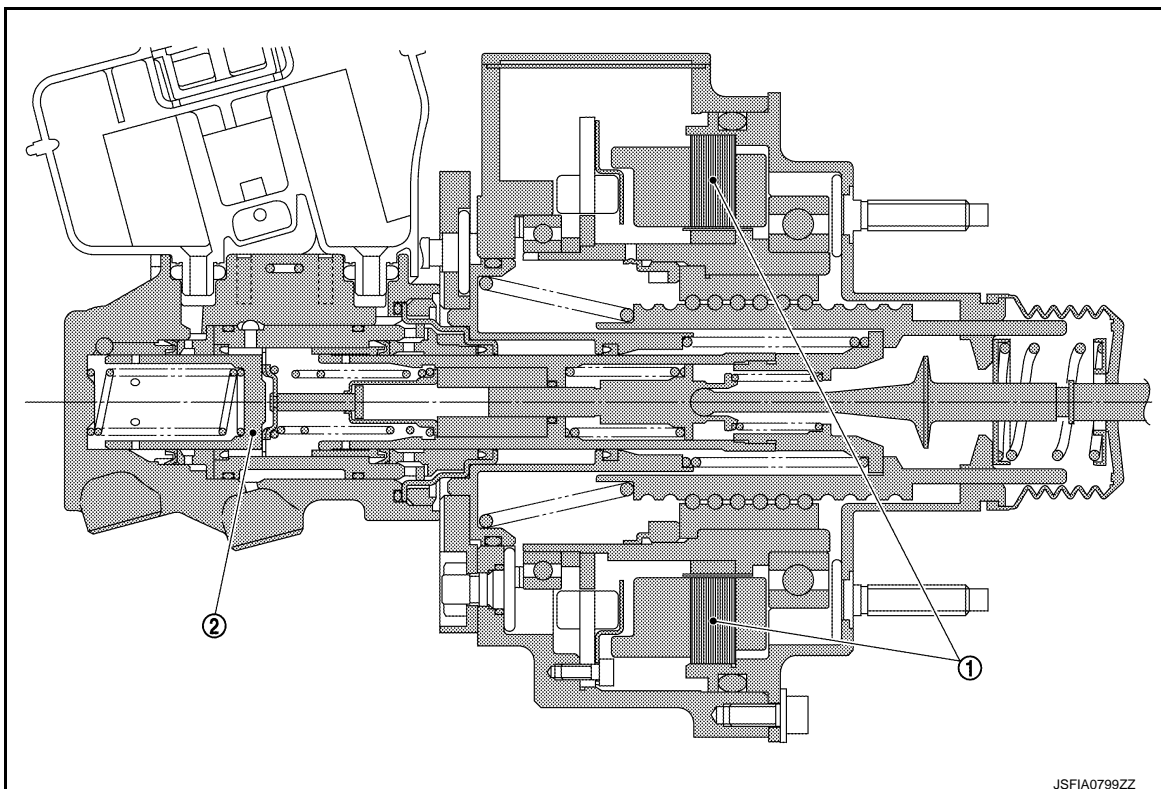

SYSTEM

< SYSTEM DESCRIPTION >

1. Motor

2. Piston

When the amount of regenerative braking increases, the motor inside the electrically-driven intelligent brake unit returns the master cylinder piston, lowering the fluid pressure. While the vehicle is stopped, because the amount of regenerative braking decreases, the motor inside the electrically-driven intelligent brake unit presses the master cylinder piston, increasing the fluid pressure.

When Control Is Stopped

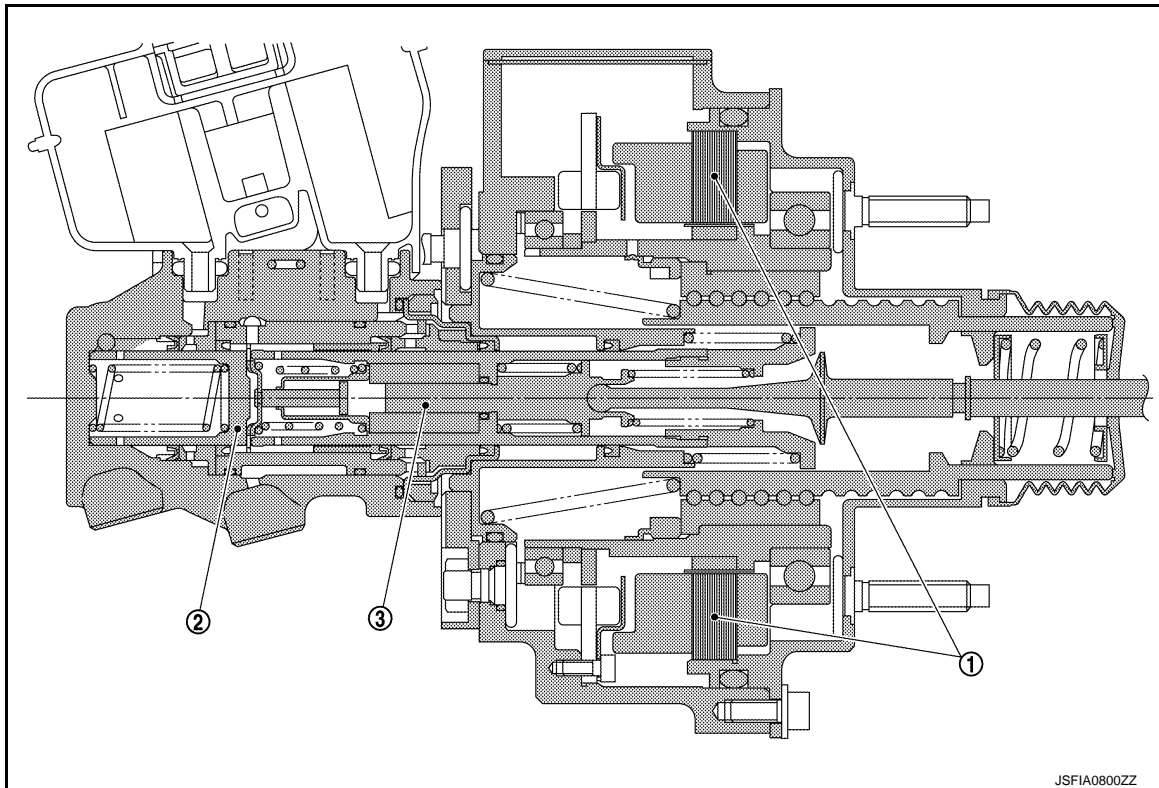

1. Motor

2. Piston

3. Input rod

The input rod crosses the cooperative regenerative brake control gap and contacts the master cylinder piston, generating fluid pressure. There is no boost force (assist force), and the braking force is determined by the force pressing on the brake pedal.

Hill start assist FUNCTION

Hill start assist FUNCTION : System Description

INFOID:000000008139791

- This function maintains brake fluid pressure so that the vehicle does not move backwards even if brake pedal is released to depress accelerator pedal to start the vehicle while it is stopped on an uphill slope by depressing brake pedal.
- This function operates when the vehicle is in stop status on a uphill slope of slope ratio 10% or more and selector lever is in the position other than P or N.
- hill start assist function is only for the start aid. It maintains the brake fluid pressure for approx. 2 seconds after releasing the brake pedal, and then decreases the pressure gradually. If the vehicle can start by the accelerator operation, the brake is released automatically and a smooth start can be performed.
- Fail-safe function is adopted. When a malfunction occurs in hill start assist function, the control is suspended for hill start assist function, Rise-up & Build-up function, Active Trace Control function and Brake force distribution function [function of the ABS actuator and electric unit (control unit)]. The vehicle status becomes the same as models without hill start assist function, Rise-up & Build-up function, Active Trace Control function and Brake force distribution function [function of the ABS actuator and electric unit (control unit)]. Refer to [BR-17. "Fail-Safe"](#).

SYSTEM DIAGRAM

NOTE:

SYSTEM

< SYSTEM DESCRIPTION >

ADAS control unit is applied to models with ICC.

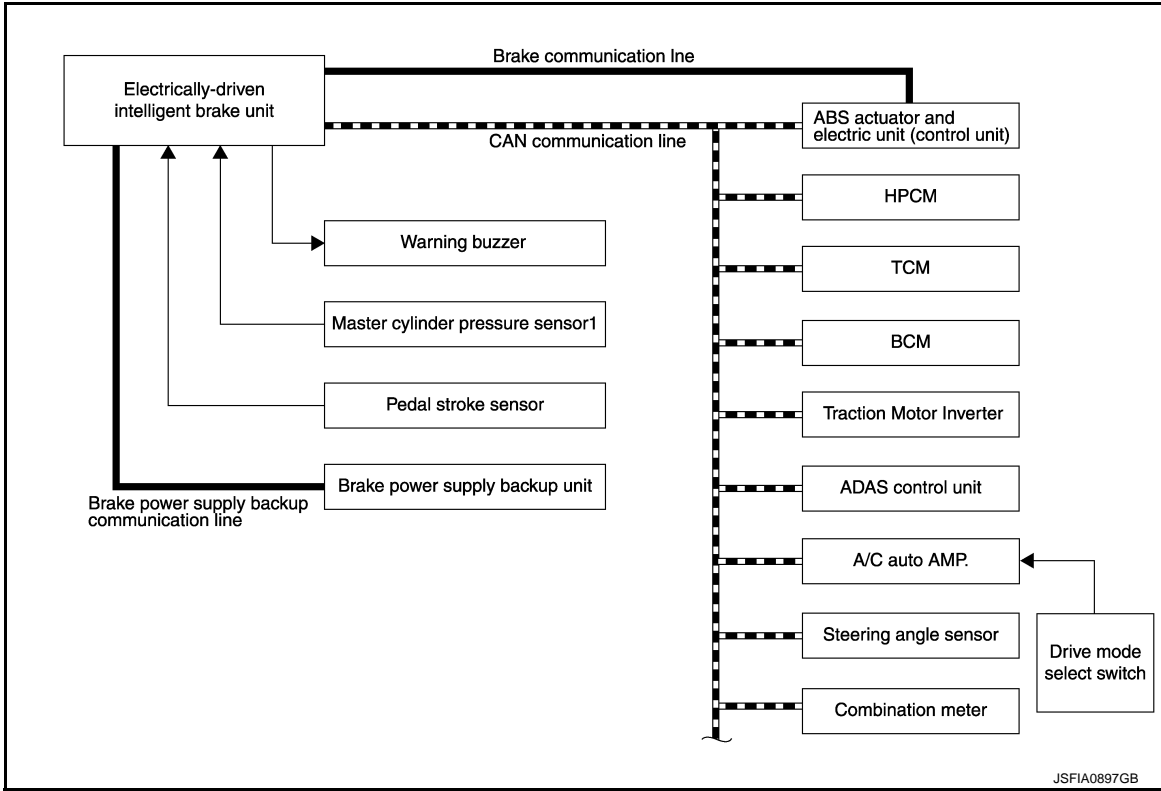

INPUT SIGNAL AND OUTOUT SIGNAL

Major signal transmission between each unit via communication lines is shown in the following table.

Component	Signal description
HPCM	Mainly transmits the following signals to electrically-driven intelligent brake unit via CAN communication. <ul style="list-style-type: none"> • HPCM control signal
Steering angle sensor	Mainly transmits the following signals to electrically-driven intelligent brake unit via CAN communication. <ul style="list-style-type: none"> • Steering angle sensor signal
ABS actuator and electric unit (control unit)	Mainly transmits the following signals to electrically-driven intelligent brake unit via CAN communication. <ul style="list-style-type: none"> • Stop lamp switch signal • ABS actuator and electric unit (control unit) control signal • Vehicle speed signal (ABS) • Stop lamp OFF relay signal* • Decel G signal • Front LH wheel speed signal • Rear LH wheel speed signal • Front RH wheel speed signal • Rear RH wheel speed signal • Yaw rate signal • Side G signal Mainly receives the following signals from electrically-driven intelligent brake unit via CAN communication. <ul style="list-style-type: none"> • Brake assist request signal • Brake backup operation signal • Brake fluid pressure command signal • Electrically-driven intelligent brake control signal
BCM	Mainly transmits the following signals to electrically-driven intelligent brake unit via CAN communication. <ul style="list-style-type: none"> • Ignition switch ON signal • Door switch signal

SYSTEM

< SYSTEM DESCRIPTION >

Component	Signal description
Traction Motor Inverter	Mainly transmits the following signals to electrically-driven intelligent brake unit via CAN communication. <ul style="list-style-type: none">• Required braking force calculation signal Mainly receives the following signals from electrically-driven intelligent brake unit via CAN communication. <ul style="list-style-type: none">• Regenerative braking force calculation signal
Control valve & TCM	Mainly transmits the following signals to electrically-driven intelligent brake unit via CAN communication. <ul style="list-style-type: none">• TCM malfunction signal• Current gear position signal
Combination meter	Mainly receives the following signals from electrically-driven intelligent brake unit via CAN communication. <ul style="list-style-type: none">• Brake warning lamp signal• Brake system warning lamp signal

*: Models with ICC

ACTIVE STABILITY ASSIST

ACTIVE STABILITY ASSIST : System Description

INFOID:000000008139792

- Combination of Active Trace Control function (function of the electrically-driven intelligent brake), Rise-up & Build-up function (function of the electrically-driven intelligent brake) and Brake force distribution function [function of the ABS actuator and electric unit (control unit)] is named to as Active stability assist. Active Trace Control function is available for models with ICC system.
- Active stability assist system is aimed to smooth the vehicle movement utilizing electrically-driven intelligent brake and VDC function for enjoyable driving with reliable feeling of the driver.
- Active Trace Control function
- Active Trace Control helps enhance the transition from braking into and then accelerating out of corners. Active Trace Control utilizes the vehicle's electrically-driven intelligent brake system to help improve cornering feel by automatically applying brakes, or smoothening engine/traction motor torque characteristics while accelerating. Furthermore, Active Trace Control will apply selective braking to help create increased steering response in S-turns. For example, if driving through an S-turn that starts with steering to the right, the right-side brakes are engaged to create a yaw moment and help turn the vehicle. When steering back to the left, left-side brakes are engaged. Refer to [BR-28. "ACTIVE STABILITY ASSIST : Active Trace Control Function"](#).
- Rise-up & Build-up function
- Rise-up & Build-up gives the drivers secure brake feeling with optimized braking characteristics according to the amount of brake operation and the behavior of vehicle. Refer to [BR-28. "ACTIVE STABILITY ASSIST : Rise-up & Build-up Function"](#).
- Brake Force Distribution function
- Brake force distribution function is refer to [BRC-43. "ACTIVE STABILITY ASSIST : Brake Force Distribution Function"](#).
- Active Trace Control can be switched to operational status or non-operational status by operating VDC OFF switch to ON/OFF.

SYSTEM DIAGRAM

NOTE:

ADAS control unit is applied to models with ICC.

SYSTEM

< SYSTEM DESCRIPTION >

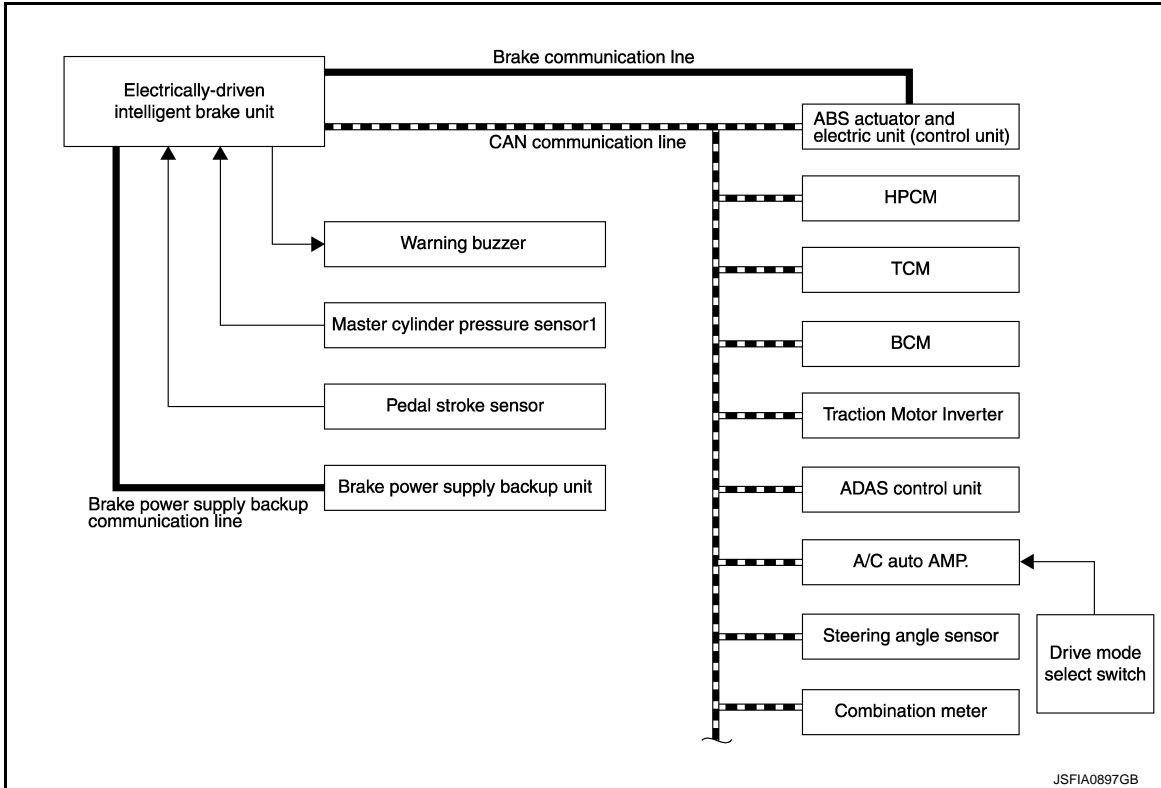

INPUT SIGNAL AND OUTOUT SIGNAL

Major signal transmission between each unit via communication lines is shown in the following table.

Rise-up & Build-up function

Component	Signal description
HPCM	Mainly transmits the following signals to electrically-driven intelligent brake unit via CAN communication. <ul style="list-style-type: none"> • HPCM control signal
Steering angle sensor	Mainly transmits the following signals to electrically-driven intelligent brake unit via CAN communication. <ul style="list-style-type: none"> • Steering angle sensor signal
ABS actuator and electric unit (control unit)	Mainly transmits the following signals to electrically-driven intelligent brake unit via CAN communication. <ul style="list-style-type: none"> • Stop lamp switch signal • ABS actuator and electric unit (control unit) control signal • Vehicle speed signal (ABS) • Stop lamp OFF relay signal* • Decel G signal • Front LH wheel speed signal • Rear LH wheel speed signal • Front RH wheel speed signal • Rear RH wheel speed signal • Yaw rate signal • Side G signal Mainly receives the following signals from electrically-driven intelligent brake unit via CAN communication. <ul style="list-style-type: none"> • Brake assist request signal • Brake backup operation signal • Brake fluid pressure command signal • Electrically-driven intelligent brake control signal
BCM	Mainly transmits the following signals to electrically-driven intelligent brake unit via CAN communication. <ul style="list-style-type: none"> • Ignition switch ON signal • Door switch signal

SYSTEM

< SYSTEM DESCRIPTION >

Component	Signal description	
Traction Motor Inverter	Mainly transmits the following signals to electrically-driven intelligent brake unit via CAN communication. <ul style="list-style-type: none"> • Required braking force calculation signal 	A
	Mainly receives the following signals from electrically-driven intelligent brake unit via CAN communication. <ul style="list-style-type: none"> • Regenerative braking force calculation signal 	B
Control valve & TCM	Mainly transmits the following signals to electrically-driven intelligent brake unit via CAN communication. <ul style="list-style-type: none"> • TCM malfunction signal • Current gear position signal 	C
Combination meter	Mainly receives the following signals from electrically-driven intelligent brake unit via CAN communication. <ul style="list-style-type: none"> • Brake warning lamp signal • Brake system warning lamp signal 	D

*: Models with ICC

Active Trace Control function

Component	Signal description	BR
ADAS control unit	Mainly transmits the following signals to electrically-driven intelligent brake unit via CAN communication. <ul style="list-style-type: none"> • Active trace control signal 	G
ECM	Mainly transmits the following signals to electrically-driven intelligent brake unit via CAN communication. <ul style="list-style-type: none"> • Accelerator pedal position signal • Engine speed signal Mainly receives the following signals from electrically-driven intelligent brake unit via CAN communication. <ul style="list-style-type: none"> • Target throttle position signal 	H
HPCM	Mainly transmits the following signals to electrically-driven intelligent brake unit via CAN communication. <ul style="list-style-type: none"> • HPCM control signal 	I
ABS actuator and electric unit (control unit)	Mainly transmits the following signals to electrically-driven intelligent brake unit via CAN communication. <ul style="list-style-type: none"> • Stop lamp switch signal • ABS actuator and electric unit (control unit) control signal • Vehicle speed signal (ABS) • Yaw rate signal • Side G signal • Decel G signal • VDC OFF switch signal • Steering angle sensor signal 	J
Electrically-driven intelligent brake unit	Mainly transmits the following signals to ADAS control unit via CAN communication. <ul style="list-style-type: none"> • Stop lamp switch signal • Vehicle speed signal (ABS) • VDC OFF switch signal • Yaw rate signal • Side G signal • Decel G signal • Steering angle sensor signal 	K
Drive mode select switch	Outputs ON/OFF status of STANDARD, SPORT, ECO, SNOW mode to A/C auto AMP.	L
A/C auto AMP.	Mainly transmits the following signals to ADAS control unit via CAN communication. <ul style="list-style-type: none"> • Drive mode select switch signal 	M
Combination meter	Mainly receives the following signals from electrically-driven intelligent brake unit via CAN communication. <ul style="list-style-type: none"> • Brake warning lamp signal • Brake system warning lamp signal Mainly receives the following signals from ADAS control unit via CAN communication. <ul style="list-style-type: none"> • IBA OFF indicator lamp signal 	N

SYSTEM

< SYSTEM DESCRIPTION >

ACTIVE STABILITY ASSIST : Rise-up & Build-up Function

INFOID:000000008139793

- Rise-up & Build-up function is controlled by electrically-driven intelligent brake unit.
- The system gradually adjusts braking power during normal braking to help provide an enhanced brake feel.
- Brake warning lamp (red) and brake system warning lamp (yellow) turns ON when Rise-up & Build-up function is malfunctioning.

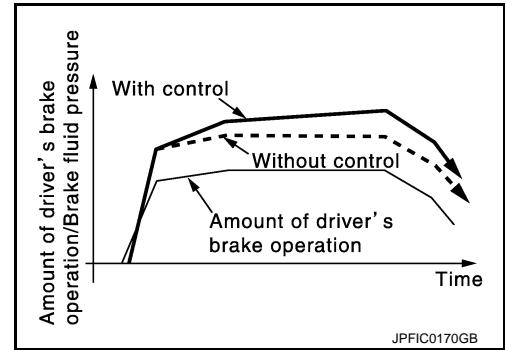

ACTIVE STABILITY ASSIST : Active Trace Control Function

INFOID:000000008139794

- Active Trace Control function is calculated by ADAS control unit and transmits command to electrically-driven intelligent brake unit and HPCM.
- This system senses driving based on the driver's steering and acceleration/braking patterns, and individually controls the braking and application of engine/traction motor torque to each of the four wheels to help smooth vehicle response.
- When the drive mode selector switch is set to the "SPORT" mode, the amount of brake control provided by Active Trace Control function is reduced.
- When the VDC OFF switch is turned OFF the VDC function, the Active Trace Control function is also turned OFF.
- Active Trace Control function is malfunctioning properly, the IBA OFF indicator lamp turns ON.

NOTE:

Effect to decrease delay of vehicle yaw rate in response to steering operation may not always be obtained in all driving conditions (example: when road surface resistance is low).

OPERATION CHARACTERISTICS

Active Trace Control helps enhance the transition from braking into and then accelerating out of corners. Active Trace Control utilizes the vehicle's electrically-driven intelligent brake system to help improve cornering feel by automatically applying brakes, or smoothing engine/traction motor torque characteristics while accelerating. Furthermore, Active Trace Control will apply selective braking to help create increased steering response in S-turns. For example, if driving through an S-turn that starts with steering to the right, the right-side brakes are engaged to create a yaw moment and help turn the vehicle.

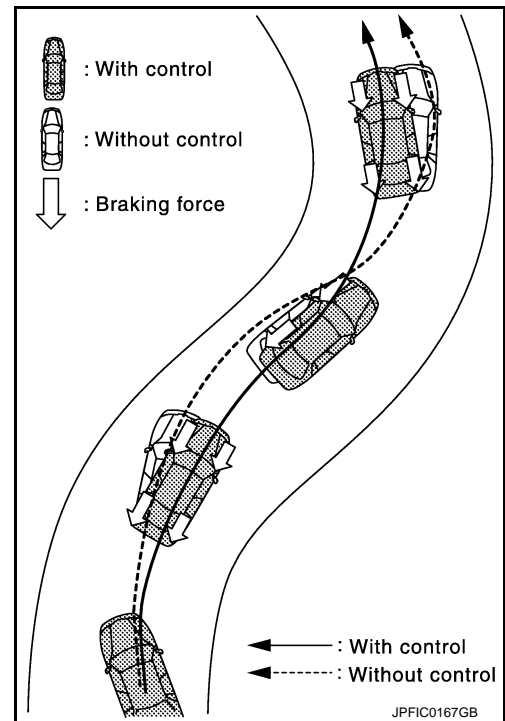

SYSTEM

< SYSTEM DESCRIPTION >

- Brake control amount and engine/traction motor output are controlled according to steering operation status by the driver and vehicle cornering status.

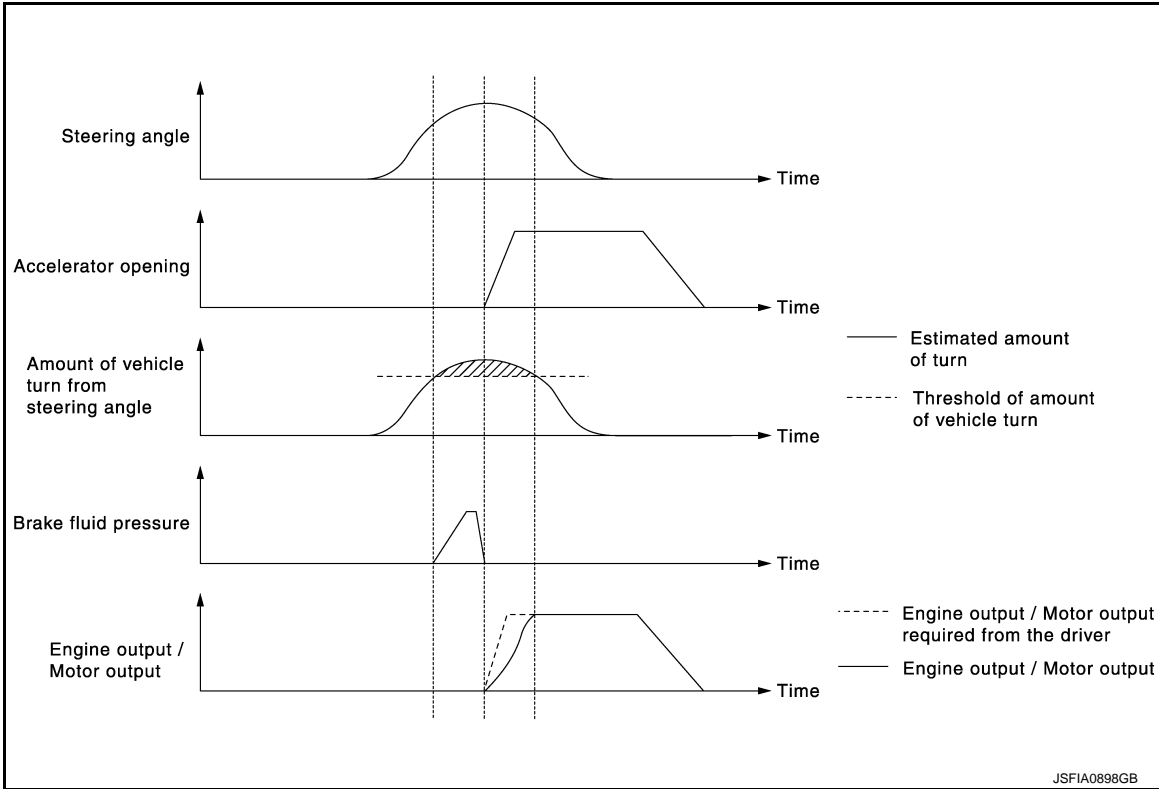

- By preventing a sudden torque change, vehicle behavior moderates. As a result, accelerator pedal operation by the driver is improved.

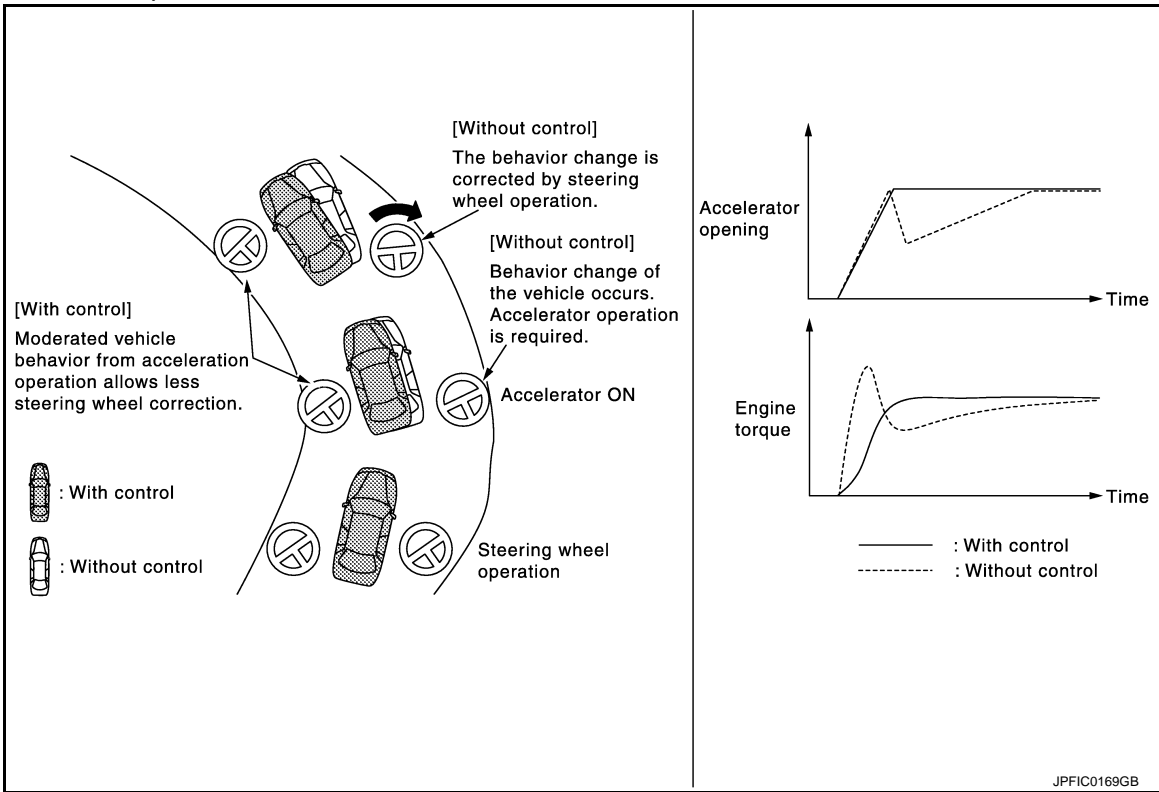

DIAGNOSIS SYSTEM (ELECTRICALLY-DRIVEN INTELLIGENT BRAKE UNIT)

< SYSTEM DESCRIPTION >

DIAGNOSIS SYSTEM (ELECTRICALLY-DRIVEN INTELLIGENT BRAKE UNIT)

CONSULT Function

INFOID:000000008139795

APPLICATION ITEM

CONSULT can display each diagnostic item using the diagnostic test modes as follows.

Mode	Function description
ECU identification	Parts number of electrically-driven intelligent brake unit can be read.
Self Diagnostic Results	Self-diagnostic results and freeze frame data can be read and erased quickly.*1
DATA MONITOR	Input/Output data in the electrically-driven intelligent brake unit can be read.
ACTIVE TEST	Diagnostic Test Mode in which CONSULT drives some actuators apart from the electrically-driven intelligent brake unit and also shifts some parameters in a specified range.*2
Work Support	Components can be quickly and accurately adjusted.

*1: The following diagnosis information is erased by erasing.

CAUTION:

After erase self-diagnosis result, turn the ignition switch OFF, to exit CONSULT. Get out of the vehicle, close all doors (including trunk lid), and wait for 3 minutes or more without opening these doors. Never operate the vehicle and CONSULT while waiting.

- DTC
- Freeze frame data (FFD)

*2: Models with ICC

ECU IDENTIFICATION

Electrically-driven intelligent brake unit part number can be read.

SELF DIAGNOSTIC RESULT

Refer to [BR-38, "DTC Index"](#).

When "CRNT" is displayed on self-diagnosis result

- The system is presently malfunctioning.

When "PAST" is displayed on self-diagnosis result

- System malfunction in the past is detected, but the system is presently normal.

Freeze frame data (FFD)

When DTC is detected, a vehicle state shown below is recorded and displayed on CONSULT.

Item name	Display item
IGN counter (0 – 39)	The number of times that ignition switch is ON after the DTC is detected is displayed. <ul style="list-style-type: none">• When "0" is displayed: It indicates that the system is presently malfunctioning.• When except "0" is displayed: It indicates that system malfunction in the past is detected, but the system is presently normal. NOTE: Each time when ignition switch is turned OFF to ON, numerical number increases in 1 → 2 → 3...38 → 39. When the operation number of times exceeds 39, the number do not increase and "39" is displayed until self-diagnosis is erased.
PEDAL STROKE VALUE	Displays the brake pedal stroke at the time the malfunction is detected.
MASTER CYL PRESSURE	Displays the brake fluid pressure generated in the master cylinder at the time the malfunction is detected.
Q axis current	Displays the current at the motor inside the electrically-driven intelligent brake unit at the time the malfunction is detected.

DATA MONITOR

DIAGNOSIS SYSTEM (ELECTRICALLY-DRIVEN INTELLIGENT BRAKE UNIT)

< SYSTEM DESCRIPTION >

Item (Unit)	Note:	
MASTER CYL PRESSURE (V)	Master cylinder pressure sensor1 voltage is displayed.	A
MASTER CYL PRES (VDC) (MPa)	Displays the master cylinder fluid pressure sensor 2 signal sent via CAN communication from the ABS actuator and electric unit (control unit).	B
MOTOR TEMPERATURE (°C)	Displays the temperature of the motor inside the electrically-driven intelligent brake unit.	C
CONTROL MODULE TEMP (°C)	Displays the temperature of the control module that is integrated with the electrically-driven intelligent brake unit.	
MST CYL PRES POWER VOLT (V)	Master cylinder pressure sensor1 power supply is displayed	D
STROKE SEN 1 POWER VOLT (V)	Stroke sensor power supply is displayed	E
MOTOR POWER SUPPLY (V)	Displays the power voltage of the motor inside the electrically-driven intelligent brake unit.	
CONTROL MODULE POWER (V)	Displays the power voltage of the control module that is integrated with the electrically-driven intelligent brake unit.	BR
STROKE SEN 1 LEARN VALUE (deg)	Displays the stroke sensor 1* learning value.	
STROKE SEN 2 LEARN VALUE (deg)	Displays the stroke sensor 2* learning value.	G
ALL SENSOR LEARNING (INCOMP/COMP)	Displays the learning values of stroke sensor 1*, stroke sensor 2*, and master cylinder pressure.	H
STROKE SEN 1 OUTPUT VOLT (V)	Displays the stroke sensor 1* output voltage.	
STEERING ANGLE SENSOR (deg)	Displays the steering angle sensor signal sent via CAN communication from the ABS actuator and electric unit (control unit).	I
DECEL G SENSOR (G)	Displays the decel G sensor signal sent via CAN communication from the ABS actuator and electric unit (control unit).	J
SIDE G SENSOR (G)	Displays the side G sensor signal sent via CAN communication from the ABS actuator and electric unit (control unit).	K
YAW RATE SENSOR SIGNAL (G)	Displays the yaw rate sensor signal sent via CAN communication from the ABS actuator and electric unit (control unit).	
WHEEL SENSOR FRONT RH (rpm)	Displays the front RH wheel sensor signal sent via CAN communication from the ABS actuator and electric unit (control unit).	L
WHEEL SENSOR FRONT LH (rpm)	Displays the front LH wheel sensor signal sent via CAN communication from the ABS actuator and electric unit (control unit).	
WHEEL SENSOR REAR RH (rpm)	Displays the rear RH wheel sensor signal sent via CAN communication from the ABS actuator and electric unit (control unit).	M
WHEEL SENSOR REAR LH (rpm)	Displays the rear LH wheel sensor signal sent via CAN communication from the ABS actuator and electric unit (control unit).	N
VEHICLE SPEED (km/h)	Displays the vehicle speed signal sent via CAN communication from the ABS actuator and electric unit (control unit).	O
ACTUAL GEAR POSITION [1/2/3/4/5/6/7/8/R/(N/R)]	Displays the shift position signal sent via CAN communication from the TCM.	
BRAKE SWITCH (On/Off)	Stop lamp switch signal input status is displayed.	P
COMMAND WAKE UP SLEEP (sleep/wake-up)	Displays the wake up signal sent via CAN communication from the combination meter.	
DOOR SWITCH (BACK DOOR) (CLOSE/OPEN)	Displays the operating status of the door switch (trunk lid), sent via CAN communication from the BCM.	
DOOR SWITCH (REAR RH) (CLOSE/OPEN)	Displays the operating status of the door switch (rear RH), sent via CAN communication from the BCM.	

DIAGNOSIS SYSTEM (ELECTRICALLY-DRIVEN INTELLIGENT BRAKE UNIT)

< SYSTEM DESCRIPTION >

Item (Unit)	Note:
DOOR SWITCH (REAR LH) (CLOSE/OPEN)	Displays the operating status of the door switch (rear LH), sent via CAN communication from the BCM.
DOOR SWITCH (FRONT RH) (CLOSE/OPEN)	Displays the operating status of the door switch (front RH), sent via CAN communication from the BCM.
DOOR SWITCH (FRONT LH) (CLOSE/OPEN)	Displays the operating status of the door switch (front LH), sent via CAN communication from the BCM.
IGNITION SIGNAL (On/Off)	Displays the operating status of the ignition switch, sent via CAN communication from the BCM.
READY STATUS (On/Off)	Displays the READY status, sent via CAN communication from the HPCM.
BACKUP UNIT DIAG RESULT (NORMAL/ERR1/ERR2/ERR3/ERR4/ ERR5/ERR6/ERR7/ERR8/ERR9/ERR10/ ERR11/ERR12/ERR13/ERR14/ERR15)	Displays the diagnosis results for the brake power supply backup unit.
BACKUP UNIT MODE	Displays the operating status of the brake power supply backup unit.
BACKUP UNIT CHAGE STATUS (CHRG1/CHRG2/FULL)	Displays the charge status of the brake power supply backup unit.

*: The stroke sensor is composed of two circuits: stroke sensor 1 and stroke sensor 2.

ACTIVE TEST

The active test is used to determine and identify details of a malfunction, based on self-diagnosis test results and data obtained in the DATA MONITOR. In response to instructions from CONSULT, instead of those from electrically-driven intelligent brake unit on the vehicle, a drive signal is sent to the actuator to check its operation.

CAUTION:

- Never perform ACTIVE TEST while driving the vehicle.
- Always bleed air from brake system before active test.
- Never perform active test when system is malfunctioning.

NOTE:

- When active test is performed while depressing the pedal, the pedal depressing stroke may change. This is not a malfunction.
- Brake warning lamp (red) and brake system warning lamp (yellow) turn ON during active test. This is not a malfunction.

Stop Lamp OFF Relay

When "On" or "Off" is selected on display screen, the following items are displayed when system is normal.

Test item	Display item	Display	
		On	Off
STOP LAMP OFF RELAY	STOP LAMP OFF RELAY	On	Off

WORK SUPPORT

Item	Description
STROKE SENSOR 0 POINT LEARNING	Perform stroke sensor learning.

ELECTRICALLY-DRIVEN INTELLIGENT BRAKE UNIT

< ECU DIAGNOSIS INFORMATION >

ECU DIAGNOSIS INFORMATION

ELECTRICALLY-DRIVEN INTELLIGENT BRAKE UNIT

Reference Value

INFOID:000000008139796

CONSULT DATA MONITOR STANDARD VALUE

Monitor item	Condition	Reference values in normal operation
MASTER CYL PRESSURE	Gradually depress the brake pedal	Resistance value increases between 0.5 – 4.5 V according to the depth of brake depression.
MASTER CYL PRES (VDC)	Gradually depress the brake pedal	Resistance value increases between 0 – 25.6 MPa according to the depth of brake depression.
MOTOR TEMPERATURE	Always	115 °C (239°F) or less
CONTROL MODULE TEMP	Always	150 °C (302°F) or less
MST CYL PRES POWER VOLT	Always	5.00 – 5.22 V
STROKE SEN 1 POWER VOLT	Always	5.00 – 5.22 V
MOTOR POWER SUPPLY	Always	4.28 – 28.0 V
CONTROL MODULE POWER	Always	11.7 – 16.2 V
STROKE SEN 1 LEARN VALUE* ¹	Always	43.32 – 64.76 deg
STROKE SEN 2 LEARN VALUE* ¹	Always	43.32 – 64.76 deg
ALL SENSOR LEARNING* ²	Learning not completed	INCOMP
	Learning completed	COMP
STROKE SEN 1 OUTPUT VOLT* ¹	Gradually depress the brake pedal	Resistance value increases between 0.51 – 4.59 V according to the depth of brake depression.
STEERING ANGLE SENSOR	When driving straight	0±3.5°
	When steering wheel is steered to LH by 90°	Approx. -90°
	When steering wheel is steered to RH by 90°	Approx. +90°
DECEL G SENSOR	Vehicle stopped	Approx. 0 G
	During acceleration	Positive value
	During deceleration	Negative value
SIDE G SENSOR	Vehicle stopped	Approx. 0 m/s ²
	Right turn	Negative value
	Left turn	Positive value
YAW RATE SENSOR SIGNAL	Vehicle stopped	Approx. 0 d/s
	Right turn	Negative value
	Left turn	Positive value
WHEEL SENSOR FRONT RH	Vehicle stopped	0.00 km/h
	Driving* ³	Almost same reading as speedometer (within ±10%)
WHEEL SENSOR FRONT LH	Vehicle stopped	0.00 km/h
	Driving* ³	Almost same reading as speedometer (within ±10%)

ELECTRICALLY-DRIVEN INTELLIGENT BRAKE UNIT

< ECU DIAGNOSIS INFORMATION >

Monitor item	Condition	Reference values in normal operation
WHEEL SENSOR REAR RH	Vehicle stopped	0.00 km/h
	Driving* ³	Almost same reading as speedometer (within ±10%)
WHEEL SENSOR REAR LH	Vehicle stopped	0.00 km/h
	Driving* ³	Almost same reading as speedometer (within ±10%)
VEHICLE SPEED	Vehicle stopped	0.00 km/h
	Driving* ³	Almost same reading as speedometer (within ±10%)
ACTUAL GEAR POSITION	Driving with 1GR	1
	Driving with 2GR	2
	Driving with 3GR	3
	Driving with 4GR	4
	Driving with 5GR	5
	Driving with 6GR	6
	Driving with 7GR	7
	R position	R
	N or P position	N/P
BRAKE SWITCH	Brake pedal is depressed.	On
	Brake pedal is not depressed.	OFF
COMMAND WAKE UP SLEEP	When command is not input from BCM	SLEEP
	When command is input from BCM	WAKEUP
DOOR SWITCH (BACK DOOR)	Trunk lid closed	CLOSE
	Trunk lid open	OPEN
DOOR SWITCH (REAR RH)	Rear RH door closed	CLOSE
	Rear RH door open	OPEN
DOOR SWITCH (REAR LH)	Rear LH door closed	CLOSE
	Rear LH door open	OPEN
DOOR SWITCH (FRONT RH)	Front RH door closed	CLOSE
	Front RH door open	OPEN
DOOR SWITCH (FRONT LH)	Front LH door closed	CLOSE
	Front LH door open	OPEN
IGNITION SIGNAL	Ignition switch ON	ON
	Ignition switch other than ON	OFF
READY STATUS	READY status	On
	Other than READY status	Off

ELECTRICALLY-DRIVEN INTELLIGENT BRAKE UNIT

< ECU DIAGNOSIS INFORMATION >

Monitor item	Condition	Reference values in normal operation	
BACKUP UNIT DIAG RESULT	Normal	NOMAL	A
	Overvoltage	ERR1	
	Communications malfunction	ERR2	B
	Charging circuit malfunction	ERR3	
	Discharge circuit open	ERR4	
	Discharge circuit shorted	ERR5	C
	Cell malfunction	ERR6	
	Backup power circuit malfunction	ERR7	
	Start signal malfunction	ERR8	D
	The control part is in abnormal condition	ERR9	
	Monitor circuit malfunction	ERR10	E
	Insulation malfunction	ERR11	
	Output circuit malfunction (other than discharge circuit)	ERR12	BR
	Temperature detection circuit malfunction	ERR13	
	Deteriorated	ERR14	
Outside the reference voltage	ERR15		
BACKUP UNIT MODE	Backup power supply mode is active	On	H
	Backup power supply mode is not activated	Off	
BACKUP UNIT CHAGE STATUS	80% or less (backup power supply not possible)	CHRG1	I
	80 -- 99%(backup power supply possible)	CHRG2	J
	100% (backup power supply possible)	FULL	

*1: The stroke sensor contains two circuits: stroke sensor 1 and stroke sensor 2.

*2: Learning for stroke sensor 1, stroke sensor 2, and master cylinder fluid pressure

*3: Check tire pressure under normal conditions.

Fail-Safe

INFOID:000000008139797

- When there is a malfunction in the power system of the electrically-driven intelligent brake unit (no voltage is generated), voltage is temporarily supplied to the electrically-driven intelligent brake unit from the brake power supply backup unit. At the same time, the brake warning lamp (red) and brake system warning lamp (yellow) turn ON and the buzzer sounds.
- When a malfunction occurs in the electrically-driven intelligent brake unit, the VDC function performs control (boost operation).
- When a malfunction occurs in the DC/DC-J/B and 12V battery, the braking force is determined by the force pressing on the brake pedal (no boost operation). At the same time, brake warning lamp (red) and the brake system warning lamp (yellow) turns ON.
- When a malfunction occurs in the electrically-driven intelligent brake and in the VDC function, the braking force is determined by the force pressing on the brake pedal (no boost operation). At the same time, the brake warning lamp (red) and brake system warning lamp (yellow) turn ON.
- When a malfunction occurs in the brake power supply backup unit, the brake system warning lamp (yellow) turns ON.
- When a malfunction occurs in the electrically-driven intelligent brake, VDC function, and power system, cooperative regenerative brake control, hill start assist function, Rise-up & Build-up function, Active Trace Control function and Brake force distribution function [function of the ABS actuator and electric unit (control unit)] are not performed.
- Brake warning lamp (red) and brake system warning lamp (yellow) in combination meter turn ON when a malfunction occurs in system (electrically-driven intelligent brake unit). The control is suspended for cooper-

ELECTRICALLY-DRIVEN INTELLIGENT BRAKE UNIT

< ECU DIAGNOSIS INFORMATION >

ative regenerative brake control, hill start assist function, Rise-up & Build-up function, Active Trace Control function and Brake force distribution function [function of the ABS actuator and electric unit (control unit)]. The vehicle status becomes the same as models without cooperative regenerative brake control, hill start assist function, Rise-up & Build-up function, Active Trace Control function and Brake force distribution function [function of the ABS actuator and electric unit (control unit)].

- IBA indicator lamp in combination meter turn ON when a malfunction occurs in system (ADAS control unit). The control is suspended for Active Trace Control function and Brake force distribution function [function of the ABS actuator and electric unit (control unit)]. The vehicle status becomes the same as models without Active Trace Control function and Brake force distribution function [function of the ABS actuator and electric unit (control unit)].

CAUTION:

Lamp ON condition of IBA OFF indicator lamp is that IBA OFF switch is in the pressed and not turned ON status.

- Mode is fixed to the mode when a malfunction occurs if CAN communication malfunction (DTC “U1000”, DTC “U1010”, DTC “U0424”) occurs between ADAS control unit and A/C auto AMP. The mode is fixed to STANDARD mode after ignition switch turns OFF to ON.

DTC	Vehicle condition
C1A60	The following functions are suspended.
C1A61	<ul style="list-style-type: none"> • Boost operation by the electrically-driven intelligent brake • Cooperative regenerative brake control
C1A62	<ul style="list-style-type: none"> • Power supply from the brake power supply backup unit • hill start assist function • Rise-up & Build-up function • Active Trace Control function • Brake force distribution function [function of the ABS actuator and electric unit (control unit)]
C1A63	<p>The following functions are suspended.</p> <ul style="list-style-type: none"> • Power supply from the brake power supply backup unit • Rise-up & Build-up function
C1A64	The following functions are suspended.
C1A65	<ul style="list-style-type: none"> • Boost operation by the electrically-driven intelligent brake • Cooperative regenerative brake control • Power supply from the brake power supply backup unit • hill start assist function • Rise-up & Build-up function • Active Trace Control function • Brake force distribution function [function of the ABS actuator and electric unit (control unit)]
C1A66	<p>The following functions are suspended.</p> <ul style="list-style-type: none"> • Cooperative regenerative brake control • hill start assist function • Rise-up & Build-up function • Active Trace Control function • Brake force distribution function [function of the ABS actuator and electric unit (control unit)]
C1A67	The following functions are suspended.
C1A68*1	<ul style="list-style-type: none"> • Rise-up & Build-up function
C1A69	The following functions are suspended.
C1A6A	<ul style="list-style-type: none"> • Boost operation by the electrically-driven intelligent brake • Cooperative regenerative brake control • Power supply from the brake power supply backup unit • hill start assist function • Rise-up & Build-up function • Active Trace Control function • Brake force distribution function [function of the ABS actuator and electric unit (control unit)]
C1A6B	The following functions are suspended.
C1A6C	<ul style="list-style-type: none"> • Backup power supply from the brake power supply backup unit
C1A6D	<ul style="list-style-type: none"> • Rise-up & Build-up function
C1A6E	<p>The following functions are suspended.</p> <ul style="list-style-type: none"> • Cooperative regenerative brake control • hill start assist function

ELECTRICALLY-DRIVEN INTELLIGENT BRAKE UNIT

< ECU DIAGNOSIS INFORMATION >

DTC	Vehicle condition	
C1A6F	The following functions are suspended. • hill start assist function	A
C1A70	The following functions are suspended. • Cooperative regenerative brake control • hill start assist function • Rise-up & Build-up function • Active Trace Control function • Brake force distribution function [function of the ABS actuator and electric unit (control unit)]	B C
C1A71	Normal control	
C1A74	The following functions are suspended. • Cooperative regenerative brake control	D
U1000	The following functions are suspended. • Cooperative regenerative brake control	E
U1010	• hill start assist function • Rise-up & Build-up function • Active Trace Control function • Brake force distribution function [function of the ABS actuator and electric unit (control unit)]	
U0424*2	Mode is fixed to the mode when a malfunction of drive mode selector occurs. The mode is fixed to STANDARD mode after ignition switch turns OFF to ON.	BR
U1510	The following functions are suspended.	G
U1511	• Rise-up & Build-up function	

*1: Models with ICC

*2: This is DTC that is detected in ADAS control unit side.

DTC Inspection Priority Chart

INFOID:000000008139798

When multiple DTCs are displayed simultaneously, check them one by one according to the following priority list.

Priority	Detected item (DTC)	
1	<ul style="list-style-type: none"> • U1000 CAN COMM CIRCUIT • U1010 CONTROL UNIT (CAN) • U0424 HVAC CAN CIR 1*1 • U1510 BRAKE CONTROL COMMUNICATION • U1511 POWER SUPPLY BACKUP UNIT COMM 	K
2	<ul style="list-style-type: none"> • C1A60 CONTROL MODULE • C1A6B POWER SUPPLY BACKUP UNIT 	L
3	<ul style="list-style-type: none"> • C1A6E EV/HEV SYSTEM • C1A6F TCM/VCM SYSTEM • C1A70 BRAKE CONTROL SYSTEM • C1A71 INTEGRATED CONTROL SYSTEM • C1A74 ST ANG SEN CIRCUIT 	M
4	<ul style="list-style-type: none"> • C1A61 MOTOR POWER SUPPLY • C1A62 CONTROL MODULE POWER SUPPLY • C1A63 BACKUP POWER SUPPLY • C1A6C POWER SUPPLY BACKUP UNIT VOLT 	N
5	<ul style="list-style-type: none"> • C1A64 STROKE SENSOR • C1A65 STROKE SENSOR SET • C1A66 MASTER PRESSURE SENSOR • C1A67 STOP LAMP SWITCH • C1A68 STOP LAMP RELAY*2 • C1A69 MOTOR • C1A6A CONTROL MODULE TEMPERATURE • C1A6D POWERSUPPLY BACKUP UNIT OUTPUT 	O P

*1: This is DTC that is detected in ADAS control unit side.

*2: Models with ICC

ELECTRICALLY-DRIVEN INTELLIGENT BRAKE UNIT

< ECU DIAGNOSIS INFORMATION >

DTC Index

INFOID:000000008139799

DTC	Display item	Refer to
C1A60	CONTROL MODULE	BR-50, "DTC Logic"
C1A61	MOTOR POWER SUPPLY	BR-58, "DTC Logic"
C1A62	CONTROL MODULE POWER SUPPLY	BR-66, "DTC Logic"
C1A63	BACKUP POWER SUPPLY	BR-75, "DTC Logic"
C1A64	STROKE SENSOR	BR-84, "DTC Logic"
C1A65	STROKE SENSOR SET	BR-96, "DTC Logic"
C1A66	MASTER PRESSURE SENSOR	BR-108, "DTC Logic"
C1A67	STOP LAMP SWITCH	BR-119, "DTC Logic"
C1A68 ^{*1}	STOP LAMP RELAY	BR-132, "DTC Logic"
C1A69	MOTOR	BR-143, "DTC Logic"
C1A6A	CONTROL MODULE TEMPERRATURE	BR-152, "DTC Logic"
C1A6B	POWER SUPPLY BACKUP UNIT	BR-161, "DTC Logic"
C1A6C	POWER SUPPLY BACKUP UNIT VOLT	BR-172, "DTC Logic"
C1A6D	POWERSUPPLY BACKUP UNIT OUTPUT	BR-180, "DTC Logic"
C1A6E	EV/HEV SYSTEM	BR-188, "DTC Logic"
C1A6F	TCM/VCM SYSTEM	BR-196, "DTC Logic"
C1A70	BRAKE CONTROL SYSTEM	BR-204, "DTC Logic"
C1A71	INTEGRATED CONTROL SYSTEM	BR-212, "DTC Logic"
C1A74	ST ANG SEN CIRCUIT	BR-220, "DTC Logic"
U1000	CAN COMM CIRCUIT	BR-228, "DTC Logic"
U1010	CONTROL UNIT (CAN)	BR-230, "DTC Logic"
U0424 ^{*2}	HVAC CAN CIR 1	BR-232, "DTC Logic"
U1510	BRAKE CONTROL COMMUNICATION	BR-233, "DTC Logic"
U1511	POWER SUPPLY BACKUP UNIT COMM	BR-241, "DTC Logic"

*1: Models with ICC

*2: This is DTC that is detected in ADAS control unit side.

ADAS CONTROL UNIT

< ECU DIAGNOSIS INFORMATION >

ADAS CONTROL UNIT

List of ECU Reference

INFOID:000000008139800

ECU name	Refer to
ADAS control unit	DAS-34. "Reference Value"
	DAS-39. "Fail-safe"
	DAS-40. "DTC Inspection Priority Chart"
	DAS-42. "DTC Index"

ACTIVE TRACE CONTROL FUNCTION

Intelligent brake assist OFF indicator lamp turns ON when a malfunction occurs in system [ABS actuator and electric unit (control unit)]. The control is suspended for Active Trace Control function. The vehicle becomes the same as models without Active Trace Control function. Refer to [DAS-15. "System Description"](#) for ON/OFF conditions of each warning lamp and indicator lamp.

CAUTION:

Lamp ON condition of intelligent brake assist OFF indicator lamp is that intelligent brake assist OFF switch is in the pressed and not turned ON status.

A
B
C
D
E
BR
G
H
I
J
K
L
M
N
O
P

BRAKE SYSTEM

< WIRING DIAGRAM >

WIRING DIAGRAM

BRAKE SYSTEM

Wiring Diagram

INFOID:000000008139801

For connector terminal arrangements, harness layouts, and alphabets in a  (option abbreviation; if not described in wiring diagram), refer to [GI-13, "Connector Information"](#).

BRAKE SYSTEM

< WIRING DIAGRAM >

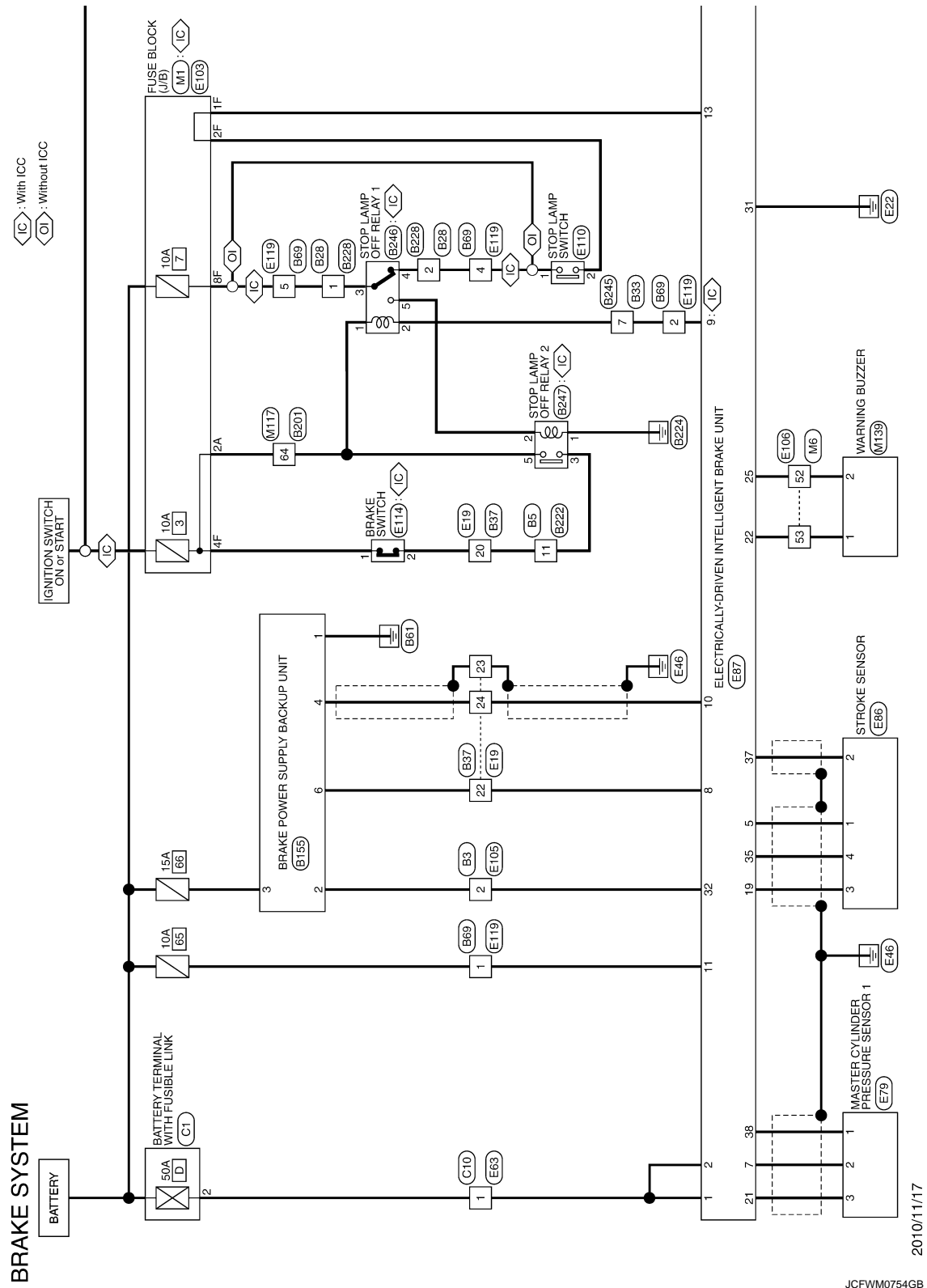

A
B
C
D
E
BR

G
H
I
J
K
L
M
N
O
P

BRAKE SYSTEM

< WIRING DIAGRAM >

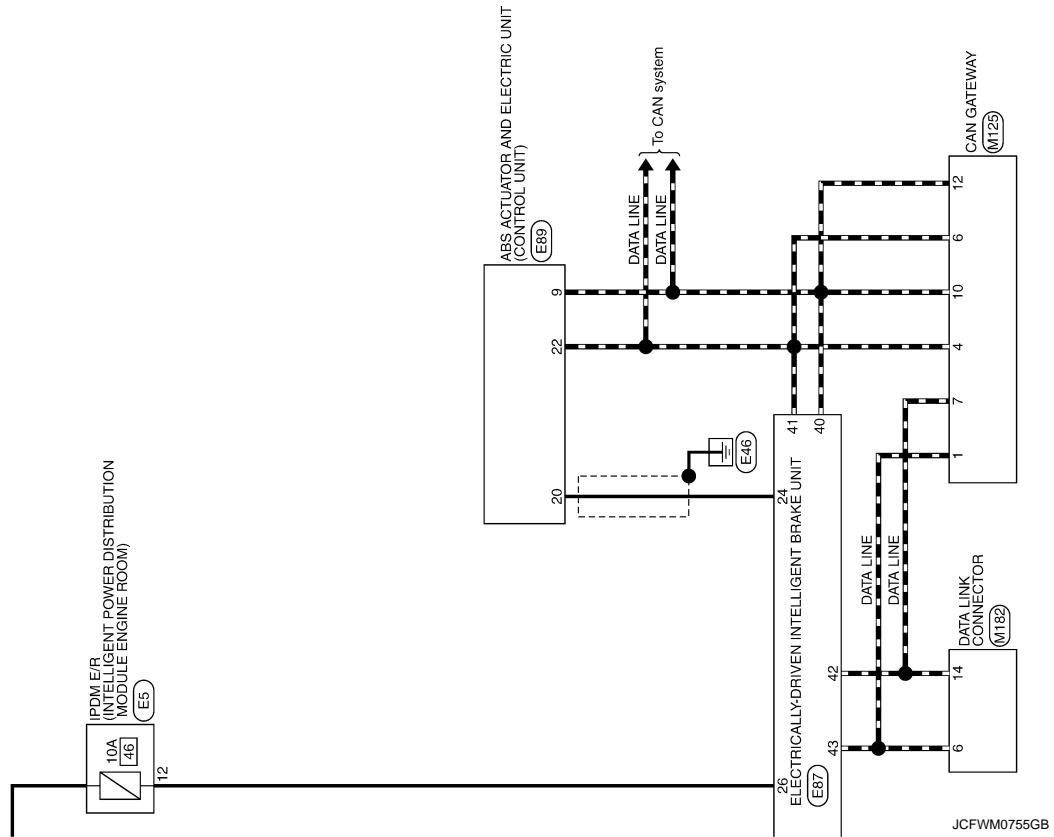

DIAGNOSIS AND REPAIR WORK FLOW

< BASIC INSPECTION >

BASIC INSPECTION

DIAGNOSIS AND REPAIR WORK FLOW

Work Flow

INFOID:000000008139802

DETAILS OF TROUBLE DIAGNOSIS FLOWCHART

1. COLLECT THE INFORMATION FROM THE CUSTOMER

It is also important to clarify customer concerns before starting the inspection. First of all, perform an interview utilizing [BR-44, "Diagnostic Work Sheet"](#) and reproduce the symptom as well as fully understand it. Depending on the situations, drive the vehicle with the customer and check the symptom.

CAUTION:

Customers are not professional. Never guess easily like "maybe the customer means that..." or "maybe the customer mentions this symptom".

>> GO TO 2.

2. CHECK SYMPTOM

Reproduce the symptom that is indicated by the customer, based on the information from the customer obtained by the interview. Also check that the symptom is not caused by fail-safe mode. Refer to [BR-35, "Fail-Safe"](#).

CAUTION:

When the symptom is caused by normal operation, fully inspect each portion and obtain the understanding of customer that the symptom is not caused by a malfunction.

>> GO TO 3.

3. PERFORM SELF-DIAGNOSIS (1)

 With CONSULT
Perform self-diagnosis.

Is DTC detected?

- YES >> Record or print self-diagnosis results and freeze frame data (FFD). GO TO 4.
- NO >> GO TO 7.

4. PERFORM SELF-DIAGNOSIS (2)

 With CONSULT

1. Turn the ignition switch OFF to ON without depressing the brake pedal.
CAUTION:
Never set the vehicle to READY/Never start the engine.
2. Repeat step 1 two times or more.
CAUTION:
Be sure to wait for 5 seconds or more after turning the ignition switch OFF.
3. Turn the ignition switch OFF to exit CONSULT.
4. Get out of the vehicle, close all doors (including trunk lid), and wait for 3 minutes or more without opening these doors.
CAUTION:
Never operate the vehicle and CONSULT while waiting.
5. Turn the ignition switch ON without depressing the brake pedal.
CAUTION:
Never set the vehicle to READY/Never start the engine.
6. Start CONSULT and erase self-diagnosis result of "BRAKE".
7. Turn the ignition switch OFF to exit CONSULT.
8. Get out of the vehicle, close all doors (including trunk lid), and wait for 3 minutes or more without opening these doors.
CAUTION:
Never operate the vehicle and CONSULT while waiting.
9. Turn the ignition switch ON without depressing the brake pedal.
CAUTION:

DIAGNOSIS AND REPAIR WORK FLOW

< BASIC INSPECTION >

Never set the vehicle to READY/Never start the engine.

10. Depress brake pedal by 100 mm (3.94 in) or more, and hold the position for 5 seconds or more.
11. Release brake pedal.
12. Start CONSULT and perform "BRAKE" self-diagnosis.
13. Perform "ADAS" self-diagnosis. (Models with ICC)

Is DTC detected?

- YES >> Record or print self-diagnosis results. GO TO 5.
NO >> GO TO 7.

5.RECHECK THE SYMPTOM

ⓂWith CONSULT

1. Erase self-diagnosis results from the memory.

CAUTION:

After erase self-diagnosis result, turn the ignition switch OFF, to exit CONSULT. Get out of the vehicle, close all doors (including trunk lid), and wait for 3 minutes or more without opening these doors. Never operate the vehicle and CONSULT while waiting.

2. Perform DTC reproduction procedures for the system that is malfunctioning.

NOTE:

When multiple DTCs are detected, refer to [BR-37. "DTC Inspection Priority Chart"](#) and then determine the order for performing the diagnosis.

Is DTC detected?

- YES >> GO TO 6.
NO >> Check harness and connectors based on the information obtained by the interview. Refer to [GI-49. "Intermittent Incident"](#).

6.REPAIR OR REPLACE ERROR-DETECTED PARTS

Repair or replace the part that is malfunctioning. Reconnect part or connector after repairing or replacing. Erase DTC from the memory when DTC is detected.

CAUTION:

After erase self-diagnosis result, turn the ignition switch OFF, to exit CONSULT. Get out of the vehicle, close all doors (including trunk lid), and wait for 3 minutes or more without opening these doors. Never operate the vehicle and CONSULT while waiting.

>> GO TO 7.

7.IDENTIFY MALFUNCTIONING SYSTEM BY SYMPTOM DIAGNOSIS

Estimate which system is malfunctioning according to the possible symptoms based on symptom diagnosis and perform check.

Can the malfunctioning part be identified?

- YES >> GO TO 8.
NO >> Check harness and connectors based on the information obtained by the interview. Refer to [GI-49. "Intermittent Incident"](#).

8.FINAL CHECK

ⓂWith CONSULT

1. Check the reference value for "BRAKE". Refer to [BR-33. "Reference Value"](#).
2. Perform the operation check. Check that the symptom is not reproduced under the same conditions as when the symptom is reproduced before.

Is the symptom reproduced?

- YES >> GO TO 3.
NO >> INSPECTION END

Diagnostic Work Sheet

INFOID:000000008139803

Description

- In general, customers have their own criteria for a symptom. Therefore, it is important to understand the symptom and status well enough by interviewing the customer about the symptom carefully. To systemize all the information for the diagnosis, prepare the interview sheet referring to the interview points.

ADDITIONAL SERVICE WHEN REPLACING ELECTRICALLY-DRIVEN INTELLIGENT BRAKE UNIT

< BASIC INSPECTION >

ADDITIONAL SERVICE WHEN REPLACING ELECTRICALLY-DRIVEN INTELLIGENT BRAKE UNIT

Description

INFOID:000000008139804

When the electrically-driven intelligent brake unit was replaced, perform stroke sensor 0 point learning. [BR-47](#), "[Work Procedure](#)".

STROKE SENSOR 0 POINT LEARNING

< BASIC INSPECTION >

STROKE SENSOR 0 POINT LEARNING

Description

INFOID:000000008139805

CAUTION:

Always perform stroke sensor 0 point learning before driving after any of the following operations is performed.

x: Necessary, -: Not necessary

Procedure	Stroke sensor 0 point learning
Electrically-driven intelligent brake unit is removed.	x
Electrically-driven intelligent brake unit is replaced.	x
Stroke sensor is removed.	x
Stroke sensor is replaced.	x
Brake pedal is removed.	x
Brake pedal is replaced.	x
Brake pedal heights are adjusted.	x

Work Procedure

INFOID:000000008139806

CAUTION:

Make sure to use CONSULT when performing stroke sensor 0 point learning. (It cannot be performed by any means other than CONSULT.)

1. VEHICLE CONDITION

1. Stop the vehicle.
2. Turn the ignition switch OFF to exit CONSULT.

>> GO TO 2.

2. CHECK 12V BATTERY

Check the 12V battery. Refer to [PG-135, "Work Flow"](#).

Is the inspection result normal?

YES >> GO TO 3.

NO >> Charge or replace the 12V battery. Refer to [PG-135, "How to Handle 12V Battery"](#) or [PG-141, "Removal and Installation"](#). GO TO 3.

3. CHECKING INSTALLATION CONDITIONS OF BRAKE COMPONENTS

Check the installation conditions of brake components.

Is the inspection result normal?

YES >> GO TO 4.

NO >> Repair or replace error-detected parts and GO TO 4.

4. CHECK BRAKE PEDAL

Check each brake pedal height. Refer to [BR-270, "Inspection and Adjustment"](#).

Is the inspection result normal?

YES >> GO TO 5.

NO >> Adjust each brake pedal height. Refer to [BR-270, "Inspection and Adjustment"](#). GO TO 5.

5. PERFORM THE SELF-DIAGNOSIS

Ⓜ With CONSULT

1. Turn the ignition switch OFF to ON without depressing the brake pedal.

CAUTION:

Never set the vehicle to READY/ Never start the engine.

2. Repeat step 1 two times or more.

CAUTION:

Be sure to wait for 5 seconds or more after turning the ignition switch OFF.

STROKE SENSOR 0 POINT LEARNING

< BASIC INSPECTION >

3. Turn the ignition switch OFF to exit CONSULT.
4. Get out of the vehicle, close all doors (including trunk lid), and wait for 3 minutes or more without opening these doors.
CAUTION:
Never operate the vehicle and CONSULT while waiting.
5. Turn the ignition switch ON without depressing the brake pedal.
CAUTION:
Never set the vehicle to READY/Never start the engine.
6. Start CONSULT and erase self-diagnosis result of "BRAKE".
7. Turn the ignition switch OFF to exit CONSULT.
8. Get out of the vehicle, close all doors (including trunk lid), and wait for 3 minutes or more without opening these doors.
CAUTION:
Never operate the vehicle and CONSULT while waiting.
9. Turn the ignition switch ON without depressing the brake pedal.
CAUTION:
Never set the vehicle to READY/Never start the engine.
10. Depress brake pedal by 100 mm (3.94 in) or more, and hold the position for 5 seconds or more.
11. Release brake pedal.
12. Start CONSULT and perform "BRAKE" self-diagnosis.

Is a malfunction detected?

- YES >> Check the DTC. Refer to [BR-38. "DTC Index"](#). GO TO 6.
NO >> GO TO 6.

6. PERFORM PEDAL STROKE SENSOR 0 POINT LEARNING

Ⓟ With CONSULT

1. Turn the ignition switch OFF to exit CONSULT, and wait for 10 seconds or more.
2. Turn the ignition switch ON without depressing the brake pedal.
CAUTION:
Never set the vehicle to READY/Never start the engine.
3. Select "BRAKE", "WORK SUPPORT" and "STROKE SENSOR 0 POINT LEARNING" according to this order.
CAUTION:
Never depress brake pedal.
4. Touch "START".

Was either "COMPLETED" or "The operation is incomplete. Try again after confirming the operation condition." displayed?

- "COMPLETED">>Touch the "END". GO TO 7.
"The operation is incomplete. Try again after confirming the operation condition.">>GO TO 2.

7. CHECK DATA MONITOR

Ⓟ With CONSULT

Select "BRAKE", "DATA MONITOR" and "STROKE SEN 1 OUTPUT VOLT" according to this order. Check that this signal is within the specified value.

STROKE SEN 1 OUTPUT VOLT : 0.8 – 1.7 V

Is the inspection result normal?

- YES >> GO TO 8.
NO >> GO TO 1.

8. ERASE SELF-DIAGNOSIS MEMORY

Ⓟ With CONSULT

1. Turn the ignition switch OFF to exit CONSULT, and wait for 10 seconds or more.
CAUTION:
Be sure to perform the operation above.
2. Turn the ignition switch ON without depressing the brake pedal.
CAUTION:
Never set the vehicle to READY/Never start the engine.
3. Start CONSULT and erase self-diagnosis result of "BRAKE".

STROKE SENSOR 0 POINT LEARNING

< BASIC INSPECTION >

4. Turn the ignition switch OFF to exit CONSULT.
5. Get out of the vehicle, close all doors (including trunk lid), and wait for 3 minutes or more without opening these doors.

CAUTION:

Never operate the vehicle and CONSULT while waiting.

Are the memories erased?

YES >> INSPECTION END

NO >> Check the items indicated by the self-diagnosis.

A

B

C

D

E

BR

G

H

I

J

K

L

M

N

O

P

C1A60 CONTROL MODULE

< DTC/CIRCUIT DIAGNOSIS >

DTC/CIRCUIT DIAGNOSIS

C1A60 CONTROL MODULE

DTC Logic

INFOID:000000008139807

DTC DETECTION LOGIC

DTC	Display item	Malfunction detection condition	Possible causes
C1A60	CONTROL MODULE	A malfunction is detected control module that is integrated with the electrically-driven intelligent brake unit.	Electrically-driven intelligent brake unit

DTC CONFIRMATION PROCEDURE

1. PRECONDITIONING

If "DTC CONFIRMATION PROCEDURE" has been previously conducted, always turn the ignition switch OFF and wait at least 10 seconds before conducting the next test.

>> GO TO 2.

2. CHECK DTC DETECTION

 With CONSULT

- Turn the ignition switch OFF to ON without depressing the brake pedal.
CAUTION:
Never set the vehicle to READY/Never start the engine.
- Repeat step 1 two times or more.
CAUTION:
Be sure to wait for 5 seconds or more after turning the ignition switch OFF.
- Turn the ignition switch OFF to exit CONSULT.
- Get out of the vehicle, close all doors (including trunk lid), and wait for 3 minutes or more without opening these doors.
CAUTION:
Never operate the vehicle and CONSULT while waiting.
- Turn the ignition switch ON without depressing the brake pedal.
CAUTION:
Never set the vehicle to READY/Never start the engine.
- Start CONSULT and erase self-diagnosis result of "BRAKE".
- Turn the ignition switch OFF to exit CONSULT.
- Get out of the vehicle, close all doors (including trunk lid), and wait for 3 minutes or more without opening these doors.
CAUTION:
Never operate the vehicle and CONSULT while waiting.
- Turn the ignition switch ON without depressing the brake pedal.
CAUTION:
Never set the vehicle to READY/Never start the engine.
- Depress brake pedal by 100 mm (3.94 in) or more, and hold the position for 5 seconds or more.
- Release brake pedal.
- Start CONSULT and perform "BRAKE" self-diagnosis.

Is DTC "C1A60" detected?

- YES >> Proceed to [BR-50, "Diagnosis Procedure"](#).
NO >> INSPECTION END

Diagnosis Procedure

INFOID:000000008139808

1. CHECK 12V BATTERY

- Turn the ignition switch OFF to exit CONSULT.
- Get out of the vehicle, close all doors (including trunk lid), and wait for 3 minutes or more without opening these doors.

C1A60 CONTROL MODULE

< DTC/CIRCUIT DIAGNOSIS >

CAUTION:

Never operate the vehicle and CONSULT while waiting.

3. Check the 12V battery terminal connections. Refer to [BR-6, "Precaution for Removing 12V Battery"](#) and [PG-135, "Work Flow"](#).
4. Check the 12V battery. Refer to [PG-135, "Work Flow"](#).

Is the inspection result normal?

YES >> GO TO 2.

NO >> Repair or replace error-detected parts and GO TO 2.

2.PERFORM SELF-DIAGNOSIS (1)

Ⓜ With CONSULT

1. Connect 12V battery cable to negative terminal.
2. Turn the ignition switch OFF to ON without depressing the brake pedal.
CAUTION:
Never set the vehicle to READY/Never start the engine.
3. Repeat step 2 two times or more.
CAUTION:
Be sure to wait for 5 seconds or more after turning the ignition switch OFF.
4. Turn the ignition switch OFF to exit CONSULT.
5. Get out of the vehicle, close all doors (including trunk lid), and wait for 3 minutes or more without opening these doors.

CAUTION:

Never operate the vehicle and CONSULT while waiting.

6. Turn the ignition switch ON without depressing the brake pedal.
CAUTION:
Never set the vehicle to READY/Never start the engine.
7. Start CONSULT and erase self-diagnosis result of "BRAKE".
8. Turn the ignition switch OFF to exit CONSULT.
9. Get out of the vehicle, close all doors (including trunk lid), and wait for 3 minutes or more without opening these doors.

CAUTION:

Never operate the vehicle and CONSULT while waiting.

10. Turn the ignition switch ON without depressing the brake pedal.
CAUTION:
Never set the vehicle to READY/Never start the engine.
11. Depress brake pedal by 100 mm (3.94 in) or more, and hold the position for 5 seconds or more.
12. Release brake pedal.
13. Start CONSULT and perform "BRAKE" self-diagnosis.

Is DTC "C1A60" detected?

YES >> GO TO 3.

NO >> INSPECTION END

3.CHECK CONNECTOR TERMINALS

1. Turn the ignition switch OFF to exit CONSULT.
2. Get out of the vehicle, close all doors (including trunk lid), and wait for 3 minutes or more without opening these doors.
CAUTION:
Never operate the vehicle and CONSULT while waiting.
3. Disconnect 12V battery cable from negative terminal. Refer to [BR-6, "Precaution for Removing 12V Battery"](#).
4. Disconnect the electrically-driven intelligent brake unit harness connector, then check for failures of pin terminals and connections.

Is the inspection result normal?

YES >> GO TO 5.

NO >> Repair or replace error-detected parts and GO TO 4.

4.PERFORM SELF-DIAGNOSIS (2)

Ⓜ With CONSULT

1. Connect the electrically-driven intelligent brake unit harness connector.

C1A60 CONTROL MODULE

< DTC/CIRCUIT DIAGNOSIS >

2. Connect 12V battery cable to negative terminal.
3. Turn the ignition switch OFF to ON without depressing the brake pedal.
CAUTION:
Never set the vehicle to READY/Never start the engine.
4. Repeat step 3 two times or more.
CAUTION:
Be sure to wait for 5 seconds or more after turning the ignition switch OFF.
5. Turn the ignition switch OFF to exit CONSULT.
6. Get out of the vehicle, close all doors (including trunk lid), and wait for 3 minutes or more without opening these doors.
CAUTION:
Never operate the vehicle and CONSULT while waiting.
7. Turn the ignition switch ON without depressing the brake pedal.
CAUTION:
Never set the vehicle to READY/Never start the engine.
8. Start CONSULT and erase self-diagnosis result of "BRAKE".
9. Turn the ignition switch OFF to exit CONSULT.
10. Get out of the vehicle, close all doors (including trunk lid), and wait for 3 minutes or more without opening these doors.
CAUTION:
Never operate the vehicle and CONSULT while waiting.
11. Turn the ignition switch ON without depressing the brake pedal.
CAUTION:
Never set the vehicle to READY/Never start the engine.
12. Depress brake pedal by 100 mm (3.94 in) or more, and hold the position for 5 seconds or more.
13. Release brake pedal.
14. Start CONSULT and perform "BRAKE" self-diagnosis.

Is DTC "C1A60" detected?

- YES >> GO TO 5.
NO >> INSPECTION END

5.CHECK IGNITION POWER SUPPLY

1. Turn the ignition switch OFF to exit CONSULT.
2. Get out of the vehicle, close all doors (including trunk lid), and wait for 3 minutes or more without opening these doors.
CAUTION:
Never operate the vehicle and CONSULT while waiting.
3. Disconnect 12V battery cable from negative terminal. Refer to [BR-6. "Precaution for Removing 12V Battery"](#).
4. Disconnect the electrically-driven intelligent brake unit harness connector.
5. Connect 12V battery cable to negative terminal.
6. Check voltage between the electrically-driven intelligent brake unit harness connector and ground.

Electrically-driven intelligent brake unit		—	Voltage
Connector	Terminal		
E87	26	Ground	Approx. 0 V

7. Turn the ignition switch ON without depressing the brake pedal.
CAUTION:
Never set the vehicle to READY/Never start the engine.
8. Check voltage between the electrically-driven intelligent brake unit harness connector and ground.

Electrically-driven intelligent brake unit		—	Voltage
Connector	Terminal		
E87	26	Ground	10 – 16 V

Is the inspection result normal?

- YES >> GO TO 8.
NO >> GO TO 6.

C1A60 CONTROL MODULE

< DTC/CIRCUIT DIAGNOSIS >

6. CHECK IGNITION POWER SUPPLY CIRCUIT

1. Turn the ignition switch OFF to exit CONSULT.
2. Get out of the vehicle, close all doors (including trunk lid), and wait for 3 minutes or more without opening these doors.
CAUTION:
Never operate the vehicle and CONSULT while waiting.
3. Disconnect 12V battery cable from negative terminal. Refer to [BR-6, "Precaution for Removing 12V Battery"](#).
4. Check 10A fuse (#46).
5. Disconnect IPDM E/R harness connector.
6. Check continuity between electrically-driven intelligent brake unit and IPDM E/R.

Electrically-driven intelligent brake unit		IPDM E/R		Continuity
Connector	Terminal	Connector	Terminal	
E87	26	E5	12	Existed

7. Check continuity between electrically-driven intelligent brake unit harness connector and ground.

Electrically-driven intelligent brake unit		—	Continuity
Connector	Terminal		
E87	26	Ground	Not existed

Is the inspection result normal?

- YES >> Perform trouble diagnosis for ignition power supply. Refer to [PG-30, "Wiring Diagram - IGNITION POWER SUPPLY -"](#).
- NO >> Repair or replace error-detected parts and GO TO 7.

7. PERFORM SELF-DIAGNOSIS (3)

Ⓜ With CONSULT

1. Connect the electrically-driven intelligent brake unit harness connector.
2. Connect IPDM E/R harness connector.
3. Connect 12V battery cable to negative terminal.
4. Turn the ignition switch OFF to ON without depressing the brake pedal.
CAUTION:
Never set the vehicle to READY/Never start the engine.
5. Repeat step 4 two times or more.
CAUTION:
Be sure to wait for 5 seconds or more after turning the ignition switch OFF.
6. Turn the ignition switch OFF to exit CONSULT.
7. Get out of the vehicle, close all doors (including trunk lid), and wait for 3 minutes or more without opening these doors.
CAUTION:
Never operate the vehicle and CONSULT while waiting.
8. Turn the ignition switch ON without depressing the brake pedal.
CAUTION:
Never set the vehicle to READY/Never start the engine.
9. Start CONSULT and erase self-diagnosis result of "BRAKE".
10. Turn the ignition switch OFF to exit CONSULT.
11. Get out of the vehicle, close all doors (including trunk lid), and wait for 3 minutes or more without opening these doors.
CAUTION:
Never operate the vehicle and CONSULT while waiting.
12. Turn the ignition switch ON without depressing the brake pedal.
CAUTION:
Never set the vehicle to READY/Never start the engine.
13. Depress brake pedal by 100 mm (3.94 in) or more, and hold the position for 5 seconds or more.
14. Release brake pedal.
15. Start CONSULT and perform "BRAKE" self-diagnosis.

C1A60 CONTROL MODULE

< DTC/CIRCUIT DIAGNOSIS >

Is DTC "C1A60" detected?

- YES >> GO TO 8.
NO >> INSPECTION END

8. CHECK 12V BATTERY POWER SUPPLY

1. Turn the ignition switch OFF to exit CONSULT.
2. Get out of the vehicle, close all doors (including trunk lid), and wait for 3 minutes or more without opening these doors.
CAUTION:
Never operate the vehicle and CONSULT while waiting.
3. Disconnect 12V battery cable from negative terminal. Refer to [BR-6. "Precaution for Removing 12V Battery"](#).
4. Disconnect the electrically-driven intelligent brake unit harness connector.
5. Connect 12V battery cable to negative terminal.
6. Check voltage between the electrically-driven intelligent brake unit harness connector terminals.

Electrically-driven intelligent brake unit		Voltage
Connector	Terminal	
E87	1 - 31	10 - 16 V
	2 - 31	
	11 - 31	

7. Turn the ignition switch ON without depressing the brake pedal.
CAUTION:
Never set the vehicle to READY/Never start the engine.
8. Check voltage between the electrically-driven intelligent brake unit harness connector terminals.

Electrically-driven intelligent brake unit		Voltage
Connector	Terminal	
E87	1 - 31	10 - 16 V
	2 - 31	
	11 - 31	

Is the inspection result normal?

- YES >> GO TO 11.
NO >> GO TO 9.

9. CHECK 12V BATTERY POWER SUPPLY CIRCUIT

1. Turn the ignition switch OFF to exit CONSULT.
2. Get out of the vehicle, close all doors (including trunk lid), and wait for 3 minutes or more without opening these doors.
CAUTION:
Never operate the vehicle and CONSULT while waiting.
3. Disconnect 12V battery cable from negative terminal. Refer to [BR-6. "Precaution for Removing 12V Battery"](#).
4. Check 50A fusible link (#D).
5. Check continuity and for short circuit between electrically-driven intelligent brake unit harness connector terminal (1) and 50A fusible link (#D).
6. Check continuity and for short circuit between electrically-driven intelligent brake unit harness connector terminal (2) and 50A fusible link (#D).
7. Check 10A fuse (#65).
8. Check continuity and for short circuit between electrically-driven intelligent brake unit harness connector terminal (11) and 10A fuse (#65).

Is the inspection result normal?

- YES >> Perform diagnosis for 12V battery power supply. Refer to [PG-14. "Wiring Diagram - BATTERY POWER SUPPLY -"](#).
NO >> Repair or replace error-detected parts and GO TO 10.

C1A60 CONTROL MODULE

< DTC/CIRCUIT DIAGNOSIS >

10. PERFORM SELF-DIAGNOSIS (4)

Ⓜ With CONSULT

1. Connect the electrically-driven intelligent brake unit harness connector.
2. Connect 12V battery cable to negative terminal.
3. Turn the ignition switch OFF to ON without depressing the brake pedal.
CAUTION:
Never set the vehicle to READY/Never start the engine.
4. Repeat step 3 two times or more.
CAUTION:
Be sure to wait for 5 seconds or more after turning the ignition switch OFF.
5. Turn the ignition switch OFF to exit CONSULT.
6. Get out of the vehicle, close all doors (including trunk lid), and wait for 3 minutes or more without opening these doors.
CAUTION:
Never operate the vehicle and CONSULT while waiting.
7. Turn the ignition switch ON without depressing the brake pedal.
CAUTION:
Never set the vehicle to READY/Never start the engine.
8. Start CONSULT and erase self-diagnosis result of "BRAKE".
9. Turn the ignition switch OFF to exit CONSULT.
10. Get out of the vehicle, close all doors (including trunk lid), and wait for 3 minutes or more without opening these doors.
CAUTION:
Never operate the vehicle and CONSULT while waiting.
11. Turn the ignition switch ON without depressing the brake pedal.
CAUTION:
Never set the vehicle to READY/Never start the engine.
12. Depress brake pedal by 100 mm (3.94 in) or more, and hold the position for 5 seconds or more.
13. Release brake pedal.
14. Start CONSULT and perform "BRAKE" self-diagnosis.

Is DTC "C1A60" detected?

YES >> GO TO 11.

NO >> INSPECTION END

11. CHECK GROUND CIRCUIT

1. Turn the ignition switch OFF to exit CONSULT.
2. Get out of the vehicle, close all doors (including trunk lid), and wait for 3 minutes or more without opening these doors.
CAUTION:
Never operate the vehicle and CONSULT while waiting.
3. Disconnect 12V battery cable from negative terminal. Refer to [BR-6. "Precaution for Removing 12V Battery"](#).
4. Disconnect the electrically-driven intelligent brake unit harness connector.
5. Check continuity between electrically-driven intelligent brake unit and ground.

Electrically-driven intelligent brake unit		—	Continuity
Connector	Terminal		
E87	31	Ground	Existed

Is the inspection result normal?

YES >> GO TO 13.

NO >> Repair or replace error-detected parts and GO TO 12.

12. PERFORM SELF-DIAGNOSIS (5)

Ⓜ With CONSULT

1. Connect the electrically-driven intelligent brake unit harness connector.
2. Connect 12V battery cable to negative terminal.
3. Turn the ignition switch OFF to ON without depressing the brake pedal.

CAUTION:

C1A60 CONTROL MODULE

< DTC/CIRCUIT DIAGNOSIS >

Never set the vehicle to READY/Never start the engine.

4. Repeat step 3 two times or more.

CAUTION:

Be sure to wait for 5 seconds or more after turning the ignition switch OFF.

5. Turn the ignition switch OFF to exit CONSULT.
6. Get out of the vehicle, close all doors (including trunk lid), and wait for 3 minutes or more without opening these doors.

CAUTION:

Never operate the vehicle and CONSULT while waiting.

7. Turn the ignition switch ON without depressing the brake pedal.

CAUTION:

Never set the vehicle to READY/Never start the engine.

8. Start CONSULT and erase self-diagnosis result of "BRAKE".
9. Turn the ignition switch OFF to exit CONSULT.
10. Get out of the vehicle, close all doors (including trunk lid), and wait for 3 minutes or more without opening these doors.

CAUTION:

Never operate the vehicle and CONSULT while waiting.

11. Turn the ignition switch ON without depressing the brake pedal.

CAUTION:

Never set the vehicle to READY/Never start the engine.

12. Depress brake pedal by 100 mm (3.94 in) or more, and hold the position for 5 seconds or more.
13. Release brake pedal.
14. Start CONSULT and perform "BRAKE" self-diagnosis.

Is DTC "C1A60" detected?

YES >> GO TO 13.

NO >> INSPECTION END

13. CHECK DATA MONITOR

 With CONSULT

1. Connect the electrically-driven intelligent brake unit harness connector.
2. Connect 12V battery cable to negative terminal.
3. Turn the ignition switch OFF to ON without depressing the brake pedal.

CAUTION:

Never set the vehicle to READY/Never start the engine.

4. Repeat step 3 two times or more.

CAUTION:

Be sure to wait for 5 seconds or more after turning the ignition switch OFF.

5. Start CONSULT and select "BRAKE" and "DATA MONITOR" according to this order.
6. Check "MOTOR POWER SUPPLY" and "CONTROL MODULE POWER". Refer to [BR-33, "Reference Value"](#).

Is the inspection result normal?

YES >> GO TO 14.

NO >> Replace the electrically-driven intelligent brake unit. Refer to [BR-288, "Removal and installation"](#).

14. PERFORM SELF-DIAGNOSIS (6)

 With CONSULT

1. Turn the ignition switch OFF to ON without depressing the brake pedal.

CAUTION:

Never set the vehicle to READY/Never start the engine.

2. Repeat step 1 two times or more.

CAUTION:

Be sure to wait for 5 seconds or more after turning the ignition switch OFF.

3. Turn the ignition switch OFF to exit CONSULT.
4. Get out of the vehicle, close all doors (including trunk lid), and wait for 3 minutes or more without opening these doors.

CAUTION:

Never operate the vehicle and CONSULT while waiting.

5. Turn the ignition switch ON without depressing the brake pedal.

CAUTION:

C1A60 CONTROL MODULE

< DTC/CIRCUIT DIAGNOSIS >

Never set the vehicle to READY/Never start the engine.

- 6. Start CONSULT and erase self-diagnosis result of "BRAKE".
- 7. Turn the ignition switch OFF to exit CONSULT.
- 8. Get out of the vehicle, close all doors (including trunk lid), and wait for 3 minutes or more without opening these doors.

CAUTION:

Never operate the vehicle and CONSULT while waiting.

- 9. Turn the ignition switch ON without depressing the brake pedal.

CAUTION:

Never set the vehicle to READY/Never start the engine.

- 10. Depress brake pedal by 100 mm (3.94 in) or more, and hold the position for 5 seconds or more.
- 11. Release brake pedal.
- 12. Start CONSULT and perform "BRAKE" self-diagnosis.

Is DTC "C1A60" detected?

- YES >> Replace the electrically-driven intelligent brake unit. Refer to [BR-288, "Removal and installation"](#).
- NO >> INSPECTION END

A
B
C
D
E
G
H
I
J
K
L
M
N
O
P

BR

C1A61 MOTOR

< DTC/CIRCUIT DIAGNOSIS >

C1A61 MOTOR

DTC Logic

INFOID:000000008139809

DTC DETECTION LOGIC

DTC	Display item	Malfunction detection condition	Possible causes
C1A61	MOTOR POWER SUPPLY	Power voltage of motor inside electrically-driven intelligent brake unit is as shown below. <ul style="list-style-type: none">• Motor power voltage $9\text{ V} \geq$ Motor power voltage• Motor power voltage: $16\text{ V} \geq$ Motor power voltage	<ul style="list-style-type: none">• Connector or harness• Electrically-driven intelligent brake unit

DTC CONFIRMATION PROCEDURE

1. PRECONDITIONING

If "DTC CONFIRMATION PROCEDURE" has been previously conducted, always turn the ignition switch OFF and wait at least 10 seconds before conducting the next test.

>> GO TO 2.

2. CHECK DTC DETECTION

 With CONSULT

1. Turn the ignition switch OFF to ON without depressing the brake pedal.
CAUTION:
Never set the vehicle to READY/Never start the engine.
2. Repeat step 1 two times or more.
CAUTION:
Be sure to wait for 5 seconds or more after turning the ignition switch OFF.
3. Turn the ignition switch OFF to exit CONSULT.
4. Get out of the vehicle, close all doors (including trunk lid), and wait for 3 minutes or more without opening these doors.
CAUTION:
Never operate the vehicle and CONSULT while waiting.
5. Turn the ignition switch ON without depressing the brake pedal.
CAUTION:
Never set the vehicle to READY/Never start the engine.
6. Start CONSULT and erase self-diagnosis result of "BRAKE".
7. Turn the ignition switch OFF to exit CONSULT.
8. Get out of the vehicle, close all doors (including trunk lid), and wait for 3 minutes or more without opening these doors.
CAUTION:
Never operate the vehicle and CONSULT while waiting.
9. Turn the ignition switch ON without depressing the brake pedal.
CAUTION:
Never set the vehicle to READY/Never start the engine.
10. Depress brake pedal by 100 mm (3.94 in) or more, and hold the position for 5 seconds or more.
11. Release brake pedal.
12. Start CONSULT and perform "BRAKE" self-diagnosis.

Is DTC "C1161" detected?

- YES >> Proceed to [BR-58, "Diagnosis Procedure"](#).
NO >> INSPECTION END

Diagnosis Procedure

INFOID:000000008139810

1. CHECK 12V BATTERY

1. Turn the ignition switch OFF to exit CONSULT.
2. Get out of the vehicle, close all doors (including trunk lid), and wait for 3 minutes or more without opening these doors.
CAUTION:

C1A61 MOTOR

< DTC/CIRCUIT DIAGNOSIS >

Never operate the vehicle and CONSULT while waiting.

3. Check the 12V battery terminal connections. Refer to [BR-6, "Precaution for Removing 12V Battery"](#) and [PG-135, "Work Flow"](#). A
4. Check the 12V battery. Refer to [PG-135, "Work Flow"](#).

Is the inspection result normal? B

YES >> GO TO 2.

NO >> Repair or replace error-detected parts and GO TO 2.

2.PERFORM SELF-DIAGNOSIS (1) C

ⓂWith CONSULT

1. Connect 12V battery cable to negative terminal. D
2. Turn the ignition switch OFF to ON without depressing the brake pedal. D
- CAUTION:**
Never set the vehicle to READY/Never start the engine.
3. Repeat step 2 two times or more. E
- CAUTION:**
Be sure to wait for 5 seconds or more after turning the ignition switch OFF.
4. Turn the ignition switch OFF to exit CONSULT.
5. Get out of the vehicle, close all doors (including trunk lid), and wait for 3 minutes or more without opening these doors. BR
- CAUTION:**
Never operate the vehicle and CONSULT while waiting.
6. Turn the ignition switch ON without depressing the brake pedal. G
- CAUTION:**
Never set the vehicle to READY/Never start the engine.
7. Start CONSULT and erase self-diagnosis result of "BRAKE". H
8. Turn the ignition switch OFF to exit CONSULT.
9. Get out of the vehicle, close all doors (including trunk lid), and wait for 3 minutes or more without opening these doors. I
- CAUTION:**
Never operate the vehicle and CONSULT while waiting.
10. Turn the ignition switch ON without depressing the brake pedal. J
- CAUTION:**
Never set the vehicle to READY/Never start the engine.
11. Depress brake pedal by 100 mm (3.94 in) or more, and hold the position for 5 seconds or more.
12. Release brake pedal. K
13. Start CONSULT and perform "BRAKE" self-diagnosis.

Is DTC "C1A61" detected? L

YES >> GO TO 3.

NO >> INSPECTION END

3.CHECK CONNECTOR TERMINALS M

1. Turn the ignition switch OFF to exit CONSULT.
2. Get out of the vehicle, close all doors (including trunk lid), and wait for 3 minutes or more without opening these doors. N
- CAUTION:**
Never operate the vehicle and CONSULT while waiting.
3. Disconnect 12V battery cable from negative terminal. Refer to [BR-6, "Precaution for Removing 12V Battery"](#). O
4. Disconnect the electrically-driven intelligent brake unit harness connector, then check for failures of pin terminals and connections.

Is the inspection result normal? P

YES >> GO TO 5.

NO >> Repair or replace error-detected parts and GO TO 4.

4.PERFORM SELF-DIAGNOSIS (2)

ⓂWith CONSULT

1. Connect the electrically-driven intelligent brake unit harness connector.
2. Connect 12V battery cable to negative terminal.

C1A61 MOTOR

< DTC/CIRCUIT DIAGNOSIS >

3. Turn the ignition switch OFF to ON without depressing the brake pedal.
CAUTION:
Never set the vehicle to READY/Never start the engine.
4. Repeat step 3 two times or more.
CAUTION:
Be sure to wait for 5 seconds or more after turning the ignition switch OFF.
5. Turn the ignition switch OFF to exit CONSULT.
6. Get out of the vehicle, close all doors (including trunk lid), and wait for 3 minutes or more without opening these doors.
CAUTION:
Never operate the vehicle and CONSULT while waiting.
7. Turn the ignition switch ON without depressing the brake pedal.
CAUTION:
Never set the vehicle to READY/Never start the engine.
8. Start CONSULT and erase self-diagnosis result of "BRAKE".
9. Turn the ignition switch OFF to exit CONSULT.
10. Get out of the vehicle, close all doors (including trunk lid), and wait for 3 minutes or more without opening these doors.
CAUTION:
Never operate the vehicle and CONSULT while waiting.
11. Turn the ignition switch ON without depressing the brake pedal.
CAUTION:
Never set the vehicle to READY/Never start the engine.
12. Depress brake pedal by 100 mm (3.94 in) or more, and hold the position for 5 seconds or more.
13. Release brake pedal.
14. Start CONSULT and perform "BRAKE" self-diagnosis.

Is DTC "C1A61" detected?

- YES >> GO TO 5.
NO >> INSPECTION END

5.CHECK IGNITION POWER SUPPLY

1. Turn the ignition switch OFF to exit CONSULT.
2. Get out of the vehicle, close all doors (including trunk lid), and wait for 3 minutes or more without opening these doors.
CAUTION:
Never operate the vehicle and CONSULT while waiting.
3. Disconnect 12V battery cable from negative terminal. Refer to [BR-6, "Precaution for Removing 12V Battery"](#).
4. Disconnect the electrically-driven intelligent brake unit harness connector.
5. Connect 12V battery cable to negative terminal.
6. Check voltage between the electrically-driven intelligent brake unit harness connector and ground.

Electrically-driven intelligent brake unit		—	Voltage
Connector	Terminal		
E87	26	Ground	Approx. 0 V

7. Turn the ignition switch ON without depressing the brake pedal.
CAUTION:
Never set the vehicle to READY/Never start the engine.
8. Check voltage between the electrically-driven intelligent brake unit harness connector and ground.

Electrically-driven intelligent brake unit		—	Voltage
Connector	Terminal		
E87	26	Ground	10 – 16 V

Is the inspection result normal?

- YES >> GO TO 8.
NO >> GO TO 6.

C1A61 MOTOR

< DTC/CIRCUIT DIAGNOSIS >

6. CHECK IGNITION POWER SUPPLY CIRCUIT

1. Turn the ignition switch OFF to exit CONSULT.
2. Get out of the vehicle, close all doors (including trunk lid), and wait for 3 minutes or more without opening these doors.
CAUTION:
Never operate the vehicle and CONSULT while waiting.
3. Disconnect 12V battery cable from negative terminal. Refer to [BR-6, "Precaution for Removing 12V Battery"](#).
4. Check 10A fuse (#46).
5. Disconnect IPDM E/R harness connector.
6. Check continuity between electrically-driven intelligent brake unit and IPDM E/R.

Electrically-driven intelligent brake unit		IPDM E/R		Continuity
Connector	Terminal	Connector	Terminal	
E87	26	E5	12	Existed

7. Check continuity between electrically-driven intelligent brake unit harness connector and ground.

Electrically-driven intelligent brake unit		—	Continuity
Connector	Terminal		
E87	26	Ground	Not existed

Is the inspection result normal?

- YES >> Perform trouble diagnosis for ignition power supply. Refer to [PG-30, "Wiring Diagram - IGNITION POWER SUPPLY -"](#).
- NO >> Repair or replace error-detected parts and GO TO 7.

7. PERFORM SELF-DIAGNOSIS (3)

Ⓜ With CONSULT

1. Connect the electrically-driven intelligent brake unit harness connector.
2. Disconnect IPDM E/R harness connector.
3. Connect 12V battery cable to negative terminal.
4. Turn the ignition switch OFF to ON without depressing the brake pedal.
CAUTION:
Never set the vehicle to READY/Never start the engine.
5. Repeat step 4 two times or more.
CAUTION:
Be sure to wait for 5 seconds or more after turning the ignition switch OFF.
6. Turn the ignition switch OFF to exit CONSULT.
7. Get out of the vehicle, close all doors (including trunk lid), and wait for 3 minutes or more without opening these doors.
CAUTION:
Never operate the vehicle and CONSULT while waiting.
8. Turn the ignition switch ON without depressing the brake pedal.
CAUTION:
Never set the vehicle to READY/Never start the engine.
9. Start CONSULT and erase self-diagnosis result of "BRAKE".
10. Turn the ignition switch OFF to exit CONSULT.
11. Get out of the vehicle, close all doors (including trunk lid), and wait for 3 minutes or more without opening these doors.
CAUTION:
Never operate the vehicle and CONSULT while waiting.
12. Turn the ignition switch ON without depressing the brake pedal.
CAUTION:
Never set the vehicle to READY/Never start the engine.
13. Depress brake pedal by 100 mm (3.94 in) or more, and hold the position for 5 seconds or more.
14. Release brake pedal.
15. Start CONSULT and perform "BRAKE" self-diagnosis.

C1A61 MOTOR

< DTC/CIRCUIT DIAGNOSIS >

Is DTC "C1A61" detected?

- YES >> GO TO 8.
NO >> INSPECTION END

8. CHECK 12V BATTERY POWER SUPPLY

1. Turn the ignition switch OFF to exit CONSULT.
2. Get out of the vehicle, close all doors (including trunk lid), and wait for 3 minutes or more without opening these doors.
CAUTION:
Never operate the vehicle and CONSULT while waiting.
3. Disconnect 12V battery cable from negative terminal. Refer to [BR-6, "Precaution for Removing 12V Battery"](#).
4. Disconnect the electrically-driven intelligent brake unit harness connector.
5. Connect 12V battery cable to negative terminal.
6. Check voltage between the electrically-driven intelligent brake unit harness connector terminals.

Electrically-driven intelligent brake unit		Voltage
Connector	Terminal	
E87	1 – 31	10 – 16 V
	2 – 31	
	11 – 31	

7. Turn the ignition switch ON without depressing the brake pedal.
CAUTION:
Never set the vehicle to READY/Never start the engine.
8. Check voltage between the electrically-driven intelligent brake unit harness connector terminals

Electrically-driven intelligent brake unit		Voltage
Connector	Terminal	
E87	1 – 31	10 – 16 V
	2 – 31	
	11 – 31	

Is the inspection result normal?

- YES >> GO TO 11.
NO >> GO TO 9.

9. CHECK 12V BATTERY POWER SUPPLY CIRCUIT

1. Turn the ignition switch OFF to exit CONSULT.
2. Get out of the vehicle, close all doors (including trunk lid), and wait for 3 minutes or more without opening these doors.
CAUTION:
Never operate the vehicle and CONSULT while waiting.
3. Disconnect 12V battery cable from negative terminal. Refer to [BR-6, "Precaution for Removing 12V Battery"](#).
4. Check 50A fusible link (#D).
5. Check continuity and for short circuit between electrically-driven intelligent brake unit harness connector terminal (1) and 50A fusible link (#D).
6. Check continuity and for short circuit between electrically-driven intelligent brake unit harness connector terminal (2) and 50A fusible link (#D).
7. Check 10A fuse (#65).
8. Check continuity and for short circuit between electrically-driven intelligent brake unit harness connector terminal (11) and 10A fuse (#65).

Is the inspection result normal?

- YES >> Perform diagnosis for 12V battery power supply. Refer to [PG-14, "Wiring Diagram - BATTERY POWER SUPPLY -"](#).
NO >> Repair or replace error-detected parts and GO TO 10.

C1A61 MOTOR

< DTC/CIRCUIT DIAGNOSIS >

10. PERFORM SELF-DIAGNOSIS (4)

Ⓜ With CONSULT

1. Connect the electrically-driven intelligent brake unit harness connector.
2. Connect 12V battery cable to negative terminal.
3. Turn the ignition switch OFF to ON without depressing the brake pedal.
CAUTION:
Never set the vehicle to READY/Never start the engine.
4. Repeat step 3 two times or more.
CAUTION:
Be sure to wait for 5 seconds or more after turning the ignition switch OFF.
5. Turn the ignition switch OFF to exit CONSULT.
6. Get out of the vehicle, close all doors (including trunk lid), and wait for 3 minutes or more without opening these doors.
CAUTION:
Never operate the vehicle and CONSULT while waiting.
7. Turn the ignition switch ON without depressing the brake pedal.
CAUTION:
Never set the vehicle to READY/Never start the engine.
8. Start CONSULT and erase self-diagnosis result of "BRAKE".
9. Turn the ignition switch OFF to exit CONSULT.
10. Get out of the vehicle, close all doors (including trunk lid), and wait for 3 minutes or more without opening these doors.
CAUTION:
Never operate the vehicle and CONSULT while waiting.
11. Turn the ignition switch ON without depressing the brake pedal.
CAUTION:
Never set the vehicle to READY/Never start the engine.
12. Depress brake pedal by 100 mm (3.94 in) or more, and hold the position for 5 seconds or more.
13. Release brake pedal.
14. Start CONSULT and perform "BRAKE" self-diagnosis.

Is DTC "C1A61" detected?

YES >> GO TO 11.

NO >> INSPECTION END

11. CHECK GROUND CIRCUIT

1. Turn the ignition switch OFF to exit CONSULT.
2. Get out of the vehicle, close all doors (including trunk lid), and wait for 3 minutes or more without opening these doors.
CAUTION:
Never operate the vehicle and CONSULT while waiting.
3. Disconnect 12V battery cable from negative terminal. Refer to [BR-6. "Precaution for Removing 12V Battery"](#).
4. Disconnect the electrically-driven intelligent brake unit harness connector.
5. Check continuity between electrically-driven intelligent brake unit and ground.

Electrically-driven intelligent brake unit		—	Continuity
Connector	Terminal		
E87	31	Ground	Existed

Is the inspection result normal?

YES >> GO TO 13.

NO >> Repair or replace error-detected parts and GO TO 12.

12. PERFORM SELF-DIAGNOSIS (5)

Ⓜ With CONSULT

1. Connect the electrically-driven intelligent brake unit harness connector.
2. Connect 12V battery cable to negative terminal.
3. Turn the ignition switch OFF to ON without depressing the brake pedal.

CAUTION:

C1A61 MOTOR

< DTC/CIRCUIT DIAGNOSIS >

Never set the vehicle to READY/Never start the engine.

4. Repeat step 3 two times or more.

CAUTION:

Be sure to wait for 5 seconds or more after turning the ignition switch OFF.

5. Turn the ignition switch OFF to exit CONSULT.
6. Get out of the vehicle, close all doors (including trunk lid), and wait for 3 minutes or more without opening these doors.

CAUTION:

Never operate the vehicle and CONSULT while waiting.

7. Turn the ignition switch ON without depressing the brake pedal.

CAUTION:

Never set the vehicle to READY/Never start the engine.

8. Start CONSULT and erase self-diagnosis result of "BRAKE".
9. Turn the ignition switch OFF to exit CONSULT.
10. Get out of the vehicle, close all doors (including trunk lid), and wait for 3 minutes or more without opening these doors.

CAUTION:

Never operate the vehicle and CONSULT while waiting.

11. Turn the ignition switch ON without depressing the brake pedal.

CAUTION:

Never set the vehicle to READY/Never start the engine.

12. Depress brake pedal by 100 mm (3.94 in) or more, and hold the position for 5 seconds or more.
13. Release brake pedal.
14. Start CONSULT and perform "BRAKE" self-diagnosis.

Is DTC "C1A61" detected?

YES >> GO TO 13.

NO >> INSPECTION END

13.CHECK DATA MONITOR

 With CONSULT

1. Connect the electrically-driven intelligent brake unit harness connector.
2. Connect 12V battery cable to negative terminal.
3. Turn the ignition switch OFF to ON without depressing the brake pedal.

CAUTION:

Never set the vehicle to READY/Never start the engine.

4. Repeat step 3 two times or more.

CAUTION:

Be sure to wait for 5 seconds or more after turning the ignition switch OFF.

5. Start CONSULT and select "BRAKE" and "DATA MONITOR" according this order.
6. Check "MOTOR POWER SUPPLY" and "CONTROL MODULE POWER". Refer to [BR-33, "Reference Value"](#).

Is the inspection result normal?

YES >> GO TO 14.

NO >> Replace the electrically-driven intelligent brake unit. Refer to [BR-288, "Removal and installation"](#).

14.PERFORM SELF-DIAGNOSIS (6)

 With CONSULT

1. Turn the ignition switch OFF to ON without depressing the brake pedal.

CAUTION:

Never set the vehicle to READY/Never start the engine.

2. Repeat step 1 two times or more.

CAUTION:

Be sure to wait for 5 seconds or more after turning the ignition switch OFF.

3. Turn the ignition switch OFF to exit CONSULT.
4. Get out of the vehicle, close all doors (including trunk lid), and wait for 3 minutes or more without opening these doors.

CAUTION:

Never operate the vehicle and CONSULT while waiting.

5. Turn the ignition switch ON without depressing the brake pedal.

CAUTION:

C1A61 MOTOR

< DTC/CIRCUIT DIAGNOSIS >

Never set the vehicle to READY/Never start the engine.

6. Start CONSULT and erase self-diagnosis result of "BRAKE".
7. Turn the ignition switch OFF to exit CONSULT.
8. Get out of the vehicle, close all doors (including trunk lid), and wait for 3 minutes or more without opening these doors.

CAUTION:

Never operate the vehicle and CONSULT while waiting.

9. Turn the ignition switch ON without depressing the brake pedal.

CAUTION:

Never set the vehicle to READY/Never start the engine.

10. Depress brake pedal by 100 mm (3.94 in) or more, and hold the position for 5 seconds or more.
11. Release brake pedal.
12. Start CONSULT and perform "BRAKE" self-diagnosis.

Is DTC "C1A61" detected?

- YES >> Replace the electrically-driven intelligent brake unit. Refer to [BR-288, "Removal and installation"](#).
- NO >> INSPECTION END

A
B
C
D
E
G
H
I
J
K
L
M
N
O
P

BR

C1A62 CONTROL MODULE

< DTC/CIRCUIT DIAGNOSIS >

C1A62 CONTROL MODULE

DTC Logic

INFOID:000000008139811

DTC DETECTION LOGIC

DTC	Display item	Malfunction detection condition	Possible causes
C1A62	CONTROL MODULE POWER SUPPLY	<ul style="list-style-type: none">• Power voltage of control module that is integrated with electrically-driven intelligent brake unit is as shown below.- Control module power voltage: $9\text{ V} \geq$ Control module power voltage- Control module power voltage: $16\text{ V} \leq$ Control module power voltage• After turning the ignition switch OFF, 12V battery terminals are disconnected with any door open (including trunk lid).• After turning the ignition switch OFF, 12V battery terminals are disconnected without waiting for 3 minutes or more after closing all doors (including trunk lid).	<ul style="list-style-type: none">• Harness or connector• Electrically-driven intelligent brake unit

DTC CONFIRMATION PROCEDURE

1. PRECONDITIONING

If "DTC CONFIRMATION PROCEDURE" has been previously conducted, always turn the ignition switch OFF and wait at least 10 seconds before conducting the next test.

>> GO TO 2.

2. CHECK DTC DETECTION

Ⓜ With CONSULT

1. Turn the ignition switch OFF to ON without depressing the brake pedal.

CAUTION:

Never set the vehicle to READY/ Never start the engine.

2. Start CONSULT and perform "BRAKE" self-diagnosis.

Is DTC "C1A62" detected?

YES >> Proceed to [BR-66. "Diagnosis Procedure"](#).

NO >> INSPECTION END

Diagnosis Procedure

INFOID:000000008139812

1. PERFORM SELF-DIAGNOSIS (1)

Ⓜ With CONSULT

1. Turn the ignition switch OFF to ON without depressing the brake pedal.

CAUTION:

Never set the vehicle to READY/ Never start the engine.

2. Start CONSULT and perform "BRAKE" self-diagnosis.

"PAST" or "CRNT" shown in self-diagnosis result ("C1162")?

YES ("PAST") >> GO TO 2.

YES ("CRNT") >> GO TO 6.

NO >> INSPECTION END

2. INTERVIEW FROM THE CUSTOMER (1)

Check to see if there is a removal history of 12V battery or 12V battery terminals.

Is there a removal history of 12V battery or 12V battery terminals?

YES >> GO TO 3.

NO >> GO TO 6.

C1A62 CONTROL MODULE

< DTC/CIRCUIT DIAGNOSIS >

3. INTERVIEW FROM THE CUSTOMER (2)

Check to see if there is a lighting history of the brake system warning lamp (yellow).

Is there a lighting history of the brake system warning lamp (yellow)?

YES >> GO TO 6.

NO >> GO TO 4.

4. INTERVIEW FROM THE CUSTOMER (3)

Check to see if the customer has an experience of feeling unusual braking force (brake pedal operation).

Does the customer has an experience of feeling unusual braking force?

YES >> GO TO 6.

NO >> GO TO 5.

5. PERFORM SELF-DIAGNOSIS (2)

 With CONSULT

1. Turn the ignition switch OFF to ON without depressing the brake pedal.

CAUTION:

Never set the vehicle to READY/Never start the engine.

2. Repeat step 1 two times or more.

CAUTION:

Be sure to wait for 5 seconds or more after turning the ignition switch OFF.

3. Turn the ignition switch OFF to exit CONSULT.

4. Get out of the vehicle, close all doors (including trunk lid), and wait for 3 minutes or more without opening these doors.

CAUTION:

Never operate the vehicle and CONSULT while waiting.

5. Turn the ignition switch ON without depressing the brake pedal.

CAUTION:

Never set the vehicle to READY/Never start the engine.

6. Start CONSULT and erase self-diagnosis result of "BRAKE".

7. Turn the ignition switch OFF to exit CONSULT.

8. Get out of the vehicle, close all doors (including trunk lid), and wait for 3 minutes or more without opening these doors.

CAUTION:

Never operate the vehicle and CONSULT while waiting.

9. Turn the ignition switch ON without depressing the brake pedal.

CAUTION:

Never set the vehicle to READY/Never start the engine.

10. Depress brake pedal by 100 mm (3.94 in) or more, and hold the position for 5 seconds or more.

11. Release brake pedal.

12. Start CONSULT and perform "BRAKE" self-diagnosis.

Is DTC "C1A62" detected?

YES >> GO TO 6.

NO >> INSPECTION END [DTC "C1A62" is detected when 12V battery terminals are disconnected after turning the power switch OFF with any door open (including trunk lid) or without waiting 3 minutes after closing all doors (including trunk lid).]

6. CHECK 12V BATTERY

1. Turn the ignition switch OFF to exit CONSULT.

2. Get out of the vehicle, close all doors (including trunk lid), and wait for 3 minutes or more without opening these doors.

CAUTION:

Never operate the vehicle and CONSULT while waiting.

3. Check the 12V battery terminal connections. Refer to [BR-6, "Precaution for Removing 12V Battery"](#) and [PG-135, "Work Flow"](#).

4. Check the 12V battery. Refer to [PG-135, "Work Flow"](#).

Is the inspection result normal?

YES >> GO TO 7.

NO >> Repair or replace error-detected parts and GO TO 7.

C1A62 CONTROL MODULE

< DTC/CIRCUIT DIAGNOSIS >

7. PERFORM SELF-DIAGNOSIS (3)

Ⓟ With CONSULT

1. Connect 12V battery cable to negative terminal.
2. Turn the ignition switch OFF to ON without depressing the brake pedal.
CAUTION:
Never set the vehicle to READY/Never start the engine.
3. Repeat step 2 two times or more.
CAUTION:
Be sure to wait for 5 seconds or more after turning the ignition switch OFF.
4. Turn the ignition switch OFF to exit CONSULT.
5. Get out of the vehicle, close all doors (including trunk lid), and wait for 3 minutes or more without opening these doors.
CAUTION:
Never operate the vehicle and CONSULT while waiting.
6. Turn the ignition switch ON without depressing the brake pedal.
CAUTION:
Never set the vehicle to READY/Never start the engine.
7. Start CONSULT and erase self-diagnosis result of "BRAKE".
8. Turn the ignition switch OFF to exit CONSULT.
9. Get out of the vehicle, close all doors (including trunk lid), and wait for 3 minutes or more without opening these doors.
CAUTION:
Never operate the vehicle and CONSULT while waiting.
10. Turn the ignition switch ON without depressing the brake pedal.
CAUTION:
Never set the vehicle to READY/Never start the engine.
11. Depress brake pedal by 100 mm (3.94 in) or more, and hold the position for 5 seconds or more.
12. Release brake pedal.
13. Start CONSULT and perform "BRAKE" self-diagnosis.

Is DTC "C1A62" detected?

YES >> GO TO 8.

NO >> INSPECTION END

8. CHECK CONNECTOR TERMINALS

1. Turn the ignition switch OFF to exit CONSULT.
2. Get out of the vehicle, close all doors (including trunk lid), and wait for 3 minutes or more without opening these doors.
CAUTION:
Never operate the vehicle and CONSULT while waiting.
3. Disconnect 12V battery cable from negative terminal. Refer to [BR-6. "Precaution for Removing 12V Battery"](#).
4. Disconnect the electrically-driven intelligent brake unit harness connector, then check for failures of pin terminals and connections.

Is the inspection result normal?

YES >> GO TO 9.

NO >> Repair or replace error-detected parts and GO TO 9.

9. PERFORM SELF-DIAGNOSIS (4)

Ⓟ With CONSULT

1. Connect the electrically-driven intelligent brake unit harness connector.
2. Connect 12V battery cable to negative terminal.
3. Turn the ignition switch OFF to ON without depressing the brake pedal.
CAUTION:
Never set the vehicle to READY/Never start the engine.
4. Repeat step 3 two times or more.
CAUTION:
Be sure to wait for 5 seconds or more after turning the ignition switch OFF.
5. Turn the ignition switch OFF to exit CONSULT.

C1A62 CONTROL MODULE

< DTC/CIRCUIT DIAGNOSIS >

6. Get out of the vehicle, close all doors (including trunk lid), and wait for 3 minutes or more without opening these doors.
CAUTION:
Never operate the vehicle and CONSULT while waiting.
7. Turn the ignition switch ON without depressing the brake pedal.
CAUTION:
Never set the vehicle to READY/Never start the engine.
8. Start CONSULT and erase self-diagnosis result of "BRAKE".
9. Turn the ignition switch OFF to exit CONSULT.
10. Get out of the vehicle, close all doors (including trunk lid), and wait for 3 minutes or more without opening these doors.
CAUTION:
Never operate the vehicle and CONSULT while waiting.
11. Turn the ignition switch ON without depressing the brake pedal.
CAUTION:
Never set the vehicle to READY/Never start the engine.
12. Depress brake pedal by 100 mm (3.94 in) or more, and hold the position for 5 seconds or more.
13. Release brake pedal.
14. Start CONSULT and perform "BRAKE" self-diagnosis.

Is DTC "C1A62" detected?

- YES >> GO TO 10.
NO >> INSPECTION END

10. CHECK IGNITION POWER SUPPLY

1. Turn the ignition switch OFF to exit CONSULT.
2. Get out of the vehicle, close all doors (including trunk lid), and wait for 3 minutes or more without opening these doors.
CAUTION:
Never operate the vehicle and CONSULT while waiting.
3. Disconnect 12V battery cable from negative terminal. Refer to [BR-6, "Precaution for Removing 12V Battery"](#).
4. Disconnect the electrically-driven intelligent brake unit harness connector.
5. Connect 12V battery cable to negative terminal.
6. Check voltage between the electrically-driven intelligent brake unit harness connector and ground.

Electrically-driven intelligent brake unit		—	Voltage
Connector	Terminal		
E87	26	Ground	Approx. 0 V

7. Turn the ignition switch ON without depressing the brake pedal.
CAUTION:
Never set the vehicle to READY/Never start the engine.
8. Check voltage between the electrically-driven intelligent brake unit harness connector and ground.

Electrically-driven intelligent brake unit		—	Voltage
Connector	Terminal		
E87	26	Ground	10 – 16 V

Is the inspection result normal?

- YES >> GO TO 13.
NO >> GO TO 11.

11. CHECK IGNITION POWER SUPPLY CIRCUIT

1. Turn the ignition switch OFF to exit CONSULT.
2. Get out of the vehicle, close all doors (including trunk lid), and wait for 3 minutes or more without opening these doors.
CAUTION:
Never operate the vehicle and CONSULT while waiting.

C1A62 CONTROL MODULE

< DTC/CIRCUIT DIAGNOSIS >

3. Disconnect 12V battery cable from negative terminal. Refer to [BR-6, "Precaution for Removing 12V Battery"](#).
4. Check 10A fuse (#46).
5. Disconnect IPDM E/R harness connector.
6. Check continuity between electrically-driven intelligent brake unit and IPDM E/R.

Electrically-driven intelligent brake unit		IPDM E/R		Continuity
Connector	Terminal	Connector	Terminal	
E87	26	E5	12	Existed

7. Check continuity between electrically-driven intelligent brake unit harness connector and ground.

Electrically-driven intelligent brake unit		—	Continuity
Connector	Terminal		
E87	26	Ground	Not existed

Is the inspection result normal?

YES >> Perform trouble diagnosis for ignition power supply. Refer to [PG-30, "Wiring Diagram - IGNITION POWER SUPPLY -"](#).

NO >> Repair or replace error-detected parts and GO TO 12.

12.PERFORM SELF-DIAGNOSIS (5)

ⓅWith CONSULT

1. Connect the electrically-driven intelligent brake unit harness connector.
2. Connect IPDM E/R harness connector.
3. Connect 12V battery cable to negative terminal.
4. Turn the ignition switch OFF to ON without depressing the brake pedal.
CAUTION:
Never set the vehicle to READY/Never start the engine.
5. Repeat step 4 two times or more.
CAUTION:
Be sure to wait for 5 seconds or more after turning the ignition switch OFF.
6. Turn the ignition switch OFF to exit CONSULT.
7. Get out of the vehicle, close all doors (including trunk lid), and wait for 3 minutes or more without opening these doors.
CAUTION:
Never operate the vehicle and CONSULT while waiting.
8. Turn the ignition switch ON without depressing the brake pedal.
CAUTION:
Never set the vehicle to READY/Never start the engine.
9. Start CONSULT and erase self-diagnosis result of "BRAKE".
10. Turn the ignition switch OFF to exit CONSULT.
11. Get out of the vehicle, close all doors (including trunk lid), and wait for 3 minutes or more without opening these doors.
CAUTION:
Never operate the vehicle and CONSULT while waiting.
12. Turn the ignition switch ON without depressing the brake pedal.
CAUTION:
Never set the vehicle to READY/Never start the engine.
13. Depress brake pedal by 100 mm (3.94 in) or more, and hold the position for 5 seconds or more.
14. Release brake pedal.
15. Start CONSULT and perform "BRAKE" self-diagnosis.

Is DTC "C1A62" detected?

YES >> GO TO 13.

NO >> INSPECTION END

13.CHECK 12V BATTERY POWER SUPPLY

1. Turn the ignition switch OFF to exit CONSULT.

C1A62 CONTROL MODULE

< DTC/CIRCUIT DIAGNOSIS >

2. Get out of the vehicle, close all doors (including trunk lid), and wait for 3 minutes or more without opening these doors.
CAUTION:
Never operate the vehicle and CONSULT while waiting.
3. Disconnect 12V battery cable from negative terminal. Refer to [BR-6, "Precaution for Removing 12V Battery"](#).
4. Disconnect the electrically-driven intelligent brake unit harness connector.
5. Connect 12V battery cable to negative terminal.
6. Check voltage between the electrically-driven intelligent brake unit harness connector terminals.

Electrically-driven intelligent brake unit		Voltage
Connector	Terminal	
E87	1 – 31	10 – 16 V
	2 – 31	
	11 – 31	

7. Turn the ignition switch ON without depressing the brake pedal.
CAUTION:
Never set the vehicle to READY/Never start the engine.
8. Check voltage between the electrically-driven intelligent brake unit harness connector terminals.

Electrically-driven intelligent brake unit		Voltage
Connector	Terminal	
E87	1 – 31	10 – 16 V
	2 – 31	
	11 – 31	

Is the inspection result normal?

- YES >> GO TO 16.
NO >> GO TO 14.

14. CHECK 12V BATTERY POWER SUPPLY CIRCUIT

1. Turn the ignition switch OFF to exit CONSULT.
2. Get out of the vehicle, close all doors (including trunk lid), and wait for 3 minutes or more without opening these doors.
CAUTION:
Never operate the vehicle and CONSULT while waiting.
3. Disconnect 12V battery cable from negative terminal. Refer to [BR-6, "Precaution for Removing 12V Battery"](#).
4. Check 50A fusible link (#D).
5. Check continuity and for short circuit between electrically-driven intelligent brake unit harness connector terminal (1) and 50A fusible link (#D).
6. Check continuity and for short circuit between electrically-driven intelligent brake unit harness connector terminal (2) and 50A fusible link (#D).
7. Check 10A fuse (#65).
8. Check continuity and for short circuit between electrically-driven intelligent brake unit harness connector terminal (11) and 10A fuse (#65).

Is the inspection result normal?

- YES >> Perform diagnosis for 12V battery power supply. Refer to [PG-14, "Wiring Diagram - BATTERY POWER SUPPLY -"](#).
NO >> Repair or replace error-detected parts and GO TO 15.

15. PERFORM SELF-DIAGNOSIS (6)

 With CONSULT

1. Connect the electrically-driven intelligent brake unit harness connector.
2. Connect 12V battery cable to negative terminal.
3. Turn the ignition switch OFF to ON without depressing the brake pedal.

CAUTION:

C1A62 CONTROL MODULE

< DTC/CIRCUIT DIAGNOSIS >

Never set the vehicle to READY/Never start the engine.

4. Repeat step 3 two times or more.

CAUTION:

Be sure to wait for 5 seconds or more after turning the ignition switch OFF.

5. Turn the ignition switch OFF to exit CONSULT.
6. Get out of the vehicle, close all doors (including trunk lid), and wait for 3 minutes or more without opening these doors.

CAUTION:

Never operate the vehicle and CONSULT while waiting.

7. Turn the ignition switch ON without depressing the brake pedal.

CAUTION:

Never set the vehicle to READY/Never start the engine.

8. Start CONSULT and erase self-diagnosis result of "BRAKE".
9. Turn the ignition switch OFF to exit CONSULT.
10. Get out of the vehicle, close all doors (including trunk lid), and wait for 3 minutes or more without opening these doors.

CAUTION:

Never operate the vehicle and CONSULT while waiting.

11. Turn the ignition switch ON without depressing the brake pedal.

CAUTION:

Never set the vehicle to READY/Never start the engine.

12. Depress brake pedal by 100 mm (3.94 in) or more, and hold the position for 5 seconds or more.
13. Release brake pedal.
14. Start CONSULT and perform "BRAKE" self-diagnosis.

Is DTC "C1A62" detected?

YES >> GO TO 16.

NO >> INSPECTION END

16. CHECK GROUND CIRCUIT

1. Turn the ignition switch OFF to exit CONSULT.
2. Get out of the vehicle, close all doors (including trunk lid), and wait for 3 minutes or more without opening these doors.

CAUTION:

Never operate the vehicle and CONSULT while waiting.

3. Disconnect 12V battery cable from negative terminal. Refer to [BR-6, "Precaution for Removing 12V Battery"](#).
4. Disconnect the electrically-driven intelligent brake unit harness connector.
5. Check continuity between electrically-driven intelligent brake unit and ground.

Electrically-driven intelligent brake unit		—	Continuity
Connector	Terminal		
E87	31	Ground	Existed

Is the inspection result normal?

YES >> GO TO 18.

NO >> Repair or replace error-detected parts and GO TO 17.

17. PERFORM SELF-DIAGNOSIS (7)

With CONSULT

1. Connect the electrically-driven intelligent brake unit harness connector.
2. Connect 12V battery cable to negative terminal.
3. Turn the ignition switch OFF to ON without depressing the brake pedal.

CAUTION:

Never set the vehicle to READY/Never start the engine.

4. Repeat step 3 two times or more.

CAUTION:

Be sure to wait for 5 seconds or more after turning the ignition switch OFF.

5. Turn the ignition switch OFF to exit CONSULT.
6. Get out of the vehicle, close all doors (including trunk lid), and wait for 3 minutes or more without opening these doors.

C1A62 CONTROL MODULE

< DTC/CIRCUIT DIAGNOSIS >

CAUTION:

Never operate the vehicle and CONSULT while waiting.

7. Turn the ignition switch ON without depressing the brake pedal.

CAUTION:

Never set the vehicle to READY/Never start the engine.

8. Start CONSULT and erase self-diagnosis result of "BRAKE".
9. Turn the ignition switch OFF to exit CONSULT.
10. Get out of the vehicle, close all doors (including trunk lid), and wait for 3 minutes or more without opening these doors.

CAUTION:

Never operate the vehicle and CONSULT while waiting.

11. Turn the ignition switch ON without depressing the brake pedal.

CAUTION:

Never set the vehicle to READY/Never start the engine.

12. Depress brake pedal by 100 mm (3.94 in) or more, and hold the position for 5 seconds or more.
13. Release brake pedal.
14. Start CONSULT and perform "BRAKE" self-diagnosis.

Is DTC "C1A62" detected?

YES >> GO TO 18.

NO >> INSPECTION END

18. CHECK DATA MONITOR

Ⓜ With CONSULT

1. Connect the electrically-driven intelligent brake unit harness connector.
2. Connect 12V battery cable to negative terminal.
3. Turn the ignition switch OFF to ON without depressing the brake pedal.

CAUTION:

Never set the vehicle to READY/Never start the engine.

4. Repeat step 3 two times or more.

CAUTION:

Be sure to wait for 5 seconds or more after turning the ignition switch OFF.

5. Start CONSULT and select "BRAKE" and "DATA MONITOR" according this order.
6. Check "MOTOR POWER SUPPLY" and "CONTROL MODULE POWER". Refer to [BR-33. "Reference Value"](#).

Is the inspection result normal?

YES >> GO TO 19.

NO >> Replace the electrically-driven intelligent brake unit. Refer to [BR-288. "Removal and installation"](#).

19. PERFORM SELF-DIAGNOSIS (8)

Ⓜ With CONSULT

1. Turn the ignition switch OFF to ON without depressing the brake pedal.

CAUTION:

Never set the vehicle to READY/Never start the engine.

2. Repeat step 1 two times or more.

CAUTION:

Be sure to wait for 5 seconds or more after turning the ignition switch OFF.

3. Turn the ignition switch OFF to exit CONSULT.
4. Get out of the vehicle, close all doors (including trunk lid), and wait for 3 minutes or more without opening these doors.

CAUTION:

Never operate the vehicle and CONSULT while waiting.

5. Turn the ignition switch ON without depressing the brake pedal.

CAUTION:

Never set the vehicle to READY/Never start the engine.

6. Start CONSULT and erase self-diagnosis result of "BRAKE".
7. Turn the ignition switch OFF to exit CONSULT.
8. Get out of the vehicle, close all doors (including trunk lid), and wait for 3 minutes or more without opening these doors.

CAUTION:

Never operate the vehicle and CONSULT while waiting.

C1A62 CONTROL MODULE

< DTC/CIRCUIT DIAGNOSIS >

9. Turn the ignition switch ON without depressing the brake pedal.

CAUTION:

Never set the vehicle to READY/Never start the engine.

10. Depress brake pedal by 100 mm (3.94 in) or more, and hold the position for 5 seconds or more.
11. Release brake pedal.
12. Start CONSULT and perform "BRAKE" self-diagnosis.

Is DTC "C1A62" detected?

YES >> GO TO 20.

NO >> INSPECTION END

20. CHECK BCM SYSTEM

Ⓟ With CONSULT

Perform self-diagnosis for "BCM". Refer to [BCS-29. "BCM : CONSULT Function \(BCM - BCM\)".](#)

Is any DTC detected?

YES >> Check the DTC. Refer to [BCS-55. "DTC Index".](#) GO TO 21.

NO >> Replace the electrically-driven intelligent brake unit. Refer to [BR-288. "Removal and installation".](#)

21. PERFORM SELF-DIAGNOSIS (9)

Ⓟ With CONSULT

1. Turn the ignition switch OFF to ON without depressing the brake pedal.

CAUTION:

Never set the vehicle to READY/Never start the engine.

2. Repeat step 1 two times or more.

CAUTION:

Be sure to wait for 5 seconds or more after turning the ignition switch OFF.

3. Turn the ignition switch OFF to exit CONSULT.
4. Get out of the vehicle, close all doors (including trunk lid), and wait for 3 minutes or more without opening these doors.

CAUTION:

Never operate the vehicle and CONSULT while waiting.

5. Turn the ignition switch ON without depressing the brake pedal.

CAUTION:

Never set the vehicle to READY/Never start the engine.

6. Start CONSULT and erase self-diagnosis result of "BRAKE".
7. Turn the ignition switch OFF to exit CONSULT.

8. Get out of the vehicle, close all doors (including trunk lid), and wait for 3 minutes or more without opening these doors.

CAUTION:

Never operate the vehicle and CONSULT while waiting.

9. Turn the ignition switch ON without depressing the brake pedal.

CAUTION:

Never set the vehicle to READY/Never start the engine.

10. Depress brake pedal by 100 mm (3.94 in) or more, and hold the position for 5 seconds or more.
11. Release brake pedal.
12. Start CONSULT and perform "BRAKE" self-diagnosis.

Is DTC "C1A62" detected?

YES >> Replace the electrically-driven intelligent brake unit. Refer to [BR-288. "Removal and installation".](#)

NO >> INSPECTION END

C1A63 BRAKE POWER SUPPLY BACKUP UNIT

< DTC/CIRCUIT DIAGNOSIS >

C1A63 BRAKE POWER SUPPLY BACKUP UNIT

DTC Logic

INFOID:000000008139813

DTC DETECTION LOGIC

DTC	Display item	Malfunction detection condition	Possible causes
C1A63	BACKUP POWER SUPPLY	Malfunction in the backup power circuit is detected.	<ul style="list-style-type: none">• Harness or connector• Electrically-driven intelligent brake unit

DTC CONFIRMATION PROCEDURE

1. PRECONDITIONING

If "DTC CONFIRMATION PROCEDURE" has been previously conducted, always turn the ignition switch OFF and wait at least 10 seconds before conducting the next test.

>> GO TO 2.

2. CHECK DTC DETECTION

 With CONSULT

1. Turn the ignition switch OFF to ON without depressing the brake pedal.
CAUTION:
Never set the vehicle to READY/Never start the engine.
2. Repeat step 1 two times or more.
CAUTION:
Be sure to wait for 5 seconds or more after turning the ignition switch OFF.
3. Turn the ignition switch OFF to exit CONSULT.
4. Get out of the vehicle, close all doors (including trunk lid), and wait for 3 minutes or more without opening these doors.
CAUTION:
Never operate the vehicle and CONSULT while waiting.
5. Turn the ignition switch ON without depressing the brake pedal.
CAUTION:
Never set the vehicle to READY/Never start the engine.
6. Start CONSULT and erase self-diagnosis result of "BRAKE".
7. Turn the ignition switch OFF to exit CONSULT.
8. Get out of the vehicle, close all doors (including trunk lid), and wait for 3 minutes or more without opening these doors.
CAUTION:
Never operate the vehicle and CONSULT while waiting.
9. Turn the ignition switch ON without depressing the brake pedal.
CAUTION:
Never set the vehicle to READY/Never start the engine.
10. Depress brake pedal by 100 mm (3.94 in) or more, and hold the position for 5 seconds or more.
11. Release brake pedal.
12. Start CONSULT and perform "BRAKE" self-diagnosis.

Is DTC "C1A63" detected?

- YES >> Proceed to [BR-75, "Diagnosis Procedure"](#).
NO >> INSPECTION END

Diagnosis Procedure

INFOID:000000008139814

1. CHECK 12V BATTERY

1. Turn the ignition switch OFF to exit CONSULT.
2. Get out of the vehicle, close all doors (including trunk lid), and wait for 3 minutes or more without opening these doors.
CAUTION:
Never operate the vehicle and CONSULT while waiting.

C1A63 BRAKE POWER SUPPLY BACKUP UNIT

< DTC/CIRCUIT DIAGNOSIS >

3. Check the 12V battery terminal connections. Refer to [BR-6. "Precaution for Removing 12V Battery"](#) and [PG-135. "Work Flow"](#).
4. Check the 12V battery. Refer to [PG-135. "Work Flow"](#).

Is the inspection result normal?

YES >> GO TO 2.

NO >> Repair or replace error-detected parts and GO TO 2.

2.PERFORM SELF-DIAGNOSIS (1)

With CONSULT

1. Connect 12V battery cable to negative terminal.
2. Turn the ignition switch OFF to ON without depressing the brake pedal.
CAUTION:
Never set the vehicle to READY/Never start the engine.
3. Repeat step 2 two times or more.
CAUTION:
Be sure to wait for 5 seconds or more after turning the ignition switch OFF.
4. Turn the ignition switch OFF to exit CONSULT.
5. Get out of the vehicle, close all doors (including trunk lid), and wait for 3 minutes or more without opening these doors.
CAUTION:
Never operate the vehicle and CONSULT while waiting.
6. Turn the ignition switch ON without depressing the brake pedal.
CAUTION:
Never set the vehicle to READY/Never start the engine.
7. Start CONSULT and erase self-diagnosis result of "BRAKE".
8. Turn the ignition switch OFF to exit CONSULT.
9. Get out of the vehicle, close all doors (including trunk lid), and wait for 3 minutes or more without opening these doors.
CAUTION:
Never operate the vehicle and CONSULT while waiting.
10. Turn the ignition switch ON without depressing the brake pedal.
CAUTION:
Never set the vehicle to READY/Never start the engine.
11. Depress brake pedal by 100 mm (3.94 in) or more, and hold the position for 5 seconds or more.
12. Release brake pedal.
13. Start CONSULT and perform "BRAKE" self-diagnosis.

Is DTC "C1A63" detected?

YES >> GO TO 3.

NO >> INSPECTION END

3.CHECK CONNECTOR TERMINALS

1. Turn the ignition switch OFF to exit CONSULT.
2. Get out of the vehicle, close all doors (including trunk lid), and wait for 3 minutes or more without opening these doors.
CAUTION:
Never operate the vehicle and CONSULT while waiting.
3. Disconnect 12V battery cable from negative terminal. Refer to [BR-6. "Precaution for Removing 12V Battery"](#).
4. Disconnect the electrically-driven intelligent brake unit harness connector, then check for failures of pin terminals and connections.
5. Disconnect the brake power supply backup unit harness connector, then check for failures of pin terminals and connections.

Is the inspection result normal?

YES >> GO TO 5.

NO >> Repair or replace error-detected parts and GO TO 4.

4.PERFORM SELF-DIAGNOSIS (2)

With CONSULT

1. Connect the electrically-driven intelligent brake unit harness connector.

C1A63 BRAKE POWER SUPPLY BACKUP UNIT

< DTC/CIRCUIT DIAGNOSIS >

2. Connect the brake power supply backup unit harness connector.
3. Connect 12V battery cable to negative terminal.
4. Turn the ignition switch OFF to ON without depressing the brake pedal.
CAUTION:
Never set the vehicle to READY/Never start the engine.
5. Repeat step 4 two times or more.
CAUTION:
Be sure to wait for 5 seconds or more after turning the ignition switch OFF.
6. Turn the ignition switch OFF to exit CONSULT.
7. Get out of the vehicle, close all doors (including trunk lid), and wait for 3 minutes or more without opening these doors.
CAUTION:
Never operate the vehicle and CONSULT while waiting.
8. Turn the ignition switch ON without depressing the brake pedal.
CAUTION:
Never set the vehicle to READY/Never start the engine.
9. Start CONSULT and erase self-diagnosis result of "BRAKE".
10. Turn the ignition switch OFF to exit CONSULT.
11. Get out of the vehicle, close all doors (including trunk lid), and wait for 3 minutes or more without opening these doors.
CAUTION:
Never operate the vehicle and CONSULT while waiting.
12. Turn the ignition switch ON without depressing the brake pedal.
CAUTION:
Never set the vehicle to READY/Never start the engine.
13. Depress brake pedal by 100 mm (3.94 in) or more, and hold the position for 5 seconds or more.
14. Release brake pedal.
15. Start CONSULT and perform "BRAKE" self-diagnosis.

Is DTC "C1A63" detected?

- YES >> GO TO 5.
 NO >> INSPECTION END

5. CHECK IGNITION POWER SUPPLY

1. Connect the brake power supply backup unit harness connector.
2. Turn the ignition switch OFF to exit CONSULT.
3. Get out of the vehicle, close all doors (including trunk lid), and wait for 3 minutes or more without opening these doors.
CAUTION:
Never operate the vehicle and CONSULT while waiting.
4. Disconnect 12V battery cable from negative terminal. Refer to [BR-6, "Precaution for Removing 12V Battery"](#).
5. Disconnect the electrically-driven intelligent brake unit harness connector.
6. Connect 12V battery cable to negative terminal.
7. Check voltage between the electrically-driven intelligent brake unit harness connector and ground.

Electrically-driven intelligent brake unit		—	Voltage
Connector	Terminal		
E87	26	Ground	Approx. 0 V

8. Turn the ignition switch ON without depressing the brake pedal.
CAUTION:
Never set the vehicle to READY/Never start the engine.
9. Check voltage between the electrically-driven intelligent brake unit harness connector and ground.

Electrically-driven intelligent brake unit		—	Voltage
Connector	Terminal		
E87	26	Ground	10 – 16 V

Is the inspection result normal?

C1A63 BRAKE POWER SUPPLY BACKUP UNIT

< DTC/CIRCUIT DIAGNOSIS >

- YES >> GO TO 8.
NO >> GO TO 6.

6. CHECK IGNITION POWER SUPPLY CIRCUIT

1. Turn the ignition switch OFF to exit CONSULT.
2. Get out of the vehicle, close all doors (including trunk lid), and wait for 3 minutes or more without opening these doors.
CAUTION:
Never operate the vehicle and CONSULT while waiting.
3. Disconnect 12V battery cable from negative terminal. Refer to [BR-6, "Precaution for Removing 12V Battery"](#).
4. Check 10A fuse (#46).
5. Disconnect IPDM E/R harness connector.
6. Check continuity between electrically-driven intelligent brake unit and IPDM E/R.

Electrically-driven intelligent brake unit		IPDM E/R		Continuity
Connector	Terminal	Connector	Terminal	
E87	26	E5	12	Existed

7. Check continuity between electrically-driven intelligent brake unit harness connector and ground.

Electrically-driven intelligent brake unit		—	Continuity
Connector	Terminal		
E87	26	Ground	Not existed

Is the inspection result normal?

- YES >> Perform trouble diagnosis for ignition power supply. Refer to [PG-30, "Wiring Diagram - IGNITION POWER SUPPLY -"](#).
- NO >> Repair or replace error-detected parts and GO TO 7.

7. PERFORM SELF-DIAGNOSIS (3)

Ⓟ With CONSULT

1. Connect the electrically-driven intelligent brake unit harness connector.
2. Connect IPDM E/R harness connector.
3. Connect 12V battery cable to negative terminal.
4. Turn the ignition switch OFF to ON without depressing the brake pedal.
CAUTION:
Never set the vehicle to READY/Never start the engine.
5. Repeat step 4 two times or more.
CAUTION:
Be sure to wait for 5 seconds or more after turning the ignition switch OFF.
6. Turn the ignition switch OFF to exit CONSULT.
7. Get out of the vehicle, close all doors (including trunk lid), and wait for 3 minutes or more without opening these doors.
CAUTION:
Never operate the vehicle and CONSULT while waiting.
8. Turn the ignition switch ON without depressing the brake pedal.
CAUTION:
Never set the vehicle to READY/Never start the engine.
9. Start CONSULT and erase self-diagnosis result of "BRAKE".
10. Turn the ignition switch OFF to exit CONSULT.
11. Get out of the vehicle, close all doors (including trunk lid), and wait for 3 minutes or more without opening these doors.
CAUTION:
Never operate the vehicle and CONSULT while waiting.
12. Turn the ignition switch ON without depressing the brake pedal.
CAUTION:
Never set the vehicle to READY/Never start the engine.
13. Depress brake pedal by 100 mm (3.94 in) or more, and hold the position for 5 seconds or more.
14. Release brake pedal.

C1A63 BRAKE POWER SUPPLY BACKUP UNIT

< DTC/CIRCUIT DIAGNOSIS >

15. Start CONSULT and perform "BRAKE" self-diagnosis.

Is DTC "C1A63" detected?

YES >> GO TO 8.

NO >> INSPECTION END

8. CHECK 12V BATTERY POWER SUPPLY

1. Turn the ignition switch OFF to exit CONSULT.

2. Get out of the vehicle, close all doors (including trunk lid), and wait for 3 minutes or more without opening these doors.

CAUTION:

Never operate the vehicle and CONSULT while waiting.

3. Disconnect 12V battery cable from negative terminal. Refer to [BR-6. "Precaution for Removing 12V Battery"](#).

4. Disconnect the electrically-driven intelligent brake unit harness connector.

5. Connect 12V battery cable to negative terminal.

6. Check voltage between the electrically-driven intelligent brake unit harness connector terminals.

Electrically-driven intelligent brake unit		Voltage
Connector	Terminal	
E87	1 – 31	10 – 16 V
	2 – 31	
	11 – 31	

7. Turn the ignition switch ON without depressing the brake pedal.

CAUTION:

Never set the vehicle to READY/Never start the engine.

8. Check voltage between the electrically-driven intelligent brake unit harness connector terminals.

Electrically-driven intelligent brake unit		Voltage
Connector	Terminal	
E87	1 – 31	10 – 16 V
	2 – 31	
	11 – 31	

Is the inspection result normal?

YES >> GO TO 11.

NO >> GO TO 9.

9. CHECK 12V BATTERY POWER SUPPLY CIRCUIT

1. Turn the ignition switch OFF to exit CONSULT.

2. Get out of the vehicle, close all doors (including trunk lid), and wait for 3 minutes or more without opening these doors.

CAUTION:

Never operate the vehicle and CONSULT while waiting.

3. Disconnect 12V battery cable from negative terminal. Refer to [BR-6. "Precaution for Removing 12V Battery"](#).

4. Check 50A fusible link (#D).

5. Check continuity and for short circuit between electrically-driven intelligent brake unit harness connector terminal (1) and 50A fusible link (#D).

6. Check continuity and for short circuit between electrically-driven intelligent brake unit harness connector terminal (2) and 50A fusible link (#D).

7. Check 10A fuse (#65).

8. Check continuity and for short circuit between electrically-driven intelligent brake unit harness connector terminal (11) and 10A fuse (#65).

Is the inspection result normal?

YES >> Perform diagnosis for 12V battery power supply. Refer to [PG-14. "Wiring Diagram - BATTERY POWER SUPPLY -"](#).

C1A63 BRAKE POWER SUPPLY BACKUP UNIT

< DTC/CIRCUIT DIAGNOSIS >

NO >> Repair or replace error-detected parts and GO TO 10.

10. PERFORM SELF-DIAGNOSIS (4)

Ⓟ With CONSULT

1. Connect the electrically-driven intelligent brake unit harness connector.
2. Connect 12V battery cable to negative terminal.
3. Turn the ignition switch OFF to ON without depressing the brake pedal.
CAUTION:
Never set the vehicle to READY/Never start the engine.
4. Repeat step 3 two times or more.
CAUTION:
Be sure to wait for 5 seconds or more after turning the ignition switch OFF.
5. Turn the ignition switch OFF to exit CONSULT.
6. Get out of the vehicle, close all doors (including trunk lid), and wait for 3 minutes or more without opening these doors.
CAUTION:
Never operate the vehicle and CONSULT while waiting.
7. Turn the ignition switch ON without depressing the brake pedal.
CAUTION:
Never set the vehicle to READY/Never start the engine.
8. Start CONSULT and erase self-diagnosis result of "BRAKE".
9. Turn the ignition switch OFF to exit CONSULT.
10. Get out of the vehicle, close all doors (including trunk lid), and wait for 3 minutes or more without opening these doors.
CAUTION:
Never operate the vehicle and CONSULT while waiting.
11. Turn the ignition switch ON without depressing the brake pedal.
CAUTION:
Never set the vehicle to READY/Never start the engine.
12. Depress brake pedal by 100 mm (3.94 in) or more, and hold the position for 5 seconds or more.
13. Release brake pedal.
14. Start CONSULT and perform "BRAKE" self-diagnosis.

Is DTC "C1A63" detected?

YES >> GO TO 11.

NO >> INSPECTION END

11. CHECK GROUND CIRCUIT

1. Turn the ignition switch OFF to exit CONSULT.
2. Get out of the vehicle, close all doors (including trunk lid), and wait for 3 minutes or more without opening these doors.
CAUTION:
Never operate the vehicle and CONSULT while waiting.
3. Disconnect 12V battery cable from negative terminal. Refer to [BR-6, "Precaution for Removing 12V Battery"](#).
4. Disconnect the electrically-driven intelligent brake unit harness connector.
5. Check continuity between electrically-driven intelligent brake unit and ground.

Electrically-driven intelligent brake unit		—	Continuity
Connector	Terminal		
E87	31	Ground	Existed

Is the inspection result normal?

YES >> GO TO 13.

NO >> Repair or replace error-detected parts and GO TO 12.

12. PERFORM SELF-DIAGNOSIS (5)

Ⓟ With CONSULT

1. Connect the electrically-driven intelligent brake unit harness connector.
2. Connect 12V battery cable to negative terminal.
3. Turn the ignition switch OFF to ON without depressing the brake pedal.

C1A63 BRAKE POWER SUPPLY BACKUP UNIT

< DTC/CIRCUIT DIAGNOSIS >

CAUTION:

Never set the vehicle to READY/Never start the engine.

4. Repeat step 3 two times or more.

CAUTION:

Be sure to wait for 5 seconds or more after turning the ignition switch OFF.

5. Turn the ignition switch OFF to exit CONSULT.
6. Get out of the vehicle, close all doors (including trunk lid), and wait for 3 minutes or more without opening these doors.

CAUTION:

Never operate the vehicle and CONSULT while waiting.

7. Turn the ignition switch ON without depressing the brake pedal.

CAUTION:

Never set the vehicle to READY/Never start the engine.

8. Start CONSULT and erase self-diagnosis result of "BRAKE".
9. Turn the ignition switch OFF to exit CONSULT.
10. Get out of the vehicle, close all doors (including trunk lid), and wait for 3 minutes or more without opening these doors.

CAUTION:

Never operate the vehicle and CONSULT while waiting.

11. Turn the ignition switch ON without depressing the brake pedal.

CAUTION:

Never set the vehicle to READY/Never start the engine.

12. Depress brake pedal by 100 mm (3.94 in) or more, and hold the position for 5 seconds or more.
13. Release brake pedal.
14. Start CONSULT and perform "BRAKE" self-diagnosis.

Is DTC "C1A63" detected?

YES >> GO TO 13.

NO >> INSPECTION END

13. CHECK DATA MONITOR

 With CONSULT

1. Connect the electrically-driven intelligent brake unit harness connector.
2. Connect 12V battery cable to negative terminal.
3. Turn the ignition switch OFF to ON without depressing the brake pedal.

CAUTION:

Never set the vehicle to READY/Never start the engine.

4. Repeat step 2 two times or more.

CAUTION:

Be sure to wait for 5 seconds or more after turning the ignition switch OFF.

5. Start CONSULT and select "BRAKE" and "DATA MONITOR" according to this order.
6. Check "MOTOR POWER SUPPLY" and "CONTROL MODULE POWER". Refer to [BR-33, "Reference Value"](#).

Is the inspection result normal?

YES >> GO TO 14.

NO >> Replace the electrically-driven intelligent brake unit. Refer to [BR-288, "Removal and installation"](#).

14. PERFORM SELF-DIAGNOSIS (6)

 With CONSULT

1. Turn the ignition switch OFF to ON without depressing the brake pedal.

CAUTION:

Never set the vehicle to READY/Never start the engine.

2. Repeat step 1 two times or more.

CAUTION:

Be sure to wait for 5 seconds or more after turning the ignition switch OFF.

3. Turn the ignition switch OFF to exit CONSULT.
4. Get out of the vehicle, close all doors (including trunk lid), and wait for 3 minutes or more without opening these doors.

CAUTION:

Never operate the vehicle and CONSULT while waiting.

5. Turn the ignition switch ON without depressing the brake pedal.

C1A63 BRAKE POWER SUPPLY BACKUP UNIT

< DTC/CIRCUIT DIAGNOSIS >

CAUTION:

Never set the vehicle to READY/Never start the engine.

6. Start CONSULT and erase self-diagnosis result of "BRAKE".
7. Turn the ignition switch OFF to exit CONSULT.
8. Get out of the vehicle, close all doors (including trunk lid), and wait for 3 minutes or more without opening these doors.

CAUTION:

Never operate the vehicle and CONSULT while waiting.

9. Turn the ignition switch ON without depressing the brake pedal.

CAUTION:

Never set the vehicle to READY/Never start the engine.

10. Depress brake pedal by 100 mm (3.94 in) or more, and hold the position for 5 seconds or more.
11. Release brake pedal.
12. Start CONSULT and perform "BRAKE" self-diagnosis.

Is DTC "C1A63", "C1A6B", "C1A6C" or "C1A6D" detected?

- YES (C1A63)>>GO TO 15.
- YES (C1A6B)>>Refer to [BR-161, "Diagnosis Procedure"](#).
- YES (C1A6C)>>Refer to [BR-172, "Diagnosis Procedure"](#).
- YES (C1A6D)>>Refer to [BR-180, "Diagnosis Procedure"](#).
- NO >> INSPECTION END

15.CHECK CIRCUIT BETWEEN ELECTRICALLY-DRIVEN INTELLIGENT BRAKE UNIT AND BRAKE POWER SUPPLY BACKUP UNIT

1. Turn the ignition switch OFF to exit CONSULT.
2. Get out of the vehicle, close all doors (including trunk lid), and wait for 3 minutes or more without opening these doors.

CAUTION:

Never operate the vehicle and CONSULT while waiting.

3. Disconnect 12V battery cable from negative terminal. Refer to [BR-6, "Precaution for Removing 12V Battery"](#).
4. Disconnect the electrically-driven intelligent brake unit harness connector.
5. Check continuity between electrically-driven intelligent brake unit and ground.

Electrically-driven intelligent brake unit		—	Continuity
Connector	Terminal		
E87	31	Ground	Existed

6. Check continuity between electrically-driven intelligent brake unit and ground.

Electrically-driven intelligent brake unit		—	Continuity
Connector	Terminal		
E87	32	Ground	Not existed

7. Disconnect the brake power supply backup unit harness connector.
8. Check continuity between electrically-driven intelligent brake unit and brake power supply backup unit.

Electrically-driven intelligent brake unit		Brake power supply backup unit		Continuity
Connector	Terminal	Connector	Terminal	
E87	32	B155	2	Existed

Is the inspection result normal?

- YES >> GO TO 16.
- NO >> Repair or replace error-detected parts and GO TO 16.

16.CHECK BRAKE POWER SUPPLY BACKUP UNIT GROUND CIRCUIT

Check continuity between brake power supply backup unit and ground.

C1A63 BRAKE POWER SUPPLY BACKUP UNIT

< DTC/CIRCUIT DIAGNOSIS >

Brake power supply backup unit		—	Continuity
Connector	Terminal		
B155	1	Ground	Existed

Is the inspection result normal?

YES >> GO TO 17.

NO >> Repair or replace error-detected parts and GO TO 17.

17.PERFORM SELF-DIAGNOSIS (7)

Ⓜ With CONSULT

1. Connect the electrically-driven intelligent brake unit harness connector.
2. Connect the brake power supply backup unit harness connector.
3. Connect 12V battery cable to negative terminal.
4. Turn the ignition switch OFF to ON without depressing the brake pedal.
CAUTION:
Never set the vehicle to READY/Never start the engine.
5. Repeat step 4 two times or more.
CAUTION:
Be sure to wait for 5 seconds or more after turning the ignition switch OFF.
6. Turn the ignition switch OFF to exit CONSULT.
7. Get out of the vehicle, close all doors (including trunk lid), and wait for 3 minutes or more without opening these doors.
CAUTION:
Never operate the vehicle and CONSULT while waiting.
8. Turn the ignition switch ON without depressing the brake pedal.
CAUTION:
Never set the vehicle to READY/Never start the engine.
9. Start CONSULT and erase self-diagnosis result of "BRAKE".
10. Turn the ignition switch OFF to exit CONSULT.
11. Get out of the vehicle, close all doors (including trunk lid), and wait for 3 minutes or more without opening these doors.
CAUTION:
Never operate the vehicle and CONSULT while waiting.
12. Turn the ignition switch ON without depressing the brake pedal.
CAUTION:
Never set the vehicle to READY/Never start the engine.
13. Depress brake pedal by 100 mm (3.94 in) or more, and hold the position for 5 seconds or more.
14. Release brake pedal.
15. Start CONSULT and perform "BRAKE" self-diagnosis.

Is DTC "C1A63" detected?

YES >> Replace the electrically-driven intelligent brake unit. Refer to [BR-288, "Removal and installation"](#).

NO >> INSPECTION END

C1A64 STROKE SENSOR

< DTC/CIRCUIT DIAGNOSIS >

C1A64 STROKE SENSOR

DTC Logic

INFOID:000000008139815

DTC DETECTION LOGIC

DTC	Display item	Malfunction detection condition	Possible causes
C1A64	STROKE SENSOR	<ul style="list-style-type: none">• Open circuit is detected in rear stroke sensor circuit.• Short circuit is detected in stroke sensor circuit.• Malfunction is detected in stroke sensor circuit.	<ul style="list-style-type: none">• Harness or connector• Stroke sensor• Electrically-driven intelligent brake unit• Stroke sensor improper installation

DTC CONFIRMATION PROCEDURE

1. PRECONDITIONING

If "DTC CONFIRMATION PROCEDURE" has been previously conducted, always turn the ignition switch OFF and wait at least 10 seconds before conducting the next test.

>> GO TO 2.

2. CHECK DTC DETECTION

Ⓜ With CONSULT

1. Turn the ignition switch OFF to ON without depressing the brake pedal.
CAUTION:
Never set the vehicle to READY/Never start the engine.
2. Repeat step 1 two times or more.
CAUTION:
Be sure to wait for 5 seconds or more after turning the ignition switch OFF.
3. Turn the ignition switch OFF to exit CONSULT.
4. Get out of the vehicle, close all doors (including trunk lid), and wait for 3 minutes or more without opening these doors.
CAUTION:
Never operate the vehicle and CONSULT while waiting.
5. Turn the ignition switch ON without depressing the brake pedal.
CAUTION:
Never set the vehicle to READY/Never start the engine.
6. Start CONSULT and erase self-diagnosis result of "BRAKE".
7. Turn the ignition switch OFF to exit CONSULT.
8. Get out of the vehicle, close all doors (including trunk lid), and wait for 3 minutes or more without opening these doors.
CAUTION:
Never operate the vehicle and CONSULT while waiting.
9. Turn the ignition switch ON without depressing the brake pedal.
CAUTION:
Never set the vehicle to READY/Never start the engine.
10. Depress brake pedal by 100 mm (3.94 in) or more, and hold the position for 5 seconds or more.
11. Release brake pedal.
12. Start CONSULT and perform "BRAKE" self-diagnosis.

Is DTC "C1A64" detected?

- YES >> Proceed to [BR-84, "Diagnosis Procedure"](#).
NO >> INSPECTION END

Diagnosis Procedure

INFOID:000000008139816

1. CHECK 12V BATTERY

1. Turn the ignition switch OFF to exit CONSULT.

C1A64 STROKE SENSOR

< DTC/CIRCUIT DIAGNOSIS >

2. Get out of the vehicle, close all doors (including trunk lid), and wait for 3 minutes or more without opening these doors.
CAUTION:
Never operate the vehicle and CONSULT while waiting.
3. Check the 12V battery terminal connections. Refer to [BR-6, "Precaution for Removing 12V Battery"](#) and [PG-135, "Work Flow"](#).
4. Check the 12V battery. Refer to [PG-135, "Work Flow"](#).

Is the inspection result normal?

YES >> GO TO 2.

NO >> Repair or replace error-detected parts and GO TO 2.

2.PERFORM SELF-DIAGNOSIS (1)

 With CONSULT

1. Connect 12V battery cable to negative terminal.
2. Turn the ignition switch OFF to ON without depressing the brake pedal.
CAUTION:
Never set the vehicle to READY/Never start the engine.
3. Repeat step 2 two times or more.
CAUTION:
Be sure to wait for 5 seconds or more after turning the ignition switch OFF.
4. Turn the ignition switch OFF to exit CONSULT.
5. Get out of the vehicle, close all doors (including trunk lid), and wait for 3 minutes or more without opening these doors.
CAUTION:
Never operate the vehicle and CONSULT while waiting.
6. Turn the ignition switch ON without depressing the brake pedal.
CAUTION:
Never set the vehicle to READY/Never start the engine.
7. Start CONSULT and erase self-diagnosis result of "BRAKE".
8. Turn the ignition switch OFF to exit CONSULT.
9. Get out of the vehicle, close all doors (including trunk lid), and wait for 3 minutes or more without opening these doors.
CAUTION:
Never operate the vehicle and CONSULT while waiting.
10. Turn the ignition switch ON without depressing the brake pedal.
CAUTION:
Never set the vehicle to READY/Never start the engine.
11. Depress brake pedal by 100 mm (3.94 in) or more, and hold the position for 5 seconds or more.
12. Release brake pedal.
13. Start CONSULT and perform "BRAKE" self-diagnosis.

Is DTC "C1A64" detected?

YES >> GO TO 3.

NO >> INSPECTION END

3.CHECK CONNECTOR TERMINALS

1. Turn the ignition switch OFF to exit CONSULT.
2. Get out of the vehicle, close all doors (including trunk lid), and wait for 3 minutes or more without opening these doors.
CAUTION:
Never operate the vehicle and CONSULT while waiting.
3. Disconnect 12V battery cable from negative terminal. Refer to [BR-6, "Precaution for Removing 12V Battery"](#).
4. Disconnect the electrically-driven intelligent brake unit harness connector, then check for failures of pin terminals and connections.
5. Disconnect the stroke sensor harness connector, then check for failures of pin terminals and connections.

Is the inspection result normal?

YES >> GO TO 5.

NO >> Repair or replace error-detected parts and GO TO 4.

4.PERFORM SELF-DIAGNOSIS (2)

C1A64 STROKE SENSOR

< DTC/CIRCUIT DIAGNOSIS >

Ⓟ With CONSULT

1. Connect the electrically-driven intelligent brake unit harness connector.
2. Connect stroke sensor harness connector.
3. Connect 12V battery cable to negative terminal.
4. Turn the ignition switch OFF to ON without depressing the brake pedal.
CAUTION:
Never set the vehicle to READY/Never start the engine.
5. Repeat step 4 two times or more.
CAUTION:
Be sure to wait for 5 seconds or more after turning the ignition switch OFF.
6. Turn the ignition switch OFF to exit CONSULT.
7. Get out of the vehicle, close all doors (including trunk lid), and wait for 3 minutes or more without opening these doors.
CAUTION:
Never operate the vehicle and CONSULT while waiting.
8. Turn the ignition switch ON without depressing the brake pedal.
CAUTION:
Never set the vehicle to READY/Never start the engine.
9. Start CONSULT and erase self-diagnosis result of "BRAKE".
10. Turn the ignition switch OFF to exit CONSULT.
11. Get out of the vehicle, close all doors (including trunk lid), and wait for 3 minutes or more without opening these doors.
CAUTION:
Never operate the vehicle and CONSULT while waiting.
12. Turn the ignition switch ON without depressing the brake pedal.
CAUTION:
Never set the vehicle to READY/Never start the engine.
13. Depress brake pedal by 100 mm (3.94 in) or more, and hold the position for 5 seconds or more.
14. Release brake pedal.
15. Start CONSULT and perform "BRAKE" self-diagnosis.

Is DTC "C1A64" detected?

- YES >> GO TO 5.
NO >> INSPECTION END

5. CHECK IGNITION POWER SUPPLY

1. Connect stroke sensor harness connector.
2. Turn the ignition switch OFF to exit CONSULT.
3. Get out of the vehicle, close all doors (including trunk lid), and wait for 3 minutes or more without opening these doors.
CAUTION:
Never operate the vehicle and CONSULT while waiting.
4. Disconnect 12V battery cable from negative terminal. Refer to [BR-6. "Precaution for Removing 12V Battery"](#).
5. Disconnect the electrically-driven intelligent brake unit harness connector.
6. Connect 12V battery cable to negative terminal.
7. Check voltage between the electrically-driven intelligent brake unit harness connector and ground.

Electrically-driven intelligent brake unit		—	Voltage
Connector	Terminal		
E87	26	Ground	Approx. 0 V

8. Turn the ignition switch ON without depressing the brake pedal.
CAUTION:
Never set the vehicle to READY/Never start the engine.
9. Check voltage between the electrically-driven intelligent brake unit harness connector and ground.

Electrically-driven intelligent brake unit		—	Voltage
Connector	Terminal		
E87	26	Ground	10 – 16 V

C1A64 STROKE SENSOR

< DTC/CIRCUIT DIAGNOSIS >

Is the inspection result normal?

YES >> GO TO 8.

NO >> GO TO 6.

6. CHECK IGNITION POWER SUPPLY CIRCUIT

1. Turn the ignition switch OFF to exit CONSULT.
2. Get out of the vehicle, close all doors (including trunk lid), and wait for 3 minutes or more without opening these doors.
CAUTION:
Never operate the vehicle and CONSULT while waiting.
3. Disconnect 12V battery cable from negative terminal. Refer to [BR-6, "Precaution for Removing 12V Battery"](#).
4. Check 10A fuse (#46).
5. Disconnect IPDM E/R harness connector.
6. Check continuity between electrically-driven intelligent brake unit and IPDM E/R.

Electrically-driven intelligent brake unit		IPDM E/R		Continuity
Connector	Terminal	Connector	Terminal	
E87	26	E5	12	Existed

7. Check continuity between electrically-driven intelligent brake unit harness connector and ground.

Electrically-driven intelligent brake unit		—	Continuity
Connector	Terminal		
E87	26	Ground	Not existed

Is the inspection result normal?

YES >> Perform trouble diagnosis for ignition power supply. Refer to [PG-30, "Wiring Diagram - IGNITION POWER SUPPLY -"](#).

NO >> Repair or replace error-detected parts and GO TO 7.

7. PERFORM SELF-DIAGNOSIS (3)

Ⓜ With CONSULT

1. Connect the electrically-driven intelligent brake unit harness connector.
2. Connect IPDM E/R harness connector.
3. Connect 12V battery cable to negative terminal.
4. Turn the ignition switch OFF to ON without depressing the brake pedal.
CAUTION:
Never set the vehicle to READY/Never start the engine.
5. Repeat step 4 two times or more.
CAUTION:
Be sure to wait for 5 seconds or more after turning the ignition switch OFF.
6. Turn the ignition switch OFF to exit CONSULT.
7. Get out of the vehicle, close all doors (including trunk lid), and wait for 3 minutes or more without opening these doors.
CAUTION:
Never operate the vehicle and CONSULT while waiting.
8. Turn the ignition switch ON without depressing the brake pedal.
CAUTION:
Never set the vehicle to READY/Never start the engine.
9. Start CONSULT and erase self-diagnosis result of "BRAKE".
10. Turn the ignition switch OFF to exit CONSULT.
11. Get out of the vehicle, close all doors (including trunk lid), and wait for 3 minutes or more without opening these doors.
CAUTION:
Never operate the vehicle and CONSULT while waiting.
12. Turn the ignition switch ON without depressing the brake pedal.
CAUTION:
Never set the vehicle to READY/Never start the engine.

C1A64 STROKE SENSOR

< DTC/CIRCUIT DIAGNOSIS >

13. Depress brake pedal by 100 mm (3.94 in) or more, and hold the position for 5 seconds or more.
14. Release brake pedal.
15. Start CONSULT and perform "BRAKE" self-diagnosis.

Is DTC "C1A64" detected?

- YES >> GO TO 8.
NO >> INSPECTION END

8. CHECK 12V BATTERY POWER SUPPLY

1. Turn the ignition switch OFF to exit CONSULT.
2. Get out of the vehicle, close all doors (including trunk lid), and wait for 3 minutes or more without opening these doors.
CAUTION:
Never operate the vehicle and CONSULT while waiting.
3. Disconnect 12V battery cable from negative terminal. Refer to [BR-6. "Precaution for Removing 12V Battery"](#).
4. Disconnect the electrically-driven intelligent brake unit harness connector.
5. Connect 12V battery cable to negative terminal.
6. Check voltage between the electrically-driven intelligent brake unit harness connector terminals.

Electrically-driven intelligent brake unit		Voltage
Connector	Terminal	
E87	1 - 31	10 - 16 V
	2 - 31	
	11 - 31	

7. Turn the ignition switch ON without depressing the brake pedal.
CAUTION:
Never set the vehicle to READY/Never start the engine.
8. Check voltage between the electrically-driven intelligent brake unit harness connector terminal.

Electrically-driven intelligent brake unit		Voltage
Connector	Terminal	
E87	1 - 31	10 - 16 V
	2 - 31	
	11 - 31	

Is the inspection result normal?

- YES >> GO TO 11.
NO >> GO TO 9.

9. CHECK 12V BATTERY POWER SUPPLY CIRCUIT

1. Turn the ignition switch OFF to exit CONSULT.
2. Get out of the vehicle, close all doors (including trunk lid), and wait for 3 minutes or more without opening these doors.
CAUTION:
Never operate the vehicle and CONSULT while waiting.
3. Disconnect 12V battery cable from negative terminal. Refer to [BR-6. "Precaution for Removing 12V Battery"](#).
4. Check 50A fusible link (#D).
5. Check continuity and for short circuit between electrically-driven intelligent brake unit harness connector terminal (1) and 50A fusible link (#D).
6. Check continuity and for short circuit between electrically-driven intelligent brake unit harness connector terminal (2) and 50A fusible link (#D).
7. Check 10A fuse (#65).
8. Check continuity and for short circuit between electrically-driven intelligent brake unit harness connector terminal (11) and 10A fuse (#65).

Is the inspection result normal?

C1A64 STROKE SENSOR

< DTC/CIRCUIT DIAGNOSIS >

- YES >> Perform diagnosis for 12V battery power supply. Refer to [PG-14, "Wiring Diagram - BATTERY POWER SUPPLY -"](#).
- NO >> Repair or replace error-detected parts and GO TO 10.

10.PERFORM SELF-DIAGNOSIS (4)

Ⓜ With CONSULT

1. Connect the electrically-driven intelligent brake unit harness connector.
2. Connect 12V battery cable to negative terminal.
3. Turn the ignition switch OFF to ON without depressing the brake pedal.
CAUTION:
Never set the vehicle to READY/Never start the engine.
4. Repeat step 3 two times or more.
CAUTION:
Be sure to wait for 5 seconds or more after turning the ignition switch OFF.
5. Turn the ignition switch OFF to exit CONSULT.
6. Get out of the vehicle, close all doors (including trunk lid), and wait for 3 minutes or more without opening these doors.
CAUTION:
Never operate the vehicle and CONSULT while waiting.
7. Turn the ignition switch ON without depressing the brake pedal.
CAUTION:
Never set the vehicle to READY/Never start the engine.
8. Start CONSULT and erase self-diagnosis result of "BRAKE".
9. Turn the ignition switch OFF to exit CONSULT.
10. Get out of the vehicle, close all doors (including trunk lid), and wait for 3 minutes or more without opening these doors.
CAUTION:
Never operate the vehicle and CONSULT while waiting.
11. Turn the ignition switch ON without depressing the brake pedal.
CAUTION:
Never set the vehicle to READY/Never start the engine.
12. Depress brake pedal by 100 mm (3.94 in) or more, and hold the position for 5 seconds or more.
13. Release brake pedal.
14. Start CONSULT and perform "BRAKE" self-diagnosis.

Is DTC "C1A64" detected?

- YES >> GO TO 11.
- NO >> INSPECTION END

11.CHECK GROUND CIRCUIT

1. Turn the ignition switch OFF to exit CONSULT.
2. Get out of the vehicle, close all doors (including trunk lid), and wait for 3 minutes or more without opening these doors.
CAUTION:
Never operate the vehicle and CONSULT while waiting.
3. Disconnect 12V battery cable from negative terminal. Refer to [BR-6, "Precaution for Removing 12V Battery"](#).
4. Disconnect the electrically-driven intelligent brake unit harness connector.
5. Check continuity between electrically-driven intelligent brake unit and ground.

Electrically-driven intelligent brake unit		—	Continuity
Connector	Terminal		
E87	31	Ground	Existed

Is the inspection result normal?

- YES >> GO TO 13.
- NO >> Repair or replace error-detected parts and GO TO 12.

12.PERFORM SELF-DIAGNOSIS (5)

Ⓜ With CONSULT

1. Connect the electrically-driven intelligent brake unit harness connector.

C1A64 STROKE SENSOR

< DTC/CIRCUIT DIAGNOSIS >

2. Connect 12V battery cable to negative terminal.
3. Turn the ignition switch OFF to ON without depressing the brake pedal.
CAUTION:
Never set the vehicle to READY/Never start the engine.
4. Repeat step 1 two times or more.
CAUTION:
Be sure to wait for 5 seconds or more after turning the ignition switch OFF.
5. Turn the ignition switch OFF to exit CONSULT.
6. Get out of the vehicle, close all doors (including trunk lid), and wait for 3 minutes or more without opening these doors.
CAUTION:
Never operate the vehicle and CONSULT while waiting.
7. Turn the ignition switch ON without depressing the brake pedal.
CAUTION:
Never set the vehicle to READY/Never start the engine.
8. Start CONSULT and erase self-diagnosis result of "BRAKE".
9. Turn the ignition switch OFF to exit CONSULT.
10. Get out of the vehicle, close all doors (including trunk lid), and wait for 3 minutes or more without opening these doors.
CAUTION:
Never operate the vehicle and CONSULT while waiting.
11. Turn the ignition switch ON without depressing the brake pedal.
CAUTION:
Never set the vehicle to READY/Never start the engine.
12. Depress brake pedal by 100 mm (3.94 in) or more, and hold the position for 5 seconds or more.
13. Release brake pedal.
14. Start CONSULT and perform "BRAKE" self-diagnosis.

Is DTC "C1A64" detected?

YES >> GO TO 13.

NO >> INSPECTION END

13. CHECK DATA MONITOR

With CONSULT

1. Connect the electrically-driven intelligent brake unit harness connector.
2. Connect 12V battery cable to negative terminal.
3. Turn the ignition switch OFF to ON without depressing the brake pedal.
CAUTION:
Never set the vehicle to READY/Never start the engine.
4. Repeat step 3 two times or more.
CAUTION:
Be sure to wait for 5 seconds or more after turning the ignition switch OFF.
5. Start CONSULT and select "BRAKE" and "DATA MONITOR" according to this order.
6. Check "MOTOR POWER SUPPLY" and "CONTROL MODULE POWER". Refer to [BR-33. "Reference Value"](#).

Is the inspection result normal?

YES >> GO TO 14.

NO >> Replace the electrically-driven intelligent brake unit. Refer to [BR-288. "Removal and installation"](#)

14. PERFORM SELF-DIAGNOSIS (6)

With CONSULT

1. Turn the ignition switch OFF to ON without depressing the brake pedal.
CAUTION:
Never set the vehicle to READY/Never start the engine.
2. Repeat step 1 two times or more.
CAUTION:
Be sure to wait for 5 seconds or more after turning the ignition switch OFF.
3. Turn the ignition switch OFF to exit CONSULT.
4. Get out of the vehicle, close all doors (including trunk lid), and wait for 3 minutes or more without opening these doors.
CAUTION:

C1A64 STROKE SENSOR

< DTC/CIRCUIT DIAGNOSIS >

Never operate the vehicle and CONSULT while waiting.

5. Turn the ignition switch ON without depressing the brake pedal.

CAUTION:

Never set the vehicle to READY/Never start the engine.

6. Start CONSULT and erase self-diagnosis result of "BRAKE".
7. Turn the ignition switch OFF to exit CONSULT.
8. Get out of the vehicle, close all doors (including trunk lid), and wait for 3 minutes or more without opening these doors.

CAUTION:

Never operate the vehicle and CONSULT while waiting.

9. Turn the ignition switch ON without depressing the brake pedal.

CAUTION:

Never set the vehicle to READY/Never start the engine.

10. Depress brake pedal by 100 mm (3.94 in) or more, and hold the position for 5 seconds or more.
11. Release brake pedal.
12. Start CONSULT and perform "BRAKE" self-diagnosis.

Is DTC "C1A64" detected?

YES >> GO TO 15.

NO >> INSPECTION END

15. STROKE SENSOR 0 POINT LEARNING (1)

 With CONSULT

Perform stroke sensor 0 point learning. Refer to [BR-47, "Work Procedure"](#).

Was either "COMPLETED" or "The operation is incomplete. Try again after confirming the operation condition." displayed?

"COMPLETED">>GO TO 16.

"The operation is incomplete. Try again after confirming the operation condition.">>GO TO 17.

16. PERFORM SELF-DIAGNOSIS (7)

 With CONSULT

1. Turn the ignition switch OFF to ON without depressing the brake pedal.

CAUTION:

Never set the vehicle to READY/Never start the engine.

2. Repeat step 1 two times or more.

CAUTION:

Be sure to wait for 5 seconds or more after turning the ignition switch OFF.

3. Turn the ignition switch OFF to exit CONSULT.
4. Get out of the vehicle, close all doors (including trunk lid), and wait for 3 minutes or more without opening these doors.

CAUTION:

Never operate the vehicle and CONSULT while waiting.

5. Turn the ignition switch ON without depressing the brake pedal.

CAUTION:

Never set the vehicle to READY/Never start the engine.

6. Start CONSULT and erase self-diagnosis result of "BRAKE".
7. Turn the ignition switch OFF to exit CONSULT.
8. Get out of the vehicle, close all doors (including trunk lid), and wait for 3 minutes or more without opening these doors.

CAUTION:

Never operate the vehicle and CONSULT while waiting.

9. Turn the ignition switch ON without depressing the brake pedal.

CAUTION:

Never set the vehicle to READY/Never start the engine.

10. Depress brake pedal by 100 mm (3.94 in) or more, and hold the position for 5 seconds or more.
11. Release brake pedal.
12. Start CONSULT and perform "BRAKE" self-diagnosis.

Is DTC "C1A64" detected?

YES >> GO TO 17.

NO >> INSPECTION END

C1A64 STROKE SENSOR

< DTC/CIRCUIT DIAGNOSIS >

17. VISUALLY CHECK STROKE SENSOR

Check the stroke sensor for damage.

Is the inspection result normal?

YES >> GO TO 18.

NO >> Repair or replace error-detected parts and GO TO 21.

18. CHECK STROKE SENSOR INSTALLATION

Check the stroke sensor for looseness and disconnection.

Is the inspection result normal?

YES >> GO TO 19.

NO >> Repair or replace error-detected parts and GO TO 21.

19. CHECK BRAKE PEDAL HEIGHT

Check each brake pedal height. Refer to [BR-270, "Inspection and Adjustment"](#).

Is the inspection result normal?

YES >> GO TO 20.

NO >> Adjust each height. Refer to [BR-270, "Inspection and Adjustment"](#). GO TO 21.

20. STROKE SENSOR 0 POINT LEARNING (2)

Perform stroke sensor 0 point learning. Refer to [BR-47, "Work Procedure"](#).

>> GO TO 21.

21. PERFORM SELF-DIAGNOSIS (8)

Ⓜ With CONSULT

1. Turn the ignition switch OFF to ON without depressing the brake pedal.

CAUTION:

Never set the vehicle to READY/Never start the engine.

2. Repeat step 1 two times or more.

CAUTION:

Be sure to wait for 5 seconds or more after turning the ignition switch OFF.

3. Turn the ignition switch OFF to exit CONSULT.

4. Get out of the vehicle, close all doors (including trunk lid), and wait for 3 minutes or more without opening these doors.

CAUTION:

Never operate the vehicle and CONSULT while waiting.

5. Turn the ignition switch ON without depressing the brake pedal.

CAUTION:

Never set the vehicle to READY/Never start the engine.

6. Start CONSULT and erase self-diagnosis result of "BRAKE".

7. Turn the ignition switch OFF to exit CONSULT.

8. Get out of the vehicle, close all doors (including trunk lid), and wait for 3 minutes or more without opening these doors.

CAUTION:

Never operate the vehicle and CONSULT while waiting.

9. Turn the ignition switch ON without depressing the brake pedal.

CAUTION:

Never set the vehicle to READY/Never start the engine.

10. Depress brake pedal by 100 mm (3.94 in) or more, and hold the position for 5 seconds or more.

11. Release brake pedal.

12. Start CONSULT and perform "BRAKE" self-diagnosis.

Is DTC "C1A64" detected?

YES >> GO TO 22.

NO >> INSPECTION END

22. CHECK STROKE SENSOR CIRCUIT (1)

1. Turn the ignition switch OFF to exit CONSULT.

C1A64 STROKE SENSOR

< DTC/CIRCUIT DIAGNOSIS >

2. Get out of the vehicle, close all doors (including trunk lid), and wait for 3 minutes or more without opening these doors.
CAUTION:
Never operate the vehicle and CONSULT while waiting.
3. Disconnect the stroke sensor harness connector.
4. Disconnect 12V battery cable from negative terminal. Refer to [BR-6, "Precaution for Removing 12V Battery"](#).
5. Disconnect the electrically-driven intelligent brake unit harness connector.
6. Check continuity between stroke sensor harness connector and electrically-driven intelligent brake unit.

Stroke sensor		Electrically-driven intelligent brake unit		Continuity
Connector	Terminal	Connector	Terminal	
E86	3	E87	19	Existed
	3		35	Not existed
	3		5	Not existed
	3		37	Not existed
	4		19	Not existed
	4		35	Existed
	4		5	Not existed
	4		37	Not existed
	1		19	Not existed
	1		35	Not existed
	1		5	Existed
	1		37	Not existed
	2		19	Not existed
	2		35	Not existed
	2		5	Not existed
	2		37	Existed

Is the inspection result normal?

YES >> GO TO 23.

NO >> Repair or replace error-detected parts and GO TO 28.

23.CHECK STROKE SENSOR POWER SUPPLY

1. Connect the electrically-driven intelligent brake unit harness connector.
2. Connect 12V battery cable to negative terminal.
3. Get out of the vehicle, close all doors (including trunk lid), and wait for 3 minutes or more without opening these doors.
CAUTION:
Never operate the vehicle and CONSULT while waiting.
4. Turn the ignition switch ON without depressing the brake pedal.
CAUTION:
Never set the vehicle to READY/Never start the engine.
5. Check the stroke sensor power voltage.

Stroke sensor		—	Voltage
Connector	Terminal		
E86	3	Ground	4.75 – 5.25 V

Is the inspection result normal?

YES >> GO TO 24.

NO >> Repair or replace error-detected parts and GO TO 24.

24.CHECK STROKE SENSOR CIRCUIT (2)

C1A64 STROKE SENSOR

< DTC/CIRCUIT DIAGNOSIS >

1. Turn the power switch OFF to exit CONSULT.
2. Get out of the vehicle, close all doors (including trunk lid), and wait for 3 minutes or more without opening these doors.
CAUTION:
Never operate the vehicle and CONSULT while waiting.
3. Disconnect 12V battery cable from negative terminal. Refer to [BR-6. "Precaution for Removing 12V Battery"](#).
4. Disconnect the stroke sensor harness connector.
5. Disconnect the electrically-driven intelligent brake unit harness connector.
6. Check the continuity between stroke sensor and ground.

Stroke sensor		—	Voltage
Connector	Terminal		
E86	2	Ground	4.75 – 5.25 V

Is the inspection result normal?

- YES >> GO TO 25.
NO >> Repair or replace error-detected parts and GO TO 25.

25.CHECK STROKE SENSOR RESISTANCE

1. Turn the ignition switch OFF to exit CONSULT.
2. Get out of the vehicle, close all doors (including trunk lid), and wait for 3 minutes or more without opening these doors.
CAUTION:
Never operate the vehicle and CONSULT while waiting.
3. Disconnect 12V battery cable from negative terminal. Refer to [BR-6. "Precaution for Removing 12V Battery"](#).
4. Connect stroke sensor harness connector.
5. Disconnect the electrically-driven intelligent brake unit harness connector.
6. Check resistance between stroke sensor connector pin terminals.

Electrically-driven intelligent brake unit		Condition	Resistance
Connector	Terminal		
E87	35 – 5	Gradually depress the brake pedal.	Resistance value decreases between 0.1 – 1.33 kΩ, according to the depth of brake depression.
	37 – 5		Resistance value increases between 0.1 – 1.33 kΩ, according to the depth of brake depression.

Is the inspection result normal?

- YES >> GO TO 28.
NO >> GO TO 26.

26.REPLACE STROKE SENSOR

Replace the stroke sensor. Refer to [BR-280. "Removal and Installation"](#).

>> GO TO 27.

27.STROKE SENOR 0 POINT LEARNING (3)

1. Connect the electrically-driven intelligent brake unit harness connector.
2. Perform stroke sensor 0 point learning. Refer to [BR-47. "Work Procedure"](#).

>> GO TO 28.

28.PERFORM SELF-DIAGNOSIS (9)

ⓅWith CONSULT

1. Connect the electrically-driven intelligent brake unit harness connector.
2. Connect 12V battery cable to negative terminal.
3. Turn the ignition switch OFF to ON without depressing the brake pedal.

C1A64 STROKE SENSOR

< DTC/CIRCUIT DIAGNOSIS >

CAUTION:

Never set the vehicle to READY/Never start the engine.

4. Repeat step 2 two times or more.

CAUTION:

Be sure to wait for 5 seconds or more after turning the ignition switch OFF.

5. Turn the ignition switch OFF to exit CONSULT.
6. Get out of the vehicle, close all doors (including trunk lid), and wait for 3 minutes or more without opening these doors.

CAUTION:

Never operate the vehicle and CONSULT while waiting.

7. Turn the ignition switch ON without depressing the brake pedal.

CAUTION:

Never set the vehicle to READY/Never start the engine.

8. Start CONSULT and erase self-diagnosis result of "BRAKE".
9. Turn the ignition switch OFF to exit CONSULT.
10. Get out of the vehicle, close all doors (including trunk lid), and wait for 3 minutes or more without opening these doors.

CAUTION:

Never operate the vehicle and CONSULT while waiting.

11. Turn the ignition switch ON without depressing the brake pedal.

CAUTION:

Never set the vehicle to READY/Never start the engine.

12. Depress brake pedal by 100 mm (3.94 in) or more, and hold the position for 5 seconds or more.
13. Release brake pedal.
14. Start CONSULT and perform "BRAKE" self-diagnosis.

Is DTC "C1A64" detected?

YES >> GO TO 22.

NO >> INSPECTION END

A
B
C
D
E
BR
G
H
I
J
K
L
M
N
O
P

C1A65 INCOMPLETE STROKE SENSOR

< DTC/CIRCUIT DIAGNOSIS >

C1A65 INCOMPLETE STROKE SENSOR

DTC Logic

INFOID:000000008139817

DTC DETECTION LOGIC

DTC	Display item	Malfunction detection condition	Possible causes
C1A65	STROKE SENSOR SET	Stroke sensor 0 point learning has not been completed.	Stroke sensor 0 point learning has not been performed.

DTC CONFIRMATION PROCEDURE

1. PRECONDITIONING

If "DTC CONFIRMATION PROCEDURE" has been previously conducted, always turn the ignition switch OFF and wait at least 10 seconds before conducting the next test.

>> GO TO 2.

2. CHECK DTC DETECTION

 With CONSULT

1. Turn the ignition switch OFF to ON without depressing the brake pedal.
CAUTION:
Never set the vehicle to READY/Never start the engine.
2. Repeat step 1 two times or more.
CAUTION:
Be sure to wait for 5 seconds or more after turning the ignition switch OFF.
3. Turn the ignition switch OFF to exit CONSULT.
4. Get out of the vehicle, close all doors (including trunk lid), and wait for 3 minutes or more without opening these doors.
CAUTION:
Never operate the vehicle and CONSULT while waiting.
5. Turn the ignition switch ON without depressing the brake pedal.
CAUTION:
Never set the vehicle to READY/Never start the engine.
6. Start CONSULT and erase self-diagnosis result of "BRAKE".
7. Turn the ignition switch OFF to exit CONSULT.
8. Get out of the vehicle, close all doors (including trunk lid), and wait for 3 minutes or more without opening these doors.
CAUTION:
Never operate the vehicle and CONSULT while waiting.
9. Turn the ignition switch ON without depressing the brake pedal.
CAUTION:
Never set the vehicle to READY/Never start the engine.
10. Depress brake pedal by 100 mm (3.94 in) or more, and hold the position for 5 seconds or more.
11. Release brake pedal.
12. Start CONSULT and perform "BRAKE" self-diagnosis.

Is DTC "C1A65" detected?

- YES >> Proceed to [BR-96, "Diagnosis Procedure"](#).
NO >> INSPECTION END

Diagnosis Procedure

INFOID:000000008139818

1. CHECK 12V BATTERY

1. Turn the ignition switch OFF to exit CONSULT.
2. Get out of the vehicle, close all doors (including trunk lid), and wait for 3 minutes or more without opening these doors.
CAUTION:
Never operate the vehicle and CONSULT while waiting.

C1A65 INCOMPLETE STROKE SENSOR

< DTC/CIRCUIT DIAGNOSIS >

3. Check the 12V battery terminal connections. Refer to [BR-6. "Precaution for Removing 12V Battery"](#) and [PG-135. "Work Flow"](#). A
4. Check the 12V battery. Refer to [PG-135. "Work Flow"](#). B

Is the inspection result normal?

- YES >> GO TO 2.
NO >> Repair or replace error-detected parts and GO TO 2.

2.PERFORM SELF-DIAGNOSIS (1)

ⓂWith CONSULT

1. Connect 12V battery cable to negative terminal.
2. Turn the ignition switch OFF to ON without depressing the brake pedal.
CAUTION:
Never set the vehicle to READY/Never start the engine.
3. Repeat step 2 two times or more.
CAUTION:
Be sure to wait for 5 seconds or more after turning the ignition switch OFF.
4. Turn the ignition switch OFF to exit CONSULT.
5. Get out of the vehicle, close all doors (including trunk lid), and wait for 3 minutes or more without opening these doors.
CAUTION:
Never operate the vehicle and CONSULT while waiting.
6. Turn the ignition switch ON without depressing the brake pedal.
CAUTION:
Never set the vehicle to READY/Never start the engine.
7. Start CONSULT and erase self-diagnosis result of "BRAKE".
8. Turn the ignition switch OFF to exit CONSULT.
9. Get out of the vehicle, close all doors (including trunk lid), and wait for 3 minutes or more without opening these doors.
CAUTION:
Never operate the vehicle and CONSULT while waiting.
10. Turn the ignition switch ON without depressing the brake pedal.
CAUTION:
Never set the vehicle to READY/Never start the engine.
11. Depress brake pedal by 100 mm (3.94 in) or more, and hold the position for 5 seconds or more.
12. Release brake pedal.
13. Start CONSULT and perform "BRAKE" self-diagnosis.

Is DTC "C1A65" detected?

- YES >> GO TO 3.
NO >> INSPECTION END

3.CHECK CONNECTOR TERMINALS

1. Turn the ignition switch OFF to exit CONSULT.
2. Get out of the vehicle, close all doors (including trunk lid), and wait for 3 minutes or more without opening these doors.
CAUTION:
Never operate the vehicle and CONSULT while waiting.
3. Disconnect 12V battery cable from negative terminal. Refer to [BR-6. "Precaution for Removing 12V Battery"](#).
4. Disconnect the electrically-driven intelligent brake unit harness connector, then check for failures of pin terminals and connections.
5. Disconnect the stroke sensor harness connector, then check for failures of pin terminals and connections.

Is the inspection result normal?

- YES >> GO TO 5.
NO >> Repair or replace error-detected parts and GO TO 4.

4.PERFORM SELF-DIAGNOSIS (2)

ⓂWith CONSULT

1. Connect the electrically-driven intelligent brake unit harness connector.
2. Connect stroke sensor harness connector.

C1A65 INCOMPLETE STROKE SENSOR

< DTC/CIRCUIT DIAGNOSIS >

3. Connect 12V battery cable to negative terminal.
4. Turn the ignition switch OFF to ON without depressing the brake pedal.
CAUTION:
Never set the vehicle to READY/Never start the engine.
5. Repeat step 4 two times or more.
CAUTION:
Be sure to wait for 5 seconds or more after turning the ignition switch OFF.
6. Turn the ignition switch OFF to exit CONSULT.
7. Get out of the vehicle, close all doors (including trunk lid), and wait for 3 minutes or more without opening these doors.
CAUTION:
Never operate the vehicle and CONSULT while waiting.
8. Turn the ignition switch ON without depressing the brake pedal.
CAUTION:
Never set the vehicle to READY/Never start the engine.
9. Start CONSULT and erase self-diagnosis result of "BRAKE".
10. Turn the ignition switch OFF to exit CONSULT.
11. Get out of the vehicle, close all doors (including trunk lid), and wait for 3 minutes or more without opening these doors.
CAUTION:
Never operate the vehicle and CONSULT while waiting.
12. Turn the ignition switch ON without depressing the brake pedal.
CAUTION:
Never set the vehicle to READY/Never start the engine.
13. Depress brake pedal by 100 mm (3.94 in) or more, and hold the position for 5 seconds or more.
14. Release brake pedal.
15. Start CONSULT and perform "BRAKE" self-diagnosis.

Is DTC "C1A65" detected?

YES >> GO TO 5.

NO >> INSPECTION END

5. CHECK IGNITION POWER SUPPLY

1. Connect stroke sensor harness connector.
2. Turn the ignition switch OFF to exit CONSULT.
3. Get out of the vehicle, close all doors (including trunk lid), and wait for 3 minutes or more without opening these doors.
CAUTION:
Never operate the vehicle and CONSULT while waiting.
4. Disconnect 12V battery cable from negative terminal. Refer to [BR-6. "Precaution for Removing 12V Battery"](#).
5. Disconnect the electrically-driven intelligent brake unit harness connector.
6. Connect 12V battery cable to negative terminal.
7. Check voltage between the electrically-driven intelligent brake unit harness connector and ground.

Electrically-driven intelligent brake unit		—	Voltage
Connector	Terminal		
E87	26	Ground	Approx. 0 V

8. Turn the ignition switch ON without depressing the brake pedal.
CAUTION:
Never set the vehicle to READY/Never start the engine.
9. Check voltage between the electrically-driven intelligent brake unit harness connector and ground.

Electrically-driven intelligent brake unit		—	Voltage
Connector	Terminal		
E87	26	Ground	10 – 16 V

Is the inspection result normal?

YES >> GO TO 8.

C1A65 INCOMPLETE STROKE SENSOR

< DTC/CIRCUIT DIAGNOSIS >

NO >> GO TO 6.

6. CHECK IGNITION POWER SUPPLY CIRCUIT

1. Turn the ignition switch OFF to exit CONSULT.
2. Get out of the vehicle, close all doors (including trunk lid), and wait for 3 minutes or more without opening these doors.
CAUTION:
Never operate the vehicle and CONSULT while waiting.
3. Disconnect 12V battery cable from negative terminal. Refer to [BR-6, "Precaution for Removing 12V Battery"](#).
4. Check 10A fuse (#46).
5. Disconnect IPDM E/R harness connector.
6. Check continuity between electrically-driven intelligent brake unit and IPDM E/R.

Electrically-driven intelligent brake unit		IPDM E/R		Continuity
Connector	Terminal	Connector	Terminal	
E87	26	E5	12	Existed

7. Check continuity between electrically-driven intelligent brake unit harness connector and ground.

Electrically-driven intelligent brake unit		—	Continuity
Connector	Terminal		
E87	26	Ground	Not existed

Is the inspection result normal?

YES >> Perform trouble diagnosis for ignition power supply. Refer to [PG-30, "Wiring Diagram - IGNITION POWER SUPPLY -"](#).

NO >> Repair or replace error-detected parts and GO TO 7.

7. PERFORM SELF-DIAGNOSIS (3)

Ⓜ With CONSULT

1. Connect the electrically-driven intelligent brake unit harness connector.
2. Connect IPDM E/R harness connector.
3. Connect 12V battery cable to negative terminal.
4. Turn the ignition switch OFF to ON without depressing the brake pedal.
CAUTION:
Never set the vehicle to READY/Never start the engine.
5. Repeat step 4 two times or more.
CAUTION:
Be sure to wait for 5 seconds or more after turning the ignition switch OFF.
6. Turn the ignition switch OFF to exit CONSULT.
7. Get out of the vehicle, close all doors (including trunk lid), and wait for 3 minutes or more without opening these doors.
CAUTION:
Never operate the vehicle and CONSULT while waiting.
8. Turn the ignition switch ON without depressing the brake pedal.
CAUTION:
Never set the vehicle to READY/Never start the engine.
9. Start CONSULT and erase self-diagnosis result of "BRAKE".
10. Turn the ignition switch OFF to exit CONSULT.
11. Get out of the vehicle, close all doors (including trunk lid), and wait for 3 minutes or more without opening these doors.
CAUTION:
Never operate the vehicle and CONSULT while waiting.
12. Turn the ignition switch ON without depressing the brake pedal.
CAUTION:
Never set the vehicle to READY/Never start the engine.
13. Depress brake pedal by 100 mm (3.94 in) or more, and hold the position for 5 seconds or more.
14. Release brake pedal.
15. Start CONSULT and perform "BRAKE" self-diagnosis.

C1A65 INCOMPLETE STROKE SENSOR

< DTC/CIRCUIT DIAGNOSIS >

Is DTC "C1A65" detected?

- YES >> GO TO 8.
NO >> INSPECTION END

8. CHECK 12V BATTERY POWER SUPPLY

1. Turn the ignition switch OFF to exit CONSULT.
2. Get out of the vehicle, close all doors (including trunk lid), and wait for 3 minutes or more without opening these doors.
CAUTION:
Never operate the vehicle and CONSULT while waiting.
3. Disconnect 12V battery cable from negative terminal. Refer to [BR-6, "Precaution for Removing 12V Battery"](#).
4. Disconnect the electrically-driven intelligent brake unit harness connector.
5. Connect 12V battery cable to negative terminal.
6. Check voltage between the electrically-driven intelligent brake unit harness connector terminals.

Electrically-driven intelligent brake unit		Voltage
Connector	Terminal	
E87	1 - 31	10 - 16 V
	2 - 31	
	11 - 31	

7. Turn the ignition switch ON without depressing the brake pedal.
CAUTION:
Never set the vehicle to READY/Never start the engine.
8. Check voltage between the electrically-driven intelligent brake unit harness connector terminal.

Electrically-driven intelligent brake unit		Voltage
Connector	Terminal	
E87	1 - 31	10 - 16 V
	2 - 31	
	11 - 31	

Is the inspection result normal?

- YES >> GO TO 11.
NO >> GO TO 9.

9. CHECK 12V BATTERY POWER SUPPLY CIRCUIT

1. Turn the ignition switch OFF to exit CONSULT.
2. Get out of the vehicle, close all doors (including trunk lid), and wait for 3 minutes or more without opening these doors.
CAUTION:
Never operate the vehicle and CONSULT while waiting.
3. Disconnect 12V battery cable from negative terminal. Refer to [BR-6, "Precaution for Removing 12V Battery"](#).
4. Check 50A fusible link (#D).
5. Check continuity and for short circuit between electrically-driven intelligent brake unit harness connector terminal (1) and 50A fusible link (#D).
6. Check continuity and for short circuit between electrically-driven intelligent brake unit harness connector terminal (2) and 50A fusible link (#D).
7. Check 10A fuse (#65).
8. Check continuity and for short circuit between electrically-driven intelligent brake unit harness connector terminal (11) and 10A fuse (#65).

Is the inspection result normal?

- YES >> Perform diagnosis for 12V battery power supply. Refer to [PG-14, "Wiring Diagram - BATTERY POWER SUPPLY -"](#).
NO >> Repair or replace error-detected parts and GO TO 10.

C1A65 INCOMPLETE STROKE SENSOR

< DTC/CIRCUIT DIAGNOSIS >

10. PERFORM SELF-DIAGNOSIS (4)

Ⓜ With CONSULT

1. Connect the electrically-driven intelligent brake unit harness connector.
2. Connect 12V battery cable to negative terminal.
3. Turn the ignition switch OFF to ON without depressing the brake pedal.
CAUTION:
Never set the vehicle to READY/Never start the engine.
4. Repeat step 3 two times or more.
CAUTION:
Be sure to wait for 5 seconds or more after turning the ignition switch OFF.
5. Turn the ignition switch OFF to exit CONSULT.
6. Get out of the vehicle, close all doors (including trunk lid), and wait for 3 minutes or more without opening these doors.
CAUTION:
Never operate the vehicle and CONSULT while waiting.
7. Turn the ignition switch ON without depressing the brake pedal.
CAUTION:
Never set the vehicle to READY/Never start the engine.
8. Start CONSULT and erase self-diagnosis result of "BRAKE".
9. Turn the ignition switch OFF to exit CONSULT.
10. Get out of the vehicle, close all doors (including trunk lid), and wait for 3 minutes or more without opening these doors.
CAUTION:
Never operate the vehicle and CONSULT while waiting.
11. Turn the ignition switch ON without depressing the brake pedal.
CAUTION:
Never set the vehicle to READY/Never start the engine.
12. Depress brake pedal by 100 mm (3.94 in) or more, and hold the position for 5 seconds or more.
13. Release brake pedal.
14. Start CONSULT and perform "BRAKE" self-diagnosis.

Is DTC "C1A65" detected?

YES >> GO TO 11.

NO >> INSPECTION END

11. CHECK GROUND CIRCUIT

1. Turn the ignition switch OFF to exit CONSULT.
2. Get out of the vehicle, close all doors (including trunk lid), and wait for 3 minutes or more without opening these doors.
CAUTION:
Never operate the vehicle and CONSULT while waiting.
3. Disconnect 12V battery cable from negative terminal. Refer to [BR-6. "Precaution for Removing 12V Battery"](#).
4. Disconnect the electrically-driven intelligent brake unit harness connector.
5. Check continuity between electrically-driven intelligent brake unit and ground.

Electrically-driven intelligent brake unit		—	Continuity
Connector	Terminal		
E87	31	Ground	Existed

Is the inspection result normal?

YES >> GO TO 13.

NO >> Repair or replace error-detected parts and GO TO 12.

12. PERFORM SELF-DIAGNOSIS (5)

Ⓜ With CONSULT

1. Connect the electrically-driven intelligent brake unit harness connector.
2. Connect 12V battery cable to negative terminal.
3. Turn the ignition switch OFF to ON without depressing the brake pedal.

CAUTION:

C1A65 INCOMPLETE STROKE SENSOR

< DTC/CIRCUIT DIAGNOSIS >

Never set the vehicle to READY/Never start the engine.

4. Repeat step 1 two times or more.

CAUTION:

Be sure to wait for 5 seconds or more after turning the ignition switch OFF.

5. Turn the ignition switch OFF to exit CONSULT.
6. Get out of the vehicle, close all doors (including trunk lid), and wait for 3 minutes or more without opening these doors.

CAUTION:

Never operate the vehicle and CONSULT while waiting.

7. Turn the ignition switch ON without depressing the brake pedal.

CAUTION:

Never set the vehicle to READY/Never start the engine.

8. Start CONSULT and erase self-diagnosis result of "BRAKE".
9. Turn the ignition switch OFF to exit CONSULT.
10. Get out of the vehicle, close all doors (including trunk lid), and wait for 3 minutes or more without opening these doors.

CAUTION:

Never operate the vehicle and CONSULT while waiting.

11. Turn the ignition switch ON without depressing the brake pedal.

CAUTION:

Never set the vehicle to READY/Never start the engine.

12. Depress brake pedal by 100 mm (3.94 in) or more, and hold the position for 5 seconds or more.
13. Release brake pedal.
14. Start CONSULT and perform "BRAKE" self-diagnosis.

Is DTC "C1A65" detected?

YES >> GO TO 13.

NO >> INSPECTION END

13.CHECK DATA MONITOR

 With CONSULT

1. Connect the electrically-driven intelligent brake unit harness connector.
2. Connect 12V battery cable to negative terminal.
3. Turn the ignition switch OFF to ON without depressing the brake pedal.

CAUTION:

Never set the vehicle to READY/Never start the engine.

4. Repeat step 3 two times or more.

CAUTION:

Be sure to wait for 5 seconds or more after turning the ignition switch OFF.

5. Start CONSULT and select "BRAKE" and "DATA MONITOR" according this order.
6. Check "MOTOR POWER SUPPLY" and "CONTROL MODULE POWER. Refer to [BR-33, "Reference Value"](#).

Is the inspection result normal?

YES >> GO TO 14.

NO >> Replace the electrically-driven intelligent brake unit. Refer to [BR-288, "Removal and installation"](#)

14.PERFORM SELF-DIAGNOSIS (6)

 With CONSULT

1. Turn the ignition switch OFF to ON without depressing the brake pedal.

CAUTION:

Never set the vehicle to READY/Never start the engine.

2. Repeat step 1 two times or more.

CAUTION:

Be sure to wait for 5 seconds or more after turning the ignition switch OFF.

3. Turn the ignition switch OFF to exit CONSULT.
4. Get out of the vehicle, close all doors (including trunk lid), and wait for 3 minutes or more without opening these doors.

CAUTION:

Never operate the vehicle and CONSULT while waiting.

5. Turn the ignition switch ON without depressing the brake pedal.

CAUTION:

C1A65 INCOMPLETE STROKE SENSOR

< DTC/CIRCUIT DIAGNOSIS >

Never set the vehicle to READY/Never start the engine.

6. Start CONSULT and erase self-diagnosis result of "BRAKE".
7. Turn the ignition switch OFF to exit CONSULT.
8. Get out of the vehicle, close all doors (including trunk lid), and wait for 3 minutes or more without opening these doors.

CAUTION:

Never operate the vehicle and CONSULT while waiting.

9. Turn the ignition switch ON without depressing the brake pedal.

CAUTION:

Never set the vehicle to READY/Never start the engine.

10. Depress brake pedal by 100 mm (3.94 in) or more, and hold the position for 5 seconds or more.
11. Release brake pedal.
12. Start CONSULT and perform "BRAKE" self-diagnosis.

Is DTC "C1A65" detected?

YES >> GO TO 15.

NO >> INSPECTION END

15. STROKE SENSOR 0 POINT LEARNING (1)

 With CONSULT

Perform stroke sensor 0 point learning. Refer to [BR-47, "Work Procedure"](#).

Was either "COMPLETED" or "The operation is incomplete. Try again after confirming the operation condition." displayed?

"COMPLETED">>GO TO 16.

"The operation is incomplete. Try again after confirming the operation condition.">>GO TO 17.

16. PERFORM SELF-DIAGNOSIS (7)

 With CONSULT

1. Turn the ignition switch OFF to ON without depressing the brake pedal.

CAUTION:

Never set the vehicle to READY/Never start the engine.

2. Repeat step 1 two times or more.

CAUTION:

Be sure to wait for 5 seconds or more after turning the ignition switch OFF.

3. Turn the ignition switch OFF to exit CONSULT.
4. Get out of the vehicle, close all doors (including trunk lid), and wait for 3 minutes or more without opening these doors.

CAUTION:

Never operate the vehicle and CONSULT while waiting.

5. Turn the ignition switch ON without depressing the brake pedal.

CAUTION:

Never set the vehicle to READY/Never start the engine.

6. Start CONSULT and erase self-diagnosis result of "BRAKE".
7. Turn the ignition switch OFF to exit CONSULT.
8. Get out of the vehicle, close all doors (including trunk lid), and wait for 3 minutes or more without opening these doors.

CAUTION:

Never operate the vehicle and CONSULT while waiting.

9. Turn the ignition switch ON without depressing the brake pedal.

CAUTION:

Never set the vehicle to READY/Never start the engine.

10. Depress brake pedal by 100 mm (3.94 in) or more, and hold the position for 5 seconds or more.
11. Release brake pedal.
12. Start CONSULT and perform "BRAKE" self-diagnosis.

Is DTC "C1A65" detected?

YES >> GO TO 17.

NO >> INSPECTION END

17. VISUALLY CHECK STROKE SENSOR

Check the stroke sensor for damage.

A

B

C

D

E

BR

G

H

I

J

K

L

M

N

O

P

C1A65 INCOMPLETE STROKE SENSOR

< DTC/CIRCUIT DIAGNOSIS >

Is the inspection result normal?

YES >> GO TO 18.

NO >> Repair or replace error-detected parts and GO TO 21.

18.CHECK STROKE SENSOR INSTALLATION

Check the stroke sensor for looseness and disconnection.

Is the inspection result normal?

YES >> GO TO 19.

NO >> Repair or replace error-detected parts and GO TO 21.

19.CHECK BRAKE PEDAL HEIGHT

Check each brake pedal height. Refer to [BR-270, "Inspection and Adjustment"](#).

Is the inspection result normal?

YES >> GO TO 20.

NO >> Adjust each height. Refer to [BR-270, "Inspection and Adjustment"](#). GO TO 21.

20.STROKE SENSOR 0 POINT LEARNING (2)

Perform stroke sensor 0 point learning. Refer to [BR-47, "Work Procedure"](#).

>> GO TO 21.

21.PERFORM SELF-DIAGNOSIS (8)

 With CONSULT

1. Turn the ignition switch OFF to ON without depressing the brake pedal.

CAUTION:

Never set the vehicle to READY/Never start the engine.

2. Repeat step 1 two times or more.

CAUTION:

Be sure to wait for 5 seconds or more after turning the ignition switch OFF.

3. Turn the ignition switch OFF to exit CONSULT.

4. Get out of the vehicle, close all doors (including trunk lid), and wait for 3 minutes or more without opening these doors.

CAUTION:

Never operate the vehicle and CONSULT while waiting.

5. Turn the ignition switch ON without depressing the brake pedal.

CAUTION:

Never set the vehicle to READY/Never start the engine.

6. Start CONSULT and erase self-diagnosis result of "BRAKE".

7. Turn the ignition switch OFF to exit CONSULT.

8. Get out of the vehicle, close all doors (including trunk lid), and wait for 3 minutes or more without opening these doors.

CAUTION:

Never operate the vehicle and CONSULT while waiting.

9. Turn the ignition switch ON without depressing the brake pedal.

CAUTION:

Never set the vehicle to READY/Never start the engine.

10. Depress brake pedal by 100 mm (3.94 in) or more, and hold the position for 5 seconds or more.

11. Release brake pedal.

12. Start CONSULT and perform "BRAKE" self-diagnosis.

Is DTC "C1A65" detected?

YES >> GO TO 22.

NO >> INSPECTION END

22.CHECK STROKE SENSOR CIRCUIT (1)

1. Turn the ignition switch OFF to exit CONSULT.

2. Get out of the vehicle, close all doors (including trunk lid), and wait for 3 minutes or more without opening these doors.

CAUTION:

Never operate the vehicle and CONSULT while waiting.

C1A65 INCOMPLETE STROKE SENSOR

< DTC/CIRCUIT DIAGNOSIS >

3. Disconnect the stroke sensor harness connector.
4. Disconnect 12V battery cable from negative terminal. Refer to [BR-6, "Precaution for Removing 12V Battery"](#).
5. Disconnect the electrically-driven intelligent brake unit harness connector.
6. Check continuity between stroke sensor harness connector and electrically-driven intelligent brake unit.

Stroke sensor		Electrically-driven intelligent brake unit		Continuity
Connector	Terminal	Connector	Terminal	
E86	3	E87	19	Existed
	3		35	Not existed
	3		5	Not existed
	3		37	Not existed
	4		19	Not existed
	4		35	Existed
	4		5	Not existed
	4		37	Not existed
	1		19	Not existed
	1		35	Not existed
	1		5	Existed
	1		37	Not existed
	2		19	Not existed
	2		35	Not existed
	2		5	Not existed
	2		37	Existed

Is the inspection result normal?

YES >> GO TO 23.

NO >> Repair or replace error-detected parts and GO TO 28.

23. CHECK STROKE SENSOR POWER SUPPLY

1. Connect the electrically-driven intelligent brake unit harness connector.
2. Connect 12V battery cable to negative terminal.
3. Get out of the vehicle, close all doors (including trunk lid), and wait for 3 minutes or more without opening these doors.
CAUTION:
Never operate the vehicle and CONSULT while waiting.
4. Turn the ignition switch ON without depressing the brake pedal.
CAUTION:
Never set the vehicle to READY/ Never start the engine.
5. Check the stroke sensor power voltage.

Stroke sensor		—	Voltage
Connector	Terminal		
E86	3	Ground	4.75 – 5.25 V

Is the inspection result normal?

YES >> GO TO 24.

NO >> Repair or replace error-detected parts and GO TO 24.

24. CHECK STROKE SENSOR CIRCUIT (2)

1. Turn the power switch OFF to exit CONSULT.
2. Get out of the vehicle, close all doors (including trunk lid), and wait for 3 minutes or more without opening these doors.
CAUTION:

C1A65 INCOMPLETE STROKE SENSOR

< DTC/CIRCUIT DIAGNOSIS >

Never operate the vehicle and CONSULT while waiting.

3. Disconnect 12V battery cable from negative terminal. Refer to [BR-6, "Precaution for Removing 12V Battery"](#).
4. Disconnect the stroke sensor harness connector.
5. Disconnect the electrically-driven intelligent brake unit harness connector.
6. Check the continuity between stroke sensor and ground.

Stroke sensor		—	Voltage
Connector	Terminal		
E86	2	Ground	4.75 – 5.25 V

Is the inspection result normal?

YES >> GO TO 25.

NO >> Repair or replace error-detected parts and GO TO 25.

25. CHECK STROKE SENSOR RESISTANCE

1. Turn the ignition switch OFF to exit CONSULT.
2. Get out of the vehicle, close all doors (including trunk lid), and wait for 3 minutes or more without opening these doors.
CAUTION:
Never operate the vehicle and CONSULT while waiting.
3. Disconnect 12V battery cable from negative terminal. Refer to [BR-6, "Precaution for Removing 12V Battery"](#).
4. Connect stroke sensor harness connector.
5. Disconnect the electrically-driven intelligent brake unit harness connector.
6. Check resistance between stroke sensor connector pin terminals.

Electrically-driven intelligent brake unit		Condition	Resistance
Connector	Terminal		
E87	35 – 5	Gradually depress the brake pedal.	Resistance value decreases between 0.1 – 1.33 kΩ, according to the depth of brake depression.
	37 – 5		Resistance value increases between 0.1 – 1.33 kΩ, according to the depth of brake depression.

Is the inspection result normal?

YES >> GO TO 28.

NO >> GO TO 26.

26. REPLACE STROKE SENSOR

Replace the stroke sensor. Refer to [BR-280, "Removal and Installation"](#).

>> GO TO 27.

27. STROKE SENSOR 0 POINT LEARNING (3)

1. Connect the electrically-driven intelligent brake unit harness connector.
2. Perform stroke sensor 0 point learning. Refer to [BR-47, "Work Procedure"](#).

>> GO TO 28.

28. PERFORM SELF-DIAGNOSIS (9)

Ⓜ With CONSULT

1. Connect the electrically-driven intelligent brake unit harness connector.
2. Connect 12V battery cable to negative terminal.
3. Turn the ignition switch OFF to ON without depressing the brake pedal.

CAUTION:

Never set the vehicle to READY/ Never start the engine.

4. Repeat step 2 two times or more.

CAUTION:

C1A65 INCOMPLETE STROKE SENSOR

< DTC/CIRCUIT DIAGNOSIS >

Be sure to wait for 5 seconds or more after turning the ignition switch OFF.

5. Turn the ignition switch OFF to exit CONSULT. A
6. Get out of the vehicle, close all doors (including trunk lid), and wait for 3 minutes or more without opening these doors.

CAUTION:

Never operate the vehicle and CONSULT while waiting. B

7. Turn the ignition switch ON without depressing the brake pedal.

CAUTION:

Never set the vehicle to READY/Never start the engine. C

8. Start CONSULT and erase self-diagnosis result of "BRAKE".
9. Turn the ignition switch OFF to exit CONSULT.
10. Get out of the vehicle, close all doors (including trunk lid), and wait for 3 minutes or more without opening these doors. D

CAUTION:

Never operate the vehicle and CONSULT while waiting.

11. Turn the ignition switch ON without depressing the brake pedal. E

CAUTION:

Never set the vehicle to READY/Never start the engine.

12. Depress brake pedal by 100 mm (3.94 in) or more, and hold the position for 5 seconds or more. BR
13. Release brake pedal.
14. Start CONSULT and perform "BRAKE" self-diagnosis.

Is DTC "C1A65" detected?

YES >> GO TO 22. G

NO >> INSPECTION END

H

I

J

K

L

M

N

O

P

C1A66 PRESSURE SENSOR

< DTC/CIRCUIT DIAGNOSIS >

C1A66 PRESSURE SENSOR

DTC Logic

INFOID:000000008139819

DTC DETECTION LOGIC

DTC	Display item	Malfunction detection condition	Possible causes
C1A66	MASTER PRESSURE SENSOR	<ul style="list-style-type: none">• Open circuit is detected in master cylinder fluid pressure sensor1 circuit.• Short circuit is detected in master cylinder fluid pressure sensor1 circuit.• Malfunction is detected in master cylinder fluid pressure sensor1.	<ul style="list-style-type: none">• Harness or connector• Master cylinder fluid pressure sensor1 improper installation• Master cylinder fluid pressure sensor1• Electrically-driven intelligent brake unit

DTC CONFIRMATION PROCEDURE

1. PRECONDITIONING

If "DTC CONFIRMATION PROCEDURE" has been previously conducted, always turn the ignition switch OFF and wait at least 10 seconds before conducting the next test.

>> GO TO 2.

2. CHECK DTC DETECTION

Ⓟ With CONSULT

1. Turn the ignition switch OFF to ON without depressing the brake pedal.
CAUTION:
Never set the vehicle to READY/Never start the engine.
2. Repeat step 1 two times or more.
CAUTION:
Be sure to wait for 5 seconds or more after turning the ignition switch OFF.
3. Turn the ignition switch OFF to exit CONSULT.
4. Get out of the vehicle, close all doors (including trunk lid), and wait for 3 minutes or more without opening these doors.
CAUTION:
Never operate the vehicle and CONSULT while waiting.
5. Turn the ignition switch ON without depressing the brake pedal.
CAUTION:
Never set the vehicle to READY/Never start the engine.
6. Start CONSULT and erase self-diagnosis result of "BRAKE".
7. Turn the ignition switch OFF to exit CONSULT.
8. Get out of the vehicle, close all doors (including trunk lid), and wait for 3 minutes or more without opening these doors.
CAUTION:
Never operate the vehicle and CONSULT while waiting.
9. Turn the ignition switch ON without depressing the brake pedal.
CAUTION:
Never set the vehicle to READY/Never start the engine.
10. Depress brake pedal by 100 mm (3.94 in) or more, and hold the position for 5 seconds or more.
11. Release brake pedal.
12. Start CONSULT and perform "BRAKE" self-diagnosis.

Is DTC "C1A66" detected?

- YES >> Proceed to [BR-108. "Diagnosis Procedure"](#).
NO >> INSPECTION END

Diagnosis Procedure

INFOID:000000008139820

1. CHECK 12V BATTERY

1. Turn the ignition switch OFF to exit CONSULT.

C1A66 PRESSURE SENSOR

< DTC/CIRCUIT DIAGNOSIS >

2. Get out of the vehicle, close all doors (including trunk lid), and wait for 3 minutes or more without opening these doors.
CAUTION:
Never operate the vehicle and CONSULT while waiting.
3. Check the 12V battery terminal connections. Refer to [BR-6, "Precaution for Removing 12V Battery"](#) and [PG-135, "Work Flow"](#).
4. Check the 12V battery. Refer to [PG-135, "Work Flow"](#).

Is the inspection result normal?

YES >> GO TO 2.

NO >> Repair or replace error-detected parts and GO TO 2.

2.PERFORM SELF-DIAGNOSIS (1)

 With CONSULT

1. Connect 12V battery cable to negative terminal.
2. Turn the ignition switch OFF to ON without depressing the brake pedal.
CAUTION:
Never set the vehicle to READY/Never start the engine.
3. Repeat step 1 two times or more.
CAUTION:
Be sure to wait for 5 seconds or more after turning the ignition switch OFF.
4. Turn the ignition switch OFF to exit CONSULT.
5. Get out of the vehicle, close all doors (including trunk lid), and wait for 3 minutes or more without opening these doors.
CAUTION:
Never operate the vehicle and CONSULT while waiting.
6. Turn the ignition switch ON without depressing the brake pedal.
CAUTION:
Never set the vehicle to READY/Never start the engine.
7. Start CONSULT and erase self-diagnosis result of "BRAKE".
8. Turn the ignition switch OFF to exit CONSULT.
9. Get out of the vehicle, close all doors (including trunk lid), and wait for 3 minutes or more without opening these doors.
CAUTION:
Never operate the vehicle and CONSULT while waiting.
10. Turn the ignition switch ON without depressing the brake pedal.
CAUTION:
Never set the vehicle to READY/Never start the engine.
11. Depress brake pedal by 100 mm (3.94 in) or more, and hold the position for 5 seconds or more.
12. Release brake pedal.
13. Start CONSULT and perform "BRAKE" self-diagnosis.

Is DTC "C1A66" detected?

YES >> GO TO 3.

NO >> INSPECTION END

3.CHECK CONNECTOR TERMINALS

1. Turn the ignition switch OFF to exit CONSULT.
2. Get out of the vehicle, close all doors (including trunk lid), and wait for 3 minutes or more without opening these doors.
CAUTION:
Never operate the vehicle and CONSULT while waiting.
3. Disconnect 12V battery cable from negative terminal. Refer to [BR-6, "Precaution for Removing 12V Battery"](#).
4. Disconnect the electrically-driven intelligent brake unit harness connector, then check for failures of pin terminals and connections.
5. Disconnect the master cylinder fluid pressure sensor1 harness connector, then check for failures of pin terminals and connections.

Is the inspection result normal?

YES >> GO TO 5.

NO >> Repair or replace error-detected parts and GO TO 4.

C1A66 PRESSURE SENSOR

< DTC/CIRCUIT DIAGNOSIS >

4. PERFORM SELF-DIAGNOSIS (2)

④ With CONSULT

1. Connect the electrically-driven intelligent brake unit harness connector.
2. Connect master cylinder fluid pressure sensor1 harness connector.
3. Connect 12V battery cable to negative terminal.
4. Turn the ignition switch OFF to ON without depressing the brake pedal.
CAUTION:
Never set the vehicle to READY/Never start the engine.
5. Repeat step 4 two times or more.
CAUTION:
Be sure to wait for 5 seconds or more after turning the ignition switch OFF.
6. Turn the ignition switch OFF to exit CONSULT.
7. Get out of the vehicle, close all doors (including trunk lid), and wait for 3 minutes or more without opening these doors.
CAUTION:
Never operate the vehicle and CONSULT while waiting.
8. Turn the ignition switch ON without depressing the brake pedal.
CAUTION:
Never set the vehicle to READY/Never start the engine.
9. Start CONSULT and erase self-diagnosis result of "BRAKE".
10. Turn the ignition switch OFF to exit CONSULT.
11. Get out of the vehicle, close all doors (including trunk lid), and wait for 3 minutes or more without opening these doors.
CAUTION:
Never operate the vehicle and CONSULT while waiting.
12. Turn the ignition switch ON without depressing the brake pedal.
CAUTION:
Never set the vehicle to READY/Never start the engine.
13. Depress brake pedal by 100 mm (3.94 in) or more, and hold the position for 5 seconds or more.
14. Release brake pedal.
15. Start CONSULT and perform "BRAKE" self-diagnosis.

Is DTC "C1A66" detected?

YES >> GO TO 5.

NO >> INSPECTION END

5. CHECK IGNITION POWER SUPPLY

1. Connect master cylinder fluid pressure sensor1 harness connector.
2. Turn the ignition switch OFF to exit CONSULT.
3. Get out of the vehicle, close all doors (including trunk lid), and wait for 3 minutes or more without opening these doors.
CAUTION:
Never operate the vehicle and CONSULT while waiting.
4. Disconnect 12V battery cable from negative terminal. Refer to [BR-6. "Precaution for Removing 12V Battery"](#).
5. Disconnect the electrically-driven intelligent brake unit harness connector.
6. Connect 12V battery cable to negative terminal.
7. Check voltage between the electrically-driven intelligent brake unit harness connector and ground.

Electrically-driven intelligent brake unit		—	Voltage
Connector	Terminal		
E87	26	Ground	Approx. 0 V

8. Turn the ignition switch ON without depressing the brake pedal.
CAUTION:
Never set the vehicle to READY/Never start the engine.
9. Check voltage between the electrically-driven intelligent brake unit harness connector and ground.

C1A66 PRESSURE SENSOR

< DTC/CIRCUIT DIAGNOSIS >

Electrically-driven intelligent brake unit		—	Voltage
Connector	Terminal		
E87	26	Ground	10 – 16 V

Is the inspection result normal?

- YES >> GO TO 8.
- NO >> GO TO 6.

6. CHECK IGNITION POWER SUPPLY CIRCUIT

1. Turn the ignition switch OFF to exit CONSULT.
2. Get out of the vehicle, close all doors (including trunk lid), and wait for 3 minutes or more without opening these doors.
CAUTION:
Never operate the vehicle and CONSULT while waiting.
3. Disconnect 12V battery cable from negative terminal. Refer to [BR-6. "Precaution for Removing 12V Battery"](#).
4. Check 10A fuse (#46).
5. Disconnect IPDM E/R harness connector.
6. Check continuity between electrically-driven intelligent brake unit and IPDM E/R.

Electrically-driven intelligent brake unit		IPDM E/R		Continuity
Connector	Terminal	Connector	Terminal	
E87	26	E5	12	Existed

7. Check continuity between electrically-driven intelligent brake unit harness connector and ground.

Electrically-driven intelligent brake unit		—	Continuity
Connector	Terminal		
E87	26	Ground	Not existed

Is the inspection result normal?

- YES >> Perform trouble diagnosis for ignition power supply. Refer to [PG-30. "Wiring Diagram - IGNITION POWER SUPPLY -"](#).
- NO >> Repair or replace error-detected parts and GO TO 7.

7. PERFORM SELF-DIAGNOSIS (3)

 With CONSULT

1. Connect the electrically-driven intelligent brake unit harness connector.
2. Connect master cylinder fluid pressure sensor1 harness connector.
3. Connect IPDM E/R harness connector.
4. Connect 12V battery cable to negative terminal.
5. Turn the ignition switch OFF to ON without depressing the brake pedal.
CAUTION:
Never set the vehicle to READY/Never start the engine.
6. Repeat step 4 two times or more.
CAUTION:
Be sure to wait for 5 seconds or more after turning the ignition switch OFF.
7. Turn the ignition switch OFF to exit CONSULT.
8. Get out of the vehicle, close all doors (including trunk lid), and wait for 3 minutes or more without opening these doors.
CAUTION:
Never operate the vehicle and CONSULT while waiting.
9. Turn the ignition switch ON without depressing the brake pedal.
CAUTION:
Never set the vehicle to READY/Never start the engine.
10. Start CONSULT and erase self-diagnosis result of "BRAKE".
11. Turn the ignition switch OFF to exit CONSULT.

C1A66 PRESSURE SENSOR

< DTC/CIRCUIT DIAGNOSIS >

12. Get out of the vehicle, close all doors (including trunk lid), and wait for 3 minutes or more without opening these doors.

CAUTION:

Never operate the vehicle and CONSULT while waiting.

13. Turn the ignition switch ON without depressing the brake pedal.

CAUTION:

Never set the vehicle to READY/Never start the engine.

14. Depress brake pedal by 100 mm (3.94 in) or more, and hold the position for 5 seconds or more.
15. Release brake pedal.
16. Start CONSULT and perform "BRAKE" self-diagnosis.

Is DTC "C1A66" detected?

YES >> GO TO 8.

NO >> INSPECTION END

8. CHECK 12V BATTERY POWER SUPPLY

1. Turn the ignition switch OFF to exit CONSULT.
2. Get out of the vehicle, close all doors (including trunk lid), and wait for 3 minutes or more without opening these doors.
CAUTION:
Never operate the vehicle and CONSULT while waiting.
3. Disconnect 12V battery cable from negative terminal. Refer to [BR-6. "Precaution for Removing 12V Battery"](#).
4. Disconnect the electrically-driven intelligent brake unit harness connector.
5. Connect 12V battery cable to negative terminal.
6. Check voltage between the electrically-driven intelligent brake unit harness connector terminal.

Electrically-driven intelligent brake unit		Voltage
Connector	Terminal	
E87	1 - 31	10 - 16 V
	2 - 31	
	11 - 31	

7. Turn the ignition switch ON without depressing the brake pedal.
CAUTION:
Never set the vehicle to READY/Never start the engine.
8. Check voltage between the electrically-driven intelligent brake unit harness connector terminal

Electrically-driven intelligent brake unit		Voltage
Connector	Terminal	
E87	1 - 31	10 - 16 V
	2 - 31	
	11 - 31	

Is the inspection result normal?

YES >> GO TO 11.

NO >> GO TO 9.

9. CHECK 12V BATTERY POWER SUPPLY CIRCUIT

1. Turn the ignition switch OFF to exit CONSULT.
2. Get out of the vehicle, close all doors (including trunk lid), and wait for 3 minutes or more without opening these doors.
CAUTION:
Never operate the vehicle and CONSULT while waiting.
3. Disconnect 12V battery cable from negative terminal. Refer to [BR-6. "Precaution for Removing 12V Battery"](#).
4. Check 50A fusible link (#D).
5. Check continuity and for short circuit between electrically-driven intelligent brake unit harness connector terminal (1) and 50A fusible link (#D).

C1A66 PRESSURE SENSOR

< DTC/CIRCUIT DIAGNOSIS >

6. Check continuity and for short circuit between electrically-driven intelligent brake unit harness connector terminal (2) and 50A fusible link (#D).
7. Check 10A fuse (#65).
8. Check continuity and for short circuit between electrically-driven intelligent brake unit harness connector terminal (11) and 10A fuse (#65).

Is the inspection result normal?

YES >> Perform diagnosis for 12V battery power supply. Refer to [PG-14, "Wiring Diagram - BATTERY POWER SUPPLY -"](#).

NO >> Repair or replace error-detected parts and GO TO 10.

10. PERFORM SELF-DIAGNOSIS (4)

Ⓜ With CONSULT

1. Connect the electrically-driven intelligent brake unit harness connector.
2. Connect 12V battery cable to negative terminal.
3. Turn the ignition switch OFF to ON without depressing the brake pedal.
CAUTION:
Never set the vehicle to READY/Never start the engine.
4. Repeat step 3 two times or more.
CAUTION:
Be sure to wait for 5 seconds or more after turning the ignition switch OFF.
5. Turn the ignition switch OFF to exit CONSULT.
6. Get out of the vehicle, close all doors (including trunk lid), and wait for 3 minutes or more without opening these doors.
CAUTION:
Never operate the vehicle and CONSULT while waiting.
7. Turn the ignition switch ON without depressing the brake pedal.
CAUTION:
Never set the vehicle to READY/Never start the engine.
8. Start CONSULT and erase self-diagnosis result of "BRAKE".
9. Turn the ignition switch OFF to exit CONSULT.
10. Get out of the vehicle, close all doors (including trunk lid), and wait for 3 minutes or more without opening these doors.
CAUTION:
Never operate the vehicle and CONSULT while waiting.
11. Turn the ignition switch ON without depressing the brake pedal.
CAUTION:
Never set the vehicle to READY/Never start the engine.
12. Depress brake pedal by 100 mm (3.94 in) or more, and hold the position for 5 seconds or more.
13. Release brake pedal.
14. Start CONSULT and perform "BRAKE" self-diagnosis.

Is DTC "C1A66" detected?

YES >> GO TO 11.

NO >> INSPECTION END

11. CHECK GROUND CIRCUIT

1. Turn the ignition switch OFF to exit CONSULT.
2. Get out of the vehicle, close all doors (including trunk lid), and wait for 3 minutes or more without opening these doors.
CAUTION:
Never operate the vehicle and CONSULT while waiting.
3. Disconnect 12V battery cable from negative terminal. Refer to [BR-6, "Precaution for Removing 12V Battery"](#).
4. Disconnect the electrically-driven intelligent brake unit harness connector.
5. Check continuity between electrically-driven intelligent brake unit and ground.

Electrically-driven intelligent brake unit		—	Continuity
Connector	Terminal		
E87	31	Ground	Existed

C1A66 PRESSURE SENSOR

< DTC/CIRCUIT DIAGNOSIS >

Is the inspection result normal?

YES >> GO TO 13.

NO >> Repair or replace error-detected parts and GO TO 12.

12.PERFORM SELF-DIAGNOSIS (5)

ⓅWith CONSULT

1. Connect the electrically-driven intelligent brake unit harness connector.
2. Connect 12V battery cable to negative terminal.
3. Turn the ignition switch OFF to ON without depressing the brake pedal.
CAUTION:
Never set the vehicle to READY/Never start the engine.
4. Repeat step 3 two times or more.
CAUTION:
Be sure to wait for 5 seconds or more after turning the ignition switch OFF.
5. Turn the ignition switch OFF to exit CONSULT.
6. Get out of the vehicle, close all doors (including trunk lid), and wait for 3 minutes or more without opening these doors.
CAUTION:
Never operate the vehicle and CONSULT while waiting.
7. Turn the ignition switch ON without depressing the brake pedal.
CAUTION:
Never set the vehicle to READY/Never start the engine.
8. Start CONSULT and erase self-diagnosis result of "BRAKE".
9. Turn the ignition switch OFF to exit CONSULT.
10. Get out of the vehicle, close all doors (including trunk lid), and wait for 3 minutes or more without opening these doors.
CAUTION:
Never operate the vehicle and CONSULT while waiting.
11. Turn the ignition switch ON without depressing the brake pedal.
CAUTION:
Never set the vehicle to READY/Never start the engine.
12. Depress brake pedal by 100 mm (3.94 in) or more, and hold the position for 5 seconds or more.
13. Release brake pedal.
14. Start CONSULT and perform "BRAKE" self-diagnosis.

Is DTC "C1A66" detected?

YES >> GO TO 13.

NO >> INSPECTION END

13.CHECK DATA MONITOR (1)

ⓅWith CONSULT

1. Connect the electrically-driven intelligent brake unit harness connector.
2. Connect 12V battery cable to negative terminal.
3. Turn the ignition switch OFF to ON without depressing the brake pedal.
CAUTION:
Never set the vehicle to READY/Never start the engine.
4. Repeat step 3 two times or more.
CAUTION:
Be sure to wait for 5 seconds or more after turning the ignition switch OFF.
5. Start CONSULT and select "BRAKE" and "DATA MONITOR" according this order.
6. Check "MOTOR POWER SUPPLY" and "CONTROL MODULE POWER". Refer to [BR-33. "Reference Value"](#).

Is the inspection result normal?

YES >> GO TO 14.

NO >> Replace the electrically-driven intelligent brake unit. Refer to [BR-288. "Removal and installation"](#).

14.PERFORM SELF-DIAGNOSIS (6)

ⓅWith CONSULT

1. Turn the ignition switch OFF to ON without depressing the brake pedal.
CAUTION:
Never set the vehicle to READY/Never start the engine.

C1A66 PRESSURE SENSOR

< DTC/CIRCUIT DIAGNOSIS >

2. Repeat step 1 two times or more.
CAUTION:
Be sure to wait for 5 seconds or more after turning the ignition switch OFF.
3. Turn the ignition switch OFF to exit CONSULT.
4. Get out of the vehicle, close all doors (including trunk lid), and wait for 3 minutes or more without opening these doors.
CAUTION:
Never operate the vehicle and CONSULT while waiting.
5. Turn the ignition switch ON without depressing the brake pedal.
CAUTION:
Never set the vehicle to READY/Never start the engine.
6. Start CONSULT and erase self-diagnosis result of "BRAKE".
7. Turn the ignition switch OFF to exit CONSULT.
8. Get out of the vehicle, close all doors (including trunk lid), and wait for 3 minutes or more without opening these doors.
CAUTION:
Never operate the vehicle and CONSULT while waiting.
9. Turn the ignition switch ON without depressing the brake pedal.
CAUTION:
Never set the vehicle to READY/Never start the engine.
10. Depress brake pedal by 100 mm (3.94 in) or more, and hold the position for 5 seconds or more.
11. Release brake pedal.
12. Start CONSULT and perform "BRAKE" self-diagnosis.

Is DTC "C1A66" detected?

- YES >> GO TO 15.
NO >> INSPECTION END

15. CHECK MASTER CYLINDER FLUID PRESSURE SENSOR1 INSTALLATION

1. Turn the ignition switch OFF to exit CONSULT.
2. Check master cylinder fluid pressure sensor1 for looseness and disconnection.

Is the inspection result normal?

- YES >> GO TO 16.
NO >> Repair or replace error-detected parts and GO TO 16.

16. PERFORM SELF-DIAGNOSIS (7)

With CONSULT

1. Turn the ignition switch OFF to ON without depressing the brake pedal.
CAUTION:
Never set the vehicle to READY/Never start the engine.
2. Repeat step 1 two times or more.
CAUTION:
Be sure to wait for 5 seconds or more after turning the ignition switch OFF.
3. Turn the ignition switch OFF to exit CONSULT.
4. Get out of the vehicle, close all doors (including trunk lid), and wait for 3 minutes or more without opening these doors.
CAUTION:
Never operate the vehicle and CONSULT while waiting.
5. Turn the ignition switch ON without depressing the brake pedal.
CAUTION:
Never set the vehicle to READY/Never start the engine.
6. Start CONSULT and erase self-diagnosis result of "BRAKE".
7. Turn the ignition switch OFF to exit CONSULT.
8. Get out of the vehicle, close all doors (including trunk lid), and wait for 3 minutes or more without opening these doors.
CAUTION:
Never operate the vehicle and CONSULT while waiting.
9. Turn the ignition switch ON without depressing the brake pedal.
CAUTION:
Never set the vehicle to READY/Never start the engine.
10. Depress brake pedal by 100 mm (3.94 in) or more, and hold the position for 5 seconds or more.

C1A66 PRESSURE SENSOR

< DTC/CIRCUIT DIAGNOSIS >

11. Release brake pedal.
12. Start CONSULT and perform "BRAKE" self-diagnosis.

Is DTC "C1A66" detected?

- YES >> GO TO 17.
 NO >> INSPECTION END

17.CHECK MASTER CYLINDER FLUID PRESSURE SENSOR1 CIRCUIT

1. Turn the ignition switch OFF to exit CONSULT.
2. Get out of the vehicle, close all doors (including trunk lid), and wait for 3 minutes or more without opening these doors.
CAUTION:
Never operate the vehicle and CONSULT while waiting.
3. Disconnect 12V battery cable from negative terminal. Refer to [BR-6, "Precaution for Removing 12V Battery"](#).
4. Disconnect master cylinder fluid pressure sensor1 harness connector.
5. Disconnect the electrically-driven intelligent brake unit harness connector.
6. Check continuity between master cylinder fluid pressure sensor1 harness connector and electrically-driven intelligent brake unit harness connector.

Master cylinder fluid pressure sensor1		Electrically-driven intelligent brake unit		Continuity
Connector	Terminal	Connector	Terminal	
E79	3	E87	21	Existed
	3		7	Not existed
	3		38	Not existed
	2		21	Not existed
	2		7	Existed
	2		38	Not existed
	1		21	Not existed
	1		7	Not existed
	1		38	Existed

Is the inspection result normal?

- YES >> GO TO 18.
 NO >> Repair or replace error-detected parts and GO TO 20.

18.CHECK MASTER CYLINDER FLUID PRESSURE SENSOR1 POWER CIRCUIT

1. Connect the electrically-driven intelligent brake unit harness connector.
2. Connect 12V battery cable to negative terminal.
3. Get out of the vehicle, close all doors (including trunk lid), and wait for 3 minutes or more without opening these doors.
CAUTION:
Never operate the vehicle and CONSULT while waiting.
4. Turn the ignition switch ON without depressing the brake pedal.
CAUTION:
Never set the vehicle to READY/Never start the engine.
5. Check the master cylinder fluid pressure sensor1 power voltage.

Master cylinder fluid pressure sensor1		—	Voltage
Connector	Terminal		
E79	3	Ground	4.75 – 5.25V

Is the inspection result normal?

- YES >> GO TO 19.
 NO >> Repair or replace error-detected parts and GO TO 19.

19.CHECK DATA MONITOR (2)

C1A66 PRESSURE SENSOR

< DTC/CIRCUIT DIAGNOSIS >

④ With CONSULT

1. Turn the ignition switch OFF to exit CONSULT.
2. Get out of the vehicle, close all doors (including trunk lid), and wait for 3 minutes or more without opening these doors.
CAUTION:
Never operate the vehicle and CONSULT while waiting.
3. Disconnect 12V battery cable from negative terminal. Refer to [BR-6, "Precaution for Removing 12V Battery"](#).
4. Connect master cylinder fluid pressure sensor1 harness connector.
5. Connect 12V battery cable to negative terminal.
6. Turn the ignition switch OFF to ON without depressing the brake pedal.
CAUTION:
Never set the vehicle to READY/Never start the engine.
7. Repeat step 4 two times or more.
CAUTION:
Be sure to wait for 5 seconds or more after turning the ignition switch OFF.
8. Start CONSULT and select "BRAKE" and "DATA MONITOR" according this order.
9. Check "MASTER CYL PRESSURE". Refer to [BR-33, "Reference Value"](#).

Is the inspection result normal?

YES >> GO TO 20.

NO >> Replace the electrically-driven intelligent brake unit. Refer to [BR-288, "Removal and installation"](#).

20. CHECK MASTER CYLINDER PRESSURE SENSOR1

1. Turn the ignition switch OFF to exit CONSULT.
2. Get out of the vehicle, close all doors (including trunk lid), and wait for 3 minutes or more without opening these doors.
CAUTION:
Never operate the vehicle and CONSULT while waiting.
3. Disconnect 12V battery cable from negative terminal. Refer to [BR-6, "Precaution for Removing 12V Battery"](#).
4. Disconnect master cylinder fluid pressure sensor1 harness connector.
5. Connect following terminals between master cylinder pressure sensor1 and harness connector (test harness).

Master cylinder pressure sensor1	Harness connector	
	Connector	Terminal
1	E79	1
2		2
3		3

6. Turn the ignition switch ON without depressing the brake pedal.
CAUTION:
Never set the vehicle to READY/Never start the engine.
7. Check that the voltage between master cylinder pressure sensor1 harness connector changes with the depth of pedal depression.
CAUTION:
Never short out the terminals while measuring voltages.

Master cylinder pressure sensor1		Voltage
Connector	Terminal	
E79	1 - 2	0.5 - 4.5 V

Is the inspection result normal?

YES >> GO TO 21.

NO >> Replace the master cylinder pressure sensor1. Refer to [BR-288, "Removal and installation"](#).

21. PERFORM SELF-DIAGNOSIS (8)

④ With CONSULT

C1A66 PRESSURE SENSOR

< DTC/CIRCUIT DIAGNOSIS >

1. Connect master cylinder fluid pressure sensor1 harness connector.
2. Turn the ignition switch OFF to ON without depressing the brake pedal.
CAUTION:
Never set the vehicle to READY/Never start the engine.
3. Repeat step 2 two times or more.
CAUTION:
Be sure to wait for 5 seconds or more after turning the ignition switch OFF.
4. Turn the ignition switch OFF to exit CONSULT.
5. Get out of the vehicle, close all doors (including trunk lid), and wait for 3 minutes or more without opening these doors.
CAUTION:
Never operate the vehicle and CONSULT while waiting.
6. Turn the ignition switch ON without depressing the brake pedal.
CAUTION:
Never set the vehicle to READY/Never start the engine.
7. Start CONSULT and erase self-diagnosis result of "BRAKE".
8. Turn the ignition switch OFF to exit CONSULT.
9. Get out of the vehicle, close all doors (including trunk lid), and wait for 3 minutes or more without opening these doors.
CAUTION:
Never operate the vehicle and CONSULT while waiting.
10. Turn the ignition switch ON without depressing the brake pedal.
CAUTION:
Never set the vehicle to READY/Never start the engine.
11. Depress brake pedal by 100 mm (3.94 in) or more, and hold the position for 5 seconds or more.
12. Release brake pedal.
13. Start CONSULT and perform "BRAKE" self-diagnosis.

Is DTC "C1A66" detected?

- YES >> Replace the electrically-driven intelligent brake unit. Refer to [BR-288, "Removal and installation"](#).
- NO >> INSPECTION END

C1A67 STOP LAMP SWITCH

< DTC/CIRCUIT DIAGNOSIS >

C1A67 STOP LAMP SWITCH

DTC Logic

INFOID:000000008139821

DTC DETECTION LOGIC

DTC	Display item	Malfunction detection condition	Possible causes
C1A67	STOP LAMP SWITCH	Stop lamp switch signal is not input when brake pedal operates.	<ul style="list-style-type: none">• Harness or connector• Stop lamp switch• Electrically-driven intelligent brake unit

DTC CONFIRMATION PROCEDURE

1. PRECONDITIONING

If "DTC CONFIRMATION PROCEDURE" has been previously conducted, always turn the ignition switch OFF and wait at least 10 seconds before conducting the next test.

>> GO TO 2.

2. CHECK DTC DETECTION

④ With CONSULT

1. Turn the ignition switch OFF to ON without depressing the brake pedal.
CAUTION:
Never set the vehicle to READY/Never start the engine.
2. Repeat step 1 two times or more.
CAUTION:
Be sure to wait for 5 seconds or more after turning the ignition switch OFF.
3. Turn the ignition switch OFF to exit CONSULT.
4. Get out of the vehicle, close all doors (including trunk lid), and wait for 3 minutes or more without opening these doors.
CAUTION:
Never operate the vehicle and CONSULT while waiting.
5. Turn the ignition switch ON without depressing the brake pedal.
CAUTION:
Never set the vehicle to READY/Never start the engine.
6. Start CONSULT and erase self-diagnosis result of "BRAKE".
7. Turn the ignition switch OFF to exit CONSULT.
8. Get out of the vehicle, close all doors (including trunk lid), and wait for 3 minutes or more without opening these doors.
CAUTION:
Never operate the vehicle and CONSULT while waiting.
9. Turn the ignition switch ON without depressing the brake pedal.
CAUTION:
Never set the vehicle to READY/Never start the engine.
10. Depress brake pedal by 100 mm (3.94 in) or more, and hold the position for 5 seconds or more.
11. Release brake pedal.
12. Start CONSULT and perform "BRAKE" self-diagnosis.

Is DTC "C1A67" detected?

- YES >> Proceed to [BR-119, "Diagnosis Procedure"](#).
NO >> INSPECTION END

Diagnosis Procedure

INFOID:000000008139822

1. CHECK STOP LAMP FOR ILLUMINATION (1)

Depress the brake pedal to a depth of 100 mm (3.94 in) or more and maintain the brake depression for 5 seconds or more to check that the stop lamp turns ON.

Is the inspection result normal?

C1A67 STOP LAMP SWITCH

< DTC/CIRCUIT DIAGNOSIS >

- YES >> GO TO 2.
 NO >> Repair or replace error-detected parts and GO TO 4.

2. CHECK STOP LAMP SWITCH CIRCUIT (1)

- Turn the ignition switch OFF to exit CONSULT.
- Get out of the vehicle, close all doors (including trunk lid), and wait for 3 minutes or more without opening these doors.
CAUTION:
Never operate the vehicle and CONSULT while waiting.
- Disconnect 12V battery cable from negative terminal. Refer to [BR-6, "Precaution for Removing 12V Battery"](#).
- Disconnect the electrically-driven intelligent brake unit harness connector.
- Connect 12V battery cable to negative terminal.
- Check voltage between the electrically-driven intelligent brake unit harness connector and ground.

Electrically-driven intelligent brake unit		—	Test condition	Voltage
Connector	Terminal			
E87	13	Ground	Brake pedal is depressed.	10 – 16 V
			Brake pedal is not depressed.	Approx. 0 V

- Turn the ignition switch ON without depressing the brake pedal.
CAUTION:
Never set the vehicle to READY/Never start the engine.
- Check voltage between the electrically-driven intelligent brake unit harness connector and ground.

Electrically-driven intelligent brake unit		—	Test condition	Voltage
Connector	Terminal			
E87	13	Ground	Brake pedal is depressed.	10 – 16 V
			Brake pedal is not depressed.	Approx. 0 V

Is the inspection result normal?

- YES (without ICC)>>GO TO 3.
 YES (with ICC)>>GO TO 4.
 NO >> GO TO 5.

3. CHECK STOP LAMP SWITCH CIRCUIT (2) (WITHOUT ICC)

- Turn the ignition switch OFF to exit CONSULT.
- Get out of the vehicle, close all doors (including trunk lid), and wait for 3 minutes or more without opening these doors.
CAUTION:
Never operate the vehicle and CONSULT while waiting.
- Disconnect 12V battery cable from negative terminal. Refer to [BR-6, "Precaution for Removing 12V Battery"](#).
- Disconnect stop lamp switch harness connector.
- Check continuity between electrically-driven intelligent brake unit and stop lamp switch harness connector.

Electrically-driven intelligent brake unit		Stop lamp switch		Continuity
Connector	Terminal	Connector	Terminal	
E87	13	E110	2	Existed

Is the inspection result normal?

- YES >> Perform diagnosis for stop lamp OFF relay system. Refer to [BR-132, "Diagnosis Procedure"](#).
 NO >> Repair or replace error-detected parts and GO TO 18.

4. CHECK STOP LAMP SWITCH CIRCUIT (2) (WITH ICC)

- Turn the ignition switch OFF to exit CONSULT.

C1A67 STOP LAMP SWITCH

< DTC/CIRCUIT DIAGNOSIS >

2. Get out of the vehicle, close all doors (including trunk lid), and wait for 3 minutes or more without opening these doors.
CAUTION:
Never operate the vehicle and CONSULT while waiting.
3. Disconnect 12V battery cable from negative terminal. Refer to [BR-6, "Precaution for Removing 12V Battery"](#).
4. Disconnect stop lamp switch harness connector.
5. Check continuity between electrically-driven intelligent brake unit and stop lamp switch harness connector.

Electrically-driven intelligent brake unit		Stop lamp switch		Continuity
Connector	Terminal	Connector	Terminal	
E87	13	E110	2	Existed

6. Disconnect stop lamp OFF relay 1 harness connector.
7. Check continuity between stop lamp OFF relay 1 and stop lamp switch harness connector.

Stop lamp OFF relay 1		Stop lamp switch		Continuity
Connector	Terminal	Connector	Terminal	
B246	4	E110	1	Existed

Is the inspection result normal?

- YES >> Perform diagnosis for stop lamp OFF relay system. Refer to [BR-132, "Diagnosis Procedure"](#).
NO >> Repair or replace error-detected parts and GO TO 18.

5.CHECK 12V BATTERY

1. Turn the ignition switch OFF to exit CONSULT.
2. Get out of the vehicle, close all doors (including trunk lid), and wait for 3 minutes or more without opening these doors.
CAUTION:
Never operate the vehicle and CONSULT while waiting.
3. Check the 12V battery terminal connections. Refer to [BR-6, "Precaution for Removing 12V Battery"](#) and [PG-135, "Work Flow"](#).
4. Check the 12V battery. Refer to [PG-135, "Work Flow"](#).

Is the inspection result normal?

- YES >> GO TO 6.
NO >> Repair or replace error-detected parts and GO TO 6.

6.PERFORM SELF-DIAGNOSIS (1)

ⓂWith CONSULT

1. Connect the electrically-driven intelligent brake unit harness connector.
2. Connect stop lamp switch harness connector.
3. Connect stop lamp OFF relay 1 harness connector. (With ICC)
4. Connect 12V battery cable to negative terminal.
5. Turn the ignition switch OFF to ON without depressing the brake pedal.
CAUTION:
Never set the vehicle to READY/Never start the engine.
6. Repeat step 2 two times or more.
CAUTION:
Be sure to wait for 5 seconds or more after turning the ignition switch OFF.
7. Turn the ignition switch OFF to exit CONSULT.
8. Get out of the vehicle, close all doors (including trunk lid), and wait for 3 minutes or more without opening these doors.
CAUTION:
Never operate the vehicle and CONSULT while waiting.
9. Turn the ignition switch ON without depressing the brake pedal.
CAUTION:
Never set the vehicle to READY/Never start the engine.
10. Start CONSULT and erase self-diagnosis result of "BRAKE".

C1A67 STOP LAMP SWITCH

< DTC/CIRCUIT DIAGNOSIS >

11. Turn the ignition switch OFF to exit CONSULT.
12. Get out of the vehicle, close all doors (including trunk lid), and wait for 3 minutes or more without opening these doors.
CAUTION:
Never operate the vehicle and CONSULT while waiting.
13. Turn the ignition switch ON without depressing the brake pedal.
CAUTION:
Never set the vehicle to READY/Never start the engine.
14. Depress brake pedal by 100 mm (3.94 in) or more, and hold the position for 5 seconds or more.
15. Release brake pedal.
16. Start CONSULT and perform "BRAKE" self-diagnosis.

Is DTC "C1A67" detected?

- YES >> GO TO 7.
NO >> INSPECTION END

7. CHECK CONNECTOR TERMINALS

1. Turn the ignition switch OFF to exit CONSULT.
2. Get out of the vehicle, close all doors (including trunk lid), and wait for 3 minutes or more without opening these doors.
CAUTION:
Never operate the vehicle and CONSULT while waiting.
3. Disconnect 12V battery cable from negative terminal. Refer to [BR-6, "Precaution for Removing 12V Battery"](#).
4. Disconnect the electrically-driven intelligent brake unit harness connector, then check for failures of pin terminals and connections.
5. Disconnect the stop lamp switch harness connector, then check for failures of pin terminals and connections.

Is the inspection result normal?

- YES >> GO TO 9.
NO >> Repair or replace error-detected parts and GO TO 8.

8. PERFORM SELF-DIAGNOSIS (2)

Ⓟ With CONSULT

1. Connect the electrically-driven intelligent brake unit harness connector.
2. Connect stop lamp switch harness connector.
3. Connect 12V battery cable to negative terminal.
4. Turn the ignition switch OFF to ON without depressing the brake pedal.
CAUTION:
Never set the vehicle to READY/Never start the engine.
5. Repeat step 4 two times or more.
CAUTION:
Be sure to wait for 5 seconds or more after turning the ignition switch OFF.
6. Turn the ignition switch OFF to exit CONSULT.
7. Get out of the vehicle, close all doors (including trunk lid), and wait for 3 minutes or more without opening these doors.
CAUTION:
Never operate the vehicle and CONSULT while waiting.
8. Turn the ignition switch ON without depressing the brake pedal.
CAUTION:
Never set the vehicle to READY/Never start the engine.
9. Start CONSULT and erase self-diagnosis result of "BRAKE".
10. Turn the ignition switch OFF to exit CONSULT.
11. Get out of the vehicle, close all doors (including trunk lid), and wait for 3 minutes or more without opening these doors.
CAUTION:
Never operate the vehicle and CONSULT while waiting.
12. Turn the ignition switch ON without depressing the brake pedal.
CAUTION:
Never set the vehicle to READY/Never start the engine.
13. Depress brake pedal by 100 mm (3.94 in) or more, and hold the position for 5 seconds or more.

C1A67 STOP LAMP SWITCH

< DTC/CIRCUIT DIAGNOSIS >

14. Release brake pedal.
15. Start CONSULT and perform "BRAKE" self-diagnosis.

Is DTC "C1A67" detected?

- YES >> GO TO 9.
NO >> INSPECTION END

9. CHECK IGNITION POWER SUPPLY

1. Connect stop lamp switch harness connector.
2. Turn the ignition switch OFF to exit CONSULT.
3. Get out of the vehicle, close all doors (including trunk lid), and wait for 3 minutes or more without opening these doors.

CAUTION:

Never operate the vehicle and CONSULT while waiting.

4. Disconnect 12V battery cable from negative terminal. Refer to [BR-6. "Precaution for Removing 12V Battery"](#).
5. Disconnect the electrically-driven intelligent brake unit harness connector.
6. Connect 12V battery cable to negative terminal.
7. Check voltage between the electrically-driven intelligent brake unit harness connector and ground.

Electrically-driven intelligent brake unit		—	Voltage
Connector	Terminal		
E87	26	Ground	Approx. 0 V

8. Turn the ignition switch ON without depressing the brake pedal.

CAUTION:

Never set the vehicle to READY/ Never start the engine.

9. Check voltage between the electrically-driven intelligent brake unit harness connector and ground.

Electrically-driven intelligent brake unit		—	Voltage
Connector	Terminal		
E87	26	Ground	10 – 16 V

Is the inspection result normal?

- YES >> GO TO 12.
NO >> GO TO 10.

10. CHECK IGNITION POWER SUPPLY CIRCUIT

1. Turn the ignition switch OFF to exit CONSULT.
2. Get out of the vehicle, close all doors (including trunk lid), and wait for 3 minutes or more without opening these doors.

CAUTION:

Never operate the vehicle and CONSULT while waiting.

3. Disconnect 12V battery cable from negative terminal. Refer to [BR-6. "Precaution for Removing 12V Battery"](#).
4. Check 10A fuse (#46).
5. Disconnect IPDM E/R harness connector.
6. Check continuity between electrically-driven intelligent brake unit and IPDM E/R.

Electrically-driven intelligent brake unit		IPDM E/R		Continuity
Connector	Terminal	Connector	Terminal	
E87	26	E5	12	Existed

7. Check continuity between electrically-driven intelligent brake unit harness connector and ground.

Electrically-driven intelligent brake unit		—	Continuity
Connector	Terminal		
E87	26	Ground	Not existed

C1A67 STOP LAMP SWITCH

< DTC/CIRCUIT DIAGNOSIS >

Is the inspection result normal?

- YES >> Perform trouble diagnosis for ignition power supply. Refer to [PG-30, "Wiring Diagram - IGNITION POWER SUPPLY -"](#).
- NO >> Repair or replace error-detected parts and GO TO 11.

11.PERFORM SELF-DIAGNOSIS (3)

ⓈWith CONSULT

1. Connect the electrically-driven intelligent brake unit harness connector.
2. Connect IPDM E/R harness connector.
3. Connect stop lamp switch harness connector.
4. Connect 12V battery cable to negative terminal.
5. Turn the ignition switch OFF to ON without depressing the brake pedal.
CAUTION:
Never set the vehicle to READY/Never start the engine.
6. Repeat step 5 two times or more.
CAUTION:
Be sure to wait for 5 seconds or more after turning the ignition switch OFF.
7. Turn the ignition switch OFF to exit CONSULT.
8. Get out of the vehicle, close all doors (including trunk lid), and wait for 3 minutes or more without opening these doors.
CAUTION:
Never operate the vehicle and CONSULT while waiting.
9. Turn the ignition switch ON without depressing the brake pedal.
CAUTION:
Never set the vehicle to READY/Never start the engine.
10. Start CONSULT and erase self-diagnosis result of "BRAKE".
11. Turn the ignition switch OFF to exit CONSULT.
12. Get out of the vehicle, close all doors (including trunk lid), and wait for 3 minutes or more without opening these doors.
CAUTION:
Never operate the vehicle and CONSULT while waiting.
13. Turn the ignition switch ON without depressing the brake pedal.
CAUTION:
Never set the vehicle to READY/Never start the engine.
14. Depress brake pedal by 100 mm (3.94 in) or more, and hold the position for 5 seconds or more.
15. Release brake pedal.
16. Start CONSULT and perform "BRAKE" self-diagnosis.

Is DTC "C1A67" detected?

- YES >> GO TO 12.
- NO >> INSPECTION END

12.CHECK 12V BATTERY POWER SUPPLY

1. Turn the ignition switch OFF to exit CONSULT.
2. Get out of the vehicle, close all doors (including trunk lid), and wait for 3 minutes or more without opening these doors.
CAUTION:
Never operate the vehicle and CONSULT while waiting.
3. Disconnect 12V battery cable from negative terminal. Refer to [BR-6, "Precaution for Removing 12V Battery"](#).
4. Disconnect the electrically-driven intelligent brake unit harness connector.
5. Connect 12V battery cable to negative terminal.
6. Check voltage between the electrically-driven intelligent brake unit harness connector terminal.

Electrically-driven intelligent brake unit		Voltage
Connector	Terminal	
E87	1 - 31	10 - 16 V
	2 - 31	
	11 - 31	

C1A67 STOP LAMP SWITCH

< DTC/CIRCUIT DIAGNOSIS >

- Turn the ignition switch ON without depressing the brake pedal.
CAUTION:
Never set the vehicle to READY/Never start the engine.
- Check voltage between the electrically-driven intelligent brake unit harness connector terminal

Electrically-driven intelligent brake unit		Voltage
Connector	Terminal	
E87	1 – 31	10 – 16 V
	2 – 31	
	11 – 31	

Is the inspection result normal?

- YES >> GO TO 15.
NO >> GO TO 13.

13.CHECK 12V BATTERY POWER SUPPLY CIRCUIT

- Turn the ignition switch OFF to exit CONSULT.
- Get out of the vehicle, close all doors (including trunk lid), and wait for 3 minutes or more without opening these doors.
CAUTION:
Never operate the vehicle and CONSULT while waiting.
- Disconnect 12V battery cable from negative terminal. Refer to [BR-6, "Precaution for Removing 12V Battery"](#).
- Check 50A fusible link (#D).
- Check continuity and for short circuit between electrically-driven intelligent brake unit harness connector terminal (1) and 50A fusible link (#D).
- Check continuity and for short circuit between electrically-driven intelligent brake unit harness connector terminal (2) and 50A fusible link (#D).
- Check 10A fuse (#65).
- Check continuity and for short circuit between electrically-driven intelligent brake unit harness connector terminal (11) and 10A fuse (#65).

Is the inspection result normal?

- YES >> Perform diagnosis for 12V battery power supply. Refer to [PG-14, "Wiring Diagram - BATTERY POWER SUPPLY -"](#).
NO >> Repair or replace error-detected parts and GO TO 14.

14.PERFORM SELF-DIAGNOSIS (4)

Ⓜ With CONSULT

- Connect the electrically-driven intelligent brake unit harness connector.
- Connect 12V battery cable to negative terminal.
- Turn the ignition switch OFF to ON without depressing the brake pedal.
CAUTION:
Never set the vehicle to READY/Never start the engine.
- Repeat step 3 two times or more.
CAUTION:
Be sure to wait for 5 seconds or more after turning the ignition switch OFF.
- Turn the ignition switch OFF to exit CONSULT.
- Get out of the vehicle, close all doors (including trunk lid), and wait for 3 minutes or more without opening these doors.
CAUTION:
Never operate the vehicle and CONSULT while waiting.
- Turn the ignition switch ON without depressing the brake pedal.
CAUTION:
Never set the vehicle to READY/Never start the engine.
- Start CONSULT and erase self-diagnosis result of "BRAKE".
- Turn the ignition switch OFF to exit CONSULT.
- Get out of the vehicle, close all doors (including trunk lid), and wait for 3 minutes or more without opening these doors.
CAUTION:

C1A67 STOP LAMP SWITCH

< DTC/CIRCUIT DIAGNOSIS >

Never operate the vehicle and CONSULT while waiting.

11. Turn the ignition switch ON without depressing the brake pedal.

CAUTION:

Never set the vehicle to READY/Never start the engine.

12. Depress brake pedal by 100 mm (3.94 in) or more, and hold the position for 5 seconds or more.
13. Release brake pedal.
14. Start CONSULT and perform "BRAKE" self-diagnosis.

Is DTC "C1A67" detected?

YES >> GO TO 15.

NO >> INSPECTION END

15. CHECK GROUND CIRCUIT

1. Turn the ignition switch OFF to exit CONSULT.
2. Get out of the vehicle, close all doors (including trunk lid), and wait for 3 minutes or more without opening these doors.
CAUTION:
Never operate the vehicle and CONSULT while waiting.
3. Disconnect 12V battery cable from negative terminal. Refer to [BR-6. "Precaution for Removing 12V Battery"](#).
4. Disconnect the electrically-driven intelligent brake unit harness connector.
5. Check continuity between electrically-driven intelligent brake unit and ground.

Electrically-driven intelligent brake unit		—	Continuity
Connector	Terminal		
E87	31	Ground	Existed

Is the inspection result normal?

YES >> GO TO 17.

NO >> Repair or replace error-detected parts and GO TO 16.

16. PERFORM SELF-DIAGNOSIS (5)

Ⓟ With CONSULT

1. Connect the electrically-driven intelligent brake unit harness connector.
2. Connect 12V battery cable to negative terminal.
3. Turn the ignition switch OFF to ON without depressing the brake pedal.
CAUTION:
Never set the vehicle to READY/Never start the engine.
4. Repeat step 3 two times or more.
CAUTION:
Be sure to wait for 5 seconds or more after turning the ignition switch OFF.
5. Turn the ignition switch OFF to exit CONSULT.
6. Get out of the vehicle, close all doors (including trunk lid), and wait for 3 minutes or more without opening these doors.
CAUTION:
Never operate the vehicle and CONSULT while waiting.
7. Turn the ignition switch ON without depressing the brake pedal.
CAUTION:
Never set the vehicle to READY/Never start the engine.
8. Start CONSULT and erase self-diagnosis result of "BRAKE".
9. Turn the ignition switch OFF to exit CONSULT.
10. Get out of the vehicle, close all doors (including trunk lid), and wait for 3 minutes or more without opening these doors.
CAUTION:
Never operate the vehicle and CONSULT while waiting.
11. Turn the ignition switch ON without depressing the brake pedal.
CAUTION:
Never set the vehicle to READY/Never start the engine.
12. Depress brake pedal by 100 mm (3.94 in) or more, and hold the position for 5 seconds or more.
13. Release brake pedal.
14. Start CONSULT and perform "BRAKE" self-diagnosis.

C1A67 STOP LAMP SWITCH

< DTC/CIRCUIT DIAGNOSIS >

Is DTC "C1A67" detected?

YES >> GO TO 17.

NO >> INSPECTION END

17. CHECK DATA MONITOR

With CONSULT

1. Turn the ignition switch OFF to ON without depressing the brake pedal.

CAUTION:

Never set the vehicle to READY/Never start the engine.

2. Repeat step 3 two times or more.

CAUTION:

Be sure to wait for 5 seconds or more after turning the ignition switch OFF.

3. Start CONSULT and select "BRAKE" and "DATA MONITOR" according to this order.
4. Check "MOTOR POWER SUPPLY" and "CONTROL MODULE POWER". Refer to [BR-33. "Reference Value"](#).

Is the inspection result normal?

YES >> GO TO 18.

NO >> Replace the electrically-driven intelligent brake unit. Refer to [BR-288. "Removal and installation"](#).

18. PERFORM SELF-DIAGNOSIS (6)

With CONSULT

1. Turn the ignition switch OFF to ON without depressing the brake pedal.

CAUTION:

Never set the vehicle to READY/Never start the engine.

2. Repeat step 1 two times or more.

CAUTION:

Be sure to wait for 5 seconds or more after turning the ignition switch OFF.

3. Turn the ignition switch OFF to exit CONSULT.
4. Get out of the vehicle, close all doors (including trunk lid), and wait for 3 minutes or more without opening these doors.

CAUTION:

Never operate the vehicle and CONSULT while waiting.

5. Turn the ignition switch ON without depressing the brake pedal.

CAUTION:

Never set the vehicle to READY/Never start the engine.

6. Start CONSULT and erase self-diagnosis result of "BRAKE".
7. Turn the ignition switch OFF to exit CONSULT.
8. Get out of the vehicle, close all doors (including trunk lid), and wait for 3 minutes or more without opening these doors.

CAUTION:

Never operate the vehicle and CONSULT while waiting.

9. Turn the ignition switch ON without depressing the brake pedal.

CAUTION:

Never set the vehicle to READY/Never start the engine.

10. Depress brake pedal by 100 mm (3.94 in) or more, and hold the position for 5 seconds or more.
11. Release brake pedal.
12. Start CONSULT and perform "BRAKE" self-diagnosis.

Is DTC "C1A67" detected?

YES >> GO TO 19.

NO >> INSPECTION END

19. VISUALLY CHECK STOP LAMP SWITCH

Check the stop lamp switch for damage.

Is the inspection result normal?

YES >> GO TO 20.

NO >> Repair or replace error-detected parts and GO TO 30.

20. CHECK STOP LAMP SWITCH INSTALLATION

Check stop lamp switch for looseness and disconnection.

C1A67 STOP LAMP SWITCH

< DTC/CIRCUIT DIAGNOSIS >

Is the inspection result normal?

YES >> GO TO 21.

NO >> Correct stop lamp switch installation or replace stop lamp switch. GO TO 30.

21. CHECK BRAKE PEDAL HEIGHT

Check each brake pedal height. Refer to [BR-270. "Inspection and Adjustment"](#).

Is the inspection result normal?

YES >> GO TO 22.

NO >> Adjust each brake pedal height. Refer to [BR-270. "Inspection and Adjustment"](#). GO TO 30.

22. STROKE SENSOR 0 POINT LEARNING

Perform stroke sensor 0 point learning. Refer to [BR-47. "Work Procedure"](#).

>> GO TO 23.

23. CHECK STOP LAMP FOR ILLUMINATION (2)

Depress the brake pedal to a depth of 100 mm (3.94 in) or more and maintain the brake depression for 5 seconds or more to check that the stop lamp turns ON.

Is the inspection result normal?

YES >> GO TO 30.

NO >> GO TO 24.

24. CHECK STOP LAMP SWITCH CLEARANCE

1. Turn the ignition switch OFF to exit CONSULT.
2. Check stop lamp clearance. Refer to [BR-270. "Inspection and Adjustment"](#).

Is the inspection result normal?

YES >> GO TO 25.

NO >> Adjust stop lamp switch clearance. Refer to [BR-270. "Inspection and Adjustment"](#). GO TO 30.

25. CHECK STOP LAMP SWITCH CIRCUIT (3)

1. Turn the ignition switch OFF to exit CONSULT.
2. Get out of the vehicle, close all doors (including trunk lid), and wait for 3 minutes or more without opening these doors.

CAUTION:

Never operate the vehicle and CONSULT while waiting.

3. Disconnect 12V battery cable from negative terminal. Refer to [BR-6. "Precaution for Removing 12V Battery"](#).
4. Disconnect the electrically-driven intelligent brake unit harness connector.
5. Connect 12V battery cable to negative terminal.
6. Check voltage between the electrically-driven intelligent brake unit harness connector and ground.

Electrically-driven intelligent brake unit		—	Test condition	Voltage
Connector	Terminal			
E87	13	Ground	Brake pedal is depressed.	10 – 16 V
			Brake pedal is not depressed.	Approx. 0 V

7. Turn the ignition switch ON without depressing the brake pedal.

CAUTION:

Never set the vehicle to READY/ Never start the engine.

8. Check voltage between the electrically-driven intelligent brake unit harness connector and ground.

Electrically-driven intelligent brake unit		—	Test condition	Voltage
Connector	Terminal			
E87	13	Ground	Brake pedal is depressed.	10 – 16 V
			Brake pedal is not depressed.	Approx. 0 V

Is the inspection result normal?

C1A67 STOP LAMP SWITCH

< DTC/CIRCUIT DIAGNOSIS >

- YES >> GO TO 28.
 NO (without ICC)>>GO TO 26.
 NO (with ICC)>>GO TO 27.

26.CHECK STOP LAMP SWITCH CIRCUIT (4) (WITHOUT ICC)

- Turn the ignition switch OFF to exit CONSULT.
- Get out of the vehicle, close all doors (including trunk lid), and wait for 3 minutes or more without opening these doors.
CAUTION:
Never operate the vehicle and CONSULT while waiting.
- Disconnect 12V battery cable from negative terminal. Refer to [BR-6, "Precaution for Removing 12V Battery"](#).
- Disconnect stop lamp switch harness connector.
- Check continuity between electrically-driven intelligent brake unit and stop lamp switch harness connector.

Electrically-driven intelligent brake unit		Stop lamp switch		Continuity
Connector	Terminal	Connector	Terminal	
E87	13	E110	2	Existed

Is the inspection result normal?

- YES >> Perform diagnosis for stop lamp OFF relay system. Refer to [BR-132, "Diagnosis Procedure"](#).
 NO >> Repair or replace error-detected parts and GO TO 30.

27.CHECK STOP LAMP SWITCH CIRCUIT (4) (WITH ICC)

- Turn the ignition switch OFF to exit CONSULT.
- Get out of the vehicle, close all doors (including trunk lid), and wait for 3 minutes or more without opening these doors.
CAUTION:
Never operate the vehicle and CONSULT while waiting.
- Disconnect 12V battery cable from negative terminal. Refer to [BR-6, "Precaution for Removing 12V Battery"](#).
- Disconnect stop lamp switch harness connector.
- Check continuity between electrically-driven intelligent brake unit and stop lamp switch harness connector.

Electrically-driven intelligent brake unit		Stop lamp switch		Continuity
Connector	Terminal	Connector	Terminal	
E87	13	E110	2	Existed

- Disconnect stop lamp OFF relay 1 harness connector.
- Check continuity between stop lamp OFF relay 1 and stop lamp switch harness connector.

Stop lamp OFF relay 1		Stop lamp switch		Continuity
Connector	Terminal	Connector	Terminal	
B246	4	E110	1	Existed

Is the inspection result normal?

- YES >> Perform diagnosis for stop lamp OFF relay system. Refer to [BR-132, "Diagnosis Procedure"](#).
 NO >> Repair or replace error-detected parts and GO TO 30.

28.CHECK STOP LAMP SWITCH

Check the stop lamp switch. Refer to [BR-130, "Component Inspection"](#).

Is the inspection result normal?

- YES >> GO TO 29.
 NO >> Replace the stop lamp switch. Refer to [BR-280, "Removal and Installation"](#). GO TO 30.

29.CHECK STOP LAMP FOR ILLUMINATION (3)

A
B
C
D
E
BR
G
H
I
J
K
L
M
N
O
P

C1A67 STOP LAMP SWITCH

< DTC/CIRCUIT DIAGNOSIS >

1. Connect stop lamp switch harness connector.
2. Connect 12V battery cable to negative terminal.
3. Connect stop lamp OFF relay 1 harness connector. (With ICC)
4. Depress the brake pedal to a depth of 100 mm (3.94 in) or more and maintain the brake depression for 5 seconds or more to check that the stop lamp turns ON.

Is the inspection result normal?

YES >> GO TO 30.

NO >> Repair or replace error-detected parts and GO TO 30.

30.PERFORM SELF-DIAGNOSIS (3)

ⓅWith CONSULT

1. Turn the ignition switch OFF to ON without depressing the brake pedal.
CAUTION:
Never set the vehicle to READY/Never start the engine.
2. Repeat step 2 two times or more.
CAUTION:
Be sure to wait for 5 seconds or more after turning the ignition switch OFF.
3. Turn the ignition switch OFF to exit CONSULT.
4. Get out of the vehicle, close all doors (including trunk lid), and wait for 3 minutes or more without opening these doors.
CAUTION:
Never operate the vehicle and CONSULT while waiting.
5. Turn the ignition switch ON without depressing the brake pedal.
CAUTION:
Never set the vehicle to READY/Never start the engine.
6. Start CONSULT and erase self-diagnosis result of "BRAKE".
7. Turn the ignition switch OFF to exit CONSULT.
8. Get out of the vehicle, close all doors (including trunk lid), and wait for 3 minutes or more without opening these doors.
CAUTION:
Never operate the vehicle and CONSULT while waiting.
9. Turn the ignition switch ON without depressing the brake pedal.
CAUTION:
Never set the vehicle to READY/Never start the engine.
10. Depress brake pedal by 100 mm (3.94 in) or more, and hold the position for 5 seconds or more.
11. Release brake pedal.
12. Start CONSULT and perform "BRAKE" self-diagnosis.

Is any DTC "C1A67" or "C1A68" detected?

YES("C1A67")>>GO TO 25.

YES("C1A68")>>Proceed to [BR-132. "Diagnosis Procedure"](#).

NO >> INSPECTION END

Component Inspection

INFOID:000000008139823

1.CHECK STOP LAMP SWITCH

1. Turn the ignition switch OFF to exit CONSULT.
2. Get out of the vehicle, close all doors (including trunk lid), and wait for 3 minutes or more without opening these doors.
CAUTION:
Never operate the vehicle and CONSULT while waiting.
3. Disconnect stop lamp switch harness connector.
4. Check continuity when stop lamp switch is operated.

C1A67 STOP LAMP SWITCH

< DTC/CIRCUIT DIAGNOSIS >

Stop lamp switch Terminal	Test condition	Continuity
1 - 2	When stop lamp switch is released (when brake pedal is depressed)	Existed
	When stop lamp switch is pressed (when brake pedal is released)	Not existed

Is the inspection result normal?

YES >> INSPECTION END

NO >> Replace the stop lamp switch. Refer to [BR-280. "Removal and Installation"](#).

A
B
C
D
E
G
H
I
J
K
L
M
N
O
P

BR

C1A68 STOP LAMP SWITCH RELAY

< DTC/CIRCUIT DIAGNOSIS >

C1A68 STOP LAMP SWITCH RELAY

DTC Logic

INFOID:000000008139824

DTC DETECTION LOGIC

DTC	Display item	Malfunction detection condition	Possible causes
C1A68	STOP LAMP RELAY	<ul style="list-style-type: none">• Open circuit is detected in stop lamp off relay 1 circuit.• Open circuit is detected in stop lamp off relay 2 circuit.• Short circuit is detected in stop lamp off relay 1 circuit.• Short circuit is detected in stop lamp off relay 2 circuit.• Malfunction is detected in stop lamp off relay 1.• Malfunction is detected in stop lamp off relay 2.	<ul style="list-style-type: none">• Harness or connector• Stop lamp OFF relay 1• Stop lamp OFF relay 2• Electrically-driven intelligent brake unit

DTC CONFIRMATION PROCEDURE

1. PRECONDITIONING

If "DTC CONFIRMATION PROCEDURE" has been previously conducted, always turn the ignition switch OFF and wait at least 10 seconds before conducting the next test.

>> GO TO 2.

2. CHECK DTC DETECTION

Ⓜ With CONSULT

1. Turn the ignition switch OFF to ON without depressing the brake pedal.
CAUTION:
Never set the vehicle to READY/Never start the engine.
2. Repeat step 1 two times or more.
CAUTION:
Be sure to wait for 5 seconds or more after turning the ignition switch OFF.
3. Turn the ignition switch OFF to exit CONSULT.
4. Get out of the vehicle, close all doors (including trunk lid), and wait for 3 minutes or more without opening these doors.
CAUTION:
Never operate the vehicle and CONSULT while waiting.
5. Turn the ignition switch ON without depressing the brake pedal.
CAUTION:
Never set the vehicle to READY/Never start the engine.
6. Start CONSULT and erase self-diagnosis result of "BRAKE".
7. Turn the ignition switch OFF to exit CONSULT.
8. Get out of the vehicle, close all doors (including trunk lid), and wait for 3 minutes or more without opening these doors.
CAUTION:
Never operate the vehicle and CONSULT while waiting.
9. Turn the ignition switch ON without depressing the brake pedal.
CAUTION:
Never set the vehicle to READY/Never start the engine.
10. Depress brake pedal by 100 mm (3.94 in) or more, and hold the position for 5 seconds or more.
11. Release brake pedal.
12. Start CONSULT and perform "BRAKE" self-diagnosis.

Is DTC "C1A68" detected?

- YES >> Proceed to [BR-132, "Diagnosis Procedure"](#).
NO >> INSPECTION END

Diagnosis Procedure

INFOID:000000008139825

1. CHECK 12V BATTERY

1. Turn the ignition switch OFF to exit CONSULT.

C1A68 STOP LAMP SWITCH RELAY

< DTC/CIRCUIT DIAGNOSIS >

2. Get out of the vehicle, close all doors (including trunk lid), and wait for 3 minutes or more without opening these doors.
CAUTION:
Never operate the vehicle and CONSULT while waiting.
3. Check the 12V battery terminal connections. Refer to [BR-6, "Precaution for Removing 12V Battery"](#) and [PG-135, "Work Flow"](#).
4. Check the 12V battery. Refer to [PG-135, "Work Flow"](#).

Is the inspection result normal?

YES >> GO TO 2.

NO >> Repair or replace error-detected parts and GO TO 2.

2.PERFORM SELF-DIAGNOSIS (1)

 With CONSULT

1. Connect 12V battery cable to negative terminal.
2. Turn the ignition switch OFF to ON without depressing the brake pedal.
CAUTION:
Never set the vehicle to READY/Never start the engine.
3. Repeat step 2 two times or more.
CAUTION:
Be sure to wait for 5 seconds or more after turning the ignition switch OFF.
4. Turn the ignition switch OFF to exit CONSULT.
5. Get out of the vehicle, close all doors (including trunk lid), and wait for 3 minutes or more without opening these doors.
CAUTION:
Never operate the vehicle and CONSULT while waiting.
6. Turn the ignition switch ON without depressing the brake pedal.
CAUTION:
Never set the vehicle to READY/Never start the engine.
7. Start CONSULT and erase self-diagnosis result of "BRAKE".
8. Turn the ignition switch OFF to exit CONSULT.
9. Get out of the vehicle, close all doors (including trunk lid), and wait for 3 minutes or more without opening these doors.
CAUTION:
Never operate the vehicle and CONSULT while waiting.
10. Turn the ignition switch ON without depressing the brake pedal.
CAUTION:
Never set the vehicle to READY/Never start the engine.
11. Depress brake pedal by 100 mm (3.94 in) or more, and hold the position for 5 seconds or more.
12. Release brake pedal.
13. Start CONSULT and perform "BRAKE" self-diagnosis.

Is DTC "C1A68" detected?

YES >> GO TO3.

NO >> INSPECTION END

3.CHECK CONNECTOR TERMINALS

1. Turn the ignition switch OFF to exit CONSULT.
2. Get out of the vehicle, close all doors (including trunk lid), and wait for 3 minutes or more without opening these doors.
CAUTION:
Never operate the vehicle and CONSULT while waiting.
3. Disconnect 12V battery cable from negative terminal. Refer to [BR-6, "Precaution for Removing 12V Battery"](#).
4. Disconnect the electrically-driven intelligent brake unit harness connector, then check for failures of pin terminals and connections.
5. Disconnect the stop lamp OFF relay 1 harness connector, then check for failures of pin terminals and connections.
6. Disconnect the stop lamp OFF relay 2 harness connector, then check for failures of pin terminals and connections.

Is the inspection result normal?

YES >> GO TO 5.

C1A68 STOP LAMP SWITCH RELAY

< DTC/CIRCUIT DIAGNOSIS >

NO >> Repair or replace error-detected parts and GO TO 4.

4. PERFORM SELF-DIAGNOSIS (2)

 With CONSULT

1. Connect the electrically-driven intelligent brake unit harness connector.
2. Connect stop lamp OFF relay 1 harness connector.
3. Connect stop lamp OFF relay 2 harness connector.
4. Connect 12V battery cable to negative terminal.
5. Turn the ignition switch OFF to ON without depressing the brake pedal.
CAUTION:
Never set the vehicle to READY/Never start the engine.
6. Repeat step 5 two times or more.
CAUTION:
Be sure to wait for 5 seconds or more after turning the ignition switch OFF.
7. Turn the ignition switch OFF to exit CONSULT.
8. Get out of the vehicle, close all doors (including trunk lid), and wait for 3 minutes or more without opening these doors.
CAUTION:
Never operate the vehicle and CONSULT while waiting.
9. Turn the ignition switch ON without depressing the brake pedal.
CAUTION:
Never set the vehicle to READY/Never start the engine.
10. Start CONSULT and erase self-diagnosis result of "BRAKE".
11. Turn the ignition switch OFF to exit CONSULT.
12. Get out of the vehicle, close all doors (including trunk lid), and wait for 3 minutes or more without opening these doors.
CAUTION:
Never operate the vehicle and CONSULT while waiting.
13. Turn the ignition switch ON without depressing the brake pedal.
CAUTION:
Never set the vehicle to READY/Never start the engine.
14. Depress brake pedal by 100 mm (3.94 in) or more, and hold the position for 5 seconds or more.
15. Release brake pedal.
16. Start CONSULT and perform "BRAKE" self-diagnosis.

Is DTC "C1A68" detected?

YES >> GO TO 5.

NO >> INSPECTION END

5. CHECK IGNITION POWER SUPPLY

1. Connect stop lamp OFF relay 1 harness connector.
2. Connect stop lamp OFF relay 2 harness connector.
3. Turn the ignition switch OFF to exit CONSULT.
4. Get out of the vehicle, close all doors (including trunk lid), and wait for 3 minutes or more without opening these doors.
CAUTION:
Never operate the vehicle and CONSULT while waiting.
5. Disconnect 12V battery cable from negative terminal. Refer to [BR-6. "Precaution for Removing 12V Battery"](#).
6. Disconnect the electrically-driven intelligent brake unit harness connector.
7. Connect 12V battery cable to negative terminal.
8. Check voltage between the electrically-driven intelligent brake unit harness connector and ground.

Electrically-driven intelligent brake unit		—	Voltage
Connector	Terminal		
E87	26	Ground	Approx. 0 V

9. Turn the ignition switch ON without depressing the brake pedal.
CAUTION:
Never set the vehicle to READY/Never start the engine.

10. Check voltage between the electrically-driven intelligent brake unit harness connector and ground.

C1A68 STOP LAMP SWITCH RELAY

< DTC/CIRCUIT DIAGNOSIS >

Electrically-driven intelligent brake unit		—	Voltage
Connector	Terminal		
E87	26	Ground	10 – 16 V

Is the inspection result normal?

YES >> GO TO 8.

NO >> GO TO 6.

6. CHECK IGNITION POWER SUPPLY CIRCUIT

- Turn the ignition switch OFF to exit CONSULT.
- Get out of the vehicle, close all doors (including trunk lid), and wait for 3 minutes or more without opening these doors.
CAUTION:
Never operate the vehicle and CONSULT while waiting.
- Disconnect 12V battery cable from negative terminal. Refer to [BR-6. "Precaution for Removing 12V Battery"](#).
- Check 10A fuse (#46).
- Disconnect IPDM E/R harness connector.
- Check continuity between electrically-driven intelligent brake unit and IPDM E/R.

Electrically-driven intelligent brake unit		IPDM E/R		Continuity
Connector	Terminal	Connector	Terminal	
E87	26	E5	12	Existed

- Check continuity between electrically-driven intelligent brake unit harness connector and ground.

Electrically-driven intelligent brake unit		—	Continuity
Connector	Terminal		
E87	26	Ground	Not existed

Is the inspection result normal?

YES >> Perform trouble diagnosis for ignition power supply. Refer to [PG-30. "Wiring Diagram - IGNITION POWER SUPPLY -"](#).

NO >> Repair or replace error-detected parts and GO TO 7.

7. PERFORM SELF-DIAGNOSIS (2)

 With CONSULT

- Connect the electrically-driven intelligent brake unit harness connector.
- Connect IPDM E/R harness connector.
- Connect 12V battery cable to negative terminal.
- Turn the ignition switch OFF to ON without depressing the brake pedal.
CAUTION:
Never set the vehicle to READY/Never start the engine.
- Repeat step 4 two times or more.
CAUTION:
Be sure to wait for 5 seconds or more after turning the ignition switch OFF.
- Turn the ignition switch OFF to exit CONSULT.
- Get out of the vehicle, close all doors (including trunk lid), and wait for 3 minutes or more without opening these doors.
CAUTION:
Never operate the vehicle and CONSULT while waiting.
- Turn the ignition switch ON without depressing the brake pedal.
CAUTION:
Never set the vehicle to READY/Never start the engine.
- Start CONSULT and erase self-diagnosis result of "BRAKE".
- Turn the ignition switch OFF to exit CONSULT.
- Get out of the vehicle, close all doors (including trunk lid), and wait for 3 minutes or more without opening these doors.

C1A68 STOP LAMP SWITCH RELAY

< DTC/CIRCUIT DIAGNOSIS >

CAUTION:

Never operate the vehicle and CONSULT while waiting.

- Turn the ignition switch ON without depressing the brake pedal.

CAUTION:

Never set the vehicle to READY/Never start the engine.

- Depress brake pedal by 100 mm (3.94 in) or more, and hold the position for 5 seconds or more.
- Release brake pedal.
- Start CONSULT and perform "BRAKE" self-diagnosis.

Is DTC "C1A68" detected?

YES >> GO TO 8.

NO >> INSPECTION END

8. CHECK 12V BATTERY POWER SUPPLY

- Turn the ignition switch OFF to exit CONSULT.
- Get out of the vehicle, close all doors (including trunk lid), and wait for 3 minutes or more without opening these doors.

CAUTION:

Never operate the vehicle and CONSULT while waiting.

- Disconnect 12V battery cable from negative terminal. Refer to [BR-6, "Precaution for Removing 12V Battery"](#).
- Disconnect the electrically-driven intelligent brake unit harness connector.
- Connect 12V battery cable to negative terminal.
- Check voltage between the electrically-driven intelligent brake unit harness connector terminal.

Electrically-driven intelligent brake unit		Voltage
Connector	Terminal	
E87	1 - 31	10 - 16 V
	2 - 31	
	11 - 31	

- Turn the ignition switch ON without depressing the brake pedal.

CAUTION:

Never set the vehicle to READY/Never start the engine.

- Check voltage between the electrically-driven intelligent brake unit harness connector terminal.

Electrically-driven intelligent brake unit		Voltage
Connector	Terminal	
E87	1 - 31	10 - 16 V
	2 - 31	
	11 - 31	

Is the inspection result normal?

YES >> GO TO 11.

NO >> GO TO 9.

9. CHECK 12V BATTERY POWER SUPPLY CIRCUIT

- Turn the ignition switch OFF to exit CONSULT.
- Get out of the vehicle, close all doors (including trunk lid), and wait for 3 minutes or more without opening these doors.

CAUTION:

Never operate the vehicle and CONSULT while waiting.

- Disconnect 12V battery cable from negative terminal. Refer to [BR-6, "Precaution for Removing 12V Battery"](#).
- Check 50A fusible link (#D).
- Check continuity and for short circuit between electrically-driven intelligent brake unit harness connector terminal (1) and 50A fusible link (#D).
- Check continuity and for short circuit between electrically-driven intelligent brake unit harness connector terminal (2) and 50A fusible link (#D).

C1A68 STOP LAMP SWITCH RELAY

< DTC/CIRCUIT DIAGNOSIS >

7. Check 10A fuse (#65).
8. Check continuity and for short circuit between electrically-driven intelligent brake unit harness connector terminal (11) and 10A fuse (#65).

Is the inspection result normal?

YES >> Perform diagnosis for 12V battery power supply. Refer to [PG-14, "Wiring Diagram - BATTERY POWER SUPPLY -"](#).

NO >> Repair or replace error-detected parts and GO TO 10.

10. PERFORM SELF-DIAGNOSIS (3)

Ⓜ With CONSULT

1. Connect the electrically-driven intelligent brake unit harness connector.
2. Connect 12V battery cable to negative terminal.
3. Turn the ignition switch OFF to ON without depressing the brake pedal.
CAUTION:
Never set the vehicle to READY/Never start the engine.
4. Repeat step 3 two times or more.
CAUTION:
Be sure to wait for 5 seconds or more after turning the ignition switch OFF.
5. Turn the ignition switch OFF to exit CONSULT.
6. Get out of the vehicle, close all doors (including trunk lid), and wait for 3 minutes or more without opening these doors.
CAUTION:
Never operate the vehicle and CONSULT while waiting.
7. Turn the ignition switch ON without depressing the brake pedal.
CAUTION:
Never set the vehicle to READY/Never start the engine.
8. Start CONSULT and erase self-diagnosis result of "BRAKE".
9. Turn the ignition switch OFF to exit CONSULT.
10. Get out of the vehicle, close all doors (including trunk lid), and wait for 3 minutes or more without opening these doors.
CAUTION:
Never operate the vehicle and CONSULT while waiting.
11. Turn the ignition switch ON without depressing the brake pedal.
CAUTION:
Never set the vehicle to READY/Never start the engine.
12. Depress brake pedal by 100 mm (3.94 in) or more, and hold the position for 5 seconds or more.
13. Release brake pedal.
14. Start CONSULT and perform "BRAKE" self-diagnosis.

Is DTC "C1A68" detected?

YES >> GO TO 11.

NO >> INSPECTION END

11. CHECK GROUND CIRCUIT

1. Turn the ignition switch OFF to exit CONSULT.
2. Get out of the vehicle, close all doors (including trunk lid), and wait for 3 minutes or more without opening these doors.
CAUTION:
Never operate the vehicle and CONSULT while waiting.
3. Disconnect 12V battery cable from negative terminal. Refer to [BR-6, "Precaution for Removing 12V Battery"](#).
4. Disconnect the electrically-driven intelligent brake unit harness connector.
5. Check continuity between electrically-driven intelligent brake unit and ground.

Electrically-driven intelligent brake unit		—	Continuity
Connector	Terminal		
E87	31	Ground	Existed

Is the inspection result normal?

YES >> GO TO 13.

C1A68 STOP LAMP SWITCH RELAY

< DTC/CIRCUIT DIAGNOSIS >

NO >> Repair or replace error-detected parts and GO TO 12.

12.PERFORM SELF-DIAGNOSIS (4)

Ⓟ With CONSULT

1. Connect the electrically-driven intelligent brake unit harness connector.
2. Connect 12V battery cable to negative terminal.
3. Turn the ignition switch OFF to ON without depressing the brake pedal.
CAUTION:
Never set the vehicle to READY/Never start the engine.
4. Repeat step 3 two times or more.
CAUTION:
Be sure to wait for 5 seconds or more after turning the ignition switch OFF.
5. Turn the ignition switch OFF to exit CONSULT.
6. Get out of the vehicle, close all doors (including trunk lid), and wait for 3 minutes or more without opening these doors.
CAUTION:
Never operate the vehicle and CONSULT while waiting.
7. Turn the ignition switch ON without depressing the brake pedal.
CAUTION:
Never set the vehicle to READY/Never start the engine.
8. Start CONSULT and erase self-diagnosis result of "BRAKE".
9. Turn the ignition switch OFF to exit CONSULT.
10. Get out of the vehicle, close all doors (including trunk lid), and wait for 3 minutes or more without opening these doors.
CAUTION:
Never operate the vehicle and CONSULT while waiting.
11. Turn the ignition switch ON without depressing the brake pedal.
CAUTION:
Never set the vehicle to READY/Never start the engine.
12. Depress brake pedal by 100 mm (3.94 in) or more, and hold the position for 5 seconds or more.
13. Release brake pedal.
14. Start CONSULT and perform "BRAKE" self-diagnosis.

Is DTC "C1A68" detected?

YES >> GO TO 13.

NO >> INSPECTION END

13.CHECK DATA MONITOR

Ⓟ With CONSULT

1. Connect the electrically-driven intelligent brake unit harness connector.
2. Connect 12V battery cable to negative terminal.
3. Turn the ignition switch OFF to ON without depressing the brake pedal.
CAUTION:
Never set the vehicle to READY/Never start the engine.
4. Repeat step 3 two times or more.
CAUTION:
Be sure to wait for 5 seconds or more after turning the ignition switch OFF.
5. Start CONSULT and select "BRAKE" and "DATA MONITOR" according this order.
6. Check "MOTOR POWER SUPPLY" and "CONTROL MODULE POWER". Refer to [BR-33, "Reference Value"](#).

Is the inspection result normal?

YES >> GO TO 14.

NO >> Replace the electrically-driven intelligent brake unit. Refer to [BR-288, "Removal and installation"](#).

14.PERFORM SELF-DIAGNOSIS (5)

Ⓟ With CONSULT

1. Turn the ignition switch OFF to ON without depressing the brake pedal.
CAUTION:
Never set the vehicle to READY/Never start the engine.
2. Repeat step 1 two times or more.
CAUTION:

C1A68 STOP LAMP SWITCH RELAY

< DTC/CIRCUIT DIAGNOSIS >

Be sure to wait for 5 seconds or more after turning the ignition switch OFF.

3. Turn the ignition switch OFF to exit CONSULT. A
4. Get out of the vehicle, close all doors (including trunk lid), and wait for 3 minutes or more without opening these doors.

CAUTION:

Never operate the vehicle and CONSULT while waiting. B

5. Turn the ignition switch ON without depressing the brake pedal.

CAUTION:

Never set the vehicle to READY/Never start the engine. C

6. Start CONSULT and erase self-diagnosis result of "BRAKE".
7. Turn the ignition switch OFF to exit CONSULT.
8. Get out of the vehicle, close all doors (including trunk lid), and wait for 3 minutes or more without opening these doors. D

CAUTION:

Never operate the vehicle and CONSULT while waiting.

9. Turn the ignition switch ON without depressing the brake pedal. E

CAUTION:

Never set the vehicle to READY/Never start the engine.

10. Depress brake pedal by 100 mm (3.94 in) or more, and hold the position for 5 seconds or more. BR
11. Release brake pedal.
12. Start CONSULT and perform "BRAKE" self-diagnosis.

Is any DTC "C1A67" or "C1A68" detected?

YES("C1A67")>>Proceed to [BR-119, "Diagnosis Procedure"](#). G

YES("C1A68")>>GO TO 15.

NO >> INSPECTION END

15.PERFORM ACTIVE TEST (1) H

ⓂWith CONSULT

Perform "ACTIVE TEST" without depressing the brake pedal. Refer to [BR-30, "CONSULT Function"](#).

CAUTION:

- After the stop lamp OFF relay is activated, wait for 10 seconds to deactivate it.
- Wait for 10 seconds after the stop lamp OFF relay is deactivated. J

>> GO TO 16.

16.PERFORM SELF-DIAGNOSIS (6) K

ⓂWith CONSULT

1. Turn the ignition switch OFF to ON without depressing the brake pedal. L

CAUTION:

Never set the vehicle to READY/Never start the engine.

2. Repeat step 1 two times or more.

CAUTION:

Be sure to wait for 5 seconds or more after turning the ignition switch OFF. M

3. Turn the ignition switch OFF to exit CONSULT.
4. Get out of the vehicle, close all doors (including trunk lid), and wait for 3 minutes or more without opening these doors. N

CAUTION:

Never operate the vehicle and CONSULT while waiting.

5. Turn the ignition switch ON without depressing the brake pedal. O

CAUTION:

Never set the vehicle to READY/Never start the engine.

6. Start CONSULT and erase self-diagnosis result of "BRAKE".
7. Turn the ignition switch OFF to exit CONSULT. P
8. Get out of the vehicle, close all doors (including trunk lid), and wait for 3 minutes or more without opening these doors.

CAUTION:

Never operate the vehicle and CONSULT while waiting.

9. Turn the ignition switch ON without depressing the brake pedal.

CAUTION:

Never set the vehicle to READY/Never start the engine.

C1A68 STOP LAMP SWITCH RELAY

< DTC/CIRCUIT DIAGNOSIS >

- Depress brake pedal by 100 mm (3.94 in) or more, and hold the position for 5 seconds or more.
- Release brake pedal.
- Start CONSULT and perform "BRAKE" self-diagnosis.

Is DTC "C1A68" detected?

- YES >> GO TO 17.
NO >> GO TO 20.

17. CHECK STOP LAMP OFF RELAY 1 CIRCUIT

- Turn the ignition switch OFF to exit CONSULT.
- Get out of the vehicle, close all doors (including trunk lid), and wait for 3 minutes or more without opening these doors.
CAUTION:
Never operate the vehicle and CONSULT while waiting.
- Disconnect 12V battery cable from negative terminal. Refer to [BR-6. "Precaution for Removing 12V Battery"](#).
- Disconnect stop lamp OFF relay 1 harness connector.
- Disconnect the electrically-driven intelligent brake unit harness connector.
- Check continuity between stop lamp OFF relay 1 and electrically-driven intelligent brake unit harness connector.

Stop lamp OFF relay 1		Electrically-driven intelligent brake unit		Continuity
Connector	Terminal	Connector	Terminal	
B246	2	E87	9	Existed

Is the inspection result normal?

- YES >> GO TO 18.
NO >> Repair or replace error-detected parts.

18. CHECK STOP LAMP OFF RELAY 1

Check stop lamp OFF relay 1. Refer to [BR-141. "Component Inspection"](#).

Is the inspection result normal?

- YES >> GO TO 19.
NO >> Replace the stop lamp OFF relay 1. GO TO 19.

19. CHECK STOP LAMP OFF RELAY 2

Check stop lamp OFF relay 2. Refer to [BR-141. "Component Inspection"](#).

Is the inspection result normal?

- YES >> GO TO 20.
NO >> Replace the stop lamp OFF relay 2.

20. PERFORM ACTIVE TEST (2)

Ⓟ With CONSULT

- Connect stop lamp OFF relay 1 harness connector.
- Connect stop lamp OFF relay 2 harness connector.
- Connect 12V battery cable to negative terminal.
- Perform "ACTIVE TEST" with the brake pedal depressed. Refer to [BR-30. "CONSULT Function"](#).

CAUTION:

- After the stop lamp OFF relay is activated, wait for 10 seconds to deactivate it.
- Wait for 10 seconds after the stop lamp OFF relay is deactivated.

>> GO TO 21.

21. PERFORM SELF-DIAGNOSIS (7)

Ⓟ With CONSULT

- Turn the ignition switch OFF to ON without depressing the brake pedal.

CAUTION:

Never set the vehicle to READY/ Never start the engine.

- Repeat step 1 two times or more.

C1A68 STOP LAMP SWITCH RELAY

< DTC/CIRCUIT DIAGNOSIS >

CAUTION:

Be sure to wait for 5 seconds or more after turning the ignition switch OFF.

3. Turn the ignition switch OFF to exit CONSULT.
4. Get out of the vehicle, close all doors (including trunk lid), and wait for 3 minutes or more without opening these doors.

CAUTION:

Never operate the vehicle and CONSULT while waiting.

5. Turn the ignition switch ON without depressing the brake pedal.

CAUTION:

Never set the vehicle to READY/Never start the engine.

6. Start CONSULT and erase self-diagnosis result of "BRAKE".
7. Turn the ignition switch OFF to exit CONSULT.
8. Get out of the vehicle, close all doors (including trunk lid), and wait for 3 minutes or more without opening these doors.

CAUTION:

Never operate the vehicle and CONSULT while waiting.

9. Turn the ignition switch ON without depressing the brake pedal.

CAUTION:

Never set the vehicle to READY/Never start the engine.

10. Depress brake pedal by 100 mm (3.94 in) or more, and hold the position for 5 seconds or more.
11. Release brake pedal.
12. Start CONSULT and perform "BRAKE" self-diagnosis.

Is DTC "C1A68" detected?

YES >> GO TO 22.

NO >> INSPECTION END

22. CHECK STOP LAMP OFF RELAY 2 CIRCUIT

 With CONSULT

1. Disconnect ICC brake switch harness connector.
2. Perform "ACTIVE TEST". Refer to [BR-30, "CONSULT Function"](#).
3. Check voltage between the ICC brake switch harness connector and ground.

ICC brake switch		—	Voltage
Connector	Terminal		
E114	2	Ground	10 – 16 V

Is the inspection result normal?

YES >> INSPECTION END

NO >> Replace the electrically-driven intelligent brake unit. Refer to [BR-288, "Removal and installation"](#).

Component Inspection

INFOID:000000008139826

1. CHECK STOP LAMP OFF RELAY 1

1. Turn the ignition switch OFF to exit CONSULT.
2. Get out of the vehicle, close all doors (including trunk lid), and wait for 3 minutes or more without opening these doors.

CAUTION:

Never operate the vehicle and CONSULT while waiting.

3. Apply 12 V between stop lamp OFF relay 1 connector terminals (1 and 2).

CAUTION:

- Never make the terminals short.
- Connect the fuse between terminals when applying the voltage.

C1A68 STOP LAMP SWITCH RELAY

< DTC/CIRCUIT DIAGNOSIS >

Stop lamp OFF relay 1		Continuity
Terminal	Condition	
3 – 4	Apply 12 V between stop lamp OFF relay 1 connector terminals (1 and 2).	Existed
	Do not apply 12 V between stop lamp OFF relay 1 connector terminals (1 and 2).	Not existed
3 – 5	Apply 12 V between stop lamp OFF relay 1 connector terminals (1 and 2).	Existed
	Do not apply 12 V between stop lamp OFF relay 1 connector terminals (1 and 2).	Not existed

4. Check resistance between stop lamp OFF relay connector terminals.

Stop lamp OFF relay 1	Resistance
Terminal	
1 – 2	Approx. 50 Ω

Is the inspection result normal?

YES >> GO TO 2.

NO >> Replace the stop lamp OFF relay 1. GO TO 2.

2. CHECK STOP LAMP OFF RELAY 2

1. Turn the ignition switch OFF to exit CONSULT.
2. Get out of the vehicle, close all doors (including trunk lid), and wait for 3 minutes or more without opening these doors.

CAUTION:

Never operate the vehicle and CONSULT while waiting.

3. Apply 12 V between stop lamp OFF relay 2 connector terminals (2 and 1).

CAUTION:

- Never make the terminals short.
- Connect the fuse between terminals when applying the voltage.

Stop lamp OFF relay 2		Continuity
Terminal	Condition	
5 – 3	Apply 12 V between stop lamp OFF relay 1 connector terminals (2 and 1).	Existed
	Do not apply 12 V between stop lamp OFF relay 1 connector terminals (2 and 1).	Not existed

4. Check resistance between stop lamp OFF relay connector terminals.

Stop lamp OFF relay 2	Resistance
Terminal	
2 – 1	Approx. 50 Ω

Is the inspection result normal?

YES >> INSPECTION END.

NO >> Replace the stop lamp OFF relay 2.

C1A69 MOTOR

< DTC/CIRCUIT DIAGNOSIS >

C1A69 MOTOR

DTC Logic

INFOID:000000008139827

DTC DETECTION LOGIC

DTC	Display item	Malfunction detection condition	Possible causes
C1A69	MOTOR	A malfunction has occurred in the motor inside the electrically-driven intelligent brake unit.	Electrically-driven intelligent brake unit

DTC CONFIRMATION PROCEDURE

1. PRECONDITIONING

If "DTC CONFIRMATION PROCEDURE" has been previously conducted, always turn the ignition switch OFF and wait at least 10 seconds before conducting the next test.

>> GO TO 2.

2. CHECK DTC DETECTION

Ⓜ With CONSULT

- Turn the ignition switch OFF to ON without depressing the brake pedal.
CAUTION:
Never set the vehicle to READY/Never start the engine.
 - Repeat step 1 two times or more.
CAUTION:
Be sure to wait for 5 seconds or more after turning the ignition switch OFF.
 - Turn the ignition switch OFF to exit CONSULT.
 - Get out of the vehicle, close all doors (including trunk lid), and wait for 3 minutes or more without opening these doors.
CAUTION:
Never operate the vehicle and CONSULT while waiting.
 - Turn the ignition switch ON without depressing the brake pedal.
CAUTION:
Never set the vehicle to READY/Never start the engine.
 - Start CONSULT and erase self-diagnosis result of "BRAKE".
 - Turn the ignition switch OFF to exit CONSULT.
 - Get out of the vehicle, close all doors (including trunk lid), and wait for 3 minutes or more without opening these doors.
CAUTION:
Never operate the vehicle and CONSULT while waiting.
 - Turn the ignition switch ON without depressing the brake pedal.
CAUTION:
Never set the vehicle to READY/Never start the engine.
 - Depress brake pedal by 100 mm (3.94 in) or more, and hold the position for 5 seconds or more.
 - Release brake pedal.
 - Start CONSULT and perform "BRAKE" self-diagnosis.
- Is DTC "C1A69" detected?
- YES >> Proceed to [BR-143, "Diagnosis Procedure"](#).
- NO >> INSPECTION END

Diagnosis Procedure

INFOID:000000008139828

1. CHECK 12V BATTERY

- Turn the ignition switch OFF to exit CONSULT.
- Get out of the vehicle, close all doors (including trunk lid), and wait for 3 minutes or more without opening these doors.
CAUTION:
Never operate the vehicle and CONSULT while waiting.

C1A69 MOTOR

< DTC/CIRCUIT DIAGNOSIS >

3. Check the 12V battery terminal connections. Refer to [BR-6. "Precaution for Removing 12V Battery"](#) and [PG-135. "Work Flow"](#).
4. Check the 12V battery. Refer to [PG-135. "Work Flow"](#).

Is the inspection result normal?

YES >> GO TO 2.

NO >> Repair or replace error-detected parts GO TO 2.

2.PERFORM SELF-DIAGNOSIS (1)

With CONSULT

1. Connect 12V battery cable to negative terminal.
2. Turn the ignition switch OFF to ON without depressing the brake pedal.
CAUTION:
Never set the vehicle to READY/Never start the engine.
3. Repeat step 2 two times or more.
CAUTION:
Be sure to wait for 5 seconds or more after turning the ignition switch OFF.
4. Turn the ignition switch OFF to exit CONSULT.
5. Get out of the vehicle, close all doors (including trunk lid), and wait for 3 minutes or more without opening these doors.
CAUTION:
Never operate the vehicle and CONSULT while waiting.
6. Turn the ignition switch ON without depressing the brake pedal.
CAUTION:
Never set the vehicle to READY/Never start the engine.
7. Start CONSULT and erase self-diagnosis result of "BRAKE".
8. Turn the ignition switch OFF to exit CONSULT.
9. Get out of the vehicle, close all doors (including trunk lid), and wait for 3 minutes or more without opening these doors.
CAUTION:
Never operate the vehicle and CONSULT while waiting.
10. Turn the ignition switch ON without depressing the brake pedal.
CAUTION:
Never set the vehicle to READY/Never start the engine.
11. Depress brake pedal by 100 mm (3.94 in) or more, and hold the position for 5 seconds or more.
12. Release brake pedal.
13. Start CONSULT and perform "BRAKE" self-diagnosis.

is DTC "C1A69" detected?

YES >> GO TO 3.

NO >> INSPECTION END

3.CHECK CONNECTOR TERMINALS

1. Turn the ignition switch OFF to exit CONSULT.
2. Get out of the vehicle, close all doors (including trunk lid), and wait for 3 minutes or more without opening these doors.
CAUTION:
Never operate the vehicle and CONSULT while waiting.
3. Disconnect 12V battery cable from negative terminal. Refer to [BR-6. "Precaution for Removing 12V Battery"](#).
4. Disconnect the electrically-driven intelligent brake unit harness connector, then check for failures of pin terminals and connections.

Is the inspection result normal?

YES >> GO TO 5.

NO >> Repair or replace error-detected parts and GO TO 4.

4.PERFORM SELF-DIAGNOSIS (2)

With CONSULT

1. Connect the electrically-driven intelligent brake unit harness connector.
2. Connect 12V battery cable to negative terminal.
3. Turn the ignition switch OFF to ON without depressing the brake pedal.

C1A69 MOTOR

< DTC/CIRCUIT DIAGNOSIS >

CAUTION:

Never set the vehicle to READY/Never start the engine.

4. Repeat step 3 two times or more.

CAUTION:

Be sure to wait for 5 seconds or more after turning the ignition switch OFF.

5. Turn the ignition switch OFF to exit CONSULT.
6. Get out of the vehicle, close all doors (including trunk lid), and wait for 3 minutes or more without opening these doors.

CAUTION:

Never operate the vehicle and CONSULT while waiting.

7. Turn the ignition switch ON without depressing the brake pedal.

CAUTION:

Never set the vehicle to READY/Never start the engine.

8. Start CONSULT and erase self-diagnosis result of "BRAKE".
9. Turn the ignition switch OFF to exit CONSULT.
10. Get out of the vehicle, close all doors (including trunk lid), and wait for 3 minutes or more without opening these doors.

CAUTION:

Never operate the vehicle and CONSULT while waiting.

11. Turn the ignition switch ON without depressing the brake pedal.

CAUTION:

Never set the vehicle to READY/Never start the engine.

12. Depress brake pedal by 100 mm (3.94 in) or more, and hold the position for 5 seconds or more.
13. Release brake pedal.
14. Start CONSULT and perform "BRAKE" self-diagnosis.

Is DTC "C1A69" detected?

YES >> GO TO 5.

NO >> INSPECTION END

5. CHECK IGNITION POWER SUPPLY

1. Turn the ignition switch OFF to exit CONSULT.
2. Get out of the vehicle, close all doors (including trunk lid), and wait for 3 minutes or more without opening these doors.

CAUTION:

Never operate the vehicle and CONSULT while waiting.

3. Disconnect 12V battery cable from negative terminal. Refer to [BR-6. "Precaution for Removing 12V Battery"](#).
4. Disconnect the electrically-driven intelligent brake unit harness connector.
5. Connect 12V battery cable to negative terminal.
6. Check voltage between the electrically-driven intelligent brake unit harness connector and ground.

Electrically-driven intelligent brake unit		—	Voltage
Connector	Terminal		
E87	26	Ground	Approx. 0 V

7. Turn the ignition switch ON without depressing the brake pedal.

CAUTION:

Never set the vehicle to READY/Never start the engine.

8. Check voltage between the electrically-driven intelligent brake unit harness connector and ground.

Electrically-driven intelligent brake unit		—	Voltage
Connector	Terminal		
E87	26	Ground	10 – 16 V

Is the inspection result normal?

YES >> GO TO 8.

NO >> GO TO 6.

6. CHECK IGNITION POWER SUPPLY CIRCUIT

C1A69 MOTOR

< DTC/CIRCUIT DIAGNOSIS >

1. Turn the ignition switch OFF to exit CONSULT.
2. Get out of the vehicle, close all doors (including trunk lid), and wait for 3 minutes or more without opening these doors.
CAUTION:
Never operate the vehicle and CONSULT while waiting.
3. Disconnect 12V battery cable from negative terminal. Refer to [BR-6. "Precaution for Removing 12V Battery"](#).
4. Check 10A fuse (#46).
5. Disconnect IPDM E/R harness connector.
6. Check continuity between electrically-driven intelligent brake unit and IPDM E/R.

Electrically-driven intelligent brake unit		IPDM E/R		Continuity
Connector	Terminal	Connector	Terminal	
E87	26	E5	12	Existed

7. Check continuity between electrically-driven intelligent brake unit harness connector and ground.

Electrically-driven intelligent brake unit		—	Continuity
Connector	Terminal		
E87	26	Ground	Not existed

Is the inspection result normal?

- YES >> Perform trouble diagnosis for ignition power supply. Refer to [PG-30. "Wiring Diagram - IGNITION POWER SUPPLY -"](#).
- NO >> Repair or replace error-detected parts and GO TO 7.

7.PERFORM SELF-DIAGNOSIS (3)

ⓐ With CONSULT

1. Connect the electrically-driven intelligent brake unit harness connector.
2. Connect IPDM E/R harness connector.
3. Connect 12V battery cable to negative terminal.
4. Turn the ignition switch OFF to ON without depressing the brake pedal.
CAUTION:
Never set the vehicle to READY/Never start the engine.
5. Repeat step 4 two times or more.
CAUTION:
Be sure to wait for 5 seconds or more after turning the ignition switch OFF.
6. Turn the ignition switch OFF to exit CONSULT.
7. Get out of the vehicle, close all doors (including trunk lid), and wait for 3 minutes or more without opening these doors.
CAUTION:
Never operate the vehicle and CONSULT while waiting.
8. Turn the ignition switch ON without depressing the brake pedal.
CAUTION:
Never set the vehicle to READY/Never start the engine.
9. Start CONSULT and erase self-diagnosis result of "BRAKE".
10. Turn the ignition switch OFF to exit CONSULT.
11. Get out of the vehicle, close all doors (including trunk lid), and wait for 3 minutes or more without opening these doors.
CAUTION:
Never operate the vehicle and CONSULT while waiting.
12. Turn the ignition switch ON without depressing the brake pedal.
CAUTION:
Never set the vehicle to READY/Never start the engine.
13. Depress brake pedal by 100 mm (3.94 in) or more, and hold the position for 5 seconds or more.
14. Release brake pedal.
15. Start CONSULT and perform "BRAKE" self-diagnosis.

Is DTC "C1A69" detected?

- YES >> GO TO 8.

C1A69 MOTOR

< DTC/CIRCUIT DIAGNOSIS >

NO >> INSPECTION END

8. CHECK 12V BATTERY POWER SUPPLY

1. Turn the ignition switch OFF to exit CONSULT.
2. Get out of the vehicle, close all doors (including trunk lid), and wait for 3 minutes or more without opening these doors.

CAUTION:

Never operate the vehicle and CONSULT while waiting.

3. Disconnect 12V battery cable from negative terminal. Refer to [BR-6, "Precaution for Removing 12V Battery"](#).
4. Disconnect the electrically-driven intelligent brake unit harness connector.
5. Connect 12V battery cable to negative terminal.
6. Check voltage between the electrically-driven intelligent brake unit harness connector terminal.

Electrically-driven intelligent brake unit		Voltage
Connector	Terminal	
E87	1 - 31	10 - 16 V
	2 - 31	
	11 - 31	

7. Turn the ignition switch ON without depressing the brake pedal.

CAUTION:

Never set the vehicle to READY/Never start the engine.

8. Check voltage between the electrically-driven intelligent brake unit harness connector terminal.

Electrically-driven intelligent brake unit		Voltage
Connector	Terminal	
E87	1 - 31	10 - 16 V
	2 - 31	
	11 - 31	

Is the inspection result normal?

YES >> GO TO 11.

NO >> GO TO 9.

9. CHECK 12V BATTERY POWER SUPPLY CIRCUIT

1. Turn the ignition switch OFF to exit CONSULT.
2. Get out of the vehicle, close all doors (including trunk lid), and wait for 3 minutes or more without opening these doors.

CAUTION:

Never operate the vehicle and CONSULT while waiting.

3. Disconnect 12V battery cable from negative terminal. Refer to [BR-6, "Precaution for Removing 12V Battery"](#).
4. Check 50A fusible link (#D).
5. Check continuity and for short circuit between electrically-driven intelligent brake unit harness connector terminal (1) and 50A fusible link (#D).
6. Check continuity and for short circuit between electrically-driven intelligent brake unit harness connector terminal (2) and 50A fusible link (#D).
7. Check 10A fuse (#65).
8. Check continuity and for short circuit between electrically-driven intelligent brake unit harness connector terminal (11) and 10A fuse (#65).

Is the inspection result normal?

YES >> Perform diagnosis for 12V battery power supply. Refer to [PG-14, "Wiring Diagram - BATTERY POWER SUPPLY -"](#).

NO >> Repair or replace error-detected parts and GO TO 10.

10. PERFORM SELF-DIAGNOSIS (4)

 With CONSULT

C1A69 MOTOR

< DTC/CIRCUIT DIAGNOSIS >

1. Connect the electrically-driven intelligent brake unit harness connector.
2. Connect 12V battery cable to negative terminal.
3. Turn the ignition switch OFF to ON without depressing the brake pedal.
CAUTION:
Never set the vehicle to READY/Never start the engine.
4. Repeat step 3 two times or more.
CAUTION:
Be sure to wait for 5 seconds or more after turning the ignition switch OFF.
5. Turn the ignition switch OFF to exit CONSULT.
6. Get out of the vehicle, close all doors (including trunk lid), and wait for 3 minutes or more without opening these doors.
CAUTION:
Never operate the vehicle and CONSULT while waiting.
7. Turn the ignition switch ON without depressing the brake pedal.
CAUTION:
Never set the vehicle to READY/Never start the engine.
8. Start CONSULT and erase self-diagnosis result of "BRAKE".
9. Turn the ignition switch OFF to exit CONSULT.
10. Get out of the vehicle, close all doors (including trunk lid), and wait for 3 minutes or more without opening these doors.
CAUTION:
Never operate the vehicle and CONSULT while waiting.
11. Turn the ignition switch ON without depressing the brake pedal.
CAUTION:
Never set the vehicle to READY/Never start the engine.
12. Depress brake pedal by 100 mm (3.94 in) or more, and hold the position for 5 seconds or more.
13. Release brake pedal.
14. Start CONSULT and perform "BRAKE" self-diagnosis.

Is DTC "C1A69" detected?

YES >> GO TO 4.

NO >> INSPECTION END

11. CHECK GROUND CIRCUIT

1. Turn the ignition switch OFF to exit CONSULT.
2. Get out of the vehicle, close all doors (including trunk lid), and wait for 3 minutes or more without opening these doors.
CAUTION:
Never operate the vehicle and CONSULT while waiting.
3. Disconnect 12V battery cable from negative terminal. Refer to [BR-6. "Precaution for Removing 12V Battery"](#).
4. Disconnect the electrically-driven intelligent brake unit harness connector.
5. Check continuity between electrically-driven intelligent brake unit and ground.

Electrically-driven intelligent brake unit		—	Continuity
Connector	Terminal		
E87	31	Ground	Existed

Is the inspection result normal?

YES >> GO TO 13.

NO >> Repair or replace the malfunctioning parts and GO TO 12.

12. PERFORM SELF-DIAGNOSIS (5)

Ⓜ With CONSULT

1. Connect the electrically-driven intelligent brake unit harness connector.
2. Connect 12V battery cable to negative terminal.
3. Turn the ignition switch OFF to ON without depressing the brake pedal.
CAUTION:
Never set the vehicle to READY/Never start the engine.
4. Repeat step 3 two times or more.
CAUTION:

C1A69 MOTOR

< DTC/CIRCUIT DIAGNOSIS >

Be sure to wait for 5 seconds or more after turning the ignition switch OFF.

5. Turn the ignition switch OFF to exit CONSULT. A
6. Get out of the vehicle, close all doors (including trunk lid), and wait for 3 minutes or more without opening these doors.

CAUTION:

Never operate the vehicle and CONSULT while waiting. B

7. Turn the ignition switch ON without depressing the brake pedal.

CAUTION:

Never set the vehicle to READY/Never start the engine. C

8. Start CONSULT and erase self-diagnosis result of "BRAKE".
9. Turn the ignition switch OFF to exit CONSULT.
10. Get out of the vehicle, close all doors (including trunk lid), and wait for 3 minutes or more without opening these doors. D

CAUTION:

Never operate the vehicle and CONSULT while waiting.

11. Turn the ignition switch ON without depressing the brake pedal. E

CAUTION:

Never set the vehicle to READY/Never start the engine.

12. Depress brake pedal by 100 mm (3.94 in) or more, and hold the position for 5 seconds or more.
13. Release brake pedal.
14. Start CONSULT and perform "BRAKE" self-diagnosis.

BR

Is DTC "C1A69" detected?

YES >> GO TO 13. G

NO >> INSPECTION END

13. CHECK DATA MONITOR (1) H

 With CONSULT

1. Connect the electrically-driven intelligent brake unit harness connector.
2. Connect 12V battery cable to negative terminal.
3. Turn the ignition switch OFF to ON without depressing the brake pedal.

CAUTION:

Never set the vehicle to READY/Never start the engine.

4. Repeat step 3 two times or more.

CAUTION:

Be sure to wait for 5 seconds or more after turning the ignition switch OFF.

5. Start CONSULT and select "BRAKE" and "DATA MONITOR" according this order.
6. Check "MOTOR POWER SUPPLY" and "CONTROL MODULE POWER". Refer to [BR-33. "Reference Value"](#). K

Is the inspection result normal? L

YES >> GO TO 14.

NO >> Replace the electrically-driven intelligent brake unit. Refer to [BR-288. "Removal and installation"](#).

14. PERFORM SELF-DIAGNOSIS (6) M

 With CONSULT

1. Turn the ignition switch OFF to ON without depressing the brake pedal.

CAUTION:

Never set the vehicle to READY/Never start the engine.

2. Repeat step 1 two times or more.

CAUTION:

Be sure to wait for 5 seconds or more after turning the ignition switch OFF.

3. Turn the ignition switch OFF to exit CONSULT.
4. Get out of the vehicle, close all doors (including trunk lid), and wait for 3 minutes or more without opening these doors. P

CAUTION:

Never operate the vehicle and CONSULT while waiting.

5. Turn the ignition switch ON without depressing the brake pedal.

CAUTION:

Never set the vehicle to READY/Never start the engine.

6. Start CONSULT and erase self-diagnosis result of "BRAKE".
7. Turn the ignition switch OFF to exit CONSULT.

C1A69 MOTOR

< DTC/CIRCUIT DIAGNOSIS >

8. Get out of the vehicle, close all doors (including trunk lid), and wait for 3 minutes or more without opening these doors.
CAUTION:
Never operate the vehicle and CONSULT while waiting.
9. Turn the ignition switch ON without depressing the brake pedal.
CAUTION:
Never set the vehicle to READY/Never start the engine.
10. Depress brake pedal by 100 mm (3.94 in) or more, and hold the position for 5 seconds or more.
11. Release brake pedal.
12. Start CONSULT and perform "BRAKE" self-diagnosis.

Is DTC "C1A69" detected?

- YES >> GO TO 15.
NO >> INSPECTION END

15.CHECK DATA MONITOR (2)

With CONSULT

1. Turn the ignition switch OFF to ON without depressing the brake pedal.
CAUTION:
Never set the vehicle to READY/Never start the engine.
2. Repeat step 1 two times or more.
CAUTION:
Be sure to wait for 5 seconds or more after turning the ignition switch OFF.
3. Start CONSULT and select "BRAKE" and "DATA MONITOR" according to this order.
4. Check "MOTOR TEMPERATURE". Refer to [BR-33. "Reference Value"](#).

"MOTOR TEMPERATURE" is 125 °C (257 °F) or more?

- YES >> GO TO 16.
NO >> Replace the electrically-driven intelligent brake unit. Refer to [BR-288. "Removal and installation"](#).

16.CHECK ENGINE ROOM

Check for any locations of abnormal heating around the electrically-driven intelligent brake unit.

Are there any heated locations?

- YES >> Perform diagnosis of the heated locations, and wait for the temperature to fall. GO TO 17.
NO >> Replace the electrically-driven intelligent brake unit. Refer to [BR-288. "Removal and installation"](#).

17.PERFORM SELF-DIAGNOSIS (7)

With CONSULT

1. Turn the ignition switch OFF to ON without depressing the brake pedal.
CAUTION:
Never set the vehicle to READY/Never start the engine.
2. Repeat step 1 two times or more.
CAUTION:
Be sure to wait for 5 seconds or more after turning the ignition switch OFF.
3. Turn the ignition switch OFF to exit CONSULT.
4. Get out of the vehicle, close all doors (including trunk lid), and wait for 3 minutes or more without opening these doors.
CAUTION:
Never operate the vehicle and CONSULT while waiting.
5. Turn the ignition switch ON without depressing the brake pedal.
CAUTION:
Never set the vehicle to READY/Never start the engine.
6. Start CONSULT and erase self-diagnosis result of "BRAKE".
7. Turn the ignition switch OFF to exit CONSULT.
8. Get out of the vehicle, close all doors (including trunk lid), and wait for 3 minutes or more without opening these doors.
CAUTION:
Never operate the vehicle and CONSULT while waiting.
9. Turn the ignition switch ON without depressing the brake pedal.
CAUTION:
Never set the vehicle to READY/Never start the engine.

C1A69 MOTOR

< DTC/CIRCUIT DIAGNOSIS >

10. Depress brake pedal by 100 mm (3.94 in) or more, and hold the position for 5 seconds or more.
11. Release brake pedal.
12. Start CONSULT and perform "BRAKE" self-diagnosis.

Is DTC "C1A69" detected?

- YES >> Replace the electrically-driven intelligent brake unit. Refer to [BR-288, "Removal and installation"](#).
- NO >> INSPECTION END

A

B

C

D

E

BR

G

H

I

J

K

L

M

N

O

P

C1A6A CONTROL MODULE

< DTC/CIRCUIT DIAGNOSIS >

C1A6A CONTROL MODULE

DTC Logic

INFOID:000000008139829

DTC DETECTION LOGIC

DTC	Display item	Malfunction detection condition	Possible causes
C1A6A	CONTROL MODULE TEMPERATURE	<ul style="list-style-type: none">• Temperature of control module that is integrated with electrically-driven intelligent brake unit is as shown below.- Control module temperature: 150 °C (302 °F) ≤ Control module• A malfunction is detected in the temperature detection circuit of the control module that is integrated with the electrically-driven intelligent brake unit.	<ul style="list-style-type: none">• Harness or connector• Electrically-driven intelligent brake unit

DTC CONFIRMATION PROCEDURE

1. PRECONDITIONING

If "DTC CONFIRMATION PROCEDURE" has been previously conducted, always turn the ignition switch OFF and wait at least 10 seconds before conducting the next test.

>> GO TO 2.

2. CHECK DTC DETECTION

Ⓟ With CONSULT

1. Turn the ignition switch OFF to ON without depressing the brake pedal.

CAUTION:

Never set the vehicle to READY/Never start the engine.

2. Repeat step 1 two times or more.

CAUTION:

Be sure to wait for 5 seconds or more after turning the ignition switch OFF.

3. Turn the ignition switch OFF to exit CONSULT.

4. Get out of the vehicle, close all doors (including trunk lid), and wait for 3 minutes or more without opening these doors.

CAUTION:

Never operate the vehicle and CONSULT while waiting.

5. Turn the ignition switch ON without depressing the brake pedal.

CAUTION:

Never set the vehicle to READY/Never start the engine.

6. Start CONSULT and erase self-diagnosis result of "BRAKE".

7. Turn the ignition switch OFF to exit CONSULT.

8. Get out of the vehicle, close all doors (including trunk lid), and wait for 3 minutes or more without opening these doors.

CAUTION:

Never operate the vehicle and CONSULT while waiting.

9. Turn the ignition switch ON without depressing the brake pedal.

CAUTION:

Never set the vehicle to READY/Never start the engine.

10. Depress brake pedal by 100 mm (3.94 in) or more, and hold the position for 5 seconds or more.

11. Release brake pedal.

12. Start CONSULT and perform "BRAKE" self-diagnosis.

Is DTC "C1A6A" detected?

YES >> Proceed to [BR-152, "Diagnosis Procedure"](#).

NO >> INSPECTION END

Diagnosis Procedure

INFOID:000000008139830

1. CHECK 12V BATTERY

C1A6A CONTROL MODULE

< DTC/CIRCUIT DIAGNOSIS >

1. Turn the ignition switch OFF to exit CONSULT.
2. Get out of the vehicle, close all doors (including trunk lid), and wait for 3 minutes or more without opening these doors.
CAUTION:
Never operate the vehicle and CONSULT while waiting.
3. Check the 12V battery terminal connections. Refer to [BR-6, "Precaution for Removing 12V Battery"](#) and [PG-135, "Work Flow"](#).
4. Check the 12V battery. Refer to [PG-135, "Work Flow"](#).

Is the inspection result normal?

YES >> GO TO 2.

NO >> Repair or replace error-detected parts and GO TO 2.

2.PERFORM SELF-DIAGNOSIS (1)

ⓂWith CONSULT

1. Connect 12V battery cable to negative terminal.
2. Turn the ignition switch OFF to ON without depressing the brake pedal.
CAUTION:
Never set the vehicle to READY/Never start the engine.
3. Repeat step 2 two times or more.
CAUTION:
Be sure to wait for 5 seconds or more after turning the ignition switch OFF.
4. Turn the ignition switch OFF to exit CONSULT.
5. Get out of the vehicle, close all doors (including trunk lid), and wait for 3 minutes or more without opening these doors.
CAUTION:
Never operate the vehicle and CONSULT while waiting.
6. Turn the ignition switch ON without depressing the brake pedal.
CAUTION:
Never set the vehicle to READY/Never start the engine.
7. Start CONSULT and erase self-diagnosis result of "BRAKE".
8. Turn the ignition switch OFF to exit CONSULT.
9. Get out of the vehicle, close all doors (including trunk lid), and wait for 3 minutes or more without opening these doors.
CAUTION:
Never operate the vehicle and CONSULT while waiting.
10. Turn the ignition switch ON without depressing the brake pedal.
CAUTION:
Never set the vehicle to READY/Never start the engine.
11. Depress brake pedal by 100 mm (3.94 in) or more, and hold the position for 5 seconds or more.
12. Release brake pedal.
13. Start CONSULT and perform "BRAKE" self-diagnosis.

Is DTC "C1A6A" detected?

YES >> GO TO 3.

NO >> INSPECTION END

3.CHECK CONNECTOR TERMINALS

1. Turn the ignition switch OFF to exit CONSULT.
2. Get out of the vehicle, close all doors (including trunk lid), and wait for 3 minutes or more without opening these doors.
CAUTION:
Never operate the vehicle and CONSULT while waiting.
3. Disconnect 12V battery cable from negative terminal. Refer to [BR-6, "Precaution for Removing 12V Battery"](#).
4. Disconnect the electrically-driven intelligent brake unit harness connector, then check for failures of pin terminals and connections.

Is the inspection result normal?

YES >> GO TO 5.

NO >> Repair or replace error-detected parts and GO TO 4.

4.PERFORM SELF-DIAGNOSIS (2)

C1A6A CONTROL MODULE

< DTC/CIRCUIT DIAGNOSIS >

Ⓟ With CONSULT

1. Connect the electrically-driven intelligent brake unit harness connector.
2. Connect 12V battery cable to negative terminal.
3. Turn the ignition switch OFF to ON without depressing the brake pedal.
CAUTION:
Never set the vehicle to READY/Never start the engine.
4. Repeat step 3 two times or more.
CAUTION:
Be sure to wait for 5 seconds or more after turning the ignition switch OFF.
5. Turn the ignition switch OFF to exit CONSULT.
6. Get out of the vehicle, close all doors (including trunk lid), and wait for 3 minutes or more without opening these doors.
CAUTION:
Never operate the vehicle and CONSULT while waiting.
7. Turn the ignition switch ON without depressing the brake pedal.
CAUTION:
Never set the vehicle to READY/Never start the engine.
8. Start CONSULT and erase self-diagnosis result of "BRAKE".
9. Turn the ignition switch OFF to exit CONSULT.
10. Get out of the vehicle, close all doors (including trunk lid), and wait for 3 minutes or more without opening these doors.
CAUTION:
Never operate the vehicle and CONSULT while waiting.
11. Turn the ignition switch ON without depressing the brake pedal.
CAUTION:
Never set the vehicle to READY/Never start the engine.
12. Depress brake pedal by 100 mm (3.94 in) or more, and hold the position for 5 seconds or more.
13. Release brake pedal.
14. Start CONSULT and perform "BRAKE" self-diagnosis.

Is DTC "C1A6A" detected?

- YES >> GO TO 5.
NO >> INSPECTION END

5. CHECK IGNITION POWER SUPPLY

1. Turn the ignition switch OFF to exit CONSULT.
2. Get out of the vehicle, close all doors (including trunk lid), and wait for 3 minutes or more without opening these doors.
CAUTION:
Never operate the vehicle and CONSULT while waiting.
3. Disconnect 12V battery cable from negative terminal. Refer to [BR-6, "Precaution for Removing 12V Battery"](#).
4. Disconnect the electrically-driven intelligent brake unit harness connector.
5. Connect 12V battery cable to negative terminal.
6. Check voltage between the electrically-driven intelligent brake unit harness connector and ground.

Electrically-driven intelligent brake unit		—	Voltage
Connector	Terminal		
E87	26	Ground	Approx. 0 V

7. Turn the ignition switch ON without depressing the brake pedal.
CAUTION:
Never set the vehicle to READY/Never start the engine.
8. Check voltage between the electrically-driven intelligent brake unit harness connector and ground.

Electrically-driven intelligent brake unit		—	Voltage
Connector	Terminal		
E87	26	Ground	10 – 16 V

Is the inspection result normal?

C1A6A CONTROL MODULE

< DTC/CIRCUIT DIAGNOSIS >

- YES >> GO TO 8.
NO >> GO TO 6.

6. CHECK IGNITION POWER SUPPLY CIRCUIT

1. Turn the ignition switch OFF to exit CONSULT.
2. Get out of the vehicle, close all doors (including trunk lid), and wait for 3 minutes or more without opening these doors.
CAUTION:
Never operate the vehicle and CONSULT while waiting.
3. Disconnect 12V battery cable from negative terminal. Refer to [BR-6, "Precaution for Removing 12V Battery"](#).
4. Check 10A fuse (#46).
5. Disconnect IPDM E/R harness connector.
6. Check continuity between electrically-driven intelligent brake unit and IPDM E/R.

Electrically-driven intelligent brake unit		IPDM E/R		Continuity
Connector	Terminal	Connector	Terminal	
E87	26	E5	12	Existed

7. Check continuity between electrically-driven intelligent brake unit harness connector and ground.

Electrically-driven intelligent brake unit		—	Continuity
Connector	Terminal		
E87	26	Ground	Not existed

Is the inspection result normal?

- YES >> Perform trouble diagnosis for ignition power supply. Refer to [PG-30, "Wiring Diagram - IGNITION POWER SUPPLY -"](#).
NO >> Repair or replace error-detected parts and GO TO 7.

7. PERFORM SELF-DIAGNOSIS (3)

Ⓜ With CONSULT

1. Connect the electrically-driven intelligent brake unit harness connector.
2. Connect IPDM E/R harness connector.
3. Connect 12V battery cable to negative terminal.
4. Turn the ignition switch OFF to ON without depressing the brake pedal.
CAUTION:
Never set the vehicle to READY/Never start the engine.
5. Repeat step 4 two times or more.
CAUTION:
Be sure to wait for 5 seconds or more after turning the ignition switch OFF.
6. Turn the ignition switch OFF to exit CONSULT.
7. Get out of the vehicle, close all doors (including trunk lid), and wait for 3 minutes or more without opening these doors.
CAUTION:
Never operate the vehicle and CONSULT while waiting.
8. Turn the ignition switch ON without depressing the brake pedal.
CAUTION:
Never set the vehicle to READY/Never start the engine.
9. Start CONSULT and erase self-diagnosis result of "BRAKE".
10. Turn the ignition switch OFF to exit CONSULT.
11. Get out of the vehicle, close all doors (including trunk lid), and wait for 3 minutes or more without opening these doors.
CAUTION:
Never operate the vehicle and CONSULT while waiting.
12. Turn the ignition switch ON without depressing the brake pedal.
CAUTION:
Never set the vehicle to READY/Never start the engine.
13. Depress brake pedal by 100 mm (3.94 in) or more, and hold the position for 5 seconds or more.
14. Release brake pedal.

C1A6A CONTROL MODULE

< DTC/CIRCUIT DIAGNOSIS >

15. Start CONSULT and perform "BRAKE" self-diagnosis.

Is DTC "C1A6A" detected?

YES >> GO TO 8.

NO >> INSPECTION END

8. CHECK 12V BATTERY POWER SUPPLY

1. Turn the ignition switch OFF to exit CONSULT.
2. Get out of the vehicle, close all doors (including trunk lid), and wait for 3 minutes or more without opening these doors.
CAUTION:
Never operate the vehicle and CONSULT while waiting.
3. Disconnect 12V battery cable from negative terminal. Refer to [BR-6, "Precaution for Removing 12V Battery"](#).
4. Disconnect the electrically-driven intelligent brake unit harness connector.
5. Connect 12V battery cable to negative terminal.
6. Check voltage between the electrically-driven intelligent brake unit harness connector terminal.

Electrically-driven intelligent brake unit		Voltage
Connector	Terminal	
E87	1 - 31	10 - 16 V
	2 - 31	
	11 - 31	

7. Turn the ignition switch ON without depressing the brake pedal.
CAUTION:
Never set the vehicle to READY/Never start the engine.
8. Check voltage between the electrically-driven intelligent brake unit harness connector terminal.

Electrically-driven intelligent brake unit		Voltage
Connector	Terminal	
E87	1 - 31	10 - 16 V
	2 - 31	
	11 - 31	

Is the inspection result normal?

YES >> GO TO 11.

NO >> GO TO 9.

9. CHECK 12V BATTERY POWER SUPPLY CIRCUIT

1. Turn the ignition switch OFF to exit CONSULT.
2. Get out of the vehicle, close all doors (including trunk lid), and wait for 3 minutes or more without opening these doors.
CAUTION:
Never operate the vehicle and CONSULT while waiting.
3. Disconnect 12V battery cable from negative terminal. Refer to [BR-6, "Precaution for Removing 12V Battery"](#).
4. Check 50A fusible link (#D).
5. Check continuity and for short circuit between electrically-driven intelligent brake unit harness connector terminal (1) and 50A fusible link (#D).
6. Check continuity and for short circuit between electrically-driven intelligent brake unit harness connector terminal (2) and 50A fusible link (#D).
7. Check 10A fuse (#65).
8. Check continuity and for short circuit between electrically-driven intelligent brake unit harness connector terminal (11) and 10A fuse (#65).

Is the inspection result normal?

YES >> Perform diagnosis for 12V battery power supply. Refer to [PG-14, "Wiring Diagram - BATTERY POWER SUPPLY -"](#).

C1A6A CONTROL MODULE

< DTC/CIRCUIT DIAGNOSIS >

NO >> Repair or replace error-detected parts and GO TO 10.

10. PERFORM SELF-DIAGNOSIS (1)

Ⓜ With CONSULT

1. Connect the electrically-driven intelligent brake unit harness connector.
2. Connect 12V battery cable to negative terminal.
3. Turn the ignition switch OFF to ON without depressing the brake pedal.
CAUTION:
Never set the vehicle to READY/Never start the engine.
4. Repeat step 3 two times or more.
CAUTION:
Be sure to wait for 5 seconds or more after turning the ignition switch OFF.
5. Turn the ignition switch OFF to exit CONSULT.
6. Get out of the vehicle, close all doors (including trunk lid), and wait for 3 minutes or more without opening these doors.
CAUTION:
Never operate the vehicle and CONSULT while waiting.
7. Turn the ignition switch ON without depressing the brake pedal.
CAUTION:
Never set the vehicle to READY/Never start the engine.
8. Start CONSULT and erase self-diagnosis result of "BRAKE".
9. Turn the ignition switch OFF to exit CONSULT.
10. Get out of the vehicle, close all doors (including trunk lid), and wait for 3 minutes or more without opening these doors.
CAUTION:
Never operate the vehicle and CONSULT while waiting.
11. Turn the ignition switch ON without depressing the brake pedal.
CAUTION:
Never set the vehicle to READY/Never start the engine.
12. Depress brake pedal by 100 mm (3.94 in) or more, and hold the position for 5 seconds or more.
13. Release brake pedal.
14. Start CONSULT and perform "BRAKE" self-diagnosis.

Is DTC "C1A6A" detected?

YES >> GO TO 11.

NO >> INSPECTION END

11. CHECK GROUND CIRCUIT

1. Turn the ignition switch OFF to exit CONSULT.
2. Get out of the vehicle, close all doors (including trunk lid), and wait for 3 minutes or more without opening these doors.
CAUTION:
Never operate the vehicle and CONSULT while waiting.
3. Disconnect 12V battery cable from negative terminal. Refer to [BR-6, "Precaution for Removing 12V Battery"](#).
4. Disconnect the electrically-driven intelligent brake unit harness connector.
5. Check continuity between electrically-driven intelligent brake unit and ground.

Electrically-driven intelligent brake unit		—	Continuity
Connector	Terminal		
E87	31	Ground	Existed

Is the inspection result normal?

YES >> GO TO 13.

NO >> Repair or replace error-detected parts and GO TO 12.

12. PERFORM SELF-DIAGNOSIS (5)

Ⓜ With CONSULT

1. Connect the electrically-driven intelligent brake unit harness connector.
2. Connect 12V battery cable to negative terminal.
3. Turn the ignition switch OFF to ON without depressing the brake pedal.

C1A6A CONTROL MODULE

< DTC/CIRCUIT DIAGNOSIS >

CAUTION:

Never set the vehicle to READY/Never start the engine.

4. Repeat step 3 two times or more.

CAUTION:

Be sure to wait for 5 seconds or more after turning the ignition switch OFF.

5. Turn the ignition switch OFF to exit CONSULT.
6. Get out of the vehicle, close all doors (including trunk lid), and wait for 3 minutes or more without opening these doors.

CAUTION:

Never operate the vehicle and CONSULT while waiting.

7. Turn the ignition switch ON without depressing the brake pedal.

CAUTION:

Never set the vehicle to READY/Never start the engine.

8. Start CONSULT and erase self-diagnosis result of "BRAKE".
9. Turn the ignition switch OFF to exit CONSULT.
10. Get out of the vehicle, close all doors (including trunk lid), and wait for 3 minutes or more without opening these doors.

CAUTION:

Never operate the vehicle and CONSULT while waiting.

11. Turn the ignition switch ON without depressing the brake pedal.

CAUTION:

Never set the vehicle to READY/Never start the engine.

12. Depress brake pedal by 100 mm (3.94 in) or more, and hold the position for 5 seconds or more.
13. Release brake pedal.
14. Start CONSULT and perform "BRAKE" self-diagnosis.

Is DTC "C1A6A" detected?

YES >> GO TO 13.

NO >> INSPECTION END

13. CHECK DATA MONITOR (1)

With CONSULT

1. Connect the electrically-driven intelligent brake unit harness connector.
2. Connect 12V battery cable to negative terminal.
3. Turn the ignition switch OFF to ON without depressing the brake pedal.

CAUTION:

Never set the vehicle to READY/Never start the engine.

4. Repeat step 3 two times or more.

CAUTION:

Be sure to wait for 5 seconds or more after turning the ignition switch OFF.

5. Start CONSULT and select "BRAKE" and "DATA MONITOR" according this order.
6. Check "MOTOR POWER SUPPLY" and "CONTROL MODULE POWER". Refer to [BR-33, "Reference Value"](#).

Is the inspection result normal?

YES >> GO TO 14.

NO >> Replace the electrically-driven intelligent brake unit. Refer to [BR-288, "Removal and installation"](#).

14. PERFORM SELF-DIAGNOSIS (6)

With CONSULT

1. Turn the ignition switch OFF to ON without depressing the brake pedal.

CAUTION:

Never set the vehicle to READY/Never start the engine.

2. Repeat step 1 two times or more.

CAUTION:

Be sure to wait for 5 seconds or more after turning the ignition switch OFF.

3. Turn the ignition switch OFF to exit CONSULT.
4. Get out of the vehicle, close all doors (including trunk lid), and wait for 3 minutes or more without opening these doors.

CAUTION:

Never operate the vehicle and CONSULT while waiting.

5. Turn the ignition switch ON without depressing the brake pedal.

C1A6A CONTROL MODULE

< DTC/CIRCUIT DIAGNOSIS >

CAUTION:

Never set the vehicle to READY/Never start the engine.

6. Start CONSULT and erase self-diagnosis result of "BRAKE".
7. Turn the ignition switch OFF to exit CONSULT.
8. Get out of the vehicle, close all doors (including trunk lid), and wait for 3 minutes or more without opening these doors.

CAUTION:

Never operate the vehicle and CONSULT while waiting.

9. Turn the ignition switch ON without depressing the brake pedal.

CAUTION:

Never set the vehicle to READY/Never start the engine.

10. Depress brake pedal by 100 mm (3.94 in) or more, and hold the position for 5 seconds or more.
11. Release brake pedal.
12. Start CONSULT and perform "BRAKE" self-diagnosis.

Is DTC "C1A6A" detected?

YES >> GO TO 15.

NO >> INSPECTION END

15.CHECK DATA MONITOR (2)

Ⓜ With CONSULT

1. Turn the ignition switch OFF to ON without depressing the brake pedal.

CAUTION:

Never set the vehicle to READY/Never start the engine.

2. Repeat step 1 two times or more.

CAUTION:

Be sure to wait for 5 seconds or more after turning the ignition switch OFF.

3. Start CONSULT and select "BRAKE" and "DATA MONITOR" according to this order.
4. Check "CONTROL MODULE TEMP". Refer to [BR-33, "Reference Value"](#).

"CONTROL MODULE TEMP" is 150 °C (302 °F) or more?

YES >> GO TO 16.

NO >> INSPECTION END

16.CHECK ENGINE ROOM

Check for any locations of abnormal heating around the electrically-driven intelligent brake unit.

Are there any heated locations?

YES >> Perform diagnosis of the heated locations, and wait for the temperature to fall. GO TO 17.

NO >> Replace the electrically-driven intelligent brake unit. Refer to [BR-288, "Removal and installation"](#)

17.PERFORM SELF-DIAGNOSIS (7)

Ⓜ With CONSULT

1. Turn the ignition switch OFF to ON without depressing the brake pedal.

CAUTION:

Never set the vehicle to READY/Never start the engine.

2. Repeat step 1 two times or more.

CAUTION:

Be sure to wait for 5 seconds or more after turning the ignition switch OFF.

3. Turn the ignition switch OFF to exit CONSULT.
4. Get out of the vehicle, close all doors (including trunk lid), and wait for 3 minutes or more without opening these doors.

CAUTION:

Never operate the vehicle and CONSULT while waiting.

5. Turn the ignition switch ON without depressing the brake pedal.

CAUTION:

Never set the vehicle to READY/Never start the engine.

6. Start CONSULT and erase self-diagnosis result of "BRAKE".
7. Turn the ignition switch OFF to exit CONSULT.
8. Get out of the vehicle, close all doors (including trunk lid), and wait for 3 minutes or more without opening these doors.

CAUTION:

C1A6A CONTROL MODULE

< DTC/CIRCUIT DIAGNOSIS >

Never operate the vehicle and CONSULT while waiting.

9. Turn the ignition switch ON without depressing the brake pedal.

CAUTION:

Never set the vehicle to READY/Never start the engine.

10. Depress brake pedal by 100 mm (3.94 in) or more, and hold the position for 5 seconds or more.
11. Release brake pedal.
12. Start CONSULT and perform "BRAKE" self-diagnosis.

Is DTC "C1A6A" detected?

- YES >> Replace the electrically-driven intelligent brake unit. Refer to [BR-288, "Removal and installation"](#).
- NO >> INSPECTION END

C1A6B BRAKE POWER SUPPLY BACKUP UNIT

< DTC/CIRCUIT DIAGNOSIS >

C1A6B BRAKE POWER SUPPLY BACKUP UNIT

DTC Logic

INFOID:000000008139831

DTC DETECTION LOGIC

DTC	Display item	Malfunction detection condition	Possible causes
C1A6B	POWER SUPPLY BACKUP UNIT	A malfunction of the brake power supply backup unit is detected.	<ul style="list-style-type: none">• Harness or connector• Fuse• Brake power supply backup unit• 12V battery is low

DTC CONFIRMATION PROCEDURE

1. PRECONDITIONING

If "DTC CONFIRMATION PROCEDURE" has been previously conducted, always turn the ignition switch OFF and wait at least 10 seconds before conducting the next test.

>> GO TO 2.

2. CHECK DTC DETECTION

Ⓜ With CONSULT

1. Turn the ignition switch OFF to ON without depressing the brake pedal.
CAUTION:
Never set the vehicle to READY/Never start the engine.
2. Repeat step 1 two times or more.
CAUTION:
Be sure to wait for 5 seconds or more after turning the ignition switch OFF.
3. Turn the ignition switch OFF to exit CONSULT.
4. Get out of the vehicle, close all doors (including trunk lid), and wait for 3 minutes or more without opening these doors.
CAUTION:
Never operate the vehicle and CONSULT while waiting.
5. Turn the ignition switch ON without depressing the brake pedal.
CAUTION:
Never set the vehicle to READY/Never start the engine.
6. Start CONSULT and erase self-diagnosis result of "BRAKE".
7. Turn the ignition switch OFF to exit CONSULT.
8. Get out of the vehicle, close all doors (including trunk lid), and wait for 3 minutes or more without opening these doors.
CAUTION:
Never operate the vehicle and CONSULT while waiting.
9. Turn the ignition switch ON without depressing the brake pedal.
CAUTION:
Never set the vehicle to READY/Never start the engine.
10. Depress brake pedal by 100 mm (3.94 in) or more, and hold the position for 5 seconds or more.
11. Release brake pedal.
12. Start CONSULT and perform "BRAKE" self-diagnosis.

Is DTC "C1A6B" detected?

YES >> Proceed to [BR-161, "Diagnosis Procedure"](#).

NO >> INSPECTION END

Diagnosis Procedure

INFOID:000000008139832

1. CHECK 12V BATTERY

1. Turn the ignition switch OFF to exit CONSULT.
2. Get out of the vehicle, close all doors (including trunk lid), and wait for 3 minutes or more without opening these doors.

C1A6B BRAKE POWER SUPPLY BACKUP UNIT

< DTC/CIRCUIT DIAGNOSIS >

CAUTION:

Never operate the vehicle and CONSULT while waiting.

3. Check the 12V battery terminal connections. Refer to [BR-6. "Precaution for Removing 12V Battery"](#) and [PG-135. "Work Flow"](#).
4. Check the 12V battery. Refer to [PG-135. "Work Flow"](#).

Is the inspection result normal?

YES >> GO TO 2.

NO >> Repair or replace error-detected parts and GO TO 2.

2.PERFORM SELF-DIAGNOSIS (1)

ⓅWith CONSULT

1. Connect 12V battery cable to negative terminal.
2. Turn the ignition switch OFF to ON without depressing the brake pedal.
CAUTION:
Never set the vehicle to READY/Never start the engine.
3. Repeat step 2 two times or more.
CAUTION:
Be sure to wait for 5 seconds or more after turning the ignition switch OFF.
4. Turn the ignition switch OFF to exit CONSULT.
5. Get out of the vehicle, close all doors (including trunk lid), and wait for 3 minutes or more without opening these doors.
CAUTION:
Never operate the vehicle and CONSULT while waiting.
6. Turn the ignition switch ON without depressing the brake pedal.
CAUTION:
Never set the vehicle to READY/Never start the engine.
7. Start CONSULT and erase self-diagnosis result of "BRAKE".
8. Turn the ignition switch OFF to exit CONSULT.
9. Get out of the vehicle, close all doors (including trunk lid), and wait for 3 minutes or more without opening these doors.
CAUTION:
Never operate the vehicle and CONSULT while waiting.
10. Turn the ignition switch ON without depressing the brake pedal.
CAUTION:
Never set the vehicle to READY/Never start the engine.
11. Depress brake pedal by 100 mm (3.94 in) or more, and hold the position for 5 seconds or more.
12. Release brake pedal.
13. Start CONSULT and perform "BRAKE" self-diagnosis.

Is DTC "C1A6B" detected?

YES >> GO TO 3.

NO >> INSPECTION END

3.CHECK CONNECTOR TERMINALS

1. Turn the ignition switch OFF to exit CONSULT.
2. Get out of the vehicle, close all doors (including trunk lid), and wait for 3 minutes or more without opening these doors.
CAUTION:
Never operate the vehicle and CONSULT while waiting.
3. Disconnect 12V battery cable from negative terminal. Refer to [BR-6. "Precaution for Removing 12V Battery"](#).
4. Disconnect the electrically-driven intelligent brake unit harness connector, then check for failures of pin terminals and connections.
5. Disconnect the brake power supply backup unit harness connector, then check for failures of pin terminals and connections.

Is the inspection result normal?

YES >> GO TO 5.

NO >> Repair or replace error-detected parts and GO TO 4.

4.PERFORM SELF-DIAGNOSIS (2)

C1A6B BRAKE POWER SUPPLY BACKUP UNIT

< DTC/CIRCUIT DIAGNOSIS >

Ⓜ With CONSULT

1. Connect the electrically-driven intelligent brake unit harness connector. A
2. Connect the brake power supply backup unit harness connector. B
3. Connect 12V battery cable to negative terminal. C
4. Turn the ignition switch OFF to ON without depressing the brake pedal. D
CAUTION:
Never set the vehicle to READY/Never start the engine.
5. Repeat step 4 two times or more. E
CAUTION:
Be sure to wait for 5 seconds or more after turning the ignition switch OFF.
6. Turn the ignition switch OFF to exit CONSULT. D
7. Get out of the vehicle, close all doors (including trunk lid), and wait for 3 minutes or more without opening these doors. E
CAUTION:
Never operate the vehicle and CONSULT while waiting.
8. Turn the ignition switch ON without depressing the brake pedal. BR
CAUTION:
Never set the vehicle to READY/Never start the engine.
9. Start CONSULT and erase self-diagnosis result of "BRAKE". G
10. Turn the ignition switch OFF to exit CONSULT. H
11. Get out of the vehicle, close all doors (including trunk lid), and wait for 3 minutes or more without opening these doors. I
CAUTION:
Never operate the vehicle and CONSULT while waiting.
12. Turn the ignition switch ON without depressing the brake pedal. J
CAUTION:
Never set the vehicle to READY/Never start the engine.
13. Depress brake pedal by 100 mm (3.94 in) or more, and hold the position for 5 seconds or more.
14. Release brake pedal.
15. Start CONSULT and perform "BRAKE" self-diagnosis.

Is DTC "C1A6B" detected?

- YES >> GO TO 5. K
 NO >> INSPECTION END L

5.CHECK IGNITION POWER SUPPLY

1. Connect the brake power supply backup unit harness connector. M
2. Turn the ignition switch OFF to exit CONSULT. N
3. Get out of the vehicle, close all doors (including trunk lid), and wait for 3 minutes or more without opening these doors. O
CAUTION:
Never operate the vehicle and CONSULT while waiting.
4. Disconnect 12V battery cable from negative terminal. Refer to [BR-6. "Precaution for Removing 12V Battery"](#). P
5. Disconnect the electrically-driven intelligent brake unit harness connector.
6. Connect 12V battery cable to negative terminal.
7. Check voltage between the electrically-driven intelligent brake unit harness connector and ground. P

Electrically-driven intelligent brake unit		—	Voltage
Connector	Terminal		
E87	26	Ground	Approx. 0 V

8. Turn the ignition switch ON without depressing the brake pedal. P
CAUTION:
Never set the vehicle to READY/Never start the engine.
9. Check voltage between the electrically-driven intelligent brake unit harness connector and ground.

Electrically-driven intelligent brake unit		—	Voltage
Connector	Terminal		
E87	26	Ground	10 – 16 V

C1A6B BRAKE POWER SUPPLY BACKUP UNIT

< DTC/CIRCUIT DIAGNOSIS >

Is the inspection result normal?

YES >> GO TO 8.

NO >> GO TO 6.

6. CHECK IGNITION POWER SUPPLY CIRCUIT

1. Turn the ignition switch OFF to exit CONSULT.
2. Get out of the vehicle, close all doors (including trunk lid), and wait for 3 minutes or more without opening these doors.
CAUTION:
Never operate the vehicle and CONSULT while waiting.
3. Disconnect 12V battery cable from negative terminal. Refer to [BR-6, "Precaution for Removing 12V Battery"](#).
4. Check 10A fuse (#46).
5. Disconnect IPDM E/R harness connector.
6. Check continuity between electrically-driven intelligent brake unit and IPDM E/R.

Electrically-driven intelligent brake unit		IPDM E/R		Continuity
Connector	Terminal	Connector	Terminal	
E87	26	E5	12	Existed

7. Check continuity between electrically-driven intelligent brake unit harness connector and ground.

Electrically-driven intelligent brake unit		—	Continuity
Connector	Terminal		
E87	26	Ground	Not existed

Is the inspection result normal?

YES >> Perform trouble diagnosis for ignition power supply. Refer to [PG-30, "Wiring Diagram - IGNITION POWER SUPPLY -"](#).

NO >> Repair or replace error-detected parts and GO TO 7.

7. PERFORM SELF-DIAGNOSIS (3)

With CONSULT

1. Connect the electrically-driven intelligent brake unit harness connector.
2. Connect IPDM E/R harness connector.
3. Connect 12V battery cable to negative terminal.
4. Turn the ignition switch OFF to ON without depressing the brake pedal.
CAUTION:
Never set the vehicle to READY/Never start the engine.
5. Repeat step 4 two times or more.
CAUTION:
Be sure to wait for 5 seconds or more after turning the ignition switch OFF.
6. Turn the ignition switch OFF to exit CONSULT.
7. Get out of the vehicle, close all doors (including trunk lid), and wait for 3 minutes or more without opening these doors.
CAUTION:
Never operate the vehicle and CONSULT while waiting.
8. Turn the ignition switch ON without depressing the brake pedal.
CAUTION:
Never set the vehicle to READY/Never start the engine.
9. Start CONSULT and erase self-diagnosis result of "BRAKE".
10. Turn the ignition switch OFF to exit CONSULT.
11. Get out of the vehicle, close all doors (including trunk lid), and wait for 3 minutes or more without opening these doors.
CAUTION:
Never operate the vehicle and CONSULT while waiting.
12. Turn the ignition switch ON without depressing the brake pedal.
CAUTION:
Never set the vehicle to READY/Never start the engine.

C1A6B BRAKE POWER SUPPLY BACKUP UNIT

< DTC/CIRCUIT DIAGNOSIS >

13. Depress brake pedal by 100 mm (3.94 in) or more, and hold the position for 5 seconds or more.
14. Release brake pedal.
15. Start CONSULT and perform "BRAKE" self-diagnosis.

Is DTC "C1A6B" detected?

- YES >> GO TO 8.
NO >> INSPECTION END

8. CHECK 12V BATTERY POWER SUPPLY

1. Turn the ignition switch OFF to exit CONSULT.
2. Get out of the vehicle, close all doors (including trunk lid), and wait for 3 minutes or more without opening these doors.
CAUTION:
Never operate the vehicle and CONSULT while waiting.
3. Disconnect 12V battery cable from negative terminal. Refer to [BR-6. "Precaution for Removing 12V Battery"](#).
4. Disconnect the electrically-driven intelligent brake unit harness connector.
5. Connect 12V battery cable to negative terminal.
6. Check voltage between the electrically-driven intelligent brake unit harness connector terminal.

Electrically-driven intelligent brake unit		Voltage
Connector	Terminal	
E87	1 – 31	10 – 16 V
	2 – 31	
	11 – 31	

7. Turn the ignition switch ON without depressing the brake pedal.
CAUTION:
Never set the vehicle to READY/ Never start the engine.
8. Check voltage between the electrically-driven intelligent brake unit harness connector terminal.

Electrically-driven intelligent brake unit		Voltage
Connector	Terminal	
E87	1 – 31	10 – 16 V
	2 – 31	
	11 – 31	

Is the inspection result normal?

- YES >> GO TO 11.
NO >> GO TO 9.

9. CHECK 12V BATTERY POWER SUPPLY CIRCUIT

1. Turn the ignition switch OFF to exit CONSULT.
2. Get out of the vehicle, close all doors (including trunk lid), and wait for 3 minutes or more without opening these doors.
CAUTION:
Never operate the vehicle and CONSULT while waiting.
3. Disconnect 12V battery cable from negative terminal. Refer to [BR-6. "Precaution for Removing 12V Battery"](#).
4. Check 50A fusible link (#D).
5. Check continuity and for short circuit between electrically-driven intelligent brake unit harness connector terminal (1) and 50A fusible link (#D).
6. Check continuity and for short circuit between electrically-driven intelligent brake unit harness connector terminal (2) and 50A fusible link (#D).
7. Check 10A fuse (#65).
8. Check continuity and for short circuit between electrically-driven intelligent brake unit harness connector terminal (11) and 10A fuse (#65).

Is the inspection result normal?

C1A6B BRAKE POWER SUPPLY BACKUP UNIT

< DTC/CIRCUIT DIAGNOSIS >

- YES >> Perform diagnosis for 12V battery power supply. Refer to [PG-14. "Wiring Diagram - BATTERY POWER SUPPLY -"](#).
- NO >> Repair or replace error-detected parts and GO TO 10.

10.PERFORM SELF-DIAGNOSIS (4)

ⓅWith CONSULT

1. Connect the electrically-driven intelligent brake unit harness connector.
2. Connect 12V battery cable to negative terminal.
3. Turn the ignition switch OFF to ON without depressing the brake pedal.
CAUTION:
Never set the vehicle to READY/Never start the engine.
4. Repeat step 3 two times or more.
CAUTION:
Be sure to wait for 5 seconds or more after turning the ignition switch OFF.
5. Turn the ignition switch OFF to exit CONSULT.
6. Get out of the vehicle, close all doors (including trunk lid), and wait for 3 minutes or more without opening these doors.
CAUTION:
Never operate the vehicle and CONSULT while waiting.
7. Turn the ignition switch ON without depressing the brake pedal.
CAUTION:
Never set the vehicle to READY/Never start the engine.
8. Start CONSULT and erase self-diagnosis result of "BRAKE".
9. Turn the ignition switch OFF to exit CONSULT.
10. Get out of the vehicle, close all doors (including trunk lid), and wait for 3 minutes or more without opening these doors.
CAUTION:
Never operate the vehicle and CONSULT while waiting.
11. Turn the ignition switch ON without depressing the brake pedal.
CAUTION:
Never set the vehicle to READY/Never start the engine.
12. Depress brake pedal by 100 mm (3.94 in) or more, and hold the position for 5 seconds or more.
13. Release brake pedal.
14. Start CONSULT and perform "BRAKE" self-diagnosis.

Is DTC "C1A6B" detected?

- YES >> GO TO 11.
- NO >> INSPECTION END

11.CHECK GROUND CIRCUIT

1. Turn the ignition switch OFF to exit CONSULT.
2. Get out of the vehicle, close all doors (including trunk lid), and wait for 3 minutes or more without opening these doors.
CAUTION:
Never operate the vehicle and CONSULT while waiting.
3. Disconnect 12V battery cable from negative terminal. Refer to [BR-6. "Precaution for Removing 12V Battery"](#).
4. Disconnect the electrically-driven intelligent brake unit harness connector.
5. Check continuity between electrically-driven intelligent brake unit and ground.

Electrically-driven intelligent brake unit		—	Continuity
Connector	Terminal		
E87	31	Ground	Existed

Is the inspection result normal?

- YES >> GO TO 13.
- NO >> Repair or replace error-detected parts and GO TO 12.

12.PERFORM SELF-DIAGNOSIS (5)

ⓅWith CONSULT

1. Connect the electrically-driven intelligent brake unit harness connector.

C1A6B BRAKE POWER SUPPLY BACKUP UNIT

< DTC/CIRCUIT DIAGNOSIS >

2. Connect 12V battery cable to negative terminal.
 3. Turn the ignition switch OFF to ON without depressing the brake pedal. A
CAUTION:
Never set the vehicle to READY/Never start the engine.
 4. Repeat step 3 two times or more. B
CAUTION:
Be sure to wait for 5 seconds or more after turning the ignition switch OFF.
 5. Turn the ignition switch OFF to exit CONSULT.
 6. Get out of the vehicle, close all doors (including trunk lid), and wait for 3 minutes or more without opening these doors. C
CAUTION:
Never operate the vehicle and CONSULT while waiting.
 7. Turn the ignition switch ON without depressing the brake pedal. D
CAUTION:
Never set the vehicle to READY/Never start the engine.
 8. Start CONSULT and erase self-diagnosis result of "BRAKE". E
 9. Turn the ignition switch OFF to exit CONSULT.
 10. Get out of the vehicle, close all doors (including trunk lid), and wait for 3 minutes or more without opening these doors. BR
CAUTION:
Never operate the vehicle and CONSULT while waiting.
 11. Turn the ignition switch ON without depressing the brake pedal. G
CAUTION:
Never set the vehicle to READY/Never start the engine.
 12. Depress brake pedal by 100 mm (3.94 in) or more, and hold the position for 5 seconds or more.
 13. Release brake pedal. H
 14. Start CONSULT and perform "BRAKE" self-diagnosis.
- Is DTC "C1A6B" detected?
- YES >> GO TO 13. I
NO >> INSPECTION END

13. CHECK DATA MONITOR (1)

With CONSULT

1. Connect the electrically-driven intelligent brake unit harness connector. J
2. Connect 12V battery cable to negative terminal.
3. Turn the ignition switch OFF to ON without depressing the brake pedal. K
CAUTION:
Never set the vehicle to READY/Never start the engine.
4. Repeat step 3 two times or more. L
CAUTION:
Be sure to wait for 5 seconds or more after turning the ignition switch OFF.
5. Start CONSULT and select "BRAKE" and "DATA MONITOR" according to this order.
6. Check "MOTOR POWER SUPPLY" and "CONTROL MODULE POWER". Refer to [BR-33. "Reference Value"](#). M

Is the inspection result normal?

- YES >> GO TO 14. N
NO >> Replace the electrically-driven intelligent brake unit. Refer to [BR-288. "Removal and installation"](#).

14. PERFORM SELF-DIAGNOSIS (2)

With CONSULT

1. Turn the ignition switch OFF to ON without depressing the brake pedal. O
CAUTION:
Never set the vehicle to READY/Never start the engine.
2. Repeat step 1 two times or more. P
CAUTION:
Be sure to wait for 5 seconds or more after turning the ignition switch OFF.
3. Turn the ignition switch OFF to exit CONSULT.
4. Get out of the vehicle, close all doors (including trunk lid), and wait for 3 minutes or more without opening these doors.
CAUTION:

C1A6B BRAKE POWER SUPPLY BACKUP UNIT

< DTC/CIRCUIT DIAGNOSIS >

Never operate the vehicle and CONSULT while waiting.

- Turn the ignition switch ON without depressing the brake pedal.

CAUTION:

Never set the vehicle to READY/Never start the engine.

- Start CONSULT and erase self-diagnosis result of "BRAKE".
- Turn the ignition switch OFF to exit CONSULT.
- Get out of the vehicle, close all doors (including trunk lid), and wait for 3 minutes or more without opening these doors.

CAUTION:

Never operate the vehicle and CONSULT while waiting.

- Turn the ignition switch ON without depressing the brake pedal.

CAUTION:

Never set the vehicle to READY/Never start the engine.

- Depress brake pedal by 100 mm (3.94 in) or more, and hold the position for 5 seconds or more.
- Release brake pedal.
- Start CONSULT and perform "BRAKE" self-diagnosis.

Is DTC "C1A6B" detected?

YES >> GO TO 15.

NO >> INSPECTION END

15. CHECK BRAKE POWER SUPPLY BACKUP UNIT CIRCUIT

- Turn the ignition switch OFF to exit CONSULT.
- Get out of the vehicle, close all doors (including trunk lid), and wait for 3 minutes or more without opening these doors.
CAUTION:
Never operate the vehicle and CONSULT while waiting.
- Disconnect 12V battery cable from negative terminal. Refer to [BR-6. "Precaution for Removing 12V Battery"](#).
- Disconnect the electrically-driven intelligent brake unit harness connector.
- Disconnect the brake power supply backup unit harness connector.
- Check continuity between electrically-driven intelligent brake unit and brake power supply backup unit.

Electrically-driven intelligent brake unit		Brake power supply backup unit		Continuity
Connector	Terminal	Connector	Terminal	
E87	32	B155	2	Existed
	32		6	Not existed
	32		4	Not existed
	8		2	Not existed
	8		6	Existed
	8		4	Not existed
	10		2	Not existed
	10		6	Not existed
	10		4	Existed

- Check continuity between electrically-driven intelligent brake unit and ground.

Electrically-driven intelligent brake unit		—	Continuity
Connector	Terminal		
E87	32	Ground	Not existed
	8		Not existed
	10		Not existed
	31		Existed

Is the inspection result normal?

YES >> GO TO 16.

C1A6B BRAKE POWER SUPPLY BACKUP UNIT

< DTC/CIRCUIT DIAGNOSIS >

NO >> Repair or replace error-detected parts and GO TO 16.

16.CHECK DATA MONITOR (2)

④ With CONSULT

1. Connect the electrically-driven intelligent brake unit harness connector.
2. Connect the brake power supply backup unit harness connector.
3. Turn the ignition switch OFF to ON without depressing the brake pedal.

CAUTION:

Never set the vehicle to READY/Never start the engine.

4. Repeat step 3 two times or more.

CAUTION:

Be sure to wait for 5 seconds or more after turning the ignition switch OFF.

5. Start CONSULT and select "BRAKE" and "DATA MONITOR" according this order.
6. Check "BACKUP UNIT DIAG RESULT". Refer to [BR-33, "Reference Value"](#).

What was the displayed data monitor result?

"NORMAL">>INSPECTION END

"ERR1">> GO TO 17.

"ERR2">> GO TO 18.

"ERR3">> Replace the brake power supply backup unit. Refer to [BR-290, "Removal and Installation"](#).

"ERR4">> Replace the brake power supply backup unit. Refer to [BR-290, "Removal and Installation"](#).

"ERR5">> Replace the brake power supply backup unit. Refer to [BR-290, "Removal and Installation"](#).

"ERR6">> Replace the brake power supply backup unit. Refer to [BR-290, "Removal and Installation"](#).

"ERR7">> GO TO 19.

"ERR8">> GO TO 17.

"ERR9">> Replace the brake power supply backup unit. Refer to [BR-290, "Removal and Installation"](#).

"ERR10">> Replace the brake power supply backup unit. Refer to [BR-290, "Removal and Installation"](#).

"ERR11">> Replace the brake power supply backup unit. Refer to [BR-290, "Removal and Installation"](#).

"ERR12">> GO TO 17.

"ERR13">> Replace the brake power supply backup unit. Refer to [BR-290, "Removal and Installation"](#).

"ERR14">> Replace the brake power supply backup unit. Refer to [BR-290, "Removal and Installation"](#).

"ERR15">> GO TO 20.

17.CHECK CIRCUIT BETWEEN ELECTRICALLY-DRIVEN INTELLIGENT BRAKE UNIT AND BRAKE POWER SUPPLY BACKUP UNIT (1)

1. Turn the ignition switch OFF to exit CONSULT.
2. Get out of the vehicle, close all doors (including trunk lid), and wait for 3 minutes or more without opening these doors.

CAUTION:

Never operate the vehicle and CONSULT while waiting.

3. Disconnect 12V battery cable from negative terminal. Refer to [BR-6, "Precaution for Removing 12V Battery"](#).
4. Disconnect the electrically-driven intelligent brake unit harness connector.
5. Disconnect the brake power supply backup unit harness connector.
6. Check continuity between electrically-driven intelligent brake unit and ground.

Electrically-driven intelligent brake unit		—	Continuity
Connector	Terminal		
E87	8	Ground	Not existed

Is the inspection result normal?

YES >> Replace the brake power supply backup unit. Refer to [BR-290, "Removal and Installation"](#).

NO >> Repair or replace error-detected parts.

18.CHECK CIRCUIT BETWEEN ELECTRICALLY-DRIVEN INTELLIGENT BRAKE UNIT AND BRAKE POWER SUPPLY BACKUP UNIT (2)

1. Turn the ignition switch OFF to exit CONSULT.
2. Get out of the vehicle, close all doors (including trunk lid), and wait for 3 minutes or more without opening these doors.

CAUTION:

Never operate the vehicle and CONSULT while waiting.

C1A6B BRAKE POWER SUPPLY BACKUP UNIT

< DTC/CIRCUIT DIAGNOSIS >

3. Disconnect 12V battery cable from negative terminal. Refer to [BR-6, "Precaution for Removing 12V Battery"](#).
4. Disconnect the electrically-driven intelligent brake unit harness connector.
5. Disconnect the brake power supply backup unit harness connector.
6. Check continuity between electrically-driven intelligent brake unit and brake power supply backup unit.

Electrically-driven intelligent brake unit		Brake power supply backup unit		Continuity
Connector	Terminal	Connector	Terminal	
E87	10	B155	4	Existed

7. Check continuity between electrically-driven intelligent brake unit and ground.

Electrically-driven intelligent brake unit		—	Continuity
Connector	Terminal		
E87	10	Ground	Not existed

Is the inspection result normal?

- YES >> Replace the brake power supply backup unit. Refer to [BR-290, "Removal and Installation"](#).
 NO >> Repair or replace error-detected parts.

19. CHECK CIRCUIT BETWEEN ELECTRICALLY-DRIVEN INTELLIGENT BRAKE UNIT AND BRAKE POWER SUPPLY BACKUP UNIT (3)

1. Turn the ignition switch OFF to exit CONSULT.
2. Get out of the vehicle, close all doors (including trunk lid), and wait for 3 minutes or more without opening these doors.

CAUTION:

Never operate the vehicle and CONSULT while waiting.

3. Disconnect 12V battery cable from negative terminal. Refer to [BR-6, "Precaution for Removing 12V Battery"](#).
4. Disconnect the electrically-driven intelligent brake unit harness connector.
5. Disconnect the brake power supply backup unit harness connector.
6. Check continuity between electrically-driven intelligent brake unit and brake power supply backup unit.

Electrically-driven intelligent brake unit		Brake power supply backup unit		Continuity
Connector	Terminal	Connector	Terminal	
E87	32	B155	2	Existed

7. Check continuity between electrically-driven intelligent brake unit and ground.

Electrically-driven intelligent brake unit		—	Continuity
Connector	Terminal		
E87	32	Ground	Not existed

Is the inspection result normal?

- YES >> Replace the brake power supply backup unit. Refer to [BR-290, "Removal and Installation"](#).
 NO >> Repair or replace error-detected parts.

20. CHECK BRAKE POWER SUPPLY BACKUP UNIT POWER

1. Turn the ignition switch OFF to exit CONSULT.
2. Get out of the vehicle, close all doors (including trunk lid), and wait for 3 minutes or more without opening these doors.

CAUTION:

Never operate the vehicle and CONSULT while waiting.

3. Disconnect the brake power supply backup unit harness connector.
4. Connect 12V battery cable to negative terminal.
5. Turn the ignition switch ON without depressing the brake pedal.

CAUTION:

Never set the vehicle to READY/ Never start the engine.

C1A6B BRAKE POWER SUPPLY BACKUP UNIT

< DTC/CIRCUIT DIAGNOSIS >

6. Check voltage between brake power supply backup unit and ground.

Brake power supply backup unit		—	Voltage
Connector	Terminal		
B155	3	Ground	9 – 16 V

Is the inspection result normal?

- YES >> Replace the brake power supply backup unit. Refer to [BR-290. "Removal and Installation"](#).
NO >> GO TO 21.

21. CHECK BRAKE POWER SUPPLY BACKUP UNIT POWER CIRCUIT

1. Check 15A fuse (#66).
2. Check continuity and for short circuit between brake power supply backup unit harness connector terminal (3) and 15A fuse (#66).

Is the inspection result normal?

- YES >> Perform diagnosis for 12V battery power supply. Refer to [PG-14. "Wiring Diagram - BATTERY POWER SUPPLY -"](#).
NO >> Repair or replace error-detected parts.

A
B
C
D
E
BR
G
H
I
J
K
L
M
N
O
P

C1A6C BRAKE POWER SUPPLY BACKUP UNIT

< DTC/CIRCUIT DIAGNOSIS >

C1A6C BRAKE POWER SUPPLY BACKUP UNIT

DTC Logic

INFOID:000000008139833

DTC DETECTION LOGIC

DTC	Display item	Malfunction detection condition	Possible causes
C1A6C	POWER SUPPLY BACKUP UNIT VOLT	Power voltage of brake power supply backup unit is as shown below. <ul style="list-style-type: none">• Power voltage of brake power supply backup unit: $9\text{ V} \geq$ Power voltage of brake power supply backup unit• Power voltage of brake power supply backup unit: $16\text{ V} \leq$ Power voltage of brake power supply backup unit	<ul style="list-style-type: none">• Harness or connector• Fuse• Brake power supply backup unit• 12V battery is low• DC/DC-J/B is overvoltage

DTC CONFIRMATION PROCEDURE

1. PRECONDITIONING

If "DTC CONFIRMATION PROCEDURE" has been previously conducted, always turn the ignition switch OFF and wait at least 10 seconds before conducting the next test.

>> GO TO 2.

2. CHECK DTC DETECTION

 With CONSULT

1. Turn the ignition switch OFF to ON without depressing the brake pedal.
CAUTION:
Never set the vehicle to READY/Never start the engine.
2. Repeat step 1 two times or more.
CAUTION:
Be sure to wait for 5 seconds or more after turning the ignition switch OFF.
3. Turn the ignition switch OFF to exit CONSULT.
4. Get out of the vehicle, close all doors (including trunk lid), and wait for 3 minutes or more without opening these doors.
CAUTION:
Never operate the vehicle and CONSULT while waiting.
5. Turn the ignition switch ON without depressing the brake pedal.
CAUTION:
Never set the vehicle to READY/Never start the engine.
6. Start CONSULT and erase self-diagnosis result of "BRAKE".
7. Turn the ignition switch OFF to exit CONSULT.
8. Get out of the vehicle, close all doors (including trunk lid), and wait for 3 minutes or more without opening these doors.
CAUTION:
Never operate the vehicle and CONSULT while waiting.
9. Turn the ignition switch ON without depressing the brake pedal.
CAUTION:
Never set the vehicle to READY/Never start the engine.
10. Depress brake pedal by 100 mm (3.94 in) or more, and hold the position for 5 seconds or more.
11. Release brake pedal.
12. Start CONSULT and perform "BRAKE" self-diagnosis.

Is DTC "C1A6C" detected?

- YES >> Proceed to [BR-172. "Diagnosis Procedure"](#).
NO >> INSPECTION END

Diagnosis Procedure

INFOID:000000008139834

1. CHECK 12V BATTERY

C1A6C BRAKE POWER SUPPLY BACKUP UNIT

< DTC/CIRCUIT DIAGNOSIS >

1. Turn the ignition switch OFF to exit CONSULT.
2. Get out of the vehicle, close all doors (including trunk lid), and wait for 3 minutes or more without opening these doors.
CAUTION:
Never operate the vehicle and CONSULT while waiting.
3. Check the 12V battery terminal connections. Refer to [BR-6, "Precaution for Removing 12V Battery"](#) and [PG-135, "Work Flow"](#).
4. Check the 12V battery. Refer to [PG-135, "Work Flow"](#).

Is the inspection result normal?

YES >> GO TO 2.

NO >> Repair or replace error-detected parts and GO TO 2.

2.PERFORM SELF-DIAGNOSIS (1)

ⓂWith CONSULT

1. Connect 12V battery cable to negative terminal.
2. Turn the ignition switch OFF to ON without depressing the brake pedal.
CAUTION:
Never set the vehicle to READY/Never start the engine.
3. Repeat step 2 two times or more.
CAUTION:
Be sure to wait for 5 seconds or more after turning the ignition switch OFF.
4. Turn the ignition switch OFF to exit CONSULT.
5. Get out of the vehicle, close all doors (including trunk lid), and wait for 3 minutes or more without opening these doors.
CAUTION:
Never operate the vehicle and CONSULT while waiting.
6. Turn the ignition switch ON without depressing the brake pedal.
CAUTION:
Never set the vehicle to READY/Never start the engine.
7. Start CONSULT and erase self-diagnosis result of "BRAKE".
8. Turn the ignition switch OFF to exit CONSULT.
9. Get out of the vehicle, close all doors (including trunk lid), and wait for 3 minutes or more without opening these doors.
CAUTION:
Never operate the vehicle and CONSULT while waiting.
10. Turn the ignition switch ON without depressing the brake pedal.
CAUTION:
Never set the vehicle to READY/Never start the engine.
11. Depress brake pedal by 100 mm (3.94 in) or more, and hold the position for 5 seconds or more.
12. Release brake pedal.
13. Start CONSULT and perform "BRAKE" self-diagnosis.

Is DTC "C1A6C" detected?

YES >> GO TO 3.

NO >> INSPECTION END

3.CHECK CONNECTOR TERMINALS

1. Turn the ignition switch OFF to exit CONSULT.
2. Get out of the vehicle, close all doors (including trunk lid), and wait for 3 minutes or more without opening these doors.
CAUTION:
Never operate the vehicle and CONSULT while waiting.
3. Disconnect 12V battery cable from negative terminal. Refer to [BR-6, "Precaution for Removing 12V Battery"](#).
4. Disconnect the electrically-driven intelligent brake unit harness connector, then check for failures of pin terminals and connections.
5. Disconnect the brake power supply backup unit harness connector, then check for failures of pin terminals and connections.

Is the inspection result normal?

YES >> GO TO 5.

NO >> Repair or replace error-detected parts and GO TO 4.

C1A6C BRAKE POWER SUPPLY BACKUP UNIT

< DTC/CIRCUIT DIAGNOSIS >

4. PERFORM SELF-DIAGNOSIS (2)

④ With CONSULT

1. Connect the electrically-driven intelligent brake unit harness connector.
2. Connect the brake power supply backup unit harness connector.
3. Connect 12V battery cable to negative terminal.
4. Turn the ignition switch OFF to ON without depressing the brake pedal.
CAUTION:
Never set the vehicle to READY/Never start the engine.
5. Repeat step 4 two times or more.
CAUTION:
Be sure to wait for 5 seconds or more after turning the ignition switch OFF.
6. Turn the ignition switch OFF to exit CONSULT.
7. Get out of the vehicle, close all doors (including trunk lid), and wait for 3 minutes or more without opening these doors.
CAUTION:
Never operate the vehicle and CONSULT while waiting.
8. Turn the ignition switch ON without depressing the brake pedal.
CAUTION:
Never set the vehicle to READY/Never start the engine.
9. Start CONSULT and erase self-diagnosis result of "BRAKE".
10. Turn the ignition switch OFF to exit CONSULT.
11. Get out of the vehicle, close all doors (including trunk lid), and wait for 3 minutes or more without opening these doors.
CAUTION:
Never operate the vehicle and CONSULT while waiting.
12. Turn the ignition switch ON without depressing the brake pedal.
CAUTION:
Never set the vehicle to READY/Never start the engine.
13. Depress brake pedal by 100 mm (3.94 in) or more, and hold the position for 5 seconds or more.
14. Release brake pedal.
15. Start CONSULT and perform "BRAKE" self-diagnosis.

Is DTC "C1A6C" detected?

YES >> GO TO 5.

NO >> INSPECTION END

5. CHECK IGNITION POWER SUPPLY

1. Connect the brake power supply backup unit harness connector.
2. Turn the ignition switch OFF to exit CONSULT.
3. Get out of the vehicle, close all doors (including trunk lid), and wait for 3 minutes or more without opening these doors.
CAUTION:
Never operate the vehicle and CONSULT while waiting.
4. Disconnect 12V battery cable from negative terminal. Refer to [BR-6. "Precaution for Removing 12V Battery"](#).
5. Disconnect the electrically-driven intelligent brake unit harness connector.
6. Connect 12V battery cable to negative terminal.
7. Check voltage between the electrically-driven intelligent brake unit harness connector and ground.

Electrically-driven intelligent brake unit		—	Voltage
Connector	Terminal		
E87	26	Ground	Approx. 0 V

8. Turn the ignition switch ON without depressing the brake pedal.
CAUTION:
Never set the vehicle to READY/Never start the engine.
9. Check voltage between the electrically-driven intelligent brake unit harness connector and ground.

C1A6C BRAKE POWER SUPPLY BACKUP UNIT

< DTC/CIRCUIT DIAGNOSIS >

Electrically-driven intelligent brake unit		—	Voltage
Connector	Terminal		
E87	26	Ground	10 – 16 V

Is the inspection result normal?

YES >> GO TO 8.

NO >> GO TO 6.

6. CHECK IGNITION POWER SUPPLY CIRCUIT

- Turn the ignition switch OFF to exit CONSULT.
- Get out of the vehicle, close all doors (including trunk lid), and wait for 3 minutes or more without opening these doors.
CAUTION:
Never operate the vehicle and CONSULT while waiting.
- Disconnect 12V battery cable from negative terminal. Refer to [BR-6. "Precaution for Removing 12V Battery"](#).
- Check 10A fuse (#46).
- Disconnect IPDM E/R harness connector.
- Check continuity between electrically-driven intelligent brake unit and IPDM E/R.

Electrically-driven intelligent brake unit		IPDM E/R		Continuity
Connector	Terminal	Connector	Terminal	
E87	26	E5	12	Existed

- Check continuity between electrically-driven intelligent brake unit harness connector and ground.

Electrically-driven intelligent brake unit		—	Continuity
Connector	Terminal		
E87	26	Ground	Not existed

Is the inspection result normal?

YES >> Perform trouble diagnosis for ignition power supply. Refer to [PG-30. "Wiring Diagram - IGNITION POWER SUPPLY -"](#).

NO >> Repair or replace error-detected parts and GO TO 7.

7. PERFORM SELF-DIAGNOSIS (3)

 With CONSULT

- Connect the electrically-driven intelligent brake unit harness connector.
- Connect the IPDM E/R harness connector.
- Connect 12V battery cable to negative terminal.
- Turn the ignition switch OFF to ON without depressing the brake pedal.
CAUTION:
Never set the vehicle to READY/Never start the engine.
- Repeat step 4 two times or more.
CAUTION:
Be sure to wait for 5 seconds or more after turning the ignition switch OFF.
- Turn the ignition switch OFF to exit CONSULT.
- Get out of the vehicle, close all doors (including trunk lid), and wait for 3 minutes or more without opening these doors.
CAUTION:
Never operate the vehicle and CONSULT while waiting.
- Turn the ignition switch ON without depressing the brake pedal.
CAUTION:
Never set the vehicle to READY/Never start the engine.
- Start CONSULT and erase self-diagnosis result of "BRAKE".
- Turn the ignition switch OFF to exit CONSULT.
- Get out of the vehicle, close all doors (including trunk lid), and wait for 3 minutes or more without opening these doors.

C1A6C BRAKE POWER SUPPLY BACKUP UNIT

< DTC/CIRCUIT DIAGNOSIS >

CAUTION:

Never operate the vehicle and CONSULT while waiting.

- Turn the ignition switch ON without depressing the brake pedal.

CAUTION:

Never set the vehicle to READY/Never start the engine.

- Depress brake pedal by 100 mm (3.94 in) or more, and hold the position for 5 seconds or more.
- Release brake pedal.
- Start CONSULT and perform "BRAKE" self-diagnosis.

Is DTC "C1A6C" detected?

- YES >> GO TO 8.
NO >> INSPECTION END

8. CHECK 12V BATTERY POWER SUPPLY

- Turn the ignition switch OFF to exit CONSULT.
- Get out of the vehicle, close all doors (including trunk lid), and wait for 3 minutes or more without opening these doors.

CAUTION:

Never operate the vehicle and CONSULT while waiting.

- Disconnect 12V battery cable from negative terminal. Refer to [BR-6, "Precaution for Removing 12V Battery"](#).
- Disconnect the electrically-driven intelligent brake unit harness connector.
- Connect 12V battery cable to negative terminal.
- Check voltage between the electrically-driven intelligent brake unit harness connector terminal.

Electrically-driven intelligent brake unit		Voltage
Connector	Terminal	
E87	1 - 31	10 - 16 V
	2 - 31	
	11 - 31	

- Turn the ignition switch ON without depressing the brake pedal.
- ### **CAUTION:**
- Never set the vehicle to READY/Never start the engine.**
- Check voltage between the electrically-driven intelligent brake unit harness connector terminal.

Electrically-driven intelligent brake unit		Voltage
Connector	Terminal	
E87	1 - 31	10 - 16 V
	2 - 31	
	11 - 31	

Is the inspection result normal?

- YES >> GO TO 11.
NO >> GO TO 9.

9. CHECK 12V BATTERY POWER SUPPLY CIRCUIT

- Turn the ignition switch OFF to exit CONSULT.
- Get out of the vehicle, close all doors (including trunk lid), and wait for 3 minutes or more without opening these doors.

CAUTION:

Never operate the vehicle and CONSULT while waiting.

- Disconnect 12V battery cable from negative terminal. Refer to [BR-6, "Precaution for Removing 12V Battery"](#).
- Check 50A fusible link (#D).
- Check continuity and for short circuit between electrically-driven intelligent brake unit harness connector terminal (1) and 50A fusible link (#D).
- Check continuity and for short circuit between electrically-driven intelligent brake unit harness connector terminal (2) and 50A fusible link (#D).

C1A6C BRAKE POWER SUPPLY BACKUP UNIT

< DTC/CIRCUIT DIAGNOSIS >

7. Check 10A fuse (#65).
8. Check continuity and for short circuit between electrically-driven intelligent brake unit harness connector terminal (11) and 10A fuse (#65).

Is the inspection result normal?

YES >> Perform diagnosis for 12V battery power supply. Refer to [PG-14, "Wiring Diagram - BATTERY POWER SUPPLY -"](#).

NO >> Repair or replace error-detected parts and GO TO 10.

10. PERFORM SELF-DIAGNOSIS (4)

Ⓜ With CONSULT

1. Connect the electrically-driven intelligent brake unit harness connector.
2. Connect 12V battery cable to negative terminal.
3. Turn the ignition switch OFF to ON without depressing the brake pedal.
CAUTION:
Never set the vehicle to READY/Never start the engine.
4. Repeat step 3 two times or more.
CAUTION:
Be sure to wait for 5 seconds or more after turning the ignition switch OFF.
5. Turn the ignition switch OFF to exit CONSULT.
6. Get out of the vehicle, close all doors (including trunk lid), and wait for 3 minutes or more without opening these doors.
CAUTION:
Never operate the vehicle and CONSULT while waiting.
7. Turn the ignition switch ON without depressing the brake pedal.
CAUTION:
Never set the vehicle to READY/Never start the engine.
8. Start CONSULT and erase self-diagnosis result of "BRAKE".
9. Turn the ignition switch OFF to exit CONSULT.
10. Get out of the vehicle, close all doors (including trunk lid), and wait for 3 minutes or more without opening these doors.
CAUTION:
Never operate the vehicle and CONSULT while waiting.
11. Turn the ignition switch ON without depressing the brake pedal.
CAUTION:
Never set the vehicle to READY/Never start the engine.
12. Depress brake pedal by 100 mm (3.94 in) or more, and hold the position for 5 seconds or more.
13. Release brake pedal.
14. Start CONSULT and perform "BRAKE" self-diagnosis.

Is DTC "C1A6C" detected?

YES >> GO TO 11.

NO >> INSPECTION END

11. CHECK GROUND CIRCUIT

1. Turn the ignition switch OFF to exit CONSULT.
2. Get out of the vehicle, close all doors (including trunk lid), and wait for 3 minutes or more without opening these doors.
CAUTION:
Never operate the vehicle and CONSULT while waiting.
3. Disconnect 12V battery cable from negative terminal. Refer to [BR-6, "Precaution for Removing 12V Battery"](#).
4. Disconnect the electrically-driven intelligent brake unit harness connector.
5. Check continuity between electrically-driven intelligent brake unit and ground.

Electrically-driven intelligent brake unit		—	Continuity
Connector	Terminal		
E87	31	Ground	Existed

Is the inspection result normal?

YES >> GO TO 13.

C1A6C BRAKE POWER SUPPLY BACKUP UNIT

< DTC/CIRCUIT DIAGNOSIS >

NO >> Repair or replace error-detected parts and GO TO 12.

12.PERFORM SELF-DIAGNOSIS (5)

ⓅWith CONSULT

1. Connect the electrically-driven intelligent brake unit harness connector.
2. Connect 12V battery cable to negative terminal.
3. Turn the ignition switch OFF to ON without depressing the brake pedal.
CAUTION:
Never set the vehicle to READY/Never start the engine.
4. Repeat step 3 two times or more.
CAUTION:
Be sure to wait for 5 seconds or more after turning the ignition switch OFF.
5. Turn the ignition switch OFF to exit CONSULT.
6. Get out of the vehicle, close all doors (including trunk lid), and wait for 3 minutes or more without opening these doors.
CAUTION:
Never operate the vehicle and CONSULT while waiting.
7. Turn the ignition switch ON without depressing the brake pedal.
CAUTION:
Never set the vehicle to READY/Never start the engine.
8. Start CONSULT and erase self-diagnosis result of "BRAKE".
9. Turn the ignition switch OFF to exit CONSULT.
10. Get out of the vehicle, close all doors (including trunk lid), and wait for 3 minutes or more without opening these doors.
CAUTION:
Never operate the vehicle and CONSULT while waiting.
11. Turn the ignition switch ON without depressing the brake pedal.
CAUTION:
Never set the vehicle to READY/Never start the engine.
12. Depress brake pedal by 100 mm (3.94 in) or more, and hold the position for 5 seconds or more.
13. Release brake pedal.
14. Start CONSULT and perform "BRAKE" self-diagnosis.

Is DTC "C1A6C" detected?

YES >> GO TO 13.

NO >> INSPECTION END

13.CHECK DATA MONITOR

ⓅWith CONSULT

1. Connect the electrically-driven intelligent brake unit harness connector.
2. Connect 12V battery cable to negative terminal.
3. Turn the ignition switch OFF to ON without depressing the brake pedal.
CAUTION:
Never set the vehicle to READY/Never start the engine.
4. Repeat step 3 two times or more.
CAUTION:
Be sure to wait for 5 seconds or more after turning the ignition switch OFF.
5. Start CONSULT and select "BRAKE" and "DATA MONITOR" according this order.
6. Check "MOTOR POWER SUPPLY" and "CONTROL MODULE POWER". Refer to [BR-33, "Reference Value"](#).

Is the inspection result normal?

YES >> GO TO 14.

NO >> Replace the electrically-driven intelligent brake unit. Refer to [BR-288, "Removal and installation"](#).

14.PERFORM SELF-DIAGNOSIS (6)

ⓅWith CONSULT

1. Turn the ignition switch OFF to ON without depressing the brake pedal.
CAUTION:
Never set the vehicle to READY/Never start the engine.
2. Repeat step 1 two times or more.
CAUTION:

C1A6C BRAKE POWER SUPPLY BACKUP UNIT

< DTC/CIRCUIT DIAGNOSIS >

Be sure to wait for 5 seconds or more after turning the ignition switch OFF.

3. Turn the ignition switch OFF to exit CONSULT. A
4. Get out of the vehicle, close all doors (including trunk lid), and wait for 3 minutes or more without opening these doors. B
CAUTION:
Never operate the vehicle and CONSULT while waiting.
5. Turn the ignition switch ON without depressing the brake pedal. C
CAUTION:
Never set the vehicle to READY/Never start the engine.
6. Start CONSULT and erase self-diagnosis result of "BRAKE". D
7. Turn the ignition switch OFF to exit CONSULT.
8. Get out of the vehicle, close all doors (including trunk lid), and wait for 3 minutes or more without opening these doors. E
CAUTION:
Never operate the vehicle and CONSULT while waiting.
9. Turn the ignition switch ON without depressing the brake pedal. BR
CAUTION:
Never set the vehicle to READY/Never start the engine.
10. Depress brake pedal by 100 mm (3.94 in) or more, and hold the position for 5 seconds or more.
11. Release brake pedal.
12. Start CONSULT and perform "BRAKE" self-diagnosis.

Is DTC "C1A6C" detected?

YES >> GO TO 15. G

NO >> INSPECTION END

15. CHECK BRAKE POWER SUPPLY BACKUP UNIT POWER H

1. Turn the ignition switch OFF to exit CONSULT. I
2. Get out of the vehicle, close all doors (including trunk lid), and wait for 3 minutes or more without opening these doors. J
CAUTION:
Never operate the vehicle and CONSULT while waiting.
3. Disconnect 12V battery cable from negative terminal. Refer to [BR-6, "Precaution for Removing 12V Battery"](#). K
4. Disconnect the brake power supply backup unit harness connector.
5. Connect 12V battery cable to negative terminal.
6. Get out of the vehicle, close all doors (including trunk lid), and wait for 3 minutes or more without opening these doors. L
CAUTION:
Never operate the vehicle and CONSULT while waiting.
7. Turn the ignition switch ON without depressing the brake pedal. M
CAUTION:
Never set the vehicle to READY/Never start the engine.
8. Check voltage between brake power supply backup unit and ground. N

Brake power supply backup unit		—	Voltage
Connector	Terminal		
B155	3	Ground	9 – 16 V

Is the inspection result normal? O

YES >> Replace the brake power supply backup unit. Refer to [BR-290, "Removal and Installation"](#).

NO (9 V or less) >> Perform diagnosis for 12V battery power supply. Refer to [PG-14, "Wiring Diagram - BATTERY POWER SUPPLY -"](#). P

NO (16 V or more) >> Perform diagnosis of the DC/DC-J/B. Refer to [HBC-49, "CONSULT Function"](#).

C1A6D BRAKE POWER SUPPLY BACKUP UNIT

< DTC/CIRCUIT DIAGNOSIS >

C1A6D BRAKE POWER SUPPLY BACKUP UNIT

DTC Logic

INFOID:000000008139835

DTC DETECTION LOGIC

DTC	Display item	Malfunction detection condition	Possible causes
C1A6D	POWER SUPPLY BACKUP UNIT OUTPUT	Output or input current of brake power supply backup unit backup line is as shown below. <ul style="list-style-type: none">Output current of brake power supply backup unit: $60A \leq$ Output current of brake power supply backup unitInput current of brake power supply backup unit: $30A \leq$ Output current of brake power supply backup unit	<ul style="list-style-type: none">Harness or connectorBrake power supply backup unit

DTC CONFIRMATION PROCEDURE

1. PRECONDITIONING

If "DTC CONFIRMATION PROCEDURE" has been previously conducted, always turn the ignition switch OFF and wait at least 10 seconds before conducting the next test.

>> GO TO 2.

2. CHECK DTC DETECTION

 With CONSULT

1. Turn the ignition switch OFF to ON without depressing the brake pedal.

CAUTION:

Never set the vehicle to READY/Never start the engine.

2. Repeat step 1 two times or more.

CAUTION:

Be sure to wait for 5 seconds or more after turning the ignition switch OFF.

3. Turn the ignition switch OFF to exit CONSULT.

4. Get out of the vehicle, close all doors (including trunk lid), and wait for 3 minutes or more without opening these doors.

CAUTION:

Never operate the vehicle and CONSULT while waiting.

5. Turn the ignition switch ON without depressing the brake pedal.

CAUTION:

Never set the vehicle to READY/Never start the engine.

6. Start CONSULT and erase self-diagnosis result of "BRAKE".

7. Turn the ignition switch OFF to exit CONSULT.

8. Get out of the vehicle, close all doors (including trunk lid), and wait for 3 minutes or more without opening these doors.

CAUTION:

Never operate the vehicle and CONSULT while waiting.

9. Turn the ignition switch ON without depressing the brake pedal.

CAUTION:

Never set the vehicle to READY/Never start the engine.

10. Depress brake pedal by 100 mm (3.94 in) or more, and hold the position for 5 seconds or more.

11. Release brake pedal.

12. Start CONSULT and perform "BRAKE" self-diagnosis.

Is DTC "C1A6D" detected?

YES >> Proceed to [BR-180. "Diagnosis Procedure"](#).

NO >> INSPECTION END

Diagnosis Procedure

INFOID:000000008139836

1. CHECK 12V BATTERY

C1A6D BRAKE POWER SUPPLY BACKUP UNIT

< DTC/CIRCUIT DIAGNOSIS >

1. Turn the ignition switch OFF to exit CONSULT.
2. Get out of the vehicle, close all doors (including trunk lid), and wait for 3 minutes or more without opening these doors.
CAUTION:
Never operate the vehicle and CONSULT while waiting.
3. Check the 12V battery terminal connections. Refer to [BR-6, "Precaution for Removing 12V Battery"](#) and [PG-135, "Work Flow"](#).
4. Check the 12V battery. Refer to [PG-135, "Work Flow"](#).

Is the inspection result normal?

YES >> GO TO 2.

NO >> Repair or replace error-detected parts and GO TO 2.

2.PERFORM SELF-DIAGNOSIS (1)

ⓂWith CONSULT

1. Connect 12V battery cable to negative terminal.
2. Turn the ignition switch OFF to ON without depressing the brake pedal.
CAUTION:
Never set the vehicle to READY/Never start the engine.
3. Repeat step 2 two times or more.
CAUTION:
Be sure to wait for 5 seconds or more after turning the ignition switch OFF.
4. Turn the ignition switch OFF to exit CONSULT.
5. Get out of the vehicle, close all doors (including trunk lid), and wait for 3 minutes or more without opening these doors.
CAUTION:
Never operate the vehicle and CONSULT while waiting.
6. Turn the ignition switch ON without depressing the brake pedal.
CAUTION:
Never set the vehicle to READY/Never start the engine.
7. Start CONSULT and erase self-diagnosis result of "BRAKE".
8. Turn the ignition switch OFF to exit CONSULT.
9. Get out of the vehicle, close all doors (including trunk lid), and wait for 3 minutes or more without opening these doors.
CAUTION:
Never operate the vehicle and CONSULT while waiting.
10. Turn the ignition switch ON without depressing the brake pedal.
CAUTION:
Never set the vehicle to READY/Never start the engine.
11. Depress brake pedal by 100 mm (3.94 in) or more, and hold the position for 5 seconds or more.
12. Release brake pedal.
13. Start CONSULT and perform "BRAKE" self-diagnosis.

Is DTC "C1A6D" detected?

YES >> GO TO 3.

NO >> INSPECTION END

3.CHECK CONNECTOR TERMINALS

1. Turn the ignition switch OFF to exit CONSULT.
2. Get out of the vehicle, close all doors (including trunk lid), and wait for 3 minutes or more without opening these doors.
CAUTION:
Never operate the vehicle and CONSULT while waiting.
3. Disconnect 12V battery cable from negative terminal. Refer to [BR-6, "Precaution for Removing 12V Battery"](#).
4. Disconnect the electrically-driven intelligent brake unit harness connector, then check for failures of pin terminals and connections.
5. Disconnect the brake power supply backup unit harness connector, then check for failures of pin terminals and connections.

Is the inspection result normal?

YES >> GO TO 5.

NO >> Repair or replace error-detected parts and GO TO 4.

C1A6D BRAKE POWER SUPPLY BACKUP UNIT

< DTC/CIRCUIT DIAGNOSIS >

4. PERFORM SELF-DIAGNOSIS (2)

④ With CONSULT

1. Connect the electrically-driven intelligent brake unit harness connector.
2. Connect the brake power supply backup unit harness connector.
3. Connect 12V battery cable to negative terminal.
4. Turn the ignition switch OFF to ON without depressing the brake pedal.
CAUTION:
Never set the vehicle to READY/Never start the engine.
5. Repeat step 4 two times or more.
CAUTION:
Be sure to wait for 5 seconds or more after turning the ignition switch OFF.
6. Turn the ignition switch OFF to exit CONSULT.
7. Get out of the vehicle, close all doors (including trunk lid), and wait for 3 minutes or more without opening these doors.
CAUTION:
Never operate the vehicle and CONSULT while waiting.
8. Turn the ignition switch ON without depressing the brake pedal.
CAUTION:
Never set the vehicle to READY/Never start the engine.
9. Start CONSULT and erase self-diagnosis result of "BRAKE".
10. Turn the ignition switch OFF to exit CONSULT.
11. Get out of the vehicle, close all doors (including trunk lid), and wait for 3 minutes or more without opening these doors.
CAUTION:
Never operate the vehicle and CONSULT while waiting.
12. Turn the ignition switch ON without depressing the brake pedal.
CAUTION:
Never set the vehicle to READY/Never start the engine.
13. Depress brake pedal by 100 mm (3.94 in) or more, and hold the position for 5 seconds or more.
14. Release brake pedal.
15. Start CONSULT and perform "BRAKE" self-diagnosis.

Is DTC "C1A6D" detected?

YES >> GO TO 5.

NO >> INSPECTION END

5. CHECK IGNITION POWER SUPPLY

1. Connect the brake power supply backup unit harness connector.
2. Turn the ignition switch OFF to exit CONSULT.
3. Get out of the vehicle, close all doors (including trunk lid), and wait for 3 minutes or more without opening these doors.
CAUTION:
Never operate the vehicle and CONSULT while waiting.
4. Disconnect 12V battery cable from negative terminal. Refer to [BR-6. "Precaution for Removing 12V Battery"](#).
5. Disconnect the electrically-driven intelligent brake unit harness connector.
6. Connect 12V battery cable to negative terminal.
7. Check voltage between the electrically-driven intelligent brake unit harness connector and ground.

Electrically-driven intelligent brake unit		—	Voltage
Connector	Terminal		
E87	26	Ground	Approx. 0 V

8. Turn the ignition switch ON without depressing the brake pedal.
CAUTION:
Never set the vehicle to READY/Never start the engine.
9. Check voltage between the electrically-driven intelligent brake unit harness connector and ground.

C1A6D BRAKE POWER SUPPLY BACKUP UNIT

< DTC/CIRCUIT DIAGNOSIS >

Electrically-driven intelligent brake unit		—	Voltage
Connector	Terminal		
E87	26	Ground	10 – 16 V

Is the inspection result normal?

YES >> GO TO 8.

NO >> GO TO 6.

6. CHECK IGNITION POWER SUPPLY CIRCUIT

- Turn the ignition switch OFF to exit CONSULT.
- Get out of the vehicle, close all doors (including trunk lid), and wait for 3 minutes or more without opening these doors.
CAUTION:
Never operate the vehicle and CONSULT while waiting.
- Disconnect 12V battery cable from negative terminal. Refer to [BR-6, "Precaution for Removing 12V Battery"](#).
- Check 10A fuse (#46).
- Disconnect IPDM E/R harness connector.
- Check continuity between electrically-driven intelligent brake unit and IPDM E/R.

Electrically-driven intelligent brake unit		IPDM E/R		Continuity
Connector	Terminal	Connector	Terminal	
E87	26	E5	12	Existed

- Check continuity between electrically-driven intelligent brake unit harness connector and ground.

Electrically-driven intelligent brake unit		—	Continuity
Connector	Terminal		
E87	26	Ground	Not existed

Is the inspection result normal?

YES >> Perform trouble diagnosis for ignition power supply. Refer to [PG-30, "Wiring Diagram - IGNITION POWER SUPPLY -"](#).

NO >> Repair or replace error-detected parts and GO TO 7.

7. PERFORM SELF-DIAGNOSIS (3)

 With CONSULT

- Connect the electrically-driven intelligent brake unit harness connector.
- Connect IPDM E/R harness connector.
- Connect 12V battery cable to negative terminal.
- Turn the ignition switch OFF to ON without depressing the brake pedal.
CAUTION:
Never set the vehicle to READY/ Never start the engine.
- Repeat step 4 two times or more.
CAUTION:
Be sure to wait for 5 seconds or more after turning the ignition switch OFF.
- Turn the ignition switch OFF to exit CONSULT.
- Get out of the vehicle, close all doors (including trunk lid), and wait for 3 minutes or more without opening these doors.
CAUTION:
Never operate the vehicle and CONSULT while waiting.
- Turn the ignition switch ON without depressing the brake pedal.
CAUTION:
Never set the vehicle to READY/ Never start the engine.
- Start CONSULT and erase self-diagnosis result of "BRAKE".
- Turn the ignition switch OFF to exit CONSULT.
- Get out of the vehicle, close all doors (including trunk lid), and wait for 3 minutes or more without opening these doors.

C1A6D BRAKE POWER SUPPLY BACKUP UNIT

< DTC/CIRCUIT DIAGNOSIS >

CAUTION:

Never operate the vehicle and CONSULT while waiting.

12. Turn the ignition switch ON without depressing the brake pedal.

CAUTION:

Never set the vehicle to READY/Never start the engine.

13. Depress brake pedal by 100 mm (3.94 in) or more, and hold the position for 5 seconds or more.
14. Release brake pedal.
15. Start CONSULT and perform "BRAKE" self-diagnosis.

Is DTC "C1A6D" detected?

YES >> GO TO 8.

NO >> INSPECTION END

8. CHECK 12V BATTERY POWER SUPPLY

1. Turn the ignition switch OFF to exit CONSULT.
2. Get out of the vehicle, close all doors (including trunk lid), and wait for 3 minutes or more without opening these doors.

CAUTION:

Never operate the vehicle and CONSULT while waiting.

3. Disconnect 12V battery cable from negative terminal. Refer to [BR-6, "Precaution for Removing 12V Battery"](#).
4. Disconnect the electrically-driven intelligent brake unit harness connector.
5. Connect 12V battery cable to negative terminal.
6. Check voltage between the electrically-driven intelligent brake unit harness connector terminal.

Electrically-driven intelligent brake unit		Voltage
Connector	Terminal	
E87	1 – 31	10 – 16 V
	2 – 31	
	11 – 31	

7. Turn the ignition switch ON without depressing the brake pedal.

CAUTION:

Never set the vehicle to READY/Never start the engine.

8. Check voltage between the electrically-driven intelligent brake unit harness connector terminal.

Electrically-driven intelligent brake unit		Voltage
Connector	Terminal	
E87	1 – 31	10 – 16 V
	2 – 31	
	11 – 31	

Is the inspection result normal?

YES >> GO TO 11.

NO >> GO TO 9.

9. CHECK 12V BATTERY POWER SUPPLY CIRCUIT

1. Turn the ignition switch OFF to exit CONSULT.
2. Get out of the vehicle, close all doors (including trunk lid), and wait for 3 minutes or more without opening these doors.

CAUTION:

Never operate the vehicle and CONSULT while waiting.

3. Disconnect 12V battery cable from negative terminal. Refer to [BR-6, "Precaution for Removing 12V Battery"](#).
4. Check 50A fusible link (#D).
5. Check continuity and for short circuit between electrically-driven intelligent brake unit harness connector terminal (1) and 50A fusible link (#D).
6. Check continuity and for short circuit between electrically-driven intelligent brake unit harness connector terminal (2) and 50A fusible link (#D).

C1A6D BRAKE POWER SUPPLY BACKUP UNIT

< DTC/CIRCUIT DIAGNOSIS >

7. Check 10A fuse (#65).
8. Check continuity and for short circuit between electrically-driven intelligent brake unit harness connector terminal (11) and 10A fuse (#65).

Is the inspection result normal?

YES >> Perform diagnosis for 12V battery power supply. Refer to [PG-14, "Wiring Diagram - BATTERY POWER SUPPLY -"](#).

NO >> Repair or replace error-detected parts and GO TO 10.

10. PERFORM SELF-DIAGNOSIS (4)

Ⓜ With CONSULT

1. Connect the electrically-driven intelligent brake unit harness connector.
2. Connect 12V battery cable to negative terminal.
3. Turn the ignition switch OFF to ON without depressing the brake pedal.
CAUTION:
Never set the vehicle to READY/Never start the engine.
4. Repeat step 3 two times or more.
CAUTION:
Be sure to wait for 5 seconds or more after turning the ignition switch OFF.
5. Turn the ignition switch OFF to exit CONSULT.
6. Get out of the vehicle, close all doors (including trunk lid), and wait for 3 minutes or more without opening these doors.
CAUTION:
Never operate the vehicle and CONSULT while waiting.
7. Turn the ignition switch ON without depressing the brake pedal.
CAUTION:
Never set the vehicle to READY/Never start the engine.
8. Start CONSULT and erase self-diagnosis result of "BRAKE".
9. Turn the ignition switch OFF to exit CONSULT.
10. Get out of the vehicle, close all doors (including trunk lid), and wait for 3 minutes or more without opening these doors.
CAUTION:
Never operate the vehicle and CONSULT while waiting.
11. Turn the ignition switch ON without depressing the brake pedal.
CAUTION:
Never set the vehicle to READY/Never start the engine.
12. Depress brake pedal by 100 mm (3.94 in) or more, and hold the position for 5 seconds or more.
13. Release brake pedal.
14. Start CONSULT and perform "BRAKE" self-diagnosis.

Is DTC "C1A6D" detected?

YES >> GO TO 11.

NO >> INSPECTION END

11. CHECK GROUND CIRCUIT

1. Turn the ignition switch OFF to exit CONSULT.
2. Get out of the vehicle, close all doors (including trunk lid), and wait for 3 minutes or more without opening these doors.
CAUTION:
Never operate the vehicle and CONSULT while waiting.
3. Disconnect 12V battery cable from negative terminal. Refer to [BR-6, "Precaution for Removing 12V Battery"](#).
4. Disconnect the electrically-driven intelligent brake unit harness connector.
5. Check continuity between electrically-driven intelligent brake unit and ground.

Electrically-driven intelligent brake unit		—	Continuity
Connector	Terminal		
E87	31	Ground	Existed

Is the inspection result normal?

YES >> GO TO 13.

C1A6D BRAKE POWER SUPPLY BACKUP UNIT

< DTC/CIRCUIT DIAGNOSIS >

NO >> Repair or replace error-detected parts and GO TO 12.

12.PERFORM SELF-DIAGNOSIS (5)

ⓅWith CONSULT

1. Connect the electrically-driven intelligent brake unit harness connector.
2. Connect 12V battery cable to negative terminal.
3. Turn the ignition switch OFF to ON without depressing the brake pedal.
CAUTION:
Never set the vehicle to READY/Never start the engine.
4. Repeat step 3 two times or more.
CAUTION:
Be sure to wait for 5 seconds or more after turning the ignition switch OFF.
5. Turn the ignition switch OFF to exit CONSULT.
6. Get out of the vehicle, close all doors (including trunk lid), and wait for 3 minutes or more without opening these doors.
CAUTION:
Never operate the vehicle and CONSULT while waiting.
7. Turn the ignition switch ON without depressing the brake pedal.
CAUTION:
Never set the vehicle to READY/Never start the engine.
8. Start CONSULT and erase self-diagnosis result of "BRAKE".
9. Turn the ignition switch OFF to exit CONSULT.
10. Get out of the vehicle, close all doors (including trunk lid), and wait for 3 minutes or more without opening these doors.
CAUTION:
Never operate the vehicle and CONSULT while waiting.
11. Turn the ignition switch ON without depressing the brake pedal.
CAUTION:
Never set the vehicle to READY/Never start the engine.
12. Depress brake pedal by 100 mm (3.94 in) or more, and hold the position for 5 seconds or more.
13. Release brake pedal.
14. Start CONSULT and perform "BRAKE" self-diagnosis.

Is DTC "C1A6D" detected?

YES >> GO TO 13.

NO >> INSPECTION END

13.CHECK DATA MONITOR

ⓅWith CONSULT

1. Connect the electrically-driven intelligent brake unit harness connector.
2. Connect 12V battery cable to negative terminal.
3. Turn the ignition switch OFF to ON without depressing the brake pedal.
CAUTION:
Never set the vehicle to READY/Never start the engine.
4. Repeat step 3 two times or more.
CAUTION:
Be sure to wait for 5 seconds or more after turning the ignition switch OFF.
5. Start CONSULT and select "BRAKE" and "DATA MONITOR" according this order.
6. Check "MOTOR POWER SUPPLY" and "CONTROL MODULE POWER". Refer to [BR-33, "Reference Value"](#).

Is the inspection result normal?

YES >> GO TO 14.

NO >> Replace the electrically-driven intelligent brake unit. Refer to [BR-288, "Removal and installation"](#).

14.PERFORM SELF-DIAGNOSIS (2)

ⓅWith CONSULT

1. Turn the ignition switch OFF to ON without depressing the brake pedal.
CAUTION:
Never set the vehicle to READY/Never start the engine.
2. Repeat step 1 two times or more.
CAUTION:

C1A6D BRAKE POWER SUPPLY BACKUP UNIT

< DTC/CIRCUIT DIAGNOSIS >

Be sure to wait for 5 seconds or more after turning the ignition switch OFF.

3. Turn the ignition switch OFF to exit CONSULT. A
4. Get out of the vehicle, close all doors (including trunk lid), and wait for 3 minutes or more without opening these doors.

CAUTION:

Never operate the vehicle and CONSULT while waiting. B

5. Turn the ignition switch ON without depressing the brake pedal.

CAUTION:

Never set the vehicle to READY/Never start the engine. C

6. Start CONSULT and erase self-diagnosis result of "BRAKE".
7. Turn the ignition switch OFF to exit CONSULT.
8. Get out of the vehicle, close all doors (including trunk lid), and wait for 3 minutes or more without opening these doors. D

CAUTION:

Never operate the vehicle and CONSULT while waiting.

9. Turn the ignition switch ON without depressing the brake pedal. E

CAUTION:

Never set the vehicle to READY/Never start the engine.

10. Depress brake pedal by 100 mm (3.94 in) or more, and hold the position for 5 seconds or more. BR
11. Release brake pedal.
12. Start CONSULT and perform "BRAKE" self-diagnosis.

Is DTC "C1A6D" detected?

YES >> GO TO 15. G

NO >> INSPECTION END

15. CHECK CIRCUIT BETWEEN ELECTRICALLY-DRIVEN INTELLIGENT BRAKE UNIT AND BRAKE POWER SUPPLY BACKUP UNIT H

1. Turn the ignition switch OFF to exit CONSULT.
2. Get out of the vehicle, close all doors (including trunk lid), and wait for 3 minutes or more without opening these doors. I

CAUTION:

Never operate the vehicle and CONSULT while waiting.

3. Disconnect 12V battery cable from negative terminal. Refer to [BR-6, "Precaution for Removing 12V Battery"](#). J
4. Disconnect the electrically-driven intelligent brake unit harness connector.
5. Disconnect the brake power supply backup unit harness connector. K
6. Check continuity between electrically-driven intelligent brake unit harness connector and ground.

Electrically-driven intelligent brake unit		—	Continuity
Connector	Terminal		
E87	32	Ground	Not existed

Is the inspection result normal?

YES >> Replace the brake power supply backup unit. Refer to [BR-290, "Removal and Installation"](#). L

NO >> Repair or replace error-detected parts. M

N

O

P

C1A6E HEV SYSTEM

< DTC/CIRCUIT DIAGNOSIS >

C1A6E HEV SYSTEM

DTC Logic

INFOID:000000008139837

DTC DETECTION LOGIC

DTC	Display item	Malfunction detection condition	Possible causes
C1A6E	EV/HEV SYSTEM	Malfunction is detected in the HPCM system.	<ul style="list-style-type: none">• Harness or connector• HPCM

DTC CONFIRMATION PROCEDURE

1. PRECONDITIONING

If "DTC CONFIRMATION PROCEDURE" has been previously conducted, always turn the ignition switch OFF and wait at least 10 seconds before conducting the next test.

>> GO TO 2.

2. CHECK DTC DETECTION

 With CONSULT

1. Turn the ignition switch OFF to ON without depressing the brake pedal.
CAUTION:
Never set the vehicle to READY/Never start the engine.
2. Repeat step 1 two times or more.
CAUTION:
Be sure to wait for 5 seconds or more after turning the ignition switch OFF.
3. Turn the ignition switch OFF to exit CONSULT.
4. Get out of the vehicle, close all doors (including trunk lid), and wait for 3 minutes or more without opening these doors.
CAUTION:
Never operate the vehicle and CONSULT while waiting.
5. Turn the ignition switch ON without depressing the brake pedal.
CAUTION:
Never set the vehicle to READY/Never start the engine.
6. Start CONSULT and erase self-diagnosis result of "BRAKE".
7. Turn the ignition switch OFF to exit CONSULT.
8. Get out of the vehicle, close all doors (including trunk lid), and wait for 3 minutes or more without opening these doors.
CAUTION:
Never operate the vehicle and CONSULT while waiting.
9. Turn the ignition switch ON without depressing the brake pedal.
CAUTION:
Never set the vehicle to READY/Never start the engine.
10. Depress brake pedal by 100 mm (3.94 in) or more, and hold the position for 5 seconds or more.
11. Release brake pedal.
12. Start CONSULT and perform "BRAKE" self-diagnosis.

Is DTC "C1A6E" detected?

- YES >> Proceed to [BR-188, "Diagnosis Procedure"](#).
NO >> INSPECTION END

Diagnosis Procedure

INFOID:000000008139838

1. PERFORM HPCM SELF DIAGNOSIS

 With CONSULT

Perform self-diagnosis for "EV/HEV". Refer to [HBC-49, "CONSULT Function"](#).

Is any DTC detected?

- YES >> Check the DTC. Refer to [HBC-71, "DTC Index"](#).
NO >> GO TO 2.

C1A6E HEV SYSTEM

< DTC/CIRCUIT DIAGNOSIS >

2.PERFORM SELF-DIAGNOSIS (1)

Ⓜ With CONSULT

1. Turn the ignition switch OFF to ON without depressing the brake pedal.
CAUTION:
Never set the vehicle to READY/Never start the engine.
 2. Repeat step 1 two times or more.
CAUTION:
Be sure to wait for 5 seconds or more after turning the ignition switch OFF.
 3. Turn the ignition switch OFF to exit CONSULT.
 4. Get out of the vehicle, close all doors (including trunk lid), and wait for 3 minutes or more without opening these doors.
CAUTION:
Never operate the vehicle and CONSULT while waiting.
 5. Turn the ignition switch ON without depressing the brake pedal.
CAUTION:
Never set the vehicle to READY/Never start the engine.
 6. Start CONSULT and erase self-diagnosis result of "BRAKE".
 7. Turn the ignition switch OFF to exit CONSULT.
 8. Get out of the vehicle, close all doors (including trunk lid), and wait for 3 minutes or more without opening these doors.
CAUTION:
Never operate the vehicle and CONSULT while waiting.
 9. Turn the ignition switch ON without depressing the brake pedal.
CAUTION:
Never set the vehicle to READY/Never start the engine.
 10. Depress brake pedal by 100 mm (3.94 in) or more, and hold the position for 5 seconds or more.
 11. Release brake pedal.
 12. Start CONSULT and perform "BRAKE" self-diagnosis.
- Is DTC "C1A6E" detected?
- YES >> GO TO 3.
NO >> INSPECTION END

3.CHECK 12V BATTERY

1. Turn the ignition switch OFF to exit CONSULT.
 2. Get out of the vehicle, close all doors (including trunk lid), and wait for 3 minutes or more without opening these doors.
CAUTION:
Never operate the vehicle and CONSULT while waiting.
 3. Check the 12V battery terminal connections. Refer to [BR-6, "Precaution for Removing 12V Battery"](#) and [PG-135, "Work Flow"](#).
 4. Check the 12V battery. Refer to [PG-135, "Work Flow"](#).
- Is the inspection result normal?
- YES >> GO TO 4.
NO >> Repair or replace error-detected parts and GO TO 4.

4.PERFORM SELF-DIAGNOSIS (2)

Ⓜ With CONSULT

1. Connect 12V battery cable to negative terminal.
2. Turn the ignition switch OFF to ON without depressing the brake pedal.
CAUTION:
Never set the vehicle to READY/Never start the engine.
3. Repeat step 2 two times or more.
CAUTION:
Be sure to wait for 5 seconds or more after turning the ignition switch OFF.
4. Turn the ignition switch OFF to exit CONSULT.
5. Get out of the vehicle, close all doors (including trunk lid), and wait for 3 minutes or more without opening these doors.
CAUTION:
Never operate the vehicle and CONSULT while waiting.

C1A6E HEV SYSTEM

< DTC/CIRCUIT DIAGNOSIS >

6. Turn the ignition switch ON without depressing the brake pedal.
CAUTION:
Never set the vehicle to READY/Never start the engine.
7. Start CONSULT and erase self-diagnosis result of "BRAKE".
8. Turn the ignition switch OFF to exit CONSULT.
9. Get out of the vehicle, close all doors (including trunk lid), and wait for 3 minutes or more without opening these doors.
CAUTION:
Never operate the vehicle and CONSULT while waiting.
10. Turn the ignition switch ON without depressing the brake pedal.
CAUTION:
Never set the vehicle to READY/Never start the engine.
11. Depress brake pedal by 100 mm (3.94 in) or more, and hold the position for 5 seconds or more.
12. Release brake pedal.
13. Start CONSULT and perform "BRAKE" self-diagnosis.

Is DTC "C1A6E" detected?

YES >> GO TO 5.

NO >> INSPECTION END

5. CHECK CONNECTOR TERMINALS

1. Turn the ignition switch OFF to exit CONSULT.
2. Get out of the vehicle, close all doors (including trunk lid), and wait for 3 minutes or more without opening these doors.
CAUTION:
Never operate the vehicle and CONSULT while waiting.
3. Disconnect 12V battery cable from negative terminal. Refer to [BR-6. "Precaution for Removing 12V Battery"](#).
4. Disconnect the electrically-driven intelligent brake unit harness connector, then check for failures of pin terminals and connections.

Is the inspection result normal?

YES >> GO TO 7.

NO >> Repair or replace error-detected parts and GO TO 6.

6. PERFORM SELF-DIAGNOSIS (3)

Ⓟ With CONSULT

1. Connect the electrically-driven intelligent brake unit harness connector.
2. Connect 12V battery cable to negative terminal.
3. Turn the ignition switch OFF to ON without depressing the brake pedal.
CAUTION:
Never set the vehicle to READY/Never start the engine.
4. Repeat step 3 two times or more.
CAUTION:
Be sure to wait for 5 seconds or more after turning the ignition switch OFF.
5. Turn the ignition switch OFF to exit CONSULT.
6. Get out of the vehicle, close all doors (including trunk lid), and wait for 3 minutes or more without opening these doors.
CAUTION:
Never operate the vehicle and CONSULT while waiting.
7. Turn the ignition switch ON without depressing the brake pedal.
CAUTION:
Never set the vehicle to READY/Never start the engine.
8. Start CONSULT and erase self-diagnosis result of "BRAKE".
9. Turn the ignition switch OFF to exit CONSULT.
10. Get out of the vehicle, close all doors (including trunk lid), and wait for 3 minutes or more without opening these doors.
CAUTION:
Never operate the vehicle and CONSULT while waiting.
11. Turn the ignition switch ON without depressing the brake pedal.
CAUTION:
Never set the vehicle to READY/Never start the engine.

C1A6E HEV SYSTEM

< DTC/CIRCUIT DIAGNOSIS >

12. Depress brake pedal by 100 mm (3.94 in) or more, and hold the position for 5 seconds or more.
13. Release brake pedal.
14. Start CONSULT and perform "BRAKE" self-diagnosis.

Is DTC "C1A6E" detected?

- YES >> GO TO 7.
 NO >> INSPECTION END

7. CHECK IGNITION POWER SUPPLY

1. Turn the ignition switch OFF to exit CONSULT.
2. Get out of the vehicle, close all doors (including trunk lid), and wait for 3 minutes or more without opening these doors.
CAUTION:
Never operate the vehicle and CONSULT while waiting.
3. Disconnect 12V battery cable from negative terminal. Refer to [BR-6. "Precaution for Removing 12V Battery"](#).
4. Disconnect the electrically-driven intelligent brake unit harness connector.
5. Connect 12V battery cable to negative terminal.
6. Check voltage between the electrically-driven intelligent brake unit harness connector and ground.

Electrically-driven intelligent brake unit		—	Voltage
Connector	Terminal		
E87	26	Ground	Approx. 0 V

7. Turn the ignition switch ON without depressing the brake pedal.
CAUTION:
Never set the vehicle to READY/ Never start the engine.
8. Check voltage between the electrically-driven intelligent brake unit harness connector and ground.

Electrically-driven intelligent brake unit		—	Voltage
Connector	Terminal		
E87	26	Ground	10 – 16 V

Is the inspection result normal?

- YES >> GO TO 10.
 NO >> GO TO 8.

8. CHECK IGNITION POWER SUPPLY CIRCUIT

1. Turn the ignition switch OFF to exit CONSULT.
2. Get out of the vehicle, close all doors (including trunk lid), and wait for 3 minutes or more without opening these doors.
CAUTION:
Never operate the vehicle and CONSULT while waiting.
3. Disconnect 12V battery cable from negative terminal. Refer to [BR-6. "Precaution for Removing 12V Battery"](#).
4. Check 10A fuse (#46).
5. Disconnect IPDM E/R harness connector.
6. Check continuity between electrically-driven intelligent brake unit and IPDM E/R.

Electrically-driven intelligent brake unit		IPDM E/R		Continuity
Connector	Terminal	Connector	Terminal	
E87	26	E5	12	Existed

7. Check continuity between electrically-driven intelligent brake unit harness connector and ground.

Electrically-driven intelligent brake unit		—	Continuity
Connector	Terminal		
E87	26	Ground	Not existed

C1A6E HEV SYSTEM

< DTC/CIRCUIT DIAGNOSIS >

Is the inspection result normal?

- YES >> Perform trouble diagnosis for ignition power supply. Refer to [PG-30, "Wiring Diagram - IGNITION POWER SUPPLY -"](#).
- NO >> Repair or replace error-detected parts and GO TO 9.

9.PERFORM SELF-DIAGNOSIS (4)

ⓈWith CONSULT

1. Connect the electrically-driven intelligent brake unit harness connector.
2. Connect IPDM E/R harness connector.
3. Connect 12V battery cable to negative terminal.
4. Turn the ignition switch OFF to ON without depressing the brake pedal.
CAUTION:
Never set the vehicle to READY/Never start the engine.
5. Repeat step 4 two times or more.
CAUTION:
Be sure to wait for 5 seconds or more after turning the ignition switch OFF.
6. Turn the ignition switch OFF to exit CONSULT.
7. Get out of the vehicle, close all doors (including trunk lid), and wait for 3 minutes or more without opening these doors.
CAUTION:
Never operate the vehicle and CONSULT while waiting.
8. Turn the ignition switch ON without depressing the brake pedal.
CAUTION:
Never set the vehicle to READY/Never start the engine.
9. Start CONSULT and erase self-diagnosis result of "BRAKE".
10. Turn the ignition switch OFF to exit CONSULT.
11. Get out of the vehicle, close all doors (including trunk lid), and wait for 3 minutes or more without opening these doors.
CAUTION:
Never operate the vehicle and CONSULT while waiting.
12. Turn the ignition switch ON without depressing the brake pedal.
CAUTION:
Never set the vehicle to READY/Never start the engine.
13. Depress brake pedal by 100 mm (3.94 in) or more, and hold the position for 5 seconds or more.
14. Release brake pedal.
15. Start CONSULT and perform "BRAKE" self-diagnosis.

Is DTC "C1A6E" detected?

- YES >> GO TO 10.
- NO >> INSPECTION END

10.CHECK 12V BATTERY POWER SUPPLY

1. Turn the ignition switch OFF to exit CONSULT.
2. Get out of the vehicle, close all doors (including trunk lid), and wait for 3 minutes or more without opening these doors.
CAUTION:
Never operate the vehicle and CONSULT while waiting.
3. Disconnect 12V battery cable from negative terminal. Refer to [BR-6, "Precaution for Removing 12V Battery"](#).
4. Disconnect the electrically-driven intelligent brake unit harness connector.
5. Connect 12V battery cable to negative terminal.
6. Check voltage between the electrically-driven intelligent brake unit harness connector terminal.

Electrically-driven intelligent brake unit		Voltage
Connector	Terminal	
E87	1 - 31	10 - 16 V
	2 - 31	
	11 - 31	

7. Turn the ignition switch ON without depressing the brake pedal.

C1A6E HEV SYSTEM

< DTC/CIRCUIT DIAGNOSIS >

CAUTION:

Never set the vehicle to READY/Never start the engine.

8. Check voltage between the electrically-driven intelligent brake unit harness connector terminal.

Electrically-driven intelligent brake unit		Voltage
Connector	Terminal	
E87	1 – 31	10 – 16 V
	2 – 31	
	11 – 31	

Is the inspection result normal?

YES >> GO TO 13.

NO >> GO TO 11.

11. CHECK 12V BATTERY POWER SUPPLY CIRCUIT

1. Turn the ignition switch OFF to exit CONSULT.
2. Get out of the vehicle, close all doors (including trunk lid), and wait for 3 minutes or more without opening these doors.

CAUTION:

Never operate the vehicle and CONSULT while waiting.

3. Disconnect 12V battery cable from negative terminal. Refer to [BR-6, "Precaution for Removing 12V Battery"](#).
4. Check 50A fusible link (#D).
5. Check continuity and for short circuit between electrically-driven intelligent brake unit harness connector terminal (1) and 50A fusible link (#D).
6. Check continuity and for short circuit between electrically-driven intelligent brake unit harness connector terminal (2) and 50A fusible link (#D).
7. Check 10A fuse (#65).
8. Check continuity and for short circuit between electrically-driven intelligent brake unit harness connector terminal (11) and 10A fuse (#65).

Is the inspection result normal?

YES >> Perform diagnosis for 12V battery power supply. Refer to [PG-14, "Wiring Diagram - BATTERY POWER SUPPLY -"](#).

NO >> Repair or replace error-detected parts and GO TO 12.

12. PERFORM SELF-DIAGNOSIS (5)

Ⓜ With CONSULT

1. Connect the electrically-driven intelligent brake unit harness connector.
 2. Connect 12V battery cable to negative terminal.
 3. Turn the ignition switch OFF to ON without depressing the brake pedal.
- CAUTION:**
Never set the vehicle to READY/Never start the engine.
4. Repeat step 3 two times or more.
- CAUTION:**
Be sure to wait for 5 seconds or more after turning the ignition switch OFF.
5. Turn the ignition switch OFF to exit CONSULT.
 6. Get out of the vehicle, close all doors (including trunk lid), and wait for 3 minutes or more without opening these doors.
- CAUTION:**
Never operate the vehicle and CONSULT while waiting.
7. Turn the ignition switch ON without depressing the brake pedal.
- CAUTION:**
Never set the vehicle to READY/Never start the engine.
8. Start CONSULT and erase self-diagnosis result of "BRAKE".
 9. Turn the ignition switch OFF to exit CONSULT.
 10. Get out of the vehicle, close all doors (including trunk lid), and wait for 3 minutes or more without opening these doors.

CAUTION:

Never operate the vehicle and CONSULT while waiting.

C1A6E HEV SYSTEM

< DTC/CIRCUIT DIAGNOSIS >

11. Turn the ignition switch ON without depressing the brake pedal.

CAUTION:

Never set the vehicle to READY/Never start the engine.

12. Depress brake pedal by 100 mm (3.94 in) or more, and hold the position for 5 seconds or more.

13. Release brake pedal.

14. Start CONSULT and perform "BRAKE" self-diagnosis.

Is DTC "C1A6E" detected?

YES >> GO TO 13.

NO >> INSPECTION END

13. CHECK GROUND CIRCUIT

1. Turn the ignition switch OFF to exit CONSULT.

2. Get out of the vehicle, close all doors (including trunk lid), and wait for 3 minutes or more without opening these doors.

CAUTION:

Never operate the vehicle and CONSULT while waiting.

3. Disconnect 12V battery cable from negative terminal. Refer to [BR-6. "Precaution for Removing 12V Battery"](#).

4. Disconnect the electrically-driven intelligent brake unit harness connector.

5. Check continuity between electrically-driven intelligent brake unit and ground.

Electrically-driven intelligent brake unit		—	Continuity
Connector	Terminal		
E87	31	Ground	Existed

Is the inspection result normal?

YES >> GO TO 15.

NO >> Repair or replace error-detected parts and GO TO 14.

14. PERFORM SELF-DIAGNOSIS (6)

Ⓟ With CONSULT

1. Connect the electrically-driven intelligent brake unit harness connector.

2. Connect 12V battery cable to negative terminal.

3. Turn the ignition switch OFF to ON without depressing the brake pedal.

CAUTION:

Never set the vehicle to READY/Never start the engine.

4. Repeat step 3 two times or more.

CAUTION:

Be sure to wait for 5 seconds or more after turning the ignition switch OFF.

5. Turn the ignition switch OFF to exit CONSULT.

6. Get out of the vehicle, close all doors (including trunk lid), and wait for 3 minutes or more without opening these doors.

CAUTION:

Never operate the vehicle and CONSULT while waiting.

7. Turn the ignition switch ON without depressing the brake pedal.

CAUTION:

Never set the vehicle to READY/Never start the engine.

8. Start CONSULT and erase self-diagnosis result of "BRAKE".

9. Turn the ignition switch OFF to exit CONSULT.

10. Get out of the vehicle, close all doors (including trunk lid), and wait for 3 minutes or more without opening these doors.

CAUTION:

Never operate the vehicle and CONSULT while waiting.

11. Turn the ignition switch ON without depressing the brake pedal.

CAUTION:

Never set the vehicle to READY/Never start the engine.

12. Depress brake pedal by 100 mm (3.94 in) or more, and hold the position for 5 seconds or more.

13. Release brake pedal.

14. Start CONSULT and perform "BRAKE" self-diagnosis.

C1A6E HEV SYSTEM

< DTC/CIRCUIT DIAGNOSIS >

Is DTC "C1A6E" detected?

YES >> GO TO 15.

NO >> INSPECTION END

15. CHECK DATA MONITOR

Ⓜ With CONSULT

1. Connect the electrically-driven intelligent brake unit harness connector.
2. Connect 12V battery cable to negative terminal.
3. Turn the ignition switch OFF to ON without depressing the brake pedal.

CAUTION:

Never set the vehicle to READY/Never start the engine.

4. Repeat step 3 two times or more.

CAUTION:

Be sure to wait for 5 seconds or more after turning the ignition switch OFF.

5. Start CONSULT and select "BRAKE" and "DATA MONITOR" according to this order.
6. Check "MOTOR POWER SUPPLY" and "CONTROL MODULE POWER". Refer to [BR-33, "Reference Value"](#).

Is the inspection result normal?

YES >> GO TO 16.

NO >> Replace the electrically-driven intelligent brake unit. Refer to [BR-288, "Removal and installation"](#).

16. PERFORM SELF-DIAGNOSIS (7)

Ⓜ With CONSULT

1. Turn the ignition switch OFF to ON without depressing the brake pedal.

CAUTION:

Never set the vehicle to READY/Never start the engine.

2. Repeat step 1 two times or more.

CAUTION:

Be sure to wait for 5 seconds or more after turning the ignition switch OFF.

3. Turn the ignition switch OFF to exit CONSULT.
4. Get out of the vehicle, close all doors (including trunk lid), and wait for 3 minutes or more without opening these doors.

CAUTION:

Never operate the vehicle and CONSULT while waiting.

5. Turn the ignition switch ON without depressing the brake pedal.

CAUTION:

Never set the vehicle to READY/Never start the engine.

6. Start CONSULT and erase self-diagnosis result of "BRAKE".
7. Turn the ignition switch OFF to exit CONSULT.
8. Get out of the vehicle, close all doors (including trunk lid), and wait for 3 minutes or more without opening these doors.

CAUTION:

Never operate the vehicle and CONSULT while waiting.

9. Turn the ignition switch ON without depressing the brake pedal.

CAUTION:

Never set the vehicle to READY/Never start the engine.

10. Depress brake pedal by 100 mm (3.94 in) or more, and hold the position for 5 seconds or more.
11. Release brake pedal.
12. Start CONSULT and perform "BRAKE" self-diagnosis.

Is any DTC "C1A6E" or "U1000" detected?

YES ("C1A6E")>>GO TO 1.

YES ("U1000")>>Refer to [BR-229, "Diagnosis Procedure"](#).

NO >> INSPECTION END

A
B
C
D
E
BR
G
H
I
J
K
L
M
N
O
P

C1A6F TCM SYSTEM

< DTC/CIRCUIT DIAGNOSIS >

C1A6F TCM SYSTEM

DTC Logic

INFOID:000000008139839

DTC DETECTION LOGIC

DTC	Display item	Malfunction detection condition	Possible causes
C1A6F	TCM/VCM SYSTEM	Malfunction is detected in the TCM system.	<ul style="list-style-type: none">• Harness or connector• TCM

DTC CONFIRMATION PROCEDURE

1. PRECONDITIONING

If "DTC CONFIRMATION PROCEDURE" has been previously conducted, always turn the ignition switch OFF and wait at least 10 seconds before conducting the next test.

>> GO TO 2.

2. CHECK DTC DETECTION

 With CONSULT

1. Turn the ignition switch OFF to ON without depressing the brake pedal.
CAUTION:
Never set the vehicle to READY/Never start the engine.
2. Repeat step 1 two times or more.
CAUTION:
Be sure to wait for 5 seconds or more after turning the ignition switch OFF.
3. Turn the ignition switch OFF to exit CONSULT.
4. Get out of the vehicle, close all doors (including trunk lid), and wait for 3 minutes or more without opening these doors.
CAUTION:
Never operate the vehicle and CONSULT while waiting.
5. Turn the ignition switch ON without depressing the brake pedal.
CAUTION:
Never set the vehicle to READY/Never start the engine.
6. Start CONSULT and erase self-diagnosis result of "BRAKE".
7. Turn the ignition switch OFF to exit CONSULT.
8. Get out of the vehicle, close all doors (including trunk lid), and wait for 3 minutes or more without opening these doors.
CAUTION:
Never operate the vehicle and CONSULT while waiting.
9. Turn the ignition switch ON without depressing the brake pedal.
CAUTION:
Never set the vehicle to READY/Never start the engine.
10. Depress brake pedal by 100 mm (3.94 in) or more, and hold the position for 5 seconds or more.
11. Release brake pedal.
12. Start CONSULT and perform "BRAKE" self-diagnosis.

Is DTC "C1A6F" detected?

- YES >> Proceed to [BR-196, "Diagnosis Procedure"](#).
NO >> INSPECTION END

Diagnosis Procedure

INFOID:000000008139840

1. PERFORM TCM SELF DIAGNOSIS

Perform self-diagnosis for "TRANSMISSION". Refer to [TM-64, "CONSULT Function"](#).

Is any DTC detected?

- YES >> Check the DTC. Refer to [TM-80, "DTC Index"](#).
NO >> GO TO 2.

C1A6F TCM SYSTEM

< DTC/CIRCUIT DIAGNOSIS >

2.PERFORM SELF-DIAGNOSIS (1)

Ⓜ With CONSULT

1. Turn the ignition switch OFF to ON without depressing the brake pedal.
CAUTION:
Never set the vehicle to READY/Never start the engine.
2. Repeat step 1 two times or more.
CAUTION:
Be sure to wait for 5 seconds or more after turning the ignition switch OFF.
3. Turn the ignition switch OFF to exit CONSULT.
4. Get out of the vehicle, close all doors (including trunk lid), and wait for 3 minutes or more without opening these doors.
CAUTION:
Never operate the vehicle and CONSULT while waiting.
5. Turn the ignition switch ON without depressing the brake pedal.
CAUTION:
Never set the vehicle to READY/Never start the engine.
6. Start CONSULT and erase self-diagnosis result of "BRAKE".
7. Turn the ignition switch OFF to exit CONSULT.
8. Get out of the vehicle, close all doors (including trunk lid), and wait for 3 minutes or more without opening these doors.
CAUTION:
Never operate the vehicle and CONSULT while waiting.
9. Turn the ignition switch ON without depressing the brake pedal.
CAUTION:
Never set the vehicle to READY/Never start the engine.
10. Depress brake pedal by 100 mm (3.94 in) or more, and hold the position for 5 seconds or more.
11. Release brake pedal.
12. Start CONSULT and perform "BRAKE" self-diagnosis.

Is DTC "C1A6F" detected?

- YES >> GO TO 3.
NO >> INSPECTION END

3.CHECK 12V BATTERY

1. Turn the ignition switch OFF to exit CONSULT.
2. Get out of the vehicle, close all doors (including trunk lid), and wait for 3 minutes or more without opening these doors.
CAUTION:
Never operate the vehicle and CONSULT while waiting.
3. Check the 12V battery terminal connections. Refer to [BR-6, "Precaution for Removing 12V Battery"](#) and [PG-135, "Work Flow"](#).
4. Check the 12V battery. Refer to [PG-135, "Work Flow"](#).

Is the inspection result normal?

- YES >> GO TO 4.
NO >> Repair or replace error-detected parts and GO TO 4.

4.PERFORM SELF-DIAGNOSIS (2)

Ⓜ With CONSULT

1. Connect 12V battery cable to negative terminal.
2. Turn the ignition switch OFF to ON without depressing the brake pedal.
CAUTION:
Never set the vehicle to READY/Never start the engine.
3. Repeat step 2 two times or more.
CAUTION:
Be sure to wait for 5 seconds or more after turning the ignition switch OFF.
4. Turn the ignition switch OFF to exit CONSULT.
5. Get out of the vehicle, close all doors (including trunk lid), and wait for 3 minutes or more without opening these doors.
CAUTION:
Never operate the vehicle and CONSULT while waiting.

C1A6F TCM SYSTEM

< DTC/CIRCUIT DIAGNOSIS >

6. Turn the ignition switch ON without depressing the brake pedal.
CAUTION:
Never set the vehicle to READY/Never start the engine.
7. Start CONSULT and erase self-diagnosis result of "BRAKE".
8. Turn the ignition switch OFF to exit CONSULT.
9. Get out of the vehicle, close all doors (including trunk lid), and wait for 3 minutes or more without opening these doors.
CAUTION:
Never operate the vehicle and CONSULT while waiting.
10. Turn the ignition switch ON without depressing the brake pedal.
CAUTION:
Never set the vehicle to READY/Never start the engine.
11. Depress brake pedal by 100 mm (3.94 in) or more, and hold the position for 5 seconds or more.
12. Release brake pedal.
13. Start CONSULT and perform "BRAKE" self-diagnosis.

Is DTC "C1A6F" detected?

- YES >> GO TO 5.
NO >> INSPECTION END

5. CHECK CONNECTOR TERMINALS

1. Turn the ignition switch OFF to exit CONSULT.
2. Get out of the vehicle, close all doors (including trunk lid), and wait for 3 minutes or more without opening these doors.
CAUTION:
Never operate the vehicle and CONSULT while waiting.
3. Disconnect 12V battery cable from negative terminal. Refer to [BR-6. "Precaution for Removing 12V Battery"](#).
4. Disconnect the electrically-driven intelligent brake unit harness connector, then check for failures of pin terminals and connections.

Is the inspection result normal?

- YES >> GO TO 7.
NO >> Repair or replace error-detected parts and GO TO 6.

6. PERFORM SELF-DIAGNOSIS (3)

Ⓟ With CONSULT

1. Connect the electrically-driven intelligent brake unit harness connector.
2. Connect 12V battery cable to negative terminal.
3. Turn the ignition switch OFF to ON without depressing the brake pedal.
CAUTION:
Never set the vehicle to READY/Never start the engine.
4. Repeat step 3 two times or more.
CAUTION:
Be sure to wait for 5 seconds or more after turning the ignition switch OFF.
5. Turn the ignition switch OFF to exit CONSULT.
6. Get out of the vehicle, close all doors (including trunk lid), and wait for 3 minutes or more without opening these doors.
CAUTION:
Never operate the vehicle and CONSULT while waiting.
7. Turn the ignition switch ON without depressing the brake pedal.
CAUTION:
Never set the vehicle to READY/Never start the engine.
8. Start CONSULT and erase self-diagnosis result of "BRAKE".
9. Turn the ignition switch OFF to exit CONSULT.
10. Get out of the vehicle, close all doors (including trunk lid), and wait for 3 minutes or more without opening these doors.
CAUTION:
Never operate the vehicle and CONSULT while waiting.
11. Turn the ignition switch ON without depressing the brake pedal.
CAUTION:
Never set the vehicle to READY/Never start the engine.

C1A6F TCM SYSTEM

< DTC/CIRCUIT DIAGNOSIS >

12. Depress brake pedal by 100 mm (3.94 in) or more, and hold the position for 5 seconds or more.
13. Release brake pedal.
14. Start CONSULT and perform "BRAKE" self-diagnosis.

Is DTC "C1A6F" detected?

- YES >> GO TO 7.
NO >> INSPECTION END

7. CHECK IGNITION POWER SUPPLY

1. Turn the ignition switch OFF to exit CONSULT.
2. Get out of the vehicle, close all doors (including trunk lid), and wait for 3 minutes or more without opening these doors.
CAUTION:
Never operate the vehicle and CONSULT while waiting.
3. Disconnect 12V battery cable from negative terminal. Refer to [BR-6. "Precaution for Removing 12V Battery"](#).
4. Disconnect the electrically-driven intelligent brake unit harness connector.
5. Connect 12V battery cable to negative terminal.
6. Check voltage between the electrically-driven intelligent brake unit harness connector and ground.

Electrically-driven intelligent brake unit		—	Voltage
Connector	Terminal		
E87	26	Ground	Approx. 0 V

7. Turn the ignition switch ON without depressing the brake pedal.
CAUTION:
Never set the vehicle to READY/Never start the engine.
8. Check voltage between the electrically-driven intelligent brake unit harness connector and ground.

Electrically-driven intelligent brake unit		—	Voltage
Connector	Terminal		
E87	26	Ground	10 – 16 V

Is the inspection result normal?

- YES >> GO TO 10.
NO >> GO TO 8.

8. CHECK IGNITION POWER SUPPLY CIRCUIT

1. Turn the ignition switch OFF to exit CONSULT.
2. Get out of the vehicle, close all doors (including trunk lid), and wait for 3 minutes or more without opening these doors.
CAUTION:
Never operate the vehicle and CONSULT while waiting.
3. Disconnect 12V battery cable from negative terminal. Refer to [BR-6. "Precaution for Removing 12V Battery"](#).
4. Check 10A fuse (#46).
5. Disconnect IPDM E/R harness connector.
6. Check continuity between electrically-driven intelligent brake unit and IPDM E/R.

Electrically-driven intelligent brake unit		IPDM E/R		Continuity
Connector	Terminal	Connector	Terminal	
E87	26	E5	12	Existed

7. Check continuity between electrically-driven intelligent brake unit harness connector and ground.

Electrically-driven intelligent brake unit		—	Continuity
Connector	Terminal		
E87	26	Ground	Not existed

C1A6F TCM SYSTEM

< DTC/CIRCUIT DIAGNOSIS >

Is the inspection result normal?

- YES >> Perform trouble diagnosis for ignition power supply. Refer to [PG-30, "Wiring Diagram - IGNITION POWER SUPPLY -"](#).
- NO >> Repair or replace error-detected parts GO TO 9.

9.PERFORM SELF-DIAGNOSIS (4)

ⓈWith CONSULT

1. Connect the electrically-driven intelligent brake unit harness connector.
2. Connect IPDM E/R harness connector.
3. Connect 12V battery cable to negative terminal.
4. Turn the ignition switch OFF to ON without depressing the brake pedal.
CAUTION:
Never set the vehicle to READY/Never start the engine.
5. Repeat step 4 two times or more.
CAUTION:
Be sure to wait for 5 seconds or more after turning the ignition switch OFF.
6. Turn the ignition switch OFF to exit CONSULT.
7. Get out of the vehicle, close all doors (including trunk lid), and wait for 3 minutes or more without opening these doors.
CAUTION:
Never operate the vehicle and CONSULT while waiting.
8. Turn the ignition switch ON without depressing the brake pedal.
CAUTION:
Never set the vehicle to READY/Never start the engine.
9. Start CONSULT and erase self-diagnosis result of "BRAKE".
10. Turn the ignition switch OFF to exit CONSULT.
11. Get out of the vehicle, close all doors (including trunk lid), and wait for 3 minutes or more without opening these doors.
CAUTION:
Never operate the vehicle and CONSULT while waiting.
12. Turn the ignition switch ON without depressing the brake pedal.
CAUTION:
Never set the vehicle to READY/Never start the engine.
13. Depress brake pedal by 100 mm (3.94 in) or more, and hold the position for 5 seconds or more.
14. Release brake pedal.
15. Start CONSULT and perform "BRAKE" self-diagnosis.

Is DTC "C1A6F" detected?

- YES >> GO TO 10.
- NO >> INSPECTION END

10.CHECK 12V BATTERY POWER SUPPLY

1. Turn the ignition switch OFF to exit CONSULT.
2. Get out of the vehicle, close all doors (including trunk lid), and wait for 3 minutes or more without opening these doors.
CAUTION:
Never operate the vehicle and CONSULT while waiting.
3. Disconnect 12V battery cable from negative terminal. Refer to [BR-6, "Precaution for Removing 12V Battery"](#).
4. Disconnect the electrically-driven intelligent brake unit harness connector.
5. Connect 12V battery cable to negative terminal.
6. Check voltage between the electrically-driven intelligent brake unit harness connector terminal.

Electrically-driven intelligent brake unit		Voltage
Connector	Terminal	
E87	1 – 31	10 – 16 V
	2 – 31	
	11 – 31	

7. Turn the ignition switch ON without depressing the brake pedal.

C1A6F TCM SYSTEM

< DTC/CIRCUIT DIAGNOSIS >

CAUTION:

Never set the vehicle to READY/Never start the engine.

8. Check voltage between the electrically-driven intelligent brake unit harness connector terminal.

Electrically-driven intelligent brake unit		Voltage
Connector	Terminal	
E87	1 – 31	10 – 16 V
	2 – 31	
	11 – 31	

Is the inspection result normal?

YES >> GO TO 13.

NO >> GO TO 11.

11. CHECK 12V BATTERY POWER SUPPLY CIRCUIT

1. Turn the ignition switch OFF to exit CONSULT.
2. Get out of the vehicle, close all doors (including trunk lid), and wait for 3 minutes or more without opening these doors.

CAUTION:

Never operate the vehicle and CONSULT while waiting.

3. Disconnect 12V battery cable from negative terminal. Refer to [BR-6, "Precaution for Removing 12V Battery"](#).
4. Check 50A fusible link (#D).
5. Check continuity and for short circuit between electrically-driven intelligent brake unit harness connector terminal (1) and 50A fusible link (#D).
6. Check continuity and for short circuit between electrically-driven intelligent brake unit harness connector terminal (2) and 50A fusible link (#D).
7. Check 10A fuse (#65).
8. Check continuity and for short circuit between electrically-driven intelligent brake unit harness connector terminal (11) and 10A fuse (#65).

Is the inspection result normal?

YES >> Perform diagnosis for 12V battery power supply. Refer to [PG-14, "Wiring Diagram - BATTERY POWER SUPPLY -"](#).

NO >> Repair or replace error-detected parts and GO TO 12.

12. PERFORM SELF-DIAGNOSIS (5)

Ⓜ With CONSULT

1. Connect the electrically-driven intelligent brake unit harness connector.
 2. Connect 12V battery cable to negative terminal.
 3. Turn the ignition switch OFF to ON without depressing the brake pedal.
- CAUTION:**
Never set the vehicle to READY/Never start the engine.
4. Repeat step 3 two times or more.
- CAUTION:**
Be sure to wait for 5 seconds or more after turning the ignition switch OFF.
5. Turn the ignition switch OFF to exit CONSULT.
 6. Get out of the vehicle, close all doors (including trunk lid), and wait for 3 minutes or more without opening these doors.
- CAUTION:**
Never operate the vehicle and CONSULT while waiting.
7. Turn the ignition switch ON without depressing the brake pedal.
- CAUTION:**
Never set the vehicle to READY/Never start the engine.
8. Start CONSULT and erase self-diagnosis result of "BRAKE".
 9. Turn the ignition switch OFF to exit CONSULT.
 10. Get out of the vehicle, close all doors (including trunk lid), and wait for 3 minutes or more without opening these doors.

CAUTION:

Never operate the vehicle and CONSULT while waiting.

C1A6F TCM SYSTEM

< DTC/CIRCUIT DIAGNOSIS >

- Turn the ignition switch ON without depressing the brake pedal.
CAUTION:
Never set the vehicle to READY/Never start the engine.
- Depress brake pedal by 100 mm (3.94 in) or more, and hold the position for 5 seconds or more.
- Release brake pedal.
- Start CONSULT and perform "BRAKE" self-diagnosis.

Is DTC "C1A6F" detected?

- YES >> GO TO 13.
NO >> INSPECTION END

13.CHECK GROUND CIRCUIT

- Turn the ignition switch OFF to exit CONSULT.
- Get out of the vehicle, close all doors (including trunk lid), and wait for 3 minutes or more without opening these doors.
CAUTION:
Never operate the vehicle and CONSULT while waiting.
- Disconnect 12V battery cable from negative terminal. Refer to [BR-6. "Precaution for Removing 12V Battery"](#).
- Disconnect the electrically-driven intelligent brake unit harness connector.
- Check continuity between electrically-driven intelligent brake unit and ground.

Electrically-driven intelligent brake unit		—	Continuity
Connector	Terminal		
E87	31	Ground	Existed

Is the inspection result normal?

- YES >> GO TO 15.
NO >> Repair or replace error-detected parts and GO TO 14.

14.PERFORM SELF-DIAGNOSIS (6)

ⓅWith CONSULT

- Connect the electrically-driven intelligent brake unit harness connector.
- Connect 12V battery cable to negative terminal.
- Turn the ignition switch OFF to ON without depressing the brake pedal.
CAUTION:
Never set the vehicle to READY/Never start the engine.
- Repeat step 3 two times or more.
CAUTION:
Be sure to wait for 5 seconds or more after turning the ignition switch OFF.
- Turn the ignition switch OFF to exit CONSULT.
- Get out of the vehicle, close all doors (including trunk lid), and wait for 3 minutes or more without opening these doors.
CAUTION:
Never operate the vehicle and CONSULT while waiting.
- Turn the ignition switch ON without depressing the brake pedal.
CAUTION:
Never set the vehicle to READY/Never start the engine.
- Start CONSULT and erase self-diagnosis result of "BRAKE".
- Turn the ignition switch OFF to exit CONSULT.
- Get out of the vehicle, close all doors (including trunk lid), and wait for 3 minutes or more without opening these doors.
CAUTION:
Never operate the vehicle and CONSULT while waiting.
- Turn the ignition switch ON without depressing the brake pedal.
CAUTION:
Never set the vehicle to READY/Never start the engine.
- Depress brake pedal by 100 mm (3.94 in) or more, and hold the position for 5 seconds or more.
- Release brake pedal.
- Start CONSULT and perform "BRAKE" self-diagnosis.

C1A6F TCM SYSTEM

< DTC/CIRCUIT DIAGNOSIS >

Is DTC "C1A6F" detected?

YES >> GO TO 15.

NO >> INSPECTION END

15. CHECK DATA MONITOR

Ⓜ With CONSULT

1. Connect the electrically-driven intelligent brake unit harness connector.
2. Connect 12V battery cable to negative terminal.
3. Turn the ignition switch OFF to ON without depressing the brake pedal.

CAUTION:

Never set the vehicle to READY/Never start the engine.

4. Repeat step 2 two times or more.

CAUTION:

Be sure to wait for 5 seconds or more after turning the ignition switch OFF.

5. Start CONSULT and select "BRAKE" and "DATA MONITOR" according to this order.

6. Check "MOTOR POWER SUPPLY" and "CONTROL MODULE POWER". Refer to [BR-33, "Reference Value"](#).

Is the inspection result normal?

YES >> GO TO 16.

NO >> Replace the electrically-driven intelligent brake unit. Refer to [BR-288, "Removal and installation"](#).

16. PERFORM SELF-DIAGNOSIS (7)

Ⓜ With CONSULT

1. Turn the ignition switch OFF to ON without depressing the brake pedal.

CAUTION:

Never set the vehicle to READY/Never start the engine.

2. Repeat step 1 two times or more.

CAUTION:

Be sure to wait for 5 seconds or more after turning the ignition switch OFF.

3. Turn the ignition switch OFF to exit CONSULT.
4. Get out of the vehicle, close all doors (including trunk lid), and wait for 3 minutes or more without opening these doors.

CAUTION:

Never operate the vehicle and CONSULT while waiting.

5. Turn the ignition switch ON without depressing the brake pedal.

CAUTION:

Never set the vehicle to READY/Never start the engine.

6. Start CONSULT and erase self-diagnosis result of "BRAKE".

7. Turn the ignition switch OFF to exit CONSULT.

8. Get out of the vehicle, close all doors (including trunk lid), and wait for 3 minutes or more without opening these doors.

CAUTION:

Never operate the vehicle and CONSULT while waiting.

9. Turn the ignition switch ON without depressing the brake pedal.

CAUTION:

Never set the vehicle to READY/Never start the engine.

10. Depress brake pedal by 100 mm (3.94 in) or more, and hold the position for 5 seconds or more.

11. Release brake pedal.

12. Start CONSULT and perform "BRAKE" self-diagnosis.

Is any DTC "C1A6F" or "U1000" detected?

YES ("C1A6F")>>GO TO 1.

YES ("U1000")>>Refer to [BR-229, "Diagnosis Procedure"](#).

NO >> INSPECTION END

A

B

C

D

E

BR

G

H

I

J

K

L

M

N

O

P

C1A70 BRAKE CONTROL SYSTEM

< DTC/CIRCUIT DIAGNOSIS >

C1A70 BRAKE CONTROL SYSTEM

DTC Logic

INFOID:000000008139841

DTC DETECTION LOGIC

DTC	Display item	Malfunction detection condition	Possible causes
C1A70	BRAKE CONTROL SYSTEM	Malfunction is detected in ABS actuator control unit system.	<ul style="list-style-type: none">• Harness or connector• ABS actuator and electric unit (control unit)

DTC CONFIRMATION PROCEDURE

1. PRECONDITIONING

If "DTC CONFIRMATION PROCEDURE" has been previously conducted, always turn the ignition switch OFF and wait at least 10 seconds before conducting the next test.

>> GO TO 2.

2. CHECK DTC DETECTION

Ⓟ With CONSULT

1. Turn the ignition switch OFF to ON without depressing the brake pedal.
CAUTION:
Never set the vehicle to READY/Never start the engine.
2. Repeat step 1 two times or more.
CAUTION:
Be sure to wait for 5 seconds or more after turning the ignition switch OFF.
3. Turn the ignition switch OFF to exit CONSULT.
4. Get out of the vehicle, close all doors (including trunk lid), and wait for 3 minutes or more without opening these doors.
CAUTION:
Never operate the vehicle and CONSULT while waiting.
5. Turn the ignition switch ON without depressing the brake pedal.
CAUTION:
Never set the vehicle to READY/Never start the engine.
6. Start CONSULT and erase self-diagnosis result of "BRAKE".
7. Turn the ignition switch OFF to exit CONSULT.
8. Get out of the vehicle, close all doors (including trunk lid), and wait for 3 minutes or more without opening these doors.
CAUTION:
Never operate the vehicle and CONSULT while waiting.
9. Turn the ignition switch ON without depressing the brake pedal.
CAUTION:
Never set the vehicle to READY/Never start the engine.
10. Depress brake pedal by 100 mm (3.94 in) or more, and hold the position for 5 seconds or more.
11. Release brake pedal.
12. Start CONSULT and perform "BRAKE" self-diagnosis.

Is DTC "C1A70" detected?

- YES >> Proceed to [BR-204, "Diagnosis Procedure"](#).
NO >> INSPECTION END

Diagnosis Procedure

INFOID:000000008139842

1. PERFORM SELF-DIAGNOSIS OF ABS ACTUATOR AND CONTROL UNIT

Perform self-diagnosis for "ABS". Refer to [BRC-45, "CONSULT Function"](#).

Is any DTC detected?

- YES >> Check the DTC. Refer to [BRC-57, "DTC Index"](#).
NO >> GO TO 2.

C1A70 BRAKE CONTROL SYSTEM

< DTC/CIRCUIT DIAGNOSIS >

2.PERFORM SELF-DIAGNOSIS (1)

Ⓜ With CONSULT

1. Turn the ignition switch OFF to ON without depressing the brake pedal.
CAUTION:
Never set the vehicle to READY/Never start the engine.
2. Repeat step 1 two times or more.
CAUTION:
Be sure to wait for 5 seconds or more after turning the ignition switch OFF.
3. Turn the ignition switch OFF to exit CONSULT.
4. Get out of the vehicle, close all doors (including trunk lid), and wait for 3 minutes or more without opening these doors.
CAUTION:
Never operate the vehicle and CONSULT while waiting.
5. Turn the ignition switch ON without depressing the brake pedal.
CAUTION:
Never set the vehicle to READY/Never start the engine.
6. Start CONSULT and erase self-diagnosis result of "BRAKE".
7. Turn the ignition switch OFF to exit CONSULT.
8. Get out of the vehicle, close all doors (including trunk lid), and wait for 3 minutes or more without opening these doors.
CAUTION:
Never operate the vehicle and CONSULT while waiting.
9. Turn the ignition switch ON without depressing the brake pedal.
CAUTION:
Never set the vehicle to READY/Never start the engine.
10. Depress brake pedal by 100 mm (3.94 in) or more, and hold the position for 5 seconds or more.
11. Release brake pedal.
12. Start CONSULT and perform "BRAKE" self-diagnosis.

Is DTC "C1A70" detected?

YES >> GO TO 3.

NO >> INSPECTION END

3.CHECK 12V BATTERY

1. Turn the ignition switch OFF to exit CONSULT.
2. Get out of the vehicle, close all doors (including trunk lid), and wait for 3 minutes or more without opening these doors.
CAUTION:
Never operate the vehicle and CONSULT while waiting.
3. Check the 12V battery terminal connections. Refer to [BR-6, "Precaution for Removing 12V Battery"](#) and [PG-135, "Work Flow"](#).
4. Check the 12V battery. Refer to [PG-135, "Work Flow"](#).

Is the inspection result normal?

YES >> GO TO 4.

NO >> Repair or replace error-detected parts and GO TO 4.

4.PERFORM SELF-DIAGNOSIS (2)

Ⓜ With CONSULT

1. Connect 12V battery cable to negative terminal.
2. Turn the ignition switch OFF to ON without depressing the brake pedal.
CAUTION:
Never set the vehicle to READY/Never start the engine.
3. Repeat step 2 two times or more.
CAUTION:
Be sure to wait for 5 seconds or more after turning the ignition switch OFF.
4. Turn the ignition switch OFF to exit CONSULT.
5. Get out of the vehicle, close all doors (including trunk lid), and wait for 3 minutes or more without opening these doors.
CAUTION:
Never operate the vehicle and CONSULT while waiting.

C1A70 BRAKE CONTROL SYSTEM

< DTC/CIRCUIT DIAGNOSIS >

6. Turn the ignition switch ON without depressing the brake pedal.
CAUTION:
Never set the vehicle to READY/Never start the engine.
7. Start CONSULT and erase self-diagnosis result of "BRAKE".
8. Turn the ignition switch OFF to exit CONSULT.
9. Get out of the vehicle, close all doors (including trunk lid), and wait for 3 minutes or more without opening these doors.
CAUTION:
Never operate the vehicle and CONSULT while waiting.
10. Turn the ignition switch ON without depressing the brake pedal.
CAUTION:
Never set the vehicle to READY/Never start the engine.
11. Depress brake pedal by 100 mm (3.94 in) or more, and hold the position for 5 seconds or more.
12. Release brake pedal.
13. Start CONSULT and perform "BRAKE" self-diagnosis.

Is DTC "C1A70" detected?

YES >> GO TO 5.

NO >> INSPECTION END

5. CHECK CONNECTOR TERMINALS

1. Turn the ignition switch OFF to exit CONSULT.
2. Get out of the vehicle, close all doors (including trunk lid), and wait for 3 minutes or more without opening these doors.
CAUTION:
Never operate the vehicle and CONSULT while waiting.
3. Disconnect 12V battery cable from negative terminal. Refer to [BR-6. "Precaution for Removing 12V Battery"](#).
4. Disconnect the electrically-driven intelligent brake unit harness connector, then check for failures of pin terminals and connections.

Is the inspection result normal?

YES >> GO TO 7.

NO >> Repair or replace error-detected parts and GO TO 6.

6. PERFORM SELF-DIAGNOSIS (3)

Ⓟ With CONSULT

1. Connect the electrically-driven intelligent brake unit harness connector.
2. Connect 12V battery cable to negative terminal.
3. Turn the ignition switch OFF to ON without depressing the brake pedal.
CAUTION:
Never set the vehicle to READY/Never start the engine.
4. Repeat step 3 two times or more.
CAUTION:
Be sure to wait for 5 seconds or more after turning the ignition switch OFF.
5. Turn the ignition switch OFF to exit CONSULT.
6. Get out of the vehicle, close all doors (including trunk lid), and wait for 3 minutes or more without opening these doors.
CAUTION:
Never operate the vehicle and CONSULT while waiting.
7. Turn the ignition switch ON without depressing the brake pedal.
CAUTION:
Never set the vehicle to READY/Never start the engine.
8. Start CONSULT and erase self-diagnosis result of "BRAKE".
9. Turn the ignition switch OFF to exit CONSULT.
10. Get out of the vehicle, close all doors (including trunk lid), and wait for 3 minutes or more without opening these doors.
CAUTION:
Never operate the vehicle and CONSULT while waiting.
11. Turn the ignition switch ON without depressing the brake pedal.
CAUTION:
Never set the vehicle to READY/Never start the engine.

C1A70 BRAKE CONTROL SYSTEM

< DTC/CIRCUIT DIAGNOSIS >

12. Depress brake pedal by 100 mm (3.94 in) or more, and hold the position for 5 seconds or more.
13. Release brake pedal.
14. Start CONSULT and perform "BRAKE" self-diagnosis.

Is DTC "C1A70" detected?

- YES >> GO TO 7.
 NO >> INSPECTION END

7. CHECK IGNITION POWER SUPPLY

1. Turn the ignition switch OFF to exit CONSULT.
2. Get out of the vehicle, close all doors (including trunk lid), and wait for 3 minutes or more without opening these doors.
CAUTION:
Never operate the vehicle and CONSULT while waiting.
3. Disconnect 12V battery cable from negative terminal. Refer to [BR-6. "Precaution for Removing 12V Battery"](#).
4. Disconnect the electrically-driven intelligent brake unit harness connector.
5. Connect 12V battery cable to negative terminal.
6. Check voltage between the electrically-driven intelligent brake unit harness connector and ground.

Electrically-driven intelligent brake unit		—	Voltage
Connector	Terminal		
E87	26	Ground	Approx. 0 V

7. Turn the ignition switch ON without depressing the brake pedal.
CAUTION:
Never set the vehicle to READY/ Never start the engine.
8. Check voltage between the electrically-driven intelligent brake unit harness connector and ground.

Electrically-driven intelligent brake unit		—	Voltage
Connector	Terminal		
E87	26	Ground	10 – 16 V

Is the inspection result normal?

- YES >> GO TO 10.
 NO >> GO TO 8.

8. CHECK IGNITION POWER SUPPLY CIRCUIT

1. Turn the ignition switch OFF to exit CONSULT.
2. Get out of the vehicle, close all doors (including trunk lid), and wait for 3 minutes or more without opening these doors.
CAUTION:
Never operate the vehicle and CONSULT while waiting.
3. Disconnect 12V battery cable from negative terminal. Refer to [BR-6. "Precaution for Removing 12V Battery"](#).
4. Check 10A fuse (#46).
5. Disconnect IPDM E/R harness connector.
6. Check continuity between electrically-driven intelligent brake unit and IPDM E/R.

Electrically-driven intelligent brake unit		IPDM E/R		Continuity
Connector	Terminal	Connector	Terminal	
E87	26	E5	12	Existed

7. Check continuity between electrically-driven intelligent brake unit harness connector and ground.

Electrically-driven intelligent brake unit		—	Continuity
Connector	Terminal		
E87	26	Ground	Not existed

C1A70 BRAKE CONTROL SYSTEM

< DTC/CIRCUIT DIAGNOSIS >

Is the inspection result normal?

- YES >> Perform trouble diagnosis for ignition power supply. Refer to [PG-30, "Wiring Diagram - IGNITION POWER SUPPLY -"](#).
- NO >> Repair or replace error-detected parts and GO TO 9.

9.PERFORM SELF-DIAGNOSIS (4)

ⓈWith CONSULT

1. Connect the electrically-driven intelligent brake unit harness connector.
2. Connect IPDM E/R harness connector.
3. Connect 12V battery cable to negative terminal.
4. Turn the ignition switch OFF to ON without depressing the brake pedal.
CAUTION:
Never set the vehicle to READY/Never start the engine.
5. Repeat step 4 two times or more.
CAUTION:
Be sure to wait for 5 seconds or more after turning the ignition switch OFF.
6. Turn the ignition switch OFF to exit CONSULT.
7. Get out of the vehicle, close all doors (including trunk lid), and wait for 3 minutes or more without opening these doors.
CAUTION:
Never operate the vehicle and CONSULT while waiting.
8. Turn the ignition switch ON without depressing the brake pedal.
CAUTION:
Never set the vehicle to READY/Never start the engine.
9. Start CONSULT and erase self-diagnosis result of "BRAKE".
10. Turn the ignition switch OFF to exit CONSULT.
11. Get out of the vehicle, close all doors (including trunk lid), and wait for 3 minutes or more without opening these doors.
CAUTION:
Never operate the vehicle and CONSULT while waiting.
12. Turn the ignition switch ON without depressing the brake pedal.
CAUTION:
Never set the vehicle to READY/Never start the engine.
13. Depress brake pedal by 100 mm (3.94 in) or more, and hold the position for 5 seconds or more.
14. Release brake pedal.
15. Start CONSULT and perform "BRAKE" self-diagnosis.

Is DTC "C1A70" detected?

- YES >> GO TO 10.
- NO >> INSPECTION END

10.CHECK 12V BATTERY POWER SUPPLY

1. Turn the ignition switch OFF to exit CONSULT.
2. Get out of the vehicle, close all doors (including trunk lid), and wait for 3 minutes or more without opening these doors.
CAUTION:
Never operate the vehicle and CONSULT while waiting.
3. Disconnect 12V battery cable from negative terminal. Refer to [BR-6, "Precaution for Removing 12V Battery"](#).
4. Disconnect the electrically-driven intelligent brake unit harness connector.
5. Connect 12V battery cable to negative terminal.
6. Check voltage between the electrically-driven intelligent brake unit harness connector terminal.

Electrically-driven intelligent brake unit		Voltage
Connector	Terminal	
E87	1 - 31	10 - 16 V
	2 - 31	
	11 - 31	

7. Turn the ignition switch ON without depressing the brake pedal.

C1A70 BRAKE CONTROL SYSTEM

< DTC/CIRCUIT DIAGNOSIS >

CAUTION:

Never set the vehicle to READY/Never start the engine.

8. Check voltage between the electrically-driven intelligent brake unit harness connector terminal.

Electrically-driven intelligent brake unit		Voltage
Connector	Terminal	
E87	1 – 31	10 – 16 V
	2 – 31	
	11 – 31	

Is the inspection result normal?

YES >> GO TO 13.

NO >> GO TO 11.

11. CHECK 12V BATTERY POWER SUPPLY CIRCUIT

1. Turn the ignition switch OFF to exit CONSULT.
2. Get out of the vehicle, close all doors (including trunk lid), and wait for 3 minutes or more without opening these doors.

CAUTION:

Never operate the vehicle and CONSULT while waiting.

3. Disconnect 12V battery cable from negative terminal. Refer to [BR-6, "Precaution for Removing 12V Battery"](#).
4. Check 50A fusible link (#D).
5. Check continuity and for short circuit between electrically-driven intelligent brake unit harness connector terminal (1) and 50A fusible link (#D).
6. Check continuity and for short circuit between electrically-driven intelligent brake unit harness connector terminal (2) and 50A fusible link (#D).
7. Check 10A fuse (#65).
8. Check continuity and for short circuit between electrically-driven intelligent brake unit harness connector terminal (11) and 10A fuse (#65).

Is the inspection result normal?

YES >> Perform diagnosis for 12V battery power supply. Refer to [PG-14, "Wiring Diagram - BATTERY POWER SUPPLY -"](#).

NO >> Repair or replace error-detected parts and GO TO 12.

12. PERFORM SELF-DIAGNOSIS (5)

Ⓜ With CONSULT

1. Connect the electrically-driven intelligent brake unit harness connector.
 2. Connect 12V battery cable to negative terminal.
 3. Turn the ignition switch OFF to ON without depressing the brake pedal.
- CAUTION:**
Never set the vehicle to READY/Never start the engine.
4. Repeat step 3 two times or more.
- CAUTION:**
Be sure to wait for 5 seconds or more after turning the ignition switch OFF.
5. Turn the ignition switch OFF to exit CONSULT.
 6. Get out of the vehicle, close all doors (including trunk lid), and wait for 3 minutes or more without opening these doors.
- CAUTION:**
Never operate the vehicle and CONSULT while waiting.
7. Turn the ignition switch ON without depressing the brake pedal.
- CAUTION:**
Never set the vehicle to READY/Never start the engine.
8. Start CONSULT and erase self-diagnosis result of "BRAKE".
 9. Turn the ignition switch OFF to exit CONSULT.
 10. Get out of the vehicle, close all doors (including trunk lid), and wait for 3 minutes or more without opening these doors.

CAUTION:

Never operate the vehicle and CONSULT while waiting.

C1A70 BRAKE CONTROL SYSTEM

< DTC/CIRCUIT DIAGNOSIS >

- Turn the ignition switch ON without depressing the brake pedal.
CAUTION:
Never set the vehicle to READY/Never start the engine.
- Depress brake pedal by 100 mm (3.94 in) or more, and hold the position for 5 seconds or more.
- Release brake pedal.
- Start CONSULT and perform "BRAKE" self-diagnosis.

Is DTC "C1A70" detected?

- YES >> GO TO 13.
NO >> INSPECTION END

13. CHECK GROUND CIRCUIT

- Turn the ignition switch OFF to exit CONSULT.
- Get out of the vehicle, close all doors (including trunk lid), and wait for 3 minutes or more without opening these doors.
CAUTION:
Never operate the vehicle and CONSULT while waiting.
- Disconnect 12V battery cable from negative terminal. Refer to [BR-6. "Precaution for Removing 12V Battery"](#).
- Disconnect the electrically-driven intelligent brake unit harness connector.
- Check continuity between electrically-driven intelligent brake unit and ground.

Electrically-driven intelligent brake unit		—	Continuity
Connector	Terminal		
E87	31	Ground	Existed

Is the inspection result normal?

- YES >> GO TO 15.
NO >> Repair or replace error-detected parts and GO TO 14.

14. PERFORM SELF-DIAGNOSIS (6)

Ⓟ With CONSULT

- Connect the electrically-driven intelligent brake unit harness connector.
- Connect 12V battery cable to negative terminal.
- Turn the ignition switch OFF to ON without depressing the brake pedal.
CAUTION:
Never set the vehicle to READY/Never start the engine.
- Repeat step 3 two times or more.
CAUTION:
Be sure to wait for 5 seconds or more after turning the ignition switch OFF.
- Turn the ignition switch OFF to exit CONSULT.
- Get out of the vehicle, close all doors (including trunk lid), and wait for 3 minutes or more without opening these doors.
CAUTION:
Never operate the vehicle and CONSULT while waiting.
- Turn the ignition switch ON without depressing the brake pedal.
CAUTION:
Never set the vehicle to READY/Never start the engine.
- Start CONSULT and erase self-diagnosis result of "BRAKE".
- Turn the ignition switch OFF to exit CONSULT.
- Get out of the vehicle, close all doors (including trunk lid), and wait for 3 minutes or more without opening these doors.
CAUTION:
Never operate the vehicle and CONSULT while waiting.
- Turn the ignition switch ON without depressing the brake pedal.
CAUTION:
Never set the vehicle to READY/Never start the engine.
- Depress brake pedal by 100 mm (3.94 in) or more, and hold the position for 5 seconds or more.
- Release brake pedal.
- Start CONSULT and perform "BRAKE" self-diagnosis.

C1A70 BRAKE CONTROL SYSTEM

< DTC/CIRCUIT DIAGNOSIS >

Is DTC "C1A70" detected?

YES >> GO TO 15.

NO >> INSPECTION END

15. CHECK DATA MONITOR

Ⓜ With CONSULT

1. Connect the electrically-driven intelligent brake unit harness connector.
2. Connect 12V battery cable to negative terminal.
3. Turn the ignition switch OFF to ON without depressing the brake pedal.

CAUTION:

Never set the vehicle to READY/Never start the engine.

4. Repeat step 3 two times or more.

CAUTION:

Be sure to wait for 5 seconds or more after turning the ignition switch OFF.

5. Start CONSULT and select "BRAKE" and "DATA MONITOR" according to this order.

6. Check "MOTOR POWER SUPPLY" and "CONTROL MODULE POWER". Refer to [BR-33, "Reference Value"](#).

Is the inspection result normal?

YES >> GO TO 16.

NO >> Replace the electrically-driven intelligent brake unit. Refer to [BR-288, "Removal and installation"](#).

16. PERFORM SELF-DIAGNOSIS (7)

Ⓜ With CONSULT

1. Turn the ignition switch OFF to ON without depressing the brake pedal.

CAUTION:

Never set the vehicle to READY/Never start the engine.

2. Repeat step 1 two times or more.

CAUTION:

Be sure to wait for 5 seconds or more after turning the ignition switch OFF.

3. Turn the ignition switch OFF to exit CONSULT.
4. Get out of the vehicle, close all doors (including trunk lid), and wait for 3 minutes or more without opening these doors.

CAUTION:

Never operate the vehicle and CONSULT while waiting.

5. Turn the ignition switch ON without depressing the brake pedal.

CAUTION:

Never set the vehicle to READY/Never start the engine.

6. Start CONSULT and erase self-diagnosis result of "BRAKE".

7. Turn the ignition switch OFF to exit CONSULT.

8. Get out of the vehicle, close all doors (including trunk lid), and wait for 3 minutes or more without opening these doors.

CAUTION:

Never operate the vehicle and CONSULT while waiting.

9. Turn the ignition switch ON without depressing the brake pedal.

CAUTION:

Never set the vehicle to READY/Never start the engine.

10. Depress brake pedal by 100 mm (3.94 in) or more, and hold the position for 5 seconds or more.

11. Release brake pedal.

12. Start CONSULT and perform "BRAKE" self-diagnosis.

Is any DTC "C1A70" or "U1000" detected?

YES ("C1A70")>>GO TO 1.

YES ("U1000")>>Refer to [BR-229, "Diagnosis Procedure"](#).

NO >> INSPECTION END

C1A71 INTEGRATED CONTROL SYSTEM

< DTC/CIRCUIT DIAGNOSIS >

C1A71 INTEGRATED CONTROL SYSTEM

DTC Logic

INFOID:000000008139843

DTC DETECTION LOGIC

DTC	Display item	Malfunction detection condition	Possible causes
C1A71	INTEGRATED CONTROL SYSTEM	Malfunction is detected in ADAS control unit system.	<ul style="list-style-type: none">• Harness or connector• ADAS control unit

DTC CONFIRMATION PROCEDURE

1. PRECONDITIONING

If "DTC CONFIRMATION PROCEDURE" has been previously conducted, always turn the ignition switch OFF and wait at least 10 seconds before conducting the next test.

>> GO TO 2.

2. CHECK DTC DETECTION

 With CONSULT

1. Turn the ignition switch OFF to ON without depressing the brake pedal.
CAUTION:
Never set the vehicle to READY/Never start the engine.
2. Repeat step 1 two times or more.
CAUTION:
Be sure to wait for 5 seconds or more after turning the ignition switch OFF.
3. Turn the ignition switch OFF to exit CONSULT.
4. Get out of the vehicle, close all doors (including trunk lid), and wait for 3 minutes or more without opening these doors.
CAUTION:
Never operate the vehicle and CONSULT while waiting.
5. Turn the ignition switch ON without depressing the brake pedal.
CAUTION:
Never set the vehicle to READY/Never start the engine.
6. Start CONSULT and erase self-diagnosis result of "BRAKE".
7. Turn the ignition switch OFF to exit CONSULT.
8. Get out of the vehicle, close all doors (including trunk lid), and wait for 3 minutes or more without opening these doors.
CAUTION:
Never operate the vehicle and CONSULT while waiting.
9. Turn the ignition switch ON without depressing the brake pedal.
CAUTION:
Never set the vehicle to READY/Never start the engine.
10. Depress brake pedal by 100 mm (3.94 in) or more, and hold the position for 5 seconds or more.
11. Release brake pedal.
12. Start CONSULT and perform "BRAKE" self-diagnosis.

Is DTC "C1A70" detected?

- YES >> Proceed to [BR-212, "Diagnosis Procedure"](#).
NO >> INSPECTION END

Diagnosis Procedure

INFOID:000000008139844

1. PERFORM ADAS SELF-DIAGNOSIS

Perform self-diagnosis for "ICC/ADAS". Refer to [CCS-28, "CONSULT Function \(ICC/ADAS\)"](#).

Is any DTC detected?

- YES >> Check the DTC. Refer to [CCS-50, "DTC Index"](#).
NO >> GO TO 2.

C1A71 INTEGRATED CONTROL SYSTEM

< DTC/CIRCUIT DIAGNOSIS >

2.PERFORM SELF-DIAGNOSIS (1)

Ⓜ With CONSULT

1. Turn the ignition switch OFF to ON without depressing the brake pedal.
CAUTION:
Never set the vehicle to READY/Never start the engine.
2. Repeat step 1 two times or more.
CAUTION:
Be sure to wait for 5 seconds or more after turning the ignition switch OFF.
3. Turn the ignition switch OFF to exit CONSULT.
4. Get out of the vehicle, close all doors (including trunk lid), and wait for 3 minutes or more without opening these doors.
CAUTION:
Never operate the vehicle and CONSULT while waiting.
5. Turn the ignition switch ON without depressing the brake pedal.
CAUTION:
Never set the vehicle to READY/Never start the engine.
6. Start CONSULT and erase self-diagnosis result of "BRAKE".
7. Turn the ignition switch OFF to exit CONSULT.
8. Get out of the vehicle, close all doors (including trunk lid), and wait for 3 minutes or more without opening these doors.
CAUTION:
Never operate the vehicle and CONSULT while waiting.
9. Turn the ignition switch ON without depressing the brake pedal.
CAUTION:
Never set the vehicle to READY/Never start the engine.
10. Depress brake pedal by 100 mm (3.94 in) or more, and hold the position for 5 seconds or more.
11. Release brake pedal.
12. Start CONSULT and perform "BRAKE" self-diagnosis.

Is DTC "C1A70" detected?

- YES >> GO TO 3.
NO >> INSPECTION END

3.CHECK 12V BATTERY

1. Turn the ignition switch OFF to exit CONSULT.
2. Get out of the vehicle, close all doors (including trunk lid), and wait for 3 minutes or more without opening these doors.
CAUTION:
Never operate the vehicle and CONSULT while waiting.
3. Check the 12V battery terminal connections. Refer to [BR-6, "Precaution for Removing 12V Battery"](#) and [PG-135, "Work Flow"](#).
4. Check the 12V battery. Refer to [PG-135, "Work Flow"](#).

Is the inspection result normal?

- YES >> GO TO 4.
NO >> Repair or replace error-detected parts and GO TO 4.

4.PERFORM SELF-DIAGNOSIS (2)

Ⓜ With CONSULT

1. Connect 12V battery cable to negative terminal.
2. Turn the ignition switch OFF to ON without depressing the brake pedal.
CAUTION:
Never set the vehicle to READY/Never start the engine.
3. Repeat step 2 two times or more.
CAUTION:
Be sure to wait for 5 seconds or more after turning the ignition switch OFF.
4. Turn the ignition switch OFF to exit CONSULT.
5. Get out of the vehicle, close all doors (including trunk lid), and wait for 3 minutes or more without opening these doors.
CAUTION:
Never operate the vehicle and CONSULT while waiting.

C1A71 INTEGRATED CONTROL SYSTEM

< DTC/CIRCUIT DIAGNOSIS >

6. Turn the ignition switch ON without depressing the brake pedal.
CAUTION:
Never set the vehicle to READY/Never start the engine.
7. Start CONSULT and erase self-diagnosis result of "BRAKE".
8. Turn the ignition switch OFF to exit CONSULT.
9. Get out of the vehicle, close all doors (including trunk lid), and wait for 3 minutes or more without opening these doors.
CAUTION:
Never operate the vehicle and CONSULT while waiting.
10. Turn the ignition switch ON without depressing the brake pedal.
CAUTION:
Never set the vehicle to READY/Never start the engine.
11. Depress brake pedal by 100 mm (3.94 in) or more, and hold the position for 5 seconds or more.
12. Release brake pedal.
13. Start CONSULT and perform "BRAKE" self-diagnosis.

Is DTC "C1A70" detected?

- YES >> GO TO 5.
NO >> INSPECTION END

5. CHECK CONNECTOR TERMINALS

1. Turn the ignition switch OFF to exit CONSULT.
2. Get out of the vehicle, close all doors (including trunk lid), and wait for 3 minutes or more without opening these doors.
CAUTION:
Never operate the vehicle and CONSULT while waiting.
3. Disconnect 12V battery cable from negative terminal. Refer to [BR-6. "Precaution for Removing 12V Battery"](#).
4. Disconnect the electrically-driven intelligent brake unit harness connector, then check for failures of pin terminals and connections.

Is the inspection result normal?

- YES >> GO TO 7.
NO >> Repair or replace error-detected parts and GO TO 6.

6. PERFORM SELF-DIAGNOSIS (3)

Ⓟ With CONSULT

1. Connect the electrically-driven intelligent brake unit harness connector.
2. Connect 12V battery cable to negative terminal.
3. Turn the ignition switch OFF to ON without depressing the brake pedal.
CAUTION:
Never set the vehicle to READY/Never start the engine.
4. Repeat step 3 two times or more.
CAUTION:
Be sure to wait for 5 seconds or more after turning the ignition switch OFF.
5. Turn the ignition switch OFF to exit CONSULT.
6. Get out of the vehicle, close all doors (including trunk lid), and wait for 3 minutes or more without opening these doors.
CAUTION:
Never operate the vehicle and CONSULT while waiting.
7. Turn the ignition switch ON without depressing the brake pedal.
CAUTION:
Never set the vehicle to READY/Never start the engine.
8. Start CONSULT and erase self-diagnosis result of "BRAKE".
9. Turn the ignition switch OFF to exit CONSULT.
10. Get out of the vehicle, close all doors (including trunk lid), and wait for 3 minutes or more without opening these doors.
CAUTION:
Never operate the vehicle and CONSULT while waiting.
11. Turn the ignition switch ON without depressing the brake pedal.
CAUTION:
Never set the vehicle to READY/Never start the engine.

C1A71 INTEGRATED CONTROL SYSTEM

< DTC/CIRCUIT DIAGNOSIS >

12. Depress brake pedal by 100 mm (3.94 in) or more, and hold the position for 5 seconds or more.
13. Release brake pedal.
14. Start CONSULT and perform "BRAKE" self-diagnosis.

Is DTC "C1A70" detected?

- YES >> GO TO 7.
NO >> INSPECTION END

7. CHECK IGNITION POWER SUPPLY

1. Turn the ignition switch OFF to exit CONSULT.
2. Get out of the vehicle, close all doors (including trunk lid), and wait for 3 minutes or more without opening these doors.
CAUTION:
Never operate the vehicle and CONSULT while waiting.
3. Disconnect 12V battery cable from negative terminal. Refer to [BR-6. "Precaution for Removing 12V Battery"](#).
4. Disconnect the electrically-driven intelligent brake unit harness connector.
5. Connect 12V battery cable to negative terminal.
6. Check voltage between the electrically-driven intelligent brake unit harness connector and ground.

Electrically-driven intelligent brake unit		—	Voltage
Connector	Terminal		
E87	26	Ground	Approx. 0 V

7. Turn the ignition switch ON without depressing the brake pedal.
CAUTION:
Never set the vehicle to READY/Never start the engine.
8. Check voltage between the electrically-driven intelligent brake unit harness connector and ground.

Electrically-driven intelligent brake unit		—	Voltage
Connector	Terminal		
E87	26	Ground	10 – 16 V

Is the inspection result normal?

- YES >> GO TO 10.
NO >> GO TO 8.

8. CHECK IGNITION POWER SUPPLY CIRCUIT

1. Turn the ignition switch OFF to exit CONSULT.
2. Get out of the vehicle, close all doors (including trunk lid), and wait for 3 minutes or more without opening these doors.
CAUTION:
Never operate the vehicle and CONSULT while waiting.
3. Disconnect 12V battery cable from negative terminal. Refer to [BR-6. "Precaution for Removing 12V Battery"](#).
4. Check 10A fuse (#46).
5. Disconnect IPDM E/R harness connector.
6. Check continuity between electrically-driven intelligent brake unit and IPDM E/R.

Electrically-driven intelligent brake unit		IPDM E/R		Continuity
Connector	Terminal	Connector	Terminal	
E87	26	E5	12	Existed

7. Check continuity between electrically-driven intelligent brake unit harness connector and ground.

Electrically-driven intelligent brake unit		—	Continuity
Connector	Terminal		
E87	26	Ground	Not existed

C1A71 INTEGRATED CONTROL SYSTEM

< DTC/CIRCUIT DIAGNOSIS >

Is the inspection result normal?

- YES >> Perform trouble diagnosis for ignition power supply. Refer to [PG-30, "Wiring Diagram - IGNITION POWER SUPPLY -"](#).
- NO >> Repair or replace error-detected parts and GO TO 9.

9.PERFORM SELF-DIAGNOSIS (4)

ⓈWith CONSULT

1. Connect the electrically-driven intelligent brake unit harness connector.
2. Connect IPDM E/R harness connector.
3. Connect 12V battery cable to negative terminal.
4. Turn the ignition switch OFF to ON without depressing the brake pedal.
CAUTION:
Never set the vehicle to READY/Never start the engine.
5. Repeat step 4 two times or more.
CAUTION:
Be sure to wait for 5 seconds or more after turning the ignition switch OFF.
6. Turn the ignition switch OFF to exit CONSULT.
7. Get out of the vehicle, close all doors (including trunk lid), and wait for 3 minutes or more without opening these doors.
CAUTION:
Never operate the vehicle and CONSULT while waiting.
8. Turn the ignition switch ON without depressing the brake pedal.
CAUTION:
Never set the vehicle to READY/Never start the engine.
9. Start CONSULT and erase self-diagnosis result of "BRAKE".
10. Turn the ignition switch OFF to exit CONSULT.
11. Get out of the vehicle, close all doors (including trunk lid), and wait for 3 minutes or more without opening these doors.
CAUTION:
Never operate the vehicle and CONSULT while waiting.
12. Turn the ignition switch ON without depressing the brake pedal.
CAUTION:
Never set the vehicle to READY/Never start the engine.
13. Depress brake pedal by 100 mm (3.94 in) or more, and hold the position for 5 seconds or more.
14. Release brake pedal.
15. Start CONSULT and perform "BRAKE" self-diagnosis.

Is DTC "C1A70" detected?

- YES >> GO TO 10.
- NO >> INSPECTION END

10.CHECK 12V BATTERY POWER SUPPLY

1. Turn the ignition switch OFF to exit CONSULT.
2. Get out of the vehicle, close all doors (including trunk lid), and wait for 3 minutes or more without opening these doors.
CAUTION:
Never operate the vehicle and CONSULT while waiting.
3. Disconnect 12V battery cable from negative terminal. Refer to [BR-6, "Precaution for Removing 12V Battery"](#).
4. Disconnect the electrically-driven intelligent brake unit harness connector.
5. Connect 12V battery cable to negative terminal.
6. Check voltage between the electrically-driven intelligent brake unit harness connector terminal.

Electrically-driven intelligent brake unit		Voltage
Connector	Terminal	
E87	1 - 31	10 - 16 V
	2 - 31	
	11 - 31	

7. Turn the ignition switch ON without depressing the brake pedal.

C1A71 INTEGRATED CONTROL SYSTEM

< DTC/CIRCUIT DIAGNOSIS >

CAUTION:

Never set the vehicle to READY/Never start the engine.

8. Check voltage between the electrically-driven intelligent brake unit harness connector terminal.

Electrically-driven intelligent brake unit		Voltage
Connector	Terminal	
E87	1 – 31	10 – 16 V
	2 – 31	
	11 – 31	

Is the inspection result normal?

YES >> GO TO 13.

NO >> GO TO 11.

11. CHECK 12V BATTERY POWER SUPPLY CIRCUIT

1. Turn the ignition switch OFF to exit CONSULT.
2. Get out of the vehicle, close all doors (including trunk lid), and wait for 3 minutes or more without opening these doors.

CAUTION:

Never operate the vehicle and CONSULT while waiting.

3. Disconnect 12V battery cable from negative terminal. Refer to [BR-6, "Precaution for Removing 12V Battery"](#).
4. Check 50A fusible link (#D).
5. Check continuity and for short circuit between electrically-driven intelligent brake unit harness connector terminal (1) and 50A fusible link (#D).
6. Check continuity and for short circuit between electrically-driven intelligent brake unit harness connector terminal (2) and 50A fusible link (#D).
7. Check 10A fuse (#65).
8. Check continuity and for short circuit between electrically-driven intelligent brake unit harness connector terminal (11) and 10A fuse (#65).

Is the inspection result normal?

YES >> Perform diagnosis for 12V battery power supply. Refer to [PG-14, "Wiring Diagram - BATTERY POWER SUPPLY -"](#).

NO >> Repair or replace error-detected parts and GO TO 12.

12. PERFORM SELF-DIAGNOSIS (5)

Ⓜ With CONSULT

1. Connect the electrically-driven intelligent brake unit harness connector.
 2. Connect 12V battery cable to negative terminal.
 3. Turn the ignition switch OFF to ON without depressing the brake pedal.
- CAUTION:**
Never set the vehicle to READY/Never start the engine.
4. Repeat step 3 two times or more.
- CAUTION:**
Be sure to wait for 5 seconds or more after turning the ignition switch OFF.
5. Turn the ignition switch OFF to exit CONSULT.
 6. Get out of the vehicle, close all doors (including trunk lid), and wait for 3 minutes or more without opening these doors.
- CAUTION:**
Never operate the vehicle and CONSULT while waiting.
7. Turn the ignition switch ON without depressing the brake pedal.
- CAUTION:**
Never set the vehicle to READY/Never start the engine.
8. Start CONSULT and erase self-diagnosis result of "BRAKE".
 9. Turn the ignition switch OFF to exit CONSULT.
 10. Get out of the vehicle, close all doors (including trunk lid), and wait for 3 minutes or more without opening these doors.

CAUTION:

Never operate the vehicle and CONSULT while waiting.

C1A71 INTEGRATED CONTROL SYSTEM

< DTC/CIRCUIT DIAGNOSIS >

11. Turn the ignition switch ON without depressing the brake pedal.

CAUTION:

Never set the vehicle to READY/Never start the engine.

12. Depress brake pedal by 100 mm (3.94 in) or more, and hold the position for 5 seconds or more.

13. Release brake pedal.

14. Start CONSULT and perform "BRAKE" self-diagnosis.

Is DTC "C1A70" detected?

YES >> GO TO 13.

NO >> INSPECTION END

13. CHECK GROUND CIRCUIT

1. Turn the ignition switch OFF to exit CONSULT.

2. Get out of the vehicle, close all doors (including trunk lid), and wait for 3 minutes or more without opening these doors.

CAUTION:

Never operate the vehicle and CONSULT while waiting.

3. Disconnect 12V battery cable from negative terminal. Refer to [BR-6. "Precaution for Removing 12V Battery"](#).

4. Disconnect the electrically-driven intelligent brake unit harness connector.

5. Check continuity between electrically-driven intelligent brake unit and ground.

Electrically-driven intelligent brake unit		—	Continuity
Connector	Terminal		
E87	31	Ground	Existed

Is the inspection result normal?

YES >> GO TO 15.

NO >> Repair or replace error-detected parts and GO TO 14.

14. PERFORM SELF-DIAGNOSIS (6)

Ⓟ With CONSULT

1. Connect the electrically-driven intelligent brake unit harness connector.

2. Connect 12V battery cable to negative terminal.

3. Turn the ignition switch OFF to ON without depressing the brake pedal.

CAUTION:

Never set the vehicle to READY/Never start the engine.

4. Repeat step 3 two times or more.

CAUTION:

Be sure to wait for 5 seconds or more after turning the ignition switch OFF.

5. Turn the ignition switch OFF to exit CONSULT.

6. Get out of the vehicle, close all doors (including trunk lid), and wait for 3 minutes or more without opening these doors.

CAUTION:

Never operate the vehicle and CONSULT while waiting.

7. Turn the ignition switch ON without depressing the brake pedal.

CAUTION:

Never set the vehicle to READY/Never start the engine.

8. Start CONSULT and erase self-diagnosis result of "BRAKE".

9. Turn the ignition switch OFF to exit CONSULT.

10. Get out of the vehicle, close all doors (including trunk lid), and wait for 3 minutes or more without opening these doors.

CAUTION:

Never operate the vehicle and CONSULT while waiting.

11. Turn the ignition switch ON without depressing the brake pedal.

CAUTION:

Never set the vehicle to READY/Never start the engine.

12. Depress brake pedal by 100 mm (3.94 in) or more, and hold the position for 5 seconds or more.

13. Release brake pedal.

14. Start CONSULT and perform "BRAKE" self-diagnosis.

C1A71 INTEGRATED CONTROL SYSTEM

< DTC/CIRCUIT DIAGNOSIS >

Is DTC "C1A70" detected?

YES >> GO TO 15.

NO >> INSPECTION END

15. CHECK DATA MONITOR

With CONSULT

1. Connect the electrically-driven intelligent brake unit harness connector.
2. Connect 12V battery cable to negative terminal.
3. Turn the ignition switch OFF to ON without depressing the brake pedal.

CAUTION:

Never set the vehicle to READY/Never start the engine.

4. Repeat step 3 two times or more.

CAUTION:

Be sure to wait for 5 seconds or more after turning the ignition switch OFF.

5. Start CONSULT and select "BRAKE" and "DATA MONITOR" according to this order.

6. Check "MOTOR POWER SUPPLY" and "CONTROL MODULE POWER". Refer to [BR-33, "Reference Value"](#).

Is the inspection result normal?

YES >> GO TO 16.

NO >> Replace the electrically-driven intelligent brake unit. Refer to [BR-288, "Removal and installation"](#).

16. PERFORM SELF-DIAGNOSIS (7)

With CONSULT

1. Turn the ignition switch OFF to ON without depressing the brake pedal.

CAUTION:

Never set the vehicle to READY/Never start the engine.

2. Repeat step 1 two times or more.

CAUTION:

Be sure to wait for 5 seconds or more after turning the ignition switch OFF.

3. Turn the ignition switch OFF to exit CONSULT.
4. Get out of the vehicle, close all doors (including trunk lid), and wait for 3 minutes or more without opening these doors.

CAUTION:

Never operate the vehicle and CONSULT while waiting.

5. Turn the ignition switch ON without depressing the brake pedal.

CAUTION:

Never set the vehicle to READY/Never start the engine.

6. Start CONSULT and erase self-diagnosis result of "BRAKE".

7. Turn the ignition switch OFF to exit CONSULT.

8. Get out of the vehicle, close all doors (including trunk lid), and wait for 3 minutes or more without opening these doors.

CAUTION:

Never operate the vehicle and CONSULT while waiting.

9. Turn the ignition switch ON without depressing the brake pedal.

CAUTION:

Never set the vehicle to READY/Never start the engine.

10. Depress brake pedal by 100 mm (3.94 in) or more, and hold the position for 5 seconds or more.

11. Release brake pedal.

12. Start CONSULT and perform "BRAKE" self-diagnosis.

Is any DTC "C1A71" or "U1000" detected?

YES ("C1A71")>>GO TO 1.

YES ("U1000")>>Refer to [BR-229, "Diagnosis Procedure"](#).

NO >> INSPECTION END

C1A74 STEERING ANGLE SENSOR

< DTC/CIRCUIT DIAGNOSIS >

C1A74 STEERING ANGLE SENSOR

DTC Logic

INFOID:000000008139845

DTC DETECTION LOGIC

DTC	Display item	Malfunction detection condition	Possible causes
C1A74	ST ANG SEN CIRCUIT	Malfunction is detected in the steering angle sensor system.	<ul style="list-style-type: none">• Harness or connector• ABS actuator and electric unit (control unit)• Steering angle sensor

DTC CONFIRMATION PROCEDURE

1. PRECONDITIONING

If "DTC CONFIRMATION PROCEDURE" has been previously conducted, always turn the ignition switch OFF and wait at least 10 seconds before conducting the next test.

>> GO TO 2.

2. CHECK DTC DETECTION

④ With CONSULT

1. Turn the ignition switch OFF to ON without depressing the brake pedal.
CAUTION:
Never set the vehicle to READY/Never start the engine.
2. Repeat step 1 two times or more.
CAUTION:
Be sure to wait for 5 seconds or more after turning the ignition switch OFF.
3. Turn the ignition switch OFF to exit CONSULT.
4. Get out of the vehicle, close all doors (including trunk lid), and wait for 3 minutes or more without opening these doors.
CAUTION:
Never operate the vehicle and CONSULT while waiting.
5. Turn the ignition switch ON without depressing the brake pedal.
CAUTION:
Never set the vehicle to READY/Never start the engine.
6. Start CONSULT and erase self-diagnosis result of "BRAKE".
7. Turn the ignition switch OFF to exit CONSULT.
8. Get out of the vehicle, close all doors (including trunk lid), and wait for 3 minutes or more without opening these doors.
CAUTION:
Never operate the vehicle and CONSULT while waiting.
9. Turn the ignition switch ON without depressing the brake pedal.
CAUTION:
Never set the vehicle to READY/Never start the engine.
10. Depress brake pedal by 100 mm (3.94 in) or more, and hold the position for 5 seconds or more.
11. Release brake pedal.
12. Start CONSULT and perform "BRAKE" self-diagnosis.

Is DTC "C1A74" detected?

- YES >> Proceed to [BR-220, "Diagnosis Procedure"](#).
NO >> INSPECTION END

Diagnosis Procedure

INFOID:000000008139846

1. CHECK 12V BATTERY

1. Turn the ignition switch OFF to exit CONSULT.
2. Get out of the vehicle, close all doors (including trunk lid), and wait for 3 minutes or more without opening these doors.
CAUTION:

C1A74 STEERING ANGLE SENSOR

< DTC/CIRCUIT DIAGNOSIS >

Never operate the vehicle and CONSULT while waiting.

3. Check the 12V battery terminal connections. Refer to [BR-6, "Precaution for Removing 12V Battery"](#) and [PG-135, "Work Flow"](#).
4. Check the 12V battery. Refer to [PG-135, "Work Flow"](#).

Is the inspection result normal?

YES >> GO TO 2.

NO >> Repair or replace error-detected parts and GO TO 2.

2.PERFORM SELF-DIAGNOSIS (1)

ⓂWith CONSULT

1. Connect 12V battery cable to negative terminal.
2. Turn the ignition switch OFF to ON without depressing the brake pedal.
CAUTION:
Never set the vehicle to READY/Never start the engine.
3. Repeat step 2 two times or more.
CAUTION:
Be sure to wait for 5 seconds or more after turning the ignition switch OFF.
4. Turn the ignition switch OFF to exit CONSULT.
5. Get out of the vehicle, close all doors (including trunk lid), and wait for 3 minutes or more without opening these doors.
CAUTION:
Never operate the vehicle and CONSULT while waiting.
6. Turn the ignition switch ON without depressing the brake pedal.
CAUTION:
Never set the vehicle to READY/Never start the engine.
7. Start CONSULT and erase self-diagnosis result of "BRAKE".
8. Turn the ignition switch OFF to exit CONSULT.
9. Get out of the vehicle, close all doors (including trunk lid), and wait for 3 minutes or more without opening these doors.
CAUTION:
Never operate the vehicle and CONSULT while waiting.
10. Turn the ignition switch ON without depressing the brake pedal.
CAUTION:
Never set the vehicle to READY/Never start the engine.
11. Depress brake pedal by 100 mm (3.94 in) or more, and hold the position for 5 seconds or more.
12. Release brake pedal.
13. Start CONSULT and perform "BRAKE" self-diagnosis.

Is DTC "C1A74" detected?

YES >> GO TO 3.

NO >> INSPECTION END

3.CHECK CONNECTOR TERMINALS

1. Turn the ignition switch OFF to exit CONSULT.
2. Get out of the vehicle, close all doors (including trunk lid), and wait for 3 minutes or more without opening these doors.
CAUTION:
Never operate the vehicle and CONSULT while waiting.
3. Disconnect 12V battery cable from negative terminal. Refer to [BR-6, "Precaution for Removing 12V Battery"](#).
4. Disconnect the electrically-driven intelligent brake unit harness connector, then check for failures of pin terminals and connections.

Is the inspection result normal?

YES >> GO TO 5.

NO >> Repair or replace error-detected parts and GO TO 4.

4.PERFORM SELF-DIAGNOSIS (2)

ⓂWith CONSULT

1. Connect the electrically-driven intelligent brake unit harness connector.
2. Connect 12V battery cable to negative terminal.

C1A74 STEERING ANGLE SENSOR

< DTC/CIRCUIT DIAGNOSIS >

3. Turn the ignition switch OFF to ON without depressing the brake pedal.
CAUTION:
Never set the vehicle to READY/Never start the engine.
4. Repeat step 3 two times or more.
CAUTION:
Be sure to wait for 5 seconds or more after turning the ignition switch OFF.
5. Turn the ignition switch OFF to exit CONSULT.
6. Get out of the vehicle, close all doors (including trunk lid), and wait for 3 minutes or more without opening these doors.
CAUTION:
Never operate the vehicle and CONSULT while waiting.
7. Turn the ignition switch ON without depressing the brake pedal.
CAUTION:
Never set the vehicle to READY/Never start the engine.
8. Start CONSULT and erase self-diagnosis result of "BRAKE".
9. Turn the ignition switch OFF to exit CONSULT.
10. Get out of the vehicle, close all doors (including trunk lid), and wait for 3 minutes or more without opening these doors.
CAUTION:
Never operate the vehicle and CONSULT while waiting.
11. Turn the ignition switch ON without depressing the brake pedal.
CAUTION:
Never set the vehicle to READY/Never start the engine.
12. Depress brake pedal by 100 mm (3.94 in) or more, and hold the position for 5 seconds or more.
13. Release brake pedal.
14. Start CONSULT and perform "BRAKE" self-diagnosis.

Is DTC "C1A74" detected?

- YES >> GO TO 5.
NO >> INSPECTION END

5.CHECK IGNITION POWER SUPPLY

1. Turn the ignition switch OFF to exit CONSULT.
2. Get out of the vehicle, close all doors (including trunk lid), and wait for 3 minutes or more without opening these doors.
CAUTION:
Never operate the vehicle and CONSULT while waiting.
3. Disconnect 12V battery cable from negative terminal. Refer to [BR-6, "Precaution for Removing 12V Battery"](#).
4. Disconnect the electrically-driven intelligent brake unit harness connector.
5. Connect 12V battery cable to negative terminal.
6. Check voltage between the electrically-driven intelligent brake unit harness connector and ground.

Electrically-driven intelligent brake unit		—	Voltage
Connector	Terminal		
E87	26	Ground	Approx. 0 V

7. Turn the ignition switch ON without depressing the brake pedal.
CAUTION:
Never set the vehicle to READY/Never start the engine.
8. Check voltage between the electrically-driven intelligent brake unit harness connector and ground.

Electrically-driven intelligent brake unit		—	Voltage
Connector	Terminal		
E87	26	Ground	10 – 16 V

Is the inspection result normal?

- YES >> GO TO 8.
NO >> GO TO 6.

C1A74 STEERING ANGLE SENSOR

< DTC/CIRCUIT DIAGNOSIS >

6. CHECK IGNITION POWER SUPPLY CIRCUIT

1. Turn the ignition switch OFF to exit CONSULT.
2. Get out of the vehicle, close all doors (including trunk lid), and wait for 3 minutes or more without opening these doors.
CAUTION:
Never operate the vehicle and CONSULT while waiting.
3. Disconnect 12V battery cable from negative terminal. Refer to [BR-6, "Precaution for Removing 12V Battery"](#).
4. Check 10A fuse (#46).
5. Disconnect IPDM E/R harness connector.
6. Check continuity between electrically-driven intelligent brake unit and IPDM E/R.

Electrically-driven intelligent brake unit		IPDM E/R		Continuity
Connector	Terminal	Connector	Terminal	
E87	26	E5	12	Existed

7. Check continuity between electrically-driven intelligent brake unit harness connector and ground.

Electrically-driven intelligent brake unit		—	Continuity
Connector	Terminal		
E87	26	Ground	Not existed

Is the inspection result normal?

- YES >> Perform trouble diagnosis for ignition power supply. Refer to [PG-30, "Wiring Diagram - IGNITION POWER SUPPLY -"](#).
- NO >> Repair or replace error-detected parts and GO TO 7.

7. PERFORM SELF-DIAGNOSIS (3)

Ⓜ With CONSULT

1. Connect the electrically-driven intelligent brake unit harness connector.
2. Connect IPDM E/R harness connector.
3. Connect 12V battery cable to negative terminal.
4. Turn the ignition switch OFF to ON without depressing the brake pedal.
CAUTION:
Never set the vehicle to READY/Never start the engine.
5. Repeat step 4 two times or more.
CAUTION:
Be sure to wait for 5 seconds or more after turning the ignition switch OFF.
6. Turn the ignition switch OFF to exit CONSULT.
7. Get out of the vehicle, close all doors (including trunk lid), and wait for 3 minutes or more without opening these doors.
CAUTION:
Never operate the vehicle and CONSULT while waiting.
8. Turn the ignition switch ON without depressing the brake pedal.
CAUTION:
Never set the vehicle to READY/Never start the engine.
9. Start CONSULT and erase self-diagnosis result of "BRAKE".
10. Turn the ignition switch OFF to exit CONSULT.
11. Get out of the vehicle, close all doors (including trunk lid), and wait for 3 minutes or more without opening these doors.
CAUTION:
Never operate the vehicle and CONSULT while waiting.
12. Turn the ignition switch ON without depressing the brake pedal.
CAUTION:
Never set the vehicle to READY/Never start the engine.
13. Depress brake pedal by 100 mm (3.94 in) or more, and hold the position for 5 seconds or more.
14. Release brake pedal.
15. Start CONSULT and perform "BRAKE" self-diagnosis.

C1A74 STEERING ANGLE SENSOR

< DTC/CIRCUIT DIAGNOSIS >

Is DTC "C1A74" detected?

- YES >> GO TO 8.
NO >> INSPECTION END

8. CHECK 12V BATTERY POWER SUPPLY

1. Turn the ignition switch OFF to exit CONSULT.
2. Get out of the vehicle, close all doors (including trunk lid), and wait for 3 minutes or more without opening these doors.
CAUTION:
Never operate the vehicle and CONSULT while waiting.
3. Disconnect 12V battery cable from negative terminal. Refer to [BR-6. "Precaution for Removing 12V Battery"](#).
4. Disconnect the electrically-driven intelligent brake unit harness connector.
5. Connect 12V battery cable to negative terminal.
6. Check voltage between the electrically-driven intelligent brake unit harness connector terminal.

Electrically-driven intelligent brake unit		Voltage
Connector	Terminal	
E87	1 - 31	10 - 16 V
	2 - 31	
	11 - 31	

7. Turn the ignition switch ON without depressing the brake pedal.
CAUTION:
Never set the vehicle to READY/Never start the engine.
8. Check voltage between the electrically-driven intelligent brake unit harness connector terminal.

Electrically-driven intelligent brake unit		Voltage
Connector	Terminal	
E87	1 - 31	10 - 16 V
	2 - 31	
	11 - 31	

Is the inspection result normal?

- YES >> GO TO 11.
NO >> GO TO 9.

9. CHECK 12V BATTERY POWER SUPPLY CIRCUIT

1. Turn the ignition switch OFF to exit CONSULT.
2. Get out of the vehicle, close all doors (including trunk lid), and wait for 3 minutes or more without opening these doors.
CAUTION:
Never operate the vehicle and CONSULT while waiting.
3. Disconnect 12V battery cable from negative terminal. Refer to [BR-6. "Precaution for Removing 12V Battery"](#).
4. Check 50A fusible link (#D).
5. Check continuity and for short circuit between electrically-driven intelligent brake unit harness connector terminal (1) and 50A fusible link (#D).
6. Check continuity and for short circuit between electrically-driven intelligent brake unit harness connector terminal (2) and 50A fusible link (#D).
7. Check 10A fuse (#65).
8. Check continuity and for short circuit between electrically-driven intelligent brake unit harness connector terminal (11) and 10A fuse (#65).

Is the inspection result normal?

- YES >> Perform diagnosis for 12V battery power supply. Refer to [PG-14. "Wiring Diagram - BATTERY POWER SUPPLY -"](#).
NO >> Repair or replace error-detected parts and GO TO 10.

C1A74 STEERING ANGLE SENSOR

< DTC/CIRCUIT DIAGNOSIS >

10. PERFORM SELF-DIAGNOSIS (4)

Ⓜ With CONSULT

1. Connect the electrically-driven intelligent brake unit harness connector.
2. Connect 12V battery cable to negative terminal.
3. Turn the ignition switch OFF to ON without depressing the brake pedal.
CAUTION:
Never set the vehicle to READY/Never start the engine.
4. Repeat step 3 two times or more.
CAUTION:
Be sure to wait for 5 seconds or more after turning the ignition switch OFF.
5. Turn the ignition switch OFF to exit CONSULT.
6. Get out of the vehicle, close all doors (including trunk lid), and wait for 3 minutes or more without opening these doors.
CAUTION:
Never operate the vehicle and CONSULT while waiting.
7. Turn the ignition switch ON without depressing the brake pedal.
CAUTION:
Never set the vehicle to READY/Never start the engine.
8. Start CONSULT and erase self-diagnosis result of "BRAKE".
9. Turn the ignition switch OFF to exit CONSULT.
10. Get out of the vehicle, close all doors (including trunk lid), and wait for 3 minutes or more without opening these doors.
CAUTION:
Never operate the vehicle and CONSULT while waiting.
11. Turn the ignition switch ON without depressing the brake pedal.
CAUTION:
Never set the vehicle to READY/Never start the engine.
12. Depress brake pedal by 100 mm (3.94 in) or more, and hold the position for 5 seconds or more.
13. Release brake pedal.
14. Start CONSULT and perform "BRAKE" self-diagnosis.

Is DTC "C1A74" detected?

YES >> GO TO 11.

NO >> INSPECTION END

11. CHECK GROUND CIRCUIT

1. Turn the ignition switch OFF to exit CONSULT.
2. Get out of the vehicle, close all doors (including trunk lid), and wait for 3 minutes or more without opening these doors.
CAUTION:
Never operate the vehicle and CONSULT while waiting.
3. Disconnect 12V battery cable from negative terminal. Refer to [BR-6. "Precaution for Removing 12V Battery"](#).
4. Disconnect the electrically-driven intelligent brake unit harness connector.
5. Check continuity between electrically-driven intelligent brake unit and ground.

Electrically-driven intelligent brake unit		—	Continuity
Connector	Terminal		
E87	31	Ground	Existed

Is the inspection result normal?

YES >> GO TO 13.

NO >> Repair or replace error-detected parts and GO TO 12.

12. PERFORM SELF-DIAGNOSIS (5)

Ⓜ With CONSULT

1. Connect the electrically-driven intelligent brake unit harness connector.
2. Connect 12V battery cable to negative terminal.
3. Turn the ignition switch OFF to ON without depressing the brake pedal.

CAUTION:

C1A74 STEERING ANGLE SENSOR

< DTC/CIRCUIT DIAGNOSIS >

Never set the vehicle to READY/Never start the engine.

4. Repeat step 3 two times or more.

CAUTION:

Be sure to wait for 5 seconds or more after turning the ignition switch OFF.

5. Turn the ignition switch OFF to exit CONSULT.
6. Get out of the vehicle, close all doors (including trunk lid), and wait for 3 minutes or more without opening these doors.

CAUTION:

Never operate the vehicle and CONSULT while waiting.

7. Turn the ignition switch ON without depressing the brake pedal.

CAUTION:

Never set the vehicle to READY/Never start the engine.

8. Start CONSULT and erase self-diagnosis result of "BRAKE".
9. Turn the ignition switch OFF to exit CONSULT.
10. Get out of the vehicle, close all doors (including trunk lid), and wait for 3 minutes or more without opening these doors.

CAUTION:

Never operate the vehicle and CONSULT while waiting.

11. Turn the ignition switch ON without depressing the brake pedal.

CAUTION:

Never set the vehicle to READY/Never start the engine.

12. Depress brake pedal by 100 mm (3.94 in) or more, and hold the position for 5 seconds or more.
13. Release brake pedal.
14. Start CONSULT and perform "BRAKE" self-diagnosis.

Is DTC "C1A74" detected?

YES >> GO TO 13.

NO >> INSPECTION END

13.CHECK DATA MONITOR

 With CONSULT

1. Connect the electrically-driven intelligent brake unit harness connector.
2. Connect 12V battery cable to negative terminal.
3. Turn the ignition switch OFF to ON without depressing the brake pedal.

CAUTION:

Never set the vehicle to READY/Never start the engine.

4. Repeat step 3 two times or more.

CAUTION:

Be sure to wait for 5 seconds or more after turning the ignition switch OFF.

5. Start CONSULT and select "BRAKE" and "DATA MONITOR" according this order.
6. Check "MOTOR POWER SUPPLY" and "CONTROL MODULE POWER". Refer to [BR-33, "Reference Value"](#).

Is the inspection result normal?

YES >> GO TO 14.

NO >> Replace the electrically-driven intelligent brake unit. Refer to [BR-288, "Removal and installation"](#).

14.PERFORM SELF-DIAGNOSIS (6)

 With CONSULT

1. Turn the ignition switch OFF to ON without depressing the brake pedal.

CAUTION:

Never set the vehicle to READY/Never start the engine.

2. Repeat step 1 two times or more.

CAUTION:

Be sure to wait for 5 seconds or more after turning the ignition switch OFF.

3. Turn the ignition switch OFF to exit CONSULT.
4. Get out of the vehicle, close all doors (including trunk lid), and wait for 3 minutes or more without opening these doors.

CAUTION:

Never operate the vehicle and CONSULT while waiting.

5. Turn the ignition switch ON without depressing the brake pedal.

CAUTION:

C1A74 STEERING ANGLE SENSOR

< DTC/CIRCUIT DIAGNOSIS >

Never set the vehicle to READY/Never start the engine.

6. Start CONSULT and erase self-diagnosis result of "BRAKE".
7. Turn the ignition switch OFF to exit CONSULT.
8. Get out of the vehicle, close all doors (including trunk lid), and wait for 3 minutes or more without opening these doors.

CAUTION:

Never operate the vehicle and CONSULT while waiting.

9. Turn the ignition switch ON without depressing the brake pedal.

CAUTION:

Never set the vehicle to READY/Never start the engine.

10. Depress brake pedal by 100 mm (3.94 in) or more, and hold the position for 5 seconds or more.
11. Release brake pedal.
12. Start CONSULT and perform "BRAKE" self-diagnosis.

Is any DTC "C1A74" or "U1000" detected?

YES ("C1A74")>>GO TO 15.

YES ("U1000")>>Refer to [BR-229. "Diagnosis Procedure"](#).

NO >> INSPECTION END

15.PERFORM SELF-DIAGNOSIS OF ABS ACTUATOR AND CONTROL UNIT

Perform self-diagnosis for "ABS". Refer to [BRC-45. "CONSULT Function"](#).

Is any DTC detected?

YES >> Check the DTC. Refer to [BRC-57. "DTC Index"](#). GO TO 16.

NO >> GO TO 16.

16.PERFORM SELF-DIAGNOSIS (7)

 With CONSULT

1. Turn the ignition switch OFF to ON without depressing the brake pedal.

CAUTION:

Never set the vehicle to READY/Never start the engine.

2. Repeat step 1 two times or more.

CAUTION:

Be sure to wait for 5 seconds or more after turning the ignition switch OFF.

3. Turn the ignition switch OFF to exit CONSULT.
4. Get out of the vehicle, close all doors (including trunk lid), and wait for 3 minutes or more without opening these doors.

CAUTION:

Never operate the vehicle and CONSULT while waiting.

5. Turn the ignition switch ON without depressing the brake pedal.

CAUTION:

Never set the vehicle to READY/Never start the engine.

6. Start CONSULT and erase self-diagnosis result of "BRAKE".
7. Turn the ignition switch OFF to exit CONSULT.
8. Get out of the vehicle, close all doors (including trunk lid), and wait for 3 minutes or more without opening these doors.

CAUTION:

Never operate the vehicle and CONSULT while waiting.

9. Turn the ignition switch ON without depressing the brake pedal.

CAUTION:

Never set the vehicle to READY/Never start the engine.

10. Depress brake pedal by 100 mm (3.94 in) or more, and hold the position for 5 seconds or more.
11. Release brake pedal.
12. Start CONSULT and perform "BRAKE" self-diagnosis.

Is DTC "C1A74" detected?

YES >> GO TO 15.

NO >> INSPECTION END

A
B
C
D
E
BR
G
H
I
J
K
L
M
N
O
P

U1000 CAN COMM CIRCUIT

< DTC/CIRCUIT DIAGNOSIS >

U1000 CAN COMM CIRCUIT

Description

INFOID:000000008139847

CAN (Controller Area Network) is a serial communication line for real time application. It is an on-vehicle multiplex communication line with high data communication speed and excellent error detection ability. Many electronic control units are equipped onto a vehicle, and each control unit shares information and links with other control units during operation (not independent). In CAN communication, control units are connected with 2 communication lines (CAN-H line, CAN-L line) allowing a high rate of information transmission with less wiring. Each control unit transmits/receives data but selectively reads required data only.

DTC Logic

INFOID:000000008139848

DTC DETECTION LOGIC

DTC	Display item	Malfunction detection condition	Possible causes
U1000	CAN COMM CIRCUIT	Electrically-driven intelligent brake unit did not receive / transmit the CAN communication signal for 2 seconds or more.	CAN communication system malfunction

DTC CONFIRMATION PROCEDURE

1. PRECONDITIONING

If "DTC CONFIRMATION PROCEDURE" has been previously conducted, always turn the ignition switch OFF and wait at least 10 seconds before conducting the next test.

>> GO TO 2.

2. CHECK DTC DETECTION

ⓘ With CONSULT

- Turn the ignition switch OFF to ON without depressing the brake pedal.
CAUTION:
Never set the vehicle to READY/Never start the engine.
- Repeat step 1 two times or more.
CAUTION:
Be sure to wait for 5 seconds or more after turning the ignition switch OFF.
- Turn the ignition switch OFF to exit CONSULT.
- Get out of the vehicle, close all doors (including trunk lid), and wait for 3 minutes or more without opening these doors.
CAUTION:
Never operate the vehicle and CONSULT while waiting.
- Turn the ignition switch ON without depressing the brake pedal.
CAUTION:
Never set the vehicle to READY/Never start the engine.
- Start CONSULT and erase self-diagnosis result of "BRAKE".
- Turn the ignition switch OFF to exit CONSULT.
- Get out of the vehicle, close all doors (including trunk lid), and wait for 3 minutes or more without opening these doors.
CAUTION:
Never operate the vehicle and CONSULT while waiting.
- Turn the ignition switch ON without depressing the brake pedal.
CAUTION:
Never set the vehicle to READY/Never start the engine.
- Depress brake pedal by 100 mm (3.94 in) or more, and hold the position for 5 seconds or more.
- Release brake pedal.
- Start CONSULT and perform "BRAKE" self-diagnosis.

Is DTC "U1000" detected?

- YES >> Proceed to [BR-229, "Diagnosis Procedure"](#).
NO >> INSPECTION END

U1000 CAN COMM CIRCUIT

< DTC/CIRCUIT DIAGNOSIS >

Diagnosis Procedure

INFOID:000000008139849

Proceed to [LAN-19, "Trouble Diagnosis Flow Chart"](#).

A

B

C

D

E

BR

G

H

I

J

K

L

M

N

O

P

U1010 CONTROL UNIT (CAN)

< DTC/CIRCUIT DIAGNOSIS >

U1010 CONTROL UNIT (CAN)

Description

INFOID:000000008139850

CAN (Controller Area Network) is a serial communication line for real time application. It is an on-vehicle multiplex communication line with high data communication speed and excellent error detection ability. Many electronic control units are equipped onto a vehicle, and each control unit shares information and links with other control units during operation (not independent). In CAN communication, control units are connected with 2 communication lines (CAN-H line, CAN-L line) allowing a high rate of information transmission with less wiring. Each control unit transmits/receives data but selectively reads required data only.

DTC Logic

INFOID:000000008139851

DTC DETECTION LOGIC

DTC	Display item	Malfunction detection condition	Possible causes
U1010	CONTROL UNIT (CAN)	A malfunction is detected at initial diagnosis of CAN controller of electrically-driven intelligent brake unit.	Electrically-driven intelligent brake unit

DTC CONFIRMATION PROCEDURE

1. PRECONDITIONING

If "DTC CONFIRMATION PROCEDURE" has been previously conducted, always turn the ignition switch OFF and wait at least 10 seconds before conducting the next test.

>> GO TO 2.

2. CHECK DTC DETECTION

Ⓜ With CONSULT

- Turn the ignition switch OFF to ON without depressing the brake pedal.
CAUTION:
Never set the vehicle to READY/Never start the engine.
- Repeat step 1 two times or more.
CAUTION:
Be sure to wait for 5 seconds or more after turning the ignition switch OFF.
- Turn the ignition switch OFF to exit CONSULT.
- Get out of the vehicle, close all doors (including trunk lid), and wait for 3 minutes or more without opening these doors.
CAUTION:
Never operate the vehicle and CONSULT while waiting.
- Turn the ignition switch ON without depressing the brake pedal.
CAUTION:
Never set the vehicle to READY/Never start the engine.
- Start CONSULT and erase self-diagnosis result of "BRAKE".
- Turn the ignition switch OFF to exit CONSULT.
- Get out of the vehicle, close all doors (including trunk lid), and wait for 3 minutes or more without opening these doors.
CAUTION:
Never operate the vehicle and CONSULT while waiting.
- Turn the ignition switch ON without depressing the brake pedal.
CAUTION:
Never set the vehicle to READY/Never start the engine.
- Depress brake pedal by 100 mm (3.94 in) or more, and hold the position for 5 seconds or more.
- Release brake pedal.
- Start CONSULT and perform "BRAKE" self-diagnosis.

Is DTC "U1010" detected?

- YES >> Proceed to [BR-231, "Diagnosis Procedure"](#).
NO >> INSPECTION END

U1010 CONTROL UNIT (CAN)

< DTC/CIRCUIT DIAGNOSIS >

Diagnosis Procedure

INFOID:000000008139852

1. CHECK SELF-DIAGNOSIS RESULTS

Check for failures in the pin terminals and connections of the electrically-driven intelligent brake unit harness connector.

Is the inspection result normal?

- YES >> Replace the electrically-driven intelligent brake unit. Refer to [BR-288, "Removal and installation"](#).
- NO >> Repair or replace error-detected parts.

A
B
C
D
E
G
H
I
J
K
L
M
N
O
P

BR

U0424 HVAC CAN CIRCUIT 1

< DTC/CIRCUIT DIAGNOSIS >

U0424 HVAC CAN CIRCUIT 1

Description

INFOID:000000008139853

ADUS control unit reads status of signal that is transmitted from A/C auto AMP. to ADAS control unit.

DTC Logic

INFOID:000000008139854

DTC DETECTION LOGIC

DTC	Display Item	Malfunction detected condition	Possible causes
U0424	HVAC CAN CIR 1	When signal that is transmitted from A/C auto AMP. is not the latest information	A/C auto AMP.

DTC CONFIRMATION PROCEDURE

1. PRECONDITIONING

If "DTC CONFIRMATION PROCEDURE" has been previously conducted, always turn the ignition switch OFF and wait at least 10 seconds before conducting the next test.

>> GO TO 2.

2. CHECK DTC DETECTION

Ⓜ With CONSULT

1. Turn the ignition switch OFF to ON without depressing the brake pedal.
2. Perform self-diagnosis for "ICC/ADAS".

Is DTC "U1010" detected?

- YES >> Proceed to diagnosis procedure. Refer to [BR-232, "Diagnosis Procedure"](#).
NO >> INSPECTION END

Diagnosis Procedure

INFOID:000000008139855

1. PERFORM ADAS CONTROL UNIT SELF-DIAGNOSIS

Ⓜ With CONSULT

Perform self-diagnosis for "ICC/ADAS".

Are DTC "U1010" and "U0424" simultaneously detected?

- YES >> Refer to [DAS-53, "Diagnosis Procedure"](#).
NO >> Replace A/C auto AMP. Refer to [HAC-183, "Removal and Installation"](#).

U1510 ABS ACTUATOR AND ELECTRIC UNIT (CONTROL UNIT) COMMUNICATION

< DTC/CIRCUIT DIAGNOSIS >

U1510 ABS ACTUATOR AND ELECTRIC UNIT (CONTROL UNIT) COMMUNICATION

DTC Logic

INFOID:000000008139856

DTC DETECTION LOGIC

DTC	Display item	Malfunction detection condition	Possible causes
U1510	BRAKE CONTROL COMMUNICATION	Signals from brake communications line* are not sent or received continuously for 4 seconds or more.	<ul style="list-style-type: none">• Harness or connector• Electrically-driven intelligent brake unit• ABS actuator and electric unit (control unit)

*: Communications line between electrically-driven intelligent brake unit and ABS actuator control unit

DTC CONFIRMATION PROCEDURE

1. PRECONDITIONING

If "DTC CONFIRMATION PROCEDURE" has been previously conducted, always turn the ignition switch OFF and wait at least 10 seconds before conducting the next test.

>> GO TO 2.

2. CHECK DTC DETECTION

④ With CONSULT

1. Turn the ignition switch OFF to ON without depressing the brake pedal.
CAUTION:
Never set the vehicle to READY/Never start the engine.
2. Repeat step 1 two times or more.
CAUTION:
Be sure to wait for 5 seconds or more after turning the ignition switch OFF.
3. Turn the ignition switch OFF to exit CONSULT.
4. Get out of the vehicle, close all doors (including trunk lid), and wait for 3 minutes or more without opening these doors.
CAUTION:
Never operate the vehicle and CONSULT while waiting.
5. Turn the ignition switch ON without depressing the brake pedal.
CAUTION:
Never set the vehicle to READY/Never start the engine.
6. Start CONSULT and erase self-diagnosis result of "BRAKE".
7. Turn the ignition switch OFF to exit CONSULT.
8. Get out of the vehicle, close all doors (including trunk lid), and wait for 3 minutes or more without opening these doors.
CAUTION:
Never operate the vehicle and CONSULT while waiting.
9. Turn the ignition switch ON without depressing the brake pedal.
CAUTION:
Never set the vehicle to READY/Never start the engine.
10. Depress brake pedal by 100 mm (3.94 in) or more, and hold the position for 5 seconds or more.
11. Release brake pedal.
12. Start CONSULT and perform "BRAKE" self-diagnosis.

Is DTC "U1510" detected?

- YES >> Proceed to [BR-233, "Diagnosis Procedure"](#).
NO >> INSPECTION END

Diagnosis Procedure

INFOID:000000008139857

1. CHECK 12V BATTERY

U1510 ABS ACTUATOR AND ELECTRIC UNIT (CONTROL UNIT) COMMUNICATION

< DTC/CIRCUIT DIAGNOSIS >

1. Turn the ignition switch OFF to exit CONSULT.
2. Get out of the vehicle, close all doors (including trunk lid), and wait for 3 minutes or more without opening these doors.
CAUTION:
Never operate the vehicle and CONSULT while waiting.
3. Check the 12V battery terminal connections. Refer to [BR-6, "Precaution for Removing 12V Battery"](#) and [PG-135, "Work Flow"](#).
4. Check the 12V battery. Refer to [PG-135, "Work Flow"](#).

Is the inspection result normal?

- YES >> GO TO 2.
NO >> Repair or replace error-detected parts and GO TO 2.

2.PERFORM SELF-DIAGNOSIS (1)

ⓅWith CONSULT

1. Connect 12V battery cable to negative terminal.
2. Turn the ignition switch OFF to ON without depressing the brake pedal.
CAUTION:
Never set the vehicle to READY/Never start the engine.
3. Repeat step 2 two times or more.
CAUTION:
Be sure to wait for 5 seconds or more after turning the ignition switch OFF.
4. Turn the ignition switch OFF to exit CONSULT.
5. Get out of the vehicle, close all doors (including trunk lid), and wait for 3 minutes or more without opening these doors.
CAUTION:
Never operate the vehicle and CONSULT while waiting.
6. Turn the ignition switch ON without depressing the brake pedal.
CAUTION:
Never set the vehicle to READY/Never start the engine.
7. Start CONSULT and erase self-diagnosis result of "BRAKE".
8. Turn the ignition switch OFF to exit CONSULT.
9. Get out of the vehicle, close all doors (including trunk lid), and wait for 3 minutes or more without opening these doors.
CAUTION:
Never operate the vehicle and CONSULT while waiting.
10. Turn the ignition switch ON without depressing the brake pedal.
CAUTION:
Never set the vehicle to READY/Never start the engine.
11. Depress brake pedal by 100 mm (3.94 in) or more, and hold the position for 5 seconds or more.
12. Release brake pedal.
13. Start CONSULT and perform "BRAKE" self-diagnosis.

Is DTC "U1510" detected?

- YES >> GO TO 3.
NO >> INSPECTION END

3.CHECK CONNECTOR TERMINALS

1. Turn the ignition switch OFF to exit CONSULT.
2. Get out of the vehicle, close all doors (including trunk lid), and wait for 3 minutes or more without opening these doors.
CAUTION:
Never operate the vehicle and CONSULT while waiting.
3. Disconnect 12V battery cable from negative terminal. Refer to [BR-6, "Precaution for Removing 12V Battery"](#).
4. Disconnect the electrically-driven intelligent brake unit harness connector, then check for failures of pin terminals and connections.

Is the inspection result normal?

- YES >> GO TO 5.
NO >> Repair or replace error-detected parts and GO TO 4.

4.PERFORM SELF-DIAGNOSIS (2)

U1510 ABS ACTUATOR AND ELECTRIC UNIT (CONTROL UNIT) COMMUNICATION

< DTC/CIRCUIT DIAGNOSIS >

Ⓜ With CONSULT

1. Connect the electrically-driven intelligent brake unit harness connector. A
2. Connect 12V battery cable to negative terminal. B
3. Turn the ignition switch OFF to ON without depressing the brake pedal.
CAUTION:
Never set the vehicle to READY/Never start the engine. C
4. Repeat step 3 two times or more.
CAUTION:
Be sure to wait for 5 seconds or more after turning the ignition switch OFF. D
5. Turn the ignition switch OFF to exit CONSULT. E
6. Get out of the vehicle, close all doors (including trunk lid), and wait for 3 minutes or more without opening these doors.
CAUTION:
Never operate the vehicle and CONSULT while waiting. BR
7. Turn the ignition switch ON without depressing the brake pedal.
CAUTION:
Never set the vehicle to READY/Never start the engine. G
8. Start CONSULT and erase self-diagnosis result of "BRAKE". H
9. Turn the ignition switch OFF to exit CONSULT. I
10. Get out of the vehicle, close all doors (including trunk lid), and wait for 3 minutes or more without opening these doors.
CAUTION:
Never operate the vehicle and CONSULT while waiting. J
11. Turn the ignition switch ON without depressing the brake pedal.
CAUTION:
Never set the vehicle to READY/Never start the engine. K
12. Depress brake pedal by 100 mm (3.94 in) or more, and hold the position for 5 seconds or more. L
13. Release brake pedal. M
14. Start CONSULT and perform "BRAKE" self-diagnosis. N

Is DTC "U1510" detected?

YES >> GO TO 5.

NO >> INSPECTION END O

5. CHECK IGNITION POWER SUPPLY

1. Turn the ignition switch OFF to exit CONSULT. P
2. Get out of the vehicle, close all doors (including trunk lid), and wait for 3 minutes or more without opening these doors.
CAUTION:
Never operate the vehicle and CONSULT while waiting. N
3. Disconnect 12V battery cable from negative terminal. Refer to [BR-6. "Precaution for Removing 12V Battery"](#). O
4. Disconnect the electrically-driven intelligent brake unit harness connector. P
5. Connect 12V battery cable to negative terminal. M
6. Check voltage between the electrically-driven intelligent brake unit harness connector and ground. N

Electrically-driven intelligent brake unit		—	Voltage
Connector	Terminal		
E87	26	Ground	Approx. 0 V

7. Turn the ignition switch ON without depressing the brake pedal.
CAUTION:
Never set the vehicle to READY/Never start the engine. O
8. Check voltage between the electrically-driven intelligent brake unit harness connector and ground. P

Electrically-driven intelligent brake unit		—	Voltage
Connector	Terminal		
E87	26	Ground	10 – 16 V

Is the inspection result normal?

U1510 ABS ACTUATOR AND ELECTRIC UNIT (CONTROL UNIT) COMMUNICATION

< DTC/CIRCUIT DIAGNOSIS >

- YES >> GO TO 8.
NO >> GO TO 6.

6. CHECK IGNITION POWER SUPPLY CIRCUIT

1. Turn the ignition switch OFF to exit CONSULT.
2. Get out of the vehicle, close all doors (including trunk lid), and wait for 3 minutes or more without opening these doors.
CAUTION:
Never operate the vehicle and CONSULT while waiting.
3. Disconnect 12V battery cable from negative terminal. Refer to [BR-6, "Precaution for Removing 12V Battery"](#).
4. Check 10A fuse (#46).
5. Disconnect IPDM E/R harness connector.
6. Check continuity between electrically-driven intelligent brake unit and IPDM E/R.

Electrically-driven intelligent brake unit		IPDM E/R		Continuity
Connector	Terminal	Connector	Terminal	
E87	26	E5	12	Existed

7. Check continuity between electrically-driven intelligent brake unit harness connector and ground.

Electrically-driven intelligent brake unit		—	Continuity
Connector	Terminal		
E87	26	Ground	Not existed

Is the inspection result normal?

- YES >> Perform trouble diagnosis for ignition power supply. Refer to [PG-30, "Wiring Diagram - IGNITION POWER SUPPLY -"](#).
- NO >> Repair or replace error-detected parts and GO TO 7.

7. PERFORM SELF-DIAGNOSIS (3)

Ⓟ With CONSULT

1. Connect the electrically-driven intelligent brake unit harness connector.
2. Connect IPDM E/R harness connector.
3. Connect 12V battery cable to negative terminal.
4. Turn the ignition switch OFF to ON without depressing the brake pedal.
CAUTION:
Never set the vehicle to READY/Never start the engine.
5. Repeat step 4 two times or more.
CAUTION:
Be sure to wait for 5 seconds or more after turning the ignition switch OFF.
6. Turn the ignition switch OFF to exit CONSULT.
7. Get out of the vehicle, close all doors (including trunk lid), and wait for 3 minutes or more without opening these doors.
CAUTION:
Never operate the vehicle and CONSULT while waiting.
8. Turn the ignition switch ON without depressing the brake pedal.
CAUTION:
Never set the vehicle to READY/Never start the engine.
9. Start CONSULT and erase self-diagnosis result of "BRAKE".
10. Turn the ignition switch OFF to exit CONSULT.
11. Get out of the vehicle, close all doors (including trunk lid), and wait for 3 minutes or more without opening these doors.
CAUTION:
Never operate the vehicle and CONSULT while waiting.
12. Turn the ignition switch ON without depressing the brake pedal.
CAUTION:
Never set the vehicle to READY/Never start the engine.
13. Depress brake pedal by 100 mm (3.94 in) or more, and hold the position for 5 seconds or more.
14. Release brake pedal.

U1510 ABS ACTUATOR AND ELECTRIC UNIT (CONTROL UNIT) COMMUNICATION

< DTC/CIRCUIT DIAGNOSIS >

15. Start CONSULT and perform "BRAKE" self-diagnosis.

Is DTC "U1510" detected?

YES >> GO TO 8.

NO >> INSPECTION END

8. CHECK 12V BATTERY POWER SUPPLY

1. Turn the ignition switch OFF to exit CONSULT.

2. Get out of the vehicle, close all doors (including trunk lid), and wait for 3 minutes or more without opening these doors.

CAUTION:

Never operate the vehicle and CONSULT while waiting.

3. Disconnect 12V battery cable from negative terminal. Refer to [BR-6. "Precaution for Removing 12V Battery"](#).

4. Disconnect the electrically-driven intelligent brake unit harness connector.

5. Connect 12V battery cable to negative terminal.

6. Check voltage between the electrically-driven intelligent brake unit harness connector terminal.

Electrically-driven intelligent brake unit		Voltage
Connector	Terminal	
E87	1 - 31	10 - 16 V
	2 - 31	
	11 - 31	

7. Turn the ignition switch ON without depressing the brake pedal.

CAUTION:

Never set the vehicle to READY/ Never start the engine.

8. Check voltage between the electrically-driven intelligent brake unit harness connector terminal.

Electrically-driven intelligent brake unit		Voltage
Connector	Terminal	
E87	1 - 31	10 - 16 V
	2 - 31	
	11 - 31	

Is the inspection result normal?

YES >> GO TO 11.

NO >> GO TO 9.

9. CHECK 12V BATTERY POWER SUPPLY CIRCUIT

1. Turn the ignition switch OFF to exit CONSULT.

2. Get out of the vehicle, close all doors (including trunk lid), and wait for 3 minutes or more without opening these doors.

CAUTION:

Never operate the vehicle and CONSULT while waiting.

3. Disconnect 12V battery cable from negative terminal. Refer to [BR-6. "Precaution for Removing 12V Battery"](#).

4. Check 50A fusible link (#D).

5. Check continuity and for short circuit between electrically-driven intelligent brake unit harness connector terminal (1) and 50A fusible link (#D).

6. Check continuity and for short circuit between electrically-driven intelligent brake unit harness connector terminal (2) and 50A fusible link (#D).

7. Check 10A fuse (#65).

8. Check continuity and for short circuit between electrically-driven intelligent brake unit harness connector terminal (11) and 10A fuse (#65).

Is the inspection result normal?

YES >> Perform diagnosis for 12V battery power supply. Refer to [PG-14. "Wiring Diagram - BATTERY POWER SUPPLY -"](#).

U1510 ABS ACTUATOR AND ELECTRIC UNIT (CONTROL UNIT) COMMUNICATION

< DTC/CIRCUIT DIAGNOSIS >

NO >> Repair or replace error-detected parts and GO TO 10.

10. PERFORM SELF-DIAGNOSIS (1)

Ⓟ With CONSULT

1. Connect the electrically-driven intelligent brake unit harness connector.
2. Connect 12V battery cable to negative terminal.
3. Turn the ignition switch OFF to ON without depressing the brake pedal.
CAUTION:
Never set the vehicle to READY/Never start the engine.
4. Repeat step 3 two times or more.
CAUTION:
Be sure to wait for 5 seconds or more after turning the ignition switch OFF.
5. Turn the ignition switch OFF to exit CONSULT.
6. Get out of the vehicle, close all doors (including trunk lid), and wait for 3 minutes or more without opening these doors.
CAUTION:
Never operate the vehicle and CONSULT while waiting.
7. Turn the ignition switch ON without depressing the brake pedal.
CAUTION:
Never set the vehicle to READY/Never start the engine.
8. Start CONSULT and erase self-diagnosis result of "BRAKE".
9. Turn the ignition switch OFF to exit CONSULT.
10. Get out of the vehicle, close all doors (including trunk lid), and wait for 3 minutes or more without opening these doors.
CAUTION:
Never operate the vehicle and CONSULT while waiting.
11. Turn the ignition switch ON without depressing the brake pedal.
CAUTION:
Never set the vehicle to READY/Never start the engine.
12. Depress brake pedal by 100 mm (3.94 in) or more, and hold the position for 5 seconds or more.
13. Release brake pedal.
14. Start CONSULT and perform "BRAKE" self-diagnosis.

Is DTC "U1510" detected?

YES >> GO TO 4.

NO >> INSPECTION END

11. CHECK GROUND CIRCUIT

1. Turn the ignition switch OFF to exit CONSULT.
2. Get out of the vehicle, close all doors (including trunk lid), and wait for 3 minutes or more without opening these doors.
CAUTION:
Never operate the vehicle and CONSULT while waiting.
3. Disconnect 12V battery cable from negative terminal. Refer to [BR-6, "Precaution for Removing 12V Battery"](#).
4. Disconnect the electrically-driven intelligent brake unit harness connector.
5. Check continuity between electrically-driven intelligent brake unit and ground.

Electrically-driven intelligent brake unit		—	Continuity
Connector	Terminal		
E87	31	Ground	Existed

Is the inspection result normal?

YES >> GO TO 13.

NO >> Repair or replace error-detected parts and GO TO 12.

12. PERFORM SELF-DIAGNOSIS (5)

Ⓟ With CONSULT

1. Connect the electrically-driven intelligent brake unit harness connector.
2. Connect 12V battery cable to negative terminal.
3. Turn the ignition switch OFF to ON without depressing the brake pedal.

U1510 ABS ACTUATOR AND ELECTRIC UNIT (CONTROL UNIT) COMMUNICATION

< DTC/CIRCUIT DIAGNOSIS >

CAUTION:

Never set the vehicle to READY/Never start the engine.

4. Repeat step 3 two times or more.

CAUTION:

Be sure to wait for 5 seconds or more after turning the ignition switch OFF.

5. Turn the ignition switch OFF to exit CONSULT.
6. Get out of the vehicle, close all doors (including trunk lid), and wait for 3 minutes or more without opening these doors.

CAUTION:

Never operate the vehicle and CONSULT while waiting.

7. Turn the ignition switch ON without depressing the brake pedal.

CAUTION:

Never set the vehicle to READY/Never start the engine.

8. Start CONSULT and erase self-diagnosis result of "BRAKE".
9. Turn the ignition switch OFF to exit CONSULT.
10. Get out of the vehicle, close all doors (including trunk lid), and wait for 3 minutes or more without opening these doors.

CAUTION:

Never operate the vehicle and CONSULT while waiting.

11. Turn the ignition switch ON without depressing the brake pedal.

CAUTION:

Never set the vehicle to READY/Never start the engine.

12. Depress brake pedal by 100 mm (3.94 in) or more, and hold the position for 5 seconds or more.
13. Release brake pedal.
14. Start CONSULT and perform "BRAKE" self-diagnosis.

Is DTC "U1510" detected?

YES >> GO TO 13.

NO >> INSPECTION END

13. CHECK DATA MONITOR

Ⓜ With CONSULT

1. Connect the electrically-driven intelligent brake unit harness connector.
2. Connect 12V battery cable to negative terminal.
3. Turn the ignition switch OFF to ON without depressing the brake pedal.

CAUTION:

Never set the vehicle to READY/Never start the engine.

4. Repeat step 3 two times or more.

CAUTION:

Be sure to wait for 5 seconds or more after turning the ignition switch OFF.

5. Start CONSULT and select "BRAKE" and "DATA MONITOR" according to this order.
6. Check "MOTOR POWER SUPPLY" and "CONTROL MODULE POWER". Refer to [BR-33, "Reference Value"](#).

Is the inspection result normal?

YES >> GO TO 14.

NO >> Replace the electrically-driven intelligent brake unit. Refer to [BR-288, "Removal and installation"](#).

14. PERFORM SELF-DIAGNOSIS (6)

Ⓜ With CONSULT

1. Turn the ignition switch OFF to ON without depressing the brake pedal.

CAUTION:

Never set the vehicle to READY/Never start the engine.

2. Repeat step 1 two times or more.

CAUTION:

Be sure to wait for 5 seconds or more after turning the ignition switch OFF.

3. Turn the ignition switch OFF to exit CONSULT.
4. Get out of the vehicle, close all doors (including trunk lid), and wait for 3 minutes or more without opening these doors.

CAUTION:

Never operate the vehicle and CONSULT while waiting.

5. Turn the ignition switch ON without depressing the brake pedal.

U1510 ABS ACTUATOR AND ELECTRIC UNIT (CONTROL UNIT) COMMUNICATION

< DTC/CIRCUIT DIAGNOSIS >

CAUTION:

Never set the vehicle to READY/Never start the engine.

6. Start CONSULT and erase self-diagnosis result of "BRAKE".
7. Turn the ignition switch OFF to exit CONSULT.
8. Get out of the vehicle, close all doors (including trunk lid), and wait for 3 minutes or more without opening these doors.

CAUTION:

Never operate the vehicle and CONSULT while waiting.

9. Turn the ignition switch ON without depressing the brake pedal.

CAUTION:

Never set the vehicle to READY/Never start the engine.

10. Depress brake pedal by 100 mm (3.94 in) or more, and hold the position for 5 seconds or more.
11. Release brake pedal.
12. Start CONSULT and perform "BRAKE" self-diagnosis.

Is DTC "U1510" detected?

YES >> GO TO 15.

NO >> INSPECTION END

15.PERFORM SELF-DIAGNOSIS OF ABS ACTUATOR AND CONTROL UNIT

Perform self-diagnosis for "ABS". Refer to [BRC-45. "CONSULT Function"](#).

Is DTC "U110D" detected?

YES >> Perform diagnosis. Refer to [BRC-136. "Diagnosis Procedure"](#).

NO >> Replace the electrically-driven intelligent brake unit. Refer to [BR-288. "Removal and installation"](#).

U1511 BRAKE POWER SUPPLY BACKUP UNIT COMMUNICATION

< DTC/CIRCUIT DIAGNOSIS >

U1511 BRAKE POWER SUPPLY BACKUP UNIT COMMUNICATION

DTC Logic

INFOID:000000008139858

DTC DETECTION LOGIC

DTC	Display item	Malfunction detection condition	Possible causes
U1511	POWER SUPPLY BACKUP UNIT COMM	Signals from power backup communications line* are not sent or received continuously for 4 seconds or more.	<ul style="list-style-type: none">• Harness or connector• Electrically-driven intelligent brake unit• Brake power supply backup unit

*: Communications line between electrically-driven intelligent brake unit and brake power supply backup unit.

DTC CONFIRMATION PROCEDURE

1. PRECONDITIONING

If "DTC CONFIRMATION PROCEDURE" has been previously conducted, always turn the ignition switch OFF and wait at least 10 seconds before conducting the next test.

>> GO TO 2.

2. CHECK DTC DETECTION

④ With CONSULT

1. Turn the ignition switch OFF to ON without depressing the brake pedal.
CAUTION:
Never set the vehicle to READY/Never start the engine.
2. Repeat step 1 two times or more.
CAUTION:
Be sure to wait for 5 seconds or more after turning the ignition switch OFF.
3. Turn the ignition switch OFF to exit CONSULT.
4. Get out of the vehicle, close all doors (including trunk lid), and wait for 3 minutes or more without opening these doors.
CAUTION:
Never operate the vehicle and CONSULT while waiting.
5. Turn the ignition switch ON without depressing the brake pedal.
CAUTION:
Never set the vehicle to READY/Never start the engine.
6. Start CONSULT and erase self-diagnosis result of "BRAKE".
7. Turn the ignition switch OFF to exit CONSULT.
8. Get out of the vehicle, close all doors (including trunk lid), and wait for 3 minutes or more without opening these doors.
CAUTION:
Never operate the vehicle and CONSULT while waiting.
9. Turn the ignition switch ON without depressing the brake pedal.
CAUTION:
Never set the vehicle to READY/Never start the engine.
10. Depress brake pedal by 100 mm (3.94 in) or more, and hold the position for 5 seconds or more.
11. Release brake pedal.
12. Start CONSULT and perform "BRAKE" self-diagnosis.

Is DTC "U1511" detected?

- YES >> Proceed to [BR-241, "Diagnosis Procedure"](#).
NO >> INSPECTION END

Diagnosis Procedure

INFOID:000000008139859

1. CHECK 12V BATTERY

1. Turn the ignition switch OFF to exit CONSULT.

U1511 BRAKE POWER SUPPLY BACKUP UNIT COMMUNICATION

< DTC/CIRCUIT DIAGNOSIS >

2. Get out of the vehicle, close all doors (including trunk lid), and wait for 3 minutes or more without opening these doors.
CAUTION:
Never operate the vehicle and CONSULT while waiting.
3. Check the 12V battery terminal connections. Refer to [BR-6, "Precaution for Removing 12V Battery"](#) and [PG-135, "Work Flow"](#).
4. Check the 12V battery. Refer to [PG-135, "Work Flow"](#).

Is the inspection result normal?

- YES >> GO TO 2.
NO >> Repair or replace error-detected parts and GO TO 2.

2.PERFORM SELF-DIAGNOSIS (1)

ⓅWith CONSULT

1. Connect 12V battery cable to negative terminal.
2. Turn the ignition switch OFF to ON without depressing the brake pedal.
CAUTION:
Never set the vehicle to READY/Never start the engine.
3. Repeat step 2 two times or more.
CAUTION:
Be sure to wait for 5 seconds or more after turning the ignition switch OFF.
4. Turn the ignition switch OFF to exit CONSULT.
5. Get out of the vehicle, close all doors (including trunk lid), and wait for 3 minutes or more without opening these doors.
CAUTION:
Never operate the vehicle and CONSULT while waiting.
6. Turn the ignition switch ON without depressing the brake pedal.
CAUTION:
Never set the vehicle to READY/Never start the engine.
7. Start CONSULT and erase self-diagnosis result of "BRAKE".
8. Turn the ignition switch OFF to exit CONSULT.
9. Get out of the vehicle, close all doors (including trunk lid), and wait for 3 minutes or more without opening these doors.
CAUTION:
Never operate the vehicle and CONSULT while waiting.
10. Turn the ignition switch ON without depressing the brake pedal.
CAUTION:
Never set the vehicle to READY/Never start the engine.
11. Depress brake pedal by 100 mm (3.94 in) or more, and hold the position for 5 seconds or more.
12. Release brake pedal.
13. Start CONSULT and perform "BRAKE" self-diagnosis.

Is DTC "U1511" detected?

- YES >> GO TO 3.
NO >> INSPECTION END

3.CHECK CONNECTOR TERMINALS

1. Turn the ignition switch OFF to exit CONSULT.
2. Get out of the vehicle, close all doors (including trunk lid), and wait for 3 minutes or more without opening these doors.
CAUTION:
Never operate the vehicle and CONSULT while waiting.
3. Disconnect 12V battery cable from negative terminal. Refer to [BR-6, "Precaution for Removing 12V Battery"](#).
4. Disconnect the electrically-driven intelligent brake unit harness connector, then check for failures of pin terminals and connections.
5. Disconnect the brake power supply backup unit harness connector, then check for failures of pin terminals and connections.

Is the inspection result normal?

- YES >> GO TO 5.
NO >> Repair or replace error-detected parts and GO TO 4.

U1511 BRAKE POWER SUPPLY BACKUP UNIT COMMUNICATION

< DTC/CIRCUIT DIAGNOSIS >

4. PERFORM SELF-DIAGNOSIS (2)

④ With CONSULT

1. Connect the electrically-driven intelligent brake unit harness connector.
2. Connect the brake power supply backup unit harness connector.
3. Connect 12V battery cable to negative terminal.
4. Turn the ignition switch OFF to ON without depressing the brake pedal.
CAUTION:
Never set the vehicle to READY/Never start the engine.
5. Repeat step 4 two times or more.
CAUTION:
Be sure to wait for 5 seconds or more after turning the ignition switch OFF.
6. Turn the ignition switch OFF to exit CONSULT.
7. Get out of the vehicle, close all doors (including trunk lid), and wait for 3 minutes or more without opening these doors.
CAUTION:
Never operate the vehicle and CONSULT while waiting.
8. Turn the ignition switch ON without depressing the brake pedal.
CAUTION:
Never set the vehicle to READY/Never start the engine.
9. Start CONSULT and erase self-diagnosis result of "BRAKE".
10. Turn the ignition switch OFF to exit CONSULT.
11. Get out of the vehicle, close all doors (including trunk lid), and wait for 3 minutes or more without opening these doors.
CAUTION:
Never operate the vehicle and CONSULT while waiting.
12. Turn the ignition switch ON without depressing the brake pedal.
CAUTION:
Never set the vehicle to READY/Never start the engine.
13. Depress brake pedal by 100 mm (3.94 in) or more, and hold the position for 5 seconds or more.
14. Release brake pedal.
15. Start CONSULT and perform "BRAKE" self-diagnosis.

Is DTC "U1511" detected?

YES >> GO TO 5.

NO >> INSPECTION END

5. CHECK IGNITION POWER SUPPLY

1. Turn the ignition switch OFF to exit CONSULT.
2. Get out of the vehicle, close all doors (including trunk lid), and wait for 3 minutes or more without opening these doors.
CAUTION:
Never operate the vehicle and CONSULT while waiting.
3. Disconnect 12V battery cable from negative terminal. Refer to [BR-6, "Precaution for Removing 12V Battery"](#).
4. Disconnect the electrically-driven intelligent brake unit harness connector.
5. Connect 12V battery cable to negative terminal.
6. Check voltage between the electrically-driven intelligent brake unit harness connector and ground.

Electrically-driven intelligent brake unit		—	Voltage
Connector	Terminal		
E87	26	Ground	Approx. 0 V

7. Turn the ignition switch ON without depressing the brake pedal.
CAUTION:
Never set the vehicle to READY/Never start the engine.
8. Check voltage between the electrically-driven intelligent brake unit harness connector and ground.

U1511 BRAKE POWER SUPPLY BACKUP UNIT COMMUNICATION

< DTC/CIRCUIT DIAGNOSIS >

Electrically-driven intelligent brake unit		—	Voltage
Connector	Terminal		
E87	26	Ground	10 – 16 V

Is the inspection result normal?

YES >> GO TO 8.

NO >> GO TO 6.

6. CHECK IGNITION POWER SUPPLY CIRCUIT

1. Turn the ignition switch OFF to exit CONSULT.
2. Get out of the vehicle, close all doors (including trunk lid), and wait for 3 minutes or more without opening these doors.
CAUTION:
Never operate the vehicle and CONSULT while waiting.
3. Disconnect 12V battery cable from negative terminal. Refer to [BR-6, "Precaution for Removing 12V Battery"](#).
4. Check 10A fuse (#46).
5. Disconnect IPDM E/R harness connector.
6. Check continuity between electrically-driven intelligent brake unit and IPDM E/R.

Electrically-driven intelligent brake unit		IPDM E/R		Continuity
Connector	Terminal	Connector	Terminal	
E87	26	E5	12	Existed

7. Check continuity between electrically-driven intelligent brake unit harness connector and ground.

Electrically-driven intelligent brake unit		—	Continuity
Connector	Terminal		
E87	26	Ground	Not existed

Is the inspection result normal?

YES >> Perform trouble diagnosis for ignition power supply. Refer to [PG-30, "Wiring Diagram - IGNITION POWER SUPPLY -"](#).

NO >> Repair or replace error-detected parts and GO TO 7.

7. PERFORM SELF-DIAGNOSIS (3)

Ⓟ With CONSULT

1. Connect the electrically-driven intelligent brake unit harness connector.
2. Connect IPDM E/R harness connector.
3. Connect 12V battery cable to negative terminal.
4. Turn the ignition switch OFF to ON without depressing the brake pedal.
CAUTION:
Never set the vehicle to READY/Never start the engine.
5. Repeat step 4 two times or more.
CAUTION:
Be sure to wait for 5 seconds or more after turning the ignition switch OFF.
6. Turn the ignition switch OFF to exit CONSULT.
7. Get out of the vehicle, close all doors (including trunk lid), and wait for 3 minutes or more without opening these doors.
CAUTION:
Never operate the vehicle and CONSULT while waiting.
8. Turn the ignition switch ON without depressing the brake pedal.
CAUTION:
Never set the vehicle to READY/Never start the engine.
9. Start CONSULT and erase self-diagnosis result of "BRAKE".
10. Turn the ignition switch OFF to exit CONSULT.
11. Get out of the vehicle, close all doors (including trunk lid), and wait for 3 minutes or more without opening these doors.

U1511 BRAKE POWER SUPPLY BACKUP UNIT COMMUNICATION

< DTC/CIRCUIT DIAGNOSIS >

CAUTION:

Never operate the vehicle and CONSULT while waiting.

12. Turn the ignition switch ON without depressing the brake pedal.

CAUTION:

Never set the vehicle to READY/Never start the engine.

13. Depress brake pedal by 100 mm (3.94 in) or more, and hold the position for 5 seconds or more.
14. Release brake pedal.
15. Start CONSULT and perform "BRAKE" self-diagnosis.

Is DTC "U1511" detected?

YES >> GO TO 8.

NO >> INSPECTION END

8. CHECK 12V BATTERY POWER SUPPLY

1. Turn the ignition switch OFF to exit CONSULT.
2. Get out of the vehicle, close all doors (including trunk lid), and wait for 3 minutes or more without opening these doors.

CAUTION:

Never operate the vehicle and CONSULT while waiting.

3. Disconnect 12V battery cable from negative terminal. Refer to [BR-6, "Precaution for Removing 12V Battery"](#).
4. Disconnect the electrically-driven intelligent brake unit harness connector.
5. Connect 12V battery cable to negative terminal.
6. Check voltage between the electrically-driven intelligent brake unit harness connector terminal.

Electrically-driven intelligent brake unit		Voltage
Connector	Terminal	
E87	1 – 31	10 – 16 V
	2 – 31	
	11 – 31	

7. Turn the ignition switch ON without depressing the brake pedal.

CAUTION:

Never set the vehicle to READY/Never start the engine.

8. Check voltage between the electrically-driven intelligent brake unit harness connector terminal.

Electrically-driven intelligent brake unit		Voltage
Connector	Terminal	
E87	1 – 31	10 – 16 V
	2 – 31	
	11 – 31	

Is the inspection result normal?

YES >> GO TO 11.

NO >> GO TO 9.

9. CHECK 12V BATTERY POWER SUPPLY CIRCUIT

1. Turn the ignition switch OFF to exit CONSULT.
2. Get out of the vehicle, close all doors (including trunk lid), and wait for 3 minutes or more without opening these doors.

CAUTION:

Never operate the vehicle and CONSULT while waiting.

3. Disconnect 12V battery cable from negative terminal. Refer to [BR-6, "Precaution for Removing 12V Battery"](#).
4. Check 50A fusible link (#D).
5. Check continuity and for short circuit between electrically-driven intelligent brake unit harness connector terminal (1) and 50A fusible link (#D).
6. Check continuity and for short circuit between electrically-driven intelligent brake unit harness connector terminal (2) and 50A fusible link (#D).

U1511 BRAKE POWER SUPPLY BACKUP UNIT COMMUNICATION

< DTC/CIRCUIT DIAGNOSIS >

7. Check 10A fuse (#65).
8. Check continuity and for short circuit between electrically-driven intelligent brake unit harness connector terminal (11) and 10A fuse (#65).

Is the inspection result normal?

YES >> Perform trouble diagnosis for 12V battery power supply. Refer to [PG-14, "Wiring Diagram - BATTERY POWER SUPPLY -"](#).

NO >> Repair or replace error-detected parts and GO TO 10.

10.PERFORM SELF-DIAGNOSIS (4)

ⓅWith CONSULT

1. Connect the electrically-driven intelligent brake unit harness connector.
2. Connect 12V battery cable to negative terminal.
3. Turn the ignition switch OFF to ON without depressing the brake pedal.
CAUTION:
Never set the vehicle to READY/Never start the engine.
4. Repeat step 3 two times or more.
CAUTION:
Be sure to wait for 5 seconds or more after turning the ignition switch OFF.
5. Turn the ignition switch OFF to exit CONSULT.
6. Get out of the vehicle, close all doors (including trunk lid), and wait for 3 minutes or more without opening these doors.
CAUTION:
Never operate the vehicle and CONSULT while waiting.
7. Turn the ignition switch ON without depressing the brake pedal.
CAUTION:
Never set the vehicle to READY/Never start the engine.
8. Start CONSULT and erase self-diagnosis result of "BRAKE".
9. Turn the ignition switch OFF to exit CONSULT.
10. Get out of the vehicle, close all doors (including trunk lid), and wait for 3 minutes or more without opening these doors.
CAUTION:
Never operate the vehicle and CONSULT while waiting.
11. Turn the ignition switch ON without depressing the brake pedal.
CAUTION:
Never set the vehicle to READY/Never start the engine.
12. Depress brake pedal by 100 mm (3.94 in) or more, and hold the position for 5 seconds or more.
13. Release brake pedal.
14. Start CONSULT and perform "BRAKE" self-diagnosis.

Is DTC "U1511" detected?

YES >> GO TO 11.

NO >> INSPECTION END

11.CHECK GROUND CIRCUIT

1. Turn the ignition switch OFF to exit CONSULT.
2. Get out of the vehicle, close all doors (including trunk lid), and wait for 3 minutes or more without opening these doors.
CAUTION:
Never operate the vehicle and CONSULT while waiting.
3. Disconnect 12V battery cable from negative terminal. Refer to [BR-6, "Precaution for Removing 12V Battery"](#).
4. Disconnect the electrically-driven intelligent brake unit harness connector.
5. Check continuity between electrically-driven intelligent brake unit and ground.

Electrically-driven intelligent brake unit		—	Continuity
Connector	Terminal		
E87	31	Ground	Existed

Is the inspection result normal?

YES >> GO TO 13.

U1511 BRAKE POWER SUPPLY BACKUP UNIT COMMUNICATION

< DTC/CIRCUIT DIAGNOSIS >

NO >> Repair or replace error-detected parts and GO TO 12.

12.PERFORM SELF-DIAGNOSIS (5)

Ⓜ With CONSULT

1. Connect the electrically-driven intelligent brake unit harness connector.
2. Connect 12V battery cable to negative terminal.
3. Turn the ignition switch OFF to ON without depressing the brake pedal.
CAUTION:
Never set the vehicle to READY/Never start the engine.
4. Repeat step 3 two times or more.
CAUTION:
Be sure to wait for 5 seconds or more after turning the ignition switch OFF.
5. Turn the ignition switch OFF to exit CONSULT.
6. Get out of the vehicle, close all doors (including trunk lid), and wait for 3 minutes or more without opening these doors.
CAUTION:
Never operate the vehicle and CONSULT while waiting.
7. Turn the ignition switch ON without depressing the brake pedal.
CAUTION:
Never set the vehicle to READY/Never start the engine.
8. Start CONSULT and erase self-diagnosis result of "BRAKE".
9. Turn the ignition switch OFF to exit CONSULT.
10. Get out of the vehicle, close all doors (including trunk lid), and wait for 3 minutes or more without opening these doors.
CAUTION:
Never operate the vehicle and CONSULT while waiting.
11. Turn the ignition switch ON without depressing the brake pedal.
CAUTION:
Never set the vehicle to READY/Never start the engine.
12. Depress brake pedal by 100 mm (3.94 in) or more, and hold the position for 5 seconds or more.
13. Release brake pedal.
14. Start CONSULT and perform "BRAKE" self-diagnosis.

Is DTC "U1511" detected?

YES >> GO TO 13.

NO >> INSPECTION END

13.CHECK DATA MONITOR (1)

Ⓜ With CONSULT

1. Connect the electrically-driven intelligent brake unit harness connector.
2. Connect 12V battery cable to negative terminal.
3. Turn the ignition switch OFF to ON without depressing the brake pedal.
CAUTION:
Never set the vehicle to READY/Never start the engine.
4. Repeat step 3 two times or more.
CAUTION:
Be sure to wait for 5 seconds or more after turning the ignition switch OFF.
5. Start CONSULT and select "BRAKE" and "DATA MONITOR" according this order.
6. Check "MOTOR POWER SUPPLY" and "CONTROL MODULE POWER". Refer to [BR-33, "Reference Value"](#).

Is the inspection result normal?

YES >> GO TO 14.

NO >> Replace the electrically-driven intelligent brake unit. Refer to [BR-288, "Removal and installation"](#).

14.PERFORM SELF-DIAGNOSIS (6)

Ⓜ With CONSULT

1. Turn the ignition switch OFF to ON without depressing the brake pedal.
CAUTION:
Never set the vehicle to READY/Never start the engine.
2. Repeat step 1 two times or more.
CAUTION:

U1511 BRAKE POWER SUPPLY BACKUP UNIT COMMUNICATION

< DTC/CIRCUIT DIAGNOSIS >

Be sure to wait for 5 seconds or more after turning the ignition switch OFF.

3. Turn the ignition switch OFF to exit CONSULT.
4. Get out of the vehicle, close all doors (including trunk lid), and wait for 3 minutes or more without opening these doors.
CAUTION:
Never operate the vehicle and CONSULT while waiting.
5. Turn the ignition switch ON without depressing the brake pedal.
CAUTION:
Never set the vehicle to READY/Never start the engine.
6. Start CONSULT and erase self-diagnosis result of "BRAKE".
7. Turn the ignition switch OFF to exit CONSULT.
8. Get out of the vehicle, close all doors (including trunk lid), and wait for 3 minutes or more without opening these doors.
CAUTION:
Never operate the vehicle and CONSULT while waiting.
9. Turn the ignition switch ON without depressing the brake pedal.
CAUTION:
Never set the vehicle to READY/Never start the engine.
10. Depress brake pedal by 100 mm (3.94 in) or more, and hold the position for 5 seconds or more.
11. Release brake pedal.
12. Start CONSULT and perform "BRAKE" self-diagnosis.

Is DTC "U1511" detected?

YES >> GO TO 15.

NO >> INSPECTION END

15. CHECK BRAKE POWER SUPPLY BACKUP UNIT CIRCUIT

1. Turn the ignition switch OFF to exit CONSULT.
2. Get out of the vehicle, close all doors (including trunk lid), and wait for 3 minutes or more without opening these doors.
CAUTION:
Never operate the vehicle and CONSULT while waiting.
3. Disconnect 12V battery cable from negative terminal. Refer to [BR-6. "Precaution for Removing 12V Battery"](#).
4. Disconnect the electrically-driven intelligent brake unit harness connector.
5. Disconnect the brake power supply backup unit harness connector.
6. Check continuity between electrically-driven intelligent brake unit and brake power supply backup unit.

Electrically-driven intelligent brake unit		Brake power supply backup unit		Continuity
Connector	Terminal	Connector	Terminal	
E87	32	B155	2	Existed
	32		6	Not existed
	32		4	Not existed
	8		2	Not existed
	8		6	Existed
	8		4	Not existed
	10		2	Not existed
	10		6	Not existed
	10		4	Existed

7. Check continuity between electrically-driven intelligent brake unit and ground.

U1511 BRAKE POWER SUPPLY BACKUP UNIT COMMUNICATION

< DTC/CIRCUIT DIAGNOSIS >

Electrically-driven intelligent brake unit		—	Continuity
Connector	Terminal		
E87	32	Ground	Not existed
	8		Not existed
	10		Not existed
	31		Existed

Is the inspection result normal?

YES >> GO TO 16.

NO >> Repair or replace error-detected parts.

16. PERFORM SELF-DIAGNOSIS (7)

Ⓜ With CONSULT

1. Connect the electrically-driven intelligent brake unit harness connector.
2. Connect the brake power supply backup unit harness connector.
3. Connect 12V battery cable to negative terminal.
4. Turn the ignition switch OFF to ON without depressing the brake pedal.
CAUTION:
Never set the vehicle to READY/Never start the engine.
5. Repeat step 1 two times or more.
CAUTION:
Be sure to wait for 5 seconds or more after turning the ignition switch OFF.
6. Turn the ignition switch OFF to exit CONSULT.
7. Get out of the vehicle, close all doors (including trunk lid), and wait for 3 minutes or more without opening these doors.
CAUTION:
Never operate the vehicle and CONSULT while waiting.
8. Turn the ignition switch ON without depressing the brake pedal.
CAUTION:
Never set the vehicle to READY/Never start the engine.
9. Start CONSULT and erase self-diagnosis result of "BRAKE".
10. Turn the ignition switch OFF to exit CONSULT.
11. Get out of the vehicle, close all doors (including trunk lid), and wait for 3 minutes or more without opening these doors.
CAUTION:
Never operate the vehicle and CONSULT while waiting.
12. Turn the ignition switch ON without depressing the brake pedal.
CAUTION:
Never set the vehicle to READY/Never start the engine.
13. Depress brake pedal by 100 mm (3.94 in) or more, and hold the position for 5 seconds or more.
14. Release brake pedal.
15. Start CONSULT and perform "BRAKE" self-diagnosis.

Is DTC "U1511" detected?

YES >> GO TO 17.

NO >> INSPECTION END

17. REPLACE BRAKE POWER SUPPLY BACKUP UNIT

Ⓜ With CONSULT

1. Replace the brake power supply backup unit. Refer to [BR-290, "Removal and Installation"](#).
2. Connect the electrically-driven intelligent brake unit harness connector.
3. Connect 12V battery cable to negative terminal.
4. Turn the ignition switch OFF to ON without depressing the brake pedal.
CAUTION:
Never set the vehicle to READY/Never start the engine.
5. Repeat step 4 two times or more.
CAUTION:
Be sure to wait for 5 seconds or more after turning the ignition switch OFF.
6. Turn the ignition switch OFF to exit CONSULT.

U1511 BRAKE POWER SUPPLY BACKUP UNIT COMMUNICATION

< DTC/CIRCUIT DIAGNOSIS >

7. Get out of the vehicle, close all doors (including trunk lid), and wait for 3 minutes or more without opening these doors.
CAUTION:
Never operate the vehicle and CONSULT while waiting.
8. Turn the ignition switch ON without depressing the brake pedal.
CAUTION:
Never set the vehicle to READY/Never start the engine.
9. Start CONSULT and erase self-diagnosis result of "BRAKE".
10. Turn the ignition switch OFF to exit CONSULT.
11. Get out of the vehicle, close all doors (including trunk lid), and wait for 3 minutes or more without opening these doors.
CAUTION:
Never operate the vehicle and CONSULT while waiting.
12. Turn the ignition switch ON without depressing the brake pedal.
CAUTION:
Never set the vehicle to READY/Never start the engine.
13. Depress brake pedal by 100 mm (3.94 in) or more, and hold the position for 5 seconds or more.
14. Release brake pedal.
15. Start CONSULT and perform "BRAKE" self-diagnosis.

Is DTC "U1511" detected?

- YES >> Replace the electrically-driven intelligent brake unit. Refer to [BR-288, "Removal and installation"](#).
- NO >> INSPECTION END

POWER SUPPLY AND GROUND CIRCUIT

< DTC/CIRCUIT DIAGNOSIS >

POWER SUPPLY AND GROUND CIRCUIT

Diagnosis Procedure

INFOID:000000008139860

1. CHECK ELECTRICALLY-DRIVEN BRAKE UNIT IGNITION POWER SUPPLY

1. Turn the ignition switch OFF to exit CONSULT.
2. Get out of the vehicle, close all doors (including trunk lid), and wait for 3 minutes or more without opening these doors.
CAUTION:
Never operate the vehicle and CONSULT while waiting.
3. Disconnect 12V battery cable from negative terminal. Refer to [BR-6. "Precaution for Removing 12V Battery"](#).
4. Disconnect the electrically-driven intelligent brake unit harness connector.
5. Connect 12V battery cable to negative terminal.
6. Check voltage between the electrically-driven intelligent brake unit harness connector and ground.

Electrically-driven intelligent brake unit		—	Voltage
Connector	Terminal		
E87	26	Ground	Approx. 0 V

7. Turn the ignition switch ON without depressing the brake pedal.
CAUTION:
Never set the vehicle to READY/Never start the engine.
8. Check voltage between the electrically-driven intelligent brake unit harness connector and ground.

Electrically-driven intelligent brake unit		—	Voltage
Connector	Terminal		
E87	26	Ground	10 – 16 V

Is the inspection result normal?

- YES >> GO TO 3.
NO >> GO TO 2.

2. CHECK ELECTRICALLY-DRIVEN BRAKE UNIT IGNITION POWER SUPPLY CIRCUIT

1. Turn the ignition switch OFF to exit CONSULT.
2. Get out of the vehicle, close all doors (including trunk lid), and wait for 3 minutes or more without opening these doors.
CAUTION:
Never operate the vehicle and CONSULT while waiting.
3. Disconnect 12V battery cable from negative terminal. Refer to [BR-6. "Precaution for Removing 12V Battery"](#).
4. Check 10A fuse (#46).
5. Disconnect IPDM E/R harness connector.
6. Check continuity between electrically-driven intelligent brake unit harness connector and IPDM E/R harness connector.

Electrically-driven intelligent brake unit		IPDM E/R		Continuity
Connector	Terminal	Connector	Terminal	
E87	26	E5	12	Existed

7. Check continuity between electrically-driven intelligent brake unit harness connector and ground.

Electrically-driven intelligent brake unit		—	Continuity
Connector	Terminal		
E87	26	Ground	Not existed

POWER SUPPLY AND GROUND CIRCUIT

< DTC/CIRCUIT DIAGNOSIS >

Is the inspection result normal?

- YES >> Perform trouble diagnosis for ignition power supply. Refer to [PG-30, "Wiring Diagram - IGNITION POWER SUPPLY -"](#).
- NO >> Repair or replace error-detected parts.

3. CHECK ELECTRICALLY-DRIVEN INTELLIGENT BRAKE UNIT 12V BATTERY POWER SUPPLY

1. Turn the ignition switch OFF to exit CONSULT.
2. Get out of the vehicle, close all doors (including trunk lid), and wait for 3 minutes or more without opening these doors.
CAUTION:
Never operate the vehicle and CONSULT while waiting.
3. Check voltage between the electrically-driven intelligent brake unit harness connector and ground.

Electrically-driven intelligent brake unit		—	Voltage
Connector	Terminal		
E87	1	Ground	Battery voltage
	2		
	11		

4. Turn the ignition switch ON without depressing the brake pedal.
CAUTION:
Never set the vehicle to READY/Never start the engine.
5. Check voltage between the electrically-driven intelligent brake unit harness connector and ground.

Electrically-driven intelligent brake unit		—	Voltage
Connector	Terminal		
E87	1	Ground	Battery voltage
	2		
	11		

Is the inspection result normal?

- YES >> GO TO 5.
- NO >> GO TO 4.

4. CHECK ELECTRICALLY-DRIVEN INTELLIGENT BRAKE UNIT 12V BATTERY POWER SUPPLY CIRCUIT

1. Turn the ignition switch OFF to exit CONSULT.
2. Get out of the vehicle, close all doors (including trunk lid), and wait for 3 minutes or more without opening these doors.
CAUTION:
Never operate the vehicle and CONSULT while waiting.
3. Disconnect 12V battery cable from negative terminal. Refer to [BR-6, "Precaution for Removing 12V Battery"](#).
4. Check 50A fusible link (#D).
5. Check continuity and for short circuit between electrically-driven intelligent brake unit harness connector terminal (1) and 50A fusible link (#D).
6. Check continuity and for short circuit between electrically-driven intelligent brake unit harness connector terminal (2) and 50A fusible link (#D).
7. Check 10A fuse (#65).
8. Check continuity and for short circuit between electrically-driven intelligent brake unit harness connector terminal (11) and 10A fuse (#65).

Is the inspection result normal?

- YES >> Perform diagnosis for 12V battery power supply. Refer to [PG-14, "Wiring Diagram - BATTERY POWER SUPPLY -"](#).
- NO >> Repair or replace error-detected parts.

5. CHECK BRAKE POWER SUPPLY BACKUP UNIT 12V BATTERY POWER SUPPLY

POWER SUPPLY AND GROUND CIRCUIT

< DTC/CIRCUIT DIAGNOSIS >

1. Turn the ignition switch OFF to exit CONSULT.
2. Get out of the vehicle, close all doors (including trunk lid), and wait for 3 minutes or more without opening these doors.
 - CAUTION:**
 - Never operate the vehicle and CONSULT while waiting.**
3. Disconnect 12V battery cable from negative terminal. Refer to [BR-6, "Precaution for Removing 12V Battery"](#).
4. Disconnect brake power supply backup unit harness connector.
5. Connect 12V battery cable to negative terminal.
6. Check voltage between brake power supply backup unit harness connector and ground.

Brake power supply backup unit		—	Voltage
Connector	Terminal		
B155	3	Ground	Battery voltage

7. Turn the ignition switch ON without depressing the brake pedal.
 - CAUTION:**
 - Never set the vehicle to READY/Never start the engine.**
8. Check voltage between brake power supply backup unit harness connector and ground.

Brake power supply backup unit		—	Voltage
Connector	Terminal		
B155	3	Ground	Battery voltage

Is the inspection result normal?

- YES >> GO TO 6.
 NO >> GO TO 7.

6.CHECK BRAKE POWER SUPPLY BACKUP UNIT 12V BATTERY POWER SUPPLY CIRCUIT

1. Turn the ignition switch OFF to exit CONSULT.
2. Get out of the vehicle, close all doors (including trunk lid), and wait for 3 minutes or more without opening these doors.
 - CAUTION:**
 - Never operate the vehicle and CONSULT while waiting.**
3. Disconnect 12V battery cable from negative terminal. Refer to [BR-6, "Precaution for Removing 12V Battery"](#).
4. Check 15A fuse (#66).
5. Check continuity and for short circuit between brake power supply backup unit harness connector terminal (3) and 15A fuse (#66).

Is the inspection result normal?

- YES >> Perform diagnosis for 12V battery power supply. Refer to [PG-14, "Wiring Diagram - BATTERY POWER SUPPLY -"](#).
 NO >> Repair or replace error-detected parts.

7.CHECK ELECTRICALLY-DRIVEN INTELLIGENT BRAKE UNIT GROUND

Check continuity between electrically-driven intelligent brake unit harness connector and ground.

Electrically-driven intelligent brake unit		—	Continuity
Connector	Terminal		
E87	31	Ground	Existed

Is the inspection result normal?

- YES >> GO TO 8.
 NO >> Repair or replace error-detected parts.

8.CHECK BRAKE POWER SUPPLY BACKUP UNIT GROUND

Check continuity between brake power supply backup unit harness connector and ground.

POWER SUPPLY AND GROUND CIRCUIT

< DTC/CIRCUIT DIAGNOSIS >

Brake power supply backup unit		—	Continuity
Connector	Terminal		
B155	1	Ground	Existed

Is the inspection result normal?

YES >> GO TO 9.

NO >> Repair or replace error-detected parts.

9.CHECK TERMINAL

- Check for failures in the pin terminals and connections of the electrically-driven intelligent brake unit harness connector.
- Check that there is no malfunction in pin terminal and connection of IPDM E/R harness connector.
- Check for failures of pin terminals and connections in brake power supply backup unit harness connector.

Is the inspection result normal?

YES >> INSPECTION END

NO >> Repair or replace error-detected parts.

WARNING BUZZER

< DTC/CIRCUIT DIAGNOSIS >

WARNING BUZZER

Diagnosis Procedure

INFOID:000000008139861

1. CHECK ELECTRICALLY-DRIVEN INTELLIGENT BRAKE UNIT POWER SUPPLY AND GROUND

Perform diagnosis of electrically-driven intelligent brake unit power supply and ground circuits. [BR-251, "Diagnosis Procedure"](#).

Is the inspection result normal?

YES >> GO TO 2.

NO >> Repair or replace error-detected parts.

2. CHECK WARNING BUZZER CIRCUIT

1. Turn the ignition switch OFF to exit CONSULT.
2. Get out of the vehicle, close all doors (including trunk lid), and wait for 3 minutes or more without opening these doors.

CAUTION:

Never operate the vehicle and CONSULT while waiting.

3. Disconnect 12V battery cable from negative terminal. Refer to [BR-6, "Precaution for Removing 12V Battery"](#).
4. Disconnect the electrically-driven intelligent brake unit harness connector.
5. Disconnect warning buzzer harness connector.
6. Check continuity between electrically-driven intelligent brake unit and warning buzzer.

Electrically-driven intelligent brake unit		Warning buzzer		Continuity
Connector	Terminal	Connector	Terminal	
E87	22	M139	1	Existed
	25		1	Not existed
	22		2	Not existed
	25		2	Existed

Is the inspection result normal?

YES >> GO TO 3.

NO >> Repair or replace error-detected parts.

3. WARNING BUZZER INSPECTION

Check warning buzzer. Refer to [BR-255, "Component Inspection"](#).

Is the inspection result normal?

YES >> Replace the electrically-driven intelligent brake unit. Refer to [BR-288, "Removal and installation"](#).

NO >> Replace the warning buzzer.

Component Inspection

INFOID:000000008139862

1. WARNING BUZZER INSPECTION

1. Turn the ignition switch OFF to exit CONSULT.
2. Get out of the vehicle, close all doors (including trunk lid), and wait for 3 minutes or more without opening these doors.

CAUTION:

Never operate the vehicle and CONSULT while waiting.

3. Disconnect 12V battery cable from negative terminal. Refer to [BR-6, "Precaution for Removing 12V Battery"](#).
4. Disconnect warning buzzer harness connector.
5. Apply voltage of 12 V between warning buzzer connector terminals 1 and 2.

WARNING BUZZER

< DTC/CIRCUIT DIAGNOSIS >

Condition	Warning buzzer
Voltage applied	Sound
Voltage not applied	No sound

Is the inspection result normal?

YES >> INSPECTION END

NO >> Replace the warning buzzer.

BRAKE WARNING LAMP

< DTC/CIRCUIT DIAGNOSIS >

BRAKE WARNING LAMP

Component Function Check

INFOID:000000008139863

1. CHECK BRAKE WARNING LAMP FUNCTION (1)

Check that brake warning lamp turns ON for approximately several second after ignition switch is turned ON.

CAUTION:

Never set the vehicle to READY/Never start the engine.

Is the inspection result normal?

YES >> GO TO 2.

NO >> Proceed to [BR-257, "Diagnosis Procedure"](#).

2. CHECK BRAKE WARNING LAMP FUNCTION (2)

Check that brake warning lamp in combination meter turns ON or OFF when brake fluid level switch is operated while brake fluid level in reservoir tank is at the specified level.

NOTE:

Brake warning lamp turns ON when brake fluid is less than the specified level (when brake fluid level switch is ON).

Is the inspection result normal?

YES >> INSPECTION END

NO >> Check brake fluid level switch system. Refer to [BRC-117, "Diagnosis Procedure"](#).

Diagnosis Procedure

INFOID:000000008139864

1. CHECK POWER AND GROUND CIRCUITS OF ELECTRICALLY-DRIVEN INTELLIGENT BRAKE UNIT

Perform diagnosis of electrically-driven intelligent brake unit power and ground circuits. Refer to [BR-251, "Diagnosis Procedure"](#).

Is the inspection result normal?

YES >> GO TO 2.

NO >> Repair or replace error-detected parts.

2. PERFORM SELF-DIAGNOSIS

 With CONSULT

Perform "BRAKE" and "ABS" self-diagnosis.

Is malfunction detected?

YES >> Check malfunctioning system.

- "BRAKE": Refer to [BR-38, "DTC Index"](#).

- "ABS": Refer to [BRC-57, "DTC Index"](#).

NO >> GO TO 3.

3. CHECK THAT BRAKE WARNING LAMP TURNS ON

Check combination meter. Refer to [MWI-36, "CONSULT Function"](#).

Is the inspection result normal?

YES >> Replace the electrically-driven intelligent brake unit. Refer to [BR-288, "Removal and installation"](#).

NO >> Replace combination meter. Refer to [MWI-81, "Removal and Installation"](#).

A
B
C
D
E
BR
G
H
I
J
K
L
M
N
O
P

BRAKE SYSTEM WARNING LAMP

< DTC/CIRCUIT DIAGNOSIS >

BRAKE SYSTEM WARNING LAMP

Component Function Check

INFOID:000000008139865

1. CHECK BRAKE SYSTEM WARNING LAMP FUNCTION

Check that brake system warning lamp turns ON for approximately several second after ignition switch is turned ON.

CAUTION:

Never set the vehicle to READY/Never start the engine.

Is the inspection result normal?

- YES >> INSPECTION END
NO >> Proceed to [BR-258, "Diagnosis Procedure"](#).

Diagnosis Procedure

INFOID:000000008139866

1. CHECK POWER AND GROUND CIRCUITS OF ELECTRICALLY-DRIVEN INTELLIGENT BRAKE UNIT

Perform diagnosis of electrically-driven intelligent brake unit power and ground circuits. [BR-251, "Diagnosis Procedure"](#).

Is the inspection result normal?

- YES >> GO TO 2.
NO >> Repair or replace error-detected parts.

2. PERFORM SELF-DIAGNOSIS

 With CONSULT

Perform "BRAKE" and "ABS" self-diagnosis.

Is a malfunction detected?

- YES >> Check the malfunctioning system.
• "BRAKE": Refer to [BR-38, "DTC Index"](#).
• "ABS": Refer to [BRC-57, "DTC Index"](#).
NO >> GO TO 3.

3. CHECK BRAKE SYSTEM WARNING LAMP ILLUMINATION

Check combination meter. Refer to [MWI-36, "CONSULT Function"](#).

Is the inspection result normal?

- YES >> Replace the electrically-driven intelligent brake unit. Refer to [BR-288, "Removal and installation"](#).
NO >> Replace combination meter. Refer to [MWI-81, "Removal and Installation"](#).

NOISE, VIBRATION AND HARSHNESS (NVH) TROUBLESHOOTING

< SYMPTOM DIAGNOSIS >

SYMPTOM DIAGNOSIS

NOISE, VIBRATION AND HARSHNESS (NVH) TROUBLESHOOTING

NVH Troubleshooting Chart

INFOID:000000008139867

Use the chart below to find the cause of the symptom. If necessary, repair or replace these parts.

Symptom		Possible cause and SUSPECTED PARTS	Reference page																			
BRAKE	Noise	Pads - damaged																			BR-276 , BR-278	
	Shake	Pads - uneven wear																				BR-276 , BR-278
	Shimmy, Judder	Shims damaged																				BR-292 , BR-298
		Rotor imbalance																				BR-276 , BR-278
		Rotor damage																				BR-276 , BR-278
		Rotor runout																				BR-276 , BR-278
		Rotor deformation																				BR-276 , BR-278
		Rotor deflection																				BR-276 , BR-278
		Rotor rust																				BR-276 , BR-278
		Rotor thickness variation																				BR-276 , BR-278
		Drum out of round																				NVH in PB section
		PROPELLER SHAFT																				NVH in DLN section
		DIFFERENTIAL																				NVH in DLN section
		AXLE AND SUSPENSION																				NVH in FAX, RAX and FSU, RSU section
		TIRE																				NVH in WT section
		ROAD WHEEL																				NVH in WT section
		DRIVE SHAFT																				NVH in RAX section
		STEERING																				NVH in ST section

A
B
C
D
E
BR
G
H
I
J
K
L
M
N
O
P

x: Applicable

UNEXPECTED BRAKE PEDAL REACTION

< SYMPTOM DIAGNOSIS >

UNEXPECTED BRAKE PEDAL REACTION

Description

INFOID:000000008139868

A malfunction of brake pedal feel (height or others) is detected when the brake pedal is depressed.

Diagnosis Procedure

INFOID:000000008139869

1.CHECK AXLE

Check that there is no significant looseness of axle.

- Front axle: Refer to [FAX-6. "Inspection"](#).
- Rear axle: Refer to [RAX-6. "Inspection"](#).

Is the inspection result normal?

- YES >> GO TO 2.
NO >> Repair or replace error-detected parts.

2.CHECK DISC ROTOR

Check disc rotor runout.

- Front: Refer to [BR-276. "DISC ROTOR : Inspection and Adjustment"](#).
- Rear: Refer to [BR-278. "DISC ROTOR : Inspection and Adjustment"](#).

Is the inspection result normal?

- YES >> GO TO 3.
NO >> Grind disc rotor.

3.CHECK BRAKE FLUID LEAKAGE

Check the fluid leakage.

- Front: Refer to [BR-284. "FRONT : Inspection"](#).
- Rear: Refer to [BR-287. "REAR : Inspection"](#).

Is the inspection result normal?

- YES >> GO TO 4.
NO >> Repair or replace error-detected parts.

4.CHECK BRAKE PEDAL

Check the brake pedal items. Refer to [BR-270. "Inspection and Adjustment"](#).

Is the inspection result normal?

- YES >> GO TO 5.
NO >> Adjust the brake pedal items. Refer to [BR-270. "Inspection and Adjustment"](#).

5.CHECK BRAKING FORCE

Check the braking force.

Is the inspection result normal?

- YES >> GO TO 6.
NO >> Check each component of brake system.

6.CHECK BRAKE PERFORMANCE

Disconnect ABS actuator and electric unit (control unit) connector so that ABS does not operate. Check that brake force is normal in this condition. Connect harness connectors after checking.

Is the inspection result normal?

- YES >> Normal
NO >> Check each component of brake system.

THE BRAKING DISTANCE IS LONG

< SYMPTOM DIAGNOSIS >

THE BRAKING DISTANCE IS LONG

Description

INFOID:000000008139870

Brake stopping distance is long when ABS function is operated.

Diagnosis Procedure

INFOID:000000008139871

CAUTION:

Brake stopping distance on slippery road like rough road, gravel road, or snowy road may become longer when ABS is operated than when ABS is not operated.

1. CHECK 12V BATTERY

1. Turn the ignition switch OFF to exit CONSULT.
2. Get out of the vehicle, close all doors (including trunk lid), and wait for 3 minutes or more without opening these doors.

CAUTION:

Never operate the vehicle and CONSULT while waiting.

3. Check the 12V battery terminal connections. Refer to [BR-6, "Precaution for Removing 12V Battery"](#) and [PG-135, "Work Flow"](#).
4. Check the 12V battery. Refer to [PG-135, "Work Flow"](#).

Is the inspection result normal?

YES >> GO TO 2.

NO >> Repair or replace error-detected parts and GO TO 2.

2. PERFORM SELF-DIAGNOSIS (1)

 With CONSULT

1. Connect 12V battery cable to negative terminal.
2. Turn the ignition switch OFF to ON without depressing the brake pedal.

CAUTION:

Never set the vehicle to READY/Never start the engine.

3. Repeat step 2 two times or more.

CAUTION:

Be sure to wait for 5 seconds or more after turning the ignition switch OFF.

4. Turn the ignition switch OFF to exit CONSULT.
5. Get out of the vehicle, close all doors (including trunk lid), and wait for 3 minutes or more without opening these doors.

CAUTION:

Never operate the vehicle and CONSULT while waiting.

6. Turn the ignition switch ON without depressing the brake pedal.

CAUTION:

Never set the vehicle to READY/Never start the engine.

7. Start CONSULT and erase self-diagnosis result of "BRAKE".
8. Turn the ignition switch OFF to exit CONSULT.
9. Get out of the vehicle, close all doors (including trunk lid), and wait for 3 minutes or more without opening these doors.

CAUTION:

Never operate the vehicle and CONSULT while waiting.

10. Turn the ignition switch ON without depressing the brake pedal.

CAUTION:

Never set the vehicle to READY/Never start the engine.

11. Depress brake pedal by 100 mm (3.94 in) or more, and hold the position for 5 seconds or more.
12. Release brake pedal.
13. Start CONSULT and perform "BRAKE" self-diagnosis.

Is DTC "C1A74" detected?

YES >> GO TO 3.

NO >> INSPECTION END

3. CHECK CONNECTOR TERMINALS

1. Turn the ignition switch OFF to exit CONSULT.

THE BRAKING DISTANCE IS LONG

< SYMPTOM DIAGNOSIS >

2. Get out of the vehicle, close all doors (including trunk lid), and wait for 3 minutes or more without opening these doors.
CAUTION:
Never operate the vehicle and CONSULT while waiting.
3. Disconnect 12V battery cable from negative terminal. Refer to [BR-6, "Precaution for Removing 12V Battery"](#).
4. Disconnect the electrically-driven intelligent brake unit harness connector, then check for failures of pin terminals and connections.

Is the inspection result normal?

- YES >> GO TO 5.
NO >> Repair or replace error-detected parts and GO TO 4.

4.PERFORM SELF-DIAGNOSIS (2)

ⓅWith CONSULT

1. Connect the electrically-driven intelligent brake unit harness connector.
2. Connect 12V battery cable to negative terminal.
3. Turn the ignition switch OFF to ON without depressing the brake pedal.
CAUTION:
Never set the vehicle to READY/Never start the engine.
4. Repeat step 3 two times or more.
CAUTION:
Be sure to wait for 5 seconds or more after turning the ignition switch OFF.
5. Turn the ignition switch OFF to exit CONSULT.
6. Get out of the vehicle, close all doors (including trunk lid), and wait for 3 minutes or more without opening these doors.
CAUTION:
Never operate the vehicle and CONSULT while waiting.
7. Turn the ignition switch ON without depressing the brake pedal.
CAUTION:
Never set the vehicle to READY/Never start the engine.
8. Start CONSULT and erase self-diagnosis result of "BRAKE".
9. Turn the ignition switch OFF to exit CONSULT.
10. Get out of the vehicle, close all doors (including trunk lid), and wait for 3 minutes or more without opening these doors.
CAUTION:
Never operate the vehicle and CONSULT while waiting.
11. Turn the ignition switch ON without depressing the brake pedal.
CAUTION:
Never set the vehicle to READY/Never start the engine.
12. Depress brake pedal by 100 mm (3.94 in) or more, and hold the position for 5 seconds or more.
13. Release brake pedal.
14. Start CONSULT and perform "BRAKE" self-diagnosis.

Is any DTC detected?

- YES >> Check the DTC. Refer to [BR-38, "DTC Index"](#). GO TO 5.
NO >> INSPECTION END

5.CHECK IGNITION POWER SUPPLY

1. Turn the ignition switch OFF to exit CONSULT.
2. Get out of the vehicle, close all doors (including trunk lid), and wait for 3 minutes or more without opening these doors.
CAUTION:
Never operate the vehicle and CONSULT while waiting.
3. Disconnect 12V battery cable from negative terminal. Refer to [BR-6, "Precaution for Removing 12V Battery"](#).
4. Disconnect the electrically-driven intelligent brake unit harness connector.
5. Connect 12V battery cable to negative terminal.
6. Check voltage between the electrically-driven intelligent brake unit harness connector and ground.

THE BRAKING DISTANCE IS LONG

< SYMPTOM DIAGNOSIS >

Electrically-driven intelligent brake unit		—	Voltage
Connector	Terminal		
E87	26	Ground	Approx. 0 V

7. Turn the ignition switch ON without depressing the brake pedal.

CAUTION:

Never set the vehicle to READY/Never start the engine.

8. Check voltage between the electrically-driven intelligent brake unit harness connector and ground.

Electrically-driven intelligent brake unit		—	Voltage
Connector	Terminal		
E87	26	Ground	10 – 16 V

Is the inspection result normal?

YES >> GO TO 8.

NO >> GO TO 6.

6. CHECK IGNITION POWER SUPPLY CIRCUIT

1. Turn the ignition switch OFF to exit CONSULT.

2. Get out of the vehicle, close all doors (including trunk lid), and wait for 3 minutes or more without opening these doors.

CAUTION:

Never operate the vehicle and CONSULT while waiting.

3. Disconnect 12V battery cable from negative terminal. Refer to [BR-6, "Precaution for Removing 12V Battery"](#).

4. Check 10A fuse (#46).

5. Disconnect IPDM E/R harness connector.

6. Check continuity between electrically-driven intelligent brake unit and IPDM E/R.

Electrically-driven intelligent brake unit		IPDM E/R		Continuity
Connector	Terminal	Connector	Terminal	
E87	26	E5	12	Existed

7. Check continuity between electrically-driven intelligent brake unit harness connector and ground.

Electrically-driven intelligent brake unit		—	Continuity
Connector	Terminal		
E87	26	Ground	Not existed

Is the inspection result normal?

YES >> Perform trouble diagnosis for ignition power supply. Refer to [PG-30, "Wiring Diagram - IGNITION POWER SUPPLY -"](#).

NO >> Repair or replace error-detected parts and GO TO 7.

7. PERFORM SELF-DIAGNOSIS (3)

Ⓜ With CONSULT

1. Connect the electrically-driven intelligent brake unit harness connector.

2. Connect IPDM E/R harness connector.

3. Connect 12V battery cable to negative terminal.

4. Turn the ignition switch OFF to ON without depressing the brake pedal.

CAUTION:

Never set the vehicle to READY/Never start the engine.

5. Repeat step 4 two times or more.

CAUTION:

Be sure to wait for 5 seconds or more after turning the ignition switch OFF.

6. Turn the ignition switch OFF to exit CONSULT.

THE BRAKING DISTANCE IS LONG

< SYMPTOM DIAGNOSIS >

7. Get out of the vehicle, close all doors (including trunk lid), and wait for 3 minutes or more without opening these doors.
CAUTION:
Never operate the vehicle and CONSULT while waiting.
8. Turn the ignition switch ON without depressing the brake pedal.
CAUTION:
Never set the vehicle to READY/Never start the engine.
9. Start CONSULT and erase self-diagnosis result of "BRAKE".
10. Turn the ignition switch OFF to exit CONSULT.
11. Get out of the vehicle, close all doors (including trunk lid), and wait for 3 minutes or more without opening these doors.
CAUTION:
Never operate the vehicle and CONSULT while waiting.
12. Turn the ignition switch ON without depressing the brake pedal.
CAUTION:
Never set the vehicle to READY/Never start the engine.
13. Depress brake pedal by 100 mm (3.94 in) or more, and hold the position for 5 seconds or more.
14. Release brake pedal.
15. Start CONSULT and perform "BRAKE" self-diagnosis.

Is any DTC detected?

- YES >> Check the DTC. Refer to [BR-38, "DTC Index"](#). GO TO 8.
NO >> INSPECTION END

8. CHECK 12V BATTERY POWER SUPPLY

1. Turn the ignition switch OFF to exit CONSULT.
2. Get out of the vehicle, close all doors (including trunk lid), and wait for 3 minutes or more without opening these doors.
CAUTION:
Never operate the vehicle and CONSULT while waiting.
3. Disconnect 12V battery cable from negative terminal. Refer to [BR-6, "Precaution for Removing 12V Battery"](#).
4. Disconnect the electrically-driven intelligent brake unit harness connector.
5. Connect 12V battery cable to negative terminal.
6. Check voltage between the electrically-driven intelligent brake unit harness connector terminal.

Electrically-driven intelligent brake unit		Voltage
Connector	Terminal	
E87	1 - 31	10 - 16 V
	2 - 31	
	11 - 31	

7. Turn the ignition switch ON without depressing the brake pedal.
CAUTION:
Never set the vehicle to READY/Never start the engine.
8. Check voltage between the electrically-driven intelligent brake unit harness connector terminal.

Electrically-driven intelligent brake unit		Voltage
Connector	Terminal	
E87	1 - 31	10 - 16 V
	2 - 31	
	11 - 31	

Is the inspection result normal?

- YES >> GO TO 11.
NO >> GO TO 9.

9. CHECK 12V BATTERY POWER SUPPLY CIRCUIT

1. Turn the ignition switch OFF to exit CONSULT.

THE BRAKING DISTANCE IS LONG

< SYMPTOM DIAGNOSIS >

2. Get out of the vehicle, close all doors (including trunk lid), and wait for 3 minutes or more without opening these doors.
CAUTION:
Never operate the vehicle and CONSULT while waiting.
3. Disconnect 12V battery cable from negative terminal. Refer to [BR-6, "Precaution for Removing 12V Battery"](#).
4. Check 50A fusible link (#D).
5. Check continuity and for short circuit between electrically-driven intelligent brake unit harness connector terminal (1) and 50A fusible link (#D).
6. Check continuity and for short circuit between electrically-driven intelligent brake unit harness connector terminal (2) and 50A fusible link (#D).
7. Check 10A fuse (#65).
8. Check continuity and for short circuit between electrically-driven intelligent brake unit harness connector terminal (11) and 10A fuse (#65).

Is the inspection result normal?

YES >> Perform diagnosis for 12V battery power supply. Refer to [PG-14, "Wiring Diagram - BATTERY POWER SUPPLY -"](#).

NO >> Repair or replace error-detected parts and GO TO 10.

10. PERFORM SELF-DIAGNOSIS (4)

Ⓜ With CONSULT

1. Connect the electrically-driven intelligent brake unit harness connector.
2. Connect 12V battery cable to negative terminal.
3. Turn the ignition switch OFF to ON without depressing the brake pedal.
CAUTION:
Never set the vehicle to READY/Never start the engine.
4. Repeat step 3 two times or more.
CAUTION:
Be sure to wait for 5 seconds or more after turning the ignition switch OFF.
5. Turn the ignition switch OFF to exit CONSULT.
6. Get out of the vehicle, close all doors (including trunk lid), and wait for 3 minutes or more without opening these doors.
CAUTION:
Never operate the vehicle and CONSULT while waiting.
7. Turn the ignition switch ON without depressing the brake pedal.
CAUTION:
Never set the vehicle to READY/Never start the engine.
8. Start CONSULT and erase self-diagnosis result of "BRAKE".
9. Turn the ignition switch OFF to exit CONSULT.
10. Get out of the vehicle, close all doors (including trunk lid), and wait for 3 minutes or more without opening these doors.
CAUTION:
Never operate the vehicle and CONSULT while waiting.
11. Turn the ignition switch ON without depressing the brake pedal.
CAUTION:
Never set the vehicle to READY/Never start the engine.
12. Depress brake pedal by 100 mm (3.94 in) or more, and hold the position for 5 seconds or more.
13. Release brake pedal.
14. Start CONSULT and perform "BRAKE" self-diagnosis.

Is any DTC detected?

YES >> Check the DTC. Refer to [BR-38, "DTC Index"](#). GO TO 11.

NO >> INSPECTION END

11. CHECK GROUND CIRCUIT

1. Turn the ignition switch OFF to exit CONSULT.
2. Get out of the vehicle, close all doors (including trunk lid), and wait for 3 minutes or more without opening these doors.
CAUTION:
Never operate the vehicle and CONSULT while waiting.

THE BRAKING DISTANCE IS LONG

< SYMPTOM DIAGNOSIS >

3. Disconnect 12V battery cable from negative terminal. Refer to [BR-6. "Precaution for Removing 12V Battery"](#).
4. Disconnect the electrically-driven intelligent brake unit harness connector.
5. Check continuity between electrically-driven intelligent brake unit and ground.

Electrically-driven intelligent brake unit		—	Continuity
Connector	Terminal		
E87	31	Ground	Existed

Is the inspection result normal?

YES >> GO TO 13.

NO >> Repair or replace error-detected parts and GO TO 12.

12.PERFORM SELF-DIAGNOSIS (5)

Ⓜ With CONSULT

1. Connect the electrically-driven intelligent brake unit harness connector.
2. Connect 12V battery cable to negative terminal.
3. Turn the ignition switch OFF to ON without depressing the brake pedal.
CAUTION:
Never set the vehicle to READY/Never start the engine.
4. Repeat step 3 two times or more.
CAUTION:
Be sure to wait for 5 seconds or more after turning the ignition switch OFF.
5. Turn the ignition switch OFF to exit CONSULT.
6. Get out of the vehicle, close all doors (including trunk lid), and wait for 3 minutes or more without opening these doors.
CAUTION:
Never operate the vehicle and CONSULT while waiting.
7. Turn the ignition switch ON without depressing the brake pedal.
CAUTION:
Never set the vehicle to READY/Never start the engine.
8. Start CONSULT and erase self-diagnosis result of "BRAKE".
9. Turn the ignition switch OFF to exit CONSULT.
10. Get out of the vehicle, close all doors (including trunk lid), and wait for 3 minutes or more without opening these doors.
CAUTION:
Never operate the vehicle and CONSULT while waiting.
11. Turn the ignition switch ON without depressing the brake pedal.
CAUTION:
Never set the vehicle to READY/Never start the engine.
12. Depress brake pedal by 100 mm (3.94 in) or more, and hold the position for 5 seconds or more.
13. Release brake pedal.
14. Start CONSULT and perform "BRAKE" self-diagnosis.

Is any DTC detected?

YES >> Check the DTC. Refer to [BR-38. "DTC Index"](#). GO TO 13.

NO >> INSPECTION END

13.CHECK DATA MONITOR

Ⓜ With CONSULT

1. Connect the electrically-driven intelligent brake unit harness connector.
2. Connect 12V battery cable to negative terminal.
3. Turn the ignition switch OFF to ON without depressing the brake pedal.
CAUTION:
Never set the vehicle to READY/Never start the engine.
4. Repeat step 3 two times or more.
CAUTION:
Be sure to wait for 5 seconds or more after turning the ignition switch OFF.
5. Start CONSULT and select "BRAKE" and "DATA MONITOR" according this order.
6. Check "MOTOR POWER SUPPLY" and "CONTROL MODULE POWER". Refer to [BR-33. "Reference Value"](#).

THE BRAKING DISTANCE IS LONG

< SYMPTOM DIAGNOSIS >

Is the inspection result normal?

YES >> GO TO 14.

NO >> Replace the electrically-driven intelligent brake unit. Refer to [BR-288. "Removal and installation"](#).

14.PERFORM SELF-DIAGNOSIS (6)

With CONSULT

1. Turn the ignition switch OFF to ON without depressing the brake pedal.

CAUTION:

Never set the vehicle to READY/Never start the engine.

2. Repeat step 1 two times or more.

CAUTION:

Be sure to wait for 5 seconds or more after turning the ignition switch OFF.

3. Turn the ignition switch OFF to exit CONSULT.

4. Get out of the vehicle, close all doors (including trunk lid), and wait for 3 minutes or more without opening these doors.

CAUTION:

Never operate the vehicle and CONSULT while waiting.

5. Turn the ignition switch ON without depressing the brake pedal.

CAUTION:

Never set the vehicle to READY/Never start the engine.

6. Start CONSULT and erase self-diagnosis result of "BRAKE".

7. Turn the ignition switch OFF to exit CONSULT.

8. Get out of the vehicle, close all doors (including trunk lid), and wait for 3 minutes or more without opening these doors.

CAUTION:

Never operate the vehicle and CONSULT while waiting.

9. Turn the ignition switch ON without depressing the brake pedal.

CAUTION:

Never set the vehicle to READY/Never start the engine.

10. Depress brake pedal by 100 mm (3.94 in) or more, and hold the position for 5 seconds or more.

11. Release brake pedal.

12. Start CONSULT and perform "BRAKE" self-diagnosis.

Is any DTC detected?

YES >> Check the DTC. Refer to [BR-38. "DTC Index"](#).

NO >> GO TO 15.

15.CHECK BRAKING FORCE

Check the braking force.

Is the inspection result normal?

YES >> GO TO 16.

NO >> Check each component of brake system.

16.CHECK BRAKE PERFORMANCE

Turn the ignition switch OFF to exit CONSULT. Disconnect ABS actuator control unit harness connector so that ABS does not operate. Check brake stopping distance in this condition. Connect harness connectors after checking.

Is the inspection result normal?

YES >> Normal

NO >> Check each component of brake system.

A
B
C
D
E
BR
G
H
I
J
K
L
M
N
O
P

VEHICLE JERKS DURING

< SYMPTOM DIAGNOSIS >

VEHICLE JERKS DURING

Description

INFOID:000000008139872

The vehicle jerks when VDC function, TCS function, ABS function, EBD function, brake LSD function, brake assist function, hill start assist function Active Trace Control function, Rise-up & Build-up function or Brake force distribution function operates.

Diagnosis Procedure

INFOID:000000008139873

1. CHECK SYMPTOM

Check whether or not the vehicle jerks when VDC function, TCS function, ABS function, EBD function, brake LSD function, brake assist function, hill start assist function Active Trace Control function, Rise-up & Build-up function or Brake force distribution function operates.

Is the inspection result normal?

- YES >> Normal
- NO >> GO TO 2.

2. PERFORM SELF-DIAGNOSIS

 With CONSULT

Perform self-diagnosis for "BRAKE".

Is any DTC detected?

- YES >> Check the DTC. Refer to [BR-38. "DTC Index"](#).
- NO >> Perform symptom diagnosis for VDC function, TCS function, ABS function, EBD function, brake LSD function, brake assist function and Brake force distribution function. Refer to [BRC-156. "Diagnosis Procedure"](#) GO TO 3.

3. CHECK CONNECTOR

 With CONSULT

1. Turn the ignition switch OFF to exit CONSULT.
2. Get out of the vehicle, close all doors (including trunk lid), and wait for 3 minutes or more without opening these doors.

CAUTION:

Never operate the vehicle and CONSULT while waiting.

3. Disconnect 12V battery cable from negative terminal. Refer to [BR-6. "Precaution for Removing 12V Battery"](#).
4. Disconnect the electrically-driven intelligent brake unit harness connector.
5. Disconnect ABS actuator and electric unit (control) unit harness connector.
6. Check connector terminal for deformation, disconnection, or looseness.
7. Connect harness connector and perform self-diagnosis for "BRAKE" again.

Is the inspection result normal?

- YES >> GO TO 4.
- NO >> Poor connection of connector terminal. Repair or replace connector terminal.

4. CHECK HPCM, ECM, TCM SELF DIAGNOSIS RESULT ITEMS

 With CONSULT

Perform self-diagnosis for "EV/HEV", "ENGINE" and "TRANSMISSION".

- "EV/HEV": Refer to [HBC-49. "CONSULT Function"](#).
- "ENGINE": Refer to [EC-53. "CONSULT Function"](#).
- "TRANSMISSION": Refer to [TM-64. "CONSULT Function"](#).

Is any DTC detected?

- YES >> Check the DTC.
 - "EV/HEV": Refer to [HBC-71. "DTC Index"](#).
 - "ENGINE": Refer to [EC-81. "DTC Index"](#).
 - "TRANSMISSION": Refer to [TM-80. "DTC Index"](#).
- NO >> Replace ABS actuator and electric unit (control unit). Refer to [BRC-163. "Removal and Installation"](#).

NORMAL OPERATING CONDITION

< SYMPTOM DIAGNOSIS >

NORMAL OPERATING CONDITION

Description

INFOID:000000008139874

Symptom	Result
Under normal control, the brake pedal may move during the operation of Active Stability Assist, LDW, LDP, Intelligent brake assist, or ICC.	This occurs when the electrically-driven intelligent brake unit is operating normally and is not a malfunction.
When the brake pedal is depressed while the ignition switch is OFF, an operating sound may occur or the pedal stroke may feel short.	
There may be an operating noise or the brake pedal may move after the brake pedal is operated.	
The driver may feel shorter pedal stroke when depressing the brake pedal during the operation of Active Stability Assist, LDW, LDP, Intelligent brake assist, or ICC.	
The driver may feel deceleration when VDC starts during steering operation.	
The brake pedal may move when ABS starts immediately after the ignition switch is turned ON.	
The brake pedal may not return to the original position during the operation of the hill start assist function.	This is not a malfunction. Under the normal operation of the electrically-driven intelligent brake, the brake pedal returns to the original position when the accelerator pedal is depressed.
An operating noise may occur when the ignition switch turned OFF (system stop sound).	This is not a malfunction. Under normal operation of the electrically-driven intelligent brake, an operating noise is generated when the system stops.
After turning the ignition switch OFF and waiting for a few minutes in the car (with all doors closed and brake pedal not depressed), the electrically-driven intelligent brake unit goes into sleep mode. If the brake pedal is depressed after the unit goes into sleep mode, the brake pedal operation may be felt awkward or the depth of pedal depression insufficient for a little while.	This is not a malfunction. Depress the brake pedal fully.

A
B
C
D
E
BR
G
H
I
J
K
L
M
N
O
P

BRAKE PEDAL

< PERIODIC MAINTENANCE >

PERIODIC MAINTENANCE

BRAKE PEDAL

Inspection and Adjustment

INFOID:000000008139875

INSPECTION

Brake Pedal Height

Check the brake pedal height (H_1) between the dash lower panel (1) and the brake pedal upper surface.

H_1 : Refer to [BR-304, "Brake Pedal"](#).

CAUTION:

Perform it with the floor trim removed.

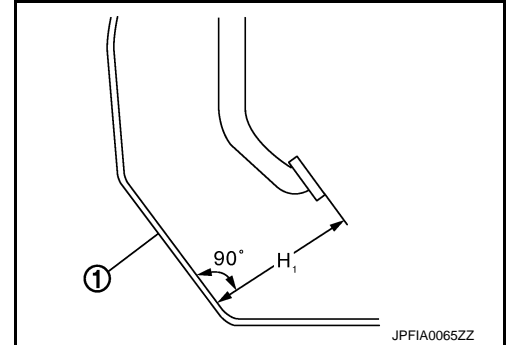

Stop Lamp Switch and ICC Brake Switch

Check the clearance (C) between the stopper rubber (1) and the stop lamp switch and ICC brake switch (2) threaded end.

C : Refer to [BR-304, "Brake Pedal"](#).

CAUTION:

The stop lamp must turn OFF when the brake pedal is released.

NOTE:

Pull the brake pedal pad to make the clearance between the stop lamp switch and ICC brake switch threaded end and the stopper rubber.

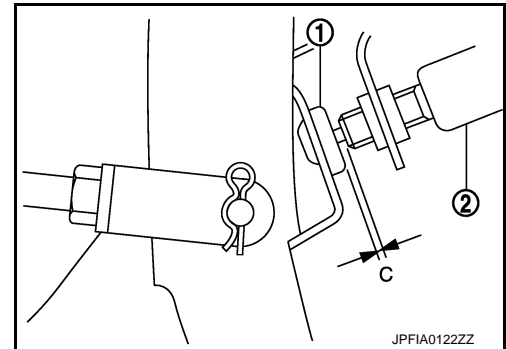

Brake Pedal Play

Press the brake pedal. Check the brake pedal play (A) (stroke until fluid pressure occurs).

A : Refer to [BR-304, "Brake Pedal"](#).

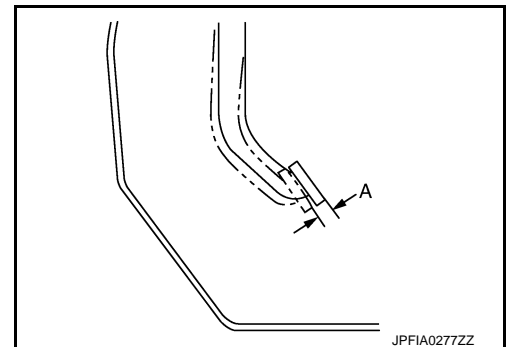

Depressed Brake Pedal Height

Check the height between the dash lower panel (1) and the top face of the brake pedal (H_2) when depressing the brake pedal with a force of 196 N (20 kg, 44 lb) while the engine is running/READY state.

H_2 : Refer to [BR-304, "Brake Pedal"](#).

CAUTION:

Perform it with the floor trim removed.

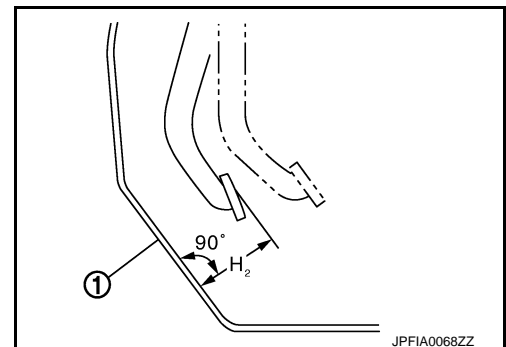

ADJUSTMENT

BRAKE PEDAL

< PERIODIC MAINTENANCE >

Brake Pedal Height

1. Remove instrument lower panel LH. Refer to [IP-13, "Removal and Installation"](#).
2. Disconnect the stop lamp switch harness connector and the ICC brake switch harness connector.
3. Loosen the stop lamp switch and ICC brake switch by turning it 45° counterclockwise.
4. Loosen the input rod lock nut (1).
5. Rotate the input rod (2), and adjust the brake pedal to the specified height.

CAUTION:

The threaded end of the input rod must project to the inner side of the clevis (3).

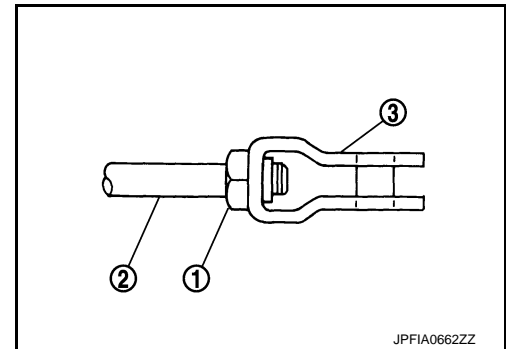

H₁ : Refer to [BR-304, "Brake Pedal"](#).

6. Tighten the lock nut. Refer to [BR-288, "Exploded View"](#).
7. Adjust the clearance between the stopper rubber and the stop lamp switch and ICC brake switch threaded end after adjusting the brake pedal height.
8. Perform stroke sensor 0-point learning. Refer to [BR-47, "Work Procedure"](#).

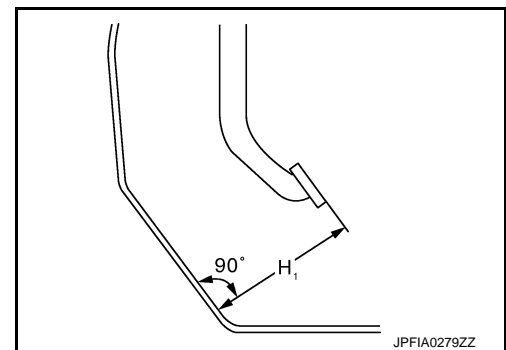

Stop Lamp Switch and ICC Brake Switch

1. Remove instrument lower panel LH. Refer to [IP-13, "Removal and Installation"](#).
2. Disconnect the stop lamp switch harness connector and the ICC brake switch harness connector.
3. Loosen the stop lamp switch and ICC brake switch by turning it 45° counterclockwise.
4. Press-fit the stop lamp switch and ICC brake switch (2) until the stop lamp switch and ICC brake switch hits the stopper rubber (1) 45° clockwise while pulling the brake pedal pad slightly.

CAUTION:

- The clearance (C) between the stopper rubber and stop lamp switch and ICC brake switch threaded end and must be the specified value.

C : Refer to [BR-304, "Brake Pedal"](#).

- The stop lamp must turn OFF when the brake pedal is released.

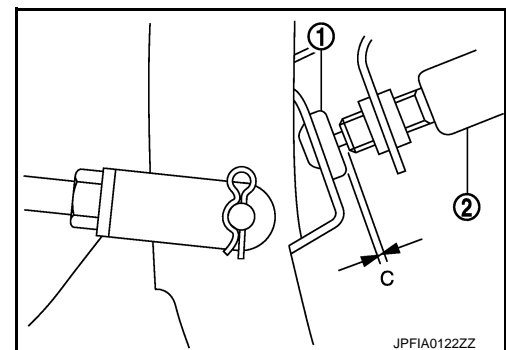

5. Perform stroke sensor 0-point learning. Refer to [BR-47, "Work Procedure"](#).

Brake Pedal Play

1. Remove instrument lower panel LH. Refer to [IP-13, "Removal and Installation"](#).
2. Disconnect the stop lamp switch harness connector and the ICC brake switch harness connector.
3. Loosen the stop lamp switch and ICC brake switch by turning it 45° counterclockwise.

BRAKE PEDAL

< PERIODIC MAINTENANCE >

4. Press-fit the stop lamp switch and ICC brake switch (2) until the stop lamp switch and ICC brake switch hits the stopper rubber (1) 45° clockwise while pulling the brake pedal pad slightly.

CAUTION:

- The clearance (C) between the stopper rubber and stop lamp switch and ICC brake switch threaded end and must be the specified value.

C : Refer to [BR-304, "Brake Pedal"](#).

- The stop lamp must turn OFF when the brake pedal is released.

5. Perform stroke sensor 0-point learning. Refer to [BR-47, "Work Procedure"](#).

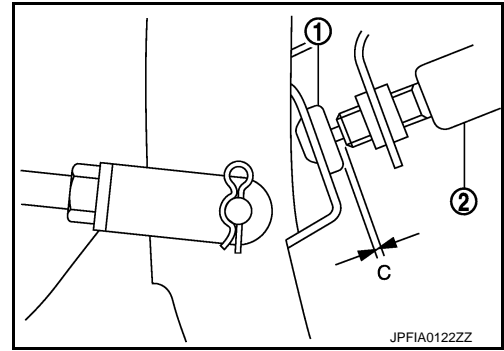

Depressed Brake Pedal Height

1. Perform the air bleeding. Refer to [BR-274, "Bleeding Brake System"](#).
2. Check the height between the dash lower panel (1) and the top face of the brake pedal (H_2) when depressing the brake pedal with a force of 196 N (20 kg, 44 lb) while the engine is running/RAEDY state.

H₂ : Refer to [BR-304, "Brake Pedal"](#).

CAUTION:

Perform it with the floor trim removed.

3. Adjust the brake pedal play after adjusting the brake pedal height, clearance between the stopper rubber and the stop lamp switch and ICC brake switch threaded end.
4. Perform stroke sensor 0-point learning. Refer to [BR-47, "Work Procedure"](#).

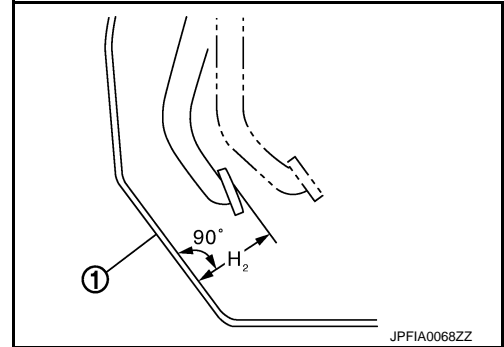

BRAKE FLUID

< PERIODIC MAINTENANCE >

BRAKE FLUID

Inspection

INFOID:000000008139876

BRAKE FLUID LEVEL

- Check that the fluid level in the reservoir tank is within the specified range (MAX – MIN lines).
- Visually check for any brake fluid leakage around the reservoir tank.
- Check the brake system for any leakage if the fluid level is extremely low (lower than MIN).
- Check the brake system for fluid leakage if the warning lamp remains illuminated even after the parking brake is released.
- Check the reservoir tank for the mixing of foreign matter (e.g. dust) and oils other than brake fluid.

BRAKE LINE

1. Check brake line (tubes and hoses) for cracks, deterioration or other damage. Replace any damaged parts.
2. Depress the brake pedal with a force of 490 N (50 kg, 110 lb) and hold down the pedal for approx. 5 seconds with the engine running/READY state. Check for any fluid leakage.

CAUTION:

Retighten the applicable connection to the specified torque and repair any abnormal (damaged, worn or deformed) part if any brake fluid leakage is present.

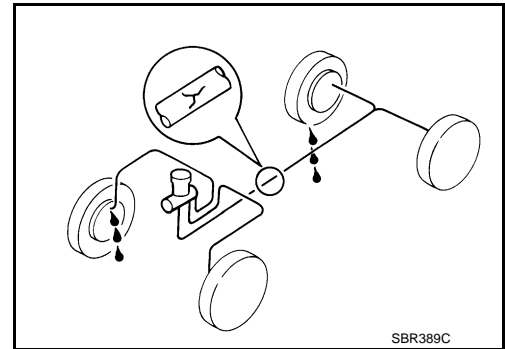

Draining

INFOID:000000008139877

CAUTION:

- **Never spill or splash brake fluid on painted surfaces. Brake fluid may seriously damage paint. Wipe it off immediately and wash with water if it gets on a painted surface. However avoid washing brake components with water.**
- **Before performing work, turn the ignition switch OFF and disconnect the ABS actuator control unit harness connector or disconnect the 12V battery cable from the negative terminal. Refer to [BR-6](#), "[Precaution for Removing 12V Battery](#)".**
- **Never operate the vehicle and CONSULT while waiting.**
- **If the brake fluid adheres to the brake caliper assembly and disc rotor, quickly wipe it off.**

1. Connect a vinyl tube to the bleed valve.
2. Depress the brake pedal and loosen the bleeder valve to gradually discharge brake fluid.

CAUTION:

Cover crowfoot and flare nut wrench with a cloth as not to damage the brake caliper assembly.

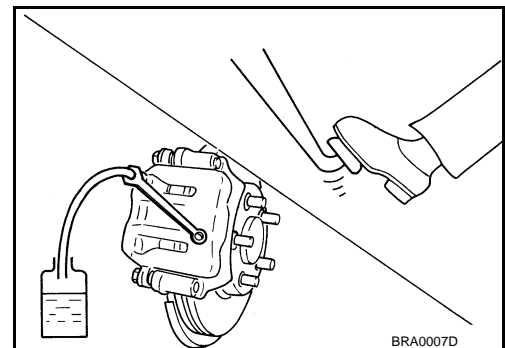

Refilling

INFOID:000000008139878

CAUTION:

If the brake fluid adheres to the brake caliper assembly and disc rotor, quickly wipe it off.

1. Check that there is no foreign material in the reservoir tank, and refill with new brake fluid.

CAUTION:

- **Never reuse drained brake fluid.**
- **Never allow oils other than brake fluid to enter the reservoir tank.**

BRAKE FLUID

< PERIODIC MAINTENANCE >

2. Loosen the bleeder valve, slowly depress the brake pedal to the full stroke, and then release the pedal. Repeat this operation at intervals of 2 or 3 seconds until all brake fluid is discharged. Then close the bleeder valve with the brake pedal depressed. Repeat the same work on each wheel.

CAUTION:

Cover crowfoot and flare nut wrench with a cloth as not to damage the brake caliper assembly.

3. Perform the air bleeding. Refer to [BR-274, "Bleeding Brake System"](#).

Bleeding Brake System

INFOID:000000008139879

CAUTION:

- Turn the ignition switch ON without depressing the brake pedal when performing the procedure.
- Monitor the fluid level in the reservoir tank while performing the air bleeding.
- If the brake fluid adheres to the brake caliper assembly and disc rotor, quickly wipe it off.

1. Check that there is no foreign material in the reservoir tank, and refill with new brake fluid.

CAUTION:

- Never reuse drained brake fluid.
- Never allow oils other than brake fluid to enter the reservoir tank.

2. Connect a vinyl tube to the bleeder valve of the rear right brake.
3. Fully depress the brake pedal 4 to 5 times.
4. Loosen the bleeder valve and bleed air with the brake pedal depressed, and then quickly tighten the bleeder valve.
5. Repeat steps 3 and 4 until all of the air is out of the brake line.
6. Tighten the bleeder valve to the specified torque.
 - Front disc brake: Refer to [BR-292, "BRAKE CALIPER ASSEMBLY : Exploded View"](#).
 - Rear disc brake: Refer to [BR-298, "BRAKE CALIPER ASSEMBLY : Exploded View"](#).
7. Repeat steps 2 to 6. Occasionally fill with the brake fluid in order to keep the reservoir tank at least half full. Bleed air in the following order: rear right brake → front left brake → rear left brake → front right brake.
8. Check that the fluid level in the reservoir tank is within the specified range after air bleeding.
9. Check each item of brake pedal. Adjust it if the measurement value is not the standard. Refer to [BR-270, "Inspection and Adjustment"](#).

ELECTRICALLY-DRIVEN INTELLIGENT BRAKE UNIT

< PERIODIC MAINTENANCE >

ELECTRICALLY-DRIVEN INTELLIGENT BRAKE UNIT

Inspection

INFOID:000000008139880

Brake fluid leakage

Check for brake fluid leakage from the brake tube connections and the electrically-driven intelligent brake unit.

A

B

C

D

E

BR

G

H

I

J

K

L

M

N

O

P

FRONT DISC BRAKE

< PERIODIC MAINTENANCE >

FRONT DISC BRAKE

BRAKE PAD

BRAKE PAD : Inspection and Adjustment

INFOID:000000008139881

INSPECTION

Check the brake pad wear thickness from an inspection hole on cylinder body. Check using a scale if necessary.

Wear thickness : Refer to [BR-304, "Front Disc Brake"](#).

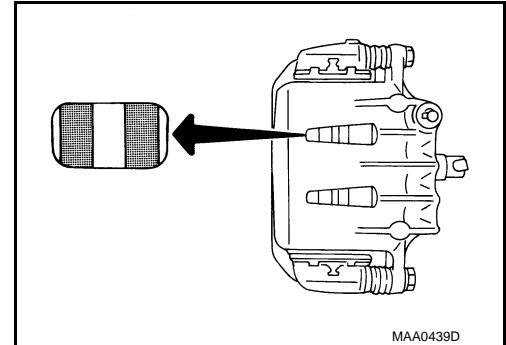

ADJUSTMENT

CAUTION:

- Burnish contact surfaces between pads according to the following procedure after refinishing or replacing brake pads, or if a soft pedal occurs at very low mileage.
- Be careful of vehicle speed because the brake does not operate firmly/securely until pads and disc rotor are securely fitted.
- Only perform this procedure under safe road and traffic conditions. Use extreme caution.

1. Drive vehicle on straight, flat road.
2. Depress brake pedal with the power to stop vehicle within 3 to 5 seconds until the vehicle stops.
3. Drive without depressing brake for a few minutes to cool the brake.
4. Repeat steps 1 to 3 until pad and disc rotor are securely fitted.

DISC ROTOR

DISC ROTOR : Inspection and Adjustment

INFOID:000000008139882

INSPECTION

Appearance

Check surface of disc rotor for uneven wear, cracks, and serious damage. Replace it if necessary. Refer to [FAX-7, "Removal and Installation"](#).

Runout

1. Fix the disc rotor to the wheel hub and bearing assembly with wheel nuts (2 points at least).
2. Check the wheel bearing axial end play before the inspection. Refer to [FAX-6, "Inspection"](#).
3. Inspect the runout with a dial indicator to measure at 10 mm (0.39 in) inside the disc edge.

Runout : Refer to [BR-304, "Front Disc Brake"](#).

4. Find the installation position that has a minimum runout by shifting the disc rotor-to-wheel hub and bearing assembly installation position by one hole at a time if the runout exceeds the limit value.
5. Refinish the disc rotor if the runout is outside the limit even after performing the above operation. [When refinishing, use the Pro-Cut PEM On-Car brake Lathe (Tool No. 38-PFM90.5) or equivalent.]

CAUTION:

- Check in advance that the thickness of the disc rotor is wear thickness + 0.3 mm (0.012 in) or more.

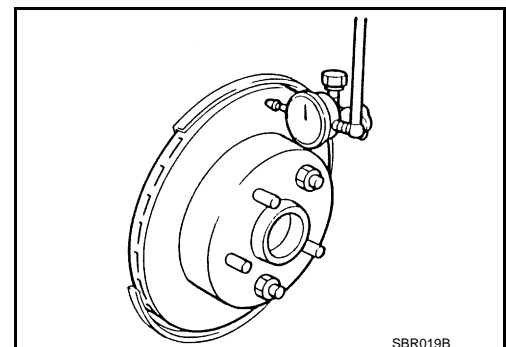

FRONT DISC BRAKE

< PERIODIC MAINTENANCE >

- If the thickness is less than wear thickness + 0.3 mm (0.012 in), replace the disc rotor. Refer to [FAX-7, "Removal and Installation"](#).

Wear thickness : Refer to [BR-304, "Front Disc Brake"](#).

Thickness

Check the thickness of the disc rotor using a micrometer. Replace the disc rotor if the thickness is below the wear limit. Refer to [FAX-7, "Removal and Installation"](#).

Wear thickness : Refer to [BR-304, "Front Disc Brake"](#).

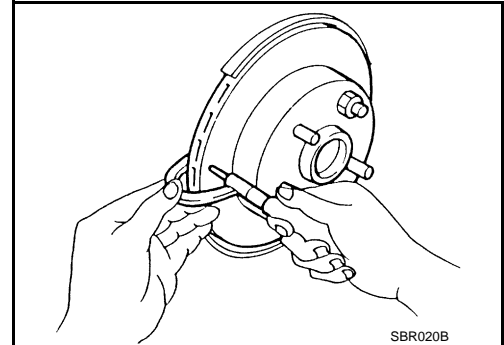

ADJUSTMENT

CAUTION:

- Burnish contact surfaces between pads according to the following procedure after refinishing or replacing pads, or if a soft pedal occurs at very low mileage.
 - Be careful of vehicle speed because the brake does not operate firmly/securely until pads and disc rotor are securely fitted.
 - Only perform this procedure under safe road and traffic conditions. Use extreme caution.
1. Drive vehicle on straight, flat road.
 2. Depress brake pedal with the power to stop vehicle within 3 to 5 seconds until the vehicle stops.
 3. Drive without depressing brake for a few minutes to cool the brake.
 4. Repeat steps 1 to 3 until pad and disc rotor are securely fitted.

REAR DISC BRAKE

< PERIODIC MAINTENANCE >

REAR DISC BRAKE

BRAKE PAD

BRAKE PAD : Inspection and Adjustment

INFOID:000000008139883

INSPECTION

Check the brake pad wear thickness from an inspection hole on cylinder body. Check using a scale if necessary.

Wear thickness : Refer to [BR-304, "Rear Disc Brake"](#).

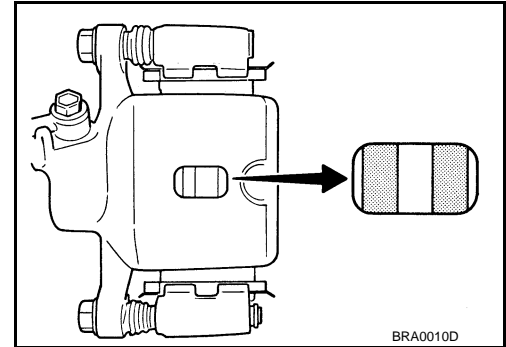

ADJUSTMENT

CAUTION:

- Burnish contact surfaces between pads according to the following procedure after refinishing or replacing brake pads, or if a soft pedal occurs at very low mileage.
- Be careful of vehicle speed because the brake does not operate firmly/securely until pads and disc rotor are securely fitted.
- Only perform this procedure under safe road and traffic conditions. Use extreme caution.

1. Drive vehicle on straight, flat road.
2. Depress brake pedal with the power to stop vehicle within 3 to 5 seconds until the vehicle stops.
3. Drive without depressing brake for a few minutes to cool the brake.
4. Repeat steps 1 to 3 until pad and disc rotor are securely fitted.

DISC ROTOR

DISC ROTOR : Inspection and Adjustment

INFOID:000000008139884

INSPECTION

Appearance

Check surface of disc rotor for uneven wear, cracks, and serious damage. Replace it if necessary. Refer to [RAX-8, "Removal and Installation"](#).

Runout

1. Fix the disc rotor to the wheel hub and bearing assembly with wheel nuts (2 points at least).
2. Check the wheel bearing axial end play before the inspection. Refer to [RAX-6, "Inspection"](#).
3. Inspect the runout with a dial indicator to measure at 10 mm (0.39 in) inside the disc edge.

Runout : Refer to [BR-304, "Rear Disc Brake"](#).

4. Find the installation position that has a minimum runout by shifting the disc rotor-to-wheel hub and bearing assembly installation position by one hole at a time if the runout exceeds the limit value.
5. Refinish the disc rotor if the runout is outside the limit even after performing the above operation. [When refinishing, use the Pro-Cut PEM On-Car brake Lathe (Tool No. 38-PFM90.5) or equivalent.]

CAUTION:

- Check in advance that the thickness of the disc rotor is wear thickness + 0.3 mm (0.012 in) or more.

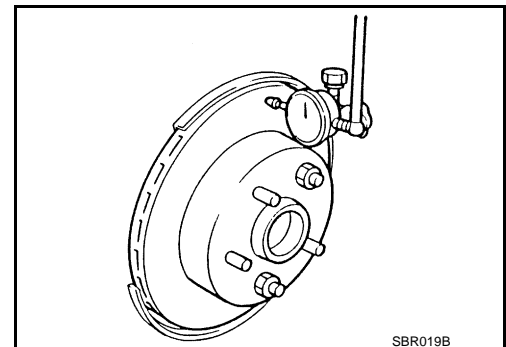

REAR DISC BRAKE

< PERIODIC MAINTENANCE >

- If the thickness is less than wear thickness + 0.3 mm (0.012 in), replace the disc rotor. Refer to [RAX-8, "Removal and Installation"](#).

Wear thickness : Refer to [BR-304, "Rear Disc Brake"](#).

Thickness

Check the thickness of the disc rotor using a micrometer. Replace the disc rotor if the thickness is below the wear limit. Refer to [RAX-8, "Removal and Installation"](#).

Wear thickness : Refer to [BR-304, "Rear Disc Brake"](#).

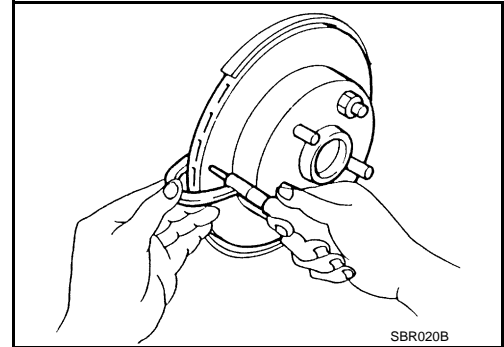

ADJUSTMENT

CAUTION:

- Burnish contact surfaces between pads according to the following procedure after refinishing or replacing pads, or if a soft pedal occurs at very low mileage.
 - Be careful of vehicle speed because the brake does not operate firmly/securely until pads and disc rotor are securely fitted.
 - Only perform this procedure under safe road and traffic conditions. Use extreme caution.
1. Drive vehicle on straight, flat road.
 2. Depress brake pedal with the power to stop vehicle within 3 to 5 seconds until the vehicle stops.
 3. Drive without depressing brake for a few minutes to cool the brake.
 4. Repeat steps 1 to 3 until pad and disc rotor are securely fitted.

BRAKE PEDAL

< REMOVAL AND INSTALLATION >

REMOVAL AND INSTALLATION

BRAKE PEDAL

Exploded View

INFOID:000000008139885

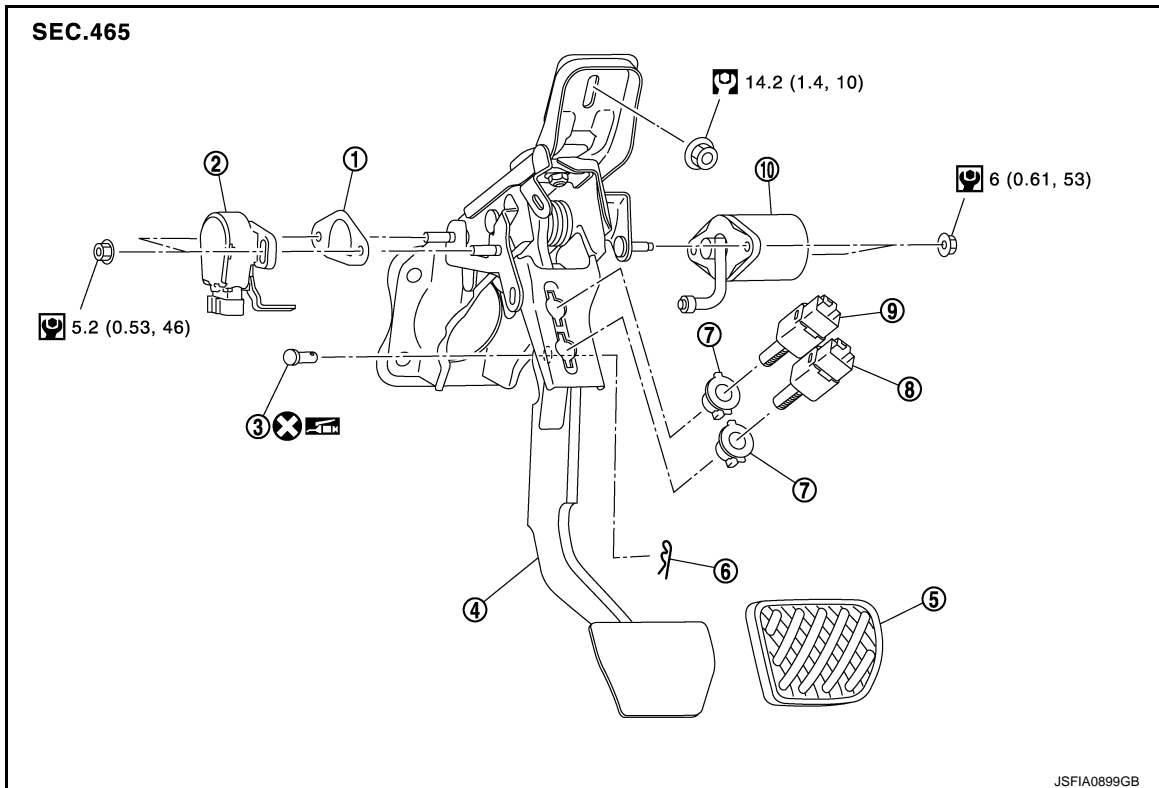

- | | | |
|------------------------------|------------------------|---------------------|
| 1. Plate | 2. Pedal stroke sensor | 3. Clevis pin |
| 4. Brake pedal assembly | 5. Brake pedal pad | 6. Snap pin |
| 7. Clip | 8. ICC brake switch | 9. Stop lamp switch |
| 10. Hysteresis unit assembly | | |

: Apply multi-purpose grease.

Refer to [GI-5. "Components"](#) for symbols not described on the above.

Removal and Installation

INFOID:000000008139886

REMOVAL

1. Remove the instrument lower panel LH. Refer to [IP-13. "Removal and Installation"](#).
2. Disconnect the brake pedal stroke sensor harness connector.
3. Disconnect the stop lamp switch harness connector and ICC brake switch harness connectors.
4. Rotate the stop lamp switch and the ICC brake switch counterclockwise to remove.
5. Remove the accelerator pedal.
 - Models without distance control assist system: Refer to [ACC-3. "MODELS WITHOUT DISTANCE CONTROL ASSIST SYSTEM : Removal and Installation"](#).
 - Models with distance control assist system: Refer to [ACC-4. "MODELS WITH DISTANCE CONTROL ASSIST SYSTEM : Removal and Installation"](#).
6. Remove the lower shaft.
 - With heated steering wheel: Refer to [ST-34. "Removal and Installation"](#).
 - Without heated steering wheel: Refer to [ST-61. "Removal and Installation"](#).
7. Remove the snap pin, and then remove the clevis pin from the clevis of brake booster.
8. Remove the BCM. Refer to [BCS-80. "Removal and Installation"](#).

BRAKE PEDAL

< REMOVAL AND INSTALLATION >

9. Remove the brake pedal assembly.

CAUTION:

- Hold the electrically-driven intelligent brake unit so as not to drop out or contact them other parts.
- Never allow the stroke of brake pedal after removal.
- If the brake pedal is displaced, move it by 100 mm (3.94 in) to check that the hysteresis unit assembly moves in conjunction with brake pedal. If a malfunction exists, replace hysteresis unit assembly.

10. Remove hysteresis unit assembly from brake pedal assembly.

CAUTION:

Never drop hysteresis unit assembly.

11. Remove the stroke sensor from brake pedal assembly.

CAUTION:

Never drop stroke sensor.

12. Perform inspection after removal. Refer to [BR-281, "Inspection and Adjustment"](#).

INSTALLATION

Note the following, and install in the reverse order of removal.

- Never allow the stroke of brake pedal.

CAUTION:

If the brake pedal is displaced, move it by 100 mm (3.94 in) to check that the hysteresis unit assembly moves in conjunction with brake pedal. If a malfunction exists, replace hysteresis unit assembly.

- Never reuse the clevis pin.
- Brake pedal assembly must be replaced after an impact.
- Apply the multi-purpose grease to the clevis pin and the matching faces.

NOTE:

The clevis pin may be inserted in either direction.

- Perform stroke sensor 0 point learning when brake pedal assembly removed and installed, or replaced. Refer to [BR-47, "Work Procedure"](#).
- To install pedal stroke sensor, securely insert rib (A) of pedal stroke sensor (1) into hole (B) of plate (2).
- Perform stroke sensor 0 point learning when pedal stroke sensor removed and installed, or replaced. Refer to [BR-47, "Work Procedure"](#).

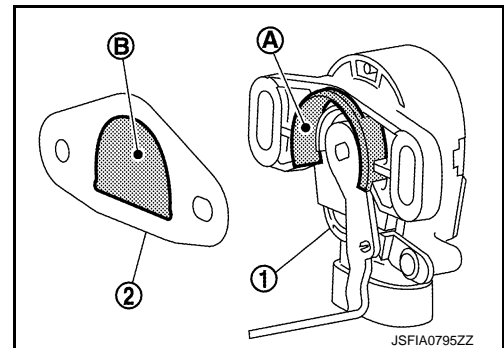

INFOID:000000008139887

Inspection and Adjustment

INSPECTION AFTER REMOVAL

- Check the brake pedal for bend, damage, and cracks on the welded parts, and replace the brake pedal assembly if necessary.
- Move it by 100 mm (3.94 in) to check that the hysteresis unit assembly moves in conjunction with brake pedal. If a malfunction exists, replace hysteresis unit assembly.

ADJUSTMENT AFTER INSTALLATION

Perform the brake pedal adjustment after installing the brake pedal assembly. Refer to [BR-270, "Inspection and Adjustment"](#).

BRAKE PIPING

< REMOVAL AND INSTALLATION >

BRAKE PIPING FRONT

FRONT : Exploded View

INFOID:000000008139888

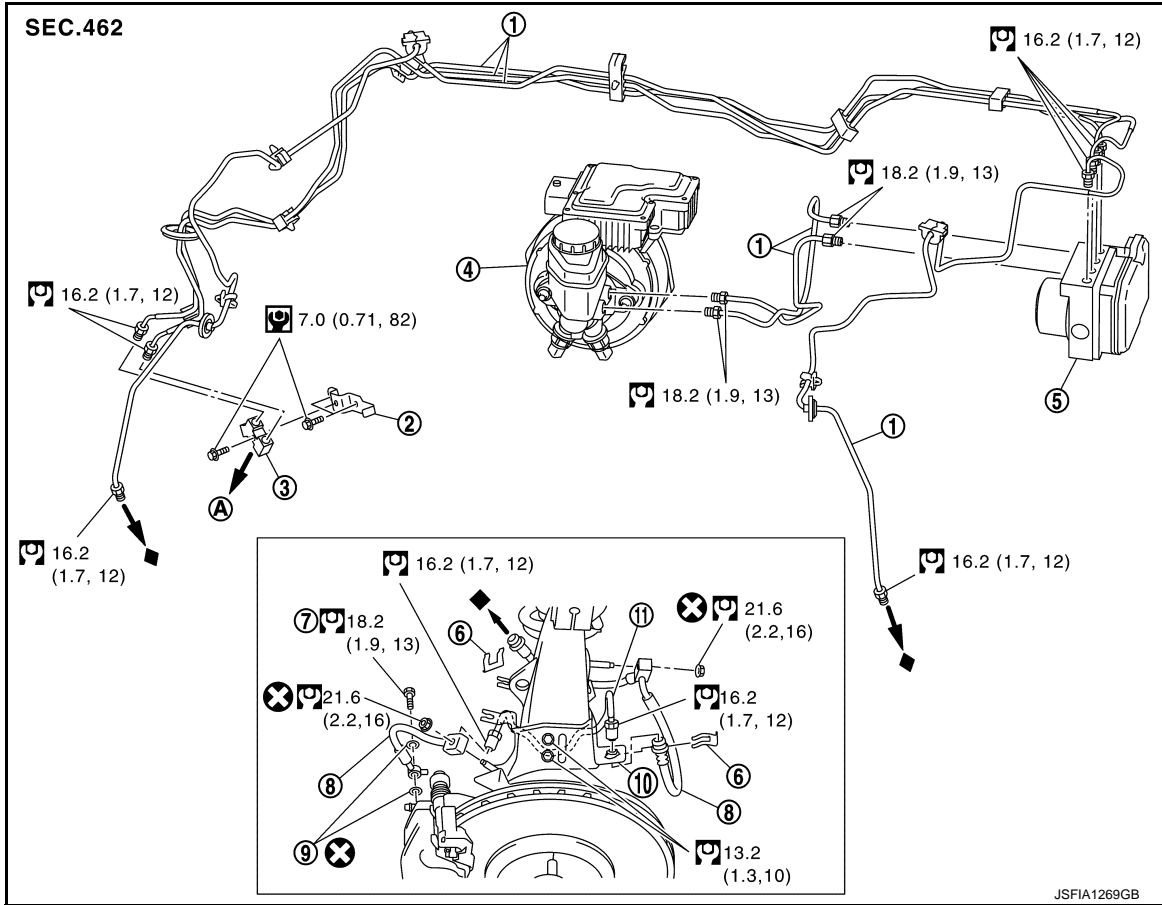

- | | | |
|---|--|------------------|
| 1. Brake tube | 2. Connector bracket | 3. Connector |
| 4. Electrically-driven intelligent brake unit | 5. ABS actuator and electric unit (control unit) | 6. Lock plate |
| 7. Union bolt | 8. Brake hose | 9. Copper washer |
| 10. Brake hose bracket | 11. Brake tube | |
| A. To rear brake tube | | |

◆: Indicates that the part is connected at points with same symbol in actual vehicle.

Refer to [GI-5, "Components"](#) for symbols in the figure.

BRAKE PIPING

< REMOVAL AND INSTALLATION >

FRONT : Hydraulic Piping

INFOID:000000008139889

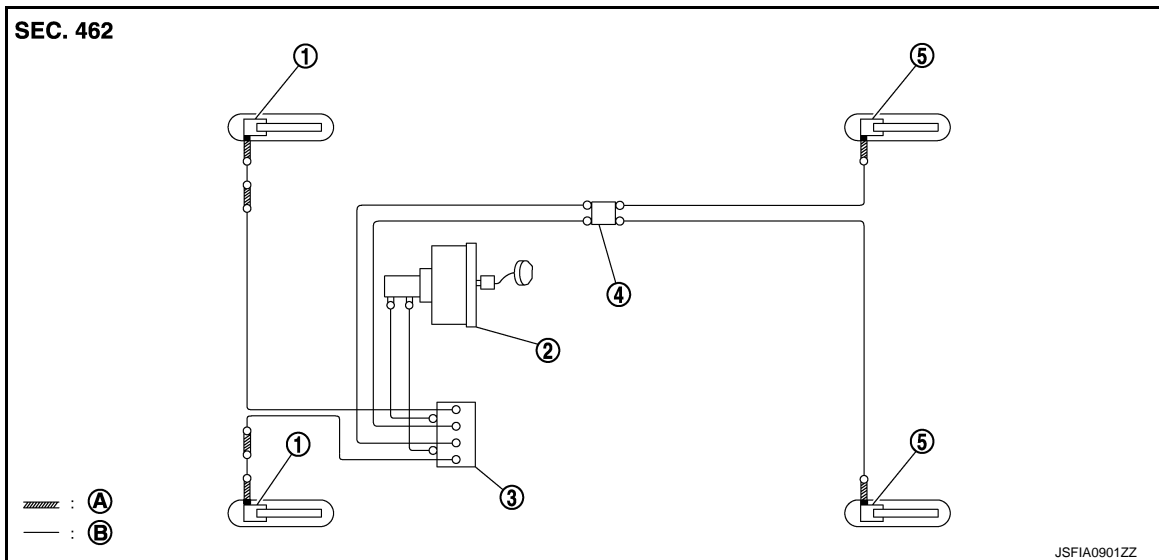

1. Front disc brake
 2. Electrically-driven intelligent brake unit
 3. ABS actuator and electric unit (control unit)
 4. Connector
 5. Rear disc brake
- A. Brake hose
B. Brake tube
- : Flare nut
■ : Union bolt

FRONT : Removal and Installation

INFOID:000000008139890

REMOVAL

CAUTION:

- Never spill or splash brake fluid on painted surfaces. Brake fluid may seriously damage paint. Wipe it off immediately and wash with water if it gets on a painted surface. However avoid washing brake components with water.
- Never depress the brake pedal. Brake fluid may splash while removing the brake hose or brake tube.
- If the brake fluid adheres to the brake caliper assembly and disc rotor, quickly wipe it off.

1. Remove tires with power tool.
2. Drain brake fluid. Refer to [BR-273. "Draining"](#).
3. Loosen the flare nut with a flare nut wrench and separate the brake tube from the brake hose, and remove the brake tube.

CAUTION:

- Never scratch the flare nut and the brake tube.
 - Never bend sharply, twist or strongly pull out the brake hose or brake tube.
 - Cover open end of brake hose or brake tube when disconnecting to prevent entrance of dirt.
4. Remove the union bolt and copper washers, and remove the brake hose from the brake caliper assembly.
 5. Remove the brake hose mounting nut.
 6. Remove the lock plate and remove the brake hose.
 7. Remove the brake hose bracket.

INSTALLATION

CAUTION:

- Never spill or splash brake fluid on painted surfaces. Brake fluid may seriously damage paint. Wipe it off immediately and wash with water if it gets on a painted surface. However avoid washing brake components with water.
- Never depress the brake pedal. Brake fluid may splash while removing the brake hose or brake tube.
- If the brake fluid adheres to the brake caliper assembly and disc rotor, quickly wipe it off.

BRAKE PIPING

< REMOVAL AND INSTALLATION >

1. Install the brake hose bracket.
2. Assemble the union bolt and the copper washer to the brake hose.

CAUTION:

Never reuse the copper washer.

3. Align the brake hose pin to the projection (A) of the brake caliper assembly and tighten the union bolt (1) to the specified torque.
4. Install the brake tube to the brake hose, temporarily tighten the flare nut by hand until it does not rotate further, and fix the brake hose to the bracket with the lock plate.

CAUTION:

- Check that all brake hose or brake tube are not twisted and bent.

- Insert lock plate, according to the following instructions:

- Steering knuckle side: Face the opening toward the front of vehicle.

- Body side: Face the opening toward the inside of vehicle.

- Securely insert the lock plate all the way to the end.

- When installing the lock plate, never damage the brake hose, brake tube, and wheel sensor harness.

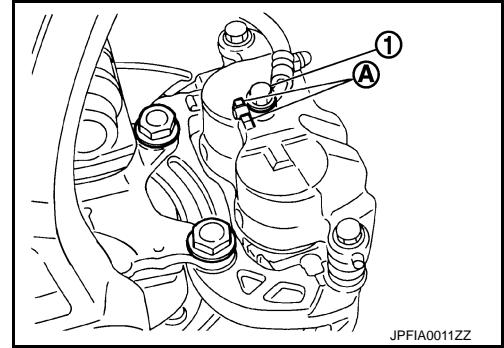

5. Tighten the flare nut to the specified torque with a flare nut crowfoot and a torque wrench.

CAUTION:

Never scratch the flare nut and the brake tube.

6. Tighten the brake hose mounting nuts to the specified torque.

CAUTION:

Never reuse the brake hose mounting nuts.

7. Refill with new brake fluid and perform the air bleeding. Refer to [BR-274, "Bleeding Brake System"](#).
8. Install tires with power tool.
9. Perform inspection after installation. Refer to [BR-284, "FRONT : Inspection"](#).

FRONT : Inspection

INFOID:000000008139891

INSPECTION AFTER INSTALLATION

1. Check the brake hoses and tubes for the following: no scratches; no twist and deformation; no interference with other components when steering the steering wheel; no looseness at connections.
2. Depress the brake pedal with a force of 785 N (80 kg, 176 lb) and hold down the pedal for approx. 5 seconds with the engine running/READY state. Check for any fluid leakage.

CAUTION:

Retighten the applicable connection to the specified torque and repair any abnormal (damaged, worn or deformed) part if any brake fluid leakage is present.

REAR

BRAKE PIPING

< REMOVAL AND INSTALLATION >

REAR : Exploded View

INFOID:000000008139892

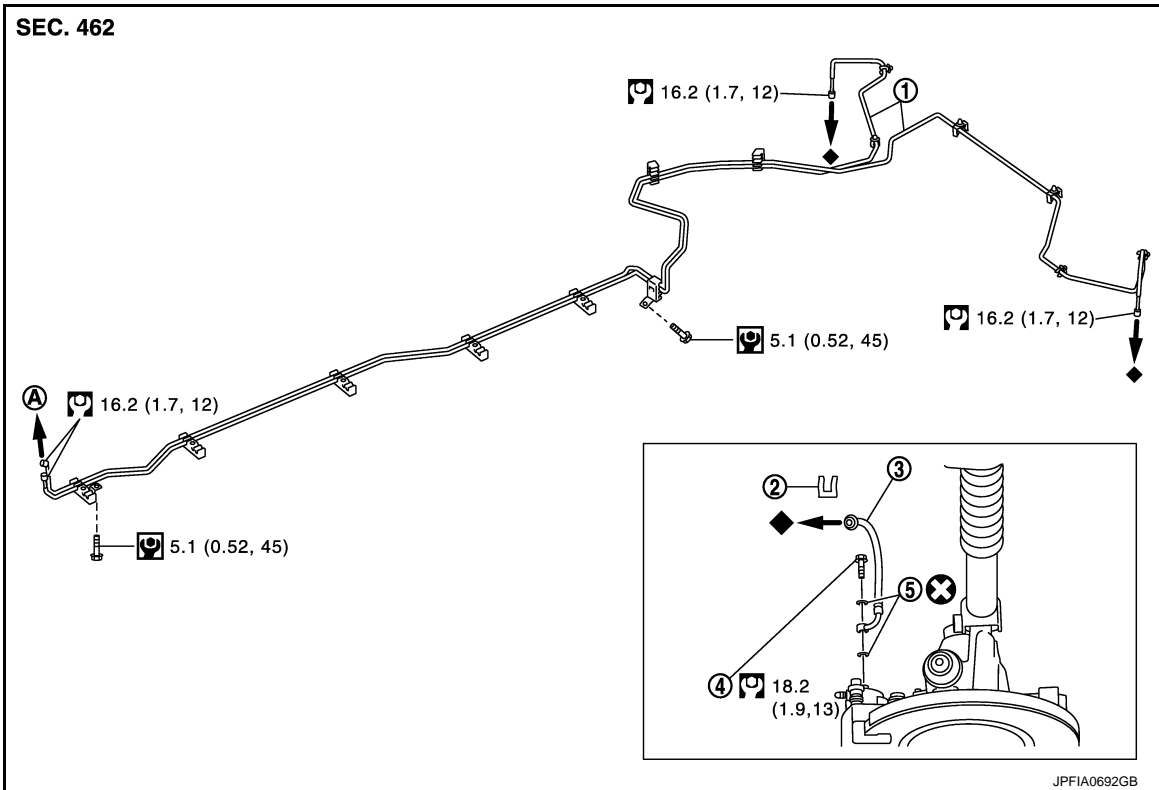

- | | | |
|-----------------|------------------|---------------|
| 1. Brake tube | 2. Lock plate | 3. Brake hose |
| 4. Union bolt | 5. Copper washer | |
| A. To connector | | |

◆: Indicates that the part is connected at points with same symbol in actual vehicle.

Refer to [GI-5, "Components"](#) for symbols in the figure.

REAR : Hydraulic Piping

INFOID:000000008139893

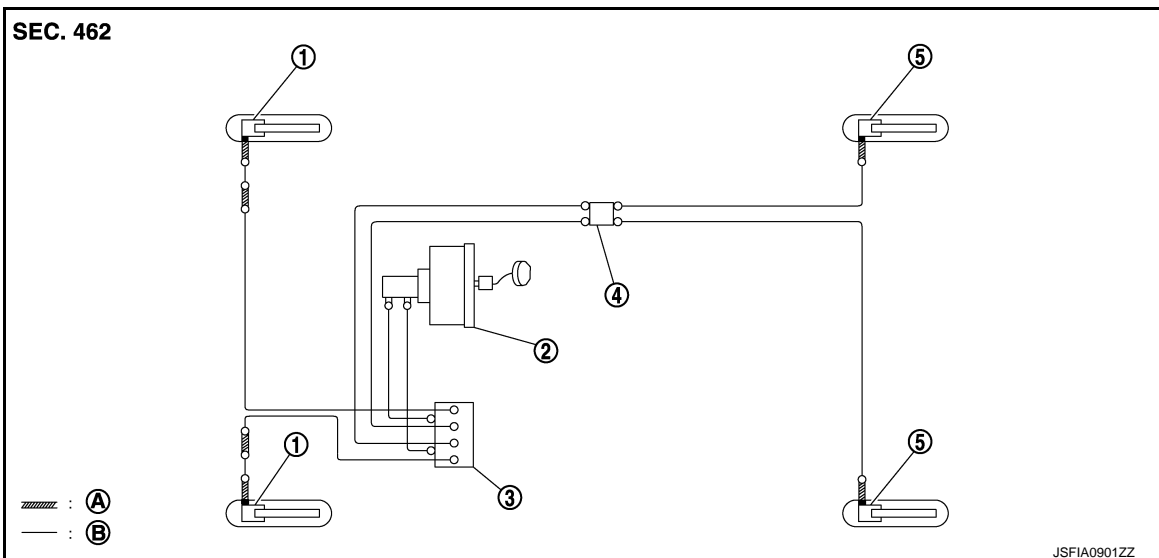

BRAKE PIPING

< REMOVAL AND INSTALLATION >

1. Front disc brake
2. Electrically-driven intelligent brake unit
3. ABS actuator and electric unit (control unit)
4. Connector
5. Rear disc brake
- A. Brake hose
- B. Brake tube

○: Flare nut

■: Union bolt

REAR : Removal and Installation

INFOID:000000008139894

REMOVAL

CAUTION:

- Never spill or splash brake fluid on painted surfaces. Brake fluid may seriously damage paint. Wipe it off immediately and wash with water if it gets on a painted surface. However avoid washing brake components with water.
- Never depress the brake pedal. Brake fluid may splash while removing the brake hose or brake tube.
- If the brake fluid adheres to the brake caliper assembly and disc rotor, quickly wipe it off.

1. Remove tires with power tool.
2. Drain brake fluid. Refer to [BR-273, "Draining"](#).
3. Loosen the flare nut with a flare nut wrench and separate the brake tube from the hose, and remove the brake tube.

CAUTION:

- Never scratch the flare nut and the brake tube.
 - Never bend sharply, twist or strongly pull out the brake hose or brake tube.
 - Cover open end of brake hose or brake tube when disconnecting to prevent entrance of dirt.
4. Remove the union bolt and copper washers, and remove the brake hose from the brake caliper assembly.
 5. Remove the lock plate and remove the brake hose.

INSTALLATION

CAUTION:

- Never spill or splash brake fluid on painted surfaces. Brake fluid may seriously damage paint. Wipe it off immediately and wash with water if it gets on a painted surface. However avoid washing brake components with water.
- Never depress the brake pedal. Brake fluid may splash while removing the brake hose or brake tube.
- If the brake fluid adheres to the brake caliper assembly and disc rotor, quickly wipe it off.

1. Assemble the union bolt and the copper washer to the brake hose.

CAUTION:

Never reuse the copper washer.

2. Install the brake hose L-pin by aligning it with the brake caliper assembly positioning hole, and tighten the union bolt (1) to the specified torque.
3. Install the brake tube to the brake hose, temporarily tighten the flare nut by hand until it does not rotate further, and fix the brake hose to the bracket with the lock plate.

CAUTION:

- Check that all brake hose or brake tube are not twisted and bent.
 - Insert lock plate, according to the following instructions:
 - Body side: Face the opening toward the inside of vehicle.
 - Securely insert the lock plate all the way to the end.
 - When installing the lock plate, never damage the brake hose and brake tube.
4. Tighten the flare nut to the specified torque with a flare nut crowfoot and a torque wrench.
- #### CAUTION:
- Never scratch the flare nut and the brake tube.
5. Refill with new brake fluid and perform the air bleeding. Refer to [BR-274, "Bleeding Brake System"](#).
 6. Install tires with power tool.
 7. Perform inspection after installation. Refer to [BR-287, "REAR : Inspection"](#).

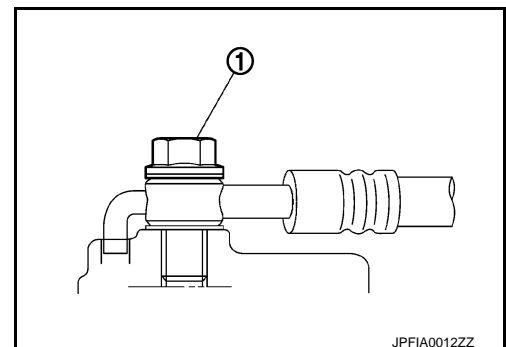

BRAKE PIPING

< REMOVAL AND INSTALLATION >

REAR : Inspection

INFOID:000000008139895

INSPECTION AFTER INSTALLATION

1. Check the brake hoses and tubes for the following: no scratches; no twist and deformation; no interference with other components when steering the steering wheel; no looseness at connections.
2. Depress the brake pedal with a force of 785 N (80 kg, 176 lb) and hold down the pedal for approx. 5 seconds with the engine running/READY state. Check for any fluid leakage.

CAUTION:

Retighten the applicable connection to the specified torque and repair any abnormal (damaged, worn or deformed) part if any brake fluid leakage is present.

A
B
C
D
E
G
H
I
J
K
L
M
N
O
P

BR

ELECTRICALLY-DRIVEN INTELLIGENT BRAKE UNIT

< REMOVAL AND INSTALLATION >

ELECTRICALLY-DRIVEN INTELLIGENT BRAKE UNIT

Exploded View

INFOID:000000008139896

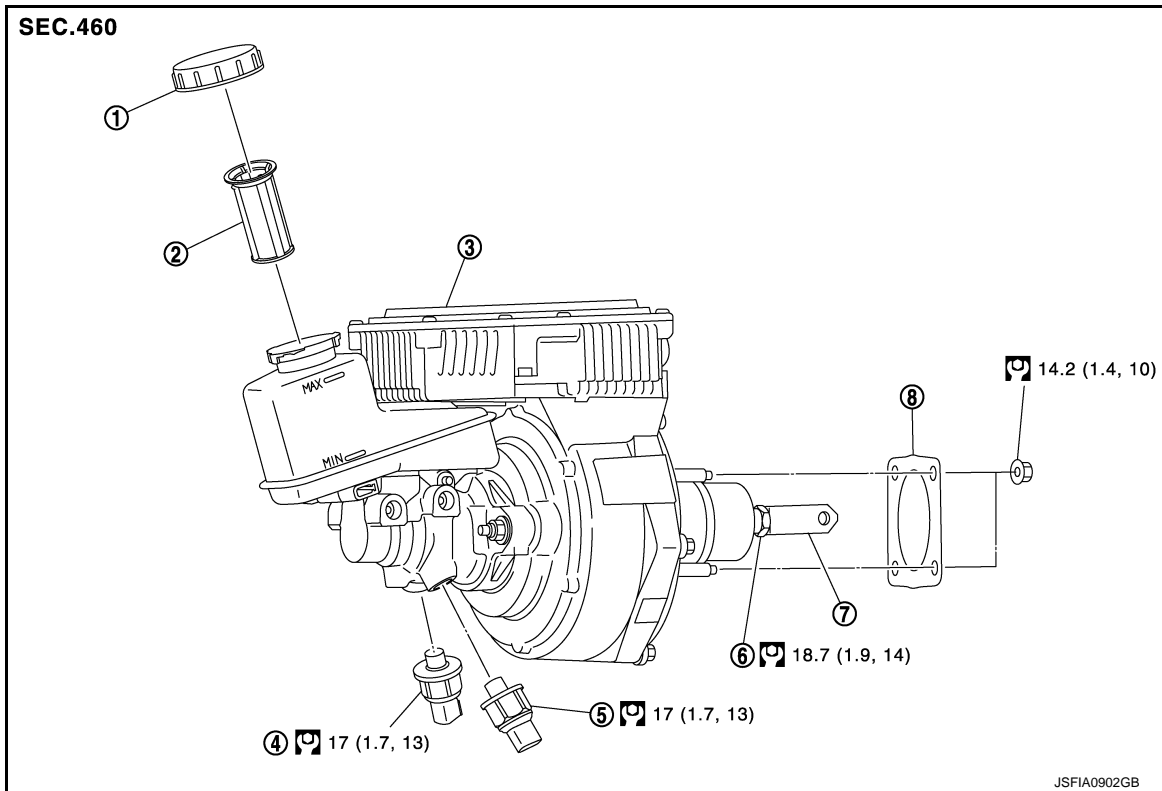

- | | | |
|-------------------------------------|-------------------------------------|---|
| 1. Reservoir cap | 2. Oil strainer | 3. Electrically-driven intelligent brake unit |
| 4. Master cylinder pressure sensor1 | 5. Master cylinder pressure sensor2 | 6. Lock nut |
| 7. Clevis | 8. Gasket | |

Refer to [GI-5. "Components"](#) for symbols in the figure.

Removal and installation

INFOID:000000008139897

CAUTION:

Never disassemble the electrically-driven intelligent brake unit other than reservoir cap, oil strainer, master cylinder pressure sensor1 and master cylinder pressure sensor2.

REMOVAL

CAUTION:

- **Never spill or splash brake fluid on painted surfaces. Brake fluid may seriously damage paint. Wipe it off immediately and wash with water if it gets on a painted surface. For brake component parts, never wash them with water.**
- **Never depress brake pedal while removing the brake tube. If this is not complied with, brake fluid may splash.**

1. Perform inspection before removal. Refer to [BR-289. "Inspection and Adjustment"](#).
2. Turn the ignition switch OFF to exit CONSULT.
3. Get out of the vehicle, close all doors (including trunk lid), and wait for 3 minutes or more without opening these doors.

CAUTION:

Never operate the vehicle and CONSULT while waiting.

4. Remove 12V battery. Refer to [PG-141. "Removal and Installation"](#).
5. Remove brake master cylinder cover and cowl top cover. Refer to [EXT-21. "Removal and Installation"](#).
6. Drain brake fluid. Refer to [BR-273. "Draining"](#).

ELECTRICALLY-DRIVEN INTELLIGENT BRAKE UNIT

< REMOVAL AND INSTALLATION >

7. Disconnect the brake fluid level switch harness connector.
8. Disconnect the electrically-driven intelligent brake unit harness connector.
9. Separate the brake tube between electrically-driven intelligent brake unit and ABS actuator and electric unit (control unit) with a flare nut wrench.

CAUTION:

Never scratch the flare nut and the brake tube.

10. Remove snap pin (1) and clevis pin (2). Refer to [BR-280, "Removal and Installation"](#).

11. Remove nuts on electrically-driven intelligent brake unit and brake pedal assembly.

CAUTION:

Hold the electrically-driven intelligent brake unit so as to avoid dropping out.

12. Remove electrically-driven intelligent brake unit.

CAUTION:

Never deform or bend the brake tube.

13. Perform inspection after removal. Refer to [BR-289, "Inspection and Adjustment"](#).

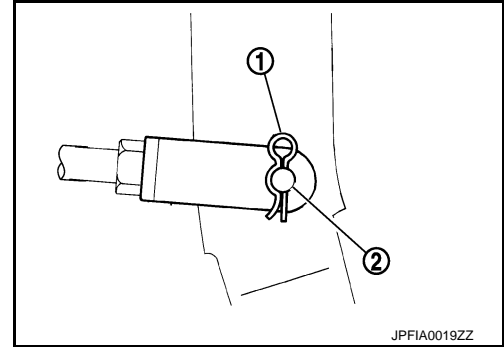

A
B
C
D
E

BR

INSTALLATION

Note the following, and install in the reverse order of removal.

- Never spill or splash brake fluid on painted surfaces. Brake fluid may seriously damage paint. Wipe it off immediately and wash with water if it gets on a painted surface. For brake component parts, never wash them with water.
- Never depress brake pedal while removing the brake tube. If this is not complied with, brake fluid may splash.
- Be careful not to damage electrically-driven intelligent brake unit stud bolt threads. If electrically-driven intelligent brake unit is tilted during installation, the dash panel may damage the threads.
- Never deform or bend the brake tubes when installing the electrically-driven intelligent brake unit.
- Never reuse clevis pin. Refer to [BR-281, "Inspection and Adjustment"](#).
- Temporarily tighten the brake tube flare nut to the electrically-driven intelligent brake unit by hand. Then tighten it to the specified torque with a crowfoot and torque wrench.
- Perform the air bleeding. Refer to [BR-274, "Bleeding Brake System"](#).
- Check each item of brake pedal. Adjust it if the measurement value is not the standard. Refer to [BR-270, "Inspection and Adjustment"](#).
- Perform stroke sensor 0 point learning when electrically-driven intelligent brake unit is removed and installed, or replaced. Refer to [BR-47, "Work Procedure"](#).

G
H
I
J
K

Inspection and Adjustment

INFOID:000000008139898

INSPECTION BEFORE REMOVAL

Check the brake fluid level switch. Refer to [BRC-117, "Diagnosis Procedure"](#).

INSPECTION AFTER REMOVAL

Input Rod Length Inspection

1. Loosen the lock nut (1) and adjust the input rod (2) to the specified length (A).

A : Refer to [BR-304, "Electrically-driven Intelligent Brake"](#).

2. Tighten the lock nut to the specified torque.

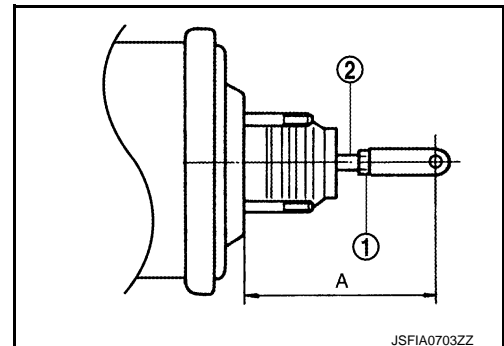

L
M
N
O
P

BRAKE POWER SUPPLY BACKUP UNIT

< REMOVAL AND INSTALLATION >

BRAKE POWER SUPPLY BACKUP UNIT

Exploded View

INFOID:000000008139899

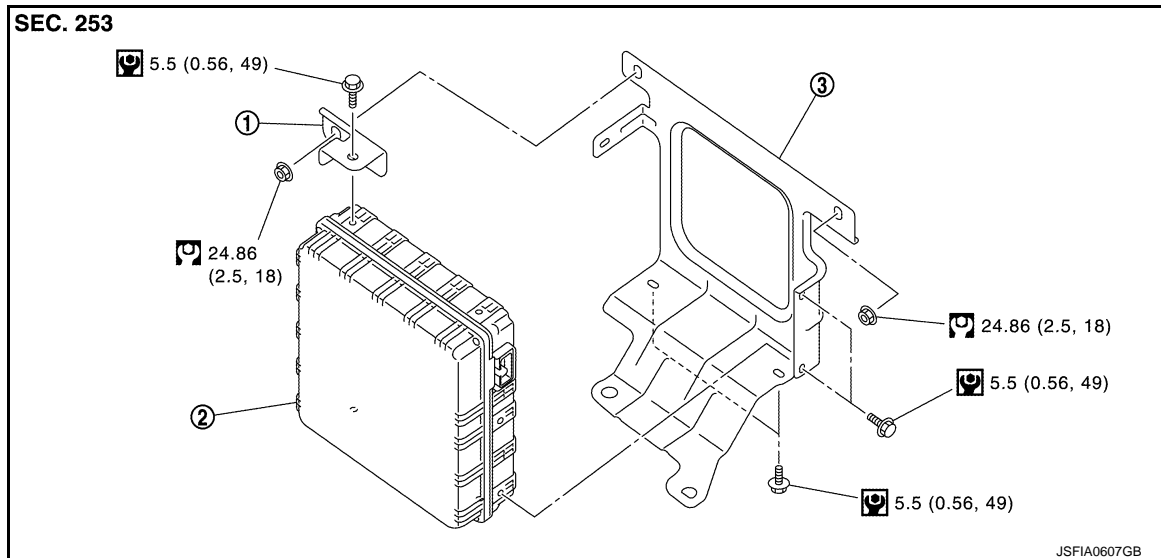

1. Bracket
2. Brake power supply backup unit
3. Brake power supply backup unit bracket

Refer to [GI-5. "Components"](#) for symbols in the figure.

Removal and Installation

INFOID:000000008139900

REMOVAL

1. Turn the ignition switch OFF to exit CONSULT.
2. Get out of the vehicle, close all doors (including trunk lid), and wait for 3 minutes or more without opening these doors.
CAUTION:
Never operate the vehicle and CONSULT while waiting.
3. Disconnect 12V battery cable from negative terminal. Refer to [BR-6. "Precaution for Removing 12V Battery"](#).
4. Remove trunk side finisher LH. Refer to [INT-52. "TRUNK SIDE FINISHER : Removal and Installation"](#).
5. Hang fuse box in a place where it will not interfere with work.
6. Disconnect brake power supply backup unit harness connector.
7. Remove brake power supply backup unit, bracket and brake power supply backup unit bracket.
CAUTION:
Never drop removed parts.
8. Remove bracket and brake power supply backup unit bracket from brake power supply backup unit.

INSTALLATION

Install in the reverse order of removal.

FRONT DISC BRAKE

< REMOVAL AND INSTALLATION >

FRONT DISC BRAKE

BRAKE PAD

BRAKE PAD : Exploded View

INFOID:000000008139901

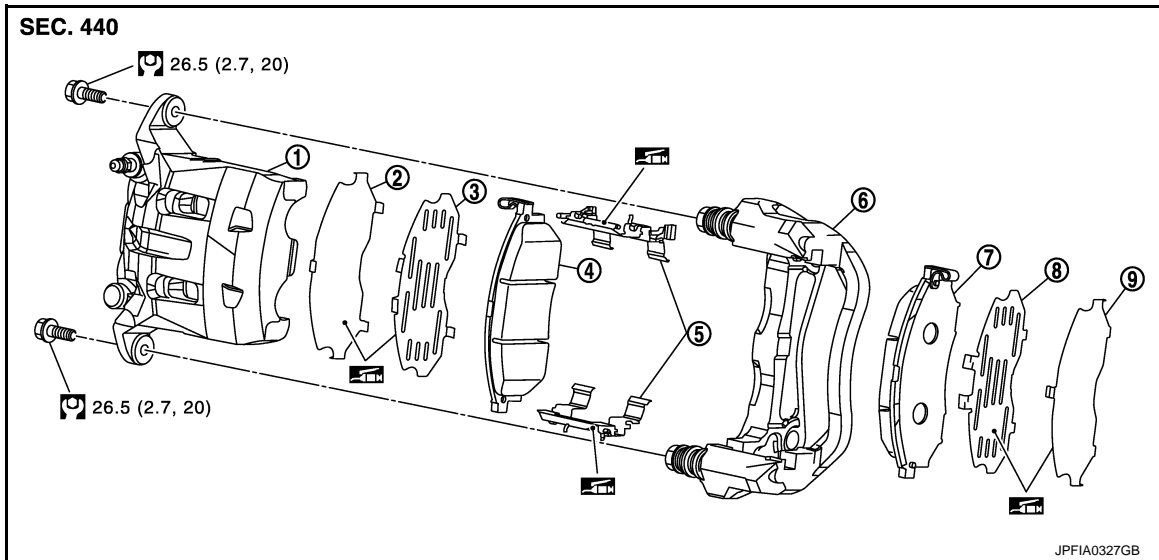

- | | | |
|-------------------------------------|---------------------|---------------------|
| 1. Cylinder body | 2. Inner shim cover | 3. Inner shim |
| 4. Inner pad (with pad wear sensor) | 5. Pad retainer | 6. Torque member |
| 7. Outer pad | 8. Outer shim | 9. Outer shim cover |

: Apply copper based brake grease.

Refer to [GI-5. "Components"](#) for symbols not described on the above.

BRAKE PAD : Removal and Installation

INFOID:000000008139902

REMOVAL

WARNING:

Since dust covering the front and rear brakes has an affect on human body, the dust must be removed with a dust collector. Never splatter the dust with an air blow gun.

CAUTION:

- Never depress the brake pedal while removing the brake pads because the piston may pop out.
- If the brake fluid or grease adheres to the brake caliper assembly and disc rotor, quickly wipe it off.

1. Remove tires with power tool.
2. Remove lower sliding pin bolt.
3. Suspend the cylinder body with suitable wire so that the brake hose will not stretch. Then remove the brake pads from the torque member.

CAUTION:

- Never deform the pad retainer when removing the pad retainer from the torque member.
- Never damage the piston boot.
- Never drop the brake pads, shims and shim covers.
- Remember each position of the removed brake pads.

4. Perform inspection after removal. Refer to [BR-292. "BRAKE PAD : Inspection"](#).

INSTALLATION

WARNING:

Since dust covering the front and rear brakes has an affect on human body, the dust must be removed with a dust collector. Never splatter the dust with an air blow gun.

CAUTION:

- Never depress the brake pedal while removing the brake pads because the piston may pop out.
- If the brake fluid or grease adheres to the brake caliper assembly and disc rotor, quickly wipe it off.

FRONT DISC BRAKE

< REMOVAL AND INSTALLATION >

1. Apply copper based brake grease to the pad retainers before installing it to the torque member if the pad retainers has been removed.

CAUTION:

- Securely assemble the pad retainers so that it will not be lifted up from the torque member.
- Never deform the pad retainers.

2. Apply copper based brake grease to the matching faces (A) between the shim and shim cover, and install shim and shim cover to the brake pad.

CAUTION:

Always replace the shims and shim covers when replacing the brake pad.

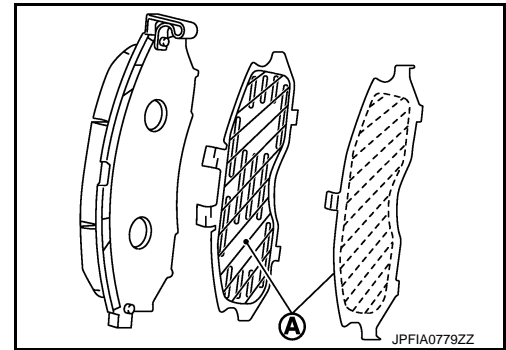

3. Install the brake pads to the torque member.

CAUTION:

Both inner and outer pads have a pad return system on the pad retainer. Install pad return lever (1) securely to pad retainer (2).

4. Install cylinder body to torque member.

CAUTION:

- Never damage the piston boot.
- When replacing brake pad with new one, check a brake fluid level in the reservoir tank because brake fluid returns to master cylinder reservoir tank when pressing piston in.

NOTE:

Use a disc brake piston tool to easily press piston.

5. Install the lower sliding pin bolt and tighten it to the specified torque.
6. Depress the brake pedal several times to check that no drag feel is present for the front disc brake. Refer to [BR-292, "BRAKE PAD : Inspection"](#).
7. Install tires with power tool.

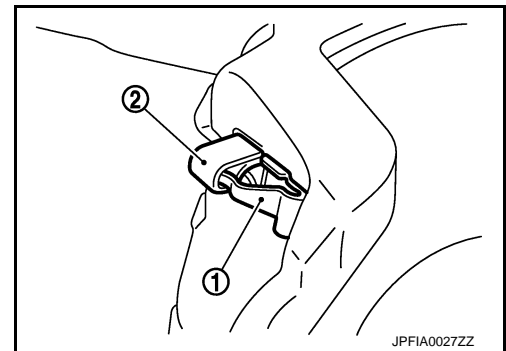

BRAKE PAD : Inspection

INFOID:000000008139903

INSPECTION AFTER REMOVAL

- Replace the shims and shim covers if rust is excessively attached.
- Eliminate rust on the pad retainers and the torque member. Replace them if rust is excessively attached.

INSPECTION AFTER INSTALLATION

1. Check a drag of front disc brake. If any drag is found, follow the procedure described below.
2. Remove brake pads. Refer to [BR-291, "BRAKE PAD : Removal and Installation"](#).
3. Press the pistons. Refer to [BR-291, "BRAKE PAD : Removal and Installation"](#).
4. Install brake pads. Refer to [BR-291, "BRAKE PAD : Removal and Installation"](#).
5. Depress the brake pedal several times.
6. Check a drag of front disc brake again. If any drag is found, disassemble the cylinder body. Refer to [BR-294, "BRAKE CALIPER ASSEMBLY : Disassembly and Assembly"](#).
7. Burnish contact surfaces brake pads and disc rotor after refinishing or replacing brake pads, or if a soft pedal occurs at very low mileage. Refer to [BR-276, "BRAKE PAD : Inspection and Adjustment"](#).

BRAKE CALIPER ASSEMBLY

BRAKE CALIPER ASSEMBLY : Exploded View

INFOID:000000008139904

REMOVAL

FRONT DISC BRAKE

< REMOVAL AND INSTALLATION >

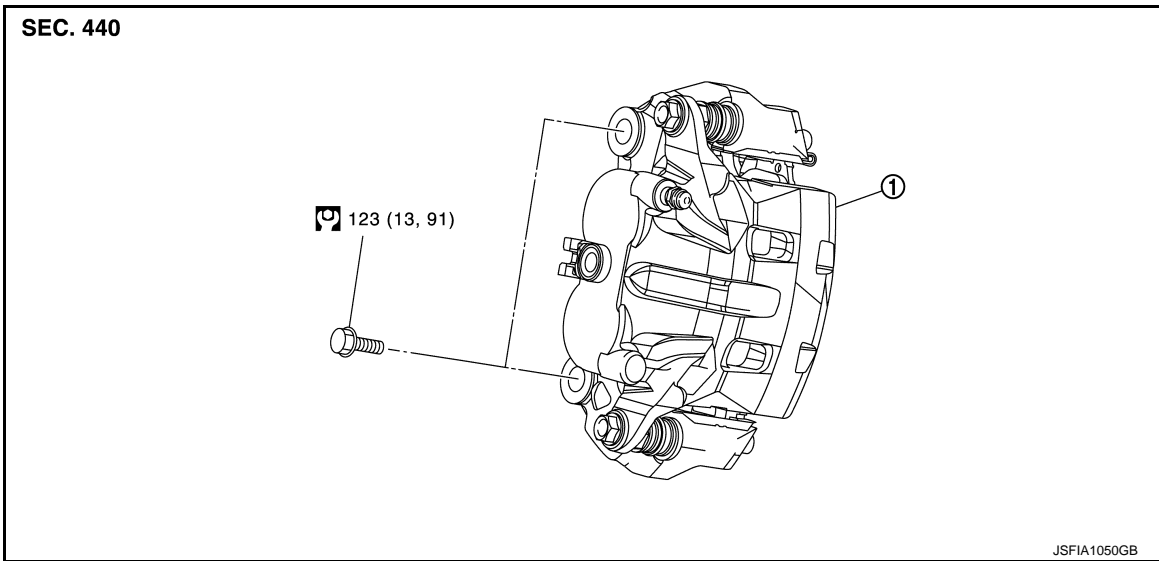

1. Brake caliper assembly

Refer to [GI-5, "Components"](#) for symbols in the figure.

DISASSEMBLY

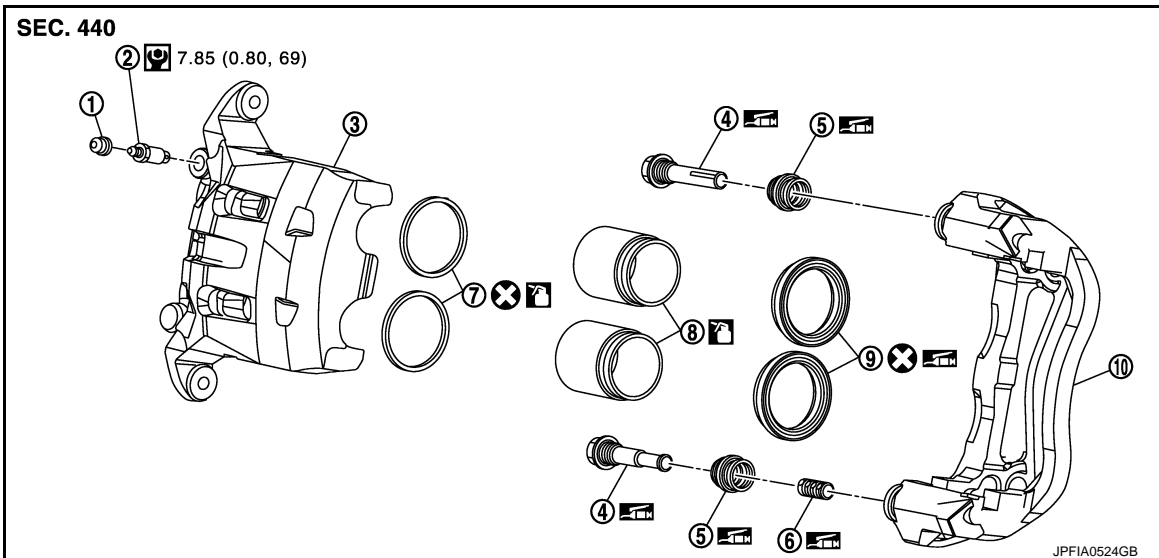

- | | | |
|-------------------|---------------------|------------------|
| 1. Cap | 2. Bleeder valve | 3. Cylinder body |
| 4. Sliding pin | 5. Sliding pin boot | 6. Bushing |
| 7. Piston seal | 8. Piston | 9. Piston boot |
| 10. Torque member | | |

: Apply rubber grease.

: Apply brake fluid.

Refer to [GI-5, "Components"](#) for symbols not described on the above.

BRAKE CALIPER ASSEMBLY : Removal and Installation

INFOID:000000008139905

REMOVAL

WARNING:

Since dust covering the front and rear brakes has an affect on human body, the dust must be removed with a dust collector. Never splatter the dust with an air blow gun.

FRONT DISC BRAKE

< REMOVAL AND INSTALLATION >

CAUTION:

- **Never spill or splash brake fluid on painted surfaces. Brake fluid may seriously damage paint. Wipe it off immediately and wash with water if it gets on a painted surface. However avoid washing brake components with water.**
- **Never depress the brake pedal while removing the brake pads because the piston may pop out.**
- **If the brake fluid or grease adheres to the brake caliper assembly and disc rotor, quickly wipe it off.**

1. Remove tires with power tool.
2. Fix the disc rotor using wheel nuts.
3. Drain brake fluid. Refer to [BR-273, "Draining"](#).
4. Remove union bolt and copper washer, and separate brake hose from brake caliper assembly. Refer to [BR-283, "FRONT : Removal and Installation"](#).
5. Remove torque member mounting bolts, and remove brake caliper assembly.

CAUTION:

Never drop brake pad and brake caliper assembly.

6. Remove disc rotor. Refer to [FAX-7, "Removal and Installation"](#).

INSTALLATION

WARNING:

Since dust covering the front and rear brakes has an affect on human body, the dust must be removed with a dust collector. Never splatter the dust with an air blow gun.

CAUTION:

- **Never spill or splash brake fluid on painted surfaces. Brake fluid may seriously damage paint. Wipe it off immediately and wash with water if it gets on a painted surface. However avoid washing brake components with water.**
- **Never depress the brake pedal while removing the brake pads because the piston may pop out.**
- **If the brake fluid or grease adheres to the brake caliper assembly and disc rotor, quickly wipe it off.**

1. Install disc rotor. Refer to [FAX-7, "Removal and Installation"](#).
2. Install the brake caliper assembly to the steering knuckle and tighten the torque member mounting bolts to the specified torque.

CAUTION:

Never spill or splash any grease and moisture on the brake caliper assembly mounting face, threads, mounting bolts and washers. Wipe out any grease and moisture.

3. Install brake hose and copper washers to brake caliper assembly. Refer to [BR-283, "FRONT : Removal and Installation"](#).
4. Refill with new brake fluid and perform the air bleeding. Refer to [BR-274, "Bleeding Brake System"](#).
5. Check a drag of front disc brake. If any drag is found, refer to [BR-296, "BRAKE CALIPER ASSEMBLY : Inspection"](#).
6. Install tires with power tool.

BRAKE CALIPER ASSEMBLY : Disassembly and Assembly

INFOID:000000008139906

DISASSEMBLY

NOTE:

Never remove the torque member, brake pad and pad retainers when disassembling and assembling the cylinder body.

1. Remove the sliding pin bolt, and remove the cylinder body from the torque member.

CAUTION:

Fix the brake pad at suitable tape so that the brake pad will not drop.

2. Remove sliding pins and sliding pin boots from torque member.
3. Remove bushing from sliding pin.

FRONT DISC BRAKE

< REMOVAL AND INSTALLATION >

- Place a wooden block as shown in the figure, and blow air from union bolt mounting hole to remove pistons and piston boots.

CAUTION:

Never get fingers caught in the pistons.

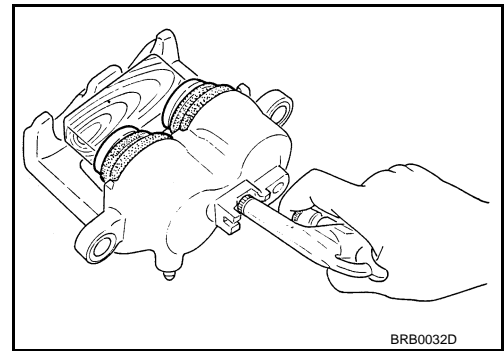

- Remove piston seals from cylinder body using suitable tool.

CAUTION:

Be careful not to damage a cylinder inner wall.

- Remove bleeder valve and cap.
- Perform inspection after disassembly. Refer to [BR-296, "BRAKE CALIPER ASSEMBLY : Inspection"](#).

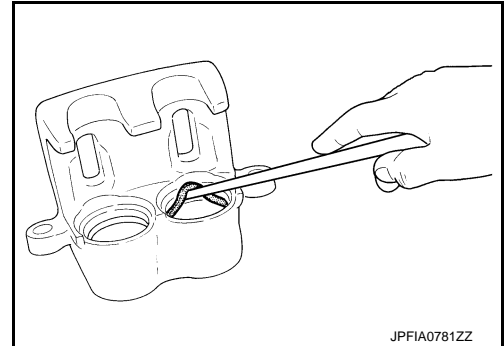

ASSEMBLY

- Install bleeder valve and cap.
- Apply new brake fluid to piston seals (1), and install them to cylinder body.

CAUTION:

Never reuse piston seals.

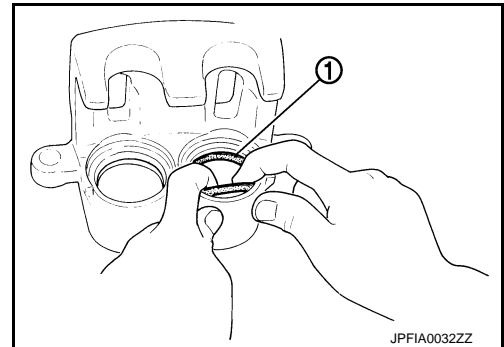

- Apply rubber grease to piston boots (1). Cover the piston (2) end with piston boot, and then install cylinder side lip on piston boot securely into a groove on cylinder body.

CAUTION:

Never reuse piston boots.

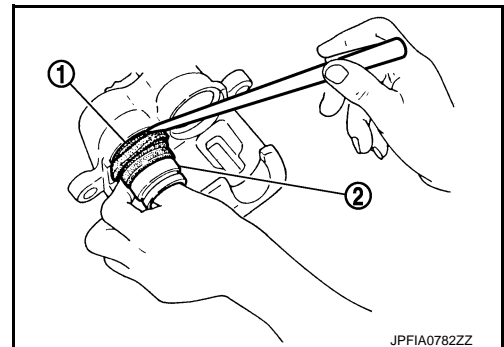

A
B
C
D
E
BR
G
H
I
J
K
L
M
N
O
P

FRONT DISC BRAKE

< REMOVAL AND INSTALLATION >

4. apply new brake fluid to pistons (1). Push piston into cylinder body by hand and push piston boot (2) piston-side lip into the piston groove.

CAUTION:

Press the pistons evenly and vary the pressing point to prevent cylinder inner wall from being rubbed.

5. Apply rubber grease to bushing, and install bushing to sliding pin.
6. Apply rubber grease to sliding pins and sliding pin boots, and install sliding pins and sliding pin boots to torque member.
7. Install the cylinder body to tighten sliding pin bolts to the specified torque.

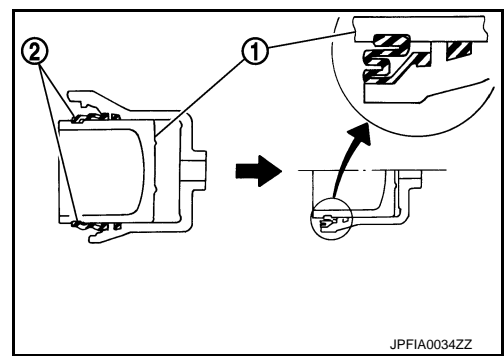

BRAKE CALIPER ASSEMBLY : Inspection

INFOID:000000008139907

INSPECTION AFTER DISASSEMBLY

Check the following items and replace if necessary.

Cylinder Body

Check the cylinder inner wall for rust, wear, cracks or damage.

CAUTION:

Always clean with new brake fluid. Never clean with mineral oil such as gasoline and light oil.

Torque Member

Check the torque member for rust, wear, cracks or damage.

Pistons

Check the surface of the piston for rust, wear, cracks or damage.

CAUTION:

A piston sliding surface is plated. Never polish with sandpaper.

Sliding Pin, Sliding Pin Boot and Bushing

Check the sliding pins, sliding pin boots and bushing for rust, wear, cracks or damage.

INSPECTION AFTER INSTALLATION

1. Check a drag of front disc brake. If any drag is found, follow the procedure described below.
2. Remove brake pads. Refer to [BR-291, "BRAKE PAD : Removal and Installation"](#).
3. Press the pistons. Refer to [BR-291, "BRAKE PAD : Removal and Installation"](#).
4. Install brake pads. Refer to [BR-291, "BRAKE PAD : Removal and Installation"](#).
5. Depress the brake pedal several times.
6. Check a drag of front disc brake again. If any drag is found, disassemble the cylinder body. Refer to [BR-294, "BRAKE CALIPER ASSEMBLY : Disassembly and Assembly"](#).
7. Burnish contact surfaces brake pads and disc rotor after refinishing or replacing disc rotor, or if a soft pedal occurs at very low mileage. Refer to [BR-276, "DISC ROTOR : Inspection and Adjustment"](#).

REAR DISC BRAKE

< REMOVAL AND INSTALLATION >

REAR DISC BRAKE

BRAKE PAD

BRAKE PAD : Exploded View

INFOID:000000008139908

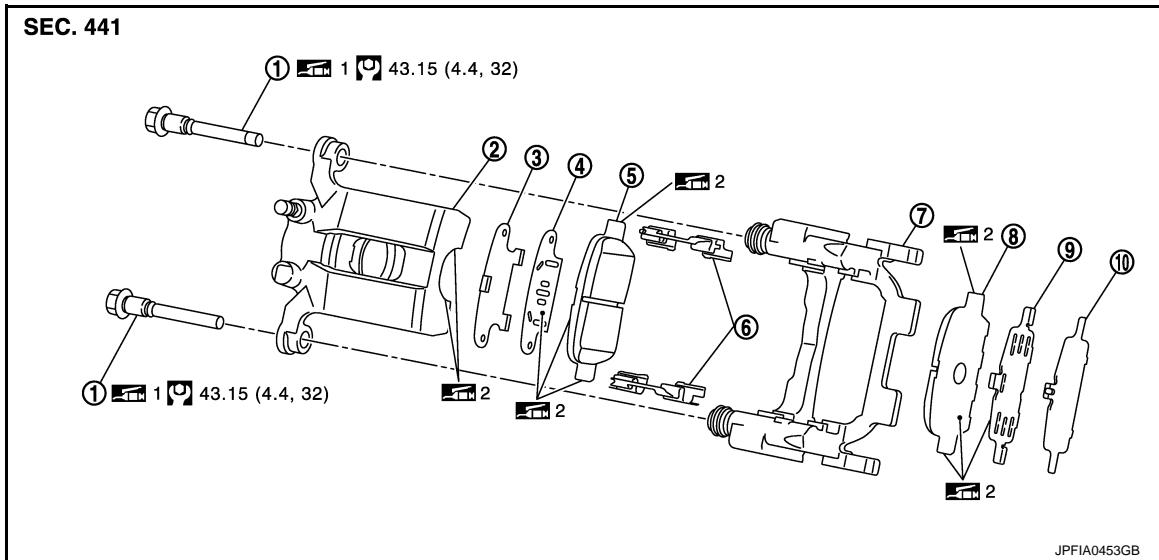

- | | | |
|----------------------|-------------------------------------|---------------------|
| 1. Sliding pin bolt | 2. Cylinder body | 3. Inner shim cover |
| 4. Inner shim | 5. Inner pad (with pad wear sensor) | 6. Pad retainer |
| 7. Torque member | 8. Outer pad | 9. Outer shim |
| 10. Outer shim cover | | |

1: Apply rubber grease.

2: Apply PBC (Poly Butyl Cuprysil) grease or silicone-based grease.

Refer to [GI-5, "Components"](#) for symbols not described on the above.

BRAKE PAD : Removal and Installation

INFOID:000000008139909

REMOVAL

WARNING:

Since dust covering the front and rear brakes has an affect on human body, the dust must be removed with a dust collector. Never splatter the dust with an air blow gun.

CAUTION:

- Never depress the brake pedal while removing the brake pads because the piston may pop out.
- If the brake fluid or grease adheres to the brake caliper assembly and disc rotor, quickly wipe it off.

1. Remove tires with power tool.
2. Remove upper sliding pin bolt.
3. Suspend the cylinder body with suitable wire so that the brake hose will not stretch. Then remove the brake pads from the torque member.

CAUTION:

- Never deform the pad retainer when removing the pad retainer from the torque member.
- Never damage the piston boot.
- Never drop the brake pads, shims and shim covers.
- Remember each position of the removed brake pads.

4. Perform inspection after removal. Refer to [BR-298, "BRAKE PAD : Inspection"](#).

INSTALLATION

WARNING:

Since dust covering the front and rear brakes has an affect on human body, the dust must be removed with a dust collector. Never splatter the dust with an air blow gun.

REAR DISC BRAKE

< REMOVAL AND INSTALLATION >

CAUTION:

- Never depress the brake pedal while removing the brake pads because the piston may pop out.
- If the brake fluid or grease adheres to the brake caliper assembly and disc rotor, quickly wipe it off.

1. Install the torque member if the pad retainers has been removed.

CAUTION:

- Securely assemble the pad retainers so that it will not be lifted up from the torque member.
- Never deform the pad retainers.

2. Apply PBC (Poly Butyl Cuprysil) grease or silicone-based grease to the matching faces (A) between the brake pad and shim, and install shim and shim cover to the brake pad.

CAUTION:

Always replace the shims and shim covers when replacing the brake pad.

3. Apply PBC (Poly Butyl Cuprysil) grease or silicone-based grease to the matching faces between the brake pad and pad retainer, and install brake pad to the torque member.

4. Apply PBC (Poly Butyl Cuprysil) grease or silicone-based grease to the pawls part of cylinder body, and install cylinder body to the torque member.

CAUTION:

- Never damage the piston boot.
- When replacing brake pad with new one, check a brake fluid level in the reservoir tank because brake fluid returns to master cylinder reservoir tank when pressing piston in.

NOTE:

Use a disc brake piston tool to easily press piston.

5. Apply rubber grease to the sliding pin bolt, install the upper sliding pin bolt and tighten it to the specified torque.
6. Depress the brake pedal several times to check that no drag feel is present for the rear disc brake. Refer to [BR-298, "BRAKE PAD : Inspection"](#).
7. Install tires with power tool.

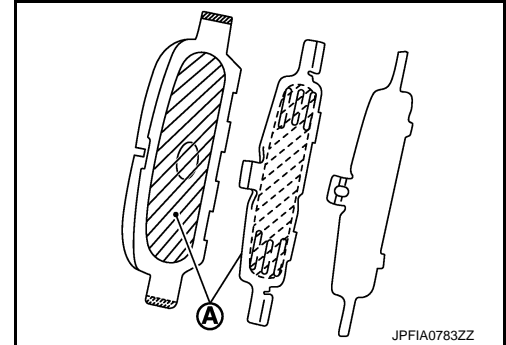

BRAKE PAD : Inspection

INFOID:000000008139910

INSPECTION AFTER REMOVAL

- Replace the shims and shim covers if rust is excessively attached.
- Eliminate rust on the pad retainers and the torque member. Replace them if rust is excessively attached.

INSPECTION AFTER INSTALLATION

1. Check a drag of rear disc brake. If any drag is found, follow the procedure described below.
2. Remove brake pads. Refer to [BR-297, "BRAKE PAD : Removal and Installation"](#).
3. Press the pistons. Refer to [BR-297, "BRAKE PAD : Removal and Installation"](#).
4. Install brake pads. Refer to [BR-297, "BRAKE PAD : Removal and Installation"](#).
5. Depress the brake pedal several times.
6. Check a drag of rear disc brake again. If any drag is found, disassemble the cylinder body. Refer to [BR-300, "BRAKE CALIPER ASSEMBLY : Disassembly and Assembly"](#).
7. Burnish contact surfaces brake pads and disc rotor after refinishing or replacing brake pads, or if a soft pedal occurs at very low mileage. Refer to [BR-278, "BRAKE PAD : Inspection and Adjustment"](#).

BRAKE CALIPER ASSEMBLY

BRAKE CALIPER ASSEMBLY : Exploded View

INFOID:000000008139911

REMOVAL

REAR DISC BRAKE

< REMOVAL AND INSTALLATION >

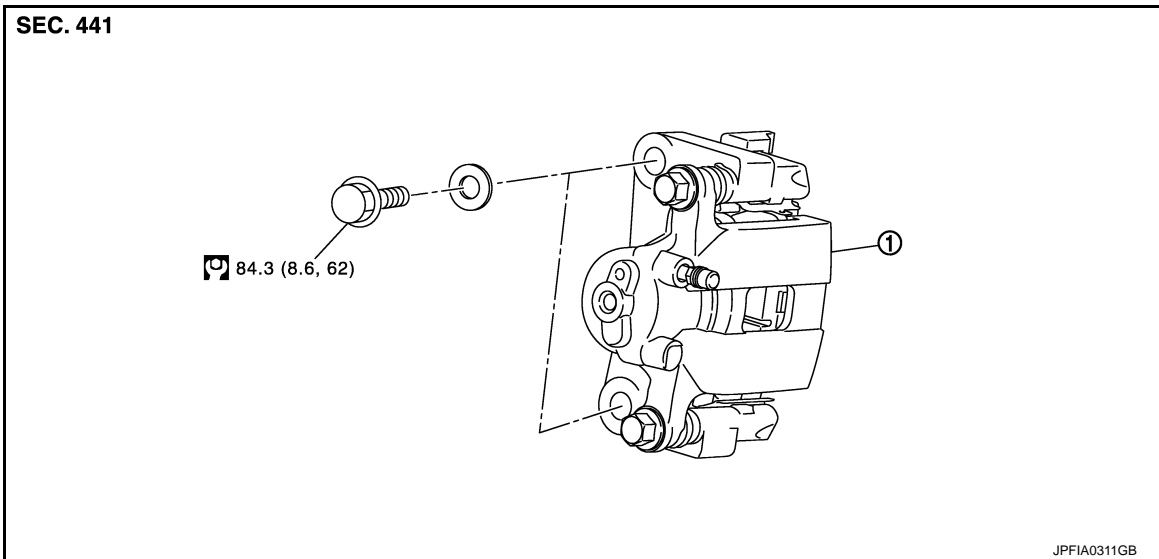

1. Brake caliper assembly

Refer to [GI-5. "Components"](#) for symbols in the figure.

DISASSEMBLY

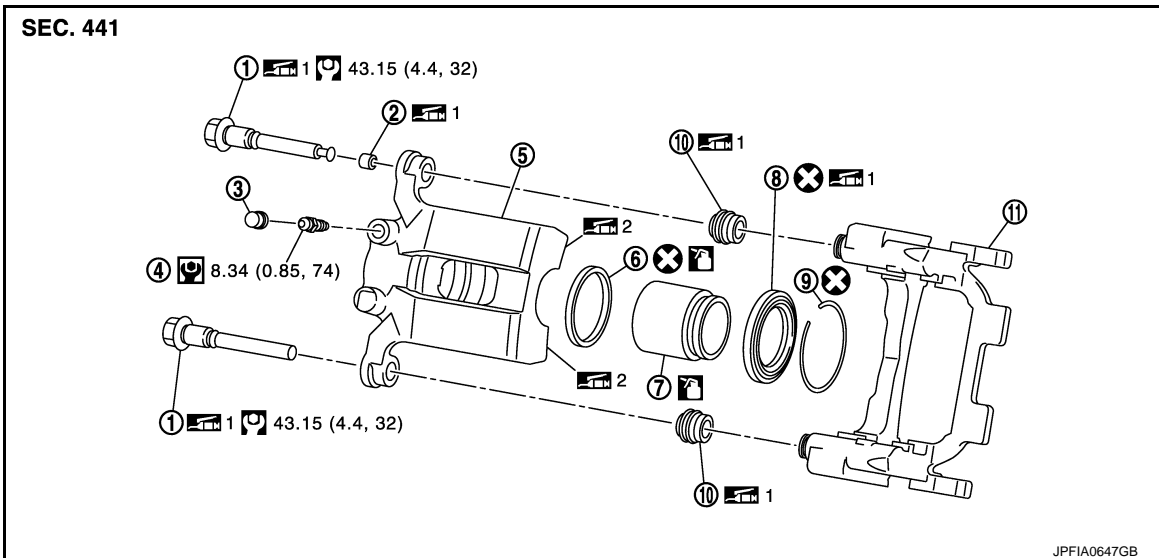

1. Sliding pin bolt

2. Bushing

3. Cap

4. Bleeder valve

5. Cylinder body

6. Piston seal

7. Piston

8. Piston boot

9. Retaining ring

10. Sliding pin boot

11. Torque member

1: Apply rubber grease.

2: Apply PBC (Poly Butyl Cuprysil) grease or silicone-based grease.

: Apply brake fluid.

Refer to [GI-5. "Components"](#) for symbols not described on the above.

BRAKE CALIPER ASSEMBLY : Removal and Installation

INFOID:000000008139912

REMOVAL

WARNING:

REAR DISC BRAKE

< REMOVAL AND INSTALLATION >

Since dust covering the front and rear brakes has an affect on human body, the dust must be removed with a dust collector. Never splatter the dust with an air blow gun.

CAUTION:

- Never spill or splash brake fluid on painted surfaces. Brake fluid may seriously damage paint. Wipe it off immediately and wash with water if it gets on a painted surface. However avoid washing brake components with water.
- Never depress the brake pedal while removing the brake pads because the piston may pop out.
- If the brake fluid or grease adheres to the brake caliper assembly and disc rotor, quickly wipe it off.

1. Remove tires with power tool.
2. Fix the disc rotor using wheel nuts.
3. Drain brake fluid. Refer to [BR-273, "Draining"](#).
4. Remove union bolt and copper washer, and separate brake hose from caliper assembly. Refer to [BR-286, "REAR : Removal and Installation"](#).
5. Remove torque member mounting bolts, and remove brake caliper assembly.

CAUTION:

Never drop brake pad and caliper assembly.

6. Remove disc rotor. Refer to [RAX-8, "Removal and Installation"](#).

INSTALLATION

WARNING:

Since dust covering the front and rear brakes has an affect on human body, the dust must be removed with a dust collector. Never splatter the dust with an air blow gun.

CAUTION:

- Never spill or splash brake fluid on painted surfaces. Brake fluid may seriously damage paint. Wipe it off immediately and wash with water if it gets on a painted surface. However avoid washing brake components with water.
- Never depress the brake pedal while removing the brake pads because the piston may pop out.
- If the brake fluid or grease adheres to the brake caliper assembly and disc rotor, quickly wipe it off.

1. Install disc rotor. Refer to [RAX-8, "Removal and Installation"](#).
2. Install the brake caliper assembly to the axle housing and tighten the torque member mounting bolts to the specified torque.

CAUTION:

Never spill or splash any grease and moisture on the brake caliper assembly mounting face, threads, mounting bolts and washers. Wipe out any grease and moisture.

3. Install brake hose and copper washers to brake caliper assembly. Refer to [BR-286, "REAR : Removal and Installation"](#).
4. Refill with new brake fluid and perform the air bleeding. Refer to [BR-274, "Bleeding Brake System"](#).
5. Check a drag of rear disc brake. If any drag is found, refer to [BR-302, "BRAKE CALIPER ASSEMBLY : Inspection"](#).
6. Install tires with power tool.

BRAKE CALIPER ASSEMBLY : Disassembly and Assembly

INFOID:000000008139913

DISASSEMBLY

NOTE:

Never remove the torque member, brake pad and pad retainers when disassembling and assembling the cylinder body.

1. Remove the sliding pin bolt, and remove the cylinder body from the torque member.

CAUTION:

Fix the brake pad at suitable tape so that the brake pad will not drop.

2. Remove sliding pin boots from torque member.
3. Remove bushing from sliding pin bolt.

REAR DISC BRAKE

< REMOVAL AND INSTALLATION >

4. Remove the retaining ring (1).

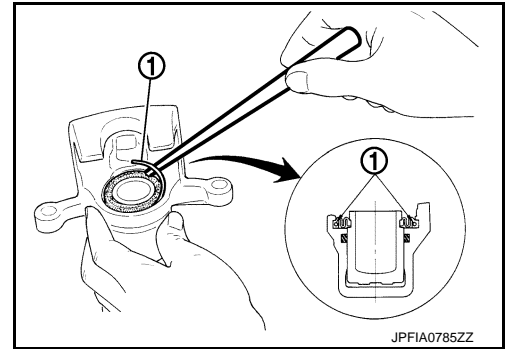

5. Place a wooden block as shown in the figure, and blow air from union bolt mounting hole to remove pistons and piston boot.

CAUTION:

Never get fingers caught in the pistons.

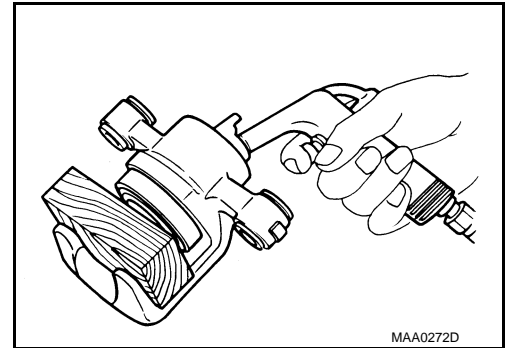

6. Remove piston seal from cylinder body using suitable tool.

CAUTION:

Be careful not to damage a cylinder inner wall.

7. Remove bleeder valve and cap.
8. Perform inspection after disassembly. Refer to [BR-302, "BRAKE CALIPER ASSEMBLY : Inspection"](#).

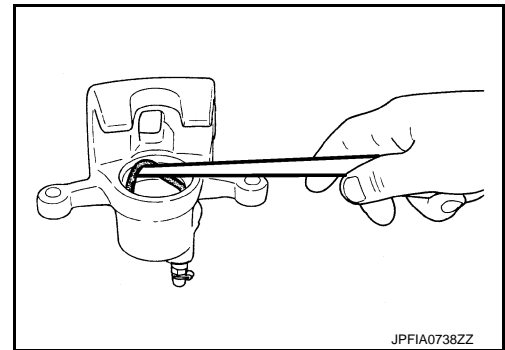

ASSEMBLY

1. Install bleeder valve and cap.
2. Apply new brake fluid to piston seal (1), and install them to cylinder body.

CAUTION:

Never reuse piston seal.

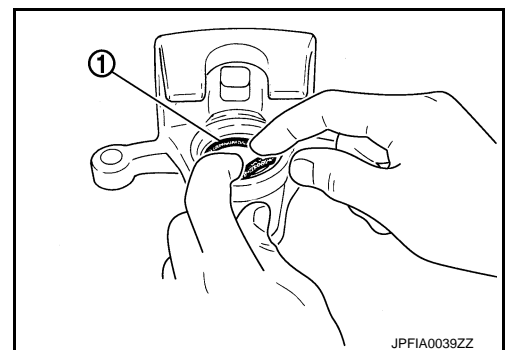

A
B
C
D
E
BR
G
H
I
J
K
L
M
N
O
P

REAR DISC BRAKE

< REMOVAL AND INSTALLATION >

3. Apply rubber grease to piston boot (1). Cover the piston (2) end with piston boot, and then install cylinder side lip on piston boot securely into a groove on cylinder body.

CAUTION:

Never reuse piston boots.

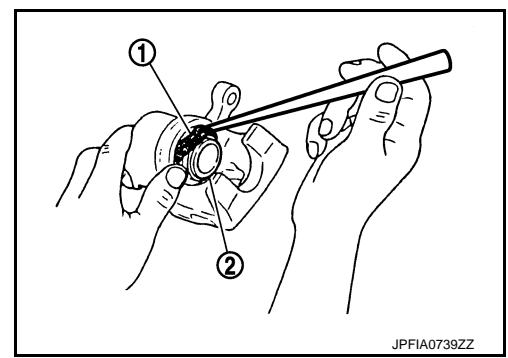

4. Apply new brake fluid to piston (1). Push piston into cylinder body by hand and push piston boot (2) piston-side lip into the piston groove.

CAUTION:

Press the pistons evenly and vary the pressing point to prevent cylinder inner wall from being rubbed.

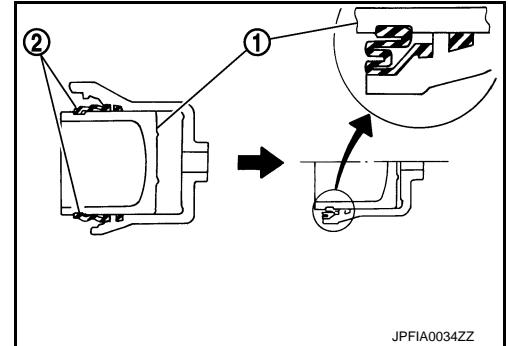

5. Install the retaining ring (1).

CAUTION:

- **Make sure that boot is securely engaged in the groove on caliper.**
- **Never reuse retaining ring.**

6. Apply rubber grease to bushing, and install bushing to sliding pin bolt.

7. Apply rubber grease to sliding pin boots, and install sliding pin boots to torque member.

8. Apply PBC (Poly Butyl Cuprysil) grease or silicone-based grease to the pawls part of cylinder body.

9. Apply rubber grease to sliding pin bolt, and install the cylinder body to tighten sliding pin bolts to the specified torque.

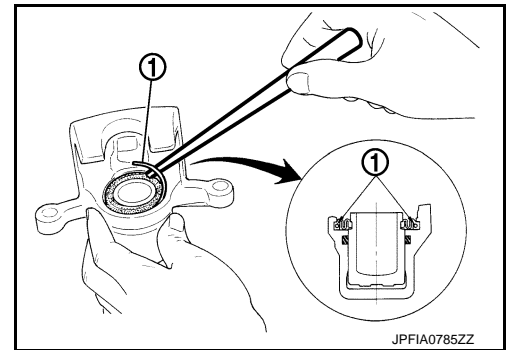

BRAKE CALIPER ASSEMBLY : Inspection

INFOID:000000008139914

INSPECTION AFTER DISASSEMBLY

Check the following items and replace if necessary.

Cylinder Body

Check the cylinder inner wall for rust, wear, cracks or damage.

CAUTION:

Always clean with new brake fluid. Never clean with mineral oil such as gasoline and light oil.

Torque Member

Check the torque member for rust, wear, cracks or damage.

Piston

Check the surface of the piston for rust, wear, cracks or damage.

CAUTION:

A piston sliding surface is plated. Never polish with sandpaper.

Sliding Pin Bolt, Sliding Pin Boot and Bushing

Check the sliding pin bolts, sliding pin boots and bushing for rust, wear, cracks or damage.

INSPECTION AFTER INSTALLATION

1. Check a drag of rear disc brake. If any drag is found, follow the procedure described below.

REAR DISC BRAKE

< REMOVAL AND INSTALLATION >

2. Remove brake pads. Refer to [BR-297, "BRAKE PAD : Removal and Installation"](#).
3. Press the pistons. Refer to [BR-297, "BRAKE PAD : Removal and Installation"](#).
4. Install brake pads. Refer to [BR-297, "BRAKE PAD : Removal and Installation"](#).
5. Depress the brake pedal several times.
6. Check a drag of rear disc brake again. If any drag is found, disassemble the cylinder body. Refer to [BR-300, "BRAKE CALIPER ASSEMBLY : Disassembly and Assembly"](#).
7. Burnish contact surfaces brake pads and disc rotor after refinishing or replacing disc rotor, or if a soft pedal occurs at very low mileage. Refer to [BR-278, "DISC ROTOR : Inspection and Adjustment"](#).

A

B

C

D

E

BR

G

H

I

J

K

L

M

N

O

P

SERVICE DATA AND SPECIFICATIONS (SDS)

< SERVICE DATA AND SPECIFICATIONS (SDS)

SERVICE DATA AND SPECIFICATIONS (SDS)

SERVICE DATA AND SPECIFICATIONS (SDS)

General Specifications

INFOID:0000000008139915

Unit: mm (in)

Front brake	Cylinder bore diameter	45.0 (1.772) × 2
	Pad length × width × thickness	130 × 50.0 × 11.0 (5.12 × 1.969 × 0.433)
	Rotor outer diameter × thickness	320 × 28.0 (12.60 × 1.102)
Rear brake	Cylinder bore diameter	42.86 (1.687)
	Pad length × width × thickness	83.0 × 31.9 × 8.5 (3.268 × 1.256 × 0.335)
	Rotor outer diameter × thickness	308 × 16.0 (12.13 × 0.630)
Master cylinder	Cylinder bore diameter	25.4 (1)
Control valve	Valve type	Electric brake force distribution
Brake booster		Electrically-driven intelligent brake
Recommended brake fluid		Refer to MA-10, "Fluids and Lubricants" .

Brake Pedal

INFOID:0000000008139916

Unit: mm (in)

Item	Standard
Brake pedal height	170.5 – 180.5 (6.71 – 7.11)
Depressed brake pedal height [Depressing 196 N (20 kg, 44 lb) while turning the engine ON]	124.0 (4.88) or more
Clearance between stop lamp switch and ICC brake switch threaded end and the stopper rubber	0.74 – 1.96 (0.0291 – 0.0772)
Brake pedal play	3 – 11 (0.12 – 0.43)

Electrically-driven Intelligent Brake

INFOID:0000000008139917

Unit: mm (in)

Item	Standard
Input rod length	135.7 – 136.7 (5.34 – 5.38)

Front Disc Brake

INFOID:0000000008139918

Unit: mm (in)

Item	Limit
Brake pad	Wear thickness 2.0 (0.079)
Disc rotor	Wear thickness 26.0 (1.024)
	Thickness variation (measured at 8 positions) 0.015 (0.0006)
	Runout (with it attached to the vehicle) 0.035 (0.0014)

Rear Disc Brake

INFOID:0000000008139919

Unit: mm (in)

Item	Limit
Brake pad	Wear thickness 2.0 (0.079)
Disc rotor	Wear thickness 14.0 (0.551)
	Thickness variation (measured at 8 positions) 0.015 (0.0006)
	Runout (with it attached to the vehicle) 0.055 (0.0022)