

SECTION **FSU**
FRONT SUSPENSION

A
B
C
D

FSU

CONTENTS

PRECAUTION	2	FRONT COIL SPRING AND SHOCK AB-	F
PRECAUTIONS	2	SORBER	9
Precaution for Supplemental Restraint System		Exploded View	9
(SRS) "AIR BAG" and "SEAT BELT PRE-TEN-		Removal and Installation	9
SIONER"	2	Disassembly and Assembly	10
Precaution Necessary for Steering Wheel Rota-		Inspection	12
tion after 12V Battery Disconnect	2	Disposal	12
Precaution for Procedure without Cowl Top Cover.....	3	TRANSVERSE LINK	13
Precautions Concerning On-board Servicing of		Exploded View	13
Hybrid Systems	3	Removal and Installation	13
Precautions for Suspension	3	Inspection	14
PREPARATION	4	UPPER LINK	15
PREPARATION	4	Exploded View	15
Special Service Tools	4	Removal and Installation	15
Commercial Service Tools	4	Inspection	15
SYMPTOM DIAGNOSIS	5	FRONT STABILIZER	17
NOISE, VIBRATION AND HARSHNESS		Exploded View	17
(NVH) TROUBLESHOOTING	5	Removal and Installation	17
NVH Troubleshooting Chart	5	Inspection	17
PERIODIC MAINTENANCE	6	FRONT SUSPENSION MEMBER	18
FRONT SUSPENSION ASSEMBLY	6	Exploded View	18
Inspection	6	Removal and Installation	18
WHEEL ALIGNMENT	7	Inspection	19
Inspection	7	SERVICE DATA AND SPECIFICATIONS	N
Adjustment	7	(SDS)	20
REMOVAL AND INSTALLATION	9	SERVICE DATA AND SPECIFICATIONS	O
		(SDS)	20
		Wheel Alignment	20
		Ball Joint	20
		Wheelarch Height	20
			P

PRECAUTIONS

< PRECAUTION >

PRECAUTION

PRECAUTIONS

Precaution for Supplemental Restraint System (SRS) "AIR BAG" and "SEAT BELT PRE-TENSIONER"

INFOID:000000008144275

The Supplemental Restraint System such as "AIR BAG" and "SEAT BELT PRE-TENSIONER", used along with a front seat belt, helps to reduce the risk or severity of injury to the driver and front passenger for certain types of collision. This system includes seat belt switch inputs and dual stage front air bag modules. The SRS system uses the seat belt switches to determine the front air bag deployment, and may only deploy one front air bag, depending on the severity of a collision and whether the front occupants are belted or unbelted. Information necessary to service the system safely is included in the "SRS AIR BAG" and "SEAT BELT" of this Service Manual.

WARNING:

Always observe the following items for preventing accidental activation.

- To avoid rendering the SRS inoperative, which could increase the risk of personal injury or death in the event of a collision that would result in air bag inflation, all maintenance must be performed by an authorized NISSAN/INFINITI dealer.
- Improper maintenance, including incorrect removal and installation of the SRS, can lead to personal injury caused by unintentional activation of the system. For removal of Spiral Cable and Air Bag Module, see "SRS AIR BAG".
- Never use electrical test equipment on any circuit related to the SRS unless instructed to in this Service Manual. SRS wiring harnesses can be identified by yellow and/or orange harnesses or harness connectors.

PRECAUTIONS WHEN USING POWER TOOLS (AIR OR ELECTRIC) AND HAMMERS

WARNING:

Always observe the following items for preventing accidental activation.

- When working near the Air Bag Diagnosis Sensor Unit or other Air Bag System sensors with the ignition ON or engine running, never use air or electric power tools or strike near the sensor(s) with a hammer. Heavy vibration could activate the sensor(s) and deploy the air bag(s), possibly causing serious injury.
- When using air or electric power tools or hammers, always switch the ignition OFF, disconnect the 12V battery, and wait at least 3 minutes before performing any service.

Precaution Necessary for Steering Wheel Rotation after 12V Battery Disconnect

INFOID:000000008144276

For vehicle with steering lock unit, if the 12V battery is disconnected or discharged, the steering wheel will lock and cannot be turned.

If turning the steering wheel is required with the 12V battery disconnected or discharged, follow the operation procedure below before starting the repair operation.

OPERATION PROCEDURE

1. Connect both 12V battery cables.

NOTE:

Supply power using jumper cables if 12V battery is discharged.

2. Turn the ignition switch to ACC position.
(At this time, the steering lock will be released.)
3. Disconnect both 12V battery cables. The steering lock will remain released with both 12V battery cables disconnected and the steering wheel can be turned.
4. Perform the necessary repair operation.
5. When the repair work is completed, re-connect both 12V battery cables. With the brake pedal released, turn the ignition switch from ACC position to ON position, then to LOCK position. (The steering wheel will lock when the ignition switch is turned to LOCK position.)
6. Perform All DTC Reading using CONSULT and delete DTC.

NOTE:

Multiple DTCs are detected when 12V battery cable is disconnected while ignition switch is in ACC position.

PRECAUTIONS

< PRECAUTION >

Precaution for Procedure without Cowl Top Cover

INFOID:000000008144277

When performing the procedure after removing cowl top cover, cover the lower end of windshield with urethane, etc to prevent damage to windshield.

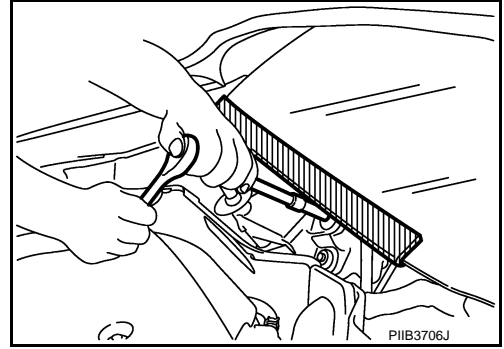

A
B
C
D

Precautions Concerning On-board Servicing of Hybrid Systems

INFOID:000000008144278

CAUTION:

Be sure to turn the ignition switch OFF before performing inspection and servicing inside the engine compartment or underneath the vehicle. If the ignition switch is ON (vehicle READY state), even if the engine is stopped, the conditions of the vehicle may cause the engine to start automatically.

If it is necessary to continually operate the engine during inspection or servicing, use the designated inspection mode. [HBC-89, "Description"](#).

FSU

F

Precautions for Suspension

INFOID:000000008144279

- When installing rubber bushings, the final tightening must be carried out under unladen conditions with tires on ground. Spilled oil might shorten the life of rubber bushings. Be sure to wipe off any spilled oil.
- Unladen conditions mean that fuel, engine coolant and lubricant are full. Spare tire, jack, hand tools and mats are in designated positions.
- After servicing suspension parts, be sure to check wheel alignment.
- Self-lock nuts are not reusable. Always use new ones when installing. Since new self-lock nuts are pre-oiled, tighten as they are.

G

H

I

J

K

L

M

N

O

P

PREPARATION

< PREPARATION >

PREPARATION

PREPARATION

Special Service Tools

INFOID:000000008144280

The actual shapes of Kent-Moore tools may differ from those of special service tools illustrated here.

Tool number (Kent-Moore No.) Tool name	Description
ST35652000 (-) Shock absorber attachment	Disassembling and assembling shock absorber
ST3127S000 (J-25765-A) Preload gauge	Measuring rotating torque of ball joint

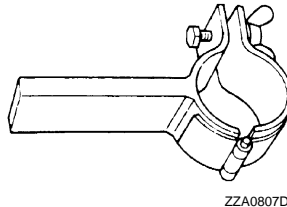

ZZA0807D

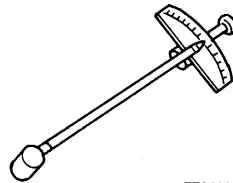

ZZA0806D

Commercial Service Tools

INFOID:000000008144281

Tool name	Description
Power tool	Loosening bolts and nuts
Spring compressor	Removing and installing coil spring

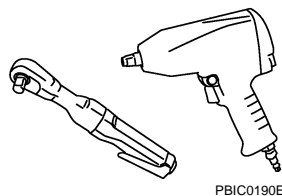

PBIC0190E

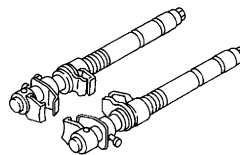

S-NT717

NOISE, VIBRATION AND HARSHNESS (NVH) TROUBLESHOOTING

< SYMPTOM DIAGNOSIS >

SYMPTOM DIAGNOSIS

NOISE, VIBRATION AND HARSHNESS (NVH) TROUBLESHOOTING

NVH Troubleshooting Chart

INFOID:000000008144282

Use chart below to find the cause of the symptom. If necessary, repair or replace these parts.

Symptom		Possible cause and SUSPECTED PARTS	Reference													
			FSU-9, FSU-13, FSU-15, FSU-17, FSU-18	FSU-12	—	—	—	FSU-9, FSU-13, FSU-15, FSU-17, FSU-18	FSU-7	FSU-17	NVH in DLN section	NVH in FAX and FSU section	NVH in WT section	NVH in BR section	NVH in ST section	
Symptom	FRONT SUSPENSION	Noise	x	x	x	x	x	x	x			x	x	x	x	x
		Shake	x	x	x	x			x			x	x	x	x	x
		Vibration	x	x	x	x	x					x	x			x
		Shimmy	x	x	x	x				x			x	x	x	x
		Judder	x	x	x								x	x	x	x
		Poor quality ride or handling	x	x	x	x	x	x		x	x		x	x		

x: Applicable

A
B
C
D
E
F
G
H
I
J
K
L
M
N
O
P

FSU

FRONT SUSPENSION ASSEMBLY

< PERIODIC MAINTENANCE >

PERIODIC MAINTENANCE

FRONT SUSPENSION ASSEMBLY

Inspection

INFOID:000000008144283

COMPONENT PART

Check the mounting conditions (looseness, backlash) of each component and component conditions (wear, damage) are normal.

Ball Joint Axial End Play

1. Set front wheels in a straight-ahead position.
2. Move axle side of transverse link and upper link in the axial direction by hand. Check there is no end play.

Axial end play : Refer to [FSU-20. "Ball Joint"](#).

CAUTION:

- Never depress brake pedal when measuring.
- Never perform with tires on level ground.
- Be careful not to damage ball joint boot. Never damage the installation position by applying excessive force.

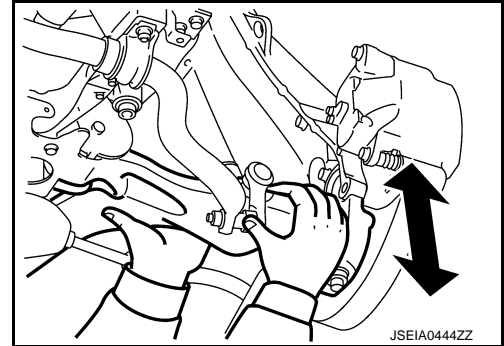

Shock absorber

Check for oil leakage, damage. Replace it if necessary.

WHEEL ALIGNMENT

< PERIODIC MAINTENANCE >

WHEEL ALIGNMENT

Inspection

INFOID:000000008144284

DESCRIPTION

CAUTION:

- **Camber, caster, kingpin inclination angles cannot be adjusted.**
- **If camber, caster, or kingpin inclination angle is outside the standard, check front suspension parts for wear and damage. Replace suspect parts if a malfunction is detected.**
- **Kingpin inclination angle is reference value, no inspection is required.**
- **Measure wheel alignment under unladen conditions.**

NOTE:

“Unladen conditions” means that fuel, engine coolant, and lubricant are full. Spare tire, jack, hand tools and mats are in designated positions.

PRELIMINARY CHECK

Check the following:

- Tires for improper air pressure and wear. Refer to [WT-64, "Tire Air Pressure"](#).
- Road wheels for runout.
- Wheel bearing axial end play. Refer to [FAX-6, "Inspection"](#).
- Transverse link or upper link ball joint axial end play. Refer to [FSU-6, "Inspection"](#).
- Shock absorber operation.
- Each mounting part of axle and suspension for looseness and deformation.
- Each of suspension member, shock absorber, upper link and transverse link for cracks, deformation and other damage.
- Vehicle height (posture).

GENERAL INFORMATION AND RECOMMENDATIONS

- A four-wheel thrust alignment should be performed.
- This type of alignment is recommended for any NISSAN/INFINITI vehicle.
- The four-wheel “thrust” process helps ensure that the vehicle is properly aligned and the steering wheel is centered.
- The alignment rack itself should be capable of accepting any NISSAN/INFINITI vehicle.
- The rack should be checked to ensure that it is level.
- Make sure the machine is properly calibrated.
- Your alignment equipment should be regularly calibrated in order to give correct information.
- Check with the manufacturer of your specific equipment for their recommended Service/Calibration Schedule.

ALIGNMENT PROCESS

IMPORTANT:

Use only the alignment specifications listed in this Service Manual.

- When displaying the alignment settings, many alignment machines use “indicators”: (Green/red, plus or minus, Go/No Go). **Never use these indicators.**
- The alignment specifications programmed into your machine that operate these indicators may not be correct.
- This may result in an ERROR.
- Most camera-type alignment machines are equipped with both “Rolling Compensation” method and optional “Jacking Compensation” method to “compensate” the alignment targets or head units. “Rolling Compensation” is the preferred method.
- If using the “Rolling Compensation” method, after installing the alignment targets or head units, push or pull on the rear wheel to move the vehicle. **Do not push or pull on the vehicle body.**
- If using the “Jacking Compensation” method, after installing the alignment targets or head units, raise the vehicle and rotate the wheels 1/2 turn both ways.

NOTE:

- Do not use the “Rolling Compensation” method if you are using sensor-type alignment equipment.
- Follow all instructions for the alignment machine you're using for more information.

Adjustment

INFOID:000000008144285

TOE-IN

WHEEL ALIGNMENT

< PERIODIC MAINTENANCE >

- Loosen the steering outer socket, and then adjust the length using steering inner socket.

Toe-in : Refer to [FSU-20, "Wheel Alignment"](#).

CAUTION:

- Always evenly adjust both toe-in alternately and adjust the difference between the left and right to the standard.
- Always fix the steering inner socket when tightening the steering outer socket.
- After toe-in adjustment, adjust neutral position of steering angle sensor. Refer to [BRC-66, "Work Procedure"](#).

FRONT COIL SPRING AND SHOCK ABSORBER

< REMOVAL AND INSTALLATION >

REMOVAL AND INSTALLATION

FRONT COIL SPRING AND SHOCK ABSORBER

Exploded View

INFOID:000000008144286

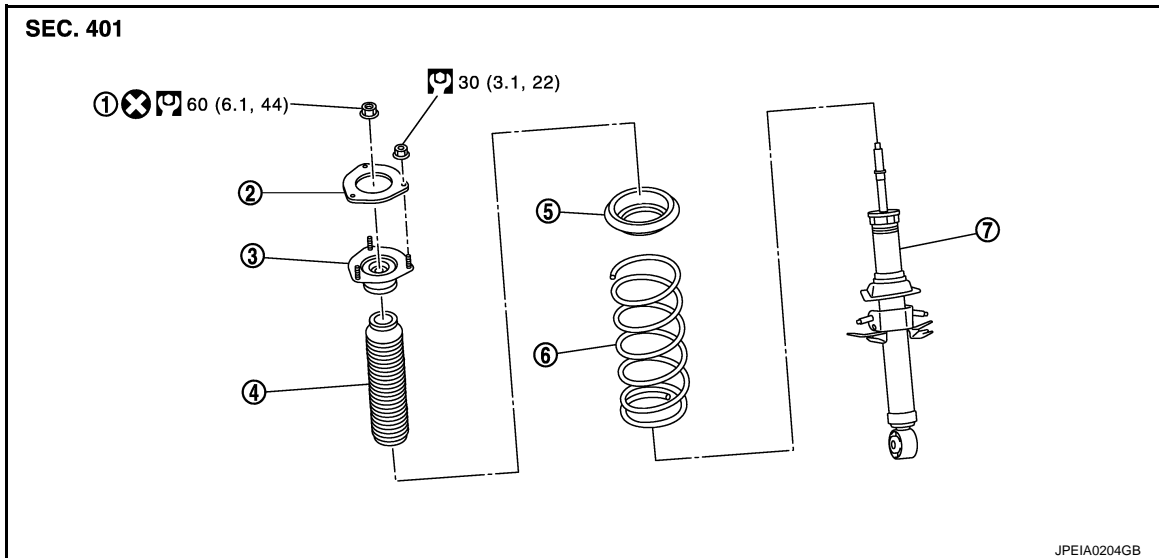

- | | | |
|------------------------|------------------|------------------------------------|
| 1. Piston rod lock nut | 2. Mounting seal | 3. Shock absorber mounting bracket |
| 4. Bound bumper | 5. Rubber seat | 6. Coil spring |
| 7. Shock absorber | | |

: N·m (kg-m, ft-lb)

: Always replace after every disassembly.

Removal and Installation

INFOID:000000008144287

REMOVAL

1. Remove tires with power tool. Refer to [WT-58, "Exploded View"](#).
2. Remove wheel sensor harness from shock absorber. Refer to [BRC-159, "FRONT WHEEL SENSOR : Removal and Installation"](#).
CAUTION:
Never pull on wheel sensor harness.
3. Remove brake hose mounting nut, and separate brake hose from shock absorber. Refer to [BR-282, "FRONT : Exploded View"](#).
4. Remove stabilizer connecting rod from transverse link. Refer to [FSU-17, "Removal and Installation"](#).
5. Separate upper link from steering knuckle. Refer to [FSU-15, "Removal and Installation"](#).
6. Remove shock absorber mounting bracket mounting nuts, and remove shock absorber assembly.

INSTALLATION

Note the following, and install in the reverse order of removal.

- Never tap on the ball joint cap of the stabilizer connecting rod with a hammer or a similar item when inserting the stabilizer connecting rod into the transverse link.
- Perform final tightening of bolts and nuts at the shock absorber lower side (rubber bushing), under unladen conditions with tires on level ground.
- Perform inspection after installation. Refer to [FSU-12, "Inspection"](#).
- After replacing the shock absorber, always follow the disposal procedure to discard the shock absorber. Refer to [FSU-12, "Disposal"](#).

FRONT COIL SPRING AND SHOCK ABSORBER

< REMOVAL AND INSTALLATION >

Disassembly and Assembly

INFOID:00000008144288

DISASSEMBLY

CAUTION:

Never damage shock absorber piston rod when removing components from shock absorber.

1. Install shock absorber attachment (A) [SST: ST35652000 (-)] to shock absorber and secure it in a vise.

CAUTION:

When installing the shock absorber attachment to shock absorber, wrap a shop cloth around shock absorber to protect it from damage.

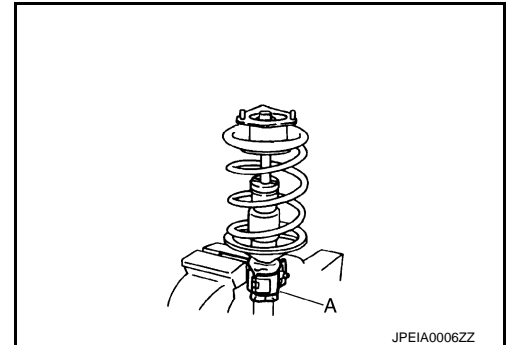

2. Using a spring compressor (A) (commercial service tool), compress coil spring between rubber seat and shock absorber until coil spring with a spring compressor is free.

CAUTION:

Be sure a spring compressor is securely attached coil spring. Compress coil spring.

3. Make sure coil spring with a spring compressor between rubber seat and shock absorber is free. And then remove piston rod lock nut while securing the piston rod tip so that piston rod does not turn.

CAUTION:

Start compressing the coil spring after checking that the spring compressor is completely attached.

4. Remove mounting seal, shock absorber mounting bracket, rubber seat, bound bumper from shock absorber.
5. After remove coil spring with a spring compressor, and then gradually release a spring compressor.

CAUTION:

Loosen while making sure coil spring attachment position does not move.

6. Remove the shock absorber attachment from shock absorber.
7. Perform inspection after disassembly. Refer to [FSU-12, "Inspection"](#).

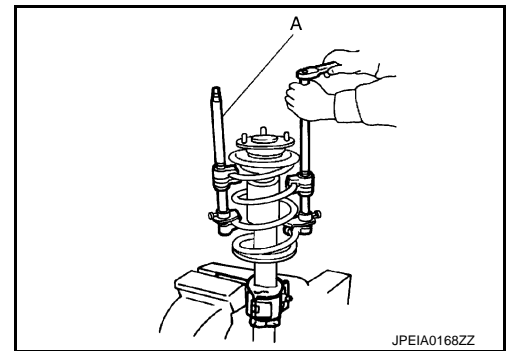

ASSEMBLY

CAUTION:

Never damage shock absorber piston rod when installing components from shock absorber.

1. Install shock absorber attachment [SST: ST35652000 (-)] to shock absorber and secure it in a vise.

CAUTION:

When installing the shock absorber attachment to shock absorber, wrap a shop cloth around shock absorber to protect it from damage.

2. Compress coil spring using a spring compressor (commercial service tool), and install it onto shock absorber.

CAUTION:

FRONT COIL SPRING AND SHOCK ABSORBER

< REMOVAL AND INSTALLATION >

- Install with the large-diameter side (A) facing up and the small-diameter side (B) facing down.
- Be sure a spring compressor is securely attached to coil spring. Compress coil spring.

3. Install the shock absorber mounting bracket and rubber seat.
4. Apply soapy water to bound bumper.

CAUTION:
Never use machine oil.

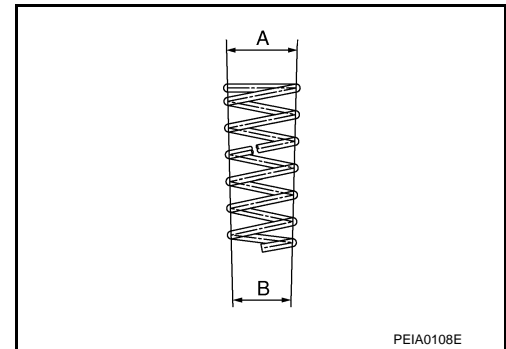

5. Insert bound bumper into shock absorber mounting bracket, and then install it to shock absorber together with rubber seat.

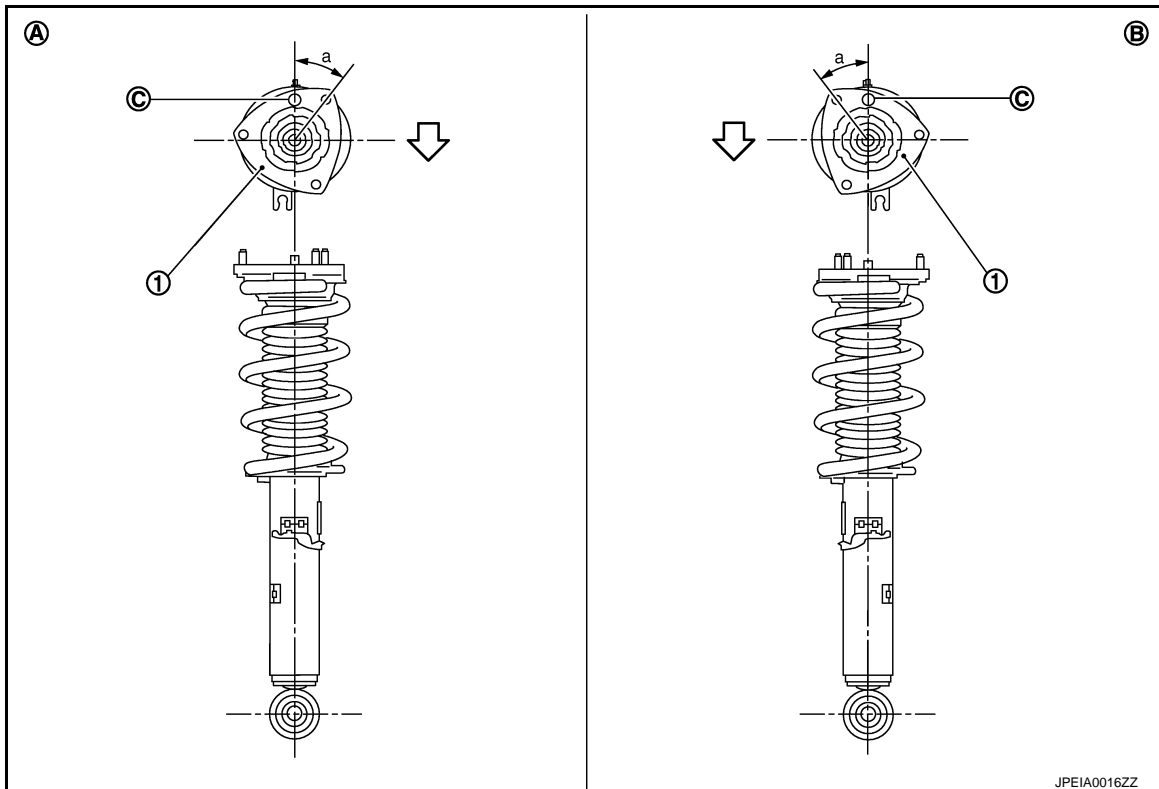

1. Shock absorber mounting bracket

A. Right side

B. Left side

C. Coil spring lower end position

⇐: Vehicle front

- Install the shock absorber mounting bracket as shown in the figure.

Angle (a) : 35.4°

- Check that the lower end of the coil spring (C) is positioned at the spring lower seat of the shock absorber.

6. Secure piston rod tip so that piston rod does not turn, then tighten piston rod lock nut with specified torque.

CAUTION:
Never reuse piston rod lock nut.

7. Gradually release a spring compressor, and remove coil spring.

CAUTION:
Loosen while making sure coil spring attachment position does not move.

8. Remove the shock absorber attachment from shock absorber.
9. Install the mounting seal to shock absorber mounting bracket.

FRONT COIL SPRING AND SHOCK ABSORBER

< REMOVAL AND INSTALLATION >

Inspection

INFOID:000000008144289

INSPECTION AFTER DISASSEMBLY

Shock absorber

Check the following items, and replace the part if necessary.

- Shock absorber for deformation, cracks or damage.
- Piston rod for damage, uneven wear or distortion.
- Oil leakage.

Shock absorber Mounting Bracket and Rubber Parts Inspection

Check shock absorber mounting bracket for cracks and rubber parts for wear. Replace it if necessary.

Coil Spring

Check coil spring for cracks, wear or damage. Replace it if necessary.

INSPECTION AFTER INSTALLATION

1. Check wheel sensor harness for proper connection. Refer to [BRC-159, "FRONT WHEEL SENSOR : Exploded View"](#).
2. Check wheel alignment. Refer to [FSU-7, "Inspection"](#).
3. Adjust neutral position of steering angle sensor. Refer to [BRC-66, "Work Procedure"](#).

Disposal

INFOID:000000008144290

1. Set shock absorber horizontally with the piston rod fully extended.
2. Drill 2 – 3 mm (0.08 – 0.12 in) hole at the position (●) from top as shown in the figure to release gas gradually.

CAUTION:

- Wear eye protection (safety glasses).
- Wear gloves.
- Be careful with metal chips or oil blown out by the compressed gas.

NOTE:

- Drill vertically in the direction show by arrow.
- Directly to the outer tube avoiding brackets.
- The gas is clear, colorless, odorless, and harmless.

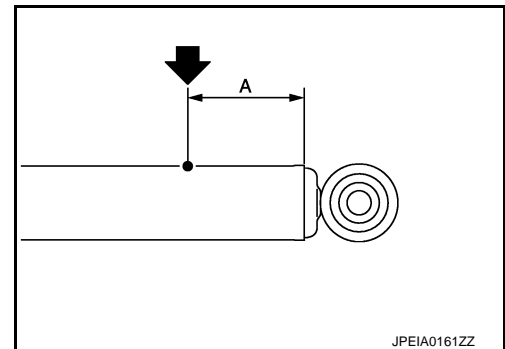

A : 20 – 30 mm (0.79 – 1.18 in)

3. Position the drilled hole downward and drain oil by moving the piston rod several times.

CAUTION:

Dispose of drained oil according to the law and local regulations.

TRANSVERSE LINK

< REMOVAL AND INSTALLATION >

TRANSVERSE LINK

Exploded View

INFOID:000000008144291

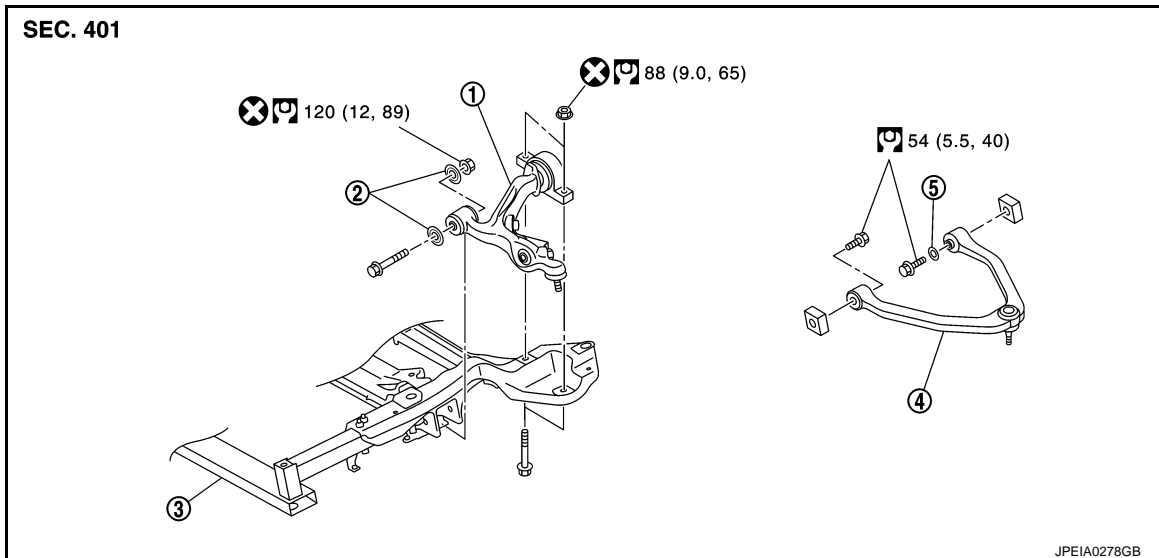

1. Transverse link
2. Stopper bushing
3. Front suspension member
4. Upper link
5. Stopper rubber

: N·m (kg-m, ft-lb)

: Always replace after every disassembly.

Removal and Installation

INFOID:000000008144292

REMOVAL

1. Remove tires with power tool. Refer to [WT-58. "Exploded View"](#).
2. Remove engine under cover with power tool. Refer to [EXT-28. "ENGINE UNDER COVER : Removal and Installation"](#).
3. Remove stabilizer connecting rod and shock absorber from transverse link. Refer to [FSU-17. "Removal and Installation"](#).
4. Separate steering outer socket from steering knuckle. Refer to [ST-37. "Removal and Installation"](#).
5. Remove transverse link from steering knuckle.
6. Set suitable jack under transverse link.
CAUTION:
 - Never damage the transverse link with a jack.
 - Check the stable condition when using a jack.
7. Remove mounting bolts, nuts, and stopper bushing, and then remove transverse link from front suspension member.
8. Perform inspection after removal. Refer to [FSU-14. "Inspection"](#).

INSTALLATION

Note the following, and install in the reverse order of removal.

- Never tap on the ball joint cap of the stabilizer connecting rod with a hammer or a similar item when inserting the stabilizer connecting rod into the transverse link.
- Perform final tightening of bolts and nuts at the front suspension member installation and shock absorber lower side (rubber bushing), under unladen conditions with tires on level ground.
- Never reuse transverse link mounting nut.
- Perform inspection after installation. Refer to [FSU-14. "Inspection"](#).

TRANSVERSE LINK

< REMOVAL AND INSTALLATION >

INFOID:000000008144293

Inspection

INSPECTION AFTER REMOVAL

Check the following items, and replace the part if necessary.

- Transverse link and bushing for deformation, cracks or damage.
- Ball joint boot for cracks or other damage, and also for grease leakage.

Swing Torque Inspection

1. Manually move ball stud to confirm it moves smoothly with no binding.
2. Move the ball stud at least ten times by hand to check for smooth movement.
3. Hook a spring balance (A) at cotter pin mounting hole. Confirm spring balance measurement value is within specifications when ball stud begins moving.

Swing torque : Refer to [FSU-20, "Ball Joint"](#).

- If swing torque exceeds standard range, replace transverse link assembly.

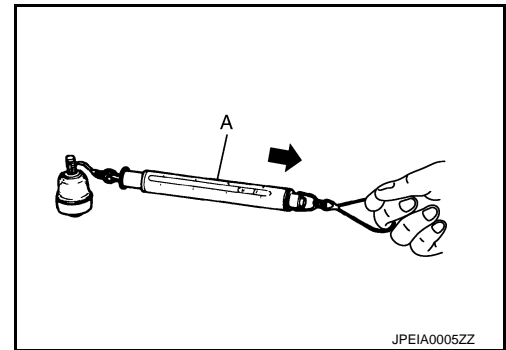

Rotating Torque Inspection

1. Manually move ball stud to confirm it moves smoothly with no binding.
2. Move the ball stud at least ten times by hand to check for smooth movement.
3. Attach mounting nut to ball stud. Make sure that rotating torque is within specifications with a preload gauge (A) [SST: ST3127S000 (J-25765-A)].

Rotating torque : Refer to [FSU-20, "Ball Joint"](#).

- If rotating torque exceeds standard range, replace transverse link assembly.

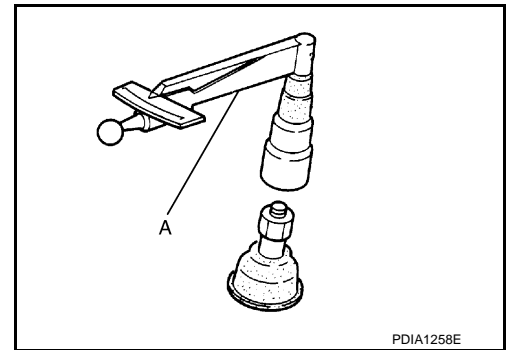

Axial End Play Inspection

1. Manually move ball stud to confirm it moves smoothly with no binding.
2. Move the ball stud at least ten times by hand to check for smooth movement.
3. Move tip of ball stud in axial direction to check for looseness.

Axial end play : Refer to [FSU-20, "Ball Joint"](#).

- If axial end play exceeds standard range, replace transverse link assembly.

INSPECTION AFTER INSTALLATION

1. Check wheel sensor harness for proper connection. Refer to [BRC-159, "FRONT WHEEL SENSOR : Exploded View"](#).
2. Check wheel alignment. Refer to [FSU-7, "Inspection"](#).
3. Adjust neutral position of steering angle sensor. Refer to [BRC-66, "Work Procedure"](#).

UPPER LINK

< REMOVAL AND INSTALLATION >

UPPER LINK

Exploded View

INFOID:000000008144294

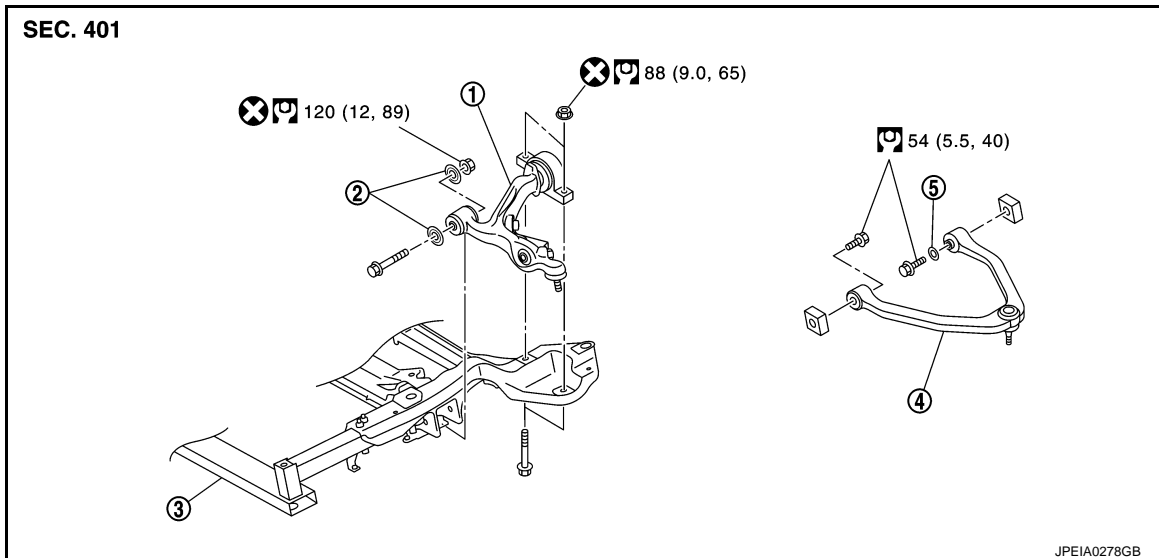

- | | | |
|--------------------|--------------------|----------------------------|
| 1. Transverse link | 2. Stopper bushing | 3. Front suspension member |
| 4. Upper link | 5. Stopper rubber | |

: N·m (kg-m, ft-lb)

: Always replace after every disassembly.

Removal and Installation

INFOID:000000008144295

REMOVAL

1. Remove tires with power tool. Refer to [WT-58. "Exploded View"](#).
2. Remove shock absorber. Refer to [FSU-9. "Removal and Installation"](#).
3. Remove mounting bolts and stopper rubber, and then remove upper link from vehicle.
4. Perform inspection after removal. Refer to [FSU-15. "Inspection"](#).

INSTALLATION

Note the following, and install in the reverse order of removal.

- Perform final tightening of bolts and nuts at the vehicle installation position (rubber bushing), under unladen conditions with tires on level ground.
- Perform inspection after installation. Refer to [FSU-15. "Inspection"](#).

Inspection

INFOID:000000008144296

INSPECTION AFTER REMOVAL

Check the following items, and replace the part if necessary.

- Upper link and bushing for deformation, cracks or damage.
- Ball joint boot for cracks or other damage, and also for grease leakage.

Swing Torque Inspection

1. Manually move ball stud to confirm it moves smoothly with no binding.
2. Move the ball stud at least ten times by hand to check for smooth movement.

UPPER LINK

< REMOVAL AND INSTALLATION >

3. Hook a spring balance (A) at cutout on ball stud. Confirm spring balance measurement value is within specifications when ball stud begins moving.

Swing torque : Refer to [FSU-20, "Ball Joint"](#).

- If swing torque exceeds standard range, replace upper link assembly.

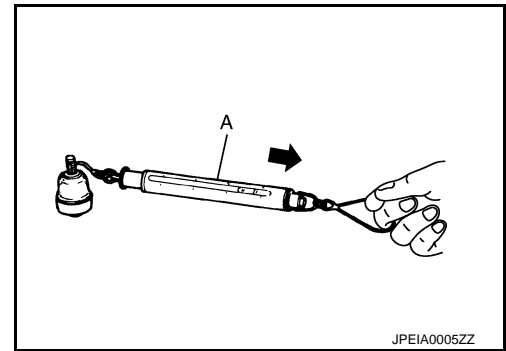

Axial End Play Inspection

1. Manually move ball stud to confirm it moves smoothly with no binding.
2. Move the ball stud at least ten times by hand to check for smooth movement.
3. Move tip of ball stud in axial direction to check for looseness.

Axial end play : Refer to [FSU-20, "Ball Joint"](#).

- If axial end play exceeds standard range, replace upper link assembly.

INSPECTION AFTER INSTALLATION

1. Check wheel sensor harness for proper connection. Refer to [BRC-159, "FRONT WHEEL SENSOR : Exploded View"](#).
2. Check wheel alignment. Refer to [FSU-7, "Inspection"](#).
3. Adjust neutral position of steering angle sensor. Refer to [BRC-66, "Work Procedure"](#).

FRONT STABILIZER

< REMOVAL AND INSTALLATION >

FRONT STABILIZER

Exploded View

INFOID:000000008144297

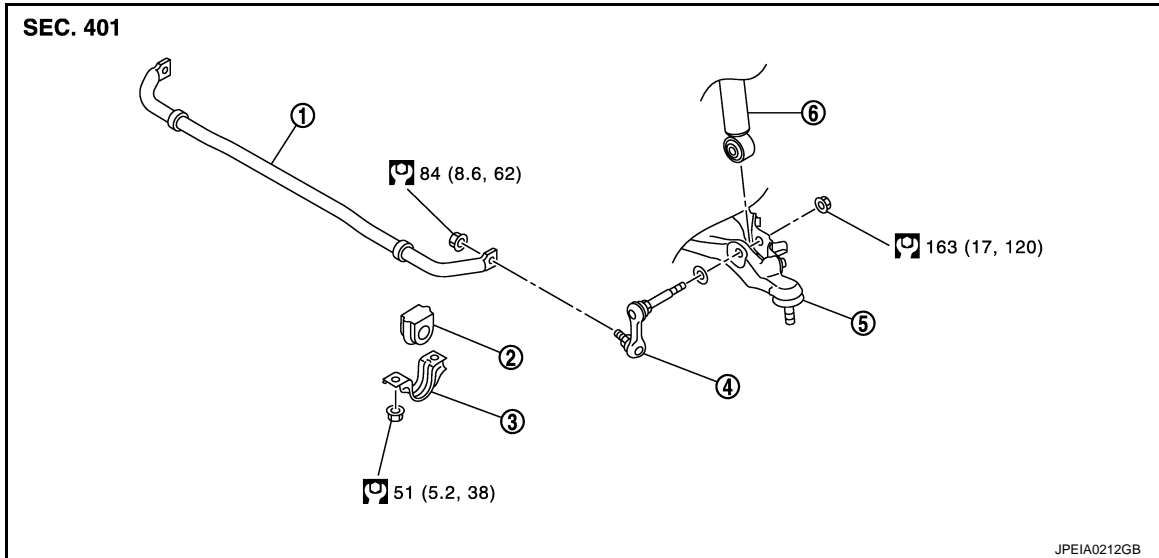

- | | | |
|------------------------------|-----------------------|---------------------|
| 1. Stabilizer bar | 2. Stabilizer bushing | 3. Stabilizer clamp |
| 4. Stabilizer connecting rod | 5. Transverse link | 6. Shock absorber |

: N·m (kg-m, ft-lb)

Removal and Installation

INFOID:000000008144298

REMOVAL

1. Remove tires with power tool. Refer to [WT-58, "Exploded View"](#).
2. Remove engine under cover with power tool. Refer to [EXT-28, "ENGINE UNDER COVER : Removal and Installation"](#).
3. Remove stabilizer connecting rods.
CAUTION:
Apply a matching mark with paint to identify the installation position.
4. Remove stabilizer clamps and stabilizer bushings.
5. Remove stabilizer bar.
6. Perform inspection after removal. Refer to [FSU-17, "Inspection"](#).

INSTALLATION

Note the following, and install in the reverse order of removal.

- Check the matching mark when installing.
- Tighten the mounting nut to the specified torque while holding a hexagonal part of stabilizer connecting rod side.

Inspection

INFOID:000000008144299

INSPECTION AFTER REMOVAL

Check stabilizer bar, stabilizer connecting rod, stabilizer bushing and stabilizer clamp for deformation, cracks or damage. Replace it if necessary.

FRONT SUSPENSION MEMBER

< REMOVAL AND INSTALLATION >

FRONT SUSPENSION MEMBER

Exploded View

INFOID:000000008144300

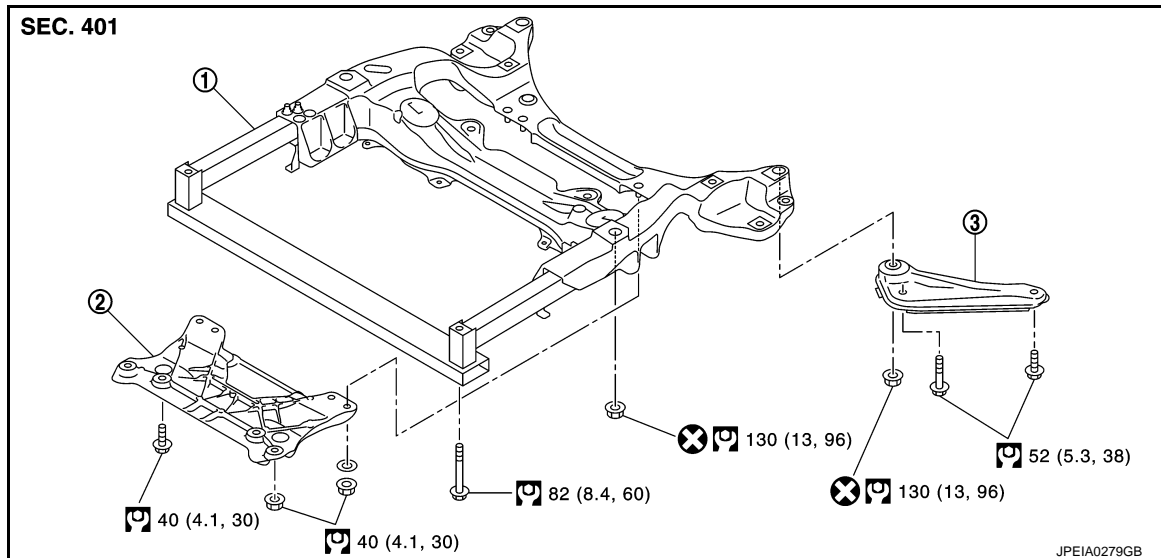

1. Front suspension member 2. Suspension member stay 3. Front suspension member stay

: N-m (kg-m, ft-lb)

: Always replace after every disassembly.

Removal and Installation

INFOID:000000008144301

REMOVAL

1. Remove tires with power tool. Refer to [WT-58, "Exploded View"](#).
2. Remove front under cover with power tool. Refer to [EXT-29, "FRONT UNDER COVER : Removal and Installation"](#).
3. Remove engine under cover with power tool. Refer to [EXT-28, "ENGINE UNDER COVER : Removal and Installation"](#).
4. Remove suspension member stay with power tool.
5. Separate steering gear assembly and lower joint. Refer to [ST-34, "Removal and Installation"](#).
6. Separate steering outer socket from steering knuckle. Refer to [ST-37, "Removal and Installation"](#).
7. Remove wheel sensor and sensor harness from steering knuckle. Refer to [BRC-159, "FRONT WHEEL SENSOR : Removal and Installation"](#).
8. Remove stabilizer connecting rod and shock absorber from transverse link. Refer to [FSU-17, "Removal and Installation"](#).
9. Remove stabilizer bar. Refer to [FSU-17, "Removal and Installation"](#).
10. Install engine slinger, and then hoist engine. Refer to [EM-78, "Removal and Installation"](#).
11. Remove transverse link from front suspension member. Refer to [FSU-13, "Removal and Installation"](#).
12. Remove steering hydraulic piping bracket and steering gear from front suspension member.
 - Steering hydraulic piping bracket: Refer to [ST-44, "Exploded View"](#).
 - Steering gear: Refer to [ST-37, "Removal and Installation"](#).
13. Set suitable jack front suspension member.

CAUTION:

 - Never damage the suspension member with a jack.
 - Check the stable condition when using a jack.
14. Remove mounting nuts between engine mounting insulator and from front suspension member. Refer to [EM-78, "Removal and Installation"](#).

FRONT SUSPENSION MEMBER

< REMOVAL AND INSTALLATION >

15. Remove front suspension member stay.
16. Remove suspension member mounting bolts and nuts, and then remove front suspension member.

CAUTION:

Operate while checking that jack supporting status is stable.

17. Perform inspection after removal. Refer to [FSU-19, "Inspection"](#).

INSTALLATION

Note the following, and install in the reverse order of removal.

- Perform final tightening of bolts and nuts at the vehicle installation position (rubber bushing), under unladen condition with tires on level ground.
- Never reuse front suspension member mounting nut.
- Never reuse front suspension member stay mounting nut.
- Perform inspection after installation. Refer to [FSU-19, "Inspection"](#).

Inspection

INFOID:000000008144302

FSU

INSPECTION AFTER REMOVAL

Check the front suspension member for significant deformation, cracks, or damages. Replace if necessary.

INSPECTION AFTER INSTALLATION

1. Check wheel sensor harness for proper connection. Refer to [BRC-159, "FRONT WHEEL SENSOR : Exploded View"](#).
2. Check wheel alignment. Refer to [FSU-7, "Inspection"](#).
3. Adjust neutral position of steering angle sensor. Refer to [BRC-66, "Work Procedure"](#).

SERVICE DATA AND SPECIFICATIONS (SDS)

< SERVICE DATA AND SPECIFICATIONS (SDS)

SERVICE DATA AND SPECIFICATIONS (SDS)

SERVICE DATA AND SPECIFICATIONS (SDS)

Wheel Alignment

INFOID:000000008144303

Item		Standard	
Camber Degree minute (Decimal degree)	Minimum	-0° 55' (-0.91°)	
	Nominal	-0° 10' (-0.17°)	
	Maximum	0° 35' (0.58°)	
	Left and right difference	0° 33' (0.55°) or less	
Caster Degree minute (Decimal degree)	Minimum	3° 10' (3.17°)	
	Nominal	4° 30' (4.50°)	
	Maximum	5° 50' (5.83°)	
	Left and right difference	0° 39' (0.65°) or less	
Kingpin inclination Degree minute (Decimal degree)	Minimum	6° 25' (6.42°)	
	Nominal	7° 10' (7.17°)	
	Maximum	7° 55' (7.91°)	
Toe-in	Total toe-in Distance	Minimum	Out 1 mm (Out 0.03 in)
		Nominal	In 1 mm (In 0.04 in)
		Maximum	In 3 mm (In 0.11 in)
	Total toe-angle Degree minute (Decimal degree)	Minimum	Out 0° 04' 48" (Out 0.08°)
		Nominal	In 0° 04' 48" (In 0.08°)
		Maximum	In 0° 14' 24" (In 0.24°)

Measure value under unladen* conditions.

*: Fuel, engine coolant and lubricant are full. Spare tire, jack, hand tools and mats are in designated positions.

Ball Joint

INFOID:000000008144304

Item		Standard
Swing torque	Transverse link	0.5 – 3.6 N·m (0.06 – 0.36 kg-m, 5 – 31 in-lb)
	Upper link	0 – 2.0 N·m (0 – 0.20 kg-m, 0 – 17 in-lb)
Measurement on spring balance	Transverse link	7.8 – 56.3 N (0.8 – 5.7 kg, 1.8 – 12.6 lb)
	Upper link	0 – 61.5 N (0 – 6.2 kg, 0 – 13.8 lb)
Rotating torque	Transverse link	0.5 – 3.9 N·m (0.06 – 0.39 kg-m, 5 – 34 in-lb)
Axial end play		0 mm (0 in)

Wheelarch Height

INFOID:000000008144305

Item	Standard
Front (Hf)	752 mm (29.61 in)

SERVICE DATA AND SPECIFICATIONS (SDS)

< SERVICE DATA AND SPECIFICATIONS (SDS)

Item	Standard
Rear (Hr)	743 mm (29.25 in)

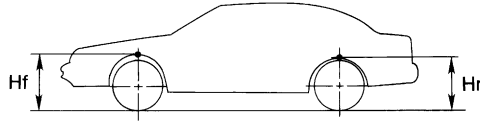

SFA818A

Measure value under unladen* conditions

*: Fuel, engine coolant and lubricant are full. Spare tire, jack, hand tools and mats are in designated positions.

A
B
C
D
F
G
H
I
J
K
L
M
N
O
P

FSU