

SECTION MA
MAINTENANCE

A
B
C
D
E
F
G
H
I
J
K
L
M
N
O
MA

CONTENTS

PREPARATION	3	ENGINE OIL	17
PREPARATION	3	ENGINE OIL : Draining	17
Special Service Tool	3	ENGINE OIL : Refilling	17
Commercial Service Tool	3	OIL FILTER	18
PERIODIC MAINTENANCE	4	OIL FILTER : Removal and Installation	18
GENERAL MAINTENANCE	4	OIL FILTER : Inspection	19
Explanation of General Maintenance	4	SPARK PLUG	19
PERIODIC MAINTENANCE	6	SPARK PLUG : Removal and Installation	19
Introduction of Periodic Maintenance	6	SPARK PLUG : Inspection	19
Schedule 1	6	EVAP VAPOR LINES	20
Schedule 2	8	EVAP VAPOR LINES : Inspection	20
RECOMMENDED FLUIDS AND LUBRI-		CHASSIS MAINTENANCE	21
CANTS	10	EXHAUST SYSTEM	21
Fluids and Lubricants	10	EXHAUST SYSTEM : Inspection	21
Engine Oil Recommendation	10	A/T FLUID	21
Engine Cooling System	11	A/T FLUID : Inspection	21
Inverter Cooling System	11	REAR PROPELLER SHAFT	21
ENGINE MAINTENANCE	12	REAR PROPELLER SHAFT : Inspection	21
ENGINE COOLANT	12	REAR DIFFERENTIAL GEAR OIL	22
ENGINE COOLANT : Inspection	12	REAR DIFFERENTIAL GEAR OIL : Inspection	22
ENGINE COOLANT : Draining	12	REAR DIFFERENTIAL GEAR OIL : Draining	22
ENGINE COOLANT : Refilling	13	REAR DIFFERENTIAL GEAR OIL : Refilling	23
ENGINE COOLANT : Flushing	14	WHEELS (BONDING WEIGHT TYPE)	23
RADIATOR CAP	15	WHEELS (BONDING WEIGHT TYPE) : Adjust-	
RADIATOR CAP : Inspection	15	ment	23
RADIATOR	16	BRAKE FLUID LEVEL AND LEAKS	24
RADIATOR : Inspection	16	BRAKE FLUID LEVEL AND LEAKS : Inspection	25
FUEL LINES	16	BRAKE LINES AND CABLES	25
FUEL LINES : Inspection	16	BRAKE LINES AND CABLES : Inspection	25
AIR CLEANER FILTER	17	BRAKE FLUID	25
AIR CLEANER FILTER : Removal and Installation	17	BRAKE FLUID : Changing	25
.....	17	DISC BRAKE	25



DISC BRAKE : Inspection	25	SEAT BELT, BUCKLES, RETRACTORS, AN- CHORS AND ADJUSTERS	29
DISC BRAKE : Front Disc Brake	26	SEAT BELT, BUCKLES, RETRACTORS, AN- CHORS AND ADJUSTERS : Inspection	29
DISC BRAKE : Rear Disc Brake	26		
STEERING GEAR AND LINKAGE	26	SERVICE DATA AND SPECIFICATIONS (SDS)	30
STEERING GEAR AND LINKAGE : Inspection	26		
POWER STEERING FLUID AND LINES	27	SERVICE DATA AND SPECIFICATIONS (SDS)	30
POWER STEERING FLUID AND LINES : Inspec- tion	27		
AXLE AND SUSPENSION PARTS	27	ENGINE COOLANT	30
AXLE AND SUSPENSION PARTS : Inspection	27	ENGINE COOLANT : Periodical Maintenance Specification	30
DRIVE SHAFT	28	ENGINE OIL	30
DRIVE SHAFT : Inspection	28	ENGINE OIL : Periodical Maintenance Specification	30
BODY MAINTENANCE	29	SPARK PLUG	30
LOCKS, HINGES AND HOOD LATCH	29	SPARK PLUG : Spark Plug	30
LOCKS, HINGES AND HOOD LATCH : Lubricat- ing	29	ROAD WHEEL	30
		ROAD WHEEL : Road Wheel	30

PREPARATION

< PREPARATION >

PREPARATION

PREPARATION

Special Service Tool

INFOID:000000008140217

The actual shapes of Kent-Moore tools may differ from those of special service tools illustrated here.

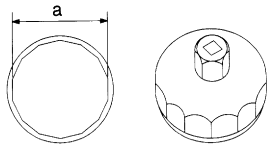
Tool number (Kent-Moore No.) Tool name	Description
KV10115801 (J-38956) Oil filter wrench <div style="text-align: center;">  <p>S-NT375</p> </div>	Removing and installing oil filter a: 64.3 mm (2.531 in)

Commercial Service Tool

INFOID:000000008140218

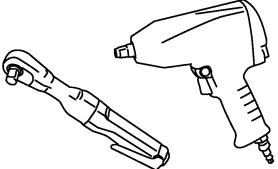
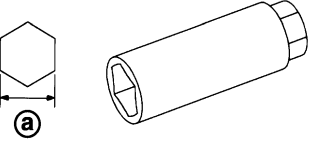
Tool name	Description
Power tool <div style="text-align: center;">  <p>PBIC0190E</p> </div>	Loosening nuts and bolts
Spark plug wrench <div style="text-align: center;">  <p>JPBIA0399ZZ</p> </div>	Removing and installing spark plug a : 14 mm (0.55 in)

A
B
C
D
E
F
G
H
I
J
K
L
M
N
O

MA

GENERAL MAINTENANCE

< PERIODIC MAINTENANCE >

PERIODIC MAINTENANCE

GENERAL MAINTENANCE

Explanation of General Maintenance

INFOID:000000008140219

General maintenance includes those items which should be checked during the normal day-to-day operation of the vehicle. They are essential if the vehicle is to continue operating properly. The owners can perform checks and inspections themselves or have their **INFINITI** retailers do them.

OUTSIDE THE VEHICLE

The maintenance items listed here should be performed from time to time, unless otherwise specified.

Item		Reference page
Tires	Check the pressure with a gauge often and always prior to long distance trips. Adjust the pressure in all tires, including the spare, to the pressure specified. Check carefully for damage, cuts or excessive wear.	WT-64
Wheel nuts	When checking the tires, make sure no nuts are missing, and check for any loose nuts. Tighten if necessary.	—
Tire rotation	Tires should be rotated every 7,500 miles (12,000 km). If the vehicle is equipped with different sized tires in the front and rear, tires cannot be rotated.	MA-23
Tire Pressure Monitoring System (TPMS) transmitter components	Replace the TPMS transmitter grommet seal, valve core and cap when the tires are replaced due to wear or age.	WT-61
Wheel alignment and balance	If the vehicle should pull to either side while driving on a straight and level road, or if you detect uneven or abnormal tire wear, there may be a need for wheel alignment. If the steering wheel or seat vibrates at normal highway speeds, wheel balancing may be needed. For additional information regarding tires, refer to "Important Tire Safety Information" (US) or "Tire Safety Information" (Canada) in the INFINITI Warranty Information Booklet.	FSU-7 RSU-6 MA-23
Windshield	Clean the windshield on a regular basis. Check the windshield at least every six months for cracks or other damage. Repair as necessary.	—
Windshield wiper blades	Check for cracks or wear if they do not wipe properly.	—
Doors and engine hood	Check that all doors and the engine hood operate properly. Also make sure that all latches lock securely. Lubricate if necessary. Make sure that the secondary latch keeps the hood from opening when the primary latch is released. When driving in areas using road salt or other corrosive materials, check lubrication frequently.	MA-29
Lamps	Make sure that the headlamps, stop lamps, tail lamps, turn signal lamps, and other lamps are all operating properly and installed securely. Also check for headlamp aim. Clean the headlamps on a regular basis.	—

INSIDE THE VEHICLE

The maintenance items listed here should be checked on a regular basis, such as when performing periodic maintenance, cleaning the vehicle, etc.

Item		Reference page
Warning lamps and chimes	Make sure that all warning lamps and chimes are operating properly.	—
Windshield wiper and washer	Check that the wipers and washer operate properly and that the wipers do not streak.	—
Windshield defroster	Check that the air comes out of the defroster outlets properly and in sufficient quantity when operating the heater or air conditioner.	—
Steering wheel	Check that it has the specified play. Check for changes in the steering condition, such as excessive play, hard steering or strange noises. Free play: Less than 35 mm (1.38 in)	—
Seats	Check seat position controls such as seat adjusters, seatback recliner, etc. to make sure they operate smoothly and that all latches lock securely in every position. Check that the head restraints move up and down smoothly and that the locks (if equipped) hold securely in all latched positions. Check that the latches lock securely for folding-down rear seatbacks.	—

GENERAL MAINTENANCE

< PERIODIC MAINTENANCE >

Item		Reference page	
Seat belts	Check that all parts of the seat belt system (e.g. buckles, anchors, adjusters and retractors) operate properly and smoothly, and are installed securely. Check the belt webbing for cuts, fraying, wear or damage.	MA-29	A
Accelerator pedal	Check the pedal for smooth operation and make sure the pedal does not catch or require uneven effort. Keep the floor mats away from the pedal.	—	B
Brakes	Check that the brake does not pull the vehicle to one side when applied.	—	C
Brake pedal and booster	Check the pedal for smooth operation and make sure it has the proper distance under it when depressed fully. Check the brake booster function. Be sure to keep the floor mats away from the pedal.	BR-270	D
Parking brake	Check that the lever or pedal has the proper travel and make sure that the vehicle is held securely on a fairly steep hill when only the parking brake is applied.	PB-4	E
Automatic transmission “Park” mechanism	Check that the lock release button on the selector lever operates properly and smoothly. On a fairly steep hill check that the vehicle is held securely with the selector lever in the P (Park) position without applying any brakes.	—	F

UNDER THE HOOD AND VEHICLE

The maintenance items listed here should be checked periodically (e.g. each time you check the engine oil or refuel).

Item		Reference page	
Windshield washer fluid	Check that there is adequate fluid in the tank.	—	G
Engine coolant level	Check the coolant level when the engine is cold.	CO-7	H
Inverter coolant level	Check the coolant level when the inverter is cold.	HCO-7	I
Radiator and hoses	Check the front of the radiator and clean off any dirt, insects, leaves, etc., that may have accumulated. Make sure the hoses have no cracks, deformation, deterioration or loose connections.	MA-16	J
Brake fluid level	Make sure that the brake fluid level is between the “MAX” and “MIN” lines on the reservoir.	MA-25	K
Battery	Check the fluid level in each cell. It should be between the “MAX” and “MIN” lines. Vehicles operated in high temperatures or under severe conditions require frequent checks of the battery fluid level.	PG-135	L
Engine oil level	Check the level on the oil level gauge after parking the vehicle on a level spot and turning off the engine.	LU-7	M
Power steering fluid level and lines	Check the level on the dipstick with the engine off. Check the lines for improper attachment, leaks, cracks, etc.	MA-27	N
Exhaust system	Make sure there are no loose supports, cracks or holes. If the sound of the exhaust seems unusual or there is a smell of exhaust fumes, immediately locate the trouble and correct it.	MA-21	O
Underbody	The underbody is frequently exposed to corrosive substances such as those used on icy roads or to control dust. It is very important to remove these substances, otherwise rust will form on the floor pan, frame, fuel lines and around the exhaust system. At the end of winter, the underbody should be thoroughly flushed with plain water, being careful to clean those areas where mud and dirt can easily accumulate.	—	O
Fluid leaks	Check under the vehicle for fuel, oil, water or other fluid leaks after the vehicle has been parked for a while. Water dripping from the air conditioner after use is normal. If you should notice any leaks or gasoline fumes are evident, check for the cause and correct it immediately.	—	O

PERIODIC MAINTENANCE

< PERIODIC MAINTENANCE >

PERIODIC MAINTENANCE

Introduction of Periodic Maintenance

INFOID:000000008140220

Two different maintenance schedules are provided, and should be used, depending upon the conditions in which the vehicle is mainly operated. **After 60,000 miles (96,000 km) or 48 months, continue the periodic maintenance at the same mileage/time intervals.**

Schedule 1	<p>Follow Periodic Maintenance Schedule 1 if the driving habits frequently include one or more of the following driving conditions:</p> <ul style="list-style-type: none"> • Repeated short trips of less than 5 miles (8 km). • Repeated short trips of less than 10 miles (16 km) with outside temperatures remaining below freezing. • Operating in hot weather in stop-and-go “rush hour” traffic. • Extensive idling and/or low speed driving for long distances, such as police, taxi or door-to-door delivery use. • Driving in dusty conditions. • Driving on rough, muddy, or salt spread roads. • Towing a trailer, using a camper or a car-top carrier. 	Emission Control System Maintenance	MA-6
		Chassis and Body Maintenance	
Schedule 2	<p>Follow Periodic Maintenance Schedule 2 if none of driving conditions shown in Schedule 1 apply to the driving habits.</p>	Emission Control System Maintenance	MA-8
		Chassis and Body Maintenance	

Schedule 1

INFOID:000000008140221

EMISSION CONTROL SYSTEM

Abbreviations: R = Replace. I = Inspect. Correct or replace if necessary. []: At the mileage intervals only

MAINTENANCE OPERATION		MAINTENANCE INTERVAL								Reference Section - Page or - Content Title
Perform at number of miles, kilometers or months, whichever comes first.	Miles x 1,000 (km x 1,000) Months	3.75 (6)	7.50 (12)	11.25 (18)	15 (24)	18.75 (30)	22.5 (36)	26.25 (42)	30 (48)	
Air cleaner filter	NOTE (1)								[R]	MA-17
EVAP vapor lines									I*	MA-20
Fuel lines									I*	MA-16
Fuel filter	NOTE (2)									—
Engine coolant*	NOTE (3)(4)									MA-12
HEV inverter coolant	NOTE (5)(6)									HCO-7
Engine oil		R	R	R	R	R	R	R	R	MA-17
Engine oil filter (Use genuine NISSAN engine oil filter or equivalent.)		R	R	R	R	R	R	R	R	MA-18
Spark plugs (Iridium-tipped type)		Replace every 105,000 miles (168,000 km).								MA-19
Intake & exhaust valve clearance*	NOTE (7)									EM-17

MAINTENANCE OPERATION		MAINTENANCE INTERVAL								Reference Section - Page or - Content Title
Perform at number of miles, kilometers or months, whichever comes first.	Miles x 1,000 (km x 1,000) Months	33.75 (54)	37.5 (60)	41.25 (66)	45 (72)	48.75 (78)	52.5 (84)	56.25 (90)	60 (96)	
Air cleaner filter	NOTE (1)								[R]	MA-17
EVAP vapor lines									I*	MA-20
Fuel lines									I*	MA-16
Fuel filter	NOTE (2)									—

PERIODIC MAINTENANCE

< PERIODIC MAINTENANCE >

MAINTENANCE OPERATION		MAINTENANCE INTERVAL								Reference Section - Page or - Content Title
Perform at number of miles, kilometers or months, whichever comes first.	Miles x 1,000 (km x 1,000) Months	33.75 (54) 27	37.5 (60) 30	41.25 (66) 33	45 (72) 36	48.75 (78) 39	52.5 (84) 42	56.25 (90) 45	60 (96) 48	
Engine coolant*	NOTE (3)(4)									MA-12
HEV inverter coolant	NOTE (5)(6)									HCO-7
Engine oil		R	R	R	R	R	R	R	R	MA-17
Engine oil filter (Use genuine NISSAN engine oil filter or equivalent.)		R	R	R	R	R	R	R	R	MA-18
Spark plugs (Iridium-tipped type)		Replace every 105,000 miles (168,000 km).								MA-19
Intake & exhaust valve clearance*	NOTE (7)									EM-17

NOTE:

- (1) If operating mainly in dusty conditions, more frequent maintenance may be required.
- (2) Maintenance-free item. For service procedures, refer to FL section.
- (3) First replacement interval is 105,000 miles (168,000 km) or 84 months. After first replacement, replace every 75,000 miles (120,000 km) or 60 months.
- (4) Use only Genuine NISSAN Long Life Antifreeze/Coolant (blue) or equivalent with proper mixture ratio of 50% anti-freeze and 50% demineralized or distilled water. Mixing any other type of coolant or the use of non-distilled water will reduce the life expectancy of the factory-fill coolant.
- (5) First replacement interval is 125,000 miles (200,000 km) or 180 months. After first replacement, replace every 75,000 miles (120,000 km) or 60 months.
- (6) Use only Genuine NISSAN Long Life Antifreeze/Coolant (blue) or equivalent with proper mixture ratio of 50% anti-freeze and 50% demineralized or distilled water. Mixing any other type of coolant or the use of non-distilled water will reduce the life expectancy of the factory-fill coolant.
- (7) Periodic maintenance is not required. However, if valve noise increases, inspect valve clearance.

* Maintenance items and intervals with "*" are recommended by INFINITI for reliable vehicle operation. The owner need not perform such maintenance in order to maintain the emission warranty or manufacturer recall liability. Other maintenance items and intervals are required.

CHASSIS AND BODY

Abbreviations: R = Replace. I = Inspect. Correct or replace if necessary.

MAINTENANCE OPERATION		MAINTENANCE INTERVAL								Reference Section - Page or - Content Title
Perform at number of miles, kilometers or months, whichever comes first.	Miles x 1,000 (km x 1,000) Months	3.75 (6) 3	7.50 (12) 6	11.25 (18) 9	15 (24) 12	18.75 (30) 15	22.5 (36) 18	26.25 (42) 21	30 (48) 24	
Brake lines & cables					I				I	MA-25
Brake fluid					R				R	MA-25
Brake pads & rotors			I		I		I		I	MA-25
Differential gear oil	NOTE (1)				I				I	MA-22
Automatic transmission fluid	NOTE (2)									MA-21
Steering gear & linkage, axle & suspension parts			I		I		I		I	MA-26 MA-27
Tire rotation	NOTE (3)									MA-4 WT-56
Drive shaft boots			I		I		I		I	MA-28
Exhaust system			I		I		I		I	MA-21
In-cabin microfilter					R				R	VTL-19

PERIODIC MAINTENANCE

< PERIODIC MAINTENANCE >

MAINTENANCE OPERATION		MAINTENANCE INTERVAL								Reference Section - Page or - Content Title
Perform at number of miles, kilometers or months, whichever comes first.	Miles x 1,000 (km x 1,000) Months	33.75 (54) 27	37.5 (60) 30	41.25 (66) 33	45 (72) 36	48.75 (78) 39	52.5 (84) 42	56.25 (90) 45	60 (96) 48	
Brake lines & cables					I				I	MA-25
Brake fluid					R				R	MA-25
Brake pads & rotors			I		I		I		I	MA-25
Differential gear oil	NOTE (1)				I				I	MA-22
Automatic transmission fluid	NOTE (2)									MA-21
Steering gear & linkage, axle & suspension parts			I		I		I		I	MA-26 MA-27
Tire rotation	NOTE (3)									MA-4 WT-56
Drive shaft boots			I		I		I		I	MA-28
Exhaust system			I		I		I		I	MA-21
In-cabin microfilter					R				R	VTL-19

NOTE:

- (1) If towing a trailer, using a camper or a car-top carrier, or driving on rough or muddy roads, change (not just inspect) fluid/oil at every 30,000 miles (48,000 km) or 24 months.
- (2) Automatic transmission fluid is maintenance-free.
- (3) Refer to "Tire rotation" under the "General maintenance" heading earlier in this section.

Schedule 2

INFOID:000000008140222

EMISSION CONTROL SYSTEM

Abbreviations: R = Replace. I = Inspect. Correct or replace if necessary. []: At the mileage intervals only

MAINTENANCE OPERATION		MAINTENANCE INTERVAL								Reference Section - Page or - Content Title
Perform at number of miles, kilometers or months, whichever comes first.	Miles x 1,000 (km x 1,000) Months	7.5 (12) 6	15 (24) 12	22.5 (36) 18	30 (48) 24	37.5 (60) 30	45 (72) 36	52.5 (84) 42	60 (96) 48	
Air cleaner filter					[R]				[R]	MA-17
EVAP vapor lines					I*				I*	MA-20
Fuel lines					I*				I*	MA-16
Fuel filter	NOTE (1)									—
Engine coolant*	NOTE (2)(3)									MA-12
HEV inverter coolant	NOTE (4)(5)									HCO-7
Engine oil		R	R	R	R	R	R	R	R	MA-17
Engine oil filter (Use genuine NISSAN engine oil filter or equivalent.)		R	R	R	R	R	R	R	R	MA-18
Spark plugs (Iridium-tipped type)		Replace every 105,000 miles (168,000 km).								MA-19
Intake & exhaust valve clearance*	NOTE (6)									EM-17

NOTE:

- (1) Maintenance-free item. For service procedures, refer to FL section.
- (2) First replacement interval is 105,000 miles (168,000 km) or 84 months. After first replacement, replace every 75,000 miles (120,000 km) or 60 months.
- (3) Use only Genuine NISSAN Long Life Antifreeze/Coolant (blue) or equivalent with proper mixture ratio of 50% anti-freeze and 50% demineralized or distilled water. Mixing any other type of coolant or the use of non-distilled water will reduce the life expectancy of the factory-fill coolant.
- (4) First replacement interval is 125,000 miles (200,000 km) or 180 months. After first replacement, replace every 75,000 miles (120,000 km) or 60 months.

PERIODIC MAINTENANCE

< PERIODIC MAINTENANCE >

(5) Use only Genuine NISSAN Long Life Antifreeze/Coolant (blue) or equivalent with proper mixture ratio of 50% anti-freeze and 50% demineralized or distilled water. Mixing any other type of coolant or the use of non-distilled water will reduce the life expectancy of the factory-fill coolant.

(6) Periodic maintenance is not required. However, if valve noise increases, inspect valve clearance.

* Maintenance items and intervals with "*" are recommended by INFINITI for reliable vehicle operation. The owner need not perform such maintenance in order to maintain the emission warranty or manufacturer recall liability. Other maintenance items and intervals are required.

CHASSIS AND BODY

Abbreviations: R = Replace. I = Inspect. Correct or replace if necessary.

MAINTENANCE OPERATION		MAINTENANCE INTERVAL								Reference Section - Page or - Content Title
		Miles x 1,000 (km x 1,000) Months	7.5 (12) 6	15 (24) 12	22.5 (36) 18	30 (48) 24	37.5 (60) 30	45 (72) 36	52.5 (84) 42	
Brake lines & cables			I		I		I		I	MA-25
Brake fluid					R				R	MA-25
Brake pads & rotors			I		I		I		I	MA-25
Differential gear oil			I		I		I		I	MA-22
Automatic transmission fluid	NOTE (1)									MA-21
Steering gear & linkage, axle & suspension parts					I				I	MA-26 MA-27
Tire rotation	NOTE (2)									MA-4 WT-56
Drive shaft boots			I		I		I		I	MA-28
Exhaust system					I				I	MA-21
In-cabin microfilter			R		R		R		R	VTL-19

NOTE:

(1) Automatic transmission fluid is maintenance-free.

(2) Refer to "Tire rotation" under the "General maintenance" heading earlier in this section.

A
B
C
D
E
F
G
H
I
J
K
L
M
N
O

MA

RECOMMENDED FLUIDS AND LUBRICANTS

< PERIODIC MAINTENANCE >

RECOMMENDED FLUIDS AND LUBRICANTS

Fluids and Lubricants

INFOID:000000008140223

		Capacity (Approximate)			Recommended Fluids/Lubricants
		US measure	Imp measure	Liter	
Engine oil Drain and refill	With oil filter change	5-1/8 qt	4-1/4 qt	4.9	<ul style="list-style-type: none"> • Engine oil with API Certification Mark*¹ • Viscosity SAE 5W-30*¹
	Without oil filter change	4-7/8 qt	4 qt	4.6	
Dry engine (Overhaul)		6 qt	5 qt	5.7	
Engine Cooling system	With reservoir tank	9-1/8 qt	7-5/8 qt	8.6	Pre-diluted Genuine NISSAN Long Life Anti-freeze/ Coolant (blue) or equivalent
	Reservoir tank	7/8 qt	3/4 qt	0.8	
High voltage Cooling system	With reservoir tank	2-6/8 qt	2-2/8 qt	2.6	
	Reservoir tank	4/8 qt	4/8 qt	0.5	
Automatic transmission fluid		7-3/8 qt* ⁶	6-1/8 qt* ⁶	7.0* ⁶	Genuine NISSAN Matic S ATF* ²
Differential gear oil		2-3/8 pt	2 pt	1.15	API GL-5 synthetic gear oil, Viscosity SAE 75W-90* ³
Power steering fluid (E-PSF)		1-1/8 qt	7/8 qt	1.0	Genuine NISSAN E-PSF or equivalent* ⁴
Brake fluid		—	—	—	Genuine NISSAN Super Heavy Duty Brake Fluid* ⁵ or equivalent DOT 3 (US FMVSS No. 116)
Multi-purpose grease		—	—	—	NLGI No. 2 (Lithium soap base)
Windshield washer fluid		—	—	—	Genuine NISSAN Windshield Washer Concentrate Cleaner & Antifreeze or equivalent
Fuel recommendation		—	—	—	Refer to GI-29, "Fuel" .

*1: For additional information, see "Engine Oil Recommendation".

*2: Using automatic transmission fluid other than Genuine NISSAN Matic S ATF will cause deterioration in driveability and automatic transmission durability, and may damage the automatic transmission, which is not covered by the INFINITI new vehicle limited warranty.

*3: See an INFINITI retailer for service for synthetic oil.

*4: Use of power steering fluid other than Genuine NISSAN E-PSF will prevent the power steering system from operating properly.

*5: Available in mainland U.S.A. through an INFINITI retailer.

*6: The fluid capacity is the reference value.

Engine Oil Recommendation

INFOID:000000008140224

NISSAN recommends the use of an energy conserving oil in order to improve fuel economy. Select only engine oils that meet the American Petroleum Institute (API) certification and International Lubricant Standardization and Approval Committee (ILSAC) certification and SAE viscosity standard. These oils have the API certification mark on the front of the container. Oils which do not have the specified quality label should not be used as they could cause engine damage.

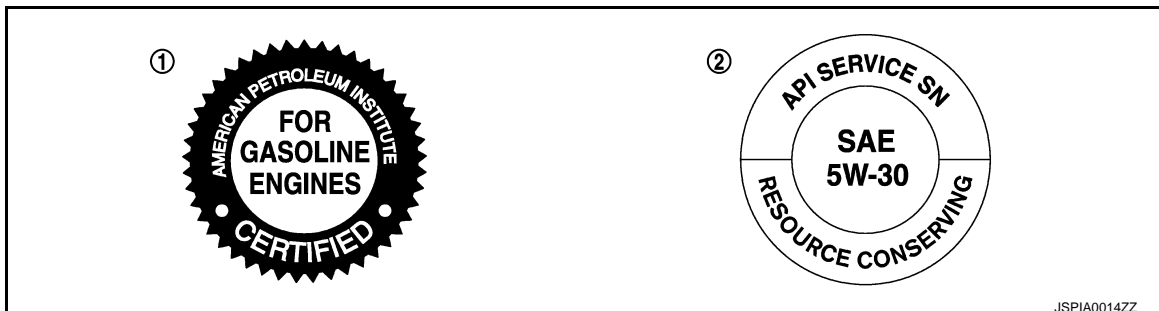

1. API certification mark

2. API service symbol

JSPIA0014ZZ

RECOMMENDED FLUIDS AND LUBRICANTS

< PERIODIC MAINTENANCE >

Engine Cooling System

INFOID:000000008140225

The engine cooling system is filled at the factory with a pre-diluted mixture of 50% Genuine NISSAN Long Life Antifreeze/Coolant (blue) and 50% water to provide year-round anti-freeze and coolant protection. The anti-freeze solution contains rust and corrosion inhibitors. Additional engine cooling system additives are not necessary.

WARNING:

- Never remove the radiator or coolant reservoir cap when the engine is hot. Wait until the engine and radiator cool down. Serious burns could be caused by high pressure fluid escaping from the radiator.
- The radiator is equipped with a pressure type radiator cap. To prevent engine damage, use only a genuine NISSAN radiator cap.

CAUTION:

- When adding or replacing coolant, be sure to use only Genuine NISSAN Long Life Antifreeze/Coolant (blue) or equivalent. Genuine NISSAN Long Life Antifreeze/Coolant (blue) is pre-diluted to provide antifreeze protection to -34°F (-37°C). If additional freeze protection is needed due to weather where you operate your vehicle, add Genuine NISSAN Long Life Antifreeze/Coolant (blue) concentrate following the directions on the container. If an equivalent coolant other than Genuine NISSAN Long Life Antifreeze/Coolant (blue) is used, follow the coolant manufacturer's instructions to maintain minimum antifreeze protection to -34°F (-37°C). The use of other types of coolant solutions other than Genuine NISSAN Long Life Antifreeze/Coolant (blue) or equivalent may damage the engine cooling system.
- Mixing any other type of coolant other than Genuine NISSAN Long Life Antifreeze/Coolant (blue), including Genuine NISSAN Long Life Antifreeze/Coolant (green), or the use of non-distilled water will reduce the life expectancy of the factory-fill coolant.

Inverter Cooling System

INFOID:000000008140226

The inverter cooling system is filled at the factory with a pre-diluted mixture of 50% Genuine NISSAN Long Life Antifreeze/Coolant (blue) and 50% water to provide year-round anti-freeze and coolant protection. The antifreeze solution contains rust and corrosion inhibitors. Additional inverter cooling system additives are not necessary.

WARNING:

- Never remove the coolant reservoir cap when the engine and inverter are hot. Wait until the engine and inverter cool down. Serious burns could be caused by high pressure fluid escaping from the radiator.
- The inverter reservoir is equipped with a pressure type cap. To prevent engine and inverter damage, use only a genuine NISSAN inverter reservoir cap.

CAUTION:

- When adding or replacing coolant, be sure to use only Genuine NISSAN Long Life Antifreeze/Coolant (blue) or equivalent. Genuine NISSAN Long Life Antifreeze/Coolant (blue) is pre-diluted to provide antifreeze protection to -34°F (-37°C). If additional freeze protection is needed due to weather where you operate your vehicle, add Genuine NISSAN Long Life Antifreeze/Coolant (blue) concentrate following the directions on the container. If an equivalent coolant other than Genuine NISSAN Long Life Antifreeze/Coolant (blue) is used, follow the coolant manufacturer's instructions to maintain minimum antifreeze protection to -34°F (-37°C). The use of other types of coolant solutions other than Genuine NISSAN Long Life Antifreeze/Coolant (blue) or equivalent may damage the inverter cooling system.
- Mixing any other type of coolant other than Genuine NISSAN Long Life Antifreeze/Coolant (blue), including Genuine NISSAN Long Life Antifreeze/Coolant (green), or the use of non-distilled water will reduce the life expectancy of the factory-fill coolant.

A
B
C
D
E
F
G
H
I
J
K
L
M
N
O

MA

ENGINE MAINTENANCE

< PERIODIC MAINTENANCE >

ENGINE MAINTENANCE

ENGINE COOLANT

ENGINE COOLANT : Inspection

INFOID:000000008140227

LEVEL

- Check if the reservoir tank engine coolant level is within the “MIN” to “MAX” when the engine is cool.

A : MAX

B : MIN

- Adjust the engine coolant level if necessary.
- Check that the reservoir tank cap is tightened.

CAUTION:

Refill Genuine NISSAN Long Life Antifreeze/Coolant (blue) or equivalent in its quality mixed with water (distilled or demineralized). Refer to [MA-10, "Fluids and Lubricants"](#).

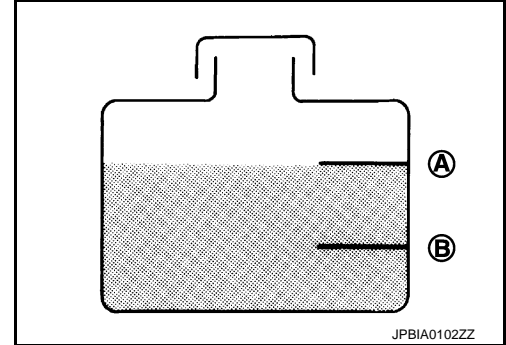

LEAKAGE

- To check for leakage, apply pressure to the cooling system with the radiator cap tester and radiator cap tester adapter (commercial service tool) (A).

Testing pressure : Refer to [CO-26, "Radiator"](#).

WARNING:

Never remove radiator cap when engine is hot. Serious burns could occur from high-pressure engine coolant escaping from engine cooling system.

CAUTION:

Higher test pressure than specified may cause radiator damage.

NOTE:

In a case that engine coolant decreases, replenish radiator with engine coolant.

- If anything is found, repair or replace damaged parts.

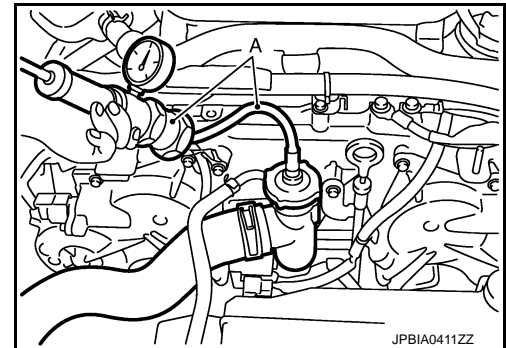

ENGINE COOLANT : Draining

INFOID:000000008140228

WARNING:

- To avoid being scalded, never change engine coolant when the engine is hot.
- Wrap a thick cloth around radiator cap and carefully remove radiator cap. First, turn radiator cap a quarter of a turn to release built-up pressure. Then turn radiator cap all the way.

1. Connect drain hose.

NOTE:

Use a general-purpose hose with the dimensions shown in the figure.

A : ϕ 15 - 16 mm (0.59 - 0.63 in)

B : 145 mm (5.71 in)

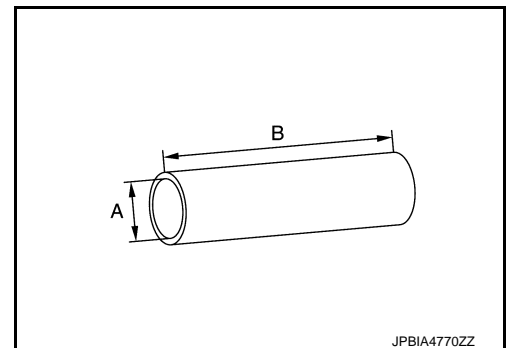

ENGINE MAINTENANCE

< PERIODIC MAINTENANCE >

2. Open radiator drain plug (1) at the bottom of radiator, and then remove radiator cap.

A : Radiator drain plug hole

↶ : Vehicle front

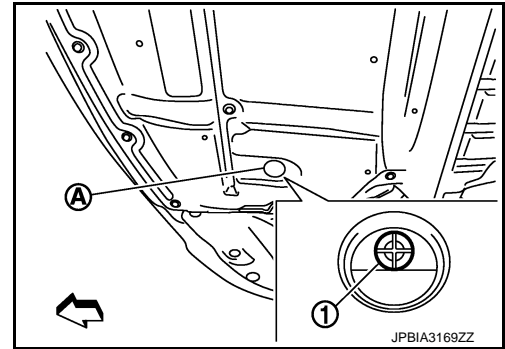

When draining all of engine coolant in the system, open water drain plugs on cylinder block. Refer to [EM-85, "Setting"](#).

3. Remove reservoir tank if necessary, and drain engine coolant and clean reservoir tank before installing.
4. Check drained engine coolant for contaminants such as rust, corrosion or discoloration. If contaminated, flush the engine cooling system. Refer to [MA-14, "ENGINE COOLANT : Flushing"](#).
5. Disconnect drain hose.

ENGINE COOLANT : Refilling

INFOID:000000008140229

CAUTION:

- Do not reuse O-rings.
- Do not put additive such as waterleak preventive, since it may cause cooling waterway clogging.
- When refilling use Genuine NISSAN Long Life Antifreeze/Coolant (blue) or equivalent in its quality mixed with water (distilled or demineralized). Refer to [MA-10, "Fluids and Lubricants"](#).

1. Remove air cleaner case (LH) and air duct (inlet). Refer to [EM-26, "Exploded View"](#).
2. Install reservoir tank if removed, and radiator drain plug.

CAUTION:

Be sure to clean drain plug and install with new O-ring.

Tightening torque : Refer to [CO-13, "Exploded View"](#).

If water drain plugs on cylinder block are removed, close and tighten them. Refer to [EM-85, "Setting"](#).

3. Check that each hose clamp has been firmly tightened.
4. Remove air relief plug (1) on radiator left side.

↶ : Vehicle front

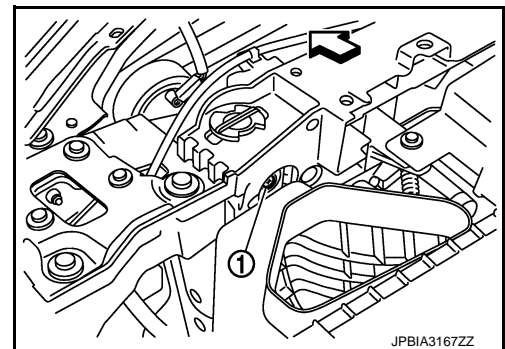

A
B
C
D
E
F
G
H
I
J
K
L
M
N
O

MA

ENGINE MAINTENANCE

< PERIODIC MAINTENANCE >

5. Fill up the radiator with cooling water.
 - Pour engine coolant through engine coolant filler neck slowly of less than 2 ℓ (2-1/8 US qt, 1-3/4 Imp qt) a minute to allow air in system to escape.

Engine coolant capacity : Refer to [CO-26](#),
(With reservoir tank at "MAX" level) "[Periodical Maintenance Specification](#)".

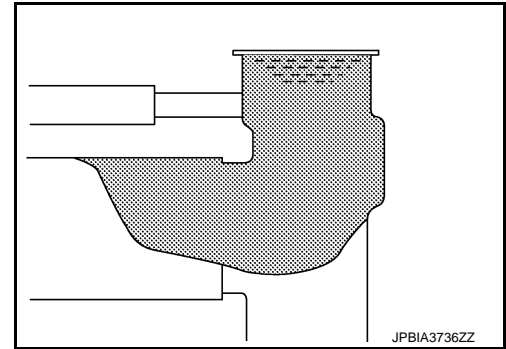

Reservoir tank engine coolant capacity : Refer to [CO-26](#),
(At "MAX" level) "[Periodical Maintenance Specification](#)".

A : MAX

B : MIN

6. When engine coolant overflows air relief hole on radiator, install air relief plug with new O-ring.

Tightening torque : Refer to [CO-13](#), "[Exploded View](#)".

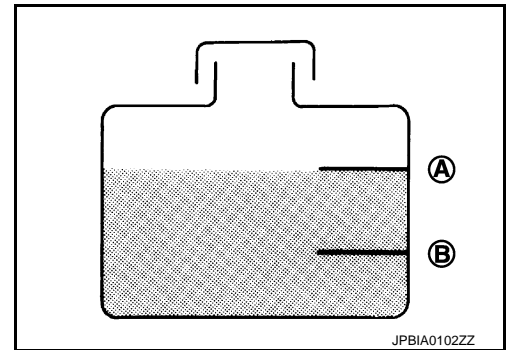

7. Refill reservoir tank to "MAX" level line with engine coolant.
8. Install air cleaner case (LH) and air duct (inlet). Refer to [EM-26](#), "[Exploded View](#)".
9. Install radiator cap.
10. Warm up engine until opening thermostat. Standard for warming-up time is approximately 10 minutes at 3,000 rpm.

NOTE:

Perform maintenance mode 5 and maintain the engine speed. Refer to [HBC-89](#), "[Description](#)".

- Check thermostat opening condition by touching radiator hose (lower) to see a flow of warm water.

CAUTION:

Watch water temperature gauge so as not to overheat engine.

11. Stop the engine and cool down to less than approximately 50°C (122°F).
 - Cool down using fan to reduce the time.
 - If necessary, refill radiator up to filler neck with engine coolant.
 - Remove the radiator cap to check the fluid level. If the fluid level is low, refill with cooling water and repeat the steps from Step 7.

12. Refill reservoir tank to "MAX" level line with engine coolant.

13. Check cooling system for leakage with engine running.

14. Check flow noise, according to the following steps.

CAUTION:

To check flow noise, turn OFF the radio and close the windows, doors, and the hood.

- a. Allow the engine to become cold (approximately 50°C or less).
- b. Start the engine, maintain 1000 rpm for approximately 30 seconds, and increase the engine speed from 1000 to 3000 rpm. Repeat this cycle three times.
- c. Check that flow noise can be heard from the heater core during the Step b operation.
- d. If flow noise can be heard, repeat from Step 12 of Refilling to Step c of Flow Noise Verification Method.
- e. Check that the reservoir tank cap is tightened.

ENGINE COOLANT : Flushing

INFOID:000000008140230

1. Install reservoir tank if removed, and radiator drain plug.

ENGINE MAINTENANCE

< PERIODIC MAINTENANCE >

CAUTION:

Be sure to clean drain plug and install with new O-ring.

Tightening torque : Refer to [CO-13, "Exploded View"](#).

If water drain plugs on cylinder block are removed, close and tighten them. Refer to [EM-85, "Setting"](#).

2. Remove air relief plug (1) on radiator.

← : Vehicle front

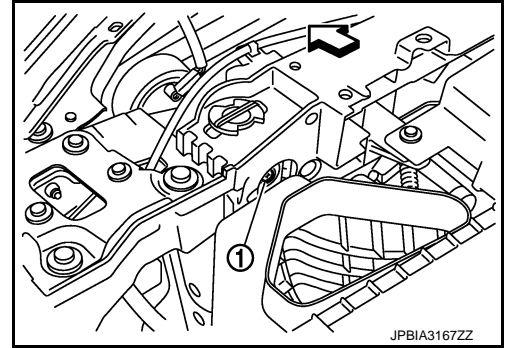

3. Fill radiator with water until water spills from the air relief holes, then close air relief plugs. Fill radiator and reservoir tank with water and reinstall radiator cap.

Tightening torque : Refer to [CO-13, "Exploded View"](#).

4. Run the engine and warm it up to normal operating temperature.

NOTE:

Perform maintenance mode 5 and maintain the engine speed. Refer to [HBC-89, "Description"](#).

5. Rev the engine two or three times under no-load.
6. Stop the engine and wait until it cools down.
7. Drain water from the system. Refer to [MA-12, "ENGINE COOLANT : Draining"](#).
8. Repeat steps 1 through 7 until clear water begins to drain from radiator.
9. Check that the reservoir tank cap is tightened.

RADIATOR CAP

RADIATOR CAP : Inspection

INFOID:000000008140231

- Check valve seat (A) of radiator cap.

B : Metal plunger

- Check if valve seat is swollen to the extent that the edge of the plunger (B) cannot be seen when watching it vertically from the top.
- Check if valve seat has no soil and damage.

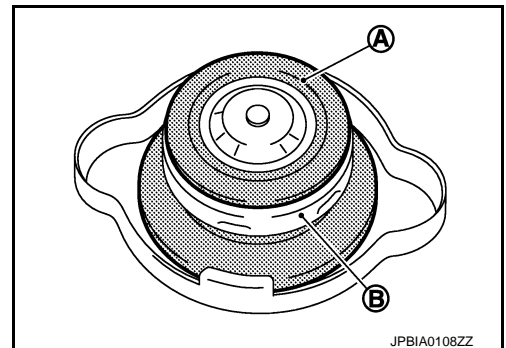

A
B
C
D
E
F
G
H
I
J
K
L
M
N
O

MA

ENGINE MAINTENANCE

< PERIODIC MAINTENANCE >

- Pull negative-pressure valve to open it, and check that it close completely when released.
- Check that there is no dirt or damage on the valve seat of radiator cap negative-pressure valve.
- Check that there are no unusualness in the opening and closing conditions of negative-pressure valve.

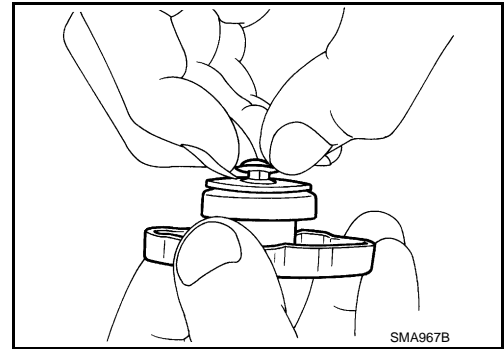

- Check radiator cap relief pressure.

Standard and limit : Refer to [CO-26, "Radiator"](#).

- When connecting radiator cap to the radiator cap tester and the radiator cap tester adapter (commercial service tool) (A), apply engine coolant to the cap seal surface.

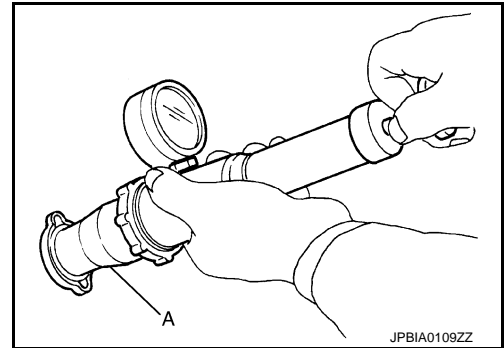

- Replace radiator cap if there is an unusualness related to the above three.

CAUTION:

When installing radiator cap, thoroughly wipe out the water outlet (front) filler neck to remove any waxy residue or foreign material.

RADIATOR

RADIATOR : Inspection

INFOID:000000008140232

Check radiator for mud or clogging. If necessary, clean radiator as follows:

- Be careful not to bend or damage radiator fins.
 - When radiator is cleaned without removal, remove all surrounding parts such as radiator cooling fan assembly and horns. Then tape harness and connectors to prevent water from entering.
1. Apply water by hose to the back side of the radiator core vertically downward.
 2. Apply water again to all radiator core surfaces once per minute.
 3. Stop washing if any stains no longer flow out from radiator.
 4. Blow air into the back side of radiator core vertically downward.
 - Use compressed air lower than 490 kPa (5 kg/cm², 71 psi) and keep distance more than 30 cm (11.8 in).
 5. Blow air again into all the radiator core surfaces once per minute until no water sprays out.

FUEL LINES

FUEL LINES : Inspection

INFOID:000000008140233

Inspect fuel lines, fuel filler cap and fuel tank for improper attachment, leakage, cracks, damage, loose connections, chafing or deterioration.

- A : Engine
- B : Fuel line
- C : Fuel tank

If necessary, repair or replace damaged parts.

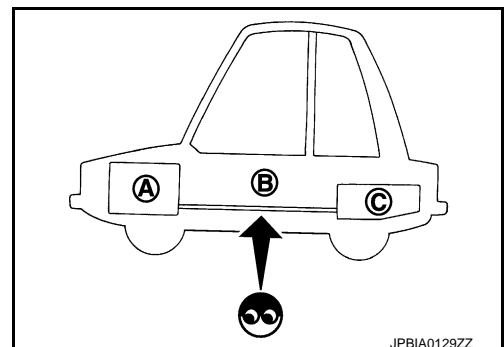

ENGINE MAINTENANCE

< PERIODIC MAINTENANCE >

AIR CLEANER FILTER

AIR CLEANER FILTER : Removal and Installation

INFOID:000000008140234

REMOVAL

1. Unhook clips (A), and remove holder (1).

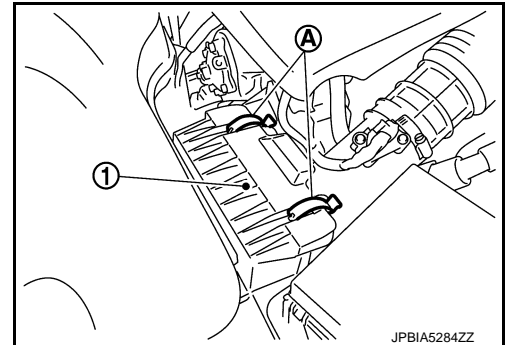

2. Remove air cleaner filter (1).

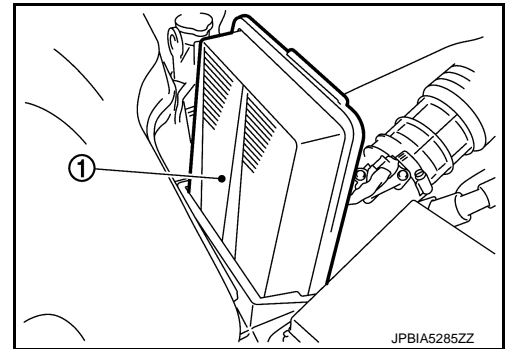

INSTALLATION

Note the following, and install in the reverse order of removal.

- Install the air cleaner filter by aligning the seal with the notch of air cleaner case.

ENGINE OIL

ENGINE OIL : Draining

INFOID:000000008140235

WARNING:

- Never get burn yourself, as engine oil may be hot.
- Prolonged and repeated contact with used engine oil may cause skin cancer. Try to avoid direct skin contact with used engine oil. If skin contact is made, wash thoroughly with soap or hand cleaner as soon as possible.

1. Warm up the engine, and check for engine oil leakage from engine components. Refer to [LU-7. "Inspection"](#).

NOTE:

Perform maintenance mode 5 and maintain the engine speed. Refer to [HBC-89. "Description"](#).

2. Stop the engine and wait for 10 minutes.
3. Loosen oil filler cap.
4. Remove undercover, using a power tool.
5. Remove drain plug and then drain engine oil.

ENGINE OIL : Refilling

INFOID:000000008140236

1. Install drain plug with new washer. Refer to [EM-43. "Exploded View"](#).

CAUTION:

Be sure to clean drain plug and install with new washer.

ENGINE MAINTENANCE

< PERIODIC MAINTENANCE >

Tightening torque : Refer to [EM-43, "Exploded View"](#).

2. Refill with new engine oil.

Engine oil specification and viscosity: Refer to [MA-10, "Fluids and Lubricants"](#).

Engine oil capacity : Refer to [LU-15, "Periodical Maintenance Specification"](#).

CAUTION:

- When filling engine oil, do not pull out oil level gauge.
- The refill capacity depends on the engine oil temperature and drain time. Use these specifications for reference only.
- Always use oil level gauge to determine the proper amount of engine oil in engine.

3. Warm up the engine and check area around drain plug and oil filter for engine oil leakage.

NOTE:

Perform maintenance mode 5 and maintain the engine speed. Refer to [HBC-89, "Description"](#).

4. Stop the engine and wait for 10 minutes.

5. Check the engine oil level. Refer to [LU-7, "Inspection"](#).

OIL FILTER

OIL FILTER : Removal and Installation

INFOID:000000008140237

REMOVAL

CAUTION:

- Oil filter is provided with relief valve. Use genuine NISSAN oil filter or equivalent.
- Never get burned when engine and engine oil may be hot.
- When removing, prepare a shop cloth to absorb any engine oil leakage or spillage.
- Never allow engine oil to adhere to drive belt.
- Completely wipe off any engine oil that adheres to engine and vehicle.

1. Remove engine undercover, using a power tool.
2. Using oil filter wrench [SST: KV10115801 (J-38956)] (B), remove oil filter.

A : Vehicle under view

↔ : Vehicle front

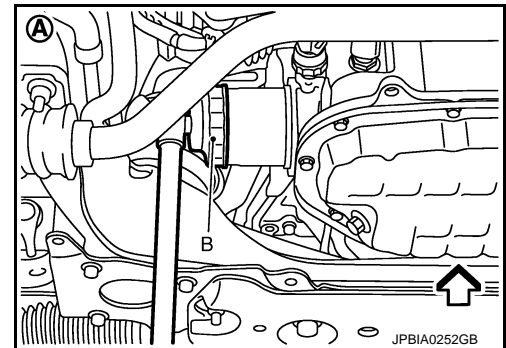

INSTALLATION

1. Remove foreign materials adhering to oil filter installation surface.
2. Apply engine oil to the oil seal contact surface of new oil filter.

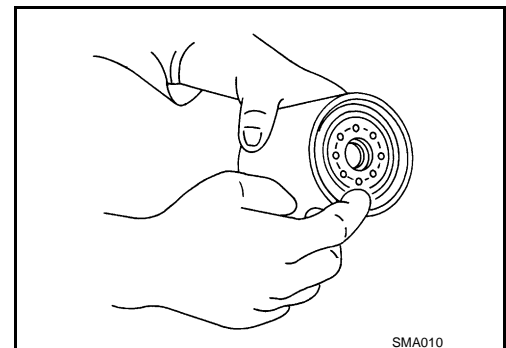

ENGINE MAINTENANCE

< PERIODIC MAINTENANCE >

3. Screw oil filter manually until it touches the installation surface, then tighten it by 2/3 turn (A). Or tighten to the specification.

Oil filter:

: 17.7 N·m (1.8 kg·m, 13 ft·lb)

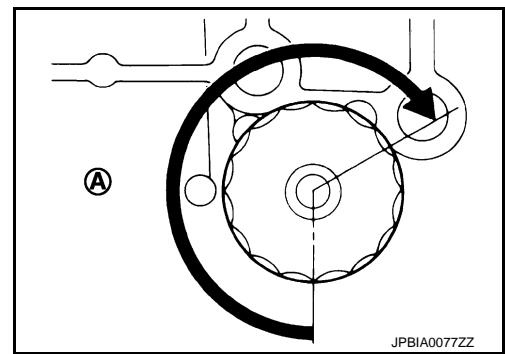

INFOID:000000008140238

OIL FILTER : Inspection

INSPECTION AFTER INSTALLATION

1. Check the engine oil level. Refer to [LU-7, "Inspection"](#).
2. Start the engine, and check there is no leak of engine oil.
NOTE:
Perform maintenance mode 5 and maintain the engine speed. Refer to [HBC-89, "Description"](#).
3. Stop the engine and wait for 10 minutes.
4. Check the engine oil level, and adjust the level. Refer to [LU-7, "Inspection"](#).

SPARK PLUG

SPARK PLUG : Removal and Installation

INFOID:000000008140239

REMOVAL

1. Remove engine cover. Refer to [EM-25, "Exploded View"](#).
2. Remove air cleaner case and air duct (bank 1 and bank 2). Refer to [EM-26, "Exploded View"](#).
3. Remove ignition coil. Refer to [EM-46, "Removal and Installation"](#).
4. Remove spark plug with a spark plug wrench (commercial service tool).

a : 14 mm (0.55 in)

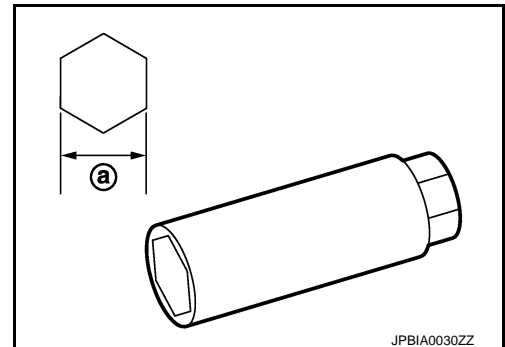

INSTALLATION

Installation is the reverse order of removal.

SPARK PLUG : Inspection

INFOID:000000008140240

INSPECTION AFTER REMOVAL

Use the standard type spark plug for normal condition.

Spark plug (Standard type) : Refer to [EM-134, "Spark Plug"](#).

CAUTION:

A
B
C
D
E
F
G
H
I
J
K
L
M
N
O

MA

ENGINE MAINTENANCE

< PERIODIC MAINTENANCE >

- Never drop or shock spark plug.
- Never use a wire brush for cleaning.
- If plug tip is covered with carbon, use spark plug cleaner to clean.

Cleaner air pressure

: Less than 588 kPa (6 kg/cm², 85 psi)

Cleaning time

: Less than 20 seconds

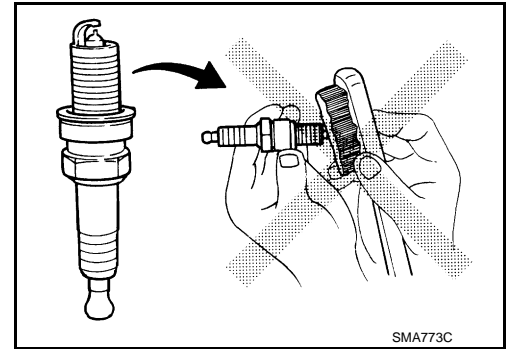

- Check and adjustment of plug gap is not required between change intervals.

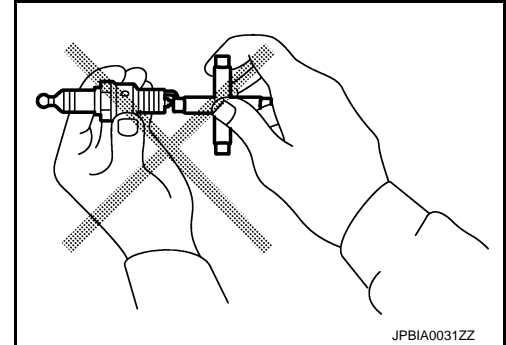

EVAP VAPOR LINES

EVAP VAPOR LINES : Inspection

INFOID:000000008140241

1. Visually inspect EVAP vapor lines for improper attachment and for cracks, damage, loose connections, chafing and deterioration. Refer to [EC-441, "Inspection"](#).
2. Inspect fuel tank filler cap vacuum relief valve for clogging, sticking, etc. Refer to [EC-331, "Component Inspection"](#).

CHASSIS MAINTENANCE

< PERIODIC MAINTENANCE >

CHASSIS MAINTENANCE

EXHAUST SYSTEM

EXHAUST SYSTEM : Inspection

INFOID:000000008140242

Check exhaust pipes, muffler and mounting for improper attachment, leaks, cracks, damage or deterioration.

- If anything is found, repair or replace damaged parts.

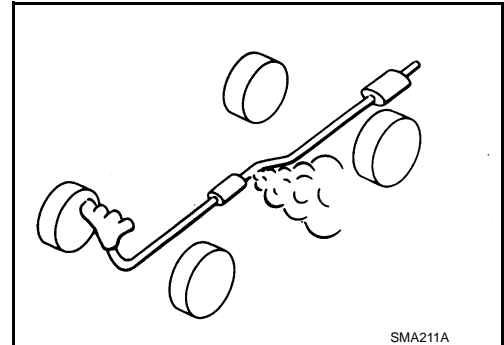

A/T FLUID

A/T FLUID : Inspection

INFOID:000000008140243

FLUID LEAKAGE

- Check transaxle surrounding area (oil seal and plug etc.) for fluid leakage.
- If anything is found, repair or replace damaged parts and adjust A/T fluid level. Refer to [TM-94, "Adjustment"](#).

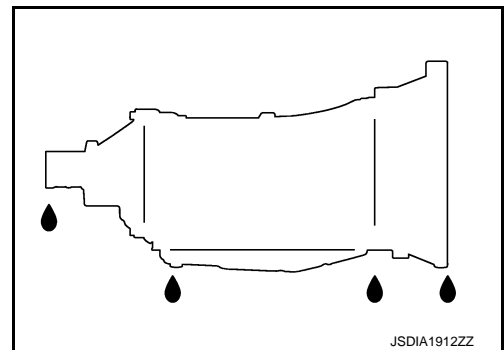

REAR PROPELLER SHAFT

REAR PROPELLER SHAFT : Inspection

INFOID:000000008140244

APPEARANCE AND NOISE

- Check the propeller shaft tube surface for dents or cracks. If malfunction is detected, replace propeller shaft assembly.
- If center bearing is noisy or damaged, replace propeller shaft assembly.

VIBRATION

If vibration is present at high speed, inspect propeller shaft runout first.

1. With a dial indicator, measure propeller shaft runout at runout measuring points by rotating final drive companion flange with hands.

**Propeller shaft
runout**

: Refer to [DLN-11, "Propeller Shaft Runout"](#).

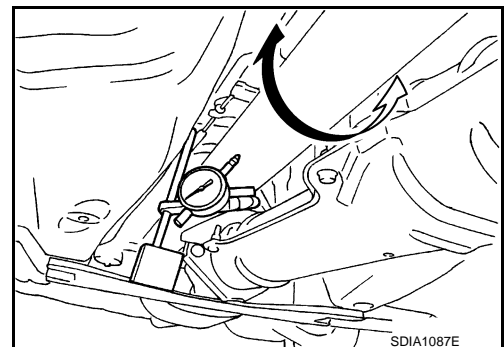

A
B
C
D
E
F
G
H
I
J
K
L
M
N
O
MA

CHASSIS MAINTENANCE

< PERIODIC MAINTENANCE >

- Propeller shaft runout measuring point (Point “△”).

⇐: Vehicle front

Dimension

- A : 172 mm (6.77 in)**
- B : 172 mm (6.77 in)**
- C : 172 mm (6.77 in)**

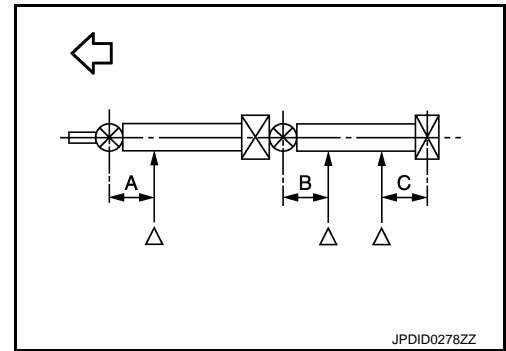

2. If runout still exceeds specifications, separate propeller shaft at final drive companion flange; then change the phase between companion flange and propeller shaft by the one bolt hole at a time and install propeller shaft.
3. If runout is more than the limit value, remove and check propeller shaft.
4. Check the vibration by driving vehicle.

REAR DIFFERENTIAL GEAR OIL

REAR DIFFERENTIAL GEAR OIL : Inspection

INFOID:000000008140245

OIL LEAKAGE

- Make sure that oil is not leaking from final drive assembly or around it.

OIL LEVEL

- Remove filler plug (1) and check oil level from filler plug mounting hole as shown in the figure.

CAUTION:

Turn the ignition switch OFF while checking oil level.

- Set a gasket on filler plug and install it on final drive assembly. Refer to [DLN-27, "Exploded View"](#).

CAUTION:

Never reuse gasket.

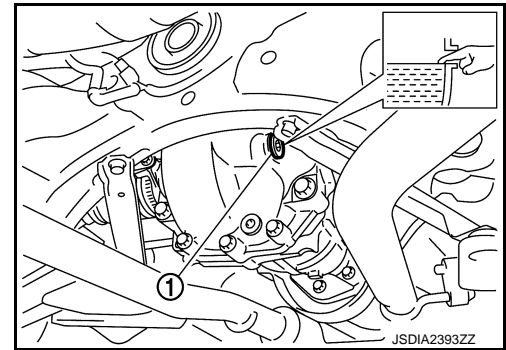

REAR DIFFERENTIAL GEAR OIL : Draining

INFOID:000000008140246

1. Turn the ignition switch OFF.
2. Remove drain plug (1) and drain gear oil.
3. Set a gasket on drain plug and install it to final drive assembly and tighten to the specified torque. Refer to [DLN-27, "Exploded View"](#).

CAUTION:

Never reuse gasket.

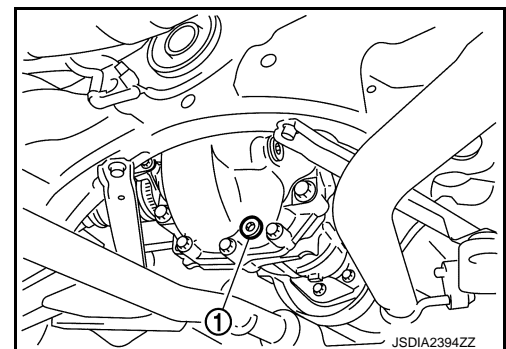

CHASSIS MAINTENANCE

< PERIODIC MAINTENANCE >

REAR DIFFERENTIAL GEAR OIL : Refilling

INFOID:000000008140247

1. Remove filler plug (1). Fill with new gear oil until oil level reaches the specified level near filler plug mounting hole.

Oil grade and viscosity : Refer to [MA-10, "Fluids and Lubricants"](#).

Oil capacity : Refer to [DLN-45, "General Specifications"](#).

2. After refilling oil, check oil level. Set a gasket to filler plug, then install it to final drive assembly. Refer to [DLN-27, "Exploded View"](#).

CAUTION:

Never reuse gasket.

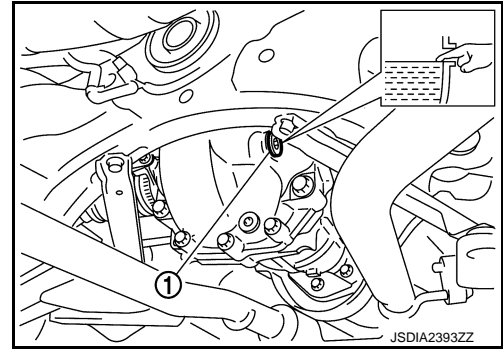

WHEELS (BONDING WEIGHT TYPE)

WHEELS (BONDING WEIGHT TYPE) : Adjustment

INFOID:000000008140248

BALANCING WHEELS (BONDING WEIGHT TYPE)

Preparation Before Adjustment

Using releasing agent, remove double-faced adhesive tape from the road wheel.

CAUTION:

- Be careful not to scratch the road wheel during removal.
- After removing double-faced adhesive tape, wipe clean traces of releasing agent from the road wheel.

Wheel Balance Adjustment

- The details of the adjustment procedure are different for each model of wheel balancer. Therefore, refer to each instruction manual.
- If a tire balance machine has adhesion balance weight mode settings and drive-in weight mode setting, select and adjust a drive-in weight mode suitable for road wheels.

1. Set road wheel on tire balance machine using the center hole as a guide. Start the tire balance machine.
2. When inner and outer unbalance values are shown on the tire balance machine indicator, multiply outer unbalance value by 5/3 to determine balance weight that should be used. Select the outer balance weight with a value closest to the calculated value above and install to the designated outer position of, or at the designated angle in relation to the road wheel.

CAUTION:

- Never install the inner balance weight before installing the outer balance weight.
- Before installing the balance weight, always to clean the mating surface of the road wheel.

- a. Indicated unbalance value $\times 5/3$ = balance weight to be installed

Calculation example:

23 g (0.81 oz) $\times 5/3$ = 38.33 g (1.35 oz) \Rightarrow 37.5 g (1.32 oz) balance weight (closer to calculated balance weight value)

NOTE:

Note that balance weight value must be closer to the calculated balance weight value.

Example:

36.2 \Rightarrow 35 g (1.23 oz)

36.3 \Rightarrow 37.5 g (1.32 oz)

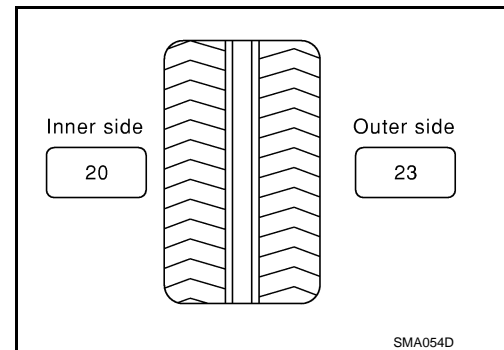

- b. Installed balance weight in the position.

A
B
C
D
E
F
G
H
I
J
K
L
M
N
O

CHASSIS MAINTENANCE

< PERIODIC MAINTENANCE >

- When installing balance weight (1) to road wheels, set it into the grooved area (A) on the inner wall of the road wheel as shown in the figure so that the balance weight center (B) is aligned with the tire balance machine indication position (angle) (C).

CAUTION:

- Always use genuine NISSAN adhesion balance weights.
- Balance weights are non-reusable; always replace with new ones.
- Never install three or more sheets of balance weight.

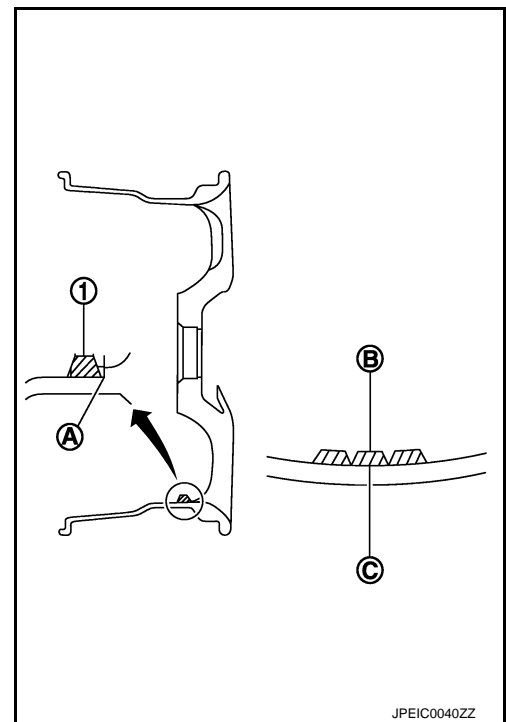

- c. If calculated balance weight value exceeds 50 g (1.76 oz), install two balance weight sheets in line with each other as shown in the figure.

CAUTION:

Never install one balance weight sheet on top of another.

3. Start the tire balance machine again.
4. Install drive-in balance weight on inner side of road wheel in the tire balance machine indication position (angle).

CAUTION:

Never install three or more balance weight.

5. Start the tire balance machine. Check that the inner and outer residual unbalance value is within the allowable unbalance value.

CAUTION:

If either residual unbalance value exceeds limit, repeat installation procedures.

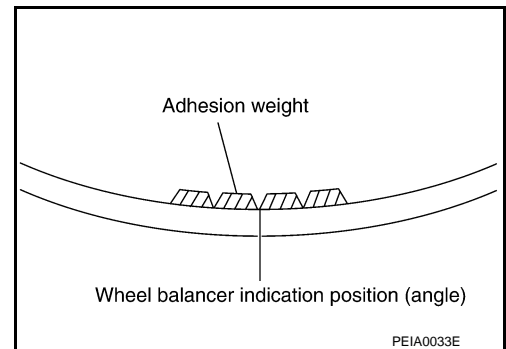

Allowable unbalance value

Dynamic (At flange) : Refer to [WT-64, "Road Wheel"](#).

Static (At flange) : Refer to [WT-64, "Road Wheel"](#).

TIRE ROTATION

- Follow the maintenance schedule for tire rotation service intervals. Refer to [MA-4, "Explanation of General Maintenance"](#).
- When installing the wheel, tighten wheel nuts to the specified torque. Refer to [WT-58, "Exploded View"](#).

CAUTION:

- Do not include the T-type spare tire when rotating the tires.
 - When installing wheels, tighten them diagonally by dividing the work two to three times in order to prevent the wheels from developing any distortion.
 - Be careful not to tighten wheel nut at torque exceeding the criteria.
 - Use NISSAN genuine wheel nuts for aluminum wheels.
- Perform the ID registration, after tire rotation. Refer to [WT-24, "Work Procedure"](#).

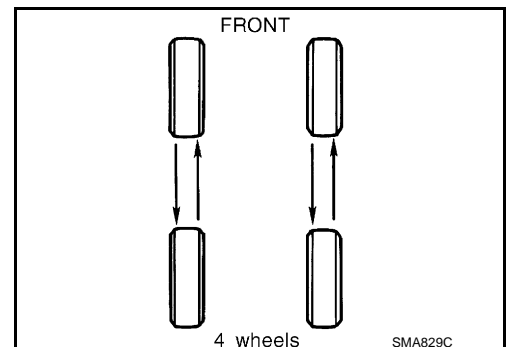

BRAKE FLUID LEVEL AND LEAKS

CHASSIS MAINTENANCE

< PERIODIC MAINTENANCE >

BRAKE FLUID LEVEL AND LEAKS : Inspection

INFOID:000000008140249

- If fluid level is extremely low, check brake system for leaks.

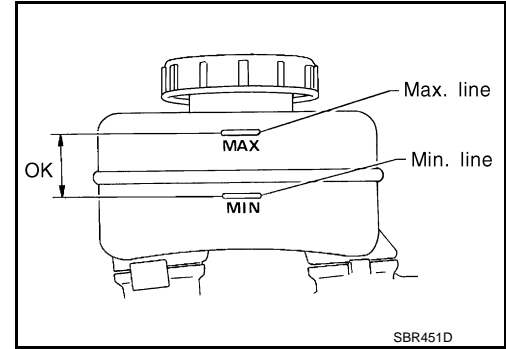

BRAKE LINES AND CABLES

BRAKE LINES AND CABLES : Inspection

INFOID:000000008140250

- Check brake fluid lines and parking brake cables for improper attachment, leaks, chafing, abrasions, deterioration, etc.

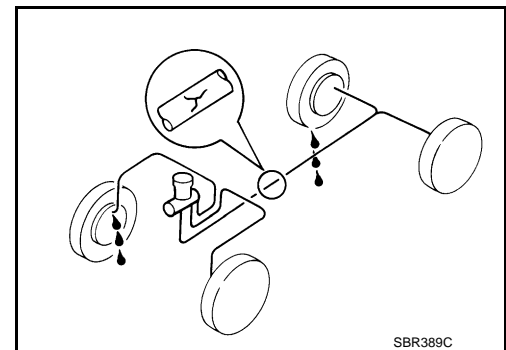

BRAKE FLUID

BRAKE FLUID : Changing

INFOID:000000008140251

1. Drain brake fluid from each bleed valve.
2. Refill until new brake fluid comes out from each bleed valve. Use same procedure as in bleeding hydraulic system to refill brake fluid.
Refer to [BR-274. "Bleeding Brake System"](#).
 - Refill with recommended Genuine NISSAN Super Heavy Duty Brake Fluid or equivalent DOT 3 (US FMVSS No. 116). Refer to [MA-10. "Fluids and Lubricants"](#).
 - Never reuse drained brake fluid.
 - Be careful not to splash brake fluid on painted areas.

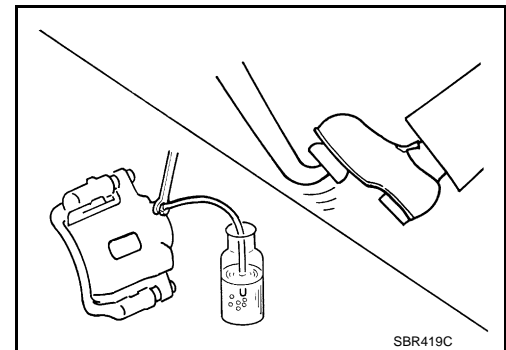

DISC BRAKE

DISC BRAKE : Inspection

INFOID:000000008140252

DISC ROTOR

Check condition, wear, and damage.

CALIPER

- Check for leakage.

A
B
C
D
E
F
G
H
I
J
K
L
M
N
O

MA

CHASSIS MAINTENANCE

< PERIODIC MAINTENANCE >

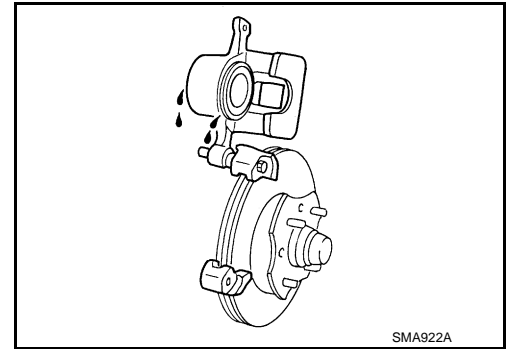

BRAKE PAD

- Check for wear or damage.

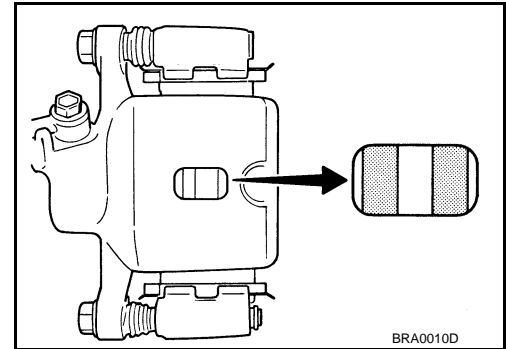

DISC BRAKE : Front Disc Brake

INFOID:000000008140253

Unit: mm (in)

Item		Limit
Brake pad	Wear thickness	2.0 (0.079)
	Wear thickness	26.0 (1.024)
Disc rotor	Thickness variation (measured at 8 positions)	0.015 (0.0006)
	Runout (with it attached to the vehicle)	0.035 (0.0014)

DISC BRAKE : Rear Disc Brake

INFOID:000000008140254

Unit: mm (in)

Item		Limit
Brake pad	Wear thickness	2.0 (0.079)
	Wear thickness	14.0 (0.551)
Disc rotor	Thickness variation (measured at 8 positions)	0.015 (0.0006)
	Runout (with it attached to the vehicle)	0.055 (0.0022)

STEERING GEAR AND LINKAGE

STEERING GEAR AND LINKAGE : Inspection

INFOID:000000008140255

STEERING GEAR

CHASSIS MAINTENANCE

< PERIODIC MAINTENANCE >

- Check gear housing and boots for looseness, damage and grease leakage.
- Check connection with steering column for looseness.

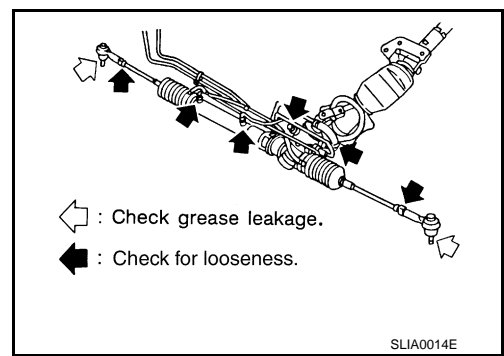

STEERING LINKAGE

Check ball joint, dust cover and other component parts for looseness, wear, damage and grease leakage.

POWER STEERING FLUID AND LINES

POWER STEERING FLUID AND LINES : Inspection

INFOID:000000008140256

Check fluid level in reservoir tank with engine off.

Use "HOT" range at fluid temperatures of 50 to 80°C (122 to 176°F) or "COLD" range at fluid temperatures of 0 to 30°C (32 to 86°F).

CAUTION:

- Do not overfill.
- Recommended fluid is Genuine NISSAN PSF or equivalent. Refer to [MA-10, "Fluids and Lubricants"](#).

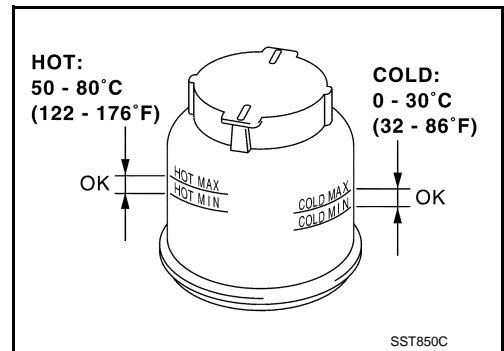

- Check lines for improper attachment, leaks, cracks, damage, loose connections, chafing and deterioration.
- Check rack boots for accumulation of power steering fluid.

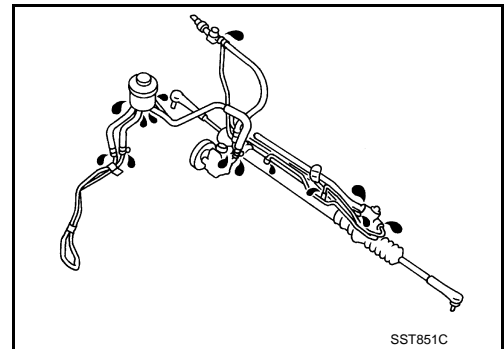

AXLE AND SUSPENSION PARTS

AXLE AND SUSPENSION PARTS : Inspection

INFOID:000000008140257

Check front and rear axle and suspension parts for excessive play, cracks, wear or other damage.

- Shake each wheel to check for excessive play.
- Check wheel bearings for smooth operation.
- Check axle and suspension nuts and bolts for looseness.
- Check strut (shock absorber) for oil leakage or other damage.
- Check suspension ball joint for grease leakage and ball joint dust cover for cracks or other damage.

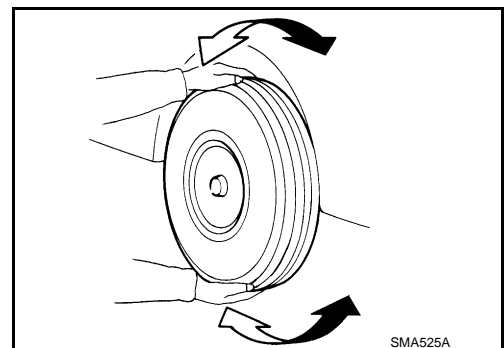

A
B
C
D
E
F
G
H
I
J
K
L
M
N
O
MA

CHASSIS MAINTENANCE

< PERIODIC MAINTENANCE >

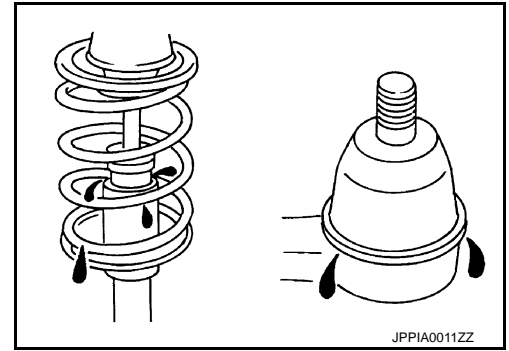

DRIVE SHAFT

DRIVE SHAFT : Inspection

Check boot and drive shaft for cracks, wear, damage and grease leakage.

INFOID:000000008140258

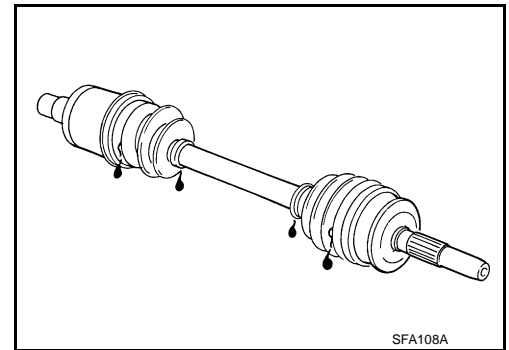

BODY MAINTENANCE

< PERIODIC MAINTENANCE >

BODY MAINTENANCE

LOCKS, HINGES AND HOOD LATCH

LOCKS, HINGES AND HOOD LATCH : Lubricating

INFOID:000000008140259

For hood and hood lock control illustration.

- Hood: Refer to [DLK-136, "Exploded View"](#).
- Hood lock control: Refer to [DLK-162, "Exploded View"](#).

For door and door lock illustration.

- Front door: Refer to [DLK-146, "Exploded View"](#).
- Front door lock: Refer to [DLK-167, "Exploded View"](#).
- Rear door: Refer to [DLK-150, "Exploded View"](#).
- Rear door lock: Refer to [DLK-170, "Exploded View"](#).

For trunk lid and trunk lid lock illustration.

- Trunk lid: Refer to [DLK-155, "Exploded View"](#).
- Trunk lid lock: Refer to [DLK-173, "Exploded View"](#).

SEAT BELT, BUCKLES, RETRACTORS, ANCHORS AND ADJUSTERS

SEAT BELT, BUCKLES, RETRACTORS, ANCHORS AND ADJUSTERS : Inspection

INFOID:000000008140260

For front seat belt illustration. Refer to [SB-5, "SEAT BELT RETRACTOR : Exploded View"](#).

For rear seat belt illustration. Refer to [SB-14, "SEAT BELT RETRACTOR : Exploded View"](#).

CAUTION:

- **After any collision, inspect all seat belt assemblies, including retractors and other attached hardwares (I.e. anchor bolt, guide rail set). Nissan recommends to replace all seat belt assemblies in use during a collision, unless not damaged and properly operating after minor collision.**

Also inspect seat belt assemblies not in use during a collision, and replace if damaged or improperly operating.

Seat belt pre-tensioner should be replaced even if the seat belts are not in use during a frontal collision where the driver and passenger air bags are deployed.

- **If any component of seat belt assembly is questionable, do not repair.**

Replace as seat belt assembly.

- **If webbing is cut, frayed, or damaged, replace belt assembly.**
- **Never oil tongue and buckle.**
- **Use a genuine NISSAN seat belt assembly.**

For details, refer to [SB-4, "SEAT BELT RETRACTOR : Inspection"](#), [SB-12, "SEAT BELT RETRACTOR : Inspection"](#) in SB section.

- Check anchors for loose mounting
- Check belts for damage
- Check retractor for smooth operation
- Check function of buckles and tongues when buckled and released

A
B
C
D
E
F
G
H
I
J
K
L
M
N
O

MA

SERVICE DATA AND SPECIFICATIONS (SDS)

< SERVICE DATA AND SPECIFICATIONS (SDS)

SERVICE DATA AND SPECIFICATIONS (SDS)

SERVICE DATA AND SPECIFICATIONS (SDS)

ENGINE COOLANT

ENGINE COOLANT : Periodical Maintenance Specification

INFOID:000000008140261

ENGINE COOLANT CAPACITY (APPROXIMATE)

Unit: ℓ (US qt, Imp qt)

Engine coolant capacity [With reservoir tank ("MAX" level)]	8.6 (9-1/8, 7-5/8)
Reservoir tank engine coolant capacity (At "MAX" level)	0.8 (7/8, 3/4)

ENGINE OIL

ENGINE OIL : Periodical Maintenance Specification

INFOID:000000008140262

ENGINE OIL CAPACITY (APPROXIMATE)

Unit: ℓ (US qt, Imp qt)

Drain and refill	With oil filter change	4.9 (5-1/8, 4-1/4)
	Without oil filter change	4.6 (4-7/8, 4)
Dry engine (Overhaul)		5.7 (6, 5)

SPARK PLUG

SPARK PLUG : Spark Plug

INFOID:000000008140263

SPARK PLUG

Unit: mm (in)

Make	DENSO
Standard type	FXE22HR11
Gap (Nominal)	1.1 (0.043)

ROAD WHEEL

ROAD WHEEL : Road Wheel

INFOID:000000008140264

CONVENTIONAL

Item		Limit
Runout	Axial runout	Less than 0.3 mm (0.012 in)
	Radial runout	
Allowable unbalance	Dynamic (At flange)	Less than 5 g (0.17 oz) (one side)
	Static (At flange)	Less than 10 g (0.35 oz)

EMERGENCY (STEEL WHEEL)

Item		Limit
Runout	Axial runout (Average)	Less than 1.5 mm (0.059 in)
	Radial runout (Average)	